

01/2009:0308  
corrected 6.8

## ACACIA, SPRAY-DRIED

## Acaciae gummi dispersione desiccatum

## DEFINITION

Spray-dried acacia is obtained from a solution of acacia.

## CHARACTERS

It dissolves completely and rapidly, after about 20 min, in twice its mass of water. The liquid obtained is colourless or yellowish, dense, viscous, adhesive, translucent and weakly acid to blue litmus paper. Spray-dried acacia is practically insoluble in ethanol (96 per cent).

## IDENTIFICATION

- A. Examined under a microscope, in *ethanol (96 per cent) R*, the powder is seen to consist predominantly of spheroidal particles about 4-40 µm in diameter, with a central cavity containing 1 or several air-bubbles; a few minute flat fragments are present. Only traces of starch granules are visible. No vegetable tissue is seen.
- B. Examine the chromatograms obtained in the test for glucose and fructose.  
*Results:* the chromatogram obtained with the test solution shows 3 zones due to galactose, arabinose and rhamnose. No other important zones are visible, particularly in the upper part of the chromatogram.
- C. Dissolve 1 g of the drug to be examined in 2 mL of *water R* by stirring frequently for 20 min. Add 2 mL of *ethanol (96 per cent) R*. After shaking a white gelatinous mucilage is formed which becomes fluid on adding 10 mL of *water R*.

## TESTS

**Solution S.** Dissolve 3.0 g of the drug to be examined in 25 mL of *water R* by stirring for 10 min. Allow to stand for 20 min and dilute to 30 mL with *water R*.

**Glucose and fructose.** Thin-layer chromatography (2.2.27).

*Test solution.* To 0.100 g in a thick-walled centrifuge tube add 2 mL of a 100 g/L solution of *trifluoroacetic acid R*, shake vigorously to dissolve the forming gel, stopper the tube and heat the mixture at 120 °C for 1 h. Centrifuge the hydrolysate, transfer the clear supernatant carefully into a 50 mL flask, add 10 mL of *water R* and evaporate to dryness under reduced pressure. To the resulting clear film add 0.1 mL of *water R* and 0.9 mL of *methanol R*. Centrifuge to separate the amorphous precipitate. Dilute the supernatant, if necessary, to 1 mL with *methanol R*.

*Reference solution.* Dissolve 10 mg of *arabinose R*, 10 mg of *galactose R*, 10 mg of *glucose R*, 10 mg of *rhamnose R* and 10 mg of *xylose R* in 1 mL of *water R* and dilute to 10 mL with *methanol R*.

*Plate:* TLC silica gel plate R.

*Mobile phase:* 16 g/L solution of *sodium dihydrogen phosphate R*, *butanol R*, *acetone R* (10:40:50 V/V/V).

*Application:* 10 µL as bands.

*Development A:* over a path of 10 cm.

*Drying A:* in a current of warm air for a few minutes.

*Development B:* over a path of 15 cm using the same mobile phase.

*Drying B:* at 110 °C for 10 min.

*Detection:* spray with *anisaldehyde solution R* and heat at 110 °C for 10 min.

*Results:* the chromatogram obtained with the reference solution shows 5 clearly separated coloured zones due to galactose (greyish-green or green), glucose (grey), arabinose (yellowish-green), xylose (greenish-grey or yellowish-grey) and rhamnose (yellowish-green), in order of increasing  $R_f$  value.

The chromatogram obtained with the test solution shows no grey zone and no greyish-green zone between the zones corresponding to galactose and arabinose in the chromatogram obtained with the reference solution.

**Starch, dextrin and agar.** To 10 mL of solution S previously boiled and cooled add 0.1 mL of 0.05 M *iodine*. No blue or reddish-brown colour develops.

## Sterculia gum

- A. Place 0.2 g in a 10 mL ground-glass-stoppered cylinder graduated in 0.1 mL. Add 10 mL of *ethanol (60 per cent V/V) R* and shake. Any gel formed occupies not more than 1.5 mL.
- B. To 1.0 g add 100 mL of *water R* and shake. Add 0.1 mL of *methyl red solution R*. Not more than 5.0 mL of 0.01 M *sodium hydroxide* is required to change the colour of the indicator.

**Tannins.** To 10 mL of solution S add 0.1 mL of *ferric chloride solution R1*. A gelatinous precipitate is formed, but neither the precipitate nor the liquid shows a dark blue colour.

**Tragacanth.** Examine the chromatograms obtained in the test for Glucose and fructose.

*Results:* the chromatogram obtained with the test solution shows no greenish-grey or yellowish-grey zone corresponding to the zone of xylose in the chromatogram obtained with the reference solution.

**Loss on drying (2.2.32):** maximum 10.0 per cent, determined on 1.000 g by drying in an oven at 105 °C.

**Total ash (2.4.16):** maximum 4.0 per cent.

## Microbial contamination

TAMC: acceptance criterion 10<sup>4</sup> CFU/g (2.6.12).

TYMC: acceptance criterion 10<sup>2</sup> CFU/g (2.6.12).

Absence of *Escherichia coli* (2.6.13).

Absence of *Salmonella* (2.6.13).

## FUNCTIONALITY-RELATED CHARACTERISTICS

*This section provides information on characteristics that are recognised as being relevant control parameters for one or more functions of the substance when used as an excipient (see chapter 5.15). This section is a non-mandatory part of the monograph and it is not necessary to verify the characteristics to demonstrate compliance. Control of these characteristics can however contribute to the quality of a medicinal product by improving the consistency of the manufacturing process and the performance of the medicinal product during use. Where control methods are cited, they are recognised as being suitable for the purpose, but other methods can also be used. Wherever results for a particular characteristic are reported, the control method must be indicated.*

*The following characteristic may be relevant for spray-dried acacia used as a viscosity-increasing agent and/or suspending agent in aqueous preparations.*

**Apparent viscosity.** Determine the dynamic viscosity using a capillary viscometer (2.2.9) or a rotating viscometer (2.2.10) on a 100 g/L solution of spray-dried acacia (dried substance).

01/2008:1585  
corrected 6.0

## ACAMPROSATE CALCIUM

## Acamprosatum calcicum

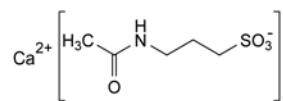
C<sub>10</sub>H<sub>20</sub>CaN<sub>2</sub>O<sub>8</sub>S<sub>2</sub>  
[77337-73-6]M<sub>r</sub> 400.5

## DEFINITION

Calcium bis[3-(acetylamino)propane-1-sulfonate].

*Content:* 98.0 per cent to 102.0 per cent (dried substance).

## CHARACTERS

*Appearance:* white or almost white powder.

*Solubility:* freely soluble in water, practically insoluble in ethanol (96 per cent) and in methylene chloride.

## IDENTIFICATION

A. Infrared absorption spectrophotometry (2.2.24).

*Comparison:* Ph. Eur. reference spectrum of *acamprosate calcium*.

B. It gives reaction (a) of calcium (2.3.1).

## TESTS

**Solution S.** Dissolve 5.0 g in *carbon dioxide-free water R* and dilute to 100 mL with the same solvent.

**Appearance of solution.** Solution S is clear (2.2.1) and colourless (2.2.2, *Method II*).

**pH** (2.2.3): 5.5 to 7.0 for solution S.

**Impurity A.** Liquid chromatography (2.2.29).

*Test solution.* Dissolve 0.40 g of the substance to be examined in *distilled water R* and dilute to 20.0 mL with the same solvent. Dilute 10.0 mL of this solution to 100.0 mL with *borate buffer solution pH 10.4 R*. Place 3.0 mL of the solution obtained in a 25 mL ground-glass-stoppered tube. Add 0.15 mL of a freshly prepared 5 g/L solution of *fluorescamine R* in *acetonitrile R*. Shake immediately and vigorously for 30 s. Place in a water-bath at 50 °C for 30 min. Cool under a stream of cold water. Centrifuge and filter the supernatant through a suitable membrane filter (nominal pore size 0.45 µm), 25 mm in diameter.

*Reference solution.* Dissolve 50 mg of *acamprosate impurity A CRS* in *distilled water R* and dilute to 200.0 mL with the same solvent. Dilute 0.4 mL of the solution to 100.0 mL with *borate buffer solution pH 10.4 R*. Treat 3.0 mL of this solution in the same way as the test solution

*Column:*

- *size:*  $l = 0.15$  m,  $\varnothing = 4.6$  mm;
- *stationary phase:* spherical octadecylsilyl silica gel for chromatography R (5 µm) with a specific surface area of 170 m<sup>2</sup>/g and a pore size of 12 nm.

*Mobile phase:* acetonitrile R, methanol R, 0.1 M phosphate buffer solution pH 6.5 R (10:10:80 V/V/V).

*Flow rate:* 1 mL/min.

*Detection:* spectrophotometer at 261 nm.

*Injection:* 20 µL.

*Run time:* 6 times the retention time of impurity A

*Retention times:* fluorescamine = about 4 min; impurity A = about 8 min; acamprosate is not detected by this system.

*Limits:*

- *impurity A:* not more than the area of the corresponding peak in the chromatogram obtained with the reference solution (0.05 per cent).

**Heavy metals** (2.4.8): maximum 10 ppm.

Dissolve 2.0 g in *distilled water R* and dilute to 20 mL with the same solvent. 12 mL of the solution complies with test A. Prepare the reference solution using 10 mL of *lead standard solution (1 ppm Pb) R*.

**Loss on drying** (2.2.32): maximum 0.4 per cent, determined on 1.000 g by drying in an oven at 105 °C.

## ASSAY

To 4 g of *cation exchange resin R* (75-150 µm) add 20 mL of *distilled water R* and stir magnetically for 10 min. Introduce this suspension into a glass column, 45 cm long and 2.2 cm in

internal diameter, equipped with a polytetrafluoroethylene flow cap covered by a glass-wool plug. Allow a few millilitres of this solution to flow, then place a plug of glass wool over the resin. Pass 50 mL of 1 M *hydrochloric acid* through the column. The pH of the eluate is close to 1. Wash with 3 quantities, each of 200 mL, of *distilled water R* to obtain an eluate at pH 6. Dissolve 0.100 g of the substance to be examined in 15 mL of *distilled water R*. Pass through the column and wash with 3 quantities, each of 25 mL, of *distilled water R*, collecting the eluate. Allow to elute until an eluate at pH 6 is obtained. Titrate the solution obtained with 0.1 M *sodium hydroxide*, determining the end-point potentiometrically (2.2.20).

1 mL of 0.1 M *sodium hydroxide* corresponds to 20.02 mg of C<sub>10</sub>H<sub>20</sub>CaN<sub>2</sub>O<sub>8</sub>S<sub>2</sub>.

## IMPURITIES



A. 3-aminopropane-1-sulfonic acid (homotaurine).

01/2008:2089

## ACARBOSE

## Acarbosum

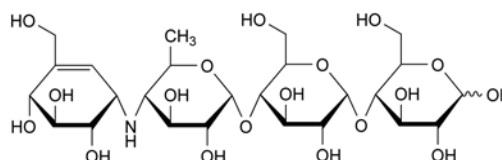

C<sub>25</sub>H<sub>43</sub>NO<sub>18</sub>  
[56180-94-0]

M<sub>r</sub> 646

## DEFINITION

O-4,6-Dideoxy-4-[[[(1S,4R,5S,6S)-4,5,6-trihydroxy-3-(hydroxymethyl)cyclohex-2-enyl]amino]-α-D-glucopyranosyl-(1→4)-O-α-D-glucopyranosyl-(1→4)-D-glucopyranose, which is produced by certain strains of *Actinoplanes utahensis*.

*Content:* 95.0 per cent to 102.0 per cent (anhydrous substance).

## CHARACTERS

*Appearance:* white or yellowish, amorphous powder, hygroscopic.

*Solubility:* very soluble in water, soluble in methanol, practically insoluble in methylene chloride.

## IDENTIFICATION

A. Infrared absorption spectrophotometry (2.2.24).

*Comparison:* acarbose for identification CRS.

B. Examine the chromatograms obtained in the assay.

*Results:* the principal peak in the chromatogram obtained with the test solution is similar in retention time and size to the principal peak in the chromatogram obtained with reference solution (a).

## TESTS

**Solution S.** Dissolve 1.00 g in *carbon dioxide-free water R* and dilute to 20.0 mL with the same solvent.

**pH** (2.2.3): 5.5 to 7.5 for solution S.

**Specific optical rotation** (2.2.7): + 168 to + 183 (anhydrous substance).

Dilute 2.0 mL of solution S to 10.0 mL with *water R*.

**Absorbance** (2.2.25): maximum 0.15 at 425 nm for solution S.

**Related substances.** Liquid chromatography (2.2.29).

*Test solution.* Dissolve 0.200 g of the substance to be examined in *water R* and dilute to 10.0 mL with the same solvent.

*Reference solution (a).* Dissolve the contents of a vial of *acarbose CRS* in 5.0 mL of *water R*.

**Reference solution (b).** Dissolve 20 mg of *acarbose for peak identification CRS* (acarbose containing impurities A, B, C, D, E, F, G and H) in 1 mL of *water R*.

**Reference solution (c).** Dilute 1.0 mL of the test solution to 100.0 mL with *water R*.

**Column:**

- **size:**  $l = 0.25$  m,  $\varnothing = 4$  mm,
- **stationary phase:** aminopropylsilyl silica gel for chromatography R (5  $\mu$ m),
- **temperature:** 35 °C.

**Mobile phase:** mix 750 volumes of *acetonitrile R1* and 250 volumes of a solution containing 0.60 g/L of *potassium dihydrogen phosphate R* and 0.35 g/L of *disodium hydrogen phosphate dihydrate R*.

**Flow rate:** 2.0 mL/min.

**Detection:** spectrophotometer at 210 nm.

**Injection:** 10  $\mu$ L of the test solution and reference solutions (b) and (c).

**Run time:** 2.5 times the retention time of acarbose.

**Identification of impurities:** use the chromatogram supplied with *acarbose for peak identification CRS* and the chromatogram obtained with reference solution (b) to identify the peaks due to impurities A, B, C, D, E, F, G and H.

**Relative retention** with reference to acarbose (retention time = about 16 min): impurity D = about 0.5; impurity H = about 0.6; impurity B = about 0.8; impurity A = about 0.9; impurity C = about 1.2; impurity E = about 1.7; impurity F = about 1.9; impurity G = about 2.2.

**System suitability:** reference solution (b):

- **peak-to-valley ratio:** minimum 1.2, where  $H_p$  = height above the baseline of the peak due to impurity A and  $H_v$  = height above the baseline of the lowest point of the curve separating this peak from the peak due to acarbose,
- the chromatogram obtained is similar to the chromatogram supplied with *acarbose for peak identification CRS*.

**Limits:**

- **correction factors:** for the calculation of contents, multiply the peak areas of the following impurities by the corresponding correction factor: impurity B = 0.63; impurity D = 0.75; impurity E = 1.25; impurity F = 1.25; impurity G = 1.25;
- **impurity A:** not more than 0.6 times the area of the principal peak in the chromatogram obtained with reference solution (c) (0.6 per cent);
- **impurity B:** not more than 0.5 times the area of the principal peak in the chromatogram obtained with reference solution (c) (0.5 per cent);
- **impurity C:** not more than 1.5 times the area of the principal peak in the chromatogram obtained with reference solution (c) (1.5 per cent);
- **impurity D:** not more than the area of the principal peak in the chromatogram obtained with reference solution (c) (1.0 per cent);
- **impurity E:** not more than 0.2 times the area of the principal peak in the chromatogram obtained with reference solution (c) (0.2 per cent);
- **impurities F, G:** for each impurity, not more than 0.3 times the area of the principal peak in the chromatogram obtained with reference solution (c) (0.3 per cent);
- **impurity H:** not more than 0.2 times the area of the principal peak in the chromatogram obtained with reference solution (c) (0.2 per cent);

- **any other impurities:** for each impurity, not more than 0.2 times the area of the principal peak in the chromatogram obtained with reference solution (c) (0.2 per cent);
- **total:** not more than 3 times the area of the principal peak in the chromatogram obtained with reference solution (c) (3.0 per cent);
- **disregard limit:** 0.1 times the area of the principal peak in the chromatogram obtained with reference solution (c) (0.1 per cent).

**Heavy metals (2.4.8):** maximum 20 ppm.

Dissolve 1.5 g in *water R* and dilute to 15 mL with the same solvent. If the solution is not clear, carry out prefiltration and use the filtrate. 10 mL complies with limit test E. Prepare the reference solution using 20 mL of *lead standard solution (1 ppm Pb) R*.

**Water (2.5.12):** maximum 4.0 per cent, determined on 0.300 g.

**Sulfated ash (2.4.14):** maximum 0.2 per cent, determined on 1.0 g.

**ASSAY**

Liquid chromatography (2.2.29) as described in the test for related substances with the following modification.

**Injection:** test solution and reference solution (a).

Calculate the percentage content of  $C_{25}H_{43}NO_{18}$  from the areas of the peaks and the declared content of *acarbose CRS*.

**STORAGE**

In an airtight container.

**IMPURITIES**

**Specified impurities:** A, B, C, D, E, F, G, H.

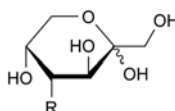
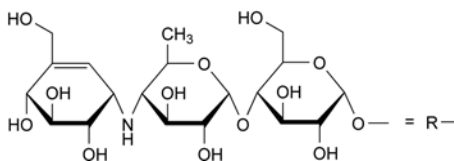

A. *O*-4,6-dideoxy-4-[(1*S*,4*R*,5*S*,6*S*)-4,5,6-trihydroxy-3-(hydroxymethyl)cyclohex-2-enyl]amino]- $\alpha$ -D-glucopyranosyl-(1 $\rightarrow$ 4)-*O*- $\alpha$ -D-glucopyranosyl-(1 $\rightarrow$ 4)-D-arabino-hex-2-ulopyranose,

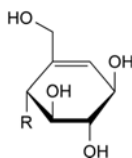

B. (1*R*,4*R*,5*S*,6*R*)-4,5,6-trihydroxy-2-(hydroxymethyl)cyclohex-2-enyl 4-*O*-[4,6-dideoxy-4-[(1*S*,4*R*,5*S*,6*S*)-4,5,6-trihydroxy-3-(hydroxymethyl)cyclohex-2-enyl]amino]- $\alpha$ -D-glucopyranosyl]- $\alpha$ -D-glucopyranoside,

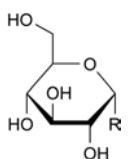

C.  $\alpha$ -D-glucopyranosyl 4-*O*-[4,6-dideoxy-4-[(1*S*,4*R*,5*S*,6*S*)-4,5,6-trihydroxy-3-(hydroxymethyl)cyclohex-2-enyl]amino]- $\alpha$ -D-glucopyranosyl]- $\alpha$ -D-glucopyranoside,

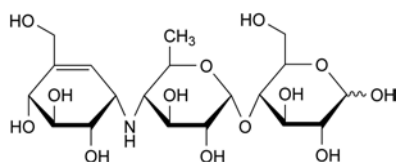
01/2008:0871  
corrected 7.0

D. 4-*O*-[4,6-dideoxy-4-[(1*S*,4*R*,5*S*,6*S*)-4,5,6-trihydroxy-3-(hydroxymethyl)cyclohex-2-enyl]amino]- $\alpha$ -D-glucopyranosyl]-D-glucopyranose,

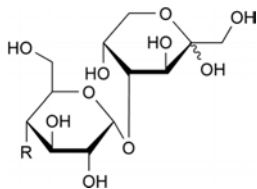

E. *O*-4,6-dideoxy-4-[(1*S*,4*R*,5*S*,6*S*)-4,5,6-trihydroxy-3-(hydroxymethyl)cyclohex-2-enyl]amino]- $\alpha$ -D-glucopyranosyl-(1 $\rightarrow$ 4)-*O*- $\alpha$ -D-glucopyranosyl-(1 $\rightarrow$ 4)-*O*- $\alpha$ -D-glucopyranosyl-(1 $\rightarrow$ 4)-D-*arabino*-hex-2-ulopyranose (4-*O*- $\alpha$ -acarbosyl-D-fructopyranose),

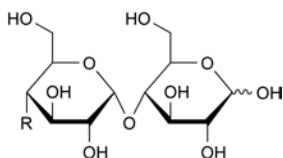

F. *O*-4,6-dideoxy-4-[(1*S*,4*R*,5*S*,6*S*)-4,5,6-trihydroxy-3-(hydroxymethyl)cyclohex-2-enyl]amino]- $\alpha$ -D-glucopyranosyl-(1 $\rightarrow$ 4)-*O*- $\alpha$ -D-glucopyranosyl-(1 $\rightarrow$ 4)-*O*- $\alpha$ -D-glucopyranosyl-(1 $\rightarrow$ 4)-D-glucopyranose (4-*O*- $\alpha$ -acarbosyl-D-glucopyranose),

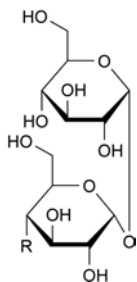

G.  $\alpha$ -D-glucopyranosyl *O*-4,6-dideoxy-4-[(1*S*,4*R*,5*S*,6*S*)-4,5,6-trihydroxy-3-(hydroxymethyl)cyclohex-2-enyl]amino]- $\alpha$ -D-glucopyranosyl-(1 $\rightarrow$ 4)-*O*- $\alpha$ -D-glucopyranosyl-(1 $\rightarrow$ 4)-*O*- $\alpha$ -D-glucopyranoside ( $\alpha$ -D-glucopyranosyl  $\alpha$ -acarboside),

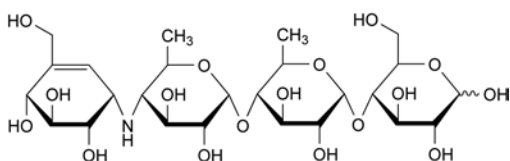

H. *O*-4,6-dideoxy-4-[(1*S*,4*R*,5*S*,6*S*)-4,5,6-trihydroxy-3-(hydroxymethyl)cyclohex-2-enyl]amino]- $\alpha$ -D-glucopyranosyl-(1 $\rightarrow$ 4)-*O*-6-deoxy- $\alpha$ -D-glucopyranosyl-(1 $\rightarrow$ 4)-D-glucopyranose.

## ACEBUTOLOL HYDROCHLORIDE

### Acebutololi hydrochloridum

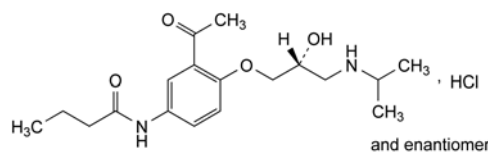

$C_{18}H_{29}ClN_2O_4$   
[34381-68-5]

$M_r$  372.9

#### DEFINITION

*N*-[3-Acetyl-4-[(2*RS*)-2-hydroxy-3-[(1-methylethyl)amino]propyl]phenyl]butanamide hydrochloride.

*Content*: 99.0 per cent to 101.0 per cent (dried substance).

#### CHARACTERS

*Appearance*: white or almost white, crystalline powder.

*Solubility*: freely soluble in water and in ethanol (96 per cent), very slightly soluble in acetone and in methylene chloride.

mp: about 143 °C.

#### IDENTIFICATION

*First identification*: B, D.

*Second identification*: A, C, D.

A. Ultraviolet and visible absorption spectrophotometry (2.2.25).

*Test solution*. Dissolve 20.0 mg in a 0.1 per cent *V/V* solution of hydrochloric acid *R* and dilute to 100.0 mL with the same acid solution. Dilute 5.0 mL of this solution to 100.0 mL with a 0.1 per cent *V/V* solution of hydrochloric acid *R*.

*Spectral range*: 220-350 nm.

*Absorption maxima*: at 233 nm and 322 nm.

*Specific absorbance at the absorption maximum*: 555 to 605 at 233 nm.

B. Infrared absorption spectrophotometry (2.2.24).

*Preparation*: discs.

*Comparison*: acebutolol hydrochloride CRS.

C. Thin-layer chromatography (2.2.27).

*Test solution*. Dissolve 20 mg of the substance to be examined in methanol *R* and dilute to 20 mL with the same solvent.

*Reference solution (a)*. Dissolve 20 mg of acebutolol hydrochloride CRS in methanol *R* and dilute to 20 mL with the same solvent.

*Reference solution (b)*. Dissolve 20 mg of pindolol CRS in methanol *R* and dilute to 20 mL with the same solvent. To 1 mL of this solution add 1 mL of reference solution (a).

*Plate*: TLC silica gel  $F_{254}$  plate *R*.

*Mobile phase*: perchloric acid *R*, methanol *R*, water *R* (5:395:600 *V/V/V*).

*Application*: 10  $\mu$ L.

*Development*: over 3/4 of the plate.

*Drying*: in air.

*Detection*: examine in ultraviolet light at 254 nm.

*System suitability*: the chromatogram obtained with reference solution (b) shows 2 clearly separated principal spots.

*Results*: the principal spot in the chromatogram obtained with the test solution is similar in position and size to the principal spot in the chromatogram obtained with reference solution (a).

D. It gives reaction (a) of chlorides (2.3.1).

## TESTS

**Appearance of solution.** The solution is not more opalescent than reference suspension II (2.2.1) and not more intensely coloured than reference solution BY<sub>5</sub> (2.2.2, Method II).

Dissolve 0.5 g in *water R* and dilute to 10 mL with the same solvent.

**pH (2.2.3):** 5.0 to 7.0.

Dissolve 0.20 g in *carbon dioxide-free water R* and dilute to 20 mL with the same solvent.

**Related substances.** Liquid chromatography (2.2.29).

**Test solution.** Dissolve 0.100 g of the substance to be examined in mobile phase A and dilute to 50.0 mL with mobile phase A.

**Reference solution (a).** Dissolve 20.0 mg of the substance to be examined in mobile phase A and dilute to 100.0 mL with mobile phase A. Dilute 0.5 mL of this solution to 50.0 mL with mobile phase A.

**Reference solution (b).** Dissolve the contents of a vial of *acebutolol impurity I CRS* in 1.0 mL of mobile phase A.

**Reference solution (c).** Mix 2.0 mL of reference solution (a) and 1.0 mL of reference solution (b) and dilute to 10.0 mL with mobile phase A.

**Reference solution (d).** Dissolve 5.0 mg of *acebutolol impurity C CRS* in 10 mL of *acetonitrile R* and dilute to 25.0 mL with mobile phase A. Dilute 0.5 mL of this solution to 50.0 mL with mobile phase A.

**Reference solution (e).** Dissolve 5.0 mg of *acebutolol impurity B CRS* in 10.0 mL of *acetonitrile R* and dilute to 25.0 mL with mobile phase A. Dilute 1.0 mL of this solution to 50.0 mL with mobile phase A.

**Column:**

- size:  $l = 0.125$  m,  $\varnothing = 4$  mm,
- stationary phase: end-capped octadecylsilyl silica gel for chromatography R (5  $\mu$ m),
- temperature: 40 °C.

**Mobile phase:**

- mobile phase A: mix 2.0 mL of *phosphoric acid R*, and 3.0 mL of *triethylamine R* and dilute to 1000 mL with *water R*;
- mobile phase B: mix equal volumes of *acetonitrile R* and mobile phase A;

Time (min)	Mobile phase A (per cent V/V)	Mobile phase B (per cent V/V)
0 - 2	98	2
2 - 30.5	98 → 10	2 → 90
30.5 - 41	10	90

**Flow rate:** 1.2 mL/min.

**Detection:** spectrophotometer at 240 nm.

**Injection:** 25  $\mu$ L.

**System suitability:** reference solution (c):

- resolution: minimum 7.0 between the peaks due to impurity I and acebutolol.

**Limits:**

- impurity B: not more than the area of the principal peak in the chromatogram obtained with reference solution (e) (0.2 per cent);
- impurity C: not more than the area of the principal peak in the chromatogram obtained with reference solution (d) (0.1 per cent);
- impurity I: not more than twice the area of the principal peak in the chromatogram obtained with reference solution (a) (0.2 per cent);

- any other impurity: for each impurity, not more than the area of the principal peak in the chromatogram obtained with reference solution (a) (0.1 per cent);
- total: not more than 5 times the area of the principal peak in the chromatogram obtained with reference solution (a) (0.5 per cent);
- disregard limit: 0.5 times the area of the principal peak in the chromatogram obtained with reference solution (a) (0.05 per cent).

**Heavy metals (2.4.8):** maximum 20 ppm.

Dissolve 0.50 g in 20.0 mL of *water R*. The solution complies with test E. Prepare the reference solution by diluting 10.0 mL of *lead standard solution (1 ppm Pb) R* to 20.0 mL with *water R*.

**Loss on drying (2.2.32):** maximum 0.5 per cent, determined on 1.000 g by drying in an oven at 105 °C for 3 h.

**Sulfated ash (2.4.14):** maximum 0.1 per cent, determined on 1.0 g.

## ASSAY

Dissolve 0.300 g in 50 mL of *ethanol (96 per cent) R* and add 1 mL of 0.1 M *hydrochloric acid*. Carry out a potentiometric titration (2.2.20), using 0.1 M *sodium hydroxide*. Read the volume added between the 2 points of inflexion.

1 mL of 0.1 M *sodium hydroxide* is equivalent to 37.29 mg of C<sub>18</sub>H<sub>29</sub>ClN<sub>2</sub>O<sub>4</sub>.

## STORAGE

Protected from light.

## IMPURITIES

**Specified impurities:** A, B, C, D, E, F, G, H, I, J, K.

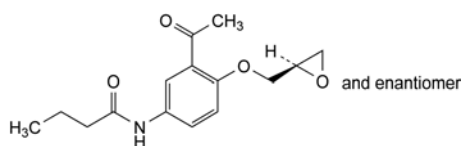

A. *N*-[3-acetyl-4-[(2*RS*)-oxiran-2-ylmethoxy]phenyl]butanamide,

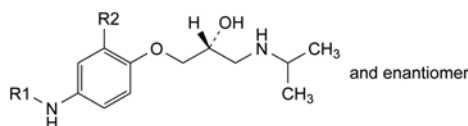

B. R1 = R2 = CO-CH<sub>3</sub>: *N*-[3-acetyl-4-[(2*RS*)-2-hydroxy-3-[(1-methylethyl)amino]propoxy]phenyl]acetamide (diacetolol),

D. R1 = H, R2 = CO-CH<sub>3</sub>: 1-[5-amino-2-[(2*RS*)-2-hydroxy-3-[(1-methylethyl)amino]propoxy]phenyl]ethanone,

E. R1 = CO-CH<sub>2</sub>-CH<sub>2</sub>-CH<sub>3</sub>, R2 = H: *N*-[4-[(2*RS*)-2-hydroxy-3-[(1-methylethyl)amino]propoxy]phenyl]butanamide,

J. R1 = CO-CH<sub>2</sub>-CH<sub>3</sub>, R2 = CO-CH<sub>3</sub>: *N*-[3-acetyl-4-[(2*RS*)-2-hydroxy-3-[(1-methylethyl)amino]propoxy]phenyl]propanamide,

K. R1 = R2 = CO-CH<sub>2</sub>-CH<sub>2</sub>-CH<sub>3</sub>: *N*-[3-butanoyl-4-[(2*RS*)-2-hydroxy-3-[(1-methylethyl)amino]propoxy]phenyl]butanamide,

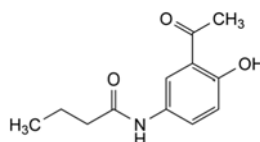

C. *N*-(3-acetyl-4-hydroxyphenyl)butanamide,

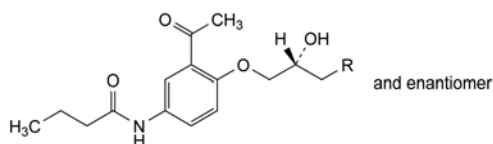

F. R = OH: *N*-[3-acetyl-4-[(2*RS*)-2,3-dihydroxypropoxy]phenyl]butanamide,

I. R = NH-CH<sub>2</sub>-CH<sub>3</sub>: *N*-[3-acetyl-4-[(2*RS*)-3-(ethylamino)-2-hydroxypropoxy]phenyl]butanamide,

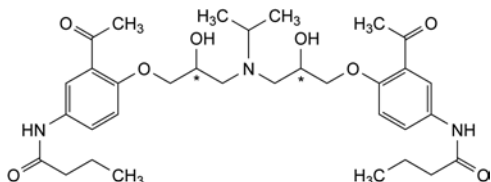

G. *N,N'*-[[[(1-methylethyl)imino]bis[(2-hydroxypropane-1,3-diyl)oxy(3-acetyl-1,4-phenylene)]]]dibutanamide (biamine),

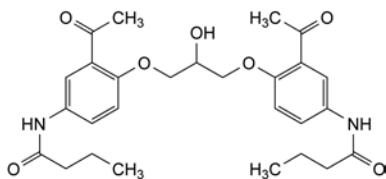

H. *N,N'*-[(2-hydroxypropane-1,3-diyl)bis[oxy(3-acetyl-1,4-phenylene)]]dibutanamide.

Add 3 mL of a 10.0 g/L solution of *hydrochloric acid R*. Allow to stand protected from light for 15 min. A blue colour develops and a precipitate is formed.

## TESTS

**Related substances.** Liquid chromatography (2.2.29). Prepare the solutions immediately before use.

**Test solution.** Dissolve 50.0 mg of the substance to be examined in a mixture of 30 volumes of mobile phase A and 70 volumes of mobile phase B and dilute to 25.0 mL with the same mixture of solvents.

**Reference solution (a).** Dissolve 21.6 mg of *diclofenac sodium CRS* (impurity A) in a mixture of 30 volumes of mobile phase A and 70 volumes of mobile phase B and dilute to 50.0 mL with the same mixture of solvents.

**Reference solution (b).** Dilute 2.0 mL of the test solution to 10.0 mL with a mixture of 30 volumes of mobile phase A and 70 volumes of mobile phase B.

**Reference solution (c).** Mix 1.0 mL of reference solution (a) and 1.0 mL of reference solution (b) and dilute to 100.0 mL with a mixture of 30 volumes of mobile phase A and 70 volumes of mobile phase B.

**Reference solution (d).** Dissolve 4.0 mg of *aceclofenac impurity F CRS* and 2.0 mg of *aceclofenac impurity H CRS* in a mixture of 30 volumes of mobile phase A and 70 volumes of mobile phase B then dilute to 10.0 mL with the same mixture of solvents.

**Reference solution (e).** Mix 1.0 mL of reference solution (b) and 1.0 mL of reference solution (d) and dilute to 100.0 mL with a mixture of 30 volumes of mobile phase A and 70 volumes of mobile phase B.

**Reference solution (f).** Dissolve the contents of a vial of *diclofenac impurity A CRS* (aceclofenac impurity I) in 1.0 mL of a mixture of 30 volumes of mobile phase A and 70 volumes of mobile phase B, add 1.5 mL of the same mixture of solvents and mix.

**Reference solution (g).** Dissolve 4 mg of *aceclofenac for peak identification CRS* (containing impurities B, C, D, E and G) in 2.0 mL of a mixture of 30 volumes of mobile phase A and 70 volumes of mobile phase B.

## Column:

- size:  $l = 0.25$  m,  $\varnothing = 4.6$  mm;
- stationary phase: spherical *end-capped octadecylsilyl silica gel for chromatography R* (5  $\mu$ m) with a pore size of 10 nm and a carbon loading of 19 per cent;
- temperature: 40 °C.

## Mobile phase:

- mobile phase A: 1.12 g/L solution of *phosphoric acid R* adjusted to pH 7.0 using a 42 g/L solution of *sodium hydroxide R*;
- mobile phase B: *water R*, *acetonitrile R* (1:9 V/V);

Time (min)	Mobile phase A (per cent V/V)	Mobile phase B (per cent V/V)
0 - 25	70 → 50	30 → 50
25 - 30	50 → 20	50 → 80
30 - 50	20	80

**Flow rate:** 1.0 mL/min.

**Detection:** spectrophotometer at 275 nm.

**Injection:** 10  $\mu$ L of the test solution and reference solutions (c), (e), (f) and (g).

**Identification of impurities:** use the chromatogram supplied with *aceclofenac for peak identification CRS* and the chromatogram obtained with reference solution (g) to identify the peaks due to impurities B, C, D, E and G.

**Relative retention** with reference to aceclofenac (retention time = about 11 min): impurity A = about 0.8; impurity G = about 1.3; impurity H = about 1.5;

07/2009:1281

## ACECLOFENAC

## Aceclofenacum

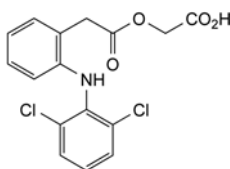

C<sub>16</sub>H<sub>13</sub>Cl<sub>2</sub>NO<sub>4</sub>  
[89796-99-6]

$M_r$  354.2

## DEFINITION

[[[2-[(2,6-Dichlorophenyl)amino]phenyl]acetyl]oxy]acetic acid.

**Content:** 99.0 per cent to 101.0 per cent (dried substance).

## CHARACTERS

**Appearance:** white or almost white, crystalline powder.

**Solubility:** practically insoluble in water, freely soluble in acetone, soluble in ethanol (96 per cent).

## IDENTIFICATION

**First identification:** B.

**Second identification:** A, C.

A. Dissolve 50.0 mg in *methanol R* and dilute to 100.0 mL with the same solvent. Dilute 2.0 mL of the solution to 50.0 mL with *methanol R*. Examined between 220 nm and 370 nm (2.2.25), the solution shows an absorption maximum at 275 nm. The specific absorbance at the absorption maximum is 320 to 350.

B. Infrared absorption spectrophotometry (2.2.24).

**Comparison:** *Ph. Eur. reference spectrum of aceclofenac*.

C. Dissolve about 10 mg in 10 mL of *ethanol (96 per cent) R*. To 1 mL of the solution, add 0.2 mL of a mixture, prepared immediately before use, of equal volumes of a 6 g/L solution of *potassium ferricyanide R* and a 9 g/L solution of *ferric chloride R*. Allow to stand protected from light for 5 min.

impurity I = about 2.3; impurity D = about 3.1;  
impurity B = about 3.2; impurity E = about 3.3;  
impurity C = about 3.5; impurity F = about 3.7.

**System suitability:** reference solution (c):

- **resolution:** minimum 5.0 between the peaks due to impurity A and aceclofenac.

**Limits:**

- **impurity A:** not more than the area of the corresponding peak in the chromatogram obtained with reference solution (c) (0.2 per cent);
- **impurities B, C, D, E, G:** for each impurity, not more than the area of the peak due to aceclofenac in the chromatogram obtained with reference solution (e) (0.2 per cent);
- **impurity F:** not more than the area of the corresponding peak in the chromatogram obtained with reference solution (e) (0.2 per cent);
- **impurity H:** not more than the area of the corresponding peak in the chromatogram obtained with reference solution (e) (0.1 per cent);
- **impurity I:** not more than the area of the corresponding peak in the chromatogram obtained with reference solution (f) (0.1 per cent);
- **unspecified impurities:** not more than 0.5 times the area of the peak due to aceclofenac in the chromatogram obtained with reference solution (e) (0.10 per cent);
- **total:** not more than 0.7 per cent;
- **disregard limit:** 0.1 times the area of the peak due to aceclofenac in the chromatogram obtained with reference solution (e) (0.02 per cent).

**Heavy metals (2.4.8):** maximum 10 ppm.

To 2.0 g in a silica crucible, add 2 mL of *sulfuric acid R* to wet the substance. Heat progressively to ignition and continue heating until an almost white or at most a greyish residue is obtained. Carry out the ignition at a temperature not exceeding 800 °C. Allow to cool. Add 3 mL of *hydrochloric acid R* and 1 mL of *nitric acid R*. Heat and evaporate slowly to dryness. Cool and add 1 mL of a 100 g/L solution of *hydrochloric acid R* and 10.0 mL of *distilled water R*. Neutralise with a 1.0 g/L solution of *ammonia R* using 0.1 mL of *phenolphthalein solution R* as indicator. Add 2.0 mL of a 60 g/L solution of *anhydrous acetic acid R* and dilute to 20 mL with *distilled water R*. 12 mL of the solution complies with test A. Prepare the reference solution using *lead standard solution (1 ppm Pb) R*.

**Loss on drying (2.2.32):** maximum 0.5 per cent, determined on 1.000 g by drying in an oven at 105 °C.

**Sulfated ash (2.4.14):** maximum 0.1 per cent, determined on 1.0 g.

#### ASSAY

Dissolve 0.300 g in 40 mL of *methanol R*. Titrate with 0.1 M *sodium hydroxide*, determining the end-point potentiometrically (2.2.20).

1 mL of 0.1 M *sodium hydroxide* is equivalent to 35.42 mg of C<sub>16</sub>H<sub>13</sub>Cl<sub>2</sub>NO<sub>4</sub>.

#### STORAGE

In an airtight container, protected from light.

#### IMPURITIES

**Specified impurities:** A, B, C, D, E, F, G, H, I.

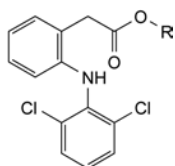

A. R = H: [2-[(2,6-dichlorophenyl)amino]phenyl]acetic acid (diclofenac),

B. R = CH<sub>3</sub>: methyl [2-[(2,6-dichlorophenyl)amino]phenyl]acetate (methyl ester of diclofenac),

C. R = C<sub>2</sub>H<sub>5</sub>: ethyl [2-[(2,6-dichlorophenyl)amino]phenyl]acetate (ethyl ester of diclofenac),

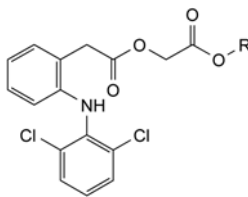

D. R = CH<sub>3</sub>: methyl [[2-[(2,6-dichlorophenyl)amino]phenyl]acetyl]oxy]acetate (methyl ester of aceclofenac),

E. R = C<sub>2</sub>H<sub>5</sub>: ethyl [[2-[(2,6-dichlorophenyl)amino]phenyl]acetyl]oxy]acetate (ethyl ester of aceclofenac),

F. R = CH<sub>2</sub>-C<sub>6</sub>H<sub>5</sub>: benzyl [[2-[(2,6-dichlorophenyl)amino]phenyl]acetyl]oxy]acetate (benzyl ester of aceclofenac),

G. R = CH<sub>2</sub>-CO<sub>2</sub>H: [[[[2-[(2,6-dichlorophenyl)amino]phenyl]acetyl]oxy]acetyl]oxy]acetic acid (acetic aceclofenac),

H. R = CH<sub>2</sub>-CO-O-CH<sub>2</sub>-CO<sub>2</sub>H: [[[[[[2-[(2,6-dichlorophenyl)amino]phenyl]acetyl]oxy]acetyl]oxy]acetyl]oxy]acetic acid (diacetic aceclofenac),

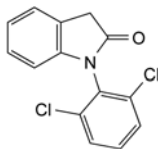

I. 1-(2,6-dichlorophenyl)-1,3-dihydro-2H-indol-2-one.

04/2008:1686  
corrected 7.0

## ACEMETACIN

### Acemetacinum

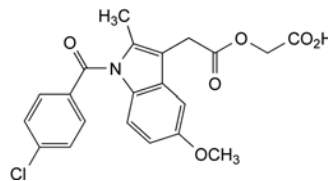

C<sub>21</sub>H<sub>18</sub>ClNO<sub>6</sub>  
[53164-05-9]

M<sub>r</sub> 415.8

#### DEFINITION

[[[1-(4-Chlorobenzoyl)-5-methoxy-2-methyl-1H-indol-3-yl]acetyl]oxy]acetic acid.

**Content:** 99.0 per cent to 101.0 per cent (dried substance).

#### CHARACTERS

**Appearance:** yellow or greenish-yellow, crystalline powder.

**Solubility:** practically insoluble in water, soluble in acetone, slightly soluble in anhydrous ethanol.

It shows polymorphism (5.9).

#### IDENTIFICATION

Infrared absorption spectrophotometry (2.2.24).

**Comparison:** acemetacin CRS.

If the spectra obtained in the solid state show differences, dissolve the substance to be examined and the reference substance separately in *acetone R*, evaporate to dryness and record new spectra using the residues.

## TESTS

**Related substances.** Liquid chromatography (2.2.29).

**Test solution.** Dissolve 0.100 g of the substance to be examined in *acetonitrile for chromatography R* and dilute to 20.0 mL with the same solvent.

**Reference solution (a).** Dilute 5.0 mL of the test solution to 50.0 mL with *acetonitrile for chromatography R*. Dilute 1.0 mL of this solution to 100.0 mL with *acetonitrile for chromatography R*.

**Reference solution (b).** Dissolve 5.0 mg of *acemetacin impurity A CRS* and 10.0 mg of *indometacin CRS* (impurity B) in *acetonitrile for chromatography R*, and dilute to 50.0 mL with the same solvent.

**Reference solution (c).** Dilute 1.0 mL of reference solution (b) to 20.0 mL with *acetonitrile for chromatography R*.

**Reference solution (d).** To 1 mL of reference solution (b), add 10 mL of the test solution and dilute to 20 mL with *acetonitrile for chromatography R*.

**Reference solution (e).** Dissolve the contents of a vial of *acemetacin impurity mixture CRS* (containing impurities C, D, E and F) in 1.0 mL of the test solution.

## Column:

- size:  $l = 0.25$  m,  $\varnothing = 4$  mm;
- stationary phase: spherical *end-capped octadecylsilyl silica gel for chromatography R* (5  $\mu$ m);
- temperature: 40 °C.

## Mobile phase:

- mobile phase A: dissolve 1.0 g of *potassium dihydrogen phosphate R* in 900 mL of *water R*, adjust to pH 6.5 with 1 M *sodium hydroxide* and dilute to 1000 mL with *water R*;
- mobile phase B: *acetonitrile for chromatography R*;

Time (min)	Mobile phase A (per cent V/V)	Mobile phase B (per cent V/V)
0 - 5	95	5
5 - 9	95 → 65	5 → 35
9 - 16	65	35
16 - 28	65 → 20	35 → 80
28 - 34	20	80

**Flow rate:** 1.0 mL/min.

**Detection:** spectrophotometer at 235 nm.

**Injection:** 20  $\mu$ L.

## Identification of impurities:

- use the chromatogram supplied with *acemetacin impurity mixture CRS* and the chromatogram obtained with reference solution (e) to identify the peaks due to impurities C, D, E and F;
- use the chromatogram obtained with reference solution (b) to identify the peak due to impurity B.

**Relative retention** with reference to *acemetacin* (retention time = about 15 min): impurity A = about 0.7; impurity B = about 0.9; impurity F = about 1.2; impurity C = about 1.3; impurity D = about 1.5; impurity E = about 2.2.

**System suitability:** reference solution (d):

- **peak-to-valley ratio:** minimum 15, where  $H_p$  = height above the baseline of the peak due to impurity B and  $H_v$  = height above the baseline of the lowest point of the curve separating this peak from the peak due to *acemetacin*.

## Limits:

- **correction factors:** for the calculation of content, multiply the peak areas of the following impurities by the corresponding correction factor: impurity C = 1.3; impurity D = 1.4; impurity F = 1.3;
- **impurity E:** not more than 3 times the area of the principal peak in the chromatogram obtained with reference solution (a) (0.3 per cent);
- **impurity B:** not more than the area of the corresponding peak in the chromatogram obtained with reference solution (c) (0.2 per cent);
- **impurity A:** not more than the area of the corresponding peak in the chromatogram obtained with reference solution (c) (0.1 per cent);
- **impurities C, D, F:** for each impurity, not more than the area of the principal peak in the chromatogram obtained with reference solution (a) (0.1 per cent);
- **unspecified impurities:** for each impurity, not more than the area of the principal peak in the chromatogram obtained with reference solution (a) (0.10 per cent);
- **total:** not more than 4 times the area of the principal peak in the chromatogram obtained with reference solution (a) (0.4 per cent);
- **disregard limit:** 0.5 times the area of the principal peak in the chromatogram obtained with reference solution (a) (0.05 per cent).

**Heavy metals** (2.4.8): maximum 20 ppm.

**Solvent mixture:** *methanol R*, *acetone R* (10:90 V/V).

0.250 g complies with test H. Prepare the reference solution using 0.5 mL of *lead standard solution (10 ppm Pb) R*.

**Loss on drying** (2.2.32): maximum 0.5 per cent, determined on 1.000 g by drying in an oven at 105 °C.

**Sulfated ash** (2.4.14): maximum 0.1 per cent, determined on 1.0 g.

## ASSAY

Dissolve 0.350 g in 20 mL of *acetone R* and add 10 mL of *water R*. Titrate with 0.1 M *sodium hydroxide*, determining the end-point potentiometrically (2.2.20).

1 mL of 0.1 M *sodium hydroxide* is equivalent to 41.58 mg of  $C_{21}H_{18}ClNO_6$ .

## STORAGE

Protected from light.

## IMPURITIES

**Specified impurities:** A, B, C, D, E, F.

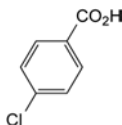

A. 4-chlorobenzoic acid,



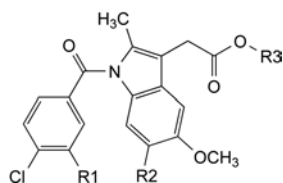

- B. R1 = R2 = R3 = H: [1-(4-chlorobenzoyl)-5-methoxy-2-methylindol-3-yl]acetic acid (indometacin),
- C. R1 = Cl, R2 = H, R3 = CH<sub>2</sub>-CO<sub>2</sub>H: [[[1-(3,4-dichlorobenzoyl)-5-methoxy-2-methyl-1*H*-indol-3-yl]acetyl]oxy]acetic acid,
- D. R1 = H, R2 = C(CH<sub>3</sub>)<sub>2</sub>, R3 = CH<sub>2</sub>-CO<sub>2</sub>H: [[[1-(4-chlorobenzoyl)-6-(1,1-dimethylethyl)-5-methoxy-2-methyl-1*H*-indol-3-yl]acetyl]oxy]acetic acid,
- E. R1 = R2 = H, R3 = CH<sub>2</sub>-CO-O-C(CH<sub>3</sub>)<sub>3</sub>: 1,1-dimethylethyl [[[1-(4-chlorobenzoyl)-5-methoxy-2-methyl-1*H*-indol-3-yl]acetyl]oxy]acetate,
- F. R1 = R2 = H, R3 = CH<sub>2</sub>-CO-O-CH<sub>2</sub>-CO<sub>2</sub>H: [[[[1-(4-chlorobenzoyl)-5-methoxy-2-methyl-1*H*-indol-3-yl]acetyl]oxy]acetyl]oxy]acetic acid.

01/2008:1282  
corrected 6.0

## ACESULFAME POTASSIUM

### Acesulfamum kalicum

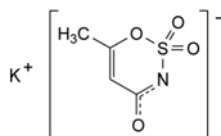

C<sub>4</sub>H<sub>4</sub>KNO<sub>4</sub>S  
[55589-62-3]

M<sub>r</sub> 201.2

#### DEFINITION

Potassium 6-methyl-1,2,3-oxathiazin-4-olate 2,2-dioxide.  
*Content*: 99.0 per cent to 101.0 per cent (dried substance).

#### CHARACTERS

*Appearance*: white or almost white, crystalline powder or colourless crystals.  
*Solubility*: soluble in water, very slightly soluble in acetone and in ethanol (96 per cent).

#### IDENTIFICATION

*First identification*: A, C.

*Second identification*: B, C.

A. Infrared absorption spectrophotometry (2.2.24).

*Comparison*: acesulfame potassium CRS.

B. Thin-layer chromatography (2.2.27).

*Test solution*. Dissolve 5 mg of the substance to be examined in water R and dilute to 5 mL with the same solvent.

*Reference solution (a)*. Dissolve 5 mg of acesulfame potassium CRS in water R and dilute to 5 mL with the same solvent.

*Reference solution (b)*. Dissolve 5 mg of acesulfame potassium CRS and 5 mg of saccharin sodium R in water R and dilute to 5 mL with the same solvent.

*Plate*: cellulose for chromatography R as the coating substance.

*Mobile phase*: concentrated ammonia R, acetone R, ethyl acetate R (10:60:60 V/V/V).

*Application*: 5 µL as bands.

*Development*: twice over a path of 15 cm.

*Drying*: in a current of warm air.

*Detection*: examine in ultraviolet light at 254 nm.

*System suitability*: reference solution (b):

– the chromatogram shows 2 clearly separated bands.

*Results*: the principal band in the chromatogram obtained with the test solution is similar in position and size to the principal band in the chromatogram obtained with reference solution (a).

C. 0.5 mL of solution S (see Tests) gives reaction (b) of potassium (2.3.1).

#### TESTS

**Solution S**. Dissolve 10.0 g in carbon dioxide-free water R and dilute to 50 mL with the same solvent.

**Appearance of solution**. Solution S is clear (2.2.1) and colourless (2.2.2, Method II).

**Acidity or alkalinity**. To 20 mL of solution S add 0.1 mL of bromothymol blue solution R1. Not more than 0.2 mL of 0.01 M hydrochloric acid or 0.01 M sodium hydroxide is required to change the colour of the indicator.

**Impurity A**. Thin-layer chromatography (2.2.27).

*Test solution*. Dissolve 0.80 g of the substance to be examined in water R and dilute to 10 mL with the same solvent.

*Reference solution (a)*. Dissolve 50 mg of acetylacetamide R (impurity A) in water R and dilute to 25 mL with the same solvent. To 5 mL of the solution add 45 mL of water R and dilute to 100 mL with methanol R.

*Reference solution (b)*. To 10 mL of reference solution (a) add 1 mL of the test solution and dilute to 20 mL with methanol R.  
*Plate*: TLC silica gel plate R.

*Mobile phase*: water R, ethanol (96 per cent) R, ethyl acetate R (2:15:74 V/V/V).

*Application*: 5 µL.

*Development*: over a path of 15 cm.

*Drying*: in air until the solvents are completely removed.

*Detection*: spray with phosphoric vanillin solution R and heat at 120 °C for about 10 min; examine in daylight.

*System suitability*: the chromatogram obtained with reference solution (a) shows a clearly visible spot and the chromatogram obtained with reference solution (b) shows 2 clearly separated spots.

*Limit*:

– *impurity A*: any spot due to impurity A is not more intense than the spot in the chromatogram obtained with reference solution (a) (0.125 per cent).

**Related substances**. Liquid chromatography (2.2.29).

*Test solution*. Dissolve 0.100 g of the substance to be examined in water R and dilute to 10.0 mL with the same solvent.

*Reference solution (a)*. Dissolve 4.0 mg of acesulfame potassium impurity B CRS in water R and dilute to 100.0 mL with the same solvent. Dilute 1.0 mL of this solution to 200.0 mL with water R.

*Reference solution (b)*. Dissolve 0.100 g of the substance to be examined in reference solution (a) and dilute to 10.0 mL with the same solution.

*Reference solution (c)*. Dilute 1.0 mL of the test solution to 100.0 mL with water R. Dilute 1.0 mL of this solution to 10.0 mL with water R.

*Column*:

– *size*: *l* = 0.25 m,  $\emptyset$  = 4.6 mm,

– *stationary phase*: octadecylsilyl silica gel for chromatography R (3 µm).

*Mobile phase*: mix 40 volumes of acetonitrile R and 60 volumes of a 3.3 g/L solution of tetrabutylammonium hydrogen sulfate R.

*Flow rate*: 1 mL/min.

*Detection*: spectrophotometer at 234 nm.

*Injection*: 20 µL.

*Run time*: 3 times the retention time of acesulfame.

04/2009:0454

*Relative retention* with reference to acesulfame (retention time = about 5.3 min): impurity B = about 1.6.

*System suitability*:

- *peak-to-valley ratio*: minimum 1.2, where  $H_p$  = height above the baseline of the peak due to impurity B and  $H_v$  = height above the baseline of the lowest point of the curve separating this peak from the peak due to acesulfame in the chromatogram obtained with reference solution (b).

*Limits*:

- *impurity B*: not more than the area of the principal peak in the chromatogram obtained with reference solution (a) (20 ppm),
- *unspecified impurities*: for each impurity, not more than the area of the principal peak in the chromatogram obtained with reference solution (c) (0.1 per cent),
- *total*: not more than the area of the principal peak in the chromatogram obtained with reference solution (c) (0.1 per cent),
- *disregard limit*: 0.5 times the area of the principal peak in the chromatogram obtained with reference solution (c) except for the peak due to impurity B (0.05 per cent).

**Fluorides**: maximum 3 ppm.

Potentiometry (2.2.36, Method I).

*Test solution*. Dissolve 3.000 g of the substance to be examined in *distilled water R*, add 15.0 mL of *total-ionic-strength-adjustment buffer R1* and dilute to 50.0 mL with *distilled water R*.

*Reference solutions*. To 0.5 mL, 1.0 mL, 1.5 mL and 3.0 mL of *fluoride standard solution (10 ppm F) R* add 15.0 mL of *total-ionic-strength-adjustment buffer R1* and dilute to 50.0 mL with *distilled water R*.

*Indicator electrode*: fluoride-selective.

*Reference electrode*: silver-silver chloride.

**Heavy metals** (2.4.8): maximum 5 ppm.

12 mL of solution S complies with test A. Prepare the reference solution using *lead standard solution (1 ppm Pb) R*.

**Loss on drying** (2.2.32): maximum 1.0 per cent, determined on 1.000 g by drying in an oven at 105 °C for 3 h.

#### ASSAY

Dissolve 0.150 g in 50 mL of *anhydrous acetic acid R*. Titrate with 0.1 M *perchloric acid*, determining the end-point potentiometrically (2.2.20).

1 mL of 0.1 M *perchloric acid* is equivalent to 20.12 mg of  $C_4H_6N_4O_3S_2$ .

#### IMPURITIES

*Specified impurities*: A, B.

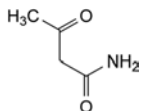

A. 3-oxobutanamide (acetylacetamide),

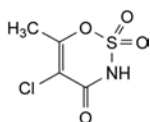

B. 5-chloro-6-methyl-1,2,3-oxathiazin-4(3H)-one 2,2-dioxide.

## ACETAZOLAMIDE

### Acetazolamidum

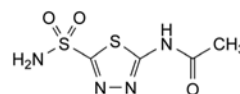

$C_4H_6N_4O_3S_2$   
[59-66-5]

$M_r$  222.2

#### DEFINITION

*N*-(5-Sulfamoyl-1,3,4-thiadiazol-2-yl)acetamide.

*Content*: 98.5 per cent to 101.0 per cent (dried substance).

#### CHARACTERS

*Appearance*: white or almost white, crystalline powder.

*Solubility*: very slightly soluble in water, slightly soluble in ethanol (96 per cent). It dissolves in dilute solutions of alkali hydroxides.

It shows polymorphism (5.9).

#### IDENTIFICATION

*First identification*: A, B.

*Second identification*: A, C, D.

A. Ultraviolet and visible absorption spectrophotometry (2.2.25).

*Solution A*. Dissolve 30.0 mg in 0.01 M *sodium hydroxide* and dilute to 100.0 mL with the same solvent. Dilute 10.0 mL of the solution to 100.0 mL with 0.01 M *sodium hydroxide*.

*Solution B*. Dilute 25.0 mL of solution A to 100.0 mL with 0.01 M *sodium hydroxide*.

*Spectral range*: 230-260 nm for solution A; 260-350 nm for solution B.

*Absorption maximum*: at 240 nm for solution A; at 292 nm for solution B.

*Specific absorbance at the absorption maximum*: 162 to 176 for solution A; 570 to 620 for solution B.

B. Infrared absorption spectrophotometry (2.2.24).

*Comparison*: acetazolamide CRS.

If the spectra obtained in the solid state show differences, dissolve the substance to be examined and the reference substance separately in *ethanol (96 per cent) R*, evaporate to dryness and record new spectra using the residues.

- C. Introduce about 20 mg into a test-tube and add 4 mL of *dilute hydrochloric acid R* and 0.2 g of *zinc powder R*. Immediately place a piece of *lead acetate paper R* over the mouth of the tube. The paper shows a brownish-black colour.
- D. Dissolve about 25 mg in a mixture of 0.1 mL of *dilute sodium hydroxide solution R* and 5 mL of *water R*. Add 0.1 mL of *copper sulfate solution R*. A greenish-blue precipitate is formed.

#### TESTS

**Appearance of solution**. The solution is not more opalescent than reference suspension II (2.2.1) and not more intensely coloured than reference solution Y<sub>5</sub> or BY<sub>5</sub> (2.2.2, Method II). Dissolve 1.0 g in 10 mL of 1 M *sodium hydroxide*.

**Related substances**. Liquid chromatography (2.2.29).

*Test solution*. Dissolve 40 mg of the substance to be examined in the mobile phase and dilute to 100.0 mL with the mobile phase.

*Reference solution (a)*. Dilute 1.0 mL of the test solution to 100.0 mL with the mobile phase. Dilute 1.0 mL of this solution to 10.0 mL with the mobile phase.

**Reference solution (b).** Dissolve the contents of a vial of *acetazolamide for system suitability CRS* (containing impurities A, B, C, D, E and F) in 1.0 mL of the mobile phase.

**Column:**

- size:  $l = 0.15$  m,  $\varnothing = 4.6$  mm;
- stationary phase: end-capped propoxybenzene silica gel for chromatography R (4  $\mu$ m).

**Mobile phase:** acetonitrile for chromatography R, 6.8 g/L solution of *potassium dihydrogen phosphate R* (10:90 V/V).

**Flow rate:** 1.0 mL/min.

**Detection:** spectrophotometer at 265 nm.

**Injection:** 25  $\mu$ L.

**Run time:** 3.5 times the retention time of acetazolamide.

**Identification of impurities:** use the chromatogram supplied with *acetazolamide for system suitability CRS* and the chromatogram obtained with reference solution (b) to identify the peaks due to impurities A, B, C, D, E and F.

**Relative retention** with reference to acetazolamide (retention time = about 8 min): impurity E = about 0.3; impurity D = about 0.4; impurity B = about 0.6; impurity C = about 1.4; impurity A = about 2.1; impurity F = about 2.6.

**System suitability:** reference solution (b):

- resolution: minimum 2.0 between the peaks due to impurities E and D.

**Limits:**

- correction factors: for the calculation of content, multiply the peak areas of the following impurities by the corresponding correction factor: impurity B = 2.3; impurity C = 2.6; impurity D = 1.6;
- impurities A, B, C, D, E, F: for each impurity, not more than 1.5 times the area of the principal peak in the chromatogram obtained with reference solution (a) (0.15 per cent);
- unspecified impurities: for each impurity, not more than the area of the principal peak in the chromatogram obtained with reference solution (a) (0.10 per cent);
- total: not more than 6 times the area of the principal peak in the chromatogram obtained with reference solution (a) (0.6 per cent);
- disregard limit: 0.5 times the area of the principal peak in the chromatogram obtained with reference solution (a) (0.05 per cent).

**Sulfates (2.4.13):** maximum 500 ppm.

To 0.4 g add 20 mL of *distilled water R* and dissolve by heating to boiling. Allow to cool with frequent shaking and filter.

**Heavy metals (2.4.8):** maximum 20 ppm.

1.0 g complies with test C. Prepare the reference solution using 2 mL of *lead standard solution (10 ppm Pb) R*.

**Loss on drying (2.2.32):** maximum 0.5 per cent, determined on 1.000 g by drying in an oven at 105 °C.

**Sulfated ash (2.4.14):** maximum 0.1 per cent, determined on 1.0 g.

**ASSAY**

Dissolve 0.200 g in 25 mL of *dimethylformamide R*. Titrate with 0.1 M *ethanolic sodium hydroxide*, determining the end-point potentiometrically (2.2.20).

1 mL of 0.1 M *ethanolic sodium hydroxide* is equivalent to 22.22 mg of  $C_4H_6N_4O_3S_2$ .

**IMPURITIES**

**Specified impurities:** A, B, C, D, E, F.

**Other detectable impurities** (the following substances would, if present at a sufficient level, be detected by one or other of the tests in the monograph. They are limited by the general acceptance criterion for other/unspecified impurities and/or by the general monograph *Substances for pharmaceutical use*

(2034). It is therefore not necessary to identify these impurities for demonstration of compliance. See also 5.10. *Control of impurities in substances for pharmaceutical use*): G.

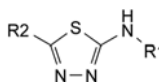

- A. R1 = CO-CH<sub>3</sub>, R2 = Cl: *N*-(5-chloro-1,3,4-thiadiazol-2-yl)acetamide,
- B. R1 = CO-CH<sub>3</sub>, R2 = H: *N*-(1,3,4-thiadiazol-2-yl)acetamide,
- C. R1 = CO-CH<sub>3</sub>, R2 = SH: *N*-(5-sulfanyl-1,3,4-thiadiazol-2-yl)acetamide,
- D. R1 = H, R2 = SO<sub>2</sub>-NH<sub>2</sub>: 5-amino-1,3,4-thiadiazole-2-sulfonamide,
- E. R1 = CO-CH<sub>3</sub>, R2 = SO<sub>2</sub>-OH: 5-acetamido-1,3,4-thiadiazole-2-sulfonic acid,

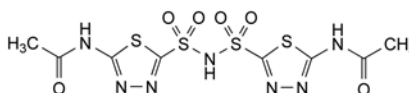

- F. *N*-[5-[(5-acetamido-1,3,4-thiadiazol-2-yl)sulfonyl]sulfamoyl]-1,3,4-thiadiazol-2-yl]acetamide,

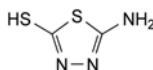

- G. 5-amino-1,3,4-thiadiazole-2-thiol.

01/2008:0590

## ACETIC ACID, GLACIAL

### Acidum aceticum glaciale

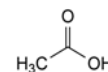

$C_2H_4O_2$   
[64-19-7]

$M_r$  60.1

**DEFINITION**

**Content:** 99.0 per cent *m/m* to 100.5 per cent *m/m*.

**CHARACTERS**

**Appearance:** crystalline mass or clear, colourless, volatile liquid.

**Solubility:** miscible with water, with ethanol (96 per cent) and with methylene chloride.

**IDENTIFICATION**

- A. A 100 g/L solution is strongly acid (2.2.4).
- B. To 0.03 mL add 3 mL of *water R* and neutralise with *dilute sodium hydroxide solution R*. The solution gives reaction (b) of acetates (2.3.1).

**TESTS**

**Solution S.** Dilute 20 mL to 100 mL with *distilled water R*.

**Appearance.** The substance to be examined is clear (2.2.1) and colourless (2.2.2, *Method II*).

**Freezing point (2.2.18):** minimum 14.8 °C.

**Reducing substances.** To 5.0 mL add 10.0 mL of *water R* and mix. To 5.0 mL of this solution add 6 mL of *sulfuric acid R*, cool and add 2.0 mL of 0.0167 M *potassium dichromate*. Allow to stand for 1 min and add 25 mL of *water R* and 1 mL of a freshly prepared 100 g/L solution of *potassium iodide R*. Titrate with 0.1 M *sodium thiosulfate*, using 1.0 mL of *starch solution R* as indicator. Not less than 1.0 mL of 0.1 M *sodium thiosulfate* solution is required.

**Chlorides (2.4.4):** maximum 25 mg/L.

Dilute 10 mL of solution S to 15 mL with *water R*.

**Sulfates (2.4.13):** maximum 50 mg/L, determined on solution S.

**Iron (2.4.9):** maximum 5 ppm.

Dilute 5.0 mL of solution A obtained in the test for heavy metals to 10.0 mL with *water R*.

**Heavy metals (2.4.8):** maximum 5 ppm.

Dissolve the residue obtained in the test for residue on evaporation by heating with 2 quantities, each of 15 mL, of *water R* and dilute to 50.0 mL (solution A). 12 mL of solution A complies with test A. Prepare the reference solution using *lead standard solution (2 ppm Pb) R*.

**Residue on evaporation:** maximum 0.01 per cent.

Evaporate 20 g to dryness on a water-bath and dry at 100-105 °C. The residue weighs a maximum of 2.0 mg.

#### ASSAY

Weigh accurately a conical flask with a ground-glass stopper containing 25 mL of *water R*. Add 1.0 mL of the substance to be examined and weigh again accurately. Add 0.5 mL of *phenolphthalein solution R* and titrate with *1 M sodium hydroxide*.

1 mL of *1 M sodium hydroxide* is equivalent to 60.1 mg of  $C_2H_4O_2$ .

#### STORAGE

In an airtight container.

01/2008:0872

## ACETONE

### Acetonum

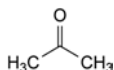

$C_3H_6O$   
[67-64-1]

$M_r$  58.08

#### DEFINITION

Propanone.

#### CHARACTERS

**Appearance:** volatile, clear, colourless liquid.

**Solubility:** miscible with water and with ethanol (96 per cent). The vapour is flammable.

#### IDENTIFICATION

A. Relative density (see Tests).

B. To 1 mL, add 3 mL of *dilute sodium hydroxide solution R* and 0.3 mL of a 25 g/L solution of *sodium nitroprusside R*. An intense red colour is produced which becomes violet with the addition of 3.5 mL of *acetic acid R*.

C. To 10 mL of a 0.1 per cent V/V solution of the substance to be examined in *ethanol (50 per cent V/V) R*, add 1 mL of a 10 g/L solution of *nitrobenzaldehyde R* in *ethanol (50 per cent V/V) R* and 0.5 mL of *strong sodium hydroxide solution R*. Allow to stand for about 2 min and acidify with *acetic acid R*. A greenish-blue colour is produced.

#### TESTS

**Appearance of solution.** To 10 mL add 10 mL of *water R*. The solution is clear (2.2.1) and colourless (2.2.2, *Method II*).

**Acidity or alkalinity.** To 5 mL add 5 mL of *carbon dioxide-free water R*, 0.15 mL of *phenolphthalein solution R* and 0.5 mL of *0.01 M sodium hydroxide*. The solution is pink. Add 0.7 mL of *0.01 M hydrochloric acid* and 0.05 mL of *methyl red solution R*. The solution is red or orange.

**Relative density (2.2.5):** 0.790 to 0.793.

**Reducing substances.** To 30 mL add 0.1 mL of *0.02 M potassium permanganate* and allow to stand in the dark for 2 h. The mixture is not completely decolourised.

**Related substances.** Gas chromatography (2.2.28).

**Test solution.** The substance to be examined.

**Reference solution (a).** To 0.5 mL of *methanol R* add 0.5 mL of *2-propanol R* and dilute to 100.0 mL with the test solution. Dilute 1.0 mL of this solution to 10.0 mL with the test solution.

**Reference solution (b).** Dilute 100 µL of *benzene R* to 100.0 mL with the test solution. Dilute 0.20 mL of this solution to 100.0 mL with the test solution.

**Column:**

- **material:** fused silica,
- **size:**  $l = 50$  m,  $\varnothing = 0.3$  mm,
- **stationary phase:** *macrogol 20 000 R* (film thickness 1 µm).

**Carrier gas:** *helium for chromatography R*.

**Linear velocity:** 21 cm/s.

**Split ratio:** 1:50.

**Temperature:**

	Time (min)	Temperature (°C)
Column	0 - 11	45 → 100
	11 - 20	100
Injection port		150
Detector		250

**Detection:** flame ionisation.

**Injection:** 1 µL.

**Retention time:** impurity C = about 7.5 min.

**System suitability:**

- **resolution:** minimum 5.0 between the peak due to impurity A (2<sup>nd</sup> peak) and the peak due to impurity B (3<sup>rd</sup> peak) in the chromatogram obtained with reference solution (a),
- **signal-to-noise ratio:** minimum 5 for the peak due to impurity C in the chromatogram obtained with reference solution (b).

**Limits:**

- **impurities A, B:** for each impurity, not more than the difference between the areas of the corresponding peaks in the chromatogram obtained with reference solution (a) and the areas of the corresponding peaks in the chromatogram obtained with the test solution (0.05 per cent V/V),
- **impurity C:** not more than the difference between the area of the peak due to impurity C in the chromatogram obtained with reference solution (b) and the area of the corresponding peak in the chromatogram obtained with the test solution (2 ppm V/V),
- **any other impurity:** for each impurity, not more than the difference between the area of the peak due to impurity A in the chromatogram obtained with reference solution (a) and the area of the corresponding peak in the chromatogram obtained with the test solution (0.05 per cent V/V).

**Matter insoluble in water.** Dilute 1.0 mL to 20 mL with *water R*. The solution is clear (2.2.1).

**Residue on evaporation:** maximum 50 ppm.

Evaporate 20.0 g to dryness on a water-bath and dry at 100-105 °C. The residue weighs a maximum of 1 mg.

**Water (2.5.12):** maximum 3 g/L, determined on 10.0 mL. Use 20 mL of *anhydrous pyridine R* as solvent.

#### STORAGE

Protected from light.

#### IMPURITIES

**Specified impurities:** A, B, C.

- A.  $CH_3-OH$ : methanol,
- B.  $CH_3-CHOH-CH_3$ : propan-2-ol (isopropanol),
- C.  $C_6H_6$ : benzene.

01/2008:1485  
corrected 6.0

## ACETYLCHOLINE CHLORIDE

## Acetylcholini chloridum

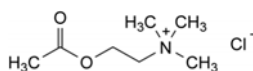
C<sub>7</sub>H<sub>16</sub>ClNO<sub>2</sub>  
[60-31-1]M<sub>r</sub> 181.7

## DEFINITION

2-(Acetyloxy)-N,N,N-trimethylethanaminium chloride.

Content: 98.5 per cent to 101.5 per cent (dried substance).

## CHARACTERS

**Appearance:** white or almost white crystalline powder or colourless crystals, very hygroscopic.**Solubility:** very soluble in water, freely soluble in alcohol, slightly soluble in methylene chloride.

## IDENTIFICATION

First identification: B, E.

Second identification: A, C, D, E.

A. Melting point (2.2.14): 149 °C to 152 °C.

Introduce the substance to be examined into a capillary tube. Dry in an oven at 100-105 °C for 3 h. Seal the tube and determine the melting point.

B. Infrared absorption spectrophotometry (2.2.24).

Comparison: acetylcholine chloride CRS.

C. Examine the chromatograms obtained in the test for related substances.

**Results:** the principal band in the chromatogram obtained with test solution (b) is similar in position, colour and size to the principal band in the chromatogram obtained with reference solution (b).

D. To 15 mg add 10 mL of dilute sodium hydroxide solution R, 2 mL of 0.02 M potassium permanganate and heat. The vapours formed change the colour of red litmus paper R to blue.

E. 0.5 mL of solution S (see Tests) gives reaction (a) of chlorides (2.3.1).

## TESTS

**Solution S.** Dissolve 5.0 g in carbon dioxide-free water R and dilute to 50 mL with the same solvent.**Appearance of solution.** Solution S is clear (2.2.1) and not more intensely coloured than reference solution Y<sub>6</sub> or BY<sub>6</sub> (2.2.2, Method II).**Acidity.** Dilute 1 mL of solution S to 10 mL with carbon dioxide-free water R. Add 0.05 mL of phenolphthalein solution R. Not more than 0.4 mL of 0.01 M sodium hydroxide is required to change the colour of the indicator to pink.**Related substances.** Thin-layer chromatography (2.2.27). Prepare the solutions immediately before use.**Test solution (a).** Dissolve 0.30 g of the substance to be examined in methanol R and dilute to 3.0 mL with the same solvent.**Test solution (b).** Dilute 1 mL of test solution (a) to 10 mL with methanol R.**Reference solution (a).** Dilute 1 mL of test solution (a) to 100 mL with methanol R.**Reference solution (b).** Dissolve 20.0 mg of acetylcholine chloride CRS in methanol R and dilute to 2.0 mL with the same solvent.**Reference solution (c).** Dissolve 20 mg of choline chloride R in methanol R, add 0.4 mL of test solution (a) and dilute to 2.0 mL with methanol R.**Plate:** TLC silica gel plate R.**Mobile phase:** mix 20 volumes of a 40 g/L solution of ammonium nitrate R, 20 volumes of methanol R and 60 volumes of acetonitrile R.**Application:** 5 µL as bands of 10 mm by 2 mm.**Development:** over 2/3 of the plate.**Detection:** spray with potassium iodobismuthate solution R3.**System suitability:** the chromatogram obtained with reference solution (c) shows 2 clearly separated bands.**Limits:**– **any impurity:** any bands in the chromatogram obtained with test solution (a), apart from the principal band, are not more intense than the principal band in the chromatogram obtained with reference solution (a) (1 per cent).**Trimethylamine.** Dissolve 0.1 g in 10 mL of sodium carbonate solution R and heat to boiling. No vapours appear which turn red litmus paper R blue.**Heavy metals (2.4.8):** maximum 10 ppm.

12 mL of solution S complies with test A. Prepare the reference solution using lead standard solution (1 ppm Pb) R.

**Loss on drying (2.2.32):** maximum 1.0 per cent, determined on 1.000 g by drying in an oven at 105 °C for 3 h.**Sulfated ash (2.4.14):** maximum 0.1 per cent, determined on the residue obtained in the test for loss on drying.

## ASSAY

Dissolve 0.200 g in 20 mL of carbon dioxide-free water R. Neutralise with 0.01 M sodium hydroxide using 0.15 mL of phenolphthalein solution R as indicator. Add 20.0 mL of 0.1 M sodium hydroxide and allow to stand for 30 min. Titrate with 0.1 M hydrochloric acid.

1 mL of 0.1 M sodium hydroxide is equivalent to 18.17 mg of C<sub>7</sub>H<sub>16</sub>ClNO<sub>2</sub>.

## STORAGE

In ampoules, protected from light.

## IMPURITIES

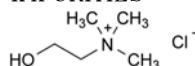

A. 2-hydroxy-N,N,N-trimethylethanaminium chloride (choline chloride),

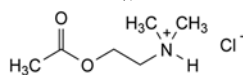

B. 2-(acetyloxy)-N,N-dimethylethanaminium chloride,

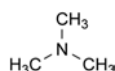

C. N,N-dimethylmethanamine.

01/2008:0967  
corrected 7.0

## ACETYLCYSTEINE

## Acetylcysteinum

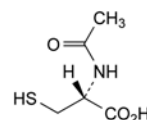
C<sub>5</sub>H<sub>9</sub>NO<sub>3</sub>S  
[616-91-1]M<sub>r</sub> 163.2

## DEFINITION

(2*R*)-2-(Acetylamino)-3-sulfanylpropanoic acid.

*Content*: 98.0 per cent to 101.0 per cent (dried substance).

## CHARACTERS

*Appearance*: white or almost white, crystalline powder or colourless crystals.

*Solubility*: freely soluble in water and in ethanol (96 per cent), practically insoluble in methylene chloride.

## IDENTIFICATION

*First identification*: A, C.

*Second identification*: A, B, D, E.

A. Specific optical rotation (see Tests).

B. Melting point (2.2.14): 104 °C to 110 °C.

C. Infrared absorption spectrophotometry (2.2.24).

*Preparation*: discs of *potassium bromide R*.

*Comparison*: *acetylcysteine CRS*.

D. Examine the chromatograms obtained in the test for related substances.

*Results*: the principal peak in the chromatogram obtained with test solution (b) is similar in retention time and size to the principal peak in the chromatogram obtained with reference solution (b).

E. To 0.5 mL of solution S (see Tests) add 0.05 mL of a 50 g/L solution of *sodium nitroprusside R* and 0.05 mL of *concentrated ammonia R*. A dark violet colour develops.

## TESTS

**Solution S.** Dissolve 1.0 g in *carbon dioxide-free water R* and dilute to 20 mL with the same solvent.

**Appearance of solution.** Solution S is clear (2.2.1) and colourless (2.2.2, *Method II*).

**pH** (2.2.3): 2.0 to 2.8.

To 2 mL of solution S add 8 mL of *carbon dioxide-free water R* and mix.

**Specific optical rotation** (2.2.7): + 21.0 to + 27.0 (dried substance).

In a 25 mL volumetric flask, mix 1.25 g with 1 mL of a 10 g/L solution of *sodium edetate R*. Add 7.5 mL of a 40 g/L solution of *sodium hydroxide R*, mix and dissolve. Dilute to 25.0 mL with *phosphate buffer solution pH 7.0 R2*.

**Related substances.** Liquid chromatography (2.2.29). *Except where otherwise prescribed, prepare the solutions immediately before use.*

*Test solution (a).* Suspend 0.80 g of the substance to be examined in 1 mL of 1 *M hydrochloric acid* and dilute to 100.0 mL with *water R*.

*Test solution (b).* Dilute 5.0 mL of test solution (a) to 100.0 mL with *water R*. Dilute 5.0 mL of this solution to 50.0 mL with *water R*.

*Test solution (c).* Use test solution (a) after storage for at least 1 h.

*Reference solution (a).* Suspend 4.0 mg of *acetylcysteine CRS*, 4.0 mg of *L-cystine R* (impurity A), 4.0 mg of *L-cysteine R* (impurity B), 4.0 mg of *acetylcysteine impurity C CRS* and 4.0 mg of *acetylcysteine impurity D CRS* in 1 mL of 1 *M hydrochloric acid* and dilute to 100.0 mL with *water R*.

*Reference solution (b).* Suspend 4.0 mg of *acetylcysteine CRS* in 1 mL of 1 *M hydrochloric acid* and dilute to 100.0 mL with *water R*.

*Column*:

– *size*:  $l = 0.25$  m,  $\varnothing = 4$  mm;

– *stationary phase*: octadecylsilyl silica gel for chromatography R (5  $\mu$ m).

*Mobile phase*: stir 3 volumes of *acetonitrile R* and 97 volumes of *water R* in a beaker; adjust to pH 3.0 with *phosphoric acid R*.

*Flow rate*: 1.0 mL/min.

*Detection*: spectrophotometer at 220 nm.

*Injection*: 20  $\mu$ L, 3 times; inject 0.01 *M hydrochloric acid* as a blank.

*Run time*: 5 times the retention time of acetylcysteine (about 30 min).

*Retention time*: impurity A = about 2.2 min; impurity B = about 2.4 min; 2-methyl-2-thiazoline-4-carboxylic acid, originating in test solution (c) = about 3.3 min; acetylcysteine = about 6.4 min; impurity C = about 12 min; impurity D = about 14 min.

*System suitability*: reference solution (a):

– *resolution*: minimum 1.5 between the peaks due to impurities A and B and minimum 2.0 between the peaks due to impurities C and D.

From the chromatogram obtained with test solution (a), calculate the percentage content of the known impurities ( $T_1$ ) and the unknown impurities ( $T_2$ ) using the following equations:

$$T_1 = \frac{A_1 \times m_2 \times 100}{A_2 \times m_1}$$

$$T_2 = \frac{A_3 \times m_3 \times 100}{A_4 \times m_1}$$

$A_1$  = peak area of individual impurity (impurity A, impurity B, impurity C and impurity D) in the chromatogram obtained with test solution (a);

$A_2$  = peak area of the corresponding individual impurity (impurity A, impurity B, impurity C and impurity D) in the chromatogram obtained with reference solution (a);

$A_3$  = peak area of unknown impurity in the chromatogram obtained with test solution (a);

$A_4$  = peak area of acetylcysteine in the chromatogram obtained with reference solution (b);

$m_1$  = mass of the substance to be examined in test solution (a);

$m_2$  = mass of the individual impurity in reference solution (a);

$m_3$  = mass of acetylcysteine in reference solution (b).

*Limits*:

– *impurities A, B, C, D*: for each impurity, maximum 0.5 per cent;

– *any other impurity*: for each impurity, maximum 0.5 per cent;

– *total*: maximum 0.5 per cent;

– *disregard limit*: 0.1 times the area of the principal peak in the chromatogram obtained with reference solution (b) (0.05 per cent); disregard any peak with a retention time of about 3.3 min due to 2-methyl-2-thiazoline-4-carboxylic acid.

**Heavy metals** (2.4.8): maximum 10 ppm.

2.0 g complies with test C. Prepare the reference solution using 2 mL of *lead standard (10 ppm Pb) R*.

**Zinc**: maximum 10 ppm.

Atomic absorption spectrometry (2.2.23, *Method II*).

*Test solution.* Dissolve 1.00 g in 0.001 *M hydrochloric acid* and dilute to 50.0 mL with the same acid.

*Reference solutions.* Prepare the reference solutions using *zinc standard solution (5 mg/mL Zn) R*, diluting with 0.001 *M hydrochloric acid*.

*Source*: zinc hollow-cathode lamp.

*Wavelength*: 213.8 nm.

*Atomisation device*: air-acetylene flame.

Use a correction procedure for non-specific absorption.

**Loss on drying** (2.2.32): maximum 1.0 per cent, determined on 1.000 g by drying in an oven *in vacuo* at 70 °C for 3 h.

**Sulfated ash (2.4.14):** maximum 0.2 per cent, determined on 1.0 g.

#### ASSAY

Dissolve 0.140 g in 60 mL of *water R* and add 10 mL of *dilute hydrochloric acid R*. After cooling in iced water, add 10 mL of *potassium iodide solution R* and titrate with 0.05 M *iodine*, using 1 mL of *starch solution R* as indicator.

1 mL of 0.05 M *iodine* is equivalent to 16.32 mg of  $C_5H_9NO_3S$ .

#### STORAGE

Protected from light.

#### IMPURITIES

*Specified impurities: A, B, C, D.*

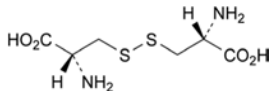

A. 3,3'-disulfanediyldis[(2R)-2-aminopropanoic acid] (L-cystine),

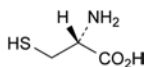

B. (2R)-2-amino-3-sulfanylpropanoic acid (L-cysteine),

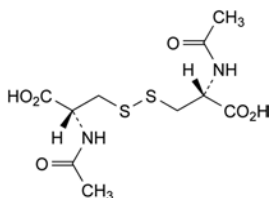

C. (2R,2'R)-3,3'-disulfanediyldis[2-(acetylamino)propanoic acid] (*N,N'*-diacetyl-L-cystine),

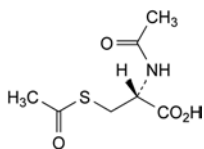

D. (2R)-2-(acetylamino)-3-(acetylsulfanyl)propanoic acid (*N,S*-diacetyl-L-cysteine).

01/2008:2168  
corrected 6.7

## $\beta$ -ACETYLDIGOXIN

### $\beta$ -Acetyldigoxinum

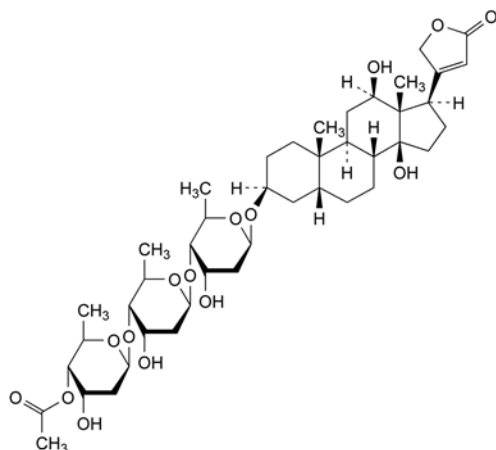

$C_{43}H_{66}O_{15}$   
[5355-48-6]

$M_r$  823

#### DEFINITION

3 $\beta$ -[(4-*O*-Acetyl-2,6-dideoxy- $\beta$ -D-*ribo*-hexopyranosyl-(1 $\rightarrow$ 4)-2,6-dideoxy- $\beta$ -D-*ribo*-hexopyranosyl-(1 $\rightarrow$ 4)-2,6-dideoxy- $\beta$ -D-*ribo*-hexopyranosyl)oxy]-12 $\beta$ ,14-dihydroxy-5 $\beta$ -card-20(22)-enolide.

*Content:* 97.0 per cent to 102.0 per cent (dried substance).

#### CHARACTERS

*Appearance:* white or almost white powder.

*Solubility:* practically insoluble in water, sparingly soluble in methylene chloride, slightly soluble in ethanol (96 per cent).

#### IDENTIFICATION

Infrared absorption spectrophotometry (2.2.24).

*Comparison:*  $\beta$ -acetyldigoxin CRS.

#### TESTS

**Specific optical rotation (2.2.7):** + 26.2 to + 28.2 (dried substance).

Dissolve 0.50 g in a mixture of equal volumes of *methanol R* and *methylene chloride R* and dilute to 25.0 mL with the same mixture of solvents.

**Related substances.** Liquid chromatography (2.2.29). *Prepare the solutions immediately before use.*

*Solvent mixture.* Mix equal volumes of *methanol R2* and *acetonitrile for chromatography R*.

*Test solution.* Dissolve 50.0 mg of the substance to be examined in the solvent mixture and dilute to 100.0 mL with the solvent mixture.

*Reference solution (a).* Dissolve 10.0 mg of  $\beta$ -acetyldigoxin CRS in the solvent mixture and dilute to 20.0 mL with the solvent mixture.

*Reference solution (b).* Dilute 1.0 mL of the test solution to 20.0 mL with the solvent mixture. Dilute 1.0 mL of this solution to 10.0 mL with the solvent mixture.

*Reference solution (c).* Dissolve 5 mg of *gitoxin CRS* (impurity D) in the solvent mixture and dilute to 100.0 mL with the solvent mixture. To 5.0 mL of this solution, add 0.5 mL of reference solution (a) and dilute to 100.0 mL with the solvent mixture.

*Reference solution (d).* Dissolve 5.0 mg of  $\beta$ -acetyldigoxin for peak identification CRS (containing impurities A and B) in 10.0 mL of the solvent mixture.

#### Column:

- size:  $l = 0.125$  m,  $\varnothing = 4.0$  mm;
- stationary phase: octadecylsilyl silica gel for chromatography R (4  $\mu$ m).

#### Mobile phase:

- mobile phase A: water for chromatography R;
- mobile phase B: acetonitrile for chromatography R;

Time (min)	Mobile phase A (per cent V/V)	Mobile phase B (per cent V/V)
0 - 10	70	30
10 - 20	70 $\rightarrow$ 35	30 $\rightarrow$ 65
20 - 20.1	35 $\rightarrow$ 70	65 $\rightarrow$ 30
20.1 - 25	70	30

*Flow rate:* 1.5 mL/min.

*Detection:* spectrophotometer at 225 nm.

*Injection:* 10  $\mu$ L of the test solution and reference solutions (b), (c) and (d).

*Identification of impurities:* use the chromatograms obtained with reference solutions (c) and (d) to identify the peaks due to impurities A, B and D.

*Relative retention* with reference to  $\beta$ -acetyldigoxin (retention time = about 9 min): impurity B = about 0.3; impurity A = about 0.7; impurity D = about 1.2.

*System suitability:* reference solution (c):

- *resolution:* minimum 1.5 between the peaks due to β-acetyldigoxin and impurity D;
- *symmetry factor:* maximum 2.5 for the peak due to β-acetyldigoxin.

*Limits:*

- *impurities A, B:* for each impurity, not more than the area of the principal peak in the chromatogram obtained with reference solution (b) (0.5 per cent);
- *impurity D:* not more than 0.6 times the area of the principal peak in the chromatogram obtained with reference solution (b) (0.3 per cent);
- *any other impurity:* for each impurity, not more than 0.4 times the area of the principal peak in the chromatogram obtained with reference solution (b) (0.2 per cent);
- *sum of impurities other than A, B and D:* not more than 1.2 times the area of the principal peak in the chromatogram obtained with reference solution (b) (0.6 per cent);
- *total:* not more than 3 times the area of the principal peak in the chromatogram obtained with reference solution (b) (1.5 per cent);
- *disregard limit:* 0.1 times the area of the principal peak in the chromatogram obtained with reference solution (b) (0.05 per cent).

The thresholds indicated under Related substances (Table 2034.1) in the general monograph *Substances for pharmaceutical use (2034)* do not apply.

**Loss on drying (2.2.32):** maximum 1.5 per cent, determined on 1.000 g by drying in an oven at 105 °C.

**Sulfated ash (2.4.14):** maximum 0.1 per cent, determined on the residue obtained in the test for loss on drying.

#### ASSAY

Liquid chromatography (2.2.29) as described in the test for related substances with the following modification.

*Injection:* test solution and reference solution (a).

Calculate the percentage content of C<sub>43</sub>H<sub>66</sub>O<sub>15</sub> from the declared content of β-acetyldigoxin CRS.

#### STORAGE

Protected from light.

#### IMPURITIES

*Specified impurities:* A, B, D.

*Other detectable impurities* (the following substances would, if present at a sufficient level, be detected by one or other of the tests in the monograph. They are limited by the general acceptance criterion for other/unspecified impurities. It is therefore not necessary to identify these impurities for demonstration of compliance. See also 5.10. *Control of impurities in substances for pharmaceutical use*): C, E, F, G, H.

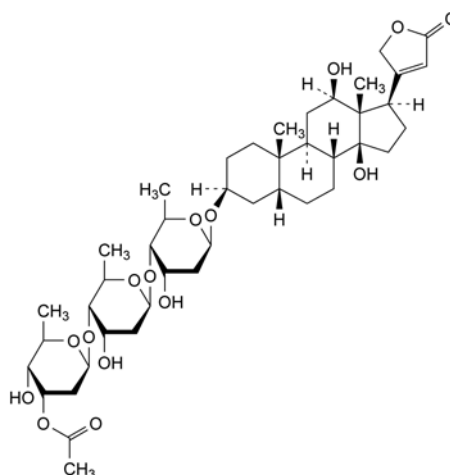

A. 3β-[(3-O-acetyl-2,6-dideoxy-β-D-ribo-hexopyranosyl-(1→4)-2,6-dideoxy-β-D-ribo-hexopyranosyl)-(1→4)-2,6-dideoxy-β-D-ribo-hexopyranosyl]oxy]-12β,14-dihydroxy-5β-card-20(22)-enolide (α-acetyldigoxin),

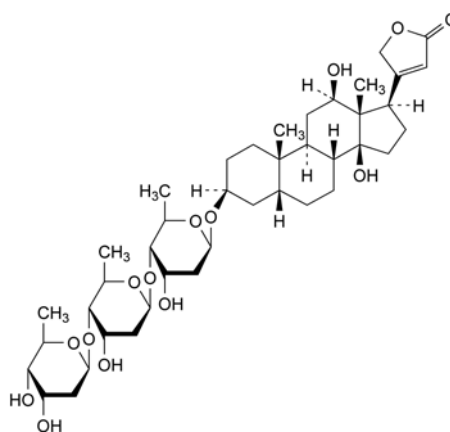

B. 3β-[(2,6-dideoxy-β-D-ribo-hexopyranosyl)-(1→4)-2,6-dideoxy-β-D-ribo-hexopyranosyl]oxy]-12β,14-dihydroxy-5β-card-20(22)-enolide (digoxin),

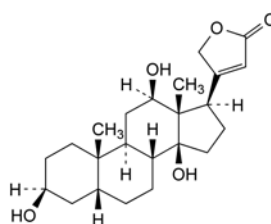

C. 3β,12β,14-trihydroxy-5β-card-20(22)-enolide (digoxigenin),



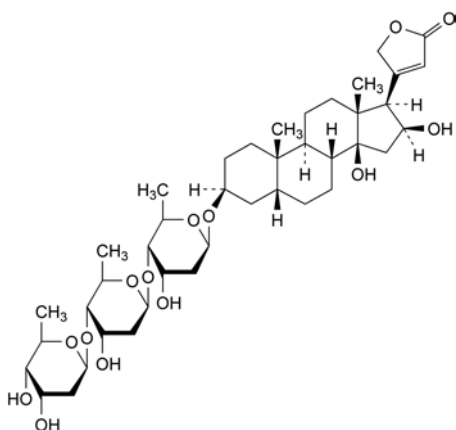

- D. 3β-[(2,6-dideoxy-β-D-ribo-hexopyranosyl-(1→4)-2,6-dideoxy-β-D-ribo-hexopyranosyl)oxy]-14,16β-dihydroxy-5β-card-20(22)-enolide (gitoxin),

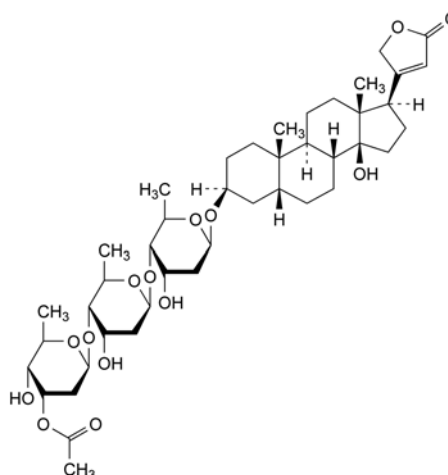

- G. 3β-[(3-O-acetyl-2,6-dideoxy-β-D-ribo-hexopyranosyl-(1→4)-2,6-dideoxy-β-D-ribo-hexopyranosyl)oxy]-14-hydroxy-5β-card-20(22)-enolide (α-acetyldigitoxin),

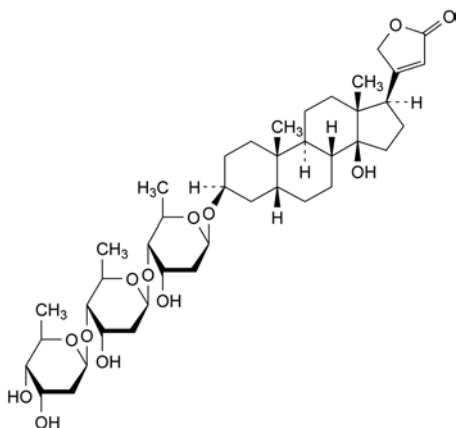

- E. 3β-[(2,6-dideoxy-β-D-ribo-hexopyranosyl-(1→4)-2,6-dideoxy-β-D-ribo-hexopyranosyl)oxy]-14-hydroxy-5β-card-20(22)-enolide (digitoxin),

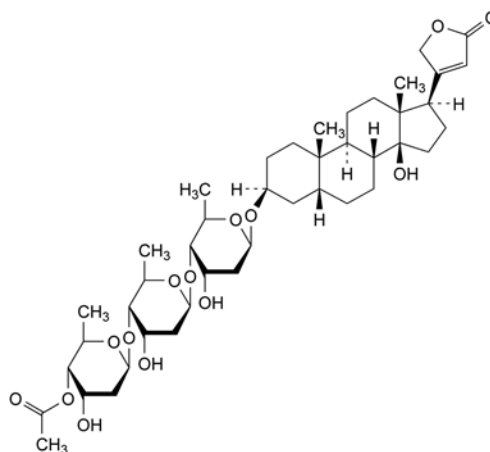

- H. 3β-[(4-O-acetyl-2,6-dideoxy-β-D-ribo-hexopyranosyl-(1→4)-2,6-dideoxy-β-D-ribo-hexopyranosyl)oxy]-14-hydroxy-5β-card-20(22)-enolide (β-acetyldigitoxin).

01/2011:0309

**ACETYLSALICYLIC ACID**

## Acidum acetylsalicylicum

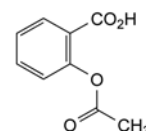
C<sub>9</sub>H<sub>8</sub>O<sub>4</sub>  
[50-78-2]M<sub>r</sub> 180.2**DEFINITION**

2-(Acetyloxy)benzoic acid.

*Content*: 99.5 per cent to 101.0 per cent (dried substance).**CHARACTERS***Appearance*: white or almost white, crystalline powder or colourless crystals.*Solubility*: slightly soluble in water, freely soluble in ethanol (96 per cent).

mp: about 143 °C (instantaneous method).

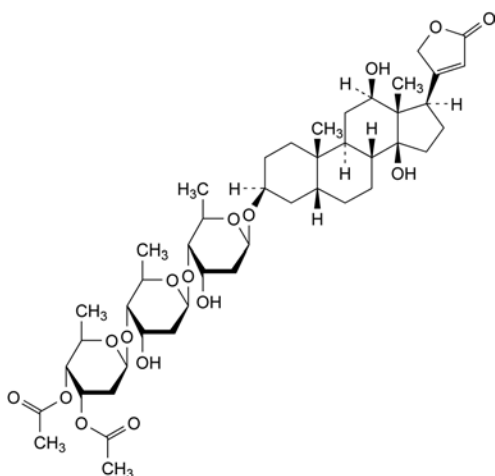
**IDENTIFICATION***First identification*: A, B.

- F. 3β-[(3,4-O-diacetyl-2,6-dideoxy-β-D-ribo-hexopyranosyl-(1→4)-2,6-dideoxy-β-D-ribo-hexopyranosyl)oxy]-12β,14-dihydroxy-5β-card-20(22)-enolide (diacetyldigoxin),

Second identification: B, C, D.

A. Infrared absorption spectrophotometry (2.2.24).

Comparison: acetylsalicylic acid CRS.

B. To 0.2 g add 4 mL of dilute sodium hydroxide solution R and boil for 3 min. Cool and add 5 mL of dilute sulfuric acid R. A crystalline precipitate is formed. Filter, wash the precipitate and dry at 100–105 °C. The melting point (2.2.14) is 156 °C to 161 °C.

C. In a test tube mix 0.1 g with 0.5 g of calcium hydroxide R. Heat the mixture and expose to the fumes produced a piece of filter paper impregnated with 0.05 mL of nitrobenzaldehyde solution R. A greenish-blue or greenish-yellow colour develops on the paper. Moisten the paper with dilute hydrochloric acid R. The colour becomes blue.

D. Dissolve with heating about 20 mg of the precipitate obtained in identification test B in 10 mL of water R and cool. The solution gives reaction (a) of salicylates (2.3.1).

#### TESTS

**Appearance of solution.** The solution is clear (2.2.1) and colourless (2.2.2, Method II).

Dissolve 1.0 g in 9 mL of ethanol (96 per cent) R.

**Related substances.** Liquid chromatography (2.2.29). Prepare the solutions immediately before use.

**Test solution.** Dissolve 0.100 g of the substance to be examined in acetonitrile for chromatography R and dilute to 10.0 mL with the same solvent.

**Reference solution (a).** Dissolve 50.0 mg of salicylic acid R (impurity C) in the mobile phase and dilute to 50.0 mL with the mobile phase. Dilute 1.0 mL of this solution to 100.0 mL with the mobile phase.

**Reference solution (b).** Dissolve 10 mg of salicylic acid R (impurity C) in the mobile phase and dilute to 10.0 mL with the mobile phase. To 1.0 mL of this solution add 0.2 mL of the test solution and dilute to 100.0 mL with the mobile phase.

**Column:**

- size:  $l = 0.25$  m,  $\varnothing = 4.6$  mm;
- stationary phase: octadecylsilyl silica gel for chromatography R (5  $\mu$ m).

**Mobile phase:** phosphoric acid R, acetonitrile for chromatography R, water R (2:400:600 V/V/V).

**Flow rate:** 1 mL/min.

**Detection:** spectrophotometer at 237 nm.

**Injection:** 10  $\mu$ L.

**Run time:** 7 times the retention time of acetylsalicylic acid.

**Identification of impurities:** use the chromatogram obtained with reference solution (a) to identify the peak due to impurity C.

**Relative retention** with reference to acetylsalicylic acid (retention time = about 5 min): impurity A = about 0.7; impurity B = about 0.8; impurity C = about 1.3; impurity D = about 2.3; impurity E = about 3.2; impurity F = about 6.0.

**System suitability:** reference solution (b):

- resolution: minimum 6.0 between the peaks due to acetylsalicylic acid and impurity C.

**Limits:**

- impurities A, B, C, D, E, F: for each impurity, not more than 1.5 times the area of the principal peak in the chromatogram obtained with reference solution (a) (0.15 per cent);
- unspecified impurities: for each impurity, not more than 0.5 times the area of the principal peak in the chromatogram obtained with reference solution (a) (0.05 per cent);
- total: not more than 2.5 times the area of the principal peak in the chromatogram obtained with reference solution (a) (0.25 per cent);
- disregard limit: 0.3 times the area of the principal peak in the chromatogram obtained with reference solution (a) (0.03 per cent).

**Heavy metals** (2.4.8): maximum 20 ppm.

Dissolve 1.0 g in 12 mL of acetone R and dilute to 20 mL with water R. 12 mL of the solution complies with test B. Prepare the reference solution using lead standard solution (1 ppm Pb) obtained by diluting lead standard solution (100 ppm Pb) R with a mixture of 6 volumes of water R and 9 volumes of acetone R.

**Loss on drying** (2.2.32): maximum 0.5 per cent, determined on 1.000 g by drying *in vacuo*.

**Sulfated ash** (2.4.14): maximum 0.1 per cent, determined on 1.0 g.

#### ASSAY

In a flask with a ground-glass stopper, dissolve 1.000 g in 10 mL of ethanol (96 per cent) R. Add 50.0 mL of 0.5 M sodium hydroxide. Close the flask and allow to stand for 1 h. Using 0.2 mL of phenolphthalein solution R as indicator, titrate with 0.5 M hydrochloric acid. Carry out a blank titration.

1 mL of 0.5 M sodium hydroxide is equivalent to 45.04 mg of  $C_9H_8O_4$ .

#### STORAGE

In an airtight container.

#### IMPURITIES

Specified impurities: A, B, C, D, E, F.

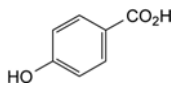

A. 4-hydroxybenzoic acid,

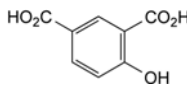

B. 4-hydroxybenzene-1,3-dicarboxylic acid (4-hydroxyisophthalic acid),

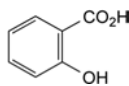

C. 2-hydroxybenzenecarboxylic acid (salicylic acid),

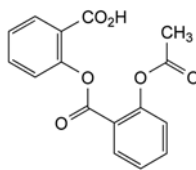

D. 2-[[2-(acetyloxy)benzoyl]oxy]benzoic acid (acetylsalicylic acid),

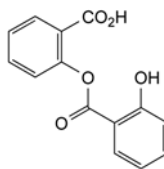

E. 2-[(2-hydroxybenzoyl)oxy]benzoic acid (salicylsalicylic acid),

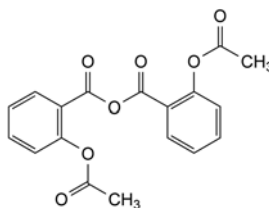

F. 2-(acetyloxy)benzoic anhydride (acetylsalicylic anhydride).

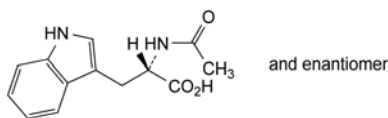
01/2009:1383 TESTS  
corrected 7.0**N-ACETYLTRYPTOPHAN***N*-AcetyltryptophanumC<sub>13</sub>H<sub>14</sub>N<sub>2</sub>O<sub>3</sub>  
[87-32-1]M<sub>r</sub> 246.3

## DEFINITION

(RS)-2-Acetylamino-3-(1*H*-indol-3-yl)propanoic acid.*Content*: 99.0 per cent to 101.0 per cent (dried substance).

## PRODUCTION

Tryptophan used for the production of *N*-acetyltryptophan complies with the test for impurity A and other related substances in the monograph on *Tryptophan* (1272).

## CHARACTERS

*Appearance*: white or almost white, crystalline powder, or colourless crystals.*Solubility*: slightly soluble in water, very soluble in ethanol (96 per cent). It dissolves in dilute solutions of alkali hydroxides.

mp: about 205 °C.

## IDENTIFICATION

*First identification*: A, B.*Second identification*: A, C, D, E.

A. Optical rotation (see Tests).

B. Infrared absorption spectrophotometry (2.2.24).

*Comparison*: *N*-acetyltryptophan CRS.

C. Thin-layer chromatography (2.2.27).

*Test solution*. Dissolve 50 mg of the substance to be examined in 0.2 mL of *concentrated ammonia R* and dilute to 10 mL with *water R*.*Reference solution (a)*. Dissolve 50 mg of *N*-acetyltryptophan CRS in 0.2 mL of *concentrated ammonia R* and dilute to 10 mL with *water R*.*Reference solution (b)*. Dissolve 10 mg of *tryptophan R* in the test solution and dilute to 2 mL with the test solution.*Plate*: TLC silica gel F<sub>254</sub> plate R.*Mobile phase*: *glacial acetic acid R*, *water R*, *butanol R* (25:25:40 V/V/V).*Application*: 2 µL.*Development*: over a path of 10 cm.*Drying*: in an oven at 100-105 °C for 15 min.*Detection*: examine in ultraviolet light at 254 nm.*System suitability*: reference solution (b):

– the chromatogram shows 2 clearly separated spots.

*Results*: the principal spot in the chromatogram obtained with the test solution is similar in position and size to the principal spot in the chromatogram obtained with reference solution (a).D. Dissolve about 2 mg in 2 mL of *water R*. Add 2 mL of *dimethylaminobenzaldehyde solution R6*. Heat on a water-bath. A blue or greenish-blue colour develops.

E. It gives the reaction of acetyl (2.3.1). Proceed as described for substances hydrolysable only with difficulty.

## TESTS

**Appearance of solution**. The solution is clear (2.2.1) and not more intensely coloured than reference solution Y<sub>7</sub> or GY<sub>7</sub> (2.2.2, *Method II*).Dissolve 1.0 g in a 40 g/L solution of *sodium hydroxide R* and dilute to 100 mL with the same alkaline solution.**Optical rotation** (2.2.7): –0.1° to +0.1°.Dissolve 2.50 g in a 40 g/L solution of *sodium hydroxide R* and dilute to 25.0 mL with the same alkaline solution.**Related substances**. Liquid chromatography (2.2.29). Prepare the test and reference solutions immediately before use.*Buffer solution pH 2.3*. Dissolve 3.90 g of *sodium dihydrogen phosphate R* in 1000 mL of *water R*. Add about 700 mL of a 2.9 g/L solution of *phosphoric acid R* and adjust to pH 2.3 with the same acid solution.*Solvent mixture*: *acetonitrile R*, *water R* (10:90 V/V).*Test solution*. Dissolve 0.10 g of the substance to be examined in a mixture of 50 volumes of *acetonitrile R* and 50 volumes of *water R* and dilute to 20.0 mL with the same mixture of solvents.*Reference solution (a)*. Dilute 1.0 mL of the test solution to 100.0 mL with the solvent mixture.*Reference solution (b)*. Dilute 4.0 mL of reference solution (a) to 100.0 mL with the solvent mixture.*Reference solution (c)*. Dissolve the contents of a vial of *1,1'-ethylidenebistryptophan CRS* in 1 mL of reference solution (b).*Column*:

- *size*: *l* = 0.25 m, Ø = 4.6 mm;
- *stationary phase*: *octadecylsilyl silica gel for chromatography R* (5 µm);
- *temperature*: 40 °C.

*Mobile phase*:

- *mobile phase A*: *acetonitrile R*, buffer solution pH 2.3 (115:885 V/V);
- *mobile phase B*: *acetonitrile R*, buffer solution pH 2.3 (350:650 V/V);

Time (min)	Mobile phase A (per cent V/V)	Mobile phase B (per cent V/V)
0 - 10	100	0
10 - 45	100 → 0	0 → 100
45 - 65	0	100

*Flow rate*: 0.7 mL/min.*Detection*: spectrophotometer at 220 nm.*Injection*: 20 µL of the test solution and reference solutions (a) and (c).*Retention time*: *N*-acetyltryptophan = about 29 min; 1,1'-ethylidenebis(tryptophan) = about 34 min.*System suitability*: reference solution (c):

- *resolution*: minimum 8.0 between the peaks due to *N*-acetyltryptophan and 1,1'-ethylidenebis(tryptophan); if necessary, adjust the time programme for the elution gradient (an increase in the duration of elution with mobile phase A produces longer retention times and a better resolution);
- *symmetry factor*: maximum 3.5 for the peak due to 1,1'-ethylidenebistryptophan in the chromatogram obtained with reference solution (c).

*Limits*:

- *impurities A, B, C, D, E, F, G, H, I, J, K, L*: for each impurity, not more than 0.25 times the area of the principal peak in the chromatogram obtained with reference solution (a) (0.25 per cent);

- *total*: not more than 0.5 times the area of the principal peak in the chromatogram obtained with reference solution (a) (0.5 per cent);
- *disregard limit*: 0.01 times the area of the principal peak the chromatogram obtained with reference solution (a) (0.01 per cent).

**Ammonium** (2.4.1, Method B): maximum 200 ppm, determined on 0.10 g.

Prepare the standard using 0.2 mL of *ammonium standard solution* (100 ppm NH<sub>4</sub>) R.

**Iron** (2.4.9): maximum 10 ppm.

Dissolve 1.0 g in 50 mL of *hydrochloric acid R1*, with heating at 50 °C. Allow to cool. In a separating funnel, shake with 3 quantities, each of 10 mL, of *methyl isobutyl ketone R1*, shaking for 3 min each time. To the combined organic layers add 10 mL of *water R* and shake for 3 min. Examine the aqueous layer.

**Heavy metals** (2.4.8): maximum 10 ppm.

2.0 g complies with test C. Prepare the reference solution using 2 mL of *lead standard solution* (10 ppm Pb) R.

**Loss on drying** (2.2.32): maximum 0.5 per cent, determined on 1.000 g by drying in an oven at 105 °C.

**Sulfated ash** (2.4.14): maximum 0.1 per cent, determined on 1.0 g.

#### ASSAY

Dissolve 0.200 g in 5 mL of *methanol R*. Add 50 mL of *anhydrous ethanol R*. Titrate with 0.1 M *sodium hydroxide*, determining the end-point potentiometrically (2.2.20).

1 mL of 0.1 M *sodium hydroxide* is equivalent to 24.63 mg of C<sub>13</sub>H<sub>14</sub>N<sub>2</sub>O<sub>3</sub>.

#### STORAGE

Protected from light.

#### IMPURITIES

*Specified impurities: A, B, C, D, E, F, G, H, I, J, K, L.*

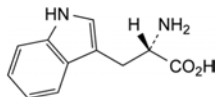

A. (S)-2-amino-3-(1H-indol-3-yl)propanoic acid (tryptophan),

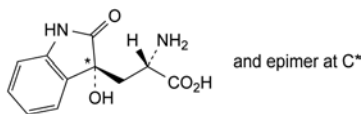

B. (S)-2-amino-3-[(3RS)-3-hydroxy-2-oxo-2,3-dihydro-1H-indol-3-yl]propanoic acid (dioxindolylalanine),

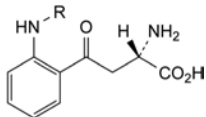

C. R = H: (S)-2-amino-4-(2-aminophenyl)-4-oxobutanoic acid (kynurenine),

E. R = CHO: (S)-2-amino-4-[2-(formylamino)phenyl]-4-oxobutanoic acid (*N*-formylkynurenine),

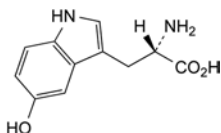

D. (S)-2-amino-3-(5-hydroxy-1H-indol-3-yl)propanoic acid (5-hydroxytryptophan),

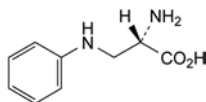

F. (S)-2-amino-3-(phenylamino)propanoic acid (3-phenylaminoalanine),

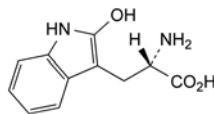

G. (S)-2-amino-3-(2-hydroxy-1H-indol-3-yl)propanoic acid (2-hydroxytryptophan),

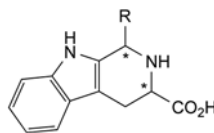

H. R = H: (3RS)-1,2,3,4-tetrahydro-9H-β-carboline-3-carboxylic acid,

I. R = CH<sub>3</sub>: 1-methyl-1,2,3,4-tetrahydro-9H-β-carboline-3-carboxylic acid,

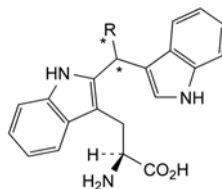

J. R = CHOH-CH<sub>2</sub>-OH: (S)-2-amino-3-[2-[2,3-dihydroxy-1-(1H-indol-3-yl)propyl]-1H-indol-3-yl]propanoic acid,

K. R = H: (S)-2-amino-3-[2-(1H-indol-3-ylmethyl)-1H-indol-3-yl]propanoic acid,

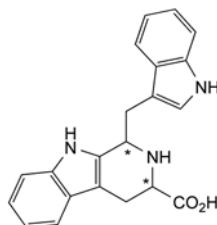

L. 1-(1H-indol-3-ylmethyl)-1,2,3,4-tetrahydro-9H-β-carboline-3-carboxylic acid.

01/2008:1384  
corrected 6.0

## N-ACETYLTYROSINE

### *N*-Acetyltyrosinum

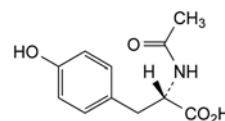

C<sub>11</sub>H<sub>13</sub>NO<sub>4</sub>  
[537-55-3]

*M*<sub>r</sub> 223.2

#### DEFINITION

*N*-Acetyltyrosine contains not less than 98.5 per cent and not more than the equivalent of 101.0 per cent of (2*S*)-2-(acetylamino)-3-(4-hydroxyphenyl)propanoic acid, calculated with reference to the dried substance.

*Content:* 98.5 per cent to 101.0 per cent (anhydrous substance).

#### CHARACTERS

*Appearance:* white or almost white, crystalline powder.

*Solubility:* slightly soluble in water, freely soluble in dimethyl sulfoxide, very slightly soluble in ethanol (96 per cent). It dissolves in dilute solutions of mineral acids and alkali hydroxides.

#### IDENTIFICATION

Infrared absorption spectrophotometry (2.2.24).

*Comparison:* aciclovir CRS.

#### TESTS

**Appearance of solution.** The solution is clear (2.2.1) and not more intensely coloured than reference solution Y<sub>7</sub> (2.2.2, Method II).

Dissolve 0.25 g in a 4 g/L solution of sodium hydroxide R and dilute to 25 mL with the same solvent.

**Related substances.** Liquid chromatography (2.2.29).

*Solvent mixture:* dimethyl sulfoxide R, water R (20:80 V/V).

*Phosphate buffer solution pH 2.5.* Dissolve 3.48 g of dipotassium hydrogen phosphate R in 1000 mL of water R and adjust to pH 2.5 with phosphoric acid R.

*Phosphate buffer solution pH 3.1.* Dissolve 3.48 g of dipotassium hydrogen phosphate R in 1000 mL of water R and adjust to pH 3.1 with phosphoric acid R.

*Test solution.* Dissolve 25 mg of the substance to be examined in 5.0 mL of dimethyl sulfoxide R and dilute to 25.0 mL with water R.

*Reference solution (a).* Dissolve 5 mg of aciclovir for system suitability CRS (containing impurities A, B, J, K, N, O and P) in 1 mL of dimethyl sulfoxide R and dilute to 5.0 mL with water R.

*Reference solution (b).* Dilute 1.0 mL of the test solution to 100.0 mL with the solvent mixture. Dilute 1.0 mL of this solution to 10.0 mL with the solvent mixture.

*Reference solution (c).* Dissolve the contents of a vial of aciclovir for peak identification 1 CRS (containing impurities C and I) in 200 µL of dimethyl sulfoxide R and dilute to 1.0 mL with water R. Prepare this solution immediately before use.

*Reference solution (d).* Dissolve the contents of a vial of aciclovir for peak identification 2 CRS (containing impurities F and G) in 1.0 mL of reference solution (a).

*Column:*

- size:  $l = 0.25$  m,  $\varnothing = 4.6$  mm;
- stationary phase: octadecylsilyl silica gel for chromatography R (5 µm).

*Mobile phase:*

- mobile phase A: acetonitrile R, phosphate buffer solution pH 3.1 (1:99 V/V);
- mobile phase B: acetonitrile R, phosphate buffer solution pH 2.5 (50:50 V/V);

Time (min)	Mobile phase A (per cent V/V)	Mobile phase B (per cent V/V)
0 - 5	100	0
5 - 27	100 → 80	0 → 20
27 - 40	80	20

*Flow rate:* 1.0 mL/min.

*Detection:* spectrophotometer at 254 nm.

*Injection:* 10 µL of the test solution and reference solutions (b), (c) and (d).

*Identification of impurities:* use the chromatogram supplied with aciclovir for peak identification 1 CRS and the chromatogram obtained with reference solution (c) to identify the peaks due to impurities C and I; use the chromatogram

supplied with aciclovir for peak identification 2 CRS and the chromatogram obtained with reference solution (d) to identify the peaks due to impurities A, B, F, G, J, K, N, O and P.

*Relative retention* with reference to aciclovir (retention time = about 13 min): impurity B = about 0.4; impurity P = about 0.7; impurity C = about 0.9; impurity N = about 1.37; impurity O = about 1.42; impurity I = about 1.57; impurity J = about 1.62; impurity F = about 1.7; impurity A = about 1.8; impurity K = about 2.5; impurity G = about 2.6.

*System suitability:*

- resolution: minimum 1.5 between the peaks due to impurity C and aciclovir in the chromatogram obtained with reference solution (c); minimum 1.5 between the peaks due to impurities F and A and minimum 1.5 between the peaks due to impurities K and G in the chromatogram obtained with reference solution (d).

*Limits:*

- correction factor: for the calculation of content, multiply the peak area of impurity I by 1.5;
- impurity B: not more than 7 times the area of the principal peak in the chromatogram obtained with reference solution (b) (0.7 per cent);
- impurity O: not more than 3 times the area of the principal peak in the chromatogram obtained with reference solution (b) (0.3 per cent);
- impurities A, G, J, K, N, P: for each impurity, not more than twice the area of the principal peak in the chromatogram obtained with reference solution (b) (0.2 per cent);
- impurities C, F, I: for each impurity, not more than the area of the principal peak in the chromatogram obtained with reference solution (b) (0.1 per cent);
- unspecified impurities: for each impurity, not more than 0.5 times the area of the principal peak in the chromatogram obtained with reference solution (b) (0.05 per cent);
- total: not more than 15 times the area of the principal peak in the chromatogram obtained with reference solution (b) (1.5 per cent);
- disregard limit: 0.3 times the area of the principal peak in the chromatogram obtained with reference solution (b) (0.03 per cent).

**Water** (2.5.12): maximum 6.0 per cent, determined on 0.500 g.

**Sulfated ash** (2.4.14): maximum 0.1 per cent, determined on 1.0 g.

#### ASSAY

Dissolve 0.150 g in 60 mL of anhydrous acetic acid R. Titrate with 0.1 M perchloric acid, determining the end-point potentiometrically (2.2.20). Carry out a blank titration.

1 mL of 0.1 M perchloric acid is equivalent to 22.52 mg of C<sub>8</sub>H<sub>11</sub>N<sub>5</sub>O<sub>3</sub>.

#### IMPURITIES

*Specified impurities:* A, B, C, F, G, I, J, K, N, O, P.

*Other detectable impurities* (the following substances would, if present at a sufficient level, be detected by one or other of the tests in the monograph. They are limited by the general acceptance criterion for other/unspecified impurities and/or by the general monograph *Substances for pharmaceutical use* (2034). It is therefore not necessary to identify these impurities for demonstration of compliance. See also 5.10. *Control of impurities in substances for pharmaceutical use*): L, M.

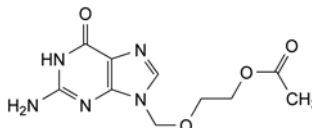

- A. 2-[(2-amino-6-oxo-1,6-dihydro-9H-purin-9-yl)methoxy]ethyl acetate,

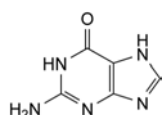

B. 2-amino-1,7-dihydro-6H-purin-6-one (guanine),

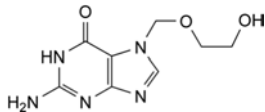

C. 2-amino-7-[(2-hydroxyethoxy)methyl]-1,7-dihydro-6H-purin-6-one,

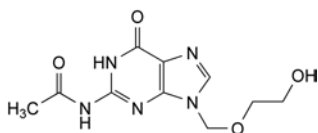

F. *N*-[9-[(2-hydroxyethoxy)methyl]-6-oxo-6,9-dihydro-1H-purin-2-yl]acetamide,

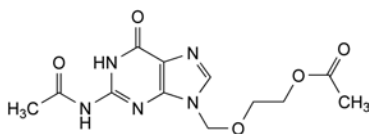

G. 2-[[2-(acetylamino)-6-oxo-1,6-dihydro-9H-purin-9-yl]methoxy]ethyl acetate,

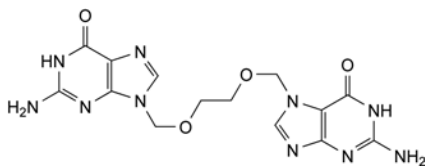

I. 2-amino-7-[[2-[(2-amino-6-oxo-1,6-dihydro-9H-purin-9-yl)methoxy]ethoxy]methyl]-1,7-dihydro-6H-purin-6-one,

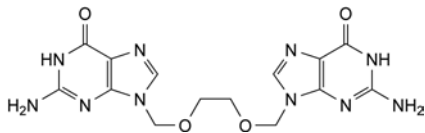

J. 9,9'-[ethylenebis(oxy)methylene]bis(2-amino-1,9-dihydro-6H-purin-6-one),

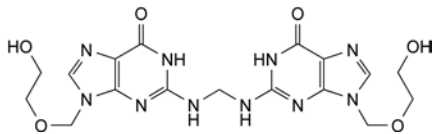

K. 2,2'-[methylendiimino]bis[9-[(2-hydroxyethoxy)methyl]-1,9-dihydro-6H-purin-6-one],

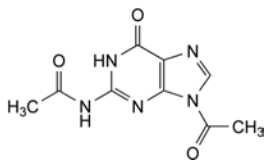

L. *N*-(9-acetyl-6-oxo-6,9-dihydro-1H-purin-2-yl)acetamide (*N*<sup>2</sup>,9-diacetylguanine),

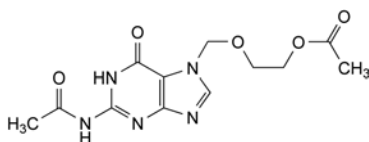

M. 2-[[2-(acetylamino)-6-oxo-1,6-dihydro-7H-purin-7-yl]methoxy]ethyl acetate,

N. unknown structure,

O. unknown structure,

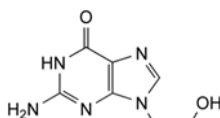

P. 2-amino-9-(2-hydroxyethyl)-1,9-dihydro-6H-purin-6-one.

07/2010:1385  
corrected 7.0

## ACITRETIN

### Acitretinum

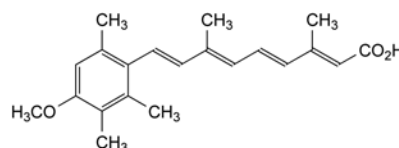

C<sub>21</sub>H<sub>26</sub>O<sub>3</sub>  
[55079-83-9]

*M*<sub>r</sub> 326.4

#### DEFINITION

(all-*E*)-9-(4-Methoxy-2,3,6-trimethylphenyl)-3,7-dimethylnona-2,4,6,8-tetraenoic acid.

*Content*: 98.0 per cent to 102.0 per cent (dried substance).

#### CHARACTERS

*Appearance*: yellow or greenish-yellow, crystalline powder.

*Solubility*: practically insoluble in water, sparingly soluble in tetrahydrofuran, slightly soluble in acetone and in ethanol (96 per cent), very slightly soluble in cyclohexane.

It is sensitive to air, heat and light, especially in solution.

It shows polymorphism.

*Carry out all operations as rapidly as possible and avoid exposure to actinic light; use freshly prepared solutions.*

#### IDENTIFICATION

*First identification*: B.

*Second identification*: A, C.

A. Ultraviolet and visible absorption spectrophotometry (2.2.25).

*Test solution*. Dissolve 15.0 mg in 10 mL of tetrahydrofuran *R* and dilute immediately to 100.0 mL with the same solvent. Dilute 2.5 mL of this solution to 100.0 mL with tetrahydrofuran *R*.

*Spectral range*: 300-400 nm.

*Absorption maximum*: at 358 nm.

*Specific absorbance at the absorption maximum*: 1350 to 1475.

B. Infrared absorption spectrophotometry (2.2.24).

*Preparation*: discs.

*Comparison*: acitretin CRS.

If the spectra obtained in the solid state show differences, dissolve the substance to be examined and the reference substance separately in 2-propanol *R* heating under reflux, filter, evaporate to dryness and record new spectra using the residues.

C. Examine the chromatograms obtained in the assay.

*Results*: the principal peak in the chromatogram obtained with test solution (b) is similar in retention time to the principal peak in the chromatogram obtained with reference solution (a).

## TESTS

**Related substances.** Liquid chromatography (2.2.29). *Maintain the sampler at 4 °C.*

*Test solution (a).* Dissolve 25.0 mg of the substance to be examined in 5 mL of *tetrahydrofuran R* and dilute immediately to 100.0 mL with *anhydrous ethanol R*.

*Test solution (b).* Dilute 10.0 mL of test solution (a) to 25.0 mL with *anhydrous ethanol R*.

*Reference solution (a).* Dissolve 25.0 mg of *acitretin CRS* in 5 mL of *tetrahydrofuran R* and dilute immediately to 100.0 mL with *anhydrous ethanol R*. Dilute 10.0 mL of this solution to 25.0 mL with *anhydrous ethanol R*.

*Reference solution (b).* Dissolve 1.0 mg of *tretinoin CRS* in *anhydrous ethanol R* and dilute to 20.0 mL with the same solvent. Mix 5.0 mL of this solution with 2.5 mL of reference solution (a) and dilute to 100.0 mL with *anhydrous ethanol R*.

*Reference solution (c).* Dilute 2.5 mL of reference solution (a) to 50.0 mL with *anhydrous ethanol R*. Dilute 3.0 mL of this solution to 20.0 mL with *anhydrous ethanol R*.

*Column:*

- size  $l = 0.25$  m,  $\varnothing = 4$  mm;
- *stationary phase:* microparticulate *octadecylsilyl silica gel for chromatography R* (5  $\mu$ m) with a specific surface area of 200 m<sup>2</sup>/g, a pore size of 15 nm and a carbon loading of 20 per cent;
- *temperature:* 25 °C.

*Mobile phase:* a 0.3 per cent V/V solution of *glacial acetic acid R* in a mixture of 8 volumes of *water R* and 92 volumes of *anhydrous ethanol R*.

*Flow rate:* 0.6 mL/min.

*Detection:* spectrophotometer at 360 nm.

*Injection:* 10  $\mu$ L of test solution (a) and reference solutions (b) and (c).

*Run time:* 2.5 times the retention time of acitretin.

*Retention time:* impurity A = about 4.8 min; tretinoin = about 5.2 min; acitretin = about 6.2 min; impurity B = about 10.2 min.

*System suitability:* reference solution (b):

- *resolution:* minimum 2.0 between the peaks due to acitretin and tretinoin; if necessary, adjust the concentration of *anhydrous ethanol R*.

*Limits:*

- *impurities A, B:* for each impurity, not more than the area of the peak due to acitretin in the chromatogram obtained with reference solution (c) (0.3 per cent);
- *total:* not more than the area of the peak due to acitretin in the chromatogram obtained with reference solution (b) (1.0 per cent);
- *disregard limit:* 0.1 times the area of the principal peak in the chromatogram obtained with reference solution (c).

**Palladium:** maximum 10 ppm.

Atomic absorption spectrometry (2.2.23, *Method I*).

*Test solution.* Introduce 2.0 g into a quartz beaker and add 3 mL of *magnesium nitrate solution R*. Heat in a muffle furnace to 350 °C at a rate of 40 °C/min to incinerate the content. Ignite at about 450 °C for 8 h and then at 550  $\pm$  50 °C for a further hour. Dissolve the residue in a mixture of 0.75 mL of *hydrochloric acid R* and 0.25 mL of *nitric acid R*, warming gently. Cool, then transfer the solution into a volumetric flask containing *water R* and dilute to 50.0 mL with the same solvent.

*Reference solution.* Dissolve 0.163 g of *heavy magnesium oxide R* in a mixture of 0.5 mL of *nitric acid R*, 1.5 mL of *hydrochloric acid R* and 50 mL of *water R*, add 2.0 mL of *palladium standard solution (20 ppm Pd R)* and dilute to 100.0 mL with *water R*.

*Source:* palladium hollow-cathode lamp.

*Wavelength:* 247.6 nm.

*Atomisation device:* air-acetylene flame.

**Heavy metals (2.4.8):** maximum 20 ppm.

2.0 g complies with test C. Prepare the reference solution using 2 mL of *lead standard solution (10 ppm Pb) R*.

**Loss on drying (2.2.32):** maximum 0.5 per cent, determined on 1.000 g by drying *in vacuo* at 100 °C for 4 h.

**Sulfated ash (2.4.14):** maximum 0.1 per cent, determined on 1.0 g.

## ASSAY

*Carry out the assay protected from light, use amber volumetric flasks and prepare the solutions immediately before use.*

Liquid chromatography (2.2.29) as described in the test for related substances with the following modifications.

*Injection:* test solution (b) and reference solution (a).

*System suitability:*

- *repeatability:* maximum relative standard deviation of 1.0 per cent after 6 injections of reference solution (a); if necessary, adjust the integration parameters.

Calculate the percentage content of C<sub>21</sub>H<sub>26</sub>O<sub>3</sub> from the declared content of *acitretin CRS*.

## STORAGE

In an airtight container, protected from light, at a temperature of 2 °C to 8 °C.

It is recommended that the contents of an opened container be used as soon as possible and any unused part be protected by an atmosphere of inert gas.

## IMPURITIES

*Specified impurities: A, B.*

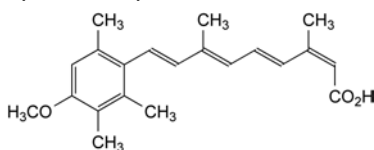

A. (2Z,4E,6E,8E)-9-(4-methoxy-2,3,6-trimethylphenyl)-3,7-dimethylnona-2,4,6,8-tetraenoic acid,

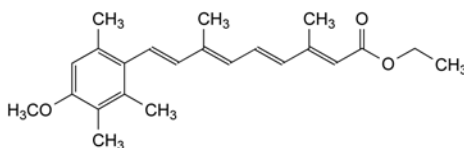

B. ethyl (all-E)-9-(4-methoxy-2,3,6-trimethylphenyl)-3,7-dimethylnona-2,4,6,8-tetraenoate.

01/2010:2445

## ADAPALENE

## Adapalenum

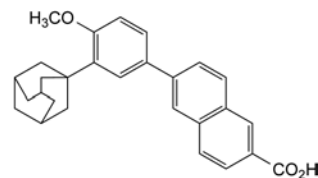

C<sub>28</sub>H<sub>28</sub>O<sub>3</sub>  
[106685-40-9]

*M<sub>r</sub>* 412.5

## DEFINITION

6-(4-Methoxy-3-tricyclo[3.3.1.1<sup>3,7</sup>]dec-1-ylphenyl)naphthalene-2-carboxylic acid.

*Content:* 98.0 per cent to 102.0 per cent (dried substance).

## CHARACTERS

*Appearance:* white or almost white powder.

**Solubility:** practically insoluble in water, sparingly soluble in tetrahydrofuran, practically insoluble in ethanol (96 per cent).

#### IDENTIFICATION

Infrared absorption spectrophotometry (2.2.24).

**Comparison:** adapalene CRS.

#### TESTS

**Appearance of solution.** The solution is clear (2.2.1) and not more intensely coloured than reference solution BY<sub>6</sub> (2.2.2, Method II).

Dissolve 0.2 g in tetrahydrofuran R and dilute to 20 mL with the same solvent.

**Related substances.** Liquid chromatography (2.2.29).

**Solvent mixture:** tetrahydrofuran R, acetonitrile R, water R (20:37:43 V/V/V).

**Test solution (a).** Dissolve 40.0 mg of the substance to be examined in 10 mL of tetrahydrofuran R, add 7 mL of the solvent mixture and dilute to 20.0 mL with tetrahydrofuran R.

**Test solution (b).** Dissolve 20.0 mg of the substance to be examined in 50 mL of tetrahydrofuran R, add 35 mL of the solvent mixture and dilute to 100.0 mL with tetrahydrofuran R. Dilute 5.0 mL of the solution to 50.0 mL with the solvent mixture.

**Reference solution (a).** Dilute 1.0 mL of test solution (a) to 10.0 mL with tetrahydrofuran R. Dilute 1.0 mL of this solution to 100.0 mL with the solvent mixture.

**Reference solution (b).** Dissolve 2.4 mg of adapalene impurity C CRS in 2 mL of tetrahydrofuran R and dilute to 20.0 mL with the same solvent. Dilute 2.0 mL of the solution to 20.0 mL with the solvent mixture. To 2.0 mL of this solution add 2.0 mL of reference solution (a) and dilute to 20.0 mL with the solvent mixture.

**Reference solution (c).** Dissolve the contents of a vial of adapalene for peak identification CRS (containing impurities A, C and D) in 0.5 mL of tetrahydrofuran R and dilute to 1.0 mL with the solvent mixture.

**Reference solution (d).** Dissolve 20.0 mg of adapalene CRS in 50 mL of tetrahydrofuran R, add 35 mL of the solvent mixture and dilute to 100.0 mL with tetrahydrofuran R. Dilute 5.0 mL of the solution to 50.0 mL with the solvent mixture.

**Column:**

- size:  $l = 0.25$  m,  $\varnothing = 4.6$  mm;
- stationary phase: end-capped phenylsilyl silica gel for chromatography R (5  $\mu$ m) with a carbon loading of 7.5 per cent;
- temperature: 30 °C.

**Mobile phase:**

- mobile phase A: glacial acetic acid R, water R (0.1:100 V/V);
- mobile phase B: tetrahydrofuran R, acetonitrile R (35:65 V/V);

Time (min)	Mobile phase A (per cent V/V)	Mobile phase B (per cent V/V)
0 - 2.5	50	50
2.5 - 40	50 → 28	50 → 72
40 - 42	28	72

**Flow rate:** 1.2 mL/min.

**Detection:** spectrophotometer at 270 nm.

**Injection:** 25  $\mu$ L of test solution (a) and reference solutions (a), (b) and (c).

**Identification of impurities:** use the chromatogram supplied with adapalene for peak identification CRS and the chromatogram obtained with reference solution (c) to identify the peaks due to impurities A, C and D.

**Relative retention** with reference to adapalene (retention time = about 20 min): impurity A = about 0.3; impurity C = about 0.9; impurity D = about 1.9.

**System suitability:** reference solution (b):

- resolution: minimum 4.5 between the peaks due to impurity C and adapalene;
- signal-to-noise ratio: minimum 10 for the peak due to impurity C.

**Limits:**

- correction factors: for the calculation of content, multiply the peak areas of the following impurities by the corresponding correction factor: impurity A = 0.7; impurity C = 7; impurity D = 1.4;
- impurity A: not more than 3 times the area of the principal peak in the chromatogram obtained with reference solution (a) (0.3 per cent);
- impurity D: not more than twice the area of the principal peak in the chromatogram obtained with reference solution (a) (0.2 per cent);
- impurity C: not more than 1.5 times the area of the principal peak in the chromatogram obtained with reference solution (a) (0.15 per cent);
- unspecified impurities: for each impurity, not more than the area of the principal peak in the chromatogram obtained with reference solution (a) (0.10 per cent);
- total: not more than 5 times the area of the principal peak in the chromatogram obtained with reference solution (a) (0.5 per cent);
- disregard limit: 0.5 times the area of the principal peak in the chromatogram obtained with reference solution (a) (0.05 per cent).

**Heavy metals** (2.4.8): maximum 20 ppm.

0.250 g complies with test G. Prepare the reference solution using 0.5 mL of lead standard solution (10 ppm Pb) R.

**Loss on drying** (2.2.32): maximum 0.5 per cent, determined on 1.000 g by drying in an oven at 105 °C for 4 h.

**Sulfated ash** (2.4.14): maximum 0.1 per cent, determined on 1.0 g.

#### ASSAY

Liquid chromatography (2.2.29) as described in the test for related substances with the following modification.

**Injection:** test solution (b) and reference solution (d).

Calculate the percentage content of adapalene from the declared content of adapalene CRS.

#### IMPURITIES

**Specified impurities:** A, C, D.

**Other detectable impurities** (the following substances would, if present at a sufficient level, be detected by one or other of the tests in the monograph. They are limited by the general acceptance criterion for other/unspecified impurities and/or by the general monograph *Substances for pharmaceutical use* (2034). It is therefore not necessary to identify these impurities for demonstration of compliance. See also 5.10. *Control of impurities in substances for pharmaceutical use*): B.

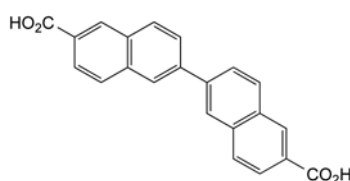

A. 2,2'-binaphthalene-6,6'-dicarboxylic acid,



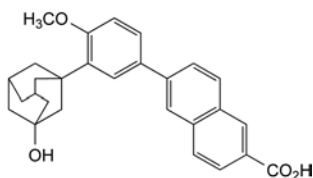

- B. 6-[3-(3-hydroxytricyclo[3.3.1.1<sup>3,7</sup>]dec-1-yl)-4-methoxyphenyl]naphthalene-2-carboxylic acid,

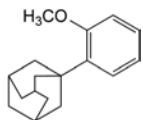

- C. 1-(2-methoxyphenyl)tricyclo[3.3.1.1<sup>3,7</sup>]decane,

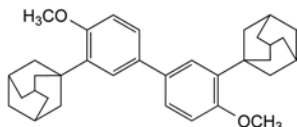

- D. 1,1'-[4,4'-bis(methoxy)biphenyl-3,3'-diyl]bis(tricyclo[3.3.1.1<sup>3,7</sup>]decane).

01/2008:0800  
corrected 6.0

## ADENINE

### Adeninum

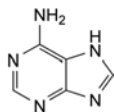

C<sub>5</sub>H<sub>5</sub>N<sub>5</sub>  
[73-24-5]

M<sub>r</sub> 135.1

#### DEFINITION

Adenine contains not less than 98.5 per cent and not more than the equivalent of 101.0 per cent of 7*H*-purin-6-amine, calculated with reference to the dried substance.

#### CHARACTERS

A white or almost white powder, very slightly soluble in water and in alcohol. It dissolves in dilute mineral acids and in dilute solutions of alkali hydroxides.

#### IDENTIFICATION

*First identification:* A.

*Second identification:* B, C.

- A. Examine by infrared absorption spectrophotometry (2.2.24), comparing with the spectrum obtained with *adenine CRS*. Examine the substances prepared as discs.
- B. Examine the chromatograms obtained in the test for related substances. The principal spot in the chromatogram obtained with test solution (b) is similar in position and size to the principal spot in the chromatogram obtained with reference solution (a).
- C. To 1 g add 3.5 mL of *propionic anhydride R* and boil for 15 min with stirring. Cool. To the resulting crystalline mass add 15 mL of *light petroleum R* and heat to boiling with vigorous stirring. Cool and filter. Wash the precipitate with two quantities, each of 5 mL, of *light petroleum R*. Dissolve the precipitate in 10 mL of *water R* and boil for 1 min. Filter the mixture at 30 °C to 40 °C. Allow to cool. Filter, and dry the precipitate at 100 °C to 105 °C for 1 h. The melting point (2.2.14) of the precipitate is 237 °C to 241 °C.

#### TESTS

**Solution S.** Suspend 2.5 g in 50 mL of *distilled water R* and boil for 3 min. Cool and dilute to 50 mL with *distilled water R*. Filter. Use the filtrate as solution S.

**Appearance of solution.** Dissolve 0.5 g in *dilute hydrochloric acid R* and dilute to 50 mL with the same acid. The solution is clear (2.2.1) and colourless (2.2.2, *Method II*).

**Acidity or alkalinity.** To 10 mL of solution S add 0.1 mL of *bromothymol blue solution R1* and 0.2 mL of 0.01 M *sodium hydroxide*. The solution is blue. Add 0.4 mL of 0.01 M *hydrochloric acid*. The solution is yellow.

**Related substances.** Examine by thin-layer chromatography (2.2.27), using *silica gel GF<sub>254</sub> R* as the coating substance.

*Test solution (a).* Dissolve 0.10 g of the substance to be examined in *dilute acetic acid R*, with heating if necessary, and dilute to 10 mL with the same acid.

*Test solution (b).* Dilute 1 mL of test solution (a) to 10 mL with *dilute acetic acid R*.

*Reference solution (a).* Dissolve 10 mg of *adenine CRS* in *dilute acetic acid R*, with heating if necessary, and dilute to 10 mL with the same acid.

*Reference solution (b).* Dilute 1 mL of test solution (b) to 20 mL with *dilute acetic acid R*.

*Reference solution (c).* Dissolve 10 mg of *adenine CRS* and 10 mg of *adenosine R* in *dilute acetic acid R*, with heating if necessary, and dilute to 10 mL with the same acid.

Apply to the plate 5 µL of each solution. Develop over a path of 12 cm using a mixture of 20 volumes of *concentrated ammonia R*, 40 volumes of *ethyl acetate R* and 40 volumes of *propanol R*. Dry the plate in a current of warm air and examine in ultraviolet light at 254 nm. Any spot in the chromatogram obtained with test solution (a), apart from the principal spot, is not more intense than the spot in the chromatogram obtained with reference solution (b) (0.5 per cent). The test is not valid unless the chromatogram obtained with reference solution (c) shows two clearly separated spots.

**Chlorides (2.4.4).** To 10 mL of solution S add 1 mL of *concentrated ammonia R* and 3 mL of *silver nitrate solution R2*. Filter. Wash the precipitate with a little *water R* and dilute the filtrate to 15 mL with *water R*. The solution complies with the limit test for chlorides (100 ppm). When carrying out the test, add 2 mL of *dilute nitric acid R* instead of 1 mL of *dilute nitric acid R*.

**Sulfates (2.4.13).** Dilute 10 mL of solution S to 15 mL with *distilled water R*. The solution complies with the limit test for sulfates (300 ppm).

**Ammonium.** Prepare a cell consisting of two watch-glasses 60 mm in diameter placed edge to edge. To the inner wall of the upper watch-glass stick a piece of *red litmus paper R* 5 mm square and wetted with a few drops of *water R*. Finely powder the substance to be examined, place 0.5 g in the lower watch-glass and suspend in 0.5 mL of *water R*. To the suspension add 0.30 g of *heavy magnesium oxide R*. Briefly triturate with a glass rod. Immediately close the cell by putting the two watch-glasses together. Heat at 40 °C for 15 min. The litmus paper is not more intensely blue coloured than a standard prepared at the same time and in the same manner using 0.05 mL of *ammonium standard solution (100 ppm NH<sub>4</sub>) R*, 0.5 mL of *water R* and 0.30 g of *heavy magnesium oxide R* (10 ppm).

**Heavy metals (2.4.8).** 1.0 g complies with limit test C for heavy metals (20 ppm). Prepare the standard using 2 mL of *lead standard solution (10 ppm Pb) R*.

**Loss on drying (2.2.32).** Not more than 0.5 per cent, determined on 1.000 g by drying in an oven at 105 °C.

**Sulfated ash (2.4.14).** Not more than 0.1 per cent, determined on 1.0 g.

## ASSAY

Dissolve 0.100 g in a mixture of 20 mL of *acetic anhydride R* and 30 mL of *anhydrous acetic acid R*. Titrate with 0.1 M *perchloric acid*, determining the end-point potentiometrically (2.2.20).

1 mL of 0.1 M *perchloric acid* is equivalent to 13.51 mg of  $C_5H_5N_5$ .

01/2009:1486

## ADENOSINE

## Adenosinum

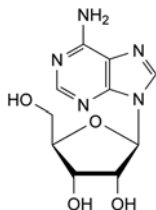

$C_{10}H_{13}N_5O_4$   
[58-61-7]

 $M_r$  267.2

## DEFINITION

9- $\beta$ -D-Ribofuranosyl-9H-purin-6-amine.

*Content*: 99.0 per cent to 101.0 per cent (dried substance).

## CHARACTERS

*Appearance*: white or almost white, crystalline powder.

*Solubility*: slightly soluble in water, soluble in hot water, practically insoluble in ethanol (96 per cent) and in methylene chloride. It dissolves in dilute mineral acids.

mp: about 234 °C.

## IDENTIFICATION

Infrared absorption spectrophotometry (2.2.24).

*Comparison*: *adenosine CRS*.

## TESTS

**Solution S.** Suspend 5.0 g in 100 mL of *distilled water R* and heat to boiling. Allow to cool, filter with the aid of vacuum and dilute to 100 mL with *distilled water R*.

**Appearance of solution.** Solution S is colourless (2.2.2, *Method II*).

**Acidity or alkalinity.** To 10 mL of solution S, add 0.1 mL of *bromocresol purple solution R* and 0.1 mL of 0.01 M *hydrochloric acid*. The solution is yellow. Add 0.4 mL of 0.01 M *sodium hydroxide*. The solution is violet-blue.

**Specific optical rotation** (2.2.7): –45 to –49 (dried substance).

Dissolve 1.25 g in 1 M *hydrochloric acid* and dilute to 50.0 mL with the same acid. Examine within 10 min of preparing the solution.

## Related substances

Liquid chromatography (2.2.29).

**Solvent mixture.** Dissolve 6.8 g of *potassium hydrogen sulfate R* and 3.4 g of *tetrabutylammonium hydrogen sulfate R* in *water R*, adjust to pH 6.5 with a 60 g/L solution of *potassium hydroxide R* and dilute to 1000 mL with the same solvent. Use a freshly prepared solvent mixture.

**Test solution.** Dissolve 20 mg of the substance to be examined in the mobile phase and dilute to 20 mL with the mobile phase.

**Reference solution (a).** Dilute 1.0 mL of the test solution to 100.0 mL with the mobile phase. Dilute 1.0 mL of this solution to 10.0 mL with the mobile phase.

**Reference solution (b).** Dissolve 5 mg of *adenine R* (impurity A) and 5 mg of *inosine R* (impurity G) in the mobile phase and dilute to 50 mL with the mobile phase. Dilute 4 mL of this solution to 100 mL with the mobile phase.

## Column:

– *size*:  $l = 0.25$  m,  $\varnothing = 4.6$  mm;

– *stationary phase*: *end-capped octadecylsilyl silica gel for chromatography R* (5  $\mu$ m).

*Mobile phase*: *water R*, solvent mixture (40:60 V/V).

*Flow rate*: 1.5 mL/min.

*Detection*: spectrophotometer at 254 nm.

*Injection*: 20  $\mu$ L.

*Run time*: 1.5 times the retention time of adenosine.

*Relative retention* with reference to adenosine (retention time = about 13 min): impurity A = about 0.3; impurity G = about 0.4.

*System suitability*: reference solution (b):

– *resolution*: minimum 1.5 between the peaks due to impurities A and G.

## Limits:

– *correction factors*: for the calculation of content, multiply the peak areas of the following impurities by the corresponding correction factor: impurity A = 0.6; impurity G = 1.4;

– *impurity A*: not more than twice the area of the principal peak in the chromatogram obtained with reference solution (a) (0.2 per cent);

– *impurity G*: not more than the area of the principal peak in the chromatogram obtained with reference solution (a) (0.1 per cent);

– *unspecified impurities*: for each impurity, not more than the area of the principal peak in the chromatogram obtained with reference solution (a) (0.10 per cent);

– *total*: not more than 5 times the area of the principal peak in the chromatogram obtained with reference solution (a) (0.5 per cent);

– *disregard limit*: 0.5 times the area of the principal peak in the chromatogram obtained with reference solution (a) (0.05 per cent).

**Chlorides** (2.4.4): maximum 100 ppm.

Dilute 10 mL of solution S to 15 mL with *water R*.

**Sulfates** (2.4.13): maximum 200 ppm, determined on solution S.

**Ammonium** (2.4.1, *Method B*): maximum 10 ppm, determined on 0.5 g.

Prepare the standard using 5 mL of *ammonium standard solution (1 ppm  $NH_4^+$ ) R*.

**Loss on drying** (2.2.32): maximum 0.5 per cent, determined on 1.000 g by drying in an oven at 105 °C.

**Sulfated ash** (2.4.14): maximum 0.1 per cent, determined on 1.0 g.

## ASSAY

Dissolve 0.200 g, warming slightly if necessary, in a mixture of 20 mL of *acetic anhydride R* and 30 mL of *anhydrous acetic acid R*. Titrate with 0.1 M *perchloric acid*, determining the end-point potentiometrically (2.2.20).

1 mL of 0.1 M *perchloric acid* is equivalent to 26.72 mg of  $C_{10}H_{13}N_5O_4$ .

## IMPURITIES

*Specified impurities*: A, G.

*Other detectable impurities* (the following substances would, if present at a sufficient level, be detected by one or other of the tests in the monograph. They are limited by the general acceptance criterion for other/unspecified impurities and/or by the general monograph *Substances for pharmaceutical use*

(2034). It is therefore not necessary to identify these impurities for demonstration of compliance. See also 5.10. *Control of impurities in substances for pharmaceutical use*): F, H.

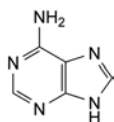

A. 7H-purin-6-amine (adenine),

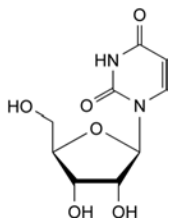

F. 1-β-D-ribofuranosylpyrimidine-2,4(1H,3H)-dione (uridine),

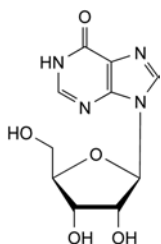

G. 9-β-D-ribofuranosyl-1,9-dihydro-6H-purin-6-one (inosine),

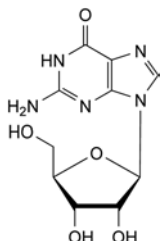

H. 2-amino-9-β-D-ribofuranosyl-1,9-dihydro-6H-purin-6-one (guanosine).

*Comparison: adipic acid CRS.*

#### TESTS

**Solution S.** Dissolve 5.0 g with heating in *distilled water R* and dilute to 50 mL with the same solvent. Allow to cool and to crystallise. Filter through a sintered-glass filter (40) (2.1.2). Wash the filter with *distilled water R*. Collect the filtrate and the washings until a volume of 50 mL is obtained.

**Appearance of solution.** The solution is clear (2.2.1) and colourless (2.2.2, *Method II*).

Dissolve 1.0 g in *methanol R* and dilute to 20 mL with the same solvent.

**Related substances.** Liquid chromatography (2.2.29).

**Test solution.** Dissolve 0.20 g of the substance to be examined in the mobile phase and dilute to 10.0 mL with the mobile phase.

**Reference solution (a).** Dissolve 20 mg of *glutaric acid R* in 1.0 mL of the test solution and dilute to 10.0 mL with the mobile phase.

**Reference solution (b).** Dilute 1.0 mL of the test solution to 100.0 mL with the mobile phase, dilute 1.0 mL of the solution to 10.0 mL with the mobile phase.

**Column:**

- size:  $l = 0.125$  m,  $\emptyset = 4.0$  mm,
- stationary phase: spherical octadecylsilyl silica gel for chromatography R (5  $\mu$ m) with a specific surface area of 350 m<sup>2</sup>/g and a pore size of 10 nm,
- temperature: 30 °C.

**Mobile phase:** mix 3 volumes of *acetonitrile R* and 97 volumes of a 24.5 g/L solution of *dilute phosphoric acid R*.

**Flow rate:** 1 mL/min.

**Detection:** spectrophotometer at 209 nm.

**Injection:** 20  $\mu$ L.

**Run time:** 3 times the retention time of adipic acid.

**System suitability:** reference solution (a):

- resolution: minimum 9.0 between the peaks due to glutaric acid and adipic acid.

**Limits:**

- any impurity: not more than the area of the principal peak in the chromatogram obtained with reference solution (b) (0.1 per cent),
- total: not more than 5 times the area of the principal peak in the chromatogram obtained with reference solution (b) (0.5 per cent),
- disregard limit: 0.5 times the area of the principal peak in the chromatogram obtained with reference solution (b) (0.05 per cent).

**Chlorides (2.4.4):** maximum 200 ppm.

2.5 mL of solution S diluted to 15 mL with *water R* complies with the limit test for chlorides.

**Nitrates:** maximum 30 ppm.

To 1 mL of solution S add 2 mL of *concentrated ammonia R*, 0.5 mL of a 10 g/L solution of *manganese sulfate R*, 1 mL of a 10 g/L solution of *sulfanilamide R* and dilute to 20 mL with *water R*. Add 0.10 g of *zinc powder R* and cool in iced water for 30 min; shake from time to time. Filter and cool 10 mL of the filtrate in iced water. Add 2.5 mL of *hydrochloric acid R1* and 1 mL of a 10 g/L solution of *naphthylethylenediamine dihydrochloride R*. Allow to stand at room temperature. After 15 min the mixture is not more intensely coloured than a standard prepared at the same time and in the same manner, using 1.5 mL of *nitrate standard solution (2 ppm NO<sub>3</sub>) R* instead of 1 mL of solution S. The test is invalid if a blank solution prepared at the same time and in the same manner, using 1 mL of *water R* instead of 1 mL of solution S, is more intensely coloured than a 2 mg/L solution of *potassium permanganate R*.

01/2008:1586  
corrected 6.0

## ADIPIC ACID

### Acidum adipicum

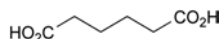

C<sub>6</sub>H<sub>10</sub>O<sub>4</sub>  
[124-04-9]

$M_r$  146.1

#### DEFINITION

Hexanedioic acid.

**Content:** 99.0 per cent to 101.0 per cent (dried substance).

#### CHARACTERS

**Appearance:** white or almost white, crystalline powder.

**Solubility:** sparingly soluble in water, soluble in boiling water, freely soluble in alcohol and in methanol, soluble in acetone.

#### IDENTIFICATION

A. Melting point (2.2.14): 151 °C to 154 °C.

B. Infrared absorption spectrophotometry (2.2.24).

**Sulfates** (2.4.13): maximum 500 ppm.

3 mL of solution S diluted to 15 mL with *distilled water R* complies with the limit test for sulfates.

**Iron** (2.4.9): maximum 10 ppm.

10 mL of solution S complies with the limit test for iron.

**Heavy metals** (2.4.8): maximum 10 ppm.

12 mL of solution S complies with test A. Prepare the reference solution using *lead standard solution (1 ppm Pb) R*.

**Loss on drying** (2.2.32): maximum 0.2 per cent, determined on 1.000 g by drying in an oven at 105 °C.

**Sulfated ash** (2.4.14): maximum 0.1 per cent.

Melt 1.0 g completely over a gas burner, then ignite the melted substance with the burner. After ignition, lower or remove the flame in order to prevent the substance from boiling and keep it burning until completely carbonised. Carry out the test for sulfated ash using the residue.

#### ASSAY

Dissolve 60.0 mg in 50 mL of *water R*. Add 0.2 mL of *phenolphthalein solution R* and titrate with *0.1 M sodium hydroxide*.

1 mL of *0.1 M sodium hydroxide* is equivalent to 7.31 mg of  $C_9H_{13}NO_3$ .

#### IMPURITIES

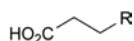

A. R =  $CH_2-CO_2H$ : pentanedioic acid (glutaric acid),

B. R =  $CO_2H$ : butanedioic acid (succinic acid),

C. R =  $[CH_2]_3-CO_2H$ : heptanedioic acid (pimelic acid).

07/2008:2303

## ADRENALINE

### Adrenalinum

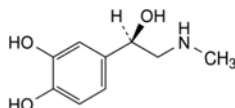

$C_9H_{13}NO_3$   
[51-43-4]

$M_r$  183.2

#### DEFINITION

4-[(1R)-1-Hydroxy-2-(methylamino)ethyl]benzene-1,2-diol.

Synthetic product.

*Content*: 99.0 per cent to 101.0 per cent (dried substance).

#### CHARACTERS

*Appearance*: white or almost white crystalline powder, becoming coloured on exposure to air and light.

*Solubility*: practically insoluble in water, in ethanol (96 per cent) and in methylene chloride. It dissolves in hydrochloric acid.

#### IDENTIFICATION

A. Infrared absorption spectrophotometry (2.2.24).

*Comparison*: *adrenaline CRS*.

B. Specific optical rotation (see Tests).

#### TESTS

**Solution S**. Dissolve 1.000 g in a 25.75 g/L solution of *hydrochloric acid R* and dilute to 50.0 mL with the same solvent. Examine the solution immediately.

**Appearance of solution**. Solution S is not more opalescent than reference suspension II (2.2.1) and not more intensely coloured than reference solution BY<sub>5</sub> (2.2.2, *Method II*).

**Specific optical rotation** (2.2.7): –50.0 to –54.0 (dried substance), determined on solution S.

**Related substances**. Liquid chromatography (2.2.29). *Prepare the solutions protected from light*.

**Solvent mixture A**. Dissolve 5.0 g of *potassium dihydrogen phosphate R* and 2.6 g of *sodium octanesulfonate R* in *water for chromatography R* and dilute to 1000 mL with the same solvent (it is usually necessary to stir for at least 30 min to achieve complete dissolution). Adjust to pH 2.8 with *phosphoric acid R*.

**Solvent mixture B**: *acetonitrile R1*, solvent mixture A (13:87 V/V).

**Test solution**. Dissolve 40 mg of the substance to be examined in 5 mL of *0.1 M hydrochloric acid* and dilute to 50.0 mL with solvent mixture B.

**Reference solution (a)**. Dilute 1.0 mL of the test solution to 100.0 mL with solvent mixture B. Dilute 1.0 mL of this solution to 10.0 mL with solvent mixture B.

**Reference solution (b)**. Dissolve 1.5 mg of *noradrenaline tartrate CRS* (impurity B) and 1.5 mg of *adrenalone hydrochloride R* (impurity C) in solvent mixture B, add 1.0 mL of the test solution and dilute to 100 mL with solvent mixture B.

**Reference solution (c)**. Dissolve the contents of a vial of *adrenaline impurity mixture CRS* (containing impurities D and E) in 1.0 mL of the blank solution.

**Reference solution (d)**. Dissolve 4 mg of *adrenaline with impurity F CRS* in 0.5 mL of *0.1 M hydrochloric acid* and dilute to 5 mL with solvent mixture B.

**Blank solution**: *0.1 M hydrochloric acid*, solvent mixture B (1:9 V/V).

#### Column:

– *size*:  $l = 0.10$  m,  $\varnothing = 4.6$  mm;

– *stationary phase*: *end-capped octadecylsilyl silica gel for chromatography R* (3  $\mu$ m);

– *temperature*: 50 °C.

#### Mobile phase:

– *mobile phase A*: *acetonitrile R1*, solvent mixture A (5:95 V/V);

– *mobile phase B*: *acetonitrile R1*, solvent mixture A (45:55 V/V);

Time (min)	Mobile phase A (per cent V/V)	Mobile phase B (per cent V/V)
0 - 15	92 → 50	8 → 50
15 - 20	50 → 92	50 → 8
20 - 25	92	8

*Flow rate*: 2.0 mL/min.

*Detection*: spectrophotometer at 210 nm.

*Injection*: 20  $\mu$ L.

*Identification of impurities*: use the chromatogram supplied with *adrenaline impurity mixture CRS* and the chromatogram obtained with reference solution (c) to identify the peaks due to impurities D and E; use the chromatogram supplied with *adrenaline with impurity F CRS* and the chromatogram obtained with reference solution (d) to identify the peak due to impurity F.

*Relative retention* with reference to adrenaline (retention time = about 4 min): impurity F = about 0.2; impurity B = about 0.8; impurity C = about 1.3; impurity D = about 3.3; impurity E = about 3.7.

*System suitability*: reference solution (b):

– *resolution*: minimum 3.0 between the peaks due to impurity B and adrenaline.

#### Limits:

– *correction factors*: for the calculation of content, multiply the peak areas of the following impurities by the corresponding correction factor: impurity D = 0.7; impurity E = 0.6;

01/2008:0254

- *impurities B, C, F*: for each impurity, not more than twice the area of the principal peak in the chromatogram obtained with reference solution (a) (0.2 per cent);
- *impurities D, E*: for each impurity, not more than the area of the principal peak in the chromatogram obtained with reference solution (a) (0.1 per cent);
- *unspecified impurities*: for each impurity, not more than the area of the principal peak in the chromatogram obtained with reference solution (a) (0.10 per cent);
- *total*: not more than 5 times the area of the principal peak in the chromatogram obtained with reference solution (a) (0.5 per cent);
- *disregard limit*: 0.5 times the area of the principal peak in the chromatogram obtained with reference solution (a) (0.05 per cent).

**Loss on drying** (2.2.32): maximum 0.5 per cent, determined on 1.000 g by drying over *diphosphorus pentoxide R* at a pressure not exceeding 0.7 kPa for 18 h.

**Sulfated ash** (2.4.14): maximum 0.1 per cent, determined on 1.0 g.

#### ASSAY

Dissolve 0.150 g in 50 mL of *anhydrous acetic acid R*. Titrate with 0.1 M *perchloric acid*, determining the end-point potentiometrically (2.2.20).

1 mL of 0.1 M *perchloric acid* is equivalent to 18.32 mg of  $C_9H_{13}NO_3$ .

#### STORAGE

Under nitrogen, protected from light.

#### IMPURITIES

*Specified impurities: B, C, D, E, F.*

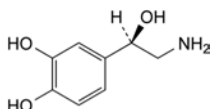

B. (1*R*)-2-amino-1-(3,4-dihydroxyphenyl)ethanol (noradrenaline),

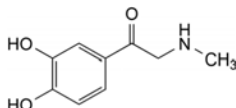

C. 1-(3,4-dihydroxyphenyl)-2-(methylamino)ethanone (adrenalone),

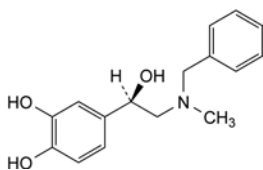

D. 4-[(1*R*)-2-(benzylmethylamino)-1-hydroxyethyl]benzene-1,2-diol,

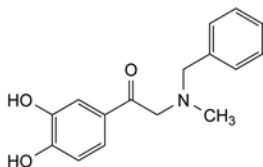

E. 2-(benzylmethylamino)-1-(3,4-dihydroxyphenyl)ethanone,

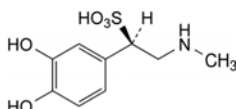

F. (1*R*)-1-(3,4-dihydroxyphenyl)-2-(methylamino)ethanesulfonic acid.

## ADRENALINE TARTRATE

### Adrenalini tartras

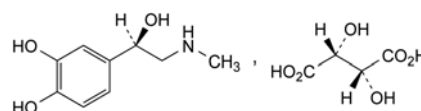

$C_{13}H_{19}NO_9$   
[51-42-3]

$M_r$  333.3

#### DEFINITION

(1*R*)-1-(3,4-Dihydroxyphenyl)-2-(methylamino)ethanol hydrogen (2*R*,3*R*)-2,3-dihydroxybutanedioate.

*Content*: 98.5 per cent to 101.0 per cent (dried substance).

#### CHARACTERS

*Appearance*: white or greyish-white, crystalline powder.

*Solubility*: freely soluble in water, slightly soluble in ethanol (96 per cent).

#### IDENTIFICATION

A. Dissolve 5 g in 50 mL of a 5 g/L solution of *sodium metabisulfite R* and make alkaline by addition of *ammonia R*. Keep the mixture at room temperature for at least 15 min and filter. Reserve the filtrate for identification test C. Wash the precipitate with 3 quantities, each of 10 mL, of *methanol R*. Dry at 80 °C. The specific optical rotation (2.2.7) of the residue (adrenaline base) is  $-50$  to  $-53.5$ , determined using a 20.0 g/L solution in 0.5 M *hydrochloric acid*.

B. Infrared absorption spectrophotometry (2.2.24).

*Preparation*: discs of adrenaline base prepared as described under identification test A.

*Comparison*: use adrenaline base prepared as described under identification test A from 50 mg of *adrenaline tartrate CRS* dissolved in 5 mL of a 5 g/L solution of *sodium metabisulfite R*. Keep the mixture at room temperature for at least 30 min. Filter through a sintered-glass filter (2.1.2).

C. 0.2 mL of the filtrate obtained in identification test A gives reaction (b) of tartrates (2.3.1).

#### TESTS

**Appearance of solution.** The solution is not more opalescent than reference suspension II (2.2.1) and not more intensely coloured than reference solution BY<sub>5</sub> (2.2.2, *Method II*).

Dissolve 0.5 g in *water R* and dilute to 10 mL with the same solvent. Examine the solution immediately.

**Related substances.** Liquid chromatography (2.2.29). *Prepare the solutions protected from light.*

*Solvent mixture A.* Dissolve 5.0 g of *potassium dihydrogen phosphate R* and then 2.6 g of *sodium octanesulfonate R* in *water for chromatography R*, and dilute to 1000 mL with the same solvent (it is usually necessary to stir for at least 30 min to achieve complete dissolution). Adjust to pH 2.8 with *phosphoric acid R*.

*Solvent mixture B:* *acetonitrile RI*, solvent mixture A (130:870 V/V).

*Test solution.* Dissolve 75 mg of the substance to be examined in 5 mL of 0.1 M *hydrochloric acid* and dilute to 50 mL with solvent mixture B.

*Reference solution (a).* Dilute 1.0 mL of the test solution to 100.0 mL with solvent mixture B. Dilute 1.0 mL of this solution to 10.0 mL with solvent mixture B.

**Reference solution (b).** Dissolve 1.5 mg of *noradrenaline tartrate CRS* (impurity B) and 1.5 mg of *adrenalone hydrochloride R* (impurity C) in solvent mixture B, add 1.0 mL of the test solution and dilute to 100.0 mL with solvent mixture B.

**Reference solution (c).** Dissolve the contents of a vial of *adrenaline impurity mixture CRS* (impurities D and E) in 0.1 mL of 0.1 M *hydrochloric acid* and 0.9 mL of solvent mixture B.

**Reference solution (d).** Dissolve 7.5 mg of *adrenaline tartrate with impurity A CRS* in 0.5 mL of 0.1 M *hydrochloric acid* and dilute to 5.0 mL with solvent mixture B.

**Blank solution:** 0.1 M *hydrochloric acid*, solvent mixture B (1:9 V/V).

**Column:**

- size:  $l = 0.10$  m,  $\varnothing = 4.6$  mm;
- stationary phase: *end-capped octadecylsilyl silica gel for chromatography R* (3  $\mu$ m);
- temperature: 50 °C.

**Mobile phase:**

- mobile phase A: *acetonitrile R1*, solvent mixture A (5:95 V/V);
- mobile phase B: *acetonitrile R1*, solvent mixture A (45:55 V/V);

Time (min)	Mobile phase A (per cent V/V)	Mobile phase B (per cent V/V)
0 - 15	92 → 50	8 → 50
15 - 20	50 → 92	50 → 8
20 - 25	92	8

**Flow rate:** 2.0 mL/min.

**Detection:** spectrophotometer at 210 nm.

**Injection:** 20  $\mu$ L.

**Identification of impurities:** use the chromatogram supplied with *adrenaline impurity mixture CRS* and the chromatogram obtained with reference solution (c) to identify the peaks due to impurities D and E; use the chromatogram supplied with *adrenaline tartrate with impurity A CRS* and the chromatogram obtained with reference solution (d) to identify the peak due to impurity A.

**Relative retention** with reference to *adrenaline* (retention time = about 4 min): impurity B = about 0.8; impurity C = about 1.3; impurity A = about 3.2; impurity D = about 3.3; impurity E = about 3.7.

**System suitability:** reference solution (b):

- resolution: minimum 3.0 between the peaks due to impurity B and *adrenaline*.

**Limits:**

- correction factors: for the calculation of content, multiply the peak areas of the following impurities by the corresponding correction factor: impurity D = 0.7; impurity E = 0.6;
- impurity A: not more than 3 times the area of the principal peak in the chromatogram obtained with reference solution (a) (0.3 per cent);
- impurities B, C: for each impurity, not more than twice the area of the principal peak in the chromatogram obtained with reference solution (a) (0.2 per cent);
- impurities D, E: for each impurity, not more than the area of the principal peak in the chromatogram obtained with reference solution (a) (0.1 per cent);
- unspecified impurities: for each impurity, not more than the area of the principal peak in the chromatogram obtained with reference solution (a) (0.10 per cent);
- total: not more than 6 times the area of the principal peak in the chromatogram obtained with reference solution (a) (0.6 per cent);

- disregard limit: 0.5 times the area of the principal peak in the chromatogram obtained with reference solution (a) (0.05 per cent).

**Loss on drying** (2.2.32): maximum 0.5 per cent, determined on 1.000 g by drying *in vacuo* for 18 h.

**Sulfated ash** (2.4.14): maximum 0.1 per cent, determined on 1.0 g.

**ASSAY**

Dissolve 0.300 g in 50 mL of *anhydrous acetic acid R*, heating gently if necessary. Titrate with 0.1 M *perchloric acid* until a bluish-green colour is obtained, using 0.1 mL of *crystal violet solution R* as indicator.

1 mL of 0.1 M *perchloric acid* is equivalent to 33.33 mg of  $C_{13}H_{19}NO_9$ .

**STORAGE**

In an airtight container, or preferably in a sealed tube under vacuum or under an inert gas, protected from light.

**IMPURITIES**

**Specified impurities:** A, B, C, D, E.

A. unknown structure,

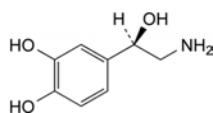

B. (1*R*)-2-amino-1-(3,4-dihydroxyphenyl)ethanol (noradrenaline),

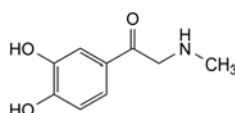

C. 1-(3,4-dihydroxyphenyl)-2-(methylamino)ethanone (adrenaline),

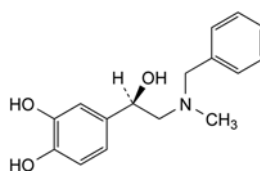

D. 4-[(1*R*)-2-(benzylmethylamino)-1-hydroxyethyl]benzene-1,2-diol,

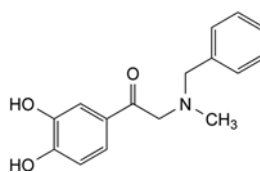

E. 2-(benzylmethylamino)-1-(3,4-dihydroxyphenyl)ethanone.

01/2009:1238

## AIR, MEDICINAL

### Aer medicinalis

**DEFINITION**

Compressed ambient air.

**Content:** 20.4 per cent V/V to 21.4 per cent V/V of oxygen (O<sub>2</sub>).

**CHARACTERS**

**Appearance:** colourless gas.

**Solubility:** at 20 °C at a pressure of 101 kPa, 1 volume dissolves in about 50 volumes of water.

## PRODUCTION

**Carbon dioxide:** maximum 500 ppm V/V, determined using an infrared analyser (2.5.24).

*Gas to be examined.* Filter the substance to be examined to avoid stray light phenomena.

*Reference gas (a).* Use a mixture of 21 per cent V/V of oxygen R and 79 per cent V/V of nitrogen R1, containing less than 1 ppm V/V of carbon dioxide R1.

*Reference gas (b).* Use a mixture of 21 per cent V/V of oxygen R and 79 per cent V/V of nitrogen R1, containing 500 ppm V/V of carbon dioxide R1.

Calibrate the apparatus and set the sensitivity using reference gases (a) and (b). Measure the content of carbon dioxide in the gas to be examined.

**Carbon monoxide:** maximum 5 ppm V/V, determined using an infrared analyser (2.5.25).

*Gas to be examined.* Filter the substance to be examined to avoid stray light phenomena.

*Reference gas (a).* Use a mixture of 21 per cent V/V of oxygen R and 79 per cent V/V of nitrogen R1, containing less than 1 ppm V/V of carbon monoxide R.

*Reference gas (b).* Use a mixture of 21 per cent V/V of oxygen R and 79 per cent V/V of nitrogen R1, containing 5 ppm V/V of carbon monoxide R.

Calibrate the apparatus and set the sensitivity using reference gases (a) and (b). Measure the content of carbon monoxide in the gas to be examined.

**Sulfur dioxide:** maximum 1 ppm V/V, determined using an ultraviolet fluorescence analyser (Figure 1238-1).

The apparatus consists of the following:

- a system generating ultraviolet radiation with a wavelength of 210 nm, made up of an ultraviolet lamp, a collimator, and a selective filter; the beam is blocked periodically by a chopper rotating at high speeds;
- a reaction chamber, through which flows the gas to be examined;
- a system that detects radiation emitted at a wavelength of 350 nm, made up of a selective filter, a photomultiplier tube and an amplifier.

*Gas to be examined.* Filter the substance to be examined.

*Reference gas (a).* Use a mixture of 21 per cent V/V of oxygen R and 79 per cent V/V of nitrogen R1.

*Reference gas (b).* Use a mixture of 21 per cent V/V of oxygen R and 79 per cent V/V of nitrogen R1, containing 0.5 ppm V/V to 2 ppm V/V of sulfur dioxide R1.

Calibrate the apparatus and set the sensitivity using reference gases (a) and (b). Measure the content of sulfur dioxide in the gas to be examined.

**Oil:** maximum 0.1 mg/m<sup>3</sup>, determined using an oil detector tube (2.1.6), when an oil-lubricated compressor is used for the production.

**Nitrogen monoxide and nitrogen dioxide:** maximum 2 ppm V/V in total, determined using a chemiluminescence analyser (2.5.26).

*Gas to be examined.* The substance to be examined.

*Reference gas (a).* Use a mixture of 21 per cent V/V of oxygen R and 79 per cent V/V of nitrogen R1, containing less than 0.05 ppm V/V of nitrogen monoxide and nitrogen dioxide.

*Reference gas (b).* Use a mixture of 2 ppm V/V of nitrogen monoxide R in nitrogen R1.

Calibrate the apparatus and set the sensitivity using reference gases (a) and (b). Measure the content of nitrogen monoxide and nitrogen dioxide in the gas to be examined.

**Water:** maximum 67 ppm V/V, determined using an electrolytic hygrometer (2.5.28), except where the competent authority decides that the following limit applies to medicinal air generated on-site and distributed in pipe-line systems operating at a pressure not greater than 10 bars and a temperature not less than 5 °C: maximum 870 ppm V/V, determined using an electrolytic hygrometer (2.5.28).

**Assay.** Determine the concentration of oxygen in air using a paramagnetic analyser (2.5.27).

## IDENTIFICATION

*First identification:* C.

*Second identification:* A, B.

- In a conical flask containing the substance to be examined, place a glowing wood splinter. The splinter remains glowing.
- Use a gas burette (Figure 1238-2) of 25 mL capacity in the form of a chamber in the middle of which is a tube graduated in 0.2 per cent between 19.0 per cent and 23.0 per cent, and isolated at each end by a tap with a conical barrel. The lower tap is joined to a tube with an olive-shaped nozzle and is used to introduce the gas into the apparatus. A cylindrical funnel above the upper tap is used to introduce the absorbent solution. Wash the burette with water R and

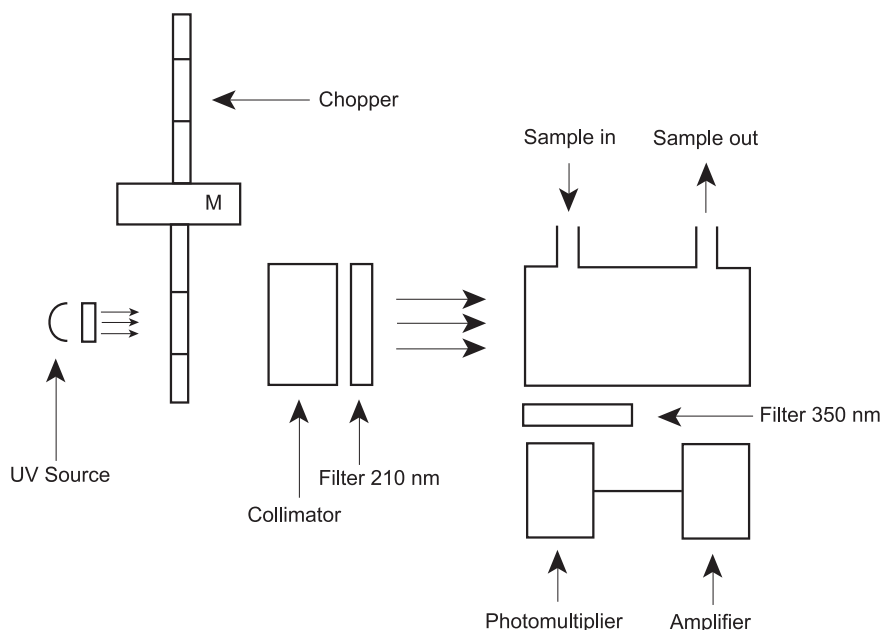

Figure 1238-1. – UV fluorescence analyser

dry. Open the 2 taps. Connect the nozzle to the source of the gas to be examined and set the flow rate to 1 L/min. Flush the burette by passing the gas to be examined through it for 1 min. Close the lower tap of the burette and immediately afterwards the upper tap. Rapidly disconnect the burette from the source of the gas to be examined. Rapidly give a half turn to the upper tap to eliminate any excess pressure in the burette. Keeping the burette vertical, fill the funnel with a freshly prepared mixture of 21 mL of a 560 g/L solution of *potassium hydroxide R* and 130 mL of a 200 g/L solution of *sodium dithionite R*. Open the upper tap slowly. The solution absorbs the oxygen and enters the burette. Allow to stand for 10 min without shaking. Read the level of the liquid meniscus on the graduated part of the burette. This figure represents the percentage V/V of oxygen. The value read is 20.4 to 21.4.

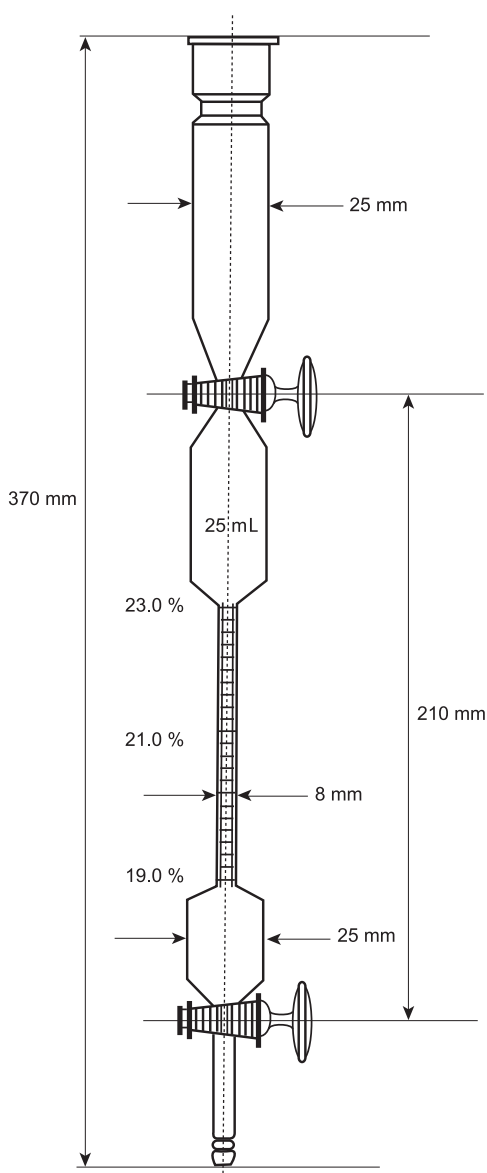

Figure 1238.-2. – Gas burette

C. It complies with the limits of the assay.

#### TESTS

**Carbon dioxide:** maximum 500 ppm V/V, determined using a carbon dioxide detector tube (2.1.6).

**Sulfur dioxide:** maximum 1 ppm V/V, determined using a sulfur dioxide detector tube (2.1.6).

**Oil:** maximum 0.1 mg/m<sup>3</sup>, determined using an oil detector tube (2.1.6), when an oil-lubricated compressor is used for the production.

**Nitrogen monoxide and nitrogen dioxide:** maximum 2 ppm V/V, determined using a nitrogen monoxide and nitrogen dioxide detector tube (2.1.6).

**Carbon monoxide:** maximum 5 ppm V/V, determined using a carbon monoxide detector tube (2.1.6).

**Water vapour:** maximum 67 ppm V/V, determined using a water vapour detector tube (2.1.6), except where the competent authority decides that the following limit applies to medicinal air generated on-site and distributed in pipe-line systems operating at a pressure not greater than 10 bars and a temperature not less than 5 °C: maximum 870 ppm V/V, determined using a water vapour detector tube (2.1.6).

#### STORAGE

As a gas, in suitable containers complying with the legal regulations or as a gas supplied by a pipe network.

#### LABELLING

Where applicable, the label states the production method, as regards to the use of an oil - lubricated compression.

#### IMPURITIES

- A. CO<sub>2</sub>: carbon dioxide,
- B. SO<sub>2</sub>: sulfur dioxide,
- C. NO: nitrogen monoxide,
- D. NO<sub>2</sub>: nitrogen dioxide,
- E. oil,
- F. CO: carbon monoxide,
- G. H<sub>2</sub>O: water.

01/2008:1684

## AIR, SYNTHETIC MEDICINAL

### Aer medicinalis artificiosus

#### DEFINITION

Mixture of *Nitrogen (1247)* and *Oxygen (0417)*.

**Content:** 95.0 per cent to 105.0 per cent of the nominal value which is between 21.0 per cent V/V to 22.5 per cent V/V of oxygen (O<sub>2</sub>).

#### CHARACTERS

Colourless and odourless gas.

**Solubility:** at a temperature of 20 °C and a pressure of 101 kPa, 1 volume dissolves in about 50 volumes of water.

#### PRODUCTION

**Water (2.5.28):** maximum 67 ppm V/V.

**Assay (2.5.27).** Carry out the determination of oxygen in gases.

#### IDENTIFICATION

**First identification:** C.

**Second identification:** A, B.

- A. In a conical flask containing the substance to be examined, place a glowing splinter of wood. The splinter remains glowing.
- B. Use a gas burette (Figure 1684.-1) of 25 mL capacity in the form of a chamber, in the middle of which is a tube graduated in 0.2 per cent between 19.0 per cent and 23.0 per cent, and isolated at each end by a tap with a conical barrel. The lower tap is joined to a tube with an olive-shaped nozzle and is used to introduce the gas into the apparatus. A cylindrical funnel above the upper tap is used to introduce the absorbent solution. Wash the burette with *water R* and



dry. Open both taps. Connect the nozzle to the source of the substance to be examined and set the flow rate to 1 L/min. Flush the burette by passing the substance to be examined through it for 1 min. Close the lower tap of the burette and immediately afterwards the upper tap. Rapidly disconnect the burette from the source of the substance to be examined. Rapidly give a half turn of the upper tap to eliminate any excess pressure in the burette. Keeping the burette vertical, fill the funnel with a freshly prepared mixture of 21 mL of a 560 g/L solution of *potassium hydroxide R* and 130 mL of a 200 g/L solution of *sodium dithionite R*. Open the upper tap slowly. The solution absorbs the oxygen and enters the burette. Allow to stand for 10 min without shaking. Read the level of the liquid meniscus on the graduated part of the burette. This figure represents the percentage V/V of oxygen. The value read is 95.0 per cent to 105.0 per cent of the nominal value.

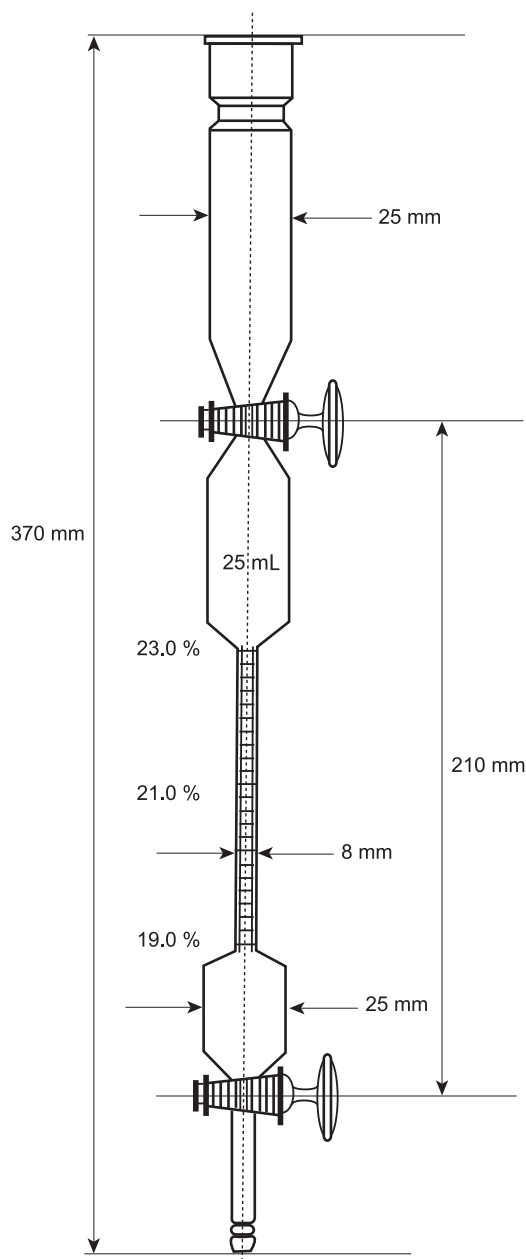

Figure 1684-1.- Gas burette

C. It complies with the limits of the assay.

#### TESTS

**Water vapour:** maximum 67 ppm V/V, determined using a water vapour detector tube (2.1.6).

#### STORAGE

As a compressed gas in suitable containers complying with the legal regulations or as a compressed gas supplied by a pipe network, after mixing of the components.

#### LABELLING

The label states the nominal content of O<sub>2</sub> in per cent V/V.

#### IMPURITIES

A. H<sub>2</sub>O: water.

01/2008:0752  
corrected 6.0

## ALANINE

### Alaninum

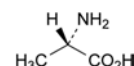

C<sub>3</sub>H<sub>7</sub>NO<sub>2</sub>  
[56-41-7]

M<sub>r</sub> 89.1

#### DEFINITION

Alanine contains not less than 98.5 per cent and not more than the equivalent of 101.0 per cent of (S)-2-aminopropanoic acid, calculated with reference to the dried substance.

#### CHARACTERS

White or almost white, crystalline powder or colourless crystals, freely soluble in water, very slightly soluble in alcohol.

#### IDENTIFICATION

*First identification:* A, B.

*Second identification:* A, C, D.

A. Specific optical rotation (see Tests).

B. Examine by infrared absorption spectrophotometry (2.2.24), comparing with the spectrum obtained with *alanine CRS*. Examine the substances prepared as discs.

C. Examine the chromatograms obtained in the test for ninhydrin-positive substances. The principal spot in the chromatogram obtained with test solution (b) is similar in position, colour and size to the principal spot in the chromatogram obtained with reference solution (a).

D. Dissolve 0.5 g in a mixture of 1 mL of *water R*, 0.5 mL of a 100 g/L solution of *sodium nitrite R* and 0.25 mL of *hydrochloric acid R1*. Shake. Gas is given off. Add 2 mL of *dilute sodium hydroxide solution R*, followed by 0.25 mL of *iodinated potassium iodide solution R*. After about 30 min, a yellow precipitate with a characteristic odour is formed.

#### TESTS

**Solution S.** Dissolve 2.5 g in *distilled water R* and dilute to 50 mL with the same solvent.

**Appearance of solution.** Dilute 10 mL of solution S to 20 mL with *water R*. The solution is clear (2.2.1) and not more intensely coloured than reference solution BY<sub>6</sub> (2.2.2, *Method II*).

**Specific optical rotation (2.2.7).** Dissolve 2.50 g in *hydrochloric acid R1* and dilute to 25.0 mL with the same acid. The specific optical rotation is + 13.5 to + 15.5, calculated with reference to the dried substance.

**Ninhydrin-positive substances.** Examine by thin-layer chromatography (2.2.27), using a *TLC silica gel plate R*.

*Test solution (a).* Dissolve 0.10 g in *water R* and dilute to 10 mL with the same solvent.

*Test solution (b).* Dilute 1 mL of test solution (a) to 50 mL with *water R*.

*Reference solution (a).* Dissolve 10 mg of *alanine CRS* in *water R* and dilute to 50 mL with the same solvent.

**Reference solution (b).** Dilute 5 mL of test solution (b) to 20 mL with *water R*.

**Reference solution (c).** Dissolve 10 mg of *alanine CRS* and 10 mg of *glycine CRS* in *water R* and dilute to 25 mL with the same solvent.

Apply separately to the plate 5 µL of each solution. Allow the plate to dry in air. Develop over a path of 15 cm with a mixture of 20 volumes of *glacial acetic acid R*, 20 volumes of *water R* and 60 volumes of *butanol R*. Allow the plate to dry in air. Spray with *ninhydrin solution R*. Heat the plate at 100 °C to 105 °C for 15 min. Any spot in the chromatogram obtained with test solution (a), apart from the principal spot, is not more intense than the spot in the chromatogram obtained with reference solution (b) (0.5 per cent). The test is not valid unless the chromatogram obtained with reference solution (c) shows two clearly separated spots.

**Chlorides (2.4.4).** Dilute 5 mL of solution S to 15 mL with *water R*. The solution complies with the limit test for chlorides (200 ppm).

**Sulfates (2.4.13).** Dilute 10 mL of solution S to 15 mL with *distilled water R*. The solution complies with the limit test for sulfates (300 ppm).

**Ammonium (2.4.1).** 50 mg complies with limit test B for ammonium (200 ppm). Prepare the standard using 0.1 mL of *ammonium standard solution (100 ppm NH<sub>4</sub>) R*.

**Iron (2.4.9).** In a separating funnel, dissolve 1.0 g in 10 mL of *dilute hydrochloric acid R*. Shake with three quantities, each of 10 mL, of *methyl isobutyl ketone RI*, shaking for 3 min each time. To the combined organic layers add 10 mL of *water R* and shake for 3 min. The aqueous layer complies with the limit test for iron (10 ppm).

**Heavy metals (2.4.8).** Dissolve 2.0 g in *water R* and dilute to 20 mL with the same solvent. 12 mL of the solution complies with limit test A for heavy metals (10 ppm). Prepare the standard using *lead standard solution (1 ppm Pb) R*.

**Loss on drying (2.2.32).** Not more than 0.5 per cent, determined on 1.000 g by drying in an oven at 105 °C.

**Sulfated ash (2.4.14).** Not more than 0.1 per cent, determined on 1.0 g.

#### ASSAY

Dissolve 80.0 mg in 3 mL of *anhydrous formic acid R*. Add 30 mL of *anhydrous acetic acid R*. Using 0.1 mL of *naphtholbenzein solution R* as indicator, titrate with 0.1 M *perchloric acid*, until the colour changes from brownish-yellow to green.

1 mL of 0.1 M *perchloric acid* is equivalent to 8.91 mg of C<sub>12</sub>H<sub>15</sub>N<sub>3</sub>O<sub>2</sub>S.

#### STORAGE

Store protected from light.

**Content:** 98.0 per cent to 102.0 per cent (dried substance).

#### CHARACTERS

**Appearance:** white or slightly yellowish powder.

**Solubility:** practically insoluble in water, freely soluble in anhydrous formic acid, very slightly soluble in methylene chloride, practically insoluble in ethanol (96 per cent).

#### IDENTIFICATION

Infrared absorption spectrophotometry (2.2.24).

**Preparation:** discs.

**Comparison:** *albendazole CRS*.

#### TESTS

**Appearance of solution.** The solution is clear (2.2.1) and not more intensely coloured than reference solution BY<sub>6</sub> (2.2.2, *Method II*).

Dissolve 0.10 g in a mixture of 1 volume of *anhydrous formic acid R* and 9 volumes of *methylene chloride R* and dilute to 10 mL with the same mixture of solvents.

**Related substances.** Liquid chromatography (2.2.29).

**Test solution.** Dissolve 25.0 mg of the substance to be examined in 5 mL of *methanol R* containing 1 per cent V/V of *sulfuric acid R* and dilute to 50.0 mL with the mobile phase.

**Reference solution (a).** Dissolve 10.0 mg of the substance to be examined in 10 mL of *methanol R* containing 1 per cent V/V of *sulfuric acid R* and dilute to 100.0 mL with the mobile phase. Dilute 0.5 mL of this solution to 20.0 mL with the mobile phase.

**Reference solution (b).** Dissolve 50.0 mg of the substance to be examined and 50 mg of *oxibendazole CRS* in 5 mL of *methanol R* containing 1 per cent V/V of *sulfuric acid R* and dilute to 100.0 mL with the mobile phase.

**Column:**

- size:  $l = 0.25$  m,  $\varnothing = 4.6$  mm;
- stationary phase: spherical *end-capped octadecylsilyl silica gel for chromatography R* (5 µm) with a pore size of 10 nm and a carbon loading of 19 per cent.

**Mobile phase:** mix 300 volumes of a 1.67 g/L solution of *ammonium dihydrogen phosphate R* and 700 volumes of *methanol R*.

**Flow rate:** 0.7 mL/min.

**Detection:** spectrophotometer at 254 nm.

**Injection:** 20 µL.

**Run time:** 1.5 times the retention time of albendazole.

**Relative retention** with reference to albendazole: impurity D = about 0.40; impurities B and C = about 0.43; impurity E = about 0.47; impurity F = about 0.57; impurity A = about 0.80.

**System suitability:** reference solution (b):

- resolution: minimum 3.0 between the peaks due to albendazole and oxibendazole.

**Limits:**

- impurities A, B, C, D, E, F: for each impurity, not more than 1.5 times the area of the principal peak in the chromatogram obtained with reference solution (a) (0.75 per cent);
- total: not more than 3 times the area of the principal peak in the chromatogram obtained with reference solution (a) (1.5 per cent);
- disregard limit: 0.1 times the area of the principal peak in the chromatogram obtained with reference solution (a) (0.05 per cent).

**Loss on drying (2.2.32):** maximum 0.5 per cent, determined on 1.000 g by drying in an oven at 105 °C for 4 h.

**Sulfated ash (2.4.14):** maximum 0.2 per cent, determined on 1.0 g.

01/2008:1386  
corrected 6.0

## ALBENDAZOLE

### Albendazolium

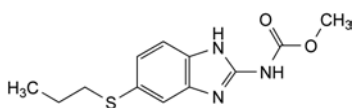

C<sub>12</sub>H<sub>15</sub>N<sub>3</sub>O<sub>2</sub>S  
[54965-21-8]

$M_r$  265.3

#### DEFINITION

Methyl [5-(propylsulfanyl)-1H-benzimidazol-2-yl]carbamate.

## ASSAY

In order to avoid overheating during the titration, mix thoroughly throughout and stop the titration immediately after the end-point has been reached.

Dissolve 0.250 g in 3 mL of anhydrous formic acid R and add 40 mL of anhydrous acetic acid R. Titrate with 0.1 M perchloric acid, determining the end-point potentiometrically (2.2.20).

1 mL of 0.1 M perchloric acid is equivalent to 26.53 mg of  $C_{12}H_{15}N_3O_2S$ .

## STORAGE

Protected from light.

## IMPURITIES

Specified impurities: A, B, C, D, E, F.

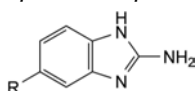

A. R = S-CH<sub>2</sub>-CH<sub>2</sub>-CH<sub>3</sub>: 5-(propylsulfanyl)-1H-benzimidazol-2-amine,

D. R = SO<sub>2</sub>-CH<sub>2</sub>-CH<sub>2</sub>-CH<sub>3</sub>: 5-(propylsulfonyl)-1H-benzimidazol-2-amine,

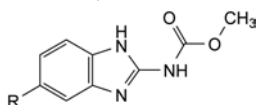

B. R = SO-CH<sub>2</sub>-CH<sub>2</sub>-CH<sub>3</sub>: methyl [5-(propylsulfinyl)-1H-benzimidazol-2-yl]carbamate,

C. R = SO<sub>2</sub>-CH<sub>2</sub>-CH<sub>2</sub>-CH<sub>3</sub>: methyl [5-(propylsulfonyl)-1H-benzimidazol-2-yl]carbamate,

E. R = H: methyl (1H-benzimidazol-2-yl)carbamate,

F. R = S-CH<sub>3</sub>: methyl [5-(methylsulfanyl)-1H-benzimidazol-2-yl]carbamate.

01/2008:1285

## ALCURONIUM CHLORIDE

## Alcuronii chloridum

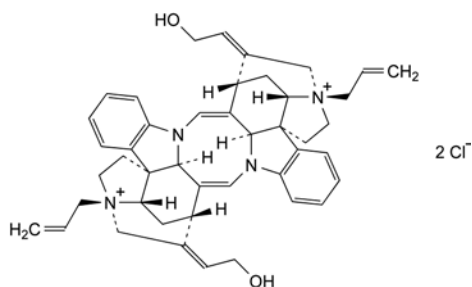

$C_{44}H_{50}Cl_2N_4O_2$   
[15180-03-7]

$M_r$  738

## DEFINITION

(1R,3aS,10S,11aS,12R,14aS,19aS,20bS,21S,22aS,23E,26E)-23,26-bis(2-Hydroxyethylidene)-1,12-bis(prop-2-enyl)-2,3,11,11a,13,14,22,22a-octahydro-10H,21H-1,21:10,12-diethano-19aH,20bH-[1,5]diazocino[1,2,3-lm:5,6,7-l'm']dipyrrolo[2',3'-d:2'',3''':d']dicarbazoleidium dichloride (4,4'-didesmethyl-4,4'-bis(prop-2-enyl)toxiferin I dichloride).

Content: 98.0 per cent to 102.0 per cent (anhydrous substance).

## CHARACTERS

Appearance: white or slightly greyish-white, crystalline powder.

Solubility: freely soluble in water and in methanol, soluble in ethanol (96 per cent), practically insoluble in cyclohexane.

Carry out the identification, tests and assay as rapidly as possible avoiding exposure to actinic light.

## IDENTIFICATION

First identification: A, C.

Second identification: B, C.

A. Infrared absorption spectrophotometry (2.2.24).

Comparison: alcuronium chloride CRS.

B. Thin-layer chromatography (2.2.27).

Test solution. Dissolve 10 mg of the substance to be examined in methanol R and dilute to 10 mL with the same solvent.

Reference solution. Dissolve 10 mg of alcuronium chloride CRS in methanol R and dilute to 10 mL with the same solvent.

Plate: TLC silica gel plate R.

Mobile phase: mix 15 volumes of a 58.4 g/L solution of sodium chloride R, 35 volumes of dilute ammonia R2 and 50 volumes of methanol R.

Application: 10 µL.

Development: over a path of 15 cm.

Drying: in air for 10 min.

Detection: spray with 0.1 M ammonium and cerium nitrate.

Results: the principal spot in the chromatogram obtained with the test solution is similar in position, colour and size to the principal spot in the chromatogram obtained with the reference solution.

C. It gives reaction (a) of chlorides (2.3.1).

## TESTS

Solution S. Dissolve 0.250 g in carbon dioxide-free water R and dilute to 25.0 mL with the same solvent.

Appearance of solution. Solution S is clear (2.2.1) and not more intensely coloured than reference solution Y<sub>6</sub>, BY<sub>6</sub> or B<sub>6</sub> (2.2.2, Method I).

Acidity or alkalinity. To 10 mL of solution S add 0.1 mL of methyl red solution R and 0.2 mL of 0.01 M hydrochloric acid. The solution is red. Add 0.4 mL of 0.01 M sodium hydroxide. The solution is yellow.

Specific optical rotation (2.2.7): -430 to -451 (anhydrous substance), determined on solution S.

Propan-2-ol (2.4.24, System A): maximum 1.0 per cent.

Related substances. Liquid chromatography (2.2.29).

Solvent mixture. Mix 100 mL of methanol R, 200 mL of acetonitrile R and 200 mL of a 6.82 g/L solution of potassium dihydrogen phosphate R. Dissolve 1.09 g of sodium laurylsulfonate for chromatography R in the mixture and adjust the apparent pH to 8.0 with a 100 g/L solution of sodium hydroxide R.

Test solution. Dissolve 0.20 g of the substance to be examined in the solvent mixture and dilute to 100.0 mL with the solvent mixture.

Reference solution (a). Dilute 0.5 mL of the test solution to 100.0 mL with the solvent mixture.

Reference solution (b). Dilute 4.0 mL of reference solution (a) to 10.0 mL with the solvent mixture.

Reference solution (c). Dilute 1.0 mL of reference solution (a) to 10.0 mL with the solvent mixture.

Reference solution (d). To 5.0 mL of the test solution add 5.0 mg of allylstrychnine bromide CRS, dissolve in the solvent mixture and dilute to 100.0 mL with the solvent mixture.

Column:

— size:  $l = 0.25$  m,  $\varnothing = 4$  mm;

— stationary phase: octylsilyl silica gel for chromatography R (5 µm).

Mobile phase: mix 200 mL of methanol R, 400 mL of acetonitrile R and 400 mL of a 6.82 g/L solution of potassium dihydrogen phosphate R. Dissolve 2.18 g of sodium

01/2008:1286

laurylsulfonate for chromatography R in the mixture and adjust the apparent pH to 5.4 with a 100 g/L solution of phosphoric acid R.

Flow rate: 1.2 mL/min.

Detection: spectrophotometer at 254 nm.

Injection: 10 µL.

Run time: twice the retention time of alcuronium.

System suitability: reference solution (d):

- resolution: minimum 4.0 between the peaks due to *N*-allylstrychnine and alcuronium.

Limits:

- impurities A, B: for each impurity, not more than the area of the principal peak in the chromatogram obtained with reference solution (a) (0.5 per cent) and not more than one of the peaks has an area greater than the area of the principal peak in the chromatogram obtained with reference solution (b) (0.2 per cent);
- total: not more than twice the area of the principal peak in the chromatogram obtained with reference solution (a) (1 per cent);
- disregard limit: the area of the principal peak in the chromatogram obtained with reference solution (c) (0.05 per cent).

Water (2.5.12): maximum 5.0 per cent, determined on 0.500 g.

Sulfated ash (2.4.14): maximum 0.1 per cent, determined on 1.0 g.

#### ASSAY

Dissolve 0.300 g by stirring in 70 mL of acetic anhydride R for 1 min. Titrate with 0.1 M perchloric acid until the colour changes from violet-blue to greenish-blue, using 0.1 mL of crystal violet solution R as indicator.

1 mL of 0.1 M perchloric acid is equivalent to 36.9 mg of C<sub>44</sub>H<sub>50</sub>Cl<sub>2</sub>N<sub>4</sub>O<sub>2</sub>.

#### STORAGE

In an airtight container under nitrogen, protected from light, at a temperature of 2 °C to 8 °C.

#### IMPURITIES

Specified impurities: A, B.

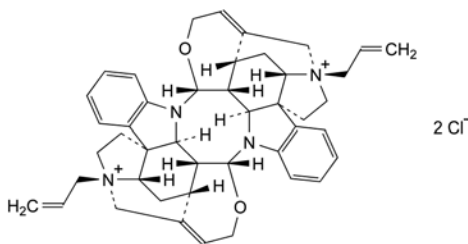

- A. (1*R*,3*a**S*,9*R*,9*a**R*,10*R*,11*a**S*,12*R*,14*a**S*,19*a**S*,20*R*,20*a**R*,20*b**S*,21*R*,22*a**S*)-1,12-bis(prop-2-enyl)-2,3,9*a*,11,11*a*,13,14,19*a*,20*a*,21,22,22*a*-dodecahydro-10*H*,20*b**H*-1,23:12,27-dimethano-9,10:20,21-bis(epoxyprop[2]eno)-9*H*,20*H*-[1,5]diazocino[1,2,3-*lm*:5,6,7-*l'm'*]dipyrrolo[2',3'-*d*:2'',3''-*d'*]dicarbazoleidinium dichloride (4,4'-diallylcarcurin V dichloride),

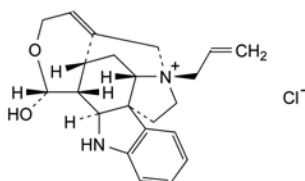

- B. (4*b**S*,7*R*,7*a**S*,8*a**R*,13*R*,13*a**R*,13*b**S*)-13-hydroxy-7-(prop-2-enyl)-5,6,7*a*,8,8*a*,11,13,13*a*,13*b*,14-decahydro-7,9-methano-7*H*-oxepino[3,4-*a*]pyrrolo[2,3-*d*]carbazolium chloride ((4*R*,17*R*)-4-allyl-17,18-epoxy-17-hydroxy-19,20-didehydrocuranium chloride).

## ALFACALCIDOL

### Alfacalcidolum

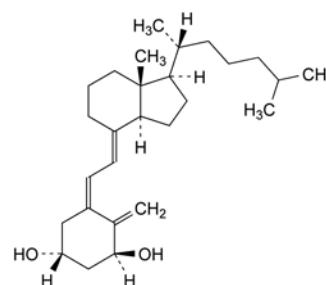

C<sub>27</sub>H<sub>44</sub>O<sub>2</sub>  
[41294-56-8]

*M*<sub>r</sub> 400.6

#### DEFINITION

(5*Z*,7*E*)-9,10-Secocholesta-5,7,10(19)-triene-1*α*,3*β*-diol.

Content: 97.0 per cent to 102.0 per cent.

#### CHARACTERS

Appearance: white or almost white crystals.

Solubility: practically insoluble in water, freely soluble in ethanol (96 per cent), soluble in fatty oils.

It is sensitive to air, heat and light.

A reversible isomerisation to pre-alfacalcidol takes place in solution, depending on temperature and time. The activity is due to both compounds.

#### IDENTIFICATION

- A. Infrared absorption spectrophotometry (2.2.24).

Comparison: Ph. Eur. reference spectrum of alfacalcidol.

- B. Examine the chromatograms obtained in the test for related substances.

Results: the principal peak in the chromatogram obtained with the test solution is similar in retention time and size to the principal peak in the chromatogram obtained with reference solution (a).

#### TESTS

**Related substances.** Liquid chromatography (2.2.29): use the normalisation procedure. Carry out the test as rapidly as possible, avoiding exposure to actinic light and air.

**Test solution.** Dissolve 1.0 mg of the substance to be examined without heating in 10.0 mL of the mobile phase.

**Reference solution (a).** Dissolve 1.0 mg of alfacalcidol CRS without heating in 10.0 mL of the mobile phase.

**Reference solution (b).** Dilute 1.0 ml of reference solution (a) to 100.0 ml with the mobile phase.

**Reference solution (c).** Heat 2 mL of reference solution (a) in a water-bath at 80 °C under a reflux condenser for 2 h and cool.

Column:

- size: *l* = 0.25 m,  $\varnothing$  = 4.0 mm;
- stationary phase: octadecylsilyl silica gel for chromatography R2 (5 µm).

Mobile phase: ammonia R, water R, acetonitrile R (1:200:800 V/V/V).

Flow rate: 2.0 mL/min.

Detection: spectrophotometer at 265 nm.

Injection: 100 µL of the test solution and reference solutions (b) and (c).

Run time: twice the retention time of alfacalcidol.

Relative retention with reference to alfacalcidol: pre-alfacalcidol = about 1.3.

01/2008:1487

*System suitability*: reference solution (c):

- *resolution*: minimum 4.0 between the peaks due to pre-alfacalcidol and alfacalcidol; if necessary, adjust the proportions of the constituents of the mobile phase.

*Limits*:

- *impurities A, B, C*: for each impurity, maximum 0.5 per cent;
- *total*: maximum 1.0 per cent;
- *disregard limit*: 0.1 times the area of the principal peak in the chromatogram obtained with reference solution (b) (0.1 per cent); disregard the peak due to pre-alfacalcidol.

#### ASSAY

Liquid chromatography (2.2.29) as described in the test for related substances with the following modification.

*Injection*: the test solution and reference solutions (a) and (c).

*System suitability*: reference solution (c):

- *repeatability*: maximum relative standard deviation of 1 per cent for the peak due to alfacalcidol after 6 injections.

Calculate the percentage content of  $C_{27}H_{44}O_2$  from the declared content of *alfacalcidol CRS*.

#### STORAGE

Under nitrogen, in an airtight container, protected from light, at a temperature of 2 °C to 8 °C.

The contents of an opened container are to be used immediately.

#### IMPURITIES

*Specified impurities*: A, B, C.

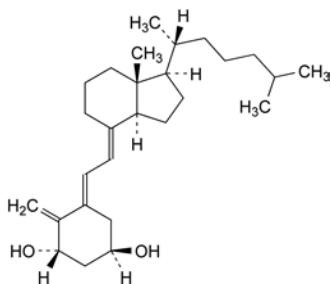

- A. (5*E*,7*E*)-9,10-secocholesta-5,7,10(19)-triene-1 $\alpha$ ,3 $\beta$ -diol (*trans*-alfacalcidol),

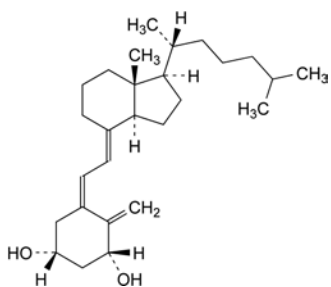

- B. (5*Z*,7*E*)-9,10-secocholesta-5,7,10(19)-triene-1 $\beta$ ,3 $\beta$ -diol (1 $\beta$ -calcidol),

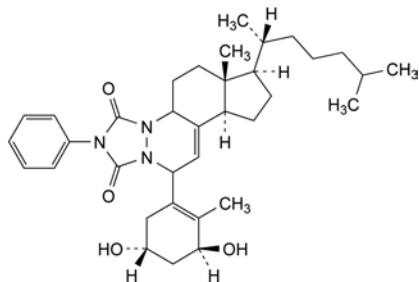

- C. triazoline adduct of pre-alfacalcidol.

## ALFADEX

### Alfadexum

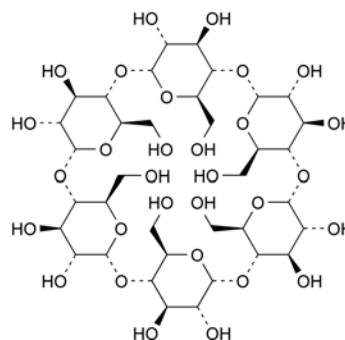

$[C_6H_{10}O_5]_6$   
[10016-20-3]

$M_r$  973

#### DEFINITION

Cyclohexakis-(1 $\rightarrow$ 4)-( $\alpha$ -D-glucopyranosyl) (cyclomaltohexaose or  $\alpha$ -cyclodextrin).

*Content*: 98.0 per cent to 101.0 per cent (dried substance).

#### CHARACTERS

*Appearance*: white or almost white, amorphous or crystalline powder.

*Solubility*: freely soluble in water and in propylene glycol, practically insoluble in anhydrous ethanol and in methylene chloride.

#### IDENTIFICATION

A. Specific optical rotation (see Tests).

B. Examine the chromatograms obtained in the assay.

*Results*: the principal peak in the chromatogram obtained with test solution (b) is similar in retention time and size to the principal peak in the chromatogram obtained with reference solution (c).

C. Dissolve 0.2 g in 2 mL of *iodine solution R4* by warming on a water-bath, and allow to stand at room temperature; a yellowish-brown precipitate is formed.

#### TESTS

**Solution S.** Dissolve 1.000 g in *carbon dioxide-free water R* and dilute to 100.0 mL with the same solvent.

**Appearance of solution.** Solution S is clear (2.2.1).

**pH** (2.2.3): 5.0 to 8.0.

Mix 1 mL of a 223.6 g/L solution of *potassium chloride R* and 30 mL of solution S.

**Specific optical rotation** (2.2.7): + 147 to + 152 (dried substance), determined on solution S.

**Reducing sugars**: maximum 0.2 per cent.

*Test solution.* To 1 mL of solution S add 1 mL of *cupri-tartaric solution R4*. Heat on a water-bath for 10 min, cool to room temperature. Add 10 mL of *ammonium molybdate reagent R1* and allow to stand for 15 min.

*Reference solution.* Prepare a reference solution at the same time and in the same manner as the test solution, using 1 mL of a 0.02 g/L solution of *glucose R*.

Measure the absorbance (2.2.25) of the test solution and the reference solution at the absorption maximum at 740 nm using *water R* as the compensation liquid. The absorbance of the test solution is not greater than that of the reference solution.

**Light-absorbing impurities.** Examine solution S between 230 nm and 750 nm. Between 230 nm and 350 nm, the absorbance (2.2.25) is not greater than 0.10. Between 350 nm and 750 nm, the absorbance (2.2.25) is not greater than 0.05.

**Related substances.** Liquid chromatography (2.2.29).

**Test solution (a).** Dissolve 0.25 g of the substance to be examined in *water R* with heating, cool and dilute to 25.0 mL with the same solvent.

**Test solution (b).** Dilute 5.0 mL of test solution (a) to 50.0 mL with *water R*.

**Reference solution (a).** Dissolve 25.0 mg of *betadex CRS* (impurity A), 25.0 mg of *gammacyclodextrin CRS* (impurity B) and 50.0 mg of *alfadex CRS* in *water R*, then dilute to 50.0 mL with the same solvent.

**Reference solution (b).** Dilute 5.0 mL of reference solution (a) to 50.0 mL with *water R*.

**Reference solution (c).** Dissolve 25.0 mg of *alfadex CRS* in *water R* and dilute to 25.0 mL with the same solvent.

**Column:**

- size:  $l = 0.25$  m,  $\varnothing = 4.6$  mm;
- stationary phase: octadecylsilyl silica gel for chromatography *R* (10  $\mu$ m).

**Mobile phase:** *methanol R*, *water R* (10:90 *V/V*).

**Flow rate:** 1.5 mL/min.

**Detection:** differential refractometer.

**Equilibration:** with the mobile phase for about 3 h.

**Injection:** 50  $\mu$ L of test solution (a) and reference solutions (a) and (b).

**Run time:** 3.5 times the retention time of *alfadex*.

**Relative retention** with reference to *alfadex* (retention time = about 10 min): impurity B = about 0.7; impurity A = about 2.2.

**System suitability:** reference solution (a):

- resolution: minimum 1.5 between the peaks due to impurity B and *alfadex*; if necessary, adjust the concentration of *methanol* in the mobile phase.

**Limits:**

- impurities A, B: for each impurity, not more than 0.5 times the area of the corresponding peak in the chromatogram obtained with reference solution (b) (0.25 per cent);
- sum of impurities other than A and B: not more than 0.5 times the area of the peak due to *alfadex* in the chromatogram obtained with reference solution (b) (0.5 per cent).

**Heavy metals** (2.4.8): maximum 10 ppm.

2.0 g complies with test C. Prepare the reference solution using 2 mL of *lead standard solution* (10 ppm *Pb*) *R*.

**Loss on drying** (2.2.32): maximum 11 per cent, determined on 1.000 g by drying in an oven at 120 °C for 2 h.

**Sulfated ash** (2.4.14): maximum 0.1 per cent, determined on 1.0 g.

#### ASSAY

Liquid chromatography (2.2.29) as described in the test for related substances with the following modifications.

**Injection:** test solution (b) and reference solutions (a) and (c).

**System suitability:** reference solution (a):

- repeatability: maximum relative standard deviation of 2.0 per cent for the peak due to *alfadex* after 5 injections.

Calculate the percentage content of  $[C_6H_{10}O_5]_6$  from the declared content of *alfadex CRS*.

#### STORAGE

In an airtight container.

#### IMPURITIES

**Specified impurities:** A, B.

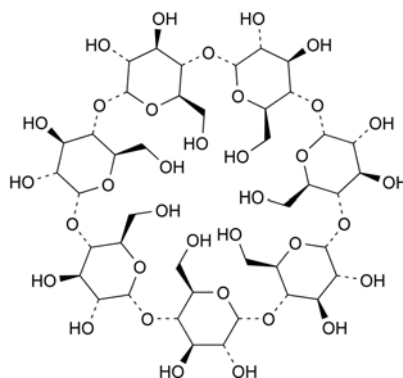

A. cycloheptakis-(1→4)-(α-D-glucopyranosyl) (betadex or cyclomaltoheptaose or β-cyclodextrin),

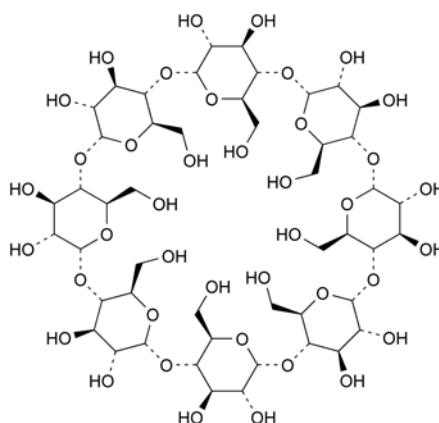

B. cyclooctakis-(1→4)-(α-D-glucopyranosyl) (cyclomaltooctaose or γ-cyclodextrin).

01/2008:1062  
corrected 7.0

## ALFENTANIL HYDROCHLORIDE

### Alfentanili hydrochloridum

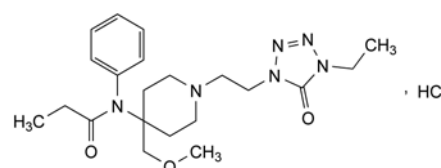

$C_{21}H_{33}ClN_6O_3$   
[69049-06-5]

$M_r$  453.0

#### DEFINITION

*N*-[1-[2-(4-Ethyl-4,5-dihydro-5-oxo-1*H*-tetrazol-1-yl)ethyl]-4-(methoxymethyl)piperidin-4-yl]-*N*-phenylpropanamide hydrochloride.

**Content:** 98.5 per cent to 101.5 per cent (anhydrous substance).

#### CHARACTERS

**Appearance:** white or almost white powder.

**Solubility:** freely soluble in water, in ethanol (96 per cent) and in methanol.

mp: about 140 °C, with decomposition.

#### IDENTIFICATION

A. Infrared absorption spectrophotometry (2.2.24).

**Comparison:** *Ph. Eur.* reference spectrum of *alfentanil hydrochloride*.

B. Dissolve 50 mg in a mixture of 0.4 mL of *ammonia R* and 2 mL of *water R*. Mix, allow to stand for 5 min and filter. Acidify the filtrate with *dilute nitric acid R*. It gives reaction (a) of chlorides (2.3.1).

## TESTS

**Appearance of solution.** The solution is clear (2.2.1) and colourless (2.2.2, *Method II*).

Dissolve 0.2 g in *water R* and dilute to 20 mL with the same solvent.

**Related substances.** Liquid chromatography (2.2.29).

**Test solution.** Dissolve 0.100 g of the substance to be examined in *methanol R* and dilute to 10.0 mL with the same solvent.

**Reference solution (a).** In order to produce impurity E *in situ*, dissolve 10 mg of the substance to be examined in 10.0 mL of *dilute hydrochloric acid R*. Heat on a water-bath under a reflux condenser for 4 h. Neutralise with 10.0 mL of *dilute sodium hydroxide solution R*. Evaporate to dryness on a water-bath. Cool and take up the residue in 10 mL of *methanol R*. Filter.

**Reference solution (b).** Dilute 1.0 mL of the test solution to 100.0 mL with *methanol R*. Dilute 5.0 mL of this solution to 20.0 mL with *methanol R*.

**Column:**

- size:  $l = 0.1$  m,  $\emptyset = 4.6$  mm;
- stationary phase: octadecylsilyl silica gel for chromatography R (3  $\mu$ m).

**Mobile phase:**

- mobile phase A: 5 g/L solution of ammonium carbonate R in a mixture of 10 volumes of *tetrahydrofuran R* and 90 volumes of *water R*;
- mobile phase B: *acetonitrile R*;

Time (min)	Mobile phase A (per cent V/V)	Mobile phase B (per cent V/V)
0 - 15	90 → 40	10 → 60
15 - 20	40	60
20 - 25	40 → 90	60 → 10

**Flow rate:** 1.5 mL/min.

**Detection:** spectrophotometer at 220 nm.

**Equilibration:** with *acetonitrile R* for at least 30 min and then with the mobile phase at the initial composition for at least 5 min.

**Injection:** 10  $\mu$ L; inject *methanol R* as a blank.

**Retention time:** impurity E = about 6 min; alfentanil = about 7 min.

**Identification of impurities:** use the chromatogram obtained with reference solution (a) to identify the peak due to impurity E; disregard any other peak.

**System suitability:** reference solution (a):

- resolution: minimum 4.0 between the peaks due to alfentanil and impurity E; if necessary, adjust the concentration of acetonitrile in the mobile phase or adjust the time programme for the linear-gradient elution.

**Limits:**

- impurities A, B, C, D, E, F, G, H: for each impurity, not more than the area of the principal peak in the chromatogram obtained with reference solution (b) (0.25 per cent);
- total: not more than twice the area of the principal peak in the chromatogram obtained with reference solution (b) (0.5 per cent);
- disregard limit: 0.2 times the area of the principal peak in the chromatogram obtained with reference solution (b) (0.05 per cent); disregard any peak due to the blank.

**Water** (2.5.12): 3.0 per cent to 4.0 per cent, determined on 0.500 g.

## ASSAY

Dissolve 0.350 g in 50 mL of a mixture of 1 volume of *ethanol (96 per cent) R* and 4 volumes of *water R* and add 5.0 mL of 0.01 M *hydrochloric acid*. Titrate with 0.1 M *sodium hydroxide*, determining the end-point potentiometrically (2.2.20). Read the volume added between the 2 points of inflexion.

1 mL of 0.1 M *sodium hydroxide* is equivalent to 45.30 mg of  $C_{21}H_{33}ClN_6O_3$ .

## STORAGE

Protected from light.

## IMPURITIES

**Specified impurities:** A, B, C, D, E, F, G, H.

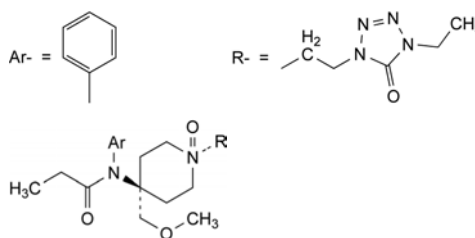

A. *cis*-N-[1-[2-(4-ethyl-4,5-dihydro-5-oxo-1H-tetrazol-1-yl)ethyl]-4-(methoxymethyl)piperidin-4-yl]-N-phenylpropanamide N-oxide,

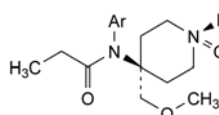

B. *trans*-N-[1-[2-(4-ethyl-4,5-dihydro-5-oxo-1H-tetrazol-1-yl)ethyl]-4-(methoxymethyl)piperidin-4-yl]-N-phenylpropanamide N-oxide,

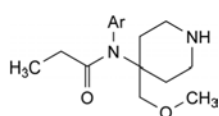

C. N-[4-(methoxymethyl)piperidin-4-yl]-N-phenylpropanamide,

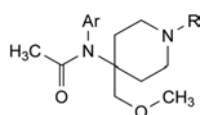

D. N-[1-[2-(4-ethyl-4,5-dihydro-5-oxo-1H-tetrazol-1-yl)ethyl]-4-(methoxymethyl)piperidin-4-yl]-N-phenylacetamide,

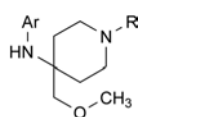

E. 1-ethyl-1,4-dihydro-4-[2-[[4-(methoxymethyl)-4-phenylamino]piperidin-1-yl]ethyl]-5H-tetrazol-5-one,

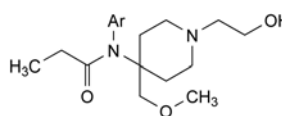

F. N-[1-(2-hydroxyethyl)-4-(methoxymethyl)piperidin-4-yl]-N-phenylpropanamide,

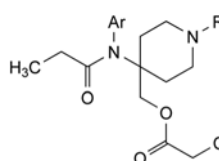

G. N-[1-[2-(4-ethyl-4,5-dihydro-5-oxo-1H-tetrazol-1-yl)ethyl]-4-(propanoyloxymethyl)piperidin-4-yl]-N-phenylpropanamide,

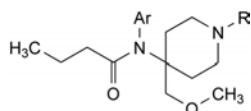

H. *N*-[1-[2-(4-ethyl-4,5-dihydro-5-oxo-1*H*-tetrazol-1-yl)ethyl]-4-(methoxymethyl)piperidin-4-yl]-*N*-phenylbutanamide.

04/2008:1287

## ALFUZOSIN HYDROCHLORIDE

### Alfuzosini hydrochloridum

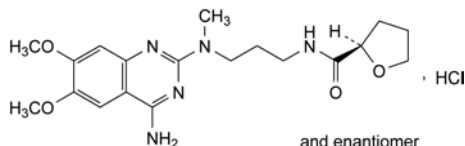

$C_{19}H_{28}ClN_5O_4$   
[81403-68-1]

$M_r$  425.9

#### DEFINITION

(2*RS*)-*N*-[3-[(4-Amino-6,7-dimethoxyquinazolin-2-yl)methylamino]propyl]tetrahydrofuran-2-carboxamide hydrochloride.

*Content*: 99.0 per cent to 101.0 per cent (anhydrous substance).

#### CHARACTERS

*Appearance*: white or almost white, crystalline powder, slightly hygroscopic.

*Solubility*: freely soluble in water, sparingly soluble in ethanol (96 per cent), practically insoluble in methylene chloride.

#### IDENTIFICATION

A. Infrared absorption spectrophotometry (2.2.24).

*Comparison*: alfuzosin hydrochloride CRS.

B. It gives reaction (a) of chlorides (2.3.1).

#### TESTS

**pH** (2.2.3): 4.0 to 5.5.

Dissolve 0.500 g in carbon dioxide-free water *R* and dilute to 25.0 mL with the same solvent. Use a freshly prepared solution.

**Related substances**. Liquid chromatography (2.2.29).

*Test solution*. Dissolve 40 mg of the substance to be examined in the mobile phase and dilute to 100.0 mL with the mobile phase.

*Reference solution (a)*. Dilute 1.0 mL of the test solution to 100.0 mL with the mobile phase. Dilute 1.0 mL of this solution to 10.0 mL with the mobile phase.

*Reference solution (b)*. Dissolve 4 mg of alfuzosin for system suitability CRS (containing impurities A and D) in the mobile phase and dilute to 10 mL with the mobile phase.

*Column*:

- *size*:  $l = 0.15$  m,  $\varnothing = 4.6$  mm;
- *stationary phase*: end-capped octadecylsilyl silica gel for chromatography *R* (5  $\mu$ m).

*Mobile phase*: mix 1 volume of tetrahydrofuran *R*, 20 volumes of acetonitrile *R* and 80 volumes of a solution prepared as follows: dilute 5.0 mL of perchloric acid *R* in 900 mL of water *R*, adjust to pH 3.5 with dilute sodium hydroxide solution *R* and dilute to 1000 mL with water *R*.

*Flow rate*: 1.5 mL/min.

*Detection*: spectrophotometer at 254 nm.

*Injection*: 10  $\mu$ L.

*Run time*: twice the retention time of alfuzosin.

*Identification of impurities*: use the chromatogram supplied with alfuzosin for system suitability CRS and the chromatogram obtained with reference solution (b) to identify the peaks due to impurities A and D.

*Relative retention* with reference to alfuzosin (retention time = about 8 min): impurity D = about 0.4; impurity A = about 1.2.

*System suitability*: reference solution (b):

- *peak-to-valley ratio*: minimum 5.0, where  $H_p$  = height above the baseline of the peak due to impurity A and  $H_v$  = height above the baseline of the lowest point of the curve separating this peak from the peak due to alfuzosin.

*Limits*:

- *impurity D*: not more than twice the area of the principal peak in the chromatogram obtained with reference solution (a) (0.2 per cent);
- *unspecified impurities*: for each impurity, not more than the area of the principal peak in the chromatogram obtained with reference solution (a) (0.10 per cent);
- *total*: not more than 3 times the area of the principal peak in the chromatogram obtained with reference solution (a) (0.3 per cent);
- *disregard limit*: 0.5 times the area of the principal peak in the chromatogram obtained with reference solution (a) (0.05 per cent).

**Water** (2.5.12): maximum 0.5 per cent, determined on 1.000 g.

**Sulfated ash** (2.4.14): maximum 0.1 per cent, determined on 1.0 g.

#### ASSAY

Dissolve 0.300 g in a mixture of 40 mL of anhydrous acetic acid *R* and 40 mL of acetic anhydride *R*. Titrate with 0.1 *M* perchloric acid, determining the end-point potentiometrically (2.2.20).

1 mL of 0.1 *M* perchloric acid is equivalent to 42.59 mg of  $C_{19}H_{28}ClN_5O_4$ .

#### STORAGE

In an airtight container, protected from light.

#### IMPURITIES

*Specified impurities*: D.

*Other detectable impurities* (the following substances would, if present at a sufficient level, be detected by one or other of the tests in the monograph. They are limited by the general acceptance criterion for other/unspecified impurities and/or by the general monograph *Substances for pharmaceutical use* (2034). It is therefore not necessary to identify these impurities for demonstration of compliance. See also 5.10. *Control of impurities in substances for pharmaceutical use*): A, B, C, E.

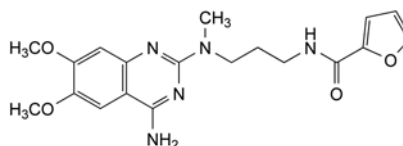

A. *N*-[3-[(4-amino-6,7-dimethoxyquinazolin-2-yl)methylamino]propyl]furan-2-carboxamide,

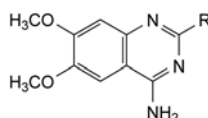

B. R = Cl: 2-chloro-6,7-dimethoxyquinazolin-4-amine,

D. R = N(CH<sub>3</sub>)-(CH<sub>2</sub>)<sub>3</sub>-NH<sub>2</sub>: *N*-(4-amino-6,7-dimethoxyquinazolin-2-yl)-*N*-methylpropane-1,3-diamine,

E. R = N(CH<sub>3</sub>)-(CH<sub>2</sub>)<sub>3</sub>-NH-CO-H: *N*-[3-[(4-amino-6,7-dimethoxyquinazolin-2-yl)methylamino]propyl]formamide,



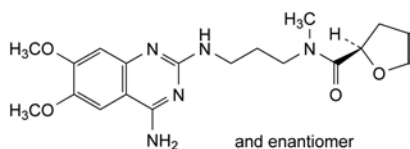

C. (2*RS*)-*N*-[3-[(4-amino-6,7-dimethoxyquinazolin-2-yl)amino]propyl]-*N*-methyltetrahydrofuran-2-carboxamide.

01/2009:0591

## ALGINIC ACID

### Acidum alginicum

#### DEFINITION

Mixture of polyuronic acids [(C<sub>6</sub>H<sub>8</sub>O<sub>6</sub>)<sub>*n*</sub>] composed of residues of D-mannuronic and L-guluronic acids, obtained mainly from algae belonging to the Phaeophyceae. A small proportion of the carboxyl groups may be neutralised.

*Content*: 19.0 per cent to 25.0 per cent of carboxyl groups (-CO<sub>2</sub>H) (dried substance).

#### CHARACTERS

*Appearance*: white or pale yellowish-brown, crystalline or amorphous powder.

*Solubility*: very slightly soluble or practically insoluble in ethanol (96 per cent), practically insoluble in organic solvents. It swells in water but does not dissolve; it dissolves in solutions of alkali hydroxides.

#### IDENTIFICATION

- To 0.2 g add 20 mL of *water R* and 0.5 mL of *sodium carbonate solution R*. Shake and filter. To 5 mL of the filtrate add 1 mL of *calcium chloride solution R*. A voluminous gelatinous mass is formed.
- To 5 mL of the filtrate obtained in identification test A add 0.5 mL of a 123 g/L solution of *magnesium sulfate R*. No voluminous gelatinous mass is formed.
- To 5 mg add 5 mL of *water R*, 1 mL of a freshly prepared 10 g/L solution of *1,3-dihydroxynaphthalene R* in *ethanol (96 per cent) R* and 5 mL of *hydrochloric acid R*. Boil gently for 3 min, cool, add 5 mL of *water R*, and shake with 15 mL of *di-isopropyl ether R*. Carry out a blank test. The upper layer obtained with the substance to be examined exhibits a deeper bluish-red colour than that obtained with the blank.

#### TESTS

**Chlorides**: maximum 1,0 per cent.

To 2.50 g add 50 mL of *dilute nitric acid R*, shake for 1 h and dilute to 100.0 mL with *dilute nitric acid R*. Filter. To 50.0 mL of the filtrate add 10.0 mL of 0.1 M *silver nitrate* and 5 mL of *toluene R*. Titrate with 0.1 M *ammonium thiocyanate*, using 2 mL of *ferric ammonium sulfate solution R2* as indicator and shaking vigorously towards the end-point.

1 mL of 0.1 M *silver nitrate* is equivalent to 3.545 mg of Cl.

**Heavy metals** (2.4.8): maximum 20 ppm.

1.0 g complies with test F. Prepare the reference solution using 2 mL of *lead standard solution (10 ppm Pb) R*.

**Loss on drying** (2.2.32): maximum 15.0 per cent, determined on 0.1000 g by drying in an oven at 105 °C for 4 h.

**Sulfated ash** (2.4.14): maximum 8.0 per cent (dried substance), determined on 0.100 g.

#### Microbial contamination

TAMC: acceptance criterion 10<sup>2</sup> CFU/g (2.6.12).

Absence of *Escherichia coli* (2.6.13).

Absence of *Salmonella* (2.6.13).

#### ASSAY

To 0.2500 g add 25 mL of *water R*, 25.0 mL of 0.1 M *sodium hydroxide* and 0.2 mL of *phenolphthalein solution R*. Titrate with 0.1 M *hydrochloric acid*.

1 mL of 0.1 M *sodium hydroxide* is equivalent to 4.502 mg of carboxyl groups (-CO<sub>2</sub>H).

#### FUNCTIONALITY-RELATED CHARACTERISTICS

*This section provides information on characteristics that are recognised as being relevant control parameters for one or more functions of the substance when used as an excipient (see chapter 5.15). This section is a non-mandatory part of the monograph and it is not necessary to verify the characteristics to demonstrate compliance. Control of these characteristics can however contribute to the quality of a medicinal product by improving the consistency of the manufacturing process and the performance of the medicinal product during use. Where control methods are cited, they are recognised as being suitable for the purpose, but other methods can also be used. Wherever results for a particular characteristic are reported, the control method must be indicated.*

*The following characteristics may be relevant for alginic acid used as disintegrant and/or binder.*

**Particle-size distribution** (2.9.31 or 2.9.38).

**Settling volume.** Place 75 mL of *water R* in a 100 mL graduated cylinder and add 1.5 g of the substance to be examined in 0.5 g portions, shaking vigorously after each addition. Dilute to 100.0 mL with *water R* and shake again until the substance is homogeneously distributed. Allow to stand for 4 h and determine the volume of the settled mass.

*The following characteristic may be relevant for alginic acid used as gelling agent or viscosity-increasing agent.*

**Apparent viscosity.** Determine the dynamic viscosity using a rotating viscometer (2.2.10).

Prepare a 20 g/L suspension of alginic acid (dried substance) and add 0.1 M *sodium hydroxide* until a solution is obtained.

01/2008:1288  
corrected 6.0

## ALLANTOIN

### Allantoinum

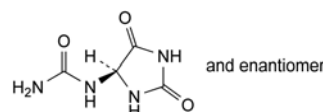

C<sub>4</sub>H<sub>6</sub>N<sub>4</sub>O<sub>3</sub>  
[97-59-6]

*M*<sub>r</sub> 158.1

#### DEFINITION

Allantoin contains not less than 98.5 per cent and not more than the equivalent of 101.0 per cent of (RS)-(2,5-dioxoimidazolidin-4-yl)urea.

#### CHARACTERS

A white or almost white, crystalline powder, slightly soluble in water, very slightly soluble in alcohol.

It melts at about 225 °C, with decomposition.

#### IDENTIFICATION

*First identification: A.*

*Second identification: B, C, D.*

A. Examine by infrared absorption spectrophotometry (2.2.24), comparing with the spectrum obtained with *allantoin CRS*.

- B. Examine the chromatograms obtained in the test for related substances. The principal spot in the chromatogram obtained with test solution (b) is similar in position, colour and size to the principal spot in the chromatogram obtained with reference solution (a).
- C. Boil 20 mg with a mixture of 1 mL of *dilute sodium hydroxide solution R* and 1 mL of *water R*. Allow to cool. Add 1 mL of *dilute hydrochloric acid R*. To 0.1 mL of the solution add 0.1 mL of a 100 g/L solution of *potassium bromide R*, 0.1 mL of a 20 g/L solution of *resorcinol R* and 3 mL of *sulfuric acid R*. Heat for 5 min to 10 min on a water-bath. A dark blue colour develops, which becomes red after cooling and pouring into about 10 mL of *water R*.
- D. Heat about 0.5 g. Ammonia vapour is evolved, which turns *red litmus paper R* blue.

## TESTS

**Solution S.** Dissolve 0.5 g in *carbon dioxide-free water R*, with heating if necessary, and dilute to 100 mL with the same solvent.

**Acidity or alkalinity.** To 5 mL of solution S add 5 mL of *carbon dioxide-free water R*, 0.1 mL of *methyl red solution R* and 0.2 mL of 0.01 M *sodium hydroxide*. The solution is yellow. Add 0.4 mL of 0.01 M *hydrochloric acid*. The solution is red.

**Optical rotation (2.2.7).** The angle of optical rotation, determined on solution S, is  $-0.10^\circ$  to  $+0.10^\circ$ .

**Reducing substances.** Shake 1.0 g with 10 mL of *water R* for 2 min. Filter. Add 1.5 mL of 0.02 M *potassium permanganate*. The solution must remain violet for at least 10 min.

**Related substances.** Examine by thin-layer chromatography (2.2.27), using a suitable *cellulose for chromatography R* as the coating substance.

**Test solution (a).** Dissolve 0.10 g of the substance to be examined in 5.0 mL of *water R* with heating. Allow to cool. Dilute to 10 mL with *methanol R*. Use the solution immediately after preparation.

**Test solution (b).** Dilute 1 mL of test solution (a) to 10 mL with a mixture of 1 volume of *methanol R* and 1 volume of *water R*.

**Reference solution (a).** Dissolve 10 mg of *allantoin CRS* in a mixture of 1 volume of *methanol R* and 1 volume of *water R* and dilute to 10 mL with the same mixture of solvents.

**Reference solution (b).** Dissolve 10 mg of *urea R* in 10 mL of *water R*. Dilute 1 mL of this solution to 10 mL with *methanol R*.

**Reference solution (c).** Mix 1 mL of reference solution (a) and 1 mL of reference solution (b).

Apply to the plate 10  $\mu$ L of test solution (a) and 5  $\mu$ L each of test solution (b), reference solution (a), reference solution (b) and reference solution (c). Develop over a path of 10 cm using a mixture of 15 volumes of *glacial acetic acid R*, 25 volumes of *water R* and 60 volumes of *butanol R*. Allow the plate to dry in air. Spray the plate with a 5 g/L solution of *dimethylaminobenzaldehyde R* in a mixture of 1 volume of *hydrochloric acid R* and 3 volumes of *methanol R*. Dry the plate in a current of hot air. Examine in daylight after 30 min. Any spot in the chromatogram obtained with test solution (a), apart from the principal spot, is not more intense than the spot in the chromatogram obtained with reference solution (b) (0.5 per cent). The test is not valid unless the chromatogram obtained with reference solution (c) shows two clearly separated principal spots.

**Loss on drying (2.2.32).** Not more than 0.1 per cent, determined on 1.000 g by drying in an oven at 105 °C.

**Sulfated ash (2.4.14).** Not more than 0.1 per cent, determined on 1.0 g.

## ASSAY

Dissolve 120.0 mg in 40 mL of *water R*. Titrate with 0.1 M *sodium hydroxide*, determining the end-point potentiometrically (2.2.20).

1 mL of 0.1 M *sodium hydroxide* is equivalent to 15.81 mg of  $C_4H_6N_4O_3$ .

## IMPURITIES

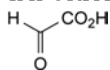

A. glyoxylic acid,

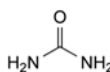

B. carbamide (urea).

01/2008:0576  
corrected 6.8

## ALLOPURINOL

## Allopurinolum

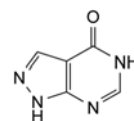

$C_5H_4N_4O$   
[315-30-0]

$M_r$  136.1

## DEFINITION

1,5-Dihydro-4H-pyrazolo[3,4-d]pyrimidin-4-one.

**Content:** 97.0 per cent to 102.0 per cent (dried substance).

## CHARACTERS

**Appearance:** white or almost white powder.

**Solubility:** very slightly soluble in water and in ethanol (96 per cent). It dissolves in dilute solutions of alkali hydroxides.

## IDENTIFICATION

**First identification:** B.

**Second identification:** A, C, D.

A. Ultraviolet and visible absorption spectrophotometry (2.2.25).

**Test solution.** Dissolve 10 mg in 1 mL of a 4 g/L solution of *sodium hydroxide R* and dilute to 100.0 mL with a 10.3 g/L solution of *hydrochloric acid R*. Dilute 10.0 mL of this solution to 100.0 mL with a 10.3 g/L solution of *hydrochloric acid R*.

**Spectral range:** 220-350 nm.

**Absorption maximum:** at 250 nm.

**Absorption minimum:** at 231 nm.

**Absorbance ratio:**  $A_{231}/A_{250} = 0.52$  to 0.62.

B. Infrared absorption spectrophotometry (2.2.24).

**Comparison:** *allopurinol CRS*.

C. Dissolve 0.3 g in 2.5 mL of *dilute sodium hydroxide solution R* and add 50 mL of *water R*. Add slowly and with shaking 5 mL of *silver nitrate solution R1*. A white precipitate is formed which does not dissolve on the addition of 5 mL of *ammonia R*.

D. Thin-layer chromatography (2.2.27).

**Test solution.** Dissolve 20 mg of the substance to be examined in *concentrated ammonia R* and dilute to 10 mL with the same solvent.

**Reference solution.** Dissolve 20 mg of *allopurinol CRS* in *concentrated ammonia R* and dilute to 10 mL with the same solvent.

**Plate:** *TLC silica gel F<sub>254</sub> plate R*.

**Mobile phase:** *anhydrous ethanol R, methylene chloride R* (40:60 V/V).

**Application:** 10  $\mu$ L.

*Development:* over 2/3 of the plate.

*Drying:* in air.

*Detection:* examine in ultraviolet light at 254 nm.

*Results:* the principal spot in the chromatogram obtained with the test solution is similar in position and size to the principal spot in the chromatogram obtained with the reference solution.

## TESTS

**Related substances.** Liquid chromatography (2.2.29). Use freshly prepared solutions. Store and inject them at 8 °C, using a cooled autosampler.

*Test solution (a).* Dissolve 25.0 mg of the substance to be examined in 2.5 mL of a 4 g/L solution of *sodium hydroxide R* and dilute immediately to 50.0 mL with the mobile phase.

*Test solution (b).* Dissolve 20.0 mg of the substance to be examined in 5.0 mL of a 4 g/L solution of *sodium hydroxide R* and dilute immediately to 250.0 mL with the mobile phase.

*Reference solution (a).* Dilute 2.0 mL of test solution (a) to 100.0 mL with the mobile phase. Dilute 5.0 mL of this solution to 100.0 mL with the mobile phase.

*Reference solution (b).* Dissolve 5 mg of *allopurinol impurity A CRS*, 5 mg of *allopurinol impurity B CRS* and 5.0 mg of *allopurinol impurity C CRS* in 5.0 mL of a 4 g/L solution of *sodium hydroxide R* and dilute immediately to 100.0 mL with the mobile phase. Dilute 1.0 mL of this solution to 100.0 mL with the mobile phase.

*Reference solution (c).* Dissolve 20.0 mg of *allopurinol CRS* in 5.0 mL of a 4 g/L solution of *sodium hydroxide R* and dilute immediately to 250.0 mL with the mobile phase.

*Column:*

- size:  $l = 0.25$  m,  $\emptyset = 4.6$  mm;
- stationary phase: *octadecylsilyl silica gel for chromatography R* (5  $\mu$ m).

*Mobile phase:* 1.25 g/L solution of *potassium dihydrogen phosphate R*.

*Flow rate:* 1.4 mL/min.

*Detection:* spectrophotometer at 230 nm.

*Injection:* 20  $\mu$ L of test solution (a) and reference solutions (a) and (b).

*Run time:* twice the retention time of allopurinol.

*Elution order:* impurity A, impurity B, impurity C, allopurinol.

*Retention time:* allopurinol = about 10 min.

*System suitability:* reference solution (b):

- resolution: minimum 1.1 between the peaks due to impurities B and C.

*Limits:*

- *impurity A:* not more than twice the area of the principal peak in the chromatogram obtained with reference solution (a) (0.2 per cent);
- *impurity B:* not more than the area of the principal peak in the chromatogram obtained with reference solution (a) (0.1 per cent);
- *impurity C:* not more than the area of the corresponding peak in the chromatogram obtained with reference solution (b) (0.1 per cent);
- *unspecified impurities:* for each impurity, not more than the area of the principal peak in the chromatogram obtained with reference solution (a) (0.10 per cent);
- *sum of impurities other than A, B and C:* not more than 3 times the area of the principal peak in the chromatogram obtained with reference solution (a) (0.3 per cent);
- *disregard limit:* 0.5 times the area of the principal peak in the chromatogram obtained with reference solution (a) (0.05 per cent).

**Impurities D and E.** Liquid chromatography (2.2.29). Use freshly prepared solutions. Store and inject them at 8 °C, using a cooled autosampler.

*Solution A:* 1.25 g/L solution of *potassium dihydrogen phosphate R*.

*Test solution.* Dissolve 50.0 mg of the substance to be examined in 5.0 mL of a 4 g/L solution of *sodium hydroxide R* and dilute immediately to 100.0 mL with solution A.

*Reference solution.* Dissolve 5.0 mg of *allopurinol impurity D CRS* and 5.0 mg of *allopurinol impurity E CRS* in 5.0 mL of a 4 g/L solution of *sodium hydroxide R* and dilute immediately to 100.0 mL with solution A. Dilute 1.0 mL of this solution to 100.0 mL with solution A.

*Column:*

- size:  $l = 0.05$  m,  $\emptyset = 4.6$  mm;
- stationary phase: *base-deactivated octadecylsilyl silica gel for chromatography R* (3  $\mu$ m).

*Mobile phase:* *methanol R*, 1.25 g/L solution of *potassium dihydrogen phosphate R* (10:90 V/V).

*Flow rate:* 2 mL/min.

*Detection:* spectrophotometer at 230 nm.

*Injection:* 20  $\mu$ L.

*Run time:* 1.5 times the retention time of impurity E.

*Retention times:* impurity D = about 3.6 min; impurity E = about 4.5 min.

*System suitability:* reference solution:

- resolution: minimum 2.0 between the peaks due to impurities D and E.

*Limits:*

- *impurity D:* not more than the area of the corresponding peak in the chromatogram obtained with the reference solution (0.1 per cent);
- *impurity E:* not more than the area of the corresponding peak in the chromatogram obtained with the reference solution (0.1 per cent).

**Impurity F.** Liquid chromatography (2.2.29).

Under the following conditions, any hydrazine in the sample reacts with benzaldehyde to give benzaldehyde azine.

*Solvent mixture.* Mix equal volumes of *dilute sodium hydroxide solution R* and *methanol R*.

*Solution A.* Dissolve 2.0 g of *benzaldehyde R* in the solvent mixture and dilute to 50.0 mL with the solvent mixture. Prepare immediately before use.

*Test solution.* Dissolve 250.0 mg of the substance to be examined in 5 mL of the solvent mixture. Add 4 mL of solution A, mix and allow to stand for 2.5 h at room temperature. Add 5.0 mL of *hexane R* and shake for 1 min. Allow the layers to separate and use the upper layer.

*Reference solution.* Dissolve 10.0 mg of *hydrazine sulfate R* in the solvent mixture by sonicating for about 2 min and dilute to 50.0 mL with the solvent mixture. Dilute 1.0 mL to 20.0 mL with the solvent mixture. Dilute 1.0 mL of this solution to 20.0 mL with the solvent mixture. To 5.0 mL of the solution obtained, add 4 mL of solution A, mix and allow to stand for 2.5 h at room temperature. Add 5.0 mL of *hexane R* and shake for 1 min. Allow the layers to separate and use the upper layer.

*Blank solution.* To 5 mL of the solvent mixture add 4 mL of solution A, mix and allow to stand for 2.5 h at room temperature. Add 5.0 mL of *hexane R* and shake for 1 min. Allow the layers to separate and use the upper layer.

*Column:*

- size:  $l = 0.25$  m,  $\emptyset = 4.0$  mm;
- stationary phase: *cyanosilyl silica gel for chromatography R* (5  $\mu$ m) with a pore size of 10 nm;
- temperature: 30 °C.

*Mobile phase:* 2-propanol R, *hexane R* (5:95 V/V).

*Flow rate:* 1.5 mL/min.

**Detection:** spectrophotometer at 310 nm.

**Injection:** 20 µL.

**Relative retention** with reference to benzaldehyde (retention time = about 2.8 min): benzaldehyde azine = about 0.8.

**System suitability:** reference solution:

- **resolution:** minimum 2 between the peaks due to benzaldehyde azine and benzaldehyde;
- **signal-to-noise ratio:** minimum 20 for the peak due to benzaldehyde azine.

**Limit:**

- **impurity F:** the area of the peak due to benzaldehyde azine in the chromatogram obtained with the test solution is not more than the area of the corresponding peak in the chromatogram obtained with the reference solution (10 ppm of hydrazine sulfate equivalent to 2.5 ppm of hydrazine).

**Heavy metals (2.4.8):** maximum 20 ppm.

1.0 g complies with test C. Prepare the reference solution using 2 mL of *lead standard solution (10 ppm Pb) R*.

**Loss on drying (2.2.32):** maximum 0.5 per cent, determined on 1.000 g by drying in an oven at 105 °C.

**Sulfated ash (2.4.14):** maximum 0.1 per cent, determined on 1.0 g.

#### ASSAY

Liquid chromatography (2.2.29) as described in the test for related substances with the following modification.

**Injection:** test solution (b) and reference solution (c).

Calculate the percentage content of C<sub>5</sub>H<sub>4</sub>N<sub>4</sub>O from the declared content of *allopurinol CRS*.

#### IMPURITIES

**Specified impurities:** A, B, C, D, E, F.

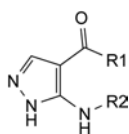

- A. R1 = NH<sub>2</sub>, R2 = H: 5-amino-1*H*-pyrazole-4-carboxamide,  
 B. R1 = NH<sub>2</sub>, R2 = CHO: 5-(formylamino)-1*H*-pyrazole-4-carboxamide,  
 D. R1 = O-C<sub>2</sub>H<sub>5</sub>, R2 = H: ethyl 5-amino-1*H*-pyrazole-4-carboxylate,  
 E. R1 = O-C<sub>2</sub>H<sub>5</sub>, R2 = CHO: ethyl 5-(formylamino)-1*H*-pyrazole-4-carboxylate,

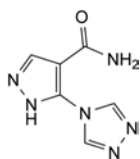

- C. 5-(4*H*-1,2,4-triazol-4-yl)-1*H*-pyrazole-4-carboxamide,  
 F. H<sub>2</sub>N-NH<sub>2</sub>: diazane (hydrazine).

01/2009:2010  
corrected 7.0

## ALMAGATE

### Almagatum

Al<sub>2</sub>Mg<sub>6</sub>C<sub>20</sub>H<sub>14</sub>4H<sub>2</sub>O  
[66827-12-1]

M<sub>r</sub> 630

#### DEFINITION

Hydrated aluminium magnesium hydroxycarbonate.

**Content:**

- aluminium: 15.0 per cent to 17.0 per cent (calculated as Al<sub>2</sub>O<sub>3</sub>),
- magnesium: 36.0 per cent to 40.0 per cent (calculated as MgO),
- carbonic acid: 12.5 per cent to 14.5 per cent (calculated as CO<sub>2</sub>).

#### CHARACTERS

**Appearance:** white or almost white, fine, crystalline powder.

**Solubility:** practically insoluble in water, in ethanol (96 per cent) and in methylene chloride. It dissolves with effervescence and heating in dilute mineral acids.

#### IDENTIFICATION

A. Infrared absorption spectrophotometry (2.2.24).

**Comparison:** *Ph. Eur. reference spectrum of almagate*.

B. Dissolve 0.15 g in *dilute hydrochloric acid R* and dilute to 20 mL with the same acid. 2 mL of the solution gives the reaction of aluminium (2.3.1).

C. 2 mL of the solution prepared under identification test B gives the reaction of magnesium (2.3.1).

#### TESTS

**pH (2.2.3):** 9.1 to 9.7.

Disperse 4.0 g in 100 mL of *carbon dioxide-free water R*, stir for 2 min and filter.

**Neutralising capacity.** Carry out the test at 37 °C. Disperse 0.5 g in 100 mL of *water R*, heat, add 100.0 mL of 0.1 M *hydrochloric acid*, previously heated and stir continuously; the pH (2.2.3) of the solution between 5 min and 20 min is not less than 3.0 and not greater than 4.5. Add 10.0 mL of 0.5 M *hydrochloric acid*, previously heated, stir continuously for 1 h and titrate with 0.1 M *sodium hydroxide* to pH 3.5; not more than 20.0 mL of 0.1 M *sodium hydroxide* is required.

**Chlorides (2.4.4):** maximum 0.1 per cent.

Dissolve 0.33 g in 5 mL of *dilute nitric acid R* and dilute to 100 mL with *water R*. 15 mL of the solution complies with the limit test for chlorides. Prepare simultaneously the standard by diluting 0.7 mL of *dilute nitric acid R* to 5 mL with *water R* and adding 10 mL of *chloride standard solution (5 ppm Cl) R*.

**Sulfates (2.4.13):** maximum 0.4 per cent.

Dissolve 0.25 g in 5 mL of *dilute hydrochloric acid R* and dilute to 100 mL with *distilled water R*. 15 mL of the solution complies with the limit test for sulfates. Prepare simultaneously the standard by adding 0.8 mL of *dilute hydrochloric acid R* to 15 mL of *sulfate standard solution (10 ppm SO<sub>4</sub>) R*.

**Sodium:** maximum 150 ppm.

Atomic absorption spectrometry (2.2.23, *Method I*).

**Test solution.** Dissolve 0.25 g in 50 mL of a 103 g/L solution of *hydrochloric acid R*.

**Reference solutions.** Prepare the reference solutions using *sodium standard solution (200 ppm Na) R*, diluted as necessary with a 103 g/L solution of *hydrochloric acid R*.

**Heavy metals (2.4.8):** maximum 20 ppm.

Dissolve 1.0 g in *dilute hydrochloric acid R* and dilute to 20.0 mL with the same acid. 12 mL of the solution complies with test A. Prepare the reference solution using *lead standard solution (1 ppm Pb) R*.

**Loss on ignition:** 43.0 per cent to 49.0 per cent, determined on 1.000 g by ignition at 900 ± 50 °C.

#### Microbial contamination

TAMC: acceptance criterion 10<sup>3</sup> CFU/g (2.6.12).

TYMC: acceptance criterion 10<sup>2</sup> CFU/g (2.6.12).

Absence of *Escherichia coli* (2.6.13).

Absence of *Pseudomonas aeruginosa* (2.6.13).

## ASSAY

01/2010:1064

**Aluminium.** Dissolve 1.000 g in 5 mL of *hydrochloric acid R*, heating if necessary. Allow to cool to room temperature and dilute to 100.0 mL with *water R* (solution A). Introduce 10.0 mL of solution A into a 250 mL conical flask, add 25.0 mL of 0.05 M *sodium edetate*, 20 mL of *buffer solution pH 3.5 R*, 40 mL of *ethanol R* and 2 mL of a freshly prepared 0.25 g/L solution of *dithizone R* in *ethanol R*. Titrate the excess of sodium edetate with 0.05 M *zinc sulfate* until the colour changes from greenish-violet to pink.

1 mL of 0.05 M *sodium edetate* is equivalent to 2.549 mg of  $\text{Al}_2\text{O}_3$ .

**Magnesium.** Introduce 10.0 mL of solution A prepared in the assay of aluminium into a 500 mL conical flask, add 200 mL of *water R*, 20 mL of *triethanolamine R* with shaking, 10 mL of *ammonium chloride buffer solution pH 10.0 R* and 50 mg of *mordant black 11 triturate R*. Titrate with 0.05 M *sodium edetate* until the colour changes from violet to pure blue.

1 mL of 0.05 M *sodium edetate* is equivalent to 2.015 mg of MgO.

**Carbonic acid:** 12.5 per cent to 14.5 per cent.

**Test sample.** Place 7.00 mg of the substance to be examined in a tin capsule. Seal the capsule.

**Reference sample.** Place 7.00 mg of *almagante CRS* in a tin capsule. Seal the capsule.

Introduce separately the test sample and the reference sample into a combustion chamber of a CHN analyser purged with *helium for chromatography R* and maintained at a temperature of 1020 °C. Simultaneously, introduce *oxygen R* at a pressure of 40 kPa and a flow rate of 20 mL/min and allow complete combustion of the sample. Sweep the combustion gases through a reduction reactor and separate the gases formed by gas chromatography (2.2.28).

**Column:**

– size:  $l = 2$  m,  $\varnothing = 4$  mm;

– stationary phase: *ethylvinylbenzene-divinylbenzene copolymer R1*.

**Carrier gas:** *helium for chromatography R*.

**Flow rate:** 100 mL/min.

**Temperature:**

– column: 65 °C;

– detector: 190 °C.

**Detection:** thermal conductivity.

**Run time:** 16 min.

**System suitability:**

– average percentage of carbon in 5 reference samples must be within  $\pm 0.2$  per cent of the value assigned to the CRS; the difference between the upper and the lower values of the percentage of carbon in these samples must be below 0.2 per cent.

Calculate the percentage content of carbonic acid in the test sample according to the following formula:

$$C \times K \times \frac{A}{m}$$

*C* = percentage content of carbonic acid in the reference sample;

*K* = mean value for the 5 reference samples of the ratio of the mass in milligrams to the area of the peak due to carbonic acid;

*A* = area of the peak due to carbonic acid in the chromatogram obtained with the test sample;

*m* = sample mass, in milligrams.

## STORAGE

In an airtight container.

## ALMOND OIL, REFINED

## Amygdalae oleum raffinatum

## DEFINITION

Fatty oil obtained from the ripe seeds of *Prunus dulcis* (Mill.) D.A. Webb var. *dulcis* or *Prunus dulcis* (Mill.) D.A. Webb var. *amara* (DC.) Buchheim or a mixture of both varieties by cold expression. It is then refined. A suitable antioxidant may be added.

## CHARACTERS

**Appearance:** pale yellow, clear liquid.

**Solubility:** slightly soluble in ethanol (96 per cent), miscible with light petroleum.

**Relative density:** about 0.916.

It solidifies at about  $-18$  °C.

## IDENTIFICATION

A. Identification of fatty oils by thin-layer chromatography (2.3.2).

**Results:** the chromatogram obtained is similar to the corresponding chromatogram shown in Figure 2.3.2.-1.

B. Composition of fatty acids (see Tests).

## TESTS

**Specific absorbance (2.2.25):** 0.2 to 6.0, determined at the absorption maximum at 270 nm.

To 0.100 g add *cyclohexane R* and dilute to 10.0 mL with the same solvent. Adapt the concentration of the solution so that the absorbance lies between 0.5 and 1.5, measured in a 1 cm cell.

**Acid value (2.5.1):** maximum 0.5, determined on 5.0 g.

**Peroxide value (2.5.5, Method A):** maximum 5.0.

**Unsaponifiable matter (2.5.7):** maximum 0.9 per cent, determined on 5.0 g.

**Composition of fatty acids (2.4.22, Method A).** Use the mixture of calibrating substances in Table 2.4.22.-3.

**Composition of the fatty-acid fraction of the oil:**

– saturated fatty acids of chain length less than  $\text{C}_{16}$ : maximum 0.1 per cent;

– palmitic acid: 4.0 per cent to 9.0 per cent;

– palmitoleic acid: maximum 0.8 per cent;

– margaric acid: maximum 0.2 per cent;

– stearic acid: maximum 3.0 per cent;

– oleic acid: 62.0 per cent to 86.0 per cent;

– linoleic acid: 20.0 per cent to 30.0 per cent;

– linolenic acid: maximum 0.4 per cent;

– arachidic acid: maximum 0.2 per cent;

– eicosenoic acid: maximum 0.3 per cent;

– behenic acid: maximum 0.2 per cent;

– erucic acid: maximum 0.1 per cent.

**Sterols (2.4.23).**

**Composition of the sterol fraction of the oil:**

– cholesterol: maximum 0.7 per cent;

– campesterol: maximum 5.0 per cent;

– stigmasterol: maximum 4.0 per cent;

–  $\beta$ -sitosterol: 73.0 per cent to 87.0 per cent;

–  $\Delta^5$ -avenasterol: minimum 5.0 per cent;

–  $\Delta^7$ -stigmasterol: maximum 3.0 per cent;

–  $\Delta^7$ -avenasterol: maximum 3.0 per cent;

– brassicasterol: maximum 0.3 per cent.

**Water (2.5.32):** maximum 0.1 per cent, determined on 1.00 g.

## STORAGE

In a well-filled container, protected from light.

01/2010:0261

## ALMOND OIL, VIRGIN

## Amygdalae oleum virginale

## DEFINITION

Fatty oil obtained by cold expression from the ripe seeds of *Prunus dulcis* (Mill.) D.A. Webb var. *dulcis* or *Prunus dulcis* (Mill.) D.A. Webb var. *amara* (DC.) Buchheim or a mixture of both varieties.

## CHARACTERS

*Appearance*: yellow, clear liquid.

*Solubility*: slightly soluble in ethanol (96 per cent), miscible with light petroleum.

*Relative density*: about 0.916.

It solidifies at about  $-18\text{ }^{\circ}\text{C}$ .

## IDENTIFICATION

*First identification*: A, C.

*Second identification*: A, B.

A. Absorbance (see Tests).

B. Identification of fatty oils by thin-layer chromatography (2.3.2).

*Results*: the chromatogram obtained is similar to the corresponding chromatogram shown in Figure 2.3.2.-1.

C. Composition of fatty acids (see Tests).

## TESTS

**Absorbance** (2.2.25): maximum 0.2, determined at the absorption maximum at 270 nm. The ratio of the absorbance measured at 232 nm to that measured at 270 nm is greater than 7.

To 0.100 g add *cyclohexane R* and dilute to 10.0 mL with the same solvent.

**Acid value** (2.5.1): maximum 2.0, determined on 5.0 g.

**Peroxide value** (2.5.5, *Method A*): maximum 15.0.

**Unsaponifiable matter** (2.5.7): maximum 0.9 per cent, determined on 5.0 g.

**Composition of fatty acids**. (2.4.22, *Method A*). Use the mixture of calibrating substances in Table 2.4.22.-3.

*Composition of the fatty-acid fraction of the oil*:

- saturated fatty acids of chain length less than  $C_{16}$ : maximum 0.1 per cent,
- palmitic acid: 4.0 per cent to 9.0 per cent,
- palmitoleic acid: maximum 0.8 per cent,
- margaric acid: maximum 0.2 per cent,
- stearic acid: maximum 3.0 per cent,
- oleic acid: 62.0 per cent to 86.0 per cent,
- linoleic acid: 20.0 per cent to 30.0 per cent,
- linolenic acid: maximum 0.4 per cent,
- arachidic acid: maximum 0.2 per cent,
- eicosenoic acid: maximum 0.3 per cent,
- behenic acid: maximum 0.2 per cent,
- erucic acid: maximum 0.1 per cent.

**Sterols** (2.4.23).

*Composition of sterol fraction of the oil*:

- cholesterol: maximum 0.7 per cent,
- campesterol: maximum 4.0 per cent,
- stigmasterol: maximum 3.0 per cent,
- $\beta$ -sitosterol: 73.0 per cent to 87.0 per cent,

- $\Delta^5$ -avenasterol: minimum 10.0 per cent,
- $\Delta^7$ -stigmastenol: maximum 3.0 per cent,
- $\Delta^7$ -avenasterol: maximum 3.0 per cent,
- brassicasterol: maximum 0.3 per cent.

**Water** (2.5.32): maximum 0.1 per cent, determined on 1.00 g.

## STORAGE

In a well-filled container, protected from light.

01/2008:1065  
corrected 6.0

## ALPRAZOLAM

## Alprazolamum

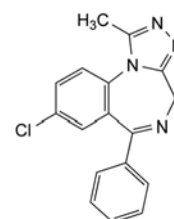

$C_{17}H_{13}ClN_4$   
[28981-97-7]

$M_r$  308.8

## DEFINITION

8-Chloro-1-methyl-6-phenyl-4H-[1,2,4]triazolo[4,3-a][1,4]-benzodiazepine.

*Content*: 99.0 per cent to 101.0 per cent (dried substance).

## CHARACTERS

*Appearance*: white or almost white, crystalline powder.

*Solubility*: practically insoluble in water, freely soluble in methylene chloride, sparingly soluble in acetone and in ethanol (96 per cent).

It shows polymorphism (5.9).

## IDENTIFICATION

*First identification*: B.

*Second identification*: A, C.

A. Dissolve the substance to be examined in the smallest necessary quantity of *ethyl acetate R* and evaporate to dryness on a water-bath. Thoroughly mix 5.0 mg of the substance to be examined with 5.0 mg of *alprazolam CRS*. The melting point (2.2.14) of the mixture does not differ by more than  $2\text{ }^{\circ}\text{C}$  from the melting point of the substance to be examined.

B. Infrared absorption spectrophotometry (2.2.24).

*Preparation*: discs.

*Comparison*: *alprazolam CRS*.

If the spectra obtained in the solid state show differences, dissolve the substance to be examined and the reference substance separately in the minimum volume of *ethyl acetate R*, evaporate to dryness on a water-bath and record new spectra using the residues.

C. Thin-layer chromatography (2.2.27).

*Test solution*. Dissolve 10 mg of the substance to be examined in *methanol R* and dilute to 10 mL with the same solvent.

*Reference solution (a)*. Dissolve 10 mg of *alprazolam CRS* in *methanol R* and dilute to 10 mL with the same solvent.

*Reference solution (b)*. Dissolve 10 mg of *alprazolam CRS* and 10 mg of *midazolam CRS* in *methanol R* and dilute to 10 mL with the same solvent.

*Plate*: TLC silica gel GF<sub>254</sub> plate *R*.

*Mobile phase*: glacial acetic acid *R*, water *R*, methanol *R*, ethyl acetate *R* (2:15:20:80 V/V/V/V).

*Application:* 5 µL.

*Development:* over a path of 12 cm.

*Drying:* in air.

*Detection:* examine in ultraviolet light at 254 nm.

*System suitability:* reference solution (b):

– the chromatogram shows 2 clearly separately spots.

*Results:* the principal spot in the chromatogram obtained with the test solution is similar in position and size to the principal spot in the chromatogram obtained with reference solution (a).

## TESTS

**Related substances.** Liquid chromatography (2.2.29).

*Buffer solution.* Dissolve 7.7 g of ammonium acetate R in 1000 mL of water R and adjust to pH 4.2 with glacial acetic acid R.

*Test solution.* Dissolve 0.100 g of the substance to be examined in dimethylformamide R and dilute to 10.0 mL with the same solvent.

*Reference solution (a).* Dissolve 2 mg of alprazolam CRS and 2 mg of triazolam CRS in dimethylformamide R and dilute to 100.0 mL with the same solvent.

*Reference solution (b).* Dilute 5.0 mL of the test solution to 100.0 mL with dimethylformamide R. Dilute 0.5 mL of this solution to 10.0 mL with dimethylformamide R.

*Column:*

- size:  $l = 0.25$  m,  $\varnothing = 4.6$  mm;
- stationary phase: phenylsilyl silica gel for chromatography R1 (5 µm).

*Mobile phase:*

- mobile phase A: buffer solution, methanol R (44:56 V/V);
- mobile phase B: buffer solution, methanol R (5:95 V/V);
- temperature: 40 °C;

Time (min)	Mobile phase A (per cent V/V)	Mobile phase B (per cent V/V)
0 - 15	98	2
15 - 35	98 → 1	2 → 99
35 - 40	1	99

*Flow rate:* 2 mL/min.

*Detection:* spectrophotometer at 254 nm.

*Injection:* 10 µL; inject dimethylformamide R as a blank.

*Retention time:* triazolam = about 9 min; alprazolam = about 10 min.

*System suitability:* reference solution (a):

- resolution: minimum 1.5 between the peaks due to triazolam and alprazolam.

*Limits:*

- total: not more than the area of the principal peak in the chromatogram obtained with reference solution (b) (0.25 per cent);
- disregard limit: 0.2 times the area of the principal peak in the chromatogram obtained with reference solution (b) (0.05 per cent).

**Loss on drying** (2.2.32): maximum 0.5 per cent, determined on 1.000 g by drying in an oven at 105 °C.

**Sulfated ash** (2.4.14): maximum 0.1 per cent, determined on 1.0 g.

## ASSAY

Dissolve 0.140 g in 50 mL of a mixture of 2 volumes of acetic anhydride R and 3 volumes of anhydrous acetic acid R.

Titrate with 0.1 M perchloric acid, determining the end-point potentiometrically (2.2.20). Titrate to the 2<sup>nd</sup> point of inflexion.

1 mL of 0.1 M perchloric acid is equivalent to 15.44 mg of C<sub>17</sub>H<sub>13</sub>ClN<sub>4</sub>.

## STORAGE

Protected from light.

## IMPURITIES

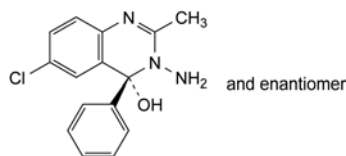

A. (4*RS*)-3-amino-6-chloro-2-methyl-4-phenyl-3,4-dihydroquinazolin-4-ol,

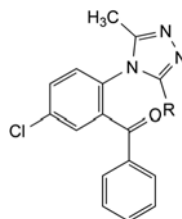

B. R = CH<sub>2</sub>OH: [5-chloro-2-[3-(hydroxymethyl)-5-methyl-4*H*-1,2,4-triazol-4-yl]phenyl]phenylmethanone,

C. R = H: [5-chloro-2-[3-methyl-4*H*-1,2,4-triazol-4-yl]phenyl]phenylmethanone,

F. R = CH<sub>2</sub>Cl: [5-chloro-2-[3-(chloromethyl)-5-methyl-4*H*-1,2,4-triazol-4-yl]phenyl]phenylmethanone,

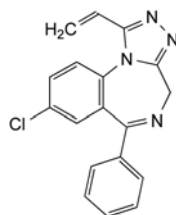

D. 8-chloro-1-ethenyl-6-phenyl-4*H*[1,2,4]triazolo[4,3-*a*][1,4]-benzodiazepine,

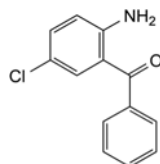

E. (2-amino-5-chlorophenyl)phenylmethanone,

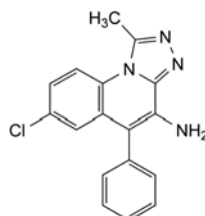

G. 7-chloro-1-methyl-5-phenyl[1,2,4]triazolo[4,3-*a*]quinolin-4-amine,

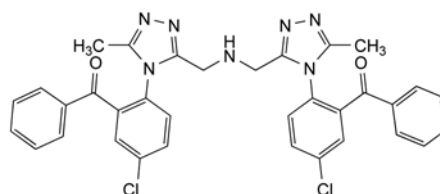

H. bis[[4-(2-benzoyl-4-chlorophenyl)-5-methyl-4*H*-1,2,4-triazol-3-yl]methyl]amine,

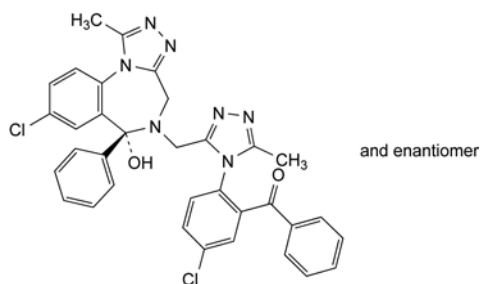

- I. [5-chloro-2-[3-[[[(6*RS*)-8-chloro-6-hydroxy-1-methyl-6-phenyl-4*H*-[1,2,4]triazolo[4,3-*a*][1,4]benzodiazepin-5(6*H*)-yl]methyl]-5-methyl-4*H*-1,2,4-triazolo-4-yl]phenyl]phenylmethanone,

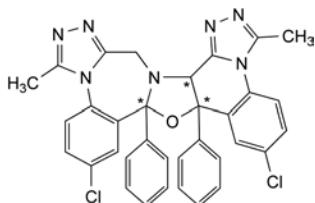

- J. 2,17-dichloro-6,13-dimethyl-18*b*,19*a*-diphenyl-8*b*,19*a*-dihydro-10*H*,18*bH*[1,2,4]triazolo[4'''',3''':1'',2'']-quinolo[3''',4''':4'',5''']oxazolo[3',2'-*d*]-1,2,4-triazolo[4,3-*a*]-[1,4]benzodiazepine.

04/2010:0876

## ALPRENOLOL HYDROCHLORIDE

## Alprenololi hydrochloridum

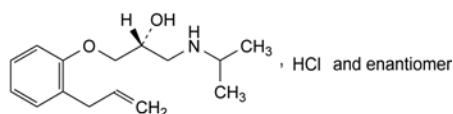

C<sub>15</sub>H<sub>24</sub>ClNO<sub>2</sub>  
[13707-88-5]

M<sub>r</sub> 285.8

## DEFINITION

(2*RS*)-1-[(1-Methylethyl)amino]-3-[2-(prop-2-enyl)phenoxy]propan-2-ol hydrochloride.

*Content*: 99.0 per cent to 101.0 per cent (dried substance).

## CHARACTERS

*Appearance*: white or almost white, crystalline powder or colourless crystals.

*Solubility*: very soluble in water, freely soluble in ethanol (96 per cent) and in methylene chloride.

## IDENTIFICATION

*First identification*: B, D.

*Second identification*: A, C, D.

A. Melting point (2.2.14): 108 °C to 112 °C.

B. Infrared absorption spectrophotometry (2.2.24).

*Comparison*: alprenolol hydrochloride CRS.

C. Examine the chromatograms obtained in the test for impurity D.

*Detection*: examine in daylight, after exposure to iodine vapour for 30 min.

*Results*: the principal spot in the chromatogram obtained with test solution (b) is similar in position, colour and size to the principal spot in the chromatogram obtained with reference solution (a).

D. It gives reaction (a) of chlorides (2.3.1).

## TESTS

**Solution S.** Dissolve 1.0 g in carbon dioxide-free water *R* and dilute to 50 mL with the same solvent.

**Appearance of solution.** Solution S is clear (2.2.1) and not more intensely coloured than reference solution B<sub>9</sub> (2.2.2, *Method II*).

**Acidity or alkalinity.** To 10 mL of solution S add 0.2 mL of methyl red solution *R* and 0.2 mL of 0.01 *M* hydrochloric acid; the solution is red. Add 0.4 mL of 0.01 *M* sodium hydroxide; the solution is yellow.

**Impurity C:** maximum 0.1 per cent.

Dissolve 0.25 g in ethanol (96 per cent) *R* and dilute to 25 mL with the same solvent. The absorbance (2.2.25) measured at 297 nm is not greater than 0.20.

**Impurity D.** Thin-layer chromatography (2.2.27).

*Test solution (a).* Dissolve 0.50 g of the substance to be examined in methanol *R* and dilute to 10 mL with the same solvent.

*Test solution (b).* Dilute 1 mL of test solution (a) to 50 mL with methanol *R*.

*Reference solution (a).* Dissolve 10 mg of alprenolol hydrochloride CRS in methanol *R* and dilute to 10 mL with the same solvent.

*Reference solution (b).* Dissolve 10 mg of alprenolol hydrochloride CRS and 10 mg of oxprenolol hydrochloride CRS in methanol *R* and dilute to 10 mL with the same solvent.

*Reference solution (c).* Dilute 5 mL of test solution (b) to 50 mL with methanol *R*.

*Plate*: TLC silica gel G plate *R*.

*Mobile phase*: place 2 beakers each containing 30 mL of ammonia *R* at the bottom of the tank containing a mixture of 5 volumes of methanol *R* and 95 volumes of ethyl acetate *R*.

*Application*: 5 µL.

*Development*: over a path of 15 cm in a tank saturated for at least 1 h.

*Drying*: at 100 °C for 15 min.

*Detection*: expose to iodine vapour for up to 6 h.

*System suitability*: reference solution (b):

– the chromatogram shows 2 clearly separated spots.

*Limits*: test solution (a):

– *impurity D*: any spot with an *R<sub>f</sub>* value greater than that of the principal spot is not more intense than the principal spot in the chromatogram obtained with reference solution (c) (0.2 per cent).

**Related substances.** Liquid chromatography (2.2.29).

*Test solution.* Dissolve 20.0 mg of the substance to be examined in the mobile phase and dilute to 10.0 mL with the mobile phase.

*Reference solution (a).* Dissolve 4.0 mg of alprenolol hydrochloride CRS and 0.8 mg of 4-isopropylphenol *R* in the mobile phase and dilute to 100.0 mL with the mobile phase.

*Reference solution (b).* Dilute 4.0 mL of the test solution to 100.0 mL with the mobile phase. Dilute 1.0 mL of this solution to 10.0 mL with the mobile phase.

*Column*:

– *size*: *l* = 0.15 m, Ø = 4 mm;

– *stationary phase*: octylsilyl silica gel for chromatography *R* (5 µm).

*Mobile phase*: mix 0.656 g of sodium octanesulfonate *R* with 150 mL of acetonitrile *R* and dilute to 500 mL with phosphate buffer pH 2.8 prepared as follows: mix 1.78 g of phosphoric acid *R* and 15.6 g of sodium dihydrogen phosphate *R* and dilute to 2000 mL with water *R*.

*Flow rate*: 1 mL/min.

*Detection*: spectrophotometer at 280 nm.

*Equilibration*: with the mobile phase for about 1 h.

*Injection*: 20 µL.

*Run time*: twice the retention time of alprenolol.

*Retention time*: alprenolol = about 11 min; 4-isopropylphenol = about 18 min.



*System suitability:* reference solution (a):

- *resolution:* minimum 5 between the peaks due to alprenolol and 4-isopropylphenol; if necessary, adjust the concentration of sodium octanesulfonate and/or acetonitrile in the mobile phase (increase the concentration of sodium octanesulfonate to increase the retention time of alprenolol and increase the concentration of acetonitrile to decrease the retention times of both compounds).

*Limits:*

- *unspecified impurities:* for each impurity, not more than 0.25 times the area of the principal peak in the chromatogram obtained with reference solution (b) (0.10 per cent);
- *total:* not more than the area of the principal peak in the chromatogram obtained with reference solution (b) (0.4 per cent);
- *disregard limit:* 0.1 times the area of the principal peak in the chromatogram obtained with reference solution (b) (0.04 per cent).

**Heavy metals (2.4.8):** maximum 10 ppm.

Dissolve 2.0 g in 20 mL of *water R*. 12 mL of the solution complies with test A. Prepare the reference solution using *lead standard solution (1 ppm Pb) R*.

**Loss on drying (2.2.32):** maximum 0.5 per cent, determined on 1.000 g by drying over *diphosphorus pentoxide R* at a pressure not exceeding 2.7 kPa.

**Sulfated ash (2.4.14):** maximum 0.1 per cent, determined on 1.0 g.

#### ASSAY

Dissolve 0.400 g in 25 mL of a mixture of equal volumes of *anhydrous ethanol R* and *water R*. Add 10 mL of 0.01 M *hydrochloric acid*. Carry out a potentiometric titration (2.2.20), using 0.1 M *sodium hydroxide*. Read the volume added between the 2 points of inflexion.

1 mL of 0.1 M *sodium hydroxide* is equivalent to 28.58 mg of  $C_{20}H_{34}O_5$ .

#### STORAGE

Protected from light.

#### IMPURITIES

*Specified impurities:* C, D.

*Other detectable impurities* (the following substances would, if present at a sufficient level, be detected by one or other of the tests in the monograph. They are limited by the general acceptance criterion for other/unspecified impurities and/or by the general monograph *Substances for pharmaceutical use (2034)*. It is therefore not necessary to identify these impurities for demonstration of compliance. See also 5.10. *Control of impurities in substances for pharmaceutical use*): A, B.

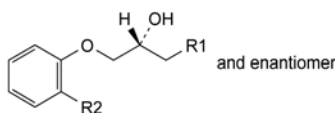

- A. R1 = OH, R2 =  $CH_2-CH=CH_2$ : (2*RS*)-3-[2-(prop-2-enyl)phenoxy]propan-1,2-diol,
- C. R1 =  $NH-CH(CH_3)_2$ , R2 =  $CH=CH-CH_3$ : (2*RS*)-1-[(1-methylethyl)amino]-3-[2-(prop-1-enyl)phenoxy]propan-2-ol,

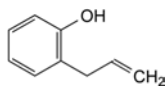

- B. 2-(prop-2-enyl)phenol,

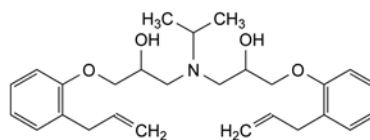

- D. 1,1'-[(1-methylethyl)imino]bis[3-[2-(prop-2-enyl)phenoxy]propan-2-ol].

01/2008:1488

## ALPROSTADIL

### Alprostadium

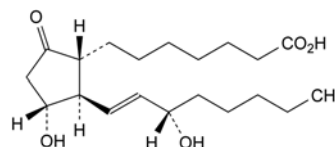

$C_{20}H_{34}O_5$   
[745-65-3]

$M_r$  354.5

#### DEFINITION

7-[(1*R*,2*R*,3*R*)-3-Hydroxy-2-[(1*E*,3*S*)-3-hydroxyoct-1-enyl]-5-oxocyclopentyl]heptanoic acid.

*Content:* 95.0 per cent to 102.5 per cent (anhydrous substance).

#### CHARACTERS

*Appearance:* white or slightly yellowish, crystalline powder.

*Solubility:* practically insoluble in water, freely soluble in alcohol, soluble in acetone, slightly soluble in ethyl acetate.

#### IDENTIFICATION

- A. Specific optical rotation (2.2.7):  $-60$  to  $-70$  (anhydrous substance).

Immediately before use, dissolve 50 mg in *alcohol R* and dilute to 10.0 mL with the same solvent.

- B. Infrared absorption spectrophotometry (2.2.24).

*Preparation:* discs.

*Comparison:* *alprostadiil CRS*.

- C. Examine the chromatograms obtained in the assay.

*Results:* the principal peak in the chromatogram obtained with the test solution is similar in retention time and size to the principal peak in the chromatogram obtained with the reference solution.

#### TESTS

**Related substances.** Liquid chromatography (2.2.29). *Prepare the solutions protected from light.*

*Test solution.* Dissolve 10.0 mg of the substance to be examined in a mixture of equal volumes of *acetonitrile R1* and *water R* and dilute to 10.0 mL with the same mixture of solvents.

*Reference solution (a).* Dilute 100  $\mu$ L of the test solution to 20.0 mL with a mixture of equal volumes of *acetonitrile R1* and *water R*.

*Reference solution (b).* Dissolve 1.0 mg of *dinoprostone impurity C CRS* (alprostadiil impurity H) and 1.0 mg of *alprostadiil CRS* in a mixture of equal volumes of *acetonitrile R1* and *water R* and dilute to 20.0 mL with the same mixture of solvents.

*Reference solution (c).* In order to prepare *in situ* the degradation compounds (impurity A and impurity B), dissolve 1 mg of the substance to be examined in 100  $\mu$ L of 1 M *sodium hydroxide* (the solution becomes brownish-red), wait for 3 min and add 100  $\mu$ L of 1 M *phosphoric acid* (yellowish-white opalescent solution); dilute to 5.0 mL with a mixture of equal volumes of *acetonitrile R1* and *water R*.

**System A****Column:**

- size:  $l = 0.25$  m,  $\varnothing = 4.0$  mm,
- stationary phase: octylsilyl base-deactivated silica gel for chromatography R ( $4 \mu\text{m}$ ) with a pore size of 6 nm,
- temperature:  $35^\circ\text{C}$ .

**Mobile phase:**

- mobile phase A. Dissolve 3.9 g of sodium dihydrogen phosphate R in water R and dilute to 1000.0 mL with the same solvent; adjust to pH 2.5 with a 2.9 g/L solution of phosphoric acid R (approximately 600 mL is required); to 740 mL of the buffer solution add 260 mL of acetonitrile R1;
- mobile phase B. Dissolve 3.9 g of sodium dihydrogen phosphate R in water R and dilute to 1000.0 mL with the same solvent; adjust to pH 2.5 with a 2.9 g/L solution of phosphoric acid R (approximately 600 mL is required); to 200 mL of the buffer solution add 800 mL of acetonitrile R1;

Time (min)	Mobile phase A (per cent V/V)	Mobile phase B (per cent V/V)
0 - 75	100	0
75 - 76	100 → 0	0 → 100
76 - 86	0	100
86 - 87	0 → 100	100 → 0
87 - 102	100	0

Flow rate: 1 mL/min.

Detection: spectrophotometer at 200 nm.

Injection: 20  $\mu\text{L}$  loop injector.

**System suitability:**

- retention time: alprostadil = about 63 min,
- resolution: minimum of 1.5 between the peaks due to impurity H and alprostadil in the chromatogram obtained with reference solution (b).

**System B**

Use the same conditions as for system A with the following mobile phase and elution programme:

- mobile phase A. Dissolve 3.9 g of sodium dihydrogen phosphate R in water R and dilute to 1000.0 mL with the same solvent; adjust to pH 2.5 with a 2.9 g/L solution of phosphoric acid R (approximately 600 mL is required); to 600 mL of the buffer solution add 400 mL of acetonitrile R1;
- mobile phase B. Use mobile phase B as described under system A;

Time (min)	Mobile phase A (per cent V/V)	Mobile phase B (per cent V/V)
0 - 50	100	0
50 - 51	100 → 0	0 → 100
51 - 61	0	100
61 - 62	0 → 100	100 → 0
62 - 72	100	0

**System suitability:**

- relative retentions with reference to alprostadil (retention time = about 7 min): impurity A = about 2.4; impurity B = about 2.6,
- resolution: minimum of 1.5 between the peaks due to impurity A and impurity B in the chromatogram obtained with reference solution (c).

Carry out the test according to system A and B.

**Limits:**

- correction factors: multiply the areas of the corresponding peaks using the correction factors in Table 1488.-1 to obtain the corrected areas,

Table 1488.-1

Impurity	Relative retention (system A)	Relative retention (system B)	Correction factor
impurity G	0.80	-	0.7
impurity F	0.88	-	0.8
impurity D	0.90	-	1.0
impurity H	0.96	-	0.7
impurity E	1.10	-	0.7
impurity C	-	1.36	1.9
impurity K	-	1.85	0.06
impurity A	-	2.32	0.7
impurity B	-	2.45	1.5
impurity I	-	4.00	1.0
impurity J	-	5.89	1.0

- impurity A (corrected area): not more than 3 times the area of the principal peak in the chromatogram obtained with reference solution (a) (1.5 per cent),
- impurity B (corrected area): not more than the area of the principal peak in the chromatogram obtained with reference solution (a) (0.5 per cent),
- any other impurity (corrected area): not more than 1.8 times the area of the principal peak in the chromatogram obtained with reference solution (a) (0.9 per cent), and not more than 1 such peak has an area greater than the area of the principal peak in the chromatogram obtained with reference solution (a) (0.5 per cent). Evaluate impurities appearing at relative retentions less than 1.2 by system A and impurities appearing at relative retentions greater than 1.2 by system B,
- total (corrected area): not more than 3 times the area of the principal peak in the chromatogram obtained with reference solution (a) (1.5 per cent),
- disregard limit: 0.1 times the area of the principal peak in the chromatogram obtained with reference solution (a) (0.05 per cent).

**Water** (2.5.32): maximum 0.5 per cent, determined on 50 mg.

**ASSAY**

Liquid chromatography (2.2.29) as described in the test for related substances, system A. Prepare the solutions protected from light.

**Test solution.** Dissolve 10.0 mg of the substance to be examined in a mixture of equal volumes of acetonitrile R1 and water R and dilute to 25.0 mL with the same mixture of solvents. Dilute 3.0 mL of the solution to 20.0 mL with a mixture of equal volumes of acetonitrile R1 and water R.

**Reference solution.** Dissolve 10.0 mg of alprostadil CRS in a mixture of equal volumes of acetonitrile R1 and water R and dilute to 25.0 mL with the same mixture of solvents. Dilute 3.0 mL of the solution to 20.0 mL with a mixture of equal volumes of acetonitrile R1 and water R.

Injection: 20  $\mu\text{L}$ .

Calculate the percentage content of  $\text{C}_{20}\text{H}_{34}\text{O}_5$ .

**STORAGE**

At a temperature of  $2^\circ\text{C}$  to  $8^\circ\text{C}$ .

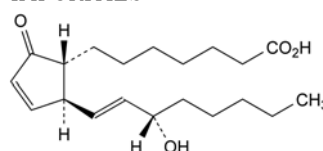
**IMPURITIES**

- A. 7-[(1R,2S)-2-[(1E,3S)-3-hydroxyoct-1-enyl]-5-oxocyclopent-3-enyl]heptanoic acid (prostaglandin A<sub>1</sub>),

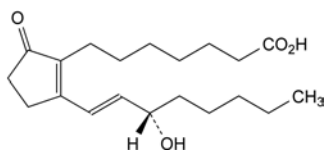

B. 7-[2-[(1E,3S)-3-hydroxyoct-1-enyl]-5-oxocyclopent-1-enyl]heptanoic acid (prostaglandin B<sub>1</sub>),

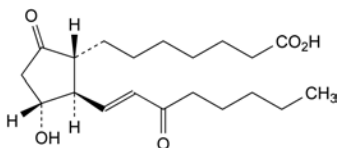

C. 7-[(1R,2R,3R)-3-hydroxy-2-[(1E)-3-oxooct-1-enyl]-5-oxocyclopentyl]heptanoic acid (15-oxoprostaglandin E<sub>1</sub>),

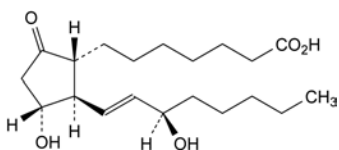

D. 7-[(1R,2R,3R)-3-hydroxy-2-[(1E,3R)-3-hydroxyoct-1-enyl]-5-oxocyclopentyl]heptanoic acid (15-epiprostaglandin E<sub>1</sub>),

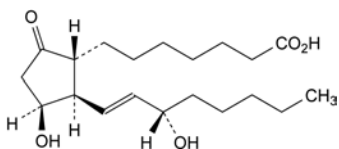

E. 7-[(1R,2R,3S)-3-hydroxy-2-[(1E,3S)-3-hydroxyoct-1-enyl]-5-oxocyclopentyl]heptanoic acid (11-epiprostaglandin E<sub>1</sub>),

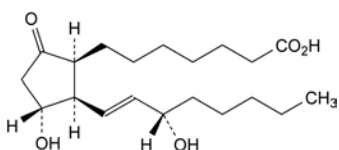

F. 7-[(1S,2R,3R)-3-hydroxy-2-[(1E,3S)-3-hydroxyoct-1-enyl]-5-oxocyclopentyl]heptanoic acid (8-epiprostaglandin E<sub>1</sub>),

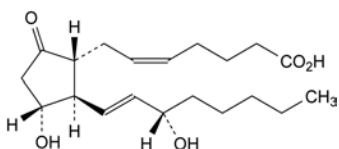

G. (5Z)-7-[(1R,2R,3R)-3-hydroxy-2-[(1E,3S)-3-hydroxyoct-1-enyl]-5-oxocyclopentyl]hept-5-enoic acid (dinoprostone),

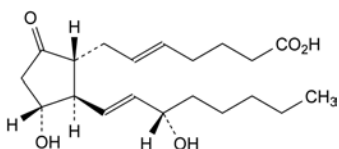

H. (5E)-7-[(1R,2R,3R)-3-hydroxy-2-[(1E,3S)-3-hydroxyoct-1-enyl]-5-oxocyclopentyl]hept-5-enoic acid ((5E)-prostaglandin E<sub>2</sub>),

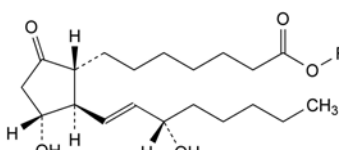

I. R = CH<sub>2</sub>CH<sub>3</sub>: ethyl 7-[(1R,2R,3R)-3-hydroxy-2-[(1E,3S)-3-hydroxyoct-1-enyl]-5-oxocyclopentyl]heptanoate (prostaglandin E<sub>1</sub>, ethyl ester),

J. R = CH(CH<sub>3</sub>)<sub>2</sub>: 1-methylethyl 7-[(1R,2R,3R)-3-hydroxy-2-[(1E,3S)-3-hydroxyoct-1-enyl]-5-oxocyclopentyl]heptanoate (prostaglandin E<sub>1</sub>, isopropyl ester),

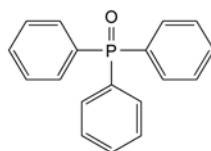

K. triphenylphosphine oxide.

01/2008:1170

## ALTEPLASE FOR INJECTION

### Alteplasmum ad iniectabile



### DEFINITION

Alteplase for injection is a sterile, freeze-dried preparation of alteplase, a tissue plasminogen activator produced by recombinant DNA technology. It has a potency of not less than 500 000 IU per milligram of protein.

Tissue plasminogen activator binds to fibrin clots and activates plasminogen, leading to the generation of plasmin and to the degradation of fibrin clots or blood coagulates.

Alteplase consists of 527 amino acids with a calculated relative molecular mass of 59 050 without consideration of the carbohydrate moieties attached at positions Asn 117, Asn 184 and Asn 448. The total relative molecular mass is approximately 65 000. Alteplase is cleaved by plasmin between amino-acids 275 and 276 into a two-chain form (A chain and B chain) that are connected by a disulfide bridge between Cys 264 and Cys 395. The single-chain form and the two-chain form show comparable fibrinolytic activity *in vitro*.

### PRODUCTION

Alteplase is produced by recombinant DNA synthesis in cell culture; the fermentation takes place in serum-free medium.

The purification process is designed to remove efficiently potential impurities, such as antibiotics, DNA and protein contaminants derived both from the host cell and from the production medium, and potential viral contaminants.

If alteplase is stored in bulk form, stability (maintenance of potency) in the intended storage conditions must be demonstrated.

The production, purification and product consistency are checked by a number of analytical methods described below, carried out routinely as in-process controls.

**Protein content.** The protein concentration of alteplase solutions is determined by measuring the absorbance (2.2.25) of the protein solution at 280 nm and at 320 nm, using formulation buffer as the compensation liquid. If dilution of alteplase samples is necessary, the samples are diluted in formulation

buffer. For the calculation of the alteplase concentration the absorbance value ( $A_{280} - A_{320}$ ) is divided by the specific absorption coefficient for alteplase of 1.9.

**Potency.** The potency of alteplase is determined in an *in-vitro* clot-lysis assay as described under Assay. The specific activity of bulk alteplase is approximately 580 000 IU per milligram of alteplase.

**N-terminal sequence.** N-terminal sequencing is applied to determine the correct N-terminal sequence and to determine semiquantitatively additional cleavage sites in the alteplase molecule, for example at position AA 275-276 or at position AA 27-28. The N-terminal sequence must conform with the sequence of human tissue plasminogen activator.

**Isoelectric focusing.** The consistency in the microheterogeneity of glycosylation of the alteplase molecule can be demonstrated by isoelectric focusing (IEF). A complex banding pattern with ten major and several minor bands in the pH range 6.5-8.5 is observed. Denaturing conditions are applied to achieve a good separation of differently charged variants of alteplase. The broad charge distribution observed is due to a population of molecules, which differ in the fine structure of biantennary and triantennary complex-type carbohydrate residues, with different degrees of substitution with sialic acids. The banding pattern of alteplase test samples must be consistent with the pattern of alteplase reference standard.

**Single-chain alteplase content.** The alteplase produced by CHO (Chinese hamster ovary) cells in serum-free medium is predominantly single-chain alteplase. The single-chain form can be separated from the two-chain form by gel-permeation liquid chromatography under reducing conditions as described under Single-chain content (see Tests). The single-chain alteplase content in bulk samples must be higher than 60 per cent.

**Tryptic-peptide mapping.** The primary structure of the alteplase molecule is verified by tryptic-peptide mapping as described under Identification B. The reduced and carboxymethylated molecule is cleaved by trypsin into about fifty peptides, which are separated by reverse-phase liquid chromatography. A characteristic chromatogram (fingerprint) is obtained. The identity of the tryptic-peptide map of a given alteplase sample with the profile of a well-characterised reference standard is an indirect confirmation of the amino-acid sequence, because even single amino-acid exchanges in individual peptides can be detected by this sensitive technique. In addition, complex peaks of the glycopeptides can be isolated from the tryptic-peptide map and separated in a second dimension, either by reverse-phase liquid chromatography under modified conditions or by capillary electrophoresis. By this two-dimensional separation of glycopeptide variants, lot-to-lot consistency of the microheterogeneity of glycosylation can be demonstrated.

The tryptic-peptide map of alteplase samples must be consistent with the tryptic-peptide map of alteplase reference standard.

**Monomer content.** The monomer content of alteplase is measured by gel-permeation liquid chromatography under non-reduced conditions as described under Monomer content (see Tests). The monomer content of alteplase bulk samples must be higher than 95 per cent.

**Type I/Type II alteplase content.** CHO cells produce two glycosylation variants of alteplase. Type I alteplase contains one polymannose-type glycosylation at position Asn 117 and two complex-type glycosylation sites at positions Asn 184 and Asn 448. Type II alteplase is only glycosylated at positions Asn 117 and Asn 448.

The ratio of Type I/Type II alteplase is constant in the range of 45 to 65 per cent of Type I and 35 to 55 per cent of Type II. The content of alteplase Type I and Type II can be determined by a densitometric scan of SDS-PAGE (sodium dodecyl sulfate polyacrylamide gel electrophoresis) gel. Plasmin-treated samples of alteplase, which are reduced and carboxymethylated before loading on the gel, are separated into three bands: Type I alteplase A-chain (AA 1-275), Type II alteplase A-chain

(AA 1-275) and alteplase B-chain (AA 276-527). The ratio of Type I/Type II alteplase is determined from a calibration curve, which is obtained by a densitometric scan of defined mixtures of purified Type I alteplase and Type II alteplase standards.

**SDS-PAGE.** SDS-PAGE (silver staining) is used to demonstrate purity of the alteplase bulk material and the integrity of the alteplase molecule. For alteplase bulk samples, no additional protein bands compared to reference standard or degradation products must occur in SDS-PAGE gels at a loading amount of 2.5 µg alteplase protein per lane and a limit of detection of 5 ng per protein (BSA) band.

**Bacterial endotoxins (2.6.14):** less than 1 IU per milligram of alteplase.

**Sialic acids.** Dialyse samples and alteplase reference standard against enzyme buffer (8.9 g/L *sodium chloride R*, 4.1 g/L *sodium acetate R*, pH 5.5) using a membrane with a cut-off point corresponding to a relative molecular mass of 10 000 for globular proteins. After dialysis, determine the protein concentration. Add 5 µL of calcium chloride solution (19.98 per cent *m/m calcium chloride R*) to 1 mL of protein solution. Add 10 milliunits of neuraminidase per milligram of protein. Incubate this solution at 37 °C for about 17 h.

Prepare standard dilutions between 1.56 mg/mL and 25.0 mg/mL from an *N-acetylneuraminic acid R* reference stock solution with a concentration of 50 mg/mL. Pipette 0.2 mL of the sample and of the protein reference standard in duplicate into reagent tubes. Pipette also 0.2 mL of the standard dilutions into reagent tubes. Add 0.25 mL of periodate reagent (5.4 g/L solution of *sodium periodate R* in a 1.25 per cent *V/V* solution of *sulfuric acid R*), mix and incubate for 30 min at 37 °C. Add 0.2 mL of arsenite reagent (20 g/L solution of *sodium arsenite R* in a 1.55 per cent *V/V* solution of *hydrochloric acid R*) and mix. A yellowish-brown colour develops and disappears. Add 2.0 mL of a 28.9 g/L solution of *thioibarbituric acid R* and mix. Heat the closed tubes in boiling water for 7.5 min and then cool them in an ice-bath for 5 min. Add 2.0 mL of a mixture of *butanol R* and *hydrochloric acid R* (95:5) and mix. Centrifuge the tubes at 3000 r/min for 3 min. Measure the absorbance of the butanol-HCl layer at 552 nm within 30 min using the butanol-HCl mixture as the compensation solution. Perform a linear-regression analysis for the *N-acetylneuraminic acid* standard. The molar content of *N-acetylneuraminic acid* for the samples and for alteplase reference standard is calculated from the calibration curve. The sialic acids content for the test samples must be within the range 70 to 130 per cent of alteplase reference standard, which contains about 3 moles of sialic acids per mole of alteplase.

**Neutral sugars.** Dilute alteplase samples and the reference standard in the assay buffer, containing 34.8 g/L of *arginine R*, 0.1 g/L of *polyisorbate 80 R* and adjusted to pH 7.4 with *phosphoric acid R*, to a protein concentration of 50 µg/mL. Prepare the following concentrations of mannose in the same assay buffer for a calibration curve: 20, 30, 40, 50 and 60 µg/mL. Pipette 2 mL of alteplase samples and reference standard, as well as 2 mL of each mannose concentration in duplicate in reagent tubes. Add 50 µL of *phenol R*, followed by 5 mL of *sulfuric acid R* in each reagent tube. Incubate the mixture for 30 min at room temperature. Measure the absorbance at 492 nm for each tube. Read the content of neutral sugars from the mannose calibration curve. The neutral sugar content is expressed in moles of neutral sugar per mole of alteplase, taking into account the dilution factor for alteplase samples and reference standard and using a relative molecular mass of 180.2 for mannose and a relative molecular mass of 59 050 for the alteplase protein moiety. The neutral sugar content of the alteplase samples must be in the range of 70 to 130 per cent compared to alteplase reference standard, which contains about 12 moles of neutral sugar per mole of alteplase.

#### CHARACTERS

A white or slightly yellow powder or solid friable mass.

Reconstitute the preparation as stated on the label immediately before carrying out the Identification, Tests (except those for solubility and water) and Assay.

## IDENTIFICATION

- A. The assay serves also to identify the preparation.  
 B. Tryptic-peptide mapping. Examine by liquid chromatography (2.2.29).

**Test solution.** Dilute the preparation to be examined with water R to obtain a solution containing about 1 mg of alteplase per millilitre. Dialyse about 2.5 mL of the solution for at least 12 h into a solution containing 480 g/L of urea R, 44 g/L of tris(hydroxymethyl)aminomethane R and 1.5 g/L of disodium edetate R and adjusted to pH 8.6, using a membrane with a cut-off point corresponding to a relative molecular mass of 10 000 for globular proteins. Measure the volume of the solution, transfer it to a clean test-tube and add per millilitre 10 µL of a 156 g/L solution of dithiothreitol R. Allow to stand for 4 h, cool in iced water and add per millilitre of solution 25 µL of a freshly prepared 190 g/L solution of iodoacetic acid R. Allow to stand in the dark for 30 min. Add per millilitre 50 µL of dithiothreitol solution to stop the reaction. Dialyse for 24 h against an 8 g/L solution of ammonium hydrogen carbonate R. Add 1 part of trypsin for peptide mapping R to 100 parts of the protein and allow to stand for 6 h to 8 h. Repeat the addition of trypsin and allow to stand for a total of 24 h.

**Reference solution.** Prepare as for the test solution using a suitable reference standard instead of the preparation to be examined.

The chromatographic procedure may be carried out using:

- a column 0.1 m long and 4.6 mm in internal diameter packed with octadecylsilyl silica gel for chromatography R (5 µm to 10 µm);

**Mobile phase A.** A 8 g/L solution of sodium dihydrogen phosphate R, adjusted to pH 2.85 with phosphoric acid R, filtered and degassed;

**Mobile phase B.** Acetonitrile R 75 per cent V/V in mobile phase A;

- as detector a spectrophotometer set at 210 nm.

Equilibrate the system with mobile phase A at a flow rate of 1 mL/min. After injection of the solution, increase the proportion of mobile phase B at a rate of 0.44 per cent per minute until the ratio of mobile phase A to mobile phase B is 60:40, then increase the proportion of mobile phase B at a rate of 1.33 per cent per minute until the ratio of mobile phase A to mobile phase B is 20:80 and then continue elution with this mixture for a further 10 min. Record the chromatogram for the reference solution: the test is not

valid unless the resolution of peaks 6 (peptides 268-275) and 7 (peptides 1-7) is at least 1.5;  $b_{0.5a}$  and  $b_{0.5b}$  are not more than 0.4 min. Inject about 100 µL of the test solution and record the chromatogram. Verify the identity of the peaks by comparison with the chromatograms of the reference solution. There should not be any additional significant peaks or shoulders, a significant peak or shoulder being defined as one with an area response equal to or greater than 5 per cent of peak 19 (peptides 278-296); no significant peak is missing. A type chromatogram for identification of the peaks cited is given at the end of the monograph (see Figure 1170-1).

## TESTS

**Appearance of solution.** The reconstituted preparation is clear (2.2.1) and not more intensely coloured than reference solution Y<sub>7</sub> (2.2.2, Method II).

**pH (2.2.3):** 7.1 to 7.5.

**Solubility.** Add the volume of the liquid stated on the label. The preparation dissolves completely within 2 min at 20 °C to 25 °C.

**Protein content.** Prepare a solution of the substance to be examined with an accurately known concentration of about 1 g/L. Using a 34.8 g/L solution of arginine R adjusted to pH 7.3 with phosphoric acid R, dilute an accurately measured volume of the solution of the substance to be examined so that the absorbance measured at the maximum at about 280 nm is 0.5 to 1.0 (test solution). Measure the absorbance (2.2.25) of the solution at the maximum at about 280 nm and at 320 nm using the arginine solution as the compensation liquid. Calculate the protein content in the portion of alteplase taken from the following expression:

$$\frac{V(A_{280} - A_{320})}{1.9}$$

in which  $V$  is the volume of arginine solution required to prepare the test solution,  $A_{280}$  is the absorbance at the maximum at about 280 nm and  $A_{320}$  is the absorbance at 320 nm.

**Single-chain content.** Examine by liquid chromatography (2.2.29).

**Test solution.** Dissolve the preparation to be examined in water R to obtain a solution containing about 1 mg of alteplase per millilitre. Place about 1 mL of the solution in a tube, add 3 mL of a 3 g/L solution of dithiothreitol R in the mobile phase, place a cap on the tube and heat at about 80 °C for 3 min to 5 min.

The chromatographic procedure may be carried out using:

- a column 0.6 m long and 7.5 mm in internal diameter packed with silica-based rigid, hydrophilic gel with spherical particles 10 µm to 13 µm in diameter, suitable for size-exclusion chromatography;

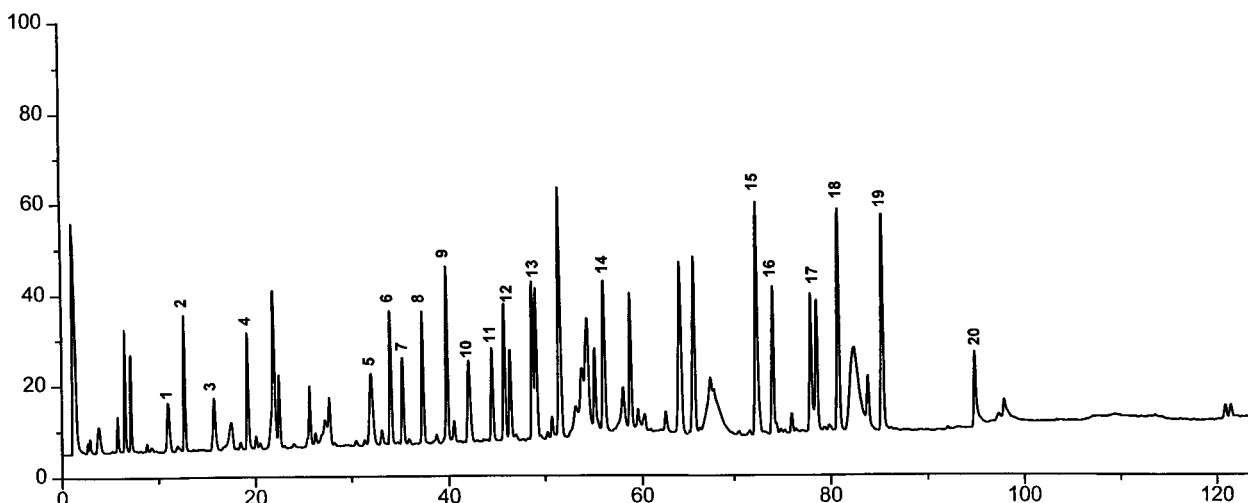

Figure 1170-1. – Chromatogram for tryptic-peptide mapping of alteplase

- as mobile phase at a flow rate of 0.5 mL/min a solution containing 30 g/L of *sodium dihydrogen phosphate R* and 1 g/L of *sodium dodecyl sulfate R*, adjusted to pH 6.8 with *dilute sodium hydroxide solution R*;
- as detector a spectrophotometer set at 214 nm.

Inject about 50 µL of the test solution and record the chromatogram. The chromatogram shows two major peaks corresponding to single-chain and two-chain alteplase. Calculate the relative amount of single-chain alteplase from the peak area values.

The test is not valid unless: the number of theoretical plates calculated on the basis of the single-chain alteplase peak is at least 1000. The content of single-chain alteplase is not less than 60 per cent of the total amount of alteplase-related substances found.

**Monomer content.** Examine by liquid chromatography (2.2.29).

**Test solution.** Reconstitute the preparation to be examined to obtain a solution containing about 1 mg per millilitre.

The chromatographic procedure may be carried out using:

- a column 0.6 m long and 7.5 mm in internal diameter packed with silica-based rigid, hydrophilic gel with spherical particles 10 µm to 13 µm in diameter, suitable for size-exclusion chromatography;
- as mobile phase at a flow rate of 0.5 mL/min a solution containing 30 g/L of *sodium dihydrogen phosphate R* and 1 g/L of *sodium dodecyl sulfate R*, adjusted to pH 6.8 with *dilute sodium hydroxide solution R*;
- as detector a spectrophotometer set at 214 nm.

Inject the test solution and record the chromatogram. The test is not valid unless the number of theoretical plates calculated for the alteplase monomer peak is at least 1000. Measure the response for all peaks, i.e. peaks corresponding to alteplase species of different molecular masses. Calculate the relative content of monomer from the area values of these peaks. The monomer content for alteplase must be at least 95 per cent.

**Water (2.5.12).** Not more than 4.0 per cent, determined by the semi-micro determination of water.

**Bacterial endotoxins (2.6.14):** less than 1 IU per milligram of protein.

**Sterility (2.6.1).** It complies with the test for sterility.

## ASSAY

The potency of alteplase is determined by comparing its ability to activate plasminogen to form plasmin with the same capacity of a reference preparation calibrated in International Units. The formation of plasmin is measured by the determination of the lysis time of a fibrin clot in given conditions.

The International Unit is the activity of a stated quantity of the International Standard of alteplase. The equivalence in International Units of the International Standard is stated by the World Health Organisation.

**Solvent buffer.** A solution containing 1.38 g/L of *sodium dihydrogen phosphate monohydrate R*, 7.10 g/L of *anhydrous disodium hydrogen phosphate R*, 0.20 g/L of *sodium azide R* and 0.10 g/L of *polysorbate 80 R*.

**Human thrombin solution.** A solution of *human thrombin R* containing 33 IU/mL in solvent buffer.

**Human fibrinogen solution.** A 2 g/L solution of *fibrinogen R* in solvent buffer.

**Human plasminogen solution.** A 1 g/L solution of *human plasminogen R* in solvent buffer.

**Test solutions.** Using a solution of the substance to be examined containing 1 g/L, prepare serial dilutions using solvent buffer, for example 1:5000, 1:10 000, 1:20 000.

**Reference solutions.** Using a solution of a suitable reference standard having an accurately known concentration of about 1 g/L (580 000 IU of alteplase per millilitre), prepare five serial dilutions using *water R* to obtain reference solutions having known concentrations in the range 9.0 IU/mL to 145 IU/mL.

To each of a set of labelled glass test-tubes, add 0.5 mL of human thrombin solution. Allocate each test and reference solution to a separate tube and add to each tube 0.5 mL of the solution allocated to it. To each of a second set of labelled glass tubes, add 20 µL of human plasminogen solution, and 1 mL of human fibrinogen solution, mix and store on ice. Beginning with the reference/thrombin mixture containing the lowest number of International Units per millilitre, record the time and separately add 200 µL of each of the thrombin mixtures to the test tubes containing the plasminogen-fibrinogen mixture. Using a vortex mixer, intermittently mix the contents of each tube for a total of 15 s and carefully place in a rack in a circulating water-bath at 37 °C. A visibly turbid clot forms within 30 s and bubbles subsequently form within the clot. Record the clot-lysis time as the time between the first addition of alteplase solution and the moment when the last bubble rises to the surface. Using a least-squares fit, determine the equation of the line using the logarithms of the concentrations of the reference preparation in International Units per millilitre versus the logarithms of the values of their clot-lysis times in seconds, according to the following equation:

$$\log t = a + b (\log U_s)$$

in which  $t$  is the clot-lysis time,  $U_s$  the activity in International Units per millilitre of the reference preparation,  $b$  is the slope and  $a$  the  $y$ -intercept of the line. The test is not valid unless the correlation coefficient is  $-0.9900$  to  $-1.0000$ . From the line equation and the clot-lysis time for the test solution, calculate the logarithm of the activity  $U_A$  from the following equation:

$$\log U_A = \frac{[(\log t) - a]}{b}$$

Calculate the alteplase activity in International Units per millilitre from the following expression:

$$D \times U_A$$

in which  $D$  is the dilution factor for the test solution. Calculate the specific activity in the portion of the substance to be examined from the following expression:

$$\frac{U_A}{P}$$

in which  $P$  is the concentration of protein obtained in the test for protein content.

The estimated potency is not less than 90 per cent and not more than 110 per cent of the stated potency.

## STORAGE

Store in a colourless, glass container, under vacuum or under an inert gas, protected from light, at a temperature of 2 °C to 30 °C.

## LABELLING

The label states:

- the number of International Units per container;
- the amount of protein per container.

## ALTIZIDE

## Altizidum

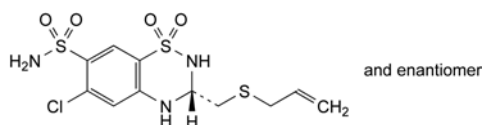

$C_{11}H_{14}ClN_3O_4S_3$   
[5588-16-9]

$M_r$  383.9

## DEFINITION

(3*RS*)-6-Chloro-3-[(prop-2-enylsulfanyl)methyl]-3,4-dihydro-2*H*-1,2,4-benzothiadiazine-7-sulfonamide 1,1-dioxide.

*Content*: 97.5 per cent to 102.0 per cent (anhydrous substance).

## CHARACTERS

*Appearance*: white or almost white powder.

*Solubility*: practically insoluble in water, soluble in methanol, practically insoluble in dichloromethane.

It shows polymorphism (5.9).

## IDENTIFICATION

Infrared absorption spectrophotometry (2.2.24).

*Comparison*: altizide CRS.

If the spectra obtained show differences, dissolve 50 mg of the substance to be examined and 50 mg of the reference substance separately in 2 mL of *acetone R* and evaporate the solvent. Precipitate by adding 1 mL of *methylene chloride R*. Evaporate to dryness and record new spectra using the residues.

## TESTS

**Impurity B.** Thin-layer chromatography (2.2.27).

*Test solution.* Dissolve 0.200 g of the substance to be examined in *acetone R* and dilute to 2.0 mL with the same solvent.

*Reference solution (a).* Dissolve 10.0 mg of *altizide impurity B CRS* in *acetone R* and dilute to 25.0 mL with the same solvent.

*Reference solution (b).* To 1.0 mL of reference solution (a) add 1.0 mL of the test solution.

*Reference solution (c).* Dilute 5.0 mL of reference solution (a) to 10.0 mL with *acetone R*.

*Plate*: TLC silica gel  $F_{254}$  plate *R*.

*Mobile phase*: *acetone R*, *methylene chloride R* (25:75 *V/V*).

*Application*: 10  $\mu$ L of the test solution and reference solutions (b) and (c).

*Development*: over 2/3 of the plate.

*Drying*: in air.

*Detection*: spray with a mixture of equal volumes of a 10 g/L solution of *potassium permanganate R* and a 50 g/L solution of *sodium carbonate R*, prepared immediately before use. Allow to stand for 30 min and examine in daylight.

*System suitability*: reference solution (b):

– the chromatogram shows 2 clearly separated spots.

*Limit*: any spot due to impurity B is not more intense than the principal spot in the chromatogram obtained with reference solution (c) (0.2 per cent).

**Related substances.** Liquid chromatography (2.2.29). Prepare the solutions immediately before use, except reference solution (b).

*Test solution.* Dissolve 50 mg of the substance to be examined in 5 mL of *acetonitrile R* and dilute to 25 mL with the mobile phase.

**07/2008:2185** *Reference solution (a).* Dilute 1.0 mL of the test solution to 100.0 mL with the mobile phase. Dilute 1.0 mL of this solution to 10.0 mL with the mobile phase.

*Reference solution (b).* In order to produce impurity A *in situ*, dissolve 50 mg of the substance to be examined in 5 mL of *acetonitrile R* and dilute to 25 mL with *water R*. Allow to stand for 30 min.

*Reference solution (c).* Dissolve 4 mg of *furosemide CRS* in 2 mL of *acetonitrile R*, add 2 mL of the test solution and dilute to 100 mL with the mobile phase.

*Column*:

– *size*:  $l = 0.15$  m,  $\varnothing = 3.9$  mm;

– *stationary phase*: end-capped octadecylsilyl silica gel for chromatography *R* (5  $\mu$ m);

– *temperature*: 30 °C.

*Mobile phase*: *acetonitrile R*, *water R* previously adjusted to pH 2.0 with *perchloric acid R* (25:75 *V/V*).

*Flow rate*: 0.7 mL/min.

*Detection*: spectrophotometer at 270 nm.

*Injection*: 5  $\mu$ L.

*Run time*: twice the retention time of altizide.

*Relative retention* with reference to altizide (retention time = about 25 min): impurity A = about 0.15; furosemide = about 1.05.

*System suitability*: reference solution (c):

– *resolution*: minimum 1.0 between the peaks due to altizide and furosemide.

*Limits*:

– *impurity A*: not more than 3 times the area of the principal peak in the chromatogram obtained with reference solution (a) (0.3 per cent);

– *unspecified impurities*: for each impurity, not more than the area of the principal peak in the chromatogram obtained with reference solution (a) (0.10 per cent);

– *total*: not more than 5 times the area of the principal peak in the chromatogram obtained with reference solution (a) (0.5 per cent);

– *disregard limit*: 0.5 times the area of the principal peak in the chromatogram obtained with reference solution (a) (0.05 per cent).

**Water** (2.5.32): maximum 0.5 per cent, determined on 50.0 mg.

**Sulfated ash** (2.4.14): maximum 0.1 per cent, determined on 1.0 g.

## ASSAY

Liquid chromatography (2.2.29) as described in the test for related substances, with the following modifications.

*Test solution.* Dissolve 25.0 mg of the substance to be examined in 2 mL of *acetonitrile R* and dilute to 25.0 mL with the mobile phase.

*Reference solution.* Dissolve 25.0 mg of *altizide CRS* in 2 mL of *acetonitrile R* and dilute to 25.0 mL with the mobile phase. Calculate the percentage content of  $C_{11}H_{14}ClN_3O_4S_3$  from the declared content of *altizide CRS*.

## IMPURITIES

*Specified impurities*: A, B.

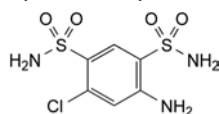

A. 4-amino-6-chlorobenzene-1,3-disulfonamide,

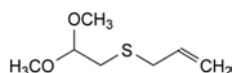

B. 3-[(2,2-dimethoxyethyl)sulfanyl]prop-1-ene.

**01/2008:0006** B. Dilute 0.3 mL of solution S2 to 2 mL with *water R*. The solution gives the reaction of aluminium (2.3.1).

## ALUM

### Alumen

$\text{AlK}(\text{SO}_4)_2 \cdot 12\text{H}_2\text{O}$   
[7784-24-9]

$M_r$  474.4

#### DEFINITION

*Content*: 99.0 per cent to 100.5 per cent of  $\text{AlK}(\text{SO}_4)_2 \cdot 12\text{H}_2\text{O}$ .

#### CHARACTERS

*Appearance*: granular powder or colourless, transparent, crystalline masses.

*Solubility*: freely soluble in water, very soluble in boiling water, soluble in glycerol, practically insoluble in ethanol (96 per cent).

#### IDENTIFICATION

- A. Solution S (see Tests) gives the reactions of sulfates (2.3.1).  
B. Solution S gives the reaction of aluminium (2.3.1).  
C. Shake 10 mL of solution S with 0.5 g of *sodium bicarbonate R* and filter. The filtrate gives reaction (a) of potassium (2.3.1).

#### TESTS

**Solution S**. Dissolve 2.5 g in *water R* and dilute to 50 mL with the same solvent.

**Appearance of solution**. Solution S is clear (2.2.1) and colourless (2.2.2, *Method II*).

**pH** (2.2.3): 3.0 to 3.5.

Dissolve 1.0 g in *carbon dioxide-free water R* and dilute to 10 mL with the same solvent.

**Ammonium** (2.4.1): maximum 0.2 per cent.

To 1 mL of solution S add 4 mL of *water R*. Dilute 0.5 mL of this solution to 14 mL with *water R*.

**Iron** (2.4.9): maximum 100 ppm.

Dilute 2 mL of solution S to 10 mL with *water R*. Use in this test 0.3 mL of *thioglycollic acid R*.

**Heavy metals** (2.4.8): maximum 20 ppm.

12 mL of solution S complies with test A. Prepare the reference solution using *lead standard solution (1 ppm Pb) R*.

#### ASSAY

Dissolve 0.900 g in 20 mL of *water R* and carry out the complexometric titration of aluminium (2.5.11).

1 mL of 0.1 M *sodium edetate* is equivalent to 47.44 mg of  $\text{AlK}(\text{SO}_4)_2 \cdot 12\text{H}_2\text{O}$ .

**01/2008:0971** [ $\text{AlO}(\text{OH})_n \cdot n\text{H}_2\text{O}$ ]

## ALUMINIUM CHLORIDE HEXAHYDRATE

### Aluminii chloridum hexahydricum

$\text{AlCl}_3 \cdot 6\text{H}_2\text{O}$   
[7784-13-6]

$M_r$  241.4

#### DEFINITION

*Content*: 95.0 per cent to 101.0 per cent.

#### CHARACTERS

*Appearance*: white or slightly yellow, crystalline powder or colourless crystals, deliquescent.

*Solubility*: very soluble in water, freely soluble in ethanol (96 per cent), soluble in glycerol.

#### IDENTIFICATION

- A. Dilute 0.1 mL of solution S2 (see Tests) to 2 mL with *water R*. The solution gives reaction (a) of chlorides (2.3.1).

#### TESTS

**Solution S1**. Dissolve 10.0 g in *distilled water R* and dilute to 100 mL with the same solvent.

**Solution S2**. Dilute 50 mL of solution S1 to 100 mL with *water R*.

**Appearance of solution**. Solution S2 is clear (2.2.1) and not more intensely coloured than reference solution B<sub>7</sub> (2.2.2, *Method II*).

**Sulfates** (2.4.13): maximum 100 ppm, determined on solution S1.

**Iron** (2.4.9): maximum 10 ppm, determined on solution S1.

**Alkali and alkaline-earth metals**: maximum 0.5 per cent.

To 20 mL of solution S2 add 100 mL of *water R* and heat to boiling. To the hot solution add 0.2 mL of *methyl red solution R*. Add *dilute ammonia R1* until the colour of the indicator changes to yellow and dilute to 150 mL with *water R*. Heat to boiling and filter. Evaporate 75 mL of the filtrate to dryness on a water-bath and ignite to constant mass. The residue weighs a maximum of 2.5 mg.

**Heavy metals** (2.4.8): maximum 20 ppm.

12 mL of solution S1 complies with test A. Prepare the reference solution using *lead standard solution (2 ppm Pb) R*.

**Water** (2.5.12): 42.0 per cent to 48.0 per cent, determined on 50.0 mg.

#### ASSAY

Dissolve 0.500 g in 25.0 mL of *water R*. Carry out the complexometric titration of aluminium (2.5.11). Titrate with 0.1 M *zinc sulfate* until the colour of the indicator changes from greyish-green to pink. Carry out a blank titration.

1 mL of 0.1 M *sodium edetate* is equivalent to 24.14 mg of  $\text{AlCl}_3 \cdot 6\text{H}_2\text{O}$ .

#### STORAGE

In an airtight container.

**04/2008:1664**

## ALUMINIUM HYDROXIDE, HYDRATED, FOR ADSORPTION

### Aluminii hydroxidum hydricum ad adsorptionem

[ $\text{AlO}(\text{OH})_n \cdot n\text{H}_2\text{O}$ ]

#### DEFINITION

*Content*: 90.0 per cent to 110.0 per cent of the content of aluminium stated on the label.

*NOTE*: shake the gel vigorously for at least 30 s immediately before examining.

#### CHARACTERS

*Appearance*: white or almost white, translucent, viscous, colloidal gel. A supernatant may be formed upon standing.

*Solubility*: a clear or almost clear solution is obtained with alkali hydroxide solutions and mineral acids.

#### IDENTIFICATION

Solution S (see Tests) gives the reaction of aluminium.

To 10 mL of solution S add about 0.5 mL of *dilute hydrochloric acid R* and about 0.5 mL of *thioacetamide reagent R*. No precipitate is formed. Add dropwise 5 mL of *dilute sodium hydroxide solution R*. Allow to stand for 1 h. A gelatinous white precipitate is formed which dissolves upon addition of 5 mL of



*dilute sodium hydroxide solution R*. Gradually add 5 mL of *ammonium chloride solution R* and allow to stand for 30 min. The gelatinous white precipitate is re-formed.

## TESTS

**Solution S.** Add 1 g to 4 mL of *hydrochloric acid R*. Heat at 60 °C for 1 h, cool, dilute to 50 mL with *distilled water R* and filter if necessary.

**pH** (2.2.3): 5.5 to 8.5.

**Adsorption power.** Dilute the substance to be examined with *distilled water R* to obtain an aluminium concentration of 5 mg/mL. Prepare *bovine albumin R* solutions with the following concentrations of bovine albumin: 0.5 mg/mL, 1 mg/mL, 2 mg/mL, 3 mg/mL, 5 mg/mL and 10 mg/mL. If necessary, adjust the gel and the *bovine albumin R* solutions to pH 6.0 with *dilute hydrochloric acid R* or *dilute sodium hydroxide solution R*.

For adsorption, mix 1 part of the diluted gel with 4 parts of each of the solutions of *bovine albumin R* and allow to stand at room temperature for 1 h. During this time shake the mixture vigorously at least 5 times. Centrifuge or filter through a non-protein-retaining filter. Immediately determine the protein content (2.5.33, *Method 2*) of either the supernatant or the filtrate.

It complies with the test if no bovine albumin is detectable in the supernatant or filtrate of the 2 mg/mL *bovine albumin R* solution (maximum level of adsorption) and in the supernatant or filtrate of *bovine albumin R* solutions of lower concentrations. Solutions containing 3 mg/mL, 5 mg/mL and 10 mg/mL *bovine albumin R* may show bovine albumin in the supernatant or filtrate, proportional to the amount of bovine albumin in the solutions.

**Sedimentation.** If necessary, adjust the substance to be examined to pH 6.0 using *dilute hydrochloric acid R* or *dilute sodium hydroxide solution R*. Dilute with *distilled water R* to obtain an aluminium concentration of approximately 5 mg/mL. If the aluminium content of the substance to be examined is lower than 5 mg/mL, adjust to pH 6.0 and dilute with a 9 g/L solution of *sodium chloride R* to obtain an aluminium concentration of about 1 mg/mL. After shaking for at least 30 s, place 25 mL of the preparation in a 25 mL graduated cylinder and allow to stand for 24 h.

It complies with the test if the volume of the clear supernatant is less than 5 mL for the gel with an aluminium content of about 5 mg/mL.

It complies with the test if the volume of the clear supernatant is less than 20 mL for the gel with an aluminium content of about 1 mg/mL.

**Chlorides** (2.4.4): maximum 0.33 per cent.

Dissolve 0.5 g in 10 mL of *dilute nitric acid R* and dilute to 500 mL with *water R*.

**Nitrates:** maximum 100 ppm.

Place 5 g in a test-tube immersed in ice-water, add 0.4 mL of a 100 g/L solution of *potassium chloride R*, 0.1 mL of *diphenylamine solution R* and, dropwise with shaking, 5 mL of *sulfuric acid R*. Transfer the tube to a water-bath at 50 °C. After 15 min, any blue colour in the solution is not more intense than that in a standard prepared at the same time and in the same manner using 5 mL of *nitrate standard solution (100 ppm NO<sub>3</sub>) R*.

**Sulfates** (2.4.13): maximum 0.5 per cent.

Dilute 2 mL of solution S to 20 mL with *water R*.

**Ammonium** (2.4.1, *Method B*): maximum 50 ppm, determined on 1.0 g.

Prepare the standard using 0.5 mL of *ammonium standard solution (100 ppm NH<sub>4</sub>) R*.

**Arsenic** (2.4.2, *Method A*): maximum 1 ppm, determined on 1 g.

**Iron** (2.4.9): maximum 15 ppm, determined on 0.67 g.

**Heavy metals** (2.4.8): maximum 20 ppm.

Dissolve 2.0 g in 10 mL of *dilute nitric acid R* and dilute to 20 mL with *water R*. The solution complies with test A. Prepare the reference solution using *lead standard solution (2 ppm Pb) R*.

**Bacterial endotoxins** (2.6.14): less than 5 IU of endotoxin per milligram of aluminium, if intended for use in the manufacture of an adsorbed product without a further appropriate procedure for the removal of bacterial endotoxins.

## ASSAY

Dissolve 2.50 g in 10 mL of *hydrochloric acid R*, heating for 30 min at 100 °C on a water-bath. Cool and dilute to 20 mL with *water R*. To 10 mL of the solution, add *concentrated ammonia R* until a precipitate is obtained. Add the smallest quantity of *hydrochloric acid R* needed to dissolve the precipitate and dilute to 20 mL with *water R*. Carry out the complexometric titration of aluminium (2.5.11). Carry out a blank titration.

## STORAGE

At a temperature not exceeding 30 °C. Do not allow to freeze. If the substance is sterile, store in a sterile, airtight, tamper-proof container.

## LABELLING

The label states the declared content of aluminium.

01/2009:1388  
corrected 7.0

## ALUMINIUM MAGNESIUM SILICATE

## Aluminii magnesi silicas

## DEFINITION

Mixture of particles with colloidal particle size of montmorillonite and saponite, free from grit and non-swelling ore.

## Content:

- *aluminium* (Al; A, 26.98): 95.0 per cent to 105.0 per cent of the value stated on the label;
- *magnesium* (Mg; A, 24.30): 95.0 per cent to 105.0 per cent of the value stated on the label.

## CHARACTERS

*Appearance:* almost white powder, granules or plates.

*Solubility:* practically insoluble in water and in organic solvents.

It swells in water to produce a colloidal dispersion.

## IDENTIFICATION

- A. Fuse 1 g with 2 g of *anhydrous sodium carbonate R*. Warm the residue with *water R* and filter. Acidify the filtrate with *hydrochloric acid R* and evaporate to dryness on a water-bath. 0.25 g of the residue gives the reaction of silicates (2.3.1).
- B. Dissolve the remainder of the residue obtained in identification test A in a mixture of 5 mL of *dilute hydrochloric acid R* and 10 mL of *water R*. Filter and add *ammonium chloride buffer solution pH 10.0 R*. A white, gelatinous precipitate is formed. Centrifuge and keep the supernatant for identification C. Dissolve the remaining precipitate in *dilute hydrochloric acid R*. The solution gives the reaction of aluminium (2.3.1).
- C. The supernatant liquid obtained after centrifugation in identification test B gives the reaction of magnesium (2.3.1).

## TESTS

**pH** (2.2.3): 9.0 to 10.0.

Disperse 5.0 g in 100 mL of *carbon dioxide-free water R*.

**Arsenic** (2.4.2, Method A): maximum 3 ppm.

Transfer 16.6 g to a 250 mL beaker containing 100 mL of *dilute hydrochloric acid R*. Mix, cover with a watch glass and boil gently, with occasional stirring, for 15 min. Allow the insoluble matter to settle and decant the supernatant liquid through a rapid-flow filter paper into a 250 mL volumetric flask, retaining as much sediment as possible in the beaker. To the residue in the beaker add 25 mL of hot *dilute hydrochloric acid R*, stir, heat to boiling, allow the insoluble matter to settle and decant the supernatant liquid through the filter into the volumetric flask. Repeat the extraction with 4 additional quantities, each of 25 mL, of hot *dilute hydrochloric acid R*, decanting each supernatant liquid through the filter into the volumetric flask. At the last extraction, transfer as much of the insoluble matter as possible onto the filter. Allow the combined filtrates to cool to room temperature and dilute to 250.0 mL with *dilute hydrochloric acid R*. Dilute 5.0 mL of this solution to 25.0 mL with *dilute hydrochloric acid R*.

**Lead**: maximum 15 ppm.

Atomic absorption spectrometry (2.2.23, Method I).

**Test solution.** Transfer 10.0 g to a 250 mL beaker containing 100 mL of *dilute hydrochloric acid R*. Mix, cover with a watch glass and boil for 15 min. Allow to cool to room temperature and allow the insoluble matter to settle. Decant the supernatant liquid through a rapid-flow filter paper into a 400 mL beaker. To the insoluble matter in the 250 mL beaker add 25 mL of hot *water R*. Stir, allow the insoluble matter to settle and decant the supernatant liquid through the filter into the 400 mL beaker. Repeat the extraction with 2 additional quantities, each of 25 mL, of *water R*, decanting each time the supernatant liquid through the filter into the 400 mL beaker. Wash the filter with 25 mL of hot *water R*, collecting this filtrate in the 400 mL beaker. Concentrate the combined filtrates to about 20 mL by gently boiling. If a precipitate appears, add about 0.1 mL of *nitric acid R*, heat to boiling and allow to cool to room temperature. Filter the concentrated extracts through a rapid-flow filter paper into a 50 mL volumetric flask. Transfer the remaining contents of the 400 mL beaker through the filter paper and into the flask with *water R*. Dilute this solution to 50.0 mL with *water R*.

**Reference solutions.** Prepare the reference solutions using *lead standard solution (10 ppm Pb) R*, diluted as necessary with *water R*.

**Source:** lead hollow-cathode lamp.

**Wavelength:** 217 nm.

**Atomisation device:** oxidising air-acetylene flame.

**Loss on drying** (2.2.32): maximum 8.0 per cent, determined on 1.000 g by drying in an oven at 105 °C.

#### Microbial contamination

TAMC: acceptance criterion 10<sup>3</sup> CFU/g (2.6.12).

TYMC: acceptance criterion 10<sup>2</sup> CFU/g (2.6.12).

Absence of *Escherichia coli* (2.6.13).

#### ASSAY

**Aluminium.** Atomic absorption spectrometry (2.2.23, Method I).

**Test solution.** In a platinum crucible mix 0.200 g with 1.0 g of *lithium metaborate R*. Heat slowly at first and ignite at 1000-1200 °C for 15 min. Allow to cool, then place the crucible in a 100 mL beaker containing 25 mL of *dilute nitric acid R* and add an additional 50 mL of *dilute nitric acid R*, filling and submerging the crucible. Place a polytetrafluoroethylene-coated magnetic stirring bar in the crucible and stir gently with a magnetic stirrer until dissolution is complete. Pour the contents into a 250 mL beaker and remove the crucible. Warm the solution and transfer through a rapid-flow filter paper into a 250 mL volumetric flask, wash the filter and beaker with *water R* and dilute to 250.0 mL with *water R* (solution A). To 20.0 mL of solution A add 20 mL of a 10 g/L solution of *sodium chloride R* and dilute to 100.0 mL with *water R*.

**Reference solutions.** Dissolve, with gentle heating, 1.000 g of *aluminium R* in a mixture of 10 mL of *hydrochloric acid R* and 10 mL of *water R*. Allow to cool, then dilute to 1000.0 mL with *water R* (1 mg of aluminium per millilitre). Into 3 identical volumetric flasks, each containing 0.20 g of *sodium chloride R*, introduce 2.0 mL, 5.0 mL and 10.0 mL of this solution respectively, and dilute to 100.0 mL with *water R*.

**Source:** aluminium hollow-cathode lamp.

**Wavelength:** 309 nm.

**Atomisation device:** oxidising acetylene-nitrous oxide flame.

**Magnesium.** Atomic absorption spectrometry (2.2.23, Method I).

**Test solution.** Dilute 25.0 mL of solution A, prepared in the assay for aluminium, to 50.0 mL with *water R*. To 5.0 mL of this solution add 20.0 mL of *lanthanum nitrate solution R* and dilute to 100.0 mL with *water R*.

**Reference solutions.** Place 1.000 g of *magnesium R* in a 250 mL beaker containing 20 mL of *water R* and carefully add 20 mL of *hydrochloric acid R*, warming if necessary to dissolve. Transfer the solution to a volumetric flask and dilute to 1000.0 mL with *water R* (1 mg of magnesium per millilitre). Dilute 5.0 mL of this solution to 250.0 mL with *water R*. Into 4 identical volumetric flasks, introduce 5.0 mL, 10.0 mL, 15.0 mL and 20.0 mL of the solution respectively. To each flask add 20.0 mL of *lanthanum nitrate solution R* and dilute to 100.0 mL with *water R*.

**Source:** magnesium hollow-cathode lamp.

**Wavelength:** 285 nm.

**Atomisation device:** reducing air-acetylene flame.

#### LABELLING

The label states the content of aluminium and magnesium.

01/2011:0311

## ALUMINIUM OXIDE, HYDRATED

### Aluminii oxidum hydricum

#### DEFINITION

**Content:** 47.0 per cent to 60.0 per cent of Al<sub>2</sub>O<sub>3</sub> (*M<sub>r</sub>* 102.0).

#### CHARACTERS

**Appearance:** white or almost white, amorphous powder.

**Solubility:** practically insoluble in water. It dissolves in dilute mineral acids and in solutions of alkali hydroxides.

#### IDENTIFICATION

Solution S (see Tests) gives the reaction of aluminium (2.3.1).

#### TESTS

**Solution S.** Dissolve 2.5 g in 15 mL of *hydrochloric acid R*, heating on a water-bath. Dilute to 100 mL with *distilled water R*.

**Appearance of solution.** Solution S is not more opalescent than reference suspension II (2.2.1) and not more intensely coloured than reference solution GY<sub>6</sub> (2.2.2, Method II).

**Alkaline impurities.** Shake 1.0 g with 20 mL of *carbon dioxide-free water R* for 1 min and filter. To 10 mL of the filtrate add 0.1 mL of *phenolphthalein solution R*. Any pink colour disappears on the addition of 0.3 mL of 0.1 M *hydrochloric acid*.

**Neutralising capacity.** Carry out the test at 37 °C. Disperse 0.5 g in 100 mL of *water R*, heat, add 100.0 mL of 0.1 M *hydrochloric acid*, previously heated, and stir continuously; the pH (2.2.3) of the solution after 10 min, 15 min and 20 min is not less than 1.8, 2.3 and 3.0 respectively and is at no time greater than 4.5. Add 10.0 mL of 0.5 M *hydrochloric acid*, previously heated, stir continuously for 1 h and titrate with 0.1 M *sodium hydroxide* to pH 3.5; not more than 35.0 mL of 0.1 M *sodium hydroxide* is required.

**Chlorides** (2.4.4): maximum 1 per cent.

Dissolve 0.1 g with heating in 10 mL of *dilute nitric acid R* and dilute to 100 mL with *water R*. Dilute 5 mL of the solution to 15 mL with *water R*.

**Sulfates** (2.4.13): maximum 1 per cent.

Dilute 4 mL of solution S to 100 mL with *distilled water R*.

**Arsenic** (2.4.2, *Method A*): maximum 4 ppm, determined on 10 mL of solution S.

**Heavy metals** (2.4.8): maximum 60 ppm.

Neutralise 20 mL of solution S with *concentrated ammonia R*, using *metanil yellow solution R* as an external indicator. Filter, if necessary, and dilute to 30 mL with *water R*. 12 mL of the solution complies with test A. Prepare the reference solution using 10 mL of *lead standard solution (1 ppm Pb) R*.

#### Microbial contamination

TAMC: acceptance criterion  $10^3$  CFU/g (2.6.12).

TYMC: acceptance criterion  $10^2$  CFU/g (2.6.12).

Absence of bile-tolerant gram-negative bacteria (2.6.13).

Absence of *Escherichia coli* (2.6.13).

#### ASSAY

Dissolve 0.800 g in 10 mL of *hydrochloric acid RI*, heating on a water-bath. Cool and dilute to 50.0 mL with *water R*. To 10.0 mL of the solution add *dilute ammonia RI* until a precipitate begins to appear. Add the smallest quantity of *dilute hydrochloric acid R* needed to dissolve the precipitate and dilute to 20 mL with *water R*. Carry out the complexometric titration of aluminium (2.5.11).

1 mL of 0.1 M *sodium edetate* is equivalent to 5.098 mg of  $\text{Al}_2\text{O}_3$ .

#### STORAGE

In an airtight container, at a temperature not exceeding 30 °C.

#### FUNCTIONALITY-RELATED CHARACTERISTICS

*This section provides information on characteristics that are recognised as being relevant control parameters for one or more functions of the substance when used as an excipient (see chapter 5.15). This section is a non-mandatory part of the monograph and it is not necessary to verify the characteristics to demonstrate compliance. Control of these characteristics can however contribute to the quality of a medicinal product by improving the consistency of the manufacturing process and the performance of the medicinal product during use. Where control methods are cited, they are recognised as being suitable for the purpose, but other methods can also be used. Wherever results for a particular characteristic are reported, the control method must be indicated.*

*The following characteristics may be relevant for hydrated aluminium oxide used as adsorbent.*

**Particle-size distribution** (2.9.31).

**Specific surface area** (2.9.26).

01/2009:2166

## ALUMINIUM PHOSPHATE GEL

### Aluminii phosphatis liquamen

#### DEFINITION

Hydrated  $\text{AlPO}_4$  in gel form.

*Content*: 19.0 per cent to 21.0 per cent of  $\text{AlPO}_4$ .

#### CHARACTERS

*Appearance*: gel.

*Solubility*: practically insoluble in water, in ethanol (96 per cent) and in methylene chloride. It dissolves in dilute solutions of mineral acids.

#### IDENTIFICATION

A. Solution S (see Tests) gives reaction (b) of phosphates (2.3.1).

B. Solution S gives the reaction of aluminium (2.3.1).

C. It complies with the assay.

#### TESTS

**Solution S**. Dissolve 2.00 g in *dilute hydrochloric acid R* and dilute to 100 mL with the same acid.

**pH** (2.2.3): 6.0 to 8.0.

**Peroxides**: maximum 150 ppm, expressed as hydrogen peroxide.

*Test solution*. Dissolve with heating 1.0 g of the substance to be examined in 5 mL of *dilute hydrochloric acid R*, then add 5 mL of *water R* and 2 mL of *divanadium pentoxide solution in sulfuric acid R*.

*Reference solution*. Dilute 1.0 mL of *dilute hydrogen peroxide solution R* to 200.0 mL with *water R*. To 1 mL of this solution add 9 mL of *water R* and 2 mL of *divanadium pentoxide solution in sulfuric acid R*.

The test solution is not more intensely coloured than the reference solution.

**Chlorides** (2.4.4): maximum 500 ppm.

Dissolve 1.3 g in 5 mL of *dilute nitric acid R* and dilute to 200 mL with *water R*.

**Soluble phosphates**: maximum 0.5 per cent, expressed as  $\text{PO}_4$ .

*Test solution*. Centrifuge 10.0 g until a clear supernatant is obtained. To 2.00 mL of the supernatant add 20.0 mL of a 10.3 g/L solution of *hydrochloric acid R* and dilute to 100.0 mL with *water R*. To 10.0 mL of this solution add 10.0 mL of *nitro-molybdovanadic reagent R* and dilute to 50.0 mL with *water R*. Allow to stand protected from light for 15 min.

*Reference solution*. Add 10.0 mL of *nitro-molybdovanadic reagent R* to 10.0 mL of a 143 mg/L solution of *potassium dihydrogen phosphate R* and dilute to 50.0 mL with *water R*. Allow to stand protected from light for 15 min.

Measure the absorbances (2.2.25) of the 2 solutions at 400 nm. The absorbance of the test solution is not greater than that of the reference solution.

**Sulfates** (2.4.13): maximum 0.2 per cent.

Dilute 25 mL of solution S to 100 mL with *distilled water R*.

**Soluble aluminium**: maximum 50 ppm.

To 16.0 g add 50 mL of *water R*. Heat to boiling for 5 min. Cool and centrifuge. Separate the supernatant. Wash the residue with 20 mL of *water R* and centrifuge. Separate the supernatant and add to the first supernatant. To the combined supernatants add 5 mL of *hydrochloric acid R* and 20 mL of *water R*. Introduce all of this solution into a 500 mL conical flask and carry out the complexometric titration of aluminium (2.5.11) using 0.01 M *sodium edetate*.

**Arsenic** (2.4.2, *Method A*): maximum 1 ppm, determined on 1.0 g.

**Heavy metals** (2.4.8): maximum 10 ppm.

Dissolve 4.0 g in *dilute hydrochloric acid R* and dilute to 20 mL with the same acid. 12 mL of the solution complies with test A. Prepare the reference solution using *lead standard solution (2 ppm Pb) R*.

**Acid neutralising capacity**. Add 2.0 g to 30 mL of 0.1 M *hydrochloric acid R* heated to 37 °C and maintain at 37 °C while shaking. Determine the pH after 15 min. The pH (2.2.3) of the mixture is 2.0 to 2.5.

**Residue on ignition**: 19.0 per cent to 23.0 per cent.

Heat 0.500 g at 50 °C for 5 hours, then ignite at  $500 \pm 50$  °C until constant mass.

#### Microbial contamination

TAMC: acceptance criterion  $10^3$  CFU/g (2.6.12).

TYMC: acceptance criterion  $10^2$  CFU/g (2.6.12).

Absence of bile-tolerant gram-negative bacteria (2.6.13).

Absence of *Escherichia coli* (2.6.13).

#### ASSAY

Dissolve with heating 0.300 g in 5 mL of *dilute hydrochloric acid R*. Add 45 mL of *water R*, 10.0 mL of 0.1 M sodium edetate and 30 mL of a mixture of equal volumes of *ammonium acetate solution R* and *dilute acetic acid R*. Heat to boiling and maintain boiling for 3 min. Cool, then add 25 mL of *ethanol (96 per cent) R*. Titrate with 0.1 M zinc sulfate, determining the end-point potentiometrically (2.2.20).

1 mL of 0.1 M zinc sulfate is equivalent to 12.2 mg of  $\text{AlPO}_4$ .

#### STORAGE

In an airtight container.

01/2008:1598  
corrected 6.0

## ALUMINIUM PHOSPHATE, HYDRATED

### Aluminii phosphas hydricus

$\text{AlPO}_4 \cdot x \text{H}_2\text{O}$   $M_r$  122.0 (anhydrous substance)

#### DEFINITION

*Content*: 94.0 per cent to 102.0 per cent of  $\text{AlPO}_4$  ( $M_r$  122.0) (ignited substance).

#### CHARACTERS

*Appearance*: white or almost white powder.

*Solubility*: very slightly soluble in water, practically insoluble in alcohol. It dissolves in dilute solutions of mineral acids and alkali hydroxides.

#### IDENTIFICATION

- A. Solution S (see Tests) gives reaction (b) of phosphates (2.3.1).  
B. Solution S gives the reaction of aluminium (2.3.1).

#### TESTS

**Solution S.** Dissolve 2.00 g in *dilute hydrochloric acid R* and dilute to 100 mL with the same acid.

**Appearance of solution.** Solution S is clear (2.2.1) and colourless (2.2.2, *Method II*).

**pH** (2.2.3): 5.5 to 7.2

Shake 4.0 g with *carbon dioxide-free water R* and dilute to 100 mL with the same solvent.

**Chlorides** (2.4.4): maximum 1.3 per cent.

Dissolve 50.0 mg in 10 mL of *dilute nitric acid R* and dilute to 200 mL with *water R*. 15 mL of the solution complies with the limit test for chlorides.

**Soluble phosphates**: maximum 1.0 per cent, calculated as  $\text{PO}_4^{3-}$ .

*Test solution.* Stir 5.0 g with 150 mL of *water R* for 2 h. Filter and wash the filter with 50 mL of *water R*. Combine the filtrate and the washings and dilute to 250.0 mL with *water R*. Dilute 10.0 mL of this solution to 100.0 mL with *water R*.

*Reference solution (a).* Dissolve 2.86 g of *potassium dihydrogen phosphate R* in *water R* and dilute to 100 mL with the same solvent.

*Reference solution (b).* Dilute 1 mL of reference solution (a) to 5 mL with *water R*.

*Reference solution (c).* Dilute 3 mL of reference solution (a) to 5 mL with *water R*.

Treat each solution as follows. To 5.0 mL add 4 mL of *dilute sulfuric acid R*, 1 mL of *ammonium molybdate solution R*, 5 mL of *water R* and 2 mL of a solution containing 0.10 g of 4-methylaminophenol sulfate R, 0.5 g of *anhydrous sodium sulfite R* and 20.0 g of *sodium metabisulfite R* in 100 mL of *water R*. Shake and allow to stand for 15 min. Dilute to 25.0 mL with *water R* and allow to stand for a further 15 min. Measure

the absorbance (2.2.25) at 730 nm. Calculate the content of soluble phosphates from a calibration curve prepared using reference solutions (a), (b) and (c) after treatment.

**Sulfates** (2.4.13): maximum 0.6 per cent.

Dilute 8 mL of solution S to 100 mL with *distilled water R*. 15 mL of the solution complies with the limit test for sulfates.

**Arsenic** (2.4.2): maximum 1 ppm.

1.0 g complies with limit test A.

**Heavy metals** (2.4.8): maximum 20 ppm.

Dissolve 1.0 g in *dilute hydrochloric acid R* and dilute to 20 mL with the same acid. 12 mL of the solution complies with limit test A. Prepare the standard using *lead standard solution (1 ppm Pb) R*.

**Loss on ignition.** 10.0 per cent to 20.0 per cent, determined on 1.000 g at  $800 \pm 50$  °C.

**Neutralising capacity.** Add 0.50 g to 30 mL of 0.1 M *hydrochloric acid* previously heated to 37 °C and maintain at this temperature for 15 min while stirring. The pH (2.2.3) of the mixture after 15 min at 37 °C is 2.0 to 2.5.

#### ASSAY

Dissolve 0.400 g in 10 mL of *dilute hydrochloric acid R* and dilute to 100.0 mL with *water R*. To 10.0 mL of the solution, add 10.0 mL of 0.1 M sodium edetate and 30 mL of a mixture of equal volumes of *ammonium acetate solution R* and *dilute acetic acid R*. Boil for 3 min, then cool. Add 25 mL of *alcohol R* and 1 mL of a freshly prepared 0.25 g/L solution of *dithizone R* in *alcohol R*. Titrate the excess of sodium edetate with 0.1 M zinc sulfate until the colour changes to pink.

1 mL of 0.1 M sodium edetate is equivalent to 12.20 mg of  $\text{AlPO}_4$ .

#### STORAGE

In an airtight container.

01/2009:1676  
corrected 7.0

## ALUMINIUM SODIUM SILICATE

### Aluminii natrii silicas

#### DEFINITION

Silicic acid aluminium sodium salt of synthetic origin.

*Content*:

- *aluminium* (Al;  $M_r$  26.98): 2.7 per cent to 7.9 per cent (dried substance);
- *sodium* (Na;  $M_r$  22.99): 3.7 per cent to 6.3 per cent (dried substance).

#### CHARACTERS

*Appearance*: white or almost white, fine, light, amorphous powder.

*Solubility*: practically insoluble in water and in organic solvents.

#### IDENTIFICATION

- A. Transfer 1.0 g to a 100 mL beaker and add 10 mL of *dilute hydrochloric acid R*. Mix, cover with a watch glass and boil for 15 min. Allow to cool to room temperature, mix and centrifuge the solution. 2 mL of the supernatant gives the reaction of aluminium (2.3.1).
- B. 2 mL of the supernatant obtained in identification test A gives reaction (a) of sodium (2.3.1).
- C. 0.2 g gives the reaction of silicates (2.3.1).

#### TESTS

**pH** (2.2.3): 9.5 to 11.5.

Disperse 5.0 g in 100 mL of *carbon dioxide-free water R*.

**Arsenic** (2.4.2, Method A): maximum 3 ppm.

Transfer 8.3 g to a 250 mL beaker containing 50 mL of *dilute hydrochloric acid R*. Mix, cover with a watch glass and boil gently, with occasional stirring, for 15 min. Centrifuge, and decant the supernatant through a rapid-flow filter paper into a 250 mL volumetric flask. To the residue in the beaker, add 25 mL of hot *dilute hydrochloric acid R*, stir, centrifuge, and decant the supernatant through the same filter into the volumetric flask. Repeat the extraction with 3 additional quantities, each of 25 mL, of hot *dilute hydrochloric acid R*, filtering each supernatant through this filter into the volumetric flask. Allow the combined filtrates to cool to room temperature and dilute to 250.0 mL with *dilute hydrochloric acid R*. Dilute 10.0 mL of the solution to 25.0 mL with *water R*.

**Lead**: maximum 5 ppm.

Atomic absorption spectrometry (2.2.23, Method I).

**Test solution.** Transfer 5.0 g to a 250 mL beaker containing 50 mL of *dilute hydrochloric acid R*. Mix, cover with a watch glass and boil for 15 min. Allow to cool to room temperature. Centrifuge, and decant the supernatant through a rapid-flow filter paper into a 250 mL beaker. To the insoluble matter add 25 mL of hot *water R*. Stir vigorously, centrifuge, and decant the supernatant through the same filter into the beaker. Repeat the extraction with 2 additional quantities, each of 25 mL, of hot *water R*, decanting each supernatant through the filter into the beaker. Wash the filter with 25 mL of hot *water R*, collecting the filtrate in the beaker. Concentrate the combined filtrates by gently boiling to about 15 mL. Add about 0.05 mL of *heavy metal-free nitric acid R*, heat to boiling and allow to cool to room temperature. Filter the concentrated extracts through a rapid-flow filter paper into a 25 mL volumetric flask. Transfer the remaining contents of the beaker through the filter paper and into the volumetric flask with *water R* and dilute to 25.0 mL with the same solvent.

**Reference solutions.** Into 4 separate 100 mL volumetric flasks, introduce respectively 3.0 mL, 5.0 mL, 10.0 mL and 15.0 mL of *lead standard solution (10 ppm Pb) R*, add 0.20 mL of *heavy metal-free nitric acid R* and dilute to 100.0 mL with *water R*.

**Source**: lead hollow-cathode lamp.

**Wavelength**: 217.0 nm.

**Atomisation device**: air-acetylene flame.

**Loss on drying** (2.2.32): maximum 8.0 per cent, determined on 1.000 g by drying in an oven at 105 °C for 4 h.

**Loss on ignition**: 5.0 per cent to 11.0 per cent (dried substance), determined on 1.000 g by ignition in a platinum crucible to constant mass at 1000 ± 25 °C.

#### Microbial contamination

TAMC: acceptance criterion 10<sup>3</sup> CFU/g (2.6.12).

TYMC: acceptance criterion 10<sup>2</sup> CFU/g (2.6.12).

Absence of *Escherichia coli* (2.6.13).

#### ASSAY

**Aluminium.** Atomic absorption spectrometry (2.2.23, Method I).

**Acid mixture.** Add 50 mL of *nitric acid R* to 500 mL of *water R*. Dissolve in this solution 17 g of *tartaric acid R* and dilute to 1000 mL with *water R*.

**Blank solution.** Dissolve 1.4 g of *anhydrous lithium metaborate R* in 60 mL of the acid mixture and dilute to 200 mL with *water R*.

**Test solution.** In a platinum crucible mix 0.200 g with 1.4 g of *anhydrous lithium metaborate R*. Heat slowly at first and ignite at 1100 ± 25 °C for 15 min. Cool, then place the crucible in a 100 mL beaker containing 60 mL of the acid mixture. Place a polytetrafluoroethylene-coated magnetic stirring bar in the crucible and stir gently with a magnetic stirrer for 16 h. Transfer the contents of the crucible into a 200 mL volumetric flask. Wash the crucible, the magnetic stirring bar and the beaker with *water R* and dilute to 200.0 mL with the same

solvent (solution A). To 10.0 mL of this solution, add 1.0 mL of *lanthanum chloride solution R* and dilute to 50.0 mL with *water R*.

**Reference solutions.** Into 5 separate 50 mL volumetric flasks, introduce respectively 1.0 mL, 2.5 mL, 5.0 mL, 7.5 mL and 10.0 mL of *aluminium standard solution (100 ppm Al) R*, add 1 mL of *lanthanum chloride solution R* and 10 mL of the blank solution, and dilute to 50.0 mL with *water R*.

**Source**: aluminium hollow-cathode lamp.

**Wavelength**: 309.3 nm.

**Atomisation device**: acetylene-nitrous oxide flame.

**Sodium.** Atomic emission spectrometry (2.2.22, Method I).

**Test solution.** To 2.0 mL of solution A, prepared in the assay of aluminium, add 1 mL of a 12.5 g/L solution of *caesium chloride R* and dilute to 20.0 mL with *water R*.

**Reference solutions.** Into 5 separate 200 mL volumetric flasks, each containing 10 mL of a 12.5 g/L solution of *caesium chloride R*, introduce respectively 1.0 mL, 2.0 mL, 4.0 mL, 6.0 mL and 10.0 mL of *sodium standard solution (200 ppm Na) R* and dilute to 200.0 mL with *water R*.

**Wavelength**: 589.0 nm.

01/2008:0165

## ALUMINIUM SULFATE

### Aluminii sulfas

Al<sub>2</sub>(SO<sub>4</sub>)<sub>3</sub>·xH<sub>2</sub>O

M<sub>r</sub> 342.1 (anhydrous substance)

#### DEFINITION

**Content**: 51.0 per cent to 59.0 per cent of Al<sub>2</sub>(SO<sub>4</sub>)<sub>3</sub>.

It contains a variable quantity of water of crystallisation.

#### CHARACTERS

**Appearance**: colourless, lustrous crystals or crystalline masses.

**Solubility**: soluble in cold water, freely soluble in hot water, practically insoluble in ethanol (96 per cent).

#### IDENTIFICATION

A. Solution S (see Tests) gives reaction (a) of sulfates (2.3.1).

B. Solution S gives the reaction of aluminium (2.3.1).

#### TESTS

**Solution S.** Dissolve 2.5 g in *water R* and dilute to 50 mL with the same solvent.

**Appearance of solution.** Solution S is not more opalescent than reference suspension III (2.2.1) and is colourless (2.2.2, Method II).

**pH** (2.2.3): 2.5 to 4.0.

Dissolve 0.5 g in *carbon dioxide-free water R* and dilute to 25 mL with the same solvent.

**Alkali and alkaline-earth metals**: maximum 0.4 per cent.

To 20 mL of solution S add 100 mL of *water R*, heat and add 0.1 mL of *methyl red solution R*. Add *dilute ammonia R1* until the colour of the indicator changes to yellow. Dilute to 150 mL with *water R*, heat to boiling and filter. Evaporate 75 mL of the filtrate to dryness on a water-bath and ignite. The residue weighs a maximum of 2 mg.

**Ammonium** (2.4.1): maximum 500 ppm.

Dilute 0.4 mL of solution S to 14 mL with *water R*.

**Iron** (2.4.9): maximum 100 ppm.

Dilute 2 mL of solution S to 10 mL with *water R*. Use 0.3 mL of *thioglycollic acid R* in this test.

**Heavy metals** (2.4.8): maximum 50 ppm.

Dilute 8 mL of solution S to 20 mL with *water R*. 12 mL of the solution complies with test A. Prepare the reference solution using *lead standard solution (1 ppm Pb) R*.

#### ASSAY

Dissolve 0.500 g in 20 mL of *water R*. Carry out the complexometric titration of aluminium (2.5.11).

1 mL of 0.1 M *sodium edetate* is equivalent to 17.11 mg of  $\text{Al}_2(\text{SO}_4)_3$ .

#### STORAGE

In an airtight container.

01/2008:2156

## ALVERINE CITRATE

Alverini citras

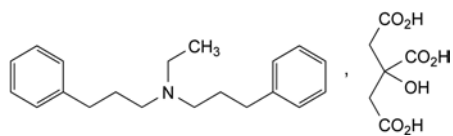

$\text{C}_{26}\text{H}_{35}\text{NO}_7$   
[5560-59-8]

$M_r$  473.6

#### DEFINITION

*N*-Ethyl-3-phenyl-*N*-(3-phenylpropyl)propan-1-amine dihydrogen 2-hydroxypropane-1,2,3-tricarboxylate.

*Content*: 99.0 per cent to 101.0 per cent (dried substance).

#### CHARACTERS

*Appearance*: white or almost white, crystalline powder.

*Solubility*: slightly soluble in water and in methylene chloride, sparingly soluble in ethanol (96 per cent).

mp: about 104 °C.

#### IDENTIFICATION

Infrared absorption spectrophotometry (2.2.24).

*Comparison*: *alverine citrate CRS*.

#### TESTS

**pH** (2.2.3): 3.5 to 4.5.

Dissolve 0.250 g in *carbon dioxide-free water R* and dilute to 50.0 mL with the same solvent.

**Related substances**. Gas chromatography (2.2.28): use the normalisation procedure. Use *freshly prepared solutions*.

*Test solution*. Dissolve 0.250 g of the substance to be examined in *water R* and dilute to 20 mL with the same solvent. Add 2 mL of *concentrated ammonia R* and shake with 3 quantities, each of 15 mL, of *methylene chloride R*. To the combined lower layers add *anhydrous sodium sulfate R*, shake, filter, and evaporate the filtrate at a temperature not exceeding 30 °C, using a rotary evaporator. Take up the residue with *methylene chloride R* and dilute to 10.0 mL with the same solvent.

*Reference solution (a)*. Dissolve 5 mg of *alverine impurity D CRS* (impurity D citrate) in 5 mL of *water R*, add 1 mL of *concentrated ammonia R* and shake with 3 quantities, each of 5 mL, of *methylene chloride R*. To the combined lower layers add *anhydrous sodium sulfate R*, shake, filter, and evaporate the filtrate at a temperature not exceeding 30 °C, using a rotary evaporator. Take up the residue with *methylene chloride R*, add 0.2 mL of the test solution and dilute to 2 mL with *methylene chloride R*.

*Reference solution (b)*. Dilute 1.0 mL of the test solution to 100.0 mL with *methylene chloride R*. Dilute 1.0 mL of this solution to 20.0 mL with *methylene chloride R*.

*Reference solution (c)*. Dissolve the contents of a vial of *alverine for peak identification CRS* (containing impurities C and E) in 1 mL of *methylene chloride R*.

*Column*:

- *material*: fused silica;
- *size*:  $l = 25$  m,  $\varnothing = 0.32$  mm;
- *stationary phase*: *poly(dimethyl)(diphenyl)siloxane R* (film thickness 0.45  $\mu\text{m}$ ).

*Carrier gas*: *helium for chromatography R*.

*Flow rate*: 2.2 mL/min.

*Split ratio*: 1:11.

*Temperature*:

	Time (min)	Temperature (°C)
Column	0 - 7	120
	7 - 13	120 → 240
	13 - 21	240
	21 - 24	240 → 290
	24 - 39	290
Injection port		290
Detector		290

*Detection*: flame ionisation.

*Injection*: 1  $\mu\text{L}$ .

*Identification of impurities*: use the chromatogram supplied with *alverine for peak identification CRS* and the chromatogram obtained with reference solution (c) to identify the peaks due to impurities C and E.

*Relative retention* with reference to alverine (retention time = about 16 min): impurity A = about 0.28; impurity B = about 0.29; impurity C = about 0.46; impurity D = about 0.97; impurity E = about 1.7.

*System suitability*: reference solution (a):

- *resolution*: minimum 3.0 between the peaks due to impurity D and alverine.

*Limits*:

- *impurities A, B*: for each impurity, maximum 0.1 per cent;
- *impurity C*: maximum 0.2 per cent;
- *impurities D, E*: for each impurity, maximum 0.3 per cent;
- *unspecified impurities*: for each impurity, maximum 0.10 per cent;
- *total*: maximum 1.0 per cent;
- *disregard limit*: the area of the principal peak in the chromatogram obtained with reference solution (b) (0.05 per cent).

**Heavy metals** (2.4.8): maximum 20 ppm.

0.5 g complies with test G. Prepare the reference solution using 1 mL of *lead standard solution (10 ppm Pb) R*.

**Loss on drying** (2.2.32): maximum 0.5 per cent, determined on 1.000 g by drying in an oven at 80 °C for 2 h.

**Sulfated ash** (2.4.14): maximum 0.1 per cent, determined on 1.0 g.

#### ASSAY

Dissolve 0.375 g in 50 mL of *anhydrous acetic acid R*. Titrate with 0.1 M *perchloric acid*, determining the end-point potentiometrically (2.2.20).

1 mL of 0.1 M *perchloric acid* is equivalent to 47.36 mg of  $\text{C}_{26}\text{H}_{35}\text{NO}_7$ .

#### STORAGE

Protected from light.

## IMPURITIES

Specified impurities: A, B, C, D, E.

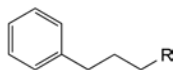

A. R = Cl: 1-chloro-3-phenylpropane,

B. R = OH: 3-phenylpropan-1-ol,

C. R = NH-C<sub>2</sub>H<sub>5</sub>: N-ethyl-3-phenylpropan-1-amine,

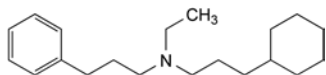

D. N-(3-cyclohexylpropyl)-N-ethyl-3-phenylpropan-1-amine,

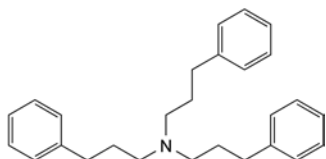

E. 3-phenyl-N,N-bis(3-phenylpropyl)propan-1-amine.

01/2008:0463  
corrected 6.5

## AMANTADINE HYDROCHLORIDE

## Amantadini hydrochloridum

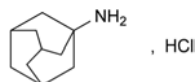

C<sub>10</sub>H<sub>18</sub>ClN  
[665-66-7]

M<sub>r</sub> 187.7

## DEFINITION

Tricyclo[3.3.1.1<sup>3,7</sup>]decan-1-amine hydrochloride.

Content: 98.5 per cent to 101.0 per cent (anhydrous substance).

## CHARACTERS

Appearance: white or almost white, crystalline powder.

Solubility: freely soluble in water and in ethanol (96 per cent).

It sublimes on heating.

## IDENTIFICATION

First identification: A, D.

Second identification: B, C, D.

A. Infrared absorption spectrophotometry (2.2.24).

Preparation: discs.

Comparison: amantadine hydrochloride CRS.

B. To 0.1 g add 1 mL of pyridine R, mix and add 0.1 mL of acetic anhydride R. Heat to boiling for about 10 s. Pour the hot solution into 10 mL of dilute hydrochloric acid R, cool to 5 °C and filter. The precipitate, washed with water R and dried in vacuo at 60 °C for 1 h, melts (2.2.14) at 147 °C to 151 °C.

C. Dissolve 0.2 g in 1 mL of 0.1 M hydrochloric acid. Add 1 mL of a 500 g/L solution of sodium nitrite R. A white precipitate is formed.

D. 1 mL of solution S (see Tests) gives reaction (a) of chlorides (2.3.1).

## TESTS

**Solution S.** Dissolve 2.5 g in carbon dioxide-free water R and dilute to 25 mL with the same solvent.

**Appearance of solution.** Solution S is clear (2.2.1) and not more intensely coloured than reference solution Y<sub>7</sub> (2.2.2, Method II).

**Acidity or alkalinity.** Dilute 2 mL of solution S to 10 mL with carbon dioxide-free water R. Add 0.1 mL of methyl red solution R and 0.2 mL of 0.01 M sodium hydroxide. The solution is yellow. Add 0.4 mL of 0.01 M hydrochloric acid. The solution is red.

**Related substances.** Gas chromatography (2.2.28): use the normalisation procedure.

**Test solution.** Dissolve 0.10 g of the substance to be examined in 2 mL of water R. Add 2 mL of a 200 g/L solution of sodium hydroxide R and 2 mL of chloroform R. Shake for 10 min. Separate the chloroform layer, dry over anhydrous sodium sulfate R and filter.

## Column:

– material: glass;

– size: *l* = 1.8 m, Ø = 2 mm;

– stationary phase: mix 19.5 g of silanised diatomaceous earth for gas chromatography R with 60 mL of a 3.3 g/L solution of potassium hydroxide R in methanol R and evaporate the solvent under reduced pressure while rotating the mixture slowly (support); dissolve 0.4 g of low-vapour-pressure hydrocarbons (type L) R in 60 mL of toluene R (dissolution requires up to 5 h), add this solution to the support and evaporate the solvent under reduced pressure while rotating the mixture slowly.

Carrier gas: nitrogen for chromatography R.

Flow rate: 30 mL/min.

Temperature:

	Time (min)	Temperature (°C)
Column	0 - 16.7	100 → 200
Injection port		220
Detector		300

Detection: flame ionisation.

Injection: 1 µL or the chosen volume.

Run time: at least 2.5 times the retention time of amantadine.

Limits:

- any impurity: for each impurity, maximum 0.3 per cent;
- total: maximum 1 per cent;
- disregard limit: disregard the peak due to the solvent.

**Heavy metals** (2.4.8): maximum 20 ppm.

12 mL of solution S complies with test A. Prepare the reference solution using lead standard solution (2 ppm Pb) R.

**Water** (2.5.12): maximum 0.5 per cent, determined on 2.000 g.

**Sulfated ash** (2.4.14): maximum 0.1 per cent, determined on 1.0 g.

## ASSAY

Dissolve 0.150 g in a mixture of 5.0 mL of 0.01 M hydrochloric acid and 50 mL of ethanol (96 per cent) R. Carry out a potentiometric titration (2.2.20), using 0.1 M sodium hydroxide. Read the volume added between the 2 points of inflexion.

1 mL of 0.1 M sodium hydroxide is equivalent to 18.77 mg of C<sub>10</sub>H<sub>18</sub>ClN.

01/2011:1489 pH (2.2.3): 4.5 to 6.0.

**AMBROXOL HYDROCHLORIDE**

## Ambroxoli hydrochloridum

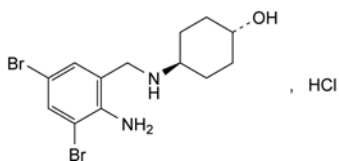

$C_{13}H_{19}Br_2ClN_2O$   
[23828-92-4]

$M_r$  414.6

**DEFINITION**

*trans*-4-[(2-Amino-3,5-dibromobenzyl)amino]cyclohexanol hydrochloride.

*Content*: 99.0 per cent to 101.0 per cent (dried substance).

**CHARACTERS**

*Appearance*: white or yellowish, crystalline powder.

*Solubility*: sparingly soluble in water, soluble in methanol, practically insoluble in methylene chloride.

**IDENTIFICATION**

*First identification*: B, D.

*Second identification*: A, C, D.

A. Ultraviolet and visible absorption spectrophotometry (2.2.25).

*Test solution*. Dissolve 20.0 mg in 0.05 M sulfuric acid and dilute to 100.0 mL with the same acid. Dilute 2.0 mL of the solution to 10.0 mL with 0.05 M sulfuric acid.

*Spectral range*: 200-350 nm.

*Absorption maxima*: at 245 nm and 310 nm.

*Absorbance ratio*:  $A_{245}/A_{310} = 3.2$  to 3.4.

B. Infrared absorption spectrophotometry (2.2.24).

*Comparison*: ambroxol hydrochloride CRS.

C. Thin-layer chromatography (2.2.27).

*Test solution*. Dissolve 50 mg of the substance to be examined in methanol R and dilute to 5 mL with the same solvent.

*Reference solution*. Dissolve 50 mg of ambroxol hydrochloride CRS in methanol R and dilute to 5 mL with the same solvent.

*Plate*: TLC silica gel  $F_{254}$  plate R.

*Mobile phase*: concentrated ammonia R, propanol R, ethyl acetate R, hexane R (1:10:20:70 V/V/V/V).

*Application*: 10  $\mu$ L.

*Development*: over 2/3 of the plate.

*Drying*: in air.

*Detection*: examine in ultraviolet light at 254 nm.

*Results*: the principal spot in the chromatogram obtained with the test solution is similar in position and size to the principal spot in the chromatogram obtained with the reference solution.

D. Dissolve 25 mg in 2.5 mL of water R, mix with 1.0 mL of dilute ammonia RI and allow to stand for 5 min. Filter and acidify the filtrate with dilute nitric acid R. The filtrate gives reaction (a) of chlorides (2.3.1).

**TESTS**

**Solution S**. Dissolve 0.75 g in methanol R and dilute to 15 mL with the same solvent.

**Appearance of solution**. Solution S is clear (2.2.1) and not more intensely coloured than reference solution  $Y_6$  (2.2.2, Method II).

Dissolve 0.2 g in carbon dioxide-free water R and dilute to 20 mL with the same solvent.

**Related substances**. Liquid chromatography (2.2.29). Prepare the solutions immediately before use.

*Test solution*. Dissolve 50 mg of the substance to be examined in water R and dilute to 50.0 mL with the same solvent.

*Reference solution (a)*. Dilute 1.0 mL of the test solution to 100.0 mL with water R. Dilute 1.0 mL of this solution to 10.0 mL with the mobile phase.

*Reference solution (b)*. In order to prepare impurity B *in situ*, dissolve 5 mg of the substance to be examined in 0.2 mL of methanol R, add 0.04 mL of a mixture of 1 volume of formaldehyde solution R and 99 volumes of water R. Heat at 60 °C for 5 min. Evaporate to dryness under a current of nitrogen. Dissolve the residue in 5 mL of water R and dilute to 20.0 mL with the mobile phase.

**Column**:

– *size*:  $l = 0.25$  m,  $\varnothing = 4.0$  mm;

– *stationary phase*: octadecylsilyl silica gel for chromatography R (5  $\mu$ m).

*Mobile phase*: a mixture of equal volumes of acetonitrile R and a solution prepared as follows: dissolve 1.32 g of ammonium phosphate R in 900 mL of water R, adjust to pH 7.0 with phosphoric acid R and dilute to 1000 mL with water R.

*Flow rate*: 1 mL/min.

*Detection*: spectrophotometer at 248 nm.

*Injection*: 20  $\mu$ L.

*Run time*: 3 times the retention time of ambroxol.

*Identification of impurities*: use the chromatogram obtained with reference solution (b) to identify the peak due to impurity B.

*Relative retention* with reference to ambroxol (retention time = about 9 min): impurity B = about 0.6.

*System suitability*: reference solution (b):

– *resolution*: minimum 4.0 between the peaks due to impurity B and ambroxol.

**Limits**:

– *unspecified impurities*: for each impurity, not more than the area of the principal peak in the chromatogram obtained with reference solution (a) (0.10 per cent),

– *total*: not more than 3 times the area of the principal peak in the chromatogram obtained with reference solution (a) (0.3 per cent),

– *disregard limit*: 0.5 times the area of the principal peak in the chromatogram obtained with reference solution (a) (0.05 per cent).

**Heavy metals** (2.4.8): maximum 20 ppm.

1.0 g complies with test C. Prepare the reference solution using 2 mL of lead standard solution (10 ppm Pb) R.

**Loss on drying** (2.2.32): maximum 0.5 per cent, determined on 1.000 g by drying in an oven at 105 °C.

**Sulfated ash** (2.4.14): maximum 0.1 per cent, determined on 1.0 g.

**ASSAY**

Dissolve 0.300 g in 70 mL of ethanol (96 per cent) R and add 5 mL of 0.01 M hydrochloric acid. Carry out a potentiometric titration (2.2.20), using 0.1 M sodium hydroxide. Read the volume added between the 2 points of inflexion.

1 mL of 0.1 M sodium hydroxide is equivalent to 41.46 mg of  $C_{13}H_{19}Br_2ClN_2O$ .

**STORAGE**

Protected from light.



## IMPURITIES

*Other detectable impurities* (the following substances would, if present at a sufficient level, be detected by one or other of the tests in the monograph. They are limited by the general acceptance criterion for other/unspecified impurities and/or by the general monograph *Substances for pharmaceutical use (2034)*. It is therefore not necessary to identify these impurities for demonstration of compliance. See also 5.10. *Control of impurities in substances for pharmaceutical use*): A, B, C, D, E.

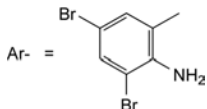

A. Ar-CH<sub>2</sub>OH: (2-amino-3,5-dibromophenyl)methanol,

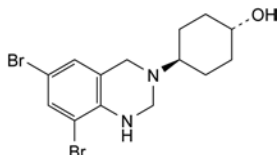

B. *trans*-4-(6,8-dibromo-1,4-dihydroquinazolin-3(2H)-yl)cyclohexanol,

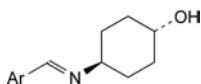

C. *trans*-4-[[*(E)*-2-amino-3,5-dibromobenzylidene]amino]cyclohexanol,

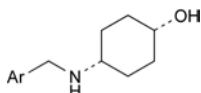

D. *cis*-4-[(2-amino-3,5-dibromobenzyl)amino]cyclohexanol,

E. Ar-CH=O: 2-amino-3,5-dibromobenzaldehyde.

C. To 50 mL of solution S add 5 mL of *strong sodium hydroxide solution R* and 0.5 mL of *benzoyl chloride R* and shake. Continue to add *benzoyl chloride R* in portions of 0.5 mL until no further precipitate is formed. Filter, wash the precipitate with *water R*, recrystallise twice from a mixture of equal volumes of *ethanol (96 per cent) R* and *water R*, then dry at 100-105 °C. The crystals melt (2.2.14) at 131 °C to 135 °C.

D. To about 2 mg add 1 mL of *sulfuric acid-formaldehyde reagent R*. An orange colour develops and quickly becomes dark-brown.

E. Solution S gives reaction (a) of sulfates (2.3.1).

## TESTS

**Solution S.** Dissolve 2.0 g in *carbon dioxide-free water R* and dilute to 100 mL with the same solvent.

**Appearance of solution.** Solution S is clear (2.2.1) and colourless (2.2.2, *Method II*).

**Acidity or alkalinity.** To 25 mL of solution S add 0.1 mL of *methyl red solution R*. Not more than 0.1 mL of 0.01 M *hydrochloric acid* or 0.01 M *sodium hydroxide* is required to change the colour of the indicator.

**Loss on drying** (2.2.32): maximum 1.0 per cent, determined on 1.00 g by drying in an oven at 105 °C.

**Sulfated ash** (2.4.14): maximum 0.1 per cent, determined on 1.0 g.

## ASSAY

Dissolve 0.300 g in 30 mL of *anhydrous acetic acid R*. Titrate with 0.1 M *perchloric acid*, determining the end-point potentiometrically (2.2.20).

1 mL of 0.1 M *perchloric acid* is equivalent to 36.85 mg of C<sub>18</sub>H<sub>28</sub>N<sub>2</sub>O<sub>4</sub>S.

## STORAGE

Protected from light.

01/2008:0368  
corrected 6.0

01/2008:0873  
corrected 6.0

## AMFETAMINE SULFATE

## Amfetamini sulfas

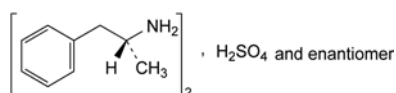

C<sub>18</sub>H<sub>28</sub>N<sub>2</sub>O<sub>4</sub>S  
[60-13-9]

M<sub>r</sub> 368.5

## DEFINITION

Bis[(2*RS*)-1-phenylpropan-2-amine] sulfate.

*Content*: 99.0 per cent to 100.5 per cent (dried substance).

## CHARACTERS

*Appearance*: white or almost white powder.

*Solubility*: freely soluble in water, slightly soluble in ethanol (96 per cent).

## IDENTIFICATION

*First identification*: A, B, E.

*Second identification*: A, C, D, E.

A. Optical rotation (2.2.7): -0.04° to +0.04° (measured in a 2 dm tube), determined on solution S (see Tests).

B. Infrared absorption spectrophotometry (2.2.24).

*Preparation*: mulls in *liquid paraffin R*.

*Comparison*: Ph. Eur. reference spectrum of *amfetamine sulfate*.

## AMIDOTRIZOIC ACID DIHYDRATE

## Acidum amidotrizoicum dihydricum

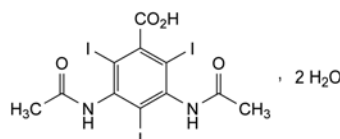

C<sub>11</sub>H<sub>9</sub>I<sub>3</sub>N<sub>2</sub>O<sub>4</sub>·2H<sub>2</sub>O  
[50978-11-5]

M<sub>r</sub> 650

## DEFINITION

Amidotrizoic acid dihydrate contains not less than 98.5 per cent and not more than the equivalent of 101.0 per cent of 3,5-bis(acetylamino)-2,4,6-triiodobenzoic acid, calculated with reference to the dried substance.

## CHARACTERS

A white or almost white, crystalline powder, very slightly soluble in water and in alcohol. It dissolves in dilute solutions of alkali hydroxides.

## IDENTIFICATION

*First identification*: A.

*Second identification*: B, C.

A. Examine by infrared absorption spectrophotometry (2.2.24), comparing with the spectrum obtained with *amidotrizoic acid dihydrate CRS*.

- B. Examine the chromatograms obtained in the test for related substances (see Tests). The principal spot in the chromatogram obtained with test solution (b) is similar in position and size to the principal spot in the chromatogram obtained with reference solution (b).
- C. Heat 50 mg gently in a small porcelain dish over a naked flame. Violet vapour is evolved.

## TESTS

**Appearance of solution.** Dissolve 1.0 g in *dilute sodium hydroxide solution R* and dilute to 20 mL with the same solvent. The solution is clear (2.2.1) and colourless (2.2.2, *Method II*).

**Related substances.** Examine by thin-layer chromatography (2.2.27), using *silica gel GF<sub>254</sub> R* as the coating substance.

**Test solution (a).** Dissolve 0.50 g of the substance to be examined in a 3 per cent *V/V* solution of *ammonia R* in *methanol R* and dilute to 10 mL with the same solvent.

**Test solution (b).** Dilute 1 mL of test solution (a) to 10 mL with a 3 per cent *V/V* solution of *ammonia R* in *methanol R*.

**Reference solution (a).** Dilute 1 mL of test solution (b) to 50 mL with a 3 per cent *V/V* solution of *ammonia R* in *methanol R*.

**Reference solution (b).** Dissolve 50 mg of *amidotrizoic acid dihydrate CRS* in a 3 per cent *V/V* solution of *ammonia R* in *methanol R* and dilute to 10 mL with the same solvent.

Apply separately to the plate 2 µL of each solution. Develop over a path of 15 cm using a mixture of 20 volumes of *anhydrous formic acid R*, 25 volumes of *methyl ethyl ketone R* and 60 volumes of *toluene R*. Allow the plate to dry until the solvents have evaporated and examine in ultraviolet light at 254 nm. Any spot in the chromatogram obtained with test solution (a), apart from the principal spot, is not more intense than the spot in the chromatogram obtained with reference solution (a) (0.2 per cent).

**Halides.** Dissolve 0.55 g in a mixture of 4 mL of *dilute sodium hydroxide solution R* and 15 mL of *water R*. Add 6 mL of *dilute nitric acid R* and filter. 15 mL of the filtrate complies with the limit test for chlorides (2.4.4) (150 ppm expressed as chloride).

**Free aromatic amines.** *Maintain the solutions and reagents in iced water protected from bright light.* To 0.50 g in a 50 mL volumetric flask add 15 mL of *water R*. Shake and add 1 mL of *dilute sodium hydroxide solution R*. Cool in iced water, add 5 mL of a freshly prepared 5 g/L solution of *sodium nitrite R* and 12 mL of *dilute hydrochloric acid R*. Shake gently and allow to stand for exactly 2 min after adding the hydrochloric acid. Add 10 mL of a 20 g/L solution of *ammonium sulfamate R*. Allow to stand for 5 min, shaking frequently, and add 0.15 mL of a 100 g/L solution of *α-naphthol R* in *alcohol R*. Shake and allow to stand for 5 min. Add 3.5 mL of *buffer solution pH 10.9 R*, mix and dilute to 50.0 mL with *water R*. The absorbance (2.2.25), measured within 20 min at 485 nm using as the compensation liquid a solution prepared at the same time and in the same manner but omitting the substance to be examined, is not greater than 0.30.

**Heavy metals** (2.4.8). Dissolve 2.0 g in 4 mL of *dilute sodium hydroxide solution R* and dilute to 20 mL with *water R*. 12 mL of this solution complies with limit test A for heavy metals (20 ppm). Prepare the standard using *lead standard solution (2 ppm Pb) R*.

**Loss on drying** (2.2.32): 4.5 per cent to 7.0 per cent, determined on 0.500 g by drying in an oven at 105 °C.

**Sulfated ash** (2.4.14). Not more than 0.1 per cent, determined on 1.0 g.

## ASSAY

To 0.150 g in a 250 mL round-bottomed flask add 5 mL of *strong sodium hydroxide solution R*, 20 mL of *water R*, 1 g of *zinc powder R* and a few glass beads. Boil under a reflux condenser for 30 min. Allow to cool and rinse the condenser with 20 mL of *water R*, adding the rinsings to the flask. Filter through a sintered-glass filter (2.1.2) and wash the filter

with several quantities of *water R*. Collect the filtrate and washings. Add 40 mL of *dilute sulfuric acid R* and titrate immediately with 0.1 M *silver nitrate*. Determine the end-point potentiometrically (2.2.20), using a suitable electrode system such as silver-mercurous sulfate.

1 mL of 0.1 M *silver nitrate* is equivalent to 20.47 mg of  $C_{11}H_{13}N_5O_4$ .

## STORAGE

Store protected from light.

## IMPURITIES

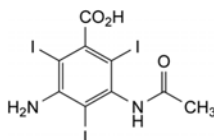

- A. 3-(acetylamino)-5-amino-2,4,6-triodobenzoic acid.

01/2010:1289

## AMIKACIN

## Amikacinum

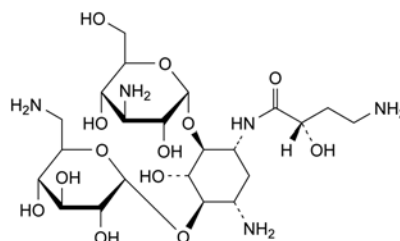

$C_{22}H_{43}N_5O_{13}$   
[37517-28-5]

$M_r$  585.6

## DEFINITION

6-*O*-(3-Amino-3-deoxy-α-D-glucopyranosyl)-4-*O*-(6-amino-6-deoxy-α-D-glucopyranosyl)-1-*N*-[(2*S*)-4-amino-2-hydroxybutanoyl]-2-deoxy-D-streptamine.

Antimicrobial substance obtained from kanamycin A.

Semi-synthetic product derived from a fermentation product.

**Content:** 96.5 per cent to 102.0 per cent (anhydrous substance).

## CHARACTERS

**Appearance:** white or almost white powder.

**Solubility:** sparingly soluble in water, slightly soluble in methanol, practically insoluble in acetone and in ethanol (96 per cent).

## IDENTIFICATION

- A. Infrared absorption spectrophotometry (2.2.24).

**Comparison:** *amikacin CRS*.

- B. Thin-layer chromatography (2.2.27).

**Test solution.** Dissolve 25 mg of the substance to be examined in *water R* and dilute to 10 mL with the same solvent.

**Reference solution (a).** Dissolve 25 mg of *amikacin CRS* in *water R* and dilute to 10 mL with the same solvent.

**Reference solution (b).** Dissolve 5 mg of *kanamycin monosulfate CRS* in 1 mL of the test solution and dilute to 10 mL with *water R*.

**Plate:** *TLC silica gel plate R*.

**Mobile phase:** the lower layer of a mixture of equal volumes of *concentrated ammonia R*, *methanol R* and *methylene chloride R*.

**Application:** 5 µL.

**Development:** over a path of 15 cm.

*Drying:* in air.

*Detection:* spray with *ninhydrin solution R1* and heat at 110 °C for 5 min.

*System suitability:* reference solution (b):

- the chromatogram shows 2 clearly separated spots.

*Results:* the principal spot in the chromatogram obtained with the test solution is similar in position, colour and size to the principal spot in the chromatogram obtained with reference solution (a).

## TESTS

**pH (2.2.3):** 9.5 to 11.5.

Dissolve 0.1 g in *carbon dioxide-free water R* and dilute to 10 mL with the same solvent.

**Specific optical rotation (2.2.7):** + 97 to + 105 (anhydrous substance).

Dissolve 0.50 g in *water R* and dilute to 25.0 mL with the same solvent.

**Related substances.** Liquid chromatography (2.2.29). *Maintain the solutions at 10 °C.*

*Test solution (a).* Dissolve 0.100 g of the substance to be examined in *water R* and dilute to 10.0 mL with the same solvent. In a ground-glass-stoppered vial, add 0.2 mL of this solution to 2.0 mL of a 10 g/L solution of *2,4,6-trinitrobenzene sulfonic acid R*, then add 3.0 mL of *pyridine R* and close the vial tightly. Shake vigorously for 30 s and heat in a water-bath at 75 °C for 45 min. Cool in cold water for 2 min and add 2 mL of *glacial acetic acid R*. Shake vigorously for 30 s.

*Test solution (b).* Dissolve 50.0 mg of the substance to be examined in *water R* and dilute to 50.0 mL with the same solvent, then prepare as prescribed for test solution (a).

*Reference solution (a).* Dissolve 10.0 mg of *amikacin CRS* in *water R* and dilute to 100.0 mL with the same solvent, then prepare as described for test solution (a).

*Reference solution (b).* Dissolve 50.0 mg of *amikacin CRS* in *water R* and dilute to 50.0 mL with the same solvent, then prepare as prescribed for test solution (a).

*Reference solution (c).* Dissolve 10 mg of *amikacin for system suitability CRS* (containing impurity A) in 1.0 mL of *water R*, then prepare as described for test solution (a).

*Blank solution.* Prepare as described for test solution (a) using 0.2 mL of *water R*.

*Column:*

- *size:*  $l = 0.25$  m,  $\varnothing = 4.6$  mm;
- *stationary phase:* *octadecylsilyl silica gel for chromatography R* (5  $\mu$ m);
- *temperature:* 30 °C.

*Mobile phase:* mix 30 volumes of a 2.7 g/L solution of *potassium dihydrogen phosphate R*, adjusted to pH 6.5 with a 22 g/L solution of *potassium hydroxide R*, and 70 volumes of *methanol R*.

*Flow rate:* 1 mL/min.

*Detection:* spectrophotometer at 340 nm.

*Injection:* 20  $\mu$ L of test solution (a) and reference solutions (a) and (c).

*Run time:* 4 times the retention time of amikacin.

*Identification of impurities:* use the chromatogram supplied with *amikacin for system suitability CRS* and the chromatogram obtained with reference solution (c) to identify the peak due to impurity A.

*Relative retention* with reference to amikacin (retention time = about 12 min): impurity A = about 1.5.

*System suitability:* reference solution (c):

- *resolution:* minimum 3.5 between the peaks due to amikacin and impurity A.

*Limits:*

- *impurity A:* not more than the area of the principal peak in the chromatogram obtained with reference solution (a) (1 per cent);
- *any other impurity:* for each impurity, not more than 0.5 times the area of the principal peak in the chromatogram obtained with reference solution (a) (0.5 per cent);
- *sum of impurities other than A:* not more than 1.5 times the area of the principal peak in the chromatogram obtained with reference solution (a) (1.5 per cent);
- *disregard limit:* 0.1 times the area of the principal peak in the chromatogram obtained with reference solution (a) (0.1 per cent); disregard any peak due to the blank.

**Water (2.5.12):** maximum 8.5 per cent, determined on 0.200 g.

**Sulfated ash (2.4.14):** maximum 0.5 per cent, determined on 1.0 g.

## ASSAY

Liquid chromatography (2.2.29) as described in the test for related substances with the following modifications.

*Injection:* test solution (b) and reference solution (b).

*System suitability:* reference solution (b):

- *repeatability:* maximum relative standard deviation of 2.0 per cent after 6 injections.

Calculate the percentage content of  $C_{22}H_{43}N_5O_{13}$  from the declared content of *amikacin CRS*.

## IMPURITIES

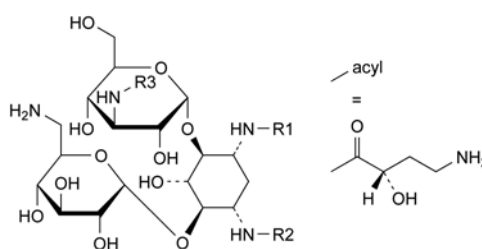

- A.  $R_1 = R_3 = H$ ,  $R_2 = \text{acyl}$ : 4-*O*-(3-amino-3-deoxy- $\alpha$ -D-glucopyranosyl)-6-*O*-(6-amino-6-deoxy- $\alpha$ -D-glucopyranosyl)-1-*N*-[(2*S*)-4-amino-2-hydroxybutanoyl]-2-deoxy-L-streptamine,
- B.  $R_1 = R_2 = \text{acyl}$ ,  $R_3 = H$ : 4-*O*-(3-amino-3-deoxy- $\alpha$ -D-glucopyranosyl)-6-*O*-(6-amino-6-deoxy- $\alpha$ -D-glucopyranosyl)-1,3-*N*-bis[(2*S*)-4-amino-2-hydroxybutanoyl]-2-deoxy-L-streptamine,
- C.  $R_1 = R_2 = H$ ,  $R_3 = \text{acyl}$ : 4-*O*-(6-amino-6-deoxy- $\alpha$ -D-glucopyranosyl)-6-*O*-[3-[(2*S*)-4-amino-2-hydroxybutanoyl]amino]-3-deoxy- $\alpha$ -D-glucopyranosyl]-2-deoxy-D-streptamine,
- D.  $R_1 = R_2 = R_3 = H$ : 6-*O*-(3-amino-3-deoxy- $\alpha$ -D-glucopyranosyl)-4-*O*-(6-amino-6-deoxy- $\alpha$ -D-glucopyranosyl)-2-deoxy-D-streptamine (kanamycin).

**01/2010:1290** **Specific optical rotation** (2.2.7): + 76 to + 84 (dried substance).  
**corrected 7.0** Dissolve 0.50 g in *water R* and dilute to 25.0 mL with the same solvent.

## AMIKACIN SULFATE

### Amikacini sulfas

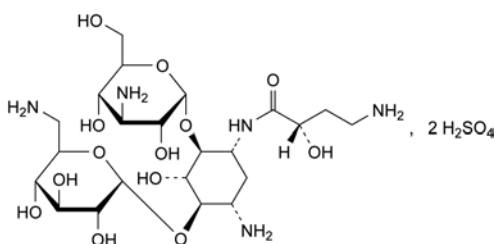

$C_{22}H_{47}N_5O_{21}S_2$   
[39831-55-5]

$M_r$  782

#### DEFINITION

6-*O*-(3-Amino-3-deoxy- $\alpha$ -D-glucopyranosyl)-4-*O*-(6-amino-6-deoxy- $\alpha$ -D-glucopyranosyl)-1-*N*-[(2*S*)-4-amino-2-hydroxybutanoyl]-2-deoxy-D-streptamine sulfate.

Antimicrobial substance obtained from kanamycin A.

Semi-synthetic product derived from a fermentation product.

**Content:** 96.5 per cent to 102.0 per cent (dried substance).

#### CHARACTERS

**Appearance:** white or almost white powder.

**Solubility:** freely soluble in water, practically insoluble in acetone and in ethanol (96 per cent).

#### IDENTIFICATION

A. Infrared absorption spectrophotometry (2.2.24).

**Comparison:** amikacin sulfate CRS.

B. Thin-layer chromatography (2.2.27).

**Test solution.** Dissolve 25 mg of the substance to be examined in *water R* and dilute to 10 mL with the same solvent.

**Reference solution (a).** Dissolve 25 mg of amikacin sulfate CRS in *water R* and dilute to 10 mL with the same solvent.

**Reference solution (b).** Dissolve 5 mg of kanamycin monosulfate CRS in 1 mL of the test solution and dilute to 10 mL with *water R*.

**Plate:** TLC silica gel plate R.

**Mobile phase:** the lower layer of a mixture of equal volumes of concentrated ammonia R, methanol R and methylene chloride R.

**Application:** 5  $\mu$ L.

**Development:** over a path of 15 cm.

**Drying:** in air.

**Detection:** spray with ninhydrin solution R1 and heat at 110 °C for 5 min.

**System suitability:** reference solution (b):

– the chromatogram shows 2 clearly separated spots.

**Results:** the principal spot in the chromatogram obtained with the test solution is similar in position, colour and size to the principal spot in the chromatogram obtained with reference solution (a).

C. It gives reaction (a) of sulfates (2.3.1).

#### TESTS

**pH** (2.2.3): 2.0 to 4.0.

Dissolve 0.1 g in carbon dioxide-free water R and dilute to 10 mL with the same solvent.

**Related substances.** Liquid chromatography (2.2.29). Maintain the solutions at 10 °C.

**Test solution (a).** Dissolve 0.100 g of the substance to be examined in *water R* and dilute to 10.0 mL with the same solvent. In a ground-glass-stoppered vial, add 0.2 mL of this solution to 2.0 mL of a 10 g/L solution of 2,4,6-trinitrobenzene sulfonic acid R, then add 3.0 mL of pyridine R and close the vial tightly. Shake vigorously for 30 s and heat in a water-bath at 75 °C for 2 h. Cool in cold water for 2 min and add 2 mL of glacial acetic acid R. Shake vigorously for 30 s.

**Test solution (b).** Dissolve 50.0 mg of the substance to be examined in *water R* and dilute to 50.0 mL with the same solvent, then prepare as prescribed for test solution (a).

**Reference solution (a).** Dissolve 7.5 mg of amikacin sulfate CRS in *water R* and dilute to 100.0 mL with the same solvent, then prepare as prescribed for test solution (a).

**Reference solution (b).** Dissolve 37.4 mg of amikacin sulfate CRS in *water R* and dilute to 50.0 mL with the same solvent, then prepare as prescribed for test solution (a).

**Reference solution (c).** Dissolve 10 mg of amikacin for system suitability CRS (containing impurity A) in 1.0 mL of *water R*, then prepare as prescribed for test solution (a).

**Blank solution.** Prepare as described for test solution (a) using 0.2 mL of *water R*.

**Column:**

- size:  $l = 0.25$  m,  $\varnothing = 4.6$  mm;
- stationary phase: octadecylsilyl silica gel for chromatography R (5  $\mu$ m);
- temperature: 30 °C.

**Mobile phase:** mix 30 volumes of a 2.7 g/L solution of potassium dihydrogen phosphate R, adjusted to pH 6.5 with a 22 g/L solution of potassium hydroxide R, and 70 volumes of methanol R.

**Flow rate:** 1 mL/min.

**Detection:** spectrophotometer at 340 nm.

**Injection:** 20  $\mu$ L of test solution (a) and reference solutions (a) and (c).

**Run time:** 4 times the retention time of amikacin.

**Identification of impurities:** use the chromatogram supplied with amikacin for system suitability CRS and the chromatogram obtained with reference solution (c) to identify the peak due to impurity A.

**Relative retention** with reference to amikacin (retention time = about 12 min): impurity A = about 1.5.

**System suitability:** reference solution (c):

- resolution: minimum 3.5 between the peaks due to amikacin and impurity A.

**Limits:**

- impurity A: not more than the area of the principal peak in the chromatogram obtained with reference solution (a) (1.0 per cent);
- any other impurity: for each impurity, not more than 0.5 times the area of the principal peak in the chromatogram obtained with reference solution (a) (0.5 per cent);
- sum of impurities other than A: not more than 1.5 times the area of the principal peak in the chromatogram obtained with reference solution (a) (1.5 per cent);
- disregard limit: 0.1 times the area of the principal peak in the chromatogram obtained with reference solution (a) (0.1 per cent); disregard any peak due to the blank and any peak eluting before the principal peak.

**Sulfate:** 23.3 per cent to 25.8 per cent (dried substance).

Dissolve 0.250 g in 100 mL of *water R* and adjust the solution to pH 11 using concentrated ammonia R. Add 10.0 mL of 0.1 M

barium chloride and about 0.5 mg of *phthalein purple R*. Titrate with 0.1 M sodium edetate adding 50 mL of ethanol (96 per cent) *R* when the colour of the solution begins to change and continue the titration until the violet-blue colour disappears.

1 mL of 0.1 M barium chloride is equivalent to 9.606 mg of sulfate (SO<sub>4</sub>).

**Loss on drying** (2.2.32): maximum 13.0 per cent, determined on 0.500 g by drying in an oven at 105 °C at a pressure not exceeding 0.7 kPa for 3 h.

**Pyrogens** (2.6.8). If intended for use in the manufacture of parenteral preparations without a further appropriate procedure for the removal of pyrogens, it complies with the test for pyrogens. Inject per kilogram of the rabbit's mass 5 mL of a solution containing 25 mg of the substance to be examined in water for injections *R*.

#### ASSAY

Liquid chromatography (2.2.29) as described in the test for related substances with the following modifications.

*Injection*: test solution (b) and reference solution (b).

*System suitability*: reference solution (b):

- *repeatability*: maximum relative standard deviation of 2.0 per cent after 6 injections.

Calculate the percentage content of C<sub>22</sub>H<sub>47</sub>N<sub>5</sub>O<sub>21</sub>S<sub>2</sub> from the declared content of C<sub>22</sub>H<sub>43</sub>N<sub>5</sub>O<sub>13</sub> in *amikacin CRS* taking into account a conversion factor of 1.335.

#### STORAGE

If the substance is sterile, store in a sterile, airtight, tamper-proof container.

#### IMPURITIES

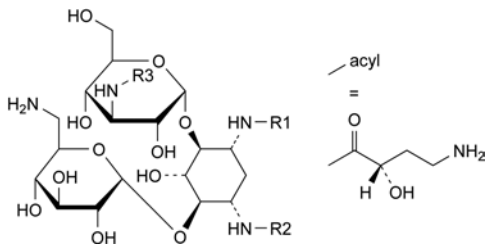

- A. R1 = R3 = H, R2 = acyl: 4-*O*-(3-amino-3-deoxy- $\alpha$ -D-glucopyranosyl)-6-*O*-(6-amino-6-deoxy- $\alpha$ -D-glucopyranosyl)-1-*N*-[(2*S*)-4-amino-2-hydroxybutanoyl]-2-deoxy-L-streptamine,
- B. R1 = R2 = acyl, R3 = H: 4-*O*-(3-amino-3-deoxy- $\alpha$ -D-glucopyranosyl)-6-*O*-(6-amino-6-deoxy- $\alpha$ -D-glucopyranosyl)-1,3-*N*-bis[(2*S*)-4-amino-2-hydroxybutanoyl]-2-deoxy-L-streptamine,
- C. R1 = R2 = H, R3 = acyl: 4-*O*-(6-amino-6-deoxy- $\alpha$ -D-glucopyranosyl)-6-*O*-[3-[(2*S*)-4-amino-2-hydroxybutanoyl]amino]-3-deoxy- $\alpha$ -D-glucopyranosyl]-2-deoxy-D-streptamine,
- D. R1 = R2 = R3 = H: 6-*O*-(3-amino-3-deoxy- $\alpha$ -D-glucopyranosyl)-4-*O*-(6-amino-6-deoxy- $\alpha$ -D-glucopyranosyl)-2-deoxy-D-streptamine (kanamycin).

04/2010:0651

## AMILORIDE HYDROCHLORIDE

### Amiloridi hydrochloridum

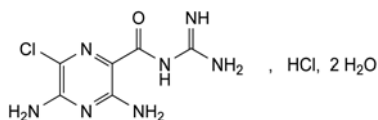

C<sub>6</sub>H<sub>9</sub>Cl<sub>2</sub>N<sub>7</sub>O<sub>2</sub>H<sub>2</sub>O  
[17440-83-4]

*M<sub>r</sub>* 302.1

#### DEFINITION

3,5-Diamino-*N*-carbamimidoyl-6-chloropyrazine-2-carboxamide hydrochloride dihydrate.

*Content*: 98.0 per cent to 101.0 per cent (anhydrous substance).

#### CHARACTERS

*Appearance*: pale yellow or greenish-yellow powder.

*Solubility*: slightly soluble in water and in anhydrous ethanol.

#### IDENTIFICATION

*First identification*: A, D.

*Second identification*: B, C, D.

A. Infrared absorption spectrophotometry (2.2.24).

*Comparison*: amiloride hydrochloride CRS.

B. Thin-layer chromatography (2.2.27).

*Test solution*. Dissolve 40 mg of the substance to be examined in methanol *R* and dilute to 10 mL with the same solvent.

*Reference solution*. Dissolve 40 mg of amiloride hydrochloride CRS in methanol *R* and dilute to 10 mL with the same solvent.

*Plate*: TLC silica gel plate *R*.

*Mobile phase*: dilute ammonia R1, water *R*, dioxan *R* (6:6:88 V/V/V); freshly prepared mixture.

*Application*: 5  $\mu$ L.

*Development*: over 2/3 of the plate.

*Drying*: in air.

*Detection*: examine in ultraviolet light at 365 nm.

*Results*: the principal spot in the chromatogram obtained with the test solution is similar in position, fluorescence and size to the principal spot in the chromatogram obtained with the reference solution.

C. Dissolve about 10 mg in 10 mL of water *R*. Add 10 mL of a 200 g/L solution of cetrimide *R*, 0.25 mL of dilute sodium hydroxide solution *R* and 1 mL of bromine water *R*. A greenish-yellow colour is produced. Add 2 mL of dilute hydrochloric acid *R*. The solution becomes deep yellow and shows blue fluorescence in ultraviolet light at 365 nm.

D. It gives reaction (b) of chlorides (2.3.1).

#### TESTS

**Free acid**. Dissolve 1.0 g in a mixture of 50 mL of methanol *R* and 50 mL of water *R* and titrate with 0.1 M sodium hydroxide, determining the end-point potentiometrically (2.2.20). Not more than 0.3 mL of 0.1 M sodium hydroxide is required to reach the end-point.

**Related substances**. Liquid chromatography (2.2.29).

*Test solution*. Dissolve 20.0 mg of the substance to be examined in a mixture of 1 volume of acetonitrile *R* and 3 volumes of water *R* and dilute to 10.0 mL with the same mixture of solvents.

*Reference solution (a)*. Dilute 1.0 mL of the test solution to 100.0 mL with a mixture of 1 volume of acetonitrile *R* and 3 volumes of water *R*.

*Reference solution (b)*. Dilute 1.0 mL of reference solution (a) to 10.0 mL with a mixture of 1 volume of acetonitrile *R* and 3 volumes of water *R*.

*Reference solution (c)*. Dissolve 5.0 mg of amiloride impurity A CRS in a mixture of 1 volume of acetonitrile *R* and 3 volumes of water *R* and dilute to 5.0 mL with the same mixture of solvents. Dilute 1.0 mL of this solution to 100.0 mL with a mixture of 1 volume of acetonitrile *R* and 3 volumes of water *R*.

*Column*:

– *size*: *l* = 0.25 m,  $\varnothing$  = 4.6 mm;

– *stationary phase*: octadecylsilyl silica gel for chromatography *R* (5  $\mu$ m).

01/2008:1687

**Mobile phase:** mix 5 volumes of *tetramethylammonium hydroxide solution R*, 250 volumes of *acetonitrile R* and 745 volumes of *water R*; adjust to pH 7.0 with a mixture of 1 volume of *phosphoric acid R* and 9 volumes of *water R*. Adjust the concentration of acetonitrile in the mobile phase so that the retention time of impurity A is 5-6 min (an increase in the concentration of acetonitrile results in a shorter retention time). Adjust the concentration of tetramethylammonium hydroxide and of phosphoric acid keeping the pH at 7.0 so that the retention time of amiloride is 9-12 min (an increase in the concentration results in a shorter retention time for amiloride).

**Flow rate:** 1 mL/min.

**Detection:** spectrophotometer at 254 nm.

**Injection:** 20 µL.

**Run time:** 5 times the retention time of amiloride.

**System suitability:** reference solution (b):

- **signal-to-noise ratio:** minimum 5.0 for the peak due to amiloride.

**Limits:**

- **unspecified impurities:** for each impurity, not more than 0.2 times the area of the peak due to impurity A in the chromatogram obtained with reference solution (c) (0.10 per cent);
- **total:** not more than the area of the peak due to impurity A in the chromatogram obtained with reference solution (c) (0.5 per cent);
- **disregard limit:** 0.1 times the area of the peak due to impurity A in the chromatogram obtained with reference solution (c) (0.05 per cent).

**Water (2.5.12):** 11.0 per cent to 13.0 per cent, determined on 0.200 g.

**Sulfated ash (2.4.14):** maximum 0.1 per cent, determined on 1.0 g.

#### ASSAY

Dissolve 0.200 g in a mixture of 5.0 mL of 0.01 M *hydrochloric acid* and 50 mL of *ethanol (96 per cent) R*. Carry out a potentiometric titration (2.2.20), using 0.1 M *sodium hydroxide*. Read the volume added between the 2 points of inflexion.

1 mL of 0.1 M *sodium hydroxide* is equivalent to 26.61 mg of C<sub>7</sub>H<sub>7</sub>Cl<sub>2</sub>N<sub>7</sub>O.

#### STORAGE

Protected from light.

#### IMPURITIES

**Other detectable impurities** (the following substances would, if present at a sufficient level, be detected by one or other of the tests in the monograph. They are limited by the general acceptance criterion for other/unspecified impurities and/or by the general monograph *Substances for pharmaceutical use (2034)*. It is therefore not necessary to identify these impurities for demonstration of compliance. See also 5.10. *Control of impurities in substances for pharmaceutical use*): A.

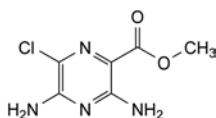

A. methyl 3,5-diamino-6-chloropyrazine-2-carboxylate.

## 4-AMINOBENZOIC ACID

### Acidum 4-aminobenzoicum

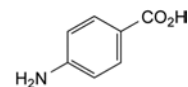

C<sub>7</sub>H<sub>7</sub>NO<sub>2</sub>  
[150-13-0]

*M<sub>r</sub>* 137.1

#### DEFINITION

4-Aminobenzoic acid.

**Content:** 99.0 per cent to 101.0 per cent (anhydrous substance).

#### CHARACTERS

**Appearance:** white or slightly yellow, crystalline powder.

**Solubility:** slightly soluble in water, freely soluble in alcohol. It dissolves in dilute solutions of alkali hydroxides.

#### IDENTIFICATION

**First identification:** B.

**Second identification:** A, C.

A. Melting point (2.2.14): 186 °C to 189 °C.

B. Infrared absorption spectrophotometry (2.2.24).

**Comparison:** 4-aminobenzoic acid CRS.

C. Thin-layer chromatography (2.2.27).

**Test solution.** Dissolve 20 mg of the substance to be examined in *methanol R* and dilute to 20 mL with the same solvent.

**Reference solution (a).** Dissolve 20 mg of 4-aminobenzoic acid CRS in *methanol R* and dilute to 20 mL with the same solvent.

**Reference solution (b).** Dissolve 10 mg of 4-nitrobenzoic acid R in 10 mL of reference solution (a).

**Plate:** suitable silica gel with a fluorescent indicator having an optimal intensity at 254 nm as the coating substance.

**Mobile phase:** *glacial acetic acid R*, *hexane R*, *methylene chloride R* (5:20:75 V/V/V).

**Application:** 1 µL.

**Development:** over a path of 10 cm.

**Drying:** in air.

**Detection:** examine in ultraviolet light at 254 nm.

**System suitability:** the chromatogram obtained with reference solution (b) shows 2 clearly separated spots.

**Results:** the principal spot in the chromatogram obtained with the test solution is similar in position and size to the principal spot in the chromatogram obtained with reference solution (a).

#### TESTS

**Appearance of solution.** The solution is clear (2.2.1) and not more intensely coloured than reference solution B<sub>3</sub> (2.2.2, *Method II*).

Dissolve 1.0 g in *alcohol R* and dilute to 20 mL with the same solvent.

**Related substances.** Liquid chromatography (2.2.29).

**Test solution.** Dissolve 25.0 mg of the substance to be examined in the mobile phase and dilute to 100.0 mL with the mobile phase.

**Reference solution.** Dissolve 25.0 mg of 4-nitrobenzoic acid R and 25.0 mg of *benzocaine R* in *methanol R* and dilute to 100.0 mL with the same solvent. Dilute 1.0 mL to 50.0 mL with the mobile phase. Dilute 1.0 mL of this solution to 10.0 mL with the mobile phase.

**Column:**

- **size:** *l* = 0.12 m,  $\varnothing$  = 4.0 mm,

– *stationary phase*: octylsilyl silica gel for chromatography R (5 µm).

*Mobile phase*: mix 20 volumes of a mixture of 70 volumes of acetone R and 80 volumes of methanol R, and 80 volumes of a solution containing 1.5 g/L of potassium dihydrogen phosphate R and 2.5 g/L of sodium octanesulfonate R adjusted to pH 2.2 with phosphoric acid R.

*Flow rate*: 1.0 mL/min.

*Detection*: spectrophotometer at 270 nm.

*Injection*: 20 µL.

*Run time*: 11 times the retention time of 4-aminobenzoic acid.

*Relative retention* with reference to 4-aminobenzoic acid (retention time = about 3 min): impurity A = about 4; impurity B = about 9.

*Limits*:

- *impurity A*: not more than the area of the corresponding peak in the chromatogram obtained with the reference solution (0.2 per cent),
- *impurity B*: not more than the area of the corresponding peak in the chromatogram obtained with the reference solution (0.2 per cent),
- *any other impurity*: not more than 0.5 times the area of the peak due to impurity A in the chromatogram obtained with the reference solution (0.1 per cent),
- *total*: not more than 2.5 times the area of the peak due to impurity A in the chromatogram obtained with the reference solution (0.5 per cent),
- *disregard limit*: 0.1 times the area of the peak due to impurity A in the chromatogram obtained with the reference solution (0.02 per cent).

**Impurity C and impurity D.** Gas chromatography (2.2.28).

*Internal standard solution.* Dissolve 20.0 mg of lauric acid R in methylene chloride R and dilute to 100.0 mL with the same solvent.

*Test solution.* Dissolve 1.000 g of the substance to be examined in 10.0 mL of an 84 g/L solution of sodium hydroxide R and extract with 2 quantities, each of 10 mL, of methylene chloride R. Combine and wash with 5 mL of water R; filter through anhydrous sodium sulfate R. Wash the filter with methylene chloride R. Evaporate in a water-bath at 50-60 °C to obtain a volume of about 1.5 mL. Add 1.0 mL of the internal standard solution and dilute to 10.0 mL with methylene chloride R.

*Reference solution (a).* Dissolve 20.0 mg of aniline R in methylene chloride R and dilute to 100.0 mL with the same solvent.

*Reference solution (b).* Dissolve 20.0 mg of *p*-toluidine R in methylene chloride R and dilute to 100.0 mL with the same solvent.

*Reference solution (c).* Dilute 0.50 mL of reference solution (a), 0.50 mL of reference solution (b) and 10.0 mL of the internal standard solution to 100.0 mL with methylene chloride R.

*Column*:

- *material*: fused silica,
- *size*: *l* = 30 m,  $\varnothing$  = 0.32 mm,
- *stationary phase*: poly[methyl(95)phenyl(5)] siloxane R (film thickness 0.5 µm).

*Carrier gas*: helium for chromatography R.

*Flow rate*: 1.0 mL/min.

*Split ratio*: 1:10.

*Temperature*:

	Time (min)	Temperature (°C)
Column	0 - 4	130
	4 - 6.5	130 → 180
	6.5 - 11.5	180
Injection port		280
Detector		300

*Detection*: flame ionisation.

*Injection*: 2 µL; inject the test solution and reference solution (c).

*Retention time*: internal standard = about 9.5 min.

*Limits*:

- *impurity C*: calculate the ratio (*R*) of the area of the peak due to impurity C to the area of the peak due to the internal standard from the chromatogram obtained with reference solution (c); calculate the ratio of the area of the peak due to impurity C to the area of the peak due to the internal standard from the chromatogram obtained with the test solution: this ratio is not greater than *R* (10 ppm),
- *impurity D*: calculate the ratio (*R*) of the area of the peak due to impurity D to the area of the peak due to the internal standard from the chromatogram obtained with reference solution (c); calculate the ratio of the area of the peak due to impurity D to the area of the peak due to the internal standard from the chromatogram obtained with the test solution: this ratio is not greater than *R* (10 ppm).

**Iron (2.4.9)**: maximum 40 ppm.

Dissolve 0.250 g in 3 mL of alcohol R and dilute to 10.0 mL with water R.

**Heavy metals (2.4.8)**: maximum 20 ppm.

1.0 g complies with test C. Prepare the reference solution using 2 mL of lead standard solution (10 ppm Pb) R.

**Water (2.5.12)**: maximum 0.2 per cent, determined on 1.00 g.

**Sulfated ash (2.4.14)**: maximum 0.1 per cent, determined on 1.0 g.

ASSAY

Dissolve 0.100 g with heating in 50 mL of carbon dioxide-free water R. Titrate with 0.1 M sodium hydroxide determining the end-point potentiometrically (2.2.20).

1 mL of 0.1 M sodium hydroxide is equivalent to 13.71 mg of C<sub>7</sub>H<sub>7</sub>NO<sub>2</sub>.

STORAGE

Protected from light.

IMPURITIES

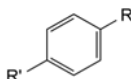

A. R = CO<sub>2</sub>H, R' = NO<sub>2</sub>: 4-nitrobenzoic acid,

B. R = CO-O-C<sub>2</sub>H<sub>5</sub>, R' = NH<sub>2</sub>: ethyl 4-aminobenzoate (benzocaine),

C. R = H, R' = NH<sub>2</sub>: aniline,

D. R = CH<sub>3</sub>, R' = NH<sub>2</sub>: 4-methylaniline (*p*-toluidine).

**01/2008:0874** *Reference solution (b).* Dilute 5 mL of test solution (b) to 20 mL with *water R*.  
**corrected 6.0**

## AMINOCAPROIC ACID

### Acidum aminocaproicum



$C_6H_{13}NO_2$   
[60-32-2]

$M_r$  131.2

#### DEFINITION

Aminocaproic acid contains not less than 98.5 per cent and not more than the equivalent of 101.0 per cent of 6-aminohexanoic acid, calculated with reference to the dried substance.

#### CHARACTERS

A white or almost white, crystalline powder or colourless crystals, freely soluble in water, slightly soluble in alcohol.

It melts at about 205 °C with decomposition.

#### IDENTIFICATION

*First identification: A.*

*Second identification: B, C, D.*

- Examine by infrared absorption spectrophotometry (2.2.24), comparing with the spectrum obtained with *aminocaproic acid CRS*. Examine the substances prepared as discs.
- Examine the chromatograms obtained in the test for ninhydrin-positive substances. The principal spot in the chromatogram obtained with the test solution (b) is similar in position, colour and size to the principal spot in the chromatogram obtained with reference solution (a).
- Dissolve 0.5 g in 4 mL of a mixture of equal volumes of *dilute hydrochloric acid R* and *water R*. Evaporate to dryness by heating on a water-bath. Dry the residue in a desiccator. Dissolve the residue in about 2 mL of boiling *ethanol R*. Allow to cool and maintain at 4 °C to 8 °C for 3 h. Filter under reduced pressure. The residue washed with about 10 mL of *acetone R* and dried at 60 °C for 30 min, melts (2.2.14) at 131 °C to 133 °C.
- Dissolve about 5 mg in 0.5 mL of *distilled water R*. Add 3 mL of *dimethylformamide R* and 2 mL of *ascorbic acid solution R*. Heat on a water-bath. An orange colour develops.

#### TESTS

**Solution S.** dissolve 10.0 g in *carbon dioxide-free water R* and dilute to 50.0 mL with the same solvent.

**Appearance of solution.** Solution S is colourless (2.2.2, *Method II*) and remains clear (2.2.1) on standing for 24 h.

**pH** (2.2.3). The pH of solution S is 7.5 to 8.0.

**Absorbance** (2.2.25).

- The absorbance of solution S at 287 nm is not more than 0.10 and at 450 nm is not more than 0.03.
- Place 2.0 g in an even layer in a shallow dish 9 cm in diameter, cover and allow to stand at 98 °C to 102 °C for 72 h. Dissolve in *water R* and dilute to 10.0 mL with the same solvent. The absorbance of the solution at 287 nm is not more than 0.15 and at 450 nm is not more than 0.03.

**Ninhydrin-positive substances.** Examine by thin-layer chromatography (2.2.27), using a suitable silica gel as the coating substance.

*Test solution (a).* Dissolve 0.10 g of the substance to be examined in *water R* and dilute to 10 mL with the same solvent.

*Test solution (b).* Dilute 1 mL of test solution (a) to 50 mL with *water R*.

*Reference solution (a).* Dissolve 10 mg of *aminocaproic acid CRS* in *water R* and dilute to 50 mL with the same solvent.

*Reference solution (c).* Dissolve 10 mg of *aminocaproic acid CRS* and 10 mg of *leucine CRS* in *water R* and dilute to 25 mL with the same solvent.

Apply separately to the plate 5 µL of each solution. Allow the plate to dry in air. Develop over a path of 15 cm using a mixture of 20 volumes of *glacial acetic acid R*, 20 volumes of *water R* and 60 volumes of *butanol R*. Dry the plate in a current of warm air. Spray with *ninhydrin solution R* and heat at 100 °C to 105 °C for 15 min. Any spot in the chromatogram obtained with the test solution (a), apart from the principal spot, is not more intense than the spot in the chromatogram obtained with reference solution (b) (0.5 per cent). The test is not valid unless the chromatogram obtained with reference solution (c) shows two clearly separated principal spots.

**Heavy metals** (2.4.8). 12 mL of solution S complies with limit test A for heavy metals (10 ppm). Prepare the standard using *lead standard solution (2 ppm Pb) R*.

**Loss on drying** (2.2.32). Not more than 0.5 per cent, determined on 1.000 g by drying in an oven at 105 °C.

**Sulfated ash** (2.4.14). Not more than 0.1 per cent, determined on 1.0 g.

#### ASSAY

Dissolve 0.100 g in 20 mL of *anhydrous acetic acid R*. Using 0.1 mL of *crystal violet solution R* as indicator, titrate with 0.1 M *perchloric acid* until the colour changes from bluish-violet to bluish-green.

1 mL of 0.1 M *perchloric acid* is equivalent to 13.12 mg of  $C_6H_{13}NO_2$ .

01/2011:1291

## AMINOGLUTETHIMIDE

### Aminoglutethimidum

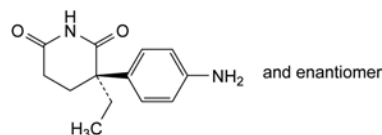

$C_{13}H_{16}N_2O_2$   
[125-84-8]

$M_r$  232.3

#### DEFINITION

(3*RS*)-3-(4-Aminophenyl)-3-ethylpiperidine-2,6-dione.

*Content:* 98.0 per cent to 101.5 per cent (dried substance).

#### CHARACTERS

*Appearance:* white or slightly yellow, crystalline powder.

*Solubility:* practically insoluble in water, freely soluble in acetone, soluble in methanol.

#### IDENTIFICATION

*First identification: B.*

*Second identification: A, C.*

- Melting point (2.2.14): 150 °C to 154 °C.
- Infrared absorption spectrophotometry (2.2.24).

*Comparison: aminoglutethimide CRS.*

- Thin-layer chromatography (2.2.27).

*Test solution.* Dissolve 25 mg of the substance to be examined in *acetone R* and dilute to 5 mL with the same solvent.

*Reference solution (a).* Dissolve 25 mg of *aminoglutethimide CRS* in *acetone R* and dilute to 5 mL with the same solvent.



*Reference solution (b).* Dissolve 25 mg of *aminoglutethimide CRS* and 25 mg of *glutethimide CRS* in *acetone R* and dilute to 5 mL with the same solvent.

*Plate:* TLC silica gel  $F_{254}$  plate *R*.

*Mobile phase:* glacial acetic acid *R*, methanol *R*, ethyl acetate *R* (0.5:15:85 V/V/V).

*Application:* 5  $\mu$ L.

*Development:* over 3/4 of the plate.

*Drying:* in air.

*Detection:* examine in ultraviolet light at 254 nm.

*System suitability:* reference solution (b):

- the chromatogram shows 2 clearly separated spots.

*Results:* the principal spot in the chromatogram obtained with the test solution is similar in position and size to the principal spot in the chromatogram obtained with reference solution (a).

## TESTS

**Solution S.** Dissolve 1.0 g in *methanol R* and dilute to 20.0 mL with the same solvent.

**Appearance of solution.** Solution S is clear (2.2.1) and not more intensely coloured than reference solution  $Y_7$  (2.2.2, Method II).

**Optical rotation** (2.2.7):  $-0.10^\circ$  to  $+0.10^\circ$ , determined on solution S.

**Related substances.** Liquid chromatography (2.2.29).

*Solvent mixture:* methanol *R*, acetate buffer solution pH 5.0 *R* (50:50 V/V).

*Test solution.* Dissolve 0.100 g of the substance to be examined in the solvent mixture and dilute to 50.0 mL with the solvent mixture.

*Reference solution (a).* Dissolve 5.0 mg of *aminoglutethimide impurity A CRS* in the solvent mixture and dilute to 25.0 mL with the solvent mixture.

*Reference solution (b).* Dilute 1.0 mL of reference solution (a) to 10.0 mL with the solvent mixture.

*Reference solution (c).* Dilute 1.0 mL of the test solution to 100.0 mL with the solvent mixture.

*Reference solution (d).* Dilute 1.0 mL of the test solution to 10.0 mL with reference solution (a).

*Column:*

- size:  $l = 0.15$  m,  $\emptyset = 3.9$  mm;
- stationary phase: octadecylsilyl silica gel for chromatography *R* (4  $\mu$ m);
- temperature: 40 °C.

*Mobile phase:* mix 27 volumes of *methanol R* and 73 volumes of acetate buffer solution pH 5.0 *R*.

*Flow rate:* 1.3 mL/min.

*Detection:* spectrophotometer at 240 nm.

*Injection:* 10  $\mu$ L of the test solution and reference solutions (b), (c) and (d).

*Run time:* 4 times the retention time of aminoglutethimide.

*Identification of impurities:* use the chromatogram obtained with reference solution (b) to identify the peak due to impurity A.

*Relative retention* with reference to aminoglutethimide (retention time = about 9 min): impurity A = about 1.3.

*System suitability:* reference solution (d):

- resolution: minimum 2.0 between the peaks due to aminoglutethimide and impurity A.

*Limits:*

- impurity A: not more than twice the area of the principal peak in the chromatogram obtained with reference solution (b) (2.0 per cent);
- unspecified impurities: for each impurity, not more than 0.1 times the area of the principal peak in the chromatogram obtained with reference solution (c) (0.10 per cent);

- sum of impurities other than A: not more than the area of the principal peak in the chromatogram obtained with reference solution (c) (1.0 per cent);
- total: maximum 2.0 per cent for the sum of the contents of all impurities;
- disregard limit: 0.05 times the area of the principal peak in the chromatogram obtained with reference solution (c) (0.05 per cent).

**Impurity D.** Liquid chromatography (2.2.29). Carry out the test protected from light. Use shaking, not sonication or heat, to dissolve the reference substance and the substance to be examined.

*Test solution.* Dissolve 0.100 g of the substance to be examined in *dimethyl sulfoxide R* and dilute to 100.0 mL with the same solvent.

*Reference solution.* Dissolve 3.0 mg of *aminoglutethimide impurity D CRS* in *dimethyl sulfoxide R* and dilute to 100.0 mL with the same solvent. Dilute 1.0 mL of this solution to 100.0 mL with *dimethyl sulfoxide R*.

*Column:*

- size:  $l = 0.12$  m,  $\emptyset = 4$  mm;
- stationary phase: octadecylsilyl silica gel for chromatography *R* (5  $\mu$ m).

*Mobile phase:* dissolve 0.285 g of *sodium edetate R* in *water R*, add 7.5 mL of *dilute acetic acid R* and 50 mL of 0.1 M *potassium hydroxide* and dilute to 1000 mL with *water R*; adjust to pH 5.0 with *glacial acetic acid R*; mix 350 mL of this solution with 650 mL of *methanol R*.

*Flow rate:* 1.0 mL/min.

*Detection:* spectrophotometer at 328 nm.

*Injection:* 10  $\mu$ L.

*System suitability:* test solution:

- number of theoretical plates: minimum 3300, calculated for the principal peak;
- mass distribution ratio: 2.0 to 5.0 for the principal peak;
- symmetry factor: maximum 1.2 for the principal peak.

*Limit:*

- impurity D: not more than the area of the principal peak in the chromatogram obtained with the reference solution (300 ppm).

**Sulfates** (2.4.13): maximum 500 ppm.

Dilute 6 mL of solution S to 15 mL with *distilled water R*.

**Heavy metals** (2.4.8): maximum 10 ppm.

Dissolve 2.0 g in 15 mL of *acetone R* and dilute to 20 mL with *water R*. 12 mL of the solution complies with test B. Prepare the reference solution using lead standard solution (1 ppm Pb) obtained by diluting lead standard solution (100 ppm Pb) *R* with a mixture of 5 mL of *water R* and 15 mL of *acetone R*.

**Loss on drying** (2.2.32): maximum 0.5 per cent, determined on 1.000 g by drying in an oven at 105 °C.

**Sulfated ash** (2.4.14): maximum 0.1 per cent, determined on 1.0 g.

## ASSAY

Dissolve 0.180 g in 50 mL of *anhydrous acetic acid R* and titrate with 0.1 M *perchloric acid*, determining the end-point potentiometrically (2.2.20).

1 mL of 0.1 M *perchloric acid* is equivalent to 23.23 mg of  $C_{13}H_{16}N_2O_2$ .

## IMPURITIES

*Specified impurities:* A, D.

*Other detectable impurities* (the following substances would, if present at a sufficient level, be detected by one or other of the tests in the monograph. They are limited by the general acceptance criterion for other/unspecified impurities and/or by the general monograph *Substances for pharmaceutical use*

(2034). It is therefore not necessary to identify these impurities for demonstration of compliance. See also 5.10. *Control of impurities in substances for pharmaceutical use*): B, C.

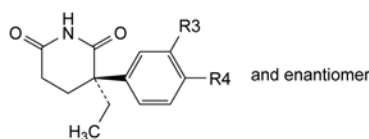

- A. R3 = NH<sub>2</sub>, R4 = H: (3*RS*)-3-(3-aminophenyl)-3-ethylpiperidine-2,6-dione (3-aminogluthethimide),
- B. R3 = NO<sub>2</sub>, R4 = H: (3*RS*)-3-ethyl-3-(3-nitrophenyl)-piperidine-2,6-dione,
- C. R3 = H, R4 = NO<sub>2</sub>: (3*RS*)-3-ethyl-3-(4-nitrophenyl)-piperidine-2,6-dione,

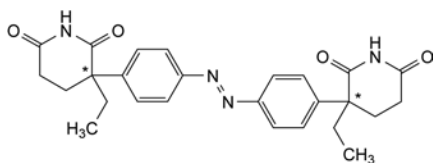

- D. 3,3'-[diazenediylbis(4,1-phenylene)]bis(3-ethylpiperidine-2,6-dione) (azogluthethimide).

01/2008:0803  
corrected 6.3

## AMIODARONE HYDROCHLORIDE

### Amiodaroni hydrochloridum

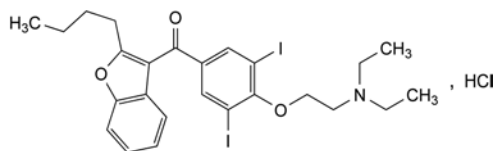

C<sub>25</sub>H<sub>30</sub>ClI<sub>2</sub>NO<sub>3</sub>  
[19774-82-4]

M<sub>r</sub> 682

#### DEFINITION

(2-Butylbenzofuran-3-yl)[4-[2-(diethylamino)ethoxy]-3,5-diiodophenyl]methanone hydrochloride.

*Content*: 98.5 per cent to 101.0 per cent (dried substance).

#### CHARACTERS

*Appearance*: white or almost white, fine, crystalline powder.

*Solubility*: very slightly soluble in water, freely soluble in methylene chloride, soluble in methanol, sparingly soluble in ethanol (96 per cent).

#### IDENTIFICATION

A. Infrared absorption spectrophotometry (2.2.24).

*Comparison*: amiodarone hydrochloride CRS.

B. It gives reaction (b) of chlorides (2.3.1).

#### TESTS

**Appearance of solution.** The solution is clear (2.2.1) and not more intensely coloured than reference solution GY<sub>5</sub> or BY<sub>5</sub> (2.2.2, *Method II*).

Dissolve 1.0 g in *methanol R* and dilute to 20 mL with the same solvent.

**pH** (2.2.3): 3.2 to 3.8.

Dissolve 1.0 g in *carbon dioxide-free water R*, heating at 80 °C, cool and dilute to 20 mL with the same solvent.

**Impurity H.** Thin-layer chromatography (2.2.27). *Prepare the solutions immediately before use and keep protected from bright light.*

*Test solution.* Dissolve 0.500 g of the substance to be examined in *methylene chloride R* and dilute to 5.0 mL with the same solvent.

*Reference solution (a).* Dissolve 10.0 mg of (2-chloroethyl)diethylamine hydrochloride *R* (impurity H) in *methylene chloride R* and dilute to 50.0 mL with the same solvent. Dilute 2.0 mL of this solution to 20.0 mL with *methylene chloride R*.

*Reference solution (b).* Mix 2.0 mL of the test solution and 2.0 mL of reference solution (a).

*Plate*: TLC silica gel F<sub>254</sub> plate *R*.

*Mobile phase*: anhydrous formic acid *R*, methanol *R*, methylene chloride *R* (5:10:85 V/V/V).

*Application*: 50 µL of the test solution and reference solution (a); 100 µL of reference solution (b).

*Development*: over 2/3 of the plate.

*Drying*: in a current of cold air.

*Detection*: spray with *potassium iodobismuthate solution R1* and then with *dilute hydrogen peroxide solution R*; examine immediately in daylight.

*System suitability*: reference solution (b):

– the spot due to impurity H is clearly visible.

*Limit*:

– *impurity H*: any spot with the same *R<sub>f</sub>* as the spot due to impurity H in the chromatogram obtained with reference solution (b), is not more intense than the spot in the chromatogram obtained with reference solution (a) (0.02 per cent).

**Related substances.** Liquid chromatography (2.2.29).

*Buffer solution pH 4.9.* To 800 mL of *water R* add 3.0 mL of *glacial acetic acid R*, adjust to pH 4.9 with *dilute ammonia R1* and dilute to 1000 mL with *water R*.

*Test solution.* Dissolve 0.125 g of the substance to be examined in a mixture of equal volumes of *acetonitrile R* and *water R* and dilute to 25.0 mL with the same mixture of solvents.

*Reference solution.* Dissolve 5 mg of *amiodarone impurity D CRS*, 5 mg of *amiodarone impurity E CRS* and 5.0 mg of *amiodarone hydrochloride CRS* in *methanol R* and dilute to 25.0 mL with the same solvent. Dilute 1.0 mL of this solution to 20.0 mL with a mixture of equal volumes of *acetonitrile R* and *water R*.

*Column*:

– *size*: *l* = 0.15 m, Ø = 4.6 mm;

– *stationary phase*: octadecylsilyl silica gel for chromatography *R* (5 µm);

– *temperature*: 30 °C.

*Mobile phase*: buffer solution pH 4.9, *methanol R*, *acetonitrile R* (30:30:40 V/V/V).

*Flow rate*: 1 mL/min.

*Detection*: spectrophotometer at 240 nm.

*Injection*: 10 µL.

*Run time*: twice the retention time of amiodarone.

*Relative retention* with reference to amiodarone (retention time = about 24 min): impurity A = about 0.26; impurity D = about 0.29; impurity E = about 0.37; impurity B = about 0.49; impurity C = about 0.55; impurity G = about 0.62; impurity F = about 0.69.

*System suitability*: reference solution:

– *resolution*: minimum 3.5 between the peaks due to impurities D and E.

*Limits*:

– *impurities A, B, C, D, E, F, G*: for each impurity, not more than the area of the peak due to amiodarone in the chromatogram obtained with the reference solution (0.2 per cent);

- *unspecified impurities*: for each impurity, not more than 0.5 times the area of the peak due to amisulpride in the chromatogram obtained with the reference solution (0.10 per cent);
- *total*: not more than 2.5 times the area of the peak due to amisulpride in the chromatogram obtained with the reference solution (0.5 per cent);
- *disregard limit*: 0.25 times the area of the peak due to amisulpride in the chromatogram obtained with the reference solution (0.05 per cent).

**Iodides**: maximum 150 ppm.

*Prepare the test and reference solutions simultaneously.*

**Solution A.** Add 1.50 g of the substance to be examined to 40 mL of *water R* at 80 °C and shake until completely dissolved. Cool and dilute to 50.0 mL with *water R*.

**Test solution.** To 15.0 mL of solution A add 1.0 mL of 0.1 M hydrochloric acid and 1.0 mL of 0.05 M potassium iodate. Dilute to 20.0 mL with *water R*. Allow to stand protected from light for 4 h.

**Reference solution.** To 15.0 mL of solution A add 1.0 mL of 0.1 M hydrochloric acid, 1.0 mL of an 88.2 mg/L solution of potassium iodide *R* and 1.0 mL of 0.05 M potassium iodate. Dilute to 20.0 mL with *water R*. Allow to stand protected from light for 4 h.

Measure the absorbances (2.2.25) of the solutions at 420 nm, using a mixture of 15.0 mL of solution A and 1.0 mL of 0.1 M hydrochloric acid diluted to 20.0 mL with *water R* as the compensation liquid. The absorbance of the test solution is not greater than half the absorbance of the reference solution.

**Heavy metals** (2.4.8): maximum 20 ppm.

1.0 g complies with test C. Prepare the reference solution using 2 mL of lead standard solution (10 ppm Pb) *R*.

**Loss on drying** (2.2.32): maximum 0.5 per cent, determined on 1.000 g by drying at 50 °C at a pressure not exceeding 0.3 kPa for 4 h.

**Sulfated ash** (2.4.14): maximum 0.1 per cent, determined on 1.0 g.

#### ASSAY

Dissolve 0.600 g in a mixture of 5.0 mL of 0.01 M hydrochloric acid and 75 mL of ethanol (96 per cent) *R*. Carry out a potentiometric titration (2.2.20), using 0.1 M sodium hydroxide. Read the volume added between the 2 points of inflexion.

1 mL of 0.1 M sodium hydroxide is equivalent to 68.18 mg of C<sub>25</sub>H<sub>30</sub>ClN<sub>2</sub>O<sub>3</sub>.

#### STORAGE

Protected from light, at a temperature not exceeding 30 °C.

#### IMPURITIES

*Specified impurities: A, B, C, D, E, F, G, H.*

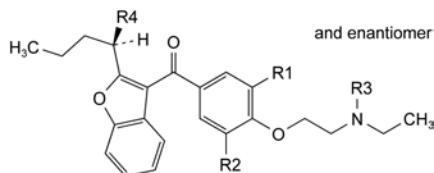

- A. R1 = R2 = R4 = H, R3 = C<sub>2</sub>H<sub>5</sub>: (2-butylbenzofuran-3-yl)[4-[2-(diethylamino)ethoxy]phenyl]methanone,
- B. R1 = R2 = I, R3 = R4 = H: (2-butylbenzofuran-3-yl)[4-[2-(ethylamino)ethoxy]-3,5-diiodophenyl]methanone,
- C. R1 = I, R2 = R4 = H, R3 = C<sub>2</sub>H<sub>5</sub>: (2-butylbenzofuran-3-yl)[4-[2-(diethylamino)ethoxy]-3-iodophenyl]methanone,
- G. R1 = R2 = I, R3 = C<sub>2</sub>H<sub>5</sub>, R4 = OCH<sub>3</sub>: [4-[2-(diethylamino)ethoxy]-3,5-diiodophenyl][2-[(1*R*)-1-methoxybutyl]benzofuran-3-yl]methanone,

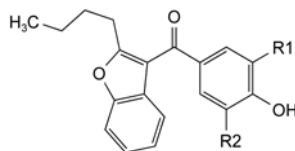

D. R1 = R2 = I: (2-butylbenzofuran-3-yl)(4-hydroxy-3,5-diiodophenyl)methanone,

E. R1 = R2 = H: (2-butylbenzofuran-3-yl)(4-hydroxyphenyl)methanone,

F. R1 = I, R2 = H: (2-butylbenzofuran-3-yl)(4-hydroxy-3-iodophenyl)methanone,

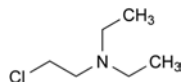

H. 2-chloro-*N,N*-diethylethanamine (2-chlorotriethylamine, (2-chloroethyl)diethylamine).

01/2008:1490  
corrected 7.0

## AMISULPRIDE

### Amisulpridum

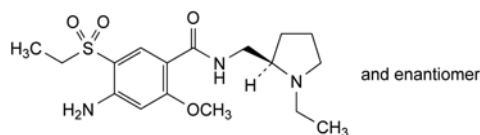

C<sub>17</sub>H<sub>27</sub>N<sub>3</sub>O<sub>4</sub>S  
[71675-85-9]

*M*<sub>r</sub> 369.5

#### DEFINITION

4-Amino-*N*-[[[(2*R*)-1-ethylpyrrolidin-2-yl]methyl]-5-(ethylsulfonyl)-2-methoxybenzamide.

*Content*: 99.0 per cent to 101.0 per cent (dried substance).

#### CHARACTERS

*Appearance*: white or almost white, crystalline powder.

*Solubility*: practically insoluble in water, freely soluble in methylene chloride, sparingly soluble in anhydrous ethanol. mp: about 126 °C.

#### IDENTIFICATION

Infrared absorption spectrophotometry (2.2.24).

*Comparison*: amisulpride CRS.

#### TESTS

**Appearance of solution.** The solution is not more opalescent than reference suspension II (2.2.1) and not more intensely coloured than reference solution Y<sub>6</sub> (2.2.2, Method II).

Dissolve 1.0 g in 3 mL of a mixture of 1 volume of acetic acid *R* and 4 volumes of *water R* and dilute to 20 mL with *water R*.

**Optical rotation** (2.2.7): –0.10° to +0.10°.

Dissolve 5.0 g in dimethylformamide *R* and dilute to 50.0 mL with the same solvent.

**Impurity A.** Thin-layer chromatography (2.2.27).

*Test solution.* Dissolve 0.20 g in methanol *R* and dilute to 10 mL with the same solvent.

*Reference solution (a).* Dissolve 5 mg of sulphiride impurity A CRS (amisulpride impurity A) in methanol *R* and dilute to 25 mL with the same solvent. Dilute 2 mL of the solution to 20 mL with methanol *R*.

*Reference solution (b).* Dilute 1 mL of the test solution to 10 mL with reference solution (a).

*Plate*: TLC silica gel G plate *R*.

**Mobile phase:** the upper layer obtained after shaking a mixture of a 50 per cent V/V solution of *concentrated ammonia R*, *anhydrous ethanol R* and *di-isopropyl ether R* (10:25:65 V/V/V).

**Application:** 10 µL.

**Development:** over a path of 12 cm.

**Drying:** in air.

**Detection:** spray with *ninhydrin solution R* and heat at 100-105 °C for 15 min.

**System suitability:** the chromatogram obtained with reference solution (b) shows 2 clearly separated spots.

**Limit:**

- **impurity A:** any spot corresponding to impurity A is not more intense than the spot in the chromatogram obtained with reference solution (a) (0.1 per cent).

**Related substances.** Examine by liquid chromatography (2.2.29).

**Test solution.** Dissolve 0.10 g in 30 mL of *methanol R* and dilute to 100.0 mL with mobile phase B.

**Reference solution (a).** Dilute 5.0 mL of the test solution to 100.0 mL with a mixture of 30 volumes of mobile phase A and 70 volumes of mobile phase B. Dilute 1.0 mL of the solution to 25.0 mL with a mixture of 30 volumes of mobile phase A and 70 volumes of mobile phase B.

**Reference solution (b).** Dissolve 5 mg of *amisulpride impurity B CRS* in 5 mL of the test solution and dilute to 50 mL with a mixture of 30 volumes of mobile phase A and 70 volumes of mobile phase B. Dilute 1 mL of the solution to 10 mL with a mixture of 30 volumes of mobile phase A and 70 volumes of mobile phase B.

**Column:**

- **size:**  $l = 0.25$  m,  $\varnothing = 4.6$  mm,
- **stationary phase:** *octylsilyl silica gel for chromatography R* (5 µm) with a carbon loading of 16 per cent, a specific surface area of 330 m<sup>2</sup>/g and a pore size of 7.5 nm.

**Mobile phase:**

- **mobile phase A:** *methanol R*,
- **mobile phase B:** 0.7 g/L solution of *sodium octanesulfonate R* in a 0.25 per cent V/V solution of *dilute sulfuric acid R*,

Time (min)	Mobile phase A (per cent V/V)	Mobile phase B (per cent V/V)
0 - 18	30 → 36	70 → 64
18 - 35	36 → 52	64 → 48
35 - 45	52	48

**Flow rate:** 1.5 mL/min.

**Detection:** spectrophotometer at 225 nm.

**Injection:** 10 µL.

**System suitability:** reference solution (b):

- **resolution:** minimum 2.0 between the peaks due to *amisulpride* and *impurity B*.

**Limits:**

- **any impurity:** not more than 0.5 times the area of the principal peak in the chromatogram obtained with reference solution (a) (0.1 per cent),
- **total:** not more than 1.5 times the area of the principal peak in the chromatogram obtained with reference solution (a) (0.3 per cent),
- **disregard limit:** 0.1 times the area of the principal peak in the chromatogram obtained with reference solution (a) (0.02 per cent).

**Chlorides (2.4.4):** maximum 200 ppm.

Shake 0.5 g with 30 mL of *water R* for 10 min. Filter. 15 mL of the filtrate complies with the test.

**Heavy metals (2.4.8):** maximum 10 ppm.

Dissolve 4.0 g by gently heating in 5 mL of *dilute acetic acid R*. Allow to cool and dilute to 20 mL with *water R*. 12 mL of the solution complies with test A. Prepare the reference solution using *lead standard solution (2 ppm Pb) R*.

**Loss on drying (2.2.32):** maximum 0.5 per cent, determined on 1.000 g by drying in an oven at 105 °C for 3 h.

**Sulfated ash (2.4.14):** maximum 0.1 per cent, determined on 1.0 g.

**ASSAY**

Dissolve 0.300 g with shaking in a mixture of 5 mL of *acetic anhydride R* and 50 mL of *anhydrous acetic acid R*. Titrate with 0.1 M *perchloric acid*, determining the end-point potentiometrically (2.2.20).

1 mL of 0.1 M *perchloric acid* is equivalent to 36.95 mg of C<sub>17</sub>H<sub>27</sub>N<sub>3</sub>O<sub>4</sub>S.

**IMPURITIES**

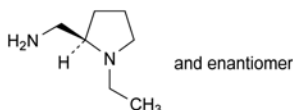

A. [(2RS)-1-ethylpyrrolidin-2-yl]methanamine,

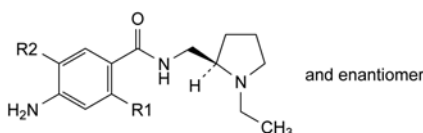

B. R<sub>1</sub> = OH, R<sub>2</sub> = SO<sub>2</sub>-CH<sub>2</sub>-CH<sub>3</sub>: 4-amino-N-[(2RS)-1-ethylpyrrolidin-2-ylmethyl]-5-(ethylsulfonyl)-2-hydroxybenzamide,

C. R<sub>1</sub> = OCH<sub>3</sub>, R<sub>2</sub> = I: 4-amino-N-[(2RS)-1-ethylpyrrolidin-2-ylmethyl]-5-iodo-2-methoxybenzamide,

D. R<sub>1</sub> = OCH<sub>3</sub>, R<sub>2</sub> = SO<sub>2</sub>-CH<sub>3</sub>: 4-amino-N-[(2RS)-1-ethylpyrrolidin-2-ylmethyl]-2-methoxy-5-(methylsulfonyl)benzamide,

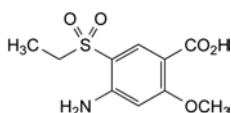

E. 4-amino-5-(ethylsulfonyl)-2-methoxybenzoic acid.

01/2008:0464  
corrected 6.3

## AMITRIPTYLINE HYDROCHLORIDE

Amitriptylini hydrochloridum

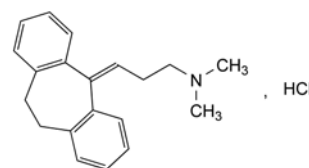

C<sub>20</sub>H<sub>24</sub>ClN  
[549-18-8]

M<sub>r</sub> 313.9

**DEFINITION**

3-(10,11-Dihydro-5H-dibenzo[*a,d*][7]annulen-5-ylidene)-N,N-dimethylpropan-1-amine hydrochloride.

**Content:** 99.0 per cent to 101.0 per cent (dried substance).

## CHARACTERS

**Appearance:** white or almost white powder or colourless crystals.

**Solubility:** freely soluble in water, in ethanol (96 per cent) and in methylene chloride.

## IDENTIFICATION

A. Infrared absorption spectrophotometry (2.2.24).

*Comparison:* amitriptyline hydrochloride CRS.

B. 20 mg gives reaction (a) of chlorides (2.3.1).

## TESTS

**Appearance of solution.** The solution is clear (2.2.1) and not more intensely coloured than reference solution B<sub>7</sub> (2.2.2, Method II).

Dissolve 1.25 g in water R and dilute to 25 mL with the same solvent.

**Acidity or alkalinity.** Dissolve 0.20 g in carbon dioxide-free water R and dilute to 10 mL with the same solvent. Add 0.1 mL of methyl red solution R and 0.2 mL of 0.01 M sodium hydroxide. The solution is yellow. Add 0.4 mL of 0.01 M hydrochloric acid. The solution is red.

**Related substances.** Liquid chromatography (2.2.29).

**Test solution.** Dissolve 50.0 mg of the substance to be examined in the mobile phase and dilute to 50.0 mL with the mobile phase.

**Reference solution (a).** Dissolve 5.0 mg of dibenzosuberone CRS (impurity A) and 5.0 mg of cyclobenzaprine hydrochloride CRS (impurity B) in 5.0 mL of the test solution and dilute to 100.0 mL with the mobile phase.

**Reference solution (b).** Dilute 1.0 mL of reference solution (a) to 50.0 mL with the mobile phase.

**Column:**

- size:  $l = 0.15$  m,  $\varnothing = 4.6$  mm;
- stationary phase: end-capped polar-embedded octadecylsilyl amorphous organosilica polymer R (5  $\mu$ m);
- temperature: 40 °C.

**Mobile phase:** mix 35 volumes of acetonitrile R and 65 volumes of a 5.23 g/L solution of dipotassium hydrogen phosphate R previously adjusted to pH 7.0 with phosphoric acid R.

**Flow rate:** 1.2 mL/min.

**Detection:** spectrophotometer at 220 nm.

**Injection:** 10  $\mu$ L.

**Run time:** 3 times the retention time of amitriptyline.

**Relative retention** with reference to amitriptyline (retention time = about 14 min): impurity B = about 0.9; impurity A = about 2.2.

**System suitability:** reference solution (a):

- resolution: minimum 2.0 between the peaks due to impurity B and amitriptyline.

**Limits:**

- impurity B: not more than the area of the corresponding peak in the chromatogram obtained with reference solution (b) (0.1 per cent);
- impurity A: not more than 0.5 times the area of the corresponding peak in the chromatogram obtained with reference solution (b) (0.05 per cent);
- unspecified impurities: for each impurity, not more than the area of the peak due to amitriptyline in the chromatogram obtained with reference solution (b) (0.10 per cent);
- total: not more than 3 times the area of the peak due to amitriptyline in the chromatogram obtained with reference solution (b) (0.3 per cent);
- disregard limit: 0.5 times the area of the peak due to amitriptyline in the chromatogram obtained with reference solution (b) (0.05 per cent).

**Heavy metals** (2.4.8): maximum 20 ppm.

1.0 g complies with test F. Prepare the reference solution using 2 mL of lead standard solution (10 ppm Pb) R.

**Loss on drying** (2.2.32): maximum 0.5 per cent, determined on 1.000 g by drying in an oven at 105 °C for 2 h.

**Sulfated ash** (2.4.14): maximum 0.1 per cent, determined on 1.0 g.

## ASSAY

Dissolve 0.250 g in 30 mL of ethanol (96 per cent) R. Titrate with 0.1 M sodium hydroxide, determining the end-point potentiometrically (2.2.20).

1 mL of 0.1 M sodium hydroxide is equivalent to 31.39 mg of C<sub>20</sub>H<sub>24</sub>ClN.

## STORAGE

Protected from light.

## IMPURITIES

**Specified impurities:** A, B.

**Other detectable impurities** (the following substances would, if present at a sufficient level, be detected by one or other of the tests in the monograph. They are limited by the general acceptance criterion for other/unspecified impurities and/or by the general monograph *Substances for pharmaceutical use* (2034). It is therefore not necessary to identify these impurities for demonstration of compliance. See also 5.10. *Control of impurities in substances for pharmaceutical use*): C, D, E, F, G.

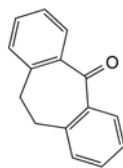

A. 10,11-dihydro-5H-dibenzo[*a,d*][7]annulen-5-one (dibenzosuberone),

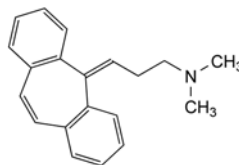

B. 3-(5H-dibenzo[*a,d*][7]annulen-5-ylidene)-*N,N*-dimethylpropan-1-amine (cyclobenzaprine),

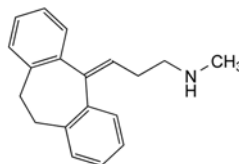

C. 3-(10,11-dihydro-5H-dibenzo[*a,d*][7]annulen-5-ylidene)-*N*-methylpropan-1-amine (nortriptyline),

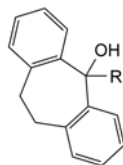

D. R = CH<sub>2</sub>-CH<sub>2</sub>-CH<sub>2</sub>-N(CH<sub>3</sub>)<sub>2</sub>; 5-[3-(dimethylamino)propyl]-10,11-dihydro-5H-dibenzo[*a,d*][7]annulen-5-ol,

G. R = H: 10,11-dihydro-5H-dibenzo[*a,d*][7]annulen-5-ol (dibenzosuberol),

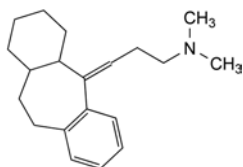

E. *N,N*-dimethyl-3-(1,2,3,4,4a,10,11,11a-octahydro-5*H*-dibenzo[*a,d*][7]annulen-5-ylidene)propan-1-amine,

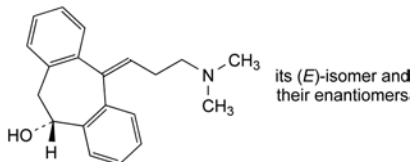

F. (5*EZ*,10*RS*)-5-[3-(dimethylamino)propylidene]-10,11-dihydro-5*H*-dibenzo[*a,d*][7]annulen-10-ol.

04/2010:1491

## AMLODIPINE BESILATE

### Amlodipini besilas

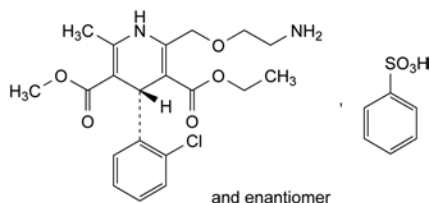

$C_{26}H_{31}ClN_2O_8S$   
[111470-99-6]

$M_r$  567.1

#### DEFINITION

3-Ethyl 5-methyl (4*RS*)-2-[(2-aminoethoxy)methyl]-4-(2-chlorophenyl)-6-methyl-1,4-dihydropyridine-3,5-dicarboxylate benzenesulfonate.

*Content*: 97.0 per cent to 102.0 per cent (anhydrous substance).

#### CHARACTERS

*Appearance*: white or almost white powder.

*Solubility*: slightly soluble in water, freely soluble in methanol, sparingly soluble in anhydrous ethanol, slightly soluble in 2-propanol.

#### IDENTIFICATION

Infrared absorption spectrophotometry (2.2.24).

*Comparison*: amlodipine besilate CRS.

#### TESTS

**Optical rotation** (2.2.7):  $-0.10^\circ$  to  $+0.10^\circ$ .

Dissolve 0.250 g in *methanol R* and dilute to 25.0 mL with the same solvent.

**Related substances**. Liquid chromatography (2.2.29). Carry out the test protected from light.

*Test solution (a)*. Dissolve 50.0 mg of the substance to be examined in *methanol R* and dilute to 50.0 mL with the same solvent.

*Test solution (b)*. Dilute 5.0 mL of test solution (a) to 100.0 mL with *methanol R*.

*Reference solution (a)*. Dilute 1.0 mL of test solution (a) to 10.0 mL with *methanol R*. Dilute 1.0 mL of this solution to 100.0 mL with *methanol R*.

*Reference solution (b)*. Dissolve 5 mg of amlodipine impurity B CRS and 5 mg of amlodipine impurity G CRS in *methanol R* and dilute to 50.0 mL with the same solvent. Dilute 1.0 mL of this solution to 10.0 mL with *methanol R*.

*Reference solution (c)*. Dissolve 5 mg of amlodipine for peak identification CRS (containing impurities D, E and F) in 10 mL of *methanol R*.

*Reference solution (d)*. Dissolve 5.0 mg of amlodipine impurity A CRS in *acetonitrile R* and dilute to 5.0 mL with the same solvent. Dilute 1.0 mL of the solution to 100.0 mL with *methanol R*. Dilute 1.0 mL of this solution to 10.0 mL with *methanol R*.

*Reference solution (e)*. Dissolve 50.0 mg of amlodipine besilate CRS in *methanol R* and dilute to 50.0 mL with the same solvent. Dilute 5.0 mL of this solution to 100.0 mL with *methanol R*.

#### Column:

- *size*:  $l = 0.25$  m,  $\varnothing = 4.0$  mm;
- *stationary phase*: octadecylsilyl silica gel for chromatography R (5  $\mu$ m);
- *temperature*: 30 °C.

*Mobile phase*: 2.3 g/L solution of ammonium acetate R, *methanol R* (30:70 V/V).

*Flow rate*: 1.5 mL/min.

*Detection*: spectrophotometer at 237 nm.

*Injection*: 20  $\mu$ L of test solution (a) and reference solutions (a), (b), (c) and (d).

*Run time*: twice the retention time of amlodipine.

*Identification of impurities*: use the chromatogram supplied with amlodipine for peak identification CRS and the chromatogram obtained with reference solution (c) to identify the peaks due to impurities D, E and F; use the chromatogram obtained with reference solution (d) to identify the peak due to impurity A.

*Relative retention* with reference to amlodipine (retention time = about 20 min): impurity G = about 0.15; impurity B = about 0.2; impurity D = about 0.5; impurity F = about 0.8; impurity E = about 1.3.

*System suitability*: reference solution (b):

- *resolution*: minimum 2.0 between the peaks due to impurities B and G.

#### Limits:

- *correction factors*: for the calculation of content, multiply the peak areas of the following impurities by the corresponding correction factor: impurity D = 1.7; impurity F = 0.7;
- *impurity D*: not more than 3 times the area of the principal peak in the chromatogram obtained with reference solution (a) (0.3 per cent);
- *impurity A*: not more than 1.5 times the area of the corresponding peak in the chromatogram obtained with reference solution (d) (0.15 per cent);
- *impurities E, F*: for each impurity, not more than 1.5 times the area of the principal peak in the chromatogram obtained with reference solution (a) (0.15 per cent);
- *unspecified impurities*: for each impurity, not more than the area of the principal peak in the chromatogram obtained with reference solution (a) (0.10 per cent);
- *total*: not more than 8 times the area of the principal peak in the chromatogram obtained with reference solution (a) (0.8 per cent);
- *disregard limit*: 0.5 times the area of the principal peak in the chromatogram obtained with reference solution (a) (0.05 per cent). Disregard any peak due to benzenesulfonate (relative retention = about 0.14).

**Water** (2.5.12): maximum 0.5 per cent, determined on 1.000 g.

**Sulfated ash** (2.4.14): maximum 0.2 per cent, determined on 1.0 g.

#### ASSAY

Liquid chromatography (2.2.29) as described in the test for related substances with the following modification.

*Injection*: test solution (b), reference solution (e).

Calculate the percentage content of  $C_{26}H_{31}ClN_2O_8S$  from the declared content of *amlodipine besilate CRS*.

#### STORAGE

In an airtight container, protected from light.

#### IMPURITIES

*Specified impurities*: A, D, E, F.

*Other detectable impurities* (the following substances would, if present at a sufficient level, be detected by one or other of the tests in the monograph. They are limited by the general acceptance criterion for other/unspecified impurities and/or by the general monograph *Substances for pharmaceutical use (2034)*. It is therefore not necessary to identify these impurities for demonstration of compliance. See also 5.10. *Control of impurities in substances for pharmaceutical use*): B, G, H.

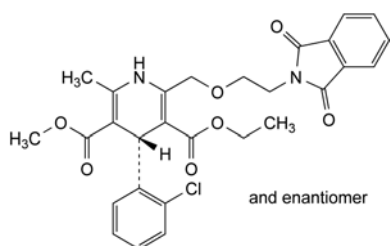

A. 3-ethyl 5-methyl (4*RS*)-4-(2-chlorophenyl)-2-[[2-(1,3-dioxo-1,3-dihydro-2*H*-isoindol-2-yl)ethoxy]methyl]-6-methyl-1,4-dihydropyridine-3,5-dicarboxylate,

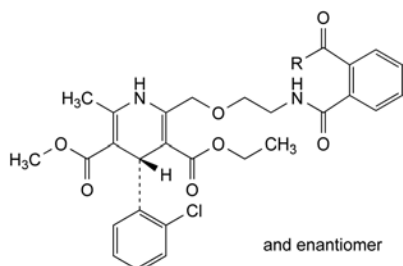

B. R =  $NHCH_3$ : 3-ethyl 5-methyl (4*RS*)-4-(2-chlorophenyl)-6-methyl-2-[[2-[[2-(methylcarbamoyl)benzoyl]amino]ethoxy]methyl]-1,4-dihydropyridine-3,5-dicarboxylate,

H. R = OH: 2-[[2-[[[(4*RS*)-4-(2-chlorophenyl)-3-(ethoxycarbonyl)-5-(methoxycarbonyl)-6-methyl-1,4-dihydropyridin-2-yl]methoxy]ethyl]carbamoyl]benzoic acid,

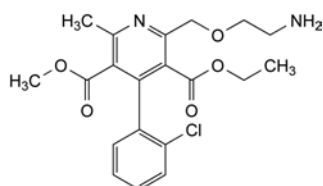

D. 3-ethyl 5-methyl 2-[(2-aminoethoxy)methyl]-4-(2-chlorophenyl)-6-methylpyridine-3,5-dicarboxylate,

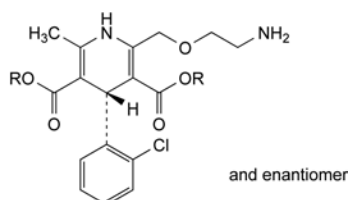

E. R =  $C_2H_5$ : diethyl (4*RS*)-2-[(2-aminoethoxy)methyl]-4-(2-chlorophenyl)-6-methyl-1,4-dihydropyridine-3,5-dicarboxylate,

F. R =  $CH_3$ : dimethyl (4*RS*)-2-[(2-aminoethoxy)methyl]-4-(2-chlorophenyl)-6-methyl-1,4-dihydropyridine-3,5-dicarboxylate,

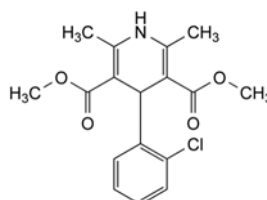

G. dimethyl 4-(2-chlorophenyl)-2,6-dimethyl-1,4-dihydropyridine-3,5-dicarboxylate.

01/2008:0877

## AMMONIA SOLUTION, CONCENTRATED

### Ammoniae solutio concentrata

$NH_3$

$M_r$  17.03

#### DEFINITION

*Content*: 25.0 per cent *m/m* to 30.0 per cent *m/m*.

#### CHARACTERS

*Appearance*: clear, colourless liquid, very caustic.

*Solubility*: miscible with water and with ethanol (96 per cent).

#### IDENTIFICATION

A. Relative density (2.2.5): 0.892 to 0.910.

B. It is strongly alkaline (2.2.4).

C. To 0.5 mL add 5 mL of *water R*. Bubble air through the solution and lead the gaseous mixture obtained over the surface of a solution containing 1 mL of 0.1 *M hydrochloric acid* and 0.05 mL of *methyl red solution R*. The colour changes from red to yellow. Add 1 mL of *sodium cobaltinitrite solution R*. A yellow precipitate is formed.

#### TESTS

**Solution S.** Evaporate 220 mL almost to dryness on a water-bath. Cool, add 1 mL of *dilute acetic acid R* and dilute to 20 mL with *distilled water R*.

**Appearance of solution.** The solution is clear (2.2.1) and colourless (2.2.2, *Method II*).

To 2 mL add 8 mL of *water R*.

**Oxidisable substances.** Cautiously add, whilst cooling, 8.8 mL to 100 mL of *dilute sulfuric acid R*. Add 0.75 mL of 0.002 *M potassium permanganate*. Allow to stand for 5 min. The solution remains faintly pink.

**Pyridine and related substances:** maximum 2 ppm, calculated as pyridine.

Measure the absorbance (2.2.25) at 252 nm using *water R* as the compensation liquid. The absorbance is not greater than 0.06.

**Carbonates:** maximum 60 ppm.

To 10 mL in a test-tube with a ground-glass neck add 10 mL of *calcium hydroxide solution R*. Stopper immediately and mix. Any opalescence in the solution is not more intense than that in a standard prepared at the same time and in the same manner using 10 mL of a 0.1 g/L solution of *anhydrous sodium carbonate R*.

**Chlorides (2.4.4):** maximum 1 ppm.

Dilute 5 mL of solution S to 15 mL with *water R*.

**Sulfates (2.4.13):** maximum 5 ppm.

Dilute 3 mL of solution S to 15 mL with *distilled water R*.

**Iron (2.4.9):** maximum 0.25 ppm.

Dilute 4 mL of solution S to 10 mL with *water R*.

**Heavy metals (2.4.8):** maximum 1 ppm.

Dilute 4 mL of solution S to 20 mL with *water R*. 12 mL of the solution complies with test A. Prepare the reference solution using *lead standard solution (2 ppm Pb) R*.

**Residue on evaporation:** maximum 20 mg/L.

Evaporate 50 mL to dryness on a water-bath and dry at 100-105 °C for 1 h. The residue weighs a maximum of 1 mg.

#### ASSAY

Weigh accurately a flask with a ground-glass neck containing 50.0 mL of 1 M hydrochloric acid. Add 2 mL of the substance to be examined and re-weigh. Add 0.1 mL of methyl red solution R as indicator. Titrate with 1 M sodium hydroxide until the colour changes from red to yellow.

1 mL of 1 M hydrochloric acid is equivalent to 17.03 mg of NH<sub>3</sub>.

#### STORAGE

Protected from air, at a temperature not exceeding 20 °C.

01/2008:2081

## AMMONIO METHACRYLATE COPOLYMER (TYPE A)

### Ammonio methacrylatis copolymerum A

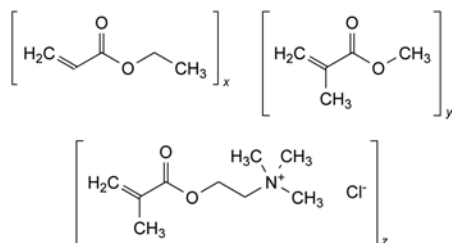

#### DEFINITION

Poly(ethyl propenoate-co-methyl 2-methylpropenoate-co-2-(trimethylammonio)ethyl 2-methylpropenoate) chloride having a mean relative molecular mass of about 150 000.

The ratio of ethyl propenoate groups to methyl 2-methylpropenoate groups to 2-(trimethylammonio)ethyl 2-methylpropenoate groups is about 1:2:0.2.

**Content of ammonio methacrylate groups:** 8.9 per cent to 12.3 per cent (dried substance).

#### CHARACTERS

**Appearance:** colourless to white or almost white granules or powder.

**Solubility:** practically insoluble in water, freely soluble in anhydrous ethanol and in methylene chloride giving clear to cloudy solutions. Due to the polymeric nature of the substance, a stirring time of up to 5 h may be necessary.

#### IDENTIFICATION

A. Infrared absorption spectrophotometry (2.2.24).

*Comparison:* Ph. Eur. reference spectrum of ammonio methacrylate copolymer (type A).

B. Viscosity (see Tests).

C. It complies with the limits of the assay.

#### TESTS

**Solution S.** Dissolve a quantity of the substance to be examined corresponding to 12.5 g of the dried substance in a mixture of 35.0 g of acetone R and 52.5 g of 2-propanol R.

**Viscosity (2.2.10):** maximum 15 mPa·s, determined on solution S.

**Apparatus:** rotating viscometer.

**Dimensions:**

– *spindle:* diameter = 25.15 mm; height = 90.74 mm; shaft diameter = 4.0 mm;

– *cylinder:* diameter = 27.62 mm; height = 0.135 m.

**Stirring speed:** 30 r/min.

**Volume of solution:** 16 mL of solution S.

**Temperature:** 20 °C.

**Appearance of a film.** Spread 2 mL of solution S evenly on a glass plate. Upon drying a clear film is formed.

**Monomers.** Liquid chromatography (2.2.29).

**Solution A.** Dissolve 3.5 g of sodium perchlorate R in water for chromatography R and dilute to 100 mL with the same solvent.

**Test solution.** Dissolve 5.00 g of the substance to be examined in methanol R and dilute to 50.0 mL with the same solvent. To 10.0 mL of this solution add 5.0 mL of solution A, dropwise, while continuously stirring. Remove the precipitated polymer by centrifugation. Use the clear supernatant solution.

**Reference solution.** Dissolve 50.0 mg of ethyl acrylate R and 10.0 mg of methyl methacrylate R in methanol R and dilute to 50.0 mL with the same solvent. Dilute 1.0 mL of the solution to 100.0 mL with methanol R. Add 10 mL of this solution to 5 mL of solution A.

**Column:**

– *size:*  $l = 0.12$  m,  $\varnothing = 4.6$  mm;

– *stationary phase:* octadecylsilyl silica gel for chromatography R (7 µm).

**Mobile phase:** dilute phosphoric acid R with water for chromatography R to obtain a solution at pH 2.0; mix 800 mL of this solution and 200 mL of methanol R, filter and degas.

**Flow rate:** 2.0 mL/min.

**Detection:** spectrophotometer at 202 nm.

**Injection:** 50 µL.

**System suitability:** reference solution:

– *resolution:* minimum 1.5 between the peaks due to impurity A and impurity B.

**Limits:**

– *impurity A:* not more than the area of the corresponding peak in the chromatogram obtained with the reference solution (100 ppm);

– *impurity B:* not more than 2.5 times the area of the corresponding peak in the chromatogram obtained with the reference solution (50 ppm).

**Methanol (2.4.24, System A):** maximum 1.5 per cent.

**Heavy metals (2.4.8):** maximum 20 ppm.

1.0 g complies with test C. Prepare the reference solution using 2.0 mL of lead standard solution (10 ppm Pb) R.

**Loss on drying (2.2.32):** maximum 3.0 per cent, determined on 1.000 g by drying *in vacuo* at 80 °C for 5 h.

#### ASSAY

Dissolve 1.000 g in a mixture of 3 mL of anhydrous formic acid R and 30 mL of anhydrous acetic acid R and heat to dissolve. Add 20 mL of acetic anhydride R. Titrate with 0.1 M perchloric acid, determining the end-point potentiometrically (2.2.20).

1 mL of 0.1 M perchloric acid is equivalent to 20.77 mg of C<sub>9</sub>H<sub>18</sub>O<sub>2</sub>NCl (ammonio methacrylate groups).

#### IMPURITIES

**Specified impurities:** A, B.

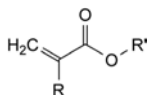

A. R = H, R' = C<sub>2</sub>H<sub>5</sub>: ethyl propenoate (ethyl acrylate),

B. R = R' = CH<sub>3</sub>: methyl 2-methylpropenoate (methyl methacrylate).



01/2008:2082

AMMONIO METHACRYLATE  
COPOLYMER (TYPE B)

## Ammonio methacrylatis copolymerum B

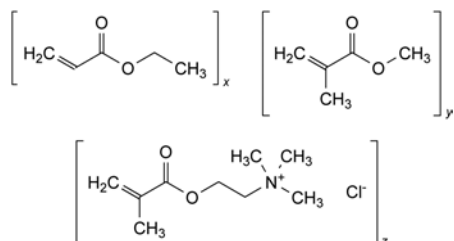

## DEFINITION

Poly(ethyl propenoate-co-methyl 2-methylpropenoate-co-2-(trimethylammonio)ethyl 2-methylpropenoate) chloride having a mean relative molecular mass of about 150 000.

The ratio of ethyl propenoate groups to methyl 2-methylpropenoate groups to 2-(trimethylammonio)ethyl 2-methylpropenoate groups is about 1:2:0.1.

Content of ammonio methacrylate groups: 4.5 per cent to 7.0 per cent (dried substance).

## CHARACTERS

**Appearance:** colourless to white or almost white granules or powder.

**Solubility:** practically insoluble in water, freely soluble in anhydrous ethanol and in methylene chloride giving clear to cloudy solutions. Due to the polymeric nature of the substance, a stirring time of up to 5 h may be necessary.

## IDENTIFICATION

A. Infrared absorption spectrophotometry (2.2.24).

*Comparison:* Ph. Eur. reference spectrum of ammonio methacrylate copolymer (type B).

B. Viscosity (see Tests).

C. It complies with the limits of the assay.

## TESTS

**Solution S.** Dissolve a quantity of the substance to be examined corresponding to 12.5 g of the dried substance in a mixture of 35.0 g of acetone R and 52.5 g of 2-propanol R.

**Viscosity (2.2.10):** maximum 15 mPas, determined on solution S.

**Apparatus:** rotating viscometer.

**Dimensions:**

– *spindle:* diameter = 25.15 mm; height = 90.74 mm; shaft diameter = 4.0 mm;

– *cylinder:* diameter = 27.62 mm; height = 0.135 m.

**Stirring speed:** 30 r/min.

**Volume of solution:** 16 mL of solution S.

**Temperature:** 20 °C.

**Appearance of a film.** Spread 2 mL of solution S evenly on a glass plate. Upon drying a clear film is formed.

**Monomers.** Liquid chromatography (2.2.29).

**Solution A.** Dissolve 3.5 g of sodium perchlorate R in water for chromatography R and dilute to 100 mL with the same solvent.

**Test solution.** Dissolve 5.00 g of the substance to be examined in methanol R and dilute to 50.0 mL with the same solvent. To 10.0 mL of this solution add 5.0 mL of solution A, dropwise, while continuously stirring. Remove the precipitated polymer by centrifugation. Use the clear supernatant solution.

**Reference solution.** Dissolve 50.0 mg of ethyl acrylate R and 10.0 mg of methyl methacrylate R in methanol R and dilute to 50.0 mL with the same solvent. Dilute 1.0 mL of the solution to 100.0 mL with methanol R. Add 10 mL of this solution to 5 mL of solution A.

**Column:**

– *size:*  $l = 0.12$  m,  $\varnothing = 4.6$  mm;

– *stationary phase:* octadecylsilyl silica gel for chromatography R (7  $\mu\text{m}$ ).

**Mobile phase:** dilute phosphoric acid R with water for chromatography R to obtain a solution at pH 2.0; mix 800 mL of this solution and 200 mL of methanol R, filter and degas.

**Flow rate:** 2.0 mL/min.

**Detection:** spectrophotometer at 202 nm.

**Injection:** 50  $\mu\text{L}$ .

**System suitability:** reference solution:

– *resolution:* minimum 1.5 between the peaks due to impurity A and impurity B.

**Limits:**

– *impurity A:* not more than the area of the corresponding peak in the chromatogram obtained with the reference solution (100 ppm);

– *impurity B:* not more than 2.5 times the area of the corresponding peak in the chromatogram obtained with the reference solution (50 ppm).

**Methanol (2.4.24, System A):** maximum 1.5 per cent.

**Heavy metals (2.4.8):** maximum 20 ppm.

1.0 g complies with test C. Prepare the reference solution using 2.0 mL of lead standard solution (10 ppm Pb) R.

**Loss on drying (2.2.32):** maximum 3.0 per cent, determined on 1.000 g by drying *in vacuo* at 80 °C for 5 h.

## ASSAY

Dissolve 2.000 g in a mixture of 3 mL of anhydrous formic acid R and 30 mL of anhydrous acetic acid R and heat to dissolve. Add 20 mL of acetic anhydride R. Titrate with 0.1 M perchloric acid, determining the end-point potentiometrically (2.2.20).

1 mL of 0.1 M perchloric acid is equivalent to 20.77 mg of  $\text{C}_9\text{H}_{18}\text{O}_2\text{NCl}$  (ammonio methacrylate groups).

## IMPURITIES

**Specified impurities:** A, B.

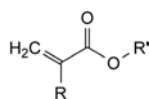

A. R = H, R' =  $\text{C}_2\text{H}_5$ ; ethyl propenoate (ethyl acrylate),

B. R = R' =  $\text{CH}_3$ ; methyl 2-methylpropenoate (methyl methacrylate).

01/2008:1389  
corrected 6.0

## AMMONIUM BROMIDE

## Ammonii bromidum

$\text{NH}_4\text{Br}$   
[12124-97-9]

$M_r$  97.9

## DEFINITION

**Content:** 98.5 per cent to 100.5 per cent (dried substance).

## CHARACTERS

**Appearance:** white or almost white, crystalline powder or colourless crystals, hygroscopic.

**Solubility:** freely soluble in water, sparingly soluble in alcohol.

It becomes yellow when exposed to light or air.

## IDENTIFICATION

- A. It gives reaction (a) of bromides (2.3.1).  
B. 10 mL of solution S (see Tests) gives the reaction of ammonium salts (2.3.1).

## TESTS

**Solution S.** Dissolve 10.0 g in *carbon dioxide-free water R* prepared from *distilled water R* and dilute to 100 mL with the same solvent.

**Appearance of solution.** Solution S is clear (2.2.1) and colourless (2.2.2, *Method II*).

**Acidity or alkalinity.** To 10 mL of solution S add 0.05 mL of *methyl red solution R*. Not more than 0.5 mL of 0.01 M *hydrochloric acid* or 0.01 M *sodium hydroxide* is required to change the colour of the indicator.

**Bromates.** To 10 mL of solution S add 1 mL of *starch solution R*, 0.1 mL of a 100 g/L solution of *potassium iodide R* and 0.25 mL of 0.5 M *sulfuric acid* and allow to stand protected from light for 5 min. No blue or violet colour develops.

**Chlorides:** maximum 0.6 per cent.

In a conical flask, dissolve 1.000 g in 20 mL of *dilute nitric acid R*. Add 5 mL of *strong hydrogen peroxide solution R* and heat on a water-bath until the solution is completely decolorised. Wash down the sides of the flask with a little *water R* and heat on a water-bath for 15 min. Allow to cool, dilute to 50 mL with *water R* and add 5.0 mL of 0.1 M *silver nitrate* and 1 mL of *dibutyl phthalate R*. Shake and titrate with 0.1 M *ammonium thiocyanate* using 5 mL of *ferric ammonium sulfate solution R2* as indicator. Not more than 1.7 mL of 0.1 M *silver nitrate* is used. Note the volume of 0.1 M *silver nitrate* used (see Assay). Carry out a blank test.

**Iodides.** To 5 mL of solution S add 0.15 mL of *ferric chloride solution R1* and 2 mL of *methylene chloride R*. Shake and allow to separate. The lower layer is colourless (2.2.2, *Method I*).

**Sulfates** (2.4.13): maximum 100 ppm.

15 mL of solution S complies with the limit test for sulfates.

**Iron** (2.4.9): maximum 20 ppm.

5 mL of solution S diluted to 10 mL with *water R* complies with the limit test for iron.

**Magnesium and alkaline-earth metals** (2.4.7): maximum 200 ppm, calculated as Ca.

10.0 g complies with the limit test for magnesium and alkaline-earth metals. The volume of 0.01 M *sodium edetate* used does not exceed 5.0 mL.

**Heavy metals** (2.4.8): maximum 10 ppm.

12 mL of solution S complies with limit test A. Prepare the standard using *lead standard solution (1 ppm Pb) R*.

**Loss on drying** (2.2.32): maximum 1.0 per cent, determined on 1.000 g by drying in an oven at 105 °C.

**Sulfated ash** (2.4.14): maximum 0.1 per cent, determined on 1.0 g.

## ASSAY

Dissolve 1.500 g in *water R* and dilute to 100.0 mL with the same solvent. To 10.0 mL of the solution add 50 mL of *water R*, 5 mL of *dilute nitric acid R*, 25.0 mL of 0.1 M *silver nitrate* and 2 mL of *dibutyl phthalate R*. Shake. Titrate with 0.1 M *ammonium thiocyanate* using 2 mL of *ferric ammonium sulfate solution R2* as indicator and shaking vigorously towards the end-point.

1 mL of 0.1 M *silver nitrate* is equivalent to 9.794 mg of  $\text{NH}_4\text{Br}$ . Calculate the percentage content of  $\text{NH}_4\text{Br}$  from the expression:

$$a - 2.763 b$$

- $a$  = percentage content of  $\text{NH}_4\text{Br}$  and  $\text{NH}_4\text{Cl}$  obtained in the assay and calculated as  $\text{NH}_4\text{Br}$ ,  
 $b$  = percentage content of Cl obtained in the test for chlorides.

## STORAGE

In an airtight container, protected from light.

01/2008:0007  
corrected 6.0

## AMMONIUM CHLORIDE

## Ammonii chloridum

$\text{NH}_4\text{Cl}$   
[12125-02-9]

$M_r$  53.49

## DEFINITION

*Content:* 99.0 per cent to 100.5 per cent (dried substance).

## CHARACTERS

*Appearance:* white or almost white, crystalline powder or colourless crystals.

*Solubility:* freely soluble in water.

## IDENTIFICATION

- A. It gives the reactions of chlorides (2.3.1).  
B. 10 mL of solution S (see Tests) gives the reaction of ammonium salts (2.3.1).

## TESTS

**Solution S.** Dissolve 10.0 g in *carbon dioxide-free water R* prepared from *distilled water R* and dilute to 100 mL with the same solvent.

**Appearance of solution.** Solution S is clear (2.2.1) and colourless (2.2.2, *Method II*).

**Acidity or alkalinity.** To 10 mL of solution S add 0.05 mL of *methyl red solution R*. Not more than 0.5 mL of 0.01 M *hydrochloric acid* or 0.01 M *sodium hydroxide* is required to change the colour of the indicator.

**Bromides and iodides.** To 10 mL of solution S add 0.1 mL of *dilute hydrochloric acid R* and 0.05 mL of *chloramine solution R*. After 1 min, add 2 mL of *chloroform R* and shake vigorously. The chloroform layer remains colourless (2.2.2, *Method I*).

**Sulfates** (2.4.13): maximum 150 ppm.

Dilute 10 mL of solution S to 15 mL with *distilled water R*.

**Calcium** (2.4.3): maximum 200 ppm.

Dilute 5 mL of solution S to 15 mL with *distilled water R*.

**Iron** (2.4.9): maximum 20 ppm.

Dilute 5 mL of solution S to 10 mL with *water R*.

**Heavy metals** (2.4.8): maximum 10 ppm.

12 mL of solution S complies with test A. Prepare the reference solution using *lead standard solution (1 ppm Pb) R*.

**Loss on drying** (2.2.32): maximum 1.0 per cent, determined on 1.00 g by drying in an oven at 105 °C for 2 h.

**Sulfated ash** (2.4.14): maximum 0.1 per cent, determined on 2.0 g.

## ASSAY

Dissolve 1.000 g in 20 mL of *water R* and add a mixture of 5 mL of *formaldehyde solution R*, previously neutralised to *phenolphthalein solution R*, and 20 mL of *water R*. After 1-2 min, titrate slowly with 1 M *sodium hydroxide*, using a further 0.2 mL of the same indicator.

1 mL of 1 M *sodium hydroxide* is equivalent to 53.49 mg of  $\text{NH}_4\text{Cl}$ .

01/2008:1772 – stationary phase: octadecylsilyl silica gel for  
corrected 7.0 chromatography R (5-10 µm).

Mobile phase: glacial acetic acid R, acetonitrile R, water R  
(6:380:614 V/V/V).

Flow rate: 1.2 mL/min.

Detection: spectrophotometer at 254 nm.

Injection: 10 µL.

Run time: 3 times the retention time of 18β-glycyrrhizic acid.

Relative retention with reference to 18β-glycyrrhizic acid  
(retention time = about 8 min): impurity A = about 0.8;  
18α-glycyrrhizic acid = about 1.2.

System suitability: reference solution (b):

– resolution: minimum 2.0 between the peaks due to  
18β-glycyrrhizic acid and 18α-glycyrrhizic acid.

Limits:

- 18α-glycyrrhizic acid: not more than twice the sum of  
the areas of the peaks in the chromatogram obtained with  
reference solution (a) (10.0 per cent),
- impurity A: not more than the sum of the areas of the peaks  
in the chromatogram obtained with reference solution (a)  
(5.0 per cent),
- any other impurity: for each impurity, not more than  
0.4 times the sum of the areas of the peaks in the  
chromatogram obtained with reference solution (a) (2.0 per  
cent),
- sum of other impurities: not more than 1.4 times the sum of  
the areas of the peaks in the chromatogram obtained with  
reference solution (a) (7.0 per cent),
- disregard limit: 0.04 times the sum of the areas of the peaks  
in the chromatogram obtained with reference solution (a)  
(0.2 per cent).

Heavy metals (2.4.8): maximum 20 ppm.

1.0 g complies with limit test C. Prepare the reference solution  
using 2 mL of lead standard solution (10 ppm Pb) R.

Water (2.5.12): maximum 6.0 per cent, determined on 0.250 g.

Sulfated ash (2.4.14): maximum 0.2 per cent, determined on  
1.0 g.

ASSAY

Dissolve 0.600 g in 60 mL of anhydrous acetic acid R heating  
at 80 °C if necessary. Cool. Titrate with 0.1 M perchloric acid,  
determining the end-point potentiometrically (2.2.20).

1 mL of 0.1 M perchloric acid is equivalent to 84.0 mg  
of C<sub>42</sub>H<sub>65</sub>NO<sub>16</sub>.

STORAGE

In an airtight container.

IMPURITIES

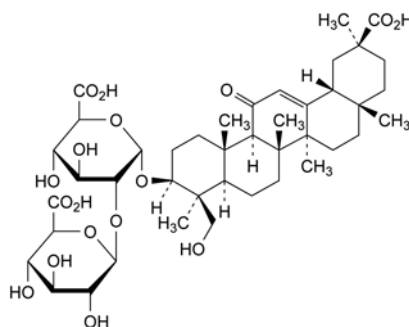

- A. (4β,20β)-3β-[[2-O-(β-D-glucopyranosyluronic acid)-α-D-glucopyranosyluronic acid]oxy]-23-hydroxy-  
11-oxoolean-12-en-29-oic acid (24-hydroxyglycyrrhizic acid).

## AMMONIUM GLYCYRRHIZATE

### Ammonii glycyrrhizas

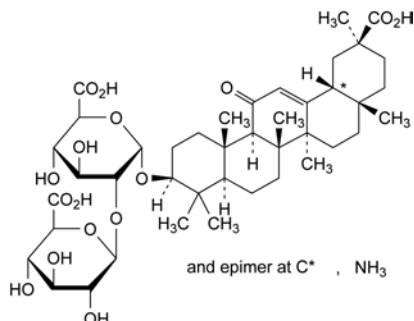

C<sub>42</sub>H<sub>65</sub>NO<sub>16</sub>  
[53956-04-0]

M<sub>r</sub> 840

#### DEFINITION

Mixture of ammonium 18α- and 18β-glycyrrhizate (ammonium salt of (20β)-3β-[[2-O-(β-D-glucopyranosyluronic acid)-α-D-glucopyranosyluronic acid]oxy]-11-oxoolean-12-en-29-oic acid), the 18β-isomer being the main component.

Content: 98.0 per cent to 102.0 per cent (anhydrous substance).

#### CHARACTERS

Appearance: white or yellowish-white, hygroscopic powder.

Solubility: slightly soluble in water, very slightly soluble in anhydrous ethanol, practically insoluble in acetone. It dissolves in dilute solutions of acids and of alkali hydroxides.

#### IDENTIFICATION

A. Infrared absorption spectrophotometry (2.2.24).

Comparison: ammonium glycyrrhizate CRS.

B. Dissolve 0.1 g in 20 mL of water R, add 2 mL of dilute sodium hydroxide solution R and heat cautiously. On heating, the solution gives off vapours that may be identified by the alkaline reaction of wet litmus paper (2.3.1).

#### TESTS

Appearance of solution. The solution is clear (2.2.1) and not more intensely coloured than reference solution BY<sub>7</sub> (2.2.2, Method I).

Dissolve 1.0 g in ethanol (20 per cent V/V) R and dilute to 100.0 mL with the same solvent.

Specific optical rotation (2.2.7): + 49.0 to + 54.0 (anhydrous substance).

Dissolve 0.5 g in ethanol (50 per cent V/V) R and dilute to 50.0 mL with the same solvent.

Related substances. Liquid chromatography (2.2.29).

Test solution. Dissolve 0.100 g of the substance to be examined in the mobile phase and dilute to 100.0 mL with the mobile phase.

Reference solution (a). Dilute 1.0 mL of the test solution to 20.0 mL with the mobile phase.

Reference solution (b). Dissolve 50 mg of ammonium glycyrrhizate CRS in the mobile phase and dilute to 50.0 mL with the mobile phase. Dilute 1.0 mL of the solution to 20.0 mL with the mobile phase.

Column:

– size: *l* = 0.25 m,  $\emptyset$  = 4.0 mm,

01/2008:1390  
corrected 6.0

## AMMONIUM HYDROGEN CARBONATE

## Ammonii hydrogenocarbonas

NH<sub>4</sub>HCO<sub>3</sub>  
[1066-33-7]M<sub>r</sub> 79.1

## DEFINITION

*Content*: 98.0 per cent to 101.0 per cent.

## CHARACTERS

*Appearance*: fine, white or almost white, crystalline powder or white or almost white crystals, slightly hygroscopic.*Solubility*: freely soluble in water, practically insoluble in ethanol (96 per cent).

It volatilises rapidly at 60 °C. The volatilisation takes place slowly at ambient temperatures if the substance is slightly moist. It is in a state of equilibrium with ammonium carbamate.

## IDENTIFICATION

- A. It gives the reaction of carbonates and bicarbonates (2.3.1).  
 B. Dissolve 50 mg in 2 mL of *water R*. The solution gives the reaction of ammonium salts (2.3.1).

## TESTS

**Solution S.** Dissolve 14.0 g in 100 mL of *distilled water R*. Boil to remove the ammonia, allow to cool and dilute to 100.0 mL with *distilled water R*.**Chlorides** (2.4.4): maximum 70 ppm.Dilute 5 mL of solution S to 15 mL with *water R*.**Sulfates** (2.4.13): maximum 70 ppm, determined on solution S.**Iron** (2.4.9): maximum 40 ppm.Dilute 1.8 mL of solution S to 10 mL with *water R*.**Heavy metals** (2.4.8): maximum 10 ppm.Dissolve cautiously 2.5 g in 25 mL of 1 M *hydrochloric acid*. 12 mL of the solution complies with test A. Prepare the reference solution using *lead standard solution (1 ppm Pb) R*.

## ASSAY

Dissolve cautiously 1.0 g in 20.0 mL of 0.5 M *sulfuric acid* and dilute to 50 mL with *water R*. Boil, cool and titrate the excess of acid with 1 M *sodium hydroxide*, using 0.1 mL of *methyl red solution R* as indicator.1 mL of 0.5 M *sulfuric acid* is equivalent to 79.1 mg of NH<sub>4</sub>HCO<sub>3</sub>.

## STORAGE

In an airtight container.

## DEFINITION

Amobarbital contains not less than 99.0 per cent and not more than the equivalent of 101.0 per cent of 5-ethyl-5-(3-methylbutyl)pyrimidin-2,4,6-(1*H*,3*H*,5*H*)-trione, calculated with reference to the dried substance.

## CHARACTERS

A white or almost white, crystalline powder, very slightly soluble in water, freely soluble in alcohol, soluble in methylene chloride. It forms water-soluble compounds with alkali hydroxides and carbonates and with ammonia.

## IDENTIFICATION

*First identification*: A, B.*Second identification*: A, C, D.

- A. Determine the melting point (2.2.14) of the substance to be examined. Mix equal parts of the substance to be examined and *amobarbital CRS* and determine the melting point of the mixture. The difference between the melting points (which are about 157 °C) is not greater than 2 °C.  
 B. Examine by infrared absorption spectrophotometry (2.2.24), comparing with the spectrum obtained with *amobarbital CRS*.  
 C. Examine by thin-layer chromatography (2.2.27), using *silica gel GF<sub>254</sub> R* as the coating substance.  
*Test solution.* Dissolve 0.1 g of the substance to be examined in *alcohol R* and dilute to 100 mL with the same solvent.  
*Reference solution.* Dissolve 0.1 g of *amobarbital CRS* in *alcohol R* and dilute to 100 mL with the same solvent.  
 Apply separately to the plate 10 µL of each solution. Develop over a path of 18 cm using the lower layer from a mixture of 5 volumes of *concentrated ammonia R*, 15 volumes of *alcohol R* and 80 volumes of *chloroform R*. Examine immediately in ultraviolet light at 254 nm. The principal spot in the chromatogram obtained with the test solution is similar in position and size to the principal spot in the chromatogram obtained with the reference solution.  
 D. It gives the reaction of non-nitrogen substituted barbiturates (2.3.1).

## TESTS

**Appearance of solution.** Dissolve 1.0 g in a mixture of 4 mL of *dilute sodium hydroxide solution R* and 6 mL of *water R*. The solution is clear (2.2.1) and not more intensely coloured than reference solution Y<sub>6</sub> (2.2.2, *Method II*).**Acidity or alkalinity.** To 1.0 g add 50 mL of *water R* and boil for 2 min. Allow to cool and filter. To 10 mL of the filtrate add 0.15 mL of *methyl red solution R* and 0.1 mL of 0.01 M *sodium hydroxide*. The solution is yellow. Add 0.2 mL of 0.01 M *hydrochloric acid*. The solution is red.**Related substances.** Examine by thin-layer chromatography (2.2.27), using *silica gel GF<sub>254</sub> R* as the coating substance.*Test solution.* Dissolve 1.0 g of the substance to be examined in *alcohol R* and dilute to 100 mL with the same solvent.*Reference solution.* Dilute 0.5 mL of the test solution to 100 mL with *alcohol R*.Apply separately to the plate 20 µL of each solution. Develop over a path of 15 cm using the lower layer from a mixture of 5 volumes of *concentrated ammonia R*, 15 volumes of *alcohol R* and 80 volumes of *chloroform R*. Examine the plate immediately in ultraviolet light at 254 nm. Any spot in the chromatogram obtained with the test solution, apart from the principal spot, is not more intense than the spot in the chromatogram obtained with the reference solution. Spray with *diphenylcarbazone mercuric reagent R*. Allow the plate to dry in air and spray with freshly prepared *alcoholic potassium hydroxide solution R* diluted 1 in 5 with *aldehyde-free alcohol R*. Heat at 100 °C to 105 °C for 5 min and examine immediately. Any spot in the chromatogram obtained with the test solution, apart from01/2008:0594  
corrected 6.0

## AMOBARBITAL

## Amobarbitalum

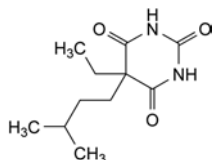
C<sub>11</sub>H<sub>18</sub>N<sub>2</sub>O<sub>3</sub>  
[57-43-2]M<sub>r</sub> 226.3

the principal spot, is not more intense than the spot in the chromatogram obtained with the reference solution (0.5 per cent).

**Loss on drying** (2.2.32). Not more than 0.5 per cent, determined on 1.000 g by drying in an oven at 105 °C.

**Sulfated ash** (2.4.14). Not more than 0.1 per cent, determined on 1.0 g.

#### ASSAY

Dissolve 0.100 g in 5 mL of *pyridine R*. Add 0.5 mL of *thymolphthalein solution R* and 10 mL of *silver nitrate solution in pyridine R*. Titrate with 0.1 M *ethanolic sodium hydroxide* until a pure blue colour is obtained. Carry out a blank titration. 1 mL of 0.1 M *ethanolic sodium hydroxide* is equivalent to 11.31 mg of  $C_{11}H_{17}N_2NaO_3$ .

01/2008:0166  
corrected 6.0

## AMOBARBITAL SODIUM

### Amobarbitalum natricum

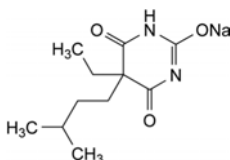

$C_{11}H_{17}N_2NaO_3$   
[64-43-7]

$M_r$  248.3

#### DEFINITION

Amobarbital sodium contains not less than 98.5 per cent and not more than the equivalent of 102.0 per cent of sodium derivative of 5-ethyl-5-(3-methylbutyl)pyrimidin-2,4,6-(1*H*,3*H*,5*H*)-trione, calculated with reference to the dried substance.

#### CHARACTERS

A white or almost white, granular powder, hygroscopic, very soluble in carbon dioxide-free water (a small fraction may be insoluble), freely soluble in alcohol.

#### IDENTIFICATION

*First identification*: A, B, E.

*Second identification*: A, C, D, E.

- A. Acidify 10 mL of solution S (see Tests) with *dilute hydrochloric acid R* and shake with 20 mL of *ether R*. Separate the ether layer, wash with 10 mL of *water R*, dry over *anhydrous sodium sulfate R* and filter. Evaporate the filtrate to dryness and dry the residue at 100 °C to 105 °C (test residue). Repeat the operations using 0.1 g of *amobarbital sodium CRS* (reference residue). Determine the melting point (2.2.14) of the test residue. Mix equal parts of the test residue and the reference residue and determine the melting point of the mixture. The difference between the melting points (which are about 157 °C) is not greater than 2 °C.
- B. Examine by infrared absorption spectrophotometry (2.2.24), comparing the spectrum obtained with the reference residue prepared from *amobarbital sodium CRS* with that obtained with the test residue (see identification test A).
- C. Examine by thin-layer chromatography (2.2.27), using *silica gel GF<sub>254</sub> R* as the coating substance.  
*Test solution*. Dissolve 0.1 g of the substance to be examined in *alcohol R* and dilute to 100 mL with the same solvent.  
*Reference solution*. Dissolve 0.1 g of *amobarbital sodium CRS* in *alcohol R* and dilute to 100 mL with the same solvent.

Apply separately to the plate 10 µL of each solution. Develop over a path of 18 cm using the lower layer of a mixture of 5 volumes of *concentrated ammonia R*, 15 volumes of *alcohol R* and 80 volumes of *chloroform R*. Examine immediately in ultraviolet light at 254 nm. The principal spot in the chromatogram obtained with the test solution is similar in position and size to the principal spot in the chromatogram obtained with the reference solution.

D. It gives the reaction of non-nitrogen substituted barbiturates (2.3.1).

E. It gives reaction (a) of sodium (2.3.1).

#### TESTS

**Solution S**. Dissolve 5.0 g in *alcohol (50 per cent V/V) R* and dilute to 50 mL with the same solvent.

**Appearance of solution**. Solution S is clear (2.2.1) and not more intensely coloured than reference solution Y<sub>7</sub> (2.2.2, *Method II*).

**pH** (2.2.3). Dissolve 5.0 g in *carbon dioxide-free water R* and dilute to 50 mL with the same solvent. Disregard any slight residue. The pH of the solution is not more than 11.0.

**Related substances**. Examine by thin-layer chromatography (2.2.27), using *silica gel GF<sub>254</sub> R* as the coating substance.

*Test solution*. Dissolve 1.0 g of the substance to be examined in *alcohol R* and dilute to 100 mL with the same solvent.

*Reference solution*. Dilute 0.5 mL of the test solution to 100 mL with *alcohol R*.

Apply separately to the plate 20 µL of each solution. Develop over a path of 15 cm using the lower layer of a mixture of 5 volumes of *concentrated ammonia R*, 15 volumes of *alcohol R* and 80 volumes of *chloroform R*. Examine the plate immediately in ultraviolet light at 254 nm. Spray with *diphenylcarbazone mercuric reagent R*. Allow the plate to dry in air and spray with freshly prepared *alcoholic potassium hydroxide solution R* diluted 1 in 5 with *aldehyde-free alcohol R*. Heat at 100 °C to 105 °C for 5 min and examine immediately. When examined in ultraviolet light and after spraying, any spot in the chromatogram obtained with the test solution, apart from the principal spot, is not more intense than the spot in the chromatogram obtained with the reference solution (0.5 per cent). Disregard any spot at the point of application.

**Loss on drying** (2.2.32). Not more than 3.0 per cent, determined on 0.50 g by drying in an oven at 130 °C.

#### ASSAY

Dissolve 0.200 g in 5 mL of *ethanol R*. Add 0.5 mL of *thymolphthalein solution R* and 10 mL of *silver nitrate solution in pyridine R*. Titrate with 0.1 M *ethanolic sodium hydroxide* until a pure blue colour is obtained. Carry out a blank titration. 1 mL of 0.1 M *ethanolic sodium hydroxide* is equivalent to 24.83 mg of  $C_{11}H_{17}N_2NaO_3$ .

#### STORAGE

Store in an airtight container.

01/2008:0577  
corrected 6.0

## AMOXICILLIN SODIUM

### Amoxicillinum natricum

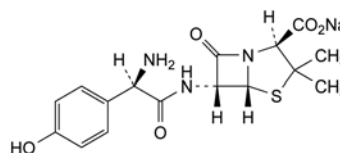

$C_{16}H_{18}N_3NaO_5S$   
[34642-77-8]

$M_r$  387.4

## DEFINITION

Sodium (2S,5R,6R)-6-[[[(2R)-2-amino-2-(4-hydroxyphenyl)-acetyl]amino]-3,3-dimethyl-7-oxo-4-thia-1-azabicyclo-[3.2.0]heptane-2-carboxylate.

Semi-synthetic product derived from a fermentation product.

*Content*: 89.0 per cent to 102.0 per cent (anhydrous substance).

## CHARACTERS

*Appearance*: white or almost white, very hygroscopic, powder.

*Solubility*: very soluble in water, sparingly soluble in anhydrous ethanol, very slightly soluble in acetone.

## IDENTIFICATION

*First identification*: A, D.

*Second identification*: B, C, D.

## A. Infrared absorption spectrophotometry (2.2.24).

*Preparation*: dissolve 0.250 g in 5 mL of *water R*, add 0.5 mL of *dilute acetic acid R*, swirl and allow to stand for 10 min in iced water. Filter the crystals and wash with 2-3 mL of a mixture of 1 volume of *water R* and 9 volumes of *acetone R*, then dry in an oven at 60 °C for 30 min.

*Comparison*: amoxicillin trihydrate CRS.

## B. Thin-layer chromatography (2.2.27).

*Test solution*. Dissolve 25 mg of the substance to be examined in 10 mL of *sodium hydrogen carbonate solution R*.

*Reference solution (a)*. Dissolve 25 mg of amoxicillin trihydrate CRS in 10 mL of *sodium hydrogen carbonate solution R*.

*Reference solution (b)*. Dissolve 25 mg of amoxicillin trihydrate CRS and 25 mg of ampicillin trihydrate CRS in 10 mL of *sodium hydrogen carbonate solution R*.

*Plate*: TLC silanised silica gel plate R.

*Mobile phase*: mix 10 volumes of *acetone R* and 90 volumes of a 154 g/L solution of *ammonium acetate R* previously adjusted to pH 5.0 with *glacial acetic acid R*.

*Application*: 1 µL.

*Development*: over a path of 15 cm.

*Drying*: in air.

*Detection*: expose to iodine vapour until the spots appear and examine in daylight.

*System suitability*: reference solution (b):

- the chromatogram shows 2 clearly separated spots.

*Results*: the principal spot in the chromatogram obtained with the test solution is similar in position, colour and size to the principal spot in the chromatogram obtained with reference solution (a).

C. Place about 2 mg in a test-tube about 150 mm long and about 15 mm in diameter. Moisten with 0.05 mL of *water R* and add 2 mL of *sulfuric acid-formaldehyde reagent R*. Mix the contents of the tube by swirling; the solution is practically colourless. Place the test-tube in a water-bath for 1 min; a dark yellow colour develops.

## D. It gives reaction (a) of sodium (2.3.1).

## TESTS

**Appearance of solution.** The solution is not more opalescent than reference suspension II (2.2.1), it may show an initial, but transient, pink colour, and after 5 min, its absorbance (2.2.25) at 430 nm is not greater than 0.20.

Dissolve 1.0 g in *water R* and dilute to 10.0 mL with the same solvent. Examine immediately after dissolution.

**pH (2.2.3)**: 8.0 to 10.0.

Dissolve 2.0 g in *carbon dioxide-free water R* and dilute to 20 mL with the same solvent.

**Specific optical rotation (2.2.7)**: + 240 to + 290 (anhydrous substance).

Dissolve 62.5 mg in a 4 g/L solution of *potassium hydrogen phthalate R* and dilute to 25.0 mL with the same solution.

**Related substances.** Liquid chromatography (2.2.29).

*Test solution (a)*. Dissolve 30.0 mg of the substance to be examined in mobile phase A and dilute to 50.0 mL with mobile phase A.

*Test solution (b)*. Dissolve 30.0 mg of the substance to be examined in mobile phase A and dilute to 20.0 mL with mobile phase A. *Prepare immediately before use.*

*Reference solution (a)*. Dissolve 30.0 mg of amoxicillin trihydrate CRS in mobile phase A and dilute to 50.0 mL with mobile phase A.

*Reference solution (b)*. Dissolve 4.0 mg of *cefadroxil CRS* in mobile phase A and dilute to 50 mL with mobile phase A. To 5.0 mL of this solution add 5.0 mL of reference solution (a) and dilute to 100 mL with mobile phase A.

*Reference solution (c)*. Dilute 2.0 mL of reference solution (a) to 20.0 mL with mobile phase A. Dilute 5.0 mL of this solution to 20.0 mL with mobile phase A.

*Reference solution (d)*. To 0.20 g of amoxicillin trihydrate R add 1.0 mL of *water R*. Shake and add dropwise *dilute sodium hydroxide solution R* to obtain a solution. The pH of the solution is about 8.5. Store the solution at room temperature for 4 h. Dilute 0.5 mL of this solution to 50.0 mL with mobile phase A.

*Column*:

- size:  $l = 0.25$  m,  $\emptyset = 4.6$  mm;
- stationary phase: octadecylsilyl silica gel for chromatography R (5 µm).

*Mobile phase*:

- mobile phase A: mix 1 volume of *acetonitrile R* and 99 volumes of a 25 per cent V/V solution of 0.2 M *potassium dihydrogen phosphate R* adjusted to pH 5.0 with *dilute sodium hydroxide solution R*;
- mobile phase B: mix 20 volumes of *acetonitrile R* and 80 volumes of a 25 per cent V/V solution of 0.2 M *potassium dihydrogen phosphate R* adjusted to pH 5.0 with *dilute sodium hydroxide solution R*;

Time (min)	Mobile phase A (per cent V/V)	Mobile phase B (per cent V/V)
0 - $t_R$	92	8
$t_R - (t_R + 25)$	92 → 0	8 → 100
$(t_R + 25) - (t_R + 40)$	0	100
$(t_R + 40) - (t_R + 55)$	92	8

$t_R$  = retention time of amoxicillin determined with reference solution (c)

If the mobile phase has been adjusted to achieve the required resolution, the adjusted composition will apply at time zero in the gradient and in the assay.

*Flow rate*: 1.0 mL/min.

*Detection*: spectrophotometer at 254 nm.

*Injection*: 50 µL of reference solutions (b) and (c) with isocratic elution at the initial mobile phase composition and 50 µL of test solution (b) and reference solution (d) according to the elution gradient described under Mobile phase; inject mobile phase A as a blank according to the elution gradient described under Mobile phase.

*Identification of impurities*: use the chromatogram obtained with reference solution (d) to identify the 3 principal peaks eluted after the main peak corresponding to impurity C, amoxicillin dimer (impurity J;  $n = 1$ ) and amoxicillin trimer (impurity J;  $n = 2$ ).

*Relative retention* with reference to amoxicillin:  
impurity C = about 3.4; impurity J ( $n = 1$ ) = about 4.1; impurity J  
( $n = 2$ ) = about 4.5.

*System suitability*: reference solution (b):

- *resolution*: minimum 2.0 between the peaks due to amoxicillin and cefadroxil; if necessary, adjust the ratio A:B of the mobile phase.

*Limits*:

- *impurity J* ( $n = 1$ ): not more than 3 times the area of the principal peak in the chromatogram obtained with reference solution (c) (3 per cent);
- *any other impurity*: for each impurity, not more than twice the area of the principal peak in the chromatogram obtained with reference solution (c) (2 per cent);
- *total*: not more than 9 times the area of the principal peak in the chromatogram obtained with reference solution (c) (9 per cent);
- *disregard limit*: 0.1 times the area of the principal peak in the chromatogram obtained with reference solution (c) (0.1 per cent).

***N,N*-Dimethylaniline** (2.4.26, *Method A or B*): maximum 20 ppm.

**2-Ethylhexanoic acid** (2.4.28): maximum 0.8 per cent *m/m*.

**Heavy metals** (2.4.8): maximum 20 ppm.

1.0 g complies with test C. Prepare the reference solution using 2 mL of lead standard solution (10 ppm Pb) R.

**Water** (2.5.12): maximum 3.0 per cent, determined on 0.400 g.

**Bacterial endotoxins** (2.6.14): less than 0.25 IU/mg, if intended for use in the manufacture of parenteral preparations without a further appropriate procedure for the removal of bacterial endotoxins.

#### ASSAY

Liquid chromatography (2.2.29) as described in the test for related substances with the following modifications.

*Mobile phase*: initial composition of the mixture of mobile phases A and B, adjusted where applicable.

*Injection*: test solution (a) and reference solution (a).

*System suitability*: reference solution (a):

- *repeatability*: maximum relative standard deviation of 1.0 per cent after 6 injections.

Calculate the percentage content of amoxicillin sodium by multiplying the percentage content of amoxicillin by 1.060.

#### STORAGE

In an airtight container. If the substance is sterile, store in a sterile, airtight, tamper-proof container.

#### IMPURITIES

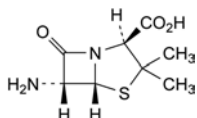

- A. (2*S*,5*R*,6*R*)-6-amino-3,3-dimethyl-7-oxo-4-thia-1-azabicyclo[3.2.0]heptane-2-carboxylic acid (6-aminopenicillanic acid),

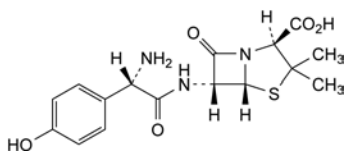

- B. (2*S*,5*R*,6*R*)-6-[[[(2*S*)-2-amino-2-(4-hydroxyphenyl)acetyl]amino]-3,3-dimethyl-7-oxo-4-thia-1-azabicyclo[3.2.0]heptane-2-carboxylic acid (L-amoxicillin),

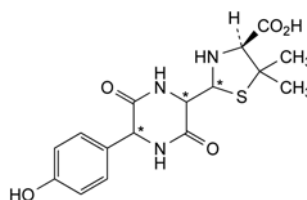

- C. (4*S*)-2-[5-(4-hydroxyphenyl)-3,6-dioxopiperazin-2-yl]-5,5-dimethylthiazolidine-4-carboxylic acid (amoxicillin diketopiperazines),

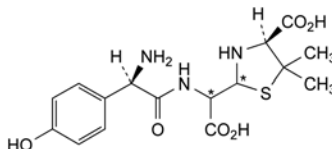

- D. (4*S*)-2-[[[(2*R*)-2-amino-2-(4-hydroxyphenyl)acetyl]amino]-carboxymethyl]-5,5-dimethylthiazolidine-4-carboxylic acid (penicilloic acids of amoxicillin),

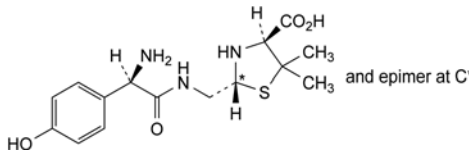

- E. (2*RS*,4*S*)-2-[[[(2*R*)-2-amino-2-(4-hydroxyphenyl)acetyl]amino]methyl]-5,5-dimethylthiazolidine-4-carboxylic acid (penilloic acids of amoxicillin),

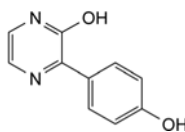

- F. 3-(4-hydroxyphenyl)pyrazin-2-ol,

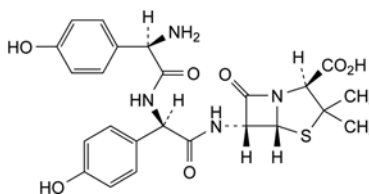

- G. (2*S*,5*R*,6*R*)-6-[[[(2*R*)-2-[[[(2*R*)-2-amino-2-(4-hydroxyphenyl)acetyl]amino]2-(4-hydroxyphenyl)acetyl]amino]-3,3-dimethyl-7-oxo-4-thia-1-azabicyclo[3.2.0]heptane-2-carboxylic acid (D-(4-hydroxyphenyl)glycyclamoxicillin),

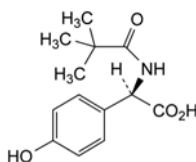

- H. (2*R*)-2-[(2,2-dimethylpropanoyl)amino]-2-(4-hydroxyphenyl)acetic acid,

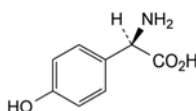

- I. (2*R*)-2-amino-2-(4-hydroxyphenyl)acetic acid,

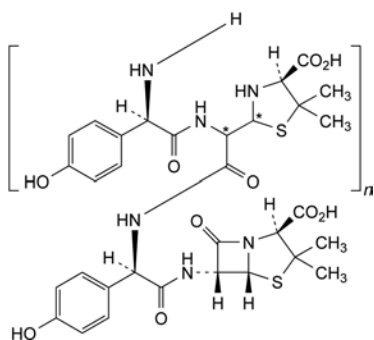

J. co-oligomers of amoxicillin and penicilloic acids of amoxicillin,

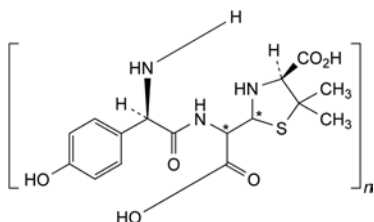

K. oligomers of penicilloic acids of amoxicillin.

01/2008:0260  
corrected 6.0

## AMOXICILLIN TRIHYDRATE

### Amoxicillinum trihydricum

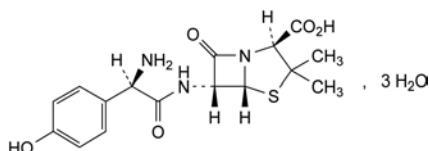

$C_{16}H_{19}N_3O_5S \cdot 3H_2O$   
[61336-70-7]

$M_r$  419.4

#### DEFINITION

(2*S*,5*R*,6*R*)-6-[[[(2*R*)-2-amino-2-(4-hydroxyphenyl)acetyl]amino]-3,3-dimethyl-7-oxo-4-thia-1-azabicyclo[3.2.0]heptane-2-carboxylic acid trihydrate.

Semi-synthetic product derived from a fermentation product.

*Content*: 95.0 per cent to 102.0 per cent (anhydrous substance).

#### CHARACTERS

*Appearance*: white or almost white, crystalline powder.

*Solubility*: slightly soluble in water, very slightly soluble in ethanol (96 per cent), practically insoluble in fatty oils. It dissolves in dilute acids and dilute solutions of alkali hydroxides.

#### IDENTIFICATION

*First identification*: A.

*Second identification*: B, C.

A. Infrared absorption spectrophotometry (2.2.24).

*Comparison*: amoxicillin trihydrate CRS.

B. Thin-layer chromatography (2.2.27).

*Test solution*. Dissolve 25 mg of the substance to be examined in 10 mL of sodium hydrogen carbonate solution R.

*Reference solution (a)*. Dissolve 25 mg of amoxicillin trihydrate CRS in 10 mL of sodium hydrogen carbonate solution R.

*Reference solution (b)*. Dissolve 25 mg of amoxicillin trihydrate CRS and 25 mg of ampicillin trihydrate CRS in 10 mL of sodium hydrogen carbonate solution R.

*Plate*: TLC silanised silica gel plate R.

*Mobile phase*: mix 10 volumes of acetone R and 90 volumes of a 154 g/L solution of ammonium acetate R previously adjusted to pH 5.0 with glacial acetic acid R.

*Application*: 1  $\mu$ L.

*Development*: over a path of 15 cm.

*Drying*: in air.

*Detection*: expose to iodine vapour until the spots appear and examine in daylight.

*System suitability*: reference solution (b):

– the chromatogram shows 2 clearly separated spots.

*Results*: the principal spot in the chromatogram obtained with the test solution is similar in position, colour and size to the principal spot in the chromatogram obtained with reference solution (a).

C. Place about 2 mg in a test-tube about 150 mm long and about 15 mm in diameter. Moisten with 0.05 mL of water R and add 2 mL of sulfuric acid-formaldehyde reagent R. Mix the contents of the tube by swirling; the solution is practically colourless. Place the test-tube in a water-bath for 1 min; a dark yellow colour develops.

#### TESTS

**Solution S**. With the aid of ultrasound or gentle heating, dissolve 0.100 g in carbon dioxide-free water R and dilute to 50.0 mL with the same solvent.

**Appearance of solution**. The solutions are not more opalescent than reference suspension II (2.2.1).

Dissolve 1.0 g in 10 mL of 0.5 M hydrochloric acid. Dissolve separately 1.0 g in 10 mL of dilute ammonia R2. Examine immediately after dissolution.

**pH (2.2.3)**: 3.5 to 5.5 for solution S.

**Specific optical rotation (2.2.7)**: + 290 to + 315 (anhydrous substance), determined on solution S.

**Related substances**. Liquid chromatography (2.2.29).

*Buffer solution pH 5.0*. To 250 mL of 0.2 M potassium dihydrogen phosphate R add dilute sodium hydroxide solution R to pH 5.0 and dilute to 1000.0 mL with water R.

*Test solution (a)*. Dissolve 30.0 mg of the substance to be examined in mobile phase A and dilute to 50.0 mL with mobile phase A.

*Test solution (b)*. Dissolve 30.0 mg of the substance to be examined in mobile phase A and dilute to 20.0 mL with mobile phase A. Prepare immediately before use.

*Reference solution (a)*. Dissolve 30.0 mg of amoxicillin trihydrate CRS in mobile phase A and dilute to 50.0 mL with mobile phase A.

*Reference solution (b)*. Dissolve 4.0 mg of cefadroxil CRS in mobile phase A and dilute to 50 mL with mobile phase A. To 5.0 mL of this solution add 5.0 mL of reference solution (a) and dilute to 100 mL with mobile phase A.

*Reference solution (c)*. Dilute 2.0 mL of reference solution (a) to 20.0 mL with mobile phase A. Dilute 5.0 mL of this solution to 20.0 mL with mobile phase A.

*Column*:

– *size*:  $l = 0.25$  m,  $\varnothing = 4.6$  mm;

– *stationary phase*: octadecylsilyl silica gel for chromatography R (5  $\mu$ m).



**Mobile phase:**

- **mobile phase A:** acetonitrile R, buffer solution pH 5.0 (1:99 V/V);
- **mobile phase B:** acetonitrile R, buffer solution pH 5.0 (20:80 V/V);

Time (min)	Mobile phase A (per cent V/V)	Mobile phase B (per cent V/V)
0 - $t_R$	92	8
$t_R - (t_R + 25)$	92 → 0	8 → 100
$(t_R + 25) - (t_R + 40)$	0	100
$(t_R + 40) - (t_R + 55)$	92	8

$t_R$  = retention time of amoxicillin determined with reference solution (c)

If the mobile phase composition has been adjusted to achieve the required resolution, the adjusted composition will apply at time zero in the gradient and in the assay.

**Flow rate:** 1.0 mL/min.

**Detection:** spectrophotometer at 254 nm.

**Injection:** 50 µL of reference solutions (b) and (c) with isocratic elution at the initial mobile phase composition and 50 µL of test solution (b) according to the elution gradient described under Mobile phase; inject mobile phase A as a blank according to the elution gradient described under Mobile phase.

**System suitability:** reference solution (b):

- **resolution:** minimum 2.0 between the peaks due to amoxicillin and cefadroxil; if necessary, adjust the ratio A:B of the mobile phase.

**Limit:**

- **any impurity:** for each impurity, not more than the area of the principal peak in the chromatogram obtained with reference solution (c) (1 per cent).

**N,N-Dimethylaniline** (2.4.26, Method A or B): maximum 20 ppm.

**Water** (2.5.12): 11.5 per cent to 14.5 per cent, determined on 0.100 g.

**Sulfated ash** (2.4.14): maximum 1.0 per cent, determined on 1.0 g.

**ASSAY**

Liquid chromatography (2.2.29) as described in the test for related substances with the following modifications.

**Mobile phase:** initial composition of the mixture of mobile phases A and B, adjusted where applicable.

**Injection:** test solution (a) and reference solution (a).

**System suitability:** reference solution (a):

- **repeatability:** maximum relative standard deviation of 1.0 per cent after 6 injections.

Calculate the percentage content of C<sub>16</sub>H<sub>19</sub>N<sub>3</sub>O<sub>5</sub>S from the declared content of amoxicillin trihydrate CRS.

**STORAGE**

In an airtight container.

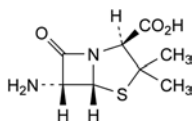
**IMPURITIES**

- A. (2*S*,5*R*,6*R*)-6-amino-3,3-dimethyl-7-oxo-4-thia-1-azabicyclo[3.2.0]heptane-2-carboxylic acid (6-aminopenicillanic acid),

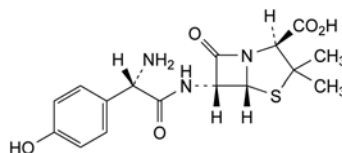

- B. (2*S*,5*R*,6*R*)-6-[[[(2*S*)-2-amino-2-(4-hydroxyphenyl)acetyl]amino]-3,3-dimethyl-7-oxo-4-thia-1-azabicyclo[3.2.0]heptane-2-carboxylic acid (L-amoxicillin),

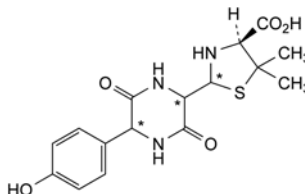

- C. (4*S*)-2-[5-(4-hydroxyphenyl)-3,6-dioxopiperazin-2-yl]-5,5-dimethylthiazolidine-4-carboxylic acid (amoxicillin diketopiperazines),

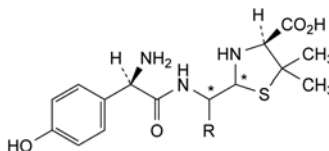

- D. R = CO<sub>2</sub>H: (4*S*)-2-[[[(2*R*)-2-amino-2-(4-hydroxyphenyl)acetyl]amino]carboxymethyl]-5,5-dimethylthiazolidine-4-carboxylic acid (penicilloic acids of amoxicillin),

- E. R = H: (2*R*,4*S*)-2-[[[(2*R*)-2-amino-2-(4-hydroxyphenyl)acetyl]amino]methyl]-5,5-dimethylthiazolidine-4-carboxylic acid (penilloic acids of amoxicillin),

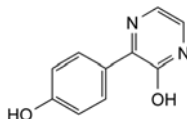

- F. 3-(4-hydroxyphenyl)pyrazin-2-ol,

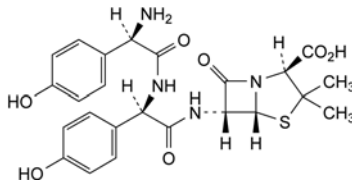

- G. (2*S*,5*R*,6*R*)-6-[[[(2*R*)-2-[(2*R*)-2-amino-2-(4-hydroxyphenyl)acetyl]amino]-2-(4-hydroxyphenyl)acetyl]amino]-3,3-dimethyl-7-oxo-4-thia-1-azabicyclo[3.2.0]heptane-2-carboxylic acid (D-(4-hydroxyphenyl)glycylamoxicillin),

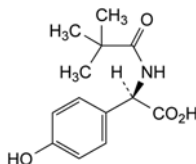

- H. (2*R*)-2-[(2,2-dimethylpropanoyl)amino]-2-(4-hydroxyphenyl)acetic acid,

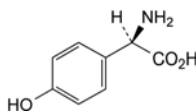

- I. (2*R*)-2-amino-2-(4-hydroxyphenyl)acetic acid,

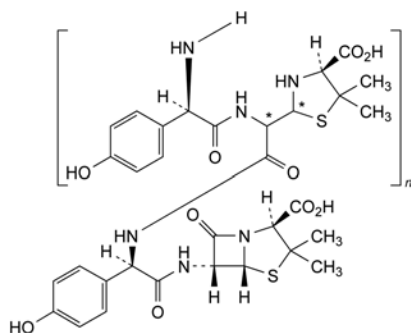

J. co-oligomers of amoxicillin and of penicilloic acids of amoxicillin,

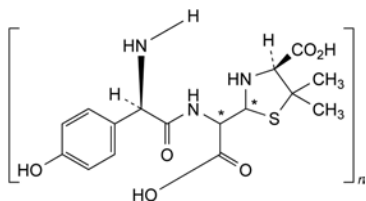

K. oligomers of penicilloic acids of amoxicillin,

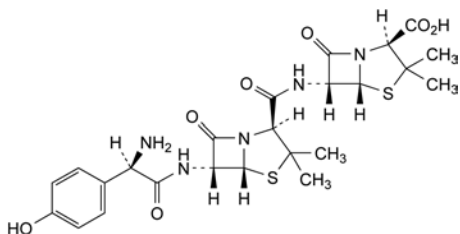

L. (2*S*,5*R*,6*R*)-6-[[[(2*S*,5*R*,6*R*)-6-[(2*R*)-2-amino-2-(4-hydroxyphenyl)acetyl]amino]-3,3-dimethyl-7-oxo-4-thia-1-azabicyclo[3.2.0]heptane-2-carbonyl]amino]-3,3-dimethyl-7-oxo-4-thia-1-azabicyclo[3.2.0]heptane-2-carboxylic acid (6-APA amoxicillin amide).

01/2009:1292  
corrected 6.6

## AMPHOTERICIN B

### Amphotericinum B

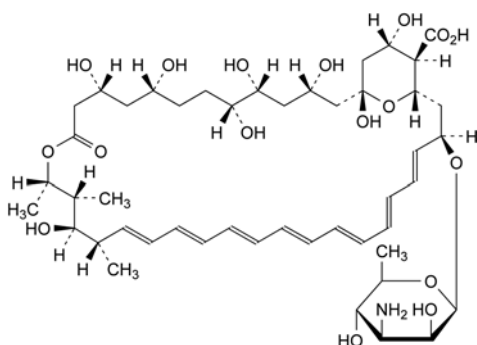

C<sub>47</sub>H<sub>73</sub>NO<sub>17</sub>  
[1397-89-3]

M<sub>r</sub> 924

#### DEFINITION

Mixture of antifungal polyenes produced by the growth of certain strains of *Streptomyces nodosus* or obtained by any other means. It consists mainly of amphotericin B which is (1*R*,3*S*,5*R*,6*R*,9*R*,11*R*,15*S*,16*R*,17*R*,18*S*,19*E*,21*E*,23*E*,25*E*,27*E*,29*E*,31*E*,33*R*,35*S*,36*R*,37*S*)-33-[(3-amino-3,6-dideoxy-β-D-mannopyranosyl)oxy]-1,3,5,6,9,11,17,37-octahydroxy-15,16,18-trimethyl-13-oxo-14,39-dioxabicyclo[33.3.1]nonatriaconta-19,21,23,25,27,29,31-heptaene-36-carboxylic acid.

*Content*: minimum 750 IU/mg (dried substance).

#### CHARACTERS

*Appearance*: yellow or orange, hygroscopic powder.

*Solubility*: practically insoluble in water, soluble in dimethyl sulfoxide and in propylene glycol, slightly soluble in dimethylformamide, very slightly soluble in methanol, practically insoluble in ethanol (96 per cent).

It is sensitive to light in dilute solutions.

#### IDENTIFICATION

*First identification*: B, D.

*Second identification*: A, C.

A. Ultraviolet and visible absorption spectrophotometry (2.2.25).

*Test solution*. Dissolve 25 mg in 5 mL of *dimethyl sulfoxide R* and dilute to 50 mL with *methanol R*. Dilute 2 mL of the solution to 200 mL with *methanol R*.

*Spectral range*: 300-450 nm.

*Absorption maxima*: at 362 nm, 381 nm and 405 nm.

*Absorbance ratios*:

–  $A_{362}/A_{381}$  = 0.57 to 0.61;

–  $A_{381}/A_{405}$  = 0.87 to 0.93.

B. Infrared absorption spectrophotometry (2.2.24).

*Comparison*: *amphotericin B CRS*.

If the spectra obtained show differences, dry the substance to be examined and reference substance at 60 °C at a pressure not exceeding 0.7 kPa for 1 h and record new spectra.

C. To 1 mL of a 0.5 g/L solution in *dimethyl sulfoxide R*, add 5 mL of *phosphoric acid R* to form a lower layer, avoiding mixing the 2 liquids. A blue ring is immediately produced at the junction of the liquids. Mix, an intense blue colour is produced. Add 15 mL of *water R* and mix; the solution becomes pale yellow.

D. Examine the chromatograms obtained in the test for related substances.

*Results*: the principal peak in the chromatogram obtained with the test solution at 383 nm is similar in retention time to the principal peak in the chromatogram obtained with reference solution (a).

#### TESTS

**Related substances.** Liquid chromatography (2.2.29). *Protect the solutions from light and use within 24 h of preparation, except for reference solution (c) which should be injected immediately after its preparation.*

*Solvent mixture*: 10 g/L solution of *ammonium acetate R*, *N-methylpyrrolidone R*, *methanol R* (1:1:2 V/V/V).

*Test solution*. Dissolve 20.0 mg of the substance to be examined in 15 mL of *N-methylpyrrolidone R* and within 2 h dilute to 50.0 mL with the solvent mixture. Dilute 5.0 mL of this solution to 25.0 mL with the solvent mixture.

*Reference solution (a)*. Dissolve 20.0 mg of *amphotericin B CRS* in 15 mL of *N-methylpyrrolidone R* and within 2 h dilute to 50.0 mL with the solvent mixture. Dilute 5.0 mL of this solution to 25.0 mL with the solvent mixture.

*Reference solution (b)*. Dilute 1.0 mL of reference solution (a) to 100.0 mL with the solvent mixture.

*Reference solution (c)*. Dissolve 20.0 mg of *nystatin CRS* in 15 mL of *N-methylpyrrolidone R* and within 2 h dilute to 50.0 mL with the solvent mixture. Dilute 5.0 mL of the solution to 25.0 mL with reference solution (a). Dilute 2.0 mL of this solution to 100.0 mL with the solvent mixture.

*Reference solution (d)*. In order to prepare impurities B and C, dissolve 10 mg of the substance to be examined in 5 mL of *N-methylpyrrolidone R* and within 2 h add 35 mL of a mixture of 1 volume of *methanol R* and 4 volumes of *anhydrous*

ethanol R. Add 0.10 mL of dilute hydrochloric acid R, mix and incubate at 25 °C for 2.5 h. Add 10 mL of 10 g/L solution of ammonium acetate R and mix.

**Reference solution (e).** Dissolve 4 mg of amphotericin B for peak identification CRS (containing impurities A and B) in 5 mL of *N*-methylpyrrolidone R and within 2 h dilute to 50 mL with the solvent mixture.

**Blank solution.** The solvent mixture.

**Column:**

- size:  $l = 0.15$  m,  $\varnothing = 4.6$  mm;
- stationary phase: base-deactivated end-capped octadecylsilyl silica gel for chromatography R (3  $\mu$ m);
- temperature: 20 °C.

**Mobile phase:**

- mobile phase A: mix 1 volume of methanol R, 3 volumes of acetonitrile R and 6 volumes of a 4.2 g/L solution of citric acid R previously adjusted to pH 4.7 using concentrated ammonia R;
- mobile phase B: mix 12 volumes of methanol R, 20 volumes of a 4.2 g/L solution of citric acid R previously adjusted to pH 3.9 using concentrated ammonia R and 68 volumes of acetonitrile R;

Time (min)	Mobile phase A (per cent V/V)	Mobile phase B (per cent V/V)
0 - 3	100	0
3 - 23	100 → 70	0 → 30
23 - 33	70 → 0	30 → 100
33 - 40	0	100

**Flow rate:** 0.8 mL/min.

**Detection:** spectrophotometer:

- at 303 nm: detection of tetraenes;
- at 383 nm: detection of heptaenes.

**Injection:** 20  $\mu$ L of the test solution and reference solutions (b), (c), (d) and (e).

**Identification of impurities:** use the chromatograms supplied with amphotericin B for peak identification CRS and the chromatograms obtained with reference solution (e) to identify the peaks due to impurities A and B.

**Relative retention** with reference to amphotericin B (retention time = about 16 min): impurity B = about 0.75; impurity A = about 0.8; nystatin = about 0.85.

**System suitability at 383 nm:** reference solution (d):

- resolution: minimum 1.5 between the 2 peaks presenting a relative retention of about 0.7.

**Limits:**

- impurity A at 303 nm: not more than 2.5 times the area of the principal peak in the chromatogram obtained with reference solution (c) (5.0 per cent); if intended for use in the manufacture of parenteral preparations: not more than the area of the principal peak in the chromatogram obtained with reference solution (c) (2.0 per cent);
- any other impurity at 303 nm: for each impurity, not more than 0.5 times the area of the principal peak in the chromatogram obtained with reference solution (c) (1.0 per cent);
- impurity B at 383 nm: not more than 4 times the area of the principal peak in the chromatogram obtained with reference solution (b) (4.0 per cent);

- any other impurity at 383 nm: for each impurity, not more than 2 times the area of the principal peak in the chromatogram obtained with reference solution (b) (2.0 per cent);
- total at 303 and 383 nm: maximum 15.0 per cent;
- disregard limit at 303 nm: 0.05 times the area of the principal peak in the chromatogram obtained with reference solution (c) (0.1 per cent);
- disregard limit at 383 nm: 0.1 times the area of the principal peak in the chromatogram obtained with reference solution (b) (0.1 per cent).

**Loss on drying (2.2.32):** maximum 5.0 per cent, determined on 1.000 g by drying in an oven at 60 °C at a pressure not exceeding 0.7 kPa.

**Sulfated ash (2.4.14):** maximum 3.0 per cent, determined on 1.0 g; if intended for use in the manufacture of parenteral preparations: maximum 0.5 per cent.

**Bacterial endotoxins (2.6.14):** less than 1.0 IU/mg, if intended for use in the manufacture of parenteral preparations without a further appropriate procedure for the removal of bacterial endotoxins.

**ASSAY**

Protect all solutions from light throughout the assay. Dissolve 25.0 mg in dimethyl sulfoxide R and dilute, with shaking, to 25.0 mL with the same solvent. Under constant stirring of this stock solution, dilute with dimethyl sulfoxide R to obtain solutions of appropriate concentrations (the following concentrations have been found suitable: 44.4, 66.7 and 100 IU/mL). Prepare final solutions by diluting 1:20 with 0.2 M phosphate buffer solution pH 10.5 so that they all contain 5 per cent V/V of dimethyl sulfoxide. Prepare the reference and the test solutions simultaneously. Carry out the microbiological assay of antibiotics (2.7.2).

**STORAGE**

Protected from light, at a temperature of 2 °C to 8 °C in an airtight container. If the substance is sterile, store in a sterile, tamper-proof container.

**LABELLING**

The label states, where applicable, that the substance is suitable for use in the manufacture of parenteral preparations.

**IMPURITIES**

**Specified impurities:** A, B.

**Other detectable impurities** (the following substances would, if present at a sufficient level, be detected by one or other of the tests in the monograph. They are limited by the general acceptance criterion for other/unspecified impurities and/or by the general monograph *Substances for pharmaceutical use (2034)*. It is therefore not necessary to identify these impurities for demonstration of compliance. See also 5.10. *Control of impurities in substances for pharmaceutical use*): C.

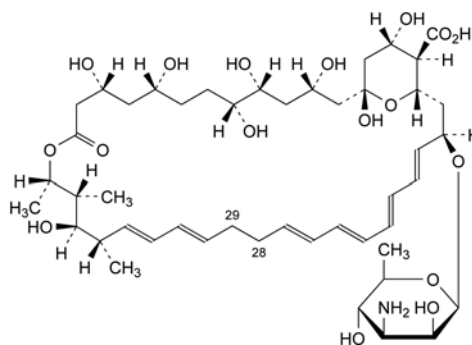

A. amphotericin A (28,29-dihydro-amphotericin B),

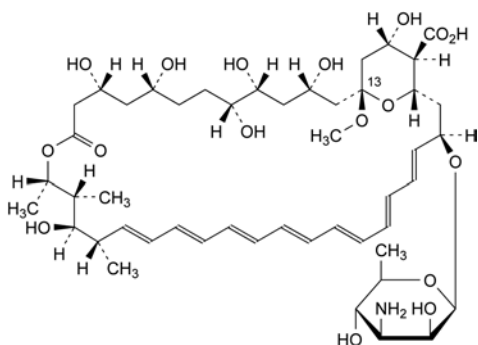

B. amphotericin X1 (13-O-methyl-amphotericin B),

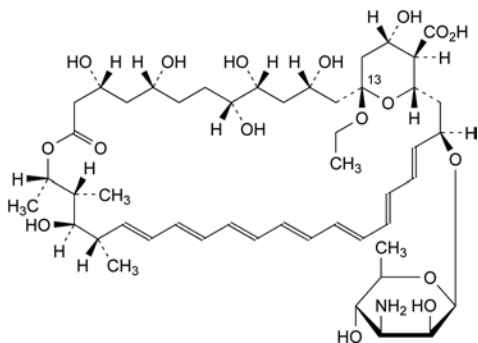

C. amphotericin X2 (13-O-ethyl-amphotericin B).

01/2008:0167  
corrected 6.0

## AMPICILLIN, ANHYDROUS

### Ampicillinum anhydricum

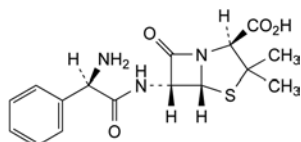
C<sub>16</sub>H<sub>19</sub>N<sub>3</sub>O<sub>4</sub>S  
[69-53-4]M<sub>r</sub> 349.4

#### DEFINITION

(2*S*,5*R*,6*R*)-6-[(2*R*)-2-Amino-2-phenylacetyl]amino]-3,3-dimethyl-7-oxo-4-thia-1-azabicyclo[3.2.0]heptane-2-carboxylic acid.

Semi-synthetic product derived from a fermentation product.

Content: 96.0 per cent to 102.0 per cent (anhydrous substance).

#### CHARACTERS

Appearance: white or almost white, crystalline powder.

Solubility: sparingly soluble in water, practically insoluble in acetone, in ethanol (96 per cent) and in fatty oils. It dissolves in dilute solutions of acids and of alkali hydroxides.

It shows polymorphism (5.9).

#### IDENTIFICATION

First identification: A, D.

Second identification: B, C, D.

A. Infrared absorption spectrophotometry (2.2.24).

Preparation: discs of potassium bromide R.

Comparison: anhydrous ampicillin CRS.

B. Thin-layer chromatography (2.2.27).

Test solution. Dissolve 25 mg of the substance to be examined in 10 mL of sodium hydrogen carbonate solution R.

Reference solution (a). Dissolve 25 mg of anhydrous ampicillin CRS in 10 mL of sodium hydrogen carbonate solution R.

Reference solution (b). Dissolve 25 mg of amoxicillin trihydrate CRS and 25 mg of anhydrous ampicillin CRS in 10 mL of sodium hydrogen carbonate solution R.

Plate: TLC silanised silica gel plate R.

Mobile phase: mix 10 volumes of acetone R and 90 volumes of a 154 g/L solution of ammonium acetate R previously adjusted to pH 5.0 with glacial acetic acid R.

Application: 1 µL.

Development: over a path of 15 cm.

Drying: in air.

Detection: expose to iodine vapour until the spots appear and examine in daylight.

System suitability: reference solution (b):

– the chromatogram shows 2 clearly separated spots.

Results: the principal spot in the chromatogram obtained with the test solution is similar in position, colour and size to the principal spot in the chromatogram obtained with reference solution (a).

C. Place about 2 mg in a test-tube about 150 mm long and about 15 mm in diameter. Moisten with 0.05 mL of water R and add 2 mL of sulfuric acid-formaldehyde reagent R. Mix the contents of the tube by swirling; the solution is practically colourless. Place the test-tube in a water-bath for 1 min; a dark yellow colour develops.

D. Water (see Tests).

#### TESTS

Appearance of solution. The solutions are not more opalescent than reference suspension II (2.2.1).

Dissolve 1.0 g in 10 mL of 1 M hydrochloric acid. Separately dissolve 1.0 g in 10 mL of dilute ammonia R2. Examine immediately after dissolution.

pH (2.2.3): 3.5 to 5.5.

Dissolve 0.1 g in carbon dioxide-free water R and dilute to 40 mL with the same solvent.

Specific optical rotation (2.2.7): + 280 to + 305 (anhydrous substance).

Dissolve 62.5 mg in water R and dilute to 25.0 mL with the same solvent.

Related substances. Liquid chromatography (2.2.29).

Test solution (a). Dissolve 27.0 mg of the substance to be examined in mobile phase A and dilute to 50.0 mL with mobile phase A.

Test solution (b). Dissolve 27.0 mg of the substance to be examined in mobile phase A and dilute to 10.0 mL with mobile phase A. Prepare immediately before use.

Reference solution (a). Dissolve 27.0 mg of anhydrous ampicillin CRS in mobile phase A and dilute to 50.0 mL with mobile phase A.

Reference solution (b). Dissolve 2.0 mg of cefradine CRS in mobile phase A and dilute to 50 mL with mobile phase A. To 5.0 mL of this solution add 5.0 mL of reference solution (a).

Reference solution (c). Dilute 1.0 mL of reference solution (a) to 20.0 mL with mobile phase A.

Column:

– size:  $l = 0.25$  m,  $\varnothing = 4.6$  mm;

– stationary phase: octadecylsilyl silica gel for chromatography R (5 µm).

**Mobile phase:**

- **mobile phase A:** mix 0.5 mL of dilute acetic acid R, 50 mL of 0.2 M potassium dihydrogen phosphate R and 50 mL of acetonitrile R, then dilute to 1000 mL with water R;
- **mobile phase B:** mix 0.5 mL of dilute acetic acid R, 50 mL of 0.2 M potassium dihydrogen phosphate R and 400 mL of acetonitrile R, then dilute to 1000 mL with water R;

Time (min)	Mobile phase A (per cent V/V)	Mobile phase B (per cent V/V)
0 - $t_R$	85	15
$t_R - (t_R + 30)$	85 → 0	15 → 100
$(t_R + 30) - (t_R + 45)$	0	100
$(t_R + 45) - (t_R + 60)$	85	15

$t_R$  = retention time of ampicillin determined with reference solution (c)

If the mobile phase composition has been adjusted to achieve the required resolution, the adjusted composition will apply at time zero in the gradient and in the assay.

**Flow rate:** 1.0 mL/min.

**Detection:** spectrophotometer at 254 nm.

**Injection:** 50 µL of reference solutions (b) and (c) with isocratic elution at the initial mobile phase composition and 50 µL of test solution (b) according to the elution gradient described under Mobile phase; inject mobile phase A as a blank according to the elution gradient described under Mobile phase.

**System suitability:** reference solution (b):

- **resolution:** minimum 3.0 between the peaks due to ampicillin and cefradin; if necessary, adjust the ratio A:B of the mobile phase.

**Limit:**

- **any impurity:** for each impurity, not more than the area of the principal peak in the chromatogram obtained with reference solution (c) (1.0 per cent).

**N,N-Dimethylaniline (2.4.26, Method B):** maximum 20 ppm.

**Water (2.5.12):** maximum 2.0 per cent, determined on 0.300 g.

**Sulfated ash (2.4.14):** maximum 0.5 per cent, determined on 1.0 g.

**ASSAY**

Liquid chromatography (2.2.29) as described in the test for related substances with the following modifications.

**Mobile phase:** initial composition of the mixture of mobile phases A and B, adjusted where applicable.

**Injection:** test solution (a) and reference solution (a).

**System suitability:** reference solution (a):

- **repeatability:** maximum relative standard deviation of 1.0 per cent after 6 injections.

Calculate the percentage content of  $C_{16}H_{19}N_3O_4S$  from the declared content of *anhydrous ampicillin CRS*.

**STORAGE**

In an airtight container, at a temperature not exceeding 30 °C.

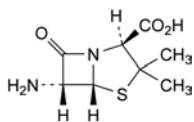
**IMPURITIES**

- A. (2*S*,5*R*,6*R*)-6-amino-3,3-dimethyl-7-oxo-4-thia-1-azabicyclo[3.2.0]heptane-2-carboxylic acid (6-aminopenicillanic acid),

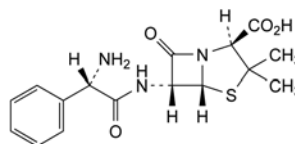

- B. (2*S*,5*R*,6*R*)-6-[(2*S*)-2-amino-2-phenylacetyl]amino]-3,3-dimethyl-7-oxo-4-thia-1-azabicyclo[3.2.0]heptane-2-carboxylic acid (L-ampicillin),

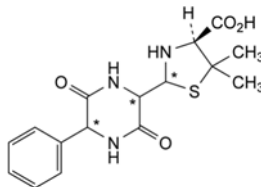

- C. (4*S*)-2-(3,6-dioxo-5-phenylpiperazin-2-yl)-5,5-dimethylthiazolidine-4-carboxylic acid (diketopiperazines of ampicillin),

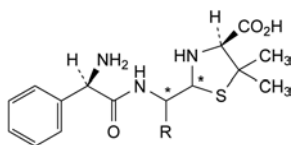

- D. R = CO<sub>2</sub>H: (4*S*)-2-[[[(2*R*)-2-amino-2-phenylacetyl]amino]-carboxymethyl]-5,5-dimethylthiazolidine-4-carboxylic acid (penicilloic acids of ampicillin),

- F. R = H: (2*RS*,4*S*)-2-[[[(2*R*)-2-amino-2-phenylacetyl]amino]-methyl]-5,5-dimethylthiazolidine-4-carboxylic acid (penilloic acids of ampicillin),

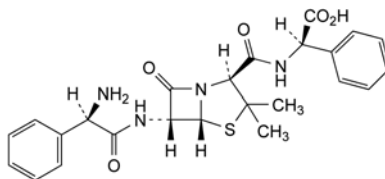

- E. (2*R*)-2-[[[(2*S*,5*R*,6*R*)-6-[(2*R*)-2-amino-2-phenylacetyl]amino]-3,3-dimethyl-7-oxo-4-thia-1-azabicyclo[3.2.0]hept-2-yl]carbonyl]amino]-2-phenylacetic acid (ampicillinyl-D-phenylglycine),

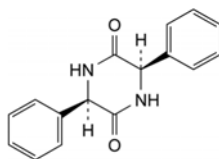

- G. (3*R*,6*R*)-3,6-diphenylpiperazine-2,5-dione,

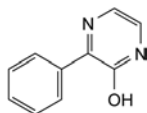

- H. 3-phenylpyrazin-2-ol,

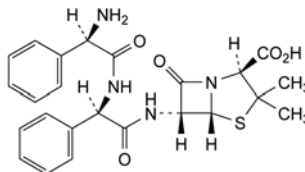

- I. (2*S*,5*R*,6*R*)-6-[(2*R*)-2-[(2*R*)-2-amino-2-phenylacetyl]amino]-2-phenylacetyl]amino]-3,3-dimethyl-7-oxo-4-thia-1-azabicyclo[3.2.0]heptane-2-carboxylic acid (D-phenylglycylampicillin),

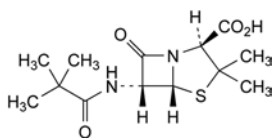

J. (2*S*,5*R*,6*R*)-6-[(2,2-dimethylpropanoyl)amino]-3,3-dimethyl-7-oxo-4-thia-1-azabicyclo[3.2.0]heptane-2-carboxylic acid,

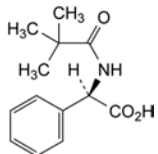

K. (2*R*)-2-[(2,2-dimethylpropanoyl)amino]-2-phenylacetic acid,

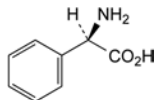

L. (2*R*)-2-amino-2-phenylacetic acid (D-phenylglycine),

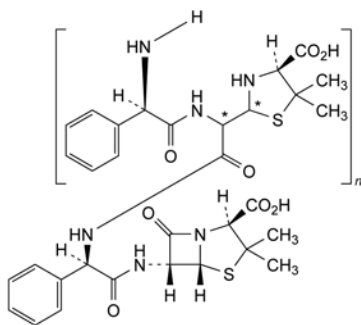

M. co-oligomers of ampicillin and of penicilloic acids of ampicillin.

01/2008:0578  
corrected 6.0

## AMPICILLIN SODIUM

### Ampicillinum natricum

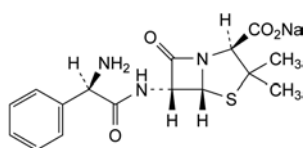

$C_{16}H_{18}N_3NaO_4S$   
[69-52-3]

$M_r$  371.4

#### DEFINITION

Sodium (2*S*,5*R*,6*R*)-6-[(2*R*)-2-amino-2-phenylacetyl]amino]-3,3-dimethyl-7-oxo-4-thia-1-azabicyclo[3.2.0]heptane-2-carboxylate.

Semi-synthetic product derived from a fermentation product.

*Content*: 91.0 per cent to 102.0 per cent (anhydrous substance).

#### CHARACTERS

*Appearance*: white or almost white powder, hygroscopic.

*Solubility*: freely soluble in water, sparingly soluble in acetone, practically insoluble in fatty oils and in liquid paraffin.

#### IDENTIFICATION

*First identification*: A, D.

*Second identification*: B, C, D.

A. Infrared absorption spectrophotometry (2.2.24).

*Preparation*: dissolve 0.250 g in 5 mL of *water R*, add 0.5 mL of *dilute acetic acid R*, swirl and allow to stand for 10 min in iced water. Filter the crystals through a small sintered-glass

filter (40) (2.1.2), applying suction, wash with 2-3 mL of a mixture of 1 volume of *water R* and 9 volumes of *acetone R*, then dry in an oven at 60 °C for 30 min.

*Comparison*: *ampicillin trihydrate CRS*.

B. Thin-layer chromatography (2.2.27).

*Test solution*. Dissolve 25 mg of the substance to be examined in 10 mL of *sodium hydrogen carbonate solution R*.

*Reference solution (a)*. Dissolve 25 mg of *ampicillin trihydrate CRS* in 10 mL of *sodium hydrogen carbonate solution R*.

*Reference solution (b)*. Dissolve 25 mg of *amoxicillin trihydrate CRS* and 25 mg of *ampicillin trihydrate CRS* in 10 mL of *sodium hydrogen carbonate solution R*.

*Plate*: *TLC silanised silica gel plate R*.

*Mobile phase*: mix 10 volumes of *acetone R* and 90 volumes of a 154 g/L solution of *ammonium acetate R* previously adjusted to pH 5.0 with *glacial acetic acid R*.

*Application*: 1 µL.

*Development*: over a path of 15 cm.

*Drying*: in air.

*Detection*: expose to iodine vapour until the spots appear and examine in daylight.

*System suitability*: reference solution (b):

– the chromatogram shows 2 clearly separated spots.

*Results*: the principal spot in the chromatogram obtained with the test solution is similar in position, colour and size to the principal spot in the chromatogram obtained with reference solution (a).

C. Place about 2 mg in a test-tube about 150 mm long and about 15 mm in diameter. Moisten with 0.05 mL of *water R* and add 2 mL of *sulfuric acid-formaldehyde reagent R*. Mix the contents of the tube by swirling; the solution is practically colourless. Place the test-tube in a water-bath for 1 min; a dark yellow colour develops.

D. It gives reaction (a) of sodium (2.3.1).

#### TESTS

**Appearance of solution.** Solutions A and B are not more opalescent than reference suspension II (2.2.1) and the absorbance (2.2.25) of solution B at 430 nm is not greater than 0.15.

Place 1.0 g in a conical flask and add slowly and with continuous swirling 10 mL of 1 M *hydrochloric acid* (solution A). Separately dissolve 1.0 g in *water R* and dilute to 10.0 mL with the same solvent (solution B). Examine immediately after dissolution.

**pH** (2.2.3): 8.0 to 10.0.

Dissolve 2.0 g in *carbon dioxide-free water R* and dilute to 20 mL with the same solvent. Measure 10 min after dissolution.

**Specific optical rotation** (2.2.7): + 258 to + 287 (anhydrous substance).

Dissolve 62.5 mg in a 4 g/L solution of *potassium hydrogen phthalate R* and dilute to 25.0 mL with the same solvent.

**Related substances.** Liquid chromatography (2.2.29).

*Test solution (a)*. Dissolve 31.0 mg of the substance to be examined in mobile phase A and dilute to 50.0 mL with mobile phase A.

*Test solution (b)*. Dissolve 31.0 mg of the substance to be examined in mobile phase A and dilute to 10.0 mL with mobile phase A. *Prepare immediately before use.*

*Reference solution (a)*. Dissolve 27.0 mg of *anhydrous ampicillin CRS* in mobile phase A and dilute to 50.0 mL with mobile phase A.

*Reference solution (b)*. Dissolve 2.0 mg of *cefradine CRS* in mobile phase A and dilute to 50 mL with mobile phase A. To 5.0 mL of this solution add 5.0 mL of reference solution (a).

**Reference solution (c).** Dilute 1.0 mL of reference solution (a) to 20.0 mL with mobile phase A.

**Reference solution (d).** To 0.20 g of the substance to be examined add 1.0 mL of water R. Heat the solution at 60 °C for 1 h. Dilute 0.5 mL of this solution to 50.0 mL with mobile phase A.

**Column:**

- size:  $l = 0.25$  m,  $\varnothing = 4.6$  mm;
- stationary phase: octadecylsilyl silica gel for chromatography R (5  $\mu$ m).

**Mobile phase:**

- mobile phase A: mix 0.5 mL of dilute acetic acid R, 50 mL of 0.2 M potassium dihydrogen phosphate R and 50 mL of acetonitrile R, then dilute to 1000 mL with water R;
- mobile phase B: mix 0.5 mL of dilute acetic acid R, 50 mL of 0.2 M potassium dihydrogen phosphate R and 400 mL of acetonitrile R, then dilute to 1000 mL with water R;

Time (min)	Mobile phase A (per cent V/V)	Mobile phase B (per cent V/V)
0 - $t_R$	85	15
$t_R - (t_R + 30)$	85 $\rightarrow$ 0	15 $\rightarrow$ 100
$(t_R + 30) - (t_R + 45)$	0	100
$(t_R + 45) - (t_R + 60)$	85	15

$t_R$  = retention time of ampicillin determined with reference solution (c)

If the mobile phase composition has been adjusted to achieve the required resolution, the adjusted composition will apply at time zero in the gradient and in the assay.

**Flow rate:** 1.0 mL/min.

**Detection:** spectrophotometer at 254 nm.

**Injection:** 50  $\mu$ L of reference solutions (b) and (c) with isocratic elution at the initial mobile phase composition and 50  $\mu$ L of test solution (b) and reference solution (d) according to the elution gradient described under Mobile phase; inject mobile phase A as a blank according to the elution gradient described under Mobile phase.

**Identification of peaks:** use the chromatogram obtained with reference solution (d) to identify the peaks due to ampicillin and ampicillin dimer.

**Relative retention** with reference to ampicillin: ampicillin dimer = about 2.8.

**System suitability:** reference solution (b):

- resolution: minimum 3.0 between the peaks due to ampicillin and cefradin; if necessary adjust the ratio A:B of the mobile phase.

**Limits:**

- ampicillin dimer: not more than 4.5 times the area of the principal peak in the chromatogram obtained with reference solution (c) (4.5 per cent);
- any other impurity: for each impurity, not more than twice the area of the principal peak in the chromatogram obtained with reference solution (c) (2 per cent).

**N,N-Dimethylaniline** (2.4.26, Method B): maximum 20 ppm.

**2-Ethylhexanoic acid** (2.4.28): maximum 0.8 per cent *m/m*.

**Methylene chloride.** Gas chromatography (2.2.28).

**Internal standard solution.** Dissolve 1.0 mL of ethylene chloride R in water R and dilute to 500.0 mL with the same solvent.

**Test solution (a).** Dissolve 1.0 g of the substance to be examined in water R and dilute to 10.0 mL with the same solvent.

**Test solution (b).** Dissolve 1.0 g of the substance to be examined in water R, add 1.0 mL of the internal standard solution and dilute to 10.0 mL with water R.

**Reference solution.** Dissolve 1.0 mL of methylene chloride R in water R and dilute to 500.0 mL with the same solvent. To 1.0 mL of this solution add 1.0 mL of the internal standard solution and dilute to 10.0 mL with water R.

**Column:**

- material: glass;
- size:  $l = 1.5$  m,  $\varnothing = 4$  mm;
- stationary phase: diatomaceous earth for gas chromatography R impregnated with 10 per cent *m/m* of macrogol 1000 R.

**Carrier gas:** nitrogen for chromatography R.

**Flow rate:** 40 mL/min.

**Temperature:**

- column: 60 °C;
- injection port: 100 °C;
- detector: 150 °C.

**Detection:** flame ionisation.

Calculate the content of methylene chloride taking its density at 20 °C to be 1.325 g/mL.

**Limit:**

- methylene chloride: maximum 0.2 per cent *m/m*.

**Heavy metals** (2.4.8): maximum 20 ppm.

1.0 g complies with test C. Prepare the reference solution using 2 mL of lead standard solution (10 ppm Pb) R.

**Water** (2.5.12): maximum 2.0 per cent, determined on 0.300 g.

**Bacterial endotoxins** (2.6.14): less than 0.15 IU/mg, if intended for use in the manufacture of parenteral preparations without a further appropriate procedure for the removal of bacterial endotoxins.

#### ASSAY

Liquid chromatography (2.2.29) as described in the test for related substances with the following modifications.

**Mobile phase:** initial composition of the mixture of mobile phases A and B, adjusted where applicable.

**Injection:** test solution (a) and reference solution (a).

**System suitability:** reference solution (a):

- repeatability: maximum relative standard deviation of 1.0 per cent after 6 injections.

Calculate the percentage content of ampicillin sodium by multiplying the percentage content of ampicillin by 1.063.

#### STORAGE

In an airtight container. If the substance is sterile, store in a sterile, airtight, tamper-proof container.

#### IMPURITIES

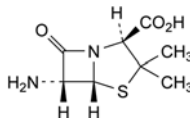

- A. (2*S*,5*R*,6*R*)-6-amino-3,3-dimethyl-7-oxo-4-thia-1-azabicyclo[3.2.0]heptane-2-carboxylic acid (6-aminopenicillanic acid),

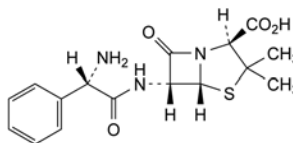

- B. (2*S*,5*R*,6*R*)-6-[[[(2*S*)-2-amino-2-phenylacetyl]amino]-3,3-dimethyl-7-oxo-4-thia-1-azabicyclo[3.2.0]heptane-2-carboxylic acid (L-ampicillin),

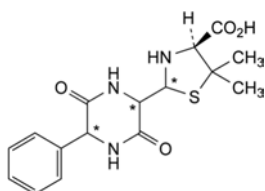

- C. (4*S*)-2-(3,6-dioxo-5-phenylpiperazin-2-yl)-5,5-dimethylthiazolidine-4-carboxylic acid (diketopiperazines of ampicillin),

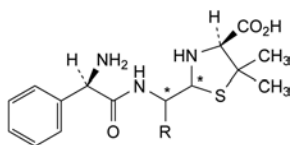

- D. R = CO<sub>2</sub>H: (4*S*)-2-[[[(2*R*)-2-amino-2-phenylacetyl]amino]carboxymethyl]-5,5-dimethylthiazolidine-4-carboxylic acid (penicilloic acids of ampicillin),

- F. R = H: (2*R*,4*S*)-2-[[[(2*R*)-2-amino-2-phenylacetyl]amino]methyl]-5,5-dimethylthiazolidine-4-carboxylic acid (penilloic acids of ampicillin),

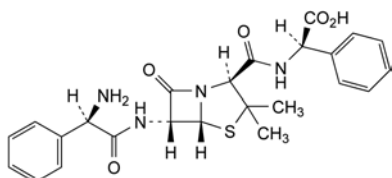

- E. (2*R*)-2-[[[(2*S*,5*R*,6*R*)-6-[[[(2*R*)-2-amino-2-phenylacetyl]amino]-3,3-dimethyl-7-oxo-4-thia-1-azabicyclo[3.2.0]hept-2-yl]carbonyl]amino]-2-phenylacetic acid (ampicillinyl-D-phenylglycine),

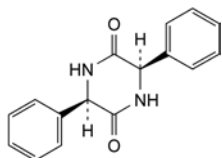

- G. (3*R*,6*R*)-3,6-diphenylpiperazine-2,5-dione,

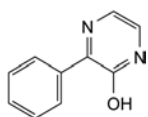

- H. 3-phenylpyrazin-2-ol,

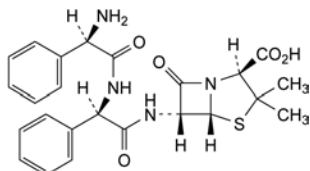

- I. (2*S*,5*R*,6*R*)-6-[[[(2*R*)-2-[[[(2*R*)-2-amino-2-phenylacetyl]amino]-2-phenylacetyl]amino]-3,3-dimethyl-7-oxo-4-thia-1-azabicyclo[3.2.0]heptane-2-carboxylic acid (D-phenylglycylampicillin),

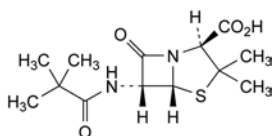

- J. (2*S*,5*R*,6*R*)-6-[(2,2-dimethylpropanoyl)amino]-3,3-dimethyl-7-oxo-4-thia-1-azabicyclo[3.2.0]heptane-2-carboxylic acid,

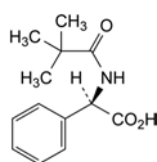

- K. (2*R*)-2-[(2,2-dimethylpropanoyl)amino]-2-phenylacetic acid,

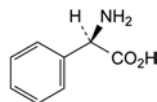

- L. (2*R*)-2-amino-2-phenylacetic acid (D-phenylglycine),

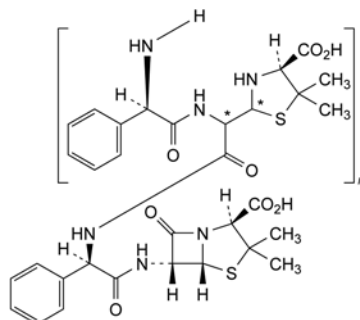

- M. co-oligomers of ampicillin and of penicilloic acids of ampicillin,

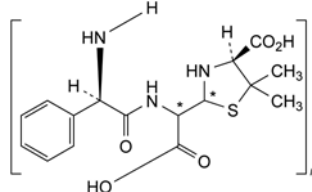

- N. oligomers of penicilloic acids of ampicillin.

01/2008:0168  
corrected 6.0

## AMPICILLIN TRIHYDRATE

### Ampicillinum trihydricum

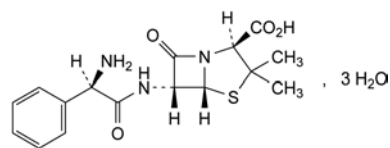

C<sub>16</sub>H<sub>19</sub>N<sub>3</sub>O<sub>4</sub>S·3H<sub>2</sub>O  
[7177-48-2]

M<sub>r</sub> 403.5

#### DEFINITION

(2*S*,5*R*,6*R*)-6-[[[(2*R*)-2-Amino-2-phenylacetyl]amino]-3,3-dimethyl-7-oxo-4-thia-1-azabicyclo[3.2.0]heptane-2-carboxylic acid trihydrate.

Semi-synthetic product derived from a fermentation product.

*Content*: 96.0 per cent to 102.0 per cent (anhydrous substance).

#### CHARACTERS

*Appearance*: white or almost white, crystalline powder.

*Solubility*: slightly soluble in water, practically insoluble in ethanol (96 per cent) and in fatty oils. It dissolves in dilute solutions of acids and of alkali hydroxides.

#### IDENTIFICATION

*First identification*: A, D.

*Second identification*: B, C, D.

A. Infrared absorption spectrophotometry (2.2.24).



Comparison: ampicillin trihydrate CRS.

B. Thin-layer chromatography (2.2.27).

**Test solution.** Dissolve 25 mg of the substance to be examined in 10 mL of sodium hydrogen carbonate solution R.

**Reference solution (a).** Dissolve 25 mg of ampicillin trihydrate CRS in 10 mL of sodium hydrogen carbonate solution R.

**Reference solution (b).** Dissolve 25 mg of amoxicillin trihydrate CRS and 25 mg of ampicillin trihydrate CRS in 10 mL of sodium hydrogen carbonate solution R.

**Plate:** TLC silanised silica gel plate R.

**Mobile phase:** mix 10 volumes of acetone R and 90 volumes of a 154 g/L solution of ammonium acetate R previously adjusted to pH 5.0 with glacial acetic acid R.

**Application:** 1 µL.

**Development:** over a path of 15 cm.

**Drying:** in air.

**Detection:** expose to iodine vapour until the spots appear and examine in daylight.

**System suitability:** reference solution (b):

– the chromatogram shows 2 clearly separated spots.

**Results:** the principal spot in the chromatogram obtained with the test solution is similar in position, colour and size to the principal spot in the chromatogram obtained with reference solution (a).

C. Place about 2 mg in a test-tube about 150 mm long and about 15 mm in diameter. Moisten with 0.05 mL of water R and add 2 mL of sulfuric acid-formaldehyde reagent R. Mix the contents of the tube by swirling; the solution is practically colourless. Place the test-tube in a water-bath for 1 min; a dark yellow colour develops.

D. Water (see Tests).

## TESTS

**Appearance of solution.** The solutions are not more opalescent than reference suspension II (2.2.1).

Dissolve 1.0 g in 10 mL of 1 M hydrochloric acid. Separately dissolve 1.0 g in 10 mL of dilute ammonia R2. Examine immediately after dissolution.

**pH (2.2.3):** 3.5 to 5.5.

Dissolve 0.1 g in carbon dioxide-free water R and dilute to 40 mL with the same solvent.

**Specific optical rotation (2.2.7):** + 280 to + 305 (anhydrous substance).

Dissolve 62.5 mg in water R and dilute to 25.0 mL with the same solvent.

**Related substances.** Liquid chromatography (2.2.29).

**Test solution (a).** Dissolve 31.0 mg of the substance to be examined in mobile phase A and dilute to 50.0 mL with mobile phase A.

**Test solution (b).** Dissolve 31.0 mg of the substance to be examined in mobile phase A and dilute to 10.0 mL with mobile phase A. Prepare immediately before use.

**Reference solution (a).** Dissolve 27.0 mg of anhydrous ampicillin CRS in mobile phase A and dilute to 50.0 mL with mobile phase A.

**Reference solution (b).** Dissolve 2 mg of cefradine CRS in mobile phase A and dilute to 50 mL with mobile phase A. To 5 mL of this solution, add 5 mL of reference solution (a).

**Reference solution (c).** Dilute 1.0 mL of reference solution (a) to 20.0 mL with mobile phase A.

**Column:**

– size:  $l = 0.25$  m,  $\varnothing = 4.6$  mm;

– stationary phase: octadecylsilyl silica gel for chromatography R (5 µm).

**Mobile phase:**

– mobile phase A: mix 0.5 mL of dilute acetic acid R, 50 mL of 0.2 M potassium dihydrogen phosphate R and 50 mL of acetonitrile R, then dilute to 1000 mL with water R;

– mobile phase B: mix 0.5 mL of dilute acetic acid R, 50 mL of 0.2 M potassium dihydrogen phosphate R and 400 mL of acetonitrile R, then dilute to 1000 mL with water R;

Time (min)	Mobile phase A (per cent V/V)	Mobile phase B (per cent V/V)
0 - $t_R$	85	15
$t_R - (t_R + 30)$	85 → 0	15 → 100
$(t_R + 30) - (t_R + 45)$	0	100
$(t_R + 45) - (t_R + 60)$	85	15

$t_R$  = retention time of ampicillin determined with reference solution (c)

If the mobile phase composition has been adjusted to achieve the required resolution, the adjusted composition will apply at time zero in the gradient and in the assay.

**Flow rate:** 1.0 mL/min.

**Detection:** spectrophotometer at 254 nm.

**Injection:** 50 µL of reference solutions (b) and (c) with isocratic elution at the initial mobile phase composition and 50 µL of test solution (b) according to the elution gradient described under Mobile phase; inject mobile phase A as a blank according to the elution gradient described under Mobile phase.

**System suitability:** reference solution (b):

– resolution: minimum 3.0 between the peaks due to ampicillin and cefradin; if necessary, adjust the ratio A:B of the mobile phase.

**Limit:**

– any impurity: for each impurity, not more than the area of the principal peak in the chromatogram obtained with reference solution (c) (1.0 per cent).

**N,N-Dimethylaniline (2.4.26, Method B):** maximum 20 ppm.

**Water (2.5.12):** 12.0 per cent to 15.0 per cent, determined on 0.100 g.

**Sulfated ash (2.4.14):** maximum 0.5 per cent, determined on 1.0 g.

## ASSAY

Liquid chromatography (2.2.29) as described in the test for related substances with the following modifications.

**Mobile phase:** initial composition of the mixture of mobile phases A and B, adjusted where applicable.

**Injection:** test solution (a) and reference solution (a).

**System suitability:** reference solution (a):

– repeatability: maximum relative standard deviation of 1.0 per cent after 6 injections.

Calculate the percentage content of ampicillin from the declared content of anhydrous ampicillin CRS.

## STORAGE

In an airtight container.

## IMPURITIES

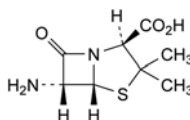

A. (2S,5R,6R)-6-amino-3,3-dimethyl-7-oxo-4-thia-1-azabicyclo[3.2.0]heptane-2-carboxylic acid (6-aminopenicillanic acid),

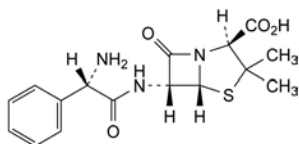

- B. (2*S*,5*R*,6*R*)-6-[(2*S*)-2-amino-2-phenylacetyl]amino]-3,3-dimethyl-7-oxo-4-thia-1-azabicyclo[3.2.0]heptane-2-carboxylic acid (L-ampicillin),

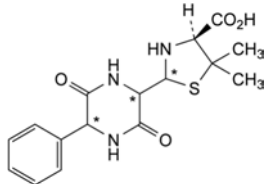

- C. (4*S*)-2-(3,6-dioxo-5-phenylpiperazin-2-yl)-5,5-dimethylthiazolidine-4-carboxylic acid (diketopiperazines of ampicillin),

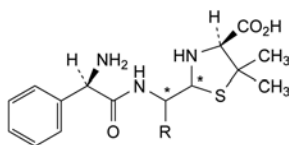

- D. R = CO<sub>2</sub>H: (4*S*)-2-[[[(2*R*)-2-amino-2-phenylacetyl]amino]carboxymethyl]-5,5-dimethylthiazolidine-4-carboxylic acid (penicilloic acids of ampicillin),

- F. R = H: (2*RS*,4*S*)-2-[[[(2*R*)-2-amino-2-phenylacetyl]amino]methyl]-5,5-dimethylthiazolidine-4-carboxylic acid (penicilloic acids of ampicillin),

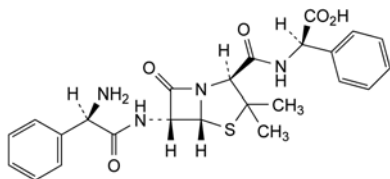

- E. (2*R*)-2-[[[(2*S*,5*R*,6*R*)-6-[(2*R*)-2-amino-2-phenylacetyl]amino]-3,3-dimethyl-7-oxo-4-thia-1-azabicyclo[3.2.0]hept-2-yl]carbonyl]amino]-2-phenylacetic acid (ampicillinyl-D-phenylglycine),

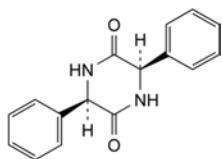

- G. (3*R*,6*R*)-3,6-diphenylpiperazine-2,5-dione,

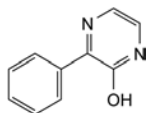

- H. 3-phenylpyrazin-2-ol,

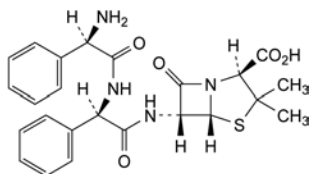

- I. (2*S*,5*R*,6*R*)-6-[[[(2*R*)-2-[(2*R*)-2-amino-2-phenylacetyl]amino]-2-phenylacetyl]amino]-3,3-dimethyl-7-oxo-4-thia-1-azabicyclo[3.2.0]heptane-2-carboxylic acid (D-phenylglycylampicillin),

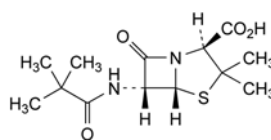

- J. (2*S*,5*R*,6*R*)-6-[(2,2-dimethylpropanoyl)amino]-3,3-dimethyl-7-oxo-4-thia-1-azabicyclo[3.2.0]heptane-2-carboxylic acid,

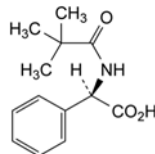

- K. (2*R*)-2-[(2,2-dimethylpropanoyl)amino]-2-phenylacetic acid,

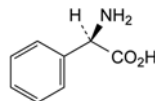

- L. (2*R*)-2-amino-2-phenylacetic acid (D-phenylglycine),

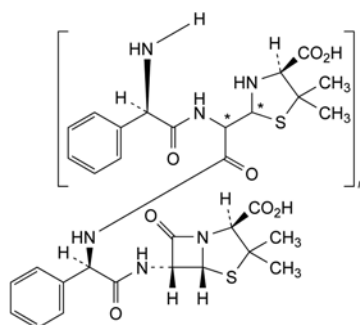

- M. co-oligomers of ampicillin and of penicilloic acids of ampicillin,

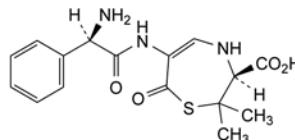

- N. (3*S*)-6-[[[(2*R*)-2-amino-2-phenylacetyl]amino]-2,2-dimethyl-7-oxo-2,3,4,7-tetrahydro-1,4-thiazepine-3-carboxylic acid.

01/2011:2405

**AMYLMETACRESOL**

## Amylmetacresolum

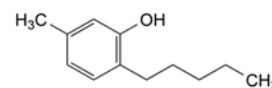
C<sub>12</sub>H<sub>18</sub>O  
[1300-94-3]M<sub>r</sub> 178.3

## DEFINITION

5-Methyl-2-pentylphenol.

*Content*: 98.0 per cent to 102.0 per cent.

## CHARACTERS

*Appearance*: clear or almost clear liquid, or solid crystalline mass, colourless or slightly yellow when freshly prepared. The substance changes colour during storage by darkening and/or discolouration to dark yellow, brownish-yellow or pink.*Solubility*: practically insoluble in water, very soluble in acetone and in ethanol (96 per cent).

It solidifies at about 22 °C.

## IDENTIFICATION

Infrared absorption spectrophotometry (2.2.24).

*Preparation*: film between 2 plates of *potassium bromide R*.

*Comparison*: *amylmetacresol CRS*.

## TESTS

**Related substances.** Gas chromatography (2.2.28): use the normalisation procedure.

*Internal standard solution.* Dissolve 0.100 g of *butylhydroxytoluene R* in *2-propanol R* and dilute to 10.0 mL with the same solvent.

*Test solution (a).* Dissolve 0.1000 g of the substance to be examined in *2-propanol R* and dilute to 10.0 mL with the same solvent.

*Test solution (b).* To 2.0 mL of test solution (a) add 2.0 mL of the internal standard solution and dilute to 10.0 mL with *2-propanol R*.

*Reference solution (a).* Dissolve 10 mg of *m-cresol R* (impurity B) and 10 mg of *p-cresol R* (impurity D) in *2-propanol R* and dilute to 100.0 mL with the same solvent.

*Reference solution (b).* Dissolve the contents of a vial of *amylmetacresol for peak identification CRS* (containing impurities A, G and K) in 1.0 mL of *2-propanol R*.

*Reference solution (c).* Dissolve 0.1000 g of *amylmetacresol CRS* in *2-propanol R* and dilute to 10.0 mL with the same solvent. To 2.0 mL of this solution add 2.0 mL of the internal standard solution and dilute to 10.0 mL with *2-propanol R*.

*Reference solution (d).* Dilute 1.0 mL of test solution (a) to 100.0 mL with *2-propanol R*. Dilute 1.0 mL of this solution to 20.0 mL with *2-propanol R*.

*Column*:

- *material*: fused silica;
- *size*:  $l = 30$  m,  $\varnothing = 0.25$  mm;
- *stationary phase*: *macrogol 20 000 R* (film thickness 0.5  $\mu$ m).

*Carrier gas*: helium for chromatography R.

*Linear velocity*: 33 cm/s.

*Split ratio*: 1:30.

*Temperature*:

	Time (min)	Temperature (°C)
Column	0 - 17.5	100 → 240
	17.5 - 32.5	240
Injection port		250
Detector		250

*Detection*: flame ionisation.

*Injection*: 1.0  $\mu$ L of test solution (a) and reference solutions (a), (b) and (d).

*Identification of impurities*: use the chromatogram supplied with *amylmetacresol for peak identification CRS* and the chromatogram obtained with reference solution (b) to identify the peaks due to impurities A, G and K.

*Relative retention* with reference to *amylmetacresol* (retention time = about 16 min): impurity G (diastereoisomer 1) = about 0.51; impurity G (diastereoisomer 2) = about 0.53; impurity D = about 0.77; impurity B = about 0.78; impurity K = about 0.95; impurity A = about 0.99.

*System suitability*: reference solution (a):

- *resolution*: minimum 1.5 between the peaks due to impurities D and B.

*Limits*:

- *impurity A*: maximum 0.6 per cent;
- *impurities G* (sum of the 2 diastereoisomers), *K*: for each impurity, maximum 0.15 per cent;

- *unspecified impurities*: for each impurity, maximum 0.10 per cent;
- *total*: maximum 1.0 per cent;
- *disregard limit*: the area of the peak due to *amylmetacresol* in the chromatogram obtained with reference solution (d) (0.05 per cent).

**Sulfated ash (2.4.14)**: maximum 0.1 per cent, determined on 1.0 g.

## ASSAY

Gas chromatography (2.2.28) as described in the test for related substances with the following modification.

*Injection*: 1.0  $\mu$ L of test solution (b) and reference solution (c). Calculate the percentage content of  $C_{12}H_{18}O$  from the declared content of *amylmetacresol CRS*.

## STORAGE

In an airtight, non-metallic container, protected from light.

## IMPURITIES

*Specified impurities*: A, G, K.

*Other detectable impurities* (the following substances would, if present at a sufficient level, be detected by one or other of the tests in the monograph. They are limited by the general acceptance criterion for other/unspecified impurities and/or by the general monograph *Substances for pharmaceutical use (2034)*. It is therefore not necessary to identify these impurities for demonstration of compliance. See also 5.10. *Control of impurities in substances for pharmaceutical use*): B, C, D, E, F, H, I, J.

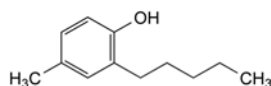

A. 4-methyl-2-pentylphenol,

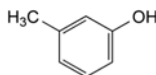

B. 3-methylphenol (*m*-cresol),

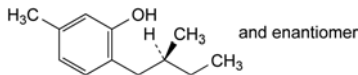

C. 5-methyl-2-[(2*RS*)-2-methylbutyl]phenol,

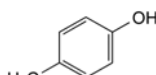

D. 4-methylphenol (*p*-cresol),

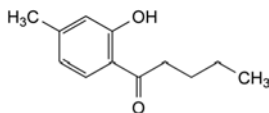

E. 1-(2-hydroxy-4-methylphenyl)pentan-1-one,

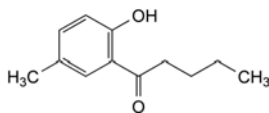

F. 1-(2-hydroxy-5-methylphenyl)pentan-1-one,

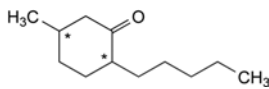

G. 5-methyl-2-pentylcyclohexanone,

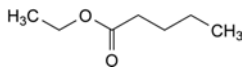

H. ethyl pentanoate,

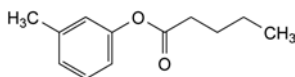

I. 3-methylphenyl pentanoate,

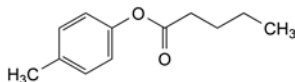

J. 4-methylphenyl pentanoate,

K. unknown structure.

01/2008:0972  
corrected 6.0**ANTAZOLINE HYDROCHLORIDE**

## Antazolini hydrochloridum

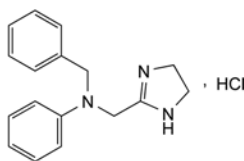
C<sub>17</sub>H<sub>20</sub>ClN<sub>3</sub>  
[2508-72-7]M<sub>r</sub> 301.8**DEFINITION**

Antazoline hydrochloride contains not less than 99.0 per cent and not more than the equivalent of 101.0 per cent of *N*-benzyl-*N*-(4,5-dihydro-1*H*-imidazol-2-yl)methylaniline hydrochloride, calculated with reference to the dried substance.

**CHARACTERS**

A white or almost white, crystalline powder, sparingly soluble in water, soluble in alcohol, slightly soluble in methylene chloride. It melts at about 240 °C, with decomposition.

**IDENTIFICATION**

*First identification:* A, D.

*Second identification:* B, C, D.

- A. Examine by infrared absorption spectrophotometry (2.2.24), comparing with the spectrum obtained with *antazoline hydrochloride CRS*. Examine the substances as discs prepared using *potassium chloride R*.
- B. Examine the chromatograms obtained in the test for related substances in daylight after spraying. The principal spot in the chromatogram obtained with test solution (b) is similar in position, colour and size to the principal spot in the chromatogram obtained with reference solution (b).
- C. To 5 mL of solution S (see Tests) add, drop by drop, *dilute sodium hydroxide solution R* until an alkaline reaction is produced. Filter. The precipitate, washed with two quantities, each of 10 mL, of *water R* and dried in a desiccator under reduced pressure, melts (2.2.14) at 119 °C to 123 °C.
- D. It gives reaction (a) of chlorides (2.3.1).

**TESTS**

**Solution S.** Dissolve 2.0 g in *carbon dioxide-free water R* prepared from *distilled water R*, heating at 60 °C if necessary. Allow to cool and dilute to 100 mL with the same solvent.

**Appearance of solution.** Solution S is clear (2.2.1) and not more intensely coloured than reference solution Y<sub>7</sub> (2.2.2, *Method II*).

**Acidity or alkalinity.** To 10 mL of solution S add 0.2 mL of *methyl red solution R*. Not more than 0.1 mL of 0.01 M *hydrochloric acid* or 0.01 M *sodium hydroxide* is required to change the colour of the indicator.

**Related substances.** Examine by thin-layer chromatography (2.2.27), using *silica gel GF<sub>254</sub> R* as the coating substance. Heat the plate at 110 °C for 15 min before using.

**Test solution (a).** Dissolve 0.10 g of the substance to be examined in *methanol R* and dilute to 5 mL with the same solvent.

**Test solution (b).** Dilute 1 mL of test solution (a) to 5 mL with *methanol R*.

**Reference solution (a).** Dilute 0.5 mL of test solution (a) to 100 mL with *methanol R*.

**Reference solution (b).** Dissolve 20 mg of *antazoline hydrochloride CRS* in *methanol R* and dilute to 5 mL with the same solvent.

**Reference solution (c).** Dissolve 20 mg of *xylometazoline hydrochloride CRS* in 1 mL of test solution (a) and dilute to 5 mL with *methanol R*.

Apply to the plate 5 µL of each solution. Develop over a path of 15 cm using a mixture of 5 volumes of *diethylamine R*, 10 volumes of *methanol R* and 85 volumes of *ethyl acetate R*. Dry the plate in a current of warm air for 15 min. Examine in ultraviolet light at 254 nm. The test is not valid unless the chromatogram obtained with reference solution (c) shows two clearly separated principal spots. Spray with a mixture of equal volumes of a 200 g/L solution of *ferric chloride R* and a 5 g/L solution of *potassium ferricyanide R*. Examine immediately in daylight. Any spot in the chromatogram obtained with test solution (a), apart from the principal spot, is not more intense than the spot in the chromatogram obtained with reference solution (a) (0.5 per cent).

**Heavy metals** (2.4.8). 1.0 g complies with limit test C for heavy metals (20 ppm). Prepare the standard using 2 mL of *lead standard solution (10 ppm Pb) R*.

**Loss on drying** (2.2.32). Not more than 0.5 per cent, determined on 1.000 g by drying in an oven at 105 °C for 3 h.

**Sulfated ash** (2.4.14). Not more than 0.1 per cent, determined on the residue obtained in the test for loss on drying.

**ASSAY**

Dissolve 0.250 g in 100 mL of *alcohol R*. Add 0.1 mL of *phenolphthalein solution R1*. Titrate with 0.1 M *alcoholic potassium hydroxide*.

1 mL of 0.1 M *alcoholic potassium hydroxide* is equivalent to 30.18 mg of C<sub>17</sub>H<sub>20</sub>ClN<sub>3</sub>.

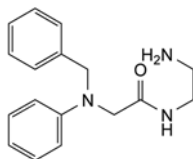
**IMPURITIES**A. *N*-(2-aminoethyl)-2-(benzylphenylamino)acetamide.

01/2008:0209

**ANTICOAGULANT AND PRESERVATIVE SOLUTIONS FOR HUMAN BLOOD**Solutioes anticoagulantes et sanguinem  
humanum conservantes**DEFINITION**

Anticoagulant and preservative solutions for human blood are sterile and pyrogen-free solutions prepared with water for injections, filtered, distributed in the final containers and sterilised. The content of sodium citrate (C<sub>6</sub>H<sub>5</sub>Na<sub>3</sub>O<sub>7</sub>·2H<sub>2</sub>O), glucose monohydrate (C<sub>6</sub>H<sub>12</sub>O<sub>6</sub>·H<sub>2</sub>O) or anhydrous glucose (C<sub>6</sub>H<sub>12</sub>O<sub>6</sub>) and sodium dihydrogen phosphate dihydrate (NaH<sub>2</sub>PO<sub>4</sub>·2H<sub>2</sub>O) is not less than 95.0 per cent and not more

**Citric acid.** To 20.0 mL add 0.1 mL of *phenolphthalein solution RI* and titrate with 0.2 M sodium hydroxide.

Calculate the content of citric acid monohydrate ( $C$ ), or anhydrous citric acid ( $C'$ ), in grams per litre from the equations:

$$C = 0.7005n - 0.4490P$$

$$C' = 0.6404n - 0.4105P$$

$n$  = number of millilitres of 0.2 M sodium hydroxide used in the titration,

$P$  = content of sodium dihydrogen phosphate dihydrate in grams per litre determined as prescribed above.

**Sodium citrate.** Prepare a chromatography column 0.10 m long and 10 mm in internal diameter and filled with *strongly acidic ion-exchange resin R* (300  $\mu\text{m}$  to 840  $\mu\text{m}$ ). Maintain a 1 cm layer of liquid above the resin at all times. Wash the column with 50 mL of de-ionised *water R* at a flow rate of 12-14 mL/min.

Dilute 10.0 mL of the solution to be examined to about 40 mL with de-ionised *water R* in a beaker and transfer to the column reservoir, washing the beaker 3 times with a few millilitres of de-ionised *water R*. Allow the solution to run through the column at a flow rate of 12-14 mL/min and collect the eluate. Wash the column with 2 quantities, each of 30 mL, and with one quantity of 50 mL, of de-ionised *water R*. The column can be used for 3 successive determinations before regeneration with 3 times its volume of *dilute hydrochloric acid R*. Titrate the combined eluate and washings (about 150 mL) with 0.2 M sodium hydroxide, using 0.1 mL of *phenolphthalein solution RI* as indicator.

Calculate the content of sodium citrate in grams per litre from the following expressions:

$$1.961n - 1.257P - 1.40C$$

$$1.961n - 1.257P - 1.53C'$$

$n$  = number of millilitres of 0.2 M sodium hydroxide used in the titration,

$P$  = content of sodium dihydrogen phosphate dihydrate in grams per litre determined as prescribed above,

$C$  = content of citric acid monohydrate in grams per litre determined as prescribed above,

$C'$  = content of anhydrous citric acid in grams per litre determined as prescribed above.

**Reducing sugars.** Dilute 5.0 mL to 100.0 mL with *water R*. Introduce 25.0 mL of the solution into a 250 mL conical flask with ground-glass neck and add 25.0 mL of *cupri-citric solution RI*. Add a few pieces of porous material, attach a reflux condenser, heat so that boiling begins within 2 min and boil for exactly 10 min. Cool and add 3 g of *potassium iodide R* dissolved in 3 mL of *water R*. Add 25 mL of a 25 per cent  $m/m$  solution of *sulfuric acid R* with caution and in small quantities. Titrate with 0.1 M sodium thiosulfate using 0.5 mL of *starch solution R*, added towards the end of the titration, as indicator ( $n_1$  mL). Carry out a blank titration using 25.0 mL of *water R* ( $n_2$  mL).

Calculate the content of reducing sugars as anhydrous glucose or as glucose monohydrate, as appropriate, from Table 0209-1.

#### STORAGE

Store in an airtight, tamper-proof container, protected from light.

#### LABELLING

The label states:

- the composition and volume of the solution,
- the maximum amount of blood to be collected in the container.

01/2008:1928

## ANTI-T LYMPHOCYTE IMMUNOGLOBULIN FOR HUMAN USE, ANIMAL

### Immunoglobulinum anti-T lymphocytorum ex animale ad usum humanum

#### DEFINITION

Animal anti-T lymphocyte immunoglobulin for human use is a liquid or freeze-dried preparation containing immunoglobulins, obtained from serum or plasma of animals, mainly rabbits or horses, immunised with human lymphocytic antigens.

The immunoglobulin has the property of diminishing the number and function of immunocompetent cells, in particular T-lymphocytes. The preparation contains principally immunoglobulin G. It may contain antibodies against other lymphocyte subpopulations and against other cells. The preparation is intended for intravenous administration, after dilution with a suitable diluent where applicable.

Applicable provisions of the monograph on *Immunosera for human use, animal (0084)* are stated below.

#### PRODUCTION

##### GENERAL PROVISIONS

The production method has been shown to yield consistently immunoglobulins of acceptable safety, potency in man and stability.

Any reagent of biological origin used in production shall be free of contamination with bacteria, fungi and viruses. The method of preparation includes a step or steps that have been shown to remove or inactivate known agents of infection.

During development studies, it shall be demonstrated that the production method yields a product that:

- does not transmit infectious agents,
- is characterised by a defined pattern of immunological activity, notably: antigen binding, complement-dependent and independent cytotoxicity, cytokine release, induction of T-cell activation, cell death,
- does not contain antibodies that cross-react with human tissues to a degree that would impair clinical safety,
- has a defined maximum content of anti-thrombocyte antibody activity,
- has a defined maximum content of haemoglobin.

The product has been shown, by suitable tests in animals and evaluation during clinical trials, to be well tolerated.

*Reference preparation.* A batch shown to be suitable for checking the validity of the assay and whose efficacy has been demonstrated in clinical trials, or a batch representative thereof.

#### ANIMALS

The animals used are of a species approved by the competent authority, are healthy and exclusively reserved for production of anti-T lymphocyte immunoglobulin. They are tested and shown to be free from a defined list of infectious agents. The introduction of animals into a closed herd follows specified procedures, including definition of quarantine measures. Where appropriate, tests for additional specific agents are considered depending on the geographical localisation of the establishment used for the breeding and production of the animals. The feed originates from a controlled source and no animal proteins are added. The suppliers of animals are certified by the competent authority.

If the animals are treated with antibiotics, a suitable withdrawal period is allowed before collection of blood or plasma. The animals are not treated with penicillin antibiotics. If a live

vaccine is administered, a suitable waiting period is imposed between vaccination and collection of serum or plasma for immunoglobulin production.

The species, origin and identification number of the animals are specified.

#### IMMUNISATION

The antigens used are identified and characterised, where appropriate. They are identified by their names and a batch number; information on the source and preparation are recorded.

The selected animals are isolated for at least 1 week before being immunised according to a defined schedule with booster injections at suitable intervals. Adjuvants may be used.

Animals are kept under general health surveillance and specific antibody production is controlled at each cycle of immunisation.

Animals are thoroughly examined before collection of blood or plasma. If an animal shows any pathological lesion not related to the immunisation process, it is not used, nor are any other of the animals in the group concerned, unless it is evident that their use will not impair the safety of the product.

Human antigens such as continuously growing T-lymphocyte cell lines or thymocytes are used to immunise the animals. Cells may be subjected to a sorting procedure. The immunising antigens are shown to be free from infectious agents by validated methods for relevant blood-borne pathogens, notably hepatitis B virus (HBV), hepatitis C virus (HCV) and human immunodeficiency virus (HIV) and other relevant adventitious agents originating from the preparation of the antigen. The cells used comply with defined requirements for purity of the cell population and freedom from adventitious agents.

#### COLLECTION OF BLOOD OR PLASMA

Collection of blood is made by venepuncture or plasmapheresis. The puncture area is shaved, cleaned and disinfected. The animals may be anaesthetised under conditions that do not influence the quality of the product.

No antimicrobial preservative is added to the plasma and serum samples. The blood or plasma is collected in such a manner as to maintain sterility of the product. The blood or plasma collection is conducted at a site separate from the area where the animals are kept or bred and the area where the immunoglobulin is purified. If the serum or plasma is stored before further processing, precautions are taken to avoid microbial contamination.

Several single plasma or serum samples may be pooled before purification. The single or pooled samples are tested before purification for the following tests.

**Tests for contaminating viruses.** Each pool is tested for contaminating viruses by suitable *in vitro* tests including inoculation to cell cultures capable of detecting a wide range of viruses relevant for the particular product. Where applicable, *in vitro* tests for contaminating viruses are carried out on the adsorbed pool, after the last production stage that may introduce viral contaminants.

#### PURIFICATION AND VIRAL INACTIVATION

The immunoglobulins are concentrated and purified by fractional precipitation, chromatography, immuno-adsorption or by other suitable chemical or physical methods. The methods are selected and validated to avoid contamination at all steps of processing and to avoid formation of protein aggregates that effect immunobiological characteristics of the product.

Unless otherwise justified and authorised, validated procedures are applied for removal and/or inactivation of viruses.

After purification and treatment for removal and/or inactivation of viruses, a stabiliser may be added to the intermediate product, which may be stored for a period defined in the light of stability data.

Only an intermediate product that complies with the following requirements may be used in the preparation of the final bulk.

If the method of preparation includes a step for adsorption of cross-reacting anti-human antibodies using material from human tissues and/or red blood cells, the human materials are submitted to a validated procedure for inactivation of infectious agents, unless otherwise justified and authorised. If erythrocytes are used for adsorption, the donors for such materials comply with the requirements for donors of blood and plasma of the monograph on *Human plasma for fractionation (0853)*. If other human material is used, it is shown by validated methods to be free from relevant blood-borne pathogens, notably HBV, HCV and HIV. If substances are used for inactivation or removal of viruses, it shall have been shown that any residues present in the final product have no adverse effects on the patients treated with the anti-T lymphocyte immunoglobulin.

#### FINAL BULK

The final bulk is prepared from a single intermediate product or from a pool of intermediate products obtained from animals of the same species. A stabiliser may be added. No antimicrobial preservative is added either during the manufacturing procedure or for preparation of the final bulk solution. During manufacturing, the solution is passed through a bacteria-retentive filter.

#### FINAL LOT

The final bulk of anti-T-lymphocyte immunoglobulin is distributed aseptically into sterile, tamper-proof containers. The containers are closed as to prevent contamination. Only a final lot that complies with the requirements prescribed below under Identification, Tests and Assay may be released for use.

#### CHARACTERS

The liquid preparation is clear or slightly opalescent and colourless or pale yellow. The freeze-dried preparation is a white or slightly yellow powder or solid friable mass, which after reconstitution gives a liquid preparation corresponding to the description above.

#### IDENTIFICATION

- A. Using a suitable range of species-specific antisera, carry out precipitation tests on the preparation to be examined. It is recommended that the test be carried out using antisera specific to the plasma proteins of each species of domestic animal commonly used in the preparation of materials of biological origin in the country concerned and antisera specific to human plasma proteins. The preparation is shown to contain proteins originating from the animal used for the anti-T lymphocyte immunoglobulin production.
- B. Examine by a suitable immunoelectrophoresis technique. Using antiserum to normal serum of the animal used for production, compare this serum and the preparation to be examined, both diluted to a concentration that will allow a clear gammaglobulin precipitation arc to be obtained on the gel. The main component of the preparation to be examined corresponds to the IgG component of normal serum of the animal used for production.
- C. The preparation complies with the assay.

#### TESTS

**Solubility.** To a container of the preparation to be examined, add the volume of the liquid for reconstitution stated on the label. The preparation dissolves completely within the time stated on the label.

**Extractable volume (2.9.17).** It complies with the requirement for extractable volume.

**pH (2.2.3).** The pH is within the limits approved for the particular product.

**Osmolality (2.2.35):** minimum 240 mosmol/kg after dilution, where applicable.

**Proteins** (2.5.33): 90 per cent to 110 per cent of the amount stated on the label.

**Stabiliser.** Determine the amount of stabiliser by a suitable physico-chemical method. The preparation contains not less than 80 per cent and not more than 120 per cent of the quantity stated on the label.

**Distribution of molecular size.** Size exclusion chromatography (2.2.30).

**Test solution.** Dilute the preparation to be examined with a 9 g/L solution of *sodium chloride R* to a concentration suitable for the chromatographic system used. A concentration in the range 2-20 g/L is usually suitable.

**Reference solution.** Dilute *human immunoglobulin (molecular size) BRP* with a 9 g/L solution of *sodium chloride R* to the same protein concentration as the test solution.

**Column:**

- size:  $l = 0.6$  m,  $\varnothing = 7.5$  mm,
- stationary phase: *silica gel for size-exclusion chromatography R*, a grade suitable for fractionation of globular proteins in the molecular mass range of 20 000 to 200 000.

**Mobile phase:** dissolve 4.873 g of *disodium hydrogen phosphate dihydrate R*, 1.741 g of *sodium dihydrogen phosphate monohydrate R* and 11.688 g of *sodium chloride R* in 1 litre of *water R*.

**Flow rate:** 0.5 mL/min.

**Detection:** spectrophotometer at 280 nm.

**Injection:** 50-600 µg of protein.

**Retention time:** identify the peaks in the chromatogram obtained with the test solution by comparison with the chromatogram obtained with the reference solution; any peak with a retention time shorter than that of dimer corresponds to polymers and aggregates.

**System suitability:**

- **reference solution:** the principal peak corresponds to IgG monomer and there is a peak corresponding to dimer with a retention time relative to monomer of  $0.85 \pm 0.05$ ,
- **test solution:** the relative retentions of monomer and dimer are  $1 \pm 0.05$  with reference to the corresponding peaks in the chromatogram obtained with the reference solution.

**Limits:**

- **total monomer and dimer:** at least 95 per cent of the total area of the peaks,
- **total polymers and aggregates:** maximum 5 per cent of the total area of the peaks.

**Purity.** Polyacrylamide gel electrophoresis (2.2.31), under non-reducing and reducing conditions.

**Resolving gel.** Non-reducing conditions: 8 per cent acrylamide; reducing conditions: 12 per cent acrylamide.

**Test solution.** Dilute the preparation to be examined to a protein concentration of 0.5-2 mg/mL.

**Reference solution.** Dilute the reference preparation to the same protein concentration as the test solution.

**Application:** 10 µL.

**Detection:** Coomassie staining.

**Results:** compared with the electropherogram of the reference solution, no additional bands are found in the electropherogram of the test solution.

**Anti-A and anti-B haemagglutinins** (2.6.20). The 1 to 64 dilution does not show agglutination.

Where applicable, dilute the preparation to be examined as prescribed for use before preparing the dilutions for the test.

**Haemolysins.** Prepare a 1 to 64 dilution of the preparation to be examined, diluted if necessary as stated on the label. Take 6 aliquots of the 1 to 64 dilution. To 1 volume of 3 of the

aliquots, add 1 volume of a 10 per cent V/V suspension of group A1, group B and group O erythrocytes in a 9 g/L solution of *sodium chloride R*, respectively. To 1 volume of the remaining 3 aliquots, add 1 volume of a 10 per cent V/V suspension of group A1, group B and group O erythrocytes in a 9 g/L solution of *sodium chloride R*, respectively, and to each aliquot 1 volume of fresh group AB serum (as a source of complement). Mix and incubate at 37 °C for 1 h. Examine the supernatant liquids for haemolysis. No signs of haemolysis are present.

**Thrombocyte antibodies.** Examined by a suitable method, the level of thrombocyte antibodies is shown to be below that approved for the specific product.

**Water** (2.5.12): maximum 3 per cent.

**Sterility** (2.6.1). It complies with the test for sterility.

**Pyrogens** (2.6.8). Unless otherwise justified and authorised, it complies with the test for pyrogens. Unless otherwise prescribed, inject 1 mL per kilogram of the rabbit's body mass.

**ASSAY**

The biological activity is determined by measuring the complement-dependent cytotoxicity on target cells. Flow cytometry is performed with read-out of dead cells stained using propidium iodide. The activity is expressed as the concentration of anti-T lymphocyte immunoglobulin in milligrams per millilitre which mediates 50 per cent cytotoxicity.

**Lymphocyte separation medium.** Commercial separation media with low viscosity and a density of 1.077 g/mL.

**Complement.** Commercial complement is suitable.

**Buffered salt solution pH 7.2.** Dissolve 8.0 g of *sodium chloride R*, 0.2 g of *potassium chloride R*, 3.18 g of *disodium hydrogen phosphate R* and 0.2 g of *potassium dihydrogen phosphate R* in *water R* and dilute to 1000.0 mL with the same solvent.

**Buffer solution for flow cytometry.** Add 40 mL of 0.1 per cent V/V *sodium azide R* and 10 mL of foetal calf serum to 440 mL of buffered salt solution pH 7.2. The foetal calf serum is inactivated at 56 °C for 30 min prior to use. Store at 4 °C.

**Propidium iodide solution.** Dissolve *propidium iodide R* in buffered salt solution pH 7.2, to a concentration of 1 mg/mL. Store this stock solution at 2-8 °C and use within 1 month. For the assay, dilute this solution with buffer solution for flow cytometry, to obtain a concentration of 5 µg/mL. Store at 2-8 °C and use within 3 h.

**Microtitre plates.** Plates used to prepare immunoglobulin dilutions are U- or V-bottomed polystyrene or poly(vinyl chloride) plates without surface treatment.

**Micronic tubes.** Suitable for flow cytometry measurement.

**Cell suspension.** Collect blood in anticoagulant from at least one healthy donor. Immediately isolate the peripheral blood mononuclear cells (PBMC) by gradient centrifugation in lymphocyte separation medium so that the PBMC form a visible clean interface between the plasma and the separation medium. Collect the layer containing the cells and dispense into centrifuge tubes containing buffered salt solution pH 7.2. Centrifuge at 400 g at 2-8 °C for 10 min. Discard the supernatant. Suspend the cell pellet in buffer solution for flow cytometry. Repeat the centrifugation and resuspension procedure of the cells twice. After the third centrifugation, resuspend the cell pellet in 1 mL of buffer solution for flow cytometry. Determine the number and vitality of the cells using a haemocytometer. Cell viability of at least 90 per cent is required. Adjust the cell number to  $7 \times 10^6$ /mL by adding buffer solution for flow cytometry. Store the cell suspension at 4 °C and use within 12 h.

If necessary, the first PBMC pellet may be resuspended in buffered salt solution pH 7.2 containing 20 per cent foetal calf serum and stored overnight at 2 °C. Centrifuge at 400 g at 2-8 °C for 10 min. Discard the supernatant. Suspend the cell pellet in buffer solution for flow cytometry. Determine the number and vitality of the cells using a haemocytometer.

Cell viability of at least 90 per cent is required. Adjust the cell number to  $7 \times 10^6$ /mL by adding buffer solution for flow cytometry.

It is also possible for cells to be immediately frozen and stored in nitrogen using the following method.

**Buffer solution for freezing.** To 20 mL of cell culture medium, add 25 mL of foetal calf serum and 5 mL of dimethyl sulfoxide (DMSO). Store this solution at 2-8 °C and use within 3 h.

$20 \times 10^6$  cells per ampoule are frozen. These ampoules are stored in liquid nitrogen.

**Buffer solution for thawing.** To 450 mL of cell culture medium, add 50 mL of foetal calf serum. Store this solution at 2-8 °C and use within 3 h.

Each ampoule is thawed in a water-bath at 37 °C with shaking. Cell suspension is repeated in a buffer solution for thawing. Centrifuge at 200 *g* at 2-8 °C for 10 min. Discard the supernatant. Suspend the cell pellet in buffer solution for flow cytometry. Repeat the procedure for centrifugation and resuspension of cells once. After the second centrifugation, resuspend the cells pellet in 1 mL of buffer solution for flow cytometry. Determine the number and vitality of the cells using a haemocytometer. Cell viability of at least 90 per cent is required. Adjust the cell number to  $7 \times 10^6$ /mL by adding buffer solution for flow cytometry. Store the cell suspension at 4 °C and use within 3 h.

**Test solutions.** For freeze-dried preparations, reconstitute as stated on the label. Prepare 3 independent series of not fewer than 7 dilutions using buffer solution for flow cytometry as diluent.

**Reference solutions.** For freeze-dried preparations, reconstitute according to the instructions for use. Prepare 3 independent dilution series of not fewer than 7 dilutions using buffer solution for flow cytometry as diluent.

Distribute 75 µL of each of the dilutions of the test solution or reference solution to each of a series of wells of a microtitre plate. Add 25 µL of the cell suspension of PBMC into each well. Add 25 µL of rabbit complement to each of the wells. Incubate at 37 °C for 30 min.

Centrifuge the plates at 200 *g* at 4 °C for 8 min, discard the supernatant and keep the plate on ice. Preparation for flow cytometry measurement is done step-wise by using a certain number of wells in order to allow labelling with *propidium iodide R* solution and measurement within a defined time period. Resuspend carefully the cell pellet of a certain number of wells with 200 µL of propidium iodide solution. Transfer the suspension into tubes. Incubate at 25 °C for 10 min then place immediately on ice.

Proceed with fluorescence measurement in a flow cytometer. Define a region including all propidium iodide-positive cells on the basis of Forward-Scattered, light (FSC) and fluorescence (FL2 or FL3 for propidium iodide). Measure the percentage of propidium iodide-positive cells, without gating but excluding debris. Analyse at least 3000 cells for each of the test and reference solutions.

Use the percentages of dead cells to estimate the potency as the concentration in milligrams per millilitre of the preparation to be examined necessary to induce 50 per cent of cytotoxicity by fitting a sigmoidal dose response curve to the data obtained with the test and the reference preparations and by using a 4-parameter logistic model (see, for example, chapter 5.3) and suitable software. The test is not valid unless the percentage of propidium iodide-positive cells at the lower asymptote of the curve is less than 15 per cent and the percentage of propidium iodide-positive cells at the upper asymptote of the curve is at least 80 per cent.

The estimated activity is 70 per cent to 130 per cent of the activity approved for the particular product.

The confidence limits ( $P = 0.95$ ) are not less than 80 per cent and not more than 125 per cent of the estimated potency.

#### STORAGE

Protected from light at the temperature stated on the label.

**Expiry date.** The expiry date is calculated from the beginning of the assay.

#### LABELLING

The label states:

- for liquid preparations, the volume of the preparation in the container and the protein content,
- for freeze-dried preparations:
  - the name and the volume of the reconstitution liquid to be added,
  - the quantity of protein in the container,
  - that the immunoserum is to be used immediately after reconstitution,
  - the time required for complete dissolution,
- the animal species of origin,
- the name and amount of stabiliser, where applicable,
- the dilution to be made before use of the product.

01/2008:0136  
corrected 6.0

## APOMORPHINE HYDROCHLORIDE

### Apomorfini hydrochloridum

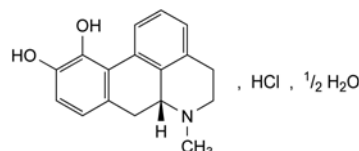

$C_{17}H_{18}ClNO_2 \cdot 1/2H_2O$   
[41372-20-7]

$M_r$  312.8

#### DEFINITION

(6a*R*)-6-Methyl-5,6,6a,7-tetrahydro-4*H*-dibenzo[*de,g*]quinoline-10,11-diol hydrochloride hemihydrate.

**Content:** 99.0 per cent to 101.0 per cent (dried substance).

#### CHARACTERS

**Appearance:** white or slightly yellowish-brown or green-tinged greyish, crystalline powder or crystals; on exposure to air and light, the green tinge becomes more pronounced.

**Solubility:** sparingly soluble in water and in alcohol, practically insoluble in toluene.

#### IDENTIFICATION

**First identification:** B, D.

**Second identification:** A, C, D.

A. Dissolve 10.0 mg in 0.1 *M* hydrochloric acid and dilute to 100.0 mL with the same acid. Dilute 10.0 mL of the solution to 100.0 mL with 0.1 *M* hydrochloric acid. Examined between 230 nm and 350 nm (2.2.25), the solution shows an absorption maximum at 273 nm and a shoulder at 300 nm to 310 nm. The specific absorbance at the maximum is 530 to 570.

B. Infrared absorption spectrophotometry (2.2.24).

**Comparison:** Ph. Eur. reference spectrum of apomorphine hydrochloride.

C. To 5 mL of solution S (see Tests) add a few millilitres of sodium hydrogen carbonate solution *R* until a permanent, white precipitate is formed. The precipitate slowly becomes greenish. Add 0.25 mL of 0.05 *M* iodine and shake. The precipitate becomes greyish-green. Collect the precipitate. The precipitate dissolves in ether *R* giving a purple solution, in methylene chloride *R* giving a violet-blue solution and in alcohol *R* giving a blue solution.



D. To 2 mL of solution S add 0.1 mL of *nitric acid R*. Mix and filter. The filtrate gives reaction (a) of chlorides (2.3.1).

## TESTS

**Solution S.** Dissolve 0.25 g without heating in *carbon dioxide-free water R* and dilute to 25 mL with the same solvent.

**Appearance of solution.** Solution S is clear (2.2.1) and not more intensely coloured than reference solution BY<sub>5</sub> or GY<sub>5</sub> (2.2.2, Method II).

**pH (2.2.3):** 4.0 to 5.0 for solution S.

**Specific optical rotation (2.2.7):** –48 to –52 (dried substance).

Dissolve 0.25 g in 0.02 M *hydrochloric acid* and dilute to 25.0 mL with the same acid.

**Related substances.** Liquid chromatography (2.2.29).

**Test solution.** Dissolve 0.25 g of the substance to be examined in a 1 per cent V/V solution of *glacial acetic acid R* and dilute to 100.0 mL with the same solution.

**Reference solution (a).** Dilute 1.0 mL of the test solution to 10.0 mL with a 1 per cent V/V solution of *glacial acetic acid R*. Dilute 1.0 mL to 100.0 mL with a 1 per cent V/V solution of *glacial acetic acid R*.

**Reference solution (b).** Dissolve 25 mg of *boldine R* in a 1 per cent V/V solution of *glacial acetic acid R* and dilute to 10.0 mL with the same solvent. To 1 mL of this solution, add 1 mL of the test solution and dilute to 10.0 mL with a 1 per cent V/V solution of *glacial acetic acid R*.

**Column:**

- size:  $l = 0.15$  m,  $\varnothing = 4.6$  mm,
- stationary phase: octadecylsilyl silica gel for chromatography R (5  $\mu$ m),
- temperature: 35 °C.

**Mobile phase:**

- mobile phase A: 1.1 g/L solution of *sodium octanesulfonate R*, adjusted to pH 2.2 using a 50 per cent m/m solution of *phosphoric acid R*,
- mobile phase B: *acetonitrile R*,

Time (min)	Mobile phase A (per cent V/V)	Mobile phase B (per cent V/V)
0 - 30	85 → 68	15 → 32
30 - 35	68	32
35 - 45	68 → 85	32 → 15

**Flow rate:** 1.5 mL/min.

**Detection:** spectrophotometer at 280 nm.

**Injection:** 10  $\mu$ L.

**System suitability:** reference solution (b):

- resolution: minimum 2.5 between the peaks due to boldine and apomorphine.

**Limits:**

- any impurity: not more than twice the area of the principal peak in the chromatogram obtained with reference solution (a) (0.2 per cent),
- total: not more than 8 times the area of the principal peak in the chromatogram obtained with reference solution (a) (0.8 per cent),
- disregard limit: 0.2 times the area of the principal peak in the chromatogram obtained with reference solution (a) (0.02 per cent).

**Heavy metals (2.4.8):** maximum 20 ppm.

1.0 g complies with limit test C. Prepare the standard using 2 mL of *lead standard solution (10 ppm Pb) R*.

**Loss on drying (2.2.32):** 2.5 per cent to 4.2 per cent, determined on 1.000 g by drying in an oven at 105 °C.

**Sulfated ash (2.4.14):** maximum 0.1 per cent, determined on 1.0 g.

## ASSAY

Dissolve 0.250 g in a mixture of 5.0 mL of 0.01 M *hydrochloric acid* and 50 mL of *alcohol R*. Carry out a potentiometric titration (2.2.20), using 0.1 M *sodium hydroxide*. Read the volume added between the first 2 points of inflexion.

1 mL of 0.1 M *sodium hydroxide* is equivalent to 30.38 mg of C<sub>17</sub>H<sub>18</sub>ClNO<sub>2</sub>.

## STORAGE

In an airtight container, protected from light.

## IMPURITIES

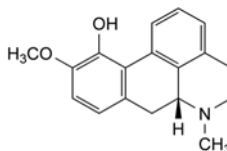

A. (6aR)-10-methoxy-6-methyl-5,6,6a,7-tetrahydro-4H-dibenzo[de,g]quinolin-11-ol (apocodeine),

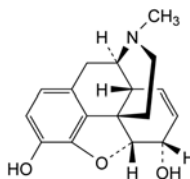

B. 7,8-didehydro-4,5 $\alpha$ -epoxy-17-methylmorphinan-3,6 $\alpha$ -diol (morphine).

01/2011:0580

## APROTININ

## Aprotininum

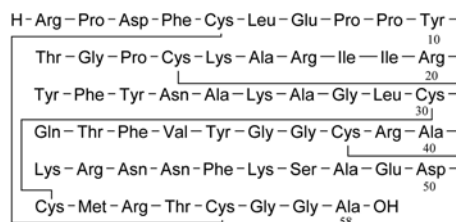

C<sub>284</sub>H<sub>432</sub>N<sub>84</sub>O<sub>79</sub>S<sub>7</sub>

M<sub>r</sub> 6511

## DEFINITION

Aprotinin is a polypeptide consisting of a chain of 58 amino acids. It inhibits stoichiometrically the activity of several proteolytic enzymes such as chymotrypsin, kallikrein, plasmin and trypsin. It contains not less than 3.0 Ph. Eur. U. of aprotinin activity per milligram, calculated with reference to the dried substance.

## PRODUCTION

The animals from which aprotinin is derived must fulfil the requirements for the health of animals suitable for human consumption.

The method of manufacture is validated to demonstrate that the product, if tested, would comply with the following tests.

**Abnormal toxicity (2.6.9).** Inject into each mouse a quantity of the substance to be examined containing 2 Ph. Eur. U. dissolved in a sufficient quantity of *water for injections R* to give a volume of 0.5 mL.

**Histamine (2.6.10):** maximum 0.2  $\mu$ g of histamine base per 3 Ph. Eur. U.

## CHARACTERS

**Appearance:** almost white hygroscopic powder.

**Solubility:** soluble in water and in isotonic solutions, practically insoluble in organic solvents.

#### IDENTIFICATION

##### A. Thin-layer chromatography (2.2.27).

**Test solution.** Solution S (see Tests).

**Reference solution.** Dilute *aprotinin solution BRP* in *water R* to obtain a concentration of 15 Ph. Eur. U./mL.

**Plate:** TLC silica gel G plate R.

**Mobile phase:** *water R*, *glacial acetic acid R* (80:100 V/V) containing 100 g/L of *sodium acetate R*.

**Application:** 10 µL.

**Development:** over a path of 12 cm.

**Drying:** in air.

**Detection:** spray with a solution of 0.1 g of *ninhydrin R* in a mixture of 6 mL of a 10 g/L solution of *cupric chloride R*, 21 mL of *glacial acetic acid R* and 70 mL of *anhydrous ethanol R*. Dry the plate at 60 °C.

**Results:** the principal spot in the chromatogram obtained with the test solution is similar in position, colour and size to the principal spot in the chromatogram obtained with the reference solution.

##### B. Determine the ability of the substance to be examined to inhibit trypsin activity using the method described below.

**Test solution.** Dilute 1 mL of solution S to 50 mL with *buffer solution pH 7.2 R*.

**Trypsin solution.** Dissolve 10 mg of *trypsin BRP* in 0.002 M *hydrochloric acid* and dilute to 100 mL with the same acid.

**Casein solution.** Dissolve 0.2 g of *casein R* in *buffer solution pH 7.2 R* and dilute to 100 mL with the same buffer solution.

**Precipitating solution:** *glacial acetic acid R*, *water R*, *anhydrous ethanol R* (1:49:50 V/V/V).

Mix 1 mL of the test solution with 1 mL of the trypsin solution. Allow to stand for 10 min and add 1 mL of the casein solution. Incubate at 35 °C for 30 min. Cool in iced water and add 0.5 mL of the precipitating solution. Shake and allow to stand at room temperature for 15 min. The solution is cloudy. Carry out a blank test under the same conditions using *buffer solution pH 7.2 R* instead of the test solution. The solution is not cloudy.

#### TESTS

**Solution S.** Prepare a solution of the substance to be examined containing 15 Ph. Eur. U./mL, calculated from the activity stated on the label.

**Appearance of solution.** Solution S is clear (2.2.1).

**Absorbance (2.2.25):** maximum 0.80 by measuring at the absorption maximum at 277 nm.

Prepare a solution of the substance to be examined containing 3.0 Ph. Eur. U./mL.

**Des-Ala-aprotinin and des-Ala-des-Gly-aprotinin.** Capillary zone electrophoresis (2.2.47): use the normalisation procedure.

**Test solution.** Prepare a solution of the substance to be examined in *water R* containing not less than 1 Ph. Eur. U./mL.

**Reference solution.** Dilute *aprotinin solution BRP* in *water R* to obtain the same concentration as the test solution.

**Capillary:**

- **material:** uncoated fused silica;
- **size:** effective length = 45-60 cm, Ø = 75 µm.

**Temperature:** 25 °C.

**CZE buffer.** Dissolve 8.21 g of *potassium dihydrogen phosphate R* in 400 mL of *water R*, adjust to pH 3.0 with *phosphoric acid R*, dilute to 500.0 mL with *water R* and filter through a membrane filter (nominal pore size 0.45 µm).

**Detection:** spectrophotometer at 214 nm.

**Between-run rinsing:** rinse the capillary for at least 1 min with 0.1 M *sodium hydroxide* filtered through a membrane filter (nominal pore size 0.45 µm) and for 2 min with the CZE buffer.

**Injection:** under pressure or vacuum (for example, 3 s at a differential pressure of 3.5 kPa).

**Migration:** apply a field strength of 0.2 kV/cm, using the CZE buffer as the electrolyte in both buffer reservoirs.

**Run time:** 30 min.

**Identification of impurities:** use the electropherogram supplied with *aprotinin solution BRP* and the electropherogram obtained with the reference solution to identify the peaks due to impurities A and B.

**Relative migration** with reference to aprotinin (migration time = about 22 min): impurity A = about 0.98; impurity B = about 0.99.

**System suitability:** reference solution after at least 6 injections:

- **migration time:** aprotinin = 19.0 min to 25.0 min;
- **resolution:** minimum 0.8 between the peaks due to impurities A and B; minimum 0.5 between the peaks due to impurity B and aprotinin;
- **peak distribution:** the electropherogram obtained is qualitatively and quantitatively similar to the electropherogram supplied with *aprotinin solution BRP*;
- **height of the principal peak:** at least 1000 times the height of the baseline noise. If necessary, adjust the sample load to give peaks of sufficient height.

**Limits:**

- **impurity A:** maximum 8.0 per cent;
- **impurity B:** maximum 7.5 per cent.

**Pyroglutamyl-aprotinin and related compounds.** Liquid chromatography (2.2.29): use the normalisation procedure.

**Test solution.** Prepare a solution of the substance to be examined in mobile phase A, containing about 5 Ph. Eur. U./mL.

**Reference solution.** Dissolve the contents of a vial of *aprotinin for system suitability CRS* in 2.0 mL of mobile phase A.

**Column:**

- **size:**  $l = 0.075$  m,  $\text{Ø} = 7.5$  mm;
- **stationary phase:** *strong cation-exchange silica gel for chromatography R* (10 µm);
- **temperature:** 40 °C.

**Mobile phase:**

- **mobile phase A:** dissolve 3.52 g of *potassium dihydrogen phosphate R* and 7.26 g of *disodium hydrogen phosphate dihydrate R* in 1000 mL of water; filter and degas;
- **mobile phase B:** dissolve 3.52 g of *potassium dihydrogen phosphate R*, 7.26 g of *disodium hydrogen phosphate dihydrate R* and 66.07 g of *ammonium sulfate R* in 1000 mL of water; filter and degas;

Time (min)	Mobile phase A (per cent V/V)	Mobile phase B (per cent V/V)
0 - 21	92 → 64	8 → 36
21 - 30	64 → 0	36 → 100

**Flow rate:** 1.0 mL/min.

**Detection:** spectrophotometer at 210 nm.

**Injection:** 40 µL.

**Relative retention** with reference to aprotinin (retention time = 17.0 min to 20.0 min): impurity C = about 0.9.

**System suitability:** reference solution:

- **resolution:** minimum 1.5 between the peaks due to impurity C and aprotinin;
- **symmetry factor:** maximum 1.3 for the peak due to aprotinin.

**Limits:**

- *impurity C*: maximum 1.0 per cent;
- *any other impurity*: maximum 0.5 per cent;
- *sum of impurities other than C*: maximum 1.0 per cent.

**Aprotinin oligomers.** Size-exclusion chromatography (2.2.30): use the normalisation procedure.

**Test solution.** Prepare a solution of the substance to be examined in *water R* containing about 5 Ph. Eur. U./mL.

**Reference solution.** Treat the substance to be examined to obtain about 2 per cent aprotinin oligomers. For example, heat freeze-dried aprotinin at about 110 °C for about 4 h. Then dissolve in *water R* to obtain a concentration of about 5 Ph. Eur. U./mL.

**Column:** 3 columns coupled in series:

- *size*:  $l = 0.30$  m,  $\varnothing = 7.8$  mm;
- *stationary phase*: *hydrophilic silica gel for chromatography R* of a grade suitable for fractionation of globular proteins in the relative molecular mass range of 20 000 to 10 000 000 (8  $\mu$ m).

**Mobile phase:** *acetonitrile R*, *glacial acetic acid R*, *water R* (2:2:6 V/V/V); filter and degas.

**Flow rate:** 1.0 mL/min.

**Detection:** spectrophotometer at 277 nm.

**Injection:** 100  $\mu$ L.

**Run time:** 40 min.

**Relative retention** with reference to aprotinin monomer (retention time = 24.5 min to 25.5 min): aprotinin dimer = about 0.9.

**System suitability:** reference solution:

- *resolution*: minimum 1.3 between the peaks due to aprotinin dimer and monomer;
- *symmetry factor*: maximum 2.5 for the peak due to aprotinin monomer.

**Limit:**

- *total*: maximum 1.0 per cent.

**Loss on drying** (2.2.32): maximum 6.0 per cent, determined on 0.100 g by drying *in vacuo*.

**Bacterial endotoxins** (2.6.14): less than 0.14 IU per European Pharmacopoeia Unit of aprotinin, if intended for use in the manufacture of parenteral preparations without a further appropriate procedure for the removal of bacterial endotoxins.

**ASSAY**

The activity of aprotinin is determined by measuring its inhibitory action on a solution of trypsin of known activity. The inhibiting activity of the aprotinin is calculated from the difference between the initial activity and the residual activity of the trypsin.

The inhibiting activity of aprotinin is expressed in European Pharmacopoeia Units. 1 Ph. Eur. U. inhibits 50 per cent of the enzymatic activity of 2 microkatal of trypsin.

Use a reaction vessel with a capacity of about 30 mL, provided with:

- a device that will maintain a temperature of  $25 \pm 0.1$  °C;
- a stirring device, such as a magnetic stirrer;
- a lid with 5 holes for accommodating the electrodes, the tip of a burette, a tube for the admission of nitrogen and the introduction of the reagents.

An automatic or manual titration apparatus may be used. In the latter case the burette is graduated in 0.05 mL and the pH-meter is provided with a wide reading scale and glass and calomel or glass-silver-silver chloride electrodes.

**Test solution.** Prepare a solution of the substance to be examined in 0.0015 M borate buffer solution pH 8.0 R expected to contain 1.67 Ph. Eur. U./mL (about 0.6 mg (*m* mg) per millilitre).

**Trypsin solution.** Prepare a solution of *trypsin BRP* containing about 0.8 microkatal per millilitre (about 1 mg/mL), using 0.001 M hydrochloric acid as the solvent. Use a freshly prepared solution and keep in iced water.

**Trypsin and aprotinin solution.** To 4.0 mL of the trypsin solution add 1.0 mL of the test solution. Dilute immediately to 40.0 mL with 0.0015 M borate buffer solution pH 8.0 R. Allow to stand at room temperature for 10 min and then keep in iced water. Use within 6 h of preparation.

**Dilute trypsin solution.** Dilute 0.5 mL of the trypsin solution to 10.0 mL with 0.0015 M borate buffer solution pH 8.0 R. Allow to stand at room temperature for 10 min and then keep in iced water.

Maintain an atmosphere of nitrogen in the reaction flask and stir continuously; introduce 9.0 mL of 0.0015 M borate buffer solution pH 8.0 R and 1.0 mL of a freshly prepared 6.9 g/L solution of *benzoylarginine ethyl ester hydrochloride R*. Adjust to pH 8.0 with 0.1 M sodium hydroxide. When the temperature has reached equilibrium at  $25 \pm 0.1$  °C, add 1.0 mL of the trypsin and aprotinin solution and start a timer. Maintain at pH 8.0 by the addition of 0.1 M sodium hydroxide and note the volume added every 30 s. Continue the reaction for 6 min. Determine the number of millilitres of 0.1 M sodium hydroxide used per second ( $n_1$  mL). Carry out, under the same conditions, a titration using 1.0 mL of the dilute trypsin solution. Determine the number of millilitres of 0.1 M sodium hydroxide used per second ( $n_2$  mL).

Calculate the aprotinin activity in European Pharmacopoeia Units per milligram using the following expression:

$$\frac{4000(2n_2 - n_1)}{m}$$

The estimated activity is not less than 90 per cent and not more than 110 per cent of the activity stated on the label.

**STORAGE**

In an airtight, tamper-proof container, protected from light.

**LABELLING**

The label states:

- the number of European Pharmacopoeia Units of aprotinin activity per milligram;
- where applicable, that the substance is suitable for use in the manufacture of parenteral preparations.

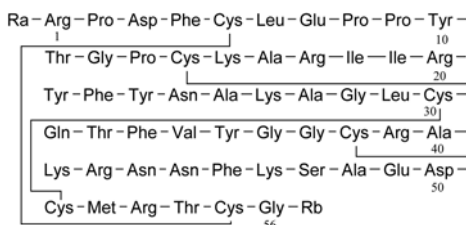
**IMPURITIES**

- Ra = H, Rb = OH: aprotinin-(1-56)-peptide,
- Ra = H, Rb = Gly-OH: aprotinin-(1-57)-peptide,
- Ra = Glp, Rb = Gly-Ala-OH: (5-oxoprolyl)aprotinin (pyroglutamylaprotinin).

01/2011:0579

## APROTININ CONCENTRATED SOLUTION

## Aprotinini solutio concentrata

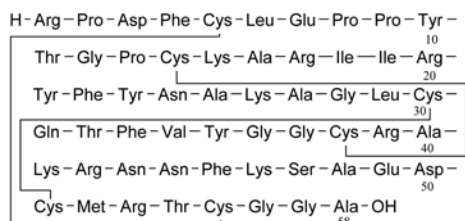
 $C_{284}H_{432}N_{84}O_{79}S_7$  $M_r$  6511

## DEFINITION

Aprotinin concentrated solution is a solution of aprotinin, a polypeptide consisting of a chain of 58 amino acids, which inhibits stoichiometrically the activity of several proteolytic enzymes such as chymotrypsin, kallikrein, plasmin and trypsin. It contains not less than 15.0 Ph. Eur. U. of aprotinin activity per millilitre.

## PRODUCTION

The animals from which aprotinin is derived must fulfil the requirements for the health of animals suitable for human consumption.

The method of manufacture is validated to demonstrate that the product, if tested, would comply with the following tests.

**Abnormal toxicity** (2.6.9). Inject into each mouse a quantity of the preparation to be examined containing 2 Ph. Eur. U. diluted with a sufficient quantity of *water for injections R* to give a volume of 0.5 mL.

**Histamine** (2.6.10): maximum 0.2 µg of histamine base per 3 Ph. Eur. U.

## CHARACTERS

**Appearance:** clear, colourless liquid.

## IDENTIFICATION

A. Thin-layer chromatography (2.2.27).

**Test solution.** Solution S (see Tests).

**Reference solution.** Dilute *aprotinin solution BRP* in *water R* to obtain a concentration of 15 Ph. Eur. U./mL.

**Plate:** TLC silica gel G plate R.

**Mobile phase:** *water R*, *glacial acetic acid R* (80:100 V/V) containing 100 g/L of *sodium acetate R*.

**Application:** 10 µL.

**Development:** over a path of 12 cm.

**Drying:** in air.

**Detection:** spray with a solution of 0.1 g of *ninhydrin R* in a mixture of 6 mL of a 10 g/L solution of *cupric chloride R*, 21 mL of *glacial acetic acid R* and 70 mL of *anhydrous ethanol R*. Dry the plate at 60 °C.

**Results:** the principal spot in the chromatogram obtained with the test solution is similar in position, colour and size to the principal spot in the chromatogram obtained with the reference solution.

B. Determine the ability of the preparation to be examined to inhibit trypsin activity using the method described below.

**Test solution.** Dilute 1 mL of solution S to 50 mL with *buffer solution pH 7.2 R*.

**Trypsin solution.** Dissolve 10 mg of *trypsin BRP* in 0.002 M *hydrochloric acid* and dilute to 100 mL with the same acid.

**Casein solution.** Dissolve 0.2 g of *casein R* in *buffer solution pH 7.2 R* and dilute to 100 mL with the same buffer solution.

**Precipitating solution:** *glacial acetic acid R*, *water R*, *anhydrous ethanol R* (1:49:50 V/V/V).

Mix 1 mL of the test solution with 1 mL of the trypsin solution. Allow to stand for 10 min and add 1 mL of the casein solution. Incubate at 35 °C for 30 min. Cool in iced water and add 0.5 mL of the precipitating solution. Shake and allow to stand at room temperature for 15 min. The solution is cloudy. Carry out a blank test under the same conditions using *buffer solution pH 7.2 R* instead of the test solution. The solution is not cloudy.

## TESTS

**Solution S.** Prepare a solution containing 15 Ph. Eur. U./mL, if necessary by dilution, on the basis of the activity stated on the label.

**Appearance of solution.** Solution S is clear (2.2.1).

**Absorbance** (2.2.25): maximum 0.80 by measuring at the absorption maximum at 277 nm.

Prepare a solution containing 3.0 Ph. Eur. U./mL.

**Des-Ala-aprotinin and des-Ala-des-Gly-aprotinin.** Capillary zone electrophoresis (2.2.47): use the normalisation procedure.

**Test solution.** Dilute the preparation to be examined in *water R* to obtain a concentration of not less than 1 Ph. Eur. U./mL.

**Reference solution.** Dilute *aprotinin solution BRP* in *water R* to obtain the same concentration as the test solution.

**Capillary:**

- **material:** uncoated fused silica;
- **size:** effective length = 45-60 cm, Ø = 75 µm.

**Temperature:** 25 °C.

**CZE buffer.** Dissolve 8.21 g of *potassium dihydrogen phosphate R* in 400 mL of *water R*, adjust to pH 3.0 with *phosphoric acid R*, dilute to 500.0 mL with *water R* and filter through a membrane filter (nominal pore size 0.45 µm).

**Detection:** spectrophotometer at 214 nm.

**Between-run rinsing:** rinse the capillary for at least 1 min with 0.1 M *sodium hydroxide* filtered through a membrane filter (nominal pore size 0.45 µm) and for 2 min with the CZE buffer.

**Injection:** under pressure or vacuum (for example, 3 s at a differential pressure of 3.5 kPa).

**Migration:** apply a field strength of 0.2 kV/cm, using the CZE buffer as the electrolyte in both buffer reservoirs.

**Run time:** 30 min.

**Identification of impurities:** use the electropherogram supplied with *aprotinin solution BRP* and the electropherogram obtained with the reference solution to identify the peaks due to impurities A and B.

**Relative migration** with reference to aprotinin (migration time = about 22 min): impurity A = about 0.98; impurity B = about 0.99.

**System suitability:** reference solution after at least 6 injections:

- **migration time:** aprotinin = 19.0 min to 25.0 min;
- **resolution:** minimum 0.8 between the peaks due to impurities A and B; minimum 0.5 between the peaks due to impurity B and aprotinin;
- **peak distribution:** the electropherogram obtained is qualitatively and quantitatively similar to the electropherogram supplied with *aprotinin solution BRP*;
- **height of the principal peak:** at least 1000 times the height of the baseline noise. If necessary, adjust the sample load to give peaks of a sufficient height.

**Limits:**

- **impurity A:** maximum 8.0 per cent;
- **impurity B:** maximum 7.5 per cent.

**Pyroglutamyl-aprotinin and related compounds.** Liquid chromatography (2.2.29): use the normalisation procedure.

**Test solution.** Dilute the preparation to be examined in mobile phase A to a concentration of about 5 Ph. Eur. U./mL.

**Reference solution.** Dissolve the contents of a vial of *aprotinin for system suitability CRS* in 2.0 mL of mobile phase A.

**Column:**

- size:  $l = 0.075$  m,  $\emptyset = 7.5$  mm;
- stationary phase: strong cation-exchange silica gel for chromatography R (10  $\mu$ m);
- temperature: 40 °C.

**Mobile phase:**

- mobile phase A: dissolve 3.52 g of *potassium dihydrogen phosphate R* and 7.26 g of *disodium hydrogen phosphate dihydrate R* in 1000 mL of water; filter and degas;
- mobile phase B: dissolve 3.52 g of *potassium dihydrogen phosphate R*, 7.26 g of *disodium hydrogen phosphate dihydrate R* and 66.07 g of *ammonium sulfate R* in 1000 mL of water; filter and degas;

Time (min)	Mobile phase A (per cent V/V)	Mobile phase B (per cent V/V)
0 - 21	92 → 64	8 → 36
21 - 30	64 → 0	36 → 100

**Flow rate:** 1.0 mL/min.

**Detection:** spectrophotometer at 210 nm.

**Injection:** 40  $\mu$ L.

**Relative retention** with reference to aprotinin (retention time = 17.0 min to 20.0 min): impurity C = about 0.9.

**System suitability:** reference solution:

- resolution: minimum 1.5 between the peaks due to impurity C and aprotinin;
- symmetry factor: maximum 1.3 for the peak due to aprotinin.

**Limits:**

- impurity C: maximum 1.0 per cent;
- any other impurity: maximum 0.5 per cent;
- sum of impurities other than C: maximum 1.0 per cent.

**Aprotinin oligomers.** Size-exclusion chromatography (2.2.30): use the normalisation procedure.

**Test solution.** Dilute the preparation to be examined in *water R* to obtain a concentration of about 5 Ph. Eur. U./mL.

**Reference solution.** Treat the substance to be examined to obtain about 2 per cent aprotinin oligomers. For example, heat freeze-dried aprotinin at about 110 °C for about 4 h. Then dissolve in *water R* to obtain a concentration of about 5 Ph. Eur. U./mL.

**Column:** 3 columns coupled in series:

- size:  $l = 0.30$  m,  $\emptyset = 7.8$  mm;
- stationary phase: hydrophilic silica gel for chromatography R of a grade suitable for fractionation of globular proteins in the relative molecular mass range of 20 000 to 10 000 000 (8  $\mu$ m).

**Mobile phase:** acetonitrile R, glacial acetic acid R, water R (2:2:6 V/V/V); filter and degas.

**Flow rate:** 1.0 mL/min.

**Detection:** spectrophotometer at 277 nm.

**Injection:** 100  $\mu$ L.

**Run time:** 40 min.

**Relative retention** with reference to aprotinin monomer (retention time = 24.5 min to 25.5 min): aprotinin dimer = about 0.9.

**System suitability:** reference solution:

- resolution: minimum 1.3 between the peaks due to aprotinin dimer and monomer;
- symmetry factor: maximum 2.5 for the peak due to aprotinin monomer.

**Limit:**

- total: maximum 1.0 per cent.

**Specific activity of the dry residue:** minimum 3.0 Ph. Eur. U. of aprotinin activity per milligram of dry residue.

Evaporate 25.0 mL to dryness in a water-bath, dry the residue at 110 °C for 15 h and weigh. From the mass of the residue and the activity determined as described below, calculate the number of European Pharmacopoeia Units per milligram of dry residue.

**Bacterial endotoxins (2.6.14):** less than 0.14 IU per European Pharmacopoeia Unit of aprotinin, if intended for use in the manufacture of parenteral preparations without a further appropriate procedure for the removal of bacterial endotoxins.

**ASSAY**

The activity of aprotinin is determined by measuring its inhibitory action on a solution of trypsin of known activity. The inhibiting activity of the aprotinin is calculated from the difference between the initial activity and the residual activity of the trypsin.

The inhibiting activity of aprotinin is expressed in European Pharmacopoeia Units. 1 Ph. Eur. U. inhibits 50 per cent of the enzymatic activity of 2 microkatal of trypsin.

Use a reaction vessel with a capacity of about 30 mL, provided with:

- a device that will maintain a temperature of  $25 \pm 0.1$  °C;
- a stirring device, such as a magnetic stirrer;
- a lid with 5 holes for accommodating the electrodes, the tip of a burette, a tube for the admission of nitrogen and the introduction of the reagents.

An automatic or manual titration apparatus may be used. In the latter case the burette is graduated in 0.05 mL and the pH-meter is provided with a wide reading scale and glass and calomel or glass-silver-silver chloride electrodes.

**Test solution.** With 0.0015 M borate buffer solution pH 8.0 R prepare an appropriate dilution (D) of the aprotinin concentrated solution expected, on the basis of the stated potency, to contain 1.67 Ph. Eur. U./mL.

**Trypsin solution.** Prepare a solution of *trypsin BRP* containing about 0.8 microkatal per millilitre (about 1 mg/mL), using 0.001 M hydrochloric acid as the solvent. Use a freshly prepared solution and keep in iced water.

**Trypsin and aprotinin solution.** To 4.0 mL of the trypsin solution add 1.0 mL of the test solution. Dilute immediately to 40.0 mL with 0.0015 M borate buffer solution pH 8.0 R. Allow to stand at room temperature for 10 min and then keep in iced water. Use within 6 h of preparation.

**Dilute trypsin solution.** Dilute 0.5 mL of the trypsin solution to 10.0 mL with 0.0015 M borate buffer solution pH 8.0 R. Allow to stand at room temperature for 10 min and then keep in iced water.

Maintain an atmosphere of nitrogen in the reaction flask and stir continuously; introduce 9.0 mL of 0.0015 M borate buffer solution pH 8.0 R and 1.0 mL of a freshly prepared 6.9 g/L solution of *benzoylarginine ethyl ester hydrochloride R*. Adjust to pH 8.0 with 0.1 M sodium hydroxide. When the temperature has reached equilibrium at  $25 \pm 0.1$  °C, add 1.0 mL of the trypsin and aprotinin solution and start a timer. Maintain at pH 8.0 by the addition of 0.1 M sodium hydroxide and note the volume added every 30 s. Continue the reaction for 6 min. Determine the number of millilitres of 0.1 M sodium hydroxide used per second ( $n_1$  mL). Carry out, under the same conditions, a titration using 1.0 mL of the dilute trypsin solution. Determine the number of millilitres of 0.1 M sodium hydroxide used per second ( $n_2$  mL).

Calculate the aprotinin activity in European Pharmacopoeia Units per millilitre using the following expression:

$$4000(2n_2 - n_1) \times D$$

D = dilution factor of the aprotinin concentrated solution to be examined in order to obtain a solution containing 1.67 Ph. Eur. U./mL.

The estimated activity is not less than 90 per cent and not more than 110 per cent of the activity stated on the label.

#### STORAGE

In an airtight, tamper-proof container, protected from light.

#### LABELLING

The label states:

- the number of European Pharmacopoeia Units of aprotinin activity per millilitre;
- where applicable, that the substance is suitable for use in the manufacture of parenteral preparations.

#### IMPURITIES

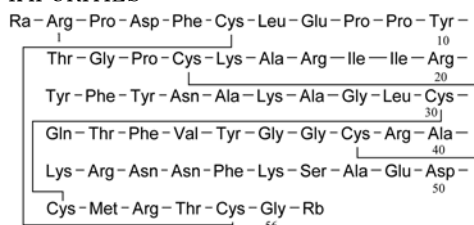

- A. Ra = H, Rb = OH: aprotinin-(1-56)-peptide,  
 B. Ra = H, Rb = Gly-OH: aprotinin-(1-57)-peptide,  
 C. Ra = Glp, Rb = Gly-Ala-OH: (5-oxopropyl)aprotinin (pyroglutamylaprotinin).

07/2010:1171  
corrected 7.0

## ARACHIS OIL, HYDROGENATED

### Arachidis oleum hydrogenatum

#### DEFINITION

Oil obtained by refining, bleaching, hydrogenating and deodorising oil obtained from the shelled seeds of *Arachis hypogaea* L. Each type of hydrogenated arachis oil is characterised by its nominal drop point.

#### CHARACTERS

**Appearance:** white or faintly yellowish, soft mass which melts to a clear, pale yellow liquid when heated.

**Solubility:** practically insoluble in water, freely soluble in methylene chloride and in light petroleum (bp: 65-70 °C), very slightly soluble in ethanol (96 per cent).

#### IDENTIFICATION

**First identification:** A, B.

**Second identification:** A, C.

- A. Drop point (see Tests).  
 B. Identification of fatty oils by thin-layer chromatography (2.3.2).  
*Results:* the chromatogram obtained is similar to the chromatogram for arachis oil shown in Figure 2.3.2.-1.  
 C. Composition of fatty acids (see Tests).

#### TESTS

**Drop point** (2.2.17): 32 °C to 43 °C, and within 3 °C of the nominal value.

**Acid value** (2.5.1): maximum 0.5.

Dissolve 10.0 g in 50 mL of the prescribed solvent by heating on a water-bath.

**Peroxide value** (2.5.5, Method A): maximum 5.0.

Dissolve 5.0 g in 30 mL of the prescribed solvent by heating on a water-bath.

**Unsaponifiable matter** (2.5.7): maximum 1.0 per cent.

**Alkaline impurities** (2.4.19). It complies with the test.

**Composition of fatty acids** (2.4.22, Method A). Use the mixture of calibrating substances in Table 2.4.22.-3.

#### Column:

- **material:** fused silica;
- **size:**  $l = 25$  m,  $\varnothing = 0.25$  mm;
- **stationary phase:** poly(cyanopropyl)siloxane R (film thickness 0.2  $\mu$ m).

**Carrier gas:** helium for chromatography R.

**Flow rate:** 0.7 mL/min.

**Split ratio:** 1:100.

#### Temperature:

- **column:** 180 °C for 20 min;
- **injection port and detector:** 250 °C.

**Detection:** flame ionisation.

**Composition of the fatty-acid fraction of the oil:**

- **saturated fatty acids of chain length less than  $C_{14}$ :** maximum 0.5 per cent;
- **myristic acid:** maximum 0.5 per cent;
- **palmitic acid:** 7.0 per cent to 16.0 per cent;
- **stearic acid:** 3.0 per cent to 19.0 per cent;
- **oleic acid and isomers:** 54.0 per cent to 78.0 per cent;
- **linoleic acid and isomers:** maximum 10.0 per cent;
- **arachidic acid:** 1.0 per cent to 3.0 per cent;
- **eicosenoic acids:** maximum 2.1 per cent;
- **behenic acid:** 1.0 per cent to 5.0 per cent;
- **erucic acid and isomers:** maximum 0.5 per cent;
- **lignoceric acid:** 0.5 per cent to 3.0 per cent.

**Nickel:** maximum 1 ppm.

Atomic absorption spectrometry (2.2.23, Method II).

**Test solution.** Into a platinum or silica crucible previously tared after ignition introduce 5.0 g. Cautiously heat and introduce into the substance a wick formed from twisted ashless filter paper. Ignite the wick. When the substance has ignited stop heating. After combustion, ignite in a muffle furnace at about 600  $\pm$  50 °C. Continue ignition until white ash is obtained. After cooling, take up the residue with 2 quantities, each of 2 mL, of dilute hydrochloric acid R and transfer into a 25 mL graduated flask. Add 0.3 mL of nitric acid R and dilute to 25.0 mL with water R.

**Reference solutions.** Prepare 3 reference solutions by adding 1.0 mL, 2.0 mL and 4.0 mL of nickel standard solution (0.2 ppm Ni) R to 2.0 mL of the test solution and diluting to 10.0 mL with water R.

**Source:** nickel hollow-cathode lamp.

**Wavelength:** 232 nm.

**Atomisation device:** graphite furnace.

**Carrier gas:** argon R.

#### STORAGE

Protected from light.

#### LABELLING

The label states the nominal drop point.

01/2010:0263

## ARACHIS OIL, REFINED

### Arachidis oleum raffinatum

#### DEFINITION

The refined fatty oil obtained from the shelled seeds of *Arachis hypogaea* L. A suitable antioxidant may be added.

#### CHARACTERS

**Appearance:** clear, yellowish, viscous liquid.

**Solubility:** very slightly soluble in ethanol (96 per cent), miscible with light petroleum.

**Relative density:** about 0.915.

It solidifies at about 2 °C.

#### IDENTIFICATION

Identification test for fatty oils by thin-layer chromatography (2.3.2).

**Results:** the chromatogram obtained is similar to the corresponding chromatogram shown in Figure 2.3.2.-1.

#### TESTS

**Acid value (2.5.1):** maximum 0.5, determined on 10.0 g.

**Peroxide value (2.5.5, Method A):** maximum 5.0.

**Unsaponifiable matter (2.5.7):** maximum 1.0 per cent, determined on 5.0 g.

**Alkaline impurities (2.4.19).** It complies with the test.

**Composition of fatty acids. (2.4.22, Method A).** Use the mixture of calibrating substances in Table 2.4.22.-3.

**Composition of the fatty-acid fraction of the oil:**

- saturated fatty acids of chain length less than  $C_{16}$ : maximum 0.4 per cent,
- palmitic acid: 7.0 per cent to 16.0 per cent,
- stearic acid: 1.3 per cent to 6.5 per cent,
- oleic acid: 35.0 per cent to 72.0 per cent,
- linoleic acid: 13.0 per cent to 43.0 per cent,
- linolenic acid: maximum 0.6 per cent,
- arachidic acid: 0.5 per cent to 3.0 per cent,
- eicosenoic acid: 0.5 per cent to 2.1 per cent,
- behenic acid: 1.0 per cent to 5.0 per cent,
- erucic acid: maximum 0.5 per cent,
- lignoceric acid: 0.5 per cent to 3.0 per cent.

**Water (2.5.32):** maximum 0.1 per cent, determined on 1.00 g.

#### STORAGE

In a well-filled container, protected from light.

01/2008:0806  
corrected 6.0

## ARGININE

### Argininum

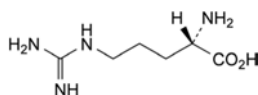

$C_6H_{14}N_4O_2$   
[74-79-3]

$M_r$  174.2

#### DEFINITION

Arginine contains not less than 98.5 per cent and not more than the equivalent of 101.0 per cent of (S)-2-amino-5-guanidinopentanoic acid, calculated with reference to the dried substance.

#### CHARACTERS

A white or almost white, crystalline powder or colourless crystals, freely soluble in water, very slightly soluble in alcohol.

#### IDENTIFICATION

**First identification:** A, C.

**Second identification:** A, B, D, E.

A. Specific optical rotation (see Tests).

B. Solution S (see Tests) is strongly alkaline (2.2.4).

C. Examine by infrared absorption spectrophotometry (2.2.24), comparing with the spectrum obtained with *arginine CRS*. Examine the substances prepared as discs.

D. Examine the chromatograms obtained in the test for ninhydrin-positive substances. The principal spot in the chromatogram obtained with test solution (b) is similar in position, colour and size to the principal spot in the chromatogram obtained with reference solution (a).

E. Dissolve about 25 mg in 2 mL of *water R*. Add 1 mL of  $\alpha$ -naphthol solution R and 2 mL of a mixture of equal volumes of *strong sodium hypochlorite solution R* and water. A red colour develops.

#### TESTS

**Solution S.** Dissolve 2.5 g in *distilled water R* and dilute to 50 mL with the same solvent.

**Appearance of solution.** Solution S is clear (2.2.1) and not more intensely coloured than reference solution BY<sub>6</sub> (2.2.2, Method II).

**Specific optical rotation (2.2.7).** Dissolve 2.00 g in *hydrochloric acid R1* and dilute to 25.0 mL with the same acid. The specific optical rotation is + 25.5 to + 28.5, calculated with reference to the dried substance.

**Ninhydrin-positive substances.** Examine by thin-layer chromatography (2.2.27), using a *TLC silica gel plate R*.

**Test solution (a).** Dissolve 0.10 g of the substance to be examined in *dilute hydrochloric acid R* and dilute to 10 mL with the same acid.

**Test solution (b).** Dilute 1 mL of test solution (a) to 50 mL with *water R*.

**Reference solution (a).** Dissolve 10 mg of *arginine CRS* in 0.1 M *hydrochloric acid* and dilute to 50 mL with the same acid.

**Reference solution (b).** Dilute 5 mL of test solution (b) to 20 mL with *water R*.

**Reference solution (c).** Dissolve 10 mg of *arginine CRS* and 10 mg of *lysine hydrochloride CRS* in 0.1 M *hydrochloric acid* and dilute to 25 mL with the same acid.

Apply to the plate 5  $\mu$ L of each solution. Allow the plate to dry in air. Develop over a path of 15 cm using a mixture of 30 volumes of *concentrated ammonia R* and 70 volumes of *2-propanol R*. Dry the plate at 100 °C to 105 °C until the ammonia disappears completely. Spray with *ninhydrin solution R* and heat at 100 °C to 105 °C for 15 min. Any spot in the chromatogram obtained with test solution (a), apart from the principal spot, is not more intense than the spot in the chromatogram obtained with reference solution (b) (0.5 per cent). The test is not valid unless the chromatogram obtained with reference solution (c) shows two clearly separated spots.

**Chlorides (2.4.4).** To 5 mL of solution S add 0.5 mL of *dilute nitric acid R* and dilute to 15 mL with *water R*. The solution complies with the limit test for chlorides (200 ppm).

**Sulfates (2.4.13).** To 10 mL of solution S, add 1.7 mL of *dilute hydrochloric acid R* and dilute to 15 mL with *distilled water R*. The solution complies with the limit test for sulfates (300 ppm).

**Ammonium (2.4.1).** 50 mg complies with limit test B for ammonium (200 ppm). Prepare the standard using 0.1 mL of *ammonium standard solution (100 ppm NH<sub>4</sub>) R*.

**Iron (2.4.9).** In a separating funnel, dissolve 1.0 g in 10 mL of *dilute hydrochloric acid R*. Shake with three quantities, each of 10 mL, of *methyl isobutyl ketone R1*, shaking for 3 min each time. To the combined organic layers add 10 mL of *water R* and shake for 3 min. The aqueous layer complies with the limit test for iron (10 ppm).

**Heavy metals (2.4.8).** Dissolve 2.0 g in *water R* and dilute to 20 mL with the same solvent. 12 mL of the solution complies with limit test A for heavy metals (10 ppm). Prepare the standard using *lead standard solution (1 ppm Pb) R*.

**Loss on drying** (2.2.32). Not more than 0.5 per cent, determined on 1.000 g by drying in an oven at 105 °C.

**Sulfated ash** (2.4.14). Not more than 0.1 per cent, determined on 1.0 g.

#### ASSAY

Dissolve 0.150 g in 50 mL of *water R*. Using 0.2 mL of *methyl red mixed solution R* as indicator, titrate with 0.1 M *hydrochloric acid* until the colour changes from green to violet-red.

1 mL of 0.1 M *hydrochloric acid* is equivalent to 17.42 mg of  $C_6H_{14}N_4O_2$ .

#### STORAGE

Store protected from light.

01/2008:2096  
corrected 6.0

## ARGININE ASPARTATE

### Arginini aspartas

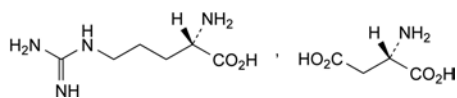

$C_{10}H_{21}N_5O_6$   
[7675-83-4]

$M_r$  307.3

#### DEFINITION

(2S)-2-Amino-5-guanidinopentanoic acid (2S)-2-aminobutanedioate.

**Content:** 99.0 per cent to 101.0 per cent (dried substance).

#### CHARACTERS

**Appearance:** white or almost white granules or powder.

**Solubility:** very soluble in water, practically insoluble in alcohol and in methylene chloride.

#### IDENTIFICATION

- Specific optical rotation (see Tests).
- Infrared absorption spectrophotometry (2.2.24).  
*Comparison:* arginine aspartate CRS.
- Examine the chromatograms obtained in the test for ninhydrin-positive substances.

**Results:** the 2 principal spots in the chromatogram obtained with test solution (b) are similar in position, colour and size to the 2 principal spots in the chromatogram obtained with reference solution (a).

#### TESTS

**Solution S.** Dissolve 5.0 g in *carbon dioxide-free water R* and dilute to 50 mL with the same solvent.

**Appearance of solution.** Solution S is clear (2.2.1) and not more intensely coloured than reference solution  $Y_7$  (2.2.2, *Method II*).

**pH** (2.2.3): 6.0 to 7.0 for solution S.

**Specific optical rotation** (2.2.7): + 25 to + 27 (dried substance). Dissolve 2.50 g in *dilute hydrochloric acid R* and dilute to 25.0 mL with the same acid.

**Ninhydrin-positive substances.** Thin-layer chromatography (2.2.27).

**Test solution (a).** Dissolve 0.20 g of the substance to be examined in *water R* and dilute to 10 mL with the same solvent.

**Test solution (b).** Dilute 1 mL of test solution (a) to 10 mL with *water R*.

**Reference solution (a).** Dissolve 25 mg of *arginine R* and 25 mg of *aspartic acid R* in *water R* and dilute to 25 mL with the same solvent.

**Reference solution (b).** Dilute 2 mL of reference solution (a) to 50 mL with *water R*.

**Plate:** TLC silica gel G plate R.

**Mobile phase:** ammonia R, propanol R (36:64 V/V).

**Application:** 5  $\mu$ L.

**Development:** over 2/3 of the plate.

**Drying:** at 100-105 °C for 10 min.

**Detection:** spray with *ninhydrin solution R* and heat at 100-105 °C for 10 min.

**System suitability:** reference solution (b):

– the chromatogram shows 2 clearly separated principal spots.

**Limit:** test solution (a):

– *any impurity:* any spots, apart from the 2 principal spots, are not more intense than each of the 2 principal spots in the chromatogram obtained with reference solution (b) (0.2 per cent).

**Chlorides** (2.4.4): maximum 200 ppm.

Dilute 2.5 mL of solution S to 15 mL with *water R*.

**Sulfates** (2.4.13): maximum 300 ppm.

To 0.5 g add 2.5 mL of *dilute hydrochloric acid R* and dilute to 15 mL with *distilled water R*. Examine after 30 min.

**Ammonium** (2.4.1): maximum 100 ppm, determined on 100 mg.

**Heavy metals** (2.4.8): maximum 20 ppm.

12 mL of solution S complies with test A. Prepare the reference solution using *lead standard solution (2 ppm Pb) R*.

**Loss on drying** (2.2.32): maximum 0.5 per cent, determined on 1.000 g by drying in an oven at 60 °C for 24 h.

**Sulfated ash** (2.4.14): maximum 0.1 per cent, determined on 1.0 g.

#### ASSAY

Dissolve 80.0 mg in 2 mL of *anhydrous formic acid R*. Add 50 mL of *anhydrous acetic acid R*. Titrate with 0.1 M *perchloric acid*, determining the end-point potentiometrically (2.2.20).

1 mL of 0.1 M *perchloric acid* is equivalent to 10.24 mg of  $C_{10}H_{21}N_5O_6$ .

01/2008:0805  
corrected 6.0

## ARGININE HYDROCHLORIDE

### Arginini hydrochloridum

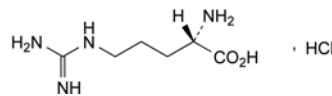

$C_6H_{15}ClN_4O_2$   
[1119-34-2]

$M_r$  210.7

#### DEFINITION

Arginine hydrochloride contains not less than 98.5 per cent and not more than the equivalent of 101.0 per cent of the hydrochloride of (S)-2-amino-5-guanidinopentanoic acid, calculated with reference to the dried substance.

#### CHARACTERS

A white or almost white, crystalline powder or colourless crystals, freely soluble in water, very slightly soluble in alcohol.

#### IDENTIFICATION

**First identification:** A, B, E.

**Second identification:** A, C, D, E.

A. Specific optical rotation (see Tests).



- B. Examine by infrared absorption spectrophotometry (2.2.24), comparing with the spectrum obtained with *arginine hydrochloride CRS*. Examine the substances prepared as discs.
- C. Examine the chromatograms obtained in the test for ninhydrin-positive substances. The principal spot in the chromatogram obtained with test solution (b) is similar in position, colour and size to the principal spot in the chromatogram obtained with reference solution (a).
- D. Dissolve about 25 mg in 2 mL of *water R*. Add 1 mL of *α-naphthol solution R* and 2 mL of a mixture of equal volumes of *strong sodium hypochlorite solution R* and *water R*. A red colour develops.
- E. It gives reaction (a) of chlorides (2.3.1).

## TESTS

**Solution S.** Dissolve 2.5 g in *distilled water R* and dilute to 50 mL with the same solvent.

**Appearance of solution.** Solution S is clear (2.2.1) and not more intensely coloured than reference solution BY<sub>6</sub> (2.2.2, *Method II*).

**Specific optical rotation (2.2.7).** Dissolve 2.00 g in *hydrochloric acid RI* and dilute to 25.0 mL with the same acid. The specific optical rotation is + 21.0 to + 23.5, calculated with reference to the dried substance.

**Ninhydrin-positive substances.** Examine by thin-layer chromatography (2.2.27), using a *TLC silica gel plate R*.

**Test solution (a).** Dissolve 0.10 g of the substance to be examined in *water R* and dilute to 10 mL with the same solvent.

**Test solution (b).** Dilute 1 mL of test solution (a) to 50 mL with *water R*.

**Reference solution (a).** Dissolve 10 mg of *arginine hydrochloride CRS* in *water R* and dilute to 50 mL with the same solvent.

**Reference solution (b).** Dilute 5 mL of test solution (b) to 20 mL with *water R*.

**Reference solution (c).** Dissolve 10 mg of *arginine hydrochloride CRS* and 10 mg of *lysine hydrochloride CRS* in *water R* and dilute to 25 mL with the same solvent.

Apply to the plate 5 µL of each solution. Allow the plate to dry in air. Develop over a path of 15 cm using a mixture of 30 volumes of *concentrated ammonia R* and 70 volumes of *2-propanol R*. Dry the plate at 100 °C to 105 °C until the ammonia disappears completely. Spray with *ninhydrin solution R* and heat at 100 °C to 105 °C for 15 min. Any spot in the chromatogram obtained with test solution (a), apart from the principal spot, is not more intense than the spot in the chromatogram obtained with reference solution (b) (0.5 per cent). The test is not valid unless the chromatogram obtained with reference solution (c) shows two clearly separated spots.

**Sulfates (2.4.13).** Dilute 10 mL of solution S to 15 mL with *distilled water R*. The solution complies with the limit test for sulfates (300 ppm).

**Ammonium (2.4.1).** 50 mg complies with limit test B for ammonium (200 ppm). Prepare the standard using 0.1 mL of *ammonium standard solution (100 ppm NH<sub>4</sub>) R*.

**Iron (2.4.9).** In a separating funnel, dissolve 1.0 g in 10 mL of *dilute hydrochloric acid R*. Shake with three quantities, each of 10 mL, of *methyl isobutyl ketone RI*, shaking for 3 min each time. To the combined organic layers add 10 mL of *water R* and shake for 3 min. The aqueous layer complies with the limit test for iron (10 ppm).

**Heavy metals (2.4.8).** Dissolve 2.0 g in *water R* and dilute to 20 mL with the same solvent. 12 mL of the solution complies with limit test A for heavy metals (10 ppm). Prepare the standard using *lead standard solution (1 ppm Pb) R*.

**Loss on drying (2.2.32).** Not more than 0.5 per cent, determined on 1.000 g by drying in an oven at 105 °C.

**Sulfated ash (2.4.14).** Not more than 0.1 per cent, determined on 1.0 g.

## ASSAY

Dissolve 0.180 g in 3 mL of *anhydrous formic acid R*. Add 30 mL of *anhydrous acetic acid R*. Using 0.1 mL of *naphtholbenzoin solution R* as indicator, titrate with 0.1 M *perchloric acid* until the colour changes from brownish-yellow to green.

1 mL of 0.1 M *perchloric acid* is equivalent to 21.07 mg of C<sub>6</sub>H<sub>15</sub>ClN<sub>4</sub>O<sub>2</sub>.

## STORAGE

Store protected from light.

07/2010:2407

## ARGON

## Argon

Ar  
[7440-37-1] A<sub>1</sub> 39.95

## DEFINITION

Gas obtained by fractional distillation of ambient air.

**Content:** minimum 99.995 per cent V/V of Ar, calculated by deduction of the sum of impurities found when performing the test for impurities and the water content.

This monograph applies to argon for medicinal use.

## CHARACTERS

**Appearance:** colourless gas.

**Solubility:** at 20 °C and at a pressure of 101 kPa, 1 volume dissolves in about 29 volumes of water.

## IDENTIFICATION

A. Verify that the gas is not oxygen using a paramagnetic analyser (2.5.27).

B. Gas chromatography (2.2.28).

**Gas to be examined.** The substance to be examined.

**Reference gas.** Use the following mixture of gases in *argon RI*: *methane RI* (5 ppm V/V), *nitrogen RI* (5 ppm V/V), *oxygen R* (5 ppm V/V).

**Column:**

- **material:** stainless steel;
- **size:** *l* = 2 m, Ø = 3 mm;
- **stationary phase:** *molecular sieve for chromatography R* (particle size 150-180 µm, pore size 0.5 nm).

**Carrier gas:** *helium for chromatography R*.

**Flow rate:** 10 mL/min.

**Temperature:**

- **column:** 50 °C;
- **detector:** 150 °C.

**Detection:** thermal conductivity.

**Injection:** 25 µL.

**System suitability:** reference gas:

- **resolution:** minimum 3.0 between the peaks due to argon/oxygen and nitrogen and minimum 2.0 between the peaks due to nitrogen and methane.

**Results:** the principal peak in the chromatogram obtained with the gas to be examined is similar in retention time to the principal peak in the chromatogram obtained with the reference gas.

## TESTS

**Impurities.** Gas chromatography (2.2.28).

**Gas to be examined.** The substance to be examined.

**Reference gas.** Use the following mixture of gases in *argon R1*: *methane R1* (5 ppm V/V), *nitrogen R1* (5 ppm V/V), *oxygen R* (5 ppm V/V).

**Column:**

- **material:** stainless steel;
- **size:**  $l = 4$  m,  $\varnothing = 4$  mm;
- **stationary phase:** *molecular sieve for chromatography R* (particle size 150–180  $\mu\text{m}$ , pore size 0.5 nm).

**Carrier gas:** *argon R1*.

**Flow rate:** 70 mL/min.

**Temperature:**

- **column:** 80 °C;
- **detector:** 40 °C.

**Detection:** discharge ionisation.

**Injection:** 1 mL.

**Sample rate:** 100 mL/min.

**Relative retention** with reference to impurity C (retention time = about 4.7 min): impurity A = about 0.4; impurity B = about 0.7.

**System suitability:** reference gas:

- **resolution:** minimum 3.0 between the peaks due to impurities A and B and minimum 2.0 between the peaks due to impurities B and C.

**Limits:**

- **impurity A:** not more than the area of the corresponding peak in the chromatogram obtained with the reference gas (5.0 ppm V/V);
- **total:** maximum 0.0040 per cent of the sum of the areas of all the peaks (40.0 ppm V/V).

**Water** (2.5.28): maximum 10.0 ppm V/V, determined using an electrolytic hygrometer.

#### STORAGE

In gaseous or liquid state, in suitable containers, complying with the legal regulations.

#### IMPURITIES

**Specified impurities:** A, D.

**Other detectable impurities:** B, C.

- oxygen,
- nitrogen,
- methane,
- water.

01/2008:1688  
corrected 6.0

## ARTICAINE HYDROCHLORIDE

### Articaini hydrochloridum

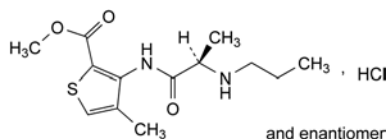

$\text{C}_{13}\text{H}_{21}\text{ClN}_2\text{O}_3\text{S}$   
[23964-57-0]

$M_r$  320.8

#### DEFINITION

Methyl 4-methyl-3-[[*(2RS)*-2-(propylamino)propanoyl]amino]thiophene-2-carboxylate hydrochloride.

**Content:** 98.5 per cent to 101.0 per cent (dried substance).

#### CHARACTERS

**Appearance:** white or almost white, crystalline powder.

**Solubility:** freely soluble in water and in alcohol.

#### IDENTIFICATION

**First identification:** B, D.

**Second identification:** A, C, D.

A. Dissolve 50.0 mg in a 1 g/L solution of *hydrochloric acid R* and dilute to 100.0 mL with the same acid. Dilute 5.0 mL of the solution to 100.0 mL with a 1 g/L solution of *hydrochloric acid R*. Examined between 200 nm and 350 nm (2.2.25), the solution shows an absorption maximum at 272 nm. The specific absorbance at the maximum is 290 to 320.

B. Infrared absorption spectrophotometry (2.2.24).

**Preparation:** place dropwise 20  $\mu\text{L}$  of the test solution on 300 mg discs.

**Test solution.** Dissolve 0.1 g in 5 mL of *water R*, add 3 mL of a saturated solution of *sodium hydrogen carbonate R* and shake twice with 2 mL of *methylene chloride R*. Combine the methylene chloride layers, dilute to 5.0 mL with *methylene chloride R* and dry over *anhydrous sodium sulfate R*.

**Comparison:** *articaine hydrochloride CRS*.

C. Thin-layer chromatography (2.2.27).

**Test solution.** Dissolve 20 mg of the substance to be examined in 5 mL of *alcohol R*.

**Reference solution.** Dissolve 20 mg of *articaine hydrochloride CRS* in 5 mL of *alcohol R*.

**Plate:** *TLC silica gel F<sub>254</sub> plate R*.

**Mobile phase:** *triethylamine R*, *ethyl acetate R*, *heptane R* (10:35:65 V/V/V).

**Application:** 5  $\mu\text{L}$ .

**Development:** over a path of 15 cm.

**Drying:** in air.

**Detection:** examine in ultraviolet light at 254 nm.

**Results:** the principal spot in the chromatogram obtained with the test solution is similar in position and size to the principal spot in the chromatogram obtained with the reference solution.

D. It gives reaction (a) of chlorides (2.3.1).

#### TESTS

**Solution S.** Dissolve 0.50 g in *water R* and dilute to 10 mL with the same solvent.

**Appearance of solution.** Solution S is clear (2.2.1) and not more intensely coloured than reference solution BY<sub>6</sub> (2.2.2, *Method I*).

**pH** (2.2.3): 4.2 to 5.2.

Dissolve 0.20 g in *carbon dioxide-free water R* and dilute to 20.0 mL with the same solvent.

**Related substances.** Liquid chromatography (2.2.29).

**Test solution.** Dissolve 10.0 mg of the substance to be examined in the mobile phase and dilute to 10.0 mL with the mobile phase.

**Reference solution (a).** Dilute 1.0 mL of the test solution to 100.0 mL with the mobile phase. Dilute 1.0 mL of this solution to 10.0 mL with the mobile phase.

**Reference solution (b).** Dissolve 10.0 mg of *articaine impurity A CRS* and 5.0 mg of *articaine impurity E CRS* in the mobile phase and dilute to 100.0 mL with the mobile phase.

**Reference solution (c).** Add 1.0 mL of reference solution (b) to 50.0 mg of *articaine hydrochloride CRS* and dilute to 50 mL with the mobile phase.

**Reference solution (d).** Dilute 1.0 mL of reference solution (b) to 50.0 mL with the mobile phase.

**Column:**

- **size:**  $l = 0.25$  m,  $\varnothing = 4.6$  mm,
- **stationary phase:** spherical *end-capped octadecylsilyl silica gel for chromatography R* (5  $\mu\text{m}$ ) with a specific surface area of 335  $\text{m}^2/\text{g}$  and a carbon loading of 19 per cent,

– temperature: 45 °C.

**Mobile phase:** mix 25 volumes of acetonitrile *R* and 75 volumes of a solution prepared as follows: dissolve 2.02 g of sodium heptanesulfonate *R* and 4.08 g of potassium dihydrogen phosphate *R* in water *R* and dilute to 1000 mL with the same solvent. Adjust to pH 2.0 with phosphoric acid *R*.

**Flow rate:** 1 mL/min.

**Detection:** spectrophotometer at 276 nm.

**Injection:** 10 µL; inject the test solution and reference solutions (a), (c) and (d).

**Run time:** 5 times the retention time of artocaine.

**Relative retentions** with reference to artocaine (retention time = about 9.3 min): impurity B = about 0.6; impurity D = about 0.7; impurity A = about 0.8; impurity E = about 0.86; impurity F = about 0.9; impurity G = about 1.7; impurity H = about 2.1; impurity I = about 2.6; impurity C = about 3.6; impurity J = about 4.0.

**System suitability:** reference solution (c):

– resolution: minimum 1.2 between the peaks due to impurity A and impurity E.

**Limits:**

- impurity A: not more than the area of the corresponding peak in the chromatogram obtained with reference solution (d) (0.2 per cent),
- any other impurity: not more than the area of the principal peak in the chromatogram obtained with reference solution (a) (0.1 per cent),
- total of other impurities: not more than 5 times the area of the principal peak in the chromatogram obtained with reference solution (a) (0.5 per cent),
- disregard limit: half the area of the principal peak in the chromatogram obtained with reference solution (a) (0.05 per cent).

**Heavy metals** (2.4.8): maximum 5 ppm.

Dissolve 4.0 g in 20.0 mL of water *R*. 12 mL of the solution complies with test A. Prepare the reference standard using lead standard solution (1 ppm Pb) *R*.

**Loss on drying** (2.2.32): maximum 0.5 per cent, determined on 1.000 g by drying in an oven at 105 °C for 5 h.

**Sulfated ash** (2.4.14): maximum 0.1 per cent, determined on 1.0 g.

#### ASSAY

Dissolve 0.250 g in a mixture of 5.0 mL of 0.01 M hydrochloric acid and 50 mL of alcohol *R*. Carry out a potentiometric titration (2.2.20) using 0.1 M sodium hydroxide. Read the volume added between the 2 points of inflexion.

1 mL of 0.1 M sodium hydroxide is equivalent to 32.08 mg of C<sub>13</sub>H<sub>21</sub>ClN<sub>2</sub>O<sub>3</sub>S.

#### STORAGE

Protected from light.

#### IMPURITIES

**Specified impurities:** A, B, C.

**Other detectable impurities** (the following substances would, if present at a sufficient level, be detected by one or other of the tests in the monograph. They are limited by the general acceptance criterion for other/unspecified impurities and/or by the general monograph *Substances for pharmaceutical use* (2034). It is therefore not necessary to identify these impurities for demonstration of compliance. See also 5.10. *Control of impurities in substances for pharmaceutical use*): D, E, F, G, H, I, J.

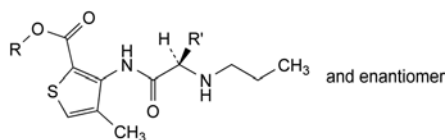

- A. R = CH<sub>3</sub>, R' = H: methyl 3-[[2-(propylamino)acetyl]amino]-4-methylthiophene-2-carboxylate (acetamidoartocaine),
- B. R = H, R' = CH<sub>3</sub>: 4-methyl-3-[[2-(propylamino)propanoyl]amino]thiophene-2-carboxylic acid (artocaine acid),
- C. R = CH(CH<sub>3</sub>)<sub>2</sub>, R' = CH<sub>3</sub>: 1-methylethyl 4-methyl-3-[[2-(propylamino)propanoyl]amino]thiophene-2-carboxylate (artocaine isopropyl ester),

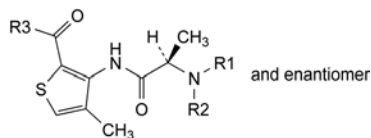

- D. R<sub>1</sub> = CH<sub>2</sub>-CH<sub>3</sub>, R<sub>2</sub> = H, R<sub>3</sub> = OCH<sub>3</sub>: methyl 3-[[2-(ethylamino)propanoyl]amino]-4-methylthiophene-2-carboxylate (ethylartocaine),
- E. R<sub>1</sub> = CH(CH<sub>3</sub>)<sub>2</sub>, R<sub>2</sub> = H, R<sub>3</sub> = OCH<sub>3</sub>: methyl 4-methyl-3-[[2-(1-methylethyl)amino]propanoyl]amino]thiophene-2-carboxylate (isopropylartocaine),
- F. R<sub>1</sub> = CH<sub>2</sub>-CH<sub>2</sub>-CH<sub>3</sub>, R<sub>2</sub> = H, R<sub>3</sub> = NH-CH<sub>2</sub>-CH<sub>2</sub>-CH<sub>3</sub>: 4-methyl-N-propyl-3-[[2-(propylamino)propanoyl]amino]thiophene-2-carboxamide (artocaine acid propionamide),
- G. R<sub>1</sub> = (CH<sub>2</sub>)<sub>3</sub>-CH<sub>3</sub>, R<sub>2</sub> = H, R<sub>3</sub> = OCH<sub>3</sub>: methyl 3-[[2-(butylamino)propanoyl]amino]-4-methylthiophene-2-carboxylate (butylartocaine),
- H. R<sub>1</sub> = R<sub>2</sub> = CH<sub>2</sub>-CH<sub>2</sub>-CH<sub>3</sub>, R<sub>3</sub> = OCH<sub>3</sub>: methyl 3-[[2-(dipropylamino)propanoyl]amino]-4-methylthiophene-2-carboxylate (dipropylartocaine),

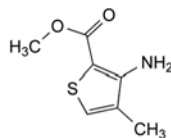

- I. methyl 3-amino-4-methylthiophene-2-carboxylate (3-aminoartocaine),

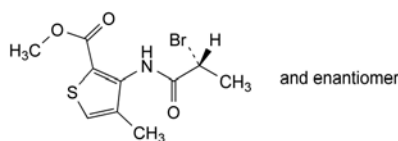

- J. methyl 3-[[2-(2-bromopropanoyl)amino]-4-methylthiophene-2-carboxylate (bromo compound).

01/2011:0253

## ASCORBIC ACID

### Acidum ascorbicum

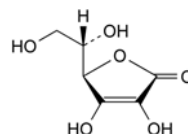

C<sub>6</sub>H<sub>8</sub>O<sub>6</sub>  
[50-81-7]

M<sub>r</sub> 176.1

#### DEFINITION

(5*R*)-5-[(1*S*)-1,2-Dihydroxyethyl]-3,4-dihydroxyfuran-2(5*H*)-one.

**Content:** 99.0 per cent to 100.5 per cent.

## CHARACTERS

**Appearance:** white or almost white, crystalline powder or colourless crystals, becoming discoloured on exposure to air and moisture.

**Solubility:** freely soluble in water, sparingly soluble in ethanol (96 per cent).

mp: about 190 °C, with decomposition.

## IDENTIFICATION

**First identification:** B, C.

**Second identification:** A, C, D.

A. Ultraviolet and visible absorption spectrophotometry (2.2.25).

**Test solution.** Dissolve 0.10 g in *water R* and dilute immediately to 100.0 mL with the same solvent. Add 1.0 mL of this solution to 10 mL of 0.1 M hydrochloric acid and dilute to 100.0 mL with *water R*.

**Absorption maximum:** at 243 nm, determined immediately after dissolution.

**Specific absorbance at the absorption maximum:** 545 to 585.

B. Infrared absorption spectrophotometry (2.2.24).

**Comparison:** ascorbic acid CRS.

C. pH (2.2.3): 2.1 to 2.6 for solution S (see Tests).

D. To 1 mL of solution S add 0.2 mL of dilute nitric acid *R* and 0.2 mL of silver nitrate solution *R2*. A grey precipitate is formed.

## TESTS

**Solution S.** Dissolve 1.0 g in carbon dioxide-free water *R* and dilute to 20 mL with the same solvent.

**Appearance of solution.** Solution S is clear (2.2.1) and not more intensely coloured than reference solution BY<sub>7</sub> (2.2.2, Method II).

**Specific optical rotation** (2.2.7): + 20.5 to + 21.5.

Dissolve 2.50 g in *water R* and dilute to 25.0 mL with the same solvent.

**Impurity E:** maximum 0.2 per cent.

**Test solution.** Dissolve 0.25 g in 5 mL of *water R*. Neutralise using dilute sodium hydroxide solution *R* and add 1 mL of dilute acetic acid *R* and 0.5 mL of calcium chloride solution *R*.

**Reference solution.** Dissolve 70 mg of oxalic acid *R* in *water R* and dilute to 500 mL with the same solvent; to 5 mL of this solution add 1 mL of dilute acetic acid *R* and 0.5 mL of calcium chloride solution *R*.

Allow the solutions to stand for 1 h. Any opalescence in the test solution is not more intense than that in the reference solution.

**Related substances.** Liquid chromatography (2.2.29). Prepare the solutions immediately before use.

**Phosphate buffer solution.** Dissolve 6.8 g of potassium dihydrogen phosphate *R* in *water R* and dilute to about 175 mL with the same solvent. Filter through a membrane filter (nominal pore size 0.45 µm) and dilute to 1000 mL with *water R*.

**Test solution.** Dissolve 0.500 g of the substance to be examined in the mobile phase and dilute to 10.0 mL with the mobile phase.

**Reference solution (a).** Dissolve 10.0 mg of ascorbic acid impurity C CRS in the mobile phase and dilute to 5.0 mL with the mobile phase.

**Reference solution (b).** Dissolve 5.0 mg of ascorbic acid impurity D CRS and 5.0 mg of ascorbic acid CRS in the mobile phase, add 2.5 mL of reference solution (a) and dilute to 100.0 mL with the mobile phase.

**Reference solution (c).** Dilute 1.0 mL of the test solution to 200.0 mL with the mobile phase. Mix 1.0 mL of this solution with 1.0 mL of reference solution (a).

**Column:**

– size:  $l = 0.25$  m,  $\varnothing = 4.6$  mm;

– stationary phase: aminopropylsilyl silica gel for chromatography *R* (5 µm);

– temperature: 45 °C.

**Mobile phase:** phosphate buffer solution, acetonitrile *R1* (25:75 V/V).

**Flow rate:** 1.0 mL/min.

**Detection:** spectrophotometer at 210 nm.

**Injection:** 20 µL of the test solution and reference solutions (b) and (c).

**Run time:** 2.5 times the retention time of ascorbic acid.

**Identification of impurities:** use the chromatogram obtained with reference solution (b) to identify the peaks due to impurities C and D.

**Relative retention** with reference to ascorbic acid (retention time = about 11 min): impurity D = about 0.4; impurity C = about 1.7.

**System suitability:**

– resolution: minimum 3.0 between the peaks due to ascorbic acid and impurity C in the chromatogram obtained with reference solution (c);

– signal-to-noise ratio: minimum 20 for the peak due to impurity C in the chromatogram obtained with reference solution (b).

**Limits:**

– impurities C, D: for each impurity, not more than 1.5 times the area of the corresponding peak in the chromatogram obtained with reference solution (b) (0.15 per cent);

– unspecified impurities: for each impurity, not more than the area of the peak due to ascorbic acid in the chromatogram obtained with reference solution (b) (0.10 per cent);

– total of impurities other than C and D: not more than twice the area of the peak due to ascorbic acid in the chromatogram obtained with reference solution (b) (0.2 per cent);

– disregard limit: 0.5 times the area of the peak due to ascorbic acid in the chromatogram obtained with reference solution (b) (0.05 per cent).

**Copper:** maximum 5 ppm.

Atomic absorption spectrometry (2.2.23, Method I).

**Test solution.** Dissolve 2.0 g in 0.1 M nitric acid and dilute to 25.0 mL with the same acid.

**Reference solutions.** Prepare the reference solutions (0.2 ppm, 0.4 ppm and 0.6 ppm) by diluting copper standard solution (10 ppm Cu) *R* with 0.1 M nitric acid.

**Source:** copper hollow-cathode lamp.

**Wavelength:** 324.8 nm.

**Atomisation device:** air-acetylene flame.

Adjust the zero of the apparatus using 0.1 M nitric acid.

**Iron:** maximum 2 ppm.

Atomic absorption spectrometry (2.2.23, Method I).

**Test solution.** Dissolve 5.0 g in 0.1 M nitric acid and dilute to 25.0 mL with the same acid.

**Reference solutions.** Prepare the reference solutions (0.2 ppm, 0.4 ppm and 0.6 ppm) by diluting iron standard solution (20 ppm Fe) *R* with 0.1 M nitric acid.

**Source:** iron hollow-cathode lamp.

**Wavelength:** 248.3 nm.

**Atomisation device:** air-acetylene flame.

Adjust the zero of the apparatus using 0.1 M nitric acid.

**Heavy metals** (2.4.8): maximum 10 ppm.

Dissolve 2.0 g in *water R* and dilute to 20 mL with the same solvent. 12 mL of the solution complies with test A. Prepare the reference solution using lead standard solution (1 ppm Pb) *R*.

**Sulfated ash** (2.4.14): maximum 0.1 per cent, determined on 1.0 g.

## ASSAY

01/2008:0807  
corrected 7.0

Dissolve 0.150 g in a mixture of 10 mL of *dilute sulfuric acid R* and 80 mL of *carbon dioxide-free water R*. Add 1 mL of *starch solution R*. Titrate with 0.05 M *iodine* until a persistent violet-blue colour is obtained.

1 mL of 0.05 M *iodine* is equivalent to 8.81 mg of C<sub>6</sub>H<sub>8</sub>O<sub>6</sub>.

## STORAGE

In a non-metallic container, protected from light.

## IMPURITIES

*Specified impurities: C, D, E.*

*Other detectable impurities* (the following substances would, if present at a sufficient level, be detected by one or other of the tests in the monograph. They are limited by the general acceptance criterion for other/unspecified impurities and/or by the general monograph *Substances for pharmaceutical use (2034)*. It is therefore not necessary to identify these impurities for demonstration of compliance. See also 5.10. *Control of impurities in substances for pharmaceutical use*): A, F, G, H.

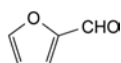

A. 2-furaldehyde,

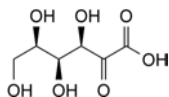

C. D-*xylulose*-5-phosphate (D-sorbosonic acid),

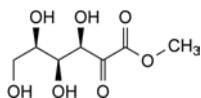

D. methyl D-*xylulose*-5-phosphate (methyl D-sorbosonate),

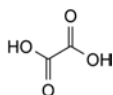

E. oxalic acid,

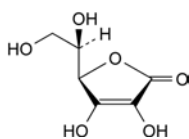

F. (5*R*)-5-[(1*R*)-1,2-dihydroxyethyl]-3,4-dihydroxyfuran-2(5*H*)-one,

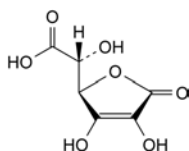

G. (2*R*)-2-[(2*R*)-3,4-dihydroxy-5-oxo-2,5-dihydrofuran-2-yl]-2-hydroxyacetic acid,

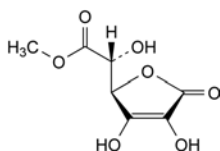

H. methyl (2*R*)-2-[(2*R*)-3,4-dihydroxy-5-oxo-2,5-dihydrofuran-2-yl]-2-hydroxyacetate.

## ASCORBYL PALMITATE

Ascorbylis palmitas

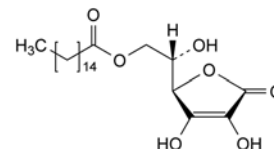

C<sub>22</sub>H<sub>38</sub>O<sub>7</sub>  
[137-66-6]

*M*<sub>r</sub> 414.5

## DEFINITION

(2*S*)-2-[(2*R*)-3,4-Dihydroxy-5-oxo-2,5-dihydrofuran-2-yl]-2-hydroxyethyl hexadecanoate.

*Content*: 98.0 per cent to 100.5 per cent (dried substance).

## CHARACTERS

*Appearance*: white or yellowish-white powder.

*Solubility*: practically insoluble in water, freely soluble in ethanol (96 per cent) and in methanol, practically insoluble in methylene chloride and in fatty oils.

## IDENTIFICATION

A. Specific optical rotation (see Tests).

B. Infrared absorption spectrophotometry (2.2.24).

*Comparison*: ascorbyl palmitate CRS.

C. Dissolve about 10 mg in 5 mL of *methanol R*. The solution decolourises *dichlorophenolindophenol standard solution R*.

## TESTS

**Solution S.** Dissolve 2.50 g in *methanol R* and dilute to 25.0 mL with the same solvent.

**Appearance of solution.** Solution S is clear (2.2.1) and not more intensely coloured than reference solution BY<sub>4</sub> (2.2.2, *Method I*).

**Specific optical rotation** (2.2.7): + 21 to + 24 (dried substance), determined on solution S.

**Related substances.** The thresholds indicated under Related substances (Table 2034.-1) in the general monograph *Substances for pharmaceutical use (2034)* do not apply.

**Heavy metals** (2.4.8): maximum 10 ppm.

2.0 g complies with test C. Prepare the reference solution using 2 mL of *lead standard solution (10 ppm Pb) R*.

**Loss on drying** (2.2.32): maximum 1.0 per cent, determined on 1.000 g by drying *in vacuo* at 60 °C for 5 h.

**Sulfated ash** (2.4.14): maximum 0.1 per cent, determined on 1.0 g.

## ASSAY

Dissolve 0.160 g in 50 mL of *methanol R*. Add 30 mL of *water R* and 1 mL of *starch solution R*. Titrate with 0.05 M *iodine* until a persistent violet-blue colour is obtained.

1 mL of 0.05 M *iodine* is equivalent to 20.73 mg of C<sub>22</sub>H<sub>38</sub>O<sub>7</sub>.

## STORAGE

In an airtight container, protected from light.

**07/2010:2086** *Detection:* spray with *ninhydrin solution R* and heat at 110 °C for 10 min.

## ASPARAGINE MONOHYDRATE

### Asparaginum monohydricum

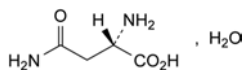

$C_4H_8N_2O_3 \cdot H_2O$   
[5794-13-8]

$M_r$  150.1

#### DEFINITION

(2S)-2,4-Diamino-4-oxobutanoic acid monohydrate.

*Content:* 99.0 per cent to 101.0 per cent (dried substance).

#### CHARACTERS

*Appearance:* white or almost white, crystalline powder or colourless crystals.

*Solubility:* slightly soluble in water, practically insoluble in ethanol (96 per cent) and in methylene chloride.

#### IDENTIFICATION

*First identification:* A, B.

*Second identification:* A, C.

A. Specific optical rotation (see Tests).

B. Infrared absorption spectrophotometry (2.2.24).

*Comparison:* asparagine monohydrate CRS.

C. Examine the chromatograms obtained in the test for ninhydrin-positive substances.

*Results:* the principal spot in the chromatogram obtained with test solution (b) is similar in position, colour and size to the principal spot in the chromatogram obtained with reference solution (c).

#### TESTS

**Solution S.** Dissolve with heating 2.0 g in *carbon dioxide-free water R* and dilute to 100 mL with the same solvent.

**Appearance of solution.** Solution S is clear (2.2.1) and colourless (2.2.2, *Method II*).

**pH** (2.2.3): 4.0 to 6.0 for solution S.

**Specific optical rotation** (2.2.7): + 33.7 to + 36.0 (dried substance).

Dissolve 2.50 g in a 309.0 g/L solution of *hydrochloric acid R* and dilute to 25.0 mL with the same acid.

**Ninhydrin-positive substances.** Thin-layer chromatography (2.2.27).

*Test solution (a).* Dissolve 0.25 g of the substance to be examined in *water R*, heating to not more than 40 °C, and dilute to 10 mL with the same solvent.

*Test solution (b).* Dilute 1 mL of test solution (a) to 10 mL with *water R*.

*Reference solution (a).* Dilute 1.0 mL of test solution (a) to 200 mL with *water R*.

*Reference solution (b).* Dissolve 25 mg of *glutamic acid R* in *water R*, add 1 mL of test solution (a) and dilute to 10 mL with *water R*.

*Reference solution (c).* Dissolve 25 mg of *asparagine monohydrate CRS* in *water R* and dilute to 10 mL with the same solvent.

*Plate:* TLC silica gel G plate R.

*Mobile phase:* glacial acetic acid R, *water R*, *butanol R* (25:25:50 V/V/V).

*Application:* 5 µL.

*Development:* over half of the plate.

*Drying:* at 110 °C for 15 min.

*System suitability:* reference solution (b):  
– the chromatogram shows 2 clearly separated principal spots.  
*Limit:* test solution (a):  
– *any impurity:* any spot, apart from the principal spot, is not more intense than the principal spot in the chromatogram obtained with reference solution (a) (0.5 per cent).

**Chlorides** (2.4.4): maximum 200 ppm.

Dilute 12.5 mL of solution S to 15 mL with *water R*.

**Sulfates** (2.4.13): maximum 200 ppm.

To 0.75 g add 2.5 mL of *dilute hydrochloric acid R* and dilute to 15 mL with *distilled water R*. Examine after 30 min.

**Ammonium** (2.4.1, *Method B*): maximum 0.1 per cent, determined on 10 mg.

**Iron** (2.4.9): maximum 10 ppm.

Dissolve 1.0 g in *dilute hydrochloric acid R* and dilute to 10 mL with the same acid. Shake 3 times with 10 mL of *methyl isobutyl ketone R1* for 3 min. Wash the combined organic phases with 10 mL of *water R* for 3 min. The aqueous phase complies with the limit test for iron.

**Heavy metals** (2.4.8): maximum 10 ppm.

Dissolve 2.0 g in a mixture of 3 mL of *dilute hydrochloric acid R* and 15 mL of *water R* with gentle warming if necessary. Dilute to 20 mL with *water R*. 12 mL of the solution complies with test A. Prepare the reference solution using *lead standard solution (1 ppm Pb) R*.

**Loss on drying** (2.2.32): 10.5 per cent to 12.5 per cent, determined on 1.000 g by drying in an oven at 130 °C for 3 h.

**Sulfated ash** (2.4.14): maximum 0.1 per cent, determined on 1.0 g.

#### ASSAY

Dissolve 0.110 g in 5 mL of *anhydrous formic acid R*. Add 50 mL of *anhydrous acetic acid R*. Titrate with 0.1 M *perchloric acid*, determining the end-point potentiometrically (2.2.20).

1 mL of 0.1 M *perchloric acid* is equivalent to 13.21 mg of  $C_4H_8N_2O_3$ .

#### IMPURITIES

*Specified impurities:* A, B.

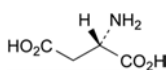

A. (2S)-2-aminobutanedioic acid (aspartic acid),

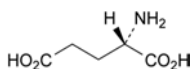

B. (2S)-2-aminopentanedioic acid (glutamic acid).

**01/2008:0973**  
**corrected 6.0**

## ASPARTAME

### Aspartamum

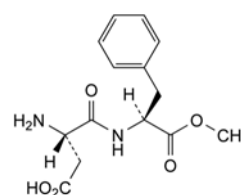

$C_{14}H_{18}N_2O_5$   
[22839-47-0]

$M_r$  294.3

## DEFINITION

(3S)-3-Amino-4-[[[(2S)-1-methoxy-1-oxo-3-phenylpropan-2-yl]amino]-4-oxobutanoic acid (methyl  $\alpha$ -L-aspartyl-L-phenylalaninate).

*Content*: 98.0 per cent to 102.0 per cent (dried substance).

## CHARACTERS

*Appearance*: white or almost white, slightly hygroscopic, crystalline powder.

*Solubility*: sparingly soluble or slightly soluble in water and in ethanol (96 per cent), practically insoluble in hexane and in methylene chloride.

## IDENTIFICATION

*First identification*: B.

*Second identification*: A, C, D.

## A. Ultraviolet and visible absorption spectrophotometry (2.2.25).

*Test solution*. Dissolve 0.1 g in *ethanol (96 per cent) R* and dilute to 100 mL with the same solvent.

*Spectral range*: 230-300 nm.

*Absorption maxima*: at 247 nm, 252 nm, 258 nm and 264 nm.

## B. Infrared absorption spectrophotometry (2.2.24).

*Preparation*: discs.

*Comparison*: *aspartame CRS*.

## C. Thin-layer chromatography (2.2.27).

*Test solution*. Dissolve 15 mg of the substance to be examined in 2.5 mL of *water R* and dilute to 10 mL with *acetic acid R*.

*Reference solution*. Dissolve 15 mg of *aspartame CRS* in 2.5 mL of *water R* and dilute to 10 mL with *acetic acid R*.

*Plate*: *TLC silica gel G plate R*.

*Mobile phase*: *water R*, *anhydrous formic acid R*, *methanol R*, *methylene chloride R* (2:4:30:64 V/V/V/V).

*Application*: 20  $\mu$ L.

*Development*: over a path of 15 cm.

*Drying*: in air.

*Detection*: spray with *ninhydrin solution R* and heat at 100-105 °C for 15 min.

*Results*: the spot in the chromatogram obtained with the test solution is similar in position, colour and size to the spot in the chromatogram obtained with the reference solution.

D. Dissolve about 20 mg in 5 mL of *methanol R* and add 1 mL of *alkaline hydroxylamine solution R1*. Heat on a water-bath for 15 min. Allow to cool and adjust to about pH 2 with *dilute hydrochloric acid R*. Add 0.1 mL of *ferric chloride solution R1*. A brownish-red colour is produced.

## TESTS

**Solution S**. Dissolve 0.8 g in *carbon dioxide-free water R* and dilute to 100 mL with the same solvent.

**Appearance of solution**. Solution S is clear (2.2.1) and not more intensely coloured than reference solution GY<sub>6</sub> (2.2.2, Method II).

**Conductivity** (2.2.38): maximum 30  $\mu$ S $\cdot$ cm<sup>-1</sup>.

Dissolve 0.80 g in *carbon dioxide-free water R* prepared from *distilled water R* and dilute to 100.0 mL with the same solvent. Measure the conductivity of the solution (C<sub>1</sub>) and that of the water used for preparing the solution (C<sub>2</sub>). The readings must be stable within 1 per cent over a period of 30 s. Calculate the conductivity of the solution of the substance to be examined using the following expression:

$$C_1 - 0.992 C_2$$

**Specific optical rotation** (2.2.7): + 14.5 to + 16.5 (dried substance).

Dissolve 2.00 g in a 690 g/L solution of *anhydrous formic acid R* and dilute to 50.0 mL with the same solution. Measure within 30 min of preparation.

**Related substances**. Liquid chromatography (2.2.29).

*Test solution*. Dissolve 0.60 g of the substance to be examined in a mixture of 1.5 volumes of *glacial acetic acid R* and 98.5 volumes of *water R* and dilute to 100.0 mL with the same mixture of solvents.

*Reference solution (a)*. Dissolve 4.5 mg of *aspartame impurity A CRS* in a mixture of 1.5 volumes of *glacial acetic acid R* and 98.5 volumes of *water R* and dilute to 50.0 mL with the same mixture of solvents.

*Reference solution (b)*. Dissolve 30.0 mg of *phenylalanine R* (impurity C) in a mixture of 15 volumes of *glacial acetic acid R* and 85 volumes of *water R* and dilute to 100.0 mL with the same mixture of solvents. Dilute 1.0 mL of this solution to 10.0 mL with *water R*.

*Reference solution (c)*. Dilute 5.0 mL of the test solution to 10.0 mL with *water R*. Dilute 3.0 mL of this solution to 100.0 mL with *water R*.

*Reference solution (d)*. Dissolve 30.0 mg of *L-aspartyl-L-phenylalanine R* (impurity B) in a mixture of 15 volumes of *glacial acetic acid R* and 85 volumes of *water R* and dilute to 100.0 mL with the same mixture of solvents. Dilute 1.0 mL of the solution to 10.0 mL with *water R*. Mix 1.0 mL of this solution with 1.0 mL of reference solution (b).

## Column

– *size*:  $l = 0.25$  m,  $\varnothing = 4.0$  mm;

– *stationary phase*: *octadecylsilyl silica gel for chromatography R* (5-10  $\mu$ m).

*Mobile phase*: mix 10 volumes of *acetonitrile R* and 90 volumes of a 6.8 g/L solution of *potassium dihydrogen phosphate R* previously adjusted to pH 3.7 with *phosphoric acid R*.

*Flow rate*: 1 mL/min.

*Detection*: spectrophotometer at 220 nm.

*Injection*: 20  $\mu$ L.

*Run time*: twice the retention time of *aspartame*.

*System suitability*: reference solution (d):

– *resolution*: minimum 3.5 between the peaks due to impurities B and C.

## Limits:

– *impurity A*: not more than the area of the principal peak in the chromatogram obtained with reference solution (a) (1.5 per cent);

– *impurity C*: not more than the area of the principal peak in the chromatogram obtained with reference solution (b) (0.5 per cent);

– *sum of impurities other than A and C*: not more than the area of the principal peak in the chromatogram obtained with reference solution (c) (1.5 per cent);

– *disregard limit*: disregard any peak due to the solvent.

**Heavy metals** (2.4.8): maximum 10 ppm.

1.0 g complies with test C. Prepare the reference solution using 1 mL of *lead standard solution (10 ppm Pb) R*.

**Loss on drying** (2.2.32): maximum 4.5 per cent, determined on 1.000 g by drying in an oven at 105 °C.

**Sulfated ash** (2.4.14): maximum 0.2 per cent, determined on 1.0 g.

## ASSAY

Dissolve 0.250 g in 1.5 mL of *anhydrous formic acid R* and 60 mL of *anhydrous acetic acid R*. Titrate immediately with 0.1 M *perchloric acid*, determining the end-point potentiometrically (2.2.20).

1 mL of 0.1 M perchloric acid is equivalent to 29.43 mg of  $C_{14}H_{18}N_2O_5$ .

#### STORAGE

In an airtight container.

#### IMPURITIES

Specified impurities: A, C.

Other detectable impurities (the following substances would, if present at a sufficient level, be detected by one or other of the tests in the monograph. They are limited by the general acceptance criterion for other/unspecified impurities and/or by the general monograph *Substances for pharmaceutical use* (2034). It is therefore not necessary to identify these impurities for demonstration of compliance. See also 5.10. *Control of impurities in substances for pharmaceutical use*): B.

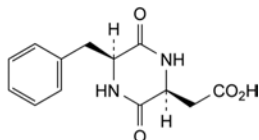

A. 2-[(2S,5S)-5-benzyl-3,6-dioxopiperazin-2-yl]acetic acid,

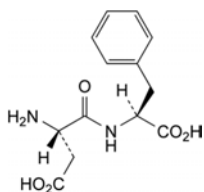

B. (3S)-3-amino-4-[[[(1S)-1-carboxy-2-phenylethyl]amino]-4-oxobutanoic acid ( $\alpha$ -L-aspartyl-L-phenylalanine),

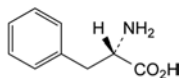

C. (2S)-2-amino-3-phenylpropanoic acid (L-phenylalanine).

01/2008:0797  
corrected 6.0

## ASPARTIC ACID

### Acidum asparticum

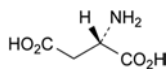

$C_4H_7NO_4$   
[56-84-8]

$M_r$  133.1

#### DEFINITION

Aspartic acid contains not less than 98.5 per cent and not more than the equivalent of 101.5 per cent of (2S)-2-aminobutanedioic acid, calculated with reference to the dried substance.

#### CHARACTERS

A white or almost white, crystalline powder or colourless crystals, slightly soluble in water, practically insoluble in alcohol. It dissolves in dilute mineral acids and in dilute solutions of alkali hydroxides.

#### IDENTIFICATION

First identification: A, C.

Second identification: A, B, D.

A. Specific optical rotation (see Tests).

B. A suspension of 1 g in 10 mL of water R is strongly acid (2.2.4).

C. Examine by infrared absorption spectrophotometry (2.2.24), comparing with the spectrum obtained with *aspartic acid CRS*. Examine the substances prepared as discs.

D. Examine the chromatograms obtained in the test for ninhydrin-positive substances. The principal spot in the chromatogram obtained with test solution (b) is similar in position, colour and size to the principal spot in the chromatogram obtained with reference solution (a).

#### TESTS

**Appearance of solution.** Dissolve 0.5 g in 1 M hydrochloric acid and dilute to 10 mL with the same acid. The solution is clear (2.2.1) and not more intensely coloured than reference solution BY<sub>6</sub> (2.2.2, Method II).

**Specific optical rotation** (2.2.7). Dissolve 2.000 g in hydrochloric acid R1 and dilute to 25.0 mL with the same acid. The specific optical rotation is + 24.0 to + 26.0, calculated with reference to the dried substance.

**Ninhydrin-positive substances.** Examine by thin-layer chromatography (2.2.27), using a TLC silica gel plate R.

*Test solution (a).* Dissolve 0.10 g of the substance to be examined in 2 mL of ammonia R and dilute to 10 mL with water R.

*Test solution (b).* Dilute 1 mL of test solution (a) to 50 mL with water R.

*Reference solution (a).* Dissolve 10 mg of *aspartic acid CRS* in 2 mL of dilute ammonia R1 and dilute to 50 mL with water R.

*Reference solution (b).* Dilute 5 mL of test solution (b) to 20 mL with water R.

*Reference solution (c).* Dissolve 10 mg of *aspartic acid CRS* and 10 mg of *glutamic acid CRS* in 2 mL of dilute ammonia R1 and dilute to 25 mL with water R.

Apply separately to the plate 5  $\mu$ L of each solution. Allow the plate to dry in air. Develop over a path of 15 cm using a mixture of 20 volumes of glacial acetic acid R, 20 volumes of water R and 60 volumes of butanol R. Allow the plate to dry in air, spray with ninhydrin solution R. Heat at 100-105 °C for 15 min. Any spot in the chromatogram obtained with test solution (a), apart from the principal spot, is not more intense than the spot in the chromatogram obtained with reference solution (b) (0.5 per cent). The test is not valid unless the chromatogram obtained with reference solution (c) shows 2 clearly separated principal spots.

**Chlorides** (2.4.4). Dissolve 0.25 g in 3 mL of dilute nitric acid R and dilute to 15 mL with water R. The solution, to which 1 mL of water R is added instead of dilute nitric acid R, complies with the limit test for chlorides (200 ppm).

**Sulfates** (2.4.13). Dissolve 0.5 g in 4 mL of hydrochloric acid R and dilute to 15 mL with distilled water R. The solution complies with the limit test for sulfates (300 ppm). Carry out the evaluation of the test after 30 min.

**Ammonium.**(2.4.1) 50 mg complies with limit test B (200 ppm). Prepare the standard using 0.1 mL of ammonium standard solution (100 ppm  $NH_4$ ) R.

**Iron** (2.4.9). In a separating funnel, dissolve 1.0 g in 10 mL of dilute hydrochloric acid R. Shake with 3 quantities, each of 10 mL, of methyl isobutyl ketone R1, shaking for 3 min each time. To the combined organic layers add 10 mL of water R and shake for 3 min. The aqueous layer complies with the limit test for iron (10 ppm).

**Heavy metals** (2.4.8). 2.0 g complies with limit test D (10 ppm). Prepare the standard using 2 mL of lead standard solution (10 ppm Pb) R.

**Loss on drying** (2.2.32). Not more than 0.5 per cent, determined on 1.000 g by drying in an oven at 105 °C.

**Sulfated ash** (2.4.14). Not more than 0.1 per cent, determined on 1.0 g.



## ASSAY

Dissolve 0.100 g in 50 mL of *carbon dioxide-free water R*, with slight heating if necessary. Cool and add 0.1 mL of *bromothymol blue solution R1*. Titrate with 0.1 M *sodium hydroxide* until the colour changes from yellow to blue.

1 mL of 0.1 M *sodium hydroxide* is equivalent to 13.31 mg of  $C_{14}H_{22}NO_3$ .

## STORAGE

Protected from light.

04/2009:0703

## ATENOLOL

## Atenololum

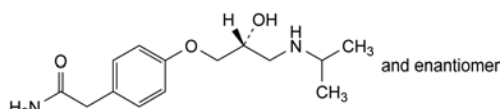

$C_{14}H_{22}N_2O_3$   
[29122-68-7]

$M_r$  266.3

## DEFINITION

2-[4-[(2*RS*)-2-Hydroxy-3-[(1-methylethyl)amino]propoxy]-phenyl]acetamide.

*Content*: 99.0 per cent to 101.0 per cent (dried substance).

## CHARACTERS

*Appearance*: white or almost white powder.

*Solubility*: sparingly soluble in water, soluble in anhydrous ethanol, slightly soluble in methylene chloride.

## IDENTIFICATION

*First identification*: C.

*Second identification*: A, B, D.

A. Melting point (2.2.14): 152 °C to 155 °C.

B. Ultraviolet and visible absorption spectrophotometry (2.2.25).

*Test solution*. Dissolve 0.100 g in *methanol R* and dilute to 100 mL with the same solvent. Dilute 10.0 mL of this solution to 100 mL with *methanol R*.

*Spectral range*: 230-350 nm.

*Absorption maxima*: at 275 nm and 282 nm.

*Absorbance ratio*:  $A_{275}/A_{282} = 1.15$  to 1.20.

C. Infrared absorption spectrophotometry (2.2.24).

*Comparison*: *atenolol CRS*.

D. Thin-layer chromatography (2.2.27).

*Test solution*. Dissolve 10 mg of the substance to be examined in 1 mL of *methanol R*.

*Reference solution*. Dissolve 10 mg of *atenolol CRS* in 1 mL of *methanol R*.

*Plate*: TLC silanised silica gel  $F_{254}$  plate *R*.

*Mobile phase*: concentrated ammonia *R1*, *methanol R* (1:99 *V/V*).

*Application*: 10 µL.

*Drying*: in air.

*Detection*: examine in ultraviolet light at 254 nm.

*Results*: the principal spot in the chromatogram obtained with the test solution is similar in position and size to the principal spot in the chromatogram obtained with the reference solution.

## TESTS

**Solution S**. Dissolve 0.10 g in *water R* and dilute to 10 mL with the same solvent.

**Appearance of solution**. Solution S is clear (2.2.1) and not more intensely coloured than degree 6 of the range of reference solutions of the most appropriate colour (2.2.2, *Method II*).

**Optical rotation** (2.2.7): + 0.10° to - 0.10°, determined on solution S.

**Related substances**. Liquid chromatography (2.2.29).

*Test solution*. Dissolve 50 mg of the substance to be examined in 20 mL of the mobile phase and dilute to 25.0 mL with the mobile phase.

*Reference solution (a)*. Dissolve 2 mg of *atenolol for system suitability CRS* (containing impurities B, F, G, I and J) in 1.0 mL of the mobile phase.

*Reference solution (b)*. Dilute 1.0 mL of the test solution to 100.0 mL with the mobile phase. Dilute 1.0 mL of this solution to 10.0 mL with the mobile phase.

*Column*:

– *size*:  $l = 0.125$  m,  $\varnothing = 4.0$  mm;

– *stationary phase*: end-capped octadecylsilyl silica gel for chromatography *R* (5 µm).

*Mobile phase*: dissolve 1.0 g of *sodium octanesulfonate R* and 0.4 g of *tetrabutylammonium hydrogen sulfate R* in 1 litre of a mixture of 20 volumes of *tetrahydrofuran R*, 180 volumes of *methanol R2*, and 800 volumes of a 3.4 g/L solution of *potassium dihydrogen phosphate R*; adjust the apparent pH to 3.0 with *phosphoric acid R*.

*Flow rate*: 0.6 mL/min.

*Detection*: spectrophotometer at 226 nm.

*Injection*: 10 µL.

*Run time*: 5 times the retention time of atenolol.

*Identification of impurities*: use the chromatogram supplied with *atenolol for system suitability CRS* and the chromatogram obtained with reference solution (a) to identify the peaks due to impurities B, F, G, I and J.

*Relative retention* with reference to atenolol (retention time = about 8 min): impurity B = about 0.3; impurity J = about 0.7; impurity I = about 0.8; impurity F = about 2.0 (pair of peaks); impurity G = about 3.5.

*System suitability*: reference solution (a):

– *resolution*: minimum 1.4 between the peaks due to impurities J (unidentified impurity) and I.

*Limits*:

– *correction factor*: for the calculation of content, multiply the peak area of impurity I by 1.5;

– *impurity B*: not more than twice the area of the principal peak in the chromatogram obtained with reference solution (b) (0.2 per cent);

– *impurities F, G, I*: for each impurity, not more than 1.5 times the area of the principal peak in the chromatogram obtained with reference solution (b) (0.15 per cent);

– *unspecified impurities*: for each impurity, not more than the area of the principal peak in the chromatogram obtained with reference solution (b) (0.10 per cent);

– *total*: not more than 5 times the area of the principal peak in the chromatogram obtained with reference solution (b) (0.5 per cent);

– *disregard limit*: 0.5 times the area of the principal peak in the chromatogram obtained with reference solution (b) (0.05 per cent).

**Chlorides** (2.4.4): maximum 0.1 per cent.

Dissolve 50 mg in a mixture of 1 mL of *dilute nitric acid R* and 15 mL of *water R*. The solution, without further addition of *dilute nitric acid R*, complies with the test.

**Loss on drying** (2.2.32): maximum 0.5 per cent, determined on 1.000 g by drying in an oven at 105 °C.

**Sulfated ash** (2.4.14): maximum 0.1 per cent, determined on 1.0 g.

## ASSAY

01/2008:1970

Dissolve 0.200 g in 80 mL of *anhydrous acetic acid R*. Titrate with 0.1 M *perchloric acid*, determining the end-point potentiometrically (2.2.20).

1 mL of 0.1 M *perchloric acid* is equivalent to 26.63 mg of  $C_{14}H_{22}N_2O_3$ .

## IMPURITIES

*Specified impurities: B, F, G, I.*

*Other detectable impurities* (the following substances would, if present at a sufficient level, be detected by one or other of the tests in the monograph. They are limited by the general acceptance criterion for other/unspecified impurities and/or by the general monograph *Substances for pharmaceutical use (2034)*. It is therefore not necessary to identify these impurities for demonstration of compliance. See also 5.10. *Control of impurities in substances for pharmaceutical use*): A, D, E, H.

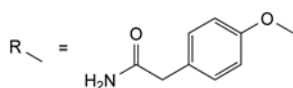

A. R-H: 2-(4-hydroxyphenyl)acetamide,

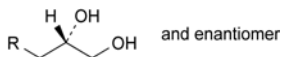

B. 2-[4-[(2*RS*)-2,3-dihydroxypropoxy]phenyl]acetamide,

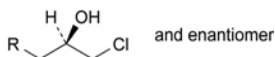

D. 2-[4-[(2*RS*)-3-chloro-2-hydroxypropoxy]phenyl]acetamide,

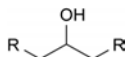

E. 2,2'-[(2-hydroxypropane-1,3-diyl)bis(oxy-4,1-phenylene)]diacetamide,

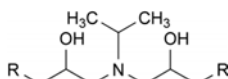

F. 2,2'-[[[(1-methylethyl)imino]bis[(2-hydroxypropane-3,1-diyl)oxy-4,1-phenylene]]diacetamide,

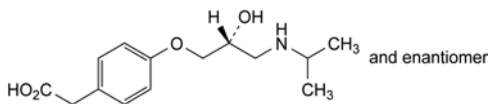

G. 2-[4-[(2*RS*)-2-hydroxy-3-[(1-methylethyl)amino]propoxy]phenyl]acetic acid,

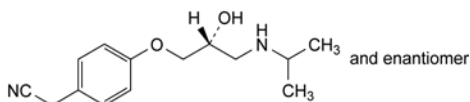

H. 2-[4-[(2*RS*)-2-hydroxy-3-[(1-methylethyl)amino]propoxy]phenyl]acetonitrile,

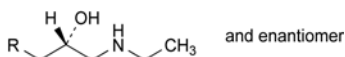

I. 2-[4-[(2*RS*)-3-(ethylamino)-2-hydroxypropoxy]phenyl]acetamide.

## ATRACURIUM BESILATE

## Atracurii besilas

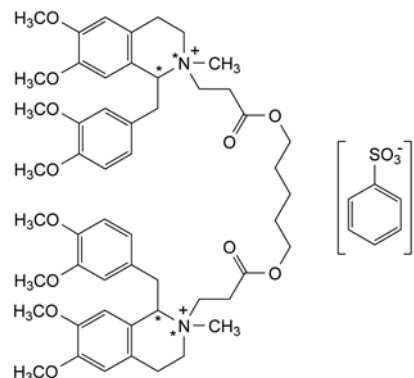

$C_{65}H_{82}N_{10}O_{18}S_2$   
[64228-81-5]

$M_r$  1243

## DEFINITION

Mixture of the *cis-cis*, *cis-trans* and *trans-trans* isomers of 2,2'-[pentane-1,5-diylbis[oxy(3-oxopropane-1,3-diyl)]]bis[1-(3,4-dimethoxybenzyl)-6,7-dimethoxy-2-methyl-1,2,3,4-tetrahydroisoquinolinium] dibenzenesulfonate.

*Content*: 96.0 per cent to 102.0 per cent (anhydrous substance).

## CHARACTERS

*Appearance*: white to yellowish-white powder, slightly hygroscopic.

*Solubility*: soluble in water, very soluble in acetonitrile, in ethanol (96 per cent) and in methylene chloride.

## IDENTIFICATION

A. Infrared absorption spectrophotometry (2.2.24).

*Comparison*: *atracurium besilate CRS*.

B. Examine the chromatograms obtained in the assay.

*Results*: the 3 principal isomeric peaks in the chromatogram obtained with test solution (a) are similar in retention time to those in the chromatogram obtained with reference solution (a).

## TESTS

**Solution S.** Dissolve 1.00 g in *water R* and dilute to 100 mL with the same solvent.

**Appearance of solution.** Solution S is clear (2.2.1) and not more intensely coloured than reference solution Y<sub>7</sub> (2.2.2, *Method II*).

**Related substances.** Liquid chromatography (2.2.29).

*Test solution (a).* Dissolve 50.0 mg of the substance to be examined in mobile phase A and dilute to 50.0 mL with mobile phase A.

*Test solution (b).* Dissolve 0.100 g of the substance to be examined in mobile phase A and dilute to 10.0 mL with mobile phase A.

*Reference solution (a).* Dissolve 50.0 mg of *atracurium besilate CRS* in mobile phase A and dilute to 50.0 mL with mobile phase A.

*Reference solution (b).* Dilute 1.0 mL of test solution (a) to 100.0 mL with mobile phase A.

*Reference solution (c).* Dissolve 20.0 mg of *methyl benzenesulfonate R* in *acetonitrile R* and dilute to 100.0 mL with the same solvent. Dilute 50 µL of the solution to 100.0 mL with mobile phase A.

*Reference solution (d).* Dissolve 2.0 mg of *atracurium for peak identification CRS* (containing impurities A1, A2, B, C1, C2, D1, D2, E, G and K) in 2.0 mL of mobile phase A.

**Reference solution (e).** Dissolve 2.0 mg of *atracurium for impurity F identification CRS* in 2.0 mL of mobile phase A.

**Column:**

- size:  $l = 0.25$  m,  $\varnothing = 4.6$  mm,
- stationary phase: base-deactivated octadecylsilyl silica gel for chromatography R (5  $\mu$ m).

**Mobile phase:**

- mobile phase A: mix 5 volumes of *methanol R*, 20 volumes of *acetonitrile R* and 75 volumes of a 10.2 g/L solution of *potassium dihydrogen phosphate R* previously adjusted to pH 3.1 with *phosphoric acid R*,
- mobile phase B: mix 20 volumes of *acetonitrile R*, 30 volumes of *methanol R* and 50 volumes of a 10.2 g/L solution of *potassium dihydrogen phosphate R* previously adjusted to pH 3.1 with *phosphoric acid R*,

Time (min)	Mobile phase A (per cent V/V)	Mobile phase B (per cent V/V)
0 - 5	80	20
5 - 15	80 → 40	20 → 60
15 - 25	40	60
25 - 30	40 → 0	60 → 100
30 - 45	0	100
45 - 50	0 → 80	100 → 20

**Flow rate:** 1 mL/min.

**Detection:** spectrophotometer at 280 nm.

**Injection:** 20  $\mu$ L of test solution (a) and reference solutions (a), (b), (d) and (e).

**Relative retention** with reference to the *atracurium cis-cis* isomer (retention time = about 30 min): impurity E = about 0.2; impurity F = about 0.25; impurity G = about 0.3; impurity D1 = about 0.45; impurity D2 = about 0.5; *atracurium trans-trans* isomer = about 0.8; *atracurium cis-trans* isomer = about 0.9; impurity A1 = about 1.04; impurity I1 = about 1.07; impurity H1 = about 1.07 (shoulder on the front of peak A2); impurity A2 (major isomer) = about 1.08; impurity K1 = about 1.09 (shoulder on the tail of peak A2); impurity I2 (major isomer) = about 1.12; impurity H2 (major isomer) = about 1.12; impurity K2 (major isomer) = about 1.12; impurity B = about 1.15; impurity C1 = about 1.2; impurity C2 (major isomer) = about 1.3.

**Identification of impurities:**

- use the chromatogram obtained with reference solution (d) and the chromatogram supplied with *atracurium for peak identification CRS* to identify the peaks due to impurities A1, A2, B, C1, C2, D1, D2, E, G and K;
- use the chromatogram obtained with reference solution (e) and the chromatogram supplied with *atracurium for impurity F identification CRS* to identify the peak due to impurity F.

**System suitability:** reference solution (a):

- resolution: minimum 1.5 between the peaks due to the *atracurium trans-trans* isomer and the *atracurium cis-trans* isomer, and minimum 1.5 between the peaks due to the *atracurium cis-trans* isomer and the *atracurium cis-cis* isomer.

**Limits:**

- correction factor: for the calculation of content, multiply the peak area of impurity G by 0.5,
- impurity E: not more than 1.5 times the sum of the areas of the peaks due to the *atracurium cis-cis*, *trans-trans* and *cis-trans* isomers in the chromatogram obtained with reference solution (b) (1.5 per cent),

- impurities A, D: for each impurity, for the sum of the areas of the 2 isomer peaks, not more than 1.5 times the sum of the areas of the peaks due to the *atracurium cis-cis*, *trans-trans* and *cis-trans* isomers in the chromatogram obtained with reference solution (b) (1.5 per cent),
- impurity C: for the sum of the areas of the 2 isomer peaks, not more than the sum of the areas of the peaks due to the *atracurium cis-cis*, *trans-trans* and *cis-trans* isomers in the chromatogram obtained with reference solution (b) (1.0 per cent),
- impurities F, G: for each impurity, not more than the sum of the areas of the peaks due to the *atracurium cis-cis*, *trans-trans* and *cis-trans* isomers in the chromatogram obtained with reference solution (b) (1.0 per cent),
- impurities H, I, K: for the sum of the areas of the isomer peaks of these impurities, not more than the sum of the areas of the peaks due to the *atracurium cis-cis*, *trans-trans* and *cis-trans* isomers in the chromatogram obtained with reference solution (b) (1.0 per cent),
- any other impurity: for each impurity, not more than 0.1 times the sum of the areas of the peaks due to the *atracurium cis-cis*, *trans-trans* and *cis-trans* isomers in the chromatogram obtained with reference solution (b) (0.1 per cent),
- total: not more than 3.5 times the sum of the areas of the peaks due to the *atracurium cis-cis*, *trans-trans* and *cis-trans* isomers in the chromatogram obtained with reference solution (b) (3.5 per cent),
- disregard limit: 0.05 times the sum of the areas of the peaks due to the *atracurium cis-cis*, *trans-trans* and *cis-trans* isomers in the chromatogram obtained with reference solution (b) (0.05 per cent).

**Impurity J.** Liquid chromatography (2.2.29) as described in the test for related substances with the following modifications.

**Mobile phase:**

Time (min)	Mobile phase A (per cent V/V)	Mobile phase B (per cent V/V)
0 - 5	80	20
5 - 15	80 → 75	20 → 25
15 - 25	75	25
25 - 30	75 → 55	25 → 45
30 - 38	55 → 0	45 → 100
38 - 45	0	100
45 - 50	0 → 80	100 → 20

**Detection:** spectrophotometer at 217 nm.

**Injection:** 100  $\mu$ L of test solution (b) and reference solution (c).

**Retention time:** impurity J = about 25 min; *atracurium trans-trans* isomer = about 38 min.

**Limit:**

- impurity J: not more than the area of the principal peak in the chromatogram obtained with reference solution (c) (10 ppm).

**Isomer composition.** Liquid chromatography (2.2.29) as described in the test for related substances with the following modifications. Use the normalisation procedure.

**Injection:** test solution (a).

**Limits:**

- *atracurium cis-cis* isomer: 55.0 per cent to 60.0 per cent,
- *atracurium cis-trans* isomer: 34.5 per cent to 38.5 per cent,
- *atracurium trans-trans* isomer: 5.0 per cent to 6.5 per cent.

**Water (2.5.12):** maximum 5.0 per cent, determined on 1.000 g.

**Sulfated ash (2.4.14):** maximum 0.1 per cent, determined on 1.0 g.

## ASSAY

Liquid chromatography (2.2.29) as described in the test for related substances with the following modification.

*Injection*: test solution (a) and reference solution (a).

Calculate the percentage content of  $C_{65}H_{82}N_2O_{18}S_2$  from the sum of the areas of the peaks due to the 3 isomers in test solution (a) and reference solution (a).

## STORAGE

In an airtight container, protected from light, at a temperature of 2 °C to 8 °C.

## IMPURITIES

*Specified impurities*: A, C, D, E, F, G, H, I, J, K.

*Other detectable impurities* (the following substances would, if present at a sufficient level, be detected by one or other of the tests in the monograph. They are limited by the general acceptance criterion for other/unspecified impurities and/or by the general monograph *Substances for pharmaceutical use* (2034). It is therefore not necessary to identify these impurities for demonstration of compliance. See also 5.10. *Control of impurities in substances for pharmaceutical use*): B.

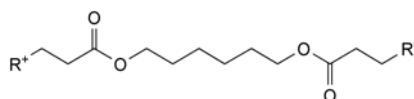
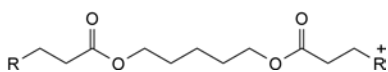
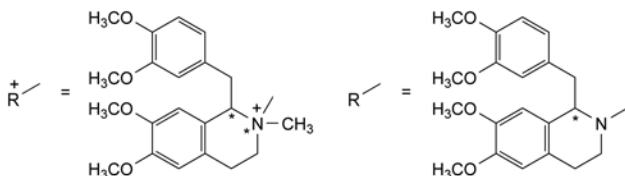

H. 2,2'-[hexane-1,6-diylbis[oxy(3-oxopropane-1,3-diyl)]]bis[1-(3,4-dimethoxybenzyl)-6,7-dimethoxy-2-methyl-1,2,3,4-tetrahydroisoquinolinium] (H1 = *cis-trans* isomer, H2 = *cis-cis* isomer),

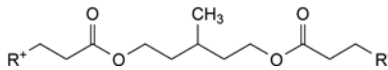

I. 2,2'-[(3-methylpentane-1,5)-diylbis[oxy(3-oxopropane-1,3-diyl)]]bis[1-(3,4-dimethoxybenzyl)-6,7-dimethoxy-2-methyl-1,2,3,4-tetrahydroisoquinolinium] (I1 = *cis-trans* isomer, I2 = *cis-cis* isomer),

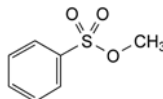

J. methyl benzenesulfonate,

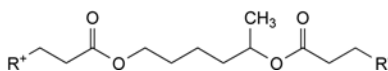

K. 2,2'-[(hexane-1,5)-diylbis[oxy(3-oxopropane-1,3-diyl)]]bis[1-(3,4-dimethoxybenzyl)-6,7-dimethoxy-2-methyl-1,2,3,4-tetrahydroisoquinolinium].

07/2010:2056

## ATROPINE

## Atropinum

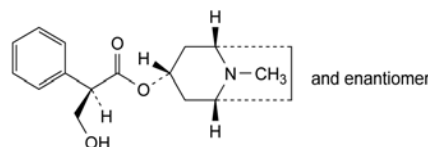

$C_{17}H_{23}NO_3$   
[51-55-8]

$M_r$  289.4

## DEFINITION

(1*R*,3*R*,5*S*)-8-Methyl-8-azabicyclo[3.2.1]oct-3-yl (2*RS*)-3-hydroxy-2-phenylpropanoate.

*Content*: 99.0 per cent to 101.0 per cent (dried substance).

## CHARACTERS

*Appearance*: white or almost white, crystalline powder or colourless crystals.

*Solubility*: very slightly soluble in water, freely soluble in ethanol (96 per cent) and in methylene chloride.

## IDENTIFICATION

*First identification*: A, B, E.

*Second identification*: A, C, D, E.

A. Melting point (2.2.14): 115 °C to 119 °C.

B. Infrared absorption spectrophotometry (2.2.24).

*Comparison*: atropine CRS.

C. Thin-layer chromatography (2.2.27).

*Test solution*. Dissolve 10 mg of the substance to be examined in *methanol R* and dilute to 10 mL with the same solvent.

*Reference solution*. Dissolve 10 mg of *atropine CRS* in *methanol R* and dilute to 10 mL with the same solvent.

*Plate*: TLC silica gel plate R.

*Mobile phase*: concentrated ammonia R, water R, acetone R (3:7:90 V/V/V).

*Application*: 10 µL.

A. 1-(3,4-dimethoxybenzyl)-2-[13-[1-(3,4-dimethoxybenzyl)-6,7-dimethoxy-3,4-dihydroisoquinolin-2(1*H*)-yl]-3,11-dioxo-4,10-dioxatridecyl]-6,7-dimethoxy-2-methyl-1,2,3,4-tetrahydroisoquinolinium (A1 = *cis-trans* isomer, A2 = *cis-cis* isomer),

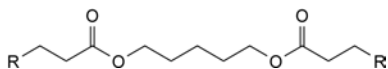

B. pentane-1,5-diyl bis[3-[1-(3,4-dimethoxybenzyl)-6,7-dimethoxy-3,4-dihydroisoquinolin-2(1*H*)-yl]propanoate],

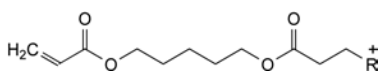

C. 1-(3,4-dimethoxybenzyl)-2-(3,11-dioxo-4,10-dioxatridec-12-enyl)-6,7-dimethoxy-2-methyl-1,2,3,4-tetrahydroisoquinolinium (C1 = *trans* isomer, C2 = *cis* isomer),

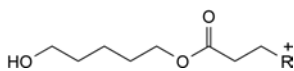

D. 1-(3,4-dimethoxybenzyl)-2-[3-[(5-hydroxypentyl)oxy]-3-oxopropyl]-6,7-dimethoxy-2-methyl-1,2,3,4-tetrahydroisoquinolinium (D1 = *trans* isomer, D2 = *cis* isomer),

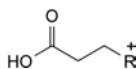

E. 3-[1-(3,4-dimethoxybenzyl)-6,7-dimethoxy-2-methyl-1,2,3,4-tetrahydroisoquinolinium]propanoate,

F.  $R^+CH_3$ : 1-(3,4-dimethoxybenzyl)-6,7-dimethoxy-2,2-dimethyl-1,2,3,4-tetrahydroisoquinolinium,

G.  $R-CH_3$ : 1-(3,4-dimethoxybenzyl)-6,7-dimethoxy-2-methyl-1,2,3,4-tetrahydroisoquinoline,

*Development:* over half of the plate.

*Drying:* at 100-105 °C for 15 min.

*Detection:* after cooling, spray with *dilute potassium iodobismuthate solution R*.

*Results:* the principal spot in the chromatogram obtained with the test solution is similar in position, colour and size to the principal spot in the chromatogram obtained with the reference solution.

- D. Place about 3 mg in a porcelain crucible and add 0.2 mL of *fuming nitric acid R*. Evaporate to dryness on a water-bath. Dissolve the residue in 0.5 mL of a 30 g/L solution of *potassium hydroxide R* in *methanol R*; a violet colour develops.
- E. Optical rotation (see Tests).

#### TESTS

**Optical rotation** (2.2.7):  $-0.70^\circ$  to  $+0.05^\circ$  (measured in a 2 dm tube).

Dissolve 1.25 g in *ethanol (96 per cent) R* and dilute to 25.0 mL with the same solvent.

**Related substances.** Liquid chromatography (2.2.29).

*Test solution.* Dissolve 24 mg of the substance to be examined in mobile phase A and dilute to 100.0 mL with mobile phase A.

*Reference solution (a).* Dilute 1.0 mL of the test solution to 100.0 mL with mobile phase A. Dilute 1.0 mL of this solution to 10.0 mL with mobile phase A.

*Reference solution (b).* Dissolve 5 mg of *atropine impurity B CRS* in the test solution and dilute to 20.0 mL with the test solution. Dilute 5.0 mL of this solution to 25.0 mL with mobile phase A.

*Reference solution (c).* Dissolve the contents of a vial of *atropine for peak identification CRS* (containing impurities A, D, E, F, G and H) in 1.0 mL of mobile phase A.

*Reference solution (d).* Dissolve 5 mg of *tropic acid R* (impurity C) in mobile phase A and dilute to 10.0 mL with mobile phase A. Dilute 1.0 mL of the solution to 100.0 mL with mobile phase A. Dilute 1.0 mL of this solution to 10.0 mL with mobile phase A.

*Column:*

- size:  $l = 0.10$  m,  $\varnothing = 4.6$  mm;
- stationary phase: *octadecylsilyl silica gel for chromatography R* (3  $\mu$ m).

*Mobile phase:*

- mobile phase A: dissolve 3.5 g of *sodium dodecyl sulfate R* in 606 mL of a 7.0 g/L solution of *potassium dihydrogen phosphate R* previously adjusted to pH 3.3 with a 5.8 g/L solution of *concentrated phosphoric acid R*, and mix with 320 mL of *acetonitrile R1*;
- mobile phase B: *acetonitrile R1*;

Time (min)	Mobile phase A (per cent V/V)	Mobile phase B (per cent V/V)
0 - 2	95	5
2 - 20	95 → 70	5 → 30

*Flow rate:* 1 mL/min.

*Detection:* spectrophotometer at 210 nm.

*Injection:* 10  $\mu$ L.

*Identification of impurities:* use the chromatogram supplied with *atropine for peak identification CRS* and the chromatogram obtained with reference solution (c) to identify the peaks due to impurities A, D, E, F, G and H; use the chromatogram obtained with reference solution (b) to identify the peak due to impurity B; use the chromatogram obtained with reference solution (d) to identify the peak due to impurity C.

*Relative retention* with reference to atropine (retention time = about 11 min): impurity C = about 0.2; impurity E = about 0.67; impurity D = about 0.73; impurity F = about 0.8; impurity B = about 0.89; impurity H = about 0.93; impurity G = about 1.1; impurity A = about 1.7.

*System suitability:* reference solution (b):

- resolution: minimum 2.5 between the peaks due to impurity B and atropine.

*Limits:*

- correction factors: for the calculation of content, multiply the peak areas of the following impurities by the corresponding correction factor: impurity A = 0.6; impurity C = 0.6;
- impurities E, H: for each impurity, not more than 3 times the area of the principal peak in the chromatogram obtained with reference solution (a) (0.3 per cent);
- impurities A, B, C, D, F, G: for each impurity, not more than twice the area of the principal peak in the chromatogram obtained with reference solution (a) (0.2 per cent);
- unspecified impurities: for each impurity, not more than the area of the principal peak in the chromatogram obtained with reference solution (a) (0.10 per cent);
- total: not more than 5 times the area of the principal peak in the chromatogram obtained with reference solution (a) (0.5 per cent);
- disregard limit: 0.5 times the area of the principal peak in the chromatogram obtained with reference solution (a) (0.05 per cent).

**Loss on drying** (2.2.32): maximum 0.2 per cent, determined on 1.000 g by drying in an oven at 105 °C for 2 h.

#### ASSAY

Dissolve 0.250 g in 40 mL of *anhydrous acetic acid R*, heating if necessary, and allow to cool. Titrate with 0.1 M *perchloric acid*, determining the end-point potentiometrically (2.2.20).

1 mL of 0.1 M *perchloric acid* is equivalent to 28.94 mg of  $C_{17}H_{23}NO_3$ .

#### STORAGE

Protected from light.

#### IMPURITIES

*Specified impurities:* A, B, C, D, E, F, G, H.

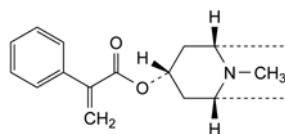

A. (1*R*,3*r*,5*S*)-8-methyl-8-azabicyclo[3.2.1]oct-3-yl 2-phenylpropenoate (apoa tropine),

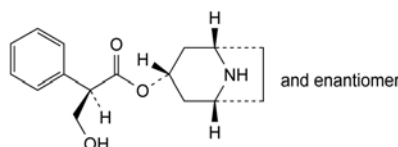

B. (1*R*,3*r*,5*S*)-8-azabicyclo[3.2.1]oct-3-yl (2*RS*)-3-hydroxy-2-phenylpropanoate (noratropine),

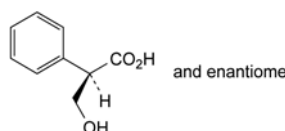

C. (2*RS*)-3-hydroxy-2-phenylpropanoic acid (tropic acid),

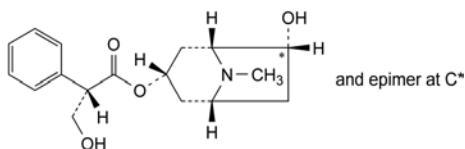

- D. (1*R*,3*S*,5*R*,6*RS*)-6-hydroxy-8-methyl-8-azabicyclo[3.2.1]oct-3-yl (2*S*)-3-hydroxy-2-phenylpropanoate (6-hydroxyhyoscyamine),

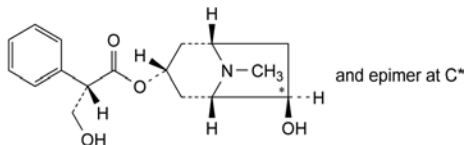

- E. (1*S*,3*R*,5*S*,6*RS*)-6-hydroxy-8-methyl-8-azabicyclo[3.2.1]oct-3-yl (2*S*)-3-hydroxy-2-phenylpropanoate (7-hydroxyhyoscyamine),

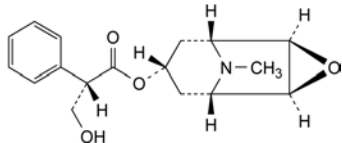

- F. (1*R*,2*R*,4*S*,5*S*,7*s*)-9-methyl-3-oxa-9-azatricyclo[3.3.1.0<sup>2,4</sup>]non-7-yl (2*S*)-3-hydroxy-2-phenylpropanoate (hyoscyine),

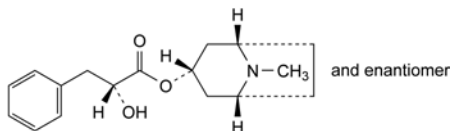

- G. (1*R*,3*r*,5*S*)-8-methyl-8-azabicyclo[3.2.1]oct-3-yl (2*RS*)-2-hydroxy-3-phenylpropanoate (littorine),

- H. unknown structure.

04/2008:0068  
corrected 7.0

## ATROPINE SULFATE

### Atropini sulfas

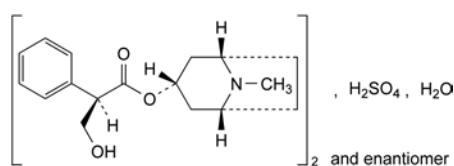

$C_{34}H_{48}N_2O_{10}S \cdot H_2O$   
[5908-99-6]

$M_r$  695

#### DEFINITION

Bis[(1*R*,3*r*,5*S*)-8-methyl-8-azabicyclo[3.2.1]oct-3-yl (2*RS*)-3-hydroxy-2-phenylpropanoate] sulfate monohydrate.

*Content*: 99.0 per cent to 101.0 per cent (anhydrous substance).

#### CHARACTERS

*Appearance*: white or almost white, crystalline powder or colourless crystals.

*Solubility*: very soluble in water, freely soluble in ethanol (96 per cent).

#### IDENTIFICATION

*First identification*: A, B, E.

*Second identification*: C, D, E, F.

A. Optical rotation (see Tests).

B. Infrared absorption spectrophotometry (2.2.24).

*Comparison*: atropine sulfate CRS.

C. Dissolve about 50 mg in 5 mL of *water R* and add 5 mL of *picric acid solution R*. The precipitate, washed with *water R* and dried at 100-105 °C for 2 h, melts (2.2.14) at 174 °C to 179 °C.

D. To about 1 mg add 0.2 mL of *fuming nitric acid R* and evaporate to dryness in a water-bath. Dissolve the residue in 2 mL of *acetone R* and add 0.1 mL of a 30 g/L solution of *potassium hydroxide R* in *methanol R*. A violet colour develops.

E. It gives the reactions of sulfates (2.3.1).

F. It gives the reaction of alkaloids (2.3.1).

#### TESTS

**pH** (2.2.3): 4.5 to 6.2.

Dissolve 0.6 g in *carbon dioxide-free water R* and dilute to 30 mL with the same solvent.

**Optical rotation** (2.2.7):  $-0.50^\circ$  to  $+0.05^\circ$  (measured in a 2 dm tube).

Dissolve 2.50 g in *water R* and dilute to 25.0 mL with the same solvent.

**Related substances**. Liquid chromatography (2.2.29).

*Test solution*. Dissolve 24 mg of the substance to be examined in mobile phase A and dilute to 100.0 mL with mobile phase A.

*Reference solution (a)*. Dilute 1.0 mL of the test solution to 100.0 mL with mobile phase A. Dilute 1.0 mL of this solution to 10.0 mL with mobile phase A.

*Reference solution (b)*. Dissolve 5 mg of *atropine impurity B CRS* in the test solution and dilute to 20 mL with the test solution. Dilute 5 mL of this solution to 25 mL with mobile phase A.

*Reference solution (c)*. Dissolve the contents of a vial of *atropine for peak identification CRS* (containing impurities A, D, E, F, G and H) in 1 mL of mobile phase A.

*Reference solution (d)*. Dissolve 5 mg of *tropic acid R* (impurity C) in mobile phase A and dilute to 10 mL with mobile phase A. Dilute 1 mL of the solution to 100 mL with mobile phase A. Dilute 1 mL of this solution to 10 mL with mobile phase A.

*Column*:

– *size*:  $l = 0.10$  m,  $\varnothing = 4.6$  mm;

– *stationary phase*: octadecylsilyl silica gel for chromatography R (3  $\mu$ m).

*Mobile phase*:

– *mobile phase A*: dissolve 3.5 g of *sodium dodecyl sulfate R* in 606 mL of a 7.0 g/L solution of *potassium dihydrogen phosphate R* previously adjusted to pH 3.3 with 0.05 M *phosphoric acid*, and mix with 320 mL of *acetonitrile RI*;

– *mobile phase B*: *acetonitrile RI*;

Time (min)	Mobile phase A (per cent V/V)	Mobile phase B (per cent V/V)
0 - 2	95	5
2 - 20	95 $\rightarrow$ 70	5 $\rightarrow$ 30

*Flow rate*: 1 mL/min.

*Detection*: spectrophotometer at 210 nm.

*Injection*: 10  $\mu$ L.

*Identification of impurities*: use the chromatogram supplied with *atropine for peak identification CRS* and the chromatogram obtained with reference solution (c) to identify the peaks due to impurities A, D, E, F, G and H. Use the chromatogram obtained with reference solution (b) to identify the peak due to impurity B, and use the chromatogram obtained with reference solution (d) to identify the peak due to impurity C.

*Relative retention* with reference to atropine (retention time = about 11 min): impurity C = about 0.2; impurity E = about 0.67; impurity D = about 0.73;

impurity F = about 0.8; impurity B = about 0.89; impurity H = about 0.93; impurity G = about 1.1; impurity A = about 1.7.

*System suitability*: reference solution (b):

- *resolution*: minimum 2.5 between the peaks due to impurity B and atropine.

*Limits*:

- *correction factors*: for the calculation of content, multiply the peak areas of the following impurities by the corresponding correction factor: impurity A = 0.6; impurity C = 0.6;
- *impurities E, H*: for each impurity, not more than 3 times the area of the principal peak in the chromatogram obtained with reference solution (a) (0.3 per cent);
- *impurities A, B, C, D, F, G*: for each impurity, not more than twice the area of the principal peak in the chromatogram obtained with reference solution (a) (0.2 per cent);
- *unspecified impurities*: for each impurity, not more than the area of the principal peak in the chromatogram obtained with reference solution (a) (0.10 per cent);
- *total*: not more than 5 times the area of the principal peak in the chromatogram obtained with reference solution (a) (0.5 per cent);
- *disregard limit*: 0.5 times the area of the principal peak in the chromatogram obtained with reference solution (a) (0.05 per cent).

**Water** (2.5.12): 2.0 per cent to 4.0 per cent, determined on 0.500 g.

**Sulfated ash** (2.4.14): maximum 0.1 per cent, determined on 1.0 g.

#### ASSAY

Dissolve 0.500 g in 30 mL of *anhydrous acetic acid R*, warming if necessary. Cool the solution. Titrate with 0.1 M *perchloric acid*, determining the end-point potentiometrically (2.2.20).

1 mL of 0.1 M *perchloric acid* is equivalent to 67.68 mg of  $C_{34}H_{48}N_2O_{10}S$ .

#### STORAGE

Protected from light.

#### IMPURITIES

*Specified impurities*: A, B, C, D, E, F, G, H.

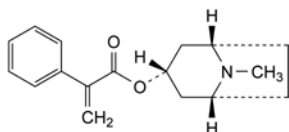

- A. (1*R*,3*r*,5*S*)-8-methyl-8-azabicyclo[3.2.1]oct-3-yl 2-phenylpropenoate (apoatropine),

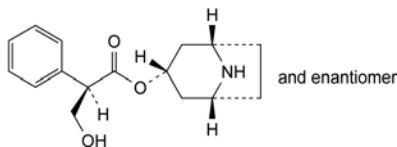

- B. (1*R*,3*r*,5*S*)-8-azabicyclo[3.2.1]oct-3-yl (2*RS*)-3-hydroxy-2-phenylpropanoate (noratropine),

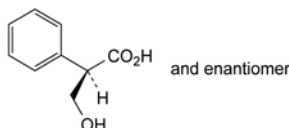

- C. (2*RS*)-3-hydroxy-2-phenylpropanoic acid (tropic acid),

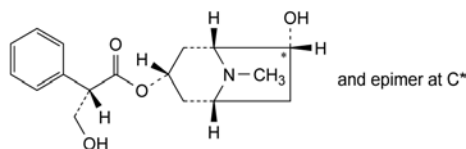

- D. (1*R*,3*S*,5*R*,6*RS*)-6-hydroxy-8-methyl-8-azabicyclo[3.2.1]oct-3-yl (2*S*)-3-hydroxy-2-phenylpropanoate (6-hydroxyhyoscyamine),

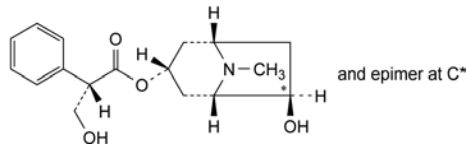

- E. (1*S*,3*R*,5*S*,6*RS*)-6-hydroxy-8-methyl-8-azabicyclo[3.2.1]oct-3-yl (2*S*)-3-hydroxy-2-phenylpropanoate (7-hydroxyhyoscyamine),

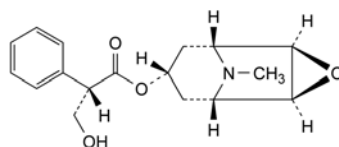

- F. (1*R*,2*R*,4*S*,5*S*,7*s*)-9-methyl-3-oxa-9-azatricyclo[3.3.1.0<sup>2,4</sup>]non-7-yl (2*S*)-3-hydroxy-2-phenylpropanoate (hyoscyine),

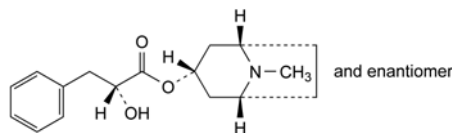

- G. (1*R*,3*r*,5*S*)-8-methyl-8-azabicyclo[3.2.1]oct-3-yl (2*RS*)-2-hydroxy-3-phenylpropanoate (littorine).

H. unknown structure.

04/2010:1708  
corrected 7.0

## AZAPERONE FOR VETERINARY USE

### Azaperonum ad usum veterinarium

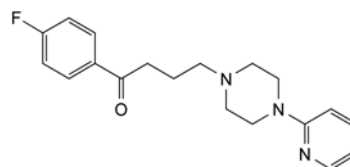

$C_{19}H_{22}FN_3O$   
[1649-18-9]

$M_r$  327.4

#### DEFINITION

1-(4-Fluorophenyl)-4-[4-(pyridin-2-yl)piperazin-1-yl]butan-1-one.

*Content*: 99.0 per cent to 101.0 per cent (dried substance).

#### CHARACTERS

*Appearance*: white or almost white powder.

*Solubility*: practically insoluble in water, freely soluble in acetone and in methylene chloride, soluble in ethanol (96 per cent).

It shows polymorphism (5.9).

#### IDENTIFICATION

Infrared absorption spectrophotometry (2.2.24).

*Preparation*: discs.

*Comparison*: azaperone CRS.

If the spectra obtained show differences, dissolve the substance to be examined and the reference substance separately in *acetone R*, evaporate to dryness and record new spectra using the residues.

## TESTS

**Appearance of solution.** The solution is clear (2.2.1) and not more intensely coloured than reference solution Y<sub>6</sub> (2.2.2, Method II).

Dissolve 1.0 g in 25 mL of a 14 g/L solution of *tartaric acid R*.

**Related substances.** Liquid chromatography (2.2.29).

**Test solution.** Dissolve 0.100 g of the substance to be examined in *methanol R* and dilute to 10.0 mL with the same solvent.

**Reference solution (a).** Dissolve 5.0 mg of *azaperone CRS* and 6.0 mg of *benperidol CRS* in *methanol R* and dilute to 200.0 mL with the same solvent.

**Reference solution (b).** Dilute 1.0 mL of the test solution to 100.0 mL with *methanol R*. Dilute 5.0 mL of the solution to 20.0 mL with *methanol R*.

**Column:**

- size:  $l = 0.10$  m,  $\varnothing = 4.6$  mm;
- stationary phase: base-deactivated octadecylsilyl silica gel for chromatography R (3  $\mu$ m);
- temperature: 25 °C.

**Mobile phase:**

- mobile phase A: dissolve 1.4 g of *anhydrous sodium sulfate R* in 900 mL of *water R*, add 16.0 mL of 0.01 M *sulfuric acid* and dilute to 1000 mL with *water R*;
- mobile phase B: *methanol R*;

Time (min)	Mobile phase A (per cent V/V)	Mobile phase B (per cent V/V)
0 - 15	95 → 20	5 → 80
15 - 20	20	80

**Flow rate:** 1.5 mL/min.

**Detection:** spectrophotometer at 230 nm.

**Injection:** 10  $\mu$ L.

**Relative retention** with reference to *azaperone* (retention time = about 9 min): impurity A = about 0.9; impurity B = about 1.1; impurity C = about 1.15.

**System suitability:** reference solution (a):

- resolution: minimum 8.0 between the peaks due to *azaperone* and to *benperidol*.

**Limits:**

- impurity A: not more than the area of the principal peak in the chromatogram obtained with reference solution (b) (0.25 per cent);
- unspecified impurities: for each impurity, not more than 0.8 times the area of the principal peak in the chromatogram obtained with reference solution (b) (0.20 per cent);
- sum of impurities B and C: not more than 3 times the area of the principal peak in the chromatogram obtained with reference solution (b) (0.75 per cent);
- total: not more than 4 times the area of the principal peak in the chromatogram obtained with reference solution (b) (1.0 per cent);
- disregard limit: 0.2 times the area of the principal peak in the chromatogram obtained with reference solution (b) (0.05 per cent).

**Loss on drying** (2.2.32): maximum 0.5 per cent, determined on 1.000 g by drying *in vacuo* at 60 °C for 4 h.

**Sulfated ash** (2.4.14): maximum 0.1 per cent, determined on 1.0 g.

## ASSAY

Dissolve 0.130 g in 70 mL of a mixture of 1 volume of *anhydrous acetic acid R* and 7 volumes of *methyl ethyl ketone R*. Titrate with 0.1 M *perchloric acid*, using 0.2 mL of *naphtholbenzein solution R* as indicator.

1 mL of 0.1 M *perchloric acid* is equivalent to 16.37 mg of C<sub>19</sub>H<sub>22</sub>FN<sub>3</sub>O.

## STORAGE

Protected from light.

## IMPURITIES

**Specified impurities:** A, B, C.

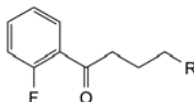
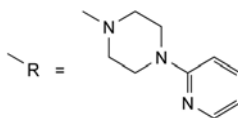

A. 1-(2-fluorophenyl)-4-[4-(pyridin-2-yl)piperazin-1-yl]butan-1-one,

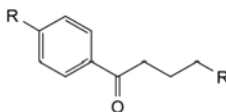

B. 4-[4-(pyridin-2-yl)piperazin-1-yl]-1-[4-(pyridin-2-yl)piperazin-1-yl]phenyl]butan-1-one,

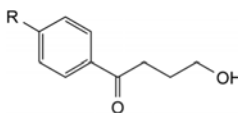

C. 4-hydroxy-1-[4-[4-(pyridin-2-yl)piperazin-1-yl]phenyl]butan-1-one.

07/2010:0369  
corrected 7.0

## AZATHIOPRINE

## Azathioprinum

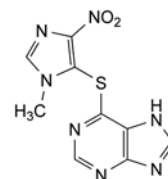

C<sub>9</sub>H<sub>7</sub>N<sub>7</sub>O<sub>2</sub>S  
[446-86-6]

$M_r$  277.3

## DEFINITION

6-[(1-Methyl-4-nitro-1H-imidazol-5-yl)sulfanyl]-7H-purine.

**Content:** 98.5 per cent to 101.0 per cent (dried substance).

## CHARACTERS

**Appearance:** pale-yellow powder.

**Solubility:** practically insoluble in water and in ethanol (96 per cent). It is soluble in dilute solutions of alkali hydroxides and sparingly soluble in dilute mineral acids.

## IDENTIFICATION

Infrared absorption spectrophotometry (2.2.24).

**Comparison:** *azathioprine CRS*.

## TESTS

**Related substances.** Liquid chromatography (2.2.29).

**Solution A.** 2.76 g/L solution of *sodium dihydrogen phosphate monohydrate R* adjusted to pH 2.5 with *phosphoric acid R*.



**Test solution.** Dissolve 10 mg of the substance to be examined in 35 mL of a 0.8 g/L solution of *sodium hydroxide R* and dilute to 100.0 mL with solution A.

**Reference solution (a).** Dissolve 5 mg of *azathioprine impurity A CRS* and 5 mg of *mercaptopurine R* (impurity B) in 8.75 mL of a 0.8 g/L solution of *sodium hydroxide R* and dilute to 25.0 mL with solution A. To 1.0 mL of this solution, add 35 mL of a 0.8 g/L solution of *sodium hydroxide R* and dilute to 100.0 mL with solution A.

**Reference solution (b).** Dissolve 2.5 mg of *azathioprine impurity G CRS* and 2.5 mg of the substance to be examined in 8.8 mL of a 0.8 g/L solution of *sodium hydroxide R* and dilute to 25.0 mL with solution A. To 1.0 mL of this solution, add 17.5 mL of a 0.8 g/L solution of *sodium hydroxide R* and dilute to 50.0 mL with solution A.

**Reference solution (c).** Dilute 1.0 mL of the test solution to 100.0 mL with solution A. Dilute 1.0 mL of this solution to 10.0 mL with solution A.

**Column:**

- size:  $l = 0.15$  m,  $\varnothing = 4.6$  mm;
- stationary phase: *phenylsilyl silica gel for chromatography R* (5  $\mu$ m);
- temperature: 30 °C.

**Mobile phase:**

- mobile phase A: *methanol R*, solution A (5:95 V/V);
- mobile phase B: solution A, *methanol R* (40:60 V/V);

Time (min)	Mobile phase A (per cent V/V)	Mobile phase B (per cent V/V)
0 - 5	100	0
5 - 15	100 → 0	0 → 100
15 - 20	0	100

**Flow rate:** 1.0 mL/min.

**Detection:** spectrophotometer at 240 nm.

**Injection:** 20  $\mu$ L.

**Identification of impurities:** use the chromatogram obtained with reference solution (a) to identify the peaks due to impurities A and B. Use the chromatogram obtained with reference solution (b) to identify the peak due to impurity G.

**Relative retention** with reference to azathioprine (retention time = about 15 min): impurity A = about 0.3; impurity B = about 0.4; impurity G = about 0.97.

**System suitability:**

- resolution: minimum 2.0 between the peaks due to impurities A and B in the chromatogram obtained with reference solution (a); minimum 2.0 between the peaks due to impurity G and azathioprine in the chromatogram obtained with reference solution (b).

**Limits:**

- impurities A, B: for each impurity, not more than 1.5 times the area of the principal peak in the chromatogram obtained with reference solution (c) (0.15 per cent);
- unspecified impurities: for each impurity, not more than the area of the principal peak in the chromatogram obtained with reference solution (c) (0.10 per cent);
- total: not more than 5 times the area of the principal peak in the chromatogram obtained with reference solution (c) (0.5 per cent);
- disregard limit: 0.5 times the area of the principal peak in the chromatogram obtained with reference solution (c) (0.05 per cent).

**Loss on drying** (2.2.32): maximum 1.0 per cent, determined on 0.500 g by drying in an oven at 105 °C.

**Sulfated ash** (2.4.14): maximum 0.1 per cent, determined on 1.0 g.

**ASSAY**

Dissolve 0.250 g in 25 mL of *dimethylformamide R*. Titrate with 0.1 M *tetrabutylammonium hydroxide*, determining the end-point potentiometrically (2.2.20).

1 mL of 0.1 M *tetrabutylammonium hydroxide* is equivalent to 27.73 mg of  $C_9H_7N_7O_2S$ .

**STORAGE**

Protected from light.

**IMPURITIES**

**Specified impurities: A, B.**

**Other detectable impurities** (the following substances would, if present at a sufficient level, be detected by one or other of the tests in the monograph. They are limited by the general acceptance criterion for other/unspecified impurities and/or by the general monograph *Substances for pharmaceutical use* (2034). It is therefore not necessary to identify these impurities for demonstration of compliance. See also 5.10. *Control of impurities in substances for pharmaceutical use*): C, D, E, F, G.

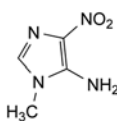

A. 1-methyl-4-nitro-1H-imidazol-5-amine,

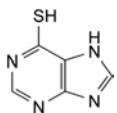

B. 7H-purine-6-thiol (mercaptopurine),

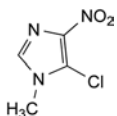

C. 5-chloro-1-methyl-4-nitro-1H-imidazole,

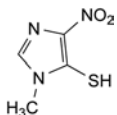

D. 1-methyl-4-nitro-1H-imidazole-5-thiol,

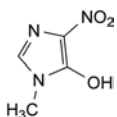

E. 1-methyl-4-nitro-1H-imidazol-5-ol,

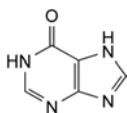

F. 1,7-dihydro-6H-purin-6-one (hypoxanthine),

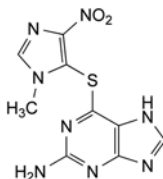

G. 6-[(1-methyl-4-nitro-1H-imidazol-5-yl)sulfanyl]-7H-purin-2-amine (thiamiprine).

01/2008:1633  
corrected 6.0

## AZELASTINE HYDROCHLORIDE

## Azelastini hydrochloridum

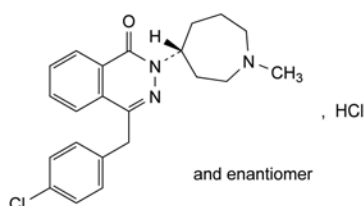
C<sub>22</sub>H<sub>25</sub>Cl<sub>2</sub>N<sub>3</sub>O  
[79307-93-0]M<sub>r</sub> 418.4

## DEFINITION

4-(4-Chlorobenzyl)-2-[(4*RS*)-1-methylhexahydro-1*H*-azepin-4-yl]phthalazin-1(2*H*)-one hydrochloride.*Content*: 99.0 per cent to 101.0 per cent (dried substance).

## CHARACTERS

*Appearance*: white or almost white, crystalline powder.*Solubility*: sparingly soluble in water, soluble in ethanol and in methylene chloride.

## IDENTIFICATION

A. Infrared absorption spectrophotometry (2.2.24).

*Comparison*: azelastine hydrochloride CRS.

B. Solution S (see Tests) gives reaction (a) of chlorides (2.3.1).

## TESTS

**Solution S.** Dissolve 1.0 g in carbon dioxide-free water R and dilute to 100 mL with the same solvent.**Appearance of solution.** Solution S is clear (2.2.1) and colourless (2.2.2, Method II).**Acidity or alkalinity.** To 10 mL of solution S add 0.2 mL of bromothymol blue solution R1. Not more than 0.1 mL of 0.01 M hydrochloric acid or 0.01 M sodium hydroxide is required to change the colour of the solution.**Related substances.** Liquid chromatography (2.2.29).*Solvent mixture*: acetonitrile for chromatography R, water R (45:55 V/V).*Test solution.* Dissolve 0.125 g of the substance to be examined in the solvent mixture and dilute to 50.0 mL with the solvent mixture.*Reference solution (a).* Dilute 1.0 mL of the test solution to 100.0 mL with the solvent mixture. Dilute 1.0 mL of this solution to 10.0 mL with the solvent mixture.*Reference solution (b).* Dissolve 1 mg of azelastine impurity B CRS, 1 mg of azelastine impurity D CRS and 1 mg of azelastine impurity E CRS in the test solution and dilute to 20 mL with the test solution.*Column*:

- size:  $l = 0.25$  m,  $\varnothing = 4.6$  mm,
- stationary phase: nitrile silica gel for chromatography R (10  $\mu$ m),
- temperature: 30 °C.

*Mobile phase*: dissolve 2.16 g of sodium octanesulfonate R and 0.68 g of potassium dihydrogen phosphate R in 740 mL of water for chromatography R, adjust to pH 3.0-3.1 with dilute phosphoric acid R, add 260 mL of acetonitrile for chromatography R and mix.*Flow rate*: 2.0 mL/min.*Detection*: spectrophotometer at 210 nm.*Injection*: 10  $\mu$ L.*Run time*: twice the retention time of azelastine.*Relative retention* with reference to azelastine (retention time = about 8-9 min): impurity A = about 0.2; impurity B = about 0.3; impurity C = about 0.4; impurity D = about 0.6; impurity E = about 1.4.*System suitability*: reference solution (b):

- resolution: minimum 4.0 between the peaks due to impurities B and D,
- the peaks due to impurities D and E are baseline separated from the principal peak.

*Limits*:

- correction factors: for the calculation of content, multiply the peak areas of the following impurities by the corresponding correction factor: impurity B = 3.6; impurity D = 0.7; impurity E = 2.1;
- impurities A, B, C, D, E: for each impurity, not more than the area of the principal peak in the chromatogram obtained with reference solution (a) (0.1 per cent);
- any other impurity: for each impurity, not more than the area of the principal peak in the chromatogram obtained with reference solution (a) (0.1 per cent);
- total: not more than twice the area of the principal peak in the chromatogram obtained with reference solution (a) (0.2 per cent);
- disregard limit: 0.5 times the area of the principal peak in the chromatogram obtained with reference solution (a) (0.05 per cent).

**Loss on drying** (2.2.32): maximum 0.5 per cent, determined on 1.000 g by drying in an oven at 105 °C.

## ASSAY

*In order to avoid overheating in the reaction medium, mix thoroughly throughout and stop the titration immediately after the end-point has been reached.*

Dissolve 0.300 g in 5 mL of anhydrous formic acid R. Add 30 mL of acetic anhydride R. Titrate quickly with 0.1 M perchloric acid, determining the end-point potentiometrically (2.2.20).

1.0 mL of 0.1 M perchloric acid is equivalent to 41.84 mg of C<sub>22</sub>H<sub>25</sub>Cl<sub>2</sub>N<sub>3</sub>O.

## IMPURITIES

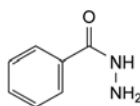
*Specified impurities*: A, B, C, D, E.

A. benzoyldiazane (benzohydrazide),

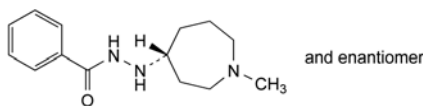
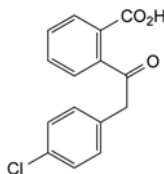
B. 1-benzoyl-2-[(4*RS*)-1-methylhexahydro-1*H*-azepin-4-yl]diazane,

C. 2-[(4-chlorophenyl)acetyl]benzoic acid,

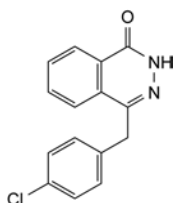

D. 4-(4-chlorobenzyl)phthalazin-1(2H)-one,

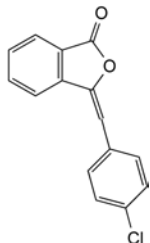

E. 3-(4-chlorobenzylidene)isobenzofuran-1(3H)-one.

01/2011:1649

## AZITHROMYCIN

## Azithromycinum

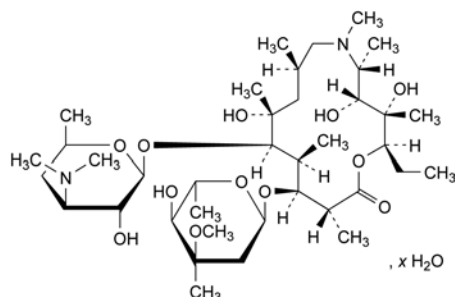
 $C_{38}H_{72}N_2O_{12} \cdot xH_2O$   
with  $x = 1$  or  $2$ 
 $M_r$  749 (anhydrous substance)

Azithromycin monohydrate: [121470-24-4]

Azithromycin dihydrate: [117772-70-0]

## DEFINITION

(2*R*,3*S*,4*R*,5*R*,8*R*,10*R*,11*R*,12*S*,13*S*,14*R*)-13-[(2,6-Dideoxy-3-*C*-methyl-3-*O*-methyl- $\alpha$ -*L*-ribo-hexopyranosyl)oxy]-2-ethyl-3,4,10-trihydroxy-3,5,6,8,10,12,14-heptamethyl-11-[[3,4,6-trideoxy-3-(dimethylamino)- $\beta$ -*D*-xylo-hexopyranosyl]oxy]-1-oxa-6-azacyclopentadecan-15-one. The degree of hydration is 1 or 2. Semi-synthetic product derived from a fermentation product.

## CHARACTERS

**Appearance:** white or almost white powder.**Solubility:** practically insoluble in water, freely soluble in anhydrous ethanol and in methylene chloride.

## IDENTIFICATION

Infrared absorption spectrophotometry (2.2.24).

**Comparison:** azithromycin CRS.

If the spectra obtained in the solid state show differences, prepare further spectra using 90 g/L solutions in methylene chloride R.

## TESTS

**Solution S.** Dissolve 0.500 g in anhydrous ethanol R and dilute to 50.0 mL with the same solvent.**Appearance of solution.** Solution S is clear (2.2.1) and colourless (2.2.2, Method II).**pH** (2.2.3): 9.0 to 11.0.

Dissolve 0.100 g in 25.0 mL of methanol R and dilute to 50.0 mL with carbon dioxide-free water R.

**Specific optical rotation** (2.2.7):  $-45$  to  $-49$  (anhydrous substance), determined on solution S.**Related substances.** Liquid chromatography (2.2.29).**Solvent mixture.** Prepare a 1.73 g/L solution of ammonium dihydrogen phosphate R adjusted to pH 10.0 with ammonia R. Transfer 350 mL of this solution to a suitable container. Add 300 mL of acetonitrile R1 and 350 mL of methanol R1. Mix well.**Test solution.** Dissolve 0.200 g of the substance to be examined in the solvent mixture and dilute to 25.0 mL with the solvent mixture.**Reference solution (a).** Dilute 1.0 mL of the test solution to 100.0 mL with the solvent mixture.**Reference solution (b).** Dissolve the contents of a vial of azithromycin for system suitability CRS (containing impurities F, H and J) in 1.0 mL of the solvent mixture and sonicate for 5 min.**Reference solution (c).** Dissolve 8.0 mg of azithromycin for peak identification CRS (containing impurities A, B, C, E, F, G, I, J, L, M, N, O and P) in 1.0 mL of the solvent mixture.**Column:**

- size:  $l = 0.25$  m,  $\varnothing = 4.6$  mm;
- stationary phase: end-capped octadecylsilyl amorphous organosilica polymer for mass spectrometry R (5  $\mu$ m);
- temperature: 60 °C.

**Mobile phase:**

- mobile phase A: 1.80 g/L solution of anhydrous disodium hydrogen phosphate R adjusted to pH 8.9 with dilute phosphoric acid R or with dilute sodium hydroxide solution R;
- mobile phase B: methanol R1, acetonitrile R1 (250:750 V/V);

Time (min)	Mobile phase A (per cent V/V)	Mobile phase B (per cent V/V)
0 - 25	50 → 45	50 → 55
25 - 30	45 → 40	55 → 60
30 - 80	40 → 25	60 → 75
80 - 81	25 → 50	75 → 50
81 - 93	50	50

**Flow rate:** 1.0 mL/min.**Detection:** spectrophotometer at 210 nm.**Injection:** 50  $\mu$ L.

**Identification of impurities:** use the chromatogram supplied with azithromycin for peak identification CRS and the chromatogram obtained with reference solution (c) to identify the peaks due to impurities A, B, C, E, F, G, I, J, L, M, N, O and P; use the chromatogram supplied with azithromycin for system suitability CRS and the chromatogram obtained with reference solution (b) to identify the peak due to impurity H.

**Relative retention** with reference to azithromycin (retention time = 45-50 min): impurity L = about 0.29; impurity M = about 0.37; impurity E = about 0.43; impurity F = about 0.51; impurity D = about 0.54; impurity J = about 0.54; impurity I = about 0.61; impurity C = about 0.73; impurity N = about 0.76; impurity H = about 0.79; impurity A = about 0.83; impurity P = about 0.92; impurity O = about 1.23; impurity G = about 1.26; impurity B = about 1.31.

**System suitability:** reference solution (b):

- **peak-to-valley ratio:** minimum 1.4, where  $H_p$  = height above the baseline of the peak due to impurity J and  $H_v$  = height above the baseline of the lowest point of the curve separating this peak from the peak due to impurity F.

**Limits:**

- **correction factors:** for the calculation of content, multiply the peak areas of the following impurities by the corresponding correction factor: impurity F = 0.3; impurity G = 0.2; impurity H = 0.1; impurity L = 2.3; impurity M = 0.6; impurity N = 0.7;
- **impurity B:** not more than twice the area of the principal peak in the chromatogram obtained with reference solution (a) (2.0 per cent);
- **impurities A, C, E, F, H, I, L, M, N, O, P:** for each impurity, not more than 0.5 times the area of the principal peak in the chromatogram obtained with reference solution (a) (0.5 per cent);
- **sum of impurities D and J:** not more than 0.5 times the area of the principal peak in the chromatogram obtained with reference solution (a) (0.5 per cent);
- **impurity G:** not more than 0.2 times the area of the principal peak in the chromatogram obtained with reference solution (a) (0.2 per cent);
- **any other impurity:** for each impurity, not more than 0.2 times the area of the principal peak in the chromatogram obtained with reference solution (a) (0.2 per cent);
- **total:** not more than 3 times the area of the principal peak in the chromatogram obtained with reference solution (a) (3.0 per cent);
- **disregard limit:** 0.1 times the area of the principal peak in the chromatogram obtained with reference solution (a) (0.1 per cent); disregard the peaks eluting before impurity L and after impurity B.

**Heavy metals (2.4.8):** maximum 25 ppm.

Dissolve 2.0 g in a mixture of 15 volumes of *water R* and 85 volumes of *anhydrous ethanol R* and dilute to 20 mL with the same mixture of solvents. 12 mL of the solution complies with test B. Prepare the reference solution using lead standard solution (2.5 ppm Pb) obtained by diluting *lead standard solution (100 ppm Pb) R* with a mixture of 15 volumes of *water R* and 85 volumes of *anhydrous ethanol R*.

**Water (2.5.12):** 1.8 per cent to 6.5 per cent, determined on 0.200 g.

**Sulfated ash (2.4.14):** maximum 0.2 per cent, determined on 1.0 g.

**ASSAY**

Liquid chromatography (2.2.29).

**Solution A.** Mix 60 volumes of *acetonitrile R1* and 40 volumes of a 6.7 g/L solution of *dipotassium hydrogen phosphate R* adjusted to pH 8.0 with *phosphoric acid R*.

**Test solution.** Dissolve 53.0 mg of the substance to be examined in 2 mL of *acetonitrile R1* and dilute to 100.0 mL with solution A.

**Reference solution (a).** Dissolve 53.0 mg of *azithromycin CRS* in 2 mL of *acetonitrile R1* and dilute to 100.0 mL with solution A.

**Reference solution (b).** Dissolve 5 mg of the substance to be examined and 5 mg of *azithromycin impurity A CRS* in 0.5 mL of *acetonitrile R1* and dilute to 10 mL with solution A.

**Column:**

- **size:**  $l = 0.25$  m,  $\varnothing = 4.6$  mm;
- **stationary phase:** octadecylsilyl vinyl polymer for chromatography R (5  $\mu$ m);
- **temperature:** 40 °C.

**Mobile phase:** mix 60 volumes of *acetonitrile R1* and 40 volumes of a 6.7 g/L solution of *dipotassium hydrogen phosphate R* adjusted to pH 11.0 with a 560 g/L solution of *potassium hydroxide R*.

**Flow rate:** 1.0 mL/min.

**Detection:** spectrophotometer at 210 nm.

**Injection:** 10  $\mu$ L.

**Run time:** 1.5 times the retention time of azithromycin.

**Retention time:** azithromycin = about 10 min.

**System suitability:** reference solution (b):

- **resolution:** minimum 3.0 between the peaks due to impurity A and azithromycin.

Calculate the percentage content of  $C_{38}H_{72}N_2O_{12}$  from the declared content of *azithromycin CRS*.

**STORAGE**

In an airtight container.

**IMPURITIES**

**Specified impurities:** A, B, C, D, E, F, G, H, I, J, L, M, N, O, P.

**Other detectable impurities** (the following substances would, if present at a sufficient level, be detected by one or other of the tests in the monograph. They are limited by the general acceptance criterion for other/unspecified impurities and/or by the general monograph *Substances for pharmaceutical use (2034)*. It is therefore not necessary to identify these impurities for demonstration of compliance. See also 5.10. *Control of impurities in substances for pharmaceutical use*): K.

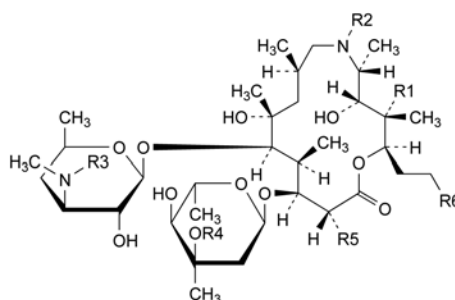

- R1 = OH, R2 = R6 = H, R3 = R4 = R5 = CH<sub>3</sub>: 6-demethylazithromycin,
- R1 = R6 = H, R2 = R3 = R4 = R5 = CH<sub>3</sub>: 3-deoxyazithromycin (azithromycin B),
- R1 = OH, R2 = R3 = R5 = CH<sub>3</sub>, R4 = R6 = H: 3'-O-demethylazithromycin (azithromycin C),
- R1 = OH, R2 = R3 = R4 = CH<sub>3</sub>, R5 = CH<sub>2</sub>OH, R6 = H: 14-demethyl-14-(hydroxymethyl)azithromycin (azithromycin F),
- R1 = OH, R2 = R4 = R5 = CH<sub>3</sub>, R3 = CHO, R6 = H: 3'-N-demethyl-3'-N-formylazithromycin,
- R1 = OH, R2 = R4 = R5 = CH<sub>3</sub>, R3 = R6 = H: 3'-N-demethylazithromycin,
- R1 = OH, R2 = R3 = R4 = R5 = R6 = CH<sub>3</sub>: 2-desethyl-2-propylazithromycin,

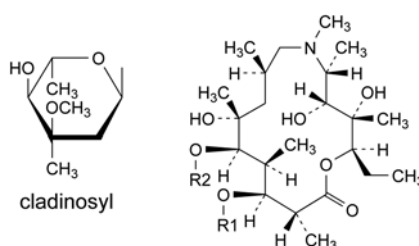

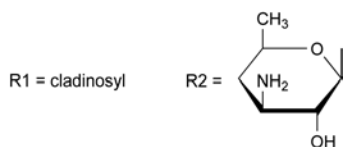

E. 3'-(*N,N*-didemethyl)azithromycin (aminoazithromycin),

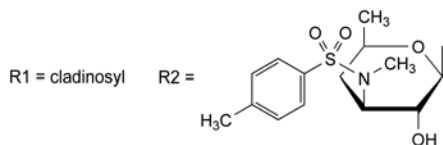

G. 3'-*N*-demethyl-3'-*N*-(4-methylphenyl)sulfonylazithromycin,

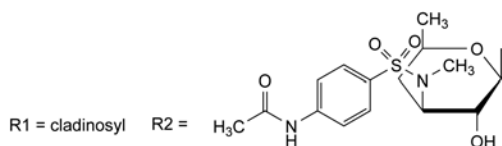

H. 3'-*N*-[[4-(acetamino)phenyl]sulfonyl]-3'-*N*-demethylazithromycin,

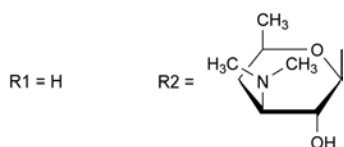

J. 13-*O*-decladinosylazithromycin,

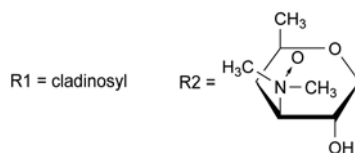

L. azithromycin 3'-*N*-oxide,

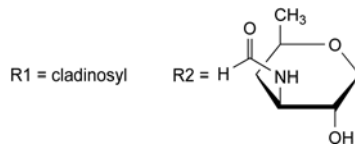

M. 3'-(*N,N*-didemethyl)-3'-*N*-formylazithromycin,

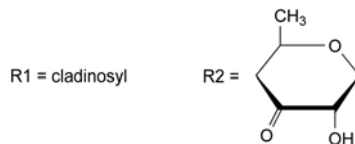

N. 3'-de(dimethylamino)-3'-oxoazithromycin,

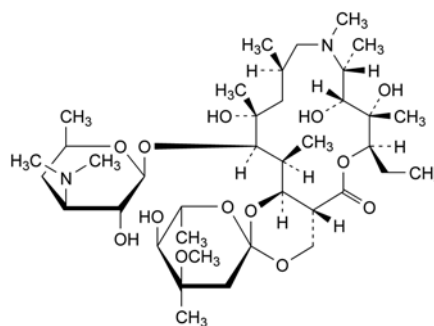

K. *C*<sup>14</sup>,1''-epoxyazithromycin (azithromycin E),

P. unknown structure.

01/2008:0808  
corrected 6.1

## BACAMPICILLIN HYDROCHLORIDE

## Bacampicillini hydrochloridum

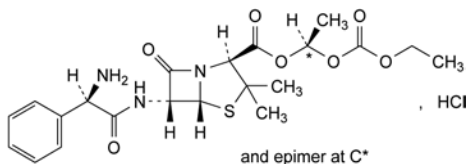
C<sub>27</sub>H<sub>28</sub>ClN<sub>3</sub>O<sub>7</sub>S  
[37661-08-8]M<sub>r</sub> 502.0

## DEFINITION

(1*RS*)-1-[(Ethoxycarbonyloxy)ethyl (2*S*,5*R*,6*R*)-6-[[*(2R)*-2-amino-2-phenylacetyl]amino]-3,3-dimethyl-7-oxo-4-thia-1-azabicyclo[3.2.0]heptane-2-carboxylate hydrochloride.

Semi-synthetic product derived from a fermentation product.

*Content*: 95.0 per cent to 102.0 per cent (anhydrous substance).

## CHARACTERS

*Appearance*: white or almost white powder or granules, hygroscopic.

*Solubility*: soluble in water, freely soluble in ethanol (96 per cent), soluble in methylene chloride.

## IDENTIFICATION

*First identification*: A, D.

*Second identification*: B, C, D.

A. Infrared absorption spectrophotometry (2.2.24).

*Comparison*: bacampicillin hydrochloride CRS.

B. Thin-layer chromatography (2.2.27).

*Test solution*. Dissolve 10 mg of the substance to be examined in 2 mL of *methanol R*.

*Reference solution (a)*. Dissolve 10 mg of bacampicillin hydrochloride CRS in 2 mL of *methanol R*.

*Reference solution (b)*. Dissolve 10 mg of bacampicillin hydrochloride CRS, 10 mg of talampicillin hydrochloride CRS and 10 mg of pivampicillin CRS in 2 mL of *methanol R*.

*Plate*: TLC silanised silica gel plate *R*.

*Mobile phase*: mix 10 volumes of a 272 g/L solution of sodium acetate *R* adjusted to pH 5.0 with glacial acetic acid *R*, 40 volumes of *water R* and 50 volumes of ethanol (96 per cent) *R*.

*Application*: 1 µL.

*Development*: over a path of 15 cm.

*Drying*: in a current of warm air.

*Detection*: spray with ninhydrin solution *R1* and heat at 60 °C for 10 min.

*System suitability*: reference solution (b):

– the chromatogram shows 3 clearly separated spots.

*Results*: the principal spot in the chromatogram obtained with the test solution is similar in position, colour and size to the principal spot in the chromatogram obtained with reference solution (a).

C. Place about 2 mg in a test-tube about 150 mm long and 15 mm in diameter. Moisten with 0.05 mL of *water R* and add 2 mL of sulfuric acid-formaldehyde reagent *R*. Mix the contents of the tube by swirling; the solution is practically colourless. Place the test-tube on a water-bath for 1 min; a dark yellow colour develops.

D. Dissolve about 25 mg in 2 mL of *water R*. Add 2 mL of dilute sodium hydroxide solution *R* and shake. Wait a few minutes and add 3 mL of dilute nitric acid *R* and 0.5 mL of silver nitrate solution *R1*. A white precipitate is formed. Add 0.5 mL of concentrated ammonia *R*. The precipitate dissolves.

## TESTS

**Appearance of solution**. Dissolve 0.200 g in 20 mL of *water R*; the solution is not more opalescent than reference suspension II (2.2.1). Dissolve 0.500 g in 10 mL of *water R*; the absorbance (2.2.25) of the solution at 430 nm is not greater than 0.10.

**pH (2.2.3)**: 3.0 to 4.5.

Dissolve 1.0 g in carbon dioxide-free *water R* and dilute to 50 mL with the same solvent.

**Specific optical rotation (2.2.7)**: + 175 to + 195 (anhydrous substance).

Dissolve 0.250 g in *water R* and dilute to 25.0 mL with the same solvent.

**Related substances**. Liquid chromatography (2.2.29). Prepare the test solution and reference solutions (a), (b) and (d) immediately before use.

*Phosphate buffer A*. Dissolve 1.4 g of sodium dihydrogen phosphate monohydrate *R* in *water R* and dilute to about 800 mL with the same solvent. Adjust to pH 3.0 with dilute phosphoric acid *R* and dilute to 1000.0 mL with *water R*.

*Phosphate buffer B*. Dissolve 2.75 g of sodium dihydrogen phosphate monohydrate *R* and 2.3 g of disodium hydrogen phosphate dihydrate *R* in *water R* and dilute to about 1800 mL with the same solvent. Adjust to pH 6.8, if necessary, using dilute phosphoric acid *R* or dilute sodium hydroxide solution *R* and dilute to 2000.0 mL with *water R*.

*Test solution*. Dissolve 30.0 mg of the substance to be examined in phosphate buffer A and dilute to 100.0 mL with phosphate buffer A.

*Reference solution (a)*. Dissolve 30.0 mg of bacampicillin hydrochloride CRS in phosphate buffer A and dilute to 100.0 mL with phosphate buffer A.

*Reference solution (b)*. Dilute 1.0 mL of reference solution (a) to 100.0 mL with phosphate buffer A.

*Reference solution (c)*. Dissolve 30 mg of the substance to be examined in phosphate buffer B and dilute to 100 mL with phosphate buffer B. Heat at 80 °C for about 30 min.

*Reference solution (d)*. Dissolve 20 mg of ampicillin trihydrate CRS (impurity I) in phosphate buffer A and dilute to 250 mL with phosphate buffer A. Dilute 5 mL of this solution to 100 mL with phosphate buffer A.

*Column*:

– size: *l* = 0.05 m, Ø = 3.9 mm;

– stationary phase: octadecylsilyl silica gel for chromatography *R* (5 µm).

*Mobile phase*: mix 30 volumes of acetonitrile *R1* and 70 volumes of a 0.06 per cent *m/m* solution of tetrahexylammonium hydrogen sulfate *R* in phosphate buffer B.

*Flow rate*: 1.0 mL/min.

*Detection*: spectrophotometer at 220 nm.

*Injection*: 20 µL of the test solution and reference solutions (b), (c) and (d).

*Run time*: 3.5 times the retention time of bacampicillin.

*System suitability*:

– the peak due to impurity I is separated from the peaks due to the solvent in the chromatogram obtained with reference solution (d);

– relative retention with reference to bacampicillin: degradation product eluting just after bacampicillin = 1.12 to 1.38 in the chromatogram obtained with reference solution (c); if necessary, adjust the concentration of tetrahexylammonium hydrogen sulfate in the mobile phase.

## Limits:

- *any impurity*: for each impurity, not more than 1.5 times the area of the principal peak in the chromatogram obtained with reference solution (b) (1.5 per cent);
- *total*: not more than 3 times the area of the principal peak in the chromatogram obtained with reference solution (b) (3 per cent);
- *disregard limit*: 0.1 times the area of the principal peak in the chromatogram obtained with reference solution (b) (0.1 per cent).

**Butyl acetate and ethyl acetate** (2.4.24, System A): maximum 2.0 per cent of butyl acetate, maximum 4.0 per cent of ethyl acetate and maximum 5.0 per cent for the sum of the contents.

**Sample solution.** Dissolve 50.0 mg of the substance to be examined in *water R* and dilute to 10.0 mL with the same solvent.

Use the method of standard additions.

**Static head-space conditions that may be used:**

- *equilibration temperature*: 60 °C;
- *equilibration time*: 20 min.

***N,N*-Dimethylaniline** (2.4.26, Method A): maximum 20 ppm.

**Water** (2.5.12): maximum 0.8 per cent, determined on 0.300 g.

**Sulfated ash** (2.4.14): maximum 1.5 per cent, determined on 1.0 g.

## ASSAY

Liquid chromatography (2.2.29) as described in the test for related substances with the following modifications.

**Injection:** test solution and reference solution (a).

**System suitability:** reference solution (a):

- *repeatability*: maximum relative standard deviation of 1.0 per cent after 6 injections.

Calculate the percentage content of  $C_{21}H_{28}ClN_3O_7S$  from the declared content of *bacampicillin hydrochloride CRS*.

## STORAGE

In an airtight container.

## IMPURITIES

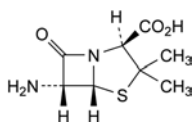

- A. (2*S*,5*R*,6*R*)-6-amino-3,3-dimethyl-7-oxo-4-thia-1-azabicyclo[3.2.0]heptane-2-carboxylic acid (6-aminopenicillanic acid),

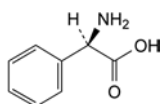

- B. (2*R*)-2-amino-2-phenylacetic acid (D-phenylglycine),

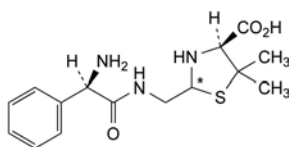

- C. (2*R,S*,4*S*)-2-[[[(2*R*)-2-amino-2-phenylacetyl]amino]-methyl]-5,5-dimethylthiazolidine-4-carboxylic acid (penilloic acids of ampicillin),

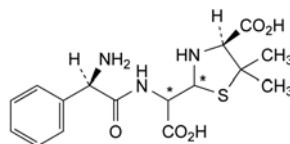

- D. (4*S*)-2-[[[(2*R*)-2-amino-2-phenylacetyl]amino]-carboxymethyl]-5,5-dimethylthiazolidine-4-carboxylic acid (penicilloic acids of ampicillin),

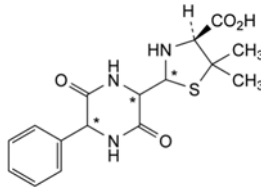

- E. (4*S*)-2-(3,6-dioxo-5-phenylpiperazin-2-yl)-5,5-dimethylthiazolidine-4-carboxylic acid (diketopiperazines of ampicillin),

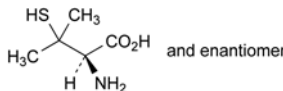

- F. (2*RS*)-2-amino-3-methyl-3-sulfanylbutanoic acid (DL-penicillamine),

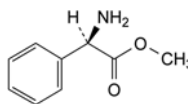

- G. methyl (2*R*)-2-amino-2-phenylacetate (methyl D-phenylglycinate),

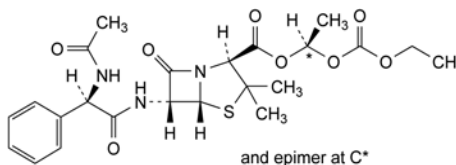

- H. (1*RS*)-1-[(ethoxycarbonyloxy)ethyl]-2-[(2*S*,5*R*,6*R*)-6-[[[(2*R*)-2-(acetylamino)-2-phenylacetyl]amino]-3,3-dimethyl-7-oxo-4-thia-1-azabicyclo[3.2.0]heptane-2-carboxylate (*N*-acetyl bacampicillin),

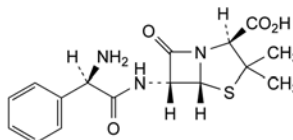

- I. (2*S*,5*R*,6*R*)-6-[[[(2*R*)-2-amino-2-phenylacetyl]amino]-3,3-dimethyl-7-oxo-4-thia-1-azabicyclo[3.2.0]heptane-2-carboxylic acid (ampicillin).

01/2008:0465

## BACITRACIN

## Bacitracinum

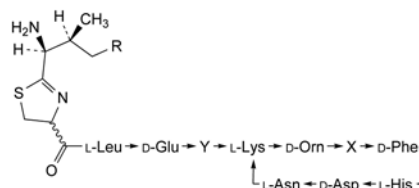

Name	Mol. Formula	X	Y	R
Bacitracin A	$C_{66}H_{103}N_{17}O_{16}S$	L-Ile	L-Ile	CH <sub>3</sub>
Bacitracin B1	$C_{65}H_{101}N_{17}O_{16}S$	L-Ile	L-Ile	H
Bacitracin B2	$C_{65}H_{101}N_{17}O_{16}S$	L-Val	L-Ile	CH <sub>3</sub>
Bacitracin B3	$C_{65}H_{101}N_{17}O_{16}S$	L-Ile	L-Val	CH <sub>3</sub>

## DEFINITION

Mixture of antimicrobial polypeptides produced by certain strains of *Bacillus licheniformis* or *Bacillus subtilis*, the main components being bacitracins A, B1, B2 and B3.

*Content*: minimum 60 IU/mg (dried substance).

## CHARACTERS

*Appearance*: white or almost white powder, hygroscopic.

*Solubility*: freely soluble in water and in ethanol (96 per cent).

## IDENTIFICATION

*First identification*: B, C.

*Second identification*: A, C.

## A. Thin-layer chromatography (2.2.27).

*Test solution*. Dissolve 10 mg of the substance to be examined in a 3.4 g/L solution of *hydrochloric acid R* and dilute to 1.0 mL with the same solution.

*Reference solution*. Dissolve 10 mg of *bacitracin zinc CRS* in a 3.4 g/L solution of *hydrochloric acid R* and dilute to 1.0 mL with the same solution.

*Plate*: TLC silica gel plate R.

*Mobile phase*: glacial acetic acid R, water R, butanol R (1:2:4 V/V/V).

*Application*: 10 µL.

*Development*: over half of the plate.

*Drying*: at 100-105 °C.

*Detection*: spray with *ninhydrin solution R1* and heat at 110 °C for 5 min.

*Results*: the spots in the chromatogram obtained with the test solution are similar in position, size and colour to the spots in the chromatogram obtained with the reference solution.

## B. Composition (see Tests).

C. Ignite 0.2 g. An insignificant residue remains which is not yellow at high temperature. Allow to cool. Dissolve the residue in 0.1 mL of *dilute hydrochloric acid R*. Add 5 mL of *water R* and 0.2 mL of *strong sodium hydroxide solution R*. No white precipitate is formed.

## TESTS

**Solution S**. Dissolve 0.25 g in *carbon dioxide-free water R* and dilute to 25 mL with the same solvent.

**Appearance of solution**. Solution S is clear (2.2.1).

**pH** (2.2.3): 6.0 to 7.0 for solution S.

**Composition**. Liquid chromatography (2.2.29): use the normalisation procedure. *Prepare the solutions immediately before use*.

*Test solution*. Dissolve 0.100 g of the substance to be examined in 50.0 mL of the mobile phase.

*Reference solution (a)*. Suspend 20.0 mg of *bacitracin zinc CRS* in *water R*, add 0.2 mL of *dilute hydrochloric acid R* and dilute to 10.0 mL with *water R*.

*Reference solution (b)*. Dilute 5.0 mL of the test solution to 100.0 mL with the mobile phase.

*Reference solution (c)*. Dilute 1.0 mL of reference solution (b) to 10.0 mL with the mobile phase.

*Reference solution (d)*. Dissolve 50.0 mg of the substance to be examined in 25.0 mL of a 40 g/L solution of *sodium edetate R* adjusted to pH 7.0 with *dilute sodium hydroxide R*. Heat in a boiling water-bath for 30 min. Cool to room temperature.

*Blank solution*. A 40 g/L solution of *sodium edetate R* adjusted to pH 7.0 with *dilute sodium hydroxide R*.

*Column*:

– *size*:  $l = 0.25$  m,  $\varnothing = 4.6$  mm;

– *stationary phase*: end-capped octadecylsilyl silica gel for chromatography R (5 µm).

*Mobile phase*: add 40 volumes of *acetonitrile R*, 300 volumes of *water R* and 520 volumes of *methanol R1* to 100 volumes of a 34.8 g/L solution of *dipotassium hydrogen phosphate R* adjusted to pH 6.0 with a 27.2 g/L solution of *potassium dihydrogen phosphate R*.

*Flow rate*: 1.0 mL/min.

*Detection*: spectrophotometer at 254 nm.

*Injection*: 100 µL; inject the blank, the test solution and reference solutions (a) and (c).

*Run time*: 3 times the retention time of bacitracin A.

*Relative retention* with reference to bacitracin A (retention time = 15 min to 25 min): bacitracin B1 = about 0.6; bacitracin B3 = about 0.8; impurity E = about 2.5.

If necessary, adjust the composition of the mobile phase by changing the amount of organic modifier whilst keeping the ratio constant between methanol and acetonitrile.

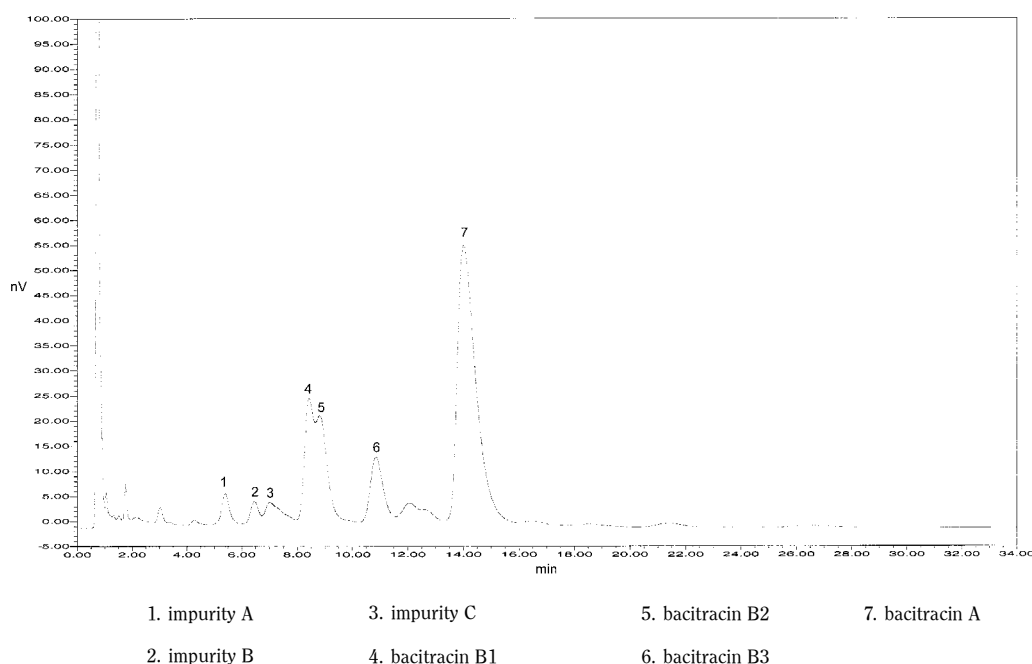

Figure 0465.-1. – Chromatogram of the test for composition in bacitracin obtained with the test solution at 254 nm



*System suitability*: reference solution (a):

- *peak-to-valley ratio*: minimum of 1.2, where  $H_p$  = height above the baseline of the peak due to bacitracin B1 and  $H_v$  = height above the baseline of the lowest point of the curve separating this peak from the peak due to bacitracin B2.

*Limits*:

- *bacitracin A*: minimum 40.0 per cent;
- *sum of bacitracins A, B1, B2 and B3*: minimum 70.0 per cent;
- *disregard limit*: the area of the peak due to bacitracin A in the chromatogram obtained with reference solution (c) (0.5 per cent); disregard any peak observed in the blank run.

**Related peptides**. Liquid chromatography (2.2.29) as described in the test for composition.

See Figure 0465.-1.

*Limit*:

- *sum of the areas of all peaks eluting before the peak due to bacitracin B1*: maximum 20.0 per cent.

**Impurity E**. Liquid chromatography (2.2.29) as described in the test for composition.

See Figure 0465.-2.

*Detection*: spectrophotometer at 254 nm; spectrophotometer at 300 nm for reference solution (d).

*Injection*: test solution and reference solutions (b) and (d).

*Limit*:

- *impurity E*: not more than 1.2 times the area of the principal peak in the chromatogram obtained with reference solution (b) (6.0 per cent).

**Loss on drying** (2.2.32): maximum 5.0 per cent, determined on 1.000 g by drying at 60 °C over *diphosphorus pentoxide R* at a pressure not exceeding 0.1 kPa for 3 h.

**Sulfated ash** (2.4.14): maximum 1.0 per cent, determined on 1.0 g.

**Sterility** (2.6.1). If intended for the preparation of ophthalmic dosage forms without a further appropriate sterilisation procedure, it complies with the test for sterility.

**Bacterial endotoxins** (2.6.14): less than 0.8 IU/mg, if intended for use in the manufacture of ophthalmic dosage forms without a further appropriate procedure for the removal of bacterial endotoxins.

#### ASSAY

Carry out the microbiological assay of antibiotics (2.7.2). Use *bacitracin zinc CRS* as the reference substance.

#### STORAGE

In an airtight container at 2 °C to 8 °C. If the substance is sterile, store in a sterile, airtight, tamper-proof container.

#### IMPURITIES

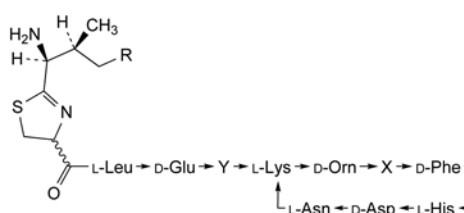

A. X = L-Val, Y = L-Ile, R = H: bacitracin C1,

B. X = L-Ile, Y = L-Val, R = H: bacitracin C2,

C. X = Y = L-Val, R = CH<sub>3</sub>: bacitracin C3,

D. X = Y = L-Val, R = H: bacitracin E,

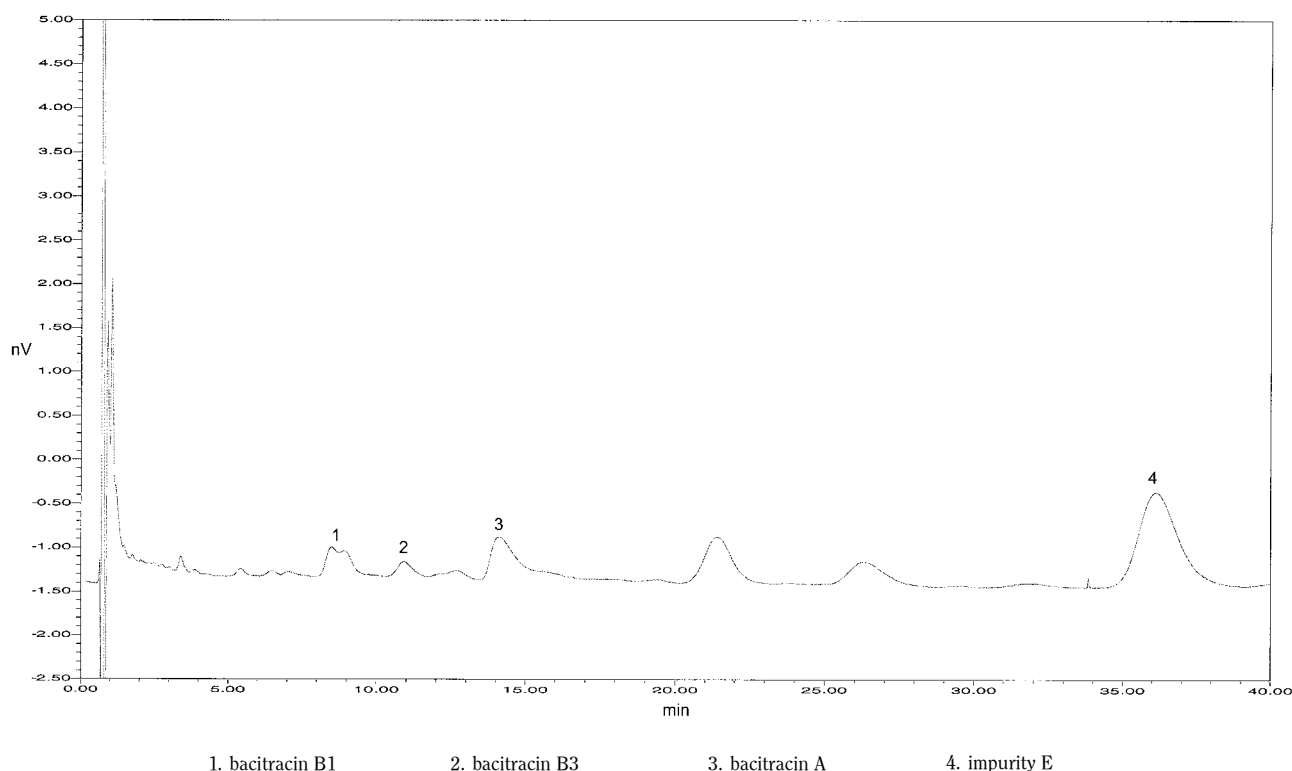
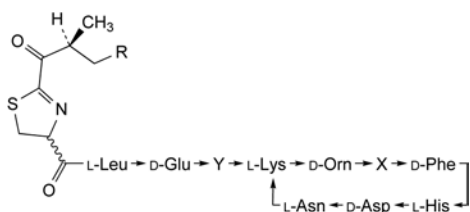

Figure 0465.-2. – Chromatogram of the test for impurity E in bacitracin obtained with reference solution (d) at 300 nm



- E. X = Y = L-Ile, R = CH<sub>3</sub>: bacitracin F,  
 F. X = Y = L-Ile, R = H: bacitracin H1,  
 G. X = L-Val, Y = L-Ile, R = CH<sub>3</sub>: bacitracin H2,  
 H. X = L-Ile, Y = L-Val, R = CH<sub>3</sub>: bacitracin H3,  
 I. X = L-Val, Y = L-Ile, R = H: bacitracin I1,  
 J. X = L-Ile, Y = L-Val, R = H: bacitracin I2,  
 K. X = Y = L-Val, R = CH<sub>3</sub>: bacitracin I3.

01/2008:0466

## BACITRACIN ZINC

### Bacitracinum zincum

#### DEFINITION

Zinc complex of bacitracin, which consists of a mixture of antimicrobial polypeptides produced by certain strains of *Bacillus licheniformis* or *Bacillus subtilis*, the main components being bacitracins A, B1, B2 and B3.

*Content*: minimum 60 IU/mg (dried substance).

#### CHARACTERS

*Appearance*: white or light yellowish-grey powder, hygroscopic.

*Solubility*: slightly soluble in water and in ethanol (96 per cent).

#### IDENTIFICATION

*First identification*: B, C.

*Second identification*: A, C.

A. Thin-layer chromatography (2.2.27).

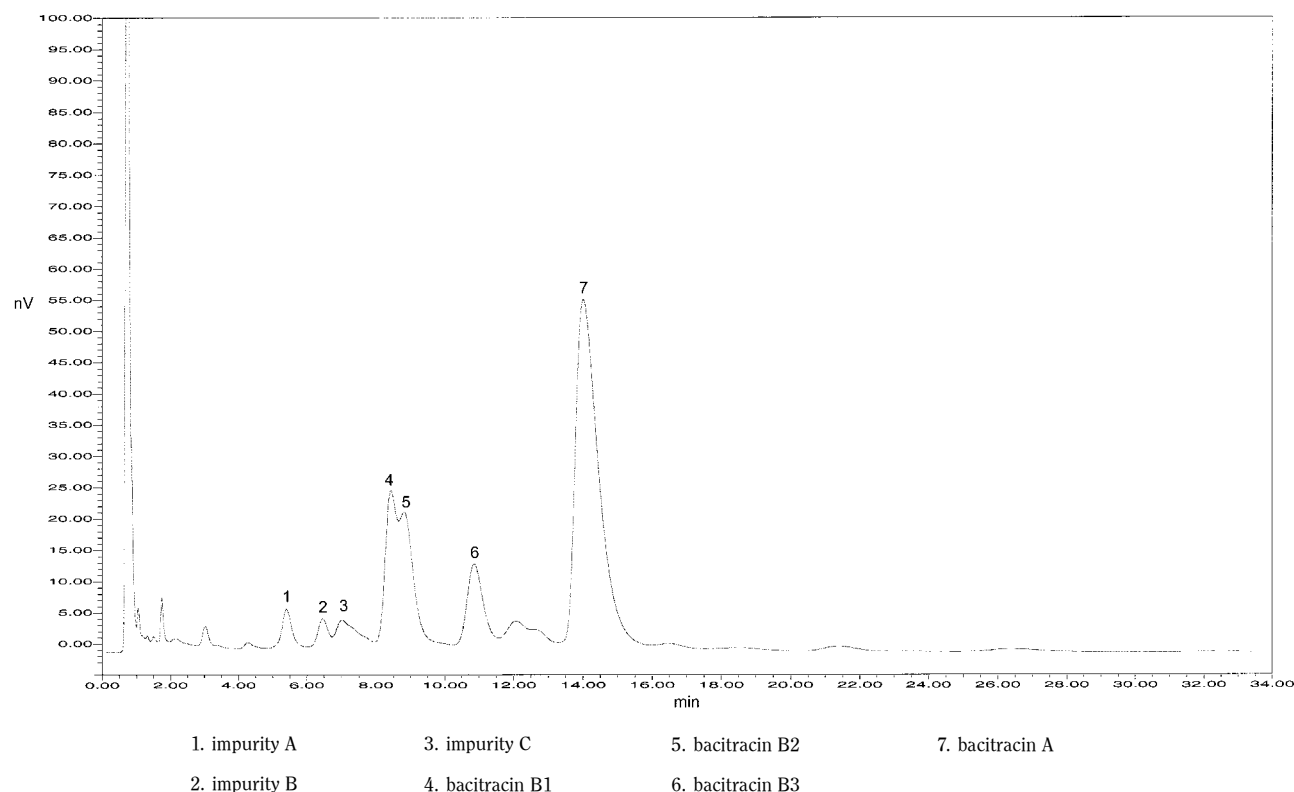

Figure 0466-1. – Chromatogram of the test for composition in bacitracin zinc obtained with the test solution at 254 nm

*Test solution*. Dissolve 10 mg of the substance to be examined in 0.5 mL of *dilute hydrochloric acid R* and dilute to 1.0 mL with *water R*.

*Reference solution*. Dissolve 10 mg of *bacitracin zinc CRS* in 0.5 mL of *dilute hydrochloric acid R* and dilute to 1.0 mL with *water R*.

*Plate*: TLC silica gel plate R.

*Mobile phase*: glacial acetic acid R, water R, butanol R (1:2:4 V/V/V).

*Application*: 10 µL.

*Development*: over half of the plate.

*Drying*: at 100-105 °C.

*Detection*: spray with *ninhydrin solution R1* and heat at 110 °C for 5 min.

*Results*: the spots in the chromatogram obtained with the test solution are similar in position, size and colour to the spots in the chromatogram obtained with the reference solution.

B. Composition (see Tests).

C. Ignite about 0.15 g, allow to cool and dissolve the residue in 1 mL of *dilute hydrochloric acid R*. Add 4 mL of *water R*. The solution gives the reaction of zinc (2.3.1).

#### TESTS

**pH** (2.2.3): 6.0 to 7.5.

Shake 1.0 g for about 1 min with 10 mL of *carbon dioxide-free water R* and filter.

**Composition**. Liquid chromatography (2.2.29): use the normalisation procedure. *Prepare the solutions immediately before use*.

*Test solution*. Dissolve 0.100 g of the substance to be examined in 50.0 mL of a 40 g/L solution of *sodium edetate R* adjusted to pH 7.0 with *dilute sodium hydroxide R*.

*Reference solution (a)*. Dissolve 20.0 mg of *bacitracin zinc CRS* in 10.0 mL of a 40 g/L solution of *sodium edetate R* adjusted to pH 7.0 with *dilute sodium hydroxide R*.

*Reference solution (b)*. Dilute 5.0 mL of the test solution to 100.0 mL with *water R*.

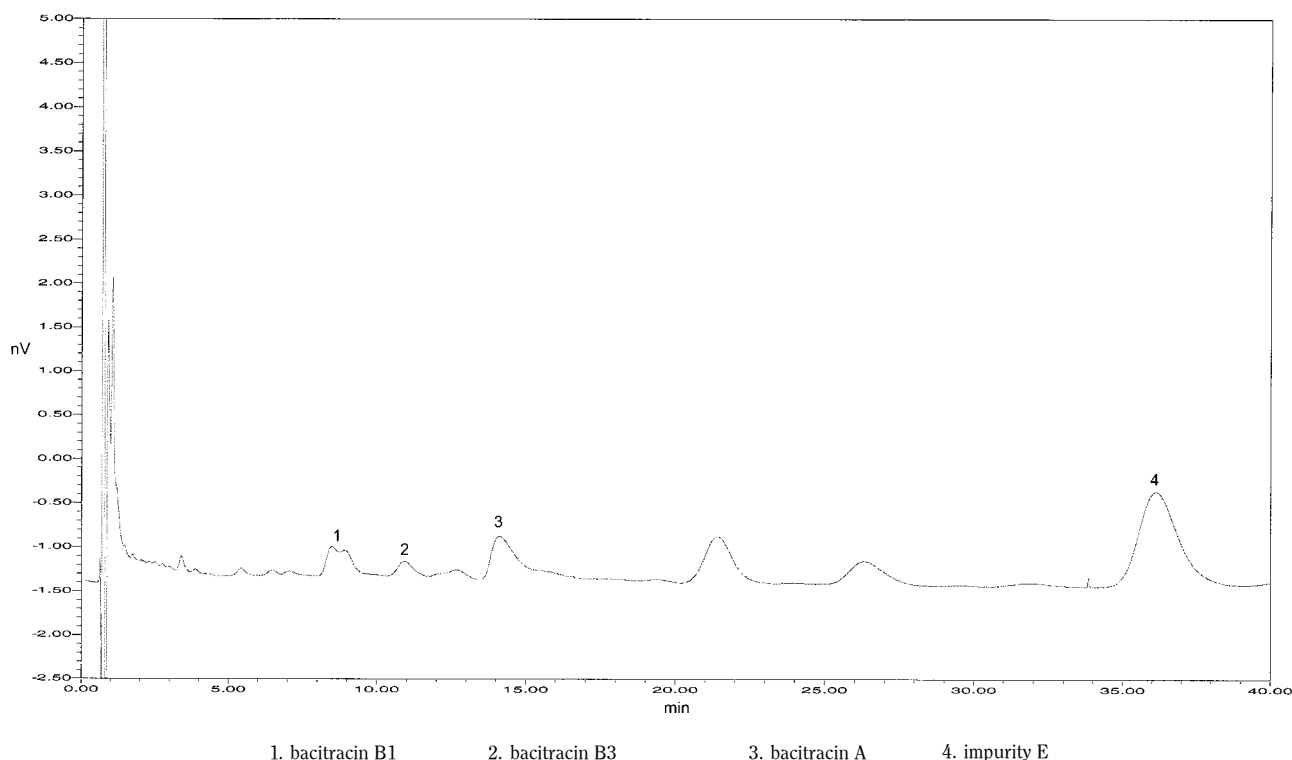

Figure 0466-2. – Chromatogram of the test for impurity E in bacitracin zinc obtained with reference solution (d) at 300 nm

**Reference solution (c).** Dilute 1.0 mL of reference solution (b) to 10.0 mL with water R.

**Reference solution (d).** Dissolve 50.0 mg of the substance to be examined in 25.0 mL of a 40 g/L solution of sodium edetate R adjusted to pH 7.0 with dilute sodium hydroxide R. Heat in a boiling water-bath for 30 min. Cool to room temperature.

**Blank solution.** A 40 g/L solution of sodium edetate R adjusted to pH 7.0 with dilute sodium hydroxide R.

**Column:**

- size:  $l = 0.25$  m,  $\varnothing = 4.6$  mm;
- stationary phase: end-capped octadecylsilyl silica gel for chromatography R (5  $\mu$ m).

**Mobile phase:** add 520 volumes of methanol R1, 40 volumes of acetonitrile R and 300 volumes of water R to 100 volumes of a 34.8 g/L solution of dipotassium hydrogen phosphate R, adjusted to pH 6.0 with a 27.2 g/L solution of potassium dihydrogen phosphate R.

**Flow rate:** 1.0 mL/min.

**Detection:** spectrophotometer at 254 nm.

**Injection:** 100  $\mu$ L; inject the blank, the test solution and reference solutions (a) and (c).

**Run time:** 3 times the retention time of bacitracin A.

**Relative retention** with reference to bacitracin A (retention time = 15 min to 25 min): bacitracin B1 = about 0.6; bacitracin B3 = about 0.8; impurity E = about 2.5.

If necessary, adjust the composition of the mobile phase by changing the amount of organic modifier whilst keeping the ratio constant between methanol and acetonitrile.

**System suitability:** reference solution (a):

- peak-to-valley ratio: minimum of 1.2, where  $H_p$  = height above the baseline of the peak due to bacitracin B1 and  $H_v$  = height above the baseline of the lowest point of the curve separating this peak from the peak due to bacitracin B2.

**Limits:**

- bacitracin A: minimum 40.0 per cent;
- sum of bacitracins A, B1, B2 and B3: minimum 70.0 per cent;

- disregard limit: the area of the peak due to bacitracin A in the chromatogram obtained with reference solution (c) (0.5 per cent); disregard any peak observed in the blank run.

**Related peptides.** Liquid chromatography (2.2.29) as described in the test for composition.

See Figure 0466-1.

**Limit:**

- sum of the areas of all peaks eluting before the peak due to bacitracin B1: maximum 20.0 per cent.

**Impurity E.** Liquid chromatography (2.2.29) as described in the test for composition.

See Figure 0466-2.

**Detection:** spectrophotometer at 254 nm; spectrophotometer at 300 nm for reference solution (d).

**Injection:** test solution and reference solutions (b) and (d).

**Limit:**

- impurity E: not more than 1.2 times the area of the principal peak in the chromatogram obtained with reference solution (b) (6.0 per cent).

**Zinc:** 4.0 per cent to 6.0 per cent (dried substance).

Dissolve 0.200 g in a mixture of 2.5 mL of dilute acetic acid R and 2.5 mL of water. Add 50 mL of water R, 50 mg of xylene orange tritrate R and sufficient hexamethylenetetramine R to produce a red colour. Add 2 g of hexamethylenetetramine R in excess. Titrate with 0.01 M sodium edetate until a yellow colour is obtained.

1 mL of 0.01 M sodium edetate is equivalent to 0.654 mg of Zn.

**Loss on drying** (2.2.32): maximum 5.0 per cent, determined on 1.000 g by drying at 60 °C over diphosphorus pentoxide R at a pressure not exceeding 0.1 kPa for 3 h.

**Sterility** (2.6.1). If intended for administration by spraying into internal body cavities without a further appropriate sterilisation procedure, it complies with the test for sterility.

**Pyrogens** (2.6.8). If intended for administration by spraying into internal body cavities without a further appropriate procedure for the removal of pyrogens, it complies with the test for pyrogens. Inject per kilogram of the rabbit's mass 1 mL of

the supernatant liquid obtained by centrifuging a suspension containing 11 mg per millilitre in a 9 g/L solution of *sodium chloride R*.

#### ASSAY

Suspend 50.0 mg in 5 mL of *water R*, add 0.5 mL of *dilute hydrochloric acid R* and dilute to 100.0 mL with *water R*. Allow the solution to stand for 30 min. Carry out the microbiological assay of antibiotics (2.7.2).

#### STORAGE

In an airtight container. If the substance is sterile, store in a sterile, airtight, tamper-proof container.

#### IMPURITIES

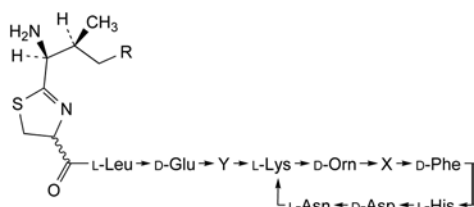

- A. X = L-Val, Y = L-Ile, R = H: bacitracin C1,  
 B. X = L-Ile, Y = L-Val, R = H: bacitracin C2,  
 C. X = Y = L-Val, R = CH<sub>3</sub>: bacitracin C3,  
 D. X = Y = L-Val, R = H: bacitracin E,

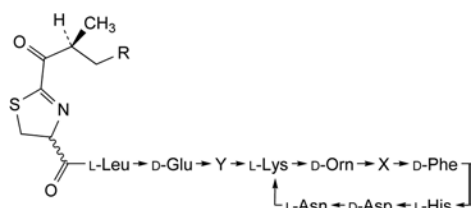

- E. X = Y = L-Ile, R = CH<sub>3</sub>: bacitracin F,  
 F. X = Y = L-Ile, R = H: bacitracin H1,  
 G. X = L-Val, Y = L-Ile, R = CH<sub>3</sub>: bacitracin H2,  
 H. X = L-Ile, Y = L-Val, R = CH<sub>3</sub>: bacitracin H3,  
 I. X = L-Val, Y = L-Ile, R = H: bacitracin I1,  
 J. X = L-Ile, Y = L-Val, R = H: bacitracin I2,  
 K. X = Y = L-Val, R = CH<sub>3</sub>: bacitracin I3.

01/2008:0653

## BACLOFEN

### Baclofenum

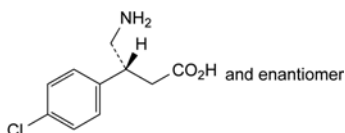

C<sub>10</sub>H<sub>12</sub>ClNO<sub>2</sub>  
 [1134-47-0]

M<sub>r</sub> 213.7

#### DEFINITION

(3*RS*)-4-Amino-3-(4-chlorophenyl)butanoic acid.

*Content*: 98.0 per cent to 101.0 per cent (anhydrous substance).

#### CHARACTERS

*Appearance*: white or almost white powder.

*Solubility*: slightly soluble in water, very slightly soluble in ethanol (96 per cent), practically insoluble in acetone. It dissolves in dilute mineral acids and in dilute solutions of alkali hydroxides.

It shows polymorphism (5.9).

#### IDENTIFICATION

*First identification*: B.

*Second identification*: A, C.

- A. Ultraviolet and visible absorption spectrophotometry (2.2.25).

*Test solution*. Dissolve 70 mg in *water R* and dilute to 100.0 mL with the same solvent.

*Spectral range*: 220-320 nm.

*Absorption maxima*: at 259 nm, 266 nm and 275 nm.

*Resolution* (2.2.25): minimum 1.5 for the absorbance ratio.

*Specific absorbance at the absorption maxima*:

- at 259 nm: 9.8 to 10.8;
- at 266 nm: 11.5 to 12.7;
- at 275 nm: 8.4 to 9.3.

- B. Infrared absorption spectrophotometry (2.2.24).

*Preparation*: discs prepared using 3 mg of substance and 300 mg of *potassium bromide R*.

*Comparison*: baclofen CRS.

If the spectra obtained in the solid state show differences, dissolve 0.1 g of each of the substances separately in 1 mL of *dilute sodium hydroxide solution R* and add 10 mL of *ethanol (96 per cent) R* and 1 mL of *dilute acetic acid R*. Allow to stand for 1 h. Filter, wash the precipitate with *ethanol (96 per cent) R* and dry *in vacuo*. Prepare new discs and record the spectra.

- C. Thin-layer chromatography (2.2.27).

*Test solution*. Dissolve 10 mg of the substance to be examined in the mobile phase and dilute to 10 mL with the mobile phase.

*Reference solution*. Dissolve 10 mg of *baclofen CRS* in the mobile phase and dilute to 10 mL with the mobile phase.

*Plate*: TLC silica gel G plate R.

*Mobile phase*: *anhydrous formic acid R*, *water R*, *methanol R*, *chloroform R*, *ethyl acetate R* (5:5:20:30:40 V/V/V/V/V).

*Application*: 5 µL.

*Development*: over a path of 12 cm.

*Drying*: allow the solvents to evaporate.

*Detection*: spray with *ninhydrin solution R3* until the plate is slightly wet. Place in an oven maintained at 100 °C for 10 min. Examine in daylight.

*Results*: the principal spot in the chromatogram obtained with the test solution is similar in position, colour and size to the principal spot in the chromatogram obtained with the reference solution.

#### TESTS

**Appearance of solution.** The solution is not more opalescent than reference suspension II (2.2.1) and not more intensely coloured than reference solution BY<sub>5</sub> (2.2.2, *Method II*).

Dissolve 0.50 g in 1 M *sodium hydroxide* and dilute to 25 mL with the same solvent.

**Related substances.** Liquid chromatography (2.2.29).

*Test solution*. Dissolve 25.0 mg of the substance to be examined in the mobile phase and dilute to 10.0 mL with the mobile phase.

*Reference solution (a)*. Dissolve 25.0 mg of *baclofen impurity A CRS* in the mobile phase and dilute to 10.0 mL with the mobile phase.

*Reference solution (b)*. Dilute 1.0 mL of reference solution (a) to 100.0 mL with the mobile phase.

*Reference solution (c)*. Dilute 2.0 mL of the test solution to 100.0 mL with the mobile phase.

*Reference solution (d)*. Dilute 2.0 mL of the test solution and 2.0 mL of reference solution (a) to 100.0 mL with the mobile phase.

## Column:

01/2008:1293

- size:  $l = 0.25$  m,  $\varnothing = 4.0$  mm;
- stationary phase: octadecylsilyl silica gel for chromatography R (10  $\mu$ m).

Mobile phase: dissolve 1.822 g of sodium hexanesulfonate R in 1 litre of a mixture of 560 volumes of water R, 440 volumes of methanol R and 5 volumes of glacial acetic acid R.

Flow rate: 2.0 mL/min.

Detection: spectrophotometer at 266 nm.

Injection: 20  $\mu$ L of the test solution and reference solutions (b), (c) and (d).

Run time: 5 times the retention time of baclofen.

System suitability: reference solution (d):

- resolution: minimum 2.0 between the peaks due to baclofen and impurity A.

## Limits:

- impurity A: not more than the area of the principal peak in the chromatogram obtained with reference solution (b) (1.0 per cent);
- total: not more than the area of the principal peak in the chromatogram obtained with reference solution (c) (2.0 per cent).

Water (2.5.12): maximum 1.0 per cent, determined on 1.000 g.

Sulfated ash (2.4.14): maximum 0.1 per cent, determined on 1.0 g.

## ASSAY

Dissolve 0.1500 g in 50 mL of anhydrous acetic acid R. Titrate with 0.1 M perchloric acid, determining the end-point potentiometrically (2.2.20).

1 mL of 0.1 M perchloric acid is equivalent to 21.37 mg of  $C_{10}H_{12}ClNO_2$ .

## IMPURITIES

Specified impurities: A.

Other detectable impurities (the following substances would, if present at a sufficient level, be detected by one or other of the tests in the monograph. They are limited by the general acceptance criterion for other/unspecified impurities and/or by the general monograph *Substances for pharmaceutical use* (2034). It is therefore not necessary to identify these impurities for demonstration of compliance. See also 5.10. *Control of impurities in substances for pharmaceutical use*): B.

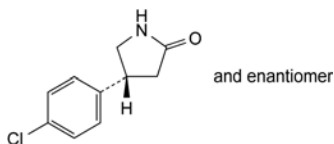

A. (4RS)-4-(4-chlorophenyl)pyrrolidin-2-one,

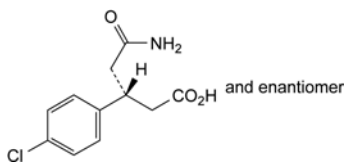

B. (3RS)-5-amino-3-(4-chlorophenyl)-5-oxopentanoic acid.

## BAMBUTEROL HYDROCHLORIDE

## Bambuteroli hydrochloridum

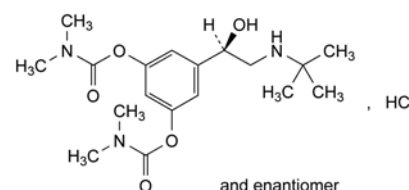

$C_{18}H_{30}ClN_3O_5$   
[81732-46-9]

$M_r$  403.9

## DEFINITION

5-[(1RS)-2-[(1,1-Dimethylethyl)amino]-1-hydroxyethyl]-1,3-phenylene bis(dimethylcarbamate) hydrochloride.

Content: 98.5 per cent to 101.5 per cent (anhydrous substance).

## CHARACTERS

Appearance: white or almost white, crystalline powder.

Solubility: freely soluble in water, soluble in ethanol (96 per cent).

It shows polymorphism (5.9).

## IDENTIFICATION

A. Infrared absorption spectrophotometry (2.2.24).

Preparation: discs.

Comparison: bambuterol hydrochloride CRS.

If the spectra obtained show differences, dissolve the substance to be examined and the reference substance separately in a mixture of 1 volume of water R and 6 volumes of acetone R, cool in ice to precipitate and dry both precipitates *in vacuo* at 50 °C to constant weight. Record new spectra using the residues.

B. It gives reaction (a) of chlorides (2.3.1).

## TESTS

**Solution S.** Dissolve 4.0 g in carbon dioxide-free water R and dilute to 20.0 mL with the same solvent.

**Acidity or alkalinity.** To 10 mL of solution S add 0.2 mL of methyl red solution R and 0.2 mL of 0.01 M hydrochloric acid. The solution is red. Add 0.4 mL of 0.01 M sodium hydroxide. The solution is yellow.

**Optical rotation** (2.2.7):  $-0.10^\circ$  to  $+0.10^\circ$ .

Dilute 1 mL of solution S to 10 mL with carbon dioxide-free water R.

**Related substances.** Liquid chromatography (2.2.29).

**Test solution.** Dissolve 5.0 mg of the substance to be examined in the mobile phase and dilute to 10.0 mL with the mobile phase.

**Reference solution (a).** Dissolve 1.0 mg of formoterol fumarate dihydrate CRS in the mobile phase and dilute to 10.0 mL with the mobile phase. Mix 0.8 mL of this solution with 0.4 mL of the test solution and dilute to 100.0 mL with the mobile phase.

**Reference solution (b).** Dilute 1.0 mL of the test solution to 50.0 mL with the mobile phase. Dilute 2.0 mL of this solution to 20.0 mL with the mobile phase.

Column:

- size:  $l = 0.15$  m,  $\varnothing = 4.6$  mm;
- stationary phase: base-deactivated octadecylsilyl silica gel for chromatography R (5  $\mu$ m).

Mobile phase: dissolve 1.3 g of sodium octanesulfonate R in 430 mL of a mixture of 25 volumes of acetonitrile R1 and 75 volumes of methanol R; then mix this solution with 570 mL of 0.050 M phosphate buffer pH 3.0 prepared as follows: dissolve

01/2008:0170  
corrected 6.0

6.90 g of *sodium dihydrogen phosphate monohydrate R* in *water R* and dilute to 1000 mL with *water R*, adjust to pH 3.0 with a 50 g/L solution of *dilute phosphoric acid R*.

*Flow rate*: 1.5 mL/min.

*Detection*: spectrophotometer at 214 nm.

*Injection*: 20 µL; inject the mobile phase as a blank.

*Run time*: 1.5 times the retention time of bambuterol.

*Retention time*: formoterol = about 7 min; bambuterol = about 9 min. If necessary, adjust the composition of the mobile phase; increase the content of phosphate buffer to increase the retention time.

*System suitability*: reference solution (a):

- *resolution*: minimum 5.0 between the peaks due to bambuterol and formoterol.

*Limits*:

- *impurities A, B, C, D, E, F*: for each impurity, not more than the area of the principal peak in the chromatogram obtained with reference solution (b) (0.2 per cent);
- *total*: not more than 3 times the area of the principal peak in the chromatogram obtained with reference solution (b) (0.6 per cent);
- *disregard limit*: 0.25 times the area of the principal peak in the chromatogram obtained with reference solution (b) (0.05 per cent); disregard any peak due to the mobile phase.

**Water** (2.5.12): maximum 0.5 per cent, determined on 0.500 g.

**Sulfated ash** (2.4.14): maximum 0.1 per cent, determined on 1.0 g.

#### ASSAY

Dissolve 0.320 g in 50 mL of *ethanol (96 per cent) R* and add 5 mL of 0.01 M *hydrochloric acid*. Carry out a potentiometric titration (2.2.20), using 0.1 M *sodium hydroxide*. Read the volume added between the 2 points of inflexion.

1 mL of 0.1 M *sodium hydroxide* is equivalent to 40.39 mg of  $C_{18}H_{30}ClN_3O_5$ .

#### IMPURITIES

*Specified impurities*: A, B, C, D, E, F.

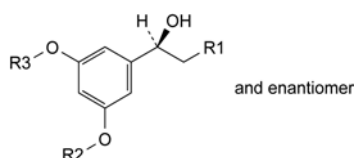

- A. R1 = NH-C(CH<sub>3</sub>)<sub>3</sub>, R2 = R3 = H: (1*RS*)-1-(3,5-dihydroxyphenyl)-2-[(1,1-dimethylethyl)amino]ethanol (terbutaline),
- B. R1 = OH, R2 = R3 = CO-N(CH<sub>3</sub>)<sub>2</sub>: 5-[(1*RS*)-1,2-dihydroxyethyl]-1,3-phenylene bis(dimethylcarbamate),
- C. R1 = NH-C(CH<sub>3</sub>)<sub>3</sub>, R2 = H, R3 = CO-N(CH<sub>3</sub>)<sub>2</sub>: 3-[(1*RS*)-2-[(1,1-dimethylethyl)amino]-1-hydroxyethyl]-5-hydroxyphenyl dimethylcarbamate,
- D. R1 = H, R2 = R3 = CO-N(CH<sub>3</sub>)<sub>2</sub>: 5-[(1*RS*)-1-hydroxyethyl]-1,3-phenylene bis(dimethylcarbamate),

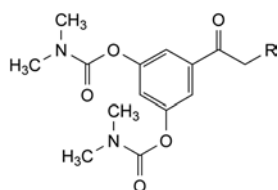

- E. R = H: 5-acetyl-1,3-phenylene bis(dimethylcarbamate),
- F. R = NH-C(CH<sub>3</sub>)<sub>3</sub>: 5-[[[(1,1-dimethylethyl)amino]acetyl]-1,3-phenylene bis(dimethylcarbamate).

## BARBITAL

### Barbitalum

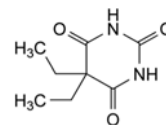

$C_8H_{12}N_2O_3$   
[57-44-3]

$M_r$  184.2

#### DEFINITION

Barbital contains not less than 99.0 per cent and not more than the equivalent of 101.0 per cent of 5,5-diethylpyrimidine-2,4,6-(1*H*,3*H*,5*H*)-trione, calculated with reference to the dried substance.

#### CHARACTERS

A white or almost white, crystalline powder or colourless crystals, slightly soluble in water, soluble in boiling water and in alcohol. It forms water-soluble compounds with alkali hydroxides and carbonates and with ammonia.

#### IDENTIFICATION

*First identification*: A, B.

*Second identification*: A, C, D.

- A. Determine the melting point (2.2.14) of the substance to be examined. Mix equal parts of the substance to be examined and *barbital CRS* and determine the melting point of the mixture. The difference between the melting points (which are about 190 °C) is not greater than 2 °C.
- B. Examine by infrared absorption spectrophotometry (2.2.24), comparing with the spectrum obtained with *barbital CRS*.
- C. Examine by thin-layer chromatography (2.2.27), using *silica gel GF<sub>254</sub> R* as the coating substance.

*Test solution*. Dissolve 75 mg of the substance to be examined in *alcohol R* and dilute to 25 mL with the same solvent.

*Reference solution*. Dissolve 75 mg of *barbital CRS* in *alcohol R* and dilute to 25 mL with the same solvent.

Apply separately to the plate 10 µL of each solution. Develop over a path of 18 cm using the lower layer of a mixture of 5 volumes of *concentrated ammonia R*, 15 volumes of *alcohol R* and 80 volumes of *chloroform R*. Examine immediately in ultraviolet light at 254 nm. The principal spot in the chromatogram obtained with the test solution is similar in position and size to the principal spot in the chromatogram obtained with the reference solution.

- D. It gives the reaction of non-nitrogen substituted barbiturates (2.3.1).

#### TESTS

**Appearance of solution**. Dissolve 1.0 g in a mixture of 4 mL of *dilute sodium hydroxide solution R* and 6 mL of *water R*. The solution is clear (2.2.1) and not more intensely coloured than reference solution  $Y_6$  (2.2.2, *Method II*).

**Acidity**. Boil 1.0 g with 50 mL of *water R* for 2 min, allow to cool and filter. To 10 mL of the filtrate add 0.15 mL of *methyl red solution R*. The solution is orange-yellow. Not more than 0.1 mL of 0.1 M *sodium hydroxide* is required to produce a pure yellow colour.

**Related substances**. Examine by thin-layer chromatography (2.2.27), using *silica gel GF<sub>254</sub> R* as the coating substance.

*Test solution*. Dissolve 1.0 g of the substance to be examined in *alcohol R* and dilute to 100 mL with the same solvent.

**Reference solution.** Dilute 0.5 mL of the test solution to 100 mL with *alcohol R*.

Apply separately to the plate 20 µL of each solution. Develop over a path of 15 cm using the lower layer of a mixture of 5 volumes of *concentrated ammonia R*, 15 volumes of *alcohol R* and 80 volumes of *chloroform R*. Examine immediately in ultraviolet light at 254 nm. Spray with *diphenylcarbazone mercuric reagent R*. Allow the plate to dry in air and spray with freshly prepared *alcoholic potassium hydroxide solution R* diluted 1 in 5 with *aldehyde-free alcohol R*. Heat at 100 °C to 105 °C for 5 min and examine immediately. When examined in ultraviolet light and after spraying, any spot in the chromatogram obtained with the test solution, apart from the principal spot, is not more intense than the spot in the chromatogram obtained with the reference solution (0.5 per cent).

**Loss on drying (2.2.32).** Not more than 0.5 per cent, determined on 1.00 g by drying in an oven at 105 °C.

**Sulfated ash (2.4.14).** Not more than 0.1 per cent, determined on 1.0 g.

#### ASSAY

Dissolve 85.0 mg in 5 mL of *pyridine R*. Add 0.5 mL of *thymolphthalein solution R* and 10 mL of *silver nitrate solution in pyridine R*. Titrate with 0.1 M *ethanolic sodium hydroxide* until a pure blue colour is obtained. Carry out a blank titration. 1 mL of 0.1 M *ethanolic sodium hydroxide* is equivalent to 9.21 mg of  $C_8H_{12}N_2O_3$ .

01/2008:0010  
corrected 7.0

## BARIUM SULFATE

### Barii sulfas

$BaSO_4$   $M_r$  233.4  
[7727-43-7]

#### CHARACTERS

**Appearance:** fine, white or almost white powder, free from gritty particles.

**Solubility:** practically insoluble in water and in organic solvents. It is very slightly soluble in acids and in solutions of alkali hydroxides.

#### IDENTIFICATION

- Boil a suspension of 0.2 g with 5 mL of a 500 g/L solution of *sodium carbonate R* for 5 min, add 10 mL of *water R*, filter and acidify a part of the filtrate with *dilute hydrochloric acid R*. The solution gives the reactions of sulfates (2.3.1).
- Wash the residue collected in the preceding test with 3 successive small quantities of *water R*. To the residue add 5 mL of *dilute hydrochloric acid R*, filter and add to the filtrate 0.3 mL of *dilute sulfuric acid R*. A white precipitate is formed that is insoluble in *dilute sodium hydroxide solution R*.

#### TESTS

**Solution S.** To 20.0 g add 40 mL of *distilled water R* and 60 mL of *dilute acetic acid R*. Boil for 5 min, filter and dilute the cooled filtrate to 100 mL with *distilled water R*.

**Acidity or alkalinity.** Heat 5.0 g with 20 mL of *carbon dioxide-free water R* on a water-bath for 5 min and filter. To 10 mL of the filtrate add 0.05 mL of *bromothymol blue solution R1*. Not more than 0.5 mL of 0.01 M *hydrochloric acid* or 0.01 M *sodium hydroxide* is required to change the colour of the indicator.

**Acid-soluble substances:** maximum 0.3 per cent.

Evaporate 25 mL of solution S to dryness on a water-bath and dry to constant mass at 100-105 °C. The residue weighs a maximum of 15 mg.

**Oxidisable sulfur compounds.** Shake 1.0 g with 5 mL of *water R* for 30 s and filter. To the filtrate add 0.1 mL of *starch solution R*, dissolve 0.1 g of *potassium iodide R* in the mixture, add 1.0 mL of a freshly prepared 3.6 mg/L solution of *potassium iodate R* and 1 mL of 1 M *hydrochloric acid* and shake well. The colour of the solution is more intense than that of a standard prepared at the same time and in the same manner, but omitting the potassium iodate.

**Soluble barium salts:** maximum 10 ppm.

To 2.5 mL of a 0.2 mg/L solution of *barium nitrate R* in a mixture of 30 volumes of *ethanol (96 per cent) R* and 70 volumes of *water R*, add 10 mL of *dilute sulfuric acid R*. Shake and allow to stand for 5 min. To 1 mL of this solution add 10 mL of solution S. Prepare a standard in the same manner using 10 mL of *barium standard solution (2 ppm Ba) R* instead of solution S.

After 10 min, any opalescence in the test solution is not more intense than that in the standard.

**Heavy metals (2.4.8):** maximum 10 ppm.

Dilute 10 mL of solution S to 20 mL with *water R*. 12 mL of the solution complies with test A. Prepare the reference solution using *lead standard solution (1 ppm Pb) R*.

**Loss on ignition:** maximum 2.0 per cent, determined on 1.0 g at  $600 \pm 50$  °C.

01/2008:1975  
corrected 6.0

## BASIC BUTYLATED METHACRYLATE COPOLYMER

### Copolymerum methacrylatis butylati basicum

#### DEFINITION

Copolymer of 2-(dimethylamino)ethyl methacrylate, butyl methacrylate and methyl methacrylate having a mean relative molecular mass of about 150 000. The ratio of 2-dimethylaminoethyl methacrylate groups to butyl methacrylate and methyl methacrylate groups is about 2:1:1. **Content of dimethylaminoethyl groups:** 20.8 per cent to 25.5 per cent (dried substance).

#### CHARACTERS

**Appearance:** colourless or yellowish granules or white or almost white powder, slightly hygroscopic.

**Solubility:** practically insoluble in water, freely soluble in methylene chloride. It dissolves slowly in alcohol.

#### IDENTIFICATION

- Infrared absorption spectrophotometry (2.2.24).  
*Comparison:* Ph. Eur. reference spectrum of basic butylated methacrylate copolymer.
- It complies with the limits of the assay.

#### TESTS

**Solution S.** Dissolve 12.5 g in a mixture of 35.0 g of *acetone R* and 52.5 g of *2-propanol R*.

**Viscosity (2.2.10):** 3 mPa·s to 6 mPa·s, determined on solution S. **Apparatus:** rotating viscosimeter.

**Dimensions:**

- *spindle:* diameter = 25.15 mm, height = 90.74 mm, shaft diameter = 4 mm,
- *cylinder:* diameter = 27.62 mm, height = 0.135 m.

**Stirring speed:** 30 r/min.

*Volume of solution*: 16 mL of solution S.

*Temperature*: 20 °C.

**Absorbance** (2.2.25): maximum 0.30 at 420 nm, determined on solution S.

**Appearance of film**. Spread evenly 1.0 mL of solution S on a glass plate. Upon drying a clear film is formed.

**Monomers**: maximum 0.3 per cent, for the sum of contents of butyl methacrylate, methyl methacrylate and 2-dimethylaminoethyl methacrylate calculated by procedures A and B.

A. Butyl methacrylate and methyl methacrylate. Liquid chromatography (2.2.29).

*Test solution*. Dissolve 1.00 g of the substance to be examined in *phosphate buffer solution pH 2.0 R* and dilute to 50.0 mL with the same buffer solution.

*Reference solution*. Dissolve 10.0 mg of *butyl methacrylate R* and 10.0 mg of *methyl methacrylate R* in 10.0 mL of *acetonitrile R* and dilute to 50.0 mL with *water R*. Dilute 1.0 mL of the solution to 50.0 mL with *water R*.

*Column*:

- size:  $l = 0.125$  m,  $\varnothing = 4.6$  mm,
- stationary phase: octadecylsilyl silica gel for chromatography R (7  $\mu$ m).

*Mobile phase*: phosphate buffer solution pH 2.0 R, methanol R (45:55 V/V).

*Flow rate*: 2.0 mL/min.

*Detection*: spectrophotometer at 205 nm.

*Injection*: 50  $\mu$ L.

B. 2-Dimethylaminoethyl methacrylate. Liquid chromatography (2.2.29).

*Test solution*. Dissolve 1.00 g of the substance to be examined in *tetrahydrofuran R* and dilute to 50.0 mL with the same solvent.

*Reference solution*. Dissolve 10.0 mg of 2-(dimethylamino)ethyl methacrylate R in *tetrahydrofuran R* and dilute to 50.0 mL with the same solvent. Dilute 2.0 mL of the solution to 50.0 mL with *tetrahydrofuran R*.

*Column*:

- size:  $l = 0.125$  m,  $\varnothing = 4.6$  mm,
- stationary phase: aminopropylsilyl silica gel for chromatography R (10  $\mu$ m).

*Mobile phase*: mix 25 volumes of a 3.404 g/L solution of potassium dihydrogen phosphate R and 75 volumes of *tetrahydrofuran R*.

*Flow rate*: 2.0 mL/min.

*Detection*: spectrophotometer at 215 nm.

*Injection*: 50  $\mu$ L.

**Heavy metals** (2.4.8): maximum 20 ppm.

2.0 g complies with limit test C. Prepare the standard using 4.0 mL of *lead standard solution (10 ppm Pb) R*.

**Loss on drying** (2.2.32): maximum 2.0 per cent, determined on 1.000 g by drying in an oven at 110 °C for 3 h.

**Sulfated ash** (2.4.14): maximum 0.1 per cent, determined on 1.0 g.

#### ASSAY

Dissolve 0.200 g in a mixture of 4 mL of *water R* and 96 mL of *anhydrous acetic acid R*. Titrate with 0.1 M *perchloric acid*, determining the end-point potentiometrically (2.2.20).

1 mL of 0.1 M *perchloric acid* is equivalent to 7.21 mg of  $C_{28}H_{37}ClO_7$ .

#### STORAGE

In an airtight container.

#### IMPURITIES

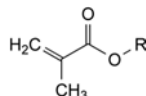

A. R =  $[\text{CH}_2]_3\text{-CH}_3$ : butyl methacrylate,

B. R =  $\text{CH}_3$ : methyl methacrylate,

C. R =  $\text{CH}_2\text{-CH}_2\text{-N}(\text{CH}_3)_2$ : 2-(dimethylamino)ethyl methacrylate.

01/2009:0654  
corrected 7.0

## BECLOMETASONE DIPROPIONATE, ANHYDROUS

### Beclometasoni dipropionas anhydricus

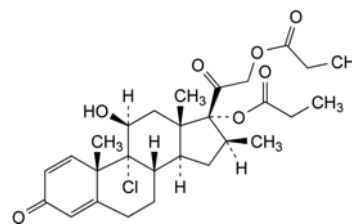

$C_{28}H_{37}ClO_7$   
[5534-09-8]

$M_r$  521.0

#### DEFINITION

9-Chloro-11 $\beta$ -hydroxy-16 $\beta$ -methyl-3,20-dioxopregna-1,4-diene-17,21-diyl dipropionate.

*Content*: 96.0 per cent to 102.0 per cent (dried substance).

#### CHARACTERS

*Appearance*: white or almost white, crystalline powder.

*Solubility*: practically insoluble in water, freely soluble in acetone, sparingly soluble in ethanol (96 per cent).

#### IDENTIFICATION

A. Infrared absorption spectrophotometry (2.2.24).

*Comparison*: *anhydrous beclometasone dipropionate CRS*.

B. Treat 25 mg by the oxygen-flask method (2.5.10). Use a mixture of 1 mL of 1 M *sodium hydroxide* and 20 mL of *water R* to absorb the combustion products. The solution gives reaction (a) of chlorides (2.3.1).

C. Loss on drying (see Tests).

#### TESTS

**Specific optical rotation** (2.2.7): + 108 to + 115 (dried substance).

Dissolve 0.100 g in *ethanol (96 per cent) R* and dilute to 10.0 mL with the same solvent.

**Related substances**. Liquid chromatography (2.2.29).

*Solvent mixture*: mobile phase A, mobile phase B (45:55 V/V).

*Test solution (a)*. Dissolve 50.0 mg of the substance to be examined in 28 mL of mobile phase B and dilute to 50.0 mL with mobile phase A.

*Test solution (b)*. Dilute 1.0 mL of test solution (a) to 50.0 mL with the solvent mixture.

*Reference solution (a)*. Dilute 5.0 mL of test solution (b) to 100.0 mL with the solvent mixture.

*Reference solution (b)*. Dissolve 5 mg of *beclometasone dipropionate for system suitability CRS* (containing impurity D) in 3 mL of mobile phase B and dilute to 5 mL with mobile phase A.

*Reference solution (c)*. Dissolve 5 mg of *beclometasone dipropionate for peak identification CRS* (containing impurities A, B, C, L and M) in 3 mL of mobile phase B and



dilute to 5 mL with mobile phase A. Use 1 mL of this solution to dissolve the contents of a vial of *beclometasone dipropionate impurities F and N CRS*.

**Reference solution (d).** Dissolve 50.0 mg of *anhydrous beclometasone dipropionate CRS* in 28 mL of mobile phase B and dilute to 50.0 mL with mobile phase A. Dilute 1.0 mL of this solution to 50.0 mL with the solvent mixture.

**Column:**

- **size:**  $l = 0.25$  m,  $\varnothing = 4.6$  mm;
- **stationary phase:** spherical difunctional bonded *end-capped octadecylsilyl silica gel for chromatography R* (5  $\mu$ m);
- **temperature:** 50 °C.

**Mobile phase:**

- **mobile phase A:** 2.72 g/L solution of *potassium dihydrogen phosphate R* adjusted to pH 2.35 with *phosphoric acid R*;
- **mobile phase B:** *tetrahydrofuran R*, *acetonitrile R*, *methanol R* (5:23:25 V/V/V);

Time (min)	Mobile phase A (per cent V/V)	Mobile phase B (per cent V/V)
0 - 4	40	60
4 - 12	40 → 45	60 → 55
12 - 59	45	55

**Flow rate:** 1.4 mL/min.

**Detection:** spectrophotometer at 254 nm.

**Injection:** 20  $\mu$ l of test solution (a) and reference solutions (a), (b) and (c).

**Identification of impurities:** use the chromatogram supplied with *beclometasone dipropionate for peak identification CRS* and the chromatogram obtained with reference solution (c) to identify the peaks due to impurities A, B, C, F, L, M and N; use the chromatogram supplied with *beclometasone dipropionate for system suitability CRS* and the chromatogram obtained with reference solution (b) to identify the peak due to impurity D.

**Relative retention** with reference to beclometasone dipropionate (retention time = about 25 min): impurity A = about 0.3; impurity B = about 0.6; impurity D = about 1.1; impurity M = about 1.2; impurity L = about 1.3; impurity C = about 1.8; impurity N = about 2.0; impurity F = about 2.2.

**System suitability:** reference solution (b):

- **peak-to-valley ratio:** minimum 1.5, where  $H_p$  = height above the baseline of the peak due to impurity D and  $H_v$  = height above the baseline of the lowest point of the curve separating this peak from the peak due to beclometasone dipropionate.

**Limits:**

- **correction factors:** for the calculation of content, multiply the peak areas of the following impurities by the corresponding correction factor: impurity F = 1.3; impurity M = 2.0;
- **impurity L:** not more than 6 times the area of the principal peak in the chromatogram obtained with reference solution (a) (0.6 per cent);
- **impurities B, F, M:** for each impurity, not more than 5 times the area of the principal peak in the chromatogram obtained with reference solution (a) (0.5 per cent);
- **impurities A, D, N:** for each impurity, not more than twice the area of the principal peak in the chromatogram obtained with reference solution (a) (0.2 per cent);
- **impurity C:** not more than 1.5 times the area of the principal peak in the chromatogram obtained with reference solution (a) (0.15 per cent);
- **unspecified impurities:** for each impurity, not more than the area of the principal peak in the chromatogram obtained with reference solution (a) (0.10 per cent);

- **total:** not more than 15 times the area of the principal peak in the chromatogram obtained with reference solution (a) (1.5 per cent);
- **disregard limit:** 0.5 times the area of the principal peak in the chromatogram obtained with reference solution (a) (0.05 per cent).

**Loss on drying (2.2.32):** maximum 0.5 per cent, determined on 1.000 g by drying in an oven at 105 °C for 3 h.

**ASSAY**

Liquid chromatography (2.2.29) as described in the test for related substances with the following modification.

**Injection:** test solution (b) and reference solution (d).

Calculate the percentage content of  $C_{28}H_{37}ClO_7$  from the declared content of *beclometasone dipropionate anhydrous CRS*.

**IMPURITIES**

**Specified impurities:** A, B, C, D, F, L, M, N.

**Other detectable impurities** (the following substances would, if present at a sufficient level, be detected by one or other of the tests in the monograph. They are limited by the general acceptance criterion for other/unspecified impurities and/or by the general monograph *Substances for pharmaceutical use (2034)*. It is therefore not necessary to identify these impurities for demonstration of compliance. See also 5.10. *Control of impurities in substances for pharmaceutical use*): E, H, I, J, O, Q, R, S, U, V.

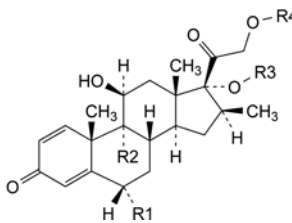

- A.  $R_1 = R_3 = H$ ,  $R_2 = Cl$ ,  $R_4 = CO-C_2H_5$ : 9-chloro-11 $\beta$ ,17-dihydroxy-16 $\beta$ -methyl-3,20-dioxopregna-1,4-dien-21-yl propanoate (beclometasone 21-propionate),
- B.  $R_1 = H$ ,  $R_2 = Cl$ ,  $R_3 = CO-C_2H_5$ ,  $R_4 = CO-CH_3$ : 21-(acetyloxy)-9-chloro-11 $\beta$ -hydroxy-16 $\beta$ -methyl-3,20-dioxopregna-1,4-dien-17-yl propanoate (beclometasone 21-acetate 17-propionate),
- C.  $R_1 = H$ ,  $R_2 = Cl$ ,  $R_3 = CO-C_2H_5$ ,  $R_4 = CO-CH_2-CH_2-CH_3$ : 9-chloro-11 $\beta$ -hydroxy-16 $\beta$ -methyl-3,20-dioxo-17-(propanoyloxy)-pregna-1,4-dien-21-yl butanoate (beclometasone 21-butyrate 17-propionate),
- D.  $R_1 = H$ ,  $R_2 = Br$ ,  $R_3 = R_4 = CO-C_2H_5$ : 9-bromo-11 $\beta$ -hydroxy-16 $\beta$ -methyl-3,20-dioxopregna-1,4-diene-17,21-diyl dipropionate,
- F.  $R_1 = Br$ ,  $R_2 = Cl$ ,  $R_3 = R_4 = CO-C_2H_5$ : 6 $\alpha$ -bromo-9-chloro-11 $\beta$ -hydroxy-16 $\beta$ -methyl-3,20-dioxopregna-1,4-diene-17,21-diyl dipropionate,

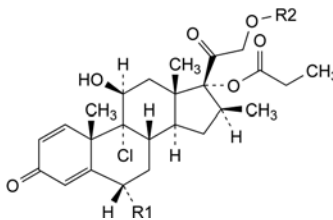

- E.  $R_1 = Cl$ ,  $R_2 = CO-C_2H_5$ : 6 $\alpha$ ,9-dichloro-11 $\beta$ -hydroxy-16 $\beta$ -methyl-3,20-dioxopregna-1,4-diene-17,21-diyl dipropionate,
- H.  $R_1 = R_2 = H$ : 9-chloro-11 $\beta$ ,21-dihydroxy-16 $\beta$ -methyl-3,20-dioxopregna-1,4-dien-17-yl propanoate (beclometasone 17-propionate),

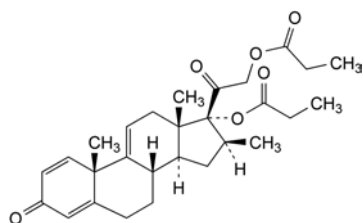

- I. 16β-methyl-3,20-dioxopregna-1,4,9(11)-triene-17,21-diyl dipropionate,

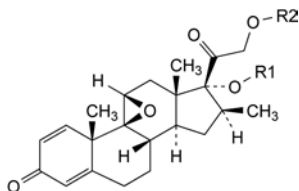

- J. R1 = R2 = CO-C<sub>2</sub>H<sub>5</sub>: 9,11β-epoxy-16β-methyl-3,20-dioxo-9β-pregna-1,4-diene-17,21-diyl dipropionate,

- R. R1 = R2 = H: 9,11β-epoxy-17,21-dihydroxy-16β-methyl-9β-pregna-1,4-diene-3,20-dione,

- U. R1 = CO-C<sub>2</sub>H<sub>5</sub>, R2 = H: 9,11β-epoxy-21-hydroxy-16β-methyl-3,20-dioxo-9β-pregna-1,4-dien-17-yl propanoate,

- V. R1 = H, R2 = CO-C<sub>2</sub>H<sub>5</sub>: 9,11β-epoxy-17-hydroxy-16β-methyl-3,20-dioxo-9β-pregna-1,4-dien-21-yl propanoate,

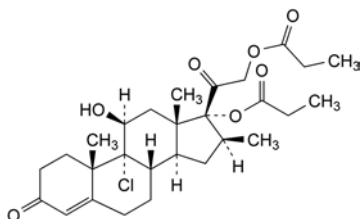

- L. 9-chloro-11β-hydroxy-16β-methyl-3,20-dioxopregna-4-ene-17,21-diyl dipropionate,

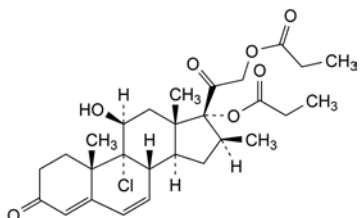

- M. 9-chloro-11β-hydroxy-16β-methyl-3,20-dioxopregna-4,6-diene-17,21-diyl dipropionate,

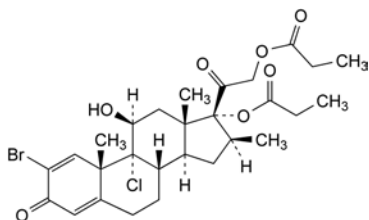

- N. 2-bromo-9-chloro-11β-hydroxy-16β-methyl-3,20-dioxopregna-1,4-diene-17,21-diyl dipropionate,

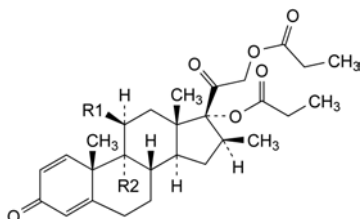

- O. R1 = R2 = Cl: 9,11β-dichloro-16β-methyl-3,20-dioxopregna-1,4-diene-17,21-diyl dipropionate,

- Q. R1 = R2 = H: 16β-methyl-3,20-dioxopregna-1,4-diene-17,21-diyl dipropionate,

- S. R1 = O-CO-C<sub>2</sub>H<sub>5</sub>, R2 = Cl: 9-chloro-16β-methyl-3,20-dioxopregna-1,4-diene-11β,17,21-triyl tripropanoate (beclometasone tripropionate).

01/2009:1709  
corrected 7.0

## BECLOMETASONE DIPROPIONATE MONOHYDRATE

Beclometasoni dipropionas monohydricus

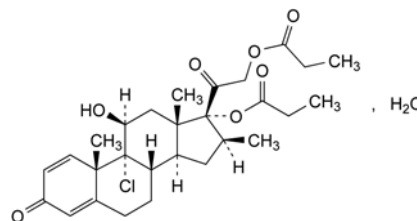

C<sub>28</sub>H<sub>37</sub>ClO<sub>7</sub>·H<sub>2</sub>O

M<sub>r</sub> 539.1

### DEFINITION

9-Chloro-11β-hydroxy-16β-methyl-3,20-dioxopregna-1,4-diene-17,21-diyl dipropionate monohydrate.

*Content*: 97.0 per cent to 102.0 per cent (dried substance).

### CHARACTERS

*Appearance*: white or almost white powder.

*Solubility*: practically insoluble in water, freely soluble in acetone, sparingly soluble in ethanol (96 per cent).

### IDENTIFICATION

- A. Infrared absorption spectrophotometry (2.2.24).

*Comparison*: beclometasone dipropionate monohydrate CRS.

- B. Treat 25 mg by the oxygen-flask method (2.5.10). Use a mixture of 1 mL of 1 M sodium hydroxide and 20 mL of water R to absorb the combustion products. The solution gives reaction (a) of chlorides (2.3.1).

- C. Loss on drying (see Tests).

### TESTS

**Specific optical rotation** (2.2.7): + 108 to + 115 (dried substance).

Dissolve 0.100 g in ethanol (96 per cent) R and dilute to 10.0 mL with the same solvent.

**Related substances**. Liquid chromatography (2.2.29).

*Solvent mixture*: mobile phase A, mobile phase B (45:55 V/V).

*Test solution (a)*. Dissolve 50.0 mg of the substance to be examined in 28 mL of mobile phase B and dilute to 50.0 mL with mobile phase A.

*Test solution (b)*. Dilute 1.0 mL of test solution (a) to 50.0 mL with the solvent mixture.

*Reference solution (a)*. Dilute 5.0 mL of test solution (b) to 100.0 mL with the solvent mixture.

*Reference solution (b)*. Dissolve 5 mg of beclometasone dipropionate for system suitability CRS (containing impurity D) in 3 mL of mobile phase B and dilute to 5 mL with mobile phase A.

*Reference solution (c)*. Dissolve 5 mg of beclometasone dipropionate for peak identification CRS (containing impurities B, C and L) in 3 mL of mobile phase B and dilute to 5 mL with mobile phase A. Use 1 mL of this solution to dissolve the contents of a vial of beclometasone dipropionate impurities F and N CRS.

**Reference solution (d).** Dissolve 50.0 mg of *beclometasone dipropionate anhydrous CRS* in 28 mL of mobile phase B and dilute to 50.0 mL with mobile phase A. Dilute 1.0 mL of this solution to 50.0 mL with the solvent mixture.

**Column:**

- size:  $l = 0.25$  m,  $\varnothing = 4.6$  mm;
- stationary phase: spherical difunctional bonded *end-capped octadecylsilyl silica gel for chromatography R* (5  $\mu$ m);
- temperature: 50 °C.

**Mobile phase:**

- mobile phase A: 2.72 g/L solution of *potassium dihydrogen phosphate R* adjusted to pH 2.35 with *phosphoric acid R*;
- mobile phase B: *tetrahydrofuran R*, *acetonitrile R*, *methanol R* (5:23:25 V/V/V);

Time (min)	Mobile phase A (per cent V/V)	Mobile phase B (per cent V/V)
0 - 4	40	60
4 - 12	40 → 45	60 → 55
12 - 59	45	55

**Flow rate:** 1.4 mL/min.

**Detection:** spectrophotometer at 254 nm.

**Injection:** 20  $\mu$ l of test solution (a) and reference solutions (a), (b) and (c).

**Identification of impurities:** use the chromatogram supplied with *beclometasone dipropionate for peak identification CRS* and the chromatogram obtained with reference solution (c) to identify the peaks due to impurities B, C, F and L; use the chromatogram supplied with *beclometasone dipropionate for system suitability CRS* and the chromatogram obtained with reference solution (b) to identify the peak due to impurity D.

**Relative retention** with reference to *beclometasone dipropionate* (retention time = about 25 min): impurity B = about 0.6; impurity D = about 1.1; impurity L = about 1.3; impurity C = about 1.8; impurity F = about 2.2.

**System suitability:** reference solution (b):

- **peak-to-valley ratio:** minimum 1.5, where  $H_p$  = height above the baseline of the peak due to impurity D and  $H_v$  = height above the baseline of the lowest point of the curve separating this peak from the peak due to *beclometasone dipropionate*.

**Limits:**

- **correction factor:** for the calculation of content, multiply the peak area of impurity F by 1.3;
- **impurity B:** not more than 5 times the area of the principal peak in the chromatogram obtained with reference solution (a) (0.5 per cent);
- **impurities C, F, L:** for each impurity, not more than 1.5 times the area of the principal peak in the chromatogram obtained with reference solution (a) (0.15 per cent);
- **unspecified impurities:** for each impurity, not more than the area of the principal peak in the chromatogram obtained with reference solution (a) (0.10 per cent);
- **total:** not more than 10 times the area of the principal peak in the chromatogram obtained with reference solution (a) (1.0 per cent);
- **disregard limit:** 0.5 times the area of the principal peak in the chromatogram obtained with reference solution (a) (0.05 per cent).

**Loss on drying (2.2.32):** 2.8 per cent to 3.8 per cent, determined on 1.000 g by drying in an oven at 105 °C for 3 h.

**ASSAY**

Liquid chromatography (2.2.29) as described in the test for related substances with the following modification.

**Injection:** test solution (b) and reference solution (d).

Calculate the percentage content of  $C_{28}H_{37}ClO_7$  from the declared content of *anhydrous beclometasone dipropionate CRS*.

**IMPURITIES**

**Specified impurities:** B, C, F, L.

**Other detectable impurities** (the following substances would, if present at a sufficient level, be detected by one or other of the tests in the monograph. They are limited by the general acceptance criterion for other/unspecified impurities and/or by the general monograph *Substances for pharmaceutical use (2034)*. It is therefore not necessary to identify these impurities for demonstration of compliance. See also 5.10. *Control of impurities in substances for pharmaceutical use*): A, D, E, H, I, J, M, N, O, Q, R, S, U, V.

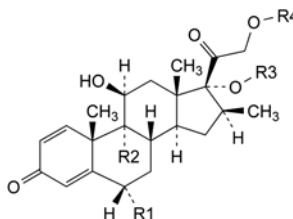

- A. R1 = R3 = H, R2 = Cl, R4 = CO-C<sub>2</sub>H<sub>5</sub>: 9-chloro-11 $\beta$ ,17-dihydroxy-16 $\beta$ -methyl-3,20-dioxopregna-1,4-dien-21-yl propanoate (*beclometasone 21-propionate*),
- D. R1 = H, R2 = Br, R3 = R4 = CO-C<sub>2</sub>H<sub>5</sub>: 9-bromo-11 $\beta$ -hydroxy-16 $\beta$ -methyl-3,20-dioxopregna-1,4-diene-17,21-diyl dipropanoate,
- E. R1 = R2 = Cl, R3 = R4 = CO-C<sub>2</sub>H<sub>5</sub>: 6 $\alpha$ ,9-dichloro-11 $\beta$ -hydroxy-16 $\beta$ -methyl-3,20-dioxopregna-1,4-diene-17,21-diyl dipropanoate,
- H. R1 = R4 = H, R2 = Cl, R3 = CO-C<sub>2</sub>H<sub>5</sub>: 9-chloro-11 $\beta$ ,21-dihydroxy-16 $\beta$ -methyl-3,20-dioxopregna-1,4-dien-17-yl propanoate (*beclometasone 17-propionate*),

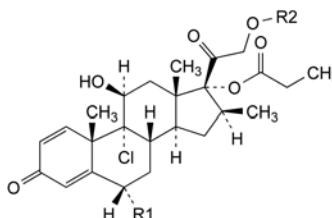

- B. R1 = H, R2 = CO-CH<sub>3</sub>: 21-(acetyloxy)-9-chloro-11 $\beta$ -hydroxy-16 $\beta$ -methyl-3,20-dioxopregna-1,4-dien-17-yl propanoate (*beclometasone 21-acetate 17-propionate*),
- C. R1 = H, R2 = CO-CH<sub>2</sub>-CH<sub>2</sub>-CH<sub>3</sub>: 9-chloro-11 $\beta$ -hydroxy-16 $\beta$ -methyl-3,20-dioxo-17-(propanoyloxy)-pregna-1,4-dien-21-yl butanoate (*beclometasone 21-butyrate 17-propionate*),
- F. R1 = Br, R2 = CO-C<sub>2</sub>H<sub>5</sub>: 6 $\alpha$ -bromo-9-chloro-11 $\beta$ -hydroxy-16 $\beta$ -methyl-3,20-dioxopregna-1,4-diene-17,21-diyl dipropanoate,

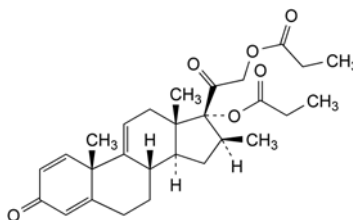

- I. 16 $\beta$ -methyl-3,20-dioxopregna-1,4,9(11)-triene-17,21-diyl dipropanoate,

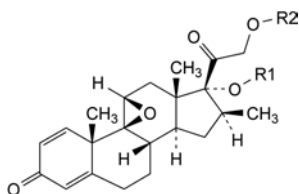

- J. R1 = R2 = CO-C<sub>2</sub>H<sub>5</sub>: 9,11β-epoxy-16β-methyl-3,20-dioxo-9β-pregna-1,4-diene-17,21-diyl dipropanoate,
- R. R1 = R2 = H: 9,11β-epoxy-17,21-dihydroxy-16β-methyl-9β-pregna-1,4-diene-3,20-dione,
- U. R1 = CO-C<sub>2</sub>H<sub>5</sub>, R2 = H: 9,11β-epoxy-21-hydroxy-16β-methyl-3,20-dioxo-9β-pregna-1,4-dien-17-yl propanoate,
- V. R1 = H, R2 = CO-C<sub>2</sub>H<sub>5</sub>: 9,11β-epoxy-17-hydroxy-16β-methyl-3,20-dioxo-9β-pregna-1,4-dien-21-yl propanoate,

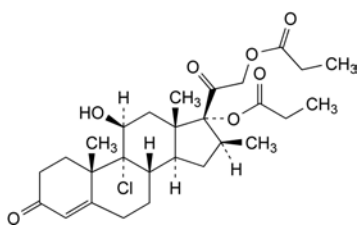

- L. 9-chloro-11β-hydroxy-16β-methyl-3,20-dioxopregna-4-ene-17,21-diyl dipropanoate,

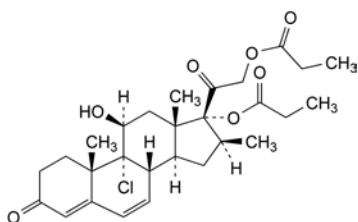

- M. 9-chloro-11β-hydroxy-16β-methyl-3,20-dioxopregna-4,6-diene-17,21-diyl dipropanoate,

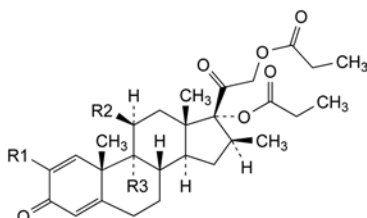

- N. R1 = Br, R2 = OH, R3 = Cl: 2-bromo-9-chloro-11β-hydroxy-16β-methyl-3,20-dioxopregna-1,4-diene-17,21-diyl dipropanoate,
- O. R1 = H, R2 = R3 = Cl: 9,11β-dichloro-16β-methyl-3,20-dioxopregna-1,4-diene-17,21-diyl dipropanoate,
- Q. R1 = R2 = R3 = H: 16β-methyl-3,20-dioxopregna-1,4-diene-17,21-diyl dipropanoate,
- S. R1 = H, R2 = O-CO-C<sub>2</sub>H<sub>5</sub>, R3 = Cl: 9-chloro-16β-methyl-3,20-dioxopregna-1,4-diene-11β,17,21-triyl tripropanoate (beclometasone tripropanoate).

01/2008:0069

**BEESWAX, WHITE**

## Cera alba

## DEFINITION

Wax obtained by bleaching yellow beeswax.

## CHARACTERS

**Appearance:** white or yellowish-white pieces or plates, translucent when thin, with a fine-grained, matt and non-crystalline fracture; when warmed in the hand they become soft and malleable.

It has an odour similar to that of yellow beeswax, though fainter and never rancid. It is tasteless and does not stick to the teeth.

**Solubility:** practically insoluble in water, partially soluble in hot ethanol (90 per cent V/V) and completely soluble in fatty and essential oils.

**Relative density:** about 0.960.

## TESTS

**Drop point (2.2.17):** 61 °C to 66 °C.

Melt the beeswax by heating on a water-bath, pour onto a glass plate and allow to cool to a semi-solid mass. Fill the metal cup by inserting the wider end into the beeswax and repeating the procedure until beeswax extrudes from the narrow opening. Remove the excess with a spatula and insert the thermometer immediately. Remove the beeswax displaced. Allow to stand at room temperature for at least 12 h before determining the drop point.

**Acid value:** 17.0 to 24.0.

To 2.00 g (*m* g), in a 250 mL conical flask fitted with a reflux condenser, add 40 mL of *xylene R* and a few glass beads. Heat until the substance is dissolved. Add 20 mL of *ethanol (96 per cent) R* and 0.5 mL of *phenolphthalein solution R1* and titrate the hot solution with 0.5 M *alcoholic potassium hydroxide* until a red colour persists for at least 10 s (*n*<sub>1</sub> mL). Carry out a blank test (*n*<sub>2</sub> mL).

$$\text{Acid value} = \frac{28.05 (n_1 - n_2)}{m}$$

**Ester value (2.5.2):** 70 to 80.

**Saponification value:** 87 to 104.

To 2.00 g (*m* g), in a 250 mL conical flask fitted with a reflux condenser, add 30 mL of a mixture of equal volumes of *ethanol (96 per cent) R* and *xylene R* and a few glass beads. Heat until the substance is dissolved. Add 25.0 mL of 0.5 M *alcoholic potassium hydroxide* and heat under a reflux condenser for 3 h. Titrate the hot solution immediately with 0.5 M *hydrochloric acid*, using 1 mL of *phenolphthalein solution R1* as indicator (*n*<sub>1</sub> mL). Reheat the solution to boiling several times during the course of the titration. Carry out a blank test (*n*<sub>2</sub> mL).

$$\text{Saponification value} = \frac{28.05 (n_2 - n_1)}{m}$$

**Ceresin, paraffins and certain other waxes.** To 3.0 g, in a 100 mL round-bottomed flask, add 30 mL of a 40 g/L solution of *potassium hydroxide R* in *aldehyde-free alcohol R* and boil gently under a reflux condenser for 2 h. Remove the condenser and immediately insert a thermometer. Place the flask in a water-bath at 80 °C and allow to cool, swirling the solution continuously. No precipitate is formed until 65 °C, although the solution may be slightly opalescent. Beginning at 65 °C, the solution may become cloudy and precipitates may be formed. At 59 °C, the solution is cloudy.

**Glycerol and other polyols:** maximum 0.5 per cent *m/m*, calculated as glycerol.

To 0.20 g add 10 mL of *alcoholic potassium hydroxide solution R* and heat on a water-bath under a reflux condenser for 30 min. Add 50 mL of *dilute sulfuric acid R*, cool and filter. Rinse the flask and the filter with *dilute sulfuric acid R*. Combine the filtrate and washings and dilute to 100.0 mL with *dilute sulfuric acid R*. Place 1.0 mL of the solution in a test-tube, add 0.5 mL of a 10.7 g/L solution of *sodium periodate R*, mix and allow to stand for 5 min. Add 1.0 mL of *decolorised fuchsin solution R* and mix. Any precipitate disappears. Place the tube in a beaker containing water at 40 °C. During cooling observe for 10-15 min. Any violet-blue colour in the solution is not more

intense than that in a standard prepared at the same time and in the same manner using 1.0 mL of a 10 mg/L solution of *glycerol R* in *dilute sulfuric acid R*.

01/2008:0070

**BEESWAX, YELLOW**

Cera flava

**DEFINITION**

Wax obtained by melting the walls of the honeycomb made by the honey-bee, *Apis mellifera* L., with hot water and removing foreign matter.

**CHARACTERS**

*Appearance*: yellow or light brown pieces or plates with a fine-grained, matt and non-crystalline fracture; when warmed in the hand they become soft and malleable.

It has a faint odour, characteristic of honey. It is tasteless and does not stick to the teeth.

*Solubility*: practically insoluble in water, partially soluble in hot ethanol (90 per cent V/V) and completely soluble in fatty and essential oils.

*Relative density*: about 0.960.

**TESTS**

**Drop point (2.2.17)**: 61 °C to 66 °C.

Melt the beeswax by heating on a water-bath, pour onto a glass plate and allow to cool to a semi-solid mass. Fill the metal cup by inserting the wider end into the beeswax and repeating the procedure until beeswax extrudes from the narrow opening. Remove the excess with a spatula and insert the thermometer immediately. Remove the beeswax displaced. Allow to stand at room temperature for at least 12 h before determining the drop point.

**Acid value**: 17.0 to 22.0.

To 2.00 g (*m* g), in a 250 mL conical flask fitted with a reflux condenser, add 40 mL of *xylene R* and a few glass beads. Heat until the substance is dissolved. Add 20 mL of *ethanol (96 per cent) R* and 0.5 mL of *phenolphthalein solution R1* and titrate the hot solution with 0.5 M *alcoholic potassium hydroxide* until a red colour persists for at least 10 s ( $n_1$  mL). Carry out a blank test ( $n_2$  mL).

$$\text{Acid value} = \frac{28.05 (n_1 - n_2)}{m}$$

**Ester value (2.5.2)**: 70 to 80.

**Saponification value**: 87 to 102.

To 2.00 g (*m* g), in a 250 mL conical flask fitted with a reflux condenser, add 30 mL of a mixture of equal volumes of *ethanol (96 per cent) R* and *xylene R* and a few glass beads. Heat until the substance is dissolved. Add 25.0 mL of 0.5 M *alcoholic potassium hydroxide* and heat under a reflux condenser for 3 h. Titrate the hot solution immediately with 0.5 M *hydrochloric acid*, using 1 mL of *phenolphthalein solution R1* as indicator ( $n_1$  mL). Reheat the solution to boiling several times during the course of the titration. Carry out a blank test ( $n_2$  mL).

$$\text{Saponification value} = \frac{28.05 (n_2 - n_1)}{m}$$

**Ceresin, paraffins and certain other waxes.** To 3.0 g, in a 100 mL round-bottomed flask, add 30 mL of a 40 g/L solution of *potassium hydroxide R* in *aldehyde-free alcohol R* and boil gently under a reflux condenser for 2 h. Remove the condenser and immediately insert a thermometer. Place the flask in a water-bath at 80 °C and allow to cool, swirling the solution continuously. No precipitate is formed until 65 °C, although

the solution may be slightly opalescent. Beginning at 65 °C, the solution may become cloudy and precipitates may be formed. At 59 °C, the solution is cloudy.

**Glycerol and other polyols**: maximum 0.5 per cent *m/m*, calculated as glycerol.

To 0.20 g add 10 mL of *alcoholic potassium hydroxide solution R* and heat on a water-bath under a reflux condenser for 30 min. Add 50 mL of *dilute sulfuric acid R*, cool and filter. Rinse the flask and the filter with *dilute sulfuric acid R*. Combine the filtrate and washings and dilute to 100.0 mL with *dilute sulfuric acid R*. Place 1.0 mL of the solution in a test-tube, add 0.5 mL of a 10.7 g/L solution of *sodium periodate R*, mix and allow to stand for 5 min. Add 1.0 mL of *decolorised fuchsin solution R* and mix. Any precipitate disappears. Place the tube in a beaker containing water at 40 °C. During cooling observe for 10-15 min. Any violet-blue colour in the solution is not more intense than that in a standard prepared at the same time and in the same manner using 1.0 mL of a 10 mg/L solution of *glycerol R* in *dilute sulfuric acid R*.

01/2011:2388

**BENAZEPRIL HYDROCHLORIDE**

Benazeprili hydrochloridum

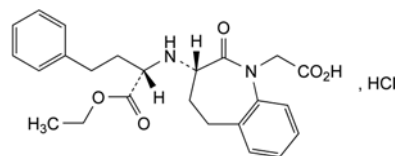

$C_{24}H_{29}ClN_2O_5$   
[86541-74-4]

 $M_r$  461.0**DEFINITION**

[(3S)-3-[[[(1S)-1-(Ethoxycarbonyl)-3-phenylpropyl]amino]-2-oxo-2,3,4,5-tetrahydro-1H-1-benzazepin-1-yl]acetic acid hydrochloride. *Content*: 97.5 per cent to 102.0 per cent (dried substance).

**CHARACTERS**

*Appearance*: white or almost white, crystalline powder, hygroscopic.

*Solubility*: slightly soluble in water, freely soluble in anhydrous ethanol, very slightly soluble in ethyl acetate, practically insoluble in cyclohexane.

It shows polymorphism (5.9).

**IDENTIFICATION**

Carry out either tests A, B, D or tests B, C, D.

A. Specific optical rotation (2.2.7): – 136 to – 141 (dried substance).  
Dissolve 1.000 g in *anhydrous ethanol R* and dilute to 50.0 mL with the same solvent.

B. Infrared absorption spectrophotometry (2.2.24).

*Comparison*: *benazepril hydrochloride CRS*.

If the spectra obtained in the solid state show differences, dissolve the substance to be examined and the reference substance separately in *methanol R*, evaporate to dryness and record new spectra using the residues.

C. Enantiomeric purity (see Tests).

D. It gives reaction (a) of chlorides (2.3.1).

**TESTS**

**Related substances.** Liquid chromatography (2.2.29).

*Test solution (a)*. Dissolve 50.0 mg of the substance to be examined in the mobile phase and dilute to 50.0 mL with the mobile phase.

*Test solution (b)*. Dilute 10.0 mL of test solution (a) to 100.0 mL with the mobile phase.

**Reference solution (a).** Dissolve 50.0 mg of *benazepril hydrochloride CRS* in the mobile phase and dilute to 50.0 mL with the mobile phase. Dilute 10.0 mL of this solution to 100.0 mL with the mobile phase.

**Reference solution (b).** Dissolve the contents of a vial of *benazepril for system suitability CRS* (containing impurities B, C, D, E, F and G) in 1.0 mL of test solution (a).

**Reference solution (c).** Dilute 1.0 mL of reference solution (a) to 50.0 mL with the mobile phase.

**Column:**

- size:  $l = 0.30$  m,  $\varnothing = 3.9$  mm;
- stationary phase: end-capped octadecylsilyl silica gel for chromatography R (10  $\mu$ m).

**Mobile phase:** add 0.2 mL of *glacial acetic acid R* to 1000 mL of a mixture of 360 volumes of *water R* and 640 volumes of *methanol R2*; add 0.81 g of *tetrabutylammonium bromide R* and stir to dissolve.

**Flow rate:** 1.0 mL/min.

**Detection:** spectrophotometer at 240 nm.

**Injection:** 25  $\mu$ L of test solution (a) and reference solutions (b) and (c).

**Run time:** 3 times the retention time of benazepril.

**Relative retention** with reference to benazepril (retention time = about 6 min): impurity E = about 0.3; impurity F = about 0.4; impurity C = about 0.5; impurity B = about 1.8; impurity D = about 2.0; impurity G = about 2.5.

**Identification of impurities:** use the chromatogram supplied with *benazepril for system suitability CRS* and the chromatogram obtained with reference solution (b) to identify the peaks due to impurities B, C, D, E, F and G.

**System suitability:** reference solution (b):

- resolution: minimum 2.5 between the peaks due to benazepril and impurity B and minimum 1.5 between the peaks due to impurities E and F.

**Limits:**

- correction factors: for the calculation of content, multiply the peak areas of the following impurities by the corresponding correction factor: impurity E = 0.5; impurity F = 0.7;
- impurity B: not more than 2.5 times the area of the principal peak in the chromatogram obtained with reference solution (c) (0.5 per cent);
- impurity C: not more than 1.5 times the area of the principal peak in the chromatogram obtained with reference solution (c) (0.3 per cent);
- impurities D, E, F, G: for each impurity, not more than the area of the principal peak in the chromatogram obtained with reference solution (c) (0.2 per cent);
- unspecified impurities: for each impurity, not more than 0.5 times the area of the principal peak in the chromatogram obtained with reference solution (c) (0.10 per cent);
- total: not more than 10 times the area of the principal peak in the chromatogram obtained with reference solution (c) (2.0 per cent);
- disregard limit: 0.25 times the area of the principal peak in the chromatogram obtained with reference solution (c) (0.05 per cent).

**Enantiomeric purity.** Liquid chromatography (2.2.29).

**Buffer solution pH 6.0.** Dissolve 3.58 g of *sodium hydrogen phosphate R* and 9.66 g of *potassium dihydrogen phosphate R* in *water R* and dilute to 1000.0 mL with the same solvent.

**Test solution.** Dissolve 50.0 mg of the substance to be examined in the mobile phase and dilute to 50.0 mL with the mobile phase.

**Reference solution (a).** Dissolve 5.0 mg of *benazepril impurity A CRS* in the mobile phase and dilute to 50.0 mL with the mobile phase.

**Reference solution (b).** Dilute 1.0 mL of reference solution (a) to 100.0 mL with the mobile phase.

**Reference solution (c).** Dilute 1.0 mL of reference solution (a) to 10.0 mL with the mobile phase. Dilute 1.0 mL of this solution to 10.0 mL with the test solution.

**Column:**

- size:  $l = 0.10$  m,  $\varnothing = 4.0$  mm;
- stationary phase: spherical silica gel AGP for chiral chromatography R (5  $\mu$ m);
- temperature: 30 °C.

**Mobile phase:** *methanol R2*, buffer solution pH 6.0 (20:80 V/V).

**Flow rate:** 0.9 mL/min.

**Detection:** spectrophotometer at 240 nm.

**Injection:** 50  $\mu$ L of the test solution and reference solutions (b) and (c).

**Run time:** 3.5 times the retention time of benazepril.

**Relative retention** with reference to benazepril (retention time = about 6 min): impurity A = about 1.9.

**System suitability:** reference solution (c):

- peak-to-valley ratio: minimum 2.5, where  $H_p$  = height above the baseline of the peak due to impurity A and  $H_v$  = height above the baseline of the lowest point of the curve separating this peak from the peak due to benazepril.

**Limit:**

- impurity A: not more than the area of the corresponding peak in the chromatogram obtained with reference solution (b) (0.1 per cent).

**Heavy metals (2.4.8):** maximum 20 ppm.

1.0 g complies with test C. Prepare the reference solution using 2 mL of *lead standard solution (10 ppm Pb) R*.

**Loss on drying (2.2.32):** maximum 1.5 per cent, determined on 1.000 g by drying *in vacuo* at 105 °C for 3 h.

**Sulfated ash (2.4.14):** maximum 0.1 per cent, determined on 1.0 g.

**ASSAY**

Liquid chromatography (2.2.29) as described in the test for related substances with the following modification.

**Injection:** test solution (b) and reference solution (a).

Calculate the percentage content of  $C_{24}H_{29}ClN_2O_5$  from the declared content of *benazepril hydrochloride CRS*.

**STORAGE**

Protected from light, in an airtight container.

**IMPURITIES**

**Specified impurities:** A, B, C, D, E, F, G.

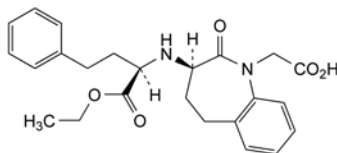

A. [(3R)-3-[[[(1R)-1-(ethoxycarbonyl)-3-phenylpropyl]amino]-2-oxo-2,3,4,5-tetrahydro-1H-1-benzazepin-1-yl]acetic acid,

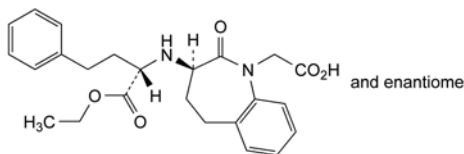

B. [(3RS)-3-[[[(1SR)-1-(ethoxycarbonyl)-3-phenylpropyl]amino]-2-oxo-2,3,4,5-tetrahydro-1H-1-benzazepin-1-yl]acetic acid,

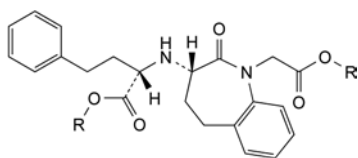

C. R = H: (2*S*)-2-[[[(3*S*)-1-(carboxymethyl)-2-oxo-2,3,4,5-tetrahydro-1*H*-1-benzazepin-3-yl]amino]-4-phenylbutanoic acid,

G. R = C<sub>2</sub>H<sub>5</sub>: ethyl (2*S*)-2-[[[(3*S*)-1-(2-ethoxy-2-oxoethyl)-2-oxo-2,3,4,5-tetrahydro-1*H*-1-benzazepin-3-yl]amino]-4-phenylbutanoate,

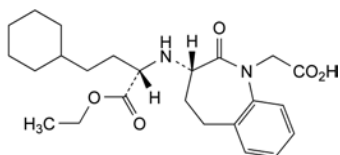

D. [(3*S*)-3-[[[(1*S*)-3-cyclohexyl-1-(ethoxycarbonyl)propyl]amino]-2-oxo-2,3,4,5-tetrahydro-1*H*-1-benzazepin-1-yl]acetic acid,

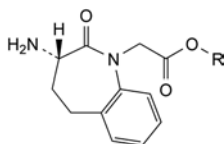

E. R = H: [(3*S*)-3-amino-2-oxo-2,3,4,5-tetrahydro-1*H*-1-benzazepin-1-yl]acetic acid,

F. R = C(CH<sub>3</sub>)<sub>3</sub>: 1,1-dimethylethyl [(3*S*)-3-amino-2-oxo-2,3,4,5-tetrahydro-1*H*-1-benzazepin-1-yl]acetate.

01/2008:0370  
corrected 6.0

## BENDROFLUMETHIAZIDE

### Bendroflumethiazidum

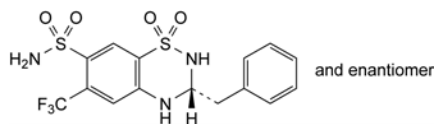

C<sub>15</sub>H<sub>14</sub>F<sub>3</sub>N<sub>3</sub>O<sub>4</sub>S<sub>2</sub>  
[73-48-3]

M<sub>r</sub> 421.4

#### DEFINITION

(3*RS*)-3-Benzyl-6-(trifluoromethyl)-3,4-dihydro-2*H*-1,2,4-benzothiadiazine-7-sulfonamide 1,1-dioxide.

*Content*: 98.0 per cent to 102.0 per cent (dried substance).

#### CHARACTERS

*Appearance*: white or almost white, crystalline powder.

*Solubility*: practically insoluble in water, freely soluble in acetone, soluble in ethanol (96 per cent).

#### IDENTIFICATION

Infrared absorption spectrophotometry (2.2.24).

*Comparison*: bendroflumethiazide CRS.

#### TESTS

**Related substances.** Liquid chromatography (2.2.29). Prepare the solutions immediately before use.

*Solvent mixture.* Mix 40 volumes of methanol R and 60 volumes of a 2.0 g/L solution of citric acid R.

*Test solution.* Dissolve 10.0 mg of the substance to be examined in the solvent mixture and dilute to 50.0 mL with the solvent mixture.

*Reference solution (a).* Dissolve 2 mg of bendroflumethiazide impurity A CRS and 2.5 mg of altizide CRS in the solvent mixture and dilute to 10 mL with the solvent mixture. Mix 1 mL of this solution with 1 mL of the test solution and dilute to 100 mL with the solvent mixture.

*Reference solution (b).* Dilute 1.0 mL of the test solution to 100.0 mL with the solvent mixture. Dilute 1.0 mL of this solution to 10.0 mL with the solvent mixture.

#### Column:

– size:  $l = 0.15$  m,  $\varnothing = 3.0$  mm;

– stationary phase: end-capped octadecylsilyl silica gel for chromatography R (5  $\mu$ m);

– temperature: 40 °C.

*Mobile phase:* mix 15 volumes of tetrahydrofuran R, 25 volumes of methanol R and 60 volumes of a 2.0 g/L solution of citric acid R.

*Flow rate:* 0.8 mL/min.

*Detection:* spectrophotometer at 273 nm.

*Injection:* 20  $\mu$ L.

*Run time:* twice the retention time of bendroflumethiazide.

*Relative retention* with reference to bendroflumethiazide (retention time = about 8 min): impurity A = about 0.2; altizide = about 0.5.

*System suitability:* reference solution (a):

– resolution: minimum 10 between the peaks due to altizide and bendroflumethiazide.

#### Limits:

– impurity A: not more than the area of the principal peak in the chromatogram obtained with reference solution (b) (0.1 per cent);

– unspecified impurities: for each impurity, not more than the area of the principal peak in the chromatogram obtained with reference solution (b) (0.10 per cent);

– total: not more than twice the area of the principal peak in the chromatogram obtained with reference solution (b) (0.2 per cent);

– disregard limit: 0.5 times the area of the principal peak in the chromatogram obtained with reference solution (b) (0.05 per cent).

**Loss on drying** (2.2.32): maximum 0.5 per cent, determined on 1.000 g by drying in an oven at 105 °C.

**Sulfated ash** (2.4.14): maximum 0.1 per cent, determined on 1.0 g.

#### ASSAY

Dissolve 0.150 g in 50 mL of dimethyl sulfoxide R. Titrate to the 2<sup>nd</sup> point of inflexion with 0.1 M tetrabutylammonium hydroxide in 2-propanol, determining the end-point potentiometrically (2.2.20). Carry out a blank titration.

1 mL of 0.1 M tetrabutylammonium hydroxide in 2-propanol is equivalent to 21.07 mg of C<sub>15</sub>H<sub>14</sub>F<sub>3</sub>N<sub>3</sub>O<sub>4</sub>S<sub>2</sub>.

#### IMPURITIES

*Specified impurities:* A.

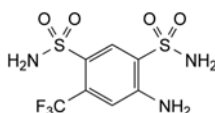

A. 4-amino-6-(trifluoromethyl)benzene-1,3-disulfonamide.

01/2008:1601  
corrected 6.0

## BENFLUOREX HYDROCHLORIDE

## Benfluorexi hydrochloridum

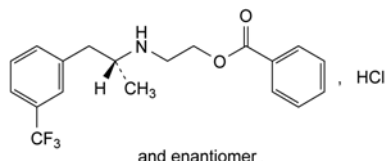
C<sub>19</sub>H<sub>21</sub>ClF<sub>3</sub>NO<sub>2</sub>  
[23642-66-2]M<sub>r</sub> 387.8

## DEFINITION

2-[[1(RS)-1-Methyl-2-[3-(trifluoromethyl)phenyl]ethyl]amino]-ethyl benzoate hydrochloride.

Content: 98.5 per cent to 101.0 per cent (dried substance).

## CHARACTERS

Appearance: white or almost white powder.

Solubility: slightly soluble in water, freely soluble in methanol, soluble in methylene chloride, sparingly soluble or soluble in alcohol.

It shows polymorphism (5.9).

## IDENTIFICATION

A. Infrared absorption spectrophotometry (2.2.24).

Preparation: mulls in liquid paraffin R.

Comparison: benfluorex hydrochloride CRS.

If the spectra obtained show differences, heat the substance to be examined and the reference substance separately in an oven at 150 °C for 3 h and record new spectra.

B. It gives reaction (a) of chlorides (2.3.1).

## TESTS

**Optical rotation** (2.2.7): -0.10° to +0.10°.

Dissolve 0.2 g in ethanol R and dilute to 20.0 mL with the same solvent.

**Impurity B.** Gas chromatography (2.2.28): use the normalisation procedure.**Test solution.** Dissolve 0.30 g of the substance to be examined in methylene chloride R and dilute to 20 mL with the same solvent. Transfer to a separating funnel, add 10 mL of a 40 g/L solution of sodium hydroxide R. Shake the flask vigorously and allow the phases to separate. Collect the organic layer.**Reference solution.** Dissolve 0.30 g of benfluorex hydrochloride for system suitability CRS in methylene chloride R and dilute to 20 mL with the same solvent. Transfer to a separating funnel and add 10 mL of a 40 g/L solution of sodium hydroxide R. Shake the flask vigorously and allow the phases to separate. Collect the organic layer.

Column:

- material: fused silica,
- size:  $l = 25$  m,  $\varnothing = 0.32$  mm,
- stationary phase: macrogol 20 000 R (film thickness 0.2  $\mu$ m).

Carrier gas: hydrogen for chromatography R.

Linear velocity: 75 cm/s.

Split ratio: 1:35.

Temperature:

- column: 220 °C,
- injection port and detector: 250 °C.

Detection: flame ionisation.

Injection: 1  $\mu$ L.

Run time: 1.5 times the retention time of benfluorex.

Relative retention with reference to benfluorex (retention time = about 4.5 min): impurity B = about 1.1.

System suitability:

- peak-to-valley ratio: minimum 2.5, where  $H_p$  = height above the baseline of the peak due to impurity B, and  $H_v$  = height above the baseline of the lowest point of the curve separating this peak from the peak due to benfluorex.

Limit:

- impurity B: maximum 0.1 per cent.

**Related substances, other than impurity B.** Liquid chromatography (2.2.29).**Test solution.** Dissolve 60.0 mg of the substance to be examined in 50 mL of acetonitrile R and dilute to 100.0 mL with water R.**Reference solution (a).** Dissolve 60.0 mg of benfluorex hydrochloride for system suitability CRS in 50 mL of acetonitrile R and dilute to 100.0 mL with water R.**Reference solution (b).** Dilute 1.0 mL of the test solution to 100.0 mL with a mixture of equal volumes of acetonitrile R and water R. Dilute 5.0 mL of this solution to 50.0 mL with the same mixture of solvents.

Column:

- size:  $l = 0.15$  m,  $\varnothing = 4.6$  mm,
- stationary phase: silica gel bonded with alkylamide groups (5  $\mu$ m),
- temperature: 60 °C.

**Mobile phase:** a mixture of equal volumes of acetonitrile R and a solution containing 2.18 g/L of potassium dihydrogen phosphate R adjusted to pH 2.5 with phosphoric acid R and 6.5 g/L of sodium decyl sulfate R.

Flow rate: 1.4 mL/min.

Detection: spectrophotometer at 210 nm.

Injection: 10  $\mu$ L.

Run time: 3 times the retention time of benfluorex.

Relative retention with reference to benfluorex (retention time = about 5 min): impurity A = about 0.9.

System suitability:

- signal-to-noise ratio: minimum 20 for the principal peak in the chromatogram obtained with reference solution (b),
- peak-to-valley ratio: minimum 2.5, where  $H_p$  = height above the baseline of the peak due to impurity A, and  $H_v$  = height above the baseline of the lowest point of the curve separating this peak from the peak due to benfluorex in the chromatogram obtained with reference solution (a).

Limits:

- any impurity: not more than the area of the principal peak in the chromatogram obtained with reference solution (b) (0.1 per cent),
- total: not more than twice the area of the principal peak in the chromatogram obtained with reference solution (b) (0.2 per cent),
- disregard limit: 0.5 times the area of the principal peak in the chromatogram obtained with reference solution (b) (0.05 per cent).

**Heavy metals** (2.4.8): maximum 20 ppm.

1.0 g complies with test C. Prepare the reference solution using 2 mL of lead standard solution (10 ppm Pb) R.

**Loss on drying** (2.2.32): maximum 0.5 per cent, determined on 1.000 g by drying in an oven at 105 °C.**Sulfated ash** (2.4.14): maximum 0.1 per cent, determined on 1.0 g.

## ASSAY

In order to avoid overheating in the reaction medium, mix thoroughly throughout and stop the titration immediately after the end-point has been reached.



Dissolve 0.250 g rapidly in 2.0 mL of *anhydrous formic acid R* and add 50.0 mL of *acetic anhydride R*. Titrate immediately with 0.1 M *perchloric acid*, determining the end-point potentiometrically (2.2.20).

1 mL of 0.1 M *perchloric acid* is equivalent to 38.78 mg of  $C_{19}H_{21}ClF_3NO_2$ .

#### IMPURITIES

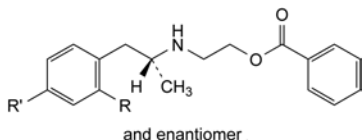

A. R =  $CF_3$ , R' = H: 2-[[[(1*RS*)-1-methyl-2-[2-(trifluoromethyl)phenyl]ethyl]amino]ethyl]benzoate,

B. R = H, R' =  $CF_3$ : 2-[[[(1*RS*)-1-methyl-2-[4-(trifluoromethyl)phenyl]ethyl]amino]ethyl]benzoate,

C. benzoic acid,

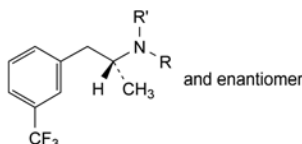

D. R =  $CH_2-CH_2-OH$ , R' = H: 2-[[[(1*RS*)-1-methyl-2-[3-(trifluoromethyl)phenyl]ethyl]amino]ethanol,

E. R =  $CH_2-CH_2-OH$ , R' =  $CO-C_6H_5$ : *N*-(2-hydroxyethyl)-*N*-[(1*RS*)-1-methyl-2-[3-(trifluoromethyl)phenyl]ethyl]benzamide,

F. R =  $CH_2-CH_2-O-CO-C_6H_5$ , R' =  $CO-C_6H_5$ : 2-[benzoyl[(1*RS*)-1-methyl-2-[3-(trifluoromethyl)phenyl]ethyl]amino]ethyl benzoate.

01/2008:1172  
corrected 6.0

## BENPERIDOL

### Benperidolum

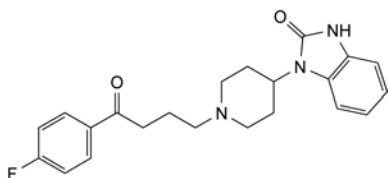

$C_{22}H_{24}FN_3O_2$   
[2062-84-2]

$M_r$  381.4

#### DEFINITION

1-[1-[4-(4-Fluorophenyl)-4-oxobutyl]piperidin-4-yl]-1,3-dihydro-2*H*-benzimidazol-2-one.

*Content*: 99.0 per cent to 101.0 per cent (dried substance).

#### CHARACTERS

*Appearance*: white or almost white powder.

*Solubility*: practically insoluble in water, freely soluble in dimethylformamide, soluble in methylene chloride, slightly soluble in ethanol (96 per cent).

It shows polymorphism (5.9).

#### IDENTIFICATION

*First identification*: A.

*Second identification*: B, C, D.

A. Infrared absorption spectrophotometry (2.2.24).

*Preparation*: discs.

*Comparison*: *benperidol CRS*.

If the spectra obtained in the solid state show differences, dissolve the substance to be examined and the reference substance separately in the minimum volume of *methyl isobutyl ketone R*, evaporate to dryness and record new spectra using the residues.

B. Thin-layer chromatography (2.2.27).

*Test solution*. Dissolve 30 mg of the substance to be examined in the mobile phase and dilute to 10 mL with the mobile phase.

*Reference solution (a)*. Dissolve 30 mg of *benperidol CRS* in the mobile phase and dilute to 10 mL with the mobile phase.

*Reference solution (b)*. Dissolve 30 mg of *benperidol CRS* and 30 mg of *droperidol CRS* in the mobile phase and dilute to 10 mL with the mobile phase.

*Plate*: TLC silica gel  $F_{254}$  plate *R*.

*Mobile phase*: acetone *R*, methanol *R* (1:9 V/V).

*Application*: 10  $\mu$ L.

*Development*: over a path of 15 cm.

*Drying*: in air.

*Detection*: examine in ultraviolet light at 254 nm.

*System suitability*: reference solution (b):

– the chromatogram shows 2 clearly separated spots.

*Results*: the principal spot in the chromatogram obtained with the test solution is similar in position and size to the principal spot in the chromatogram obtained with reference solution (a).

C. Dissolve about 10 mg in 5 mL of *anhydrous ethanol R*. Add 0.5 mL of *dinitrobenzene solution R* and 0.5 mL of 2 M *alcoholic potassium hydroxide R*. A violet colour is produced which becomes brownish-red after 20 min.

D. Mix about 5 mg with 45 mg of *heavy magnesium oxide R* and ignite in a crucible until an almost white residue is obtained (usually less than 5 min). Allow to cool, add 1 mL of *water R*, 0.05 mL of *phenolphthalein solution R1* and about 1 mL of *dilute hydrochloric acid R* to render the solution colourless. Filter. To a freshly prepared mixture of 0.1 mL of *alizarin S solution R* and 0.1 mL of *zirconyl nitrate solution R*, add 1.0 mL of the filtrate. Mix, allow to stand for 5 min and compare the colour of the solution with that of a blank prepared in the same manner. The test solution is yellow and the blank is red.

#### TESTS

**Related substances.** Liquid chromatography (2.2.29). Prepare the solutions immediately before use.

*Test solution*. Dissolve 0.10 g of the substance to be examined in *dimethylformamide R* and dilute to 10.0 mL with the same solvent.

*Reference solution (a)*. Dissolve 2.5 mg of *benperidol CRS* and 2.5 mg of *droperidol CRS* in *dimethylformamide R* and dilute to 100.0 mL with the same solvent.

*Reference solution (b)*. Dilute 1.0 mL of the test solution to 100.0 mL with *dimethylformamide R*. Dilute 5.0 mL of this solution to 20.0 mL with *dimethylformamide R*.

*Column*:

– *size*:  $l = 0.1$  m,  $\varnothing = 4.6$  mm;

– *stationary phase*: base-deactivated octadecylsilyl silica gel for chromatography *R* (3  $\mu$ m).

**Mobile phase:**

- mobile phase A: 10 g/L solution of *tetrabutylammonium hydrogen sulfate R*;
- mobile phase B: *acetonitrile R*;

Time (min)	Mobile phase A (per cent V/V)	Mobile phase B (per cent V/V)
0 - 15	100 → 60	0 → 40
15 - 20	60	40
20 - 25	100	0

**Flow rate:** 1.5 mL/min.

**Detection:** spectrophotometer at 275 nm.

**Equilibration:** with *acetonitrile R* for at least 30 min and then with the mobile phase at the initial composition for at least 5 min.

**Injection:** 10 µL; inject *dimethylformamide R* as a blank.

**Retention time:** benperidol = about 6.5 min; droperidol = about 7 min.

**System suitability:** reference solution (a):

- **resolution:** minimum 2.0 between the peaks due to benperidol and droperidol; if necessary, adjust the concentration of acetonitrile in the mobile phase or adjust the time programme for the linear gradient.

**Limits:**

- **impurities A, B, C, D, E:** for each impurity, not more than the area of the principal peak in the chromatogram obtained with reference solution (b) (0.25 per cent);
- **total:** not more than twice the area of the principal peak in the chromatogram obtained with reference solution (b) (0.5 per cent);
- **disregard limit:** 0.2 times the area of the principal peak in the chromatogram obtained with reference solution (b) (0.05 per cent); disregard any peak due to the blank.

**Loss on drying (2.2.32):** maximum 0.5 per cent, determined on 1.000 g by drying in an oven at 105 °C.

**Sulfated ash (2.4.14):** maximum 0.1 per cent, determined on 1.0 g in a platinum crucible.

**ASSAY**

Dissolve 0.300 g in 50 mL of a mixture of 1 volume of *anhydrous acetic acid R* and 7 volumes of *methyl ethyl ketone R* and titrate with 0.1 M *perchloric acid*, using 0.2 mL of *naphtholbenzein solution R* as indicator.

1 mL of 0.1 M *perchloric acid* is equivalent to 38.14 mg of  $C_{22}H_{24}FN_3O_2$ .

**STORAGE**

Protected from light.

**IMPURITIES**

**Specified impurities:** A, B, C, D, E.

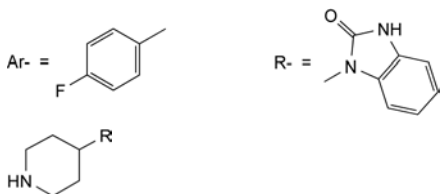

A. 1-(piperidin-4-yl)-1,3-dihydro-2H-benzimidazol-2-one,

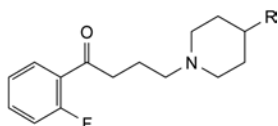

B. 1-[1-[4-(2-fluorophenyl)-4-oxobutyl]piperidin-4-yl]-1,3-dihydro-2H-benzimidazol-2-one,

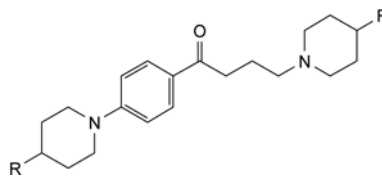

C. 1-[1-[4-oxo-4-[4-[4-(2-oxo-2,3-dihydro-1H-benzimidazol-1-yl)piperidin-1-yl]phenyl]butyl]piperidin-4-yl]-1,3-dihydro-2H-benzimidazol-2-one,

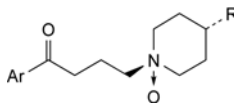

D. *cis*-1-[1-[4-(4-fluorophenyl)-4-oxobutyl]piperidin-4-yl]-1,3-dihydro-2H-benzimidazol-2-one,

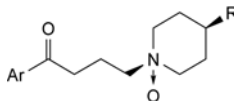

E. *trans*-1-[1-[4-(4-fluorophenyl)-4-oxobutyl]piperidin-4-yl]-1,3-dihydro-2H-benzimidazol-2-one.

04/2009:1173

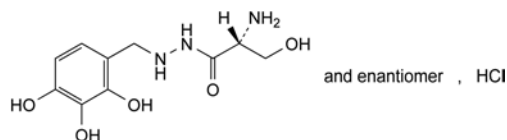
**BENSERAZIDE HYDROCHLORIDE****Benserazidi hydrochloridum**

$C_{10}H_{16}ClN_3O_5$   
[14919-77-8]

$M_r$  293.7

**DEFINITION**

(2*R*,3*S*)-2-Amino-3-hydroxy-2'-(2,3,4-trihydroxybenzyl)propanohydrazide hydrochloride.

**Content:** 98.5 per cent to 101.0 per cent (anhydrous substance).

**CHARACTERS**

**Appearance:** white or yellowish-white or orange-white, crystalline powder.

**Solubility:** freely soluble in water, very slightly soluble in anhydrous ethanol, practically insoluble in acetone.

It shows polymorphism (5.9).

**IDENTIFICATION**

A. Infrared absorption spectrophotometry (2.2.24).

**Comparison:** *benserazide hydrochloride CRS*.

If the spectra obtained show differences, dissolve the substance to be examined and the reference substance separately in hot *methanol R*, evaporate to dryness and record new spectra using the residues.

B. Solution S (see Tests) gives reaction (b) of chlorides (2.3.1).

**TESTS**

**Solution S.** Dissolve 1.0 g in *carbon dioxide-free water R* and dilute to 100 mL with the same solvent.

**Appearance of solution.** Solution S is clear (2.2.1) and not more intensely coloured than reference solution BY<sub>6</sub> (2.2.2, *Method II*).

**pH (2.2.3):** 4.0 to 5.0 for solution S.

**Related substances.** Liquid chromatography (2.2.29).

**All solutions must be injected immediately or stored at 4 °C.**

**Test solution.** Dissolve 0.100 g of the substance to be examined in *methanol R2* and dilute to 50.0 mL with the same solvent.

**Reference solution (a).** Dissolve 5.0 mg of *benserazide impurity A CRS*, 5.0 mg of *benserazide impurity C CRS* and 5.0 mg of *benserazide hydrochloride CRS* in *methanol R2* and dilute to 50.0 mL with the same solvent. Dilute 5.0 mL of this solution to 50.0 mL with *methanol R2*.

**Reference solution (b).** Dilute 2.0 mL of reference solution (a) to 10.0 mL with *methanol R2*.

**Reference solution (c).** Dissolve 5 mg of *benserazide for peak identification CRS* (containing impurities A, B and C) in *methanol R2* and dilute to 5.0 mL with the same solvent.

**Column:**

- size:  $l = 0.25$  m,  $\varnothing = 4$  mm;
- stationary phase: *octylsilyl silica gel for chromatography R* (5  $\mu$ m);
- temperature: 30 °C.

**Mobile phase:**

- mobile phase A: dissolve 2.2 g of *sodium heptanesulfonate monohydrate R* and 6.8 g of *potassium dihydrogen phosphate R* in 900 mL of *water R*, add 50 mL of *methanol R2* and adjust to pH 3.5 with *phosphoric acid R*;
- mobile phase B: dissolve 2.2 g of *sodium heptanesulfonate monohydrate R* and 6.8 g of *potassium dihydrogen phosphate R* in 500 mL of *water R*, adjust to pH 3.5 with *phosphoric acid R* and add 500 mL of *methanol R2*;

Time (min)	Mobile phase A (per cent V/V)	Mobile phase B (per cent V/V)
0 - 15	100 → 0	0 → 100
15 - 25	0	100

**Flow rate:** 1.3 mL/min.

**Detection:** spectrophotometer at 210 nm.

**Injection:** 5  $\mu$ L.

**Identification of impurities:** use the chromatogram supplied with *benserazide for peak identification CRS* and the chromatogram obtained with reference solution (c) to identify the peaks due to impurities A, B and C; doubling of the peak due to impurity C, related to separation of the (*EZ*)-isomers, may be observed.

**Relative retention** with reference to *benserazide* (retention time = about 9 min): impurity A = about 0.6; impurity C = about 1.2; impurity B = about 1.5.

**System suitability:** reference solution (a):

- resolution: minimum 5.0 between the peaks due to *benserazide* and impurity C; use the 1<sup>st</sup> peak of impurity C if 2 peaks occur.

**Limits:**

- correction factor: for the calculation of content, multiply the peak area of impurity B by 0.7;
- impurity A: not more than the area of the corresponding peak in the chromatogram obtained with reference solution (a) (0.5 per cent);
- impurity B: not more than the area of the peak due to *benserazide* in the chromatogram obtained with reference solution (a) (0.5 per cent);
- impurity C: not more than the area of the corresponding peak or pair of peaks in the chromatogram obtained with reference solution (a) (0.5 per cent);
- unspecified impurities: for each impurity, not more than the area of the peak due to *benserazide* in the chromatogram obtained with reference solution (b) (0.10 per cent);
- sum of impurities other than A: not more than twice the area of the peak due to *benserazide* in the chromatogram obtained with reference solution (a) (1.0 per cent);
- disregard limit: 0.5 times the area of the peak due to *benserazide* in the chromatogram obtained with reference solution (b) (0.05 per cent).

**Heavy metals (2.4.8):** maximum 20 ppm.

1.0 g complies with test C. Prepare the reference solution using 2 mL of *lead standard solution (10 ppm Pb) R*.

**Water (2.5.12):** maximum 1.0 per cent, determined on 0.500 g.

**Sulfated ash (2.4.14):** maximum 0.1 per cent, determined on 1.0 g.

**ASSAY**

*In order to avoid overheating during the titration, mix thoroughly throughout and stop the titration immediately after the end-point has been reached.*

Dissolve 0.250 g in 5 mL of *anhydrous formic acid R*. Add 70 mL of *anhydrous acetic acid R*. Titrate immediately with 0.1 M *perchloric acid*, determining the end-point potentiometrically (2.2.20).

1 mL of 0.1 M *perchloric acid* is equivalent to 29.37 mg of  $C_{10}H_{16}ClN_3O_5$ .

**STORAGE**

Protected from light.

**IMPURITIES**

**Specified impurities: A, B, C.**

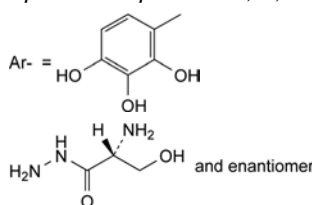

A. (2*RS*)-2-amino-3-hydroxypropanohydrazide,

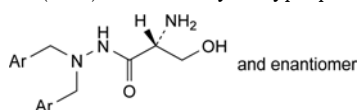

B. (2*RS*)-2-amino-3-hydroxy-2',2'-bis(2,3,4-trihydroxybenzyl)propanohydrazide,

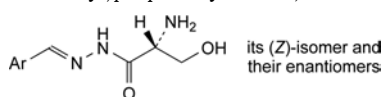

C. (2*RS*)-2-amino-3-hydroxy-2'-(1*EZ*)-(2,3,4-trihydroxybenzylidene)propanohydrazide.

04/2009:0467

## BENTONITE

### Bentonitum

**DEFINITION**

Natural clay containing a high proportion of montmorillonite, a native hydrated aluminium silicate in which some aluminium and silicon atoms may be replaced by other atoms such as magnesium and iron.

**CHARACTERS**

**Appearance:** very fine, homogeneous, greyish-white powder with a more or less yellowish or pinkish tint.

**Solubility:** practically insoluble in water and in aqueous solutions.

It swells with a little water forming a malleable mass.

**IDENTIFICATION**

A. To 0.5 g in a metal crucible add 1 g of *potassium nitrate R* and 3 g of *sodium carbonate R* and heat until the mixture melts. Allow to cool. To this residue add 20 mL of boiling *water R*, mix and filter. Wash the insoluble residue with 50 mL of *water R*. To this residue add 1 mL of *hydrochloric*

acid R and 5 mL of water R. Filter. To the filtrate add 1 mL of strong sodium hydroxide solution R and filter. To this filtrate add 3 mL of ammonium chloride solution R. A gelatinous white precipitate is formed.

04/2009:0372  
corrected 7.0

B. Add 2.0 g in 20 portions to 100 mL of a 10 g/L solution of sodium laurilsulfate R in a 100 mL graduated cylinder about 30 mm in diameter. Allow 2 min between additions for each portion to settle. Allow to stand for 2 h. The apparent volume of the sediment is not less than 22 mL.

C. 0.25 g gives the reaction of silicates (2.3.1).

#### TESTS

**Alkalinity.** To 2 g add 100 mL of carbon dioxide-free water R and shake for 5 min. To 5 mL of this suspension add 0.1 mL of thymolphthalein solution R. The liquid becomes bluish. Add 0.1 mL of 0.1 M hydrochloric acid. The liquid is decolourised within 5 min.

**Coarse particles:** maximum 0.5 per cent.

To 20 g add 1000 mL of water R and mix for 15 min using a high-speed mixer capable of operating at not less than 5000 r/min. Transfer the suspension to a wet sieve (75), tared after drying at 100-105 °C. Wash with 3 quantities, each of 500 mL, of water R, ensuring that any agglomerates have been dispersed. Dry the sieve at 100-105 °C and weigh. The particles on the sieve weigh a maximum of 0.1 g.

**Heavy metals (2.4.8):** maximum 50 ppm.

To 5.0 g add 7.5 mL of dilute hydrochloric acid R and 27.5 mL of water R. Boil for 5 min. Centrifuge and filter the supernatant liquid. Wash the centrifugation residue with water R and filter. Dilute the combined filtrates to 50.0 mL with water R. To 5 mL of this solution add 5 mL of water R, 10 mL of hydrochloric acid R and 25 mL of methyl isobutyl ketone R and shake for 2 min. Separate the layers. Evaporate the aqueous layer to dryness on a water-bath. Dissolve the residue in 1 mL of acetic acid R, dilute to 25 mL with water R and filter. 12 mL of the filtrate complies with test A. Prepare the reference solution using lead standard solution (1 ppm Pb) R.

**Loss on drying (2.2.32):** maximum 15 per cent, determined on 1.000 g by drying in an oven at 105 °C.

#### Microbial contamination

TAMC: acceptance criterion  $10^3$  CFU/g (2.6.12).

#### FUNCTIONALITY-RELATED CHARACTERISTICS

This section provides information on characteristics that are recognised as being relevant control parameters for one or more functions of the substance when used as an excipient (see chapter 5.15). This section is a non-mandatory part of the monograph and it is not necessary to verify the characteristics to demonstrate compliance. Control of these characteristics can however contribute to the quality of a medicinal product by improving the consistency of the manufacturing process and the performance of the medicinal product during use. Where control methods are cited, they are recognised as being suitable for the purpose, but other methods can also be used. Wherever results for a particular characteristic are reported, the control method must be indicated.

The following characteristics may be relevant for bentonite used as viscosity-increasing agent or suspending agent.

**Sedimentation volume.** To 6.0 g add 200 mL of water R and mix for 20 min using a high-speed mixer capable of operating at 10 000 r/min. Transfer 100 mL of this suspension to a graduated cylinder. Allow to stand for 24 h. The volume of the clear supernatant liquid is not greater than 2 mL.

**Swelling power with water:** see Identification B.

## BENZALKONIUM CHLORIDE

### Benzalkonii chloridum

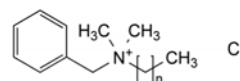

[8001-54-5]

#### DEFINITION

Mixture of alkylbenzyltrimethylammonium chlorides, the alkyl groups mainly having chain lengths of C<sub>12</sub>, C<sub>14</sub> and C<sub>16</sub>.

**Content:** 95.0 per cent to 104.0 per cent of alkylbenzyltrimethylammonium chlorides (anhydrous substance) calculated using the average relative molecular mass (see Tests).

#### CHARACTERS

**Appearance:** white or yellowish-white powder or gelatinous, yellowish-white fragments, hygroscopic. On heating it forms a clear molten mass.

**Solubility:** very soluble in water and in ethanol (96 per cent). An aqueous solution froths copiously when shaken.

#### IDENTIFICATION

**First identification:** B, E.

**Second identification:** A, C, D, E.

A. Ultraviolet and visible absorption spectrophotometry (2.2.25).

**Test solution.** Dissolve 80 mg in water R and dilute to 100.0 mL with the same solvent.

**Spectral range:** 220-350 nm.

**Absorption maxima:** at 257 nm, 263 nm and 269 nm.

**Shoulder:** at about 250 nm.

B. Examine the chromatograms obtained in the test for average relative molecular mass and ratio of alkyl components.

**Results:** the principal peaks in the chromatogram obtained with the test solution are similar in retention time to the principal peaks in the chromatogram obtained with the reference solution.

C. To 2 mL of solution S (see Tests) add 0.1 mL of glacial acetic acid R and, dropwise, 1 mL of sodium tetraphenylborate solution R. A white precipitate is formed. Filter. Dissolve the precipitate in a mixture of 1 mL of acetone R and 5 mL of ethanol (96 per cent) R, heating to not more than 70 °C. Add water R dropwise to the warm solution until a slight opalescence forms. Heat gently until the solution is clear and allow to cool. White crystals separate. Filter, wash with 3 quantities, each of 10 mL, of water R and dry in vacuo over diphosphorus pentoxide R or anhydrous silica gel R at a temperature not exceeding 50 °C. The crystals melt (2.2.14) at 127 °C to 133 °C.

D. To 5 mL of dilute sodium hydroxide solution R add 0.1 mL of bromophenol blue solution R1 and 5 mL of methylene chloride R and shake. The methylene chloride layer is colourless. Add 0.1 mL of solution S and shake. The methylene chloride layer becomes blue.

E. To 2 mL of solution S add 1 mL of dilute nitric acid R. A white precipitate is formed which dissolves on the addition of 5 mL of ethanol (96 per cent) R. The solution gives reaction (a) of chlorides (2.3.1).

#### TESTS

**Solution S.** Dissolve 1.0 g in carbon dioxide-free water R and dilute to 100 mL with the same solvent.

**Appearance of solution.** Solution S is clear (2.2.1) and not more intensely coloured than reference solution Y<sub>6</sub> (2.2.2, Method II).

**Acidity or alkalinity.** To 50 mL of solution S add 0.1 mL of *bromocresol purple solution R*. Not more than 0.1 mL of 0.1 M *hydrochloric acid* or 0.1 M *sodium hydroxide* is required to change the colour of the indicator.

**Average relative molecular mass and ratio of alkyl components.** Liquid chromatography (2.2.29).

**Test solution.** Dissolve 0.400 g of the substance to be examined in *water R* and dilute to 100.0 mL with the same solvent.

**Reference solution.** Dissolve 40 mg of *benzalkonium chloride for system suitability CRS* in *water R* and dilute to 10.0 mL with the same solvent.

**Column:**

- size:  $l = 0.25$  m,  $\varnothing = 4.6$  mm;
- stationary phase: end-capped nitrile silica gel for chromatography R (5  $\mu$ m).

**Mobile phase:** mix 45 volumes of *acetonitrile R* and 55 volumes of a 13.6 g/L solution of *sodium acetate R* previously adjusted to pH 5.0 with *glacial acetic acid R*.

**Flow rate:** 2.0 mL/min.

**Detection:** spectrophotometer at 254 nm.

**Injection:** 10  $\mu$ L.

**Identification of homologues:** use the chromatogram supplied with *benzalkonium chloride for system suitability CRS* and the chromatogram obtained with the reference solution to identify the peaks due to  $C_{12}$ ,  $C_{14}$  and  $C_{16}$ .

**Relative retention** with reference to  $C_{12}$  homologue (retention time = about 6 min):  $C_{14}$  homologue = about 1.1;  $C_{16}$  homologue = about 1.3.

**System suitability:** reference solution:

- resolution: minimum 1.5 between the peaks due to the  $C_{12}$  and  $C_{14}$  homologues.

Calculate the average relative molecular mass of the sample by summing the products for each homologue, using the following expression:

$$W \left( \frac{A}{B} \right)$$

- $A$  = area of the peak due to the given homologue in the chromatogram obtained with the test solution;
- $B$  = sum of the areas of the peaks due to all homologues in the chromatogram obtained with the test solution;
- $W$  = relative molecular mass for the given homologue: 340, 368 and 396 for the  $C_{12}$ ,  $C_{14}$  and  $C_{16}$  homologues, respectively.

Calculate the percentage of each homologue, using the following expression:

$$100 \left( \frac{C}{D} \right)$$

- $C$  = product of the relative molecular mass of the given homologue and the area of the corresponding peak in the chromatogram obtained with the test solution;
- $D$  = sum of the  $C$  values for all homologues quantified.

**Limits:**

- $C_{12}$  homologue: minimum 40 per cent;
- $C_{14}$  homologue: minimum 20 per cent;
- sum of  $C_{12}$  and  $C_{14}$  homologues: minimum 70 per cent.

**Impurities A, B and C.** Liquid chromatography (2.2.29). Prepare the solutions immediately before use.

**Test solution.** Dissolve 0.50 g of the substance to be examined in *methanol RI* and dilute to 10.0 mL with the same solvent.

**Reference solution (a).** Dissolve 25.0 mg of *benzyl alcohol CRS* (impurity A) in *methanol RI* and dilute to 100.0 mL with the same solvent.

**Reference solution (b).** Dissolve 75.0 mg of *benzaldehyde CRS* (impurity B) in *methanol RI* and dilute to 100.0 mL with the same solvent. Dilute 1.0 mL of this solution to 10.0 mL with *methanol RI*.

**Reference solution (c).** Dilute 1.0 mL of reference solution (a) to 10.0 mL with *methanol RI*.

**Column:**

- size:  $l = 0.15$  m,  $\varnothing = 4.6$  mm;
- stationary phase: end-capped octadecylsilyl silica gel for chromatography R (5  $\mu$ m);
- temperature: 30 °C.

**Mobile phase:**

– **mobile phase A:** dissolve 1.09 g of *sodium hexanesulfonate R* and 6.9 g of *sodium dihydrogen phosphate monohydrate R* in *water R*; adjust to pH 3.5 with *concentrated phosphoric acid R* and dilute to 1000.0 mL with the same solvent;

– **mobile phase B:** *methanol RI*;

Time (min)	Mobile phase A (per cent V/V)	Mobile phase B (per cent V/V)
0 - 10	80	20
10 - 14	80 → 50	20 → 50
14 - 35	50	50
35 - 36	50 → 20	50 → 80
36 - 55	20	80

**Flow rate:** 1.0 mL/min.

**Detection:** spectrophotometer at 210 nm for impurities A and C, and at 257 nm for impurity B.

**Injection:** 20  $\mu$ L.

**Relative retention** with reference to impurity A (retention time = about 10 min): impurity B = about 1.3; impurity C = 2.4.

**System suitability:** at 210 nm:

- **signal-to-noise ratio:** minimum 10 for the principal peak in the chromatogram obtained with reference solution (c);
- **symmetry factor:** minimum 0.6 for the peak due to impurity A in the chromatogram obtained with reference solution (a).

**Limits:**

- **correction factor:** for the calculation of content, multiply the peak area of impurity C by 1.3;
- **impurity A:** not more than the area of the corresponding peak in the chromatogram obtained with reference solution (a) (0.5 per cent);
- **impurity B:** not more than the area of the corresponding peak in the chromatogram obtained with reference solution (b) (0.15 per cent);
- **impurity C:** not more than 0.1 times the area of the principal peak in the chromatogram obtained with reference solution (a) (0.05 per cent).

**Amines and amine salts.** Dissolve 5.0 g with heating in 20 mL of a mixture of 3 volumes of 1 M *hydrochloric acid* and 97 volumes of *methanol R* and add 100 mL of *2-propanol R*. Pass a stream of *nitrogen R* slowly through the solution. Titrate with up to 12.0 mL of 0.1 M *tetrabutylammonium hydroxide* and record the potentiometric titration curve (2.2.20). If the curve shows 2 points of inflexion, the volume of titrant added between the 2 points is not greater than 5.0 mL. If the curve shows no point of inflexion, the substance to be examined does not comply with the test. If the curve shows 1 point of inflexion, repeat the test but add 3.0 mL of a 25.0 g/L solution of *dimethyldecylamine R* in *2-propanol R* before the titration. If the titration curve after addition of 12.0 mL of the titrant shows only 1 point of inflexion, the substance to be examined does not comply with the test.

**Water (2.5.12):** maximum 10 per cent, determined on 0.300 g.

**Sulfated ash** (2.4.14): maximum 0.1 per cent, determined on 1.0 g.

#### ASSAY

Dissolve 2.00 g in *water R* and dilute to 100.0 mL with the same solvent. Transfer 25.0 mL of the solution to a separating funnel, add 25 mL of *methylene chloride R*, 10 mL of 0.1 M *sodium hydroxide* and 10.0 mL of a freshly prepared 50 g/L solution of *potassium iodide R*. Shake well, allow to separate and discard the methylene chloride layer. Shake the aqueous layer with 3 quantities, each of 10 mL, of *methylene chloride R* and discard the methylene chloride layers. To the aqueous layer add 40 mL of *hydrochloric acid R*, allow to cool and titrate with 0.05 M *potassium iodate* until the deep-brown colour is almost discharged. Add 5 mL of *methylene chloride R* and continue the titration, shaking vigorously, until the methylene chloride layer no longer changes colour. Carry out a blank titration on a mixture of 10.0 mL of the freshly prepared 50 g/L solution of *potassium iodide R*, 20 mL of *water R* and 40 mL of *hydrochloric acid R*.

1 mL of 0.05 M *potassium iodate* is equivalent to  $\frac{x}{10}$  mg of benzalkonium chloride where  $x$  is the average relative molecular mass of the sample.

#### STORAGE

In an airtight container.

#### IMPURITIES

*Specified impurities: A, B, C.*



A. R = CH<sub>2</sub>OH: benzyl alcohol,

B. R = CHO: benzaldehyde,

C. R = CH<sub>2</sub>Cl: (chloromethyl)benzene.

04/2009:0371  
corrected 7.0

## BENZALKONIUM CHLORIDE SOLUTION

### Benzalkonii chloridi solutio

#### DEFINITION

Aqueous solution of a mixture of alkylbenzyltrimethylammonium chlorides, the alkyl groups mainly having chain lengths of C<sub>12</sub>, C<sub>14</sub> and C<sub>16</sub>.

*Content:* 475 g/L to 525 g/L of alkylbenzyltrimethylammonium chlorides, calculated using the average relative molecular mass (see Tests). The solution may contain ethanol (96 per cent).

#### CHARACTERS

*Appearance:* clear, colourless or slightly yellowish liquid.

*Solubility:* miscible with water and with ethanol (96 per cent).

It froths copiously when shaken.

#### IDENTIFICATION

*First identification:* B, E.

*Second identification:* A, C, D, E.

A. Ultraviolet and visible absorption spectrophotometry (2.2.25).

*Test solution.* Dilute 0.3 mL to 100.0 mL with *water R*.

*Spectral range:* 220-350 nm.

*Absorption maxima:* at 257 nm, 263 nm and 269 nm.

*Shoulder:* at about 250 nm.

B. Examine the chromatograms obtained in the test for average relative molecular mass and ratio of alkyl components.

*Results:* the principal peaks in the chromatogram obtained with the test solution are similar in retention time to the principal peaks in the chromatogram obtained with the reference solution.

C. To 0.05 mL add 2 mL of *water R*, 0.1 mL of *glacial acetic acid R* and, dropwise, 1 mL of *sodium tetraphenylborate solution R*. A white precipitate is formed. Filter. Dissolve the precipitate in a mixture of 1 mL of *acetone R* and 5 mL of *ethanol (96 per cent) R*, heating to not more than 70 °C. Add *water R* dropwise to the warm solution until a slight opalescence forms. Heat gently until the solution is clear and allow to cool. White crystals separate. Filter, wash with 3 quantities, each of 10 mL, of *water R* and dry *in vacuo* over *diphosphorus pentoxide R* or *anhydrous silica gel R* at a temperature not exceeding 50 °C. The crystals melt (2.2.14) at 127 °C to 133 °C.

D. To 5 mL of *dilute sodium hydroxide solution R* add 0.1 mL of *bromophenol blue solution R1* and 5 mL of *methylene chloride R* and shake. The methylene chloride layer is colourless. Add 0.05 mL of the solution to be examined and shake. The methylene chloride layer becomes blue.

E. To 0.05 mL add 1 mL of *dilute nitric acid R*. A white precipitate is formed which dissolves on the addition of 5 mL of *ethanol (96 per cent) R*. The solution gives reaction (a) of chlorides (2.3.1).

#### TESTS

**Solution S.** Dilute 2.0 g to 100 mL with *carbon dioxide-free water R*.

**Appearance of solution.** Solution S is clear (2.2.1) and not more intensely coloured than reference solution Y<sub>6</sub> (2.2.2, *Method II*).

**Acidity or alkalinity.** To 50 mL of solution S add 0.1 mL of *bromocresol purple solution R*. Not more than 0.1 mL of 0.1 M *hydrochloric acid* or 0.1 M *sodium hydroxide* is required to change the colour of the indicator.

**Average relative molecular mass and ratio of alkyl components.** Liquid chromatography (2.2.29).

*Test solution.* Determine the density (2.2.5) of the solution to be examined. Dilute a quantity of the solution to be examined equivalent to about 0.400 g of benzalkonium chloride to 100.0 mL with *water R*.

*Reference solution.* Dissolve 40 mg of *benzalkonium chloride for system suitability CRS* in *water R* and dilute to 10.0 mL with the same solvent.

#### Column:

– *size:*  $l = 0.25$  m,  $\varnothing = 4.6$  mm;

– *stationary phase:* end-capped nitrile silica gel for chromatography R (5 µm).

*Mobile phase:* mix 45 volumes of *acetonitrile R* and 55 volumes of a 13.6 g/L solution of *sodium acetate R* previously adjusted to pH 5.0 with *glacial acetic acid R*.

*Flow rate:* 2.0 mL/min.

*Detection:* spectrophotometer at 254 nm.

*Injection:* 10 µL.

*Identification of homologues:* use the chromatogram supplied with *benzalkonium chloride for system suitability CRS* and the chromatogram obtained with the reference solution to identify the peaks due to homologues C<sub>12</sub>, C<sub>14</sub> and C<sub>16</sub>.

*Relative retention* with reference to C<sub>12</sub> homologue (retention time = about 6 min): C<sub>14</sub> homologue = about 1.1; C<sub>16</sub> homologue = about 1.3.

*System suitability:* reference solution:

– *resolution:* minimum 1.5 between the peaks due to the C<sub>12</sub> and C<sub>14</sub> homologues.

Calculate the average relative molecular mass of the sample by summing the products for each homologue, using the following expression:

$$W \left( \frac{A}{B} \right)$$

- A* = area of the peak due to the given homologue in the chromatogram obtained with the test solution;  
*B* = sum of the areas of the peaks due to all homologues in the chromatogram obtained with the test solution;  
*W* = relative molecular mass for the given homologue: 340, 368 and 396 for the C<sub>12</sub>, C<sub>14</sub> and C<sub>16</sub> homologues, respectively.

Calculate the percentage of each homologue, using the following expression:

$$100 \left( \frac{C}{D} \right)$$

- C* = product of the relative molecular mass of the given homologue and the area of the corresponding peak in the chromatogram obtained with the test solution;  
*D* = sum of the *C* values for all homologues quantified.

#### Limits:

- C<sub>12</sub> homologue: minimum 40 per cent;
- C<sub>14</sub> homologue: minimum 20 per cent;
- sum of C<sub>12</sub> and C<sub>14</sub> homologues: minimum 70 per cent.

**Impurities A, B and C.** Liquid chromatography (2.2.29). Prepare the solutions immediately before use.

**Test solution.** Determine the density (2.2.5) of the solution to be examined. Dilute a quantity of the solution to be examined equivalent to 2.5 g of benzalkonium chloride to 50.0 mL with methanol R1.

**Reference solution (a).** Dissolve 25.0 mg of benzyl alcohol CRS (impurity A) in methanol R1 and dilute to 100.0 mL with the same solvent.

**Reference solution (b).** Dissolve 75.0 mg of benzaldehyde CRS (impurity B) in methanol R1 and dilute to 100.0 mL with the same solvent. Dilute 1.0 mL of this solution to 10.0 mL with methanol R1.

**Reference solution (c).** Dilute 1.0 mL of reference solution (a) to 10.0 mL with methanol R1.

#### Column:

- size: *l* = 0.15 m, Ø = 4.6 mm;
- stationary phase: end-capped octadecylsilyl silica gel for chromatography R (5 µm);
- temperature: 30 °C.

#### Mobile phase:

- mobile phase A: dissolve 1.09 g of sodium hexanesulfonate R and 6.9 g of sodium dihydrogen phosphate monohydrate R in water R; adjust to pH 3.5 with concentrated phosphoric acid R and dilute to 1000.0 mL with the same solvent;
- mobile phase B: methanol R1;

Time (min)	Mobile phase A (per cent V/V)	Mobile phase B (per cent V/V)
0 - 10	80	20
10 - 14	80 → 50	20 → 50
14 - 35	50	50
35 - 36	50 → 20	50 → 80
36 - 55	20	80

**Flow rate:** 1.0 mL/min.

**Detection:** spectrophotometer at 210 nm for impurities A and C, and at 257 nm for impurity B.

**Injection:** 20 µL.

**Relative retention** with reference to impurity A (retention time = about 10 min): impurity B = about 1.3; impurity C = about 2.4.

**System suitability:** at 210 nm:

- signal-to-noise ratio: minimum 10 for the principal peak in the chromatogram obtained with reference solution (c);
- symmetry factor: minimum 0.6 for the peak due to impurity A in the chromatogram obtained with reference solution (a).

#### Limits:

- correction factor: for the calculation of content, multiply the peak area of impurity C by 1.3;
- impurity A: not more than the area of the corresponding peak in the chromatogram obtained with reference solution (a) (0.5 per cent);
- impurity B: not more than the area of the corresponding peak in the chromatogram obtained with reference solution (b) (0.15 per cent);
- impurity C: not more than 0.1 times the area of the principal peak in the chromatogram obtained with reference solution (a) (0.05 per cent).

**Amines and amine salts.** Mix 10.0 g, while heating, with 20 mL of a mixture of 3 volumes of 1 M hydrochloric acid and 97 volumes of methanol R and add 100 mL of 2-propanol R. Pass a stream of nitrogen R slowly through the solution. Titrate with up to 12.0 mL of 0.1 M tetrabutylammonium hydroxide and record the potentiometric titration curve (2.2.20). If the curve shows 2 points of inflexion, the volume of titrant added between the 2 points is not greater than 5.0 mL. If the curve shows no point of inflexion, the solution to be examined does not comply with the test. If the curve shows 1 point of inflexion, repeat the test but add 3.0 mL of a 25.0 g/L solution of dimethyldodecylamine R in 2-propanol R before the titration. If the titration curve after the addition of 12.0 mL of the titrant shows only 1 point of inflexion, the solution to be examined does not comply with the test.

**Sulfated ash (2.4.14):** maximum 0.1 per cent, determined on 1.0 g.

#### ASSAY

Determine the density (2.2.5) of the solution to be examined. Dilute 4.00 g to 100.0 mL with water R. Transfer 25.0 mL of the solution to a separating funnel, add 25 mL of methylene chloride R, 10 mL of 0.1 M sodium hydroxide and 10.0 mL of a freshly prepared 50 g/L solution of potassium iodide R. Shake well, allow to separate and discard the methylene chloride layer. Shake the aqueous layer with 3 quantities, each of 10 mL, of methylene chloride R and discard the methylene chloride layers. To the aqueous layer add 40 mL of hydrochloric acid R, allow to cool and titrate with 0.05 M potassium iodate until the deep-brown colour is almost discharged. Add 5 mL of methylene chloride R and continue the titration, shaking vigorously, until the methylene chloride layer no longer changes colour. Carry out a blank titration on a mixture of 10.0 mL of the freshly prepared 50 g/L solution of potassium iodide R, 20 mL of water R and 40 mL of hydrochloric acid R.

1 mL of 0.05 M potassium iodate is equivalent to  $\frac{x}{10}$  mg of benzalkonium chloride where *x* is the average relative molecular mass of the sample.

#### LABELLING

The label states the content of ethanol (96 per cent), if any.

#### IMPURITIES

Specified impurities: A, B, C.



- A. R = CH<sub>2</sub>OH: benzyl alcohol,  
 B. R = CHO: benzaldehyde,  
 C. R = CH<sub>2</sub>Cl: (chloromethyl)benzene.

01/2008:1393

## BENZBROMARONE

### Benzbromaronum

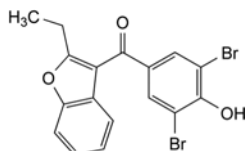

C<sub>17</sub>H<sub>12</sub>Br<sub>2</sub>O<sub>3</sub>  
 [3562-84-3]

M<sub>r</sub> 424.1

#### DEFINITION

(3,5-Dibromo-4-hydroxyphenyl)(2-ethylbenzofuran-3-yl)-methanone.

*Content*: 98.0 per cent to 101.0 per cent (dried substance).

#### CHARACTERS

*Appearance*: white or almost white, crystalline powder.

*Solubility*: practically insoluble in water, freely soluble in acetone and in methylene chloride, sparingly soluble in ethanol (96 per cent).

mp: about 152 °C.

#### IDENTIFICATION

A. Infrared absorption spectrophotometry (2.2.24).

*Comparison*: benzbromarone CRS.

B. By means of a copper wire, previously ignited, introduce a small amount of the substance to be examined into the non-luminous part of a flame. The colour of the flame becomes green.

#### TESTS

**Appearance of solution.** The solution is clear (2.2.1) and not more intensely coloured than reference solution Y<sub>5</sub> (2.2.2, Method II).

Dissolve 1.25 g in *dimethylformamide R* and dilute to 25 mL with the same solvent.

**Acidity or alkalinity.** Shake 0.5 g with 10 mL of *carbon dioxide-free water R* for 1 min and filter. To 2.0 mL of the filtrate add 0.1 mL of *methyl red solution R* and 0.1 mL of 0.01 M *hydrochloric acid*. The solution is red. Add 0.3 mL of 0.01 M *sodium hydroxide*. The solution is yellow.

**Related substances.** Liquid chromatography (2.2.29).

*Test solution.* Dissolve 0.125 g of the substance to be examined in 30 mL of *methanol R* and dilute to 50.0 mL with the mobile phase.

*Reference solution (a).* Dilute 1.0 mL of the test solution to 100.0 mL with the mobile phase. Dilute 1.0 mL of this solution to 10.0 mL with the mobile phase.

*Reference solution (b).* Dissolve 10 mg of *benzaronum CRS* (impurity C) in the mobile phase and dilute to 20 mL with the mobile phase. To 5 mL of this solution add 1 mL of the test solution and dilute to 100 mL with the mobile phase.

*Column*:

– size: *l* = 0.25 m,  $\emptyset$  = 4.6 mm;

– *stationary phase*: octadecylsilyl silica gel for chromatography R (5  $\mu$ m).

*Mobile phase*: glacial acetic acid R, acetonitrile R, water R, methanol R (5:25:300:990 V/V/V/V).

*Flow rate*: 1.5 mL/min.

*Detection*: spectrophotometer at 231 nm.

*Injection*: 20  $\mu$ L.

*Run time*: 2.5 times the retention time of benzbromarone.

*Relative retention* with reference to benzbromarone: impurity A = about 0.6; impurity B = about 2.

*System suitability*: reference solution (b):

– *resolution*: minimum 10.0 between the peaks due to impurity C (1<sup>st</sup> peak) and benzbromarone (2<sup>nd</sup> peak).

*Limits*:

– *impurity A*: not more than 4 times the area of the principal peak in the chromatogram obtained with reference solution (a) (0.4 per cent);

– *impurity B*: not more than 10 times the area of the principal peak in the chromatogram obtained with reference solution (a) (1.0 per cent);

– *unspecified impurities*: for each impurity, not more than the area of the principal peak in the chromatogram obtained with reference solution (a) (0.10 per cent);

– *sum of impurities other than A and B*: not more than twice the area of the principal peak in the chromatogram obtained with reference solution (a) (0.2 per cent);

– *disregard limit*: 0.2 times the area of the principal peak in the chromatogram obtained with reference solution (a) (0.02 per cent).

**Halides expressed as chlorides (2.4.4)**: maximum 400 ppm.

Shake 1.25 g with a mixture of 5 mL of *dilute nitric acid R* and 15 mL of *water R*. Filter. Rinse the filter with *water R* and dilute the filtrate to 25 mL with the same solvent. Dilute 2.5 mL of this solution to 15 mL with *water R*.

**Iron (2.4.9)**: maximum 125 ppm.

Moisten the residue obtained in the test for sulfated ash with 2 mL of *hydrochloric acid R* and evaporate to dryness on a water-bath. Add 0.05 mL of *hydrochloric acid R* and 10 mL of *water R*, heat to boiling and maintain boiling for 1 min. Allow to cool. Rinse the crucible with *water R*, collect the rinsings and dilute to 25 mL with *water R*. Dilute 2 mL of this solution to 10 mL with *water R*.

**Heavy metals (2.4.8)**: maximum 20 ppm.

0.5 g complies with test C. Prepare the reference solution using 1 mL of *lead standard solution (10 ppm Pb) R*.

**Loss on drying (2.2.32)**: maximum 0.5 per cent, determined on 1.000 g by drying *in vacuo* at 50 °C for 4 h.

**Sulfated ash (2.4.14)**: maximum 0.1 per cent, determined on 1.0 g.

#### ASSAY

Dissolve 0.300 g in 60 mL of *methanol R*. Stir until completely dissolved and add 10 mL of *water R*. Titrate with 0.1 M *sodium hydroxide*, determining the end-point potentiometrically (2.2.20).

1 mL of 0.1 M *sodium hydroxide* is equivalent to 42.41 mg of C<sub>17</sub>H<sub>12</sub>Br<sub>2</sub>O<sub>3</sub>.

#### STORAGE

Protected from light.

#### IMPURITIES

*Specified impurities*: A, B.

*Other detectable impurities* (the following substances would, if present at a sufficient level, be detected by one or other of the tests in the monograph. They are limited by the general acceptance criterion for other/unspecified impurities and/or by the general monograph *Substances for pharmaceutical use*



(2034). It is therefore not necessary to identify these impurities for demonstration of compliance. See also 5.10. *Control of impurities in substances for pharmaceutical use*): C.

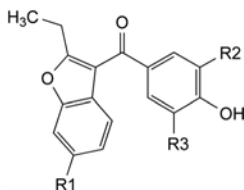

- A. R1 = R2 = H, R3 = Br: (3-bromo-4-hydroxyphenyl)(2-ethylbenzofuran-3-yl)methanone,  
 B. R1 = R2 = R3 = Br: (6-bromo-2-ethylbenzofuran-3-yl)(3,5-dibromo-4-hydroxyphenyl)methanone,  
 C. R1 = R2 = R3 = H: (2-ethylbenzofuran-3-yl)(4-hydroxyphenyl)methanone (benzarone).

01/2008:0974  
corrected 6.0

## BENZETHONIUM CHLORIDE

### Benzethonii chloridum

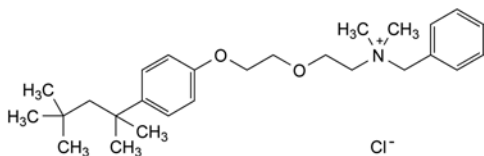

$C_{27}H_{42}ClNO_2$   
[121-54-0]

$M_r$  448.1

#### DEFINITION

*N*-Benzyl-*N,N*-dimethyl-2-[2-[4-(1,1,3,3-tetramethylbutyl)-phenoxy]ethoxy]ethanaminium chloride.

*Content*: 97.0 per cent to 103.0 per cent (dried substance).

#### CHARACTERS

*Appearance*: white or yellowish-white powder.

*Solubility*: very soluble in water and in ethanol (96 per cent), freely soluble in methylene chloride.

An aqueous solution froths copiously when shaken.

#### IDENTIFICATION

A. Melting point (2.2.14): 158 °C to 164 °C, after drying at 105 °C for 4 h.

B. Thin-layer chromatography (2.2.27).

*Test solution*. Dissolve 25 mg of the substance to be examined in water *R* and dilute to 5 mL with the same solvent.

*Reference solution*. Dissolve 25 mg of benzethonium chloride CRS in water *R* and dilute to 5 mL with the same solvent.

*Plate*: TLC silica gel  $F_{254}$  plate *R*.

*Mobile phase*: glacial acetic acid *R*, water *R*, methanol *R* (5:5:100 V/V/V).

*Application*: 20 µL.

*Development*: over a path of 12 cm.

*Drying*: in a current of warm air.

*Detection*: examine in ultraviolet light at 254 nm.

*Results*: the principal spot in the chromatogram obtained with the test solution is similar in position and size to the principal spot in the chromatogram obtained with the reference solution.

C. To 5 mL of dilute sodium hydroxide solution *R* add 0.1 mL of bromophenol blue solution *R1* and 5 mL of methylene chloride *R* and shake. The lower layer is colourless. Add 0.1 mL of solution S (see Tests) and shake. A blue colour develops in the lower layer.

D. To 2 mL of solution S add 1 mL of dilute nitric acid *R*. A white precipitate is formed which dissolves upon addition of 5 mL of ethanol (96 per cent) *R*. The solution gives reaction (a) of chlorides (2.3.1).

#### TESTS

**Solution S**. Dissolve 5.0 g in carbon dioxide-free water *R* and dilute to 50 mL with the same solvent.

**Appearance of solution**. Solution S is clear (2.2.1) and not more intensely coloured than reference solution  $Y_6$  (2.2.2, Method II).

**Acidity or alkalinity**. To 25 mL of solution S add 0.1 mL of phenolphthalein solution *R*. The solution is colourless. Add 0.3 mL of 0.01 M sodium hydroxide. The solution is pink. Add 0.1 mL of methyl red solution *R* and 0.5 mL of 0.01 M hydrochloric acid. The solution is orange-red.

**Volatile bases and salts of volatile bases** (2.4.1, Method B): maximum 50 ppm, determined on 0.20 g.

Prepare the standard using 0.1 mL of ammonium standard solution (100 ppm  $NH_4$ ) *R*. Replace heavy magnesium oxide by 2.0 mL of strong sodium hydroxide solution *R*.

**Loss on drying** (2.2.32): maximum 5.0 per cent, determined on 1.000 g by drying in an oven at 105 °C for 4 h.

**Sulfated ash** (2.4.14): maximum 0.1 per cent, determined on 1.0 g.

#### ASSAY

Dissolve 2.000 g in water *R* and dilute to 100.0 mL with the same solvent. Transfer 25.0 mL of the solution to a separating funnel, add 10 mL of a 4 g/L solution of sodium hydroxide *R*, 10.0 mL of a freshly prepared 50 g/L solution of potassium iodide *R* and 25 mL of methylene chloride *R*. Shake vigorously, allow to separate and discard the lower layer. Shake the upper layer with 3 quantities, each of 10 mL, of methylene chloride *R* and discard the lower layers. To the upper layer add 40 mL of hydrochloric acid *R*, allow to cool and titrate with 0.05 M potassium iodate until the deep brown colour is almost discharged. Add 4 mL of methylene chloride *R* and continue the titration, shaking vigorously, until the lower layer is no longer brown. Carry out a blank titration using a mixture of 10.0 mL of a freshly prepared 50 g/L solution of potassium iodide *R*, 20 mL of water *R* and 40 mL of hydrochloric acid *R*. 1 mL of 0.05 M potassium iodate is equivalent to 44.81 mg of  $C_{27}H_{42}ClNO_2$ .

#### STORAGE

Protected from light.

01/2008:0011  
corrected 6.0

## BENZOCAINE

### Benzocainum

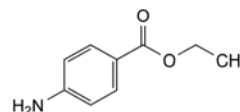

$C_9H_{11}NO_2$   
[94-09-7]

$M_r$  165.2

#### DEFINITION

Ethyl 4-aminobenzoate.

*Content*: 99.0 per cent to 101.0 per cent (dried substance).

## CHARACTERS

**Appearance:** white or almost white, crystalline powder or colourless crystals.

**Solubility:** very slightly soluble in water, freely soluble in ethanol (96 per cent).

## IDENTIFICATION

**First identification:** A, B.

**Second identification:** A, C, D.

A. Melting point (2.2.14): 89 °C to 92 °C.

B. Infrared absorption spectrophotometry (2.2.24).

*Comparison:* benzocaine CRS.

C. To about 50 mg in a test tube add 0.2 mL of a 500 g/L solution of *chromium trioxide R*. Cover the mouth of the tube with a piece of filter paper moistened with a freshly prepared mixture of equal volumes of a 50 g/L solution of *sodium nitroprusside R* and a 200 g/L solution of *piperazine hydrate R*. Boil gently for at least 30 s. A blue colour develops on the filter paper.

D. Dissolve about 50 mg in *ethanol (96 per cent) R* and dilute to 100 mL with the same solvent. 2 mL of the solution gives the reaction of primary aromatic amines (2.3.1).

## TESTS

**Appearance of solution.** The solution is clear (2.2.1) and colourless (2.2.2, Method II).

Dissolve 1.0 g in *ethanol (96 per cent) R* and dilute to 20 mL with the same solvent.

**Acidity or alkalinity.** Dissolve 0.5 g in 10 mL of *ethanol (96 per cent) R* previously neutralised to 0.05 mL of *phenolphthalein solution R*. Add 10 mL of *carbon dioxide-free water R*. The solution remains colourless and not more than 0.5 mL of 0.01 M *sodium hydroxide* is required to change the colour of the indicator.

**Loss on drying** (2.2.32): maximum 0.5 per cent, determined on 1.00 g by drying *in vacuo*.

**Sulfated ash** (2.4.14): maximum 0.1 per cent, determined on 1.0 g.

## ASSAY

Carry out the determination of primary aromatic amino-nitrogen (2.5.8), using 0.400 g dissolved in a mixture of 25 mL of *hydrochloric acid R* and 50 mL of *water R*.

1 mL of 0.1 M *sodium nitrite* is equivalent to 16.52 mg of  $C_6H_5NO_2$ .

## STORAGE

Protected from light.

**Content:** 99.0 per cent to 100.5 per cent.

## CHARACTERS

**Appearance:** white or almost white, crystalline powder or colourless crystals.

**Solubility:** slightly soluble in water, soluble in boiling water, freely soluble in ethanol (96 per cent) and in fatty oils.

## IDENTIFICATION

A. Melting point (2.2.14): 121 °C to 124 °C.

B. Solution S (see Tests) gives reaction (a) of benzoates (2.3.1).

## TESTS

**Solution S.** Dissolve 5.0 g in *ethanol (96 per cent) R* and dilute to 100 mL with the same solvent.

**Appearance of solution.** Solution S is clear (2.2.1) and colourless (2.2.2, Method II).

**Carbonisable substances.** Dissolve 0.5 g with shaking in 5 mL of *sulfuric acid R*. After 5 min, the solution is not more intensely coloured than reference solution Y<sub>5</sub> (2.2.2, Method I).

**Oxidisable substances.** Dissolve 0.2 g in 10 mL of boiling *water R*. Cool, shake and filter. To the filtrate add 1 mL of *dilute sulfuric acid R* and 0.2 mL of 0.02 M *potassium permanganate*. After 5 min, the solution is still coloured pink.

**Halogenated compounds and halides:** maximum 300 ppm.

*All glassware used must be chloride-free and may be prepared by soaking overnight in a 500 g/L solution of nitric acid R, rinsed with water R and stored full of water R. It is recommended that glassware be reserved for this test.*

**Solution (a).** Dissolve 6.7 g in a mixture of 40 mL of 1 M *sodium hydroxide* and 50 mL of *ethanol (96 per cent) R* and dilute to 100.0 mL with *water R*. To 10.0 mL of this solution add 7.5 mL of *dilute sodium hydroxide solution R* and 0.125 g of *nickel-aluminium alloy R* and heat on a water-bath for 10 min. Allow to cool to room temperature, filter into a 25 mL volumetric flask and wash with 3 quantities, each of 2 mL, of *ethanol (96 per cent) R*. Dilute the filtrate and washings to 25.0 mL with *water R*. This solution is used to prepare solution A.

**Solution (b).** In the same manner, prepare a similar solution without the substance to be examined. This solution is used to prepare solution B.

In four 25 mL volumetric flasks, place separately 10 mL of solution (a), 10 mL of solution (b), 10 mL of *chloride standard solution (8 ppm Cl) R* (used to prepare solution C) and 10 mL of *water R*. To each flask add 5 mL of *ferric ammonium sulfate solution R5*, mix and add dropwise and with swirling 2 mL of *nitric acid R* and 5 mL of *mercuric thiocyanate solution R*. Shake. Dilute the contents of each flask to 25.0 mL with *water R* and allow the solutions to stand in a water-bath at 20 °C for 15 min. Measure at 460 nm the absorbance (2.2.25) of solution A using solution B as the compensation liquid, and the absorbance of solution C using the solution obtained with 10 mL of *water R* as the compensation liquid. The absorbance of solution A is not greater than that of solution C.

**Heavy metals** (2.4.8): maximum 10 ppm.

12 mL of solution S complies with test B. Prepare the reference solution using a mixture of 5 mL of *lead standard solution (1 ppm Pb) R* and 5 mL of *ethanol (96 per cent) R*.

**Sulfated ash** (2.4.14): maximum 0.1 per cent, determined on 1.0 g.

## ASSAY

Dissolve 0.200 g in 20 mL of *ethanol (96 per cent) R* and titrate with 0.1 M *sodium hydroxide*, using 0.1 mL of *phenol red solution R* as indicator, until the colour changes from yellow to violet-red.

1 mL of 0.1 M *sodium hydroxide* is equivalent to 12.21 mg of  $C_6H_5O_2$ .

01/2008:0066  
corrected 6.4

## BENZOIC ACID

Acidum benzoicum

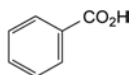

$C_7H_6O_2$   
[65-85-0]

$M_r$  122.1

## DEFINITION

Benzenecarboxylic acid.

01/2008:0704 **Related substances.** Liquid chromatography (2.2.29). Prepare the solutions immediately before use.

## BENZOYL PEROXIDE, HYDROUS

### Benzoylis peroxidum cum aqua

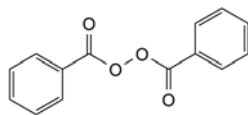

$C_{14}H_{10}O_4$   $M_r$  242.2 (anhydrous substance)  
Anhydrous benzoyl peroxide: [94-36-0]

#### DEFINITION

##### Content:

- *dibenzoyl peroxide*: 70.0 per cent to 77.0 per cent;
- *water*: minimum 20.0 per cent.

#### CHARACTERS

*Appearance*: white or almost white, amorphous or granular powder.

*Solubility*: practically insoluble in water, soluble in acetone, soluble in methylene chloride with the separation of water, slightly soluble in ethanol (96 per cent).

It loses water rapidly on exposure to air with a risk of explosion.

Mix the entire sample thoroughly before carrying out the following tests.

#### IDENTIFICATION

*First identification*: B

*Second identification*: A, C, D.

A. Ultraviolet and visible absorption spectrophotometry (2.2.25).

*Solution A*. Dissolve 80.0 mg in *ethanol (96 per cent) R* and dilute to 100.0 mL with the same solvent. Dilute 10.0 mL of the solution to 100.0 mL with *ethanol (96 per cent) R*.

*Solution B*. Dilute 10.0 mL of solution A to 100.0 mL with *ethanol (96 per cent) R*.

*Spectral ranges*: 250-300 nm for solution A; 220-250 nm for solution B.

*Absorption maxima*: at 274 nm for solution A; at 235 nm for solution B.

*Shoulder*: at about 282 nm for solution A.

*Absorbance ratio*:  $A_{235}/A_{274} = 1.17$  to 1.21.

B. Infrared absorption spectrophotometry (2.2.24).

*Comparison*: Ph. Eur. reference spectrum of *hydrous benzoyl peroxide*.

C. Dissolve about 25 mg in 2 mL of *acetone R*. Add 1 mL of a 10 g/L solution of *diethylphenylenediamine sulfate R* and mix. A red colour develops which quickly darkens and becomes dark violet within 5 min.

D. To 1 g add 5 mL of *ethanol (96 per cent) R*, 5 mL of *dilute sodium hydroxide solution R* and 10 mL of *water R*. Boil the mixture under reflux for 20 min. Cool. The solution gives reaction (c) of benzoates (2.3.1).

#### TESTS

**Acidity.** Dissolve a quantity of the substance to be examined containing the equivalent of 1.0 g of dibenzoyl peroxide in 25 mL of *acetone R*, add 75 mL of *water R* and filter. Wash the residue with two quantities, each of 10 mL, of *water R*. Combine the filtrate and the washings and add 0.25 mL of *phenolphthalein solution R1*. Not more than 1.25 mL of 0.1 M *sodium hydroxide* is required to change the colour of the indicator. Carry out a blank test.

**Test solution.** Dissolve a quantity of the substance to be examined containing the equivalent of 0.10 g of dibenzoyl peroxide in *acetonitrile R* and dilute to 50 mL with the same solvent.

**Reference solution (a).** Dilute 1.0 mL of the test solution to 100.0 mL with *acetonitrile R*. Dilute 1.0 mL of this solution to 10.0 mL with *acetonitrile R*.

**Reference solution (b).** Dissolve 30.0 mg of *benzoic acid R* in the mobile phase and dilute to 100.0 mL with the mobile phase. Dilute 1.0 mL of the solution to 10.0 mL with the mobile phase.

**Reference solution (c).** Dissolve 50.0 mg of *ethyl benzoate R* in the mobile phase and dilute to 100.0 mL with the mobile phase. Dilute 1.0 mL of the solution to 100.0 mL with the mobile phase.

**Reference solution (d).** Dissolve 50.0 mg of *benzaldehyde R* in the mobile phase and dilute to 100.0 mL with the mobile phase. Dilute 1.0 mL of the solution to 100.0 mL with the mobile phase.

**Reference solution (e).** Dissolve 30.0 mg of *benzoic acid R* and 30.0 mg of *benzaldehyde R* in the mobile phase and dilute to 100.0 mL with the mobile phase. Dilute 1.0 mL of the solution to 10.0 mL with the mobile phase.

##### Column:

- *size*:  $l = 0.25$  m,  $\varnothing = 4.6$  mm;
- *stationary phase*: *octadecylsilyl silica gel for chromatography R* (10  $\mu$ m).

*Mobile phase*: *glacial acetic acid R*, *acetonitrile R*, *water R* (1:500:500 V/V/V).

*Flow rate*: 1 mL/min.

*Detection*: spectrophotometer at 235 nm.

*Injection*: 20  $\mu$ L loop injector.

*Run time*: 2 times the retention time of dibenzoyl peroxide.

*Relative retention* with reference to dibenzoyl peroxide (retention time = about 28.4 min): impurity B = about 0.15; impurity A = about 0.2; impurity C = about 0.4.

*System suitability*: reference solution (e):

- *resolution*: minimum 6 between the peaks corresponding to benzoic acid and benzaldehyde.

##### Limits:

- *impurity A*: not more than the area of the principal peak in the chromatogram obtained with reference solution (d) (0.25 per cent);
- *impurity B*: not more than the area of the principal peak in the chromatogram obtained with reference solution (b) (1.5 per cent);
- *impurity C*: not more than the area of the principal peak in the chromatogram obtained with reference solution (c) (0.25 per cent);
- *unspecified impurities*: for each impurity, not more than the area of the principal peak in the chromatogram obtained with reference solution (a) (0.10 per cent);
- *disregard limit*: 0.2 times the area of the principal peak in the chromatogram obtained with reference solution (a) (0.02 per cent).

**Chlorides** (2.4.4): maximum 0.4 per cent.

Dissolve a quantity of the substance to be examined containing the equivalent of 0.5 g of dibenzoyl peroxide in 15 mL of *acetone R*. Add, while stirring, 50 mL of 0.05 M *nitric acid*. Allow to stand for 10 min and filter. Wash the residue with 2 quantities, each of 10 mL, of 0.05 M *nitric acid*. Combine the filtrate and the washings and dilute to 100 mL with 0.05 M *nitric acid*. Dilute 2.5 mL of the solution to 15.0 mL with *water R*.

#### ASSAY

**Solution (a).** Dissolve 2.500 g immediately before use in 75 mL of *dimethylformamide R* and dilute to 100.0 mL with the same solvent.

**Dibenzoyl peroxide.** To 5.0 mL of solution (a) add 20 mL of *acetone R* and 3 mL of a 500 g/L solution of *potassium iodide R* and mix. Allow to stand for 1 min. Titrate with 0.1 M *sodium thiosulfate* using 1 mL of *starch solution R*, added towards the end of the titration, as indicator. Carry out a blank titration.

1 mL of 0.1 M *sodium thiosulfate* is equivalent to 12.11 mg of  $C_{14}H_{10}O_4$ .

**Water (2.5.12).** Carry out the semi-micro determination of water, using 5.0 mL of solution (a). Use as the solvent a mixture of 20.0 mL of *anhydrous methanol R* and 3.0 mL of a 100 g/L solution of *potassium iodide R* in *dimethylformamide R*. After adding solution (a), stir for 5 min before starting the titration. Carry out a blank determination.

Calculate the percentage content of water using the following expression:

$$\frac{(n_1 - n_2) \times w \times 2}{m} + (p \times 0.0744)$$

- $n_1$  = number of millilitres of *iodosulfurous reagent R* used in the sample determination,  
 $n_2$  = number of millilitres of *iodosulfurous reagent R* used in the blank determination,  
 $w$  = water equivalent of *iodosulfurous reagent R* in milligrams of water per millilitre of reagent,  
 $m$  = mass of the substance to be examined used for the preparation of solution (a) in grams,  
 $p$  = percentage content of dibenzoyl peroxide.

#### STORAGE

In a container that has been treated to reduce static discharge and that has a device for release of excess pressure, at a temperature of 2 °C to 8 °C, protected from light.

#### IMPURITIES

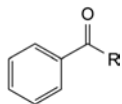

- A. R = H: benzaldehyde,  
 B. R = OH: benzoic acid,  
 C. R = O-CH<sub>2</sub>-CH<sub>3</sub>: ethyl benzoate.

07/2009:0256

## BENZYL ALCOHOL

### Alcohol benzylicus

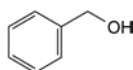

$C_7H_8O$   
 [100-51-6]

$M_r$  108.1

#### DEFINITION

Phenylmethanol.

*Content*: 98.0 per cent to 100.5 per cent.

#### CHARACTERS

*Appearance*: clear, colourless, oily liquid.

*Solubility*: soluble in water, miscible with ethanol (96 per cent) and with fatty and essential oils.

*Relative density*: 1.043 to 1.049.

#### IDENTIFICATION

Infrared absorption spectrophotometry (2.2.24).

*Comparison*: *benzyl alcohol CRS*.

#### TESTS

**Appearance of solution.** Shake 2.0 mL with 60 mL of *water R*. It dissolves completely. The solution is clear (2.2.1) and colourless (2.2.2, *Method II*).

**Acidity.** To 10 mL add 10 mL of *ethanol (96 per cent) R* and 1 mL of *phenolphthalein solution R*. Not more than 1 mL of 0.1 M *sodium hydroxide* is required to change the colour of the indicator to pink.

**Refractive index (2.2.6)**: 1.538 to 1.541.

**Peroxide value (2.5.5)**: maximum 5.

**Related substances.** Gas chromatography (2.2.28).

*Test solution.* The substance to be examined.

*Standard solution (a).* Dissolve 0.100 g of *ethylbenzene R* in the test solution and dilute to 10.0 mL with the same solution. Dilute 2.0 mL of this solution to 20.0 mL with the test solution.

*Standard solution (b).* Dissolve 2.000 g of *dicyclohexyl R* in the test solution and dilute to 10.0 mL with the same solution. Dilute 2.0 mL of this solution to 20.0 mL with the test solution.

*Reference solution (a).* Dissolve 0.750 g of *benzaldehyde R* and 0.500 g of *cyclohexylmethanol R* in the test solution and dilute to 25.0 mL with the test solution. Add 1.0 mL of this solution to a mixture of 2.0 mL of standard solution (a) and 3.0 mL of standard solution (b) and dilute to 20.0 mL with the test solution.

*Reference solution (b).* Dissolve 0.250 g of *benzaldehyde R* and 0.500 g of *cyclohexylmethanol R* in the test solution and dilute to 25.0 mL with the test solution. Add 1.0 mL of this solution to a mixture of 2.0 mL of standard solution (a) and 2.0 mL of standard solution (b) and dilute to 20.0 mL with the test solution.

*Column*:

- *material*: fused silica;
- *size*:  $l = 30$  m,  $\varnothing = 0.32$  mm;
- *stationary phase*: *macrogol 20 000 R* (film thickness 0.5  $\mu$ m).

*Carrier gas*: *helium for chromatography R*.

*Linear velocity*: 25 cm/s.

*Temperature*:

	Time (min)	Temperature (°C)
Column	0 - 34	50 → 220
	34 - 69	220
Injection port		200
Detector		310

*Detection*: flame ionisation.

*Benzyl alcohol not intended for parenteral administration*

*Injection*: without air-plug, 0.1  $\mu$ L of the test solution and reference solution (a).

*Relative retention* with reference to benzyl alcohol (retention time = about 26 min): ethylbenzene = about 0.28; dicyclohexyl = about 0.59; impurity A = about 0.68; impurity B = about 0.71.

*System suitability*: reference solution (a):

- *resolution*: minimum 3.0 between the peaks due to impurities A and B.

If any peaks in the chromatogram obtained with the test solution have the same retention time as the peaks due to ethyl benzene or dicyclohexyl, subtract the areas of any such peaks from the peak areas at these retention times in the chromatograms obtained with reference solutions (a) or (b) (corrected peak areas of ethyl benzene and dicyclohexyl). Any such peaks in the chromatogram obtained with the test solution are to be included in the assessments for the sum of other peaks.

**Limits:**

- *impurity A*: not more than the difference between the area of the peak due to impurity A in the chromatogram obtained with reference solution (a) and the area of the peak due to impurity A in the chromatogram obtained with the test solution (0.15 per cent);
- *impurity B*: not more than the difference between the area of the peak due to impurity B in the chromatogram obtained with reference solution (a) and the area of the peak due to impurity B in the chromatogram obtained with the test solution (0.10 per cent);
- *sum of other peaks with a relative retention less than that of benzyl alcohol*: not more than 4 times the area of the peak due to ethylbenzene in the chromatogram obtained with reference solution (a) corrected if necessary as described above (0.04 per cent);
- *sum of peaks with a relative retention greater than that of benzyl alcohol*: not more than the area of the peak due to dicyclohexyl in the chromatogram obtained with reference solution (a) corrected if necessary as described above (0.3 per cent);
- *disregard limit*: 0.01 times the area of the peak due to ethylbenzene in the chromatogram obtained with reference solution (a) corrected if necessary as described above (0.0001 per cent).

**Benzyl alcohol intended for parenteral administration**

**Injection:** without air-plug, 0.1 µL of the test solution and reference solution (b).

**Relative retention** with reference to benzyl alcohol (retention time = about 26 min): ethylbenzene = about 0.28; dicyclohexyl = about 0.59; impurity A = about 0.68; impurity B = about 0.71.

**System suitability:** reference solution (b):

- *resolution*: minimum 3.0 between the peaks due to impurities A and B.

If any peaks in the chromatogram obtained with the test solution have the same retention times as the peaks due to ethyl benzene or dicyclohexyl, subtract the areas of any such peaks from the peak areas at these retention times in the chromatograms obtained with reference solutions (a) or (b) (corrected peak areas of ethyl benzene and dicyclohexyl). Any such peaks in the chromatogram obtained with the test solution are to be included in the assessments for the sum of other peaks.

**Limits:**

- *impurity A*: not more than the difference between the area of the peak due to impurity A in the chromatogram obtained with reference solution (b) and the area of the peak due to impurity A in the chromatogram obtained with the test solution (0.05 per cent);
- *impurity B*: not more than the difference between the area of the peak due to impurity B in the chromatogram obtained with reference solution (b) and the area of the peak due to impurity B in the chromatogram obtained with the test solution (0.10 per cent);
- *sum of other peaks with a relative retention less than that of benzyl alcohol*: not more than twice the area of the peak due to ethylbenzene in the chromatogram obtained with reference solution (b) corrected if necessary as described above (0.02 per cent);
- *sum of peaks with a relative retention greater than that of benzyl alcohol*: not more than the area of the peak due to dicyclohexyl in the chromatogram obtained with reference solution (b) corrected if necessary as described above (0.2 per cent);
- *disregard limit*: 0.01 times the area of the peak due to ethylbenzene in the chromatogram obtained with reference solution (b) corrected if necessary as described above (0.0001 per cent).

**Residue on evaporation:** maximum 0.05 per cent.

After ensuring that the substance to be examined complies with the test for peroxide value, evaporate 10.0 g to dryness in a tared quartz or porcelain crucible or platinum dish on a hot plate at a temperature not exceeding 200 °C. Ensure that the substance to be examined does not boil during evaporation. Dry the residue on the hot plate for 1 h and allow to cool in a desiccator. The residue weighs a maximum of 5 mg.

**ASSAY**

To 0.900 g (*m* g) add 15.0 mL of a freshly prepared mixture of 1 volume of *acetic anhydride R* and 7 volumes of *pyridine R* and boil under a reflux condenser on a water-bath for 30 min. Cool and add 25 mL of *water R*. Using 0.25 mL of *phenolphthalein solution R* as indicator, titrate with 1 M *sodium hydroxide* ( $n_1$  mL). Carry out a blank titration ( $n_2$  mL).

Calculate the percentage content of C<sub>7</sub>H<sub>8</sub>O using the following expression:

$$\frac{10.81 (n_2 - n_1)}{m}$$

**STORAGE**

In an airtight container, under nitrogen, protected from light and at a temperature between 2 °C and 8 °C.

**LABELLING**

The label states, where applicable, that the substance is suitable for use in the manufacture of parenteral preparations.

**IMPURITIES**

**Specified impurities:** A, B.

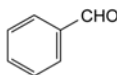

A. benzaldehyde,

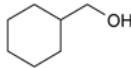

B. cyclohexylmethanol.

01/2008:0705

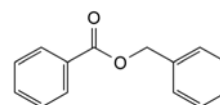
**BENZYL BENZOATE****Benzylis benzoas**

C<sub>14</sub>H<sub>12</sub>O<sub>2</sub>  
[120-51-4]

*M*<sub>r</sub> 212.2

**DEFINITION**

Phenylmethyl benzoate.

**Content:** 99.0 per cent to 100.5 per cent.

**CHARACTERS**

**Appearance:** colourless or almost colourless crystals or colourless or almost colourless, oily liquid.

**Solubility:** practically insoluble in water, miscible with ethanol (96 per cent), with methylene chloride and with fatty and essential oils.

**Eb:** about 320 °C.

**IDENTIFICATION**

**First identification:** A.

**Second identification:** B, C.

A. Infrared absorption spectrophotometry (2.2.24).

*Comparison: Ph. Eur. reference spectrum of benzyl benzoate.*

- B. To 2 g add 25 mL of *alcoholic potassium hydroxide solution R* and boil under a reflux condenser for 2 h. Remove the ethanol on a water-bath, add 50 mL of *water R* and distill. Collect about 25 mL of distillate and use it for identification test C. Acidify the liquid remaining in the distillation flask with *dilute hydrochloric acid R*. A white precipitate is formed that, when washed with *water R* and dried *in vacuo* melts (2.2.14) at 121 °C to 124 °C.
- C. To the distillate obtained in identification test B add 2.5 g of *potassium permanganate R* and 5 mL of *dilute sodium hydroxide solution R*. Boil under a reflux condenser for 15 min, cool and filter. Acidify the filtrate with *dilute hydrochloric acid R*. A white precipitate is formed that, when washed with *water R* and dried *in vacuo*, melts (2.2.14) at 121 °C to 124 °C.

#### TESTS

**Acidity.** Dissolve 2.0 g in *ethanol (96 per cent) R* and dilute to 10 mL with the same solvent. Titrate with 0.1 M *sodium hydroxide* using *phenolphthalein solution R* as indicator. Not more than 0.2 mL is required to change the colour of the indicator to pink.

**Relative density (2.2.5):** 1.118 to 1.122.

**Refractive index (2.2.6):** 1.568 to 1.570.

**Freezing point (2.2.18):** minimum 17.0 °C.

**Sulfated ash (2.4.14):** maximum 0.1 per cent, determined on 1.0 g.

#### ASSAY

To 2.000 g add 50.0 mL of 0.5 M *alcoholic potassium hydroxide* and boil gently under a reflux condenser for 1 h. Titrate the hot solution with 0.5 M *hydrochloric acid* using 1 mL of *phenolphthalein solution R* as indicator. Carry out a blank determination.

1 mL of 0.5 M *alcoholic potassium hydroxide* is equivalent to 106.1 mg of C<sub>14</sub>H<sub>12</sub>O<sub>2</sub>.

#### STORAGE

In an airtight, well-filled container, protected from light.

01/2008:0373  
corrected 6.0

## BENZYLpenicillin, BENZathine

### Benzylpenicillinum benzathinum

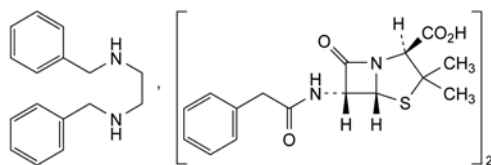

C<sub>48</sub>H<sub>56</sub>N<sub>6</sub>O<sub>8</sub>S<sub>2</sub>  
[1538-09-6]

M<sub>r</sub> 909

#### DEFINITION

*N,N'*-Dibenzylethane-1,2-diamine compound (1:2) with (2*S*,5*R*,6*R*)-3,3-dimethyl-7-oxo-6-[(phenylacetyl)amino]-4-thia-1-azabicyclo[3.2.0]heptane-2-carboxylic acid.

Substance produced by the growth of certain strains of *Penicillium notatum* or related organisms, or obtained by any other means.

#### Content:

- *benzathine benzylpenicillin*: 96.0 per cent to 102.0 per cent (anhydrous substance);

- *N,N'*-dibenzylethylenediamine (benzathine C<sub>16</sub>H<sub>20</sub>N<sub>2</sub>; M<sub>r</sub> 240.3): 24.0 per cent to 27.0 per cent (anhydrous substance).

It contains a variable quantity of water. Dispersing or suspending agents may be added.

#### CHARACTERS

**Appearance:** white or almost white powder.

**Solubility:** very slightly soluble in water, freely soluble in dimethylformamide and in formamide, slightly soluble in ethanol (96 per cent).

#### IDENTIFICATION

**First identification:** A.

**Second identification:** B, C, D.

- A. Infrared absorption spectrophotometry (2.2.24).

*Comparison: benzathine benzylpenicillin CRS.*

- B. Thin-layer chromatography (2.2.27).

**Test solution.** Dissolve 25 mg of the substance to be examined in 5 mL of *methanol R*.

**Reference solution.** Dissolve 25 mg of *benzathine benzylpenicillin CRS* in 5 mL of *methanol R*.

**Plate:** TLC silanised silica gel plate R.

**Mobile phase:** mix 30 volumes of *acetone R* and 70 volumes of a 154 g/L solution of *ammonium acetate R* adjusted to pH 7.0 with *ammonia R*.

**Application:** 1 µL.

**Development:** over a path of 15 cm.

**Drying:** in air.

**Detection:** expose to iodine vapour until the spots appear and examine in daylight.

**System suitability:** reference solution:

- the chromatogram shows 2 clearly separated spots.

**Results:** the 2 principal spots in the chromatogram obtained with the test solution are similar in position, colour and size to the 2 principal spots in the chromatogram obtained with the reference solution.

- C. Place about 2 mg in a test-tube about 150 mm long and 15 mm in diameter. Moisten with 0.05 mL of *water R* and add 2 mL of *sulfuric acid-formaldehyde reagent R*. Mix the contents of the tube by swirling; the solution is practically colourless. Place the test-tube on a water-bath for 1 min; a reddish-brown colour develops.
- D. To 0.1 g add 2 mL of 1 M *sodium hydroxide* and shake for 2 min. Shake the mixture with 2 quantities, each of 3 mL, of *ether R*. Evaporate the combined ether layers to dryness and dissolve the residue in 1 mL of *ethanol (50 per cent V/V) R*. Add 5 mL of *picric acid solution R*, heat at 90 °C for 5 min and allow to cool slowly. Separate the crystals and recrystallise from *ethanol (25 per cent V/V) R* containing 10 g/L of *picric acid R*. The crystals melt (2.2.14) at about 214 °C.

#### TESTS

**Acidity or alkalinity.** To 0.50 g add 100 mL of *carbon dioxide-free water R* and shake for 5 min. Filter through a sintered-glass filter (2.1.2). To 20 mL of the filtrate add 0.1 mL of *bromothymol blue solution R1*. The solution is green or yellow. Not more than 0.2 mL of 0.02 M *sodium hydroxide* is required to change the colour of the indicator to blue.

**Related substances.** Liquid chromatography (2.2.29). Prepare the solutions immediately before use, using sonication (for about 2 min) to dissolve the samples. Avoid any overheating during the sample preparation.

**Test solution.** Dissolve 70.0 mg of the substance to be examined in 25 mL of *methanol R* and dilute to 50.0 mL with a solution containing 6.8 g/L of *potassium dihydrogen phosphate R* and 1.02 g/L of *disodium hydrogen phosphate R*.

**Reference solution (a).** Dissolve 70.0 mg of benzathine benzylpenicillin CRS in 25 mL of methanol R and dilute to 50.0 mL with a solution containing 6.8 g/L of potassium dihydrogen phosphate R and 1.02 g/L of disodium hydrogen phosphate R.

**Reference solution (b).** Dilute 1.0 mL of reference solution (a) to 100.0 mL with mobile phase A.

**Column:**

- size:  $l = 0.25$  m,  $\varnothing = 4.0$  mm;
- stationary phase: end-capped octadecylsilyl silica gel for chromatography R (5  $\mu$ m);
- temperature: 40 °C.

**Mobile phase:**

- mobile phase A: mix 10 volumes of a 34 g/L solution of potassium dihydrogen phosphate R adjusted to pH 3.5 with phosphoric acid R, 30 volumes of methanol R and 60 volumes of water R;
- mobile phase B: mix 10 volumes of a 34 g/L solution of potassium dihydrogen phosphate R adjusted to pH 3.5 with phosphoric acid R, 30 volumes of water R and 60 volumes of methanol R;

Time (min)	Mobile phase A (per cent V/V)	Mobile phase B (per cent V/V)
0 - 10	75	25
10 - 20	75 → 0	25 → 100
20 - 55	0	100
55 - 70	75	25

**Flow rate:** 1 mL/min.

**Detection:** spectrophotometer at 220 nm.

**Injection:** 20  $\mu$ L.

**System suitability:** reference solution (a):

- relative retention with reference to benzylpenicillin: benzathine = 0.3 to 0.4; impurity C = about 2.4; if necessary, adjust the concentration of methanol in the mobile phase.

**Limits:**

- impurity C: not more than twice the sum of the areas of the 2 principal peaks in the chromatogram obtained with reference solution (b) (2 per cent);
- any other impurity: for each impurity, not more than the sum of the areas of the 2 principal peaks in the chromatogram obtained with reference solution (b) (1 per cent);
- disregard limit: 0.05 times the sum of the areas of the 2 principal peaks in the chromatogram obtained with reference solution (b) (0.05 per cent).

**Water (2.5.12):** 5.0 per cent to 8.0 per cent, determined on 0.300 g.

**Bacterial endotoxins (2.6.14, Method E):** less than 0.13 IU/mL, if intended for use in the manufacture of parenteral preparations without a further appropriate procedure for the removal of bacterial endotoxins.

Suspend 20 mg in 20 mL of a solution of 0.1 M sodium hydroxide diluted 1 to 100, shake thoroughly and centrifuge. Examine the supernatant.

**ASSAY**

Liquid chromatography (2.2.29) as described in the test for related substances with the following modifications.

**Mobile phase:** phosphate buffer solution pH 3.5 R, methanol R, water R (10:35:55 V/V/V).

**Injection:** test solution and reference solution (a).

Calculate the percentage contents of benzathine and benzathine benzylpenicillin. Calculate the percentage content of benzathine benzylpenicillin by multiplying the percentage content of benzylpenicillin by 1.36.

**STORAGE**

In an airtight container. If the substance is sterile, store in a sterile, airtight, tamper-proof container.

**IMPURITIES**

**Specified impurities: C.**

**Other detectable impurities** (the following substances would, if present at a sufficient level, be detected by one or other of the tests in the monograph. They are limited by the general acceptance criterion for other/unspecified impurities and/or by the general monograph *Substances for pharmaceutical use (2034)*. It is therefore not necessary to identify these impurities for demonstration of compliance. See also 5.10. *Control of impurities in substances for pharmaceutical use*): A, B, D, E, F.

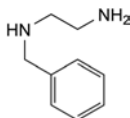

A. monobenzylethylenediamine,

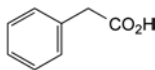

B. phenylacetic acid,

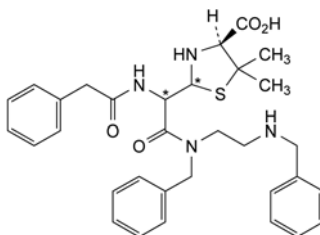

C. benzylpenicilloic acids benzathide,

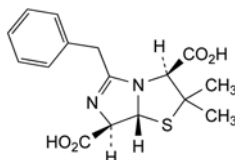

D. (3*S*,7*R*,7*aR*)-5-benzyl-2,2-dimethyl-2,3,7,7*a*-tetrahydroimidazo[5,1-*b*]thiazole-3,7-dicarboxylic acid (penillic acid of benzylpenicillin),

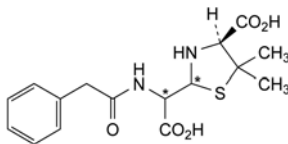

E. (4*S*)-2-[carboxy[(phenylacetyl)amino]methyl]-5,5-dimethylthiazolidine-4-carboxylic acid (penicilloic acids of benzylpenicillin),

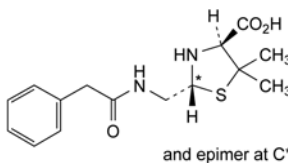

F. (2*RS*,4*S*)-2-[(phenylacetyl)amino]methyl]-5,5-dimethylthiazolidine-4-carboxylic acid (penilloic acids of benzylpenicillin).

01/2008:0113 **Specific optical rotation** (2.2.7): + 270 to + 300 (dried substance).  
corrected 6.0

## BENZYLPENICILLIN POTASSIUM

### Benzylpenicillinum kalicum

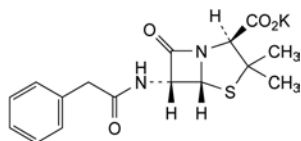

$C_{16}H_{17}KN_2O_4S$   
[113-98-4]

$M_r$  372.5

#### DEFINITION

Potassium (2*S*,5*R*,6*R*)-3,3-dimethyl-7-oxo-6-[(phenylacetyl)-amino]-4-thia-1-azabicyclo[3.2.0]heptane-2-carboxylate.

Substance produced by the growth of certain strains of *Penicillium notatum* or related organisms, or obtained by any other means.

*Content*: 96.0 per cent to 102.0 per cent (dried substance).

#### CHARACTERS

*Appearance*: white or almost white, crystalline powder.

*Solubility*: very soluble in water, practically insoluble in fatty oils and in liquid paraffin.

#### IDENTIFICATION

*First identification*: A, D.

*Second identification*: B, C, D.

A. Infrared absorption spectrophotometry (2.2.24).

*Comparison*: benzylpenicillin potassium CRS.

B. Thin-layer chromatography (2.2.27).

*Test solution*. Dissolve 25 mg of the substance to be examined in 5 mL of water R.

*Reference solution (a)*. Dissolve 25 mg of benzylpenicillin potassium CRS in 5 mL of water R.

*Reference solution (b)*. Dissolve 25 mg of benzylpenicillin potassium CRS and 25 mg of phenoxymethylpenicillin potassium CRS in 5 mL of water R.

*Plate*: TLC silanised silica gel plate R.

*Mobile phase*: mix 30 volumes of acetone R and 70 volumes of a 154 g/L solution of ammonium acetate R previously adjusted to pH 5.0 with glacial acetic acid R.

*Application*: 1  $\mu$ L.

*Development*: over a path of 15 cm.

*Drying*: in air.

*Detection*: expose to iodine vapour until the spots appear and examine in daylight.

*System suitability*: reference solution (b):

– the chromatogram shows 2 clearly separated spots.

*Results*: the principal spot in the chromatogram obtained with the test solution is similar in position, colour and size to the principal spot in obtained with reference solution (a).

C. Place about 2 mg in a test-tube about 150 mm long and 15 mm in diameter. Moisten with 0.05 mL of water R and add 2 mL of sulfuric acid-formaldehyde reagent R. Mix the contents of the tube by swirling; the solution is practically colourless. Place the test-tube on a water-bath for 1 min; a reddish-brown colour develops.

D. It gives reaction (a) of potassium (2.3.1).

#### TESTS

**pH** (2.2.3): 5.5 to 7.5.

Dissolve 2.0 g in carbon dioxide-free water R and dilute to 20 mL with the same solvent.

Dissolve 0.500 g in carbon dioxide-free water R and dilute to 25.0 mL with the same solvent.

**Absorbance** (2.2.25). Dissolve 94.0 mg in water R and dilute to 50.0 mL with the same solvent. Measure the absorbance of the solution at 325 nm, 280 nm and at the absorption maximum at 264 nm, diluting the solution, if necessary, for the measurement at 264 nm. The absorbances at 325 nm and 280 nm do not exceed 0.10 and that at the absorption maximum at 264 nm is 0.80 to 0.88, calculated on the basis of the undiluted (1.88 g/L) solution. Verify the resolution of the apparatus (2.2.25); the ratio of the absorbances is at least 1.7.

**Related substances**. Liquid chromatography (2.2.29). Prepare the solutions immediately before use.

*Test solution (a)*. Dissolve 50.0 mg of the substance to be examined in water R and dilute to 50.0 mL with the same solvent.

*Test solution (b)*. Dissolve 80.0 mg of the substance to be examined in water R and dilute to 20.0 mL with the same solvent.

*Reference solution (a)*. Dissolve 50.0 mg of benzylpenicillin sodium CRS in water R and dilute to 50.0 mL with the same solvent.

*Reference solution (b)*. Dissolve 10 mg of benzylpenicillin sodium CRS and 10 mg of phenylacetic acid R (impurity B) in water R, then dilute to 50 mL with the same solvent.

*Reference solution (c)*. Dilute 4.0 mL of reference solution (a) to 100.0 mL with water R.

*Column*:

- size:  $l = 0.25$  m,  $\varnothing = 4.6$  mm;
- stationary phase: octadecylsilyl silica gel for chromatography R (5  $\mu$ m).

*Mobile phase*:

- mobile phase A: mix 10 volumes of a 68 g/L solution of potassium dihydrogen phosphate R adjusted to pH 3.5 with a 500 g/L solution of dilute phosphoric acid R, 30 volumes of methanol R and 60 volumes of water R;
- mobile phase B: mix 10 volumes of a 68 g/L solution of potassium dihydrogen phosphate R adjusted to pH 3.5 with a 500 g/L solution of dilute phosphoric acid R, 40 volumes of water R and 50 volumes of methanol R;

Time (min)	Mobile phase A (per cent V/V)	Mobile phase B (per cent V/V)
0 - $t_R$	70	30
$t_R - (t_R + 20)$	70 $\rightarrow$ 0	30 $\rightarrow$ 100
$(t_R + 20) - (t_R + 35)$	0	100
$(t_R + 35) - (t_R + 50)$	70	30

$t_R$  = retention time of benzylpenicillin determined with reference solution (c)

If the mobile phase composition has been adjusted to achieve the required resolution, the adjusted composition will apply at time zero in the gradient and in the assay.

*Flow rate*: 1.0 mL/min.

*Detection*: spectrophotometer at 225 nm.

*Injection*: 20  $\mu$ L of reference solutions (b) and (c) with isocratic elution at the initial mobile phase composition and 20  $\mu$ L of test solution (b) according to the elution gradient described under Mobile phase; inject water R as a blank according to the elution gradient described under Mobile phase.

*System suitability*: reference solution (b):

- resolution: minimum 6.0 between the peaks due to impurity B and benzylpenicillin; if necessary, adjust the ratio A:B of the mobile phase.



**Limit:**

- *any impurity*: for each impurity, not more than the area of the principal peak in the chromatogram obtained with reference solution (c) (1 per cent).

**Loss on drying** (2.2.32): maximum 1.0 per cent, determined on 1.000 g by drying in an oven at 105 °C.

**Bacterial endotoxins** (2.6.14, *Method E*): less than 0.16 IU/mg, if intended for use in the manufacture of parenteral preparations without a further appropriate procedure for the removal of bacterial endotoxins.

**ASSAY**

Liquid chromatography (2.2.29) as described in the test for related substances with the following modifications.

**Mobile phase**: initial composition of the mixture of mobile phases A and B, adjusted where applicable.

**Injection**: test solution (a) and reference solution (a).

Calculate the percentage content of  $C_{16}H_{17}KN_2O_4S$  by multiplying the percentage content of benzylpenicillin sodium by 1.045.

**STORAGE**

In an airtight container. If the substance is sterile, store in a sterile, airtight, tamper-proof container.

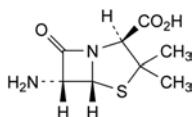
**IMPURITIES**

- A. (2*S*,5*R*,6*R*)-6-amino-3,3-dimethyl-7-oxo-4-thia-1-azabicyclo[3.2.0]heptane-2-carboxylic acid (6-aminopenicillanic acid),

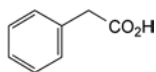

- B. phenylacetic acid,

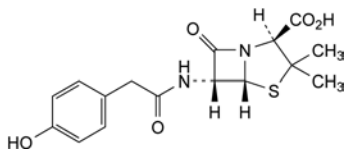

- C. (2*S*,5*R*,6*R*)-6-[(4-hydroxyphenyl)acetyl]amino-3,3-dimethyl-7-oxo-4-thia-1-azabicyclo[3.2.0]heptane-2-carboxylic acid,

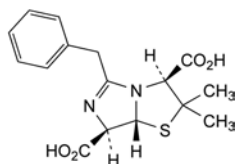

- D. (3*S*,7*R*,7*aR*)-5-benzyl-2,2-dimethyl-2,3,7,7*a*-tetrahydroimidazo[5,1-*b*]thiazole-3,7-dicarboxylic acid (penicillic acid of benzylpenicillin),

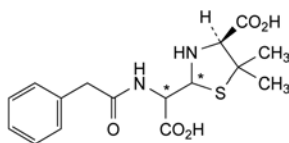

- E. (4*S*)-2-[carboxy[(phenylacetyl)amino]methyl]-5,5-dimethylthiazolidine-4-carboxylic acid (penicilloic acids of benzylpenicillin),

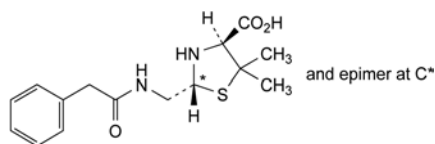

- F. (2*RS*,4*S*)-2-[(phenylacetyl)amino]methyl]-5,5-dimethylthiazolidine-4-carboxylic acid (penicilloic acids of benzylpenicillin).

01/2008:0115  
corrected 6.0

**BENZYLPENICILLIN, PROCAINE**

## Benzylpenicillinum procainum

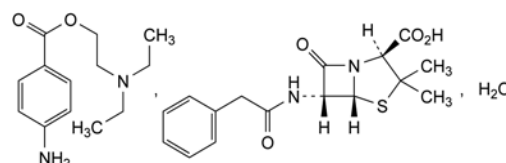

$C_{29}H_{38}N_4O_6S \cdot H_2O$   
[6130-64-9]

$M_r$  588.7

**DEFINITION**

(2*S*,5*R*,6*R*)-3,3-Dimethyl-7-oxo-6-[(phenylacetyl)amino]-4-thia-1-azabicyclo[3.2.0]heptane-2-carboxylic acid compound with 2-(diethylamino)ethyl 4-aminobenzoate monohydrate.

Substance produced by the growth of certain strains of *Penicillium notatum* or related organisms, or obtained by any other means.

**Content:**

- *procaine benzylpenicillin*: 96.0 per cent to 102.0 per cent (anhydrous substance);
- *procaine* ( $C_{13}H_{20}N_2O_2$ ;  $M_r$  236.3): 39.0 per cent to 42.0 per cent (anhydrous substance).

Dispersing or suspending agents (for example, lecithin and polysorbate 80) may be added.

**CHARACTERS**

**Appearance**: white or almost white, crystalline powder.

**Solubility**: slightly soluble in water, sparingly soluble in ethanol (96 per cent).

**IDENTIFICATION**

**First identification**: A.

**Second identification**: B, C, D.

- A. Infrared absorption spectrophotometry (2.2.24).

**Comparison**: *procaine benzylpenicillin CRS*.

- B. Thin-layer chromatography (2.2.27).

**Test solution**. Dissolve 25 mg of the substance to be examined in 5 mL of *acetone R*.

**Reference solution**. Dissolve 25 mg of *procaine benzylpenicillin CRS* in 5 mL of *acetone R*.

**Plate**: *TLC silanised silica gel plate R*.

**Mobile phase**: mix 30 volumes of *acetone R* and 70 volumes of a 154 g/L solution of *ammonium acetate R* previously adjusted to pH 7.0 with *ammonia R*.

**Application**: 1 µL.

**Development**: over a path of 15 cm.

**Drying**: in air.

**Detection**: expose to iodine vapour until the spots appear and examine in daylight.

**System suitability**: reference solution:

- the chromatogram shows 2 clearly separated spots.

01/2008:0114 **Specific optical rotation** (2.2.7): + 285 to + 310 (dried substance).  
corrected 6.0

## BENZYLPENICILLIN SODIUM

### Benzylpenicillinum natricum

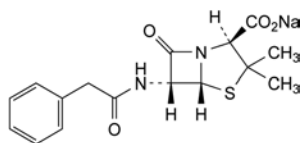

$C_{16}H_{17}N_2NaO_4S$   
[69-57-8]

$M_r$  356.4

#### DEFINITION

Sodium (2*S*,5*R*,6*R*)-3,3-dimethyl-7-oxo-6-[(phenylacetyl)-amino]-4-thia-1-azabicyclo[3.2.0]heptane-2-carboxylate.

Substance produced by the growth of certain strains of *Penicillium notatum* or related organisms, or obtained by any other means.

*Content*: 96.0 per cent to 102.0 per cent (dried substance).

#### CHARACTERS

*Appearance*: white or almost white, crystalline powder.

*Solubility*: very soluble in water, practically insoluble in fatty oils and in liquid paraffin.

#### IDENTIFICATION

*First identification*: A, D.

*Second identification*: B, C, D.

A. Infrared absorption spectrophotometry (2.2.24).

*Comparison*: benzylpenicillin sodium CRS.

B. Thin-layer chromatography (2.2.27).

*Test solution*. Dissolve 25 mg of the substance to be examined in 5 mL of water R.

*Reference solution (a)*. Dissolve 25 mg of benzylpenicillin sodium CRS in 5 mL of water R.

*Reference solution (b)*. Dissolve 25 mg of benzylpenicillin sodium CRS and 25 mg of phenoxymethylpenicillin potassium CRS in 5 mL of water R.

*Plate*: TLC silanised silica gel plate R.

*Mobile phase*: mix 30 volumes of acetone R and 70 volumes of a 154 g/L solution of ammonium acetate R previously adjusted to pH 5.0 with glacial acetic acid R.

*Application*: 1  $\mu$ L.

*Development*: over a path of 15 cm.

*Drying*: in air.

*Detection*: expose to iodine vapour until the spots appear and examine in daylight.

*System suitability*: reference solution (b):

– the chromatogram shows 2 clearly separated spots.

*Results*: the principal spot in the chromatogram obtained with the test solution is similar in position, colour and size to the principal spot in the chromatogram obtained with reference solution (a).

C. Place about 2 mg in a test-tube about 150 mm long and 15 mm in diameter. Moisten with 0.05 mL of water R and add 2 mL of sulfuric acid-formaldehyde reagent R. Mix the contents of the tube by swirling; the solution is practically colourless. Place the test-tube on a water-bath for 1 min; a reddish-brown colour develops.

D. It gives reaction (a) of sodium (2.3.1).

#### TESTS

**pH** (2.2.3): 5.5 to 7.5.

Dissolve 2.0 g in carbon dioxide-free water R and dilute to 20 mL with the same solvent.

Dissolve 0.500 g in carbon dioxide-free water R and dilute to 25.0 mL with the same solvent.

**Absorbance** (2.2.25). Dissolve 90.0 mg in water R and dilute to 50.0 mL with the same solvent. Measure the absorbance of the solution at 325 nm, at 280 nm and at the absorption maximum at 264 nm, diluting the solution, if necessary, for the measurement at 264 nm. The absorbances at 325 nm and 280 nm are not greater than 0.10 and the absorbance at the absorption maximum at 264 nm is 0.80 to 0.88, calculated on the basis of the undiluted (1.80 g/L) solution. Verify the resolution of the apparatus (2.2.25); the ratio of the absorbances is at least 1.7.

**Related substances**. Liquid chromatography (2.2.29). Prepare the solutions immediately before use.

*Test solution (a)*. Dissolve 50.0 mg of the substance to be examined in water R and dilute to 50.0 mL with the same solvent.

*Test solution (b)*. Dissolve 80.0 mg of the substance to be examined in water R and dilute to 20.0 mL with the same solvent.

*Reference solution (a)*. Dissolve 50.0 mg of benzylpenicillin sodium CRS in water R and dilute to 50.0 mL with the same solvent.

*Reference solution (b)*. Dissolve 10 mg of benzylpenicillin sodium CRS and 10 mg of phenylacetic acid R (impurity B) in water R, then dilute to 50 mL with the same solvent.

*Reference solution (c)*. Dilute 4.0 mL of reference solution (a) to 100.0 mL with water R.

*Column*:

– *size*:  $l = 0.25$  m,  $\varnothing = 4.6$  mm;

– *stationary phase*: octadecylsilyl silica gel for chromatography R (5  $\mu$ m).

*Mobile phase*:

– *mobile phase A*: mix 10 volumes of a 68 g/L solution of potassium dihydrogen phosphate R adjusted to pH 3.5 with a 500 g/L solution of dilute phosphoric acid R, 30 volumes of methanol R and 60 volumes of water R;

– *mobile phase B*: mix 10 volumes of a 68 g/L solution of potassium dihydrogen phosphate R adjusted to pH 3.5 with a 500 g/L solution of dilute phosphoric acid R, 40 volumes of water R and 50 volumes of methanol R;

Time (min)	Mobile phase A (per cent V/V)	Mobile phase B (per cent V/V)
0 - $t_R$	70	30
$t_R - (t_R + 20)$	70 $\rightarrow$ 0	30 $\rightarrow$ 100
$(t_R + 20) - (t_R + 35)$	0	100
$(t_R + 35) - (t_R + 50)$	70	30

$t_R$  = retention time of benzylpenicillin determined with reference solution (c)

If the mobile phase composition has been adjusted to achieve the required resolution, the adjusted composition will apply at time zero in the gradient and in the assay.

*Flow rate*: 1.0 mL/min.

*Detection*: spectrophotometer at 225 nm.

*Injection*: 20  $\mu$ L of reference solutions (b) and (c) with isocratic elution at the initial mobile phase composition and 20  $\mu$ L of test solution (b) according to the elution gradient described under Mobile phase; inject water R as a blank according to the elution gradient described under Mobile phase.

*System suitability*: reference solution (b):

– *resolution*: minimum 6.0 between the peaks due to impurity B and benzylpenicillin; if necessary, adjust the ratio A:B of the mobile phase.

**Limit:**

- *any impurity*: for each impurity, not more than the area of the principal peak in the chromatogram obtained with reference solution (c) (1 per cent).

**2-Ethylhexanoic acid** (2.4.28): maximum 0.5 per cent *m/m*.

**Loss on drying** (2.2.32): maximum 1.0 per cent, determined on 1.000 g by drying in an oven at 105 °C.

**Bacterial endotoxins** (2.6.14, *Method E*): less than 0.16 IU/mg, if intended for use in the manufacture of parenteral preparations without a further appropriate procedure for the removal of bacterial endotoxins.

**ASSAY**

Liquid chromatography (2.2.29) as described in the test for related substances with the following modifications.

**Mobile phase**: initial composition of the mixture of mobile phases A and B, adjusted where applicable.

**Injection**: test solution (a) and reference solution (a).

Calculate the percentage content of  $C_{16}H_{17}N_2NaO_4S$  from the declared content of *benzylpenicillin sodium CRS*.

**STORAGE**

In an airtight container. If the substance is sterile, store in a sterile, airtight, tamper-proof container.

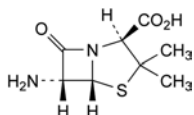
**IMPURITIES**

- A. (2*S*,5*R*,6*R*)-6-amino-3,3-dimethyl-7-oxo-4-thia-1-azabicyclo[3.2.0]heptane-2-carboxylic acid (6-aminopenicillanic acid),

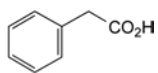

- B. phenylacetic acid,

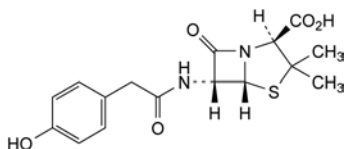

- C. (2*S*,5*R*,6*R*)-6-[(4-hydroxyphenyl)acetyl]amino-3,3-dimethyl-7-oxo-4-thia-1-azabicyclo[3.2.0]heptane-2-carboxylic acid,

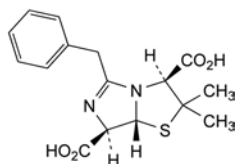

- D. (3*S*,7*R*,7*aR*)-5-benzyl-2,2-dimethyl-2,3,7,7*a*-tetrahydroimidazo[5,1-*b*]thiazole-3,7-dicarboxylic acid (penillic acid of benzylpenicillin),

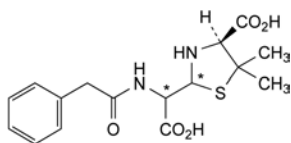

- E. (4*S*)-2-[carboxy[(phenylacetyl)amino]methyl]-5,5-dimethylthiazolidine-4-carboxylic acid (penicilloic acids of benzylpenicillin),

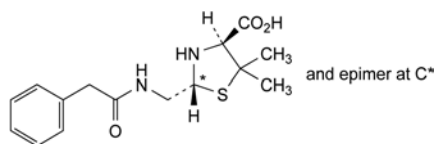

- F. (2*RS*,4*S*)-2-[[[(phenylacetyl)amino]methyl]-5,5-dimethylthiazolidine-4-carboxylic acid (penilloic acids of benzylpenicillin).

01/2008:1069

**BETACAROTENE**

## Betacarotenum

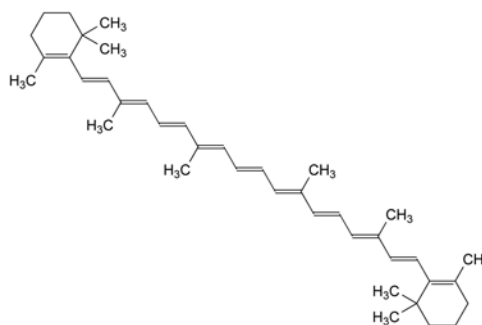

$C_{40}H_{56}$   
[7235-40-7]

$M_r$  536.9

**DEFINITION**

(all-*E*)-3,7,12,16-Tetramethyl-1,18-bis(2,6,6-trimethylcyclohex-1-enyl)octadeca-1,3,5,7,9,11,13,15,17-nonaene.

**Content**: 96.0 per cent to 101.0 per cent (dried substance).

**CHARACTERS**

**Appearance**: brown-red or brownish-red, crystalline powder.

**Solubility**: practically insoluble in water, slightly soluble in cyclohexane, practically insoluble in anhydrous ethanol.

It is sensitive to air, heat and light, especially in solution.

*Carry out all operations as rapidly as possible avoiding exposure to actinic light; use freshly prepared solutions.*

**IDENTIFICATION**

Ultraviolet and visible absorption spectrophotometry (2.2.25).

**Test solution (a)**. Dissolve 50.0 mg in 10 mL of *chloroform R* and dilute immediately to 100.0 mL with *cyclohexane R*. Dilute 5.0 mL of this solution to 100.0 mL with *cyclohexane R*.

**Test solution (b)**. Dilute 5.0 mL of test solution (a) to 50.0 mL with *cyclohexane R*.

**Absorption maximum**: at 455 nm for test solution (b).

**Absorbance ratio**:  $A_{455} / A_{483} = 1.14$  to 1.18 for test solution (b).

**TESTS**

**Related substances**. Determine the absorbance (2.2.25) of test solutions (b) and (a) used in Identification, at 455 nm and at 340 nm respectively.

**Absorbance ratio**:  $A_{455} / A_{340}$ : minimum 1.5.

The thresholds indicated under Related substances (Table 2034.1) in the general monograph *Substances for pharmaceutical use (2034)* do not apply.

**Heavy metals** (2.4.8): maximum 10 ppm.

2.0 g complies with test D. Prepare the reference solution using 2 mL of *lead standard solution (10 ppm Pb) R*.

**Loss on drying** (2.2.32): maximum 0.2 per cent, determined on 1.000 g by drying *in vacuo* over *diphosphorus pentoxide R* at 40 °C for 4 h.

**Sulfated ash** (2.4.14): maximum 0.2 per cent, determined on 1.0 g, moistened with a mixture of 2 mL of *dilute sulfuric acid R* and 5 mL of *ethanol (96 per cent) R*.

#### ASSAY

Measure the absorbance (2.2.25) of test solution (b) used in Identification at the absorption maximum at 455 nm, using *cyclohexane R* as the compensation liquid.

Calculate the content of  $C_{40}H_{56}$  taking the specific absorbance to be 2500.

#### STORAGE

In an airtight container, protected from light, at a temperature not exceeding 25 °C.

01/2008:1070  
corrected 7.0

## BETADEX

### Betadexum

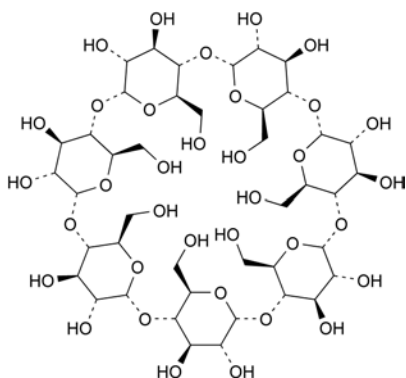

$[C_6H_{10}O_5]_7$   
[7585-39-9]

$M_r$  1135

#### DEFINITION

Cycloheptakis-(1→4)-( $\alpha$ -D-glucopyranosyl) (cyclomaltoheptaose or  $\beta$ -cyclodextrin).

**Content:** 98.0 per cent to 101.0 per cent (dried substance).

#### CHARACTERS

**Appearance:** white or almost white, amorphous or crystalline powder.

**Solubility:** sparingly soluble in water, freely soluble in propylene glycol, practically insoluble in anhydrous ethanol and in methylene chloride.

#### IDENTIFICATION

A. Specific optical rotation (see Tests).

B. Examine the chromatograms obtained in the assay.

**Results:** the principal peak in the chromatogram obtained with test solution (b) is similar in retention time and size to the principal peak in the chromatogram obtained with reference solution (c).

C. Dissolve 0.2 g in 2 mL of *iodine solution R4* by warming on a water-bath, and allow to stand at room temperature. A yellowish-brown precipitate is formed.

#### TESTS

**Solution S.** Dissolve 1.000 g in *carbon dioxide-free water R* with heating, allow to cool and dilute to 100.0 mL with the same solvent.

**Appearance of solution.** Solution S is clear (2.2.1).

**pH** (2.2.3): 5.0 to 8.0.

To 10 mL of solution S add 0.1 mL of a saturated solution of *potassium chloride R*.

**Specific optical rotation** (2.2.7): + 160 to + 164 (dried substance), determined on solution S.

**Reducing sugars:** maximum 0.2 per cent.

**Test solution.** To 1 mL of solution S add 1 mL of *cupri-tartaric solution R4*. Heat on a water-bath for 10 min, cool to room temperature. Add 10 mL of *ammonium molybdate reagent R1* and allow to stand for 15 min.

**Reference solution.** Prepare a reference solution at the same time and in the same manner as the test solution, using 1 mL of a 0.02 g/L solution of *glucose R*.

Measure the absorbance (2.2.25) of the test solution and the reference solution at the absorption maximum at 740 nm using *water R* as the compensation liquid. The absorbance of the test solution is not greater than that of the reference solution.

**Light-absorbing impurities.** Examine solution S between 230 nm and 750 nm. Between 230 nm and 350 nm, the absorbance (2.2.25) is not greater than 0.10. Between 350 nm and 750 nm, the absorbance (2.2.25) is not greater than 0.05.

**Related substances.** Liquid chromatography (2.2.29).

**Test solution (a).** Dissolve 0.25 g of the substance to be examined in *water R* with heating, cool and dilute to 25.0 mL with the same solvent.

**Test solution (b).** Dilute 5.0 mL of test solution (a) to 50.0 mL with *water R*.

**Reference solution (a).** Dissolve 25.0 mg of *alfadex CRS* (impurity A), 25.0 mg of *gammacyclodextrin CRS* (impurity B) and 50.0 mg of *betadex CRS* in *water R*, then dilute to 50.0 mL with the same solvent.

**Reference solution (b).** Dilute 5.0 mL of reference solution (a) to 50.0 mL with *water R*.

**Reference solution (c).** Dissolve 25.0 mg of *betadex CRS* in *water R* and dilute to 25.0 mL with the same solvent.

**Column:**

– **size:**  $l = 0.25$  m,  $\varnothing = 4.6$  mm;

– **stationary phase:** *octadecylsilyl silica gel for chromatography R* (10  $\mu$ m).

**Mobile phase:** *methanol R*, *water R* (10:90 V/V).

**Flow rate:** 1.5 mL/min.

**Detection:** differential refractometer.

**Equilibration:** with the mobile phase for about 3 h.

**Injection:** 50  $\mu$ L of test solution (a) and reference solutions (a) and (b).

**Run time:** 1.5 times the retention time of betadex.

**Relative retention** with reference to betadex (retention time = about 10 min): impurity B = about 0.3; impurity A = about 0.45.

**System suitability:** reference solution (a):

– **resolution:** minimum 1.5 between the peaks due to impurities B and A; if necessary, adjust the concentration of methanol in the mobile phase.

**Limits:**

– **impurities A, B:** for each impurity, not more than 0.5 times the area of the corresponding peak in the chromatogram obtained with reference solution (b) (0.25 per cent);

– **sum of impurities other than A and B:** not more than 0.5 times the area of the peak due to betadex in the chromatogram obtained with reference solution (b) (0.5 per cent).

**Residual solvents.** Head-space gas chromatography (2.2.28): use the standard additions method.

**Internal standard:** *ethylene chloride R*.

**Test solutions.** In each of 4 identical 20 mL flasks, dissolve 0.5 g of the substance to be examined in *water R* and add 0.10 g of *calcium chloride R* and 30  $\mu$ L of  *$\alpha$ -amylase solution R*. Add 1 mL of reference solutions (a), (b), (c) and (d), adding a different solution to each flask. Dilute to 10 mL with *water R*.

**Reference solutions.** Prepare a 10 µL/L solution of *ethylene chloride R* (reference solution (a)). Prepare reference solutions (b), (c) and (d) from reference solution (a) to contain respectively, per litre, 5 µL, 10 µL and 15 µL of both *trichloroethylene R* and *toluene R*.

**Column:**

- *material:* fused silica;
- *size:*  $l = 25$  m,  $\varnothing = 0.32$  mm;
- *stationary phase:* *macrogol 20 000 R* (film thickness 1 µm).

**Carrier gas:** *helium for chromatography R*.

**Static head-space conditions which may be used:**

- *equilibration temperature:* 45 °C;
- *equilibration time:* 2 h.

**Temperature:**

- *column:* 50 °C;
- *injection port:* 140 °C;
- *detector:* 280 °C.

**Detection:** flame ionisation.

**Injection:** 200 µL of the head space, at least 3 times.

**Retention time:** toluene = about 10 min.

**System suitability:**

- *resolution:* minimum 1.1 between the peaks due to trichloroethylene and toluene; minimum 1.1 between the peaks due to toluene and ethylene chloride;
- *repeatability:* maximum relative standard deviations of the ratios of the areas of the peaks due to trichloroethylene and toluene to that of the peak due to ethylene chloride of 5 per cent.

Calculate the content of trichloroethylene and of toluene taking their relative densities to be 1.46 and 0.87, respectively.

**Limits:**

- *trichloroethylene:* maximum 10 ppm;
- *toluene:* maximum 10 ppm.

**Heavy metals (2.4.8):** maximum 10 ppm.

1.0 g complies with test C. Prepare the reference solution using 1 mL of *lead standard solution (10 ppm Pb) R*.

**Loss on drying (2.2.32):** maximum 16.0 per cent, determined on 1.000 g by drying in an oven at 120 °C for 2 h.

**Sulfated ash (2.4.14):** maximum 0.1 per cent, determined on 1.0 g.

**ASSAY**

Liquid chromatography (2.2.29) as described in the test for related substances with the following modifications.

**Injection:** test solution (b) and reference solutions (a) and (c).

**System suitability:** reference solution (a):

- *repeatability:* maximum relative standard deviation of the area of the peak due to betadex of 2.0 per cent.

Calculate the percentage content of  $[C_6H_{10}O_5]_7$  from the declared content of *betadex CRS*.

**STORAGE**

In an airtight container.

**IMPURITIES**

**Specified impurities:** A, B.

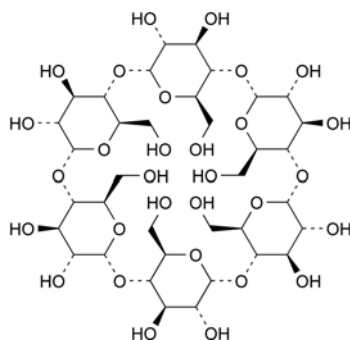

A. cyclohexakis-(1→4)-(α-D-glucopyranosyl) (alfadex or cyclomaltohexaose or α-cyclodextrin),

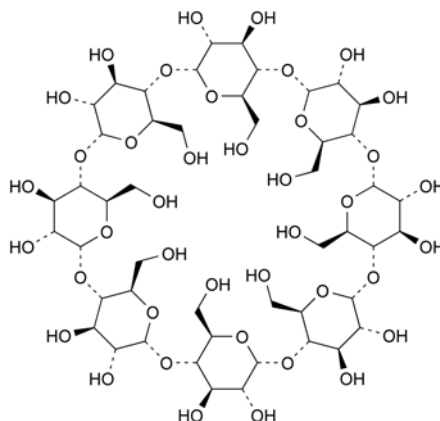

B. cyclooctakis-(1→4)-(α-D-glucopyranosyl) (cyclomaltooctaose or γ-cyclodextrin).

01/2008:1665  
corrected 6.0

## BETAHISTINE DIHYDROCHLORIDE

### Betahistini dihydrochloridum

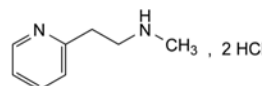

$C_8H_{14}Cl_2N_2$   
[5579-84-0]

$M_r$  209.1

#### DEFINITION

*N*-Methyl-2-(pyridin-2-yl)ethanamine dihydrochloride.

**Content:** 99.0 per cent to 101.0 per cent (dried substance).

#### CHARACTERS

**Appearance:** white or slightly yellow powder, very hygroscopic.

**Solubility:** very soluble in water, soluble in ethanol (96 per cent), practically insoluble in 2-propanol.

#### IDENTIFICATION

**First identification:** B, D.

**Second identification:** A, C, D.

A. Melting point (2.2.14): 150 °C to 154 °C.

B. Infrared absorption spectrophotometry (2.2.24).

*Comparison:* *betahistine dihydrochloride CRS*.

C. Thin-layer chromatography (2.2.27).

**Test solution.** Dissolve 10 mg of the substance to be examined in 2 mL of *ethanol (96 per cent) R*.

**Reference solution.** Dissolve 10 mg of *betahistine dihydrochloride CRS* in 2 mL of *ethanol (96 per cent) R*.

**Plate:** TLC silica gel GF<sub>254</sub> plate R.

*Mobile phase: concentrated ammonia R, ethyl acetate R, methanol R (0.75:15:30 V/V/V).*

*Application: 2 µL.*

*Development: over 2/3 of the plate.*

*Drying: at 110 °C for 10 min.*

*Detection: examine in ultraviolet light at 254 nm.*

*Results: the principal spot in the chromatogram obtained with the test solution is similar in position and size to the principal spot in the chromatogram obtained with the reference solution.*

D. It gives reaction (a) of chlorides (2.3.1).

#### TESTS

**Solution S.** Dissolve 5.0 g in *carbon dioxide-free water R*, and dilute to 50 mL with the same solvent.

**Appearance of solution.** Solution S is clear (2.2.1) and not more intensely coloured than reference solution B<sub>8</sub> (2.2.2, Method II).

**pH (2.2.3):** 2.0 to 3.0 for solution S.

**Related substances.** Liquid chromatography (2.2.29).

*Test solution.* Dissolve 25 mg of the substance to be examined in the mobile phase and dilute to 25.0 mL with the mobile phase.

*Reference solution (a).* Dissolve 10 mg of *betahistine dihydrochloride CRS* and 10 mg of *2-vinylpyridine R* in the mobile phase and dilute to 50.0 mL with the mobile phase. Dilute 2.0 mL of the solution to 50.0 mL with the mobile phase.

*Reference solution (b).* Dilute 1.0 mL of the test solution to 100.0 mL with the mobile phase.

*Reference solution (c).* Dilute 2.0 mL of reference solution (b) to 10.0 mL with the mobile phase.

*Column:*

- *size: l = 0.15 m, Ø = 3.0 mm;*
- *stationary phase: end-capped octadecylsilyl base deactivated silica gel for chromatography R (5 µm).*

*Mobile phase:* dissolve 2.0 g of *sodium dodecyl sulfate R* in a mixture of 15 mL of a 10 per cent V/V solution of *sulfuric acid R*, 35 mL of a 17 g/L solution of *tetrabutylammonium hydrogen sulfate R* and 650 mL of *water R*; adjust to pH 3.3 using *dilute sodium hydroxide solution R* and mix with 300 mL of *acetonitrile R*.

*Flow rate: 1 mL/min.*

*Detection: spectrophotometer at 260 nm.*

*Injection: 20 µL.*

*Run time: 4 times the retention time of betahistine.*

*Relative retention with reference to betahistine (retention time = about 7 min): impurity B = about 0.2; impurity A = about 0.3; impurity C = about 3.*

*System suitability: reference solution (a):*

- *resolution: minimum 3.5 between the peaks due to 2-vinylpyridine and betahistine.*

*Limits:*

- *correction factor: for the calculation of content, multiply the peak area of impurity B by 0.4;*
- *impurities A, B, C: for each impurity, not more than the area of the principal peak in the chromatogram obtained with reference solution (c) (0.2 per cent);*
- *unspecified impurities: for each impurity, not more than 0.5 times of the area of the principal peak in the chromatogram obtained with reference solution (c) (0.10 per cent);*
- *total: not more than 0.5 times the area of the principal peak in the chromatogram obtained with reference solution (b) (0.5 per cent);*
- *disregard limit: 0.25 times the area of the principal peak in the chromatogram obtained with reference solution (c) (0.05 per cent).*

**Loss on drying (2.2.32):** maximum 1.0 per cent, determined on 1.000 g by drying in an oven at 105 °C.

**Sulfated ash (2.4.14):** maximum 0.1 per cent, determined on 1.0 g.

#### ASSAY

Dissolve 80.0 mg in 50 mL of *ethanol (96 per cent) R*. Titrate with 0.1 M *sodium hydroxide*, determining the end-point potentiometrically (2.2.20). Read the volume added to reach the second point of inflexion.

1 mL of 0.1 M *sodium hydroxide* is equivalent to 10.46 mg of C<sub>8</sub>H<sub>14</sub>Cl<sub>2</sub>N<sub>2</sub>.

#### STORAGE

In an airtight container.

#### IMPURITIES

*Specified impurities: A, B, C.*

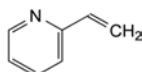

A. 2-ethenylpyridine (2-vinylpyridine),

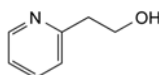

B. 2-(pyridin-2-yl)ethanol,

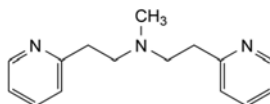

C. *N*-methyl-2-(pyridin-2-yl)-*N*-[2-(pyridin-2-yl)ethyl]ethanamine.

07/2010:1071

## BETAHISTINE MESILATE

### Betahistini mesilas

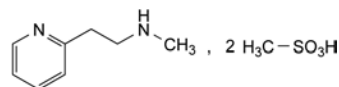

C<sub>10</sub>H<sub>20</sub>N<sub>2</sub>O<sub>6</sub>S<sub>2</sub>  
[54856-23-4]

M<sub>r</sub> 328.4

#### DEFINITION

*N*-Methyl-2-(pyridin-2-yl)ethanamine bis(methanesulfonate).

**Content:** 98.0 per cent to 101.0 per cent (anhydrous substance).

#### PRODUCTION

The production method must be evaluated to determine the potential for formation of alkyl mesilates, which is particularly likely to occur if the reaction medium contains lower alcohols. Where necessary, the production method is validated to demonstrate that alkyl mesilates are not detectable in the final product.

#### CHARACTERS

**Appearance:** white or almost white, crystalline powder, very hygroscopic.

**Solubility:** very soluble in water, freely soluble in ethanol (96 per cent), very slightly soluble in 2-propanol.

#### IDENTIFICATION

**First identification: B.**

**Second identification: A, C, D.**

A. **Melting point (2.2.14):** 108 °C to 112 °C.

B. **Infrared absorption spectrophotometry (2.2.24).**

**Comparison: betahistine mesilate CRS.**

## C. Thin-layer chromatography (2.2.27).

**Test solution.** Dissolve 10 mg of the substance to be examined in *ethanol (96 per cent) R* and dilute to 2 mL with the same solvent.

**Reference solution.** Dissolve 10 mg of *betahistine mesilate CRS* in *ethanol (96 per cent) R* and dilute to 2 mL with the same solvent.

**Plate:** TLC silica gel  $F_{254}$  plate *R*.

**Mobile phase:** concentrated ammonia *R*, ethyl acetate *R*, methanol *R* (0.75:15:30 V/V/V).

**Application:** 2  $\mu$ L.

**Development:** over 3/4 of the plate.

**Drying:** at 110 °C for 10 min.

**Detection:** examine in ultraviolet light at 254 nm.

**Results:** the principal spot in the chromatogram obtained with the test solution is similar in position and size to the principal spot in the chromatogram obtained with the reference solution.

- D. To 0.1 g add 5 mL of *dilute hydrochloric acid R* and shake for about 5 min. Add 1 mL of *barium chloride solution RI*. The solution remains clear. To a further 0.1 g add 0.5 g of *anhydrous sodium carbonate R*, mix and ignite until a white residue is obtained. Allow to cool and dissolve the residue in 7 mL of *water R*. The solution gives reaction (a) of sulfates (2.3.1).

## TESTS

**Solution S.** Dissolve 5.0 g in *carbon dioxide-free water R* prepared from *distilled water R*, and dilute to 50 mL with the same solvent.

**Appearance of solution.** Solution S is clear (2.2.1) and colourless (2.2.2, *Method II*).

**pH (2.2.3):** 2.0 to 3.0 for solution S.

**Related substances.** Liquid chromatography (2.2.29).

**Test solution.** Dissolve 50 mg of the substance to be examined in the mobile phase and dilute to 10.0 mL with the mobile phase.

**Reference solution (a).** Dissolve 10 mg of *betahistine mesilate CRS* and 10 mg of *2-vinylpyridine R* (impurity A) in the mobile phase and dilute to 50.0 mL with the mobile phase. Dilute 2.0 mL of this solution to 50.0 mL with the mobile phase.

**Reference solution (b).** Dilute 1.0 mL of the test solution to 100.0 mL with the mobile phase.

**Reference solution (c).** Dilute 2.0 mL of reference solution (b) to 10.0 mL with the mobile phase.

**Column:**

- size:  $l = 0.25$  m,  $\varnothing = 4.6$  mm;
- stationary phase: octadecylsilyl silica gel for chromatography *R* (5  $\mu$ m).

**Mobile phase:** dissolve 2.0 g of *sodium dodecyl sulfate R* in a mixture of 15 volumes of a 10 per cent V/V solution of *sulfuric acid R*, 35 volumes of a 17 g/L solution of *tetrabutylammonium hydrogen sulfate R* and 650 volumes of *water R*; adjust to pH 3.3 using *dilute sodium hydroxide solution R* and mix with 300 volumes of *acetonitrile R*.

**Flow rate:** 1 mL/min.

**Detection:** spectrophotometer at 260 nm.

**Injection:** 20  $\mu$ L.

**Run time:** 3 times the retention time of betahistine mesilate.

**Retention time:** betahistine mesilate = about 8 min.

**System suitability:** reference solution (a):

- resolution: minimum 3.5 between the peaks due to impurity A and betahistine mesilate.

**Limits:**

- impurity A: not more than the area of the principal peak in the chromatogram obtained with reference solution (c) (0.2 per cent);

- unspecified impurities: for each impurity, not more than 0.1 times the area of the principal peak in the chromatogram obtained with reference solution (b) (0.10 per cent);
- total: not more than 0.5 times the area of the principal peak in the chromatogram obtained with reference solution (b) (0.5 per cent);
- disregard limit: 0.05 times the area of the principal peak in the chromatogram obtained with reference solution (b) (0.05 per cent).

**2-Propanol (2.4.24):** maximum 0.5 per cent.

**Chlorides (2.4.4):** maximum 35 ppm.

To 14 mL of solution S add 1 mL of *water R*.

**Sulfates (2.4.13):** maximum 250 ppm.

Dilute 6 mL of solution S to 15 mL with *distilled water R*.

**Heavy metals (2.4.8):** maximum 20 ppm.

12 mL of solution S complies with test A. Prepare the reference solution using *lead standard solution (2 ppm Pb) R*.

**Water (2.5.12):** maximum 2.0 per cent, determined on 0.50 g.

## ASSAY

Dissolve 0.140 g in 50 mL of a mixture of 1 volume of *anhydrous acetic acid R* and 7 volumes of *acetic anhydride R*. Titrate with 0.1 M *perchloric acid*, determining the end-point potentiometrically (2.2.20).

1 mL of 0.1 M *perchloric acid* is equivalent to 16.42 mg of  $C_{10}H_{20}N_2O_6S_2$ .

## STORAGE

In an airtight container.

## IMPURITIES

**Specified impurities:** A.

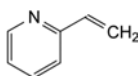

A. 2-ethenylpyridine (2-vinylpyridine).

01/2008:0312  
corrected 6.0

## BETAMETHASONE

## Betamethasonum

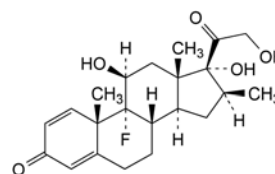

$C_{22}H_{29}FO_5$   
[378-44-9]

$M_r$  392.5

## DEFINITION

9-Fluoro-11 $\beta$ ,17,21-trihydroxy-16 $\beta$ -methylpregna-1,4-diene-3,20-dione.

**Content:** 97.0 per cent to 103.0 per cent (dried substance).

## CHARACTERS

**Appearance:** white or almost white, crystalline powder.

**Solubility:** practically insoluble in water, sparingly soluble in anhydrous ethanol, very slightly soluble in methylene chloride.

## IDENTIFICATION

**First identification:** B, C.

**Second identification:** A, C, D, E.

A. Dissolve 10.0 mg in *anhydrous ethanol R* and dilute to 100.0 mL with the same solvent. Place 2.0 mL of this solution in a stoppered tube, add 10.0 mL of *phenylhydrazine-sulfuric acid solution R*, mix and heat in a water-bath at 60 °C for 20 min. Cool immediately. The absorbance (2.2.25) measured at 419 nm is not greater than 0.10.

B. Infrared absorption spectrophotometry (2.2.24).

*Comparison: betamethasone CRS.*

If the spectra obtained in the solid state show differences, dissolve the substance to be examined and the reference substance separately in the minimum volume of *methylene chloride R*, evaporate to dryness on a water-bath and record new spectra using the residues.

C. Thin-layer chromatography (2.2.27).

*Solvent mixture: methanol R, methylene chloride R (1:9 V/V).*

*Test solution.* Dissolve 10 mg of the substance to be examined in the solvent mixture and dilute to 10 mL with the solvent mixture.

*Reference solution (a).* Dissolve 20 mg of *betamethasone CRS* in the solvent mixture and dilute to 20 mL with the solvent mixture.

*Reference solution (b).* Dissolve 10 mg of *dexamethasone CRS* in reference solution (a) and dilute to 10 mL with reference solution (a).

*Plate: TLC silica gel F<sub>254</sub> plate R.*

*Mobile phase: butanol R saturated with water R, toluene R, ether R (5:10:85 V/V/V).*

*Application: 5 µL.*

*Development: over a path of 15 cm.*

*Drying: in air.*

*Detection A: examine in ultraviolet light at 254 nm.*

*Results A: the principal spot in the chromatogram obtained with the test solution is similar in position and size to the principal spot in the chromatogram obtained with reference solution (a).*

*Detection B: spray with alcoholic solution of sulfuric acid R. Heat at 120 °C for 10 min or until the spots appear. Allow to cool. Examine in daylight and in ultraviolet light at 365 nm.*

*Results: the principal spot in the chromatogram obtained with the test solution is similar in position, colour in daylight, fluorescence in ultraviolet light at 365 nm and size to the principal spot in the chromatogram obtained with reference solution (a).*

*System suitability: reference solution (b):*

– the chromatogram shows 2 spots which may, however, not be completely separated.

D. Mix about 5 mg with 45 mg of *heavy magnesium oxide R* and ignite in a crucible until an almost white residue is obtained (usually less than 5 min). Allow to cool, add 1 mL of *water R*, 0.05 mL of *phenolphthalein solution R1* and about 1 mL of *dilute hydrochloric acid R* to render the solution colourless. Filter. Add 1.0 mL of the filtrate to a freshly prepared mixture of 0.1 mL of *alizarin S solution R* and 0.1 mL of *zirconyl nitrate solution R*. Mix, allow to stand for 5 min and compare the colour of the solution with that of a blank prepared in the same manner. The test solution is yellow and the blank is red.

E. Add about 2 mg to 2 mL of *sulfuric acid R* and shake to dissolve. Within 5 min, a deep reddish-brown colour develops. Add this solution to 10 mL of *water R* and mix. The colour is discharged and a clear solution remains.

## TESTS

**Specific optical rotation (2.2.7):** + 118 to + 126 (dried substance).

Dissolve 0.125 g in *methanol R* and dilute to 25.0 mL with the same solvent.

**Related substances.** Liquid chromatography (2.2.29).

*Test solution.* Dissolve 25.0 mg of the substance to be examined in a mixture of equal volumes of *acetonitrile R* and *methanol R* and dilute to 10.0 mL with the same mixture of solvents.

*Reference solution (a).* Dissolve 2 mg of *betamethasone CRS* and 2 mg of *methylprednisolone CRS* in mobile phase A, then dilute to 100.0 mL with mobile phase A.

*Reference solution (b).* Dilute 1.0 mL of the test solution to 100.0 mL with mobile phase A.

*Column:*

- *size: l* = 0.25 m,  $\varnothing$  = 4.6 mm;
- *stationary phase: octadecylsilyl silica gel for chromatography R (5 µm);*
- *temperature: 45 °C.*

*Mobile phase:*

- *mobile phase A: in a 1000 mL volumetric flask mix 250 mL of acetonitrile R with 700 mL of water R and allow to equilibrate; dilute to 1000 mL with water R and mix again;*
- *mobile phase B: acetonitrile R;*

Time (min)	Mobile phase A (per cent V/V)	Mobile phase B (per cent V/V)
0 - 15	100	0
15 - 40	100 → 0	0 → 100
40 - 41	0 → 100	100 → 0
41 - 46	100	0

*Flow rate: 2.5 mL/min.*

*Detection: spectrophotometer at 254 nm.*

*Equilibration: with mobile phase B for at least 30 min and then with mobile phase A for 5 min. For subsequent chromatograms, use the conditions described from 40 min to 46 min.*

*Injection: 20 µL; inject the mixture of equal volumes of acetonitrile R and methanol R as a blank.*

*Retention time: methylprednisolone = about 11.5 min; betamethasone = about 12.5 min.*

*System suitability: reference solution (a):*

– *resolution: minimum 1.5 between the peaks due to methylprednisolone and betamethasone; if necessary, adjust the concentration of acetonitrile in mobile phase A.*

*Limits:*

- *impurities A, B, C, D, E, F, G, H, I, J: for each impurity, not more than the area of the principal peak in the chromatogram obtained with reference solution (b) (1.0 per cent), and not more than 1 such peak has an area greater than 0.5 times the area of the principal peak in the chromatogram obtained with reference solution (b) (0.5 per cent);*
- *total: not more than twice the area of the principal peak in the chromatogram obtained with reference solution (b) (2.0 per cent);*
- *disregard limit: 0.05 times the area of the principal peak in the chromatogram obtained with reference solution (b) (0.05 per cent).*

**Loss on drying (2.2.32):** maximum 0.5 per cent, determined on 0.500 g by drying in an oven at 105 °C.

## ASSAY

Dissolve 0.100 g in *ethanol (96 per cent) R* and dilute to 100.0 mL with the same solvent. Dilute 2.0 mL of this solution to 100.0 mL with *ethanol (96 per cent) R*. Measure the absorbance (2.2.25) at the absorption maximum at 238.5 nm.

Calculate the content of C<sub>22</sub>H<sub>29</sub>FO<sub>5</sub> taking the specific absorbance to be 395.

## STORAGE

Protected from light.



## IMPURITIES

Specified impurities: A, B, C, D, E, F, G, H, I, J.

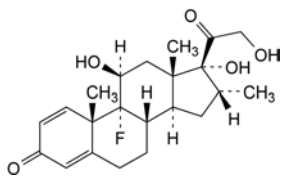

- A. 9-fluoro-11β,17,21-trihydroxy-16α-methylpregna-1,4-diene-3,20-dione (dexamethasone),

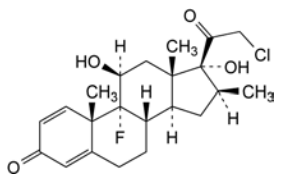

- B. 21-chloro-9-fluoro-11β,17-dihydroxy-16β-methylpregna-1,4-diene-3,20-dione,

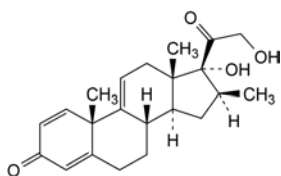

- C. 17,21-dihydroxy-16β-methylpregna-1,4,9(11)-triene-3,20-dione,

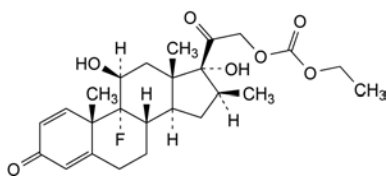

- D. 9-fluoro-11β,17-dihydroxy-16β-methyl-3,20-dioxopregna-1,4-dien-21-yl ethoxycarboxylate,

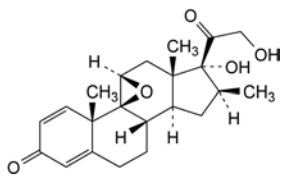

- E. 9,11β-epoxy-17,21-dihydroxy-16β-methyl-9β-pregna-1,4-diene-3,20-dione,

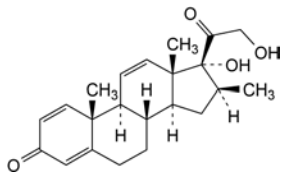

- F. 17,21-dihydroxy-16β-methylpregna-1,4,11-triene-3,20-dione,

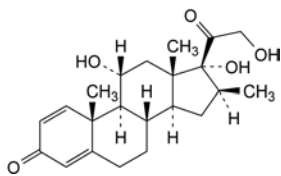

- G. 11α,17,21-trihydroxy-16β-methylpregna-1,4-diene-3,20-dione,

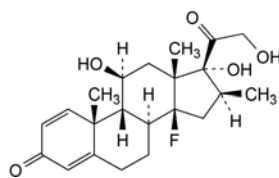

- H. 14-fluoro-11β,17,21-trihydroxy-16β-methyl-8α,9β,14β-pregna-1,4-diene-3,20-dione,

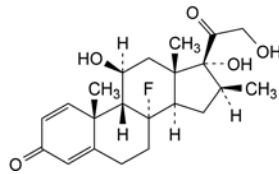

- I. 8-fluoro-11β,17,21-trihydroxy-16β-methyl-8α,9β-pregna-1,4-diene-3,20-dione,

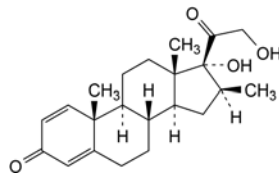

- J. 17,21-dihydroxy-16β-methylpregna-1,4-diene-3,20-dione.

01/2008:0975

## BETAMETHASONE ACETATE

## Betamethasoni acetas

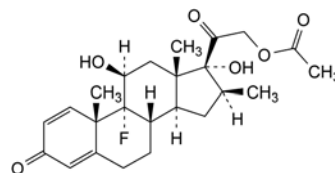
 $C_{24}H_{31}FO_6$   
[987-24-6]
 $M_r$  434.5

## DEFINITION

9-Fluoro-11β,17-dihydroxy-16β-methyl-3,20-dioxopregna-1,4-dien-21-yl acetate.

*Content*: 97.0 per cent to 103.0 per cent (anhydrous substance).

## CHARACTERS

*Appearance*: white or almost white, crystalline powder.*Solubility*: practically insoluble in water, freely soluble in acetone, soluble in ethanol (96 per cent) and in methylene chloride.

It shows polymorphism (5.9).

## IDENTIFICATION

*First identification*: B, C.*Second identification*: A, C, D, E, F.

A. Dissolve 10.0 mg in *anhydrous ethanol R* and dilute to 100.0 mL with the same solvent. Place 2.0 mL of this solution in a ground-glass-stoppered tube, add 10.0 mL of *phenylhydrazine-sulfuric acid solution R*, mix and heat in a water-bath at 60 °C for 20 min. Cool immediately. The absorbance (2.2.25) measured at 419 nm is not greater than 0.10.

B. Infrared absorption spectrophotometry (2.2.24).

*Comparison*: *betamethasone acetate CRS*.

If the spectra obtained in the solid state show differences, dissolve the substance to be examined and the reference substance separately in the minimum volume of *methanol R*, evaporate to dryness on a water-bath and record new spectra using the residues.

C. Thin-layer chromatography (2.2.27).

**Solvent mixture:** *methanol R*, *methylene chloride R* (1:9 V/V).

**Test solution.** Dissolve 10 mg of the substance to be examined in the solvent mixture and dilute to 10 mL with the solvent mixture.

**Reference solution (a).** Dissolve 20 mg of *betamethasone acetate CRS* in the solvent mixture and dilute to 20 mL with the solvent mixture.

**Reference solution (b).** Dissolve 10 mg of *prednisolone acetate CRS* in reference solution (a) and dilute to 10 mL with reference solution (a).

**Plate:** *TLC silica gel F<sub>254</sub> plate R*.

**Mobile phase:** add a mixture of 1.2 volumes of *water R* and 8 volumes of *methanol R* to a mixture of 15 volumes of *ether R* and 77 volumes of *methylene chloride R*.

**Application:** 5 µL.

**Development:** over a path of 15 cm.

**Drying:** in air.

**Detection A:** examine in ultraviolet light at 254 nm.

**Results A:** the principal spot in the chromatogram obtained with the test solution is similar in position and size to the principal spot in the chromatogram obtained with reference solution (a).

**Detection B:** spray with *alcoholic solution of sulfuric acid R*. Heat at 120 °C for 10 min or until the spots appear. Allow to cool. Examine in daylight and in ultraviolet light at 365 nm.

**Results B:** the principal spot in the chromatogram obtained with the test solution is similar in position, colour in daylight, fluorescence in ultraviolet light at 365 nm and size to the principal spot in the chromatogram obtained with reference solution (a).

**System suitability:** reference solution (b):

- the chromatogram shows 2 clearly separated spots.

D. Add about 2 mg to 2 mL of *sulfuric acid R* and shake to dissolve. Within 5 min, a deep reddish-brown colour develops. Add this solution to 10 mL of *water R* and mix. The colour is discharged and a clear solution remains.

E. Mix about 5 mg with 45 mg of *heavy magnesium oxide R* and ignite in a crucible until an almost white residue is obtained (usually less than 5 min). Allow to cool, add 1 mL of *water R*, 0.05 mL of *phenolphthalein solution R1* and about 1 mL of *dilute hydrochloric acid R* to render the solution colourless. Filter. To a freshly prepared mixture of 0.1 mL of *alizarin S solution R* and 0.1 mL of *zirconyl nitrate solution R*, add 1.0 mL of the filtrate. Mix, allow to stand for 5 min and compare the colour of the solution with that of a blank prepared in the same manner. The test solution is yellow and the blank is red.

F. About 10 mg gives the reaction of acetyl (2.3.1).

### TESTS

**Specific optical rotation (2.2.7):** + 120 to + 128 (anhydrous substance).

Dissolve 0.250 g in *dioxan R* and dilute to 25.0 mL with the same solvent.

**Related substances.** Liquid chromatography (2.2.29).

**Test solution.** Dissolve 25.0 mg of the substance to be examined in 4 mL of *acetonitrile R* and dilute to 10.0 mL with the same solvent.

**Reference solution (a).** Dissolve 2 mg of *betamethasone acetate CRS* and 2 mg of *dexamethasone acetate CRS* (impurity B) in the mobile phase, then dilute to 100.0 mL with the mobile phase.

**Reference solution (b).** Dilute 1.0 mL of the test solution to 100.0 mL with the mobile phase.

**Column:**

- size:  $l = 0.25$  m,  $\varnothing = 4.6$  mm;
- stationary phase: *octadecylsilyl silica gel for chromatography R* (5 µm).

**Mobile phase:** in a 1000 mL volumetric flask mix 380 mL of *acetonitrile R* with 550 mL of *water R* and allow to equilibrate; dilute to 1000 mL with *water R* and mix again.

**Flow rate:** 1 mL/min.

**Detection:** spectrophotometer at 254 nm.

**Equilibration:** with the mobile phase for about 30 min.

**Injection:** 20 µL.

**Run time:** 2.5 times the retention time of betamethasone acetate.

**Retention time:** betamethasone acetate = about 19 min; impurity B = about 22 min.

**System suitability:** reference solution (a):

- resolution: minimum 3.3 between the peaks due to betamethasone acetate and impurity B; if necessary, adjust slightly the concentration of acetonitrile in the mobile phase.

**Limits:**

- impurities A, B, C, D: for each impurity, not more than 0.5 times the area of the principal peak in the chromatogram obtained with reference solution (b) (0.5 per cent);
- total: not more than 1.25 times the area of the principal peak in the chromatogram obtained with reference solution (b) (1.25 per cent);
- disregard limit: 0.05 times the area of the principal peak in the chromatogram obtained with reference solution (b) (0.05 per cent).

**Water (2.5.12):** maximum 4.0 per cent, determined on 0.100 g.

### ASSAY

Dissolve 0.100 g in *ethanol (96 per cent) R* and dilute to 100.0 mL with the same solvent. Dilute 2.0 mL of this solution to 100.0 mL with *ethanol (96 per cent) R*. Measure the absorbance (2.2.25) at the absorption maximum at 240 nm.

Calculate the content of  $C_{24}H_{31}FO_6$  taking the specific absorbance to be 350.

### STORAGE

Protected from light.

### IMPURITIES

**Specified impurities:** A, B, C, D.

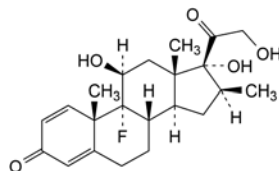

A. 9-fluoro-11β,17,21-trihydroxy-16β-methylpregna-1,4-diene-3,20-dione (betamethasone),

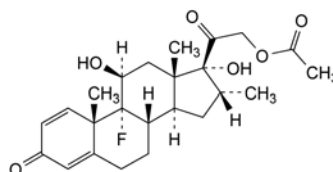

B. 9-fluoro-11β,17-dihydroxy-16α-methyl-3,20-dioxopregna-1,4-dien-21-yl acetate (dexamethasone acetate),

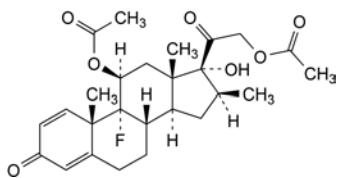

- C. 9-fluoro-17-hydroxy-16β-methyl-3,20-dioxopregna-1,4-diene-11β,21-diyl diacetate (betamethasone 11,21-diacetate),

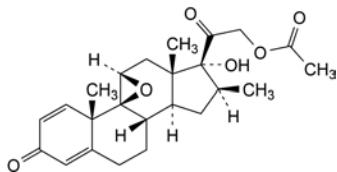

- D. 9,11β-epoxy-17-hydroxy-16β-methyl-3,20-dioxo-9β-pregna-1,4-diene-21-yl acetate.

01/2008:0809  
corrected 6.0

## BETAMETHASONE DIPROPIONATE

### Betamethasoni dipropionas

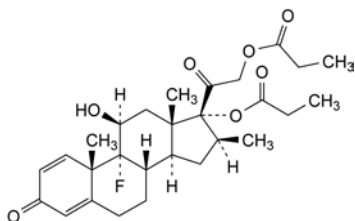

$C_{28}H_{37}FO_7$   
[5593-20-4]

$M_r$  504.6

#### DEFINITION

9-Fluoro-11β-hydroxy-16β-methyl-3,20-dioxopregna-1,4-diene-17,21-diyl dipropionate.

Content: 97.0 per cent to 103.0 per cent (dried substance).

#### CHARACTERS

Appearance: white or almost white, crystalline powder.

Solubility: practically insoluble in water, freely soluble in acetone and in methylene chloride, sparingly soluble in ethanol (96 per cent).

#### IDENTIFICATION

First identification: B, C.

Second identification: A, D, E, F.

- A. Dissolve 10.0 mg in *anhydrous ethanol R* and dilute to 100.0 mL with the same solvent. Place 2.0 mL of this solution in a ground-glass-stoppered tube, add 10.0 mL of *phenylhydrazine-sulfuric acid solution R*, mix and heat in a water-bath at 60 °C for 20 min. Cool immediately. The absorbance (2.2.25) measured at 419 nm is not more than 0.10.
- B. Infrared absorption spectrophotometry (2.2.24).  
Comparison: *betamethasone dipropionate CRS*.
- C. Thin-layer chromatography (2.2.27).  
Solvent mixture: *methanol R*, *methylene chloride R* (1:9 V/V).  
Test solution. Dissolve 10 mg of the substance to be examined in the solvent mixture and dilute to 10 mL with the solvent mixture.  
Reference solution (a). Dissolve 10 mg of *betamethasone dipropionate CRS* in the solvent mixture and dilute to 10 mL with the solvent mixture.

Reference solution (b). Dissolve 10 mg of *desoxycortone acetate CRS* in the solvent mixture and dilute to 10 mL with the solvent mixture. Dilute 5 mL of this solution to 10 mL with reference solution (a).

Plate: TLC silica gel  $F_{254}$  plate R.

Mobile phase: add a mixture of 1.2 volumes of *water R* and 8 volumes of *methanol R* to a mixture of 15 volumes of *ether R* and 77 volumes of *methylene chloride R*.

Application: 5 μL.

Development: over a path of 15 cm.

Drying: in air.

Detection A: examine in ultraviolet light at 254 nm.

Results A: the principal spot in the chromatogram obtained with the test solution is similar in position and size to the principal spot in the chromatogram obtained with reference solution (a).

Detection B: spray with *alcoholic solution of sulfuric acid R*. Heat at 120 °C for 10 min or until the spots appear. Allow to cool. Examine in daylight and in ultraviolet light at 365 nm.

Results B: the principal spot in the chromatogram obtained with the test solution is similar in position, colour in daylight, fluorescence in ultraviolet light at 365 nm and size to the principal spot in the chromatogram obtained with reference solution (a).

System suitability: reference solution (b):

– the chromatogram shows 2 clearly separated spots.

#### D. Thin-layer chromatography (2.2.27).

Test solution (a). Dissolve 25 mg of the substance to be examined in *methanol R* with gentle heating and dilute to 5 mL with the same solvent (solution A). Dilute 2 mL of this solution to 10 mL with *methylene chloride R*.

Test solution (b). Transfer 2 mL of solution A to a 15 mL glass tube with a ground-glass stopper or a polytetrafluoroethylene cap. Add 10 mL of *saturated methanolic potassium hydrogen carbonate solution R* and immediately pass a current of *nitrogen R* briskly through the solution for 5 min. Stopper the tube. Heat in a water-bath at 45 °C, protected from light, for 2 h. Allow to cool.

Reference solution (a). Dissolve 25 mg of *betamethasone dipropionate CRS* in *methanol R* with gentle heating and dilute to 5 mL with the same solvent (solution B). Dilute 2 mL of this solution to 10 mL with *methylene chloride R*.

Reference solution (b). Transfer 2 mL of solution B to a 15 mL glass tube with a ground-glass stopper or a polytetrafluoroethylene cap. Add 10 mL of *saturated methanolic potassium hydrogen carbonate solution R* and immediately pass a current of *nitrogen R* briskly through the solution for 5 min. Stopper the tube. Heat in a water-bath at 45 °C, protected from light, for 2 h. Allow to cool.

Plate: TLC silica gel  $F_{254}$  plate R.

Mobile phase: add a mixture of 1.2 volumes of *water R* and 8 volumes of *methanol R* to a mixture of 15 volumes of *ether R* and 77 volumes of *methylene chloride R*.

Application: 5 μL.

Development: over a path of 15 cm.

Drying: in air.

Detection A: examine in ultraviolet light at 254 nm.

Results A: the principal spot in each of the chromatograms obtained with the test solutions is similar in position and size to the principal spot in the chromatogram obtained with the corresponding reference solution.

Detection B: spray with *alcoholic solution of sulfuric acid R*. Heat at 120 °C for 10 min or until the spots appear. Allow to cool. Examine in daylight and in ultraviolet light at 365 nm.

Results B: the principal spot in each of the chromatograms obtained with the test solutions is similar in position, colour in daylight, fluorescence in ultraviolet light at 365 nm and size to the principal spot in the chromatogram obtained with

the corresponding reference solution. The principal spot in each of the chromatograms obtained with test solution (b) and reference solution (b) has an  $R_f$  value distinctly lower than that of the principal spots in each of the chromatograms obtained with test solution (a) and reference solution (a).

- E. Add about 2 mg to 2 mL of *sulfuric acid R* and shake to dissolve. Within 5 min, a deep reddish-brown colour develops. Add this solution to 10 mL of *water R* and mix. The colour is discharged and a clear solution remains.
- F. Mix about 5 mg with 45 mg of *heavy magnesium oxide R* and ignite in a crucible until an almost white residue is obtained (usually less than 5 min). Allow to cool, add 1 mL of *water R*, 0.05 mL of *phenolphthalein solution R1* and about 1 mL of *dilute hydrochloric acid R* to render the solution colourless. Filter. Add 1.0 mL of the filtrate to a freshly prepared mixture of 0.1 mL of *alizarin S solution R* and 0.1 mL of *zirconyl nitrate solution R*. Mix, allow to stand for 5 min and compare the colour of the solution with that of a blank prepared in the same manner. The test solution is yellow and the blank is red.

#### TESTS

**Specific optical rotation (2.2.7):** + 63 to + 70 (dried substance). Dissolve 0.250 g in *dioxan R* and dilute to 25.0 mL with the same solvent.

**Related substances.** Liquid chromatography (2.2.29).

*Test solution.* Dissolve 62.5 mg of the substance to be examined in the mobile phase and dilute to 25.0 mL with the mobile phase.

*Reference solution (a).* Dissolve 2.5 mg of *betamethasone dipropionate CRS* and 2.5 mg of *anhydrous beclomethasone dipropionate CRS* in the mobile phase and dilute to 50.0 mL with the same solvent.

*Reference solution (b).* Dilute 1.0 mL of the test solution to 50.0 mL with the mobile phase.

*Column:*

- *size:*  $l = 0.25$  m,  $\varnothing = 4.6$  mm;
- *stationary phase:* octadecylsilyl silica gel for chromatography R (5  $\mu$ m).

*Mobile phase:* mix carefully 350 mL of *water R* with 600 mL of *acetonitrile R* and allow to equilibrate; dilute to 1000 mL with *water R* and mix again.

*Flow rate:* 1 mL/min.

*Detection:* spectrophotometer at 254 nm.

*Equilibration:* with the mobile phase for about 45 min.

*Injection:* 20  $\mu$ L.

*Run time:* 2.5 times the retention time of betamethasone dipropionate.

*Retention time:* betamethasone dipropionate = about 9 min; beclomethasone dipropionate = about 10.7 min.

*System suitability:* reference solution (a):

- *resolution:* minimum 2.5 between the peaks due to betamethasone dipropionate and beclomethasone dipropionate; if necessary, adjust the concentration of acetonitrile in the mobile phase.

*Limits:*

- *any impurity:* for each impurity, not more than 0.75 times the area of the principal peak in the chromatogram obtained with reference solution (b) (1.5 per cent), and not more than 1 such peak has an area greater than 0.5 times the area of the principal peak in the chromatogram obtained with reference solution (b) (1 per cent);
- *total:* not more than 1.25 times the area of the principal peak in the chromatogram obtained with reference solution (b) (2.5 per cent);
- *disregard limit:* 0.025 times the area of the principal peak in the chromatogram obtained with reference solution (b) (0.05 per cent).

**Loss on drying (2.2.32):** maximum 1.0 per cent, determined on 0.500 g by drying in an oven at 105 °C.

#### ASSAY

Dissolve 50.0 mg in *ethanol (96 per cent) R* and dilute to 100.0 mL with the same solvent. Dilute 2.0 mL of this solution to 50.0 mL with *ethanol (96 per cent) R*. Measure the absorbance (2.2.25) at the absorption maximum at 240 nm.

Calculate the content of  $C_{28}H_{37}FO_7$  taking the specific absorbance to be 305.

#### STORAGE

Protected from light.

01/2008:0810

## BETAMETHASONE SODIUM PHOSPHATE

### Betamethasoni natrii phosphas

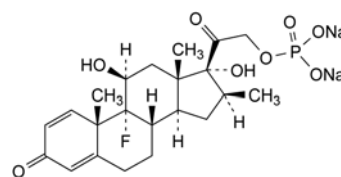

$C_{22}H_{28}FNa_2O_8P$   
[151-73-5]

$M_r$  516.4

#### DEFINITION

9-Fluoro-11 $\beta$ ,17-dihydroxy-16 $\beta$ -methyl-3,20-dioxopregna-1,4-dien-21-yl disodium phosphate.

*Content:* 96.0 per cent to 103.0 per cent (anhydrous substance).

#### CHARACTERS

*Appearance:* white or almost white powder, very hygroscopic.

*Solubility:* freely soluble in water, slightly soluble in ethanol (96 per cent), practically insoluble in methylene chloride.

#### IDENTIFICATION

*First identification:* B, C.

*Second identification:* A, C, D, E, F.

- A. Dissolve 10.0 mg in 5 mL of *water R* and dilute to 100.0 mL with *anhydrous ethanol R*. Place 2.0 mL of this solution in a ground-glass-stoppered tube, add 10.0 mL of *phenylhydrazine-sulfuric acid solution R*, mix and heat in a water-bath at 60 °C for 20 min. Cool immediately. The absorbance (2.2.25) measured at the absorption maximum at 450 nm is not more than 0.10.

- B. Infrared absorption spectrophotometry (2.2.24).

*Comparison:* betamethasone sodium phosphate CRS.

If the spectra obtained in the solid state show differences, dissolve the substance to be examined and the reference substance separately in the minimum volume of *ethanol (96 per cent) R*, evaporate to dryness on a water-bath and record new spectra using the residues.

- C. Thin-layer chromatography (2.2.27).

*Test solution.* Dissolve 10 mg of the substance to be examined in *methanol R* and dilute to 10 mL with the same solvent.

*Reference solution (a).* Dissolve 10 mg of *betamethasone sodium phosphate CRS* in *methanol R* and dilute to 10 mL with the same solvent.

*Reference solution (b).* Dissolve 10 mg of *prednisolone sodium phosphate CRS* in *methanol R* and dilute to 10 mL with the same solvent. Dilute 5 mL of this solution to 10 mL with reference solution (a).

*Plate:* TLC silica gel F<sub>254</sub> plate R.

*Mobile phase:* glacial acetic acid R, water R, butanol R (20:20:60 V/V/V).

*Application:* 5 µL.

*Development:* over a path of 15 cm.

*Drying:* in air.

*Detection A:* examine in ultraviolet light at 254 nm.

*Results A:* the principal spot in the chromatogram obtained with the test solution is similar in position and size to the principal spot in the chromatogram obtained with reference solution (a).

*Detection B:* spray with alcoholic solution of sulfuric acid R. Heat at 120 °C for 10 min or until the spots appear. Allow to cool. Examine in daylight and in ultraviolet light at 365 nm.

*Results B:* the principal spot in the chromatogram obtained with the test solution is similar in position, colour in daylight, fluorescence in ultraviolet light at 365 nm and size to the principal spot in the chromatogram obtained with reference solution (a).

*System suitability:* reference solution (b):

- the chromatogram shows 2 spots which may, however, not be completely separated.

D. Add about 2 mg to 2 mL of sulfuric acid R and shake to dissolve. Within 5 min, an intense reddish-brown colour develops. Add the solution to 10 mL of water R and mix. The colour is discharged and a clear solution remains.

E. Mix about 5 mg with 45 mg of heavy magnesium oxide R and ignite in a crucible until an almost white residue is obtained (usually less than 5 min). Allow to cool, add 1 mL of water R, 0.05 mL of phenolphthalein solution R1 and about 1 mL of dilute hydrochloric acid R to render the solution colourless. Filter. Add 1.0 mL of the filtrate to a freshly prepared mixture of 0.1 mL of alizarin S solution R and 0.1 mL of zirconyl nitrate solution R. Mix, allow to stand for 5 min and compare the colour of the solution with that of a blank prepared in the same manner. The test solution is yellow and the blank is red.

F. To about 40 mg add 2 mL of sulfuric acid R and heat gently until white fumes are evolved. Add nitric acid R dropwise, continue the heating until the solution is almost colourless and cool. Add 2 mL of water R, heat until white fumes are again evolved, cool, add 10 mL of water R and neutralise to red litmus paper R with dilute ammonia R1. The solution gives reaction (a) of sodium (2.3.1) and reaction (b) of phosphates (2.3.1).

## TESTS

**Solution S.** Dissolve 1.0 g in carbon dioxide-free water R and dilute to 20 mL with the same solvent.

**Appearance of solution.** Solution S is clear (2.2.1) and not more intensely coloured than reference solution B<sub>7</sub> (2.2.2, Method II).

**pH (2.2.3):** 7.5 to 9.0.

Dilute 1 mL of solution S to 5 mL with carbon dioxide-free water R.

**Specific optical rotation (2.2.7):** + 98 to + 104 (anhydrous substance).

Dissolve 0.250 g in water R and dilute to 25.0 mL with the same solvent.

**Related substances.** Liquid chromatography (2.2.29).

*Test solution.* Dissolve 62.5 mg of the substance to be examined in the mobile phase and dilute to 25.0 mL with the mobile phase.

*Reference solution (a).* Dissolve 25 mg of betamethasone sodium phosphate CRS and 25 mg of dexamethasone sodium phosphate CRS in the mobile phase and dilute to 25.0 mL with the mobile phase. Dilute 1.0 mL of this solution to 25.0 mL with the mobile phase.

*Reference solution (b).* Dilute 1.0 mL of the test solution to 50.0 mL with the mobile phase.

*Column:*

- *size:*  $l = 0.25$  m,  $\varnothing = 4.6$  mm;
- *stationary phase:* octadecylsilyl silica gel for chromatography R (5 µm).

*Mobile phase:* in a 250 mL conical flask, weigh 1.360 g of potassium dihydrogen phosphate R and 0.600 g of hexylamine R, mix and allow to stand for 10 min and then dissolve in 185 mL of water R; add 65 mL of acetonitrile R, mix and filter (0.45 µm).

*Flow rate:* 1 mL/min.

*Detection:* spectrophotometer at 254 nm.

*Equilibration:* with the mobile phase for about 45 min.

*Injection:* 20 µL.

*Run time:* twice the retention time of betamethasone sodium phosphate.

*Retention time:* betamethasone sodium phosphate = about 14 min; dexamethasone sodium phosphate = about 15.5 min.

*System suitability:* reference solution (a):

- *resolution:* minimum 2.0 between the peaks due to betamethasone sodium phosphate and dexamethasone sodium phosphate; if necessary, increase the concentration of acetonitrile or increase the concentration of water in the mobile phase.

*Limits:*

- *any impurity:* for each impurity, not more than the area of the principal peak in the chromatogram obtained with reference solution (b) (2 per cent), and not more than 1 such peak has an area greater than 0.5 times the area of the principal peak in the chromatogram obtained with reference solution (b) (1 per cent);
- *total:* not more than 1.5 times the area of the principal peak in the chromatogram obtained with reference solution (b) (3 per cent);
- *disregard limit:* 0.025 times the area of the principal peak in the chromatogram obtained with reference solution (b) (0.05 per cent).

**Inorganic phosphate:** maximum 1 per cent.

Dissolve 50 mg in water R and dilute to 100 mL with the same solvent. To 10 mL of this solution add 5 mL of molybdovanadic reagent R, mix and allow to stand for 5 min. Any yellow colour in the solution is not more intense than that in a standard prepared at the same time and in the same manner using 10 mL of phosphate standard solution (5 ppm PO<sub>4</sub>) R.

**Water (2.5.12):** maximum 8.0 per cent, determined on 0.200 g.

## ASSAY

Dissolve 0.100 g in water R and dilute to 100.0 mL with the same solvent. Dilute 5.0 mL of this solution to 250.0 mL with water R. Measure the absorbance (2.2.25) at the absorption maximum at 241 nm.

Calculate the content of C<sub>22</sub>H<sub>28</sub>FNa<sub>2</sub>O<sub>8</sub>P taking the specific absorbance to be 297.

## STORAGE

In an airtight container, protected from light.

01/2009:0811 Column:

**BETAMETHASONE VALERATE**

## Betamethasoni valeras

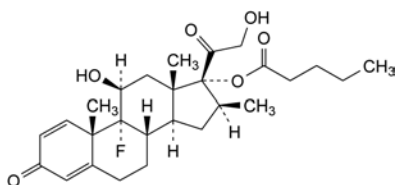

$C_{27}H_{37}FO_6$   
[2152-44-5]

 $M_r$  476.6**DEFINITION**

9-Fluoro-11 $\beta$ ,21-dihydroxy-16 $\beta$ -methyl-3,20-dioxopregna-1,4-dien-17-yl pentanoate.

*Content:* 97.0 per cent to 103.0 per cent (dried substance).

**CHARACTERS**

*Appearance:* white or almost white, crystalline powder.

*Solubility:* practically insoluble in water, freely soluble in acetone and in methylene chloride, soluble in ethanol (96 per cent).

mp: about 192 °C, with decomposition.

**IDENTIFICATION**

A. Infrared absorption spectrophotometry (2.2.24).

*Comparison:* betamethasone 17-valerate CRS.

If the spectra obtained in the solid state show differences, dissolve the substance to be examined and the reference substance separately in the minimum volume of *methylene chloride R*, evaporate to dryness on a water-bath and record new spectra using the residues.

B. Examine the chromatograms obtained in the test for related substances.

*Results:* the principal peak in the chromatogram obtained with the test solution is similar in retention time and size to the principal peak in the chromatogram obtained with reference solution (b).

**TESTS**

**Specific optical rotation** (2.2.7): + 77 to + 83 (dried substance).

Dissolve 0.250 g in *anhydrous ethanol R* and dilute to 25.0 mL with the same solvent.

**Related substances.** Liquid chromatography (2.2.29). Carry out the test protected from light. Prepare the solutions immediately before use.

*Solvent mixture:* glacial acetic acid R, mobile phase (1:1000 V/V).

*Test solution.* Dissolve 50 mg of the substance to be examined in the solvent mixture and dilute to 20.0 mL with the solvent mixture.

*Reference solution (a).* Dilute 1.0 mL of the test solution to 100.0 mL with the solvent mixture. Dilute 1.0 mL of this solution to 10.0 mL with the solvent mixture.

*Reference solution (b).* Dissolve 12.5 mg of betamethasone valerate for system suitability CRS (containing impurities D and G) in 5.0 mL of the solvent mixture. Use 1.0 mL of this solution to dissolve the contents of a vial of betamethasone valerate impurity mixture CRS (containing impurities C, H and I).

*Reference solution (c).* Dissolve 6 mg of betamethasone CRS (impurity A) and 3 mg of betamethasone 21-valerate CRS (impurity E) in 30.0 mL of the solvent mixture. Dilute 1.0 mL of this solution to 10.0 mL with the solvent mixture.

– size:  $l = 0.25$  m,  $\varnothing = 4.6$  mm;

– stationary phase: end-capped octadecylsilyl silica gel for chromatography R (5  $\mu$ m);

– temperature: 20 °C.

*Mobile phase:* acetonitrile R, water R (50:50 V/V).

*Flow rate:* 1 mL/min.

*Detection:* spectrophotometer at 239 nm.

*Injection:* 20  $\mu$ L.

*Run time:* 2.5 times the retention time of betamethasone valerate.

*Identification of impurities:* use the chromatogram supplied with betamethasone valerate for system suitability CRS and the chromatogram obtained with reference solution (b) to identify the peaks due to impurities C, D, G, H and I; use the chromatogram obtained with reference solution (c) to identify the peaks due to impurities A and E.

*Relative retention* with reference to betamethasone valerate (retention time = about 20 min): impurity A = about 0.3; impurity I = about 0.6; impurity C = about 0.8; impurity H = about 1.3; impurity D = about 1.4; impurity E = about 1.6; impurity G = about 2.0.

*System suitability:* reference solution (b):

– resolution: minimum 1.7 between the peaks due to impurities H and D.

**Limits:**

- impurity A: not more than 7 times the area of the principal peak in the chromatogram obtained with reference solution (a) (0.7 per cent);
- impurities E, G: for each impurity, not more than 3 times the area of the principal peak in the chromatogram obtained with reference solution (a) (0.3 per cent);
- impurities C, H, I: for each impurity, not more than 1.5 times the area of the principal peak in the chromatogram obtained with reference solution (a) (0.15 per cent);
- unspecified impurities: for each impurity, not more than the area of the principal peak in the chromatogram obtained with reference solution (a) (0.10 per cent);
- total: not more than 15 times the area of the principal peak in the chromatogram obtained with reference solution (a) (1.5 per cent);
- disregard limit: 0.5 times the area of the principal peak in the chromatogram obtained with reference solution (a) (0.05 per cent).

**Loss on drying** (2.2.32): maximum 0.5 per cent, determined on 1.000 g by drying in an oven at 105 °C.

**ASSAY**

Dissolve 50.0 mg in *ethanol (96 per cent) R* and dilute to 100.0 mL with the same solvent. Dilute 2.0 mL of this solution to 50.0 mL with *ethanol (96 per cent) R*. Measure the absorbance (2.2.25) at the absorption maximum at 240 nm.

Calculate the content of  $C_{27}H_{37}FO_6$  taking the specific absorbance to be 325.

**STORAGE**

Protected from light.

**IMPURITIES**

*Specified impurities:* A, C, E, G, H, I.

*Other detectable impurities* (the following substances would, if present at a sufficient level, be detected by one or other of the tests in the monograph. They are limited by the general acceptance criterion for other/unspecified impurities and/or by the general monograph *Substances for pharmaceutical use* (2034). It is therefore not necessary to identify these impurities for demonstration of compliance. See also 5.10. *Control of impurities in substances for pharmaceutical use*): B, D, F.

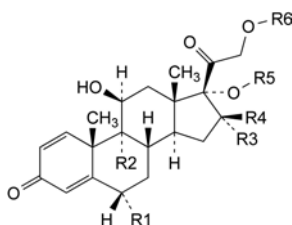

- A. R1 = R3 = R5 = R6 = H, R2 = F, R4 = CH<sub>3</sub>: 9-fluoro-11β, 17,21-trihydroxy-16β-methylpregna-1,4-diene-3,20-dione (betamethasone),
- C. R1 = R4 = R6 = H, R2 = F, R3 = CH<sub>3</sub>, R5 = CO-[CH<sub>2</sub>]<sub>3</sub>-CH<sub>3</sub>: 9-fluoro-11β,21-dihydroxy-16α-methyl-3,20-dioxopregna-1,4-dien-17-yl pentanoate (dexamethasone 17-valerate),
- E. R1 = R3 = R5 = H, R2 = F, R4 = CH<sub>3</sub>, R6 = CO-[CH<sub>2</sub>]<sub>3</sub>-CH<sub>3</sub>: 9-fluoro-11β,17-dihydroxy-16β-methyl-3,20-dioxopregna-1,4-dien-21-yl pentanoate (betamethasone 21-valerate),
- G. R1 = Br, R2 = F, R3 = R6 = H, R4 = CH<sub>3</sub>, R5 = CO-[CH<sub>2</sub>]<sub>3</sub>-CH<sub>3</sub>: 6α-bromo-9-fluoro-11β,21-dihydroxy-16β-methyl-3,20-dioxopregna-1,4-dien-17-yl pentanoate (6α-bromo-betamethasone valerate),
- H. R1 = R3 = R6 = H, R2 = Cl, R4 = CH<sub>3</sub>, R5 = CO-[CH<sub>2</sub>]<sub>3</sub>-CH<sub>3</sub>: 9-chloro-11β,21-dihydroxy-16β-methyl-3,20-dioxopregna-1,4-dien-17-yl pentanoate (beclo-methasone 17-valerate),
- I. R1 = R3 = R4 = R6 = H, R2 = F, R5 = CO-[CH<sub>2</sub>]<sub>3</sub>-CH<sub>3</sub>: 9-fluoro-11β,21-dihydroxy-3,20-dioxopregna-1,4-dien-17-yl pentanoate (9-fluoro-prednisolone 17-valerate),

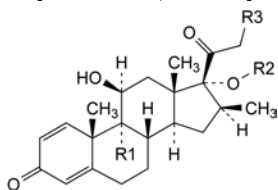

- B. R1 = F, R2 = R3 = H: 9-fluoro-11β,17-dihydroxy-16β-methylpregna-1,4-diene-3,20-dione (21-deoxybetamethasone),
- D. R1 = Br, R2 = CO-[CH<sub>2</sub>]<sub>3</sub>-CH<sub>3</sub>, R3 = OH: 9-bromo-11β,21-dihydroxy-16β-methyl-3,20-dioxopregna-1,4-dien-17-yl pentanoate (9-bromo-betamethasone valerate),

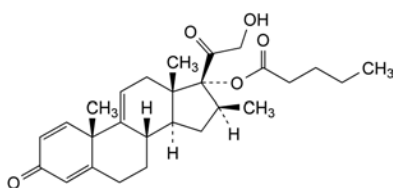

- F. 21-hydroxy-16β-methyl-3,20-dioxopregna-1,4,9(11)-trien-17-yl pentanoate (betamethasone valerate δ-9(11)).

01/2008:1072  
corrected 6.0

## BETAXOLOL HYDROCHLORIDE

### Betaxololi hydrochloridum

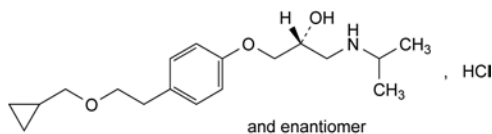

C<sub>18</sub>H<sub>30</sub>ClNO<sub>3</sub>  
[63659-19-8]

M<sub>r</sub> 343.9

#### DEFINITION

(2*R*)-1-[4-[2-(Cyclopropylmethoxy)ethyl]phenoxy]-3-[(1-methylethyl)amino]propan-2-ol hydrochloride.

*Content*: 98.5 per cent to 101.5 per cent (dried substance).

#### CHARACTERS

*Appearance*: white or almost white, crystalline powder.

*Solubility*: very soluble in water, freely soluble in ethanol (96 per cent), soluble in methylene chloride.

#### IDENTIFICATION

*First identification*: B, D.

*Second identification*: A, C, D.

- A. Melting point (2.2.14): 113 °C to 117 °C.
- B. Infrared absorption spectrophotometry (2.2.24).  
*Comparison*: betaxolol hydrochloride CRS.
- C. Thin-layer chromatography (2.2.27).

*Test solution*. Dissolve 10 mg of the substance to be examined in 1 mL of *methanol R*.

*Reference solution (a)*. Dissolve 20 mg of *betaxolol hydrochloride CRS* in 2 mL of *methanol R*.

*Reference solution (b)*. Dissolve 10 mg of *oxprenolol hydrochloride CRS* in 1 mL of reference solution (a).

*Plate*: TLC octadecylsilyl silica gel F<sub>254</sub> plate R.

*Mobile phase*: perchloric acid R, *methanol R*, *water R* (0.5:50:50 V/V/V).

*Application*: 2 µL.

*Development*: over a path of 10 cm.

*Drying*: in air.

*System suitability*: reference solution (b):

- the chromatogram shows 2 clearly separated spots.

*Detection A*: examine in ultraviolet light at 254 nm.

*Results A*: the principal spot in the chromatogram obtained with the test solution is similar in position and size to the principal spot in the chromatogram obtained with reference solution (a).

*Detection B*: spray with a 50 g/L solution of *vanillin R* in a mixture of 5 volumes of *sulfuric acid R*, 10 volumes of *glacial acetic acid R* and 85 volumes of *methanol R*. Heat at 100-105 °C until the colour of the spots reaches maximum intensity (10-15 min). Examine in daylight.

*Results B*: the principal spot in the chromatogram obtained with the test solution is similar in position, colour and size to the principal spot in the chromatogram obtained with reference solution (a).

- D. It gives reaction (a) of chlorides (2.3.1).

#### TESTS

**Appearance of solution.** The solution is clear (2.2.1) and colourless (2.2.2, *Method II*).

Dissolve 0.5 g in *water R* and dilute to 25 mL with the same solvent.

**Acidity or alkalinity.** Dissolve 0.20 g in *carbon dioxide-free water R* and dilute to 20 mL with the same solvent. Add 0.2 mL of *methyl red solution R* and 0.2 mL of 0.01 M *hydrochloric acid*. The solution is red. Add 0.4 mL of 0.01 M *sodium hydroxide*. The solution is yellow.

**Related substances.** Liquid chromatography (2.2.29).

*Test solution*. Dissolve 10.0 mg of the substance to be examined in the mobile phase and dilute to 5.0 mL with the mobile phase.

*Reference solution (a)*. Dissolve 8 mg of the substance to be examined and 4 mg of *betaxolol impurity A CRS* in 20.0 mL of the mobile phase.

*Reference solution (b)*. Dilute 1.0 mL of the test solution to 100.0 mL with the mobile phase.

*Column*:

- *size*: *l* = 0.25 m, Ø = 4 mm;
- *stationary phase*: octylsilyl silica gel for chromatography R (5 µm).

07/2010:1394

**Mobile phase:** mix 175 mL of *acetonitrile R* with 175 mL of *methanol R* and dilute the mixture to 1 litre with a 3.4 g/L solution of *potassium dihydrogen phosphate R*, previously adjusted to pH 3.0 with *phosphoric acid R*.

**Flow rate:** 1.5 mL/min.

**Detection:** spectrophotometer at 273 nm.

**Injection:** 20 µL.

**Run time:** 4 times the retention time of betaxolol.

**System suitability:** reference solution (a):

- **resolution:** minimum 2.0 between the peaks due to impurity A and betaxolol.

**Limits:**

- **impurities A, B, C, D, E:** for each impurity, not more than 0.3 times the area of the peak in the chromatogram obtained with reference solution (b) (0.3 per cent);
- **total:** not more than the area of the peak in the chromatogram obtained with reference solution (b) (1.0 per cent);
- **disregard limit:** 0.025 times the area of the peak in the chromatogram obtained with reference solution (b) (0.025 per cent).

**Heavy metals (2.4.8):** maximum 10 ppm.

Dissolve 2.0 g in 20 mL of *water R*. 12 mL of the solution complies with test A. Prepare the reference solution using 10 mL of *lead standard solution (1 ppm Pb) R*.

**Loss on drying (2.2.32):** maximum 0.5 per cent, determined on 1.000 g by drying in an oven at 105 °C.

**Sulfated ash (2.4.14):** maximum 0.1 per cent, determined on 1.0 g.

#### ASSAY

Dissolve 0.300 g in a mixture of 10.0 mL of 0.01 M *hydrochloric acid* and 50 mL of *ethanol (96 per cent) R*. Carry out a potentiometric titration (2.2.20), using 0.1 M *sodium hydroxide*. Read the volume added between the 2 points of inflexion.

1 mL of 0.1 M *sodium hydroxide* is equivalent to 34.39 mg of C<sub>18</sub>H<sub>30</sub>ClNO<sub>3</sub>.

#### STORAGE

Protected from light.

#### IMPURITIES

**Specified impurities:** A, B, C, D, E.

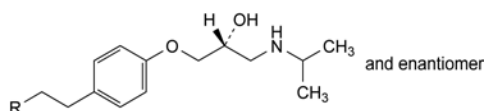

A. R = H: (2RS)-1-(4-ethylphenoxy)-3-[(1-methylethyl)amino]propan-2-ol,

B. R = OH: (2RS)-1-[4-(2-hydroxyethyl)phenoxy]-3-[(1-methylethyl)amino]propan-2-ol,

E. R = O-CH<sub>2</sub>-CH<sub>2</sub>-CH<sub>2</sub>-CH<sub>3</sub>: (2RS)-1-[4-(2-butoxyethyl)phenoxy]-3-[(1-methylethyl)amino]propan-2-ol,

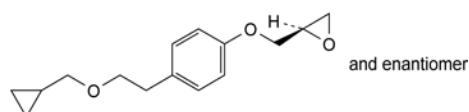

C. 2-[[4-[2-(cyclopropylmethoxy)ethyl]phenoxy]methyl]oxirane,

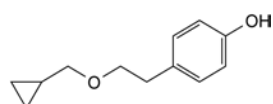

D. 4-[2-(cyclopropylmethoxy)ethyl]phenol.

## BEZAFIBRATE

### Bezafibratum

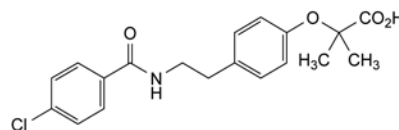

C<sub>19</sub>H<sub>20</sub>ClNO<sub>4</sub>  
[41859-67-0]

M<sub>r</sub> 361.8

#### DEFINITION

2-[4-[2-[(4-Chlorobenzoyl)amino]ethyl]phenoxy]-2-methylpropanoic acid.

**Content:** 98.0 per cent to 102.0 per cent (dried substance).

#### CHARACTERS

**Appearance:** white or almost white, crystalline powder.

**Solubility:** practically insoluble in water, freely soluble in dimethylformamide, sparingly soluble in acetone and in ethanol (96 per cent). It dissolves in dilute solutions of alkali hydroxides. It shows polymorphism (5.9).

#### IDENTIFICATION

**First identification:** A, B.

**Second identification:** A, C.

A. Melting point (2.2.14): 181 °C to 185 °C.

B. Infrared absorption spectrophotometry (2.2.24).

**Comparison:** bezafibrate CRS.

If the spectra obtained show differences, dissolve the substance to be examined and the reference substance separately in *methanol R* and evaporate to dryness. Dry the residues *in vacuo* at 80 °C for 1 h and record new spectra using the residues.

C. Thin-layer chromatography (2.2.27).

**Test solution.** Dissolve 10 mg of the substance to be examined in *methanol R* and dilute to 5 mL with the same solvent.

**Reference solution.** Dissolve 10 mg of bezafibrate CRS in *methanol R* and dilute to 5 mL with the same solvent.

**Plate:** TLC silica gel F<sub>254</sub> plate R.

**Mobile phase:** glacial acetic acid R, methyl ethyl ketone R, xylene R (2.7:30:60 V/V/V).

**Application:** 5 µL.

**Development:** over half of the plate.

**Drying:** at 120 °C for at least 15 min.

**Detection:** examine in ultraviolet light at 254 nm.

**Results:** the principal spot in the chromatogram obtained with the test solution is similar in position and size to the principal spot in the chromatogram obtained with the reference solution.

#### TESTS

**Solution S.** Dissolve 1.0 g in *dimethylformamide R* and dilute to 20 mL with the same solvent.

**Appearance of solution.** Solution S is clear (2.2.1) and not more intensely coloured than reference solution BY<sub>5</sub> (2.2.2, Method II).

**Related substances.** Liquid chromatography (2.2.29).

**Test solution.** Dissolve 50.0 mg of the substance to be examined in the mobile phase and dilute to 100.0 mL with the mobile phase.

**Reference solution (a).** Dilute 10.0 mL of the test solution to 100.0 mL with the mobile phase. Dilute 5.0 mL of this solution to 100.0 mL with the mobile phase.



*Reference solution (b).* Dilute 5.0 mL of reference solution (a) to 50.0 mL with the mobile phase.

*Reference solution (c).* To 1 mL of the test solution, add 1 mL of 0.1 M hydrochloric acid and evaporate to dryness on a hot plate. Dissolve the residue in 20 mL of the mobile phase.

*Column:*

- size:  $l = 0.125$  m,  $\varnothing = 4$  mm;
- stationary phase: octadecylsilyl silica gel for chromatography R (5  $\mu$ m).

*Mobile phase:* mix 40 volumes of a 2.72 g/L solution of potassium dihydrogen phosphate R adjusted to pH 2.3 with phosphoric acid R, and 60 volumes of methanol R.

*Flow rate:* 1 mL/min.

*Detection:* spectrophotometer at 228 nm.

*Injection:* 20  $\mu$ L.

*Run time:* the time necessary to detect the ester, which, depending on the route of synthesis, may be impurity C, D or E.

*Relative retention* with reference to bezafibrate (retention time = about 6.0 min): impurity A = about 0.5; impurity B = about 0.6; impurity C = about 1.5; impurity D = about 2.3; impurity E = about 6.2.

*System suitability:*

- resolution: minimum 5.0 between the 2 principal peaks in the chromatogram obtained with reference solution (c);
- signal-to-noise ratio: minimum 5 for the principal peak in the chromatogram obtained with reference solution (b).

*Limits:*

- impurities A, B, C, D, E: for each impurity, not more than the area of the principal peak in the chromatogram obtained with reference solution (a) (0.5 per cent);
- unspecified impurities: for each impurity, not more than 0.2 times the area of the principal peak in the chromatogram obtained with reference solution (a) (0.10 per cent);
- total: not more than 1.5 times the area of the principal peak in the chromatogram obtained with reference solution (a) (0.75 per cent);
- disregard limit: 0.1 times the area of the principal peak in the chromatogram obtained with reference solution (a) (0.05 per cent).

**Chlorides** (2.4.4): maximum 300 ppm.

Dilute 10 mL of solution S to 50 mL with water R. Filter the resultant suspension through a wet filter previously washed with water R until free from chlorides. Prepare the standard using 9 mL of chloride standard solution (5 ppm Cl) R and 6 mL of water R.

**Heavy metals** (2.4.8): maximum 10 ppm.

2.0 g complies with test C. Prepare the reference solution using 2 mL of lead standard solution (10 ppm Pb) R.

**Loss on drying** (2.2.32): maximum 0.5 per cent, determined on 1.000 g by drying in an oven at 105 °C.

**Sulfated ash** (2.4.14): maximum 0.1 per cent, determined on 1.0 g.

**ASSAY**

Dissolve 0.300 g in 50 mL of a mixture of 25 volumes of water R and 75 volumes of ethanol (96 per cent) R. Using 0.1 mL of phenolphthalein solution R as indicator, titrate with 0.1 M sodium hydroxide until a pink colour is obtained. Carry out a blank titration.

1 mL of 0.1 M sodium hydroxide is equivalent to 36.18 mg of  $C_{19}H_{20}ClNO_4$ .

**IMPURITIES**

*Specified impurities:* A, B, C, D, E.

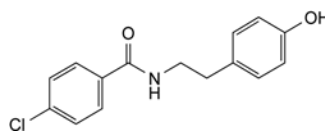

A. 4-chloro-N-[2-(4-hydroxyphenyl)ethyl]benzamide (chlorobenzoyltyramine),

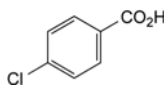

B. 4-chlorobenzoic acid,

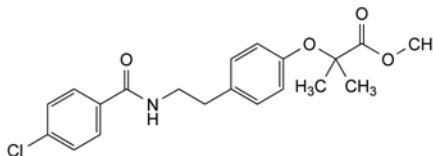

C. methyl 2-[4-[2-[(4-chlorobenzoyl)amino]ethyl]phenoxy]-2-methylpropanoate,

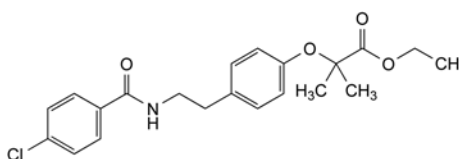

D. ethyl 2-[4-[2-[(4-chlorobenzoyl)amino]ethyl]phenoxy]-2-methylpropanoate,

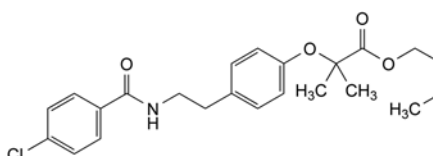

E. butyl 2-[4-[2-[(4-chlorobenzoyl)amino]ethyl]phenoxy]-2-methylpropanoate.

01/2008:1395  
corrected 6.5

## BIFONAZOLE

### Bifonazolium

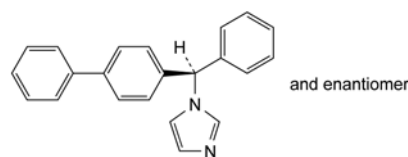

$C_{22}H_{18}N_2$   
[60628-96-8]

$M_r$  310.4

**DEFINITION**

1-[(RS)-(Biphenyl-4-yl)phenylmethyl]-1H-imidazole.

*Content:* 98.0 per cent to 100.5 per cent (dried substance).

**CHARACTERS**

*Appearance:* white or almost white, crystalline powder.

*Solubility:* practically insoluble in water, sparingly soluble in anhydrous ethanol.

It shows polymorphism (5.9).

**IDENTIFICATION**

Infrared absorption spectrophotometry (2.2.24).

*Comparison:* bifonazole CRS.

If the spectra obtained in the solid state show differences, dissolve the substance to be examined and the reference substance separately in the minimum volume of *2-propanol R*, evaporate to dryness and record new spectra using the residues.

## TESTS

**Optical rotation** (2.2.7):  $-0.10^\circ$  to  $+0.10^\circ$ .

Dissolve 0.20 g in 20.0 mL of *methanol R*.

**Related substances.** Liquid chromatography (2.2.29).

**Buffer solution pH 3.2.** Mix 2.0 mL of *phosphoric acid R* with *water R* and dilute to 1000.0 mL with the same solvent. Adjust to pH 3.2 with *triethylamine R*.

**Test solution.** Dissolve 50.0 mg of the substance to be examined in 25 mL of *acetonitrile R* and dilute to 50.0 mL with buffer solution pH 3.2.

**Reference solution (a).** Dilute 0.25 mL of the test solution to 50.0 mL with buffer solution pH 3.2.

**Reference solution (b).** Dissolve 25.0 mg of *imidazole R* (impurity C) in *acetonitrile R* and dilute to 25.0 mL with the same solvent. Dilute 0.25 mL of this solution to 100.0 mL with buffer solution pH 3.2.

**Reference solution (c).** Dissolve 5.0 mg of *bifonazole impurity B CRS* in *acetonitrile R* and dilute to 5.0 mL with the same solvent.

**Reference solution (d).** Mix 0.25 mL of the test solution and 0.25 mL of reference solution (c) and dilute to 50.0 mL with buffer solution pH 3.2.

## Column:

- size:  $l = 0.125$  m,  $\varnothing = 4.6$  mm;
- stationary phase: *octadecylsilyl silica gel for chromatography R* (5  $\mu$ m);
- temperature: 40 °C.

## Mobile phase:

- mobile phase A: *acetonitrile R1*, buffer solution pH 3.2 (20:80 V/V);
- mobile phase B: buffer solution pH 3.2, *acetonitrile R1* (20:80 V/V);

Time (min)	Mobile phase A (per cent V/V)	Mobile phase B (per cent V/V)
0 - 8	60	40
8 - 12	60 → 10	40 → 90
12 - 30	10	90

Flow rate: 1 mL/min.

Detection: spectrophotometer at 210 nm.

Injection: 50  $\mu$ L of the test solution and reference solutions (a), (b) and (d).

Retention time: impurity B = about 4 min; bifonazole = about 4.5 min.

System suitability: reference solution (d):

- resolution: minimum 2.5 between the peaks due to impurity B and bifonazole.

## Limits:

- impurity B: not more than 3 times the area of the principal peak in the chromatogram obtained with reference solution (a) (1.5 per cent);
- impurity C: not more than the area of the corresponding peak in the chromatogram obtained with reference solution (b) (0.25 per cent);
- impurities A, D: for each impurity, not more than the area of the principal peak in the chromatogram obtained with reference solution (a) (0.5 per cent);
- total: not more than 4 times the area of the principal peak in the chromatogram obtained with reference solution (a) (2 per cent);

- disregard limit: 0.1 times the area of the principal peak in the chromatogram obtained with reference solution (a) (0.05 per cent).

**Loss on drying** (2.2.32): maximum 0.5 per cent, determined on 1.000 g by drying in an oven at 105 °C.

**Sulfated ash** (2.4.14): maximum 0.1 per cent, determined on 1.0 g.

## ASSAY

Dissolve 0.250 g in 80 mL of *anhydrous acetic acid R*. Titrate with 0.1 M *perchloric acid*, determining the end-point potentiometrically (2.2.20).

1 mL of 0.1 M *perchloric acid* is equivalent to 31.04 mg of  $C_{22}H_{18}N_2$ .

## IMPURITIES

Specified impurities: A, B, C, D.

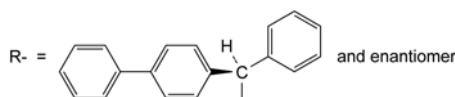

A. R-OH: (RS)-(biphenyl-4-yl)phenylmethanol,

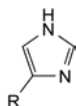

B. 4-[(RS)-(biphenyl-4-yl)phenylmethyl]-1H-imidazole,



C. 1H-imidazole,

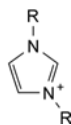

D. 1,3-bis[(biphenyl-4-yl)phenylmethyl]-1H-imidazolium ion.

01/2008:1073  
corrected 6.0

## BIOTIN

## Biotinum

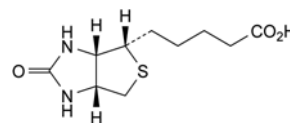

$C_{10}H_{16}N_2O_3S$   
[58-85-5]

$M_r$  244.3

## DEFINITION

Biotin contains not less than 98.5 per cent and not more than the equivalent of 101.0 per cent of 5-[(3aS,4S,6aR)-2-oxohexahydrothieno[3,4-d]imidazol-4-yl]pentanoic acid, calculated with reference to the dried substance.

## CHARACTERS

A white or almost white, crystalline powder or colourless crystals, very slightly soluble in water and in alcohol, practically insoluble in acetone. It dissolves in dilute solutions of alkali hydroxides.

## IDENTIFICATION

First identification: A.

Second identification: B, C.

- A. Examine by infrared absorption spectrophotometry (2.2.24), comparing with the spectrum obtained with *biotin CRS*.
- B. Examine the chromatograms obtained in the test for related substances (see Tests). The principal spot in the chromatogram obtained with test solution (b) is similar in position and size to the principal spot in the chromatogram obtained with reference solution (a).
- C. Dissolve about 10 mg in 20 mL of *water R* with heating. Allow to cool. Add 0.1 mL of *bromine water R*. The bromine water is decolourised.

## TESTS

**Solution S.** Dissolve 0.250 g in a 4 g/L solution of *sodium hydroxide R* and dilute to 25.0 mL with the same alkaline solution.

**Appearance of solution.** Solution S is clear (2.2.1) and colourless (2.2.2, *Method II*).

**Specific optical rotation (2.2.7).** The specific optical rotation is + 89 to + 93, determined on solution S and calculated with reference to the dried substance.

**Related substances.** Examine by thin-layer chromatography (2.2.27), using as the coating substance a suitable silica gel (5 µm). Prepare the solutions immediately before use and keep protected from bright light.

**Test solution (a).** Dissolve 50 mg of the substance to be examined in *glacial acetic acid R* and dilute to 10 mL with the same solvent.

**Test solution (b).** Dilute 1 mL of test solution (a) to 10 mL with *glacial acetic acid R*.

**Reference solution (a).** Dissolve 5 mg of *biotin CRS* in *glacial acetic acid R* and dilute to 10 mL with the same solvent.

**Reference solution (b).** Dilute 1 mL of test solution (b) to 20 mL with *glacial acetic acid R*.

**Reference solution (c).** Dilute 1 mL of test solution (b) to 40 mL with *glacial acetic acid R*.

Apply to the plate 10 µL of each solution. Develop over a path of 15 cm using a mixture of 5 volumes of *methanol R*, 25 volumes of *glacial acetic acid R* and 75 volumes of *toluene R*. Dry the plate in a current of warm air. Allow to cool and spray with *4-dimethylaminocinnamaldehyde solution R*. Examine immediately in daylight. Any spot in the chromatogram obtained with test solution (a), apart from the principal spot, is not more intense than the spot in the chromatogram obtained with reference solution (b) (0.5 per cent) and at most one such spot is more intense than the spot in the chromatogram obtained with reference solution (c) (0.25 per cent).

**Heavy metals (2.4.8).** 1.0 g complies with limit test C for heavy metals (10 ppm). Prepare the standard using 10 mL of *lead standard solution (1 ppm Pb) R*.

**Loss on drying (2.2.32).** Not more than 1.0 per cent, determined on 1.000 g by drying in an oven at 105 °C.

**Sulfated ash (2.4.14).** Not more than 0.1 per cent, determined on 1.0 g.

## ASSAY

Suspend 0.200 g in 5 mL of *dimethylformamide R*. Heat until the substance has dissolved completely. Add 50 mL of *ethanol R* and titrate with 0.1 M *tetrabutylammonium hydroxide*, determining the end-point potentiometrically (2.2.20).

1 mL of 0.1 M *tetrabutylammonium hydroxide* is equivalent to 24.43 mg of C<sub>21</sub>H<sub>30</sub>N<sub>2</sub>O<sub>3</sub>S.

## STORAGE

Store protected from light.

## IMPURITIES

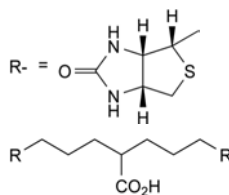

- A. di[3-[(3a*S*,4*S*,6a*R*)-2-oxohexahydrothieno[3,4-*d*]imidazol-4-yl]propyl]acetic acid,

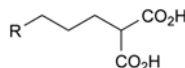

- B. 4-[(3a*S*,4*S*,6a*R*)-2-oxohexahydrothieno[3,4-*d*]imidazol-4-yl]butane-1,1-dicarboxylic acid,

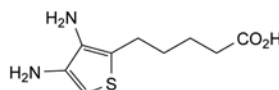

- C. 5-(3,4-diamino-2-thienyl)pentanoic acid,

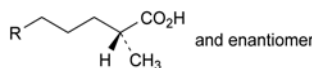

- D. 2-methyl-5-[(3a*S*,4*S*,6a*R*)-2-oxohexahydrothieno[3,4-*d*]imidazol-4-yl]pentanoic acid,

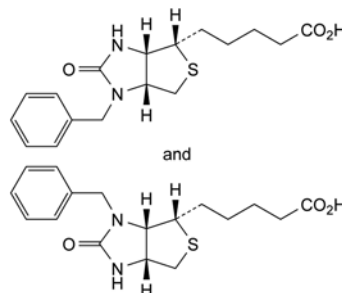

- E. 5-[(3a*S*,4*S*,6a*R*)-3-benzyl-2-oxohexahydrothieno[3,4-*d*]imidazol-4-yl]pentanoic acid and 5-[(3a*S*,4*S*,6a*R*)-1-benzyl-2-oxohexahydrothieno[3,4-*d*]imidazol-4-yl]pentanoic acid.

01/2008:1074  
corrected 6.0

## BIPERIDEN HYDROCHLORIDE

## Biperideni hydrochloridum

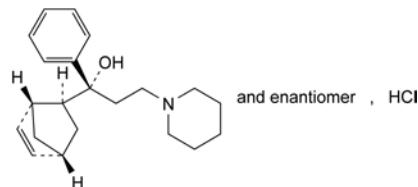

C<sub>21</sub>H<sub>30</sub>ClNO  
[1235-82-1]

M<sub>r</sub> 347.9

## DEFINITION

(1*RS*)-1-[(1*RS*,2*SR*,4*RS*)-Bicyclo[2.2.1]hept-5-en-2-yl]-1-phenyl-3-(piperidin-1-yl)propan-1-ol hydrochloride.

*Content*: 99.0 per cent to 101.0 per cent (dried substance).

## CHARACTERS

*Appearance*: white or almost white, crystalline powder.

*Solubility*: slightly soluble in water and in alcohol, very slightly soluble in methylene chloride.

mp: about 280 °C, with decomposition.

## IDENTIFICATION

First identification: A, D.

Second identification: B, C, D.

A. Infrared absorption spectrophotometry (2.2.24).

Comparison: biperiden hydrochloride CRS.

B. Thin-layer chromatography (2.2.27).

Test solution. Dissolve 25 mg of the substance to be examined in methanol R and dilute to 5 mL with the same solvent.

Reference solution (a). Dissolve 25 mg of biperiden hydrochloride CRS in methanol R and dilute to 5 mL with the same solvent.

Reference solution (b). Dissolve 5 mg of biperiden impurity A CRS in reference solution (a) and dilute to 2 mL with the same solution.

Plate: TLC silica gel F<sub>254</sub> plate R.

Mobile phase: diethylamine R, methanol R, toluene R (1:1:20 V/V/V).

Application: 5 µL.

Development: over a path of 15 cm.

Drying: in air.

Detection A: examine in ultraviolet light at 254 nm.

Results A: the principal spot in the chromatogram obtained with the test solution is similar in position and size to the principal spot in the chromatogram obtained with reference solution (a).

Detection B: spray with dilute potassium iodobismuthate solution R and then with sodium nitrite solution R and examine in daylight.

Results B: the principal spot in the chromatogram obtained with the test solution is similar in position, colour and size to the principal spot in the chromatogram obtained with reference solution (a).

System suitability: reference solution (b):

– the chromatogram shows 2 clearly separated spots.

C. To about 20 mg add 5 mL of phosphoric acid R. A green colour develops.

D. It gives reaction (a) of chlorides (2.3.1).

## TESTS

**Solution S.** Dissolve 0.10 g in carbon dioxide-free water R, heating gently if necessary, and dilute to 50 mL with the same solvent.

**Appearance of solution.** Solution S is not more opalescent than reference suspension II (2.2.1) and is colourless (2.2.2, Method II).

**pH (2.2.3):** 5.0 to 6.5 for solution S.

**Related substances.** Gas chromatography (2.2.28).

Test solution. Dissolve 0.10 g of the substance to be examined in methanol R and dilute to 10 mL with the same solvent.

Reference solution (a). Dilute 0.5 mL of the test solution to 100 mL with methanol R. Dilute 10 mL of this solution to 50 mL with methanol R.

Reference solution (b). Dissolve 5 mg of the substance to be examined and 5 mg of biperiden impurity A CRS in methanol R and dilute to 5 mL with the same solvent. Dilute 1 mL of the solution to 10 mL with methanol R.

Column:

- material: fused silica,
- size:  $l = 50$  m,  $\varnothing = 0.25$  mm,
- stationary phase: poly(dimethyl)(diphenyl)(divinyl)siloxane R (film thickness 0.25 µm).

Carrier gas: nitrogen for chromatography R.

Flow rate: 0.4 mL/min.

Split ratio: 1:250.

Temperature:

	Time (min)	Temperature (°C)
Column	0 - 5	200
	5 - 40	200 → 270
Injection port		250
Detector		300

Detection: flame ionisation.

Injection: 2 µL.

Run time: twice the retention time of biperiden.

Relative retention with reference to biperiden: impurities A, B and C = between 0.95 and 1.05.

System suitability:

- resolution: minimum 2.5 between the peak due to biperiden (1<sup>st</sup> peak) and the peak due to impurity A (2<sup>nd</sup> peak) in the chromatogram obtained with reference solution (b),
- signal-to-noise ratio: minimum 6 for the principal peak in the chromatogram obtained with reference solution (a).

Limits:

- impurities A, B, C: for each impurity, maximum 0.50 per cent of the area of the principal peak,
- any other impurity: for each impurity, maximum 0.10 per cent of the area of the principal peak,
- total of impurities A, B and C: maximum 1.0 per cent of the area of the principal peak,
- total of impurities other than A, B and C: maximum 0.50 per cent of the area of the principal peak,
- disregard limit: 0.05 per cent of the area of the principal peak.

**Impurity F (2.4.24):** maximum 2 ppm.

**Heavy metals (2.4.8):** maximum 20 ppm.

1.0 g complies with test D. Prepare the reference solution using 2 mL of lead standard solution (10 ppm Pb) R.

**Loss on drying (2.2.32):** maximum 0.5 per cent, determined on 1.000 g by drying in an oven at 105 °C for 2 h.

**Sulfated ash (2.4.14):** maximum 0.1 per cent, determined on 1.0 g.

## ASSAY

Dissolve 0.200 g in 60 mL of alcohol R. In a closed vessel, titrate with 0.1 M alcoholic potassium hydroxide, determining the end-point potentiometrically (2.2.20).

1 mL of 0.1 M alcoholic potassium hydroxide is equivalent to 34.79 mg of C<sub>21</sub>H<sub>30</sub>ClNO.

## STORAGE

In an airtight container, protected from light.

## IMPURITIES

Specified impurities: A, B, C, F.

Other detectable impurities (the following substances would, if present at a sufficient level, be detected by one or other of the tests in the monograph. They are limited by the general acceptance criterion for other/unspecified impurities and/or by the general monograph Substances for pharmaceutical use (2034). It is therefore not necessary to identify these impurities for demonstration of compliance. See also 5.10. Control of impurities in substances for pharmaceutical use): D, E.

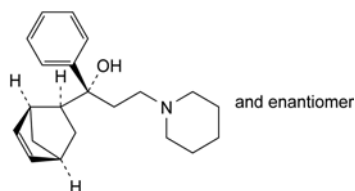

- A. (1*RS*)-1-[(1*SR*,2*SR*,4*SR*)-bicyclo[2.2.1]hept-5-en-2-yl]-1-phenyl-3-(piperidin-1-yl)propan-1-ol (*endo* form),

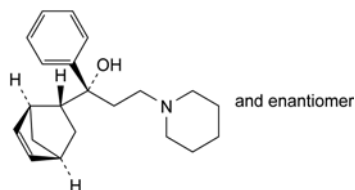

- B. (1*RS*)-1-[(1*SR*,2*RS*,4*SR*)-bicyclo[2.2.1]hept-5-en-2-yl]-1-phenyl-3-(piperidin-1-yl)propan-1-ol,

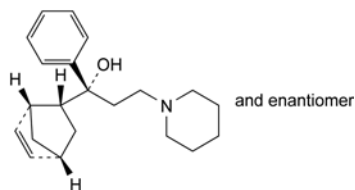

- C. (1*RS*)-1-[(1*RS*,2*RS*,4*RS*)-bicyclo[2.2.1]hept-5-en-2-yl]-1-phenyl-3-(piperidin-1-yl)propan-1-ol,

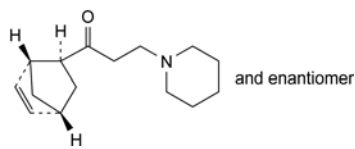

- D. 1-[(1*RS*,2*SR*,4*RS*)-bicyclo[2.2.1]hept-5-en-2-yl]-3-(piperidin-1-yl)propan-1-one,

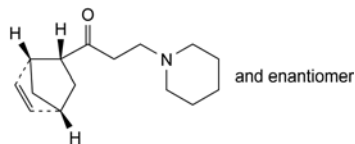

- E. 1-[(1*RS*,2*RS*,4*RS*)-bicyclo[2.2.1]hept-5-en-2-yl]-3-(piperidin-1-yl)propan-1-one,

- F. benzene.

01/2008:0595  
corrected 6.0

## BISACODYL

### Bisacodylum

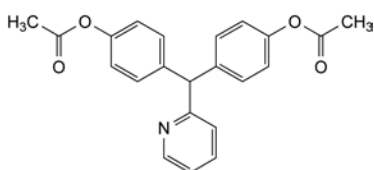

$C_{22}H_{19}NO_4$   
[603-50-9]

$M_r$  361.4

#### DEFINITION

4,4'-(Pyridin-2-ylmethylene)diphenyl diacetate.

*Content*: 98.0 per cent to 101.0 per cent (dried substance).

#### CHARACTERS

*Appearance*: white or almost white, crystalline powder.

*Solubility*: practically insoluble in water, soluble in acetone, sparingly soluble in ethanol (96 per cent). It dissolves in dilute mineral acids.

#### IDENTIFICATION

*First identification*: C.

*Second identification*: A, B, D.

A. Melting point (2.2.14): 131 °C to 135 °C.

B. Ultraviolet and visible absorption spectrophotometry (2.2.25).

*Test solution*. Dissolve 10.0 mg in a 6 g/L solution of potassium hydroxide R in methanol R and dilute to 100.0 mL with the same solution. Dilute 10.0 mL of this solution to 100.0 mL with a 6 g/L solution of potassium hydroxide R in methanol R.

*Spectral range*: 220-350 nm.

*Absorption maximum*: at 248 nm.

*Shoulder*: at 290 nm.

*Specific absorbance at the absorption maximum*: 632 to 672.

C. Infrared absorption spectrophotometry (2.2.24).

*Comparison*: bisacodyl CRS.

If the spectra obtained in the solid state show differences, dissolve the substance to be examined and the reference substance separately in chloroform R, evaporate to dryness and record new spectra using the residues.

D. Thin-layer chromatography (2.2.27).

*Test solution*. Dissolve 20 mg of the substance to be examined in acetone R and dilute to 10 mL with the same solvent.

*Reference solution*. Dissolve 20 mg of bisacodyl CRS in acetone R and dilute to 10 mL with the same solvent.

*Plate*: TLC silica gel GF<sub>254</sub> plate R.

*Mobile phase*: methyl ethyl ketone R, xylene R (50:50 V/V).

*Application*: 10 µL.

*Development*: over a path of 10 cm.

*Drying*: in air, if necessary heating at 100-105 °C.

*Detection*: spray with a mixture of equal volumes of 0.05 M iodine and dilute sulfuric acid R.

*Results*: the principal spot in the chromatogram obtained with the test solution is similar in position and size to the principal spot in the chromatogram obtained with the reference solution.

#### TESTS

**Acidity or alkalinity**. To 1.0 g add 20 mL of carbon dioxide-free water R, shake, heat to boiling, cool and filter. Add 0.2 mL of 0.01 M sodium hydroxide and 0.1 mL of methyl red solution R. The solution is yellow. Not more than 0.4 mL of 0.01 M hydrochloric acid is required to change the colour of the indicator to red.

**Related substances**. Liquid chromatography (2.2.29). Prepare the solutions immediately before use.

*Solvent mixture*: glacial acetic acid R, acetonitrile R, water R (4:30:66 V/V/V).

*Test solution*. Dissolve 50 mg of the substance to be examined in 25 mL of acetonitrile R and dilute to 50.0 mL with the solvent mixture.

*Reference solution (a)*. Dilute 1.0 mL of the test solution to 100.0 mL with the solvent mixture. Dilute 1.0 mL of this solution to 10.0 mL with the solvent mixture.

*Reference solution (b)*. Dissolve 2.0 mg of bisacodyl for system suitability CRS (containing impurities A, B, C, D and E) in 1.0 mL of acetonitrile R and dilute to 2.0 mL with the solvent mixture.

*Reference solution (c).* Dissolve 5.0 mg of *bisacodyl* for peak identification CRS (containing impurity F) in 2.5 mL of *acetonitrile R* and dilute to 5.0 mL with the solvent mixture.

*Column:*

- size:  $l = 0.25$  m,  $\varnothing = 4.6$  mm;
- stationary phase: end-capped octadecylsilyl silica gel for chromatography R (5  $\mu$ m).

*Mobile phase:* mix 45 volumes of *acetonitrile R* and 55 volumes of a 1.58 g/L solution of *ammonium formate R* previously adjusted to pH 5.0 with *anhydrous formic acid R*.

*Flow rate:* 1.5 mL/min.

*Detection:* spectrophotometer at 265 nm.

*Injection:* 20  $\mu$ L.

*Run time:* 3.5 times the retention time of *bisacodyl*.

*Identification of impurities:* use the chromatogram supplied with *bisacodyl* for system suitability CRS and the chromatogram obtained with reference solution (b) to identify the peaks due to impurities A, B, C, D and E.

*Relative retention* with reference to *bisacodyl* (retention time = about 13 min): impurity A = about 0.2; impurity B = about 0.4; impurity C = about 0.45; impurity D = about 0.8; impurity E = about 0.9; impurity F = about 2.6.

*System suitability:* reference solution (b):

- peak-to-valley ratio: minimum 1.5, where  $H_p$  = height above the baseline of the peak due to impurity E and  $H_v$  = height above the baseline of the lowest point of the curve separating this peak from the peak due to *bisacodyl*.

*Limits:*

- correction factor: for the calculation of content, multiply the peak area of impurity A by 0.7;
- impurities A, B: for each impurity, not more than the area of the principal peak in the chromatogram obtained with reference solution (a) (0.1 per cent);
- impurities C, E: for each impurity, not more than 5 times the area of the principal peak in the chromatogram obtained with reference solution (a) (0.5 per cent);
- impurity D: not more than twice the area of the principal peak in the chromatogram obtained with reference solution (a) (0.2 per cent);
- impurity F: not more than 3 times the area of the principal peak in the chromatogram obtained with reference solution (a) (0.3 per cent);
- unspecified impurities: for each impurity, not more than the area of the principal peak in the chromatogram obtained with reference solution (a) (0.10 per cent);
- total: not more than 10 times the area of the principal peak in the chromatogram obtained with reference solution (a) (1.0 per cent);
- disregard limit: 0.5 times the area of the principal peak in the chromatogram obtained with reference solution (a) (0.05 per cent).

**Loss on drying** (2.2.32): maximum 0.5 per cent, determined on 0.500 g by drying in an oven at 105 °C.

**Sulfated ash** (2.4.14): maximum 0.1 per cent, determined on 1.0 g.

**ASSAY**

Dissolve 0.300 g in 60 mL of *anhydrous acetic acid R*. Titrate with 0.1 M *perchloric acid* determining the end-point potentiometrically (2.2.20).

1 mL of 0.1 M *perchloric acid* is equivalent to 36.14 mg of  $C_{22}H_{19}NO_4$ .

**STORAGE**

Protected from light.

**IMPURITIES**

*Specified impurities:* A, B, C, D, E, F.

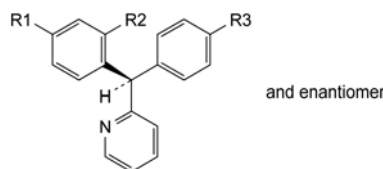

- R1 = R3 = OH, R2 = H: 4,4'-(pyridin-2-ylmethylene)diphenol,
- R1 = H, R2 = R3 = OH: 2-[(*RS*)-(4-hydroxyphenyl)(pyridin-2-yl)methyl]phenol,
- R1 = OH, R2 = H, R3 = O-CO-CH<sub>3</sub>: 4-[(*RS*)-(4-hydroxyphenyl)(pyridin-2-yl)methyl]phenyl acetate,
- R1 = H, R2 = R3 = O-CO-CH<sub>3</sub>: 2-[(*RS*)-[4-(acetyloxy)phenyl](pyridin-2-yl)methyl]phenyl acetate,
- unknown structure,
- unknown structure.

01/2008:0012  
corrected 7.0

## BISMUTH SUBCARBONATE

### Bismuthi subcarbonas

**DEFINITION**

*Content:* 80.0 per cent to 82.5 per cent of Bi (A, 209.0) (dried substance).

**CHARACTERS**

*Appearance:* white or almost white powder.

*Solubility:* practically insoluble in water and in ethanol (96 per cent). It dissolves with effervescence in mineral acids.

**IDENTIFICATION**

- It gives the reaction of carbonates (2.3.1).
- It gives the reactions of bismuth (2.3.1).

**TESTS**

**Solution S.** Shake 5.0 g with 10 mL of *water R* and add 20 mL of *nitric acid R*. Heat to dissolve, cool and dilute to 100 mL with *water R*.

**Appearance of solution.** Solution S is not more opalescent than reference suspension II (2.2.1) and is colourless (2.2.2, *Method II*).

**Chlorides** (2.4.4): maximum 500 ppm.

To 6.6 mL of solution S add 4 mL of *nitric acid R* and dilute to 50 mL with *water R*.

**Nitrates:** maximum 0.4 per cent.

To 0.25 g in a 125 mL conical flask, add 20 mL of *water R*, 0.05 mL of *indigo carmine solution R1* and then, as a single addition but with caution, 30 mL of *sulfuric acid R*. Titrate immediately with *indigo carmine solution R1* until a stable blue colour is obtained. Not more than  $n$  mL of the titrant is required,  $n$  being the volume corresponding to 1 mg of  $NO_3^-$ .

**Alkali and alkaline-earth metals:** maximum 1.0 per cent.

To 1.0 g add 10 mL of *water R* and 10 mL of *acetic acid R*. Boil for 2 min, cool and filter. Wash the residue with 20 mL of *water R*. To the combined filtrate and washings add 2 mL of *dilute hydrochloric acid R* and 20 mL of *water R*. Boil and pass *hydrogen sulfide R* through the boiling solution until no further precipitate is formed. Filter, wash the residue with *water R*, evaporate the combined filtrate and washings to dryness on a water-bath and add 0.5 mL of *sulfuric acid R*. Ignite gently and allow to cool. The residue weighs a maximum of 10 mg.

**Arsenic** (2.4.2, *Method A*): maximum 5 ppm.

To 0.5 g in a distillation flask add 5 mL of *water R* and 7 mL of *sulfuric acid R*, allow to cool and add 5 g of *reducing mixture R* and 10 mL of *hydrochloric acid R*. Heat the contents

of the flask to boiling gradually over 15-30 min and continue heating at such a rate that the distillation proceeds steadily until the volume in the flask is reduced by half or until 5 min after the air-condenser has become full of steam. It is important that distillation be discontinued before fumes of sulfur trioxide appear. Collect the distillate in a tube containing 15 mL of *water R* cooled in ice-water. Wash down the condenser with *water R* and dilute the distillate to 25 mL with the same solvent. Prepare the standard using a mixture of 2.5 mL of *arsenic standard solution (1 ppm As) R* and 22.5 mL of *water R*.

**Copper:** maximum 50 ppm.

To 5 mL of solution S, add 2 mL of *ammonia R* and dilute to 50 mL with *water R*. Filter. To 10 mL of the filtrate add 1 mL of a 1 g/L solution of *sodium diethyldithiocarbamate R*. The solution is not more intensely coloured than a standard prepared at the same time in the same manner using a mixture of 0.25 mL of *copper standard solution (10 ppm Cu) R* and 9.75 mL of *water R* instead of 10 mL of the filtrate.

**Lead:** maximum 20 ppm.

Atomic absorption spectrometry (2.2.23, Method II).

*Test solution.* Dissolve 12.5 g in 75 mL of a mixture of equal volumes of *lead-free nitric acid R* and *water R*. Boil for 1 min, cool and dilute to 100.0 mL with *water R*.

*Reference solutions.* Prepare the reference solutions using appropriate quantities of lead standard solution and a 37 per cent V/V solution of *lead-free nitric acid R*.

*Source:* lead hollow-cathode lamp.

*Wavelength:* 283.3 nm (depending on the apparatus, the line at 217.0 nm may be used).

*Atomisation device:* air-acetylene flame.

**Silver:** maximum 25 ppm.

To 2.0 g add 1 mL of *water R* and 4 mL of *nitric acid R*. Heat gently until dissolved and dilute to 11 mL with *water R*. Cool and add 2 mL of 1 M *hydrochloric acid*. Allow to stand protected from light for 5 min. Any opalescence in the solution is not more intense than that in a standard prepared at the same time in the same manner using a mixture of 10 mL of *silver standard solution (5 ppm Ag) R*, 1 mL of *nitric acid R* and 2 mL of 1 M *hydrochloric acid*.

**Loss on drying (2.2.32):** maximum 1.0 per cent, determined on 1.000 g by drying in an oven at 105 °C.

#### ASSAY

Dissolve 0.500 g in 3 mL of *nitric acid R* and dilute to 250 mL with *water R*. Carry out the complexometric titration of bismuth (2.5.11).

1 mL of 0.1 M *sodium edetate* is equivalent to 20.90 mg of Bi.

#### STORAGE

Protected from light.

01/2008:1493  
corrected 7.0

## BISMUTH SUBGALLATE

### Bismuthi subgallas

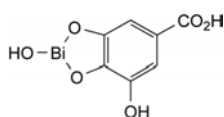

C<sub>7</sub>H<sub>5</sub>BiO<sub>6</sub>  
[99-26-3]

M<sub>r</sub> 394.1

#### DEFINITION

Complex of bismuth and gallic acid.

*Content:* 48.0 per cent to 51.0 per cent of Bi (A<sub>r</sub> 209.0) (dried substance).

#### CHARACTERS

*Appearance:* yellow powder.

*Solubility:* practically insoluble in water and in ethanol (96 per cent). It dissolves in mineral acids with decomposition and in solutions of alkali hydroxides, producing a reddish-brown liquid.

#### IDENTIFICATION

A. Mix 0.1 g with 5 mL of *water R* and 0.1 mL of *phosphoric acid R*. Heat to boiling and maintain boiling for 2 min. Cool and filter. To the filtrate, add 1.5 mL of *ferric chloride solution RI*; a blackish-blue colour develops.

B. It gives reaction (b) of bismuth (2.3.1).

#### TESTS

**Solution S.** In a porcelain or quartz dish, ignite 1.0 g, increasing the temperature very gradually. Heat in a muffle furnace at 600 ± 50 °C for 2 h. Cool and dissolve the residue with warming in 4 mL of a mixture of equal volumes of *lead-free nitric acid R* and *water R* and dilute to 20 mL with *water R*.

**Acidity.** Shake 1.0 g with 20 mL of *water R* for 1 min and filter. To the filtrate add 0.1 mL of *methyl red solution R*. Not more than 0.15 mL of 0.1 M *sodium hydroxide* is required to change the colour of the indicator to yellow.

**Chlorides (2.4.4):** maximum 200 ppm.

To 0.5 g add 10 mL of *dilute nitric acid R*. Heat on a water-bath for 5 min and filter. Dilute 5 mL of the filtrate to 15 mL with *water R*.

**Nitrates:** maximum 0.2 per cent.

To 1.0 g add 25 mL of *water R* then 25 mL of a mixture of 2 volumes of *sulfuric acid R* and 9 volumes of *water R*. Heat at about 50 °C for 1 min with stirring and filter. To 10 mL of the filtrate, carefully add 30 mL of *sulfuric acid R*. The solution is not more intensely brownish-yellow than a reference solution prepared at the same time as follows: to 0.4 g of *gallic acid R*, add 20 mL of *nitrate standard solution (100 ppm NO<sub>3</sub>) R* and 30 mL of a mixture of 2 volumes of *sulfuric acid R* and 9 volumes of *water R*, then filter; to 10 mL of the filtrate, carefully add 30 mL of *sulfuric acid R*.

**Copper:** maximum 50 ppm.

Atomic absorption spectrometry (2.2.23, Method I).

*Test solution.* Solution S.

*Reference solutions.* Prepare the reference solutions using *copper standard solution (10 ppm Cu) R* and diluting with a 6.5 per cent V/V solution of *lead-free nitric acid R*.

*Source:* copper hollow-cathode lamp.

*Wavelength:* 324.7 nm.

*Atomisation device:* air-acetylene flame.

**Lead:** maximum 20 ppm.

Atomic absorption spectrometry (2.2.23, Method II).

*Test solution.* Solution S.

*Reference solutions.* Prepare the reference solutions using *lead standard solution (10 ppm Pb) R* and diluting with a 6.5 per cent V/V solution of *lead-free nitric acid R*.

*Source:* lead hollow-cathode lamp.

*Wavelength:* 283.3 nm (depending on the apparatus, the line at 217.0 nm may be used).

*Atomisation device:* air-acetylene flame.

**Silver:** maximum 25 ppm.

Atomic absorption spectrometry (2.2.23, Method I).

*Test solution.* Solution S.

*Reference solutions.* Prepare the reference solutions using *silver standard solution (5 ppm Ag) R* and diluting with a 6.5 per cent V/V solution of *lead-free nitric acid R*.

*Source:* silver hollow-cathode lamp.

*Wavelength:* 328.1 nm.

*Atomisation device:* air-acetylene flame.

**Substances not precipitated by ammonia:** maximum 1.0 per cent.

In a porcelain or quartz dish, ignite 2.0 g, increasing the temperature very gradually to  $600 \pm 50$  °C; allow to cool. Moisten the residue with 2 mL of *nitric acid R*, evaporate to dryness on a water-bath and carefully heat and ignite once more at  $600 \pm 50$  °C. After cooling, dissolve the residue in 5 mL of *nitric acid R* and dilute to 20 mL with *water R*. To 10 mL of this solution, add *concentrated ammonia R* until alkaline and filter. Wash the residue with *water R* and evaporate the combined filtrate and washings to dryness on a water-bath. Add 0.3 mL of *dilute sulfuric acid R* and ignite. The residue weighs a maximum of 10 mg.

**Loss on drying (2.2.32):** maximum 7.0 per cent, determined on 1.000 g by drying in an oven at 105 °C for 3 h.

#### ASSAY

To 0.300 g add 10 mL of a mixture of equal volumes of *nitric acid R* and *water R*, heat to boiling and maintain boiling for 2 min. Add 0.1 g of *potassium chlorate R*, heat to boiling and maintain boiling for 1 min. Add 10 mL of *water R* and heat until the solution becomes colourless. To the hot solution, add 200 mL of *water R* and 50 mg of *xylene orange triturate R*. Titrate with 0.1 M *sodium edetate* until a yellow colour is obtained.

1 mL of 0.1 M *sodium edetate* is equivalent to 20.90 mg of Bi.

#### STORAGE

Protected from light.

01/2008:1494  
corrected 7.0

## BISMUTH SUBNITRATE, HEAVY

### Bismuthi subnitratis ponderosus

$4[\text{BiNO}_3(\text{OH})_2] \cdot \text{BiO}(\text{OH})$   $M_r$  1462  
[1304-85-4]

#### DEFINITION

**Content:** 71.0 per cent to 74.0 per cent of Bi ( $A_r$  209.0) (dried substance).

#### CHARACTERS

**Appearance:** white or almost white powder.

**Solubility:** practically insoluble in water and in ethanol (96 per cent). It dissolves in mineral acids with decomposition.

#### IDENTIFICATION

- Dilute 1 mL of solution S1 (see Tests) to 5 mL with *water R* and add 0.3 mL of *potassium iodide solution R*. A black precipitate is formed which dissolves into an orange solution with the addition of 2 mL of *potassium iodide solution R*.
- It gives reaction (b) of bismuth (2.3.1).
- It gives the reaction of nitrates (2.3.1).
- pH (2.2.3): maximum 2.0 for solution S2 (see Tests).

#### TESTS

**Solution S1.** Shake 5.0 g by gently heating in 10 mL of *water R* and add 20 mL of *nitric acid R*. Heat until dissolution, cool and dilute to 100 mL with *water R*.

**Solution S2.** Place 1.00 g in a 20 mL volumetric flask and add 2.0 mL of *lead-free nitric acid R*. Allow acid attack to take place without heating and if necessary warm slightly at the end to completely dissolve the test sample. Add 10 mL of *water R*, shake and add, in small fractions, 4.5 mL of *lead-free ammonia R*; shake and allow to cool. Dilute to 20.0 mL with *water R*, shake again and allow the solids to settle. The clear supernatant solution is solution S2.

**Acidity.** Suspend 1.0 g in 15 mL of *water R* and shake several times. Allow to stand for 5 min and filter. To 10 mL of the filtrate, add 0.5 mL of *phenolphthalein solution R1*. Not more than 0.5 mL of 0.1 M *sodium hydroxide* is required to change the colour of the indicator to pink.

**Chlorides (2.4.4):** maximum 200 ppm.

To 5.0 mL of solution S1, add 3 mL of *nitric acid R* and dilute to 15 mL with *water R*.

**Copper:** maximum 50 ppm.

Atomic absorption spectrometry (2.2.23, *Method I*).

**Test solution.** Solution S2.

**Reference solutions.** Prepare the reference solutions using *copper standard solution (10 ppm Cu) R* and diluting with a 37 per cent V/V solution of *lead-free nitric acid R*.

**Source:** copper hollow-cathode lamp.

**Wavelength:** 324.7 nm.

**Atomisation device:** air-acetylene flame.

**Lead:** maximum 20 ppm.

Atomic absorption spectrometry (2.2.23, *Method II*).

**Test solution.** Solution S2.

**Reference solutions.** Prepare the reference solutions using *lead standard solution (10 ppm Pb) R* and diluting with a 37 per cent V/V solution of *lead-free nitric acid R*.

**Source:** lead hollow-cathode lamp.

**Wavelength:** 283.3 nm (depending on the apparatus, the line at 217.0 nm may be used).

**Atomisation device:** air-acetylene flame.

**Silver:** maximum 25 ppm.

Atomic absorption spectrometry (2.2.23, *Method I*).

**Test solution.** Solution S2.

**Reference solutions.** Prepare the reference solutions using *silver standard solution (5 ppm Ag) R* and diluting with a 37 per cent V/V solution of *lead-free nitric acid R*.

**Source:** silver hollow-cathode lamp.

**Wavelength:** 328.1 nm.

**Atomisation device:** air-acetylene flame.

**Substances not precipitated by ammonia:** maximum 1.0 per cent.

To 20 mL of solution S1, add *concentrated ammonia R* until an alkaline reaction is produced and filter. Wash the residue with *water R*, and evaporate the combined filtrate and washings to dryness on a water-bath. To the residue, add 0.3 mL of *dilute sulfuric acid R* and ignite. The residue weighs a maximum of 10 mg.

**Loss on drying (2.2.32):** maximum 3.0 per cent, determined on 1.000 g by drying in an oven at 105 °C.

#### ASSAY

Dissolve with heating 0.250 g in 10 mL of a mixture of 2 volumes of *perchloric acid R* and 5 volumes of *water R*. To the hot solution, add 200 mL of *water R* and 50 mg of *xylene orange triturate R*. Titrate with 0.1 M *sodium edetate* until a yellow colour is obtained.

1 mL of 0.1 M *sodium edetate* is equivalent to 20.90 mg of Bi.

01/2008:1495  
corrected 7.0

## BISMUTH SUBSALICYLATE

### Bismuthi subsalicylas

$\text{C}_7\text{H}_5\text{BiO}_4$   $M_r$  362.1  
[14882-18-9]

#### DEFINITION

Complex of bismuth and salicylic acid.



**Content:** 56.0 per cent to 59.4 per cent of Bi (A, 209.0) (dried substance).

#### CHARACTERS

**Appearance:** white or almost white powder.

**Solubility:** practically insoluble in water and in alcohol. It dissolves in mineral acids with decomposition.

#### IDENTIFICATION

- A. To 0.5 g add 10 mL of *hydrochloric acid R1*. Heat on a boiling water-bath for 5 min. Cool and filter. Retain the filtrate for identification test B. Wash the residue with *dilute hydrochloric acid R* and then with *water R*. Dissolve the residue in 0.5-1 mL of *dilute sodium hydroxide solution R*. Add 15 mL of *water R*. Neutralise with *dilute hydrochloric acid R*. The solution gives reaction (a) of salicylates (2.3.1).
- B. The filtrate obtained in identification test A gives reaction (b) of bismuth (2.3.1).

#### TESTS

**Solution S.** In a porcelain or quartz dish, ignite 1.0 g, increasing the temperature very gradually. Heat in a muffle furnace at  $600 \pm 25$  °C for 2 h. Cool and dissolve the residue with warming in 4 mL of a mixture of equal volumes of *lead-free nitric acid R* and *water R* and dilute to 20 mL with *water R*.

**Acidity.** Shake 2.0 g with 30 mL of *ether R* for 1 min and filter. To the filtrate add 30 mL of *alcohol R* and 0.1 mL of *thymol blue solution R*. Not more than 0.35 mL of 0.1 M *sodium hydroxide* is required to change the colour of the indicator to blue.

**Chlorides (2.4.4):** maximum 200 ppm.

Dissolve 0.250 g in a mixture of 2 mL of *nitric acid R*, 5 mL of *water R* and 8 mL of *methanol R*.

**Nitrates:** maximum 0.4 per cent.

To 0.1 g add 10 mL of *water R* and, with caution, 20 mL of *sulfuric acid R* and stir. The solution is not more intensely yellow coloured than a reference solution prepared at the same time using 0.1 g of *salicylic acid R*, 6 mL of *water R*, 4 mL of *nitrate standard solution (100 ppm NO<sub>3</sub>) R* and 20 mL of *sulfuric acid R*.

**Copper:** maximum 50 ppm.

Atomic absorption spectrometry (2.2.23, *Method I*).

**Test solution.** Solution S.

**Reference solutions.** Prepare the reference solutions using *copper standard solution (10 ppm Cu) R* and diluting with a 6.5 per cent V/V solution of *lead-free nitric acid R*.

**Source:** copper hollow-cathode lamp.

**Wavelength:** 324.7 nm.

**Atomisation device:** air-acetylene flame.

**Lead:** maximum 20 ppm.

Atomic absorption spectrometry (2.2.23, *Method II*).

**Test solution.** Solution S.

**Reference solutions.** Prepare the reference solutions using *lead standard solution (10 ppm Pb) R* and diluting with a 6.5 per cent V/V solution of *lead-free nitric acid R*.

**Source:** lead hollow-cathode lamp.

**Wavelength:** 283.3 nm (depending on the apparatus, the line at 217.0 nm may be used).

**Atomisation device:** air-acetylene flame.

**Silver:** maximum 25 ppm.

Atomic absorption spectrometry (2.2.23, *Method I*).

**Test solution.** Solution S.

**Reference solutions.** Prepare the reference solutions using *silver standard solution (5 ppm Ag) R* and diluting with a 6.5 per cent V/V solution of *lead-free nitric acid R*.

**Source:** silver hollow-cathode lamp.

**Wavelength:** 328.1 nm.

**Atomisation device:** air-acetylene flame.

**Soluble bismuth:** maximum 40 ppm.

Atomic absorption spectrometry (2.2.23, *Method I*).

**Test solution.** Suspend 5.0 g in 100 mL of *water R*. Stir constantly for 2 h at 20-23 °C. Filter through filter paper (slow filtration) then through a cellulose micropore membrane filter (0.1 µm). To 10.0 mL of clear filtrate, add 0.1 mL of *nitric acid R*.

**Reference solutions.** Prepare the reference solutions using *bismuth standard solution (100 ppm Bi) R* and diluting with a mixture of equal volumes of *dilute nitric acid R* and *water R*.

**Source:** bismuth hollow-cathode lamp.

**Wavelength:** 223.06 nm.

**Atomisation device:** air-acetylene flame.

**Loss on drying (2.2.32):** maximum 1.0 per cent, determined on 1.000 g by drying in an oven at 105 °C.

#### ASSAY

Dissolve with heating 0.300 g in 10 mL of a mixture of 2 volumes of *perchloric acid R* and 5 volumes of *water R*. To the hot solution, add 200 mL of *water R* and 50 mg of *xylene orange triturate R*. Titrate with 0.1 M *sodium edetate* until a yellow colour is obtained.

1 mL of 0.1 M *sodium edetate* is equivalent to 20.90 mg of Bi.

#### STORAGE

Protected from light.

04/2008:1710  
corrected 6.4

## BISOPROLOL FUMARATE

### Bisoprololi fumaras

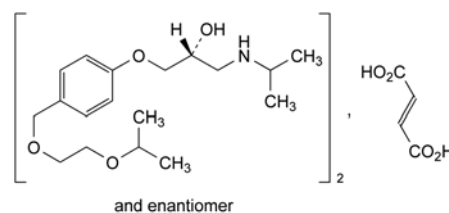

C<sub>40</sub>H<sub>66</sub>N<sub>2</sub>O<sub>12</sub>  
[104344-23-2]

M<sub>r</sub> 767

#### DEFINITION

(RS)-1-[4-[[2-(1-Methylethoxy)ethoxy]methyl]phenoxy]-3-[(1-methylethyl)amino]propan-2-ol fumarate.

**Content:** 99.0 per cent to 101.0 per cent (anhydrous substance).

#### CHARACTERS

**Appearance:** white or almost white, slightly hygroscopic powder.

**Solubility:** very soluble in water, freely soluble in methanol.

It shows polymorphism (5.9).

#### IDENTIFICATION

Infrared absorption spectrophotometry (2.2.24).

**Comparison:** *bisoprolol fumarate CRS*.

If the spectra obtained in the solid state show differences, dissolve the substance to be examined and the reference substance separately in *methanol R*, evaporate and dry the residue at 60 °C at a pressure not exceeding 0.7 kPa and record new spectra using the residues.

#### TESTS

##### Related substances

A. Impurities A and E. Liquid chromatography (2.2.29).

**Test solution.** Dissolve 25 mg of the substance to be examined in mobile phase A and dilute to 25.0 mL with mobile phase A.

*Reference solution (a).* Dilute 1.0 mL of the test solution to 100.0 mL with mobile phase A. Dilute 1.0 mL of this solution to 10.0 mL with mobile phase A.

*Reference solution (b).* Dissolve the contents of a vial of *bisoprolol for system suitability method A CRS* (containing impurities A, B and E) in 1.0 mL of mobile phase A.

*Column:*

- size:  $l = 0.25$  m,  $\varnothing = 4.6$  mm;
- stationary phase: octadecylsilyl silica gel for chromatography R (5  $\mu$ m);
- temperature: 30 °C.

*Mobile phase:*

- mobile phase A: mix 10 volumes of acetonitrile R1 and 90 volumes of a solution containing 0.4 mL/L of triethylamine R1 and 3.12 g/L of sodium dihydrogen phosphate R, previously adjusted to pH 4.2 with dilute phosphoric acid R;
- mobile phase B: mix 25 volumes of a solution containing 0.4 mL/L of triethylamine R1 and 3.12 g/L of sodium dihydrogen phosphate R, previously adjusted to pH 4.2 with dilute phosphoric acid R and 75 volumes of acetonitrile R1;

Time (min)	Mobile phase A (per cent V/V)	Mobile phase B (per cent V/V)
0 - 40	95 → 10	5 → 90
40 - 45	10	90
45 - 50	10 → 95	90 → 5
50 - 60	95	5

*Flow rate:* 1.0 mL/min.

*Detection:* spectrophotometer at 225 nm.

*Injection:* 10  $\mu$ L.

*Identification of impurities:* use the chromatogram supplied with *bisoprolol for system suitability method A CRS* and the chromatogram obtained with reference solution (b) to identify the peaks due to fumaric acid and impurities A, B and E.

*Relative retention* with reference to bisoprolol (retention time = about 14.5 min): impurity A = about 0.25; impurity G = about 1.05; impurity B = about 1.1; impurity E = about 1.3.

*System suitability:* reference solution (b):

- resolution: minimum 5.0 between the peaks due to bisoprolol and impurity B.

*Limits:*

- impurity A: not more than 3 times the area of the principal peak in the chromatogram obtained with reference solution (a) (0.3 per cent);
- impurity E: not more than twice the area of the principal peak in the chromatogram obtained with reference solution (a) (0.2 per cent);
- unspecified impurities: for each impurity, not more than the area of the principal peak in the chromatogram obtained with reference solution (a) (0.10 per cent);
- total: not more than 3 times the area of the principal peak in the chromatogram obtained with reference solution (a) (0.3 per cent);
- disregard limit: 0.5 times the area of the principal peak in the chromatogram obtained with reference solution (a) (0.05 per cent); disregard the peak due to fumaric acid and any peak due to impurity G.

#### B. Impurities A and G. Liquid chromatography (2.2.29).

*Solvent mixture:* acetonitrile R1, water for chromatography R (20:80 V/V).

*Test solution.* Dissolve 25 mg of the substance to be examined in the solvent mixture and dilute to 25.0 mL with the solvent mixture.

*Reference solution (a).* Dilute 1.0 mL of the test solution to 100.0 mL with the solvent mixture. Dilute 2.0 mL of this solution to 10.0 mL with the solvent mixture.

*Reference solution (b).* Dissolve the contents of a vial of *bisoprolol for system suitability method B CRS* (containing impurities A and G) in 1.0 mL of the solvent mixture.

*Column:*

- size:  $l = 0.25$  m,  $\varnothing = 4.6$  mm;
- stationary phase: octadecylsilyl silica gel for chromatography R (5  $\mu$ m);
- temperature: 30 °C.

*Mobile phase:*

- mobile phase A: 10 g/L solution of phosphoric acid R;
- mobile phase B: 10 g/L solution of phosphoric acid R in acetonitrile R1;

Time (min)	Mobile phase A (per cent V/V)	Mobile phase B (per cent V/V)
0 - 35	90 → 20	10 → 80
35 - 40	20 → 90	80 → 10
40 - 50	90	10

*Flow rate:* 1.0 mL/min.

*Detection:* spectrophotometer at 225 nm.

*Injection:* 10  $\mu$ L.

*Identification of impurities:* use the chromatogram supplied with *bisoprolol for system suitability method B CRS* and the chromatogram obtained with reference solution (b) to identify the peaks due to fumaric acid and impurities A and G.

*Relative retention* with reference to bisoprolol (retention time = about 13.4 min): impurity A = about 0.4; impurity G = about 1.02; impurity E = about 1.2.

*System suitability:* reference solution (b):

- peak-to-valley ratio: minimum 2.5, where  $H_p$  = height above the baseline of the peak due to impurity G, and  $H_v$  = height above the baseline of the lowest point of the curve separating this peak from the peak due to bisoprolol.

*Limits:*

- impurity G: not more than 2.5 times the area of the principal peak in the chromatogram obtained with reference solution (a) (0.5 per cent);
- impurity A: not more than 1.5 times the area of the principal peak in the chromatogram obtained with reference solution (a) (0.3 per cent);
- unspecified impurities: for each impurity, not more than 0.5 times the area of the principal peak in the chromatogram obtained with reference solution (a) (0.10 per cent);
- total: not more than 2.5 times the area of the principal peak in the chromatogram obtained with reference solution (a) (0.5 per cent);
- disregard limit: 0.25 times the area of the principal peak in the chromatogram obtained with reference solution (a) (0.05 per cent); disregard the peak due to fumaric acid and any peak due to impurity E.

**Water (2.5.12):** maximum 0.5 per cent, determined on 1.000 g.

**Sulfated ash (2.4.14):** maximum 0.1 per cent, determined on 1.0 g.

**ASSAY**

Dissolve 0.300 g in 50 mL of *anhydrous acetic acid R*. Titrate with 0.1 M *perchloric acid*, determining the end-point potentiometrically (2.2.20).

1 mL of 0.1 M perchloric acid is equivalent to 38.35 mg of  $C_{40}H_{66}N_2O_{12}$ .

### STORAGE

In an airtight container, protected from light.

### IMPURITIES

Specified impurities: A, E, G.

Other detectable impurities (the following substances would, if present at a sufficient level, be detected by one or other of the tests in the monograph. They are limited by the general acceptance criterion for other/unspecified impurities and/or by the general monograph *Substances for pharmaceutical use (2034)*. It is therefore not necessary to identify these impurities for demonstration of compliance. See also 5.10. *Control of impurities in substances for pharmaceutical use*):

– by method A: B, C, D, F;

– by method B: B, K, L, N, Q, R, S, T, U.

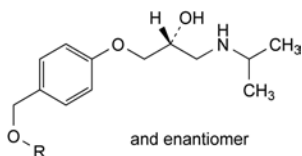

A. R = H: (RS)-1-(4-hydroxymethyl-phenoxy)-3-isopropylaminopropan-2-ol,

B. R =  $CH_2-CH_2-O-[CH_2]_2-CH_3$ : (RS)-1-isopropylamino-3-[4-(2-propoxy-ethoxymethyl)phenoxy]propan-2-ol,

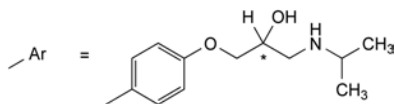

C. Ar- $CH_2$ -Ar: (RS)-1-[4-[4-(2-hydroxy-3-isopropylamino-propoxy)benzyl]phenoxy]-3-isopropylaminopropan-2-ol,

D. Ar- $CH_2$ -O- $CH_2$ -Ar: (RS)-1-[4-[4-(2-hydroxy-3-isopropylaminopropoxy)benzyloxymethyl]phenoxy]-3-isopropylaminopropan-2-ol,

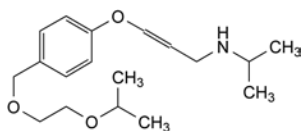

E. (EZ)-[3-[4-(2-isopropoxy-ethoxymethyl)phenoxy]allyl]-isopropylamine,

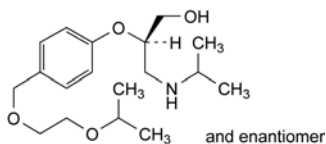

F. (RS)-2-[4-(2-isopropoxy-ethoxymethyl)phenoxy]-3-isopropylaminopropan-2-ol,

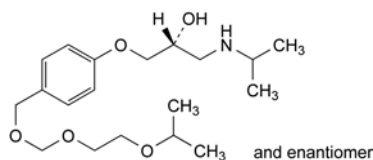

G. (2RS)-1-[4-[(2-isopropoxyethoxy)methoxy]methyl]phenoxy]-3-isopropylaminopropan-2-ol,

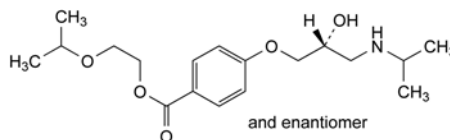

K. 2-isopropoxyethyl 4-[(2RS)-2-hydroxy-3-(isopropylamino)propyl]oxy]benzoate,

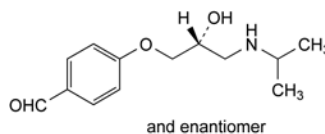

L. 4-[(2RS)-2-hydroxy-3-(isopropylamino)propyl]oxy]benzaldehyde,

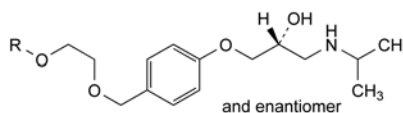

N. R =  $C_2H_5$ : [(2RS)-1-[4-[(2-ethoxyethoxy)methyl]phenoxy]-3-isopropylaminopropan-2-ol,

Q. R =  $CH_3$ : (2RS)-1-(isopropylamino)-3-[4-(2-methoxyethoxy)methyl]phenoxypropan-2-ol,

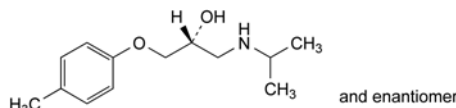

R. (2RS)-1-(isopropylamino)-3-(4-methylphenoxy)propan-2-ol,

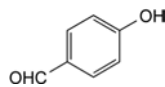

S. 4-hydroxybenzaldehyde,

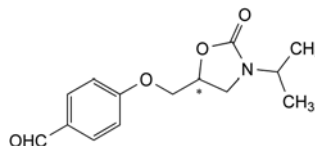

T. 4-[(3-isopropyl-2-oxo-1,3-oxazolidin-5-yl)methoxy]benzaldehyde,

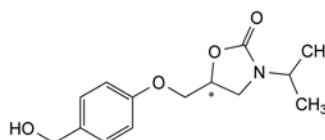

U. 5-[4-(hydroxymethyl)phenoxy]methyl]-3-isopropyl-1,3-oxazolidin-2-one.

01/2008:0976  
corrected 7.0

## BLEOMYCIN SULFATE

## Bleomycini sulfas

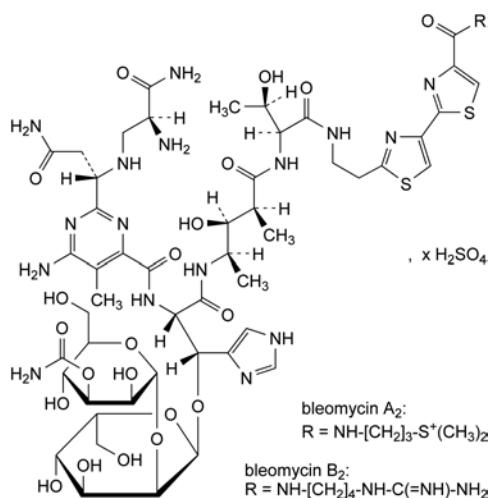

[9041-93-4]

## DEFINITION

Sulfate of a mixture of glycopeptides produced by *Streptomyces verticillus* or by any other means; the 2 principal components of the mixture are *N*-[3-(dimethylsulfonio)propyl]bleomycinamide (bleomycin A<sub>2</sub>) and *N*-[4-(carbamimidoylamino)butyl]bleomycinamide (bleomycin B<sub>2</sub>).

*Potency*: minimum 1500 IU/mg (dried substance).

## CHARACTERS

*Appearance*: white or yellowish-white, very hygroscopic powder.

*Solubility*: very soluble in water, slightly soluble in anhydrous ethanol, practically insoluble in acetone.

## IDENTIFICATION

A. Examine the chromatograms obtained in the test for composition.

*Results*: the 2 principal peaks in the chromatogram obtained with the test solution are similar in retention time and size to the 2 principal peaks in the chromatogram obtained with reference solution (a).

B. It gives the reactions of sulfates (2.3.1).

## TESTS

**Appearance of solution.** The solution is clear (2.2.1) and its absorbance (2.2.25) at 430 nm is not greater than 0.10.

Dissolve 0.200 g in *water R* and dilute to 10.0 mL with the same solvent.

**pH** (2.2.3): 4.5 to 6.0.

Dissolve 50 mg in *carbon dioxide-free water R* and dilute to 10 mL with the same solvent.

**Composition.** Liquid chromatography (2.2.29): use the normalisation procedure.

*Test solution.* Dissolve 25.0 mg of the substance to be examined in *water R* and dilute to 50.0 mL with the same solvent.

*Reference solution (a).* Dissolve 25.0 mg of *bleomycin sulfate CRS* in *water R* and dilute to 50.0 mL with the same solvent.

*Reference solution (b).* Dilute 1.5 mL of reference solution (a) to 100.0 mL with *water R*.

*Column*:

– *size*:  $l = 0.25$  m,  $\varnothing = 4.6$  mm;

– *stationary phase*: octadecylsilyl silica gel for chromatography *R* (7  $\mu$ m).

*Mobile phase*:

– *mobile phase A*: methanol *R*;

– *mobile phase B*: dissolve 0.960 g of *sodium pentanesulfonate R* in 900 mL of acetic acid (4.8 g/L C<sub>2</sub>H<sub>4</sub>O<sub>2</sub>), add 1.86 g of *sodium edetate R*, dilute to 1000 mL with the same solvent and adjust to pH 4.3 with *ammonia R*;

Time (min)	Mobile phase A (per cent V/V)	Mobile phase B (per cent V/V)
0 - 60	10 → 40	90 → 60
60 - end	40	60

*Flow rate*: 1.2 mL/min.

*Detection*: spectrophotometer at 254 nm.

*Injection*: 20  $\mu$ L.

*Run time*: until impurity D is eluted (about 80 min).

*Relative retention* with reference to bleomycin A<sub>2</sub>: impurity D = 1.5 to 2.5.

*System suitability*:

- *resolution*: minimum 5 between the peaks due to bleomycin A<sub>2</sub> (1<sup>st</sup> principal peak) and bleomycin B<sub>2</sub> (2<sup>nd</sup> principal peak) in the chromatogram obtained with reference solution (a);
- *signal-to-noise ratio*: minimum 20 for the principal peak in the chromatogram obtained with reference solution (b);
- *repeatability*: maximum relative standard deviation of 2 per cent for the principal peak after 6 injections of reference solution (a).

*Limits*:

- *bleomycin A<sub>2</sub>*: 55 per cent to 70 per cent;
- *bleomycin B<sub>2</sub>*: 25 per cent to 32 per cent;
- *sum of bleomycin A<sub>2</sub> and B<sub>2</sub>*: minimum 85 per cent;
- *impurity D*: maximum 5.5 per cent;
- *sum of impurities other than D*: maximum 9.5 per cent;
- *disregard limit*: 0.1 per cent of the total.

**Copper**: maximum 200 ppm.

Atomic absorption spectrometry (2.2.23, *Method I*).

*Test solution.* Dissolve 50 mg in *water R* and dilute to 10.0 mL with the same solvent.

*Reference solution.* Dilute 1.0 mL of *copper standard solution (10 ppm Cu) R* to 10.0 mL with *water R*.

*Source*: copper hollow-cathode lamp.

*Wavelength*: 324.7 nm.

*Atomisation device*: air-acetylene flame.

**Loss on drying** (2.2.32): maximum 3.0 per cent, determined on 50 mg by drying at 60 °C at a pressure not exceeding 0.67 kPa for 3 h.

**Bacterial endotoxins** (2.6.14): less than 5 IU/mg, if intended for use in the manufacture of parenteral preparations without a further appropriate procedure for the removal of bacterial endotoxins.

## ASSAY

Carry out the microbiological assay of antibiotics (2.7.2), using the diffusion method. Use *bleomycin sulfate CRS* as the chemical reference substance.

## STORAGE

In an airtight container, at a temperature of 2 °C to 8 °C. If the substance is sterile, store in a sterile, airtight, tamper-proof container.

## IMPURITIES

*Specified impurities*: D.

*Other detectable impurities* (the following substances would, if present at a sufficient level, be detected by one or other of the tests in the monograph. They are limited by the general acceptance criterion for other/unspecified impurities and/or by the general monograph *Substances for pharmaceutical use* (2034). It is therefore not necessary to identify these impurities for demonstration of compliance. See also 5.10. *Control of impurities in substances for pharmaceutical use*): A, B, C.

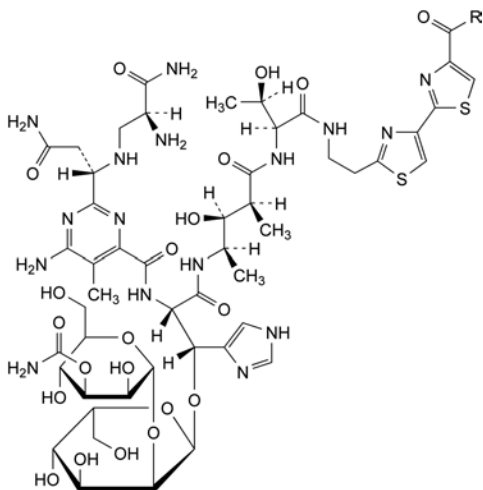

- A. R = OH: bleomycinic acid,  
 B. R = NH-[CH<sub>2</sub>]<sub>3</sub>-NH-[CH<sub>2</sub>]<sub>4</sub>-NH<sub>2</sub>: bleomycin A<sub>5</sub>,  
 C. R = NH-[CH<sub>2</sub>]<sub>4</sub>-NH-C(=NH)-NH-[CH<sub>2</sub>]<sub>4</sub>-NH-C(=NH)-NH<sub>2</sub>:  
 bleomycin B<sub>4</sub>,  
 D. R = NH-[CH<sub>2</sub>]<sub>3</sub>-S-CH<sub>3</sub>: demethylbleomycin A<sub>2</sub>.

01/2010:2105

## BORAGE (STARFLOWER) OIL, REFINED

### *Boraginis officinalis oleum raffinatum*

#### DEFINITION

Fatty oil obtained from seeds of *Borago officinalis* L. by extraction and/or expression. It is then refined. A suitable antioxidant may be added.

#### CHARACTERS

*Appearance*: clear, light yellow or yellow liquid.

*Solubility*: practically insoluble in water and in ethanol (96 per cent), miscible with light petroleum.

*Relative density*: about 0.921.

*Refractive index*: about 1.476.

#### IDENTIFICATION

*First identification*: B.

*Second identification*: A.

- A. Identification of fatty oils by thin-layer chromatography (2.3.2).

*Results*: the chromatogram obtained is similar to the corresponding chromatogram shown in Figure 2.3.2-1.

- B. Composition of fatty acids (see Tests).

#### TESTS

**Acid value** (2.5.1): maximum 0.5, or maximum 0.3 if intended for use in the manufacture of parenteral preparations.

**Peroxide value** (2.5.5, Method A): maximum 10.0, or maximum 5.0 if intended for use in the manufacture of parenteral preparations.

**Unsaponifiable matter** (2.5.7): maximum 2.0 per cent, determined on 5.0 g.

**Alkaline impurities** (2.4.19). It complies with the test.

**Composition of fatty acids** (2.4.22, Method A). Use the mixture of calibrating substances in Table 2.4.22-3.

*Composition of the fatty-acid fraction of the oil*:

- saturated fatty acids of chain length less than C<sub>16</sub>: maximum 0.3 per cent,
- palmitic acid: 9.0 per cent to 12.0 per cent,
- palmitoleic acid: maximum 0.6 per cent,
- stearic acid: 2.0 per cent to 6.0 per cent,
- oleic acid: 12.0 per cent to 22.0 per cent,
- linoleic acid: 30.0 per cent to 41.0 per cent,
- gamma-linolenic acid: 17.0 per cent to 27.0 per cent,
- alpha-linolenic acid: maximum 0.5 per cent,
- arachidic acid: maximum 0.5 per cent,
- eicosenoic acid: 2.8 per cent to 4.4 per cent,
- erucic acid: maximum 3.0 per cent,
- nervonic acid: maximum 4.5 per cent.

**Brassicasterol** (2.4.23): maximum 0.3 per cent in the sterol fraction of the oil.

**Water** (2.5.32): maximum 0.1 per cent, determined on 1.00 g.

#### STORAGE

Under an inert gas, in a well-filled, airtight container, protected from light.

#### LABELLING

The label states, where applicable, that the oil is suitable for use in the manufacture of parenteral preparations.

01/2008:0013  
corrected 6.0

## BORAX

### Borax

Na<sub>2</sub>B<sub>4</sub>O<sub>7</sub>·10H<sub>2</sub>O  
[1303-96-4]

*M*, 381.4

#### DEFINITION

Disodium tetraborate decahydrate.

*Content*: 99.0 per cent to 103.0 per cent of Na<sub>2</sub>B<sub>4</sub>O<sub>7</sub>·10H<sub>2</sub>O.

#### CHARACTERS

*Appearance*: white or almost white, crystalline powder, colourless crystals or crystalline masses, efflorescent.

*Solubility*: soluble in water, very soluble in boiling water, freely soluble in glycerol.

#### IDENTIFICATION

- A. To 1 mL of solution S (see Tests) add 0.1 mL of *sulfuric acid R* and 5 mL of *methanol R* and ignite. The flame has a green border.
- B. To 5 mL of solution S add 0.1 mL of *phenolphthalein solution R*. The solution is red. On the addition of 5 mL of *glycerol (85 per cent) R* the colour disappears.
- C. Solution S gives the reactions of sodium (2.3.1).

#### TESTS

**Solution S**. Dissolve 4.0 g in *carbon dioxide-free water R* prepared from *distilled water R* and dilute to 100 mL with the same solvent.

**Appearance of solution**. Solution S is clear (2.2.1) and colourless (2.2.2, Method II).

**pH** (2.2.3): 9.0 to 9.6 for solution S.

**Sulfates** (2.4.13): maximum 50 ppm, determined on solution S. Use in this test 1.0 mL of *acetic acid R*. Prepare the standard using a mixture of 3 mL of *sulfate standard solution (10 ppm SO<sub>4</sub>) R* and 12 mL of *distilled water R*.

**Ammonium** (2.4.1): maximum 10 ppm.

Dilute 6 mL of solution S to 14 mL with *water R*. Prepare the standard using a mixture of 2.5 mL of *ammonium standard solution* (1 ppm NH<sub>4</sub>) *R* and 7.5 mL of *water R*.

**Arsenic** (2.4.2, *Method A*): maximum 5 ppm, determined on 5 mL of solution S.

**Calcium** (2.4.3): maximum 100 ppm, determined on solution S. Prepare the standard using a mixture of 6 mL of *calcium standard solution* (10 ppm Ca) *R* and 9 mL of *distilled water R*.

**Heavy metals** (2.4.8): maximum 25 ppm.

12 mL of solution S complies with test A. Prepare the reference solution using *lead standard solution* (1 ppm Pb) *R*.

#### ASSAY

Dissolve 20 g of *mannitol R* in 100 mL of *water R*, heating if necessary, cool and add 0.5 mL of *phenolphthalein solution R* and neutralise with 0.1 M *sodium hydroxide* until a pink colour is obtained. Add 3.00 g of the substance to be examined, heat until dissolution is complete, cool, and titrate with 1 M *sodium hydroxide* until the pink colour reappears.

1 mL of 1 M *sodium hydroxide* is equivalent to 0.1907 g of Na<sub>2</sub>B<sub>4</sub>O<sub>7</sub>·10H<sub>2</sub>O.

01/2008:0001  
corrected 6.0

## BORIC ACID

### Acidum boricum

H<sub>3</sub>BO<sub>3</sub>  
[10043-35-3]

*M<sub>r</sub>* 61.8

#### DEFINITION

*Content*: 99.0 per cent to 100.5 per cent.

#### CHARACTERS

*Appearance*: white or almost white, crystalline powder, colourless, shiny plates greasy to the touch, or white or almost white crystals.

*Solubility*: soluble in water and in ethanol (96 per cent), freely soluble in boiling water and in glycerol (85 per cent).

#### IDENTIFICATION

- Dissolve 0.1 g by gently heating in 5 mL of *methanol R*, add 0.1 mL of *sulfuric acid R* and ignite the solution. The flame has a green border.
- Solution S (see Tests) is acid (2.2.4).

#### TESTS

**Solution S.** Dissolve 3.3 g in 80 mL of boiling *distilled water R*, cool and dilute to 100 mL with *carbon dioxide-free water R* prepared from *distilled water R*.

**Appearance of solution.** Solution S is clear (2.2.1) and colourless (2.2.2, *Method II*).

**pH** (2.2.3): 3.8 to 4.8 for solution S.

**Solubility in ethanol (96 per cent).** The solution is not more opalescent than reference suspension II (2.2.1) and is colourless (2.2.2, *Method II*).

Dissolve 1.0 g in 10 mL of boiling *ethanol* (96 per cent) *R*.

**Organic matter.** It does not darken on progressive heating to dull redness.

**Sulfates** (2.4.13): maximum 450 ppm.

Dilute 10 mL of solution S to 15 mL with *distilled water R*.

**Heavy metals** (2.4.8): maximum 15 ppm.

12 mL of solution S complies with test A. Prepare the reference solution using a mixture of 2.5 mL of *lead standard solution* (2 ppm Pb) *R* and 7.5 mL of *water R*.

#### ASSAY

Dissolve 1.000 g with heating in 100 mL of *water R* containing 15 g of *mannitol R*. Titrate with 1 M *sodium hydroxide*, using 0.5 mL of *phenolphthalein solution R* as indicator, until a pink colour is obtained.

1 mL of 1 M *sodium hydroxide* is equivalent to 61.8 mg of H<sub>3</sub>BO<sub>3</sub>.

01/2008:2113

## BOTULINUM TOXIN TYPE A FOR INJECTION

### Toxinum botulinicum typum A ad iniectionabile

#### DEFINITION

Botulinum toxin type A for injection is a dried preparation containing purified botulinum neurotoxin type A which may be present in the form of a complex with haemagglutinins and non-toxic proteins. Botulinum neurotoxin type A or its haemagglutinin complex is prepared by a suitable purification process of the liquid supernatant from a broth-culture of a suitable strain of *Clostridium botulinum* type A.

The purified complexes consist of several proteins and can be of various sizes. The largest complex (relative molecular mass of about 900 000) consists of a 150 000 relative molecular mass neurotoxin, a 130 000 relative molecular mass non-toxic protein and various haemagglutinins ranging between relative molecular mass 14 000 and 43 000. The purified toxin moiety is composed of only the same 150 000 relative molecular mass neurotoxin as is found in the 900 000 relative molecular mass neurotoxin complex, which is initially produced as a single chain and further cleaved (nicked) by endogenous proteases into a fully active, disulfide-linked, 54 000 relative molecular mass light chain and a 97 000 relative molecular mass heavy chain. The preparation is reconstituted before use, as stated on the label.

#### PRODUCTION

##### GENERAL PROVISIONS

Production of the toxin is based on seed cultures, managed in a defined seed-lot system in which the ability to produce toxin is conserved. The production method must be shown to yield consistently product of activity and profile comparable to that of lots shown in clinical studies to be of adequate safety and efficacy.

The production method is validated to demonstrate that the product, if tested, would comply with the general test of abnormal toxicity (2.6.9) using not less than the maximum human clinical dose, in the presence of a suitable amount of specific botulinum type A antitoxin used for neutralisation.

The production method and stability of the finished product and relevant intermediates are evaluated using the tests below. Such tests include the specific toxin activity per milligram of protein of purified toxin in an appropriate functional model of toxin activity and may be supported by tests confirming the presence of botulinum toxin type A, and, if appropriate, associated non-toxic proteins.

##### BACTERIAL SEED LOTS

A highly toxigenic strain of *C. botulinum* of known toxin type A and confirmed absence of genes encoding other botulinum toxins (particularly botulinum toxin type B), with known origin and history, is grown using suitable media. The bacterial strain, used for the master seed lot, shall be identified by historical records that include information on its origin and the tests used to characterise the strain. These will include morphological, cultural, biochemical, genetic and serological properties of the strain. The master seed lot and the working seed lot, where

applicable, must be demonstrated to have identical profiles. Only a seed lot that complies with the following requirements may be used.

**Identification.** Each seed lot is identified as containing pure cultures of *C. botulinum* type A bacteria with no extraneous bacterial or fungal contamination.

**Microbial purity.** Each seed lot complies with the requirements for absence of contaminating micro-organisms. The purity of bacterial cultures is verified by methods of suitable sensitivity. These may include inoculation into suitable media and examination of colony morphology.

**Phenotypic parameters.** Each seed lot must have a known fatty acid profile, sugar fermentation profile (glucose, lactose, mannose, etc.) and proteolytic activity and must demonstrate relevant lipase, lecithinase and gelatinase activity.

**Genetic purity.** Each seed lot must have information on the toxin gene sequence and comply with requirements for the absence of other genes encoding other toxin serotypes.

**Production of active toxin.** A bacterial strain producing a high yield of active toxin, as determined by an acute toxicity assay, is suitable. Seed lots should demonstrate a capability of producing at least a minimum toxicity level appropriate for the manufacturing process and scale.

#### MANUFACTURER'S REFERENCE PREPARATIONS

During development, reference preparations are established for subsequent verification of batch consistency during production and for control of the bulk purified toxin and finished product. They are derived from representative batches of botulinum toxin type A that are characterised as described under Bulk Purified Toxin.

The reference preparations are suitably characterised for their intended purpose and are stored in suitably sized aliquots under conditions ensuring their suitability.

#### BULK PURIFIED TOXIN

*C. botulinum* type A strain is grown anaerobically, in suitable media, from which cultures are selected for step-up incubations under a suitably controlled anaerobic atmosphere through the seed culture and bulk fermentation stages to allow maximum production of toxin. The toxin is purified by suitable methods to remove nucleic acids and components likely to cause adverse reactions.

Only a purified toxin that complies with the following requirements may be used in the preparation of the final bulk. For each test and for each product, limits of acceptance are established and each new purified toxin must comply with these limits.

**Residual reagents.** Removal of residual reagents used in purification steps is confirmed by suitable limit tests or by validation of the process.

**Nucleic acids.** Removal of nucleic acids is confirmed by suitable limit tests or by validation of the process.

**Immunological identity.** The presence of specific type A toxin is confirmed by a suitable immunochemical method (2.7.1).

**Specific activity.** The specific activity is confirmed in a mouse model of toxicity or by *in vivo/ex vivo* methods validated with respect to the LD50 assay and expressed in mouse LD50 units per milligram of protein. Specific activity must not be less than  $1 \times 10^8$  mouse LD50 units per milligram of protein for the 150 000 relative molecular mass neurotoxin and must not be less than  $1 \times 10^7$  mouse LD50 units per milligram of protein for the 900 000 relative molecular mass neurotoxin complex.

**Protein.** The total protein concentration is determined by a suitable method. An acceptable value is established for the product and each batch must be shown to comply with the limits.

**Protein profile.** Identity and protein composition are determined by polyacrylamide gel electrophoresis (2.2.31) under reducing or non-reducing conditions or by other

suitable physicochemical methods such as size-exclusion chromatography (2.2.30), comparing with suitable reference standards.

**Total viable count.** It complies with the limits approved for the particular product.

#### FINAL BULK

The final bulk is prepared by adding approved excipients to the bulk purified toxin. The solution is filtered through a bacteria-retentive filter. If human albumin is added, it complies with the monograph on *Human albumin solution* (0255).

#### FINAL LOT

The final bulk is distributed aseptically into sterile, tamper-proof containers. Uniformity of fill is verified during filling and the test for uniformity of content (2.9.6) is not required. The containers are closed so as to prevent contamination.

Only a final lot that is within the limits approved for the particular product and is satisfactory with respect to each of the requirements given below under Identification, Tests and Assay may be released for use.

**pH** (2.2.3). The pH of the reconstituted product is within  $\pm 0.5$  pH units of the limit approved for the particular product.

**Water:** not more than the limit approved for the particular product.

#### IDENTIFICATION

The presence of botulinum toxin type A is confirmed by a suitable immunochemical method (2.7.1).

#### TESTS

**Sterility** (2.6.1). It complies with the test for sterility.

**Bacterial endotoxins** (2.6.14): less than 10 IU per vial.

#### ASSAY

The potency of the reconstituted product is determined by an LD50 assay in mice or by a method validated with respect to the LD50 assay. The potency is expressed in terms of the LD50 for mice or relative to the reference preparation.

For determination of the LD50, graded doses of the product are injected intraperitoneally into groups of mice and the LD50 is calculated by the usual statistical methods (5.3) from the mouse lethality in each group. A suitable reference preparation is assayed in parallel; the potency of the toxin is expressed relative to the reference or the value found for the reference is within suitable limits defined in terms of the assigned potency.

After validation with respect to the LD50 assay (reference method), the product may also be assayed by other methods that are preferable in terms of animal welfare, including 1 of the following:

1. endopeptidase assay *in vitro*;
2. *ex vivo* assay using the mouse phrenic nerve diaphragm;
3. mouse bioassay using paralysis as the end-point.

For these other methods, the potency is calculated with respect to a suitable reference preparation calibrated in mouse LD50 units.

The estimated potency is not less than 80 per cent and not more than 125 per cent of the stated potency. The confidence limits ( $P = 0.95$ ) are not less than 80 per cent and not more than 125 per cent of the estimated potency.

The test may be repeated but when more than 1 test is performed, the results of all valid tests must be combined in the estimate of potency.

#### LABELLING

The label states:

- the number of units of toxin per vial with a statement that units are product specific and not applicable to other preparations containing botulinum toxin type A,
- the name and the volume of the diluent to be added for reconstitution of a dried product.

01/2008:2262

**BOVINE SERUM**

## Serum bovinum

## DEFINITION

Liquid fraction of blood obtained from the ox (*Bos taurus* L.) and from which cells, fibrin and clotting factors have been removed.

Different types of bovine serum are used:

- *adult bovine serum* obtained at slaughter from cattle that are declared fit for human consumption;
- *calf serum* obtained at slaughter from animals, fit for human consumption, before the age of 12 months;
- *new-born calf serum* obtained at slaughter from animals before the age of 20 days;
- *foetal bovine serum* obtained from normal foetuses from dams fit for human consumption;
- *donor bovine serum* obtained by repeated bleeding of donor animals from controlled donor herds.

*This monograph provides a general quality specification for bovine serum. Various measures are applied during the production of bovine serum aimed at obtaining a product that is acceptable as regards viral safety. No single measure, nor the combination of measures outlined below can guarantee complete viral safety but they rather reduce the risk involved in the use of serum in the manufacture of medicinal products. It is therefore necessary for the manufacturer of a medicinal product to take account of this when choosing the serum for a particular use by making a risk assessment.*

## PRODUCTION

All stages of serum production are submitted to a suitable quality management system.

Traceability of serum is maintained from the final container to the abattoir of origin (for blood collected from slaughtered animals) or to the herd of origin (for blood collected from donor animals).

Further guarantee of the safety and quality of serum may be ensured by the use of a controlled donor herd. Where serum is obtained from such a herd, the animals are subjected to regular veterinary examination to ascertain their health status. Animals introduced into the herd are traceable as regards source, breeding and rearing history. The introduction of animals into the herd follows specified procedures, including defined quarantine measures. During the quarantine period the animals are observed and tested to establish that they are free from all agents and antibodies from which the donor herd is claimed to be free. It may be necessary to test the animals in quarantine for freedom from additional agents, depending on factors such as information available on their breeding and rearing history. It is recommended that animals in the herd should not be vaccinated against bovine viral diarrhoea virus. Tests are carried out for any agent and/or antibody from which the herd is claimed to be free.

Serum is obtained by separation of the serum from blood cells and clot under conditions designed to minimise microbial contamination. Serum from a number of animals is pooled and a batch number is allocated to the pool. Appropriate steps are taken to ensure homogeneity of the harvested material, intermediate pools and the final batch. Suitable measures (for example filtration) are taken to ensure sterility or a low bioburden. Before further processing, the serum is tested for sterility or bioburden. General and specific tests for viral contaminants are carried out as described below.

A step or steps for virus inactivation/removal are applied to serum intended for production of immunological veterinary medicinal products. Unless otherwise justified and authorised

for a particular medicinal product, a step or steps for virus inactivation/removal are applied to serum intended for production of human and non-immunological veterinary medicinal products.

## INACTIVATION

The inactivation procedure applied is validated with respect to a suitable representative range of viruses covering different types (enveloped, non-enveloped, DNA, RNA viruses). The optimal choice of relevant and model viruses depends strongly on the specific inactivation/removal procedure; representative viruses with different degrees of resistance to the type of treatment must be included. Bovine viral diarrhoea virus must be included in the viruses used for validation. Serum free from antibodies against bovine viral diarrhoea virus is used in part or all of the validation studies.

For bovine serum intended for use in immunological veterinary medicinal products, for inactivation by gamma irradiation a minimum dose of 30 kGy is applied, unless otherwise justified and authorised.

Critical parameters for the method of virus inactivation/removal are established and the parameters used in the validation study are strictly adhered to during subsequent application of the procedures to each batch of serum.

For inactivation by gamma irradiation, critical parameters include:

- the temperature;
- packaging configuration;
- distribution of dosimeters to assess the effective dose received by the product whatever its position;
- the minimum and maximum dose received.

## QUALITY CONTROL TESTS APPLIED TO EACH BATCH

A suitable sample size for each batch is established. Specific tests for viral contaminants are validated with respect to sensitivity and specificity. The cell cultures used for general tests for viral contaminants are shown to be sensitive to a suitable range of potential contaminants. Control cells used in the tests are cultivated, where relevant, with a bovine serum controlled and inactivated as described in this monograph. Serum free from antibodies to bovine viral diarrhoea virus is required for validation of the effect of antibodies on the detection limits for bovine viral diarrhoea virus.

**Tests carried out on the batch prior to treatment**

The following tests are carried out on the serum (before any virus inactivation/removal steps, where applicable).

*Tests for viral contaminants.* General tests supplemented by specific tests are carried out.

*General tests.* Validated tests are carried out by inoculation of the serum on at least 2 distinct cell lines, one of which is of bovine origin. The cell lines used are suitable for detecting haemadsorbing viruses such as bovine parainfluenza virus 3 and cytopathic agents such as bovine herpesvirus 1.

*Specific tests for viral contaminants (if not detected by general tests), where relevant in view of the country of origin of the serum:* bluetongue virus, bovine adenovirus, bovine parvovirus, bovine respiratory syncytial virus, bovine viral diarrhoea virus, rabies virus and reovirus. Depending on the country of origin, specific tests for other viruses may be needed. The animal health status of countries is defined by the 'Office International des Epizooties' (OIE).

For serum to be subjected to a virus inactivation/removal procedure, if evidence of viral contamination is found in any of the tests described above, the serum is acceptable only if the virus is identified and shown to be present in an amount that has been shown in a validation study to be effectively inactivated.

For serum that is not to be subjected to a virus inactivation/removal procedure, if evidence of viral contamination is found in any of the tests described above, the serum is not acceptable.



A test for bovine viral diarrhoea virus antibodies is carried out; an acceptance criterion for the titre is established taking account of the risk assessment.

**Composition.** The content of a suitable selection of the following components is determined and shown to be within the expected range for the type of serum: cholesterol,  $\alpha$ -,  $\beta$ - and  $\gamma$ -globulin, albumin, creatinine, bilirubin, glucose, serum aspartate transaminase (SAST, formerly SGOT - serum glutamic-oxaloacetic transaminase), serum alanine transaminase (SALT, formerly SGPT - glutamic-pyruvic transaminase), phosphorus, potassium, calcium, sodium and pH.

#### Tests carried out on the batch post-treatment

If bovine viral diarrhoea virus was detected before virus inactivation/removal, the following test for bovine viral diarrhoea virus is carried out after virus inactivation/removal.

**Test for bovine viral diarrhoea virus.** A validated test for bovine viral diarrhoea virus is carried out, for example by inoculation into susceptible cell cultures, followed by not fewer than 3 subcultures and detection by immunostaining. No evidence of the presence of bovine viral diarrhoea virus is found.

#### IDENTIFICATION

- The electrophoretic pattern corresponds to that for serum and is consistent with the type (foetal or other) of bovine serum.
- Bovine origin is confirmed by a suitable immunochemical method (2.7.1).

#### TESTS

**Osmolality** (2.2.35): 280 mosmol/kg to 365 mosmol/kg for foetal bovine serum and 240 mosmol/kg to 340 mosmol/kg for other types.

**Total protein** (2.5.33): 30 mg/mL to 45 mg/mL for foetal bovine serum and minimum 35 mg/mL for other types.

**Haemoglobin:** maximum 4 mg/mL, determined by a validated method, such as spectrophotometry.

**Bacterial endotoxins** (2.6.14): less than 10 IU/mL for donor bovine serum, less than 25 IU/mL for foetal bovine serum, less than 100 IU/mL for other types.

**Sterility** (2.6.1). It complies with the test. Use 10 mL for each medium.

**Mycoplasmas** (2.6.7). It complies with the test.

#### STORAGE

Frozen at  $-10\text{ }^{\circ}\text{C}$  or below.

#### LABELLING

The label states:

- the type of serum;
- where applicable, that the serum has been inactivated and the inactivation method;
- where the serum has been inactivated by gamma irradiation, the target minimum dose of the irradiation procedure.

01/2008:0879

## BROMAZEPAM

### Bromazepamum

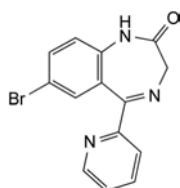

$\text{C}_{14}\text{H}_{10}\text{BrN}_3\text{O}$   
[1812-30-2]

$M_r$  316.2

#### DEFINITION

7-Bromo-5-(pyridin-2-yl)-1,3-dihydro-2H-1,4-benzodiazepin-2-one.

**Content:** 99.0 per cent to 101.0 per cent (dried substance).

#### CHARACTERS

**Appearance:** white or yellowish, crystalline powder.

**Solubility:** practically insoluble in water, slightly soluble or sparingly soluble in ethanol (96 per cent) and in methylene chloride.

#### IDENTIFICATION

Infrared absorption spectrophotometry (2.2.24).

**Comparison:** bromazepam CRS.

#### TESTS

**Related substances.** Liquid chromatography (2.2.29). Prepare the solutions immediately before use.

**Test solution.** Dissolve 10.0 mg of the substance to be examined in 9 mL of a mixture of 1 volume of acetonitrile R and 8 volumes of methanol R. Dilute to 20.0 mL with an 11.33 g/L solution of potassium dihydrogen phosphate R previously adjusted to pH 7.0 with a 100 g/L solution of potassium hydroxide R.

**Reference solution (a).** Dilute 1.0 mL of the test solution to 100.0 mL with the mobile phase. Dilute 1.0 mL of this solution to 10.0 mL with the mobile phase.

**Reference solution (b).** Dissolve 5 mg of bromazepam for system suitability CRS (containing impurities A, B, C, D and E) in 5 mL of a mixture of 1 volume of acetonitrile R and 8 volumes of methanol R. Dilute to 10.0 mL with an 11.33 g/L solution of potassium dihydrogen phosphate R previously adjusted to pH 7.0 with a 100 g/L solution of potassium hydroxide R.

**Column:**

- size:  $l = 0.15\text{ m}$ ,  $\varnothing = 4.6\text{ mm}$ ;
- stationary phase: end-capped octadecylsilyl silica gel for chromatography R (3.5  $\mu\text{m}$ );
- temperature:  $50\text{ }^{\circ}\text{C}$ .

**Mobile phase:** mix 5 volumes of acetonitrile R, 45 volumes of methanol R and 50 volumes of an 11.33 g/L solution of potassium dihydrogen phosphate R previously adjusted to pH 7.0 with a 100 g/L solution of potassium hydroxide R.

**Flow rate:** 1.0 mL/min.

**Detection:** spectrophotometer at 235 nm.

**Injection:** 20  $\mu\text{L}$ .

**Run time:** 4 times the retention time of bromazepam.

**Identification of impurities:** use the chromatogram supplied with bromazepam for system suitability CRS and the chromatogram obtained with reference solution (b) to identify the peaks due to impurities A, B, C, D and E.

**Relative retention** with reference to bromazepam (retention time = about 5 min): impurity D = about 1.4; impurity A = about 1.5; impurity C = about 1.6; impurity E = about 2.1; impurity B = about 2.2.

**System suitability:** reference solution (b):

- resolution: minimum 4.0 between the peaks due to bromazepam and impurity D and minimum 1.2 between the peaks due to impurities A and C.

**Limits:**

- correction factors: for the calculation of content, multiply the peak areas of the following impurities by the corresponding correction factor: impurity A = 1.3; impurity B = 1.8; impurity E = 2.1;
- impurities A, B, E: for each impurity, not more than the area of the principal peak in the chromatogram obtained with reference solution (a) (0.1 per cent);
- unspecified impurities: for each impurity, not more than the area of the principal peak in the chromatogram obtained with reference solution (a) (0.10 per cent);

- *total*: not more than twice the area of the principal peak in the chromatogram obtained with reference solution (a) (0.2 per cent);
- *disregard limit*: 0.5 times the area of the principal peak in the chromatogram obtained with reference solution (a) (0.05 per cent).

**Loss on drying** (2.2.32): maximum 0.2 per cent, determined on 1.000 g by drying at 80 °C at a pressure not exceeding 2.7 kPa for 4 h.

**Sulfated ash** (2.4.14): maximum 0.1 per cent, determined on 1.0 g.

#### ASSAY

Dissolve 0.250 g in 20 mL of *anhydrous acetic acid R*. Add 50 mL of *acetic anhydride R*. Titrate with 0.1 M *perchloric acid*, determining the end-point potentiometrically (2.2.20).

1 mL of 0.1 M *perchloric acid* is equivalent to 31.62 mg of  $C_{14}H_{10}BrN_3O$ .

#### STORAGE

Protected from light.

#### IMPURITIES

*Specified impurities*: A, B, E.

*Other detectable impurities* (the following substances would, if present at a sufficient level, be detected by one or other of the tests in the monograph. They are limited by the general acceptance criterion for other/unspecified impurities and/or by the general monograph *Substances for pharmaceutical use* (2034). It is therefore not necessary to identify these impurities for demonstration of compliance. See also 5.10. *Control of impurities in substances for pharmaceutical use*): C, D.

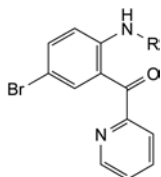

- A. R = H: (2-amino-5-bromophenyl)(pyridin-2-yl)methanone,
- B. R = CO-CH<sub>2</sub>-Cl: *N*-[4-bromo-2-(pyridin-2-ylcarbonyl)phenyl]-2-chloroacetamide,
- E. R = CO-CH<sub>2</sub>-Br: 2-bromo-*N*-[4-bromo-2-(pyridin-2-ylcarbonyl)phenyl]acetamide,

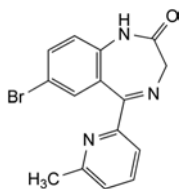

- C. 7-bromo-5-(6-methylpyridin-2-yl)-1,3-dihydro-2*H*-1,4-benzodiazepin-2-one,

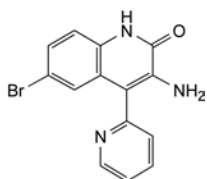

- D. 3-amino-6-bromo-4-(pyridin-2-yl)quinolin-2(1*H*)-one.

01/2008:0706  
corrected 6.0

## BROMHEXINE HYDROCHLORIDE

### Bromhexini hydrochloridum

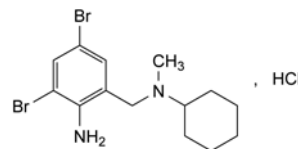

$C_{14}H_{21}Br_2ClN_2$   
[611-75-6]

$M_r$  412.6

#### DEFINITION

*N*-(2-Amino-3,5-dibromobenzyl)-*N*-methylcyclohexanamine hydrochloride.

*Content*: 98.5 per cent to 101.5 per cent (dried substance).

#### CHARACTERS

*Appearance*: white or almost white, crystalline powder.

*Solubility*: very slightly soluble in water, slightly soluble in alcohol and in methylene chloride.

It shows polymorphism (5.9).

#### IDENTIFICATION

*First identification*: A, E.

*Second identification*: B, C, D, E.

A. Infrared absorption spectrophotometry (2.2.24).

*Comparison*: bromhexine hydrochloride CRS.

If the spectra obtained in the solid state show differences, dissolve the substance to be examined and the reference substance separately in *methanol R*, evaporate to dryness and record new spectra using the residues.

B. Thin-layer chromatography (2.2.27).

*Test solution*. Dissolve 20 mg of the substance to be examined in *methanol R* and dilute to 10 mL with the same solvent.

*Reference solution*. Dissolve 20 mg of *bromhexine hydrochloride CRS* in *methanol R* and dilute to 10 mL with the same solvent.

*Plate*: TLC silica gel  $F_{254}$  plate R.

*Mobile phase*: glacial acetic acid R, water R, butanol R (17:17:66 V/V/V).

*Application*: 20 µL.

*Development*: over 3/4 of the plate.

*Drying*: in air.

*Detection*: examine in ultraviolet light at 254 nm.

*Results*: the principal spot in the chromatogram obtained with the test solution is similar in position and size to the principal spot in the chromatogram obtained with the reference solution.

C. Dissolve about 25 mg in a mixture of 1 mL of *dilute sulfuric acid R* and 50 mL of *water R*. Add 2 mL of *methylene chloride R* and 5 mL of *chloramine solution R* and shake. A brownish-yellow colour develops in the lower layer.

D. Dissolve about 1 mg in 3 mL of 0.1 M *hydrochloric acid*. The solution gives the reaction of primary aromatic amines (2.3.1).

E. Dissolve about 20 mg in 1 mL of *methanol R* and add 1 mL of *water R*. The solution gives reaction (a) of chlorides (2.3.1).

## TESTS

**Appearance of solution.** The solution is clear (2.2.1) and not more intensely coloured than reference solution Y<sub>6</sub> (2.2.2, Method II).

Dissolve 0.6 g in *methanol R* and dilute to 20 mL with the same solvent.

**Related substances.** Liquid chromatography (2.2.29).

**Test solution.** Dissolve 50 mg of the substance to be examined in *methanol R* and dilute to 10.0 mL with the same solvent.

**Reference solution (a).** Dissolve 5 mg of *bromhexine impurity C CRS* in *methanol R*, add 1.0 mL of the test solution and dilute to 10.0 mL with the same solvent.

**Reference solution (b).** Dilute 1.0 mL of the test solution to 100.0 mL with *methanol R*. Dilute 1.0 mL of this solution to 10.0 mL with *methanol R*.

**Column:**

- size:  $l = 0.12$  m,  $\varnothing = 4.6$  mm,
- stationary phase: end-capped octadecylsilyl silica gel for chromatography R (3  $\mu$ m).

**Mobile phase:** mix 0.50 mL of *phosphoric acid R* in 950 mL of *water R*, adjust to pH 7.0 with *triethylamine R* (about 1.5 mL) and dilute to 1000 mL with *water R*; mix 20 volumes of this solution with 80 volumes of *acetonitrile R*.

**Flow rate:** 1.0 mL/min.

**Detection:** spectrophotometer at 248 nm.

**Injection:** 10  $\mu$ L.

**Run time:** 2.5 times the retention time of bromhexine.

**Relative retention** with reference to bromhexine (retention time = about 11 min): impurity A = about 0.1; impurity B = about 0.2; impurity C = about 0.4; impurity D = about 0.5.

**System suitability:** reference solution (a):

- resolution: minimum 12.0 between the peaks due to impurity C and bromhexine.

**Limits:**

- any impurity: not more than twice the area of the principal peak in the chromatogram obtained with reference solution (b) (0.2 per cent), and not more than 1 such peak has an area greater than the area of the principal peak in the chromatogram obtained with reference solution (b) (0.1 per cent),
- total: not more than 3 times the area of the principal peak in the chromatogram obtained with reference solution (b) (0.3 per cent),
- disregard limit: 0.5 times the area of the principal peak in the chromatogram obtained with reference solution (b) (0.05 per cent).

**Loss on drying** (2.2.32): maximum 1.0 per cent, determined on 1.000 g by drying in an oven at 105 °C.

**Sulfated ash** (2.4.14): maximum 0.1 per cent, determined on 1.0 g.

## ASSAY

Dissolve 0.300 g in 70 mL of *alcohol R* and add 1 mL of 0.1 M *hydrochloric acid*. Carry out a potentiometric titration (2.2.20), using 0.1 M *sodium hydroxide*. Read the volume between the 2 points of inflexion.

1 mL of 0.1 M *sodium hydroxide* is equivalent to 41.26 mg of C<sub>33</sub>H<sub>44</sub>BrN<sub>5</sub>O<sub>8</sub>S.

## STORAGE

Protected from light.

## IMPURITIES

**Specified impurities:** A, B, C, D.

**Other detectable impurities** (the following substances would, if present at a sufficient level, be detected by one or other of the tests in the monograph. They are limited by the general

acceptance criterion for other/unspecified impurities and/or by the general monograph *Substances for pharmaceutical use* (2034). It is therefore not necessary to identify these impurities for demonstration of compliance. See also 5.10. *Control of impurities in substances for pharmaceutical use*): E.

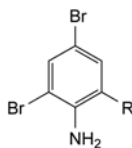

A. R = CH<sub>2</sub>OH: (2-amino-3,5-dibromophenyl)methanol,

B. R = CHO: 2-amino-3,5-dibromobenzaldehyde,

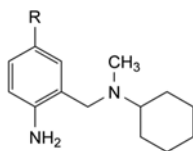

C. R = H: *N*-(2-aminobenzyl)-*N*-methylcyclohexanamine,

D. R = Br: *N*-(2-amino-5-bromobenzyl)-*N*-methylcyclohexanamine,

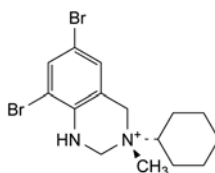

E. (3*RS*)-6,8-dibromo-3-cyclohexyl-3-methyl-1,2,3,4-tetrahydroquinazolin-3-ium.

01/2008:0596

## BROMOCRIPTINE MESILATE

## Bromocriptini mesilas

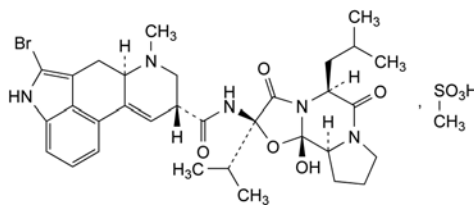

C<sub>33</sub>H<sub>44</sub>BrN<sub>5</sub>O<sub>8</sub>S  
[22260-51-1]

M<sub>r</sub> 751

## DEFINITION

(6*aR*,9*R*)-5-Bromo-*N*-[(2*R*,5*S*,10*aS*,10*bS*)-10*b*-hydroxy-2-(1-methylethyl)-5-(2-methylpropyl)-3,6-dioxooctahydro-8*H*-oxazolo[3,2-*a*]pyrrolo[2,1-*c*]pyrazin-2-yl]-7-methyl-4,6,6*a*,7,8,9-hexahydroindolo[4,3-*g*]quinoline-9-carboxamide monomethanesulfonate.

**Content:** 98.0 per cent to 101.0 per cent (dried substance).

## PRODUCTION

The production method must be evaluated to determine the potential for formation of alkyl mesilates, which is particularly likely to occur if the reaction medium contains lower alcohols. Where necessary, the production method is validated to demonstrate that alkyl mesilates are not detectable in the final product.

## CHARACTERS

**Appearance:** white or slightly coloured, fine crystalline powder.

**Solubility:** practically insoluble in water, freely soluble in methanol, soluble in ethanol (96 per cent), sparingly soluble in methylene chloride.

It is very sensitive to light.

The identification, tests and assay are to be carried out as rapidly as possible, protected from light.

## IDENTIFICATION

First identification: B.

Second identification: A, C, D, E.

A. Ultraviolet and visible absorption spectrophotometry (2.2.25).

*Test solution.* Dissolve 10.0 mg in 10 mL of *methanol R* and dilute to 200.0 mL with 0.01 M *hydrochloric acid*.

*Spectral range:* 250-380 nm.

*Absorption maximum:* at 305 nm.

*Absorption minimum:* at 270 nm.

*Specific absorbance at the absorption maximum:* 120 to 135 (dried substance).

B. Infrared absorption spectrophotometry (2.2.24).

*Comparison:* bromocriptine mesilate CRS.

C. Thin-layer chromatography (2.2.27). Prepare the solutions immediately before use.

*Solvent mixture:* ethanol (96 per cent) R, *methanol R*, *methylene chloride R* (30:30:40 V/V/V).

*Test solution.* Dissolve 10 mg of the substance to be examined in the solvent mixture and dilute to 10 mL with the solvent mixture.

*Reference solution.* Dissolve 10 mg of bromocriptine mesilate CRS in the solvent mixture and dilute to 10 mL with the solvent mixture.

*Plate:* TLC silica gel G plate R.

*Mobile phase:* concentrated ammonia R, water R, 2-propanol R, *methylene chloride R*, ether R (0.1:1.5:3:88:100 V/V/V/V).

*Application:* 10 µL.

*Development:* immediately in an unsaturated tank, over a path of 15 cm.

*Drying:* in a current of cold air for 2 min.

*Detection:* spray with ammonium molybdate solution R3 and dry at 100 °C until the spots appear (about 10 min).

*Results:* the principal spot in the chromatogram obtained with the test solution is similar in position, colour and size to the principal spot in the chromatogram obtained with the reference solution.

D. To 0.1 g add 5 mL of dilute hydrochloric acid R and shake for about 5 min. Filter and add 1 mL of barium chloride solution RI. The filtrate remains clear. To a further 0.1 g add 0.5 g of anhydrous sodium carbonate R, mix and ignite until a white residue is obtained. Allow to cool and dissolve the residue in 7 mL of water R (solution A). Solution A gives reaction (a) of sulfates (2.3.1).

E. Solution A obtained in identification test D gives reaction (a) of bromides (2.3.1).

## TESTS

**Appearance of solution.** The solution is clear (2.2.1) and not more intensely coloured than reference solution B<sub>5</sub>, BY<sub>5</sub> or Y<sub>5</sub> (2.2.2, Method II).

Dissolve 0.25 g in *methanol R* and dilute to 25 mL with the same solvent.

**pH** (2.2.3): 3.1 to 3.8.

Dissolve 0.2 g in a mixture of 2 volumes of *methanol R* and 8 volumes of carbon dioxide-free water R and dilute to 20 mL with the same mixture of solvents.

**Specific optical rotation** (2.2.7): + 95 to + 105 (dried substance).

Dissolve 0.100 g in a mixture of equal volumes of *methanol R* and *methylene chloride R* and dilute to 10.0 mL with the same mixture of solvents.

**Related substances.** Liquid chromatography (2.2.29).

*Solvent mixture:* buffer solution pH 2.0 R, *methanol R* (50:50 V/V).

*Test solution.* Dissolve 0.500 g of the substance to be examined in 5.0 mL of *methanol R* and dilute to 10.0 mL with *buffer solution pH 2.0 R*.

*Reference solution (a).* Dilute 1.0 mL of the test solution to 100.0 mL with the solvent mixture.

*Reference solution (b).* Dilute 1.0 mL of reference solution (a) to 10.0 mL with the solvent mixture.

*Reference solution (c).* Dissolve the contents of a vial of bromocriptine mesilate for system suitability CRS (containing impurities A and B) in 1.0 mL of the solvent mixture.

*Column:*

- size:  $l = 0.12$  m,  $\varnothing = 4$  mm;
- stationary phase: octadecylsilyl silica gel for chromatography R (5 µm).

*Mobile phase:*

- mobile phase A: 0.791 g/L solution of ammonium carbonate R;
- mobile phase B: acetonitrile R;

Time (min)	Mobile phase A (per cent V/V)	Mobile phase B (per cent V/V)
0 - 30	90 → 40	10 → 60
30 - 45	40	60

*Flow rate:* 2 mL/min.

*Detection:* spectrophotometer at 300 nm.

*Injection:* 20 µL.

*Identification of impurities:* use the chromatogram supplied with bromocriptine mesilate for system suitability CRS and the chromatogram obtained with reference solution (c) to identify the peaks due to impurities A and B.

*Relative retention* with reference to bromocriptine: impurity C = about 1.2.

*System suitability:* reference solution (c):

- resolution: minimum 1.1 between the peaks due to impurities A and B.

*Limits:*

- impurity A: not more than 0.2 times the area of the principal peak in the chromatogram obtained with reference solution (b) (0.02 per cent);
- impurity C: not more than 4 times the area of the principal peak in the chromatogram obtained with reference solution (b) (0.4 per cent);
- impurities B, D, E, F, G: for each impurity, not more than twice the area of the principal peak in the chromatogram obtained with reference solution (b) (0.2 per cent) and not more than 1 such peak has an area greater than the area of the principal peak in the chromatogram obtained with reference solution (b) (0.1 per cent);
- total: not more than 1.5 times the area of the principal peak in the chromatogram obtained with reference solution (a) (1.5 per cent);
- disregard limit: 0.5 times the area of the principal peak in the chromatogram obtained with reference solution (b) (0.05 per cent), apart from the peak due to impurity A.

**Loss on drying** (2.2.32): maximum 3.0 per cent, determined on 0.500 g by drying *in vacuo* at 80 °C for 5 h.

## ASSAY

Dissolve 0.500 g in 80 mL of a mixture of 10 volumes of anhydrous acetic acid R and 70 volumes of acetic anhydride R. Titrate with 0.1 M perchloric acid, determining the end-point potentiometrically (2.2.20).

1 mL of 0.1 M perchloric acid is equivalent to 75.1 mg of C<sub>33</sub>H<sub>44</sub>BrN<sub>5</sub>O<sub>8</sub>S.

## STORAGE

In an airtight container, protected from light, at a temperature not exceeding  $-15\text{ }^{\circ}\text{C}$ .

## IMPURITIES

Specified impurities: A, B, C, D, E, F, G.

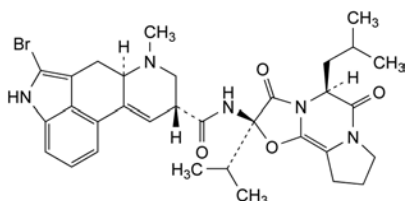

- A. (6aR,9R)-5-bromo-N-[(2R,5S)-2-(1-methylethyl)-5-(2-methylpropyl)-3,6-dioxo-2,3,5,6,9,10-hexahydro-8H-oxazolo[3,2-a]pyrrolo[2,1-c]pyrazin-2-yl]-7-methyl-4,6,6a,7,8,9-hexahydroindolo[4,3-fg]quinoline-9-carboxamide (2-bromodehydro- $\alpha$ -ergocriptine),

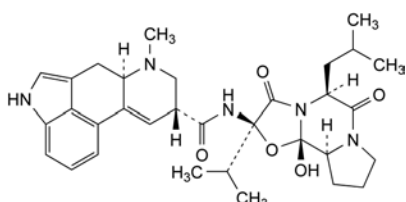

- B. (6aR,9R)-N-[(2R,5S,10aS,10bS)-10b-hydroxy-2-(1-methylethyl)-5-(2-methylpropyl)-3,6-dioxo-2,3,5,6,9,10-hexahydro-8H-oxazolo[3,2-a]pyrrolo[2,1-c]pyrazin-2-yl]-7-methyl-4,6,6a,7,8,9-hexahydroindolo[4,3-fg]quinoline-9-carboxamide ( $\alpha$ -ergocriptine),

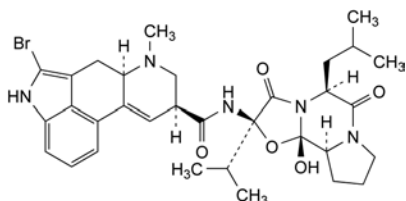

- C. (6aR,9S)-5-bromo-N-[(2R,5S,10aS,10bS)-10b-hydroxy-2-(1-methylethyl)-5-(2-methylpropyl)-3,6-dioxo-2,3,5,6,9,10-hexahydro-8H-oxazolo[3,2-a]pyrrolo[2,1-c]pyrazin-2-yl]-7-methyl-4,6,6a,7,8,9-hexahydroindolo[4,3-fg]quinoline-9-carboxamide ((9S)-2-bromo- $\alpha$ -ergocriptine),

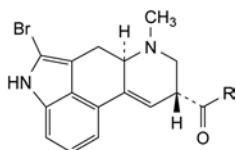

- D. R = OH: (6aR,9R)-5-bromo-7-methyl-4,6,6a,7,8,9-hexahydroindolo[4,3-fg]quinoline-9-carboxylic acid,

- E. R = NH<sub>2</sub>: (6aR,9R)-5-bromo-7-methyl-4,6,6a,7,8,9-hexahydroindolo[4,3-fg]quinoline-9-carboxamide,

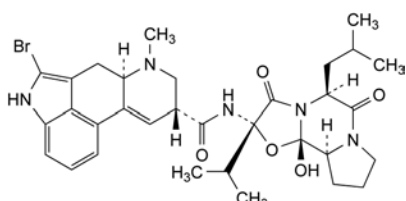

- F. (6aR,9R)-5-bromo-N-[(2S,5S,10aS,10bS)-10b-hydroxy-2-(1-methylethyl)-5-(2-methylpropyl)-3,6-dioxo-2,3,5,6,9,10-hexahydro-8H-oxazolo[3,2-a]pyrrolo[2,1-c]pyrazin-2-yl]-7-methyl-4,6,6a,7,8,9-hexahydroindolo[4,3-fg]quinoline-9-carboxamide ((2'S)-2-bromo- $\alpha$ -ergocriptine),

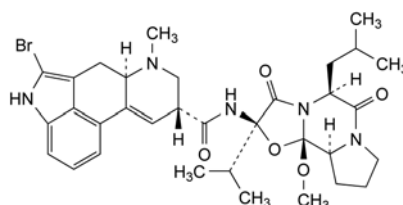

- G. (6aR,9R)-5-bromo-N-[(2R,5S,10aS,10bS)-10b-methoxy-2-(1-methylethyl)-5-(2-methylpropyl)-3,6-dioxo-2,3,5,6,9,10-hexahydro-8H-oxazolo[3,2-a]pyrrolo[2,1-c]pyrazin-2-yl]-7-methyl-4,6,6a,7,8,9-hexahydroindolo[4,3-fg]quinoline-9-carboxamide (2-bromo-10'-O-methyl- $\alpha$ -ergocriptine).

01/2008:1178  
corrected 6.0

## BROMPERIDOL

## Bromperidolum

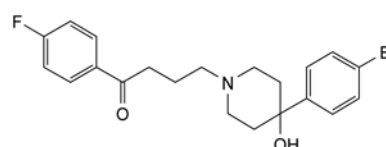

C<sub>21</sub>H<sub>23</sub>BrFNO<sub>2</sub>  
[10457-90-6]

M<sub>r</sub> 420.3

## DEFINITION

4-[4-(4-Bromophenyl)-4-hydroxypiperidin-1-yl]-1-(4-fluorophenyl)butan-1-one.

Content: 99.0 per cent to 101.0 per cent (dried substance).

## CHARACTERS

Appearance: white or almost white powder.

Solubility: practically insoluble in water, sparingly soluble in methanol and in methylene chloride, slightly soluble in ethanol (96 per cent).

## IDENTIFICATION

First identification: B, E.

Second identification: A, C, D, E.

A. Melting point (2.2.14):  $156\text{ }^{\circ}\text{C}$  to  $159\text{ }^{\circ}\text{C}$ .

B. Infrared absorption spectrophotometry (2.2.24).

Preparation: discs.

Comparison: bromperidol CRS.

C. Thin layer chromatography (2.2.27).

Test solution. Dissolve 10 mg of the substance to be examined in methanol R and dilute to 10 mL with the same solvent.

Reference solution (a). Dissolve 10 mg of bromperidol CRS in methanol R and dilute to 10 mL with the same solvent.

Reference solution (b). Dissolve 10 mg of bromperidol CRS and 10 mg of haloperidol CRS in methanol R and dilute to 10 mL with the same solvent.

Plate: TLC octadecylsilyl silica gel plate R.

Mobile phase: tetrahydrofuran R, methanol R, 58 g/L solution of sodium chloride R (10:45:45 V/V/V).

Application: 1  $\mu\text{L}$ .

Development: in an unsaturated tank over a path of 15 cm.

Drying: in air.

Detection: examine in ultraviolet light at 254 nm.

System suitability: reference solution (b):

– the chromatogram shows 2 spots which may, however, not be completely separated.

**Results:** the principal spot in the chromatogram obtained with the test solution is similar in position and size to the principal spot in the chromatogram obtained with reference solution (a).

- D. Dissolve about 10 mg in 5 mL of *anhydrous ethanol R*. Add 0.5 mL of *dinitrobenzene solution R* and 0.5 mL of *2 M alcoholic potassium hydroxide solution R*. A violet colour is produced that becomes brownish-red after 20 min.
- E. To 0.1 g in a porcelain crucible add 0.5 g of *anhydrous sodium carbonate R*. Heat over an open flame for 10 min. Allow to cool. Take up the residue with 5 mL of *dilute nitric acid R* and filter. To 1 mL of the filtrate add 1 mL of *water R*. The solution gives reaction (a) of bromides (2.3.1).

#### TESTS

**Appearance of solution.** The solution is clear (2.2.1) and not more intensely coloured than reference solution Y<sub>7</sub> (2.2.2, Method II).

Dissolve 0.2 g in 20 mL of a 1 per cent V/V solution of *lactic acid R*.

**Related substances.** Liquid chromatography (2.2.29).

**Test solution.** Dissolve 0.100 g of the substance to be examined in *methanol R* and dilute to 10.0 mL with the same solvent.

**Reference solution (a).** Dissolve 2.5 mg of *bromperidol CRS* and 5.0 mg of *haloperidol CRS* in *methanol R* and dilute to 50.0 mL with the same solvent.

**Reference solution (b).** Dilute 5.0 mL of the test solution to 100.0 mL with *methanol R*. Dilute 1.0 mL of this solution to 10.0 mL with *methanol R*.

**Column:**

- size:  $l = 0.1$  m,  $\emptyset = 4.0$  mm;
- stationary phase: base-deactivated octadecylsilyl silica gel for chromatography R (3  $\mu$ m).

**Mobile phase:**

- mobile phase A: 17 g/L solution of *tetrabutylammonium hydrogen sulfate R*;
- mobile phase B: *acetonitrile R*;

Time (min)	Mobile phase A (per cent V/V)	Mobile phase B (per cent V/V)
0 - 15	90 → 50	10 → 50
15 - 20	50	50
20 - 25	90	10

**Flow rate:** 1.5 mL/min.

**Detection:** spectrophotometer at 230 nm.

**Equilibration:** with *acetonitrile R* for at least 30 min and then with the mobile phase at the initial composition for at least 5 min.

**Injection:** 10  $\mu$ L; inject *methanol R* as a blank.

**Retention time:** haloperidol = about 5.5 min; bromperidol = about 6 min.

**System suitability:** reference solution (a):

- resolution: minimum 3.0 between the peaks due to haloperidol and bromperidol; if necessary, adjust the concentration of acetonitrile in the mobile phase or adjust the time programme for the linear gradient elution.

**Limits:**

- impurities A, B, C, D, E, F: for each impurity, not more than the area of the principal peak in the chromatogram obtained with reference solution (b) (0.5 per cent);
- total: not more than twice the area of the principal peak in the chromatogram obtained with reference solution (b) (1 per cent);
- disregard limit: 0.1 times the area of the principal peak in the chromatogram obtained with reference solution (b) (0.05 per cent); disregard any peak due to the blank.

**Loss on drying (2.2.32):** maximum 0.5 per cent, determined on 1.000 g by drying in an oven at 105 °C.

**Sulfated ash (2.4.14):** maximum 0.1 per cent, determined on 1.0 g in a platinum crucible.

#### ASSAY

Dissolve 0.300 g in 50 mL of a mixture of 1 volume of *anhydrous acetic acid R* and 7 volumes of *methyl ethyl ketone R*. Titrate with 0.1 M *perchloric acid*, using 0.2 mL of *naphtholbenzein solution R* as indicator.

1 mL of 0.1 M *perchloric acid* is equivalent to 42.03 mg of C<sub>21</sub>H<sub>23</sub>BrFNO<sub>2</sub>.

#### STORAGE

Protected from light.

#### IMPURITIES

**Specified impurities:** A, B, C, D, E, F.

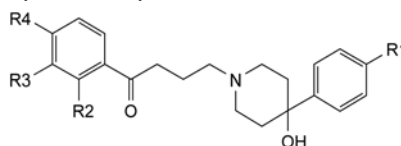

- A. R<sub>1</sub> = R<sub>2</sub> = R<sub>3</sub> = H, R<sub>4</sub> = F: 1-(4-fluorophenyl)-4-(4-hydroxy-4-phenylpiperidin-1-yl)butan-1-one,
- B. R<sub>1</sub> = Br, R<sub>2</sub> = F, R<sub>3</sub> = R<sub>4</sub> = H: 4-[4-(4-bromophenyl)-4-hydroxypiperidin-1-yl]-1-(2-fluorophenyl)butan-1-one,
- C. R<sub>1</sub> = C<sub>6</sub>H<sub>5</sub>, R<sub>2</sub> = R<sub>3</sub> = H, R<sub>4</sub> = F: 4-[4-(biphenyl-4-yl)-4-hydroxypiperidin-1-yl]-1-(4-fluorophenyl)butan-1-one,
- D. R<sub>1</sub> = Br, R<sub>2</sub> = H, R<sub>3</sub> = C<sub>2</sub>H<sub>5</sub>, R<sub>4</sub> = F: 4-[4-(4-bromophenyl)-4-hydroxypiperidin-1-yl]-1-(3-ethyl-4-fluorophenyl)butan-1-one,

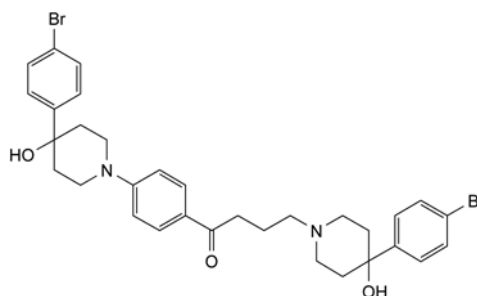

- E. 4-[4-(4-bromophenyl)-4-hydroxypiperidin-1-yl]-1-[4-(4-bromophenyl)-4-hydroxypiperidin-1-yl]phenyl]butan-1-one,

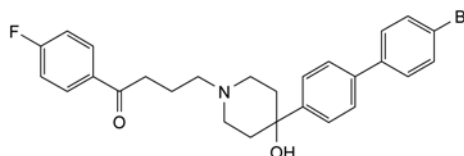

- F. 4-[4-(4'-bromobiphenyl-4-yl)-4-hydroxypiperidin-1-yl]-1-(4-fluorophenyl)butan-1-one.

01/2008:1397

## BROMPERIDOL DECANOATE

### Bromperidoli decanoas

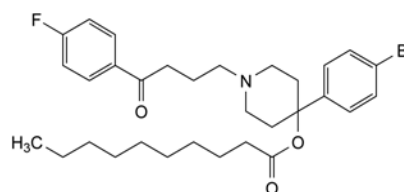

C<sub>31</sub>H<sub>41</sub>BrFNO<sub>3</sub>  
[75067-66-2]

M<sub>r</sub> 574.6

## DEFINITION

4-(4-Bromophenyl)-1-[4-(4-fluorophenyl)-4-oxobutyl]piperidin-4-yl decanoate.

*Content*: 98.5 per cent to 101.0 per cent (dried substance).

## CHARACTERS

*Appearance*: white or almost white powder.

*Solubility*: practically insoluble in water, very soluble in methylene chloride, soluble in ethanol (96 per cent).

*mp*: about 60 °C.

## IDENTIFICATION

A. Infrared absorption spectrophotometry (2.2.24).

*Preparation*: mulls in *liquid paraffin R*.

*Comparison*: *bromperidol decanoate CRS*.

B. To 0.1 g in a porcelain crucible add 0.5 g of *anhydrous sodium carbonate R*. Heat over an open flame for 10 min. Allow to cool. Take up the residue with 5 mL of *dilute nitric acid R* and filter. To 1 mL of the filtrate add 1 mL of *water R*. The solution gives reaction (a) of bromides (2.3.1).

## TESTS

**Appearance of solution.** The solution is clear (2.2.1) and not more intensely coloured than reference solution B<sub>5</sub> (2.2.2, *Method II*).

Dissolve 2.0 g in *methylene chloride R* and dilute to 20 mL with the same solvent.

**Related substances.** Liquid chromatography (2.2.29). Prepare the solutions immediately before use and protect from light.

*Test solution.* Dissolve 0.100 g of the substance to be examined in *methanol R* and dilute to 10.0 mL with the same solvent.

*Reference solution (a).* Dissolve 2.5 mg of *bromperidol decanoate CRS* and 2.5 mg of *haloperidol decanoate CRS* in *methanol R* and dilute to 50.0 mL with the same solvent.

*Reference solution (b).* Dilute 5.0 mL of the test solution to 100.0 mL with *methanol R*. Dilute 1.0 mL of this solution to 10.0 mL with *methanol R*.

*Column*:

- size:  $l = 0.1$  m,  $\emptyset = 4.0$  mm;
- stationary phase: base-deactivated octadecylsilyl silica gel for chromatography R (3  $\mu$ m).

*Mobile phase*:

- mobile phase A: 27 g/L solution of *tetrabutylammonium hydrogen sulfate R*;
- mobile phase B: *acetonitrile R*;

Time (min)	Mobile phase A (per cent V/V)	Mobile phase B (per cent V/V)
0 - 30	80 → 40	20 → 60
30 - 35	40	60
35 - 40	40 → 80	60 → 20

*Flow rate*: 1.5 mL/min.

*Detection*: spectrophotometer at 230 nm.

*Equilibration*: with *acetonitrile R* for at least 30 min and then with the mobile phase at the initial composition for at least 5 min.

*Injection*: 10  $\mu$ L; inject *methanol R* as a blank.

*Retention time*: haloperidol decanoate = about 24 min; bromperidol decanoate = about 24.5 min.

*System suitability*: reference solution (a):

- resolution: minimum 1.5 between the peaks due to haloperidol decanoate and bromperidol decanoate; if necessary, adjust the gradient or the time programme for the linear gradient elution.

## Limits:

- *impurities A, B, C, D, E, F, G, H, I, J, K*: for each impurity, not more than the area of the principal peak in the chromatogram obtained with reference solution (b) (0.5 per cent);
- *total*: not more than 3 times the area of the principal peak in the chromatogram obtained with reference solution (b) (1.5 per cent);
- *disregard limit*: 0.1 times the area of the principal peak in the chromatogram obtained with reference solution (b) (0.05 per cent); disregard any peak due to the blank.

**Loss on drying** (2.2.32): maximum 0.5 per cent, determined on 1.000 g by drying *in vacuo* at 30 °C.

**Sulfated ash** (2.4.14): maximum 0.1 per cent, determined on 1.0 g in a platinum crucible.

## ASSAY

Dissolve 0.450 g in 50 mL of a mixture of 1 volume of *anhydrous acetic acid R* and 7 volumes of *methyl ethyl ketone R*. Titrate with 0.1 M *perchloric acid* using 0.2 mL of *naphtholbenzein solution R* as indicator.

1 mL of 0.1 M *perchloric acid* is equivalent to 57.46 mg of C<sub>31</sub>H<sub>41</sub>BrFNO<sub>3</sub>.

## STORAGE

At a temperature below 25 °C, protected from light.

## IMPURITIES

*Specified impurities*: A, B, C, D, E, F, G, H, I, J, K.

*Other detectable impurities* (the following substances would, if present at a sufficient level, be detected by one or other of the tests in the monograph. They are limited by the general acceptance criterion for other/unspecified impurities and/or by the general monograph *Substances for pharmaceutical use* (2034). It is therefore not necessary to identify these impurities for demonstration of compliance. See also 5.10. *Control of impurities in substances for pharmaceutical use*): L.

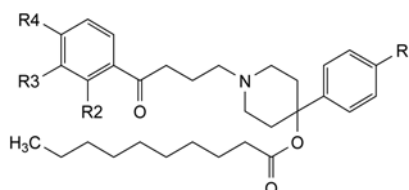

- A. R1 = R2 = R3 = H, R4 = F: 1-[4-(4-fluorophenyl)-4-oxobutyl]-4-phenylpiperidin-4-yl decanoate,
- B. R1 = Br, R2 = F, R3 = R4 = H: 4-(4-bromophenyl)-1-[4-(2-fluorophenyl)-4-oxobutyl]-piperidin-4-yl decanoate,
- C. R1 = Br, R2 = H, R3 = C<sub>2</sub>H<sub>5</sub>, R4 = F: 4-(4-bromophenyl)-1-[4-(3-ethyl-4-fluorophenyl)-4-oxobutyl]-piperidin-4-yl decanoate,
- F. R1 = C<sub>6</sub>H<sub>5</sub>, R2 = R3 = H, R4 = F: 4-(biphenyl-4-yl)-1-[4-(4-fluorophenyl)-4-oxobutyl]piperidin-4-yl decanoate,

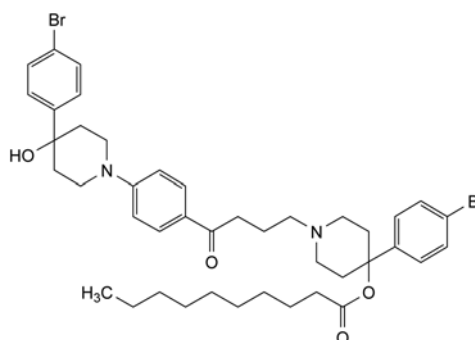

- D. 4-(4-bromophenyl)-1-[4-[4-(4-bromophenyl)-4-hydroxypiperidin-1-yl]phenyl]-4-oxobutyl]piperidin-4-yl decanoate,

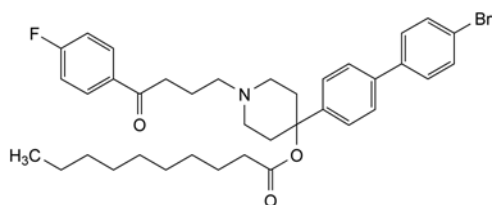

E. 4-(4'-bromobiphenyl-4-yl)-1-[4-(4-fluorophenyl)-4-oxobutyl]piperidin-4-yl decanoate,

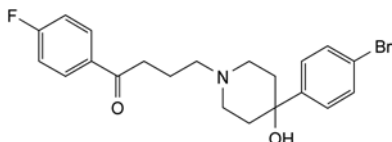

G. 4-[4-(4-bromophenyl)-4-hydroxypiperidin-1-yl]-1-(4-fluorophenyl)butan-1-one (bromperidol),

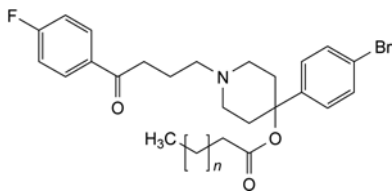
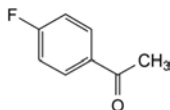
H.  $n = 5$ : 4-(4-bromophenyl)-1-[4-(4-fluorophenyl)-4-oxobutyl]piperidin-4-yl octanoate,I.  $n = 6$ : 4-(4-bromophenyl)-1-[4-(4-fluorophenyl)-4-oxobutyl]piperidin-4-yl nonanoate,J.  $n = 8$ : 4-(4-bromophenyl)-1-[4-(4-fluorophenyl)-4-oxobutyl]piperidin-4-yl undecanoate,K.  $n = 9$ : 4-(4-bromophenyl)-1-[4-(4-fluorophenyl)-4-oxobutyl]piperidin-4-yl dodecanoate,

L. 1-(4-fluorophenyl)ethanone.

01/2008:0977  
corrected 6.0**BROMPHENIRAMINE MALEATE**

## Brompheniramini maleas

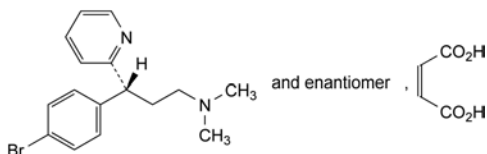
 $C_{20}H_{23}BrN_2O_4$   
[980-71-2] $M_r$  435.3

## DEFINITION

(3*RS*)-3-(4-Bromophenyl)-*N,N*-dimethyl-3-(pyridin-2-yl)propan-1-amine (*Z*)-butenedioate.*Content*: 98.0 per cent to 101.0 per cent (dried substance).

## CHARACTERS

*Appearance*: white or almost white, crystalline powder.*Solubility*: soluble in water, freely soluble in ethanol (96 per cent), in methanol and in methylene chloride.

## IDENTIFICATION

*First identification*: A, B, C, D, E.*Second identification*: A, B, E, F.

A. Melting point (2.2.14): 130 °C to 135 °C.

B. Ultraviolet and visible absorption spectrophotometry (2.2.25).

*Test solution*. Dissolve 65 mg in 0.1 *M* hydrochloric acid and dilute to 100.0 mL with the same acid. Dilute 5.0 mL of this solution to 100.0 mL with 0.1 *M* hydrochloric acid.*Spectral range*: 220-320 nm.*Absorption maximum*: at 265 nm.*Specific absorbance at the absorption maximum*: 190 to 210.

C. Infrared absorption spectrophotometry (2.2.24).

*Preparation*: discs of potassium bromide *R*.*Comparison*: brompheniramine maleate *CRS*.

D. Examine the chromatograms obtained in the test for related substances.

*System suitability*: reference solution (c):

– the chromatogram shows 2 principal peaks with retention times corresponding to the retention times of the peaks obtained with reference solutions (a) and (b).

*Results*: the principal peak in the chromatogram obtained with the test solution is similar in retention time and size to the principal peak in the chromatogram obtained with reference solution (a).

E. Thin-layer chromatography (2.2.27).

*Test solution*. Dissolve 0.10 g of the substance to be examined in methanol *R* and dilute to 5.0 mL with the same solvent.*Reference solution*. Dissolve 56 mg of maleic acid *R* in methanol *R* and dilute to 10 mL with the same solvent.*Plate*: TLC silica gel  $F_{254}$  plate *R*.*Mobile phase*: water *R*, anhydrous formic acid *R*, methanol *R*, di-isopropyl ether *R* (3:7:20:70 V/V/V/V).*Application*: 5  $\mu$ L.*Development*: over a path of 12 cm.*Drying*: in a current of air for a few minutes.*Detection*: examine in ultraviolet light at 254 nm.*Results*: the chromatogram obtained with the test solution shows 2 clearly separated spots. The upper spot is similar in position and size to the spot in the chromatogram obtained with the reference solution.F. To 0.15 g in a porcelain crucible add 0.5 g of anhydrous sodium carbonate *R*. Heat over an open flame for 10 min. Allow to cool. Take up the residue in 10 mL of dilute nitric acid *R* and filter. To 1 mL of the filtrate add 1 mL of water *R*. The solution gives reaction (a) of bromides (2.3.1).

## TESTS

**Appearance of solution**. The solution is clear (2.2.1) and not more intensely coloured than reference solution BY<sub>6</sub> (2.2.2, Method II).Dissolve 2.0 g in methanol *R* and dilute to 20 mL with the same solvent.**pH** (2.2.3): 4.0 to 5.0.Dissolve 0.20 g in 20 mL of carbon dioxide-free water *R*.**Optical rotation** (2.2.7):  $-0.2^\circ$  to  $+0.2^\circ$  (measured in a 2 dm tube).Dissolve 2.5 g in water *R* and dilute to 25.0 mL with the same solvent.**Related substances**. Gas chromatography (2.2.28).*Test solution*. Dissolve 0.10 g of the substance to be examined in 10 mL of methylene chloride *R*.*Reference solution (a)*. Dissolve 10 mg of brompheniramine maleate *CRS* in methylene chloride *R* and dilute to 1 mL with the same solvent.



*Reference solution (b).* Dissolve 5 mg of *chlorphenamine maleate CRS* (impurity A) in *methylene chloride R* and dilute to 1 mL with the same solvent.

*Reference solution (c).* To 0.5 mL of the test solution add 0.5 mL of reference solution (b).

*Column:*

- *material:* glass;
- *size:*  $l = 2.3$  m,  $\varnothing = 2$  mm;
- *stationary phase:* acid- and base-washed *silanised diatomaceous earth for gas chromatography R* (135–175  $\mu\text{m}$ ) impregnated with 3 per cent *m/m* of *polymethylphenylsiloxane R*.

*Carrier gas:* nitrogen for chromatography R.

*Flow rate:* 20 mL/min.

*Temperature:*

- *column:* 205 °C;
- *injection port and detector:* 250 °C.

*Detection:* flame ionisation.

*Injection:* 1  $\mu\text{L}$ .

*Run time:* 2.5 times the retention time of brompheniramine.

*System suitability:* reference solution (c):

- *resolution:* minimum 1.5 between the peaks due to brompheniramine and impurity A.

*Limits:*

- *impurities A, B, C:* for each impurity, maximum 0.4 per cent of the area of the principal peak;
- *total:* maximum 1 per cent of the area of the principal peak;
- *disregard limit:* 0.1 per cent of the area of the principal peak.

**Heavy metals (2.4.8):** maximum 20 ppm.

1.0 g complies with test C. Prepare the reference solution using 2 mL of *lead standard solution (10 ppm Pb) R*.

**Loss on drying (2.2.32):** maximum 0.5 per cent, determined on 1.000 g by drying in an oven at 105 °C for 3 h.

**Sulfated ash (2.4.14):** maximum 0.1 per cent, determined on 1.0 g.

**ASSAY**

Dissolve 0.260 g in 50 mL of *anhydrous acetic acid R*. Titrate with 0.1 M *perchloric acid*, determining the end-point potentiometrically (2.2.20).

1 mL of 0.1 M *perchloric acid* is equivalent to 21.77 mg of  $\text{C}_{20}\text{H}_{23}\text{BrN}_2\text{O}_4$ .

**STORAGE**

Protected from light.

**IMPURITIES**

*Specified impurities: A, B, C.*

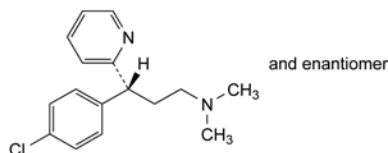

A. (3*R*)-3-(4-chlorophenyl)-*N,N*-dimethyl-3-(pyridin-2-yl)propan-1-amine (chlorphenamine),

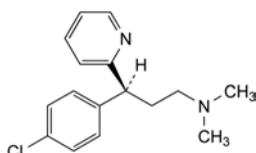

B. (3*S*)-3-(4-chlorophenyl)-*N,N*-dimethyl-3-(pyridin-2-yl)propan-1-amine (dexchlorpheniramine),

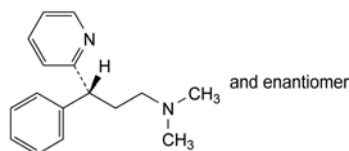

C. (3*RS*)-*N,N*-dimethyl-3-phenyl-3-(pyridin-2-yl)propan-1-amine (pheniramine).

01/2008:2197  
corrected 7.0

## BROTIZOLAM

### Brotizolamum

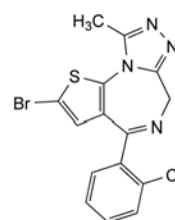

$\text{C}_{15}\text{H}_{10}\text{BrClN}_4\text{S}$   
[57801-81-7]

$M_r$  393.7

**DEFINITION**

2-Bromo-4-(2-chlorophenyl)-9-methyl-6*H*-thieno-[3,2- $\eta$ ][1,2,4]-triazolo[4,3-*a*][1,4]diazepine.

*Content:* 99.0 per cent to 101.0 per cent (dried substance).

**CHARACTERS**

*Appearance:* white or yellowish powder.

*Solubility:* practically insoluble in water, sparingly soluble or slightly soluble in methanol, slightly soluble in ethanol (96 per cent).

**IDENTIFICATION**

Infrared absorption spectrophotometry (2.2.24).

*Comparison:* *brotizolam CRS*.

**TESTS**

**Related substances.** Liquid chromatography (2.2.29). Carry out the test protected from light and prepare the solutions immediately before use.

*Test solution.* Dissolve 50.0 mg of the substance to be examined in *acetonitrile R* and dilute to 50.0 mL with the same solvent.

*Reference solution (a).* Dilute 1.0 mL of the test solution to 100.0 mL of *acetonitrile R*. Dilute 1.0 mL of this solution to 10.0 mL with *acetonitrile R*.

*Reference solution (b).* Dissolve 5 mg of the substance to be examined and 5 mg of *brotizolam impurity B CRS* in 50 mL of *acetonitrile R*. Dilute 2 mL of this solution to 20 mL with *acetonitrile R*.

*Column:*

- *size:*  $l = 0.15$  m,  $\varnothing = 4.6$  mm;
- *stationary phase:* *octylsilyl silica gel for chromatography R* (5  $\mu\text{m}$ );
- *temperature:* 40 °C.

*Mobile phase:*

- *mobile phase A*: 2 g/L solution of *sodium heptanesulfonate monohydrate R*;
- *mobile phase B*: mix 25 volumes of a 2 g/L solution of *sodium heptanesulfonate R* and 75 volumes of *acetonitrile R*;

Time (min)	Mobile phase A (per cent V/V)	Mobile phase B (per cent V/V)
0 - 4	63	37
4 - 15	63 → 12	37 → 88

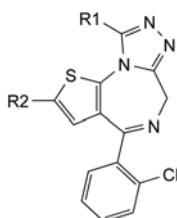

- A. R1 = CH<sub>3</sub>, R2 = H: 4-(2-chlorophenyl)-9-methyl-6*H*-thieno[3,2-*f*][1,2,4]triazolo[4,3-*a*][1,4]diazepine (desbromobrotizolam),
- B. R1 = H, R2 = Br: 2-bromo-4-(2-chlorophenyl)-6*H*-thieno[3,2-*f*][1,2,4]triazolo[4,3-*a*][1,4]diazepine (desmethylbrotizolam).

01/2010:1075

*Flow rate*: 2.0 mL/min.*Detection*: spectrophotometer at 242 nm.*Injection*: 5 µL.

*Relative retention* with reference to brotizolam (retention time = about 7.4 min): impurity A = about 0.5; impurity B = about 0.9.

*System suitability*: reference solution (b):

- *resolution*: minimum 5.0 between the peaks due to impurity B and brotizolam.

*Limits:*

- *impurity B*: not more than the area of the principal peak in the chromatogram obtained with reference solution (a) (0.1 per cent);
- *unspecified impurities*: for each impurity, not more than the area of the principal peak in the chromatogram obtained with reference solution (a) (0.10 per cent);
- *total*: not more than twice the area of the principal peak in the chromatogram obtained with reference solution (a) (0.2 per cent);
- *disregard limit*: 0.5 times the area of the principal peak in the chromatogram obtained with reference solution (a) (0.05 per cent).

**Chlorides** (2.4.4): maximum 100 ppm.Dissolve 0.67 g in 20.0 mL of *methanol R*, mix and filter.**Loss on drying** (2.2.32): maximum 0.5 per cent, determined on 1.000 g by drying in an oven at 105 °C.**Sulfated ash** (2.4.14): maximum 0.1 per cent, determined on 1.0 g.

## ASSAY

Dissolve 0.150 g in a mixture of 25 mL of *glacial acetic acid R* and 50 mL of *acetic anhydride R*. Titrate to the second point of inflexion with 0.1 M *perchloric acid*, determining the end-point potentiometrically (2.2.20).

1 mL of 0.1 M *perchloric acid* is equivalent to 19.68 mg of C<sub>15</sub>H<sub>10</sub>BrClN<sub>4</sub>S.

## IMPURITIES

*Specified impurities*: B.

*Other detectable impurities* (the following substances would, if present at a sufficient level, be detected by one or other of the tests in the monograph. They are limited by the general acceptance criterion for other/unspecified impurities and/or by the general monograph *Substances for pharmaceutical use* (2034). It is therefore not necessary to identify these impurities for demonstration of compliance. See also 5.10. *Control of impurities in substances for pharmaceutical use*): A.

## BUDESONIDE

## Budesonidum

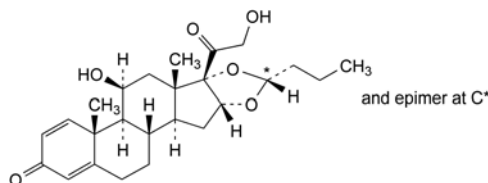
C<sub>25</sub>H<sub>34</sub>O<sub>6</sub>  
[51333-22-3]M<sub>r</sub> 430.5

## DEFINITION

Mixture of the C-22*S* (epimer A) and the C-22*R* (epimer B) epimers of 16α,17-[(1*RS*)-butylidenebis(oxy)]-11β,21-dihydroxypregna-1,4-diene-3,20-dione.

*Content*: 97.5 per cent to 102.0 per cent (dried substance).

## CHARACTERS

*Appearance*: white or almost white, crystalline powder.*Solubility*: practically insoluble in water, freely soluble in methylene chloride, sparingly soluble in ethanol (96 per cent).

## IDENTIFICATION

*First identification*: A.*Second identification*: B, C, D.

A. Infrared absorption spectrophotometry (2.2.24).

*Comparison*: budesonide CRS.

B. Thin-layer chromatography (2.2.27).

*Solvent mixture*: *methanol R*, *methylene chloride R* (10:90 V/V).*Test solution*. Dissolve 25 mg of the substance to be examined in the solvent mixture and dilute to 10 mL with the solvent mixture.*Reference solution (a)*. Dissolve 25 mg of *budesonide CRS* in the solvent mixture and dilute to 10 mL with the solvent mixture.*Reference solution (b)*. Dissolve 12.5 mg of *triamcinolone acetonide CRS* in reference solution (a) and dilute to 5 mL with reference solution (a).*Plate*: TLC silica gel F<sub>254</sub> plate R.*Mobile phase*: add a mixture of 1.2 volumes of *water R* and 8 volumes of *methanol R* to a mixture of 15 volumes of *ether R* and 77 volumes of *methylene chloride R*.*Application*: 5 µL.*Development*: over a path of 15 cm.*Drying*: in air.*Detection A*: examine in ultraviolet light at 254 nm.*Results A*: the principal spot in the chromatogram obtained with the test solution is similar in position and size to the principal spot in the chromatogram obtained with reference solution (a).

**Detection B:** spray with alcoholic solution of sulfuric acid R; heat at 120 °C for 10 min or until the spots appear and allow to cool; examine the chromatograms in daylight and in ultraviolet light at 365 nm.

**Results B:** the principal spot in the chromatogram obtained with the test solution is similar in position, colour in daylight, fluorescence in ultraviolet light at 365 nm and size to the principal spot in the chromatogram obtained with reference solution (a).

**System suitability:** reference solution (b):

- the chromatogram shows 2 clearly separated spots.

C. Dissolve about 2 mg in 2 mL of sulfuric acid R. Within 5 min a yellow colour develops. Within 30 min the colour changes to brown or reddish-brown. Cautiously add the solution to 10 mL of water R and mix. The colour fades and a clear solution remains.

D. Dissolve about 1 mg in 2 mL of a solution containing 2 g of phosphomolybdic acid R dissolved in a mixture of 10 mL of dilute sodium hydroxide solution R, 15 mL of water R and 25 mL of glacial acetic acid R. Heat for 5 min on a water-bath. Cool in iced water for 10 min and add 3 mL of dilute sodium hydroxide solution R. The solution is blue.

## TESTS

**Related substances.** Liquid chromatography (2.2.29). Carry out the test protected from light.

**Solvent mixture:** acetonitrile R, phosphate buffer solution pH 3.2 R (32:68 V/V).

**Test solution (a).** Dissolve 50 mg of the substance to be examined in 15 mL of acetonitrile R and dilute to 50 mL with phosphate buffer solution pH 3.2 R.

**Test solution (b).** Dissolve 25.0 mg of the substance to be examined in 15 mL of acetonitrile R and dilute to 50.0 mL with phosphate buffer solution pH 3.2 R.

**Reference solution (a).** Dilute 1.0 mL of test solution (a) to 10.0 mL with the solvent mixture. Dilute 1.0 mL of this solution to 100.0 mL with the solvent mixture.

**Reference solution (b).** Dissolve 5 mg of budesonide for system suitability CRS (containing impurities A, D, G, K and L) in 1.5 mL of acetonitrile R and dilute to 5 mL with phosphate buffer solution pH 3.2 R.

**Reference solution (c).** Dissolve 25.0 mg of budesonide CRS in 15 mL of acetonitrile R and dilute to 50.0 mL with phosphate buffer solution pH 3.2 R.

**Column:**

- size:  $l = 0.15$  m,  $\varnothing = 4.6$  mm;
- stationary phase: end-capped octadecylsilyl silica gel for chromatography R (3  $\mu$ m);
- temperature: 50 °C.

**Mobile phase:**

- mobile phase A: anhydrous ethanol R, acetonitrile R, phosphate buffer solution pH 3.2 R (2:32:68 V/V/V);
- mobile phase B: acetonitrile R, phosphate buffer solution pH 3.2 R (50:50 V/V);

Time (min)	Mobile phase A (per cent V/V)	Mobile phase B (per cent V/V)
0 - 38	100	0
38 - 50	100 → 0	0 → 100
50 - 60	0	100

**Flow rate:** 1 mL/min.

**Detection:** spectrophotometer at 240 nm.

**Injection:** 20  $\mu$ L of test solution (a) and reference solutions (a) and (b).

**Identification of impurities:** use the chromatogram supplied with budesonide for system suitability CRS and the chromatogram obtained with reference solution (b) to identify the peaks due to impurities A, D, G, K and L.

**Relative retention** with reference to budesonide epimer B (retention time = about 17 min): impurity A = about 0.1; epimers of impurity D = about 0.63 and 0.67; impurity L = about 0.95; epimers of impurity G = about 1.2 and 1.3; epimers of impurity K = about 2.9 and 3.0.

**System suitability:** reference solution (b):

- peak-to-valley ratio: minimum 2.5, where  $H_p$  = height above the baseline of the 1<sup>st</sup> of the 2 peaks due to impurity G and  $H_v$  = height above the baseline of the lowest point of the curve separating this peak from the peak due to budesonide epimer A (the 2<sup>nd</sup> of the 2 principal peaks); and minimum 3, where  $H_p$  = height above the baseline of the peak due to impurity L and  $H_v$  = height above the baseline of the lowest point of the curve separating this peak from the peak due to budesonide epimer B (the 1<sup>st</sup> of the 2 principal peaks).

**Limits:**

- correction factors: for the calculation of content, multiply the peak areas of the following impurities by the corresponding correction factor: impurity D = 1.8; impurity K = 1.3;
- impurities A, L: for each impurity, not more than twice the sum of the areas of the 2 peaks due to the budesonide epimers in the chromatogram obtained with reference solution (a) (0.2 per cent);
- impurities D, K: for each impurity, for the sum of the areas of the 2 epimer peaks, not more than twice the sum of the areas of the 2 peaks due to the budesonide epimers in the chromatogram obtained with reference solution (a) (0.2 per cent);
- unspecified impurities: for each individual peak, not more than the sum of the areas of the 2 peaks due to the budesonide epimers in the chromatogram obtained with reference solution (a) (0.10 per cent);
- total: not more than 5 times the sum of the areas of the 2 peaks due to the budesonide epimers in the chromatogram obtained with reference solution (a) (0.5 per cent);
- disregard limit: 0.5 times the sum of the areas of the 2 peaks due to the budesonide epimers in the chromatogram obtained with reference solution (a) (0.05 per cent).

**Epimer A.** Liquid chromatography (2.2.29) as described in the test for related substances with the following modifications.

**Mobile phase:**

Time (min)	Mobile phase A (per cent V/V)	Mobile phase B (per cent V/V)
0 - 21	100	0
21 - 22	100 → 0	0 → 100
22 - 31	0	100

**Injection:** 20  $\mu$ L of test solution (b) and reference solutions (b) and (c).

**Retention time:** budesonide epimer B = about 17 min; budesonide epimer A = about 19 min.

**System suitability:**

- resolution: minimum 1.5 between the 2 principal peaks (budesonide epimers A and B) in the chromatogram obtained with reference solution (c);
- peak-to-valley ratio: minimum 3, where  $H_p$  = height above the baseline of the peak due to impurity L and  $H_v$  = height above the baseline of the lowest point of the curve separating this peak from the peak due to budesonide epimer B (the 1<sup>st</sup> of the 2 principal peaks) in the chromatogram obtained with reference solution (b).

**Limit:**

- epimer A: 40.0 per cent to 51.0 per cent of the sum of the areas of the 2 peaks due to the budesonide epimers.

**Loss on drying (2.2.32):** maximum 0.5 per cent, determined on 1.000 g by drying in an oven at 105 °C.

**ASSAY**

Liquid chromatography (2.2.29). Examine the chromatograms obtained in the test for epimer A.

Calculate the percentage content of C<sub>25</sub>H<sub>34</sub>O<sub>6</sub> from the sum of the areas of the 2 peaks due to the budesonide epimers and the declared content of *budesonide CRS*.

**IMPURITIES**

*Specified impurities: A, D, K, L.*

*Other detectable impurities* (the following substances would, if present at a sufficient level, be detected by one or other of the tests in the monograph. They are limited by the general acceptance criterion for other/unspecified impurities and/or by the general monograph *Substances for pharmaceutical use (2034)*. It is therefore not necessary to identify these impurities for demonstration of compliance. See also 5.10. *Control of impurities in substances for pharmaceutical use*): B, C, E, F, G, H, I, J.

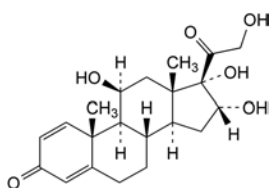

A. 11β,16α,17,21-tetrahydroxypregna-1,4-diene-3,20-dione,

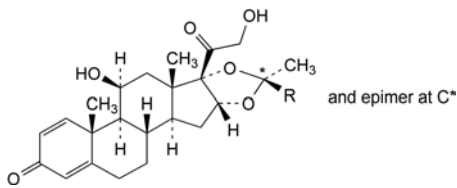

B. R = H: 16α,17-[(1RS)-ethylidenebis(oxy)]-11β,21-dihydroxypregna-1,4-diene-3,20-dione,

F. R = CH<sub>3</sub>: 16α,17-[1-methylethylidenebis(oxy)]-11β,21-dihydroxypregna-1,4-diene-3,20-dione,

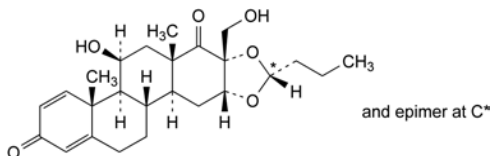

C. 16α,17-[(1RS)-butylidenebis(oxy)]-11β-hydroxy-17-(hydroxymethyl)-D-homoandrosta-1,4-diene-3,17a-dione,

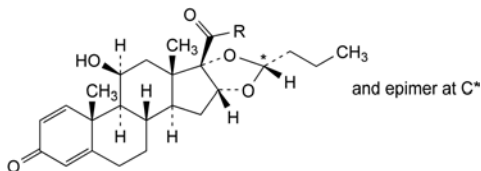

D. R = CHO: 16α,17-[(1RS)-butylidenebis(oxy)]-11β-hydroxy-3,20-dioxopregna-1,4-dien-21-al,

K. R = CH<sub>2</sub>-O-CO-CH<sub>3</sub>: 16α,17-[(1RS)-butylidenebis(oxy)]-11β,21-dihydroxypregna-1,4-diene-3,20-dione-21-acetate,

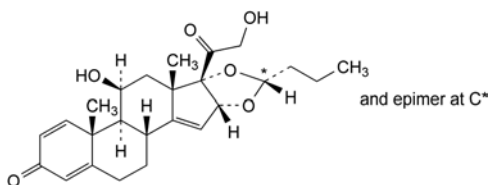

E. 16α,17-[(1RS)-butylidenebis(oxy)]-11β,21-dihydroxypregna-1,4,14-triene-3,20-dione,

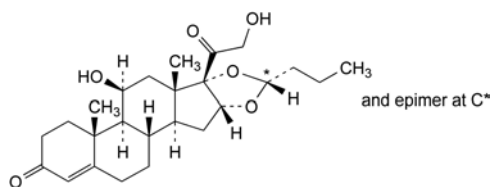

G. 16α,17-[(1RS)-butylidenebis(oxy)]-11β,21-dihydroxypregna-4-ene-3,20-dione.

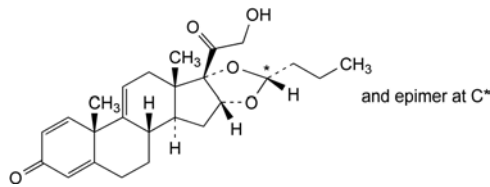

H. 16α,17-[(1RS)-butylidenebis(oxy)]-21-hydroxypregna-1,4,9(11)-triene-3,20-dione,

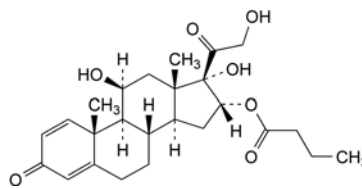

I. 11β,17,21-trihydroxy-3,20-dioxopregna-1,4-dien-16α-yl butanoate,

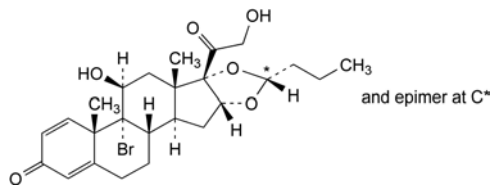

J. 16α,17-[(1RS)-butylidenebis(oxy)]-9α-bromo-11β,21-dihydroxypregna-1,4-diene-3,20-dione,

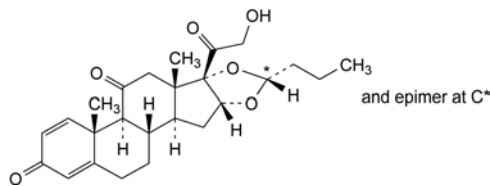

L. 16α,17-[(1RS)-butylidenebis(oxy)]-21-hydroxypregna-1,4-diene-3,11,20-trione.

01/2008:1179

**BUFEXAMAC**

**Bufexamacum**

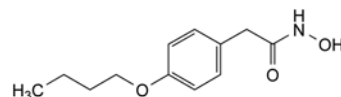

C<sub>12</sub>H<sub>17</sub>NO<sub>3</sub>  
[2438-72-4]

M<sub>r</sub> 223.3

**DEFINITION**

2-(4-Butoxyphenyl)-N-hydroxyacetamide.

*Content:* 98.5 per cent to 101.5 per cent (dried substance).

**CHARACTERS**

*Appearance:* white or almost white, crystalline powder.

*Solubility:* practically insoluble in water, soluble in dimethylformamide, slightly soluble in ethyl acetate and in methanol.

## IDENTIFICATION

*First identification:* B.

*Second identification:* A, C.

A. Ultraviolet and visible absorption spectrophotometry (2.2.25).

*Test solution.* Dissolve 20 mg in *methanol R* and dilute to 20 mL with the same solvent. Dilute 1 mL of this solution to 50 mL with *methanol R*.

*Spectral range:* 210-360 nm.

*Absorption maxima:* at 228 nm, 277 nm and 284 nm.

B. Infrared absorption spectrophotometry (2.2.24).

*Preparation:* discs.

*Comparison:* *bufexamac CRS*.

C. Thin-layer chromatography (2.2.27).

*Test solution.* Dissolve 10 mg of the substance to be examined in *methanol R* and dilute to 5 mL with the same solvent.

*Reference solution (a).* Dissolve 20 mg of *bufexamac CRS* in *methanol R* and dilute to 10 mL with the same solvent.

*Reference solution (b).* Dissolve 10 mg of *salicylic acid R* in reference solution (a) and dilute to 5 mL with the same solution.

*Plate:* TLC silica gel  $F_{254}$  plate *R*.

*Mobile phase:* glacial acetic acid *R*, dioxan *R*, toluene *R* (4:20:90 V/V/V).

*Application:* 10  $\mu$ L.

*Development:* over a path of 15 cm.

*Drying:* in a current of warm air.

*Detection:* examine in ultraviolet light at 254 nm.

*System suitability:* reference solution (b):

– the chromatogram shows 2 clearly separated spots.

*Results:* the principal spot in the chromatogram obtained with the test solution is similar in position and size to the principal spot in the chromatogram obtained with reference solution (a).

## TESTS

**Related substances.** Liquid chromatography (2.2.29).

*Test solution.* Dissolve 50.0 mg of the substance to be examined in the mobile phase and dilute to 20.0 mL with the mobile phase.

*Reference solution (a).* Dilute 5.0 mL of the test solution to 25.0 mL with the mobile phase. Dilute 1.0 mL of this solution to 100.0 mL with the mobile phase.

*Reference solution (b).* Dissolve 5 mg of *bufexamac CRS* and 5 mg of *salicylic acid R* in the mobile phase and dilute to 10 mL with the mobile phase. Dilute 1 mL of this solution to 10 mL with the mobile phase.

*Column:*

– *size:*  $l = 0.25$  m,  $\varnothing = 4.6$  mm;

– *stationary phase:* octadecylsilyl silica gel for chromatography *R* (5  $\mu$ m) with a specific surface area of 350 m<sup>2</sup>/g and a pore size of 10 nm.

*Mobile phase:* mix 30 volumes of a 1.4 g/L solution of dipotassium hydrogen phosphate *R* and 70 volumes of *methanol R*, then adjust to pH 3.6 with dilute phosphoric acid *R*.

*Flow rate:* 1 mL/min.

*Detection:* spectrophotometer at 275 nm.

*Injection:* 20  $\mu$ L.

*Run time:* 4 times the retention time of *bufexamac*.

*System suitability:* reference solution (b):

– *resolution:* minimum 2.0 between the peaks due to salicylic acid and *bufexamac*.

*Limits:*

- *impurities A, B, C, D:* for each impurity, not more than the area of the principal peak in the chromatogram obtained with reference solution (a) (0.2 per cent);
- *total:* not more than 2.5 times the area of the principal peak in the chromatogram obtained with reference solution (a) (0.5 per cent);
- *disregard limit:* 0.05 times the area of the principal peak in the chromatogram obtained with reference solution (a) (0.01 per cent).

**Loss on drying** (2.2.32): maximum 0.5 per cent, determined on 1.000 g by drying *in vacuo* at 80 °C for 3 h.

**Sulfated ash** (2.4.14): maximum 0.1 per cent, determined on 1.0 g.

## ASSAY

Dissolve 0.200 g in 50 mL of *dimethylformamide R*. Titrate with 0.1 M *lithium methoxide*, determining the end-point potentiometrically (2.2.20).

1 mL of 0.1 M *lithium methoxide* is equivalent to 22.33 mg of C<sub>12</sub>H<sub>17</sub>NO<sub>3</sub>.

## STORAGE

Protected from light.

## IMPURITIES

*Specified impurities:* A, B, C, D.

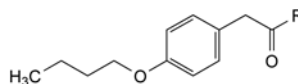

- A. R = OH: 2-(4-butoxyphenyl)acetic acid,
- B. R = OCH<sub>3</sub>: methyl 2-(4-butoxyphenyl)acetate,
- C. R = OC<sub>4</sub>H<sub>9</sub>: butyl 2-(4-butoxyphenyl)acetate,
- D. R = NH<sub>2</sub>: 2-(4-butoxyphenyl)acetamide.

01/2011:1398

## BUFLOMEDIL HYDROCHLORIDE

## Bufloxedili hydrochloridum

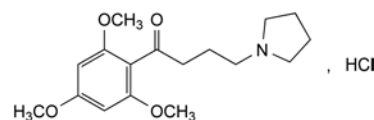

C<sub>17</sub>H<sub>26</sub>ClNO<sub>4</sub>  
[35543-24-9]

$M_r$  343.9

## DEFINITION

4-(Pyrrolidin-1-yl)-1-(2,4,6-trimethoxyphenyl)butan-1-one hydrochloride.

*Content:* 98.5 per cent to 101.5 per cent (dried substance).

## CHARACTERS

*Appearance:* white or almost white, microcrystalline powder.

*Solubility:* freely soluble in water, soluble in ethanol (96 per cent), very slightly soluble in acetone.

mp: about 195 °C, with decomposition.

## IDENTIFICATION

*First identification:* B, D.

*Second identification:* A, C, D.

A. Ultraviolet and visible absorption spectrophotometry (2.2.25).

*Test solution.* Dissolve 25.0 mg in *ethanol (96 per cent) R* and dilute to 50.0 mL with the same solvent. Dilute 2.0 mL of the solution to 20.0 mL with *ethanol (96 per cent) R*.

*Spectral range:* 220-350 nm.

*Absorption maximum:* at 275 nm.

*Specific absorbance at the absorption maximum:* 143 to 149.

**B.** Infrared absorption spectrophotometry (2.2.24).

*Comparison:* buflomedil hydrochloride CRS.

**C.** Thin-layer chromatography (2.2.27).

*Test solution.* Dissolve 40 mg of the substance to be examined in *methanol R* and dilute to 2 mL with the same solvent.

*Reference solution.* Dissolve 40 mg of *buflomedil hydrochloride CRS* in *methanol R* and dilute to 2 mL with the same solvent.

*Plate:* TLC silica gel  $F_{254}$  plate *R*.

*Mobile phase:* triethylamine *R*, 2-propanol *R*, toluene *R* (5:50:50 V/V/V).

*Application:* 10  $\mu$ L.

*Development:* over 3/4 of the plate.

*Drying:* in air.

*Detection:* examine in ultraviolet light at 254 nm.

*Results:* the principal spot in the chromatogram obtained with the test solution is similar in position and size to the principal spot in the chromatogram obtained with the reference solution.

**D.** It gives reaction (a) of chlorides (2.3.1).

**TESTS**

**Solution S.** Dissolve 2.5 g in *carbon dioxide-free water R* and dilute to 50 mL with the same solvent.

**Appearance of solution.** Solution S is clear (2.2.1) and colourless (2.2.2, *Method II*).

**pH** (2.2.3): 5.0 to 6.5 for solution S.

**Related substances.** Liquid chromatography (2.2.29).

*Test solution.* Dissolve 0.10 g of the substance to be examined in the mobile phase and dilute to 10.0 mL with the mobile phase.

*Reference solution (a).* Dilute 0.5 mL of the test solution to 100.0 mL with the mobile phase. Dilute 5.0 mL of this solution to 10.0 mL with the mobile phase.

*Reference solution (b).* Dissolve 2 mg of *buflomedil impurity B CRS* in the mobile phase, add 0.5 mL of the test solution and dilute to 100.0 mL with the mobile phase.

*Column:*

- *size:*  $l = 0.25$  m,  $\varnothing = 4.6$  mm;
- *stationary phase:* end-capped octadecylsilyl silica gel for chromatography *R* (5  $\mu$ m);
- *temperature:* 40 °C.

*Mobile phase:* mix 45 volumes of *acetonitrile R1* and 55 volumes of a 9.25 g/L solution of *potassium dihydrogen phosphate R* adjusted to pH 2.5 with *phosphoric acid R*.

*Flow rate:* 1 mL/min.

*Detection:* spectrophotometer at 210 nm.

*Injection:* 10  $\mu$ L.

*Run time:* twice the retention time of buflomedil.

*Identification of impurities:* use the chromatogram obtained with reference solution (b) to identify the peak due to impurity B.

*Relative retention* with reference to buflomedil (retention time = about 5 min): impurity B = about 0.6; impurity C = about 0.7; impurity A = about 1.5.

*System suitability:* reference solution (b):

- *resolution:* minimum 5.0 between the peaks due to impurity B and buflomedil.

*Limits:*

- *impurities A, B, C:* for each impurity, not more than the area of the principal peak in the chromatogram obtained with reference solution (a) (0.25 per cent),

- *unspecified impurities:* for each impurity, not more than 0.4 times the area of the principal peak in the chromatogram obtained with reference solution (a) (0.10 per cent),
- *total:* not more than twice the area of the principal peak in the chromatogram obtained with reference solution (a) (0.5 per cent),
- *disregard limit:* 0.2 times the area of the principal peak in the chromatogram obtained with reference solution (a) (0.05 per cent).

**Heavy metals** (2.4.8): maximum 10 ppm.

2.0 g complies with test C. Prepare the reference solution using 2 mL of *lead standard solution (10 ppm Pb) R*.

**Loss on drying** (2.2.32): maximum 0.5 per cent, determined on 1.000 g by drying in an oven at 105 °C for 2 h.

**Sulfated ash** (2.4.14): maximum 0.1 per cent, determined on 1.0 g.

**ASSAY**

Dissolve 0.300 g in 15 mL of *anhydrous acetic acid R* and add 35 mL of *acetic anhydride R*. Titrate with 0.1 M *perchloric acid*, determining the end-point potentiometrically (2.2.20).

1 mL of 0.1 M *perchloric acid* is equivalent to 34.39 mg of  $C_{17}H_{26}ClNO_4$ .

**IMPURITIES**

*Specified impurities:* A, B, C.

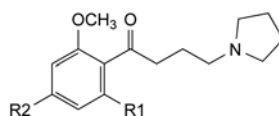

- A. R1 = OH, R2 = OCH<sub>3</sub>: 4-(pyrrolidin-1-yl)-1-(2-hydroxy-4,6-dimethoxyphenyl)butan-1-one,
- B. R1 = OCH<sub>3</sub>, R2 = OH: 4-(pyrrolidin-1-yl)-1-(4-hydroxy-2,6-dimethoxyphenyl)butan-1-one,
- C. R1 = R2 = OH: 4-(pyrrolidin-1-yl)-1-(2,4-dihydroxy-6-methoxyphenyl)butan-1-one.

01/2008:1076  
corrected 6.0

**BUMETANIDE**

Bumetanidum

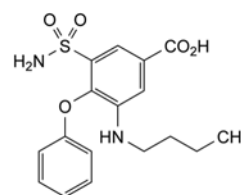

$C_{17}H_{20}N_2O_5S$   
[28395-03-1]

$M_r$  364.4

**DEFINITION**

3-(Butylamino)-4-phenoxy-5-sulfamoylbenzoic acid.

*Content:* 99.0 per cent to 101.0 per cent (dried substance).

**CHARACTERS**

*Appearance:* white or almost white, crystalline powder.

*Solubility:* practically insoluble in water, soluble in acetone and in alcohol, slightly soluble in methylene chloride. It dissolves in dilute solutions of alkali hydroxides.

It shows polymorphism (5.9).

mp: about 233 °C.

**IDENTIFICATION**

Infrared absorption spectrophotometry (2.2.24).

*Comparison: bumetanide CRS.*

If the spectra obtained in the solid state show differences, dissolve the substance to be examined and the reference substance separately in *acetone R*, evaporate to dryness and record new spectra using the residues.

#### TESTS

**Appearance of solution.** The solution is clear (2.2.1) and colourless (2.2.2, Method II).

Dissolve 0.1 g in a 6 g/L solution of *potassium hydroxide R* and dilute to 20 mL with the same solution.

**Related substances.** Liquid chromatography (2.2.29).

*Test solution.* Dissolve 50 mg of the substance to be examined in the mobile phase and dilute to 25.0 mL with the mobile phase.

*Reference solution (a).* Dilute 1.0 mL of the test solution to 100.0 mL with the mobile phase. Dilute 1.0 mL of this solution to 10.0 mL with the mobile phase.

*Reference solution (b).* Dissolve 2 mg of *bumetanide impurity A CRS* and 2 mg of *bumetanide impurity B CRS* in the mobile phase and dilute to 10.0 mL with the mobile phase. Dilute 1.0 mL of this solution to 100.0 mL with the mobile phase.

*Column:*

- size:  $l = 0.15$  m,  $\varnothing = 4.6$  mm,
- stationary phase: end-capped octylsilyl silica gel for chromatography R (3.5  $\mu$ m).

*Mobile phase:* mix 70 volumes of *methanol R*, 25 volumes of *water for chromatography R* and 5 volumes of a 27.2 g/L solution of *potassium dihydrogen phosphate R* previously adjusted to pH 7.0 with a 280 g/L solution of *potassium hydroxide R*; add *tetrahexylammonium bromide R* to this mixture to obtain a concentration of 2.17 g/L.

*Flow rate:* 1.0 mL/min.

*Detection:* spectrophotometer at 254 nm.

*Injection:* 10  $\mu$ L.

*Run time:* 5 times the retention time of bumetanide.

*Relative retention* with reference to bumetanide (retention time = about 6 min): impurity B = about 0.4; impurity A = about 0.6; impurity D = about 2.5; impurity C = about 4.4.

*System suitability:* reference solution (b):

- resolution: minimum 2.0 between the peaks due to impurity A and impurity B.

*Limits:*

- *impurities A, B, C, D:* for each impurity, not more than the area of the principal peak in the chromatogram obtained with reference solution (a) (0.1 per cent),
- *other impurities:* for each impurity, not more than the area of the principal peak in the chromatogram obtained with reference solution (a) (0.1 per cent),
- *total:* not more than twice the area of the principal peak in the chromatogram obtained with reference solution (a) (0.2 per cent),
- *disregard limit:* 0.5 times the area of the principal peak in the chromatogram obtained with reference solution (a) (0.05 per cent).

**Loss on drying** (2.2.32): maximum 0.5 per cent, determined on 1.000 g by drying in an oven at 105 °C for 4 h.

**Sulfated ash** (2.4.14): maximum 0.1 per cent, determined on 1.0 g.

#### ASSAY

Dissolve 0.300 g in 50 mL of *alcohol R*. Add 0.1 mL of *phenol red solution R*. Titrate with 0.1 M *sodium hydroxide* until a violet-red colour is obtained. Carry out a blank titration.

1 mL of 0.1 M *sodium hydroxide* is equivalent to 36.44 mg of  $C_{17}H_{20}N_2O_5S$ .

#### STORAGE

Protected from light.

#### IMPURITIES

*Specified impurities: A, B, C, D.*

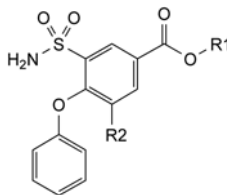

- A. R1 = H, R2 = NO<sub>2</sub>: 3-nitro-4-phenoxy-5-sulfamoylbenzoic acid,  
 B. R1 = H, R2 = NH<sub>2</sub>: 3-amino-4-phenoxy-5-sulfamoylbenzoic acid,  
 C. R1 = C<sub>4</sub>H<sub>9</sub>, R2 = NH-C<sub>4</sub>H<sub>9</sub>: butyl 3-(butylamino)-4-phenoxy-5-sulfamoylbenzoate,

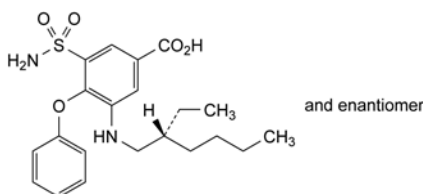

- D. 3-[[[(2RS)-2-ethylhexyl]amino]-4-phenoxy-5-sulfamoylbenzoic acid.

01/2008:0541  
corrected 6.0

## BUPIVACAINE HYDROCHLORIDE

### Bupivacaini hydrochloridum

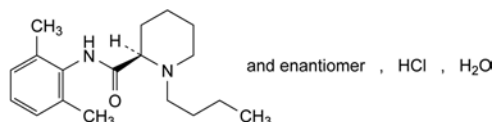

$C_{18}H_{29}ClN_2O_2 \cdot H_2O$   
[14252-80-3]

$M_r$  342.9

#### DEFINITION

(2RS)-1-Butyl-N-(2,6-dimethylphenyl)piperidine-2-carboxamide hydrochloride monohydrate.

*Content:* 98.5 per cent to 101.0 per cent (dried substance).

#### CHARACTERS

*Appearance:* white or almost white, crystalline powder or colourless crystals.

*Solubility:* soluble in water, freely soluble in alcohol. mp: about 254 °C, with decomposition.

#### IDENTIFICATION

*First identification: A, D.*

*Second identification: B, C, D.*

A. Infrared absorption spectrophotometry (2.2.24).

*Preparation:* discs of *potassium bromide R*.

*Comparison:* *bupivacaine hydrochloride CRS*.

B. Thin-layer chromatography (2.2.27).

*Test solution.* Dissolve 25 mg of the substance to be examined in *methanol R* and dilute to 5 mL with the same solvent.

*Reference solution.* Dissolve 25 mg of *bupivacaine hydrochloride CRS* in *methanol R* and dilute to 5 mL with the same solvent.

*Plate:* TLC silica gel G plate R.

Mobile phase: concentrated ammonia R, methanol R (0.1:100 V/V).

Application: 5 µL.

Development: over a path of 10 cm.

Drying: in air.

Detection: spray with dilute potassium iodobismuthate solution R.

Results: the principal spot in the chromatogram obtained with the test solution is similar in position, colour and size to the principal spot in the chromatogram obtained with the reference solution.

- C. Dissolve 0.1 g in 10 mL of water R, add 2 mL of dilute sodium hydroxide solution R and shake with 2 quantities, each of 15 mL, of ether R. Dry the combined ether layers over anhydrous sodium sulfate R and filter. Evaporate the ether, recrystallise the residue from alcohol (90 per cent V/V) R and dry under reduced pressure. The crystals melt (2.2.14) at 105 °C to 108 °C.

- D. It gives reaction (a) of chlorides (2.3.1).

## TESTS

**Solution S.** Dissolve 1.0 g in carbon dioxide-free water R and dilute to 50 mL with the same solvent.

**Appearance of solution.** Solution S is clear (2.2.1) and colourless (2.2.2, Method II).

**Acidity or alkalinity.** To 10 mL of solution S add 0.2 mL of 0.01 M sodium hydroxide; the pH (2.2.3) is not less than 4.7. Add 0.4 mL of 0.01 M hydrochloric acid; the pH is not greater than 4.7.

**Related substances.** Gas chromatography (2.2.28).

**Internal standard solution.** Dissolve 25 mg of methyl behenate R in methylene chloride R and dilute to 500 mL with the same solvent.

**Test solution.** Dissolve 50.0 mg of the substance to be examined in 2.5 mL of water R, add 2.5 mL of dilute sodium hydroxide solution R and extract with 2 quantities, each of 5 mL, of the internal standard solution. Filter the lower layer.

**Reference solution (a).** Dissolve 10 mg of the substance to be examined, 10 mg of bupivacaine impurity B CRS and 10 mg of bupivacaine impurity E CRS in 2.5 mL of water R, add 2.5 mL of dilute sodium hydroxide solution R and extract with 2 quantities, each of 5 mL, of the internal standard solution. Filter the lower layer and dilute to 20 mL with the internal standard solution.

**Reference solution (b).** Dilute 1.0 mL of the test solution to 100.0 mL with the internal standard solution.

**Reference solution (c).** Dilute 5.0 mL of reference solution (b) to 10.0 mL with the internal standard solution.

**Reference solution (d).** Dilute 1.0 mL of reference solution (b) to 10.0 mL with the internal standard solution.

**Column:**

- material: fused silica,
- size:  $l = 30$  m,  $\varnothing = 0.32$  mm,
- stationary phase: poly(dimethyl)(diphenyl)siloxane R (film thickness 0.25 µm).

**Carrier gas:** helium for chromatography R.

**Flow rate:** 2.5 mL/min.

**Split ratio:** 1:12.

**Temperature:**

	Time (min)	Temperature (°C)
	0	180
Column	0 - 10	180 → 230
	10 - 15	230
Injection port		250
Detector		250

Detection: flame ionisation.

Injection: 1 µL.

Relative retention with reference to bupivacaine (retention time = about 10 min): impurity C = about 0.5; impurity A = about 0.6; impurity B = about 0.7; impurity D = about 0.8; impurity E = about 1.1; internal standard = about 1.4.

System suitability: reference solution (a):

- resolution: minimum 3.0 between the peaks due to bupivacaine and impurity E.

Limits:

- impurity B: calculate the ratio ( $R$ ) of the area of the principal peak to the area of the peak due to the internal standard from the chromatogram obtained with reference solution (c); from the chromatogram obtained with the test solution, calculate the ratio of the area of the peak due to impurity B to the area of the peak due to the internal standard: this ratio is not greater than  $R$  (0.5 per cent),
- any other impurity: calculate the ratio ( $R$ ) of the area of the principal peak to the area of the peak due to the internal standard from the chromatogram obtained with reference solution (d); from the chromatogram obtained with the test solution, calculate the ratio of the area of any peak, apart from the principal peak, the peak due to impurity B and the peak due to the internal standard, to the area of the peak due to the internal standard: this ratio is not greater than  $R$  (0.1 per cent),
- total: calculate the ratio ( $R$ ) of the area of the principal peak to the area of the peak due to the internal standard from the chromatogram obtained with reference solution (b); from the chromatogram obtained with the test solution, calculate the ratio of the sum of the areas of any peaks, apart from the principal peak and the peak due to the internal standard, to the area of the peak due to the internal standard: this ratio is not greater than  $R$  (1.0 per cent),
- disregard limit: ratio less than 0.01 times  $R$  (0.01 per cent).

**2,6-Dimethylaniline:** maximum 100 ppm.

Dissolve 0.50 g in methanol R and dilute to 10 mL with the same solvent. To 2 mL of the solution add 1 mL of a freshly prepared 10 g/L solution of dimethylaminobenzaldehyde R in methanol R and 2 mL of glacial acetic acid R and allow to stand for 10 min. Any yellow colour in the solution is not more intense than that in a standard prepared at the same time and in the same manner using 2 mL of a 5 mg/L solution of 2,6-dimethylaniline R in methanol R.

**Heavy metals (2.4.8):** maximum 10 ppm.

Dissolve 2.0 g in a mixture of 15 volumes of water R and 85 volumes of methanol R and dilute to 20 mL with the same mixture of solvents. 12 mL of the solution complies with limit test B. Prepare the standard using lead standard solution (1 ppm Pb) obtained by diluting lead standard solution (100 ppm Pb) R with a mixture of 15 volumes of water R and 85 volumes of methanol R.

**Loss on drying (2.2.32):** 4.5 per cent to 6.0 per cent, determined on 1.000 g by drying in an oven at 105 °C.

**Sulfated ash (2.4.14):** maximum 0.1 per cent, determined on 1.0 g.



## ASSAY

Dissolve 0.250 g in a mixture of 20 mL of *water R* and 25 mL of *alcohol R*. Add 5.0 mL of 0.01 M *hydrochloric acid*. Carry out a potentiometric titration (2.2.20), using 0.1 M *ethanolic sodium hydroxide*. Read the volume added between the 2 points of inflexion.

1 mL of 0.1 M *ethanolic sodium hydroxide* is equivalent to 32.49 mg of C<sub>18</sub>H<sub>29</sub>ClN<sub>2</sub>O.

## STORAGE

Protected from light.

## IMPURITIES

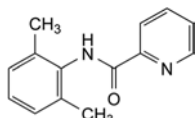

A. *N*-(2,6-dimethylphenyl)pyridine-2-carboxamide,

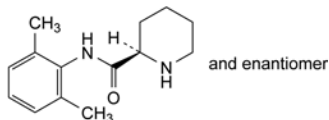

B. (2*RS*)-*N*-(2,6-dimethylphenyl)piperidine-2-carboxamide,

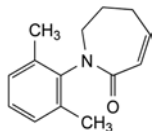

C. 1-(2,6-dimethylphenyl)-1,5,6,7-tetrahydro-2*H*-azepin-2-one,

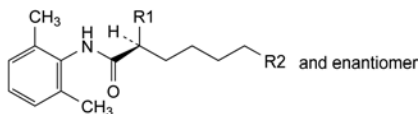

D. R1 = R2 = Cl: (2*RS*)-2,6-dichloro-*N*-(2,6-dimethylphenyl)hexanamide,

E. R1 = H, R2 = NH-(CH<sub>2</sub>)<sub>3</sub>-CH<sub>3</sub>: 6-(butylamino)-*N*-(2,6-dimethylphenyl)hexanamide,

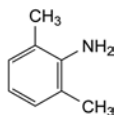

F. 2,6-dimethylaniline.

## CHARACTERS

*Appearance*: white or almost white, crystalline powder.

*Solubility*: very slightly soluble in water, freely soluble in acetone, soluble in methanol, slightly soluble in cyclohexane. It dissolves in dilute solutions of acids.

mp: about 217 °C.

## IDENTIFICATION

Infrared absorption spectrophotometry (2.2.24).

*Comparison*: *buprenorphine CRS*.

## TESTS

**Solution S.** Dissolve 0.250 g in *anhydrous ethanol R* and dilute to 25.0 mL with the same solvent.

**Appearance of solution.** Solution S is clear (2.2.1) and colourless (2.2.2, *Method II*).

**Specific optical rotation (2.2.7)**: – 103 to – 107 (dried substance), determined on solution S.

**Related substances.** Liquid chromatography (2.2.29).

*Test solution.* Dissolve 50.0 mg of the substance to be examined in *methanol R* and dilute to 10.0 mL with the same solvent.

*Reference solution (a).* Dilute 1.0 mL of the test solution to 100.0 mL with *methanol R*. Dilute 1.0 mL of this solution to 10.0 mL with *methanol R*.

*Reference solution (b).* Dissolve 5 mg of *buprenorphine for system suitability CRS* (containing impurities A, B, F, G, H and J) in 1.0 mL of *methanol R*.

*Column*:

- *size*: *l* = 0.05 m, Ø = 4.6 mm;
- *stationary phase*: *end-capped octadecylsilyl silica gel for chromatography R* (3.5 µm);
- *temperature*: 30 °C.

*Mobile phase*:

- *mobile phase A*: mix 10 volumes of *acetonitrile R* and 90 volumes of the following solution: dissolve 5.44 g of *potassium dihydrogen phosphate R* in 900 mL of *water R*, adjust to pH 4.5 with a 5 per cent V/V solution of *phosphoric acid R* and dilute to 1000 mL with *water R*;
- *mobile phase B*: *acetonitrile R*;

Time (min)	Mobile phase A (per cent V/V)	Mobile phase B (per cent V/V)
0 - 2	89	11
2 - 12	89 → 64	11 → 36
12 - 15	64 → 41	36 → 59
15 - 20	41 → 39	59 → 61

*Flow rate*: 1.3 mL/min.

*Detection*: spectrophotometer at 240 nm.

*Injection*: 5 µL.

*Identification of impurities*: use the chromatogram supplied with *buprenorphine for system suitability CRS* and the chromatogram obtained with reference solution (b) to identify the peaks due to impurities A, B, F, G, H and J.

*Relative retention* with reference to buprenorphine (retention time = about 8.5 min): impurity B = about 0.4; impurity J = about 1.1; impurity F = about 1.27; impurity H = about 1.33; impurity A = about 1.40; impurity G = about 1.8.

*System suitability*: reference solution (b):

- *resolution*: minimum 1.5 between the peaks due to buprenorphine and impurity J.

*Limits*:

- *correction factor*: for the calculation of content, multiply the peak area of impurity G by 0.3;
- *impurity H*: not more than 2.5 times the area of the principal peak in the chromatogram obtained with reference solution (a) (0.25 per cent);

07/2009:1180  
corrected 7.0

## BUPRENORPHINE

## Buprenorphinum

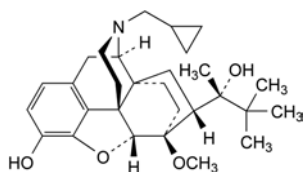

C<sub>29</sub>H<sub>41</sub>NO<sub>4</sub>  
[52485-79-7]

*M<sub>r</sub>* 467.6

## DEFINITION

(2*S*)-2-[17-(Cyclopropylmethyl)-4,5α-epoxy-3-hydroxy-6-methoxy-6α,14-ethano-14α-morphinan-7α-yl]-3,3-dimethylbutan-2-ol.

*Content*: 98.5 per cent to 101.5 per cent (dried substance).

- *impurities A, B, F, J*: for each impurity, not more than twice the area of the principal peak in the chromatogram obtained with reference solution (a) (0.2 per cent);
- *impurity G*: not more than 1.5 times the area of the principal peak in the chromatogram obtained with reference solution (a) (0.15 per cent);
- *unspecified impurities*: for each impurity, not more than the area of the principal peak in the chromatogram obtained with reference solution (a) (0.10 per cent);
- *total*: not more than 7 times the area of the principal peak in the chromatogram obtained with reference solution (a) (0.7 per cent);
- *disregard limit*: 0.5 times the area of the principal peak in the chromatogram obtained with reference solution (a) (0.05 per cent).

**Loss on drying** (2.2.32): maximum 1.0 per cent, determined on 1.000 g by drying in an oven at 105 °C.

#### ASSAY

Dissolve 0.400 g in 40 mL of *anhydrous acetic acid R*. Titrate with 0.1 M *perchloric acid*, determining the end-point potentiometrically (2.2.20).

1 mL of 0.1 M *perchloric acid* is equivalent to 46.76 mg of  $C_{29}H_{41}NO_4$ .

#### STORAGE

Protected from light.

#### IMPURITIES

*Specified impurities: A, B, F, G, H, J.*

*Other detectable impurities* (the following substances would, if present at a sufficient level, be detected by one or other of the tests in the monograph. They are limited by the general acceptance criterion for other/unspecified impurities and/or by the general monograph *Substances for pharmaceutical use* (2034). It is therefore not necessary to identify these impurities for demonstration of compliance. See also 5.10. *Control of impurities in substances for pharmaceutical use*): *C, D, E, I.*

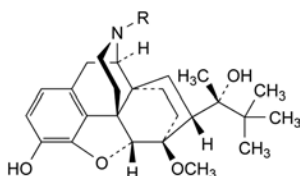

- A. R =  $CH_2-CH_2-CH=CH_2$ : (2*S*)-2-[17-(but-3-enyl)-4,5 $\alpha$ -epoxy-3-hydroxy-6-methoxy-6 $\alpha$ ,14-ethano-14 $\alpha$ -morphinan-7 $\alpha$ -yl]-3,3-dimethylbutan-2-ol,
- B. R = H: (2*S*)-2-(4,5 $\alpha$ -epoxy-3-hydroxy-6-methoxy-6 $\alpha$ ,14-ethano-14 $\alpha$ -morphinan-7 $\alpha$ -yl)-3,3-dimethylbutan-2-ol (norbuprenorphine),
- H. R =  $CH_2-CH_2-CH_2-CH_3$ : (2*S*)-2-[17-butyl-4,5 $\alpha$ -epoxy-3-hydroxy-6-methoxy-6 $\alpha$ ,14-ethano-14 $\alpha$ -morphinan-7 $\alpha$ -yl]-3,3-dimethylbutan-2-ol,

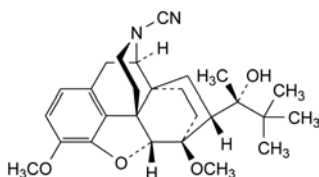

- C. 4,5 $\alpha$ -epoxy-7 $\alpha$ -[(1*S*)-1-hydroxy-1,2,2-trimethylpropyl]-3,6-dimethoxy-6 $\alpha$ ,14-ethano-14 $\alpha$ -morphinan-17-carbonitrile,

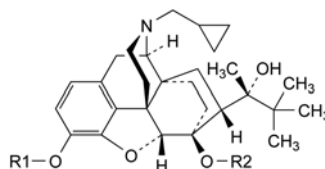

- D. R1 = R2 =  $CH_3$ : (2*S*)-2-[17-(cyclopropylmethyl)-4,5 $\alpha$ -epoxy-3,6-dimethoxy-6 $\alpha$ ,14-ethano-14 $\alpha$ -morphinan-7 $\alpha$ -yl]-3,3-dimethylbutan-2-ol (3-*O*-methylbuprenorphine),
- E. R1 = R2 = H: (2*S*)-2-[17-(cyclopropylmethyl)-4,5 $\alpha$ -epoxy-3,6-dihydroxy-6 $\alpha$ ,14-ethano-14 $\alpha$ -morphinan-7 $\alpha$ -yl]-3,3-dimethylbutan-2-ol (6-*O*-desmethylbuprenorphine),

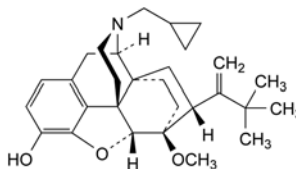

- F. 17-(cyclopropylmethyl)-4,5 $\alpha$ -epoxy-6-methoxy-7 $\alpha$ -[1-(1,1-dimethylethyl)ethenyl]-6 $\alpha$ ,14-ethano-14 $\alpha$ -morphinan-3-ol,

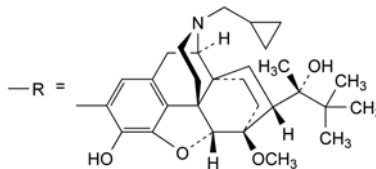

- G. R-R: 17,17'-di(cyclopropylmethyl)-4,5 $\alpha$ ;4',5 $\alpha'$ -diepoxy-7 $\alpha$ ,7 $\alpha'$ -di[(1*S*)-1-hydroxy-1,2,2-trimethylpropyl]-6,6'-dimethoxy-2,2'-bi(6 $\alpha$ ,14-ethano-14 $\alpha$ -morphinan)-3,3'-diol (2,2'-bibuprenorphine),

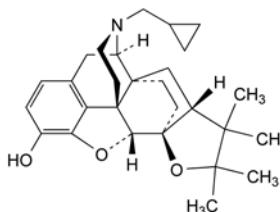

- I. 17-(cyclopropylmethyl)-4'',4'',5'',5''-tetramethyl-4'',5''-dihydro-(7 $\beta$ H)-6 $\alpha$ ,14-ethano-(5 $\beta$ H)-difurano-[2',3',4',5':4,12,13,5;2'',3'':6,7]-14 $\alpha$ -morphinan-3-ol,

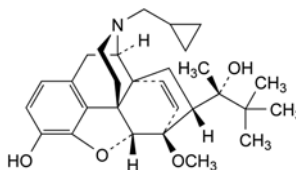

- J. (2*S*)-2-[17-(cyclopropylmethyl)-4,5 $\alpha$ -epoxy-3-hydroxy-6-methoxy-6 $\alpha$ ,14-etheno-14 $\alpha$ -morphinan-7 $\alpha$ -yl]-3,3-dimethylbutan-2-ol.

07/2009:1181  
corrected 6.6

## BUPRENORPHINE HYDROCHLORIDE

### Buprenorphini hydrochloridum

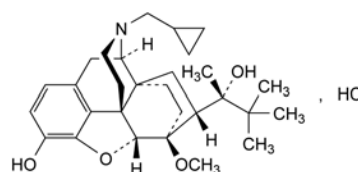

$C_{29}H_{42}ClNO_4$   
[53152-21-9]

$M_r$  504.1

## DEFINITION

(2S)-2-[17-(Cyclopropylmethyl)-4,5 $\alpha$ -epoxy-3-hydroxy-6-methoxy-6 $\alpha$ ,14-ethano-14 $\alpha$ -morphinan-7 $\alpha$ -yl]-3,3-dimethylbutan-2-ol hydrochloride.

*Content*: 98.5 per cent to 101.5 per cent (dried substance).

## CHARACTERS

*Appearance*: white or almost white, crystalline powder.

*Solubility*: sparingly soluble in water, freely soluble in methanol, soluble in ethanol (96 per cent), practically insoluble in cyclohexane.

## IDENTIFICATION

A. Infrared absorption spectrophotometry (2.2.24).

*Comparison*: buprenorphine hydrochloride CRS.

B. 3 mL of solution S (see Tests) gives reaction (a) of chlorides (2.3.1).

## TESTS

**Solution S.** Dissolve 0.250 g in 5.0 mL of *methanol R* and, while stirring, dilute to 25.0 mL with *carbon dioxide-free water R*.

**Appearance of solution.** Solution S is clear (2.2.1) and colourless (2.2.2, *Method II*).

**Acidity or alkalinity.** To 10.0 mL of solution S add 0.05 mL of *methyl red solution R*. Not more than 0.2 mL of 0.02 M *sodium hydroxide* or 0.02 M *hydrochloric acid* is required to change the colour of the indicator.

**Specific optical rotation** (2.2.7): –92 to –98 (dried substance). Dissolve 0.200 g in *methanol R* and dilute to 20.0 mL with the same solvent.

**Related substances.** Liquid chromatography (2.2.29).

*Test solution.* Dissolve 50.0 mg of the substance to be examined in *methanol R* and dilute to 10.0 mL with the same solvent.

*Reference solution (a).* Dilute 1.0 mL of the test solution to 100.0 mL with *methanol R*. Dilute 1.0 mL of this solution to 10.0 mL with *methanol R*.

*Reference solution (b).* Dissolve 5 mg of *buprenorphine for system suitability CRS* (containing impurities A, B, F, G, H and J) in 1.0 mL of *methanol R*.

*Column*:

- *size*:  $l = 0.05$  m,  $\varnothing = 4.6$  mm;
- *stationary phase*: end-capped octadecylsilyl silica gel for chromatography R (3.5  $\mu$ m);
- *temperature*: 30 °C.

*Mobile phase*:

- *mobile phase A*: mix 10 volumes of *acetonitrile R* and 90 volumes of the following solution: dissolve 5.44 g of *potassium dihydrogen phosphate R* in 900 mL of *water R*, adjust to pH 4.5 with a 5 per cent V/V solution of *phosphoric acid R* and dilute to 1000 mL with *water R*;
- *mobile phase B*: *acetonitrile R*;

Time (min)	Mobile phase A (per cent V/V)	Mobile phase B (per cent V/V)
0 - 2	89	11
2 - 12	89 → 64	11 → 36
12 - 15	64 → 41	36 → 59
15 - 20	41 → 39	59 → 61

*Flow rate*: 1.3 mL/min.

*Detection*: spectrophotometer at 240 nm.

*Injection*: 5  $\mu$ L.

*Identification of impurities*: use the chromatogram supplied with *buprenorphine for system suitability CRS* and the chromatogram obtained with reference solution (b) to identify the peaks due to impurities A, B, F, G, H and J.

*Relative retention* with reference to buprenorphine (retention time = about 8.5 min): impurity B = about 0.4; impurity J = about 1.1; impurity F = about 1.27; impurity H = about 1.33; impurity A = about 1.40; impurity G = about 1.8.

*System suitability*: reference solution (b):

- *resolution*: minimum 1.5 between the peaks due to buprenorphine and impurity J.

*Limits*:

- *correction factor*: for the calculation of content, multiply the peak area of impurity G by 0.3;
- *impurity H*: not more than 2.5 times the area of the principal peak in the chromatogram obtained with reference solution (a) (0.25 per cent);
- *impurities A, B, F, J*: for each impurity, not more than twice the area of the principal peak in the chromatogram obtained with reference solution (a) (0.2 per cent);
- *impurity G*: not more than 1.5 times the area of the principal peak in the chromatogram obtained with reference solution (a) (0.15 per cent);
- *unspecified impurities*: for each impurity, not more than the area of the principal peak in the chromatogram obtained with reference solution (a) (0.10 per cent);
- *total*: not more than 7 times the area of the principal peak in the chromatogram obtained with reference solution (a) (0.7 per cent);
- *disregard limit*: 0.5 times the area of the principal peak in the chromatogram obtained with reference solution (a) (0.05 per cent).

**Loss on drying** (2.2.32): maximum 1.0 per cent, determined on 1.000 g by heating in an oven at 115-120 °C.

## ASSAY

Dissolve 0.400 g in a mixture of 5 mL of 0.01 M *hydrochloric acid* and 50 mL of *ethanol (96 per cent) R*. Carry out a potentiometric titration (2.2.20), using 0.1 M *sodium hydroxide*. Read the volume added between the 2 points of inflexion. Carry out a blank titration.

1 mL of 0.1 M *sodium hydroxide* is equivalent to 50.41 mg of  $C_{29}H_{42}ClNO_4$ .

## STORAGE

Protected from light.

## IMPURITIES

*Specified impurities*: A, B, F, G, H, J.

*Other detectable impurities* (the following substances would, if present at a sufficient level, be detected by one or other of the tests in the monograph. They are limited by the general acceptance criterion for other/unspecified impurities and/or by the general monograph *Substances for pharmaceutical use* (2034). It is therefore not necessary to identify these impurities for demonstration of compliance. See also 5.10. *Control of impurities in substances for pharmaceutical use*): C, D, E, I.

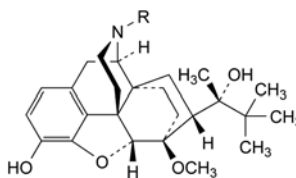

A. R =  $CH_2-CH_2-CH=CH_2$ : (2S)-2-[17-(but-3-enyl)-4,5 $\alpha$ -epoxy-3-hydroxy-6-methoxy-6 $\alpha$ ,14-ethano-14 $\alpha$ -morphinan-7 $\alpha$ -yl]-3,3-dimethylbutan-2-ol,

B. R = H: (2S)-2-(4,5 $\alpha$ -epoxy-3-hydroxy-6-methoxy-6 $\alpha$ ,14-ethano-14 $\alpha$ -morphinan-7 $\alpha$ -yl)-3,3-dimethylbutan-2-ol (norbuprenorphine),

H. R =  $CH_2-CH_2-CH_2-CH_3$ : (2S)-2-[17-butyl-4,5 $\alpha$ -epoxy-3-hydroxy-6-methoxy-6 $\alpha$ ,14-ethano-14 $\alpha$ -morphinan-7 $\alpha$ -yl]-3,3-dimethylbutan-2-ol,

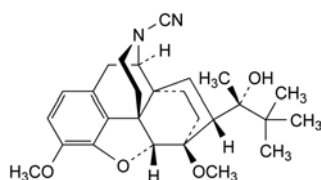
01/2008:1077  
corrected 6.3

C. 4,5 $\alpha$ -epoxy-7 $\alpha$ -[(1*S*)-1-hydroxy-1,2,2-trimethylpropyl]-3,6-dimethoxy-6 $\alpha$ ,14-ethano-14 $\alpha$ -morphinan-17-carbonitrile,

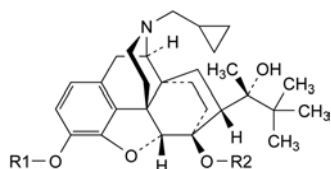

D. R1 = R2 = CH<sub>3</sub>: (2*S*)-2-[17-(cyclopropylmethyl)-4,5 $\alpha$ -epoxy-3,6-dimethoxy-6 $\alpha$ ,14-ethano-14 $\alpha$ -morphinan-7 $\alpha$ -yl]-3,3-dimethylbutan-2-ol (3-*O*-methylbuprenorphine),

E. R1 = R2 = H: (2*S*)-2-[17-(cyclopropylmethyl)-4,5 $\alpha$ -epoxy-3,6-dihydroxy-6 $\alpha$ ,14-ethano-14 $\alpha$ -morphinan-7 $\alpha$ -yl]-3,3-dimethylbutan-2-ol (6-*O*-desmethylbuprenorphine),

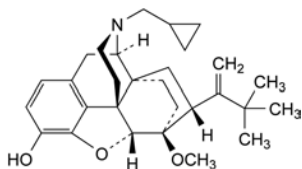

F. 17-(cyclopropylmethyl)-4,5 $\alpha$ -epoxy-6-methoxy-7 $\alpha$ -[1-(1,1-dimethylethyl)ethenyl]-6 $\alpha$ ,14-ethano-14 $\alpha$ -morphinan-3-ol,

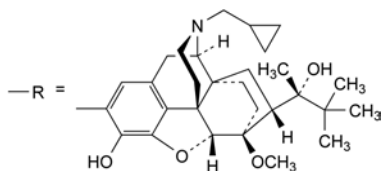

G. R-R: 17,17'-di(cyclopropylmethyl)-4,5 $\alpha$ ;4',5 $\alpha'$ -diepoxy-7 $\alpha$ ,7 $\alpha'$ -di[(1*S*)-1-hydroxy-1,2,2-trimethylpropyl]-6,6'-dimethoxy-2,2'-bi(6 $\alpha$ ,14-ethano-14 $\alpha$ -morphinan)-3,3'-diol (2,2'-bibuprenorphine),

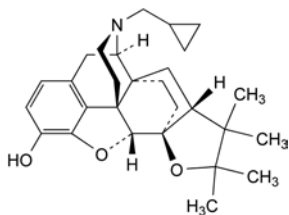

I. 17-(cyclopropylmethyl)-4'',4'',5'',5''-tetramethyl-4'',5''-dihydro-(7 $\beta$ *H*)-6 $\alpha$ ,14-ethano-(5 $\beta$ *H*)-difurano-[2'',3'',4'',5'':4,12,13,5;2'',3'':6,7]-14 $\alpha$ -morphinan-3-ol,

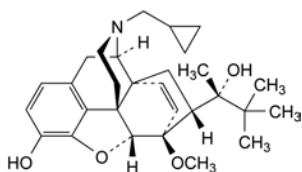

J. (2*S*)-2-[17-(cyclopropylmethyl)-4,5 $\alpha$ -epoxy-3-hydroxy-6-methoxy-6 $\alpha$ ,14-ethano-14 $\alpha$ -morphinan-7 $\alpha$ -yl]-3,3-dimethylbutan-2-ol.

## BUSERELIN

### Buserelinum

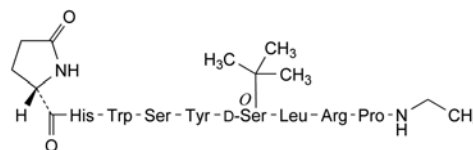

C<sub>60</sub>H<sub>86</sub>N<sub>16</sub>O<sub>13</sub>  
[57982-77-1]

*M*<sub>r</sub> 1239

#### DEFINITION

5-Oxo-L-prolyl-L-histidyl-L-tryptophyl-L-seryl-L-tyrosyl-O-(1,1-dimethylethyl)-D-seryl-L-leucyl-L-arginyl-N-ethyl-L-prolinamide. Synthetic nonapeptide analogue of human gonadotrophin-releasing hormone GnRH with agonistic activity to gonadorelin. It is obtained by chemical synthesis and is available as an acetate.

*Content*: 95.0 per cent to 102.0 per cent (anhydrous, acetic acid-free substance).

#### CHARACTERS

*Appearance*: white or slightly yellowish powder, hygroscopic.

*Solubility*: sparingly soluble in water and in dilute acids.

#### IDENTIFICATION

A. Examine the chromatograms obtained in the assay.

*Results*: the principal peak in the chromatogram obtained with the test solution is similar in retention time and size to the principal peak in the chromatogram obtained with reference solution (b).

B. Nuclear magnetic resonance spectrometry (2.2.33).

*Preparation*: 4 mg/mL solution in a mixture of 20 volumes of deuterated acetic acid R and 80 volumes of deuterium oxide R.

*Comparison*: 4 mg/mL solution of buserelin CRS in a mixture of 20 volumes of deuterated acetic acid R and 80 volumes of deuterium oxide R (dissolve the contents of a vial of buserelin CRS in this solvent mixture to obtain the desired concentration).

*Operating conditions*: field strength: minimum 300 MHz.

*Results*: the <sup>1</sup>H NMR spectrum obtained is qualitatively similar to the <sup>1</sup>H NMR spectrum obtained with buserelin CRS.

C. Amino acid analysis (2.2.56). For protein hydrolysis use Method 1 and for analysis use Method 1.

Express the content of each amino acid in moles. Calculate the relative proportions of the amino acids, taking 1/6 of the sum of the number of moles of glutamic acid, histidine, tyrosine, leucine, arginine and proline as equal to 1. The values fall within the following limits: serine 1.4 to 2.0; proline 0.8 to 1.2; glutamic acid 0.9 to 1.1; leucine 0.9 to 1.1; tyrosine 0.9 to 1.1; histidine 0.9 to 1.1; arginine 0.9 to 1.1. Not more than traces of other amino acids are present, with the exception of tryptophan.

#### TESTS

**Appearance of solution.** A 10 g/L solution is clear (2.2.1) and not more intensely coloured than reference solution Y<sub>7</sub> (2.2.2, Method II).

**Specific optical rotation** (2.2.7): -49 to -58 (anhydrous, acetic acid-free substance), determined on a 10 g/L solution.

**Specific absorbance** (2.2.25): 49 to 56, measured at the absorption maximum at 278 nm (anhydrous, acetic acid-free substance).

Dissolve 10.0 mg in 100.0 mL of 0.01 M hydrochloric acid.

**Related substances.** Liquid chromatography (2.2.29).

**Test solution.** Dissolve 5.0 mg of the substance to be examined in 5.0 mL of the mobile phase.

**Reference solution (a).** Dissolve the contents of a vial of *D-His-buserelin CRS* in the mobile phase. Dilute an appropriate volume of this solution in the mobile phase to obtain a final concentration of 1 mg/mL. Add 1.0 mL of the test solution to 1.0 mL of this solution.

**Reference solution (b).** Dissolve the contents of a vial of *buserelin CRS* in the mobile phase. Dilute an appropriate volume of this solution in the mobile phase to obtain a final concentration of 1.0 mg/mL.

**Reference solution (c).** Dilute 1.0 mL of the test solution to 100.0 mL with the mobile phase.

**Column:**

- *size:*  $l = 0.25$  m,  $\emptyset = 4$  mm;
- *stationary phase:* octadecylsilyl silica gel for chromatography R (5  $\mu$ m).

**Mobile phase:** mix 200 mL of *acetonitrile R* and 700 mL of an 11.2 g/L solution of *phosphoric acid R* and adjust to pH 2.5 with *triethylamine R*.

**Flow rate:** 0.8 mL/min.

**Detection:** spectrophotometer at 220 nm.

**Injection:** 10  $\mu$ L of the test solution, reference solution (a) and reference solution (c).

**Relative retention** with reference to *buserelin* (retention time = about 36 min): impurity B = about 0.76; impurity C = about 0.83; impurity A = about 0.90; impurity D = about 0.94; impurity E = about 0.94.

**System suitability:** reference solution (a):

- *resolution:* minimum 1.5 between the peaks due to impurity A and *buserelin*.

**Limits:**

- *sum of impurities D and E:* not more than 3 times the area of the principal peak in the chromatogram obtained with reference solution (c) (3 per cent);
- *any other impurity:* for each impurity, not more than 3 times the area of the principal peak in the chromatogram obtained with reference solution (c) (3 per cent);
- *total:* not more than 5 times the area of the principal peak in the chromatogram obtained with reference solution (c) (5 per cent);
- *disregard limit:* 0.1 times the area of the principal peak in the chromatogram obtained with reference solution (c) (0.1 per cent).

**Acetic acid** (2.5.34): 3.0 per cent to 7.0 per cent.

**Test solution.** Dissolve 20.0 mg of the substance to be examined in a mixture of 5 volumes of mobile phase B and 95 volumes of mobile phase A and dilute to 10.0 mL with the same mixture of solvents.

**Water** (2.5.12): maximum 4.0 per cent, determined on 80.0 mg.

**Bacterial endotoxins** (2.6.14): less than 55.5 IU/mg, if intended for use in the manufacture of parenteral preparations without a further appropriate procedure for the removal of bacterial endotoxins.

#### ASSAY

Liquid chromatography (2.2.29) as described in the test for related substances with the following modification.

**Injection:** 10  $\mu$ L of the test solution and reference solution (b). Calculate the content of *buserelin* ( $C_{60}H_{86}N_{16}O_{13}$ ) using the areas of the peaks in the chromatograms obtained and the declared content of  $C_{60}H_{86}N_{16}O_{13}$  in *buserelin CRS*.

#### STORAGE

In an airtight container, protected from light, at a temperature of 2 °C to 8 °C. If the substance is sterile, store in an airtight, sterile, tamper-proof container.

#### LABELLING

The label states the mass of peptide in the container.

#### IMPURITIES

*Specified impurities: A, B, C, D, E.*

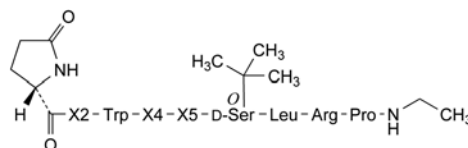

A. X2 = D-His, X4 = L-Ser, X5 = L-Tyr: [2-D-histidine]buserelin,

B. X2 = L-His, X4 = D-Ser, X5 = L-Tyr: [4-D-serine]buserelin,

D. X2 = L-His, X4 = L-Ser, X5 = D-Tyr: [5-D-tyrosine]buserelin,

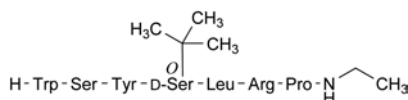

C. *buserelin*-(3-9)-peptide,

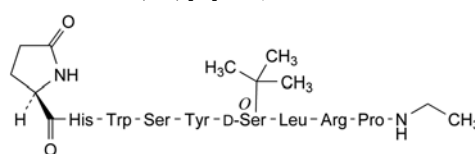

E. [1-(5-oxo-D-proline)]buserelin.

01/2008:1711  
corrected 6.0

## BUSPIRONE HYDROCHLORIDE

### Buspironi hydrochloridum

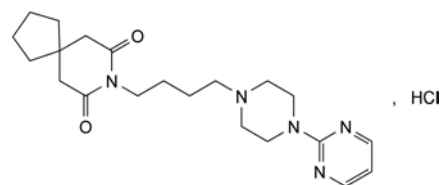

$C_{21}H_{32}ClN_5O_2$   
[33386-08-2]

$M_r$  422.0

#### DEFINITION

8-[4-[4-(Pyrimidin-2-yl)piperazin-1-yl]butyl]-8-azaspiro[4.5]-decane-7,9-dione hydrochloride.

**Content:** 99.0 per cent to 101.0 per cent (dried substance).

#### CHARACTERS

**Appearance:** white or almost white, crystalline powder.

**Solubility:** freely soluble in water and in methanol, practically insoluble in acetone.

It shows polymorphism (5.9).

#### IDENTIFICATION

A. Infrared absorption spectrophotometry (2.2.24).

*Comparison:* *buspirone hydrochloride CRS*.

If the spectra obtained in the solid state show differences, dissolve the substance to be examined and the reference substance separately in *methanol R*, evaporate to dryness on a water-bath and record new spectra using the residues.

B. It gives reaction (a) of chlorides (2.3.1).

#### TESTS

**Related substances.** Liquid chromatography (2.2.29).

**Test solution.** Dissolve 25.0 mg of the substance to be examined in mobile phase A and dilute to 25.0 mL with mobile phase A.

*Reference solution (a).* Dilute 1.0 mL of the test solution to 100.0 mL with mobile phase A. Dilute 1.0 mL of this solution to 10.0 mL with mobile phase A.

*Reference solution (b).* Dissolve the contents of a vial of buspirone for system suitability CRS (containing impurities E, G, J, L and N) in 2.0 mL of mobile phase A and sonicate for 10 min.

*Column:*

- size:  $l = 0.15$  m,  $\varnothing = 4.6$  mm,
- stationary phase: octadecylsilyl silica gel for chromatography R (5  $\mu$ m),
- temperature: 40 °C.

*Mobile phase:*

- mobile phase A: mix 950 volumes of a solution containing 6.8 g/L of potassium dihydrogen phosphate R and 0.93 g/L of sodium hexanesulfonate monohydrate R, previously adjusted to pH 3.4 with phosphoric acid R and 50 volumes of acetonitrile RI;
- mobile phase B: mix 250 volumes of a solution containing 3.4 g/L of potassium dihydrogen phosphate R and 3.52 g/L of sodium hexanesulfonate monohydrate R, previously adjusted to pH 2.2 with phosphoric acid R and 750 volumes of acetonitrile RI,

Time (min)	Mobile phase A (per cent V/V)	Mobile phase B (per cent V/V)
0 - 6	90	10
6 - 34	90 → 42	10 → 58
34 - 45	42	58
45 - 55	42 → 0	58 → 100
55 - 56	0 → 100	100 → 0
56 - 60	100	0
60 - 61	100 → 90	0 → 10

*Flow rate:* 1 mL/min.

*Detection:* variable wavelength spectrophotometer capable of operating at 240 nm and at 210 nm.

*Injection:* 20  $\mu$ L.

*Identification of impurities:* use the chromatogram supplied with buspirone for system suitability CRS and the chromatogram obtained with reference solution (b) to identify the peaks due to impurities E, G, J, L and N.

*Relative retention at 240 nm* with reference to buspirone (retention time = about 25 min): impurity A = about 0.2; impurity B = about 0.3; impurity C = about 0.6; impurity D = about 0.7; impurity E = about 0.8; impurity F = about 0.9; impurity G = about 1.05; impurity H = about 1.1; impurity I = about 1.2; impurity J = about 1.5.

*Relative retention at 210 nm* with reference to buspirone (retention time = about 25 min): impurity K = about 0.6; impurity L = about 1.7; impurity M = about 1.8; impurity N = about 1.9.

*System suitability:* reference solution (b):

- peak-to-valley ratio at 240 nm: minimum 5.0, where  $H_p$  = height above the baseline of the peak due to impurity G and  $H_v$  = height above the baseline of the lowest point of the curve separating this peak from the peak due to buspirone;
- resolution at 210 nm: minimum 4.0 between the peaks due to impurity L and impurity N;
- the chromatograms obtained are similar to the chromatograms supplied with buspirone for system suitability CRS.

*Limits:* spectrophotometer at 240 nm:

- correction factor: for the calculation of content, multiply the peak area of impurity J by 2,

- impurity E: not more than 3 times the area of the principal peak in the chromatogram obtained with reference solution (a) (0.3 per cent),
- impurity J: not more than twice the area of the principal peak in the chromatogram obtained with reference solution (a) (0.2 per cent),
- any other impurity: for each impurity, not more than the area of the principal peak in the chromatogram obtained with reference solution (a) (0.1 per cent),
- total: not more than 4 times the area of the principal peak in the chromatogram obtained with reference solution (a) (0.4 per cent),
- disregard limit: 0.5 times the area of the principal peak in the chromatogram obtained with reference solution (a) (0.05 per cent).

*Limits:* spectrophotometer at 210 nm:

- impurity K: not more than the area of the principal peak in the chromatogram obtained with reference solution (a) (0.1 per cent),
- any other impurity eluting with a relative retention greater than 1.6: for each impurity, not more than the area of the principal peak in the chromatogram obtained with reference solution (a) (0.1 per cent),
- total: not more than twice the area of the principal peak in the chromatogram obtained with reference solution (a) (0.2 per cent),
- disregard limit: 0.5 times the area of the principal peak in the chromatogram obtained with reference solution (a) (0.05 per cent).

**Loss on drying (2.2.32):** maximum 0.5 per cent, determined on 1.000 g by drying at 105 °C.

**Sulfated ash (2.4.14):** maximum 0.1 per cent, determined on 1.0 g.

#### ASSAY

Dissolve 0.150 g in 10 mL of glacial acetic acid R and add 50 mL of acetic anhydride R. Titrate with 0.1 M perchloric acid, determining the end-point potentiometrically (2.2.20).

1 mL of 0.1 M perchloric acid is equivalent to 21.10 mg of C<sub>21</sub>H<sub>32</sub>ClN<sub>5</sub>O<sub>2</sub>.

#### STORAGE

Protected from light.

#### IMPURITIES

*Specified impurities:* E, J, K.

*Other detectable impurities* (the following substances would, if present at a sufficient level, be detected by one or other of the tests in the monograph. They are limited by the general acceptance criterion for other/unspecified impurities and/or by the general monograph *Substances for pharmaceutical use (2034)*. It is therefore not necessary to identify these impurities for demonstration of compliance. See also 5.10. *Control of impurities in substances for pharmaceutical use*): A, B, C, D, F, G, H, I, L, M, N.

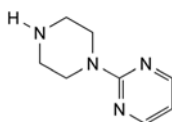

A. 2-(piperazin-1-yl)pyrimidine,

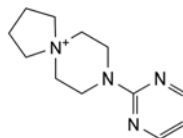

B. 8-(pyrimidin-2-yl)-8-aza-5-azoniaspiro[4.5]decane,

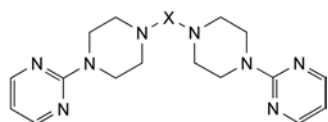

C. X = [CH<sub>2</sub>]<sub>4</sub>: 2,2'-[butane-1,4-diylbis(piperazine-1,4-diyl)]dipyrimidine,

D. X = [CH<sub>2</sub>]<sub>4</sub>-O-[CH<sub>2</sub>]<sub>4</sub>: 2,2'-[oxybis[butane-1,4-diyl(piperazine-1,4-diyl)]]dipyrimidine,

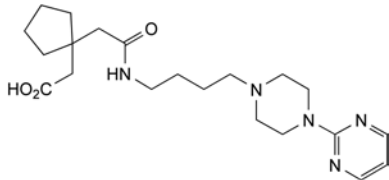

E. [1-[2-oxo-2-[[4-[4-(pyrimidin-2-yl)piperazin-1-yl]butyl]amino]ethyl]cyclopentyl]acetic acid,

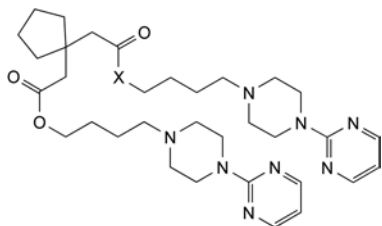

F. X = NH: 4-[4-(pyrimidin-2-yl)piperazin-1-yl]butyl [1-[2-oxo-2-[[4-[4-(pyrimidin-2-yl)piperazin-1-yl]butyl]amino]ethyl]cyclopentyl]acetate,

H. X = O: bis[4-[4-(pyrimidin-2-yl)piperazin-1-yl]butyl] (cyclopentane-1,1-diyl)diacetate,

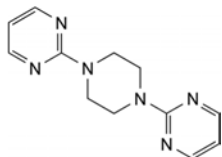

G. 2,2'-(piperazine-1,4-diyl)dipyrimidine,

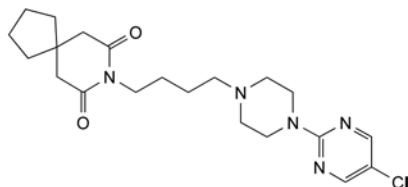

I. 8-[4-[4-(5-chloropyrimidin-2-yl)piperazin-1-yl]butyl]-8-azaspiro[4.5]decane-7,9-dione,

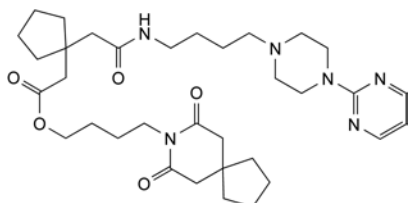

J. 4-(7,9-dioxo-8-azaspiro[4.5]dec-8-yl)butyl [1-[2-oxo-2-[[4-[4-(pyrimidin-2-yl)piperazin-1-yl]butyl]amino]ethyl]cyclopentyl]acetate,

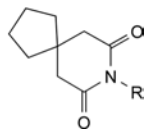

K. R = H: 8-azaspiro[4.5]decane-7,9-dione,

L. R = [CH<sub>2</sub>]<sub>4</sub>-Cl: 8-(4-chlorobutyl)-8-azaspiro[4.5]decane-7,9-dione,

M. R = [CH<sub>2</sub>]<sub>4</sub>-Br: 8-(4-bromobutyl)-8-azaspiro[4.5]decane-7,9-dione,

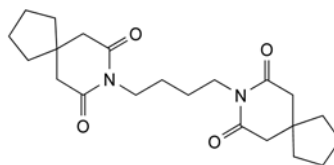

N. 8,8'-(butane-1,4-diyl)bis(8-azaspiro[4.5]decane-7,9-dione).

01/2008:0542

## BUSULFAN

### Busulfanum

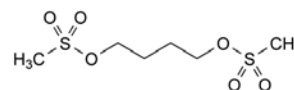

C<sub>6</sub>H<sub>14</sub>O<sub>6</sub>S<sub>2</sub>  
[55-98-1]

M<sub>r</sub> 246.3

#### DEFINITION

Butane-1,4-diyl di(methanesulfonate).

*Content*: 99.0 per cent to 100.5 per cent (dried substance).

#### CHARACTERS

*Appearance*: white or almost white, crystalline powder.

*Solubility*: very slightly soluble in water, freely soluble in acetone and in acetonitrile, very slightly soluble in ethanol (96 per cent).

mp: about 116 °C.

#### IDENTIFICATION

*First identification*: A.

*Second identification*: B, C, D.

A. Infrared absorption spectrophotometry (2.2.24).

*Comparison*: busulfan CRS.

B. Thin-layer chromatography (2.2.27).

*Test solution*. Dissolve 20 mg of the substance to be examined in 2 mL of *acetone R*.

*Reference solution*. Dissolve 20 mg of *busulfan CRS* in 2 mL of *acetone R*.

*Plate*: TLC silica gel G plate R.

*Mobile phase*: *acetone R*, *toluene R* (50:50 V/V).

*Application*: 5 µL.

*Development*: over a path of 15 cm.

*Drying*: in a current of warm air.

*Detection*: spray with *anisaldehyde solution R* and heat at 120 °C.

*Results*: the principal spot in the chromatogram obtained with the test solution is similar in position, colour and size to the principal spot in the chromatogram obtained with the reference solution.

C. To 0.1 g add 5 mL of 1 M *sodium hydroxide*. Heat until a clear solution is obtained. Allow to cool. To 2 mL of the solution add 0.1 mL of *potassium permanganate solution R*. The colour changes from purple through violet to blue and finally to green. Filter and add 1 mL of *ammoniacal silver nitrate solution R*. A precipitate is formed.

D. To 0.1 g add 0.1 g of *potassium nitrate R* and 0.25 g of *sodium hydroxide R*, mix and heat to fusion. Allow to cool and dissolve the residue in 5 mL of *water R*. Adjust to pH 1-2 using *dilute hydrochloric acid R*. The solution gives reaction (a) of sulfates (2.3.1).

## TESTS

**Appearance of solution.** The solution is clear (2.2.1) and not more intensely coloured than reference solution B<sub>7</sub> (2.2.2, Method II).

Dissolve 0.25 g in 20 mL of *acetonitrile R*, dilute to 25 mL with *water R* and examine immediately.

**Acidity.** Dissolve 0.20 g with heating in 50 mL of *anhydrous ethanol R*. Add 0.1 mL of *methyl red solution R*. Not more than 0.05 mL of 0.1 M *sodium hydroxide* is required to change the colour of the indicator.

**Loss on drying** (2.2.32): maximum 2.0 per cent, determined on 1.000 g by drying *in vacuo* at 60 °C.

**Sulfated ash** (2.4.14): maximum 0.1 per cent, determined on 1.0 g.

## ASSAY

To 0.250 g add 50 mL of *water R*. Shake. Boil under a reflux condenser for 30 min and, if necessary, make up to the initial volume with *water R*. Allow to cool. Using 0.3 mL of *phenolphthalein solution R* as indicator, titrate with 0.1 M *sodium hydroxide* until a pink colour is obtained.

1 mL of 0.1 M *sodium hydroxide* is equivalent to 12.32 mg of C<sub>6</sub>H<sub>14</sub>O<sub>6</sub>S<sub>2</sub>.

## STORAGE

In an airtight container, protected from light.

01/2008:0881

## BUTYL PARAHYDROXYBENZOATE

## Butylis parahydroxybenzoas

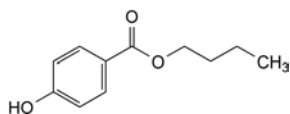

C<sub>11</sub>H<sub>14</sub>O<sub>3</sub>  
[94-26-8]

M<sub>r</sub> 194.2

## DEFINITION

Butyl 4-hydroxybenzoate.

**Content:** 98.0 per cent to 102.0 per cent.

## CHARACTERS

**Appearance:** white or almost white, crystalline powder or colourless crystals.

**Solubility:** very slightly soluble in water, freely soluble in alcohol and in methanol.

## IDENTIFICATION

**First identification:** A, B.

**Second identification:** A, C, D.

A. Melting point (2.2.14): 68 °C to 71 °C.

B. Infrared absorption spectrophotometry (2.2.24).

**Comparison:** *butyl parahydroxybenzoate CRS*.

C. Examine the chromatograms obtained in the test for related substances.

**Results:** the principal spot in the chromatogram obtained with test solution (b) is similar in position and size to the principal spot in the chromatogram obtained with reference solution (b).

D. To about 10 mg in a test-tube add 1 mL of *sodium carbonate solution R*, boil for 30 s and cool (solution A). To a further 10 mg in a similar test-tube add 1 mL of *sodium carbonate solution R*; the substance partly dissolves (solution B). Add at the same time to solution A and solution B 5 mL of *aminopyrazolone solution R* and 1 mL of *potassium ferricyanide solution R* and mix. Solution B is yellow to

orange-brown. Solution A is orange to red, the colour being clearly more intense than any similar colour which may be obtained with solution B.

## TESTS

**Solution S.** Dissolve 1.0 g in *alcohol R* and dilute to 10 mL with the same solvent.

**Appearance of solution.** Solution S is clear (2.2.1) and not more intensely coloured than reference solution BY<sub>6</sub> (2.2.2, Method II).

**Acidity.** To 2 mL of solution S add 3 mL of *alcohol R*, 5 mL of *carbon dioxide-free water R* and 0.1 mL of *bromocresol green solution R*. Not more than 0.1 mL of 0.1 M *sodium hydroxide* is required to change the colour of the indicator to blue.

**Related substances.** Thin-layer chromatography (2.2.27).

**Test solution (a).** Dissolve 0.10 g of the substance to be examined in *acetone R* and dilute to 10 mL with the same solvent.

**Test solution (b).** Dilute 1 mL of test solution (a) to 10 mL with *acetone R*.

**Reference solution (a).** Dilute 0.5 mL of test solution (a) to 100 mL with *acetone R*.

**Reference solution (b).** Dissolve 10 mg of *butyl parahydroxybenzoate CRS* in *acetone R* and dilute to 10 mL with the same solvent.

**Reference solution (c).** Dissolve 10 mg of *propyl parahydroxybenzoate R* in 1 mL of test solution (a) and dilute to 10 mL with *acetone R*.

**Plate:** suitable octadecylsilyl silica gel with a fluorescent indicator having an optimal intensity at 254 nm as the coating substance.

**Mobile phase:** *glacial acetic acid R, water R, methanol R* (1:30:70 V/V/V).

**Application:** 2 µL.

**Development:** over a path of 15 cm.

**Drying:** in air.

**Detection:** examine in ultraviolet light at 254 nm.

**System suitability:** the chromatogram obtained with reference solution (c) shows 2 clearly separated principal spots.

## Limits:

– **any impurity:** any spot in the chromatogram obtained with test solution (a), apart from the principal spot, is not more intense than the spot in the chromatogram obtained with reference solution (a) (0.5 per cent).

**Sulfated ash** (2.4.14): maximum 0.1 per cent, determined on 1.0 g.

## ASSAY

To 1.000 g add 20.0 mL of 1 M *sodium hydroxide*. Heat at about 70 °C for 1 h. Cool rapidly in an ice bath. Prepare a blank in the same manner. Carry out the titration on the solutions at room temperature. Titrate the excess sodium hydroxide with 0.5 M *sulfuric acid*, continuing the titration until the second point of inflexion and determining the end-point potentiometrically (2.2.20).

1 mL of 1 M *sodium hydroxide* is equivalent to 194.2 mg of C<sub>11</sub>H<sub>14</sub>O<sub>3</sub>.

## IMPURITIES

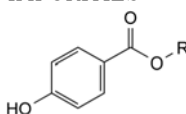

A. R = H: 4-hydroxybenzoic acid,

B. R = CH<sub>3</sub>: methyl 4-hydroxybenzoate,

C. R = CH<sub>2</sub>-CH<sub>3</sub>: ethyl 4-hydroxybenzoate,

D. R = CH<sub>2</sub>-CH<sub>2</sub>-CH<sub>3</sub>: propyl 4-hydroxybenzoate.



01/2008:0880

**BUTYLHYDROXYANISOLE**

## Butylhydroxyanisolum

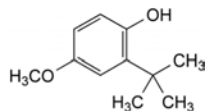

$C_{11}H_{16}O_2$   
[25013-16-5]

 $M_r$  180.3**DEFINITION**

Butylhydroxyanisole is 2-(1,1-dimethylethyl)-4-methoxyphenol containing not more than 10 per cent of 3-(1,1-dimethylethyl)-4-methoxyphenol.

**CHARACTERS**

A white, yellowish or slightly pinkish, crystalline powder, practically insoluble in water, very soluble in methylene chloride, freely soluble in alcohol and in fatty oils. It dissolves in dilute solutions of alkali hydroxides.

**IDENTIFICATION**

- A. Examine the chromatograms obtained in the test for related substances. The principal spot in the chromatogram obtained with test solution (b) is similar in position, colour and size to the principal spot in the chromatogram obtained with reference solution (a).
- B. To 0.5 mL of solution S (see Tests) add 10 mL of *aminopyrazolone solution R* and 1 mL of *potassium ferricyanide solution R*. Mix and add 10 mL of *methylene chloride R*. Shake vigorously. After separation, the organic layer is red.
- C. Dissolve about 10 mg in 2 mL of *alcohol R*. Add 1 mL of a 1 g/L solution of *testosterone propionate R* in *alcohol R* and 2 mL of *dilute sodium hydroxide solution R*. Heat in a water-bath at 80 °C for 10 min and allow to cool. A red colour develops.

**TESTS**

**Solution S.** Dissolve 2.5 g in *alcohol R* and dilute to 25 mL with the same solvent.

**Appearance of solution.** Solution S is clear (2.2.1) and not more intensely coloured than intensity 5 of the range of reference solutions of the most appropriate colour (2.2.2, *Method II*).

**Related substances.** Examine by thin-layer chromatography (2.2.27), using *silica gel G R* as the coating substance.

**Test solution (a).** Dissolve 0.25 g of the substance to be examined in *methylene chloride R* and dilute to 10 mL with the same solvent.

**Test solution (b).** Dilute 1 mL of test solution (a) to 10 mL with *methylene chloride R*.

**Reference solution (a).** Dissolve 25 mg of *butylhydroxyanisole CRS* in *methylene chloride R* and dilute to 10 mL with the same solvent.

**Reference solution (b).** Dilute 1 mL of reference solution (a) to 20 mL with *methylene chloride R*.

**Reference solution (c).** Dissolve 50 mg of *hydroquinone R* in 5 mL of *alcohol R* and dilute to 100 mL with *methylene chloride R*. Dilute 1 mL of this solution to 10 mL with *methylene chloride R*.

Apply separately to the plate 5 µL of each solution. Develop over a path of 10 cm using *methylene chloride R*. Allow the plate to dry in air and spray with a freshly prepared mixture of 10 volumes of *potassium ferricyanide solution R*, 20 volumes of *ferric chloride solution RI* and 70 volumes of *water R*. In the chromatogram obtained with test solution (a): any

violet-blue spot with an  $R_F$  value of about 0.35 (corresponding to 3-(1,1-dimethylethyl)-4-methoxyphenol) is not more intense than the principal spot in the chromatogram obtained with reference solution (a) (10 per cent); any spot corresponding to hydroquinone is not more intense than the principal spot in the chromatogram obtained with reference solution (c) (0.2 per cent); any spot, apart from the principal spot and any spots corresponding to 3-(1,1-dimethylethyl)-4-methoxyphenol and hydroquinone, is not more intense than the principal spot in the chromatogram obtained with reference solution (b) (0.5 per cent).

**Heavy metals (2.4.8).** 1.0 g complies with limit test C for heavy metals (10 ppm). Prepare the standard using 1 mL of *lead standard solution (10 ppm Pb) R*.

**Sulfated ash (2.4.14).** Not more than 0.1 per cent, determined on 1.0 g.

**STORAGE**

Store protected from light.

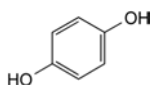
**IMPURITIES**

A. benzene-1,4-diol (hydroquinone).

01/2008:0581

**BUTYLHYDROXYTOLUENE**

## Butylhydroxytoluenum

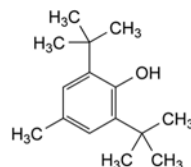

$C_{15}H_{24}O$   
[128-37-0]

 $M_r$  220.4**DEFINITION**

Butylhydroxytoluene is 2,6-bis(1,1-dimethylethyl)-4-methylphenol.

**CHARACTERS**

A white or yellowish-white, crystalline powder, practically insoluble in water, very soluble in acetone, freely soluble in alcohol and in vegetable oils.

**IDENTIFICATION**

**First identification:** A, C.

**Second identification:** A, B, D.

- A. Freezing-point (see Tests).
- B. Dissolve 0.500 g in *ethanol R* and dilute to 100.0 mL with the same solvent. Dilute 1.0 mL of this solution to 100.0 mL with *ethanol R*. Examined between 230 nm and 300 nm (2.2.25), the solution shows an absorption maximum at 278 nm. The specific absorbance at the maximum is 80 to 90.
- C. Examine by infrared absorption spectrophotometry (2.2.24), comparing with the spectrum obtained with *butylhydroxytoluene CRS*.
- D. Dissolve about 10 mg in 2 mL of *alcohol R*. Add 1 mL of a 1 g/L solution of *testosterone propionate R* in *alcohol R* and 2 mL of *dilute sodium hydroxide solution R*. Heat in a water-bath at 80 °C for 10 min and allow to cool. A blue colour develops.

## TESTS

**Appearance of solution.** Dissolve 1.0 g in *methanol R* and dilute to 10 mL with the same solvent. The solution is clear (2.2.1) and not more intensely coloured than reference solution Y<sub>5</sub> or BY<sub>5</sub> (2.2.2, Method II).

**Freezing-point** (2.2.18): 69 °C to 70 °C.

**Related substances.** Examine by thin-layer chromatography (2.2.27), using *silica gel G R* as the coating substance.

**Test solution.** Dissolve 0.2 g of the substance to be examined in *methanol R* and dilute to 10.0 mL with the same solvent.

**Reference solution.** Dilute 1 mL of the test solution to 200 mL with *methanol R*.

Apply separately to the plate 10 µL of each solution. Develop over a path of 15 cm using *methylene chloride R*. Dry the plate in air and spray with a freshly prepared mixture of 10 volumes of *potassium ferricyanide solution R*, 20 volumes of *ferric chloride solution R1* and 70 volumes of *water R*. Any spot in the chromatogram obtained with the test solution, apart from the principal spot, is not more intense than the spot in the chromatogram obtained with the reference solution (0.5 per cent).

**Sulfated ash** (2.4.14). Not more than 0.1 per cent, determined on 1.0 g.

01/2008:1773 *Detection*: spectrophotometer at 280 nm.*Injection*: 20 µL of the test solution and reference solutions (b) and (c).*Run time*: 4 times the retention time of cabergoline.*Relative retention* with reference to cabergoline (retention time = about 12 min): impurity D = about 0.3; impurity B = about 0.6; impurity A = about 0.8; impurity C = about 2.9.*System suitability*: reference solution (c):– *resolution*: minimum 3.0 between the peaks due to cabergoline and impurity A.*Limits*:

- *impurities A, C*: for each impurity, not more than 1.5 times the area of the principal peak in the chromatogram obtained with reference solution (b) (0.3 per cent);
- *impurities B, D*: for each impurity, not more than 0.5 times the area of the principal peak in the chromatogram obtained with reference solution (b) (0.1 per cent);
- *any other impurity*: for each impurity, not more than 0.5 times the area of the principal peak in the chromatogram obtained with reference solution (b) (0.1 per cent);
- *total*: not more than 4 times the area of the principal peak in the chromatogram obtained with reference solution (b) (0.8 per cent);
- *disregard limit*: 0.25 times the area of the principal peak in the chromatogram obtained with reference solution (b) (0.05 per cent).

**Water** (2.5.12): maximum 0.5 per cent, determined on 1.000 g.**ASSAY**

Liquid chromatography (2.2.29) as described in the test for related substances with the following modification.

*Injection*: test solution and reference solution (a).Calculate the percentage content of C<sub>26</sub>H<sub>37</sub>N<sub>5</sub>O<sub>2</sub> from the areas of the peaks and the declared content of *cabergoline CRS*.**STORAGE**

Protected from light.

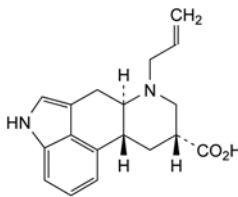
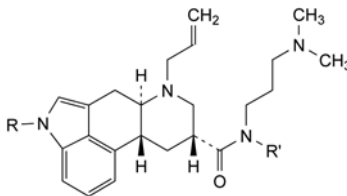
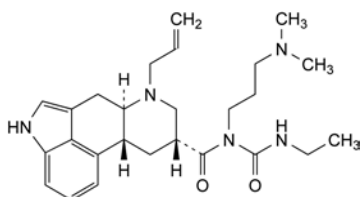
**IMPURITIES***Specified impurities*: A, B, C, D.A. (6a*R*,9*R*,10a*R*)-7-(prop-2-enyl)-4,6,6a,7,8,9,10,10a-octahydroindolo[4,3-*fg*]quinoline-9-carboxylic acid,B. R = CO-NH-C<sub>2</sub>H<sub>5</sub>, R' = H: (6a*R*,9*R*,10a*R*)-*N*<sup>9</sup>-[3-(dimethylamino)propyl]-*N*<sup>4</sup>-ethyl-7-(prop-2-enyl)-6a,7,8,9,10,10a-hexahydroindolo[4,3-*fg*]quinoline-4,9(6*H*)-dicarboxamide,C. R = R' = CO-NH-C<sub>2</sub>H<sub>5</sub>: (6a*R*,9*R*,10a*R*)-*N*<sup>9</sup>-[3-(dimethylamino)propyl]-*N*<sup>4</sup>-ethyl-*N*<sup>9</sup>-(ethylcarbamoyl)-7-(prop-2-enyl)-6a,7,8,9,10,10a-hexahydroindolo[4,3-*fg*]quinoline-4,9(6*H*)-dicarboxamide,D. R = R' = H: (6a*R*,9*R*,10a*R*)-*N*-[3-(dimethylamino)propyl]-7-(prop-2-enyl)-4,6,6a,7,8,9,10,10a-octahydroindolo[4,3-*fg*]quinoline-9-carboxamide.**CABERGOLINE****Cabergolinum**C<sub>26</sub>H<sub>37</sub>N<sub>5</sub>O<sub>2</sub>  
[81409-90-7]*M<sub>r</sub>* 451.6**DEFINITION**1-Ethyl-3-[3-(dimethylamino)propyl]-3-[[[(6a*R*,9*R*,10a*R*)-7-(prop-2-enyl)-4,6,6a,7,8,9,10,10a-octahydroindolo[4,3-*fg*]quinolin-9-yl]carbonyl]urea.*Content*: 98.0 per cent to 102.0 per cent (anhydrous substance).**CHARACTERS***Appearance*: white or almost white, crystalline powder.*Solubility*: practically insoluble in water, freely soluble in ethanol (96 per cent), very slightly soluble in hexane. It is slightly soluble in 0.1 M hydrochloric acid.

It shows polymorphism (5.9).

**IDENTIFICATION**

A. Specific optical rotation (see Tests).

B. Infrared absorption spectrophotometry (2.2.24).

*Comparison*: cabergoline CRS.If the spectra obtained in the solid state show differences, dissolve 50 mg of the substance to be examined and 50 mg of the reference substance separately in 1 mL of *ethanol* (96 per cent) *R*, evaporate to dryness and record new spectra using the residues.**TESTS****Specific optical rotation** (2.2.7): –77 to –83 (anhydrous substance).Dissolve 0.100 g in *ethanol* (96 per cent) *R* and dilute to 50.0 mL with the same solvent.**Related substances**. Liquid chromatography (2.2.29). Prepare the solutions immediately before use and protected from light.*Test solution*. Dissolve 30.0 mg of the substance to be examined in the mobile phase and dilute to 25.0 mL with the mobile phase.*Reference solution* (a). Dissolve 30.0 mg of *cabergoline CRS* in the mobile phase and dilute to 25.0 mL with the mobile phase.*Reference solution* (b). Dilute 1.0 mL of the test solution to 100.0 mL with the mobile phase. Dilute 10.0 mL of this solution to 50.0 mL with the mobile phase.*Reference solution* (c). Suspend 50 mg of the substance to be examined in 10 mL of 0.1 M *sodium hydroxide*. Stir for about 15 min. To 1 mL of the suspension add 1 mL of 0.1 M *hydrochloric acid* and dilute to 10 mL with the mobile phase. Sonicate until dissolution is complete. The main degradation product obtained is impurity A.*Column*:

- *size*: *l* = 0.25 m, Ø = 4.6 mm,
- *stationary phase*: octadecylsilyl silica gel for chromatography *R* (10 µm).

*Mobile phase*: mix 16 volumes of *acetonitrile R* and 84 volumes of a freshly prepared 6.8 g/L solution of *potassium dihydrogen phosphate R* previously adjusted to pH 2.0 with *phosphoric acid R*. Add 0.2 volumes of *triethylamine R*.*Flow rate*: 1.2 mL/min.

## CAFFEINE

## Coffeinum

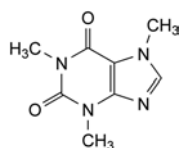

$C_8H_{10}N_4O_2$   
[58-08-2]

$M_r$  194.2

## DEFINITION

1,3,7-Trimethyl-3,7-dihydro-1H-purine-2,6-dione.

*Content*: 98.5 per cent to 101.5 per cent (dried substance).

## CHARACTERS

*Appearance*: white or almost white, crystalline powder or silky, white or almost white, crystals.

*Solubility*: sparingly soluble in water, freely soluble in boiling water, slightly soluble in ethanol (96 per cent). It dissolves in concentrated solutions of alkali benzoates or salicylates.

It sublimates readily.

## IDENTIFICATION

*First identification*: A, B, E.

*Second identification*: A, C, D, E, F.

A. Melting point (2.2.14): 234 °C to 239 °C.

B. Infrared absorption spectrophotometry (2.2.24).

*Comparison*: caffeine CRS.

C. To 2 mL of a saturated solution add 0.05 mL of *iodinated potassium iodide solution R*. The solution remains clear. Add 0.1 mL of *dilute hydrochloric acid R*; a brown precipitate is formed. Neutralise with *dilute sodium hydroxide solution R*; the precipitate dissolves.

D. In a ground-glass-stoppered tube, dissolve about 10 mg in 0.25 mL of a mixture of 0.5 mL of *acetylacetone R* and 5 mL of *dilute sodium hydroxide solution R*. Heat in a water-bath at 80 °C for 7 min. Cool and add 0.5 mL of *dimethylaminobenzaldehyde solution R2*. Heat again in a water-bath at 80 °C for 7 min. Allow to cool and add 10 mL of *water R*; an intense blue colour develops.

E. Loss on drying (see Tests).

F. It gives the reaction of xanthines (2.3.1).

## TESTS

**Solution S.** Dissolve 0.5 g with heating in 50 mL of *carbon dioxide-free water R* prepared from *distilled water R*, cool and dilute to 50 mL with the same solvent.

**Appearance of solution.** Solution S is clear (2.2.1) and colourless (2.2.2, *Method II*).

**Acidity.** To 10 mL of solution S add 0.05 mL of *bromothymol blue solution R1*; the solution is green or yellow. Not more than 0.2 mL of 0.01 M *sodium hydroxide* is required to change the colour of the indicator to blue.

**Related substances.** Liquid chromatography (2.2.29).

*Test solution.* Dissolve 0.100 g of the substance to be examined in the mobile phase and dilute to 50.0 mL with the mobile phase. Dilute 1.0 mL of this solution to 10.0 mL with the mobile phase.

*Reference solution (a).* Dilute 2.0 mL of the test solution to 100.0 mL with the mobile phase. Dilute 1.0 mL of this solution to 10.0 mL with the mobile phase.

**04/2008:0267** *Reference solution (b).* Dissolve 5 mg of *caffeine for system suitability CRS* (containing impurities A, C, D and F) in the mobile phase and dilute to 5 mL with the mobile phase. Dilute 2 mL of this solution to 10 mL with the mobile phase.

*Column*:

– *size*:  $l = 0.15$  m,  $\varnothing = 4.6$  mm;

– *stationary phase*: base-deactivated end-capped octadecylsilyl silica gel for chromatography R (5  $\mu$ m).

*Mobile phase*: mix 20 volumes of *tetrahydrofuran R*, 25 volumes of *acetonitrile R* and 955 volumes of a solution containing 0.82 g/L of *anhydrous sodium acetate R* previously adjusted to pH 4.5 with *glacial acetic acid R*.

*Flow rate*: 1.0 mL/min.

*Detection*: spectrophotometer at 275 nm.

*Injection*: 10  $\mu$ L.

*Run time*: 1.5 times the retention time of caffeine.

*Identification of impurities*: use the chromatogram supplied with *caffeine for system suitability CRS* and the chromatogram obtained with reference solution (b) to identify the peaks due to impurities A, C, D and F.

*Retention time*: caffeine = about 8 min.

*System suitability*: reference solution (b):

– *resolution*: minimum 2.5 between the peaks due to impurities C and D and minimum 2.5 between the peaks due to impurities F and A.

*Limits*:

– *unspecified impurities*: for each impurity, not more than 0.5 times the area of the principal peak in the chromatogram obtained with reference solution (a) (0.10 per cent);

– *total*: not more than 0.5 times the area of the principal peak in the chromatogram obtained with reference solution (a) (0.1 per cent);

– *disregard limit*: 0.25 times the area of the principal peak in the chromatogram obtained with reference solution (a) (0.05 per cent).

**Sulfates** (2.4.13): maximum 500 ppm, determined on 15 mL of solution S.

Prepare the standard using a mixture of 7.5 mL of *sulfate standard solution (10 ppm  $SO_4$ ) R* and 7.5 mL of *distilled water R*.

**Heavy metals** (2.4.8): maximum 20 ppm.

1.0 g complies with test C. Prepare the reference solution using 2 mL of *lead standard solution (10 ppm Pb) R*.

**Loss on drying** (2.2.32): maximum 0.5 per cent, determined on 1.000 g by drying in an oven at 105 °C for 1 h.

**Sulfated ash** (2.4.14): maximum 0.1 per cent, determined on 1.0 g.

## ASSAY

Dissolve 0.170 g with heating in 5 mL of *anhydrous acetic acid R*. Allow to cool, add 10 mL of *acetic anhydride R* and 20 mL of *toluene R*. Titrate with 0.1 M *perchloric acid*, determining the end-point potentiometrically (2.2.20).

1 mL of 0.1 M *perchloric acid* is equivalent to 19.42 mg of  $C_8H_{10}N_4O_2$ .

## IMPURITIES

*Other detectable impurities* (the following substances would, if present at a sufficient level, be detected by one or other of the tests in the monograph. They are limited by the general acceptance criterion for other/unspecified impurities and/or by the general monograph *Substances for pharmaceutical use* (2034). It is therefore not necessary to identify these impurities for demonstration of compliance. See also 5.10. *Control of impurities in substances for pharmaceutical use*): A, B, C, D, E, F.

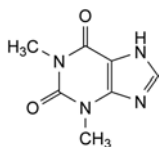

A. 1,3-dimethyl-3,7-dihydro-1H-purine-2,6-dione (theophylline),

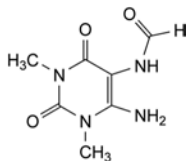

B. N-(6-amino-1,3-dimethyl-2,4-dioxo-1,2,3,4-tetrahydropyrimidin-5-yl)formamide,

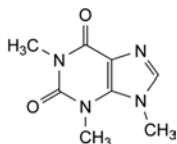

C. 1,3,9-trimethyl-3,9-dihydro-1H-purine-2,6-dione (isocaffeine),

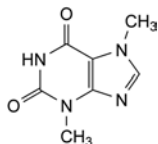

D. 3,7-dimethyl-3,7-dihydro-1H-purine-2,6-dione (theobromine),

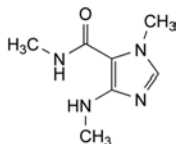

E. N,1-dimethyl-4-(methylamino)-1H-imidazole-5-carboxamide (caffeidine),

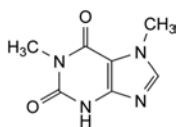

F. 1,7-dimethyl-3,7-dihydro-1H-purine-2,6-dione.

07/2009:0268

## CAFFEINE MONOHYDRATE

### Coffeinum monohydricum

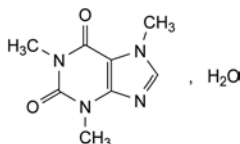

$C_8H_{10}N_4O_2 \cdot H_2O$   
[5743-12-4]

$M_r$  212.2

#### DEFINITION

1,3,7-Trimethyl-3,7-dihydro-1H-purine-2,6-dione monohydrate.

Content: 98.5 per cent to 101.5 per cent (dried substance).

#### CHARACTERS

**Appearance:** white or almost white, crystalline powder or silky, white or almost white crystals.

**Solubility:** sparingly soluble in water, freely soluble in boiling water, slightly soluble in ethanol (96 per cent). It dissolves in concentrated solutions of alkali benzoates or salicylates.

It sublimes readily.

#### IDENTIFICATION

**First identification:** A, B, E.

**Second identification:** A, C, D, E, F.

A. Melting point (2.2.14): 234 °C to 239 °C, determined after drying at 100-105 °C.

B. Infrared absorption spectrophotometry (2.2.24).

**Preparation:** dry the substance to be examined at 100-105 °C before use.

**Comparison:** caffeine CRS.

C. To 2 mL of a saturated solution add 0.05 mL of *iodinated potassium iodide solution R*; the solution remains clear. Add 0.1 mL of *dilute hydrochloric acid R*; a brown precipitate is formed. Neutralise with *dilute sodium hydroxide solution R*; the precipitate dissolves.

D. In a glass-stoppered tube, dissolve about 10 mg in 0.25 mL of a mixture of 0.5 mL of *acetylacetone R* and 5 mL of *dilute sodium hydroxide solution R*. Heat in a water-bath at 80 °C for 7 min. Cool and add 0.5 mL of *dimethylaminobenzaldehyde solution R2*. Heat again in a water-bath at 80 °C for 7 min. Allow to cool and add 10 mL of *water R*; an intense blue colour develops.

E. Loss on drying (see Tests).

F. It gives the reaction of xanthines (2.3.1).

#### TESTS

**Solution S.** Dissolve 0.5 g with heating in 50 mL of *carbon dioxide-free water R* prepared from *distilled water R*, cool, and dilute to 50 mL with the same solvent.

**Appearance of solution.** Solution S is clear (2.2.1) and colourless (2.2.2, *Method II*).

**Acidity.** To 10 mL of solution S add 0.05 mL of *bromothymol blue solution R1*; the solution is green or yellow. Not more than 0.2 mL of 0.01 M *sodium hydroxide* is required to change the colour of the indicator to blue.

**Related substances.** Liquid chromatography (2.2.29).

**Test solution.** Dissolve 0.110 g of the substance to be examined in the mobile phase and dilute to 50.0 mL with the mobile phase. Dilute 1.0 mL of this solution to 10.0 mL with the mobile phase.

**Reference solution (a).** Dilute 2.0 mL of the test solution to 100.0 mL with the mobile phase. Dilute 1.0 mL of this solution to 10.0 mL with the mobile phase.

**Reference solution (b).** Dissolve 5 mg of *caffeine for system suitability CRS* (containing impurities A, C, D and F) in the mobile phase and dilute to 5.0 mL with the mobile phase. Dilute 2.0 mL of this solution to 10.0 mL with the mobile phase.

**Column:**

– size:  $l = 0.15$  m,  $\varnothing = 4.6$  mm;

– stationary phase: base-deactivated end-capped octadecylsilyl silica gel for chromatography R (5  $\mu$ m).

**Mobile phase.** Mix 20 volumes of *tetrahydrofuran R*, 25 volumes of *acetonitrile R* and 955 volumes of a solution containing 0.82 g/L of *anhydrous sodium acetate R* previously adjusted to pH 4.5 with *glacial acetic acid R*.

**Flow rate:** 1.0 mL/min.

**Detection:** spectrophotometer at 275 nm.

**Injection:** 10  $\mu$ L.

**Run time:** 1.5 times the retention time of caffeine.

**Identification of impurities:** use the chromatogram supplied with *caffeine for system suitability CRS* and the chromatogram obtained with reference solution (b) to identify the peaks due to impurities A, C, D and F.

**Retention time:** caffeine = about 8 min.

**System suitability:** reference solution (b):

– resolution: minimum 2.5 between the peaks due to impurities C and D; minimum 2.5 between the peaks due to impurities F and A.

## Limits:

- *unspecified impurities*: for each impurity, not more than 0.5 times the area of the principal peak in the chromatogram obtained with reference solution (a) (0.10 per cent);
- *total*: not more than 0.5 times the area of the principal peak in the chromatogram obtained with reference solution (a) (0.1 per cent);
- *disregard limit*: 0.25 times the area of the principal peak in the chromatogram obtained with reference solution (a) (0.05 per cent).

**Sulfates (2.4.13)**: maximum 500 ppm, determined on 15 mL of solution S.

Prepare the standard using a mixture of 7.5 mL of *sulfate standard solution (10 ppm SO<sub>4</sub>) R* and 7.5 mL of *distilled water R*.

**Heavy metals (2.4.8)**: maximum 20 ppm.

1.0 g complies with test C. Prepare the reference solution using 2 mL of *lead standard solution (10 ppm Pb) R*.

**Loss on drying (2.2.32)**: 5.0 per cent to 9.0 per cent, determined on 1.000 g by drying in an oven at 105 °C for 1 h.

**Sulfated ash (2.4.14)**: maximum 0.1 per cent, determined on 1.0 g.

## ASSAY

Dissolve 0.170 g, previously dried at 100-105 °C, with heating in 5 mL of *anhydrous acetic acid R*. Allow to cool, and add 10 mL of *acetic anhydride R* and 20 mL of *toluene R*. Titrate with 0.1 M *perchloric acid*, determining the end-point potentiometrically (2.2.20).

1 mL of 0.1 M *perchloric acid* is equivalent to 19.42 mg of C<sub>27</sub>H<sub>44</sub>O<sub>2</sub>·H<sub>2</sub>O.

## IMPURITIES

*Other detectable impurities* (the following substances would, if present at a sufficient level, be detected by one or other of the tests in the monograph. They are limited by the general acceptance criterion for other/unspecified impurities and/or by the general monograph *Substances for pharmaceutical use (2034)*. It is therefore not necessary to identify these impurities for demonstration of compliance. See also 5.10. *Control of impurities in substances for pharmaceutical use*): A, B, C, D, E, F.

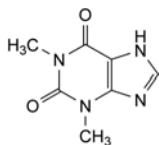

A. 1,3-dimethyl-3,7-dihydro-1H-purine-2,6-dione (theophylline),

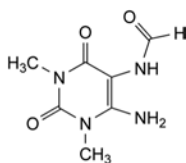

B. *N*-(6-amino-1,3-dimethyl-2,4-dioxo-1,2,3,4-tetrahydropyrimidin-5-yl)formamide,

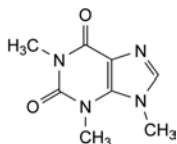

C. 1,3,9-trimethyl-3,9-dihydro-1H-purine-2,6-dione (isocaffeine),

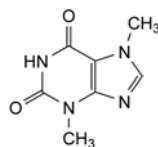

D. 3,7-dimethyl-3,7-dihydro-1H-purine-2,6-dione (theobromine),

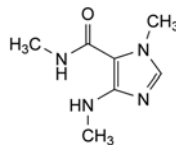

E. *N*,1-dimethyl-4-(methylamino)-1H-imidazole-5-carboxamide (caffeine),

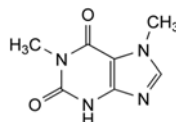

F. 1,7-dimethyl-3,7-dihydro-1H-purine-2,6-dione.

01/2008:1295  
corrected 6.0

## CALCIFEDIOL

## Calcifediolum

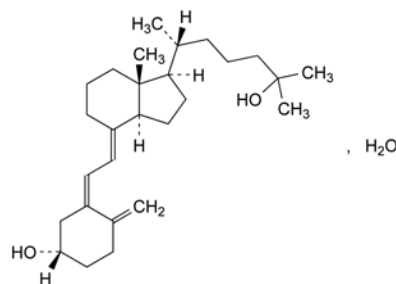

C<sub>27</sub>H<sub>44</sub>O<sub>2</sub>·H<sub>2</sub>O  
[63283-36-3]

M<sub>r</sub> 418.7

## DEFINITION

(5*Z*,7*E*)-9,10-Secocholesta-5,7,10(19)-triene-3β,25-diol monohydrate.

*Content*: 97.0 per cent to 102.0 per cent (anhydrous substance).

## CHARACTERS

*Appearance*: white or almost white crystals.

*Solubility*: practically insoluble in water, freely soluble in ethanol (96 per cent), soluble in fatty oils.

It is sensitive to air, heat and light.

A reversible isomerisation to pre-calcifediol takes place in solution, depending on temperature and time. The activity is due to both compounds.

## IDENTIFICATION

A. Infrared absorption spectrophotometry (2.2.24).

*Preparation*: mix 2 mg of the substance to be examined and 225 mg of *potassium bromide R*.

*Comparison*: *Ph. Eur. reference spectrum of calcifediol*.

B. Examine the chromatograms obtained in the assay.

*Results*: the principal peak in the chromatogram obtained with the test solution is similar in retention time and size to the principal peak in the chromatogram obtained with reference solution (a).

## TESTS

**Related substances.** Liquid chromatography (2.2.29): use the normalisation procedure. Carry out the test as rapidly as possible, avoiding exposure to actinic light and air.

**Test solution.** Dissolve 1.0 mg of the substance to be examined without heating in 10.0 mL of the mobile phase.

**Reference solution (a).** Dissolve 1.0 mg of calcifediol CRS without heating in 10.0 mL of the mobile phase.

**Reference solution (b).** Dilute 1.0 mL of reference solution (a) to 100.0 mL with the mobile phase.

**Reference solution (c).** Heat 2 mL of reference solution (a) in a water-bath at 80 °C under a reflux condenser for 2 h and cool.

**Column:**

- size:  $l = 0.15$  m,  $\varnothing = 4.6$  mm;
- stationary phase: octylsilyl silica gel for chromatography R1 (5 µm).

**Mobile phase:** water R, methanol R (200:800 V/V).

**Flow rate:** 1.5 mL/min.

**Detection:** spectrophotometer at 265 nm.

**Injection:** 50 µL of the test solution and reference solutions (b) and (c).

**Run time:** twice the retention time of calcifediol.

**Relative retention** with reference to calcifediol (retention time = about 11 min): pre-calcifediol = about 1.3.

**System suitability:** reference solution (c):

- resolution: minimum 5.0 between the peaks due to pre-calcifediol and calcifediol; if necessary, adjust the proportions of the constituents in the mobile phase.

**Limits:**

- impurities A, B, C, D: for each impurity, maximum 0.5 per cent;
- total: maximum 1.0 per cent;
- disregard limit: 0.1 times the area of the principal peak in the chromatogram obtained with reference solution (b) (0.1 per cent); disregard the peak due to pre-alfacalcidol.

**Water** (2.5.32): 3.8 per cent to 5.0 per cent, determined on 10.0 mg.

## ASSAY

Liquid chromatography (2.2.29) as described in the test for related substances with the following modifications.

**Injection:** the test solution and reference solutions (a) and (c).

**System suitability:** reference solution (c):

- repeatability: maximum relative standard deviation of 1 per cent for the peak due to calcifediol after 6 injections.

Calculate the percentage content of  $C_{27}H_{44}O_2$  from the declared content of calcifediol CRS.

## STORAGE

Under nitrogen, in an airtight container, protected from light, at a temperature of 2 °C to 8 °C.

The contents of an opened container are to be used immediately.

## IMPURITIES

**Specified impurities:** A, B, C, D.

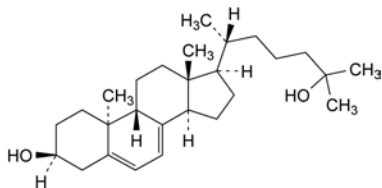

A. 9β,10α-cholesta-5,7-diene-3β,25-diol,

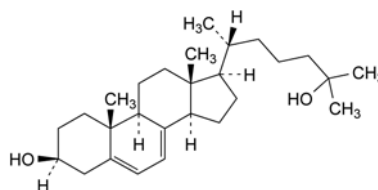

B. cholesta-5,7-diene-3β,25-diol,

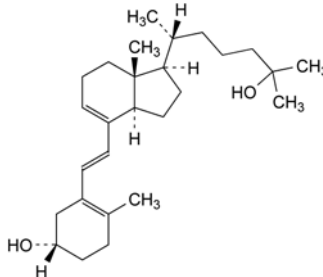

C. (6E)-9,10-secocholesta-5(10),6,8-triene-3β,25-diol,

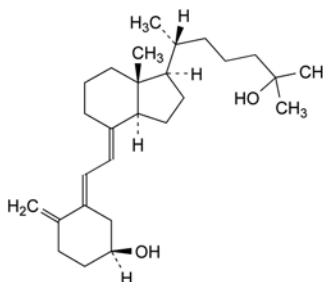

D. (5E,7E)-9,10-secocholesta-5,7,10(19)-triene-3β,25-diol.

01/2008:2011  
corrected 7.0

## CALCIPOTRIOL, ANHYDROUS

## Calcipotriolum anhydricum

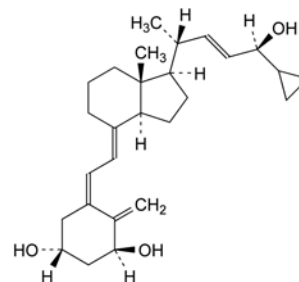

$C_{27}H_{40}O_3$   
[112965-21-6]

$M_r$  412.6

## DEFINITION

(5Z,7E,22E,24S)-24-Cyclopropyl-9,10-secocholesta-5,7,10(19),22-tetraene-1α,3β,24-triol.

**Content:** 95.5 per cent to 102.0 per cent (dried substance).

## CHARACTERS

**Appearance:** white or almost white, crystalline powder.

**Solubility:** practically insoluble in water, freely soluble in ethanol (96 per cent), slightly soluble in methylene chloride. It is sensitive to heat and light.

A reversible isomerisation to pre-calcipotriol takes place in solution, depending on temperature and time. The activity is due to both compounds.

## IDENTIFICATION

A. Infrared absorption spectrophotometry (2.2.24).

*Comparison: Ph. Eur. reference spectrum of anhydrous calcipotriol.*

B. Loss on drying (see Tests).

*Carry out the tests for related substances and the assay as rapidly as possible and protected from actinic light and air.*

## TESTS

### Related substances

A. Thin-layer chromatography (2.2.27).

*Solution A.* To 1 mL of triethylamine R add 9 mL of chloroform R.

*Test solution.* Dissolve 1 mg of the substance to be examined in 100 µL of solution A.

*Reference solution (a).* To 10 µL of the test solution add 990 µL of solution A.

*Reference solution (b).* To 250 µL of reference solution (a) add 750 µL of solution A.

*Reference solution (c).* To 100 µL of reference solution (a) add 900 µL of solution A.

*Reference solution (d).* Place 2 mg of the substance to be examined in a vial and dissolve in 200 µL of solution A. Close the vial and keep it in a water bath at 60 °C for 2 h.

*Plate: TLC silica gel F<sub>254</sub> plate R.*

*Mobile phase: 2-methylpropanol R, methylene chloride R (20:80 V/V).*

*Application:* 10 µL of the test solution and reference solutions (b), (c) and (d).

*Development:* over 2/3 of the plate.

*Drying:* in air, then at 140 °C for 10 min.

*Detection:* spray the hot plate with an alcoholic solution of sulfuric acid R, dry at 140 °C for not more than 1 min and examine in ultraviolet light at 366 nm.

*Relative retention* with reference to calcipotriol ( $R_F$  = about 0.4): impurity G = about 0.4; impurity H = about 0.4; pre-calcipotriol = about 0.9; impurity A = about 1.2.

*System suitability:* reference solution (d):

- the chromatogram shows a secondary spot due to pre-calcipotriol.

*Limits:*

- *impurity A:* any spot due to impurity A is not more intense than the spot in the chromatogram obtained with reference solution (b) (0.25 per cent),
- *impurities G, H:* any spot due to impurity G or H is not more intense than the spot in the chromatogram obtained with reference solution (b) (0.25 per cent for the sum),
- *any other impurity:* any other spot is not more intense than the spot in the chromatogram obtained with reference solution (c) (0.1 per cent).

B. Liquid chromatography (2.2.29).

*Solution A.* Dissolve 1.32 g of ammonium phosphate R in water R and dilute to 10.0 mL with the same solvent.

*Solvent mixture:* solution A, water R, methanol R (3:297:700 V/V/V).

*Test solution (a).* Dissolve 2.00 mg of the substance to be examined in the solvent mixture and dilute to 5.0 mL with the solvent mixture.

*Test solution (b).* Dissolve 2.00 mg of the substance to be examined in the solvent mixture and dilute to 20.0 mL with the same solvent mixture.

*Reference solution (a).* Dilute 1.0 mL of test solution (a) to 100.0 mL with the solvent mixture.

*Reference solution (b).* Dilute 1.0 mL of reference solution (a) to 10.0 mL with the solvent mixture.

*Reference solution (c).* Dissolve 1.0 mg of calcipotriol monohydrate CRS (containing impurities B, C and D) in the solvent mixture and dilute to 2.5 mL with the solvent mixture.

*Reference solution (d).* Dissolve 2.00 mg of calcipotriol monohydrate CRS in the solvent mixture and dilute to 20.0 mL with the solvent mixture.

*Column:*

- *size:*  $l = 0.10$  m,  $\varnothing = 4.0$  mm,
- *stationary phase:* octadecylsilyl silica gel for chromatography R (3 µm).

*Mobile phase:* water R, methanol R (30:70 V/V).

*Flow rate:* 1.0 mL/min.

*Detection:* spectrophotometer at 264 nm.

*Injection:* 20 µL of test solution (a) and reference solutions (a), (b) and (c).

*Run time:* twice the retention time of calcipotriol.

*Relative retention* with reference to calcipotriol (retention time = about 13.5 min): impurity B = about 0.86; impurity C = about 0.92; impurity D = about 1.3.

*System suitability:* reference solution (c):

- *peak-to-valley ratio:* minimum 1.5, where  $H_p$  = height above the baseline of the peak due to impurity C and  $H_v$  = height above the baseline of the lowest point of the curve separating this peak from the peak due to calcipotriol,
- the chromatogram obtained is similar to the chromatogram supplied with calcipotriol monohydrate CRS.

*Limits:*

- *impurity B:* not more than 0.5 times the area of the principal peak in the chromatogram obtained with reference solution (a) (0.5 per cent),
- *impurities C, D:* for each impurity, not more than the area of the principal peak in the chromatogram obtained with reference solution (a) (1.0 per cent),
- *any other impurity:* for each impurity, not more than the area of the principal peak in the chromatogram obtained with reference solution (b) (0.1 per cent),
- *total:* not more than 2.5 times the area of the principal peak in the chromatogram obtained with reference solution (a) (2.5 per cent),
- *disregard limit:* 0.5 times the area of the principal peak in the chromatogram obtained with reference solution (b) (0.05 per cent).

**Loss on drying:** maximum 1.0 per cent, determined on 5 mg by thermogravimetry (2.2.34). Heat to 105 °C at a rate of 10 °C/min and maintain at 105 °C for 60 min.

### ASSAY

Liquid chromatography (2.2.29) as described in the test for related substances with the following modification.

*Injection:* test solution (b) and reference solution (d).

Calculate the percentage content of C<sub>27</sub>H<sub>40</sub>O<sub>3</sub> from the areas of the peaks and the declared content of calcipotriol monohydrate CRS.

### STORAGE

In an airtight container, protected from light at –20 °C or below.

### IMPURITIES

*Specified impurities:* A, B, C, D, G, H.

*Other detectable impurities* (the following substances would, if present at a sufficient level, be detected by one or other of the tests in the monograph. They are limited by the general acceptance criterion for other/unspecified impurities and/or by the general monograph *Substances for pharmaceutical use (2034)*. It is therefore not necessary to identify these impurities for demonstration of compliance. See also 5.10. *Control of impurities in substances for pharmaceutical use*): E, F, I.



By thin-layer chromatography: A, G, H, I.

By liquid chromatography: B, C, D, E, F.

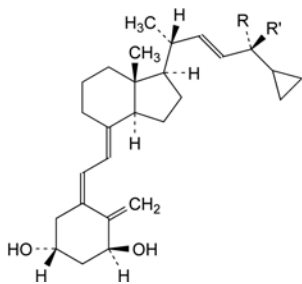

A. R + R' = O: (5*Z*,7*E*,22*E*)-24-cyclopropyl-1 $\alpha$ ,3 $\beta$ -dihydroxy-9,10-secochola-5,7,10(19),22-tetraene-24-one,

D. R = OH, R' = H: (5*Z*,7*E*,22*E*,24*R*)-24-cyclopropyl-9,10-secochola-5,7,10(19),22-tetraene-1 $\alpha$ ,3 $\beta$ ,24-triol (24-*epi*-calcipotriol),

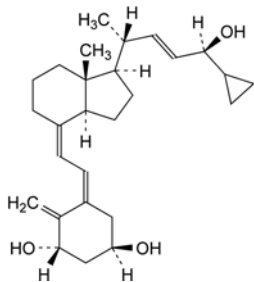

B. (5*Z*,7*Z*,22*E*,24*S*)-24-cyclopropyl-9,10-secochola-5,7,10(19),22-tetraene-1 $\alpha$ ,3 $\beta$ ,24-triol ((7*Z*)-calcipotriol),

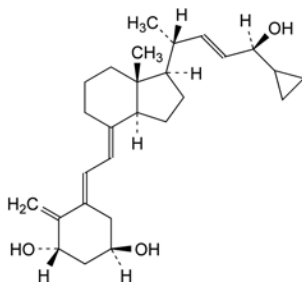

C. (5*E*,7*E*,22*E*,24*S*)-24-cyclopropyl-9,10-secochola-5,7,10(19),22-tetraene-1 $\alpha$ ,3 $\beta$ ,24-triol ((5*E*)-calcipotriol),

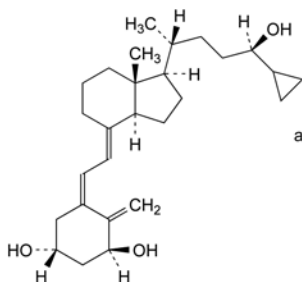

E. *rac*-(5*Z*,7*E*,22*E*,24*S*)-24-cyclopropyl-9,10-secochola-5,7,10(19)-triene-1 $\alpha$ ,3 $\beta$ ,24-triol,

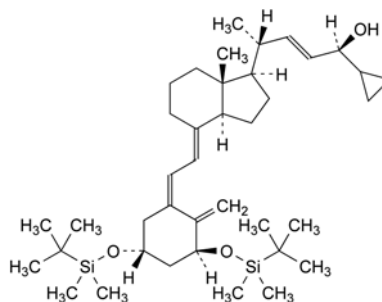

F. (5*Z*,7*E*,22*E*,24*S*)-24-cyclopropyl-1 $\alpha$ ,3 $\beta$ -bis[(1,1-dimethylethyl)dimethylsilyloxy]-9,10-secochola-5,7,10(19),22-tetraene-24-ol,

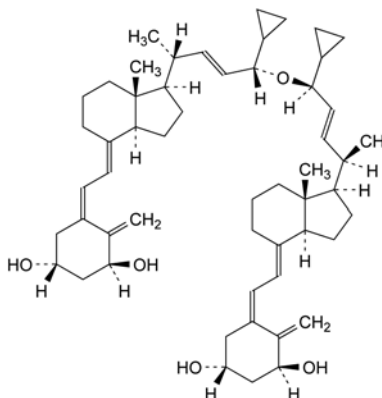

G. 24,24'-oxybis[(5*Z*,7*E*,22*E*,24*S*)-24-cyclopropyl-9,10-secochola-5,7,10(19),22-tetraene-1 $\alpha$ ,3 $\beta$ -diol],

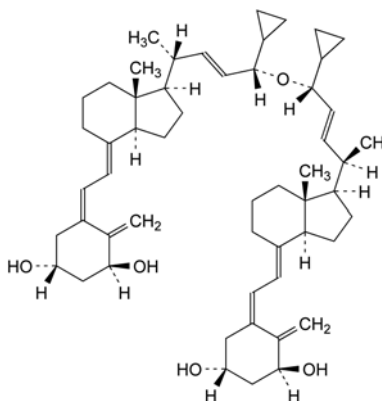

H. (5*Z*,7*E*,22*E*,24*R*)-24-cyclopropyl-24-[[5*Z*,7*E*,22*E*,24*S*)-24-cyclopropyl-1 $\alpha$ ,3 $\beta$ -dihydroxy-9,10-secochola-5,7,10(19),22-tetraen-24-yl]oxy]-9,10-secochola-5,7,10(19),22-tetraene-1 $\alpha$ ,3 $\beta$ -diol,

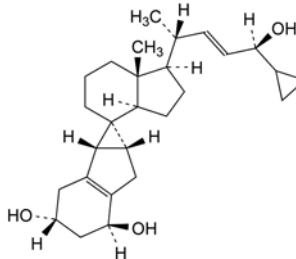

I. (6*S*,7*R*,8*R*,22*E*,24*S*)-24-cyclopropyl-6,8:7,19-dicyclo-9,10-secochola-5(10),22-diene-1 $\alpha$ ,3 $\beta$ ,24-triol (suprasterol of calcipotriol).

01/2008:2284

## CALCIPOTRIOL MONOHYDRATE

## Calcipotriolum monohydricum

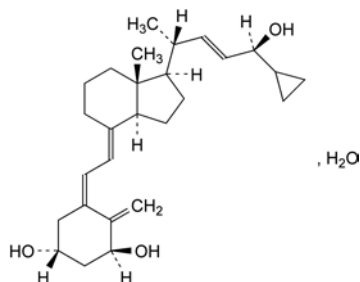

$C_{27}H_{40}O_3 \cdot H_2O$   
[147657-22-5]

 $M_r$  430.6

## DEFINITION

(5*Z*,7*E*,22*E*,24*S*)-24-Cyclopropyl-9,10-secocyclopropane-5,7,10(19),22-tetraene-1 $\alpha$ ,3 $\beta$ ,24-triol monohydrate.

*Content*: 95.5 per cent to 102.0 per cent (anhydrous substance).

## CHARACTERS

*Appearance*: white or almost white, crystalline powder.

*Solubility*: practically insoluble in water, freely soluble in ethanol (96 per cent), slightly soluble in methylene chloride.

It is sensitive to light.

A reversible isomerisation to pre-calcipotriol takes place in solution, depending on temperature and time. The activity is due to both compounds.

## IDENTIFICATION

## A. Infrared absorption spectrophotometry (2.2.24).

*Comparison*: Ph. Eur. reference spectrum of calcipotriol monohydrate.

## B. Water (see Tests).

Carry out the tests for related substances and the assay as rapidly as possible and protected from actinic light and air.

## TESTS

## Related substances

## A. Thin-layer chromatography (2.2.27).

*Solution A*. To 1 mL of triethylamine R add 9 mL of chloroform R.

*Test solution*. Dissolve 1 mg of the substance to be examined in 100  $\mu$ L of solution A.

*Reference solution (a)*. To 10  $\mu$ L of the test solution add 990  $\mu$ L of solution A.

*Reference solution (b)*. To 250  $\mu$ L of reference solution (a) add 750  $\mu$ L of solution A.

*Reference solution (c)*. To 100  $\mu$ L of reference solution (a) add 900  $\mu$ L of solution A.

*Reference solution (d)*. Place 2 mg of the substance to be examined in a vial and dissolve in 200  $\mu$ L of solution A. Close the vial and keep it in a water bath at 60 °C for 2 h.

*Plate*: TLC silica gel F<sub>254</sub> plate R.

*Mobile phase*: 2-methylpropanol R, methylene chloride R (20:80 V/V).

*Application*: 10  $\mu$ L of the test solution and reference solutions (b), (c) and (d).

*Development*: over 2/3 of the plate.

*Drying*: in air, then at 140 °C for 10 min.

*Detection*: spray the hot plate with an alcoholic solution of sulfuric acid R, dry at 140 °C for not more than 1 min and examine in ultraviolet light at 366 nm.

*Relative retention* with reference to calcipotriol ( $R_F$  = about 0.4): impurity G = about 0.4; impurity H = about 0.4; pre-calcipotriol = about 0.9; impurity A = about 1.2.

*System suitability*: reference solution (d):

- the chromatogram shows a secondary spot due to pre-calcipotriol.

*Limits*:

- *impurity A*: any spot due to impurity A is not more intense than the spot in the chromatogram obtained with reference solution (b) (0.25 per cent),
- *impurities G, H*: any spot due to impurity G or H is not more intense than the spot in the chromatogram obtained with reference solution (b) (0.25 per cent for the sum),
- *any other impurity*: any other spot is not more intense than the spot in the chromatogram obtained with reference solution (c) (0.1 per cent).

## B. Liquid chromatography (2.2.29).

*Solution A*. Dissolve 1.32 g of ammonium phosphate R in water R and dilute to 10.0 mL with the same solvent.

*Solvent mixture*: solution A, water R, methanol R (3:297:700 V/V/V).

*Test solution (a)*. Dissolve 2.00 mg of the substance to be examined in the solvent mixture and dilute to 5.0 mL with the solvent mixture.

*Test solution (b)*. Dissolve 2.00 mg of the substance to be examined in the solvent mixture and dilute to 20.0 mL with the same solvent mixture.

*Reference solution (a)*. Dilute 1.0 mL of test solution (a) to 100.0 mL with the solvent mixture.

*Reference solution (b)*. Dilute 1.0 mL of reference solution (a) to 10.0 mL with the solvent mixture.

*Reference solution (c)*. Dissolve 1.0 mg of calcipotriol monohydrate CRS (containing impurities B, C and D) in the solvent mixture and dilute to 2.5 mL with the solvent mixture.

*Reference solution (d)*. Dissolve 2.00 mg of calcipotriol monohydrate CRS in the solvent mixture and dilute to 20.0 mL with the solvent mixture.

*Column*:

- *size*:  $l = 0.10$  m,  $\varnothing = 4.0$  mm,
- *stationary phase*: octadecylsilyl silica gel for chromatography R (3  $\mu$ m).

*Mobile phase*: water R, methanol R (30:70 V/V).

*Flow rate*: 1.0 mL/min.

*Detection*: spectrophotometer at 264 nm.

*Injection*: 20  $\mu$ L of test solution (a) and reference solutions (a), (b) and (c).

*Run time*: twice the retention time of calcipotriol.

*Relative retention* with reference to calcipotriol (retention time = about 13.5 min): impurity B = about 0.86; impurity C = about 0.92; impurity D = about 1.3.

*System suitability*: reference solution (c):

- *peak-to-valley ratio*: minimum 1.5, where  $H_p$  = height above the baseline of the peak due to impurity C and  $H_v$  = height above the baseline of the lowest point of the curve separating this peak from the peak due to calcipotriol,
- the chromatogram obtained is similar to the chromatogram supplied with calcipotriol monohydrate CRS.

**Limits:**

- *impurity B*: not more than 0.5 times the area of the principal peak in the chromatogram obtained with reference solution (a) (0.5 per cent),
- *impurities C, D*: for each impurity, not more than the area of the principal peak in the chromatogram obtained with reference solution (a) (1.0 per cent),
- *any other impurity*: for each impurity, not more than the area of the principal peak in the chromatogram obtained with reference solution (b) (0.1 per cent),
- *total*: not more than 2.5 times the area of the principal peak in the chromatogram obtained with reference solution (a) (2.5 per cent),
- *disregard limit*: 0.5 times the area of the principal peak in the chromatogram obtained with reference solution (b) (0.05 per cent).

**Water (2.5.12)**: 3.3 per cent to 5.0 per cent, determined on 0.100 g.

**ASSAY**

Liquid chromatography (2.2.29) as described in the test for related substances with the following modification.

**Injection**: test solution (b) and reference solution (d).

Calculate the percentage content of  $C_{27}H_{40}O_3$  from the areas of the peaks and the declared content of *calcipotriol monohydrate CRS*.

**STORAGE**

In an airtight container, protected from light.

**IMPURITIES**

**Specified impurities**: A, B, C, D, G, H.

**Other detectable impurities** (the following substances would, if present at a sufficient level, be detected by one or other of the tests in the monograph. They are limited by the general acceptance criterion for other/unspecified impurities and/or by the general monograph *Substances for pharmaceutical use (2034)*. It is therefore not necessary to identify these impurities for demonstration of compliance. See also 5.10. *Control of impurities in substances for pharmaceutical use*): E, F, I.

**By thin-layer chromatography**: A, G, H, I.

**By liquid chromatography**: B, C, D, E, F.

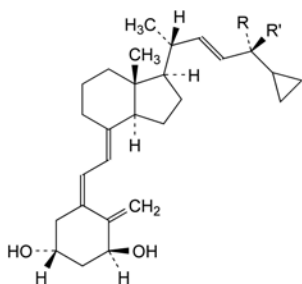

A.  $R + R' = O$ : (5*Z*,7*E*,22*E*)-24-cyclopropyl-1 $\alpha$ ,3 $\beta$ -dihydroxy-9,10-secochola-5,7,10(19),22-tetraen-24-one,

D.  $R = OH, R' = H$ : (5*Z*,7*E*,22*E*,24*R*)-24-cyclopropyl-9,10-secochola-5,7,10(19),22-tetraene-1 $\alpha$ ,3 $\beta$ ,24-triol (24-*epi*-calcipotriol),

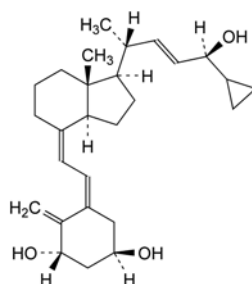

B. (5*Z*,7*Z*,22*E*,24*S*)-24-cyclopropyl-9,10-secochola-5,7,10(19),22-tetraene-1 $\alpha$ ,3 $\beta$ ,24-triol ((7*Z*)-calcipotriol),

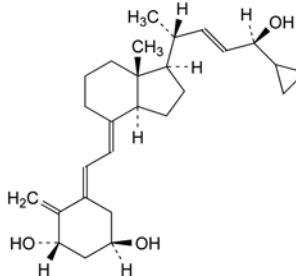

C. (5*E*,7*E*,22*E*,24*S*)-24-cyclopropyl-9,10-secochola-5,7,10(19),22-tetraene-1 $\alpha$ ,3 $\beta$ ,24-triol ((5*E*)-calcipotriol),

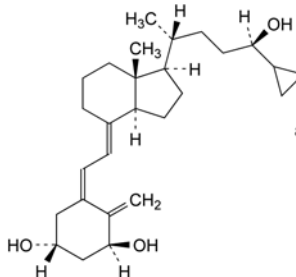

E. *rac*-(5*Z*,7*E*,22*E*,24*S*)-24-cyclopropyl-9,10-secochola-5,7,10(19)-triene-1 $\alpha$ ,3 $\beta$ ,24-triol,

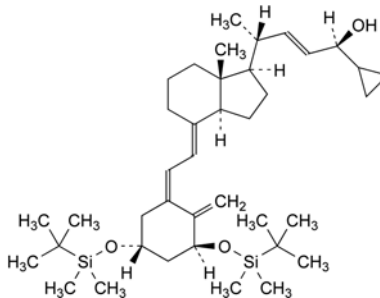

F. (5*Z*,7*E*,22*E*,24*S*)-24-cyclopropyl-1 $\alpha$ ,3 $\beta$ -bis[(1,1-dimethylethyl)dimethylsilyloxy]-9,10-secochola-5,7,10(19),22-tetraen-24-ol,

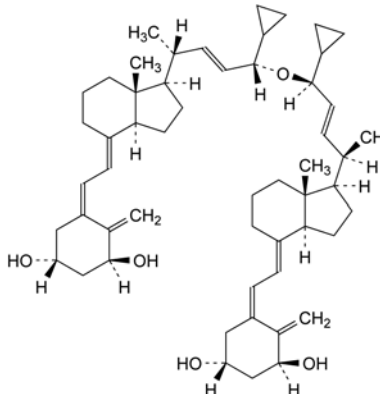

G. 24,24'-oxybis[(5*Z*,7*E*,22*E*,24*S*)-24-cyclopropyl-9,10-secochola-5,7,10(19),22-tetraene-1 $\alpha$ ,3 $\beta$ -diol],

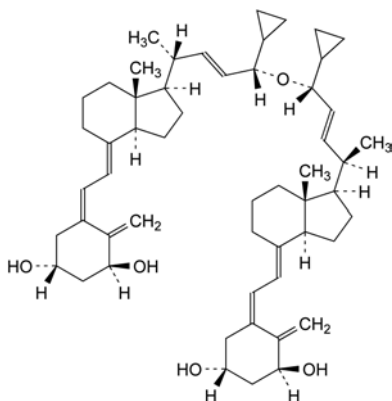

- H. (5*Z*,7*E*,22*E*,24*R*)-24-cyclopropyl-24-[(5*Z*,7*E*,22*E*,24*S*)-24-cyclopropyl-1 $\alpha$ ,3 $\beta$ -dihydroxy-9,10-secochola-5,7,10(19),22-tetraen-24-yl]oxy]-9,10-secochola-5,7,10(19),22-tetraene-1 $\alpha$ ,3 $\beta$ -diol,

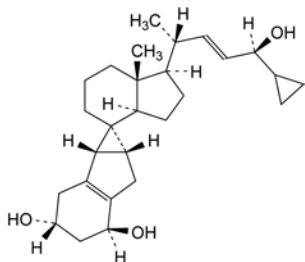

- I. (6*S*,7*R*,8*R*,22*E*,24*S*)-24-cyclopropyl-6,8:7,19-dicyclo-9,10-secochola-5(10),22-diene-1 $\alpha$ ,3 $\beta$ ,24-triol (suprasterol of calcipotriol).

01/2008:0471

## CALCITONIN (SALMON)

### Calcitoninum salmonis

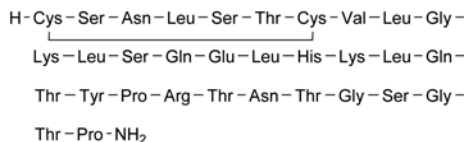
C<sub>145</sub>H<sub>240</sub>N<sub>44</sub>O<sub>48</sub>S<sub>2</sub>M<sub>r</sub> 3432

#### DEFINITION

Polypeptide having the structure determined for salmon calcitonin I. It lowers the calcium concentration in plasma of mammals by diminishing the rate of bone resorption. It is obtained by chemical synthesis or by a method based on recombinant DNA (rDNA) technology. It is available as an acetate.

*Content*: 90.0 per cent to 105.0 per cent of the peptide C<sub>145</sub>H<sub>240</sub>N<sub>44</sub>O<sub>48</sub>S<sub>2</sub> (anhydrous and acetic acid-free substance). By convention, for the purpose of labelling calcitonin (salmon) preparations, 1 mg of calcitonin (salmon) (C<sub>145</sub>H<sub>240</sub>N<sub>44</sub>O<sub>48</sub>S<sub>2</sub>) is equivalent to 6000 IU of biological activity.

#### PRODUCTION

The following requirements apply only to calcitonin (salmon) produced by a method based on rDNA technology.

Prior to release the following tests are carried out on each batch of final bulk product unless exemption has been granted by the competent authority.

**Host-cell-derived proteins.** The limit is approved by the competent authority.

**Host-cell or vector-derived DNA.** The limit is approved by the competent authority.

#### CHARACTERS

*Appearance*: white or almost white powder.

*Solubility*: freely soluble in water.

#### IDENTIFICATION

A. Examine the chromatograms obtained in the assay.

*Results*: the principal peak in the chromatogram obtained with the test solution is similar in retention time and size to the principal peak in the chromatogram obtained with the reference solution.

*The following requirement applies only to calcitonin (salmon) obtained by chemical synthesis.*

B. Amino acid analysis (2.2.56).

Express the content of each amino acid in moles. Calculate the relative proportions of the amino acids taking as equivalent to 1 the sum, divided by 20, of the number of moles of aspartic acid, glutamic acid, proline, glycine, valine, leucine, histidine, arginine and lysine. The values fall within the following limits: aspartic acid: 1.8 to 2.2; glutamic acid: 2.7 to 3.3; proline: 1.7 to 2.3; glycine: 2.7 to 3.3; valine: 0.9 to 1.1; leucine: 4.5 to 5.3; histidine: 0.9 to 1.1; arginine: 0.9 to 1.1; lysine: 1.8 to 2.2; serine: 3.2 to 4.2; threonine: 4.2 to 5.2; tyrosine: 0.7 to 1.1; half-cystine: 1.4 to 2.1.

*The following requirement applies only to calcitonin (salmon) produced by a method based on rDNA technology.*

C. Peptide mapping (2.2.55).

#### SELECTIVE CLEAVAGE OF THE PEPTIDE BONDS

*Test solution.* Prepare a 1 mg/mL solution of the substance to be examined. Transfer 1.0 mL to a clean tube. Add 100  $\mu$ L of 1 M tris-hydrochloride buffer solution pH 8.0 R and 20  $\mu$ L of a freshly prepared 1.0 mg/mL solution of *trypsin for peptide mapping R*. Allow to stand at 2-8 °C for 16-20 h. Stop the reaction by adding 10  $\mu$ L of a 50 per cent V/V solution of *trifluoroacetic acid R*. Cap the vial and mix. Centrifuge the vials to remove air bubbles.

*Reference solution.* Prepare at the same time and in the same manner as for the test solution but using *calcitonin (salmon) CRS* instead of the substance to be examined.

*CHROMATOGRAPHIC SEPARATION.* Liquid chromatography (2.2.29).

#### Column:

- size:  $l = 0.25$  m,  $\varnothing = 4.6$  mm;
- stationary phase: octadecylsilyl silica gel for chromatography R (5  $\mu$ m) with a pore size of 30 nm.

#### Mobile phase:

- mobile phase A: mix 1 mL of *trifluoroacetic acid R* and 1000 mL of *water R*; filter and degas;
- mobile phase B: mix 0.850 mL of *trifluoroacetic acid R*, 200 mL of *water R* and 800 mL of *acetonitrile for chromatography R*; filter and degas;

Time (min)	Mobile phase A (per cent V/V)	Mobile phase B (per cent V/V)
0 - 50	100 $\rightarrow$ 65	0 $\rightarrow$ 35
50 - 60	65 $\rightarrow$ 40	35 $\rightarrow$ 60
60 - 60.1	40 $\rightarrow$ 0	60 $\rightarrow$ 100
60.1 - 65.1	0	100
65.1 - 65.2	0 $\rightarrow$ 100	100 $\rightarrow$ 0
65.2 - 80.2	100	0

*Flow rate*: 1.2 mL/min.

*Detection*: spectrophotometer at 214 nm.

*Equilibration*: at initial conditions for at least 15 min. Carry out a blank run using the above-mentioned gradient.

*Injection*: 20  $\mu$ L.

**System suitability:** the chromatograms obtained with the test solution and the reference solution are qualitatively similar to the chromatogram of calcitonin (salmon) digest supplied with *calcitonin (salmon) CRS*.

**Results:** the profile of the chromatogram obtained with the test solution corresponds to that of the chromatogram obtained with the reference solution: the retention times of the fragment peaks in the chromatogram obtained with the test solution are within 5 per cent of the retention times of the fragments obtained with the reference solution; the peak area ratios of the fragment peaks in the chromatogram obtained with the test solution, normalised to the area of peak  $T_2$ , are within 5 per cent of the corresponding peak ratios in the chromatogram obtained with the reference solution.

## TESTS

**Acetic acid (2.5.34):** 4.0 per cent to 15.0 per cent.

**Test solution.** Dissolve 10.0 mg of the substance to be examined in a mixture of 5 volumes of mobile phase B and 95 volumes of mobile phase A and dilute to 10.0 mL with the same mixture of mobile phases.

**Related substances.** Liquid chromatography (2.2.29): use the normalisation procedure.

*The following requirement applies to calcitonin (salmon), whether obtained by chemical synthesis or by a method based on rDNA technology.*

A. **Test solution.** Prepare a 1.0 mg/mL solution of the substance to be examined in mobile phase A.

**Reference solution.** Dissolve the contents of a vial of *calcitonin (salmon) CRS* in mobile phase A to obtain a concentration of 1.0 mg/mL.

**Resolution solution.** Dissolve the contents of a vial of *N-acetyl-Cys<sup>1</sup>-calcitonin CRS* in 400 µL of mobile phase A and add 100 µL of the test solution.

**Column:**

- size:  $l = 0.25$  m,  $\emptyset = 4.6$  mm;
- stationary phase: *octadecylsilyl silica gel for chromatography R* (5 µm);
- temperature: 65 °C.

**Mobile phase:**

- mobile phase A: dissolve 3.26 g of *tetramethylammonium hydroxide R* in 900 mL of *water R*, adjust to pH 2.5 with *phosphoric acid R* and mix with 100 mL of *acetonitrile for chromatography R*; filter and degas;
- mobile phase B: dissolve 1.45 g of *tetramethylammonium hydroxide R* in 400 mL of *water R*, adjust to pH 2.5 with *phosphoric acid R* and mix with 600 mL of *acetonitrile for chromatography R*; filter and degas;

Time (min)	Mobile phase A (per cent V/V)	Mobile phase B (per cent V/V)
0 - 30	72 → 48	28 → 52
30 - 32	48 → 72	52 → 28
32 - 55	72	28

**Flow rate:** 1.0 mL/min.

**Detection:** spectrophotometer at 220 nm.

**Injection:** 20 µL.

**Relative retention** with reference to calcitonin (salmon) (retention time = about 20 min): impurity B = about 0.8; impurity C = about 0.9; impurity D = about 1.05; impurity A = about 1.15.

**System suitability:** resolution solution:

- resolution: minimum 5.0 between the peaks due to calcitonin (salmon) and impurity A,
- symmetry factor: maximum 2.5 for the peak due to impurity A.

**Limits:**

- impurities A, B, C, D: for each impurity, maximum 3.0 per cent; other unidentified, specified impurities may occur that co-elute with impurities A, B, C and D; the acceptance criterion applies irrespective of whether these impurities co-elute;
- total: maximum 5.0 per cent;
- disregard limit: 0.1 per cent.

*The following requirement applies only to calcitonin (salmon) produced by a method based on rDNA technology.*

B. **Test solution.** Prepare a 0.5 mg/mL solution of the substance to be examined. To 1.0 mL of this solution add 100 µL of 0.25 M citrate buffer solution pH 3.0 R.

**Resolution solution.** Prepare a 1 mg/mL solution of the substance to be examined. Mix 1 volume of the solution and 1 volume of *calcitonin-Gly CRS*. To 1.0 mL of this mixture add 100 µL of 0.25 M citrate buffer solution pH 3.0 R.

**Column:**

- size:  $l = 0.20$  m,  $\emptyset = 4.6$  mm;
- stationary phase: a suitable polysulfoethylaspartamide ion-exchange gel (5 µm).

**Mobile phase:**

- mobile phase A: mix 15 volumes of *acetonitrile for chromatography R* and 85 volumes of a 2.72 g/L solution of *potassium dihydrogen phosphate R* adjusted to pH 5.0 with a 600 g/L solution of *potassium hydroxide R*;
- mobile phase B: mix 15 volumes of *acetonitrile for chromatography R* and 85 volumes of a solution containing 2.72 g/L of *potassium dihydrogen phosphate R* and 29.22 g/L of *sodium chloride R* adjusted to pH 4.6 with a 600 g/L solution of *potassium hydroxide R*;

Time (min)	Mobile phase A (per cent V/V)	Mobile phase B (per cent V/V)
0 - 10	100 → 0	0 → 100
10 - 15	0	100
15 - 15.1	0 → 100	100 → 0
15.1 - 22.1	100	0

**Flow rate:** 1.2 mL/min.

**Detection:** spectrophotometer at 220 nm.

**Injection:** 50 µL; rinse the injector with a 40 per cent V/V solution of *acetonitrile for chromatography R*.

**Relative retention** with reference to calcitonin (salmon) (retention time = about 9 min): impurity G = about 0.4; impurity F = about 0.6; impurity E = about 0.9.

**System suitability:** resolution solution:

- resolution: minimum 3.0 between the peaks due to impurity E and calcitonin (salmon).

**Limits:**

- impurity E: maximum 0.6 per cent;
- impurities F, G: for each impurity, maximum 0.2 per cent.

**Water (2.5.32):** maximum 10.0 per cent.

**Acetic acid and water:** maximum 20 per cent, calculated by adding together the percentage contents of acetic acid and water determined by the methods described above.

**Bacterial endotoxins (2.6.14):** less than 25 IU/mg, if intended for use in the manufacture of parenteral preparations without a further appropriate procedure for the removal of bacterial endotoxins.

## ASSAY

Liquid chromatography (2.2.29) as described in the test for related substances. Use method A for calcitonin (salmon) obtained by chemical synthesis and method B for calcitonin (salmon) obtained by a method based on rDNA technology.

Calculate the content of calcitonin (salmon) ( $C_{145}H_{240}N_{44}O_{48}S_2$ ) from the area of the principal peak in each of the chromatograms obtained with the test solution and the reference solution and the declared content of  $C_{145}H_{240}N_{44}O_{48}S_2$  in *calcitonin (salmon) CRS*. Proceed with tangential integration of the peak areas.

## STORAGE

Protected from light at a temperature between 2 °C and 8 °C. If the substance is sterile, store in a sterile, airtight, tamper-proof container.

## LABELLING

The label states:

- the calcitonin peptide content ( $C_{145}H_{240}N_{44}O_{48}S_2$ );
- the origin: synthetic or rDNA technology.

## IMPURITIES

*Specified impurities: A, B, C, D, E, F, G.*



- A. R1 = CO-CH<sub>3</sub>, R2 = NH<sub>2</sub>, X = L-Leu: acetylcalcitonin (salmon),  
 B. R1 = H, R2 = NH<sub>2</sub>, X = D-Leu: [9-D-leucine]calcitonin (salmon),  
 E. R1 = H, R2 = NH-CH<sub>2</sub>-CO<sub>2</sub>H, X = L-Leu: salmon calcitoninylglycine,



- C. des-22-tyrosine-calcitonin (salmon),  
 D. O-acetylated calcitonin (salmon),

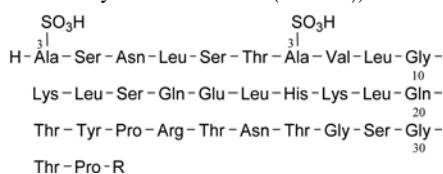

- F. R = NH<sub>2</sub>: [1,7-bis(3-sulfo-L-alanine)]calcitonin (salmon),  
 G. R = NH-CH<sub>2</sub>-CO<sub>2</sub>H: [1,7-bis(3-sulfo-L-alanine)]calcitoninylglycine (salmon).

*Content:* 97.0 per cent to 103.0 per cent.

## CHARACTERS

*Appearance:* white or almost white crystals.

*Solubility:* practically insoluble in water, freely soluble in ethanol (96 per cent), soluble in fatty oils.

It is sensitive to air, heat and light.

A reversible isomerisation to pre-calcitriol takes place in solution, depending on temperature and time. The activity is due to both compounds.

## IDENTIFICATION

A. Infrared absorption spectrophotometry (2.2.24).

*Comparison: Ph. Eur. reference spectrum of calcitriol.*

B. Examine the chromatograms obtained in the assay.

*Results:* the principal peak in the chromatogram obtained with the test solution is similar in retention time and size to the principal peak in the chromatogram obtained with reference solution (a).

## TESTS

**Related substances.** Liquid chromatography (2.2.29): use the normalisation procedure. *Carry out the test as rapidly as possible, avoiding exposure to actinic light and air.*

*Test solution.* Dissolve 1.000 mg of the substance to be examined without heating in 10.0 mL of the mobile phase.

*Reference solution (a).* Dissolve 1.000 mg of *calcitriol CRS* without heating in 10.0 mL of the mobile phase.

*Reference solution (b).* Dilute 1.0 mL of reference solution (a) to 100.0 mL with the mobile phase.

*Reference solution (c).* Heat 2 mL of reference solution (a) at 80 °C for 30 min.

*Column:*

- size:  $l = 0.25$  m,  $\varnothing = 4.6$  mm;
- stationary phase: octylsilyl silica gel for chromatography R1 (5 µm);
- temperature: 40 °C.

*Mobile phase:* mix 450 volumes of a 1.0 g/L solution of *tris(hydroxymethyl)aminomethane R* adjusted to pH 7.0-7.5 with *phosphoric acid R*, and 550 volumes of *acetonitrile R*.

*Flow rate:* 1.0 mL/min.

*Detection:* spectrophotometer at 230 nm.

*Injection:* 50 µL.

*Run time:* twice the retention time of calcitriol.

*Relative retention* with reference to calcitriol (retention time = about 14 min): pre-calcitriol = about 0.9.

*System suitability:*

- resolution: minimum 3.5 between the peaks due to calcitriol and pre-calcitriol in the chromatogram obtained with reference solution (c);
- number of theoretical plates: minimum 10 000, calculated for the peak due to calcitriol in the chromatogram obtained with reference solution (a).

*Limits:*

- impurities A, B, C: for each impurity, maximum 0.5 per cent;
- total: maximum 1.0 per cent;
- disregard limit: 0.1 times the area of the principal peak in the chromatogram obtained with reference solution (b) (0.1 per cent); disregard the peak due to pre-calcitriol.

## ASSAY

Liquid chromatography (2.2.29) as described in the test for related substances with the following modifications.

*Injection:* the test solution and reference solution (a).

*System suitability:* reference solution (a):

- repeatability: maximum relative standard deviation of 1 per cent for the peak due to calcitriol after 6 injections.

01/2008:0883  
corrected 6.4

## CALCITRIOL

## Calcitriolum

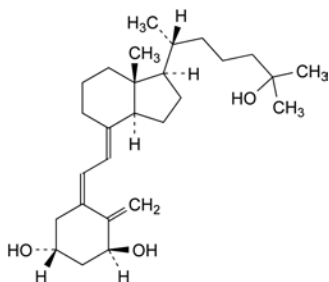

$C_{27}H_{44}O_3$   
[32222-06-3]

$M_r$  416.6

## DEFINITION

(5Z,7E)-9,10-Secocholesta-5,7,10(19)-triene-1 $\alpha$ ,3 $\beta$ ,25-triol.

Calculate the percentage content of  $C_{27}H_{44}O_3$  from the declared content of *calcitriol CRS*.

#### STORAGE

Under nitrogen, in an airtight container, protected from light, at a temperature of 2 °C to 8 °C.

The contents of an opened container are to be used immediately.

#### IMPURITIES

*Specified impurities: A, B, C.*

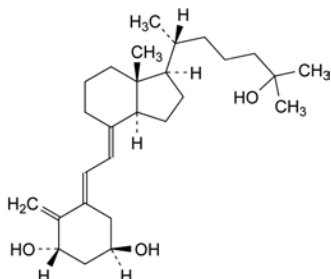

- A. (5*E*,7*E*)-9,10-secocholesta-5,7,10(19)-triene-1 $\alpha$ ,3 $\beta$ ,25-triol (*trans*-calcitriol),

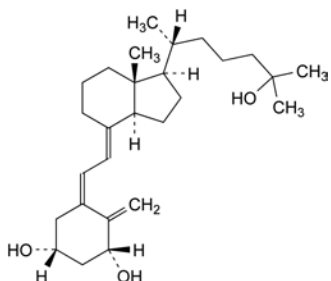

- B. (5*Z*,7*E*)-9,10-secocholesta-5,7,10(19)-triene-1 $\beta$ ,3 $\beta$ ,25-triol (1 $\beta$ -calcitriol),

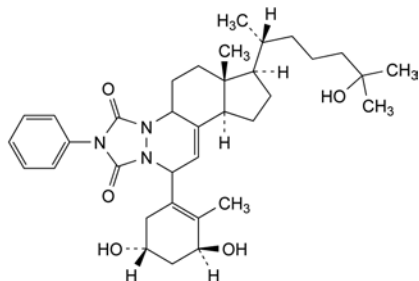

- C. (6*aR*,7*R*,9*aR*)-11-[(3*S*,5*R*)-3,5-dihydroxy-2-methylcyclohex-1-enyl]-7-[(1*R*)-5-hydroxy-1,5-dimethylhexyl]-6*a*-methyl-2-phenyl-5,6,6*a*,7,8,9,9*a*,11-octahydro-1*H*,4*aH*-cyclopenta[1,2,4]triazolo[1,2-*a*]cinnoline-1,3(2*H*)-dione (triazoline adduct of pre-calcitriol).

*Solubility*: freely soluble in water, slightly soluble in ethanol (96 per cent).

#### IDENTIFICATION

- A. It gives reaction (b) of calcium (2.3.1).  
B. It gives reaction (b) of acetates (2.3.1).

#### TESTS

**Solution S.** Dissolve 5.0 g in *carbon dioxide-free water R* and dilute to 50.0 mL with the same solvent.

**Appearance of solution.** Solution S is clear (2.2.1) and colourless (2.2.2, *Method II*).

**pH** (2.2.3): 7.2 to 8.2.

Dilute 5.0 mL of solution S to 10.0 mL with *carbon dioxide-free water R*.

**Readily oxidisable substances.** Dissolve 2.0 g in boiling *water R* and dilute to 100 mL with boiling *water R*, add a few glass beads, 6 mL of 5 *M* *sulfuric acid* and 0.3 mL of 0.02 *M* *potassium permanganate*, mix, boil gently for 5 min and allow the precipitate to settle. The pink colour in the supernatant is not completely discharged.

**Chlorides** (2.4.4): maximum 330 ppm.

Dissolve 0.15 g in *water R* and dilute to 15 mL with the same solvent.

**Fluorides**: maximum 50 ppm.

Potentiometry (2.2.36, *Method I*).

**Test solution.** In a 50 mL volumetric flask, dissolve 0.200 g in a 10.3 g/L solution of *hydrochloric acid R*, add 5.0 mL of *fluoride standard solution (1 ppm F) R* and dilute to 50.0 mL with a 10.3 g/L solution of *hydrochloric acid R*. To 20.0 mL of the solution add 20.0 mL of *total-ionic-strength-adjustment buffer R* and 3 mL of an 82 g/L solution of *anhydrous sodium acetate R*. Adjust to pH 5.2 with *ammonia R* and dilute to 50.0 mL with *distilled water R*.

**Reference solutions.** To 0.25 mL, 0.5 mL, 0.75 mL and 1.0 mL of *fluoride standard solution (10 ppm F) R* add 20.0 mL of *total-ionic-strength-adjustment buffer R* and dilute to 50.0 mL with *distilled water R*.

**Indicator electrode**: fluoride selective.

**Reference electrode**: silver-silver chloride.

Take into account the addition of fluoride to the test solution for the calculation.

**Nitrates.** To 10.0 mL of solution S add 5 mg of *sodium chloride R*, 0.05 mL of *indigo carmine solution R* and add with stirring, 10 mL of *nitrogen-free sulfuric acid R*. The blue colour remains for at least 10 min.

**Sulfates** (2.4.13): maximum 600 ppm.

Dissolve 0.25 g in *distilled water R* and dilute to 15 mL with the same solvent.

**Aluminium** (2.4.17): maximum 1 ppm, if intended for use in the manufacture of peritoneal dialysis solutions, haemofiltration solutions or haemodialysis solutions.

**Test solution.** Dissolve 4.0 g of the substance to be examined in 100 mL of *water R* and add 10 mL of *acetate buffer solution pH 6.0 R*.

**Reference solution.** Mix 2 mL of *aluminium standard solution (2 ppm Al) R*, 10 mL of *acetate buffer solution pH 6.0 R* and 98 mL of *water R*.

**Blank solution.** Mix 10 mL of *acetate buffer solution pH 6.0 R* and 100 mL of *water R*.

**Arsenic** (2.4.2): maximum 3 ppm.

3.3 mL of solution S complies with test A.

**Barium**: maximum 50 ppm.

Atomic emission spectrometry (2.2.22, *Method II*).

**Test solution.** Dissolve 5.00 g of the substance to be examined in *water R* and dilute to 100.0 mL with the same solvent.

01/2011:2128

## CALCIUM ACETATE, ANHYDROUS

### Calcii acetas anhydricus

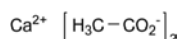

$C_4H_6CaO_4$   
[62-54-4]

$M_r$  158.2

#### DEFINITION

Calcium diacetate.

*Content*: 99.0 per cent to 101.0 per cent (anhydrous substance).

#### CHARACTERS

*Appearance*: white or almost white, hygroscopic powder.

**Reference solutions.** Prepare the reference solutions using *barium standard solution (0.1 per cent Ba) R*, diluted as necessary with *water R*.

**Wavelength:** 455.4 nm.

**Iron (2.4.9):** maximum 20 ppm, if intended for use in the manufacture of parenteral preparations or haemodialysis solutions.

Dilute 5 mL of solution S to 10 mL of *water R*.

**Magnesium:** maximum 500 ppm.

Atomic absorption spectrometry (2.2.23, *Method II*).

**Test solution.** Dissolve 50.0 mg of the substance to be examined in *water R* and dilute to 100.0 mL with the same solvent.

**Reference solutions.** Prepare the reference solutions using *magnesium standard solution (0.1 per cent Mg) R*, diluted as necessary with *water R*.

**Source:** magnesium hollow-cathode lamp.

**Wavelength:** 285.2 nm.

**Atomisation device:** air-acetylene flame.

**Potassium:** maximum 500 ppm, if intended for use in the manufacture of parenteral preparations or haemodialysis solutions.

Atomic emission spectrometry (2.2.22, *Method II*).

**Test solution.** Dissolve 1.00 g of the substance to be examined in *water R* and dilute to 25.0 mL with the same solvent.

**Reference solutions.** Prepare the reference solutions using *potassium standard solution (0.2 per cent K) R*, diluted as necessary with *water R*.

**Wavelength:** 766.5 nm.

**Sodium:** maximum 500 ppm, if intended for use in the manufacture of parenteral preparations or haemodialysis solutions.

Atomic emission spectrometry (2.2.22, *Method II*).

**Test solution.** Dissolve 1.00 g of the substance to be examined in *water R* and dilute to 100.0 mL with the same solvent.

**Reference solutions.** Prepare the reference solutions using *sodium standard solution (200 ppm Na) R*, diluted as necessary with *water R*.

**Wavelength:** 589 nm.

**Strontium:** maximum 500 ppm, if intended for use in the manufacture of parenteral preparations or haemodialysis solutions.

Atomic emission spectrometry (2.2.22, *Method II*).

**Test solution.** Dissolve 2.00 g of the substance to be examined in *water R* and dilute to 100.0 mL with the same solvent.

**Reference solutions.** Prepare the reference solutions using *strontium standard solution (1.0 per cent Sr) R*, diluted as necessary with *water R*.

**Wavelength:** 460.7 nm.

**Heavy metals (2.4.8):** maximum 10 ppm.

Dissolve 4.0 g in *water R* and dilute to 20 mL with the same solvent. 12 mL of the solution complies with test A. Prepare the reference solution using *lead standard solution (2 ppm Pb) R*.

**Water (2.5.12):** maximum 7.0 per cent, determined on 0.100 g. Add 2 mL of *anhydrous acetic acid R* to the titration vessel in addition to the methanol. Clean the titration vessel after each determination.

#### ASSAY

Dissolve 0.150 g in 100 mL of *water R* and carry out the complexometric titration of calcium (2.5.11).

1 mL of 0.1 M *sodium edetate* is equivalent to 15.82 mg of  $C_4H_6CaO_4$ .

#### STORAGE

In an airtight container.

#### LABELLING

The label states, where applicable, that the substance is suitable for use in the manufacture of parenteral preparations, peritoneal dialysis solutions, haemofiltration solutions or haemodialysis solutions.

01/2008:1182  
corrected 7.0

## CALCIUM ASCORBATE

### Calcii ascorbas

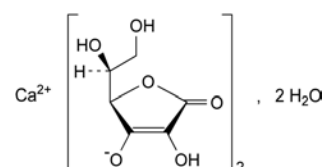

$C_{12}H_{14}CaO_{12} \cdot 2H_2O$   
[5743-28-2]

$M_r$  426.3

#### DEFINITION

Calcium di[(*R*)-2-[(*S*)-1,2-dihydroxyethyl]-4-hydroxy-5-oxo-2*H*-furan-3-olate] dihydrate.

**Content:** 99.0 per cent to 100.5 per cent of  $C_{12}H_{14}CaO_{12} \cdot 2H_2O$ .

#### CHARACTERS

**Appearance:** white or slightly yellowish, crystalline powder.

**Solubility:** freely soluble in water, practically insoluble in ethanol (96 per cent).

#### IDENTIFICATION

**First identification:** A, B, E.

**Second identification:** A, C, D, E.

A. Specific optical rotation (see Tests).

B. Infrared absorption spectrophotometry (2.2.24).

**Comparison:** *Ph. Eur. reference spectrum of calcium ascorbate.*

C. Dilute 1 mL of solution S (see Tests) to 10 mL with *water R*. To 2 mL of the solution add 0.2 mL of a 100 g/L solution of *ferrous sulfate R*. A deep violet colour develops.

D. To 1 mL of solution S add 0.2 mL of *dilute nitric acid R* and 0.2 mL of *silver nitrate solution R2*. A grey precipitate is formed.

E. The substance gives reaction (b) of calcium (2.3.1).

#### TESTS

**Solution S.** Dissolve 5.00 g in *carbon dioxide-free water R* and dilute to 50.0 mL with the same solvent.

**Appearance of solution.** Solution S is clear (2.2.1) and not more intensely coloured than reference solution  $Y_6$  (2.2.2, *Method II*). Examine the colour of the solution immediately after preparation of the solution.

**pH (2.2.3):** 6.8 to 7.4 for solution S.

**Specific optical rotation (2.2.7):** + 95 to + 97 (dried substance), determined using freshly prepared solution S.

**Related substances.** The thresholds indicated under Related substances (Table 2034.-1) in the general monograph *Substances for pharmaceutical use (2034)* do not apply.

**Fluorides:** maximum 10 ppm.

Potentiometry (2.2.36, *Method I*).

**Test solution.** In a 50 mL volumetric flask, dissolve 1.000 g in a 10.3 g/L solution of *hydrochloric acid R*, add 5.0 mL of *fluoride standard solution (1 ppm F) R* and dilute to 50.0 mL with a 10.3 g/L solution of *hydrochloric acid R*. To 20.0 mL of the solution add 20.0 mL of *total-ionic-strength-adjustment*



buffer R and 3 mL of an 82 g/L solution of *anhydrous sodium acetate R*. Adjust to pH 5.2 with *ammonia R* and dilute to 50.0 mL with *distilled water R*.

**Reference solutions.** To 0.25 mL, 0.5 mL, 1.0 mL, 2.0 mL and 5.0 mL of *fluoride standard solution (10 ppm F) R* add 20.0 mL of *total-ionic-strength-adjustment buffer R* and dilute to 50.0 mL with *distilled water R*.

**Indicator electrode:** fluoride selective.

**Reference electrode:** silver-silver chloride.

Take into account the addition of fluoride to the test solution for the calculation.

**Copper:** maximum 5 ppm.

Atomic absorption spectrometry (2.2.23, *Method I*).

**Test solution.** Dissolve 2.0 g in a 9.7 g/L solution of *nitric acid R* and dilute to 25.0 mL with the same acid solution.

**Reference solutions.** Prepare the reference solutions using *copper standard solution (10 ppm Cu) R*, diluting with a 9.7 g/L solution of *nitric acid R*.

**Source:** copper hollow-cathode lamp.

**Wavelength:** 324.8 nm.

**Atomisation device:** air-acetylene flame.

**Iron:** maximum 2 ppm.

Atomic absorption spectrometry (2.2.23, *Method I*).

**Test solution.** Dissolve 5.0 g in a 9.7 g/L solution of *nitric acid R* and dilute to 25.0 mL with the same acid solution.

**Reference solutions.** Prepare the reference solutions using *iron standard solution (10 ppm Fe) R*, diluting with a 9.7 g/L solution of *nitric acid R*.

**Source:** iron hollow-cathode lamp.

**Wavelength:** 248.3 nm.

**Atomisation device:** air-acetylene flame.

**Heavy metals (2.4.8):** maximum 10 ppm.

2.0 g complies with test D. Prepare the reference solution using 2.0 mL of *lead standard solution (10 ppm Pb) R*.

**Loss on drying (2.2.32):** maximum 0.1 per cent, determined on 1.000 g by drying in an oven at 105 °C for 2 h.

#### ASSAY

Dissolve 80.0 mg in a mixture of 10 mL of *dilute sulfuric acid R* and 80 mL of *carbon dioxide-free water R*. Add 1 mL of *starch solution R*. Titrate with 0.05 M *iodine* until a persistent violet-blue colour is obtained.

1 mL of 0.05 M *iodine* is equivalent to 10.66 mg of  $C_{12}H_{14}CaO_{12} \cdot 2H_2O$ .

#### STORAGE

In a non-metallic container, protected from light.

B. 0.2 mL of solution S (see Tests) gives the reactions of calcium (2.3.1).

#### TESTS

**Solution S.** Dissolve 5.0 g in 80 mL of *dilute acetic acid R*. When the effervescence ceases, boil for 2 min. Allow to cool, dilute to 100 mL with *dilute acetic acid R* and filter, if necessary, through a sintered-glass filter (2.1.2).

**Substances insoluble in acetic acid:** maximum 0.2 per cent.

Wash any residue obtained during the preparation of solution S with 4 quantities, each of 5 mL, of hot *water R* and dry at 100-105 °C for 1 h. The residue weighs a maximum of 10 mg.

**Chlorides (2.4.4):** maximum 330 ppm.

Dilute 3 mL of solution S to 15 mL with *water R*.

**Sulfates (2.4.13):** maximum 0.25 per cent.

Dilute 1.2 mL of solution S to 15 mL with *distilled water R*.

**Arsenic (2.4.2, Method A):** maximum 4 ppm, determined on 5 mL of solution S.

**Barium.** To 10 mL of solution S add 10 mL of *calcium sulfate solution R*. After at least 15 min, any opalescence in the solution is not more intense than that in a mixture of 10 mL of solution S and 10 mL of *distilled water R*.

**Iron (2.4.9):** maximum 200 ppm.

Dissolve 50 mg in 5 mL of *dilute hydrochloric acid R* and dilute to 10 mL with *water R*.

**Magnesium and alkali metals:** maximum 1.5 per cent.

Dissolve 1.0 g in 12 mL of *dilute hydrochloric acid R*. Boil the solution for about 2 min and add 20 mL of *water R*, 1 g of *ammonium chloride R* and 0.1 mL of *methyl red solution R*. Add *dilute ammonia RI* until the colour of the indicator changes and then add 2 mL in excess. Heat to boiling and add 50 mL of hot *ammonium oxalate solution R*. Allow to stand for 4 h, dilute to 100 mL with *water R* and filter through a suitable filter. To 50 mL of the filtrate add 0.25 mL of *sulfuric acid R*. Evaporate to dryness on a water-bath and ignite to constant mass at 600 ± 50 °C. The residue weighs a maximum of 7.5 mg.

**Heavy metals (2.4.8):** maximum 20 ppm.

12 mL of solution S complies with test A. Prepare the reference solution using *lead standard solution (1 ppm Pb) R*.

**Loss on drying (2.2.32):** maximum 2.0 per cent, determined on 1.000 g by drying in an oven at 200 ± 10 °C.

#### ASSAY

Dissolve 0.150 g in a mixture of 3 mL of *dilute hydrochloric acid R* and 20 mL of *water R*. Boil for 2 min, allow to cool and dilute to 50 mL with *water R*. Carry out the complexometric titration of calcium (2.5.11).

1 mL of 0.1 M *sodium edetate* is equivalent to 10.01 mg of  $CaCO_3$ .

07/2008:0014

## CALCIUM CARBONATE

### Calcii carbonas

$CaCO_3$   
[471-34-1]

$M_r$  100.1

#### DEFINITION

**Content:** 98.5 per cent to 100.5 per cent (dried substance).

#### CHARACTERS

**Appearance:** white or almost white powder.

**Solubility:** practically insoluble in water.

#### IDENTIFICATION

A. It gives the reaction of carbonates (2.3.1).

#### FUNCTIONALITY-RELATED CHARACTERISTICS

*This section provides information on characteristics that are recognised as being relevant control parameters for one or more functions of the substance when used as an excipient (see chapter 5.15). This section is a non-mandatory part of the monograph and it is not necessary to verify the characteristics to demonstrate compliance. Control of these characteristics can however contribute to the quality of a medicinal product by improving the consistency of the manufacturing process and the performance of the medicinal product during use. Where control methods are cited, they are recognised as being suitable for the purpose, but other methods can also be used. Wherever results for a particular characteristic are reported, the control method must be indicated.*

*The following characteristics may be relevant for calcium carbonate used as filler in tablets and capsules.*

**Particle-size distribution (2.9.31 or 2.9.38).**

**Powder flow (2.9.36).**

01/2008:0015  
corrected 6.0**CALCIUM CHLORIDE DIHYDRATE**

## Calcii chloridum dihydricum

CaCl<sub>2</sub>·2H<sub>2</sub>O  
[10035-04-8]M<sub>r</sub> 147.0

## DEFINITION

*Content:* 97.0 per cent to 103.0 per cent of CaCl<sub>2</sub>·2H<sub>2</sub>O.

## CHARACTERS

*Appearance:* white or almost white, crystalline powder, hygroscopic.*Solubility:* freely soluble in water, soluble in ethanol (96 per cent).

## IDENTIFICATION

- A. Solution S (see Tests) gives reaction (a) of chlorides (2.3.1).  
 B. It gives the reactions of calcium (2.3.1).  
 C. It complies with the limits of the assay.

## TESTS

**Solution S.** Dissolve 10.0 g in *carbon dioxide-free water R* prepared from *distilled water R* and dilute to 100 mL with the same solvent.**Appearance of solution.** Solution S is clear (2.2.1) and not more intensely coloured than reference solution Y<sub>6</sub> (2.2.2, *Method II*).**Acidity or alkalinity.** To 10 mL of freshly prepared solution S add 0.1 mL of *phenolphthalein solution R*. If the solution is red, not more than 0.2 mL of 0.01 M *hydrochloric acid* is required to discharge the colour and if the solution is colourless, not more than 0.2 mL of 0.01 M *sodium hydroxide* is required to turn it red.**Sulfates** (2.4.13): maximum 300 ppm.Dilute 5 mL of solution S to 15 mL with *distilled water R*.**Aluminium.** To 10 mL of solution S add 2 mL of *ammonium chloride solution R* and 1 mL of *dilute ammonia RI* and boil the solution. No turbidity or precipitate is formed.

If intended for use in the manufacture of dialysis solutions, the above test is replaced by the following test for aluminium (2.4.17): maximum 1 ppm.

**Prescribed solution.** Dissolve 4 g in 100 mL of *water R* and add 10 mL of *acetate buffer solution pH 6.0 R*.**Reference solution.** Mix 2 mL of *aluminium standard solution (2 ppm Al) R*, 10 mL of *acetate buffer solution pH 6.0 R* and 98 mL of *water R*.**Blank solution.** Mix 10 mL of *acetate buffer solution pH 6.0 R* and 100 mL of *water R*.**Barium.** To 10 mL of solution S add 1 mL of *calcium sulfate solution R*. After at least 15 min, any opalescence in the solution is not more intense than that in a mixture of 1 mL of *distilled water R* and 10 mL of solution S.**Iron** (2.4.9): maximum 10 ppm, determined on solution S.**Magnesium and alkali metals:** maximum 0.5 per cent.To a mixture of 20 mL of solution S and 80 mL of *water R* add 2 g of *ammonium chloride R* and 2 mL of *dilute ammonia RI*, heat to boiling and pour into the boiling solution a hot solution of 5 g of *ammonium oxalate R* in 75 mL of *water R*. Allow to stand for 4 h, dilute to 200 mL with *water R* and filter through a suitable filter. To 100 mL of the filtrate add 0.5 mL of *sulfuric acid R*. Evaporate to dryness on a water-bath and ignite to constant mass at 600 ± 50 °C. The residue weighs a maximum of 5 mg.**Heavy metals** (2.4.8): maximum 20 ppm.12 mL of solution S complies with test A. Prepare the reference solution using *lead standard solution (2 ppm Pb) R*.

## ASSAY

Dissolve 0.280 g in 100 mL of *water R* and carry out the complexometric titration of calcium (2.5.11).1 mL of 0.1 M *sodium edetate* is equivalent to 14.70 mg of CaCl<sub>2</sub>·2H<sub>2</sub>O.

## LABELLING

The label states, where applicable, that the substance is suitable for use in the manufacture of dialysis solutions.

## STORAGE

In an airtight container.

01/2008:0707  
corrected 6.0**CALCIUM CHLORIDE HEXAHYDRATE**

## Calcii chloridum hexahydricum

CaCl<sub>2</sub>·6H<sub>2</sub>O  
[7774-34-7]M<sub>r</sub> 219.1

## DEFINITION

*Content:* 97.0 per cent to 103.0 per cent of CaCl<sub>2</sub>·6H<sub>2</sub>O.

## CHARACTERS

*Appearance:* white or almost white, crystalline mass or colourless crystals.*Solubility:* very soluble in water, freely soluble in ethanol (96 per cent).

It solidifies at about 29 °C.

## IDENTIFICATION

- A. Solution S (see Tests) gives reaction (a) of chlorides (2.3.1).  
 B. It gives the reactions of calcium (2.3.1).  
 C. It complies with the limits of the assay.

## TESTS

**Solution S.** Dissolve 15.0 g in *carbon dioxide-free water R* prepared from *distilled water R* and dilute to 100 mL with the same solvent.**Appearance of solution.** Solution S is clear (2.2.1) and not more intensely coloured than reference solution Y<sub>6</sub> (2.2.2, *Method II*).**Acidity or alkalinity.** To 10 mL of freshly prepared solution S add 0.1 mL of *phenolphthalein solution R*. If the solution is red, not more than 0.2 mL of 0.01 M *hydrochloric acid* is required to discharge the colour and if the solution is colourless, not more than 0.2 mL of 0.01 M *sodium hydroxide* is required to turn it red.**Sulfates** (2.4.13): maximum 200 ppm.Dilute 5 mL of solution S to 15 mL with *distilled water R*.**Aluminium.** To 10 mL of solution S add 2 mL of *ammonium chloride solution R* and 1 mL of *dilute ammonia RI*. Heat to boiling. No turbidity or precipitate is formed.

If intended for use in the manufacture of dialysis solutions, the above test is replaced by the following test for aluminium (2.4.17): maximum 1 ppm.

**Prescribed solution.** Dissolve 6 g in 100 mL of *water R* and add 10 mL of *acetate buffer solution pH 6.0 R*.**Reference solution.** Mix 2 mL of *aluminium standard solution (2 ppm Al) R*, 10 mL of *acetate buffer solution pH 6.0 R* and 98 mL of *water R*.**Blank solution.** Mix 10 mL of *acetate buffer solution pH 6.0 R* and 100 mL of *water R*.

**Barium.** To 10 mL of solution S add 1 mL of *calcium sulfate solution R*. After at least 15 min, any opalescence in the solution is not more intense than that in a mixture of 1 mL of *distilled water R* and 10 mL of solution S.

**Iron (2.4.9):** maximum 7 ppm, determined on solution S.

**Magnesium and alkali metals:** maximum 0.3 per cent.

To a mixture of 20 mL of solution S and 80 mL of *water R* add 2 g of *ammonium chloride R* and 2 mL of *dilute ammonia R1*, heat to boiling and pour into the boiling solution a hot solution of 5 g of *ammonium oxalate R* in 75 mL of *water R*. Allow to stand for 4 h, dilute to 200 mL with *water R* and filter through a suitable filter. To 100 mL of the filtrate add 0.5 mL of *sulfuric acid R*. Evaporate to dryness on a water-bath and ignite to constant mass at  $600 \pm 50$  °C. The residue weighs a maximum of 5 mg.

**Heavy metals (2.4.8):** maximum 15 ppm.

12 mL of solution S complies with test A. Prepare the reference solution using *lead standard solution (2 ppm Pb) R*.

#### ASSAY

Dissolve 0.200 g in 100 mL of *water R*. Carry out the complexometric titration of calcium (2.5.11).

1 mL of 0.1 M *sodium edetate* is equivalent to 21.91 mg of  $\text{CaCl}_2 \cdot 6\text{H}_2\text{O}$ .

#### LABELLING

The label states, where applicable, that the substance is suitable for use in the manufacture of dialysis solutions.

07/2008:1183  
corrected 7.0

## CALCIUM DOBESILATE MONOHYDRATE

### Calcii dobesilas monohydricus

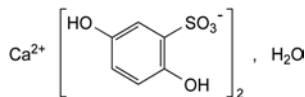

$\text{C}_{12}\text{H}_{10}\text{CaO}_{10}\text{S}_2 \cdot \text{H}_2\text{O}$   
[20123-80-2]

$M_r$  436.4

#### DEFINITION

Calcium di(2,5-dihydroxybenzenesulfonate) monohydrate.

**Content:** 99.0 per cent to 101.0 per cent (anhydrous substance).

#### CHARACTERS

**Appearance:** white or almost white, hygroscopic powder.

**Solubility:** very soluble in water, freely soluble in anhydrous ethanol, very slightly soluble in 2-propanol, practically insoluble in methylene chloride.

#### IDENTIFICATION

A. Ultraviolet and visible absorption spectrophotometry (2.2.25).

**Test solution.** Dissolve 0.100 g in *water R* and dilute to 200.0 mL with the same solvent. Dilute 5.0 mL of this solution to 100.0 mL with *water R*.

**Spectral range:** 210-350 nm.

**Absorption maxima:** at 221 nm and 301 nm.

**Specific absorbance at the absorption maximum at 301 nm:** 174 to 181.

B. Mix 1 mL of *ferric chloride solution R2*, 1 mL of a freshly prepared 10 g/L solution of *potassium ferricyanide R* and 0.1 mL of *nitric acid R*. To this mixture add 5 mL of freshly prepared solution S (see Tests): a blue colour and a precipitate are immediately produced.

C. 2 mL of freshly prepared solution S gives reaction (b) of calcium (2.3.1).

#### TESTS

**Solution S.** Dissolve 10.0 g in *carbon dioxide-free water R* and dilute to 100 mL with the same solvent.

**Appearance of solution.** Solution S, when freshly prepared, is clear (2.2.1) and colourless (2.2.2, *Method II*).

**pH (2.2.3):** 4.5 to 6.0 for solution S.

**Related substances.** Liquid chromatography (2.2.29). *Keep all solutions at 2-8 °C.*

**Buffer solution.** Dissolve 1.2 g of *anhydrous sodium dihydrogen phosphate R* in 900 mL of *water for chromatography R*, adjust to pH 6.5 with *disodium hydrogen phosphate solution R* and dilute to 1000 mL with *water for chromatography R*.

**Test solution.** Dissolve 0.100 g of the substance to be examined in *water R* and dilute to 10.0 mL with the same solvent.

**Reference solution (a).** Dilute 1.0 mL of the test solution to 100.0 mL with *water R*. Dilute 1.0 mL of this solution to 10.0 mL with *water R*.

**Reference solution (b).** Dissolve 10 mg of the substance to be examined and 10 mg of *hydroquinone R* (impurity A) in *water R* and dilute to 10 mL with the same solvent. Dilute 1 mL of this solution to 100 mL with *water R*.

#### Column:

– **size:**  $l = 0.25$  m,  $\varnothing = 4.6$  mm;

– **stationary phase:** spherical *end-capped octadecylsilyl silica gel for chromatography R* (5  $\mu\text{m}$ ).

**Mobile phase:** *acetonitrile R1*, buffer solution (10:90 V/V).

**Flow rate:** 0.8 mL/min.

**Detection:** spectrophotometer at 220 nm.

**Injection:** 10  $\mu\text{L}$ .

**Run time:** 2.5 times the retention time of dobesilate.

**Relative retention** with reference to dobesilate (retention time = about 6 min): impurity A = about 1.7.

**System suitability:** reference solution (b):

– **resolution:** minimum 8.0 between the peaks due to dobesilate and impurity A.

#### Limits:

– **correction factor:** for the calculation of content, multiply the peak area of impurity A by 0.6;

– **impurity A:** not more than the area of the principal peak in the chromatogram obtained with reference solution (a) (0.1 per cent);

– **unspecified impurities:** for each impurity, not more than the area of the principal peak in the chromatogram obtained with reference solution (a) (0.10 per cent);

– **total:** not more than twice the area of the principal peak in the chromatogram obtained with reference solution (a) (0.2 per cent);

– **disregard limit:** 0.5 times the area of the principal peak in the chromatogram obtained with reference solution (a) (0.05 per cent).

**Heavy metals (2.4.8):** maximum 15 ppm.

1.0 g complies with test C. Prepare the reference solution using 1.5 mL of *lead standard solution (10 ppm Pb) R*.

**Iron (2.4.9):** maximum 10 ppm, determined on 10 mL of solution S.

**Water (2.5.12):** 4.0 per cent to 6.0 per cent, determined on 0.500 g.

#### ASSAY

Dissolve 0.200 g in a mixture of 10 mL of *water R* and 40 mL of *dilute sulfuric acid R*. Titrate with 0.1 M *cerium sulfate*, determining the end-point potentiometrically (2.2.20).

1 mL of 0.1 M *cerium sulfate* is equivalent to 10.45 mg of  $\text{C}_{12}\text{H}_{10}\text{CaO}_{10}\text{S}_2$ .

## STORAGE

In an airtight container, protected from light.

## IMPURITIES

Specified impurities: A.

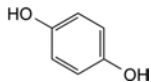

A. benzene-1,4-diol (hydroquinone).

01/2009:0978  
corrected 7.0

## CALCIUM FOLINATE

## Calcii folinas

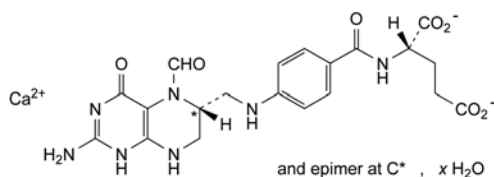

$C_{20}H_{21}CaN_7O_7 \cdot xH_2O$

$M_r$  511.5 (anhydrous substance)

## DEFINITION

Calcium (2*S*)-2-[[4-[[[(6*RS*)-2-amino-5-formyl-4-oxo-1,4,5,6,7,8-hexahydropteridin-6-yl]methyl]amino]benzoyl]amino]pentanedioate.

## Content:

- calcium folinate ( $C_{20}H_{21}CaN_7O_7$ ): 97.0 per cent to 102.0 per cent (anhydrous substance);
- calcium (Ca;  $A_r$  40.08): 7.54 per cent to 8.14 per cent (anhydrous substance).

It contains a variable amount of water.

## CHARACTERS

**Appearance:** white or light yellow, amorphous or crystalline, hygroscopic powder.

**Solubility:** sparingly soluble in water, practically insoluble in acetone and in ethanol (96 per cent).

The amorphous form may produce supersaturated solutions in water.

## IDENTIFICATION

**First identification:** A, B, D.

**Second identification:** A, C, D.

- A. Specific optical rotation (see Tests).  
B. Infrared absorption spectrophotometry (2.2.24).

**Preparation:** discs.

**Comparison:** calcium folinate CRS.

If the spectra obtained show differences, dissolve the substance to be examined and the reference substance separately in the minimum volume of *water R* and add dropwise sufficient *acetone R* to produce a precipitate. Allow to stand for 15 min, collect the precipitate by centrifugation, wash the precipitate with 2 small quantities of *acetone R* and dry. Record new spectra using the residues.

- C. Thin-layer chromatography (2.2.27).

**Test solution.** Dissolve 15 mg of the substance to be examined in a 3 per cent *V/V* solution of *ammonia R* and dilute to 5 mL with the same solvent.

**Reference solution.** Dissolve 15 mg of *calcium folinate CRS* in a 3 per cent *V/V* solution of *ammonia R* and dilute to 5 mL with the same solvent.

**Plate:** *cellulose for chromatography F<sub>254</sub> R* as the coating substance.

**Mobile phase:** the lower layer of a mixture of 1 volume of *isoamyl alcohol R* and 10 volumes of a 50 g/L solution of *citric acid R* previously adjusted to pH 8 with *ammonia R*.

**Application:** 5  $\mu$ L.

**Development:** over a path of 15 cm.

**Drying:** in air.

**Detection:** examine in ultraviolet light at 254 nm.

**Results:** the principal spot in the chromatogram obtained with the test solution is similar in position and size to the principal spot in the chromatogram obtained with the reference solution.

- D. It gives reaction (b) of calcium (2.3.1).

Carry out the tests and the assay as rapidly as possible, protected from actinic light.

## TESTS

**Solution S.** Dissolve 1.25 g in *carbon dioxide-free water R*, heating at 40 °C if necessary, and dilute to 50.0 mL with the same solvent.

**Appearance of solution.** Solution S is clear (2.2.1) and its absorbance (2.2.25) at 420 nm is not greater than 0.60. Use *water R* as the compensation liquid.

**pH (2.2.3):** 6.8 to 8.0 for solution S.

**Specific optical rotation (2.2.7):** + 14.4 to + 18.0 (anhydrous substance), determined on solution S.

**Acetone, ethanol and methanol.** Head-space gas chromatography (2.2.28): use the standard additions method.

**Test solution.** Dissolve 0.25 g of the substance to be examined in *water R* and dilute to 10.0 mL with the same solvent.

**Reference solution.** Dilute 0.125 g of *acetone R*, 0.750 g of *anhydrous ethanol R* and 0.125 g of *methanol R* in *water R* and dilute to 1000.0 mL with *water R*.

## Column:

- material: fused silica;
  - size:  $l = 10$  m,  $\varnothing = 0.32$  mm;
  - stationary phase: *styrene-divinylbenzene copolymer R*.
- Carrier gas: *nitrogen for chromatography R*.

Flow rate: 4 mL/min.

Static head-space conditions that may be used:

- equilibration temperature: 80 °C;
- equilibration time: 20 min;
- pressurisation time: 30 s.

## Temperature:

	Time (min)	Temperature (°C)
Column	0 - 6	125 → 185
	6 - 15	185
Injection port		250
Detector		250

**Detection:** flame ionisation.

**Injection:** at least 3 times.

## Limits:

- acetone: maximum 0.5 per cent;
- ethanol: maximum 3.0 per cent;
- methanol: maximum 0.5 per cent.

**Related substances.** Liquid chromatography (2.2.29).

**Test solution.** Dissolve 10.0 mg of the substance to be examined in *water R* and dilute to 10.0 mL with the same solvent.

**Reference solution (a).** Dissolve 10.0 mg of *calcium folinate CRS* in *water R* and dilute to 10.0 mL with the same solvent.

**Reference solution (b).** Dilute 1.0 mL of reference solution (a) to 100.0 mL with *water R*.

**Reference solution (c).** Dissolve 10.0 mg of *formylfolic acid CRS* (impurity D) in the mobile phase and dilute to 100.0 mL with the mobile phase. Dilute 1.0 mL of this solution to 10.0 mL with *water R*.

**Reference solution (d).** Dilute 1.0 mL of reference solution (b) to 10.0 mL with *water R*.

**Reference solution (e).** Dilute 5.0 mL of reference solution (c) to 10.0 mL with reference solution (b).

**Column:**

- size:  $l = 0.25$  m,  $\varnothing = 4$  mm;
- stationary phase: octadecylsilyl silica gel for chromatography R (5  $\mu$ m);
- temperature: 40 °C.

**Mobile phase:** mix 220 mL of *methanol R* and 780 mL of a solution containing 2.0 mL of *tetrabutylammonium hydroxide solution (400 g/L) R* and 2.2 g of *disodium hydrogen phosphate R*, previously adjusted to pH 7.8 with *phosphoric acid R*.

**Flow rate:** 1 mL/min.

**Detection:** spectrophotometer at 280 nm.

**Injection:** 10  $\mu$ L of the test solution and reference solutions (b), (c), (d) and (e).

**Run time:** 2.5 times the retention time of folinate.

**System suitability:** reference solution (e):

- resolution: minimum 2.2 between the peaks due to folinate and impurity D.

**Limits:**

- impurity D: not more than the area of the principal peak in the chromatogram obtained with reference solution (c) (1 per cent);
- impurities A, B, C, E, F, G: for each impurity, not more than the area of the principal peak in the chromatogram obtained with reference solution (b) (1 per cent);
- sum of impurities other than D: not more than 2.5 times the area of the principal peak in the chromatogram obtained with reference solution (b) (2.5 per cent);
- disregard limit: the area of the principal peak in the chromatogram obtained with reference solution (d) (0.1 per cent).

**Chlorides:** maximum 0.5 per cent.

Dissolve 0.300 g in 50 mL of *water R* heating at 40 °C if necessary. Add 10 mL of 2M *nitric acid* and titrate with 0.005 M *silver nitrate* determining the end-point potentiometrically (2.2.20).

1 mL of 0.005 M *silver nitrate* is equivalent to 0.177 mg of Cl.

**Heavy metals (2.4.8):** maximum 50 ppm.

1.0 g complies with test F. Prepare the reference solution using 5 mL of *lead standard solution (10 ppm Pb) R*.

**Platinum:** maximum 20 ppm.

Atomic absorption spectrometry (2.2.23, *Method II*).

**Test solution.** Dissolve 1.00 g in *water R* and dilute to 100.0 mL with the same solvent.

**Reference solutions.** Prepare the reference solutions using *platinum standard solution (30 ppm Pt) R*, diluted as necessary with a mixture of 1 volume of *nitric acid R* and 99 volumes of *water R*.

**Source:** platinum hollow-cathode lamp.

**Wavelength:** 265.9 nm.

**Water (2.5.12):** maximum 17.0 per cent.

Dissolve 0.100 g in a mixture of 50 mL of the titration solvent and 15 mL of *formamide R*. Stir for about 6 min before titrating and use a suitable titrant that does not contain pyridine.

**Bacterial endotoxins (2.6.14):** less than 0.5 IU/mg, if intended for use in the manufacture of parenteral preparations without a further appropriate procedure for the removal of bacterial endotoxins.

## ASSAY

**Calcium.** Dissolve 0.400 g in 150 mL of *water R* and dilute to 300 mL with the same solvent. Carry out the complexometric titration of calcium (2.5.11).

1 mL of 0.1 M *sodium edetate* is equivalent to 4.008 mg of Ca.

**Calcium folinate.** Liquid chromatography (2.2.29) as described in the test for related substances with the following modifications.

**Injection:** test solution and reference solution (a).

**System suitability:**

- repeatability: maximum relative standard deviation of 2.0 per cent after 6 injections of reference solution (a).

Calculate the percentage content of  $C_{20}H_{21}CaN_7O_7$  from the declared content of *calcium folinate CRS*.

## STORAGE

In an airtight container, protected from light. If the substance is sterile, store in a sterile, airtight, tamper-proof container.

## IMPURITIES

**Specified impurities:** A, B, C, D, E, F, G.

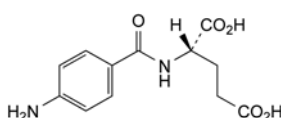

A. (2S)-2-[(4-aminobenzoyl)amino]pentanedioic acid,

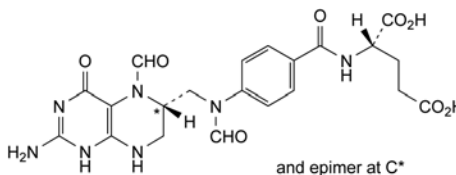

B. (2S)-2-[[4-[[[(6RS)-2-amino-5-formyl-4-oxo-1,4,5,6,7,8-hexahydropteridin-6-yl]methyl]formylamino]benzoyl]amino]pentanedioic acid (5,10-diformyltetrahydrofolic acid), and epimer at C\*

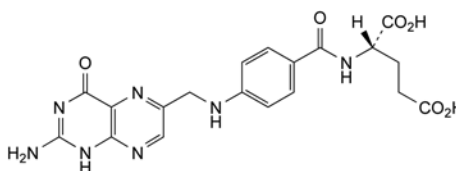

C. (2S)-2-[[4-[[[(2-amino-4-oxo-1,4-dihydropteridin-6-yl)methyl]amino]benzoyl]amino]pentanedioic acid (folic acid),

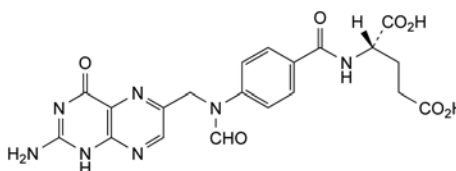

D. (2S)-2-[[4-[[[(2-amino-4-oxo-1,4-dihydropteridin-6-yl)methyl]formylamino]benzoyl]amino]pentanedioic acid (10-formylfolic acid),

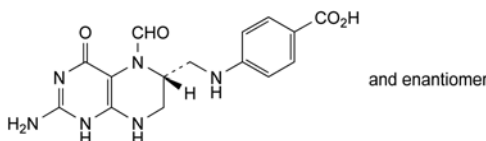

E. 4-[[[(6RS)-2-amino-5-formyl-4-oxo-1,4,5,6,7,8-hexahydropteridin-6-yl]methyl]amino]benzoic acid (5-formyltetrahydrofolic acid), and enantiomer

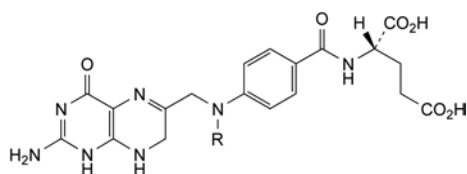

- F. R = CHO: (2S)-2-[[4-[[[(2-amino-4-oxo-1,4,7,8-tetrahydropteridin-6-yl)methyl]formylamino]benzoyl]amino]pentanedioic acid (10-formylidihydrofolic acid),
- G. R = H: (2S)-2-[[4-[[[(2-amino-4-oxo-1,4,7,8-tetrahydropteridin-6-yl)methyl]amino]benzoyl]amino]pentanedioic acid (dihydrofolic acid).

01/2008:1399  
corrected 6.8

## CALCIUM GLUCOHEPTONATE

### Calcii glucoheptonas

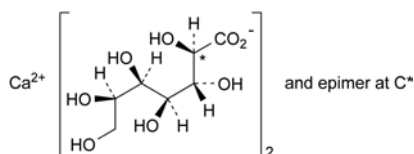

$C_{14}H_{26}CaO_{16}$

$M_r$  490.4

#### DEFINITION

Mixture in variable proportions, of calcium di(D-glycero-D-guloheptonate) and calcium di(D-glycero-D-ido-heptonate).

**Content:** 98.0 per cent to 102.0 per cent of calcium 2,3,4,5,6,7-hexahydroxyheptanoate (dried substance).

#### CHARACTERS

**Appearance:** white or very slightly yellow, amorphous powder, hygroscopic.

**Solubility:** very soluble in water, practically insoluble in acetone and in ethanol (96 per cent).

#### IDENTIFICATION

A. Thin-layer chromatography (2.2.27).

**Test solution.** Dissolve 20 mg of the substance to be examined in 1 mL of *water R*.

**Reference solution (a).** Dissolve 20 mg of *calcium glucoheptonate CRS* in 1 mL of *water R*.

**Reference solution (b).** Dissolve 10 mg of *calcium gluconate CRS* in 0.5 mL of the test solution and dilute to 1 mL with *water R*.

**Plate:** *cellulose for chromatography R1* as the coating substance.

**Mobile phase:** *anhydrous formic acid R, water R, acetone R, butanol R* (20:20:30:30 V/V/V/V); use a freshly prepared mixture.

**Application:** 10  $\mu$ L as bands of 20 mm by 2 mm.

**Development:** in a tank previously allowed to saturate for 10 min, over a path of 12 cm.

**Drying:** in air.

**Detection:** spray with 0.02 M *potassium permanganate*.

**System suitability:** reference solution (b):

- the chromatogram shows 2 clearly separated spots.

**Results:** the principal spot in the chromatogram obtained with the test solution is similar in position and size to the principal spot in the chromatogram obtained with reference solution (a).

B. 0.2 mL of solution S (see Tests) gives reaction (b) of calcium (2.3.1).

#### TESTS

**Solution S.** Dissolve 10.0 g in *carbon dioxide-free water R* prepared from *distilled water R* and dilute to 100 mL with the same solvent.

**Appearance of solution.** Solution S is clear (2.2.1) and not more intensely coloured than reference solution  $Y_6$  (2.2.2, *Method II*).

**pH** (2.2.3): 6.0 to 8.0 for solution S.

**Reducing sugars:** maximum 1 per cent, expressed as glucose.

Dissolve 1.0 g in 5 mL of *water R* with the aid of gentle heat. Cool and add 20 mL of *cupri-citric solution R* and a few glass beads. Heat so that boiling begins after 4 min and maintain boiling for 3 min. Cool rapidly and add 100 mL of a 2.4 per cent V/V solution of *glacial acetic acid R* and 20.0 mL of 0.025 M *iodine*. With continuous shaking, add 25 mL of a mixture of 6 volumes of *hydrochloric acid R* and 94 volumes of *water R* until the precipitate dissolves, titrate the excess of iodine with 0.05 M *sodium thiosulfate* using 1 mL of *starch solution R* added towards the end of the titration, as indicator. Not less than 12.6 mL of 0.05 M *sodium thiosulfate* is required.

**Cyanide.** Dissolve 5.0 g in 50 mL of *water R* and add 2.0 g of *tartaric acid R*. Place this solution in a distillation apparatus (2.2.11). The plain bend adapter attached to the end of the condenser has a vertical part that is long enough to extend to 1 cm from the bottom of a 50 mL test-tube used as a receiver. Place 10 mL of *water R* and 2 mL of 0.1 M *sodium hydroxide* into the receiver. Distil, collect 25 mL of distillate and dilute to 50 mL with *water R*. To 25 mL of this solution add 25 mg of *ferrous sulfate R* and boil for a short time. After cooling to about 70 °C add 10 mL of *hydrochloric acid R1*. After 30 min, filter the solution and wash the filter. A yellow spot appears on the filter; there is no blue or green spot.

**Chlorides** (2.4.4): maximum 100 ppm.

To 5 mL of solution S, add 10 mL of *water R*.

**Sulfates** (2.4.13): maximum 100 ppm, determined on solution S.

**Iron** (2.4.9): maximum 40 ppm.

Dilute 2.5 mL of solution S to 10 mL with *water R*.

**Heavy metals** (2.4.8): maximum 10 ppm.

Dissolve 2.0 g in 10 mL of *buffer solution pH 3.5 R* and dilute to 20 mL with *water R*. 12 mL of the solution complies with test A. Prepare the reference solution using *lead standard solution (1 ppm Pb) R*.

**Loss on drying** (2.2.32): maximum 5.0 per cent, determined on 1.000 g by drying in an oven at 105 °C for 3 h.

**Bacterial endotoxins** (2.6.14): less than 167 IU/g, if intended for use in the manufacture of parenteral preparations without a further appropriate procedure for the removal of bacterial endotoxins.

#### ASSAY

Dissolve 0.800 g in a mixture of 2 mL of 3 M *hydrochloric acid* and 150 mL of *water R*. While stirring, add 12.5 mL of 0.1 M *sodium edetate*, 15 mL of 1 M *sodium hydroxide* and 0.3 g of *hydroxynaphthol blue, sodium salt R*. Titrate with 0.1 M *sodium edetate* until the colour changes from violet to pure blue.

1 mL of 0.1 M *sodium edetate* is equivalent to 49.04 mg of  $C_{14}H_{26}CaO_{16}$ .

#### STORAGE

In an airtight container. If the substance is sterile, store in a sterile, airtight, tamper-proof container.

01/2009:0172 **Chlorides** (2.4.4): maximum 200 ppm.Dilute 12.5 mL of solution S to 15 mL with *water R*.**Sulfates** (2.4.13): maximum 100 ppm.Dissolve 10.0 g with heating in a mixture of 10 mL of *acetic acid R* and 90 mL of *distilled water R*.**Magnesium and alkali metals**: maximum 0.4 per cent.Dissolve 1.00 g in 100 mL of boiling *water R*, add 10 mL of *ammonium chloride solution R*, 1 mL of *ammonia R* and, dropwise, 50 mL of hot *ammonium oxalate solution R*. Allow to stand for 4 h, dilute to 200 mL with *water R* and filter. Evaporate 100 mL of the filtrate to dryness and ignite. The residue weighs a maximum of 2 mg.**Heavy metals** (2.4.8): maximum 10 ppm.2.0 g complies with test D. Heat the substance to be examined gradually and with care until it is almost completely transformed into a white mass and then ignite. Prepare the reference solution using 2 mL of *lead standard solution (10 ppm Pb) R*.**Microbial contamination**TAMC: acceptance criterion  $10^3$  CFU/g (2.6.12).TYMC: acceptance criterion  $10^2$  CFU/g (2.6.12).

ASSAY

Dissolve 0.8000 g in 20 mL of hot *water R*, allow to cool and dilute to 300 mL with *water R*. Carry out the complexometric titration of calcium (2.5.11).1 mL of 0.1 M *sodium edetate* is equivalent to 44.84 mg of  $C_{12}H_{22}CaO_{14},H_2O$ .

01/2009:2364

**CALCIUM GLUCONATE, ANHYDROUS**

## Calcii gluconas anhydricus

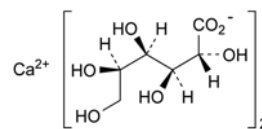
 $C_{12}H_{22}CaO_{14}$  $M_r$  430.4

DEFINITION

Anhydrous calcium D-gluconate.

**Content**: 98.0 per cent to 102.0 per cent (dried substance).

CHARACTERS

**Appearance**: white or almost white, crystalline or granular powder.**Solubility**: sparingly soluble in water, freely soluble in boiling water.

IDENTIFICATION

A. Thin-layer chromatography (2.2.27).

**Test solution**. Dissolve 20 mg of the substance to be examined in 1 mL of *water R*, heating if necessary in a water-bath at 60 °C.**Reference solution**. Dissolve 20 mg of *calcium gluconate CRS* in 1 mL of *water R*, heating if necessary in a water-bath at 60 °C.**Plate**: TLC silica gel plate R (5-40  $\mu$ m) [or TLC silica gel plate R (2-10  $\mu$ m)].**Mobile phase**: concentrated ammonia R, ethyl acetate R, water R, ethanol (96 per cent) R (10:10:30:50 V/V/V/V).**Application**: 1  $\mu$ L.**Development**: over 2/3 of the plate.**Drying**: at 100 °C for 20 min, then allow to cool.**CALCIUM GLUCONATE**

## Calcii gluconas

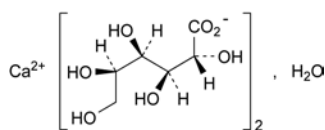
 $C_{12}H_{22}CaO_{14},H_2O$  $M_r$  448.4

DEFINITION

Calcium D-gluconate monohydrate.

**Content**: 98.5 per cent to 102.0 per cent of  $C_{12}H_{22}CaO_{14},H_2O$ .

CHARACTERS

**Appearance**: white or almost white, crystalline or granular powder.**Solubility**: sparingly soluble in water, freely soluble in boiling water.

IDENTIFICATION

A. Thin-layer chromatography (2.2.27).

**Test solution**. Dissolve 20 mg of the substance to be examined in 1 mL of *water R*, heating if necessary in a water-bath at 60 °C.**Reference solution**. Dissolve 20 mg of *calcium gluconate CRS* in 1 mL of *water R*, heating if necessary in a water-bath at 60 °C.**Plate**: TLC silica gel G plate R.**Mobile phase**: concentrated ammonia R, ethyl acetate R, water R, ethanol (96 per cent) R (10:10:30:50 V/V/V/V).**Application**: 5  $\mu$ L.**Development**: over a path of 10 cm.**Drying**: at 100 °C for 20 min. Allow to cool.**Detection**: spray with a 50 g/L solution of *potassium dichromate R* in a 40 per cent *m/m* solution of *sulfuric acid R*.**Results**: after 5 min, the principal spot in the chromatogram obtained with the test solution is similar in position, colour and size to the principal spot in the chromatogram obtained with the reference solution.

B. Solution S (see Tests) gives the reactions of calcium (2.3.1).

TESTS

**Solution S**. Dissolve 1.0 g in *water R* heated to 60 °C and dilute to 50 mL with the same solvent.**Appearance of solution**. At 60 °C, solution S is not more intensely coloured than reference solution  $Y_6$  (2.2.2, Method II). After cooling, it is not more opalescent than reference suspension II (2.2.1).**Organic impurities and boric acid**. Introduce 0.5 g into a porcelain dish previously rinsed with *sulfuric acid R* and placed in a bath of iced water. Add 2 mL of cooled *sulfuric acid R* and mix. No yellow or brown colour develops. Add 1 mL of *chromotrope II B solution R*. A violet colour develops and does not become dark blue. The solution is not more intensely coloured than that of a mixture of 1 mL of *chromotrope II B solution R* and 2 mL of cooled *sulfuric acid R*.**Sucrose and reducing sugars**. Dissolve 0.5 g in a mixture of 2 mL of *hydrochloric acid R1* and 10 mL of *water R*. Boil for 5 min, allow to cool, add 10 mL of *sodium carbonate solution R* and allow to stand. Dilute to 25 mL with *water R* and filter. To 5 mL of the filtrate add 2 mL of *cupri-tartaric solution R* and boil for 1 min. Allow to stand for 2 min. No red precipitate is formed.

**Detection:** spray with a solution containing 25 g/L of ammonium molybdate R and 10 g/L of cerium sulfate R in dilute sulfuric acid R, and heat at 100-105 °C for about 10 min.

**Results:** the principal spot in the chromatogram obtained with the test solution is similar in position, colour and size to the principal spot in the chromatogram obtained with the reference solution.

01/2009:0979  
corrected 7.0

## CALCIUM GLUCONATE FOR INJECTION

### Calcii gluconas ad iniectionabile

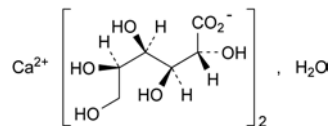

$C_{12}H_{22}CaO_{14}\cdot H_2O$

$M_r$  448.4

#### DEFINITION

Calcium D-gluconate monohydrate.

**Content:** 99.0 per cent to 101.0 per cent of  $C_{12}H_{22}CaO_{14}\cdot H_2O$ .

#### CHARACTERS

**Appearance:** white or almost white, crystalline or granular powder.

**Solubility:** sparingly soluble in water, freely soluble in boiling water.

#### IDENTIFICATION

A. Thin-layer chromatography (2.2.27).

**Test solution.** Dissolve 20 mg of the substance to be examined in 1 mL of water R, heating if necessary in a water-bath at 60 °C.

**Reference solution.** Dissolve 20 mg of calcium gluconate CRS in 1 mL of water R, heating if necessary in a water-bath at 60 °C.

**Plate:** TLC silica gel G plate R.

**Mobile phase:** concentrated ammonia R, ethyl acetate R, water R, ethanol (96 per cent) R (10:10:30:50 V/V/V/V).

**Application:** 5 µL.

**Development:** over a path of 10 cm.

**Drying:** at 100 °C for 20 min and allow to cool.

**Detection:** spray with a 50 g/L solution of potassium dichromate R in a 40 per cent m/m solution of sulfuric acid R.

**Results:** after 5 min, the principal spot in the chromatogram obtained with the test solution is similar in position, colour and size to the principal spot in the chromatogram obtained with the reference solution.

B. About 20 mg gives reaction (b) of calcium (2.3.1).

#### TESTS

**Solution S.** To 10.0 g add 90 mL of boiling distilled water R and boil with stirring, for not more than 10 s, until completely dissolved, then dilute to 100.0 mL with the same solvent.

**Appearance of solution.** At 60 °C, solution S is not more intensely coloured than reference solution B<sub>7</sub> (2.2.2, Method II). After cooling to 20 °C, it is not more opalescent than reference suspension II (2.2.1).

**pH** (2.2.3): 6.4 to 8.3.

Dissolve 1.0 g in 20 mL of carbon dioxide-free water R, heating on a water-bath.

**Organic impurities and boric acid.** Introduce 0.5 g into a porcelain dish previously rinsed with sulfuric acid R and placed in a bath of iced water. Add 2 mL of cooled sulfuric acid R and mix. No yellow or brown colour develops. Add 1 mL of chromotrope II B solution R. A violet colour develops and does not become dark blue. The solution is not more intensely coloured than that of a mixture of 1 mL of chromotrope II B solution R and 2 mL of cooled sulfuric acid R.

B. Solution S (see Tests) gives the reactions of calcium (2.3.1).

C. Loss on drying (see Tests).

#### TESTS

**Solution S.** Dissolve 1.0 g in water R heated to 60 °C and dilute to 50 mL with the same solvent.

**Appearance of solution.** At 60 °C, solution S is not more intensely coloured than reference solution Y<sub>6</sub> (2.2.2, Method II). After cooling, it is not more opalescent than reference suspension II (2.2.1).

**Organic impurities and boric acid.** Place 0.5 g in a porcelain dish previously rinsed with sulfuric acid R and placed in a bath of iced water. Add 2 mL of cooled sulfuric acid R and mix. No yellow or brown colour develops. Add 1 mL of chromotrope II B solution R. A violet colour develops and does not become dark blue. Compare the colour obtained with that of a mixture of 1 mL of chromotrope II B solution R and 2 mL of cooled sulfuric acid R.

**Sucrose and reducing sugars.** Dissolve 0.5 g in a mixture of 2 mL of hydrochloric acid R1 and 10 mL of water R. Boil for 5 min, allow to cool, add 10 mL of sodium carbonate solution R and allow to stand for 10 min. Dilute to 25 mL with water R and filter. To 5 mL of the filtrate add 2 mL of cupri-tartaric solution R and boil for 1 min. Allow to stand for 2 min. No red precipitate is formed.

**Chlorides** (2.4.4): maximum 200 ppm.

Dilute 12.5 mL of solution S to 15 mL with water R.

**Sulfates** (2.4.13): maximum 100 ppm.

Dissolve 10.0 g with heating in a mixture of 10 mL of acetic acid R and 90 mL of distilled water R.

**Magnesium and alkali metals:** maximum 0.4 per cent (expressed as MgO).

Dissolve 1.00 g in 100 mL of boiling water R, add 10 mL of ammonium chloride solution R, 1 mL of ammonia R and, dropwise, 50 mL of hot ammonium oxalate solution R. Allow to stand for 4 h, dilute to 200 mL with water R and filter. Evaporate 100 mL of the filtrate to dryness and ignite. The residue weighs a maximum of 2 mg.

**Heavy metals** (2.4.8): maximum 10 ppm.

2.0 g complies with test D. Heat the substance to be examined gradually and with care until it is almost completely transformed into a white mass, and then ignite. Prepare the reference solution using 2 mL of lead standard solution (10 ppm Pb) R.

**Loss on drying** (2.2.32): maximum 2.0 per cent, determined on 1.000 g by drying in an oven at 105 °C for 16 h.

#### Microbial contamination

TAMC: acceptance criterion 10<sup>3</sup> CFU/g (2.6.12).

TYMC: acceptance criterion 10<sup>2</sup> CFU/g (2.6.12).

#### ASSAY

Dissolve 0.350 g in 20 mL of hot water R, allow to cool and dilute to 300 mL with water R. Carry out the complexometric titration of calcium (2.5.11).

1 mL of 0.1 M sodium edetate is equivalent to 43.04 mg of  $C_{12}H_{22}CaO_{14}$ .



**Oxalates.** Liquid chromatography (2.2.29).

**Test solution.** Dissolve 1.00 g of the substance to be examined in *water for chromatography R* and dilute to 100.0 mL with the same solvent.

**Reference solution.** Dissolve 1.00 g of the substance to be examined in *water for chromatography R*, add 0.5 mL of a 0.152 g/L solution of *sodium oxalate R* in *water for chromatography R* and dilute to 100.0 mL with the same solvent.

**Precolumn:**

- size:  $l = 30$  mm,  $\varnothing = 4$  mm;
- stationary phase: suitable strong anion exchange resin (30–50  $\mu\text{m}$ ).

**Columns 1 and 2:**

- size:  $l = 0.25$  m,  $\varnothing = 4$  mm;
- stationary phase: suitable strong anion exchange resin (30–50  $\mu\text{m}$ ).

**Anion-suppressor column:** connected in series with the precolumn and analytical columns and equipped with a micromembrane that separates the mobile phase from the suppressor regeneration solution, flowing countercurrent to the mobile phase.

**Mobile phase:** dissolve 0.212 g of *anhydrous sodium carbonate R* and 63 mg of *sodium hydrogen carbonate R* in *water for chromatography R* and dilute to 1000.0 mL with the same solvent.

**Flow rate of the mobile phase:** 2 mL/min.

**Suppressor regeneration solution:** 1.23 g/L solution of *sulfuric acid R* in *water for chromatography R*.

**Flow rate of the suppressor regeneration solution:** 4 mL/min.

**Detection:** conductance.

**Injection:** 50  $\mu\text{L}$ .

**System suitability:** reference solution:

- **repeatability:** maximum relative standard deviation of the area of the peak due to oxalate of 2.0 per cent after 5 injections.

Inject 50  $\mu\text{L}$  of each solution 3 times. Calculate the content of oxalates in parts per million using the following expression:

$$\frac{S_T \times 50}{S_R - S_T}$$

$S_T$  = area of the peak due to oxalate in the chromatogram obtained with the test solution;

$S_R$  = area of the peak due to oxalate in the chromatogram obtained with the reference solution.

**Limit:**

- **oxalates:** maximum 100 ppm.

**Sucrose and reducing sugars.** Dissolve 0.5 g in a mixture of 2 mL of *hydrochloric acid R1* and 10 mL of *water R*. Boil for 5 min, allow to cool, add 10 mL of *sodium carbonate solution R* and allow to stand for 10 min. Dilute to 25 mL with *water R* and filter. To 5 mL of the filtrate add 2 mL of *cupri-tartaric solution R* and boil for 1 min. Allow to stand for 2 min. No red precipitate is formed.

**Chlorides (2.4.4):** maximum 50 ppm.

To 10 mL of previously filtered solution S add 5 mL of *water R*.

**Phosphates (2.4.11):** maximum 100 ppm.

Dilute 1 mL of solution S to 100 mL with *water R*.

**Sulfates (2.4.13):** maximum 50 ppm, determined on previously filtered solution S.

Prepare the standard using a mixture of 7.5 mL of *sulfate standard solution (10 ppm  $\text{SO}_4$ ) R* and 7.5 mL of *distilled water R*.

**Iron:** maximum 5 ppm.

Atomic absorption spectrometry (2.2.23, *Method I*).

**Test solution.** Introduce 2.0 g into a 100 mL polytetrafluoroethylene beaker and add 5 mL of *nitric acid R*. Boil, evaporating almost to dryness. Add 1 mL of *strong hydrogen peroxide solution R* and evaporate again almost to dryness. Repeat the hydrogen peroxide treatment until a clear solution is obtained. Using 2 mL of *nitric acid R*, transfer the solution into a 25 mL volumetric flask. Dilute to 25.0 mL with *dilute hydrochloric acid R*. In the same manner, prepare a compensation solution using 0.65 g of *calcium chloride R1* instead of the substance to be examined.

**Reference solutions.** Prepare the reference solutions from *iron solution (20 ppm Fe) R* diluted with *dilute hydrochloric acid R*.

**Source:** iron hollow-cathode lamp.

**Wavelength:** 248.3 nm.

**Atomisation device:** air-acetylene flame.

Carry out a basic correction using a deuterium lamp.

**Magnesium and alkali metals:** maximum 0.4 per cent.

To 0.50 g add a mixture of 1.0 mL of *dilute acetic acid R* and 10.0 mL of *water R* and rapidly boil, whilst shaking, until completely dissolved. To the boiling solution add 5.0 mL of *ammonium oxalate solution R* and allow to stand for at least 6 h. Filter through a sintered-glass filter (1.6) (2.1.2) into a porcelain crucible. Carefully evaporate the filtrate to dryness and ignite. The residue weighs not more than 2 mg.

**Heavy metals (2.4.8):** maximum 10 ppm.

12 mL of solution S complies with test A. Prepare the reference solution using *lead standard solution (1 ppm Pb) R*.

**Bacterial endotoxins (2.6.14):** less than 167 IU/g.

**Microbial contamination**

TAMC: acceptance criterion  $10^2$  CFU/g (2.6.12).

**ASSAY**

Dissolve 0.350 g in 20 mL of hot *water R*, allow to cool and dilute to 300 mL with *water R*. Carry out the complexometric titration of calcium (2.5.11). Use 50 mg of *calconcarboxylic acid triturate R*.

1 mL of 0.1 M *sodium edetate* is equivalent to 44.84 mg of  $\text{C}_{12}\text{H}_{22}\text{CaO}_{14}\text{H}_2\text{O}$ .

01/2008:0980  
corrected 6.0

## CALCIUM GLYCEROPHOSPHATE

### Calcii glycerophosphas

$\text{C}_3\text{H}_7\text{CaO}_6\text{P}$

$M_r$  210.1

**DEFINITION**

Mixture in variable proportions of the calcium salt of (RS)-2,3-dihydroxypropyl phosphate and of 2-hydroxy-1-(hydroxymethyl)ethyl phosphate which may be hydrated.

**Content:** 18.6 per cent to 19.4 per cent of Ca (dried substance).

**CHARACTERS**

**Appearance:** white or almost white powder, hygroscopic.

**Solubility:** sparingly soluble in water, practically insoluble in ethanol (96 per cent).

**IDENTIFICATION**

A. Mix 1 g with 1 g of *potassium hydrogen sulfate R* in a test tube fitted with a glass tube. Heat strongly and direct the white vapour towards a piece of filter paper impregnated with a freshly prepared 10 g/L solution of *sodium nitroprusside R*. The filter paper develops a blue colour in contact with *piperidine R*.

- B. Ignite 0.1 g in a crucible. Take up the residue with 5 mL of *nitric acid R* and heat on a water-bath for 1 min. Filter. The filtrate gives reaction (b) of phosphates (2.3.1).
- C. It gives reaction (b) of calcium (2.3.1).

## TESTS

**Solution S.** Dissolve 1.5 g at room temperature in *carbon dioxide-free water R* prepared from *distilled water R* and dilute to 150 mL with the same solvent.

**Appearance of solution.** Solution S is not more opalescent than reference suspension III (2.2.1).

**Acidity or alkalinity.** To 100 mL of solution S add 0.1 mL of *phenolphthalein solution R*. Not more than 1.5 mL of 0.1 M *hydrochloric acid* or 0.5 mL of 0.1 M *sodium hydroxide* is required to change the colour of the indicator.

**Citric acid.** Shake 5.0 g with 20 mL of *carbon dioxide-free water R* and filter. To the filtrate add 0.15 mL of *sulfuric acid R* and filter again. To the filtrate add 5 mL of *mercuric sulfate solution R* and heat to boiling. Add 0.5 mL of a 3.2 g/L solution of *potassium permanganate R* and again heat to boiling. No precipitate is formed.

**Glycerol and ethanol (96 per cent)-soluble substances:** maximum 0.5 per cent.

Shake 1.000 g with 25 mL of *ethanol (96 per cent) R* for 1 min. Filter. Evaporate the filtrate on a water-bath and dry the residue at 70 °C for 1 h. The residue weighs a maximum of 5 mg.

**Chlorides (2.4.4):** maximum 500 ppm.

Dissolve 0.1 g in a mixture of 2 mL of *acetic acid R* and 8 mL of *water R* and dilute to 15 mL with *water R*.

**Phosphates (2.4.11):** maximum 400 ppm.

Dilute 2.5 mL of solution S to 100 mL with *water R*.

**Sulfates (2.4.13):** maximum 0.1 per cent, determined on solution S.

**Arsenic (2.4.2, Method A):** maximum 3 ppm.

Dissolve 0.33 g in *water R* and dilute to 25 mL with the same solvent.

**Iron (2.4.9):** maximum 50 ppm, determined on 0.20 g.

**Heavy metals (2.4.8):** maximum 20 ppm.

Dissolve 2.0 g in 10 mL of *buffer solution pH 3.5 R* and dilute to 20 mL with *water R*. 12 mL of the solution complies with test A. Prepare the reference solution using *lead standard solution (2 ppm Pb) R*.

**Loss on drying (2.2.32):** maximum 12.0 per cent, determined on 1.000 g by drying in an oven at 150 °C for 4 h.

## ASSAY

Dissolve 0.200 g in *water R*. Carry out the complexometric titration of calcium (2.5.11).

1 mL of 0.1 M *sodium edetate* is equivalent to 4.008 mg of Ca.

04/2009:0981

## CALCIUM HYDROGEN PHOSPHATE, ANHYDROUS

### Calcii hydrogenophosphas anhydricus

CaHPO<sub>4</sub>  
[7757-93-9]

M<sub>r</sub> 136.1

## DEFINITION

**Content:** 98.0 per cent to 103.0 per cent.

## CHARACTERS

**Appearance:** white or almost white, crystalline powder, or colourless crystals.

**Solubility:** practically insoluble in water and in ethanol (96 per cent). It dissolves in dilute hydrochloric acid and in dilute nitric acid.

## IDENTIFICATION

A. Dissolve with heating 0.1 g in 10 mL of *dilute hydrochloric acid R*. Add 2.5 mL of *dilute ammonia R1*, shake, and add 5 mL of a 35 g/L solution of *ammonium oxalate R*. A white precipitate is produced.

B. Dissolve 0.1 g in 5 mL of *dilute nitric acid R*, add 2 mL of *ammonium molybdate solution R* and heat at 70 °C for 2 min. A yellow precipitate is produced.

C. It complies with the limits of the assay.

## TESTS

**Solution S.** Dissolve 2.5 g in 20 mL of *dilute hydrochloric acid R*, filter if necessary and add *dilute ammonia R1* until a precipitate is formed. Add just sufficient *dilute hydrochloric acid R* to dissolve the precipitate and dilute to 50 mL with *distilled water R*.

**Acid-insoluble substances:** maximum 0.2 per cent.

Dissolve 5.0 g in 40 mL of *water R*, add 10 mL of *hydrochloric acid R* and heat to boiling for 5 min. Cool, then collect the insoluble substances using ashless filter paper. Wash with *water R* until turbidity is no longer produced when *silver nitrate solution R2* is added. Ignite at 600 ± 50 °C. The residue weighs not more than 10 mg.

**Carbonates.** Shake 0.5 g with 5 mL of *carbon dioxide-free water R* and add 1 mL of *hydrochloric acid R*. No effervescence is produced.

**Chlorides:** maximum 0.25 per cent.

**Test solution.** Dissolve 0.20 g in a mixture of 20 mL of *water R* and 13 mL of *dilute nitric acid R*, dilute to 100 mL with *water R* and filter if necessary. Use 50 mL of this solution.

**Reference solution.** To 0.70 mL of 0.01 M *hydrochloric acid*, add 6 mL of *dilute nitric acid R* and dilute to 50 mL with *water R*.

Add 1 mL of *silver nitrate solution R2* to the test solution and to the reference solution and mix. After standing for 5 min protected from light, any opalescence in the test solution is not more intense than that in the reference solution.

**Fluorides:** maximum 100 ppm.

Potentiometry (2.2.36, Method II).

**Chelating solution.** Dissolve 45 g of *cyclohexylenedinitrilotetraacetic acid R* in 75 mL of *sodium hydroxide solution R* and dilute to 250 mL with *water R*.

**Test solution.** Dissolve 1.000 g in 4 mL of *hydrochloric acid R1*, add 20 mL of chelating solution, 2.7 mL of *glacial acetic acid R* and 2.8 g of *sodium chloride R*, adjust to pH 5-6 with *sodium hydroxide solution R* and dilute to 50.0 mL with *water R*.

**Reference solution.** Dissolve 4.42 g of *sodium fluoride R*, previously dried at 300 °C for 12 h, in *water R* and dilute to 1000.0 mL with the same solvent. Dilute 50.0 mL of this solution to 500.0 mL with *total-ionic-strength-adjustment buffer R* (200 ppm F).

**Indicator electrode:** fluoride-selective.

**Reference electrode:** silver-silver chloride.

Carry out the measurement on 20.0 mL of the test solution. Add at least 3 times 0.10 mL of the reference solution and carry out the measurement after each addition. Calculate the concentration of fluorides using the calibration curve.

**Sulfates:** maximum 0.5 per cent.

**Test solution.** Dissolve 0.5 g in a mixture of 5 mL of *water R* and 5 mL of *dilute hydrochloric acid R* and dilute to 100 mL with *water R*. Filter if necessary. To 20 mL of this solution, add 1 mL of *dilute hydrochloric acid R* and dilute to 50 mL with *water R*.

**Reference solution.** To 1.0 mL of 0.005 M sulfuric acid, add 1 mL of dilute hydrochloric acid R and dilute to 50 mL with water R. Filter if necessary.

To the test solution and to the reference solution, add 2 mL of a 120 g/L solution of barium chloride R and allow to stand for 10 min. Any opalescence in the test solution is not more intense than that in the reference solution.

**Arsenic (2.4.2, Method A):** maximum 10 ppm, determined on 2 mL of solution S.

**Barium.** To 0.5 g, add 10 mL of water R and heat to boiling. While stirring, add 1 mL of hydrochloric acid R dropwise. Allow to cool and filter if necessary. Add 2 mL of a 10 g/L solution of dipotassium sulfate R and allow to stand for 10 min. No turbidity is produced.

**Iron (2.4.9):** maximum 400 ppm.

Dilute 0.5 mL of solution S to 10 mL with water R.

**Heavy metals (2.4.8):** maximum 40 ppm.

Dilute 10 mL of solution S to 20 mL with water R. 12 mL of the solution complies with test A. Prepare the reference solution using lead standard solution (1 ppm Pb) R.

**Loss on ignition:** 6.6 per cent to 8.5 per cent, determined on 1.000 g to constant mass at 800-825 °C.

#### ASSAY

Dissolve 0.4 g in 12 mL of dilute hydrochloric acid R and dilute to 200 mL with water R. To 20.0 mL of this solution add 25.0 mL of 0.02 M sodium edetate, 50 mL of water R, 5 mL of ammonium chloride buffer solution pH 10.7 R and about 25 mg of mordant black 11 tritrate R. Titrate the excess of sodium edetate with 0.02 M zinc sulfate. Carry out a blank titration.

1 mL of 0.02 M sodium edetate is equivalent to 2.72 mg of CaHPO<sub>4</sub>.

#### FUNCTIONALITY-RELATED CHARACTERISTICS

*This section provides information on characteristics that are recognised as being relevant control parameters for one or more functions of the substance when used as an excipient (see chapter 5.15). This section is a non-mandatory part of the monograph and it is not necessary to verify the characteristics to demonstrate compliance. Control of these characteristics can however contribute to the quality of a medicinal product by improving the consistency of the manufacturing process and the performance of the medicinal product during use. Where control methods are cited, they are recognised as being suitable for the purpose, but other methods can also be used. Wherever results for a particular characteristic are reported, the control method must be indicated.*

*The following characteristics may be relevant for anhydrous calcium hydrogen phosphate used as filler in tablets and capsules.*

**Particle-size distribution (2.9.31 or 2.9.38).**

**Bulk and tapped density (2.9.34).**

**Powder flow (2.9.36).**

04/2009:0116

## CALCIUM HYDROGEN PHOSPHATE DIHYDRATE

Calcii hydrogenophosphas dihydricus

CaHPO<sub>4</sub>·2H<sub>2</sub>O  
[7789-77-7]

M<sub>r</sub> 172.1

#### DEFINITION

**Content:** 98.0 per cent to 105.0 per cent.

#### CHARACTERS

**Appearance:** white or almost white, crystalline powder.

**Solubility:** practically insoluble in water and in ethanol (96 per cent). It dissolves in dilute hydrochloric acid and in dilute nitric acid.

#### IDENTIFICATION

A. Dissolve with heating 0.1 g in 10 mL of dilute hydrochloric acid R. Add 2.5 mL of dilute ammonia R1, shake and add 5 mL of a 35 g/L solution of ammonium oxalate R. A white precipitate is produced.

B. Dissolve 0.1 g in 5 mL of dilute nitric acid R, add 2 mL of ammonium molybdate solution R and heat at 70 °C for 2 min. A yellow precipitate is produced.

C. It complies with the limits of the assay.

#### TESTS

**Solution S.** Dissolve 2.5 g in 20 mL of dilute hydrochloric acid R, filter if necessary and add dilute ammonia R1 until a precipitate is formed. Add just sufficient dilute hydrochloric acid R to dissolve the precipitate and dilute to 50 mL with distilled water R.

**Acid-insoluble substances:** maximum 0.2 per cent.

Dissolve 5.0 g in 40 mL of water R, add 10 mL of hydrochloric acid R and heat to boiling for 5 min. Cool, then collect the insoluble substances using ashless filter paper. Wash with water R until turbidity is no longer produced when silver nitrate solution R2 is added to the filtrate. Ignite at 600 ± 50 °C. The residue weighs not more than 10 mg.

**Carbonates.** Shake 0.5 g with 5 mL of carbon dioxide-free water R and add 1 mL of hydrochloric acid R. No effervescence is produced.

**Chlorides:** maximum 0.25 per cent.

**Test solution.** Dissolve 0.20 g in a mixture of 20 mL of water R and 13 mL of dilute nitric acid R, dilute to 100 mL with water R and filter if necessary. Use 50 mL of this solution.

**Reference solution.** To 0.70 mL of 0.01 M hydrochloric acid, add 6 mL of dilute nitric acid R and dilute to 50 mL with water R.

Add 1 mL of silver nitrate solution R2 to the test solution and to the reference solution and mix. After standing for 5 min protected from light, any opalescence in the test solution is not more intense than that in the reference solution.

**Fluorides:** maximum 100 ppm.

Potentiometry (2.2.36, Method II).

**Chelating solution.** Dissolve 45 g of cyclohexylenedinitrilotetraacetic acid R in 75 mL of sodium hydroxide solution R and dilute to 250 mL with water R.

**Test solution.** Dissolve 1.000 g in 4 mL of hydrochloric acid R1, add 20 mL of chelating solution, 2.7 mL of glacial acetic acid R and 2.8 g of sodium chloride R, adjust to pH 5-6 with sodium hydroxide solution R and dilute to 50.0 mL with water R.

**Reference solution.** Dissolve 4.42 g of sodium fluoride R, previously dried at 300 °C for 12 h, in water R and dilute to 1000.0 mL with the same solvent. Dilute 50.0 mL of this solution to 500.0 mL with total-ionic-strength-adjustment buffer R (200 ppm F).

**Indicator electrode:** fluoride-selective.

**Reference electrode:** silver-silver chloride.

Carry out the measurement on 20.0 mL of the test solution. Add at least 3 times 0.10 mL of the reference solution and carry out the measurement after each addition. Calculate the concentration of fluorides using the calibration curve.

**Sulfates:** maximum 0.5 per cent.

**Test solution.** Dissolve 0.5 g in a mixture of 5 mL of water R and 5 mL of dilute hydrochloric acid R and dilute to 100 mL with water R. Filter if necessary. To 20 mL of this solution, add 1 mL of dilute hydrochloric acid R and dilute to 50 mL with water R.

**Reference solution.** To 1.0 mL of 0.005 M sulfuric acid, add 1 mL of dilute hydrochloric acid R and dilute to 50 mL with water R. Filter if necessary.

To the test solution and to the reference solution, add 2 mL of a 120 g/L solution of barium chloride R and allow to stand for 10 min. Any opalescence in the test solution is not more intense than that in the reference solution.

**Arsenic (2.4.2, Method A):** maximum 10 ppm, determined on 2 mL of solution S.

**Barium.** To 0.5 g, add 10 mL of water R and heat to boiling. While stirring, add 1 mL of hydrochloric acid R dropwise. Allow to cool and filter if necessary. Add 2 mL of a 10 g/L solution of dipotassium sulfate R and allow to stand for 10 min. No turbidity is produced.

**Iron (2.4.9):** maximum 400 ppm.

Dilute 0.5 mL of solution S to 10 mL with water R.

**Heavy metals (2.4.8):** maximum 40 ppm.

Dilute 10 mL of solution S to 20 mL with water R. 12 mL of the solution complies with test A. Prepare the reference solution using lead standard solution (1 ppm Pb) R.

**Loss on ignition:** 24.5 per cent to 26.5 per cent, determined on 1.000 g by ignition to constant mass at 800-825 °C.

#### ASSAY

Dissolve 0.4 g in 12 mL of dilute hydrochloric acid R and dilute to 200 mL with water R. To 20.0 mL of this solution add 25.0 mL of 0.02 M sodium edetate, 50 mL of water R, 5 mL of ammonium chloride buffer solution pH 10.7 R and about 25 mg of mordant black 11 triturate R. Titrate the excess of sodium edetate with 0.02 M zinc sulfate. Carry out a blank titration.

1 mL of 0.02 M sodium edetate is equivalent to 3.44 mg of CaHPO<sub>4</sub>·2H<sub>2</sub>O.

#### FUNCTIONALITY-RELATED CHARACTERISTICS

*This section provides information on characteristics that are recognised as being relevant control parameters for one or more functions of the substance when used as an excipient (see chapter 5.15). This section is a non-mandatory part of the monograph and it is not necessary to verify the characteristics to demonstrate compliance. Control of these characteristics can however contribute to the quality of a medicinal product by improving the consistency of the manufacturing process and the performance of the medicinal product during use. Where control methods are cited, they are recognised as being suitable for the purpose, but other methods can also be used. Wherever results for a particular characteristic are reported, the control method must be indicated.*

*The following characteristics may be relevant for calcium hydrogen phosphate dihydrate used as filler in tablets and capsules.*

**Particle-size distribution (2.9.31 or 2.9.38).**

**Bulk and tapped density (2.9.34).**

**Powder flow (2.9.36).**

01/2008:1078

## CALCIUM HYDROXIDE

### Calcii hydroxidum

Ca(OH)<sub>2</sub>  
[1305-62-0]

M<sub>r</sub> 74.1

#### DEFINITION

**Content:** 95.0 per cent to 100.5 per cent.

#### CHARACTERS

**Appearance:** white or almost white, fine powder.

**Solubility:** practically insoluble in water.

#### IDENTIFICATION

A. To 0.80 g in a mortar, add 10 mL of water R and 0.5 mL of phenolphthalein solution R and mix. The suspension turns red. On addition of 17.5 mL of 1 M hydrochloric acid, the suspension becomes colourless without effervescing. The red colour occurs again when the mixture is triturated for 1 min. On addition of a further 6 mL of 1 M hydrochloric acid and triturating, the solution becomes colourless.

B. Dissolve about 0.1 g in dilute hydrochloric acid R and dilute to 10 mL with water R. 5 mL of the solution give reaction (b) of calcium (2.3.1).

#### TESTS

**Matter insoluble in hydrochloric acid:** maximum 0.5 per cent.

Dissolve 2.0 g in 30 mL of hydrochloric acid R. Boil the solution and filter. Wash the residue with hot water R. The residue weighs a maximum of 10 mg.

**Carbonates:** maximum 5.0 per cent of CaCO<sub>3</sub>.

Add 5.0 mL of 1 M hydrochloric acid to the titrated solution obtained under Assay and titrate with 1 M sodium hydroxide using 0.5 mL of methyl orange solution R as indicator.

1 mL of 1 M hydrochloric acid is equivalent to 50.05 mg of CaCO<sub>3</sub>.

**Chlorides (2.4.4):** maximum 330 ppm.

Dissolve 0.30 g in a mixture of 2 mL of nitric acid R and 10 mL of water R and dilute to 30 mL with water R.

**Sulfates (2.4.13):** maximum 0.4 per cent.

Dissolve 0.15 g in a mixture of 5 mL of dilute hydrochloric acid R and 10 mL of distilled water R and dilute to 60 mL with distilled water R.

**Arsenic (2.4.2, Method A):** maximum 4 ppm.

Dissolve 0.50 g in 5 mL of brominated hydrochloric acid R and dilute to 50 mL with water R. Use 25 mL of this solution.

**Magnesium and alkali metals:** maximum 4.0 per cent calculated as sulfates.

Dissolve 1.0 g in a mixture of 10 mL of hydrochloric acid R and 40 mL of water R. Boil and add 50 mL of a 63 g/L solution of oxalic acid R. Neutralise with ammonia R and dilute to 200 mL with water R. Allow to stand for 1 h and filter through a suitable filter. To 100 mL of the filtrate, add 0.5 mL of sulfuric acid R. Cautiously evaporate to dryness and ignite. The residue weighs a maximum of 20 mg.

**Heavy metals (2.4.8):** maximum 20 ppm.

Dissolve 1.0 g in 10 mL of hydrochloric acid RI and evaporate to dryness on a water-bath. Dissolve the residue in 20 mL of water R and filter. 12 mL of the filtrate complies with test A. Prepare the reference solution using lead standard solution (1 ppm Pb) R.

#### ASSAY

To 1.500 g in a mortar, add 20-30 mL of water R and 0.5 mL of phenolphthalein solution R. Titrate with 1 M hydrochloric acid by triturating the substance until the red colour disappears. The final solution is used in the tests for carbonates.

1 mL of 1 M hydrochloric acid is equivalent to 37.05 mg of Ca(OH)<sub>2</sub>.

01/2008:2118  
corrected 6.0

## CALCIUM LACTATE, ANHYDROUS

Calcii lactas anhydricus

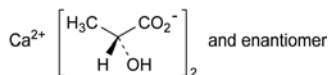
 $\text{C}_6\text{H}_{10}\text{CaO}_6$  $M_r$  218.2

## DEFINITION

Calcium bis(2-hydroxypropanoate) or mixture of calcium (2*R*)-, (2*S*)- and (2*RS*)-2-hydroxypropanoates.

*Content*: 98.0 per cent to 102.0 per cent (dried substance).

## CHARACTERS

*Appearance*: white or almost white, crystalline or granular powder.

*Solubility*: soluble in water, freely soluble in boiling water, very slightly soluble in ethanol (96 per cent).

## IDENTIFICATION

- Loss on drying (see Tests).
- It gives the reaction of lactates (2.3.1).
- It gives reaction (b) of calcium (2.3.1).

## TESTS

**Solution S.** Dissolve 5.0 g with heating in *carbon dioxide-free water R* prepared from *distilled water R*, allow to cool and dilute to 100 mL with the same solvent.

**Appearance of solution.** Solution S is not more opalescent than reference suspension II (2.2.1) and not more intensely coloured than reference solution BY<sub>6</sub> (2.2.2, *Method II*).

**Acidity or alkalinity.** To 10 mL of solution S add 0.1 mL of *phenolphthalein solution R* and 0.5 mL of 0.01 *M hydrochloric acid*. The solution is colourless. Not more than 2.0 mL of 0.01 *M sodium hydroxide* is required to change the colour of the indicator to pink.

**Chlorides** (2.4.4): maximum 200 ppm.

Dilute 5 mL of solution S to 15 mL with *water R*.

**Sulfates** (2.4.13): maximum 400 ppm.

Dilute 7.5 mL of solution S to 15 mL with *distilled water R*.

**Barium.** To 10 mL of solution S add 1 mL of *calcium sulfate solution R*. Allow to stand for 15 min. Any opalescence in the solution is not more intense than that in a mixture of 1 mL of *distilled water R* and 10 mL of solution S.

**Iron** (2.4.9): maximum 50 ppm.

Dilute 4 mL of solution S to 10 mL with *water R*.

**Magnesium and alkali salts:** maximum 1 per cent.

To 20 mL of solution S add 20 mL of *water R*, 2 g of *ammonium chloride R* and 2 mL of *dilute ammonia R1*. Heat to boiling and rapidly add 40 mL of hot *ammonium oxalate solution R*. Allow to stand for 4 h, dilute to 100.0 mL with *water R* and filter. To 50.0 mL of the filtrate add 0.5 mL of *sulfuric acid R*. Evaporate to dryness and ignite the residue to constant mass at 600 ± 50 °C. The residue weighs a maximum of 5 mg.

**Heavy metals** (2.4.8): maximum 10 ppm.

Dissolve 2.0 g in *water R* and dilute to 20 mL with the same solvent. 12 mL of the solution complies with test A. Prepare the reference solution using *lead standard solution (1 ppm Pb) R*.

**Loss on drying** (2.2.32): maximum 3.0 per cent, determined on 0.500 g by drying in an oven at 125 °C.

## ASSAY

Dissolve 0.200 g in *water R* and dilute to 300 mL with the same solvent. Carry out the complexometric titration of calcium (2.5.11).

1 mL of 0.1 *M sodium edetate* is equivalent to 21.82 mg of  $\text{C}_6\text{H}_{10}\text{CaO}_6$ .

01/2008:2117  
corrected 6.0

## CALCIUM LACTATE MONOHYDRATE

Calcii lactas monohydricus

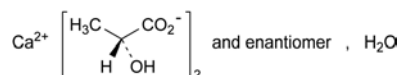
 $\text{C}_6\text{H}_{10}\text{CaO}_6 \cdot \text{H}_2\text{O}$  $M_r$  236.0

## DEFINITION

Calcium bis(2-hydroxypropanoate) or mixture of calcium (2*R*)-, (2*S*)- and (2*RS*)-2-hydroxypropanoates monohydrates.

*Content*: 98.0 per cent to 102.0 per cent (dried substance).

## CHARACTERS

*Appearance*: white or almost white, crystalline or granular powder.

*Solubility*: soluble in water, freely soluble in boiling water, very slightly soluble in ethanol (96 per cent).

## IDENTIFICATION

- Loss on drying (see Tests).
- It gives the reaction of lactates (2.3.1).
- It gives reaction (b) of calcium (2.3.1).

## TESTS

**Solution S.** Dissolve 5.4 g (equivalent to 5.0 g of the dried substance) with heating in *carbon dioxide-free water R* prepared from *distilled water R*, allow to cool and dilute to 100 mL with the same solvent.

**Appearance of solution.** Solution S is not more opalescent than reference suspension II (2.2.1) and not more intensely coloured than reference solution BY<sub>6</sub> (2.2.2, *Method II*).

**Acidity or alkalinity.** To 10 mL of solution S add 0.1 mL of *phenolphthalein solution R* and 0.5 mL of 0.01 *M hydrochloric acid*. The solution is colourless. Not more than 2.0 mL of 0.01 *M sodium hydroxide* is required to change the colour of the indicator to pink.

**Chlorides** (2.4.4): maximum 200 ppm.

Dilute 5 mL of solution S to 15 mL with *water R*.

**Sulfates** (2.4.13): maximum 400 ppm.

Dilute 7.5 mL of solution S to 15 mL with *distilled water R*.

**Barium.** To 10 mL of solution S add 1 mL of *calcium sulfate solution R*. Allow to stand for 15 min. Any opalescence in the solution is not more intense than that in a mixture of 1 mL of *distilled water R* and 10 mL of solution S.

**Iron** (2.4.9): maximum 50 ppm.

Dilute 4 mL of solution S to 10 mL with *water R*.

**Magnesium and alkali salts:** maximum 1 per cent.

To 20 mL of solution S add 20 mL of *water R*, 2 g of *ammonium chloride R* and 2 mL of *dilute ammonia R1*. Heat to boiling and rapidly add 40 mL of hot *ammonium oxalate solution R*. Allow to stand for 4 h, dilute to 100.0 mL with *water R* and filter. To 50.0 mL of the filtrate add 0.5 mL of *sulfuric acid R*. Evaporate to dryness and ignite the residue to constant mass at 600 ± 50 °C. The residue weighs a maximum of 5 mg.

**Heavy metals** (2.4.8): maximum 10 ppm.

Dissolve a quantity equivalent to 2.0 g of the dried substance in *water R* and dilute to 20 mL with the same solvent. 12 mL of the solution complies with test A. Prepare the reference solution using *lead standard solution (1 ppm Pb) R*.

**Loss on drying** (2.2.32): 5.0 per cent to 8.0 per cent, determined on 0.500 g by drying in an oven at 125 °C.

#### ASSAY

Dissolve a quantity equivalent to 0.200 g of the dried substance in *water R* and dilute to 300 mL with the same solvent. Carry out the complexometric titration of calcium (2.5.11).

1 mL of 0.1 M *sodium edetate* is equivalent to 21.82 mg of  $C_6H_{10}CaO_6$ .

01/2008:0468  
corrected 6.0

## CALCIUM LACTATE PENTAHYDRATE

### Calcii lactas pentahydricus

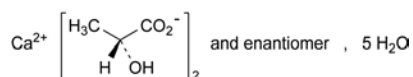

$C_6H_{10}CaO_6 \cdot 5H_2O$   $M_r$  308.3

#### DEFINITION

Calcium bis(2-hydroxypropanoate) or mixture of calcium (2*R*)-, (2*S*)- and (2*RS*)-2-hydroxypropanoates pentahydrates.

**Content:** 98.0 per cent to 102.0 per cent (dried substance).

#### CHARACTERS

**Appearance:** white or almost white, crystalline or granular powder, slightly efflorescent.

**Solubility:** soluble in water, freely soluble in boiling water, very slightly soluble in ethanol (96 per cent).

#### IDENTIFICATION

- Loss on drying (see Tests).
- It gives the reaction of lactates (2.3.1).
- It gives reaction (b) of calcium (2.3.1).

#### TESTS

**Solution S.** Dissolve 7.1 g (equivalent to 5.0 g of the dried substance) with heating in *carbon dioxide-free water R* prepared from *distilled water R*, allow to cool and dilute to 100 mL with the same solvent.

**Appearance of solution.** Solution S is not more opalescent than reference suspension II (2.2.1) and not more intensely coloured than reference solution BY<sub>6</sub> (2.2.2, *Method II*).

**Acidity or alkalinity.** To 10 mL of solution S add 0.1 mL of *phenolphthalein solution R* and 0.5 mL of 0.01 M *hydrochloric acid*. The solution is colourless. Not more than 2.0 mL of 0.01 M *sodium hydroxide* is required to change the colour of the indicator to pink.

**Chlorides** (2.4.4): maximum 200 ppm.

Dilute 5 mL of solution S to 15 mL with *water R*.

**Sulfates** (2.4.13): maximum 400 ppm.

Dilute 7.5 mL of solution S to 15 mL with *distilled water R*.

**Barium.** To 10 mL of solution S add 1 mL of *calcium sulfate solution R*. Allow to stand for 15 min. Any opalescence in the solution is not more intense than that in a mixture of 1 mL of *distilled water R* and 10 mL of solution S.

**Iron** (2.4.9): maximum 50 ppm.

Dilute 4 mL of solution S to 10 mL with *water R*.

**Magnesium and alkali salts:** maximum 1 per cent.

To 20 mL of solution S add 20 mL of *water R*, 2 g of *ammonium chloride R* and 2 mL of *dilute ammonia RI*. Heat to boiling and rapidly add 40 mL of hot *ammonium oxalate solution R*. Allow to stand for 4 h, dilute to 100.0 mL with *water R* and filter. To 50.0 mL of the filtrate add 0.5 mL of *sulfuric acid R*. Evaporate to dryness and ignite the residue to constant mass at 600 ± 50 °C. The residue weighs a maximum of 5 mg.

**Heavy metals** (2.4.8): maximum 10 ppm.

Dissolve a quantity equivalent to 2.0 g of the dried substance in *water R* and dilute to 20 mL with the same solvent. 12 mL of the solution complies with test A. Prepare the reference solution using *lead standard solution (1 ppm Pb) R*.

**Loss on drying** (2.2.32): 22.0 per cent to 27.0 per cent, determined on 0.500 g by drying in an oven at 125 °C.

#### ASSAY

Dissolve a quantity equivalent to 0.200 g of the dried substance in *water R* and dilute to 300 mL with the same solvent. Carry out the complexometric titration of calcium (2.5.11).

1 mL of 0.1 M *sodium edetate* is equivalent to 21.82 mg of  $C_6H_{10}CaO_6$ .

01/2008:0469  
corrected 6.0

## CALCIUM LACTATE TRIHYDRATE

### Calcii lactas trihydricus

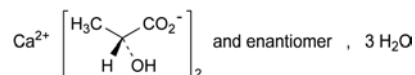

$C_6H_{10}CaO_6 \cdot 3H_2O$   $M_r$  272.3

#### DEFINITION

Calcium bis(2-hydroxypropanoate) or mixture of calcium (2*R*)-, (2*S*)- and (2*RS*)-2-hydroxypropanoates trihydrates.

**Content:** 98.0 per cent to 102.0 per cent (dried substance).

#### CHARACTERS

**Appearance:** white or almost white, crystalline or granular powder.

**Solubility:** soluble in water, freely soluble in boiling water, very slightly soluble in ethanol (96 per cent).

#### IDENTIFICATION

- Loss on drying (see Tests).
- It gives the reaction of lactates (2.3.1).
- It gives reaction (b) of calcium (2.3.1).

#### TESTS

**Solution S.** Dissolve 6.2 g (equivalent to 5.0 g of the dried substance) with heating in *carbon dioxide-free water R* prepared from *distilled water R*, allow to cool and dilute to 100 mL with the same solvent.

**Appearance of solution.** Solution S is not more opalescent than reference suspension II (2.2.1) and not more intensely coloured than reference solution BY<sub>6</sub> (2.2.2, *Method II*).

**Acidity or alkalinity.** To 10 mL of solution S add 0.1 mL of *phenolphthalein solution R* and 0.5 mL of 0.01 M *hydrochloric acid*. The solution is colourless. Not more than 2.0 mL of 0.01 M *sodium hydroxide* is required to change the colour of the indicator to pink.

**Chlorides** (2.4.4): maximum 200 ppm.

Dilute 5 mL of solution S to 15 mL with *water R*.

**Sulfates** (2.4.13): maximum 400 ppm.

Dilute 7.5 mL of solution S to 15 mL with *distilled water R*.

**Barium.** To 10 mL of solution S add 1 mL of *calcium sulfate solution R*. Allow to stand for 15 min. Any opalescence in the solution is not more intense than that in a mixture of 1 mL of *distilled water R* and 10 mL of solution S.

**Iron (2.4.9):** maximum 50 ppm.

Dilute 4 mL of solution S to 10 mL with *water R*.

**Magnesium and alkali salts:** maximum 1 per cent.

To 20 mL of solution S add 20 mL of *water R*, 2 g of *ammonium chloride R* and 2 mL of *dilute ammonia R1*. Heat to boiling and rapidly add 40 mL of hot *ammonium oxalate solution R*. Allow to stand for 4 h, dilute to 100.0 mL with *water R* and filter. To 50.0 mL of the filtrate add 0.5 mL of *sulfuric acid R*. Evaporate to dryness and ignite the residue to constant mass at  $600 \pm 50$  °C. The residue weighs a maximum of 5 mg.

**Heavy metals (2.4.8):** maximum 10 ppm.

Dissolve a quantity equivalent to 2.0 g of the dried substance in *water R* and dilute to 20 mL with the same solvent. 12 mL of the solution complies with test A. Prepare the reference solution using *lead standard solution (1 ppm Pb) R*.

**Loss on drying (2.2.32):** 15.0 per cent to 20.0 per cent, determined on 0.500 g by drying in an oven at 125 °C.

#### ASSAY

Dissolve a quantity equivalent to 0.200 g of the dried substance in *water R* and dilute to 300 mL with the same solvent. Carry out the complexometric titration of calcium (2.5.11).

1 mL of 0.1 M *sodium edetate* is equivalent to 21.82 mg of  $C_6H_{10}CaO_6$ .

01/2008:1606  
corrected 7.0

## CALCIUM LEVOFOLINATE PENTAHYDRATE

Calcii levofolinas pentahydricus

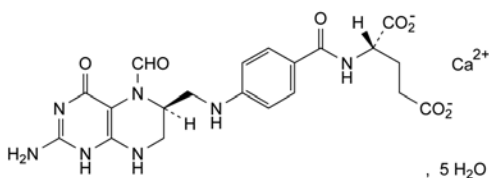

$C_{20}H_{21}CaN_7O_7 \cdot 5H_2O$   
[80433-71-2]

$M_r$  511.5 (anhydrous substance)

#### DEFINITION

Calcium (2S)-2-[[4-[[[(6S)-2-amino-5-formyl-4-oxo-1,4,5,6,7,8-hexahydropteridin-6-yl]methyl]amino]benzoyl]amino]-pentanedioate pentahydrate.

**Content:**

- *calcium levofolinate* ( $C_{20}H_{21}CaN_7O_7$ ;  $M_r$  511.5): 97.0 per cent to 102.0 per cent (anhydrous substance);
- *calcium* (Ca;  $A_r$  40.08): 7.54 per cent to 8.14 per cent (anhydrous substance).

#### CHARACTERS

**Appearance:** white or light yellow, amorphous or crystalline powder, hygroscopic.

**Solubility:** slightly soluble in water, practically insoluble in acetone and in ethanol (96 per cent).

#### IDENTIFICATION

**First identification:** A, B, D.

**Second identification:** A, C, D.

A. Specific optical rotation (see Tests).

B. Infrared absorption spectrophotometry (2.2.24).

**Preparation:** discs.

**Comparison:** *calcium folinate CRS*.

If the spectra obtained show differences, dissolve the substance to be examined and the reference substance separately in the minimum quantity of *water R* and add dropwise sufficient *acetone R* to produce a precipitate. Allow to stand for 15 min, collect the precipitate by centrifugation, wash the precipitate twice with a minimum quantity of *acetone R* and dry. Record new spectra using the residues.

C. Thin-layer chromatography (2.2.27).

**Test solution.** Dissolve 15 mg of the substance to be examined in a 3 per cent V/V solution of *ammonia R* and dilute to 5 mL with the same solvent.

**Reference solution.** Dissolve 15 mg of *calcium folinate CRS* in a 3 per cent V/V solution of *ammonia R* and dilute to 5 mL with the same solvent.

**Plate:** *cellulose for chromatography F<sub>254</sub> R* as the coating substance.

**Mobile phase:** the lower layer of a mixture of 1 volume of *isoamyl alcohol R* and 10 volumes of a 50 g/L solution of *citric acid R* previously adjusted to pH 8 with *ammonia R*.

**Application:** 5 µL.

**Development:** over a path of 15 cm.

**Drying:** in air.

**Detection:** examine in ultraviolet light at 254 nm.

**Results:** the principal spot in the chromatogram obtained with the test solution is similar in position and size to the principal spot in the chromatogram obtained with the reference solution.

D. It gives reaction (b) of calcium (2.3.1).

Carry out the tests and the assay as rapidly as possible, protected from bright light.

#### TESTS

**Solution S.** Dissolve 0.40 g in *carbon dioxide-free water R*, heating at 40 °C if necessary, and dilute to 50.0 mL with the same solvent.

**Appearance of solution.** Solution S is clear (2.2.1) and its absorbance (2.2.25) at 420 nm has a maximum of 0.25.

**pH (2.2.3):** 7.5 to 8.5 for solution S.

**Specific optical rotation (2.2.7):** – 10 to – 15 (anhydrous substance), measured at 25 °C.

Dissolve 0.200 g in *tris(hydroxymethyl)aminomethane solution R* previously adjusted to pH 8.1 with *sodium hydroxide solution R* or *hydrochloric acid R1* and dilute to 20.0 mL with the same solvent.

**Acetone and ethanol.** Head-space gas chromatography (2.2.28): use the standard additions method.

**Test solution.** Dissolve 0.25 g of the substance to be examined in *water R* and dilute to 10.0 mL with the same solvent.

**Reference solution.** Dissolve 0.125 g of *acetone R* and 0.750 g of *anhydrous ethanol R* in *water R* and dilute to 1000.0 mL with *water R*.

**Column:**

- **material:** fused silica;
  - **size:**  $l = 10$  m,  $\varnothing = 0.32$  mm;
  - **stationary phase:** *styrene-divinylbenzene copolymer R*.
- Carrier gas:** *nitrogen for chromatography R*.
- Flow rate:** 4 mL/min.

**Static head-space conditions which may be used:**

- **equilibration temperature:** 80 °C;
- **equilibration time:** 20 min;
- **pressurisation time:** 30 s.

## Temperature:

	Time (min)	Temperature (°C)
Column	0 - 14	80 → 220
Injection port		110
Detector		270

Detection: flame ionisation.

Injection: at least 3 times.

## Limits:

- acetone: maximum 0.5 per cent,
- ethanol: maximum 3.0 per cent.

**Related substances.** Liquid chromatography (2.2.29).

**Test solution.** Dissolve 10.0 mg of the substance to be examined in water R and dilute to 10.0 mL with the same solvent.

**Reference solution (a).** Dissolve 10.0 mg of calcium folinate CRS in water R and dilute to 10.0 mL with the same solvent.

**Reference solution (b).** Dilute 1.0 mL of reference solution (a) to 100.0 mL with water R.

**Reference solution (c).** Dissolve 10.0 mg of formylfolic acid CRS in the mobile phase and dilute to 100.0 mL with the mobile phase. Dilute 1.0 mL of this solution to 10.0 mL with water R.

**Reference solution (d).** Dilute 1.0 mL of reference solution (b) to 20.0 mL with water R.

**Reference solution (e).** Dilute 5.0 mL of reference solution (c) to 10.0 mL with reference solution (b).

## Column:

- size:  $l = 0.25$  m,  $\varnothing = 4$  mm;
- stationary phase: octadecylsilyl silica gel for chromatography R (5  $\mu$ m);
- temperature: 40 °C.

**Mobile phase:** mix 220 mL of methanol R and 780 mL of a solution containing 2.0 mL of tetrabutylammonium hydroxide solution (400 g/L) R and 2.2 g of disodium hydrogen phosphate R previously adjusted to pH 7.8 with phosphoric acid R. If necessary adjust the concentration of methanol R to achieve the prescribed resolution.

Flow rate: 1 mL/min.

Detection: spectrophotometer at 280 nm.

Injection: 10  $\mu$ L.

Run time: 2.5 times the retention time of the principal peak in the chromatogram obtained with the test solution.

System suitability: reference solution (e):

- resolution: minimum of 2.2 between the peaks due to folinate and to impurity D.

## Limits:

- impurity D: not more than 0.8 times the area of the principal peak in the chromatogram obtained with reference solution (c) (0.8 per cent);
- any other impurity: not more than 0.8 times the area of the principal peak in the chromatogram obtained with reference solution (b) (0.8 per cent);
- sum of other impurities: not more than twice the area of the principal peak in the chromatogram obtained with reference solution (b) (2.0 per cent);
- disregard limit: area of the principal peak in the chromatogram obtained with reference solution (d) (0.05 per cent).

**Impurity H.** Liquid chromatography (2.2.29): use the normalisation procedure.

**Test solution.** Dissolve 50.0 mg of the substance to be examined in water R and dilute to 100.0 mL with the same solvent.

**Reference solution (a).** Dissolve 10.0 mg of calcium folinate CRS in water R and dilute to 20.0 mL with the same solvent.

**Reference solution (b).** Dilute 1.0 mL of reference solution (a) to 100.0 mL with water R.

## Column:

- size:  $l = 0.15$  m,  $\varnothing = 4$  mm;
- stationary phase: human albumin coated silica gel for chromatography R (5  $\mu$ m);
- temperature: 40 °C.

**Mobile phase:** dissolve 9.72 g of sodium dihydrogen phosphate R in 890 mL of water R and adjust to pH 5.0 with sodium hydroxide solution R; add 100 mL of 2-propanol R and 10 mL of acetonitrile R.

Flow rate: 1 mL/min.

Detection: spectrophotometer at 286 nm.

Injection: 10  $\mu$ L.

Retention times: levofolate = about 9 min; impurity H = about 19 min.

## System suitability:

- resolution: minimum of 5.0 between the peaks due to levofolate and to impurity H in the chromatogram obtained with reference solution (a). The sum of the areas of the 2 peaks is 100 per cent. The peak area of impurity H is 48 per cent to 52 per cent. In the chromatogram obtained with reference solution (b) 2 clearly visible peaks are obtained.

## Limit:

- impurity H: maximum 0.5 per cent.

**Chlorides:** maximum 0.5 per cent.

Dissolve 0.300 g in 50 mL of water R heating at 40 °C if necessary. Add 10 mL of 2 M nitric acid and titrate with 0.005 M silver nitrate determining the end-point potentiometrically (2.2.20).

1 mL of 0.005 M silver nitrate is equivalent to 0.177 mg of Cl.

**Platinum:** maximum 10 ppm.

Atomic absorption spectrometry (2.2.23, Method II).

**Test solution.** Dissolve 1.0 g in water R and dilute to 100.0 mL with the same solvent.

**Reference solutions.** Prepare the reference solutions using platinum standard solution (30 ppm Pt) R, diluted as necessary with a mixture of 1 volume of nitric acid R and 99 volumes of water R.

Source: platinum hollow-cathode lamp.

Wavelength: 265.9 nm.

**Heavy metals (2.4.8):** maximum 50 ppm.

1.0 g complies with test F. Prepare the reference solution using 5 mL of lead standard solution (10 ppm Pb) R.

**Water (2.5.12):** 10.0 per cent to 17.0 per cent, determined on 0.200 g (ground to a very fine powder). Stir the substance to be examined in the titration solvent for about 15 min before titrating and use iodousulfurous reagent R as titrant.

**Bacterial endotoxins (2.6.14):** less than 0.5 IU/mg, if intended for use in the manufacture of parenteral preparations without a further appropriate procedure for the removal of bacterial endotoxins.

## ASSAY

**Calcium.** Dissolve 0.400 g in 150 mL of water R and dilute to 300 mL with the same solvent. Carry out the complexometric titration of calcium (2.5.11).

1 mL of 0.1 M sodium edetate is equivalent to 4.008 mg of Ca.

**Calcium folinate.** Liquid chromatography (2.2.29) as described in the test for related substances.

Calculate the percentage content of  $C_{20}H_{21}CaN_7O_7$  from the areas of the peaks in the chromatograms obtained with the test



solution and reference solution (a) and the declared content of *calcium folinate CRS*.

#### STORAGE

In an airtight container, protected from light. If the substance is sterile, store in a sterile, airtight, tamper-proof container.

#### IMPURITIES

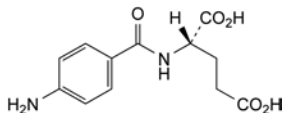

A. (2S)-2-[(4-aminobenzoyl)amino]pentanedioic acid,

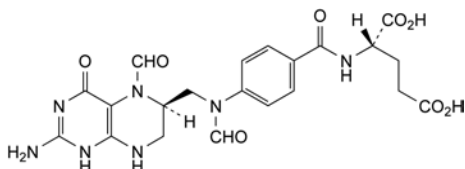

B. (2S)-2-[[4-[[[(6R)-2-amino-5-formyl-4-oxo-1,4,5,6,7,8-hexahydropteridin-6-yl]methyl]formylamino]benzoyl]amino]pentanedioic acid (5,10-diformyltetrahydrofolic acid),

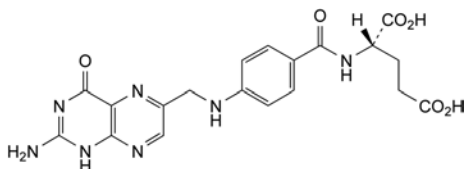

C. (2S)-2-[[4-[[[(2-amino-4-oxo-1,4-dihydropteridin-6-yl)methyl]amino]benzoyl]amino]pentanedioic acid (folic acid),

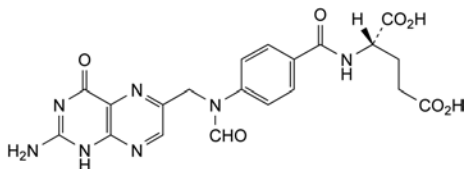

D. (2S)-2-[[4-[[[(2-amino-4-oxo-1,4-dihydropteridin-6-yl)methyl]formylamino]benzoyl]amino]pentanedioic acid (10-formylfolic acid),

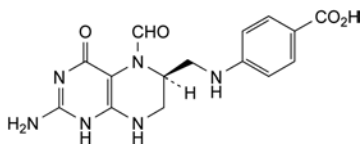

E. 4-[[[(6S)-2-amino-5-formyl-4-oxo-1,4,5,6,7,8-hexahydropteridin-6-yl]methyl]amino]benzoic acid (5-formyltetrahydroptericoic acid),

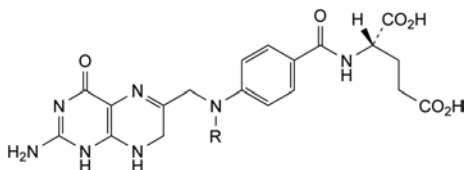

F. R = CHO: (2S)-2-[[4-[[[(2-amino-4-oxo-1,4,7,8-tetrahydropteridin-6-yl)methyl]formylamino]benzoyl]amino]pentanedioic acid (10-formyldihydrofolic acid),

G. R = H: (2S)-2-[[4-[[[(2-amino-4-oxo-1,4,7,8-tetrahydropteridin-6-yl)methyl]amino]benzoyl]amino]pentanedioic acid (dihydrofolic acid),

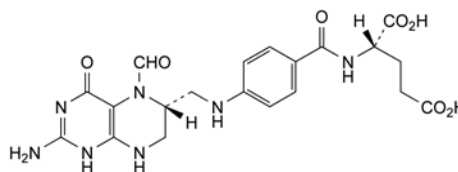

H. (2S)-2-[[4-[[[(6R)-2-amino-5-formyl-4-oxo-1,4,5,6,7,8-hexahydropteridin-6-yl]methyl]amino]benzoyl]amino]pentanedioic acid.

01/2008:1296  
corrected 6.0

## CALCIUM LEVULINATE DIHYDRATE

### Calcii laevulinas dihydricus

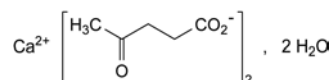

$C_{10}H_{14}CaO_6 \cdot 2H_2O$   
[5743-49-7]

$M_r$  306.3

#### DEFINITION

Calcium di(4-oxopentanoate) dihydrate.

*Content*: 98.0 per cent to 101.0 per cent (dried substance).

#### CHARACTERS

*Appearance*: white or almost white, crystalline powder.

*Solubility*: freely soluble in water, very slightly soluble in ethanol (96 per cent), practically insoluble in methylene chloride.

#### IDENTIFICATION

*First identification*: A, D, E.

*Second identification*: B, C, D, E.

A. Infrared absorption spectrophotometry (2.2.24).

*Comparison*: calcium levulinate dihydrate CRS.

B. Thin-layer chromatography (2.2.27).

*Test solution*. Dissolve 60 mg of the substance to be examined in *water R* and dilute to 1 mL with the same solvent.

*Reference solution*. Dissolve 60 mg of *calcium levulinate dihydrate CRS* in *water R* and dilute to 1 mL with the same solvent.

*Plate*: TLC silica gel plate R.

*Mobile phase*: concentrated ammonia R, ethyl acetate R, water R, ethanol (96 per cent) R (10:10:30:50 V/V/V/V).

*Application*: 10 µL.

*Development*: over a path of 10 cm.

*Drying*: at 100-105 °C for 20 min and allow to cool.

*Detection*: spray with a 30 g/L solution of *potassium permanganate R*. Dry in a current of warm air for about 5 min or until the spots become yellow. Examine in daylight.

*Results*: the principal spot in the chromatogram obtained with the test solution is similar in position, colour and size to the principal spot in the chromatogram obtained with the reference solution.

C. To 1 mL of solution S (see Tests), add 20 mL of a 2.5 g/L solution of *dinitrophenylhydrazine R* in *dilute hydrochloric acid R*. Allow to stand for 15 min. Filter, wash the precipitate with *water R*. Dry the precipitate in an oven at 100-105 °C. The melting point (2.2.14) is 203 °C to 210 °C.

D. It gives reaction (b) of calcium (2.3.1).

E. Loss on drying (see Tests).

## TESTS

**Solution S.** Dissolve 10.0 g in *carbon dioxide-free water R* prepared from *distilled water R* and dilute to 100.0 mL with the same solvent.

**Appearance of solution.** Solution S is clear (2.2.1) and not more intensely coloured than reference solution Y<sub>6</sub> (2.2.2, Method II).

**pH (2.2.3):** 6.8 to 7.8 for solution S.

**Oxidisable substances.** To 1 mL of solution S, add 10 mL of *water R*, 1 mL of *dilute sulfuric acid R* and 0.25 mL of a 3.0 g/L solution of *potassium permanganate R*. Mix. After 5 min, the violet colour of the mixture is still visible.

**Sucrose and reducing sugars.** To 5 mL of solution S add 2 mL of *hydrochloric acid R1* and dilute to 10 mL with *water R*. Heat to boiling for 5 min and allow to cool. Add 10 mL of *sodium carbonate solution R*. Allow to stand for 5 min, dilute to 25 mL with *water R* and filter. To 5 mL of the filtrate add 2 mL of *cupri-tartaric solution R* and heat to boiling for 1 min. No red precipitate is formed.

**Chlorides (2.4.4):** maximum 50 ppm.

Dilute 10 mL of solution S to 15 mL with *water R*.

**Sulfates (2.4.13):** maximum 200 ppm.

Dilute 7.5 mL of solution S to 15 mL with *distilled water R*.

**Magnesium and alkali metals:** maximum 1.0 per cent.

To 10 mL of solution S, add 80 mL of *water R*, 10 mL of *ammonium chloride solution R* and 1 mL of *ammonia R*. Heat to boiling. To the boiling solution, add dropwise 50 mL of warm *ammonium oxalate solution R*. Allow to stand for 4 h, then dilute to 200 mL with *water R* and filter. To 100 mL of the filtrate, add 0.5 mL of *sulfuric acid R*. Evaporate to dryness on a water-bath and ignite to constant mass at 600 ± 50 °C. The residue weighs a maximum of 5.0 mg.

**Heavy metals (2.4.8):** maximum 10 ppm.

12 mL of solution S complies with test A. Prepare the reference solution using *lead standard solution (1 ppm Pb) R*.

**Loss on drying (2.2.32):** 11.0 per cent to 12.5 per cent, determined on 0.200 g by drying at 105 °C.

**Pyrogens (2.6.8).** If intended for use in the manufacture of parenteral preparations without a further appropriate procedure for the removal of pyrogens, it complies with the test for pyrogens. Inject per kilogram of the rabbit's mass 4 mL of a solution containing per millilitre 50 mg of the substance to be examined.

## ASSAY

Dissolve 0.240 g in 50 mL of *water R*. Carry out the complexometric titration of calcium (2.5.11).

1 mL of 0.1 M *sodium edetate* is equivalent to 27.03 mg of C<sub>10</sub>H<sub>14</sub>CaO<sub>6</sub>.

## STORAGE

Protected from light.

## DEFINITION

Calcium pantothenate contains not less than 98.0 per cent and not more than the equivalent of 101.0 per cent of calcium bis[3-[(2R)-2,4-dihydroxy-3,3-dimethylbutanoyl]amino]propanoate], calculated with reference to the dried substance.

## CHARACTERS

A white or almost white powder, slightly hygroscopic, freely soluble in water, slightly soluble in alcohol.

## IDENTIFICATION

A. Specific optical rotation (see Tests).

B. Examine the chromatograms obtained in the test for 3-aminopropionic acid. The principal spot in the chromatogram obtained with test solution (b) is similar in position, colour and size to the principal spot in the chromatogram obtained with reference solution (a).

C. To 1 mL of solution S (see Tests) add 1 mL of *dilute sodium hydroxide solution R* and 0.1 mL of *copper sulfate solution R*. A blue colour develops.

D. It gives reaction (a) of calcium (2.3.1).

## TESTS

**Solution S.** Dissolve 2.50 g in *carbon dioxide-free water R* and dilute to 50.0 mL with the same solvent.

**Appearance of solution.** Solution S is clear (2.2.1) and colourless (2.2.2, Method II).

**pH (2.2.3).** The pH of solution S is 6.8 to 8.0.

**Specific optical rotation (2.2.7):** +25.5 to +27.5, determined on solution S and calculated with reference to the dried substance.

**3-Aminopropionic acid.** Examine by thin-layer chromatography (2.2.27), using *silica gel G R* as the coating substance.

**Test solution (a).** Dissolve 0.2 g of the substance to be examined in *water R* and dilute to 5 mL with the same solvent.

**Test solution (b).** Dilute 1 mL of test solution (a) to 10 mL with *water R*.

**Reference solution (a).** Dissolve 20 mg of *calcium pantothenate CRS* in *water R* and dilute to 5 mL with the same solvent.

**Reference solution (b).** Dissolve 10 mg of *3-aminopropionic acid R* in *water R* and dilute to 50 mL with the same solvent.

Apply separately to the plate 5 µL of each solution. Develop over a path of 12 cm using a mixture of 35 volumes of *water R* and 65 volumes of *ethanol R*. Dry the plate in a current of air and spray with *ninhydrin solution R1*. Heat at 110 °C for 10 min. Any spot corresponding to 3-aminopropionic acid in the chromatogram obtained with test solution (a) is not more intense than the spot in the chromatogram obtained with reference solution (b) (0.5 per cent).

**Chlorides (2.4.4).** 5 mL of solution S diluted to 15 mL with *water R* complies with the limit test for chlorides (200 ppm).

**Heavy metals (2.4.8).** 12 mL of solution S complies with limit test A for heavy metals (20 ppm). Prepare the standard using *lead standard solution (1 ppm Pb) R*.

**Loss on drying (2.2.32).** Not more than 3.0 per cent, determined on 1.000 g by drying in an oven at 105 °C.

## ASSAY

Dissolve 0.180 g in 50 mL of *anhydrous acetic acid R*. Titrate with 0.1 M *perchloric acid* determining the end-point potentiometrically (2.2.20).

1 mL of 0.1 M *perchloric acid* is equivalent to 23.83 mg of C<sub>18</sub>H<sub>32</sub>CaN<sub>2</sub>O<sub>10</sub>.

## STORAGE

Store in an airtight container.

01/2008:0470  
corrected 6.0

## CALCIUM PANTOTHENATE

## Calcii pantothenas

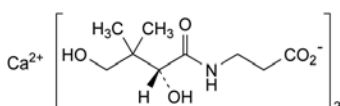

C<sub>18</sub>H<sub>32</sub>CaN<sub>2</sub>O<sub>10</sub>  
[137-08-6]

M<sub>r</sub> 476.5

04/2009:1052 ASSAY

**CALCIUM PHOSPHATE****Tricalcii phosphas****DEFINITION**

Mixture of calcium phosphates.

*Content*: 35.0 per cent to 40.0 per cent of Ca ( $A_r$  40.08).

**CHARACTERS**

*Appearance*: white or almost white powder.

*Solubility*: practically insoluble in water. It dissolves in dilute hydrochloric acid and in dilute nitric acid.

**IDENTIFICATION**

- A. Dissolve 0.1 g in 5 mL of a 25 per cent V/V solution of *nitric acid R*. The solution gives reaction (b) of phosphates (2.3.1).  
 B. It gives reaction (b) of calcium (2.3.1). Filter before adding *potassium ferrocyanide solution R*.  
 C. It complies with the limits of the assay.

**TESTS**

**Solution S**. Dissolve 2.50 g in 20 mL of *dilute hydrochloric acid R*. If the solution is not clear, filter it. Add *dilute ammonia R1* dropwise until a precipitate is formed. Dissolve the precipitate by adding *dilute hydrochloric acid R* and dilute to 50 mL with *distilled water R*.

**Chlorides** (2.4.4): maximum 0.15 per cent.

Dissolve 0.22 g in a mixture of 1 mL of *nitric acid R* and 10 mL of *water R* and dilute to 100 mL with *water R*.

**Fluorides**: maximum 75 ppm.

Potentiometry (2.2.36, *Method II*).

*Test solution*. Dissolve 0.250 g in 0.1 M *hydrochloric acid*, add 5.0 mL of *fluoride standard solution (1 ppm F) R* and dilute to 50.0 mL with 0.1 M *hydrochloric acid*. To 20.0 mL of this solution add 20.0 mL of *total-ionic-strength-adjustment buffer R* and 3 mL of an 82 g/L solution of *anhydrous sodium acetate R*. Adjust to pH 5.2 with *ammonia R* and dilute to 50.0 mL with *distilled water R*.

*Reference solution*. *Fluoride standard solution (10 ppm F) R*.

*Indicator electrode*: fluoride-selective.

*Reference electrode*: silver-silver chloride.

Carry out the measurements on the test solution, then add at least 3 quantities, each of 0.5 mL, of the reference solution, carrying out a measurement after each addition. Calculate the concentration of fluorides using the calibration curve, taking into account the addition of fluoride to the test solution.

**Sulfates** (2.4.13): maximum 0.5 per cent.

Dilute 1 mL of solution S to 25 mL with *distilled water R*.

**Arsenic** (2.4.2, *Method A*): maximum 4 ppm, determined on 5 mL of solution S.

**Iron** (2.4.9): maximum 400 ppm.

Dilute 0.5 mL of solution S to 10 mL with *water R*.

**Heavy metals** (2.4.8): maximum 30 ppm.

Dilute 13 mL of solution S to 20 mL with *water R*. 12 mL of the solution complies with test A. Prepare the reference solution using *lead standard solution (1 ppm Pb) R*.

**Acid-insoluble matter**: maximum 0.2 per cent.

Dissolve 5.0 g in a mixture of 10 mL of *hydrochloric acid R* and 30 mL of *water R*. Filter, wash the residue with *water R* and dry to constant mass at 100-105 °C. The residue weighs a maximum of 10 mg.

**Loss on ignition**: maximum 8.0 per cent, determined on 1.000 g by ignition at 800 ± 50 °C for 30 min.

Dissolve 0.200 g in a mixture of 1 mL of *hydrochloric acid R1* and 5 mL of *water R*. Add 25.0 mL of 0.1 M *sodium edetate* and dilute to 200 mL with *water R*. Adjust to about pH 10 with *concentrated ammonia R*. Add 10 mL of *ammonium chloride buffer solution pH 10.0 R* and a few milligrams of *mordant black 11 triturate R*. Titrate the excess sodium edetate with 0.1 M *zinc sulfate* until the colour changes from blue to violet. 1 mL of 0.1 M *sodium edetate* is equivalent to 4.008 mg of Ca.

**FUNCTIONALITY-RELATED CHARACTERISTICS**

*This section provides information on characteristics that are recognised as being relevant control parameters for one or more functions of the substance when used as an excipient (see chapter 5.15). This section is a non-mandatory part of the monograph and it is not necessary to verify the characteristics to demonstrate compliance. Control of these characteristics can however contribute to the quality of a medicinal product by improving the consistency of the manufacturing process and the performance of the medicinal product during use. Where control methods are cited, they are recognised as being suitable for the purpose, but other methods can also be used. Wherever results for a particular characteristic are reported, the control method must be indicated.*

*The following characteristics may be relevant for calcium phosphate is used as a filler in tablets and capsules.*

**Particle-size distribution** (2.9.31 or 2.9.38).

**Bulk and tapped density** (2.9.34).

**Powder flow** (2.9.36).

07/2010:0882  
corrected 7.0**CALCIUM STEARATE****Calcii stearas**

[1592-23-0]

**DEFINITION**

Mixture of calcium salts of different fatty acids consisting mainly of stearic (octadecanoic) acid [(C<sub>17</sub>H<sub>35</sub>COO)<sub>2</sub>Ca;  $M_r$  607] and palmitic (hexadecanoic) acid [(C<sub>15</sub>H<sub>31</sub>COO)<sub>2</sub>Ca;  $M_r$  550.9] with minor proportions of other fatty acids.

**Content**:

- *calcium*: 6.4 per cent to 7.4 per cent ( $A_r$  40.08) (dried substance);
- *stearic acid in the fatty acid fraction*: minimum 40.0 per cent;
- *sum of stearic acid and palmitic acid in the fatty acid fraction*: minimum 90.0 per cent.

**CHARACTERS**

*Appearance*: fine, white or almost white, crystalline powder.

*Solubility*: practically insoluble in water and in ethanol (96 per cent).

**IDENTIFICATION**

*First identification*: C, D.

*Second identification*: A, B, D.

- A. Freezing point (2.2.18): minimum 53 °C, for the residue obtained in the preparation of solution S (see Tests).  
 B. Acid value (2.5.1): 195 to 210.  
 Dissolve 0.200 g of the residue obtained in the preparation of solution S in 25 mL of the prescribed mixture of solvents.  
 C. Examine the chromatograms obtained in the test for fatty acid composition.

**Results:** the retention times of the principal peaks in the chromatogram obtained with the test solution are approximately the same as those of the principal peaks in the chromatogram obtained with the reference solution.

- D. Neutralise 5 mL of solution S to red litmus paper R using strong sodium hydroxide solution R. The solution gives reaction (b) of calcium (2.3.1).

#### TESTS

**Solution S.** To 5.0 g add 50 mL of peroxide-free ether R, 20 mL of dilute nitric acid R and 20 mL of distilled water R. Boil under a reflux condenser until dissolution is complete. Allow to cool. In a separating funnel, separate the aqueous layer and shake the ether layer with 2 quantities, each of 5 mL, of distilled water R. Combine the aqueous layers, wash with 15 mL of peroxide-free ether R and dilute the aqueous layer to 50 mL with distilled water R (solution S). Evaporate the ether layer to dryness and dry the residue at 100-105 °C. Keep the residue for identification tests A and B.

**Acidity or alkalinity.** To 1.0 g add 20 mL of carbon dioxide-free water R and boil for 1 min with continuous shaking. Cool and filter. To 10 mL of the filtrate add 0.05 mL of bromothymol blue solution RI. Not more than 0.5 mL of 0.01 M hydrochloric acid or 0.01 M sodium hydroxide is required to change the colour of the indicator.

**Chlorides (2.4.4):** maximum 0.1 per cent.

Dilute 0.5 mL of solution S to 15 mL with water R.

**Sulfates (2.4.13):** maximum 0.3 per cent.

Dilute 0.5 mL of solution S to 15 mL with distilled water R.

**Cadmium:** maximum 3 ppm.

Atomic absorption spectrometry (2.2.23, Method II).

**Test solution.** Place 50.0 mg in a polytetrafluoroethylene digestion bomb and add 0.5 mL of a mixture of 1 volume of hydrochloric acid R and 5 volumes of cadmium- and lead-free nitric acid R. Allow to digest at 170 °C for 5 h. Allow to cool. Dissolve the residue in water R and dilute to 5.0 mL with the same solvent.

**Reference solutions.** Prepare the reference solutions using cadmium standard solution (10 ppm Cd) R, diluted if necessary with a 1 per cent V/V solution of hydrochloric acid R.

**Source:** cadmium hollow-cathode lamp.

**Wavelength:** 228.8 nm.

**Atomisation device:** graphite furnace.

**Lead:** maximum 10 ppm.

Atomic absorption spectrometry (2.2.23, Method II).

**Test solution.** Use the solution described in the test for cadmium.

**Reference solutions.** Prepare the reference solutions using lead standard solution (10 ppm Pb) R, diluted if necessary with water R.

**Source:** lead hollow-cathode lamp.

**Wavelength:** 283.3 nm; 217.0 nm may be used depending on the apparatus.

**Atomisation device:** graphite furnace.

**Nickel:** maximum 5 ppm.

Atomic absorption spectrometry (2.2.23, Method II).

**Test solution.** Use the solution described in the test for cadmium.

**Reference solutions.** Prepare the reference solutions using nickel standard solution (10 ppm Ni) R, diluted if necessary with water R.

**Source:** nickel hollow-cathode lamp.

**Wavelength:** 232.0 nm.

**Atomisation device:** graphite furnace.

**Loss on drying (2.2.32):** maximum 6.0 per cent, determined on 1.000 g by drying in an oven at 105 °C.

#### Microbial contamination

TAMC: acceptance criterion 10<sup>3</sup> CFU/g (2.6.12).

TYMC: acceptance criterion 10<sup>2</sup> CFU/g (2.6.12).

Absence of *Escherichia coli* (2.6.13).

Absence of *Salmonella* (2.6.13).

#### ASSAY

**Calcium.** To 0.500 g in a 250 mL conical flask add 50 mL of a mixture of equal volumes of anhydrous ethanol R and butanol R, 5 mL of concentrated ammonia R, 3 mL of ammonium chloride buffer solution pH 10.0 R, 30.0 mL of 0.1 M sodium edetate and 15 mg of mordant black 11 triturate R. Heat to 45-50 °C until the solution is clear. Cool and titrate with 0.1 M zinc sulfate until the colour changes from blue to violet. Carry out a blank titration.

1 mL of 0.1 M sodium edetate is equivalent to 4.008 mg of Ca.

**Composition of fatty acids.** Gas chromatography (2.2.28): use the normalisation procedure.

**Test solution.** In a conical flask fitted with a reflux condenser, dissolve 0.10 g of the substance to be examined in 5 mL of boron trifluoride-methanol solution R. Boil under a reflux condenser for 10 min. Add 4 mL of heptane R through the condenser. Boil under a reflux condenser for 10 min. Allow to cool. Add 20 mL of saturated sodium chloride solution R. Shake and allow the layers to separate. Remove about 2 mL of the organic layer and dry over 0.2 g of anhydrous sodium sulfate R. Dilute 1.0 mL of the solution to 10.0 mL with heptane R.

**Reference solution.** Prepare the reference solution in the same manner as the test solution using 50.0 mg of palmitic acid CRS and 50.0 mg of stearic acid CRS instead of calcium stearate.

**Column:**

- material: fused silica;
- size:  $l = 30$  m,  $\varnothing = 0.32$  mm;
- stationary phase: macrogol 20 000 R (film thickness 0.5  $\mu$ m).

**Carrier gas:** helium for chromatography R.

**Flow rate:** 2.4 mL/min.

**Temperature:**

	Time (min)	Temperature (°C)
Column	0 - 2	70
	2 - 36	70 → 240
	36 - 41	240
Injection port		220
Detector		260

**Detection:** flame ionisation.

**Injection:** 1  $\mu$ L.

**Relative retention** with reference to methyl stearate: methyl palmitate = about 0.9.

**System suitability:** reference solution:

- resolution: minimum 5.0 between the peaks due to methyl palmitate and methyl stearate.

Calculate the content of palmitic acid and stearic acid. Disregard the peak due to the solvent.

#### FUNCTIONALITY-RELATED CHARACTERISTICS

This section provides information on characteristics that are recognised as being relevant control parameters for one or more functions of the substance when used as an excipient (see chapter 5.15). This section is a non-mandatory part of the monograph and it is not necessary to verify the characteristics to demonstrate compliance. Control of these characteristics can however contribute to the quality of a medicinal product by improving the consistency of the manufacturing process and the performance of the medicinal product during use. Where control methods are cited, they are recognised as being

suitable for the purpose, but other methods can also be used. Wherever results for a particular characteristic are reported, the control method must be indicated.

The following characteristics may be relevant for calcium stearate used as a lubricant in tablets and capsules.

**Particle-size distribution** (2.9.31).

**Specific surface area** (2.9.26, Method I). Determine the specific surface area in the  $P/P_0$  range of 0.05 to 0.15.

Sample outgassing: 2 h at 40 °C.

04/2009:0982

## CALCIUM SULFATE DIHYDRATE

### Calcii sulfas dihydricus

CaSO<sub>4</sub>·2H<sub>2</sub>O  
[10101-41-4]

$M_r$  172.2

#### DEFINITION

Content: 98.0 per cent to 102.0 per cent of CaSO<sub>4</sub>·2H<sub>2</sub>O.

#### CHARACTERS

**Appearance:** white or almost white fine powder.

**Solubility:** very slightly soluble in water, practically insoluble in ethanol (96 per cent).

#### IDENTIFICATION

A. Loss on ignition (see Tests).

B. Solution S (see Tests) gives reaction (a) of sulfates (2.3.1).

C. Solution S gives reaction (a) of calcium (2.3.1).

#### TESTS

**Solution S.** Dissolve 1.0 g in 50 mL of a 10 per cent V/V solution of *hydrochloric acid R* by heating at 50 °C for 5 min. Allow to cool.

**Acidity or alkalinity.** Shake 1.5 g with 15 mL of *carbon dioxide-free water R* for 5 min. Allow to stand for 5 min and filter. To 10 mL of the filtrate add 0.1 mL of *phenolphthalein solution R* and 0.25 mL of 0.01 M *sodium hydroxide*. The solution is red. Add 0.30 mL of 0.01 M *hydrochloric acid*. The solution is colourless. Add 0.2 mL of *methyl red solution R*. The solution is reddish-orange.

**Chlorides** (2.4.4): maximum 300 ppm.

Shake 0.5 g with 15 mL of *water R* for 5 min. Allow to stand for 15 min and filter. Dilute 5 mL of the filtrate to 15 mL with *water R*.

**Arsenic** (2.4.2, Method A): maximum 10 ppm, determined on 5 mL of solution S.

**Iron** (2.4.9): maximum 100 ppm.

To 0.25 g add a mixture of 5 mL of *hydrochloric acid R* and 20 mL of *water R*. Heat to boiling, cool and filter.

**Heavy metals** (2.4.8): maximum 20 ppm.

To 2.5 g add a mixture of 2 mL of *hydrochloric acid R* and 15 mL of *water R*. Heat to boiling. Cool and then add 0.5 mL of *phenolphthalein solution R*. Cautiously add *concentrated ammonia R* until the colour changes to pink. Add 0.5 mL of *glacial acetic acid R* and dilute to 25 mL with *water R*. Filter. 12 mL of the filtrate complies with test A. Prepare the reference solution using *lead standard solution (2 ppm Pb) R*.

**Loss on ignition:** 18.0 per cent to 22.0 per cent, determined on 1.000 g by ignition to constant mass at 800 ± 50 °C.

#### ASSAY

Dissolve 0.150 g in 120 mL of *water R*. Carry out the complexometric titration of calcium (2.5.11).

1 mL of 0.1 M *sodium edetate* is equivalent to 17.22 mg of CaSO<sub>4</sub>·2H<sub>2</sub>O.

#### FUNCTIONALITY-RELATED CHARACTERISTICS

This section provides information on characteristics that are recognised as being relevant control parameters for one or more functions of the substance when used as an excipient (see chapter 5.15). This section is a non-mandatory part of the monograph and it is not necessary to verify the characteristics to demonstrate compliance. Control of these characteristics can however contribute to the quality of a medicinal product by improving the consistency of the manufacturing process and the performance of the medicinal product during use. Where control methods are cited, they are recognised as being suitable for the purpose, but other methods can also be used. Wherever results for a particular characteristic are reported, the control method must be indicated.

The following characteristics may be relevant for calcium sulfate dihydrate used as filler in tablets and capsules.

**Particle-size distribution** (2.9.31 or 2.9.38).

**Bulk and tapped density** (2.9.34).

**Powder flow** (2.9.36).

01/2008:1400  
corrected 7.0

## D-CAMPHOR

### D-Camphora

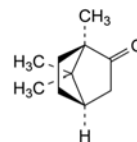

C<sub>10</sub>H<sub>16</sub>O  
[464-49-3]

$M_r$  152.2

#### DEFINITION

(1*R*,4*R*)-1,7,7-Trimethylbicyclo[2.2.1]heptan-2-one.

#### CHARACTERS

**Appearance:** white or almost white, crystalline powder or friable, crystalline masses.

Highly volatile even at room temperature.

**Solubility:** slightly soluble in water, very soluble in alcohol and in light petroleum, freely soluble in fatty oils, very slightly soluble in glycerol.

#### IDENTIFICATION

**First identification:** A, C.

**Second identification:** A, B, D.

A. Specific optical rotation (see Tests).

B. Melting point (2.2.14): 175 °C to 179 °C.

C. Infrared absorption spectrophotometry (2.2.24).

**Comparison:** *racemic camphor CRS*.

D. Dissolve 1.0 g in 30 mL of *methanol R*. Add 1.0 g of *hydroxylamine hydrochloride R* and 1.0 g of *anhydrous sodium acetate R*. Boil under a reflux condenser for 2 h. Allow to cool and add 100 mL of *water R*. Filter, wash the precipitate obtained with 10 mL of *water R* and recrystallise from 10 mL of a mixture of 4 volumes of *alcohol R* and 6 volumes of *water R*. The crystals, dried *in vacuo*, melt (2.2.14) at 118 °C to 121 °C.

#### TESTS

Carry out the weighings and dissolution rapidly.

**Solution S.** Dissolve 2.50 g in 10 mL of *alcohol R* and dilute to 25.0 mL with the same solvent.

**Appearance of solution.** Solution S is clear (2.2.1) and colourless (2.2.2, Method II).

**Acidity or alkalinity.** To 10 mL of solution S add 0.1 mL of *phenolphthalein solution R1*. The solution is colourless. Not more than 0.2 mL of 0.1 M sodium hydroxide is required to change the colour of the indicator.

**Specific optical rotation (2.2.7):** + 40.0 to + 43.0, determined on solution S.

**Related substances.** Gas chromatography (2.2.28).

**Test solution.** Dissolve 2.50 g of the substance to be examined in *heptane R* and dilute to 25.0 mL with the same solvent.

**Reference solution (a).** Dilute 1.0 mL of the test solution to 100.0 mL with *heptane R*.

**Reference solution (b).** Dilute 10.0 mL of reference solution (a) to 20.0 mL with *heptane R*.

**Reference solution (c).** Dissolve 0.50 g of *borneol R* in *heptane R* and dilute to 25.0 mL with the same solvent. Dilute 5.0 mL of the solution to 50.0 mL with *heptane R*.

**Reference solution (d).** Dissolve 50 mg of *linalol R* and 50 mg of *bornyl acetate R* in *heptane R* and dilute to 100.0 mL with the same solvent.

**Column:**

– size:  $l = 30$  m,  $\varnothing = 0.25$  mm,

– stationary phase: *macrogol 20 000 R* (0.25  $\mu$ m).

**Carrier gas:** *helium for chromatography R*.

**Split ratio:** 1:70.

**Flow rate:** 45 cm/s.

**Temperature:**

	Time (min)	Temperature (°C)
Column	0 - 10	50
	10 - 35	50 → 100
	35 - 45	100 → 200
	45 - 55	200
Injection port		220
Detector		250

**Detection:** flame ionisation.

**Injection:** 1  $\mu$ L.

**System suitability:** reference solution (d).

– **resolution:** minimum 3.0 between the peaks due to *bornyl acetate* and to *linalol*.

**Limits:**

– **borneol:** not more than the area of the principal peak in the chromatogram obtained with reference solution (c) (2.0 per cent),

– **any other impurity:** not more than half of the area of the principal peak in the chromatogram obtained with reference solution (a) (0.5 per cent),

– **total of other impurities:** not more than 4 times the area of the principal peak in the chromatogram obtained with reference solution (a) (4.0 per cent),

– **disregard limit:** 0.1 times the area of the principal peak in the chromatogram obtained with reference solution (b) (0.05 per cent).

**Halogens:** maximum 100 ppm.

Dissolve 1.0 g in 10 mL of *2-propanol R* in a distillation flask. Add 1.5 mL of *dilute sodium hydroxide solution R* and 50 mg of *nickel-aluminium alloy R*. Heat on a water-bath until the *2-propanol R* has evaporated. Allow to cool and add 5 mL of *water R*. Mix and filter through a wet filter previously washed with *water R* until free from chlorides. Dilute the filtrate to

10.0 mL with *water R*. To 5.0 mL of the solution, add *nitric acid R* dropwise until the precipitate which forms is redissolved and dilute to 15 mL with *water R*. The solution complies with the limit test for chlorides (2.4.4).

**Residue on evaporation (2.8.9):** maximum 0.05 per cent.

Evaporate 2.0 g on a water-bath and dry in an oven at 100-105 °C for 1 h. The residue weighs a maximum of 1 mg.

**Water.** Dissolve 1 g in 10 mL of *light petroleum R*. The solution is clear (2.2.1).

## IMPURITIES

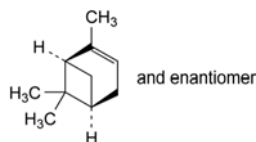

A. 2,6,6-trimethylbicyclo[3.1.1]hept-2-ene ( $\alpha$ -pinene),

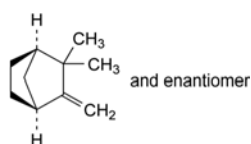

B. 2,2-dimethyl-3-methylenebicyclo[2.2.1]heptane (camphene),

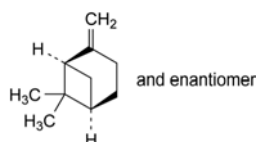

C. 6,6-dimethyl-2-methylenebicyclo[3.1.1]heptane ( $\beta$ -pinene),

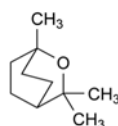

D. 1,3,3-trimethyl-2-oxabicyclo[2.2.2]octane (cineole),

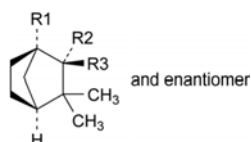

E. R1 = CH<sub>3</sub>, R2 + R3 = O: 1,3,3-trimethylbicyclo[2.2.1]heptan-2-one (fenchone),

F. R1 = CH<sub>3</sub>, R2 = OH, R3 = H: *exo*-1,3,3-trimethylbicyclo[2.2.1]heptan-2-ol (fenchol),

G. R1 = H, R2 = OH, R3 = CH<sub>3</sub>: *exo*-2,3,3-trimethylbicyclo[2.2.1]heptan-2-ol (camphene hydrate),

H. R1 = H, R2 = CH<sub>3</sub>, R3 = OH: *endo*-2,3,3-trimethylbicyclo[2.2.1]heptan-2-ol (methylcamphenilol),

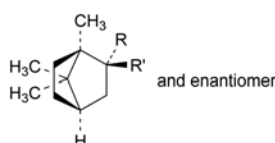

I. R = OH, R' = H: *exo*-1,7,7-trimethylbicyclo[2.2.1]heptan-2-ol (*exo*-borneol),

J. R = H, R' = OH: *endo*-1,7,7-trimethylbicyclo[2.2.1]heptan-2-ol (*endo*-borneol).

01/2008:0655  
corrected 6.0

## CAMPHOR, RACEMIC

Camphora racemica

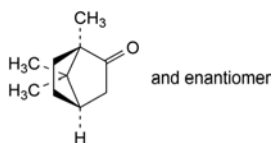
C<sub>10</sub>H<sub>16</sub>O  
[76-22-2]M<sub>r</sub> 152.2

## DEFINITION

(1*RS*,4*RS*)-1,7,7-Trimethylbicyclo[2.2.1]heptan-2-one.

## CHARACTERS

**Appearance:** white or almost white, crystalline powder or friable, crystalline masses, highly volatile even at room temperature.

**Solubility:** slightly soluble in water, very soluble in ethanol (96 per cent) and in light petroleum, freely soluble in fatty oils, very slightly soluble in glycerol.

## IDENTIFICATION

**First identification:** A, C.

**Second identification:** A, B, D.

A. Optical rotation (see Tests).

B. Melting point (2.2.14): 172 °C to 180 °C.

C. Infrared absorption spectrophotometry (2.2.24).

**Preparation:** mulls in liquid paraffin R.

**Comparison:** racemic camphor CRS.

D. Dissolve 1.0 g in 30 mL of methanol R. Add 1.0 g of hydroxylamine hydrochloride R and 1.0 g of anhydrous sodium acetate R. Boil under a reflux condenser for 2 h. Allow to cool and add 100 mL of water R. A precipitate is formed. Filter, wash with 10 mL of water R and recrystallise from 10 mL of a mixture of 4 volumes of ethanol (96 per cent) R and 6 volumes of water R. The crystals, dried in vacuo, melt (2.2.14) at 118 °C to 121 °C.

## TESTS

Carry out the weighings rapidly.

**Solution S.** Dissolve 2.50 g in 10 mL of ethanol (96 per cent) R and dilute to 25.0 mL with the same solvent.

**Appearance of solution.** Solution S is clear (2.2.1) and colourless (2.2.2, Method II).

**Acidity or alkalinity.** Dissolve 1.0 g in 10 mL of ethanol (96 per cent) R and add 0.1 mL of phenolphthalein solution R1. The solution is colourless. Not more than 0.2 mL of 0.1 M sodium hydroxide is required to change the colour of the indicator.

**Optical rotation** (2.2.7): –0.15° to +0.15°, determined on solution S.

**Related substances.** Gas chromatography (2.2.28).

**Test solution.** Dissolve 50 mg of the substance to be examined in hexane R and dilute to 50.0 mL with the same solvent.

**Reference solution (a).** Dissolve 50 mg of the substance to be examined and 50 mg of bornyl acetate R in hexane R and dilute to 50.0 mL with the same solvent.

**Reference solution (b).** Dilute 1.0 mL of the test solution to 200.0 mL with hexane R.

**Column:**

- size:  $l = 2$  m,  $\varnothing = 2$  mm;
- stationary phase: diatomaceous earth for gas chromatography R impregnated with 10 per cent *m/m* of macrogol 20 000 R.

**Carrier gas:** nitrogen for chromatography R.

**Flow rate:** 30 mL/min.

**Temperature:**

– column: 130 °C;

– injection port and detector: 200 °C.

**Detection:** flame ionisation.

**Injection:** 1 µL.

**Run time:** 3 times the retention time of camphor.

**System suitability:**

– **resolution:** minimum 1.5 between the peaks due to camphor and bornyl acetate in the chromatogram obtained with reference solution (a);

– **signal-to-noise ratio:** minimum 5 for the principal peak in the chromatogram obtained with reference solution (b).

**Limits:**

– **any impurity:** for each impurity, not more than 2 per cent of the area of the principal peak;

– **total:** not more than 4 per cent of the area of the principal peak;

– **disregard limit:** the area of the principal peak in the chromatogram obtained with reference solution (b).

**Halogens:** maximum 100 ppm.

Dissolve 1.0 g in 10 mL of 2-propanol R in a distillation flask. Add 1.5 mL of dilute sodium hydroxide solution R and 50 mg of nickel-aluminium alloy R. Heat on a water-bath until the 2-propanol R has evaporated. Allow to cool and add 5 mL of water R. Mix and filter through a wet filter previously washed with water R until free from chlorides. Dilute the filtrate to 10.0 mL with water R. To 5.0 mL of this solution, add nitric acid R dropwise until the precipitate which forms is redissolved and dilute to 15 mL with water R. The solution complies with the limit test for chlorides (2.4.4).

**Water.** Dissolve 1 g in 10 mL of light petroleum R. The solution is clear (2.2.1).

**Residue on evaporation:** maximum 0.05 per cent.

Evaporate 2.0 g on a water-bath and dry at 100-105 °C for 1 h. The residue weighs not more than 1 mg.

01/2008:1401

## CAPRYLIC ACID

Acidum caprylicum

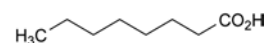
C<sub>8</sub>H<sub>16</sub>O<sub>2</sub>  
[124-07-2]M<sub>r</sub> 144.2

## DEFINITION

Octanoic acid.

**Content:** 99.0 per cent to 100.5 per cent (anhydrous substance).

## CHARACTERS

**Appearance:** clear, colourless or slightly yellowish, oily liquid.

**Solubility:** very slightly soluble in water, very soluble in acetone and in ethanol (96 per cent). It dissolves in dilute solutions of alkali hydroxides.

## IDENTIFICATION

A. Relative density (see Tests).

B. Examine the chromatograms obtained in the test for related substances.

**Results:** the principal peak in the chromatogram obtained with the test solution is similar in retention time and size to the principal peak in the chromatogram obtained with reference solution (a).

## TESTS

**Appearance.** The substance to be examined is clear (2.2.1) and not more intensely coloured than reference solution Y<sub>5</sub> (2.2.2, Method II).

**Relative density** (2.2.5): 0.909 to 0.912.

**Related substances.** Gas chromatography (2.2.28): use the normalisation procedure.

**Test solution.** Dissolve 0.10 g of the substance to be examined in ethyl acetate R and dilute to 10.0 mL with the same solvent.

**Reference solution (a).** Dissolve 0.10 g of caprylic acid CRS in ethyl acetate R and dilute to 10.0 mL with the same solvent.

**Reference solution (b).** Dilute 1.0 mL of the test solution to 100.0 mL with ethyl acetate R. Dilute 5.0 mL of this solution to 50.0 mL with ethyl acetate R.

**Column:**

- material: fused silica;
- size:  $l = 30$  m,  $\varnothing = 0.25$  mm;
- stationary phase: macrogol 20 000 2-nitroterephthalate R (film thickness 0.25  $\mu$ m).

**Carrier gas:** helium for chromatography R.

**Flow rate:** 1.5 mL/min.

**Split ratio:** 1:100.

**Temperature:**

	Time (min)	Temperature (°C)
Column	0 - 1	100
	1 - 25	100 → 220
	25 - 35	220
Injection port		250
Detector		250

**Detection:** flame ionisation.

**Injection:** 1  $\mu$ L.

**System suitability:** reference solution (b):

- signal-to-noise ratio: minimum 5 for the principal peak.

**Limits:**

- any impurity: for each impurity, maximum 0.3 per cent;
- total: maximum 0.5 per cent;
- disregard limit: 0.5 times the area of the principal peak in the chromatogram obtained with reference solution (b) (0.05 per cent).

**Heavy metals** (2.4.8): maximum 10 ppm.

Dissolve 2.0 g in ethanol (96 per cent) R and dilute to 20 mL with the same solvent. 12 mL of the solution complies with test B. Prepare the reference solution using 1 mL of lead standard solution (10 ppm Pb) R and 9 mL of ethanol (96 per cent) R.

**Water** (2.5.12): maximum 0.7 per cent, determined on 1.000 g.

**Sulfated ash** (2.4.14): maximum 0.1 per cent, determined on 1.0 g.

## ASSAY

Dissolve 0.125 g in 25 mL of ethanol (96 per cent) R. Titrate with 0.1 M sodium hydroxide, determining the end-point potentiometrically (2.2.20).

1 mL of 0.1 M sodium hydroxide is equivalent to 14.42 mg of C<sub>8</sub>H<sub>16</sub>O<sub>2</sub>.

## IMPURITIES

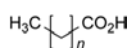

- A.  $n = 4$ : hexanoic acid,
- B.  $n = 5$ : heptanoic acid,

C.  $n = 7$ : nonanoic acid,

D.  $n = 8$ : decanoic acid,

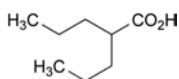

E. 2-propylpentanoic acid (valproic acid),

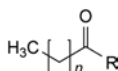

F. R = OCH<sub>3</sub>,  $n = 6$ : methyl octanoate,

G. R = OC<sub>2</sub>H<sub>5</sub>,  $n = 6$ : ethyl octanoate,

H. R = OCH<sub>3</sub>,  $n = 8$ : methyl decanoate,

I. R = CH<sub>3</sub>,  $n = 8$ : undecan-2-one,

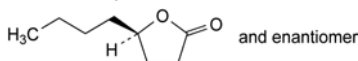

J. 5-butyltetrahydrofuran-2-one ( $\gamma$ -hydroxyoctanoic acid lactone).

01/2008:1184  
corrected 6.0

## CAPRYLOCAPROYL MACROGOLGLYCERIDES

### Macrogolglyceridorum caprylocaprates

## DEFINITION

Mixtures of monoesters, diesters and triesters of glycerol and monoesters and diesters of macrogols with a mean relative molecular mass between 200 and 400.

They are obtained by partial alcoholysis of medium-chain triglycerides using macrogol or by esterification of glycerol and macrogol with caprylic (octanoic) acid and capric (decanoic) acid or a mixture of glycerol esters and condensates of ethylene oxide with caprylic acid and capric acid. They may contain free macrogols.

## CHARACTERS

**Appearance:** pale-yellow, oily liquid.

**Solubility:** dispersible in hot water, freely soluble in methylene chloride.

**Density:** about 1.0 at 20 °C.

**Refractive index:** about 1.4 at 20 °C.

## IDENTIFICATION

A. Thin-layer chromatography (2.2.27).

**Test solution.** Dissolve 1.0 g of the substance to be examined in methylene chloride R and dilute to 20 mL with the same solvent.

**Plate:** TLC silica gel plate R.

**Mobile phase:** hexane R, ether R (30:70 V/V).

**Application:** 50  $\mu$ L.

**Development:** over a path of 15 cm.

**Drying:** in air.

**Detection:** spray with a 0.1 g/L solution of rhodamine B R in ethanol (96 per cent) R and examine in ultraviolet light at 365 nm.

**Results:** the chromatogram shows a spot due to triglycerides with an  $R_F$  value of about 0.9 ( $R_{st}$  1) and spots due to 1,3-diglycerides ( $R_{st}$  0.7), to 1,2-diglycerides ( $R_{st}$  0.6), to monoglycerides ( $R_{st}$  0.1) and to esters of macrogol ( $R_{st}$  0).

B. Hydroxyl value (see Tests).

C. Saponification value (see Tests).

D. Composition of fatty acids (see Tests).



## TESTS

**Viscosity** (2.2.9). Carry out the determination at  $20 \pm 0.5$  °C.

Ethylene oxide units per molecule (nominal value)	Type of macrogol	Viscosity (mPa·s)
4	200	30 to 50
6	300	60 to 80
8	400	80 to 110

**Acid value** (2.5.1): maximum 2.0, determined on 2.0 g.

**Hydroxyl value** (2.5.3, Method A). Use 1.0 g.

Ethylene oxide units per molecule (nominal value)	Type of macrogol	Hydroxyl value
4	200	80 to 120
6	300	140 to 180
8	400	170 to 205

**Peroxide value** (2.5.5, Method A): maximum 6.0, determined on 2.0 g.

**Saponification value** (2.5.6). Use 2.0 g.

Ethylene oxide units per molecule (nominal value)	Type of macrogol	Saponification value
4	200	265 to 285
6	300	170 to 190
8	400	85 to 105

**Alkaline impurities.** Introduce 5.0 g into a test-tube and carefully add a mixture, neutralised if necessary with 0.01 M hydrochloric acid or with 0.01 M sodium hydroxide, of 0.05 mL of a 0.4 g/L solution of bromophenol blue R in ethanol (96 per cent) R, 0.3 mL of water R and 10 mL of ethanol (96 per cent) R. Shake and allow to stand. Not more than 1.0 mL of 0.01 M hydrochloric acid is required to change the colour of the upper layer to yellow.

**Free glycerol:** maximum 5.0 per cent.

Dissolve 1.20 g in 25.0 mL of methylene chloride R. Heat if necessary. After cooling, add 100 mL of water R. Shake and add 25.0 mL of periodic acetic acid solution R. Shake and allow to stand for 30 min. Add 40 mL of a 75 g/L solution of potassium iodide R. Allow to stand for 1 min. Add 1 mL of starch solution R. Titrate the iodine with 0.1 M sodium thiosulfate. Carry out a blank titration.

1 mL of 0.1 M sodium thiosulfate is equivalent to 2.3 mg of glycerol.

**Composition of fatty acids** (2.4.22, Method A).

Composition of the fatty-acid fraction of the substance:

- caproic acid: maximum 2.0 per cent;
- caprylic acid: 50.0 per cent to 80.0 per cent;
- capric acid: 20.0 per cent to 50.0 per cent;
- lauric acid: maximum 3.0 per cent;
- myristic acid: maximum 1.0 per cent.

**Ethylene oxide and dioxan** (2.4.25): maximum 1 ppm of ethylene oxide and maximum 10 ppm of dioxan.

**Heavy metals** (2.4.8): maximum 10 ppm.

2.0 g complies with test C. Prepare the reference solution using 2 mL of lead standard solution (10 ppm Pb) R.

**Water** (2.5.12): maximum 1.0 per cent, determined on 1.0 g. Use a mixture of 30 volumes of anhydrous methanol R and 70 volumes of methylene chloride R as solvent.

**Total ash** (2.4.16): maximum 0.1 per cent.

## LABELLING

The label states the type of macrogol used (mean relative molecular mass) or the number of ethylene oxide units per molecule (nominal value).

01/2011:1079

## CAPTOPRIL

## Captoprilum

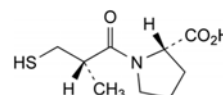

$C_9H_{15}NO_3S$   
[62571-86-2]

$M_r$  217.3

## DEFINITION

(2S)-1-[(2S)-2-Methyl-3-sulfanylpropanoyl]pyrrolidine-2-carboxylic acid.

*Content:* 98.0 per cent to 101.5 per cent (dried substance).

## CHARACTERS

*Appearance:* white or almost white, crystalline powder.

*Solubility:* soluble in water, freely soluble in methanol and in methylene chloride. It dissolves in dilute solutions of alkali hydroxides.

## IDENTIFICATION

A. Specific optical rotation (see Tests).

B. Infrared absorption spectrophotometry (2.2.24).

*Comparison:* captopril CRS.

## TESTS

**Solution S.** Dissolve 0.5 g in carbon dioxide-free water R and dilute to 25 mL with the same solvent.

**Appearance of solution.** Solution S is clear (2.2.1) and colourless (2.2.2, Method II).

**pH** (2.2.3): 2.0 to 2.6 for solution S.

**Specific optical rotation** (2.2.7):  $-127$  to  $-132$  (dried substance).

Dissolve 0.250 g in anhydrous ethanol R and dilute to 25.0 mL with the same solvent.

**Impurity F.** Gas chromatography (2.2.28).

*Reagent solution.* Add 2.8 mL of acetyl chloride R dropwise to 17.2 mL of anhydrous methanol R at 0 °C and mix. Allow to stand for 20 min at room temperature before use.

*Test solution.* Introduce 20.0 mg of the substance to be examined into a vial and add 1.0 mL of the reagent solution. Mix and heat at 60 °C for 30 min. Evaporate to dryness under a stream of nitrogen R. Dissolve the residue in 0.5 mL of ethyl acetate R, add 0.5 mL of pentafluoropropionic anhydride R, mix and heat at 60 °C for 30 min. Evaporate to dryness under a stream of nitrogen R. Dissolve the residue in 1.0 mL of butyl acetate R.

*Reference solution (a).* Dissolve the contents of a vial of captopril for system suitability CRS (containing impurity F) in 1.0 mL of the reagent solution. Prepare as described for the test solution.

*Reference solution (b).* Mix 0.25 mL of reference solution (a) and 0.75 mL of butyl acetate R.

*Column:*

- material: fused silica;
- size:  $l = 25$  m,  $\varnothing = 0.32$  mm;
- stationary phase: poly(dimethyl)(diphenyl)siloxane R (film thickness 1  $\mu$ m).

*Carrier gas:* helium for chromatography R.

Flow rate: 1.2 mL/min.

Split ratio: 1:20.

Temperature:

	Time (min)	Temperature (°C)
Column	0 - 10	200
	10 - 14	200 → 240
	14 - 34	240
Injection port		270
Detector		300

Detection: flame ionisation.

Injection: 1 µL.

Relative retention with reference to captopril (retention time = about 6 min): impurity F = about 0.96.

System suitability:

- resolution: minimum 1.5 between the peaks due to impurity F and captopril in the chromatogram obtained with reference solution (a);
- signal-to-noise ratio: minimum 10 for the peak due to impurity F in the chromatogram obtained with reference solution (b).

Calculate the percentage content of impurity F using the following expression:

$$\frac{A}{A + B} \times 100$$

- A = area of the peak due to impurity F in the chromatogram obtained with the test solution;
- B = area of the peak due to captopril in the chromatogram obtained with the test solution.

Limit:

- impurity F: maximum 0.2 per cent.

**Related substances.** Liquid chromatography (2.2.29).

**Solvent mixture:** phosphoric acid R, acetonitrile R1, water R (0.8:100:900 V/V/V).

**Test solution.** Dissolve 0.125 g of the substance to be examined in the solvent mixture and dilute to 25.0 mL with the solvent mixture.

**Reference solution (a).** Dissolve 5.0 mg of captopril impurity B CRS, 5.0 mg of captopril impurity C CRS and 5.0 mg of captopril impurity D CRS in the solvent mixture. Add 1.0 mL of the test solution and dilute to 50.0 mL with the solvent mixture. Dilute 1.0 mL of this solution to 20.0 mL with the solvent mixture. Prepare immediately before use.

**Reference solution (b).** Dissolve 5 mg of the substance to be examined and 5 mg of captopril impurity E CRS in acetonitrile R and dilute to 25.0 mL with the same solvent. Dilute 4 mL of the solution to 50.0 mL with the solvent mixture.

**Reference solution (c).** In order to prepare impurity A *in situ*, introduce 1.0 mL of the test solution into a volumetric flask and add 230 µL of 0.05 M iodine. If the solution is not colourless, add 0.1 M sodium thiosulfate dropwise until it becomes colourless, and dilute to 50.0 mL with the solvent mixture. Dilute 5.0 mL of this solution to 20.0 mL with the solvent mixture.

**Reference solution (d).** Dilute 1.0 mL of the test solution to 100.0 mL with the solvent mixture.

**Column:**

- size:  $l = 0.3$  m,  $\emptyset = 3.9$  mm;
- stationary phase: end-capped octadecylsilyl silica gel for chromatography R (10 µm);
- temperature: 50 °C.

**Mobile phase:**

- mobile phase A: phosphoric acid R, water R (0.8:1000 V/V);

- mobile phase B: phosphoric acid R, acetonitrile R1, water R (0.8:500:500 V/V/V);

Time (min)	Mobile phase A (per cent V/V)	Mobile phase B (per cent V/V)
0 - 5	90	10
5 - 20	90 → 50	10 → 50
20 - 45	50	50

Flow rate: 1.5 mL/min.

Detection: spectrophotometer at 210 nm.

Injection: 25 µL.

**Identification of impurities:** use the chromatogram obtained with reference solution (a) to identify the peaks due to impurities B, C and D; use the chromatogram obtained with reference solution (b) to identify the peak due to impurity E; use the chromatogram obtained with reference solution (c) to identify the peak due to impurity A.

Relative retention with reference to captopril (retention time = about 15 min): impurity C = about 0.6; impurity D = about 0.8; impurity E = about 0.9; impurity B = about 1.3; impurity A = about 1.7.

System suitability:

- resolution: minimum 2.0 between the peaks due to impurity E and captopril in the chromatogram obtained with reference solution (b).

Limits:

- impurity A: not more than the area of the principal peak in the chromatogram obtained with reference solution (d) (1.0 per cent);
- impurities B, C, D: for each impurity, not more than 1.5 times the area of the corresponding peak in the chromatogram obtained with reference solution (a) (0.15 per cent);
- impurity E: not more than 1.5 times the area of the peak due to captopril in the chromatogram obtained with reference solution (a) (0.15 per cent);
- unspecified impurities: for each impurity, not more than the area of the peak due to captopril in the chromatogram obtained with reference solution (a) (0.10 per cent);
- total: not more than 1.2 times the area of the principal peak in the chromatogram obtained with reference solution (d) (1.2 per cent);
- disregard limit: 0.5 times the area of the peak due to captopril in the chromatogram obtained with reference solution (a) (0.05 per cent).

**Heavy metals (2.4.8):** maximum 20 ppm.

**Solvent:** water R.

0.50 g complies with test H. Prepare the reference solution using 1 mL of lead standard solution (10 ppm Pb) R.

**Loss on drying (2.2.32):** maximum 1.0 per cent, determined on 1.000 g by drying under high vacuum at 60 °C for 3 h.

**Sulfated ash (2.4.14):** maximum 0.2 per cent, determined on 1.0 g.

**ASSAY**

Dissolve 0.150 g in 30 mL of water R. Titrate with 0.05 M iodine, determining the end-point potentiometrically (2.2.20). Use a combined platinum electrode.

1 mL of 0.05 M iodine is equivalent to 21.73 mg of C<sub>9</sub>H<sub>15</sub>NO<sub>3</sub>S.

**IMPURITIES**

**Specified impurities:** A, B, C, D, E, F.

**Other detectable impurities** (the following substances would, if present at a sufficient level, be detected by one or other of the tests in the monograph. They are limited by the general acceptance criterion for other/unspecified impurities and/or by the general monograph *Substances for pharmaceutical use*

(2034). It is therefore not necessary to identify these impurities for demonstration of compliance. See also 5.10. *Control of impurities in substances for pharmaceutical use*: G, H, I, J, L, M, N, O.

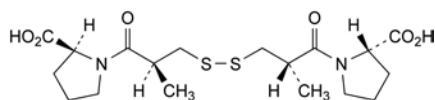

- A. 1,1'-[disulfanediy]bis[(2S)-2-methyl-1-oxopropane-3,1-diyl]bis[(2S)-pyrrolidine-2-carboxylic] acid (captopril disulfide),

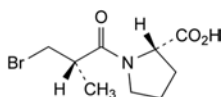

- B. (2S)-1-[(2S)-3-bromo-2-methylpropanoyl]pyrrolidine-2-carboxylic acid,

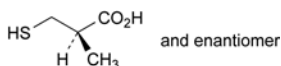

- C. (2RS)-2-methyl-3-sulfanylpropanoic acid,

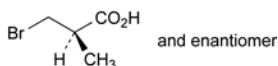

- D. (2RS)-3-bromo-2-methylpropanoic acid,

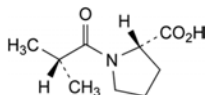

- E. (2S)-1-(2-methylpropanoyl)pyrrolidine-2-carboxylic acid,

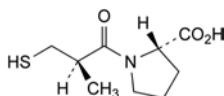

- F. (2S)-1-[(2R)-2-methyl-3-sulfanylpropanoyl]pyrrolidine-2-carboxylic acid (*epi*-captopril),

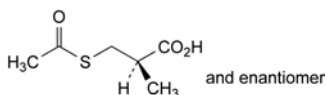

- G. (2RS)-3-(acetylsulfanyl)-2-methylpropanoic acid,

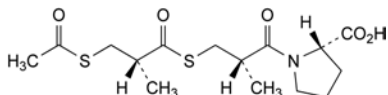

- H. (2S)-1-[(2S)-3-[(2R)-3-(acetylsulfanyl)-2-methylpropanoyl]-sulfanyl]-2-methylpropanoyl]pyrrolidine-2-carboxylic acid,

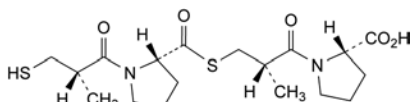

- I. (2S)-1-[(2S)-3-[[[(2S)-1-(2S)-2-methyl-3-sulfanylpropanoyl]pyrrolidin-2-yl]carbonyl]sulfanyl]-2-methylpropanoyl]pyrrolidine-2-carboxylic acid,

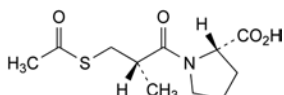

- J. (2S)-1-[(2S)-3-(acetylsulfanyl)-2-methylpropanoyl]pyrrolidine-2-carboxylic acid (acetylcaptopril),

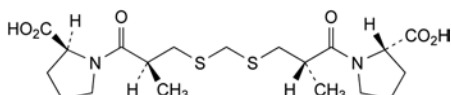

- L. 1,1'-[methylenebis[sulfanediy]l]bis[(2S)-2-methyl-1-oxopropane-3,1-diyl]bis[(2S)-pyrrolidine-2-carboxylic] acid,

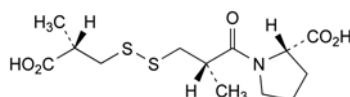

- M. (2S)-1-[(2S)-3-[(2S)-2-carboxypropyl]disulfanyl]-2-methylpropanoyl]pyrrolidine-2-carboxylic acid,

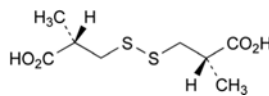

- N. 3,3'-disulfanediy]bis[(2S)-2-methylpropanoic] acid.

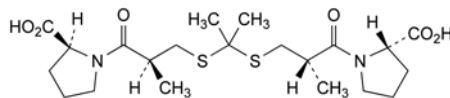

- O. 1,1'-[propane-2,2-diylbis[sulfanediy]l]bis[(2S)-2-methyl-1-oxopropane-3,1-diyl]bis[(2S)-pyrrolidine-2-carboxylic] acid,

01/2008:1971  
corrected 6.0

## CARBACHOL

### Carbacholum

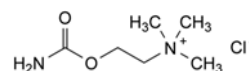

$C_6H_{15}ClN_2O_2$   
[51-83-2]

$M_r$  182.7

#### DEFINITION

2-(Carbamoyloxy)-*N,N,N*-trimethylethanaminium chloride.

*Content*: 99.0 per cent to 101.5 per cent (dried substance).

#### CHARACTERS

*Appearance*: white or almost white, crystalline, hygroscopic powder.

*Solubility*: very soluble in water, sparingly soluble in alcohol, practically insoluble in acetone.

#### IDENTIFICATION

*First identification*: A, C.

*Second identification*: B, C.

A. Infrared absorption spectrophotometry (2.2.24).

*Comparison*: carbachol CRS.

B. Examine the chromatograms obtained in the test for related substances.

*Results*: the principal spot in the chromatogram obtained with test solution (b) is similar in position, colour and size to the principal spot in the chromatogram obtained with reference solution (a).

C. 0.5 mL of solution S (see Tests) gives reaction (a) of chlorides (2.3.1).

#### TESTS

**Solution S.** Dissolve 2.5 g in *carbon dioxide-free water R* and dilute to 25 mL with the same solvent.

**Appearance of solution.** Solution S is clear (2.2.1) and colourless (2.2.2, *Method II*).

**Acidity or alkalinity.** To 2.0 mL of solution S, add 0.05 mL of *methyl red mixed solution R*. Not more than 0.2 mL of 0.01 M *hydrochloric acid* or 0.01 M *sodium hydroxide* is required to change the colour of the indicator.

**Related substances.** Thin-layer chromatography (2.2.27).

*Prepare the solutions immediately before use.*

**Test solution (a).** Dissolve 0.20 g of the substance to be examined in *methanol R* and dilute to 5.0 mL with the same solvent.

**Test solution (b).** Dilute 2.0 mL of test solution (a) to 20.0 mL with *methanol R*.

**Reference solution (a).** Dissolve 20 mg of *carbachol CRS* in *methanol R* and dilute to 5.0 mL with the same solvent.

**Reference solution (b).** Dissolve 8 mg of *choline chloride R* and 8 mg of *acetylcholine chloride CRS* in *methanol R* and dilute to 10.0 mL with the same solvent. Dilute 5.0 mL to 10.0 mL with *methanol R*.

**Plate:** *cellulose for chromatography R* as the coating substance.

**Mobile phase:** *water R, methanol R* (10:90 V/V).

**Application:** 10 µL.

**Development:** over 2/3 of the plate.

**Detection:** spray with *potassium iodobismuthate solution R3*.

**System suitability:** the chromatogram obtained with reference solution (b) shows 2 clearly separated spots.

**Limits:** in the chromatogram obtained with test solution (a):

- **any impurity:** any spot, apart from the principal spot, is not more intense than one or other of the 2 principal spots in the chromatogram obtained with reference solution (b) (1 per cent). Compare the spots with the spot of the most appropriate colour in the chromatogram obtained with reference solution (b).

**Heavy metals (2.4.8):** maximum 20 ppm.

12 mL of solution S complies with limit test A. Prepare the standard using *lead standard solution (2 ppm Pb) R*.

**Loss on drying (2.2.32):** maximum 1.0 per cent, determined on 1.000 g by drying in an oven at 105 °C for 2 h.

**Sulfated ash (2.4.14):** maximum 0.1 per cent, determined on 1.0 g of the residue obtained in the test for loss on drying.

#### ASSAY

Dissolve 0.150 g in a mixture of 10 mL of *anhydrous acetic acid R* and 40 mL of *acetic anhydride R*. Titrate with 0.1 M *perchloric acid*. Determine the end-point potentiometrically (2.2.20).

1 mL of 0.1 M *perchloric acid* is equivalent to 18.27 mg of C<sub>6</sub>H<sub>15</sub>ClN<sub>2</sub>O<sub>2</sub>.

#### STORAGE

In an airtight container, protected from light.

#### IMPURITIES

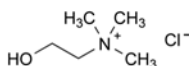

- A. 2-hydroxy-*N,N,N*-trimethylethanaminium chloride (choline chloride).

04/2010:0543

## CARBAMAZEPINE

### Carbamazepinum

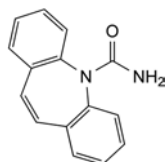

C<sub>15</sub>H<sub>12</sub>N<sub>2</sub>O  
[298-46-4]

*M*<sub>r</sub> 236.3

#### DEFINITION

5*H*-Dibenzo[*b,f*]azepine-5-carboxamide.

**Content:** 98.0 per cent to 102.0 per cent (dried substance).

#### CHARACTERS

**Appearance:** white or almost white, crystalline powder.

**Solubility:** very slightly soluble in water, freely soluble in methylene chloride, sparingly soluble in acetone and in ethanol (96 per cent).

It shows polymorphism (5.9). The acceptable crystalline form corresponds to *carbamazepine CRS*.

#### IDENTIFICATION

A. Melting point (2.2.14): 189 °C to 193 °C.

B. Infrared absorption spectrophotometry (2.2.24).

**Comparison:** *carbamazepine CRS*.

**Preparation:** examine the substances as discs without prior treatment.

#### TESTS

**Acidity or alkalinity.** To 1.0 g add 20 mL of *carbon dioxide-free water R*, shake for 15 min and filter. To 10 mL of the filtrate add 0.05 mL of *phenolphthalein solution R1* and 0.5 mL of 0.01 M *sodium hydroxide*; the solution is red. Add 1.0 mL of 0.01 M *hydrochloric acid*; the solution is colourless. Add 0.15 mL of *methyl red solution R*; the solution is red.

**Related substances.** Liquid chromatography (2.2.29).

**Test solution (a).** Dissolve 60.0 mg of the substance to be examined in *methanol R2* and dilute to 20.0 mL with the same solvent. Sonicate. Dilute 10.0 mL of this solution to 20.0 mL with *water R*.

**Test solution (b).** Dilute 10.0 mL of test solution (a) to 50.0 mL with a mixture of equal volumes of *methanol R2* and *water R*.

**Reference solution (a).** Dissolve 7.5 mg of *carbamazepine CRS*, 7.5 mg of *carbamazepine impurity A CRS* and 7.5 mg of *iminodibenzyl R* (impurity E) in *methanol R2* and dilute to 100.0 mL with the same solvent. Dilute 1.0 mL of this solution to 50.0 mL with a mixture of equal volumes of *methanol R2* and *water R*.

**Reference solution (b).** Dissolve 60.0 mg of *carbamazepine CRS* in *methanol R2* and dilute to 20.0 mL with the same solvent. Sonicate. Dilute 5.0 mL of this solution to 50.0 mL with a mixture of equal volumes of *methanol R2* and *water R*.

**Column:**

- **size:** *l* = 0.25 m, Ø = 4.6 mm;
- **stationary phase:** *nitrile silica gel for chromatography R1* (10 µm).

**Mobile phase:** *tetrahydrofuran R, methanol R2, water R* (3:12:85 V/V/V); to 1000 mL of this solution add 0.2 mL of *anhydrous formic acid R* and 0.5 mL of *triethylamine R*.

**Flow rate:** 2.0 mL/min.

**Detection:** spectrophotometer at 230 nm.

**Injection:** 20 µL of test solution (a) and reference solution (a).

**Run time:** 8 times the retention time of carbamazepine.

**Relative retention** with reference to carbamazepine (retention time = about 10 min): impurity A = about 0.9; impurity E = about 3.5.

**System suitability:**

- **resolution:** minimum 1.7 between the peaks due to impurity A and carbamazepine in the chromatogram obtained with reference solution (a).

**Limits:**

- **impurities A, E:** for each impurity, not more than 1.5 times the area of the corresponding peak in the chromatogram obtained with reference solution (a) (0.15 per cent);
- **unspecified impurities:** not more than the area of the peak due to carbamazepine in the chromatogram obtained with reference solution (a) (0.10 per cent);
- **total:** not more than 5 times the area of the peak due to carbamazepine in the chromatogram obtained with reference solution (a) (0.5 per cent);
- **disregard limit:** 0.5 times the area of the peak due to carbamazepine in the chromatogram obtained with reference solution (a) (0.05 per cent).

**Chlorides** (2.4.4): maximum 140 ppm.

Suspend 0.715 g in 20 mL of *water R* and boil for 10 min. Cool and dilute to 20 mL with *water R*. Filter through a membrane filter (nominal pore size 0.8 µm). Dilute 10 mL of the filtrate to 15 mL with *water R*. This solution complies with the limit test for chlorides.

**Heavy metals** (2.4.8): maximum 20 ppm.

1.0 g complies with test C. Prepare the reference solution using 2 mL of *lead standard solution (10 ppm Pb) R*.

**Loss on drying** (2.2.32): maximum 0.5 per cent, determined on 1.000 g by drying in an oven at 105 °C for 2 h.

**Sulfated ash** (2.4.14): maximum 0.1 per cent, determined on 1.0 g.

#### ASSAY

Liquid chromatography (2.2.29) as described in the test for related substances with the following modifications.

*Injection*: test solution (b) and reference solution (b).

*System suitability*:

– *repeatability*: reference solution (b).

Calculate the percentage content of C<sub>15</sub>H<sub>12</sub>N<sub>2</sub>O from the declared content of *carbamazepine CRS*.

#### STORAGE

In an airtight container.

#### IMPURITIES

*Specified impurities*: A, E.

*Other detectable impurities* (the following substances would, if present at a sufficient level, be detected by one or other of the tests in the monograph. They are limited by the general acceptance criterion for other/unspecified impurities and/or by the general monograph *Substances for pharmaceutical use (2034)*. It is therefore not necessary to identify these impurities for demonstration of compliance. See also 5.10. *Control of impurities in substances for pharmaceutical use*): B, C, D, F, G.

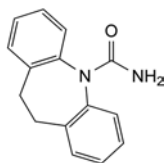

A. 10,11-dihydro-5H-dibenzo[*b,f*]azepine-5-carboxamide (10,11-dihydrocarbamazepine),

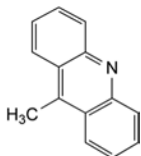

B. 9-methylacridine,

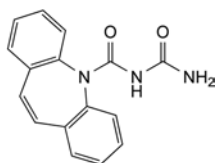

C. (5H-dibenzo[*b,f*]azepin-5-ylcarbonyl)urea (*N*-carbamoyl-carbamazepine),

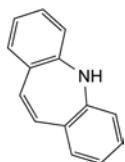

D. 5H-dibenzo[*b,f*]azepine (iminostilbene),

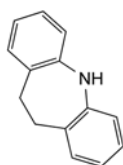

E. 10,11-dihydro-5H-dibenzo[*b,f*]azepine (iminodibenzyl),

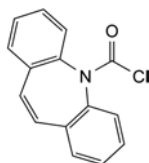

F. 5H-dibenzo[*b,f*]azepine-5-carbonyl chloride (5-chlorocarbonyliminostilbene),

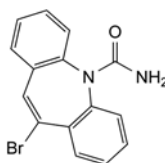

G. 10-bromo-5H-dibenzo[*b,f*]azepine-5-carboxamide (10-bromocarbamazepine).

04/2010:1185  
corrected 7.0

## CARBASALATE CALCIUM

### Carbasalatum calcicum

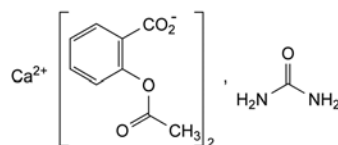

C<sub>19</sub>H<sub>18</sub>CaN<sub>2</sub>O<sub>9</sub>  
[5749-67-7]

*M<sub>r</sub>* 458.4

#### DEFINITION

Equimolecular compound of calcium di[2-(acetoxy)benzoate] and urea.

*Content*: 99.0 per cent to 101.0 per cent (anhydrous substance).

#### CHARACTERS

*Appearance*: white or almost white, crystalline powder.

*Solubility*: freely soluble in water and in dimethylformamide, practically insoluble in acetone and in anhydrous methanol.

*Protect the substance from moisture during handling.*

*Examination in aqueous solutions has to be performed immediately after preparation.*

#### IDENTIFICATION

*First identification*: B, E.

*Second identification*: A, C, D, E.

A. Ultraviolet and visible absorption spectrophotometry (2.2.25).

*Test solution*. Dissolve 0.250 g in *water R* and dilute to 100.0 mL with the same solvent. To 1.0 mL of the solution add 75 mL of *water R* and 5 mL of *dilute hydrochloric acid R*, mix and dilute to 100.0 mL with *water R*. Examine immediately.

*Spectral range*: 220-350 nm.

*Absorption maxima*: at 228 nm and 276 nm.

*Specific absorbance at the absorption maxima*:

- at 228 nm: 363 to 379,
- at 276 nm: 49 to 53.

## B. Infrared absorption spectrophotometry (2.2.24).

*Comparison: Ph. Eur. reference spectrum of carbasalate calcium.*

C. Dissolve 0.1 g in 10 mL of *water R*, boil for 2 min and cool. The solution gives reaction (a) of salicylates (2.3.1).D. Heat 0.2 g with 0.2 g of *sodium hydroxide R*; a yellow or yellowish-brown colour is produced and the vapour turns *red litmus paper R* blue.

## E. It gives reaction (a) of calcium (2.3.1).

## TESTS

**Appearance of solution.** The solution is not more opalescent than reference suspension II (2.2.1) and is colourless (2.2.2, *Method II*).

Dissolve 2.5 g in 50 mL of *water R*.

**Related substances.** Liquid chromatography (2.2.29). Prepare the solutions immediately before use.

*Solvent mixture: phosphoric acid R, methanol R, acetonitrile for chromatography R* (0.5:8:92 V/V/V).

*Test solution.* Dissolve 0.100 g of the substance to be examined in 5 mL of the solvent mixture, sonicate for 15 min and dilute to 10.0 mL with the solvent mixture. Filter the solution through a membrane filter (nominal pore size 0.45 µm).

*Reference solution (a).* Dissolve 10.0 mg of *salicylic acid CRS* (impurity C) in the solvent mixture and dilute to 100.0 mL with the solvent mixture.

*Reference solution (b).* Dilute 1.0 mL of reference solution (a) to 10.0 mL with the solvent mixture.

*Reference solution (c).* Dissolve 2 mg of *carbasalate impurity B CRS* in 20.0 mL of the solvent mixture.

*Reference solution (d).* Dilute 1.0 mL of the test solution to 10.0 mL with the solvent mixture. Mix 1.0 mL of this solution with 5.0 mL of reference solution (a), add 1.0 mL of reference solution (c) and dilute to 10.0 mL with the solvent mixture.

*Column:*

- *size:*  $l = 0.25$  m,  $\varnothing = 4.0$  mm;
- *stationary phase:* spherical *end-capped octadecylsilyl silica gel for chromatography R* (5 µm);
- *temperature:* 40 °C.

*Mobile phase: phosphoric acid R, acetonitrile for chromatography R, water R* (0.5:40:60 V/V/V).

*Flow rate:* 1.8 mL/min.

*Detection:* spectrophotometer at 240 nm.

*Injection:* 10 µL of the test solution and reference solutions (b) and (d).

*Run time:* 8 times the retention time of acetylsalicylic acid.

*Identification of impurities:* use the chromatogram obtained with reference solution (d) to identify the peaks due to impurities B and C.

*Relative retention* with reference to acetylsalicylic acid (retention time = about 2 min): impurity C = about 1.3; impurity B = about 2.5.

*System suitability:* reference solution (d):

- *resolution:* minimum 5.0 between the peaks due to acetylsalicylic acid and impurity C.

*Limits:*

- *impurity C:* not more than 5 times the area of the corresponding peak in the chromatogram obtained with reference solution (b) (0.5 per cent);
- *impurity B:* not more than 1.5 times the area of the principal peak in the chromatogram obtained with reference solution (b) (0.15 per cent);
- *unspecified impurities:* for each impurity, not more than 0.5 times the area of the principal peak in the chromatogram obtained with reference solution (b) (0.05 per cent);

– *total:* not more than 7 times the area of the principal peak in the chromatogram obtained with reference solution (b) (0.7 per cent);

– *disregard limit:* 0.3 times the area of the principal peak in the chromatogram obtained with reference solution (b) (0.03 per cent).

**Sodium:** maximum 0.1 per cent.

Atomic emission spectrometry (2.2.22, *Method I*).

*Test solution.* Dissolve 1.0 g in 500.0 mL of *water R*.

**Heavy metals** (2.4.8): maximum 10 ppm.

Dissolve 2.0 g in 8 mL of *water R* with heating, cool and add 12 mL of *acetone R*. 12 mL of the solution complies with test B. Prepare the reference solution using 10 mL of *lead standard solution (1 ppm Pb) R*.

**Water** (2.5.12): maximum 0.1 per cent, determined on 1.000 g. Use a mixture of 15 mL of *anhydrous methanol R* and 15 mL of *dimethylformamide R* as the solvent.

## ASSAY

In a flask with a ground-glass stopper, dissolve 0.400 g in 25 mL of *water R*. Add 25.0 mL of 0.1 M *sodium hydroxide*. Close the flask and allow to stand for 2 h. Titrate with 0.1 M *hydrochloric acid*, using 0.2 mL of *phenolphthalein solution R*. Carry out a blank titration.

1 mL of 0.1 M *sodium hydroxide* is equivalent to 22.92 mg of  $C_{19}H_{18}CaN_2O_9$ .

## STORAGE

In an airtight container.

## IMPURITIES

*Specified impurities: B, C.*

*Other detectable impurities* (the following substances would, if present at a sufficient level, be detected by one or other of the tests in the monograph. They are limited by the general acceptance criterion for other/unspecified impurities and/or by the general monograph *Substances for pharmaceutical use* (2034). It is therefore not necessary to identify these impurities for demonstration of compliance. See also 5.10. *Control of impurities in substances for pharmaceutical use*): A, D.

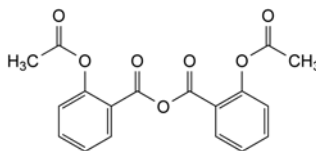

A. 2-(acetyloxy)benzoic anhydride,

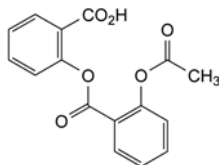

B. 2-[[2-(acetyloxy)benzoyl]oxy]benzoic acid (acetylsalicylsalicylic acid),

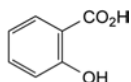

C. 2-hydroxybenzenecarboxylic acid (salicylic acid),

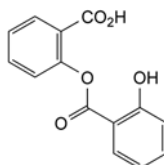

D. 2-[(2-hydroxybenzoyl)oxy]benzoic acid (salicylsalicylic acid).

01/2008:0755  
corrected 6.0

## CARBIDOPA

## Carbidopum

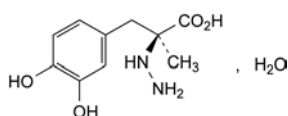
C<sub>10</sub>H<sub>14</sub>N<sub>2</sub>O<sub>4</sub>·H<sub>2</sub>O  
[38821-49-7]M<sub>r</sub> 244.2

## DEFINITION

(2S)-3-(3,4-Dihydroxyphenyl)-2-hydrazino-2-methylpropanoic acid monohydrate.

Content: 98.5 per cent to 101.0 per cent (dried substance).

## CHARACTERS

Appearance: white or yellowish-white powder.

Solubility: slightly soluble in water, very slightly soluble in ethanol (96 per cent), practically insoluble in methylene chloride. It dissolves in dilute solutions of mineral acids.

## IDENTIFICATION

First identification: A, C.

Second identification: A, B, D, E.

A. Specific optical rotation (see Tests).

B. Ultraviolet and visible absorption spectrophotometry (2.2.25).

*Test solution.* Dissolve 50.0 mg in a 8.5 g/L solution of hydrochloric acid R in methanol R and dilute to 100.0 mL with the same solution. Dilute 10.0 mL of this solution to 100.0 mL with a 8.5 g/L solution of hydrochloric acid R in methanol R.

Spectral range: 230-350 nm.

Absorption maximum: at 283 nm.

Specific absorbance at the absorption maximum: 135 to 150 (dried substance).

C. Infrared absorption spectrophotometry (2.2.24).

Preparation: discs.

Comparison: carbidopa CRS.

D. Shake vigorously about 5 mg with 10 mL of water R for 1 min and add 0.3 mL of ferric chloride solution R2. An intense green colour is produced, which quickly turns to reddish-brown.

E. Suspend about 20 mg in 5 mL of water R and add 5 mL of cupri-tartaric solution R. On heating, the colour of the solution changes to dark brown and a red precipitate is formed.

## TESTS

**Appearance of solution.** The solution is clear (2.2.1) and not more intensely coloured than reference solution BY<sub>6</sub> or B<sub>6</sub> (2.2.2, Method II).

Dissolve 0.25 g in 25 mL of 1 M hydrochloric acid.

**Specific optical rotation** (2.2.7): -22.5 to -26.5 (dried substance).

With the aid of an ultrasonic bath, dissolve completely 0.250 g in aluminium chloride solution R and dilute to 25.0 mL with the same solution.

**Hydrazine.** Thin-layer chromatography (2.2.27).

*Test solution (a).* Dissolve 0.50 g in dilute hydrochloric acid R and dilute to 2.0 mL with the same acid.

*Test solution (b).* Place 25 g of strongly basic anion exchange resin R into each of 2 conical flasks with ground-glass stoppers. To each, add 150 mL of carbon dioxide-free water R and shake

from time to time during 30 min. Decant the liquid from both flasks and repeat the process with further quantities, each of 150 mL, of carbon dioxide-free water R.

Take two 100 mL measuring cylinders 3.5-4.5 cm in internal diameter and label these A and B. Into cylinder A, transfer as completely as possible the resin from 1 conical flask using 60 mL of carbon dioxide-free water R; into cylinder B, transfer the 2<sup>nd</sup> quantity of resin, this time using 20 mL of carbon dioxide-free water R.

Into each cylinder, insert a gas-inlet tube, the end of which has an internal diameter of 2-3 mm and which reaches almost to the bottom of the cylinder. Pass a rapid stream of nitrogen for chromatography R through each mixture so that homogeneous suspensions are formed. After 30 min, without interrupting the gas flow, add 1.0 mL of test solution (a) to cylinder A; after 1 min stop the gas flow into cylinder A and transfer the contents, through a moistened filter paper, into cylinder B. After 1 min, stop the gas flow to cylinder B and pour the solution immediately through a moistened filter paper into a freshly prepared mixture of 1 mL of a 200 g/L solution of salicylaldehyde R in methanol R and 20 mL of phosphate buffer solution pH 5.5 R in a conical flask; shake thoroughly for 1 min and heat in a water-bath at 60 °C for 15 min. The liquid becomes clear. Allow to cool, add 2.0 mL of toluene R and shake vigorously for 2 min. Transfer the mixture into a centrifuge tube and centrifuge.

Separate the toluene layer in a 100 mL separating funnel and shake vigorously with 2 quantities, each of 20 mL, of a 200 g/L solution of sodium metabisulfite R and finally with 2 quantities, each of 50 mL, of water R. Separate the toluene layer.

*Reference solution (a).* Dissolve 10 mg of hydrazine sulfate R in dilute hydrochloric acid R and dilute to 50 mL with the same acid. Dilute 1.0 mL of this solution to 10.0 mL with dilute hydrochloric acid R.

*Reference solution (b).* Prepare the solution at the same time and in the same manner as described for test solution (b) using 1.0 mL of reference solution (a) instead of 1.0 mL of test solution (a).

Plate: TLC silanised silica gel plate R.

Mobile phase: water R, methanol R (10:20 V/V).

Application: 10 µL of test solution (b) and reference solution (b).

Development: over a path of 10 cm.

Drying: in air.

Detection: examine in ultraviolet light at 365 nm.

Limit:

– hydrazine: any spot showing a yellow fluorescence is not more intense than the corresponding spot in the chromatogram obtained with reference solution (b) (20 ppm).

**Methyldopa and methylcarbidopa.** Liquid chromatography (2.2.29).

*Test solution.* Dissolve 0.100 g of the substance to be examined in 0.1 M hydrochloric acid and dilute to 10.0 mL with the same acid.

*Reference solution (a).* Dissolve the contents of a vial of methylcarbidopa CRS in 0.1 M hydrochloric acid, add 1 mg of methyldopa CRS and dilute to 20.0 mL with the same acid.

*Reference solution (b).* Dissolve 5 mg of carbidopa CRS and 5 mg of methyldopa CRS in 0.1 M hydrochloric acid and dilute to 10.0 mL with the same acid.

Column:

– size: l = 0.25 m, Ø = 4.6 mm;

– stationary phase: octylsilyl silica gel for chromatography R (5 µm).

Mobile phase: methanol R, 14 g/L solution of potassium dihydrogen phosphate R (2:98 V/V).

Flow rate: 1 mL/min.

Detection: spectrophotometer at 282 nm.

Injection: 20 µL.

*System suitability*: reference solution (b):

- *resolution*: minimum 4.0 between the peaks due to methylidopa and carbidopa.

*Limits*:

- *methylidopa and methylcarbidopa*: for each impurity, not more than the area of the corresponding peak in the chromatogram obtained with reference solution (a) (0.5 per cent).

**Heavy metals** (2.4.8): maximum 20 ppm.

1.0 g complies with test C. Prepare the reference solution using 2 mL of *lead standard solution* (10 ppm Pb) R.

**Loss on drying** (2.2.32): 6.9 per cent to 7.9 per cent, determined on 1.000 g by drying in an oven at 105 °C.

**Sulfated ash** (2.4.14): maximum 0.1 per cent, determined on 1.0 g.

#### ASSAY

Dissolve 0.150 g with gentle heating in 75 mL of *anhydrous acetic acid* R. Titrate with 0.1 M *perchloric acid*, determining the end-point potentiometrically (2.2.20).

1 mL of 0.1 M *perchloric acid* is equivalent to 22.62 mg of C<sub>10</sub>H<sub>14</sub>N<sub>2</sub>O<sub>4</sub>.

#### STORAGE

Protected from light.

*Drying*: in air for 30 min.

*Detection*: examine in ultraviolet light at 254 nm.

*Results*: the principal spot in the chromatogram obtained with the test solution is similar in position and size to the principal spot in the chromatogram obtained with the reference solution.

- D. Dissolve about 10 mg in a mixture of 50 mL of *water* R and 0.05 mL of *dilute hydrochloric acid* R. Add 1 mL of *potassium iodobismuthate solution* R. A red precipitate is formed.

#### TESTS

**Impurity A and other related substances.** Liquid chromatography (2.2.29).

*Test solution.* Dissolve 5.0 mg of the substance to be examined in 10.0 mL of a mixture of 20 volumes of *acetonitrile* R and 80 volumes of *water* R. Use this solution within 5 min of preparation.

*Reference solution (a).* Dissolve 5 mg of *thiamazole* R and 0.10 g of *carbimazole* CRS in a mixture of 20 volumes of *acetonitrile* R and 80 volumes of *water* R and dilute to 100.0 mL with the same mixture of solvents. Dilute 1.0 mL of this solution to 10.0 mL with a mixture of 20 volumes of *acetonitrile* R and 80 volumes of *water* R.

*Reference solution (b).* Dissolve 5.0 mg of *thiamazole* R in a mixture of 20 volumes of *acetonitrile* R and 80 volumes of *water* R and dilute to 10.0 mL with the same mixture of solvents. Dilute 1.0 mL of this solution to 100.0 mL with a mixture of 20 volumes of *acetonitrile* R and 80 volumes of *water* R.

*Column*:

- *size*:  $l = 0.15$  m,  $\varnothing = 3.9$  mm,
- *stationary phase*: *octadecylsilyl silica gel for chromatography* R (5 µm).

*Mobile phase*: *acetonitrile* R, *water* R (10:90 V/V).

*Flow rate*: 1 mL/min.

*Detection*: spectrophotometer at 254 nm.

*Injection*: 10 µL.

*Run time*: 1.5 times the retention time of carbimazole.

*Retention time*: carbimazole = about 6 min.

*System suitability*: reference solution (a):

- *resolution*: minimum 5.0 between the peaks due to impurity A and carbimazole.

*Limits*:

- *impurity A*: not more than half the area of the principal peak in the chromatogram obtained with reference solution (b) (0.5 per cent),
- *any other impurity*: not more than 0.1 times the area of the principal peak in the chromatogram obtained with reference solution (b) (0.1 per cent).

**Loss on drying** (2.2.32): maximum 0.5 per cent, determined on 1.000 g by drying in a desiccator over *diphosphorus pentoxide* R at a pressure not exceeding 0.7 kPa for 24 h.

**Sulfated ash** (2.4.14): maximum 0.1 per cent, determined on 1.0 g.

#### ASSAY

Dissolve 50.0 mg in *water* R and dilute to 500.0 mL with the same solvent. To 10.0 mL add 10 mL of *dilute hydrochloric acid* R and dilute to 100.0 mL with *water* R. Measure the absorbance (2.2.25) at the maximum at 291 nm. Calculate the content of C<sub>7</sub>H<sub>10</sub>N<sub>2</sub>O<sub>2</sub>S taking the specific absorbance to be 557.

#### IMPURITIES

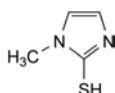

- A. 1-methyl-1H-imidazole-2-thiol (thiamazole).

01/2008:0884

## CARBIMAZOLE

### Carbimazolium

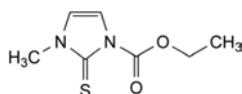

C<sub>7</sub>H<sub>10</sub>N<sub>2</sub>O<sub>2</sub>S  
[22232-54-8]

$M_r$  186.2

#### DEFINITION

Ethyl 3-methyl-2-thioxo-2,3-dihydro-1H-imidazole-1-carboxylate.

*Content*: 98.0 per cent to 102.0 per cent (dried substance).

#### CHARACTERS

*Appearance*: white or yellowish-white, crystalline powder.

*Solubility*: slightly soluble in water, soluble in acetone and in alcohol.

#### IDENTIFICATION

*First identification*: B.

*Second identification*: A, C, D.

A. Melting point (2.2.14): 122 °C to 125 °C.

B. Infrared absorption spectrophotometry (2.2.24).

*Preparation*: discs.

*Comparison*: *carbimazole* CRS.

C. Thin-layer chromatography (2.2.27).

*Test solution.* Dissolve 10 mg of the substance to be examined in *methylene chloride* R and dilute to 10 mL with the same solvent.

*Reference solution.* Dissolve 10 mg of *carbimazole* CRS in *methylene chloride* R and dilute to 10 mL with the same solvent.

*Plate*: TLC silica gel GF<sub>254</sub> plate R.

*Mobile phase*: *acetone* R, *methylene chloride* R (20:80 V/V).

*Application*: 10 µL.

*Development*: over a path of 15 cm.



01/2008:0885  
corrected 6.0

## CARBOCISTEINE

## Carbocisteinum

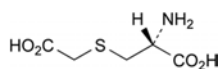
C<sub>5</sub>H<sub>9</sub>NO<sub>4</sub>S  
[638-23-3]M<sub>r</sub> 179.2

## DEFINITION

Carbocisteine contains not less than 98.5 per cent and not more than the equivalent of 101.0 per cent of (2*R*)-2-amino-3-[(carboxymethyl)sulfanyl]propanoic acid, calculated with reference to the dried substance.

## CHARACTERS

A white or almost white, crystalline powder, practically insoluble in water and in alcohol. It dissolves in dilute mineral acids and in dilute solutions of alkali hydroxides.

## IDENTIFICATION

First identification: A, B.

Second identification: A, C, D.

- A. Specific optical rotation (see Tests).
- B. Examine by infrared absorption spectrophotometry (2.2.24), comparing with the spectrum obtained with *carbocisteine CRS*. Examine the substances prepared as discs.
- C. Examine the chromatograms obtained in the test for ninhydrin-positive substances. The principal spot in the chromatogram obtained with test solution (b) is similar in position, colour and size to the principal spot in the chromatogram obtained with reference solution (a).
- D. Dissolve 0.1 g in 4.5 mL of *dilute sodium hydroxide solution R*. Heat on a water-bath for 10 min. Cool and add 1 mL of a 25 g/L solution of *sodium nitroprusside R*. A dark red colour is produced, which changes to brown and then to yellow within a few minutes.

## TESTS

**Solution S.** Disperse 5.00 g in 20 mL of *water R* and add dropwise with shaking 2.5 mL of *strong sodium hydroxide solution R*. Adjust to pH 6.3 with *1 M sodium hydroxide* and dilute to 50.0 mL with *water R*.

**Appearance of solution.** Solution S is clear (2.2.1) and colourless (2.2.2, *Method II*).

**pH (2.2.3).** Shake 0.2 g with 20 mL of *carbon dioxide-free water R*. The pH of the suspension is 2.8 to 3.0.

**Specific optical rotation (2.2.7):** –32.5 to –35.5, determined on solution S and calculated with reference to the dried substance.

**Ninhydrin-positive substances.** Examine by thin-layer chromatography (2.2.27), using a suitable silica gel as the coating substance.

**Test solution (a).** Dissolve 0.10 g of the substance to be examined in *dilute ammonia R2* and dilute to 10 mL with the same solvent.

**Test solution (b).** Dilute 1 mL of test solution (a) to 50 mL with *water R*.

**Reference solution (a).** Dissolve 10 mg of *carbocisteine CRS* in *dilute ammonia R2* and dilute to 50 mL with the same solvent.

**Reference solution (b).** Dilute 5 mL of test solution (b) to 20 mL with *water R*.

**Reference solution (c).** Dissolve 10 mg of *carbocisteine CRS* and 10 mg of *arginine hydrochloride CRS* in 5 mL of *dilute ammonia R2* and dilute to 25 mL with *water R*.

Apply separately to the plate 5 µL of each solution. Allow the plate to dry in air. Develop over a path of 15 cm using a mixture of 20 volumes of *glacial acetic acid R*, 20 volumes of *water R* and 60 volumes of *butanol R*. Dry the plate in a current of warm air. Spray with *ninhydrin solution R* and heat at 100 °C to 105 °C for 15 min. Any spot in the chromatogram obtained with test solution (a), apart from the principal spot, is not more intense than the spot in the chromatogram obtained with reference solution (b) (0.5 per cent). The test is not valid unless the chromatogram obtained with reference solution (c) shows two clearly separated principal spots.

**Chlorides (2.4.4).** Dissolve 33 mg in 5 mL of *dilute nitric acid R* and dilute to 15 mL with *water R*. The solution, without further addition of nitric acid, complies with the limit test for chlorides (0.15 per cent).

**Sulfates (2.4.13).** Dissolve 0.5 g in 5 mL of *dilute hydrochloric acid R* and dilute to 15 mL with *distilled water R*. The solution complies with the limit test for sulfates (300 ppm).

**Heavy metals (2.4.8).** 2.0 g complies with limit test D for heavy metals (10 ppm). Prepare the standard using 2 mL of *lead standard solution (10 ppm Pb) R*.

**Loss on drying (2.2.32).** Not more than 0.5 per cent, determined on 1.000 g by drying in an oven at 105 °C for 2 h.

**Sulfated ash (2.4.14).** Not more than 0.3 per cent, determined on 1.0 g.

## ASSAY

Dissolve 0.150 g in 10 mL of *anhydrous formic acid R* with slight heating and shake until dissolution is complete. Add 50 mL of *anhydrous acetic acid R*. Titrate with *0.1 M perchloric acid*, determining the end-point potentiometrically (2.2.20). 1 mL of *0.1 M perchloric acid* is equivalent to 17.92 mg of C<sub>5</sub>H<sub>9</sub>NO<sub>4</sub>S.

## STORAGE

Store protected from light.

04/2009:1299

## CARBOMERS

## Carbomera

## DEFINITION

High-molecular-mass polymers of acrylic acid cross-linked with alkenyl ethers of sugars or polyalcohols.

**Content:** 56.0 per cent to 68.0 per cent of carboxylic acid (–CO<sub>2</sub>H) groups (dried substance).

## CHARACTERS

**Appearance:** white or almost white, fluffy, hygroscopic powder.

**Solubility:** swells in water and in other polar solvents after dispersion and neutralisation with sodium hydroxide solution.

## IDENTIFICATION

First identification: A.

Second identification: B, C, D.

A. Infrared absorption spectrophotometry (2.2.24).

**Main bands:** at 1710 ± 5 cm<sup>-1</sup>, 1454 ± 5 cm<sup>-1</sup>, 1414 ± 5 cm<sup>-1</sup>, 1245 ± 5 cm<sup>-1</sup>, 1172 ± 5 cm<sup>-1</sup>, 1115 ± 5 cm<sup>-1</sup> and 801 ± 5 cm<sup>-1</sup>, with the strongest band at 1710 ± 5 cm<sup>-1</sup>.

B. Adjust a 10 g/L dispersion to about pH 7.5 with *1 M sodium hydroxide*. A highly viscous gel is formed.

C. Add 2 mL of a 100 g/L solution of *calcium chloride R*, with continuous stirring, to 10 mL of the gel from identification test B. A white precipitate is immediately produced.

D. Add 0.5 mL of *thymol blue solution R* to 10 mL of a 10 g/L dispersion. An orange colour is produced. Add 0.5 mL of *cresol red solution R* to 10 mL of a 10 g/L dispersion. A yellow colour is produced.

## TESTS

**Free acrylic acid.** Liquid chromatography (2.2.29).

**Test solution.** Mix 0.125 g of the substance to be examined with a 25 g/L solution of *aluminium potassium sulfate R* and dilute to 25.0 mL with the same solution. Heat the suspension at 50 °C for 20 min with shaking, then shake the suspension at room temperature for 60 min. Centrifuge and use the clear supernatant solution as the test solution.

**Reference solution.** Dissolve 62.5 mg of *acrylic acid R* in a 25 g/L solution of *aluminium potassium sulfate R* and dilute to 100.0 mL with the same solution. Dilute 1.0 mL of this solution to 50.0 mL with a 25 g/L solution of *aluminium potassium sulfate R*.

**Column:**

- size:  $l = 0.12$  m,  $\varnothing = 4.6$  mm;
- stationary phase: *octadecylsilyl silica gel for chromatography R* (5  $\mu$ m).

**Mobile phase:**

- mobile phase A: 1.361 g/L solution of *potassium dihydrogen phosphate R*, adjusted to pH 2.5 using *dilute phosphoric acid R*;
- mobile phase B: mixture of equal volumes of a 1.361 g/L solution of *potassium dihydrogen phosphate R* and *acetonitrile for chromatography R*;

Time (min)	Mobile phase A (per cent V/V)	Mobile phase B (per cent V/V)
0 - 8	100	0
8 - 9	100 → 0	0 → 100
9 - 20	0	100

**Flow rate:** 1 mL/min.

**Detection:** spectrophotometer at 205 nm.

**Injection:** 20  $\mu$ L.

**Retention time:** acrylic acid = about 6.0 min.

**Limit:**

- *acrylic acid*: not more than the area of the corresponding peak in the chromatogram obtained with the reference solution (0.25 per cent).

**Benzene.** Gas chromatography (2.4.24, System A).

**Solution A.** Dissolve 0.100 g of *benzene R* in *dimethyl sulfoxide R* and dilute to 100.0 mL with the same solvent. Dilute 1.0 mL of the solution to 100.0 mL with *water R*. Dilute 1.0 mL of this solution to 100.0 mL with *water R*.

**Test solution.** Weigh 50.0 mg of the substance to be examined into an injection vial and add 5.0 mL of *water R* and 1.0 mL of *dimethyl sulfoxide R*.

**Reference solution.** Weigh 50.0 mg of the substance to be examined into an injection vial and add 4.0 mL of *water R*, 1.0 mL of *dimethyl sulfoxide R* and 1.0 mL of solution A.

Close the vials with a tight rubber membrane stopper coated with polytetrafluoroethylene and secure with an aluminium crimped cap. Shake to obtain a homogeneous dispersion.

**Static head-space conditions that may be used:**

- equilibration temperature: 80 °C;
- equilibration time: 60 min;
- transfer-line temperature: 90 °C.

**Injection:** 1 mL of the gaseous phase of the test solution and 1 mL of the gaseous phase of the reference solution; repeat these injections twice more.

**System suitability:**

- repeatability: maximum relative standard deviation of the differences in area between the analyte peaks obtained from the 3 replicate pair injections of the reference solution and the test solution is 15 per cent.

**Limit:**

- *benzene*: the mean area of the peak due to benzene in the chromatograms obtained with the test solution is not greater than 0.5 times the mean area of the peak due to benzene in the chromatograms obtained with the reference solution (2 ppm).

**Heavy metals (2.4.8):** maximum 20 ppm.

1.0 g complies with test C. Prepare the reference solution using 2 mL of *lead standard solution (10 ppm Pb) R*.

**Loss on drying (2.2.32):** maximum 3.0 per cent, determined on 1.000 g by drying *in vacuo* at 80 °C for 60 min.

**Sulfated ash (2.4.14):** maximum 4.0 per cent, determined on 1.0 g.

## ASSAY

Slowly add 50 mL of *water R* to 0.120 g whilst stirring and heating at 60 °C for 15 min. Stop heating, add 150 mL of *water R* and continue stirring for 30 min. Add 2 g of *potassium chloride R* and titrate with 0.2 M *sodium hydroxide*, determining the end-point potentiometrically (2.2.20).

1 mL of 0.2 M *sodium hydroxide* is equivalent to 9.0 mg of carboxylic acid (-CO<sub>2</sub>H) groups.

## STORAGE

In an airtight container.

## FUNCTIONALITY-RELATED CHARACTERISTICS

This section provides information on characteristics that are recognised as being relevant control parameters for one or more functions of the substance when used as an excipient (see chapter 5.15). This section is a non-mandatory part of the monograph and it is not necessary to verify the characteristics to demonstrate compliance. Control of these characteristics can however contribute to the quality of a medicinal product by improving the consistency of the manufacturing process and the performance of the medicinal product during use. Where control methods are cited, they are recognised as being suitable for the purpose, but other methods can also be used. Wherever results for a particular characteristic are reported, the control method must be indicated.

The following characteristics may be relevant for carbomers used as viscosity-increasing agents and gelling agents.

**Apparent viscosity (2.2.10):** the nominal apparent viscosity is typically between 300 mPa·s and 115 000 mPa·s. For a product with a nominal apparent viscosity of 20 000 mPa·s or greater, the apparent viscosity is typically 70.0 per cent to 130.0 per cent of the nominal value; for a product with a nominal apparent viscosity of less than 20 000 mPa·s, the apparent viscosity is typically 50.0 per cent to 150.0 per cent of the nominal value.

Dry the substance to be examined *in vacuo* at 80 °C for 1 h. Carefully add 2.50 g of the previously dried substance to be examined to 500 mL of *water R* in a 1000 mL beaker while stirring continuously at 1000 ± 50 r/min, with the stirrer shaft set at an angle of 60° to one side of the beaker. Add the previously dried substance over a period of 45-90 s, at a uniform rate, ensuring that loose agglomerates of powder are broken up, and continue stirring at 1000 ± 50 r/min for 15 min. Remove the stirrer and place the beaker containing the dispersion in a water-bath at 25 ± 1 °C for 30 min. Insert the stirrer to a depth necessary to ensure that air is not drawn into the dispersion and, while stirring at 300 ± 25 r/min, titrate with a glass-calomel electrode system to pH 7.3-7.8 by adding a 180 g/L solution of *sodium hydroxide R* below the surface, determining the end-point potentiometrically (2.2.20). The total volume of the 180 g/L solution of *sodium hydroxide R* used is about 6.2 mL. Allow 2-3 min before the final pH determination. If the final pH exceeds 7.8, discard the preparation and prepare another using a smaller amount of sodium hydroxide for titration. Return the neutralised preparation to the water-bath at 25 °C for 1 h, then perform the viscosity determination without delay to avoid slight viscosity changes that occur 75 min after neutralisation.

Determine the viscosity using a rotating viscometer with a spindle rotating at 20 r/min, using a spindle suitable for the expected apparent viscosity.

**Carboxylic acid groups:** see Assay.

01/2008:0375 *Limit:*

## CARBON DIOXIDE

### Carbonei dioxidum

CO<sub>2</sub>  
[124-38-9]

*M<sub>r</sub>* 44.01

#### DEFINITION

*Content:* minimum 99.5 per cent V/V of CO<sub>2</sub> in the gaseous phase.

This monograph applies to carbon dioxide for medicinal use.

#### CHARACTERS

*Appearance:* colourless gas.

*Solubility:* at 20 °C and at a pressure of 101 kPa, 1 volume dissolves in about 1 volume of water.

#### PRODUCTION

*Examine the gaseous phase.*

*If the test is performed on a cylinder of gas, keep the cylinder of the substance to be examined at room temperature for not less than 6 h before carrying out the tests. Keep the cylinder in the vertical position with the outlet valve uppermost.*

**Carbon monoxide.** Gas chromatography (2.2.28).

*Gas to be examined.* The substance to be examined.

*Reference gas.* A mixture containing 5 ppm V/V of carbon monoxide R in nitrogen R1.

*Column:*

- *material:* stainless steel,
- *size:* *l* = 2 m, Ø = 4 mm,
- *stationary phase:* an appropriate molecular sieve for chromatography (0.5 nm).

*Carrier gas:* helium for chromatography R.

*Flow rate:* 60 mL/min.

*Temperature:*

- *column:* 50 °C,
- *injection port and detector:* 130 °C.

*Detection:* flame ionisation with methaniser.

*Injection:* loop injector.

Adjust the injected volumes and the operating conditions so that the height of the peak due to carbon monoxide in the chromatogram obtained with the reference gas is at least 35 per cent of the full scale of the recorder.

*Limit:*

- *carbon monoxide:* not more than the area of the corresponding peak in the chromatogram obtained with the reference gas (5 ppm V/V).

**Nitrogen monoxide and nitrogen dioxide:** maximum 2 ppm V/V in total, determined using a chemiluminescence analyser (2.5.26).

*Gas to be examined.* The substance to be examined.

*Reference gas (a).* Carbon dioxide R1.

*Reference gas (b).* A mixture containing 2 ppm V/V of nitrogen monoxide R in carbon dioxide R1 or in nitrogen R1.

Calibrate the apparatus and set the sensitivity using reference gases (a) and (b). Measure the content of nitrogen monoxide and nitrogen dioxide in the gas to be examined.

If nitrogen is used instead of carbon dioxide in reference gas (b), multiply the result obtained by the quenching correction factor in order to correct the quenching effect on the analyser response caused by the carbon dioxide matrix effect.

The quenching correction factor is determined by applying a known reference mixture of nitrogen monoxide in carbon dioxide and comparing the actual content with the content indicated by the analyser which has been calibrated with a NO/N<sub>2</sub> reference mixture.

$$\text{Quenching correction factor} = \frac{\text{actual nitrogen monoxide content}}{\text{indicated nitrogen monoxide content}}$$

**Total sulfur:** maximum 1 ppm V/V, determined using an ultraviolet fluorescence analyser after oxidation of the sulfur compounds by heating at 1000 °C (Figure 0375.-1).

The apparatus consists of the following:

- a system generating ultraviolet radiation with a wavelength of 210 nm, made up of an ultraviolet lamp, a collimator, and a selective filter; the beam is blocked periodically by a chopper rotating at high speed,
- a reaction chamber through which flows the previously filtered gas to be examined,
- a system that detects radiation emitted at a wavelength of 350 nm, made up of a selective filter, a photomultiplier tube and an amplifier.

*Gas to be examined.* The substance to be examined.

*Reference gas (a).* Carbon dioxide R1.

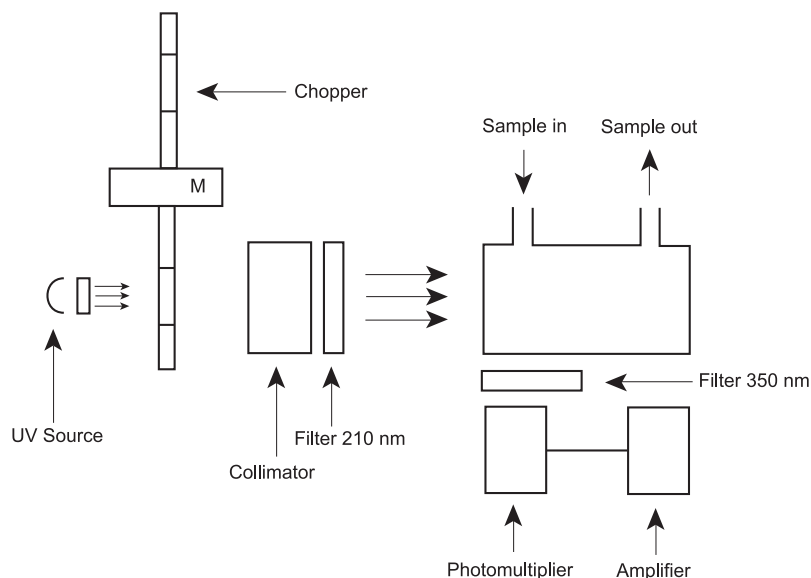

Figure 0375.-1.– UV Fluorescence Analyser

01/2011:2408

*Reference gas (b).* A mixture containing between 0.5 ppm V/V and 2 ppm V/V of *hydrogen sulfide RI* in *carbon dioxide RI*.

Calibrate the apparatus and set the sensitivity using reference gases (a) and (b). Pass the gas to be examined through a quartz oven heated to 1000 °C. *Oxygen R* is circulated in the oven at a tenth of the flow rate of the gas to be examined. Measure the sulfur dioxide content in the gaseous mixture leaving the oven.

**Water:** maximum 67 ppm V/V, determined using an electrolytic hygrometer (2.5.28).

**Assay.** Infrared analyser (2.5.24).

*Gas to be examined.* The substance to be examined. It must be filtered to avoid stray light phenomena.

*Reference gas (a).* *Carbon dioxide RI*.

*Reference gas (b).* A mixture containing 95.0 per cent V/V of *carbon dioxide RI* and 5.0 per cent V/V of *nitrogen RI*.

Calibrate the apparatus and set the sensitivity using reference gases (a) and (b). Measure the content of carbon dioxide in the gas to be examined.

#### IDENTIFICATION

*First identification:* A.

*Second identification:* B, C.

A. Infrared absorption spectrophotometry (2.2.24).

*Comparison:* Ph. Eur. reference spectrum of carbon dioxide.

B. Place a glowing splinter of wood in an atmosphere of the substance to be examined. It is extinguished.

C. Pass a stream of the substance to be examined through *barium hydroxide solution R*. A white precipitate is formed which dissolves with effervescence in *dilute acetic acid R*.

#### TESTS

*Examine the gaseous phase.*

*If the test is performed on a cylinder of gas, keep the cylinder of the substance to be examined at room temperature for not less than 6 h before carrying out the tests. Keep the cylinder in the vertical position with the outlet valve uppermost.*

**Carbon monoxide:** maximum 5 ppm V/V, determined using a carbon monoxide detector tube (2.1.6).

**Hydrogen sulfide:** maximum 1 ppm V/V, determined using a hydrogen sulfide detector tube (2.1.6).

**Nitrogen monoxide and nitrogen dioxide:** maximum 2 ppm V/V in total, determined using a nitrogen monoxide and nitrogen dioxide detector tube (2.1.6).

**Sulfur dioxide:** maximum 2 ppm V/V, determined using a sulfur dioxide detector tube (2.1.6).

**Water vapour:** maximum 67 ppm V/V, determined using a water vapour detector tube (2.1.6).

#### STORAGE

Store liquefied under pressure in suitable containers complying with the legal regulations.

#### IMPURITIES

A. NO: nitrogen monoxide,

B. NO<sub>2</sub>: nitrogen dioxide,

C. CO: carbon monoxide,

D. total sulfur,

E. H<sub>2</sub>O: water.

## CARBON MONOXIDE

### Carbonei monoxidum

CO  
[630-08-0] M<sub>r</sub> 28.00

#### DEFINITION

Gas obtained by steam reforming (catalytic oxidation) of hydrocarbons.

*Content:* minimum 99.5 per cent V/V of CO.

This monograph applies to carbon monoxide for medicinal use.

#### CHARACTERS

*Appearance:* colourless, flammable gas.

*Solubility:* at 20 °C and at a pressure of 101 kPa, 2.266 volumes of carbon monoxide dissolve in 100 volumes of water.

#### IDENTIFICATION

*Carry out either test A or B.*

A. Infrared absorption spectrophotometry (2.2.24).

*Comparison:* Ph. Eur. reference spectrum of carbon monoxide.

B. It complies with the limits of the assay.

#### TESTS

**Carbon dioxide.** Gas chromatography (2.2.28).

*Gas to be examined.* The substance to be examined.

*Reference gas.* A mixture containing 300 ppm V/V of *carbon dioxide RI* in *carbon monoxide R*.

*Column:*

- *material:* stainless steel;
- *size:*  $l = 2$  m,  $\varnothing = 2$  mm;
- *stationary phase:* an appropriate divinylbenzene porous polymer (149-177  $\mu\text{m}$ ).

*Carrier gas:* helium for chromatography R.

*Flow rate:* 30 mL/min.

*Temperature:*

- *column:* 50 °C;
- *detector:* 220 °C.

*Detection:* thermal conductivity.

*Injection:* 1 mL.

*Run time:* 3 min.

*Relative retention* with reference to carbon monoxide (retention time = about 0.4 min): carbon dioxide = about 3.5.

*Limit:*

- *carbon dioxide:* not more than the area of the corresponding peak in the chromatogram obtained with the reference gas (300 ppm V/V).

**Methane.** Gas chromatography (2.2.28).

*Gas to be examined.* The substance to be examined.

*Reference gas.* A mixture containing 100 ppm V/V of *methane R* in *carbon monoxide R*.

*Column:*

- *material:* stainless steel;
- *size:*  $l = 2$  m,  $\varnothing = 4$  mm;
- *stationary phase:* ethylvinylbenzene-divinylbenzene copolymer R (177-250  $\mu\text{m}$ ).

*Carrier gas:* nitrogen for chromatography R.

*Flow rate:* 10 mL/min.

*Temperature:*

- *column:* 95 °C;
- *detector:* 240 °C.

07/2009:1081  
corrected 7.0*Detection*: flame ionisation.*Injection*: 1 mL.*Run time*: 3 min.*Retention time*: methane = about 1.8 min.*Limit*:

- *methane*: not more than the area of the corresponding peak in the chromatogram obtained with the reference gas (100 ppm V/V).

**Hydrogen.** Gas chromatography.*Gas to be examined.* The substance to be examined.*Reference gas.* A mixture containing 300 ppm V/V of *hydrogen for chromatography R* in *carbon monoxide R*.*Column*:

- *material*: stainless steel;
- *size*:  $l = 2$  m,  $\varnothing = 2$  mm;
- *stationary phase*: molecular sieve for chromatography (149-177  $\mu\text{m}$ ) with a nominal pore size of 0.5 nm.

*Carrier gas*: argon for chromatography R.*Flow rate*: 30 mL/min.*Temperature*:

- *column*: 100 °C;
- *detector*: 160 °C.

*Detection*: thermal conductivity.*Injection*: 1 mL.*Run time*: 4 min.*Relative retention* with reference to carbon monoxide (retention time = about 2.3 min): hydrogen = about 0.4.*Limit*:

- *hydrogen*: not more than the area of the corresponding peak in the chromatogram obtained with the reference gas (300 ppm V/V).

**Nickel tetracarbonyl and iron pentacarbonyl**: not detectable, using a detector tube having a limit of detection of 0.1 ppm V/V (2.1.6).**Water**: maximum 10 ppm V/V, determined using an electrolytic hygrometer (2.5.28).**ASSAY**

Infrared analyser (2.5.25).

*Gas to be examined.* The substance to be examined, previously filtered to avoid stray light phenomena.*Reference gas (a).* Carbon monoxide R.*Reference gas (b).* A mixture containing 95.0 per cent V/V of carbon monoxide R and 5.0 per cent V/V of nitrogen R1.

Calibrate the apparatus and set the sensitivity using reference gases (a) and (b). Measure the content of carbon monoxide in the gas to be examined.

**STORAGE**

Under pressure in suitable containers complying with the legal regulations.

**IMPURITIES***Specified impurities*: A, B, C, D, E, F.

- A. CO<sub>2</sub>: carbon dioxide,
- B. CH<sub>4</sub>: methane,
- C. H<sub>2</sub>: hydrogen,
- D. Ni(CO)<sub>4</sub>: nickel tetracarbonyl,
- E. Fe(CO)<sub>5</sub>: iron pentacarbonyl,
- F. H<sub>2</sub>O: water.

**CARBOPLATIN**

## Carboplatinum

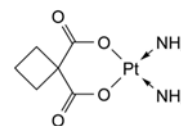
C<sub>6</sub>H<sub>12</sub>N<sub>2</sub>O<sub>4</sub>Pt  
[41575-94-4]M<sub>r</sub> 371.3**DEFINITION**

(SP-4-2)-Diammine[cyclobutan-1,1-dicarboxylato(2-)-O,O']platin.

*Content*: 98.0 per cent to 102.0 per cent (dried substance).**CHARACTERS***Appearance*: colourless, crystalline powder.*Solubility*: sparingly soluble in water, very slightly soluble in acetone and in ethanol (96 per cent).

mp: about 200 °C, with decomposition.

**IDENTIFICATION**

Infrared absorption spectrophotometry (2.2.24).

*Comparison*: Ph. Eur. reference spectrum of carboplatin.**TESTS****Solution S.** Dissolve 0.25 g in carbon dioxide-free water R and dilute to 25 mL with the same solvent.**Appearance of solution.** Solution S is clear (2.2.1) and colourless (2.2.2, Method II).**Impurity B and acidity**: maximum 0.5 per cent, calculated as impurity B.

To 10 mL of solution S add 0.1 mL of phenolphthalein solution R1. The solution is colourless. Not more than 0.7 mL of 0.01 M sodium hydroxide is required to change the colour of the indicator to pink.

**Related substances.** Liquid chromatography (2.2.29).*Test solution.* Dissolve 20.0 mg of the substance to be examined in a mixture of equal volumes of acetonitrile R and water R and dilute to 20.0 mL with the same mixture of solvents.*Reference solution.* Dilute 0.5 mL of the test solution to 200.0 mL with the mobile phase.*Column*:

- *size*:  $l = 0.25$  m,  $\varnothing = 4.6$  mm;
- *stationary phase*: aminopropylsilyl silica gel for chromatography R (5  $\mu\text{m}$ ).

*Mobile phase*: water R, acetonitrile R (13:87 V/V).*Flow rate*: 2 mL/min.*Detection*: spectrophotometer at 230 nm.*Injection*: 10  $\mu\text{L}$ .*Run time*: 2.5 times the retention time of carboplatin.*Relative retention* with reference to carboplatin (retention time = about 7 min): impurity A = about 0.3.*System suitability*: test solution:

- *number of theoretical plates*: minimum 5000; if necessary, adjust the concentration of acetonitrile in the mobile phase;
- *mass distribution ratio*: minimum 4.0; if necessary, adjust the concentration of acetonitrile in the mobile phase;
- *symmetry factor*: maximum 2.0; if necessary, adjust the concentration of acetonitrile in the mobile phase.

## Limits:

01/2008:1712

- *impurity A*: not more than the area of the principal peak in the chromatogram obtained with the reference solution (0.25 per cent);
- *total*: not more than twice the area of the principal peak in the chromatogram obtained with the reference solution (0.5 per cent);
- *disregard limit*: 0.2 times the area of the principal peak in the chromatogram obtained with the reference solution (0.05 per cent).

**Chlorides** (2.4.4): maximum 100 ppm.

Dissolve 0.5 g in *water R*, heating slightly if necessary, and dilute to 20 mL with the same solvent. Filter if necessary. Dilute 10 mL of this solution to 15 mL with *water R*. Prepare the standard using 5 mL of *chloride standard solution (5 ppm Cl) R*.

**Ammonium** (2.4.1, *Method B*): maximum 100 ppm, determined on 0.20 g.

Prepare the standard using 0.2 mL of *ammonium standard solution (100 ppm NH<sub>4</sub>) R*.

**Silver**: maximum 10 ppm.

Atomic emission spectrometry (2.2.57).

*Test solution*. Dissolve 0.50 g in a 1 per cent V/V solution of *nitric acid R* and dilute to 50.0 mL with the same solution.

*Reference solutions*. Prepare the reference solutions using *silver standard solution (5 ppm Ag) R*, diluting with a 1 per cent V/V solution of *nitric acid R*.

*Wavelength*: 328.1 nm.

**Soluble barium**: maximum 10 ppm.

Atomic emission spectrometry (2.2.57).

*Test solution*. Use the solution described in the test for silver.

*Reference solutions*. Prepare the reference solutions using *barium standard solution (50 ppm Ba) R*, diluting with a 1 per cent V/V solution of *nitric acid R*.

*Wavelength*: 455.4 nm.

**Loss on drying** (2.2.32): maximum 0.5 per cent, determined on 1.000 g by drying in an oven at 105 °C.

## ASSAY

Use the residue obtained in the test for loss on drying. Ignite 0.200 g of the residue to constant mass at 800 ± 50 °C.

1 mg of the residue is equivalent to 1.903 mg of C<sub>25</sub>H<sub>47</sub>N<sub>2</sub>O<sub>8</sub>Pt.

## STORAGE

Protected from light.

## IMPURITIES

*Specified impurities*: A, B.

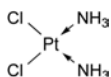

A. *cis*-diamminedichloroplatinum(II) (cisplatin),

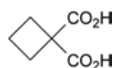

B. cyclobutane-1,1-dicarboxylic acid.

## CARBOPROST TROMETAMOL

## Carboprostum trometamol

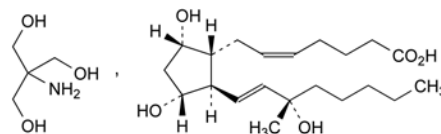

C<sub>25</sub>H<sub>47</sub>N<sub>2</sub>O<sub>8</sub>  
[58551-69-2]

*M<sub>r</sub>* 489.7

## DEFINITION

2-Amino-2-(hydroxymethyl)propane-1,3-diol (5*Z*)-7-[(1*R*,2*R*,3*R*,5*S*)-3,5-dihydroxy-2-[(1*E*,3*S*)-3-hydroxy-3-methyloct-1-enyl]cyclopentyl]hept-5-enoate ((15*S*)-15-methyl-PGF<sub>2</sub>).

*Content*: 94.0 per cent to 102.0 per cent (anhydrous substance).

## CHARACTERS

*Appearance*: white or almost white powder.

*Solubility*: soluble in water.

## IDENTIFICATION

A. Specific optical rotation (see Tests).

B. Infrared absorption spectrophotometry (2.2.24).

*Comparison*: *Ph. Eur. reference spectrum of carboprost trometamol*.

## TESTS

**Specific optical rotation** (2.2.7): + 18 to + 24 (anhydrous substance).

Dissolve 0.100 g in *ethanol (96 per cent) R* and dilute to 10.0 mL with the same solvent.

**Related substances**. Liquid chromatography (2.2.29).

*Test solution*. Dissolve 15.0 mg of the substance to be examined in a mixture of 23 volumes of *acetonitrile R* and 77 volumes of *water for chromatography R* and dilute to 10.0 mL with the same mixture of solvents.

*Reference solution (a)*. Dissolve 15.0 mg of *carboprost trometamol CRS* (containing impurity A) in a mixture of 23 volumes of *acetonitrile R* and 77 volumes of *water for chromatography R* and dilute to 10.0 mL with the same mixture of solvents.

*Reference solution (b)*. Dilute 1.0 mL of reference solution (a) and 0.15 mL of (15*R*)-15-methylprostaglandin *F*<sub>2α</sub> *R* (impurity B) to 100.0 mL with a mixture of 23 volumes of *acetonitrile R* and 77 volumes of *water for chromatography R*.

*Reference solution (c)*. Dilute 2.0 mL of the test solution to 20.0 mL with a mixture of 23 volumes of *acetonitrile R* and 77 volumes of *water for chromatography R*. Dilute 2.0 mL of this solution to 20.0 mL with a mixture of 23 volumes of *acetonitrile R* and 77 volumes of *water for chromatography R*.

*Column*:

– *size*: *l* = 0.15 m, Ø = 4.6 mm,

– *stationary phase*: octadecylsilyl silica gel for chromatography *R1* (5 µm) with a pore size of 8-10 nm and a carbon loading of 12-19 per cent.

*Mobile phase*: mix 23 volumes of *acetonitrile R1* and 77 volumes of a 2.44 g/L solution of *sodium dihydrogen phosphate R* in *water for chromatography R* previously adjusted to pH 2.5 with *phosphoric acid R*.

*Flow rate*: 1.0 mL/min.

*Detection*: spectrophotometer at 200 nm.

*Injection*: 20 µL.

*Run time*: 1.3 times the retention time of carboprost.

01/2008:1689

*Relative retention* with reference to carboprost (retention time = about 80 min): impurity B = about 0.85; impurity A = about 0.9.

*Identification of impurities:* use the chromatogram obtained with reference solution (a) and the chromatogram supplied with *carboprost trometamol CRS* to identify the peak due to impurity A.

*System suitability:*

- *resolution:* minimum 3.4 between the peaks due to impurity B and carboprost in the chromatogram obtained with reference solution (b);
- *peak-to-valley ratio:* minimum 3.0, where  $H_p$  = height above the baseline of the peak due to impurity A and  $H_v$  = height above the baseline of the lowest point of the curve separating this peak from the peak due to impurity B in the chromatogram obtained with reference solution (a).

*Limits:*

- *impurity A:* not more than 3 times the area of the principal peak in the chromatogram obtained with reference solution (c) (3.0 per cent),
- *impurity B:* not more than the area of the principal peak in the chromatogram obtained with reference solution (c) (1.0 per cent),
- *unspecified impurities:* for each impurity, not more than 0.1 times the area of the principal peak in the chromatogram obtained with reference solution (c) (0.10 per cent),
- *total:* not more than 4 times the area of the principal peak in the chromatogram obtained with reference solution (c) (4.0 per cent),
- *disregard limit:* 0.05 times the area of the principal peak in the chromatogram obtained with reference solution (c) (0.05 per cent).

**Water** (2.5.32): maximum 0.5 per cent, determined on 50 mg.

#### ASSAY

Liquid chromatography (2.2.29) as described in the test for related substances with the following modifications.

*Mobile phase:* mix 27 volumes of *acetonitrile R1* and 73 volumes of a 2.44 g/L solution of *sodium dihydrogen phosphate R* in *water for chromatography R* previously adjusted to pH 2.5 with *phosphoric acid R*.

*Injection:* test solution and reference solution (a).

*Run time:* 1.2 times the retention time of carboprost.

*Retention time:* carboprost = about 29 min.

Calculate the percentage content of  $C_{25}H_{47}NO_8$  using the declared content of *carboprost trometamol CRS*.

#### STORAGE

At a temperature below  $-15^\circ\text{C}$ .

#### IMPURITIES

*Specified impurities:* A, B.

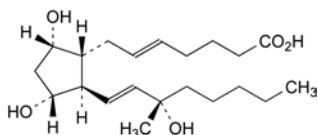

- A. (5E)-7-[(1R,2R,3R,5S)-3,5-dihydroxy-2-[(1E,3S)-3-hydroxy-3-methyloct-1-enyl]cyclopentyl]hept-5-enoic acid,

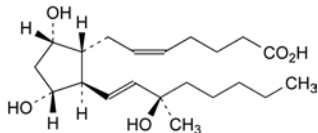

- B. (5Z)-7-[(1R,2R,3R,5S)-3,5-dihydroxy-2-[(1E,3R)-3-hydroxy-3-methyloct-1-enyl]cyclopentyl]hept-5-enoic acid.

## CARISOPRODOL

### Carisoprodolum

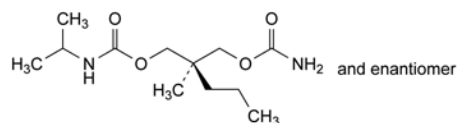

$C_{12}H_{24}N_2O_4$   
[78-44-4]

$M_r$  260.3

#### DEFINITION

(2RS)-2-[(Carbamoyloxy)methyl]-2-methylpentyl (1-methylethyl)carbamate.

*Content:* 98.0 per cent to 102.0 per cent (dried substance).

#### CHARACTERS

*Appearance:* white or almost white, fine powder.

*Solubility:* very slightly soluble in water, freely soluble in acetone, in alcohol and in methylene chloride.

#### IDENTIFICATION

*First identification:* A, B.

*Second identification:* A, C, D.

A. Melting point (2.2.14):  $92^\circ\text{C}$  to  $95^\circ\text{C}$ .

B. Infrared absorption spectrophotometry (2.2.24).

*Comparison:* *carisoprodol CRS*.

C. Examine the chromatograms obtained in the test for related substances.

*Results:* the principal spot in the chromatogram obtained with test solution (b) is similar in position, colour and size to the principal spot in the chromatogram obtained with reference solution (d).

D. Dissolve 0.2 g in 15 mL of a 28 g/L solution of *potassium hydroxide R* in *alcohol R* and boil under a reflux condenser for 15 min. Add 0.5 mL of *glacial acetic acid R* and 1 mL of a 50 g/L solution of *cobalt nitrate R* in *ethanol R*. An intense blue colour develops.

#### TESTS

**Optical rotation** (2.2.7):  $-0.10^\circ$  to  $+0.10^\circ$ .

Dissolve 2.5 g in *alcohol R* and dilute to 25.0 mL with the same solvent.

**Related substances.** Thin-layer chromatography (2.2.27).

*Test solution (a).* Dissolve 0.20 g of the substance to be examined in *methylene chloride R* and dilute to 10 mL with the same solvent.

*Test solution (b).* Dilute 1 mL of test solution (a) to 10 mL with *methylene chloride R*.

*Reference solution (a).* Dissolve 5.0 mg of *meprobamate CRS* in *methylene chloride R* and dilute to 50 mL with the same solvent.

*Reference solution (b).* Dilute 1 mL of test solution (b) to 50 mL with *methylene chloride R*.

*Reference solution (c).* Dilute 5 mL of reference solution (b) to 10 mL with *methylene chloride R*.

*Reference solution (d).* Dissolve 20 mg of *carisoprodol CRS* in *methylene chloride R* and dilute to 10 mL with the same solvent.

*Reference solution (e).* Dissolve 10 mg of *carisoprodol impurity A CRS* in 5 mL of reference solution (d) and dilute to 50 mL with *methylene chloride R*.

*Plate:* TLC silica gel plate R.

*Mobile phase:* *acetone R*, *methylene chloride R* (20:80 V/V).

*Application:* 5  $\mu\text{L}$ .

**Development:** over a path of 15 cm.

**Drying:** in air for 15 min.

**Detection:** spray with a solution prepared as follows: dissolve 5 g of *phosphomolybdic acid R* in a mixture of 50 mL of *glacial acetic acid R* and 10 mL of *sulfuric acid R*, and dilute to 100 mL with *glacial acetic acid R*. Heat the plate at 100-105 °C for 30 min.

**System suitability:**

- the chromatogram obtained with reference solution (c) shows 1 clearly visible spot,
- the chromatogram obtained with reference solution (e) shows 2 clearly separated spots.

**Limits:** in the chromatogram obtained with test solution (a):

- *impurity D*: any spot due to impurity D is not more intense than the spot in the chromatogram obtained with reference solution (a) (0.5 per cent),
- *any other impurity*: any spot, apart from the principal spot and any spot due to impurity D, is not more intense than the spot in the chromatogram obtained with reference solution (b) (0.2 per cent).

**Heavy metals (2.4.8):** maximum 10 ppm.

2.0 g complies with limit test C. Prepare the standard using 2 mL of *lead standard solution (10 ppm Pb) R*.

**Loss on drying (2.2.32):** maximum 0.5 per cent, determined on 1.000 g *in vacuo* at 60 °C for 3 h.

**Sulfated ash (2.4.14):** maximum 0.1 per cent, determined on 1.0 g.

#### ASSAY

Dissolve 0.100 g in 15 mL of a 25 per cent *V/V* solution of *sulfuric acid R* and boil under a reflux condenser for 3 h. Cool, dissolve by cautiously adding 30 mL of *water R*, cool again and place in a steam-distillation apparatus. Add 40 mL of *strong sodium hydroxide solution R* and distil immediately by passing steam through the mixture. Collect the distillate into 40 mL of a 40 g/L solution of *boric acid R* until the total volume in the receiver reaches about 200 mL. Add 0.25 mL of *methyl red mixed solution R*. Titrate with 0.1 M *hydrochloric acid*, until the colour changes from green to violet. Carry out a blank titration.

1 mL of 0.1 M *hydrochloric acid* is equivalent to 13.02 mg of  $C_{12}H_{24}N_2O_4$ .

#### IMPURITIES

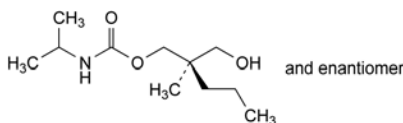

A. (2*RS*)-2-(hydroxymethyl)-2-methylpentyl (1-methylethyl)-carbamate,

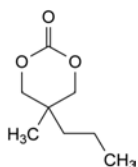

B. 5-methyl-5-propyl-1,3-dioxan-2-one,

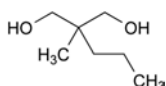

C. 2-methyl-2-propylpropane-1,3-diol,

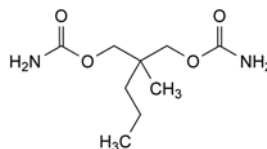

D. 2-methyl-2-propylpropane-1,3-diyl dicarbamate (meprobamate).

04/2010:2360  
corrected 7.0

## CARMELLOSE

### Carmellosum

#### DEFINITION

Polycarboxymethylether of cellulose.

#### CHARACTERS

**Appearance:** white or almost white powder, hygroscopic.

**Solubility:** practically insoluble in anhydrous ethanol. It swells with water to form a suspension and becomes viscid in 1 M sodium hydroxide.

#### IDENTIFICATION

A. pH (2.2.3): 3.5 to 5.0.

Suspend 1.0 g in 100 mL of *water R*.

B. Infrared absorption spectrophotometry (2.2.24).

*Comparison:* *carmellose CRS*.

#### TESTS

**Chlorides:** maximum 0.36 per cent.

Shake 0.8 g with 50 mL of *water R*, dissolve in 10 mL of 1 M *sodium hydroxide* and dilute to 100 mL with *water R*. Heat on a water-bath a mixture of 10 mL of *dilute nitric acid R* and 20 mL of this solution until a flocculent precipitate is produced. Cool, centrifuge and take out the supernatant liquid. Wash the precipitate with 3 quantities, each of 10 mL, of *water R*, centrifuging each time. Combine the supernatant liquid and the washings and dilute to 100 mL with *water R*. To 25 mL of this solution add 6 mL of *dilute nitric acid R* and dilute to 50 mL with *water R* (test solution). Prepare the reference solution with 0.40 mL of 0.01 M *hydrochloric acid*. Add 1 mL of *silver nitrate solution R2* to the test solution and the reference solution. Allow to stand protected from light for 5 min. Any opalescence in the test solution is not more intense than that in the reference solution.

**Sulfates:** maximum 0.72 per cent.

Shake 0.40 g with 25 mL of *water R*, dissolve in 5 mL of 1 M *sodium hydroxide* and add 20 mL of *water R*. Heat this solution with 2.5 mL of *hydrochloric acid R* in a water-bath until a flocculent precipitate is produced. Cool, centrifuge, and take out the supernatant liquid. Wash the precipitate with 3 quantities, each of 10 mL, of *water R*, centrifuging each time. Combine the supernatant liquid and the washings, and dilute to 100 mL with *water R*. Filter, and discard the first 5 mL of the filtrate. To 25 mL of the filtrate add 1 mL of *dilute hydrochloric acid R* and dilute to 50 mL with *water R* (test solution). Prepare the reference solution with 1.5 mL of 0.005 M *sulfuric acid*. Add 2 mL of a 120 g/L solution of *barium chloride R* to the test solution and the reference solution. Mix and allow to stand for 10 min. The white turbidity produced in the test solution is not thicker than that in the reference solution.

**Heavy metals:** maximum 20 ppm.

Place 1.0 g in a quartz or porcelain crucible. Cover loosely with a lid and carbonise by gentle ignition. Cool and add 2 mL of *nitric acid R* and 5 drops of *sulfuric acid R*. Heat cautiously until white fumes are no longer evolved and incinerate by ignition at 500-600 °C. Cool and add 2 mL of *hydrochloric acid R*. Evaporate to dryness on a water-bath. Moisten the



residue with 3 drops of *hydrochloric acid R*, add 10 mL of hot *water R* and heat for 2 min. Add 1 drop of *phenolphthalein solution R1*, add *dilute ammonia R1* dropwise until the solution develops a pale red colour. Add 2 mL of *dilute acetic acid R*, filter if necessary, and wash with 10 mL of *water R*. Transfer the filtrate and washings to a test-tube, and dilute to 50 mL with *water R* (test solution). Prepare the reference solution as follows: evaporate a mixture of 2 mL of *nitric acid R*, 5 drops of *sulfuric acid R* and 2 mL of *hydrochloric acid R* on a water-bath, then evaporate to dryness on a sand-bath. Moisten the residue with 3 drops of *hydrochloric acid R*. Proceed as described for the test solution, then add 2.0 mL of *lead standard solution (10 ppm Pb) R* and dilute to 50 mL with *water R*.

Add 0.1 mL of *sodium sulfide solution R1* to the test solution and the reference solution and allow to stand for 5 min. The colour of the test solution is not more intense than that of the reference solution.

**Loss on drying (2.2.32):** maximum 8.0 per cent, determined on 1.000 g by drying in an oven at 105 °C for 4 h.

**Sulfated ash (2.4.14):** maximum 1.5 per cent, determined on 1.0 g.

#### STORAGE

In an airtight container.

01/2008:0886  
corrected 6.0

## CARMELLOSE CALCIUM

### Carmellosum calcicum

[9050-04-8]

#### DEFINITION

Calcium salt of a partly *O*-carboxymethylated cellulose.

#### CHARACTERS

**Appearance:** white or yellowish-white powder, hygroscopic after drying.

**Solubility:** practically insoluble in acetone, in alcohol and in toluene. It swells with water to form a suspension.

#### IDENTIFICATION

- Shake 0.1 g thoroughly with 10 mL of *water R*. Add 2 mL of *dilute sodium hydroxide solution R* and allow to stand for 10 min (solution A). Dilute 1 mL of solution A to 5 mL with *water R*. To 0.05 mL add 0.5 mL of a 0.5 g/L solution of *chromotropic acid, sodium salt R* in a 75 per cent *m/m* solution of *sulfuric acid R* and heat on a water-bath for 10 min. A reddish-violet colour develops.
- Shake 5 mL of solution A obtained in identification test A with 10 mL of *acetone R*. A white, flocculent precipitate is produced.
- Shake 5 mL of solution A obtained in identification test A with 1 mL of *ferric chloride solution R1*. A brown, flocculent precipitate is formed.
- Ignite 1 g and dissolve the residue in a mixture of 5 mL of *acetic acid R* and 10 mL of *water R*. Filter if necessary and boil the filtrate for a few minutes. Cool and neutralise with *dilute ammonia R1*. The solution gives reaction (a) of calcium (2.3.1).

#### TESTS

**Solution S.** Shake 1.0 g with 50 mL of *distilled water R*, add 5 mL of *dilute sodium hydroxide solution R* and dilute to 100 mL with *distilled water R*.

**Alkalinity.** Shake 1.0 g thoroughly with 50 mL of *carbon dioxide-free water R* and add 0.05 mL of *phenolphthalein solution R*. No red colour develops.

**Chlorides (2.4.4):** maximum 0.36 per cent.

Heat 28 mL of solution S with 10 mL of *dilute nitric acid R* on a water-bath until a flocculent precipitate is produced. Cool, centrifuge and separate the supernatant liquid. Wash the precipitate with 3 quantities, each of 10 mL, of *water R*, centrifuging each time. Combine the supernatant liquid and the washings and dilute to 100 mL with *water R*. To 25 mL add 6 mL of *dilute nitric acid R* and dilute to 50 mL with *water R*. Dilute 10 mL of the solution to 15 mL with *water R*.

**Sulfates (2.4.13):** maximum 1 per cent.

Heat 20 mL of solution S with 1 mL of *hydrochloric acid R* on a water-bath until a flocculent precipitate is produced. Cool, centrifuge and separate the supernatant liquid. Wash the precipitate with 3 quantities, each of 10 mL, of *distilled water R*, centrifuging each time. Combine the supernatant liquid and the washings and dilute to 100 mL with *distilled water R*. To 25 mL add 1 mL of *dilute hydrochloric acid R* and dilute to 50 mL with *distilled water R*.

**Heavy metals (2.4.8):** maximum 20 ppm.

1.0 g complies with test D. Prepare the reference solution using 2 mL of *lead standard solution (10 ppm Pb) R*.

**Loss on drying (2.2.32):** maximum 10.0 per cent, determined on 1.000 g by drying in an oven at 105 °C for 4 h.

**Sulfated ash (2.4.14):** 10.0 per cent to 20.0 per cent, determined on 1.0 g in a platinum crucible.

#### STORAGE

In an airtight container.

01/2008:0472  
corrected 6.0

## CARMELLOSE SODIUM

### Carmellosum natricum

[9004-32-4]

#### DEFINITION

Carmellose sodium (carboxymethylcellulose sodium) is the sodium salt of a partly *O*-carboxymethylated cellulose. It contains not less than 6.5 per cent and not more than 10.8 per cent of sodium (Na), calculated with reference to the dried substance.

#### CHARACTERS

A white or almost white, granular powder, hygroscopic after drying, practically insoluble in acetone, in ethanol and in toluene. It is easily dispersed in water giving colloidal solutions.

#### IDENTIFICATION

- To 10 mL of solution S (see Tests) add 1 mL of *copper sulfate solution R*. A blue, cotton-like precipitate is formed.
- Boil 5 mL of solution S for a few minutes. No precipitate is formed.
- The solution prepared from the sulfated ash in the test for heavy metals gives the reactions of sodium (2.3.1).

#### TESTS

**Solution S.** Sprinkle a quantity of the substance to be examined equivalent to 1.0 g of the dried substance onto 90 mL of *carbon dioxide-free water R* at 40 °C to 50 °C stirring vigorously. Continue stirring until a colloidal solution is obtained, cool and dilute to 100 mL with *carbon dioxide-free water R*.

01/2008:1186  
corrected 7.0

**Appearance of solution.** Solution S is not more opalescent than reference suspension III (2.2.1) and not more intensely coloured than reference solution Y<sub>6</sub> (2.2.2, Method II).

**pH (2.2.3).** The pH of solution S is 6.0 to 8.0.

**Apparent viscosity.** While stirring, introduce a quantity of the substance to be examined equivalent to 2.00 g of the dried substance into 50 mL of *water R* heated to 90 °C. For a product of low viscosity, use if necessary, the quantity required to give the concentration indicated on the label. Allow to cool, dilute to 100.0 mL with *water R* and stir until dissolution is complete. Determine the viscosity (2.2.10) using a rotating viscometer at 20 °C and a shear rate of 10 s<sup>-1</sup>. If it is impossible to obtain a shear rate of exactly 10 s<sup>-1</sup>, use a shear rate slightly higher and a rate slightly lower and interpolate. The apparent viscosity is not less than 75 per cent and not more than 140 per cent of the value stated on the label.

**Sodium glycollate.** Place a quantity of the substance to be examined equivalent to 0.500 g of dried substance in a beaker. Add 5 mL of *acetic acid R* and 5 mL of *water R*. Stir until dissolution is complete (about 30 min). Add 80 mL of *acetone R* and 2 g of *sodium chloride R*. Filter through a fast filter paper impregnated with *acetone R* into a volumetric flask, rinse the beaker and filter with *acetone R* and dilute the filtrate to 100.0 mL with the same solvent. Allow to stand for 24 h without shaking. Use the clear supernatant liquid to prepare the test solution.

In a volumetric flask, dissolve 0.310 g of *glycollic acid R*, previously dried *in vacuo* over *diphosphorus pentoxide R*, in *water R* and dilute to 1000.0 mL with the same solvent. Place 5.0 mL of this solution in a volumetric flask, add 5 mL of *acetic acid R* and allow to stand for about 30 min. Add 80 mL of *acetone R* and 2 g of *sodium chloride R* and dilute to 100.0 mL with *acetone R*. Use this solution to prepare the reference solution.

Place 2.0 mL of each solution in a separate 25 mL volumetric flask. Heat on a water-bath to eliminate acetone. Cool to room temperature and add 5.0 mL of *2,7-dihydroxynaphthalene solution R* to each flask. Shake and add 15.0 mL of *2,7-dihydroxynaphthalene solution R*. Close the flasks with aluminium foil and heat on a water-bath for 20 min. Cool under running water and dilute to 25.0 mL with *sulfuric acid R*. Within 10 min, transfer 10.0 mL of each solution to a flat-bottomed tube. Examine the solutions viewing vertically. The test solution is not more intensely coloured than the reference solution (0.4 per cent).

**Chlorides (2.4.4).** Dilute 2 mL of solution S to 15 mL with *water R*. The solution complies with the limit test for chlorides (0.25 per cent).

**Heavy metals (2.4.8).** To the residue obtained in the determination of the sulfated ash, add 1 mL of *hydrochloric acid R* and evaporate on a water-bath. Take up the residue in 20 mL of *water R*. 12 mL of the solution complies with limit test A for heavy metals (20 ppm). Prepare the standard using *lead standard solution (1 ppm Pb) R*.

**Loss on drying (2.2.32).** Not more than 10.0 per cent, determined on 1.000 g by drying in an oven at 105 °C.

**Sulfated ash (2.4.14):** 20.0 per cent to 33.3 per cent, determined on 1.0 g using a mixture of equal volumes of *sulfuric acid R* and *water R* and calculated with reference to the dried substance. These limits correspond to a content of 6.5 per cent to 10.8 per cent of sodium (Na).

## LABELLING

The label states the apparent viscosity in millipascal seconds for a 20 g/L solution; for a product of low viscosity, the label states the concentration of the solution to be used and the apparent viscosity in millipascal seconds.

## CARMELLOSE SODIUM, LOW-SUBSTITUTED

### Carmellosum natricum substitutum humile

[9050-32-4]

#### DEFINITION

Low-substituted sodium carboxymethylcellulose. Sodium salt of a partly *O*-(carboxymethylated) cellulose.

**Content:** 2.0 per cent to 4.5 per cent of sodium (Na) (dried substance).

#### CHARACTERS

**Appearance:** white or almost white powder or short fibres.

**Solubility:** practically insoluble in acetone, in anhydrous ethanol and in toluene. It swells in water to form a gel.

#### IDENTIFICATION

- Shake 1 g with 100 mL of a 100 g/L solution of *sodium hydroxide R*. A suspension is produced.
- Shake 1 g with 50 mL of *water R*. Transfer 1 mL of the mixture to a test tube, add 1 mL of *water R* and 0.05 mL of a freshly prepared 40 g/L solution of *α-naphthol R* in *methanol R*. Incline the test tube and add carefully 2 mL of *sulfuric acid R* down the side so that it forms a lower layer. A reddish-purple colour develops at the interface.
- Sulfated ash (2.4.14) (see Tests).
- The solution prepared for the test for heavy metals gives reaction (a) of sodium (2.3.1).

#### TESTS

**pH (2.2.3):** 6.0 to 8.5.

Shake 1 g with 100 mL of *carbon dioxide-free water R* for 5 min. Centrifuge.

**Sodium chloride and sodium glycollate:** maximum 0.5 per cent (dried substance) for the sum of the percentage contents.

**Sodium chloride.** Place 5.00 g in a 250 mL conical flask, add 50 mL of *water R* and 5 mL of *strong hydrogen peroxide solution R* and heat on a water bath for 20 min, stirring occasionally to ensure total hydration. Cool, add 100 mL of *water R* and 10 mL of *nitric acid R*. Titrate with 0.05 M *silver nitrate* determining the end-point potentiometrically (2.2.20) using a silver-based indicator electrode and a double-junction reference electrode containing a 100 g/L solution of *potassium nitrate R* in the outer jacket and a standard filling solution in the inner jacket.

1 mL of 0.05 M *silver nitrate* is equivalent to 2.922 mg of NaCl.

**Sodium glycollate.** Place a quantity of the substance to be examined equivalent to 0.500 g of the dried substance in a beaker. Add 5 mL of *glacial acetic acid R* and 5 mL of *water R* and stir to ensure total hydration (about 30 min). Add 80 mL of *acetone R* and 2 g of *sodium chloride R*. Stir for several minutes to ensure complete precipitation of the carboxymethylcellulose. Filter through a fast filter paper impregnated with *acetone R* into a volumetric flask, rinse the beaker and filter with *acetone R* and dilute the filtrate to 100.0 mL with the same solvent. Allow to stand for 24 h without shaking. Use the clear supernatant as the test solution.

Prepare the reference solutions as follows: in a 100 mL volumetric flask, dissolve 0.100 g of *glycollic acid R*, previously dried *in vacuo* over *diphosphorus pentoxide R*, in *water R* and dilute to 100.0 mL with the same solvent. Transfer 0.5 mL, 1.0 mL, 1.5 mL and 2.0 mL of the solution to separate volumetric flasks; dilute the contents of each flask to 5.0 mL with *water R*, add 5 mL of *glacial acetic acid R*, dilute to 100.0 mL with *acetone R* and mix.

Transfer 2.0 mL of the test solution and 2.0 mL of each of the reference solutions to separate 25 mL volumetric flasks. Heat the uncovered flasks in a water-bath to eliminate the acetone. Allow to cool and add 5.0 mL of *2,7-dihydroxynaphthalene solution R* to each flask. Mix, add a further 15.0 mL of *2,7-dihydroxynaphthalene solution R* and mix again. Close the flasks with aluminium foil and heat in a water-bath for 20 min. Cool and dilute to 25.0 mL with *sulfuric acid R*.

Measure the absorbance (2.2.25) of each solution at 540 nm. Prepare a blank using 2.0 mL of a solution containing 5 per cent *V/V* each of *glacial acetic acid R* and *water R* in *acetone R*. Prepare a standard curve using the absorbances obtained with the reference solutions. From the standard curve and the absorbance of the test solution, determine the mass *a*, in milligrams, of glycollic acid in the substance to be examined and calculate the content of sodium glycolate from the following expression:

$$\frac{10 \times 1.29 \times a}{(100 - b) m}$$

- 1.29 = the factor converting glycollic acid to sodium glycolate,  
*b* = the loss on drying as a percentage,  
*m* = the mass of the substance to be examined, in grams.

**Water-soluble substances:** maximum 70.0 per cent.

Disperse 5.00 g in 400.0 mL of *water R* and stir for 1 min every 10 min during the first 30 min. Allow to stand for 1 h and centrifuge, if necessary. Decant 100.0 mL of the supernatant liquid onto a fast filter paper in a vacuum filtration funnel, apply vacuum and collect 75.0 mL of the filtrate. Evaporate to dryness and dry the residue at 100-105 °C for 4 h.

**Heavy metals (2.4.8):** maximum 20 ppm.

To the residue obtained in the determination of the sulfated ash add 1 mL of *hydrochloric acid R* and evaporate on a water-bath. Take up the residue in 20 mL of *water R* (this solution is used for identification test D). 12 mL of the solution complies with test A. Prepare the reference solution using *lead standard solution (1 ppm Pb) R*.

**Loss on drying (2.2.32):** maximum 10.0 per cent, determined on 1.000 g by drying in an oven at 105 °C.

**Sulfated ash (2.4.14):** 6.5 per cent to 13.5 per cent (dried substance), corresponding to a content of 2.0 per cent to 4.5 per cent of Na.

Use 1.0 g with a mixture of equal volumes of *sulfuric acid R* and *water R*.

#### FUNCTIONALITY-RELATED CHARACTERISTICS

*This section provides information on characteristics that are recognised as being relevant control parameters for one or more functions of the substance when used as an excipient (see chapter 5.15). This section is a non-mandatory part of the monograph and it is not necessary to verify the characteristics to demonstrate compliance. Control of these characteristics can however contribute to the quality of a medicinal product by improving the consistency of the manufacturing process and the performance of the medicinal product during use. Where control methods are cited, they are recognised as being suitable for the purpose, but other methods can also be used. Wherever results for a particular characteristic are reported, the control method must be indicated.*

*The following characteristic may be relevant for low-substituted carmellose sodium used as disintegrant.*

**Settling volume:** 15.0 mL to 35.0 mL.

In a 100 mL graduated cylinder, place 20 mL of *2-propanol R*, add 5.0 g of the substance to be examined and shake vigorously. Dilute to 30 mL with *2-propanol R* then to 50 mL with *water R* and shake vigorously. Within 15 min, repeat the shaking

3 times. Allow to stand for 4 h and determine the volume of the settled mass.

01/2008:1187

## CARMUSTINE

### Carmustinum

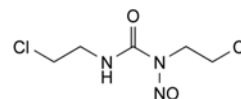

C<sub>5</sub>H<sub>9</sub>Cl<sub>2</sub>N<sub>3</sub>O<sub>2</sub>  
 [154-93-8]

*M*<sub>r</sub> 214.1

#### DEFINITION

Carmustine contains not less than 98.0 per cent and not more than the equivalent of 102.0 per cent of 1,3-bis(2-chloroethyl)-1-nitrosourea, calculated with reference to the anhydrous substance.

#### CHARACTERS

A yellowish, granular powder, very slightly soluble in water, very soluble in methylene chloride, freely soluble in ethanol. It melts at about 31 °C with decomposition.

#### IDENTIFICATION

Examine by infrared absorption spectrophotometry (2.2.24), comparing with the *Ph. Eur. reference spectrum of carmustine*. Examine the melted substances prepared as films.

#### TESTS

**1,3-Bis(2-chloroethyl)urea (impurity A).** Examine by thin-layer chromatography (2.2.27), using a suitable silica gel as the coating substance.

*Test solution.* Dissolve 0.10 g of the substance to be examined in *methylene chloride R* and dilute to 5 mL with the same solvent.

*Reference solution (a).* Dissolve 2 mg of *carmustine impurity A CRS* in *methylene chloride R* and dilute to 10 mL with the same solvent.

*Reference solution (b).* Dilute 1 mL of the test solution to 10 mL with *methylene chloride R*. To 5 mL of this solution, add 5 mL of reference solution (a).

Apply separately to the plate 2 µL of each solution. Develop over a path of 10 cm using a mixture of 10 volumes of *methanol R* and 90 volumes of *methylene chloride R*. Allow the plate to dry in air. Spray with *diethylamine R* and heat at 125 °C for 10 min. Allow to cool and spray with *silver nitrate solution R2*. Expose to ultraviolet light at 365 nm until brown to black spots appear. Any spot corresponding to carmustine impurity A in the chromatogram obtained with the test solution is not more intense than the spot in the chromatogram obtained with reference solution (a) (1 per cent). The test is not valid unless the chromatogram obtained with reference solution (b) shows two clearly separated spots.

**Water (2.5.12).** Not more than 1.0 per cent, determined on 0.50 g by the semi-micro determination of water.

#### ASSAY

Dissolve 0.100 g in 30 mL of *ethanol R* and dilute to 100.0 mL with *water R*. Dilute 3.0 mL of the solution to 100.0 mL with *water R*. Measure the absorbance (2.2.25) at the maximum at 230 nm.

Calculate the content of C<sub>5</sub>H<sub>9</sub>Cl<sub>2</sub>N<sub>3</sub>O<sub>2</sub> taking the specific absorbance to be 270.

#### STORAGE

Store in an airtight container, protected from light, at a temperature of 2 °C to 8 °C.

## IMPURITIES

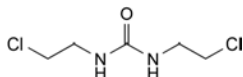

A. 1,3-bis(2-chloroethyl)urea.

01/2008:0597

## CARNAUBA WAX

## Cera carnauba

## DEFINITION

Purified wax obtained from the leaves of *Copernicia cerifera* Mart.

## CHARACTERS

**Appearance:** pale yellow or yellow powder, flakes or hard masses.

**Solubility:** practically insoluble in water, soluble on heating in ethyl acetate and in xylene, practically insoluble in alcohol.

**Relative density:** about 0.97.

## IDENTIFICATION

Thin-layer chromatography (2.2.27).

**Test solution.** Dissolve 0.10 g of the substance to be examined with heating in 5 mL of *chloroform R*. Use the warm solution.

**Reference solution.** Dissolve 5 mg of *menthol R*, 5 µL of *menthyl acetate R* and 5 mg of *thymol R* in 10 mL of *toluene R*.

**Plate:** TLC silica gel plate R.

**Mobile phase:** *ethyl acetate R*, *chloroform R* (2:98 V/V).

**Application:** 30 µL of the test solution and 10 µL of the reference solution as bands 20 mm by 3 mm.

**Development:** over half of the plate.

**Drying:** in air.

**Detection:** spray with a freshly prepared 200 g/L solution of *phosphomolybdic acid R* in *alcohol R* (about 10 mL for a 20 cm plate). Heat at 100-105 °C for 10-15 min.

**Results:** the chromatogram obtained with the reference solution shows in the lower part a dark blue zone (menthol), above this zone a reddish zone (thymol) and in the upper part a dark blue zone (menthyl acetate). The chromatogram obtained with the test solution shows a large blue zone (triacontanol = melissyl alcohol) at a level between the thymol and menthol zones in the chromatogram obtained with the reference solution. Further blue zones are visible in the upper part of the chromatogram obtained with the test solution, at levels between those of the menthyl acetate and thymol zones in the chromatogram obtained with the reference solution; above these zones further zones are visible in the chromatogram obtained with the test solution; the zone with the highest  $R_f$  value is very pronounced. A number of faint zones are visible below the triacontanol zone and the point of application is coloured blue.

## TESTS

**Appearance of solution.** The solution is clear (2.2.1) and not more intensely coloured than a 50 mg/L solution of *potassium dichromate R* (2.2.2, Method II).

Dissolve 0.10 g with heating in *chloroform R* and dilute to 10 mL with the same solvent.

**Melting point** (2.2.15): 80 °C to 88 °C.

Melt the substance to be examined carefully on a water-bath before introduction into the capillary tubes. Allow the tubes to stand in the refrigerator for 24 h or at 0 °C for 2 h.

**Acid value:** 2 to 7.

To 2.000 g ( $m$  g) in a 250 mL conical flask fitted with a reflux condenser add 40 mL of *xylene R* and a few glass beads. Heat

with stirring until the substance is completely dissolved. Add 20 mL of *alcohol R* and 1 mL of *bromothymol blue solution R3* and titrate the hot solution with 0.5 M *alcoholic potassium hydroxide* until a green colour persisting for at least 10 s is obtained ( $n_1$  mL). Carry out a blank test ( $n_2$  mL). Calculate the acid value from the expression:

$$\frac{28.05 (n_1 - n_2)}{m}$$

**Saponification value:** 78 to 95.

To 2.000 g ( $m$  g) in a 250 mL conical flask fitted with a reflux condenser add 40 mL of *xylene R* and a few glass beads. Heat with stirring until the substance is completely dissolved. Add 20 mL of *alcohol R* and 20.0 mL of 0.5 M *alcoholic potassium hydroxide*. Boil under a reflux condenser for 3 h. Add 1 mL of *phenolphthalein solution R1* and titrate the hot solution immediately with 0.5 M *hydrochloric acid* until the red colour disappears. Repeat the heating and titration until the colour no longer reappears on heating ( $n_3$  mL). Carry out a blank test ( $n_4$  mL). Calculate the saponification value from the expression:

$$\frac{28.05 (n_4 - n_3)}{m}$$

**Total ash** (2.4.16): maximum 0.25 per cent, determined on 2.0 g.

## STORAGE

Protected from light.

07/2008:2201  
corrected 7.0

## CARPROFEN FOR VETERINARY USE

## Carprofenum ad usum veterinarium

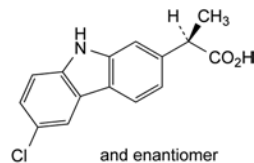

$C_{15}H_{12}ClNO_2$   
[53716-49-7]

$M_r$  273.7

## DEFINITION

(2*RS*)-2-(6-Chloro-9*H*-carbazol-2-yl)propanoic acid.

**Content:** 98.5 per cent to 101.5 per cent (dried substance).

## CHARACTERS

**Appearance:** white or almost white, crystalline powder.

**Solubility:** practically insoluble in water, freely soluble in acetone, soluble in methanol, slightly soluble in 2-propanol. It shows polymorphism (5.9).

## IDENTIFICATION

Infrared absorption spectrophotometry (2.2.24).

**Comparison:** *carprofen CRS*.

If the spectra obtained in the solid state show differences, dissolve the substance to be examined and the reference substance separately in *acetone R*, evaporate to dryness and record new spectra using the residues.

## TESTS

**Appearance of solution.** The solution is clear (2.2.1) and not more intensely coloured than reference solution BY<sub>3</sub> (2.2.2, Method II).

Dissolve 1.0 g in *methanol R* and dilute to 25 mL with the same solvent.

**Related substances.** Liquid chromatography (2.2.29). Carry out the test protected from light.

**Test solution.** Dissolve 50 mg of the substance to be examined in the mobile phase and dilute to 100.0 mL with the mobile phase.

**Reference solution (a).** Dissolve 2.5 mg of *carprofen* for system suitability CRS (containing impurity C) in the mobile phase and dilute to 10.0 mL with the mobile phase.

**Reference solution (b).** Dilute 1.0 mL of the test solution to 100.0 mL with the mobile phase. Dilute 1.0 mL of this solution to 10.0 mL with the mobile phase.

**Column:**

- size:  $l = 0.25$  m,  $\varnothing = 4.6$  mm;
- stationary phase: end-capped polar-embedded octadecylsilyl amorphous organosilica polymer R (5  $\mu$ m).

**Mobile phase:** mix 30 volumes of a 1.36 g/L solution of potassium dihydrogen phosphate R adjusted to pH 3.0 with phosphoric acid R and 70 volumes of methanol R2.

**Flow rate:** 1.3 mL/min.

**Detection:** spectrophotometer at 235 nm.

**Injection:** 20  $\mu$ L.

**Run time:** 4 times the retention time of *carprofen*.

**Retention time:** *carprofen* = about 10 min.

**System suitability:** reference solution (a):

- resolution: minimum 1.5 between the peaks due to impurity C and *carprofen*.

**Limits:**

- unspecified impurities: for each impurity, not more than twice the area of the principal peak in the chromatogram obtained with reference solution (b) (0.20 per cent);
- total: not more than 5 times the area of the principal peak in the chromatogram obtained with reference solution (b) (0.5 per cent);
- disregard limit: the area of the principal peak in the chromatogram obtained with reference solution (b) (0.1 per cent).

**Heavy metals** (2.4.8): maximum 20 ppm.

Dissolve 1.0 g in ethanol (96 per cent) R and dilute to 20 mL with the same solvent. 12 mL of the solution complies with test B. Prepare the reference solution using lead standard solution (2 ppm Pb) R.

**Loss on drying** (2.2.32): maximum 0.5 per cent, determined on 1.000 g by drying in an oven at 105 °C for 2 h.

**Sulfated ash** (2.4.14): maximum 0.1 per cent, determined on 1.0 g.

**ASSAY**

Dissolve 0.200 g in 50 mL of ethanol (96 per cent) R. Add 1.0 mL of 0.1 M hydrochloric acid. Titrate with 0.1 M sodium hydroxide, determining the end-point potentiometrically (2.2.20). Read the volume added between the 2 points of inflexion.

1 mL of 0.1 M sodium hydroxide is equivalent to 27.37 mg of  $C_{15}H_{12}ClNO_2$ .

**STORAGE**

Protected from light.

**IMPURITIES**

**Other detectable impurities** (the following substances would, if present at a sufficient level, be detected by one or other of the tests in the monograph. They are limited by the general acceptance criterion for other/unspecified impurities and/or by the general monograph *Substances for pharmaceutical use* (2034). It is therefore not necessary to identify these impurities for demonstration of compliance. See also 5.10. *Control of impurities in substances for pharmaceutical use*): A, B, C, D, E, F, G, H.

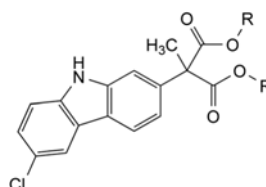

A. R = H: 2-(6-chloro-9*H*-carbazol-2-yl)-2-methylpropanedioic acid,

F. R = C<sub>2</sub>H<sub>5</sub>: diethyl 2-(6-chloro-9*H*-carbazol-2-yl)-2-methylpropanedioate,

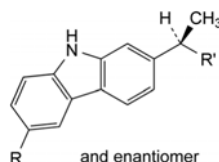

B. R = H, R' = CO<sub>2</sub>H: (2*RS*)-2-(9*H*-carbazol-2-yl)propanoic acid,

C. R = Cl, R' = OH: (1*RS*)-1-(6-chloro-9*H*-carbazol-2-yl)ethanol,

G. R = Cl, R' = CO-O-C<sub>2</sub>H<sub>5</sub>: ethyl (2*RS*)-2-(6-chloro-9*H*-carbazol-2-yl)propanoate,

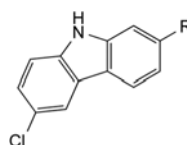

D. R = CO-CH<sub>3</sub>: 1-(6-chloro-9*H*-carbazol-2-yl)ethanone,

E. R = H: 3-chloro-9*H*-carbazole,

H. R = C<sub>2</sub>H<sub>5</sub>: 6-chloro-2-ethyl-9*H*-carbazole.

01/2011:2138

## CARRAGEENAN

### Carrageenanum

#### DEFINITION

Carrageenans are polysaccharides extracted from different Rhodophyceae with boiling water or aqueous alkali solutions. Carrageenan is separated by alcohol precipitation, potassium chloride precipitation, gel pressing, drum drying or freezing. The alcohol used during separation and purification is generally 2-propanol. The main components are potassium, sodium, calcium or magnesium salts of the sulfate esters of D-galactose and 3,6-anhydro-D-galactose copolymers. They exist in different proportions depending on the biological origin of the polymer. The prevalent copolymers are designated as  $\kappa$ -,  $\iota$ - and  $\lambda$ -carrageenan.

#### CHARACTERS

**Appearance:** yellowish, brownish, or white or almost white powder.

**Solubility:** soluble in water giving a viscous or colloidal solution, insoluble in organic solvents.

#### IDENTIFICATION

A. Prepare a 20 g/L dispersion and heat in a water-bath at 80 °C (Solution A). Allow to cool; it becomes more viscous upon cooling and may form a gel.

To 10 mL of solution A, while still hot, add 4 drops of a 100 g/L solution of potassium chloride R, mix and allow to cool. A 'brittle' gel indicates a carrageenan of a predominantly  $\kappa$ -type; an 'elastic' gel indicates a predominantly  $\iota$ -type; if the solution does not form a gel, the carrageenan is of a predominantly  $\lambda$ -type.

B. Dilute 1 volume of solution A with about 4 volumes of *water R* and add 2-3 drops of a 0.5 g/L solution of *methylene blue R* in *ethanol (96 per cent) R*. A blue precipitate is formed.

C. Infrared absorption spectrophotometry (2.2.24).

*Preparation:* prepare a 2 g/L solution of the substance to be examined and cast films (5 µm thick when dry) on a suitable non-sticking surface.

Carrageenan has strong, broad absorption bands, typical of all polysaccharides, in the 1000-1100 cm<sup>-1</sup> region. Absorption maxima are 1065 cm<sup>-1</sup> and 1020 cm<sup>-1</sup> for gelling and non-gelling types, respectively. Other characteristic absorption bands and their intensities relative to the absorbance at 1050 cm<sup>-1</sup> are shown in Table 2138-1.

Table 2138-1. – *Characteristic absorption bands for carrageenan identification by infrared absorption spectrophotometry*

Wave-number (cm <sup>-1</sup> )	Molecular structure	Absorbance relative to the absorbance at 1050 cm <sup>-1</sup>		
		κ	ι	λ
1220 - 1260	Ester sulfate	0.7 - 1.2	1.2 - 1.6	1.4 - 2.0
928 - 933	3,6-anhydro-D-galactose	0.3 - 0.6	0.2 - 0.4	≤ 0.2
840 - 850	Galactose-4-sulfate	0.3 - 0.5	0.2 - 0.4	-
825 - 830	Galactose-2-sulfate	-	-	0.2 - 0.4
810 - 820	Galactose-6-sulfate	-	-	0.1 - 0.3
800 - 805	3,6-anhydro-D-galactose-2-sulfate	≤ 0.2	0.2 - 0.4	-

TESTS

**Apparent viscosity (2.2.10):** minimum 5 mPas. Heat a 15 g/L dispersion (dried substance) at 80 °C for at least 15 min to dissolve. Compensate for any loss of water by evaporation, allow to cool to 75 °C and carry out the test at this temperature.

**Heavy metals (2.4.8):** maximum 20 ppm.

Dissolve 2.0 g in 30 mL of *water R* and shake for 2 min. Allow to stand and separate the aqueous layer. 12 mL of the solution complies with test A. Prepare the reference solution using *lead standard solution (1 ppm Pb) R*.

**Loss on drying (2.2.32):** maximum 12.0 per cent, determined on 1.000 g by drying in an oven at 105 °C.

**Total ash (2.4.16):** maximum 40.0 per cent.

**Ash insoluble in hydrochloric acid (2.8.1):** maximum 2.0 per cent.

LABELLING

The label states the type of carrageenan.

FUNCTIONALITY-RELATED CHARACTERISTICS

*This section provides information on characteristics that are recognised as being relevant control parameters for one or more functions of the substance when used as an excipient (see chapter 5.15). This section is a non-mandatory part of the monograph and it is not necessary to verify the characteristics to demonstrate compliance. Control of these characteristics can however contribute to the quality of a medicinal product by improving the consistency of the manufacturing process and the performance of the medicinal product during use. Where control methods are cited, they are recognised as being suitable for the purpose, but other methods can also be used. Wherever results for a particular characteristic are reported, the control method must be indicated.*

*The following characteristics may be relevant for carrageenan used as viscosity-increasing agent.*

**Gel formation:** see Identification A.

**Apparent viscosity:** see Tests.

01/2008:1972  
corrected 6.0

CARTEOLOL HYDROCHLORIDE

Carteololi hydrochloridum

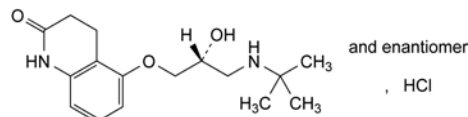

C<sub>16</sub>H<sub>25</sub>N<sub>2</sub>O<sub>3</sub>Cl  
[51781-21-6]

M<sub>r</sub> 328.8

DEFINITION

5-[(2*RS*)-3-[(1,1-Dimethylethyl)amino]-2-hydroxypropoxy]-3,4-dihydroquinolin-2(1*H*)-one hydrochloride.

*Content:* 99.0 per cent to 101.0 per cent (dried substance).

CHARACTERS

*Appearance:* white or almost white crystals or crystalline powder.

*Solubility:* soluble in water, sparingly soluble in methanol, slightly soluble in ethanol 96 per cent, practically insoluble in methylene chloride.

IDENTIFICATION

A. Infrared absorption spectrophotometry (2.2.24).

*Comparison:* *Ph. Eur. reference spectrum of carteolol hydrochloride.*

B. It gives reaction (a) of chlorides (2.3.1).

TESTS

**Appearance of solution.** The solution is clear (2.2.1) and colourless (2.2.2, *Method II*).

Dissolve 0.300 g in *water R* and dilute to 10 mL with the same solvent.

**pH (2.2.3):** 5.0 to 6.0.

Dissolve 0.250 g in *carbon dioxide-free water R* and dilute to 25 mL with the same solvent.

**Related substances.** Liquid chromatography (2.2.29).

*Test solution.* Dissolve 20.0 mg of the substance to be examined in the mobile phase and dilute to 10.0 mL with the mobile phase.

*Reference solution (a).* Dilute 1.0 mL of the test solution to 100.0 mL with the mobile phase.

*Reference solution (b).* Dilute 1.0 mL of reference solution (a) to 10.0 mL with the mobile phase.

*Reference solution (c).* Dissolve 10 mg of *carteolol for system suitability CRS* in the mobile phase and dilute to 5 mL with the mobile phase.

*Reference solution (d).* Dilute 5.0 mL of reference solution (b) to 10.0 mL with the mobile phase.

*Column:*

- *size:* l = 0.25 m, Ø = 4.6 mm;
- *stationary phase:* octadecylsilyl silica gel for chromatography R (5 µm).

*Mobile phase:* mix 1 volume of *methanol R2*, 20 volumes of *acetonitrile R* and 79 volumes of a 2.82 g/L solution of *sodium hexanesulfonate R*.

*Flow rate:* 1 mL/min.

*Detection:* spectrophotometer at 252 nm.

*Injection:* 20 µL.

*Identification of impurities:* use the chromatogram supplied with *carteolol for system suitability CRS* to identify the peak due to impurity H.

**System suitability:**

- the chromatogram obtained with reference solution (c) is similar to the chromatogram provided with *carvedilol for system suitability CRS*; the peaks due to impurity H and carvedilol show base-line separation;
- *signal-to-noise ratio*: minimum 10 for the principal peak in the chromatogram obtained with reference solution (d);
- *number of theoretical plates*: minimum 6000, calculated for the principal peak in the chromatogram obtained with reference solution (a).

**Limits:**

- *impurity H*: not more than twice the area of the principal peak in the chromatogram obtained with reference solution (b) (0.2 per cent);
- *unspecified impurities*: for each impurity, not more than the area of the principal peak in the chromatogram obtained with reference solution (b) (0.10 per cent);
- *total*: not more than half the area of the principal peak in the chromatogram obtained with reference solution (a) (0.5 per cent);
- *disregard limit*: 0.2 times the area of the principal peak in the chromatogram obtained with reference solution (b) (0.02 per cent).

**Loss on drying** (2.2.32): maximum 0.5 per cent, determined on 1.000 g by drying in an oven at 105 °C for 3 h.

**Sulfated ash** (2.4.14): maximum 0.1 per cent, determined on 1.0 g.

**ASSAY**

Dissolve 0.250 g in 60 mL of *ethanol (96 per cent) R*. Add 5.0 mL of 0.01 M *hydrochloric acid*. Carry out a potentiometric titration (2.2.20), using 0.1 M *sodium hydroxide*. Read the volume added between the 2 points of inflexion.

1 mL of 0.1 M *sodium hydroxide* is equivalent to 32.88 mg of C<sub>16</sub>H<sub>25</sub>N<sub>2</sub>O<sub>3</sub>Cl.

**STORAGE**

In an airtight container.

**IMPURITIES**

*Specified impurities: H.*

*Other detectable impurities* (the following substances would, if present at a sufficient level, be detected by one or other of the tests in the monograph. They are limited by the general acceptance criterion for other/unspecified impurities and/or by the general monograph *Substances for pharmaceutical use (2034)*. It is therefore not necessary to identify these impurities for demonstration of compliance. See also 5.10. *Control of impurities in substances for pharmaceutical use*): A, B, C, D, E, F, G, I.

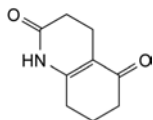

A. 4,6,7,8-tetrahydroquinoline-2,5(1*H*,3*H*)-dione,

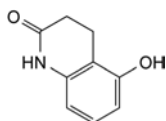

B. 5-hydroxy-3,4-dihydroquinolin-2(1*H*)-one,

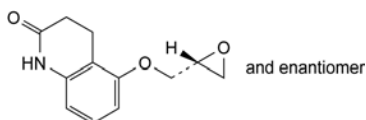

C. 5-[(2*RS*)-oxiran-2-yl]methoxy-3,4-dihydroquinolin-2(1*H*)-one,

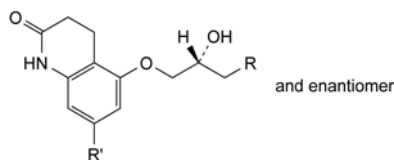

D. R = Cl, R' = H: 5-[(2*RS*)-3-chloro-2-hydroxypropoxy]-3,4-dihydroquinolin-2(1*H*)-one,

F. R = OCH<sub>3</sub>, R' = H: 5-[(2*RS*)-2-hydroxy-3-methoxypropoxy]-3,4-dihydroquinolin-2(1*H*)-one,

G. R = OH, R' = H: 5-[(2*RS*)-2,3-dihydroxypropoxy]-3,4-dihydroquinolin-2(1*H*)-one,

I. R = NH-C(CH<sub>3</sub>)<sub>3</sub>, R' = Br: 7-bromo-5-[(2*RS*)-3-[(1,1-dimethylethyl)amino]-2-hydroxypropoxy]-3,4-dihydroquinolin-2(1*H*)-one,

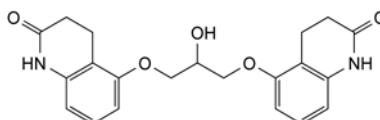

E. 5,5'-[(2-hydroxypropan-1,3-diyl)bis(oxy)]bis(3,4-dihydroquinolin-2(1*H*)-one),

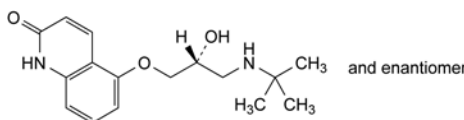

H. 5-[(2*RS*)-3-[(1,1-dimethylethyl)amino]-2-hydroxypropoxy]-quinolin-2(1*H*)-one.

01/2008:1745  
corrected 6.0

**CARVEDILOL**

## Carvedilolum

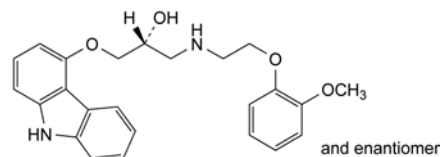

C<sub>24</sub>H<sub>26</sub>N<sub>2</sub>O<sub>4</sub>  
[72956-09-3]

M<sub>r</sub> 406.5

**DEFINITION**

(2*RS*)-1-(9*H*-Carbazol-4-yloxy)-3-[[2-(2-methoxyphenoxy)ethyl]amino]propan-2-ol.

*Content*: 99.0 per cent to 101.0 per cent (dried substance).

**CHARACTERS**

*Appearance*: white or almost white, crystalline powder.

*Solubility*: practically insoluble in water, slightly soluble in alcohol, practically insoluble in dilute acids.

It shows polymorphism (5.9).

**IDENTIFICATION**

Infrared absorption spectrophotometry (2.2.24).

*Comparison*: Ph. Eur. reference spectrum of carvedilol.

If the spectrum obtained shows differences, dissolve the substance to be examined in 2-propanol R, evaporate to dryness and record a new spectrum using the residue.

**TESTS**

**Related substances.** Liquid chromatography (2.2.29).

*Test solution.* Dissolve 25.0 mg of the substance to be examined in the mobile phase and dilute to 25.0 mL with the mobile phase.

**Reference solution (a).** Dilute 1.0 mL of the test solution to 100.0 mL with the mobile phase. Dilute 1.0 mL of this solution to 10.0 mL with the mobile phase.

**Reference solution (b).** Dissolve 5.0 mg of *carvedilol impurity C CRS* in 5.0 mL of the test solution and dilute to 100.0 mL with the mobile phase.

**Reference solution (c).** Dilute 1.0 mL of reference solution (b) to 100.0 mL with the mobile phase. Dilute 2.0 mL of this solution to 10.0 mL with the mobile phase.

**Column:**

- size:  $l = 0.125$  m,  $\varnothing = 4.6$  mm,
- stationary phase: *octylsilyl silica gel for chromatography R* (5  $\mu$ m),
- temperature: 55 °C.

**Mobile phase:** dissolve 1.77 g of *potassium dihydrogen phosphate R* in *water R* and dilute to 650 mL with the same solvent; adjust to pH 2.0 with *phosphoric acid R* and add 350 mL of *acetonitrile R*.

**Flow rate:** 1.0 mL/min.

**Detection:** spectrophotometer at 240 nm.

**Injection:** 20  $\mu$ L.

**Run time:** 8 times the retention time of carvedilol.

**Relative retention** with reference to carvedilol (retention time = about 4 min): impurity A = about 0.6; impurity C = about 3.5; impurity B = about 6.7.

**System suitability:** reference solution (b):

- resolution: minimum 17 between the peaks due to carvedilol and to impurity C.

**Limits:**

- correction factor: for the calculation of content, multiply the peak area of impurity A by 2,
- impurity A: not more than twice the area of the principal peak in the chromatogram obtained with reference solution (a) (0.2 per cent),
- impurity C: not more than twice the area of the corresponding peak in the chromatogram obtained with reference solution (c) (0.02 per cent),
- any other impurity: not more than the area of the principal peak in the chromatogram obtained with reference solution (a) (0.1 per cent),
- total: not more than 5 times the area of the principal peak in the chromatogram obtained with reference solution (a) (0.5 per cent),
- disregard limit: the area of the principal peak in the chromatogram obtained with reference solution (c) (0.01 per cent).

**Heavy metals (2.4.8):** maximum 10 ppm.

2.0 g complies with limit test C. Prepare the standard using 2.0 mL of *lead standard solution (10 ppm Pb) R*.

**Loss on drying (2.2.32):** maximum 0.5 per cent, determined on 1.000 g by drying in an oven at 105 °C.

**Sulfated ash (2.4.14):** maximum 0.1 per cent, determined on 1.0 g.

**ASSAY**

Dissolve 0.350 g in 60 mL of *anhydrous acetic acid R*. Titrate with 0.1 M *perchloric acid*, determining the end-point potentiometrically (2.2.20).

1 mL of 0.1 M *perchloric acid* is equivalent to 40.65 mg of  $C_{24}H_{46}N_2O_4$ .

**IMPURITIES**

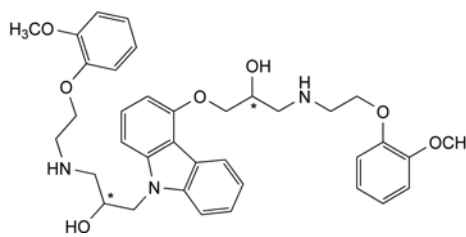

- A. 1-[[9-[2-hydroxy-3-[[2-(2-methoxyphenoxy)ethyl]amino]propyl]-9H-carbazol-4-yl]oxy]-3-[[2-(2-methoxyphenoxy)ethyl]amino]propan-2-ol,

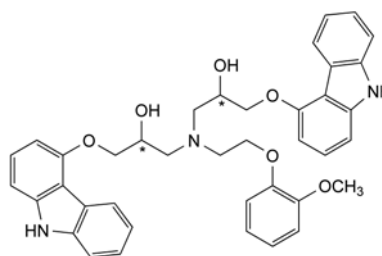

- B. 1,1'-[[2-(2-methoxyphenoxy)ethyl]nitrilo]bis[3-(9H-carbazol-4-yloxy)propan-2-ol],

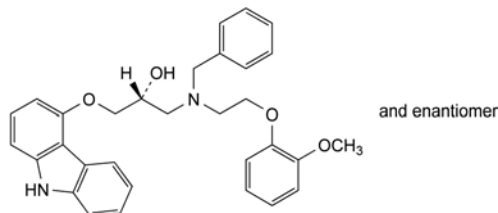

- C. (2RS)-1-[benzyl[2-(2-methoxyphenoxy)ethyl]amino]-3-(9H-carbazol-4-yloxy)propan-2-ol.

01/2008:1497

## CASTOR OIL, HYDROGENATED

### Ricini oleum hydrogenatum

**DEFINITION**

Fatty oil obtained by hydrogenation of *Virgin Castor oil (0051)*. It consists mainly of the triglyceride of 12-hydroxystearic (12-hydroxyoctadecanoic) acid.

**CHARACTERS**

**Appearance:** fine, almost white or pale yellow powder or almost white or pale yellow masses or flakes.

**Solubility:** practically insoluble in water, slightly soluble in methylene chloride, very slightly soluble in anhydrous ethanol, practically insoluble in light petroleum.

**IDENTIFICATION**

- A. Melting point (2.2.14): 83 °C to 88 °C.  
 B. Hydroxyl value (see Tests).  
 C. Composition of fatty acids (see Tests).

**TESTS**

**Acid value (2.5.1):** maximum 4.0, determined on 10.0 g dissolved in 75 mL of hot *ethanol (96 per cent) R*.

**Hydroxyl value (2.5.3, Method A):** 145 to 165, determined on a warm solution.

**Iodine value (2.5.4, Method A):** maximum 5.0.

**Alkaline impurities.** Dissolve 1.0 g by gentle heating in a mixture of 1.5 mL of *ethanol (96 per cent) R* and 3 mL of *toluene R*. Add 0.05 mL of a 0.4 g/L solution of *bromophenol*



blue R in ethanol (96 per cent R. Not more than 0.2 mL of 0.01 M hydrochloric acid is required to change the colour of the indicator to yellow.

**Composition of fatty acids (2.4.22).** Use the mixture of calibrating substances in Table 2.4.22.-3.

**Test solution.** Introduce 75 mg of the substance to be examined into a 10 mL centrifuge tube with a screw cap. Dissolve in 2 mL of 1,1-dimethylethyl methyl ether R1 by shaking and heat gently (50-60 °C). Add, when still warm, 1 mL of a 12 g/L solution of sodium R in anhydrous methanol R, prepared with the necessary precautions, and mix vigorously for at least 5 min. Add 5 mL of distilled water R and mix vigorously for about 30 s. Centrifuge for 15 min at 1500 g. Use the upper layer.

**Reference solution.** Dissolve 50 mg of methyl 12-hydroxystearate CRS and 50 mg of methyl stearate CRS in 10.0 mL of 1,1-dimethylethyl methyl ether R1.

**Column:**

- material: fused silica;
- size:  $l = 30$  m;  $\varnothing = 0.25$  mm;
- stationary phase: macrogol 20 000 R (film thickness 0.25  $\mu$ m).

**Carrier gas:** helium for chromatography R.

**Flow rate:** 0.9 mL/min.

**Split ratio:** 1:100.

**Temperature:**

	Time (min)	Temperature (°C)
Column	0 - 55	215
Injection port		250
Detector		250

**Detection:** flame ionisation.

**Injection:** 1  $\mu$ L.

Calculate the fraction of each fatty-acid using the following expression:

$$A_{x,s,c} / \sum A_{x,s,c} \times 100 \text{ per cent } m/m$$

$A_{x,s,c}$  = corrected peak area of the fatty acid in the test solution:

$$A_{x,s,c} = A_{x,s} \times R_c$$

$R_c$  = relative correction factor for the peak due to methyl 12-hydroxystearate:

$$R_c = \frac{m_{1,r} \times A_{2,r}}{A_{1,r} \times m_{2,r}}$$

$R_c$  = 1 for peaks corresponding to each of the other specified fatty acids or any unspecified fatty acid;

$m_{1,r}$  = mass of methyl 12-hydroxystearate in the reference solution;

$m_{2,r}$  = mass of methyl stearate in the reference solution;

$A_{1,r}$  = area of any peak due to methyl 12-hydroxystearate in the chromatogram obtained with the reference solution;

$A_{2,r}$  = area of any peak due to methyl stearate in the chromatogram obtained with the reference solution;

$A_{x,s}$  = area of the peaks due to any specified or unspecified fatty acid methyl esters.

**Composition of the fatty acid fraction of the oil:**

- palmitic acid: not more than 2.0 per cent;
- stearic acid: 7.0 per cent to 14.0 per cent;
- arachidic acid: not more than 1.0 per cent;

- 12-oxostearic acid: not more than 5.0 per cent;
- 12-hydroxystearic acid: 78.0 per cent to 91.0 per cent;
- any other fatty acid: not more than 3.0 per cent.

**Nickel (2.4.31):** maximum 1 ppm.

**STORAGE**

In a well-filled container.

**IMPURITIES**

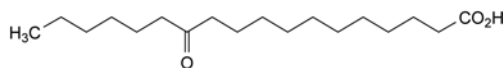

A. 12-oxostearic acid.

01/2008:2367

## CASTOR OIL, REFINED

### Ricini oleum raffinatum

**DEFINITION**

Fatty oil obtained from the seeds of *Ricinus communis* L. by cold expression. It is then refined. A suitable antioxidant may be added.

**PRODUCTION**

During the expression step, the temperature of the oil must not exceed 50 °C.

**CHARACTERS**

**Appearance:** clear, almost colourless or slightly yellow, viscous, hygroscopic liquid.

**Solubility:** slightly soluble in light petroleum, miscible with ethanol (96 per cent) and with glacial acetic acid.

**Relative density:** about 0.958.

**Refractive index:** about 1.479.

**Viscosity:** about 1000 mPas.

**IDENTIFICATION**

**First identification:** B.

**Second identification:** A.

A. A mixture of 2 mL of the substance to be examined and 8 mL of ethanol (96 per cent) R is clear (2.2.1).

B. Composition of fatty acids (see Tests).

**TESTS**

**Appearance.** The substance to be examined is clear (2.2.1) and not more intensely coloured (2.2.2, Method II) than 20 mL of a mixture of 0.25 mL of blue primary solution, 0.25 mL of red primary solution, 0.8 mL of yellow primary solution, and 18.7 mL of a solution prepared by diluting 4.0 mL of hydrochloric acid R1 to 100.0 mL with water R.

**Optical rotation (2.2.7):** + 3.5° to + 6.0°.

**Specific absorbance (2.2.25):** maximum 1.5, determined in ethanol (96 per cent) R at the absorption maximum between 268 nm and 270 nm.

**Acid value (2.5.1):** maximum 0.8.

Dissolve 5.00 g in 25 mL of the prescribed mixture of solvents.

**Hydroxyl value (2.5.3, Method A):** minimum 150.

**Peroxide value (2.5.5, Method A):** maximum 5.0.

**Unsaponifiable matter (2.5.7):** maximum 0.8 per cent, determined on 5.0 g.

**Oil obtained by extraction and adulteration.** In a ground-glass-stoppered tube about 125 mm long and 18 mm in internal diameter, thoroughly mix 3 mL of the substance to be examined with 3 mL of carbon disulfide R. Shake for 3 min with 1 mL of sulfuric acid R. The mixture is less intensely

coloured than a freshly prepared mixture of 3.2 mL of *ferric chloride solution R1*, 2.3 mL of *water R* and 0.5 mL of *dilute ammonia R1*.

**Composition of fatty acids.** Gas chromatography (2.4.22) with the following modifications.

Use the mixture of calibrating substances in Table 2.4.22.-3.

**Test solution.** Introduce 75 mg of the substance to be examined into a 10 mL centrifuge tube with a screw cap. Dissolve in 2 mL of *1,1-dimethylethyl methyl ether R1* with shaking and heat gently (50-60 °C). To the still-warm solution, add 1 mL of a 12 g/L solution of *sodium R* in *anhydrous methanol R*, prepared with the necessary precautions, and shake vigorously for at least 5 min. Add 5 mL of *distilled water R* and shake vigorously for about 30 s. Centrifuge for 15 min at 1500 *g*. Use the upper layer.

**Reference solution.** Dissolve 50 mg of *methyl ricinoleate CRS* and 50 mg of *methyl stearate CRS* in 10.0 mL of *1,1-dimethylethyl methyl ether R1*.

**Column:**

- **material:** fused silica;
- **size:**  $l = 30$  m,  $\varnothing = 0.25$  mm;
- **stationary phase:** *macrogol 20 000 R* (film thickness 0.25  $\mu$ m).

**Carrier gas:** *helium for chromatography R*.

**Flow rate:** 0.9 mL/min.

**Split ratio:** 1:100.

**Temperature:**

	Time (min)	Temperature (°C)
Column	0 - 55	215
Injection port		250
Detector		250

**Detection:** flame ionisation.

**Injection:** 1  $\mu$ L.

Calculate the percentage content of each fatty acid by the normalisation procedure.

Correct the area of the peak due to methyl ricinoleate, multiplying by a factor (*R*) calculated using the following expression:

$$\frac{m_1 \times A_2}{A_1 \times m_2}$$

$m_1$  = mass of methyl ricinoleate in the reference solution;

$m_2$  = mass of methyl stearate in the reference solution;

$A_1$  = area of the peak due to methyl ricinoleate in the chromatogram obtained with the reference solution;

$A_2$  = area of the peak due to methyl stearate in the chromatogram obtained with the reference solution.

**Composition of the fatty-acid fraction of the oil:**

- **palmitic acid:** maximum 2.0 per cent;
- **stearic acid:** maximum 2.5 per cent;
- **oleic acid and isomers:** 2.5 per cent to 6.0 per cent;
- **linoleic acid:** 2.5 per cent to 7.0 per cent;
- **linolenic acid:** maximum 1.0 per cent;
- **eicosenoic acid:** maximum 1.0 per cent;
- **ricinoleic acid:** 85.0 per cent to 92.0 per cent;
- **any other fatty acid:** maximum 1.0 per cent.

**Water (2.5.32):** maximum 0.2 per cent, determined on 5.00 g, if intended for use in the manufacture of parenteral preparations.

#### STORAGE

In an airtight, well-filled container, protected from light.

#### LABELLING

The label states, where applicable, that the substance is suitable for use in the manufacture of parenteral preparations.

01/2008:0051

## CASTOR OIL, VIRGIN

### Ricini oleum virginale

#### DEFINITION

Fatty oil obtained by cold expression from the seeds of *Ricinus communis* L. A suitable antioxidant may be added.

#### CHARACTERS

**Appearance:** clear, almost colourless or slightly yellow, viscous, hygroscopic liquid.

**Solubility:** slightly soluble in light petroleum, miscible with ethanol (96 per cent) and with glacial acetic acid.

**Relative density:** about 0.958.

**Refractive index:** about 1.479.

#### IDENTIFICATION

**First identification:** D.

**Second identification:** A, B, C.

A. Optical rotation (see Tests).

B. Hydroxyl value (see Tests).

C. Iodine value (2.5.4): 82 to 90.

D. Composition of fatty acids (see Tests).

#### TESTS

**Optical rotation (2.2.7):** + 3.5° to + 6.0°.

**Specific absorbance (2.2.25):** maximum 1.0, determined at the absorption maximum at 269 nm  $\pm$  1 nm.

To 1.0 g add *ethanol (96 per cent) R* and dilute to 100.0 mL with the same solvent.

**Acid value (2.5.1):** maximum 2.0.

Dissolve 5.0 g in 25 mL of the prescribed mixture of solvents.

**Hydroxyl value (2.5.3, Method A):** minimum 150.

**Peroxide value (2.5.5):** maximum 10.0.

**Unsaponifiable matter (2.5.7):** maximum 0.8 per cent, determined on 5.0 g.

**Composition of fatty acids.** Gas chromatography (2.4.22) with the following modifications.

Use the mixture of calibrating substances in Table 2.4.22.-3.

**Test solution.** Introduce 75 mg of the substance to be examined into a 10 mL centrifuge tube with a screw cap. Dissolve in 2 mL of *1,1-dimethylethyl methyl ether R1* with shaking and heat gently (50-60 °C). Add, when still warm, 1 mL of a 12 g/L solution of *sodium R* in *anhydrous methanol R*, prepared with the necessary precautions, and mix vigorously for at least 5 min. Add 5 mL of *distilled water R* and mix vigorously for about 30 s. Centrifuge for 15 min at 1500 *g*. Use the upper layer.

**Reference solution.** Dissolve 50 mg of *methyl ricinoleate CRS* and 50 mg of *methyl stearate CRS* in 10.0 mL of *1,1-dimethylethyl methyl ether R1*.

**Column:**

- **material:** fused silica;
- **size:**  $l = 30$  m,  $\varnothing = 0.25$  mm;
- **stationary phase:** *macrogol 20 000 R* (film thickness 0.25  $\mu$ m).

**Carrier gas:** *helium for chromatography R*.

**Flow rate:** 0.9 mL/min.

**Split ratio:** 1:100.

## Temperature:

	Time (min)	Temperature (°C)
Column	0 - 55	215
Injection port		250
Detector		250

Detection: flame ionisation.

Injection: 1 µL.

Calculate the percentage content of each fatty acid by the normalisation procedure.

Correct the area of the peak due to methyl ricinoleate, multiplying by a factor *R* calculated using the following expression:

$$R = \frac{m_1 \times A_2}{A_1 \times m_2}$$

$m_1$  = mass of methyl ricinoleate in the reference solution,

$m_2$  = mass of methyl stearate in the reference solution,

$A_1$  = area of the peak due to methyl ricinoleate in the chromatogram obtained with the reference solution,

$A_2$  = area of the peak due to methyl stearate in the chromatogram obtained with the reference solution.

## Composition of the fatty-acid fraction of the oil:

- palmitic acid: maximum 2.0 per cent;
- stearic acid: maximum 2.5 per cent;
- oleic acid and isomers (C18:1 equivalent chain length on macrogol 20 000: 18.3): 2.5 per cent to 6.0 per cent;
- linoleic acid (C18:2 equivalent chain length on macrogol 20 000: 18.8): 2.5 per cent to 7.0 per cent;
- linolenic acid (C18:3 equivalent chain length on macrogol 20 000: 19.2): maximum 1.0 per cent;
- eicosenoic acid (C20:1 equivalent chain length on macrogol 20 000: 20.2): maximum 1.0 per cent;
- ricinoleic acid (equivalent chain length on macrogol 20 000: 23.9): 85.0 per cent to 92.0 per cent;
- any other fatty acid: maximum 1.0 per cent.

Water (2.5.12): maximum 0.3 per cent, determined on 5.0 g.

## STORAGE

In an airtight, well-filled container, protected from light.

01/2008:0986  
corrected 6.5

## CEFACTOR

## Cefaclorum

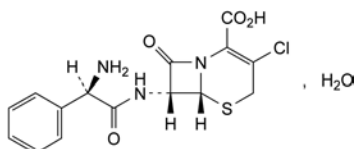

C<sub>15</sub>H<sub>14</sub>ClN<sub>3</sub>O<sub>4</sub>S·H<sub>2</sub>O  
[70356-03-5]

*M<sub>r</sub>* 385.8

## DEFINITION

(6*R*,7*R*)-7-[[*(2R)*-2-Amino-2-phenylacetyl]amino]-3-chloro-8-oxo-5-thia-1-azabicyclo[4.2.0]oct-2-ene-2-carboxylic acid monohydrate.

Semi-synthetic product derived from a fermentation product.

Content: 96.0 per cent to 102.0 per cent of C<sub>15</sub>H<sub>14</sub>ClN<sub>3</sub>O<sub>4</sub>S (anhydrous substance).

## CHARACTERS

Appearance: white or slightly yellow powder.

Solubility: slightly soluble in water, practically insoluble in methanol and in methylene chloride.

## IDENTIFICATION

Infrared absorption spectrophotometry (2.2.24).

Comparison: cefaclor CRS.

## TESTS

pH (2.2.3): 3.0 to 4.5.

Suspend 0.250 g in carbon dioxide-free water *R* and dilute to 10 mL with the same solvent.

Specific optical rotation (2.2.7): + 101 to + 111 (anhydrous substance).

Dissolve 0.250 g in a 10 g/L solution of hydrochloric acid *R* and dilute to 25.0 mL with the same solution.

Related substances. Liquid chromatography (2.2.29).

Test solution. Dissolve 50.0 mg of the substance to be examined in 10.0 mL of a 2.7 g/L solution of sodium dihydrogen phosphate *R* adjusted to pH 2.5 with phosphoric acid *R*.

Reference solution (a). Dissolve 2.5 mg of cefaclor CRS and 5.0 mg of delta-3-cefaclor CRS (impurity D) in 100.0 mL of a 2.7 g/L solution of sodium dihydrogen phosphate *R* adjusted to pH 2.5 with phosphoric acid *R*.

Reference solution (b). Dilute 1.0 mL of the test solution to 100.0 mL with a 2.7 g/L solution of sodium dihydrogen phosphate *R* adjusted to pH 2.5 with phosphoric acid *R*.

Column:

- size: *l* = 0.25 m, Ø = 4.6 mm;
- stationary phase: end-capped octadecylsilyl silica gel for chromatography *R* (5 µm).

Mobile phase:

- mobile phase A: 7.8 g/L solution of sodium dihydrogen phosphate *R* adjusted to pH 4.0 with phosphoric acid *R*;
- mobile phase B: mix 450 mL of acetonitrile *R* with 550 mL of mobile phase A;

Time (min)	Mobile phase A (per cent V/V)	Mobile phase B (per cent V/V)
0 - 30	95 → 75	5 → 25
30 - 45	75 → 0	25 → 100
45 - 55	0	100

Flow rate: 1.0 mL/min.

Detection: spectrophotometer at 220 nm.

Injection: 20 µL.

System suitability: reference solution (a):

- resolution: minimum 2 between the peaks due to cefaclor and impurity D; if necessary, adjust the acetonitrile content in the mobile phase;
- symmetry factor: maximum 1.2 for the peak due to cefaclor; if necessary, adjust the acetonitrile content in the mobile phase.

Limits:

- any impurity: for each impurity, not more than 0.5 times the area of the principal peak in the chromatogram obtained with reference solution (b) (0.5 per cent);
- total: not more than twice the area of the principal peak in the chromatogram obtained with reference solution (b) (2 per cent);
- disregard limit: 0.1 times the area of the principal peak in the chromatogram obtained with reference solution (b) (0.1 per cent).

Heavy metals (2.4.8): maximum 30 ppm.

1.0 g complies with test C. Prepare the reference solution using 3 mL of lead standard solution (10 ppm Pb) *R*.

**Water (2.5.12):** 3.0 per cent to 6.5 per cent, determined on 0.200 g.

#### ASSAY

Liquid chromatography (2.2.29).

**Test solution.** Dissolve 15.0 mg of the substance to be examined in the mobile phase and dilute to 50.0 mL with the mobile phase.

**Reference solution (a).** Dissolve 15.0 mg of *cefactor CRS* in the mobile phase and dilute to 50.0 mL with the mobile phase.

**Reference solution (b).** Dissolve 3.0 mg of *cefactor CRS* and 3.0 mg of *delta-3-cefactor CRS* (impurity D) in the mobile phase and dilute to 10.0 mL with the mobile phase.

**Column:**

- **size:**  $l = 0.25$  m,  $\varnothing = 4.6$  mm;
- **stationary phase:** octadecylsilyl silica gel for chromatography R (5  $\mu$ m).

**Mobile phase:** add 220 mL of *methanol R* to a mixture of 780 mL of *water R*, 10 mL of *triethylamine R* and 1 g of *sodium pentanesulfonate R*, then adjust to pH 2.5 with *phosphoric acid R*.

**Flow rate:** 1.5 mL/min.

**Detection:** spectrophotometer at 265 nm.

**Injection:** 20  $\mu$ L.

**System suitability:**

- **resolution:** minimum 2.5 between the peaks due to cefactor and impurity D in the chromatogram obtained with reference solution (b); if necessary, adjust the concentration of methanol in the mobile phase;
- **symmetry factor:** maximum 1.5 for the peak due to cefactor in the chromatogram obtained with reference solution (b);
- **repeatability:** maximum relative standard deviation of 1.0 per cent after 6 injections of reference solution (a).

#### IMPURITIES

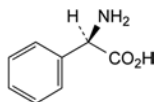

A. (2*R*)-2-amino-2-phenylacetic acid (phenylglycine),

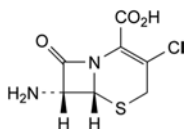

B. (6*R*,7*R*)-7-amino-3-chloro-8-oxo-5-thia-1-azabicyclo[4.2.0]oct-2-ene-2-carboxylic acid,

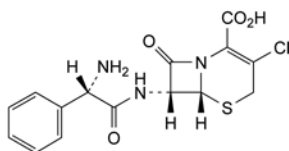

C. (6*R*,7*R*)-7-[(2*S*)-2-amino-2-phenylacetyl]amino]-3-chloro-8-oxo-5-thia-1-azabicyclo[4.2.0]oct-2-ene-2-carboxylic acid,

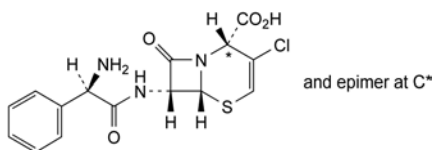

D. (2*R*,6*R*,7*R*)- and (2*S*,6*R*,7*R*)-7-[(2*R*)-2-amino-2-phenylacetyl]amino]-3-chloro-8-oxo-5-thia-1-azabicyclo[4.2.0]oct-2-ene-2-carboxylic acid (delta-3-cefactor),

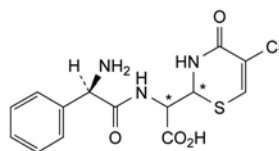

E. 2-[[[(2*R*)-2-amino-2-phenylacetyl]amino]-2-(5-chloro-4-oxo-3,4-dihydro-2*H*-1,3-thiazin-2-yl)acetic acid,

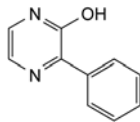

F. 3-phenylpyrazin-2-ol,

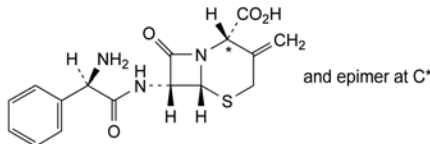

G. (2*R*,6*R*,7*R*)- and (2*S*,6*R*,7*R*)-7-[(2*R*)-2-amino-2-phenylacetyl]amino]-3-methylene-8-oxo-5-thia-1-azabicyclo[4.2.0]octane-2-carboxylic acid (isocefalexine),

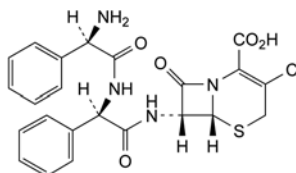

H. (6*R*,7*R*)-7-[[[(2*R*)-2-[(2*R*)-2-amino-2-phenylacetyl]amino]-2-phenylacetyl]amino]-3-chloro-8-oxo-5-thia-1-azabicyclo[4.2.0]oct-2-ene-2-carboxylic acid (*N*-phenylglycyl cefactor).

04/2008:0813  
corrected 7.0

## CEFADROXIL MONOHYDRATE

### Cefadroxilum monohydricum

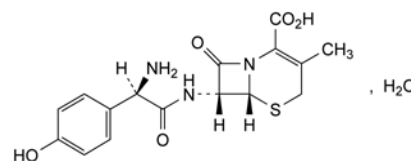

$C_{16}H_{17}N_3O_5S \cdot H_2O$   
[66592-87-8]

$M_r$  381.4

#### DEFINITION

(6*R*,7*R*)-7-[[[(2*R*)-2-Amino-2-(4-hydroxyphenyl)acetyl]amino]-3-methyl-8-oxo-5-thia-1-azabicyclo[4.2.0]oct-2-ene-2-carboxylic acid monohydrate.

Semi-synthetic product derived from a fermentation product.

**Content:** 95.0 per cent to 102.0 per cent (anhydrous substance).

#### CHARACTERS

**Appearance:** white or almost white powder.

**Solubility:** slightly soluble in water, very slightly soluble in ethanol (96 per cent).

#### IDENTIFICATION

Infrared absorption spectrophotometry (2.2.24).

**Comparison:** *cefadroxil CRS*.

## TESTS

**pH** (2.2.3): 4.0 to 6.0.

Suspend 1.0 g in *carbon dioxide-free water R* and dilute to 20 mL with the same solvent.

**Specific optical rotation** (2.2.7): + 165 to + 178 (anhydrous substance).

Dissolve 0.500 g in *water R* and dilute to 50.0 mL with the same solvent.

**Related substances.** Liquid chromatography (2.2.29).

**Test solution.** Dissolve 50.0 mg of the substance to be examined in mobile phase A and dilute to 50.0 mL with mobile phase A.

**Reference solution (a).** Dissolve 10.0 mg of *D-α-(4-hydroxyphenyl)glycine CRS* (impurity A) in mobile phase A and dilute to 10.0 mL with mobile phase A.

**Reference solution (b).** Dissolve 10.0 mg of *7-aminodesacetoxycephalosporanic acid CRS* (impurity B) in *phosphate buffer solution pH 7.0 R5* and dilute to 10.0 mL with the same buffer solution.

**Reference solution (c).** Dilute 1.0 mL of reference solution (a) and 1.0 mL of reference solution (b) to 100.0 mL with mobile phase A.

**Reference solution (d).** Dissolve 10 mg of *dimethylformamide R* and 10 mg of *dimethylacetamide R* in mobile phase A and dilute to 10.0 mL with mobile phase A. Dilute 1.0 mL of this solution to 100.0 mL with mobile phase A.

**Reference solution (e).** Dilute 1.0 mL of reference solution (c) to 25.0 mL with mobile phase A.

**Column:**

- size:  $l = 0.10$  m,  $\varnothing = 4.6$  mm,
- stationary phase: spherical octadecylsilyl silica gel for chromatography R (5  $\mu$ m).

**Mobile phase:**

- mobile phase A: *phosphate buffer solution pH 5.0 R*,
- mobile phase B: *methanol R2*,

Time (min)	Mobile phase A (per cent V/V)	Mobile phase B (per cent V/V)
0 - 1	98	2
1 - 20	98 → 70	2 → 30

**Flow rate:** 1.5 mL/min.

**Detection:** spectrophotometer at 220 nm.

**Injection:** 20  $\mu$ L of the test solution and reference solutions (c), (d) and (e).

**Relative retention** with reference to cefadroxil (retention time = about 6 min): dimethylformamide = about 0.4; dimethylacetamide = about 0.75.

**System suitability:**

- resolution: minimum 5.0 between the peaks due to impurities A and B in the chromatogram obtained with reference solution (c),
- signal-to-noise ratio: minimum 10 for the 2<sup>nd</sup> peak in the chromatogram obtained with reference solution (e).

**Limits:**

- impurity A: not more than the area of the 1<sup>st</sup> peak in the chromatogram obtained with reference solution (c) (1.0 per cent),
- any other impurity: for each impurity, not more than the area of the 2<sup>nd</sup> peak in the chromatogram obtained with reference solution (c) (1.0 per cent),

- total: not more than 3 times the area of the 2<sup>nd</sup> peak in the chromatogram obtained with reference solution (c) (3.0 per cent),
- disregard limit: 0.05 times the area of the 2<sup>nd</sup> peak in the chromatogram obtained with reference solution (c) (0.05 per cent); disregard the peaks due to dimethylformamide and dimethylacetamide.

***N,N*-Dimethylaniline** (2.4.26, Method B): maximum 20 ppm.

**Water** (2.5.12): 4.0 per cent to 6.0 per cent, determined on 0.200 g.

**Sulfated ash** (2.4.14): maximum 0.5 per cent, determined on 1.0 g.

## ASSAY

Liquid chromatography (2.2.29).

**Test solution.** Dissolve 50.0 mg of the substance to be examined in the mobile phase and dilute to 100.0 mL with the mobile phase.

**Reference solution (a).** Dissolve 50.0 mg of *cefadroxil CRS* in the mobile phase and dilute to 100.0 mL with the mobile phase.

**Reference solution (b).** Dissolve 5 mg of *cefadroxil CRS* and 50 mg of *amoxicillin trihydrate CRS* in the mobile phase and dilute to 100 mL with the mobile phase.

**Column:**

- size:  $l = 0.25$  m,  $\varnothing = 4.6$  mm,
- stationary phase: octadecylsilyl silica gel for chromatography R (5  $\mu$ m).

**Mobile phase:** acetonitrile R, a 2.72 g/L solution of *potassium dihydrogen phosphate R* (4:96 V/V).

**Flow rate:** 1 mL/min.

**Detection:** spectrophotometer at 254 nm.

**Injection:** 20  $\mu$ L.

**System suitability:** reference solution (b):

- resolution: minimum 5.0 between the peaks due to cefadroxil and to amoxicillin.

Calculate the percentage content of cefadroxil.

## STORAGE

Protected from light.

## IMPURITIES

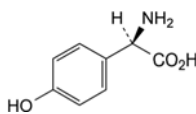

A. (2*R*)-2-amino-2-(4-hydroxyphenyl)acetic acid,

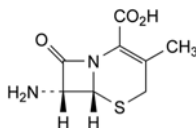

B. (6*R*,7*R*)-7-amino-3-methyl-8-oxo-5-thia-1-azabicyclo[4.2.0]oct-2-ene-2-carboxylic acid (7-ADCA),

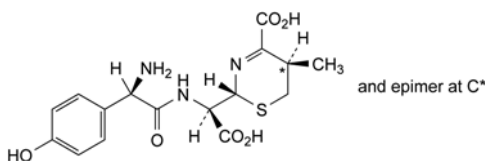

C. (2*R*,5*RS*)-2-[(*R*)-[(2*R*)-2-amino-2-(4-hydroxyphenyl)acetyl]amino]carboxymethyl]-5-methyl-5,6-dihydro-2*H*-1,3-thiazine-4-carboxylic acid,

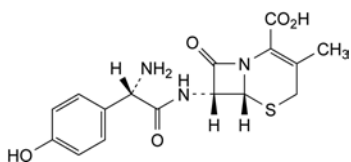

- D. (6*R*,7*R*)-7-[(2*S*)-2-amino-2-(4-hydroxyphenyl)acetyl]amino]-3-methyl-8-oxo-5-thia-1-azabicyclo[4.2.0]oct-2-ene-2-carboxylic acid (L-cefadroxil),

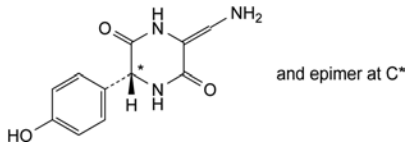

- E. (6*RS*)-3-(aminomethylene)-6-(4-hydroxyphenyl)piperazine-2,5-dione,

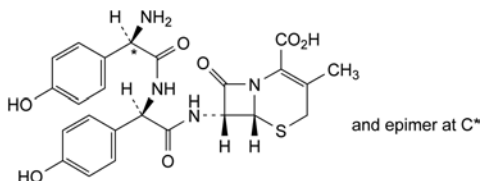

- F. (6*R*,7*R*)-7-[(2*R*)-2-[(2*R*)-2-amino-2-(4-hydroxyphenyl)acetyl]amino]-2-(4-hydroxyphenyl)acetyl]amino]-3-methyl-8-oxo-5-thia-1-azabicyclo[4.2.0]oct-2-ene-2-carboxylic acid,

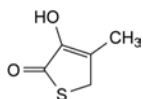

- G. 3-hydroxy-4-methylthiophen-2(5*H*)-one,

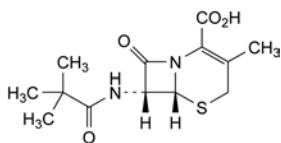

- H. (6*R*,7*R*)-7-[(2,2-dimethylpropanoyl)amino]-3-methyl-8-oxo-5-thia-1-azabicyclo[4.2.0]oct-2-ene-2-carboxylic acid (7-ADCA pivalamide).

04/2008:0708  
corrected 7.0

## CEFALEXIN MONOHYDRATE

### Cefalexinum monohydricum

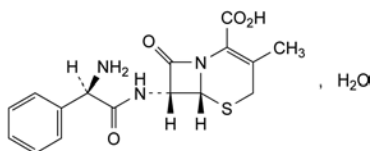

$C_{16}H_{17}N_3O_4S \cdot H_2O$   
[23325-78-2]

$M_r$  365.4

#### DEFINITION

(6*R*,7*R*)-7-[(2*R*)-2-Amino-2-phenylacetyl]amino]-3-methyl-8-oxo-5-thia-1-azabicyclo[4.2.0]oct-2-ene-2-carboxylic acid monohydrate.

Semi-synthetic product derived from a fermentation product.

*Content*: 95.0 per cent to 102.0 per cent (anhydrous substance).

#### CHARACTERS

*Appearance*: white or almost white, crystalline powder.

*Solubility*: sparingly soluble in water, practically insoluble in ethanol (96 per cent).

#### IDENTIFICATION

Infrared absorption spectrophotometry (2.2.24).

*Comparison*: cefalexin monohydrate CRS.

#### TESTS

**pH** (2.2.3): 4.0 to 5.5.

Dissolve 50 mg in carbon dioxide-free water *R* and dilute to 10 mL with the same solvent.

**Specific optical rotation** (2.2.7): + 149 to + 158 (anhydrous substance).

Dissolve 0.125 g in phthalate buffer solution pH 4.4 *R* and dilute to 25.0 mL with the same solvent.

**Related substances**. Liquid chromatography (2.2.29).

*Test solution*. Dissolve 50.0 mg of the substance to be examined in mobile phase A and dilute to 50.0 mL with mobile phase A.

*Reference solution (a)*. Dissolve 10.0 mg of *D*-phenylglycine *R* in mobile phase A and dilute to 10.0 mL with mobile phase A.

*Reference solution (b)*. Dissolve 10.0 mg of 7-aminodesacetoxycephalosporanic acid CRS in phosphate buffer solution pH 7.0 *R5* and dilute to 10.0 mL with mobile phase A.

*Reference solution (c)*. Dilute 1.0 mL of reference solution (a) and 1.0 mL of reference solution (b) to 100.0 mL with mobile phase A.

*Reference solution (d)*. Dissolve 10 mg of dimethylformamide *R* and 10 mg of dimethylacetamide *R* in mobile phase A and dilute to 10.0 mL with mobile phase A. Dilute 1.0 mL of this solution to 100.0 mL with mobile phase A.

*Reference solution (e)*. Dilute 1.0 mL of reference solution (c) to 20.0 mL with mobile phase A.

*Reference solution (f)*. Dissolve 10 mg of cefotaxime sodium CRS in mobile phase A and dilute to 10.0 mL with mobile phase A. To 1.0 mL of this solution add 1.0 mL of the test solution and dilute to 100 mL with mobile phase A.

*Column*:

– *size*:  $l = 0.10$  m,  $\varnothing = 4.6$  mm;

– *stationary phase*: spherical octadecylsilyl silica gel for chromatography *R* (5  $\mu$ m).

*Mobile phase*:

– *mobile phase A*: phosphate buffer solution pH 5.0 *R*;

– *mobile phase B*: methanol *R2*;

Time (min)	Mobile phase A (per cent V/V)	Mobile phase B (per cent V/V)
0 - 1	98	2
1 - 20	98 → 70	2 → 30

*Flow rate*: 1.5 mL/min.

*Detection*: spectrophotometer at 220 nm.

*Injection*: 20  $\mu$ L of the test solution and reference solutions (c), (d), (e) and (f).

*System suitability*:

– *resolution*: minimum 2.0 between the peaks due to impurities A and B in the chromatogram obtained with reference solution (c) and minimum 1.5 between the peaks due to cefalexin and cefotaxime in the chromatogram obtained with reference solution (f).

*Limits*:

– *impurity B*: not more than the area of the 2<sup>nd</sup> peak in the chromatogram obtained with reference solution (c) (1.0 per cent);

– *any other impurity*: not more than the area of the 1<sup>st</sup> peak in the chromatogram obtained with reference solution (c) (1.0 per cent);

– *total*: not more than 3 times the area of the 1<sup>st</sup> peak in the chromatogram obtained with reference solution (c) (3.0 per cent);

– *disregard limit*: the area of the 2<sup>nd</sup> peak in the chromatogram obtained with reference solution (e) (0.05 per cent); disregard any peaks due to dimethylformamide or dimethylacetamide.

***N,N*-Dimethylaniline** (2.4.26, *Method B*): maximum 20 ppm.

**Water** (2.5.12): 4.0 per cent to 8.0 per cent, determined on 0.300 g.

**Sulfated ash** (2.4.14): maximum 0.2 per cent, determined on 1.0 g.

#### ASSAY

Liquid chromatography (2.2.29).

*Test solution*. Dissolve 50.0 mg of the substance to be examined in *water R* and dilute to 100.0 mL with the same solvent.

*Reference solution (a)*. Dissolve 50.0 mg of *cefalexin monohydrate CRS* in *water R* and dilute to 100.0 mL with the same solvent.

*Reference solution (b)*. Dissolve 10 mg of *cefradine CRS* in 20 mL of reference solution (a) and dilute to 100 mL with *water R*.

*Column*:

- *size*:  $l = 0.25$  m,  $\varnothing = 4.6$  mm;
- *stationary phase*: octadecylsilyl silica gel for chromatography *R* (5  $\mu$ m).

*Mobile phase*: methanol *R*, acetonitrile *R*, 13.6 g/L solution of potassium dihydrogen phosphate *R*, water *R* (2:5:10:83 V/V/V/V).

*Flow rate*: 1.5 mL/min.

*Detection*: spectrophotometer at 254 nm.

*Injection*: 20  $\mu$ L.

*System suitability*: reference solution (b):

- *resolution*: minimum 4.0 between the peaks due to cefalexin and cefradine.

Calculate the percentage content of cefalexin monohydrate.

#### STORAGE

Protected from light.

#### IMPURITIES

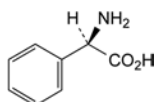

A. (2*R*)-2-amino-2-phenylacetic acid (D-phenylglycine),

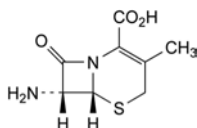

B. (6*R*,7*R*)-7-amino-3-methyl-8-oxo-5-thia-1-azabicyclo[4.2.0]oct-2-ene-2-carboxylic acid (7-aminodesacetoxycephalosporanic acid, 7-ADCA),

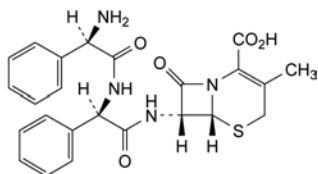

C. (6*R*,7*R*)-7-[[[(2*R*)-2-[[[(2*R*)-2-amino-2-phenylacetyl]amino]-2-phenylacetyl]amino]-3-methyl-8-oxo-5-thia-1-azabicyclo[4.2.0]oct-2-ene-2-carboxylic acid,

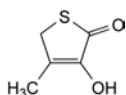

D. 3-hydroxy-4-methylthiophen-2(5*H*)-one,

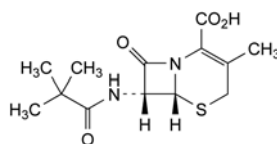

E. (6*R*,7*R*)-7-[(2,2-dimethylpropanoyl)amino]-3-methyl-8-oxo-5-thia-1-azabicyclo[4.2.0]oct-2-ene-2-carboxylic acid (7-ADCA pivalamide),

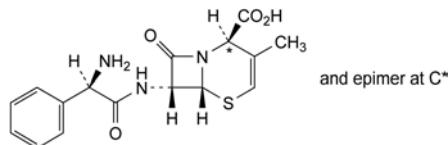

F. (2*RS*,6*R*,7*R*)-7-[[[(2*R*)-2-amino-2-phenylacetyl]amino]-3-methyl-8-oxo-5-thia-1-azabicyclo[4.2.0]oct-3-ene-2-carboxylic acid (delta-2-cefalexin).

01/2008:0987  
corrected 7.0

## CEFALOTIN SODIUM

### Cefalotinum natricum

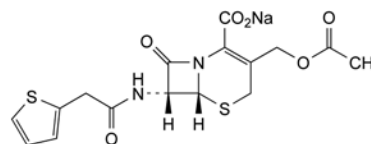

$C_{16}H_{15}N_2NaO_6S_2$   
[58-71-9]

$M_r$  418.4

#### DEFINITION

Sodium (6*R*,7*R*)-3-[(acetyloxy)methyl]-8-oxo-7-[(thiophen-2-ylacetyl)amino]-5-thia-1-azabicyclo[4.2.0]oct-2-ene-2-carboxylate. Semi-synthetic product derived from a fermentation product.

*Content*: 96.0 per cent to 102.0 per cent (anhydrous substance).

#### CHARACTERS

*Appearance*: white or almost white powder.

*Solubility*: freely soluble in water, slightly soluble in anhydrous ethanol.

#### IDENTIFICATION

A. Infrared absorption spectrophotometry (2.2.24).

*Comparison*: cefalotin sodium *CRS*.

B. It gives reaction (a) of sodium (2.3.1).

#### TESTS

**Solution S**. Dissolve 2.50 g in carbon dioxide-free water *R* and dilute to 25.0 mL with the same solvent.

**Appearance of solution**. Solution S is clear (2.2.1) and its absorbance (2.2.25) at 450 nm is not greater than 0.20.

**pH** (2.2.3): 4.5 to 7.0 for solution S.

**Specific optical rotation** (2.2.7): + 124 to + 134 (anhydrous substance).

Dissolve 1.25 g in water *R* and dilute to 25.0 mL with the same solvent.

**Related substances**. Liquid chromatography (2.2.29). Prepare the solutions immediately before use.

*Test solution (a)*. Dissolve 75.0 mg of the substance to be examined in water *R* and dilute to 25.0 mL with the same solvent.

*Test solution (b)*. Dilute 5.0 mL of test solution (a) to 50.0 mL with water *R*.

**Reference solution (a).** Dissolve 75.0 mg of *cefalotin sodium CRS* in *water R* and dilute to 25.0 mL with the same solvent. Dilute 5.0 mL of this solution to 50.0 mL with *water R*.

**Reference solution (b).** Dilute 1.0 mL of test solution (a) to 100.0 mL with *water R*.

**Reference solution (c).** Mix 1 mL of test solution (a), 1 mL of *hydrochloric acid R1* and 8 mL of *water R*. Heat at 60 °C for 12 min and cool to room temperature in iced water. Inject immediately.

**Reference solution (d).** Dissolve 5 mg of *cefalotin for impurity B identification CRS* in *water R* and dilute to 5 mL with the same solvent.

**Column:**

- size:  $l = 0.25$  m,  $\varnothing = 4.6$  mm;
- stationary phase: *end-capped octadecylsilyl silica gel for chromatography R* (5  $\mu$ m);
- temperature: 40 °C.

**Mobile phase:**

- mobile phase A: mix 3 volumes of *acetonitrile R1* and 97 volumes of a 1.742 g/L solution of *dipotassium hydrogen phosphate R* previously adjusted to pH 2.5 with *phosphoric acid R*;
- mobile phase B: mix 40 volumes of *acetonitrile R1* and 60 volumes of a 1.742 g/L solution of *dipotassium hydrogen phosphate R* previously adjusted to pH 2.5 with *phosphoric acid R*;

Time (min)	Mobile phase A (per cent V/V)	Mobile phase B (per cent V/V)
0 - 30	100 → 0	0 → 100
30 - 35	0	100

**Flow rate:** 1.0 mL/min.

**Detection:** spectrophotometer at 220 nm.

**Injection:** 20  $\mu$ L of test solution (a) and reference solutions (b), (c) and (d).

**Relative retention** with reference to cefalotin (retention time = about 26 min): impurity C = about 0.2; impurity B = about 0.7; impurity A = about 0.8; impurity D = about 0.9.

**System suitability:** reference solution (c):

- resolution: minimum 7.0 between the peaks due to impurity D and cefalotin.

**Limits:**

- impurity B: not more than the area of the principal peak in the chromatogram obtained with reference solution (b) (1.0 per cent);
- impurity D: not more than 0.5 times the area of the principal peak in the chromatogram obtained with reference solution (b) (0.5 per cent);
- any other impurity: for each impurity, not more than 0.25 times the area of the principal peak in the chromatogram obtained with reference solution (b) (0.25 per cent);
- total: not more than 3 times the area of the principal peak in the chromatogram obtained with reference solution (b) (3.0 per cent);
- disregard limit: 0.05 times the area of the principal peak in the chromatogram obtained with reference solution (b) (0.05 per cent).

***N,N*-Dimethylaniline** (2.4.26, *Method B*): maximum 20 ppm.

**2-Ethylhexanoic acid** (2.4.28): maximum 0.5 per cent.

**Water** (2.5.12): maximum 1.5 per cent, determined on 0.500 g.

**Bacterial endotoxins** (2.6.14): less than 0.13 IU/mg, if intended for use in the manufacture of parenteral preparations without a further appropriate procedure for the removal of bacterial endotoxins.

**ASSAY**

Liquid chromatography (2.2.29) as described in the test for related substances with the following modifications.

**Mobile phase:** mix 14 volumes of *acetonitrile R* and 86 volumes of a 6.967 g/L solution of *dipotassium hydrogen phosphate R* previously adjusted to pH 6.0 with *phosphoric acid R*.

**Detection:** spectrophotometer at 260 nm.

**Injection:** 5  $\mu$ L of test solution (b) and reference solution (a).

**Run time:** 1.5 times the retention time of cefalotin (retention time = about 10 min).

Calculate the percentage content of  $C_{16}H_{15}N_2NaO_6S_2$  using the chromatogram obtained with reference solution (a) and the declared content of *cefalotin sodium CRS*.

**STORAGE**

Protected from light. If the substance is sterile, store in a sterile, airtight, tamper-proof container.

**IMPURITIES**

**Specified impurities:** B, D.

**Other detectable impurities** (the following substances would, if present at a sufficient level, be detected by one or other of the tests in the monograph. They are limited by the general acceptance criterion for other/unspecified impurities and/or by the general monograph *Substances for pharmaceutical use* (2034). It is therefore not necessary to identify these impurities for demonstration of compliance. See also 5.10. *Control of impurities in substances for pharmaceutical use*): A, C.

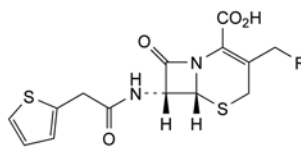

A. R = H: (6*R*,7*R*)-3-methyl-8-oxo-7-[(thiophen-2-ylacetyl)amino]-5-thia-1-azabicyclo[4.2.0]oct-2-ene-2-carboxylic acid (deacetoxycefalotin),

B. R = OH: (6*R*,7*R*)-3-(hydroxymethyl)-8-oxo-7-[(thiophen-2-ylacetyl)amino]-5-thia-1-azabicyclo[4.2.0]oct-2-ene-2-carboxylic acid (deacetylcefalotin),

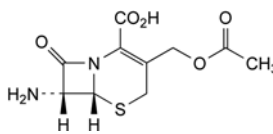

C. (6*R*,7*R*)-3-[(acetyloxy)methyl]-7-amino-8-oxo-5-thia-1-azabicyclo[4.2.0]oct-2-ene-2-carboxylic acid (7-ACA),

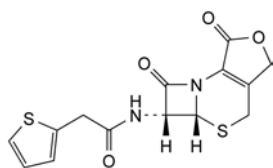

D. (5*aR*,6*R*)-6-[(thiophen-2-ylacetyl)amino]-5*a*,6-dihydro-3*H*,7*H*-azeto[2,1-*b*]furo[3,4-*d*][1,3]thiazine-1,7(4*H*)-dione (cefalotin lactone).



01/2008:1402 *Reference solution (b)*. Dilute 1.0 mL of the test solution to 100.0 mL with the solvent mixture.  
corrected 7.0

## CEFAMANDOLE NAFATE

### Cefamandoli nafas

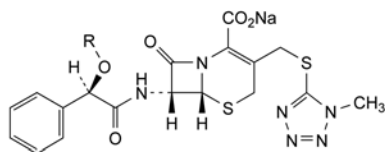

Compound	R	Molecular Formula	$M_r$
Cefamandole nafate	CHO	$C_{19}H_{17}N_6NaO_6S_2$	512.5
Cefamandole sodium	H	$C_{18}H_{17}N_6NaO_5S_2$	484.5

Cefamandole nafate: [42540-40-9]

Cefamandole sodium: [30034-03-8]

#### DEFINITION

Mixture of sodium (6*R*,7*R*)-7-[[[(2*R*)-2-(formyloxy)-2-phenylacetyl]amino]-3-[[[(1-methyl-1*H*-tetrazol-5-yl)sulfanyl]methyl]-8-oxo-5-thia-1-azabicyclo[4.2.0]oct-2-ene-2-carboxylate and sodium (6*R*,7*R*)-7-[[[(2*R*)-2-hydroxy-2-phenylacetyl]amino]-3-[[[(1-methyl-1*H*-tetrazol-5-yl)sulfanyl]methyl]-8-oxo-5-thia-1-azabicyclo[4.2.0]oct-2-ene-2-carboxylate (cefamandole sodium), with sodium carbonate.

Semi-synthetic product derived from a fermentation product.

#### Content:

- *cefamandole nafate* ( $C_{19}H_{17}N_6NaO_6S_2$ ): 93.0 per cent to 102.0 per cent (anhydrous and sodium carbonate-free substance), for the sum of the content of cefamandole nafate and cefamandole sodium expressed as cefamandole nafate;
- *cefamandole sodium* ( $C_{18}H_{17}N_6NaO_5S_2$ ): maximum 10.0 per cent (anhydrous and sodium carbonate-free substance);
- *sodium carbonate* ( $Na_2CO_3$ ): 4.8 per cent to 6.4 per cent.

#### CHARACTERS

*Appearance*: white or almost white powder.

*Solubility*: freely soluble in water, sparingly soluble in methanol.

#### IDENTIFICATION

A. Infrared absorption spectrophotometry (2.2.24).

*Comparison*: cefamandole nafate CRS.

B. It gives reaction (a) of sodium (2.3.1).

#### TESTS

**Solution S**. Dissolve 2.5 g in carbon dioxide-free water *R* and dilute to 25 mL with the same solvent.

**Appearance of solution**. Solution S is clear (2.2.1) and its absorbance (2.2.25) at 475 nm is not greater than 0.03.

**pH**: 6.0 to 8.0 for solution S, measured after 30 min.

**Specific optical rotation** (2.2.7): –35.0 to –45.0 (anhydrous and sodium carbonate-free substance).

Dissolve 1.00 g in acetate buffer solution pH 4.7 *R1* and dilute to 10.0 mL with the same solvent.

**Related substances**. Liquid chromatography (2.2.29). Prepare the solutions immediately before use.

**Solvent mixture**. Mix 18 volumes of acetonitrile *R* and 75 volumes of a 10 per cent *V/V* solution of triethylamine *R* previously adjusted to pH 2.5 with phosphoric acid *R*.

**Test solution**. Dissolve 0.100 g of the substance to be examined in the solvent mixture and dilute to 10.0 mL with the solvent mixture.

**Reference solution (a)**. Dilute 1 mL of the test solution to 10 mL with the solvent mixture, then heat at 60 °C for 30 min.

**Reference solution (b)**. Dilute 1.0 mL of the test solution to 100.0 mL with the solvent mixture.

#### Column:

- *size*:  $l = 0.25$  m,  $\varnothing = 4.6$  mm;
- *stationary phase*: octadecylsilyl silica gel for chromatography *R* (5  $\mu$ m).

#### Mobile phase:

- *triethylamine phosphate solution*: dissolve 2.0 g of sodium pentanesulfonate *R* in 350 mL of water *R*, add 40 mL of triethylamine *R*, adjust to pH 2.5 with phosphoric acid *R* and dilute to 700 mL with water *R*;
- *mobile phase A*: mix 1 volume of the triethylamine phosphate solution and 2 volumes of water *R*;
- *mobile phase B*: mix equal volumes of the triethylamine phosphate solution, methanol *R* and acetonitrile *R*;

Time (min)	Mobile phase A (per cent <i>V/V</i> )	Mobile phase B (per cent <i>V/V</i> )
0 - 1	100	0
1 - 35	100 → 0	0 → 100

*Flow rate*: 1.5 mL/min.

*Detection*: spectrophotometer at 254 nm.

*Injection*: 20  $\mu$ L loop injector.

*Relative retention* with reference to cefamandole nafate (retention time = about 24 min): cefamandole = about 0.8.

*System suitability*: reference solution (a):

- *resolution*: minimum 5.0 between the peaks due to cefamandole and cefamandole nafate.

#### Limits:

- *any impurity*: for each impurity, not more than the area of the principal peak in the chromatogram obtained with reference solution (b) (1.0 per cent);
- *total*: not more than 5 times the area of the principal peak in the chromatogram obtained with reference solution (b) (5.0 per cent);
- *disregard limit*: 0.1 times the area of the principal peak in the chromatogram obtained with reference solution (b) (0.1 per cent).

**2-Ethylhexanoic acid** (2.4.28): maximum 0.3 per cent *m/m*.

**Heavy metals** (2.4.8): maximum 20 ppm.

1.0 g complies with test C. Prepare the reference solution using 2 mL of lead standard solution (10 ppm Pb) *R*.

**Water** (2.5.12): maximum 2.0 per cent, determined on 0.500 g.

**Bacterial endotoxins** (2.6.14): less than 0.15 IU/mg, if intended for use in the manufacture of parenteral preparations without a further appropriate procedure for the removal of bacterial endotoxins.

#### ASSAY

**Cefamandole nafate**. Liquid chromatography (2.2.29). Prepare the solutions immediately before use.

**Test solution**. Dissolve 50.0 mg of the substance to be examined in the mobile phase and dilute to 100.0 mL with the mobile phase.

**Reference solution (a)**. Dissolve 50.0 mg of cefamandole nafate CRS in the mobile phase and dilute to 100.0 mL with the mobile phase.

**Reference solution (b)**. Dilute 1 mL of the test solution to 10 mL with the mobile phase, then heat at 60 °C for 30 min.

#### Column:

- *size*:  $l = 0.25$  m,  $\varnothing = 4.6$  mm;
- *stationary phase*: octadecylsilyl silica gel for chromatography *R* (5  $\mu$ m).

01/2008:1650  
corrected 6.0

**Mobile phase:** mix 25 volumes of *acetonitrile R* and 75 volumes of a 10 per cent *V/V* solution of *triethylamine R* previously adjusted to pH 2.5 with *phosphoric acid R*.

**Flow rate:** 1.0 mL/min.

**Detection:** spectrophotometer at 254 nm.

**Injection:** 20 µL loop injector.

**System suitability:**

- **resolution:** minimum 7.0 between the 2 principal peaks in the chromatogram obtained with reference solution (b);
- **repeatability:** maximum relative standard deviation of 0.8 per cent after a series of single injections of not less than 3 freshly prepared reference solutions (a).

Calculate the percentage content of cefamandole nafate ( $C_{19}H_{17}N_6NaO_6S_2$ ) from the sum of the contents of cefamandole nafate and cefamandole sodium expressed as cefamandole nafate, using the declared content of *cefamandole nafate CRS*.

1 mg of cefamandole sodium is equivalent to 1.0578 mg of cefamandole nafate.

**Sodium carbonate.** Dissolve 0.500 g in 50 mL of *water R*. Titrate with 0.1 M *hydrochloric acid*, determining the end-point potentiometrically (2.2.20).

1 mL of 0.1 M *hydrochloric acid* is equivalent to 5.3 mg of  $Na_2CO_3$ .

#### STORAGE

In an airtight container, protected from light. If the substance is sterile, store in a sterile, airtight, tamper-proof container.

#### LABELLING

The label states that the substance contains sodium carbonate.

#### IMPURITIES

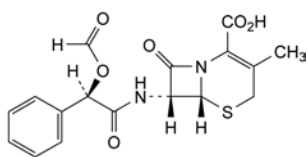

- A. (6*R*,7*R*)-7-[(2*R*)-2-(formyloxy)-2-phenylacetyl]amino]-3-methyl-8-oxo-5-thia-1-azabicyclo[4.2.0]oct-2-ene-2-carboxylic acid (formylmandeloyl-7-amino-desacetoxy-cephalosporanic acid),

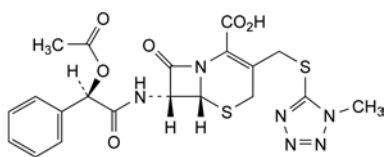

- C. (6*R*,7*R*)-7-[(2*R*)-2-(acetyloxy)-2-phenylacetyl]amino]-3-[(1-methyl-1*H*-tetrazol-5-yl)sulfanyl]methyl]-8-oxo-5-thia-1-azabicyclo[4.2.0]oct-2-ene-2-carboxylic acid (*O*-acetylcefamandole),

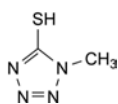

- D. 1-methyl-1*H*-tetrazole-5-thiol,

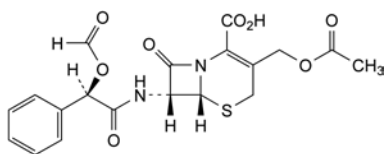

- E. (6*R*,7*R*)-7-[(2*R*)-2-(formyloxy)-2-phenylacetyl]amino]-3-[(acetyloxy)methyl]-8-oxo-5-thia-1-azabicyclo[4.2.0]oct-2-ene-2-carboxylic acid (formylmandeloyl-7-ACA).

## CEFAPIRIN SODIUM

### Cefapirinum natrium

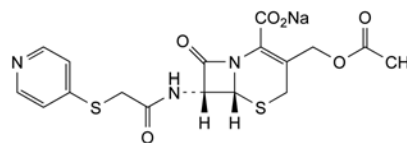

$C_{17}H_{16}N_3NaO_6S_2$   
[24356-60-3]

$M_r$  445.5

#### DEFINITION

Sodium (6*R*,7*R*)-3-[(acetyloxy)methyl]-8-oxo-7-[[[(pyridin-4-yl)sulfanyl]acetyl]amino]-5-thia-1-azabicyclo[4.2.0]oct-2-ene-2-carboxylate.

Semi-synthetic product derived from a fermentation product.

**Content:** 96.0 per cent to 102.0 per cent (anhydrous substance).

#### CHARACTERS

**Appearance:** white or pale yellow powder.

**Solubility:** soluble in water, practically insoluble in methylene chloride.

#### IDENTIFICATION

A. Infrared absorption spectrophotometry (2.2.24).

*Comparison:* cefapirin sodium CRS.

B. It gives reaction (a) of sodium (2.3.1).

#### TESTS

**Appearance of solution.** Dissolve 2.0 g in *water R* and dilute to 10.0 mL with the same solvent. The solution is clear (2.2.1). Dilute 5.0 mL to 10.0 mL with *water R*. The absorbance (2.2.25) of this solution at 450 nm is not greater than 0.25.

**pH (2.2.3):** 6.5 to 8.5.

Dissolve 0.100 g in *carbon dioxide-free water R* and dilute to 10.0 mL with the same solvent.

**Specific optical rotation (2.2.7):** + 150 to + 165 (anhydrous substance).

Dissolve 0.500 g in *water R* and dilute to 25.0 mL with the same solvent.

**Related substances.** Liquid chromatography (2.2.29). Prepare the solutions immediately before use.

**Test solution.** Dissolve 42 mg of the substance to be examined in the mobile phase and dilute to 200.0 mL with the mobile phase.

**Reference solution (a).** Dissolve 42 mg of *cefapirin sodium CRS* in the mobile phase and dilute to 200.0 mL with the mobile phase.

**Reference solution (b).** Dilute 1.0 mL of the test solution to 100.0 mL with the mobile phase.

**Reference solution (c).** Dilute 1.0 mL of reference solution (b) to 20.0 mL with the mobile phase.

**Reference solution (d).** Mix 1 mL of the test solution, 8 mL of the mobile phase and 1 mL of *hydrochloric acid R1*. Heat at 60 °C for 10 min.

**Column:**

- **size:**  $l = 0.30$  m,  $\varnothing = 4$  mm,
- **stationary phase:** octadecylsilyl silica gel for chromatography R (10 µm).

**Mobile phase:** mix 80 mL of *dimethylformamide R*, 4.0 mL of *glacial acetic acid R* and 20 mL of a 4.5 per cent (*m/m*) solution of *potassium hydroxide R*. Dilute to 2 L with *water R*.

**Flow rate:** 2.0 mL/min.

**Detection:** spectrophotometer at 254 nm.

01/2008:1403

**Injection:** 20 µL of the test solution and reference solutions (b), (c) and (d).

**Run time:** twice the retention time of cefapirin.

**Relative retention** with reference to cefapirin (retention time = about 13 min): impurity B = about 0.3; impurity C = about 0.5; impurity A = about 0.75.

**System suitability:** reference solution (d):

– **resolution:** minimum 2.0 between the peaks due to cefapirin and impurity A.

**Limits:**

- **any impurity:** for each impurity, not more than the area of the principal peak in the chromatogram obtained with reference solution (b) (1.0 per cent), and not more than 1 such peak has an area greater than 0.3 times the area of the principal peak in the chromatogram obtained with reference solution (b) (0.3 per cent),
- **total:** not more than twice the area of the principal peak in the chromatogram obtained with reference solution (b) (2.0 per cent),
- **disregard limit:** area of the principal peak in the chromatogram obtained with reference solution (c) (0.05 per cent).

**N,N-Dimethylaniline (2.4.26, Method B):** maximum 20 ppm.

**2-Ethylhexanoic acid (2.4.28):** maximum 0.5 per cent.

**Water (2.5.12):** maximum 2.0 per cent, determined on 0.300 g.

**Bacterial endotoxins (2.6.14):** less than 0.17 IU/mg, if intended for use in the manufacture of parenteral preparations without a further appropriate procedure for the removal of bacterial endotoxins.

#### ASSAY

Liquid chromatography (2.2.29) as described in the test for related substances with the following modification.

**Injection:** test solution and reference solution (a).

Calculate the percentage content of  $C_{17}H_{16}N_3NaO_6S_2$ .

#### STORAGE

Protected from light. If the substance is sterile, store in a sterile, tamper-proof container.

#### IMPURITIES

**Specified impurities:** A, B, C.

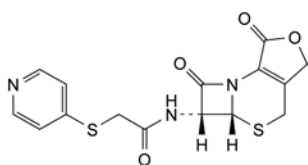

- A. (5a*R*,6*R*)-6-[[[(pyridin-4-yl)sulfanyl]acetyl]amino]-5a,6-dihydro-3*H*,7*H*-azeto[2,1-*b*]furo[3,4-*d*]1,3]thiazine-1,7(4*H*)-dione (deacetylcefapirin lactone),

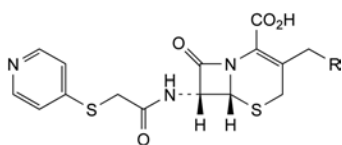

- B. R = OH: (6*R*,7*R*)-3-(hydroxymethyl)-8-oxo-7-[[[(pyridin-4-yl)sulfanyl]acetyl]amino]-5-thia-1-azabicyclo[4.2.0]oct-2-ene-2-carboxylic acid (deacetylcefapirin),
- C. R = H: (6*R*,7*R*)-3-methyl-8-oxo-7-[[[(pyridin-4-yl)sulfanyl]acetyl]amino]-5-thia-1-azabicyclo[4.2.0]oct-2-ene-2-carboxylic acid (deacetoxycefapirin).

## CEFATRIZINE PROPYLENE GLYCOL

### Cefatrizinum propylen glycolum

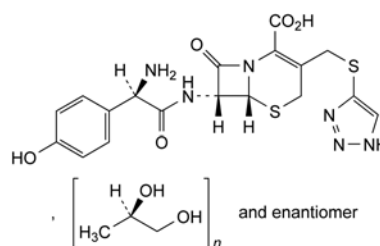

$C_{18}H_{18}N_6O_5S_2 \cdot (C_3H_8O_2)_n$

$M_r$  462.5 (base)

#### DEFINITION

Mixture of (6*R*,7*R*)-7-[[[(2*R*)-2-amino-2-(4-hydroxyphenyl)-acetyl]amino]-8-oxo-3-[[[(1*H*-1,2,3-triazol-4-yl)sulfanyl]-methyl]-5-thia-1-azabicyclo[4.2.0]oct-2-ene-2-carboxylic acid and propane-1,2-diol in molecular proportions of about 1:1.

**Content:** 95.0 per cent to 102.0 per cent of  $C_{18}H_{18}N_6O_5S_2$  (anhydrous substance).

#### CHARACTERS

**Appearance:** white or almost white powder.

**Solubility:** slightly soluble in water, practically insoluble in ethanol (96 per cent) and in methylene chloride.

#### IDENTIFICATION

- A. Infrared absorption spectrophotometry (2.2.24).

**Comparison:** cefatrizine propylene glycol CRS.

- B. Examine the chromatograms obtained in the test for propylene glycol.

**Results:** the principal peak in the chromatogram obtained with the test solution is similar in retention time and size to the principal peak in the chromatogram obtained with reference solution (b).

#### TESTS

**Specific optical rotation (2.2.7):** + 63 to + 69 (anhydrous substance).

Dissolve 0.400 g in 1 *M* hydrochloric acid and dilute to 20.0 mL with the same acid.

**Propylene glycol.** Gas chromatography (2.2.28).

**Solvent mixture:** acetone *R*, water *R* (20:80 *V/V*).

**Internal standard solution.** Dissolve 1.0 g of dimethylacetamide *R* in the solvent mixture and dilute to 50.0 mL with the solvent mixture.

**Test solution.** Introduce 0.40 g of the substance to be examined into a ground-glass-stoppered test-tube. Add 3.0 mL of the internal standard solution, 1.0 mL of the solvent mixture and 2.0 mL of hydrochloric acid *R*. Seal the test-tube and shake.

**Reference solution (a).** Dissolve 2.0 g of propylene glycol *R* in the solvent mixture and dilute to 100.0 mL with the solvent mixture.

**Reference solution (b).** Introduce into a ground-glass-stoppered test-tube 1.0 mL of reference solution (a) and 1.0 mL of the internal standard solution.

**Column:**

- **material:** stainless steel;
- **size:**  $l = 2$  m,  $\varnothing = 2$  mm;
- **stationary phase:** ethylvinylbenzene-divinylbenzene copolymer *R* (150-180 µm).

**Carrier gas:** nitrogen for chromatography *R*.

**Flow rate:** 30 mL/min.

**Temperature:**

- column: 200 °C;
- injection port and detector: 250 °C.

**Detection:** flame ionisation.

**Injection:** 1 µL of the test solution and reference solution (b).

**Limit:**

- propylene glycol: 13.0 per cent to 18.0 per cent.

**Related substances.** Liquid chromatography (2.2.29).

**Test solution.** Dissolve 60.0 mg of the substance to be examined in the mobile phase and dilute to 100.0 mL with the mobile phase.

**Reference solution (a).** Dissolve 60.0 mg of cefatrizine propylene glycol CRS in the mobile phase and dilute to 100.0 mL with the mobile phase.

**Reference solution (b).** Dissolve 30.0 mg of cefatrizine impurity A CRS in buffer solution pH 7.0 R and dilute to 100.0 mL with the same buffer solution.

**Reference solution (c).** Dilute 0.6 mL of reference solution (a) to 100.0 mL with the mobile phase.

**Reference solution (d).** Dilute 1.0 mL of reference solution (b) to 100.0 mL with buffer solution pH 7.0 R.

**Reference solution (e).** To 1.0 mL of reference solution (a) add 1.0 mL of reference solution (b) and dilute to 10.0 mL with the mobile phase.

**Column:**

- size:  $l = 0.25$  m,  $\varnothing = 4$  mm;
- stationary phase: octadecylsilyl silica gel for chromatography R (5 µm).

**Mobile phase:** mix 5 volumes of acetonitrile R and 95 volumes of a 2.72 g/L solution of potassium dihydrogen phosphate R in water R.

**Flow rate:** 2 mL/min.

**Detection:** spectrophotometer at 272 nm.

**Injection:** 20 µL of the test solution and reference solutions (c), (d) and (e).

**Run time:** at least twice the retention time of cefatrizine.

**System suitability:** reference solution (e):

- resolution: minimum 5.0 between the peaks due to cefatrizine and impurity A.

**Limits:**

- impurity A: not more than the area of the corresponding peak in the chromatogram obtained with reference solution (d) (0.5 per cent);
- any other impurity: for each impurity, not more than the area of the principal peak in the chromatogram obtained with reference solution (c) (0.6 per cent);
- sum of impurities other than A: not more than 3.5 times the area of the principal peak in the chromatogram obtained with reference solution (c) (2.1 per cent);
- disregard limit: 0.05 times the area of the principal peak in the chromatogram obtained with reference solution (c) (0.03 per cent).

**Water (2.5.12):** maximum 1.5 per cent, determined on 0.500 g.

**Sulfated ash (2.4.14):** maximum 0.1 per cent, determined on 1.0 g.

**ASSAY**

Liquid chromatography (2.2.29) as described in the test for related substances with the following modifications.

**Injection:** test solution and reference solution (a).

**System suitability:** reference solution (a):

- repeatability: maximum relative standard deviation of 1.0 per cent after 6 injections.

Calculate the percentage content of  $C_{18}H_{18}N_6O_5S_2$  from the declared content of  $C_{18}H_{18}N_6O_5S_2$  in cefatrizine propylene glycol CRS.

**IMPURITIES**

**Specified impurities:** A.

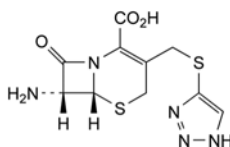

- A. (6*R*,7*R*)-7-amino-8-oxo-3-[[[(1*H*-1,2,3-triazol-4-yl)sulfanyl]methyl]-5-thia-1-azabicyclo[4.2.0]oct-2-ene-2-carboxylic acid (7-ACA triazole).

01/2008:0988  
corrected 6.0

**CEFAZOLIN SODIUM**

## Cefazolinum natricum

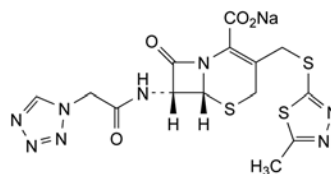

$C_{14}H_{13}N_8NaO_4S_3$   
[27164-46-1]

$M_r$  476.5

**DEFINITION**

Sodium (6*R*,7*R*)-3-[[[(5-methyl-1,3,4-thiadiazol-2-yl)sulfanyl]methyl]-8-oxo-7-[(1*H*-tetrazol-1-yl)acetyl]amino]-5-thia-1-azabicyclo[4.2.0]oct-2-ene-2-carboxylate.

Semi-synthetic product derived from a fermentation product.

**Content:** 95.0 per cent to 102.0 per cent (anhydrous substance).

**CHARACTERS**

**Appearance:** white or almost white powder, very hygroscopic.

**Solubility:** freely soluble in water, very slightly soluble in ethanol (96 per cent).

It shows polymorphism (5.9).

**IDENTIFICATION**

- A. Infrared absorption spectrophotometry (2.2.24).

**Preparation:** dissolve 0.150 g in 5 mL of water R, add 0.5 mL of dilute acetic acid R, swirl and allow to stand for 10 min in iced water. Filter the precipitate and rinse with 1-2 mL of water R. Dissolve in a mixture of 1 volume of water R and 9 volumes of acetone R. Evaporate the solvent almost to dryness, then dry in an oven at 60 °C for 30 min.

**Comparison:** cefazolin CRS.

- B. It gives reaction (a) of sodium (2.3.1).

**TESTS**

**Solution S.** Dissolve 2.50 g in carbon dioxide-free water R and dilute to 25.0 mL with the same solvent.

**Appearance of solution.** Solution S is clear (2.2.1) and its absorbance (2.2.25) at 430 nm is not greater than 0.15.

**pH (2.2.3):** 4.0 to 6.0 for solution S.

**Specific optical rotation (2.2.7):** – 15 to – 24 (anhydrous substance).

Dissolve 1.25 g in water R and dilute to 25.0 mL with the same solvent.

**Absorbance (2.2.25).** Dissolve 0.100 g in water R and dilute to 100.0 mL with the same solvent. Dilute 2.0 mL of the solution to 100.0 mL with sodium hydrogen carbonate solution R. Examined between 220 nm and 350 nm, the solution shows an absorption maximum at 272 nm. The specific absorbance at the maximum is 260 to 300 (anhydrous substance).

**Related substances.** Liquid chromatography (2.2.29).

**Test solution.** Dissolve 50.0 mg of the substance to be examined in mobile phase A and dilute to 20.0 mL with the same mobile phase.

**Reference solution (a).** Dilute 1.0 mL of the test solution to 100.0 mL with mobile phase A.

**Reference solution (b).** Dissolve 20 mg of the substance to be examined in 10 mL of a 2 g/L solution of *sodium hydroxide R*. Allow to stand for 15-30 min. Dilute 1.0 mL of the solution to 20 mL with mobile phase A.

**Column:**

- size:  $l = 0.125$  m,  $\varnothing = 4.0$  mm;
- stationary phase: octadecylsilyl silica gel for chromatography R (3  $\mu$ m);
- temperature: 45 °C.

**Mobile phase:**

- mobile phase A: solution containing 14.54 g/L of *disodium hydrogen phosphate R* and 3.53 g/L of *potassium dihydrogen phosphate R*;
- mobile phase B: acetonitrile for chromatography R;

Time (min)	Mobile phase A (per cent V/V)	Mobile phase B (per cent V/V)
0 - 2	98	2
2 - 4	98 → 85	2 → 15
4 - 10	85 → 60	15 → 40
10 - 11.5	60 → 35	40 → 65
11.5 - 12	35	65
12 - 15	35 → 98	65 → 2
15 - 21	98	2

**Flow rate:** 1.2 mL/min.

**Detection:** spectrophotometer at 254 nm.

**Injection:** 5  $\mu$ L.

**System suitability:** reference solution (b):

- resolution: minimum 2.0 between the peaks due to cefazolin and impurity L (see Figure 0988.-1).

**Limits:**

- any impurity: for each impurity, not more than the area of the principal peak in the chromatogram obtained with reference solution (a) (1.0 per cent);
- total: not more than 3.5 times the area of the principal peak in the chromatogram obtained with reference solution (a) (3.5 per cent);
- disregard limit: 0.05 times the area of the principal peak in the chromatogram obtained with reference solution (a) (0.05 per cent).

**N,N-Dimethylaniline (2.4.26, Method B):** maximum 20 ppm.

**Water (2.5.12):** maximum 6.0 per cent, determined on 0.300 g.

**Bacterial endotoxins (2.6.14):** less than 0.15 IU/mg, if intended for use in the manufacture of parenteral preparations without a further appropriate procedure for the removal of bacterial endotoxins.

**ASSAY**

Liquid chromatography (2.2.29).

**Test solution.** Dissolve 50.0 mg of the substance to be examined in the mobile phase and dilute to 50.0 mL with the mobile phase.

**Reference solution (a).** Dissolve 50.0 mg of *cefazolin CRS* in the mobile phase and dilute to 50.0 mL with the mobile phase.

**Reference solution (b).** Dissolve 5.0 mg of *cefuroxime sodium CRS* in 10.0 mL of reference solution (a) and dilute to 100.0 mL with the mobile phase.

**Column:**

- size:  $l = 0.25$  m,  $\varnothing = 4.6$  mm;
- stationary phase: octadecylsilyl silica gel for chromatography R (5  $\mu$ m).

**Mobile phase:** mix 10 volumes of *acetonitrile R* and 90 volumes of a solution containing 2.77 g/L of *disodium hydrogen phosphate R* and 1.86 g/L of *citric acid R*.

**Flow rate:** 1.0 mL/min.

**Detection:** spectrophotometer at 270 nm.

**Injection:** 20  $\mu$ L.

**System suitability:** reference solution (b):

- resolution: minimum 2.0 between the peaks due to cefazolin and cefuroxime.

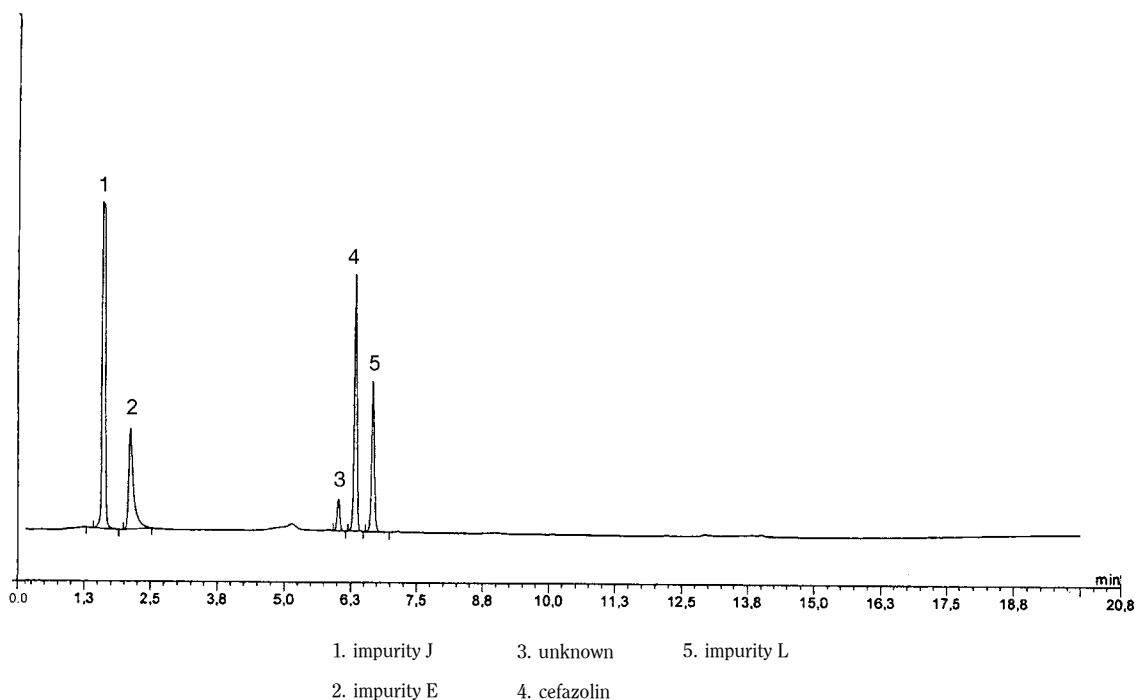

Figure 0988.-1. – Chromatogram for the test for related substances of cefazolin sodium: reference solution (b) (in situ degradation)

Calculate the percentage content of cefazolin sodium by multiplying the percentage content of cefazolin by 1.048.

## STORAGE

In an airtight container, protected from light. If the substance is sterile, store in a sterile, airtight, tamper-proof container.

## IMPURITIES

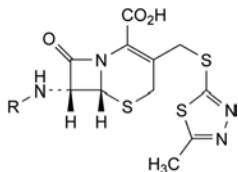

- A. R = H: (6*R*,7*R*)-7-amino-3-[[5-methyl-1,3,4-thiadiazol-2-yl)sulfanyl]methyl]-8-oxo-5-thia-1-azabicyclo[4.2.0]oct-2-ene-2-carboxylic acid,
- B. R = CO-C(CH<sub>3</sub>)<sub>3</sub>: (6*R*,7*R*)-7-[(2,2-dimethylpropanoyl)amino]-3-[[5-methyl-1,3,4-thiadiazol-2-yl)sulfanyl]methyl]-8-oxo-5-thia-1-azabicyclo[4.2.0]oct-2-ene-2-carboxylic acid,

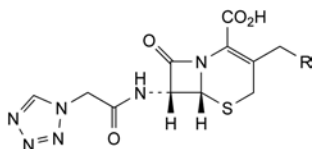

- C. R = H: (6*R*,7*R*)-3-methyl-8-oxo-7-[(1*H*-tetrazol-1-ylacetyl)amino]-5-thia-1-azabicyclo[4.2.0]oct-2-ene-2-carboxylic acid,
- D. R = O-CO-CH<sub>3</sub>: (6*R*,7*R*)-3-[(acetyloxy)methyl]-8-oxo-7-[(1*H*-tetrazol-1-ylacetyl)amino]-5-thia-1-azabicyclo[4.2.0]oct-2-ene-2-carboxylic acid,

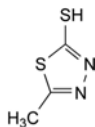

- E. 5-methyl-1,3,4-thiadiazol-2-thiol (MMTD),

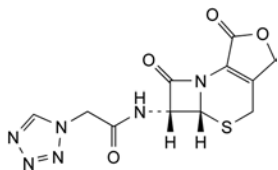

- G. (5*aR*,6*R*)-6-[(1*H*-tetrazol-1-ylacetyl)amino]-5*a*,6-dihydro-3*H*,7*H*-azeto[2,1-*b*]furo[3,4-*d*][1,3]thiazine-1,7(4*H*)-dione,

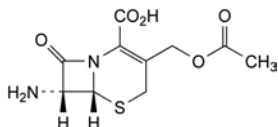

- H. (6*R*,7*R*)-3-[(acetyloxy)methyl]-7-amino-8-oxo-5-thia-1-azabicyclo[4.2.0]oct-2-ene-2-carboxylic acid (7-ACA),

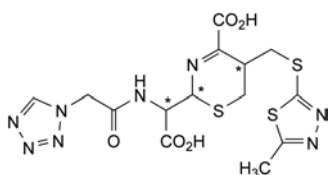

- I. 2-[carboxy[(1*H*-tetrazol-1-ylacetyl)amino]methyl]-5-[[5-methyl-1,3,4-thiadiazol-2-yl)sulfanyl]methyl]-5,6-dihydro-2*H*-1,3-thiazine-4-carboxylic acid (cefazoloic acid),

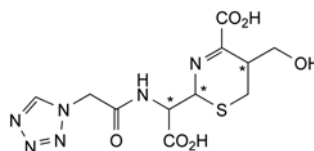

- J. 2-[carboxy[(1*H*-tetrazol-1-ylacetyl)amino]methyl]-5-[(hydroxymethyl)-5,6-dihydro-2*H*-1,3-thiazine-4-carboxylic acid (hydrolysed cefazoloic acid),

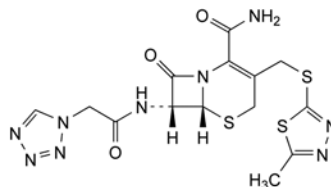

- K. (6*R*,7*R*)-3-[[5-methyl-1,3,4-thiadiazol-2-yl)sulfanyl]methyl]-8-oxo-7-[(1*H*-tetrazol-1-ylacetyl)amino]-5-thia-1-azabicyclo[4.2.0]oct-2-ene-2-carboxamide (cefazolinamide),

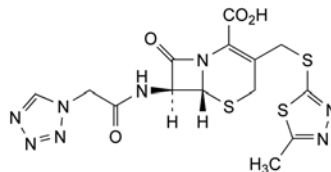

- L. (6*R*,7*S*)-3-[[5-methyl-1,3,4-thiadiazol-2-yl)sulfanyl]methyl]-8-oxo-7-[(1*H*-tetrazol-1-ylacetyl)amino]-5-thia-1-azabicyclo[4.2.0]oct-2-ene-2-carboxylic acid.

01/2008:2126

## CEFEPIME DIHYDROCHLORIDE MONOHYDRATE

### Cefepimi dihydrochloridum monohydricum

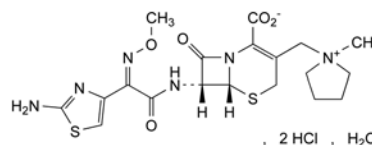

C<sub>19</sub>H<sub>26</sub>Cl<sub>2</sub>N<sub>6</sub>O<sub>5</sub>S<sub>2</sub>·H<sub>2</sub>O  
[123171-59-5]

M<sub>r</sub> 571.5

## DEFINITION

(6*R*,7*R*)-7-[(2*Z*)-(2-Aminothiazol-4-yl)(methoxyimino)acetyl]amino]-3-[(1-methylpyrrolidinio)methyl]-8-oxo-5-thia-1-azabicyclo[4.2.0]oct-2-ene-2-carboxylate dihydrochloride monohydrate. Semi-synthetic product derived from a fermentation product.

*Content*: 97.0 per cent to 102.0 per cent (anhydrous substance).

## CHARACTERS

*Appearance*: white or almost white, crystalline powder.

*Solubility*: freely soluble in water and in methanol, practically insoluble in methylene chloride.

## IDENTIFICATION

A. Infrared absorption spectrophotometry (2.2.24).

*Comparison*: cefepime dihydrochloride monohydrate CRS.

B. It gives reaction (a) of chlorides (2.3.1).

## TESTS

**Appearance of solution.** The solution is clear (2.2.1) and not more intensely coloured than reference solution Y<sub>3</sub> (2.2.2, Method II).

Dissolve 2.0 g in *water R* and dilute to 20 mL with the same solvent.

**Specific optical rotation** (2.2.7): + 40 to + 45 (anhydrous substance).

Dissolve 0.250 g in *water R* and dilute to 25.0 mL with the same solvent.

**Impurity G.** Liquid chromatography (2.2.29). Prepare the solutions immediately before use.

**Test solution.** Dissolve 0.100 g of the substance to be examined in 0.01 M nitric acid and dilute to 10.0 mL with the same acid.

**Reference solution (a).** Dilute 0.250 g of *N-methylpyrrolidine R* (impurity G) to 100.0 mL with *water R*. Dilute 2.0 mL of this solution to 100.0 mL with 0.01 M nitric acid.

**Reference solution (b).** Dilute 0.250 g of *pyrrolidine R* to 100 mL with 0.01 M nitric acid. Dilute 2 mL of the solution to 100 mL with 0.01 M nitric acid. Mix 5 mL of this solution with 5 mL of reference solution (a).

**Column:**

- size:  $l = 0.05$  m,  $\varnothing = 4.6$  mm;
- stationary phase: strong cation-exchange resin R (5  $\mu$ m).

**Mobile phase:** mix 1 volume of *acetonitrile R* and 100 volumes of 0.01 M nitric acid; filter through a 0.2  $\mu$ m filter.

**Flow rate:** 1 mL/min.

**Detection:** conductivity detector.

**Injection:** 100  $\mu$ L.

**Run time:** 1.1 times the retention time of cefepime (retention time = about 50 min, eluting as a broadened peak).

**System suitability:**

- symmetry factor: maximum 2.5 for the peak due to impurity G in the chromatogram obtained with reference solution (a);
- repeatability: maximum relative standard deviation of 5.0 per cent after 6 injections of reference solution (a);
- peak-to-valley ratio: minimum 3 between the peaks due to pyrrolidine and impurity G in the chromatogram obtained with reference solution (b).

Calculate the percentage content of impurity G in the test solution using reference solution (a).

**Limit:**

- impurity G: maximum 0.5 per cent.

**Related substances.** Liquid chromatography (2.2.29). Prepare the solutions immediately before use or keep refrigerated at 4–8 °C for not more than 12 h.

**Test solution.** Dissolve 70.0 mg of the substance to be examined in mobile phase A and dilute to 50.0 mL with mobile phase A. Sonicate for 30 s and stir for about 5 min.

**Reference solution (a).** Dissolve 70.0 mg of *cefepime dihydrochloride monohydrate CRS* in mobile phase A and dilute to 50.0 mL with mobile phase A. Sonicate for 30 s and stir for about 5 min.

**Reference solution (b).** Dilute 1.0 mL of the test solution to 10.0 mL with mobile phase A. Dilute 2.0 mL of this solution to 100.0 mL with mobile phase A.

**Reference solution (c).** Dissolve 7 mg of *cefepime dihydrochloride monohydrate for system suitability CRS* (containing impurities A, B, E and F) in mobile phase A and dilute to 5 mL with mobile phase A.

**Column:**

- size:  $l = 0.25$  m,  $\varnothing = 4.6$  mm;
- stationary phase: end-capped octadecylsilyl silica gel for chromatography R (5  $\mu$ m).

**Mobile phase:**

- mobile phase A: mix 10 volumes of *acetonitrile R* and 90 volumes of a 0.68 g/L solution of *potassium dihydrogen phosphate R* previously adjusted to pH 5.0 with 0.5 M *potassium hydroxide*;

- mobile phase B: mix equal volumes of *acetonitrile R* and a 0.68 g/L solution of *potassium dihydrogen phosphate R* previously adjusted to pH 5.0 with 0.5 M *potassium hydroxide*;

Time (min)	Mobile phase A (per cent V/V)	Mobile phase B (per cent V/V)
0 - 10	100	0
10 - 30	100 → 50	0 → 50
30 - 35	50	50
35 - 36	50 → 100	50 → 0
36 - 45	100	0

**Flow rate:** 1 mL/min.

**Detection:** spectrophotometer at 254 nm.

**Injection:** 10  $\mu$ L of the test solution and reference solutions (b) and (c).

**Identification of impurities:** use the chromatogram supplied with *cefepime dihydrochloride monohydrate for system suitability CRS* and the chromatogram obtained with reference solution (c) to identify the peaks due to impurities A, B, E and F.

**Relative retention with reference to cefepime** (retention time = about 7 min): impurity E = about 0.4; impurity F = about 0.8; impurity A = about 2.5; impurity B = about 4.1.

**System suitability:** reference solution (c):

- resolution: minimum 1.5 between the peaks due to impurity F and cefepime.

**Limits:**

- correction factors: for the calculation of content, multiply the peak areas of the following impurities by the corresponding correction factor: impurity A = 1.4; impurity B = 1.4; impurity E = 1.8;
- impurity A: not more than 1.5 times the area of the principal peak in the chromatogram obtained with reference solution (b) (0.3 per cent);
- impurities B, F: for each impurity, not more than the area of the principal peak in the chromatogram obtained with reference solution (b) (0.2 per cent);
- impurity E: not more than 0.5 times the area of the principal peak in the chromatogram obtained with reference solution (b) (0.1 per cent);
- unspecified impurities: for each impurity, not more than 0.5 times the area of the principal peak in the chromatogram obtained with reference solution (b) (0.10 per cent);
- total: not more than 5 times the area of the principal peak in the chromatogram obtained with reference solution (b) (1.0 per cent);
- disregard limit: 0.25 times the area of the principal peak in the chromatogram obtained with reference solution (b) (0.05 per cent).

**Water** (2.5.12): 3.0 per cent to 4.5 per cent, determined on 0.400 g.

**Bacterial endotoxins** (2.6.14): less than 0.04 IU/mg, if intended for use in the manufacture of parenteral preparations without a further appropriate procedure for the removal of bacterial endotoxins.

**ASSAY**

Liquid chromatography (2.2.29) as described in the test for related substances with the following modifications.

**Mobile phase:** mobile phase A.

**Injection:** test solution and reference solution (a).

**Run time:** 1.4 times the retention time of cefepime.

Calculate the percentage content of  $C_{19}H_{26}Cl_2N_6O_5S_2$  from the declared content of *cefepime dihydrochloride monohydrate CRS*.

## STORAGE

Protected from light. If the substance is sterile, store in a sterile, airtight, tamper-proof container.

## IMPURITIES

Specified impurities: A, B, E, F, G.

Other detectable impurities (the following substances would, if present at a sufficient level, be detected by one or other of the tests in the monograph. They are limited by the general acceptance criterion for other/unspecified impurities and/or by the general monograph *Substances for pharmaceutical use (2034)*. It is therefore not necessary to identify these impurities for demonstration of compliance. See also 5.10. *Control of impurities in substances for pharmaceutical use*): C, D.

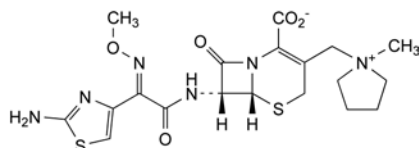

G. N-methylpyrrolidine.

01/2008:1188  
corrected 6.0

## CEFIXIME

## Cefiximum

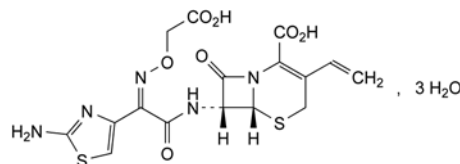

$C_{16}H_{15}N_5O_7S_2 \cdot 3H_2O$

$M_r$  507.5

## DEFINITION

(6*R*,7*R*)-7-[[*(Z)*-2-(2-Aminothiazol-4-yl)-2-((carboxymethoxy)imino)acetyl]amino]-3-[(1-methylpyrrolidinio)methyl]-8-oxo-5-thia-1-azabicyclo[4.2.0]oct-2-ene-2-carboxylic acid trihydrate.

Semi-synthetic product derived from a fermentation product.

*Content*: 95.0 per cent to 102.0 per cent (anhydrous substance).

## CHARACTERS

*Appearance*: white or almost white, slightly hygroscopic powder.

*Solubility*: slightly soluble in water, soluble in methanol, sparingly soluble in anhydrous ethanol, practically insoluble in ethyl acetate.

## IDENTIFICATION

Infrared absorption spectrophotometry (2.2.24).

*Comparison*: cefixime CRS.

If the spectra obtained show differences, dissolve the substance to be examined and the reference substance separately in *methanol R*, evaporate to dryness and record new spectra using the residues.

## TESTS

**pH** (2.2.3): 2.6 to 4.1.

Suspend 0.5 g in *carbon dioxide-free water R* and dilute to 10 mL with the same solvent.

**Related substances**. Liquid chromatography (2.2.29).

*Test solution*. Dissolve 25.0 mg of the substance to be examined in the mobile phase and dilute to 25.0 mL with the mobile phase.

*Reference solution (a)*. Dissolve 25.0 mg of *cefixime CRS* in the mobile phase and dilute to 25.0 mL with the mobile phase.

*Reference solution (b)*. Dilute 1.0 mL of reference solution (a) to 100.0 mL with the mobile phase.

*Reference solution (c)*. Dissolve 10 mg of *cefixime CRS* in 10 mL of *water R*. Heat on a water-bath for 45 min and cool (*in situ* preparation of impurity D). Inject immediately.

*Column*:

– *size*:  $l = 0.125$  m,  $\emptyset = 4$  mm;

– *stationary phase*: octadecylsilyl silica gel for chromatography R (5  $\mu$ m);

– *temperature*: 40 °C.

– *Mobile phase*: mix 250 volumes of *acetonitrile R* and 750 volumes of a tetrabutylammonium hydroxide solution prepared as follows: dissolve 8.2 g of *tetrabutylammonium hydroxide R* in *water R* and dilute to 800 mL with the same solvent; adjust to pH 6.5 with *dilute phosphoric acid R* and dilute to 1000 mL with *water R*.

*Flow rate*: 1.0 mL/min.

- A. (6*R*,7*R*)-7-[[*(2E)*-(2-aminothiazol-4-yl)(methoxyimino)acetyl]amino]-3-[(1-methylpyrrolidinio)methyl]-8-oxo-5-thia-1-azabicyclo[4.2.0]oct-2-ene-2-carboxylate (*anti*-cefepime),

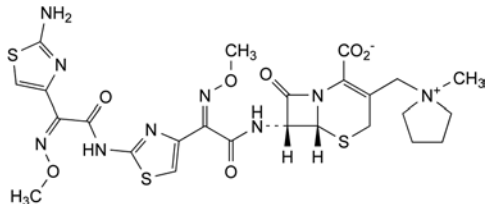

- B. (6*R*,7*R*)-7-[[*(2Z)*-2-[[*(2Z)*-(2-aminothiazol-4-yl)-(methoxyimino)acetyl]amino]thiazol-4-yl](methoxyimino)acetyl]amino]-3-[(1-methylpyrrolidinio)methyl]-8-oxo-5-thia-1-azabicyclo[4.2.0]oct-2-ene-2-carboxylate,

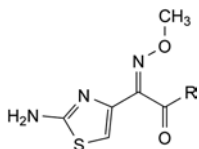

- C. R = NH-CH<sub>2</sub>-CHO: (*2Z*)-2-(2-aminothiazol-4-yl)-*N*-(formylmethyl)-2-(methoxyimino)acetamide,

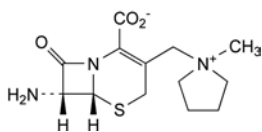

- D. R = OH: (*2Z*)-2-(2-aminothiazol-4-yl)(methoxyimino)acetic acid,

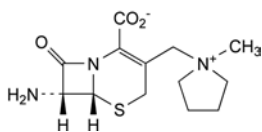

- E. (6*R*,7*R*)-7-amino-3-[(1-methylpyrrolidinio)methyl]-8-oxo-5-thia-1-azabicyclo[4.2.0]oct-2-ene-2-carboxylate,

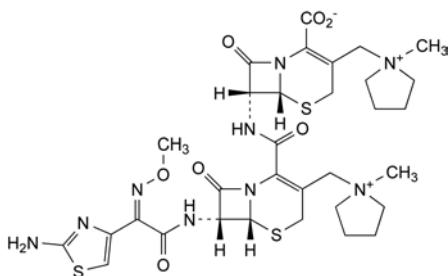

- F. (6*R*,7*R*)-7-[[[(6*R*,7*R*)-7-[[*(2Z)*-(2-aminothiazol-4-yl)-(methoxyimino)acetyl]amino]-3-[(1-methylpyrrolidinio)methyl]-8-oxo-5-thia-1-azabicyclo[4.2.0]oct-2-en-2-yl]carbonyl]amino]-3-[(1-methylpyrrolidinio)methyl]-8-oxo-5-thia-1-azabicyclo[4.2.0]oct-2-ene-2-carboxylate,



**Detection:** spectrophotometer at 254 nm.

**Injection:** 10 µL of the test solution and reference solutions (b) and (c).

**Run time:** 3 times the retention time of cefixime.

**System suitability:** reference solution (c):

- **resolution:** minimum 2.0 between the peaks due to cefixime and impurity D; if necessary, adjust the concentration of acetonitrile in the mobile phase.

**Limits:**

- **any impurity:** for each impurity, not more than 0.5 times the area of the principal peak in the chromatogram obtained with reference solution (b) (0.5 per cent);
- **total:** not more than 3 times the area of the principal peak in the chromatogram obtained with reference solution (b) (3 per cent);
- **disregard limit:** 0.1 times the area of the principal peak in the chromatogram obtained with reference solution (b) (0.1 per cent).

**Ethanol (2.4.24).** Head-space gas chromatography (2.2.28): use the standard additions method.

**Sample solution.** Dissolve 0.250 g of the substance to be examined in a mixture of 1 volume of *dimethylacetamide R* and 4 volumes of *water R* and dilute to 25.0 mL with the same mixture of solvents.

**Limit:**

- **ethanol:** maximum 1.0 per cent *m/m*.

**Water (2.5.12):** 9.0 per cent to 12.0 per cent, determined on 0.200 g.

**Sulfated ash (2.4.14):** maximum 0.2 per cent, determined on 1.0 g.

#### ASSAY

Liquid chromatography (2.2.29) as described in the test for related substances with the following modifications.

**Injection:** the test solution and reference solution (a).

**System suitability:** reference solution (a):

- **repeatability:** maximum relative standard deviation of 1.0 per cent after 6 injections.

Calculate the percentage content of  $C_{16}H_{15}N_5O_7S_2$  from the declared content of *cefixime CRS*.

#### STORAGE

In an airtight container, protected from light.

#### IMPURITIES

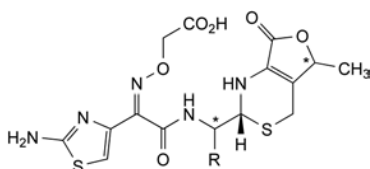

- A. R = CO<sub>2</sub>H: 2-[[[(Z)-2-(2-aminothiazol-4-yl)-2-[(carboxymethoxy)imino]acetyl]amino]-2-(2*R*)-5-methyl-7-oxo-1,2,5,7-tetrahydro-4*H*-furo[3,4-*d*][1,3]thiazin-2-yl]acetic acid,
- B. R = H: 2-[[[(Z)-1-(2-aminothiazol-4-yl)-2-[[[(2*R*,5*RS*)-5-methyl-7-oxo-1,2,5,7-tetrahydro-4*H*-furo[3,4-*d*][1,3]thiazin-2-yl]methyl]amino]-2-oxoethylidene]amino]oxy]acetic acid,

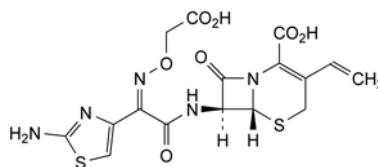

- C. (6*R*,7*S*)-7-[[[(Z)-2-(2-aminothiazol-4-yl)-2-[(carboxymethoxy)imino]acetyl]amino]-3-ethenyl-8-oxo-5-thia-1-azabicyclo[4.2.0]oct-2-ene-2-carboxylic acid (cefixime 7-epimer),

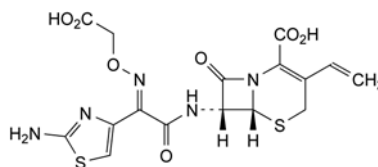

- D. (6*R*,7*R*)-7-[[[(E)-2-(2-aminothiazol-4-yl)-2-[(carboxymethoxy)imino]acetyl]amino]-3-ethenyl-8-oxo-5-thia-1-azabicyclo[4.2.0]oct-2-ene-2-carboxylic acid (cefixime *E*-isomer),

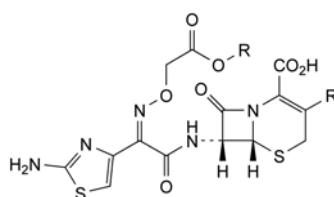

- E. R = H, R' = CH<sub>3</sub>: (6*R*,7*R*)-7-[[[(Z)-2-(2-aminothiazol-4-yl)-2-[(carboxymethoxy)imino]acetyl]amino]-3-methyl-8-oxo-5-thia-1-azabicyclo[4.2.0]oct-2-ene-2-carboxylic acid,
- F. R = C<sub>2</sub>H<sub>5</sub>, R' = CH=CH<sub>2</sub>: (6*R*,7*R*)-7-[[[(Z)-2-(2-aminothiazol-4-yl)-2-[(2-ethoxy-2-oxoethoxy)imino]acetyl]amino]-3-ethenyl-8-oxo-5-thia-1-azabicyclo[4.2.0]oct-2-ene-2-carboxylic acid.

01/2008:1404  
corrected 6.4

## CEFOPERAZONE SODIUM

### Cefoperazonum natricum

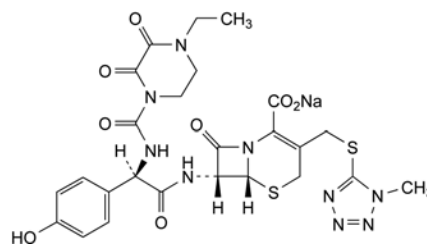

$C_{25}H_{26}N_9NaO_8S_2$   
[62893-20-3]

$M_r$  668

#### DEFINITION

Sodium (6*R*,7*R*)-7-[[[(2*R*)-2-[[[(4-ethyl-2,3-dioxopiperazin-1-yl)carbonyl]amino]-2-(4-hydroxyphenyl)acetyl]amino]-3-[[[(1-methyl-1*H*-tetrazol-5-yl)sulfanyl]methyl]-8-oxo-5-thia-1-azabicyclo[4.2.0]oct-2-ene-2-carboxylate.

Semi-synthetic product derived from a fermentation product.

**Content:** 95.0 per cent to 102.0 per cent (anhydrous substance).

#### CHARACTERS

**Appearance:** white or slightly yellow, hygroscopic powder.

**Solubility:** freely soluble in water, soluble in methanol, slightly soluble in ethanol (96 per cent).

If crystalline, it shows polymorphism (5.9).

## IDENTIFICATION

## A. Infrared absorption spectrophotometry (2.2.24).

*Preparation:* dissolve the substance to be examined in *methanol R* and evaporate to dryness; examine the residue.

*Comparison:* Ph. Eur. reference spectrum of *cefoperazone sodium*.

## B. Examine the chromatograms obtained in the assay.

*Results:* the principal peak in the chromatogram obtained with test solution (a) is similar in retention time and size to the principal peak in the chromatogram obtained with reference solution (a).

## C. It gives reaction (a) of sodium (2.3.1).

## TESTS

**Appearance of solution.** The solution is clear (2.2.1) and its absorbance (2.2.25) at 430 nm is not greater than 0.15.

Dissolve 2.5 g in *water R* and dilute to 25.0 mL with the same solvent.

**pH** (2.2.3): 4.5 to 6.5.

Dissolve 2.5 g in *carbon dioxide-free water R* and dilute to 10 mL with the same solvent.

**Related substances.** Liquid chromatography (2.2.29). Prepare the solutions immediately before use.

*Test solution (a).* Dissolve 25.0 mg of the substance to be examined in the mobile phase and dilute to 250.0 mL with the mobile phase.

*Test solution (b).* Dissolve 25.0 mg of the substance to be examined in the mobile phase and dilute to 50.0 mL with the mobile phase.

*Reference solution (a).* Dissolve 25.0 mg of *cefoperazone dihydrate CRS* in the mobile phase and dilute to 250.0 mL with the mobile phase.

*Reference solution (b).* Dilute 5.0 mL of reference solution (a) to 100.0 mL with the mobile phase.

**Column:**

- size:  $l = 0.15$  m,  $\varnothing = 4.6$  mm;
- stationary phase: *end-capped octadecylsilyl silica gel for chromatography R* (5  $\mu$ m).

**Mobile phase:** mix 884 volumes of *water R*, 110 volumes of *acetonitrile R*, 3.5 volumes of a 60 g/L solution of *acetic acid R* and 2.5 volumes of a triethylammonium acetate solution prepared as follows: dilute 14 mL of *triethylamine R* and 5.7 mL of *glacial acetic acid R* to 100 mL with *water R*.

**Flow rate:** 1 mL/min.

**Detection:** spectrophotometer at 254 nm.

**Injection:** 20  $\mu$ L of test solution (b) and reference solutions (a) and (b).

**Run time:** 2.5 times the retention time of cefoperazone.

**Retention time:** cefoperazone = about 15 min.

**System suitability:** reference solution (a):

- **number of theoretical plates:** minimum 5000, calculated for the principal peak; if necessary, adjust the content of *acetonitrile R* in the mobile phase;
- **symmetry factor:** maximum 1.6 for the principal peak; if necessary, adjust the content of *acetonitrile R* in the mobile phase.

**Limits:**

- **any impurity:** for each impurity, not more than 1.5 times the area of the principal peak in the chromatogram obtained with reference solution (b) (1.5 per cent);
- **total:** not more than 4.5 times the area of the principal peak in the chromatogram obtained with reference solution (b) (4.5 per cent);

- **disregard limit:** 0.1 times the area of the principal peak in the chromatogram obtained with reference solution (b) (0.1 per cent).

**Acetone** (2.4.24, *System B*): maximum 2.0 per cent.

**Sample solution.** Dissolve 0.500 g of the substance to be examined in *water R* and dilute to 10.0 mL with the same solvent.

**Solvent solution.** Dissolve 0.350 g of *acetone R* in *water R* and dilute to 100.0 mL with the same solvent. Dilute 10.0 mL of this solution to 100.0 mL with *water R*.

Prepare each of 4 injection vials as shown in the table below:

Vial No.	Sample solution (mL)	Solvent solution (mL)	Water R (mL)
1	1.0	0	4.0
2	1.0	1.0	3.0
3	1.0	2.0	2.0
4	1.0	3.0	1.0

**Static head-space conditions that may be used:**

- **equilibration time:** 15 min;
- **transfer-line temperature:** 110 °C.

**Temperature:**

- **Column:** 40 °C for 10 min.

**Heavy metals** (2.4.8): maximum 5 ppm.

2.0 g complies with test C. Prepare the reference solution using 1 mL of *lead standard solution (10 ppm Pb) R*.

**Water** (2.5.12): maximum 5.0 per cent, determined on 0.200 g.

**Bacterial endotoxins** (2.6.14): less than 0.20 IU/mg, if intended for use in the manufacture of parenteral preparations without a further appropriate procedure for the removal of bacterial endotoxins.

## ASSAY

Liquid chromatography (2.2.29) as described in the test for related substances with the following modifications.

**Injection:** test solution (a) and reference solution (a).

**System suitability:** reference solution (a):

- **repeatability:** maximum relative standard deviation of 1.0 per cent after 6 injections.

Calculate the percentage content of cefoperazone sodium by multiplying the percentage content of cefoperazone by 1.034.

## STORAGE

In an airtight container, protected from light, at a temperature of 2 °C to 8 °C. If the substance is sterile, store in a sterile, airtight, tamper-proof container.

## IMPURITIES

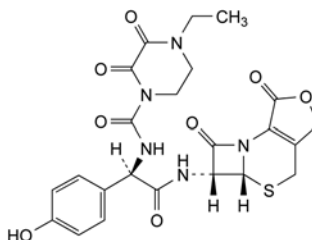

- A. (5a*R*,6*R*)-6-[[[(2*R*)-2-[(4-ethyl-2,3-dioxopiperazin-1-yl)carbonyl]amino]-2-(4-hydroxyphenyl)acetyl]amino]-5a,6-dihydro-3*H*,7*H*-azeto[2,1-*b*]furo[3,4-*d*][1,3]thiazine-1,7(4*H*)-dione,

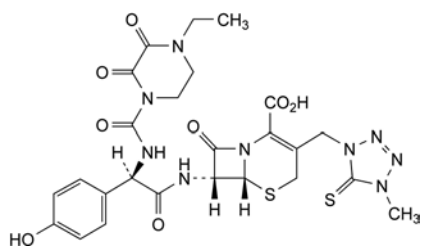

- B. (6*R*,7*R*)-7-[(2*R*)-2-[(4-ethyl-2,3-dioxopiperazin-1-yl)carbonyl]amino]-2-(4-hydroxyphenyl)acetyl]amino]-3-[(4-methyl-5-thioxo-4,5-dihydro-1*H*-tetrazol-1-yl)methyl]-8-oxo-5-thia-1-azabicyclo[4.2.0]oct-2-ene-2-carboxylic acid,

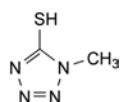

- C. 1-methyl-1*H*-tetrazole-5-thiol,

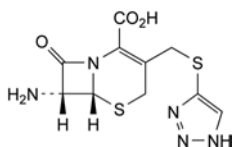

- D. (6*R*,7*R*)-7-amino-8-oxo-3-[(1*H*-1,2,3-triazol-4-ylsulfanyl)methyl]-5-thia-1-azabicyclo[4.2.0]oct-2-ene-2-carboxylic acid (7-TACA),

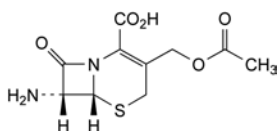

- E. (6*R*,7*R*)-3-[(acetyloxy)methyl]-7-amino-8-oxo-5-thia-1-azabicyclo[4.2.0]oct-2-ene-2-carboxylic acid (7-ACA),

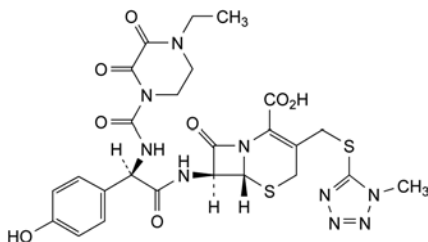

- F. (6*R*,7*S*)-7-[(2*R*)-2-[(4-ethyl-2,3-dioxopiperazine-1-yl)carbonyl]amino]-2-(4-hydroxyphenyl)acetyl]amino]-3-[(1-methyl-1*H*-tetrazol-5-yl)sulfanyl]methyl]-8-oxo-5-thia-1-azabicyclo[4.2.0]oct-2-ene-2-carboxylic acid.

01/2008:0989

## CEFOTAXIME SODIUM

### Cefotaximum natriicum

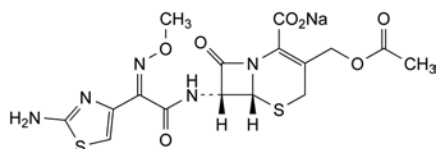

$C_{16}H_{16}N_5NaO_7S_2$   
[64485-93-4]

$M_r$  477.4

#### DEFINITION

Sodium (6*R*,7*R*)-3-[(acetyloxy)methyl]-7-[(2*Z*)-2-(2-aminothiazol-4-yl)-2-(methoxyimino)acetyl]amino]-8-oxo-5-thia-1-azabicyclo[4.2.0]oct-2-ene-2-carboxylate.

Semi-synthetic product derived from a fermentation product.

*Content*: 96.0 per cent to 102.0 per cent (anhydrous substance).

#### CHARACTERS

*Appearance*: white or slightly yellow powder, hygroscopic.

*Solubility*: freely soluble in water, sparingly soluble in methanol.

#### IDENTIFICATION

A. Infrared absorption spectrophotometry (2.2.24).

*Comparison*: cefotaxime sodium CRS.

B. It gives reaction (a) of sodium (2.3.1).

#### TESTS

**Solution S.** Dissolve 2.5 g in carbon dioxide-free water *R* and dilute to 25.0 mL with the same solvent.

**Appearance of solution.** Solution S is clear (2.2.1). Add 1 mL of glacial acetic acid *R* to 10 mL of solution S. The solution, examined immediately, is clear.

**pH** (2.2.3): 4.5 to 6.5 for solution S.

**Specific optical rotation** (2.2.7): + 58.0 to + 64.0 (anhydrous substance).

Dissolve 0.100 g in water *R* and dilute to 10.0 mL with the same solvent.

**Absorbance** (2.2.25): maximum 0.40 at 430 nm for solution S.

**Specific absorbance** (2.2.25): 360 to 390, determined at the absorption maximum at 235 nm (anhydrous substance).

Dissolve 20.0 mg in water *R* and dilute to 100.0 mL with the same solvent. Dilute 10.0 mL of the solution to 100.0 mL with water *R*.

**Related substances.** Liquid chromatography (2.2.29). Prepare the solutions immediately before use.

*Solution A*: mobile phase B, mobile phase A (14:86 *V/V*).

*Test solution.* Dissolve 40.0 mg of the substance to be examined in solution A and dilute to 50.0 mL with the same solution.

*Reference solution (a).* Dissolve 8.0 mg of cefotaxime acid CRS in solution A and dilute to 10.0 mL with the same solution.

*Reference solution (b).* Dilute 1.0 mL of the test solution to 100.0 mL with solution A.

*Reference solution (c).* Add 1.0 mL of dilute hydrochloric acid *R* to 4.0 mL of the test solution. Heat the solution at 40 °C for 2 h. Add 5.0 mL of buffer solution pH 6.6 *R* and 1.0 mL of dilute sodium hydroxide solution *R*.

*Reference solution (d).* Dissolve 4 mg of cefotaxime for peak identification CRS (containing impurities A, B, C, E and F) in 5 mL of solution A.

*Column*:

- size:  $l = 0.15$  m,  $\varnothing = 3.9$  mm,
- stationary phase: octadecylsilyl silica gel for chromatography *R* (5  $\mu$ m),
- temperature: 30 °C.

*Mobile phase*:

- mobile phase A: 7.1 g/L solution of disodium hydrogen phosphate *R* adjusted to pH 6.25 using phosphoric acid *R*;
- mobile phase B: methanol *R*;

Time (min)	Mobile phase A (per cent <i>V/V</i> )	Mobile phase B (per cent <i>V/V</i> )
0 - 7	86	14
7 - 9	86 → 82	14 → 18
9 - 16	82	18
16 - 45	82 → 60	18 → 40
45 - 50	60	40
50 - 55	60 → 86	40 → 14
55 - 60	86	14

*Flow rate*: 1.0 mL/min.

*Detection*: spectrophotometer at 235 nm.

**Injection:** 10 µL of the test solution and reference solutions (b), (c) and (d).

**Identification of impurities:** use the chromatogram supplied with cefotaxime for peak identification CRS and the chromatogram obtained with reference solution (d) to identify the peaks due to impurities A, B, C, E and F.

**Relative retention** with reference to cefotaxime (retention time = about 13 min): impurity B = about 0.3; impurity A = about 0.5; impurity E = about 0.6; impurity C = about 1.9; impurity D = about 2.3; impurity F = about 2.4; impurity G = about 3.1.

**System suitability:** reference solution (c):

- **resolution:** minimum 3.5 between the peaks due to impurity E and cefotaxime;
- **symmetry factor:** maximum 2.0 for the peak due to cefotaxime.

**Limits:**

- **impurities A, B, C, D, E, F:** for each impurity, not more than the area of the principal peak in the chromatogram obtained with reference solution (b) (1.0 per cent);
- **any other impurity:** for each impurity, not more than 0.2 times the area of the principal peak in the chromatogram obtained with reference solution (b) (0.2 per cent);
- **total:** not more than 3 times the area of the principal peak in the chromatogram obtained with reference solution (b) (3.0 per cent);
- **disregard limit:** 0.05 times the area of the principal peak in the chromatogram obtained with reference solution (b) (0.05 per cent).

**Ethanol** (2.4.24, System A): maximum 1.0 per cent.

***N,N*-Dimethylaniline** (2.4.26, Method B): maximum 20 ppm.

**2-Ethylhexanoic acid** (2.4.28): maximum 0.5 per cent *m/m*.

**Water** (2.5.12): maximum 3.0 per cent, determined on 0.300 g.

**Bacterial endotoxins** (2.6.14): less than 0.05 IU/mg, if intended for use in the manufacture of parenteral preparations without a further appropriate procedure for the removal of bacterial endotoxins.

## ASSAY

Liquid chromatography (2.2.29) as described in the test for related substances with the following modification.

**Injection:** test solution and reference solution (a).

Calculate the percentage content of  $C_{16}H_{16}N_5NaO_7S_2$  by multiplying the percentage content of cefotaxime by 1.048.

## STORAGE

In an airtight container, protected from light. If the substance is sterile, store in a sterile, airtight, tamper-proof container.

## IMPURITIES

**Specified impurities:** A, B, C, D, E, F.

**Other detectable impurities** (the following substances would, if present at a sufficient level, be detected by one or other of the tests in the monograph. They are limited by the general acceptance criterion for other/unspecified impurities and/or by the general monograph *Substances for pharmaceutical use* (2034). It is therefore not necessary to identify these impurities for demonstration of compliance. See also 5.10. *Control of impurities in substances for pharmaceutical use*): G.

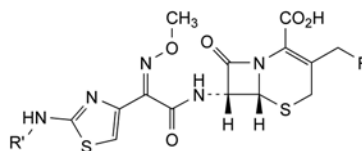

A. R = R' = H: (6*R*,7*R*)-7-[[*(2Z)*-2-(2-aminothiazol-4-yl)-2-(methoxyimino)acetyl]amino]-3-methyl-8-oxo-5-thia-1-azabicyclo[4.2.0]oct-2-ene-2-carboxylic acid (deacetoxycefotaxime),

B. R = OH, R' = H: (6*R*,7*R*)-7-[[*(2Z)*-2-(2-aminothiazol-4-yl)-2-(methoxyimino)acetyl]amino]-3-(hydroxymethyl)-8-oxo-5-thia-1-azabicyclo[4.2.0]oct-2-ene-2-carboxylic acid (deacetylcefotaxime),

C. R = O-CO-CH<sub>3</sub>, R' = CHO: (6*R*,7*R*)-3-[(acetyloxy)methyl]-7-[[*(2Z)*-2-[2-(formylamino)thiazol-4-yl]-2-(methoxyimino)acetyl]amino]-8-oxo-5-thia-1-azabicyclo[4.2.0]oct-2-ene-2-carboxylic acid (*N*-formylcefotaxime),

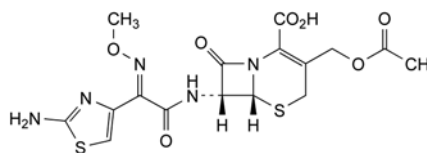

D. (6*R*,7*R*)-3-[(acetyloxy)methyl]-7-[[*(2E)*-2-(2-aminothiazol-4-yl)-2-(methoxyimino)acetyl]amino]-8-oxo-5-thia-1-azabicyclo[4.2.0]oct-2-ene-2-carboxylic acid (*E*-cefotaxime),

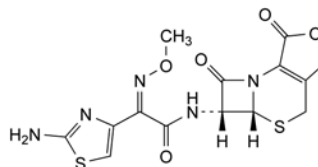

E. (5*aR*,6*R*)-6-[[*(2Z)*-2-(2-aminothiazol-4-yl)-2-(methoxyimino)acetyl]amino]-5*a*,6-dihydro-3*H*,7*H*-azeto[2,1-*b*]furo[3,4-*d*][1,3]thiazine-1,7(4*H*)-dione (deacetylcefotaxime lactone),

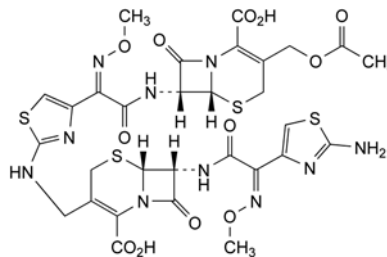

F. (6*R*,7*R*)-3-[(acetyloxy)methyl]-7-[[*(2Z)*-2-[2-[[*(6R*,7*R*)-7-[[*(2Z)*-2-(2-aminothiazol-4-yl)-2-(methoxyimino)acetyl]amino]-2-carboxy-8-oxo-5-thia-1-azabicyclo[4.2.0]oct-2-en-2-yl]methyl]amino]thiazol-4-yl]-2-(methoxyimino)acetyl]amino]-8-oxo-5-thia-1-azabicyclo[4.2.0]oct-2-ene-2-carboxylic acid (cefotaxime dimer),

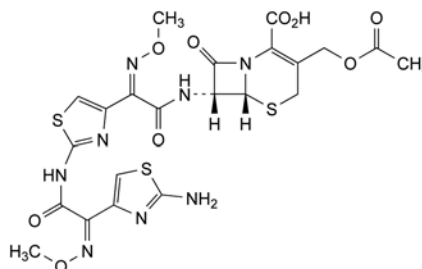

G. (6*R*,7*R*)-3-[(acetyloxy)methyl]-7-[[*(2Z)*-2-[2-[[*(2Z)*-2-(2-aminothiazol-4-yl)-2-(methoxyimino)acetyl]amino]thiazol-4-yl]-2-(methoxyimino)acetyl]amino]-8-oxo-5-thia-1-azabicyclo[4.2.0]oct-2-ene-2-carboxylic acid (ATA cefotaxime).

01/2008:0990  
corrected 6.0

## CEFOXITIN SODIUM

## Cefoxitinum natrium

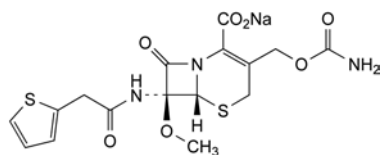
C<sub>16</sub>H<sub>16</sub>N<sub>3</sub>NaO<sub>7</sub>S<sub>2</sub>  
[33564-30-6]M<sub>r</sub> 449.4

## DEFINITION

Sodium (6R,7S)-3-[(carbamoyloxy)methyl]-7-methoxy-8-oxo-7-[[thiophen-2-yl]acetyl]amino]-5-thia-1-azabicyclo[4.2.0]oct-2-ene-2-carboxylate.

Semi-synthetic product derived from a fermentation product.

*Content*: 95.0 per cent to 102.0 per cent (anhydrous substance).

## CHARACTERS

*Appearance*: white or almost white powder, very hygroscopic.

*Solubility*: very soluble in water, sparingly soluble in alcohol.

## IDENTIFICATION

A. Infrared absorption spectrophotometry (2.2.24).

*Comparison*: cefoxitin sodium CRS.

B. It gives reaction (a) of sodium (2.3.1).

## TESTS

**Solution S.** Dissolve 2.50 g in carbon dioxide-free water R and dilute to 25 mL with the same solvent.

**Appearance of solution.** Solution S is clear (2.2.1) and not more intensely coloured than intensity 5 of the range of reference solutions of the most appropriate colour (2.2.2, Method II).

**pH (2.2.3):** 4.2 to 7.0.

Dilute 2 mL of solution S to 20 mL with carbon dioxide-free water R.

**Specific optical rotation (2.2.7):** + 206 to + 214 (anhydrous substance).

Dissolve 0.250 g in methanol R and dilute to 25.0 mL with the same solvent.

**Absorbance (2.2.25).** Dissolve 0.100 g in water R and dilute to 100.0 mL with the same solvent. Dilute 2.0 mL of the solution to 100.0 mL with sodium hydrogen carbonate solution R. Examined between 220 nm and 350 nm, the solution shows an absorption maximum at 236 nm and a broad absorption maximum at about 262 nm. The specific absorbance at this broad maximum is 190 to 210 (anhydrous substance).

**Related substances.** Liquid chromatography (2.2.29). Prepare the solutions immediately before use.

**Solution A.** Dilute 20 mL of a 34.8 g/L solution of dipotassium hydrogen phosphate R adjusted to pH 6.8 with phosphoric acid R to 1000 mL with water R.

**Test solution.** Dissolve 50.0 mg of the substance to be examined in solution A and dilute to 10.0 mL with the same solution.

**Reference solution (a).** Dilute 1.0 mL of the test solution to 100.0 mL with solution A.

**Reference solution (b).** To 1.0 mL of the test solution add 7.0 mL of water R and 2.0 mL of methanol R. Add 25 mg of sodium carbonate R, stir for 10 min at room temperature, then heat in a water-bath at 70 °C for 30 min. Allow to cool. Add 3 drops of glacial acetic acid R and 1 mL of the test solution and mix.

**Column:**

– size:  $l = 0.25$  m,  $\emptyset = 4.6$  mm,

– *stationary phase*: phenylsilyl silica gel for chromatography R (5 µm) with a specific surface area of 300 m<sup>2</sup>/g and a pore size of 7 nm.

**Mobile phase:**

– *mobile phase A*: water R adjusted to pH 2.7 with anhydrous formic acid R,

– *mobile phase B*: acetonitrile R,

Time (min)	Mobile phase A (per cent V/V)	Mobile phase B (per cent V/V)
0 - 12	90	10
12 - 37	90 → 80	10 → 20
37 - 50	80 → 60	20 → 40
50 - 55	60 → 20	40 → 80
55 - 60	20	80
60 - 62	20 → 90	80 → 10
62 - 70	90	10

*Flow rate*: 1 mL/min.

*Detection*: spectrophotometer at 235 nm.

*Injection*: 50 µL.

*Relative retentions* with reference to cefoxitin (retention time = about 34 min): impurity A = about 0.82; impurity B = about 1.16; impurity C = about 1.27; impurity D = about 1.31.

*System suitability*: reference solution (b):

– *resolution*: minimum 5.0 between the 2 principal peaks.

**Limits:**

– *any impurity*: not more than half the area of the principal peak in the chromatogram obtained with reference solution (a) (0.5 per cent),

– *total*: not more than 4 times the area of the principal peak in the chromatogram obtained with reference solution (a) (4.0 per cent),

– *disregard limit*: 0.05 times the area of the principal peak in the chromatogram obtained with reference solution (a) (0.05 per cent).

**Water (2.5.12)**: maximum 1.0 per cent, determined on 0.500 g.

**Bacterial endotoxins (2.6.14)**: less than 0.13 IU/mg, if intended for use in the manufacture of parenteral preparations without a further appropriate procedure for the removal of bacterial endotoxins.

## ASSAY

Liquid chromatography (2.2.29).

**Test solution.** Dissolve 25.0 mg of the substance to be examined in water R and dilute to 25.0 mL with the same solvent.

**Reference solution (a).** Dissolve 25.0 mg of cefoxitin sodium CRS in water R and dilute to 25.0 mL with the same solvent.

**Reference solution (b).** Dissolve 20.0 mg of 2-(2-thienyl)acetic acid R in water R and dilute to 25.0 mL with the same solvent.

**Reference solution (c).** Mix 1.0 mL of reference solution (a) and 5.0 mL of reference solution (b).

**Column:**

– size:  $l = 0.25$  m,  $\emptyset = 4.6$  mm,

– *stationary phase*: octadecylsilyl silica gel for chromatography R (5 µm).

**Mobile phase**: acetic acid R, acetonitrile R, water R (1:19:81 V/V/V).

*Flow rate*: 1 mL/min.

*Detection*: spectrophotometer at 254 nm.

*Injection*: 20 µL; inject the test solution and reference solutions (a) and (c).

*System suitability*: reference solution (c):

- *resolution*: minimum 3.5 between the 2 principal peaks.
- Calculate the percentage content of cefoxitin sodium.

#### STORAGE

In an airtight container. If the substance is sterile, store in a sterile, airtight, tamper-proof container.

#### IMPURITIES

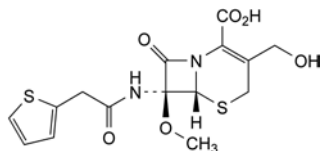

- A. (6*R*,7*S*)-3-(hydroxymethyl)-7-methoxy-8-oxo-7-[[[(thiophen-2-yl)acetyl]amino]-5-thia-1-azabicyclo[4.2.0]oct-2-ene-2-carboxylic acid (decarbomoylcefloxitin),

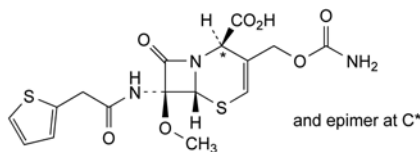

- B. (2*RS*,6*R*,7*S*)-3-[(carbamoyloxy)methyl]-7-methoxy-8-oxo-7-[[[(thiophen-2-yl)acetyl]amino]-5-thia-1-azabicyclo[4.2.0]oct-3-ene-2-carboxylic acid (delta-3-cefoxitin),

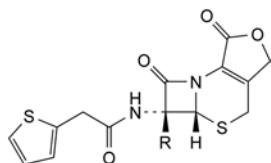

- C. R = H: (5*aR*,6*R*)-6-[[[(thiophen-2-yl)acetyl]amino]-5*a*,6-dihydro-3*H*,7*H*-azeto[2,1-*b*]furo[3,4-*d*][1,3]thiazine-1,7(4*H*)-dione (cefalotin lactone),

- D. R = OCH<sub>3</sub>: (5*aR*,6*S*)-6-methoxy-6-[[[(thiophen-2-yl)acetyl]amino]-5*a*,6-dihydro-3*H*,7*H*-azeto[2,1-*b*]furo[3,4-*d*][1,3]thiazine-1,7(4*H*)-dione (cefloxitin lactone).

01/2011:2341

## CEFPODOXIME PROXETIL

### Cefpodoximum proxetili

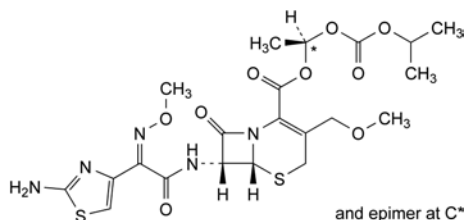

C<sub>21</sub>H<sub>27</sub>N<sub>5</sub>O<sub>9</sub>S<sub>2</sub>  
[87239-81-4]

*M<sub>r</sub>* 557.6

#### DEFINITION

(1*RS*)-1-[[[(1-Methylethoxy)carbonyloxy]ethyl (6*R*,7*R*)-7-[[[(2*Z*)-2-(2-aminothiazol-4-yl)-2-(methoxyimino)acetyl]amino]-3-(methoxymethyl)-8-oxo-5-thia-1-azabicyclo[4.2.0]oct-2-ene-2-carboxylate.

Semi-synthetic product derived from a fermentation product.

*Content*: 94.0 per cent to 102.0 per cent (anhydrous substance).

#### CHARACTERS

*Appearance*: white or pale yellow or light brown, amorphous powder.

*Solubility*: very slightly soluble or practically insoluble in water, very soluble in acetonitrile and in methanol, freely soluble in anhydrous ethanol.

#### IDENTIFICATION

Infrared absorption spectrophotometry (2.2.24).

*Comparison*: cefpodoxime proxetil CRS.

#### TESTS

**Diastereoisomer ratio.** Liquid chromatography (2.2.29) as described under Assay. Use the normalisation procedure.

*Limit*: test solution:

- the ratio of the area of the peak due to cefpodoxime proxetil diastereoisomer II to the sum of the areas of the peaks due to cefpodoxime proxetil diastereoisomers I and II is between 0.5 and 0.6.

**Related substances.** Liquid chromatography (2.2.29). Prepare the solutions immediately before use or store them at 2-8 °C.

*Solvent mixture*: glacial acetic acid *R*, acetonitrile *R*, water *R* (2:99:99 *V/V/V*).

*Test solution.* Dissolve 50 mg of the substance to be examined in the solvent mixture and dilute to 50.0 mL with the solvent mixture.

*Reference solution (a).* Dilute 1.0 mL of the test solution to 100.0 mL with the solvent mixture.

*Reference solution (b).* Dissolve 5 mg of cefpodoxime proxetil for peak identification CRS (containing impurities B, C and D) in 5.0 mL of the solvent mixture.

*Reference solution (c).* Dissolve 5 mg of cefpodoxime proxetil for impurity H identification CRS in 5.0 mL of the solvent mixture.

*Column*:

- *size*: *l* = 0.15 m, Ø = 4.6 mm;
- *stationary phase*: end-capped octadecylsilyl silica gel for chromatography *R* (5 µm);
- *temperature*: maintain at a constant temperature of 20 °C.

*Mobile phase*:

- *mobile phase A*: anhydrous formic acid *R*, methanol *R*, water *R* (1:400:600 *V/V/V*);
- *mobile phase B*: anhydrous formic acid *R*, water *R*, methanol *R* (1:50:950 *V/V/V*);

Time (min)	Mobile phase A (per cent <i>V/V</i> )	Mobile phase B (per cent <i>V/V</i> )
0 - 65	95	5
65 - 145	95 → 15	5 → 85
145 - 155	15	85

*Flow rate*: 0.6 mL/min.

*Detection*: spectrophotometer at 254 nm.

*Injection*: 20 µL.

*Identification of impurities*: use the chromatogram supplied with cefpodoxime proxetil for peak identification CRS and the chromatogram obtained with reference solution (b) to identify the peaks due to impurities B, C and D; use the chromatogram supplied with cefpodoxime proxetil for impurity H identification CRS and the chromatogram obtained with reference solution (c) to identify the peaks due to impurity H.

*Relative retention* with reference to cefpodoxime proxetil diastereoisomer II (retention time = about 58 min): diastereoisomer I of impurity B = about 0.68; diastereoisomer I of cefpodoxime proxetil = about 0.74; impurity C = about 0.82; diastereoisomer II of impurity B = about 0.85; impurity D (2 peaks) = about 0.88 and 1.13; peaks due to diastereoisomers of impurity H: between about 1.9 and 2.3.

**System suitability:**

- the chromatogram obtained with reference solution (b) is similar to the chromatogram supplied with *cefpodoxime proxetil* for peak identification CRS;
- **resolution**: minimum 6.0 between the peaks due to cefpodoxime proxetil diastereoisomers I and II in the chromatogram obtained with reference solution (a);
- **peak-to-valley ratio**: minimum 1.1, where  $H_p$  = height above the baseline of the peak due to diastereoisomer II of impurity B and  $H_v$  = height above the baseline of the lowest point of the curve separating this peak from the peak due to impurity C in the chromatogram obtained with reference solution (b).

**Limits:**

- **impurity C**: not more than twice the sum of the areas of the 2 principal peaks in the chromatogram obtained with reference solution (a) (2.0 per cent);
- **impurity D (sum of the 2 diastereoisomers)**: not more than the sum of the areas of the 2 principal peaks in the chromatogram obtained with reference solution (a) (1.0 per cent);
- **impurity H (sum of the diastereoisomers)**: not more than the sum of the areas of the 2 principal peaks in the chromatogram obtained with reference solution (a) (1.0 per cent);
- **impurity B (sum of the 2 diastereoisomers)**: not more than 0.5 times the sum of the areas of the 2 principal peaks in the chromatogram obtained with reference solution (a) (0.5 per cent);
- **any other impurity**: for each impurity, not more than 0.2 times the sum of the areas of the 2 principal peaks in the chromatogram obtained with reference solution (a) (0.2 per cent);
- **total**: not more than 4 times the sum of the areas of the 2 principal peaks in the chromatogram obtained with reference solution (a) (4.0 per cent);
- **disregard limit**: 0.05 times the sum of the areas of the 2 principal peaks in the chromatogram obtained with reference solution (a) (0.05 per cent).

**Water (2.5.12)**: maximum 2.5 per cent, determined on 0.500 g.

**ASSAY**

Liquid chromatography (2.2.29).

**Solution A**: 20 mg/L solution of *anhydrous citric acid R* in *acetonitrile R*.

**Test solution**. Dissolve 30.0 mg of the substance to be examined in solution A and dilute to 50.0 mL with solution A.

**Reference solution**. Dissolve 30.0 mg of *cefpodoxime proxetil* CRS in solution A and dilute to 50.0 mL with solution A.

**Column:**

- **size**:  $l = 0.15$  m,  $\varnothing = 4.6$  mm;
- **stationary phase**: *end-capped octadecylsilyl silica gel for chromatography R* (5  $\mu$ m);
- **temperature**: 40 °C.

**Mobile phase**: *methanol R*, *water R* (9:11 V/V).

**Flow rate**: 0.8 mL/min.

**Detection**: spectrophotometer at 240 nm.

**Injection**: 10  $\mu$ L.

**Run time**: 1.2 times the retention time of cefpodoxime proxetil diastereoisomer II.

**Retention time**: cefpodoxime proxetil diastereoisomer II = about 30 min.

**System suitability: reference solution:**

- **resolution**: minimum 4.0 between the peaks due to cefpodoxime proxetil diastereoisomers I and II.

Calculate the percentage content of  $C_{21}H_{27}N_5O_9S_2$  from the sum of the areas of the 2 peaks due to the diastereoisomers and using the declared content of *cefpodoxime proxetil* CRS.

**STORAGE**

Protected from light.

**IMPURITIES**

**Specified impurities: B, C, D, H.**

**Other detectable impurities** (the following substances would, if present at a sufficient level, be detected by one or other of the tests in the monograph. They are limited by the general acceptance criterion for other/unspecified impurities and/or by the general monograph *Substances for pharmaceutical use (2034)*. It is therefore not necessary to identify these impurities for demonstration of compliance. See also 5.10. *Control of impurities in substances for pharmaceutical use*): A, E, F, G.

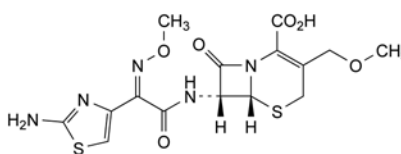

- A. (6*R*,7*R*)-7-[[[(2*Z*)-2-(2-aminothiazol-4-yl)-2-(methoxyimino)acetyl]amino]-3-(methoxymethyl)-8-oxo-5-thia-1-azabicyclo[4.2.0]oct-2-ene-2-carboxylic acid (cefpodoxime),

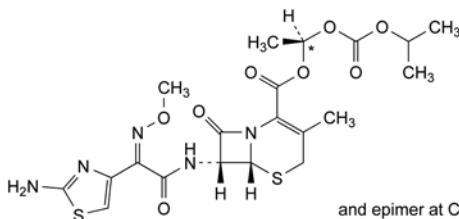

- B. (1*R*,*S*)-1-[[[(1-methylethoxy)carbonyl]oxy]ethyl (6*R*,7*R*)-7-[[[(2*Z*)-2-(2-aminothiazol-4-yl)-2-(methoxyimino)acetyl]amino]-3-methyl-8-oxo-5-thia-1-azabicyclo[4.2.0]oct-2-ene-2-carboxylate (ADCA-analogue of cefpodoxime proxetil),

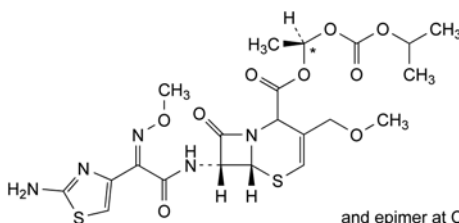

- C. (1*R*,*S*)-1-[[[(1-methylethoxy)carbonyl]oxy]ethyl (6*R*,7*R*)-7-[[[(2*Z*)-2-(2-aminothiazol-4-yl)-2-(methoxyimino)acetyl]amino]-3-(methoxymethyl)-8-oxo-5-thia-1-azabicyclo[4.2.0]oct-3-ene-2-carboxylate (delta-2-cefpodoxime proxetil),

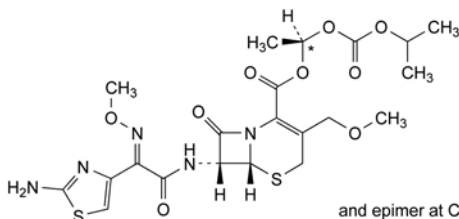

- D. (1*R*,*S*)-1-[[[(1-methylethoxy)carbonyl]oxy]ethyl (6*R*,7*R*)-7-[[[(2*E*)-2-(2-aminothiazol-4-yl)-2-(methoxyimino)acetyl]amino]-3-(methoxymethyl)-8-oxo-5-thia-1-azabicyclo[4.2.0]oct-2-ene-2-carboxylate (anti-cefpodoxime proxetil),

07/2010:0814

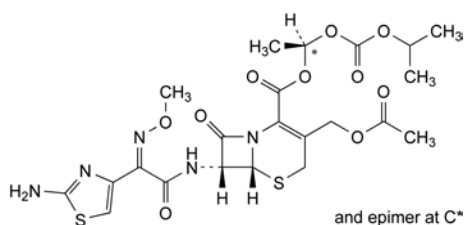

- E. (1*RS*)-1-[[[(1-methylethoxy)carbonyl]oxy]ethyl (6*R*,7*R*)-3-(acetoxymethyl)-7-[[*(2Z)*-2-(2-aminothiazol-4-yl)-2-(methoxyimino)acetyl]amino]-8-oxo-5-thia-1-azabicyclo[4.2.0]oct-2-ene-2-carboxylate (ACA-analogue of cefpodoxime proxetil),

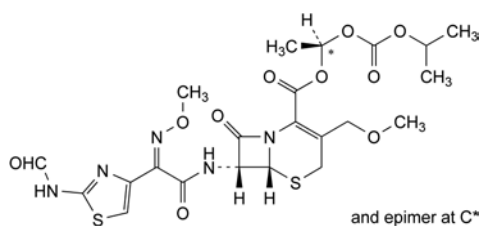

- F. (1*RS*)-1-[[[(1-methylethoxy)carbonyl]oxy]ethyl (6*R*,7*R*)-7-[[*(2Z)*-2-[(2-formylamino)thiazol-4-yl]-2-(methoxyimino)acetyl]amino]-3-(methoxymethyl)-8-oxo-5-thia-1-azabicyclo[4.2.0]oct-2-ene-2-carboxylate (*N*-formyl cefpodoxime proxetil),

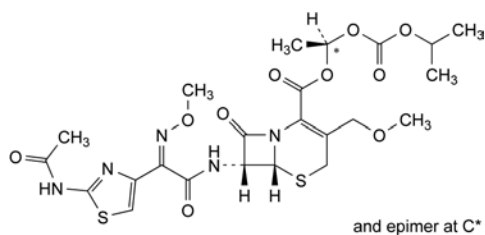

- G. (1*RS*)-1-[[[(1-methylethoxy)carbonyl]oxy]ethyl (6*R*,7*R*)-7-[[*(2Z)*-2-(2-acetylaminio)thiazol-4-yl]-2-(methoxyimino)acetyl]amino]-3-(methoxymethyl)-8-oxo-5-thia-1-azabicyclo[4.2.0]oct-2-ene-2-carboxylate (*N*-acetyl-cefpodoxime proxetil),

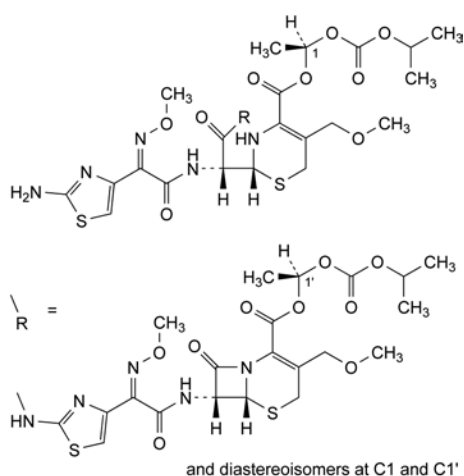

- H. mixture of the diastereoisomers of 1-[[[(1-methylethoxy)carbonyl]oxy]ethyl (6*R*,7*R*)-7-[[*(2Z)*-2-[[*(2R)*-2-[[*(2Z)*-2-(2-aminothiazol-4-yl)-2-(methoxyimino)acetyl]amino]-2-[[*(2R)*-5-(methoxymethyl)-4-[[1-[[[(1-methylethoxy)carbonyl]oxy]ethoxy]carbonyl]-3,6-dihydro-2*H*-1,3-thiazin-2-yl]acetyl]amino]thiazol-4-yl]-2-(methoxyimino)acetyl]amino]-3-(methoxymethyl)-8-oxo-5-thia-1-azabicyclo[4.2.0]oct-2-ene-2-carboxylate (cefpodoxime proxetil dimer).

## CEFRADINE

### Cefradinum

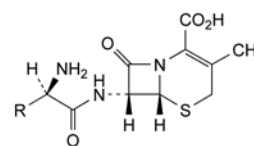

Compound	R	Mol. Formula	<i>M<sub>r</sub></i>
cefradine		C <sub>16</sub> H <sub>19</sub> N <sub>3</sub> O <sub>4</sub> S	349.4
cefalexin		C <sub>16</sub> H <sub>17</sub> N <sub>3</sub> O <sub>4</sub> S	347.4
4',5'-dihydrocefradine		C <sub>16</sub> H <sub>21</sub> N <sub>3</sub> O <sub>4</sub> S	351.4

Cefradine: [38821-53-3]

#### DEFINITION

*Main component*: (6*R*,7*R*)-7-[[*(2R)*-amino(cyclohexa-1,4-dienyl)acetyl]amino]-3-methyl-8-oxo-5-thia-1-azabicyclo[4.2.0]oct-2-ene-2-carboxylic acid (cefradine).

Semi-synthetic product derived from a fermentation product.

#### Content:

- *cefradine*: minimum 90.0 per cent (anhydrous substance);
- *cefalexin*: maximum 5.0 per cent (anhydrous substance);
- *4',5'-dihydrocefradine*: maximum 2.0 per cent (anhydrous substance);
- *sum of the percentage contents of cefradine, cefalexin and 4',5'-dihydrocefradine*: 96.0 per cent to 102.0 per cent (anhydrous substance).

#### CHARACTERS

*Appearance*: white or slightly yellow, hygroscopic powder.

*Solubility*: sparingly soluble in water, practically insoluble in ethanol 96 per cent and in hexane.

#### IDENTIFICATION

Infrared absorption spectrophotometry (2.2.24).

*Comparison*: *cefradine CRS*.

If the spectra obtained in the solid state show differences, dissolve 30 mg of the substance to be examined and of the reference substance separately in 10 mL of *methanol R*, evaporate to dryness at 40 °C at a pressure less than 2 kPa and record new spectra using the residues.

#### TESTS

**Solution S.** Dissolve 2.50 g in *sodium carbonate solution R* and dilute to 25.0 mL with the same solvent.

**Appearance of solution.** Solution S is not more opalescent than reference suspension II (2.2.1). Allow solution S to stand for 5 min. The absorbance (2.2.25) of solution S measured at 450 nm is not greater than 0.60.

**pH (2.2.3):** 3.5 to 6.0.

Dissolve 0.100 g in *carbon dioxide-free water R* and dilute to 10 mL with the same solvent.

**Specific optical rotation (2.2.7):** + 80.0 to + 90.0 (anhydrous substance).

Dissolve 0.250 g in *acetate buffer solution pH 4.6 R* and dilute to 25.0 mL with the same solution.



**Related substances.** Liquid chromatography (2.2.29).

**Test solution.** Dissolve 0.300 g of the substance to be examined in mobile phase A and dilute to 50.0 mL with mobile phase A.

**Reference solution (a).** Dissolve 3.0 mg of *cyclohexa-1,4-dienylglycine CRS* (impurity B) in mobile phase A and dilute to 100.0 mL with mobile phase A.

**Reference solution (b).** Dissolve 3 mg of the substance to be examined and 3 mg of *cefalexin CRS* in mobile phase A and dilute to 25 mL with mobile phase A.

**Reference solution (c).** Dilute 1.0 mL of test solution to 100.0 mL with mobile phase A.

**Reference solution (d).** Dissolve 6 mg of *cefradine for peak identification CRS* (containing impurities C, D and E) in 1.0 mL of mobile phase A.

**Reference solution (e).** Dissolve the contents of a vial of *cefradine impurity mixture CRS* (impurities A and G) in 1.0 mL of mobile phase A.

**Column:**

- size:  $l = 0.15$  m,  $\varnothing = 4.6$  mm;
- stationary phase: *octadecylsilyl silica gel for chromatography R* (5  $\mu\text{m}$ );
- temperature: 30 °C.

**Mobile phase:**

- mobile phase A: 2.72 g/L solution of *potassium dihydrogen phosphate R* adjusted to pH 3.0 with *dilute phosphoric acid R*;
- mobile phase B: *methanol R2*;

Time (min)	Mobile phase A (per cent V/V)	Mobile phase B (per cent V/V)
0 - 2.5	99.5 → 97	0.5 → 3
2.5 - 11	97 → 75	3 → 25
11 - 13	75 → 60	25 → 40
13 - 16	60	40
16 - 19	60 → 20	40 → 80
19 - 19.1	20 → 99.5	80 → 0.5
19.1 - 25	99.5	0.5

**Flow rate:** 1.0 mL/min.

**Detection:** spectrophotometer at 220 nm.

**Injection:** 25  $\mu\text{L}$ .

**Identification of impurities:** use the chromatogram supplied with *cefradine for peak identification CRS* and the chromatogram obtained with reference solution (d) to identify the peaks due to impurities C, D and E. Use the chromatogram supplied with *cefradine impurity mixture CRS* and the chromatogram obtained with reference solution (e) to identify the peaks due to impurities A and G.

**Relative retention** with reference to cefradine (retention time = about 15 min): impurity A = about 0.27; impurity B = about 0.32; impurity C = about 0.53; impurity D = about 0.63; impurity E = about 0.80; impurity F = about 0.92; cefalexin = about 0.95; 4',5'-dihydrocefradine = about 1.06; impurity G = about 1.32.

**System suitability:** reference solution (b):

- resolution: minimum 4.0 between the peaks due to cefalexin and cefradine.

**Limits:**

- impurity B: not more than 0.5 times the area of the principal peak in the chromatogram obtained with reference solution (a) (0.25 per cent);

- impurities A, C, D, E, F, G: for each impurity, not more than 0.25 times the area of the principal peak in the chromatogram obtained with reference solution (c) (0.25 per cent);
- any other impurity: for each impurity, not more than 0.25 times the area of the principal peak in the chromatogram obtained with reference solution (c) (0.25 per cent);
- total: not more than twice the area of the principal peak in the chromatogram obtained with reference solution (c) (2.0 per cent);
- disregard limit: 0.05 times the area of the principal peak in the chromatogram obtained with reference solution (c) (0.05 per cent); disregard the peaks due to cefalexin and 4',5'-dihydrocefradine.

**N,N-Dimethylaniline (2.4.26, Method B):** maximum 20 ppm.

**Water (2.5.12):** maximum 6.0 per cent, determined on 0.300 g.

**Sulfated ash (2.4.14):** maximum 0.2 per cent, determined on 1.0 g.

**ASSAY**

Liquid chromatography (2.2.29).

**Test solution.** Dissolve 50.0 mg of the substance to be examined in *phosphate buffer solution pH 5.0 R* and dilute to 100.0 mL with the same solution.

**Reference solution (a).** Dissolve 50.0 mg of *cefradine CRS* (containing 4',5'-dihydrocefradine) in *phosphate buffer solution pH 5.0 R* and dilute to 100.0 mL with the same solution.

**Reference solution (b).** Dissolve 5.0 mg of *cefalexin CRS* in *phosphate buffer solution pH 5.0 R* and dilute to 100.0 mL with the same solution.

**Reference solution (c).** Dilute 1 mL of reference solution (a) to 10 mL with *phosphate buffer solution pH 5.0 R*. Mix 5 mL of this solution with 5 mL of reference solution (b).

**Column:**

- size:  $l = 0.10$  m,  $\varnothing = 4.6$  mm;
- stationary phase: *octadecylsilyl silica gel for chromatography R* (5  $\mu\text{m}$ ).

**Mobile phase:** *methanol R*, *phosphate buffer solution pH 5.0 R* (25:75 V/V).

**Flow rate:** 1.5 mL/min.

**Detection:** spectrophotometer at 254 nm.

**Injection:** 5  $\mu\text{L}$ .

**Run time:** twice the retention time of cefradine.

**Relative retention** with reference to cefradine (retention time = about 3 min): cefalexin = about 0.7; 4',5'-dihydrocefradine = about 1.5.

**System suitability:** reference solution (c):

- resolution: minimum 4.0 between the peaks due to cefalexin and cefradine.

Calculate the percentage content of cefradine using the chromatogram obtained with reference solution (a) and the declared content of *cefradine CRS*. Calculate the percentage content of cefalexin using the chromatogram obtained with reference solution (b) and the declared content of *cefalexin CRS*. Calculate the percentage content of 4',5'-dihydrocefradine using the chromatogram obtained with reference solution (b) and multiplying the area of the peak due to 4',5'-dihydrocefradine by a correction factor of 1.6.

**STORAGE**

In an airtight container, protected from light, at a temperature of 2 °C to 8 °C.

**IMPURITIES**

**Specified impurities:** A, B, C, D, E, F, G.

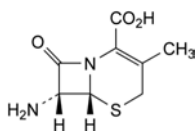

- A. (6*R*,7*R*)-7-amino-3-methyl-8-oxo-5-thia-1-azabicyclo[4.2.0]oct-2-ene-2-carboxylic acid (7-aminodeacetoxycephalosporanic acid, 7-ADCA),

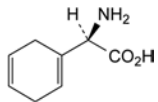

- B. (2*R*)-amino(cyclohexa-1,4-dienyl)acetic acid (D-dihydrophenylglycine, cyclohexa-1,4-dienylglycine),

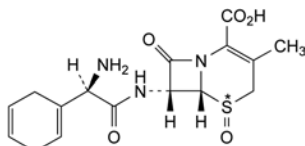

- C. (6*R*,7*R*)-7-[(2*R*)-amino(cyclohexa-1,4-dienyl)acetyl]amino-3-methyl-8-oxo-5-thia-1-azabicyclo[4.2.0]oct-2-ene-2-carboxylic acid 5-oxide (isomer 1),

- D. (6*R*,7*R*)-7-[(2*R*)-amino(cyclohexa-1,4-dienyl)acetyl]amino-3-methyl-8-oxo-5-thia-1-azabicyclo[4.2.0]oct-2-ene-2-carboxylic acid 5-oxide (isomer 2),

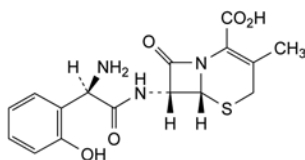

- E. ((6*R*,7*R*)-7-[(2*R*)-amino(2-hydroxyphenyl)acetyl]amino)-3-methyl-8-oxo-5-thia-1-azabicyclo[4.2.0]oct-2-ene-2-carboxylic acid,

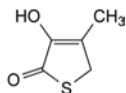

- F. 3-hydroxy-4-methylthiophen-2(5*H*)-one,

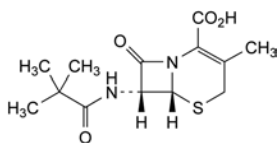

- G. (6*R*,7*R*)-7-[(2,2-dimethylpropanoyl)amino]-3-methyl-8-oxo-5-thia-1-azabicyclo[4.2.0]oct-2-ene-2-carboxylic acid (7-ADCA pivalamide).

Semi-synthetic product derived from a fermentation product.

*Content*: 95.0 per cent to 102.0 per cent (anhydrous substance).

#### CHARACTERS

*Appearance*: white or almost white, crystalline powder.

*Solubility*: slightly soluble in water and in methanol, practically insoluble in acetone and in ethanol (96 per cent). It dissolves in acid and alkali solutions.

#### IDENTIFICATION

Infrared absorption spectrophotometry (2.2.24).

*Comparison*: ceftazidime CRS.

#### TESTS

**Solution S.** Dissolve 0.25 g in *carbon dioxide-free water R* and dilute to 50 mL with the same solvent.

**Appearance of solution.** Solution S is clear (2.2.1) and colourless (2.2.2, *Method II*).

**pH (2.2.3)**: 3.0 to 4.0 for solution S.

**Related substances.** Liquid chromatography (2.2.29).

*Test solution.* Suspend 0.150 g of the substance to be examined in 5 mL of *acetonitrile R*, dissolve by adding *water R* and dilute to 100 mL with the same solvent.

*Reference solution (a).* To 1.0 mL of the test solution add 5.0 mL of *acetonitrile R* and dilute to 100.0 mL with *water R*. Dilute 1.0 mL of this solution to 5.0 mL with *water R*.

*Reference solution (b).* Suspend 3 mg of *ceftazidime impurity A CRS* and 3 mg of *ceftazidime CRS* in 5 mL of *acetonitrile R*, dissolve by adding *water R* and dilute to 20 mL with the same solvent. Dilute 1 mL of this solution to 20 mL with *water R*.

*Reference solution (c).* Suspend 3 mg of *ceftazidime for peak identification CRS* (containing impurities A, B and G) in 0.5 mL of *acetonitrile R*, dissolve by adding *water R* and dilute to 2 mL with the same solvent.

*Column*:

- size:  $l = 0.25$  m,  $\varnothing = 4.6$  mm;
- stationary phase: octadecylsilyl silica gel for chromatography R (5  $\mu$ m);
- temperature: 40 °C.

*Mobile phase*:

- mobile phase A: solution containing 3.6 g of *disodium hydrogen phosphate R* and 1.4 g of *potassium dihydrogen phosphate R* in 1 litre of *water R*, adjusted to pH 3.4 with a 10 per cent V/V solution of *phosphoric acid R*;
- mobile phase B: *acetonitrile for chromatography R*;

Time (min)	Mobile phase A (per cent V/V)	Mobile phase B (per cent V/V)
0 - 4	96 → 89	4 → 11
4 - 5	89	11
5 - 8	89 → 84	11 → 16
8 - 11	84 → 80	16 → 20
11 - 15	80 → 50	20 → 50
15 - 18	50 → 20	50 → 80
18 - 22	20	80

*Flow rate*: 1.3 mL/min.

*Detection*: spectrophotometer at 254 nm.

*Injection*: 10  $\mu$ L.

*Relative retention* with reference to ceftazidime (retention time = about 8 min): impurity F = about 0.4; impurity G = about 0.8; impurity A = about 0.9; impurity B = about 1.4.

07/2009:1405

## CEFTAZIDIME PENTAHYDRATE

### Ceftazidimum pentahydricum

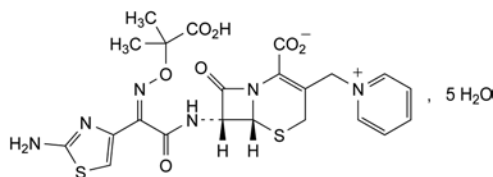

$C_{22}H_{22}N_6O_7S_2 \cdot 5H_2O$   
[78439-06-2]

$M_r$  637

#### DEFINITION

(6*R*,7*R*)-7-[(2*Z*)-2-(2-Aminothiazol-4-yl)-2-[(1-carboxy-1-methylethoxy)imino]acetyl]amino]-8-oxo-3-[(1-pyridinio)methyl]-5-thia-1-azabicyclo[4.2.0]oct-2-ene-2-carboxylate pentahydrate.

**Identification of impurities:** use the chromatogram supplied with *ceftazidime for peak identification CRS* and the chromatogram obtained with reference solution (c) to identify the peaks due to impurities A, B and G.

**System suitability:** reference solution (b):

- **resolution:** minimum 4.0 between the peaks due to impurity A and ceftazidime.

**Limits:**

- **correction factor:** for the calculation of content, multiply the peak area of impurity G by 3.0;
- **impurities A, B, G:** for each impurity, not more than the area of the principal peak in the chromatogram obtained with reference solution (a) (0.2 per cent);
- **unspecified impurities:** for each impurity, not more than 0.5 times the area of the principal peak in the chromatogram obtained with reference solution (a) (0.10 per cent);
- **total:** not more than 5 times the area of the principal peak in the chromatogram obtained with reference solution (a) (1.0 per cent);
- **disregard limit:** 0.25 times the area of the principal peak in the chromatogram obtained with reference solution (a) (0.05 per cent); disregard the peak due to impurity F.

**Impurity F.** Liquid chromatography (2.2.29). Prepare the solutions immediately before use.

**Test solution.** Dissolve 0.500 g of the substance to be examined in a 10 per cent V/V solution of *phosphate buffer solution pH 7.0 R4* and dilute to 100.0 mL with the same solvent.

**Reference solution (a).** Dissolve 1.00 g of *pyridine R* in *water R* and dilute to 100.0 mL with the same solvent. Dilute 5.0 mL of this solution to 200.0 mL with *water R*. To 1.0 mL of this solution, add 10 mL of *phosphate buffer solution pH 7.0 R4* and dilute to 100.0 mL with *water R*.

**Reference solution (b).** Dilute 1 mL of the test solution to 200 mL with a 10 per cent V/V solution of *phosphate buffer solution pH 7.0 R4*. To 1 mL of this solution add 20 mL of reference solution (a) and dilute to 200 mL with a 10 per cent V/V solution of *phosphate buffer solution pH 7.0 R4*.

**Column:**

- **size:**  $l = 0.25$  m,  $\emptyset = 4.6$  mm;
- **stationary phase:** *octadecylsilyl silica gel for chromatography R* (5  $\mu$ m).

**Mobile phase:** mix 8 volumes of a 28.8 g/L solution of *ammonium dihydrogen phosphate R* previously adjusted to pH 7.0 with *ammonia R*, 24 volumes of *acetonitrile R* and 68 volumes of *water R*.

**Flow rate:** 1.0 mL/min.

**Detection:** spectrophotometer at 255 nm.

**Injection:** 20  $\mu$ L.

**Run time:** 10 min.

**System suitability:** reference solution (b):

- **resolution:** minimum 7.0 between the peaks due to ceftazidime and impurity F.

**Limit:**

- **impurity F:** not more than the area of the principal peak in the chromatogram obtained with reference solution (a) (500 ppm).

**Heavy metals (2.4.8):** maximum 20 ppm.

1.0 g complies with test F. Prepare the reference solution using 2.0 mL of *lead standard solution (10 ppm Pb) R*.

**Water (2.5.12):** 13.0 per cent to 15.0 per cent, determined on 0.100 g.

**Bacterial endotoxins (2.6.14):** less than 0.10 IU/mg, if intended for use in the manufacture of parenteral preparations without a further appropriate procedure for the removal of bacterial endotoxins.

**ASSAY**

Liquid chromatography (2.2.29).

**Test solution.** Dissolve 25.0 mg of the substance to be examined in the mobile phase and dilute to 25.0 mL with the mobile phase.

**Reference solution (a).** Dissolve 25.0 mg of *ceftazidime CRS* in the mobile phase and dilute to 25.0 mL with the mobile phase.

**Reference solution (b).** Dissolve 5.0 mg of *ceftazidime impurity A CRS* in 5.0 mL of reference solution (a).

**Column:**

- **size:**  $l = 0.15$  m,  $\emptyset = 4.6$  mm;
- **stationary phase:** *hexylsilyl silica gel for chromatography R* (5  $\mu$ m).

**Mobile phase:** dissolve 4.3 g of *disodium hydrogen phosphate R* and 2.7 g of *potassium dihydrogen phosphate R* in 980 mL of *water R*, then add 20 mL of *acetonitrile R*.

**Flow rate:** 2 mL/min.

**Detection:** spectrophotometer at 245 nm.

**Injection:** 20  $\mu$ L.

**Run time:** 6 min.

**Relative retention** with reference to ceftazidime (retention time = about 4.5 min): impurity A = about 0.7.

**System suitability:** reference solution (b):

- **resolution:** minimum 1.5 between the peaks due to impurity A and ceftazidime.

Calculate the content of ceftazidime ( $C_{22}H_{22}N_6O_7S_2$ ) from the declared content of  $C_{22}H_{22}N_6O_7S_2$  in *ceftazidime CRS*.

**STORAGE**

In an airtight container. If the substance is sterile, store in a sterile, airtight, tamper-proof container.

**IMPURITIES**

**Specified impurities:** A, B, F, G.

**Other detectable impurities** (the following substances would, if present at a sufficient level, be detected by one or other of the tests in the monograph. They are limited by the general acceptance criterion for other/unspecified impurities and/or by the general monograph *Substances for pharmaceutical use (2034)*. It is therefore not necessary to identify these impurities for demonstration of compliance. See also 5.10. *Control of impurities in substances for pharmaceutical use*): C, E, H.

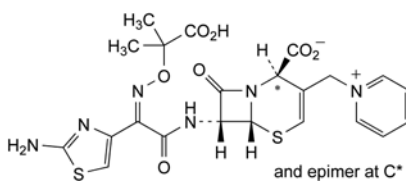

- A. (2*RS*,6*R*,7*R*)-7-[(2*Z*)-2-(2-aminothiazol-4-yl)-2-[(1-carboxy-1-methylethoxy)imino]acetyl]amino]-8-oxo-3-[(1-pyridinio)methyl]-5-thia-1-azabicyclo[4.2.0]oct-3-ene-2-carboxylate ( $\Delta$ -2-ceftazidime),

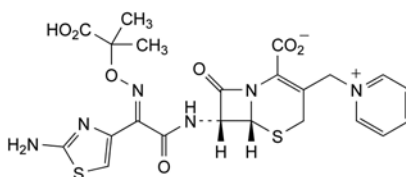

- B. (6*R*,7*R*)-7-[(2*E*)-2-(2-aminothiazol-4-yl)-2-[(1-carboxy-1-methylethoxy)imino]acetyl]amino]-8-oxo-3-[(1-pyridinio)methyl]-5-thia-1-azabicyclo[4.2.0]oct-2-ene-2-carboxylate,

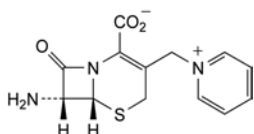

- C. (6*R*,7*R*)-7-amino-8-oxo-3-[(1-pyridinio)methyl]-5-thia-1-azabicyclo[4.2.0]oct-2-ene-2-carboxylate,

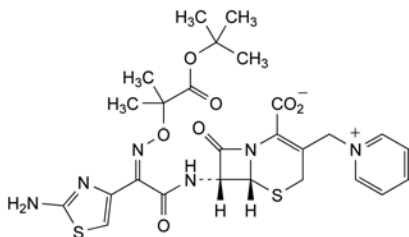

- E. (6*R*,7*R*)-7-[[[(2*Z*)-2-(2-aminothiazol-4-yl)-2-[[2-(1,1-dimethylethoxy)-1,1-dimethyl-2-oxoethoxy]imino]acetyl]amino]-8-oxo-3-[(1-pyridinio)methyl]-5-thia-1-azabicyclo[4.2.0]oct-2-ene-2-carboxylate,



- F. pyridine,

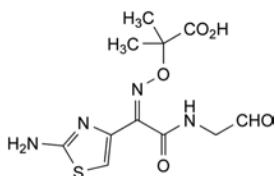

- G. 2-[[[(1*Z*)-1-(2-aminothiazol-4-yl)-2-[(oxoethyl)amino]-2-oxoethylidene]amino]oxy]-2-methylpropanoic acid,

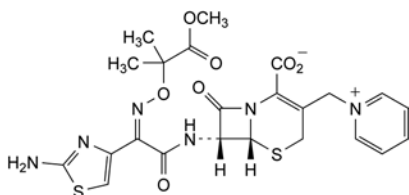

- H. (6*R*,7*R*)-7-[[[(2*Z*)-2-(2-aminothiazol-4-yl)-2-[(2-methoxy-1,1-dimethyl-2-oxoethoxy)imino]acetyl]amino]-8-oxo-3-[(1-pyridinio)methyl]-5-thia-1-azabicyclo[4.2.0]oct-2-ene-2-carboxylate.

07/2009:2344

## CEFTAZIDIME PENTAHYDRATE WITH SODIUM CARBONATE FOR INJECTION

Ceftazidimum pentahydricum et natrii carbonas ad iniectabile

### DEFINITION

Sterile mixture of *Ceftazidime pentahydrate* (1405) and *Anhydrous sodium carbonate* (0773).

Ceftazidime pentahydrate is a semi-synthetic product derived from a fermentation product.

### Content:

- *ceftazidime*: 93.0 per cent to 105.0 per cent (dried and carbonate-free substance);
- *sodium carbonate*: 8.0 per cent to 10.0 per cent.

### CHARACTERS

*Appearance*: white or pale yellow powder.

*Solubility*: freely soluble in water and in methanol, practically insoluble in acetone.

### IDENTIFICATION

- A. Examine the chromatograms obtained in the assay.

*Results*: the principal peak in the chromatogram obtained with the test solution is similar in retention time to the principal peak in the chromatogram obtained with reference solution (a).

- B. It gives the reaction of carbonates (2.3.1).

### TESTS

**Solution S.** Dissolve 2.60 g in *carbon dioxide-free water R* and dilute to 20.0 mL with the same solvent.

**Appearance of solution.** Solution S is clear (2.2.1) and its absorbance (2.2.25) at 425 nm is not greater than 0.50.

**pH** (2.2.3): 5.0 to 7.5 for solution S.

**Related substances.** Liquid chromatography (2.2.29).

*Test solution.* Suspend 0.150 g of the substance to be examined in 5 mL of *acetonitrile R*, dissolve by adding *water R* and dilute to 100 mL with the same solvent.

*Reference solution (a).* To 1.0 mL of the test solution add 5.0 mL of *acetonitrile R* and dilute to 100.0 mL with *water R*. Dilute 1.0 mL of this solution to 5.0 mL with *water R*.

*Reference solution (b).* Suspend 3 mg of *ceftazidime CRS* and 3 mg of *ceftazidime impurity A CRS* in 5 mL of *acetonitrile R*, dissolve by adding *water R* and dilute to 20 mL with the same solvent. Dilute 1 mL of this solution to 20 mL with *water R*.

*Reference solution (c).* Suspend 3 mg of *ceftazidime for peak identification CRS* (containing impurities A, B and G) in 0.5 mL of *acetonitrile R*, dissolve by adding *water R* and dilute to 2 mL with the same solvent.

### Column:

- *size*:  $l = 0.25$  m,  $\varnothing = 4.6$  mm;
- *stationary phase*: *octadecylsilyl silica gel for chromatography R* (5  $\mu$ m);
- *temperature*: 40 °C.

### Mobile phase:

- *mobile phase A*: solution containing 3.6 g of *disodium hydrogen phosphate R* and 1.4 g of *potassium dihydrogen phosphate R* in 1 litre of *water R*, adjusted to pH 3.4 with a 10 per cent *V/V* solution of *phosphoric acid R*;
- *mobile phase B*: *acetonitrile for chromatography R*;

Time (min)	Mobile phase A (per cent V/V)	Mobile phase B (per cent V/V)
0 - 4	96 → 89	4 → 11
4 - 5	89	11
5 - 8	89 → 84	11 → 16
8 - 11	84 → 80	16 → 20
11 - 15	80 → 50	20 → 50
15 - 18	50 → 20	50 → 80
18 - 22	20	80

*Flow rate*: 1.3 mL/min.

*Detection*: spectrophotometer at 254 nm.

*Injection*: 10  $\mu$ L.

*Relative retention* with reference to ceftazidime (retention time = about 8 min): impurity F = about 0.4; impurity G = about 0.8; impurity A = about 0.9; impurity B = about 1.4.

*Identification of impurities*: use the chromatogram supplied with *ceftazidime for peak identification CRS* and the chromatogram obtained with reference solution (c) to identify the peaks due to impurities A, B and G.

*System suitability*: reference solution (b):

- *resolution*: minimum 4.0 between the peaks due to impurity A and ceftazidime.

**Limits:**

- **correction factor:** for the calculation of content, multiply the peak area of impurity G by 3.0;
- **impurities A, B, G:** for each impurity, not more than the area of the principal peak in the chromatogram obtained with reference solution (a) (0.2 per cent);
- **unspecified impurities:** for each impurity, not more than 0.5 times the area of the principal peak in the chromatogram obtained with reference solution (a) (0.10 per cent);
- **total:** not more than 5 times the area of the principal peak in the chromatogram obtained with reference solution (a) (1.0 per cent);
- **disregard limit:** 0.25 times the area of the principal peak in the chromatogram obtained with reference solution (a) (0.05 per cent); disregard the peak due to impurity F.

**Impurity F.** Liquid chromatography (2.2.29). Prepare the solutions immediately before use.

**Test solution.** Dissolve 0.500 g of the substance to be examined in a 10 per cent V/V phosphate buffer solution pH 7.0 R4 and dilute to 100.0 mL with the same buffer solution.

**Reference solution (a).** Dissolve 1.00 g of pyridine R in water R and dilute to 100.0 mL with the same solvent. Dilute 5.0 mL of this solution to 200.0 mL with water R. To 1.0 mL of this solution add 10.0 mL of phosphate buffer solution pH 7.0 R4 and dilute to 100.0 mL with water R.

**Reference solution (b).** Dilute 1.0 mL of the test solution to 200.0 mL with a 10 per cent V/V phosphate buffer solution pH 7.0 R4. To 1.0 mL of this solution add 20.0 mL of reference solution (a) and dilute to 200.0 mL with a 10 per cent V/V phosphate buffer solution pH 7.0 R4.

**Column:**

- **size:**  $l = 0.25$  m,  $\emptyset = 4.6$  mm;
- **stationary phase:** octadecylsilyl silica gel for chromatography R (5  $\mu$ m).

**Mobile phase:** mix 8 volumes of a 28.8 g/L solution of ammonium dihydrogen phosphate R previously adjusted to pH 7.0 with ammonia R, 24 volumes of acetonitrile R and 68 volumes of water R.

**Flow rate:** 1.0 mL/min.

**Detection:** spectrophotometer at 255 nm.

**Injection:** 20  $\mu$ L.

**Run time:** 10 min.

**System suitability:** reference solution (b):

- **resolution:** minimum 7.0 between the peaks due to ceftazidime and impurity F.

**Limit:**

- **impurity F:** not more than 6 times the area of the principal peak in the chromatogram obtained with reference solution (a) (0.3 per cent).

**Loss on drying** (2.2.32): maximum 13.5 per cent, determined on 0.300 g. Dry *in vacuo* at 25 °C at a pressure not exceeding 0.67 kPa for 4 h then heat the residue *in vacuo* at 100 °C at a pressure not exceeding 0.67 kPa for 3 h.

**Bacterial endotoxins** (2.6.14): less than 0.10 IU/mg, if intended for use in the manufacture of parenteral preparations without a further appropriate procedure for the removal of bacterial endotoxins.

**ASSAY**

**Ceftazidime.** Liquid chromatography (2.2.29).

**Test solution.** Dissolve 25.0 mg of the substance to be examined in the mobile phase and dilute to 25.0 mL with the mobile phase.

**Reference solution (a).** Dissolve 25.0 mg of ceftazidime CRS in the mobile phase and dilute to 25.0 mL with the mobile phase.

**Reference solution (b).** Dissolve 5.0 mg of ceftazidime impurity A CRS in 5.0 mL of reference solution (a).

**Column:**

- **size:**  $l = 0.15$  m,  $\emptyset = 4.6$  mm;
- **stationary phase:** hexylsilyl silica gel for chromatography R (5  $\mu$ m).

**Mobile phase:** dissolve 4.3 g of disodium hydrogen phosphate R and 2.7 g of potassium dihydrogen phosphate R in 980 mL of water R, then add 20 mL of acetonitrile R.

**Flow rate:** 2 mL/min.

**Detection:** spectrophotometer at 245 nm.

**Injection:** 20  $\mu$ L.

**Run time:** 6 min.

**Relative retention** with reference to ceftazidime (retention time = about 4.5 min): impurity A = about 0.7.

**System suitability:** reference solution (b):

- **resolution:** minimum 1.5 between the peaks due to impurity A and ceftazidime.

Calculate the content of ceftazidime ( $C_{22}H_{22}N_6O_7S_2$ ) from the declared content of  $C_{22}H_{22}N_6O_7S_2$  in ceftazidime CRS.

**Sodium carbonate.** Atomic absorption spectrometry (2.2.23, Method I).

**Caesium chloride buffer solution.** To 12.7 g of caesium chloride R add 500 mL of water R and 86 mL of hydrochloric acid R and dilute to 1000.0 mL with water R.

**Sodium standard solution (1000 mg/L).** Dissolve 3.70 g of sodium nitrate R in water R and dilute to 500 mL with the same solvent, add 48.5 g of nitric acid R and dilute to 1000 mL with water R.

**Test solution.** Dissolve 650.0 mg of the substance to be examined in water R and dilute to 100.0 mL with the same solvent. To 10.0 mL of this solution add 5.0 mL of caesium chloride buffer solution and dilute to 50.0 mL with water R.

**Reference solution.** Into 4 identical flasks, each containing 20.0 mL of caesium chloride buffer solution, introduce respectively 0 mL, 5.00 mL, 10.00 mL and 15.00 mL of sodium standard solution (1000 mg/L) and dilute to 200.0 mL with water R.

**Source:** sodium hollow-cathode lamp.

**Wavelength:** 330.2 nm to 330.3 nm.

**Atomisation device:** air-acetylene flame.

Calculate the percentage content of sodium carbonate.

**STORAGE**

In a sterile, airtight, tamper-proof container, protected from light and humidity.

**LABELLING**

The label states the percentage content *m/m* of ceftazidime.

**IMPURITIES**

**Specified impurities:** A, B, F, G.

**Other detectable impurities** (the following substances would, if present at a sufficient level, be detected by one or other of the tests in the monograph. They are limited by the general acceptance criterion for other/unspecified impurities and/or by the general monograph *Substances for pharmaceutical use* (2034). It is therefore not necessary to identify these impurities for demonstration of compliance. See also 5.10. *Control of impurities in substances for pharmaceutical use*): C, E, H.

01/2008:0991

## CEFTRIAXONE SODIUM

## Ceftriaxonum natriicum

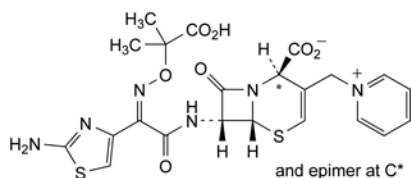

- A. (2*RS*,6*R*,7*R*)-7-[[*(2Z)*-2-(2-aminothiazol-4-yl)-2-[(1-carboxy-1-methylethoxy)imino]acetyl]amino]-8-oxo-3-[(1-pyridinio)methyl]-5-thia-1-azabicyclo[4.2.0]oct-3-ene-2-carboxylate ( $\Delta$ -2-ceftazidime),

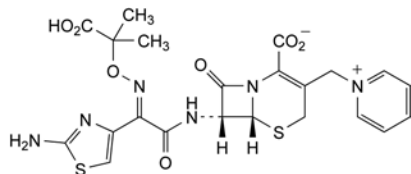

- B. (6*R*,7*R*)-7-[[*(2E)*-2-(2-aminothiazol-4-yl)-2-[(1-carboxy-1-methylethoxy)imino]acetyl]amino]-8-oxo-3-[(1-pyridinio)methyl]-5-thia-1-azabicyclo[4.2.0]oct-2-ene-2-carboxylate,

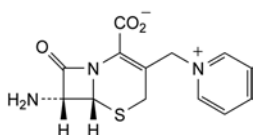

- C. (6*R*,7*R*)-7-amino-8-oxo-3-[(1-pyridinio)methyl]-5-thia-1-azabicyclo[4.2.0]oct-2-ene-2-carboxylate,

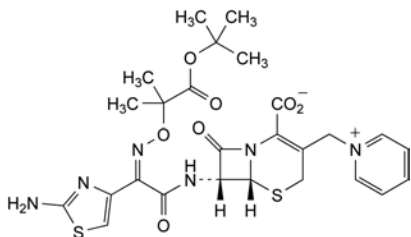

- E. (6*R*,7*R*)-7-[[*(2Z)*-2-(2-aminothiazol-4-yl)-2-[[2-(1,1-dimethylethoxy)-1,1-dimethyl-2-oxoethoxy]imino]acetyl]amino]-8-oxo-3-[(1-pyridinio)methyl]-5-thia-1-azabicyclo[4.2.0]oct-2-ene-2-carboxylate,



- F. pyridine,

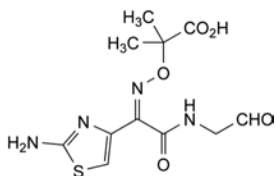

- G. 2-[[[(1*Z*)-1-(2-aminothiazol-4-yl)-2-[(oxoethyl)amino]-2-oxoethylidene]amino]oxy]-2-methylpropanoic acid,

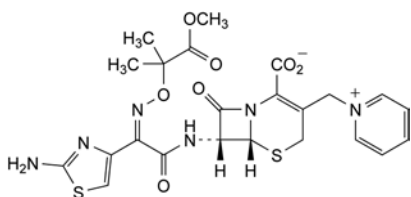

- H. (6*R*,7*R*)-7-[[*(2Z)*-2-(2-aminothiazol-4-yl)-2-[(2-methoxy-1,1-dimethyl-2-oxoethoxy)imino]acetyl]amino]-8-oxo-3-[(1-pyridinio)methyl]-5-thia-1-azabicyclo[4.2.0]oct-2-ene-2-carboxylate.

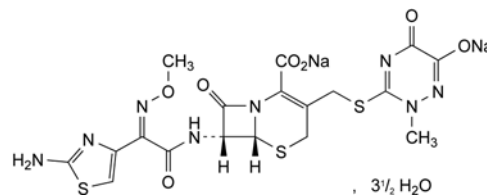

$C_{18}H_{16}N_8Na_2O_7S_3 \cdot 3\frac{1}{2}H_2O$   
[104376-79-6]

$M_r$  662

## DEFINITION

Disodium (6*R*,7*R*)-7-[[*(2Z)*-2-(2-aminothiazol-4-yl)(methoxyimino)acetyl]amino]-3-[[*(2E)*-2-(2-aminothiazol-4-yl)sulfanyl]methyl]-8-oxo-5-thia-1-azabicyclo[4.2.0]oct-2-ene-2-carboxylate 3.5 hydrate.

Semi-synthetic product derived from a fermentation product.

*Content*: 96.0 per cent to 102.0 per cent (anhydrous substance).

## CHARACTERS

*Appearance*: almost white or yellowish, slightly hygroscopic, crystalline powder.

*Solubility*: freely soluble in water, sparingly soluble in methanol, very slightly soluble in anhydrous ethanol.

## IDENTIFICATION

- A. Infrared absorption spectrophotometry (2.2.24).

*Comparison*: ceftriaxone sodium CRS.

- B. It gives reaction (a) of sodium (2.3.1).

## TESTS

**Solution S.** Dissolve 2.40 g in carbon dioxide-free water *R* and dilute to 20.0 mL with the same solvent.

**Appearance of solution.** The solution is clear (2.2.1) and not more intensely coloured than reference solution  $Y_5$  or  $BY_5$  (2.2.2).

Dilute 2 mL of solution S to 20 mL with water *R*.

**pH** (2.2.3): 6.0 to 8.0 for solution S.

**Specific optical rotation** (2.2.7):  $-155$  to  $-170$  (anhydrous substance).

Dissolve 0.250 g in water *R* and dilute to 25.0 mL with the same solvent.

**Related substances.** Liquid chromatography (2.2.29).

*Test solution.* Dissolve 30.0 mg of the substance to be examined in the mobile phase and dilute to 100.0 mL with the mobile phase.

*Reference solution (a).* Dissolve 30.0 mg of ceftriaxone sodium CRS in the mobile phase and dilute to 100.0 mL with the mobile phase.

*Reference solution (b).* Dissolve 5.0 mg of ceftriaxone sodium CRS and 5.0 mg of ceftriaxone impurity A CRS in the mobile phase and dilute to 100.0 mL with the mobile phase.

*Reference solution (c).* Dilute 1.0 mL of the test solution to 100.0 mL with the mobile phase.

*Column*:

- size:  $l = 0.25$  m,  $\varnothing = 4.6$  mm;
- stationary phase: octadecylsilyl silica gel for chromatography *R* (5  $\mu$ m).

*Mobile phase:* dissolve 2.0 g of tetradecylammonium bromide *R* and 2.0 g of tetraheptylammonium bromide *R* in a mixture of 440 mL of water *R*, 55 mL of 0.067 M phosphate buffer solution pH 7.0 *R*, 5.0 mL of citrate buffer solution pH 5.0 prepared by dissolving 20.17 g of citric acid *R* in 800 mL of

water R, adjusting to pH 5.0 with strong sodium hydroxide solution R and diluting to 1000.0 mL with water R, and 500 mL of acetonitrile R.

Flow rate: 1.5 mL/min.

Detection: spectrophotometer at 254 nm.

Injection: 20 µL of the test solution and reference solutions (b) and (c).

Run time: twice the retention time of ceftriaxone.

System suitability: reference solution (b):

- resolution: minimum 3.0 between the peaks due to ceftriaxone and impurity A.

Limits:

- any impurity: not more than the area of the principal peak in the chromatogram obtained with reference solution (c) (1.0 per cent);
- total: not more than 4 times the area of the principal peak in the chromatogram obtained with reference solution (c) (4.0 per cent);
- disregard limit: 0.1 times the area of the principal peak in the chromatogram obtained with reference solution (c) (0.1 per cent).

**N,N-Dimethylaniline** (2.4.26, Method B): maximum 20 ppm.

**2-Ethylhexanoic acid** (2.4.28): maximum 0.8 per cent *m/m*.

**Water** (2.5.12): 8.0 per cent to 11.0 per cent, determined on 0.100 g.

**Bacterial endotoxins** (2.6.14): less than 0.08 IU/mg, if intended for use in the manufacture of parenteral preparations without a further appropriate procedure for the removal of bacterial endotoxins.

#### ASSAY

Liquid chromatography (2.2.29) as described in the test for related substances with the following modification.

Injection: test solution and reference solution (a).

Calculate the percentage content of  $C_{18}H_{16}N_8Na_2O_7S_3$  from the declared content of ceftriaxone sodium CRS.

#### STORAGE

In an airtight container protected from light. If the substance is sterile, store in a sterile, airtight, tamper-proof container.

#### IMPURITIES

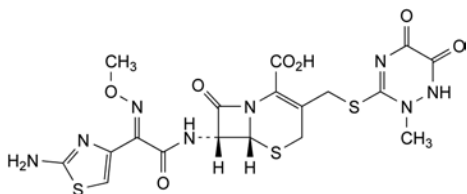

- A. (6*R*,7*R*)-7-[[[(*E*)-2-aminothiazol-4-yl](methoxyimino)acetyl]amino]-3-[[[(2-methyl-5,6-dioxo-1,2,5,6-tetrahydro-1,2,4-triazin-3-yl)sulfanyl]methyl]-8-oxo-5-thia-1-azabicyclo[4.2.0]oct-2-ene-2-carboxylic acid (*E*-isomer),

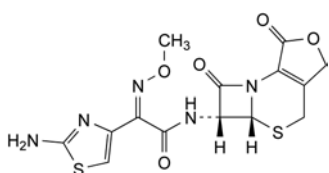

- B. (5*aR*,6*R*)-6-[[[(*Z*)-2-aminothiazol-4-yl](methoxyimino)acetyl]amino]-5*a*,6-dihydro-3*H*,7*H*-azeto[2,1-*b*]furo[3,4-*d*][1,3]thiazine-1,7(4*H*)-dione,

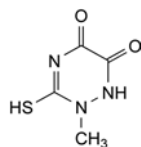

- C. 2-methyl-3-sulfanyl-1,2-dihydro-1,2,4-triazine-5,6-dione,

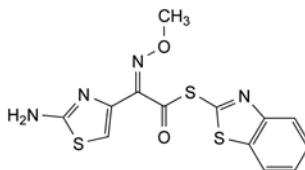

- D. *S*-benzothiazol-2-yl ((*Z*)-2-aminothiazol-4-yl)(methoxyimino)thioacetate,

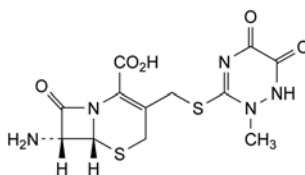

- E. (6*R*,7*R*)-7-amino-3-[[[(2-methyl-5,6-dioxo-1,2,5,6-tetrahydro-1,2,4-triazin-3-yl)sulfanyl]methyl]-8-oxo-5-thia-1-azabicyclo[4.2.0]oct-2-ene-2-carboxylic acid.

01/2008:1300  
corrected 6.0

## CEFUROXIME AXETIL

### Cefuroximum axetil

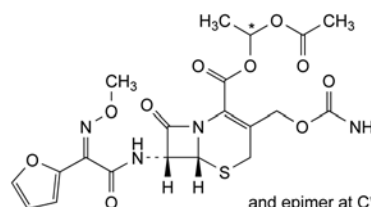

$C_{20}H_{22}N_4O_{10}S$   
[64544-07-6]

$M_r$  510.5

#### DEFINITION

Mixture of the 2 diastereoisomers of (1*RS*)-1-(acetyloxy)ethyl (6*R*,7*R*)-3-[(carbamoyloxy)methyl]-7-[[(*Z*)-2-(furan-2-yl)-2-(methoxyimino)acetyl]amino]-8-oxo-5-thia-1-azabicyclo[4.2.0]oct-2-ene-2-carboxylate.

Semi-synthetic product derived from a fermentation product.

*Content*: 96.0 per cent to 102.0 per cent (anhydrous substance).

#### CHARACTERS

*Appearance*: white or almost white powder.

*Solubility*: slightly soluble in water, soluble in acetone, in ethyl acetate and in methanol, slightly soluble in ethanol (96 per cent).

#### IDENTIFICATION

- A. Infrared absorption spectrophotometry (2.2.24).

*Comparison*: cefuroxime axetil CRS.

- B. Examine the chromatograms obtained in the assay.

*Results*: the principal peaks in the chromatogram obtained with the test solution are similar in retention time and size to the peaks due to cefuroxime axetil diastereoisomers A and B in the chromatogram obtained with reference solution (d).

## TESTS

**Related substances.** Liquid chromatography (2.2.29): use the normalisation procedure. Prepare the test solution and reference solution (d) immediately before use.

**Test solution.** Dissolve 10.0 mg of the substance to be examined in the mobile phase and dilute to 50.0 mL with the mobile phase.

**Reference solution (a).** Dilute 1.0 mL of the test solution to 100.0 mL with the mobile phase.

**Reference solution (b).** In order to prepare *in situ* impurity A, heat 5 mL of the test solution at 60 °C for 1 h.

**Reference solution (c).** In order to prepare *in situ* impurity B, expose 5 mL of the test solution to ultraviolet light at 254 nm for 24 h.

**Reference solution (d).** Dissolve 10.0 mg of cefuroxime axetil CRS in the mobile phase and dilute to 50.0 mL with the mobile phase.

**Column:**

- size:  $l = 0.25$  m,  $\varnothing = 4.6$  mm;
- stationary phase: trimethylsilyl silica gel for chromatography R (5  $\mu$ m).

**Mobile phase:** methanol R, 23 g/L solution of ammonium dihydrogen phosphate R (38:62 V/V).

**Flow rate:** 1.0 mL/min.

**Detection:** spectrophotometer at 278 nm.

**Injection:** 20  $\mu$ L of the test solution and reference solutions (a), (b) and (c).

**Identification of impurities:** use the chromatogram obtained with reference solution (b) to identify the pair of peaks due to impurity A and use the chromatogram obtained with reference solution (c) to identify the pair of peaks due to impurity B.

**Relative retention** with reference to cefuroxime axetil diastereoisomer A: cefuroxime axetil diastereoisomer B = about 0.9, impurity A = about 1.2; impurity B = 1.7 and 2.1.

**System suitability:** reference solution (b):

- resolution: minimum 1.5 between the peaks due to cefuroxime axetil diastereoisomer A and impurity A.

**Limits:**

- impurity A: maximum 1.5 per cent for the sum of the pair of peaks;
- impurity B: maximum 1.0 per cent for the sum of the pair of peaks;
- impurity E: maximum 0.5 per cent;
- any other impurity: for each impurity, maximum 0.5 per cent;
- total: maximum 3.0 per cent;
- disregard limit: 0.05 times the area of the 2 principal peaks in the chromatogram obtained with reference solution (a) (0.05 per cent).

**Diastereoisomer ratio.** Liquid chromatography (2.2.29) as described in the test for related substances.

**Limit:** test solution:

- the ratio of the area of the peak due to cefuroxime axetil diastereoisomer A to the sum of the areas of the peaks due to cefuroxime axetil diastereoisomers A and B is between 0.48 and 0.55.

**Acetone (2.4.24):** maximum 1.1 per cent.

**Water (2.5.12):** maximum 1.5 per cent, determined on 0.400 g.

## ASSAY

Liquid chromatography (2.2.29) as described in the test for related substances with the following modifications.

**Injection:** test solution and reference solution (d).

**System suitability:** reference solution (d):

- resolution: minimum 1.5 between the peaks due to cefuroxime axetil diastereoisomers A and B;
- repeatability: maximum relative standard deviation of 2.0 per cent for the sum of the peaks due to cefuroxime axetil diastereoisomers A and B after 6 injections.

Calculate the percentage content of  $C_{20}H_{22}N_4O_{10}S$  from the sum of the areas of the 2 diastereoisomer peaks and the declared content of  $C_{20}H_{22}N_4O_{10}S$  in cefuroxime axetil CRS.

## STORAGE

In an airtight container, protected from light.

## IMPURITIES

**Specified impurities:** A, B, E.

**Other detectable impurities** (the following substances would, if present at a sufficient level, be detected by one or other of the tests in the monograph. They are limited by the general acceptance criterion for other/unspecified impurities and/or by the general monograph *Substances for pharmaceutical use (2034)*. It is therefore not necessary to identify these impurities for demonstration of compliance. See also 5.10. *Control of impurities in substances for pharmaceutical use*): C, D.

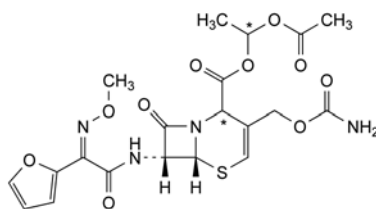

A. 1-(acetyloxy)ethyl (6R,7R)-3-[(carbamoyloxy)methyl]-7-[[Z]-2-(furan-2-yl)-2-(methoxyimino)acetyl]amino]-8-oxo-5-thia-1-azabicyclo[4.2.0]oct-3-ene-2-carboxylate ( $\Delta^3$ -isomers),

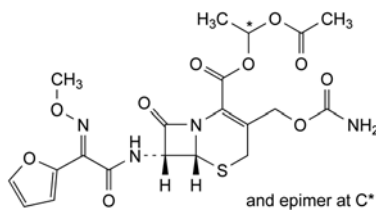

B. (1R,S)-1-(acetyloxy)ethyl (6R,7R)-3-[(carbamoyloxy)methyl]-7-[[E]-2-(furan-2-yl)-2-(methoxyimino)acetyl]amino]-8-oxo-5-thia-1-azabicyclo[4.2.0]oct-2-ene-2-carboxylate (*E*-isomers),

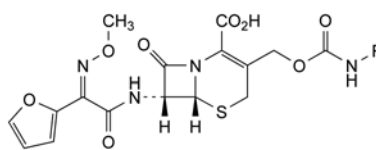

C. R = CO-CCl<sub>3</sub>: (6R,7R)-7-[[Z]-2-(furan-2-yl)-2-(methoxyimino)acetyl]amino]-8-oxo-3-[[[(trichloroacetyl)carbamoyl]oxy]methyl]-5-thia-1-azabicyclo[4.2.0]oct-2-ene-2-carboxylic acid,

D. R = H: cefuroxime.

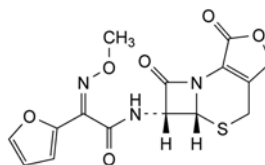

E. (5aR,6R)-6-[[[2Z]-2-(furan-2-yl)-2-(methoxyimino)acetyl]amino]-5a,6-dihydro-3H,7H-azeto[2,1-b]furo[3,4-d][1,3]thiazine-1,7(4H)-dione (des-carbamoylcefuroxime lactone).



01/2008:0992  
corrected 6.0

## CEFUROXIME SODIUM

## Cefuroximum natriicum

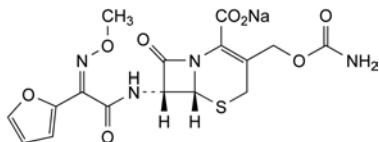
C<sub>16</sub>H<sub>15</sub>N<sub>4</sub>NaO<sub>8</sub>S  
[56238-63-2]M<sub>r</sub> 446.4

## DEFINITION

Sodium (6*R*,7*R*)-3-[(carbamoyloxy)methyl]-7-[[*Z*]-  
(furan-2-yl)(methoxyimino)acetyl]amino]-8-oxo-5-thia-1-  
azabicyclo[4.2.0]oct-2-ene-2-carboxylate.

Semi-synthetic product derived from a fermentation product.

*Content*: 96.0 per cent to 102.0 per cent (anhydrous substance).

## CHARACTERS

*Appearance*: white or almost white, slightly hygroscopic powder.

*Solubility*: freely soluble in water, very slightly soluble in ethanol (96 per cent).

## IDENTIFICATION

A. Infrared absorption spectrophotometry (2.2.24).

*Comparison*: cefuroxime sodium CRS.

B. It gives reaction (a) of sodium (2.3.1).

## TESTS

**Solution S.** Dissolve 2.0 g in carbon dioxide-free water *R* and dilute to 20.0 mL with the same solvent.

**Appearance of solution.** Solution S is not more opalescent than reference suspension II (2.2.1). The absorbance (2.2.25) of solution S measured at 450 nm is not greater than 0.25.

**pH** (2.2.3): 5.5 to 8.5.

Dilute 2 mL of solution S to 20 mL with carbon dioxide-free water *R*.

**Specific optical rotation** (2.2.7): + 59 to + 66 (anhydrous substance).

Dissolve 0.500 g in acetate buffer solution pH 4.6 *R* and dilute to 25.0 mL with the same buffer solution.

**Related substances.** Liquid chromatography (2.2.29). Prepare the solutions immediately before use or keep at 2-8 °C.

*Test solution (a).* Dissolve 25.0 mg of the substance to be examined in water *R* and dilute to 25.0 mL with the same solvent.

*Test solution (b).* Dilute 5.0 mL of test solution (a) to 50.0 mL with water *R*.

*Reference solution (a).* Dissolve 25.0 mg of cefuroxime sodium CRS in water *R* and dilute to 25.0 mL with the same solvent. Dilute 5.0 mL to 50.0 mL with water *R*.

*Reference solution (b).* Place 20 mL of reference solution (a) in a water-bath at 80 °C for 15 min. Cool and inject immediately.

*Reference solution (c).* Dilute 1.0 mL of test solution (a) to 100.0 mL with water *R*.

## Column:

- size:  $l = 0.125$  m,  $\varnothing = 4.6$  mm;
- stationary phase: hexylsilyl silica gel for chromatography *R* (5  $\mu$ m).

*Mobile phase*: mix 1 volume of acetonitrile *R* and 99 volumes of an acetate buffer solution pH 3.4, prepared by dissolving 6.01 g of glacial acetic acid *R* and 0.68 g of sodium acetate *R* in water *R* and diluting to 1000 mL with the same solvent.

*Flow rate*: 1.5 mL/min.

*Detection*: spectrophotometer at 273 nm.

*Injection*: 20  $\mu$ L loop injector; inject test solution (a) and reference solutions (b) and (c).

*Run time*: 4 times the retention time of cefuroxime.

*System suitability*: reference solution (b):

- resolution: minimum 2.0 between the peaks due to cefuroxime and impurity A.

## Limits:

- impurity A: not more than the area of the principal peak in the chromatogram obtained with reference solution (c) (1.0 per cent);
- any other impurity: not more than the area of the principal peak in the chromatogram obtained with reference solution (c) (1.0 per cent);
- total: not more than 3 times the area of the principal peak in the chromatogram obtained with reference solution (c) (3.0 per cent);
- disregard limit: 0.05 times the area of the principal peak in the chromatogram obtained with reference solution (c) (0.05 per cent).

***N,N*-Dimethylaniline** (2.4.26, Method B): maximum 20 ppm.

**2-Ethylhexanoic acid** (2.4.28): maximum 0.5 per cent *m/m*.

**Water** (2.5.12): maximum 3.5 per cent, determined on 0.400 g.

**Bacterial endotoxins** (2.6.14): less than 0.10 IU/mg, if intended for use in the manufacture of parenteral preparations without a further appropriate procedure for the removal of bacterial endotoxins.

## ASSAY

Liquid chromatography (2.2.29) as described in the test for related substances with the following modification.

*Injection*: test solution (b) and reference solution (a).

Calculate the percentage content of cefuroxime sodium.

## STORAGE

In an airtight container. If the substance is sterile, store in a sterile, airtight, tamper-proof container.

## IMPURITIES

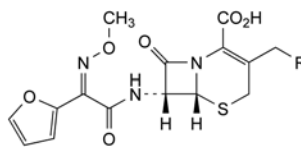

- R = OH: (6*R*,7*R*)-7-[[*Z*]-[(furan-2-yl)(methoxyimino)acetyl]amino]-3-(hydroxymethyl)-8-oxo-5-thia-1-azabicyclo[4.2.0]oct-2-ene-2-carboxylic acid (descarbamoyl-cefuroxime),
- R = O-CO-CH<sub>3</sub>: (6*R*,7*R*)-3-[(acetyloxy)methyl]-7-[[*Z*]-[(furan-2-yl)(methoxyimino)acetyl]amino]-8-oxo-5-thia-1-azabicyclo[4.2.0]oct-2-ene-2-carboxylic acid,
- R = H: (6*R*,7*R*)-7-[[*Z*]-[(furan-2-yl)(methoxyimino)acetyl]amino]-3-methyl-8-oxo-5-thia-1-azabicyclo[4.2.0]oct-2-ene-2-carboxylic acid,
- R = O-CO-NH-CO-CCl<sub>3</sub>: (6*R*,7*R*)-7-[[*Z*]-[(furan-2-yl)(methoxyimino)acetyl]amino]-8-oxo-3-[[[trichloroacetyl]carbamoyloxy]methyl]-5-thia-1-azabicyclo[4.2.0]oct-2-ene-2-carboxylic acid,

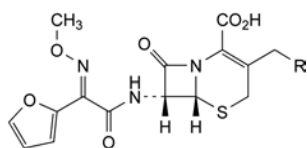

- E. R = O-CO-NH<sub>2</sub>: (6*R*,7*R*)-3-[(carbamoyloxy)methyl]-7-[[*(E)*-(furan-2-yl)(methoxyimino)acetyl]amino]-8-oxo-5-thia-1-azabicyclo[4.2.0]oct-2-ene-2-carboxylic acid (*trans*-cefuroxime),
- F. R = OH: (6*R*,7*R*)-7-[[*(E)*-(furan-2-yl)(methoxyimino)acetyl]amino]-3-(hydroxymethyl)-8-oxo-5-thia-1-azabicyclo[4.2.0]oct-2-ene-2-carboxylic acid,
- G. R = O-CO-CH<sub>3</sub>: (6*R*,7*R*)-3-[(acetyloxy)methyl]-7-[[*(E)*-(furan-2-yl)(methoxyimino)acetyl]amino]-8-oxo-5-thia-1-azabicyclo[4.2.0]oct-2-ene-2-carboxylic acid,

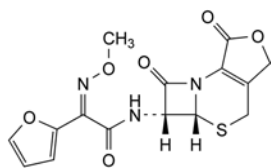

- H. (5*aR*,6*R*)-6-[[*(Z)*-(furan-2-yl)(methoxyimino)acetyl]amino]-5*a*,6-dihydro-3*H*,7*H*-azeto[2,1-*b*]furo[3,4-*d*][1,3]thiazine-1,7(4*H*)-dione,

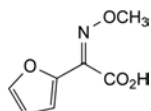

- I. (*Z*)-(furan-2-yl)(methoxyimino)acetic acid.

01/2008:1632  
corrected 6.0

## CELIPROLOL HYDROCHLORIDE

### Celiprololi hydrochloridum

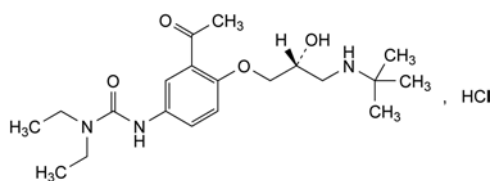

and enantiomer

C<sub>20</sub>H<sub>34</sub>ClN<sub>3</sub>O<sub>4</sub>  
[57470-78-7]

M<sub>r</sub> 416.0

#### DEFINITION

3-[3-Acetyl-4-[(2*RS*)-3-[(1,1-dimethylethyl)amino]-2-hydroxypropoxy]phenyl]-1,1-diethylurea hydrochloride.

*Content*: 99.0 per cent to 101.0 per cent (dried substance).

#### CHARACTERS

*Appearance*: white or very slightly yellow, crystalline powder.

*Solubility*: freely soluble in water and in methanol, soluble in ethanol (96 per cent), very slightly soluble in methylene chloride.

It shows polymorphism (5.9).

#### IDENTIFICATION

- A. Infrared absorption spectrophotometry (2.2.24).

*Comparison*: celiprolol hydrochloride CRS.

If the spectra obtained in the solid state show differences, dissolve the substance to be examined and the reference substance separately in *methanol R*, evaporate to dryness and record new spectra using the residues.

- B. It gives reaction (a) of chlorides (2.3.1).

#### TESTS

**Optical rotation** (2.2.7):  $-0.10^\circ$  to  $+0.10^\circ$ .

Dissolve 1.0 g in *water R* and dilute to 10.0 mL with the same solvent.

**Related substances**. Liquid chromatography (2.2.29). Prepare the solutions immediately before use.

*Test solution*. Dissolve 0.100 g of the substance to be examined in mobile phase A and dilute to 20.0 mL with mobile phase A.

*Reference solution (a)*. Dissolve 2 mg of the substance to be examined and 2 mg of *acebutolol hydrochloride R* in mobile phase A and dilute to 50.0 mL with mobile phase A.

*Reference solution (b)*. Dissolve 10 mg of the substance to be examined in 2 mL of mobile phase A and allow to stand for 24 h (for identification of impurity A).

*Reference solution (c)*. Dilute 1.0 mL of the test solution to 100.0 mL with mobile phase A. Dilute 1.0 mL of this solution to 10.0 mL with mobile phase A.

*Reference solution (d)*. Dissolve 10 mg of *celiprolol for peak identification CRS* in mobile phase A and dilute to 2 mL with mobile phase A.

*Reference solution (e)*. This solution is only prepared if required (see below) and is used to determine the identity of impurity I which co-elutes with impurity H (the 2 impurities originate from different routes of synthesis). Dissolve the contents of a vial of *celiprolol impurity I CRS* in mobile phase A and dilute to 2.0 mL with mobile phase A.

#### Column:

- size:  $l = 0.15$  m,  $\varnothing = 4.6$  mm,
- stationary phase: octylsilyl silica gel for chromatography *R* (5  $\mu$ m),
- temperature: 30 °C.

#### Mobile phase:

- mobile phase A: mix 91 mL of *tetrahydrofuran R*, 63 mL of *acetonitrile R1*, 0.6 mL of *pentafluoropropanoic acid R* and 0.2 mL of *trifluoroacetic acid R*; dilute to 1000 mL with *water R*;
- mobile phase B: *acetonitrile R1*;

Time (min)	Mobile phase A (per cent V/V)	Mobile phase B (per cent V/V)
0 - 50	100 → 80	0 → 20
50 - 51	80 → 100	20 → 0
51 - 65	100	0

*Flow rate*: 1.4 mL/min.

*Detection*: spectrophotometer at 232 nm.

*Injection*: 10  $\mu$ L.

*Identification of impurities*: use the chromatogram supplied with *celiprolol for peak identification CRS* and the chromatogram obtained with reference solution (d) to identify the peaks due to impurities B, E and F.

*Relative retention* with reference to celiprolol (retention time = about 10 min): impurity A = about 0.3; impurity D = about 0.7; impurity G = about 1.2; impurity B = about 1.4; impurity F = about 1.6; impurity C = about 2.2; impurity H or I = about 2.5; impurity E = about 3.9.

*System suitability*: reference solution (a):

- resolution: minimum 4.0 between the peaks due to celiprolol and acebutolol.

#### Limits:

- correction factors: for the calculation of content, multiply the peak areas of the following impurities by the corresponding correction factor: impurity A = 4.0; impurity B = 1.5; impurity E = 2.3; impurity F = 0.5; impurity I = 1.7;

- *any impurity*: for each impurity, not more than twice the area of the principal peak in the chromatogram obtained with reference solution (c) (0.2 per cent), and not more than 1 such peak has an area greater than the area of the principal peak in the chromatogram obtained with reference solution (c) (0.1 per cent);
- *total*: not more than 5 times the area of the principal peak in the chromatogram obtained with reference solution (c) (0.5 per cent);
- if any of the above limits are exceeded and if a peak occurs with a relative retention of about 2.5 (impurity H or I), the identity of this peak has to be clarified by use of a UV spectrum recorded with a diode array detector; if this spectrum is different from the one obtained with reference solution (e), no correction factor is applied;
- *disregard limit*: 0.5 times the area of the principal peak in the chromatogram obtained with reference solution (c) (0.05 per cent).

**Loss on drying** (2.2.32): maximum 0.5 per cent, determined on 1.000 g by drying in an oven at 105 °C for 3 h.

#### ASSAY

Dissolve 0.350 g under an atmosphere of nitrogen in 50 mL of *ethanol* (96 per cent) *R* and add 1.0 mL of 0.1 *M* hydrochloric acid. Carry out a potentiometric titration (2.2.20), using 0.1 *M* sodium hydroxide. Read the volume added between the 2 points of inflexion.

1 mL of 0.1 *M* sodium hydroxide is equivalent to 41.60 mg of  $C_{20}H_{34}ClN_3O_4$ .

#### STORAGE

Protected from light.

#### IMPURITIES

*Specified impurities*: A, B, C, D, E, F, G, H, I.

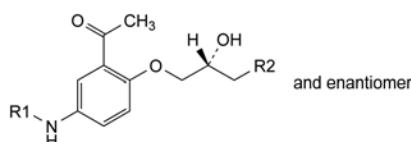

- A. R1 = H, R2 = NH-C(CH<sub>3</sub>)<sub>3</sub>: 1-[5-amino-2-[(2*RS*)-3-[(1,1-dimethylethyl)amino]-2-hydroxypropoxy]phenyl]ethanone,
- C. R1 = CO-NH-C(CH<sub>3</sub>)<sub>3</sub>, R2 = NH-C(CH<sub>3</sub>)<sub>3</sub>: 1-[3-acetyl-4-[(2*RS*)-3-[(1,1-dimethylethyl)amino]-2-hydroxypropoxy]phenyl]-3-(1,1-dimethylethyl)urea,
- D. R1 = CO-N(C<sub>2</sub>H<sub>5</sub>)<sub>2</sub>, R2 = N(C<sub>2</sub>H<sub>5</sub>)<sub>2</sub>: 3-[3-acetyl-4-[(2*RS*)-3-(diethylamino)-2-hydroxypropoxy]phenyl]-1,1-diethylurea,
- H. R1 = CO-N(C<sub>2</sub>H<sub>5</sub>)<sub>2</sub>, R2 = Br: 3-[3-acetyl-4-[(2*RS*)-3-bromo-2-hydroxypropoxy]phenyl]-1,1-diethylurea (bromhydrin compound),

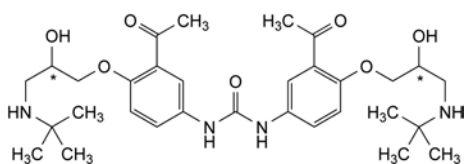

- B. 1,3-bis[3-acetyl-4-[3-[(1,1-dimethylethyl)amino]-2-hydroxypropoxy]phenyl]urea,

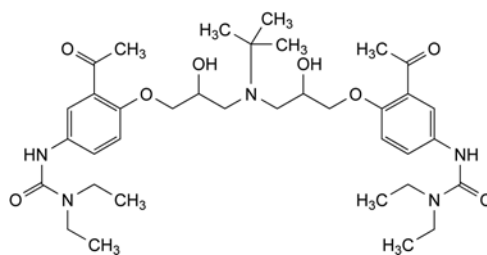

- E. 1,1'-[[[(1,1-dimethylethyl)imino]bis[(2-hydroxypropane-1,3-diol)oxy(3-acetyl-1,4-phenylene)]]bis(3,3-diethylurea),

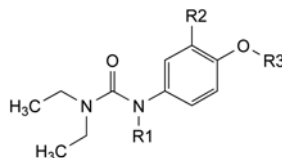

- F. R1 = R3 = H, R2 = CO-CH<sub>3</sub>: 3-(3-acetyl-4-hydroxyphenyl)-1,1-diethylurea,
- I. R1 = CO-CH<sub>3</sub>, R2 = H, R3 = C<sub>2</sub>H<sub>5</sub>: 1-acetyl-1-(4-ethoxyphenyl)-3,3-diethylurea,

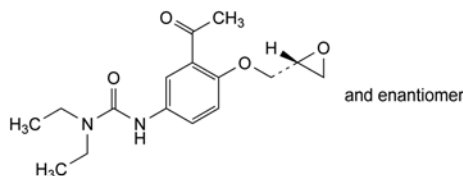

- G. 3-[3-acetyl-4-[(*RS*)-oxiranyl]methoxy]phenyl]-1,1-diethylurea.

01/2009:0887

## CELLULOSE ACETATE

### Cellulosi acetas

#### DEFINITION

Partly or completely *O*-acetylated cellulose.

#### CHARACTERS

*Appearance*: white, yellowish-white or greyish-white, hygroscopic powder or granules.

*Solubility*: practically insoluble in water, soluble in acetone, in formic acid and in a mixture of equal volumes of methanol and methylene chloride, practically insoluble in ethanol (96 per cent).

#### IDENTIFICATION

Infrared absorption spectrophotometry (2.2.24).

*Comparison*: cellulose acetate CRS.

*Preparation*: prepare a 100 g/L solution of cellulose acetate, previously dried, in *dioxane R*, and spread 1 drop of the solution between 2 sodium chloride plates; separate the plates, heat them both at 105 °C for 1 h, and reassemble the dried plates.

#### TESTS

**Free acid**: maximum 0.1 per cent, calculated as acetic acid (dried substance).

To 5.00 g in a 250 mL conical flask, add 150 mL of *carbon dioxide-free water R*, insert the stopper, swirl the suspension gently and allow to stand for 3 h. Filter, then wash the flask and the filter with *carbon dioxide-free water R*, adding these washings to the filtrate. Add 0.1 mL of *phenolphthalein solution R1* and titrate the combined filtrate and washings with 0.01 *M* sodium hydroxide until a pale pink colour is obtained.

1 mL of 0.01 *M* sodium hydroxide is equivalent to 0.6005 mg of free acid, calculated as acetic acid.

**Heavy metals** (2.4.8): maximum 10 ppm.

2.0 g complies with test D. Prepare the reference solution using 2 mL of *lead standard solution* (10 ppm Pb) R.

**Loss on drying** (2.2.32): maximum 5.0 per cent, determined on 1.000 g by drying in an oven at 105 °C for 3 h.

**Sulfated ash** (2.4.14): maximum 0.1 per cent, determined on 1.0 g.

#### Microbial contamination

TAMC: acceptance criterion 10<sup>3</sup> CFU/g (2.6.12).

TYMC: acceptance criterion 10<sup>2</sup> CFU/g (2.6.12).

Absence of *Escherichia coli* (2.6.13).

Absence of *Salmonella* (2.6.13).

#### STORAGE

In an airtight container.

#### FUNCTIONALITY-RELATED CHARACTERISTICS

*This section provides information on characteristics that are recognised as being relevant control parameters for one or more functions of the substance when used as an excipient (see chapter 5.15). This section is a non-mandatory part of the monograph and it is not necessary to verify the characteristics to demonstrate compliance. Control of these characteristics can however contribute to the quality of a medicinal product by improving the consistency of the manufacturing process and the performance of the medicinal product during use. Where control methods are cited, they are recognised as being suitable for the purpose, but other methods can also be used. Wherever results for a particular characteristic are reported, the control method must be indicated.*

*The following characteristics may be relevant for cellulose acetate used as film former.*

**Apparent viscosity.** Dissolve 10 g in a mixture of 50 mL of *methanol R* and 50 mL of *methylene chloride R* by shaking. Determine the viscosity of this solution at 20 ± 0.1 °C using a rotating viscometer (2.2.10).

**Acetyl groups** (C<sub>2</sub>H<sub>3</sub>O): typically 29.0 per cent to 44.8 per cent of acetyl groups (dried substance) and typically 90.0 per cent to 110.0 per cent of the nominal acetyl content (dried substance).

A. Cellulose acetate containing not more than 42.0 per cent of acetyl groups

To 2.000 g in a 500 mL conical flask, add 100 mL of *acetone R* and 10 mL of *water R*. Close the flask and stir with a magnetic stirrer until dissolution is complete. Add 30.0 mL of 1 M *sodium hydroxide* with constant stirring. A finely divided precipitate of regenerated cellulose, free from lumps, is obtained. Close the flask and stir with a magnetic stirrer for 30 min. Add 100 mL of *water R* at 80 °C, washing down the sides of the flask, stir for 2 min and cool to room temperature. Titrate with 0.5 M *sulfuric acid*, using 0.1 mL of *phenolphthalein solution R* as indicator. Carry out a blank titration.

Calculate the percentage content of acetyl groups using the following expression:

$$\frac{4.305 (n_2 - n_1)}{(100 - d) \times m} \times 100$$

- d* = loss on drying as a percentage;  
*m* = mass of the substance to be examined, in grams;  
*n*<sub>1</sub> = number of millilitres of 0.5 M *sulfuric acid* used in the test;  
*n*<sub>2</sub> = number of millilitres of 0.5 M *sulfuric acid* used in the blank titration.

B. Cellulose acetate containing more than 42.0 per cent of acetyl groups

To 2.000 g in a 500 mL conical flask, add 30 mL of *dimethyl sulfoxide R* and 100 mL of *acetone R*. Close the flask and stir with a magnetic stirrer for 16 h. Add 30.0 mL of 1 M *sodium hydroxide* with constant stirring. Close the flask and stir with a magnetic stirrer for 6 min. Allow to stand without stirring for 60 min. Resume stirring and add 100 mL of *water R* at 80 °C, washing down the sides of the flask, stir for 2 min and cool to room temperature. Titrate with 0.5 M *hydrochloric acid*, using 0.1 mL of *phenolphthalein solution R* as indicator. Add 0.5 mL of 0.5 M *hydrochloric acid* in excess, stir for 5 min and allow to stand for 30 min. Titrate with 0.5 M *sodium hydroxide*, until a persistent pink colour is obtained, stirring with a magnetic stirrer. Calculate the net number of millimoles of 0.5 M *sodium hydroxide* consumed, taking the mean of 2 blank titrations into consideration.

Calculate the percentage content of acetyl groups using the following expression:

$$\frac{4.305 \times n}{(100 - d) \times m} \times 100$$

- d* = loss on drying as a percentage;  
*m* = mass of the substance to be examined, in grams;  
*n* = net number of millimoles of 0.5 M *sodium hydroxide* consumed.

*The following characteristics may be relevant for cellulose acetate used as matrix former in prolonged-release tablets.*

**Apparent viscosity:** see test above.

**Acetyl groups:** see test above.

**Molecular mass distribution** (2.2.30).

**Particle-size distribution** (2.9.31).

**Powder flow** (2.9.36).

01/2008:1406  
corrected 6.0

## CELLULOSE ACETATE BUTYRATE

### Cellulosi acetas butyras

#### DEFINITION

Partly or completely *O*-acetylated and *O*-butyrate cellulose.

*Content:*

- *acetyl groups* (C<sub>2</sub>H<sub>3</sub>O): 2.0 per cent to 30.0 per cent (dried substance); 90.0 per cent to 110.0 per cent of that stated on the label (dried substance);
- *butyryl groups* (C<sub>4</sub>H<sub>7</sub>O): 16.0 per cent to 53.0 per cent (dried substance); 90.0 per cent to 110.0 per cent of that stated on the label (dried substance).

#### CHARACTERS

*Appearance:* white, yellowish-white or greyish-white powder or granules, slightly hygroscopic.

*Solubility:* practically insoluble in water, soluble in acetone, in formic acid and in a mixture of equal volumes of methanol and methylene chloride, practically insoluble in ethanol (96 per cent).

#### IDENTIFICATION

A. Infrared absorption spectrophotometry (2.2.24).

*Comparison:* Ph. Eur. reference spectrum of cellulose acetate butyrate.

The intensity of the bands may vary according to the degree of substitution.

B. It complies with the limits of the assay.

## TESTS

**Acidity.** To 5.00 g in a 250 mL conical flask, add 150 mL of *carbon dioxide-free water R*, insert the stopper, swirl the suspension gently and allow to stand for 3 h. Filter, wash the flask and the filter with *carbon dioxide-free water R*. Combine the filtrate and washings. Add 0.1 mL of *phenolphthalein solution RI*. Not more than 3.0 mL of 0.01 M sodium hydroxide is required to change the colour of the indicator.

**Heavy metals (2.4.8):** maximum 20 ppm.

1.0 g complies with test F. Prepare the reference solution using 2 mL of *lead standard solution (10 ppm Pb) R*.

**Loss on drying (2.2.32):** maximum 2.0 per cent, determined on 1.000 g by drying in an oven at 105 °C for 3 h.

**Total ash (2.4.16):** maximum 0.1 per cent.

## ASSAY

Liquid chromatography (2.2.29).

**Test solution.** To 1.000 g of the substance to be examined in a 500 mL conical flask, add 100 mL of *acetone R* and 10 mL of *water R*. Close the flask and stir with a magnetic stirrer until dissolution is complete. Add 30.0 mL of 1 M sodium hydroxide with constant stirring. Close the flask and stir with a magnetic stirrer for 30 min. Add 100 mL of hot *water R* at 80 °C, washing down the sides of the flask and stir for 2 min. Cool, centrifuge or filter the suspension and wash the residue with *water R*. Combine the filtrate and washings, adjust to pH 3 with *dilute phosphoric acid R* and dilute to 500.0 mL with *water R*.

**Reference solution.** Dissolve 0.200 g of *glacial acetic acid R* and 0.400 g of *butyric acid R* in *water R*, adjust to pH 3 with *dilute phosphoric acid R* and dilute to 500.0 mL with *water R*.

**Column:**

- *dimensions:*  $l = 0.25$  m,  $\varnothing = 4.6$  mm;
- *stationary phase:* octadecylsilyl silica gel for chromatography R (5  $\mu$ m).

**Mobile phase:**

- *mobile phase A:* *methanol R*;
- *mobile phase B:* *phosphate buffer solution pH 3.0 RI*;

Time (min)	Mobile phase A (per cent V/V)	Mobile phase B (per cent V/V)
0 - 30	5	95
30 - 35	5 → 20	95 → 80
35 - 60	20	80
60 - 61	5	95

**Flow rate:** 1.2 mL/min.

**Detection:** spectrophotometer at 210 nm.

**Injection:** 20  $\mu$ L.

Calculate the percentage content of acetic acid and butyric acid using the chromatograms obtained with the 2 solutions. To calculate the percentage content of acetyl (C<sub>2</sub>H<sub>3</sub>O) and of butyryl (C<sub>4</sub>H<sub>7</sub>O) groups, multiply the percentage content of acetic acid and butyric acid by 0.717 and 0.807, respectively.

## STORAGE

In an airtight container.

## LABELLING

The label states the nominal percentage content of acetyl and butyryl groups.

01/2009:0314

## CELLULOSE ACETATE PHTHALATE

## Cellulosi acetas phthalas

[9004-38-0]

## DEFINITION

Partly *O*-acetylated and *O*-phthalylated cellulose.

## CHARACTERS

**Appearance:** white or almost white, free-flowing powder or colourless flakes, hygroscopic.

**Solubility:** practically insoluble in water, freely soluble in acetone, soluble in diethylene glycol, practically insoluble in ethanol (96 per cent) and in methylene chloride. It dissolves in dilute solutions of alkali hydroxides.

## IDENTIFICATION

Infrared absorption spectrophotometry (2.2.24).

**Comparison:** *cellulose acetate phthalate CRS*.

## TESTS

**Free acid:** maximum 3.0 per cent, calculated as phthalic acid (anhydrous substance).

Shake 3.0 g for 2 h with 100 mL of a 50 per cent V/V solution of *methanol R* and filter. Wash the flask and the filter with 2 quantities, each of 10 mL, of a 50 per cent V/V solution of *methanol R*. Combine the filtrate and washings, add *phenolphthalein solution R* and titrate with 0.1 M sodium hydroxide until a faint pink colour is obtained. Carry out a blank titration on 120 mL of a 50 per cent V/V solution of *methanol R*.

1 mL of 0.1 M sodium hydroxide is equivalent to 8.3 mg of free acid, calculated as phthalic acid.

**Heavy metals (2.4.8):** maximum 10 ppm.

2.0 g complies with test C. Prepare the reference solution using 2 mL of *lead standard solution (10 ppm Pb) R*.

**Water (2.5.12):** maximum 5.0 per cent, determined on 0.500 g.

Carry out the test using a mixture of 2 volumes of *methylene chloride R* and 3 volumes of *anhydrous ethanol R*.

**Sulfated ash (2.4.14):** maximum 0.1 per cent, determined on 1.0 g.

## STORAGE

In an airtight container.

## FUNCTIONALITY-RELATED CHARACTERISTICS

*This section provides information on characteristics that are recognised as being relevant control parameters for one or more functions of the substance when used as an excipient (see chapter 5.15). This section is a non-mandatory part of the monograph and it is not necessary to verify the characteristics to demonstrate compliance. Control of these characteristics can however contribute to the quality of a medicinal product by improving the consistency of the manufacturing process and the performance of the medicinal product during use. Where control methods are cited, they are recognised as being suitable for the purpose, but other methods can also be used. Wherever results for a particular characteristic are reported, the control method must be indicated.*

*The following characteristics may be relevant for cellulose acetate phthalate used as film former in gastro-resistant tablets and capsules.*

**Apparent viscosity (2.2.9):** typically 45 mPas to 90 mPas, determined at 25 °C.

Dissolve 15 g, calculated with reference to the anhydrous substance, in 85 g of a mixture of 1 part of *water R* and 249 parts of *acetone R*.

**Solubility of a film.** Dissolve about 0.15 g in 1 mL of *acetone R* and pour onto a clear glass plate. A film is formed. Take a piece of the film and place it in a flask containing 0.1 M hydrochloric acid. It does not dissolve. Then place the piece of film in a flask containing *phosphate buffer solution pH 6.8 R*. It dissolves.

**Phthaloyl groups** (C<sub>8</sub>H<sub>5</sub>O<sub>3</sub>; M<sub>r</sub> 149.1): typically 30.0 per cent to 36.0 per cent (anhydrous and acid-free substance). Dissolve 1.000 g in 50 mL of a mixture of 2 volumes of *acetone R* and 3 volumes of *ethanol (96 per cent) R*. Add 0.1 mL of *phenolphthalein solution R* and titrate with 0.1 M *sodium hydroxide*. Carry out a blank titration.

Calculate the percentage content of phthaloyl groups (*P*) using the following expression:

$$\frac{14\,910n}{(100 - a)(100 - S)m} - \frac{179.5S}{(100 - S)}$$

- a* = percentage content of water;  
*m* = mass of the substance to be examined, in grams;  
*n* = volume of 0.1 M *sodium hydroxide* used, in millilitres;  
*S* = percentage content of free acid (see Tests).

**Acetyl groups** (C<sub>2</sub>H<sub>3</sub>O; M<sub>r</sub> 43.05): typically 21.5 per cent to 26.0 per cent (anhydrous and acid free substance). To 0.100 g add 25.0 mL of 0.1 M *sodium hydroxide* and heat on a water-bath under a reflux condenser for 30 min. Cool, add 0.1 mL of *phenolphthalein solution R* and titrate with 0.1 M *hydrochloric acid*. Carry out a blank titration.

Calculate the percentage content of acetyl groups using the following expression:

$$\left[ \frac{4305(n_2 - n_1)}{(100 - a)(100 - S)m} - \frac{51.8S}{(100 - S)} \right] - 0.578P$$

- a* = percentage content of water;  
*m* = mass of the substance to be examined, in grams;  
*n*<sub>1</sub> = volume of 0.1 M *hydrochloric acid* used in the test, in millilitres;  
*n*<sub>2</sub> = volume of 0.1 M *hydrochloric acid* used in the blank titration, in millilitres;  
*P* = percentage content of phthaloyl groups;  
*S* = percentage content of free acid (see Tests).

01/2009:0316  
corrected 7.0

## CELLULOSE, MICROCRYSTALLINE

### Cellulosum microcristallinum

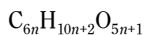
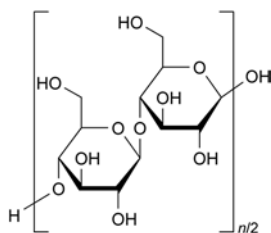

#### DEFINITION

Purified, partly depolymerised cellulose prepared by treating alpha-cellulose, obtained as a pulp from fibrous plant material, with mineral acids.

#### CHARACTERS

*Appearance*: white or almost white, fine or granular powder.

*Solubility*: practically insoluble in water, in acetone, in anhydrous ethanol, in toluene, in dilute acids and in a 50 g/L solution of sodium hydroxide.

#### IDENTIFICATION

- A. Place about 10 mg on a watch-glass and disperse in 2 mL of *iodinated zinc chloride solution R*. The substance becomes violet-blue.  
 B. The degree of polymerisation is not more than 350.

Transfer 1.300 g to a 125 mL conical flask. Add 25.0 mL of *water R* and 25.0 mL of *cupriethylenediamine hydroxide solution R*. Immediately purge the solution with *nitrogen R*, insert the stopper and shake until completely dissolved. Transfer an appropriate volume of the solution to a suitable capillary viscometer (2.2.9). Equilibrate the solution at 25 ± 0.1 °C for at least 5 min. Record the flow time (*t*<sub>1</sub>) in seconds between the 2 marks on the viscometer. Calculate the kinematic viscosity (*ν*<sub>1</sub>) of the solution using the following expression:

$$t_1 (k_1)$$

where *k*<sub>1</sub> is the viscometer constant.

Dilute a suitable volume of *cupriethylenediamine hydroxide solution R* with an equal volume of *water R* and measure the flow time (*t*<sub>2</sub>) using a suitable capillary viscometer. Calculate the kinematic viscosity (*ν*<sub>2</sub>) of the solvent using the following expression:

$$t_2 (k_2)$$

where *k*<sub>2</sub> is the viscometer constant.

Determine the relative viscosity (*η*<sub>rel</sub>) of the substance to be examined using the following expression:

$$\nu_1/\nu_2$$

Determine the intrinsic viscosity ([*η*]<sub>c</sub>) by interpolation, using the intrinsic viscosity table (Table 0316-1).

Calculate the degree of polymerisation (*P*) using the following expression:

$$\frac{95 [\eta]_c}{m [(100 - b)/100]}$$

where *m* is the mass in grams of the substance to be examined and *b* is the loss on drying as a percentage.

#### TESTS

**Solubility**. Dissolve 50 mg in 10 mL of *ammoniacal solution of copper tetrammine R*. It dissolves completely, leaving no residue.

**pH (2.2.3)**: 5.0 to 7.5 for the supernatant liquid.

Shake 5 g with 40 mL of *carbon dioxide-free water R* for 20 min and centrifuge.

**Conductivity (2.2.38)**. The conductivity of the test solution does not exceed the conductivity of the water by more than 75 μS·cm<sup>-1</sup>.

Use as test solution the supernatant liquid obtained in the test for pH. Measure the conductivity of the supernatant liquid after a stable reading has been obtained and measure the conductivity of the water used to prepare the test solution.

**Ether-soluble substances:** maximum 0.05 per cent (5 mg) for the difference between the weight of the residue and the weight obtained from a blank determination.

Place 10.0 g in a chromatography column about 20 mm in internal diameter and pass 50 mL of *peroxide-free ether R* through the column. Evaporate the eluate to dryness. Dry the residue at 105 °C for 30 min, allow to cool in a desiccator and weigh. Carry out a blank determination.

**Water-soluble substances:** maximum 0.25 per cent (12.5 mg) for the difference between the mass of the residue and the mass obtained from a blank determination.

Shake 5.0 g with 80 mL of *water R* for 10 min. Filter through a filter paper with the aid of vacuum into a tared flask. Evaporate to dryness on a water-bath avoiding charring. Dry at 105 °C for 1 h, allow to stand in a desiccator and weigh. Carry out a blank determination.

Table 0316-1. – *Intrinsic viscosity table*

Intrinsic viscosity $[\eta]_c$ at different values of relative viscosity $\eta_{rel}$										
$\eta_{rel}$	$[\eta]_c$									
	0.00	0.01	0.02	0.03	0.04	0.05	0.06	0.07	0.08	0.09
1.1	0.098	0.106	0.115	0.125	0.134	0.143	0.152	0.161	0.170	0.180
1.2	0.189	0.198	0.207	0.216	0.225	0.233	0.242	0.250	0.259	0.268
1.3	0.276	0.285	0.293	0.302	0.310	0.318	0.326	0.334	0.342	0.350
1.4	0.358	0.367	0.375	0.383	0.391	0.399	0.407	0.414	0.422	0.430
1.5	0.437	0.445	0.453	0.460	0.468	0.476	0.484	0.491	0.499	0.507
1.6	0.515	0.522	0.529	0.536	0.544	0.551	0.558	0.566	0.573	0.580
1.7	0.587	0.595	0.602	0.608	0.615	0.622	0.629	0.636	0.642	0.649
1.8	0.656	0.663	0.670	0.677	0.683	0.690	0.697	0.704	0.710	0.717
1.9	0.723	0.730	0.736	0.743	0.749	0.756	0.762	0.769	0.775	0.782
2.0	0.788	0.795	0.802	0.809	0.815	0.821	0.827	0.833	0.840	0.846
2.1	0.852	0.858	0.864	0.870	0.876	0.882	0.888	0.894	0.900	0.906
2.2	0.912	0.918	0.924	0.929	0.935	0.941	0.948	0.953	0.959	0.965
2.3	0.971	0.976	0.983	0.988	0.994	1.000	1.006	1.011	1.017	1.022
2.4	1.028	1.033	1.039	1.044	1.050	1.056	1.061	1.067	1.072	1.078
2.5	1.083	1.089	1.094	1.100	1.105	1.111	1.116	1.121	1.126	1.131
2.6	1.137	1.142	1.147	1.153	1.158	1.163	1.169	1.174	1.179	1.184
2.7	1.190	1.195	1.200	1.205	1.210	1.215	1.220	1.225	1.230	1.235
2.8	1.240	1.245	1.250	1.255	1.260	1.265	1.270	1.275	1.280	1.285
2.9	1.290	1.295	1.300	1.305	1.310	1.314	1.319	1.324	1.329	1.333
3.0	1.338	1.343	1.348	1.352	1.357	1.362	1.367	1.371	1.376	1.381
3.1	1.386	1.390	1.395	1.400	1.405	1.409	1.414	1.418	1.423	1.427
3.2	1.432	1.436	1.441	1.446	1.450	1.455	1.459	1.464	1.468	1.473
3.3	1.477	1.482	1.486	1.491	1.496	1.500	1.504	1.508	1.513	1.517
3.4	1.521	1.525	1.529	1.533	1.537	1.542	1.546	1.550	1.554	1.558
3.5	1.562	1.566	1.570	1.575	1.579	1.583	1.587	1.591	1.595	1.600
3.6	1.604	1.608	1.612	1.617	1.621	1.625	1.629	1.633	1.637	1.642
3.7	1.646	1.650	1.654	1.658	1.662	1.666	1.671	1.675	1.679	1.683
3.8	1.687	1.691	1.695	1.700	1.704	1.708	1.712	1.715	1.719	1.723
3.9	1.727	1.731	1.735	1.739	1.742	1.746	1.750	1.754	1.758	1.762
4.0	1.765	1.769	1.773	1.777	1.781	1.785	1.789	1.792	1.796	1.800
4.1	1.804	1.808	1.811	1.815	1.819	1.822	1.826	1.830	1.833	1.837
4.2	1.841	1.845	1.848	1.852	1.856	1.859	1.863	1.867	1.870	1.874
4.3	1.878	1.882	1.885	1.889	1.893	1.896	1.900	1.904	1.907	1.911
4.4	1.914	1.918	1.921	1.925	1.929	1.932	1.936	1.939	1.943	1.946

Intrinsic viscosity $[\eta]_c$ at different values of relative viscosity $\eta_{rel}$										
$\eta_{rel}$	$[\eta]_c$									
	0.00	0.01	0.02	0.03	0.04	0.05	0.06	0.07	0.08	0.09
4.5	1.950	1.954	1.957	1.961	1.964	1.968	1.971	1.975	1.979	1.982
4.6	1.986	1.989	1.993	1.996	2.000	2.003	2.007	2.010	2.013	2.017
4.7	2.020	2.023	2.027	2.030	2.033	2.037	2.040	2.043	2.047	2.050
4.8	2.053	2.057	2.060	2.063	2.067	2.070	2.073	2.077	2.080	2.083
4.9	2.087	2.090	2.093	2.097	2.100	2.103	2.107	2.110	2.113	2.116
5.0	2.119	2.122	2.125	2.129	2.132	2.135	2.139	2.142	2.145	2.148
5.1	2.151	2.154	2.158	2.160	2.164	2.167	2.170	2.173	2.176	2.180
5.2	2.183	2.186	2.190	2.192	2.195	2.197	2.200	2.203	2.206	2.209
5.3	2.212	2.215	2.218	2.221	2.224	2.227	2.230	2.233	2.236	2.240
5.4	2.243	2.246	2.249	2.252	2.255	2.258	2.261	2.264	2.267	2.270
5.5	2.273	2.276	2.279	2.282	2.285	2.288	2.291	2.294	2.297	2.300
5.6	2.303	2.306	2.309	2.312	2.315	2.318	2.320	2.324	2.326	2.329
5.7	2.332	2.335	2.338	2.341	2.344	2.347	2.350	2.353	2.355	2.358
5.8	2.361	2.364	2.367	2.370	2.373	2.376	2.379	2.382	2.384	2.387
5.9	2.390	2.393	2.396	2.400	2.403	2.405	2.408	2.411	2.414	2.417
6.0	2.419	2.422	2.425	2.428	2.431	2.433	2.436	2.439	2.442	2.444
6.1	2.447	2.450	2.453	2.456	2.458	2.461	2.464	2.467	2.470	2.472
6.2	2.475	2.478	2.481	2.483	2.486	2.489	2.492	2.494	2.497	2.500
6.3	2.503	2.505	2.508	2.511	2.513	2.516	2.518	2.521	2.524	2.526
6.4	2.529	2.532	2.534	2.537	2.540	2.542	2.545	2.547	2.550	2.553
6.5	2.555	2.558	2.561	2.563	2.566	2.568	2.571	2.574	2.576	2.579
6.6	2.581	2.584	2.587	2.590	2.592	2.595	2.597	2.600	2.603	2.605
6.7	2.608	2.610	2.613	2.615	2.618	2.620	2.623	2.625	2.627	2.630
6.8	2.633	2.635	2.637	2.640	2.643	2.645	2.648	2.650	2.653	2.655
6.9	2.658	2.660	2.663	2.665	2.668	2.670	2.673	2.675	2.678	2.680
7.0	2.683	2.685	2.687	2.690	2.693	2.695	2.698	2.700	2.702	2.705
7.1	2.707	2.710	2.712	2.714	2.717	2.719	2.721	2.724	2.726	2.729
7.2	2.731	2.733	2.736	2.738	2.740	2.743	2.745	2.748	2.750	2.752
7.3	2.755	2.757	2.760	2.762	2.764	2.767	2.769	2.771	2.774	2.776
7.4	2.779	2.781	2.783	2.786	2.788	2.790	2.793	2.795	2.798	2.800
7.5	2.802	2.805	2.807	2.809	2.812	2.814	2.816	2.819	2.821	2.823
7.6	2.826	2.828	2.830	2.833	2.835	2.837	2.840	2.842	2.844	2.847
7.7	2.849	2.851	2.854	2.856	2.858	2.860	2.863	2.865	2.868	2.870
7.8	2.873	2.875	2.877	2.879	2.881	2.884	2.887	2.889	2.891	2.893
7.9	2.895	2.898	2.900	2.902	2.905	2.907	2.909	2.911	2.913	2.915
8.0	2.918	2.920	2.922	2.924	2.926	2.928	2.931	2.933	2.935	2.937
8.1	2.939	2.942	2.944	2.946	2.948	2.950	2.952	2.955	2.957	2.959
8.2	2.961	2.963	2.966	2.968	2.970	2.972	2.974	2.976	2.979	2.981
8.3	2.983	2.985	2.987	2.990	2.992	2.994	2.996	2.998	3.000	3.002
8.4	3.004	3.006	3.008	3.010	3.012	3.015	3.017	3.019	3.021	3.023
8.5	3.025	3.027	3.029	3.031	3.033	3.035	3.037	3.040	3.042	3.044



Intrinsic viscosity $[\eta]_c$ at different values of relative viscosity $\eta_{rel}$										
$\eta_{rel}$	$[\eta]_c$									
	0.00	0.01	0.02	0.03	0.04	0.05	0.06	0.07	0.08	0.09
8.6	3.046	3.048	3.050	3.052	3.054	3.056	3.058	3.060	3.062	3.064
8.7	3.067	3.069	3.071	3.073	3.075	3.077	3.079	3.081	3.083	3.085
8.8	3.087	3.089	3.092	3.094	3.096	3.098	3.100	3.102	3.104	3.106
8.9	3.108	3.110	3.112	3.114	3.116	3.118	3.120	3.122	3.124	3.126
9.0	3.128	3.130	3.132	3.134	3.136	3.138	3.140	3.142	3.144	3.146
9.1	3.148	3.150	3.152	3.154	3.156	3.158	3.160	3.162	3.164	3.166
9.2	3.168	3.170	3.172	3.174	3.176	3.178	3.180	3.182	3.184	3.186
9.3	3.188	3.190	3.192	3.194	3.196	3.198	3.200	3.202	3.204	3.206
9.4	3.208	3.210	3.212	3.214	3.215	3.217	3.219	3.221	3.223	3.225
9.5	3.227	3.229	3.231	3.233	3.235	3.237	3.239	3.241	3.242	3.244
9.6	3.246	3.248	3.250	3.252	3.254	3.256	3.258	3.260	3.262	3.264
9.7	3.266	3.268	3.269	3.271	3.273	3.275	3.277	3.279	3.281	3.283
9.8	3.285	3.287	3.289	3.291	3.293	3.295	3.297	3.298	3.300	3.302
9.9	3.304	3.305	3.307	3.309	3.311	3.313	3.316	3.318	3.320	3.321

Intrinsic viscosity $[\eta]_c$ at different values of relative viscosity $\eta_{rel}$										
$\eta_{rel}$	$[\eta]_c$									
	0.0	0.1	0.2	0.3	0.4	0.5	0.6	0.7	0.8	0.9
10	3.32	3.34	3.36	3.37	3.39	3.41	3.43	3.45	3.46	3.48
11	3.50	3.52	3.53	3.55	3.56	3.58	3.60	3.61	3.63	3.64
12	3.66	3.68	3.69	3.71	3.72	3.74	3.76	3.77	3.79	3.80
13	3.80	3.83	3.85	3.86	3.88	3.89	3.90	3.92	3.93	3.95
14	3.96	3.97	3.99	4.00	4.02	4.03	4.04	4.06	4.07	4.09
15	4.10	4.11	4.13	4.14	4.15	4.17	4.18	4.19	4.20	4.22
16	4.23	4.24	4.25	4.27	4.28	4.29	4.30	4.31	4.33	4.34
17	4.35	4.36	4.37	4.38	4.39	4.41	4.42	4.43	4.44	4.45
18	4.46	4.47	4.48	4.49	4.50	4.52	4.53	4.54	4.55	4.56
19	4.57	4.58	4.59	4.60	4.61	4.62	4.63	4.64	4.65	4.66

**Heavy metals (2.4.8):** maximum 10 ppm.

2.0 g complies with test C. Prepare the reference solution using 2 mL of *lead standard solution (10 ppm Pb) R*.

**Loss on drying (2.2.32):** maximum 7.0 per cent, determined on 1.000 g by drying in an oven at 105 °C for 3 h.

**Sulfated ash (2.4.14):** maximum 0.1 per cent, determined on 1.0 g.

#### Microbial contamination

TAMC: acceptance criterion  $10^3$  CFU/g (2.6.12).

TYMC: acceptance criterion  $10^2$  CFU/g (2.6.12).

Absence of *Escherichia coli* (2.6.13).

Absence of *Pseudomonas aeruginosa* (2.6.13).

Absence of *Staphylococcus aureus* (2.6.13).

Absence of *Salmonella* (2.6.13).

#### FUNCTIONALITY-RELATED CHARACTERISTICS

*This section provides information on characteristics that are recognised as being relevant control parameters for one or more functions of the substance when used as an excipient (see chapter 5.15). This section is a non-mandatory part of the monograph and it is not necessary to verify the characteristics to demonstrate compliance. Control of these characteristics can however contribute to the quality of a medicinal product by improving the consistency of the manufacturing process and the performance of the medicinal product during use. Where control methods are cited, they are recognised as being suitable for the purpose, but other methods can also be used. Wherever results for a particular characteristic are reported, the control method must be indicated.*

*The following characteristics may be relevant for microcrystalline cellulose used as binder, diluent or disintegrant.*

**Particle-size distribution (2.9.31 or 2.9.38).**

**Powder flow (2.9.36).**

01/2009:0315

 $\nu_1/\nu_2$ 

## CELLULOSE, POWDERED

## Cellulosi pulvis

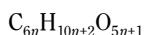
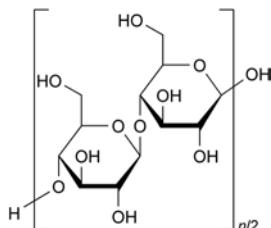

## DEFINITION

Purified, mechanically disintegrated cellulose prepared by processing alpha-cellulose obtained as a pulp from fibrous plant material.

## CHARACTERS

**Appearance:** white or almost white, fine or granular powder.

**Solubility:** practically insoluble in water, slightly soluble in a 50 g/L solution of sodium hydroxide, practically insoluble in acetone, in anhydrous ethanol, in toluene, in dilute acids and in most organic solvents.

## IDENTIFICATION

A. Place about 10 mg on a watch-glass and disperse in 2 mL of *iodinated zinc chloride solution R*. The substance becomes violet-blue.

B. The degree of polymerisation is greater than 440.

Transfer 0.250 g to a 125 mL conical flask. Add 25.0 mL of *water R* and 25.0 mL of *cupriethylenediamine hydroxide solution R*. Immediately purge the solution with *nitrogen R*, insert the stopper and shake until completely dissolved. Transfer an appropriate volume of the solution to a suitable capillary viscometer (2.2.9). Equilibrate the solution at  $25 \pm 0.1$  °C for at least 5 min. Record the flow time ( $t_1$ ) in seconds between the 2 marks on the viscometer. Calculate the kinematic viscosity ( $\nu_1$ ) of the solution using the following expression:

$$t_1 (k_1)$$

where  $k_1$  is the viscometer constant.

Dilute a suitable volume of *cupriethylenediamine hydroxide solution R* with an equal volume of *water R* and measure the flow time ( $t_2$ ) using a suitable capillary viscometer. Calculate the kinematic viscosity ( $\nu_2$ ) of the solvent using the following expression:

$$t_2 (k_2)$$

where  $k_2$  is the viscometer constant.

Determine the relative viscosity ( $\eta_{rel}$ ) of the substance to be examined using the following expression:

Determine the intrinsic viscosity ( $[\eta]_c$ ) by interpolation, using the intrinsic viscosity table (Table 0315-1).

Calculate the degree of polymerisation ( $P$ ) using the following expression:

$$\frac{95 [\eta]_c}{m [(100 - b) / 100]}$$

where  $m$  is the mass in grams of the substance to be examined and  $b$  is the loss on drying as a percentage.

## TESTS

**Solubility.** Dissolve 50 mg in 10 mL of *ammoniacal solution of copper tetrammine R*. It dissolves completely, leaving no residue.

**pH (2.2.3):** 5.0 to 7.5 for the supernatant liquid.

Mix 10 g with 90 mL of *carbon dioxide-free water R* and allow to stand with occasional stirring for 1 h.

**Ether-soluble substances:** maximum 0.15 per cent (15 mg) for the difference between the mass of the residue and the mass obtained from a blank determination.

Place 10.0 g in a chromatography column about 20 mm in internal diameter and pass 50 mL of *peroxide-free ether R* through the column. Evaporate the eluate to dryness in a previously dried and tared evaporating dish, with the aid of a current of air in a fume hood. After all the ether has evaporated, dry the residue at 105 °C for 30 min, allow to cool in a desiccator and weigh. Carry out a blank determination.

**Water-soluble substances:** maximum 1.5 per cent (15.0 mg) for the difference between the mass of the residue and the mass obtained from a blank determination.

Shake 6.0 g with 90 mL of *carbon dioxide-free water R* for 10 min. Filter with the aid of vacuum into a tared flask. Discard the first 10 mL of the filtrate and pass the filtrate through the same filter a second time, if necessary, to obtain a clear filtrate. Evaporate a 15.0 mL portion of the filtrate to dryness in a tared evaporating dish without charring. Dry at 105 °C for 1 h, allow to cool in a desiccator and weigh. Carry out a blank determination.

**Heavy metals (2.4.8):** maximum 10 ppm.

2.0 g complies with test C. Prepare the reference solution using 2 mL of *lead standard solution (10 ppm Pb) R*.

**Loss on drying (2.2.32):** maximum 6.5 per cent, determined on 1.000 g by drying in an oven at 105 °C for 3 h.

**Sulfated ash (2.4.14):** maximum 0.3 per cent (dried substance), determined on 1.0 g.

**Microbial contamination**

TAMC: acceptance criterion  $10^3$  CFU/g (2.6.12).

TYMC: acceptance criterion  $10^2$  CFU/g (2.6.12).

Absence of *Escherichia coli* (2.6.13).

Absence of *Pseudomonas aeruginosa* (2.6.13).

Absence of *Staphylococcus aureus* (2.6.13).

Absence of *Salmonella* (2.6.13).

## FUNCTIONALITY-RELATED CHARACTERISTICS

*This section provides information on characteristics that are recognised as being relevant control parameters for one or more functions of the substance when used as an excipient (see chapter 5.15). This section is a non-mandatory part of the monograph and it is not necessary to verify the characteristics to demonstrate compliance. Control of these characteristics can however contribute to the quality of a medicinal product by improving the consistency of the manufacturing process*

*and the performance of the medicinal product during use. Where control methods are cited they are recognised as being suitable for the purpose but other methods can also be used. Wherever results for a particular characteristic are reported, the control method must be indicated.*

*The following characteristics may be relevant for powdered cellulose used as diluent or disintegrant.*

**Particle-size distribution (2.9.31 or 2.9.38).**

**Powder flow (2.9.36).**

Table 0315.-1. – Intrinsic viscosity table

Intrinsic viscosity $[\eta]_c$ at different values of relative viscosity $\eta_{rel}$										
$\eta_{rel}$	$[\eta]_c$									
	0.00	0.01	0.02	0.03	0.04	0.05	0.06	0.07	0.08	0.09
1.1	0.098	0.106	0.115	0.125	0.134	0.143	0.152	0.161	0.170	0.180
1.2	0.189	0.198	0.207	0.216	0.225	0.233	0.242	0.250	0.259	0.268
1.3	0.276	0.285	0.293	0.302	0.310	0.318	0.326	0.334	0.342	0.350
1.4	0.358	0.367	0.375	0.383	0.391	0.399	0.407	0.414	0.422	0.430
1.5	0.437	0.445	0.453	0.460	0.468	0.476	0.484	0.491	0.499	0.507
1.6	0.515	0.522	0.529	0.536	0.544	0.551	0.558	0.566	0.573	0.580
1.7	0.587	0.595	0.602	0.608	0.615	0.622	0.629	0.636	0.642	0.649
1.8	0.656	0.663	0.670	0.677	0.683	0.690	0.697	0.704	0.710	0.717
1.9	0.723	0.730	0.736	0.743	0.749	0.756	0.762	0.769	0.775	0.782
2.0	0.788	0.795	0.802	0.809	0.815	0.821	0.827	0.833	0.840	0.846
2.1	0.852	0.858	0.864	0.870	0.876	0.882	0.888	0.894	0.900	0.906
2.2	0.912	0.918	0.924	0.929	0.935	0.941	0.948	0.953	0.959	0.965
2.3	0.971	0.976	0.983	0.988	0.994	1.000	1.006	1.011	1.017	1.022
2.4	1.028	1.033	1.039	1.044	1.050	1.056	1.061	1.067	1.072	1.078
2.5	1.083	1.089	1.094	1.100	1.105	1.111	1.116	1.121	1.126	1.131
2.6	1.137	1.142	1.147	1.153	1.158	1.163	1.169	1.174	1.179	1.184
2.7	1.190	1.195	1.200	1.205	1.210	1.215	1.220	1.225	1.230	1.235
2.8	1.240	1.245	1.250	1.255	1.260	1.265	1.270	1.275	1.280	1.285
2.9	1.290	1.295	1.300	1.305	1.310	1.314	1.319	1.324	1.329	1.333
3.0	1.338	1.343	1.348	1.352	1.357	1.362	1.367	1.371	1.376	1.381
3.1	1.386	1.390	1.395	1.400	1.405	1.409	1.414	1.418	1.423	1.427
3.2	1.432	1.436	1.441	1.446	1.450	1.455	1.459	1.464	1.468	1.473
3.3	1.477	1.482	1.486	1.491	1.496	1.500	1.504	1.508	1.513	1.517
3.4	1.521	1.525	1.529	1.533	1.537	1.542	1.546	1.550	1.554	1.558
3.5	1.562	1.566	1.570	1.575	1.579	1.583	1.587	1.591	1.595	1.600
3.6	1.604	1.608	1.612	1.617	1.621	1.625	1.629	1.633	1.637	1.642
3.7	1.646	1.650	1.654	1.658	1.662	1.666	1.671	1.675	1.679	1.683
3.8	1.687	1.691	1.695	1.700	1.704	1.708	1.712	1.715	1.719	1.723
3.9	1.727	1.731	1.735	1.739	1.742	1.746	1.750	1.754	1.758	1.762
4.0	1.765	1.769	1.773	1.777	1.781	1.785	1.789	1.792	1.796	1.800
4.1	1.804	1.808	1.811	1.815	1.819	1.822	1.826	1.830	1.833	1.837
4.2	1.841	1.845	1.848	1.852	1.856	1.859	1.863	1.867	1.870	1.874
4.3	1.878	1.882	1.885	1.889	1.893	1.896	1.900	1.904	1.907	1.911

Intrinsic viscosity $[\eta]_c$ at different values of relative viscosity $\eta_{rel}$										
$\eta_{rel}$	$[\eta]_c$									
	0.00	0.01	0.02	0.03	0.04	0.05	0.06	0.07	0.08	0.09
4.4	1.914	1.918	1.921	1.925	1.929	1.932	1.936	1.939	1.943	1.946
4.5	1.950	1.954	1.957	1.961	1.964	1.968	1.971	1.975	1.979	1.982
4.6	1.986	1.989	1.993	1.996	2.000	2.003	2.007	2.010	2.013	2.017
4.7	2.020	2.023	2.027	2.030	2.033	2.037	2.040	2.043	2.047	2.050
4.8	2.053	2.057	2.060	2.063	2.067	2.070	2.073	2.077	2.080	2.083
4.9	2.087	2.090	2.093	2.097	2.100	2.103	2.107	2.110	2.113	2.116
5.0	2.119	2.122	2.125	2.129	2.132	2.135	2.139	2.142	2.145	2.148
5.1	2.151	2.154	2.158	2.160	2.164	2.167	2.170	2.173	2.176	2.180
5.2	2.183	2.186	2.190	2.192	2.195	2.197	2.200	2.203	2.206	2.209
5.3	2.212	2.215	2.218	2.221	2.224	2.227	2.230	2.233	2.236	2.240
5.4	2.243	2.246	2.249	2.252	2.255	2.258	2.261	2.264	2.267	2.270
5.5	2.273	2.276	2.279	2.282	2.285	2.288	2.291	2.294	2.297	2.300
5.6	2.303	2.306	2.309	2.312	2.315	2.318	2.320	2.324	2.326	2.329
5.7	2.332	2.335	2.338	2.341	2.344	2.347	2.350	2.353	2.355	2.358
5.8	2.361	2.364	2.367	2.370	2.373	2.376	2.379	2.382	2.384	2.387
5.9	2.390	2.393	2.396	2.400	2.403	2.405	2.408	2.411	2.414	2.417
6.0	2.419	2.422	2.425	2.428	2.431	2.433	2.436	2.439	2.442	2.444
6.1	2.447	2.450	2.453	2.456	2.458	2.461	2.464	2.467	2.470	2.472
6.2	2.475	2.478	2.481	2.483	2.486	2.489	2.492	2.494	2.497	2.500
6.3	2.503	2.505	2.508	2.511	2.513	2.516	2.518	2.521	2.524	2.526
6.4	2.529	2.532	2.534	2.537	2.540	2.542	2.545	2.547	2.550	2.553
6.5	2.555	2.558	2.561	2.563	2.566	2.568	2.571	2.574	2.576	2.579
6.6	2.581	2.584	2.587	2.590	2.592	2.595	2.597	2.600	2.603	2.605
6.7	2.608	2.610	2.613	2.615	2.618	2.620	2.623	2.625	2.627	2.630
6.8	2.633	2.635	2.637	2.640	2.643	2.645	2.648	2.650	2.653	2.655
6.9	2.658	2.660	2.663	2.665	2.668	2.670	2.673	2.675	2.678	2.680
7.0	2.683	2.685	2.687	2.690	2.693	2.695	2.698	2.700	2.702	2.705
7.1	2.707	2.710	2.712	2.714	2.717	2.719	2.721	2.724	2.726	2.729
7.2	2.731	2.733	2.736	2.738	2.740	2.743	2.745	2.748	2.750	2.752
7.3	2.755	2.757	2.760	2.762	2.764	2.767	2.769	2.771	2.774	2.776
7.4	2.779	2.781	2.783	2.786	2.788	2.790	2.793	2.795	2.798	2.800
7.5	2.802	2.805	2.807	2.809	2.812	2.814	2.816	2.819	2.821	2.823
7.6	2.826	2.828	2.830	2.833	2.835	2.837	2.840	2.842	2.844	2.847
7.7	2.849	2.851	2.854	2.856	2.858	2.860	2.863	2.865	2.868	2.870
7.8	2.873	2.875	2.877	2.879	2.881	2.884	2.887	2.889	2.891	2.893
7.9	2.895	2.898	2.900	2.902	2.905	2.907	2.909	2.911	2.913	2.915
8.0	2.918	2.920	2.922	2.924	2.926	2.928	2.931	2.933	2.935	2.937
8.1	2.939	2.942	2.944	2.946	2.948	2.950	2.952	2.955	2.957	2.959
8.2	2.961	2.963	2.966	2.968	2.970	2.972	2.974	2.976	2.979	2.981
8.3	2.983	2.985	2.987	2.990	2.992	2.994	2.996	2.998	3.000	3.002
8.4	3.004	3.006	3.008	3.010	3.012	3.015	3.017	3.019	3.021	3.023

Intrinsic viscosity $[\eta]_c$ at different values of relative viscosity $\eta_{rel}$										
$\eta_{rel}$	$[\eta]_c$									
	0.00	0.01	0.02	0.03	0.04	0.05	0.06	0.07	0.08	0.09
8.5	3.025	3.027	3.029	3.031	3.033	3.035	3.037	3.040	3.042	3.044
8.6	3.046	3.048	3.050	3.052	3.054	3.056	3.058	3.060	3.062	3.064
8.7	3.067	3.069	3.071	3.073	3.075	3.077	3.079	3.081	3.083	3.085
8.8	3.087	3.089	3.092	3.094	3.096	3.098	3.100	3.102	3.104	3.106
8.9	3.108	3.110	3.112	3.114	3.116	3.118	3.120	3.122	3.124	3.126
9.0	3.128	3.130	3.132	3.134	3.136	3.138	3.140	3.142	3.144	3.146
9.1	3.148	3.150	3.152	3.154	3.156	3.158	3.160	3.162	3.164	3.166
9.2	3.168	3.170	3.172	3.174	3.176	3.178	3.180	3.182	3.184	3.186
9.3	3.188	3.190	3.192	3.194	3.196	3.198	3.200	3.202	3.204	3.206
9.4	3.208	3.210	3.212	3.214	3.215	3.217	3.219	3.221	3.223	3.225
9.5	3.227	3.229	3.231	3.233	3.235	3.237	3.239	3.241	3.242	3.244
9.6	3.246	3.248	3.250	3.252	3.254	3.256	3.258	3.260	3.262	3.264
9.7	3.266	3.268	3.269	3.271	3.273	3.275	3.277	3.279	3.281	3.283
9.8	3.285	3.287	3.289	3.291	3.293	3.295	3.297	3.298	3.300	3.302
9.9	3.304	3.305	3.307	3.309	3.311	3.313	3.316	3.318	3.320	3.321

  

Intrinsic viscosity $[\eta]_c$ at different values of relative viscosity $\eta_{rel}$										
$\eta_{rel}$	$[\eta]_c$									
	0.0	0.1	0.2	0.3	0.4	0.5	0.6	0.7	0.8	0.9
10	3.32	3.34	3.36	3.37	3.39	3.41	3.43	3.45	3.46	3.48
11	3.50	3.52	3.53	3.55	3.56	3.58	3.60	3.61	3.63	3.64
12	3.66	3.68	3.69	3.71	3.72	3.74	3.76	3.77	3.79	3.80
13	3.80	3.83	3.85	3.86	3.88	3.89	3.90	3.92	3.93	3.95
14	3.96	3.97	3.99	4.00	4.02	4.03	4.04	4.06	4.07	4.09
15	4.10	4.11	4.13	4.14	4.15	4.17	4.18	4.19	4.20	4.22
16	4.23	4.24	4.25	4.27	4.28	4.29	4.30	4.31	4.33	4.34
17	4.35	4.36	4.37	4.38	4.39	4.41	4.42	4.43	4.44	4.45
18	4.46	4.47	4.48	4.49	4.50	4.52	4.53	4.54	4.55	4.56
19	4.57	4.58	4.59	4.60	4.61	4.62	4.63	4.64	4.65	4.66

**07/2010:1084** *Solubility*: freely soluble in water, practically insoluble in acetone and in methylene chloride.

## CETIRIZINE DIHYDROCHLORIDE

### Cetirizini dihydrochloridum

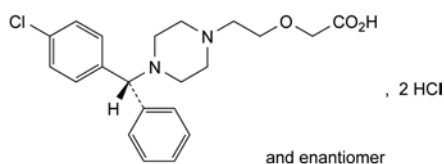

$C_{21}H_{27}Cl_3N_2O_3$   
[83881-52-1]

$M_r$  461.8

#### DEFINITION

(*RS*)-2-[2-[4-(4-Chlorophenyl)phenylmethyl]piperazin-1-yl]ethoxy]acetic acid dihydrochloride.

*Content*: 99.0 per cent to 100.5 per cent (dried substance).

#### CHARACTERS

*Appearance*: white or almost white powder.

#### IDENTIFICATION

*First identification*: B, D.

*Second identification*: A, C, D.

A. Ultraviolet and visible absorption spectrophotometry (2.2.25).

*Test solution*. Dissolve 20.0 mg in 50 mL of a 10.3 g/L solution of *hydrochloric acid R* and dilute to 100.0 mL with the same acid. Dilute 10.0 mL of this solution to 100.0 mL with a 10.3 g/L solution of *hydrochloric acid R*.

*Spectral range*: 210-350 nm.

*Absorption maximum*: at 231 nm.

*Specific absorbance at the absorption maximum*: 359 to 381.

B. Infrared absorption spectrophotometry (2.2.24).

*Comparison*: *cetirizine dihydrochloride CRS*.

C. Thin-layer chromatography (2.2.27).

**Test solution.** Dissolve 10 mg of the substance to be examined in *water R* and dilute to 5 mL with the same solvent.

**Reference solution (a).** Dissolve 10 mg of *cetirizine dihydrochloride CRS* in *water R* and dilute to 5 mL with the same solvent.

**Reference solution (b).** Dissolve 10 mg of *chlorphenamine maleate CRS* in *water R* and dilute to 5 mL with the same solvent. To 1 mL of the solution add 1 mL of reference solution (a).

**Plate:** TLC silica gel GF<sub>254</sub> plate R.

**Mobile phase:** ammonia R, methanol R, methylene chloride R (1:10:90 V/V/V).

**Application:** 5 µL.

**Development:** over 2/3 of the plate.

**Drying:** in a current of cold air.

**Detection:** examine in ultraviolet light at 254 nm.

**System suitability:** reference solution (b):

- the chromatogram obtained shows 2 clearly separated spots.

**Results:** the principal spot in the chromatogram obtained with the test solution is similar in position and size to the principal spot in the chromatogram obtained with reference solution (a).

D. It gives reaction (a) of chlorides (2.3.1).

## TESTS

**Solution S.** Dissolve 1.0 g in *carbon dioxide-free water R* and dilute to 20 mL with the same solvent.

**Appearance of solution.** Solution S is clear (2.2.1) and not more intensely coloured than reference solution BY<sub>7</sub> (2.2.2, Method II).

**pH (2.2.3):** 1.2 to 1.8 for solution S.

**Related substances.** Liquid chromatography (2.2.29).

**Test solution.** Dissolve 20 mg of the substance to be examined in the mobile phase and dilute to 100.0 mL with the mobile phase.

**Reference solution (a).** Dissolve 2 mg of *cetirizine dihydrochloride CRS* and 2 mg of *cetirizine impurity A CRS* in the mobile phase and dilute to 10.0 mL with the mobile phase. Dilute 1.0 mL of the solution to 100.0 mL with the mobile phase.

**Reference solution (b).** Dilute 2.0 mL of the test solution to 50.0 mL with the mobile phase. Dilute 5.0 mL of this solution to 100.0 mL with the mobile phase.

**Reference solution (c).** Dissolve the contents of a vial of *cetirizine impurity mixture CRS* (impurities B, C, D, E and F) in 1.0 mL of mobile phase.

**Column:**

- size:  $l = 0.25$  m,  $\varnothing = 4.6$  mm;
  - stationary phase: silica gel for chromatography R (5 µm).
- Mobile phase:** dilute sulfuric acid R, water R, acetonitrile R (0.4:6.6:93 V/V/V).

**Flow rate:** 1 mL/min.

**Detection:** spectrophotometer at 230 nm.

**Injection:** 20 µL.

**Run time:** 3 times the retention time of cetirizine.

**Identification of impurities:**

- use the chromatogram supplied with *cetirizine impurity mixture CRS* and the chromatogram obtained with reference solution (c) to identify the peaks due to impurities B, C, D, E and F;
- use the chromatogram obtained with reference solution (a) to identify the peak due to impurity A.

**Relative retention** with reference to cetirizine (retention time = about 10 min): impurity D = about 0.6; impurity B = about 0.8; impurity C = about 0.9; impurity E = about 1.2; impurity F = about 1.37; impurity A = about 1.42.

**System suitability:** reference solution (a):

- resolution: minimum 3.0 between the peaks due to cetirizine and impurity A;
- symmetry factor: maximum 2.0.

**Limits:**

- impurities A, B, C, D, E, F: for each impurity, not more than 0.75 times the area of the principal peak in the chromatogram obtained with reference solution (b) (0.15 per cent);
- unspecified impurities: for each impurity, not more than 0.5 times the area of the principal peak in the chromatogram obtained with reference solution (b) (0.10 per cent);
- total: not more than 1.5 times the area of the principal peak in the chromatogram obtained with reference solution (b) (0.3 per cent);
- disregard limit: 0.25 times the area of the principal peak in the chromatogram obtained with reference solution (b) (0.05 per cent).

**Loss on drying (2.2.32):** maximum 0.5 per cent, determined on 1.000 g by drying in an oven at 105 °C.

**Sulfated ash (2.4.14):** maximum 0.2 per cent, determined on 1.0 g.

## ASSAY

Dissolve 0.100 g in 70 mL of a mixture of 30 volumes of *water R* and 70 volumes of *acetone R*. Titrate with 0.1 M sodium hydroxide to the 2<sup>nd</sup> point of inflexion. Determine the end-point potentiometrically (2.2.20). Carry out a blank titration.

1 mL of 0.1 M sodium hydroxide is equivalent to 15.39 mg of C<sub>21</sub>H<sub>27</sub>Cl<sub>3</sub>N<sub>2</sub>O<sub>3</sub>.

## STORAGE

Protected from light.

## IMPURITIES

**Specified impurities:** A, B, C, D, E, F.

**Other detectable impurities** (the following substances would, if present at a sufficient level, be detected by one or other of the tests in the monograph. They are limited by the general acceptance criterion for other/unspecified impurities and/or by the general monograph *Substances for pharmaceutical use (2034)*. It is therefore not necessary to identify these impurities for demonstration of compliance. See also 5.10. *Control of impurities in substances for pharmaceutical use*): G.

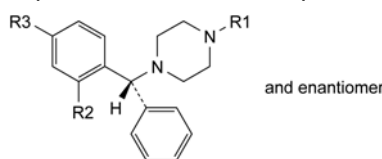

- R1 = R2 = H, R3 = Cl: (RS)-1-[(4-chlorophenyl)phenylmethyl]piperazine,
- R1 = CH<sub>2</sub>-CO<sub>2</sub>H, R2 = H, R3 = Cl: (RS)-2-[4-[(4-chlorophenyl)phenylmethyl]piperazin-1-yl]acetic acid,
- R1 = CH<sub>2</sub>-CH<sub>2</sub>-O-CH<sub>2</sub>-CO<sub>2</sub>H, R2 = Cl, R3 = H: (RS)-2-[2-[4-[(2-chlorophenyl)phenylmethyl]piperazin-1-yl]ethoxy]acetic acid,
- R1 = CH<sub>2</sub>-[CH<sub>2</sub>-O-CH<sub>2</sub>]<sub>2</sub>-CO<sub>2</sub>H, R2 = H, R3 = Cl: (RS)-2-[2-[2-[4-[(4-chlorophenyl)phenylmethyl]piperazin-1-yl]ethoxy]ethoxy]acetic acid (ethoxycetirizine),
- R1 = CH<sub>2</sub>-CH<sub>2</sub>-O-CH<sub>2</sub>-CO<sub>2</sub>H, R2 = R3 = H: [2-[4-(diphenylmethyl)piperazin-1-yl]ethoxy]acetic acid,
- R1 = CH<sub>2</sub>-CH<sub>2</sub>-OH, R2 = H, R3 = Cl: 2-[4-[(RS)-(4-chlorophenyl)phenylmethyl]piperazin-1-yl]ethanol,

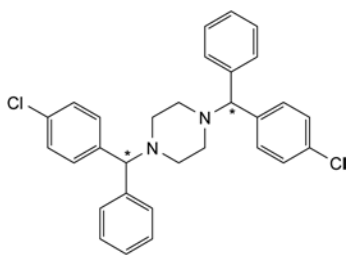

D. 1,4-bis[(4-chlorophenyl)phenylmethyl]piperazine.

01/2008:0702

**CETOSTEARYL ALCOHOL**

## Alcohol cetylicus et stearylicus

## DEFINITION

Mixture of solid aliphatic alcohols, mainly octadecan-1-ol (stearyl alcohol;  $C_{18}H_{38}O$ ;  $M_r$  270.5) and hexadecan-1-ol (cetyl alcohol;  $C_{16}H_{34}O$ ;  $M_r$  242.4), of animal or vegetable origin.

## Content:

- *stearyl alcohol*: minimum 40.0 per cent,
- *sum of the contents of stearyl alcohol and cetyl alcohol*: minimum 90.0 per cent.

## CHARACTERS

*Appearance*: white or pale yellow, wax-like mass, plates, flakes or granules.

*Solubility*: practically insoluble in water, soluble in ethanol (96 per cent) and in light petroleum. When melted, it is miscible with fatty oils, with liquid paraffin and with melted wool fat.

## IDENTIFICATION

Examine the chromatograms obtained in the assay.

*Results*: the 2 principal peaks in the chromatogram obtained with the test solution are similar in retention time to the principal peaks in the chromatogram obtained with the reference solution.

## TESTS

**Appearance of solution.** The solution is clear (2.2.1) and not more intensely coloured than reference solution B<sub>6</sub> (2.2.2, Method II).

Dissolve 0.50 g in 20 mL of boiling *ethanol (96 per cent) R*. Allow to cool.

**Melting point (2.2.14)**: 49 °C to 56 °C.

**Acid value (2.5.1)**: maximum 1.0.

**Hydroxyl value (2.5.3, Method A)**: 208 to 228.

**Iodine value (2.5.4, Method A)**: maximum 2.0.

Dissolve 2.00 g in *methylene chloride R* and dilute to 25 mL with the same solvent.

**Saponification value (2.5.6)**: maximum 2.0.

## ASSAY

Gas chromatography (2.2.28): use the normalisation procedure.

*Test solution.* Dissolve 0.100 g of the substance to be examined in *ethanol (96 per cent) R* and dilute to 10.0 mL with the same solvent.

*Reference solution.* Dissolve 60 mg of *cetyl alcohol CRS* and 40 mg of *stearyl alcohol CRS* in *ethanol (96 per cent) R* and dilute to 10 mL with the same solvent. Dilute 1 mL of this solution to 10 mL with *ethanol (96 per cent) R*.

## Column:

- *size*:  $l = 30$  m,  $\varnothing = 0.32$  mm,
- *stationary phase*: *poly(dimethyl)siloxane R* (1  $\mu$ m).

*Carrier gas*: *helium for chromatography R*.

*Flow rate*: 1 mL/min.

*Split ratio*: 1:100.

*Temperature*:

	Time (min)	Temperature (°C)
Column	0 - 20	150 → 250
	20 - 40	250
Injection port		250
Detector		250

*Detection*: flame ionisation.

*Injection*: 1  $\mu$ L.

*System suitability*: reference solution:

- *resolution*: minimum 5.0 between the peaks due to cetyl alcohol and stearyl alcohol.

Calculate the percentage contents of  $C_{16}H_{34}O$  and  $C_{18}H_{38}O$ .

07/2008:0801  
corrected 6.2**CETOSTEARYL ALCOHOL (TYPE A), EMULSIFYING**

## Alcohol cetylicus et stearylicus emulsificans A

## DEFINITION

Mixture of cetostearyl alcohol and sodium cetostearyl sulfate. A suitable buffer may be added.

## Content:

- *cetostearyl alcohol*: minimum 80.0 per cent (anhydrous substance);
- *sodium cetostearyl sulfate*: minimum 7.0 per cent (anhydrous substance).

## CHARACTERS

*Appearance*: white or pale yellow, waxy mass, plates, flakes or granules.

*Solubility*: soluble in hot water giving an opalescent solution, practically insoluble in cold water, slightly soluble in ethanol (96 per cent).

## IDENTIFICATION

*First identification*: B, C, D.

*Second identification*: A, C.

A. Thin-layer chromatography (2.2.27).

*Test solution (a).* Dissolve 0.1 g of the substance to be examined in 10 mL of *trimethylpentane R*, heating on a water-bath. Shake with 2 mL of *ethanol (70 per cent V/V) R* and allow to separate. Use the lower layer as test solution (b). Dilute 1 mL of the upper layer to 8 mL with *trimethylpentane R*.

*Test solution (b).* Use the lower layer obtained in the preparation of test solution (a).

*Reference solution (a).* Dissolve 24 mg of *cetyl alcohol CRS* and 16 mg of *stearyl alcohol CRS* in 10 mL of *trimethylpentane R*.

*Reference solution (b).* Dissolve 20 mg of *sodium cetostearyl sulfate R* in 10 mL of *ethanol (70 per cent V/V) R*, heating on a water-bath.

*Plate*: *TLC silanised silica gel plate R*.

*Mobile phase*: *water R, acetone R, methanol R* (20:40:40 V/V/V).

*Application*: 2  $\mu$ L.

*Development*: over a path of 12 cm.

*Drying*: in air.

**Detection:** spray with a 50 g/L solution of *phosphomolybdic acid R* in *ethanol (96 per cent) R*; heat at 120 °C until spots appear (about 3 h).

**Results:**

- the 2 principal spots in the chromatogram obtained with test solution (a) are similar in position and colour to the principal spots in the chromatogram obtained with reference solution (a);
- 2 of the spots in the chromatogram obtained with test solution (b) are similar in position and colour to the principal spots in the chromatogram obtained with reference solution (b).

B. Examine the chromatograms obtained in the assay.

**Results:** the 2 principal peaks in the chromatogram obtained with test solution (b) are similar in retention time to the 2 principal peaks in the chromatogram obtained with the reference solution.

C. It gives a yellow colour to a non-luminous flame.

D. To 0.3 g add 20 mL of *anhydrous ethanol R* and heat to boiling on a water-bath with shaking. Filter the mixture immediately, evaporate to dryness and take up the residue in 7 mL of *water R*. To 1 mL of the solution add 0.1 mL of a 1 g/L solution of *methylene blue R*, 2 mL of *dilute sulfuric acid R* and 2 mL of *methylene chloride R* and shake. A blue colour develops in the lower layer.

#### TESTS

**Acid value (2.5.1):** maximum 2.0.

**Iodine value (2.5.4, Method A):** maximum 3.0.

Dissolve 2.00 g in 25 mL of *methylene chloride R*.

**Saponification value (2.5.6):** maximum 2.0.

**Water (2.5.12):** maximum 3.0 per cent, determined on 2.50 g.

#### ASSAY

**Cetostearyl alcohol.** Gas chromatography (2.2.28).

**Internal standard solution.** Dissolve 0.60 g of *heptadecanol CRS* in *anhydrous ethanol R* and dilute to 150 mL with the same solvent.

**Test solution (a).** Dissolve 0.300 g of the substance to be examined in 50 mL of the internal standard solution, add 50 mL of *water R* and shake with 4 quantities, each of 25 mL, of *pentane R*, adding *sodium chloride R*, if necessary, to facilitate the separation of the layers. Combine the organic layers. Wash with 2 quantities, each of 30 mL, of *water R*, dry over *anhydrous sodium sulfate R* and filter.

**Test solution (b).** Dissolve 0.300 g of the substance to be examined in 50 mL of *anhydrous ethanol R*, add 50 mL of *water R* and shake with 4 quantities, each of 25 mL, of *pentane R*, adding *sodium chloride R*, if necessary, to facilitate the separation of the layers. Combine the organic layers. Wash with 2 quantities, each of 30 mL, of *water R*, dry over *anhydrous sodium sulfate R* and filter.

**Reference solution.** Dissolve 50 mg of *cetyl alcohol CRS* and 50 mg of *stearyl alcohol CRS* in *anhydrous ethanol R* and dilute to 10 mL with the same solvent.

**Column:**

- *material:* fused silica;
- *size:*  $l = 25$  m,  $\varnothing = 0.25$  mm;
- *stationary phase:* *poly(dimethyl)siloxane R*.

**Carrier gas:** *nitrogen for chromatography R*.

**Flow rate:** 1 mL/min.

**Split ratio:** 1:100.

**Temperature:**

	Time (min)	Temperature (°C)
Column	0 - 20	150 → 250
Injection port		250
Detector		250

**Detection:** flame ionisation.

**Elution order:** *cetyl alcohol*, *heptadecanol*, *stearyl alcohol*.

Inject 1 µL of test solution (a) and 1 µL of test solution (b). If the chromatogram obtained with test solution (b) shows a peak with the same retention time as the peak due to the internal standard in the chromatogram obtained with test solution (a), calculate the ratio  $r$  using the following expression:

$$\frac{S_{ci}}{S_i}$$

$S_{ci}$  = area of the peak due to *cetyl alcohol* in the chromatogram obtained with test solution (b);

$S_i$  = area of the peak with the same retention time as the peak due to the internal standard in the chromatogram obtained with test solution (a).

If  $r$  is less than 300, calculate the corrected area  $S_{Ha(corr)}$  of the peak due to the internal standard in the chromatogram obtained with test solution (a) using the following expression:

$$S'_{Ha} - \frac{S_i \times S_c}{S_{ci}}$$

$S'_{Ha}$  = area of the peak due to the internal standard in the chromatogram obtained with test solution (a);

$S_c$  = area of the peak due to *cetyl alcohol* in the chromatogram obtained with test solution (a).

Inject, under the same conditions, equal volumes of the reference solution and of test solution (a). Identify the peaks in the chromatogram obtained with test solution (a) by comparing their retention times with those of the peaks in the chromatogram obtained with the reference solution and determine the area of each peak.

Calculate the percentage content of *cetyl alcohol* using the following expression:

$$S_A \frac{100 \times m_H}{S_{Ha(corr)} \times m}$$

$S_A$  = area of the peak due to *cetyl alcohol* in the chromatogram obtained with test solution (a);

$m_H$  = mass of the internal standard in test solution (a), in milligrams;

$S_{Ha(corr)}$  = corrected area of the peak due to the internal standard in the chromatogram obtained with test solution (a);

$m$  = mass of the substance to be examined in test solution (a), in milligrams.

Calculate the percentage content of *stearyl alcohol* using the following expression:

$$S_B \frac{100 \times m_H}{S_{Ha(corr)} \times m}$$

$S_B$  = area of the peak due to *stearyl alcohol* in the chromatogram obtained with test solution (a).

The percentage content of *cetostearyl alcohol* corresponds to the sum of the percentage content of *cetyl alcohol* and of *stearyl alcohol*.

**Sodium cetostearyl sulfate.** Disperse 0.300 g in 25 mL of *methylene chloride R*. Add 50 mL of *water R* and 10 mL of *dimidium bromide-sulfan blue mixed solution R*. Titrate with



0.004 M benzethonium chloride, using sonication, heating and allowing the layers to separate before each addition, until the colour of the lower layer changes from pink to grey.

1 mL of 0.004 M benzethonium chloride is equivalent to 1.434 mg of sodium cetostearyl sulfate.

#### LABELLING

The label states, where applicable, the name and concentration of any added buffer.

07/2008:0802  
corrected 6.2

## CETOSTEARYL ALCOHOL (TYPE B), EMULSIFYING

### Alcohol cetylicus et stearylicus emulsificans B

#### DEFINITION

Mixture of cetostearyl alcohol and sodium laurilsulfate. A suitable buffer may be added.

#### Content:

- *cetostearyl alcohol*: minimum 80.0 per cent (anhydrous substance);
- *sodium laurilsulfate*: minimum 7.0 per cent (anhydrous substance).

#### CHARACTERS

*Appearance*: white or pale yellow, waxy mass, plates, flakes or granules.

*Solubility*: soluble in hot water giving an opalescent solution, practically insoluble in cold water, slightly soluble in ethanol (96 per cent).

#### IDENTIFICATION

*First identification*: B, C, D.

*Second identification*: A, C.

#### A. Thin-layer chromatography (2.2.27).

*Test solution (a)*. Dissolve 0.1 g of the substance to be examined in 10 mL of *trimethylpentane R*, heating on a water-bath. Shake with 2 mL of *ethanol (70 per cent V/V) R* and allow to separate. Use the lower layer as test solution (b). Dilute 1 mL of the upper layer to 8 mL with *trimethylpentane R*.

*Test solution (b)*. Use the lower layer obtained in the preparation of test solution (a).

*Reference solution (a)*. Dissolve 24 mg of *cetyl alcohol CRS* and 16 mg of *stearyl alcohol CRS* in 10 mL of *trimethylpentane R*.

*Reference solution (b)*. Dissolve 20 mg of *sodium laurilsulfate CRS* in 10 mL of *ethanol (70 per cent V/V) R*, heating on a water-bath.

*Plate*: TLC silanised silica gel plate R.

*Mobile phase*: *water R*, *acetone R*, *methanol R* (20:40:40 V/V/V).

*Application*: 2 µL.

*Development*: over a path of 12 cm.

*Drying*: in air.

*Detection*: spray with a 50 g/L solution of *phosphomolybdic acid R* in *ethanol (96 per cent) R*; heat at 120 °C until spots appear (about 3 h).

#### Results:

- the 2 principal spots in the chromatogram obtained with test solution (a) are similar in position and colour to the principal spots in the chromatogram obtained with reference solution (a);

- 1 of the spots in the chromatogram obtained with test solution (b) is similar in position and colour to the principal spot in the chromatogram obtained with reference solution (b).

#### B. Examine the chromatograms obtained in the assay.

*Results*: the 2 principal peaks in the chromatogram obtained with test solution (b) are similar in retention time to the 2 principal peaks in the chromatogram obtained with the reference solution.

#### C. It gives a yellow colour to a non-luminous flame.

- D. To 0.3 g add 20 mL of *anhydrous ethanol R* and heat to boiling on a water-bath with shaking. Filter the mixture immediately, evaporate to dryness and take up the residue in 7 mL of *water R*. To 1 mL of the solution add 0.1 mL of a 1 g/L solution of *methylene blue R*, 2 mL of *dilute sulfuric acid R* and 2 mL of *methylene chloride R* and shake. A blue colour develops in the lower layer.

#### TESTS

**Acid value (2.5.1)**: maximum 2.0.

**Iodine value (2.5.4, Method A)**: maximum 3.0.

Dissolve 2.00 g in 25 mL of *methylene chloride R*.

**Saponification value (2.5.6)**: maximum 2.0.

**Water (2.5.12)**: maximum 3.0 per cent, determined on 2.50 g.

#### ASSAY

**Cetostearyl alcohol**. Gas chromatography (2.2.28).

*Internal standard solution*. Dissolve 0.60 g of *heptadecanol CRS* in *anhydrous ethanol R* and dilute to 150 mL with the same solvent.

*Test solution (a)*. Dissolve 0.300 g of the substance to be examined in 50 mL of the internal standard solution, add 50 mL of *water R* and shake with 4 quantities, each of 25 mL, of *pentane R*, adding *sodium chloride R*, if necessary, to facilitate the separation of the layers. Combine the organic layers. Wash with 2 quantities, each of 30 mL, of *water R*, dry over *anhydrous sodium sulfate R* and filter.

*Test solution (b)*. Dissolve 0.300 g of the substance to be examined in 50 mL of *anhydrous ethanol R*, add 50 mL of *water R* and shake with 4 quantities, each of 25 mL, of *pentane R*, adding *sodium chloride R*, if necessary, to facilitate the separation of the layers. Combine the organic layers. Wash with 2 quantities, each of 30 mL, of *water R*, dry over *anhydrous sodium sulfate R* and filter.

*Reference solution*. Dissolve 50 mg of *cetyl alcohol CRS* and 50 mg of *stearyl alcohol CRS* in *anhydrous ethanol R* and dilute to 10 mL with the same solvent.

#### Column:

- *material*: fused silica;
- *size*:  $l = 25$  m,  $\varnothing = 0.25$  mm;
- *stationary phase*: *poly(dimethyl)siloxane R*.

*Carrier gas*: *nitrogen for chromatography R*.

*Flow rate*: 1 mL/min.

*Split ratio*: 1:100.

*Temperature*:

	Time (min)	Temperature (°C)
Column	0 - 20	150 → 250
Injection port		250
Detector		250

*Detection*: flame ionisation.

*Elution order*: *cetyl alcohol*, *heptadecanol*, *stearyl alcohol*.

01/2008:1085

Inject 1 µL of test solution (a) and 1 µL of test solution (b). If the chromatogram obtained with test solution (b) shows a peak with the same retention time as the peak due to the internal standard in the chromatogram obtained with test solution (a), calculate the ratio  $r$  using the following expression:

$$\frac{S_{ci}}{S_i}$$

$S_{ci}$  = area of the peak due to cetyl alcohol in the chromatogram obtained with test solution (b);

$S_i$  = area of the peak with the same retention time as the peak due to the internal standard in the chromatogram obtained with test solution (a).

If  $r$  is less than 300, calculate the corrected area  $S'_{Ha(corr)}$  of the peak due to the internal standard in the chromatogram obtained with test solution (a) using the following expression:

$$S'_{Ha} - \frac{S_i \times S_c}{S_{ci}}$$

$S'_{Ha}$  = area of the peak due to the internal standard in the chromatogram obtained with test solution (a);

$S_c$  = area of the peak due to cetyl alcohol in the chromatogram obtained with test solution (a).

Inject, under the same conditions, equal volumes of the reference solution and of test solution (a). Identify the peaks in the chromatogram obtained with test solution (a) by comparing their retention times with those of the peaks in the chromatogram obtained with the reference solution and determine the area of each peak.

Calculate the percentage content of cetyl alcohol using the following expression:

$$S_A \frac{100 \times m_H}{S_{Ha(corr)} \times m}$$

$S_A$  = area of the peak due to cetyl alcohol in the chromatogram obtained with test solution (a);

$m_H$  = mass of the internal standard in test solution (a), in milligrams;

$S_{Ha(corr)}$  = corrected area of the peak due to the internal standard in the chromatogram obtained with test solution (a);

$m$  = mass of the substance to be examined in test solution (a), in milligrams.

Calculate the percentage content of stearyl alcohol using the following expression:

$$S_B \frac{100 \times m_H}{S_{Ha(corr)} \times m}$$

$S_B$  = area of the peak due to stearyl alcohol in the chromatogram obtained with test solution (a).

The percentage content of cetostearyl alcohol corresponds to the sum of the percentage content of cetyl alcohol and of stearyl alcohol.

**Sodium laurilsulfate.** Disperse 0.300 g in 25 mL of *methylene chloride R*. Add 50 mL of *water R* and 10 mL of *dimidium bromide-sulfan blue mixed solution R*. Titrate with 0.004 M *benzethonium chloride*, using sonication, heating, and allowing the layers to separate before each addition, until the colour of the lower layer changes from pink to grey.

1 mL of 0.004 M *benzethonium chloride* is equivalent to 1.154 mg of sodium laurilsulfate.

#### LABELLING

The label states, where applicable, the name and concentration of any added buffer.

## CETOSTEARYL ISONONANOATE

### Cetostearylis isononanoas

#### DEFINITION

Mixture of esters of cetostearyl alcohol with isononanoic acid, mainly 3,5,5-trimethylhexanoic acid.

#### CHARACTERS

*Appearance:* clear, colourless or slightly yellowish liquid.

*Solubility:* practically insoluble in water, soluble in ethanol (96 per cent) and in light petroleum, miscible with fatty oils and with liquid paraffins.

*Viscosity:* 15 mPa·s to 30 mPa·s.

*Relative density:* 0.85 to 0.86.

*Refractive index:* 1.44 to 1.45.

#### IDENTIFICATION

A. On cooling, turbidity occurs below 15 °C.

B. Saponification value (see Tests).

C. Infrared absorption spectrophotometry (2.2.24).

*Comparison:* Ph. Eur. reference spectrum of cetostearyl isononanoate.

#### TESTS

**Appearance.** The substance to be examined is clear (2.2.1) and not more intensely coloured than reference solution Y<sub>6</sub> (2.2.2, Method I).

**Acid value** (2.5.1): maximum 1.0, determined on 5.0 g.

**Hydroxyl value** (2.5.3, Method A): maximum 5.0.

**Iodine value** (2.5.4, Method A): maximum 1.0.

**Saponification value** (2.5.6): 135 to 148, determined on 1.0 g.

**Heavy metals** (2.4.8): maximum 10 ppm.

2.0 g complies with test D. Prepare the reference solution using 2 mL of *lead standard solution (10 ppm Pb) R*.

**Water** (2.5.12): maximum 0.2 per cent, determined on 10.0 g.

**Total ash** (2.4.16): maximum 0.2 per cent, determined on 2.0 g.

01/2008:0378  
corrected 6.0

## CETRIMIDE

### Cetrimidium

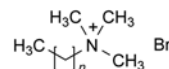

#### DEFINITION

Cetrimide consists of trimethyltetradecylammonium bromide and may contain smaller amounts of dodecyl- and hexadecyl-trimethylammonium bromides.

*Content:* 96.0 per cent to 101.0 per cent of alkyltrimethylammonium bromides, calculated as C<sub>17</sub>H<sub>38</sub>BrN ( $M_r$  336.4) (dried substance).

#### CHARACTERS

*Appearance:* white or almost white, voluminous, free-flowing powder.

*Solubility:* freely soluble in water and in alcohol.

#### IDENTIFICATION

A. Dissolve 0.25 g in *alcohol R* and dilute to 25.0 mL with the same solvent. At wavelengths from 260 nm to 280 nm, the absorbance (2.2.25) of the solution has a maximum of 0.05.

B. Dissolve about 5 mg in 5 mL of *buffer solution pH 8.0 R*. Add about 10 mg of *potassium ferricyanide R*. A yellow precipitate is formed. Prepare a blank in the same manner but omitting the substance to be examined: a yellow solution is observed but no precipitate is formed.

C. Solution S (see Tests) froths copiously when shaken.

D. Thin-layer chromatography (2.2.27).

*Test solution.* Dissolve 0.10 g of the substance to be examined in *water R* and dilute to 5 mL with the same solvent.

*Reference solution.* Dissolve 0.10 g of *trimethyltetradecylammonium bromide CRS* in *water R* and dilute to 5 mL with the same solvent.

*Plate:* TLC silica gel  $F_{254}$  silanised plate *R*.

*Mobile phase:* acetone *R*, 270 g/L solution of sodium acetate *R*, methanol *R* (20:35:45 V/V/V).

*Application:* 1  $\mu$ L.

*Development:* over a path of 12 cm.

*Drying:* in a current of hot air.

*Detection:* allow to cool; expose the plate to iodine vapour and examine in daylight.

*Result:* the principal spot in the chromatogram obtained with the test solution is similar in position, colour and size to the principal spot in the chromatogram obtained with the reference solution.

E. It gives reaction (a) of bromides (2.3.1).

#### TESTS

**Solution S.** Dissolve 2.0 g in *carbon dioxide-free water R* and dilute to 100 mL with the same solvent.

**Appearance of solution.** Solution S is clear (2.2.1) and colourless (2.2.2, *Method II*).

**Acidity or alkalinity.** To 50 mL of solution S add 0.1 mL of *bromocresol purple solution R*. Not more than 0.1 mL of 0.1 M *hydrochloric acid* or 0.1 M *sodium hydroxide* is required to change the colour of the indicator.

**Amines and amine salts.** Dissolve 5.0 g in 30 mL of a mixture of 1 volume of 1 M *hydrochloric acid* and 99 volumes of *methanol R* and add 100 mL of *2-propanol R*. Pass a stream of *nitrogen R* slowly through the solution. Gradually add 15.0 mL of 0.1 M *tetrabutylammonium hydroxide* and record the potentiometric titration curve (2.2.20). If the curve shows 2 points of inflexion, the volume of titrant added between the 2 points is not greater than 2.0 mL.

**Loss on drying** (2.2.32): maximum 2.0 per cent, determined on 1.000 g by drying in an oven at 105 °C for 2 h.

**Sulfated ash** (2.4.14): maximum 0.5 per cent, determined on 1.0 g.

#### ASSAY

Dissolve 2.000 g in *water R* and dilute to 100.0 mL with the same solvent. Transfer 25.0 mL of the solution to a separating funnel, add 25 mL of *chloroform R*, 10 mL of 0.1 M *sodium hydroxide* and 10.0 mL of a freshly prepared 50 g/L solution of *potassium iodide R*. Shake, allow to separate and discard the chloroform layer. Shake the aqueous layer with 3 quantities, each of 10 mL, of *chloroform R* and discard the chloroform layers. Add 40 mL of *hydrochloric acid R*, allow to cool and titrate with 0.05 M *potassium iodate* until the deep brown colour is almost discharged. Add 2 mL of *chloroform R* and continue the titration, shaking vigorously, until the colour of the chloroform layer no longer changes. Carry out a blank titration on a mixture of 10.0 mL of the freshly prepared 50 g/L solution of *potassium iodide R*, 20 mL of *water R* and 40 mL of *hydrochloric acid R*.

1 mL of 0.05 M *potassium iodate* is equivalent to 33.64 mg of  $C_{17}H_{35}BrN$ .

01/2008:0540

## CETYL ALCOHOL

### Alcohol cetylicus

#### DEFINITION

Mixture of solid alcohols, mainly hexadecan-1-ol ( $C_{16}H_{34}O$ ;  $M_r$  242.4), of animal or vegetable origin.

*Content:* minimum 95.0 per cent of  $C_{16}H_{34}O$ .

#### CHARACTERS

*Appearance:* white or almost white, unctuous mass, powder, flakes or granules.

*Solubility:* practically insoluble in water, freely soluble or sparingly soluble in ethanol (96 per cent). When melted, it is miscible with vegetable and animal oils, with liquid paraffin and with melted wool fat.

#### IDENTIFICATION

Examine the chromatograms obtained in the assay.

*Results:* the principal peak in the chromatogram obtained with the test solution is similar in retention time to the principal peak in the chromatogram obtained with reference solution (a).

#### TESTS

**Appearance of solution.** The solution is clear (2.2.1) and not more intensely coloured than reference solution B<sub>6</sub> (2.2.2, *Method II*).

Dissolve 0.50 g in 20 mL of boiling *ethanol (96 per cent) R*. Allow to cool.

**Melting point** (2.2.14): 46 °C to 52 °C.

**Acid value** (2.5.1): maximum 1.0.

**Hydroxyl value** (2.5.3, *Method A*): 218 to 238.

**Iodine value** (2.5.4, *Method A*): maximum 2.0.

Dissolve 2.00 g in *methylene chloride R* and dilute to 25 mL with the same solvent.

**Saponification value** (2.5.6): maximum 2.0.

#### ASSAY

Gas chromatography (2.2.28): use the normalisation procedure.

*Test solution.* Dissolve 0.100 g of the substance to be examined in *ethanol (96 per cent) R* and dilute to 10.0 mL with the same solvent.

*Reference solution (a).* Dissolve 50 mg of *cetyl alcohol CRS* in *ethanol (96 per cent) R* and dilute to 5 mL with the same solvent.

*Reference solution (b).* Dissolve 50 mg of *stearyl alcohol R* in *ethanol (96 per cent) R* and dilute to 10 mL with the same solvent.

*Reference solution (c).* Mix 1 mL of reference solution (a) and 1 mL of reference solution (b) and dilute to 10 mL with *ethanol (96 per cent) R*.

*Column:*

– size:  $l = 30$  m,  $\varnothing = 0.32$  mm,

– stationary phase: *poly(dimethyl)siloxane R* (1  $\mu$ m).

*Carrier gas:* helium for chromatography *R*.

*Flow rate:* 1 mL/min.

*Split ratio:* 1:100.

## Temperature:

	Time (min)	Temperature (°C)
Column	0 - 20	150 → 250
	20 - 40	250
Injection port		250
Detector		250

Detection: flame ionisation.

Injection: 1 µL of the test solution and reference solutions (a) and (c).

System suitability: reference solution (c):

– resolution: minimum 5.0 between the peaks due to cetyl alcohol and stearyl alcohol.

Calculate the percentage content of C<sub>16</sub>H<sub>34</sub>O.

01/2008:1906

## CETYL PALMITATE

## Cetylis palmitas

## DEFINITION

Mixture of C<sub>14</sub>-C<sub>18</sub> esters of lauric (dodecanoic), myristic (tetradecanoic), palmitic (hexadecanoic) and stearic (octadecanoic) acids ('Cetyl esters wax').

Content (expressed as hexadecyl hexadecanoate): 10.0 per cent to 20.0 per cent for Cetyl palmitate 15, 60.0 per cent to 70.0 per cent for Cetyl palmitate 65 and minimum 90.0 per cent for Cetyl palmitate 95.

## CHARACTERS

Appearance: white or almost white, waxy plates, flakes or powder.

Solubility: practically insoluble in water, soluble in boiling anhydrous ethanol and in methylene chloride, slightly soluble in light petroleum, practically insoluble in anhydrous ethanol. mp: about 45 °C for Cetyl palmitate 15 and Cetyl palmitate 65 and about 52 °C for Cetyl palmitate 95.

## IDENTIFICATION

- A. It complies with the limits of the assay and the chromatogram obtained with the test solution shows the typical main peak(s).
- B. Saponification value (see Tests).

## TESTS

Appearance of solution. The solution is not more intensely coloured than reference solution Y<sub>6</sub> (2.2.2, Method II).

Dissolve 4.0 g in methylene chloride R and dilute to 20 mL with the same solvent.

Acid value (2.5.1): maximum 4.0.

Dissolve 10.0 g in 50 mL of the solvent mixture described by heating under reflux on a water-bath for 5 min.

Hydroxyl value (2.5.3, Method A): maximum 20.0.

Iodine value (2.5.4, Method A): maximum 2.0.

Saponification value (2.5.6): 105 to 120.

Heat under reflux for 2 h.

Alkaline impurities. Dissolve 2.0 g 'with gentle heating' in a mixture of 1.5 mL of ethanol (96 per cent) R and 3 mL of toluene R. Add 0.05 mL of a 0.4 g/L solution of bromophenol blue R in ethanol (96 per cent) R. Not more than 0.4 mL of 0.01 M hydrochloric acid is required to change the colour of the solution to yellow.

Nickel (2.4.31): maximum 1 ppm.

Water (2.5.12): maximum 0.3 per cent, determined on 1.0 g using a mixture of equal volumes of anhydrous methanol R and methylene chloride R as solvent.

Total ash (2.4.16): maximum 0.2 per cent, determined on 1.0 g.

## ASSAY

Gas chromatography (2.2.28): use the normalisation procedure. Test solution. Dissolve 20.0 mg of the substance to be examined in hexane R and dilute to 20.0 mL with the same solvent.

Reference solution (a). Dissolve 20.0 mg of cetyl palmitate 95 CRS in hexane R and dilute to 20.0 mL with the same solvent.

Reference solution (b). Dissolve 20.0 mg of cetyl palmitate 15 CRS in hexane R and dilute to 20.0 mL with the same solvent.

## Column:

- material: stainless steel;
- size: *l* = 10 m, Ø = 0.53 mm;
- stationary phase: poly(dimethyl)siloxane R (film thickness 2.65 µm).

Carrier gas: helium for chromatography R.

Flow rate: 6.5 mL/min.

Split ratio: 1:10.

## Temperature:

	Time (min)	Temperature (°C)
Column	0 - 10	100 → 300
	10 - 15	300
Injection port		350
Detector		350

Detection: flame ionisation.

Injection: 1 µL.

Relative retention with reference to cetyl palmitate (retention time = about 9 min): cetyl alcohol = about 0.3; palmitic acid = about 0.4; lauric ester = about 0.8; myristic ester = about 0.9; stearic ester = about 1.1.

System suitability: reference solution (b):

- resolution: minimum of 1.5 between the peaks due to cetyl palmitate and cetyl stearate.

## STORAGE

At a temperature not exceeding 25 °C.

## LABELLING

The label states the type of cetyl palmitate.

01/2008:0379  
corrected 6.0

## CETYLPIRIDINIUM CHLORIDE

## Cetylpyridinii chloridum

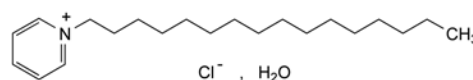

C<sub>21</sub>H<sub>38</sub>ClN, H<sub>2</sub>O  
[6004-24-6]

*M*<sub>r</sub> 358.0

## DEFINITION

Cetylpyridinium chloride contains not less than 96.0 per cent and not more than the equivalent of 101.0 per cent of 1-hexadecylpyridinium chloride, calculated with reference to the anhydrous substance.

## CHARACTERS

A white or almost white powder, slightly soapy to the touch, soluble in water and in alcohol. An aqueous solution froths copiously when shaken.

## IDENTIFICATION

*First identification:* B, D.

*Second identification:* A, C, D.

- A. Dissolve 0.10 g in *water R* and dilute to 100.0 mL with the same solvent. Dilute 5.0 mL of this solution to 100.0 mL with *water R*. Examined between 240 nm and 300 nm (2.2.25), the solution shows an absorption maximum at 259 nm and 2 shoulders at about 254 nm and at about 265 nm. The specific absorbance at the maximum is 126 to 134, calculated with reference to the anhydrous substance.
- B. Examine by infrared absorption spectrophotometry (2.2.24), comparing with the spectrum obtained with *cetylpyridinium chloride CRS*. Examine the substances in the solid state.
- C. To 5 mL of *dilute sodium hydroxide solution R* add 0.1 mL of *bromophenol blue solution R1* and 5 mL of *chloroform R* and shake. The chloroform layer is colourless. Add 0.1 mL of solution S (see Tests) and shake. The chloroform layer becomes blue.
- D. Solution S gives reaction (a) of chlorides (2.3.1).

## TESTS

**Solution S.** Dissolve 1.0 g in *carbon dioxide-free water R* and dilute to 100 mL with the same solvent.

**Appearance of solution.** Solution S is not more opalescent than reference suspension II (2.2.1) and is colourless (2.2.2, *Method II*).

**Acidity.** To 50 mL of solution S add 0.1 mL of *phenolphthalein solution R*. Not more than 2.5 mL of 0.02 M *sodium hydroxide* is required to change the colour of the indicator.

**Amines and amine salts.** Dissolve 5.0 g with heating in 20 mL of a mixture of 3 volumes of 1 M *hydrochloric acid* and 97 volumes of *methanol R* and add 100 mL of *2-propanol R*. Pass a stream of *nitrogen R* slowly through the solution. Gradually add 12.0 mL of 0.1 M *tetrabutylammonium hydroxide* and record the potentiometric titration curve (2.2.20). If the curve shows 2 points of inflexion, the volume of titrant added between the two points is not greater than 5.0 mL. If the curve shows no point of inflexion, the substance to be examined does not comply with the test. If the curve shows one point of inflexion, repeat the test but add 3.0 mL of a 25.0 g/L solution of *dimethyldecylamine R* in *2-propanol R* before the titration. If the titration curve after the addition of 12.0 mL of the titrant shows only one point of inflexion, the substance to be examined does not comply with the test.

**Water (2.5.12):** 4.5 per cent to 5.5 per cent, determined on 0.300 g by the semi-micro determination of water.

**Sulfated ash (2.4.14).** Not more than 0.2 per cent, determined on 1.0 g.

## ASSAY

Dissolve 2.00 g in *water R* and dilute to 100.0 mL with the same solvent. Transfer 25.0 mL of the solution to a separating funnel, add 25 mL of *chloroform R*, 10 mL of 0.1 M *sodium hydroxide* and 10.0 mL of a freshly prepared 50 g/L solution of *potassium iodide R*. Shake well, allow to separate and discard the chloroform layer. Shake the aqueous layer with three quantities, each of 10 mL, of *chloroform R* and discard the chloroform layers. To the aqueous layer add 40 mL of *hydrochloric acid R*, allow to cool and titrate with 0.05 M *potassium iodate* until the deep-brown colour is almost discharged. Add 2 mL of *chloroform R* and continue the titration, shaking vigorously, until the chloroform layer no longer changes colour. Carry out a blank titration on a mixture of 10.0 mL of the freshly prepared 50 g/L solution of *potassium iodide R*, 20 mL of *water R* and 40 mL of *hydrochloric acid R*.

1 mL of 0.05 M *potassium iodate* is equivalent to 34.0 mg of  $C_{21}H_{38}ClN$ .

01/2009:0313  
corrected 7.0

## CHARCOAL, ACTIVATED

## Carbo activatus

## DEFINITION

Obtained from vegetable matter by suitable carbonisation processes intended to confer a high adsorption power.

## CHARACTERS

*Appearance:* black, light powder free from grittiness.

*Solubility:* practically insoluble in all usual solvents.

## IDENTIFICATION

A. When heated to redness it burns slowly without a flame.

B. Adsorption power (see Tests).

## TESTS

**Solution S.** To 2.0 g in a conical flask with a ground-glass neck add 50 mL of *dilute hydrochloric acid R*. Boil gently under a reflux condenser for 1 h, filter and wash the filter with *dilute hydrochloric acid R*. Evaporate the combined filtrate and washings to dryness on a water-bath, dissolve the residue in 0.1 M *hydrochloric acid* and dilute to 50.0 mL with the same acid.

**Acidity or alkalinity.** To 2.0 g add 40 mL of *water R* and boil for 5 min. Cool, restore to the original mass with *carbon dioxide-free water R* and filter. Reject the first 20 mL of the filtrate. To 10 mL of the filtrate add 0.25 mL of *bromothymol blue solution R1* and 0.25 mL of 0.02 M *sodium hydroxide*. The solution is blue. Not more than 0.75 mL of 0.02 M *hydrochloric acid* is required to change the colour of the indicator to yellow.

**Acid-soluble substances:** maximum 3 per cent.

To 1.0 g add 25 mL of *dilute nitric acid R* and boil for 5 min. Filter whilst hot through a sintered-glass filter (10) (2.1.2) and wash with 10 mL of hot *water R*. Evaporate the combined filtrate and washings to dryness on a water-bath, add to the residue 1 mL of *hydrochloric acid R*, evaporate to dryness again and dry the residue to constant mass at 100-105 °C. The residue weighs a maximum of 30 mg.

**Alkali-soluble coloured substances.** To 0.25 g add 10 mL of *dilute sodium hydroxide solution R* and boil for 1 min. Cool, filter and dilute the filtrate to 10 mL with *water R*. The solution is not more intensely coloured than reference solution GY<sub>4</sub> (2.2.2, *Method II*).

**Ethanol (96 per cent) soluble substances:** maximum 0.5 per cent.

To 2.0 g add 50 mL of *ethanol (96 per cent) R* and boil under a reflux condenser for 10 min. Filter immediately, cool, and dilute to 50 mL with *ethanol (96 per cent) R*. The filtrate is not more intensely coloured than reference solution Y<sub>6</sub> or BY<sub>6</sub> (2.2.2, *Method II*). Evaporate 40 mL of the filtrate to dryness and dry to constant mass at 100-105 °C. The residue weighs a maximum of 8 mg.

**Fluorescent substances.** In an intermittent-extraction apparatus, treat 10.0 g with 100 mL of *cyclohexane R1* for 2 h. Collect the liquid and dilute to 100 mL with *cyclohexane R1*. Examine in ultraviolet light at 365 nm. The fluorescence of the solution is not more intense than that of a solution of 83 µg of *quinine R* in 1000 mL of 0.005 M *sulfuric acid* examined under the same conditions.

**Sulfides.** To 1.0 g in a conical flask add 5 mL of *hydrochloric acid R1* and 20 mL of *water R*. Heat to boiling. The fumes released do not turn *lead acetate paper R* brown.

**Copper:** maximum 25 ppm.

Atomic absorption spectrometry (2.2.23, *Method I*).

*Test solution.* Use solution S.

*Reference solutions.* Prepare the reference solutions using *copper standard solution (0.1 per cent Cu) R* and diluting with 0.1 M hydrochloric acid.

*Source:* copper hollow-cathode lamp.

*Wavelength:* 325.0 nm.

*Atomisation device:* air-acetylene flame.

**Lead:** maximum 10 ppm.

Atomic absorption spectrometry (2.2.23, *Method I*).

*Test solution.* Use solution S.

*Reference solutions.* Prepare the reference solutions using *lead standard solution (100 ppm Pb) R* and diluting with 0.1 M hydrochloric acid.

*Source:* lead hollow-cathode lamp.

*Wavelength:* 283.3 nm; 217.0 nm may be used depending on the apparatus.

*Atomisation device:* air-acetylene flame.

**Zinc:** maximum 25 ppm.

Atomic absorption spectrometry (2.2.23, *Method I*).

*Test solution.* Use solution S.

*Reference solutions.* Prepare the reference solutions using *zinc standard solution (100 ppm Zn) R* and diluting with 0.1 M hydrochloric acid.

*Source:* zinc hollow-cathode lamp.

*Wavelength:* 214.0 nm.

*Atomisation device:* air-acetylene flame.

**Loss on drying** (2.2.32): maximum 15 per cent, determined on 1.00 g by drying in an oven at 120 °C for 4 h.

**Sulfated ash** (2.4.14): maximum 5.0 per cent, determined on 1.0 g.

**Adsorption power.** To 0.300 g in a 100 mL ground-glass-stoppered conical flask add 25.0 mL of a freshly prepared solution of 0.5 g of *phenazone R* in 50 mL of *water R*. Shake thoroughly for 15 min. Filter and reject the first 5 mL of filtrate. To 10.0 mL of the filtrate add 1.0 g of *potassium bromide R* and 20 mL of *dilute hydrochloric acid R*. Using 0.1 mL of *methyl red solution R* as indicator, titrate with 0.0167 M *potassium bromate* until the red colour is discharged. Titrate slowly (1 drop every 15 s) towards the end of the titration. Carry out a blank titration using 10.0 mL of the phenazone solution.

Calculate the quantity of phenazone adsorbed per 100 g of activated charcoal from the following expression:

$$\frac{2.353(a - b)}{m}$$

*a* = number of millilitres of 0.0167 M *potassium bromate* used for the blank;

*b* = number of millilitres of 0.0167 M *potassium bromate* used for the test;

*m* = mass in grams of the substance to be examined.

Minimum 40 g of phenazone is adsorbed per 100 g of activated charcoal, calculated with reference to the dried substance.

#### Microbial contamination

TAMC: acceptance criterion 10<sup>3</sup> CFU/g (2.6.12).

TYMC: acceptance criterion 10<sup>2</sup> CFU/g (2.6.12).

#### STORAGE

In an airtight container.

01/2008:1189

corrected 6.0

## CHENODEOXYCHOLIC ACID

### Acidum chenodeoxycholicum

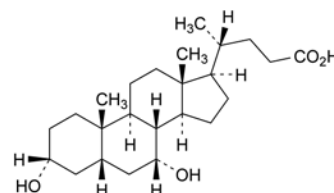

C<sub>24</sub>H<sub>40</sub>O<sub>4</sub>  
[474-25-9]

*M*<sub>r</sub> 392.6

#### DEFINITION

Chenodeoxycholic acid contains not less than 99.0 per cent and not more than the equivalent of 101.0 per cent of 3 $\alpha$ ,7 $\alpha$ -dihydroxy-5 $\beta$ -cholan-24-oic acid, calculated with reference to the dried substance.

#### CHARACTERS

A white or almost white powder, very slightly soluble in water, freely soluble in alcohol, soluble in acetone, slightly soluble in methylene chloride.

#### IDENTIFICATION

*First identification:* A.

*Second identification:* B, C.

- Examine by infrared absorption spectrophotometry (2.2.24), comparing with the spectrum obtained with *chenodeoxycholic acid CRS*. Examine the substances prepared as discs using *potassium bromide R*.
- Examine the chromatograms obtained in the test for related substances. The principal spot in the chromatogram obtained with test solution (b) is similar in position, colour and size to the principal spot in the chromatogram obtained with reference solution (a).
- Dissolve about 10 mg in 1 mL of *sulfuric acid R*. Add 0.1 mL of *formaldehyde solution R* and allow to stand for 5 min. Add 5 mL of *water R*. The suspension obtained is greenish-blue.

#### TESTS

**Specific optical rotation** (2.2.7). Dissolve 0.500 g in *methanol R* and dilute to 25.0 mL with the same solvent. The specific optical rotation is + 11.0 to + 13.0, calculated with reference to the dried substance.

**Related substances.** Examine by thin-layer chromatography (2.2.27), using a suitable silica gel as the coating substance.

*Test solution (a).* Dissolve 0.40 g of the substance to be examined in a mixture of 1 volume of *water R* and 9 volumes of *acetone R* and dilute to 10 mL with the same mixture of solvents.

*Test solution (b).* Dilute 1 mL of test solution (a) to 10 mL with a mixture of 1 volume of *water R* and 9 volumes of *acetone R*.

*Reference solution (a).* Dissolve 40 mg of *chenodeoxycholic acid CRS* in a mixture of 1 volume of *water R* and 9 volumes of *acetone R* and dilute to 10 mL with the same mixture of solvents.

*Reference solution (b).* Dissolve 20 mg of *lithocholic acid CRS* in a mixture of 1 volume of *water R* and 9 volumes of *acetone R* and dilute to 10 mL with the same mixture of solvents. Dilute 2 mL of the solution to 100 mL with a mixture of 1 volume of *water R* and 9 volumes of *acetone R*.

*Reference solution (c).* Dissolve 20 mg of *ursodeoxycholic acid CRS* in a mixture of 1 volume of *water R* and 9 volumes of *acetone R* and dilute to 50 mL with the same mixture of solvents.

**Reference solution (d).** Dissolve 20 mg of *cholic acid CRS* in a mixture of 1 volume of *water R* and 9 volumes of *acetone R* and dilute to 100 mL with the same mixture of solvents.

**Reference solution (e).** Dilute 0.5 mL of test solution (a) to 20 mL with a mixture of 1 volume of *water R* and 9 volumes of *acetone R*. Dilute 1 mL of the solution to 10 mL with a mixture of 1 volume of *water R* and 9 volumes of *acetone R*.

**Reference solution (f).** Dissolve 10 mg of *chenodeoxycholic acid CRS* in reference solution (c) and dilute to 25 mL with the same solution.

Apply separately to the plate 5 µL of each solution. Develop in an unsaturated tank over a path of 15 cm using a mixture of 1 volume of *glacial acetic acid R*, 30 volumes of *acetone R* and 60 volumes of *methylene chloride R*. Dry the plate at 120 °C for 10 min. Spray the plate immediately with a 47.6 g/L solution of *phosphomolybdic acid R* in a mixture of 1 volume of *sulfuric acid R* and 20 volumes of *glacial acetic acid R* and heat again at 120 °C until blue spots appear on a lighter background.

In the chromatogram obtained with test solution (a): any spot corresponding to lithocholic acid is not more intense than the principal spot in the chromatogram obtained with reference solution (b) (0.1 per cent); any spot corresponding to ursodeoxycholic acid is not more intense than the principal spot in the chromatogram obtained with reference solution (c) (1 per cent); any spot corresponding to cholic acid is not more intense than the principal spot in the chromatogram obtained with reference solution (d) (0.5 per cent); any spot apart from the principal spot and any spots corresponding to lithocholic acid, ursodeoxycholic acid and cholic acid, is not more intense than the principal spot in the chromatogram obtained with reference solution (e) (0.25 per cent). The test is not valid unless the chromatogram obtained with reference solution (f) shows two clearly separated principal spots.

**Heavy metals (2.4.8).** 1.0 g complies with limit test C for heavy metals (20 ppm). Prepare the standard using 2 mL of *lead standard solution (10 ppm Pb) R*.

**Loss on drying (2.2.32).** Not more than 1.5 per cent, determined on 1.000 g by drying in an oven at 105 °C.

**Sulfated ash (2.4.14).** Not more than 0.1 per cent, determined on 1.0 g.

#### ASSAY

Dissolve 0.350 g in 50 mL of *alcohol R*, previously neutralised to 0.2 mL of *phenolphthalein solution R*. Add 50 mL of *water R* and titrate with 0.1 M *sodium hydroxide* until a pink colour is obtained.

1 mL of 0.1 M *sodium hydroxide* is equivalent to 39.26 mg of C<sub>24</sub>H<sub>40</sub>O<sub>4</sub>.

#### IMPURITIES

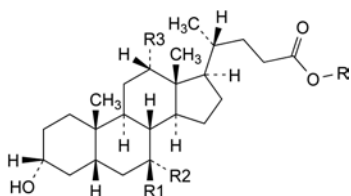

- A. R = H, R1 = OH, R2 = H, R3 = H: 3α,7β-dihydroxy-5β-cholan-24-oic acid (ursodeoxycholic acid),
- B. R = H, R1 = H, R2 = OH, R3 = OH: 3α,7α,12α-trihydroxy-5β-cholan-24-oic acid (cholic acid),
- C. R = H, R1 = H, R2 = H, R3 = H: 3α-hydroxy-5β-cholan-24-oic acid (lithocholic acid),
- D. R = H, R1 = OH, R2 = H, R3 = OH: 3α,7β,12α-trihydroxy-5β-cholan-24-oic acid (ursocholic acid),
- E. R = H, R1 = H, R2 = H, R3 = OH: 3α,12α-dihydroxy-5β-cholan-24-oic acid (deoxycholic acid),

F. R = H, R1+R2 = O, R3 = H: 3α-hydroxy-7-oxo-5β-cholan-24-oic acid,

G. R = CH<sub>3</sub>, R1 = OH, R2 = H, R3 = H: methyl 3α,7β-dihydroxy-5β-cholan-24-oate.

01/2008:1774  
corrected 6.5

## CHITOSAN HYDROCHLORIDE

### Chitosani hydrochloridum

#### DEFINITION

Chitosan hydrochloride is the chloride salt of an unbranched binary heteropolysaccharide consisting of the two units *N*-acetyl-D-glucosamine and D-glucosamine, obtained by partial deacetylation of chitin normally leading to a degree of deacetylation of 70.0 per cent to 95.0 per cent. Chitin is extracted from the shells of shrimp and crab.

#### PRODUCTION

The animals from which chitosan hydrochloride is derived must fulfil the requirements for the health of animals suitable for human consumption to the satisfaction of the competent authority. It must have been shown to what extent the method of production allows inactivation or removal of any contamination by viruses or other infectious agents.

#### CHARACTERS

**Appearance:** white or almost white, fine powder.

**Solubility:** sparingly soluble in water, practically insoluble in anhydrous ethanol.

#### IDENTIFICATION

A. Infrared absorption spectrophotometry (2.2.24).

**Preparation:** discs.

**Comparison:** *chitosan hydrochloride CRS*.

B. It gives reaction (a) of chlorides (2.3.1).

C. Dilute 50 mL of solution S (see Tests) to 250 mL with a 25 per cent V/V solution of *ammonia R*. A voluminous gelatinous mass is formed.

D. To 10 mL of solution S add 90 mL of *acetone R*. A voluminous gelatinous mass is formed.

#### TESTS

**Solution S.** Dissolve 1.0 g in 100 mL of *water R* and stir vigorously for 20 min with a mechanical stirrer.

**Appearance of solution.** Solution S is not more opalescent than reference suspension II (2.2.1) and not more intensely coloured than reference solution BY<sub>5</sub> (2.2.2, *Method II*).

**Matter insoluble in water:** maximum 0.5 per cent.

Add 2.00 g to 400.0 mL of *water R* while stirring until no further dissolution takes place. Transfer the solution to a 2 litre beaker, and add 200 mL of *water R*. Boil the solution gently for 2 h, covering the beaker during the operation. Filter through a sintered-glass filter (40) (2.1.2), wash the residue with water and dry to constant weight in an oven at 100-105 °C. The residue weighs a maximum of 10 mg.

**pH (2.2.3):** 4.0 to 6.0 for solution S.

**Viscosity (2.2.10):** 80 per cent to 120 per cent of the value stated on the label, determined on solution S.

Determine the viscosity using a rotating viscometer at 20 °C with a spindle rotating at 20 r/min, using a suitable spindle for the range of the expected viscosity.

#### Degree of deacetylation

**Test solution.** Dissolve 0.250 g in *water R* and dilute to 50.0 mL with the same solvent, stirring vigorously. Dilute 1.0 mL of this solution to 100.0 mL with *water R*. Measure the absorbance

01/2008:0265

(2.2.25) from 200 nm to 205 nm as the first derivative of the absorbance curve. Determine the pH of the solution.

**Reference solutions.** Prepare solutions of 1.0 µg/mL, 5.0 µg/mL, 15.0 µg/mL and 35.0 µg/mL of *N*-acetylglucosamine R in water R. Measure the absorbance (2.2.25) from 200 nm to 205 nm of each solution as the first derivative of the absorption curve. Make a standard curve by plotting the first derivative at 202 nm as a function of the concentration of *N*-acetylglucosamine, and calculate the slope of the curve by least squares linear regression. Use the standard curve to determine the equivalent amount of *N*-acetylglucosamine for the substance to be examined.

Calculate the degree of deacetylation (molar) using the following expression:

$$\frac{100 \times M_1 \times (C_1 - C_2)}{(M_1 \times C_1) - [(M_1 - M_3) \times C_2]}$$

- $C_1$  = concentration of chitosan hydrochloride in the test solution in micrograms per millilitre;  
 $C_2$  = concentration of *N*-acetylglucosamine in the test solution, as determined from the standard curve prepared using the reference solution in micrograms per millilitre;  
 $M_1$  = 203 (relative molecular mass of *N*-acetylglucosamine unit (C<sub>8</sub>H<sub>13</sub>NO<sub>5</sub>) in polymer);  
 $M_3$  = relative molecular mass of chitosan hydrochloride.

$M_3$  is calculated from the pH in solution, assuming a pK<sub>a</sub> value of 6.8, using the following equations:

$$M_3 = f \times M_2 + (1 - f) \times (M_2 + 36.5)$$

$$f = \frac{p}{1 + p}$$

$$p = 10^{(pH - pK_a)}$$

- $M_2$  = 161 (relative molecular mass of deacetylated unit (glucosamine) (C<sub>6</sub>H<sub>11</sub>NO<sub>4</sub>) in polymer).

**Chlorides:** 10.0 per cent to 20.0 per cent.

Introduce 0.200 g into a 250 mL borosilicate flask fitted with a reflux condenser. Add 40 mL of a mixture of 1 volume of *nitric acid* R and 2 volumes of *water* R. Boil gently under a reflux condenser for 5 min. Cool and add 25 mL of *water* R through the condenser. Add 16.0 mL of 0.1 M *silver nitrate*, shake vigorously and titrate with 0.1 M *ammonium thiocyanate*, using 1 mL of *ferric ammonium sulfate solution R2* as indicator, and shaking vigorously towards the end-point. Carry out a blank titration.

1 mL of 0.1 M *silver nitrate* is equivalent to 3.55 mg of Cl.

**Heavy metals** (2.4.8): maximum 40 ppm.

1.0 g complies with test F. Prepare the reference solution using 4 mL of *lead standard solution (10 ppm Pb)* R.

**Loss on drying** (2.2.32): maximum 10 per cent, determined on 1.000 g by drying in an oven at 105 °C.

**Sulfated ash** (2.4.14): maximum 1.0 per cent, determined on 1.0 g.

#### STORAGE

At a temperature of 2 °C to 8 °C, protected from moisture and light.

#### LABELLING

The label states the nominal viscosity in millipascal seconds for a 10 g/L solution in *water* R.

## CHLORAL HYDRATE

### Chlorali hydras

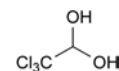

C<sub>2</sub>H<sub>3</sub>Cl<sub>3</sub>O<sub>2</sub>  
[302-17-0]

$M_r$  165.4

#### DEFINITION

2,2,2-Trichloroethane-1,1-diol.

**Content:** 98.5 per cent to 101.0 per cent.

#### CHARACTERS

**Appearance:** colourless, transparent crystals.

**Solubility:** very soluble in water, freely soluble in ethanol (96 per cent).

#### IDENTIFICATION

- A. To 10 mL of solution S (see Tests) add 2 mL of *dilute sodium hydroxide solution R*. The mixture becomes cloudy and, when heated, gives off an odour of chloroform.  
 B. To 1 mL of solution S add 2 mL of *sodium sulfide solution R*. A yellow colour develops which quickly becomes reddish-brown. On standing for a short time, a red precipitate may be formed.

#### TESTS

**Solution S.** Dissolve 3.0 g in *carbon dioxide-free water R* and dilute to 30 mL with the same solvent.

**Appearance of solution.** Solution S is clear (2.2.1) and colourless (2.2.2, *Method II*).

**pH** (2.2.3): 3.5 to 5.5 for solution S.

**Chloral alcoholate.** Warm 1.0 g with 10 mL of *dilute sodium hydroxide solution R*, filter the supernatant solution and add 0.05 M *iodine* dropwise until a yellow colour is obtained. Allow to stand for 1 h. No precipitate is formed.

**Chlorides** (2.4.4): maximum 100 ppm.

Dilute 5 mL of solution S to 15 mL with *water* R.

**Heavy metals** (2.4.8): maximum 20 ppm.

10 mL of solution S diluted to 20 mL with *water* R complies with test A. Prepare the reference solution using *lead standard solution (1 ppm Pb)* R.

**Non-volatile residue:** maximum 0.1 per cent.

Evaporate 2.000 g on a water-bath. The residue weighs a maximum of 2 mg.

#### ASSAY

Dissolve 4.000 g in 10 mL of *water* R and add 40.0 mL of 1 M *sodium hydroxide*. Allow to stand for exactly 2 min and titrate with 0.5 M *sulfuric acid*, using 0.1 mL of *phenolphthalein solution R* as indicator. Titrate the neutralised solution with 0.1 M *silver nitrate*, using 0.2 mL of *potassium chromate solution R* as indicator. Calculate the number of millilitres of 1 M *sodium hydroxide* used by deducting from the volume of 1 M *sodium hydroxide*, added at the beginning of the titration, the volume of 0.5 M *sulfuric acid* used in the 1<sup>st</sup> titration and two-fifteenths of the volume of 0.1 M *silver nitrate* used in the 2<sup>nd</sup> titration.

1 mL of 1 M *sodium hydroxide* is equivalent to 0.1654 g of C<sub>2</sub>H<sub>3</sub>Cl<sub>3</sub>O<sub>2</sub>.

#### STORAGE

In an airtight container.



**01/2008:0137** **Sulfated ash** (2.4.14). Not more than 0.1 per cent, determined on 1.0 g.  
**corrected 6.0**

## CHLORAMBUCIL

### Chlorambucilum

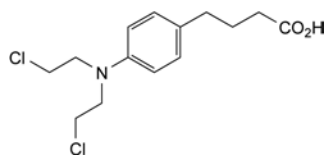

$C_{14}H_{19}Cl_2NO_2$   
[305-03-3]

$M_r$  304.2

#### DEFINITION

Chlorambucil contains not less than 98.5 per cent and not more than the equivalent of 101.0 per cent of 4-4-[di(2-chloroethyl)amino]phenylbutyric acid, calculated with reference to the anhydrous substance.

#### CHARACTERS

A white or almost white, crystalline powder, practically insoluble in water, freely soluble in acetone and in alcohol.

#### IDENTIFICATION

*First identification:* A, B.

*Second identification:* A, C, D.

- Melting point (2.2.14): 64 °C to 67 °C.
- Examine by infrared absorption spectrophotometry (2.2.24), comparing with the spectrum obtained with *chlorambucil CRS*.
- To 0.4 g add 10 mL of *dilute hydrochloric acid R*, mix and allow to stand for 30 min, shaking from time to time. Filter and wash the precipitate with 2 quantities, each of 10 mL, of *water R*. To 10 mL of the combined filtrate and washings add 0.5 mL of *potassium tetraiodomercurate solution R*. A pale-brown precipitate is formed. To another 10 mL of the combined filtrate and washings add 0.2 mL of *potassium permanganate solution R*. The colour of the latter is discharged immediately.
- Dissolve 50 mg in 5 mL of *acetone R* and dilute to 10 mL with *water R*. Add 0.05 mL of *dilute nitric acid R* and 0.2 mL of *silver nitrate solution R2*. No opalescence is produced immediately. Heat the solution on a water-bath; an opalescence develops.

#### TESTS

**Related substances.** Examine by thin-layer chromatography (2.2.27), using *silica gel GF<sub>254</sub> R* as the coating substance. Carry out all operations as rapidly as possible protected from light. Prepare the solutions immediately before use.

*Test solution.* Dissolve 0.2 g of the substance to be examined in *acetone R* and dilute to 10 mL with the same solvent.

*Reference solution (a).* Dilute 1 mL of the test solution to 50 mL with *acetone R*.

*Reference solution (b).* Dilute 25 mL of reference solution (a) to 100 mL with *acetone R*.

Apply separately to the plate 5 µL of each solution. Develop over a path of 10 cm using a mixture of 20 volumes of *methyl ethyl ketone R*, 20 volumes of *heptane R*, 25 volumes of *methanol R* and 40 volumes of *toluene R*. Examine in ultraviolet light at 254 nm. Any spot in the chromatogram obtained with the test solution, apart from the principal spot, is not more intense than the spot in the chromatogram obtained with reference solution (a) (2.0 per cent) and at most 1 such spot is more intense than the spot in the chromatogram obtained with reference solution (b) (0.5 per cent).

**Water** (2.5.12). Not more than 0.5 per cent, determined on 1.000 g by the semi-micro determination of water.

#### ASSAY

Dissolve 0.200 g in 10 mL of *acetone R* and add 10 mL of *water R*. Titrate with 0.1 M *sodium hydroxide*, using 0.1 mL of *phenolphthalein solution R* as indicator.

1 mL of 0.1 M *sodium hydroxide* is equivalent to 30.42 mg of  $C_{14}H_{19}Cl_2NO_2$ .

#### STORAGE

Store protected from light.

**01/2008:0071**  
**corrected 6.0**

## CHLORAMPHENICOL

### Chloramphenicolum

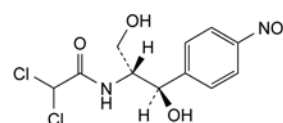

$C_{11}H_{12}Cl_2N_2O_5$   
[56-75-7]

$M_r$  323.1

#### DEFINITION

Chloramphenicol is 2,2-dichloro-*N*[(1*R*,2*R*)-2-hydroxy-1-(hydroxymethyl)-2-(4-nitrophenyl)ethyl]acetamide, produced by the growth of certain strains of *Streptomyces venezuelae* in a suitable medium. It is normally prepared by synthesis. It contains not less than 98.0 per cent and not more than the equivalent of 102.0 per cent of  $C_{11}H_{12}Cl_2N_2O_5$ , calculated with reference to the dried substance.

#### CHARACTERS

A white, greyish-white or yellowish-white, fine, crystalline powder or fine crystals, needles or elongated plates, slightly soluble in water, freely soluble in alcohol and in propylene glycol.

A solution in ethanol is dextrorotatory and a solution in ethyl acetate is laevorotatory.

#### IDENTIFICATION

*First identification:* A, B.

*Second identification:* A, C, D, E.

- Melting point (2.2.14): 149 °C to 153 °C.
- Examine by infrared absorption spectrophotometry (2.2.24), comparing with the spectrum obtained with *chloramphenicol CRS*.
- Examine the chromatograms obtained in the test for related substances. The principal spot in the chromatogram obtained with 1 µL of the test solution is similar in position and size to the principal spot in the chromatogram obtained with reference solution (a).
- Dissolve about 10 mg in 1 mL of *alcohol (50 per cent V/V) R*, add 3 mL of a 10 g/L solution of *calcium chloride R* and 50 mg of *zinc powder R* and heat on a water-bath for 10 min. Filter the hot solution and allow to cool. Add 0.1 mL of *benzoyl chloride R* and shake for 1 min. Add 0.5 mL of *ferric chloride solution R1* and 2 mL of *chloroform R* and shake. The aqueous layer is coloured light violet-red to purple.
- To 50 mg in a porcelain crucible add 0.5 g of *anhydrous sodium carbonate R*. Heat over an open flame for 10 min. Allow to cool. Take up the residue with 5 mL of *dilute nitric acid R* and filter. To 1 mL of the filtrate add 1 mL of *water R*. The solution gives reaction (a) of chlorides (2.3.1).

## TESTS

01/2008:0473  
corrected 6.0

**Acidity or alkalinity.** To 0.1 g add 20 mL of *carbon dioxide-free water R*, shake and add 0.1 mL of *bromothymol blue solution RI*. Not more than 0.1 mL of 0.02 M *hydrochloric acid* or 0.02 M *sodium hydroxide* is required to change the colour of the indicator.

**Specific optical rotation (2.2.7).** Dissolve 1.50 g in *ethanol R* and dilute to 25.0 mL with the same solvent. The specific optical rotation is + 18.5 to + 20.5.

**Related substances.** Examine by thin-layer chromatography (2.2.27), using *silica gel GF<sub>254</sub> R* as the coating substance.

**Test solution.** Dissolve 0.10 g of the substance to be examined in *acetone R* and dilute to 10 mL with the same solvent.

**Reference solution (a).** Dissolve 0.10 g of *chloramphenicol CRS* in *acetone R* and dilute to 10 mL with the same solvent.

**Reference solution (b).** Dilute 0.5 mL of reference solution (a) to 100 mL with *acetone R*.

Apply separately to the plate 1 µL and 20 µL of the test solution, 1 µL of reference solution (a) and 20 µL of reference solution (b). Develop over a path of 15 cm using a mixture of 1 volume of *water R*, 10 volumes of *methanol R* and 90 volumes of *chloroform R*. Allow the plate to dry in air and examine in ultraviolet light at 254 nm. Any spot in the chromatogram obtained with 20 µL of the test solution, apart from the principal spot, is not more intense than the spot in the chromatogram obtained with reference solution (b) (0.5 per cent).

**Chlorides (2.4.4).** To 1.00 g add 20 mL of *water R* and 10 mL of *nitric acid R* and shake for 5 min. Filter through a filter paper previously washed by filtering 5 mL portions of *water R* until 5 mL of filtrate no longer becomes opalescent on addition of 0.1 mL of *nitric acid R* and 0.1 mL of *silver nitrate solution RI*. 15 mL of the filtrate complies with the limit test for chlorides (100 ppm).

**Loss on drying (2.2.32).** Not more than 0.5 per cent, determined on 1.000 g by drying in an oven at 105 °C.

**Sulfated ash (2.4.14).** Not more than 0.1 per cent, determined on 2.0 g.

**Pyrogens (2.6.8).** If intended for use in the manufacture of parenteral preparations without a further appropriate procedure for the removal of pyrogens, it complies with the test for pyrogens. Inject per kilogram of the rabbit's mass 2.5 mL of a solution containing per millilitre 2 mg of the substance to be examined.

## ASSAY

Dissolve 0.100 g in *water R* and dilute to 500.0 mL with the same solvent. Dilute 10.0 mL of this solution to 100.0 mL with *water R*. Measure the absorbance (2.2.25) at the maximum at 278 nm.

Calculate the content of C<sub>11</sub>H<sub>12</sub>Cl<sub>2</sub>N<sub>2</sub>O<sub>5</sub> taking the specific absorbance to be 297.

## STORAGE

Store protected from light. If the substance is sterile, store in a sterile, airtight, tamper-proof container.

## CHLORAMPHENICOL PALMITATE

## Chloramphenicoli palmitas

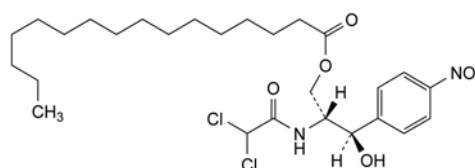
C<sub>27</sub>H<sub>42</sub>Cl<sub>2</sub>N<sub>2</sub>O<sub>6</sub>  
[530-43-8]M<sub>r</sub> 561.6

## DEFINITION

Chloramphenicol palmitate contains not less than 98.0 per cent and not more than the equivalent of 102.0 per cent of (2*R*, 3*R*)-2-[(dichloroacetyl)amino]-3-hydroxy-3-(4-nitrophenyl)propyl hexadecanoate, calculated with reference to the dried substance. Semi-synthetic product derived from a fermentation product.

## CHARACTERS

A white or almost white, fine, unctuous powder, practically insoluble in water, freely soluble in acetone, sparingly soluble in ethanol (96 per cent), very slightly soluble in hexane. It melts at 87 °C to 95 °C.

It shows polymorphism (5.9). The thermodynamically stable form has low bioavailability following oral administration.

## IDENTIFICATION

A. Examine by thin-layer chromatography (2.2.27), using *TLC silanised silica gel plate R*.

**Test solution.** Dissolve 50 mg of the substance to be examined in a mixture of 1 mL of 1 M *sodium hydroxide* and 5 mL of *acetone R* and allow to stand for 30 min. Add 1.1 mL of 1 M *hydrochloric acid* and 3 mL of *acetone R*.

**Reference solution (a).** Dissolve 10 mg of *chloramphenicol CRS* in *acetone R* and dilute to 5 mL with the same solvent.

**Reference solution (b).** Dissolve 10 mg of *palmitic acid R* in *acetone R* and dilute to 5 mL with the same solvent.

**Reference solution (c).** Dissolve 10 mg of the substance to be examined in *acetone R* and dilute to 5 mL with the same solvent.

Apply to the plate 4 µL of each solution. Develop over a path of 15 cm using a mixture of 30 volumes of a 100 g/L solution of *ammonium acetate R* and 70 volumes of *ethanol (96 per cent) R*. Allow the plate to dry in air and spray with a solution containing 0.2 g/L of *dichlorofluorescein R* and 0.1 g/L of *rhodamine B R* in *ethanol (96 per cent) R*. Allow the plate to dry in air and examine in ultraviolet light at 254 nm. The chromatogram obtained with the test solution shows 3 spots corresponding in position to the principal spots in the chromatograms obtained with reference solutions (a), (b) and (c).

B. Dissolve 0.2 g in 2 mL of *pyridine R*, add 2 mL of a 100 g/L solution of *potassium hydroxide R* and heat on a water-bath. A red colour is produced.

C. Dissolve about 10 mg in 5 mL of *ethanol (96 per cent) R* and add 4.5 mL of *dilute sulfuric acid R* and 50 mg of *zinc powder R*. Allow to stand for 10 min and if necessary decant the supernatant liquid or filter. Cool the solution in iced water and add 0.5 mL of *sodium nitrite solution R*. Allow to stand for 2 min and add 1 g of *urea R*, 2 mL of *strong sodium hydroxide solution R* and 1 mL of *β-naphthol solution R*. A red colour develops.

## TESTS

**Acidity.** Dissolve 1.0 g in 5 mL of a mixture of equal volumes of *ethanol (96 per cent) R* and *ether R*, warming to 35 °C. Add 0.2 mL of *phenolphthalein solution R*. Not more than 0.4 mL of 0.1 M *sodium hydroxide* is required to produce a pink colour persisting for 30 s.

**Specific optical rotation (2.2.7).** Dissolve 1.25 g in *anhydrous ethanol R* and dilute to 25.0 mL with the same solvent. The specific optical rotation is + 22.5 to + 25.5.

**Free chloramphenicol:** maximum 450 ppm. Dissolve 1.0 g, with gentle heating, in 80 mL of *xylene R*. Cool and shake with 3 quantities, each of 15 mL, of *water R*. Dilute the combined aqueous extracts to 50 mL with *water R* and shake with 10 mL of *toluene R*. Allow to separate and discard the toluene layer. Centrifuge a portion of the aqueous layer and measure the absorbance (A) (2.2.25) at the maximum at 278 nm using as the compensation liquid a blank solution having an absorbance not greater than 0.05.

Calculate the content of free chloramphenicol in parts per million from the expression:

$$\frac{A \times 10^4}{5.96}$$

**Related substances.** Examine by thin-layer chromatography (2.2.27), using *silica gel GF<sub>254</sub> R* as the coating substance.

**Test solution.** Dissolve 0.1 g of the substance to be examined in *acetone R* and dilute to 10 mL with the same solvent.

**Reference solution (a).** Dissolve 20 mg of *chloramphenicol palmitate isomer CRS* in *acetone R* and dilute to 10 mL with the same solvent. Dilute 1 mL of this solution to 10 mL with *acetone R*.

**Reference solution (b).** Dissolve 20 mg of *chloramphenicol dipalmitate CRS* in *acetone R* and dilute to 10 mL with the same solvent. Dilute 1 mL of this solution to 10 mL with *acetone R*.

**Reference solution (c).** Dissolve 5 mg of *chloramphenicol CRS* in *acetone R* and dilute to 10 mL with the same solvent. Dilute 1 mL of this solution to 10 mL with *acetone R*.

Apply to the plate 10 µL of each solution. Develop over a path of 15 cm using a mixture of 10 volumes of *methanol R*, 40 volumes of *chloroform R* and 50 volumes of *cyclohexane R*. Allow the plate to dry in air and examine in ultraviolet light at 254 nm. In the chromatogram obtained with the test solution, any spots due to chloramphenicol palmitate isomer and chloramphenicol dipalmitate are not more intense than the corresponding spots in the chromatograms obtained with reference solutions (a) and (b) respectively (2.0 per cent) and any spot, apart from the principal spot and the spots due to chloramphenicol palmitate isomer and chloramphenicol dipalmitate, is not more intense than the principal spot in the chromatogram obtained with reference solution (c) (0.5 per cent).

**Loss on drying (2.2.32):** maximum 0.5 per cent, determined on 1.000 g by heating at 80 °C over *diphosphorus pentoxide R* at a pressure not exceeding 0.1 kPa for 3 h.

**Sulfated ash (2.4.14):** maximum 0.1 per cent, determined on 1.0 g.

## ASSAY

Dissolve 90.0 mg in *ethanol (96 per cent) R* and dilute to 100.0 mL with the same solvent. Dilute 10.0 mL of this solution to 250.0 mL with *ethanol (96 per cent) R*. Measure the absorbance (2.2.25) of the solution at the maximum at 271 nm.

Calculate the content of C<sub>27</sub>H<sub>42</sub>Cl<sub>2</sub>N<sub>2</sub>O<sub>6</sub> taking the specific absorbance to be 178.

## STORAGE

Protected from light.

## IMPURITIES

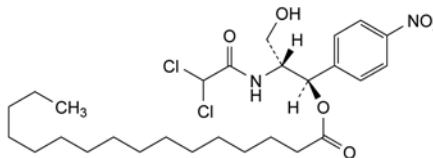

A. (1*R*,2*R*)-2-[(dichloroacetyl)amino]-3-hydroxy-1-(4-nitrophenyl)propyl hexadecanoate (chloramphenicol palmitate isomer),

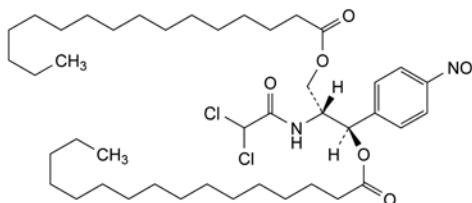

B. (1*R*,2*R*)-2-[(dichloroacetyl)amino]-1-(4-nitrophenyl)propane-1,3-diyl bishexadecanoate (chloramphenicol dipalmitate).

01/2008:0709  
corrected 6.0

## CHLORAMPHENICOL SODIUM SUCCINATE

### Chloramphenicoli natrii succinas

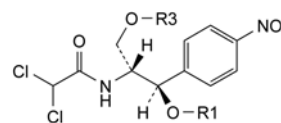

1 isomer : R1 = CO-CH<sub>2</sub>-CH<sub>2</sub>-CO<sub>2</sub>Na, R3 = H

3 isomer : R1 = H, R3 = CO-CH<sub>2</sub>-CH<sub>2</sub>-CO<sub>2</sub>Na

C<sub>15</sub>H<sub>15</sub>Cl<sub>2</sub>N<sub>2</sub>NaO<sub>8</sub>

M<sub>r</sub> 445.2

## DEFINITION

Mixture in variable proportions of sodium (2*R*,3*R*)-2-[(dichloroacetyl)amino]-3-hydroxy-3-(4-nitrophenyl)propyl butanedioate (3 isomer) and of sodium (1*R*,2*R*)-2-[(dichloroacetyl)amino]-3-hydroxy-1-(4-nitrophenyl)propyl butanedioate (1 isomer).

Semi-synthetic product derived from a fermentation product.

**Content:** 98.0 per cent to 102.0 per cent (anhydrous substance).

## CHARACTERS

**Appearance:** white or yellowish-white powder, hygroscopic.

**Solubility:** very soluble in water, freely soluble in ethanol (96 per cent).

## IDENTIFICATION

A. Thin-layer chromatography (2.2.27).

**Test solution.** Dissolve 20 mg of the substance to be examined in 2 mL of *acetone R*.

**Reference solution (a).** Dissolve 20 mg of *chloramphenicol sodium succinate CRS* in 2 mL of *acetone R*.

**Reference solution (b).** Dissolve 20 mg of *chloramphenicol CRS* in 2 mL of *acetone R*.

**Plate:** TLC silica gel GF<sub>254</sub> plate R.

**Mobile phase:** dilute acetic acid R, *methanol R*, *chloroform R* (1:14:85 V/V/V).

**Application:** 2 µL.

**Development:** over a path of 15 cm.

**Drying:** in air.

**Detection:** examine in ultraviolet light at 254 nm.

**Results:** the 2 principal spots in the chromatogram obtained with the test solution are similar in position and size to the 2 principal spots in the chromatogram obtained with reference solution (a); their positions are different from that of the principal spot in the chromatogram obtained with reference solution (b).

- B. Dissolve about 10 mg in 1 mL of *ethanol (50 per cent V/V) R*, add 3 mL of a 10 g/L solution of *calcium chloride R* and 50 mg of *zinc powder R* and heat on a water-bath for 10 min. Filter the hot solution and allow to cool. Add 0.1 mL of *benzoyl chloride R* and shake for 1 min. Add 0.5 mL of *ferric chloride solution R1* and 2 mL of *chloroform R* and shake. The upper layer is light violet-red or purple.
- C. Dissolve 50 mg in 1 mL of *pyridine R*. Add 0.5 mL of *dilute sodium hydroxide solution R* and 1.5 mL of *water R*. Heat in a water-bath for 3 min. A red colour develops. Add 2 mL of *nitric acid R* and cool under running water. Add 1 mL of *0.1 M silver nitrate*. A white precipitate is formed slowly.
- D. It gives reaction (a) of sodium (2.3.1).

#### TESTS

**pH (2.2.3):** 6.4 to 7.0.

Dissolve 2.50 g in *carbon dioxide-free water R* and dilute to 10 mL with the same solvent.

**Specific optical rotation (2.2.7):** + 5.0 to + 8.0 (anhydrous substance).

Dissolve 0.50 g in *water R* and dilute to 10.0 mL with the same solvent.

**Chloramphenicol and chloramphenicol disodium disuccinate.** Liquid chromatography (2.2.29).

**Test solution.** Dissolve 25.0 mg of the substance to be examined in the mobile phase and dilute to 100.0 mL with the mobile phase.

**Reference solution (a).** Dissolve 10.0 mg of *chloramphenicol CRS* in the mobile phase and dilute to 100.0 mL with the mobile phase (solution A). Dilute 5.0 mL of this solution to 100.0 mL with the mobile phase.

**Reference solution (b).** Dissolve 10.0 mg of *chloramphenicol disodium disuccinate CRS* in the mobile phase and dilute to 100.0 mL with the mobile phase (solution B). Dilute 5.0 mL of this solution to 100.0 mL with the mobile phase.

**Reference solution (c).** Dissolve 25 mg of the substance to be examined in the mobile phase, add 5 mL of solution A and 5 mL of solution B and dilute to 100 mL with the mobile phase.

**Column:**

- size:  $l = 0.25$  m,  $\varnothing = 4.6$  mm;
- stationary phase: octadecylsilyl silica gel for chromatography R (5  $\mu$ m).

**Mobile phase:** 20 g/L solution of *phosphoric acid R*, *methanol R*, *water R* (5:40:55 V/V/V).

**Flow rate:** 1.0 mL/min.

**Detection:** spectrophotometer at 275 nm.

**Injection:** 20  $\mu$ L.

**System suitability:** reference solution (c):

- the 2 peaks corresponding to those in the chromatograms obtained with reference solutions (a) and (b) are clearly separated from the peaks corresponding to the 2 principal peaks in the chromatogram obtained with the test solution; if necessary, adjust the methanol content of the mobile phase.

**Limits:**

- *chloramphenicol*: not more than the area of the principal peak in the chromatogram obtained with reference solution (a) (2.0 per cent);
- *chloramphenicol disodium disuccinate*: not more than the area of the principal peak in the chromatogram obtained with reference solution (b) (2.0 per cent).

**Water (2.5.12):** maximum 2.0 per cent, determined on 0.500 g.

**Pyrogens (2.6.8).** If intended for use in the manufacture of parenteral preparations without a further appropriate procedure for removal of pyrogens, it complies with the test for pyrogens. Inject per kilogram of the rabbit's mass 2.5 mL of a solution in *water for injections R* containing 2 mg of the substance to be examined per millilitre.

#### ASSAY

Dissolve 0.200 g in *water R* and dilute to 500.0 mL with the same solvent. Dilute 5.0 mL of this solution to 100.0 mL with *water R*. Measure the absorbance (2.2.25) at the absorption maximum at 276 nm.

Calculate the content of  $C_{15}H_{15}Cl_2N_2NaO_8$ , taking the specific absorbance to be 220.

#### STORAGE

In an airtight container, protected from light. If the substance is sterile, store in a sterile, airtight, tamper-proof container, protected from light.

01/2008:1086  
corrected 7.0

## CHLORCYCLIZINE HYDROCHLORIDE

### Chlorcyclizini hydrochloridum

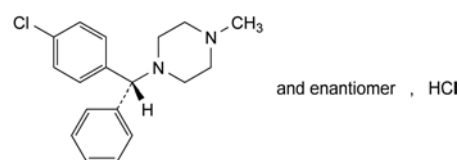

$C_{18}H_{22}Cl_2N_2$   
[14362-31-3]

$M_r$  337.3

#### DEFINITION

Chlorcyclizine hydrochloride contains not less than 99.0 per cent and not more than the equivalent of 101.0 per cent of (RS)-1-[(4-chlorophenyl)phenylmethyl]-4-methylpiperazine hydrochloride, calculated with reference to the dried substance.

#### CHARACTERS

A white or almost white, crystalline powder, freely soluble in water and in methylene chloride, soluble in alcohol.

#### IDENTIFICATION

**First identification:** B, D.

**Second identification:** A, C, D.

- A. Dissolve 10.0 mg in a 5 g/L solution of *sulfuric acid R* and dilute to 100.0 mL with the same acid. Dilute 10.0 mL of the solution to 100.0 mL with a 5 g/L solution of *sulfuric acid R*. Examined between 215 nm and 300 nm (2.2.25), the solution shows an absorption maximum at 231 nm. The specific absorbance at the maximum is 475 to 525, calculated with reference to the dried substance.
- B. Examine by infrared absorption spectrophotometry (2.2.24), comparing with the spectrum obtained with *chlorcyclizine hydrochloride CRS*. Examine the substances prepared as discs.
- C. Examine the chromatograms obtained in the test for related substances (see Tests). The principal spot in the chromatogram obtained with test solution (b) is similar in position and size to the principal spot in the chromatogram obtained with reference solution (a).
- D. It gives reaction (a) of chlorides (2.3.1).

#### TESTS

**Appearance of solution.** Dissolve 0.5 g in *water R* and dilute to 10 mL with the same solvent. The solution is clear (2.2.1) and colourless (2.2.2, *Method II*).

01/2008:0656  
corrected 6.0

**pH (2.2.3).** Dissolve 0.10 g in *carbon dioxide-free water R* and dilute to 10 mL with the same solvent. The pH of the solution is 5.0 to 6.0.

**Related substances.** Examine by thin-layer chromatography (2.2.27), using a plate coated with a suitable silica gel.

**Test solution (a).** Dissolve 0.20 g of the substance to be examined in *methanol R* and dilute to 10 mL with the same solvent.

**Test solution (b).** Dilute 5 mL of test solution (a) to 100 mL with *methanol R*.

**Reference solution (a).** Dissolve 10 mg of *chlorcyclizine hydrochloride CRS* in *methanol R* and dilute to 10 mL with the same solvent.

**Reference solution (b).** Dissolve 5 mg of *methylpiperazine R* in *methanol R* and dilute to 50 mL with the same solvent.

**Reference solution (c).** Dilute 1 mL of test solution (b) to 25 mL with *methanol R*.

**Reference solution (d).** Dissolve 10 mg of *hydroxyzine hydrochloride CRS* and 10 mg of *chlorcyclizine hydrochloride CRS* in *methanol R* and dilute to 10 mL with the same solvent.

Apply separately to the plate 10 µL of each solution and develop over a path of 15 cm using a mixture of 2 volumes of *concentrated ammonia R*, 13 volumes of *methanol R* and 85 volumes of *methylene chloride R*. Allow the plate to dry in air and expose it to iodine vapour for 10 min. In the chromatogram obtained with test solution (a): any spot corresponding to methylpiperazine is not more intense than the spot in the chromatogram obtained with reference solution (b) (0.5 per cent); any spot, apart from the principal spot and any spot corresponding to methylpiperazine, is not more intense than the spot in the chromatogram obtained with reference solution (c) (0.2 per cent). The test is not valid unless the chromatogram obtained with reference solution (d) shows two clearly separated spots.

**Loss on drying (2.2.32).** Not more than 1.0 per cent, determined on 1.000 g by drying in an oven at 130 °C.

**Sulfated ash (2.4.14).** Not more than 0.1 per cent, determined on 1.0 g.

#### ASSAY

Dissolve 0.200 g in a mixture of 1 mL of 0.1 M *hydrochloric acid* and 50 mL of *methanol R*. Carry out a potentiometric titration (2.2.20), using 0.1 M *sodium hydroxide*. Read the volume added between the two points of inflexion.

1 mL of 0.1 M *sodium hydroxide* is equivalent to 33.73 mg of C<sub>16</sub>H<sub>14</sub>ClN<sub>3</sub>O.

#### STORAGE

Store protected from light.

#### IMPURITIES

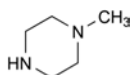

A. *N*-methylpiperazine.

## CHLORDIAZEPOXIDE

### Chlordiazepoxidum

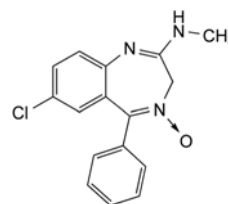

C<sub>16</sub>H<sub>14</sub>ClN<sub>3</sub>O  
[58-25-3]

*M<sub>r</sub>* 299.8

#### DEFINITION

7-Chloro-*N*-methyl-5-phenyl-3*H*-1,4-benzodiazepin-2-amine 4-oxide.

**Content:** 99.0 per cent to 101.0 per cent (dried substance).

#### CHARACTERS

**Appearance:** almost white or light yellow, crystalline powder.

**Solubility:** practically insoluble in water, sparingly soluble in ethanol (96 per cent).

It shows polymorphism (5.9).

#### IDENTIFICATION

Infrared absorption spectrophotometry (2.2.24).

**Comparison:** *chlordiazepoxide CRS*.

If the spectra obtained in the solid state show differences, dissolve the substance to be examined and the reference substance separately in *methylene chloride R*, evaporate to dryness and record new spectra using the residues.

#### TESTS

**Related substances.** Liquid chromatography (2.2.29). Carry out the test protected from bright light and prepare the solutions immediately before use.

**Test solution.** Dissolve 20.0 mg of the substance to be examined in the mobile phase and dilute to 100.0 mL with the mobile phase.

**Reference solution (a).** Dilute 1.0 mL of the test solution to 100.0 mL with the mobile phase. Dilute 2.0 mL of this solution to 10.0 mL with the mobile phase.

**Reference solution (b).** Dissolve 5 mg of *chlordiazepoxide impurity A CRS* in the mobile phase, add 25.0 mL of the test solution and dilute to 100.0 mL with the mobile phase. Dilute 2.0 mL of this solution to 50.0 mL with the mobile phase.

**Reference solution (c).** Dissolve 4.0 mg of *aminochlorobenzophenone R* in the mobile phase and dilute to 100.0 mL with the mobile phase. Dilute 1.0 mL of this solution to 100.0 mL with the mobile phase.

**Column:**

- size: *l* = 0.15 m, Ø = 4.6 mm,
- stationary phase: octadecylsilyl silica gel for chromatography *R* (5 µm).

**Mobile phase:** acetonitrile *R*, water *R* (50:50 *V/V*).

**Flow rate:** 1.0 mL/min.

**Detection:** spectrophotometer at 254 nm.

**Injection:** 10 µL.

**Run time:** 6 times the retention time of chlordiazepoxide.

**Relative retention** with reference to chlordiazepoxide (retention time = about 3.6 min): impurity A = about 0.7; impurity B = about 2.3; impurity C = about 3.9.

*System suitability*: reference solution (b):

01/2008:0474

- *resolution*: minimum 5.0 between the peaks due to impurity A and chlordiazepoxide.

*Limits*:

- *impurities A, B*: for each impurity, not more than the area of the principal peak in the chromatogram obtained with reference solution (a) (0.2 per cent),
- *impurity C*: not more than the area of the principal peak in the chromatogram obtained with reference solution (c) (0.2 per cent),
- *unspecified impurities*: for each impurity, not more than 0.5 times the area of the principal peak in the chromatogram obtained with reference solution (a) (0.10 per cent),
- *total*: not more than 2.5 times the area of the principal peak in the chromatogram obtained with reference solution (a) (0.5 per cent),
- *disregard limit*: 0.25 times the area of the principal peak in the chromatogram obtained with reference solution (a) (0.05 per cent).

**Loss on drying** (2.2.32): maximum 0.5 per cent, determined on 1.000 g by drying in an oven at 105 °C.

**Sulfated ash** (2.4.14): maximum 0.1 per cent, determined on 1.0 g.

#### ASSAY

Dissolve 0.250 g, with heating if necessary, in 80 mL of *anhydrous acetic acid R*. Titrate with 0.1 M *perchloric acid* determining the end-point potentiometrically (2.2.20).

1 mL of 0.1 M *perchloric acid* is equivalent to 29.98 mg of C<sub>16</sub>H<sub>14</sub>ClN<sub>3</sub>O.

#### STORAGE

Protected from light.

#### IMPURITIES

*Specified impurities*: A, B, C.

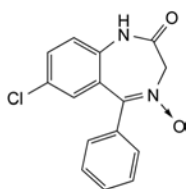

- A. 7-chloro-5-phenyl-1,3-dihydro-2H-1,4-benzodiazepin-2-one 4-oxide,

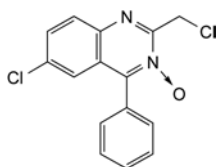

- B. 6-chloro-2-(chloromethyl)-4-phenylquinazoline 3-oxide,

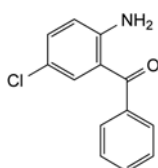

- C. (2-amino-5-chlorophenyl)phenylmethanone (aminochlorobenzophenone).

## CHLORDIAZEPOXIDE HYDROCHLORIDE

### Chlordiazepoxidi hydrochloridum

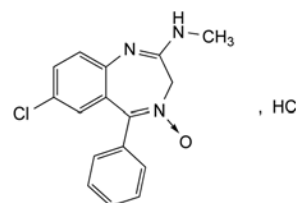

C<sub>16</sub>H<sub>15</sub>Cl<sub>2</sub>N<sub>3</sub>O  
[438-41-5]

M<sub>r</sub> 336.2

#### DEFINITION

7-Chloro-*N*-methyl-5-phenyl-3*H*-1,4-benzodiazepin-2-amine 4-oxide hydrochloride.

*Content*: 99.0 per cent to 101.0 per cent (dried substance).

#### CHARACTERS

*Appearance*: white or slightly yellow, crystalline powder.

*Solubility*: soluble in water, sparingly soluble in ethanol (96 per cent).

It shows polymorphism (5.9).

#### IDENTIFICATION

- A. Infrared absorption spectrophotometry (2.2.24).

*Comparison*: *chlordiazepoxide hydrochloride CRS*.

If the spectra obtained in the solid state show differences, dissolve 100 mg in 9 mL of *water R* and add 1 mL of *dilute sodium hydroxide solution R*. Extract with 10 mL of *methylene chloride R* in a separating funnel. Evaporate the organic layer and dry the residue obtained at 100-105 °C. Proceed in the same way with the reference substance. Record new spectra using the residues.

- B. Dissolve 50 mg in 5 mL of *water R*, add 1 mL of *dilute ammonia RI*, mix, allow to stand for 5 min and filter. Acidify the filtrate with *dilute nitric acid R*. The solution gives reaction (a) of chlorides (2.3.1).

#### TESTS

**Appearance of solution.** The solution is clear (2.2.1) and not more intensely coloured than reference solution GY<sub>6</sub> (2.2.2, *Method II*).

Dissolve 2.5 g in *water R* and dilute to 25 mL with the same solvent.

**Related substances.** Liquid chromatography (2.2.29). Carry out the following operations protected from bright light and prepare the solutions immediately before use.

*Test solution.* Dissolve 20.0 mg of the substance to be examined in the mobile phase and dilute to 100.0 mL with the mobile phase.

*Reference solution (a).* Dilute 1.0 mL of the test solution to 100.0 mL with the mobile phase. Dilute 2.0 mL of this solution to 10.0 mL with the mobile phase.

*Reference solution (b).* Dissolve 5 mg of *chlordiazepoxide impurity A CRS* in the mobile phase, add 25.0 mL of the test solution and dilute to 100.0 mL with the mobile phase. Dilute 2.0 mL of this solution to 50.0 mL with the mobile phase.

*Reference solution (c).* Dissolve 4.0 mg of *aminochlorobenzophenone R* in the mobile phase and dilute to 100.0 mL with the mobile phase. Dilute 1.0 mL of this solution to 100.0 mL with the mobile phase.

*Column*:

- *size*: *l* = 0.15 m, Ø = 4.6 mm,

– *stationary phase*: octadecylsilyl silica gel for chromatography R (5 µm).  
*Mobile phase*: acetonitrile R, water R (50:50 V/V).  
*Flow rate*: 1.0 mL/min.  
*Detection*: spectrophotometer at 254 nm.

*Injection*: 10 µL.

*Run time*: 6 times the retention time of chlordiazepoxide.

*Relative retention* with reference to chlordiazepoxide (retention time = about 3.6 min): impurity A = about 0.7; impurity B = about 2.3; impurity C = about 3.9.

*System suitability*: reference solution (b):

– *resolution*: minimum 5.0 between the peaks due to impurity A and chlordiazepoxide.

*Limits*:

- *impurities A, B*: for each impurity, not more than the area of the principal peak in the chromatogram obtained with reference solution (a) (0.2 per cent),
- *impurity C*: not more than the area of the principal peak in the chromatogram obtained with reference solution (c) (0.2 per cent),
- *unspecified impurities*: for each impurity, not more than 0.5 times the area of the principal peak in the chromatogram obtained with reference solution (a) (0.10 per cent),
- *total*: not more than 2.5 times the area of the principal peak in the chromatogram obtained with reference solution (a) (0.5 per cent),
- *disregard limit*: 0.25 times the area of the principal peak in the chromatogram obtained with reference solution (a) (0.05 per cent).

**Loss on drying** (2.2.32): maximum 0.5 per cent, determined on 1.000 g by drying *in vacuo* at 60 °C for 4 h.

**Sulfated ash** (2.4.14): maximum 0.1 per cent, determined on 1.0 g.

#### ASSAY

Dissolve 0.250 g in 50 mL of *water R*. Titrate with 0.1 M silver nitrate, determining the end-point potentiometrically (2.2.20).

1 mL of 0.1 M silver nitrate is equivalent to 33.62 mg of C<sub>16</sub>H<sub>15</sub>Cl<sub>2</sub>N<sub>3</sub>O.

#### STORAGE

Protected from light.

#### IMPURITIES

*Specified impurities*: A, B, C.

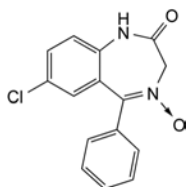

A. 7-chloro-5-phenyl-1,3-dihydro-2H-1,4-benzodiazepin-2-one 4-oxide,

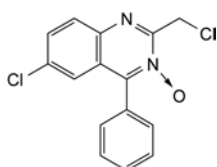

B. 6-chloro-2-(chloromethyl)-4-phenylquinazoline 3-oxide,

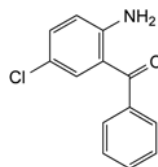

C. (2-amino-5-chlorophenyl)phenylmethanone (aminochlorobenzophenone).

01/2008:0657  
corrected 7.0

## CHLORHEXIDINE DIACETATE

### Chlorhexidini diacetat

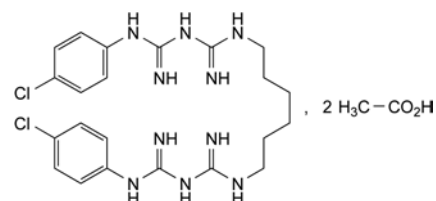

C<sub>26</sub>H<sub>38</sub>Cl<sub>2</sub>N<sub>10</sub>O<sub>4</sub>  
[56-95-1]

*M<sub>r</sub>* 625.6

#### DEFINITION

1,1'-(Hexane-1,6-diyldis[5-(4-chlorophenyl)biguanide] diacetate.

*Content*: 98.0 per cent to 101.0 per cent (dried substance).

#### CHARACTERS

*Appearance*: white or almost white, microcrystalline powder.

*Solubility*: sparingly soluble in water, soluble in ethanol (96 per cent), slightly soluble in glycerol and in propylene glycol.

#### IDENTIFICATION

*First identification*: A.

*Second identification*: B, C, D.

A. Infrared absorption spectrophotometry (2.2.24).

*Comparison*: chlorhexidine diacetate CRS.

B. Dissolve about 5 mg in 5 mL of a warm 10 g/L solution of *cetrimide R* and add 1 mL of *strong sodium hydroxide solution R* and 1 mL of *bromine water R*. A deep red colour is produced.

C. Dissolve 0.3 g in 10 mL of a mixture of equal volumes of *hydrochloric acid R* and *water R*. Add 40 mL of *water R*, filter if necessary and cool in iced water. Make alkaline to *titan yellow paper R* by adding dropwise, and with stirring, *strong sodium hydroxide solution R* and add 1 mL in excess. Filter, wash the precipitate with *water R* until the washings are free from alkali and recrystallise from *ethanol (70 per cent V/V) R*. Dry at 100-105 °C. The residue melts (2.2.14) at 132 °C to 136 °C.

D. It gives reaction (a) of acetates (2.3.1).

#### TESTS

**Chloroaniline**: maximum 500 ppm.

Dissolve 0.20 g in 25 mL of *water R* with shaking if necessary. Add 1 mL of *hydrochloric acid R* and dilute to 30 mL with *water R*. Add rapidly and with thorough mixing after each addition: 2.5 mL of *dilute hydrochloric acid R*, 0.35 mL of *sodium nitrite solution R*, 2 mL of a 50 g/L solution of *ammonium sulfamate R*, 5 mL of a 1.0 g/L solution of *naphthylethylenediamine dihydrochloride R* and 1 mL of *ethanol (96 per cent) R*, dilute to 50.0 mL with *water R* and allow to stand for 30 min. Any reddish-blue colour in the solution is not more intense than that in a standard prepared at the same time and in the same manner, using a mixture of 10.0 mL of a 0.010 g/L solution of *chloroaniline R* in *dilute*

hydrochloric acid R and 20 mL of dilute hydrochloric acid R instead of the solution of the substance to be examined.

**Related substances.** Liquid chromatography (2.2.29).

**Test solution.** Dissolve 0.200 g of the substance to be examined in the mobile phase and dilute to 100 mL with the mobile phase.

**Reference solution (a).** Dissolve 15 mg of chlorhexidine for performance test CRS in the mobile phase and dilute to 10.0 mL with the mobile phase.

**Reference solution (b).** Dilute 2.5 mL of the test solution to 100 mL with the mobile phase.

**Reference solution (c).** Dilute 2.0 mL of reference solution (b) to 10 mL with the mobile phase. Dilute 1.0 mL of this solution to 10 mL with the mobile phase.

**Column:**

- size:  $l = 0.2$  m,  $\varnothing = 4$  mm;
- stationary phase: octadecylsilyl silica gel for chromatography R (5  $\mu$ m).

**Mobile phase:** solution of 2.0 g of sodium octanesulfonate R in a mixture of 120 mL of glacial acetic acid R, 270 mL of water R and 730 mL of methanol R.

**Flow rate:** 1.0 mL/min.

**Detection:** spectrophotometer at 254 nm.

**Equilibration:** with the mobile phase for at least 1 h.

**Injection:** 10  $\mu$ L.

**Run time:** 6 times the retention time of chlorhexidine.

**System suitability:** reference solution (a):

- the chromatogram obtained is similar to the chromatogram supplied with chlorhexidine for performance test CRS in that the peaks due to impurity A and impurity B precede that due to chlorhexidine; if necessary, adjust the concentration of acetic acid in the mobile phase (increasing the concentration decreases the retention times).

**Limits:**

- total: not more than the area of the principal peak in the chromatogram obtained with reference solution (b) (2.5 per cent);
- disregard limit: the area of the principal peak in the chromatogram obtained with reference solution (c) (0.05 per cent); disregard any peak with a relative retention time with reference to chlorhexidine of 0.25 or less.

**Loss on drying (2.2.32):** maximum 3.5 per cent, determined on 1.000 g by drying in an oven at 105 °C.

**Sulfated ash (2.4.14):** maximum 0.15 per cent, determined on 1.0 g.

**ASSAY**

Dissolve 0.140 g in 100 mL of anhydrous acetic acid R and titrate with 0.1 M perchloric acid. Determine the end-point potentiometrically (2.2.20).

1 mL of 0.1 M perchloric acid is equivalent to 15.64 mg of  $C_{26}H_{38}Cl_2N_{10}O_4$ .

**IMPURITIES**

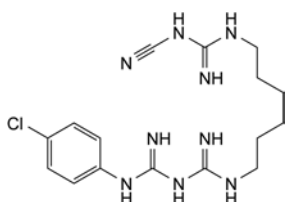

A. 1-(4-chlorophenyl)-5-[6-[(cyanocarbamimidoyl)amino]hexyl]biguanide,

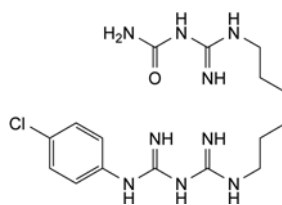

B. [[6-[[[(4-chlorophenyl)carbamimidoyl]carbamimidoyl]amino]hexyl]carbamimidoyl]urea,

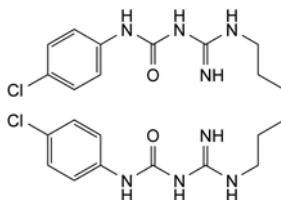

C. 1,1'-[hexane-1,6-diylbis(iminocarbonimidoyl)]bis[3-(4-chlorophenyl)urea],

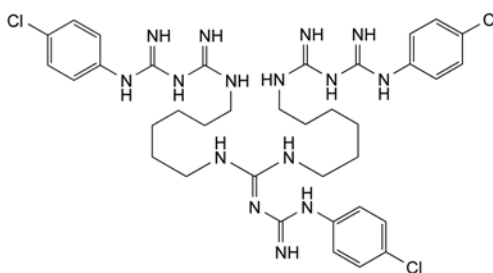

D. 1,1'-[[[(4-chlorophenyl)carbamimidoyl]imino]methylene]bis[imino(hexane-1,6-diyl)]]bis[5-(4-chlorophenyl)biguanide].

01/2008:0658  
corrected 7.0

## CHLORHEXIDINE DIGLUCONATE SOLUTION

### Chlorhexidini digluconatis solutio

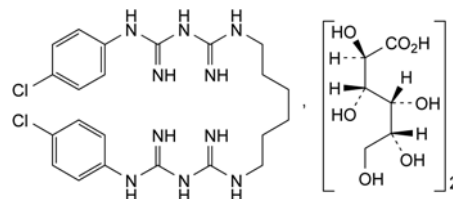

$C_{34}H_{54}Cl_2N_{10}O_{14}$   
[18472-51-0]

$M_r$  898

**DEFINITION**

Aqueous solution of 1,1'-(hexane-1,6-diyl)bis[5-(4-chlorophenyl)biguanide] di-D-gluconate.

**Content:** 190 g/L to 210 g/L.

**CHARACTERS**

**Appearance:** almost colourless or pale-yellowish liquid.

**Solubility:** miscible with water, with not more than 3 parts of acetone and with not more than 5 parts of ethanol (96 per cent).

**IDENTIFICATION**

**First identification:** A, B.

**Second identification:** B, C, D.

A. Infrared absorption spectrophotometry (2.2.24).

**Preparation:** to 1 mL add 40 mL of water R, cool in iced water, make alkaline to titan yellow paper R by adding dropwise, and with stirring, strong sodium hydroxide solution R and add 1 mL in excess. Filter, wash the



precipitate with *water R* until the washings are free from alkali and recrystallise from *ethanol (70 per cent V/V) R*. Dry at 100-105 °C. Examine the residue.

*Comparison: chlorhexidine CRS.*

**B. Thin-layer chromatography (2.2.27).**

*Test solution.* Dilute 10.0 mL of the preparation to be examined to 50 mL with *water R*.

*Reference solution.* Dissolve 25 mg of *calcium gluconate CRS* in 1 mL of *water R*.

*Plate: TLC silica gel G plate R.*

*Mobile phase: concentrated ammonia R, ethyl acetate R, water R, ethanol (96 per cent) R (10:10:30:50 V/V/V/V).*

*Application: 5 µL.*

*Development: over a path of 10 cm.*

*Drying: at 100 °C for 20 min and allow to cool.*

*Detection: spray with a 50 g/L solution of potassium dichromate R in a 40 per cent m/m solution of sulfuric acid R.*

*Results: after 5 min, the principal spot in the chromatogram obtained with the test solution is similar in position, colour and size to the principal spot in the chromatogram obtained with the reference solution.*

**C. To 1 mL add 40 mL of water R, cool in iced water, make alkaline to titan yellow paper R by adding dropwise, and with stirring, strong sodium hydroxide solution R and add 1 mL in excess. Filter, wash the precipitate with water R until the washings are free from alkali and recrystallise from ethanol (70 per cent V/V) R. Dry at 100-105 °C. The residue melts (2.2.14) at 132 °C to 136 °C.**

**D. To 0.05 mL add 5 mL of a 10 g/L solution of cetrimide R, 1 mL of strong sodium hydroxide solution R and 1 mL of bromine water R; a deep red colour is produced.**

**TESTS**

**Relative density (2.2.5):** 1.06 to 1.07.

**pH (2.2.3):** 5.5 to 7.0.

Dilute 5.0 mL to 100 mL with *carbon dioxide-free water R*.

**Chloroaniline:** maximum 0.25 per cent, calculated with reference to chlorhexidine digluconate at a nominal concentration of 200 g/L.

Dilute 2.0 mL to 100 mL with *water R*. To 10 mL of this solution add 2.5 mL of *dilute hydrochloric acid R* and dilute to 20 mL with *water R*. Add rapidly and with thorough mixing after each addition: 0.35 mL of *sodium nitrite solution R*, 2 mL of a 50 g/L solution of *ammonium sulfamate R*, 5 mL of a 1 g/L solution of *naphthyle thylenediamine dihydrochloride R*, 1 mL of *ethanol (96 per cent) R*; dilute to 50.0 mL with *water R* and allow to stand for 30 min. Any reddish-blue colour in the solution is not more intense than that in a standard prepared at the same time and in the same manner using a mixture of 10.0 mL of a 0.010 g/L solution of *chloroaniline R* in *dilute hydrochloric acid R* and 10 mL of *water R* instead of the dilution of the preparation to be examined.

**Related substances.** Liquid chromatography (2.2.29).

*Test solution.* Dilute 5.0 mL of the preparation to be examined to 50.0 mL with the mobile phase. Dilute 5.0 mL of this solution to 50.0 mL with the mobile phase.

*Reference solution (a).* Dissolve 15 mg of *chlorhexidine for performance test CRS* in the mobile phase and dilute to 10.0 mL with the mobile phase.

*Reference solution (b).* Dilute 3.0 mL of the test solution to 100 mL with the mobile phase.

*Reference solution (c).* Dilute 1.0 mL of reference solution (b) to 50 mL with the mobile phase.

*Column:*

– size:  $l = 0.2$  m,  $\varnothing = 4$  mm;

– *stationary phase: octadecylsilyl silica gel for chromatography R (5 µm).*

*Mobile phase:* solution of 2.0 g of *sodium octanesulfonate R* in a mixture of 120 mL of *glacial acetic acid R*, 270 mL of *water R* and 730 mL of *methanol R*.

*Flow rate:* 1.0 mL/min.

*Detection:* spectrophotometer at 254 nm.

*Equilibration:* with the mobile phase for at least 1 hour.

*Injection:* 10 µL.

*Run time:* 6 times the retention time of chlorhexidine.

*System suitability:* reference solution (a):

– the chromatogram obtained is similar to the chromatogram supplied with *chlorhexidine for performance test CRS* in that the peaks due to impurity A and impurity B precede that due to chlorhexidine; if necessary, adjust the concentration of acetic acid in the mobile phase (increasing the concentration decreases the retention times).

*Limits:*

– *total:* not more than the area of the principal peak in the chromatogram obtained with reference solution (b) (3.0 per cent);

– *disregard limit:* the area of the principal peak in the chromatogram obtained with reference solution (c) (0.06 per cent); disregard any peak with a relative retention time with reference to the principal peak of 0.25 or less.

**ASSAY**

Determine the density (2.2.5) of the preparation to be examined. Transfer 1.00 g to a 250 mL beaker and add 50 mL of *anhydrous acetic acid R*. Titrate with *0.1 M perchloric acid*. Determine the end-point potentiometrically (2.2.20).

1 mL of *0.1 M perchloric acid* is equivalent to 22.44 mg of  $C_{34}H_{54}Cl_2N_{10}O_{14}$ .

**STORAGE**

Protected from light.

**IMPURITIES**

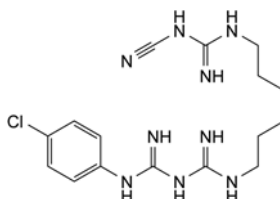

**A.** 1-(4-chlorophenyl)-5-[6-[(cyanocarbamimidoyl)amino]hexyl]biguanide,

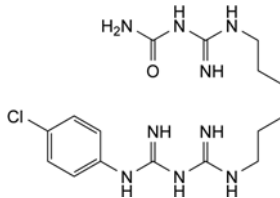

**B.** [[6-[[[(4-chlorophenyl)carbamimidoyl]carbamimidoyl]amino]hexyl]carbamimidoyl]urea,

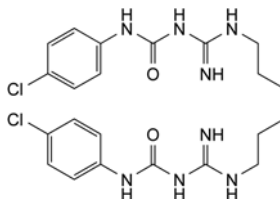

**C.** 1,1'-[hexane-1,6-diylbis(iminocarbonimidoyl)]bis[3-(4-chlorophenyl)urea],

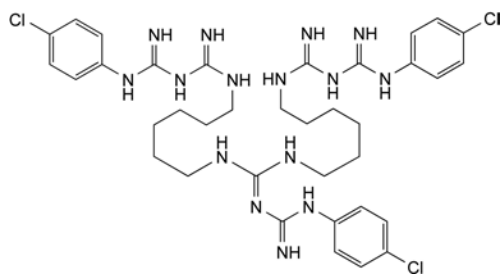

D. 1,1'-[[[(4-chlorophenyl)carbamidimidoyl]imino]methylene]-bis[imino(hexane-1,6-diyl)]bis[5-(4-chlorophenyl)biguanide].

01/2008:0659  
corrected 7.0

## CHLORHEXIDINE DIHYDROCHLORIDE

### Chlorhexidini dihydrochloridum

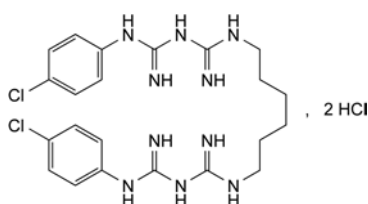

$C_{22}H_{32}Cl_4N_{10}$   
[3697-42-5]

$M_r$  578.4

#### DEFINITION

1,1'-(Hexane-1,6-diyl)bis[5-(4-chlorophenyl)biguanide] dihydrochloride.

*Content*: 98.0 per cent to 101.0 per cent (dried substance).

#### CHARACTERS

*Appearance*: white or almost white, crystalline powder.

*Solubility*: sparingly soluble in water and in propylene glycol, very slightly soluble in ethanol (96 per cent).

#### IDENTIFICATION

*First identification*: A, D.

*Second identification*: B, C, D.

A. Infrared absorption spectrophotometry (2.2.24).

*Comparison*: chlorhexidine dihydrochloride CRS.

B. Dissolve about 5 mg in 5 mL of a warm 10 g/L solution of *cetrimide R* and add 1 mL of *strong sodium hydroxide solution R* and 1 mL of *bromine water R*. A dark red colour is produced.

C. Dissolve 0.3 g in 10 mL of a mixture of equal volumes of *hydrochloric acid R* and *water R*. Add 40 mL of *water R*, filter if necessary and cool in iced water. Make alkaline to *titan yellow paper R* by adding dropwise, and with stirring, *strong sodium hydroxide solution R* and add 1 mL in excess. Filter, wash the precipitate with *water R* until the washings are free from alkali and recrystallise from *ethanol (70 per cent V/V) R*. Dry at 100-105 °C. The residue melts (2.2.14) at 132 °C to 136 °C.

D. It gives reaction (a) of chlorides (2.3.1).

#### TESTS

**Chloroaniline**: maximum 500 ppm.

To 0.20 g add 1 mL of *hydrochloric acid R*, shake for about 30 s, dilute to 30 mL with *water R* and shake until a clear solution is obtained. Add rapidly and with thorough mixing after each addition: 2.5 mL of *dilute hydrochloric acid R*, 0.35 mL of *sodium nitrite solution R*, 2 mL of a 50 g/L solution of *ammonium sulfamate R*, 5 mL of a 1.0 g/L solution of *naphthylethylenediamine dihydrochloride R* and 1 mL of

*ethanol (96 per cent) R*; dilute to 50.0 mL with *water R* and allow to stand for 30 min. Any reddish-blue colour in the solution is not more intense than that in a standard prepared at the same time and in the same manner using a mixture of 10.0 mL of a 0.010 g/L solution of *chloroaniline R* in *dilute hydrochloric acid R* and 20 mL of *dilute hydrochloric acid R* instead of the solution of the substance to be examined.

**Related substances**. Liquid chromatography (2.2.29).

*Test solution*. Dissolve 0.200 g of the substance to be examined in the mobile phase and dilute to 100 mL with the mobile phase.

*Reference solution (a)*. Dissolve 15 mg of *chlorhexidine for performance test CRS* in the mobile phase and dilute to 10.0 mL with the mobile phase.

*Reference solution (b)*. Dilute 2.5 mL of the test solution to 100 mL with the mobile phase.

*Reference solution (c)*. Dilute 2.0 mL of reference solution (b) to 10 mL with the mobile phase. Dilute 1.0 mL of this solution to 10 mL with the mobile phase.

*Column*:

– *size*:  $l = 0.2$  m,  $\varnothing = 4$  mm;

– *stationary phase*: octadecylsilyl silica gel for chromatography R (5 µm).

*Mobile phase*: solution of 2.0 g of *sodium octanesulfonate R* in a mixture of 120 mL of *glacial acetic acid R*, 270 mL of *water R* and 730 mL of *methanol R*.

*Flow rate*: 1.0 mL/min.

*Detection*: spectrophotometer at 254 nm.

*Equilibration*: with the mobile phase for at least 1 h.

*Injection*: 10 µL.

*Run time*: 6 times the retention time of chlorhexidine.

*System suitability*: reference solution (a):

– the chromatogram obtained is similar to the chromatogram supplied with *chlorhexidine for performance test CRS* in that the peaks due to impurity A and impurity B precede that due to chlorhexidine; if necessary, adjust the concentration of acetic acid in the mobile phase (increasing the concentration decreases the retention times).

*Limits*:

– *total*: not more than the area of the principal peak in the chromatogram obtained with reference solution (b) (2.5 per cent);

– *disregard limit*: the area of the principal peak in the chromatogram obtained with reference solution (c) (0.05 per cent); disregard any peak with a relative retention time with reference to chlorhexidine of 0.25 or less.

**Loss on drying** (2.2.32): maximum 1.0 per cent, determined on 1.000 g by drying in an oven at 105 °C.

**Sulfated ash** (2.4.14): maximum 0.1 per cent, determined on 1.0 g.

#### ASSAY

Dissolve 100.0 mg in 5 mL of *anhydrous formic acid R* and add 70 mL of *acetic anhydride R*. Titrate with 0.1 M *perchloric acid*, determining the end-point potentiometrically (2.2.20).

1 mL of 0.1 M *perchloric acid* is equivalent to 14.46 mg of  $C_{22}H_{32}Cl_4N_{10}$ .

#### IMPURITIES

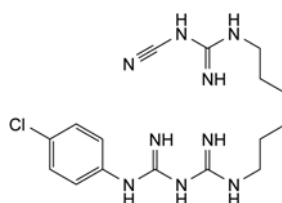

A. 1-(4-chlorophenyl)-5-[6-[(cyanocarbamidimidoyl)amino]hexyl]biguanide,

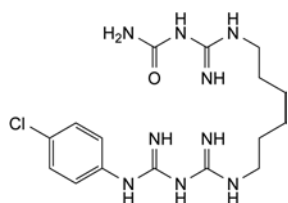

- B. [[6-[[[(4-chlorophenyl)carbamidoyl]carbamidoyl]amino]hexyl]carbamidoyl]urea,

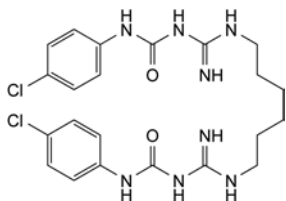

- C. 1,1'-[hexane-1,6-diylium]bis[3-(4-chlorophenyl)urea],

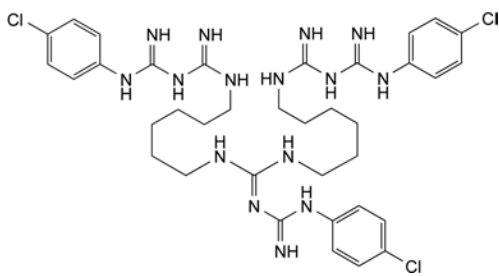

- D. 1,1'-[[[[[(4-chlorophenyl)carbamidoyl]imino]methylene]bis[imino(hexane-1,6-diylium)]]bis[5-(4-chlorophenyl)biguanide].

01/2008:0382  
corrected 6.0

## CHLOROBUTANOL, ANHYDROUS

Chlorobutanolum anhydricum

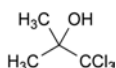

$C_4H_7Cl_3O$   
[57-15-8]

$M_r$  177.5

### DEFINITION

1,1,1-Trichloro-2-methylpropan-2-ol.

*Content*: 98.0 per cent to 101.0 per cent (anhydrous substance).

### CHARACTERS

*Appearance*: white or almost white, crystalline powder or colourless crystals, sublimes readily.

*Solubility*: slightly soluble in water, very soluble in ethanol (96 per cent), soluble in glycerol (85 per cent).

mp: about 95 °C (without previous drying).

### IDENTIFICATION

- Add about 20 mg to a mixture of 1 mL of *pyridine R* and 2 mL of *strong sodium hydroxide solution R*. Heat in a water-bath and shake. Allow to stand. The pyridine layer becomes red.
- Add about 20 mg to 5 mL of *ammoniacal silver nitrate solution R* and warm slightly. A black precipitate is formed.
- To about 20 mg add 3 mL of *1 M sodium hydroxide* and shake to dissolve. Add 5 mL of *water R* and then, slowly, 2 mL of *iodinated potassium iodide solution R*. A yellowish precipitate is formed.
- Water (see Tests).

### TESTS

**Solution S.** Dissolve 5 g in *ethanol (96 per cent) R* and dilute to 10 mL with the same solvent.

**Appearance of solution.** Solution S is not more opalescent than reference suspension II (2.2.1) and not more intensely coloured than reference solution BY<sub>5</sub> (2.2.2, *Method II*).

**Acidity.** To 4 mL of solution S add 15 mL of *ethanol (96 per cent) R* and 0.1 mL of *bromothymol blue solution R1*. Not more than 1.0 mL of *0.01 M sodium hydroxide* is required to change the colour of the indicator to blue.

**Chlorides** (2.4.4): maximum 300 ppm.

Dissolve 0.17 g in 5 mL of *ethanol (96 per cent) R* and dilute to 15 mL with *water R*. When preparing the standard, replace the 5 mL of *water R* by 5 mL of *ethanol (96 per cent) R*.

**Water** (2.5.12): maximum 1.0 per cent, determined on 2.00 g.

**Sulfated ash** (2.4.14): maximum 0.1 per cent, determined on 1.0 g.

### ASSAY

Dissolve 0.100 g in 20 mL of *ethanol (96 per cent) R*. Add 10 mL of *dilute sodium hydroxide solution R*, heat in a water-bath for 5 min and cool. Add 20 mL of *dilute nitric acid R*, 25.0 mL of *0.1 M silver nitrate* and 2 mL of *dibutyl phthalate R* and shake vigorously. Add 2 mL of *ferric ammonium sulfate solution R2* and titrate with *0.1 M ammonium thiocyanate* until an orange colour is obtained.

1 mL of *0.1 M silver nitrate* is equivalent to 5.92 mg of  $C_4H_7Cl_3O$ .

### STORAGE

In an airtight container.

01/2008:0383  
corrected 6.0

## CHLOROBUTANOL HEMIHYDRATE

Chlorobutanolum hemihydricum

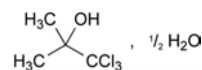

$C_4H_7Cl_3O \cdot \frac{1}{2}H_2O$   
[6001-64-5]

$M_r$  186.5

### DEFINITION

1,1,1-Trichloro-2-methylpropan-2-ol hemihydrate.

*Content*: 98.0 per cent to 101.0 per cent (anhydrous substance).

### CHARACTERS

*Appearance*: white or almost white, crystalline powder or colourless crystals, sublimes readily.

*Solubility*: slightly soluble in water, very soluble in ethanol (96 per cent), soluble in glycerol (85 per cent).

mp: about 78 °C (without previous drying).

### IDENTIFICATION

- Add about 20 mg to a mixture of 1 mL of *pyridine R* and 2 mL of *strong sodium hydroxide solution R*. Heat in a water-bath and shake. Allow to stand. The pyridine layer becomes red.
- Add about 20 mg to 5 mL of *ammoniacal silver nitrate solution R* and warm slightly. A black precipitate is formed.
- To about 20 mg add 3 mL of *1 M sodium hydroxide* and shake to dissolve. Add 5 mL of *water R* and then, slowly, 2 mL of *iodinated potassium iodide solution R*. A yellowish precipitate is formed.
- Water (see Tests).

## TESTS

**Solution S.** Dissolve 5 g in *ethanol (96 per cent) R* and dilute to 10 mL with the same solvent.

**Appearance of solution.** Solution S is not more opalescent than reference suspension II (2.2.1) and not more intensely coloured than reference solution BY<sub>5</sub> (2.2.2, Method II).

**Acidity.** To 4 mL of solution S add 15 mL of *ethanol (96 per cent) R* and 0.1 mL of *bromothymol blue solution R1*. Not more than 1.0 mL of 0.01 M *sodium hydroxide* is required to change the colour of the indicator to blue.

**Chlorides** (2.4.4): maximum 100 ppm.

To 1 mL of solution S add 4 mL of *ethanol (96 per cent) R* and dilute to 15 mL with *water R*. When preparing the standard, replace the 5 mL of *water R* by 5 mL of *ethanol (96 per cent) R*.

**Water** (2.5.12): 4.5 per cent to 5.5 per cent, determined on 0.300 g.

**Sulfated ash** (2.4.14): maximum 0.1 per cent, determined on 1.0 g.

## ASSAY

Dissolve 0.100 g in 20 mL of *ethanol (96 per cent) R*. Add 10 mL of *dilute sodium hydroxide solution R*, heat in a water-bath for 5 min and cool. Add 20 mL of *dilute nitric acid R*, 25.0 mL of 0.1 M *silver nitrate* and 2 mL of *dibutyl phthalate R* and shake vigorously. Add 2 mL of *ferric ammonium sulfate solution R2* and titrate with 0.1 M *ammonium thiocyanate* until an orange colour is obtained.

1 mL of 0.1 M *silver nitrate* is equivalent to 5.92 mg of C<sub>7</sub>H<sub>7</sub>ClO.

## STORAGE

In an airtight container.

C. To 5 mL of solution S (see Tests) add 0.1 mL of *ferric chloride solution R1*. A bluish colour is produced.

## TESTS

**Solution S.** To 3.0 g, finely powdered, add 60 mL of *carbon dioxide-free water R*, shake for 2 min and filter.

**Appearance of solution.** The solution is clear (2.2.1) and not more intensely coloured than reference solution BY<sub>6</sub> (2.2.2, Method II).

Dissolve 1.25 g in *ethanol (96 per cent) R* and dilute to 25 mL with the same solvent.

**Acidity.** To 10 mL of solution S add 0.1 mL of *methyl red solution R*. The solution is orange or red. Not more than 0.2 mL of 0.01 M *sodium hydroxide* is required to produce a pure yellow colour.

**Related substances.** Gas chromatography (2.2.28): use the normalisation procedure.

**Test solution.** Dissolve 1.0 g of the substance to be examined in *acetone R* and dilute to 100 mL with the same solvent.

**Reference solution.** Dilute 1.0 mL of the test solution to 100.0 mL with *acetone R*. Dilute 5.0 mL of this solution to 100.0 mL with *acetone R*.

## Column:

- material: glass;
- size:  $l = 1.80$  m,  $\varnothing = 3\text{--}4$  mm;
- stationary phase: silanised diatomaceous earth for gas chromatography R impregnated with 3.5 per cent *m/m* of polymethylphenylsiloxane R.

Carrier gas: nitrogen for chromatography R.

Flow rate: 30 mL/min.

## Temperature:

- column: 125 °C;
- injection port: 210 °C;
- detector: 230 °C.

Detection: flame ionisation.

Run time: 3 times the retention time of chlorocresol.

Retention time: chlorocresol = about 8 min.

## Limits:

- unspecified impurities: for each impurity, maximum 0.10 per cent;
- total: maximum 1 per cent;
- disregard limit: the area of the principal peak in the chromatogram obtained with the reference solution (0.05 per cent).

**Non-volatile matter:** maximum 0.1 per cent.

Evaporate 2.0 g to dryness on a water-bath and dry the residue at 100–105 °C. The residue weighs not more than 2 mg.

## ASSAY

In a ground-glass-stoppered flask, dissolve 70.0 mg in 30 mL of *glacial acetic acid R*. Add 25.0 mL of 0.0167 M *potassium bromate*, 20 mL of a 150 g/L solution of *potassium bromide R* and 10 mL of *hydrochloric acid R*. Allow to stand protected from light for 15 min. Add 1 g of *potassium iodide R* and 100 mL of *water R*. Titrate with 0.1 M *sodium thiosulfate*, shaking vigorously and using 1 mL of *starch solution R*, added towards the end of the titration, as indicator. Carry out a blank titration.

1 mL of 0.0167 M *potassium bromate* is equivalent to 3.565 mg of C<sub>7</sub>H<sub>7</sub>ClO.

## STORAGE

Protected from light.

01/2011:0384

## CHLOROCRESOL

## Chlorocresolum

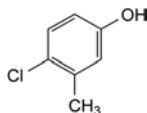

C<sub>7</sub>H<sub>7</sub>ClO  
[59-50-7]

*M*<sub>r</sub> 142.6

## DEFINITION

4-Chloro-3-methylphenol.

Content: 98.0 per cent to 101.0 per cent.

## CHARACTERS

**Appearance:** white or almost white, crystalline powder or compacted crystalline masses supplied as pellets or colourless or white crystals.

**Solubility:** slightly soluble in water, very soluble in ethanol (96 per cent), freely soluble in fatty oils. It dissolves in solutions of alkali hydroxides.

## IDENTIFICATION

A. Melting point (2.2.14): 64 °C to 67 °C.

B. To 0.1 g add 0.2 mL of *benzoyl chloride R* and 0.5 mL of *dilute sodium hydroxide solution R*. Shake vigorously until a white, crystalline precipitate is formed. Add 5 mL of *water R* and filter. The precipitate, recrystallised from 5 mL of *methanol R* and dried at 70 °C, melts (2.2.14) at 85 °C to 88 °C.

01/2008:0544  
corrected 6.0

## CHLOROQUINE PHOSPHATE

## Chloroquini fosphas

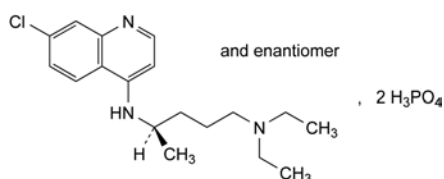
 $C_{18}H_{32}ClN_3O_8P_2$   
[50-63-5]
 $M_r$  515.9

## DEFINITION

Chloroquine phosphate contains not less than 98.5 per cent and not more than the equivalent of 101.0 per cent of  $N^7$ -(7-chloroquinolin-4-yl)- $N^1,N^1$ -diethylpentane-1,4-diamine bis(dihydrogen phosphate), calculated with reference to the dried substance.

## CHARACTERS

A white or almost white, crystalline powder, hygroscopic, freely soluble in water, very slightly soluble in alcohol and in methanol.

It exists in 2 forms, one of which melts at about 195 °C and the other at about 218 °C.

## IDENTIFICATION

First identification: B, D.

Second identification: A, C, D.

- A. Dissolve 0.100 g in *water R* and dilute to 100.0 mL with the same solvent. Dilute 1.0 mL of this solution to 100.0 mL with *water R*. Examined between 210 nm and 370 nm (2.2.25), the solution shows absorption maxima at 220 nm, 235 nm, 256 nm, 329 nm and 342 nm. The specific absorbances at the maxima are respectively 600 to 660, 350 to 390, 300 to 330, 325 to 355 and 360 to 390.
- B. Examine by infrared absorption spectrophotometry (2.2.24), comparing with the spectrum obtained with the base isolated from *chloroquine sulfate CRS*. Record the spectra using solutions prepared as follows: dissolve separately 0.1 g of the substance to be examined and 80 mg of the reference substance in 10 mL of *water R*, add 2 mL of *dilute sodium hydroxide solution R* and shake with 2 quantities, each of 20 mL, of *methylene chloride R*; combine the organic layers, wash with *water R*, dry over *anhydrous sodium sulfate R*, evaporate to dryness and dissolve the residues separately, each in 2 mL of *methylene chloride R*.
- C. Dissolve 25 mg in 20 mL of *water R* and add 8 mL of *picric acid solution R1*. The precipitate, washed with *water R*, with *alcohol R* and finally with *methylene chloride R*, melts (2.2.14) at 206-209 °C.
- D. Dissolve 0.1 g in 10 mL of *water R*, add 2 mL of *dilute sodium hydroxide solution R* and shake with 2 quantities, each of 20 mL, of *methylene chloride R*. The aqueous layer, acidified by the addition of *nitric acid R*, gives reaction (b) of phosphates (2.3.1).

## TESTS

**Solution S.** Dissolve 2.5 g in *carbon dioxide-free water R* and dilute to 25 mL with the same solvent.

**Appearance of solution.** Solution S is clear (2.2.1) and not more intensely coloured than reference solution BY<sub>5</sub> or GY<sub>5</sub> (2.2.2, *Method II*).

**pH** (2.2.3). The pH of solution S is 3.8 to 4.3.

**Related substances.** Examine by thin-layer chromatography (2.2.27), using *silica gel GF<sub>254</sub> R* as the coating substance.

**Test solution.** Dissolve 0.50 g of the substance to be examined in *water R* and dilute to 10 mL with the same solvent.

**Reference solution (a).** Dilute 1 mL of the test solution to 100 mL with *water R*.

**Reference solution (b).** Dilute 5 mL of reference solution (a) to 10 mL with *water R*.

Apply to the plate 2 µL of each solution. Develop over a path of 12 cm using a mixture of 10 volumes of *diethylamine R*, 40 volumes of *cyclohexane R* and 50 volumes of *chloroform R*. Allow the plate to dry in air. Examine in ultraviolet light at 254 nm. Any spot in the chromatogram obtained with the test solution, apart from the principal spot, is not more intense than the spot in the chromatogram obtained with reference solution (a) (1.0 per cent) and not more than one such spot is more intense than the spot in the chromatogram obtained with reference solution (b) (0.5 per cent).

**Heavy metals** (2.4.8). Dissolve 2.0 g in 10 mL of *water R*. Add 5 mL of *concentrated ammonia R* and shake with 40 mL of *methylene chloride R*. Filter the aqueous layer and neutralise the filtrate with *glacial acetic acid R*. Heat on a water-bath to eliminate methylene chloride, allow to cool and dilute to 20.0 mL with *water R*. 12 mL of this solution complies with limit test A for heavy metals (20 ppm). Prepare the standard using *lead standard solution (2 ppm Pb) R*.

**Loss on drying** (2.2.32): maximum 2.0 per cent, determined on 1.000 g by drying in an oven at 105 °C.

## ASSAY

Dissolve 0.200 g in 50 mL of *anhydrous acetic acid R*. Titrate with 0.1 M *perchloric acid* determining the end-point potentiometrically (2.2.20).

1 mL of 0.1 M *perchloric acid* is equivalent to 25.79 mg of  $C_{18}H_{32}ClN_3O_8P_2$ .

## STORAGE

In an airtight container, protected from light.

01/2008:0545

## CHLOROQUINE SULFATE

## Chloroquini sulfas

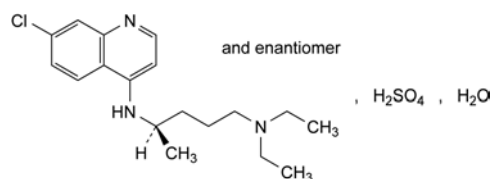
 $C_{18}H_{28}ClN_3O_4S \cdot H_2O$ 
 $M_r$  436.0

## DEFINITION

Chloroquine sulfate contains not less than 98.5 per cent and not more than the equivalent of 101.0 per cent of  $N^7$ -(7-chloroquinolin-4-yl)- $N^1,N^1$ -diethylpentane-1,4-diamine sulfate, calculated with reference to the anhydrous substance.

## CHARACTERS

A white or almost white, crystalline powder, freely soluble in water and in methanol, very slightly soluble in ethanol (96 per cent).

It melts at about 208 °C (instantaneous method).

## IDENTIFICATION

First identification: B, D.

Second identification: A, C, D.

- A. Dissolve 0.100 g in *water R* and dilute to 100.0 mL with the same solvent. Dilute 1.0 mL of this solution to 100.0 mL with *water R*. Examined between 210 nm and 370 nm (2.2.25), the solution shows absorption maxima at 220 nm, 235 nm, 256 nm, 329 nm and 342 nm. The specific absorbances at the maxima are respectively 730 to 810, 430 to 470, 370 to 410, 400 to 440 and 430 to 470.
- B. Examine by infrared absorption spectrophotometry (2.2.24), comparing with the spectrum obtained with the base isolated from *chloroquine sulfate CRS*. Record the spectra using solutions prepared as follows: dissolve separately 0.1 g of the substance to be examined and of the reference substance in 10 mL of *water R*, add 2 mL of *dilute sodium hydroxide solution R* and shake with 2 quantities, each of 20 mL, of *methylene chloride R*; combine the organic layers, wash with *water R*, dry over *anhydrous sodium sulfate R*, evaporate to dryness and dissolve the residues separately each in 2 mL of *methylene chloride R*.
- C. Dissolve 25 mg in 20 mL of *water R* and add 8 mL of *picric acid solution R1*. The precipitate, washed with *water R*, with *ethanol (96 per cent) R* and finally with *ether R*, melts (2.2.14) at 206 °C to 209 °C.
- D. It gives reaction (a) of sulfates (2.3.1).

## TESTS

**Solution S.** Dissolve 2.0 g in *carbon dioxide-free water R* and dilute to 25 mL with the same solvent.

**Appearance of solution.** Solution S is clear (2.2.1) and not more intensely coloured than reference solution BY<sub>5</sub> or GY<sub>5</sub> (2.2.2, *Method II*).

**pH** (2.2.3). The pH of solution S is 4.0 to 5.0.

**Related substances.** Examine by thin-layer chromatography (2.2.27), using *silica gel GF<sub>254</sub> R* as the coating substance.

**Test solution.** Dissolve 0.50 g of the substance to be examined in *water R* and dilute to 10 mL with the same solvent.

**Reference solution (a).** Dilute 1 mL of the test solution to 100 mL with *water R*.

**Reference solution (b).** Dilute 5 mL of reference solution (a) to 10 mL with *water R*.

Apply separately to the plate 2 µL of each solution. Develop over a path of 12 cm using a mixture of 10 volumes of *diethylamine R*, 40 volumes of *cyclohexane R* and 50 volumes of *methylene chloride R*. Allow the plate to dry in air. Examine in ultraviolet light at 254 nm. Any spot in the chromatogram obtained with the test solution, apart from the principal spot, is not more intense than the spot in the chromatogram obtained with reference solution (a) (1.0 per cent) and not more than one such spot is more intense than the spot in the chromatogram obtained with reference solution (b) (0.5 per cent).

**Heavy metals** (2.4.8). Dissolve 2.0 g in 10 mL of *water R*. Add 5 mL of *concentrated ammonia R* and shake with 40 mL of *ether R*. Filter the aqueous layer and neutralise the filtrate with *glacial acetic acid R*. Heat on a water-bath to eliminate ether, allow to cool and dilute to 20.0 mL with *water R*. 12 mL of this solution complies with test A (20 ppm). Prepare the reference solution using *lead standard solution (2 ppm Pb) R*.

**Water** (2.5.12): 3.0 per cent to 5.0 per cent, determined on 0.500 g.

**Sulfated ash** (2.4.14). Not more than 0.1 per cent, determined on 1.0 g.

## ASSAY

Dissolve 0.400 g in 50 mL of *anhydrous acetic acid R*. Titrate with 0.1 M *perchloric acid* determining the end-point potentiometrically (2.2.20).

1 mL of 0.1 M *perchloric acid* is equivalent to 41.8 mg of C<sub>18</sub>H<sub>28</sub>ClN<sub>3</sub>O<sub>4</sub>S.

## STORAGE

Store in an airtight container, protected from light.

01/2008:0385  
corrected 6.0

## CHLOROTHIAZIDE

## Chlorothiazidum

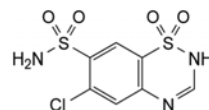

C<sub>7</sub>H<sub>6</sub>ClN<sub>3</sub>O<sub>4</sub>S<sub>2</sub>  
[58-94-6]

M<sub>r</sub> 295.7

## DEFINITION

Chlorothiazide contains not less than 98.0 per cent and not more than the equivalent of 102.0 per cent of 6-chloro-2H-1,2,4-benzothiazine-7-sulfonamide 1,1-dioxide, calculated with reference to the dried substance.

## CHARACTERS

A white or almost white, crystalline powder, very slightly soluble in water, sparingly soluble in acetone, slightly soluble in alcohol. It dissolves in dilute solutions of alkali hydroxides.

## IDENTIFICATION

*First identification:* B, C.

*Second identification:* A, C, D.

- A. Dissolve 80.0 mg in 100 mL of 0.1 M *sodium hydroxide* and dilute to 1000.0 mL with *water R*. Dilute 10.0 mL of the solution to 100.0 mL with 0.01 M *sodium hydroxide*. Examined between 220 nm and 320 nm (2.2.25), the solution shows 2 absorption maxima, at 225 nm and 292 nm, and a shoulder at about 310 nm. The specific absorbances at the maxima are 725 to 800 and 425 to 455, respectively.
- B. Examine by infrared absorption spectrophotometry (2.2.24), comparing with the spectrum obtained with *chlorothiazide CRS*.
- C. Examine by thin-layer chromatography (2.2.27), using *silica gel GF<sub>254</sub> R* as the coating substance.  
**Test solution.** Dissolve 25 mg of the substance to be examined in *acetone R* and dilute to 5 mL with the same solvent.  
**Reference solution.** Dissolve 25 mg of *chlorothiazide CRS* in *acetone R* and dilute to 5 mL with the same solvent.  
Apply to the plate 2 µL of each solution. Develop over a path of 10 cm using *ethyl acetate R*. Dry the plate in a current of air and examine in ultraviolet light at 254 nm. The principal spot in the chromatogram obtained with the test solution is similar in position and size to the principal spot in the chromatogram obtained with the reference solution.
- D. To 0.1 g add a pellet of *sodium hydroxide R* and heat strongly. Gas is evolved which turns *red litmus paper R* blue. After cooling, take up the residue with 10 mL of *dilute hydrochloric acid R*. Gas is evolved which turns *lead acetate paper R* black.

## TESTS

**Solution S.** To 1.0 g of the powdered substance to be examined add 50 mL of *water R*, shake for 2 min and filter.

**Acidity or alkalinity.** To 10 mL of solution S add 0.2 mL of 0.01 M *sodium hydroxide* and 0.15 mL of *methyl red solution R*. The solution is yellow. Not more than 0.4 mL of 0.01 M *hydrochloric acid* is required to change the colour of the indicator to red.

**Related substances.** Examine by thin-layer chromatography (2.2.27), using *silica gel G R* as the coating substance.

**Test solution.** Dissolve 25 mg of the substance to be examined in *acetone R* and dilute to 5 mL with the same solvent.

**Reference solution.** Dilute 1 mL of the test solution to 100 mL with *acetone R*.

Apply to the plate 5 µL of each solution. Develop over a path of 15 cm using a mixture of 15 volumes of *2-propanol R* and 85 volumes of *ethyl acetate R*. Dry the plate in a current of air until the solvents have evaporated (about 10 min) and spray with a mixture of equal volumes of *alcoholic solution of sulfuric acid R* and *alcohol R*; use about 10 mL for a plate 200 mm square and spray in small portions, allowing the solvent to evaporate each time to avoid excessive wetting. Heat at 100-105 °C for 30 min and immediately place the plate above, but not in contact with, 10 mL of a saturated solution of *sodium nitrite R* in a glass tank. Carefully add 0.5 mL of *sulfuric acid R* to the sodium nitrite solution, close the tank, and allow to stand for 15 min. Remove the plate, heat in a ventilated oven at 40 °C for 15 min and spray with 3 quantities, each of 5 mL, of a freshly prepared 5 g/L solution of *naphthylethylenediamine dihydrochloride R* in *alcohol R*. Examine the plate by transmitted light. Any spot in the chromatogram obtained with the test solution, apart from the principal spot, is not more intense than the spot in the chromatogram obtained with the reference solution (1.0 per cent).

**Chlorides (2.4.4).** 15 mL of solution S complies with the limit test for chlorides (160 ppm).

**Heavy metals (2.4.8).** 1.0 g complies with limit test C for heavy metals (20 ppm). Prepare the standard using 2 mL of *lead standard solution (10 ppm Pb) R*.

**Loss on drying (2.2.32).** Not more than 1.0 per cent, determined on 1.000 g by drying in an oven at 105 °C.

**Sulfated ash (2.4.14).** Not more than 0.1 per cent, determined on 1.0 g.

#### ASSAY

Dissolve 0.250 g in 50 mL of *dimethylformamide R*. Titrate with 0.1 M *tetrabutylammonium hydroxide in 2-propanol* determining the end-point potentiometrically (2.2.20) at the first point of inflexion. Carry out a blank titration.

1 mL of 0.1 M *tetrabutylammonium hydroxide in 2-propanol* is equivalent to 29.57 mg of C<sub>7</sub>H<sub>6</sub>ClN<sub>3</sub>O<sub>4</sub>S<sub>2</sub>.

04/2008:0386

## CHLORPHENAMINE MALEATE

### Chlorphenamini maleas

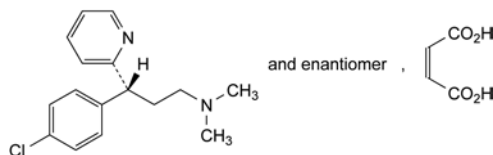

C<sub>20</sub>H<sub>23</sub>ClN<sub>2</sub>O<sub>4</sub>  
[113-92-8]

M<sub>r</sub> 390.9

#### DEFINITION

(3*RS*)-3-(4-Chlorophenyl)-*N,N*-dimethyl-3-(pyridin-2-yl)propan-1-amine hydrogen (*Z*)-butenedioate.

**Content:** 98.0 per cent to 101.0 per cent (dried substance).

#### CHARACTERS

**Appearance:** white or almost white, crystalline powder.

**Solubility:** freely soluble in water, soluble in ethanol (96 per cent).

#### IDENTIFICATION

A. Melting point (2.2.14): 130 °C to 135 °C.

B. Infrared absorption spectrophotometry (2.2.24).

*Comparison:* chlorphenamine maleate CRS.

C. Optical rotation (see Tests).

#### TESTS

**Solution S.** Dissolve 2.0 g in *water R* and dilute to 20.0 mL with the same solvent.

**Appearance of solution.** Solution S is clear (2.2.1) and not more intensely coloured than reference solution BY<sub>6</sub> (2.2.2, Method II).

**Optical rotation (2.2.7):** −0.10° to +0.10°, determined on solution S.

**Related substances.** Liquid chromatography (2.2.29).

**Test solution.** Dissolve 0.100 g of the substance to be examined in the mobile phase and dilute to 100.0 mL with the mobile phase.

**Reference solution (a).** Dilute 0.5 mL of the test solution to 100.0 mL with the mobile phase.

**Reference solution (b).** Dilute 1.0 mL of reference solution (a) to 10.0 mL with the mobile phase.

**Reference solution (c).** Dissolve 5 mg of *chlorphenamine impurity C CRS* in 5 mL of the test solution and dilute to 50.0 mL with the mobile phase. Dilute 2 mL of this solution to 20 mL with the mobile phase.

**Reference solution (d).** Dissolve 5 mg of *2,2'-dipyridylamine R* (impurity B) in the mobile phase and dilute to 100 mL with the mobile phase.

**Reference solution (e).** Dissolve the contents of a vial of *chlorphenamine impurity A CRS* in 2 mL of the test solution. Sonicate for 5 min.

**Column:**

– size: *l* = 0.30 m, Ø = 3.9 mm;

– stationary phase: octadecylsilyl silica gel for chromatography R (10 µm).

**Mobile phase:** mix 20 volumes of *acetonitrile R* and 80 volumes of a 8.57 g/L solution of *ammonium dihydrogen phosphate R* previously adjusted to pH 3.0 with *phosphoric acid R*.

**Flow rate:** 1.2 mL/min.

**Detection:** spectrophotometer at 225 nm.

**Injection:** 20 µL.

**Run time:** 3.5 times the retention time of chlorphenamine.

**Relative retention** with reference to chlorphenamine (retention time = about 11 min): maleic acid = about 0.2; impurity A = about 0.3; impurity B = about 0.4; impurity C = about 0.9; impurity D = about 3.0.

**System suitability:** reference solution (c):

– **resolution:** minimum 1.5 between the peaks due to impurity C and chlorphenamine.

**Limits:**

– **correction factors:** for the calculation of contents, multiply the peak areas of the following impurities by the corresponding correction factor: impurity A = 1.5; impurity B = 1.4;

– **impurity A:** not more than 0.4 times the area of the principal peak in the chromatogram obtained with reference solution (a) (0.2 per cent);

– **impurities B, C, D:** for each impurity, not more than 0.2 times the area of the principal peak in the chromatogram obtained with reference solution (a) (0.1 per cent);

– **unspecified impurities:** for each impurity, not more than 0.2 times the area of the principal peak in the chromatogram obtained with reference solution (a) (0.10 per cent);

- *total*: not more than the area of the principal peak in the chromatogram obtained with reference solution (a) (0.5 per cent);
- *disregard limit*: the area of the principal peak in the chromatogram obtained with reference solution (b) (0.05 per cent); disregard the peaks due to the blank and maleic acid.

01/2008:0475  
corrected 7.0

**Heavy metals** (2.4.8): maximum 20 ppm.

1.0 g complies with test C. Prepare the reference solution using 2 mL of *lead standard solution* (10 ppm Pb) R.

**Loss on drying** (2.2.32): maximum 0.5 per cent, determined on 1.000 g by drying in an oven at 105 °C for 4 h.

**Sulfated ash** (2.4.14): maximum 0.1 per cent, determined on 1.0 g.

#### ASSAY

Dissolve 0.150 g in 25 mL of *anhydrous acetic acid* R. Titrate with 0.1 M *perchloric acid*, determining the end-point potentiometrically (2.2.20).

1 mL of 0.1 M *perchloric acid* is equivalent to 19.54 mg of C<sub>20</sub>H<sub>23</sub>ClN<sub>2</sub>O<sub>4</sub>.

#### STORAGE

Protected from light.

#### IMPURITIES

*Specified impurities: A, B, C, D.*

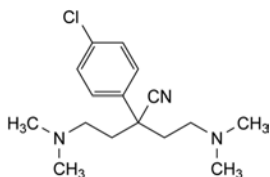

- A. 2-(4-chlorophenyl)-4-(dimethylamino)-2-[2-(dimethylamino)ethyl]butanenitrile,

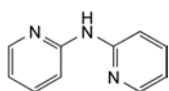

- B. *N*-(pyridin-2-yl)pyridin-2-amine (2,2'-dipyridylamine),

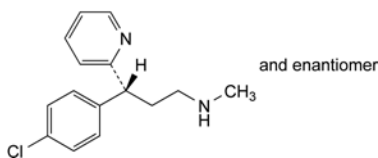

- C. (3*RS*)-3-(4-chlorophenyl)-*N*-methyl-3-(pyridin-2-yl)propan-1-amine,

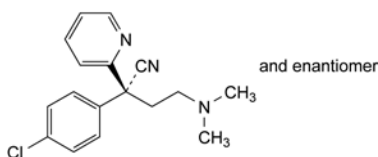

- D. (2*RS*)-2-(4-chlorophenyl)-4-(dimethylamino)-2-(pyridin-2-yl)butanenitrile.

## CHLORPROMAZINE HYDROCHLORIDE

### Chlorpromazini hydrochloridum

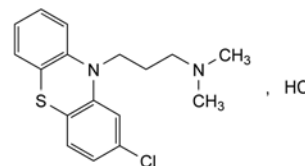

C<sub>17</sub>H<sub>20</sub>Cl<sub>2</sub>N<sub>2</sub>S  
[69-09-0]

*M*<sub>r</sub> 355.3

#### DEFINITION

3-(2-Chloro-10*H*-phenothiazin-10-yl)-*N,N*-dimethylpropan-1-amine hydrochloride.

*Content*: 99.0 per cent to 101.0 per cent (dried substance).

#### CHARACTERS

*Appearance*: white or almost white, crystalline powder.

*Solubility*: very soluble in water, freely soluble in ethanol (96 per cent).

It decomposes on exposure to air and light.

mp: about 196 °C.

#### IDENTIFICATION

*First identification: B, D.*

*Second identification: A, C, D.*

- A. Ultraviolet and visible absorption spectrophotometry (2.2.25). Prepare the solutions protected from bright light and measure the absorbances immediately.

*Test solution*. Dissolve 50.0 mg in a 10.3 g/L solution of *hydrochloric acid* R and dilute to 500.0 mL with the same solution. Dilute 5.0 mL of the solution to 100.0 mL with a 10.3 g/L solution of *hydrochloric acid* R.

*Spectral range*: 230-340 nm.

*Absorption maximum*: at 254 nm and 306 nm.

*Specific absorbance at the absorption maximum*:

– at 254 nm: 890 to 960.

- B. Infrared absorption spectrophotometry (2.2.24).

*Comparison*: *chlorpromazine hydrochloride* CRS.

- C. Identification test for phenothiazines by thin-layer chromatography (2.3.3): use *chlorpromazine hydrochloride* CRS to prepare the reference solution.

- D. It gives reaction (b) of chlorides (2.3.1).

#### TESTS

**pH** (2.2.3): 3.5 to 4.5. Carry out the test protected from light and use freshly prepared solutions.

Dissolve 1.0 g in *carbon dioxide-free water* R and dilute to 10 mL with the same solvent.

**Related substances**. Liquid chromatography (2.2.29). Carry out the test protected from light and use freshly prepared solutions.

*Test solution*. Dissolve 40 mg of the substance to be examined in the mobile phase and dilute to 100.0 mL with the mobile phase.

*Reference solution (a)*. Dissolve 4 mg of *chlorpromazine impurity D* CRS in the mobile phase and dilute to 10.0 mL with the mobile phase. To 1 mL of this solution add 1 mL of the test solution and dilute to 100.0 mL with the mobile phase.

*Reference solution (b)*. Dilute 1.0 mL of the test solution to 20.0 mL with the mobile phase. Dilute 1.0 mL of this solution to 10.0 mL with the mobile phase.



**Reference solution (c).** Dissolve 4.0 mg of *chlorpromazine impurity A CRS* in the mobile phase and dilute to 100.0 mL with the mobile phase. Dilute 1.0 mL of this solution to 100.0 mL with the mobile phase.

**Reference solution (d).** Dissolve 4 mg of *promazine hydrochloride CRS* (impurity C) and 4.0 mg of *chlorpromazine impurity E CRS* in the mobile phase and dilute to 100.0 mL with the mobile phase. Dilute 1.0 mL of this solution to 100.0 mL with the mobile phase.

**Column:**

- size:  $l = 0.25$  m,  $\varnothing = 4.0$  mm,
- stationary phase: base-deactivated octylsilyl silica gel for chromatography R (5  $\mu$ m).

**Mobile phase:** mix 0.2 volumes of *thiodiethylene glycol R* with 50 volumes of *acetonitrile R* and 50 volumes of a 0.5 per cent V/V solution of *trifluoroacetic acid R* previously adjusted to pH 5.3 with *tetramethylethylenediamine R*.

**Flow rate:** 1.0 mL/min.

**Detection:** spectrophotometer at 254 nm.

**Injection:** 10  $\mu$ L.

**Run time:** 4 times the retention time of chlorpromazine.

**Relative retention** with reference to chlorpromazine (retention time = about 8 min): impurity A = about 0.4; impurity B = about 0.5; impurity C = about 0.7; impurity D = about 0.9; impurity E = about 3.4.

**System suitability:** reference solution (a):

- resolution: minimum 2.0 between the peaks due to impurity D and chlorpromazine.

**Limits:**

- **impurity A:** not more than the area of the corresponding peak in the chromatogram obtained with reference solution (c) (0.1 per cent);
- **impurities B, C, D:** for each impurity, not more than 0.6 times the area of the principal peak in the chromatogram obtained with reference solution (b) (0.3 per cent);
- **impurity E:** not more than the area of the corresponding peak in the chromatogram obtained with reference solution (d) (0.1 per cent);
- **any other impurity:** for each impurity, not more than 0.2 times the area of the principal peak in the chromatogram obtained with reference solution (b) (0.1 per cent);
- **total:** not more than twice the area of the principal peak in the chromatogram obtained with reference solution (b) (1.0 per cent);
- **disregard limit:** 0.1 times the area of the principal peak in the chromatogram obtained with reference solution (b) (0.05 per cent).

**Heavy metals (2.4.8):** maximum 10 ppm.

1.0 g complies with test C. Prepare the reference solution using 1 mL of *lead standard solution (10 ppm Pb) R*.

**Loss on drying (2.2.32):** maximum 0.5 per cent, determined on 1.000 g by drying in an oven at 105 °C.

**Sulfated ash (2.4.14):** maximum 0.1 per cent, determined on 1.0 g.

**ASSAY**

Dissolve 0.250 g in a mixture of 5.0 mL of 0.1 M *hydrochloric acid* and 50 mL of *ethanol (96 per cent) R*. Carry out a potentiometric titration (2.2.20), using 0.1 M *sodium hydroxide*. Read the volume added between the 2 points of inflexion.

1 mL of 0.1 M *sodium hydroxide* is equivalent to 35.53 mg of  $C_{17}H_{20}Cl_2N_2S$ .

**STORAGE**

In an airtight container, protected from light.

**IMPURITIES**

**Specified impurities:** A, B, C, D, E.

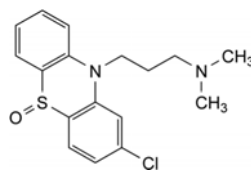

A. 3-(2-chloro-10H-phenothiazin-10-yl)-*N,N*-dimethylpropan-1-amine *S*-oxide (chlorpromazine sulfoxide),

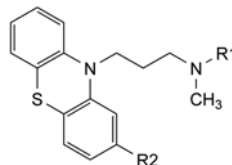

B. R1 =  $[CH_2]_3-N(CH_3)_2$ , R2 = Cl: *N*-[3-(2-chloro-10H-phenothiazin-10-yl)propyl]-*N,N',N'*-trimethylpropane-1,3-diamine,

C. R1 =  $CH_3$ , R2 = H: 3-(10H-phenothiazin-10-yl)-*N,N*-dimethylpropan-1-amine (promazine),

D. R1 = H, R2 = Cl: 3-(2-chloro-10H-phenothiazin-10-yl)-*N*-methylpropan-1-amine (desmethylchlorpromazine),

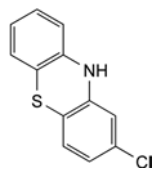

E. 2-chloro-10H-phenothiazine.

01/2008:1087  
corrected 6.0

## CHLORPROPAMIDE

### Chlorpropamidum

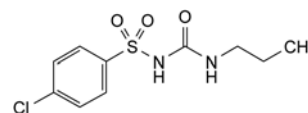

$C_{10}H_{13}ClN_2O_3S$   
[94-20-2]

$M_r$  276.7

#### DEFINITION

Chlorpropamide contains not less than 99.0 per cent and not more than the equivalent of 101.0 per cent of 1-[(4-chlorophenyl)sulfonyl]-3-propylurea, calculated with reference to the dried substance.

#### CHARACTERS

A white or almost white, crystalline powder, practically insoluble in water, freely soluble in acetone and in methylene chloride, soluble in alcohol. It dissolves in dilute solutions of alkali hydroxides.

It shows polymorphism (5.9).

#### IDENTIFICATION

**First identification:** C, D.

**Second identification:** A, B, D.

A. Melting point (2.2.14): 126 °C to 130 °C.

B. Dissolve 0.10 g in *methanol R* and dilute to 50.0 mL with the same solvent. Dilute 5.0 mL of the solution to 100.0 mL with 0.01 M *hydrochloric acid*. Dilute 10.0 mL of the solution to 100.0 mL with 0.01 M *hydrochloric acid*. Examined between 220 nm and 350 nm (2.2.25), the solution shows an absorption maximum at 232 nm. The specific absorption at the maximum is 570 to 630.

- C. Examine by infrared absorption spectrophotometry (2.2.24), comparing with the spectrum obtained with *chlorpropamide CRS*. Examine the substances prepared as discs. If the spectra obtained show differences, dissolve the substance to be examined and the reference substance in *methylene chloride R*, evaporate to dryness and record the new spectra using the residues.
- D. Heat 0.1 g with 2 g of *anhydrous sodium carbonate R* until a dull red colour appears for 10 min. Allow to cool, extract the residue with about 5 mL of *water R*, dilute to 10 mL with *water R* and filter. The solution gives the reaction (a) of chloride (2.3.1).

## TESTS

**Related substances.** Examine by thin-layer chromatography (2.2.27), using a suitable silica gel as the coating substance.

**Test solution.** Dissolve 0.50 g of the substance to be examined in *acetone R* and dilute to 10 mL with the same solvent.

**Reference solution (a).** Dissolve 15 mg of *4-chlorobenzene-sulfonamide R* (chlorpropamide impurity A) in *acetone R* and dilute to 100 mL with the same solvent.

**Reference solution (b).** Dissolve 15 mg of *chlorpropamide impurity B CRS* in *acetone R* and dilute to 100 mL with the same solvent.

**Reference solution (c).** Dilute 0.3 mL of the test solution to 100 mL with *acetone R*.

**Reference solution (d).** Dilute 5 mL of reference solution (c) to 15 mL with *acetone R*.

**Reference solution (e).** Dissolve 0.10 g of the substance to be examined, 5 mg of *4-chlorobenzenesulfonamide R* and 5 mg of *chlorpropamide impurity B CRS* in *acetone R* and dilute to 10 mL with the same solvent.

Apply to the plate 5 µL of each solution. Develop over a path of 15 cm using a mixture of 11.5 volumes of *concentrated ammonia R*, 30 volumes of *cyclohexane R*, 50 volumes of *methanol R* and 100 volumes of *methylene chloride R*. Allow the plate to dry in a current of cold air, heat at 110 °C for 10 min. At the bottom of a chromatographic tank, place an evaporating dish containing a mixture of 1 volume of *hydrochloric acid R*, 1 volume of *water R* and 2 volumes of a 50 g/L solution of *potassium permanganate R*, close the tank and allow to stand for 15 min. Place the dried hot plate in the tank and close the tank. Leave the plate in contact with the chlorine vapour for 2 min. Withdraw the plate and place it in a current of cold air until the excess of chlorine is removed and an area of coating below the points of application does not give a blue colour with a drop of *potassium iodide and starch solution R*. Spray with *potassium iodide and starch solution R*. In the chromatogram obtained with the test solution: any spot corresponding to impurity A is not more intense than the spot in the chromatogram obtained with reference solution (a) (0.3 per cent); any spot corresponding to impurity B is not more intense than the spot in the chromatogram obtained with reference solution (b) (0.3 per cent); any spot, apart from the principal spot and any spot corresponding to impurity A and B, is not more intense than the spot in the chromatogram obtained with reference solution (c) (0.3 per cent); not more than two such spots are more intense than the spot in the chromatogram obtained with reference solution (d) (0.1 per cent). The test is not valid unless the chromatogram obtained with reference solution (e) shows three clearly separated spots with approximate  $R_f$  values of 0.4, 0.6 and 0.9 corresponding to chlorpropamide, impurity A and impurity B respectively.

**Heavy metals (2.4.8).** Dissolve 2.0 g in a mixture of 15 volumes of *water R* and 85 volumes of *acetone R* and dilute to 20 mL with the same mixture of solvents. 12 mL of solution complies with limit test B for heavy metals (20 ppm). Prepare the standard using lead standard solution (2 ppm Pb) prepared by diluting *lead standard solution (100 ppm Pb) R* with a mixture of 15 volumes of *water R* and 85 volumes of *acetone R*.

**Loss on drying (2.2.32).** Not more than 0.5 per cent, determined on 1.000 g by drying in an oven at 100 °C to 105 °C.

**Sulfated ash (2.4.14).** Not more than 0.1 per cent, determined on 1.0 g.

## ASSAY

Dissolve 0.250 g in 50 mL of *alcohol R* previously neutralised using *phenolphthalein solution R1* as indicator and add 25 mL of *water R*. Titrate with 0.1 M *sodium hydroxide* until a pink colour is obtained.

1 mL of 0.1 M *sodium hydroxide* is equivalent to 27.67 mg of  $C_{10}H_{13}ClN_2O_3S$ .

## STORAGE

Store protected from light.

## IMPURITIES

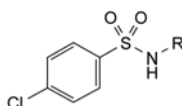

A. R = H: 4-chlorobenzenesulfonamide,

C. R = CO-NH<sub>2</sub>: [(4-chlorophenyl)sulfonyl]urea.

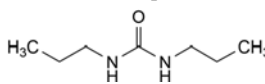

B. 1,3-dipropylurea,

01/2008:0815

## CHLORPROTHIXENE HYDROCHLORIDE

## Chlorprothixeni hydrochloridum

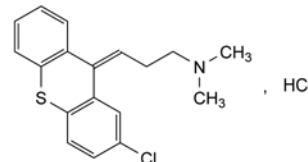

$C_{18}H_{19}Cl_2NS$   
[6469-93-8]

$M_r$  352.3

## DEFINITION

(Z)-3-(2-Chloro-9H-thioxanthen-9-ylidene)-N,N-dimethylpropan-1-amine hydrochloride.

**Content:** 99.0 per cent to 101.0 per cent (dried substance).

## CHARACTERS

**Appearance:** white or almost white, crystalline powder.

**Solubility:** soluble in water and in alcohol, slightly soluble in methylene chloride.

mp: about 220 °C.

## IDENTIFICATION

**First identification:** A, E.

**Second identification:** B, C, D, E.

A. Infrared absorption spectrophotometry (2.2.24).

**Preparation:** dissolve 0.25 g in 10 mL of *water R*. Add 1 mL of *dilute sodium hydroxide solution R*. Shake with 20 mL of *methylene chloride R*. Separate the organic layer and wash with 5 mL of *water R*. Evaporate the organic layer to dryness and dry the residue at 40-50 °C. Examine the residues prepared as discs.

**Comparison:** *chlorprothixene hydrochloride CRS*.

B. Dissolve 0.2 g in a mixture of 5 mL of *dioxan R* and 5 mL of a 1.5 g/L solution of *sodium nitrite R*. Add 0.8 mL of *nitric acid R*. After 10 min add the solution to 20 mL of *water R*. 1 h later filter the precipitate formed. The filtrate

is used immediately for identification test C. Dissolve the precipitate by warming in about 15 mL of *alcohol R* and add the solution to 10 mL of *water R*. Filter and dry the precipitate at 100-105 °C for 2 h. The melting point (2.2.14) is 152 °C to 154 °C.

- C. To 1 mL of the filtrate obtained in identification test B, add 0.2 mL of a suspension of 50 mg of *fast red B salt R* in 1 mL of *alcohol R*. Add 1 mL of 0.5 M *alcoholic potassium hydroxide*. A dark red colour is produced. Carry out a blank test.
- D. Dissolve about 20 mg in 2 mL of *nitric acid R*. A red colour is produced. Add 5 mL of *water R* and examine in ultraviolet light at 365 nm. The solution shows green fluorescence.
- E. It gives reaction (a) of chlorides (2.3.1).

#### TESTS

**Solution S.** Dissolve 0.25 g in *carbon dioxide-free water R* and dilute to 25 mL with the same solvent.

**Appearance of solution.** Solution S is clear (2.2.1) and colourless (2.2.2, *Method II*).

**pH** (2.2.3): 4.4 to 5.2 for solution S.

**Related substances.** Liquid chromatography (2.2.29). Carry out the test protected from bright light.

**Test solution.** Dissolve 20.0 mg of the substance to be examined in the mobile phase and dilute to 20.0 mL with the mobile phase.

**Reference solution (a).** Dissolve 20.0 mg of *chlorprothixene hydrochloride CRS* (with a defined content of *E*-isomer) in the mobile phase and dilute to 20.0 mL with the mobile phase.

**Reference solution (b).** Dilute 2.0 mL of the test solution to 100.0 mL with the mobile phase. Dilute 3.0 mL of this solution to 20.0 mL with the mobile phase.

**Column:**

- size:  $l = 0.12$  m,  $\emptyset = 4.0$  mm,
- stationary phase: base-deactivated octadecylsilyl silica gel for chromatography R (3  $\mu$ m or 5  $\mu$ m).

**Mobile phase:** solution containing 6.0 g/L of *potassium dihydrogen phosphate R*, 2.9 g/L of *sodium laurilsulfate R* and 9 g/L of *tetrabutylammonium bromide R* in a mixture of 50 volumes of *methanol R*, 400 volumes of *acetonitrile R* and 550 volumes of *distilled water R*.

**Flow rate:** 1.5 mL/min.

**Detection:** spectrophotometer at 254 nm.

**Equilibration:** for about 30 min with the mobile phase.

**Injection:** 20  $\mu$ L.

**Run time:** twice the retention time of chlorprothixene.

**Relative retention** with reference to chlorprothixene: impurity E = about 1.55.

**System suitability:** reference solution (a):

- retention time: chlorprothixene = about 10 min,
- relative retention with reference to chlorprothixene: *E*-isomer = about 1.35.

**Limits:**

- *E*-isomer: not more than 2.0 per cent, calculated from the area of the corresponding peak in the chromatogram obtained with reference solution (a) and taking into account the assigned content of this isomer in *chlorprothixene hydrochloride CRS*,
- impurity E: not more than 3 times the area of the principal peak in the chromatogram obtained with reference solution (b) (0.3 per cent taking into account a response factor of 3),
- any other impurity: not more than the area of the principal peak in the chromatogram obtained with reference solution (b) (0.3 per cent),
- total of any other impurity: not more than 2.33 times the area of the principal peak in the chromatogram obtained with reference solution (b) (0.7 per cent),

- disregard limit: 0.1 times the area of the principal peak in the chromatogram obtained with reference solution (b) (0.03 per cent).

**Heavy metals** (2.4.8): maximum 20 ppm.

1.0 g complies with limit test F. Prepare the standard using 2 mL of *lead standard solution (10 ppm Pb) R*.

**Loss on drying** (2.2.32): maximum 0.5 per cent, determined on 1.000 g by drying *in vacuo* at 60 °C for 3 h.

**Sulfated ash** (2.4.14): maximum 0.1 per cent, determined on 1.0 g.

#### ASSAY

Dissolve 0.300 g in a mixture of 5.0 mL of 0.01 M *hydrochloric acid* and 50 mL of *alcohol R*. Carry out a potentiometric titration (2.2.20), using 0.1 M *sodium hydroxide*. Read the volume added between the 2 points of inflexion.

1 mL of 0.1 M *sodium hydroxide* is equivalent to 35.23 mg of  $C_{18}H_{19}Cl_2NS$ .

#### STORAGE

Protected from light.

#### IMPURITIES

**Specified impurities:** A, B, C, D, E, F.

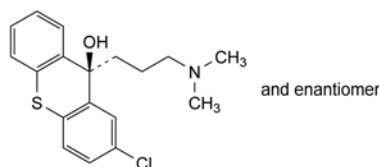

A. (*RS*)-2-chloro-9-[3-(dimethylamino)propyl]-9*H*-thioxanthen-9-ol,

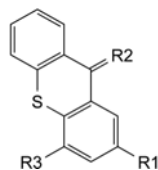

B. R1 = H, R2 = CH-CH<sub>2</sub>-CH<sub>2</sub>-N(CH<sub>3</sub>)<sub>2</sub>, R3 = H: *N,N*-dimethyl-3-(9*H*-thioxanthen-9-ylidene)propan-1-amine,

C. R1 = Cl, R2 = CH-CH<sub>2</sub>-CH<sub>2</sub>-NH-CH<sub>3</sub>, R3 = H: (*Z*)-3-(2-chloro-9*H*-thioxanthen-9-ylidene)-*N*-methylpropan-1-amine,

D. R1 = H, R2 = CH-CH<sub>2</sub>-CH<sub>2</sub>-N(CH<sub>3</sub>)<sub>2</sub>, R3 = Cl: (*Z*)-3-(4-chloro-9*H*-thioxanthen-9-ylidene)-*N,N*-dimethylpropan-1-amine,

E. R1 = Cl, R2 = O, R3 = H: 2-chloro-9*H*-thioxanthen-9-one,

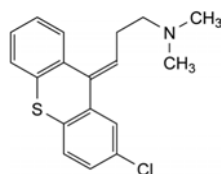

F. (*E*)-3-(2-chloro-9*H*-thioxanthen-9-ylidene)-*N,N*-dimethylpropan-1-amine (*E*-isomer).

01/2008:0546

## CHLORTALIDONE

### Chlortalidonum

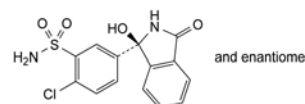

$C_{14}H_{11}ClN_2O_4S$   
[77-36-1]

$M_r$  338.8

## DEFINITION

2-Chloro-5-[(1*R,S*)-1-hydroxy-3-oxo-2,3-dihydro-1*H*-isoindol-1-yl]benzenesulfonamide.

*Content*: 97.0 per cent to 102.0 per cent (dried substance).

## CHARACTERS

*Appearance*: white or yellowish-white powder.

*Solubility*: very slightly soluble in water, soluble in acetone and in methanol, practically insoluble in methylene chloride. It dissolves in dilute solutions of alkali hydroxides.

It shows polymorphism (5.9).

## IDENTIFICATION

Infrared absorption spectrophotometry (2.2.24).

*Comparison*: chlortalidone CRS.

If the spectra obtained in the solid state show differences, dissolve the substance to be examined and the reference substance separately in *methanol R*, evaporate to dryness and record new spectra using the residues.

## TESTS

**Acidity**. Dissolve 1.0 g with heating in a mixture of 25 mL of *acetone R* and 25 mL of *carbon dioxide-free water R*. Cool. Titrate with 0.1 M *sodium hydroxide*, determining the end-point potentiometrically (2.2.20). Not more than 0.75 mL of 0.1 M *sodium hydroxide* is required.

**Related substances**. Liquid chromatography (2.2.29).

*Solvent mixture*. Mix 2 volumes of a 2 g/L solution of *sodium hydroxide R*, 48 volumes of mobile phase B and 50 volumes of mobile phase A.

*Test solution (a)*. Dissolve 50.0 mg of the substance to be examined in the solvent mixture and dilute to 50.0 mL with the solvent mixture.

*Test solution (b)*. Dilute 10.0 mL of test solution (a) to 100.0 mL with the solvent mixture.

*Reference solution (a)*. Dilute 1.0 mL of test solution (a) to 100.0 mL with the solvent mixture. Dilute 1.0 mL of this solution to 10.0 mL with the solvent mixture.

*Reference solution (b)*. Dissolve the contents of a vial of *chlortalidone for peak identification CRS* (containing impurities B, G and J) in 1 mL of the solvent mixture.

*Reference solution (c)*. Dissolve 50.0 mg of *chlortalidone CRS* in the solvent mixture and dilute to 50.0 mL with the solvent mixture. Dilute 10.0 mL of this solution to 100.0 mL with the solvent mixture.

*Column*:

- *size*:  $l = 0.25$  m,  $\varnothing = 4.6$  mm;
- *stationary phase*: octylsilyl silica gel for chromatography R (5  $\mu$ m);
- *temperature*: 40 °C.

*Mobile phase*:

- *mobile phase A*: dissolve 1.32 g of *ammonium phosphate R* in about 900 mL of *water R* and adjust to pH 5.5 with *dilute phosphoric acid R*; dilute to 1000 mL with *water R*;
- *mobile phase B*: *methanol R2*;

Time (min)	Mobile phase A (per cent V/V)	Mobile phase B (per cent V/V)
0 - 16	65	35
16 - 21	65 → 50	35 → 50
21 - 35	50	50
35 - 45	50 → 65	50 → 35

*Flow rate*: 1.4 mL/min.

*Detection*: spectrophotometer at 220 nm.

*Injection*: 20  $\mu$ L of test solution (a) and reference solutions (a) and (b).

*Identification of impurities*: use the chromatogram obtained with reference solution (b) and the chromatogram supplied with *chlortalidone for peak identification CRS* to identify the peaks due to impurities B, G and J.

*Relative retention* with reference to chlortalidone (retention time = about 7 min): impurity B = about 0.7; impurity J = about 0.9; impurity G = about 6.

*System suitability*: reference solution (b):

- *resolution*: minimum 1.5 between the peaks due to impurity J and chlortalidone.

*Limits*:

- *impurity B*: not more than 7 times the area of the principal peak in the chromatogram obtained with reference solution (a) (0.7 per cent);
- *impurity J*: not more than 3 times the area of the principal peak in the chromatogram obtained with reference solution (a) (0.3 per cent);
- *impurity G*: not more than 2 times the area of the principal peak in the chromatogram obtained with reference solution (a) (0.2 per cent);
- *unspecified impurities*: for each impurity, not more than the area of the principal peak in the chromatogram obtained with reference solution (a) (0.10 per cent);
- *total*: not more than 12 times the area of the principal peak in the chromatogram obtained with reference solution (a) (1.2 per cent);
- *disregard limit*: 0.5 times the area of the principal peak in the chromatogram obtained with reference solution (a) (0.05 per cent).

**Chlorides** (2.4.4): maximum 350 ppm.

Triturate 0.3 g finely, add 30 mL of *water R*, shake for 5 min and filter. 15 mL of the filtrate complies with the test. Prepare the standard using 10 mL of *chloride standard solution (5 ppm Cl) R*.

**Loss on drying** (2.2.32): maximum 0.5 per cent, determined on 1.000 g by drying in an oven at 105 °C.

**Sulfated ash** (2.4.14): maximum 0.1 per cent, determined on 1.0 g.

## ASSAY

Liquid chromatography (2.2.29) as described in the test for related substances with the following modification.

*Injection*: 20  $\mu$ L of test solution (b) and reference solution (c).

Calculate the percentage content of  $C_{14}H_{11}ClN_2O_4S$  from the declared content of *chlortalidone CRS*.

## IMPURITIES

*Specified impurities*: B, G, J.

*Other detectable impurities* (the following substances would, if present at a sufficient level, be detected by one or other of the tests in the monograph. They are limited by the general acceptance criterion for other/unspecified impurities and/or by the general monograph *Substances for pharmaceutical use (2034)*. It is therefore not necessary to identify these impurities for demonstration of compliance. See also 5.10. *Control of impurities in substances for pharmaceutical use*): A, C, D, E, F, H, I.

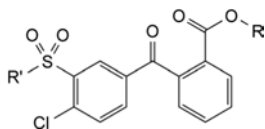

- A. R = H, R' = OH: 2-(4-chloro-3-sulfobenzoyl)benzoic acid,  
 B. R = H, R' = NH<sub>2</sub>: 2-(4-chloro-3-sulfamoylbenzoyl)benzoic acid,  
 C. R = C<sub>2</sub>H<sub>5</sub>, R' = NH<sub>2</sub>: ethyl 2-(4-chloro-3-sulfamoylbenzoyl)-benzoate,  
 I. R = CH(CH<sub>3</sub>)<sub>2</sub>, R' = NH<sub>2</sub>: 1-methylethyl 2-(4-chloro-3-sulfamoylbenzoyl)benzoate,

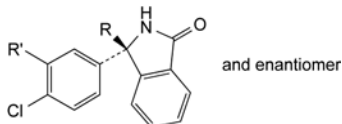

- D. R = OC<sub>2</sub>H<sub>5</sub>, R' = SO<sub>2</sub>-NH<sub>2</sub>: 2-chloro-5-[(1*RS*)-1-ethoxy-3-oxo-2,3-dihydro-1*H*-isoindol-1-yl]benzenesulfonamide,  
 E. R = H, R' = SO<sub>2</sub>-NH<sub>2</sub>: 2-chloro-5-[(1*RS*)-3-oxo-2,3-dihydro-1*H*-isoindol-1-yl]benzenesulfonamide,  
 G. R = OH, R' = Cl: (3*RS*)-3-(3,4-dichlorophenyl)-3-hydroxy-2,3-dihydro-1*H*-isoindol-1-one,  
 H. R = OCH(CH<sub>3</sub>)<sub>2</sub>, R' = SO<sub>2</sub>-NH<sub>2</sub>: 2-chloro-5-[(1*RS*)-1-(1-methylethoxy)-3-oxo-2,3-dihydro-1*H*-isoindol-1-yl]benzenesulfonamide,

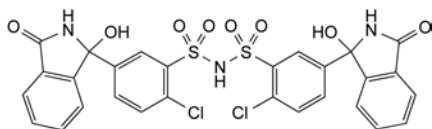

- F. bis[2-chloro-5-(1-hydroxy-3-oxo-2,3-dihydro-1*H*-isoindol-1-yl)benzenesulfonyl]amine,  
 J. impurity of unknown structure with a relative retention of about 0.9.

01/2008:0173

## CHLORTETRACYCLINE HYDROCHLORIDE

### Chlortetracyclini hydrochloridum

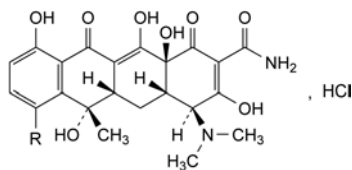

Compound	R	Molecular formula	M <sub>r</sub>
Chlortetracycline hydrochloride	Cl	C <sub>22</sub> H <sub>24</sub> Cl <sub>2</sub> N <sub>2</sub> O <sub>8</sub>	515.3
Tetracycline hydrochloride	H	C <sub>22</sub> H <sub>25</sub> ClN <sub>2</sub> O <sub>8</sub>	480.9

#### DEFINITION

Mixture of antibiotics, the main component being the hydrochloride of (4*S*,4*aS*,5*aS*,6*S*,12*aS*)-7-chloro-4-(dimethylamino)-3,6,10,12,12*a*-pentahydroxy-6-methyl-1,11-dioxo-1,4,4*a*,5,5*a*,6,11,12*a*-octahydro-2,4,6,8-tetracycline-2-carboxamide (chlortetracycline hydrochloride), a substance produced by the growth of certain strains of *Streptomyces aureofaciens* or obtained by any other means.

#### Content:

- C<sub>22</sub>H<sub>24</sub>Cl<sub>2</sub>N<sub>2</sub>O<sub>8</sub>: minimum 89.5 per cent (anhydrous substance),
- C<sub>22</sub>H<sub>25</sub>ClN<sub>2</sub>O<sub>8</sub>: maximum 8.0 per cent (anhydrous substance),

- 94.5 per cent to 102.0 per cent for the sum of the contents of chlortetracycline hydrochloride and tetracycline hydrochloride (anhydrous substance).

#### CHARACTERS

*Appearance*: yellow powder.

*Solubility*: slightly soluble in water and in alcohol. It dissolves in solutions of alkali hydroxides and carbonates.

#### IDENTIFICATION

- A. Thin-layer chromatography (2.2.27).

*Test solution*. Dissolve 5 mg of the substance to be examined in *methanol R* and dilute to 10 mL with the same solvent.

*Reference solution (a)*. Dissolve 5 mg of *chlortetracycline hydrochloride CRS* in *methanol R* and dilute to 10 mL with the same solvent.

*Reference solution (b)*. Dissolve 5 mg of *chlortetracycline hydrochloride CRS*, 5 mg of *doxycycline R* and 5 mg of *demeclocycline hydrochloride R* in *methanol R* and dilute to 10 mL with the same solvent.

*Plate*: TLC octadecylsilyl silica gel F<sub>254</sub> plate *R*.

*Mobile phase*: mix 20 volumes of *acetonitrile R*, 20 volumes of *methanol R* and 60 volumes of a 63 g/L solution of *oxalic acid R* previously adjusted to pH 2 with *concentrated ammonia R*.

*Application*: 1 µL.

*Development*: over 3/4 of the plate.

*Drying*: in air.

*Detection*: examine in ultraviolet light at 254 nm.

*System suitability*: the chromatogram obtained with reference solution (b) shows 3 clearly separated spots.

*Results*: the principal spot in the chromatogram obtained with the test solution is similar in position and size to the principal spot in the chromatogram obtained with reference solution (a).

- B. To about 2 mg add 5 mL of *sulfuric acid R*. A deep blue colour develops which becomes bluish-green. Add the solution to 2.5 mL of *water R*. The colour becomes brownish.  
 C. It gives reaction (a) of chlorides (2.3.1).

#### TESTS

*pH* (2.2.3): 2.3 to 3.3.

Dissolve 0.1 g in 10 mL of *carbon dioxide-free water R*, heating slightly.

*Specific optical rotation* (2.2.7): –235 to –250 (anhydrous substance).

Dissolve 0.125 g in *water R* and dilute to 50.0 mL with the same solvent.

*Absorbance* (2.2.25): maximum 0.40 at 460 nm.

Dissolve 0.125 g in *water R* and dilute to 25.0 mL with the same solvent.

*Related substances*. Liquid chromatography (2.2.29). Prepare the solutions immediately before use.

*Test solution*. Dissolve 25.0 mg of the substance to be examined in 0.01 *M hydrochloric acid* and dilute to 25.0 mL with the same acid.

*Reference solution (a)*. Dissolve 25.0 mg of *chlortetracycline hydrochloride CRS* in 0.01 *M hydrochloric acid* and dilute to 25.0 mL with the same acid.

*Reference solution (b)*. Dissolve 10.0 mg of *4-epichlortetracycline hydrochloride CRS* in 0.01 *M hydrochloric acid* and dilute to 25.0 mL with the same acid.

*Reference solution (c)*. Dissolve 20.0 mg of *tetracycline hydrochloride CRS* in 0.01 *M hydrochloric acid* and dilute to 25.0 mL with the same acid.

*Reference solution (d)*. Mix 5.0 mL of reference solution (a) and 10.0 mL of reference solution (b) and dilute to 25.0 mL with 0.01 *M hydrochloric acid*.

**Reference solution (e).** Mix 5.0 mL of reference solution (b) and 5.0 mL of reference solution (c) and dilute to 50.0 mL with 0.01 M hydrochloric acid.

**Reference solution (f).** Dilute 1.0 mL of reference solution (c) to 20.0 mL with 0.01 M hydrochloric acid. Dilute 5.0 mL of this solution to 200.0 mL with 0.01 M hydrochloric acid.

**Column:**

- size:  $l = 0.25$  m,  $\varnothing = 4.6$  mm,
- stationary phase: octylsilyl silica gel for chromatography R (5  $\mu$ m),
- temperature: 35 °C.

**Mobile phase:** to 500 mL of water R, add 50 mL of perchloric acid solution R, shake and add 450 mL of dimethyl sulfoxide R,

**Flow rate:** 1 mL/min.

**Detection:** spectrophotometer at 280 nm.

**Injection:** 20  $\mu$ L; inject the test solution and reference solutions (d), (e) and (f).

**System suitability:** reference solution (d):

- resolution: minimum 2.0 between the peaks due to impurity A and to chlortetracycline; if necessary, adjust the dimethyl sulfoxide content in the mobile phase,
- symmetry factor: maximum 1.3 for the peak due to chlortetracycline.

**Limits:**

- impurity A: not more than the area of the corresponding peak in the chromatogram obtained with reference solution (e) (4.0 per cent),
- total of other impurities eluting between the solvent peak and the peak corresponding to chlortetracycline: not more than 0.25 times the area of the peak due to impurity A in the chromatogram obtained with reference solution (e) (1.0 per cent),
- disregard limit: area of the principal peak in the chromatogram obtained with reference solution (f) (0.1 per cent).

**Heavy metals (2.4.8):** maximum 50 ppm.

0.5 g complies with limit test C. Prepare the standard using 2.5 mL of lead standard solution (10 ppm Pb) R.

**Water (2.5.12):** maximum 2.0 per cent, determined on 0.300 g.

**Sulfated ash (2.4.14):** maximum 0.5 per cent, determined on 1.0 g.

**Bacterial endotoxins (2.6.14):** less than 1 IU/mg, if intended for use in the manufacture of parenteral preparations without a further appropriate procedure for the removal of bacterial endotoxins.

#### ASSAY

Liquid chromatography (2.2.29) as described in the test for related substances with the following modification.

**Injection:** test solution and reference solutions (a) and (e).

Calculate the percentage content of  $C_{22}H_{24}Cl_2N_2O_8$  using the chromatogram obtained with reference solution (a). Calculate the percentage content of  $C_{22}H_{25}ClN_2O_8$  using the chromatogram obtained with reference solution (e).

#### STORAGE

Protected from light. If the substance is sterile, store in a sterile, airtight, tamper-proof container.

#### IMPURITIES

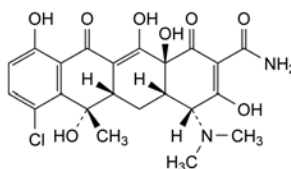

- A. (4*R*,4*aS*,5*aS*,6*S*,12*aS*)-7-chloro-4-(dimethylamino)-3,6,10,12,12*a*-pentahydroxy-6-methyl-1,11-dioxo-1,4,4*a*,5,5*a*,6,11,12*a*-octahydrotetracycline-2-carboxamide (4-epichlortetracycline),
- B. demeclocycline.

01/2008:0072

## CHOLECALCIFEROL

### Cholecalciferolum

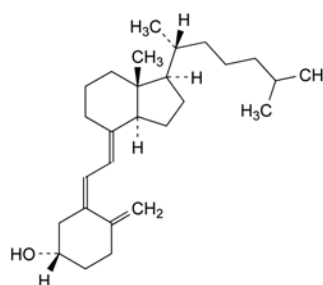

$C_{27}H_{44}O$   
[67-97-0]

$M_r$  384.6

#### DEFINITION

(5*Z*,7*E*)-9,10-Secocholesta-5,7,10(19)-trien-3 $\beta$ -ol.

**Content:** 97.0 per cent to 102.0 per cent.

1 mg of cholecalciferol is equivalent to 40 000 IU of antirachitic activity (vitamin D) in rats.

#### CHARACTERS

**Appearance:** white or almost white crystals.

**Solubility:** practically insoluble in water, freely soluble in ethanol (96 per cent), soluble in trimethylpentane and in fatty oils.

It is sensitive to air, heat and light. Solutions in solvents without an antioxidant are unstable and are to be used immediately.

A reversible isomerisation to pre-cholecalciferol takes place in solution, depending on temperature and time. The activity is due to both compounds.

#### IDENTIFICATION

Infrared absorption spectrophotometry (2.2.24).

**Comparison:** cholecalciferol CRS.

#### TESTS

**Specific optical rotation (2.2.7):** + 105 to + 112, determined within 30 min of preparing the solution.

Dissolve 0.200 g rapidly in aldehyde-free alcohol R without heating and dilute to 25.0 mL with the same solvent.

**Related substances.** Liquid chromatography (2.2.29). Prepare the solutions immediately before use, avoiding exposure to actinic light and air.

**Test solution.** Dissolve 10.0 mg of the substance to be examined in trimethylpentane R without heating and dilute to 10.0 mL with the same solvent.

**Reference solution (a).** Dissolve 10.0 mg of cholecalciferol CRS in trimethylpentane R without heating and dilute to 10.0 mL with the same solvent.

**Reference solution (b).** Dilute 1.0 mL of *cholecalciferol for system suitability CRS* (containing impurity A) to 5.0 mL with the mobile phase. Heat in a water-bath at 90 °C under a reflux condenser for 45 min and cool (formation of pre-cholecalciferol).

**Reference solution (c).** Dilute 10.0 mL of reference solution (a) to 100.0 mL with the mobile phase. Dilute 1.0 mL of this solution to 100.0 mL with the mobile phase.

**Column:**

- size:  $l = 0.25$  m,  $\varnothing = 4.6$  mm;
- stationary phase: silica gel for chromatography R (5  $\mu$ m).

**Mobile phase:** pentanol R, hexane R (3:997 V/V).

**Flow rate:** 2 mL/min.

**Detection:** spectrophotometer at 265 nm.

**Injection:** 5  $\mu$ L of the test solution and reference solutions (b) and (c).

**Run time:** twice the retention time of cholecalciferol.

**Relative retention** with reference to cholecalciferol (retention time = about 19 min): pre-cholecalciferol = about 0.5; impurity A = about 0.6.

**System suitability:** reference solution (b):

- resolution: minimum 1.5 between the peaks due to pre-cholecalciferol and impurity A.

**Limits:**

- **impurity A:** not more than the area of the principal peak in the chromatogram obtained with reference solution (c) (0.1 per cent);
- **unspecified impurities:** for each impurity, not more than the area of the principal peak in the chromatogram obtained with reference solution (c) (0.10 per cent);
- **total:** not more than 10 times the area of the principal peak in the chromatogram obtained with reference solution (c) (1.0 per cent);
- **disregard limit:** 0.5 times the area of the principal peak in the chromatogram obtained with reference solution (c) (0.05 per cent); disregard the peak due to pre-cholecalciferol.

## ASSAY

Liquid chromatography (2.2.29) as described in the test for related substances, with the following modification.

**Injection:** test solution and reference solution (a).

Calculate the percentage content of cholecalciferol ( $C_{27}H_{44}O$ ) from the declared content of *cholecalciferol CRS*.

## STORAGE

In an airtight container, under nitrogen, protected from light, at a temperature of 2 °C to 8 °C.

The contents of an opened container are to be used immediately.

## IMPURITIES

**Specified impurities:** A.

**Other detectable impurities** (the following substances would, if present at a sufficient level, be detected by one or other of the tests in the monograph. They are limited by the general acceptance criterion for other/unspecified impurities and/or by the general monograph *Substances for pharmaceutical use* (2034). It is therefore not necessary to identify these impurities for demonstration of compliance. See also 5.10. *Control of impurities in substances for pharmaceutical use*): B, C, D, E.

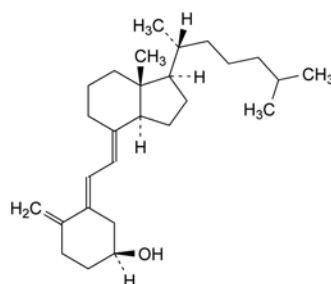

A. (5*E*,7*E*)-9,10-secocholesta-5,7,10(19)-trien-3 $\beta$ -ol (*trans*-cholecalciferol, *trans*-vitamin D<sub>3</sub>),

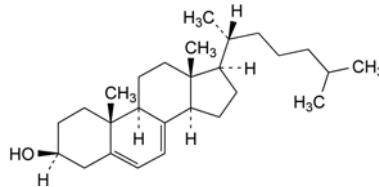

B. cholesta-5,7-dien-3 $\beta$ -ol (7,8-didehydrocholesterol, provitamin D<sub>3</sub>),

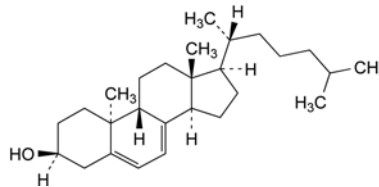

C. 9 $\beta$ ,10 $\alpha$ -cholesta-5,7-dien-3 $\beta$ -ol (lumisterol<sub>3</sub>),

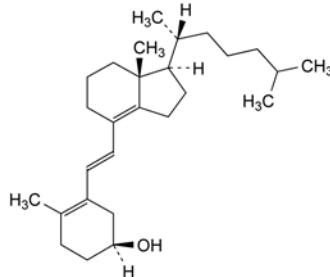

D. (6*E*)-9,10-secocholesta-5(10),6,8(14)-trien-3 $\beta$ -ol (iso-tachysterol<sub>3</sub>),

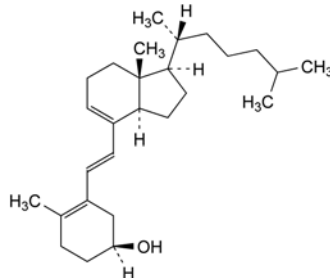

E. (6*E*)-9,10-secocholesta-5(10),6,8-trien-3 $\beta$ -ol (tachysterol<sub>3</sub>).

01/2008:0575  
corrected 6.5

## CHOLECALCIFEROL CONCENTRATE (OILY FORM)

### Cholecalciferolum densatum oleosum

#### DEFINITION

Solution of *Cholecalciferol* (0072) in a suitable vegetable fatty oil, authorised by the competent authority.

**Content:** 90.0 per cent to 110.0 per cent of the cholecalciferol content stated on the label, which is not less than 500 000 IU/g.

It may contain suitable stabilisers such as antioxidants.

#### CHARACTERS

*Appearance:* clear, yellow liquid.

*Solubility:* practically insoluble in water, slightly soluble in anhydrous ethanol, miscible with solvents of fats.

Partial solidification may occur, depending on the temperature.

#### IDENTIFICATION

*First identification:* A, C.

*Second identification:* A, B.

A. Thin-layer chromatography (2.2.27). Prepare the solutions immediately before use.

*Test solution.* Dissolve an amount of the preparation to be examined corresponding to 400 000 IU in *ethylene chloride R* containing 10 g/L of *squalane R* and 0.1 g/L of *butylhydroxytoluene R* and dilute to 4 mL with the same solution.

*Reference solution (a).* Dissolve 10 mg of *cholecalciferol CRS* in *ethylene chloride R* containing 10 g/L of *squalane R* and 0.1 g/L of *butylhydroxytoluene R* and dilute to 4 mL with the same solution.

*Reference solution (b).* Dissolve 10 mg of *ergocalciferol CRS* in *ethylene chloride R* containing 10 g/L of *squalane R* and 0.1 g/L of *butylhydroxytoluene R* and dilute to 4 mL with the same solution.

*Plate:* TLC silica gel G plate R.

*Mobile phase:* a 0.1 g/L solution of *butylhydroxytoluene R* in a mixture of equal volumes of *cyclohexane R* and *peroxide-free ether R*.

*Application:* 20 µL.

*Development:* immediately, protected from light, over a path of 15 cm.

*Drying:* in air.

*Detection:* spray with *sulfuric acid R*.

*Results:* the chromatogram obtained with the test solution shows immediately a bright yellow principal spot which rapidly becomes orange-brown, then gradually greenish-grey, remaining so for 10 min. This spot is similar in position, colour and size to the spot in the chromatogram obtained with reference solution (a). The chromatogram obtained with reference solution (b) shows immediately at the same level an orange principal spot which gradually becomes reddish-brown and remains so for 10 min.

B. Ultraviolet and visible absorption spectrophotometry (2.2.25).

*Test solution.* Prepare a solution in *cyclohexane R* containing the equivalent of about 400 IU/mL.

*Spectral range:* 250-300 nm.

*Absorption maximum:* at 267 nm.

C. Examine the chromatograms obtained in the assay.

*Results:* the principal peak in the chromatogram obtained with the test solution is similar in retention time to the principal peak in the chromatogram obtained with reference solution (a).

#### TESTS

**Acid value** (2.5.1): maximum 2.0.

Dissolve 5.0 g in 25 mL of the prescribed mixture of solvents.

**Peroxide value** (2.5.5, Method A): maximum 20.

#### Related substances

The thresholds indicated under Related substances (Table 2034.-1) in the general monograph *Substances for pharmaceutical use (2034)* do not apply.

#### ASSAY

Carry out the assay as rapidly as possible, avoiding exposure to actinic light and air.

Liquid chromatography (2.2.29).

*Test solution.* Dissolve a quantity of the preparation to be examined, weighed with an accuracy of 0.1 per cent, equivalent to about 400 000 IU, in 10.0 mL of *toluene R* and dilute to 100.0 mL with the mobile phase.

*Reference solution (a).* Dissolve 10.0 mg of *cholecalciferol CRS* without heating in 10.0 mL of *toluene R* and dilute to 100.0 mL with the mobile phase.

*Reference solution (b).* Dilute 1.0 mL of *cholecalciferol for system suitability CRS* to 5.0 mL with the mobile phase. Heat in a water-bath at 90 °C under a reflux condenser for 45 min and cool.

*Reference solution (c).* Dissolve 0.10 g of *cholecalciferol CRS* without heating in *toluene R* and dilute to 100.0 mL with the same solvent.

*Reference solution (d).* Dilute 5.0 mL of reference solution (c) to 50.0 mL with the mobile phase. Keep the solution in iced water.

*Reference solution (e).* Place 5.0 mL of reference solution (c) in a volumetric flask, add about 10 mg of *butylhydroxytoluene R* and displace air from the flask with *nitrogen R*. Heat in a water-bath at 90 °C under a reflux condenser protected from light and under *nitrogen R* for 45 min. Cool and dilute to 50.0 mL with the mobile phase.

*Column:*

– *size:*  $l = 0.25$  m,  $\varnothing = 4.6$  mm;

– *stationary phase:* silica gel for chromatography R (5 µm).

*Mobile phase:* *pentanol R*, *hexane R* (3:997 V/V).

*Flow rate:* 2 mL/min.

*Detection:* spectrophotometer at 254 nm.

*Injection:* the chosen volume of each solution (the same volume for reference solution (a) and for the test solution); automatic injection device or sample loop recommended.

*Relative retention* with reference to cholecalciferol: pre-cholecalciferol = about 0.4; *trans*-cholecalciferol = about 0.5.

*System suitability:* reference solution (b):

– *resolution:* minimum 1.0 between the peaks due to pre-cholecalciferol and *trans*-cholecalciferol; if necessary adjust the proportions of the constituents and the flow rate of the mobile phase to obtain this resolution;

– *repeatability:* maximum relative standard deviation of 1.0 per cent for the peak due to cholecalciferol after 6 injections.

Calculate the conversion factor ( $f$ ) using the following expression:

$$\frac{K - L}{M}$$

$K$  = area (or height) of the peak due to cholecalciferol in the chromatogram obtained with reference solution (d);

$L$  = area (or height) of the peak due to cholecalciferol in the chromatogram obtained with reference solution (e);

$M$  = area (or height) of the peak due to pre-cholecalciferol in the chromatogram obtained with reference solution (e).

The value of  $f$  determined in duplicate on different days may be used during the entire procedure.



Calculate the content of cholecalciferol in International Units per gram using the following expression:

$$\frac{m'}{V'} \times \frac{V}{m} \times \frac{S_D + (f \times S_p)}{S'_D} \times 40\,000 \times 1000$$

- $m$  = mass of the preparation to be examined in the test solution, in milligrams;
- $m'$  = mass of *cholecalciferol CRS* in reference solution (a), in milligrams;
- $V$  = volume of the test solution (100 mL);
- $V'$  = volume of reference solution (a) (100 mL);
- $S_D$  = area (or height) of the peak due to cholecalciferol in the chromatogram obtained with the test solution;
- $S'_D$  = area (or height) of the peak due to cholecalciferol in the chromatogram obtained with reference solution (a);
- $S_p$  = area (or height) of the peak due to pre-cholecalciferol in the chromatogram obtained with the test solution;
- $f$  = conversion factor.

#### STORAGE

In an airtight, well-filled container, protected from light. The contents of an opened container are to be used as soon as possible; any unused part is to be protected by an atmosphere of nitrogen.

#### LABELLING

The label states:

- the number of International Units per gram;
- the method of restoring the solution if partial solidification occurs.

01/2008:0574  
corrected 6.5

## CHOLECALCIFEROL CONCENTRATE (POWDER FORM)

### Cholecalciferoli pulvis

#### DEFINITION

Powder concentrate obtained by dispersing an oily solution of *Cholecalciferol (0072)* in an appropriate matrix, which is usually based on a combination of gelatin and carbohydrates of suitable quality, authorised by the competent authority.

*Content*: 90.0 per cent to 110.0 per cent of the cholecalciferol content stated on the label, which is not less than 100 000 IU/g. It may contain suitable stabilisers such as antioxidants.

#### CHARACTERS

*Appearance*: white or yellowish-white, small particles.

*Solubility*: practically insoluble, swells, or forms a dispersion in water, depending on the formulation.

#### IDENTIFICATION

*First identification*: A, C.

*Second identification*: A, B.

A. Thin-layer chromatography (2.2.27). Prepare the solutions immediately before use.

*Test solution*. Place 10.0 mL of the test solution prepared for the assay in a suitable flask and evaporate to dryness under reduced pressure by swirling in a water-bath at 40 °C. Cool under running water and restore atmospheric pressure with nitrogen R. Dissolve the residue immediately in 0.4 mL of ethylene chloride R containing 10 g/L of squalane R and 0.1 g/L of butylhydroxytoluene R.

*Reference solution (a)*. Dissolve 10 mg of *cholecalciferol CRS* in ethylene chloride R containing 10 g/L of squalane R and 0.1 g/L of butylhydroxytoluene R and dilute to 4 mL with the same solution.

*Reference solution (b)*. Dissolve 10 mg of *ergocalciferol CRS* in ethylene chloride R containing 10 g/L of squalane R and 0.1 g/L of butylhydroxytoluene R and dilute to 4 mL with the same solution.

*Plate*: TLC silica gel G plate R.

*Mobile phase*: a 0.1 g/L solution of butylhydroxytoluene R in a mixture of equal volumes of cyclohexane R and peroxide-free ether R.

*Application*: 20 µL.

*Development*: immediately, protected from light, over a path of 15 cm.

*Drying*: in air.

*Detection*: spray with sulfuric acid R.

*Results*: the chromatogram obtained with the test solution shows immediately a bright yellow principal spot, which rapidly becomes orange-brown, then gradually greenish-grey, remaining so for 10 min. This spot is similar in position, colour and size to the spot in the chromatogram obtained with reference solution (a). The chromatogram obtained with reference solution (b) shows immediately at the same level an orange principal spot, which gradually becomes reddish-brown and remains so for 10 min.

B. Ultraviolet and visible absorption spectrophotometry (2.2.25).

*Test solution*. Place 5.0 mL of the test solution prepared for the assay in a suitable flask and evaporate to dryness under reduced pressure by swirling in a water-bath at 40 °C. Cool under running water and restore atmospheric pressure with nitrogen R. Dissolve the residue immediately in 50.0 mL of cyclohexane R.

*Spectral range*: 250-300 nm.

*Absorption maximum*: at 265 nm.

C. Examine the chromatograms obtained in the assay.

*Results*: the principal peak in the chromatogram obtained with the test solution is similar in retention time to the principal peak in the chromatogram obtained with reference solution (a).

#### TESTS

##### Related substances

The thresholds indicated under Related substances (Table 2034.1) in the general monograph *Substances for pharmaceutical use (2034)* do not apply.

##### ASSAY

Carry out the assay as rapidly as possible, avoiding exposure to actinic light and air.

Liquid chromatography (2.2.29).

*Test solution*. Introduce into a saponification flask a quantity of the preparation to be examined, weighed with an accuracy of 0.1 per cent, equivalent to about 100 000 IU. Add 5 mL of water R, 20 mL of anhydrous ethanol R, 1 mL of sodium ascorbate solution R and 3 mL of a freshly prepared 50 per cent m/m solution of potassium hydroxide R. Heat in a water-bath under a reflux condenser for 30 min. Cool rapidly under running water. Transfer the liquid to a separating funnel with the aid of 2 quantities, each of 15 mL, of water R, 1 quantity of 10 mL of ethanol (96 per cent) R and 2 quantities, each of 50 mL, of pentane R. Shake vigorously for 30 s. Allow to stand until the 2 layers are clear. Transfer the lower aqueous-alcoholic layer to a 2<sup>nd</sup> separating funnel and shake with a mixture of 10 mL of ethanol (96 per cent) R and 50 mL of pentane R. After separation, transfer the aqueous-alcoholic layer to a 3<sup>rd</sup> separating funnel and the pentane layer to the 1<sup>st</sup> separating funnel, washing the 2<sup>nd</sup> separating funnel with 2 quantities,

each of 10 mL, of *pentane R* and adding the washings to the 1<sup>st</sup> separating funnel. Shake the aqueous-alcoholic layer with 50 mL of *pentane R* and add the pentane layer to the 1<sup>st</sup> funnel. Wash the pentane layer with 2 quantities, each of 50 mL, of a freshly prepared 30 g/L solution of *potassium hydroxide R* in *ethanol (10 per cent V/V) R*, shaking vigorously, then wash with successive quantities, each of 50 mL, of *water R* until the washings are neutral to phenolphthalein. Transfer the washed pentane extract to a ground-glass-stoppered flask. Evaporate the contents of the flask to dryness under reduced pressure by swirling in a water-bath at 40 °C. Cool under running water and restore atmospheric pressure with *nitrogen R*. Dissolve the residue immediately in 5.0 mL of *toluene R* and add 20.0 mL of the mobile phase to obtain a solution containing about 4000 IU/mL.

**Reference solution (a).** Dissolve 10.0 mg of *cholecalciferol CRS*, without heating, in 10.0 mL of *toluene R* and dilute to 100.0 mL with the mobile phase.

**Reference solution (b).** Dilute 1.0 mL of *cholecalciferol for system suitability CRS* to 5.0 mL with the mobile phase. Heat in a water-bath at 90 °C under a reflux condenser for 45 min and cool.

**Reference solution (c).** Dissolve 0.10 g of *cholecalciferol CRS*, without heating, in *toluene R* and dilute to 100.0 mL with the same solvent.

**Reference solution (d).** Dilute 5.0 mL of reference solution (c) to 50.0 mL with the mobile phase. Keep the solution in iced water.

**Reference solution (e).** Place 5.0 mL of reference solution (c) in a volumetric flask, add about 10 mg of *butylhydroxytoluene R* and displace the air from the flask with *nitrogen R*. Heat in a water-bath at 90 °C under a reflux condenser, protected from light and under *nitrogen R*, for 45 min. Cool and dilute to 50.0 mL with the mobile phase.

**Column:**

- size:  $l = 0.25$  m,  $\varnothing = 4.6$  mm;
  - stationary phase: *silica gel for chromatography R* (5 µm).
- Mobile phase:** *pentanol R*, *hexane R* (3:997 V/V).

**Flow rate:** 2 mL/min.

**Detection:** spectrophotometer at 254 nm.

**Injection:** the chosen volume of each solution (the same volume for reference solution (a) and for the test solution); automatic injection device or sample loop recommended.

**Relative retention** with reference to cholecalciferol: pre-cholecalciferol = about 0.4; *trans*-cholecalciferol = about 0.5.

**System suitability:** reference solution (b):

- **resolution:** minimum 1.0 between the peaks due to pre-cholecalciferol and *trans*-cholecalciferol; if necessary, adjust the proportions of the constituents and the flow rate of the mobile phase to obtain this resolution;
- **repeatability:** maximum relative standard deviation of 1.0 per cent for the peak due to cholecalciferol after 6 injections.

Calculate the conversion factor ( $f$ ) using the following expression:

$$\frac{K - L}{M}$$

- $K$  = area (or height) of the peak due to cholecalciferol in the chromatogram obtained with reference solution (d);
- $L$  = area (or height) of the peak due to cholecalciferol in the chromatogram obtained with reference solution (e);
- $M$  = area (or height) of the peak due to pre-cholecalciferol in the chromatogram obtained with reference solution (e).

The value of  $f$  determined in duplicate on different days may be used during the entire procedure.

Calculate the content of cholecalciferol in International Units per gram using the following expression:

$$\frac{m'}{V'} \times \frac{V}{m} \times \frac{S_D + (f \times S_p)}{S'_D} \times 40\,000 \times 1000$$

- $m$  = mass of the preparation to be examined in the test solution, in milligrams;
- $m'$  = mass of *cholecalciferol CRS* in reference solution (a), in milligrams;
- $V$  = volume of the test solution (25 mL);
- $V'$  = volume of reference solution (a) (100 mL);
- $S_D$  = area (or height) of the peak due to cholecalciferol in the chromatogram obtained with the test solution;
- $S'_D$  = area (or height) of the peak due to cholecalciferol in the chromatogram obtained with reference solution (a);
- $S_p$  = area (or height) of the peak due to pre-cholecalciferol in the chromatogram obtained with the test solution;
- $f$  = conversion factor.

#### STORAGE

In an airtight, well-filled container, protected from light. The contents of an opened container are to be used as soon as possible; any unused part is to be protected by an atmosphere of nitrogen.

#### LABELLING

The label states the number of International Units per gram.

01/2008:0598  
corrected 6.5

## CHOLECALCIFEROL CONCENTRATE (WATER-DISPERSIBLE FORM)

### Cholecalciferolum in aqua dispergibile

#### DEFINITION

Solution of *Cholecalciferol (0072)* in a suitable vegetable fatty oil, authorised by the competent authority, to which suitable solubilisers have been added.

**Content:** 90.0 per cent to 115.0 per cent of the cholecalciferol content stated on the label, which is not less than 100 000 IU/g. It may contain suitable stabilisers such as antioxidants.

#### CHARACTERS

**Appearance:** slightly yellowish liquid of variable opalescence and viscosity.

Highly concentrated solutions may become cloudy at low temperatures or form a gel at room temperature.

#### IDENTIFICATION

**First identification:** A, C, D.

**Second identification:** A, B, D.

A. Thin-layer chromatography (2.2.27). Prepare the solutions immediately before use.

**Test solution.** Place 10.0 mL of the test solution prepared for the assay in a suitable flask and evaporate to dryness under reduced pressure by swirling in a water-bath at 40 °C. Cool under running water and restore atmospheric pressure with *nitrogen R*. Dissolve the residue immediately in 0.4 mL of *ethylene chloride R* containing 10 g/L of *squalane R* and 0.1 g/L of *butylhydroxytoluene R*.

**Reference solution (a).** Dissolve 10 mg of *cholecalciferol CRS* in *ethylene chloride R* containing 10 g/L of *squalane R* and 0.1 g/L of *butylhydroxytoluene R* and dilute to 4 mL with the same solution.

**Reference solution (b).** Dissolve 10 mg of *ergocalciferol CRS* in *ethylene chloride R* containing 10 g/L of *squalane R* and 0.1 g/L of *butylhydroxytoluene R* and dilute to 4 mL with the same solution.

**Plate:** TLC silica gel G plate R.

**Mobile phase:** a 0.1 g/L solution of *butylhydroxytoluene R* in a mixture of equal volumes of *cyclohexane R* and *peroxide-free ether R*.

**Application:** 20 µL.

**Development:** immediately, protected from light, over a path of 15 cm.

**Drying:** in air.

**Detection:** spray with *sulfuric acid R*.

**Results:** the chromatogram obtained with the test solution shows immediately a bright yellow principal spot, which rapidly becomes orange-brown, then gradually greenish-grey, remaining so for 10 min. This spot is similar in position, colour and size to the principal spot in the chromatogram obtained with reference solution (a). The chromatogram obtained with reference solution (b) shows immediately at the same level an orange principal spot, which gradually becomes reddish-brown and remains so for 10 min.

#### B. Ultraviolet and visible absorption spectrophotometry (2.2.25).

**Test solution.** Place 5.0 mL of the test solution prepared for the assay in a suitable flask and evaporate to dryness under reduced pressure by swirling in a water-bath at 40 °C. Cool under running water and restore atmospheric pressure with *nitrogen R*. Dissolve the residue immediately in 50.0 mL of *cyclohexane R*.

**Spectral range:** 250-300 nm.

**Absorption maximum:** at 265 nm.

#### C. Examine the chromatograms obtained in the assay.

**Results:** the principal peak in the chromatogram obtained with the test solution is similar in retention time to the principal peak in the chromatogram obtained with reference solution (a).

#### D. Mix about 1 g with 10 mL of *water R* previously warmed to 50 °C, and cool to 20 °C. Immediately after cooling, a uniform, slightly opalescent and slightly yellow dispersion is obtained.

### TESTS

#### Related substances

The thresholds indicated under Related substances (Table 2034-1) in the general monograph *Substances for pharmaceutical use (2034)* do not apply.

#### ASSAY

Carry out the assay as rapidly as possible, avoiding exposure to actinic light and air.

Liquid chromatography (2.2.29).

**Test solution.** Introduce into a saponification flask a quantity of the preparation to be examined, weighed with an accuracy of 0.1 per cent, equivalent to about 100 000 IU. Add 5 mL of *water R*, 20 mL of *anhydrous ethanol R*, 1 mL of *sodium ascorbate solution R* and 3 mL of a freshly prepared 50 per

cent *m/m* solution of *potassium hydroxide R*. Heat in a water-bath under a reflux condenser for 30 min. Cool rapidly under running water. Transfer the liquid to a separating funnel with the aid of 2 quantities, each of 15 mL, of *water R*, 1 quantity of 10 mL of *ethanol (96 per cent) R* and 2 quantities, each of 50 mL, of *pentane R*. Shake vigorously for 30 s. Allow to stand until the 2 layers are clear. Transfer the aqueous-alcoholic layer to a 2<sup>nd</sup> separating funnel and shake with a mixture of 10 mL of *ethanol (96 per cent) R* and 50 mL of *pentane R*. After separation, transfer the aqueous-alcoholic layer to a 3<sup>rd</sup> separating funnel and the pentane layer to the 1<sup>st</sup> separating funnel, washing the 2<sup>nd</sup> separating funnel with 2 quantities, each of 10 mL, of *pentane R* and adding the washings to the 1<sup>st</sup> separating funnel. Shake the aqueous-alcoholic layer with 50 mL of *pentane R* and add the pentane layer to the 1<sup>st</sup> funnel. Wash the pentane layer with 2 quantities, each of 50 mL, of a freshly prepared 30 g/L solution of *potassium hydroxide R* in *ethanol (10 per cent V/V) R*, shaking vigorously, and then wash with successive quantities, each of 50 mL, of *water R* until the washings are neutral to phenolphthalein. Transfer the washed pentane extract to a ground-glass-stoppered flask. Evaporate the contents of the flask to dryness under reduced pressure by swirling in a water-bath at 40 °C. Cool under running water and restore atmospheric pressure with *nitrogen R*. Dissolve the residue immediately in 5.0 mL of *toluene R* and add 20.0 mL of the mobile phase to obtain a solution containing about 4000 IU/mL.

**Reference solution (a).** Dissolve 10.0 mg of *cholecalciferol CRS*, without heating, in 10.0 mL of *toluene R* and dilute to 100.0 mL with the mobile phase.

**Reference solution (b).** Dilute 1.0 mL of *cholecalciferol for system suitability CRS* to 5.0 mL with the mobile phase. Heat in a water-bath at 90 °C under a reflux condenser for 45 min and cool.

**Reference solution (c).** Dissolve 0.10 g of *cholecalciferol CRS*, without heating, in *toluene R* and dilute to 100.0 mL with the same solvent.

**Reference solution (d).** Dilute 5.0 mL of reference solution (c) to 50.0 mL with the mobile phase. Keep the solution in iced water.

**Reference solution (e).** Place 5.0 mL of reference solution (c) in a volumetric flask, add about 10 mg of *butylhydroxytoluene R* and displace the air from the flask with *nitrogen R*. Heat in a water-bath at 90 °C under a reflux condenser, protected from light and under *nitrogen R*, for 45 min. Cool and dilute to 50.0 mL with the mobile phase.

**Column:**

– size:  $l = 0.25$  m,  $\varnothing = 4.6$  mm;

– stationary phase: silica gel for chromatography R (5 µm).

**Mobile phase:** *pentanol R*, *hexane R* (3:997 V/V).

**Flow rate:** 2 mL/min.

**Detection:** spectrophotometer at 254 nm.

**Injection:** the chosen volume of each solution (the same volume for reference solution (a) and for the test solution); automatic injection device or sample loop recommended.

**Relative retention** with reference to cholecalciferol: pre-cholecalciferol = about 0.4; *trans*-cholecalciferol = about 0.5.

**System suitability:** reference solution (b):

– resolution: minimum 1.0 between the peaks due to pre-cholecalciferol and *trans*-cholecalciferol; if necessary, adjust the proportions of the constituents and the flow rate of the mobile phase to obtain this resolution;

– repeatability: maximum relative standard deviation of 1.0 per cent for the peak due to cholecalciferol after 6 injections.

Calculate the conversion factor ( $f$ ) using the following expression:

$$\frac{K - L}{M}$$

- $K$  = area (or height) of the peak due to cholecalciferol in the chromatogram obtained with reference solution (d);
- $L$  = area (or height) of the peak due to cholecalciferol in the chromatogram obtained with reference solution (e);
- $M$  = area (or height) of the peak due to pre-cholecalciferol in the chromatogram obtained with reference solution (e).

The value of  $f$  determined in duplicate on different days may be used during the entire procedure.

Calculate the content of cholecalciferol in International Units per gram using the following expression:

$$\frac{m'}{V'} \times \frac{V}{m} \times \frac{S_D + (f \times S_p)}{S'_D} \times 40\,000 \times 1000$$

- $m$  = mass of the preparation to be examined in the test solution, in milligrams;
- $m'$  = mass of *cholecalciferol CRS* in reference solution (a), in milligrams;
- $V$  = volume of the test solution (25 mL);
- $V'$  = volume of reference solution (a) (100 mL);
- $S_D$  = area (or height) of the peak due to cholecalciferol in the chromatogram obtained with the test solution;
- $S'_D$  = area (or height) of the peak due to cholecalciferol in the chromatogram obtained with reference solution (a);
- $S_p$  = area (or height) of the peak due to pre-cholecalciferol in the chromatogram obtained with the test solution;
- $f$  = conversion factor.

#### STORAGE

In an airtight, well-filled container, protected from light, at the temperature stated on the label.

The contents of an opened container are to be used as soon as possible; any unused part is to be protected by an atmosphere of inert gas.

#### LABELLING

The label states:

- the number of International Units per gram;
- the storage temperature.

01/2008:0993

## CHOLESTEROL

### Cholesterolum

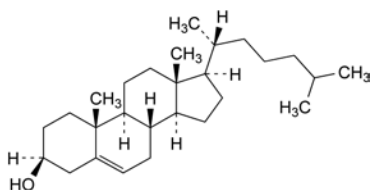

$C_{27}H_{46}O$   
[57-88-5]

$M_r$  386.7

#### DEFINITION

Cholest-5-en-3 $\beta$ -ol.

#### Content:

- *cholesterol*: minimum 95.0 per cent (dried substance);
- *total sterols*: 97.0 per cent to 103.0 per cent (dried substance).

#### CHARACTERS

*Appearance*: white or almost white, crystalline powder.

*Solubility*: practically insoluble in water, sparingly soluble in acetone and in ethanol (96 per cent).

It is sensitive to light.

#### IDENTIFICATION

A. Melting point (2.2.14): 147 °C to 150 °C.

B. Thin-layer chromatography (2.2.27). Prepare the solutions immediately before use.

*Test solution*. Dissolve 10 mg of the substance to be examined in *ethylene chloride R* and dilute to 5 mL with the same solvent.

*Reference solution*. Dissolve 10 mg of *cholesterol CRS* in *ethylene chloride R* and dilute to 5 mL with the same solvent.

*Plate*: TLC silica gel G plate R.

*Mobile phase*: ethyl acetate R, toluene R (33:66 V/V).

*Application*: 20  $\mu$ L.

*Development*: immediately, protected from light, over a path of 15 cm.

*Drying*: in air.

*Detection*: spray 3 times with *antimony trichloride solution R*; examine within 3-4 min.

*Results*: the principal spot in the chromatogram obtained with the test solution is similar in position, colour and size to the principal spot in the chromatogram obtained with the reference solution.

C. Dissolve about 5 mg in 2 mL of *methylene chloride R*. Add 1 mL of *acetic anhydride R*, 0.01 mL of *sulfuric acid R* and shake. A pink colour is produced which rapidly changes to red, then to blue and finally to brilliant green.

#### TESTS

**Solubility in ethanol (96 per cent)**. In a stoppered flask, dissolve 0.5 g in 50 mL of *ethanol (96 per cent) R* at 50 °C. Allow to stand for 2 h. No deposit or turbidity is formed.

**Acidity**. Dissolve 1.0 g in 10 mL of *ether R*, add 10.0 mL of 0.1 M *sodium hydroxide* and shake for about 1 min. Heat gently to eliminate ether and then boil for 5 min. Cool, add 10 mL of *water R* and 0.1 mL of *phenolphthalein solution R* as indicator and titrate with 0.1 M *hydrochloric acid* until the pink colour just disappears, stirring the solution vigorously throughout the titration. Carry out a blank titration. The difference between the volumes of 0.1 M *hydrochloric acid* required to change the colour of the indicator in the blank and in the test is not more than 0.3 mL.

**Loss on drying (2.2.32)**: maximum 0.3 per cent, determined on 1.000 g by drying *in vacuo* at 60 °C for 4 h.

**Sulfated ash (2.4.14)**: maximum 0.1 per cent, determined on 1.0 g.

#### ASSAY

Gas chromatography (2.2.28).

*Internal standard solution*. Dissolve 0.100 g of *pregnenolone isobutyrate CRS* in *heptane R* and dilute to 100.0 mL with the same solvent.

*Test solution*. Dissolve 25.0 mg of the substance to be examined in the internal standard solution and dilute to 25.0 mL with the same solution.

*Reference solution*. Dissolve 25.0 mg of *cholesterol CRS* in the internal standard solution and dilute to 25.0 mL with the same solution.

*Column*:

- *material*: fused silica;

01/2009:2064

- size:  $l = 30$  m,  $\varnothing = 0.25$  mm;
- stationary phase: poly(dimethyl)siloxane *R* (film thickness 0.25  $\mu\text{m}$ ).

Carrier gas: helium for chromatography *R*.

Flow rate: 2 mL/min.

Split ratio: 1:25.

Temperature:

- column: 275 °C;
- injection port: 285 °C;
- detector: 300 °C.

Detection: flame ionisation.

Injection: 1.0  $\mu\text{L}$ .

System suitability: reference solution:

- resolution: minimum 10.0 between the peaks due to pregnenolone isobutyrate and cholesterol.

Calculate the percentage content of cholesterol from the declared content in *cholesterol CRS*. Calculate the percentage content of total sterols by adding together the contents of cholesterol and other substances with a retention time less than or equal to 1.5 times the retention time of cholesterol. Disregard the peaks due to the internal standard and the solvent.

#### STORAGE

Protected from light.

#### LABELLING

The label states the source material for the production of cholesterol (for example bovine brain and spinal cord, wool fat or chicken eggs).

#### IMPURITIES

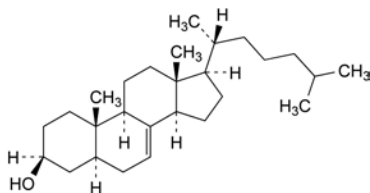

A. 5 $\alpha$ -cholest-7-en-3 $\beta$ -ol (lathosterol),

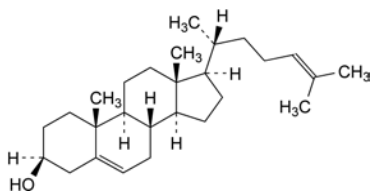

B. cholesta-5,24-dien-3 $\beta$ -ol (desmosterol),

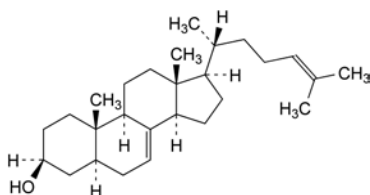

C. 5 $\alpha$ -cholesta-7,24-dien-3 $\beta$ -ol.

## CHONDROITIN SULFATE SODIUM

### Chondroitini natrii sulfas

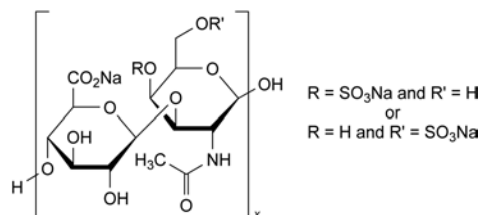

#### DEFINITION

Natural copolymer based mainly on the 2 disaccharides: [4-( $\beta$ -D-glucopyranosyluronic acid)-(1 $\rightarrow$ 3)-[2-(acetylamino)-2-deoxy- $\beta$ -D-galactopyranosyl 4-sulfate]-(1 $\rightarrow$ )] and [4-( $\beta$ -D-glucopyranosyluronic acid)-(1 $\rightarrow$ 3)-[2-(acetylamino)-2-deoxy- $\beta$ -D-galactopyranosyl 6-sulfate]-(1 $\rightarrow$ )], sodium salt. On complete hydrolysis it liberates D-galactosamine, D-glucuronic acid, acetic acid and sulfuric acid. It is obtained from cartilage of both terrestrial and marine origins. Depending on the animal species of origin, it shows different proportions of 4-sulfate and 6-sulfate groups.

Content: 95 per cent to 105 per cent (dried substance).

#### PRODUCTION

The animals from which chondroitin sulfate sodium is derived must fulfil the requirements for the health of animals suitable for human consumption.

#### CHARACTERS

Appearance: white or almost white, hygroscopic powder.

Solubility: freely soluble in water, practically insoluble in acetone and in ethanol (96 per cent).

#### IDENTIFICATION

A. Infrared absorption spectrophotometry (2.2.24).

Preparation: discs of potassium bromide *R*.

Comparison: for chondroitin sulfate sodium of terrestrial origin use *chondroitin sulfate sodium CRS* and for chondroitin sulfate sodium of marine origin use *chondroitin sulfate sodium (marine) CRS*.

B. Solution S1 (see Tests) gives reaction (b) of sodium (2.3.1).

C. Examine the electropherograms obtained in the test for related substances.

Results: the principal band in the electropherogram obtained with the test solution is similar in position to the principal band in the electropherogram obtained with reference solution (a).

#### TESTS

**Solution S1.** Dissolve 2.500 g in 50.0 mL of carbon dioxide-free water *R*.

**Solution S2.** Dilute 1.0 mL of solution S1 to 10.0 mL with water *R*.

pH (2.2.3): 5.5 to 7.5 for solution S1.

**Specific optical rotation (2.2.7):** – 20 to – 30 (terrestrial origin) or – 12 to – 19 (marine origin) (dried substance), determined on solution S1.

**Intrinsic viscosity:** 0.01 m<sup>3</sup>/kg to 0.15 m<sup>3</sup>/kg.

Test solution (a). Weigh 5.000 g ( $m_{\text{op}}$ ) of the substance to be examined and add about 80 mL of an 11.7 g/L solution of sodium chloride *R* at room temperature. Dissolve by shaking at room temperature for 30 min. Dilute to 100.0 mL with an 11.7 g/L solution of sodium chloride *R*. Filter through a membrane filter (nominal pore size 0.45  $\mu\text{m}$ ) and discard

the first 10 mL. The concentration of test solution (a) is only indicative and must be adjusted after an initial measurement of the viscosity of test solution (a).

**Test solution (b).** To 15.0 mL of test solution (a) add 5.0 mL of an 11.7 g/L solution of *sodium chloride R*.

**Test solution (c).** To 10.0 mL of test solution (a) add 10.0 mL of an 11.7 g/L solution of *sodium chloride R*.

**Test solution (d).** To 5.0 mL of test solution (a) add 15.0 mL of an 11.7 g/L solution of *sodium chloride R*.

Determine the flow-time (2.2.9) for an 11.7 g/L solution of *sodium chloride R* ( $t_0$ ) and the flow times for the 4 test solutions ( $t_1$ ,  $t_2$ ,  $t_3$  and  $t_4$ ), at  $25.00 \pm 0.03$  °C. Use an appropriate suspended level viscometer (specifications: viscometer constant = about  $0.005 \text{ mm}^2/\text{s}^2$ , kinematic viscosity range =  $1\text{--}5 \text{ mm}^2/\text{s}$ , internal diameter of tube  $R = 0.53 \text{ mm}$ , volume of bulb  $C = 5.6 \text{ mL}$ , internal diameter of tube  $N = 2.8\text{--}3.2 \text{ mm}$ ) with a funnel-shaped lower capillary end. Use the same viscometer for all measurements; measure all outflow times in triplicate. The test is not valid unless the results do not differ by more than 0.35 per cent from the mean and if the flow time  $t_1$  is not less than  $1.6 \times t_0$  and not more than  $1.8 \times t_0$ . If this is not the case, adjust the concentration of test solution (a) and repeat the procedure.

#### Calculation of the relative viscosities

Since the densities of the chondroitin sulfate solutions and of the solvent are almost equal, the relative viscosities  $\eta_{ri}$  (being  $\eta_{r1}$ ,  $\eta_{r2}$ ,  $\eta_{r3}$  and  $\eta_{r4}$ ) can be calculated from the ratio of the flow times for the respective solutions  $t_i$  (being  $t_1$ ,  $t_2$ ,  $t_3$  and  $t_4$ ) to the flow time of the solvent  $t_0$ , but taking into account the kinetic energy correction factor for the capillary ( $B = 30\ 800 \text{ s}^3$ ), as shown below:

$$\frac{t_i - \frac{B}{t_i^2}}{t_0 - \frac{B}{t_0^2}}$$

#### Calculation of the concentrations

Calculate the concentration  $c_1$  (expressed in  $\text{kg}/\text{m}^3$ ) of chondroitin sulfate sodium in test solution (a) using the following expression:

$$m_{\text{op}} \times \frac{x}{100} \times \frac{100 - h}{100} \times 10$$

$x$  = percentage content of chondroitin sulfate sodium as determined in the assay;

$h$  = loss on drying as a percentage.

Calculate the concentration  $c_2$  (expressed in  $\text{kg}/\text{m}^3$ ) of chondroitin sulfate sodium in test solution (b) using the following expression:

$$c_1 \times 0.75$$

Calculate the concentration  $c_3$  (expressed in  $\text{kg}/\text{m}^3$ ) of chondroitin sulfate sodium in test solution (c) using the following expression:

$$c_1 \times 0.50$$

Calculate the concentration  $c_4$  (expressed in  $\text{kg}/\text{m}^3$ ) of chondroitin sulfate sodium in test solution (d) using the following expression:

$$c_1 \times 0.25$$

#### Calculation of the intrinsic viscosity

The specific viscosity  $\eta_{si}$  of the test solution (being  $\eta_{s1}$ ,  $\eta_{s2}$ ,  $\eta_{s3}$  and  $\eta_{s4}$ ) is calculated from the relative viscosities  $\eta_{ri}$  (being  $\eta_{r1}$ ,  $\eta_{r2}$ ,  $\eta_{r3}$  and  $\eta_{r4}$ ) according to the following expression:

$$\eta_{ri} - 1$$

The intrinsic viscosity  $[\eta]$ , defined as

$$[\eta] = \lim_{c \rightarrow 0} \left( \frac{\eta_s}{c} \right)$$

is calculated by linear least-squares regression analysis using the following equation:

$$\frac{\eta_{si}}{c_i} = c_i \times k_H + [\eta]$$

$c_i$  = concentration of the substance to be examined expressed in  $\text{kg}/\text{m}^3$ ;

$k_H$  = Huggins' constant.

#### Related substances. Electrophoresis (2.2.31).

**Buffer solution A** (0.1 M barium acetate pH 5.0). Dissolve 25.54 g of *barium acetate R* in 900 mL of *water R*. Adjust to pH 5.0 with *glacial acetic acid R* and dilute to 1000.0 mL with *water R*.

**Buffer solution B** (1 M barium acetate pH 5.0). Dissolve 255.43 g of *barium acetate R* in 900 mL of *water R*. Adjust to pH 5.0 with *glacial acetic acid R* and dilute to 1000.0 mL with *water R*.

**Staining solution.** Dissolve 1.0 g of *toluidine blue R* and 2.0 g of *sodium chloride R* in 1000 mL of 0.01 M *hydrochloric acid*. Filter.

**Test solution.** Prepare a 30 mg/mL solution of the substance to be examined in *water R*.

**Reference solution (a).** Prepare a 30 mg/mL solution of *chondroitin sulfate sodium CRS* in *water R*.

**Reference solution (b).** Dilute 2.0 mL of reference solution (a) to 100.0 mL with *water R*.

**Reference solution (c).** Mix equal volumes of reference solution (b) and *water R*.

**Procedure.** Allow the electrophoresis support to cool the plate to 10 °C. Pre-equilibrate the agarose gel for 1 min in buffer solution A. Remove excess liquid by careful decanting. Dry the gel for approximately 5 min. Place 400 mL of buffer solution B into each of the containers of the electrophoresis equipment. Transfer 1  $\mu\text{L}$  of each solution to the slots of the agarose gel. Pipette a few millilitres of a 50 per cent V/V solution of *glycerol R* onto the cooled plate of the electrophoresis equipment and place the gel in the middle of the ceramic plate. Place a wick, saturated with buffer solution B, at the positive and negative sides of the agarose gel. Ensure that there is good contact between the electrophoresis buffer and the agarose gel. Perform the electrophoresis under the following conditions: 75 mA/gel, resulting in a voltage of 100–150 V (maximum 300–400 V) for a gel of about 12 cm  $\times$  10 cm. Carry out the electrophoresis for 12 min. Place the gel in a mixture consisting of 10 volumes of *anhydrous ethanol R* and 90 volumes of buffer solution A for 2 min. Carry out the electrophoresis for 20 min. Place the gel in a mixture consisting of 30 volumes of *anhydrous ethanol R* and 70 volumes of buffer solution A for 2 min. Carry out the electrophoresis for 20 min. Stain the gel in the staining solution for 10 min. Destain the gel for 15 min under running tap water followed by 10–15 min with *water R* until the band in the electropherogram obtained with reference solution (c) is visible. Allow the gel to dry.

#### System suitability:

- the electropherogram obtained with reference solution (c) shows a visible band;
- the band in the electropherogram obtained with reference solution (b) is clearly visible and similar in position to the band in the electropherogram obtained with reference solution (a).

**Results:** any secondary band in the electropherogram obtained with the test solution is not more intense than the band in the electropherogram obtained with reference solution (b) (2 per cent).

**Protein** (2.5.33, Method 2): maximum 3.0 per cent (dried substance).

**Test solution.** Dilute 1.0 mL of solution S1 to 50.0 mL with 0.1 M sodium hydroxide.

**Reference solutions.** Dissolve about 0.100 g of bovine albumin R, accurately weighed, in 0.1 M sodium hydroxide and dilute to 50.0 mL with the same solvent. Carry out all additional dilutions using 0.1 M sodium hydroxide.

**Chlorides** (2.4.4): maximum 0.5 per cent.

Dilute 1 mL of solution S2 to 15 mL with water R. Do not add diluted nitric acid. Prepare the standard using 5 mL of chloride standard solution (5 ppm Cl) and 10 mL of water R.

**Heavy metals** (2.4.8): maximum 20 ppm.

1.0 g complies with test C. Prepare the reference solution using 2 mL of lead standard solution (10 ppm Pb) R.

**Loss on drying** (2.2.32): maximum 12.0 per cent, determined on 1.000 g by drying in an oven at 105 °C for 4 h.

#### Microbial contamination

TAMC: acceptance criterion 10<sup>3</sup> CFU/g (2.6.12).

TYMC: acceptance criterion 10<sup>2</sup> CFU/g (2.6.12).

Absence of *Staphylococcus aureus* (2.6.13).

Absence of *Pseudomonas aeruginosa* (2.6.13).

Absence of *Escherichia coli* (2.6.13).

Absence of *Salmonella* (2.6.13).

Absence of bile-tolerant gram-negative bacteria (2.6.13).

#### ASSAY

**Test solution (a).** Weigh 0.100 g (*m*<sub>1</sub>) of the substance to be examined, dissolve in water R and dilute to 100.0 mL with the same solvent.

**Test solution (b).** Dilute 5.0 mL of test solution (a) to 50.0 mL with water R.

**Reference solution (a).** Weigh 0.100 g (*m*<sub>0</sub>) of chondroitin sulfate sodium CRS, previously dried as described in the test for loss on drying, dissolve in water R and dilute to 100.0 mL with the same solvent.

**Reference solution (b).** Dilute 5.0 mL of reference solution (a) to 50.0 mL with water R.

**Titrant solution (a).** Weigh 4.000 g of cetylpyridinium chloride monohydrate R and dilute to 1000 mL with water R.

**Titrant solution (b).** Weigh 1.000 g of cetylpyridinium chloride monohydrate R and dilute to 1000 mL with water R.

Perform either visual or photometric titration as follows:

**Visual titration.** Titrate 40.0 mL of reference solution (a) and 40.0 mL of test solution (a) with titrant solution (a). The solution becomes turbid. At the end point, the liquid appears clear, with an almost-white precipitate in suspension. The precipitate is more apparent if 0.1 mL of a 1 per cent solution of methylene blue R is added before starting the titration. The precipitated particles are more apparent against the blue background.

**Photometric titration.** Titrate 50.0 mL of reference solution (b) and 50.0 mL of test solution (b) with titrant solution (b). To determine the end point, use a suitable autotitrator equipped with a phototrode at a suitable wavelength (none is critical) in the visible range.

Calculate the percentage content of chondroitin sulfate sodium using the following expression:

$$\frac{v_1 \times m_0}{v_0 \times m_1} \times \frac{100}{100 - h} \times Z$$

*v*<sub>0</sub> = volume of appropriate titrant solution when titrating the appropriate reference solution, in millilitres;

*v*<sub>1</sub> = volume of appropriate titrant solution when titrating the appropriate test solution, in millilitres;

*h* = loss on drying of the substance to be examined, as a percentage;

*Z* = percentage content of H<sub>2</sub>O(C<sub>14</sub>H<sub>19</sub>NNa<sub>2</sub>O<sub>14</sub>S)<sub>x</sub> in chondroitin sulfate sodium CRS.

#### STORAGE

In an airtight container, protected from light.

#### LABELLING

The label states the origin of the substance (marine or terrestrial).

01/2011:0476

## CHYMOTRYPSIN

### Chymotrypsinum

[9004-07-3]

#### DEFINITION

Chymotrypsin is a proteolytic enzyme obtained by the activation of chymotrypsinogen extracted from the pancreas of beef (*Bos taurus* L.). It has an activity of not less than 5.0 microkatal per milligram. In solution it has maximal enzymic activity at about pH 8; the activity is reversibly inhibited at pH 3, the pH at which it is most stable.

#### PRODUCTION

The animals from which chymotrypsin is derived must fulfil the requirements for the health of animals suitable for human consumption. Furthermore, the tissues used shall not include any specified risk material as defined by any relevant international or, where appropriate, national legislation.

The method of manufacture is validated to demonstrate that the product, if tested, would comply with the following test.

**Histamine** (2.6.10): not more than 1 µg (calculated as histamine base) per 5 microkatal of chymotrypsin activity. Before carrying out the test, heat the solution of the substance to be examined on a water-bath for 30 min.

#### CHARACTERS

**Appearance:** white or almost white, crystalline or amorphous powder, hygroscopic if amorphous.

**Solubility:** sparingly soluble in water.

#### IDENTIFICATION

A. Dilute 1 mL of solution S (see Tests) to 10 mL with water R. In a depression in a white spot-plate, mix 0.05 mL of this solution with 0.2 mL of the substrate solution. A purple colour develops.

**Substrate solution.** To 24.0 mg of acetyltirosine ethyl ester R add 0.2 mL of ethanol (96 per cent) R and swirl to dissolve. Add 2.0 mL of 0.067 M phosphate buffer solution pH 7.0 R and 1 mL of methyl red mixed solution R and dilute to 10.0 mL with water R.

B. Dilute 0.5 mL of solution S to 5 mL with water R. Add 0.10 mL of a 20 g/L solution of tosylphenylalanylchloromethane R in ethanol (96 per cent) R. Adjust to pH 7.0 and shake for 2 h. In a depression in a white spot-plate, mix 0.05 mL of

this solution with 0.2 mL of the substrate solution (see Identification test A). No colour develops within 3 min of mixing.

## TESTS

**Solution S.** Dissolve 0.10 g in *carbon dioxide-free water R* and dilute to 10.0 mL with the same solvent.

**Appearance of solution.** Solution S is not more opalescent than reference suspension II (2.2.1).

**pH (2.2.3):** 3.0 to 5.0 for solution S.

**Specific absorbance (2.2.25):** 18.5 to 22.5, determined at the absorption maximum at 281 nm; maximum 8, determined at the absorption minimum at 250 nm.

Dissolve 30.0 mg in 0.001 M *hydrochloric acid* and dilute to 100.0 mL with the same acid.

**Trypsin.**

**Substrate solution.** To 98.5 mg of *tosylarginine methyl ester hydrochloride R*, suitable for assaying trypsin, add 5 mL of *tris(hydroxymethyl)aminomethane buffer solution pH 8.1 R* and swirl to dissolve. Add 2.5 mL of *methyl red mixed solution R* and dilute to 25.0 mL with *water R*.

**Test solution.** Transfer to a depression in a white spot-plate 0.01 mL of *tris(hydroxymethyl)aminomethane buffer solution pH 8.1 R* and 0.1 mL of solution S. Add 0.2 mL of the substrate solution.

**Reference solution.** At the same time and in the same manner as for the test solution, prepare a solution using the substance to be examined to which not more than 1 per cent *m/m* of *trypsin BRP* has been added.

Start a timer. No colour appears in the test solution within 3-5 min after the addition of the substrate solution. A purple colour is produced in the control solution.

**Loss on drying (2.2.32):** not more than 5.0 per cent, determined on 0.100 g by drying at 60 °C at a pressure not exceeding 0.7 kPa for 2 h.

## ASSAY

The activity of chymotrypsin is determined by comparing the rate at which it hydrolyses *acetyltyrosine ethyl ester R* with the rate at which *chymotrypsin BRP* hydrolyses the same substrate under the same conditions.

**Apparatus.** Use a reaction vessel of about 30 mL capacity provided with:

- a device that will maintain a temperature of 25.0 ± 0.1 °C;
- a stirring device, for example a magnetic stirrer;
- a lid with holes for the insertion of electrodes, the tip of a burette, a tube for the admission of nitrogen and the introduction of reagents.

An automatic or manual titration apparatus may be used. For the latter, the burette is graduated in 0.005 mL and the pH meter is provided with a wide scale and glass-calomel or glass-silver-silver chloride electrodes.

**Test solution.** Dissolve 25.0 mg of the substance to be examined in 0.001 M *hydrochloric acid* and dilute to 250.0 mL with the same acid.

**Reference solution.** Dissolve 25.0 mg of *chymotrypsin BRP* in 0.001 M *hydrochloric acid* and dilute to 250.0 mL with the same acid.

Store the solutions at 0-5 °C. Warm 1 mL of each solution to about 25 °C over 15 min and use 50 µL of each solution (corresponding to about 25 nanokatals) for each titration. Carry out the titration in an atmosphere of nitrogen. Transfer 10.0 mL of 0.01 M *calcium chloride solution R* to the reaction vessel and, while stirring, add 0.35 mL of 0.2 M *acetyltyrosine ethyl ester solution R*. When the temperature is steady at 25.0 ± 0.1 °C (after about 5 min), adjust to pH 8.0 exactly with 0.02 M *sodium hydroxide*. Add 50 µL of the test solution (equivalent to about 5 µg of the substance to be examined) and start a timer. Maintain at pH 8.0 by the addition of 0.02 M

*sodium hydroxide*, noting the volume added every 30 s. Calculate the volume of 0.02 M *sodium hydroxide* used per second between 30 s and 210 s. Carry out a titration in the same manner using the reference solution and calculate the volume of 0.02 M *sodium hydroxide* used per second.

Calculate the activity in microkatals per milligram using the following expression:

$$\frac{m' \times V}{m \times V'} \times A$$

- m* = mass of the substance to be examined, in milligrams;  
*m'* = mass of *chymotrypsin BRP*, in milligrams;  
*V* = volume of 0.02 M *sodium hydroxide* used per second by the test solution;  
*V'* = volume of 0.02 M *sodium hydroxide* used per second by the reference solution;  
*A* = activity of *chymotrypsin BRP*, in microkatals per milligram.

## STORAGE

In an airtight container at 2 °C to 8 °C, protected from light.

## LABELLING

The label states:

- the quantity of chymotrypsin and the total activity in microkatals per container;
- for the amorphous substance, that it is hygroscopic.

07/2010:1407

## CICLOPIROX

## Ciclopiroxum

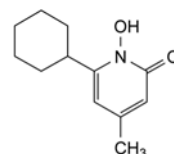

C<sub>12</sub>H<sub>17</sub>NO<sub>2</sub>  
 [29342-05-0]

M<sub>r</sub> 207.3

## DEFINITION

6-Cyclohexyl-1-hydroxy-4-methylpyridin-2(1H)-one.

**Content:** 98.0 per cent to 101.0 per cent (dried substance).

## CHARACTERS

**Appearance:** white or yellowish-white, crystalline powder.

**Solubility:** slightly soluble in water, freely soluble in anhydrous ethanol and in methylene chloride.

## IDENTIFICATION

**First identification: B.**

**Second identification: A, C.**

A. Melting point (2.2.14): 140 °C to 145 °C.

B. Infrared absorption spectrophotometry (2.2.24).

**Comparison:** *ciclopirox CRS*.

C. Thin-layer chromatography (2.2.27).

**Test solution.** Dissolve 20 mg of the substance to be examined in *methanol R* and dilute to 10 mL with the same solvent.

**Reference solution.** Dissolve 20 mg of *ciclopirox CRS* in *methanol R* and dilute to 10 mL with the same solvent.

**Plate:** *TLC silica gel F<sub>254</sub> plate R*.

**Pretreatment:** before use predevelop with the mobile phase until the solvent front has migrated to the top of the plate. Allow to dry in air for 5 min.



**Mobile phase:** concentrated ammonia R, water R, ethanol (96 per cent) R (10:15:75 V/V/V).

**Application:** 10 µL.

**Development:** over 2/3 of the plate.

**Drying:** in air for 10 min.

**Detection A:** examine in ultraviolet light at 254 nm.

**Results A:** the principal spot in the chromatogram obtained with the test solution is similar in position and size to the principal spot in the chromatogram obtained with the reference solution.

**Detection B:** spray with a 20 g/L solution of ferric chloride R in anhydrous ethanol R.

**Results B:** the principal spot in the chromatogram obtained with the test solution is similar in position, colour and size to the principal spot in the chromatogram obtained with the reference solution.

## TESTS

**Appearance of solution.** The solution is clear (2.2.1) and not more intensely coloured than reference solution Y<sub>5</sub> (2.2.2, Method II).

Dissolve 2.0 g in methanol R and dilute to 10 mL with the same solvent.

**Related substances.** Liquid chromatography (2.2.29). Carry out the operations avoiding exposure to actinic light. All materials which are in direct contact with the substance to be examined like column materials, reagents, solvents and others should contain only very low amounts of extractable metal cations.

**Solvent mixture:** acetonitrile R, mobile phase (1:9 V/V).

**Test solution.** Dissolve 30.0 mg of the substance to be examined in 15 mL of the solvent mixture. If necessary, use an ultrasonic bath. Dilute to 20.0 mL with the solvent mixture.

**Reference solution (a).** Dissolve 15.0 mg of ciclopirox impurity A CRS and 15.0 mg of ciclopirox impurity B CRS in the solvent mixture and dilute to 10.0 mL with the solvent mixture.

**Reference solution (b).** Dilute 1.0 mL of reference solution (a) to 200.0 mL with the solvent mixture.

**Reference solution (c).** Dilute 2.0 mL of reference solution (b) to 10.0 mL with the solvent mixture.

**Reference solution (d).** Mix 5.0 mL of reference solution (a) with 5.0 mL of the test solution.

**Column:**

- size:  $l = 0.08$  m,  $\varnothing = 4$  mm;
- stationary phase: nitrile silica gel for chromatography R2 (5 µm).

In order to ensure desorption of disruptive metal ions, every new column is to be rinsed with the rinsing solution over a period of not less than 15 h and then with the mobile phase for not less than 5 h at a flow rate of 0.2 mL/min.

**Rinsing solution:** glacial acetic acid R, acetylacetone R, acetonitrile R, water R (1:1:500:500 V/V/V/V).

**Mobile phase:** mix 0.1 mL of glacial acetic acid R, 230 mL of acetonitrile R and 770 mL of a 0.96 g/L solution of sodium edetate R.

**Flow rate:** 0.7 mL/min.

**Detection:** spectrophotometer at 220 nm and at 298 nm.

**Injection:** 10 µL of the test solution and reference solutions (b), (c) and (d); inject the solvent mixture as a blank.

**Run time:** 2.5 times the retention time of ciclopirox.

**Retention time:** ciclopirox = 8 min to 11 min; if necessary adjust the ratio of the 0.96 g/L solution of sodium edetate to acetonitrile in the mobile phase.

**Relative retention** with reference to ciclopirox: impurity A = about 0.5; impurity C = about 0.9; impurity B = about 1.3.

**System suitability:**

- resolution: minimum 2.0 between the peaks due to ciclopirox and impurity B in the chromatogram obtained with reference solution (d);
- symmetry factor: 0.8 to 2.0 for the principal peak in the chromatogram obtained with the test solution.

**Limits:**

- impurity A at 220 nm: not more than the area of the corresponding peak in the chromatogram obtained with reference solution (b) (0.5 per cent);
- impurities B, C at 298 nm: for each impurity, not more than the area of the peak due to impurity B in the chromatogram obtained with reference solution (b) (0.5 per cent);
- unspecified impurities at 298 nm: for each impurity, not more than the area of the peak due to impurity B in the chromatogram obtained with reference solution (c) (0.10 per cent);
- sum of impurities other than B at 298 nm: not more than the area of the peak due to impurity B in the chromatogram obtained with reference solution (b) (0.5 per cent);
- disregard limit at 298 nm: 0.5 times the area of the peak due to impurity B in the chromatogram obtained with reference solution (c) (0.05 per cent).

**Heavy metals** (2.4.8): maximum 10 ppm.

2.0 g complies with test C. Prepare the reference solution using 2 mL of lead standard solution (10 ppm Pb) R.

**Loss on drying** (2.2.32): maximum 1.5 per cent, determined on 1.000 g by drying *in vacuo* at 60 °C over diphosphorus pentoxide R.

**Sulfated ash** (2.4.14): maximum 0.1 per cent, determined on 1.0 g.

## ASSAY

Dissolve 0.150 g in 20 mL of methanol R. Add 20 mL of water R and titrate with 0.1 M sodium hydroxide, determining the end-point potentiometrically (2.2.20). Carry out a blank titration.

1 mL of 0.1 M sodium hydroxide is equivalent to 20.73 mg of C<sub>12</sub>H<sub>17</sub>NO<sub>2</sub>.

## STORAGE

Protected from light.

## IMPURITIES

**Specified impurities:** A, B, C.

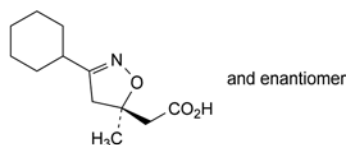

A. (RS)-2-(3-cyclohexyl-5-methyl-4,5-dihydroisoxazol-5-yl)acetic acid,

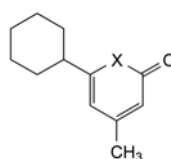

B. X = O: 6-cyclohexyl-4-methyl-2H-pyran-2-one,

C. X = NH: 6-cyclohexyl-4-methylpyridin-2(1H)-one.

07/2010:1302

## CICLOPIROX OLAMINE

## Ciclopirox olaminum

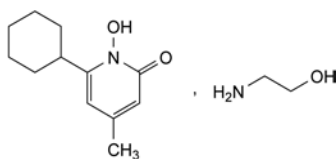

$C_{14}H_{24}N_2O_3$   
[41621-49-2]

$M_r$  268.4

## DEFINITION

6-Cyclohexyl-1-hydroxy-4-methylpyridin-2(1H)-one and 2-aminoethanol.

## Content:

- ciclopirox ( $C_{12}H_{17}NO_2$ ;  $M_r$  207.3): 76.0 per cent to 78.5 per cent (dried substance);
- 2-aminoethanol ( $C_2H_7NO$ ;  $M_r$  61.1): 22.2 per cent to 23.3 per cent (dried substance).

## CHARACTERS

*Appearance*: white or pale yellow, crystalline powder.

*Solubility*: sparingly soluble in water, very soluble in ethanol (96 per cent) and in methylene chloride, slightly soluble in ethyl acetate, practically insoluble in cyclohexane.

It shows polymorphism (5.9).

## IDENTIFICATION

*First identification*: A.

*Second identification*: B.

A. Infrared absorption spectrophotometry (2.2.24).

*Comparison*: ciclopirox olamine CRS.

If the spectra obtained in the solid state show differences, dissolve the substance to be examined and the reference substance separately in the minimum volume of *ethyl acetate R*, evaporate to dryness on a water-bath and record new spectra using the residues.

B. Thin-layer chromatography (2.2.27).

*Test solution*. Dissolve 25 mg of the substance to be examined in *methanol R* and dilute to 10 mL with the same solvent.

*Reference solution*. Dissolve 25 mg of *ciclopirox olamine CRS* in *methanol R* and dilute to 10 mL with the same solvent.

*Plate*: TLC silica gel  $F_{254}$  plate *R*.

Before use wash 2 plates by allowing a mixture of 10 volumes of *concentrated ammonia R*, 15 volumes of *water R* and 75 volumes of *anhydrous ethanol R* to migrate until the solvent front has reached the top of the plate. Allow the plates to dry in air for 5 min.

*Mobile phase*: *concentrated ammonia R*, *water R*, *anhydrous ethanol R* (10:15:75 V/V/V).

*Application*: 10  $\mu$ L.

*Development*: over 2/3 of the plate.

*Drying*: in air for 10 min.

*Detection A*: examine in ultraviolet light at 254 nm.

*Results A*: the principal spot in the chromatogram obtained with the test solution is similar in position and size to the principal spot in the chromatogram obtained with the reference solution.

*Detection B*: spray one plate with *ferric chloride solution R3*.

*Results B*: the principal spot in the chromatogram obtained with the test solution is similar in position, colour and size to the principal spot in the chromatogram obtained with the reference solution.

*Detection C*: spray the second plate with *ninhydrin solution R*. Heat at 110 °C until the spots appear.

*Results C*: the principal spot in the chromatogram obtained with the test solution is similar in position, colour and size to the principal spot in the chromatogram obtained with the reference solution.

## TESTS

**Appearance of solution**. The solution is clear (2.2.1) and not more intensely coloured than reference solution BY<sub>7</sub> (2.2.2, *Method II*).

Dissolve 2.0 g in *methanol R* and dilute to 20 mL with the same solvent.

**pH** (2.2.3): 8.0 to 9.0.

Dissolve 1.0 g in *carbon dioxide-free water R* and dilute to 100 mL with the same solvent.

**Related substances**. Liquid chromatography (2.2.29). Carry out the operations avoiding exposure to actinic light. All materials which are in direct contact with the substance to be examined, such as column materials, reagents, solvents, etc. should contain only small amounts of extractable metal cations.

*Solvent mixture*: *acetonitrile R*, mobile phase (1:9 V/V).

*Test solution*. Dissolve 40.0 mg of the substance to be examined (corresponding to about 30 mg of ciclopirox) in a mixture of 20  $\mu$ L of *anhydrous acetic acid R*, 2 mL of *acetonitrile R*, and 15 mL of the mobile phase. If necessary, use an ultrasonic bath. Dilute to 20.0 mL with the mobile phase.

*Reference solution (a)*. Dissolve 15.0 mg of *ciclopirox impurity A CRS* and 15.0 mg of *ciclopirox impurity B CRS* in a mixture of 1 mL of *acetonitrile R* and 7 mL of the mobile phase. Dilute to 10.0 mL with the mobile phase.

*Reference solution (b)*. Dilute 1.0 mL of reference solution (a) to 200.0 mL with the solvent mixture.

*Reference solution (c)*. Dilute 2.0 mL of reference solution (b) to 10.0 mL with the solvent mixture.

*Reference solution (d)*. Mix 5.0 mL of reference solution (a) with 5.0 mL of the test solution.

*Column*:

- *size*:  $l = 80$  mm,  $\varnothing = 4$  mm;
- *stationary phase*: *nitrile silica gel for chromatography R* (5  $\mu$ m).

In order to ensure desorption of interfering metal ions, a new column is to be rinsed with the rinsing solution over a period of at least 15 h and then with the mobile phase for at least 5 h at a flow rate of 0.2 mL/min.

*Rinsing solution*: *acetylacetone R*, *anhydrous acetic acid R*, *acetonitrile R*, *water R* (1:1:500:500 V/V/V/V).

*Mobile phase*: a mixture of 0.1 volumes of *anhydrous acetic acid R*, 230 volumes of *acetonitrile R* and 770 volumes of a 0.96 g/L solution of *sodium edetate R*. If the retention time of the principal peak in the chromatogram obtained with the test solution is not between 8 min and 11 min adjust the ratio of the 0.96 g/L solution of sodium edetate to acetonitrile accordingly.

*Flow rate*: 0.7 mL/min.

*Detection*: spectrophotometer at 220 nm and 298 nm.

*Injection*: 10  $\mu$ L of the test solution and reference solutions (b), (c) and (d).

*Run time*: 2.5 times the retention time of ciclopirox.

*Relative retention* with reference to ciclopirox:  
impurity A = about 0.5; impurity C = about 0.9;  
impurity B = about 1.3.

**System suitability:**

- **resolution:** minimum of 2.0 between the peaks due to impurity B and ciclopirox in the chromatogram obtained with reference solution (d);
- **symmetry factor:** 0.8 to 2.0 for the principal peak in the chromatogram obtained with the test solution.

**Limits:**

- **impurity A at 220 nm:** not more than the area of the corresponding peak in the chromatogram obtained with reference solution (b) (0.5 per cent);
- **impurities B, C at 298 nm:** for each impurity, not more than the area of the peak due to impurity B in the chromatogram obtained with reference solution (b) (0.5 per cent);
- **unspecified impurities at 298 nm:** for each impurity, not more than the area of the peak due to impurity B in the chromatogram obtained with reference solution (c) (0.10 per cent);
- **sum of impurities other than B at 298 nm:** not more than the area of the peak due to impurity B in the chromatogram obtained with reference solution (b) (0.5 per cent);
- **disregard limit at 298 nm:** 0.5 times the area of the peak due to impurity B in the chromatogram obtained with reference solution (c) (0.05 per cent).

**Heavy metals (2.4.8):** maximum 20 ppm.

1.0 g complies with test C. Prepare the reference solution using 2 mL of *lead standard solution (10 ppm Pb) R*.

**Loss on drying (2.2.32):** maximum 1.5 per cent, determined on 1.000 g by drying under high vacuum.

**Sulfated ash (2.4.14):** maximum 0.1 per cent, determined on 1.0 g.

**ASSAY**

**2-Aminoethanol.** Dissolve 0.250 g in 25 mL of *anhydrous acetic acid R*. Titrate with 0.1 M *perchloric acid*, determining the end-point potentiometrically (2.2.20).

1 mL of 0.1 M *perchloric acid* is equivalent to 6.108 mg of  $C_2H_7NO$ .

**Ciclopirox.** Dissolve 0.200 g in 2 mL of *methanol R*. Add 38 mL of *water R*, swirl and titrate immediately with 0.1 M *sodium hydroxide*, determining the end-point potentiometrically (2.2.20). Carry out a blank titration.

Use 0.1 M *sodium hydroxide*, the titre of which has been determined under the conditions prescribed above using 0.100 g of *benzoic acid RV*.

1 mL of 0.1 M *sodium hydroxide* is equivalent to 20.73 mg of  $C_{12}H_{17}NO_2$ .

**STORAGE**

Protected from light.

**IMPURITIES**

**Specified impurities:** A, B, C.

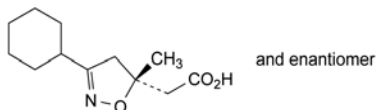

A. (RS)-2-(3-cyclohexyl-5-methyl-4,5-dihydroisoxazol-5-yl)acetic acid,

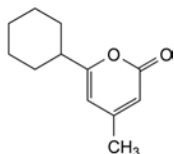

B. 6-cyclohexyl-4-methyl-2H-pyran-2-one,

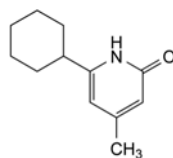

C. 6-cyclohexyl-4-methylpyridin-2(1H)-one.

01/2008:0994

**CICLOSPORIN****Ciclosporinum**

$C_{62}H_{111}N_{11}O_{12}$

$M_r$  1203

**DEFINITION**

Cyclo[[*(2S,3R,4R,6E)*-3-hydroxy-4-methyl-2-(methylamino)-oct-6-enoyl]-L-2-aminobutanoyl-*N*-methylglycyl-*N*-methyl-L-leucyl-L-valyl-*N*-methyl-L-leucyl-L-alanyl-D-alanyl-*N*-methyl-L-leucyl-*N*-methyl-L-leucyl-*N*-methyl-L-valyl].

Substance produced by *Beauveria nivea (Tolypocladium inflatum Gams)* or obtained by any other means.

**Content:** 98.5 per cent to 102.0 per cent (dried substance).

**CHARACTERS**

**Appearance:** white or almost white powder.

**Solubility:** practically insoluble in water, freely soluble in anhydrous ethanol and in methylene chloride.

**IDENTIFICATION**

A. Infrared absorption spectrophotometry (2.2.24).

*Comparison:* ciclosporin CRS.

B. Examine the chromatograms obtained in the assay.

**Results:** the principal peak in the chromatogram obtained with the test solution is similar in retention time to the principal peak in the chromatogram obtained with reference solution (a).

**TESTS**

**Appearance of solution.** The solution is clear (2.2.1) and not more intensely coloured than reference solution  $Y_5$ ,  $BY_5$  or  $R_7$  (2.2.2, *Method II*).

Dissolve 1.5 g in *anhydrous ethanol R* and dilute to 15 mL with the same solvent.

**Specific optical rotation (2.2.7):** – 185 to – 193 (dried substance).

Dissolve 0.125 g in *methanol R* and dilute to 25.0 mL with the same solvent.

**Related substances.** Liquid chromatography (2.2.29).

**Solvent mixture:** acetonitrile *R*, *water R* (50:50 V/V).

**Test solution.** Dissolve 30.0 mg of the substance to be examined in the solvent mixture and dilute to 25.0 mL with the solvent mixture.

**Reference solution (a).** Dissolve 30.0 mg of *ciclosporin CRS* in the solvent mixture and dilute to 25.0 mL with the solvent mixture.

**Reference solution (b).** Dilute 2.0 mL of reference solution (a) to 200.0 mL with the solvent mixture.

**Reference solution (c).** Dissolve the contents of a vial of *ciclosporin for system suitability CRS* in 5.0 mL of the mobile phase.

## Column:

- size:  $l = 0.25$  m,  $\varnothing = 4$  mm;
- stationary phase: octadecylsilyl silica gel for chromatography R (3.5  $\mu$ m);
- temperature: 80 °C.

The column is connected to the injection port by a steel capillary tube about 1 m long, having an internal diameter of 0.25 mm and maintained at 80 °C.

Mobile phase: phosphoric acid R, 1,1-dimethylethyl methyl ether R, acetonitrile R, water R (1.50:430:520 V/V/V/V).

Flow rate: 1.5 mL/min.

Detection: spectrophotometer at 210 nm.

Injection: 20  $\mu$ L of the test solution and reference solutions (b) and (c).

Run time: 1.7 times the retention time of ciclosporin.

System suitability: reference solution (c):

- retention time: ciclosporin = 25 min to 30 min; if necessary, adjust the ratio of acetonitrile to water in the mobile phase;
- peak-to-valley ratio: minimum 1.4, where  $H_p$  = height above the baseline of the peak due to ciclosporin U and  $H_v$  = height above the baseline of the lowest point of the curve separating this peak from the peak due to ciclosporin; if necessary, adjust the ratio of 1,1-dimethylethyl methyl ether to acetonitrile in the mobile phase.

## Limits:

- any impurity: for each impurity, not more than 0.7 times the area of the principal peak in the chromatogram obtained with reference solution (b) (0.7 per cent);
- total: not more than 1.5 times the area of the principal peak in the chromatogram obtained with reference solution (b) (1.5 per cent);
- disregard limit: 0.05 times the area of the principal peak in the chromatogram obtained with reference solution (b) (0.05 per cent).

Heavy metals (2.4.8): maximum 20 ppm.

The residue obtained in the test for loss on drying complies with test C. Prepare the reference solution using 2 mL of lead standard solution (10 ppm Pb) R.

Loss on drying (2.2.32): maximum 2.0 per cent, determined on 1.000 g at 60 °C at a pressure not exceeding 15 Pa for 3 h.

Bacterial endotoxins (2.6.14): less than 0.84 IU/mg, if intended for use in the manufacture of parenteral preparations without a further appropriate procedure for the removal of bacterial endotoxins. Dissolve 50 mg of the substance to be examined in a mixture of 280 mg of ethanol (96 per cent) R and 650 mg of polyoxyethylated castor oil R and dilute to the required concentration using water for BET.

## ASSAY

Liquid chromatography (2.2.29) as described in the test for related substances with the following modifications.

Injection: test solution and reference solution (a).

System suitability: reference solutions (a):

- repeatability: maximum relative standard deviation of 1.0 per cent after 6 injections.

Calculate the percentage content of  $C_{62}H_{111}N_{11}O_{12}$  from the declared content of ciclosporin CRS.

## STORAGE

In an airtight container, protected from light. If the substance is sterile, store in a sterile, airtight, tamper-proof container.

## IMPURITIES

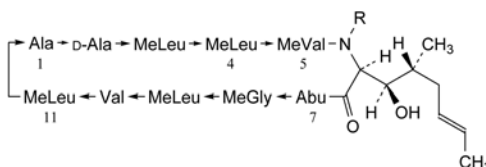

- A. different ciclosporins [difference with ciclosporin (R = CH<sub>3</sub>: ciclosporin A)]: ciclosporin B [7-L-Ala]; ciclosporin C [7-L-Thr]; ciclosporin D [7-L-Val]; ciclosporin E [5-L-Val]; ciclosporin G [7-(L-2-aminopentanoyl)]; ciclosporin H [5-D-MeVal]; ciclosporin L [R = H]; ciclosporin T [4-L-Leu]; ciclosporin U [11-L-Leu]; ciclosporin V [1-L-Abu],



- B. [6-[(2S,3R,4R)-3-hydroxy-4-methyl-2-(methylamino)octanoic acid]]ciclosporin A,  
C. isociclosporin A.

01/2008:1408  
corrected 6.1

## CILASTATIN SODIUM

## Cilastatinum natriicum

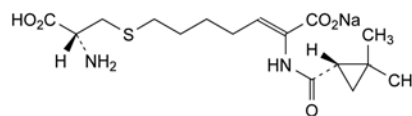

$C_{16}H_{25}N_2NaO_5S$   
[81129-83-1]

$M_r$  380.4

## DEFINITION

Sodium (Z)-7-[[[(R)-2-amino-2-carboxyethyl]sulfanyl]-2-[[[(1S)-2,2-dimethylcyclopropyl]carbonyl]amino]hept-2-enoate.

Content: 98.0 per cent to 101.5 per cent (anhydrous substance).

## CHARACTERS

Appearance: white or light yellow amorphous, hygroscopic powder.

Solubility: very soluble in water and in methanol, slightly soluble in anhydrous ethanol, very slightly soluble in dimethyl sulfoxide, practically insoluble in acetone and in methylene chloride.

## IDENTIFICATION

- A. Specific optical rotation (see Tests).  
B. Infrared absorption spectrophotometry (2.2.24).  
Comparison: cilastatin sodium CRS.  
C. It gives reaction (a) of sodium (2.3.1).

## TESTS

**Solution S.** Dissolve 1.0 g in carbon dioxide-free water R and dilute to 100 mL with the same solvent.

**Appearance of solution.** Solution S is clear (2.2.1) and not more intensely coloured than reference solution Y<sub>6</sub> (2.2.2, Method II).

**pH (2.2.3):** 6.5 to 7.5 for solution S.

**Specific optical rotation (2.2.7):** + 41.5 to + 44.5 (anhydrous substance).

Dissolve 0.250 g in a mixture of 1 volume of hydrochloric acid R and 120 volumes of methanol R, then dilute to 25.0 mL with the same mixture of solvents.

**Related substances.** Liquid chromatography (2.2.29).

**Test solution.** Dissolve 32.0 mg of the substance to be examined in water R and dilute to 20.0 mL with the same solvent.

**Reference solution (a).** Dilute 2.0 mL of the test solution to 100.0 mL with water R. Dilute 5.0 mL of this solution to 100.0 mL with water R.

**Reference solution (b).** Dilute 5.0 mL of the test solution to 100.0 mL with water R. Dilute 2.0 mL of this solution to 20.0 mL with water R.

**Reference solution (c).** Dissolve 16 mg of the substance to be examined in dilute hydrogen peroxide solution R and dilute to 10.0 mL with the same solution. Allow to stand for 30 min. Dilute 1 mL of this solution to 100 mL with water R.

**Reference solution (d).** Dissolve 32 mg of mesityl oxide R (impurity D) in 100 mL of water R. Dilute 1 mL of this solution to 50 mL with water R.

**Column:**

- size:  $l = 0.25$  m,  $\emptyset = 4.6$  mm;
- stationary phase: octadecylsilyl silica gel for chromatography R (5  $\mu$ m);
- temperature: 50 °C.

**Mobile phase:**

- mobile phase A: mix 300 volumes of acetonitrile R1 and 700 volumes of a 0.1 per cent V/V solution of phosphoric acid R in water R;
- mobile phase B: 0.1 per cent V/V solution of phosphoric acid R in water R;

Time (min)	Mobile phase A (per cent V/V)	Mobile phase B (per cent V/V)
0 - 30	15 → 100	85 → 0
30 - 46	100	0
46 - 56	100 → 15	0 → 85

**Flow rate:** 2.0 mL/min.

**Detection:** spectrophotometer at 210 nm.

**Injection:** 20  $\mu$ L.

**System suitability:**

- the chromatogram obtained with reference solution (c) shows 3 principal peaks: the first 2 peaks (impurity A) may elute without being completely resolved;
- mass distribution ratio: minimum 10 for the peak due to cilastatin (3<sup>rd</sup> peak) in the chromatogram obtained with reference solution (c);
- signal-to-noise ratio: minimum 5.0 for the principal peak in the chromatogram obtained with reference solution (a).

**Limits:**

- impurities A, B, C: for each impurity, not more than the area of the principal peak in the chromatogram obtained with reference solution (b) (0.5 per cent);
- total: not more than twice the area of the principal peak in the chromatogram obtained with reference solution (b) (1 per cent);
- disregard limit: the area of the principal peak in the chromatogram obtained with reference solution (a) (0.1 per cent); disregard any peak corresponding to the peak due to impurity D in the chromatogram obtained with reference solution (d).

**Impurity D, acetone and methanol.** Gas chromatography (2.2.28).

**Internal standard solution.** Dissolve 0.5 mL of propanol R in water R and dilute to 1000 mL with the same solvent.

**Test solution.** Dissolve 0.200 g of the substance to be examined in water R, add 2.0 mL of the internal standard solution and dilute to 10.0 mL with water R.

**Reference solution.** Dissolve 2.0 mL of acetone R, 0.5 mL of methanol R and 0.5 mL of mesityl oxide R (impurity D) in water R and dilute to 1000 mL with the same solvent. To 2.0 mL of this solution add 2.0 mL of the internal standard solution and dilute to 10.0 mL with water R. This solution contains 316  $\mu$ g of acetone, 79  $\mu$ g of methanol and 86  $\mu$ g of impurity D per millilitre.

**Column:**

- material: fused silica;
- size:  $l = 30$  m,  $\emptyset = 0.53$  mm;
- stationary phase: macrogol 20 000 R (film thickness 1.0  $\mu$ m).

**Carrier gas:** helium for chromatography R.

**Flow rate:** 9 mL/min.

**Temperature:**

	Time (min)	Temperature (°C)
Column	0 - 2.5	50
	2.5 - 5	50 → 70
	5 - 5.5	70
Injection port		160
Detector		220

**Detection:** flame ionisation.

**Injection:** 1  $\mu$ L.

Calculate the percentage contents of acetone, methanol and impurity D using the following expression:

$$\left(\frac{C}{W}\right) \times \left(\frac{R_u}{R_s}\right)$$

$C$  = concentration of the solvent in the reference solution, in  $\mu$ g/mL;

$W$  = quantity of cilastatin sodium in the test solution, in milligrams;

$R_u$  = ratio of the area of the solvent peak to the area of the propanol peak in the chromatogram obtained with the test solution;

$R_s$  = ratio of the area of the solvent peak to the area of the propanol peak in the chromatogram obtained with the reference solution.

**Limits:**

- acetone: maximum 1.0 per cent  $m/m$ ;
- methanol: maximum 0.5 per cent  $m/m$ ;
- impurity D: maximum 0.4 per cent  $m/m$ .

**Heavy metals (2.4.8):** maximum 20 ppm.

1.0 g complies with test C. Prepare the reference solution using 2.0 mL of lead standard solution (10 ppm Pb) R.

**Water (2.5.12):** maximum 2.0 per cent, determined on 0.50 g.

**Bacterial endotoxins (2.6.14):** less than 0.17 IU/mg, if intended for use in the manufacture of parenteral preparations without a further appropriate procedure for the removal of bacterial endotoxins.

**ASSAY**

Dissolve 0.300 g in 30 mL of methanol R and add 5 mL of water R. Add 0.1 M hydrochloric acid to a pH of about 3.0. Carry out a potentiometric titration (2.2.20), using 0.1 M sodium hydroxide. 3 jumps of potential are observed. Titrate to the 3<sup>rd</sup> equivalence point.

1 mL of 0.1 M sodium hydroxide is equivalent to 19.02 mg of  $C_{16}H_{25}N_2NaO_5S$ .

## STORAGE

In an airtight container, at a temperature not exceeding 8 °C. If the substance is sterile, store in a sterile, airtight, tamper-proof container.

## IMPURITIES

Specified impurities: A, B, C, D.

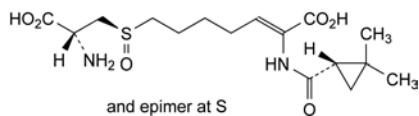

A. (Z)-7-[(RS)-[(R)-2-amino-2-carboxyethyl]sulfinyl]-2-[[[(1S)-2,2-dimethylcyclopropyl]carbonyl]amino]hept-2-enoic acid,

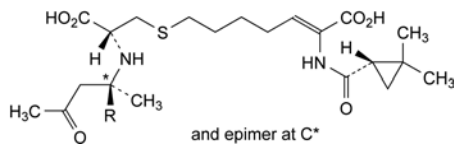

B. R = H: (Z)-7-[(R)-2-[[[(1RS)-1-methyl-3-oxobutyl]amino]-2-carboxyethyl]sulfonyl]-2-[[[(1S)-2,2-dimethylcyclopropyl]carbonyl]amino]hept-2-enoic acid,

C. R = CH<sub>3</sub>: (Z)-7-[(R)-2-[[[(1,1-dimethyl-3-oxobutyl)amino]-2-carboxyethyl]sulfonyl]-2-[[[(1S)-2,2-dimethylcyclopropyl]carbonyl]amino]hept-2-enoic acid,

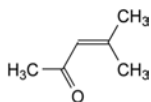

D. 4-methylpent-3-en-2-one (mesityl oxide).

with the same buffer solution. Carry out the determination at 365 nm.

**Impurity A.** Thin-layer chromatography (2.2.27).

*Test solution.* Dissolve 0.20 g of the substance to be examined in *methanol R* and dilute to 5.0 mL with the same solvent.

*Reference solution (a).* Dissolve 2 mg of *cilazapril impurity A CRS* in *methanol R* and dilute to 50.0 mL with the same solvent.

*Reference solution (b).* Dissolve 5 mg of *cilazapril impurity A CRS* and 5 mg of the substance to be examined in *methanol R* and dilute to 10.0 mL with the same solvent.

*Plate:* TLC silica gel plate R.

*Mobile phase:* glacial acetic acid R, water R, hexane R, methanol R, ethyl acetate R (5:5:15:15:60 V/V/V/V).

*Application:* 5 µL.

*Development:* over a path of 10 cm.

*Drying:* in a current of cold air for 10 min.

*Detection:* spray with a freshly prepared mixture of 1 volume of *potassium iodobismuthate solution R* and 10 volumes of *dilute acetic acid R* and then with *dilute hydrogen peroxide solution R*.

*System suitability:* reference solution (b):

– the chromatogram shows 2 clearly separated spots.

*Limit:*

– *impurity A:* any spot due to impurity A is not more intense than the corresponding spot in the chromatogram obtained with reference solution (a) (0.1 per cent).

**Related substances.** Liquid chromatography (2.2.29).

*Test solution.* Dissolve 25.0 mg of the substance to be examined in the mobile phase and dilute to 50.0 mL with the mobile phase.

*Reference solution (a).* Dilute 1.0 mL of the test solution to 50.0 mL with the mobile phase. Dilute 5.0 mL of this solution to 20.0 mL with the mobile phase.

*Reference solution (b).* Dissolve 5.0 mg of *cilazapril impurity D CRS* in the test solution and dilute to 10.0 mL with the test solution.

*Column:*

– *size:* *l* = 0.25 m,  $\emptyset$  = 4.6 mm;

– *stationary phase:* octadecylsilyl silica gel for chromatography R (5 µm).

*Mobile phase:* mix 10 volumes of *triethylamine R* and 750 volumes of *water R*, adjust to pH 2.30 with *phosphoric acid R*, and add 200 volumes of *tetrahydrofuran R*.

*Flow rate:* 1.0 mL/min.

*Detection:* spectrophotometer at 214 nm.

*Injection:* 20 µL.

*Run time:* twice the retention time of cilazapril; when impurity A is present, it may be necessary to continue the chromatography until it is eluted.

*Relative retention* with reference to cilazapril: impurity B = about 0.6; impurity D = about 0.9; impurity C = about 1.6; impurity A = 4 to 5.

*System suitability:* reference solution (b):

– *resolution:* minimum 2.5 between the peaks due to impurity D and cilazapril;

– *symmetry factor:* maximum 3.0 for the peak due to cilazapril.

*Limits:*

– *impurity B:* not more than the area of the principal peak in the chromatogram obtained with reference solution (a) (0.5 per cent);

– *impurity D:* not more than 0.4 times the area of the principal peak in the chromatogram obtained with reference solution (a) (0.2 per cent);

– *impurity C:* not more than 0.2 times the area of the principal peak in the chromatogram obtained with reference solution (a) (0.1 per cent);

01/2008:1499

## CILAZAPRIL

## Cilazaprilum

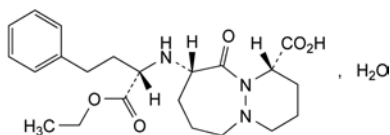

C<sub>22</sub>H<sub>31</sub>N<sub>3</sub>O<sub>5</sub>·H<sub>2</sub>O  
[92077-78-6]

*M<sub>r</sub>* 435.5

## DEFINITION

(1S,9S)-9-[[[(1S)-1-(Ethoxycarbonyl)-3-phenylpropyl]amino]-10-oxooctahydro-6H-pyridazino[1,2-a][1,2]diazepine-1-carboxylic acid monohydrate.

*Content:* 98.5 per cent to 101.5 per cent (anhydrous substance).

## CHARACTERS

*Appearance:* white or almost white, crystalline powder.

*Solubility:* slightly soluble in water, freely soluble in methanol and in methylene chloride.

## IDENTIFICATION

A. Infrared absorption spectrophotometry (2.2.24).

*Comparison:* cilazapril CRS.

B. Specific optical rotation (see Tests).

## TESTS

**Specific optical rotation** (2.2.7): –383 to –399 (anhydrous substance).

Dissolve 0.200 g in 0.067 M phosphate buffer solution pH 7.0 R, with the aid of ultrasound if necessary, and dilute to 50.0 mL

- *unspecified impurities*: for each impurity, not more than 0.2 times the area of the principal peak in the chromatogram obtained with reference solution (a) (0.10 per cent);
- *total*: not more than twice the area of the principal peak in the chromatogram obtained with reference solution (a) (1 per cent);
- *disregard limit*: 0.1 times the area of the principal peak in the chromatogram obtained with reference solution (a) (0.05 per cent); disregard any peak due to impurity A.

**Water** (2.5.12): 3.5 per cent to 5.0 per cent, determined on 0.300 g.

**Sulfated ash** (2.4.14): maximum 0.1 per cent, determined on 1.0 g.

#### ASSAY

Dissolve 0.300 g in 10 mL of *anhydrous ethanol R* and add 50 mL of *water R*. Titrate with 0.1 M *sodium hydroxide*, determining the end-point potentiometrically (2.2.20). Carry out a blank titration.

1 mL of 0.1 M *sodium hydroxide* is equivalent to 41.75 mg of  $C_{22}H_{31}N_3O_5$ .

#### STORAGE

Protected from light.

#### IMPURITIES

*Specified impurities*: A, B, C, D.

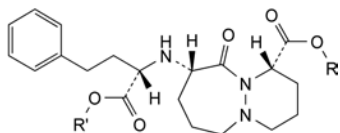

- A. R = C(CH<sub>3</sub>)<sub>3</sub>, R' = C<sub>2</sub>H<sub>5</sub>: 1,1-dimethylethyl (1S,9S)-9-[(S)-1-(ethoxycarbonyl)-3-phenylpropyl]amino]-10-oxooctahydro-6H-pyridazino[1,2-a][1,2]diazepine-1-carboxylate,
- B. R = R' = H: (1S,9S)-9-[(S)-1-carboxy-3-phenylpropyl]amino]-10-oxooctahydro-6H-pyridazino[1,2-a][1,2]diazepine-1-carboxylic acid,
- C. R = R' = C<sub>2</sub>H<sub>5</sub>: ethyl (1S,9S)-9-[(S)-1-(ethoxycarbonyl)-3-phenylpropyl]amino]-10-oxooctahydro-6H-pyridazino[1,2-a][1,2]diazepine-1-carboxylate,

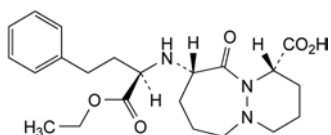

- D. (1S,9S)-9-[(R)-1-(ethoxycarbonyl)-3-phenylpropyl]amino]-10-oxooctahydro-6H-pyridazino[1,2-a][1,2]diazepine-1-carboxylic acid.

01/2010:0756  
corrected 6.8

## CIMETIDINE

### Cimetidinum

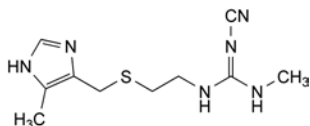

$C_{10}H_{16}N_6S$   
[51481-61-9]

$M_r$  252.3

#### DEFINITION

2-Cyano-1-methyl-3-[2-[[[5-methyl-1H-imidazol-4-yl)methyl]sulfonyl]ethyl]guanidine.

*Content*: 98.5 per cent to 101.5 per cent (dried substance).

#### CHARACTERS

*Appearance*: white or almost white powder.

*Solubility*: slightly soluble in water, soluble in ethanol (96 per cent), practically insoluble in methylene chloride. It dissolves in dilute mineral acids.

It shows polymorphism (5.9).

#### IDENTIFICATION

*First identification*: B.

*Second identification*: A, C.

A. Melting point (2.2.14): 139 °C to 144 °C.

If necessary, dissolve the substance to be examined in 2-propanol R, evaporate to dryness and determine the melting point again.

B. Infrared absorption spectrophotometry (2.2.24).

*Comparison*: *cimetidine CRS*.

If the spectra obtained in the solid state show differences, dissolve the substance to be examined and the reference substance separately in 2-propanol R, evaporate to dryness and record new spectra using the residues.

C. Thin-layer chromatography (2.2.27).

*Test solution*. Dissolve 10 mg of the substance to be examined in *methanol R* and dilute to 10 mL with the same solvent.

*Reference solution*. Dissolve 10 mg of *cimetidine CRS* in *methanol R* and dilute to 10 mL with the same solvent.

*Plate*: TLC silica gel GF<sub>254</sub> plate R.

*Mobile phase*: concentrated ammonia R, *methanol R*, *ethyl acetate R* (15:20:65 V/V/V).

*Application*: 5 µL.

*Development*: over 3/4 of the plate.

*Drying*: in a current of cold air.

*Detection*: expose to iodine vapour until maximum contrast has been obtained and examine in ultraviolet light at 254 nm.

*Results*: the principal spot in the chromatogram obtained with the test solution is similar in position and size to the principal spot in the chromatogram obtained with the reference solution.

#### TESTS

**Appearance of solution**. The solution is clear (2.2.1) and not more intensely coloured than reference solution Y<sub>5</sub> (2.2.2, *Method II*).

Dissolve 3.0 g in 12 mL of 1 M *hydrochloric acid* and dilute to 20 mL with *water R*.

**Related substances**. Liquid chromatography (2.2.29).

*Test solution*. Dissolve 20 mg of the substance to be examined in mobile phase A and dilute to 50.0 mL with mobile phase A.

*Reference solution (a)*. Dilute 1.0 mL of the test solution to 100.0 mL with mobile phase A. Dilute 2.0 mL of this solution to 10.0 mL with mobile phase A.

*Reference solution (b)*. Dissolve the contents of a vial of *cimetidine for system suitability CRS* (containing impurities B, C, D, E, G and H) in 1.0 mL of mobile phase A.

*Reference solution (c)*. Dissolve 4 mg of *cimetidine for peak identification CRS* (containing impurity F) in mobile phase A and dilute to 10.0 mL with mobile phase A.

*Column*:

– *size*:  $l = 0.25$  m,  $\varnothing = 4.6$  mm;

– *stationary phase*: end-capped octadecylsilyl silica gel for chromatography R (5 µm).

**Mobile phase A:** mix 0.4 volumes of *diethylamine R* and 780 volumes of a 1.1 g/L solution of *sodium hexanesulfonate R*; adjust to pH 2.8 with *phosphoric acid R*; add 250 volumes of *methanol R2*;

**Mobile phase B:** *methanol R2*;

Time (min)	Mobile phase A (per cent V/V)	Mobile phase B (per cent V/V)
0 - 60	100	0
60 - 65	100 → 90	0 → 10
65 - 120	90	10

**Flow rate:** 1.1 mL/min.

**Detection:** spectrophotometer at 220 nm.

**Injection:** 50 µL.

**Identification of impurities:** use the chromatogram supplied with *cimetidine for system suitability CRS* and the chromatogram obtained with reference solution (b) to identify the peaks due to impurities B, C, D, E, G and H; use the chromatogram supplied with *cimetidine for peak identification CRS* and the chromatogram obtained with reference solution (c) to identify the peak due to impurity F.

**Relative retention** with reference to cimetidine (retention time = about 18 min): impurity G = about 0.2; impurity E = about 0.4; impurity D = about 1.5; impurity C = about 1.6; impurity B = about 2.0; impurity H = about 2.3; impurity F = about 4.6.

**System suitability:** reference solution (b):

- **resolution:** minimum 1.5 between the peaks due to impurities D and C.

**Limits:**

- **correction factors:** for the calculation of content, multiply the peak areas of the following impurities by the corresponding correction factor: impurity C = 2.5; impurity D = 3.3; impurity E = 0.7; impurity G = 0.6.
- **impurities B, C, D, E, F, G, H:** for each impurity, not more than the area of the principal peak in the chromatogram obtained with reference solution (a) (0.2 per cent);
- **unspecified impurities:** for each impurity, not more than 0.5 times the area of the principal peak in the chromatogram obtained with reference solution (a) (0.10 per cent);
- **total:** not more than 5 times the area of the principal peak in the chromatogram obtained with reference solution (a) (1.0 per cent);
- **disregard limit:** 0.25 times the area of the principal peak in the chromatogram obtained with reference solution (a) (0.05 per cent).

**Heavy metals (2.4.8):** maximum 20 ppm.

1.0 g complies with test C. Prepare the reference solution using 2 mL of *lead standard solution (10 ppm Pb) R*.

**Loss on drying (2.2.32):** maximum 0.5 per cent, determined on 1.000 g by drying in an oven at 105 °C.

**Sulfated ash (2.4.14):** maximum 0.2 per cent, determined on 1.0 g.

**ASSAY**

Dissolve 0.200 g in 60 mL of *anhydrous acetic acid R*. Titrate with 0.1 M *perchloric acid* determining the end point potentiometrically (2.2.20).

1 mL of 0.1 M *perchloric acid* is equivalent to 25.23 mg of C<sub>10</sub>H<sub>16</sub>N<sub>6</sub>S

**STORAGE**

Protected from light.

**IMPURITIES**

**Specified impurities:** B, C, D, E, F, G, H.

**Other detectable impurities** (the following substances would, if present at a sufficient level, be detected by one or other of the tests in the monograph. They are limited by the general acceptance criterion for other/unspecified impurities and/or by the general monograph *Substances for pharmaceutical use (2034)*. It is therefore not necessary to identify these impurities for demonstration of compliance. See also 5.10. *Control of impurities in substances for pharmaceutical use*): A, I, J.

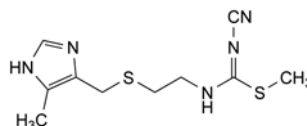

A. methyl 3-cyano-1-[2-[(5-methyl-1H-imidazol-4-yl)methyl]sulfanyl]ethyl]carbamimidiothioate,

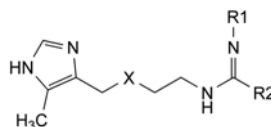

B. R1 = CN, R2 = O-CH<sub>3</sub>, X = S: methyl 3-cyano-1-[2-[(5-methyl-1H-imidazol-4-yl)methyl]sulfanyl]ethyl]carbamimidate,

C. R1 = CO-NH<sub>2</sub>, R2 = NH-CH<sub>3</sub>, X = S: 1-[(methylamino)-[2-[(5-methyl-1H-imidazol-4-yl)methyl]sulfanyl]ethyl]amino]methylidene]urea,

D. R1 = H, R2 = NH-CH<sub>3</sub>, X = S: 1-methyl-3-[2-[(5-methyl-1H-imidazol-4-yl)methyl]sulfanyl]ethyl]guanidine,

E. R1 = CN, R2 = NH-CH<sub>3</sub>, X = SO: 2-cyano-1-methyl-3-[2-[(5-methyl-1H-imidazol-4-yl)methyl]sulfanyl]ethyl]guanidine,

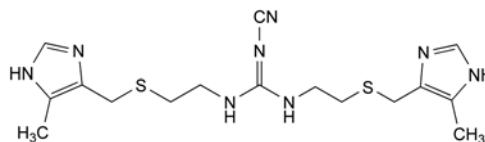

F. 2-cyano-1,3-bis[2-[(5-methyl-1H-imidazol-4-yl)methyl]sulfanyl]ethyl]guanidine,

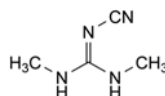

G. 2-cyano-1,3-dimethylguanidine,

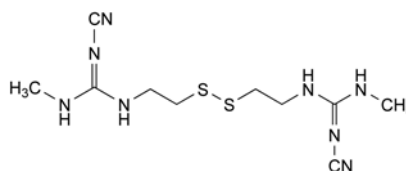

H. 1,1'-(disulfaneyldiethylene)bis(2-cyano-3-methylguanidine),

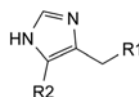

I. R1 = OH, R2 = C<sub>2</sub>H<sub>5</sub>: (5-ethyl-1H-imidazol-4-yl)methanol,

J. R1 = S-CH<sub>2</sub>-CH<sub>2</sub>-NH<sub>2</sub>, R2 = CH<sub>3</sub>: 2-[(5-methyl-1H-imidazol-4-yl)methyl]sulfanyl]ethanamine.



01/2010:1500 **Related substances.** Liquid chromatography (2.2.29).**CIMETIDINE HYDROCHLORIDE**

## Cimetidini hydrochloridum

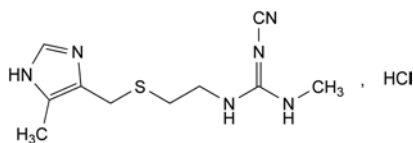
C<sub>10</sub>H<sub>17</sub>ClN<sub>6</sub>S  
[70059-30-2]M<sub>r</sub> 288.8**DEFINITION**

2-Cyano-1-methyl-3-[2-[[5-methyl-1H-imidazol-4-yl)methyl]sulfonyl]ethyl]guanidine hydrochloride.

*Content:* 98.5 per cent to 101.5 per cent (dried substance).**CHARACTERS***Appearance:* white or almost white, crystalline powder.*Solubility:* freely soluble in water, sparingly soluble in anhydrous ethanol.**IDENTIFICATION***First identification:* B, D.*Second identification:* A, C, D.

A. Ultraviolet and visible absorption spectrophotometry (2.2.25).

*Test solution.* Dissolve 70 mg in 0.2 M sulfuric acid and dilute to 100.0 mL with the same acid. Dilute 2.0 mL of this solution to 100.0 mL with 0.2 M sulfuric acid.*Specific absorbance at the absorption maximum at 218 nm:* 650 to 705.

B. Infrared absorption spectrophotometry (2.2.24).

*Comparison:* cimetidine hydrochloride CRS.

C. Thin-layer chromatography (2.2.27).

*Test solution.* Dissolve 10 mg of the substance to be examined in methanol R and dilute to 10 mL with the same solvent.*Reference solution.* Dissolve 10 mg of cimetidine hydrochloride CRS in methanol R and dilute to 10 mL with the same solvent.*Plate:* TLC silica gel GF<sub>254</sub> plate R.*Mobile phase:* concentrated ammonia R, methanol R, ethyl acetate R (15:20:65 V/V/V).*Application:* 5 µL.*Development:* over 3/4 of the plate.*Drying:* in a current of cold air*Detection:* expose to iodine vapour until maximum contrast has been obtained and examine in ultraviolet light at 254 nm.*Results:* the principal spot in the chromatogram obtained with the test solution is similar in position and size to the principal spot in the chromatogram obtained with the reference solution.

D. It gives reaction (a) of chlorides (2.3.1).

**TESTS****Appearance of solution.** The solution is clear (2.2.1) and not more intensely coloured than reference solution Y<sub>5</sub> (2.2.2, Method II).

Dissolve 3.0 g in 12 mL of 1 M hydrochloric acid and dilute to 20 mL with water R.

**pH** (2.2.3): 4.0 to 5.0.

Dissolve 100 mg in carbon dioxide-free water R and dilute to 10.0 mL with the same solvent.

*Test solution.* Dissolve 20 mg of the substance to be examined in mobile phase A and dilute to 50.0 mL with mobile phase A.*Reference solution (a).* Dilute 1.0 mL of the test solution to 100.0 mL with mobile phase A. Dilute 2.0 mL of this solution to 10.0 mL with mobile phase A.*Reference solution (b).* Dissolve the contents of a vial of cimetidine for system suitability CRS (containing impurities B, C, D, E, G and H) in 1.0 mL of mobile phase A.*Reference solution (c).* Dissolve 4 mg of cimetidine for peak identification CRS (containing impurity F) in mobile phase A and dilute to 10.0 mL with mobile phase A.*Column:*– *size:* l = 0.25 m, Ø = 4.6 mm;– *stationary phase:* end-capped octadecylsilyl silica gel for chromatography R (5 µm).*Mobile phase A:* mix 0.4 volumes of diethylamine R and 780 volumes of a 1.1 g/L solution of sodium hexanesulfonate R. Adjust to pH 2.8 with phosphoric acid R and add 250 volumes of methanol R2;*Mobile phase B:* methanol R2;

Time (min)	Mobile phase A (per cent V/V)	Mobile phase B (per cent V/V)
0 - 60	100	0
60 - 65	100 → 90	0 → 10
65 - 120	90	10

*Flow rate:* 1.1 mL/min.*Detection:* spectrophotometer at 220 nm.*Injection:* 50 µL.*Identification of impurities:* use the chromatogram supplied with cimetidine for system suitability CRS and the chromatogram obtained with reference solution (b) to identify the peaks due to the impurities B, C, D, E, G and H; use the chromatogram supplied with cimetidine for peak identification CRS and the chromatogram obtained with reference solution (c) to identify the peak due to impurity F.*Relative retention* with reference to cimetidine (retention time = about 18 min): impurity G = about 0.2; impurity E = about 0.4; impurity D = about 1.5; impurity C = about 1.6; impurity B = about 2.0; impurity H = about 2.3; impurity F = about 4.6.*System suitability:* reference solution (b):– *resolution:* minimum 1.5 between the peaks due to impurities D and C.*Limits:*– *correction factors:* for the calculation of content, multiply the peak areas of the following impurities by the corresponding correction factor: impurity C = 2.5; impurity D = 3.3; impurity E = 0.7; impurity G = 0.6;– *impurities B, C, D, E, F, G, H:* for each impurity, not more than the area of the principal peak in the chromatogram obtained with reference solution (a) (0.2 per cent);– *unspecified impurities:* for each impurity, not more than 0.5 times the area of the principal peak in the chromatogram obtained with reference solution (a) (0.10 per cent);– *total:* not more than 5 times the area of the principal peak in the chromatogram obtained with reference solution (a) (1.0 per cent);– *disregard limit:* 0.25 times the area of the principal peak in the chromatogram obtained with reference solution (a) (0.05 per cent).**Heavy metals** (2.4.8): maximum 20 ppm.

1.0 g complies with test C. Prepare the reference solution using 2 mL of lead standard solution (10 ppm Pb) R.

**Loss on drying** (2.2.32): maximum 1.0 per cent, determined on 1.000 g by drying in an oven at 105 °C.

**Sulfated ash** (2.4.14): maximum 0.2 per cent, determined on 1.0 g.

#### ASSAY

Dissolve 0.200 g in a mixture of 5 mL of 0.01 M hydrochloric acid and 50 mL of ethanol (96 per cent) R. Carry out a potentiometric titration (2.2.20), using 0.1 M sodium hydroxide. Read the volume added between the 2 points of inflexion.

1 mL of 0.1 M sodium hydroxide is equivalent to 28.88 mg of C<sub>10</sub>H<sub>17</sub>ClN<sub>3</sub>S.

#### STORAGE

Protected from light.

#### IMPURITIES

Specified impurities: B, C, D, E, F, G, H.

Other detectable impurities (the following substances would, if present at a sufficient level, be detected by one or other of the tests in the monograph. They are limited by the general acceptance criterion for other/unspecified impurities and/or by the general monograph *Substances for pharmaceutical use* (2034). It is therefore not necessary to identify these impurities for demonstration of compliance. See also 5.10. *Control of impurities in substances for pharmaceutical use*): A, I, J.

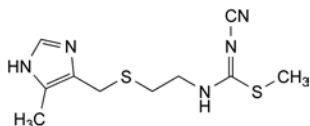

A. methyl 3-cyano-1-[2-[[[(5-methyl-1H-imidazol-4-yl)methyl]sulfonyl]ethyl]carbamimidothioate,

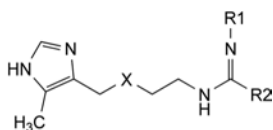

B. R1 = CN, R2 = O-CH<sub>3</sub>, X = S: methyl 3-cyano-1-[2-[[[(5-methyl-1H-imidazol-4-yl)methyl]sulfonyl]ethyl]carbamimidate,

C. R1 = CO-NH<sub>2</sub>, R2 = NH-CH<sub>3</sub>, X = S: 1-[(methylamino)-[[2-[[[(5-methyl-1H-imidazol-4-yl)methyl]sulfonyl]ethyl]amino]methylidene]urea,

D. R1 = H, R2 = NH-CH<sub>3</sub>, X = S: 1-methyl-3-[2-[[[(5-methyl-1H-imidazol-4-yl)methyl]sulfonyl]ethyl]guanidine,

E. R1 = CN, R2 = NH-CH<sub>3</sub>, X = SO: 2-cyano-1-methyl-3-[2-[[[(5-methyl-1H-imidazol-4-yl)methyl]sulfonyl]ethyl]guanidine,

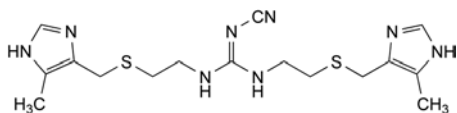

F. 2-cyano-1,3-bis[2-[[[(5-methyl-1H-imidazol-4-yl)methyl]sulfonyl]ethyl]guanidine.

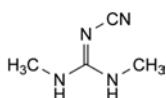

G. 2-cyano-1,3-dimethylguanidine,

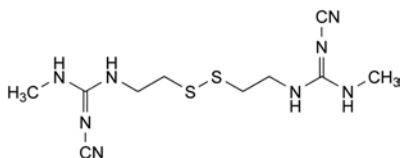

H. 1,1'-(disulfanediyldiethylene)bis(2-cyano-3-methylguanidine),

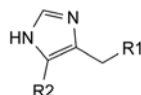

I. R1 = OH, R2 = C<sub>2</sub>H<sub>5</sub>: (5-ethyl-1H-imidazol-4-yl)methanol,

J. R1 = S-CH<sub>2</sub>-CH<sub>2</sub>-NH<sub>2</sub>, R2 = CH<sub>3</sub>: 2-[[[(5-methyl-1H-imidazol-4-yl)methyl]sulfonyl]ethanamine.

01/2008:1088

## CINCHOCAINE HYDROCHLORIDE

### Cinchocaini hydrochloridum

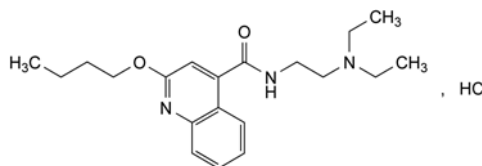

C<sub>20</sub>H<sub>30</sub>ClN<sub>3</sub>O<sub>2</sub>  
[61-12-1]

M<sub>r</sub> 379.9

#### DEFINITION

Cinchocaine hydrochloride contains not less than 98.5 per cent and not more than the equivalent of 101.0 per cent of 2-butoxy-N-[2-(diethylamino)ethyl]quinoline-4-carboxamide hydrochloride, calculated with reference to the dried substance.

#### CHARACTERS

A white or almost white, crystalline powder or colourless crystals, hygroscopic, very soluble in water, freely soluble in acetone, in alcohol and in methylene chloride. It agglomerates very easily.

#### IDENTIFICATION

First identification: B, E.

Second identification: A, C, D, E.

- Dissolve 60.0 mg in 1 M hydrochloric acid and dilute to 100 mL with the same acid. Dilute 2 mL of the solution to 100 mL with 1 M hydrochloric acid. Examined between 220 nm and 350 nm (2.2.25), the solution shows two absorption maxima, at 246 nm and 319 nm. The ratio of the absorbance measured at 246 nm to that measured at 319 nm is 2.7 to 3.0.
- Examine by infrared absorption spectrophotometry (2.2.24), comparing with the spectrum obtained with *cinchocaine hydrochloride CRS*. Examine the substances prepared as discs using *potassium chloride R*.
- Examine the chromatograms obtained in the test for related substances. The principal spot in the chromatogram obtained with test solution (b) is similar in position and size to the principal spot in the chromatogram obtained with reference solution (a).
- Dissolve 0.5 g in 5 mL of water R. Add 1 mL of dilute ammonia R2. A white precipitate is formed. Filter, wash the precipitate with five quantities, each of 10 mL, of water R and dry in a desiccator. It melts at 64 °C to 66 °C (2.2.14).
- It gives reaction (a) of chlorides (2.3.1).

#### TESTS

**Solution S.** Dissolve 5.0 g in carbon dioxide-free water R prepared from distilled water R, and dilute to 50 mL with the same solvent.

**Appearance of solution.** Solution S is clear (2.2.1) and not more intensely coloured than reference solution Y<sub>6</sub> (2.2.2, Method II).

**pH** (2.2.3). Dilute 10 mL of solution S to 50 mL with carbon dioxide-free water R. The pH of the solution is 5.0 to 6.0.

01/2008:1973

**Related substances.** Examine by thin-layer chromatography (2.2.27), using as the coating substance a suitable silica gel with a fluorescent indicator having an optimal intensity at 254 nm.

**Test solution (a).** Dissolve 0.20 g of the substance to be examined in *methanol R* and dilute to 5 mL with the same solvent.

**Test solution (b).** Dilute 1 mL of test solution (a) to 10 mL with *methanol R*.

**Reference solution (a).** Dissolve 20 mg of *cinchocaine hydrochloride CRS* in *methanol R* and dilute to 5 mL with the same solvent.

**Reference solution (b).** Dilute 1 mL of test solution (b) to 20 mL with *methanol R*.

**Reference solution (c).** Dilute 1 mL of test solution (b) to 50 mL with *methanol R*.

**Reference solution (d).** Dissolve 20 mg of *benzocaine CRS* in *methanol R* and dilute to 5 mL with the same solvent. Dilute 1 mL of the solution and 1 mL of reference solution (a) to 20 mL with *methanol R*.

Apply separately to the plate 5 µL of each solution. Develop over a path of 15 cm using a mixture of 1 volume of *ammonia R*, 5 volumes of *methanol R*, 30 volumes of *acetone R* and 50 volumes of *toluene R*. Dry the plate in a current of warm air for 15 min. Examine in ultraviolet light at 254 nm. Any spot in the chromatogram obtained with test solution (a), apart from the principal spot, is not more intense than the principal spot in the chromatogram obtained with reference solution (b) (0.5 per cent) and at most one such spot is more intense than the spot in the chromatogram obtained with reference solution (c) (0.2 per cent). The test is not valid unless the chromatogram obtained with reference solution (d) shows two clearly separated spots.

**Heavy metals (2.4.8).** 12 mL of solution S complies with limit test A for heavy metals (20 ppm). Prepare the standard using *lead standard solution (2 ppm Pb) R*.

**Loss on drying (2.2.32).** Not more than 2.0 per cent, determined on 0.500 g by drying *in vacuo* at 60 °C.

**Sulfated ash (2.4.14).** Not more than 0.1 per cent, determined on 1.0 g.

#### ASSAY

Dissolve 0.300 g in a mixture of 15.0 mL of 0.01 M *hydrochloric acid* and 50 mL of *alcohol R*. Carry out a potentiometric titration (2.2.20), using 0.1 M *sodium hydroxide*. Read the volume added between the two points of inflexion.

1 mL of 0.1 M *sodium hydroxide* is equivalent to 37.99 mg of  $C_{10}H_{18}O$ .

#### STORAGE

Store in an airtight container, protected from light.

#### IMPURITIES

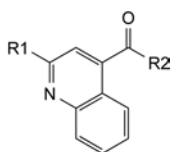

- A. R1 = Cl, R2 = NH-[CH<sub>2</sub>]<sub>2</sub>-N(C<sub>2</sub>H<sub>5</sub>)<sub>2</sub>: 2-chloro-*N*-[2-(diethylamino)ethyl]quinoline-4-carboxamide,
- B. R1 = R2 = OH: 2-hydroxyquinoline-4-carboxylic acid,
- C. R1 = OH, R2 = NH-[CH<sub>2</sub>]<sub>2</sub>-N(C<sub>2</sub>H<sub>5</sub>)<sub>2</sub>: *N*-[2-(diethylamino)ethyl]-2-hydroxyquinoline-4-carboxamide,
- D. R1 = O-[CH<sub>2</sub>]<sub>3</sub>-CH<sub>3</sub>, R2 = OH: 2-butoxyquinoline-4-carboxylic acid.

## CINEOLE

### Cineolum

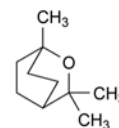

$C_{10}H_{18}O$   
[470-82-6]

$M_r$  154.3

#### DEFINITION

1,3,3-Trimethyl-2-oxabicyclo[2.2.2]octane.

#### CHARACTERS

**Appearance:** clear colourless liquid.

**Solubility:** practically insoluble in water, miscible with alcohol and with methylene chloride.

It solidifies at about 0.5 °C.

#### IDENTIFICATION

A. Refractive index (see Tests).

B. Thin-layer chromatography (2.2.27).

**Test solution.** Dilute 1 mL of solution S (see Tests) to 25 mL with *alcohol R*.

**Reference solution.** Mix 80 mg of *cineole CRS* with *alcohol R* and dilute to 10 mL with the same solvent.

**Plate:** TLC silica gel plate R.

**Mobile phase:** *ethyl acetate R*, *toluene R* (10:90 V/V).

**Application:** 2 µL.

**Development:** over 2/3 of the plate.

**Drying:** in a current of cold air.

**Detection:** spray with *anisaldehyde solution R*, heat at 100-105 °C for 5 min.

**Results:** the principal spot in the chromatogram obtained with the test solution is similar in position, colour and size to the principal spot in the chromatogram obtained with the reference solution.

C. To 0.1 mL add 4 mL of *sulfuric acid R*. An orange-red colour develops. Add 0.2 mL of *formaldehyde solution R*. The colour changes to deep brown.

#### TESTS

**Solution S.** Dilute 2.00 g to 10.0 mL with *alcohol R*.

**Appearance of solution.** Solution S is clear (2.2.1) and colourless (2.2.2, *Method I*).

**Chiral impurities.** The optical rotation (2.2.7) of solution S is -0.10° to +0.10°.

**Refractive index (2.2.6):** 1.456 to 1.460.

**Related substances.** Gas chromatography (2.2.28).

**Internal standard solution.** Dissolve 1.0 g of *camphor R* in *heptane R* and dilute to 200 mL with the same solvent.

**Test solution (a).** Dissolve 2.5 g of the substance to be examined in *heptane R* and dilute to 25.0 mL with the same solvent.

**Test solution (b).** Dissolve 2.5 g of the substance to be examined in *heptane R*, add 5.0 mL of the internal standard solution and dilute to 25.0 mL with *heptane R*.

**Reference solution (a).** To 2.0 mL of test solution (a) add 20.0 mL of the internal standard solution and dilute to 100.0 mL with *heptane R*.

**Reference solution (b).** Dissolve 50 mg of *1,4-cineole R* and 50 mg of the substance to be examined in *heptane R* and dilute to 50.0 mL with the same solvent.

**Column:**

– size:  $l = 30$  m,  $\varnothing = 0.25$  mm,

– *stationary phase*: macrogol 20 000 R (film thickness 0.25 µm).

*Carrier gas*: helium for chromatography R.

*Linear velocity*: 45 cm/s.

*Split-ratio*: 1:70.

*Temperature*:

	Time (min)	Temperature (°C)
Column	0 - 10	50
	10 - 35	50 → 100
	35 - 45	100 → 200
	45 - 55	200
Injection port		220
Detector		250

*Detection*: flame ionisation.

*Injection*: 1 µL.

*System suitability*: reference solution (b):

– *resolution*: minimum 10 between the peaks due to impurity A and to cineole.

*Limits*:

- *total*: calculate the ratio (*R*) of the area of the peak due to cineole to the area of the peak due to the internal standard from the chromatogram obtained with reference solution (a); from the chromatogram obtained with test solution (b), calculate the ratio of the sum of the areas of any peaks, apart from the principal peak and the peak due to the internal standard, to the area of the peak due to internal standard: this ratio is not greater than *R* (2 per cent),
- *disregard limit*: 0.025 times the area of the principal peak in the chromatogram obtained with reference solution (a) (0.05 per cent).

**Residue on evaporation**: maximum 0.1 per cent.

To 2.0 g add 5 mL of *water R*, evaporate to dryness on a water-bath and dry at 100-105 °C for 1 h. The residue weighs a maximum of 2 mg.

#### STORAGE

In an airtight container, protected from light.

#### IMPURITIES

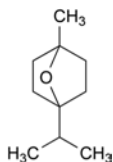

- A. 1-methyl-4-(1-methylethyl)-7-oxabicyclo[2.2.1]heptane (1,4-cineole).

01/2008:0816  
corrected 6.0

## CINNARIZINE

### Cinnarizinum

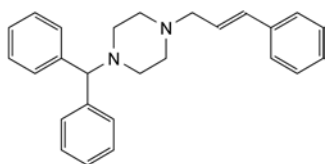

C<sub>26</sub>H<sub>28</sub>N<sub>2</sub>  
[298-57-7]

*M<sub>r</sub>* 368.5

#### DEFINITION

(*E*)-1-(Diphenylmethyl)-4-(3-phenylprop-2-enyl)piperazine.

*Content*: 99.0 per cent to 101.0 per cent (dried substance).

#### CHARACTERS

*Appearance*: white or almost white powder.

*Solubility*: practically insoluble in water, freely soluble in methylene chloride, soluble in acetone, slightly soluble in ethanol (96 per cent) and in methanol.

#### IDENTIFICATION

*First identification*: A, B.

*Second identification*: A, C, D.

A. Melting point (2.2.14): 118 °C to 122 °C.

B. Infrared absorption spectrophotometry (2.2.24).

*Preparation*: discs.

*Comparison*: cinnarizine CRS.

C. Thin-layer chromatography (2.2.27).

*Test solution*. Dissolve 10 mg of the substance to be examined in *methanol R* and dilute to 20 mL with the same solvent.

*Reference solution (a)*. Dissolve 10 mg of *cinnarizine CRS* in *methanol R* and dilute to 20 mL with the same solvent.

*Reference solution (b)*. Dissolve 10 mg of *cinnarizine CRS* and 10 mg of *flunarizine dihydrochloride CRS* in *methanol R* and dilute to 20 mL with the same solvent.

*Plate*: TLC octadecylsilyl silica gel F<sub>254</sub> plate R.

*Mobile phase*: 1 M sodium chloride, *methanol R*, *acetone R* (20:30:50 V/V/V).

*Application*: 5 µL.

*Development*: in an unsaturated tank, over a path of 15 cm.

*Drying*: in air.

*Detection*: examine in ultraviolet light at 254 nm.

*System suitability*: reference solution (b):

– the chromatogram shows 2 clearly separated spots.

*Results*: the principal spot in the chromatogram obtained with the test solution is similar in position and size to the principal spot in the chromatogram obtained with reference solution (a).

D. Dissolve 0.2 g of *anhydrous citric acid R* in 10 mL of *acetic anhydride R* in a water-bath at 80 °C and maintain the temperature of the water-bath at 80 °C for 10 min. Add about 20 mg of the substance to be examined. A purple colour develops.

#### TESTS

**Appearance of solution**. The solution is clear (2.2.1) and not more intensely coloured than reference solution BY<sub>7</sub> (2.2.2, *Method II*).

Dissolve 0.5 g in *methylene chloride R* and dilute to 20 mL with the same solvent.

**Acidity or alkalinity**. Suspend 0.5 g in 15 mL of *water R*. Boil for 2 min. Cool and filter. Dilute the filtrate to 20 mL with *carbon dioxide-free water R*. To 10 mL of this solution add 0.1 mL of *phenolphthalein solution R* and 0.25 mL of 0.01 M *sodium hydroxide*. The solution is pink. To 10 mL of the solution add 0.1 mL of *methyl red solution R* and 0.25 mL of 0.01 M *hydrochloric acid*. The solution is red.

**Related substances**. Liquid chromatography (2.2.29).

*Test solution*. Dissolve 25.0 mg of the substance to be examined in *methanol R* and dilute to 10.0 mL with the same solvent.

*Reference solution (a)*. Dissolve 12.5 mg of *cinnarizine CRS* and 15.0 mg of *flunarizine dihydrochloride CRS* in *methanol R* and dilute to 100.0 mL with the same solvent. Dilute 1.0 mL of this solution to 20.0 mL with *methanol R*.

*Reference solution (b)*. Dilute 1.0 mL of the test solution to 100.0 mL with *methanol R*. Dilute 5.0 mL of this solution to 20.0 mL with *methanol R*.

## Column:

- size:  $l = 0.1$  m,  $\emptyset = 4.0$  mm;
- stationary phase: base-deactivated octadecylsilyl silica gel for chromatography R (3  $\mu$ m).

## Mobile phase:

- mobile phase A: 10 g/L solution of ammonium acetate R;
- mobile phase B: 0.2 per cent V/V solution of glacial acetic acid R in acetonitrile R1;

Time (min)	Mobile phase A (per cent V/V)	Mobile phase B (per cent V/V)
0 - 20	75 → 10	25 → 90
20 - 25	10	90

If necessary, adjust the concentration of glacial acetic acid in mobile phase B to obtain a horizontal baseline in the chromatogram.

Flow rate: 1.5 mL/min.

Detection: spectrophotometer at 230 nm.

Equilibration: with the mobile phase at the initial composition for at least 30 min.

Injection: 10  $\mu$ L; inject methanol R as a blank.

Retention time: cinnarizine = about 11 min; flunarizine = about 11.5 min.

System suitability: reference solution (a):

- resolution: minimum 5.0 between the peaks due to cinnarizine and flunarizine; if necessary, adjust the time programme for the gradient elution.

## Limits:

- impurities A, B, C, D, E: for each impurity, not more than the area of the principal peak in the chromatogram obtained with reference solution (b) (0.25 per cent);
- total: not more than twice the area of the principal peak in the chromatogram obtained with reference solution (b) (0.5 per cent);
- disregard limit: 0.2 times the area of the principal peak in the chromatogram obtained with reference solution (b) (0.05 per cent); disregard any peak due to the blank.

Heavy metals (2.4.8): maximum 20 ppm.

Dissolve 1.0 g in a mixture of 15 volumes of water R and 85 volumes of acetone R. Add dilute hydrochloric acid R until dissolution is complete. Dilute to 20 mL with a mixture of 15 volumes of water R and 85 volumes of acetone R. 12 mL of the solution complies with test B. Prepare the reference solution using 10 mL of lead standard solution (1 ppm Pb) obtained by diluting lead standard solution (100 ppm Pb) R with a mixture of 15 volumes of water R and 85 volumes of acetone R.

Loss on drying (2.2.32): maximum 0.5 per cent, determined on 1.000 g by drying in an oven *in vacuo* at 60 °C for 4 h.

Sulfated ash (2.4.14): maximum 0.1 per cent, determined on 1.0 g.

## ASSAY

Dissolve 0.150 g in 50 mL of a mixture of 1 volume of anhydrous acetic acid R and 7 volumes of ethyl methyl ketone R. Titrate with 0.1 M perchloric acid, using 0.2 mL of naphtholbenzein solution R as indicator.

1 mL of 0.1 M perchloric acid is equivalent to 18.43 mg of  $C_{26}H_{28}N_2$ .

## STORAGE

Protected from light.

## IMPURITIES

Specified impurities: A, B, C, D, E.

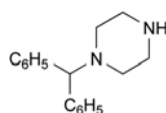

A. 1-(diphenylmethyl)piperazine,

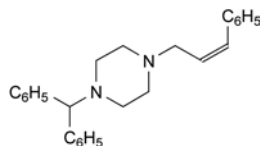

B. (Z)-1-(diphenylmethyl)-4-(3-phenylprop-2-enyl)piperazine,

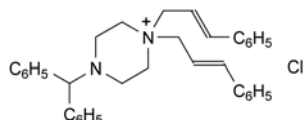

C. (4-(diphenylmethyl)-1,1-bis[(E)-3-phenylprop-2-enyl]piperazinium chloride,

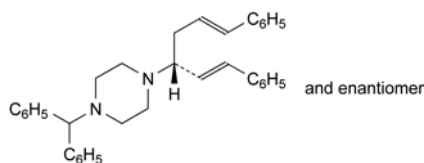

D. 1-(diphenylmethyl)-4-[(1R,3E)-4-phenyl-1-(E)-2-phenylethenyl]but-3-enyl]piperazine,

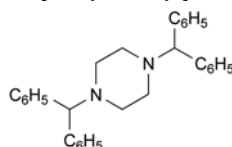

E. 1,4-bis(diphenylmethyl)piperazine.

01/2008:2013

## CIPROFIBRATE

## Ciprofibratum

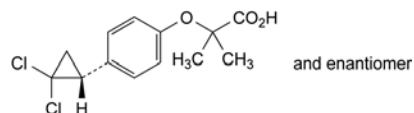

$C_{13}H_{14}Cl_2O_3$   
[52214-84-3]

$M_r$  289.2

## DEFINITION

2-[4-[(1R,3E)-2,2-Dichlorocyclopropyl]phenoxy]-2-methylpropanoic acid.

Content: 99.0 per cent to 101.0 per cent (anhydrous substance).

## CHARACTERS

Appearance: white or slightly yellow, crystalline powder.

Solubility: practically insoluble in water, freely soluble in anhydrous ethanol, soluble in toluene.

mp: about 115 °C.

## IDENTIFICATION

Infrared absorption spectrophotometry (2.2.24).

Comparison: ciprofibrate CRS.

## TESTS

Appearance of solution. The solution is clear (2.2.1) and not more intensely coloured than reference solution BY<sub>4</sub> (2.2.2, Method II).

Dissolve 1.0 g in anhydrous ethanol R and dilute to 10.0 mL with the same solvent.

**Related substances.** Liquid chromatography (2.2.29).

**Test solution.** Dissolve 0.125 g of the substance to be examined in a mixture of equal volumes of *acetonitrile R* and *water R* and dilute to 50 mL with the same mixture of solvents.

**Reference solution (a).** Dilute 1.0 mL of the test solution to 100.0 mL with a mixture of equal volumes of *acetonitrile R* and *water R*. Dilute 1.0 mL of this solution to 10.0 mL with a mixture of equal volumes of *acetonitrile R* and *water R*.

**Reference solution (b).** Dissolve the contents of a vial of *ciprofibrate for system suitability CRS* in 2.0 mL of a mixture of equal volumes of *acetonitrile R* and *water R*.

**Column:**

- size:  $l = 0.15$  m,  $\varnothing = 4.6$  mm,
- stationary phase: *octylsilyl silica gel for chromatography R* (5  $\mu$ m).

**Mobile phase:**

- mobile phase A: 1.36 g/L solution of *potassium dihydrogen phosphate R* adjusted to pH 2.2 with *phosphoric acid R*,
- mobile phase B: *acetonitrile R*,

Time (min)	Mobile phase A (per cent V/V)	Mobile phase B (per cent V/V)
0 - 30	75 → 30	25 → 70
30 - 40	30	70
40 - 42	30 → 75	70 → 25

**Flow rate:** 1.5 mL/min.

**Detection:** spectrophotometer at 230 nm.

**Injection:** 10  $\mu$ L.

**Identification of impurities:** use the chromatogram supplied with *ciprofibrate for system suitability CRS* to identify the peaks due to impurities A, B, C, D and E.

**Relative retention** with reference to ciprofibrate (retention time = about 18 min): impurity A = about 0.7; impurity B = about 0.8; impurity C = about 0.95; impurity D = about 1.3; impurity E = about 1.5.

**System suitability:** reference solution (b):

- resolution: baseline separation between the peaks due to impurity C and ciprofibrate.

**Limits:**

- correction factor: for the calculation of content, multiply the peak area of impurity A by 2.3,
- impurities A, C, D: for each impurity, not more than the area of the principal peak in the chromatogram obtained with reference solution (a) (0.1 per cent),
- impurity B: not more than twice the area of the principal peak in the chromatogram obtained with reference solution (a) (0.2 per cent),
- impurity E: not more than 8 times the area of the principal peak in the chromatogram obtained with reference solution (a) (0.8 per cent),
- any other impurity: for each impurity, not more than the area of the principal peak in the chromatogram obtained with reference solution (a) (0.1 per cent),
- total of other impurities: not more than 5 times the area of the principal peak in the chromatogram obtained with reference solution (a) (0.5 per cent),
- disregard limit: 0.5 times the area of the principal peak in the chromatogram obtained with reference solution (a) (0.05 per cent).

**Chlorides (2.4.4):** maximum 350 ppm.

To 0.190 g add 20 mL of *water R* and treat in an ultrasonic bath for 8 min. Filter. 15 mL of the filtrate complies with the test.

**Water (2.5.12):** maximum 0.5 per cent, determined on 1.000 g.

**Sulfated ash (2.4.14):** maximum 0.1 per cent, determined on 1.0 g.

**ASSAY**

Dissolve 0.250 g in a mixture of 20 mL of *water R* and 40 mL of *anhydrous ethanol R*. Titrate with 0.1 M *sodium hydroxide*, determining the end-point potentiometrically (2.2.20).

1 mL of 0.1 M *sodium hydroxide* is equivalent to 28.92 mg of  $C_{17}H_{18}FN_3O_3$ .

**STORAGE**

In an airtight container, protected from light.

**IMPURITIES**

**Specified impurities:** A, B, C, D, E.

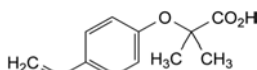

A. 2-(4-ethenylphenoxy)-2-methylpropanoic acid,

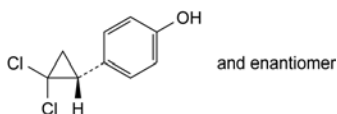

B. 4-[(1R)-2,2-dichlorocyclopropyl]phenol,

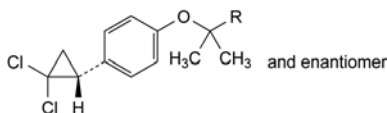

C. R =  $CH_2OH$ : 2-[4-[(1R)-2,2-dichlorocyclopropyl]phenoxy]-2-methylpropan-1-ol,

D. R =  $CO-OCH_3$ : methyl 2-[4-[(1R)-2,2-dichlorocyclopropyl]phenoxy]-2-methylpropanoate,

E. R =  $CO-OC_2H_5$ : ethyl 2-[4-[(1R)-2,2-dichlorocyclopropyl]phenoxy]-2-methylpropanoate.

01/2008:1089

## CIPROFLOXACIN

### Ciprofloxacinum

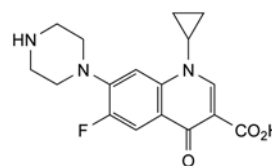

$C_{17}H_{18}FN_3O_3$   
[85721-33-1]

$M_r$  331.4

**DEFINITION**

1-Cyclopropyl-6-fluoro-4-oxo-7-(piperazin-1-yl)-1,4-dihydroquinoline-3-carboxylic acid.

**Content:** 99.0 per cent to 101.0 per cent (dried substance).

**CHARACTERS**

**Appearance:** almost white or pale yellow, crystalline powder, slightly hygroscopic.

**Solubility:** practically insoluble in water, very slightly soluble in anhydrous ethanol and in methylene chloride.

**IDENTIFICATION**

Infrared absorption spectrophotometry (2.2.24).

**Comparison:** *ciprofloxacin CRS*.

## TESTS

**Appearance of solution.** The solution is clear (2.2.1) and not more intensely coloured than reference solution GY<sub>5</sub> (2.2.2, Method II).

Dissolve 0.25 g in 0.1 M hydrochloric acid and dilute to 20 mL with the same solvent.

**Impurity A.** Thin-layer chromatography (2.2.27).

**Test solution.** Dissolve 50 mg of the substance to be examined in dilute ammonia RI and dilute to 5 mL with the same solvent.

**Reference solution.** Dissolve 10 mg of ciprofloxacin impurity A CRS in a mixture of 0.1 mL of dilute ammonia RI and 90 mL of water R and dilute to 100 mL with water R. Dilute 2 mL of the solution to 10 mL with water R.

**Plate:** TLC silica gel F<sub>254</sub> plate R.

**Application:** 5 µL.

At the bottom of a chromatographic tank, place an evaporating dish containing 50 mL of concentrated ammonia R. Expose the plate to the ammonia vapour for 15 min in the closed tank. Withdraw the plate, transfer to a 2<sup>nd</sup> chromatographic tank and proceed with development.

**Mobile phase:** acetonitrile R, concentrated ammonia R, methanol R, methylene chloride R (10:20:40:40 V/V/V/V).

**Development:** over 3/4 of the plate.

**Drying:** in air.

**Detection:** examine in ultraviolet light at 254 nm.

**Limit:**

- **impurity A:** any spot corresponding to impurity A is not more intense than the principal spot in the chromatogram obtained with the reference solution (0.2 per cent).

**Related substances.** Liquid chromatography (2.2.29).

**Test solution.** To 25.0 mg of the substance to be examined add 0.2 mL of dilute phosphoric acid R and dilute to 50.0 mL with the mobile phase and treat in an ultrasonic bath until a clear solution is obtained.

**Reference solution (a).** Dilute 1.0 mL of the test solution to 100.0 mL with the mobile phase. Dilute 1.0 mL of this solution to 5.0 mL with the mobile phase.

**Reference solution (b).** Dissolve 5 mg of ciprofloxacin hydrochloride for peak identification CRS in the mobile phase and dilute to 10.0 mL with the mobile phase.

**Column:**

- **size:**  $l = 0.25$  m,  $\varnothing = 4.6$  mm;
- **stationary phase:** base-deactivated octadecylsilyl silica gel for chromatography R (5 µm);
- **temperature:** 40 °C.

**Mobile phase:** mix 13 volumes of acetonitrile R and 87 volumes of a 2.45 g/L solution of phosphoric acid R, previously adjusted to pH 3.0 with triethylamine R.

**Flow rate:** 1.5 mL/min.

**Detection:** spectrophotometer at 278 nm.

**Injection:** 50 µL.

**Run time:** twice the retention time of ciprofloxacin.

**Identification of impurities:** use the chromatogram supplied with ciprofloxacin hydrochloride for peak identification CRS and the chromatogram obtained with reference solution (b) to identify the peaks due to impurities B, C, D and E.

**Relative retention** with reference to ciprofloxacin (retention time = about 9 min): impurity E = about 0.4; impurity F = about 0.5; impurity B = about 0.6; impurity C = about 0.7; impurity D = about 1.2.

**System suitability:** reference solution (b):

- **resolution:** minimum 1.3 between the peaks due to impurity B and impurity C.

**Limits:**

- **correction factors:** for the calculation of contents, multiply the peak areas of the following impurities by the corresponding correction factor: impurity B = 0.7; impurity C = 0.6; impurity D = 1.4; impurity E = 6.7;
- **impurities B, C, D, E:** for each impurity, not more than the area of the principal peak in the chromatogram obtained with reference solution (a) (0.2 per cent);
- **unspecified impurities:** for each impurity, not more than 0.5 times the area of the principal peak in the chromatogram obtained with reference solution (a) (0.10 per cent);
- **total:** not more than 2.5 times the area of the principal peak in the chromatogram obtained with reference solution (a) (0.5 per cent);
- **disregard limit:** 0.25 times the area of the principal peak in the chromatogram obtained with reference solution (a) (0.05 per cent).

**Heavy metals (2.4.8):** maximum 20 ppm.

Dissolve 0.5 g in dilute acetic acid R and dilute to 30 mL with the same solvent. Add 2 mL of water R instead of 2 mL of buffer solution pH 3.5 R. The filtrate complies with test E. Prepare the reference solution using 10 mL of lead standard solution (1 ppm Pb) R.

**Loss on drying (2.2.32):** maximum 1.0 per cent, determined on 1.000 g by drying under vacuum at 120 °C.

**Sulfated ash (2.4.14):** maximum 0.1 per cent, determined on 1.0 g in a platinum crucible.

## ASSAY

Dissolve 0.300 g in 80 mL of glacial acetic acid R. Titrate with 0.1 M perchloric acid, determining the end-point potentiometrically (2.2.20).

1 mL of 0.1 M perchloric acid is equivalent to 33.14 mg of C<sub>17</sub>H<sub>18</sub>FN<sub>3</sub>O<sub>3</sub>.

## STORAGE

In an airtight container, protected from light.

## IMPURITIES

**Specified impurities:** A, B, C, D, E.

**Other detectable impurities** (the following substances would, if present at a sufficient level, be detected by one or other of the tests in the monograph. They are limited by the general acceptance criterion for other/unspecified impurities and/or by the general monograph *Substances for pharmaceutical use (2034)*. It is therefore not necessary to identify these impurities for demonstration of compliance. See also 5.10. *Control of impurities in substances for pharmaceutical use*): F.

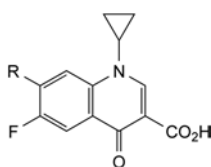

A. R = Cl: 7-chloro-1-cyclopropyl-6-fluoro-4-oxo-1,4-dihydroquinoline-3-carboxylic acid (fluoroquinolonic acid),

C. R = NH-[CH<sub>2</sub>]<sub>2</sub>-NH<sub>2</sub>: 7-[(2-aminoethyl)amino]-1-cyclopropyl-6-fluoro-4-oxo-1,4-dihydroquinoline-3-carboxylic acid (ethylenediamine compound),

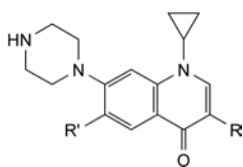

- B. R = CO<sub>2</sub>H, R' = H: 1-cyclopropyl-4-oxo-7-(piperazin-1-yl)-1,4-dihydroquinoline-3-carboxylic acid (desfluoro compound),
- E. R = H, R' = F: 1-cyclopropyl-6-fluoro-7-(piperazin-1-yl)quinolin-4(1*H*)-one (decarboxylated compound),
- F. R = CO<sub>2</sub>H, R' = OH: 1-cyclopropyl-6-hydroxy-4-oxo-7-(piperazin-1-yl)-1,4-dihydroquinoline-3-carboxylic acid,

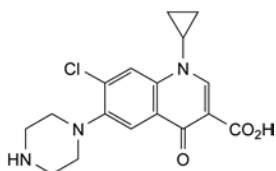

- D. 7-chloro-1-cyclopropyl-4-oxo-6-(piperazin-1-yl)-1,4-dihydroquinoline-3-carboxylic acid.

01/2008:0888

## CIPROFLOXACIN HYDROCHLORIDE

## Ciprofloxacinum hydrochloridum

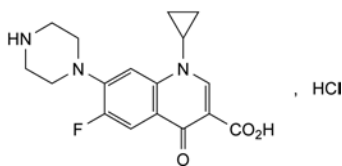

C<sub>17</sub>H<sub>19</sub>ClFN<sub>3</sub>O<sub>3</sub>  
[86393-32-0]

M<sub>r</sub> 367.8

## DEFINITION

1-Cyclopropyl-6-fluoro-4-oxo-7-(piperazin-1-yl)-1,4-dihydroquinoline-3-carboxylic acid hydrochloride.

Content: 98.0 per cent to 102.0 per cent (anhydrous substance).

## CHARACTERS

**Appearance:** pale yellow, crystalline powder, slightly hygroscopic.

**Solubility:** soluble in water, slightly soluble in methanol, very slightly soluble in anhydrous ethanol, practically insoluble in acetone, in ethyl acetate and in methylene chloride.

## IDENTIFICATION

A. Infrared absorption spectrophotometry (2.2.24).

*Preparation:* discs.

*Comparison:* ciprofloxacin hydrochloride CRS.

B. 0.1 g gives reaction (b) of chlorides (2.3.1).

## TESTS

**Solution S.** Dissolve 0.5 g in carbon dioxide-free water R and dilute to 20 mL with the same solvent.

**Appearance of solution.** The solution is clear (2.2.1) and not more intensely coloured than reference solution GY<sub>5</sub> (2.2.2, Method II).

Dilute 10 mL of solution S to 20 mL with carbon dioxide-free water R.

**pH** (2.2.3): 3.5 to 4.5 for solution S.

**Impurity A.** Thin-layer chromatography (2.2.27).

*Test solution.* Dissolve 50 mg of the substance to be examined in water R and dilute to 5 mL with the same solvent.

*Reference solution.* Dissolve 10 mg of ciprofloxacin impurity A CRS in a mixture of 0.1 mL of dilute ammonia R1 and 90 mL of water R and dilute to 100 mL with water R. Dilute 2 mL of the solution to 10 mL with water R.

*Plate:* TLC silica gel F<sub>254</sub> plate R.

*Application:* 5 µL.

At the bottom of a chromatographic tank, place an evaporating dish containing 50 mL of concentrated ammonia R. Expose the plate to the ammonia vapour for 15 min in the closed tank. Withdraw the plate, transfer to a 2<sup>nd</sup> chromatographic tank and proceed with development.

*Mobile phase:* acetonitrile R, concentrated ammonia R, methanol R, methylene chloride R (10:20:40:40 V/V/V/V).

*Development:* over 3/4 of the plate.

*Drying:* in air.

*Detection:* examine in ultraviolet light at 254 nm.

*Limit:*

- *impurity A:* any spot corresponding to impurity A is not more intense than the principal spot in the chromatogram obtained with the reference solution (0.2 per cent).

**Related substances.** Liquid chromatography (2.2.29).

*Test solution.* Dissolve 25.0 mg of the substance to be examined in the mobile phase and dilute to 50.0 mL with the mobile phase.

*Reference solution (a).* Dissolve 25.0 mg of ciprofloxacin hydrochloride CRS in the mobile phase and dilute to 50.0 mL with the mobile phase.

*Reference solution (b).* Dissolve 5 mg of ciprofloxacin hydrochloride for peak identification CRS in the mobile phase and dilute to 10.0 mL with the mobile phase.

*Reference solution (c).* Dilute 1.0 mL of the test solution to 50.0 mL with the mobile phase. Dilute 1.0 mL of this solution to 10.0 mL with the mobile phase.

*Column:*

- *size:* l = 0.25 m, Ø = 4.6 mm;
- *stationary phase:* base-deactivated octadecylsilyl silica gel for chromatography R (5 µm);
- *temperature:* 40 °C.

*Mobile phase:* mix 13 volumes of acetonitrile R and 87 volumes of a 2.45 g/L solution of phosphoric acid R, previously adjusted to pH 3.0 with triethylamine R.

*Flow rate:* 1.5 mL/min.

*Detection:* spectrophotometer at 278 nm.

*Injection:* 50 µL.

*Run time:* twice the retention time of ciprofloxacin.

*Identification of impurities:* use the chromatogram supplied with ciprofloxacin hydrochloride for peak identification CRS and the chromatogram obtained with reference solution (b) to identify the peaks due to impurities B, C, D and E.

*Relative retention* with reference to ciprofloxacin (retention time = about 9 min): impurity E = about 0.4; impurity F = about 0.5; impurity B = about 0.6; impurity C = about 0.7; impurity D = about 1.2.

*System suitability:* reference solution (b):

- *resolution:* minimum 1.3 between the peaks due to impurity B and impurity C.

*Limits:*

- *correction factors:* for the calculation of contents, multiply the peak areas of the following impurities by the corresponding correction factor: impurity B = 0.7; impurity C = 0.6; impurity D = 1.4; impurity E = 6.7;
- *impurities B, C, D, E:* for each impurity, not more than the area of the principal peak in the chromatogram obtained with reference solution (c) (0.2 per cent);
- *unspecified impurities:* not more than 0.5 times the area of the principal peak in the chromatogram obtained with reference solution (c) (0.1 per cent);



01/2009:0599  
corrected 7.0

- *total*: not more than 2.5 times the area of the principal peak in the chromatogram obtained with reference solution (c) (0.5 per cent);
- *disregard limit*: 0.25 times the area of the principal peak in the chromatogram obtained with reference solution (c) (0.05 per cent).

**Heavy metals** (2.4.8): maximum 20 ppm.

Dissolve 0.25 g in *water R* and dilute to 30 mL with the same solvent. Carry out the prefiltration. The filtrate complies with test E. Prepare the reference solution using 5 mL of *lead standard solution (1 ppm Pb) R*.

**Water** (2.5.12): maximum 6.7 per cent, determined on 0.200 g.

**Sulfated ash** (2.4.14): maximum 0.1 per cent, determined on 1.0 g in a platinum crucible.

#### ASSAY

Liquid chromatography (2.2.29) as described in the test for related substances with the following modifications.

**Injection**: 10 µL of the test solution and reference solution (a). Calculate the percentage content of C<sub>17</sub>H<sub>19</sub>ClFN<sub>3</sub>O<sub>3</sub>.

#### STORAGE

In an airtight container, protected from light.

#### IMPURITIES

*Specified impurities*: A, B, C, D, E.

*Other detectable impurities* (the following substances would, if present at a sufficient level, be detected by one or other of the tests in the monograph. They are limited by the general acceptance criterion for other/unspecified impurities and/or by the general monograph *Substances for pharmaceutical use (2034)*. It is therefore not necessary to identify these impurities for demonstration of compliance. See also 5.10. *Control of impurities in substances for pharmaceutical use*): F.

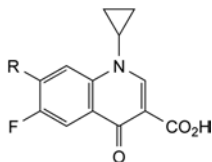

- A. R = Cl: 7-chloro-1-cyclopropyl-6-fluoro-4-oxo-1,4-dihydroquinoline-3-carboxylic acid (fluoroquinolonic acid),
- C. R = NH-(CH<sub>2</sub>)<sub>2</sub>-NH<sub>2</sub>: 7-[(2-aminoethyl)amino]-1-cyclopropyl-6-fluoro-4-oxo-1,4-dihydroquinoline-3-carboxylic acid (ethylenediamine compound),

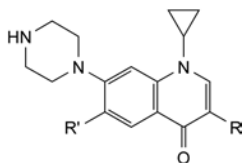

- B. R = CO<sub>2</sub>H, R' = H: 1-cyclopropyl-4-oxo-7-(piperazin-1-yl)-1,4-dihydroquinoline-3-carboxylic acid (desfluoro compound),
- E. R = H, R' = F: 1-cyclopropyl-6-fluoro-7-(piperazin-1-yl)quinolin-4(1H)-one (decarboxylated compound),
- F. R = CO<sub>2</sub>H, R' = OH: 1-cyclopropyl-6-hydroxy-4-oxo-7-(piperazin-1-yl)-1,4-dihydroquinoline-3-carboxylic acid,

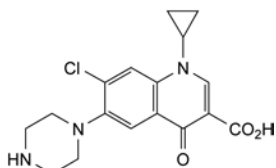

- D. 7-chloro-1-cyclopropyl-4-oxo-6-(piperazin-1-yl)-1,4-dihydroquinoline-3-carboxylic acid.

## CISPLATIN

### Cisplatinum

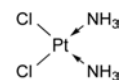

PtCl<sub>2</sub>(NH<sub>3</sub>)<sub>2</sub>  
[15663-27-1]

M<sub>r</sub> 300.0

#### DEFINITION

*cis*-Diamminedichloroplatinum(II).

*Content*: 97.0 per cent to 102.0 per cent.

#### CHARACTERS

*Appearance*: yellow powder, or yellow or orange-yellow crystals.

*Solubility*: slightly soluble in water, sparingly soluble in dimethylformamide, practically insoluble in ethanol (96 per cent).

*Carry out identification test B, the tests (except that for silver) and the assay protected from light.*

#### IDENTIFICATION

*First identification*: A, B.

*Second identification*: B, C.

A. Infrared absorption spectrophotometry (2.2.24).

*Comparison*: *cisplatin CRS*.

B. Thin-layer chromatography (2.2.27).

*Test solution*. Dilute 1 mL of solution S2 (see Tests) to 10 mL with *dimethylformamide R*.

*Reference solution*. Dissolve 10 mg of *cisplatin CRS* in 5 mL of *dimethylformamide R*.

*Plate*: *cellulose for chromatography R1* as the coating substance.

*Pretreatment*: activate the plate by heating at 150 °C for 1 h.

*Mobile phase*: *acetone R, dimethylformamide R (10:90 V/V)*.

*Application*: 2 µL.

*Development*: over 2/3 of the plate.

*Drying*: in air.

*Detection*: spray with a 50 g/L solution of *stannous chloride R* in a mixture of equal volumes of *dilute hydrochloric acid R* and *water R*. Examine after 1 h.

*Results*: the principal spot in the chromatogram obtained with the test solution is similar in position, colour and size to the principal spot in the chromatogram obtained with the reference solution.

C. Add 50 mg to 2 mL of *dilute sodium hydroxide solution R* in a glass dish. Evaporate to dryness. Dissolve the residue in a mixture of 0.5 mL of *nitric acid R* and 1.5 mL of *hydrochloric acid R*. Evaporate to dryness. The residue is orange. Dissolve the residue in 0.5 mL of *water R* and add 0.5 mL of *ammonium chloride solution R*. A yellow, crystalline precipitate is formed.

#### TESTS

**Solution S1**. Dissolve 25 mg in a 9 g/L solution of *sodium chloride R* in *carbon dioxide-free water R* and dilute to 25 mL with the same solvent.

**Solution S2**. Dissolve 0.20 g in *dimethylformamide R* and dilute to 10 mL with the same solvent.

**Appearance of solution S1**. Solution S1 is clear (2.2.1) and not more intensely coloured than reference solution GY<sub>5</sub> (2.2.2, *Method II*).

**Appearance of solution S2**. Solution S2 is clear (2.2.1).

**pH** (2.2.3): 4.5 to 6.0 for solution S1, measured immediately after preparation.

**Related substances.** Liquid chromatography (2.2.29). Carry out the test protected from light. Do not heat or sonicate any platinum-containing solution. All solutions are to be used within 4 h.

**Test solution.** Dissolve 25.0 mg of the substance to be examined in a 9.0 g/L solution of sodium chloride R and dilute to 25.0 mL with the same solution.

**Reference solution (a).** Dissolve 25.0 mg of cisplatin CRS in a 9.0 g/L solution of sodium chloride R and dilute to 25.0 mL with the same solution.

**Reference solution (b).** Dissolve 5.0 mg of cisplatin impurity A CRS in a 9.0 g/L solution of sodium chloride R and dilute to 50.0 mL with the same solution.

**Reference solution (c).** Dissolve 5.6 mg of cisplatin impurity B CRS in a 9.0 g/L solution of sodium chloride R and dilute to 100.0 mL with the same solution.

**Reference solution (d).** Mix 0.05 mL of the test solution with 5.0 mL of reference solution (b) and 5.0 mL of reference solution (c) and dilute to 25.0 mL with a 9.0 g/L solution of sodium chloride R.

**Reference solution (e).** Dilute 5.0 mL of reference solution (d) to 20.0 mL with a 9.0 g/L solution of sodium chloride R.

**Blank solution:** 9.0 g/L solution of sodium chloride R.

**Column:**

- size:  $l = 0.25$  m,  $\varnothing = 4.0$  mm;
- stationary phase: base-deactivated octylsilyl silica gel for chromatography R (4  $\mu$ m);
- temperature: 30 °C.

**Mobile phase:** dissolve 1.08 g of sodium octanesulfonate R, 1.70 g of tetrabutylammonium hydrogen sulfate R and 2.72 g of potassium dihydrogen phosphate R in water for chromatography R and dilute to 950 mL with the same solvent. Adjust to pH 5.9 with 1 M sodium hydroxide and dilute to 1000 mL with water for chromatography R.

**Flow rate:** 1.0 mL/min.

**Detection:** spectrophotometer at 210 nm.

**Injection:** 20  $\mu$ L of the test solution, reference solutions (d) and (e), and the blank solution.

**Run time:** 7 times the retention time of cisplatin.

The displacement peak is the latest eluting peak of the group of injection peaks in the chromatogram obtained with the blank solution.

**Identification of cisplatin aquo complex:** use the chromatogram supplied with cisplatin CRS and the chromatogram obtained with reference solution (a) to identify the peak due to cisplatin aquo complex.

**Relative retention** with reference to cisplatin (retention time = about 3.8 min): displacement peak = about 0.5; impurity A = about 0.6; impurity B = about 0.7; cisplatin aquo complex = about 1.2.

**System suitability:** reference solution (d):

- resolution: minimum 2.5 between the peaks due to impurities A and B, the displacement peak and the peak due to impurity A are well separated.

**Limits:**

- impurity A: not more than the area of the corresponding peak in the chromatogram obtained with reference solution (d) (2.0 per cent);
- impurity B: not more than the area of the corresponding peak in the chromatogram obtained with reference solution (d) (1.0 per cent);

- unspecified impurities: for each impurity, not more than 0.5 times the area of the peak due to cisplatin in the chromatogram obtained with reference solution (d) (0.10 per cent);
- sum of impurities other than A and B: not more than 2.5 times the area of the peak due to cisplatin in the chromatogram obtained with reference solution (d) (0.5 per cent);
- disregard limit: the area of the peak due to cisplatin in the chromatogram obtained with reference solution (e) (0.05 per cent). Disregard any peak due to the cisplatin aquo complex.

**Silver:** maximum 250 ppm.

Atomic absorption spectrometry (2.2.23, Method I).

**Test solution.** Dissolve 0.100 g in 15 mL of nitric acid R, heating to 80 °C. Cool and dilute to 25.0 mL with water R.

**Reference solutions.** To suitable volumes (10 mL to 30 mL) of silver standard solution (5 ppm Ag) R add 50 mL of nitric acid R and dilute to 100.0 mL with water R.

**Source:** silver hollow-cathode lamp, preferably using a transmission band of 0.5 nm.

**Wavelength:** 328 nm.

**Atomisation device:** fuel-lean air-acetylene flame.

Carry out a blank determination.

#### ASSAY

Liquid chromatography (2.2.29) as described in the test for related substances with the following modification.

**Injection:** 10  $\mu$ L of the test solution and reference solution (a).

Calculate the percentage content of  $\text{PtCl}_2(\text{NH}_3)_2$  from the sum of the areas of the peaks due to cisplatin and cisplatin aquo complex and from the declared content of cisplatin CRS.

#### STORAGE

In an airtight container, protected from light.

#### IMPURITIES

**Specified impurities:** A, B.

**Other detectable impurities** (the following substances would, if present at a sufficient level, be detected by one or other of the tests in the monograph. They are limited by the general acceptance criterion for other/unspecified impurities and/or by the general monograph *Substances for pharmaceutical use* (2034). It is therefore not necessary to identify these impurities for demonstration of compliance. See also 5.10. *Control of impurities in substances for pharmaceutical use*): C.

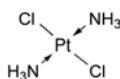

A. trans-diamminedichloroplatinum(II) (transplatin),

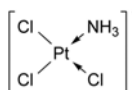

B. amminetrichloroplatinate(-),

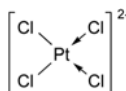

C. tetrachloroplatinate(2-).

01/2009:2288 *Detection*: spectrophotometer at 230 nm and at 254 nm.  
corrected 6.4 *Injection*: 40 µL.

## CITALOPRAM HYDROBROMIDE

### Citaloprami hydrobromidum

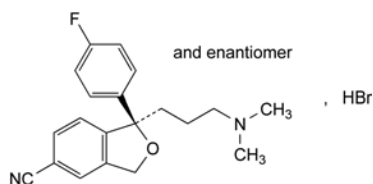

$C_{20}H_{22}BrFN_3O$   
[59729-32-7]

$M_r$  405.3

#### DEFINITION

(1*RS*)-1-[3-(Dimethylamino)propyl]-1-(4-fluorophenyl)-1,3-dihydroisobenzofuran-5-carbonitrile hydrobromide.

*Content*: 99.0 per cent to 101.5 per cent (dried substance).

#### CHARACTERS

*Appearance*: white or almost white, crystalline powder.

*Solubility*: sparingly soluble in water and in anhydrous ethanol.

#### IDENTIFICATION

A. Optical rotation (see Tests).

B. Infrared absorption spectrophotometry (2.2.24).

*Comparison*: citalopram hydrobromide CRS.

C. It gives reaction (a) of bromides (2.3.1).

#### TESTS

**Optical rotation** (2.2.7):  $-0.10^\circ$  to  $+0.10^\circ$ .

Dissolve 1.0 g in *methanol R* and dilute to 20 mL with the same solvent.

**Related substances**. Liquid chromatography (2.2.29).

*Test solution*. Dissolve 50 mg of the substance to be examined in mobile phase A and dilute to 100.0 mL with mobile phase A.

*Reference solution (a)*. Dilute 1.0 mL of the test solution to 100.0 mL with mobile phase A (solution A). Dilute 1.0 mL of solution A to 10.0 mL with mobile phase A.

*Reference solution (b)*. Dissolve the contents of a vial of *citalopram for system suitability CRS* (impurities B, D, F and G) in 1.0 mL of solution A.

*Column*:

- *size*:  $l = 0.25$  m,  $\emptyset = 4.6$  mm;
- *stationary phase*: end-capped octadecylsilyl silica gel for chromatography R (4 µm);
- *temperature*: 40 °C.

*Mobile phase*:

- *mobile phase A*: dissolve 1.58 g of *ammonium formate R* in 500 mL of a mixture of 4 volumes of *acetonitrile R*, 32 volumes of *methanol R* and 64 volumes of *water R*;
- *mobile phase B*: dissolve 1.58 g of *ammonium formate R* in 500 mL of a mixture of 32 volumes of *water R* and 68 volumes of *acetonitrile R*;

Time (min)	Mobile phase A (per cent V/V)	Mobile phase B (per cent V/V)
0 - 2	100	0
2 - 25	100 → 40	0 → 60
25 - 30	40	60

*Flow rate*: 1.0 mL/min.

*Identification of impurities*: use the chromatogram supplied with *citalopram for system suitability CRS* and the chromatogram obtained with reference solution (b) to identify the peaks due to impurities B, D, F and G.

*Relative retention* with reference to citalopram (retention time = about 19 min): impurity G = about 0.5; impurity B = about 0.7; impurity D = about 0.9; impurity F = about 1.6.

*System suitability*: reference solution (b):

- *resolution*: minimum 1.5 between the peaks due to impurity D and citalopram at 230 nm.

*Limits*:

- *correction factors*: for the calculation of content, multiply the peak area of the following impurities by the corresponding correction factor: impurity F = 1.4; impurity G = 0.6;
- *impurity D at 230 nm*: not more than twice the area of the principal peak in the chromatogram obtained with reference solution (a) (0.2 per cent);
- *impurities B, F at 230 nm*: for each impurity, not more than 1.5 times the area of the principal peak in the chromatogram obtained with reference solution (a) (0.15 per cent);
- *impurity G at 254 nm*: not more than 1.5 times the area of the principal peak in the chromatogram obtained with reference solution (a) (0.15 per cent);
- *unspecified impurities at 230 nm and 254 nm*: for each impurity, not more than the area of the principal peak in the chromatogram obtained with reference solution (a) (0.10 per cent);
- *sum of impurities at 230 nm*: not more than 5 times the area of the principal peak in the chromatogram obtained with reference solution (a) (0.5 per cent);
- *disregard limit at 230 nm*: 0.5 times the area of the principal peak in the chromatogram obtained with reference solution (a) (0.05 per cent).

**Heavy metals** (2.4.8): maximum 20 ppm.

Dissolve 0.5 g in *ethanol (96 per cent) R* and dilute to 20 mL with the same solvent. 12 mL of the solution complies with test B. Prepare the reference solution using lead standard solution (0.5 ppm Pb) obtained by diluting *lead standard solution (100 ppm Pb) R* with *ethanol (96 per cent) R*. Filter the solutions through a membrane filter (nominal pore size 0.45 µm).

**Loss on drying** (2.2.32): maximum 0.5 per cent, determined on 1.000 g by drying in an oven at 105 °C for 4 h.

**Sulfated ash** (2.4.14): maximum 0.1 per cent, determined on 1.0 g in a platinum crucible.

#### ASSAY

Dissolve 0.300 g in 50 mL of *ethanol (96 per cent) R* and add 0.5 mL of 0.1 M *hydrochloric acid*. Carry out a potentiometric titration (2.2.20), using 0.1 M *sodium hydroxide*. Read the volume added between the 2 points of inflexion.

1 mL of 0.1 M *sodium hydroxide* is equivalent to 40.53 mg of  $C_{20}H_{22}BrFN_3O$ .

#### IMPURITIES

*Specified impurities*: B, D, F, G.

*Other detectable impurities* (the following substances would, if present at a sufficient level, be detected by one or other of the tests in the monograph. They are limited by the general acceptance criterion for other/unspecified impurities and/or by the general monograph *Substances for pharmaceutical use (2034)*. It is therefore not necessary to identify these impurities for demonstration of compliance. See also 5.10. *Control of impurities in substances for pharmaceutical use*): A, C, E.

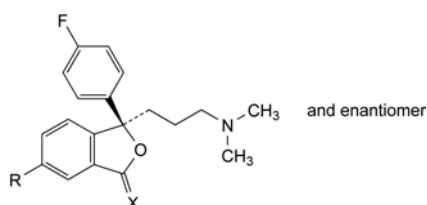

- A. R = CO-NH<sub>2</sub>, X = H<sub>2</sub>: (1*RS*)-1-[3-(dimethylamino)propyl]-1-(4-fluorophenyl)-1,3-dihydroisobenzofuran-5-carboxamide,  
 C. R = CN, X = O: (3*RS*)-6-cyano-3-[3-(dimethylamino)propyl]-3-(4-fluorophenyl)isobenzofuran-1(3*H*)-one,  
 E. R = Cl, X = H<sub>2</sub>: 3-[(1*RS*)-5-chloro-1-(4-fluorophenyl)-1,3-dihydroisobenzofuran-1-yl]-*N,N*-dimethylpropan-1-amine,

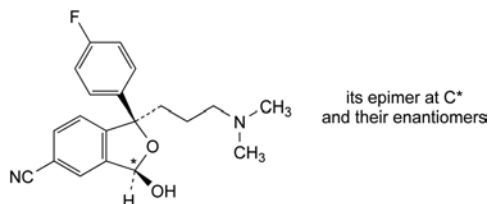

- B. 1-[3-(dimethylamino)propyl]-1-(4-fluorophenyl)-3-hydroxy-1,3-dihydroisobenzofuran-5-carbonitrile,

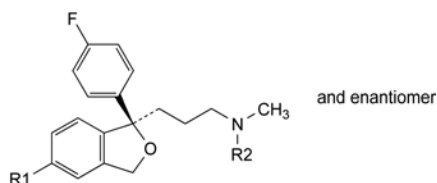

- D. R<sub>1</sub> = CN, R<sub>2</sub> = H: (1*RS*)-1-(4-fluorophenyl)-1-[3-(methylamino)propyl]-1,3-dihydroisobenzofuran-5-carbonitrile,  
 F. R<sub>1</sub> = Br, R<sub>2</sub> = CH<sub>3</sub>: 3-[(1*RS*)-5-bromo-1-(4-fluorophenyl)-1,3-dihydroisobenzofuran-1-yl]-*N,N*-dimethylpropan-1-amine,  
 G. R<sub>1</sub> = CO-[CH<sub>2</sub>]<sub>3</sub>-N(CH<sub>3</sub>)<sub>2</sub>, R<sub>2</sub> = CH<sub>3</sub>: 4-(dimethylamino)-1-[(1*RS*)-1-[3-(dimethylamino)propyl]-1-(4-fluorophenyl)-1,3-dihydroisobenzofuran-5-yl]butan-1-one.

01/2009:2203  
corrected 6.4

## CITALOPRAM HYDROCHLORIDE

### Citaloprami hydrochloridum

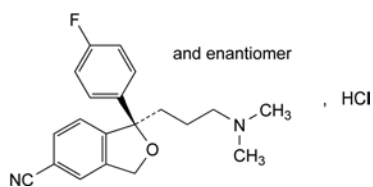

C<sub>20</sub>H<sub>22</sub>ClFN<sub>2</sub>O  
[85118-27-0]

M<sub>r</sub> 360.9

#### DEFINITION

(1*RS*)-1-[3-(Dimethylamino)propyl]-1-(4-fluorophenyl)-1,3-dihydroisobenzofuran-5-carbonitrile hydrochloride.

Content: 99.0 per cent to 101.5 per cent (dried substance).

#### CHARACTERS

Appearance: white or almost white, crystalline powder.

Solubility: very soluble in water, freely soluble in anhydrous ethanol.

#### IDENTIFICATION

A. Optical rotation (see Tests).

B. Infrared absorption spectrophotometry (2.2.24).

Comparison: citalopram hydrochloride CRS.

C. It gives reaction (a) of chlorides (2.3.1).

#### TESTS

**Solution S.** Dissolve 1.0 g in *methanol R* and dilute to 20 mL with the same solvent.

**Appearance of solution.** Solution S, examined immediately after preparation, is clear (2.2.1) and not more intensely coloured than reference solution Y<sub>6</sub> (2.2.2, *Method II*).

**Optical rotation** (2.2.7): −0.10° to +0.10°, determined on solution S.

**Related substances.** Liquid chromatography (2.2.29).

**Test solution.** Dissolve 50 mg of the substance to be examined in mobile phase A and dilute to 100.0 mL with mobile phase A.

**Reference solution (a).** Dilute 1.0 mL of the test solution to 100.0 mL with mobile phase A (solution A). Dilute 1.0 mL of solution A to 10.0 mL with mobile phase A.

**Reference solution (b).** Dissolve the contents of a vial of *citalopram for system suitability CRS* (impurities B and D) in 1.0 mL of solution A.

#### Column:

– size: *l* = 0.25 m, Ø = 4.6 mm;

– stationary phase: end-capped octadecylsilyl silica gel for chromatography R (4 µm);

– temperature: 40 °C.

#### Mobile phase:

– mobile phase A: dissolve 1.58 g of *ammonium formate R* in 500 mL of a mixture of 4 volumes of *acetonitrile R*, 32 volumes of *methanol R* and 64 volumes of *water R*;

– mobile phase B: dissolve 1.58 g of *ammonium formate R* in 500 mL of a mixture of 32 volumes of *water R* and 68 volumes of *acetonitrile R*;

Time (min)	Mobile phase A (per cent V/V)	Mobile phase B (per cent V/V)
0 - 2	100	0
2 - 25	100 → 40	0 → 60
25 - 30	40	60

Flow rate: 1.0 mL/min.

Detection: spectrophotometer at 230 nm.

Injection: 40 µL.

**Identification of impurities:** use the chromatogram supplied with *citalopram for system suitability CRS* and the chromatogram obtained with reference solution (b) to identify the peaks due to impurities B and D.

**Relative retention** with reference to citalopram (retention time = about 19 min): impurity B = about 0.7; impurity D = about 0.9.

**System suitability:** reference solution (b):

– resolution: minimum 1.5 between the peaks due to impurity D and citalopram.

#### Limits:

– impurity B: not more than 1.5 times the area of the principal peak in the chromatogram obtained with reference solution (a) (0.15 per cent);

– unspecified impurities: for each impurity, not more than the area of the principal peak in the chromatogram obtained with reference solution (a) (0.10 per cent);

– total: not more than twice the area of the principal peak in the chromatogram obtained with reference solution (a) (0.2 per cent);

– disregard limit: 0.5 times the area of the principal peak in the chromatogram obtained with reference solution (a) (0.05 per cent).

**Heavy metals** (2.4.8): maximum 20 ppm.

Dissolve 1.0 g in 20 mL of *water R*. 12 mL of the solution complies with test A. Prepare the reference solution using *lead standard solution (1 ppm Pb) R*.

**Loss on drying** (2.2.32): maximum 0.5 per cent, determined on 1.000 g by drying in an oven at 105 °C for 4 h.

**Sulfated ash** (2.4.14): maximum 0.1 per cent, determined on 1.0 g in a platinum crucible.

#### ASSAY

Dissolve 0.250 g in 50 mL of *ethanol (96 per cent) R* and add 0.5 mL of 0.1 M *hydrochloric acid*. Carry out a potentiometric titration (2.2.20), using 0.1 M *sodium hydroxide*. Read the volume added between the 2 points of inflexion.

1 mL of 0.1 M *sodium hydroxide* is equivalent to 36.09 mg of  $C_{20}H_{22}ClFN_2O$ .

#### IMPURITIES

*Specified impurities: B.*

*Other detectable impurities* (the following substances would, if present at a sufficient level, be detected by one or other of the tests in the monograph. They are limited by the general acceptance criterion for other/unspecified impurities and/or by the general monograph *Substances for pharmaceutical use (2034)*. It is therefore not necessary to identify these impurities for demonstration of compliance. See also 5.10. *Control of impurities in substances for pharmaceutical use*): A, C, D, E, F.

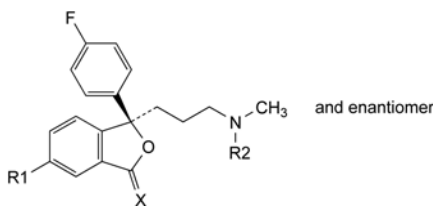

- A. R1 = CO-NH<sub>2</sub>, R2 = CH<sub>3</sub>, X = H<sub>2</sub>: (1*RS*)-1-[3-(dimethylamino)propyl]-1-(4-fluorophenyl)-1,3-dihydroisobenzofuran-5-carboxamide,
- C. R1 = CN, R2 = CH<sub>3</sub>, X = O: (3*RS*)-6-cyano-3-[3-(dimethylamino)propyl]-3-(4-fluorophenyl)isobenzofuran-1(3*H*)-one,
- D. R1 = CN, R2 = H, X = H<sub>2</sub>: (1*RS*)-1-(4-fluorophenyl)-1-[3-(methylamino)propyl]-1,3-dihydroisobenzofuran-5-carbonitrile,
- E. R1 = Cl, R2 = CH<sub>3</sub>, X = H<sub>2</sub>: 3-[(1*RS*)-5-chloro-1-(4-fluorophenyl)-1,3-dihydroisobenzofuran-1-yl]-*N,N*-dimethylpropan-1-amine,
- F. R1 = Br, R2 = CH<sub>3</sub>, X = H<sub>2</sub>: 3-[(1*RS*)-5-bromo-1-(4-fluorophenyl)-1,3-dihydroisobenzofuran-1-yl]-*N,N*-dimethylpropan-1-amine,

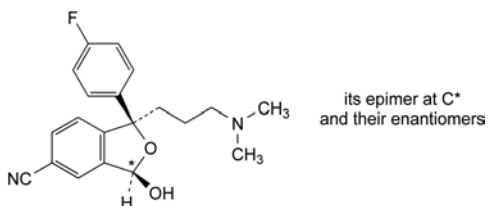

- B. 1-[3-(dimethylamino)propyl]-1-(4-fluorophenyl)-3-hydroxy-1,3-dihydroisobenzofuran-5-carbonitrile.

01/2008:0455  
corrected 6.0

## CITRIC ACID, ANHYDROUS

### Acidum citricum anhydricum

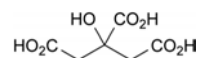

$C_6H_8O_7$   
[77-92-9]

$M_r$  192.1

#### DEFINITION

2-Hydroxypropane-1,2,3-tricarboxylic acid.

*Content*: 99.5 per cent to 100.5 per cent (anhydrous substance).

#### CHARACTERS

*Appearance*: white or almost white, crystalline powder, colourless crystals or granules.

*Solubility*: very soluble in water, freely soluble in ethanol (96 per cent).

mp: about 153 °C, with decomposition.

#### IDENTIFICATION

*First identification: B, E.*

*Second identification: A, C, D, E.*

- A. Dissolve 1 g in 10 mL of *water R*. The solution is strongly acidic (2.2.4).
- B. Infrared absorption spectrophotometry (2.2.24).  
*Preparation*: dry the substance to be examined and the reference substance at 100-105 °C for 2 h.  
*Comparison*: *anhydrous citric acid CRS*.
- C. Add about 5 mg to a mixture of 1 mL of *acetic anhydride R* and 3 mL of *pyridine R*. A red colour develops.
- D. Dissolve 0.5 g in 5 mL of *water R*, neutralise using 1 M *sodium hydroxide* (about 7 mL), add 10 mL of *calcium chloride solution R* and heat to boiling. A white precipitate is formed.
- E. Water (see Tests).

#### TESTS

**Appearance of solution.** The solution is clear (2.2.1) and not more intensely coloured than reference solution Y<sub>7</sub>, BY<sub>7</sub> or GY<sub>7</sub> (2.2.2, *Method II*).

Dissolve 2.0 g in *water R* and dilute to 10 mL with the same solvent.

**Readily carbonisable substances.** To 1.0 g in a cleaned test tube add 10 mL of *sulfuric acid R* and immediately heat the mixture in a water-bath at 90 ± 1 °C for 60 min. Cool rapidly immediately afterwards. The solution is not more intensely coloured than a mixture of 1 mL of red primary solution and 9 mL of yellow primary solution (2.2.2, *Method I*).

**Oxalic acid:** maximum 360 ppm, calculated as anhydrous oxalic acid.

Dissolve 0.80 g in 4 mL of *water R*. Add 3 mL of *hydrochloric acid R* and 1 g of *zinc R* in granules. Boil for 1 min. Allow to stand for 2 min. Transfer the supernatant liquid to a test-tube containing 0.25 mL of a 10 g/L solution of *phenylhydrazine hydrochloride R* and heat to boiling. Cool rapidly, transfer to a graduated cylinder and add an equal volume of *hydrochloric acid R* and 0.25 mL of a 50 g/L solution of *potassium ferricyanide R*. Shake and allow to stand for 30 min. Any pink colour in the solution is not more intense than that in a standard prepared at the same time in the same manner using 4 mL of a 0.1 g/L solution of *oxalic acid R*.

**Sulfates** (2.4.13): maximum 150 ppm.

Dissolve 2.0 g in *distilled water R* and dilute to 30 mL with the same solvent.

**Aluminium** (2.4.17): maximum 0.2 ppm, if intended for use in the manufacture of dialysis solutions.

**Prescribed solution.** Dissolve 20 g in 100 mL of *water R* and add 10 mL of *acetate buffer solution pH 6.0 R*.

**Reference solution.** Mix 2 mL of *aluminium standard solution (2 ppm Al) R*, 10 mL of *acetate buffer solution pH 6.0 R* and 98 mL of *water R*.

**Blank solution.** Mix 10 mL of *acetate buffer solution pH 6.0 R* and 100 mL of *water R*.

**Heavy metals** (2.4.8): maximum 10 ppm.

Dissolve 5.0 g in several portions in 39 mL of *dilute sodium hydroxide solution R* and dilute to 50 mL with *distilled water R*. 12 mL of the solution complies with test A. Prepare the reference solution using *lead standard solution (1 ppm Pb) R*.

**Water** (2.5.12): maximum 1.0 per cent, determined on 2.000 g.

**Sulfated ash** (2.4.14): maximum 0.1 per cent, determined on 1.0 g.

**Bacterial endotoxins** (2.6.14): less than 0.5 IU/mg, if intended for use in the manufacture of parenteral preparations without a further appropriate procedure for the removal of bacterial endotoxins.

#### ASSAY

Dissolve 0.550 g in 50 mL of *water R*. Titrate with *1 M sodium hydroxide*, using 0.5 mL of *phenolphthalein solution R* as indicator.

1 mL of *1 M sodium hydroxide* is equivalent to 64.03 mg of  $C_6H_8O_7$ .

#### LABELLING

The label states, where applicable, that the substance is intended for use in the manufacture of dialysis solutions.

01/2008:0456  
corrected 6.0

## CITRIC ACID MONOHYDRATE

### Acidum citricum monohydricum

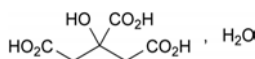

$C_6H_8O_7 \cdot H_2O$   
[5949-29-1]

$M_r$  210.1

#### DEFINITION

2-Hydroxypropane-1,2,3-tricarboxylic acid monohydrate.

**Content:** 99.5 per cent to 100.5 per cent (anhydrous substance).

#### CHARACTERS

**Appearance:** white or almost white, crystalline powder, colourless crystals or granules, efflorescent.

**Solubility:** very soluble in water, freely soluble in ethanol (96 per cent).

#### IDENTIFICATION

**First identification:** B, E.

**Second identification:** A, C, D, E.

A. Dissolve 1 g in 10 mL of *water R*. The solution is strongly acidic (2.2.4).

B. Infrared absorption spectrophotometry (2.2.24).

**Preparation:** dry the substance to be examined and the reference substance at 100-105 °C for 2 h.

**Comparison:** *citric acid monohydrate CRS*.

C. Add about 5 mg to a mixture of 1 mL of *acetic anhydride R* and 3 mL of *pyridine R*. A red colour develops.

D. Dissolve 0.5 g in 5 mL of *water R*, neutralise using *1 M sodium hydroxide* (about 7 mL), add 10 mL of *calcium chloride solution R* and heat to boiling. A white precipitate is formed.

E. *Water* (see Tests).

#### TESTS

**Appearance of solution.** The solution is clear (2.2.1) and not more intensely coloured than reference solution Y<sub>7</sub>, BY<sub>7</sub> or GY<sub>7</sub> (2.2.2, *Method II*).

Dissolve 2.0 g in *water R* and dilute to 10 mL with the same solvent.

**Readily carbonisable substances.** To 1.0 g in a cleaned test tube add 10 mL of *sulfuric acid R* and immediately heat the mixture in a water-bath at 90 ± 1 °C for 60 min. Cool rapidly immediately afterwards. The solution is not more intensely coloured than a mixture of 1 mL of red primary solution and 9 mL of yellow primary solution (2.2.2, *Method I*).

**Oxalic acid:** maximum 360 ppm, calculated as anhydrous oxalic acid.

Dissolve 0.80 g in 4 mL of *water R*. Add 3 mL of *hydrochloric acid R* and 1 g of *zinc R* in granules. Boil for 1 min. Allow to stand for 2 min. Transfer the supernatant liquid to a test-tube containing 0.25 mL of a 10 g/L solution of *phenylhydrazine hydrochloride R* and heat to boiling. Cool rapidly, transfer to a graduated cylinder and add an equal volume of *hydrochloric acid R* and 0.25 mL of a 50 g/L solution of *potassium ferricyanide R*. Shake and allow to stand for 30 min. Any pink colour in the solution is not more intense than that in a standard prepared at the same time in the same manner using 4 mL of a 0.1 g/L solution of *oxalic acid R*.

**Sulfates** (2.4.13): maximum 150 ppm.

Dissolve 2.0 g in *distilled water R* and dilute to 30 mL with the same solvent.

**Aluminium** (2.4.17): maximum 0.2 ppm, if intended for use in the manufacture of dialysis solutions.

**Prescribed solution.** Dissolve 20 g in 100 mL of *water R* and add 10 mL of *acetate buffer solution pH 6.0 R*.

**Reference solution.** Mix 2 mL of *aluminium standard solution (2 ppm Al) R*, 10 mL of *acetate buffer solution pH 6.0 R* and 98 mL of *water R*.

**Blank solution.** Mix 10 mL of *acetate buffer solution pH 6.0 R* and 100 mL of *water R*.

**Heavy metals** (2.4.8): maximum 10 ppm.

Dissolve 5.0 g in several portions in 39 mL of *dilute sodium hydroxide solution R* and dilute to 50 mL with *distilled water R*. 12 mL of the solution complies with test A. Prepare the reference solution using *lead standard solution (1 ppm Pb) R*.

**Water** (2.5.12): 7.5 per cent to 9.0 per cent, determined on 0.500 g.

**Sulfated ash** (2.4.14): maximum 0.1 per cent, determined on 1.0 g.

**Bacterial endotoxins** (2.6.14): less than 0.5 IU/mg, if intended for use in the manufacture of parenteral preparations without a further appropriate procedure for the removal of bacterial endotoxins.

#### ASSAY

Dissolve 0.550 g in 50 mL of *water R*. Titrate with *1 M sodium hydroxide*, using 0.5 mL of *phenolphthalein solution R* as indicator.

1 mL of *1 M sodium hydroxide* is equivalent to 64.03 mg of  $C_6H_8O_7$ .

#### STORAGE

In an airtight container.

## LABELLING

The label states, where applicable, that the substance is intended for use in the manufacture of dialysis solutions.

01/2011:2174

## CLADRIBINE

## Cladribinum

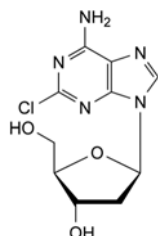

$C_{10}H_{12}ClN_5O_3$   
[4291-63-8]

 $M_r$  285.7

## DEFINITION

2-Chloro-9-(2-deoxy- $\beta$ -D-erythro-pentofuranosyl)-9H-purin-6-amine.

*Content*: 97.0 per cent to 102.0 per cent (anhydrous substance).

## CHARACTERS

*Appearance*: white or almost white, crystalline powder.

*Solubility*: slightly soluble in water, soluble in dimethyl sulfoxide, slightly soluble in methanol, practically insoluble in acetonitrile.

It shows polymorphism (5.9).

## IDENTIFICATION

A. Specific optical rotation (see Tests).

B. Infrared absorption spectrophotometry (2.2.24).

*Comparison*: cladribine CRS.

If the spectra obtained in the solid state show differences, dissolve the substance to be examined in the minimum volume of *methanol R* and evaporate to dryness. Dry the precipitate at 100 °C for 2 h and record a new spectrum using the residue.

## TESTS

**Appearance of solution.** The solution is clear (2.2.1) and colourless (2.2.2, Method II).

Disperse 0.15 g in *water R*, dilute to 50 mL with the same solvent and sonicate until dissolution is complete.

**Specific optical rotation** (2.2.7):  $-21.0$  to  $-27.0$  (anhydrous substance).

Dissolve 0.25 g in *dimethyl sulfoxide R* and dilute to 25.0 mL with the same solvent.

**Impurity E.** Thin-layer chromatography (2.2.27).

*Test solution.* Dissolve 40.0 mg of the substance to be examined in *dimethylformamide R* and dilute to 2.0 mL with the same solvent.

*Reference solution (a).* Dissolve 5.0 mg of *2-deoxy-D-ribose R* (impurity E) in *dimethylformamide R* and dilute to 25.0 mL with the same solvent. Dilute 3.0 mL of this solution to 10.0 mL with *dimethylformamide R*.

*Reference solution (b).* Dissolve 10.0 mg of *2-deoxy-D-ribose R* (impurity E) in *dimethylformamide R* and dilute to 5.0 mL with the same solvent. Mix 9 volumes of this solution with 1 volume of the test solution.

*Plate*: TLC silica gel  $F_{254}$  plate *R*.

*Mobile phase*: concentrated ammonia *R*, ethanol (96 per cent) *R*, ethyl acetate *R* (20:40:40 V/V/V).

*Application*: 5  $\mu$ L as bands of 10 mm; thoroughly dry the points of application in a current of warm air.

*Development*: over 2/3 of the plate.

*Drying*: in air, then heat at 45 °C for 10 min.

*Detection*: spray with a solution containing 0.5 g of *thymol R* in a mixture of 5 mL of *sulfuric acid R* and 95 mL of *ethanol (96 per cent) R*; heat at 110 °C for 20 min or until the spots appear.

*System suitability*: reference solution (b):

– the chromatogram shows 2 clearly separated spots.

*Limit*:

– *impurity E*: any spot due to impurity E is not more intense than the spot in the chromatogram obtained with reference solution (a) (0.3 per cent).

**Related substances.** Liquid chromatography (2.2.29).

*Solvent mixture*: acetonitrile *R*, water *R* (10:90 V/V).

*Test solution (a).* Dissolve 25.0 mg of the substance to be examined in the solvent mixture and dilute to 5.0 mL with the solvent mixture.

*Test solution (b).* Dissolve 20.0 mg of the substance to be examined in the solvent mixture and dilute to 100.0 mL with the solvent mixture.

*Reference solution (a).* Dissolve 20.0 mg of *cladribine CRS* in the solvent mixture and dilute to 100.0 mL with the solvent mixture.

*Reference solution (b).* Dilute 1.0 mL of test solution (a) to 100.0 mL with the solvent mixture.

*Reference solution (c).* Dilute 1.0 mL of reference solution (b) to 10.0 mL with the solvent mixture.

*Reference solution (d).* Dissolve 1.0 mg of *cladribine impurity C CRS* in reference solution (b) and dilute to 25.0 mL with the same solution.

*Reference solution (e).* Dilute 5.0 mL of reference solution (c) to 10.0 mL with the solvent mixture.

*Reference solution (f).* Dissolve 3 mg of *cladribine for peak identification CRS* (containing impurities A, B, C and D) in 2 mL of the solvent mixture.

*Column*:

– *size*:  $l = 0.25$  m,  $\varnothing = 4.6$  mm;

– *stationary phase*: base-deactivated octylsilyl silica gel for chromatography *R* (5  $\mu$ m).

*Mobile phase*:

– *mobile phase A*: water for chromatography *R*;

– *mobile phase B*: acetonitrile for chromatography *R*;

– *mobile phase C*: 50 g/L solution of *phosphoric acid R* in water for chromatography *R*;

Time (min)	Mobile phase A (per cent V/V)	Mobile phase B (per cent V/V)	Mobile phase C (per cent V/V)
0 - 10	80 $\rightarrow$ 70	10 $\rightarrow$ 20	10
10 - 25	70 $\rightarrow$ 20	20 $\rightarrow$ 70	10
25 - 30	20	70	10

*Flow rate*: 0.8 mL/min.

*Detection*: spectrophotometer at 252 nm.

*Injection*: 20  $\mu$ L of test solution (a) and reference solutions (c), (d), (e) and (f).

*Identification of impurities*: use the chromatogram supplied with *cladribine for peak identification CRS* and the chromatogram obtained with reference solution (f) to identify the peaks due to impurities A, B, C and D.

*Relative retention* with reference to cladribine (retention time = about 10 min): impurity A = about 0.33; impurity B = about 0.44; impurity C = about 0.73; impurity D = about 0.92.

*System suitability*: reference solution (d):

- *resolution*: minimum 4.5 between the peaks due to impurity C and cladribine.

*Limits*:

- *correction factors*: for the calculation of content, multiply the peak areas of the following impurities by the corresponding correction factor: impurity B = 1.7; impurity C = 0.8;
- *impurities A, C*: for each impurity, not more than 3 times the area of the principal peak in the chromatogram obtained with reference solution (c) (0.3 per cent);
- *impurities B, D*: for each impurity, not more than twice the area of the principal peak in the chromatogram obtained with reference solution (c) (0.2 per cent);
- *unspecified impurities*: for each impurity, not more than the area of the principal peak in the chromatogram obtained with reference solution (c) (0.10 per cent);
- *total*: not more than 10 times the area of the principal peak in the chromatogram obtained with reference solution (c) (1.0 per cent);
- *disregard limit*: the area of the principal peak in the chromatogram obtained with reference solution (e) (0.05 per cent).

**Water** (2.5.32): maximum 0.5 per cent, determined on 0.100 g.

**Bacterial endotoxins** (2.6.14): less than 3 IU/mg, if intended for use in the manufacture of parenteral preparations without a further appropriate procedure for the removal of bacterial endotoxins.

#### ASSAY

Liquid chromatography (2.2.29) as described in the test for related substances with the following modification.

*Injection*: test solution (b) and reference solution (a).

Calculate the percentage content of  $C_{10}H_{12}ClN_5O_3$  from the declared content of *cladribine CRS*.

#### STORAGE

Protected from light, at a temperature of 2 °C to 8 °C. If the substance is sterile, store in a sterile, airtight, tamper-proof container.

#### LABELLING

The label states, where applicable, that the substance is suitable for use in the manufacture of parenteral preparations.

#### IMPURITIES

*Specified impurities*: A, B, C, D, E.

*Other detectable impurities* (the following substances would, if present at a sufficient level, be detected by one or other of the tests in the monograph. They are limited by the general acceptance criterion for other/unspecified impurities and/or by the general monograph *Substances for pharmaceutical use* (2034). It is therefore not necessary to identify these impurities for demonstration of compliance. See also 5.10. *Control of impurities in substances for pharmaceutical use*): F, G.

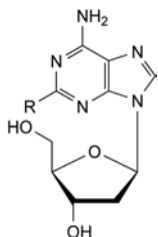

- A. R =  $NH_2$ : 9-(2-deoxy- $\beta$ -D-*erythro*-pentofuranosyl)-9H-purin-2,6-diamine,
- B. R =  $OCH_3$ : 9-(2-deoxy- $\beta$ -D-*erythro*-pentofuranosyl)-2-methoxy-9H-purin-6-amine,

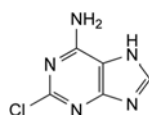

- C. 2-chloro-7H-purin-6-amine (2-chloroadenine),

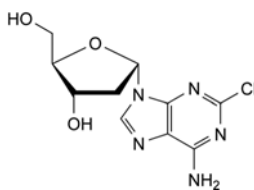

- D. 2-chloro-9-(2-deoxy- $\alpha$ -D-*erythro*-pentofuranosyl)-9H-purin-6-amine,

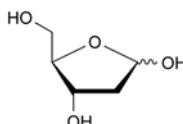

- E. 2-deoxy-D-*erythro*-pentofuranose (2-deoxy-D-ribose),

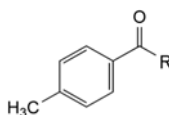

- F. R =  $NH_2$ : 4-methylbenzamide,

- G. R =  $OCH_3$ : methyl 4-methylbenzoate.

01/2008:1651  
corrected 7.0

## CLARITHROMYCIN

### Clarithromycinum

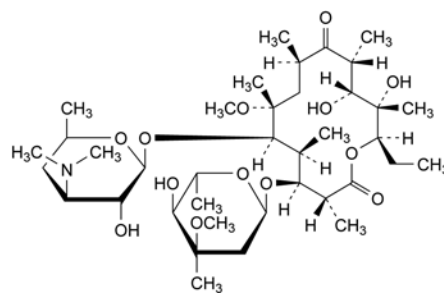

$C_{38}H_{69}NO_{13}$   
[81103-11-9]

$M_r$  748

#### DEFINITION

(3*R*,4*S*,5*S*,6*R*,7*R*,9*R*,11*R*,12*R*,13*S*,14*R*)-4-[(2,6-Dideoxy-3-*C*-methyl-3-*O*-methyl- $\alpha$ -*L*-ribo-hexopyranosyl)oxy]-14-ethyl-12,13-dihydroxy-7-methoxy-3,5,7,9,11,13-hexamethyl-6-[[3,4,6-trideoxy-3-(dimethylamino)- $\beta$ -D-xylo-hexopyranosyl]oxy]oxacyclotetradecane-2,10-dione (6-*O*-methylerythromycin A).

Semi-synthetic product derived from a fermentation product.

*Content*: 96.0 per cent to 102.0 per cent (anhydrous substance).

#### CHARACTERS

*Appearance*: white or almost white, crystalline powder.

*Solubility*: practically insoluble in water, soluble in acetone and in methylene chloride, slightly soluble in methanol.

#### IDENTIFICATION

Infrared absorption spectrophotometry (2.2.24).

*Comparison*: *clarithromycin CRS*.



## TESTS

**Solution S.** Dissolve 0.500 g in *methylene chloride R* and dilute to 50.0 mL with the same solvent.

**Appearance of solution.** Solution S is clear or not more opalescent than reference suspension II (2.2.1) and not more intensely coloured than reference solution Y<sub>7</sub> (2.2.2, Method II).

**Specific optical rotation** (2.2.7): –94 to –102 (anhydrous substance), determined on solution S.

**Related substances.** Liquid chromatography (2.2.29).

**Test solution.** Dissolve 75.0 mg of the substance to be examined in 25 mL of *acetonitrile R1* and dilute to 50.0 mL with *water R*.

**Reference solution (a).** Dissolve 75.0 mg of *clarithromycin CRS* in 25 mL of *acetonitrile R1* and dilute to 50.0 mL with *water R*.

**Reference solution (b).** Dilute 5.0 mL of reference solution (a) to 100.0 mL with a mixture of equal volumes of *acetonitrile R1* and *water R*.

**Reference solution (c).** Dilute 1.0 mL of reference solution (b) to 10.0 mL with a mixture of equal volumes of *acetonitrile R1* and *water R*.

**Reference solution (d).** Dissolve 15.0 mg of *clarithromycin for peak identification CRS* in 5.0 mL of *acetonitrile R1* and dilute to 10.0 mL with *water R*.

**Blank solution.** Dilute 25.0 mL of *acetonitrile R1* to 50.0 mL with *water R* and mix.

## Column:

- size:  $l = 0.10$  m,  $\varnothing = 4.6$  mm,
- stationary phase: octadecylsilyl silica gel for chromatography R (3.5  $\mu$ m),
- temperature: 40 °C.

## Mobile phase:

- mobile phase A: a 4.76 g/L solution of *potassium dihydrogen phosphate R* adjusted to pH 4.4 with *dilute phosphoric acid R* or a 45 g/L solution of *potassium hydroxide R*, filtered through a C18 filtration kit,
- mobile phase B: *acetonitrile R1*,

Time (min)	Mobile phase A (per cent V/V)	Mobile phase B (per cent V/V)
0 - 32	75 → 40	25 → 60
32 - 34	40	60

**Flow rate:** 1.1 mL/min.

**Detection:** spectrophotometer at 205 nm.

**Injection:** 10  $\mu$ L of the blank solution, the test solution and reference solutions (b), (c) and (d).

**Relative retention  $r$**  (not  $r_c$ ) with reference to clarithromycin (retention time = about 11 min): impurity I = about 0.38; impurity A = about 0.42; impurity J = about 0.63; impurity L = about 0.74; impurity B = about 0.79; impurity M = about 0.81; impurity C = about 0.89; impurity D = about 0.96; impurity N = about 1.15; impurity E = about 1.27; impurity F = about 1.33; impurity P = about 1.35; impurity O = about 1.41; impurity K = about 1.59; impurity G = about 1.72; impurity H = about 1.82.

## System suitability:

- **symmetry factor:** maximum 1.7 for the peak due to clarithromycin in the chromatogram obtained with reference solution (b),

- **peak-to-valley ratio:** minimum 3.0, where  $H_p$  = height above the baseline of the peak due to impurity D and  $H_v$  = height above the baseline of the lowest point of the curve separating this peak from the peak due to clarithromycin in the chromatogram obtained with reference solution (d).

## Limits:

- **correction factors:** for the calculation of contents, multiply the peak areas of the following impurities by the corresponding correction factor: impurity G = 0.27; impurity H = 0.15; use the chromatogram supplied with *clarithromycin for peak identification CRS* to identify the peaks;
- **any impurity:** not more than twice the area of the principal peak in the chromatogram obtained with reference solution (c) (1.0 per cent), and not more than 4 such peaks have an area greater than 0.8 times the area of the principal peak in the chromatogram obtained with reference solution (c) (0.4 per cent);
- **total:** not more than 7 times the area of the principal peak in the chromatogram obtained with reference solution (c) (3.5 per cent);
- **disregard limit:** 0.2 times the area of the principal peak in the chromatogram obtained with reference solution (c) (0.1 per cent); disregard the peaks eluting before impurity I and after impurity H.

**Heavy metals** (2.4.8): maximum 20 ppm.

Dissolve 1.0 g in a mixture of 15 volumes of *water R* and 85 volumes of *dioxan R* and dilute to 20 mL with the same mixture of solvents. 12 mL of the solution complies with test B. Prepare the reference solution using lead standard solution (1 ppm Pb) obtained by diluting *lead standard solution (100 ppm Pb) R* with a mixture of 15 volumes of *water R* and 85 volumes of *dioxan R*.

**Water** (2.5.12): maximum 2.0 per cent, determined on 0.500 g.

**Sulfated ash** (2.4.14): maximum 0.2 per cent, determined on 0.5 g.

## ASSAY

Liquid chromatography (2.2.29) as described in the test for related substances with the following modifications.

**Injection:** test solution and reference solution (a).

Calculate the percentage content of  $C_{38}H_{69}NO_{13}$ .

## IMPURITIES

**Specified impurities:** A, B, C, D, E, F, G, H, I, J, K, L, M, N, O, P.

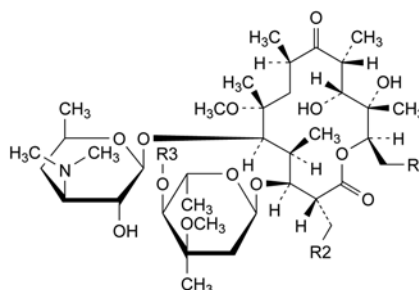

A. R1 = CH<sub>3</sub>, R2 = OH, R3 = H: 2-demethyl-2-(hydroxymethyl)-6-O-methylerythromycin A (clarithromycin F),

B. R1 = R2 = R3 = H: 6-O-methyl-15-norerythromycin A,

P. R1 = R3 = CH<sub>3</sub>, R2 = H: 4',6-di-O-methylerythromycin A,

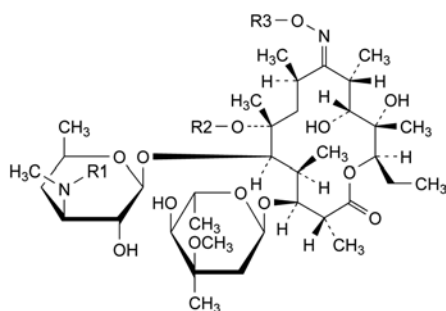

C. R1 = R2 = CH<sub>3</sub>, R3 = H: 6-*O*-methylerythromycin A (*E*)-9-oxime,

G. R1 = R2 = R3 = CH<sub>3</sub>: 6-*O*-methylerythromycin A (*E*)-9-(*O*-methyloxime),

J. R1 = CH<sub>3</sub>, R2 = R3 = H: erythromycin A (*E*)-9-oxime,

M. R1 = R3 = H, R2 = CH<sub>3</sub>: 3'-*N*-demethyl-6-*O*-methylerythromycin A (*E*)-9-oxime,

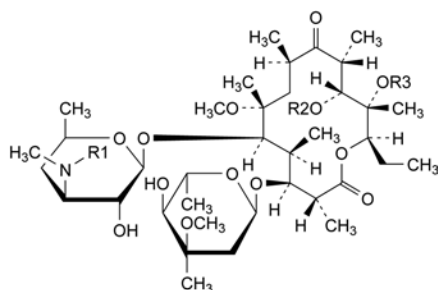

D. R1 = R2 = R3 = H: 3'-*N*-demethyl-6-*O*-methylerythromycin A,

E. R1 = R2 = CH<sub>3</sub>, R3 = H: 6,11-di-*O*-methylerythromycin A,

F. R1 = R3 = CH<sub>3</sub>, R2 = H: 6,12-di-*O*-methylerythromycin A,

H. R1 = CHO, R2 = R3 = H: 3'-*N*-demethyl-3'-*N*-formyl-6-*O*-methylerythromycin A,

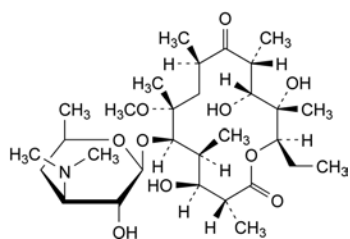

I. 3-*O*-decladinosyl-6-*O*-methylerythromycin A,

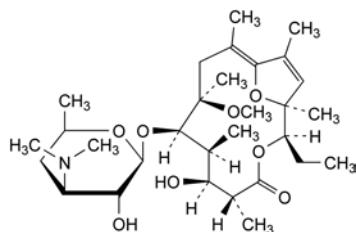

K. (1*S*,2*R*,5*R*,6*S*,7*S*,8*R*,9*R*,11*Z*)-2-ethyl-6-hydroxy-9-methoxy-1,5,7,9,11,13-hexamethyl-8-[[3,4,6-trideoxy-3-(dimethylamino)-β-*D*-xylo-hexopyranosyl]oxy]-3,15-dioxabicyclo[10.2.1]pentadeca-11,13-dien-4-one (3-*O*-decladinosyl-8,9:10,11-dianhydro-6-*O*-methylerythromycin A-9,12-hemiketal),

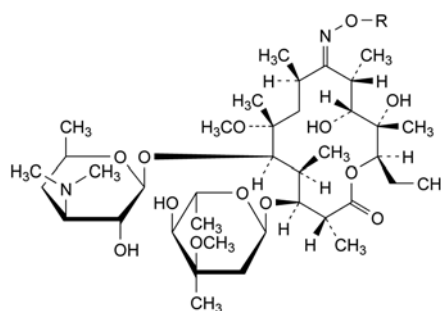

L. R = H: 6-*O*-methylerythromycin A (*Z*)-9-oxime,

O. R = CH<sub>3</sub>: 6-*O*-methylerythromycin A (*Z*)-9-(*O*-methyloxime),

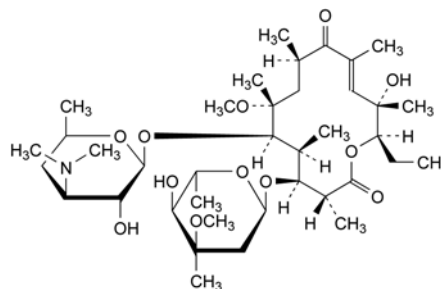

N. (10*E*)-10,11-didehydro-11-deoxy-6-*O*-methylerythromycin A.

07/2010:1714

## CLAZURIL FOR VETERINARY USE

### Clazurilum ad usum veterinarium

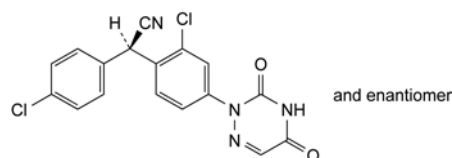

C<sub>17</sub>H<sub>10</sub>Cl<sub>2</sub>N<sub>4</sub>O<sub>2</sub>  
[101831-36-1]

M<sub>r</sub> 373.2

#### DEFINITION

(2*RS*)-[2-Chloro-4-(3,5-dioxo-4,5-dihydro-1,2,4-triazin-2(3*H*)-yl)phenyl](4-chlorophenyl)acetone nitrile.

*Content*: 99.0 per cent to 101.0 per cent (dried substance).

#### CHARACTERS

*Appearance*: white or light yellow powder.

*Solubility*: practically insoluble in water, freely soluble in dimethylformamide, slightly soluble in ethanol (96 per cent) and in methylene chloride.

#### IDENTIFICATION

A. Melting point (2.2.14): 199 °C to 203 °C.

B. Infrared absorption spectrophotometry (2.2.24).

*Comparison*: clazuril CRS.

#### TESTS

**Related substances.** Liquid chromatography (2.2.29).

*Solvent mixture*: tetrahydrofuran R, water R (50:50 V/V).

*Test solution*. Dissolve 20.0 mg of the substance to be examined in the solvent mixture and dilute to 20.0 mL with the solvent mixture.

*Reference solution (a)*. Dissolve 5 mg of clazuril for system suitability CRS (containing impurities A, B, C, D, E, F, G, H and I) in the solvent mixture and dilute to 5.0 mL with the solvent mixture.

**Reference solution (b).** Dilute 1.0 mL of the test solution to 100.0 mL with the solvent mixture. Dilute 2.0 mL of this solution to 10.0 mL with the solvent mixture.

**Column:**

- size:  $l = 0.10$  m,  $\varnothing = 4.6$  mm;
- stationary phase: octadecylsilyl silica gel for chromatography R (3  $\mu$ m);
- temperature: 35 °C.

**Mobile phase:**

- mobile phase A: mix 100 volumes of a 7.7 g/L solution of ammonium acetate R adjusted to pH 6.2 with a 10 per cent V/V solution of anhydrous formic acid R, 150 volumes of acetonitrile R and 750 volumes of water R;
- mobile phase B: mix 50 volumes of water R, 100 volumes of a 7.7 g/L solution of ammonium acetate R adjusted to pH 6.2 with a 10 per cent V/V solution of anhydrous formic acid R and 850 volumes of acetonitrile R;

Time (min)	Mobile phase A (per cent V/V)	Mobile phase B (per cent V/V)
0 - 20	100 → 0	0 → 100
20 - 25	0	100

**Flow rate:** 1.0 mL/min.

**Detection:** spectrophotometer at 230 nm.

**Injection:** 5  $\mu$ L.

**Identification of impurities:** use the chromatogram supplied with clazuril for system suitability CRS and the chromatogram obtained with reference solution (a) to identify the peaks due to impurities A, B, C, D, E, F, G, H and I.

**Relative retention** with reference to clazuril (retention time = about 16 min): impurity A = about 0.6; impurity B = about 0.78; impurity C = about 0.80; impurity D = about 0.86; impurity E = about 0.9; impurity F = about 0.95; impurity G = about 0.98; impurity H = about 1.1; impurity I = about 1.2.

**System suitability:** reference solution (a):

- peak-to-valley ratio: minimum 1.5, where  $H_p$  = height above the baseline of the peak due to impurity G and  $H_v$  = height above the baseline of the lowest point of the curve separating this peak from the peak due to clazuril,
- the chromatogram obtained is similar to the chromatogram supplied with clazuril for system suitability CRS.

**Limits:**

- correction factors: for the calculation of contents, multiply the peak areas of the following impurities by the corresponding correction factor: impurity G = 1.4; impurity H = 0.8;
- impurities A, B, C, D, E, F, G, H, I: for each impurity, not more than the area of the principal peak in the chromatogram obtained with reference solution (b) (0.2 per cent);
- unspecified impurities: for each impurity, not more than the area of the principal peak in the chromatogram obtained with reference solution (b) (0.20 per cent);
- total: not more than 3 times the area of the principal peak in the chromatogram obtained with reference solution (b) (0.6 per cent);
- disregard limit: 0.25 times the area of the principal peak in the chromatogram obtained with reference solution (b) (0.05 per cent); disregard the peaks due to the solvents.

**Loss on drying (2.2.32):** maximum 0.5 per cent, determined on 1.000 g by drying in an oven at 105 °C for 4 h.

**Sulfated ash (2.4.14):** maximum 0.1 per cent, determined on 1.0 g.

**ASSAY**

Dissolve about 0.260 g in 35 mL of tetrahydrofuran R and add 35 mL of water R. Titrate with 0.1 M sodium hydroxide, determining the end-point potentiometrically (2.2.20). Carry out a blank titration.

1 mL of 0.1 M sodium hydroxide is equivalent to 37.32 mg of  $C_{17}H_{10}Cl_2N_4O_2$ .

**STORAGE**

Protected from light.

**IMPURITIES**

**Specified impurities:** A, B, C, D, E, F, G, H, I.

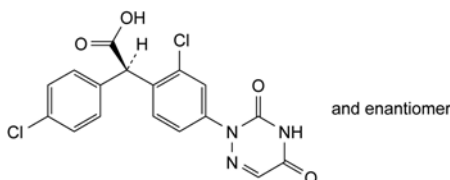

A. (2RS)-2-[2-chloro-4-[(RS)-(4-chlorophenyl)cyanomethyl]phenyl]phenyl[(4-chlorophenyl)acetic acid], and enantiomer

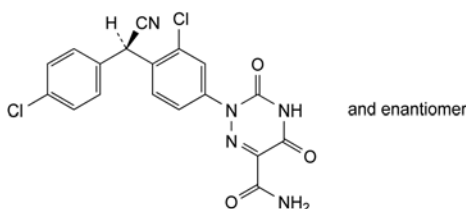

B. 2-[3-chloro-4-[(RS)-(4-chlorophenyl)cyanomethyl]phenyl]-3,5-dioxo-2,3,4,5-tetrahydro-1,2,4-triazine-6-carboxamide, and enantiomer

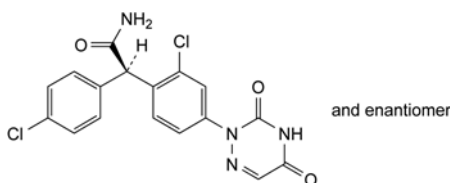

C. (2RS)-2-[2-chloro-4-[(RS)-(4-chlorophenyl)cyanomethyl]phenyl]phenyl-2-(4-chlorophenyl)acetamide, and enantiomer

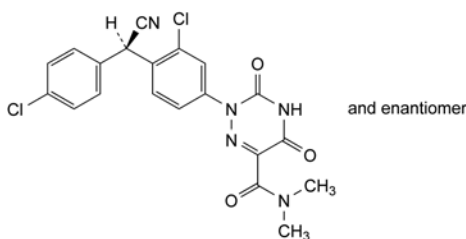

D. 2-[3-chloro-4-[(RS)-(4-chlorophenyl)cyanomethyl]phenyl]-N,N-dimethyl-3,5-dioxo-2,3,4,5-tetrahydro-1,2,4-triazine-6-carboxamide, and enantiomer

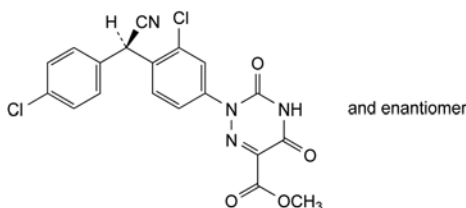

E. methyl 2-[3-chloro-4-[(RS)-(4-chlorophenyl)cyanomethyl]phenyl]-3,5-dioxo-2,3,4,5-tetrahydro-1,2,4-triazine-6-carboxylate, and enantiomer

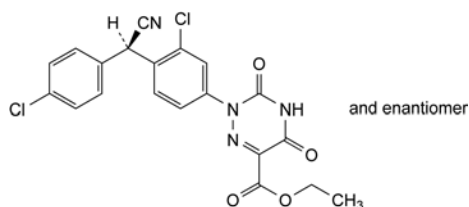

- F. ethyl 2-[3-chloro-4-[(*RS*)-(4-chlorophenyl)cyanomethyl]phenyl]-3,5-dioxo-2,3,4,5-tetrahydro-1,2,4-triazine-6-carboxylate,

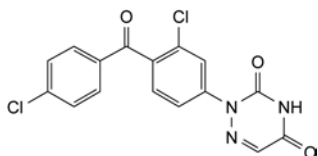

- G. 2-[3-chloro-4-(4-chlorobenzoyl)phenyl]-1,2,4-triazine-3,5-(2*H*,4*H*)-dione,

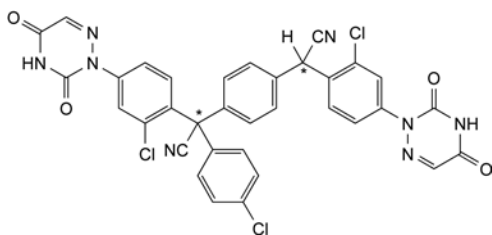

- H. [2-chloro-4-(3,5-dioxo-4,5-dihydro-1,2,4-triazin-2(3*H*)-yl)phenyl][4-[[2-chloro-4-(3,5-dioxo-4,5-dihydro-1,2,4-triazin-2(3*H*)-yl)phenyl]cyanomethyl]phenyl](4-chlorophenyl)acetonitrile,

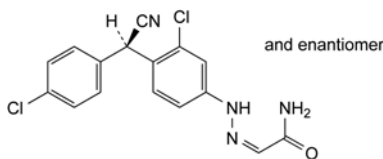

- I. (*Z*)-2-[[3-chloro-4-[(*RS*)-(4-chlorophenyl)cyanomethyl]phenyl]diazanylidene]acetamide.

01/2011:1303

## CLEBOPRIDE MALATE

### Clebopridi malas

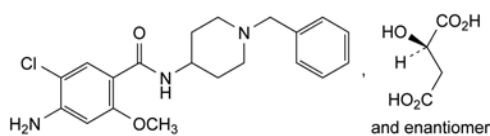

$C_{24}H_{30}ClN_3O_7$   
[57645-91-7]

$M_r$  508.0

#### DEFINITION

4-Amino-*N*-(1-benzylpiperidin-4-yl)-5-chloro-2-methoxybenzamide acid (*RS*)-2-hydroxybutanedioate.

*Content*: 98.5 per cent to 101.0 per cent (dried substance).

#### CHARACTERS

*Appearance*: white or almost white, crystalline powder.

*Solubility*: sparingly soluble in water and in methanol, slightly soluble in anhydrous ethanol, practically insoluble in methylene chloride.

mp: about 164 °C, with decomposition.

#### IDENTIFICATION

*First identification*: B, C.

*Second identification*: A, C, D.

- A. Ultraviolet and visible absorption spectrophotometry (2.2.25).

*Test solution*. Dissolve 20.0 mg in *water R* and dilute to 100.0 mL with the same solvent. Dilute 10.0 mL of the solution to 100.0 mL with *water R*.

*Spectral range*: 230-350 nm.

*Absorption maxima*: at 270 nm and 307 nm.

*Specific absorbance at the absorption maxima*:

- at 270 nm: 252 to 278;
- at 307 nm: 204 to 226.

- B. Infrared absorption spectrophotometry (2.2.24).

*Comparison*: *clebopride malate CRS*.

- C. Dissolve 20 mg in 1 mL of *sulfuric acid R*, add 1 mL of *β-naphthol solution R1* and mix. The solution examined in daylight is yellow with blue fluorescence.

- D. Thin-layer chromatography (2.2.27).

*Test solution*. Dissolve 5 mg of the substance to be examined in *anhydrous ethanol R* and dilute to 10 mL with the same solvent.

*Reference solution (a)*. Dissolve 5 mg of *clebopride malate CRS* in *anhydrous ethanol R* and dilute to 10 mL with the same solvent.

*Reference solution (b)*. Dissolve 5 mg of *clebopride malate CRS* and 5 mg of *metoclopramide hydrochloride CRS* in *anhydrous ethanol R* and dilute to 10 mL with the same solvent.

*Plate*: TLC silica gel  $F_{254}$  plate *R*.

*Mobile phase*: concentrated ammonia *R*, acetone *R*, methanol *R*, toluene *R* (2:14:14:70 *V/V/V/V*).

*Application*: 5 µL as bands of 10 mm by 3 mm.

*Development*: over 3/4 of the plate.

*Drying*: in air.

*Detection*: examine in ultraviolet light at 254 nm.

*System suitability*: reference solution (b):

- the chromatogram shows 2 clearly separated bands.

*Results*: the principal band in the chromatogram obtained with the test solution is similar in position and size to the principal band in the chromatogram obtained with reference solution (a).

#### TESTS

**Solution S**. Dissolve 1.0 g in *carbon dioxide-free water R* and dilute to 100 mL with the same solvent.

**Appearance of solution**. Solution S, examined immediately after preparation, is clear (2.2.1) and colourless (2.2.2, *Method I*).

**pH (2.2.3)**: 3.8 to 4.2 for solution S.

**Related substances**. Liquid chromatography (2.2.29).

*Test solution*. Dissolve 0.100 g of the substance to be examined in the mobile phase and dilute to 100.0 mL with the mobile phase.

*Reference solution (a)*. Dilute 1.0 mL of the test solution to 100.0 mL with the mobile phase. Dilute 1.0 mL of this solution to 10.0 mL with the mobile phase.

*Reference solution (b)*. Dissolve 10 mg of the substance to be examined and 10 mg of *metoclopramide hydrochloride CRS* in the mobile phase and dilute to 100.0 mL with the mobile phase. Dilute 1.0 mL of the solution to 10.0 mL with the mobile phase.

*Column*:

- *size*:  $l = 0.12$  m,  $\varnothing = 4.0$  mm;
- *stationary phase*: octadecylsilyl silica gel for chromatography *R* (5 µm).

*Mobile phase*: mix 20 volumes of *acetonitrile R1* and 80 volumes of a 1 g/L solution of *sodium heptanesulfonate R* adjusted to pH 2.5 with *phosphoric acid R*.

Flow rate: 1 mL/min.

Detection: spectrophotometer at 215 nm.

Injection: 20 µL.

Run time: twice the retention time of clebopride.

Relative retention with reference to clebopride (retention time = about 15 min): metoclopramide = about 0.45.

System suitability: reference solution (b):

– resolution: minimum 5.0 between the peaks due to metoclopramide and clebopride.

Limits:

– unspecified impurities: for each impurity, not more than the area of the principal peak in the chromatogram obtained with reference solution (a) (0.10 per cent);

– total: not more than 3 times the area of the principal peak in the chromatogram obtained with reference solution (a) (0.3 per cent);

– disregard limit: 0.5 times the area of the principal peak in the chromatogram obtained with reference solution (a) (0.05 per cent); disregard the 2 peaks eluting within the first 2 min.

Chlorides: maximum 100 ppm.

Prepare the solutions at the same time.

Test solution. Dissolve 0.530 g in 20.0 mL of anhydrous acetic acid R, add 6 mL of dilute nitric acid R and dilute to 50.0 mL with water R.

Reference solution. To 1.5 mL of 0.001 M hydrochloric acid add 20.0 mL of anhydrous acetic acid R and 6 mL of dilute nitric acid R and dilute to 50.0 mL with water R.

Transfer both recently prepared solutions to separate test-tubes. Add to each tube 1 mL of silver nitrate solution R2. Allow to stand for 5 min protected from light. Examine the tubes laterally against a black background. Any opalescence in the test solution is not more intense than that in the reference solution.

Sulfates: maximum 100 ppm.

Prepare the solutions at the same time.

Test solution. Dissolve 3.00 g in 20.0 mL of glacial acetic acid R, heating gently if necessary. Allow to cool and dilute to 50.0 mL with water R.

Reference solution. To 9 mL of sulfate standard solution (10 ppm SO<sub>4</sub>) R1 add 6 mL of glacial acetic acid R.

Into 2 test-tubes introduce 1.5 mL of sulfate standard solution (10 ppm SO<sub>4</sub>) R1 and add 1 mL of a 250 g/L solution of barium chloride R. Shake and allow to stand for 1 min. To one of the tubes add 15 mL of the test solution and to the other add 15 mL of the reference solution. After 5 min, any opalescence in the tube containing the test solution is not more intense than that in the tube containing the reference solution.

Heavy metals (2.4.8): maximum 20 ppm.

1.0 g complies with test D. Prepare the reference solution using 2 mL of lead standard solution (10 ppm Pb) R.

Loss on drying (2.2.32): maximum 0.5 per cent, determined on 1.000 g by drying in an oven at 105 °C.

Sulfated ash (2.4.14): maximum 0.1 per cent, determined on 1.0 g.

#### ASSAY

Dissolve 0.400 g in 50 mL of anhydrous acetic acid R. Titrate with 0.1 M perchloric acid, determining the end-point potentiometrically (2.2.20).

1 mL of 0.1 M perchloric acid is equivalent to 50.80 mg of C<sub>24</sub>H<sub>30</sub>ClN<sub>3</sub>O<sub>7</sub>.

#### STORAGE

Protected from light.

#### IMPURITIES

Other detectable impurities (the following substances would, if present at a sufficient level, be detected by one or other of the tests in the monograph. They are limited by the general acceptance criterion for other/unspecified impurities and/or by the general monograph *Substances for pharmaceutical use* (2034). It is therefore not necessary to identify these impurities for demonstration of compliance. See also 5.10. *Control of impurities in substances for pharmaceutical use*): A, B, C.

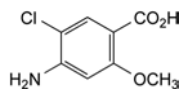

A. 4-amino-5-chloro-2-methoxybenzoic acid,

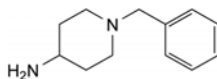

B. 1-benzylpiperidin-4-amine,

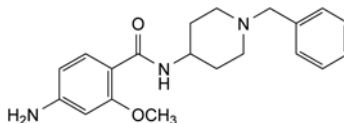

C. 4-amino-N-(1-benzylpiperidin-4-yl)-2-methoxybenzamide.

01/2008:1190  
corrected 6.1

## CLEMASTINE FUMARATE

### Clemastini fumaras

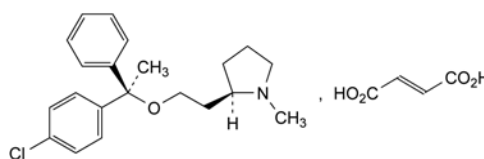

C<sub>25</sub>H<sub>30</sub>ClNO<sub>5</sub>  
[14976-57-9]

M<sub>r</sub> 460.0

#### DEFINITION

(2R)-2-[2-[(R)-1-(4-Chlorophenyl)-1-phenylethoxy]ethyl]-1-methylpiperolidine (E)-butenedioate.

Content: 98.5 per cent to 101.0 per cent (dried substance).

#### CHARACTERS

Appearance: white or almost white, crystalline powder.

Solubility: very slightly soluble in water, sparingly soluble in ethanol (70 per cent V/V), slightly soluble in ethanol (50 per cent V/V) and in methanol.

#### IDENTIFICATION

First identification: A, B.

Second identification: A, C, D.

A. Specific optical rotation (see Tests).

B. Infrared absorption spectrophotometry (2.2.24).

Comparison: clemastine fumarate CRS.

C. Examine the chromatograms obtained in the test for related substances.

Results: the principal spot in the chromatogram obtained with test solution (b) is similar in position, colour and size to the principal spot in the chromatogram obtained with reference solution (a).

D. Thin-layer chromatography (2.2.27).

Test solution. Dissolve 40 mg of the substance to be examined in methanol R and dilute to 2 mL with the same solvent.

**Reference solution.** Dissolve 50 mg of *fumaric acid CRS* in *ethanol (96 per cent) R* and dilute to 10 mL with the same solvent.

**Plate:** TLC silica gel G plate R.

**Mobile phase:** water R, anhydrous formic acid R, di-isopropyl ether R (5:25:70 V/V/V).

**Application:** 5 µL.

**Development:** over a path of 15 cm.

**Drying:** at 100-105 °C for 30 min and allow to cool.

**Detection:** spray with a 16 g/L solution of *potassium permanganate R* and examine in daylight.

**Results:** the spot with the highest  $R_f$  value in the chromatogram obtained with the test solution is similar in position, colour and size to the principal spot in the chromatogram obtained with the reference solution.

## TESTS

**Solution S.** Dissolve 0.500 g in *methanol R* and dilute to 50.0 mL with the same solvent.

**Appearance of solution.** Solution S is clear (2.2.1) and not more intensely coloured than reference solution BY<sub>7</sub> (2.2.2, Method II).

**pH (2.2.3):** 3.2 to 4.2.

Suspend 1.0 g in 10 mL of *carbon dioxide-free water R*.

**Specific optical rotation (2.2.7):** + 15.0 to + 18.0 (dried substance), determined on solution S.

**Related substances.** Thin-layer chromatography (2.2.27).

**Test solution (a).** Dissolve 0.100 g of the substance to be examined in *methanol R* and dilute to 5.0 mL with the same solvent.

**Test solution (b).** Dilute 1.0 mL of test solution (a) to 10.0 mL with *methanol R*.

**Reference solution (a).** Dissolve 20.0 mg of *clemastine fumarate CRS* in *methanol R* and dilute to 10.0 mL with the same solvent.

**Reference solution (b).** Dilute 1.5 mL of test solution (b) to 50.0 mL with *methanol R*.

**Reference solution (c).** Dilute 0.5 mL of test solution (b) to 50.0 mL with *methanol R*.

**Reference solution (d).** Dissolve 10.0 mg of *diphenhydramine hydrochloride CRS* in 5.0 mL of reference solution (a).

**Plate:** TLC silica gel G plate R.

**Mobile phase:** concentrated ammonia R, *methanol R*, *tetrahydrofuran R* (1:20:80 V/V/V).

**Application:** 5 µL.

**Development:** over a path of 15 cm.

**Drying:** in a current of cold air for 5 min.

**Detection:** spray with a freshly prepared mixture of 1 volume of *potassium iodobismuthate solution R* and 10 volumes of *dilute acetic acid R* and then with *dilute hydrogen peroxide solution R*; cover the plate immediately with a glass plate of the same size and examine the chromatograms after 2 min.

**System suitability:** reference solution (d):

– the chromatogram shows 2 clearly separated spots.

**Limits:** test solution (a):

- **any impurity:** any spot, apart from the principal spot, is not more intense than the principal spot in the chromatogram obtained with reference solution (b) (0.3 per cent) and at most 4 such spots are more intense than the principal spot in the chromatogram obtained with reference solution (c) (0.1 per cent);
- **disregard limit:** disregard any spot remaining at the point of application (fumaric acid).

**Impurity C.** Liquid chromatography (2.2.29).

**Solvent mixture:** *acetonitrile RI*, 10 g/L solution of *ammonium dihydrogen phosphate R* (25:75 V/V).

**Test solution.** Dissolve 20 mg of the substance to be examined in the solvent mixture and dilute to 100 mL with the solvent mixture.

**Reference solution (a).** Dissolve 6 mg of *1-(4-chlorophenyl)-1-phenylethanol CRS* (impurity C) in the solvent mixture and dilute to 100 mL with the solvent mixture.

**Reference solution (b).** Dilute 1 mL of reference solution (a) to 100 mL with the solvent mixture.

**Reference solution (c).** Dissolve 10 mg of the substance to be examined in the solvent mixture and dilute to 100 mL with the solvent mixture. To 1 mL of this solution add 1 mL of reference solution (a) and dilute to 100 mL with the solvent mixture.

**Column:**

- **size:**  $l = 0.1$  m,  $\varnothing = 4.6$  mm;
- **stationary phase:** *octadecylsilyl silica gel for chromatography R* (5 µm).

**Mobile phase:** *phosphoric acid R*, *acetonitrile RI*, 10 g/L solution of *ammonium dihydrogen phosphate R* (0.1:45:55 V/V/V).

**Flow rate:** 1 mL/min.

**Detection:** spectrophotometer at 220 nm.

**Injection:** 100 µL.

**System suitability:** reference solution (c):

- **resolution:** minimum 2.2 between the peaks due to clemastine and impurity C.

**Limit:**

- **impurity C:** not more than the area of the principal peak in the chromatogram obtained with reference solution (b) (0.3 per cent).

**Loss on drying (2.2.32):** maximum 0.5 per cent, determined on 1.000 g by drying in an oven at 105 °C for 6 h.

**Sulfated ash (2.4.14):** maximum 0.1 per cent, determined on 1.0 g.

## ASSAY

Dissolve 0.350 g in 60 mL of *anhydrous acetic acid R*. Titrate with 0.1 M *perchloric acid*, determining the end-point potentiometrically (2.2.20).

1 mL of 0.1 M *perchloric acid* is equivalent to 46.00 mg of  $C_{25}H_{30}ClNO_5$ .

## IMPURITIES

**Specified impurities:** A, B, C.

**Other detectable impurities** (the following substances would, if present at a sufficient level, be detected by one or other of the tests in the monograph. They are limited by the general acceptance criterion for other/unspecified impurities and/or by the general monograph *Substances for pharmaceutical use (2034)*. It is therefore not necessary to identify these impurities for demonstration of compliance. See also 5.10. *Control of impurities in substances for pharmaceutical use*): D.

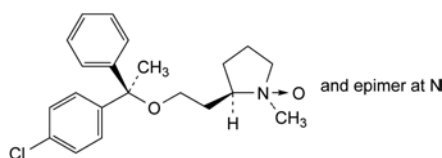

A. (1*R*,2*R*)-2-[2-[(*R*)-1-(4-chlorophenyl)-1-phenylethoxy]ethyl]-1-methylpyrrolidine 1-oxide,

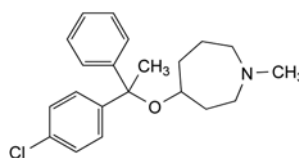

B. 4-[1-(4-chlorophenyl)-1-phenylethoxy]-1-methylazepane,

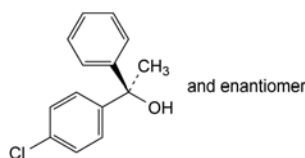

C. (RS)-1-(4-chlorophenyl)-1-phenylethanol,

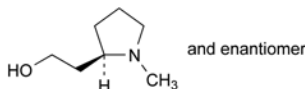

D. 2-[(2RS)-1-methylpyrrolidin-2-yl]ethanol.

01/2008:1409

## CLENBUTEROL HYDROCHLORIDE

### Clenbuteroli hydrochloridum

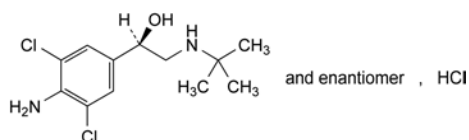

$C_{12}H_{19}Cl_3N_2O$   
[21898-19-1]

$M_r$  313.7

#### DEFINITION

(1RS)-1-(4-Amino-3,5-dichlorophenyl)-2-[(1,1-dimethylethyl)amino]ethanol hydrochloride.

Content: 99.0 per cent to 101.0 per cent (anhydrous substance).

#### CHARACTERS

Appearance: white or almost white, crystalline powder.

Solubility: soluble in water and in ethanol (96 per cent), slightly soluble in acetone.

mp: about 173 °C, with decomposition.

#### IDENTIFICATION

First identification: A, C.

Second identification: B, C.

A. Infrared absorption spectrophotometry (2.2.24).

Comparison: clenbuterol hydrochloride CRS.

B. Thin-layer chromatography (2.2.27).

Test solution. Dissolve 10 mg of the substance to be examined in 10 mL of methanol R.

Reference solution. Dissolve 10 mg of clenbuterol hydrochloride CRS in 10 mL of methanol R.

Plate: TLC silica gel  $F_{254}$  plate R.

Mobile phase: ammonia R, anhydrous ethanol R, toluene R (0.15:10:15 V/V/V).

Application: 10  $\mu$ L.

Development: over a path of 10 cm.

Drying: in air.

Detection: spray with a 10 g/L solution of sodium nitrite R in 1 M hydrochloric acid and dip after 10 min in a 4 g/L solution of naphthylethylenediamine dihydrochloride R in methanol R. Allow to dry in air.

Results: the principal spot in the chromatogram obtained with the test solution is similar in position, colour and size to the principal spot in the chromatogram obtained with the reference solution.

C. It gives reaction (a) of chlorides (2.3.1).

#### TESTS

**Solution S.** Dissolve 0.5 g in 10 mL of carbon dioxide-free water R.

**Appearance of solution.** Solution S is not more opalescent than reference suspension II (2.2.1) and not more intensely coloured than reference solution  $Y_6$  (2.2.2, Method II).

pH (2.2.3): 5.0 to 7.0 for solution S.

**Optical rotation** (2.2.7):  $-0.10^\circ$  to  $+0.10^\circ$ .

Dissolve 0.30 g in water R and dilute to 10.0 mL with the same solvent. Filter if necessary.

**Related substances.** Liquid chromatography (2.2.29).

Test solution. Disperse 100.0 mg of the substance to be examined in the mobile phase and dilute to 50.0 mL with the mobile phase.

Reference solution (a). Dilute 0.1 mL of the test solution to 100.0 mL with water R.

Reference solution (b). Dissolve 5 mg of clenbuterol impurity B CRS in 10 mL of the mobile phase, add 2.5 mL of the test solution and dilute to 25.0 mL with the mobile phase.

Column:

– size:  $l = 0.125$  m,  $\varnothing = 4$  mm,

– stationary phase: end-capped octadecylsilyl silica gel for chromatography R (5  $\mu$ m),

– temperature: 40 °C.

Mobile phase: mix 200 volumes of acetonitrile R, 200 volumes of methanol R and 600 volumes of a solution prepared as follows: dissolve 3.0 g of sodium decanesulfonate R and 5.0 g of potassium dihydrogen phosphate R in 900 mL of water R, adjust to pH 3.0 with dilute phosphoric acid R and dilute to 1000 mL with water R.

Flow rate: 0.5 mL/min.

Detection: spectrophotometer at 215 nm.

Injection: 5  $\mu$ L.

Run time: 1.5 times the retention time of clenbuterol.

Retention time: clenbuterol = about 29 min.

System suitability: reference solution (b):

– resolution: minimum 4.0 between the peaks due to impurity B and clenbuterol.

Limits:

– impurities A, B, C, D, E, F: for each impurity, not more than the area of the principal peak in the chromatogram obtained with reference solution (a) (0.1 per cent),

– any other impurity: for each impurity, not more than the area of the principal peak in the chromatogram obtained with reference solution (a) (0.1 per cent),

– total: not more than twice the area of the principal peak in the chromatogram obtained with reference solution (a) (0.2 per cent),

– disregard limit: 0.5 times the area of the principal peak in the chromatogram obtained with reference solution (a) (0.05 per cent).

**Water** (2.5.12): maximum 1.0 per cent, determined on 0.500 g.

**Sulfated ash** (2.4.14): maximum 0.1 per cent, determined on 1.0 g.

#### ASSAY

Dissolve 0.250 g in 50 mL of ethanol (96 per cent) R and add 5.0 mL of 0.01 M hydrochloric acid. Titrate with 0.1 M sodium hydroxide, determining the end-point potentiometrically (2.2.20). Read the volume added between the 2 points of inflexion.

1 mL of 0.1 M sodium hydroxide is equivalent to 31.37 mg of  $C_{12}H_{19}Cl_3N_2O$ .

#### IMPURITIES

Specified impurities: A, B, C, D, E, F.

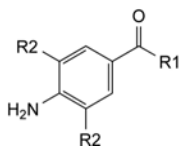

- A. R1 = H, R2 = Cl: 4-amino-3,5-dichlorobenzaldehyde,  
 B. R1 = CH<sub>2</sub>-NH-C(CH<sub>3</sub>)<sub>3</sub>, R2 = Cl: 1-(4-amino-3,5-dichlorophenyl)-2-[(1,1-dimethylethyl)amino]ethanone,  
 C. R1 = CH<sub>3</sub>, R2 = Cl: 1-(4-amino-3,5-dichlorophenyl)ethanone,  
 D. R1 = CH<sub>3</sub>, R2 = H: 1-(4-aminophenyl)ethanone,  
 E. R1 = CH<sub>2</sub>Br, R2 = Cl: 1-(4-amino-3,5-dichlorophenyl)-2-bromoethanone,

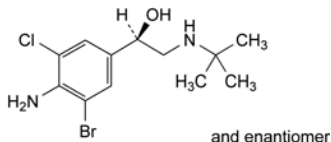

- F. (1*R*S)-1-(4-amino-3-bromo-5-chlorophenyl)-2-[(1,1-dimethylethyl)amino]ethanol.

01/2008:0582  
corrected 6.0

## CLINDAMYCIN HYDROCHLORIDE

### Clindamycini hydrochloridum

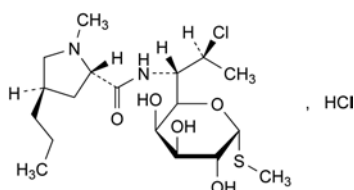

C<sub>18</sub>H<sub>34</sub>Cl<sub>2</sub>N<sub>2</sub>O<sub>5</sub>S  
[21462-39-5]

M<sub>r</sub> 461.5

#### DEFINITION

Methyl 7-chloro-6,7,8-trideoxy-6-[[[(2*S*,4*R*)-1-methyl-4-propylpyrrolidin-2-yl]carbonyl]amino]-1-thio-L-threo-α-D-galactopyranoside hydrochloride. It contains a variable quantity of water.

Semi-synthetic product derived from a fermentation product.

*Content*: 91.0 per cent to 102.0 per cent (anhydrous substance).

#### CHARACTERS

*Appearance*: white or almost white, crystalline powder.

*Solubility*: very soluble in water, slightly soluble in ethanol (96 per cent).

#### IDENTIFICATION

*First identification*: A, D.

*Second identification*: B, C, D.

A. Infrared absorption spectrophotometry (2.2.24).

*Comparison*: clindamycin hydrochloride CRS.

B. Thin-layer chromatography (2.2.27).

*Test solution*. Dissolve 10 mg of the substance to be examined in *methanol R* and dilute to 10 mL with the same solvent.

*Reference solution (a)*. Dissolve 10 mg of *clindamycin hydrochloride CRS* in *methanol R* and dilute to 10 mL with the same solvent.

*Reference solution (b)*. Dissolve 10 mg of *clindamycin hydrochloride CRS* and 10 mg of *lincomycin hydrochloride CRS* in *methanol R* and dilute to 10 mL with the same solvent.

*Plate*: TLC silica gel G plate R.

*Mobile phase*: mix 19 volumes of 2-propanol R, 38 volumes of a 150 g/L solution of *ammonium acetate R* adjusted to pH 9.6 with *ammonia R*, and 43 volumes of *ethyl acetate R*.

*Application*: 5 µL.

*Development*: over a path of 15 cm using the upper layer of the mobile phase.

*Drying*: in air.

*Detection*: spray with a 1 g/L solution of *potassium permanganate R*.

*System suitability*: the chromatogram obtained with reference solution (b) shows 2 clearly separated spots.

*Results*: the principal spot in the chromatogram obtained with the test solution is similar in position, colour and size to the principal spot in the chromatogram obtained with reference solution (a).

C. Dissolve about 10 mg in 2 mL of *dilute hydrochloric acid R* and heat on a water-bath for 3 min. Add 3 mL of *sodium carbonate solution R* and 1 mL of a 20 g/L solution of *sodium nitroprusside R*. A violet-red colour develops.

D. Dissolve 0.1 g in *water R* and dilute to 10 mL with the same solvent. The solution gives reaction (a) of chlorides (2.3.1).

#### TESTS

*pH* (2.2.3): 3.0 to 5.0.

Dissolve 1.0 g in *carbon dioxide-free water R* and dilute to 10 mL with the same solvent.

*Specific optical rotation* (2.2.7): + 135 to + 150 (anhydrous substance).

Dissolve 1.000 g in *water R* and dilute to 25.0 mL with the same solvent.

*Related substances*. Liquid chromatography (2.2.29).

*Test solution*. Dissolve 50.0 mg of the substance to be examined in the mobile phase and dilute to 50.0 mL with the mobile phase.

*Reference solution (a)*. Dissolve 50.0 mg of *clindamycin hydrochloride CRS* in the mobile phase and dilute to 50.0 mL with the mobile phase.

*Reference solution (b)*. Dilute 2.0 mL of the test solution to 100.0 mL with the mobile phase.

*Column*:

– *size*: *l* = 0.25 m,  $\varnothing$  = 4.6 mm,

– *stationary phase*: octadecylsilyl silica gel for chromatography R (5 µm).

*Mobile phase*: mix 45 volumes of *acetonitrile R* and 55 volumes of a 6.8 g/L solution of *potassium dihydrogen phosphate R* adjusted to pH 7.5 with a 250 g/L solution of *potassium hydroxide R*.

*Flow rate*: 1 mL/min.

*Detection*: spectrophotometer at 210 nm.

*Injection*: 20 µL.

*Run time*: twice the retention time of clindamycin.

*System suitability*: reference solution (a):

– *relative retention* with reference to clindamycin (retention time = about 10 min): impurity A = about 0.4; impurity B = about 0.65; impurity C = about 0.8.

*Limits*:

– *impurity B*: not more than the area of the principal peak in the chromatogram obtained with reference solution (b) (2.0 per cent),

– *impurity C*: not more than twice the area of the principal peak in the chromatogram obtained with reference solution (b) (4.0 per cent),

– *any other impurity*: not more than 0.5 times the area of the principal peak in the chromatogram obtained with reference solution (b) (1.0 per cent),



- *total*: not more than 3 times the area of the principal peak in the chromatogram obtained with reference solution (b) (6.0 per cent),
- *disregard limit*: 0.025 times the area of the principal peak in the chromatogram obtained with reference solution (b) (0.05 per cent).

**Water** (2.5.12): 3.0 per cent to 6.0 per cent, determined on 0.500 g.

**Sulfated ash** (2.4.14): maximum 0.5 per cent, determined on 1.0 g.

#### ASSAY

Liquid chromatography (2.2.29) as described in the test for related substances with the following modifications.

**Injection**: 20 µL of the test solution and reference solution (a).

**System suitability**:

- *repeatability*: maximum relative standard deviation of 0.85 per cent after 6 injections of reference solution (a).

#### STORAGE

In an airtight container.

#### IMPURITIES

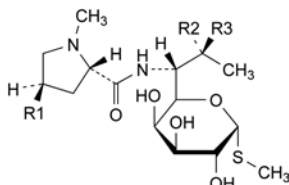

- A. R1 = CH<sub>2</sub>-CH<sub>2</sub>-CH<sub>3</sub>, R2 = OH, R3 = H: methyl 6,8-dideoxy-6-[[[(2*S*,4*R*)-1-methyl-4-propylpyrrolidin-2-yl]carbonyl]amino]-1-thio-*D*-erythro- $\alpha$ -*D*-galacto-octopyranoside (lincomycin),
- B. R1 = C<sub>2</sub>H<sub>5</sub>, R2 = H, R3 = Cl: methyl 7-chloro-6,7,8-trideoxy-6-[[[(2*S*,4*R*)-4-ethyl-1-methylpyrrolidin-2-yl]carbonyl]amino]-1-thio-*L*-threo- $\alpha$ -*D*-galacto-octopyranoside (clindamycin B),
- C. R1 = CH<sub>2</sub>-CH<sub>2</sub>-CH<sub>3</sub>, R2 = Cl, R3 = H: methyl 7-chloro-6,7,8-trideoxy-6-[[[(2*S*,4*R*)-1-methyl-4-propylpyrrolidin-2-yl]carbonyl]amino]-1-thio-*D*-erythro- $\alpha$ -*D*-galacto-octopyranoside (7-epiclindamycin).

01/2008:0996  
corrected 6.0

## CLINDAMYCIN PHOSPHATE

### Clindamycini phosphas

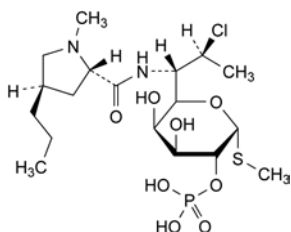

C<sub>18</sub>H<sub>34</sub>ClN<sub>2</sub>O<sub>8</sub>PS  
[24729-96-2]

*M<sub>r</sub>* 505.0

#### DEFINITION

Methyl 7-chloro-6,7,8-trideoxy-6-[[[(2*S*,4*R*)-1-methyl-4-propylpyrrolidin-2-yl]carbonyl]amino]-1-thio-*L*-threo- $\alpha$ -*D*-galacto-octopyranoside 2-(dihydrogen phosphate).

Semi-synthetic product derived from a fermentation product.

**Content**: 95.0 per cent to 102.0 per cent (anhydrous substance).

#### CHARACTERS

**Appearance**: white or almost white, slightly hygroscopic powder.

**Solubility**: freely soluble in water, very slightly soluble in ethanol (96 per cent), practically insoluble in methylene chloride.

It shows polymorphism (5.9).

#### IDENTIFICATION

**First identification**: A, D.

**Second identification**: B, C, D.

A. Infrared absorption spectrophotometry (2.2.24).

**Preparation**: discs of potassium bromide *R*.

In 2 separate tubes place 50 mg of the substance to be examined and 50 mg of *clindamycin phosphate CRS*. Add 0.2 mL of *water R* and heat until completely dissolved. Evaporate to dryness under reduced pressure and dry the residues at 100-105 °C for 2 h.

**Comparison**: *clindamycin phosphate CRS*.

B. Thin-layer chromatography (2.2.27).

**Test solution**. Dissolve 20 mg of the substance to be examined in *methanol R* and dilute to 10 mL with the same solvent.

**Reference solution (a)**. Dissolve 20 mg of *clindamycin phosphate CRS* in *methanol R* and dilute to 10 mL with the same solvent.

**Reference solution (b)**. Dissolve 10 mg of *lincomycin hydrochloride CRS* in 5 mL of reference solution (a).

**Plate**: TLC silica gel plate *R*.

**Mobile phase**: glacial acetic acid *R*, *water R*, *butanol R* (20:20:60 *V/V/V*).

**Application**: 5 µL.

**Development**: over a path of 12 cm.

**Drying**: at 100-105 °C for 30 min.

**Detection**: spray with a 1 g/L solution of *potassium permanganate R*.

**System suitability**: reference solution (b):

- the chromatogram shows 2 principal spots.

**Results**: the principal spot in the chromatogram obtained with the test solution is similar in position, colour and size to the principal spot in the chromatogram obtained with reference solution (a).

C. Dissolve about 10 mg in 2 mL of *dilute hydrochloric acid R* and heat in a water-bath for 3 min. Add 4 mL of *sodium carbonate solution R* and 1 mL of a 20 g/L solution of *sodium nitroprusside R*. Prepare a standard in the same manner using *clindamycin phosphate CRS*. The colour of the test solution corresponds to that of the standard.

D. Boil 0.1 g under a reflux condenser with a mixture of 5 mL of *strong sodium hydroxide solution R* and 5 mL of *water R* for 90 min. Cool and add 5 mL of *nitric acid R*. Extract with 3 quantities, each of 15 mL, of *methylene chloride R* and discard the extracts. Filter the upper layer through a paper filter. The filtrate gives reaction (b) of phosphates (2.3.1).

#### TESTS

**Solution S**. Dissolve 1.00 g in *carbon dioxide-free water R*. Heat gently if necessary. Cool and dilute to 25.0 mL with *carbon dioxide-free water R*.

**Appearance of the solution**. Solution S is clear (2.2.1) and colourless (2.2.2, *Method II*).

**pH** (2.2.3): 3.5 to 4.5.

Dilute 5.0 mL of solution S to 20 mL with *carbon dioxide-free water R*.

**Specific optical rotation** (2.2.7): + 115 to + 130 (anhydrous substance).

Dissolve 0.250 g in *water R* and dilute to 25.0 mL with the same solvent.

**Related substances.** Liquid chromatography (2.2.29).

**Test solution.** Dissolve 75.0 mg of the substance to be examined in the mobile phase and dilute to 25.0 mL with the mobile phase.

**Reference solution (a).** Dissolve 75.0 mg of *clindamycin phosphate CRS* in the mobile phase and dilute to 25.0 mL with the mobile phase.

**Reference solution (b).** Dissolve 5.0 mg of *lincomycin hydrochloride CRS* (impurity A) and 15.0 mg of *clindamycin hydrochloride CRS* (impurity E) in 5.0 mL of reference solution (a), then dilute to 100.0 mL with the mobile phase.

**Reference solution (c).** Dilute 1.0 mL of reference solution (a) to 100.0 mL with the mobile phase.

**Column:**

- size:  $l = 0.25$  m,  $\varnothing = 4.6$  mm;
- stationary phase: *octylsilyl silica gel for chromatography R* (5–10  $\mu$ m).

**Mobile phase:** mix 200 mL of *acetonitrile R1* and 800 mL of a 13.6 g/L solution of *potassium dihydrogen phosphate R* previously adjusted to pH 2.5 with *phosphoric acid R*.

**Flow rate:** 1.0 mL/min.

**Detection:** spectrophotometer at 210 nm.

**Injection:** 20  $\mu$ L of the test solution and reference solutions (b) and (c).

**Run time:** the retention time of impurity E.

**System suitability:** reference solution (b):

- **resolution:** minimum 6.0 between the peaks due to clindamycin phosphate (2<sup>nd</sup> peak) and impurity E (3<sup>rd</sup> peak); if necessary, adjust the concentration of acetonitrile in the mobile phase;
- **symmetry factor:** maximum 1.5 for the peak due to clindamycin phosphate;
- the peak due to impurity A (1<sup>st</sup> peak) is clearly separated from the peak due to the solvent.

**Limits:**

- **any impurity:** for each impurity, not more than 2.5 times the area of the peak due to clindamycin phosphate in the chromatogram obtained with reference solution (c) (2.5 per cent);
- **total:** not more than 4 times the area of the peak due to clindamycin phosphate in the chromatogram obtained with reference solution (c) (4.0 per cent);
- **disregard limit:** 0.1 times the area of the principal peak in the chromatogram obtained with reference solution (c) (0.1 per cent).

**Water (2.5.12):** maximum 6.0 per cent, determined on 0.250 g.

**Bacterial endotoxins (2.6.14):** less than 0.6 IU/mg, if intended for use in the manufacture of parenteral preparations without a further appropriate procedure for removal of bacterial endotoxins.

#### ASSAY

Liquid chromatography (2.2.29) as described in the test for related substances with the following modifications.

**Injection:** the test solution and reference solution (a).

**System suitability:** reference solution (a):

- **repeatability:** maximum relative standard deviation of 1.0 per cent after 6 injections; if necessary, adjust the integrator parameters.

Calculate the percentage content of  $C_{18}H_{34}ClN_2O_8PS$  from the declared content of *clindamycin phosphate CRS*.

#### STORAGE

In an airtight container, at a temperature not exceeding 30 °C. If the substance is sterile, store in a sterile, airtight, tamper-proof container.

#### IMPURITIES

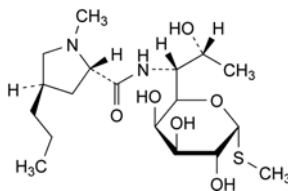

A. methyl 6,8-dideoxy-6-[[[(2*S*,4*R*)-1-methyl-4-propylpyrrolidin-2-yl]carbonyl]amino]-1-thio-D-erythro- $\alpha$ -D-galactooctopyranoside (lincomycin),

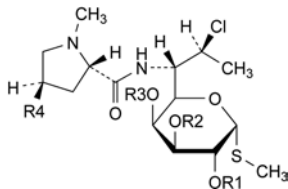

- B. R1 = PO<sub>3</sub>H<sub>2</sub>, R2 = R3 = H, R4 = C<sub>2</sub>H<sub>5</sub>: clindamycin B 2-(dihydrogen phosphate),
- C. R1 = R3 = H, R2 = PO<sub>3</sub>H<sub>2</sub>, R4 = C<sub>3</sub>H<sub>7</sub>: clindamycin 3-(dihydrogen phosphate),
- D. R1 = R2 = H, R3 = PO<sub>3</sub>H<sub>2</sub>, R4 = C<sub>3</sub>H<sub>7</sub>: clindamycin 4-(dihydrogen phosphate),
- E. R1 = R2 = R3 = H, R4 = C<sub>3</sub>H<sub>7</sub>: clindamycin.

01/2008:2111

## CLIOQUINOL

### Clioquinolum

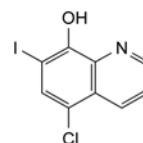

$C_9H_5ClINO$   
[130-26-7]

$M_r$  305.5

#### DEFINITION

5-Chloro-7-iodoquinolin-8-ol.

**Content:** 98.0 per cent to 102.0 per cent (dried substance).

#### CHARACTERS

**Appearance:** almost white, light yellow, brownish-yellow or yellowish-grey powder.

**Solubility:** practically insoluble in water, sparingly soluble in methylene chloride, very slightly soluble or slightly soluble in ethanol (96 per cent).

#### IDENTIFICATION

**First identification:** B.

**Second identification:** A, C, D.

A. Dissolve 40.0 mg in *methanol R* and dilute to 100.0 mL with the same solvent. Dilute 10.0 mL to 100.0 mL with *methanol R* (solution A). Examined between 280 nm and 350 nm (2.2.25), solution A shows an absorption maximum at 321 nm. Dilute 10.0 mL of solution A to 100.0 mL with *methanol R* (solution B). Examined between 230 nm and 280 nm, solution B shows an absorption maximum at 255 nm. The specific absorbance at this absorption maximum is 1530 to 1660.

B. Infrared absorption spectrophotometry (2.2.24).

**Preparation:** discs of *potassium bromide R*.

**Comparison:** *clioquinol CRS*.

C. When heated, violet fumes are produced.

D. Dissolve about 1 mg in 5 mL of *ethanol (96 per cent) R*. Add 0.05 mL of *ferric chloride solution R1*. A dark green colour develops.

## TESTS

**Acidity or alkalinity.** Shake 0.5 g with 10 mL of *carbon dioxide-free water R* and filter. To the filtrate add 0.2 mL of *phenolphthalein solution R*. The solution is colourless. Not more than 0.5 mL of 0.01 M *sodium hydroxide* is required to change the colour of the indicator to pink.

**Related substances.** Liquid chromatography (2.2.29).

**Test solution.** Dissolve 50.0 mg of the substance to be examined in *methanol R* and dilute to 50.0 mL with the same solvent, heating gently if necessary. Dilute 10.0 mL of the solution to 25.0 mL with the mobile phase.

**Reference solution (a).** Dissolve 20.0 mg of *5-chloroquinolin-8-ol R*, 10.0 mg of *5,7-dichloroquinolin-8-ol R*, 5 mg of the substance to be examined and 10.0 mg of *5,7-diidoquinolin-8-ol R* in *methanol R*, heating gently if necessary and dilute to 20.0 mL with the same solvent. Dilute 4.0 mL of the solution to 50.0 mL with the mobile phase.

**Reference solution (b).** Dilute 1.0 mL of reference solution (a) to 10.0 mL with the mobile phase.

**Reference solution (c).** Dilute 1.0 mL of the test solution to 100.0 mL with the mobile phase. Dilute 1.0 mL of this solution to 20.0 mL with the mobile phase.

**Column:**

- size:  $l = 0.15$  m,  $\varnothing = 3.9$  mm,
- stationary phase: *octylsilyl silica gel for chromatography R* (5  $\mu$ m).

**Mobile phase:** dissolve 0.50 g of *sodium edetate R* in 350 mL of *water R*, add 4.0 mL of *hexylamine R* and mix. Adjust to pH 3.0 with *phosphoric acid R*. Add 600 mL of *methanol R* and dilute to 1000 mL with *water R*.

**Flow rate:** 1.3 mL/min.

**Detection:** spectrophotometer at 254 nm.

**Injection:** 20  $\mu$ L.

**Run time:** 4 times the retention time of clobazam.

**Relative retention** with reference to clobazam (retention time = about 10 min): impurity A = about 0.4; impurity B = about 0.7; impurity C = about 1.3.

**System suitability:** reference solution (a):

- resolution: minimum 3.0 between the peaks due to clobazam and impurity C.

**Limits:**

- **impurity A:** not more than the area of the corresponding peak in the chromatogram obtained with reference solution (b) (2.0 per cent),
- **impurity B:** not more than the area of the corresponding peak in the chromatogram obtained with reference solution (b) (1.0 per cent),
- **impurity C:** not more than the area of the corresponding peak in the chromatogram obtained with reference solution (b) (1.0 per cent),
- **unspecified impurities:** for each impurity, not more than twice the area of the principal peak in the chromatogram obtained with reference solution (c) (0.10 per cent),
- **total of the nominal contents of impurities A, B, C and unspecified impurities:** maximum 3.0 per cent,
- **disregard limit:** the area of the principal peak in the chromatogram obtained with reference solution (c) (0.05 per cent).

**Halides:** maximum 140 ppm, expressed as chlorides.

Shake 0.5 g with 25 mL of *water R* for 1 min and filter. To the filtrate add 0.5 mL of *dilute nitric acid R* and 0.5 mL of *silver nitrate solution R2*. Allow to stand for 5 min. Any opalescence is not more intense than that in a standard prepared at the same time by adding 0.5 mL of *silver nitrate solution R2* to 25 mL

of *water R* containing 0.2 mL of 0.01 M *hydrochloric acid* and 0.5 mL of *dilute nitric acid R*.

**Loss on drying (2.2.32):** maximum 0.5 per cent, determined on 1.000 g by drying over *diphosphorus pentoxide R* at a pressure not exceeding 0.7 kPa for 24 h.

**Sulfated ash (2.4.14):** maximum 0.1 per cent, determined on 1.0 g.

## ASSAY

Dissolve 0.200 g in 20 mL of *acetic anhydride R* and add 30 mL of *glacial acetic acid R*. Titrate with 0.1 M *perchloric acid*, determining the end-point potentiometrically (2.2.20).

1 mL of 0.1 M *perchloric acid* is equivalent to 30.55 mg of total quinolines, calculated as clobazam.

## STORAGE

Protected from light.

## IMPURITIES

**Specified impurities:** A, B, C.

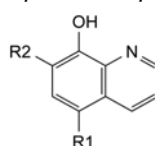

- A. R1 = Cl, R2 = H: 5-chloroquinolin-8-ol,
- B. R1 = R2 = Cl: 5,7-dichloroquinolin-8-ol,
- C. R1 = R2 = I: 5,7-diidoquinolin-8-ol.

01/2008:1974  
corrected 6.0

## CLOBAZAM

## Clobazamum

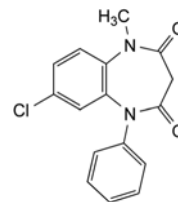

$C_{16}H_{13}ClN_2O_2$   
[22316-47-8]

$M_r$  300.7

## DEFINITION

7-Chloro-1-methyl-5-phenyl-1,5-dihydro-3H-1,5-benzodiazepine-2,4-dione.

**Content:** 97.0 per cent to 103.0 per cent (dried substance).

## CHARACTERS

**Appearance:** white or almost white, crystalline powder.

**Solubility:** slightly soluble in water, freely soluble in methylene chloride, sparingly soluble in alcohol.

## IDENTIFICATION

Infrared absorption spectrophotometry (2.2.24).

**Comparison:** *Ph. Eur. reference spectrum of clobazam.*

## TESTS

**Related substances.** Liquid chromatography (2.2.29).

**Test solution.** Dissolve 10.0 mg of the substance to be examined in the mobile phase and dilute to 50.0 mL with the mobile phase.

**Reference solution (a).** Dissolve 5.0 mg of *clobazam impurity A CRS* in the mobile phase and dilute to 50.0 mL with the mobile phase. Dilute 1.0 mL of the solution to 100.0 mL with the mobile phase.

**Reference solution (b).** Dissolve 5 mg of *chlordiazepoxide CRS* and 5 mg of *clonazepam CRS* in the mobile phase and dilute to 50 mL with the mobile phase. Dilute 1 mL of the solution to 100 mL with the mobile phase.

**Reference solution (c).** Dilute 1.0 mL of the test solution to 200.0 mL with the mobile phase.

**Column:**

- size:  $l = 0.25$  m,  $\varnothing = 4.6$  mm,
  - stationary phase: octadecylsilyl silica gel for chromatography R (5  $\mu$ m).
- Mobile phase: acetonitrile R, water R (40:60 V/V).

Flow rate: 1 mL/min.

Detection: spectrophotometer at 230 nm.

Injection: 20  $\mu$ L.

Run time: 5 times the retention time of clobazam.

Retention time: clobazam = about 15 min.

System suitability: reference solution (b):

- resolution: minimum 1.3 between the peaks due to chlordiazepoxide and clonazepam.

Limits:

- impurity A: not more than the area of the principal peak in the chromatogram obtained with reference solution (a) (0.5 per cent),
- any other impurity: not more than 0.4 times the area of the principal peak in the chromatogram obtained with reference solution (c) (0.2 per cent),
- total of other impurities: not more than twice the area of the principal peak in the chromatogram obtained with reference solution (c) (1.0 per cent),
- disregard limit: 0.1 times the area of the principal peak in the chromatogram obtained with reference solution (c) (0.05 per cent).

**Loss on drying (2.2.32):** maximum 0.5 per cent, determined on 1.000 g by drying in an oven at 105 °C.

**Sulfated ash (2.4.14):** maximum 0.1 per cent, determined on the residue obtained in the test for loss on drying.

#### ASSAY

Dissolve 50.0 mg in *alcohol R* and dilute to 100.0 mL with the same solvent. Dilute 2.0 mL of the solution to 250.0 mL with *alcohol R*. Measure the absorbance (2.2.25) at the maximum at 232 nm.

Calculate the content of  $C_{16}H_{13}ClN_2O_2$  taking the specific absorbance to be 1380.

#### IMPURITIES

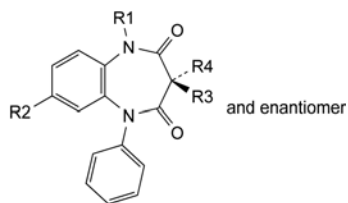

- A. R1 = R3 = R4 = H, R2 = Cl: 7-chloro-5-phenyl-1,5-dihydro-3H-1,5-benzodiazepine-2,4-dione,
- B. R1 = CH<sub>3</sub>, R2 = R3 = R4 = H: 1-methyl-5-phenyl-1,5-dihydro-3H-1,5-benzodiazepine-2,4-dione,
- C. R1 = R3 = CH<sub>3</sub>, R2 = Cl, R4 = H: (3*RS*)-7-chloro-1,3-dimethyl-5-phenyl-1,5-dihydro-3H-1,5-benzodiazepine-2,4-dione,
- D. R1 = R3 = R4 = CH<sub>3</sub>, R2 = Cl: 7-chloro-1,3,3-trimethyl-5-phenyl-1,5-dihydro-3H-1,5-benzodiazepine-2,4-dione,

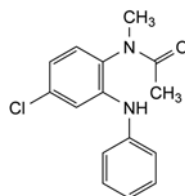

E. *N*-[4-chloro-2-(phenylamino)phenyl]-*N*-methylacetamide,

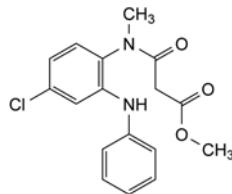

F. methyl 3-[[4-chloro-2-(phenylamino)phenyl]methylamino]-3-oxopropanoate.

01/2008:2127  
corrected 6.0

## CLOBETASOL PROPIONATE

### Clobetasoli propionas

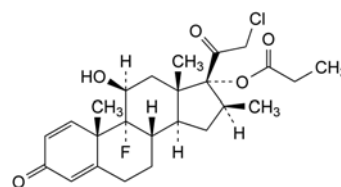

$C_{25}H_{32}ClFO_5$   
[25122-46-7]

$M_r$  467.0

#### DEFINITION

21-Chloro-9-fluoro-11 $\beta$ -hydroxy-16 $\beta$ -methyl-3,20-dioxopregna-1,4-dien-17-yl propanoate.

**Content:** 97.0 per cent to 102.0 per cent (dried substance).

#### CHARACTERS

**Appearance:** white or almost white, crystalline powder.

**Solubility:** practically insoluble in water, freely soluble in acetone, sparingly soluble in ethanol (96 per cent).

#### IDENTIFICATION

Infrared absorption spectrophotometry (2.2.24).

**Comparison:** *clobetasol propionate CRS*.

#### TESTS

**Specific optical rotation (2.2.7):** + 112 to + 118 (dried substance).

Dissolve 0.500 g in *acetone R* and dilute to 50.0 mL with the same solvent.

**Related substances.** Liquid chromatography (2.2.29).

**Test solution (a).** Dissolve 20.0 mg of the substance to be examined in the mobile phase and dilute to 20.0 mL with the mobile phase.

**Test solution (b).** Dissolve 20.0 mg of the substance to be examined in the mobile phase and dilute to 100.0 mL with the mobile phase.

**Reference solution (a).** Dissolve 20.0 mg of *clobetasol propionate CRS* in the mobile phase and dilute to 100.0 mL with the mobile phase.

**Reference solution (b).** Dissolve the contents of a vial of *clobetasol impurity J CRS* in 2.0 mL of the mobile phase. To 0.5 mL of this solution add 0.5 mL of test solution (b) and dilute to 20.0 mL with the mobile phase.

**Reference solution (c).** Dissolve the contents of a vial of *clobetasol for peak identification CRS* (containing impurities A, B, C, D, E, L and M) in 2 mL of the mobile phase.

**Reference solution (d).** Dilute 1.0 mL of test solution (a) to 50.0 mL with the mobile phase. Dilute 5.0 mL of this solution to 20.0 mL with the mobile phase.

**Column:**

- **size:**  $l = 0.15$  m,  $\varnothing = 4.6$  mm;
- **stationary phase:** spherical octadecylsilyl silica gel for chromatography R (5  $\mu$ m);
- **temperature:** 30 °C.

**Mobile phase:** mix 10 volumes of *methanol R*, 42.5 volumes of a 7.85 g/L solution of *sodium dihydrogen phosphate monohydrate R* adjusted to pH 5.5 with a 100 g/L solution of *sodium hydroxide R* and 47.5 volumes of *acetonitrile R*.

**Flow rate:** 1.0 mL/min.

**Detection:** spectrophotometer at 240 nm.

**Injection:** 10  $\mu$ L of test solution (a) and reference solutions (b), (c) and (d).

**Run time:** 3 times the retention time of clobetasol propionate.

**Identification of impurities:** use the chromatogram supplied with *clobetasol for peak identification CRS* and the chromatogram obtained with reference solution (c) to identify the peaks due to impurities A, B, C, D, E, L and M.

**Relative retention** with reference to clobetasol propionate (retention time = about 10 min): impurity A = about 0.4; impurity B = about 0.6; impurity C = about 0.9; impurity J = about 1.1; impurity D = about 1.2; impurity L = about 1.3; impurity M = about 1.6; impurity E = about 2.1.

**System suitability:**

- **resolution:** minimum 2.0 between the peaks due to clobetasol propionate and impurity J in the chromatogram obtained with reference solution (b);
- the chromatogram obtained with reference solution (c) is similar to the chromatogram supplied with *clobetasol for peak identification CRS*.

**Limits:**

- **correction factors:** for the calculation of content, multiply the peak areas of the following impurities by the corresponding correction factor: impurity B = 0.6; impurity C = 1.5;
- **impurity E:** not more than 1.4 times the area of the principal peak in the chromatogram obtained with reference solution (d) (0.7 per cent);
- **impurity D:** not more than the area of the principal peak in the chromatogram obtained with reference solution (d) (0.5 per cent);
- **impurities B, C:** for each impurity, not more than 0.6 times the area of the principal peak in the chromatogram obtained with reference solution (d) (0.3 per cent);
- **impurities A, L, M:** for each impurity, not more than 0.4 times the area of the principal peak in the chromatogram obtained with reference solution (d) (0.2 per cent);
- **unspecified impurities:** for each impurity, not more than 0.2 times the area of the principal peak in the chromatogram obtained with reference solution (d) (0.10 per cent);
- **total:** not more than 4 times the area of the principal peak in the chromatogram obtained with reference solution (d) (2.0 per cent);
- **disregard limit:** 0.1 times the area of the principal peak in the chromatogram obtained with reference solution (d) (0.05 per cent).

**Loss on drying (2.2.32):** maximum 0.5 per cent, determined on 1.000 g by drying in an oven at 105 °C for 3 h.

**Sulfated ash (2.4.14):** maximum 0.1 per cent, determined on 1.0 g.

**ASSAY**

Liquid chromatography (2.2.29) as described in the test for related substances with the following modification.

**Injection:** test solution (b) and reference solution (a).

Calculate the percentage content of  $C_{25}H_{32}ClFO_5$  using the chromatogram obtained with reference solution (a) and the declared content of *clobetasol propionate CRS*.

**STORAGE**

Protected from light.

**IMPURITIES**

**Specified impurities:** A, B, C, D, E, L, M.

**Other detectable impurities** (the following substances would, if present at a sufficient level, be detected by one or other of the tests in the monograph. They are limited by the general acceptance criterion for other/unspecified impurities and/or by the general monograph *Substances for pharmaceutical use (2034)*. It is therefore not necessary to identify these impurities for demonstration of compliance. See also 5.10. *Control of impurities in substances for pharmaceutical use*): F, G, H, I, J, K.

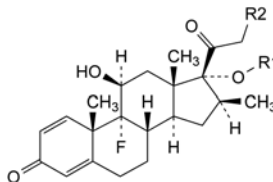

- A. R1 =  $CO-C_2H_5$ , R2 = OH: 9-fluoro-11 $\beta$ ,21-dihydroxy-16 $\beta$ -methyl-3,20-dioxopregna-1,4-dien-17-yl propanoate (betamethasone 17-propionate),
- G. R1 = H, R2 = Cl: 21-chloro-9-fluoro-11 $\beta$ ,17-dihydroxy-16 $\beta$ -methylpregna-1,4-diene-3,20-dione (clobetasol),
- H. R1 =  $CO-C_2H_5$ , R2 = H: 9-fluoro-11 $\beta$ -hydroxy-16 $\beta$ -methyl-3,20-dioxopregna-1,4-dien-17-yl propanoate,
- I. R1 =  $CO-C_2H_5$ , R2 =  $O-SO_2-CH_3$ : 9-fluoro-11 $\beta$ -hydroxy-16 $\beta$ -methyl-21-[(methylsulfonyl)oxy]-3,20-dioxopregna-1,4-dien-17-yl propanoate,
- K. R1 = H, R2 =  $O-CO-C_2H_5$ : 9-fluoro-11 $\beta$ ,17-dihydroxy-16 $\beta$ -methyl-3,20-dioxopregna-1,4-dien-21-yl propanoate (betamethasone 21-propionate),

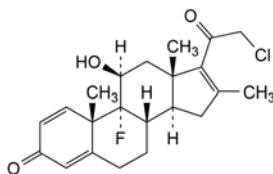

- B. 21-chloro-9-fluoro-11 $\beta$ -hydroxy-16-methylpregna-1,4,16-triene-3,20-dione,

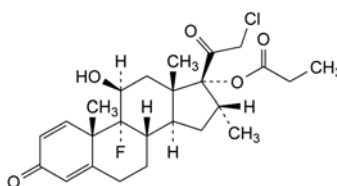

- C. 21-chloro-9-fluoro-11 $\beta$ -hydroxy-16 $\alpha$ -methyl-3,20-dioxopregna-1,4-dien-17-yl propanoate,

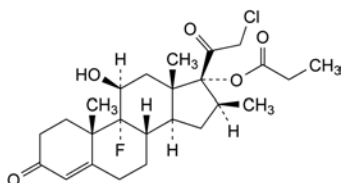

D. 21-chloro-9-fluoro-11 $\beta$ -hydroxy-16 $\beta$ -methyl-3,20-dioxopregna-4-en-17-yl propanoate (1,2-dihydroclobetasol 17-propionate),

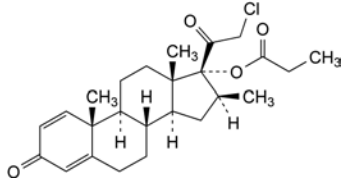

E. 21-chloro-16 $\beta$ -methyl-3,20-dioxopregna-1,4-dien-17-yl propanoate,

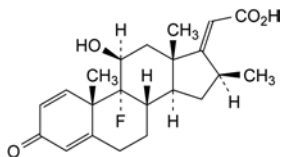

F. 9-fluoro-11 $\beta$ -hydroxy-16 $\beta$ -methyl-3-oxopregna-1,4,17(20)-trien-21-oic acid,

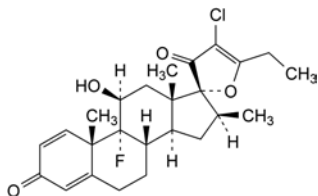

J. (17*R*)-4'-chloro-5'-ethyl-9-fluoro-11 $\beta$ -hydroxy-16 $\beta$ -methylspiro[androst-1,4-diene-17,2'(3'*H*)-furan]-3,3'-dione (17 $\alpha$ -spiro compound),

L. unknown structure,

M. unknown structure.

01/2010:1090  
corrected 6.7

## CLOBETASONE BUTYRATE

### Clobetasoni butyras

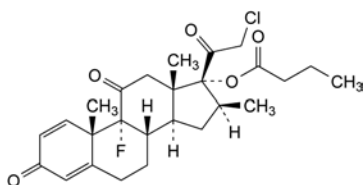

$C_{26}H_{32}ClFO_5$   
[25122-57-0]

$M_r$  479.0

#### DEFINITION

21-Chloro-9-fluoro-16 $\beta$ -methyl-3,11,20-trioxopregna-1,4-dien-17-yl butanoate.

*Content*: 97.0 per cent to 102.0 per cent (dried substance).

#### CHARACTERS

*Appearance*: white or almost white powder.

*Solubility*: practically insoluble in water, freely soluble in acetone and in methylene chloride, slightly soluble in ethanol (96 per cent).

mp: about 178 °C.

#### IDENTIFICATION

Infrared absorption spectrophotometry (2.2.24).

*Comparison*: clobetasone butyrate CRS.

#### TESTS

**Specific optical rotation** (2.2.7): + 131 to + 138 (dried substance).

Dissolve 0.250 g in *ethanol R1* and dilute to 25.0 mL with the same solvent.

**Related substances**. Liquid chromatography (2.2.29). Prepare the solutions immediately before use.

*Solvent mixture*: anhydrous formic acid R, acetonitrile R, water R (0.1:43:57 V/V/V).

*Test solution*. Dissolve 65 mg of the substance to be examined in 5.0 mL of acetonitrile R and dilute to 25.0 mL with the solvent mixture.

*Reference solution (a)*. Dissolve 13 mg of clobetasone butyrate for system suitability CRS (containing impurity F) in 1 mL of acetonitrile R and dilute to 5.0 mL with the solvent mixture.

*Reference solution (b)*. Dilute 1.0 mL of the test solution to 100.0 mL with the solvent mixture. Dilute 1.0 mL of this solution to 10.0 mL with the solvent mixture.

#### Column:

– size:  $l = 0.15$  m,  $\varnothing = 4.6$  mm;

– stationary phase: end-capped octadecylsilyl silica gel for chromatography R (3.5  $\mu$ m);

– temperature: 40 °C.

#### Mobile phase:

– mobile phase A: anhydrous formic acid R, water R (0.1:99.9 V/V);

– mobile phase B: anhydrous formic acid R, acetonitrile R (0.1:99.9 V/V);

Time (min)	Mobile phase A (per cent V/V)	Mobile phase B (per cent V/V)
0 - 3	57	43
3 - 26	57 $\rightarrow$ 43	43 $\rightarrow$ 57

*Flow rate*: 1.5 mL/min.

*Detection*: spectrophotometer at 241 nm.

*Injection*: 10  $\mu$ L.

*Identification of impurities*: use the chromatogram supplied with clobetasone butyrate for system suitability CRS and the chromatogram obtained with reference solution (a) to identify the peak due to impurity F.

*Relative retention* with reference to clobetasone butyrate (retention time = about 14 min): impurity F = about 0.9.

#### System suitability:

– resolution: minimum 3.5 between the peaks due to impurity F and clobetasone butyrate in the chromatogram obtained with reference solution (a);

– signal-to-noise ratio: minimum 10 for the principal peak in the chromatogram obtained with reference solution (b).

#### Limits:

– unspecified impurities: for each impurity, not more than the area of the principal peak in the chromatogram obtained with reference solution (b) (0.10 per cent);

– total: not more than 5 times the area of the principal peak in the chromatogram obtained with reference solution (b) (0.5 per cent);

– disregard limit: 0.5 times the area of the principal peak in the chromatogram obtained with reference solution (b) (0.05 per cent).

**Loss on drying** (2.2.32): maximum 0.5 per cent, determined on 1.000 g by drying in an oven at 105 °C.

## ASSAY

Dissolve 20.0 mg in *ethanol* (96 per cent) *R* and dilute to 100.0 mL with the same solvent. Dilute 5.0 mL of the solution to 50.0 mL with *ethanol* (96 per cent) *R*. Measure the absorbance (2.2.25) at the absorption maximum at 235 nm.

Calculate the content of  $C_{26}H_{32}ClFO_5$ , taking the specific absorbance to be 327.

## STORAGE

Protected from light.

## IMPURITIES

*Other detectable impurities* (the following substances would, if present at a sufficient level, be detected by one or other of the tests in the monograph. They are limited by the general acceptance criterion for other/unspecified impurities and/or by the general monograph *Substances for pharmaceutical use* (2034). It is therefore not necessary to identify these impurities for demonstration of compliance. See also 5.10. *Control of impurities in substances for pharmaceutical use*): A, C, D, E, F, G, H, I.

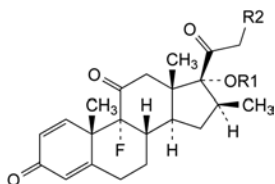

- A. R1 = H, R2 = Cl: 21-chloro-9-fluoro-17-hydroxy-16 $\beta$ -methylpregna-1,4-diene-3,11,20-trione (clobetasone),
- G. R1 = CO-CH<sub>2</sub>-CH<sub>2</sub>-CH<sub>3</sub>, R2 = O-CO-CH<sub>2</sub>-CH<sub>3</sub>: 9-fluoro-16 $\beta$ -methyl-3,11,20-trioxo-21-(propanoyloxy)pregna-1,4-dien-17-yl butanoate,
- H. R1 = CO-CH<sub>2</sub>-CH<sub>2</sub>, R2 = Cl: 21-chloro-9-fluoro-16 $\beta$ -methyl-3,11,20-trioxopregna-1,4-dien-17-yl propanoate (17-*O*-propionyl clobetasone),
- I. R1 = CO-CH(CH<sub>3</sub>)<sub>2</sub>, R2 = Cl: 21-chloro-9-fluoro-16 $\beta$ -methyl-3,11,20-trioxopregna-1,4-dien-17-yl 2-methylpropanoate (17-*O*-isobutyryl clobetasone),

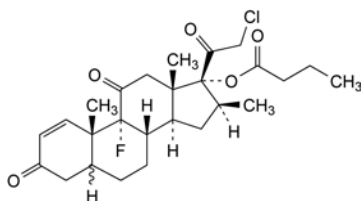

- C. 21-chloro-9-fluoro-16 $\beta$ -methyl-3,11,20-trioxopregn-1-en-17-yl butanoate (4,5-dihydroclobetasone butyrate),

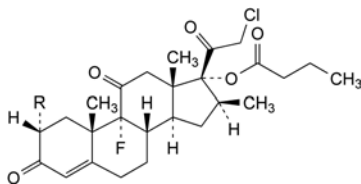

- D. R = Br: 2 $\alpha$ -bromo-21-chloro-9-fluoro-16 $\beta$ -methyl-3,11,20-trioxopregn-1-en-17-yl butanoate (2-bromoclobetasone butyrate),
- E. R = H: 21-chloro-9-fluoro-16 $\beta$ -methyl-3,11,20-trioxopregn-4-en-17-yl butanoate (1,2-dihydroclobetasone butyrate),

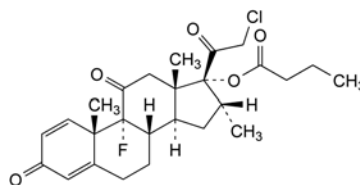

- F. 21-chloro-9-fluoro-16 $\alpha$ -methyl-3,11,20-trioxopregna-1,4-dien-17-yl butanoate (16 $\alpha$ -methyl clobetasone butyrate).

07/2008:1777

## CLODRONATE DISODIUM TETRAHYDRATE

Dinatrii clodronas tetrahydricus

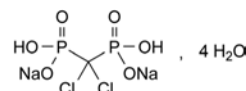

CH<sub>2</sub>Cl<sub>2</sub>Na<sub>2</sub>O<sub>6</sub>P<sub>2</sub>·4H<sub>2</sub>O

*M*<sub>r</sub> 360.9

## DEFINITION

Disodium (dichloromethylene)bis(hydrogen phosphonate) tetrahydrate.

*Content*: 99.0 per cent to 101.0 per cent (anhydrous substance).

## CHARACTERS

*Appearance*: white or almost white, crystalline powder.

*Solubility*: freely soluble in water, practically insoluble in ethanol (96 per cent), slightly soluble in methanol.

## IDENTIFICATION

A. Infrared absorption spectrophotometry (2.2.24).

*Comparison*: clodronate disodium tetrahydrate CRS.

B. Dissolve 0.5 g in 10 mL of *water R*. The solution gives reaction (a) of sodium (2.3.1).

## TESTS

**Solution S.** Dissolve 1.0 g in *carbon dioxide-free water R* and dilute to 20 mL with the same solvent.

**Appearance of solution.** Solution S is clear (2.2.1) and colourless (2.2.2, *Method II*).

**pH** (2.2.3): 3.0 to 4.5, for solution S.

**Related substances.** Liquid chromatography (2.2.29).

*Test solution.* Dissolve 0.125 g of the substance to be examined in 30 mL of *water R*, sonicate for 10 min and dilute to 50.0 mL with *water R* (*test stock solution*). Dilute 10.0 mL of the test stock solution to 20.0 mL of *water R*.

*Reference solution (a).* Dilute 1.0 mL of the test solution to 10.0 mL with *water R*. Dilute 1.0 mL of this solution to 50.0 mL with *water R*.

*Reference solution (b).* Dissolve 1 mg of *clodronate impurity D CRS* in 10 mL of *water R*, sonicate for 10 min and dilute to 20.0 mL with *water R*. Mix 2.0 mL of this solution with 10.0 mL of the test stock solution and dilute to 20.0 mL with *water R*.

*Reference solution (c).* Dilute 1.0 mL of a 0.3 g/L solution of *phosphoric acid R* (impurity B) to 100.0 mL with *water R*.

*Precolumn*:

- *size*: *l* = 0.05 m,  $\varnothing$  = 4 mm;
- *stationary phase*: anion exchange resin *R*;
- *particle size*: 9  $\mu$ m.

*Column*:

- *size*: *l* = 0.25 m,  $\varnothing$  = 4 mm;
- *stationary phase*: anion exchange resin *R*;
- *particle size*: 9  $\mu$ m.

**Mobile phase:**

- **mobile phase A:** 0.21 g/L solution of *sodium hydroxide R* in *carbon dioxide-free water R*; close immediately, mix and use under helium pressure;
- **mobile phase B:** 4.2 g/L solution of *sodium hydroxide R* in *carbon dioxide-free water R*; close immediately, mix and use under helium pressure;

Time (min)	Mobile phase A (per cent V/V)	Mobile phase B (per cent V/V)
0 - 10	90 → 60	10 → 40
10 - 22	60 → 50	40 → 50
22 - 23	50 → 20	50 → 80
23 - 25	20	80

**Flow rate:** 1 mL/min.

**Detection:** conductivity detector. Use a self-regenerating anion suppressor.

**Injection:** 20 µL.

**Identification of impurities:** use the chromatogram obtained with reference solution (c) to identify the peak due to impurity B.

**Relative retention** with reference to clodronate (retention time = about 13 min): impurities A and B = about 0.7; impurity D = about 1.1.

**System suitability:** reference solution (b):

- **peak-to-valley ratio:** minimum 3, where  $H_p$  = height above the baseline of the peak due to impurity D and  $H_v$  = height above the baseline of the lowest point of the curve separating this peak from the peak due to clodronate.

**Limits:**

- **sum of impurities A and B:** not more than the area of the principal peak in the chromatogram obtained with reference solution (a) (0.2 per cent);
- **unspecified impurities:** for each impurity, not more than 0.5 times the area of the principal peak in the chromatogram obtained with reference solution (a) (0.10 per cent);
- **total:** not more than 1.5 times the area of the principal peak in the chromatogram obtained with reference solution (a) (0.3 per cent);
- **disregard limit:** 0.25 times the area of the principal peak in the chromatogram obtained with reference solution (a) (0.05 per cent).

**Heavy metals (2.4.8):** maximum 20 ppm.

0.5 g complies with test G. Prepare the reference solution using 1 mL of *lead standard solution (10 ppm Pb) R*.

**Water (2.5.12):** 18.5 per cent to 21.0 per cent, determined on 0.100 g.

**ASSAY**

Dissolve 0.140 g in 10 mL of *water R*. Add 10 mL of *concentrated sodium hydroxide solution R* and some glass beads. Boil until the solution is completely decolourised (about 10 min). Cool in an ice-bath and add 30 mL of *water R* and 10 mL of *nitric acid R*. Titrate with 0.1 M *silver nitrate*, determining the end-point potentiometrically (2.2.20).

1 mL of 0.1 M *silver nitrate* is equivalent to 14.44 mg of  $\text{CH}_2\text{Cl}_2\text{Na}_2\text{O}_6\text{P}_2$ .

**IMPURITIES**

**Specified impurities:** A, B.

**Other detectable impurities** (the following substances would, if present at a sufficient level, be detected by one or other of the tests in the monograph. They are limited by the general acceptance criterion for other/unspecified impurities and/or by the general monograph *Substances for pharmaceutical use (2034)*. It is therefore not necessary to identify these impurities for demonstration of compliance. See also 5.10. *Control of impurities in substances for pharmaceutical use*): D.

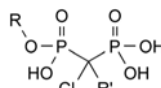

- A. R =  $\text{CH}(\text{CH}_3)_2$ , R' = Cl: [dichloro[hydroxy(1-methylethoxy)phosphinoyl]methyl]phosphonic acid,  
 D. R = R' = H: (chloromethylene)bis(phosphonic acid),  
 B.  $\text{H}_3\text{PO}_4$ : phosphoric acid.

01/2008:2054

**CLOFAZIMINE**

## Clofaziminum

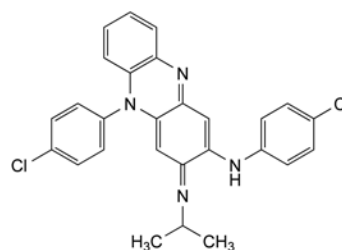

$\text{C}_{27}\text{H}_{22}\text{Cl}_2\text{N}_4$   
 [2030-63-9]

$M_r$  473.4

**DEFINITION**

*N*,5-Bis(4-chlorophenyl)-3-[(1-methylethyl)imino]-3,5-dihydrophenazin-2-amine.

**Content:** 99.0 per cent to 101.0 per cent (dried substance).

**CHARACTERS**

**Appearance:** reddish-brown, fine powder.

**Solubility:** practically insoluble in water, soluble in methylene chloride, very slightly soluble in ethanol (96 per cent).

It shows polymorphism (5.9).

**IDENTIFICATION**

**First identification:** A.

**Second identification:** B, C.

A. Infrared absorption spectrophotometry (2.2.24).

**Comparison:** *clofazimine CRS*.

If the spectra obtained in the solid state show differences, dissolve the substance to be examined and the reference substance separately in *methylene chloride R*, evaporate to dryness and record new spectra using the residues.

B. Thin-layer chromatography (2.2.27).

**Test solution.** Dissolve 10 mg of the substance to be examined in *methylene chloride R* and dilute to 10 mL with the same solvent.

**Reference solution.** Dissolve 10 mg of *clofazimine CRS* in *methylene chloride R* and dilute to 10 mL with the same solvent.

**Plate:** *TLC silica gel GF<sub>254</sub> plate R*.

**Mobile phase:** *propanol R, methylene chloride R* (6:85 V/V).

**Application:** 5 µL.

**First development:** over 2/3 of the plate.

**Drying:** horizontally in air for 5 min.

**Second development:** over 2/3 of the plate.

**Drying:** in air for 5 min.

**Detection:** examine in ultraviolet light at 254 nm.

**Results:** the principal spot in the chromatogram obtained with the test solution is similar in position and size to the principal spot in the chromatogram obtained with the reference solution.



C. Dissolve 2 mg in 3 mL of *acetone R* and add 0.1 mL of *hydrochloric acid R*. An intense violet colour is produced. Add 0.5 mL of a 200 g/L solution of *sodium hydroxide R*; the colour changes to orange-red.

## TESTS

**Related substances.** Liquid chromatography (2.2.29). Prepare the solutions immediately before use.

**Test solution.** Dissolve 50 mg of the substance to be examined in the mobile phase and dilute to 100 mL with the mobile phase.

**Reference solution (a).** Dilute 1.0 mL of the test solution to 100.0 mL with the mobile phase. Dilute 1.0 mL of this solution to 10.0 mL with the mobile phase.

**Reference solution (b).** Dissolve 5.0 mg of *clofazimine for system suitability CRS* in the mobile phase and dilute to 10.0 mL with the mobile phase.

**Column:**

- size:  $l = 0.25$  m,  $\varnothing = 4.6$  mm,
- stationary phase: *octylsilyl silica gel for chromatography R* (5  $\mu$ m).

**Mobile phase:** dissolve 2.25 g of *sodium laurilsulfate R*, 0.85 g of *tetrabutylammonium hydrogen sulfate R* and 0.885 g of *disodium hydrogen phosphate R* in *water R*. Adjust to pH 3.0 with *dilute phosphoric acid R* and dilute to 500 mL with *water R*. Mix 35 volumes of this solution and 65 volumes of *acetonitrile R*.

**Flow rate:** 1 mL/min.

**Detection:** spectrophotometer at 280 nm.

**Injection:** 20  $\mu$ L.

**Run time:** 3 times the retention time of *clofazimine*.

**Identification of impurities:** use the chromatogram supplied with *clofazimine for system suitability CRS* to identify the peak due to impurity B.

**Relative retention** with reference to *clofazimine* (retention time = about 15 min): impurity A = about 0.7; impurity B = about 0.8.

**System suitability:** reference solution (b):

- resolution: baseline separation between the peaks due to impurity B and *clofazimine*.

**Limits:**

- **impurity A:** not more than the area of the principal peak in the chromatogram obtained with reference solution (a) (0.1 per cent),
- **impurity B:** not more than 3 times the area of the principal peak in the chromatogram obtained with reference solution (a) (0.3 per cent),
- **any other impurity:** for each impurity, not more than the area of the principal peak in the chromatogram obtained with reference solution (a) (0.1 per cent),
- **total:** not more than 5 times the area of the principal peak in the chromatogram obtained with reference solution (a) (0.5 per cent),
- **disregard limit:** 0.5 times the area of the principal peak in the chromatogram obtained with reference solution (a) (0.05 per cent).

**Heavy metals** (2.4.8): maximum 10 ppm.

2.0 g complies with test C. Prepare the reference solution using 2 mL of *lead standard solution (10 ppm Pb) R*.

**Loss on drying** (2.2.32): maximum 0.5 per cent, determined on 1.000 g by drying in an oven at 105 °C.

**Sulfated ash** (2.4.14): maximum 0.1 per cent, determined on 1.0 g.

## ASSAY

Dissolve 0.400 g in 5 mL of *methylene chloride R* and add 20 mL of *acetone R* and 5 mL of *anhydrous acetic acid R*. Titrate with 0.1 M *perchloric acid*, determining the end-point potentiometrically (2.2.20).

1 mL of 0.1 M *perchloric acid* is equivalent to 47.34 mg of  $C_{27}H_{22}Cl_2N_4$ .

## IMPURITIES

**Specified impurities:** A, B.

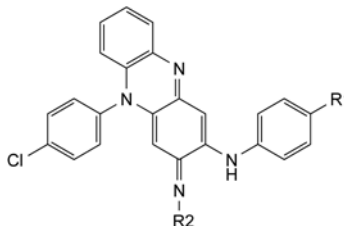

- A. R1 = Cl, R2 = H: *N*,5-bis(4-chlorophenyl)-3-imino-3,5-dihydrophenazin-2-amine,
- B. R1 = H, R2 =  $CH(CH_3)_2$ : 5-(4-chlorophenyl)-3-[(1-methylethyl)imino]-*N*-phenyl-3,5-dihydrophenazin-2-amine.

01/2008:0318

## CLOFIBRATE

## Clofibratum

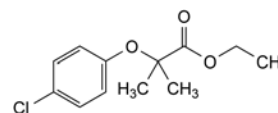

$C_{12}H_{15}ClO_3$   
[637-07-0]

$M_r$  242.7

## DEFINITION

Ethyl 2-(4-chlorophenoxy)-2-methylpropionate.

## CHARACTERS

**Appearance:** clear, almost colourless liquid.

**Solubility:** very slightly soluble in water, miscible with ethanol (96 per cent).

## IDENTIFICATION

A. Infrared absorption spectrophotometry (2.2.24).

**Comparison:** *clofibrate CRS*.

B. Ultraviolet and visible absorption spectrophotometry (2.2.25).

**Test solution (a).** Dissolve 0.10 g in *methanol R* and dilute to 100.0 mL with the same solvent. Dilute 10.0 mL of this solution to 100.0 mL with *methanol R*.

**Test solution (b).** Dilute 10.0 mL of test solution (a) to 100.0 mL with *methanol R*.

**Spectral range:** 250-350 nm for test solution (a); 220-250 nm for test solution (b).

**Absorption maxima:** at 280 nm and 288 nm for test solution (a); at 226 nm for test solution (b).

**Specific absorbances at the absorption maxima:**

- at 226 nm: about 460 for test solution (b);
- at 280 nm: about 44 for test solution (a);
- at 288 nm: about 31 for test solution (a).

## TESTS

**Relative density** (2.2.5): 1.138 to 1.147.

**Refractive index** (2.2.6): 1.500 to 1.505.

**Acidity.** To 1.0 g add 10 mL of *anhydrous ethanol R* and 0.1 mL of *phenol red solution R*. Not more than 1.0 mL of 0.01 M *sodium hydroxide* is required to change the colour of the indicator.

**Volatile related substances.** Gas chromatography (2.2.28).

01/2008:0997

**Test solution.** To 10.0 g of the substance to be examined add a mixture of 10 mL of *dilute sodium hydroxide solution R* and 10 mL of *water R*. Shake, separate the lower (organic) layer, wash with 5 mL of *water R* and add the washings to the aqueous layer. Dry the organic layer with *anhydrous sodium sulfate R* and use as the test solution. Reserve the aqueous layer for the test for 4-chlorophenol.

**Reference solution (a).** Dissolve 0.12 g of the substance to be examined in *chloroform R* and dilute to 100.0 mL with the same solvent. Dilute 1.0 mL of this solution to 10.0 mL with *chloroform R*.

**Reference solution (b).** Dissolve 0.12 g of *methyl 2-(4-chlorophenoxy)-2-methylpropionate CRS* in the substance to be examined and dilute to 10.0 mL with the same solvent. Dilute 1.0 mL of the solution to 10.0 mL with the substance to be examined. Dilute 1.0 mL of this solution to 10.0 mL with the substance to be examined.

**Column:**

- size:  $l = 1.5$  m,  $\emptyset = 4$  mm;
- stationary phase: silanised diatomaceous earth for gas chromatography R (250-420  $\mu\text{m}$ ) impregnated with 30 per cent *m/m* of poly(dimethyl)siloxane R; or silanised diatomaceous earth for gas chromatography R (150-180  $\mu\text{m}$ ) impregnated with 10 per cent *m/m* of poly(dimethyl)siloxane R;
- temperature: 185 °C.

**Carrier gas:** nitrogen for chromatography R.

**Detection:** flame ionisation.

**Injection:** 2  $\mu\text{L}$ .

**System suitability:** reference solution (b):

- peak-to-valley ratio: minimum 4, where  $H_p$  = height above the baseline of the peak due to methyl 2-(4-chlorophenoxy)-2-methylpropionate and  $H_v$  = height above the baseline of the lowest point of the curve separating this peak from the peak due to clofibrate.

**Limit:**

- total: not more than 10 times the area of the peak due to clofibrate in the chromatogram obtained with reference solution (a) (0.1 per cent).

**4-Chlorophenol.** Gas chromatography (2.2.28) as described in the test for volatile related substances with the following modifications.

**Test solution.** Shake the aqueous layer reserved in the test for volatile related substances with 2 quantities, each of 5 mL, of *chloroform R* and discard the organic layers. Acidify the aqueous layer by the dropwise addition of *hydrochloric acid R*. Shake with 3 quantities, each of 3 mL, of *chloroform R*. Combine the organic layers and dilute to 10.0 mL with *chloroform R*.

**Reference solution.** Dissolve 0.25 g of *chlorophenol R* in *chloroform R* and dilute to 100.0 mL with the same solvent. Dilute 1.0 mL of this solution to 100.0 mL with *chloroform R*.

**Limit:**

- 4-chlorophenol: not more than the area of the peak due to 4-chlorophenol in the chromatogram obtained with the reference solution (25 ppm).

## CLOMIFENE CITRATE

Clomifeni citras

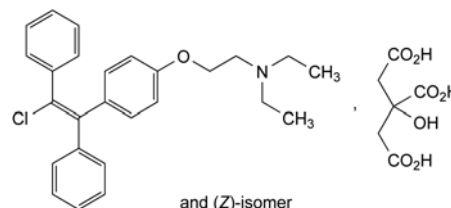

and (Z)-isomer

$\text{C}_{32}\text{H}_{36}\text{ClNO}_8$   
[50-41-9]

$M_r$  598.1

### DEFINITION

Mixture of the (E)- and (Z)-isomers of 2-[4-(2-chloro-1,2-diphenylethenyl)phenoxy]-N,N-diethylethanamine dihydrogen citrate.

**Content:** 98.0 per cent to 101.0 per cent (anhydrous substance).

### CHARACTERS

**Appearance:** white or pale yellow, crystalline powder.

**Solubility:** slightly soluble in water, sparingly soluble in ethanol (96 per cent).

### IDENTIFICATION

A. Infrared absorption spectrophotometry (2.2.24).

**Preparation:** discs of *potassium bromide R*.

**Comparison:** *clomifene citrate CRS*.

B. Dissolve about 5 mg in 5 mL of a mixture of 1 volume of *acetic anhydride R* and 5 volumes of *pyridine R*, then heat in a water-bath. A deep red colour is produced.

### TESTS

**Prepare the solutions protected from light in brown-glass vessels. Ensure minimum exposure of the solutions to daylight until they are required for chromatography.**

**Related substances.** Liquid chromatography (2.2.29).

**Test solution.** Dissolve 12.5 mg of the substance to be examined in the mobile phase and dilute to 10.0 mL with the mobile phase.

**Reference solution (a).** Dissolve 12.5 mg of *clomifene citrate for performance test CRS* in the mobile phase and dilute to 10.0 mL with the mobile phase.

**Reference solution (b).** Dilute 1.0 mL of the test solution to 50.0 mL with the mobile phase.

**Column:**

- size:  $l = 0.25$  m,  $\emptyset = 4.6$  mm;
- stationary phase: *butylsilyl silica gel for chromatography R* (5  $\mu\text{m}$ ).

**Mobile phase:** mix 400 mL of *acetonitrile R* with 600 mL of *water R* and add 8.0 mL of *diethylamine R*; adjust to pH 6.2 with about 1-2 mL of *phosphoric acid R*, taking care to reduce progressively the volume of each addition as the required pH is approached.

**Flow rate:** 1.2 mL/min.

**Detection:** spectrophotometer at 233 nm.

**Equilibration:** with the mobile phase for about 1 h.

**Injection:** 10  $\mu\text{L}$ .

**Run time:** 4 times the retention time of clomifene.

**System suitability:** reference solution (a):

- peak-to-valley ratio: minimum 15, where  $H_p$  = height above the baseline of the peak due to impurity A and  $H_v$  = height above the baseline of the lowest point of the curve separating this peak from the peak due to clomifene; if necessary, adjust the concentration of acetonitrile in the mobile phase;

- the chromatogram obtained is similar to the chromatogram supplied with *clomifene citrate for performance test CRS*.

**Limits:**

- *impurity A*: not more than the area of the principal peak in the chromatogram obtained with reference solution (b) (2.0 per cent);
- *impurities B, C, D, E, F, G, H*: for each impurity, not more than 0.5 times the area of the principal peak in the chromatogram obtained with reference solution (b) (1.0 per cent);
- *total*: not more than 1.25 times the area of the principal peak in the chromatogram obtained with reference solution (b) (2.5 per cent);
- *disregard limit*: 0.025 times the area of the principal peak in the chromatogram obtained with reference solution (b) (0.05 per cent); disregard any peak with a retention time relative to the clomifene peak of 0.2 or less.

**(Z)-isomer.** Liquid chromatography (2.2.29).

**Test solution.** Dissolve 25 mg of the substance to be examined in 25 mL of 0.1 M hydrochloric acid, add 5 mL of 1 M sodium hydroxide and shake with 3 quantities, each of 25 mL, of ethanol-free chloroform R. Wash the combined extracts with 10 mL of water R, dry over anhydrous sodium sulfate R and dilute to 100 mL with ethanol-free chloroform R. To 20 mL of this solution add 0.1 mL of triethylamine R and dilute to 100 mL with hexane R.

**Reference solution.** Dissolve 25 mg of *clomifene citrate CRS* in 25 mL of 0.1 M hydrochloric acid, add 5 mL of 1 M sodium hydroxide and shake with 3 quantities, each of 25 mL, of ethanol-free chloroform R. Wash the combined extracts with 10 mL of water R, dry over anhydrous sodium sulfate R and dilute to 100 mL with ethanol-free chloroform R. To 20 mL of this solution add 0.1 mL of triethylamine R and dilute to 100 mL with hexane R.

**Column:**

- *size*:  $l = 0.3$  m,  $\emptyset = 4$  mm;
  - *stationary phase*: silica gel for chromatography R (10  $\mu$ m).
- Mobile phase:** triethylamine R, ethanol-free chloroform R, hexane R (1:200:800 V/V/V).

**Flow rate:** 2 mL/min.

**Detection:** spectrophotometer at 302 nm.

**Equilibration:** with the mobile phase for about 2 h.

**Injection:** 50  $\mu$ L.

**Identification of peaks:** the chromatogram obtained with the reference solution shows a peak due to the (*E*)-isomer just before a peak due to the (*Z*)-isomer.

**System suitability:** reference solution:

- *resolution*: minimum 1.0 between the peaks due to the (*E*)- and (*Z*)-isomers; if necessary, adjust the relative proportions of ethanol-free chloroform and hexane in the mobile phase.

Measure the area of the peak due to the (*Z*)-isomer in the chromatograms obtained with the test solution and the reference solution. Calculate the content of the (*Z*)-isomer, as a percentage of the total clomifene citrate present, from the declared content of *clomifene citrate CRS*.

**Limit:**

- (*Z*)-isomer: 30.0 per cent to 50.0 per cent.

**Water** (2.5.12): maximum 1.0 per cent, determined on 1.000 g.

**ASSAY**

Dissolve 0.500 g in 50 mL of anhydrous acetic acid R. Titrate with 0.1 M perchloric acid, determining the end-point potentiometrically (2.2.20).

1 mL of 0.1 M perchloric acid is equivalent to 59.81 mg of  $C_{32}H_{36}ClNO_8$ .

**STORAGE**

Protected from light.

**IMPURITIES**

**Specified impurities:** A, B, C, D, E, F, G, H.

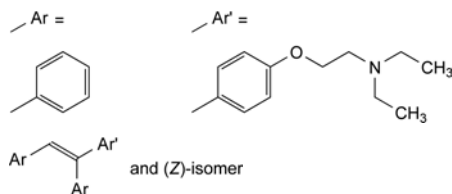

A. 2-[4-(1,2-diphenylethenyl)phenoxy]-*N,N*-diethylethanamine,



B. [4-[2-(diethylamino)ethoxy]phenyl]phenylmethanone,

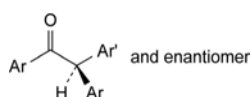

C. (2*RS*)-2-[4-[2-(diethylamino)ethoxy]phenyl]-1,2-diphenylethanone,

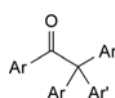

D. 2,2-bis[4-[2-(diethylamino)ethoxy]phenyl]-1,2-diphenylethanone,

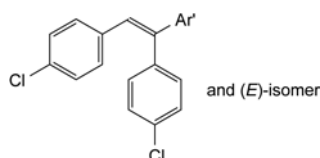

E. 2-[4-[1,2-bis(4-chlorophenyl)ethenyl]phenoxy]-*N,N*-diethylethanamine,

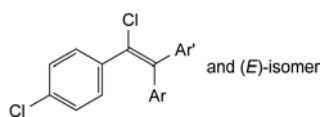

F. 2-[4-[2-chloro-2-(4-chlorophenyl)-1-phenylethenyl]phenoxy]-*N,N*-diethylethanamine,

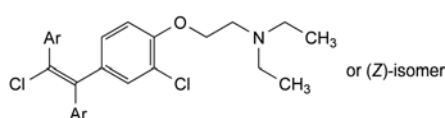

GH. 2-[2-chloro-4-(2-chloro-1,2-diphenylethenyl)phenoxy]-*N,N*-diethylethanamine (G. higher-melting-point isomer; H. lower-melting-point isomer).

01/2008:0889  
corrected 6.0

**CLOMIPRAMINE HYDROCHLORIDE**

## Clomipramini hydrochloridum

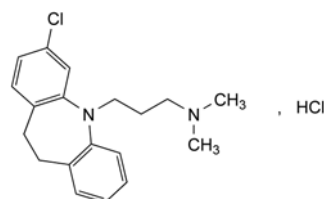

$C_{19}H_{24}Cl_2N_2$   
[17321-77-6]

$M_r$ , 351.3

## DEFINITION

3-(3-Chloro-10,11-dihydro-5H-dibenzo[*b,f*]azepin-5-yl)-*N,N*-dimethylpropan-1-amine hydrochloride.

*Content*: 99.0 per cent to 101.0 per cent (dried substance).

## CHARACTERS

*Appearance*: white or slightly yellow, crystalline powder, slightly hygroscopic.

*Solubility*: freely soluble in water and in methylene chloride, soluble in alcohol.

It shows polymorphism (5.9).

## IDENTIFICATION

*First identification*: B, E.

*Second identification*: A, C, D, E.

A. Melting point (2.2.14): 191 °C to 195 °C.

B. Infrared absorption spectrophotometry (2.2.24).

*Preparation*: discs of *potassium bromide R*. The transmittance at about 2000 cm<sup>-1</sup> (5 µm) is at least 65 per cent without compensation.

*Comparison*: *clomipramine hydrochloride CRS*.

C. Thin-layer chromatography (2.2.27). Prepare the solutions immediately before use and protected from light.

*Test solution*. Dissolve 20 mg of the substance to be examined in *methanol R* and dilute to 10 mL with the same solvent.

*Reference solution*. Dissolve 20 mg of *clomipramine hydrochloride CRS* in *methanol R* and dilute to 10 mL with the same solvent.

*Plate*: *TLC silica gel G plate R*.

*Mobile phase*: concentrated ammonia R, acetone R, ethyl acetate R (5:25:75 V/V/V).

*Application*: 5 µL.

*Development*: over a path of 15 cm.

*Drying*: in air.

*Detection*: spray with a 5 g/L solution of *potassium dichromate R* in a 20 per cent V/V solution of *sulfuric acid R*. Examine immediately.

*Results*: the principal spot in the chromatogram obtained with the test solution is similar in position, colour and size to the principal spot in the chromatogram obtained with the reference solution.

D. Dissolve about 5 mg in 2 mL of *nitric acid R*. An intense blue colour develops.

E. Dissolve about 50 mg in 5 mL of *water R* and add 1 mL of *dilute ammonia RI*. Mix, allow to stand for 5 min and filter. Acidify the filtrate with *dilute nitric acid R*. The solution gives reaction (a) of chlorides (2.3.1).

## TESTS

**Solution S**. Dissolve 2.0 g in *carbon dioxide-free water R* and dilute to 20 mL with the same solvent.

**Appearance of solution**. Solution S is clear (2.2.1) and not more intensely coloured than reference solution Y<sub>5</sub> (2.2.2, Method I).

**pH** (2.2.3): 3.5 to 5.0 for solution S.

**Related substances**. Liquid chromatography (2.2.29). Prepare the solutions immediately before use and protected from light.

*Test solution*. Dissolve 20.0 mg of the substance to be examined in a mixture of 25 volumes of mobile phase B and 75 volumes of mobile phase A and dilute to 10.0 mL with the same mixture of mobile phases.

*Reference solution (a)*. Dissolve 22.6 mg of *imipramine hydrochloride CRS*, 4.0 mg of *clomipramine impurity C CRS*, 4.0 mg of *clomipramine impurity D CRS* and 2.0 mg of *clomipramine impurity F CRS* in a mixture of 25 volumes of mobile phase B and 75 volumes of mobile phase A and dilute

to 100.0 mL with the same mixture of mobile phases. Dilute 1.0 mL of this solution to 10.0 mL with a mixture of 25 volumes of mobile phase B and 75 volumes of mobile phase A.

*Reference solution (b)*. Dilute 1.0 mL of the test solution to 100.0 mL with a mixture of 25 volumes of mobile phase B and 75 volumes of mobile phase A.

*Reference solution (c)*. Dissolve 10.0 mg of *clomipramine hydrochloride CRS* and 3.0 mg of *clomipramine impurity C CRS* in a mixture of 25 volumes of mobile phase B and 75 volumes of mobile phase A and dilute to 20.0 mL with the same mixture of mobile phases. Dilute 1.0 mL of this solution to 10.0 mL with a mixture of 25 volumes of mobile phase B and 75 volumes of mobile phase A.

*Column*:

- size: *l* = 0.25 m, Ø = 4.6 mm,
- stationary phase: *cyanopropylsilyl silica gel for chromatography R* (5 µm),
- temperature: 30 °C.

*Mobile phase*:

- *mobile phase A*: dissolve 1.2 g of *sodium dihydrogen phosphate R* in *water R*, add 1.1 mL of *nonylamine R*, adjust to pH 3.0 with *phosphoric acid R* and dilute to 1000 mL with *water R*,
- *mobile phase B*: *acetonitrile R*.

Time (min)	Mobile phase A (per cent V/V)	Mobile phase B (per cent V/V)
0 - 10	75	25
10 - 20	75 → 65	25 → 35
20 - 32	65	35
32 - 34	65 → 75	35 → 25
34 - 44	75	25

*Flow rate*: 1.5 mL/min.

*Detection*: spectrophotometer at 254 nm.

*Injection*: 20 µL.

*Relative retentions* with reference to clomipramine (retention time = about 8 min): impurity A = about 0.5; impurity B = about 0.7; impurity C = about 0.9; impurity D = about 1.7; impurity E = about 2.5; impurity F = about 3.4; impurity G = about 4.3.

*System suitability*: reference solution (c):

- *resolution*: minimum 3.0 between the peaks due to clomipramine and to impurity C.

*Limits*:

- *impurity B*: not more than the area of the corresponding peak in the chromatogram obtained with reference solution (a) (1.0 per cent),
- *impurity C, D*: for each impurity, not more than the area of the corresponding peak in the chromatogram obtained with reference solution (a) (0.2 per cent),
- *impurity F*: not more than the area of the corresponding peak in the chromatogram obtained with reference solution (a) (0.1 per cent),
- *any other impurity*: not more than 0.1 times the area of the principal peak in the chromatogram obtained with reference solution (b) (0.1 per cent),
- *total of other impurities*: not more than 0.2 times the area of the principal peak in the chromatogram obtained with reference solution (b) (0.2 per cent),
- *total*: not more than the area of the principal peak in the chromatogram obtained with reference solution (b) (1.0 per cent),
- *disregard limit*: 0.01 times the area of the principal peak in the chromatogram obtained with reference solution (b) (0.01 per cent).

01/2008:0890  
corrected 6.0**Heavy metals** (2.4.8): maximum 20 ppm.2.0 g complies with test C. Prepare the reference solution using 4 mL of *lead standard solution* (10 ppm Pb) R.**Loss on drying** (2.2.32): maximum 0.5 per cent, determined on 1.000 g by drying in an oven at 105 °C.**Sulfated ash** (2.4.14): maximum 0.1 per cent, determined on 1.0 g.

## ASSAY

Dissolve 0.250 g in 50 mL of *alcohol R* and add 5.0 mL of 0.01 M *hydrochloric acid*. Carry out a potentiometric titration (2.2.20), using 0.1 M *sodium hydroxide*. Read the volume added between the 2 points of inflexion.1 mL of 0.1 M *sodium hydroxide* is equivalent to 35.13 mg of C<sub>15</sub>H<sub>10</sub>ClN<sub>3</sub>O<sub>3</sub>.

## STORAGE

In an airtight container, protected from light.

## IMPURITIES

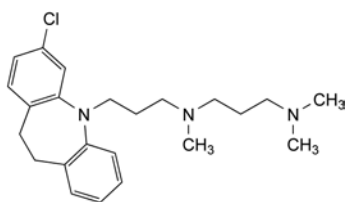
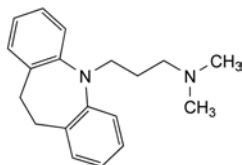
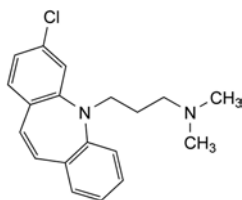
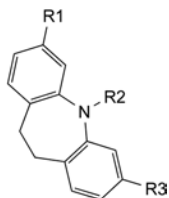
A. *N*-[3-(3-chloro-10,11-dihydro-5*H*-dibenzo[*b,f*]azepin-5-yl)propyl]-*N,N,N'*-trimethylpropane-1,3-diamine,B. 3-(10,11-dihydro-5*H*-dibenzo[*b,f*]azepin-5-yl)-*N,N*-dimethylpropan-1-amine (imipramine),C. 3-(3-chloro-5*H*-dibenzo[*b,f*]azepin-5-yl)-*N,N*-dimethylpropan-1-amine,D. R<sub>1</sub> = R<sub>3</sub> = Cl, R<sub>2</sub> = CH<sub>2</sub>-CH<sub>2</sub>-CH<sub>2</sub>-N(CH<sub>3</sub>)<sub>2</sub>:  
3-(3,7-dichloro-10,11-dihydro-5*H*-dibenzo[*b,f*]azepin-5-yl)-*N,N*-dimethylpropan-1-amine,E. R<sub>1</sub> = R<sub>2</sub> = R<sub>3</sub> = H: 10,11-dihydro-5*H*-dibenzo[*b,f*]azepine (iminodibenzyl),F. R<sub>1</sub> = Cl, R<sub>2</sub> = R<sub>3</sub> = H: 3-chloro-10,11-dihydro-5*H*-dibenzo[*b,f*]azepine,G. R<sub>1</sub> = Cl, R<sub>2</sub> = CH<sub>2</sub>-CH=CH<sub>2</sub>, R<sub>3</sub> = H: 3-chloro-5-(prop-2-enyl)-10,11-dihydro-5*H*-dibenzo[*b,f*]azepine.

## CLONAZEPAM

## Clonazepamum

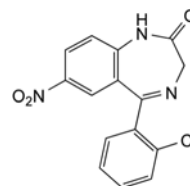
C<sub>15</sub>H<sub>10</sub>ClN<sub>3</sub>O<sub>3</sub>  
[1622-61-3]M<sub>r</sub> 315.7

## DEFINITION

5-(2-Chlorophenyl)-7-nitro-1,3-dihydro-2*H*-1,4-benzodiazepin-2-one.*Content*: 99.0 per cent to 101.0 per cent (dried substance).

## CHARACTERS

*Appearance*: slightly yellowish, crystalline powder.*Solubility*: practically insoluble in water, slightly soluble in alcohol and in methanol.

mp: about 239 °C.

## IDENTIFICATION

Infrared absorption spectrophotometry (2.2.24).

*Comparison*: Ph. Eur. reference spectrum of clonazepam.

## TESTS

**Related substances.** Liquid chromatography (2.2.29). Carry out the test protected from light and prepare the solutions immediately before use.*Solvent mixture*: tetrahydrofuran R, methanol R, water R (10:42:48 V/V/V).*Test solution.* Dissolve 0.100 g of the substance to be examined in *methanol R* and dilute to 20.0 mL with the same solvent. Dilute 1.0 mL to 10.0 mL with the solvent mixture.*Reference solution (a).* Dilute 1.0 mL of the test solution to 100.0 mL with the solvent mixture. Dilute 1.0 mL of the solution to 10.0 mL with the solvent mixture.*Reference solution (b).* Dissolve 5 mg of the substance to be examined and 5 mg of *flunitrazepam R* in the solvent mixture and dilute to 100.0 mL with the solvent mixture.*Reference solution (c).* Dissolve 1.0 mg of *clonazepam impurity B CRS* in the solvent mixture and dilute to 20.0 mL with the solvent mixture. Dilute 1.0 mL of the solution to 100.0 mL with the solvent mixture.*Column*:– size: *l* = 0.15 m, Ø = 4.6 mm,

– stationary phase: end-capped octylsilyl silica gel for chromatography R (5 µm).

*Mobile phase*: mix 10 volumes of tetrahydrofuran R, 42 volumes of methanol R and 48 volumes of a 6.6 g/L solution of ammonium phosphate R previously adjusted to pH 8.0 with a 40 g/L solution of sodium hydroxide R or dilute phosphoric acid R.*Flow rate*: 1.0 mL/min.*Detection*: spectrophotometer at 254 nm.*Injection*: 10 µL.*Run time*: 3 times the retention time of clonazepam.*Relative retention* with reference to clonazepam (retention time = about 7 min): impurity B = about 2.1; impurity A = about 2.4.

*System suitability*: reference solution (b):

- *resolution*: minimum 1.8 between the peaks due to flunitrazepam and to clonazepam.

*Limits*:

- *impurity A*: not more than the area of the principal peak in the chromatogram obtained with reference solution (a) (0.1 per cent),
- *impurity B*: not more than the area of the principal peak in the chromatogram obtained with reference solution (c) (0.1 per cent)
- *any other impurity*: for each impurity, not more than the area of the principal peak in the chromatogram obtained with reference solution (a) (0.1 per cent),
- *total*: not more than twice the area of the principal peak in the chromatogram obtained with reference solution (a) (0.2 per cent),
- *disregard limit*: 0.5 times the area of the principal peak in the chromatogram obtained with reference solution (a) (0.05 per cent).

**Loss on drying** (2.2.32): maximum 0.5 per cent, determined on 1.000 g by drying in an oven at 105 °C for 4 h.

**Sulfated ash** (2.4.14): maximum 0.1 per cent, determined on 1.0 g.

#### ASSAY

Dissolve 0.275 g in 50 mL of *acetic anhydride R*. Titrate with 0.1 M *perchloric acid*, determining the end-point potentiometrically (2.2.20).

1 mL of 0.1 M *perchloric acid* is equivalent to 31.57 mg of C<sub>15</sub>H<sub>10</sub>ClN<sub>3</sub>O<sub>3</sub>.

#### STORAGE

Protected from light.

#### IMPURITIES

*Specified impurities*: A, B.

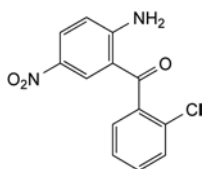

A. (2-amino-5-nitrophenyl)(2-chlorophenyl)methanone,

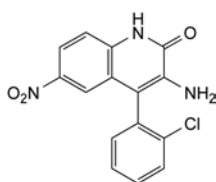

B. 3-amino-4-(2-chlorophenyl)-6-nitroquinolin-2(1H)-one.

01/2008:0477  
corrected 6.3

## CLONIDINE HYDROCHLORIDE

### Clonidini hydrochloridum

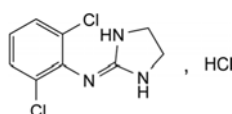

C<sub>9</sub>H<sub>10</sub>Cl<sub>2</sub>N<sub>3</sub>  
[4205-91-8]

M<sub>r</sub> 266.6

#### DEFINITION

2,6-Dichloro-*N*-(imidazolidin-2-ylidene)aniline hydrochloride.

*Content*: 98.5 per cent to 101.0 per cent (dried substance).

#### CHARACTERS

*Appearance*: white or almost white, crystalline powder.

*Solubility*: soluble in water and in anhydrous ethanol.

#### IDENTIFICATION

*First identification*: B, D.

*Second identification*: A, C, D.

A. Ultraviolet and visible absorption spectrophotometry (2.2.25).

*Test solution*. Dissolve 30.0 mg in 0.01 M *hydrochloric acid* and dilute to 100.0 mL with the same acid.

*Spectral range*: 245-350 nm.

*Absorption maxima*: at 272 nm and 279 nm.

*Point of inflexion*: at 265 nm.

*Specific absorbance at the absorption maxima*:

– at 272 nm: about 18;

– at 279 nm: about 16.

B. Infrared absorption spectrophotometry (2.2.24).

*Comparison*: *clonidine hydrochloride CRS*.

C. Thin-layer chromatography (2.2.27).

*Test solution*. Dissolve 5 mg of the substance to be examined in *methanol R* and dilute to 5 mL with the same solvent.

*Reference solution*. Dissolve 5 mg of *clonidine hydrochloride CRS* in *methanol R* and dilute to 5 mL with the same solvent.

*Plate*: *TLC silica gel G plate R*.

*Mobile phase*: *glacial acetic acid R*, *butanol R*, *water R* (10:40:50 V/V/V); allow to separate, filter the upper layer and use the filtrate.

*Application*: 10 µL.

*Development*: over 2/3 of the plate.

*Drying*: in air.

*Detection*: spray with *potassium iodobismuthate solution R2*. Allow to dry in air for 1 h. Spray again with *potassium iodobismuthate solution R2* and then immediately spray with a 50 g/L solution of *sodium nitrite R*.

*Results*: the principal spot in the chromatogram obtained with the test solution is similar in position, colour and size to the principal spot in the chromatogram obtained with the reference solution.

D. It gives reaction (a) of chlorides (2.3.1).

#### TESTS

**Solution S**. Dissolve 1.25 g in *carbon dioxide-free water R* and dilute to 25 mL with the same solvent.

**Appearance of solution**. Solution S is clear (2.2.1) and not more intensely coloured than reference solution Y<sub>7</sub> (2.2.2, *Method II*).

**pH** (2.2.3): 4.0 to 5.0 for solution S.

**Related substances**. Liquid chromatography (2.2.29).

*Test solution*. Dissolve 50 mg of the substance to be examined in mobile phase A and dilute to 50 mL with mobile phase A.

*Reference solution (a)*. Dilute 1.0 mL of the test solution to 100.0 mL with mobile phase A. Dilute 1.0 mL of this solution to 10.0 mL with mobile phase A.

*Reference solution (b)*. Dissolve 5 mg of *clonidine impurity B CRS* in 2 mL of *acetonitrile R* and dilute to 5 mL with mobile phase A. To 1 mL of this solution, add 1 mL of the test solution and dilute to 10 mL with mobile phase A.

*Column*:

– *size*: *l* = 0.15 m, Ø = 3.0 mm;

– *stationary phase*: *propylsilyl silica gel for chromatography R* (5 µm);

– *temperature*: 40 °C.

**Mobile phase:**

- **mobile phase A:** dissolve 4 g of *potassium dihydrogen phosphate R* in 1000 mL of *water R*, and adjust to pH 4.0 with *phosphoric acid R*;
- **mobile phase B:** mobile phase A, *acetonitrile R1* (25:75 V/V);

Time (min)	Mobile phase A (per cent V/V)	Mobile phase B (per cent V/V)
0	90	10
0 - 15	90 → 30	10 → 70
15 - 15.1	30 → 90	70 → 10
15.1 - 20	90	10

**Flow rate:** 1.5 mL/min.

**Detection:** spectrophotometer at 210 nm.

**Injection:** 5 µL.

**System suitability:** reference solution (b):

- **resolution:** minimum 5 between the peaks due to clonidine and impurity B.

**Limits:**

- **unspecified impurities:** for each impurity, not more than the area of the principal peak in the chromatogram obtained with reference solution (a) (0.10 per cent);
- **total:** not more than twice the area of the principal peak in the chromatogram obtained with reference solution (a) (0.2 per cent);
- **disregard limit:** 0.5 times the area of the principal peak in the chromatogram obtained with reference solution (a) (0.05 per cent).

**Loss on drying (2.2.32):** maximum 0.5 per cent, determined on 1.000 g by drying in an oven at 105 °C.

**Sulfated ash (2.4.14):** maximum 0.1 per cent, determined on 1.0 g.

**ASSAY**

Dissolve 0.200 g in 70 mL of *ethanol (96 per cent) R*. Titrate with 0.1 M *ethanolic sodium hydroxide* determining the end-point potentiometrically (2.2.20).

1 mL of 0.1 M *sodium hydroxide* is equivalent to 26.66 mg of C<sub>9</sub>H<sub>10</sub>Cl<sub>3</sub>N<sub>3</sub>.

**IMPURITIES**

**Other detectable impurities** (the following substances would, if present at a sufficient level, be detected by one or other of the tests in the monograph. They are limited by the general acceptance criterion for other/unspecified impurities and/or by the general monograph *Substances for pharmaceutical use (2034)*. It is therefore not necessary to identify these impurities for demonstration of compliance. See also 5.10. *Control of impurities in substances for pharmaceutical use*): A, B, C.

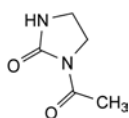

A. 1-acetylimidazolidin-2-one,

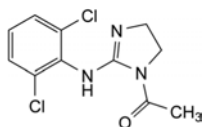

B. 1-acetyl-2-[(2,6-dichlorophenyl)amino]-4,5-dihydro-1H-imidazole,

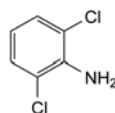

C. 2,6-dichloroaniline.

04/2008:1747  
corrected 7.0

**CLOPAMIDE**

## Clopamidum

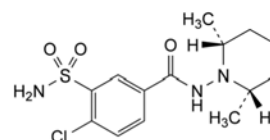

C<sub>14</sub>H<sub>20</sub>ClN<sub>3</sub>O<sub>3</sub>S  
[636-54-4]

M<sub>r</sub> 345.8

**DEFINITION**

4-Chloro-*N*-[(2*RS*,6*SR*)-2,6-dimethylpiperidin-1-yl]-3-sulfamoylbenzamide.

**Content:** 99.0 per cent to 101.0 per cent (dried substance).

**PRODUCTION**

The production method is evaluated to determine the potential for formation of an *N*-nitroso compound (*cis*-2,6-dimethyl-1-nitrosopiperidine). Where necessary, the production method is validated to demonstrate that the *N*-nitroso compound is absent in the final product.

**CHARACTERS**

**Appearance:** white or almost white, hygroscopic, crystalline powder.

**Solubility:** slightly soluble in water and in anhydrous ethanol, sparingly soluble in methanol.

It shows polymorphism (5.9).

**IDENTIFICATION**

Infrared absorption spectrophotometry (2.2.24).

**Comparison:** *clopamide CRS*.

If the spectra obtained in the solid state show differences, dissolve the substance to be examined and the reference substance separately in the minimum volume of *methanol R*, evaporate to dryness on a water-bath and record new spectra using the residues.

**TESTS**

**Related substances.** Liquid chromatography (2.2.29).

**Test solution.** Dissolve 100 mg of the substance to be examined in *methanol R* and dilute to 10.0 mL with the same solvent.

**Reference solution (a).** Dissolve 10 mg of *clopamide for system suitability CRS* (containing impurities B, C and H) in 1.0 mL of *methanol R*.

**Reference solution (b).** Dilute 2.0 mL of the test solution to 100.0 mL with *methanol R*. Dilute 2.0 mL of this solution to 40.0 mL with *methanol R*.

**Column:**

– **size:** *l* = 0.15 m, Ø = 4.6 mm;

– **stationary phase:** *end-capped octylsilyl silica gel for chromatography R* (5 µm).

**Mobile phase:**

– **mobile phase A:** dissolve 1.0 g of *ammonium acetate R* in 950 mL of *water R*, adjust to pH 2.0 with *phosphoric acid R* and dilute to 1000 mL with *water R*;

– **mobile phase B:** *acetonitrile R*;

- *mobile phase C: water R, tetrahydrofuran for chromatography R* (20:80 V/V); this mobile phase allows adequate rinsing of the system;

Time (min)	Mobile phase A (per cent V/V)	Mobile phase B (per cent V/V)	Mobile phase C (per cent V/V)
0 - 35	95 → 75	5 → 25	0
35 - 45	75 → 35	25 → 65	0
45 - 50	35 → 30	65 → 0	0 → 70
50 - 60	30	0	70

*Flow rate:* 0.4 mL/min.

*Detection:* spectrophotometer at 235 nm.

*Injection:* 10 µL.

*Identification of impurities:* use the chromatogram supplied with *clopamide for system suitability CRS* and the chromatogram obtained with reference solution (a) to identify the peaks due to impurities B, C and H.

*Relative retention* with reference to *clopamide* (retention time = about 33 min): impurity C = about 0.8; impurity H = about 1.2; impurity B = about 1.4.

*System suitability:* reference solution (a):

- *resolution:* minimum 3 between the peaks due to impurity C and *clopamide*.

*Limits:*

- *correction factors:* for the calculation of content, multiply the peak areas of the following impurities by the corresponding correction factor: impurity B = 0.5; impurity H = 0.4;
- *impurities B, C, H:* for each impurity, not more than twice the area of the principal peak in the chromatogram obtained with reference solution (b) (0.2 per cent);
- *unspecified impurities:* for each impurity, not more than the area of the principal peak in the chromatogram obtained with reference solution (b) (0.10 per cent);
- *total:* not more than 10 times the area of the principal peak in the chromatogram obtained with reference solution (b) (1.0 per cent);
- *disregard limit:* 0.5 times the area of the principal peak in the chromatogram obtained with reference solution (b) (0.05 per cent).

**Heavy metals (2.4.8):** maximum 20 ppm.

Dissolve 0.25 g in a mixture of 20 volumes of *acetone R* and 85 volumes of *methanol R* and dilute to 20 mL with the same mixture of solvents. 20 mL of the solution complies with modified test B. Prepare the reference solution by diluting 0.5 mL of *lead standard solution (10 ppm Pb) R* to 20 mL with a mixture of 20 volumes of *acetone R* and 85 volumes of *methanol R*. Prepare the blank solution by using 20 mL of a mixture of 20 volumes of *acetone R* and 85 volumes of *methanol R*.

Filter the solutions through a membrane filter (nominal pore size 0.45 µm) to evaluate the result.

**Loss on drying (2.2.32):** maximum 2.5 per cent, determined on 1.000 g by drying in an oven at 105 °C.

**Sulfated ash (2.4.14):** maximum 0.1 per cent, determined on 1.0 g.

**ASSAY**

Dissolve 0.280 g in 70 mL of *anhydrous acetic acid R*. Titrate with 0.1 M *perchloric acid*, determining the end-point potentiometrically (2.2.20).

1 mL of 0.1 M *perchloric acid* is equivalent to 34.58 mg of C<sub>14</sub>H<sub>20</sub>ClN<sub>3</sub>O<sub>3</sub>S.

**STORAGE**

In an airtight container, protected from light.

## IMPURITIES

*Specified impurities:* B, C, H.

*Other detectable impurities* (the following substances would, if present at a sufficient level, be detected by one or other of the tests in the monograph. They are limited by the general acceptance criterion for other/unspecified impurities and/or by the general monograph *Substances for pharmaceutical use (2034)*. It is therefore not necessary to identify these impurities for demonstration of compliance. See also 5.10. *Control of impurities in substances for pharmaceutical use*): A, G.

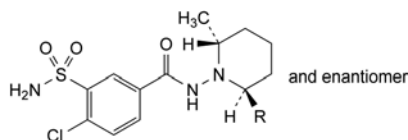

A. R = CH<sub>3</sub>: 4-chloro-*N*-[(2*RS*,6*RS*)-2,6-dimethylpiperidin-1-yl]-3-sulfamoylbenzamide (*trans*-clopamide),

G. R = H: 4-chloro-*N*-[(2*RS*)-2-methylpiperidin-1-yl]-3-sulfamoylbenzamide,

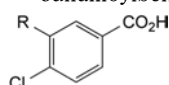

B. R = H: 4-chlorobenzoic acid,

C. R = SO<sub>2</sub>-NH<sub>2</sub>: 4-chloro-3-sulfamoylbenzoic acid,

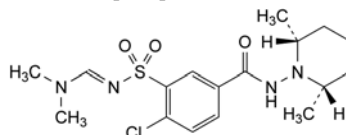

H. 4-chloro-3-[(*E*)-[(dimethylamino)methylene]sulfamoyl]-*N*-[(2*RS*,6*SR*)-2,6-dimethylpiperidin-1-yl]benzamide.

01/2008:1716  
corrected 7.0

## CLOSANTEL SODIUM DIHYDRATE FOR VETERINARY USE

Closantelum natrium dihydricum  
ad usum veterinarium

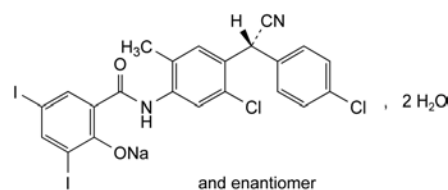

C<sub>22</sub>H<sub>13</sub>Cl<sub>2</sub>N<sub>2</sub>NaO<sub>2</sub>·2H<sub>2</sub>O  
[61438-64-0]

M<sub>r</sub> 721

## DEFINITION

*N*-[5-Chloro-4-[(*RS*)-(4-chlorophenyl)cyanomethyl]-2-methylphenyl]-2-hydroxy-3,5-diiodobenzamide sodium salt dihydrate.

*Content:* 98.5 per cent to 101.5 per cent (anhydrous substance).

## CHARACTERS

*Appearance:* yellow powder, slightly hygroscopic.

*Solubility:* very slightly soluble in water, freely soluble in ethanol (96 per cent), soluble in methanol.

It shows polymorphism (5.9).

## IDENTIFICATION

A. Infrared absorption spectrophotometry (2.2.24).

*Preparation:* discs without recrystallisation.

*Comparison:* *closantel sodium dihydrate CRS*.



B. Dissolve 0.1 g in 2 mL of *ethanol (96 per cent) R*. The solution gives reaction (a) of sodium (2.3.1).

#### TESTS

**Appearance of solution.** The solution is clear (2.2.1) and not more intensely coloured than reference solution GY<sub>4</sub> (2.2.2, Method II).

Dissolve 0.50 g in *ethanol (96 per cent) R* and dilute to 50 mL with the same solvent.

**Related substances.** Liquid chromatography (2.2.29). Prepare the solutions immediately before use and protect from light.

**Test solution.** Dissolve 0.100 g of the substance to be examined in *methanol R* and dilute to 10.0 mL with the same solvent.

**Reference solution (a).** Dissolve 10 mg of *closantel for system suitability CRS* (containing impurities A to J) in *methanol R* and dilute to 1.0 mL with the same solvent.

**Reference solution (b).** Dilute 1.0 mL of the test solution to 100.0 mL with *methanol R*. Dilute 5.0 mL of this solution to 25.0 mL with *methanol R*.

#### Column:

- size:  $l = 0.10$  m,  $\varnothing = 4.6$  mm,
- stationary phase: base-deactivated octadecylsilyl silica gel for chromatography R (3  $\mu$ m),
- temperature: 35 °C.

#### Mobile phase:

- mobile phase A: to 100 mL of a 7.7 g/L solution of *ammonium acetate R* previously adjusted to pH 4.3 with *acetic acid R*, add 50 mL of *acetonitrile R* and 850 mL of *water R*;
- mobile phase B: to 100 mL of a 7.7 g/L solution of *ammonium acetate R* previously adjusted to pH 4.3 with *acetic acid R*, add 50 mL of *water R* and 850 mL of *acetonitrile R*;

Time (min)	Mobile phase A (per cent V/V)	Mobile phase B (per cent V/V)
0 - 2	50	50
2 - 22	50 → 20	50 → 80
22 - 27	20	80

Flow rate: 1.5 mL/min.

Detection: spectrophotometer at 240 nm.

Injection: 10  $\mu$ L.

**Relative retention** with reference to *closantel* (retention time = about 16 min): impurity A = about 0.07; impurity B = about 0.48; impurity C = about 0.62; impurity D = about 0.65; impurity E = about 0.82; impurity F = about 0.89; impurity G = about 0.93; impurity H = about 1.13; impurity I = about 1.16; impurity J = about 1.55.

**System suitability:** reference solution (a):

- resolution: baseline separation between the peaks due to impurity G and *closantel*,

– the chromatogram obtained is similar to the chromatogram supplied with *closantel for system suitability CRS*.

#### Limits:

- correction factors: for the calculation of contents, multiply the peak areas of the following impurities by the corresponding correction factor: impurity A = 1.5; impurity B = 1.3;
- impurity G: not more than 2.5 times the area of the principal peak in the chromatogram obtained with reference solution (b) (0.5 per cent);
- impurities F, H, I: for each impurity, not more than 1.5 times the area of the principal peak in the chromatogram obtained with reference solution (b) (0.3 per cent);
- impurities A, B, C, D, E, J: for each impurity, not more than the area of the principal peak in the chromatogram obtained with reference solution (b) (0.2 per cent);
- any other impurity: for each impurity, not more than the area of the principal peak in the chromatogram obtained with reference solution (b) (0.2 per cent);
- total: not more than 7.5 times the area of the principal peak in the chromatogram obtained with reference solution (b) (1.5 per cent);
- disregard limit: 0.25 times the area of the principal peak in the chromatogram obtained with reference solution (b) (0.05 per cent).

**Water (2.5.12):** 4.8 per cent to 5.8 per cent, determined on 0.250 g.

Use a mixture of 1 volume of *dimethylformamide R* and 4 volumes of *methanol R* as the solvent.

#### ASSAY

Dissolve 0.500 g in 50 mL of a mixture of 1 volume of *anhydrous acetic acid R* and 7 volumes of *methyl ethyl ketone R*. Titrate with 0.1 M *perchloric acid*, determining the end-point potentiometrically (2.2.20).

1 mL of 0.1 M *perchloric acid* is equivalent to 68.5 mg of C<sub>22</sub>H<sub>13</sub>Cl<sub>2</sub>I<sub>2</sub>N<sub>2</sub>NaO<sub>2</sub>.

#### STORAGE

In an airtight container, protected from light.

#### IMPURITIES

**Specified impurities:** A, B, C, D, E, F, G, H, I, J.

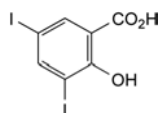

A. 2-hydroxy-3,5-diiodobenzoic acid,

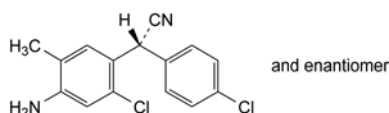

B. (2RS)-(4-amino-2-chloro-5-methylphenyl)(4-chlorophenyl)ethanenitrile,

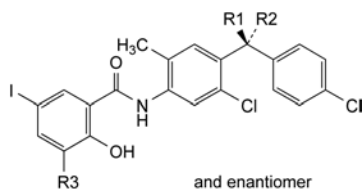

- C. R1 = H, R2 = CO<sub>2</sub>H, R3 = I: (2*RS*)-[2-chloro-4-[(2-hydroxy-3,5-diiodobenzoyl)amino]-5-methylphenyl](4-chlorophenyl)acetic acid,
- D. R1 = H, R2 = CONH<sub>2</sub>, R3 = I: *N*-[4-[(1*RS*)-2-amino-1-(4-chlorophenyl)-2-oxoethyl]-5-chloro-2-methylphenyl]-2-hydroxy-3,5-diiodobenzamide,
- E. R1 = H, R2 = CN, R3 = Cl: 3-chloro-*N*-[5-chloro-4-[(*RS*)-(4-chlorophenyl)cyanomethyl]-2-methylphenyl]-2-hydroxy-5-iodobenzamide,
- F. R1 + R2 = O, R3 = I: *N*-[5-chloro-4-(4-chlorobenzoyl)-2-methylphenyl]-2-hydroxy-3,5-diiodobenzamide,
- G. R1 = H, R2 = C(=NH)OCH<sub>3</sub>, R3 = I: methyl (2*RS*)-2-[2-chloro-4-[(2-hydroxy-3,5-diiodobenzoyl)amino]-5-methylphenyl]-2-(4-chlorophenyl)acetimidate,
- H. R1 = H, R2 = CO-OCH<sub>3</sub>, R3 = I: methyl (2*RS*)-[2-chloro-4-[(2-hydroxy-3,5-diiodobenzoyl)amino]-5-methylphenyl](4-chlorophenyl)acetate,
- I. R1 = R3 = H, R2 = CN: *N*-[5-chloro-4-[(*RS*)-(4-chlorophenyl)cyanomethyl]-2-methylphenyl]-2-hydroxy-5-iodobenzamide,

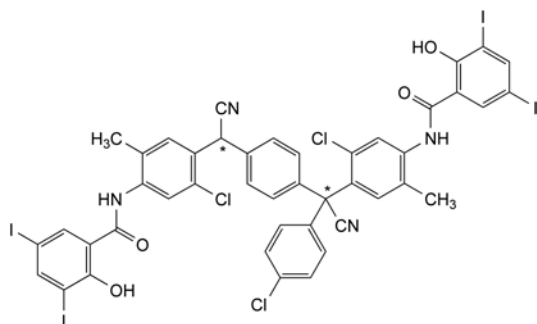

- J. *N*-[5-chloro-4-[[4-[[2-chloro-4-[(2-hydroxy-3,5-diiodobenzoyl)amino]-5-methylphenyl]cyanomethyl]phenyl](4-chlorophenyl)cyanomethyl]-2-methylphenyl]-2-hydroxy-3,5-diiodobenzamide.

04/2008:0757

**CLOTRIMAZOLE**

## Clotrimazolum

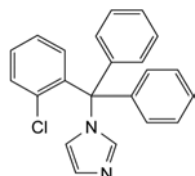

C<sub>22</sub>H<sub>17</sub>ClN<sub>2</sub>  
[23593-75-1]

M<sub>r</sub> 344.8**DEFINITION**1-[(2-Chlorophenyl)diphenylmethyl]-1*H*-imidazole.*Content*: 98.5 per cent to 100.5 per cent (dried substance).**CHARACTERS***Appearance*: white or pale yellow, crystalline powder.*Solubility*: practically insoluble in water, soluble in ethanol (96 per cent) and in methylene chloride.**IDENTIFICATION***First identification*: B.*Second identification*: A, C.

A. Melting point (2.2.14): 141 °C to 145 °C.

B. Infrared absorption spectrophotometry (2.2.24).

*Comparison*: clotrimazole CRS.

C. Thin-layer chromatography (2.2.27).

*Test solution*. Dissolve 50 mg of the substance to be examined in ethanol (96 per cent) *R* and dilute to 5 mL with the same solvent.*Reference solution*. Dissolve 50 mg of clotrimazole CRS in ethanol (96 per cent) *R* and dilute to 5 mL with the same solvent.*Plate*: TLC silica gel *F*<sub>254</sub> plate *R*.*Mobile phase*: concentrated ammonia *R*1, propanol *R*, toluene *R* (0.5:10:90 V/V/V).*Application*: 10 µL.*Development*: over 2/3 of the plate.*Drying*: in air.*Detection*: examine in ultraviolet light at 254 nm.*Results*: the principal spot in the chromatogram obtained with the test solution is similar in position and size to the principal spot in the chromatogram obtained with the reference solution.**TESTS****Related substances**. Liquid chromatography (2.2.29).*Test solution*. Dissolve 50.0 mg of the substance to be examined in acetonitrile *R*1 and dilute to 50.0 mL with the same solvent.*Reference solution (a)*. Dilute 1.0 mL of the test solution to 100.0 mL with acetonitrile *R*1. Dilute 1.0 mL of this solution to 10.0 mL with acetonitrile *R*1.*Reference solution (b)*. Dissolve the contents of a vial of clotrimazole for peak identification CRS (containing impurities A, B and F) in 1.0 mL of acetonitrile *R*1.*Reference solution (c)*. Dissolve 5.0 mg of imidazole CRS (impurity D) and 5.0 mg of clotrimazole impurity E CRS in acetonitrile *R*1 and dilute to 100.0 mL with the same solvent. Dilute 1.0 mL of this solution to 25.0 mL with acetonitrile *R*1.*Column*:– size: *l* = 0.15 m, Ø = 4.6 mm;– stationary phase: spherical end-capped octylsilyl silica gel for chromatography *R* (5 µm);

– temperature: 40 °C.

*Mobile phase*:– mobile phase A: dissolve 1.0 g of potassium dihydrogen phosphate *R* and 0.5 g of tetrabutylammonium hydrogen sulfate *R*1 in water *R* and dilute to 1000 mL with the same solvent;– mobile phase B: acetonitrile *R*1;

Time (min)	Mobile phase A (per cent V/V)	Mobile phase B (per cent V/V)
0 - 3	75	25
3 - 25	75 → 20	25 → 80
25 - 30	20	80

*Flow rate*: 1.0 mL/min.*Detection*: spectrophotometer at 210 nm.*Injection*: 10 µL.*Relative retention* with reference to clotrimazole (retention time = about 12 min): impurity D = about 0.1; impurity F = about 0.9; impurity B = about 1.1; impurity E = about 1.5; impurity A = about 1.8.

*System suitability*: reference solution (b):

- *resolution*: minimum 1.5 between the peaks due to impurity F and clotrimazole;
- the chromatogram obtained is similar to the chromatogram supplied with *clotrimazole for peak identification CRS*.

*Limits*:

- *impurities A, B*: for each impurity, not more than twice the area of the principal peak in the chromatogram obtained with reference solution (a) (0.2 per cent);
- *impurities D, E*: for each impurity, not more than the area of the corresponding peak in the chromatogram obtained with reference solution (c) (0.2 per cent);
- *impurity F*: not more than the area of the principal peak in the chromatogram obtained with reference solution (a) (0.1 per cent);
- *unspecified impurities*: for each impurity, not more than the area of the principal peak in the chromatogram obtained with reference solution (a) (0.10 per cent);
- *total*: not more than 5 times the area of the principal peak in the chromatogram obtained with reference solution (a) (0.5 per cent);
- *disregard limit*: 0.5 times the area of the principal peak in the chromatogram obtained with reference solution (a) (0.05 per cent).

**Loss on drying** (2.2.32): maximum 0.5 per cent, determined on 1.000 g by drying in an oven at 105 °C.

**Sulfated ash** (2.4.14): maximum 0.1 per cent, determined on 1.0 g.

#### ASSAY

Dissolve 0.300 g in 80 mL of *anhydrous acetic acid R*. Using 0.3 mL of *naphtholbenzein solution R* as indicator, titrate with 0.1 M *perchloric acid* until the colour changes from brownish-yellow to green.

1 mL of 0.1 M *perchloric acid* is equivalent to 34.48 mg of  $C_{22}H_{17}ClN_2$ .

#### STORAGE

Protected from light.

#### IMPURITIES

*Specified impurities*: A, B, D, E, F.

*Other detectable impurities* (the following substances would, if present at a sufficient level, be detected by one or other of the tests in the monograph. They are limited by the general acceptance criterion for other/unspecified impurities and/or by the general monograph *Substances for pharmaceutical use* (2034). It is therefore not necessary to identify these impurities for demonstration of compliance. See also 5.10. *Control of impurities in substances for pharmaceutical use*): C.

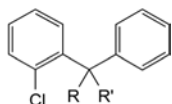

- A. R = OH, R' = C<sub>6</sub>H<sub>5</sub>: (2-chlorophenyl)diphenylmethanol,  
 C. R = Cl, R' = C<sub>6</sub>H<sub>5</sub>: 1-chloro-2-(chlorodiphenylmethyl)benzene,  
 E. R + R' = O: (2-chlorophenyl)phenylmethanone (2-chlorobenzophenone),

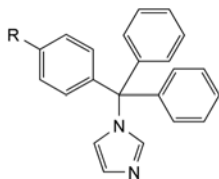

- B. R = Cl: 1-[(4-chlorophenyl)diphenylmethyl]-1H-imidazole,  
 F. R = H: 1-(triphenylmethyl)-1H-imidazole (deschloro-clotrimazole),



D. imidazole.

01/2008:0661

## CLOXACILLIN SODIUM

### Cloxacillinum natricum

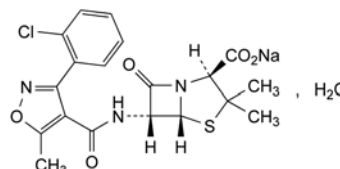

$C_{19}H_{17}ClN_3NaO_5S \cdot H_2O$   
 [7081-44-9]

$M_r$  475.9

#### DEFINITION

Sodium (2S,5R,6R)-6-[[[3-(2-chlorophenyl)-5-methylisoxazol-4-yl]carbonyl]amino]-3,3-dimethyl-7-oxo-4-thia-1-azabicyclo[3.2.0]heptane-2-carboxylate monohydrate.

Semi-synthetic product derived from a fermentation product.

*Content*: 95.0 per cent to 102.0 per cent (anhydrous substance).

#### CHARACTERS

*Appearance*: white or almost white, hygroscopic, crystalline powder.

*Solubility*: freely soluble in water and in methanol, soluble in ethanol (96 per cent).

#### IDENTIFICATION

*First identification*: A, D.

*Second identification*: B, C, D.

A. Infrared absorption spectrophotometry (2.2.24).

*Preparation*: discs.

*Comparison*: cloxacillin sodium CRS.

B. Thin-layer chromatography (2.2.27).

*Test solution*. Dissolve 25 mg of the substance to be examined in 5 mL of *water R*.

*Reference solution (a)*. Dissolve 25 mg of *cloxacillin sodium CRS* in 5 mL of *water R*.

*Reference solution (b)*. Dissolve 25 mg of *cloxacillin sodium CRS*, 25 mg of *dicloxacillin sodium CRS* and 25 mg of *flucloxacillin sodium CRS* in 5 mL of *water R*.

*Plate*: TLC silanised silica gel plate R.

*Mobile phase*: mix 30 volumes of *acetone R* and 70 volumes of a 154 g/L solution of *ammonium acetate R*, then adjust to pH 5.0 with *glacial acetic acid R*.

*Application*: 1 µL.

*Development*: over a path of 15 cm.

*Drying*: in air.

*Detection*: expose to iodine vapour until the spots appear; examine in daylight.

*System suitability*: reference solution (b):

- the chromatogram shows 3 clearly separated spots.

*Results*: the principal spot in the chromatogram obtained with the test solution is similar in position, colour and size to the principal spot in the chromatogram obtained with reference solution (a).

- C. Place about 2 mg in a test-tube about 150 mm long and 15 mm in diameter. Moisten with 0.05 mL of *water R* and add 2 mL of *sulfuric acid-formaldehyde reagent R*. Mix the contents of the tube by swirling; the solution is slightly greenish-yellow. Place the test-tube in a water-bath for 1 min; the solution becomes yellow.

D. It gives reaction (a) of sodium (2.3.1).

### TESTS

**Solution S.** Dissolve 2.50 g in carbon dioxide-free water R and dilute to 25.0 mL with the same solvent.

**Appearance of solution.** Solution S is clear (2.2.1) and its absorbance (2.2.25) at 430 nm is not greater than 0.04.

**pH (2.2.3):** 5.0 to 7.0 for solution S.

**Specific optical rotation (2.2.7):** + 160 to + 169 (anhydrous substance).

Dissolve 0.250 g in water R and dilute to 25.0 mL with the same solvent.

**Related substances.** Liquid chromatography (2.2.29).

**Test solution (a).** Dissolve 50.0 mg of the substance to be examined in the mobile phase and dilute to 50.0 mL with the mobile phase.

**Test solution (b).** Dilute 5.0 mL of test solution (a) to 50.0 mL with the mobile phase.

**Reference solution (a).** Dissolve 50.0 mg of cloxacillin sodium CRS in the mobile phase and dilute to 50.0 mL with the mobile phase. Dilute 5.0 mL of this solution to 50.0 mL with the mobile phase.

**Reference solution (b).** Dilute 5.0 mL of test solution (b) to 50.0 mL with the mobile phase.

**Reference solution (c).** Dissolve 5 mg of flucloxacillin sodium CRS and 5 mg of cloxacillin sodium CRS in the mobile phase and dilute to 50.0 mL with the mobile phase.

**Column:**

- size:  $l = 0.25$  m,  $\varnothing = 4$  mm;
- stationary phase: octadecylsilyl silica gel for chromatography R (5  $\mu$ m).

**Mobile phase:** mix 25 volumes of acetonitrile R and 75 volumes of a 2.7 g/L solution of potassium dihydrogen phosphate R adjusted to pH 5.0 with dilute sodium hydroxide solution R.

**Flow rate:** 1.0 mL/min.

**Detection:** spectrophotometer at 225 nm.

**Injection:** 20  $\mu$ L of test solution (a) and reference solutions (b) and (c).

**Run time:** 5 times the retention time of cloxacillin.

**System suitability:** reference solution (c):

- resolution: minimum 2.5 between the peaks due to cloxacillin (1<sup>st</sup> peak) and flucloxacillin (2<sup>nd</sup> peak).

**Limits:**

- any impurity: not more than the area of the principal peak in the chromatogram obtained with reference solution (b) (1.0 per cent);
- total: not more than 5 times the area of the principal peak in the chromatogram obtained with reference solution (b) (5.0 per cent);
- disregard limit: 0.05 times the area of the principal peak in the chromatogram obtained with reference solution (b) (0.05 per cent).

***N,N*-Dimethylaniline (2.4.26, Method B):** maximum 20 ppm.

**2-Ethylhexanoic acid (2.4.28):** maximum 0.8 per cent *m/m*.

**Water (2.5.12):** 3.0 per cent to 4.5 per cent, determined on 0.300 g.

**Bacterial endotoxins (2.6.14):** less than 0.20 IU/mg, if intended for use in the manufacture of parenteral preparations without a further appropriate procedure for the removal of bacterial endotoxins.

### ASSAY

Liquid chromatography (2.2.29) as described in the test for related substances with the following modifications.

**Injection:** test solution (b) and reference solution (a).

**System suitability:**

- repeatability: maximum relative standard deviation of 1.0 per cent after 6 injections of reference solution (a).

Calculate the percentage content of  $C_{19}H_{17}ClN_3NaO_5S$  from the declared content of cloxacillin sodium CRS.

### STORAGE

In an airtight container, at a temperature not exceeding 25 °C. If the substance is sterile, store in a sterile, airtight, tamper-proof container.

### IMPURITIES

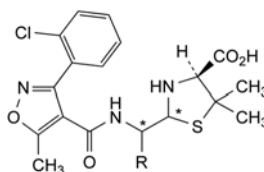

- A. R = CO<sub>2</sub>H: (4*S*)-2-[carboxy[[[3-(2-chlorophenyl)-5-methylisoxazol-4-yl]carbonyl]amino]methyl]-5,5-dimethylthiazolidine-4-carboxylic acid (penicilloic acid of cloxacillin),
- B. R = H: (2*R,S*,4*S*)-2-[[[3-(2-chlorophenyl)-5-methylisoxazol-4-yl]carbonyl]amino]methyl]-5,5-dimethylthiazolidine-4-carboxylic acid (penilloic acid of cloxacillin),

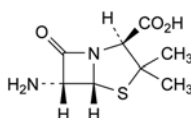

- C. (2*S*,5*R*,6*R*)-6-amino-3,3-dimethyl-7-oxo-4-thia-1-azabicyclo[3.2.0]heptane-2-carboxylic acid (6-aminopenicillanic acid),

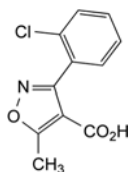

- D. 3-(2-chlorophenyl)-5-methylisoxazole-4-carboxylic acid,

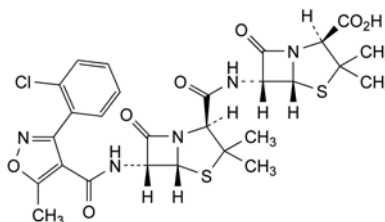

- E. (2*S*,5*R*,6*R*)-6-[[[(2*S*,5*R*,6*R*)-6-[[[3-(2-chlorophenyl)-5-methylisoxazol-4-yl]carbonyl]amino]-3,3-dimethyl-7-oxo-4-thia-1-azabicyclo[3.2.0]hept-2-yl]carbonyl]amino]-3,3-dimethyl-7-oxo-4-thia-1-azabicyclo[3.2.0]heptane-2-carboxylic acid (6-APA cloxacillin amide).

## CLOZAPINE

## Clozapinum

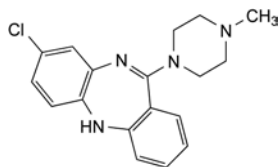

$C_{18}H_{19}ClN_4$   
[5786-21-0]

$M_r$  326.8

## DEFINITION

8-Chloro-11-(4-methylpiperazin-1-yl)-5H-dibenzo[b,e][1,4]-diazepine.

*Content*: 99.0 per cent to 101.0 per cent (dried substance).

## CHARACTERS

*Appearance*: yellow, crystalline powder.

*Solubility*: practically insoluble in water, freely soluble in methylene chloride, soluble in ethanol (96 per cent). It dissolves in dilute acetic acid.

## IDENTIFICATION

A. Melting point (2.2.14): 182 °C to 186 °C.

B. Infrared absorption spectrophotometry (2.2.24).

*Comparison*: clozapine CRS.

## TESTS

**Related substances.** Liquid chromatography (2.2.29).

*Solvent mixture*: water R, methanol R2 (20:80 V/V).

*Solution A.* Dissolve 2.04 g of potassium dihydrogen phosphate R in 1000 mL of water R and adjust to pH 2.4 ± 0.05 with dilute phosphoric acid R.

*Test solution.* Dissolve 75 mg of the substance to be examined in 80 mL of methanol R2 and dilute to 100 mL with water R.

*Reference solution (a).* Dilute 1.0 mL of the test solution to 10.0 mL with the solvent mixture. Dilute 1.0 mL of this solution to 100.0 mL with the solvent mixture.

*Reference solution (b).* Dissolve the contents of a vial of clozapine for peak identification CRS (containing impurities A, B, C and D) in 1.0 mL of the solvent mixture.

*Column*:

- size:  $l = 0.125$  m,  $\varnothing = 4.6$  mm;
- stationary phase: end-capped octadecylsilyl silica gel for chromatography R (5  $\mu$ m).

*Mobile phase*:

- mobile phase A: acetonitrile for chromatography R, methanol R2, solution A (1:1:8 V/V/V);
- mobile phase B: acetonitrile for chromatography R, methanol R2, solution A (4:4:2 V/V/V);

Time (min)	Mobile phase A (per cent V/V)	Mobile phase B (per cent V/V)
0 - 4	100	0
4 - 24	100 → 0	0 → 100
24 - 29	0	100

*Flow rate*: 1.2 mL/min.

*Detection*: spectrophotometer at 257 nm.

*Injection*: 20  $\mu$ L.

*Identification of impurities*: use the chromatogram supplied with clozapine for peak identification CRS and the chromatogram obtained with reference solution (b) to identify the peaks due to impurities A, B, C and D.

01/2008:1191 *Relative retention* with reference to clozapine (retention time = about 11 min): impurity C = about 0.9; impurity D = about 1.1; impurity A = about 1.6; impurity B = about 1.7.

*System suitability*: reference solution (b):

- *resolution*: minimum 2.5 between the peaks due to impurity C and clozapine;
- the chromatogram obtained with reference solution (b) is similar to the chromatogram supplied with clozapine for peak identification CRS.

*Limits*:

- *correction factor*: for the calculation of content, multiply the peak area of impurity D by 2.7;
- *impurity A*: not more than the area of the principal peak in the chromatogram obtained with reference solution (a) (0.1 per cent);
- *impurities B, D*: for each impurity, not more than twice the area of the principal peak in the chromatogram obtained with reference solution (a) (0.2 per cent);
- *impurity C*: not more than 3 times the area of the principal peak in the chromatogram obtained with reference solution (a) (0.3 per cent);
- *unspecified impurities*: for each impurity, not more than the area of the principal peak in the chromatogram obtained with reference solution (a) (0.10 per cent);
- *total*: not more than 6 times the area of the principal peak in the chromatogram obtained with reference solution (a) (0.6 per cent);
- *disregard limit*: 0.5 times the area of the principal peak in the chromatogram obtained with reference solution (a) (0.05 per cent).

**Heavy metals** (2.4.8): maximum 20 ppm.

1.0 g complies with test C. Prepare the reference solution using 2 mL of lead standard solution (10 ppm Pb) R.

**Loss on drying** (2.2.32): maximum 0.5 per cent, determined on 1.000 g by drying in an oven at 105 °C.

**Sulfated ash** (2.4.14): maximum 0.1 per cent, determined on 1.0 g.

## ASSAY

Dissolve 0.100 g in 50 mL of anhydrous acetic acid R. Titrate with 0.1 M perchloric acid, determining the end-point potentiometrically (2.2.20).

1 mL of 0.1 M perchloric acid is equivalent to 16.34 mg of  $C_{18}H_{19}ClN_4$ .

## IMPURITIES

*Specified impurities*: A, B, C, D.

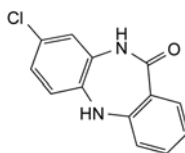

A. 8-chloro-5,10-dihydro-11H-dibenzo[b,e][1,4]diazepin-11-one,

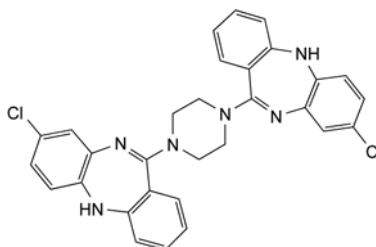

B. 11,11'-(piperazine-1,4-diyl)bis(8-chloro-5H-dibenzo[b,e][1,4]diazepine),

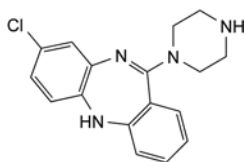
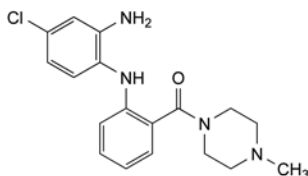
C. 8-chloro-11-(piperazin-1-yl)-5H-dibenzo[*b,e*][1,4]diazepine,

D. 1-[2-[(2-amino-4-chlorophenyl)amino]benzoyl]-4-methylpiperazine.

01/2008:0073  
corrected 6.0

## COCAINE HYDROCHLORIDE

## Cocaini hydrochloridum

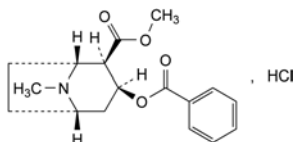
C<sub>17</sub>H<sub>22</sub>ClNO<sub>4</sub>  
[53-21-4]M<sub>r</sub> 339.8

## DEFINITION

Methyl (1*R*,2*R*,3*S*,5*S*)-3-(benzoyloxy)-8-methyl-8-azabicyclo[3.2.1]octane-2-carboxylate hydrochloride.*Content*: 98.5 per cent to 101.0 per cent (dried substance).

## CHARACTERS

*Appearance*: white or almost white, crystalline powder or colourless crystals.*Solubility*: very soluble in water, freely soluble in alcohol, slightly soluble in methylene chloride.

mp: about 197 °C, with decomposition.

## IDENTIFICATION

*First identification*: B, D.*Second identification*: A, C, D, E.

A. Dissolve 20.0 mg in 0.01 M hydrochloric acid and dilute to 100.0 mL with the same acid. Dilute 5.0 mL of the solution to 50.0 mL with 0.01 M hydrochloric acid. Examined between 220 nm and 350 nm (2.2.25), the solution shows 2 absorption maxima, at 233 nm and 273 nm. The specific absorbance at 233 nm is 378 to 402.

B. Infrared absorption spectrophotometry (2.2.24).

*Comparison*: Ph. Eur. reference spectrum of cocaine hydrochloride.

C. Dissolve 0.1 g in 5 mL of water R and add 1 mL of dilute ammonia R2. A white precipitate is formed. Initiate crystallisation by scratching the wall of the tube with a glass rod. The crystals, washed with water R and dried in vacuo, melt (2.2.14) at 96 °C to 99 °C.

D. It gives reaction (a) of chlorides (2.3.1).

E. It gives the reaction of alkaloids (2.3.1).

## TESTS

**Solution S.** Dissolve 0.5 g in water R and dilute to 25 mL with the same solvent.**Appearance of solution.** Solution S is clear (2.2.1) and colourless (2.2.2, Method II).**Acidity.** To 10 mL of solution S add 0.05 mL of methyl red solution R. Not more than 0.2 mL of 0.02 M sodium hydroxide is required to change the colour of the indicator.**Specific optical rotation** (2.2.7): –70 to –73 (dried substance). Dissolve 0.50 g in water R and dilute to 20.0 mL with the same solvent.**Readily carbonisable substances.** To 0.2 g add 2 mL of sulfuric acid R. After 15 min, the solution is not more intensely coloured than reference solution BY<sub>5</sub> (2.2.2, Method I).**Related substances.** Examine by liquid chromatography (2.2.29).*Test solution.* Dissolve 25.0 mg of the substance to be examined in the mobile phase and dilute to 50.0 mL with the mobile phase.*Reference solution (a).* Dilute 1.0 mL of the test solution to 50.0 mL with the mobile phase. Dilute 5.0 mL of this solution to 100.0 mL with the mobile phase.*Reference solution (b).* Dissolve 25 mg of the substance to be examined in 0.01 M sodium hydroxide and dilute to 10.0 mL with the same solvent. Dilute 1.0 mL of the solution to 10.0 mL with 0.01 M sodium hydroxide. Allow the solution to stand for 15 min.*Column*:– size: *l* = 0.15 m, Ø = 4.6 mm,– stationary phase: end-capped octadecylsilyl silica gel for chromatography R (5 µm) with a specific surface area of 335 m<sup>2</sup>/g, a pore size of 10 nm and a carbon loading of 19.1 per cent,

– temperature: 35 °C.

*Mobile phase*: triethylamine R, tetrahydrofuran R, acetonitrile R, water R (0.5:100:430:479.5 V/V/V/V).*Flow rate*: 1 mL/min.*Detection*: spectrophotometer at 216 nm.*Injection*: 20 µL.*Relative retention* with reference to cocaine (retention time = about 7.4 min): degradation product = about 0.7.*System suitability*: reference solution (b):

– resolution: minimum of 5 between the peaks due to cocaine and to the degradation product.

*Limits*:

– any impurity eluting after the principal peak: not more than the area of the principal peak in the chromatogram obtained with reference solution (a) (0.1 per cent),

– total: not more than 5 times the area of the principal peak in the chromatogram obtained with reference solution (a) (0.5 per cent),

– disregard limit: 0.5 times the area of the principal peak in the chromatogram obtained with reference solution (a) (0.05 per cent).

**Loss on drying** (2.2.32): maximum 0.5 per cent, determined on 1.000 g by drying in an oven at 105 °C.**Sulfated ash** (2.4.14): maximum 0.1 per cent, determined on the residue from the test for loss on drying.

## ASSAY

Dissolve 0.250 g in a mixture of 5.0 mL of 0.01 M hydrochloric acid and 50 mL of alcohol R. Carry out a potentiometric titration (2.2.20), using 0.1 M sodium hydroxide. Read the volume added between the 2 points of inflexion.

1 mL of 0.1 M sodium hydroxide is equivalent to 33.98 mg of C<sub>17</sub>H<sub>22</sub>ClNO<sub>4</sub>.

## STORAGE

Protected from light.

## IMPURITIES

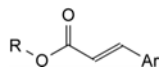
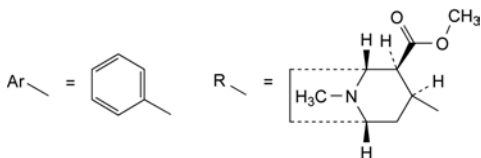

- A. methyl (1*R*,2*R*,3*S*,5*S*)-8-methyl-3-[[*E*]-3-phenylpropenoyl]oxy]-8-azabicyclo[3.2.1]octane-2-carboxylate (cinnamoylcocaine),

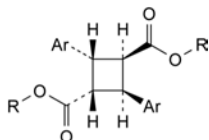

- B. bis[(1*R*,2*R*,3*S*,5*S*)-2-(methoxycarbonyl)-8-methyl-8-azabicyclo[3.2.1]oct-3-yl] (1*r*,2*c*,3*t*,4*t*)-2,4-diphenylcyclobutane-1,3-dicarboxylate ( $\alpha$ -truxilline),

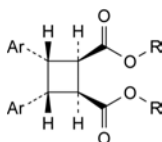

- C. bis[(1*R*,2*R*,3*S*,5*S*)-2-(methoxycarbonyl)-8-methyl-8-azabicyclo[3.2.1]oct-3-yl] (1*r*,2*c*,3*t*,4*t*)-3,4-diphenylcyclobutane-1,2-dicarboxylate ( $\beta$ -truxilline).

01/2010:1410

## COCONUT OIL, REFINED

## Cocois oleum raffinatum

[8001-31-8]

## DEFINITION

Fatty oil obtained from the dried, solid part of the endosperm of *Cocos nucifera* L., then refined.

## CHARACTERS

*Appearance*: white or almost white, unctuous mass.

*Solubility*: practically insoluble in water, freely soluble in methylene chloride and in light petroleum (bp: 65-70 °C), very slightly soluble in ethanol (96 per cent).

*Refractive index*: about 1.449, determined at 40 °C.

## IDENTIFICATION

- A. Melting point (see Tests).  
B. Composition of fatty acids (see Tests).

## TESTS

**Melting point** (2.2.14): 23 °C to 26 °C.

**Acid value** (2.5.1): maximum 0.5, determined on 20.0 g.

**Peroxide value** (2.5.5, Method A): maximum 5.0.

**Unsaponifiable matter** (2.5.7): maximum 1.0 per cent, determined on 5.0 g.

**Alkaline impurities** (2.4.19). It complies with the test.

**Composition of fatty acids** (2.4.22, Method B). Refined coconut oil is melted under gentle heating to a homogeneous liquid prior to sampling.

*Reference solution*. Dissolve 15.0 mg of *tricaproin CRS*, 80.0 mg of *tristearin CRS*, 0.150 g of *tricaprin CRS*, 0.200 g of *tricaprylin CRS*, 0.450 g of *trimyristin CRS* and 1.25 g of *trilaurin CRS* in a mixture of 2 volumes of *methylene chloride R* and 8 volumes of *heptane R*, then dilute to 50 mL with the same mixture of solvents heating at 45-50 °C. Transfer 2 mL of this mixture to a 10 mL centrifuge tube with a screw cap and evaporate the solvent in a current of *nitrogen R*. Dissolve with 1 mL of *heptane R* and 1 mL of *dimethyl carbonate R* and mix vigorously under gentle heating (50-60 °C). Add, while still warm, 1 mL of a 12 g/L solution of *sodium R* in *anhydrous methanol R*, prepared with the necessary precautions, and mix vigorously for about 5 min. Add 3 mL of *distilled water R* and mix vigorously for about 30 s. Centrifuge for 15 min at 1500 *g*. Inject 1  $\mu$ L of the organic phase.

Calculate the percentage content of each fatty acid using the following expression:

$$\frac{A_{x,s,c}}{\sum A_{x,s,c}} \times 100 \text{ per cent } m/m$$

$A_{x,s,c}$  is the corrected peak area of each fatty acid in the test solution:

$$A_{x,s,c} = A_{x,s} \times R_c$$

$R_c$  is the relative correction factor:

$$R_c = \frac{m_{x,r} \times A_{1,r}}{A_{x,r} \times m_{1,r}}$$

for the peaks due to caproic, caprylic, capric, lauric and myristic acid methyl esters.

$m_{x,r}$  = mass of tricaproin, tricapyrin, tricaprillin, trilaurin or trimyristin in the reference solution, in milligrams;

$m_{1,r}$  = mass of tristearin in the reference solution, in milligrams;

$A_{x,r}$  = area of the peaks due to caproic, caprylic, capric, lauric and myristic acid methyl esters in the reference solution;

$A_{1,r}$  = area of the peak due to stearic acid methyl ester in the reference solution;

$A_{x,s}$  = area of the peaks due to any specified or unspecified fatty acid methyl esters;

$R_c$  = 1 for the peaks due to each of the remaining specified fatty acid methyl esters or any unspecified fatty acid methyl ester.

*Composition of the fatty-acid fraction of the oil*:

- *caproic acid* ( $R_{Rt}$  0.11): maximum 1.5 per cent,
- *caprylic acid* ( $R_{Rt}$  0.23): 5.0 per cent to 11.0 per cent,
- *capric acid* ( $R_{Rt}$  0.56): 4.0 per cent to 9.0 per cent,
- *lauric acid* ( $R_{Rt}$  0.75): 40.0 per cent to 50.0 per cent,
- *myristic acid* ( $R_{Rt}$  0.85): 15.0 per cent to 20.0 per cent,
- *palmitic acid* ( $R_{Rt}$  0.93): 7.0 per cent to 12.0 per cent,
- *stearic acid* ( $R_{Rt}$  1.00): 1.5 per cent to 5.0 per cent,
- *oleic acid and isomers* ( $R_{Rt}$  1.01): 4.0 per cent to 10.0 per cent,
- *linoleic acid* ( $R_{Rt}$  1.03): 1.0 per cent to 3.0 per cent,
- *linolenic acid* ( $R_{Rt}$  1.06): maximum 0.2 per cent,
- *arachidic acid* ( $R_{Rt}$  1.10): maximum 0.2 per cent,
- *eicosenoic acid* ( $R_{Rt}$  1.11): maximum 0.2 per cent.

**Water** (2.5.32): maximum 0.1 per cent, determined on 1.00 g.

## STORAGE

In a well-filled container, protected from light.

01/2008:1411 *Composition of the fatty alcohol fraction of the substance:***COCOYL CAPRYLOCAPRATE****Cocoylis caprylocapras****DEFINITION**

Mixture of esters of saturated C<sub>12</sub> - C<sub>18</sub> alcohols with caprylic (octanoic) and capric (decanoic) acids obtained by the reaction of these acids with vegetable saturated fatty alcohols.

**CHARACTERS**

*Appearance:* slightly yellowish liquid.

*Solubility:* practically insoluble in water, miscible with ethanol (96 per cent) and with liquid paraffin.

*Relative density:* about 0.86.

*Refractive index:* about 1.445.

*Viscosity:* about 11 mPas.

**IDENTIFICATION**

A. Freezing point (2.2.18): maximum 15 °C.

B. Infrared absorption spectrophotometry (2.2.24).

*Comparison:* cocoyl caprylocaprate CRS.

C. Composition of fatty acids and fatty alcohols (see Tests).

**TESTS**

**Appearance.** The substance to be examined is not more intensely coloured than reference solution Y<sub>5</sub> (2.2.2, Method I).

**Acid value** (2.5.1): maximum 0.5, determined on 5.00 g.

**Hydroxyl value** (2.5.3, Method A): maximum 5.0.

**Iodine value** (2.5.4, Method A): maximum 1.0.

**Saponification value** (2.5.6): 160 to 173.

**Composition of fatty acids and fatty alcohols** (2.4.22, Method C). Use the chromatogram obtained with the following reference solution for identification of the peaks due to the fatty alcohols.

*Reference solution.* Dissolve the amounts of the substances listed in the following table in 10 mL of *heptane R*.

Substance	Amount (mg)
<i>Methyl caproate R</i>	10
<i>Methyl caprylate R</i>	90
<i>Methyl caprate R</i>	50
<i>Methyl laurate R</i>	20
<i>Methyl myristate R</i>	10
<i>Methyl palmitate R</i>	10
<i>Methyl stearate R</i>	10
<i>Capric alcohol R</i>	10
<i>Lauryl alcohol R</i>	100
<i>Myristyl alcohol R</i>	40
<i>Cetyl alcohol CRS</i>	30
<i>Stearyl alcohol CRS</i>	20

Consider the sum of the areas of the peaks due to the fatty acids listed below to be equal to 100 and the sum of the areas of the peaks due to the fatty alcohols listed below to be equal to 100.

*Composition of the fatty acid fraction of the substance:*

- *caproic acid:* maximum 2.0 per cent,
- *caprylic acid:* 50.0 per cent to 80.0 per cent,
- *capric acid:* 20.0 per cent to 50.0 per cent,
- *lauric acid:* maximum 3.0 per cent,
- *myristic acid:* maximum 2.0 per cent.

*Composition of the fatty alcohol fraction of the substance:*

- *capric alcohol:* maximum 3.0 per cent,
- *lauryl alcohol:* 48.0 per cent to 63.0 per cent,
- *myristyl alcohol:* 18.0 per cent to 27.0 per cent,
- *cetyl alcohol:* 6.0 per cent to 13.0 per cent,
- *stearyl alcohol:* 9.0 per cent to 16.0 per cent.

**Water** (2.5.12): maximum 0.1 per cent, determined on 5.00 g.

**Total ash** (2.4.16): maximum 0.1 per cent, determined on 1.0 g.

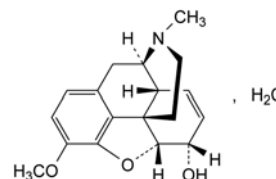
04/2008:0076  
corrected 7.0**CODEINE****Codeinum**

C<sub>18</sub>H<sub>21</sub>NO<sub>3</sub>·H<sub>2</sub>O  
[6059-47-8]

M<sub>r</sub> 317.4

**DEFINITION**

7,8-Didehydro-4,5α-epoxy-3-methoxy-17-methylmorphinan-6α-ol monohydrate.

*Content:* 99.0 per cent to 101.0 per cent (dried substance).

**CHARACTERS**

*Appearance:* white or almost white, crystalline powder or colourless crystals.

*Solubility:* soluble in boiling water, freely soluble in ethanol (96 per cent).

**IDENTIFICATION**

*First identification:* A, C.

*Second identification:* A, B, D, E.

A. Melting point (2.2.14): 155 °C to 159 °C.

B. Ultraviolet and visible absorption spectrophotometry (2.2.25).

*Test solution.* To 2.0 mL of solution S (see Tests) add 50 mL of *water R* then 10 mL of 1 M *sodium hydroxide* and dilute to 100.0 mL with *water R*.

*Spectral range:* 250-350 nm.

*Absorption maximum:* at 284 nm.

*Specific absorbance at the absorption maximum:* about 50 (dried substance).

C. Infrared absorption spectrophotometry (2.2.24).

*Preparation:* dried substance prepared as a disc of *potassium bromide R*.

*Comparison:* codeine CRS.

D. To about 10 mg add 1 mL of *sulfuric acid R* and 0.05 mL of *ferric chloride solution R2* and heat on a water-bath. A blue colour develops. Add 0.05 mL of *nitric acid R*. The colour changes to red.

E. It gives the reaction of alkaloids (2.3.1).

**TESTS**

**Solution S.** Dissolve 50 mg in *carbon dioxide-free water R* and dilute to 10.0 mL with the same solvent.

**Appearance of solution.** Solution S is clear (2.2.1) and colourless (2.2.2, Method II).



**Specific optical rotation** (2.2.7): – 142 to – 146 (dried substance).

Dissolve 0.50 g in *ethanol* (96 per cent) *R* and dilute to 25.0 mL with the same solvent.

**Related substances.** Liquid chromatography (2.2.29).

**Test solution.** Dissolve 0.100 g of the substance to be examined and 0.100 g of *sodium octanesulfonate R* in the mobile phase and dilute to 10.0 mL with the mobile phase.

**Reference solution (a).** Dissolve 5.0 mg of *codeine impurity A CRS* in the mobile phase and dilute to 5.0 mL with the mobile phase.

**Reference solution (b).** Dilute 1.0 mL of reference solution (a) to 20.0 mL with the mobile phase.

**Reference solution (c).** Dilute 1.0 mL of the test solution to 50.0 mL with the mobile phase. Dilute 5.0 mL of this solution to 100.0 mL with the mobile phase.

**Reference solution (d).** To 0.25 mL of the test solution, add 2.5 mL of reference solution (a).

**Column:**

- size:  $l = 0.25$  m,  $\varnothing = 4.6$  mm;
- stationary phase: end-capped octylsilyl silica gel for chromatography *R* (5  $\mu$ m).

**Mobile phase:** dissolve 1.08 g of *sodium octanesulfonate R* in a mixture of 20 mL of *glacial acetic acid R* and 250 mL of *acetonitrile R* and dilute to 1000 mL with *water R*.

**Flow rate:** 2 mL/min.

**Detection:** spectrophotometer at 245 nm.

**Injection:** 10  $\mu$ L.

**Run time:** 10 times the retention time of codeine.

**Relative retention** with reference to codeine (retention time = about 6 min): impurity B = about 0.6; impurity E = about 0.7; impurity A = about 2.0; impurity C = about 2.3; impurity D = about 3.6.

**System suitability:** reference solution (d):

- resolution: minimum 3 between the peaks due to codeine and impurity A.

**Limits:**

- correction factor: for the calculation of content, multiply the peak area of impurity C by 0.25;
- impurity A: not more than twice the area of the principal peak in the chromatogram obtained with reference solution (b) (1.0 per cent);
- impurities B, C, D, E: for each impurity, not more than twice the area of the principal peak in the chromatogram obtained with reference solution (c) (0.2 per cent);
- unspecified impurities: for each impurity, not more than the area of the principal peak in the chromatogram obtained with reference solution (c) (0.10 per cent);
- sum of impurities other than A: not more than 10 times the area of the principal peak in the chromatogram obtained with reference solution (c) (1.0 per cent);
- disregard limit: 0.5 times the area of the principal peak in the chromatogram obtained with reference solution (c) (0.05 per cent).

**Loss on drying** (2.2.32): 4.0 per cent to 6.0 per cent, determined on 1.000 g by drying in an oven at 105 °C.

**Sulfated ash** (2.4.14): maximum 0.1 per cent, determined on 1.0 g.

**ASSAY**

Dissolve 0.250 g in 10 mL of *anhydrous acetic acid R*. Add 20 mL of *dioxan R*. Titrate with 0.1 M *perchloric acid*, using 0.05 mL of *crystal violet solution R* as indicator.

1 mL of 0.1 M *perchloric acid* is equivalent to 29.94 mg of  $C_{18}H_{21}NO_3$ .

**STORAGE**

Protected from light.

**IMPURITIES**

**Specified impurities:** A, B, C, D, E.

**Other detectable impurities** (the following substances would, if present at a sufficient level, be detected by one or other of the tests in the monograph. They are limited by the general acceptance criterion for other/unspecified impurities and/or by the general monograph *Substances for pharmaceutical use* (2034). It is therefore not necessary to identify these impurities for demonstration of compliance. See also 5.10. *Control of impurities in substances for pharmaceutical use*): F, G.

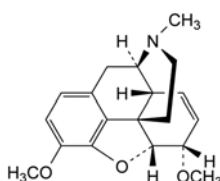

A. 7,8-dihydro-4,5 $\alpha$ -epoxy-3,6 $\alpha$ -dimethoxy-17-methylmorphinan (methylcodeine),

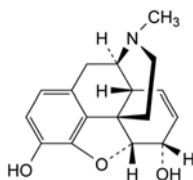

B. 7,8-dihydro-4,5 $\alpha$ -epoxy-17-methylmorphinan-3,6 $\alpha$ -diol (morphine),

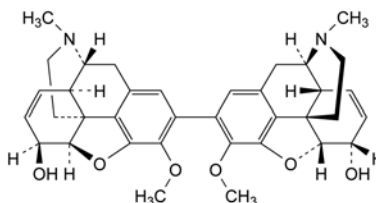

C. 7,7',8,8'-tetrahydro-4,5 $\alpha$ :4',5' $\alpha$ -diepoxy-3,3'-dimethoxy-17,17'-dimethyl-2,2'-bimorphinan-6 $\alpha$ ,6' $\alpha$ -diol (codeine dimer),

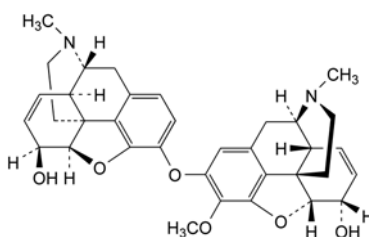

D. 7,8-dihydro-2-[(7,8-dihydro-4,5 $\alpha$ -epoxy-6 $\alpha$ -hydroxy-17-methylmorphinan-3-yl)oxy]-4,5 $\alpha$ -epoxy-3-methoxy-17-methylmorphinan-6 $\alpha$ -ol (3-O-(codein-2-yl)morphine),

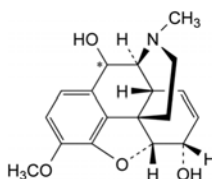

E. 7,8-dihydro-4,5 $\alpha$ -epoxy-3-methoxy-17-methylmorphinan-6 $\alpha$ ,10-diol,

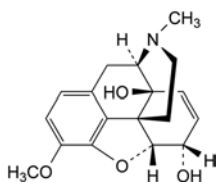

F. 7,8-didehydro-4,5 $\alpha$ -epoxy-3-methoxy-17-methylmorphinan-6 $\alpha$ ,14-diol,

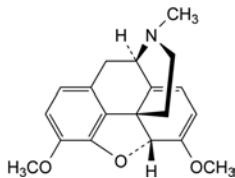

G. 6,7,8,14-tetrahydro-4,5 $\alpha$ -epoxy-3,6-dimethoxy-17-methylmorphinan (thebaine).

01/2008:1412

## CODEINE HYDROCHLORIDE DIHYDRATE

Codeini hydrochloridum dihydricum

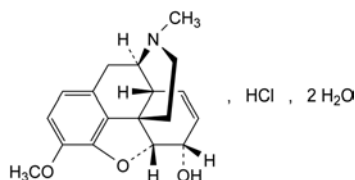

$C_{18}H_{22}ClNO_3 \cdot 2H_2O$

$M_r$  371.9

### DEFINITION

7,8-Didehydro-4,5 $\alpha$ -epoxy-3-methoxy-17-methylmorphinan-6 $\alpha$ -ol hydrochloride dihydrate.

*Content*: 99.0 per cent to 101.0 per cent (anhydrous substance).

### CHARACTERS

*Appearance*: white or almost white, crystalline powder or small, colourless crystals.

*Solubility*: soluble in water, slightly soluble in ethanol (96 per cent), practically insoluble in cyclohexane.

### IDENTIFICATION

*First identification*: A, D.

*Second identification*: B, C, D, E.

A. Infrared absorption spectrophotometry (2.2.24).

*Comparison*: Ph. Eur. reference spectrum of codeine hydrochloride dihydrate.

B. To 5 mL of solution S (see Tests) add 1 mL of a mixture of equal volumes of *strong sodium hydroxide solution R* and *water R* and initiate crystallisation, if necessary, by scratching the wall of the tube with a glass rod and cooling in iced water. Wash the precipitate with *water R* and dry at 100–105 °C. It melts (2.2.15) at 155 °C to 159 °C.

C. To about 10 mg add 1 mL of *sulfuric acid R* and 0.05 mL of *ferric chloride solution R2* and heat on a water-bath. A blue colour develops. Add 0.05 mL of *nitric acid R*. The colour changes to red.

D. Solution S gives reaction (a) of chlorides (2.3.1).

E. It gives the reaction of alkaloids (2.3.1).

### TESTS

**Solution S.** Dissolve 2.00 g in *carbon dioxide-free water R* prepared from *distilled water R* and dilute to 50.0 mL with the same solvent.

**Appearance of solution.** Solution S is clear (2.2.1) and not more intensely coloured than reference solution Y<sub>6</sub> (2.2.2, *Method II*).

**Acidity or alkalinity.** To 5 mL of solution S add 5 mL of *carbon dioxide-free water R*. Add 0.05 mL of *methyl red solution R* and 0.2 mL of 0.02 M *hydrochloric acid*; the solution is red. Add 0.4 mL of 0.02 M *sodium hydroxide*; the solution becomes yellow.

**Specific optical rotation** (2.2.7): –117 to –121 (anhydrous substance).

Dilute 5.0 mL of solution S to 10.0 mL with *water R*.

**Related substances.** Liquid chromatography (2.2.29).

*Test solution.* Dissolve 0.100 g of the substance to be examined and 0.100 g of *sodium octanesulfonate R* in the mobile phase and dilute to 10.0 mL with the mobile phase.

*Reference solution (a).* Dissolve 5.0 mg of *codeine impurity A CRS* in the mobile phase and dilute to 5.0 mL with the mobile phase.

*Reference solution (b).* Dilute 1.0 mL of reference solution (a) to 20.0 mL with the mobile phase.

*Reference solution (c).* Dilute 1.0 mL of the test solution to 50.0 mL with the mobile phase. Dilute 5.0 mL of this solution to 100.0 mL with the mobile phase.

*Reference solution (d).* To 0.25 mL of the test solution add 2.5 mL of reference solution (a).

*Column*:

– *size*:  $l = 0.25$  m,  $\varnothing = 4.6$  mm;

– *stationary phase*: end-capped octylsilyl silica gel for chromatography R (5  $\mu$ m).

*Mobile phase*: dissolve 1.08 g of *sodium octanesulfonate R* in a mixture of 20 mL of *glacial acetic acid R* and 250 mL of *acetonitrile R* and dilute to 1000 mL with *water R*.

*Flow rate*: 2 mL/min.

*Detection*: spectrophotometer at 245 nm.

*Injection*: 10  $\mu$ L.

*Run time*: 10 times the retention time of codeine.

*Relative retention* with reference to codeine (retention time = about 6 min): impurity B = about 0.6; impurity E = about 0.7; impurity A = about 2.0; impurity C = about 2.3; impurity D = about 3.6.

*System suitability*: reference solution (d):

– *resolution*: minimum 3 between the peaks due to codeine and impurity A.

*Limits*:

– *correction factor*: for the calculation of content, multiply the peak area of impurity C by 0.25;

– *impurity A*: not more than twice the area of the principal peak in the chromatogram obtained with reference solution (b) (1.0 per cent);

– *impurities B, C, D, E*: for each impurity, not more than twice the area of the principal peak in the chromatogram obtained with reference solution (c) (0.2 per cent);

– *unspecified impurities*: for each impurity, not more than the area of the principal peak in the chromatogram obtained with reference solution (c) (0.10 per cent);

– *sum of impurities other than A*: not more than 10 times the area of the principal peak in the chromatogram obtained with reference solution (c) (1.0 per cent);

– *disregard limit*: 0.5 times the area of the principal peak in the chromatogram obtained with reference solution (c) (0.05 per cent).

**Sulfates** (2.4.13): maximum 0.1 per cent.

Dilute 5 mL of solution S to 20 mL with *distilled water R*.

**Water** (2.5.12): 8.0 per cent to 10.5 per cent, determined on 0.250 g.

## ASSAY

Dissolve 0.300 g in a mixture of 5 mL of 0.01 M hydrochloric acid R and 30 mL of ethanol (96 per cent) R. Carry out a potentiometric titration (2.2.20), using 0.1 M sodium hydroxide. Read the volume added between the 2 points of inflexion.

1 mL of 0.1 M sodium hydroxide is equivalent to 33.59 mg of  $C_{18}H_{22}ClNO_3$ .

## STORAGE

Protected from light.

## IMPURITIES

Specified impurities: A, B, C, D, E.

Other detectable impurities (the following substances would, if present at a sufficient level, be detected by one or other of the tests in the monograph. They are limited by the general acceptance criterion for other/unspecified impurities and/or by the general monograph *Substances for pharmaceutical use* (2034). It is therefore not necessary to identify these impurities for demonstration of compliance. See also 5.10. *Control of impurities in substances for pharmaceutical use*): F, G.

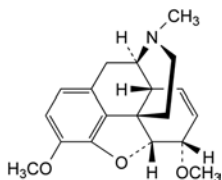

- A. 7,8-didehydro-4,5 $\alpha$ -epoxy-3,6 $\alpha$ -dimethoxy-17-methylmorphinan (methylcodeine),

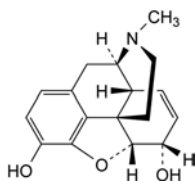

- B. 7,8-didehydro-4,5 $\alpha$ -epoxy-17-methylmorphinan-3,6 $\alpha$ -diol (morphine),

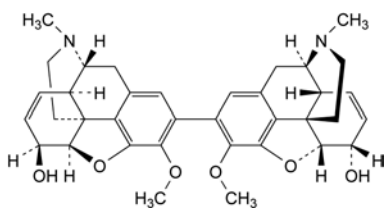

- C. 7,7',8,8'-tetrahydro-4,5 $\alpha$ :4',5' $\alpha$ -diepoxy-3,3'-dimethoxy-17,17'-dimethyl-2,2'-bimorphinanyl-6 $\alpha$ ,6' $\alpha$ -diol (codeine dimer),

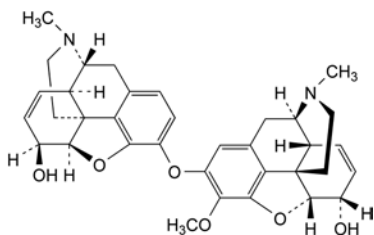

- D. 7,8-didehydro-2-[(7,8-didehydro-4,5 $\alpha$ -epoxy-6 $\alpha$ -hydroxy-17-methylmorphinan-3-yl)oxy]-4,5 $\alpha$ -epoxy-3-methoxy-17-methylmorphinan-6 $\alpha$ -ol (3-O-(codein-2-yl)morphine),

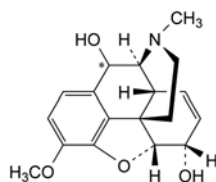

- E. 7,8-didehydro-4,5 $\alpha$ -epoxy-3-methoxy-17-methylmorphinan-6 $\alpha$ ,10-diol,

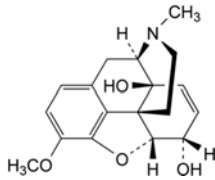

- F. 7,8-didehydro-4,5 $\alpha$ -epoxy-3-methoxy-17-methylmorphinan-6 $\alpha$ ,14-diol,

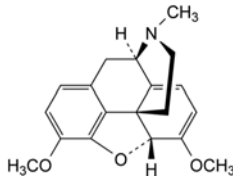

- G. 6,7,8,14-tetrahydro-4,5 $\alpha$ -epoxy-3,6-dimethoxy-17-methylmorphinan (thebaine).

01/2011:0074

## CODEINE PHOSPHATE HEMIHYDRATE

Codeini phosphas hemihydricus

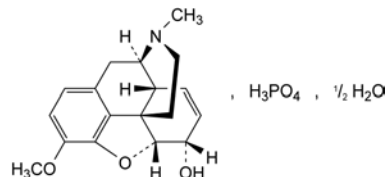

$C_{18}H_{24}NO_7P \cdot \frac{1}{2}H_2O$   
[41444-62-6]

 $M_r$  406.4

## DEFINITION

7,8-Didehydro-4,5 $\alpha$ -epoxy-3-methoxy-17-methylmorphinan-6 $\alpha$ -ol phosphate hemihydrate.

*Content*: 98.5 per cent to 101.0 per cent (dried substance).

## CHARACTERS

*Appearance*: white or almost white, crystalline powder or small, colourless crystals.

*Solubility*: freely soluble in water, slightly soluble or very slightly soluble in ethanol (96 per cent).

## IDENTIFICATION

*First identification*: B, E, F.

*Second identification*: A, C, D, E, F, G.

A. Ultraviolet and visible absorption spectrophotometry (2.2.25).

*Test solution*. Dilute 1.0 mL of solution S (see Tests) to 100.0 mL with water R. To 25.0 mL of this solution add 25 mL of water R then 10 mL of 1 M sodium hydroxide and dilute to 100.0 mL with water R.

*Spectral range*: 250-350 nm.

*Absorption maximum*: at 284 nm.

*Specific absorbance at the absorption maximum*: about 38 (dried substance).

B. Infrared absorption spectrophotometry (2.2.24).

**Preparation:** dissolve 0.20 g in 4 mL of *water R*. Add 1 mL of a mixture of equal volumes of *strong sodium hydroxide solution R* and *water R* and initiate crystallisation, if necessary, by scratching the wall of the tube with a glass rod and cooling in iced water. Wash the precipitate with *water R* and dry at 100-105 °C. Examine the dried precipitate prepared as discs using *potassium bromide R*.

**Comparison:** *Ph. Eur. reference spectrum of codeine*.

- C. Dissolve 0.20 g in 4 mL of *water R*. Add 1 mL of a mixture of equal volumes of *strong sodium hydroxide solution R* and *water R* and initiate crystallisation, if necessary, by scratching the wall of the tube with a glass rod and cooling in iced water. The precipitate, washed with *water R* and dried at 100-105 °C, melts (2.2.14) at 155 °C to 159 °C.
- D. To about 10 mg add 1 mL of *sulfuric acid R* and 0.05 mL of *ferric chloride solution R2* and heat on a water-bath. A blue colour develops. Add 0.05 mL of *nitric acid R*. The colour changes to red.
- E. Loss on drying (see Tests).
- F. Solution S gives reaction (a) of phosphates (2.3.1).
- G. It gives the reaction of alkaloids (2.3.1).

#### TESTS

**Solution S.** Dissolve 1.00 g in *carbon dioxide-free water R* prepared from *distilled water R* and dilute to 25.0 mL with the same solvent.

**pH (2.2.3):** 4.0 to 5.0 for solution S.

**Specific optical rotation (2.2.7):** –98 to –102 (dried substance). Dilute 5.0 mL of solution S to 10.0 mL with *water R*.

**Related substances.** Liquid chromatography (2.2.29).

**Test solution.** Dissolve 0.100 g of the substance to be examined and 0.100 g of *sodium octanesulfonate R* in the mobile phase and dilute to 10.0 mL with the mobile phase.

**Reference solution (a).** Dissolve 5.0 mg of *codeine impurity A CRS* in the mobile phase and dilute to 5.0 mL with the mobile phase.

**Reference solution (b).** Dilute 1.0 mL of reference solution (a) to 20.0 mL with the mobile phase.

**Reference solution (c).** Dilute 1.0 mL of the test solution to 50.0 mL with the mobile phase. Dilute 5.0 mL of this solution to 100.0 mL with the mobile phase.

**Reference solution (d).** To 0.25 mL of the test solution add 2.5 mL of reference solution (a).

**Column:**

- size:  $l = 0.25$  m,  $\varnothing = 4.6$  mm;
- stationary phase: end-capped octylsilyl silica gel for chromatography R (5  $\mu$ m).

**Mobile phase:** dissolve 1.08 g of *sodium octanesulfonate R* in a mixture of 20 mL of *glacial acetic acid R* and 250 mL of *acetonitrile R* and dilute to 1000 mL with *water R*.

**Flow rate:** 2 mL/min.

**Detection:** spectrophotometer at 245 nm.

**Injection:** 10  $\mu$ L.

**Run time:** 10 times the retention time of codeine.

**Relative retention** with reference to codeine (retention time = about 6 min): impurities B and E = about 0.7; impurity A = about 2.0; impurity C = about 2.3; impurity D = about 3.6.

**System suitability:** reference solution (d):

- resolution: minimum 3 between the peaks due to codeine and impurity A.

**Limits:**

- correction factor: for the calculation of content, multiply the peak area of impurity C by 0.25;
- impurity A: not more than twice the area of the principal peak in the chromatogram obtained with reference solution (b) (1.0 per cent);

- sum of impurities B and E: not more than 4 times the area of the principal peak in the chromatogram obtained with reference solution (c) (0.4 per cent);
- impurities C, D: for each impurity, not more than twice the area of the principal peak in the chromatogram obtained with reference solution (c) (0.2 per cent);
- unspecified impurities: for each impurity, not more than the area of the principal peak in the chromatogram obtained with reference solution (c) (0.10 per cent);
- sum of impurities other than A: not more than 10 times the area of the principal peak in the chromatogram obtained with reference solution (c) (1.0 per cent);
- disregard limit: 0.5 times the area of the principal peak in the chromatogram obtained with reference solution (c) (0.05 per cent).

**Sulfates (2.4.13):** maximum 0.1 per cent.

Dilute 5 mL of solution S to 20 mL with *distilled water R*.

**Loss on drying (2.2.32):** 1.5 per cent to 3.0 per cent, determined on 1.000 g by drying in an oven at 105 °C.

#### ASSAY

Dissolve 0.350 g in a mixture of 10 mL of *anhydrous acetic acid R* and 20 mL of *dioxan R*. Titrate with 0.1 M *perchloric acid* using 0.05 mL of *crystal violet solution R* as indicator.

1 mL of 0.1 M *perchloric acid* is equivalent to 39.74 mg of  $C_{18}H_{24}NO_7P$ .

#### STORAGE

Protected from light.

#### IMPURITIES

**Specified impurities:** A, B, C, D, E.

**Other detectable impurities** (the following substances would, if present at a sufficient level, be detected by one or other of the tests in the monograph. They are limited by the general acceptance criterion for other/unspecified impurities and/or by the general monograph *Substances for pharmaceutical use (2034)*. It is therefore not necessary to identify these impurities for demonstration of compliance. See also 5.10. *Control of impurities in substances for pharmaceutical use*): F, G.

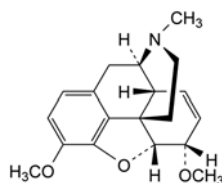

A. 7,8-didehydro-4,5 $\alpha$ -epoxy-3,6 $\alpha$ -dimethoxy-17-methylmorphinan (methylcodeine),

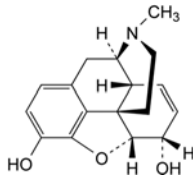

B. 7,8-didehydro-4,5 $\alpha$ -epoxy-17-methylmorphinan-3,6 $\alpha$ -diol (morphine),

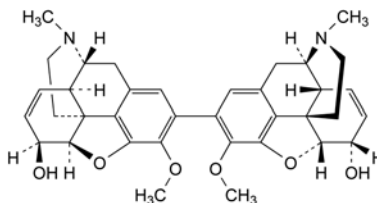

C. 7,7',8,8'-tetrahydro-4,5 $\alpha$ :4',5' $\alpha$ -diepoxy-3,3'-dimethoxy-17,17'-dimethyl-2,2'-bimorphinanyl-6 $\alpha$ ,6' $\alpha$ -diol (codeine dimer),

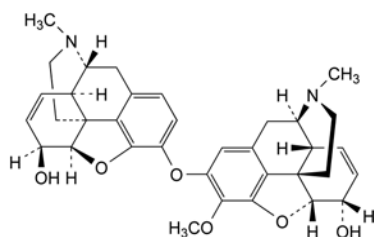

- D. 7,8-didehydro-2-[(7,8-didehydro-4,5 $\alpha$ -epoxy-6 $\alpha$ -hydroxy-17-methylmorphinan-3-yl)oxy]-4,5 $\alpha$ -epoxy-3-methoxy-17-methylmorphinan-6 $\alpha$ -ol (3-*O*-(codein-2-yl)morphine),

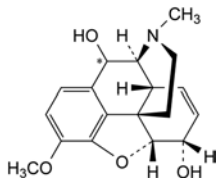

- E. 7,8-didehydro-4,5 $\alpha$ -epoxy-3-methoxy-17-methylmorphinan-6 $\alpha$ ,10-diol,

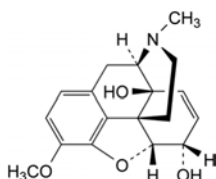

- F. 7,8-didehydro-4,5 $\alpha$ -epoxy-3-methoxy-17-methylmorphinan-6 $\alpha$ ,14-diol,

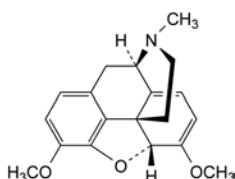

- G. 6,7,8,14-tetrahydro-4,5 $\alpha$ -epoxy-3,6-dimethoxy-17-methylmorphinan (thebaine).

01/2008:0075  
corrected 6.0

## CODEINE PHOSPHATE SESQUIHYDRATE

Codeini phosphas sesquihydricus

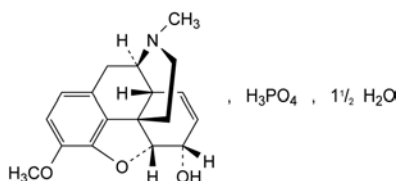

$C_{18}H_{24}NO_7P \cdot 1\frac{1}{2}H_2O$   
[5913-76-8]

$M_r$  424.4

### DEFINITION

7,8-Didehydro-4,5 $\alpha$ -epoxy-3-methoxy-17-methylmorphinan-6 $\alpha$ -ol phosphate sesquihydrate.

*Content*: 98.5 per cent to 101.0 per cent (dried substance).

### CHARACTERS

*Appearance*: white or almost white, crystalline powder or small, colourless crystals.

*Solubility*: freely soluble in water, slightly soluble in ethanol (96 per cent).

### IDENTIFICATION

*First identification*: B, E, F.

*Second identification*: A, C, D, E, F, G.

- A. Ultraviolet and visible absorption spectrophotometry (2.2.25).

*Test solution*. Dilute 1.0 mL of solution S (see Tests) to 100.0 mL with *water R*. To 25.0 mL of this solution add 25 mL of *water R* then 10 mL of 1 M *sodium hydroxide* and dilute to 100.0 mL with *water R*.

*Spectral range*: 250-350 nm.

*Absorption maximum*: at 284 nm.

*Specific absorbance at the absorption maximum*: about 38 (dried substance).

- B. Infrared absorption spectrophotometry (2.2.24).

*Preparation*: dissolve 0.20 g in 4 mL of *water R*. Add 1 mL of a mixture of equal volumes of *strong sodium hydroxide solution R* and *water R* and initiate crystallisation, if necessary, by scratching the wall of the tube with a glass rod and cooling in iced water. Wash the precipitate with *water R* and dry at 100-105 °C. Examine the dried precipitate prepared as discs using *potassium bromide R*.

*Comparison*: *Ph. Eur. reference spectrum of codeine*.

- C. Dissolve 0.20 g in 4 mL of *water R*. Add 1 mL of a mixture of equal volumes of *strong sodium hydroxide solution R* and *water R* and initiate crystallisation, if necessary, by scratching the wall of the tube with a glass rod and cooling in iced water. The precipitate, washed with *water R* and dried at 100-105 °C, melts (2.2.14) at 155 °C to 159 °C.

- D. To about 10 mg add 1 mL of *sulfuric acid R* and 0.05 mL of *ferric chloride solution R2* and heat on a water-bath. A blue colour develops. Add 0.05 mL of *nitric acid R*. The colour changes to red.

- E. Loss on drying (see Tests).

- F. Solution S gives reaction (a) of phosphates (2.3.1).

- G. It gives the reaction of alkaloids (2.3.1).

### TESTS

**Solution S**. Dissolve 1.00 g in *carbon dioxide-free water R* prepared from *distilled water R* and dilute to 25.0 mL with the same solvent.

**pH** (2.2.3): 4.0 to 5.0 for solution S.

**Specific optical rotation** (2.2.7): –98 to –102 (dried substance). Dilute 5.0 mL of solution S to 10.0 mL with *water R*.

**Related substances**. Liquid chromatography (2.2.29).

*Test solution*. Dissolve 0.100 g of the substance to be examined and 0.100 g of *sodium octanesulfonate R* in the mobile phase and dilute to 10.0 mL with the mobile phase.

*Reference solution (a)*. Dissolve 5.0 mg of *codeine impurity A CRS* in the mobile phase and dilute to 5.0 mL with the mobile phase.

*Reference solution (b)*. Dilute 1.0 mL of reference solution (a) to 20.0 mL with the mobile phase.

*Reference solution (c)*. Dilute 1.0 mL of the test solution to 50.0 mL with the mobile phase. Dilute 5.0 mL of this solution to 100.0 mL with the mobile phase.

*Reference solution (d)*. To 0.25 mL of the test solution add 2.5 mL of reference solution (a).

*Column*:

– *size*:  $l = 0.25$  m,  $\varnothing = 4.6$  mm;

– *stationary phase*: end-capped octylsilyl silica gel for chromatography R (5  $\mu$ m).

*Mobile phase*: dissolve 1.08 g of *sodium octanesulfonate R* in a mixture of 20 mL of *glacial acetic acid R* and 250 mL of *acetonitrile R* and dilute to 1000 mL with *water R*.

*Flow rate*: 2 mL/min.

*Detection*: spectrophotometer at 245 nm.

**Injection:** 10 µL.

**Run time:** 10 times the retention time of codeine.

**Relative retention** with reference to codeine (retention time = about 6 min): impurity B = about 0.6; impurity E = about 0.7; impurity A = about 2.0; impurity C = about 2.3; impurity D = about 3.6.

**System suitability:** reference solution (d):

- **resolution:** minimum 3 between the peaks due to codeine and impurity A.

**Limits:**

- **correction factor:** for the calculation of content, multiply the peak area of impurity C by 0.25;
- **impurity A:** not more than twice the area of the principal peak in the chromatogram obtained with reference solution (b) (1.0 per cent);
- **impurities B, C, D, E:** for each impurity, not more than twice the area of the principal peak in the chromatogram obtained with reference solution (c) (0.2 per cent);
- **unspecified impurities:** for each impurity, not more than the area of the principal peak in the chromatogram obtained with reference solution (c) (0.10 per cent);
- **sum of impurities other than A:** not more than 10 times the area of the principal peak in the chromatogram obtained with reference solution (c) (1.0 per cent);
- **disregard limit:** 0.5 times the area of the principal peak in the chromatogram obtained with reference solution (c) (0.05 per cent).

**Sulfates (2.4.13):** maximum 0.1 per cent.

Dilute 5 mL of solution S to 20 mL with *distilled water R*.

**Loss on drying (2.2.32):** 5.0 per cent to 7.5 per cent, determined on 0.500 g by drying in an oven at 105 °C.

#### ASSAY

Dissolve 0.350 g in a mixture of 10 mL of *anhydrous acetic acid R* and 20 mL of *dioxan R*. Titrate with 0.1 M *perchloric acid* using 0.05 mL of *crystal violet solution R* as indicator.

1 mL of 0.1 M *perchloric acid* is equivalent to 39.74 mg of  $C_{18}H_{24}NO_7P$ .

#### STORAGE

Protected from light.

#### IMPURITIES

**Specified impurities:** A, B, C, D, E.

**Other detectable impurities** (the following substances would, if present at a sufficient level, be detected by one or other of the tests in the monograph. They are limited by the general acceptance criterion for other/unspecified impurities and/or by the general monograph *Substances for pharmaceutical use (2034)*. It is therefore not necessary to identify these impurities for demonstration of compliance. See also 5.10. *Control of impurities in substances for pharmaceutical use*): F, G.

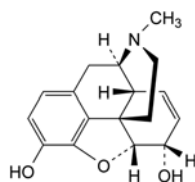

B. 7,8-didehydro-4,5α-epoxy-17-methylmorphinan-3,6α-diol (morphine),

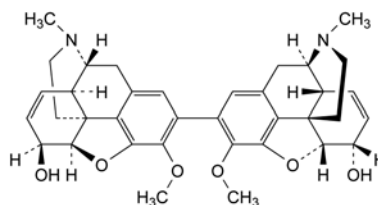

C. 7,7',8,8'-tetrahydro-4,5α:4',5'α-diepoxy-3,3'-dimethoxy-17,17'-dimethyl-2,2'-bimorphinanyl-6α,6'α-diol (codeine dimer),

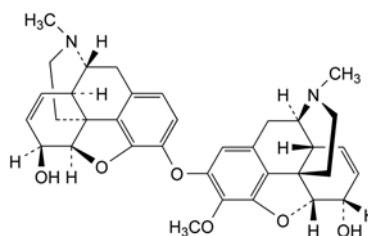

D. 7,8-didehydro-2-[(7,8-didehydro-4,5α-epoxy-6α-hydroxy-17-methylmorphinan-3-yl)oxy]-4,5α-epoxy-3-methoxy-17-methylmorphinan-6α-ol (3-O-(codein-2-yl)morphine),

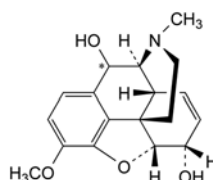

E. 7,8-didehydro-4,5α-epoxy-3-methoxy-17-methylmorphinan-6α,10-diol,

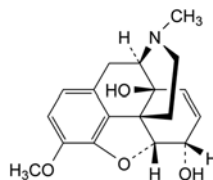

F. 7,8-didehydro-4,5α-epoxy-3-methoxy-17-methylmorphinan-6α,14-diol,

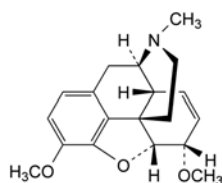

A. 7,8-didehydro-4,5α-epoxy-3,6α-dimethoxy-17-methylmorphinan (methycodeine),

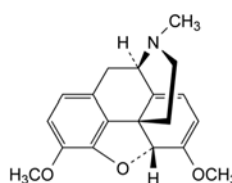

G. 6,7,8,14-tetrahydro-4,5α-epoxy-3,6-dimethoxy-17-methylmorphinan (thebaine).

01/2008:2060 IDENTIFICATION  
corrected 6.3

## CODERGOCRINE MESILATE

## Codergocrini mesilas

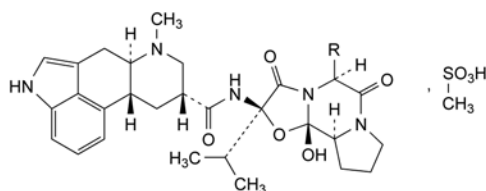

Name	Mol. Formula	$M_r$	R
dihydroergocornine mesilate	$C_{32}H_{45}N_5O_8S$	660	
dihydroergocristine mesilate	$C_{36}H_{45}N_5O_8S$	708	
$\alpha$ -dihydroergocryptine mesilate	$C_{33}H_{47}N_5O_8S$	674	
$\beta$ -dihydroergocryptine mesilate	$C_{33}H_{47}N_5O_8S$	674	

## DEFINITION

A mixture of:

- (6a*R*,9*R*,10a*R*)-*N*[(2*R*,5*S*,10a*S*,10b*S*)-10b-hydroxy-2,5-bis(1-methylethyl)-3,6-dioxooctahydro-8*H*-oxazo[3,2-*a*]pyrrolo[2,1-*c*]pyrazin-2-yl]-7-methyl-4,6,6a,7,8,9,10,10a-octahydroindolo[4,3-*fg*]quinoline-9-carboxamide methanesulfonate (dihydroergocornine mesilate);
- (6a*R*,9*R*,10a*R*)-*N*[(2*R*,5*S*,10a*S*,10b*S*)-5-benzyl-10b-hydroxy-2-(1-methylethyl)-3,6-dioxooctahydro-8*H*-oxazo[3,2-*a*]pyrrolo[2,1-*c*]pyrazin-2-yl]-7-methyl-4,6,6a,7,8,9,10,10a-octahydroindolo[4,3-*fg*]quinoline-9-carboxamide methanesulfonate (dihydroergocristine mesilate);
- (6a*R*,9*R*,10a*R*)-*N*[(2*R*,5*S*,10a*S*,10b*S*)-10b-hydroxy-2-(1-methylethyl)-5-(2-methylpropyl)-3,6-dioxooctahydro-8*H*-oxazo[3,2-*a*]pyrrolo[2,1-*c*]pyrazin-2-yl]-7-methyl-4,6,6a,7,8,9,10,10a-octahydroindolo[4,3-*fg*]quinoline-9-carboxamide methanesulfonate ( $\alpha$ -dihydroergocryptine mesilate);
- (6a*R*,9*R*,10a*R*)-*N*[(2*R*,5*S*,10a*S*,10b*S*)-10b-hydroxy-2-(1-methylethyl)-5-[(1*R**S*)-1-methylpropyl]-3,6-dioxooctahydro-8*H*-oxazo[3,2-*a*]pyrrolo[2,1-*c*]pyrazin-2-yl]-7-methyl-4,6,6a,7,8,9,10,10a-octahydroindolo[4,3-*fg*]quinoline-9-carboxamide methanesulfonate ( $\beta$ -dihydroergocryptine mesilate or epicriptine mesilate).

*Content*: 98.0 per cent to 102.0 per cent (dried substance).

## PRODUCTION

The production method must be evaluated to determine the potential for formation of alkyl mesilates, which is particularly likely to occur if the reaction medium contains lower alcohols. Where necessary, the production method is validated to demonstrate that alkyl mesilates are not detectable in the final product.

## CHARACTERS

*Appearance*: white or yellowish powder.*Solubility*: sparingly soluble in water, sparingly soluble to soluble in ethanol (96 per cent), slightly soluble in methylene chloride.

## A. Thin-layer chromatography (2.2.27).

*Test solution*. Dissolve 0.20 g of the substance to be examined in a mixture of 1 volume of *methanol R* and 9 volumes of *methylene chloride R* and dilute to 5 mL with the same mixture of solvents.

*Reference solution*. Dissolve 0.20 g of *methanesulfonic acid R* in a mixture of 1 volume of *methanol R* and 9 volumes of *methylene chloride R* and dilute to 5 mL with the same mixture of solvents.

*Plate*: TLC silica gel plate *R*.*Mobile phase*: *water R*, *concentrated ammonia R*, *butanol R*, *acetone R* (5:10:20:65 V/V/V/V).*Application*: 10  $\mu$ L.*Development*: over 2/3 of the plate.*Drying*: in a current of cold air for not more than 1 min.*Detection*: spray with a 1 g/L solution of *bromocresol purple R* in *methanol R*, adjusted to a violet-red colour with 0.05 mL of *dilute ammonia R1*.*Drying*: in a current of hot air at 100 °C.

*Results*: the principal spot in the chromatogram obtained with the test solution is similar in position and colour to the principal spot in the chromatogram obtained with the reference solution.

## B. Examine the chromatograms obtained in the test for composition.

*Results*: the 4 principal peaks in the chromatogram obtained with the test solution are similar in retention time to the 4 principal peaks in the chromatogram obtained with the reference solution.

## TESTS

**pH** (2.2.3): 4.2 to 5.2.Dissolve 0.10 g in *carbon dioxide-free water R* and dilute to 20 mL with the same solvent.**Composition**. Liquid chromatography (2.2.29): use the normalisation procedure.

*Test solution*. Dissolve 20 mg of the substance to be examined in a mixture of 1 volume of *anhydrous ethanol R* and 2 volumes of a 10 g/L solution of *tartaric acid R* and dilute to 10 mL with the same mixture of solvents.

*Reference solution*. Dissolve 20 mg of *codergocrine mesilate CRS* in a mixture of 1 volume of *anhydrous ethanol R* and 2 volumes of a 10 g/L solution of *tartaric acid R* and dilute to 10 mL with the same mixture of solvents.

*Column*:– *size*:  $l = 0.15$  m,  $\varnothing = 4.6$  mm;– *stationary phase*: *octadecylsilyl silica gel for chromatography R* (5  $\mu$ m).*Mobile phase*: *triethylamine R*, *acetonitrile R*, *water R* (2.5:25:75 V/V/V).*Flow rate*: 1.5 mL/min.*Detection*: spectrophotometer at 280 nm.*Injection*: 20  $\mu$ L.*Run time*: 20 min.*Elution order*: dihydroergocornine,  $\alpha$ -dihydroergocryptine, dihydroergocristine,  $\beta$ -dihydroergocryptine.*System suitability*: test solution:– *resolution*: minimum 3 between any 2 consecutive principal peaks.*Composition*:

- *dihydroergocornine*: 30.0 per cent to 35.0 per cent;
- $\alpha$ -*dihydroergocryptine*: 20.0 per cent to 25.0 per cent;
- *dihydroergocristine*: 30.0 per cent to 35.0 per cent;
- $\beta$ -*dihydroergocryptine*: 10.0 per cent to 13.0 per cent;
- *disregard limit*: 1.0 per cent.

01/2009:2398

**Related substances.** Thin-layer chromatography (2.2.27).  
Perform the test as rapidly as possible and protected from direct light. Prepare the test solution last and immediately before application on the plate.

**Test solution.** Dissolve 0.40 g of the substance to be examined in a mixture of 1 volume of *methanol R* and 9 volumes of *methylene chloride R* and dilute to 5.0 mL with the same mixture of solvents.

**Reference solution (a).** Dissolve 40 mg of *dihydroergocristine mesilate CRS* in a mixture of 1 volume of *methanol R* and 9 volumes of *methylene chloride R* and dilute to 10.0 mL with the same mixture of solvents. Dilute 3.0 mL of the solution to 50.0 mL with a mixture of 1 volume of *methanol R* and 9 volumes of *methylene chloride R*.

**Reference solution (b).** To 2.0 mL of reference solution (a), add 1.0 mL of a mixture of 1 volume of *methanol R* and 9 volumes of *methylene chloride R*.

**Reference solution (c).** To 1.0 mL of reference solution (a), add 2.0 mL of a mixture of 1 volume of *methanol R* and 9 volumes of *methylene chloride R*.

**Reference solution (d).** To 1.0 mL of reference solution (a), add 5.0 mL of a mixture of 1 volume of *methanol R* and 9 volumes of *methylene chloride R*.

**Plate:** TLC silica gel plate R.

**Mobile phase:** concentrated ammonia R, *methanol R*, *ethyl acetate R*, *methylene chloride R* (1:3:50:50 V/V/V/V).

**Application:** 10 µL.

**Drying:** in the dark for 2 min after the application of the last solution.

**First development:** in an unsaturated tank, over 2/3 of the plate.

**Drying:** in a current of cold air for not more than 1 min.

**Second development:** in an unsaturated tank, over 2/3 of the plate; use freshly prepared mobile phase.

**Drying:** in a current of cold air for not more than 1 min.

**Detection:** spray thoroughly with *dimethylaminobenzaldehyde solution R7* and dry in a current of hot air until the spot in the chromatogram obtained with reference solution (d) is clearly visible.

**System suitability:** test solution:

- the chromatogram shows at least 3 separated secondary spots.

**Limits:**

- **any impurity:** any spots, apart from the principal spot, are not more intense than the spot in the chromatogram obtained with reference solution (a) (0.3 per cent); not more than 4 such spots are more intense than the spot in the chromatogram obtained with reference solution (c) (0.1 per cent) and 2 of these may be more intense than the spot in the chromatogram obtained with reference solution (b) (0.2 per cent).

**Loss on drying (2.2.32):** maximum 5.0 per cent, determined on 0.500 g by drying at 120 °C under high vacuum.

#### ASSAY

Dissolve 0.500 g in 60 mL of *pyridine R*. Pass a stream of *nitrogen R* over the surface of the solution and titrate with 0.1 M *tetrabutylammonium hydroxide*, determining the end-point potentiometrically (2.2.20).

1 mL of 0.1 M *tetrabutylammonium hydroxide* is equivalent to 68.04 mg of *codergocrine mesilate* (average  $M_r$  = 680).

#### STORAGE

Protected from light.

## COD-LIVER OIL, FARMED

### Iecoris aselli oleum domesticum

#### DEFINITION

Purified fatty oil obtained from the fresh livers of farmed cod, *Gadus morhua* L., solid substances being removed by cooling and filtering.

**Content:**

- **sum of the contents of EPA and DHA (expressed as triglycerides):** 10.0 per cent to 28.0 per cent;
- **vitamin A:** 50 IU (15 µg) to 500 IU (150 µg) per gram;
- **vitamin D<sub>3</sub>:** maximum 50 IU (1.3 µg) per gram.

Authorised antioxidants in concentrations not exceeding the levels specified by the competent authority may be added.

#### PRODUCTION

The fish shall only be given feed with a composition that is in accordance with the relevant EU or other applicable regulations.

#### CHARACTERS

**Appearance:** clear, pale yellowish liquid.

**Solubility:** practically insoluble in water, slightly soluble in alcohol (96 per cent), miscible with light petroleum.

#### IDENTIFICATION

A. Examine the <sup>13</sup>C NMR spectra obtained in the test for positional distribution (β(2)-acyl) of fatty acids (see Tests). The spectra contain peaks between 172 ppm and 173 ppm with shifts similar to those in the spectrum shown in Figure 2398-1.

The positional distribution (β(2)-acyl) for cervonic (docosahexaenoic) acid (C22:6 n-3; DHA), timnodonic (eicosapentaenoic) acid (C20:5 n-3; EPA) and moroctic acid (C18:4 n-3) complies with the limits.

B. Linoleic acid (see Tests).

#### TESTS

**Acid value (2.5.1):** maximum 2.0.

**Anisidine value (2.5.36):** maximum 10.0.

**Peroxide value (2.5.5, Method B):** maximum 5.0.

**Unsaponifiable matter (2.5.7):** maximum 1.5 per cent, determined on 2.0 g, and extracting with 3 quantities, each of 50 mL, of *peroxide-free ether R*.

**Stearin.** Heat at least 10 mL to 60-90 °C then allow to cool for 3 h in a bath of iced water or a thermostatically controlled bath at 0 ± 0.5 °C. If necessary, to eliminate insoluble matter, filter the sample after heating. The sample remains clear.

**Positional distribution (β(2)-acyl) of fatty acids.** Nuclear magnetic resonance spectrometry (2.2.33).

**Test solution.** Dissolve 190-210 mg of the substance to be examined in 500 µL of *deuterated chloroform R*. Prepare at least 3 samples and examine within 3 days.

**Apparatus:** high resolution FT-NMR spectrometer operating at minimum 300 MHz.

**Acquisition of <sup>13</sup>C NMR spectra.** The following parameters may be used:

- **sweep width:** 200 ppm (–5 ppm to 195 ppm);
- **irradiation frequency offset:** 95 ppm;
- **time domain:** 64 K;
- **pulse delay:** 2 s;
- **pulse program:** zgig 30 (inverse gated, 30° excitation pulse);
- **dummy scans:** 4;
- **number of scans:** 4096.



**Processing and plotting.** The following parameters may be used:

- *size*: 64 K (zero-filling);
- *window multiplication*: exponential;
- *Lorentzian broadening factor*: 0.2 Hz.

Use the CDCl<sub>3</sub> signal for shift referencing. The shift of the central peak of the 1:1:1 triplet is set to 77.16 ppm.

Plot the spectral region δ 171.5–173.5 ppm. Compare the spectrum with the spectrum shown in Figure 2398.-1. The shift values lie within the ranges given in Table 2398.-1.

Table 2398.-1. – *Shift values*

Signal	Shift range (ppm)
β(2) DHA	172.05 - 172.09
α(2) DHA	172.43 - 172.47
β(2) EPA	172.52 - 172.56
α(2) EPA	172.90 - 172.94
β(2) C18:4	172.56 - 172.60
α(2) C18:4	172.95 - 172.99

**System suitability:**

- *signal-to-noise ratio*: minimum 5 for the smallest relevant peak corresponding to α(2) C18:4 signal (in the range δ 172.95–172.99 ppm);
- *peak width at half-height*: maximum 0.02 ppm for the central CDCl<sub>3</sub> signal (at δ 77.16 ppm).

**Calculation of positional distribution (β(2)-acyl):** use the following expression:

$$\frac{100 \times \beta(2)}{\alpha(2) + \beta(2)}$$

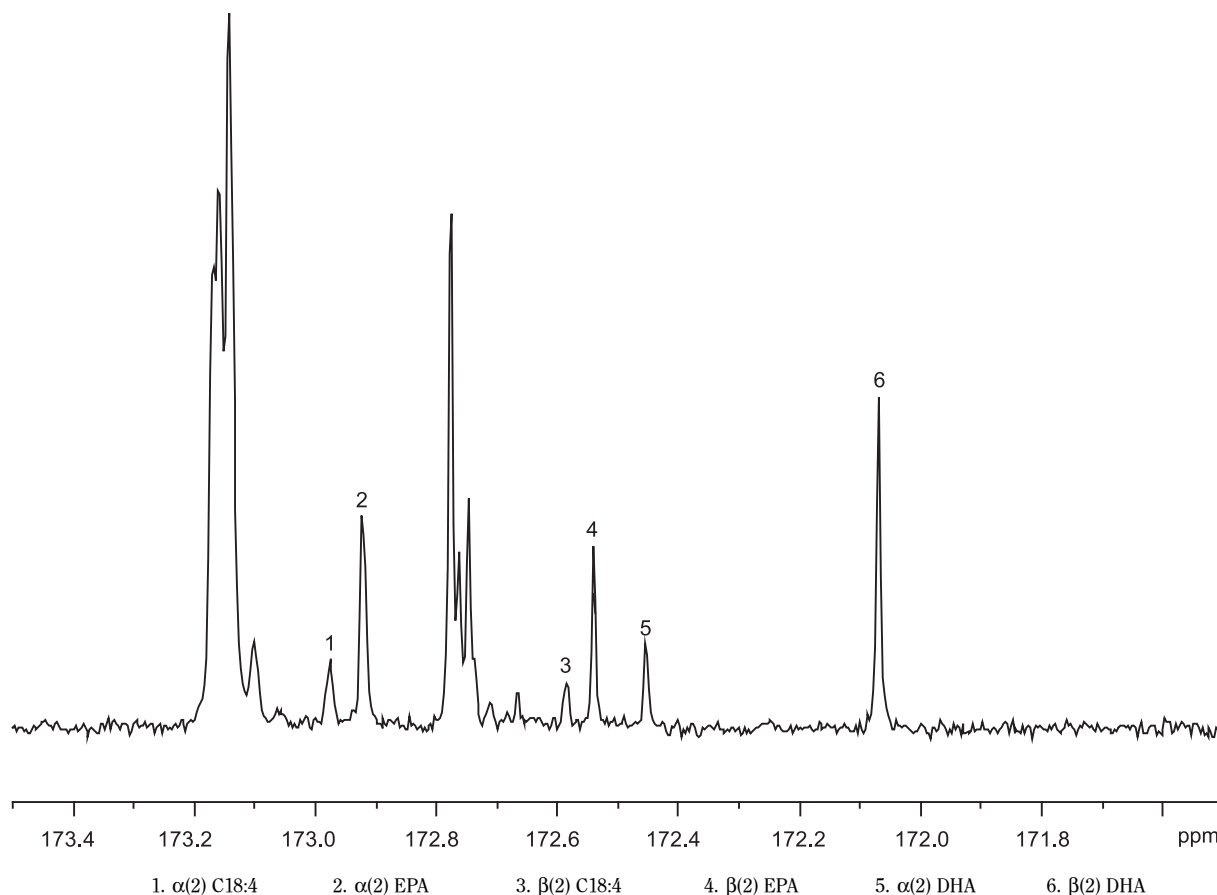

Figure 2398.-1. – <sup>13</sup>C NMR spectrum carbonyl region of farmed cod-liver oil

α(2) = peak area of the corresponding α(2)-carbonyl peak;  
β(2) = peak area of β(2)-carbonyl peak from C22:6 n-3, C20:5 n-3 or C18:4 n-3, respectively.

**Limits:**

The positional distribution (β(2)-acyl) is 71 per cent to 81 per cent for cervonic (docosahexaenoic) acid (C22:6 n-3; DHA), 32 per cent to 40 per cent for timnodonic (eicosapentaenoic) acid (C20:5 n-3; EPA) and 28 per cent to 38 per cent for morotic acid (C18:4 n-3).

**Composition of fatty acids (2.4.29).** For identification of the peaks, see the chromatogram shown in Figure 2398.-2.

The 24 largest peaks of the methyl esters account for more than 90 per cent of the total area (these correspond to, in common elution order: 14:0, 15:0, 16:0, 16:1 n-7, 16:4 n-1, 18:0, 18:1 n-9, 18:1 n-7, 18:2 n-6, 18:3 n-3, 18:4 n-3, 20:1 n-11, 20:1 n-9, 20:1 n-7, 20:2 n-6, 20:4 n-6, 20:3 n-3, 20:4 n-3, 20:5 n-3, 22:1 n-11, 22:1 n-9, 21:5 n-3, 22:5 n-3, 22:6 n-3).

**Linoleic acid (2.4.29):** 3.0 per cent to 11.0 per cent.

**ASSAY**

**EPA and DHA (2.4.29).** See the chromatogram shown in Figure 2398.-2.

**Vitamin A.** Carry out the test as rapidly as possible, avoiding exposure to actinic light and air, oxidising agents, oxidation catalysts (for example, copper and iron) and acids.

Use method A. If method A is found not to be valid, use method B.

**METHOD A**

Ultraviolet absorption spectrophotometry (2.2.25).

**Test solution.** To 1.00 g in a round-bottomed flask, add 3 mL of a freshly prepared 50 per cent *m/m* solution of potassium hydroxide *R* and 30 mL of anhydrous ethanol *R*. Boil under reflux in a current of nitrogen *R* for 30 min. Cool rapidly and add 30 mL of water *R*. Extract with 50 mL of ether *R*.

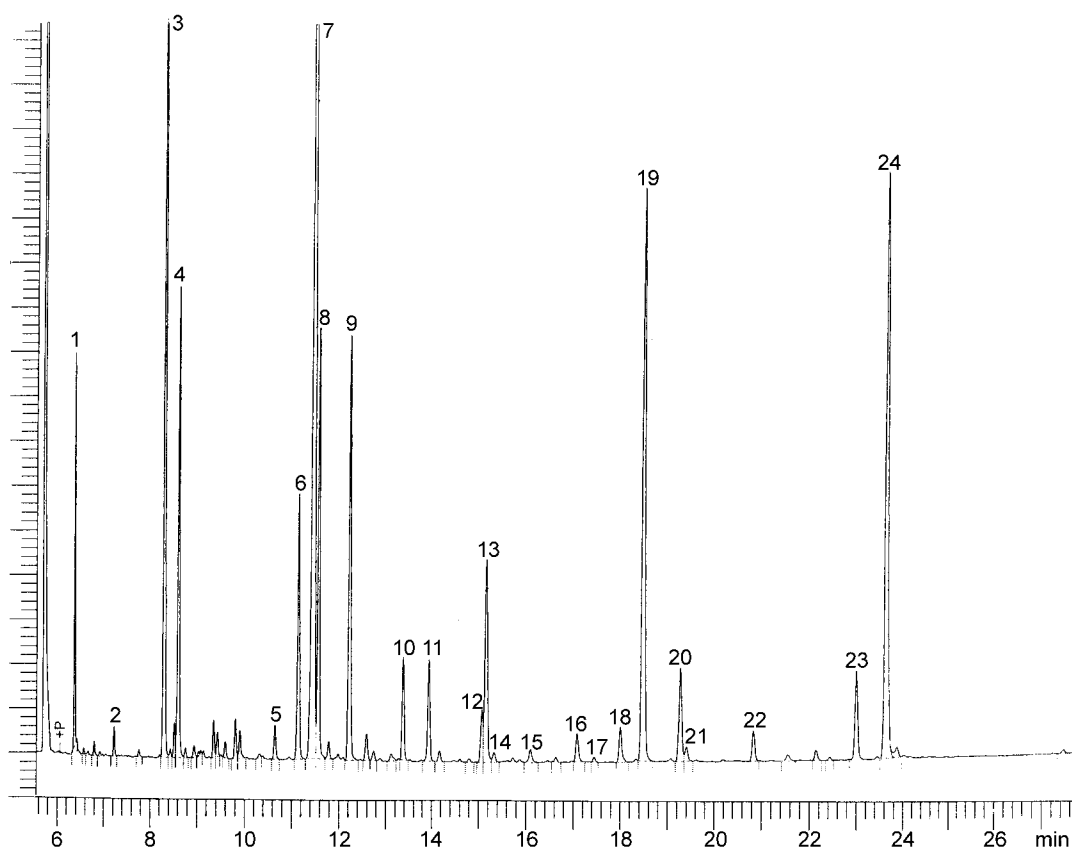

1. C14:0	5. C16:4 n-1	9. C18:2 n-6	13. C20:1 n-9	17. C20:3 n-3	21. C22:1 n-9
2. C15:0	6. C18:0	10. C18:3 n-3	14. C20:1 n-7	18. C20:4 n-3	22. C21:5 n-3
3. C16:0	7. C18:1 n-9	11. C18:4 n-3	15. C20:2 n-6	19. C20:5 n-3	23. C22:5 n-3
4. C16:1 n-7	8. C18:1 n-7	12. C20:1 n-11	16. C20:4 n-6	20. C22:1 n-11	24. C22:6 n-3

Figure 2398.-2. – Chromatogram for the test for composition of fatty acids of farmed cod-liver oil

Repeat the extraction 3 times and discard the lower layer after complete separation. Wash the combined upper layers with 4 quantities, each of 50 mL, of *water R*, and evaporate to dryness under a gentle current of *nitrogen R* at a temperature not exceeding 30 °C or in a rotary evaporator at a temperature not exceeding 30 °C under reduced pressure (water ejector). Dissolve the residue in sufficient *2-propanol R1* to give an expected concentration of vitamin A equivalent to 10-15 IU/mL.

Measure the absorbances of the solution at 300 nm, 310 nm, 325 nm and 334 nm and at the wavelength of maximum absorption with a suitable spectrophotometer in 1 cm specially matched cells, using *2-propanol R1* as the compensation liquid.

Calculate the content of vitamin A, as all-*trans*-retinol, in International Units per gram, using the following expression:

$$A_{325} \times \frac{1821}{100m} \times V$$

$A_{325}$  = absorbance at 325 nm;

$m$  = mass of the substance to be examined, in grams;

$V$  = total volume of solution containing 10-15 IU of vitamin A per millilitre;

1821 = conversion factor for the specific absorbance of all-*trans*-retinol, in International Units.

The above expression can be used only if  $A_{325}$  has a value of not greater than  $A_{325, \text{corr}}/0.970$ , where  $A_{325, \text{corr}}$  is the corrected absorbance at 325 nm and is given by the following equation:

$$A_{325, \text{corr}} = 6.815A_{325} - 2.555A_{310} - 4.260A_{334}$$

$A$  designates the absorbance at the wavelength indicated by the subscript.

If  $A_{325}$  has a value greater than  $A_{325, \text{corr}}/0.970$ , calculate the content of vitamin A using the following expression:

$$A_{325, \text{corr}} \times \frac{1821}{100m} \times V$$

The assay is not valid unless:

- the wavelength of maximum absorption lies between 323 nm and 327 nm;
- the absorbance at 300 nm relative to that at 325 nm is at most 0.73.

#### METHOD B

Liquid chromatography (2.2.29).

**Test solution.** Prepare duplicates. To 2.00 g in a round-bottomed flask, add 5 mL of a freshly prepared 100 g/L solution of *ascorbic acid R*, 10 mL of a freshly prepared 800 g/L solution of *potassium hydroxide R* and 100 mL of *anhydrous ethanol R*. Boil under a reflux condenser on a water-bath for 15 min. Add 100 mL of a 10 g/L solution of *sodium chloride R* and cool. Transfer the solution to a 500 mL separating funnel, rinsing the round-bottomed flask with about 75 mL of a 10 g/L solution of *sodium chloride R* and then with 150 mL of a mixture of equal volumes of *light petroleum R1* and *ether R*. Shake for 1 min. When the layers have separated completely, discard the lower layer and wash the upper layer, first with 50 mL of a 30 g/L solution of *potassium hydroxide R* in a 10 per cent *V/V* solution of *anhydrous ethanol R* and then with 3 quantities, each of 50 mL, of a 10 g/L solution of *sodium chloride R*. Filter the upper layer through 5 g of *anhydrous sodium sulfate R* on a fast filter paper into a 250 mL flask suitable for a rotary evaporator. Wash the funnel with 10 mL of fresh extraction mixture, filter and combine the upper layers. Distil them at

a temperature not exceeding 30 °C under reduced pressure (water ejector) and fill with *nitrogen R* when evaporation is completed. Alternatively, evaporate the solvent under a gentle current of *nitrogen R* at a temperature not exceeding 30 °C. Dissolve the residue in *2-propanol R*, transfer to a 25 mL volumetric flask and dilute to 25 mL with *2-propanol R*. Gentle heating in an ultrasonic bath may be required. *A large fraction of the white residue is cholesterol, constituting approximately 50 per cent m/m of the unsaponifiable matter of cod-liver oil.*

**Reference solution (a).** Prepare a solution of *retinol acetate CRS* in *2-propanol RI* so that 1 mL contains about 1000 IU of all-*trans*-retinol.

The exact concentration of reference solution (a) is assessed by ultraviolet absorption spectrophotometry (2.2.25). Dilute reference solution (a) with *2-propanol RI* to a presumed concentration of 10-15 IU/mL and measure the absorbance at 326 nm in matched 1 cm cells using *2-propanol RI* as the compensation liquid.

Calculate the content of vitamin A in International Units per millilitre of reference solution (a) using the following expression, taking into account the assigned content of *retinol acetate CRS*:

$$A_{326} \times \frac{1900 \times V_2}{100 \times V_1}$$

$A_{326}$  = absorbance at 326 nm;

$V_1$  = volume of reference solution (a) used;

$V_2$  = volume of the diluted solution;

1900 = conversion factor for the specific absorbance of *retinol acetate CRS*, in International Units.

**Reference solution (b).** Proceed as described for the test solution but using 2.00 mL of reference solution (a) in place of the substance to be examined.

The exact concentration of reference solution (b) is assessed by ultraviolet absorption spectrophotometry (2.2.25). Dilute reference solution (b) with *2-propanol RI* to a presumed all-*trans*-retinol concentration of 10-15 IU/mL and measure the absorbance at 325 nm in matched 1 cm cells using *2-propanol RI* as the compensation liquid.

Calculate the content of all-*trans*-retinol in International Units per millilitre of reference solution (b), using the following expression:

$$A_{325} \times \frac{1821 \times V_3}{100 \times V_4}$$

$A_{325}$  = absorbance at 325 nm;

$V_3$  = volume of the diluted solution;

$V_4$  = volume of reference solution (b) used;

1821 = conversion factor for the specific absorbance of all-*trans*-retinol, in International Units.

**Column:**

– size:  $l = 0.25$  m,  $\emptyset = 4.6$  mm;

– stationary phase: octadecylsilyl silica gel for chromatography R (5-10  $\mu$ m).

**Mobile phase:** water R, methanol R (3:97 V/V).

**Flow rate:** 1 mL/min.

**Detection:** spectrophotometer at 325 nm.

**Injection:** 10  $\mu$ L; inject in triplicate the test solution and reference solution (b).

**Retention time:** all-*trans*-retinol =  $5 \pm 1$  min.

**System suitability:**

– the chromatogram obtained with the test solution shows a peak that corresponds to the peak due to all-*trans*-retinol in the chromatogram obtained with reference solution (b);

- the results obtained with the duplicate test solutions do not differ by more than 5 per cent;
- the recovery of all-*trans*-retinol in reference solution (b) as assessed by direct absorption spectrophotometry is greater than 95 per cent.

Calculate the content of vitamin A using the following expression:

$$A_1 \times \frac{C \times V}{A_2} \times \frac{1}{m}$$

$A_1$  = area of the peak due to all-*trans*-retinol in the chromatogram obtained with the test solution;

$A_2$  = area of the peak due to all-*trans*-retinol in the chromatogram obtained with reference solution (b);

$C$  = concentration of *retinol acetate CRS* in reference solution (a) as assessed prior to the saponification, in International Units per millilitre (= 1000 IU/mL);

$V$  = volume of reference solution (a) treated (2.00 mL);

$m$  = mass of the substance to be examined in the test solution (2.00 g).

**Vitamin D<sub>3</sub>.** Liquid chromatography (2.2.29). Carry out the assay as rapidly as possible, avoiding exposure to actinic light and air.

**Internal standard solution.** Dissolve 0.50 mg of *ergocalciferol CRS* in 100 mL of *anhydrous ethanol R*.

**Test solution (a).** To 4.00 g in a round-bottomed flask, add 5 mL of a freshly prepared 100 g/L solution of *ascorbic acid R*, 10 mL of a freshly prepared 800 g/L solution of *potassium hydroxide R* and 100 mL of *anhydrous ethanol R*. Boil under a reflux condenser on a water-bath for 30 min. Add 100 mL of a 10 g/L solution of *sodium chloride R* and cool the solution to room temperature. Transfer the solution to a 500 mL separating funnel, rinsing the round-bottomed flask with about 75 mL of a 10 g/L solution of *sodium chloride R* and then with 150 mL of a mixture of equal volumes of *light petroleum R1* and *ether R*. Shake for 1 min. When the layers have separated completely, discard the lower layer and wash the upper layer, first with 50 mL of a 30 g/L solution of *potassium hydroxide R* in a 10 per cent V/V solution of *anhydrous ethanol R*, and then with 3 quantities, each of 50 mL, of a 10 g/L solution of *sodium chloride R*. Filter the upper layer through 5 g of *anhydrous sodium sulfate R* on a fast filter paper into a 250 mL flask suitable for a rotary evaporator. Wash the funnel with 10 mL of fresh extraction mixture, filter and combine the upper layers. Distil them at a temperature not exceeding 30 °C under reduced pressure (water ejector) and fill with *nitrogen R* when evaporation is completed. Alternatively, evaporate the solvent under a gentle current of *nitrogen R* at a temperature not exceeding 30 °C. Dissolve the residue in 1.5 mL of the mobile phase described under Purification. Gentle heating in an ultrasonic bath may be required. *A large fraction of the white residue is cholesterol, constituting approximately 50 per cent m/m of the unsaponifiable matter of cod-liver oil.*

**Test solution (b).** Prepare duplicates. To 4.00 g add 2.0 mL of the internal standard solution and proceed as described for test solution (a).

**Reference solution (a).** Dissolve 0.50 mg of *cholecalciferol CRS* in 100.0 mL of *anhydrous ethanol R*.

**Reference solution (b).** In a round-bottomed flask, add 2.0 mL of reference solution (a) and 2.0 mL of the internal standard solution and proceed as described for test solution (a).

**PURIFICATION**

**Column:**

– size:  $l = 0.25$  m,  $\emptyset = 4.6$  mm;

– stationary phase: nitrile silica gel for chromatography R (10  $\mu$ m).

**Mobile phase:** isoamyl alcohol R, hexane R (1.6:98.4 V/V).

**Flow rate:** 1.1 mL/min.

**Detection:** spectrophotometer at 265 nm.

Inject 350 µL of reference solution (b). Collect the eluate from 2 min before until 2 min after the retention time of cholecalciferol, in a ground-glass-stoppered tube containing 1 mL of a 1 g/L solution of *butylhydroxytoluene R* in *hexane R*. Repeat the procedure with test solutions (a) and (b). Evaporate the eluates obtained from reference solution (b) and from test solutions (a) and (b), separately, to dryness at a temperature not exceeding 30 °C under a gentle current of *nitrogen R*. Dissolve each residue in 1.5 mL of *acetonitrile R*.

#### DETERMINATION

**Column:**

- size:  $l = 0.15$  m,  $\varnothing = 4.6$  mm;
- stationary phase: *octadecylsilyl silica gel for chromatography R* (5 µm).

**Mobile phase:** *phosphoric acid R*, 96 per cent *V/V* solution of *acetonitrile R* (0.2:99.8 *V/V*).

**Flow rate:** 1.0 mL/min.

**Detection:** spectrophotometer at 265 nm.

**Injection:** 2 quantities not exceeding 200 µL of each of the 3 solutions obtained under Purification.

**System suitability:**

- **resolution:** minimum 1.4 between the peaks due to ergocalciferol and cholecalciferol in the chromatogram obtained with reference solution (b);
- the results obtained with the test solution (b) duplicates do not differ by more than 5 per cent.

Calculate the content of vitamin D<sub>3</sub> in International Units per gram using the following expression, taking into account the assigned content of *cholecalciferol CRS*:

$$\frac{A_2}{A_6} \times \frac{A_3}{A_4 - \left[ \frac{A_5}{A_1} \right] \times A_2} \times \frac{m_2}{m_1} \times \frac{V_2}{V_1} \times 40$$

- $m_1$  = mass of the sample in test solution (b), in grams;
- $m_2$  = total mass of *cholecalciferol CRS* used for the preparation of reference solution (a), in micrograms (500 µg);
- $A_1$  = area (or height) of the peak due to cholecalciferol in the chromatogram obtained with test solution (a);
- $A_2$  = area (or height) of the peak due to cholecalciferol in the chromatogram obtained with test solution (b);
- $A_3$  = area (or height) of the peak due to ergocalciferol in the chromatogram obtained with reference solution (b);
- $A_4$  = area (or height) of the peak due to ergocalciferol in the chromatogram obtained with test solution (b);
- $A_5$  = area (or height) of a possible peak in the chromatogram obtained with test solution (a) with the same retention time as the peak co-eluting with ergocalciferol in test solution (b);
- $A_6$  = area (or height) of the peak due to cholecalciferol in the chromatogram obtained with reference solution (b);
- $V_1$  = total volume of reference solution (a) (100 mL);
- $V_2$  = volume of reference solution (a) used for preparing reference solution (b) (2.0 mL).

#### STORAGE

In an airtight and well-filled container, protected from light. If no antioxidant is added, store under an inert gas.

Once the container has been opened, its contents are used as soon as possible and any part of the contents not used at once is protected by an atmosphere of inert gas.

#### LABELLING

The label states:

- the concentration of EPA and DHA as a sum;
- the number of International Units of vitamin A per gram;
- the number of International Units of vitamin D<sub>3</sub> per gram.

01/2009:1192

## COD-LIVER OIL (TYPE A)

### Iecoris aselli oleum A

#### DEFINITION

Purified fatty oil obtained from the fresh livers of wild cod, *Gadus morhua* L. and other species of *Gadidae*, solid substances being removed by cooling and filtering. A suitable antioxidant may be added.

**Content:** 600 IU (180 µg) to 2500 IU (750 µg) of vitamin A per gram and 60 IU (1.5 µg) to 250 IU (6.25 µg) of vitamin D<sub>3</sub> per gram.

#### CHARACTERS

**Appearance:** clear, yellowish, liquid.

**Solubility:** practically insoluble in water, slightly soluble in ethanol (96 per cent), miscible with light petroleum.

#### IDENTIFICATION

**First identification:** A, B, C.

**Second identification:** C, D.

- A. In the assay for vitamin A using method A, the test solution shows an absorption maximum (2.2.25) at  $325 \pm 2$  nm. In the assay for vitamin A using method B, the chromatogram obtained with the test solution shows a peak corresponding to the peak of all-*trans*-retinol in the chromatogram obtained with the reference solution.
- B. In the assay for vitamin D<sub>3</sub>, the chromatogram obtained with test solution (a) shows a peak corresponding to the peak of cholecalciferol in the chromatogram obtained with reference solution (b).
- C. Composition of fatty acids (see Tests).
- D. To 0.1 g add 0.5 mL of *methylene chloride R* and 1 mL of *antimony trichloride solution R*. Mix. A deep blue colour develops in about 10 s.

#### TESTS

**Colour:** not more intensely coloured than a reference solution prepared as follows: to 3.0 mL of red primary solution add 25.0 mL of yellow primary solution and dilute to 50.0 mL with a 10 g/L solution of *hydrochloric acid R* (2.2.2, *Method II*).

**Relative density** (2.2.5): 0.917 to 0.930.

**Refractive index** (2.2.6): 1.477 to 1.484.

**Acid value** (2.5.1): maximum 2.0.

**Anisidine value** (2.5.36): maximum 30.0.

**Iodine value** (2.5.4, *Method B*): 150 to 180.

Use *starch solution R2*.

**Peroxide value** (2.5.5, *Method B*): maximum 10.0.

**Unsaponifiable matter** (2.5.7): maximum 1.5 per cent, determined on 2.0 g, and extracting with 3 quantities, each of 50 mL, of *peroxide-free ether R*.

**Stearin.** Heat at least 10 mL to 60-90 °C then allow to cool for 3 h in a bath of iced water or a thermostatically-controlled bath at  $0 \pm 0.5$  °C. If necessary, to eliminate insoluble matter, filter the sample after heating. The sample remains clear.

**Composition of fatty acids.** Gas chromatography (2.2.28).

Trivial name of fatty acid	Nomenclature	Lower limit area (per cent)	Upper limit area (per cent)
<i>Saturated fatty acids:</i>			
Myristic acid	14:0	2.0	6.0
Palmitic acid	16:0	7.0	14.0
Stearic acid	18:0	1.0	4.0
<i>Mono-unsaturated fatty acids:</i>			
Palmitoleic acid	16:1 n-7	4.5	11.5
<i>cis</i> -Vaccenic acid	18:1 n-7	2.0	7.0
Oleic acid	18:1 n-9	12.0	21.0
Gadoleic acid	20:1 n-11	1.0	5.5
Gondoic acid	20:1 n-9	5.0	17.0
Erucic acid	22:1 n-9	0	1.5
Cetoleic acid (22:1 n-11)	22:1 n-11+13	5.0	12.0
<i>Poly-unsaturated fatty acids:</i>			
Linoleic acid	18:2 n-6	0.5	3.0
$\alpha$ -Linolenic acid	18:3 n-3	0	2.0
Moroctic acid	18:4 n-3	0.5	4.5
Timnodonic (eicosapentaenoic) acid (EPA)	20:5 n-3	7.0	16.0
Cervonic (docosahexaenoic) acid (DHA)	22:6 n-3	6.0	18.0

**Test solution.** Introduce about 0.45 g of the substance to be examined into a 10 mL volumetric flask, dissolve in *hexane R* containing 50 mg of *butylhydroxytoluene R* per litre and dilute to 10.0 mL with the same solvent. Transfer 2.0 mL of this solution into a quartz tube and evaporate the solvent with a gentle current of *nitrogen R*. Add 1.5 mL of a 20 g/L solution of *sodium hydroxide R* in *methanol R*, cover with *nitrogen R*, cap tightly with a polytetrafluoroethylene-lined cap, mix and heat in a water-bath for 7 min. Cool, add 2 mL of *boron trichloride-methanol solution R*, cover with *nitrogen R*, cap tightly, mix and heat in a water-bath for 30 min. Cool to 40-50 °C, add 1 mL of *trimethylpentane R*, cap and vortex or shake vigorously for at least 30 s. Immediately add 5 mL of *saturated sodium chloride solution R*, cover with *nitrogen R*, cap and vortex or shake vigorously for at least 15 s. Allow the upper layer to become clear and transfer it to a separate tube. Shake the methanol layer once more with 1 mL of *trimethylpentane R* and combine the trimethylpentane extracts. Wash the combined extracts with 2 quantities, each of 1 mL, of *water R* and dry over *anhydrous sodium sulfate R*. Prepare 2 solutions for each sample.

**Column:**

- *material:* fused silica;
- *size:*  $l = 30$  m,  $\varnothing = 0.25$  mm;
- *stationary phase:* *macrogol 20 000 R* (film thickness 0.25  $\mu$ m).

**Carrier gas:** *hydrogen for chromatography R* or *helium for chromatography R*, where oxygen scrubber is applied.

**Split ratio:** 1:200.

**Temperature:**

	Time (min)	Temperature (°C)
Column	0 - 55	170 → 225
	55 - 75	225
Injection port		250
Detector		280

**Detection:** flame ionisation.

**Injection:** 1  $\mu$ L, twice.

**System suitability:**

- the 15 fatty acids to be tested are satisfactorily identified from the chromatogram shown in Figure 1192.-1;
- injection of a mixture of equal amounts of *methyl palmitate R*, *methyl stearate R*, *methyl arachidate R* and *methyl behenate R* gives area percentages of 24.4, 24.8, 25.2 and 25.6 ( $\pm 0.5$  per cent), respectively;
- *resolution:* minimum 1.3 between the peaks due to methyl oleate and methyl *cis*-vaccenate; the resolution between the pair due to methyl gadoleate and methyl gondoate is sufficient for purposes of identification and area measurement.

Calculate the area per cent for each fatty acid methyl ester using the following expression:

$$\frac{A_x}{A_t} \times 100$$

$A_x$  = peak area of fatty acid  $x$ ;

$A_t$  = sum of the peak areas (up to C22:6 n-3).

The calculation is not valid unless:

- the total area is based only on peaks due solely to fatty acid methyl esters;
- the number of fatty acid methyl ester peaks exceeding 0.05 per cent of the total area is at least 24;

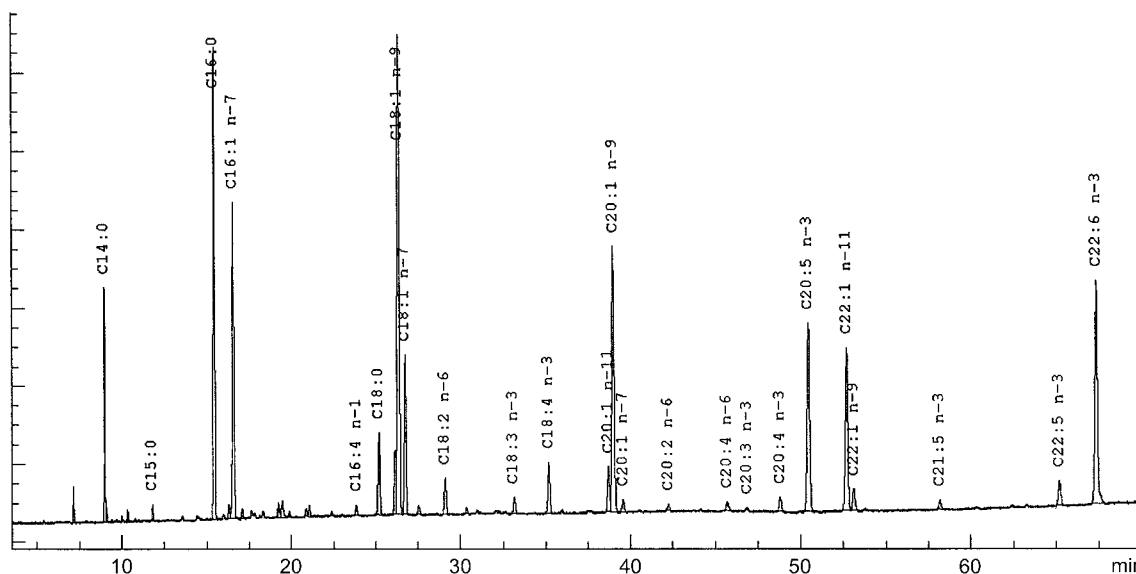

Figure 1192.-1. – Chromatogram for the test for composition of fatty acids of cod-liver oil (type A)

- the 24 largest peaks of the methyl esters account for more than 90 per cent of the total area. (These correspond to, in common elution order: 14:0, 15:0, 16:0, 16:1 n-7, 16:4 n-1, 18:0, 18:1 n-9, 18:1 n-7, 18:2 n-6, 18:3 n-3, 18:4 n-3, 20:1 n-11, 20:1 n-9, 20:1 n-7, 20:2 n-6, 20:4 n-6, 20:3 n-3, 20:4 n-3, 20:5 n-3, 22:1 n-11, 22:1 n-9, 21:5 n-3, 22:5 n-3, 22:6 n-3).

## ASSAY

**Vitamin A.** Carry out the test as rapidly as possible, avoiding exposure to actinic light and air, oxidising agents, oxidation catalysts (for example, copper and iron) and acids.

Use method A. If method A is found not to be valid, use method B.

## METHOD A

Ultraviolet absorption spectrophotometry (2.2.25).

**Test solution.** To 1.00 g in a round-bottomed flask, add 3 mL of a freshly prepared 50 per cent *m/m* solution of *potassium hydroxide R* and 30 mL of *anhydrous ethanol R*. Boil under reflux in a current of *nitrogen R* for 30 min. Cool rapidly and add 30 mL of *water R*. Extract with 50 mL of *ether R*. Repeat the extraction 3 times and discard the lower layer after complete separation. Wash the combined upper layers with 4 quantities, each of 50 mL, of *water R*, and evaporate to dryness under a gentle current of *nitrogen R* at a temperature not exceeding 30 °C or in a rotary evaporator at a temperature not exceeding 30 °C under reduced pressure (water ejector). Dissolve the residue in sufficient *2-propanol RI* to give an expected concentration of vitamin A equivalent to 10-15 IU/mL.

Measure the absorbances of the solution at 300 nm, 310 nm, 325 nm and 334 nm and at the wavelength of maximum absorption with a suitable spectrophotometer in 1 cm specially matched cells, using *2-propanol RI* as the compensation liquid.

Calculate the content of vitamin A, as *all-trans-retinol*, in International Units per gram, using the following expression:

$$A_{325} \times \frac{1821}{100m} \times V$$

$A_{325}$  = absorbance at 325 nm;

$m$  = mass of the substance to be examined, in grams;

$V$  = total volume of solution containing 10-15 IU of vitamin A per millilitre;

1821 = conversion factor for the specific absorbance of *all-trans-retinol*, in International Units.

The above expression can be used only if  $A_{325}$  has a value of not greater than  $A_{325, \text{corr}}/0.970$ , where  $A_{325, \text{corr}}$  is the corrected absorbance at 325 nm and is given by the following equation:

$$A_{325, \text{corr}} = 6.815A_{325} - 2.555A_{310} - 4.260A_{334}$$

$A$  designates the absorbance at the wavelength indicated by the subscript.

If  $A_{325}$  has a value greater than  $A_{325, \text{corr}}/0.970$ , calculate the content of vitamin A using the following expression:

$$A_{325, \text{corr}} \times \frac{1821}{100m} \times V$$

The assay is not valid unless:

- the wavelength of the maximum absorption lies between 323 nm and 327 nm;
- the absorbance at 300 nm relative to that at 325 nm is at most 0.73.

## METHOD B

Liquid chromatography (2.2.29).

**Test solution.** Prepare duplicates. To 2.00 g in a round-bottomed flask, add 5 mL of a freshly prepared 100 g/L solution of *ascorbic acid R*, 10 mL of a freshly prepared 800 g/L solution of *potassium hydroxide R* and 100 mL of *anhydrous ethanol R*. Boil under a reflux condenser on a water-bath for 15 min. Add 100 mL of a 10 g/L solution of *sodium chloride R* and cool.

Transfer the solution to a 500 mL separating funnel, rinsing the round-bottomed flask with about 75 mL of a 10 g/L solution of *sodium chloride R* and then with 150 mL of a mixture of equal volumes of *light petroleum RI* and *ether R*. Shake for 1 min. When the layers have separated completely, discard the lower layer and wash the upper layer, first with 50 mL of a 30 g/L solution of *potassium hydroxide R* in a 10 per cent *V/V* solution of *anhydrous ethanol R* and then with 3 quantities, each of 50 mL, of a 10 g/L solution of *sodium chloride R*. Filter the upper layer through 5 g of *anhydrous sodium sulfate R* on a fast filter paper into a 250 mL flask suitable for a rotary evaporator. Wash the funnel with 10 mL of fresh extraction mixture, filter and combine the upper layers. Distil them at a temperature not exceeding 30 °C under reduced pressure (water ejector) and fill with *nitrogen R* when evaporation is completed. Alternatively, evaporate the solvent under a gentle current of *nitrogen R* at a temperature not exceeding 30 °C. Dissolve the residue in *2-propanol R*, transfer to a 25 mL volumetric flask and dilute to 25 mL with *2-propanol R*. Gentle heating in an ultrasonic bath may be required. A large fraction of the white residue is *cholesterol*, constituting approximately 50 per cent *m/m* of the unsaponifiable matter of cod-liver oil.

**Reference solution (a).** Prepare a solution of *retinol acetate CRS* in *2-propanol RI* so that 1 mL contains about 1000 IU of *all-trans-retinol*.

The exact concentration of reference solution (a) is assessed by ultraviolet absorption spectrophotometry (2.2.25). Dilute reference solution (a) with *2-propanol RI* to a presumed concentration of 10-15 IU/mL and measure the absorbance at 326 nm in matched 1 cm cells using *2-propanol RI* as the compensation liquid.

Calculate the content of vitamin A in International Units per millilitre of reference solution (a) using the following expression, taking into account the assigned content of *retinol acetate CRS*:

$$A_{326} \times \frac{1900 \times V_2}{100 \times V_1}$$

$A_{326}$  = absorbance at 326 nm;

$V_1$  = volume of reference solution (a) used;

$V_2$  = volume of the diluted solution;

1900 = conversion factor for the specific absorbance of *retinol acetate CRS*, in International Units.

**Reference solution (b).** Proceed as described for the test solution but using 2.00 mL of reference solution (a) in place of the substance to be examined.

The exact concentration of reference solution (b) is assessed by ultraviolet absorption spectrophotometry (2.2.25). Dilute reference solution (b) with *2-propanol RI* to a presumed *all-trans-retinol* concentration of 10-15 IU/mL and measure the absorbance at 325 nm in matched 1 cm cells using *2-propanol RI* as the compensation liquid.

Calculate the content of *all-trans-retinol* in International Units per millilitre of reference solution (b), using the following expression:

$$A_{325} \times \frac{1821 \times V_3}{100 \times V_4}$$

$A_{325}$  = absorbance at 325 nm;

$V_3$  = volume of the diluted solution;

$V_4$  = volume of reference solution (b) used;

1821 = conversion factor for the specific absorbance of *all-trans-retinol*, in International Units.

**Column:**

– size:  $l = 0.25$  m,  $\varnothing = 4.6$  mm;

– stationary phase: *octadecylsilyl silica gel for chromatography R* (5-10  $\mu\text{m}$ ).

*Mobile phase:* water R, methanol R (3:97 V/V).

*Flow rate:* 1 mL/min.

*Detection:* spectrophotometer at 325 nm.

*Injection:* 10 µL; inject in triplicate the test solution and reference solution (b).

*Retention time:* all-*trans*-retinol = 5 ± 1 min.

*System suitability:*

- the chromatogram obtained with the test solution shows a peak that corresponds to the peak due to all-*trans*-retinol in the chromatogram obtained with reference solution (b);
- the results obtained with the duplicate test solutions do not differ by more than 5 per cent;
- the recovery of all-*trans*-retinol in reference solution (b) as assessed by direct absorption spectrophotometry is greater than 95 per cent.

Calculate the content of vitamin A using the following expression:

$$A_1 \times \frac{C \times V}{A_2} \times \frac{1}{m}$$

- $A_1$  = area of the peak due to all-*trans*-retinol in the chromatogram obtained with the test solution;
- $A_2$  = area of the peak due to all-*trans*-retinol in the chromatogram obtained with reference solution (b);
- $C$  = concentration of *retinol acetate CRS* in reference solution (a) as assessed prior to the saponification, in International Units per millilitre (= 1000 IU/mL);
- $V$  = volume of reference solution (a) treated (2.00 mL);
- $m$  = mass of the substance to be examined in the test solution (2.00 g).

**Vitamin D<sub>3</sub>.** Liquid chromatography (2.2.29). Carry out the assay as rapidly as possible, avoiding exposure to actinic light and air.

*Internal standard solution.* Dissolve 0.50 mg of *ergocalciferol CRS* in 100 mL of *anhydrous ethanol R*.

*Test solution (a).* To 4.00 g in a round-bottomed flask, add 5 mL of a freshly prepared 100 g/L solution of *ascorbic acid R*, 10 mL of a freshly prepared 800 g/L solution of *potassium hydroxide R* and 100 mL of *anhydrous ethanol R*. Boil under a reflux condenser on a water-bath for 30 min. Add 100 mL of a 10 g/L solution of *sodium chloride R* and cool the solution to room temperature. Transfer the solution to a 500 mL separating funnel, rinsing the round-bottomed flask with about 75 mL of a 10 g/L solution of *sodium chloride R* and then with 150 mL of a mixture of equal volumes of *light petroleum R1* and *ether R*. Shake for 1 min. When the layers have separated completely, discard the lower layer and wash the upper layer, first with 50 mL of a 30 g/L solution of *potassium hydroxide R* in a 10 per cent V/V solution of *anhydrous ethanol R*, and then with 3 quantities, each of 50 mL, of a 10 g/L solution of *sodium chloride R*. Filter the upper layer through 5 g of *anhydrous sodium sulfate R* on a fast filter paper into a 250 mL flask suitable for a rotary evaporator. Wash the funnel with 10 mL of fresh extraction mixture, filter and combine the upper layers. Distil them at a temperature not exceeding 30 °C under reduced pressure (water ejector) and fill with *nitrogen R* when evaporation is completed. Alternatively, evaporate the solvent under a gentle current of *nitrogen R* at a temperature not exceeding 30 °C. Dissolve the residue in 1.5 mL of the mobile phase described under Purification. Gentle heating in an ultrasonic bath may be required. A large fraction of the white residue is cholesterol, constituting approximately 50 per cent m/m of the unsaponifiable matter of cod-liver oil.

*Test solution (b).* Prepare duplicates. To 4.00 g add 2.0 mL of the internal standard solution and proceed as described for test solution (a).

*Reference solution (a).* Dissolve 0.50 mg of *cholecalciferol CRS* in 100.0 mL of *anhydrous ethanol R*.

*Reference solution (b).* Into a round-bottomed flask, add 2.0 mL of reference solution (a) and 2.0 mL of the internal standard solution and proceed as described for test solution (a).

**PURIFICATION**

*Column:*

- size:  $l = 0.25$  m,  $\varnothing = 4.6$  mm;
- stationary phase: *nitrile silica gel for chromatography R* (10 µm).

*Mobile phase:* *isoamyl alcohol R*, *hexane R* (1.6:98.4 V/V).

*Flow rate:* 1.1 mL/min.

*Detection:* spectrophotometer at 265 nm.

Inject 350 µL of reference solution (b). Collect the eluate from 2 min before until 2 min after the retention time of cholecalciferol, in a ground-glass-stoppered tube containing 1 mL of a 1 g/L solution of *butylhydroxytoluene R* in *hexane R*. Repeat the procedure with test solutions (a) and (b). Evaporate the eluates obtained from reference solution (b) and from test solutions (a) and (b), separately, to dryness at a temperature not exceeding 30 °C under a gentle current of *nitrogen R*. Dissolve each residue in 1.5 mL of *acetonitrile R*.

**DETERMINATION**

*Column:*

- size:  $l = 0.15$  m,  $\varnothing = 4.6$  mm;
- stationary phase: *octadecylsilyl silica gel for chromatography R* (5 µm).

*Mobile phase:* *phosphoric acid R*, 96 per cent V/V solution of *acetonitrile R* (0.2:99.8 V/V).

*Flow rate:* 1.0 mL/min.

*Detection:* spectrophotometer at 265 nm.

*Injection:* 2 quantities not exceeding 200 µL of each of the 3 solutions obtained under Purification.

*System suitability:*

- resolution: minimum 1.4 between the peaks due to ergocalciferol and cholecalciferol in the chromatogram obtained with reference solution (b);
- the results obtained with test solution (b) duplicates do not differ by more than 5 per cent.

Calculate the content of vitamin D<sub>3</sub> in International Units per gram using the following expression, taking into account the assigned content of *cholecalciferol CRS*:

$$\frac{A_2}{A_6} \times \frac{A_3}{A_4 - \left[ \frac{A_5}{A_1} \right] \times A_2} \times \frac{m_2}{m_1} \times \frac{V_2}{V_1} \times 40$$

- $m_1$  = mass of the sample in test solution (b), in grams;
- $m_2$  = total mass of *cholecalciferol CRS* used for the preparation of reference solution (a), in micrograms (500 µg);
- $A_1$  = area (or height) of the peak due to cholecalciferol in the chromatogram obtained with test solution (a);
- $A_2$  = area (or height) of the peak due to cholecalciferol in the chromatogram obtained with test solution (b);
- $A_3$  = area (or height) of the peak due to ergocalciferol in the chromatogram obtained with reference solution (b);
- $A_4$  = area (or height) of the peak due to ergocalciferol in the chromatogram obtained with test solution (b);
- $A_5$  = area (or height) of a possible peak in the chromatogram obtained with test solution (a) with the same retention time as the peak co-eluting with ergocalciferol in test solution (b);

- $A_6$  = area (or height) of the peak due to cholecalciferol in the chromatogram obtained with reference solution (b);
- $V_1$  = total volume of reference solution (a) (100 mL);
- $V_2$  = volume of reference solution (a) used for preparing reference solution (b) (2.0 mL).

## STORAGE

In an airtight and well-filled container, protected from light. If no antioxidant is added, store under an inert gas.

Once the container has been opened, its contents are used as soon as possible and any part of the contents not used at once is protected by an atmosphere of inert gas.

## LABELLING

The label states:

- the number of International Units of vitamin A per gram;
- the number of International Units of vitamin D<sub>3</sub> per gram.

01/2009:1193

## COD-LIVER OIL (TYPE B)

## Iecoris aselli oleum B

## DEFINITION

Purified fatty oil obtained from the fresh livers of wild cod, *Gadus morhua* L. and other species of *Gadidae*, solid substances being removed by cooling and filtering. A suitable antioxidant may be added.

**Content:** 600 IU (180 µg) to 2500 IU (750 µg) of vitamin A per gram and 60 IU (1.5 µg) to 250 IU (6.25 µg) of vitamin D<sub>3</sub> per gram.

## CHARACTERS

**Appearance:** clear, yellowish liquid.

**Solubility:** practically insoluble in water, slightly soluble in ethanol (96 per cent), miscible with light petroleum.

## IDENTIFICATION

**First identification:** A, B, C.

**Second identification:** C, D.

- A. In the assay for vitamin A using method A, the test solution shows an absorption maximum (2.2.25) at  $325 \pm 2$  nm. In the assay for vitamin A using method B, the chromatogram obtained with the test solution shows a peak corresponding to the peak of all-*trans*-retinol in the chromatogram obtained with the reference solution.
- B. In the assay for vitamin D<sub>3</sub>, the chromatogram obtained with test solution (a) shows a peak corresponding to the peak of cholecalciferol in the chromatogram obtained with reference solution (b).
- C. Composition of fatty acids (see Tests).
- D. To 0.1 g add 0.5 mL of *methylene chloride R* and 1 mL of *antimony trichloride solution R*. Mix. A deep blue colour develops in about 10 s.

## TESTS

**Colour:** not more intensely coloured than a reference solution prepared as follows: to 3.0 mL of red primary solution add 25.0 mL of yellow primary solution and dilute to 50.0 mL with a 10 g/L solution of *hydrochloric acid R* (2.2.2, Method II).

**Relative density** (2.2.5): 0.917 to 0.930.

**Refractive index** (2.2.6): 1.477 to 1.484.

**Acid value** (2.5.1): maximum 2.0.

**Iodine value** (2.5.4, Method B): 150 to 180.

Use *starch solution R2*.

**Peroxide value** (2.5.5, Method B): maximum 10.0.

**Unsaponifiable matter** (2.5.7): maximum 1.5 per cent, determined on 2.0 g and extracting with 3 quantities, each of 50 mL, of *peroxide-free ether R*.

**Stearin.** Heat at least 10 mL to 60-90 °C then allow to cool for 3 h in a bath of iced water or a thermostatically-controlled bath at  $0 \pm 0.5$  °C. If necessary, to eliminate insoluble matter, filter the sample after heating. The sample remains clear.

**Composition of fatty acids.** Gas chromatography (2.2.28).

Trivial name of fatty acid	Nomenclature	Lower limit area (per cent)	Upper limit area (per cent)
<i>Saturated fatty acids:</i>			
Myristic acid	14:0	2.0	6.0
Palmitic acid	16:0	7.0	14.0
Stearic acid	18:0	1.0	4.0
<i>Mono-unsaturated fatty acids:</i>			
Palmitoleic acid	16:1 n-7	4.5	11.5
<i>cis</i> -Vaccenic acid	18:1 n-7	2.0	7.0
Oleic acid	18:1 n-9	12.0	21.0
Gadoleic acid	20:1 n-11	1.0	5.5
Gondoic acid	20:1 n-9	5.0	17.0
Erucic acid	22:1 n-9	0	1.5
Cetoleic acid (22:1 n-11)	22:1 n-11+13	5.0	12.0
<i>Poly-unsaturated fatty acids:</i>			
Linoleic acid	18:2 n-6	0.5	3.0
$\alpha$ -Linolenic acid	18:3 n-3	0	2.0
Morotic acid	18:4 n-3	0.5	4.5
Timnodonic (eicosapentaenoic) acid (EPA)	20:5 n-3	7.0	16.0
Cervonic (docosahexaenoic) acid (DHA)	22:6 n-3	6.0	18.0

**Test solution.** Introduce about 0.45 g of the substance to be examined into a 10 mL volumetric flask, dissolve in *hexane R* containing 50 mg of *butylhydroxytoluene R* per litre and dilute to 10.0 mL with the same solvent. Transfer 2.0 mL of the solution into a quartz tube and evaporate the solvent with a gentle current of *nitrogen R*. Add 1.5 mL of a 20 g/L solution of *sodium hydroxide R* in *methanol R*, cover with *nitrogen R*, cap tightly with a polytetrafluoroethylene lined cap, mix and heat in a water-bath for 7 min. Cool, add 2 mL of *boron trichloride-methanol solution R*, cover with *nitrogen R*, cap tightly, mix and heat in a water-bath for 30 min. Cool to 40-50 °C, add 1 mL of *trimethylpentane R*, cap and vortex or shake vigorously for at least 30 s. Immediately add 5 mL of *saturated sodium chloride solution R*, cover with *nitrogen R*, cap and vortex or shake thoroughly for at least 15 s. Allow the upper layer to become clear and transfer to a separate tube. Shake the methanol layer once more with 1 mL of *trimethylpentane R* and combine the trimethylpentane extracts. Wash the combined extracts with 2 quantities, each of 1 mL, of *water R* and dry over *anhydrous sodium sulfate R*. Prepare 2 solutions for each sample.

**Column:**

- **material:** fused silica;
- **size:**  $l = 30$  m,  $\emptyset = 0.25$  mm;
- **stationary phase:** *macrogol 20 000 R* (film thickness 0.25 µm).

**Carrier gas:** *hydrogen for chromatography R* or *helium for chromatography R*, where oxygen scrubber is applied.

**Split ratio:** 1:200.



## Temperature:

	Time (min)	Temperature (°C)
Column	0 - 55	170 → 225
	55 - 75	225
Injection port		250
Detector		280

Detection: flame ionisation.

Injection: 1 µL, twice.

## System suitability:

- the 15 fatty acids to be tested are satisfactorily identified from the chromatogram shown in Figure 1193.-1;
- injection of a mixture of equal amounts of *methyl palmitate R*, *methyl stearate R*, *methyl arachidate R*, and *methyl behenate R* give area percentages of 24.4, 24.8, 25.2 and 25.6 (± 0.5 per cent), respectively;
- *resolution*: minimum of 1.3 between the peaks due to methyl oleate and methyl *cis*-vaccenate; the resolution between the pair due to methyl gadoleate and methyl gondoate is sufficient for purposes of identification and area measurement.

Calculate the area per cent for each fatty acid methyl ester using the following expression:

$$\frac{A_x}{A_t} \times 100$$

$A_x$  = peak area of fatty acid  $x$ ;

$A_t$  = sum of the peak areas (up to C22:6 n-3).

The calculation is not valid unless:

- the total area is based only on peaks due to solely fatty acids methyl esters;
- the number of fatty acid methyl ester peaks exceeding 0.05 per cent of the total area is at least 24;
- the 24 largest peaks of the methyl esters account for more than 90 per cent of the total area. (These correspond to, in common elution order: 14:0, 15:0, 16:0, 16:1 n-7, 16:4 n-1, 18:0, 18:1 n-9, 18:1 n-7, 18:2 n-6, 18:3 n-3, 18:4 n-3, 20:1 n-11, 20:1 n-9, 20:1 n-7, 20:2 n-6, 20:4 n-6, 20:3 n-3, 20:4 n-3, 20:5 n-3, 22:1 n-11, 22:1 n-9, 21:5 n-3, 22:5 n-3, 22:6 n-3).

## ASSAY

**Vitamin A.** Carry out the test as rapidly as possible, avoiding exposure to actinic light and air, oxidising agents, oxidation catalysts (for example, copper and iron) and acids.

Use method A. If method A is found not to be valid, use method B.

## METHOD A

Ultraviolet absorption spectrophotometry (2.2.25).

**Test solution.** To 1.00 g in a round-bottomed flask, add 3 mL of a freshly prepared 50 per cent *m/m* solution of *potassium hydroxide R* and 30 mL of *anhydrous ethanol R*. Boil under reflux in a current of *nitrogen R* for 30 min. Cool rapidly and add 30 mL of *water R*. Extract with 50 mL of *ether R*. Repeat the extraction 3 times and discard the lower layer after complete separation. Wash the combined upper layers with 4 quantities, each of 50 mL, of *water R* and evaporate to dryness under a gentle current of *nitrogen R* at a temperature not exceeding 30 °C or in a rotary evaporator at a temperature not exceeding 30 °C under reduced pressure (water ejector). Dissolve the residue in sufficient *2-propanol R1* to give an expected concentration of vitamin A equivalent to 10-15 IU/mL. Measure the absorbances of the solution at 300 nm, 310 nm, 325 nm and 334 nm and at the wavelength of maximum absorption with a suitable spectrophotometer in 1 cm specially matched cells, using *2-propanol R1* as the compensation liquid. Calculate the content of vitamin A, as all-*trans*-retinol, in International Units per gram using the following expression:

$$A_{325} \times \frac{1821}{100m} \times V$$

$A_{325}$  = absorbance at 325 nm;

$m$  = mass of the substance to be examined, in grams;

$V$  = total volume of solution containing 10-15 IU of vitamin A per millilitre;

1821 = conversion factor for the specific absorbance of all-*trans*-retinol, in International Units.

The above expression can be used only if  $A_{325}$  has a value of not greater than  $A_{325,corr}/0.970$  where  $A_{325,corr}$  is the corrected absorbance at 325 nm and is given by the equation:

$$A_{325,corr} = 6.815A_{325} - 2.555A_{310} - 4.260A_{334}$$

$A$  designates the absorbance at the wavelength indicated by the subscript.

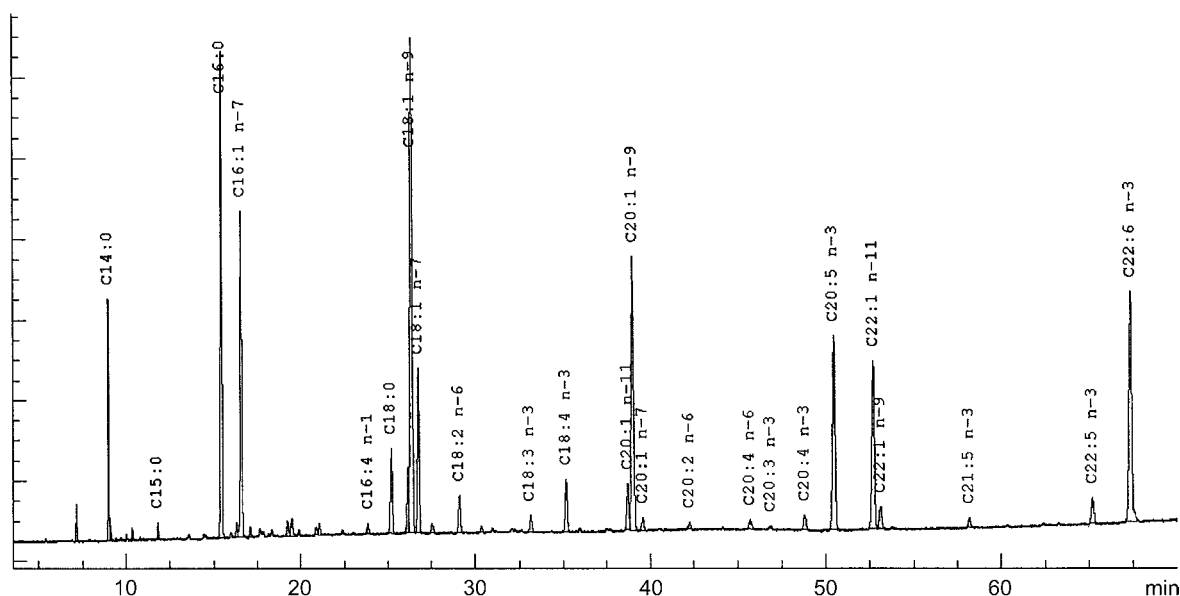

Figure 1193.-1. – Chromatogram for the test for composition of fatty acids of cod-liver oil (type B)

If  $A_{325}$  has a value greater than  $A_{325, \text{corr}}/0.970$ , calculate the content of vitamin A using the following expression:

$$A_{325, \text{corr}} \times \frac{1821}{100m} \times V$$

The assay is not valid unless:

- the wavelength of maximum absorption lies between 323 nm and 327 nm;
- the absorbance at 300 nm relative to that at 325 nm is at most 0.73.

#### METHOD B

Liquid chromatography (2.2.29).

**Test solution.** Prepare duplicates. To 2.00 g in a round-bottomed flask, add 5 mL of a freshly prepared 100 g/L solution of *ascorbic acid R* and 10 mL of a freshly prepared 800 g/L solution of *potassium hydroxide R* and 100 mL of *anhydrous ethanol R*. Boil under a reflux condenser on a water-bath for 15 min. Add 100 mL of a 10 g/L solution of *sodium chloride R* and cool. Transfer the solution to a 500 mL separating funnel rinsing the round-bottomed flask with about 75 mL of a 10 g/L solution of *sodium chloride R* and then with 150 mL of a mixture of equal volumes of *ether R* and *light petroleum RI*. Shake for 1 min. When the layers have separated completely, discard the lower layer and wash the upper layer, first with 50 mL of a 30 g/L solution of *potassium hydroxide R* in a 10 per cent V/V solution of *anhydrous ethanol R* and then with 3 quantities, each of 50 mL, of a 10 g/L solution of *sodium chloride R*. Filter the upper layer through 5 g of *anhydrous sodium sulfate R* on a fast filter paper into a 250 mL flask suitable for a rotary evaporator. Wash the funnel with 10 mL of fresh extraction mixture, filter and combine the upper layers. Distil them at a temperature not exceeding 30 °C under reduced pressure (water ejector) and fill with *nitrogen R* when evaporation is completed. Alternatively evaporate the solvent under a gentle current of *nitrogen R* at a temperature not exceeding 30 °C. Dissolve the residue in *2-propanol R*, transfer to a 25 mL volumetric flask and dilute to 25 mL with *2-propanol R*. Gentle heating in an ultrasonic bath may be required. (A large fraction of the white residue is cholesterol, constituting approximately 50 per cent of the unsaponifiable matter of cod-liver oil).

**Reference solution (a).** Prepare a solution of *retinol acetate CRS* in *2-propanol RI* so that 1 mL contains about 1000 IU of all-*trans*-retinol.

The exact concentration of reference solution (a) is assessed by ultraviolet absorption spectrophotometry (2.2.25). Dilute reference solution (a) with *2-propanol RI* to a presumed concentration of 10-15 IU/mL and measure the absorbance at 326 nm in matched 1 cm cells using *2-propanol RI* as the compensation liquid.

Calculate the content of vitamin A in International Units per millilitre of reference solution (a) using the following expression, taking into account the assigned content of *retinol acetate CRS*:

$$A_{326} \times \frac{1900 \times V_2}{100 \times V_1}$$

$A_{326}$  = absorbance at 326 nm;

$V_1$  = volume of reference solution (a) used;

$V_2$  = volume of the diluted solution;

1900 = conversion factor for the specific absorbance of *retinol acetate CRS*, in International Units.

**Reference solution (b).** Proceed as described for the test solution but using 2.00 mL of reference solution (a) in place of the substance to be examined.

The exact concentration of reference solution (b) is assessed by ultraviolet absorption spectrophotometry (2.2.25). Dilute reference solution (b) with *2-propanol RI* to a presumed

concentration of 10-15 IU/mL of all-*trans*-retinol and measure the absorbance at 325 nm in matched 1 cm cells using *2-propanol RI* as the compensation liquid.

Calculate the content of all-*trans*-retinol in International Units per millilitre of reference solution (b) from the expression:

$$A_{325} \times \frac{1821 \times V_3}{100 \times V_4}$$

$A_{325}$  = absorbance at 325 nm;

$V_3$  = volume of the diluted solution;

$V_4$  = volume of reference solution (b) used;

1821 = conversion factor for the specific absorbance of all-*trans*-retinol, in International Units.

**Column:**

– size:  $l = 0.25$  m,  $\varnothing = 4.6$  mm;

– stationary phase: *octadecylsilyl silica gel for chromatography R* (5-10  $\mu\text{m}$ ).

**Mobile phase:** *water R*, *methanol R* (3:97 V/V).

**Flow rate:** 1 mL/min.

**Detection:** spectrophotometer at 325 nm.

**Injection:** 10  $\mu\text{L}$ ; inject in triplicate the test solution and reference solution (b).

**Retention time:** all-*trans*-retinol =  $5 \pm 1$  min.

**System suitability:**

- the chromatogram obtained with the test solution shows a peak due to that of all-*trans*-retinol in the chromatogram obtained with reference solution (b);
- the results obtained with the duplicate test solutions do not differ by more than 5 per cent;
- the recovery of all-*trans*-retinol in reference solution (b) as assessed by direct absorption spectrophotometry is greater than 95 per cent.

Calculate the content of vitamin A using the following expression:

$$A_1 \times \frac{C \times V}{A_2} \times \frac{1}{m}$$

$A_1$  = area of the peak due to all-*trans*-retinol in the chromatogram obtained with the test solution;

$A_2$  = area of the peak due to all-*trans*-retinol in the chromatogram obtained with reference solution (b);

$C$  = concentration of *retinol acetate CRS* in reference solution (a) as assessed prior to the saponification, in International Units per millilitre (= 1000 IU/mL);

$V$  = volume of reference solution (a) treated (2.00 mL);

$m$  = mass of the substance to be examined in the test solution (2.00 g).

**Vitamin D<sub>3</sub>.** Liquid chromatography (2.2.29). Carry out the assay as rapidly as possible, avoiding exposure to actinic light and air.

**Internal standard solution.** Dissolve 0.50 mg of *ergocalciferol CRS* in 100 mL of *anhydrous ethanol R*.

**Test solution (a).** To 4.00 g in a round-bottomed flask, add 5 mL of a freshly prepared 100 g/L solution of *ascorbic acid R*, 10 mL of a freshly prepared 800 g/L solution of *potassium hydroxide R* and 100 mL of *anhydrous ethanol R*. Boil under a reflux condenser on a water-bath for 30 min. Add 100 mL of a 10 g/L solution of *sodium chloride R* and cool the solution to room temperature. Transfer the solution to a 500 mL separating funnel rinsing the round-bottomed flask with about 75 mL of a 10 g/L solution of *sodium chloride R* and then with 150 mL of a mixture of equal volumes of *ether R* and *light petroleum RI*. Shake for 1 min. When the layers have separated completely, discard the lower layer and wash the upper layer, first with 50 mL of a 30 g/L solution of *potassium hydroxide R* in a 10 per cent V/V solution of *anhydrous ethanol R*, and then

with 3 quantities, each of 50 mL, of a 10 g/L solution of *sodium chloride R*. Filter the upper layer through 5 g of *anhydrous sodium sulfate R* on a fast filter paper into a 250 mL flask suitable for a rotary evaporator. Wash the funnel with 10 mL of fresh extraction mixture, filter and combine the upper layers. Distil them at a temperature not exceeding 30 °C under reduced pressure (water ejector) and fill with *nitrogen R* when evaporation is completed. Alternatively evaporate the solvent under a gentle current of *nitrogen R* at a temperature not exceeding 30 °C. Dissolve the residue in 1.5 mL of the mobile phase described under Purification. Gentle heating in an ultrasonic bath may be required. (A large fraction of the white residue is cholesterol, constituting approximately 50 per cent *m/m* of the unsaponifiable matter of cod-liver oil).

**Test solution (b).** Prepare duplicates. To 4.00 g add 2.0 mL of the internal standard solution and proceed as described for test solution (a).

**Reference solution (a).** Dissolve 0.50 mg of *cholecalciferol CRS* in 100.0 mL of *anhydrous ethanol R*.

**Reference solution (b).** In a round-bottomed flask, add 2.0 mL of reference solution (a) and 2.0 mL of the internal standard solution and proceed as described for test solution (a).

#### PURIFICATION

**Column:**

- size:  $l = 0.25$  m,  $\varnothing = 4.6$  mm;
- stationary phase: *nitrile silica gel for chromatography R* (10  $\mu$ m).

**Mobile phase:** *isoamyl alcohol R*, *hexane R* (1.6:98.4 V/V).

**Flow rate:** 1.1 mL/min.

**Detection:** spectrophotometer at 265 nm.

Inject 350  $\mu$ L of reference solution (b). Collect the eluate from 2 min before until 2 min after the retention time of cholecalciferol, in a ground-glass-stoppered tube containing 1 mL of a 1 g/L solution of *butylhydroxytoluene R* in *hexane R*. Repeat the procedure with test solutions (a) and (b). Evaporate the eluates obtained from reference solution (b) and from test solutions (a) and (b), separately, to dryness at a temperature not exceeding 30 °C under a gentle current of *nitrogen R*. Dissolve each residue in 1.5 mL of *acetonitrile R*.

#### DETERMINATION

**Column:**

- size:  $l = 0.15$  m,  $\varnothing = 4.6$  mm;
- stationary phase: *octadecylsilyl silica gel for chromatography R* (5  $\mu$ m).

**Mobile phase:** *phosphoric acid R*, a 96 per cent V/V solution of *acetonitrile R* (0.2:99.8 V/V).

**Flow rate:** 1.0 mL/min.

**Detection:** spectrophotometer at 265 nm.

**Injection:** 2 quantities not exceeding 200  $\mu$ L of each of the 3 solutions obtained under Purification.

**System suitability:**

- resolution: minimum 1.4 between the peaks due to ergocalciferol and cholecalciferol in the chromatogram obtained with reference solution (b);
- the results obtained with the test solution (b) duplicates do not differ by more than 5 per cent.

Calculate the content of vitamin D<sub>3</sub> in International Units per gram using the following expression, taking into account the assigned content of *cholecalciferol CRS*:

$$\frac{A_2}{A_6} \times \frac{A_3}{A_4 - \left[ \frac{A_5}{A_1} \right] \times A_2} \times \frac{m_2}{m_1} \times \frac{V_2}{V_1} \times 40$$

- $m_1$  = mass of the sample in test solution (b) in grams;
- $m_2$  = total mass of *cholecalciferol CRS* used for the preparation of reference solution (a) in micrograms (500  $\mu$ g);
- $A_1$  = area (or height) of the peak due to cholecalciferol in the chromatogram obtained with test solution (a);
- $A_2$  = area (or height) of the peak due to cholecalciferol in the chromatogram obtained with test solution (b);
- $A_3$  = area (or height) of the peak due to ergocalciferol in the chromatogram obtained with reference solution (b);
- $A_4$  = area (or height) of the peak due to ergocalciferol in the chromatogram obtained with test solution (b);
- $A_5$  = area (or height) of a possible peak in the chromatogram obtained with test solution (a) with the same retention time as the peak co-eluting with ergocalciferol in test solution (b);
- $A_6$  = area (or height) of the peak due to cholecalciferol in the chromatogram obtained with reference solution (b);
- $V_1$  = total volume of reference solution (a) (100 mL);
- $V_2$  = volume of reference solution (a) used for preparing reference solution (b) (2.0 mL).

#### STORAGE

In an airtight and well-filled container, protected from light. If no antioxidant is added, store under an inert gas.

Once the container has been opened, its contents are used as soon as possible and any part of the contents not used at once is protected by an atmosphere of inert gas.

#### LABELLING

The label states:

- the number of International Units of vitamin A, per gram;
- the number of International Units of vitamin D<sub>3</sub>, per gram.

01/2008:0758  
corrected 7.0

## COLCHICINE

### Colchicinum

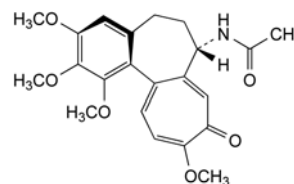

C<sub>22</sub>H<sub>25</sub>NO<sub>6</sub>  
[64-86-8]

$M_r$  399.4

#### DEFINITION

(-)-N-[(7S,12aS)-1,2,3,10-Tetramethoxy-9-oxo-5,6,7,9-tetrahydrobenzo[a]heptalen-7-yl]acetamide.

**Content:** 97.0 per cent to 102.0 per cent (anhydrous substance).

#### CHARACTERS

**Appearance:** yellowish-white, amorphous or crystalline powder.

**Solubility:** very soluble in water, rapidly recrystallising from concentrated solutions as the sesquihydrate, freely soluble in ethanol (96 per cent), practically insoluble in cyclohexane.

#### IDENTIFICATION

**First identification:** B.

**Second identification:** A, C, D.

A. Ultraviolet and visible absorption spectrophotometry (2.2.25).

with 3 quantities, each of 50 mL, of a 10 g/L solution of *sodium chloride R*. Filter the upper layer through 5 g of *anhydrous sodium sulfate R* on a fast filter paper into a 250 mL flask suitable for a rotary evaporator. Wash the funnel with 10 mL of fresh extraction mixture, filter and combine the upper layers. Distil them at a temperature not exceeding 30 °C under reduced pressure (water ejector) and fill with *nitrogen R* when evaporation is completed. Alternatively evaporate the solvent under a gentle current of *nitrogen R* at a temperature not exceeding 30 °C. Dissolve the residue in 1.5 mL of the mobile phase described under Purification. Gentle heating in an ultrasonic bath may be required. (A large fraction of the white residue is cholesterol, constituting approximately 50 per cent *m/m* of the unsaponifiable matter of cod-liver oil).

**Test solution (b).** Prepare duplicates. To 4.00 g add 2.0 mL of the internal standard solution and proceed as described for test solution (a).

**Reference solution (a).** Dissolve 0.50 mg of *cholecalciferol CRS* in 100.0 mL of *anhydrous ethanol R*.

**Reference solution (b).** In a round-bottomed flask, add 2.0 mL of reference solution (a) and 2.0 mL of the internal standard solution and proceed as described for test solution (a).

#### PURIFICATION

**Column:**

- size:  $l = 0.25$  m,  $\varnothing = 4.6$  mm;
- stationary phase: *nitrile silica gel for chromatography R* (10  $\mu$ m).

**Mobile phase:** *isoamyl alcohol R*, *hexane R* (1.6:98.4 V/V).

**Flow rate:** 1.1 mL/min.

**Detection:** spectrophotometer at 265 nm.

Inject 350  $\mu$ L of reference solution (b). Collect the eluate from 2 min before until 2 min after the retention time of cholecalciferol, in a ground-glass-stoppered tube containing 1 mL of a 1 g/L solution of *butylhydroxytoluene R* in *hexane R*. Repeat the procedure with test solutions (a) and (b). Evaporate the eluates obtained from reference solution (b) and from test solutions (a) and (b), separately, to dryness at a temperature not exceeding 30 °C under a gentle current of *nitrogen R*. Dissolve each residue in 1.5 mL of *acetonitrile R*.

#### DETERMINATION

**Column:**

- size:  $l = 0.15$  m,  $\varnothing = 4.6$  mm;
- stationary phase: *octadecylsilyl silica gel for chromatography R* (5  $\mu$ m).

**Mobile phase:** *phosphoric acid R*, a 96 per cent V/V solution of *acetonitrile R* (0.2:99.8 V/V).

**Flow rate:** 1.0 mL/min.

**Detection:** spectrophotometer at 265 nm.

**Injection:** 2 quantities not exceeding 200  $\mu$ L of each of the 3 solutions obtained under Purification.

**System suitability:**

- resolution: minimum 1.4 between the peaks due to ergocalciferol and cholecalciferol in the chromatogram obtained with reference solution (b);
- the results obtained with the test solution (b) duplicates do not differ by more than 5 per cent.

Calculate the content of vitamin D<sub>3</sub> in International Units per gram using the following expression, taking into account the assigned content of *cholecalciferol CRS*:

$$\frac{A_2}{A_6} \times \frac{A_3}{A_4 - \left[ \frac{A_5}{A_1} \right] \times A_2} \times \frac{m_2}{m_1} \times \frac{V_2}{V_1} \times 40$$

- $m_1$  = mass of the sample in test solution (b) in grams;
- $m_2$  = total mass of *cholecalciferol CRS* used for the preparation of reference solution (a) in micrograms (500  $\mu$ g);
- $A_1$  = area (or height) of the peak due to cholecalciferol in the chromatogram obtained with test solution (a);
- $A_2$  = area (or height) of the peak due to cholecalciferol in the chromatogram obtained with test solution (b);
- $A_3$  = area (or height) of the peak due to ergocalciferol in the chromatogram obtained with reference solution (b);
- $A_4$  = area (or height) of the peak due to ergocalciferol in the chromatogram obtained with test solution (b);
- $A_5$  = area (or height) of a possible peak in the chromatogram obtained with test solution (a) with the same retention time as the peak co-eluting with ergocalciferol in test solution (b);
- $A_6$  = area (or height) of the peak due to cholecalciferol in the chromatogram obtained with reference solution (b);
- $V_1$  = total volume of reference solution (a) (100 mL);
- $V_2$  = volume of reference solution (a) used for preparing reference solution (b) (2.0 mL).

#### STORAGE

In an airtight and well-filled container, protected from light. If no antioxidant is added, store under an inert gas.

Once the container has been opened, its contents are used as soon as possible and any part of the contents not used at once is protected by an atmosphere of inert gas.

#### LABELLING

The label states:

- the number of International Units of vitamin A, per gram;
- the number of International Units of vitamin D<sub>3</sub>, per gram.

01/2008:0758  
corrected 7.0

## COLCHICINE

### Colchicinum

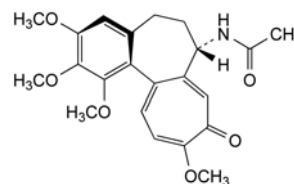

C<sub>22</sub>H<sub>25</sub>NO<sub>6</sub>  
[64-86-8]

$M_r$  399.4

#### DEFINITION

(-)-N-[(7S,12aS)-1,2,3,10-Tetramethoxy-9-oxo-5,6,7,9-tetrahydrobenzo[*a*]heptalen-7-yl]acetamide.

**Content:** 97.0 per cent to 102.0 per cent (anhydrous substance).

#### CHARACTERS

**Appearance:** yellowish-white, amorphous or crystalline powder.

**Solubility:** very soluble in water, rapidly recrystallising from concentrated solutions as the sesquihydrate, freely soluble in ethanol (96 per cent), practically insoluble in cyclohexane.

#### IDENTIFICATION

**First identification:** B.

**Second identification:** A, C, D.

A. Ultraviolet and visible absorption spectrophotometry (2.2.25).

**Test solution.** Dissolve 5 mg in *ethanol (96 per cent) R* and dilute to 100.0 mL with the same solvent. Dilute 5.0 mL of this solution to 25.0 mL with *ethanol (96 per cent) R*.

**Spectral range:** 230-400 nm.

**Absorption maxima:** at 243 nm and 350 nm.

**Absorbance ratio:**  $A_{243}/A_{350} = 1.7$  to 1.9.

#### B. Infrared absorption spectrophotometry (2.2.24).

**Preparation:** discs of *potassium bromide R*.

**Comparison:** *colchicine CRS*.

#### C. To 0.5 mL of solution S (see Tests) add 0.5 mL of dilute hydrochloric acid R and 0.15 mL of ferric chloride solution R1. The solution is yellow and becomes dark green on boiling for 30 s. Cool, add 2 mL of methylene chloride R and shake. The organic layer is greenish-yellow.

#### D. Dissolve about 30 mg in 1 mL of ethanol (96 per cent) R and add 0.15 mL of ferric chloride solution R1. A brownish-red colour develops.

### TESTS

**Solution S.** Dissolve 0.10 g in *water R* and dilute to 20 mL with the same solvent.

**Appearance of solution.** Solution S is clear (2.2.1) and not more intensely coloured than reference solution GY<sub>3</sub> (2.2.2, Method II).

**Acidity or alkalinity.** To 10 mL of solution S add 0.1 mL of *bromothymol blue solution R1*. Either the solution does not change colour or it becomes green. Not more than 0.1 mL of 0.01 M *sodium hydroxide* is required to change the colour of the indicator to blue.

**Specific optical rotation (2.2.7):** -235 to -250 (anhydrous substance).

Dissolve 50.0 mg in *ethanol (96 per cent) R* and dilute to 10.0 mL with the same solvent.

**Related substances.** Liquid chromatography (2.2.29).

**Solvent mixture:** *methanol R, water R* (50:50 V/V).

**Test solution.** Dissolve 20.0 mg of the substance to be examined in the solvent mixture and dilute to 20.0 mL with the solvent mixture.

**Reference solution (a).** Dissolve 5 mg of *colchicine for system suitability CRS* in the solvent mixture and dilute to 5.0 mL with the solvent mixture.

**Reference solution (b).** Dilute 1.0 mL of the test solution to 100.0 mL with the solvent mixture.

**Reference solution (c).** Dilute 1 mL of reference solution (b) to 20.0 mL with the solvent mixture.

**Column:**

- size:  $l = 0.25$  m,  $\varnothing = 4.6$  mm;
- stationary phase: *octylsilyl silica gel for chromatography R1* (5  $\mu$ m).

**Mobile phase:** mix 450 volumes of a 6.8 g/L solution of *potassium dihydrogen phosphate R* and 530 volumes of *methanol R*. After cooling to room temperature, adjust the volume to 1000 mL with *methanol R*. Adjust the apparent pH to 5.5 with *dilute phosphoric acid R*.

**Flow rate:** 1 mL/min.

**Detection:** spectrophotometer at 254 nm.

**Injection:** 20  $\mu$ L.

**Run time:** 3 times the retention time of *colchicine*.

**Relative retention** with reference to *colchicine* (retention time = about 7 min): impurity D = about 0.4; impurity E = about 0.7; impurity B = about 0.8; impurity A = about 0.94; impurity C = about 1.2.

**System suitability:** reference solution (a):

**Peak-to-valley ratio:** minimum 2, where  $H_p$  = height above the baseline of the peak due to impurity A and  $H_v$  = height above the baseline of the lowest point of the curve separating this peak from the peak due to *colchicine*.

**Limits:**

- **impurity A:** not more than 3.5 times the area of the principal peak in the chromatogram obtained with reference solution (b) (3.5 per cent);
- **any other impurity:** not more than the area of the principal peak in the chromatogram obtained with reference solution (b) (1 per cent);
- **total:** not more than 5 times the area of the principal peak in the chromatogram obtained with reference solution (b) (5 per cent);
- **disregard limit:** the area of the principal peak in the chromatogram obtained with reference solution (c) (0.05 per cent).

**Colchicine:** maximum 0.2 per cent.

Dissolve 50 mg in *water R* and dilute to 5 mL with the same solvent. Add 0.1 mL of *ferric chloride solution R1*. The solution is not more intensely coloured than a mixture of 1 mL of red primary solution, 2 mL of yellow primary solution and 2 mL of blue primary solution (2.2.2, Method II).

**Chloroform (2.4.24):** maximum 500 ppm.

**Ethyl acetate (2.4.24):** maximum 6.0 per cent *m/m*.

**Water (2.5.12):** maximum 2.0 per cent, determined on 0.500 g.

**Sulfated ash (2.4.14):** maximum 0.1 per cent, determined on 0.5 g.

### ASSAY

Dissolve 0.250 g with gentle heating in a mixture of 10 mL of *acetic anhydride R* and 20 mL of *toluene R*. Titrate with 0.1 M *perchloric acid*, determining the end-point potentiometrically (2.2.20).

1 mL of 0.1 M *perchloric acid* is equivalent to 39.94 mg of C<sub>22</sub>H<sub>25</sub>NO<sub>6</sub>.

### STORAGE

Protected from light.

### IMPURITIES

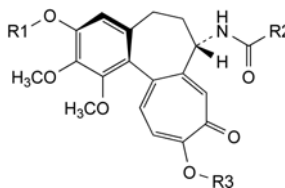

A. R<sub>1</sub> = R<sub>3</sub> = CH<sub>3</sub>, R<sub>2</sub> = H: *N*-[(7*S*,12*aS*)-1,2,3,10-tetramethoxy-9-oxo-5,6,7,9-tetrahydrobenzo[*a*]heptalen-7-yl]formamide (*N*-deacetyl-*N*-formylcolchicine),

E. R<sub>1</sub> = H, R<sub>2</sub> = R<sub>3</sub> = CH<sub>3</sub>: *N*-[(7*S*,12*aS*)-3-hydroxy-1,2,10-trimethoxy-9-oxo-5,6,7,9-tetrahydrobenzo[*a*]heptalen-7-yl]acetamide (3-*O*-demethylcolchicine),

F. R<sub>1</sub> = R<sub>2</sub> = CH<sub>3</sub>, R<sub>3</sub> = H: *N*-[(7*S*,12*aS*)-10-hydroxy-1,2,3-trimethoxy-9-oxo-5,6,7,9-tetrahydrobenzo[*a*]heptalen-7-yl]acetamide (colchicine),

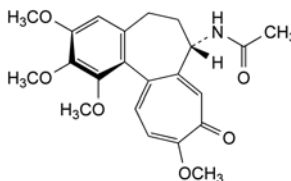

B. (-)-*N*-[(7*S*,12*aR*)-1,2,3,10-tetramethoxy-9-oxo-5,6,7,9-tetrahydrobenzo[*a*]heptalen-7-yl]acetamide (conformational isomer),

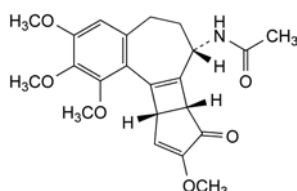

- C. *N*-[(7*S*,7*bR*,10*aS*)-1,2,3,9-tetramethoxy-8-oxo-5,6,7,7*b*,8,10*a*-hexahydrobenzo[*a*]cyclopenta[3,4]-cyclobuta[1,2-*c*]cyclohepten-7-yl]acetamide (β-lumicolchicine),

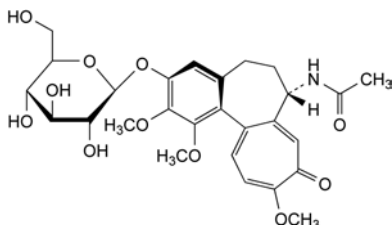

- D. *N*-[(7*S*,12*aS*)-3-(β-*D*-glucopyranosyloxy)-1,2,10-trimethoxy-9-oxo-5,6,7,9-tetrahydrobenzo[*a*]heptalen-7-yl]acetamide (colchicoside).

01/2008:1775

## COLESTYRAMINE

### Colestyraminum

[11041-12-6]

#### DEFINITION

Strongly basic anion-exchange resin in chloride form, consisting of styrene-divinylbenzene copolymer with quaternary ammonium groups.

**Nominal exchange capacity:** 1.8 g to 2.2 g of sodium glycocholate per gram (dried substance).

#### CHARACTERS

**Appearance:** white or almost white, fine powder, hygroscopic.

**Solubility:** insoluble in water, in methylene chloride and in ethanol (96 per cent).

#### IDENTIFICATION

- A. Infrared absorption spectrophotometry (2.2.24).

*Comparison:* colestyramine CRS.

- B. Chloride (see Tests).

#### TESTS

**pH** (2.2.3): 4.0 to 6.0.

Suspend 0.100 g in 10 mL of *water R* and allow to stand for 10 min.

**Dialysable quaternary amines:** maximum 500 ppm, expressed as benzyltrimethylammonium chloride.

**Test solution.** Place a 25 cm piece of cellulose dialysis tubing having a molecular weight cut-off of 12 000-14 000 and an inflated diameter of 3-6 cm (flat width of 5-9 cm) in *water R* to hydrate until pliable, appropriately sealing one end. Introduce 2.0 g of the substance to be examined into the tube and add 10 mL of *water R*. Seal the tube and completely immerse it in 100 mL of *water R* in a suitable vessel and stir the liquid for 16 h to effect dialysis. Use the dialysate as test solution.

**Reference solution.** Prepare the reference solution in a similar manner but using 10 mL of a freshly prepared 0.1 g/L solution of *benzyltrimethylammonium chloride R* instead of the substance to be examined.

Transfer 5.0 mL of the test solution to a separating funnel and add 5 mL of a 3.8 g/L solution of *disodium tetraborate R*, 1 mL of a solution containing 1.5 g/L of *bromothymol blue R* and 4.05 g/L of *sodium carbonate R* and 10 mL of *chloroform R*. Shake the mixture vigorously for 1 min, allow the phases to separate and transfer the clear organic layer to a 25 mL volumetric flask. Repeat the extraction with a further 10 mL of *chloroform R*, combine the organic layers and dilute to 25 mL with *chloroform R*. Measure the absorbance (2.2.25) of the solution at the absorption maximum at 420 nm, using as compensation liquid a solution prepared in the same manner but using 5.0 mL of *water R* instead of the test solution.

Repeat the operation using 5.0 mL of the reference solution.

The absorbance obtained with the test solution is not greater than that obtained with the reference solution.

**Impurity A.** Liquid chromatography (2.2.29).

**Test solution.** Shake 5.0 g with 10 mL of *acetone R* for 30 min. Centrifuge and use the supernatant liquid.

**Reference solution (a).** Dissolve 5 mg of *styrene R* in *acetone R* and dilute to 100.0 mL with the same solvent. Dilute 1.0 mL of the solution to 100.0 mL with *acetone R*.

**Reference solution (b).** Dissolve 0.35 mL of *styrene R* in *acetone R* and dilute to 100.0 mL with the same solvent. Dilute 1.0 mL of the solution to 100.0 mL with *acetone R*.

**Reference solution (c).** Dissolve 0.35 mL of *toluene R* in *acetone R* and dilute to 100.0 mL with the same solvent.

**Reference solution (d).** Mix 1.0 mL of reference solution (b) and 1.0 mL of reference solution (c) with *acetone R* and dilute to 100.0 mL with the same solvent.

#### Column:

- **size:**  $l = 0.30$  m,  $\varnothing = 3.9$  mm,
- **stationary phase:** octadecylsilyl silica gel for chromatography *R* (10  $\mu$ m) with a specific surface area of 330 m<sup>2</sup>/g and a pore size of 12.5 nm.

**Mobile phase:** acetonitrile *R*, *water R* (50:50 V/V).

**Flow rate:** 2.0 mL/min.

**Detection:** spectrophotometer at 254 nm.

**Injection:** 20  $\mu$ L of test solution and reference solutions (a) and (d).

**System suitability:** reference solution (d):

- **resolution:** minimum 1.5 between the peaks due to impurity A and toluene.

#### Limit:

- **impurity A:** not more than the area of the principal peak in the chromatogram obtained with reference solution (a) (1 ppm).

**Chloride:** 13.0 per cent to 17.0 per cent (dried substance).

To 0.2 g add 100 mL of *water R* and 50 mg of *potassium nitrate R*. Add, with stirring, 2 mL of *nitric acid R* and titrate with 0.1 *M silver nitrate*, determining the end-point potentiometrically (2.2.20).

1 mL of 0.1 *M silver nitrate* is equivalent to 3.55 mg of Cl.

**Heavy metals** (2.4.8): maximum 20 ppm.

1.0 g complies with test F. Prepare the reference solution using 2 mL of *lead standard solution (10 ppm Pb) R*.

**Loss on drying** (2.2.32): maximum 12 per cent, determined on 1.000 g by drying in an oven at 70 °C over *diphosphorus pentoxide R* at a pressure not exceeding 7 kPa for 16 h.

**Sulfated ash** (2.4.14): maximum 0.1 per cent, determined on 1.0 g.

#### ASSAY

**Exchange capacity.** Liquid chromatography (2.2.29).

**Solution A.** Dissolve 1.500 g of *sodium glycocholate R* in a solution containing 4 g/L of *potassium dihydrogen phosphate R* and 12 g/L of *dipotassium hydrogen phosphate R* and dilute to 100.0 mL with the same solution.

**Test solution.** Add 20.0 mL of solution A to a quantity of the substance to be examined equivalent to about 0.100 g of the dried substance. Shake mechanically for 2 h and centrifuge for 15 min. Dilute 5.0 mL of the supernatant liquid to 50.0 mL with *water R*.

**Reference solution (a).** Dilute 4.0 mL of solution A to 100.0 mL with *water R*.

**Reference solution (b).** Dissolve 60 mg of *sodium glycocholate R* and 30 mg of *sodium taurodeoxycholate R* in *water R* and dilute to 100 mL with the same solvent. Dilute 1 mL of the solution to 10 mL with *water R*.

**Column:**

- size:  $l = 0.25$  m,  $\varnothing = 4.6$  mm,
- stationary phase: octadecylsilyl silica gel for chromatography R (5  $\mu$ m).

**Mobile phase:** mix 35 volumes of *acetonitrile R* and 65 volumes of a 10.9 g/L solution of *potassium dihydrogen phosphate R* adjusted to pH 3.0 with *phosphoric acid R*.

**Flow rate:** 1.5 mL/min.

**Detection:** spectrophotometer at 214 nm.

**Injection:** 50  $\mu$ L.

**Run time:** twice the retention time of glycocholate.

**System suitability:** reference solution (b):

- resolution: minimum 1.5 between the peaks due to glycocholate and taurodeoxycholate.

Calculate the nominal exchange capacity using the following expression:

$$\frac{(2.5 A_1 - A_2) \times m_1 \times 1.2}{12.5 \times A_1 \times m_2}$$

- $A_1$  = area of the peak due to glycocholate in the chromatogram obtained with reference solution (a),
- $A_2$  = area of the peak due to glycocholate in the chromatogram obtained with the test solution,
- $m_1$  = mass, in milligrams, of *sodium glycocholate R* used in the preparation of solution A,
- $m_2$  = mass, in milligrams, of the dried substance to be examined used in the preparation of the test solution,
- 1.2 = correction factor to convert the true exchange capacity to the conventionally used nominal exchange capacity.

#### STORAGE

In an airtight container.

#### IMPURITIES

**Specified impurities:** A.

A. styrene.

01/2008:0319  
corrected 6.0

## COLISTIMETHATE SODIUM

### Colistimethatum natricum

[8068-28-8]

#### DEFINITION

Colistimethate sodium is prepared from colistin by the action of formaldehyde and sodium hydrogen sulfite.

Semi-synthetic product derived from a fermentation product.

**Content:** minimum 11 500 IU/mg (dried substance).

#### CHARACTERS

**Appearance:** white or almost white, hygroscopic powder.

**Solubility:** very soluble in water, slightly soluble in ethanol (96 per cent), practically insoluble in acetone.

#### IDENTIFICATION

A. Thin-layer chromatography (2.2.27).

**Test solution.** Dissolve 5 mg of the substance to be examined in 1 mL of a mixture of equal volumes of *hydrochloric acid R* and *water R*. Heat at 135 °C in a sealed tube for 5 h. Evaporate to dryness on a water-bath and continue the heating until the hydrochloric acid has evaporated. Dissolve the residue in 0.5 mL of *water R*.

**Reference solution (a).** Dissolve 20 mg of *leucine R* in *water R* and dilute to 10 mL with the same solvent.

**Reference solution (b).** Dissolve 20 mg of *threonine R* in *water R* and dilute to 10 mL with the same solvent.

**Reference solution (c).** Dissolve 20 mg of *phenylalanine R* in *water R* and dilute to 10 mL with the same solvent.

**Reference solution (d).** Dissolve 20 mg of *serine R* in *water R* and dilute to 10 mL with the same solvent.

**Plate:** TLC silica gel G plate R.

Carry out the following procedures protected from light.

**Mobile phase:** *water R*, *phenol R* (25:75 V/V).

**Application:** 5  $\mu$ L as bands of 10 mm, then place the plate in the chromatographic tank so that it is not in contact with the mobile phase, and allow it to become impregnated with the vapour of the mobile phase for at least 12 h.

**Development:** over a path of 12 cm using the same mobile phase.

**Drying:** at 100-105 °C.

**Detection:** spray with *ninhydrin solution R1* and heat at 110 °C for 5 min.

**Results:** the chromatogram obtained with the test solution shows zones corresponding to those in the chromatograms obtained with reference solutions (a) and (b), but shows no zones corresponding to those in the chromatograms obtained with reference solutions (c) and (d); the chromatogram obtained with the test solution also shows a zone with a very low  $R_f$  value (2,4-diaminobutyric acid).

B. Dissolve about 5 mg in 3 mL of *water R*. Add 3 mL of *dilute sodium hydroxide solution R*. Shake and add 0.5 mL of a 10 g/L solution of *copper sulfate R*. A violet colour is produced.

C. Dissolve about 50 mg in 1 mL of 1 M *hydrochloric acid* and add 0.5 mL of 0.01 M *iodine*. The solution is decolourised and gives reaction (a) of sulfates (2.3.1).

D. It gives reaction (b) of sodium (2.3.1).

#### TESTS

**Appearance of solution.** The solution is clear (2.2.1).

Dissolve 0.16 g in 10 mL of *water R*.

**pH (2.2.3):** 6.5 to 8.5.

Dissolve 0.1 g in *carbon dioxide-free water R* and dilute to 10 mL with the same solvent. Measure after 30 min.

**Specific optical rotation (2.2.7):** –46 to –51 (dried substance).

Dissolve 1.25 g in *water R* and dilute to 25.0 mL with the same solvent.

**Free colistin.** Dissolve 80 mg in 3 mL of *water R*. Add 0.1 mL of a 100 g/L solution of *silicotungstic acid R*; 10-20 s after addition of the reagent, the solution is not more opalescent than reference suspension II (2.2.1).

**Total sulfite.** Work in a fume cupboard. Dissolve 0.100 g in 5 mL of *water R* and add 5 mL of a 100 g/L solution of *sodium hydroxide R* and 0.3 g of *potassium cyanide R*. Boil gently for 3 min and then cool. Neutralise with 0.5 M *sulfuric acid* using 0.2 mL of *methyl orange solution R* as indicator. Add an excess of 0.5 mL of the acid and 0.2 g of *potassium iodide R*.

Titrate with 0.05 M iodine using 1 mL of starch solution R as indicator. The volume of 0.05 M iodine used in the titration is 5.5 mL to 7.0 mL.

**Loss on drying** (2.2.32): maximum 5.0 per cent, determined on 1.000 g by drying at 60 °C over diphosphorus pentoxide R at a pressure not exceeding 670 Pa for 3 h.

**Sulfated ash** (2.4.14): 16 per cent to 21 per cent, determined on 0.50 g.

**Pyrogens** (2.6.8). If intended for use in the manufacture of parenteral preparations without a further appropriate procedure for removal of pyrogens, it complies with the test. Inject, per kilogram of the rabbit's mass, 1 mL of a solution in water for injections R containing 2.5 mg of the substance to be examined per millilitre.

#### ASSAY

Carry out the microbiological assay of antibiotics (2.7.2).

#### STORAGE

In an airtight container, protected from light. If the substance is sterile, store in a sterile, airtight, tamper-proof container.

01/2008:0320

## COLISTIN SULFATE

### Colistini sulfas

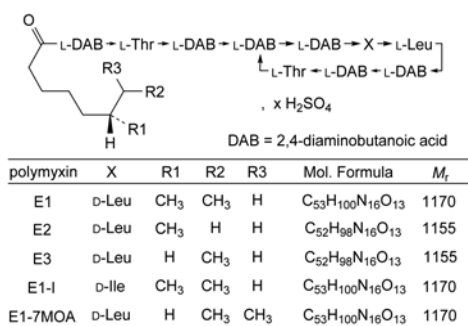

#### DEFINITION

A mixture of the sulfates of polypeptides produced by certain strains of *Bacillus polymyxa* var. *colistinus* or obtained by any other means.

#### Content:

- sum of polymyxins E1, E2, E3, E1-I and E1-7MOA: minimum 77.0 per cent (dried substance);
- polymyxin E1-I: maximum 10.0 per cent (dried substance);
- polymyxin E1-7MOA: maximum 10.0 per cent (dried substance);
- polymyxin E3: maximum 10.0 per cent (dried substance).

#### CHARACTERS

**Appearance:** white or almost white, hygroscopic powder.

**Solubility:** freely soluble in water, slightly soluble in ethanol (96 per cent), practically insoluble in acetone.

#### IDENTIFICATION

**First identification:** B, E.

**Second identification:** A, C, D, E.

A. Thin-layer chromatography (2.2.27).

**Test solution.** Dissolve 5 mg of the substance to be examined in 1 mL of a mixture of equal volumes of hydrochloric acid R and water R. Heat at 135 °C in a sealed tube for 5 h. Evaporate to dryness on a water-bath and continue the heating until moistened blue litmus paper R does not turn red. Dissolve the residue in 0.5 mL of water R.

**Reference solution (a).** Dissolve 20 mg of leucine R in water R and dilute to 10 mL with the same solvent.

**Reference solution (b).** Dissolve 20 mg of threonine R in water R and dilute to 10 mL with the same solvent.

**Reference solution (c).** Dissolve 20 mg of phenylalanine R in water R and dilute to 10 mL with the same solvent.

**Reference solution (d).** Dissolve 20 mg of serine R in water R and dilute to 10 mL with the same solvent.

**Plate:** TLC silica gel G plate R.

Carry out the following procedures protected from light.

**Mobile phase:** water R, phenol R (25:75 V/V).

**Application:** 5 µL as 10 mm bands, then place the plate in the chromatographic tank so that it is not in contact with the mobile phase, and allow it to become impregnated with the vapour of the mobile phase for at least 12 h.

**Development:** over a path of 12 cm.

**Drying:** at 100-105 °C.

**Detection:** spray with ninhydrin solution R1 and heat at 110 °C for 5 min.

**Results:** the chromatogram obtained with the test solution shows zones corresponding to those in the chromatograms obtained with reference solutions (a) and (b), but shows no zones corresponding to those in the chromatograms obtained with reference solutions (c) and (d); the chromatogram obtained with the test solution also shows a zone with a very low *R<sub>F</sub>* value (2,4-diaminobutyric acid).

B. Examine the chromatograms obtained in the assay.

**Results:** the peaks due to polymyxin E1 and polymyxin E2 in the chromatogram obtained with the test solution are similar in retention time to the corresponding peaks in the chromatogram obtained with reference solution (a).

C. Dissolve about 5 mg in 3 mL of water R. Add 3 mL of dilute sodium hydroxide solution R. Shake and add 0.5 mL of a 10 g/L solution of copper sulfate R. A violet colour is produced.

D. Dissolve about 50 mg in 1 mL of 1 M hydrochloric acid and add 0.5 mL of 0.01 M iodine. The solution remains coloured.

E. It gives reaction (a) of sulfates (2.3.1).

#### TESTS

**pH** (2.2.3): 4.0 to 6.0.

Dissolve 0.1 g in carbon dioxide-free water R and dilute to 10 mL with the same solvent.

**Specific optical rotation** (2.2.7): – 63 to – 73 (dried substance).

Dissolve 1.25 g in water R and dilute to 25.0 mL with the same solvent.

**Related substances.** Liquid chromatography (2.2.29): use the normalisation procedure.

**Test solution.** Dissolve 25.0 mg of the substance to be examined in 40 mL of water R and dilute to 50.0 mL with acetonitrile R.

**Reference solution (a).** Dissolve 25.0 mg of colistin sulfate CRS in 40 mL of water R and dilute to 50.0 mL with acetonitrile R.

**Reference solution (b).** Dilute 1.0 mL of reference solution (a) to 100.0 mL with a mixture of 20 volumes of acetonitrile R and 80 volumes of water R.

#### Column:

– size: *l* = 0.15 m, Ø = 4.6 mm;

– stationary phase: end-capped octadecylsilyl silica gel for chromatography R (3.5 µm);

– temperature: 30 °C.

**Mobile phase:** mix 22 volumes of acetonitrile R and 78 volumes of a solution prepared as follows: dissolve 4.46 g of anhydrous sodium sulfate R in 900 mL of water R, adjust to pH 2.4 with dilute phosphoric acid R and dilute to 1000 mL with water R.

**Flow rate:** 1.0 mL/min.

**Detection:** spectrophotometer at 215 nm.

**Injection:** 20 µL.

**Run time:** 1.5 times the retention time of polymyxin E1.



01/2008:0891  
corrected 6.0

*Relative retention* with reference to polymyxin E1 (retention time = about 16 min): polymyxin E2 = about 0.45; polymyxin E3 = about 0.5; polymyxin E1-I = about 0.8; polymyxin E1-7MOA = about 1.1.

*System suitability*: reference solution (a):

- *resolution*: minimum 8.0 between the peaks due to polymyxin E2 and polymyxin E1, minimum 6.0 between the peaks due to polymyxin E2 and polymyxin E1-I, minimum 2.5 between the peaks due to polymyxin E1-I and polymyxin E1, minimum 1.5 between the peaks due to polymyxin E1 and polymyxin E1-7MOA;
- the chromatogram obtained is similar to the chromatogram supplied with *colistin sulfate CRS*.

*Limits*:

- *any impurity*: maximum 4.0 per cent;
- *total*: maximum 23.0 per cent;
- *disregard limit*: the area of the peak due to polymyxin E1 in the chromatogram obtained with reference solution (b); disregard the peaks due to polymyxins E2, E3, E1-I, E1 and E1-7MOA.

**Sulfate**: 16.0 per cent to 18.0 per cent (dried substance).

Dissolve 0.250 g in 100 mL of *water R* and adjust to pH 11 with *concentrated ammonia R*. Add 10.0 mL of 0.1 M *barium chloride* and about 0.5 mg of *phthalein purple R*. Titrate with 0.1 M *sodium edetate*, adding 50 mL of *ethanol (96 per cent) R* when the colour of the solution begins to change and continuing the titration until the violet-blue colour disappears.

1 mL of 0.1 M *barium chloride* is equivalent to 9.606 mg of  $\text{SO}_4$ .

**Loss on drying** (2.2.32): maximum 3.5 per cent, determined on 1.000 g by drying at 60 °C over *diphosphorus pentoxide R* at a pressure not exceeding 670 Pa for 3 h.

**Sulfated ash** (2.4.14): maximum 1.0 per cent, determined on 1.0 g.

## ASSAY

Liquid chromatography (2.2.29) as described in the test for related substances with the following modification.

*Injection*: test solution and reference solution (a).

Calculate the percentage content of polymyxin E3, of polymyxin E1-I, of polymyxin E1-7MOA, and of the sum of polymyxins E1, E2, E3, E1-I and E1-7MOA, using the following expression:

$$C_{Ei} = \frac{A_{Ei} \times m_2 \times D_{Ei}}{m_1 \times B_{Ei}}$$

- $C_{Ei}$  = percentage content of polymyxin  $Ei$ ;
- $A_{Ei}$  = area of the peak due to polymyxin  $Ei$  in the chromatogram obtained with the test solution;
- $m_1$  = mass in milligrams of the substance to be examined (dried substance) in the test solution;
- $B_{Ei}$  = area of the peak due to polymyxin  $Ei$  in the chromatogram obtained with reference solution (a);
- $m_2$  = mass in milligrams of *colistin sulfate CRS* in reference solution (a);
- $D_{Ei}$  = declared percentage content for polymyxin  $Ei$  in *colistin sulfate CRS*.

## STORAGE

In an airtight container, protected from light.

## COPOVIDONE

### Copovidonum

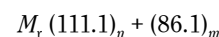
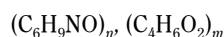
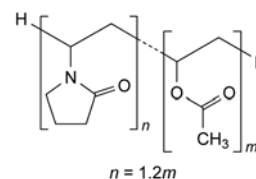

## DEFINITION

Copovidone is a copolymer of 1-ethenylpyrrolidin-2-one and ethenyl acetate in the mass proportion 3:2.

*Content*:

- nitrogen (N;  $A_r$  14.01): 7.0 per cent to 8.0 per cent (dried substance),
- ethenyl acetate  $\text{C}_4\text{H}_6\text{O}_2$ ;  $M_r$  86.10): 35.3 per cent to 42.0 per cent (dried substance).

*K-value*: 90.0 per cent to 110.0 per cent of the value stated on the label.

## CHARACTERS

*Aspect*: white or yellowish-white powder or flakes, hygroscopic.

*Solubility*: freely soluble in water, in alcohol and in methylene chloride.

## IDENTIFICATION

*First identification*: A.

*Second identification*: B, C.

A. Infrared absorption spectrophotometry (2.2.24).

*Comparison*: Ph. Eur. reference spectrum of copovidone.

B. To 1 mL of solution S (see Tests) add 5 mL of *water R* and 0.2 mL of 0.05 M *iodine*. A red colour appears.

C. Dissolve 0.7 g of *hydroxylamine hydrochloride R* in 10 mL of *methanol R*, add 20 mL of a 40 g/L solution of *sodium hydroxide R* and filter if necessary. To 5 mL of the solution add 0.1 g of the substance to be examined and boil for 2 min. Transfer 50  $\mu\text{L}$  to a filter paper and add 0.1 mL of a mixture of equal volumes of *ferric chloride solution RI* and *hydrochloric acid R*. A violet colour appears.

## TESTS

**Solution S**. Dissolve 10 g in *water R* and dilute to 100 mL with the same solvent. Add the substance to be examined to the *water R* in small portions with constant stirring.

**Appearance of solution**. Solution S is not more opalescent than reference suspension III (2.2.1) and not more intensely coloured than reference solution B<sub>5</sub>, R<sub>5</sub> or BY<sub>5</sub> (2.2.2, *Method II*).

**Aldehydes**: maximum 500 ppm, expressed as acetaldehyde.

*Test solution*. Dissolve 1.0 g of the substance to be examined in *phosphate buffer solution pH 9.0 R* and dilute to 100.0 mL with the same solvent. Stopper the flask and heat at 60 °C for 1 h. Allow to cool.

*Reference solution*. Dissolve 0.140 g of *acetaldehyde ammonia trimer trihydrate R* in *water R* and dilute to 200.0 mL with the same solvent. Dilute 1.0 mL of this solution to 100.0 mL with *phosphate buffer solution pH 9.0 R*.

Into 3 identical spectrophotometric cells with a path length of 1 cm, introduce separately 0.5 mL of the test solution, 0.5 mL of the reference solution and 0.5 mL of *water R* (blank). To each cell, add 2.5 mL of *phosphate buffer solution pH 9.0 R* and 0.2 mL of *nicotinamide-adenine dinucleotide solution R*. Mix and stopper tightly. Allow to stand at  $22 \pm 2$  °C for 2-3 min and

measure the absorbance (2.2.25) of each solution at 340 nm, using *water R* as the compensation liquid. To each cell, add 0.05 mL of *aldehyde dehydrogenase solution R*, mix and stopper tightly. Allow to stand at  $22 \pm 2$  °C for 5 min. Measure the absorbance of each solution at 340 nm using *water R* as compensation liquid. Determine the content of aldehydes using the expression:

$$\frac{(A_{t2} - A_{t1}) - (A_{b2} - A_{b1})}{(A_{s2} - A_{s1}) - (A_{b2} - A_{b1})} \times \frac{100\,000 \times C}{m}$$

- $A_{t1}$  = absorbance of the test solution before the addition of aldehyde dehydrogenase,  
 $A_{t2}$  = absorbance of the test solution after the addition of aldehyde dehydrogenase,  
 $A_{s1}$  = absorbance of the reference solution before the addition of aldehyde dehydrogenase,  
 $A_{s2}$  = absorbance of the reference solution after the addition of aldehyde dehydrogenase,  
 $A_{b1}$  = absorbance of the blank before the addition of aldehyde dehydrogenase,  
 $A_{b2}$  = absorbance of the blank after the addition of aldehyde dehydrogenase,  
 $m$  = mass of povidone, in grams, calculated with reference to the dried substance,  
 $C$  = concentration (mg/mL), of acetaldehyde in the reference solution, calculated from the weight of the acetaldehyde ammonia trimer trihydrate with the factor 0.72.

**Peroxides:** maximum 400 ppm, expressed as  $H_2O_2$ .

Dilute 10 mL of solution S to 25 mL with *water R*. Add 2 mL of *titanium trichloride-sulfuric acid reagent R* and allow to stand for 30 min. The absorbance (2.2.25) of the solution, measured at 405 nm using a mixture of 25 mL of a 40 g/L solution of the substance to be examined and 2 mL of a 13 per cent V/V solution of *sulfuric acid R* as the compensation liquid, is not greater than 0.35.

**Hydrazine.** Thin-layer chromatography (2.2.27). Use freshly prepared solutions.

**Test solution.** To 25 mL of solution S add 0.5 mL of a 50 g/L solution of *salicylaldehyde R* in *methanol R*, mix and heat in a water-bath at 60 °C for 15 min. Allow to cool, add 2.0 mL of *xylene R*, shake for 2 min and centrifuge. Use the clear supernatant layer.

**Reference solution.** Dissolve 9 mg of *salicylaldehyde azine R* in *xylene R* and dilute to 100 mL with the same solvent. Dilute 1 mL of this solution to 10 mL with *xylene R*.

**Plate:** TLC silanised silica gel plate R.

**Mobile phase:** *water R*, *methanol R* (20:80 V/V).

**Application:** 10 µL.

**Development:** over a path of 15 cm.

**Drying:** in air.

**Detection:** examine in ultraviolet light at 365 nm.

**Limit:**

- *hydrazine:* any spot corresponding to salicylaldehyde azine in the chromatogram obtained with the test solution is not more intense than the spot in the chromatogram obtained with the reference solution (1 ppm).

**Monomers:** maximum 0.1 per cent.

Dissolve 10.0 g in 30 mL of *methanol R* and add slowly 20.0 mL of *iodine bromide solution R*. Allow to stand for 30 min protected from light with repeated shaking. Add 10 mL of a 100 g/L solution of *potassium iodide R* and titrate with 0.1 M *sodium thiosulfate* until a yellow colour is obtained. Continue titration dropwise until the solution becomes colourless. Carry out a blank titration. Not more than 1.8 mL of 0.1 M *sodium thiosulfate* is used.

**Impurity A.** Liquid chromatography (2.2.29).

**Test solution.** Dissolve 100 mg of the substance to be examined in *water R* and dilute to 50.0 mL with the same solvent.

**Reference solution.** Dissolve 100 mg of *2-pyrrolidone R* in *water R* and dilute to 100 mL with the same solvent. Dilute 1.0 mL to 100.0 mL with *water R*.

**Precolumn:**

- **size:**  $l = 0.025$  m,  $\emptyset = 4$  mm,

- **stationary phase:** end-capped octadecylsilyl silica gel for chromatography R (5 µm).

**Column:**

- **size:**  $l = 0.25$  m,  $\emptyset = 4$  mm,

- **stationary phase:** spherical aminohexadecylsilyl silica gel for chromatography R (5 µm),

- **temperature:** 30 °C.

**Mobile phase:** *water R*, adjusted to pH 2.4 with *phosphoric acid R*.

**Flow rate:** 1 mL/min.

**Detection:** spectrophotometer at 205 nm. A detector is placed between the precolumn and the analytical column. A second detector is placed after the analytical column.

**Injection:** 10 µL. When impurity A has left the precolumn (after about 1.2 min) switch the flow directly from the pump to the analytical column. Before the next chromatogram is run, wash the precolumn by reversed flow.

**Limit:**

- **impurity A:** not more than the area of the principal peak obtained with the reference solution (0.5 per cent).

**Heavy metals (2.4.8):** maximum 20 ppm.

12 mL of solution S complies with limit test A. Prepare the standard using *lead standard solution (2 ppm Pb) R*.

**Loss on drying (2.2.32):** maximum 5.0 per cent, determined on 0.500 g by drying in an oven at 105 °C.

**Sulfated ash (2.4.14):** maximum 0.1 per cent, determined on 1.0 g.

**Viscosity, expressed as K-value.** Dilute 5.0 mL of solution S to 50.0 mL with *water R*. Allow to stand for 1 h and determine the viscosity (2.2.9) of the solution at  $25 \pm 0.1$  °C using viscometer No. 1 with a minimum flow time of 100 s. Calculate the K-value from the expression:

$$\frac{1.5 \log \eta - 1}{0.15 + 0.003c} + \frac{\sqrt{300c \log \eta + (c + 1.5c \log \eta)^2}}{0.15c + 0.003c^2}$$

$c$  = percentage concentration (g/100 mL) of the substance to be examined, calculated with reference to the dried substance,

$\eta$  = viscosity of the solution relative to that of water.

**ASSAY**

**Ethenyl acetate.** Determine the saponification value (2.5.6) on 2.00 g of the substance to be examined. Multiply the result obtained by 0.1534 to obtain the percentage content of the ethenyl acetate component.

**Nitrogen.** Carry out the determination of nitrogen (2.5.9) using 30.0 mg of the substance to be examined and 1 g of a mixture of 3 parts of *copper sulfate R* and 997 parts of *dipotassium sulfate R*, heating until a clear, light green solution is obtained and then for a further 45 min.

**STORAGE**

In an airtight container.

**LABELLING**

The label states the K-value.

## IMPURITIES



A. pyrrolidin-2-one (2-pyrrolidone).

01/2008:0893  
corrected 7.0

## COPPER SULFATE, ANHYDROUS

Cupri sulfas anhydricus

CuSO<sub>4</sub>  
[7758-98-7]

M<sub>r</sub> 159.6

## DEFINITION

*Content*: 99.0 per cent to 101.0 per cent (dried substance).

## CHARACTERS

*Appearance*: greenish-grey powder, very hygroscopic.

*Solubility*: freely soluble in water, slightly soluble in methanol, practically insoluble in ethanol (96 per cent).

## IDENTIFICATION

- Add several drops of *dilute ammonia R2* to 1 mL of solution S (see Tests). A blue precipitate is formed. On further addition of *dilute ammonia R2* the precipitate dissolves and a dark blue colour is produced.
- Loss on drying (see Tests).
- Dilute 1 mL of solution S to 5 mL with *water R*. The solution gives reaction (a) of sulfates (2.3.1).

## TESTS

**Solution S.** Dissolve 1.6 g in *water R* and dilute to 50 mL with the same solvent.

**Appearance of solution.** Solution S is clear (2.2.1).

**Chlorides (2.4.4):** maximum 150 ppm.

Dilute 10 mL of solution S to 15 mL with *water R*.

**Iron:** maximum 150 ppm.

Atomic absorption spectrometry (2.2.23, *Method I*).

*Test solution.* Dissolve 0.32 g in 10 mL of *water R*, add 2.5 mL of *lead-free nitric acid R* and dilute to 25.0 mL with *water R*.

*Reference solutions.* Prepare the reference solutions using *iron standard solution (20 ppm Fe) R*, adding 2.5 mL of *lead-free nitric acid R* and diluting to 25.0 mL with *water R*.

*Source:* iron hollow-cathode lamp.

*Wavelength:* 248.3 nm.

*Atomisation device:* air-acetylene flame.

*Copper may form explosive acetylides with acetylene. Therefore, clean the burner thoroughly before any residues become dry.*

**Lead:** maximum 80 ppm.

Atomic absorption spectrometry (2.2.23, *Method I*).

*Test solution.* Dissolve 1.6 g in 10 mL of *water R*, add 2.5 mL of *lead-free nitric acid R* and dilute to 25.0 mL with *water R*.

*Reference solutions.* Prepare the reference solutions using *lead standard solution (100 ppm Pb) R*, adding 2.5 mL of *lead-free nitric acid R* and diluting to 25.0 mL with *water R*.

*Source:* lead hollow-cathode lamp.

*Wavelength:* 217.0 nm.

*Atomisation device:* air-acetylene flame.

*Copper may form explosive acetylides with acetylene. Therefore, clean the burner thoroughly before any residues become dry.*

**Loss on drying (2.2.32):** maximum 1.0 per cent, determined on 0.500 g by drying in an oven at 250 ± 10 °C.

## ASSAY

Dissolve 0.125 g in 50 mL of *water R*. Add 2 mL of *sulfuric acid R* and 3 g of *potassium iodide R*. Titrate with 0.1 M *sodium thiosulfate*, using 1 mL of *starch solution R*, added towards the end of the titration.

1 mL of 0.1 M *sodium thiosulfate* is equivalent to 15.96 mg of CuSO<sub>4</sub>.

## STORAGE

In an airtight container.

01/2008:0894  
corrected 7.0

## COPPER SULFATE PENTAHYDRATE

Cupri sulfas pentahydricus

CuSO<sub>4</sub>·5H<sub>2</sub>O  
[7758-99-8]

M<sub>r</sub> 249.7

## DEFINITION

*Content*: 99.0 per cent to 101.0 per cent.

## CHARACTERS

*Appearance*: blue, crystalline powder or transparent, blue crystals.

*Solubility*: freely soluble in water, soluble in methanol, practically insoluble in ethanol (96 per cent).

## IDENTIFICATION

- Add several drops of *dilute ammonia R2* to 1 mL of solution S (see Tests). A blue precipitate is formed. On further addition of *dilute ammonia R2* the precipitate dissolves and a dark blue colour is produced.
- Loss on drying (see Tests).
- Dilute 1 mL of solution S to 5 mL with *water R*. The solution gives reaction (a) of sulfates (2.3.1).

## TESTS

**Solution S.** Dissolve 5 g in *water R* and dilute to 100 mL with the same solvent.

**Appearance of solution.** Solution S is clear (2.2.1).

**Chlorides (2.4.4):** maximum 100 ppm.

Dilute 10 mL of solution S to 15 mL with *water R*.

**Iron:** maximum 100 ppm.

Atomic absorption spectrometry (2.2.23, *Method I*).

*Test solution.* Dissolve 0.5 g in 10 mL of *water R*, add 2.5 mL of *lead-free nitric acid R* and dilute to 25.0 mL with *water R*.

*Reference solutions.* Prepare the reference solutions using *iron standard solution (20 ppm Fe) R*, adding 2.5 mL of *lead-free nitric acid R* and diluting to 25.0 mL with *water R*.

*Source:* iron hollow-cathode lamp.

*Wavelength:* 248.3 nm.

*Atomisation device:* air-acetylene flame.

*Copper may form explosive acetylides with acetylene. Therefore, clean the burner thoroughly before any residues become dry.*

**Lead:** maximum 50 ppm.

Atomic absorption spectrometry (2.2.23, *Method I*).

*Test solution.* Dissolve 2.5 g in 10 mL of *water R*, add 2.5 mL of *lead-free nitric acid R* and dilute to 25.0 mL with *water R*.

*Reference solutions.* Prepare the reference solutions using *lead standard solution (100 ppm Pb) R*, adding 2.5 mL of *lead-free nitric acid R* and diluting to 25.0 mL with *water R*.

*Source:* lead hollow-cathode lamp.

*Wavelength:* 217.0 nm.

*Atomisation device:* air-acetylene flame.

Copper may form explosive acetylides with acetylene. Therefore, clean the burner thoroughly before any residues become dry.

**Loss on drying** (2.2.32): 35.0 per cent to 36.5 per cent, determined on 0.500 g by drying in an oven at  $250 \pm 10$  °C.

#### ASSAY

Dissolve 0.200 g in 50 mL of *water R*. Add 2 mL of *sulfuric acid R* and 3 g of *potassium iodide R*. Titrate with 0.1 M *sodium thiosulfate*, adding 1 mL of *starch solution R* towards the end of the titration.

1 mL 0.1 M *sodium thiosulfate* is equivalent to 24.97 mg of  $\text{CuSO}_4 \cdot 5\text{H}_2\text{O}$ .

01/2008:0321  
corrected 6.0

## CORTISONE ACETATE

### Cortisoni acetat

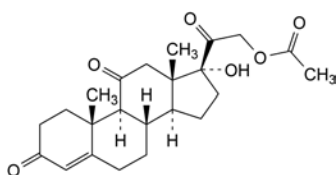

$\text{C}_{23}\text{H}_{30}\text{O}_6$   
[50-04-4]

$M_r$  402.5

#### DEFINITION

17-Hydroxy-3,11,20-trioxopregn-4-en-21-yl acetate.

**Content:** 97.0 per cent to 103.0 per cent (dried substance).

#### CHARACTERS

**Appearance:** white or almost white, crystalline powder.

**Solubility:** practically insoluble in water, freely soluble in methylene chloride, soluble in dioxan, sparingly soluble in acetone, slightly soluble in ethanol (96 per cent) and in methanol.

It shows polymorphism (5.9).

#### IDENTIFICATION

**First identification:** A, B.

**Second identification:** C, D, E.

A. Infrared absorption spectrophotometry (2.2.24).

**Comparison:** cortisone acetate CRS.

If the spectra obtained in the solid state show differences, record new spectra using 50 g/L solutions in *methylene chloride R* in a 0.2 mm cell.

B. Thin-layer chromatography (2.2.27).

**Solvent mixture:** *methanol R*, *methylene chloride R* (1:9 V/V).

**Test solution.** Dissolve 10 mg of the substance to be examined in the solvent mixture and dilute to 10 mL with the solvent mixture.

**Reference solution (a).** Dissolve 20 mg of *cortisone acetate CRS* in the solvent mixture and dilute to 20 mL with the solvent mixture.

**Reference solution (b).** Dissolve 10 mg of *hydrocortisone acetate R* in reference solution (a) and dilute to 10 mL with reference solution (a).

**Plate:** TLC silica gel  $F_{254}$  plate R.

**Mobile phase:** add a mixture of 1.2 volumes of *water R* and 8 volumes of *methanol R* to a mixture of 15 volumes of *ether R* and 77 volumes of *methylene chloride R*.

**Application:** 5  $\mu\text{L}$ .

**Development:** over a path of 15 cm.

**Drying:** in air.

**Detection A:** examine in ultraviolet light at 254 nm.

**Results A:** the principal spot in the chromatogram obtained with the test solution is similar in position and size to the principal spot in the chromatogram obtained with reference solution (a).

**Detection B:** spray with *alcoholic solution of sulfuric acid R*. Heat at 120 °C for 10 min or until the spots appear. Allow to cool. Examine in daylight and in ultraviolet light at 365 nm.

**Results B:** the principal spot in the chromatogram obtained with the test solution is similar in position, colour in daylight, fluorescence in ultraviolet light at 365 nm and size to the principal spot in the chromatogram obtained with reference solution (a).

**System suitability:** reference solution (b):

– the chromatogram shows 2 clearly separated spots.

C. Thin-layer chromatography (2.2.27).

**Test solution (a).** Dissolve 25 mg of the substance to be examined in *methanol R* with gentle heating and dilute to 5 mL with the same solvent (solution A). Dilute 2 mL of this solution to 10 mL with *methylene chloride R*.

**Test solution (b).** Transfer 2 mL of solution A to a 15 mL glass tube with a ground-glass stopper or a polytetrafluoroethylene cap. Add 10 mL of *saturated methanolic potassium hydrogen carbonate solution R* and immediately pass a stream of *nitrogen R* briskly through the solution for 5 min. Stopper the tube. Heat in a water-bath at 45 °C protected from light for 2.5 h. Allow to cool.

**Reference solution (a).** Dissolve 25 mg of *cortisone acetate CRS* in *methanol R* with gentle heating and dilute to 5 mL with the same solvent (solution B). Dilute 2 mL of this solution to 10 mL with *methylene chloride R*.

**Reference solution (b).** Transfer 2 mL of solution B to a 15 mL glass tube with a ground-glass stopper or a polytetrafluoroethylene cap. Add 10 mL of *saturated methanolic potassium hydrogen carbonate solution R* and immediately pass a stream of *nitrogen R* briskly through the solution for 5 min. Stopper the tube. Heat in a water-bath at 45 °C protected from light for 2.5 h. Allow to cool.

**Plate:** TLC silica gel  $F_{254}$  plate R.

**Mobile phase:** add a mixture of 1.2 volumes of *water R* and 8 volumes of *methanol R* to a mixture of 15 volumes of *ether R* and 77 volumes of *methylene chloride R*.

**Application:** 5  $\mu\text{L}$ .

**Development:** over a path of 15 cm.

**Drying:** in air.

**Detection A:** examine in ultraviolet light at 254 nm.

**Results A:** the principal spot in each of the chromatograms obtained with the test solutions is similar in position and size to the principal spot in the chromatogram obtained with the corresponding reference solution.

**Detection B:** spray with *alcoholic solution of sulfuric acid R* and heat at 120 °C for 10 min or until the spots appear. Allow to cool. Examine in daylight and in ultraviolet light at 365 nm.

**Results B:** the principal spot in each of the chromatograms obtained with the test solutions is similar in position, colour in daylight, fluorescence in ultraviolet light at 365 nm and size to the principal spot in the chromatogram obtained with the corresponding reference solution. The principal spots in the chromatograms obtained with test solution (b) and reference solution (b) have an  $R_F$  value distinctly lower than that of the principal spots in the chromatograms obtained with test solution (a) and reference solution (a).

D. Add about 2 mg to 2 mL of *sulfuric acid R* and shake to dissolve. Within 5 min, a faint yellow colour develops. Add this solution to 10 mL of *water R* and mix. The colour is discharged and a clear solution remains.

E. About 10 mg gives the reaction of acetyl (2.3.1).

#### TESTS

**Specific optical rotation** (2.2.7): + 211 to + 220 (dried substance).

Dissolve 0.250 g in *dioxan R* and dilute to 25.0 mL with the same solvent.

**Related substances.** Liquid chromatography (2.2.29). Prepare the solutions immediately before use.

**Test solution.** Dissolve 25.0 mg of the substance to be examined in *acetonitrile R* and dilute to 10.0 mL with the same solvent.

**Reference solution (a).** Dissolve 2 mg of *cortisone acetate CRS* and 2 mg of *hydrocortisone acetate CRS* (impurity A) in *acetonitrile R* and dilute to 100.0 mL with the same solvent.

**Reference solution (b).** Dilute 1.0 mL of the test solution to 100.0 mL with *acetonitrile R*.

**Column:**

- size:  $l = 0.25$  m,  $\emptyset = 4.6$  mm;
- stationary phase: octadecylsilyl silica gel for chromatography *R* (5  $\mu$ m).

**Mobile phase:** in a 1000 mL volumetric flask mix 400 mL of *acetonitrile R* with 550 mL of *water R* and allow to equilibrate; dilute to 1000 mL with *water R* and mix again.

**Flow rate:** 1 mL/min.

**Detection:** spectrophotometer at 254 nm.

**Equilibration:** with the mobile phase for about 30 min.

**Injection:** 20  $\mu$ L; inject *acetonitrile R* as a blank.

**Run time:** twice the retention time of cortisone acetate.

**Retention time:** impurity A = about 10 min; cortisone acetate = about 12 min.

**System suitability:** reference solution (a):

- resolution: minimum 4.2 between the peaks due to impurity A and cortisone acetate; if necessary, adjust the concentration of acetonitrile in the mobile phase.

**Limits:**

- impurity A: not more than 0.5 times the area of the principal peak in the chromatogram obtained with reference solution (b) (0.5 per cent);
- total: not more than 1.5 times the area of the principal peak in the chromatogram obtained with reference solution (b) (1.5 per cent);
- disregard limit: 0.05 times the area of the principal peak in the chromatogram obtained with reference solution (b) (0.05 per cent).

**Loss on drying** (2.2.32): maximum 0.5 per cent, determined on 0.500 g by drying in an oven at 105 °C.

#### ASSAY

Dissolve 0.100 g in *ethanol (96 per cent) R* and dilute to 100.0 mL with the same solvent. Dilute 2.0 mL of this solution to 100.0 mL with *ethanol (96 per cent) R*. Measure the absorbance (2.2.25) at the absorption maximum at 237 nm.

Calculate the content of  $C_{23}H_{30}O_6$  taking the specific absorbance to be 395.

#### STORAGE

Protected from light.

#### IMPURITIES

**Specified impurities:** A.

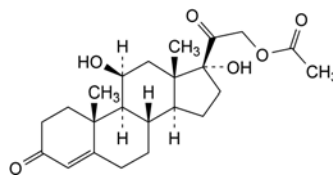

- A. 11 $\beta$ ,17-dihydroxy-3,20-dioxopregn-4-en-21-yl acetate (hydrocortisone acetate).

01/2008:0036  
corrected 7.0

## COTTON, ABSORBENT

### Lanugo gossypii absorbens

#### DEFINITION

Absorbent cotton consists of new fibres or good quality combers obtained from the seed-coat of various species of the genus *Gossypium* L., cleaned, purified, bleached and carefully carded. It may not contain any compensatory colouring matter.

#### CHARACTERS

It is white or almost white and is composed of fibres of average length not less than 10 mm, determined by a suitable method, and contains not more than traces of leaf residue, pericarp, seed-coat or other impurities. It offers appreciable resistance when pulled. It does not shed any appreciable quantity of dust when gently shaken.

#### IDENTIFICATION

- A. Examined under a microscope, each fibre is seen to consist of a single cell, up to about 4 cm long and up to 40  $\mu$ m wide, in the form of a flattened tube with thick and rounded walls and often twisted.
- B. When treated with *iodinated zinc chloride solution R*, the fibres become violet.
- C. To 0.1 g add 10 mL of *zinc chloride-formic acid solution R*. Heat to 40 °C and allow to stand for 2 h 30 min, shaking occasionally. It does not dissolve.

#### TESTS

**Solution S.** Place 15.0 g in a suitable vessel, add 150 mL of *water R*, close the vessel and allow to macerate for 2 h. Decant the solution, squeeze the residual liquid carefully from the sample with a glass rod and mix. Reserve 10 mL of the solution for the test for surface-active substances and filter the remainder.

**Acidity or alkalinity.** To 25 mL of solution S add 0.1 mL of *phenolphthalein solution R* and to another 25 mL add 0.05 mL of *methyl orange solution R*. Neither solution is pink.

**Foreign fibres.** Examined under a microscope, it is seen to consist exclusively of typical cotton fibres, except that occasionally a few isolated foreign fibres may be present.

**Fluorescence.** Examine a layer about 5 mm in thickness under ultraviolet light at 365 nm. It displays only a slight brownish-violet fluorescence and a few yellow particles. It shows no intense blue fluorescence, apart from that which may be shown by a few isolated fibres.

**Neps.** Spread about 1 g evenly between 2 colourless transparent plates each 10 cm square. Examine for neps by transmitted light and compare with *Cotton wool standard for neps CRS*. The product to be examined is not more neppy than the standard.

#### Absorbency

**Apparatus.** A dry cylindrical copper wire basket 8.0 cm high and 5.0 cm in diameter. The wire of which the basket is constructed is about 0.4 mm in diameter, the mesh is 1.5 cm to 2.0 cm wide and the mass of the basket is  $2.7 \pm 0.3$  g.

01/2008:1305  
corrected 7.0

**Sinking time.** Not more than 10 s. Weigh the basket to the nearest centigram ( $m_1$ ). Take a total of 5.00 g in approximately equal quantities from 5 different places in the product to be examined, place loosely in the basket and weigh the filled basket to the nearest centigram ( $m_2$ ). Fill a beaker 11 cm to 12 cm in diameter to a depth of 10 cm with water at about 20 °C. Hold the basket horizontally and drop it from a height of about 10 mm into the water. Measure with a stopwatch the time taken for the basket to sink below the surface of the water. Calculate the result as the average of 3 tests.

**Water-holding capacity.** Not less than 23.0 g of water per gram. After the sinking time has been measured, remove the basket from the water, allow it to drain for exactly 30 s suspended in a horizontal position over the beaker, transfer it to a tared beaker ( $m_3$ ) and weigh to the nearest centigram ( $m_4$ ). Calculate the water-holding capacity per gram of absorbent cotton using the following expression:

$$\frac{m_4 - (m_2 + m_3)}{m_2 - m_1}$$

Calculate the result as the average of 3 tests.

**Ether-soluble substances.** Not more than 0.50 per cent. In an extraction apparatus, extract 5.00 g with *ether R* for 4 h at a rate of at least 4 extractions per hour. Evaporate the ether extract and dry the residue to constant mass at 100 °C to 105 °C.

**Extractable colouring matter.** In a narrow percolator, slowly extract 10.0 g with *alcohol R* until 50 mL of extract is obtained. The liquid obtained is not more intensely coloured (2.2.2, *Method II*) than reference solution  $Y_5$ ,  $GY_6$  or a reference solution prepared as follows: to 3.0 mL of blue primary solution add 7.0 mL of hydrochloric acid (10 g/L HCl). Dilute 0.5 mL of this solution to 10.0 mL with hydrochloric acid (10 g/L HCl).

**Surface-active substances.** Introduce the 10 mL portion of solution S reserved before filtration into a 25 mL graduated ground-glass-stoppered cylinder with an external diameter of 20 mm and a wall thickness of not greater than 1.5 mm, previously rinsed 3 times with *sulfuric acid R* and then with *water R*. Shake vigorously 30 times in 10 s, allow to stand for 1 min and repeat the shaking. After 5 min, any foam present must not cover the entire surface of the liquid.

**Water-soluble substances.** Not more than 0.50 per cent. Boil 5.000 g in 500 mL of *water R* for 30 min, stirring frequently. Replace the water lost by evaporation. Decant the liquid, squeeze the residual liquid carefully from the sample with a glass rod and mix. Filter the liquid whilst hot. Evaporate 400 mL of the filtrate (corresponding to 4/5 of the mass of the sample taken) and dry the residue to constant mass at 100 °C to 105 °C.

**Loss on drying (2.2.32).** Not more than 8.0 per cent, determined on 5.000 g by drying in an oven at 105 °C.

**Sulfated ash (2.4.14).** Not more than 0.40 per cent. Introduce 5.00 g into a previously heated and cooled, tared crucible. Heat cautiously over a naked flame and then carefully to dull redness at 600 °C. Allow to cool, add a few drops of *dilute sulfuric acid R*, then heat and incinerate until all the black particles have disappeared. Allow to cool. Add a few drops of *ammonium carbonate solution R*. Evaporate and incinerate carefully, allow to cool and weigh again. Repeat the incineration for periods of 5 min to constant mass.

## STORAGE

Store in a dust-proof package in a dry place.

## COTTONSEED OIL, HYDROGENATED

### Gossypii oleum hydrogenatum

#### DEFINITION

Product obtained by refining and hydrogenation of oil obtained from seeds of cultivated plants of various varieties of *Gossypium hirsutum* L. or of other species of *Gossypium*. The product consists mainly of triglycerides of palmitic and stearic acids.

#### CHARACTERS

**Appearance:** white or almost white mass or powder which melts to a clear, pale yellow liquid when heated.

**Solubility:** practically insoluble in water, freely soluble in methylene chloride and in toluene, very slightly soluble in ethanol (96 per cent).

#### IDENTIFICATION

A. Melting point (see Tests).

B. Composition of fatty acids (see Tests).

#### TESTS

**Melting point (2.2.14):** 57 °C to 70 °C.

**Acid value (2.5.1):** maximum 0.5.

Dissolve 10.0 g in 50 mL of a hot mixture of equal volumes of *ethanol (96 per cent) R* and *toluene R*, previously neutralised with 0.1 M *potassium hydroxide* using 0.5 mL of *phenolphthalein solution RI* as indicator. Titrate the solution immediately while still hot.

**Peroxide value (2.5.5, Method A):** maximum 5.0.

**Unsaponifiable matter (2.5.7):** maximum 1.0 per cent, determined on 5.0 g.

**Alkaline impurities.** Dissolve by gentle heating 2.0 g in a mixture of 1.5 mL of *ethanol (96 per cent) R* and 3 mL of *toluene R*. Add 0.05 mL of a 0.4 g/L solution of *bromophenol blue R* in *ethanol (96 per cent) R*. Not more than 0.4 mL of 0.01 M *hydrochloric acid* is required to change the colour to yellow.

**Composition of fatty acids (2.4.22, Method A).** Use the mixture of calibrating substances in Table 2.4.22-3.

#### Column:

- *material:* fused silica;
- *size:*  $l = 25$  m,  $\varnothing = 0.25$  mm;
- *stationary phase:* *poly(cyanopropyl)siloxane R* (film thickness 0.2  $\mu$ m).

*Carrier gas:* *helium for chromatography R*.

*Flow rate:* 0.65 mL/min.

*Split ratio:* 1:100.

#### Temperature:

- *column:* 180 °C for 35 min;
- *injection port and detector:* 250 °C.

*Detection:* flame ionisation.

*Composition of the fatty-acid fraction of the oil:*

- *saturated fatty acids of chain length less than  $C_{14}$ :* maximum 0.2 per cent;
- *myristic acid:* maximum 1.0 per cent;
- *palmitic acid:* 19.0 per cent to 26.0 per cent;
- *stearic acid:* 68.0 per cent to 80.0 per cent;
- *oleic acid and isomers:* maximum 4.0 per cent;
- *linoleic acid and isomers:* maximum 1.0 per cent;
- *arachidic acid:* maximum 1.0 per cent;
- *behenic acid:* maximum 1.0 per cent;
- *lignoceric acid:* maximum 0.5 per cent.

**Nickel:** maximum 1 ppm.

Atomic absorption spectrometry (2.2.23, *Method II*).

**Test solution.** Introduce 5.0 g into a platinum or silica crucible tared after ignition. Cautiously heat and introduce into the substance a wick formed from twisted ashless filter paper. Ignite the wick. When the substance ignites, stop heating. After combustion, ignite in a muffle furnace at about  $600 \pm 50$  °C. Continue the incineration until white ash is obtained. After cooling, take up the residue with 2 quantities, each of 2 mL, of *dilute hydrochloric acid R* and transfer into a 25 mL graduated flask. Add 0.3 mL of *nitric acid R* and dilute to 25.0 mL with *distilled water R*.

**Reference solutions.** Prepare 3 reference solutions by adding 1.0 mL, 2.0 mL and 4.0 mL of *nickel standard solution (0.2 ppm Ni) R* to 2.0 mL portions of the test solution, diluting to 10.0 mL with *distilled water R*.

**Source:** nickel hollow-cathode lamp.

**Wavelength:** 232 nm.

**Atomisation device:** graphite furnace.

**Carrier gas:** argon R.

**STORAGE**

Protected from light.

01/2008:1628

## CRESOL, CRUDE

### Cresolum crudum

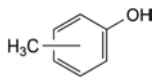

C<sub>7</sub>H<sub>8</sub>O

M<sub>r</sub> 108.1

**DEFINITION**

Mixture of 2-, 3- and 4-methylphenol.

**CHARACTERS**

**Appearance:** colourless or pale brown liquid.

**Solubility:** sparingly soluble in water, miscible with alcohol and with methylene chloride.

**IDENTIFICATION**

- To 0.5 mL add 300 mL of *water R*, mix and filter. To 10 mL of the filtrate add 1 mL of *ferric chloride solution R1*. A blue colour is produced.
- To 10 mL of the filtrate obtained in identification test A, add 1 mL of *bromine water R*. A pale yellow flocculent precipitate is produced.
- Relative density (see Tests).

**TESTS**

**Solution S.** To 2.5 g of the substance to be examined add 50 mL of *water R*, shake for 1 min and filter through a moistened filter.

**Acidity or alkalinity.** To 10 mL of solution S add 0.1 mL of *methyl red solution R* and 0.2 mL of 0.01 M *sodium hydroxide*. The solution is yellow. Add 0.3 mL of 0.01 M *hydrochloric acid*. The solution is red.

**Relative density (2.2.5):** 1.029 to 1.044.

**Distillation range (2.2.11):** a maximum of 2.0 per cent *V/V* distils below 188 °C and a minimum of 80 per cent *V/V* distils between 195 °C and 205 °C.

**Sulfur compounds.** Place 20 mL in a small conical flask. Over the mouth of the flask fix a piece of filter paper moistened with *lead acetate solution R*. Heat on a water-bath for 5 min. Not more than a light yellow colour is produced on the filter paper.

**Residue on evaporation:** maximum 0.1 per cent.

Evaporate 2.0 g to dryness on a water-bath and dry at 100-105 °C for 1 h. The residue weighs not more than 2 mg.

**STORAGE**

Protected from light.

01/2009:0985  
corrected 6.5

## CROSCARMELLOSE SODIUM

### Carmellosum natricum conexum

**DEFINITION**

Cross-linked sodium carboxymethylcellulose.

Sodium salt of a cross-linked, partly *O*-carboxymethylated cellulose.

**CHARACTERS**

**Appearance:** white or greyish-white powder.

**Solubility:** practically insoluble in acetone, in anhydrous ethanol and in toluene.

**IDENTIFICATION**

- Mix 1 g with 100 mL of a solution containing 4 ppm of *methylene blue R*, stir the mixture and allow it to settle. The substance to be examined absorbs the methylene blue and settles as a blue, fibrous mass.
- Mix 1 g with 50 mL of *water R*. Transfer 1 mL of the mixture to a small test-tube and add 1 mL of *water R* and 0.05 mL of a freshly prepared 40 g/L solution of *α-naphthol R* in *methanol R*. Incline the test-tube and carefully add 2 mL of *sulfuric acid R* down the side so that it forms a lower layer. A reddish-violet colour develops at the interface.
- The solution prepared from the sulfated ash in the test for heavy metals (see Tests) gives reaction (a) of sodium (2.3.1).

**TESTS**

**pH (2.2.3):** 5.0 to 7.0 for the suspension.

Shake 1 g with 100 mL of *carbon dioxide-free water R* for 5 min.

**Sodium chloride and sodium glycollate:** maximum 0.5 per cent (dried substance) for the sum of the percentage contents of sodium chloride and sodium glycollate.

**Sodium chloride.** Place 5.00 g in a 250 mL conical flask, add 50 mL of *water R* and 5 mL of *strong hydrogen peroxide solution R* and heat on a water-bath for 20 min, stirring occasionally to ensure total hydration. Cool, add 100 mL of *water R* and 10 mL of *nitric acid R*. Titrate with 0.05 M *silver nitrate*, determining the end-point potentiometrically (2.2.20) using a silver indicator electrode and a double-junction reference electrode containing a 100 g/L solution of *potassium nitrate R* in the outer jacket and a standard filling solution in the inner jacket, and stirring constantly.

1 mL of 0.05 M *silver nitrate* is equivalent to 2.922 mg of NaCl.

**Sodium glycollate.** Place a quantity of the substance to be examined equivalent to 0.500 g of the dried substance in a 100 mL beaker. Add 5 mL of *glacial acetic acid R* and 5 mL of *water R* and stir to ensure total hydration (about 15 min). Add 50 mL of *acetone R* and 1 g of *sodium chloride R*. Stir for several minutes to ensure complete precipitation of the carboxymethylcellulose. Filter through a fast filter paper impregnated with *acetone R* into a volumetric flask, rinse the beaker and the filter with 30 mL of *acetone R* and dilute the filtrate to 100.0 mL with the same solvent. Allow to stand for 24 h without shaking. Use the clear supernatant to prepare the test solution.

Prepare the reference solutions as follows: in a 100 mL volumetric flask, dissolve 0.100 g of *glycollic acid R*, previously dried *in vacuo* over *diphosphorus pentoxide R* at room

temperature overnight, in *water R* and dilute to 100.0 mL with the same solvent; use the solution within 30 days; transfer 1.0 mL, 2.0 mL, 3.0 mL and 4.0 mL of the solution to separate volumetric flasks, dilute the contents of each flask to 5.0 mL with *water R*, add 5 mL of *glacial acetic acid R*, dilute to 100.0 mL with *acetone R* and mix.

Transfer 2.0 mL of the test solution and 2.0 mL of each of the reference solutions to separate 25 mL volumetric flasks. Heat the uncovered flasks for 20 min on a water-bath to eliminate acetone. Allow to cool and add 5.0 mL of *2,7-dihydroxynaphthalene solution R* to each flask. Mix, add a further 15.0 mL of *2,7-dihydroxynaphthalene solution R* and mix again. Close the flasks with aluminium foil and heat on a water-bath for 20 min. Cool and dilute to 25.0 mL with *sulfuric acid R*.

Measure the absorbance (2.2.25) of each solution at 540 nm. Prepare a blank using 2.0 mL of a solution containing 5 per cent *V/V* each of *glacial acetic acid R* and *water R* in *acetone R*. Prepare a standard curve using the absorbances obtained with the reference solutions. From the standard curve and the absorbance of the test solution, determine the mass (*a*) of glycollic acid in the substance to be examined, in milligrams, and calculate the content of sodium glycollate using the following expression:

$$\frac{10 \times 1.29 \times a}{(100 - b) m}$$

- 1.29 = the factor converting glycollic acid to sodium glycollate;  
*b* = loss on drying as a percentage;  
*m* = mass of the substance to be examined, in grams.

**Water-soluble substances:** maximum 10.0 per cent.

Disperse 10.00 g in 800.0 mL of *water R* and stir for 1 min every 10 min during the first 30 min. Allow to stand for 1 h and centrifuge if necessary. Decant 200.0 mL of the supernatant liquid onto a fast filter paper in a vacuum filtration funnel, apply vacuum and collect 150.0 mL of the filtrate. Evaporate to dryness and dry the residue at 100-105 °C for 4 h.

**Heavy metals (2.4.8):** maximum 20 ppm.

To the residue obtained in the determination of the sulfated ash add 1 mL of *hydrochloric acid R* and evaporate on a water-bath. Take up the residue in 20 mL of *water R*. 12 mL of the solution complies with test A. Prepare the reference solution using *lead standard solution (1 ppm Pb) R*.

**Loss on drying (2.2.32):** maximum 10.0 per cent, determined on 1.000 g by drying in an oven at 105 °C for 6 h.

**Sulfated ash (2.4.14):** 14.0 per cent to 28.0 per cent (dried substance), determined on 1.0 g, using a mixture of equal volumes of *sulfuric acid R* and *water R*.

**Microbial contamination**

TAMC: acceptance criterion 10<sup>3</sup> CFU/g (2.6.12).

TYMC: acceptance criterion 10<sup>2</sup> CFU/g (2.6.12).

Absence of *Escherichia coli* (2.6.13).

#### FUNCTIONALITY-RELATED CHARACTERISTICS

*This section provides information on characteristics that are recognised as being relevant control parameters for one or more functions of the substance when used as an excipient (see chapter 5.15). This section is a non-mandatory part of the monograph and it is not necessary to verify the characteristics to demonstrate compliance. Control of these characteristics can however contribute to the quality of a medicinal product by improving the consistency of the manufacturing process and the performance of the medicinal product during use. Where control methods are cited, they are recognised as being suitable for the purpose, but other methods can also be used. Wherever results for a particular characteristic are reported, the control method must be indicated.*

*The following characteristics may be relevant for croscarmellose sodium used as disintegrant.*

**Settling volume.** Place 75 mL of *water R* in a 100 mL graduated cylinder and add 1.5 g of the substance to be examined in 0.5 g portions, shaking vigorously after each addition. Dilute to 100.0 mL with *water R* and shake again until the substance is homogeneously distributed. Allow to stand for 4 h. The settling volume is between 10.0 mL and 30.0 mL.

**Degree of substitution:** 0.60 to 0.85 (dried substance).

Place 1.000 g in a 500 mL conical flask, add 300 mL of a 100 g/L solution of *sodium chloride R* and 25.0 mL of *0.1 M sodium hydroxide*, stopper the flask and allow to stand for 5 min, shaking occasionally. Add 0.05 mL of *m-cresol purple solution R* and about 15 mL of *0.1 M hydrochloric acid* from a burette. Insert the stopper and shake. If the solution is violet, add *0.1 M hydrochloric acid* in 1 mL portions until the solution becomes yellow, shaking after each addition. Titrate with *0.1 M sodium hydroxide* until the colour turns to violet.

Calculate the number of milliequivalents (*M*) of base required to neutralise the equivalent of 1 g of dried substance.

Calculate the degree of acid carboxymethyl substitution (*A*) using the following expression:

$$\frac{1150M}{(7102 - 412M - 80C)}$$

*C* = sulfated ash as a percentage.

Calculate the degree of sodium carboxymethyl substitution (*S*) using the following expression:

$$\frac{(162 + 58A) C}{(7102 - 80C)}$$

The degree of substitution is the sum of *A* and *S*.

**Particle size distribution (2.9.31 or 2.9.38).**

**Hausner ratio (2.9.36).**

01/2009:0892

## CROSPVIDONE

### Crosopovidonum

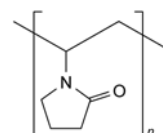

(C<sub>6</sub>H<sub>9</sub>NO)<sub>n</sub>  
 [9003-39-8]

*M<sub>r</sub>* (111.1)<sub>n</sub>

#### DEFINITION

Cross-linked homopolymer of 1-ethenylpyrrolidin-2-one.

**Content:** 11.0 per cent to 12.8 per cent of N (*A<sub>r</sub>* 14.01) (dried substance).

#### CHARACTERS

**Appearance:** hygroscopic, white or yellowish-white powder or flakes.

2 types of crosopovidone are available, depending on the particle size: type A and type B.

**Solubility:** practically insoluble in water, in ethanol 96 per cent and in methylene chloride.

#### IDENTIFICATION

A. Infrared absorption spectrophotometry (2.2.24).

*Comparison:* crosopovidone CRS.

B. Suspend 1 g in 10 mL of *water R*, add 0.1 mL of *0.05 M iodine* and shake for 30 s. Add 1 mL of *starch solution R* and shake. No blue colour develops within 30 s.



- C. To 10 mL of *water R*, add 0.1 g and shake. A suspension is formed and no clear solution is obtained within 15 min.
- D. *The analytical screens must be clean and dry. For this purpose the screens are washed in hot water and allowed to dry overnight in a drying cabinet at 105 °C.*

Place 20 g in a 1000 mL conical flask, add 500 mL of *water R* and shake the suspension for 30 min. Pour the suspension through a 63 µm analytical screen, previously tared, and rinse the screen with *water R* until the filtrate is clear. Dry the screen and sample residue at 105 °C for 5 h in a drying cabinet without circulating air. Cool in a desiccator for 30 min and weigh.

Calculate the percentage screening residue (fraction of sample particles having a diameter of more than 63 µm), using the following expression:

$$\frac{m_1 - m_3}{m_2} \times 100$$

- $m_1$  = mass of the screen and sample residue, after drying for 5 h, in grams;
- $m_2$  = mass of the sample, in grams;
- $m_3$  = mass of the screen, in grams.

If the screening residue fraction is more than 15 per cent, the substance is classified as type A; if the screening residue fraction is less than or equal to 15 per cent, the substance is classified as type B.

## TESTS

**Peroxides.** Type A: maximum 400 ppm expressed as H<sub>2</sub>O<sub>2</sub>; type B: maximum 1000 ppm expressed as H<sub>2</sub>O<sub>2</sub>.

Suspend 2.0 g in 50 mL of *water R*. To 25 mL of this suspension add 2 mL of *titanium trichloride-sulfuric acid reagent R*. Allow to stand for 30 min and filter. The absorbance (2.2.25) of the filtrate, measured at 405 nm using a mixture of 25 mL of a filtered 40 g/L suspension of the substance to be examined and 2 mL of a 13 per cent V/V solution of *sulfuric acid R* as the compensation liquid, has a maximum of 0.35.

For type B use 10 mL of the suspension and dilute to 25 mL with *water R* for the test.

**Water-soluble substances:** maximum 1.0 per cent.

Place 25.0 g in a 400 mL beaker, add 200 mL of *water R* and stir for 1 h using a magnetic stirrer. Transfer the suspension to a 250.0 mL volumetric flask, rinsing with *water R*, and dilute to volume with the same solvent. Allow the bulk of the solids to settle. Filter about 100 mL of the almost clear supernatant liquid through a membrane filter (nominal pore size 0.45 µm), protected by superimposing a membrane filter (nominal pore size 3 µm). While filtering, stir the liquid above the membrane filter manually or by means of a mechanical stirrer, taking care not to damage the membrane filter. Transfer 50.0 mL of the clear filtrate to a tared 100 mL beaker, evaporate to dryness and dry at 105-110 °C for 3 h. The residue weighs a maximum of 50 mg.

**Impurity A.** Liquid chromatography (2.2.29).

*Test solution.* Suspend 1.250 g in 50.0 mL of *methanol R* and shake for 60 min. Leave the bulk to settle and filter through a membrane filter (nominal pore size 0.2 µm).

*Reference solution (a).* Dissolve 50 mg of *1-vinylpyrrolidin-2-one R* (impurity A) in *methanol R* and dilute to 100.0 mL with the same solvent. Dilute 1.0 mL of this solution to 100.0 mL with *methanol R*. Dilute 5.0 mL of this solution to 100.0 mL with the mobile phase.

*Reference solution (b).* Dissolve 10 mg of *1-vinylpyrrolidin-2-one R* (impurity A) and 0.50 g of *vinyl acetate R* in *methanol R* and dilute to 100 mL with the same solvent. Dilute 1.0 mL of this solution to 100.0 mL with the mobile phase.

*Precolumn:*

- size:  $l = 0.025$  m,  $\emptyset = 4$  mm;
- stationary phase: octadecylsilyl silica gel for chromatography R (5 µm).

*Column:*

- size:  $l = 0.25$  m,  $\emptyset = 4$  mm;
- stationary phase: octadecylsilyl silica gel for chromatography R (5 µm);
- temperature: 40 °C.

*Mobile phase:* acetonitrile R, *water R* (10:90 V/V).

*Flow rate:* adjusted so that the retention time of the peak due to impurity A is about 10 min.

*Detection:* spectrophotometer at 235 nm.

*Injection:* 50 µL. After each injection of the test solution, wash the precolumn by passing the mobile phase backwards, at the same flow rate as applied in the test, for 30 min.

*System suitability:*

- resolution: minimum 2.0 between the peaks due to impurity A and vinyl acetate in the chromatogram obtained with reference solution (b);
- repeatability: maximum relative standard deviation of 2.0 per cent after 5 injections of reference solution (a).

*Limit:*

- impurity A: not more than the area of the principal peak in the chromatogram obtained with reference solution (a) (10 ppm).

**Heavy metals (2.4.8):** maximum 10 ppm.

2.0 g complies with test D. Prepare the reference solution using 2 mL of *lead standard solution (10 ppm Pb) R*.

**Loss on drying (2.2.32):** maximum 5.0 per cent, determined on 0.500 g by drying in an oven at 105 °C.

**Sulfated ash (2.4.14):** maximum 0.1 per cent, determined on 1.0 g.

## ASSAY

Place 100.0 mg of the substance to be examined ( $m$  mg) in a combustion flask and add 5 g of a mixture of 1 g of *copper sulfate R*, 1 g of *titanium dioxide R* and 33 g of *dipotassium sulfate R*, and 3 glass beads. Wash any adhering particles from the neck into the flask with a small quantity of *water R*. Add 7 mL of *sulfuric acid R*, allowing it to run down the insides of the flask, and mix the contents by rotation. Close the mouth of the flask loosely, for example by means of a glass bulb with a short stem, to avoid excessive loss of sulfuric acid. Heat gradually at first, then increase the temperature until there is vigorous boiling with condensation of sulfuric acid in the neck of the flask; precautions are to be taken to prevent the upper part of the flask from becoming overheated. Continue the heating for 45 min. Cool, dissolve the solid material by cautiously adding 20 mL of *water R* to the mixture, cool again and place in a steam-distillation apparatus. Add 30 mL of *strong sodium hydroxide solution R* through the funnel, rinse the funnel cautiously with 10 mL of *water R* and distil immediately by passing steam through the mixture. Collect 80-100 mL of distillate in a mixture of 30 mL of a 40 g/L solution of *boric acid R* and 0.05 mL of *bromocresol green-methyl red solution R* and enough *water R* to cover the tip of the condenser. Towards the end of the distillation lower the receiver so that the tip of the condenser is above the surface of the acid solution and rinse the end part of the condenser with a small quantity of *water R*. Titrate the distillate with 0.025 M *sulfuric acid* until the colour of the solution changes from green through pale greyish-blue to pale greyish-red-purple ( $n_1$  mL of 0.025 M *sulfuric acid*).

Repeat the test using about 100 mg of *glucose R* in place of the substance to be examined ( $n_2$  mL of 0.025 M *sulfuric acid*).

Percentage content of nitrogen:

$$\frac{0.7004(n_1 - n_2)}{m} \times 100$$

#### STORAGE

In an airtight container.

#### LABELLING

The label states the type (type A or type B).

#### IMPURITIES

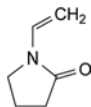

A. 1-ethenylpyrrolidin-2-one (1-vinylpyrrolidin-2-one).

#### FUNCTIONALITY-RELATED CHARACTERISTICS

*This section provides information on characteristics that are recognised as being relevant control parameters for one or more functions of the substance when used as an excipient (see chapter 5.15). This section is a non-mandatory part of the monograph and it is not necessary to verify the characteristics to demonstrate compliance. Control of these characteristics can however contribute to the quality of a medicinal product by improving the consistency of the manufacturing process and the performance of the medicinal product during use. Where control methods are cited, they are recognised as being suitable for the purpose, but other methods can also be used. Wherever results for a particular characteristic are reported, the control method must be indicated.*

*The following characteristics may be relevant for crosopovidone used as disintegrant.*

**Hydration capacity.** Introduce 2.0 g into a 100 mL centrifuge tube and add 40 mL of *water R*. Shake vigorously until a suspension is obtained. Shake again 5 min and 10 min later, then centrifuge for 15 min at 750 g. Decant the supernatant liquid and weigh the residue. The hydration capacity is the ratio of the mass of the residue to the initial mass of the sample. It is typically 3 to 9.

**Particle-size distribution (2.9.31).**

**Powder flow (2.9.36).**

*The following characteristic may be relevant for crosopovidone used as suspension stabiliser.*

**Settling volume.** Introduce 10 g into a 100 mL graduated cylinder and add 90 mL of *water R*. Shake vigorously. Dilute to 100 mL with *water R*, washing the powder residues from the walls of the cylinder. Allow to stand for 24 h, then read the volume of the sediment. It is typically greater than 60 mL.

07/2010:1194

## CROTAMITON

### Crotamitonum

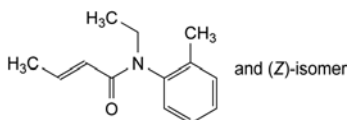

C<sub>13</sub>H<sub>17</sub>NO  
[483-63-6]

M<sub>r</sub> 203.3

#### DEFINITION

N-Ethyl-N-(2-methylphenyl)but-2-enamide.

*Content:*

- sum of the (E)- and (Z)-isomers: 96.0 per cent to 102.0 per cent;
- (Z)-isomer: maximum 15.0 per cent.

#### CHARACTERS

*Appearance:* colourless or pale yellow, oily liquid.

*Solubility:* slightly soluble in water, miscible with ethanol (96 per cent).

At low temperatures it may partly or completely solidify.

#### IDENTIFICATION

*First identification:* B.

*Second identification:* A, C, D.

A. Ultraviolet and visible absorption spectrophotometry (2.2.25).

*Test solution.* Dissolve 25.0 mg in *cyclohexane R* and dilute to 100.0 mL with the same solvent. Dilute 1.0 mL of this solution to 10.0 mL with *cyclohexane R*.

*Spectral range:* 220-300 nm.

*Absorption maximum:* at 242 nm.

*Specific absorbance at the absorption maximum:* 300 to 330.

B. Infrared absorption spectrophotometry (2.2.24).

*Comparison:* crotamiton CRS.

C. Thin-layer chromatography (2.2.27).

*Test solution.* Dissolve 25 mg of the substance to be examined in *anhydrous ethanol R* and dilute to 10 mL with the same solvent.

*Reference solution.* Dissolve 25 mg of crotamiton CRS in *anhydrous ethanol R* and dilute to 10 mL with the same solvent.

*Plate:* TLC silica gel F<sub>254</sub> plate R.

*Mobile phase:* shake 98 volumes of *methylene chloride R* with 2 volumes of *concentrated ammonia R*, dry over *anhydrous sodium sulfate R*, filter and mix 97 volumes of the filtrate with 3 volumes of *2-propanol R*.

*Application:* 5 µL.

*Development:* over a 2/3 of the plate.

*Drying:* in air.

*Detection:* examine in ultraviolet light at 254 nm.

*Results:* the principal spot in the chromatogram obtained with the test solution is similar in position and size to the principal spot in the chromatogram obtained with the reference solution.

D. To 10 mL of a saturated solution add a few drops of a 3 g/L solution of *potassium permanganate R*. A brown colour is produced and a brown precipitate is formed on standing.

#### TESTS

**Relative density (2.2.5):** 1.006 to 1.011.

**Refractive index (2.2.6):** 1.540 to 1.542.

**Free amines:** maximum 500 ppm, expressed as ethylaminotoluene.

Dissolve 5.00 g in 16 mL of *methylene chloride R* and add 4.0 mL of *glacial acetic acid R*. Add 0.1 mL of *metanil yellow solution R* and 1.0 mL of 0.02 M *perchloric acid*. The solution is red-violet.

**Chlorides:** maximum 100 ppm.

Boil 5.0 g under a reflux condenser for 1 h with 25 mL of *ethanol (96 per cent) R* and 5 mL of a 200 g/L solution of *sodium hydroxide R*. Cool, add 5 mL of *water R* and shake with 25 mL of *ether R*. Dilute the lower layer to 20 mL with *water R*; add 5 mL of *nitric acid R*, dilute to 50 mL with *water R* and add 1 mL of a freshly prepared 50 g/L solution of *silver nitrate R*. Any opalescence in the solution is not more intense than that in a mixture of 1 mL of a freshly prepared 50 g/L solution of *silver nitrate R* and a solution prepared by diluting 5 mL of a 200 g/L solution of *sodium hydroxide R* to 20 mL with *water R* and adding 1.5 mL of 0.01 M *hydrochloric acid*, 5 mL of *nitric acid R* and diluting to 50 mL with *water R*.

**Related substances.** Liquid chromatography (2.2.29).

**Test solution (a).** Dissolve 50.0 mg of the substance to be examined in the mobile phase and dilute to 100.0 mL with the mobile phase.

**Test solution (b).** Dilute 1.0 mL of test solution (a) to 20.0 mL with the mobile phase.

**Reference solution (a).** Dissolve 50.0 mg of *crotamiton* CRS in the mobile phase and dilute to 100.0 mL with the mobile phase. Dilute 1.0 mL of this solution to 20.0 mL with the mobile phase.

**Reference solution (b).** Dissolve 15.0 mg of *crotamiton impurity A* CRS in the mobile phase and dilute to 20.0 mL with the mobile phase. Dilute 1.0 mL of this solution to 50.0 mL with the mobile phase.

**Reference solution (c).** Dilute 1.0 mL of test solution (a) to 100.0 mL with the mobile phase.

**Reference solution (d).** Dissolve 15 mg of *crotamiton impurity A* CRS in the mobile phase and dilute to 100.0 mL with the mobile phase. Dilute 1.0 mL of this solution to 10.0 mL with test solution (a).

**Column:**

- size:  $l = 0.25$  m,  $\varnothing = 4$  mm;
  - stationary phase: silica gel for chromatography R (5  $\mu$ m).
- Mobile phase: tetrahydrofuran R, cyclohexane R (8:92 V/V).

Flow rate: 1.0 mL/min.

Detection: spectrophotometer at 242 nm.

Injection: 20  $\mu$ L of test solution (a) and reference solutions (b), (c) and (d).

Run time: 2.5 times the retention time of the (*E*)-isomer.

Relative retention with reference to the (*E*)-isomer:  
(*Z*)-isomer = about 0.5; impurity A = about 0.8.

System suitability: reference solution (d):

- resolution: minimum 4.5 between the peaks due to impurity A and the (*E*)-isomer.

**Limits:**

- *impurity A*: not more than the area of the corresponding peak in the chromatogram obtained with reference solution (b) (3.0 per cent);
- *unspecified impurities*: for each impurity, not more than 0.1 times the sum of the areas of the peaks due to the (*Z*)- and (*E*)-isomers in the chromatogram obtained with reference solution (c) (0.10 per cent);
- *sum of impurities other than A*: not more than the sum of the areas of the peaks due to the (*Z*)- and (*E*)-isomers in the chromatogram obtained with reference solution (c) (1.0 per cent);
- *disregard limit*: 0.02 times the sum of the areas of the peaks due to the (*Z*)- and (*E*)-isomers in the chromatogram obtained with reference solution (c) (0.02 per cent).

**Sulfated ash** (2.4.14): maximum 0.1 per cent, determined on 1.0 g.

**ASSAY**

Liquid chromatography (2.2.29) as described in the test for related substances with the following modification.

**Injection:** test solution (b) and reference solution (a).

Calculate the percentage content of  $C_{13}H_{17}NO$  from the sum of the areas of the peaks due to the (*Z*)- and (*E*)-isomers in the chromatograms obtained. Calculate the content of the (*Z*)-isomer, as a percentage of the total content of the (*E*)- and (*Z*)-isomers, from the chromatogram obtained with test solution (b).

**STORAGE**

Protected from light.

**IMPURITIES**

Specified impurities: A.

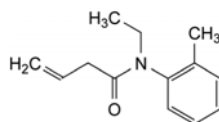

A. *N*-ethyl-*N*-(2-methylphenyl)but-3-enamide.

01/2008:0547  
corrected 6.0

## CYANOCOBALAMIN

### Cyanocobalaminum

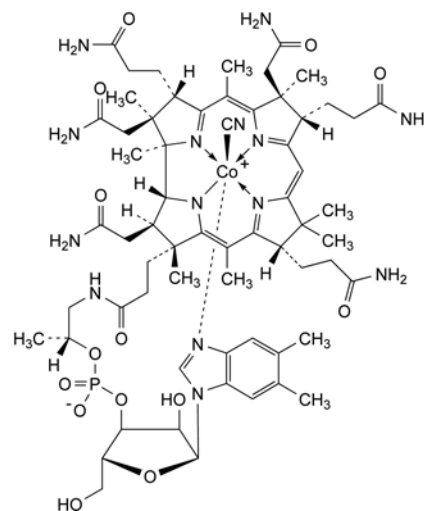

$C_{63}H_{88}CoN_{14}O_{14}P$   
[68-19-9]

$M_r$  1355

**DEFINITION**

$\alpha$ -(5,6-Dimethylbenzimidazol-1-yl)cobamide cyanide.

**Content:** 96.0 per cent to 102.0 per cent (dried substance).

This monograph applies to cyanocobalamin produced by fermentation.

**CHARACTERS**

**Appearance:** dark red, crystalline powder or dark red crystals.

**Solubility:** sparingly soluble in water and in ethanol (96 per cent), practically insoluble in acetone.

The anhydrous substance is very hygroscopic.

**IDENTIFICATION**

A. Ultraviolet and visible absorption spectrophotometry (2.2.25).

**Test solution.** Dissolve 2.5 mg in *water* R and dilute to 100.0 mL with the same solvent.

**Spectral range:** 260-610 nm.

**Absorption maxima:** at 278 nm, 361 nm and from 547 nm to 559 nm.

**Absorbance ratio:**

–  $A_{361} / A_{547-559} = 3.15$  to 3.45;

–  $A_{361} / A_{278} = 1.70$  to 1.90.

B. Thin-layer chromatography (2.2.27). Carry out the test protected from light.

**Test solution.** Dissolve 2 mg of the substance to be examined in 1 mL of a mixture of equal volumes of *ethanol* (96 per cent) R and *water* R.

**Reference solution.** Dissolve 2 mg of *cyanocobalamin* CRS in 1 mL of a mixture of equal volumes of *ethanol* (96 per cent) R and *water* R.

**Plate:** TLC silica gel G plate R.

**Mobile phase:** dilute ammonia R1, *methanol* R, *methylene chloride* R (9:30:45 V/V/V).

*Application:* 10 µL.

*Development:* in an unsaturated tank, over a path of 12 cm.

*Drying:* in air.

*Detection:* examine in daylight.

*Results:* the principal spot in the chromatogram obtained with the test solution is similar in position, colour and size to the principal spot in the chromatogram obtained with the reference solution.

07/2008:1092

## CYCLIZINE HYDROCHLORIDE

### Cyclizini hydrochloridum

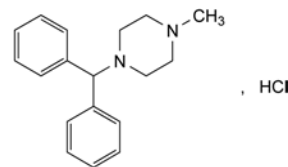

$C_{18}H_{23}ClN_2$   
[305-25-3]

$M_r$  302.8

#### DEFINITION

1-(Diphenylmethyl)-4-methylpiperazine hydrochloride.

*Content:* 98.5 per cent to 101.0 per cent (dried substance).

#### CHARACTERS

*Appearance:* white or almost white, crystalline powder.

*Solubility:* slightly soluble in water and in ethanol (96 per cent).

#### IDENTIFICATION

*First identification:* B, E.

*Second identification:* A, C, D, E.

A. Ultraviolet and visible absorption spectrophotometry (2.2.25).

*Test solution (a).* Dissolve 20.0 mg in a 5 g/L solution of sulfuric acid R and dilute to 100.0 mL with the same acid solution.

*Test solution (b).* Dilute 10.0 mL of test solution (a) to 100.0 mL with a 5 g/L solution of sulfuric acid R.

*Spectral range:* 240-350 nm for test solution (a); 210-240 nm for test solution (b).

*Resolution (2.2.25):* minimum 1.7.

*Absorption maxima:* at 258 nm and 262 nm for test solution (a); at 225 nm for test solution (b).

*Absorbance ratio:*  $A_{262}/A_{258} = 1.0$  to 1.1.

*Specific absorbance at the absorption maximum at 225 nm:* 370 to 410 for test solution (b).

B. Infrared absorption spectrophotometry (2.2.24).

*Comparison:* cyclizine hydrochloride CRS.

C. Thin-layer chromatography (2.2.27).

*Test solution.* Dissolve 10 mg of the substance to be examined in methanol R and dilute to 10 mL with the same solvent.

*Reference solution.* Dissolve 10 mg of cyclizine hydrochloride CRS in methanol R and dilute to 10 mL with the same solvent.

*Plate:* TLC silica gel GF<sub>254</sub> plate R.

*Mobile phase:* concentrated ammonia R, methanol R, methylene chloride R (2:13:85 V/V/V).

*Application:* 20 µL.

*Development:* over 2/3 of the plate.

*Drying:* in air for 30 min.

*Detection:* expose to iodine vapour for 10 min.

*Results:* the principal spot in the chromatogram obtained with the test solution is similar in position, colour and size to the principal spot in the chromatogram obtained with the reference solution.

D. Dissolve 0.5 g in 10 mL of ethanol (60 per cent) R, heating if necessary. Cool in iced water. Add 1 mL of dilute sodium hydroxide solution R and 10 mL of water R. Filter, wash the precipitate with water R and dry at 60 °C at a pressure not exceeding 0.7 kPa for 2 h. The melting point (2.2.14) is 105 °C to 108 °C.

#### TESTS

**Related substances.** Liquid chromatography (2.2.29).

*Test solution.* Dissolve 10.0 mg of the substance to be examined in the mobile phase and dilute to 10.0 mL with the mobile phase. *Use within 1 h.*

*Reference solution (a).* Dilute 3.0 mL of the test solution to 100.0 mL with the mobile phase. *Use within 1 h.*

*Reference solution (b).* Dilute 5.0 mL of the test solution to 50.0 mL with the mobile phase. Dilute 1.0 mL of this solution to 100.0 mL with the mobile phase. *Use within 1 h.*

*Reference solution (c).* Dissolve 25 mg of the substance to be examined in 10 mL of water R, warming if necessary. Allow to cool and add 5 mL of a 1.0 g/L solution of chloramine R and 0.5 mL of 0.05 M hydrochloric acid, then dilute to 25 mL with water R. Shake and allow to stand for 5 min. Dilute 1 mL of this solution to 10 mL with the mobile phase and inject immediately.

*Column:*

– *size:*  $l = 0.25$  m,  $\varnothing = 4$  mm;

– *stationary phase:* octylsilyl silica gel for chromatography R (5 µm).

*Mobile phase:* mix 26.5 volumes of methanol R and 73.5 volumes of a 10 g/L solution of disodium hydrogen phosphate R adjusted to pH 3.5 with phosphoric acid R and use within 2 days.

*Flow rate:* 0.8 mL/min.

*Detection:* spectrophotometer at 361 nm.

*Injection:* 20 µL.

*Run time:* 3 times the retention time of cyanocobalamin.

*System suitability:*

- the chromatogram obtained with reference solution (c) shows 2 principal peaks;
- *resolution:* minimum 2.5 between the 2 principal peaks in the chromatogram obtained with reference solution (c);
- *signal-to-noise ratio:* minimum 5 for the principal peak in the chromatogram obtained with reference solution (b).

*Limits:*

- *total:* not more than the area of the principal peak in the chromatogram obtained with reference solution (a) (3 per cent);
- *disregard limit:* the area of the principal peak in the chromatogram obtained with reference solution (b) (0.1 per cent).

**Loss on drying (2.2.32):** maximum 12.0 per cent, determined on 20.00 mg by drying *in vacuo* at 105 °C for 2 h.

#### ASSAY

Dissolve 25.00 mg in water R and dilute to 1000.0 mL with the same solvent. Measure the absorbance (2.2.25) at the absorption maximum at 361 nm.

Calculate the content of  $C_{18}H_{23}ClN_2$  taking the specific absorbance to be 207.

#### STORAGE

In an airtight container, protected from light.

E. It gives reaction (a) of chlorides (2.3.1).

## TESTS

**pH** (2.2.3): 4.5 to 5.5.

Dissolve 0.5 g in a mixture of 40 volumes of *ethanol* (96 per cent) *R* and 60 volumes of *carbon dioxide-free water R* and dilute to 25 mL with the same mixture of solvents.

**Related substances.** Gas chromatography (2.2.28). Prepare the solutions immediately before use.

**Test solution.** Dissolve 0.250 g of the substance to be examined in 4.0 mL of *methanol R* and dilute to 5.0 mL with 1 M *sodium hydroxide*.

**Reference solution (a).** Dissolve 25 mg of the substance to be examined in 10.0 mL of *methanol R*. Dilute 1.0 mL of this solution to 50.0 mL with *methanol R*.

**Reference solution (b).** Dissolve 5 mg of the substance to be examined, 5.0 mg of *cyclizine impurity A CRS* and 5.0 mg of *cyclizine impurity B CRS* in *methanol R* and dilute to 20.0 mL with the same solvent.

**Column:**

- **material:** fused silica;
- **size:**  $l = 25$  m,  $\varnothing = 0.33$  mm;
- **stationary phase:** *poly(dimethyl)(diphenyl)siloxane R* (film thickness 0.50  $\mu$ m).

**Carrier gas:** helium for chromatography *R*.

**Flow rate:** 1.0 mL/min.

**Split ratio:** 1:25.

**Temperature:**

	Time (min)	Temperature (°C)
Column	0 - 14	100 → 240
	14 - 16	240 → 270
	16 - 30	270
Injection port		250
Detector		290

**Detection:** flame ionisation.

**Injection:** 1  $\mu$ L.

**Relative retention** with reference to cyclizine (retention time = about 15 min): impurity A = about 0.2; impurity B = about 0.7.

**System suitability:** reference solution (b):

- **peak-to-valley ratio:** minimum 50, where  $H_p$  = height above the baseline of the peak due to impurity A and  $H_v$  = height above the baseline of the lowest point of the curve separating this peak from the peak due to methanol.

**Limits:**

- **impurities A, B:** for each impurity, not more than the area of the corresponding peak in the chromatogram obtained with reference solution (b) (0.5 per cent);
- **unspecified impurities:** for each impurity, not more than the area of the principal peak in the chromatogram obtained with reference solution (a) (0.10 per cent);
- **total:** not more than 10 times the area of the principal peak in the chromatogram obtained with reference solution (a) (1.0 per cent);
- **disregard limit:** 0.5 times the area of the principal peak in the chromatogram obtained with reference solution (a) (0.05 per cent).

**Loss on drying** (2.2.32): maximum 1.0 per cent, determined on 1.000 g by drying in an oven at 130 °C.

**Sulfated ash** (2.4.14): maximum 0.1 per cent, determined on 1.0 g.

## ASSAY

*In order to avoid overheating in the reaction medium, mix thoroughly throughout and stop the titration immediately after the end-point has been reached.*

Dissolve 0.120 g in 15 mL of *anhydrous formic acid R* and add 40 mL of *acetic anhydride R*. Titrate with 0.1 M *perchloric acid*, determining the end-point potentiometrically (2.2.20).

1 mL of 0.1 M *perchloric acid* is equivalent to 15.14 mg of  $C_{18}H_{23}ClN_2$ .

## STORAGE

Protected from light.

## IMPURITIES

**Specified impurities:** A, B.

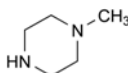

A. 1-methylpiperazine,

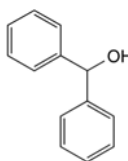

B. diphenylmethanol (benzhydrol).

04/2009:1093

## CYCLOPENTOLATE HYDROCHLORIDE

## Cyclopentolati hydrochloridum

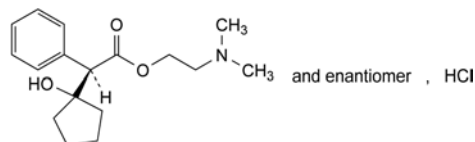

$C_{17}H_{26}ClNO_3$   
[5870-29-1]

$M_r$  327.8

## DEFINITION

2-(Dimethylamino)ethyl (2*RS*)-(1-hydroxycyclopentyl)-(phenyl)acetate hydrochloride.

**Content:** 98.5 per cent to 101.5 per cent (dried substance).

## CHARACTERS

**Appearance:** white or almost white, crystalline powder.

**Solubility:** very soluble in water, freely soluble in ethanol (96 per cent).

It shows polymorphism (5.9).

## IDENTIFICATION

**First identification:** B, D.

**Second identification:** A, C, D.

A. Melting point (2.2.14): 135 °C to 141 °C.

B. Infrared absorption spectrophotometry (2.2.24).

*Preparation:* discs of *potassium chloride R*.

*Comparison:* *cyclopentolate hydrochloride CRS*.

If the spectra obtained show differences, dissolve the substance to be examined and the reference substance separately in *ethanol* (96 per cent) *R*, evaporate to dryness and record new spectra using the residues.

C. Thin-layer chromatography (2.2.27).

**Test solution.** Dissolve 10 mg of the substance to be examined in 5 mL of *ethanol* (96 per cent) *R*.

**Reference solution.** Dissolve 10 mg of *cyclopentolate hydrochloride CRS* in *ethanol (96 per cent) R* and dilute to 5 mL with the same solvent.

**Plate:** *TLC silica gel plate R*.

**Mobile phase:** *concentrated ammonia R, water R, butyl acetate R, 2-propanol R* (5:15:30:50 V/V/V/V).

**Application:** 10 µL.

**Development:** over 2/3 of the plate.

**Drying:** in air.

**Detection:** spray with *alcoholic solution of sulfuric acid R* and heat at 120 °C for 30 min; examine in ultraviolet light at 365 nm.

**Result:** the principal spot in the chromatogram obtained with the test solution is similar in position, fluorescence and size to the principal spot in the chromatogram obtained with the reference solution.

D. It gives reaction (a) of chlorides (2.3.1).

#### TESTS

**pH (2.2.3):** 4.5 to 5.5.

Dissolve 0.2 g in *carbon dioxide-free water R* and dilute to 20 mL with the same solvent.

**Related substances.** Liquid chromatography (2.2.29). Prepare the solutions immediately before use.

**Test solution.** Dissolve 20 mg of the substance to be examined in *water R* and dilute to 20.0 mL with the same solvent.

**Reference solution (a).** Dilute 1.0 mL of the test solution to 100.0 mL with *water R*. Dilute 5.0 mL of this solution to 10.0 mL with *water R*.

**Reference solution (b).** Dissolve 10 mg of *cyclopentolate for system suitability CRS* (containing impurity C) in *water R* and dilute to 10.0 mL with the same solvent.

**Column:**

– *size:*  $l = 0.125$  m,  $\varnothing = 4.0$  mm;

– *stationary phase:* spherical *end-capped hexylsilyl silica gel for chromatography R* (5 µm).

**Mobile phase:** dissolve 0.66 g of *ammonium phosphate R* in *water R*, adjust to pH 3.0 with *phosphoric acid R* and dilute to 1000 mL with *water R*; mix and filter; mix 55 volumes of this solution and 45 volumes of *acetonitrile R1*.

**Flow rate:** 1.0 mL/min.

**Detection:** spectrophotometer at 220 nm.

**Injection:** 20 µL.

**Run time:** 2.5 times the retention time of cyclopentolate.

**Identification of impurities:** use the chromatogram supplied with *cyclopentolate for system suitability CRS* and the chromatogram obtained with reference solution (b) to identify the peak due to impurity C.

**Relative retention** with reference to cyclopentolate (retention time = about 4 min): impurity C = about 0.9.

**System suitability:** reference solution (b):

– **peak-to-valley ratio:** minimum 6, where  $H_p$  = height above the baseline of the peak due to impurity C and  $H_v$  = height above the baseline of the lowest point of the curve separating this peak from the peak due to cyclopentolate.

**Limits:**

– **correction factor:** for the calculation of content, multiply the peak area of impurity C by 2.0;

– **impurity C:** not more than the area of the principal peak in the chromatogram obtained with reference solution (a) (0.5 per cent);

– **unspecified impurities:** for each impurity, not more than 0.2 times the area of the principal peak in the chromatogram obtained with reference solution (a) (0.10 per cent);

– **total:** not more than twice the area of the principal peak in the chromatogram obtained with reference solution (a) (1.0 per cent);

– **disregard limit:** 0.1 times the area of the principal peak in the chromatogram obtained with reference solution (a) (0.05 per cent).

**Loss on drying (2.2.32):** maximum 0.5 per cent, determined on 1.000 g by drying in an oven at 105 °C for 4 h.

**Sulfated ash (2.4.14):** maximum 0.1 per cent, determined on 1.0 g.

#### ASSAY

Dissolve 0.250 g in a mixture of 1.0 mL of 0.1 M *hydrochloric acid* and 50 mL of *ethanol (96 per cent) R*. Carry out a potentiometric titration (2.2.20), using 0.1 M *sodium hydroxide*. Read the volume added between the 2 points of inflexion.

1 mL of 0.1 M *sodium hydroxide* is equivalent to 32.79 mg of  $C_{17}H_{26}ClNO_3$ .

#### IMPURITIES

**Specified impurities:** C.

**Other detectable impurities** (the following substances would, if present at a sufficient level, be detected by one or other of the tests in the monograph. They are limited by the general acceptance criterion for other/unspecified impurities and/or by the general monograph *Substances for pharmaceutical use (2034)*. It is therefore not necessary to identify these impurities for demonstration of compliance. See also 5.10. *Control of impurities in substances for pharmaceutical use*): A, B.

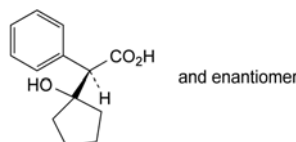

A. (2RS)-(1-hydroxycyclopentyl)(phenyl)acetic acid,

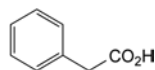

B. phenylacetic acid,

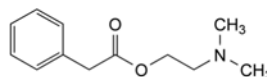

C. 2-(dimethylamino)ethyl phenylacetate.

01/2008:0711

## CYCLOPHOSPHAMIDE

### Cyclophosphamidum

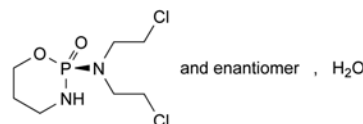

$C_{12}H_{15}Cl_2N_2O_2P, H_2O$   
[6055-19-2]

$M_r$  279.1

#### DEFINITION

Cyclophosphamide contains not less than 98.0 per cent and not more than the equivalent of 102.0 per cent of (2RS)-N,N-bis(2-chloroethyl)tetrahydro-2H-1,3,2-oxazaphosphorin-2-amine 2-oxide, calculated with reference to the anhydrous substance.

#### CHARACTERS

A white or almost white, crystalline powder, soluble in water, freely soluble in alcohol.

#### IDENTIFICATION

**First identification:** B.

**Second identification:** A, C, D.

- A. Determine the melting point (2.2.14) of the substance to be examined. Mix equal parts of the substance to be examined and *cyclophosphamide CRS* and determine the melting point of the mixture. The difference between the melting points (which are about 51 °C) is not greater than 2 °C.
- B. Examine by infrared absorption spectrophotometry (2.2.24), comparing with the spectrum obtained with *cyclophosphamide CRS*.
- C. Examine the chromatograms obtained in the test for related substances. The principal spot in the chromatogram obtained with test solution (b) is similar in position, colour and size to the principal spot in the chromatogram obtained with reference solution (a).
- D. Dissolve 0.1 g in 10 mL of *water R* and add 5 mL of *silver nitrate solution RI*; the solution remains clear. Boil, a white precipitate is formed which dissolves in *concentrated ammonia R* and is reprecipitated on the addition of *dilute nitric acid R*.

## TESTS

**Solution S.** Dissolve 0.50 g in *carbon dioxide-free water R* and dilute to 25.0 mL with the same solvent.

**Appearance of solution.** Solution S is clear (2.2.1) and not more intensely coloured than reference solution Y<sub>6</sub> (2.2.2, *Method II*).

**pH (2.2.3).** The pH of solution S is 4.0 to 6.0, determined immediately after preparation of the solution.

**Related substances.** Examine by thin-layer chromatography (2.2.27), using *silica gel G R* as the coating substance.

**Test solution (a).** Dissolve 0.10 g of the substance to be examined in *alcohol R* and dilute to 5 mL with the same solvent.

**Test solution (b).** Dilute 1 mL of test solution (a) to 10 mL with *alcohol R*.

**Reference solution (a).** Dissolve 10 mg of *cyclophosphamide CRS* in *alcohol R* and dilute to 5 mL with the same solvent.

**Reference solution (b).** Dilute 0.1 mL of test solution (a) to 10 mL with *alcohol R*.

Apply separately to the plate 10 µL of each solution. Develop over a path of 15 cm using a mixture of 2 volumes of *anhydrous formic acid R*, 4 volumes of *acetone R*, 12 volumes of *water R* and 80 volumes of *methyl ethyl ketone R*. Dry the plate in a current of warm air and heat at 110 °C for 10 min. At the bottom of a chromatographic tank, place an evaporating dish containing a 50 g/L solution of *potassium permanganate R* and add an equal volume of *hydrochloric acid R*. Place the plate whilst still hot in the tank and close the tank. Leave the plate in contact with the chlorine gas for 2 min. Withdraw the plate and place it in a current of cold air until the excess of chlorine is removed and an area of coating below the points of application gives at most a very faint blue colour with a drop of *potassium iodide and starch solution R*. Avoid prolonged exposure to cold air. Spray with *potassium iodide and starch solution R* and allow to stand for 5 min. Any spot in the chromatogram obtained with test solution (a), apart from the principal spot, is not more intense than the spot in the chromatogram obtained with reference solution (b) (1.0 per cent). Disregard any spot remaining at the point of application.

**Chlorides (2.4.4).** Dissolve 0.15 g in *water R* and dilute to 15 mL with the same solvent. The freshly prepared solution complies with the limit test for chlorides (330 ppm).

**Phosphates (2.4.11).** Dissolve 0.10 g in *water R* and dilute to 100 mL with the same solvent. The solution complies with the limit test for phosphates (100 ppm).

**Heavy metals (2.4.8).** 1.0 g complies with limit test C for heavy metals (20 ppm). Prepare the standard using 2 mL of *lead standard solution (10 ppm Pb) R*.

**Water (2.5.12):** 6.0 per cent to 7.0 per cent, determined on 0.300 g by the semi-micro determination of water.

## ASSAY

Dissolve 0.100 g in 50 mL of a 1 g/L solution of *sodium hydroxide R* in *ethylene glycol R* and boil under a reflux condenser for 30 min. Allow to cool and rinse the condenser with 25 mL of *water R*. Add 75 mL of *2-propanol R*, 15 mL of *dilute nitric acid R*, 10.0 mL of *0.1 M silver nitrate* and 2.0 mL of *ferric ammonium sulfate solution R2* and titrate with *0.1 M ammonium thiocyanate*.

1 mL of *0.1 M silver nitrate* is equivalent to 13.05 mg of C<sub>7</sub>H<sub>15</sub>Cl<sub>2</sub>N<sub>2</sub>O<sub>2</sub>P.

07/2009:0817

## CYPROHEPTADINE HYDROCHLORIDE

## Cyproheptadini hydrochloridum

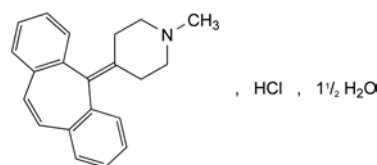

C<sub>21</sub>H<sub>22</sub>ClN, 1½H<sub>2</sub>O  
[41354-29-4]

M<sub>r</sub> 350.9

## DEFINITION

4-(5*H*-Dibenzo[*a,d*][7]annulen-5-ylidene)-1-methylpiperidine hydrochloride sesquihydrate.

**Content:** 98.5 per cent to 101.0 per cent (anhydrous substance).

## CHARACTERS

**Appearance:** white or slightly yellow, crystalline powder.

**Solubility:** slightly soluble in water, freely soluble in methanol, sparingly soluble in ethanol (96 per cent).

## IDENTIFICATION

A. Infrared absorption spectrophotometry (2.2.24).

*Comparison:* *cyproheptadine hydrochloride CRS*.

B. A saturated solution gives reaction (b) of chlorides (2.3.1).

## TESTS

**Acidity.** Dissolve 0.10 g in *water R* and dilute to 25 mL with the same solvent. Add 0.1 mL of *methyl red solution R*. Not more than 0.15 mL of *0.01 M sodium hydroxide* is required to change the colour of the indicator.

**Related substances.** Liquid chromatography (2.2.29).

**Test solution.** Dissolve 40.0 mg of the substance to be examined in mobile phase A and dilute to 20.0 mL with mobile phase A.

**Reference solution (a).** Dilute 1.0 mL of the test solution to 100.0 mL with mobile phase A. Dilute 1.0 mL of this solution to 10.0 mL with mobile phase A.

**Reference solution (b).** Dissolve 2.0 mg of *dibenzocycloheptene CRS* (impurity A), 2.0 mg of *dibenzosuberone CRS* (impurity B) and 2.0 mg of *cyproheptadine impurity C CRS* in mobile phase A, add 1.0 mL of the test solution and dilute to 100.0 mL with mobile phase A.

**Reference solution (c).** Dilute 1.0 mL of reference solution (b) to 10.0 mL with mobile phase A.

**Column:**

– *size:* *l* = 0.25 m, Ø = 4.6 mm;

– *stationary phase:* *octylsilyl silica gel for chromatography R* (5 µm).

**Mobile phase:**

– *mobile phase A:* dissolve 6.12 g of *potassium dihydrogen phosphate R* in 900 mL of *water R*, adjust to pH 4.5 with *phosphoric acid R* and dilute to 1000 mL with *water R*; mix 60 volumes of this solution and 40 volumes of *acetonitrile for chromatography R*;

- *mobile phase B*: dissolve 6.12 g of *potassium dihydrogen phosphate R* in 900 mL of *water R*, adjust to pH 4.5 with *phosphoric acid R* and dilute to 1000 mL with *water R*; mix 40 volumes of this solution and 60 volumes of *acetonitrile for chromatography R*;

Time (min)	Mobile phase A (per cent V/V)	Mobile phase B (per cent V/V)
0 - 10.0	100	0
10.0 - 10.1	100 → 0	0 → 100
10.1 - 35	0	100

*Flow rate*: 1.0 mL/min.

*Detection*: spectrophotometer at 230 nm.

*Injection*: 10 µL.

*Relative retention* with reference to cyproheptadine (retention time = about 8 min): impurity C = about 0.7; impurity B = about 2.6; impurity A = about 3.9.

*System suitability*: reference solution (b):

- *resolution*: minimum 7.0 between the peaks due to impurity C and cyproheptadine.

*Limits*:

- *impurities A, B, C*: for each impurity, not more than 1.5 times the area of the corresponding peak in the chromatogram obtained with reference solution (c) (0.15 per cent);
- *unspecified impurities*: for each impurity, not more than the area of the principal peak in the chromatogram obtained with reference solution (a) (0.10 per cent);
- *total*: not more than 5 times the area of the principal peak in the chromatogram obtained with reference solution (a) (0.5 per cent);
- *disregard limit*: 0.5 times the area of the principal peak in the chromatogram obtained with reference solution (a) (0.05 per cent).

**Water (2.5.12)**: 7.0 per cent to 9.0 per cent, determined on 0.200 g.

**Sulfated ash (2.4.14)**: maximum 0.1 per cent, determined on 1.0 g.

#### ASSAY

Dissolve 0.250 g in a mixture of 5.0 mL of 0.01 M *hydrochloric acid* and 50 mL of *ethanol (96 per cent) R*. Carry out a potentiometric titration (2.2.20), using 0.1 M *sodium hydroxide*. Read the volume added between the 2 points of inflexion.

1 mL of 0.1 M *sodium hydroxide* is equivalent to 32.39 mg of C<sub>21</sub>H<sub>22</sub>ClN.

#### STORAGE

Protected from light.

#### IMPURITIES

*Specified impurities*: A, B, C.

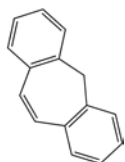

A. 5H-dibenzo[*a,d*][7]annulene (dibenzocycloheptene),

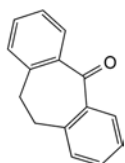

B. 10,11-dihydro-5H-dibenzo[*a,d*][7]annulen-5-one (dibenzosuberone),

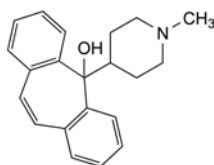

C. 5-(1-methylpiperidin-4-yl)-5H-dibenzo[*a,d*][7]annulen-5-ol.

07/2010:1094

## CYPROTERONE ACETATE

### Cyproteroni acetas

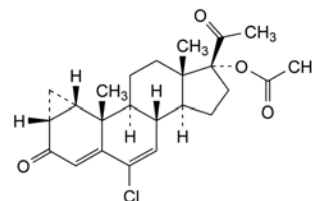

C<sub>24</sub>H<sub>29</sub>ClO<sub>4</sub>  
[427-51-0]

*M<sub>r</sub>* 416.9

#### DEFINITION

6-Chloro-3,20-dioxo-1β,2β-dihydro-3′*H*-cyclopropa-[1,2]pregna-1,4,6-trien-17-yl acetate.

*Content*: 97.0 per cent to 103.0 per cent (dried substance).

#### CHARACTERS

*Appearance*: white or almost white, crystalline powder.

*Solubility*: practically insoluble in water, very soluble in methylene chloride, freely soluble in acetone, soluble in methanol, sparingly soluble in anhydrous ethanol.

*mp*: about 210 °C.

#### IDENTIFICATION

*First identification*: A.

*Second identification*: B, C, D, E.

A. Infrared absorption spectrophotometry (2.2.24).

*Comparison*: cyproterone acetate CRS.

B. Thin-layer chromatography (2.2.27).

*Test solution*. Dissolve 20 mg of the substance to be examined in *methylene chloride R* and dilute to 10 mL with the same solvent.

*Reference solution*. Dissolve 10 mg of *cyproterone acetate CRS* in *methylene chloride R* and dilute to 5 mL with the same solvent.

*Plate*: TLC silica gel F<sub>254</sub> plate R.

*Mobile phase*: cyclohexane R, ethyl acetate R (50:50 V/V).

*Application*: 5 µL.

*Development*: twice over 3/4 of the plate; dry the plate in air between the 2 developments.

*Drying*: in air.

*Detection*: examine in ultraviolet light at 254 nm.

*Results*: the principal spot in the chromatogram obtained with the test solution is similar in position and size to the principal spot in the chromatogram obtained with the reference solution.

C. To about 1 mg add 2 mL of *sulfuric acid R* and heat on a water-bath for 2 min. A red colour develops. Cool. Add this solution cautiously to 4 mL of *water R* and shake. The solution becomes violet.

D. Incinerate about 30 mg with 0.3 g of *anhydrous sodium carbonate R* over a naked flame for about 10 min. Cool and dissolve the residue in 5 mL of *dilute nitric acid R*. Filter. To 1 mL of the filtrate add 1 mL of *water R*. The solution gives reaction (a) of chlorides (2.3.1).



E. It gives the reaction of acetyl (2.3.1).

## TESTS

**Specific optical rotation** (2.2.7): + 152 to + 157 (dried substance).

Dissolve 0.25 g in *acetone R* and dilute to 25.0 mL with the same solvent.

**Related substances.** Liquid chromatography (2.2.29).

**Test solution.** Dissolve 10 mg of the substance to be examined in *acetonitrile R* and dilute to 10.0 mL with the same solvent.

**Reference solution (a).** Dilute 1.0 mL of the test solution to 100.0 mL with *acetonitrile R*.

**Reference solution (b).** Dissolve the contents of a vial of *cyproterone impurity mixture CRS* (impurities F and I) in 1.0 mL of the test solution.

**Column:**

- size:  $l = 0.125$  m,  $\varnothing = 4.6$  mm;
- stationary phase: *end-capped octadecylsilyl silica gel for chromatography R* (3  $\mu$ m).

**Mobile phase:** *acetonitrile R*, *water R* (40:60 V/V).

**Flow rate:** 1.5 mL/min.

**Detection:** spectrophotometer at 254 nm.

**Injection:** 20  $\mu$ L.

**Run time:** twice the retention time of cyproterone acetate.

**Identification of impurities:** use the chromatogram supplied with *cyproterone impurity mixture CRS* and the chromatogram obtained with reference solution (b) to identify the peaks due to impurities F and I.

**Relative retention** with reference to cyproterone acetate (retention time = about 22 min): impurity F = about 0.5; impurity I = about 0.9.

**System suitability:** reference solution (b):

- resolution: minimum 1.5 between the peaks due to impurity I and cyproterone acetate.

**Limits:**

- **impurity F:** not more than 0.4 times the area of the principal peak in the chromatogram obtained with reference solution (a) (0.4 per cent);
- **unspecified impurities:** for each impurity, not more than 0.1 times the area of the principal peak in the chromatogram obtained with reference solution (a) (0.10 per cent);
- **total:** not more than 0.5 times the area of the principal peak in the chromatogram obtained with reference solution (a) (0.5 per cent);
- **disregard limit:** 0.05 times the area of the principal peak in the chromatogram obtained with reference solution (a) (0.05 per cent).

**Loss on drying** (2.2.32): maximum 0.5 per cent, determined on 1.000 g by drying at 80 °C at a pressure not exceeding 0.7 kPa.

**Sulfated ash** (2.4.14): maximum 0.1 per cent, determined on 1.0 g.

## ASSAY

Dissolve 50.0 mg in *methanol R* and dilute to 50.0 mL with the same solvent. Dilute 1.0 mL of this solution to 100.0 mL with *methanol R*. Measure the absorbance (2.2.25) at the absorption maximum at 282 nm.

Calculate the content of  $C_{24}H_{29}ClO_4$  taking the specific absorbance to be 414.

## STORAGE

Protected from light.

## IMPURITIES

**Specified impurities:** F.

**Other detectable impurities** (the following substances would, if present at a sufficient level, be detected by one or other of the tests in the monograph. They are limited by the general acceptance criterion for other/unspecified impurities and/or by the general monograph *Substances for pharmaceutical use* (2034). It is therefore not necessary to identify these impurities for demonstration of compliance. See also 5.10. *Control of impurities in substances for pharmaceutical use*): A, B, C, D, E, G, H, I.

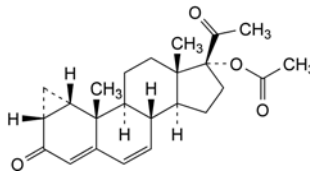

A. 3,20-dioxo-1 $\beta$ ,2 $\beta$ -dihydro-3'*H*-cyclopropa[1,2]pregna-1,4,6-trien-17-yl acetate,

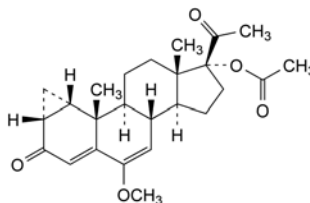

B. 6-methoxy-3,20-dioxo-1 $\beta$ ,2 $\beta$ -dihydro-3'*H*-cyclopropa[1,2]pregna-1,4,6-trien-17-yl acetate,

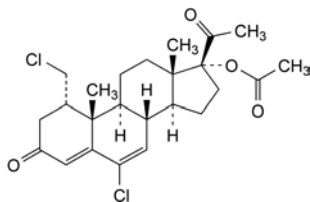

C. 6-chloro-1 $\alpha$ -(chloromethyl)-3,20-dioxopregna-4,6-dien-17-yl acetate,

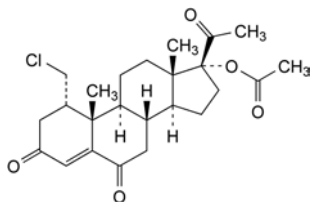

D. 1 $\alpha$ -(chloromethyl)-3,6,20-trioxopregn-4-en-17-yl acetate,

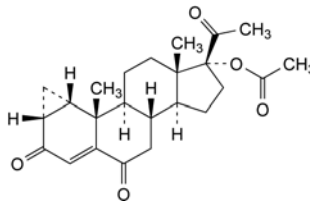

E. 3,6,20-trioxo-1 $\beta$ ,2 $\beta$ -dihydro-3'*H*-cyclopropa[1,2]pregna-1,4-dien-17-yl acetate,

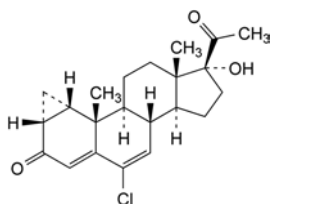

F. 6-chloro-17-hydroxy-1 $\beta$ ,2 $\beta$ -dihydro-3'*H*-cyclopropa[1,2]pregna-1,4,6-trien-3,20-dione,

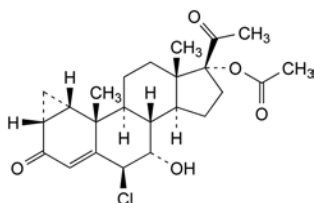

- G. 6β-chloro-7α-hydroxy-3,20-dioxo-1β,2β-dihydro-3'H-cyclopropa[1,2]pregna-1,4-dien-17-yl acetate,

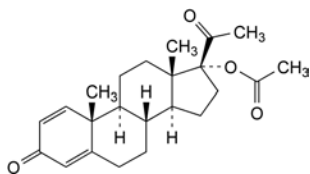

- H. 3,20-dioxopregna-1,4-dien-17-yl acetate,

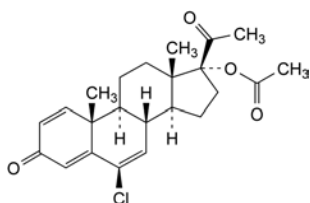

- I. 6-chloro-3,20-dioxopregna-1,4,6-trien-17-yl acetate (delmadinone acetate).

01/2008:0895  
corrected 6.0

## CYSTEINE HYDROCHLORIDE MONOHYDRATE

### Cysteini hydrochloridum monohydricum

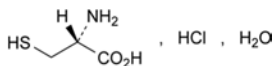

$C_3H_7ClNO_2S \cdot H_2O$   
[7048-04-6]

$M_r$  175.6

#### DEFINITION

Cysteine hydrochloride monohydrate contains not less than 98.5 per cent and not more than the equivalent of 101.0 per cent of (2*R*)-2-amino-3-sulfanylpropanoic acid hydrochloride, calculated with reference to the dried substance.

#### CHARACTERS

A white or almost white, crystalline powder or colourless crystals, freely soluble in water, slightly soluble in alcohol.

#### IDENTIFICATION

*First identification:* A, B, E.

*Second identification:* A, C, D, E.

- Specific optical rotation (see Tests).
- Examine by infrared absorption spectrophotometry (2.2.24), comparing with the spectrum obtained with *cysteine hydrochloride monohydrate CRS*. Examine the substances prepared as discs.
- Examine the chromatograms obtained in the test for ninhydrin-positive substances. The principal spot in the chromatogram obtained with test solution (b) is similar in position, colour, and size to the principal spot in the chromatogram obtained with reference solution (b).
- Dissolve about 5 mg in 1 mL of *dilute sodium hydroxide solution R*. Add 1 mL of a 30 g/L solution of *sodium nitroprusside R*. An intense violet colour develops which becomes brownish-red and then orange. Add 1 mL of *hydrochloric acid R*. The solution becomes green.

E. It gives reaction (a) of chlorides (2.3.1).

#### TESTS

**Solution S.** Dissolve 2.5 g in *distilled water R* and dilute to 50 mL with the same solvent.

**Appearance of solution.** Dilute 10 mL of solution S to 20 mL with *water R*. The solution is clear (2.2.1) and not more intensely coloured than reference solution BY<sub>6</sub> (2.2.2, *Method II*).

**Specific optical rotation (2.2.7).** Dissolve 2.00 g in *hydrochloric acid R1* and dilute to 25.0 mL with the same acid. The specific optical rotation is + 5.5 to + 7.0, calculated with reference to the dried substance.

**Ninhydrin-positive substances.** Examine by thin-layer chromatography (2.2.27), using a *TLC silica gel plate R*.

**Test solution (a).** Dissolve 0.20 g of the substance to be examined in *water R* and dilute to 10 mL with the same solvent. To 5 mL of the solution add 5 mL of a 40 g/L solution of *N-ethylmaleimide R* in *alcohol R*. Allow to stand for 5 min.

**Test solution (b).** Dilute 1 mL of test solution (a) to 50 mL with *water R*.

**Reference solution (a).** Dissolve 20 mg of *cysteine hydrochloride monohydrate CRS* in *water R* and dilute to 10 mL with the same solvent. Add 10 mL of a 40 g/L solution of *N-ethylmaleimide R* in *alcohol R*. Allow to stand for 5 min.

**Reference solution (b).** Dilute 2 mL of reference solution (a) to 10 mL with *water R*.

**Reference solution (c).** Dilute 5 mL of test solution (b) to 20 mL with *water R*.

**Reference solution (d).** Dissolve 10 mg of *tyrosine CRS* in 10 mL of reference solution (a) and dilute to 25 mL with *water R*.

Apply separately to the plate 5 μL of each test solution and reference solutions (b), (c), and (d). Develop over a path of 15 cm using a mixture of 20 volumes of *glacial acetic acid R*, 20 volumes of *water R* and 60 volumes of *butanol R*. Dry the plate at 80 °C for 30 min. Spray with *ninhydrin solution R* and heat at 100 °C to 105 °C for 15 min. Any spot in the chromatogram obtained with test solution (a), apart from the principal spot, is not more intense than the spot in the chromatogram obtained with reference solution (c) (0.5 per cent). The test is not valid unless the chromatogram obtained with reference solution (d) shows 2 clearly separated principal spots.

**Sulfates (2.4.13).** Dilute 10 mL of solution S to 15 mL with *distilled water R*. The solution complies with the limit test for sulfates (300 ppm).

**Ammonium (2.4.1).** 50 mg complies with limit test B for ammonium (200 ppm). Prepare the standard using 0.1 mL of *ammonium standard solution (100 ppm NH<sub>4</sub>) R*.

**Iron (2.4.9).** In a separating funnel, dissolve 0.50 g in 10 mL of *dilute hydrochloric acid R*. Shake with 3 quantities, each of 10 mL, of *methyl isobutyl ketone R1*, shaking for 3 min each time. To the combined organic layers add 10 mL of *water R* and shake for 3 min. The aqueous layer complies with the limit test for iron (20 ppm).

**Heavy metals (2.4.8).** Dissolve 2.0 g in *water R*. Adjust to pH 3 to 4 with *concentrated ammonia R* and dilute to 20 mL with *water R*. 12 mL of the solution complies with limit test A for heavy metals (10 ppm). Prepare the standard using *lead standard solution (1 ppm Pb) R*.

**Loss on drying (2.2.32):** 8.0 per cent to 12.0 per cent, determined on 1.000 g by drying at a pressure not exceeding 0.7 kPa for 24 h.

**Sulfated ash (2.4.14).** Not more than 0.1 per cent, determined on 1.0 g.

## ASSAY

In a ground-glass stoppered flask dissolve 0.300 g of the substance to be examined and 4 g of *potassium iodide R* in 20 mL of *water R*. Cool the solution in iced water and add 3 mL of *hydrochloric acid R1* and 25.0 mL of 0.05 M *iodine*. Stopper the flask and allow to stand in the dark for 20 min. Titrate with 0.1 M *sodium thiosulfate* using 3 mL of *starch solution R*, added towards the end of the titration, as indicator. Carry out a blank titration.

1 mL of 0.05 M *iodine* is equivalent to 15.76 mg of  $C_3H_8ClNO_2S$ .

## STORAGE

Store protected from light.

01/2008:0998  
corrected 6.0

## CYSTINE

## Cystinum

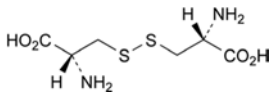

$C_6H_{12}N_2O_4S_2$   
[56-89-3]

$M_r$  240.3

## DEFINITION

Cystine contains not less than 98.5 per cent and not more than the equivalent of 101.0 per cent of 3,3'-disulfanediybis[(2*R*)-2-aminopropanoic acid], calculated with reference to the dried substance.

## CHARACTERS

A white or almost white, crystalline powder, practically insoluble in water and in alcohol. It dissolves in dilute solutions of alkali hydroxides.

## IDENTIFICATION

*First identification:* A, B.

*Second identification:* A, C, D.

- A. Specific optical rotation (see Tests).
- B. Examine by infrared absorption spectrophotometry (2.2.24), comparing with the spectrum obtained with *cystine CRS*. Examine the substances prepared as discs.
- C. Examine the chromatograms obtained in the test for ninhydrin-positive substances. The principal spot in the chromatogram obtained with test solution (b) is similar in position, colour and size to the principal spot in the chromatogram obtained with reference solution (a).
- D. To 0.1 g carefully add 1 mL of *strong hydrogen peroxide solution R* and 0.1 mL of *ferric chloride solution R1*. Allow to cool. Add 1 mL of *dilute hydrochloric acid R* and 5 mL of *water R*. Add 1 mL of *barium chloride solution R1*. Turbidity or a white precipitate develops within 3 min.

## TESTS

**Appearance of solution.** Dissolve 1.0 g in *dilute hydrochloric acid R* and dilute to 10 mL with the same acid. The solution is clear (2.2.1) and not more intensely coloured than reference solution Y<sub>7</sub> (2.2.2, *Method II*).

**Specific optical rotation** (2.2.7). Dissolve 0.50 g in 1 M *hydrochloric acid* and dilute to 25.0 mL with the same acid. The specific optical rotation is –218 to –224, calculated with reference to the dried substance.

**Ninhydrin-positive substances.** Examine by thin-layer chromatography (2.2.27), using a *TLC silica gel plate R*.

*Test solution (a).* Dissolve 0.10 g of the substance to be examined in 1 M *hydrochloric acid* and dilute to 10 mL with the same acid.

*Test solution (b).* Dilute 1 mL of test solution (a) to 50 mL with *water R*.

*Reference solution (a).* Dissolve 10 mg of *cystine CRS* in 1 mL of 1 M *hydrochloric acid* and dilute to 50 mL with *water R*.

*Reference solution (b).* Dilute 2 mL of test solution (b) to 20 mL with *water R*.

*Reference solution (c).* Dissolve 10 mg of *cystine CRS* and 10 mg of *arginine hydrochloride CRS* in 1 mL of 1 M *hydrochloric acid* and dilute to 25 mL with *water R*.

Apply separately to the plate 5 µL of each solution. Develop over a path of 15 cm using a mixture of 30 volumes of *concentrated ammonia R* and 70 volumes of 2-*propanol R*. Allow the plate to dry in air. Spray with *ninhydrin solution R* and heat at 100 °C to 105 °C for 15 min. Any spot in the chromatogram obtained with test solution (a), apart from the principal spot, is not more intense than the spot in the chromatogram obtained with reference solution (b) (0.2 per cent). The test is not valid unless the chromatogram obtained with reference solution (c) shows two clearly separated spots.

**Chlorides** (2.4.4). Dissolve 0.25 g in 5 mL of *dilute nitric acid R* and dilute to 15 mL with *water R*. The solution, without further addition of nitric acid, complies with the limit test for chlorides (200 ppm).

**Sulfates** (2.4.13). Dissolve 0.5 g in 5 mL of *dilute hydrochloric acid R* and dilute to 15 mL with *distilled water R*. The solution complies with the limit test for sulfates (300 ppm).

**Ammonium** (2.4.1). 0.10 g complies with limit test B for ammonium (200 ppm). Prepare the standard using 0.2 mL of *ammonium standard solution (100 ppm NH<sub>4</sub>) R*.

**Iron** (2.4.9). In a separating funnel, dissolve 1.0 g in 10 mL of *dilute hydrochloric acid R*. Shake with three quantities, each of 10 mL, of *methyl isobutyl ketone R1*, shaking for 3 min each time. To the combined organic layers add 10 mL of *water R* and shake for 3 min. The aqueous layer complies with the limit test for iron (10 ppm).

**Heavy metals** (2.4.8). 2.0 g complies with limit test D for heavy metals (10 ppm). Prepare the standard using 2 mL of *lead standard solution (10 ppm Pb) R*.

**Loss on drying** (2.2.32). Not more than 0.5 per cent, determined on 1.000 g by drying in an oven at 105 °C.

**Sulfated ash** (2.4.14). Not more than 0.1 per cent, determined on 1.0 g.

## ASSAY

In a flask with a ground-glass stopper, dissolve 0.100 g in a mixture of 2 mL of *dilute sodium hydroxide solution R* and 10 mL of *water R*. Add 10 mL of a 200 g/L solution of *potassium bromide R*, 50.0 mL of 0.0167 M *potassium bromate* and 15 mL of *dilute hydrochloric acid R*. Stopper the flask and cool in iced water. Allow to stand in the dark for 10 min. Add 1.5 g of *potassium iodide R*. After 1 min, titrate with 0.1 M *sodium thiosulfate*, using 2 mL of *starch solution R*, added towards the end-point, as indicator. Carry out a blank titration.

1 mL of 0.0167 M *potassium bromate* is equivalent to 2.403 mg of  $C_6H_{12}N_2O_4S_2$ .

## STORAGE

Store protected from light.

## CYTARABINE

## Cytarabinum

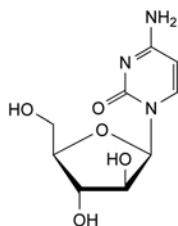

$C_9H_{13}N_3O_5$   
[147-94-4]

$M_r$  243.2

## DEFINITION

Cytarabine contains not less than 99.0 per cent and not more than the equivalent of 100.5 per cent of 4-amino-1- $\beta$ -D-arabinofuranosylpyrimidin-2(1*H*)-one, calculated with reference to the dried substance.

## CHARACTERS

A white or almost white, crystalline powder, freely soluble in water, very slightly soluble in alcohol and in methylene chloride. It melts at about 215 °C.

## IDENTIFICATION

- Dissolve 20.0 mg in 0.1 *M* hydrochloric acid and dilute to 100.0 mL with the same acid. Dilute 5.0 mL of the solution to 100.0 mL with 0.1 *M* hydrochloric acid. Examined between 230 nm and 350 nm (2.2.25), the solution shows an absorption maximum at 281 nm. The specific absorbance at the maximum is 540 to 570.
- Examine by infrared absorption spectrophotometry (2.2.24), comparing with the spectrum obtained with *cytarabine* CRS. Examine the substances prepared as discs.
- Examine the chromatograms obtained in the test for related substances in ultraviolet light at 254 nm. The principal spot in the chromatogram obtained with test solution (b) is similar in position and size to the principal spot in the chromatogram obtained with reference solution (a).

## TESTS

**Appearance of solution.** Dissolve 1.0 g in *water R* and dilute to 10 mL with the same solvent. The solution is clear (2.2.1) and not more intensely coloured than reference solution  $Y_5$  (2.2.2, Method II).

**Specific optical rotation** (2.2.7). Dissolve 0.250 g in *water R* and dilute to 25.0 mL with the same solvent. The specific optical rotation is + 154 to + 160, calculated with reference to the dried substance.

**01/2008:0760 Related substances.** Examine by thin-layer chromatography (2.2.27), using *silica gel GF<sub>254</sub> R* as the coating substance.

**Test solution (a).** Dissolve 0.25 g of the substance to be examined in *water R* and dilute to 5 mL with the same solvent.

**Test solution (b).** Dilute 2 mL of test solution (a) to 50 mL with *water R*.

**Reference solution (a).** Dissolve 10 mg of *cytarabine* CRS in *water R* and dilute to 5 mL with the same solvent.

**Reference solution (b).** Dilute 0.5 mL of test solution (a) to 100 mL with *water R*.

**Reference solution (c).** Dissolve 20 mg of *uridine R* and 20 mg of *uracil arabinoside* CRS in *methanol R* and dilute to 10 mL with the same solvent.

Apply separately to the plate 5  $\mu$ L of each solution. Develop over a path of 15 cm using a mixture of 15 volumes of *water R*, 20 volumes of *acetone R* and 65 volumes of *methyl ethyl ketone R*. Allow the plate to dry in air and examine in ultraviolet light at 254 nm. Any spot in the chromatogram obtained with test solution (a), apart from the principal spot, is not more intense than the spot in the chromatogram obtained with reference solution (b) (0.5 per cent). The test is not valid unless the chromatogram obtained with reference solution (c) shows two clearly separated spots.

**Loss on drying** (2.2.32). Not more than 1.0 per cent, determined on 0.250 g by drying over *diphosphorus pentoxide R* at 60 °C at a pressure of 0.2 kPa to 0.7 kPa for 3 h.

**Sulfated ash** (2.4.14). Not more than 0.5 per cent, determined on 1.0 g.

## ASSAY

Dissolve 0.200 g in 60 mL of *anhydrous acetic acid R*, warming if necessary. Titrate with 0.1 *M perchloric acid* determining the end-point potentiometrically (2.2.20).

1 mL of 0.1 *M perchloric acid* is equivalent to 24.32 mg of  $C_9H_{13}N_3O_5$ .

## STORAGE

Store in an airtight container, protected from light.

## IMPURITIES

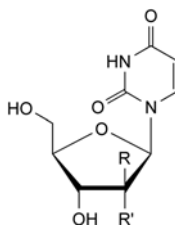

- R = OH, R' = H: 1- $\beta$ -D-arabinofuranosylpyrimidine-2,4(1*H*, 3*H*)-dione (uracil arabinoside),
- R = H, R' = OH: 1- $\beta$ -D-ribofuranosylpyrimidine-2,4(1*H*, 3*H*)-dione (uridine).

## 01/2008:1691 Related substances

## DACARBAZINE

## Dacarbazinum

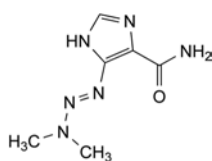

C<sub>6</sub>H<sub>10</sub>N<sub>6</sub>O  
[4342-03-4]

M<sub>r</sub> 182.2

## DEFINITION

5-[(1E)-3,3-Dimethyltriazen-1-enyl]-1H-imidazole-4-carboxamide.

Content: 98.5 per cent to 101.0 per cent (anhydrous substance).

## CHARACTERS

Appearance: white or slightly yellowish, crystalline powder.

Solubility: slightly soluble in water and in anhydrous ethanol, practically insoluble in methylene chloride.

## IDENTIFICATION

First identification: B.

Second identification: A, C.

A. Ultraviolet and visible absorption spectrophotometry (2.2.25).

Test solution. Dissolve 15.0 mg in 100.0 mL of 0.1 M hydrochloric acid. Dilute 5.0 mL of this solution to 100.0 mL with 0.1 M hydrochloric acid.

Spectral range: 200-400 nm.

Absorption maximum: at 323 nm.

Shoulder: at 275 nm.

Specific absorbance at the absorption maximum: 1024 to 1131.

B. Infrared absorption spectrophotometry (2.2.24).

Comparison: dacarbazine CRS.

C. Thin-layer chromatography (2.2.27).

Test solution. Dissolve 2.0 mg of the substance to be examined in methanol R and dilute to 5.0 mL with the same solvent.

Reference solution. Dissolve 2.0 mg of dacarbazine CRS in methanol R and dilute to 5.0 mL with the same solvent.

Plate: TLC silica gel F<sub>254</sub> plate R.

Mobile phase: glacial acetic acid R, water R, butanol R (1:2:5 V/V/V).

Application: 10 µL.

Development: over 2/3 of the plate.

Drying: in air.

Detection: examine in ultraviolet light at 254 nm.

Results: the principal spot in the chromatogram obtained with the test solution is similar in position and size to the principal spot in the chromatogram obtained with the reference solution.

## TESTS

Appearance of solution. The solution is clear (2.2.1) and not more intensely coloured than reference solution BY<sub>6</sub> (2.2.2, Method II).

Dissolve 0.25 g in a 210 g/L solution of citric acid R and dilute to 25.0 mL with the same solution.

A. Liquid chromatography (2.2.29). Use freshly prepared solutions and protect them from light.

Test solution. Dissolve 50.0 mg of the substance to be examined and 75 mg of citric acid R in distilled water R and dilute to 5.0 mL with the same solvent.

Reference solution (a). Dissolve 5.0 mg of dacarbazine impurity A CRS in distilled water R and dilute to 50.0 mL with the same solvent. Dilute 5.0 mL of this solution to 25.0 mL with distilled water R.

Reference solution (b). Dissolve 5.0 mg of dacarbazine impurity B CRS in distilled water R, add 0.5 mL of the test solution and dilute to 10.0 mL with distilled water R. Dilute 1.0 mL of this solution to 50.0 mL with distilled water R.

Column:

– size:  $l = 0.25$  m,  $\varnothing = 4.5$  mm;

– stationary phase: octadecylsilyl silica gel for chromatography R (5 µm).

Mobile phase: 15.63 g/L solution of glacial acetic acid R containing 2.33 g/L of sodium dioctyl sulfosuccinate R. As the mobile phase contains sodium dioctyl sulfosuccinate, it must be freshly prepared every day, and the column must be flushed with a mixture of equal volumes of methanol R and water R, after all tests have been completed or at the end of the day, for at least 2 h.

Flow rate: 1.2 mL/min.

Detection: spectrophotometer at 254 nm.

Injection: 25 µL of the test solution and reference solution (a).

Run time: 3 times the retention time of impurity A.

Retention time: impurity A = about 3 min.

Limits:

- impurity A: not more than the area of the corresponding peak in the chromatogram obtained with reference solution (a) (0.2 per cent);
- unspecified impurities eluting after impurity A: for each impurity, not more than 0.5 times the area of the principal peak in the chromatogram obtained with reference solution (a) (0.10 per cent).

B. Liquid chromatography (2.2.29) as described in related substances test A with the following modifications.

Mobile phase: mix 45 volumes of a 15.63 g/L solution of glacial acetic acid R containing 2.33 g/L of sodium dioctyl sulfosuccinate R with 55 volumes of methanol R.

Injection: 10 µL of the test solution and reference solution (b).

Run time: twice the retention time of dacarbazine.

Relative retention with reference to dacarbazine (retention time = about 12 min): impurity B = about 0.7.

System suitability: reference solution (b):

- resolution: minimum 1.5 between the peaks due to impurity B and dacarbazine.

Limits:

- impurity B: not more than the area of the corresponding peak in the chromatogram obtained with reference solution (b) (0.1 per cent);
- unspecified impurities: for each impurity, not more than the area of the peak due to dacarbazine in the chromatogram obtained with reference solution (b) (0.10 per cent);
- total: not more than 5 times the area of the peak due to dacarbazine in the chromatogram obtained with reference solution (b) (0.5 per cent);
- disregard limit: 0.5 times the area of the peak due to dacarbazine in the chromatogram obtained with reference solution (b) (0.05 per cent).

**Impurity D.** Head-space gas chromatography (2.2.28).

**Test solution.** Introduce 0.200 g of the substance to be examined into a 20 mL vial and firmly attach the septum and cap. Using a 10 µL syringe, inject 5 µL of *water R* into the vial.

**Reference solution (a).** Dilute 2.5 mL of *dimethylamine solution R* (impurity D) to 100.0 mL with *water R* (solution A). Firmly attach the septum and cap to a 20 mL vial. Using a 10 µL syringe, inject 10 µL of solution A into the vial.

**Reference solution (b).** Firmly attach the septum and cap to a 20 mL vial. Using a 10 µL syringe, inject 10 µL of solution A and 10 µL of a 10 g/L solution of *triethylamine R* into the vial.

**Column:**

- *material*: fused silica;
- *size*:  $l = 30.0$  m,  $\varnothing = 0.53$  mm;
- *stationary phase*: *base-deactivated polyethyleneglycol R* (film thickness 1.0 µm).

**Carrier gas:** *helium for chromatography R*.

**Flow rate:** 13 mL/min.

**Split ratio:** 1:1.

**Static head-space conditions that may be used:**

- *equilibration temperature*: 60 °C;
- *equilibration time*: 10 min;
- *transfer-line temperature*: 90 °C;
- *pressurisation time*: 30 s.

**Temperature:**

	Time (min)	Temperature (°C)
Column	0 - 3	35
	3 - 11	35 → 165
Injection port		180
Detector		220

**Detection:** flame ionisation.

**Injection:** 1 mL.

**System suitability:** reference solution (b):

- *resolution*: minimum 2.5 between the peaks due to impurity D and triethylamine.

**Limit:**

- *impurity D*: not more than the area of the corresponding peak in the chromatogram obtained with reference solution (a) (0.05 per cent).

**Water (2.5.12):** maximum 0.5 per cent, determined on 1.00 g.

**Sulfated ash (2.4.14):** maximum 0.1 per cent, determined on 1.0 g.

**ASSAY**

Dissolve 0.150 g in 30 mL of *anhydrous acetic acid R*. Titrate with 0.1 M *perchloric acid*, determining the end-point potentiometrically (2.2.20).

1 mL of 0.1 M *perchloric acid* is equivalent to 18.22 mg of  $C_6H_{10}N_6O$ .

**STORAGE**

At a temperature of 2 °C to 8 °C, protected from light.

**IMPURITIES**

**Specified impurities:** A, B, D.

**Other detectable impurities** (the following substances would, if present at a sufficient level, be detected by one or other of the tests in the monograph. They are limited by the general acceptance criterion for other/unspecified impurities and/or by the general monograph *Substances for pharmaceutical use (2034)*. It is therefore not necessary to identify these impurities for demonstration of compliance. See also 5.10. *Control of impurities in substances for pharmaceutical use*): C.

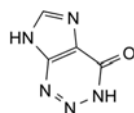

A. 3,7-dihydro-4H-imidazo[4,5-d]-1,2,3-triazin-4-one (2-azahypoxanthine),

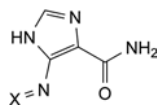

B. X = H<sub>2</sub>: 5-amino-1H-imidazole-4-carboxamide,

C. X = NH: 5-diazenyl-1H-imidazole-4-carboxamide,

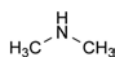

D. *N*-methylmethanamine.

01/2008:1195

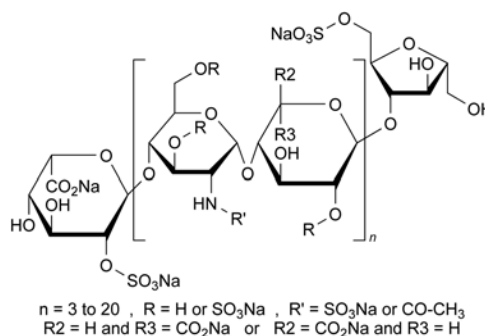
**DALTEPARIN SODIUM****Dalteparinum natricum****DEFINITION**

Dalteparin sodium is the sodium salt of a low-molecular-mass heparin that is obtained by nitrous acid depolymerisation of heparin from porcine intestinal mucosa. The majority of the components have a 2-*O*-sulfo- $\alpha$ -L-idopyranosuronic acid structure at the non-reducing end and a 6-*O*-sulfo-2,5-anhydro-D-mannitol structure at the reducing end of their chain.

*Dalteparin sodium complies with the monograph*

*Low-molecular-mass heparins (0828) with the modifications and additional requirements below.*

The mass-average relative molecular mass ranges between 5600 and 6400, with a characteristic value of about 6000.

The degree of sulfatation is 2.0 to 2.5 per disaccharide unit.

The potency is not less than 110 IU and not more than 210 IU of anti-factor Xa activity per milligram, calculated with reference to the dried substance. The anti-factor IIa activity is not less than 35 IU/mg and not more than 100 IU/mg, calculated with reference to the dried substance. The ratio of anti-factor Xa activity to anti-factor IIa activity is between 1.9 and 3.2.

**PRODUCTION**

Dalteparin sodium is produced by a validated manufacturing and purification procedure under conditions designed to minimise the presence of N-NO groups.

The manufacturing procedure must have been shown to reduce any contamination by N-NO groups to approved limits using an appropriate, validated quantification method.

**IDENTIFICATION**

Carry out identification test A as described in the monograph *Low-molecular-mass heparins (0828)* using *dalteparin sodium CRS*.

Carry out identification test C as described in the monograph *Low-molecular-mass heparins (0828)*. The following requirements apply.

The mass-average relative molecular mass ranges between 5600 and 6400. The mass percentage of chains lower than 3000 is not more than 13.0 per cent. The mass percentage of chains higher than 8000 ranges between 15.0 per cent and 25.0 per cent.

#### TESTS

**Appearance of solution.** Dissolve 1 g in 10 mL of *water R*. The solution is clear (2.2.1) and not more intensely coloured than intensity 5 of the range of reference solutions of the most appropriate colour (2.2.2, *Method II*).

**Nitrite.** Not more than 5 ppm. Examine by liquid chromatography (2.2.29). *Rinse all volumetric flasks at least three times with water R before the preparation of the solutions.*

**Test solution.** Dissolve 80.0 mg of the substance to be examined in *water R* and dilute to 10.0 mL with the same solvent. Allow to stand for at least 30 min.

**Reference solution (a).** Dissolve 60.0 mg of *sodium nitrite R* in *water R* and dilute to 1000.0 mL with the same solvent.

*For the preparation of reference solution (b), use a pipette previously rinsed with reference solution (a).*

**Reference solution (b).** Dilute 1.00 mL of reference solution (a) to 50.0 mL with *water R*.

*Before preparing reference solutions (c), (d) and (e), rinse all pipettes with reference solution (b).*

**Reference solution (c).** Dilute 1.00 mL of reference solution (b) to 100.0 mL with *water R* (corresponding to 1 ppm of nitrite in the test sample).

**Reference solution (d).** Dilute 3.00 mL of reference solution (b) to 100.0 mL with *water R* (corresponding to 3 ppm of nitrite in the test sample).

**Reference solution (e).** Dilute 5.00 mL of reference solution (b) to 100.0 mL with *water R* (corresponding to 5 ppm of nitrite in the test sample).

The chromatographic procedure may be carried out using:

- a column 0.125 m long and 4.3 mm in internal diameter packed with a strong anion-exchange resin;
- as mobile phase at a flow rate of 1.0 mL/min a solution consisting of 13.61 g of *sodium acetate R* dissolved in *water R*, adjusted to pH 4.3 with *phosphoric acid R* and diluted to 1000 mL with *water R*;
- as detector an appropriate electrochemical device with the following characteristics and settings: a suitable working electrode, a detector potential of + 1.00 V versus Ag/AgCl reference electrode and a detector sensitivity of 0.1 µA full scale.

Inject 100 µL of reference solution (d). When the chromatograms are recorded in the prescribed conditions, the retention time for nitrite is 3.3 to 4.0 min. The test is not valid unless:

- the number of theoretical plates calculated for the nitrite peak is at least 7000 per metre per column (dalteparin sodium will block the binding sites of the stationary phase, which will cause shorter retention times and lower separation efficiency for the analyte; the initial performance of the column may be partially restored using a 58 g/L solution of *sodium chloride R* at a flow rate of 1.0 mL/min for 1 h; after regeneration the column is rinsed with 200 mL to 400 mL of *water R*);
- the symmetry factor for the nitrite peak is less than 3;
- the relative standard deviation of the peak area for nitrite obtained from 6 injections is less than 3.0 per cent.

Inject 100 µL each of reference solutions (c) and (e). The test is not valid unless:

- the correlation factor for a linear relationship between concentration and response for reference solutions (c), (d) and (e) is at least 0.995;

- the signal-to-noise ratio for reference solution (c) is not less than 5 (if the noise level is too high, electrode recalibration is recommended);
- a blank injection of *water R* does not give rise to spurious peaks.

Inject 100 µL of the test solution. Calculate the content of nitrite from the peak areas in the chromatogram obtained with reference solutions (c), (d) and (e).

**Boron.** Not more than 1 ppm, determined by inductively coupled plasma atomic emission spectroscopy.

Boron is determined by measurement of the emission from an inductively coupled plasma (ICP) at a wavelength specific to boron. The emission line at 249.733 nm is used. Use an appropriate apparatus, whose settings have been optimised as directed by the manufacturer.

**Test solution.** Dissolve 0.2500 g of the substance to be examined in about 2 mL of *water for chromatography R*, add 100 µL of *nitric acid R* and dilute to 10.00 mL with the same solvent.

**Reference solution (a).** Prepare a 1 per cent V/V solution of *nitric acid R* in *water for chromatography R* (blank).

**Reference solution (b).** Prepare a 11.4 µg/mL solution of *boric acid R* in a 1 per cent V/V solution of *nitric acid R* in *water for chromatography R* (STD<sub>cal</sub>).

**Reference solution (c).** Dissolve 0.2500 g of a reference dalteparin sodium with no detectable boron in about 2 mL of *water for chromatography R*, add 100 µL of *nitric acid R* and dilute to 10.00 mL with the same solvent (STD<sub>0</sub>).

**Reference solution (d).** Dissolve 0.2500 g of a reference dalteparin sodium with no boron detected in about 2 mL of a 1 per cent V/V solution of *nitric acid R* in *water for chromatography R*, add 10 µL of a 5.7 mg/mL solution of *boric acid R* and dilute to 10.00 mL with the same solvent (STD<sub>1</sub>). This solution contains 1 µg/mL of boron.

Calculate the content of boron in the substance to be examined, using the following correction factor:

$$f = \frac{(\text{STD}_1 - \text{STD}_0) \times 2}{(\text{STD}_{\text{cal}} - \text{blank})}$$

**Loss on drying (2.2.32).** Not more than 5.0 per cent, determined on 1.000 g by drying in an oven at 60 °C over *diphosphorus pentoxide R* at a pressure not exceeding 670 Pa for 3 h.

01/2011:2090

## DANAPAROID SODIUM

### Danaparoidum natricum

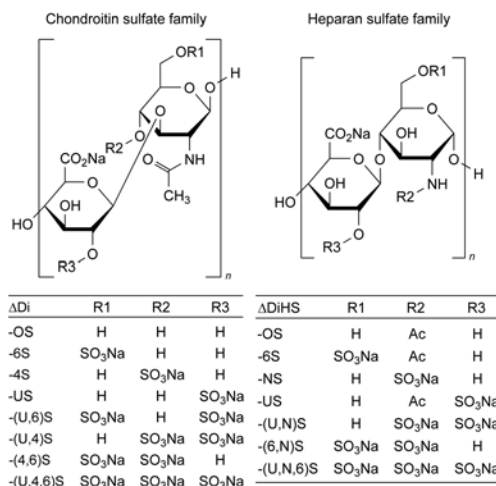

## DEFINITION

Preparation containing the sodium salts of a mixture of sulfated glycosaminoglycans present in porcine tissues. Danaparoid sodium is prepared from the intestinal mucosa of pigs. Its major constituents are heparan sulfate and dermatan sulfate. On complete hydrolysis it liberates D-glucosamine, D-galactosamine, D-glucuronic acid, L-iduronic acid, acetic acid and sulfuric acid. It has the characteristic property of enhancing the inactivation of activated factor X (factor Xa) by antithrombin. It has a negligible effect on the inactivation rate of thrombin by antithrombin.

**Potency:** 11.0 to 17.0 anti-factor Xa units per milligram (dried substance).

## PRODUCTION

The animals from which danaparoid sodium is derived must fulfil the requirements for the health of animals suitable for human consumption. It is prepared using a process that ensures that the relative proportion of active sulfated glycosaminoglycans is consistent. It is produced by methods of manufacturing designed to minimise or eliminate endotoxins and hypotensive substances.

## CHARACTERS

**Appearance:** white or almost white, hygroscopic powder.

**Solubility:** freely soluble in water.

## IDENTIFICATION

- A. The ratio of anti-factor Xa activity to anti-factor IIa activity, determined as described under Assay and Tests respectively, is not less than 22.
- B. Molecular mass distribution (see Tests): the mass-average relative molecular mass ranges between 4000 and 7000.

## TESTS

**pH (2.2.3):** 5.5 to 7.0.

Dissolve 0.5 g of the dried substance to be examined in *carbon dioxide-free water R* and dilute to 50 mL with the same solvent.

**Anti-factor IIa activity:** maximum 0.5 units per milligram (dried substance).

**Test solutions.** Prepare 2 independent series of dilutions in geometric progression of the substance to be examined in *phosphate buffer solution pH 6.5 R* and in the concentration range of 0.0005 to 0.005 units of anti-factor IIa activity per millilitre.

**Reference solutions.** Prepare 2 independent series of dilutions in geometric progression of *danaparoid sodium CRS* in *phosphate buffer solution pH 6.5 R* and in the concentration range of 0.0005 to 0.005 units of anti-factor IIa activity per millilitre.

Transfer 50 µL of each solution into the wells of a 96-well microtitre plate. To each well add 50 µL of *antithrombin III solution R3* and 50 µL of *human thrombin solution R1*. Shake the microtitre plate but do not allow bubbles to form. Incubate for 75 min. To each well add 50 µL of *chromogenic substrate R4*. Shake the microtitre plate. Measure the absorbances at 405 nm (2.2.25) using a suitable reading device, exactly 4 min after the addition of the chromogenic substrate. The reaction may be stopped using 75 µL of a 20 per cent *V/V* solution of *glacial acetic acid R*. Determine the blank amidolytic activity in a similar manner, using *phosphate buffer solution pH 6.5 R* as the blank solution (minimum 10 blanks per microtitre plate). Calculate the activity of the substance to be examined in units of anti-factor IIa activity per milligram using a suitable statistical method, for example the parallel-line assay.

**Chondroitin sulfate and dermatan sulfate.** Chondroitin sulfate: maximum 8.5 per cent (dried substance); dermatan sulfate: 8.0 per cent to 16.0 per cent (dried substance).

Determine by selective enzymatic degradation.

**Test solutions.** Dry the substance to be examined at 60 °C over *diphosphorus pentoxide R* at a pressure of about 670 Pa for 3 h. Dissolve 0.200 g of the dried substance in 10.0 mL of *water R*. Dilute this solution as necessary to obtain 3 test solutions containing 20 mg/mL, 10 mg/mL and 5 mg/mL of the dried substance to be examined in *water R*.

**Chondroitin sulfate reference solutions.** Dry *chondroitin sulfate CRS* over *diphosphorus pentoxide R* at room temperature at a pressure of about 670 Pa for 16 h. Prepare solutions containing 1 mg/mL, 2 mg/mL and 3 mg/mL of dried *chondroitin sulfate CRS* in *water R*.

**Dermatan sulfate reference solutions.** Dry *dermatan sulfate CRS* over *diphosphorus pentoxide R* at room temperature at a pressure of about 670 Pa for 16 h. Prepare solutions containing 1 mg/mL, 2 mg/mL and 3 mg/mL of dried *dermatan sulfate CRS* in *water R*.

**Chondroitinase ABC solution.** Dissolve *chondroitinase ABC R* in *tris-sodium acetate-sodium chloride buffer solution pH 8.0 R* to obtain an activity of 0.5-1.0 units per millilitre.

**Chondroitinase AC solution.** Dissolve *chondroitinase AC R* in *tris-sodium acetate-sodium chloride buffer solution pH 7.4 R* to obtain an activity of 1.0-2.0 units per millilitre.

## Procedure:

- **Degradation with chondroitinase ABC:** label 2 sets of 10 tubes in triplicate: T1, T2 and T3 for the test solutions; SD1, SD2 and SD3 for the dermatan sulfate reference solutions; SC1, SC2 and SC3 for the chondroitin sulfate reference solutions; and B for the blank (*water R*). To each tube add 1.25 mL of *tris-sodium acetate buffer solution pH 8.0 R* and 150 µL of the test solutions, dermatan sulfate reference solutions, chondroitin sulfate reference solutions or *water R*. To each tube in 1 set of tubes add 75 µL of chondroitinase ABC solution. To determine the blank response level, add 75 µL of *tris-sodium acetate-sodium chloride buffer solution pH 8.0 R* to each tube in the other set of tubes. Mix the contents of the tubes using a vortex mixer, cover with appropriate stoppers and incubate at 37 °C for at least 24 h.
- **Degradation with chondroitinase AC:** label 7 tubes in triplicate: T1, T2 and T3 for the test solutions; SC1, SC2 and SC3 for the chondroitin sulfate reference solutions; and B for the blank (*water R*). To each tube add 1.25 mL of *tris-sodium acetate buffer solution pH 7.4 R* and 150 µL of the test solutions, chondroitin sulfate reference solutions or *water R*. Add 75 µL of chondroitinase AC solution to each tube. Mix the contents of the tubes using a vortex mixer, cover with appropriate stoppers and incubate at 37 °C for at least 24 h. After the incubation period mix the contents of the tubes using a vortex mixer and dilute to 12 times with *water R*. Measure the absorbances (2.2.25) of the diluted solutions at 234 nm against *water R* using a suitable spectrophotometer.

**Calculation:** calculate the mean blank absorbance of each reference solution, i.e. the mean of the absorbances of the reference solutions to which no chondroitinase ABC has been added. Subtract the mean blank absorbance value from the individual absorbance of each reference solution. Calculate linear regression curves for the 2 chondroitin sulfate reference and the dermatan sulfate reference by plotting the blank-corrected absorbances against the concentrations.



Calculate the average percentage content of dermatan sulfate in the test solutions of all tested concentrations using the following expression:

$$\frac{A_2 - A_1 - \frac{(A_3 - A_1 - I_1) \times B_2}{B_1} - I_2 - I_3}{B_3 \times C} \times 100$$

- $A_1$  = blank absorbance of the test solution;  
 $A_2$  = absorbance of the test solution with chondroitinase ABC;  
 $A_3$  = absorbance of the test solution with chondroitinase AC;  
 $B_1$  = gradient of the curve obtained with the chondroitin sulfate reference solutions with chondroitinase AC;  
 $B_2$  = gradient of the curve obtained with the chondroitin sulfate reference solutions with chondroitinase ABC;  
 $B_3$  = gradient of the curve obtained with the dermatan sulfate reference solutions with chondroitinase ABC;  
 $C$  = concentration of the test solution, in milligrams per millilitre;  
 $I_1$  = y-intercept of the curve obtained with the chondroitin sulfate reference solutions with chondroitinase AC;  
 $I_2$  = y-intercept of the curve obtained with the chondroitin sulfate reference solutions with chondroitinase ABC;  
 $I_3$  = y-intercept of the curve obtained with the dermatan sulfate reference solutions with chondroitinase ABC.

Calculate the average percentage content of chondroitin sulfate in the test solutions for all tested concentrations using the following expression:

$$\frac{(A_3 - A_1 - I_1) \times 100}{B_1 \times C}$$

**Molecular mass distribution.** Size-exclusion chromatography (2.2.30).

**Test solution.** Dissolve 10 mg of the substance to be examined in 2 mL of the mobile phase.

**Reference solution.** Dissolve 10 mg of danaparoid sodium CRS in 2 mL of the mobile phase.

**Column:**

- size:  $l = 0.60$  m,  $\varnothing = 7.5$  mm;
- stationary phase: hydrophilic silica gel for chromatography R (10  $\mu$ m) with a fractionation range for proteins with a relative molecular mass of approximately 5000-100 000;
- temperature: 30 °C.

**Mobile phase:** 28.4 g/L solution of anhydrous sodium sulfate R adjusted to pH 5.0 with dilute sulfuric acid R.

**Flow rate:** 0.9 mL/min  $\pm$  2 per cent.

**Detection:** spectrophotometer at 210 nm.

**Injection:** 100  $\mu$ L.

**Run time:** for a period of time ensuring complete elution of sample and solvent peaks (about 40 min).

**System suitability:** inject the reference solution twice. The difference between the retention times corresponding to the maxima of the peaks is not more than 5 s.

**Calibration:** calibration is achieved by taking the relevant part of the chromatogram obtained with the reference solution, i.e. excluding the sharp peak at the end of the chromatogram, and matching the chromatogram obtained with the test solution with the calibration table obtained with the reference solution. From the calibration curve obtained, determine the molecular mass distribution of the sample. A calibration table is supplied with danaparoid sodium CRS.

**Limits:**

- chains with a relative molecular mass less than 2000: maximum 13 per cent;
- chains with a relative molecular mass less than 4000: maximum 39 per cent;
- chains with a relative molecular mass between 4000 and 8000: minimum 50 per cent;
- chains with a relative molecular mass higher than 8000: maximum 19 per cent;
- chains with a relative molecular mass higher than 10 000: maximum 11 per cent.

**Nitrogen (2.5.9):** 2.4 per cent to 3.0 per cent (dried substance).

**Nucleic acids:** maximum 0.5 per cent (dried substance).

**Test solution.** Weigh about 50 mg of the dried substance to be examined into a centrifuge tube and dissolve in 200  $\mu$ L of water R.

**Reference solution.** Dissolve about 50 mg of ribonucleic acid CRS in 5 mL of 0.1 M sodium hydroxide and dilute to 20.0 mL with water R. Transfer 200  $\mu$ L of the solution into a centrifuge tube.

Add 4.0 mL of a 50 g/L solution of trichloroacetic acid R to each tube and mix. Place all tubes in boiling water for 30 min. Allow to cool to room temperature. Add again 4.0 mL of a 50 g/L solution of trichloroacetic acid R to each tube and mix. If any of the test solutions is not clear, sonicate all the tubes in an ultrasonic bath for 10 min and centrifuge at 1500 g for 15 min. Dilute 1.0 mL of the clear supernatant to 4.0 mL with water R. Measure the absorbances of the diluted reference and test solutions at 265 nm (2.2.25) against a blank solution prepared in the same manner, and calculate the percentage nucleic acid content of the sample.

**Total protein (2.5.33, Method 2):** maximum 0.5 per cent.

Dissolve the substance to be examined in water R. Use bovine albumin R as the reference substance.

**Sodium:** 9.0 per cent to 11.0 per cent (dried substance).

Atomic absorption spectrometry (2.2.23, Method I).

**Test solution.** Dissolve 0.125 g of the substance to be examined in 100.0 mL of a 1.27 mg/mL solution of caesium chloride R in 0.1 M hydrochloric acid.

**Reference solutions.** Prepare reference solutions containing 50 ppm, 100 ppm and 150 ppm of Na by diluting sodium standard solution (1000 ppm Na) R with a 1.27 mg/mL solution of caesium chloride R in 0.1 M hydrochloric acid.

**Source:** sodium hollow-cathode lamp.

**Wavelength:** 330.3 nm.

**Atomisation device:** air-acetylene flame.

**Loss on drying (2.2.32):** maximum 5.0 per cent, determined on 0.500 g by drying in an oven at 60 °C over diphosphorus pentoxide R at a pressure of 670 Pa for 3 h.

**Bacterial endotoxins (2.6.14):** less than 0.02 IU per unit of anti-factor Xa activity, if intended for use in the manufacture of parenteral preparations without a further appropriate procedure for the removal of bacterial endotoxins.

**ASSAY**

The anticoagulant activity of danaparoid sodium is determined *in vitro* by an assay which determines its ability to accelerate the inhibition of factor Xa by antithrombin III (anti-factor Xa assay).

**Test solutions.** Prepare 2 independent series of dilutions in geometric progression of the substance to be examined in tris(hydroxymethyl)aminomethane EDTA buffer solution pH 8.4 R and in the concentration range of 0.1 to 0.32 units of anti-factor Xa activity per millilitre.

**Reference solutions.** Prepare 2 independent series of dilutions in geometric progression of *danaparoid sodium CRS* in *tris(hydroxymethyl)aminomethane EDTA buffer solution pH 8.4 R* and in the concentration range of 0.08 to 0.35 units of anti-factor Xa activity per millilitre.

Transfer 40 µL of each solution into the wells of a 96-well microtitre plate. Add 40 µL of *antithrombin III solution R4* to each well and shake the microtitre plate but do not allow bubbles to form. Add 40 µL of *bovine factor Xa solution R1* to each well. Exactly 2 min after the addition of the factor Xa solution, add 80 µL of *chromogenic substrate R5*. Measure the absorbance at 405 nm (2.2.25) using a suitable reading device, exactly 4 min after the addition of the factor Xa solution. The reaction may be stopped using 75 µL of a 20 per cent V/V solution of *glacial acetic acid R*. Determine the blank amidolytic activity in the same manner, using *tris(hydroxymethyl)aminomethane EDTA buffer solution pH 8.4 R* as the blank (minimum 8 blanks per microtitre plate). Calculate the potency of the substance to be examined in units of anti-factor Xa activity per milligram using a suitable statistical method, for example the parallel-line assay.

#### STORAGE

In an airtight container. If the substance is sterile, store in a sterile, airtight, tamper-proof container.

#### LABELLING

The label states the number of units of anti-factor Xa activity per milligram.

01/2008:0077  
corrected 6.0

## DAPSONE

### Dapsonum

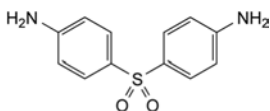

$C_{12}H_{12}N_2O_2S$   
[80-08-0]

$M_r$  248.3

#### DEFINITION

Dapsone contains not less than 99.0 per cent and not more than the equivalent of 101.0 per cent of 4,4'-sulfonyldianiline, calculated with reference to the dried substance.

#### CHARACTERS

A white or slightly yellowish-white, crystalline powder, very slightly soluble in water, freely soluble in acetone, sparingly soluble in alcohol. It dissolves freely in dilute mineral acids.

#### IDENTIFICATION

- Melting point (2.2.14): 175 °C to 181 °C.
- Dissolve 50.0 mg in *methanol R* and dilute to 100.0 mL with the same solvent. Dilute 1.0 mL of this solution to 100.0 mL with *methanol R*. Examined between 230 nm and 350 nm (2.2.25), the solution shows 2 absorption maxima, at 260 nm and 295 nm. The specific absorbances at these maxima are 700 to 760 and 1150 to 1250, respectively.
- Examine the chromatograms obtained in the test for related substances. The principal spot in the chromatogram obtained with test solution (b) is similar in position, colour and size to the principal spot in the chromatogram obtained with reference solution (a).

#### TESTS

**Related substances.** Examine by thin-layer chromatography (2.2.27), using *silica gel G R* as the coating substance.

**Test solution (a).** Dissolve 0.10 g of the substance to be examined in *methanol R* and dilute to 10 mL with the same solvent.

**Test solution (b).** Dilute 1 mL of test solution (a) to 10 mL with *methanol R*.

**Reference solution (a).** Dissolve 10 mg of *dapsone CRS* in *methanol R* and dilute to 10 mL with the same solvent.

**Reference solution (b).** Dilute 1 mL of test solution (b) to 10 mL with *methanol R*.

**Reference solution (c).** Dilute 2 mL of reference solution (b) to 10 mL with *methanol R*.

Apply separately to the plate 1 µL of test solution (b), 1 µL of reference solution (a), 10 µL of test solution (a), 10 µL of reference solution (b) and 10 µL of reference solution (c). Develop in an unsaturated tank over a path of 15 cm using a mixture of 1 volume of *concentrated ammonia R*, 6 volumes of *methanol R*, 20 volumes of *ethyl acetate R* and 20 volumes of *heptane R*. Allow the plate to dry in air. Spray the plate with a 1 g/L solution of *4-dimethylaminocinnamaldehyde R* in a mixture of 1 volume of *hydrochloric acid R* and 99 volumes of *alcohol R*. Examine in daylight. Any spot in the chromatogram obtained with test solution (a), apart from the principal spot, is not more intense than the spot in the chromatogram obtained with reference solution (b) (1.0 per cent) and not more than 2 such spots are more intense than the spot in the chromatogram obtained with reference solution (c) (0.2 per cent).

**Loss on drying** (2.2.32). Not more than 1.5 per cent, determined on 1.000 g by drying in an oven at 105 °C.

**Sulfated ash** (2.4.14). Not more than 0.1 per cent, determined on 1.0 g.

#### ASSAY

Dissolve 0.100 g in 50 mL of *dilute hydrochloric acid R*. Carry out the determination of primary aromatic amino-nitrogen (2.5.8).

1 mL of 0.1 M *sodium nitrite* is equivalent to 12.42 mg of  $C_{12}H_{12}N_2O_2S$ .

#### STORAGE

Store protected from light.

01/2008:0662

## DAUNORUBICIN HYDROCHLORIDE

### Daunorubicini hydrochloridum

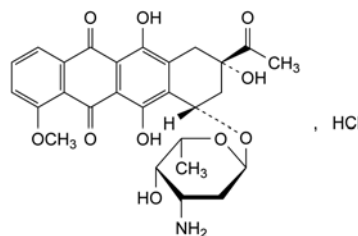

$C_{27}H_{30}ClNO_{10}$   
[23541-50-6]

$M_r$  564.0

#### DEFINITION

(8*S*,10*S*)-8-Acetyl-10-[(3-amino-2,3,6-trideoxy- $\alpha$ -L-lyxo-hexopyranosyl)oxy]-6,8,11-trihydroxy-1-methoxy-7,8,9,10-tetrahydrotetracene-5,12-dione hydrochloride.

Substance produced by certain strains of *Streptomyces coeruleorubidus* or of *Streptomyces peucetius* or obtained by any other means.

**Content:** 95.0 per cent to 102.0 per cent (anhydrous substance).

## PRODUCTION

It is produced by methods of manufacture designed to eliminate or minimise the presence of histamine.

## CHARACTERS

*Appearance*: crystalline, orange-red powder, hygroscopic.

*Solubility*: freely soluble in water and in methanol, slightly soluble in alcohol, practically insoluble in acetone.

## IDENTIFICATION

## A. Infrared absorption spectrophotometry (2.2.24).

*Comparison*: daunorubicin hydrochloride CRS.

## B. Dissolve about 10 mg in 0.5 mL of nitric acid R, add 0.5 mL of water R and heat over a flame for 2 min. Allow to cool and add 0.5 mL of silver nitrate solution RI. A white precipitate is formed.

## TESTS

**pH** (2.2.3): 4.5 to 6.5.

Dissolve 50 mg in carbon dioxide-free water R and dilute to 10 mL with the same solvent.

**Related substances**. Liquid chromatography (2.2.29). Prepare the solutions immediately before use.

*Test solution*. Dissolve 50.0 mg of the substance to be examined in the mobile phase and dilute to 50.0 mL with the mobile phase.

*Reference solution (a)*. Dissolve 50.0 mg of daunorubicin hydrochloride CRS in the mobile phase and dilute to 50.0 mL with the mobile phase.

*Reference solution (b)*. Dissolve 10 mg of doxorubicin hydrochloride CRS and 10 mg of epirubicin hydrochloride CRS in the mobile phase and dilute to 100.0 mL with the mobile phase. Dilute 1.0 mL of the solution to 10.0 mL with the mobile phase.

*Reference solution (c)*. Dissolve 5.0 mg of daunorubicinone CRS and 5.0 mg of doxorubicin hydrochloride CRS in the mobile phase and dilute to 100.0 mL with the mobile phase. Dilute 1.0 mL of the solution to 10.0 mL with the mobile phase.

*Reference solution (d)*. Dilute 1.0 mL of reference solution (a) to 200.0 mL with the mobile phase.

*Column*:

- *size*:  $l = 0.25$  m,  $\varnothing = 4.0$  mm,
- *stationary phase*: end-capped octadecylsilyl silica gel for chromatography R (5  $\mu$ m).

*Mobile phase*: mixture of equal volumes of acetonitrile R and a solution containing 2.88 g/L of sodium laurilsulfate R and 2.25 g/L of phosphoric acid R.

*Flow rate*: 1 mL/min.

*Detection*: spectrophotometer at 254 nm.

*Injection*: 5  $\mu$ L; inject the test solution and reference solutions (b), (c) and (d).

*Run time*: twice the retention time of daunorubicin.

*Relative retention* with reference to daunorubicin (retention time = about 15 min): impurity A = about 0.4; impurity D = about 0.5; epirubicin = about 0.6; impurity B = about 0.7.

*System suitability*: reference solution (b):

- *resolution*: minimum of 2.0 between the peaks due to impurity D and epirubicin.

*Limits*:

- *impurity A*: not more than the area of the corresponding peak in the chromatogram obtained with reference solution (c) (0.5 per cent),
- *impurity B*: not more than 3 times the area of the principal peak in the chromatogram obtained with reference solution (d) (1.5 per cent),

- *impurity D*: not more than the area of the corresponding peak in the chromatogram obtained with reference solution (c) (0.5 per cent),
- *any other impurity*: not more than the area of the principal peak in the chromatogram obtained with reference solution (d) (0.5 per cent),
- *total of other impurities*: not more than 5 times the area of the principal peak in the chromatogram obtained with reference solution (d) (2.5 per cent),
- *disregard limit*: 0.1 times the area of the principal peak in the chromatogram obtained with reference solution (d) (0.05 per cent).

**Butanol** (2.4.24, System B): maximum 1.0 per cent.

**Water** (2.5.12): maximum 3.0 per cent, determined on 0.100 g.

**Bacterial endotoxins** (2.6.14): less than 4.3 IU/mg, if intended for use in the manufacture of parenteral preparations without a further appropriate procedure for the removal of bacterial endotoxins.

## ASSAY

Liquid chromatography (2.2.29) as described in the test for related substances.

*Injection*: test solution and reference solution (a).

Calculate the percentage content of  $C_{27}H_{30}ClNO_{10}$ .

## STORAGE

In an airtight container, protected from light. If the substance is sterile, store in a sterile, airtight, tamper-proof container.

## IMPURITIES

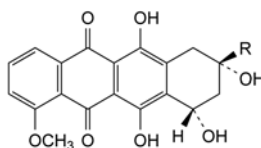

A. R = CO-CH<sub>3</sub>: (8S,10S)-8-acetyl-6,8,10,11-tetrahydroxy-1-methoxy-7,8,9,10-tetrahydrotetracene-5,12-dione (daunorubicin aglycone, daunorubicinone),

E. R = CHOH-CH<sub>3</sub>: (8S,10S)-6,8,10,11-tetrahydroxy-8-[(1R)-1-hydroxyethyl]-1-methoxy-7,8,9,10-tetrahydrotetracene-5,12-dione (13-dihydrodaunorubicinone),

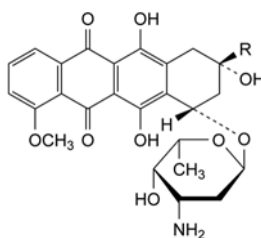

B. R = CHOH-CH<sub>3</sub>: (8S,10S)-10-[(3-amino-2,3,6-trideoxy- $\alpha$ -L-lyxo-hexopyranosyl)oxy]-6,8,11-trihydroxy-8-[(1R)-1-hydroxyethyl]-1-methoxy-7,8,9,10-tetrahydrotetracene-5,12-dione (daunorubicinol),

C. R = CH<sub>2</sub>-CO-CH<sub>3</sub>: (8S,10S)-10-[(3-amino-2,3,6-trideoxy- $\alpha$ -L-lyxo-hexopyranosyl)oxy]-6,8,11-trihydroxy-1-methoxy-8-(2-oxopropyl)-7,8,9,10-tetrahydrotetracene-5,12-dione (feudomycin B),

D. R = CO-CH<sub>2</sub>-OH: doxorubicin,

F. R = CO-CH<sub>2</sub>-CH<sub>3</sub>: (8S,10S)-10-[(3-amino-2,3,6-trideoxy- $\alpha$ -L-lyxo-hexopyranosyl)oxy]-6,8,11-trihydroxy-1-methoxy-8-propanoyl-7,8,9,10-tetrahydrotetracene-5,12-dione (8-ethyl-daunorubicin).

## DECYL OLEATE

### Decylis oleas

#### DEFINITION

Mixture consisting of decyl esters of fatty acids, mainly oleic (*cis*-9-octadecenoic) acid.

A suitable antioxidant may be added.

#### CHARACTERS

*Appearance*: clear, pale yellow or colourless liquid.

*Solubility*: practically insoluble in water, miscible with ethanol (96 per cent), with methylene chloride and with light petroleum (bp: 40-60 °C).

#### IDENTIFICATION

- Relative density (see Tests).
- Saponification value (see Tests).
- Oleic acid (see Tests).

#### TESTS

**Relative density** (2.2.5): 0.860 to 0.870.

**Acid value** (2.5.1): maximum 1.0, determined on 10.0 g.

**Iodine value** (2.5.4, Method A): 55 to 70.

**Peroxide value** (2.5.5, Method A): maximum 10.0.

**Saponification value** (2.5.6): 130 to 140, determined on 2.0 g.

**Oleic acid** (2.4.22, Method A): minimum 60.0 per cent in the fatty acid fraction of the substance.

**Water** (2.5.12): maximum 1.0 per cent, determined on 1.00 g.

**Total ash** (2.4.16): maximum 0.1 per cent, determined on 2.0 g.

#### STORAGE

Protected from light.

#### 01/2008:1307 CHARACTERS

*Appearance*: white or almost white powder.

*Solubility*: freely soluble in water, slightly soluble in methanol, very slightly soluble in ethanol (96 per cent).

#### IDENTIFICATION

*First identification*: A, D.

*Second identification*: B, C, D.

A. Infrared absorption spectrophotometry (2.2.24).

*Preparation*: discs.

*Comparison*: *deferroxamine mesilate CRS*.

If the spectra obtained show differences, dissolve the substance to be examined and the reference substance separately in *ethanol (96 per cent) R*, evaporate to dryness and record new spectra using the residues.

B. Dissolve about 5 mg in 5 mL of *water R*. Add 2 mL of a 5 g/L solution of *trisodium phosphate dodecahydrate R* and 0.5 mL of a 25 g/L solution of *sodium naphthoquinonesulfonate R*. A brownish-black colour develops.

C. Solution A obtained in the Assay is brownish-red. To 10 mL of solution A add 3 mL of *ether R* and shake. The organic layer is colourless. To 10 mL of solution A add 3 mL of *benzyl alcohol R* and shake. The organic layer is brownish-red.

D. Dissolve 0.1 g in 5 mL of *dilute hydrochloric acid R*. Add 1 mL of *barium chloride solution R2*. The solution is clear. In a porcelain crucible, mix 0.1 g with 1 g of *anhydrous sodium carbonate R*, heat and ignite over a naked flame. Allow to cool. Dissolve the residue in 10 mL of *water R*, heating if necessary, and filter. The filtrate gives reaction (a) of sulfates (2.3.1).

#### TESTS

**Solution S**. Dissolve 2.5 g in *carbon dioxide-free water R* prepared from *distilled water R* and dilute to 25 mL with the same solvent.

**Appearance of solution**. Solution S is clear (2.2.1) and not more intensely coloured than reference solution  $Y_5$  (2.2.2, Method II).

**pH** (2.2.3): 3.7 to 5.5 for freshly prepared solution S.

**Related substances**. Liquid chromatography (2.2.29). Prepare the solutions immediately before use, protected from light.

*Test solution*. Dissolve 50.0 mg of the substance to be examined in the mobile phase and dilute to 50.0 mL with the mobile phase.

*Reference solution (a)*. Dissolve 10.0 mg of *deferroxamine mesilate CRS* in the mobile phase and dilute to 10.0 mL with the mobile phase.

*Reference solution (b)*. Dilute 1.0 mL of the test solution to 25.0 mL with the mobile phase.

*Column*:

- size:  $l = 0.25$  m,  $\varnothing = 4.6$  mm;
- stationary phase: octadecylsilyl silica gel for chromatography R (10  $\mu$ m).

*Mobile phase*: dissolve 1.32 g of *ammonium phosphate R* and 0.37 g of *sodium edetate R* in 950 mL of *water R*; adjust to pH 2.8 with *phosphoric acid R* (about 3-4 mL) and add 55 mL of *tetrahydrofuran R*.

*Flow rate*: 2 mL/min.

*Detection*: spectrophotometer at 220 nm.

*Injection*: 20  $\mu$ L.

*Run time*: 3 times the retention time of deferroxamine.

*System suitability*: reference solution (a):

- resolution: minimum 1.0 between the peak with a relative retention time of about 0.8 and the principal peak.

*Limits*:

- impurity A: not more than the area of the principal peak in the chromatogram obtained with reference solution (b) (4.0 per cent);

#### 01/2008:0896

## DEFEROXAMINE MESILATE

### Deferoxamini mesilas

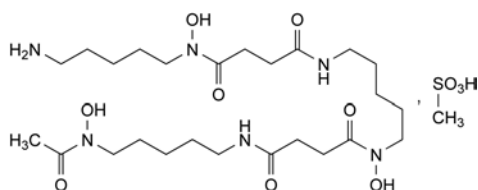

$C_{26}H_{52}N_6O_{11}S$   
[138-14-7]

$M_r$  657

#### DEFINITION

*N'*-[5-[[4-[[5-(Acetylhydroxyamino)pentyl]amino]-4-oxobutanoyl]hydroxyamino]pentyl]-*N*-(5-aminopentyl)-*N*-hydroxybutanediamide methanesulfonate.

*Content*: 98.0 per cent to 102.0 per cent (anhydrous substance).

#### PRODUCTION

The production method must be evaluated to determine the potential for formation of alkyl mesilates, which is particularly likely to occur if the reaction medium contains lower alcohols. Where necessary, the production method is validated to demonstrate that alkyl mesilates are not detectable in the final product.

01/2008:2169

- *total*: not more than 1.75 times the area of the principal peak in the chromatogram obtained with reference solution (b) (7.0 per cent);
- *disregard limit*: 0.02 times the area of the principal peak in the chromatogram obtained with reference solution (b) (0.08 per cent).

**Chlorides** (2.4.4): maximum 330 ppm.

Dilute 2 mL of solution S to 20 mL with *water R*.

**Sulfates** (2.4.13): maximum 400 ppm.

Dilute 5 mL of solution S to 20 mL with *distilled water R*.

**Heavy metals** (2.4.8): maximum 10 ppm.

2.0 g complies with test C. Prepare the reference solution using 2 mL of *lead standard solution (10 ppm Pb) R*.

**Water** (2.5.12): maximum 2.0 per cent, determined on 1.000 g.

**Sulfated ash** (2.4.14): maximum 0.1 per cent, determined on 1.0 g.

**Bacterial endotoxins** (2.6.14): less than 0.025 IU/mg, if intended for use in the manufacture of parenteral preparations without a further appropriate procedure for the removal of bacterial endotoxins.

#### ASSAY

Dissolve 0.500 g in 25 mL of *water R*. Add 4 mL of 0.05 M *sulfuric acid*. Titrate with 0.1 M *ferric ammonium sulfate*. Towards the end of the titration, titrate uniformly and at a rate of about 0.2 mL/min. Determine the end-point potentiometrically (2.2.20) using a platinum indicator electrode and a calomel reference electrode. Retain the titrated solution (solution A) for identification test C.

1 mL of 0.1 M *ferric ammonium sulfate* is equivalent to 65.68 mg of  $C_{13}H_{18}Br_2ClNO_2 \cdot H_2O$ .

#### STORAGE

Protected from light, at a temperature of 2 °C to 8 °C. If the substance is sterile, store in a sterile, airtight, tamper-proof container.

#### IMPURITIES

*Specified impurities: A.*

*Other detectable impurities* (the following substances would, if present at a sufficient level, be detected by one or other of the tests in the monograph. They are limited by the general acceptance criterion for other/unspecified impurities and/or by the general monograph *Substances for pharmaceutical use (2034)*. It is therefore not necessary to identify these impurities for demonstration of compliance. See also 5.10. *Control of impurities in substances for pharmaceutical use*): B.

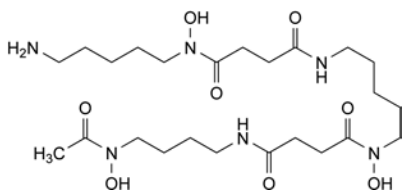

A. *N*'-[5-[[4-[[4-(acetylhydroxyamino)butyl]amino]-4-oxobutanoyl]hydroxyamino]pentyl]-*N*-(5-aminopentyl)-*N*-hydroxybutanediamide (desferrioxamine A<sub>1</sub>),

B. other desferrioxamines.

## DEMBREXINE HYDROCHLORIDE MONOHYDRATE FOR VETERINARY USE

Dembrexini hydrochloridum monohydricum ad usum veterinarium

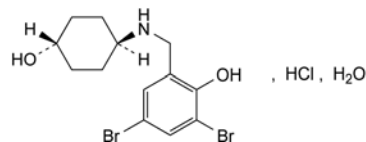

$C_{13}H_{18}Br_2ClNO_2 \cdot H_2O$   
[52702-51-9]

$M_r$  433.6

#### DEFINITION

*trans*-4-[(3,5-Dibromo-2-hydroxybenzyl)amino]cyclohexanol hydrochloride monohydrate.

*Content*: 98.0 per cent to 101.0 per cent (anhydrous substance).

#### CHARACTERS

*Appearance*: white or almost white, crystalline powder.

*Solubility*: slightly soluble in water, freely soluble in methanol, slightly soluble in anhydrous ethanol.

#### IDENTIFICATION

A. Infrared absorption spectrophotometry (2.2.24).

*Comparison*: dembrexine hydrochloride monohydrate CRS.

B. It gives reaction (a) of chlorides (2.3.1).

#### TESTS

**Related substances.** Liquid chromatography (2.2.29). Prepare the solutions immediately before use.

*Test solution.* Dissolve 25.0 mg of the substance to be examined in *methanol R* and dilute to 10.0 mL with the same solvent.

*Reference solution (a).* Dilute 1.0 mL of the test solution to 50.0 mL with *methanol R*. Dilute 1.0 mL of this solution to 10.0 mL with *methanol R*.

*Reference solution (b).* Dissolve 2.5 mg of *tribromophenol R* (impurity E) in *methanol R* and dilute to 50.0 mL with the same solvent. To 1.0 mL of this solution add 1.0 mL of the test solution and dilute to 10.0 mL with *methanol R*.

*Blank solution.* *Methanol R*.

*Column*:

- *size*:  $l = 0.15$  m,  $\varnothing = 4.0$  mm;
- *stationary phase*: end-capped octadecylsilyl silica gel for chromatography R (5  $\mu$ m);
- *temperature*: 40 °C.

*Mobile phase*:

- *mobile phase A*: dissolve 1.0 g of *potassium dihydrogen phosphate R* in 900 mL of *water R*, adjust to pH 7.4 with 0.5 M *potassium hydroxide* and dilute to 1000 mL with *water R*; mix 80 volumes of this solution with 20 volumes of *methanol R*;
- *mobile phase B*: *methanol R*, *acetonitrile R* (20:80 V/V);

Time (min)	Mobile phase A (per cent V/V)	Mobile phase B (per cent V/V)
0 - 7	75	25
7 - 15	75 → 50	25 → 50
15 - 20	50	50
20 - 25	50 → 75	50 → 25
25 - 30	75	25

*Flow rate*: 1.0 mL/min.

*Detection*: spectrophotometer at 250 nm.

*Injection*: 10 µL.

*Relative retention* with reference to dembrexine (retention time = about 6 min): impurity A = about 2.3; impurity B = about 1.3.

*System suitability*: reference solution (b):

- *resolution*: minimum 2 between the peaks due to dembrexine and impurity E.

*Limits*:

- *impurities A, B*: for each impurity, not more than the area of the principal peak in the chromatogram obtained with reference solution (a) (0.2 per cent);
- *unspecified impurities*: for each impurity, not more than the area of the principal peak in the chromatogram obtained with reference solution (a) (0.2 per cent);
- *total*: not more than 2.5 times the area of the principal peak in the chromatogram obtained with reference solution (a) (0.5 per cent);
- *disregard limit*: 0.5 times the area of the principal peak in the chromatogram obtained with reference solution (a) (0.1 per cent); disregard any peak due to the blank.

**Water** (2.5.12): 3.5 per cent to 5.0 per cent, determined on 0.500 g.

**Sulfated ash** (2.4.14): maximum 0.1 per cent, determined on 1.0 g.

#### ASSAY

Dissolve 0.350 g in 40 mL of *methanol R*. Add 40 mL of *acetone R* and 1 mL of 0.1 M *hydrochloric acid*. Carry out a potentiometric titration (2.2.20) using 0.1 M *sodium hydroxide*. Read the volume added between the 2 points of inflexion.

1 mL of 0.1 M *sodium hydroxide* is equivalent to 41.56 mg of C<sub>21</sub>H<sub>22</sub>Cl<sub>2</sub>N<sub>2</sub>O<sub>8</sub>.

#### IMPURITIES

*Specified impurities*: A, B.

*Other detectable impurities* (the following substances would, if present at a sufficient level, be detected by one or other of the tests in the monograph. They are limited by the general acceptance criterion for other/unspecified impurities and/or by the general monograph *Substances for pharmaceutical use* (2034). It is therefore not necessary to identify these impurities for demonstration of compliance. See also 5.10. *Control of impurities in substances for pharmaceutical use*): C, D, E.

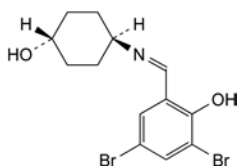

A. *trans*-4-[(3,5-dibromo-2-hydroxybenzylidene)amino]cyclohexanol,

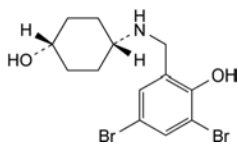

B. *cis*-4-[(3,5-dibromo-2-hydroxybenzyl)amino]cyclohexanol,

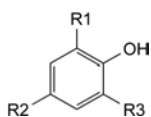

C. R1 = CHO, R2 = R3 = Br: 3,5-dibromo-2-hydroxybenzaldehyde,

D. R1 = CHO, R2 = R3 = H: 2-hydroxybenzaldehyde (salicylaldehyde),

E. R1 = R2 = R3 = Br: 2,4,6-tribromophenol.

01/2008:0176

## DEMECLOCYCLINE HYDROCHLORIDE

### Demeclocyclini hydrochloridum

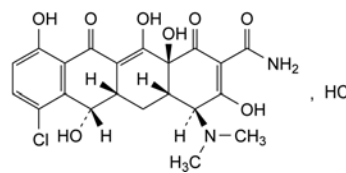

C<sub>21</sub>H<sub>22</sub>Cl<sub>2</sub>N<sub>2</sub>O<sub>8</sub>  
[64-73-3]

*M<sub>r</sub>* 501.3

#### DEFINITION

(4*S*,4*aS*,5*aS*,6*S*,12*aS*)-7-Chloro-4-(dimethylamino)-3,6,10,12,12*a*-pentahydroxy-1,11-dioxo-1,4,4*a*,5,5*a*,6,11,12*a*-octahydrotetracene-2-carboxamide hydrochloride.

Substance produced by certain strains of *Streptomyces aureofaciens* or obtained by any other means.

*Content*: 89.5 per cent to 102.0 per cent (anhydrous substance).

#### CHARACTERS

*Appearance*: yellow powder.

*Solubility*: soluble or sparingly soluble in water, slightly soluble in alcohol, very slightly soluble in acetone. It dissolves in solutions of alkali hydroxides and carbonates.

#### IDENTIFICATION

A. Thin-layer chromatography (2.2.27).

*Test solution*. Dissolve 5 mg of the substance to be examined in *methanol R* and dilute to 10 mL with the same solvent.

*Reference solution (a)*. Dissolve 5 mg of *demeclocycline hydrochloride CRS* in *methanol R* and dilute to 10 mL with the same solvent.

*Reference solution (b)*. Dissolve 5 mg of *demeclocycline hydrochloride CRS*, 5 mg of *chlortetracycline hydrochloride R* and 5 mg of *tetracycline hydrochloride R* in *methanol R* and dilute to 10 mL with the same solvent.

*Plate*: TLC octadecylsilyl silica gel F<sub>254</sub> plate R.

*Mobile phase*: mix 20 volumes of *acetonitrile R*, 20 volumes of *methanol R* and 60 volumes of a 63 g/L solution of *oxalic acid R* previously adjusted to pH 2 with *concentrated ammonia R*.

*Application*: 1 µL.

*Development*: over 3/4 of the plate.

*Drying*: in air.

*Detection*: examine in ultraviolet light at 254 nm.

*System suitability*: the chromatogram obtained with reference solution (b) shows 3 clearly separated spots.

*Results*: the principal spot in the chromatogram obtained with the test solution is similar in position and size to the principal spot in the chromatogram obtained with reference solution (a).

B. To about 2 mg add 5 mL of *sulfuric acid R*. A violet colour develops. Add the solution to 2.5 mL of *water R*. The colour becomes yellow.

C. It gives reaction (a) of chlorides (2.3.1).

#### TESTS

**pH** (2.2.3): 2.0 to 3.0.

Dissolve 0.1 g in *carbon dioxide-free water R* and dilute to 10 mL with the same solvent.

**Specific optical rotation** (2.2.7): –248 to –263 (anhydrous substance).

Dissolve 0.250 g in 0.1 M *hydrochloric acid* and dilute to 25.0 mL with the same acid.

**Specific absorbance (2.2.25):** 340 to 370 determined at the maximum at 385 nm (anhydrous substance).

Dissolve 10.0 mg in 0.01 M hydrochloric acid and dilute to 100.0 mL with the same acid. To 10.0 mL of the solution add 12 mL of dilute sodium hydroxide solution R and dilute to 100.0 mL with water R.

**Related substances.** Liquid chromatography (2.2.29). Prepare the solutions immediately before use.

**Test solution.** Dissolve 25.0 mg of the substance to be examined in 0.01 M hydrochloric acid and dilute to 25.0 mL with the same acid.

**Reference solution (a).** Dissolve 25.0 mg of demeclocycline hydrochloride CRS in 0.01 M hydrochloric acid and dilute to 25.0 mL with the same acid.

**Reference solution (b).** Dissolve 5.0 mg of 4-epidemeclocycline hydrochloride CRS in 0.01 M hydrochloric acid and dilute to 25.0 mL with the same acid.

**Reference solution (c).** Mix 1.0 mL of reference solution (a) and 5.0 mL of reference solution (b) and dilute to 25.0 mL with 0.01 M hydrochloric acid.

**Reference solution (d).** Dilute 5.0 mL of reference solution (a) to 100.0 mL with 0.01 M hydrochloric acid.

**Column:**

- size:  $l = 0.25$  m,  $\varnothing = 4.6$  mm,
- stationary phase: styrene-divinylbenzene copolymer R (8  $\mu$ m),
- temperature: 60 °C,

**Mobile phase:** weigh 80.0 g of 2-methyl-2-propanol R and transfer to a 1000 mL volumetric flask with the aid of 200 mL of water R; add 100 mL of a 35 g/L solution of dipotassium hydrogen phosphate R adjusted to pH 9.0 with dilute phosphoric acid R, 150 mL of a 10 g/L solution of tetrabutylammonium hydrogen sulfate R adjusted to pH 9.0 with dilute sodium hydroxide solution R and 10 mL of a 40 g/L solution of sodium edetate R adjusted to pH 9.0 with dilute sodium hydroxide solution R; dilute to 1000 mL with water R.

**Flow rate:** 1 mL/min.

**Detection:** spectrophotometer at 254 nm.

**Injection:** 20  $\mu$ L; inject the test solution and reference solutions (c) and (d).

**System suitability:** reference solution (c):

- resolution: minimum of 2.8 between the peaks due to impurity B (1<sup>st</sup> peak) and demeclocycline (2<sup>nd</sup> peak); if necessary, adjust the 2-methyl-2-propanol content of the mobile phase or lower the pH of the mobile phase,
- symmetry factor: maximum 1.25 for the peak due to demeclocycline.

**Limits:**

- any impurity: not more than the area of the principal peak in the chromatogram obtained with reference solution (d) (5.0 per cent), and not more than 1 such peak has an area greater than 0.8 times the area of the principal peak in the chromatogram obtained with reference solution (d) (4.0 per cent),
- total: not more than twice the area of the principal peak in the chromatogram obtained with reference solution (d) (10.0 per cent),
- disregard limit: 0.02 times the area of the principal peak in the chromatogram obtained with reference solution (d) (0.1 per cent).

**Heavy metals (2.4.8):** maximum 50 ppm.

0.5 g complies with limit test C. Prepare the standard using 2.5 mL of lead standard solution (10 ppm Pb) R.

**Water (2.5.12):** maximum 3.0 per cent, determined on 1.000 g.

**Sulfated ash (2.4.14):** maximum 0.5 per cent, determined on 1.0 g.

#### ASSAY

Liquid chromatography (2.2.29) as described in the test for related substances with the following modification.

**Injection:** test solution and reference solution (a). Calculate the percentage content of  $C_{21}H_{22}Cl_2N_2O_8$ .

#### STORAGE

Protected from light.

#### IMPURITIES

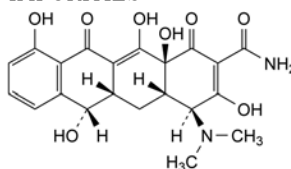

A. (4S,4aS,5aS,6S,12aS)-4-(dimethylamino)-3,6,10,12,12a-pentahydroxy-1,11-dioxo-1,4,4a,5,5a,6,11,12a-octahydrotetracycline-2-carboxamide (demethyltetracycline),

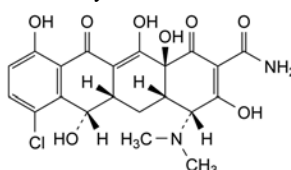

B. (4R,4aS,5aS,6S,12aS)-7-chloro-4-(dimethylamino)-3,6,10,12,12a-pentahydroxy-1,11-dioxo-1,4,4a,5,5a,6,11,12a-octahydrotetracycline-2-carboxamide (4-epidemeclocycline).

01/2008:1308  
corrected 6.0

## DEPTROPINE CITRATE

### Deptropini citras

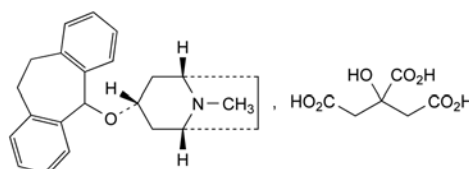

$C_{29}H_{35}NO_8$   
[2169-75-7]

$M_r$  525.6

#### DEFINITION

Deptropine citrate contains not less than 98.0 per cent and not more than the equivalent of 101.0 per cent of (1R,3r,5S)-3-(10,11-dihydro-5H-dibenzo[a,d][7]annulen-5-yloxy)-8-methyl-8-azabicyclo[3.2.1]octane dihydrogen citrate, calculated with reference to the dried substance.

#### CHARACTERS

A white or almost white, microcrystalline powder, very slightly soluble in water and in ethanol, practically insoluble in methylene chloride.

It melts at about 170 °C, with decomposition.

#### IDENTIFICATION

**First identification:** A.

**Second identification:** B, C, D, E.

A. Examine by infrared absorption spectrophotometry (2.2.24), comparing with the spectrum obtained with deptropine citrate CRS.

B. Examine the chromatograms obtained in the test for related substances. The principal spot in the chromatogram obtained with test solution (b) is similar in position, colour and size to the principal spot in the chromatogram obtained with reference solution (b).

- C. To about 1 mg add 0.5 mL of *sulfuric acid R*. A stable red-orange colour develops.
- D. Dissolve about 1 mg in 0.25 mL of *perchloric acid R* and warm gently until the solution becomes turbid. Add 5 mL of *glacial acetic acid R*; a pink colour with an intense green fluorescence appears.
- E. To about 5 mg add 1 mL of *acetic anhydride R* and 5 mL of *pyridine R*. A purple colour develops.

## TESTS

**pH (2.2.3).** Suspend 0.25 g in *carbon dioxide-free water R*, dilute to 25 mL with the same solvent and filter. The pH of the solution is 3.7 to 4.5.

**Related substances.** Examine by thin-layer chromatography (2.2.27), using as the coating substance a suitable silica gel with a fluorescent indicator having an optimal intensity at 254 nm.

**Test solution (a).** Dissolve 0.10 g of the substance to be examined in *methanol R* and dilute to 10 mL with the same solvent.

**Test solution (b).** Dilute 1 mL of test solution (a) to 10 mL with *methanol R*.

**Reference solution (a).** Dilute 1.0 mL of test solution (a) to 100.0 mL with *methanol R*.

**Reference solution (b).** Dissolve 20 mg of *depropine citrate CRS* in *methanol R* and dilute to 2 mL with the same solvent. Dilute 1 mL of the solution to 10 mL with *methanol R*.

**Reference solution (c).** Dissolve 5 mg of *tropine CRS* in *methanol R* and dilute to 100.0 mL with the same solvent.

**Reference solution (d).** Dissolve 10 mg of *depropine citrate CRS* and 10 mg of *tropine CRS* in *methanol R* and dilute to 25 mL with the same solvent.

Apply to the plate 40 µL of each solution. Develop over a path of 10 cm using a mixture of 8 volumes of *concentrated ammonia R* and 92 volumes of *butanol R*. Dry the plate at 100 °C to 105 °C until the ammonia has completely evaporated. Examine in ultraviolet light at 254 nm. Any spot in the chromatogram obtained with test solution (a), apart from the principal spot, is not more intense than the spot in the chromatogram obtained with reference solution (a) (1 per cent). Spray with *dilute potassium iodobismuthate solution R* and then with a 10 g/L solution of *sodium nitrite R*. Expose the plate to iodine vapours. Examine in daylight and in ultraviolet light at 254 nm. In the chromatogram obtained with test solution (a): any spot corresponding to tropine is not more intense than the spot in the chromatogram obtained with reference solution (c) (0.5 per cent); any spot, apart from the principal spot and any spot corresponding to tropine, is not more intense than the spot in the chromatogram obtained with reference solution (a) (1 per cent). The test is not valid unless the chromatogram obtained with reference solution (d) shows two clearly separated spots.

**Heavy metals (2.4.8).** 1.0 g complies with limit test C for heavy metals (20 ppm). Prepare the standard using 2 mL of *lead standard solution (10 ppm Pb) R*.

**Loss on drying (2.2.32).** Not more than 2.0 per cent, determined on 1.000 g by drying in an oven at 105 °C for 4 h.

**Sulfated ash (2.4.14).** Not more than 0.1 per cent, determined on 1.0 g.

## ASSAY

Dissolve 0.400 g in 50 mL of *anhydrous acetic acid R*. Titrate with 0.1 M *perchloric acid*, determining the end-point potentiometrically (2.2.20).

1 mL of 0.1 M *perchloric acid* is equivalent to 52.56 mg of  $C_{30}H_{40}NO_8$ .

## STORAGE

Store protected from light.

## IMPURITIES

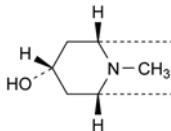

- A. (1*R*,3*r*,5*S*)-8-methyl-8-azabicyclo[3.2.1]octan-3-ol (tropine),

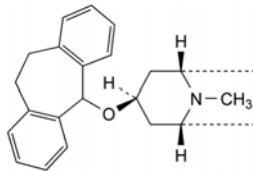

- B. (1*R*,3*s*,5*S*)-3-(10,11-dihydro-5*H*-dibenzo[*a,d*][7]annulen-5-yloxy)-8-methyl-8-azabicyclo[3.2.1]octane (pseudodeptropine),

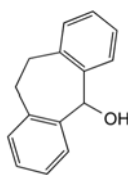

- C. 10,11-dihydro-5*H*-dibenzo[*a,d*][7]annulen-5-ol (dibenzocycloheptadienol),

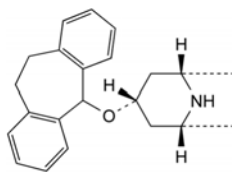

- D. (1*R*,3*r*,5*S*)-3-(10,11-dihydro-5*H*-dibenzo[*a,d*][7]annulen-5-yloxy)-8-azabicyclo[3.2.1]octane (demethyldepropine).

01/2008:1413  
corrected 6.0

## DEQUALINIUM CHLORIDE

## Dequalinii chloridum

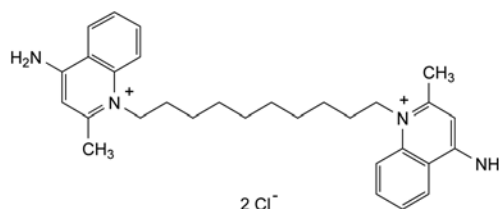

$C_{30}H_{40}Cl_2N_4$   
[522-51-0]

$M_r$  527.6

## DEFINITION

1,1'-(decane-1,10-diyl)bis(4-amino-2-methylquinolinium) dichloride (dried substance).

**Content:** 95.0 per cent to 101.0 per cent.

## CHARACTERS

**Appearance:** white or yellowish-white powder, hygroscopic.

**Solubility:** slightly soluble in water and in ethanol (96 per cent).



## IDENTIFICATION

First identification: B, E.

Second identification: A, C, D, E.

## A. Ultraviolet and visible absorption spectrophotometry (2.2.25).

**Test solution.** Dissolve about 10 mg in *water R* and dilute to 100 mL with the same solvent. Dilute 10 mL of the solution to 100 mL with *water R*.

**Spectral range:** 230-350 nm.

**Absorption maxima:** at 240 nm and 326 nm.

**Shoulder:** at 336 nm.

**Absorbance ratios:**

$$- A_{240}/A_{326} = 1.56 \text{ to } 1.80;$$

$$- A_{326}/A_{336} = 1.12 \text{ to } 1.30.$$

## B. Infrared absorption spectrophotometry (2.2.24).

**Spectral range:** 600-2000  $\text{cm}^{-1}$ .

**Comparison:** *dequalinium chloride CRS*.

C. To 5 mL of solution S (see Tests) add 5 mL of *potassium ferricyanide solution R*. A yellow precipitate is formed.D. To 10 mL of solution S add 1 mL of *dilute nitric acid R*. A white precipitate is formed. Filter and reserve the filtrate for identification test E.

## E. The filtrate from identification test D gives reaction (a) of chlorides (2.3.1).

## TESTS

**Solution S.** Dissolve 0.2 g in 90 mL of *carbon dioxide-free water R*, heating if necessary, and dilute to 100 mL with the same solvent.

**Appearance of solution.** Solution S is clear (2.2.1) and colourless (2.2.2, *Method II*).

**Acidity or alkalinity.** To 5 mL of solution S add 0.1 mL of *bromothymol blue solution RI*. Not more than 0.2 mL of 0.01 M *hydrochloric acid* or 0.01 M *sodium hydroxide* is required to change the colour of the indicator.

**Related substances.** Liquid chromatography (2.2.29).

**Test solution.** Dissolve 10.0 mg of the substance to be examined in the mobile phase and dilute to 10.0 mL with the mobile phase.

**Reference solution (a).** Dissolve 10.0 mg of *dequalinium chloride for performance test CRS* in the mobile phase and dilute to 10.0 mL with the mobile phase.

**Reference solution (b).** Dissolve 10.0 mg of *dequalinium chloride CRS* in the mobile phase and dilute to 10.0 mL with the mobile phase. Dilute 1.0 mL of the solution to 50.0 mL with the mobile phase.

**Column:**

– size:  $l = 0.25 \text{ m}$ ,  $\varnothing = 4.6 \text{ mm}$ ;

– stationary phase: *end-capped octadecylsilyl silica gel for chromatography R*.

**Mobile phase:** dissolve 2 g of *sodium hexanesulfonate R* in 300 mL of *water R*; adjust to pH 4.0 with *acetic acid R* and add 700 mL of *methanol R*.

**Flow rate:** 1.5 mL/min.

**Detection:** spectrophotometer at 240 nm.

**Injection:** 10  $\mu\text{L}$ .

**Run time:** 5 times the retention time of *dequalinium chloride*.

**System suitability:** reference solution (a):

– **peak-to-valley ratio:** minimum 2.0, where  $H_p$  = height above the baseline of the peak due to impurity B and  $H_v$  = height above the baseline of the lowest point of the curve separating this peak from the peak due to *dequalinium chloride*. If necessary, adjust the concentration of *methanol* in the mobile phase.

## Limits:

- **impurity A:** not more than 0.5 times the area of the principal peak in the chromatogram obtained with reference solution (b) (1 per cent);
- **total of impurities other than A:** not more than 5 times the area of the principal peak in the chromatogram obtained with reference solution (b) (10 per cent);
- **disregard limit:** 0.025 times the area of the principal peak in the chromatogram obtained with reference solution (b) (0.05 per cent).

**Readily carbonisable substances.** Dissolve 20 mg in 2 mL of *sulfuric acid R*. After 5 min the solution is not more intensely coloured than reference solution BY<sub>4</sub> (2.2.2, *Method I*).

**Loss on drying** (2.2.32): maximum 7.0 per cent, determined on 1.000 g by drying at 105 °C at a pressure not exceeding 0.7 kPa.

**Sulfated ash** (2.4.14): maximum 0.1 per cent, determined on 1.0 g.

## ASSAY

*In order to avoid overheating in the reaction medium, mix thoroughly throughout and stop the titration immediately after the end-point has been reached.*

Dissolve 0.200 g in 5 mL of *anhydrous formic acid R* and add 50 mL of *acetic anhydride R*. Titrate with 0.1 M *perchloric acid*, determining the end-point potentiometrically (2.2.20).

1 mL of 0.1 M *perchloric acid* is equivalent to 26.38 mg of  $\text{C}_{30}\text{H}_{40}\text{Cl}_2\text{N}_4$ .

## STORAGE

In an airtight container.

## IMPURITIES

**Specified impurities:** A.

**Other detectable impurities** (the following substances would, if present at a sufficient level, be detected by one or other of the tests in the monograph. They are limited by the general acceptance criterion for other/unspecified impurities and/or by the general monograph *Substances for pharmaceutical use* (2034). It is therefore not necessary to identify these impurities for demonstration of compliance. See also 5.10. *Control of impurities in substances for pharmaceutical use*): B, C.

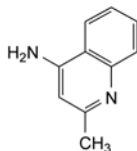

A. 2-methylquinolin-4-amine,

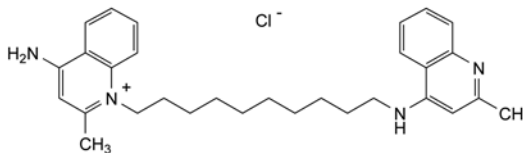

B. 4-amino-1-[10-[(2-methylquinolin-4-yl)amino]decyl]-2-methylquinolinium chloride,

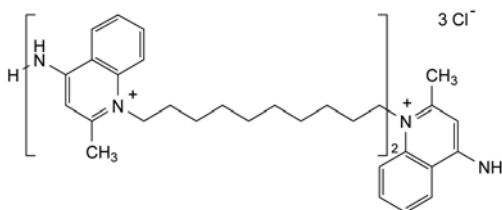

C. 1-[10-(4-amino-2-methylquinolinio)decyl]-4-[[10-(4-amino-2-methylquinolinio)decyl]amino]-2-methylquinolinium trichloride.

04/2008:1666 *Detection*: flame ionisation.  
corrected 7.0 *Injection*: 2.0 µL.

## DESFLURANE

### Desfluranum

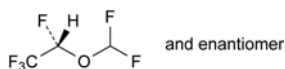

C<sub>3</sub>H<sub>2</sub>F<sub>6</sub>O  
[57041-67-5]

*M<sub>r</sub>* 168.0

#### DEFINITION

(2*RS*)-2-(Difluoromethoxy)-1,1,1,2-tetrafluoroethane.

#### CHARACTERS

*Appearance*: clear, colourless, mobile, heavy liquid.

*Solubility*: practically insoluble in water, miscible with anhydrous ethanol.

*Relative density*: 1.47, determined at 15 °C.

bp: about 22 °C.

#### IDENTIFICATION

Infrared absorption spectrophotometry (2.2.24).

*Preparation*: examine the substance in the gaseous state.

*Comparison*: *Ph. Eur. reference spectrum of desflurane*.

#### TESTS

*The substance to be examined must be cooled to a temperature below 10 °C and the tests must be carried out at a temperature below 20 °C.*

**Acidity or alkalinity.** To 20 mL add 20 mL of carbon dioxide-free water *R*, shake for 3 min and allow to stand. Collect the upper layer and add 0.2 mL of bromocresol purple solution *R*. Not more than 0.1 mL of 0.01 *M* sodium hydroxide or 0.6 mL of 0.01 *M* hydrochloric acid is required to change the colour of the indicator.

**Related substances.** Gas chromatography (2.2.28).

*Test solution.* The substance to be examined.

*Reference solution (a).* Introduce 25 mL of the substance to be examined into a 50 mL flask fitted with a septum, and add 0.50 mL of desflurane impurity A *CRS* and 1.0 mL of isoflurane *CRS* (impurity B). Add 50 µL of acetone *R* (impurity H), 10 µL of chloroform *R* (impurity F) and 50 µL of methylene chloride *R* (impurity E) to the solution, using an airtight syringe, and dilute to 50.0 mL with the substance to be examined. Dilute 5.0 mL of this solution to 50.0 mL with the substance to be examined. Store at a temperature below 10 °C.

*Reference solution (b).* Dilute 5.0 mL of reference solution (a) to 50.0 mL with the substance to be examined. Store at a temperature below 10 °C.

*Reference solution (c).* Dilute 5.0 mL of reference solution (b) to 25.0 mL with the substance to be examined. Store at a temperature below 10 °C.

*Column*:

- *material*: fused silica;
- *size*: *l* = 105 m, Ø = 0.32 mm;
- *stationary phase*: poly[methyl(trifluoropropylmethyl)siloxane] *R* (film thickness 1.5 µm).

*Carrier gas*: helium for chromatography *R*.

*Flow rate*: 2.0 mL/min.

*Split ratio*: 1:25.

*Temperature*:

- *column*: 30 °C;
- *injection port*: 150 °C;
- *detector*: 200 °C.

*Detection*: flame ionisation.

*Injection*: 2.0 µL.

*Run time*: 35 min.

*Relative retention* with reference to desflurane (retention time = about 11.5 min): impurity C = about 1.06; impurity D = about 1.09; impurity A = about 1.14; impurity G = about 1.39; impurity E = about 1.5; impurity B = about 1.7; impurity F = about 2.2; impurity H = about 2.6.

*System suitability*: reference solution (a):

- *number of theoretical plates*: minimum 20 000, calculated for the peak due to impurity A;
- *symmetry factor*: maximum 2.0 for the peak due to impurity B.

*Limits*:

- *impurity B*: not more than the difference between the area of the corresponding peak in the chromatogram obtained with reference solution (a) and the area of the corresponding peak in the chromatogram obtained with the test solution (0.2 per cent *V/V*);
- *impurity A*: not more than the difference between the area of the corresponding peak in the chromatogram obtained with reference solution (a) and the area of the corresponding peak in the chromatogram obtained with the test solution (0.1 per cent *V/V*);
- *impurities C, D, G*: for each impurity, not more than the difference between the area of the peak due to impurity A in the chromatogram obtained with reference solution (b) and the area of the peak due to impurity A in the chromatogram obtained with the test solution (0.01 per cent *V/V*);
- *impurities E, H*: for each impurity, not more than the difference between the area of the corresponding peak in the chromatogram obtained with reference solution (a) and the area of the corresponding peak in the chromatogram obtained with the test solution (0.01 per cent *V/V*);
- *impurity F*: not more than the difference between the area of the corresponding peak in the chromatogram obtained with reference solution (a) and the area of the corresponding peak in the chromatogram obtained with the test solution (0.002 per cent *V/V*);
- *unspecified impurities*: for each impurity, not more than 0.5 times the difference between the area of the peak due to impurity A in the chromatogram obtained with reference solution (b) and the area of the peak due to impurity A in the chromatogram obtained with the test solution (0.005 per cent *V/V*);
- *sum of impurities other than A, B, C, D, E, F, G and H*: not more than the difference between the area of the peak due to impurity A in the chromatogram obtained with reference solution (b) and the area of the peak due to impurity A in the chromatogram obtained with the test solution (0.01 per cent *V/V*);
- *disregard limit*: the difference between the area of the peak due to impurity A in the chromatogram obtained with reference solution (c) and the area of the peak due to impurity A in the chromatogram obtained with the test solution (0.002 per cent *V/V*).

**Fluorides**: maximum 10 ppm.

Potentiometry (2.2.36, Method I).

*Test solution.* To 10.0 mL in a separating funnel, add 10 mL of a mixture of 30.0 mL of dilute ammonia *R2* and 70.0 mL of distilled water *R*. Shake for 1 min and collect the upper layer. Repeat this extraction procedure twice, collecting the upper layer each time. Adjust the combined upper layers to pH 5.2 with dilute hydrochloric acid *R*. Add 5.0 mL of fluoride standard solution (1 ppm F) *R* and dilute to 50.0 mL with distilled water *R*. To 20.0 mL of this solution add 20.0 mL of total-ionic-strength-adjustment buffer *R* and dilute to 50.0 mL with distilled water *R*.

01/2008:0481  
corrected 6.0

**Reference solutions.** To each of 1.0 mL, 2.0 mL, 3.0 mL, 4.0 mL and 5.0 mL of *fluoride standard solution (10 ppm F) R* add 20.0 mL of *total-ionic-strength-adjustment buffer R* and dilute to 50.0 mL with *distilled water R*.

**Indicator electrode:** fluoride selective.

**Reference electrode:** silver-silver chloride.

Carry out the measurements on 20 mL of each solution. Calculate the concentration of fluorides using the calibration curve, taking into account the addition of fluoride to the test solution.

**Antimony:** maximum 3 ppm.

Atomic absorption spectrometry (2.2.23, *Method I*).

**Solvent mixture:** hydrochloric acid R, nitric acid R (50:50 V/V).

**Test solution.** Transfer 10 g, cooled to below 10 °C, to a tared flask containing 20 mL of *water R* cooled to below 5 °C. Add 1 mL of the solvent mixture and leave at room temperature until the desflurane has evaporated completely. Subsequently, reduce the volume to about 8 mL on a hot plate. Cool to room temperature and transfer to a volumetric flask. Add 1 mL of the solvent mixture and adjust to 10.0 mL with *water R*.

**Reference solutions.** To each of 1.0 mL, 2.0 mL, 3.0 mL, 4.0 mL and 5.0 mL of *antimony standard solution (100 ppm Sb) R* add 20 mL of the solvent mixture and dilute to 100.0 mL with *water R*.

**Source:** antimony hollow-cathode lamp using a transmission band of 0.2 nm and a 75 per cent lamp current.

**Wavelength:** 217.6 nm.

**Atomisation device:** air-acetylene flame.

**Non-volatile matter:** maximum 100 mg/L.

Evaporate 20.0 mL to dryness with the aid of a stream of *nitrogen R*. The residue weighs not more than 2.0 mg.

#### STORAGE

In a glass bottle fitted with a polyethylene-lined cap. Before opening the bottle, cool the contents to below 10 °C.

#### IMPURITIES

**Specified impurities:** A, B, C, D, E, F, G, H.

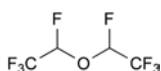

A. 1,1'-oxybis(1,2,2,2-tetrafluoroethane),

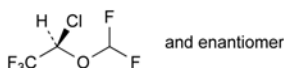

B. (2*RS*)-2-chloro-2-(difluoromethoxy)-1,1,1-trifluoroethane (isofluorane),



C. R = H, R' = F: dichlorofluoromethane,

D. R = Cl, R' = F: trichlorofluoromethane,

E. R = R' = H: dichloromethane (methylene chloride),

F. R = H, R' = Cl: trichloromethane (chloroform),

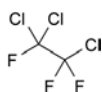

G. 1,1,2-trichloro-1,2,2-trifluoroethane,

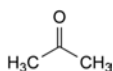

H. propanone (acetone).

## DESIPRAMINE HYDROCHLORIDE

### Desipramini hydrochloridum

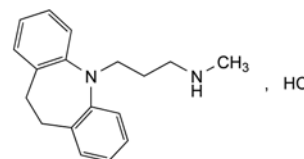

C<sub>18</sub>H<sub>23</sub>ClN<sub>2</sub>  
[58-28-6]

M<sub>r</sub> 302.8

#### DEFINITION

Desipramine hydrochloride contains not less than 99.0 per cent and not more than the equivalent of 101.0 per cent of 3-(10, 11-dihydro-5*H*-dibenzo[*b,f*]azepin-5-yl)-*N*-methylpropan-1-amine hydrochloride, calculated with reference to the dried substance.

#### CHARACTERS

A white or almost white, crystalline powder, soluble in water and in alcohol.

It melts at about 214 °C.

#### IDENTIFICATION

**First identification:** B, E.

**Second identification:** A, C, D, E.

- A. Dissolve 40.0 mg in 0.01 *M* hydrochloric acid and dilute to 100.0 mL with the same acid. Dilute 5.0 mL of the solution to 100.0 mL with 0.01 *M* hydrochloric acid. Examined between 230 nm and 350 nm (2.2.25), the solution shows an absorption maximum at 251 nm and a shoulder at 270 nm. The specific absorbance at the maximum is 255 to 285.
- B. Examine by infrared absorption spectrophotometry (2.2.24), comparing with the spectrum obtained with *desipramine hydrochloride CRS*.
- C. Examine the chromatograms obtained in the test for related substances. The principal spot in the chromatogram obtained with test solution (b) is similar in position, colour and size to the principal spot in the chromatogram obtained with reference solution (a).
- D. Dissolve about 50 mg in 3 mL of *water R* and add 0.05 mL of a 25 g/L solution of *quinhydrone R* in *methanol R*. An intense pink colour develops within about 15 min.
- E. To 0.5 mL of solution S (see Tests) add 1.5 mL of *water R*. The solution gives reaction (a) of chlorides (2.3.1).

#### TESTS

**Solution S.** Dissolve 1.25 g in *carbon dioxide-free water R*, warming to not more than 30 °C if necessary, and dilute to 25 mL with the same solvent.

**Appearance of solution.** Solution S, examined immediately after preparation, is not more intensely coloured than reference solution BY<sub>6</sub> (2.2.2, *Method II*).

**Acidity or alkalinity.** To 10 mL of solution S add 0.1 mL of *methyl red solution R* and 0.3 mL of 0.01 *M* sodium hydroxide. The solution is yellow. Not more than 0.5 mL of 0.01 *M* hydrochloric acid is required to change the colour of the indicator to red.

**Related substances.** Carry out the test protected from bright light. Examine by thin-layer chromatography (2.2.27), using a *TLC silica gel plate R*.

**Test solution (a).** Dissolve 0.10 g of the substance to be examined in a mixture of equal volumes of *ethanol R* and *methylene chloride R* and dilute to 10 mL with the same mixture of solvents. Prepare immediately before use.

**Test solution (b).** Dilute 1 mL of test solution (a) to 10 mL with a mixture of equal volumes of *ethanol R* and *methylene chloride R*.

**Reference solution (a).** Dissolve 25 mg of *desipramine hydrochloride CRS* in a mixture of equal volumes of *ethanol R* and *methylene chloride R* and dilute to 25 mL with the same mixture of solvents. *Prepare immediately before use.*

**Reference solution (b).** Dilute 1 mL of reference solution (a) to 50 mL with a mixture of equal volumes of *ethanol R* and *methylene chloride R*.

Apply to the plate 5 µL of each solution. Develop over a path of 7 cm using a mixture of 1 volume of *water R*, 10 volumes of *anhydrous acetic acid R* and 10 volumes of *toluene R*. Dry the plate in a current of air for 10 min, spray with a 5 g/L solution of *potassium dichromate R* in a mixture of 1 volume of *sulfuric acid R* and 4 volumes of *water R* and examine immediately. Any spot in the chromatogram obtained with test solution (a), apart from the principal spot, is not more intense than the spot in the chromatogram obtained with reference solution (b) (0.2 per cent).

**Heavy metals (2.4.8).** 2.0 g complies with limit test C for heavy metals (20 ppm). Prepare the standard using 4 mL of *lead standard solution (10 ppm Pb) R*.

**Loss on drying (2.2.32).** Not more than 0.5 per cent, determined on 1.000 g by drying in an oven at 105 °C.

**Sulfated ash (2.4.14).** Not more than 0.1 per cent, determined on 1.0 g.

#### ASSAY

Dissolve 0.2500 g in a mixture of 5 mL of 0.01 M *hydrochloric acid* and 50 mL of *alcohol R*. Carry out a potentiometric titration (2.2.20), using 0.1 M *sodium hydroxide*. Read the volume added between the two points of inflexion.

1 mL of 0.1 M *sodium hydroxide* is equivalent to 30.28 mg of C<sub>47</sub>H<sub>74</sub>O<sub>19</sub>.

#### STORAGE

Store protected from light.

01/2008:0482  
corrected 6.0

## DESLANOSIDE

### Deslanosidum

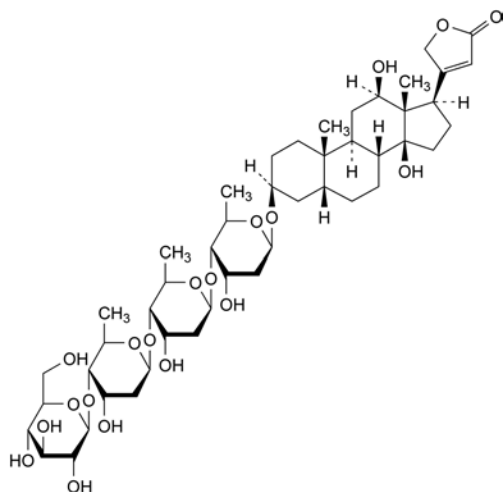

C<sub>47</sub>H<sub>74</sub>O<sub>19</sub>  
[17598-65-1]

M<sub>r</sub> 943

#### DEFINITION

Deslanoside contains not less than 95.0 per cent and not more than the equivalent of 105.0 per cent of 3β-[(*O*-β-D-glucopyranosyl-(1→4)-*O*-2,6-dideoxy-β-D-ribo-hexopyranosyl-(1→4)-*O*-2,6-dideoxy-β-D-ribo-hexopyranosyl-(1→4)-2,6-dideoxy-β-D-ribo-hexopyranosyl)oxy]-12β,14-dihydroxy-5β,14β-card-20(22)-enolide, calculated with reference to the dried substance.

#### CHARACTERS

A white or almost white, crystalline or finely crystalline powder, hygroscopic, practically insoluble in water, very slightly soluble in alcohol. In an atmosphere of low relative humidity, it loses water.

#### IDENTIFICATION

**First identification: A.**

**Second identification: B, C, D.**

- Examine by infrared absorption spectrophotometry (2.2.24), comparing with the spectrum obtained with *deslanoside CRS*. When comparing the spectra, special attention is given to the absence of a distinct absorption maximum at about 1260 cm<sup>-1</sup> and to the intensity of the absorption maximum at about 1740 cm<sup>-1</sup>. Examine the substances in discs prepared by dissolving 1 mg of the substance to be examined or 1 mg of the reference substance in 0.3 mL of *methanol R* and triturating with about 0.4 g of dry, finely powdered *potassium bromide R* until the mixture is uniform and completely dry.
- Examine the chromatograms obtained in the test for related substances. The principal band in the chromatogram obtained with test solution (b) is similar in position, colour and size to the principal band in the chromatogram obtained with reference solution (a).
- Suspend about 0.5 mg in 0.2 mL of *alcohol (60 per cent V/V) R*. Add 0.1 mL of *dinitrobenzoic acid solution R* and 0.1 mL of *dilute sodium hydroxide solution R*. A violet colour develops.
- Dissolve about 5 mg in 5 mL of *glacial acetic acid R* and add 0.05 mL of *ferric chloride solution R1*. Cautiously add 2 mL of *sulfuric acid R*, avoiding mixing the two liquids. Allow to stand; a brown but not reddish ring develops at the interface and a greenish-yellow, then bluish-green colour diffuses from it to the upper layer.

#### TESTS

**Solution S.** Dissolve 0.20 g in a mixture of equal volumes of *chloroform R* and *methanol R* and dilute to 10 mL with the same mixture of solvents.

**Appearance of solution.** Solution S is clear (2.2.1) and colourless (2.2.2, *Method II*).

**Specific optical rotation (2.2.7).** Dissolve 0.200 g in *anhydrous pyridine R* and dilute to 10.0 mL with the same solvent. The specific optical rotation is + 6.5 to + 8.5, calculated with reference to the dried substance.

**Related substances.** Examine by thin-layer chromatography (2.2.27), using *silica gel G R* as the coating substance.

**Test solution (a).** Use solution S.

**Test solution (b).** Dilute 1 mL of test solution (a) to 10 mL with a mixture of equal volumes of *chloroform R* and *methanol R*.

**Reference solution (a).** Dissolve 20 mg of *deslanoside CRS* in a mixture of equal volumes of *chloroform R* and *methanol R* and dilute to 10 mL with the same mixture of solvents.

**Reference solution (b).** Dilute 2.5 mL of reference solution (a) to 10 mL with a mixture of equal volumes of *chloroform R* and *methanol R*.

**Reference solution (c).** Dilute 1 mL of reference solution (a) to 10 mL with a mixture of equal volumes of *chloroform R* and *methanol R*.

Apply separately to the plate as 10 mm bands 5 µL of each solution. Develop immediately over a path of 15 cm using a mixture of 3 volumes of *water R*, 36 volumes of *methanol R* and 130 volumes of *methylene chloride R*. Dry the plate in a current of warm air, spray with a mixture of 5 volumes of *sulfuric acid R* and 95 volumes of *alcohol R* and heat at 140 °C for 15 min. Examine in daylight. In the chromatogram obtained with test solution (a), any band, apart from the principal band, is not more intense than the band in the chromatogram obtained with reference solution (b) (2.5 per cent) and at most two such bands are more intense than the band in the chromatogram obtained with reference solution (c) (1.0 per cent).

**Loss on drying** (2.2.32). Not more than 5.0 per cent, determined on 0.500 g by drying *in vacuo* at 105 °C.

**Sulfated ash** (2.4.14). Not more than 0.1 per cent, determined on the residue obtained in the test for loss on drying.

#### ASSAY

Dissolve 50.0 mg in *alcohol R* and dilute to 50.0 mL with the same solvent. Dilute 5.0 mL of this solution to 100.0 mL with *alcohol R*. Prepare a reference solution in the same manner, using 50.0 mg of *deslanoside CRS* (undried). To 5.0 mL of each solution add 3.0 mL of *alkaline sodium picrate solution R* and allow to stand protected from bright light in a water-bath at 20 ± 1 °C for 40 min. Measure the absorbance (2.2.25) of each solution at the maximum at 484 nm, using as the compensation liquid a mixture of 3.0 mL of *alkaline sodium picrate solution R* and 5.0 mL of *alcohol R* prepared at the same time.

Calculate the content of C<sub>47</sub>H<sub>74</sub>O<sub>19</sub> from the absorbances measured and the concentrations of the solutions.

#### STORAGE

Store in an airtight, glass container, protected from light, at a temperature below 10 °C.

07/2009:0712

## DESMOPRESSIN

### Desmopressinum

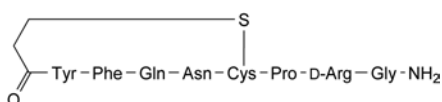

C<sub>46</sub>H<sub>64</sub>N<sub>14</sub>O<sub>12</sub>S<sub>2</sub>  
[16679-58-6]

M<sub>r</sub> 1069

#### DEFINITION

(3-Sulfanylpropanoyl)-L-tyrosyl-L-phenylalanyl-L-glutaminyl-L-asparaginyl-L-cysteinyl-L-prolyl-D-arginylglycinamide cyclic (1→6)-disulfide.

Synthetic cyclic nonapeptide, available as an acetate.

**Content:** 95.0 per cent to 105.0 per cent (anhydrous and acetic acid-free substance).

#### CHARACTERS

**Appearance:** white or almost white, fluffy powder.

**Solubility:** soluble in water, in ethanol (96 per cent) and in glacial acetic acid.

#### IDENTIFICATION

A. Examine the chromatograms obtained in the assay.

**Results:** the retention time and size of the principal peak in the chromatogram obtained with the test solution are approximately the same as those of the principal peak in the chromatogram obtained with the reference solution.

B. Amino acid analysis (2.2.56). For hydrolysis use Method 1 and for analysis use Method 1.

Express the content of each amino acid in moles. Calculate the relative proportions of the amino acids, taking 1/6 of the sum of the number of moles of aspartic acid, glutamic acid, proline, glycine, arginine and phenylalanine as equal to 1. The values fall within the following limits: aspartic acid: 0.90 to 1.10; glutamic acid: 0.90 to 1.10; proline: 0.90 to 1.10; glycine: 0.90 to 1.10; arginine: 0.90 to 1.10; phenylalanine: 0.90 to 1.10; tyrosine: 0.70 to 1.05; half-cystine: 0.30 to 1.05. Lysine, isoleucine and leucine are absent; not more than traces of other amino acids are present.

#### TESTS

**Specific optical rotation** (2.2.7): –72 to –82 (anhydrous and acetic acid-free substance).

Dissolve 10.0 mg in a 1 per cent V/V solution of *glacial acetic acid R* and dilute to 5.0 mL with the same acid.

**Related substances.** Liquid chromatography (2.2.29): use the normalisation procedure.

**Test solution.** Dissolve 1.0 mg of the substance to be examined in 2.0 mL of *water R*.

**Resolution solution.** Dissolve the contents of a vial of *oxytocin/desmopressin validation mixture CRS* in 500 µL of *water R*.

**Column:**

- size:  $l = 0.12$  m,  $\varnothing = 4.0$  mm;
- stationary phase: octadecylsilyl silica gel for chromatography R (5 µm).

**Mobile phase:**

- mobile phase A: 0.067 M phosphate buffer solution pH 7.0 R; filter and degas;
- mobile phase B: acetonitrile for chromatography R, mobile phase A (50:50 V/V); filter and degas.

Time (min)	Mobile phase A (per cent V/V)	Mobile phase B (per cent V/V)
0 - 4	76	24
4 - 18	76 → 58	24 → 42
18 - 35	58 → 48	42 → 52
35 - 40	48 → 76	52 → 24
40 - 50	76	24

**Flow rate:** 1.5 mL/min.

**Detection:** spectrophotometer at 220 nm.

**Injection:** 50 µL.

**Retention time:** desmopressin = about 16 min; oxytocin = about 17 min.

**System suitability:** resolution solution:

- resolution: minimum 1.5 between the peaks due to desmopressin and oxytocin.

**Limits:**

- unspecified impurities: for each impurity, maximum 0.5 per cent;
- total: maximum 1.5 per cent;
- disregard limit: 0.05 per cent.

**Acetic acid** (2.5.34): 3.0 per cent to 8.0 per cent.

**Test solution.** Dissolve 20.0 mg of the substance to be examined in a mixture of 5 volumes of mobile phase B and 95 volumes of mobile phase A and dilute to 10.0 mL with the same mixture of mobile phases.

**Water** (2.5.32): maximum 6.0 per cent, determined on 20.0 mg.

**Bacterial endotoxins** (2.6.14): less than 500 IU/mg, if intended for use in the manufacture of parenteral preparations without a further appropriate procedure for the removal of bacterial endotoxins.

## ASSAY

Liquid chromatography (2.2.29) as described in the test for related substances with the following modifications.

**Reference solution.** Dissolve the contents of a vial of *desmopressin CRS* in *water R* to obtain a concentration of 0.5 mg/mL.

**Mobile phase:** mobile phase B, mobile phase A (40:60 V/V).

**Flow rate:** 2.0 mL/min.

**Retention time:** desmopressin = about 5 min.

Calculate the content of desmopressin ( $C_{46}H_{64}N_{14}O_{12}S_2$ ) from the declared content of  $C_{46}H_{64}N_{14}O_{12}S_2$  in *desmopressin CRS*.

## STORAGE

In an airtight container, protected from light, at a temperature of 2 °C to 8 °C. If the substance is sterile, store in a sterile, airtight, tamper-proof container.

## LABELLING

The label states:

- the mass of peptide per container;
- where applicable, that the substance is suitable for use in the manufacture of parenteral preparations.

## IMPURITIES

**Other detectable impurities** (the following substances would, if present at a sufficient level, be detected by one or other of the tests in the monograph. They are limited by the general acceptance criterion for other/unspecified impurities and/or by the general monograph *Substances for pharmaceutical use (2034)*. It is therefore not necessary to identify these impurities for demonstration of compliance. See also 5.10. *Control of impurities in substances for pharmaceutical use*): A, B, C, D, E, F, G.

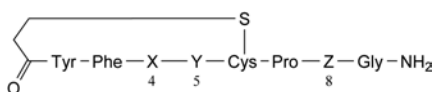

- A. X = Gln, Y = Asp, Z = D-Arg: [5-L-aspartic acid]desmopressin,  
 B. X = Glu, Y = Asn, Z = D-Arg: [4-L-glutamic acid]desmopressin,  
 D. X = Gln, Y = Asn, Z = L-Arg: [8-L-arginine]desmopressin,

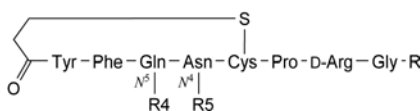

- C. R = OH, R<sub>4</sub> = R<sub>5</sub> = H: [9-glycine]desmopressin,  
 E. R = NH<sub>2</sub>, R<sub>4</sub> = CH<sub>2</sub>-NH-CO-CH<sub>3</sub>, R<sub>5</sub> = H: N<sup>5,4</sup>-[(acetylamino)methyl]desmopressin,  
 F. R = NH<sub>2</sub>, R<sub>4</sub> = H, R<sub>5</sub> = CH<sub>2</sub>-NH-CO-CH<sub>3</sub>: N<sup>4,5</sup>-[(acetylamino)methyl]desmopressin,  
 G. R = N(CH<sub>3</sub>)<sub>2</sub>, R<sub>4</sub> = R<sub>5</sub> = H: N<sup>1,9</sup>,N<sup>1,9</sup>-dimethyldesmopressin.

01/2008:1717

## DESOGESTREL

## Desogestrelum

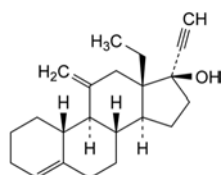

$C_{22}H_{30}O$   
 [54024-22-5]

$M_r$  310.5

## DEFINITION

13-Ethyl-11-methylidene-18,19-dinor-17 $\alpha$ -pregn-4-en-20-yn-17-ol.

**Content:** 98.0 per cent to 102.0 per cent (dried substance).

## CHARACTERS

**Appearance:** white or almost white, crystalline powder.

**Solubility:** practically insoluble in water, very soluble in methanol, freely soluble in anhydrous ethanol and in methylene chloride.

## IDENTIFICATION

A. Infrared absorption spectrophotometry (2.2.24).

**Comparison:** *desogestrel CRS*.

B. Specific optical rotation (see Tests).

## TESTS

**Specific optical rotation (2.2.7):** + 53 to + 57 (dried substance).

Dissolve 0.250 g in *anhydrous ethanol R* and dilute to 25.0 mL with the same solvent.

**Related substances.** Liquid chromatography (2.2.29).

**Test solution.** Dissolve 20.0 mg of the substance to be examined in 25 mL of *acetonitrile R1* and dilute to 50.0 mL with *water R*.

**Reference solution (a).** Dissolve 4 mg of *desogestrel for system suitability CRS* (containing impurities A, B, C and D) in 5 mL of *acetonitrile R1* and dilute to 10.0 mL with *water R*.

**Reference solution (b).** Dilute 1.0 mL of the test solution to 100.0 mL with a mixture of equal volumes of *acetonitrile R1* and *water R*.

**Reference solution (c).** Dilute 1.0 mL of reference solution (b) to 10.0 mL with a mixture of equal volumes of *acetonitrile R1* and *water R*.

**Reference solution (d).** Dissolve 20.0 mg of *desogestrel CRS* in 25 mL of *acetonitrile R1* and dilute to 50.0 mL with *water R*.

**Column:**

- **size:**  $l = 0.25$  m,  $\varnothing = 4.6$  mm,
- **stationary phase:** sterically protected *octadecylsilyl silica gel for chromatography R* (5  $\mu$ m),
- **temperature:** 50 °C.

**Mobile phase:** *water R*, *acetonitrile R1* (27:73 V/V).

**Flow rate:** 1.0 mL/min.

**Detection:** spectrophotometer at 205 nm.

**Injection:** 15  $\mu$ L of the test solution and reference solutions (a), (b) and (c).

**Run time:** 2.5 times the retention time of desogestrel.

**Identification of impurities:** use the chromatogram supplied with *desogestrel for system suitability CRS* and the chromatogram obtained with reference solution (a) to identify the peaks due to impurities A, B, C and D.

**Relative retention** with reference to desogestrel (retention time = about 22 min): impurity E = about 0.2; impurity D = about 0.25; impurity B = about 0.7; impurity A = about 0.95; impurity C = about 1.05.

**System suitability:** reference solution (a):

- **peak-to-valley ratio:** minimum 2.0, where  $H_p$  = height above the baseline of the peak due to impurity C and  $H_v$  = height above the baseline of the lowest point of the curve separating this peak from the peak due to desogestrel.

**Limits:**

- **correction factors:** for the calculation of content, multiply the peak area of the following impurities by the corresponding correction factor: impurity A = 1.8, impurity D = 1.5;
- **impurities A, B, C:** for each impurity, not more than twice the area of the principal peak in the chromatogram obtained with reference solution (c) (0.2 per cent);
- **impurity D:** not more than the area of the principal peak in the chromatogram obtained with reference solution (c) (0.1 per cent);

04/2010:0322

- *unspecified impurities*: for each impurity, not more than the area of the principal peak in the chromatogram obtained with reference solution (c) (0.10 per cent);
- *total*: not more than 0.5 times the area of the principal peak in the chromatogram obtained with reference solution (b) (0.5 per cent);
- *disregard limit*: 0.5 times the area of the principal peak in the chromatogram obtained with reference solution (c) (0.05 per cent).

**Loss on drying** (2.2.32): maximum 0.5 per cent, determined on 1.000 g by drying *in vacuo* at a pressure not exceeding 2 kPa.

**Sulfated ash** (2.4.14): maximum 0.1 per cent, determined on 1.0 g.

#### ASSAY

Liquid chromatography (2.2.29) as described in the test for related substances with the following modification.

*Injection*: test solution and reference solution (d).

Calculate the percentage content of  $C_{23}H_{30}O$  from the areas of the peaks and the declared content of *desogestrel CRS*.

#### IMPURITIES

*Specified impurities*: A, B, C, D.

*Other detectable impurities* (the following substances would, if present at a sufficient level, be detected by one or other of the tests in the monograph. They are limited by the general acceptance criterion for other/unspecified impurities and/or by the general monograph *Substances for pharmaceutical use* (2034). It is therefore not necessary to identify these impurities for demonstration of compliance. See also 5.10. *Control of impurities in substances for pharmaceutical use*): E.

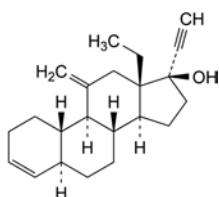

- A. 13-ethyl-11-methylidene-18,19-dinor-5 $\alpha$ ,17 $\alpha$ -pregn-3-en-20-yn-17-ol (desogestrel  $\Delta^3$ -isomer),

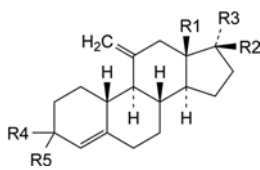

- B. R1 = CH<sub>3</sub>, R2 = OH, R3 = C $\equiv$ CH, R4 = R5 = H: 11-methylidene-19-nor-17 $\alpha$ -pregn-4-en-20-yn-17-ol,
- C. R1 = C<sub>2</sub>H<sub>5</sub>, R2 + R3 = O, R4 = R5 = H: 13-ethyl-11-methylidene-19-nor-17 $\alpha$ -pregn-4-en-17-one,
- D. R1 = C<sub>2</sub>H<sub>5</sub>, R2 = OH, R3 = C $\equiv$ CH, R4 + R5 = O: 13-ethyl-17-hydroxy-11-methylidene-18,19-dinor-17 $\alpha$ -pregn-4-en-20-yn-3-one,

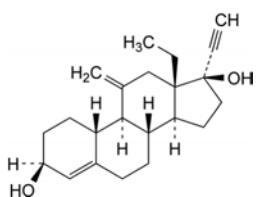

- E. 13-ethyl-11-methylidene-18,19-dinor-17 $\alpha$ -pregn-4-en-20-yn-3 $\beta$ ,17-diol.

## DESOXYCORTONE ACETATE

### Desoxycortoni acetat

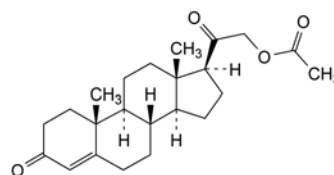

$C_{23}H_{32}O_4$   
[56-47-3]

$M_r$  372.5

#### DEFINITION

3,20-Dioxopregn-4-en-21-yl acetate.

*Content*: 97.0 per cent to 103.0 per cent (dried substance).

#### CHARACTERS

*Appearance*: white or almost white, crystalline powder or colourless crystals.

*Solubility*: practically insoluble in water, freely soluble in methylene chloride, soluble in acetone, sparingly soluble in ethanol (96 per cent), slightly soluble in propylene glycol and in fatty oils.

#### IDENTIFICATION

*First identification*: B, C.

*Second identification*: A, C, D, E.

- A. Melting point (2.2.14): 157 °C to 161 °C.
- B. Infrared absorption spectrophotometry (2.2.24).  
*Comparison*: desoxycortone acetate CRS.
- C. Thin-layer chromatography (2.2.27).

*Solvent mixture*: methanol R, methylene chloride R (1:9 V/V).

*Test solution*. Dissolve 10 mg of the substance to be examined in the solvent mixture and dilute to 10 mL with the solvent mixture.

*Reference solution (a)*. Dissolve 20 mg of desoxycortone acetate CRS in the solvent mixture and dilute to 20 mL with the solvent mixture.

*Reference solution (b)*. Dissolve 10 mg of cortisone acetate R in reference solution (a) and dilute to 10 mL with reference solution (a).

*Plate*: TLC silica gel F<sub>254</sub> plate R.

*Mobile phase*: add a mixture of 1.2 volumes of water R and 8 volumes of methanol R to a mixture of 15 volumes of ether R and 77 volumes of methylene chloride R.

*Application*: 5  $\mu$ L.

*Development*: over 2/3 of the plate.

*Drying*: in air.

*Detection A*: examine in ultraviolet light at 254 nm.

*Results A*: the principal spot in the chromatogram obtained with the test solution is similar in position and size to the principal spot in the chromatogram obtained with reference solution (a).

*Detection B*: spray with alcoholic solution of sulfuric acid R, heat at 120 °C for 10 min or until the spots appear, and allow to cool; examine in daylight and in ultraviolet light at 365 nm.

**Results B:** the principal spot in the chromatogram obtained with the test solution is similar in position, colour in daylight, fluorescence in ultraviolet light at 365 nm and size to the principal spot in the chromatogram obtained with reference solution (a).

**System suitability:** reference solution (b):

– the chromatogram shows 2 clearly separated spots.

D. Add about 2 mg to 2 mL of *sulfuric acid R* and shake to dissolve. Within 5 min, a yellow colour develops. Add this solution to 2 mL of *water R* and mix. The resulting solution is dichroic, showing an intense blue colour by transparency, and red fluorescence that is particularly intense in ultraviolet light at 365 nm.

E. About 10 mg gives the reaction of acetyl (2.3.1).

#### TESTS

**Specific optical rotation (2.2.7):** + 171 to + 179 (dried substance).

Dissolve 0.250 g in *dioxan R* and dilute to 25.0 mL with the same solvent.

**Related substances.** Liquid chromatography (2.2.29).

**Test solution.** Dissolve 25.0 mg of the substance to be examined in the mobile phase and dilute to 10.0 mL with the mobile phase.

**Reference solution (a).** Dissolve 2 mg of *desoxycortone acetate CRS* and 2 mg of *betamethasone 17-valerate CRS* in the mobile phase and dilute to 200.0 mL with the mobile phase.

**Reference solution (b).** Dilute 1.0 mL of the test solution to 200.0 mL with the mobile phase.

**Column:**

- size:  $l = 0.25$  m,  $\emptyset = 4.6$  mm;
- stationary phase: *octadecylsilyl silica gel for chromatography R* (5  $\mu$ m).

**Mobile phase:** in a 1000 mL volumetric flask mix 350 mL of *water R* with 600 mL of *acetonitrile R* and allow to equilibrate; dilute to 1000 mL with *water R* and mix again.

**Flow rate:** 1 mL/min.

**Detection:** spectrophotometer at 254 nm.

**Equilibration:** with the mobile phase for about 30 min.

**Injection:** 20  $\mu$ L.

**Run time:** 3 times the retention time of desoxycortone acetate.

**Retention time:** betamethasone 17-valerate = about 7.5 min; desoxycortone acetate = about 9.5 min.

**System suitability:** reference solution (a):

- resolution: minimum 4.5 between the peaks due to betamethasone 17-valerate and desoxycortone acetate; if necessary, adjust the concentration of acetonitrile in the mobile phase.

**Limits:**

- *unspecified impurities:* for each impurity, not more than 0.2 times the area of the principal peak in the chromatogram obtained with reference solution (b) (0.10 per cent);
- *total:* not more than the area of the principal peak in the chromatogram obtained with reference solution (b) (0.5 per cent);
- *disregard limit:* 0.1 times the area of the principal peak in the chromatogram obtained with reference solution (b) (0.05 per cent).

**Loss on drying (2.2.32):** maximum 0.5 per cent, determined on 0.500 g by drying in an oven at 105 °C.

#### ASSAY

Dissolve 0.100 g in *ethanol (96 per cent) R* and dilute to 100.0 mL with the same solvent. Dilute 2.0 mL of this solution to 100.0 mL with *ethanol (96 per cent) R*. Measure the absorbance (2.2.25) at the absorption maximum at 240 nm.

Calculate the content of  $C_{23}H_{32}O_4$  taking the specific absorbance to be 450.

#### STORAGE

Protected from light.

01/2008:1414  
corrected 6.0

## DETOMIDINE HYDROCHLORIDE FOR VETERINARY USE

Detomidini hydrochloridum  
ad usum veterinarium

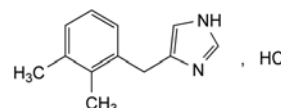

$C_{12}H_{15}ClN_2$   
[90038-01-0]

$M_r$  222.7

#### DEFINITION

4-(2,3-Dimethylbenzyl)-1H-imidazole hydrochloride.

**Content:** 98.5 per cent to 101.5 per cent (dried substance).

#### CHARACTERS

**Appearance:** white or almost white, hygroscopic, crystalline powder.

**Solubility:** soluble in water, freely soluble in ethanol (96 per cent), very slightly soluble in methylene chloride, practically insoluble in acetone.

mp: about 160 °C.

#### IDENTIFICATION

A. Infrared absorption spectrophotometry (2.2.24).

**Preparation:** discs.

**Comparison:** *detomidine hydrochloride CRS*.

If the spectra obtained show differences, dry the substance to be examined and the reference substance separately in an oven at 100-105 °C and record new spectra.

B. It gives reaction (a) of chlorides (2.3.1).

#### TESTS

**Appearance of solution.** The solution is clear (2.2.1) and colourless (2.2.2, *Method II*).

Dissolve 0.25 g in *water R* and dilute to 25 mL with the same solvent.

**Related substances.** Liquid chromatography (2.2.29).

**Test solution.** Dissolve 25.0 mg of the substance to be examined in 20 mL of the mobile phase and dilute to 50.0 mL with the mobile phase.

**Reference solution (a).** Dilute 0.20 mL of the test solution to 100.0 mL with the mobile phase.

**Reference solution (b).** Dissolve 1 mg of *detomidine impurity B CRS* in the mobile phase and dilute to 100 mL with the mobile phase. Dilute 1 mL of this solution to 10 mL with reference solution (a).

**Column:**

- size:  $l = 0.15$  m,  $\emptyset = 4.6$  mm;
- stationary phase: *octylsilyl silica gel for chromatography R* (5  $\mu$ m).

**Mobile phase:** *acetonitrile R*, 2.64 g/L solution of *ammonium phosphate R* (35:65 V/V).

**Flow rate:** 1 mL/min.

**Detection:** spectrophotometer at 220 nm.

**Injection:** 20  $\mu$ L.

**Run time:** 4 times the retention time of detomidine.



04/2010:0388

*Relative retention* with reference to detomidine (retention time = about 7 min): impurity A = about 0.4; impurity B = about 2.0; impurity C = about 3.0.

*System suitability*: reference solution (b):

- *resolution*: minimum 5 between the peaks due to detomidine and impurity B.

*Limits*:

- *correction factor*: multiply by 2.7 the area of any peak due to impurity C and its diastereoisomer eluting with a relative retention time of about 3;
- *impurity C*: for the sum of the areas of the peaks due to impurity C and its diastereoisomer, not more than 2.5 times the area of the principal peak in the chromatogram obtained with reference solution (a) (0.5 per cent);
- *any other impurity*: for each impurity, not more than the area of the principal peak in the chromatogram obtained with reference solution (a) (0.2 per cent);
- *total*: not more than 5 times the area of the principal peak in the chromatogram obtained with reference solution (a) (1 per cent);
- *disregard limit*: 0.25 times the area of the principal peak in the chromatogram obtained with reference solution (a) (0.05 per cent).

**Loss on drying** (2.2.32): maximum 0.5 per cent, determined on 1.000 g by drying in oven at 105 °C.

**Sulfated ash** (2.4.14): maximum 0.1 per cent, determined on 1.0 g.

#### ASSAY

Dissolve 0.170 g in 50 mL of *ethanol (96 per cent) R*. Add 5.0 mL of 0.01 M *hydrochloric acid*. Carry out a potentiometric titration (2.2.20), using 0.1 M *sodium hydroxide*. Read the volume added between the 2 points of inflexion.

1 mL of 0.1 M *sodium hydroxide* is equivalent to 22.27 mg of  $C_{22}H_{29}FO_5$ .

#### STORAGE

In an airtight container.

#### IMPURITIES

*Specified impurities*: C.

*Other detectable impurities* (the following substances would, if present at a sufficient level, be detected by one or other of the tests in the monograph. They are limited by the general acceptance criterion for other/unspecified impurities and/or by the general monograph *Substances for pharmaceutical use (2034)*. It is therefore not necessary to identify these impurities for demonstration of compliance. See also 5.10. *Control of impurities in substances for pharmaceutical use*): A, B.

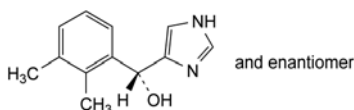

A. (RS)-(2,3-dimethylphenyl)(1H-imidazol-4-yl)methanol,

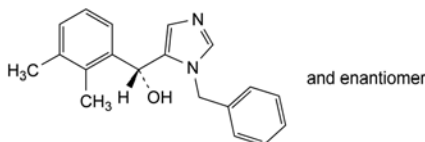

B. (RS)-(1-benzyl-1H-imidazol-5-yl)(2,3-dimethylphenyl)methanol,

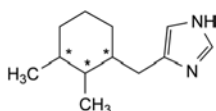

C. 4-[(2,3-dimethylcyclohexyl)methyl]-1H-imidazole.

## DEXAMETHASONE

### Dexamethasonum

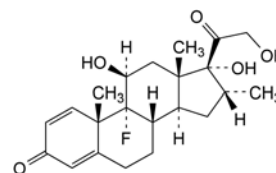

$C_{22}H_{29}FO_5$   
[50-02-2]

$M_r$  392.5

#### DEFINITION

9-Fluoro-11 $\beta$ ,17,21-trihydroxy-16 $\alpha$ -methylpregna-1,4-diene-3,20-dione.

*Content*: 97.0 per cent to 103.0 per cent (dried substance).

#### CHARACTERS

*Appearance*: white or almost white, crystalline powder.

*Solubility*: practically insoluble in water, sparingly soluble in anhydrous ethanol, slightly soluble in methylene chloride.

#### IDENTIFICATION

*First identification*: B, C.

*Second identification*: A, C, D, E.

A. Dissolve 10.0 mg in *anhydrous ethanol R* and dilute to 100.0 mL with the same solvent. Place 2.0 mL of this solution in a stoppered test tube, add 10.0 mL of *phenylhydrazine-sulfuric acid solution R*, mix and heat in a water-bath at 60 °C for 20 min. Cool immediately. The absorbance (2.2.25) measured at the absorption maximum at 419 nm is not less than 0.4.

B. Infrared absorption spectrophotometry (2.2.24).

*Comparison*: dexamethasone CRS.

C. Thin-layer chromatography (2.2.27).

*Solvent mixture*: *methanol R*, *methylene chloride R* (1:9 V/V).

*Test solution*. Dissolve 10 mg of the substance to be examined in the solvent mixture and dilute to 10 mL with the solvent mixture.

*Reference solution (a)*. Dissolve 20 mg of *dexamethasone CRS* in the solvent mixture and dilute to 20 mL with the solvent mixture.

*Reference solution (b)*. Dissolve 10 mg of *betamethasone CRS* in reference solution (a) and dilute to 10 mL with reference solution (a).

*Plate*: TLC silica gel  $F_{254}$  plate R.

*Mobile phase*: *butanol R* saturated with *water R*, *toluene R*, *ether R* (5:10:85 V/V/V).

*Application*: 5  $\mu$ L.

*Development*: over 2/3 of the plate.

*Drying*: in air.

*Detection A*: examine in ultraviolet light at 254 nm.

*Results A*: the principal spot in the chromatogram obtained with the test solution is similar in position and size to the principal spot in the chromatogram obtained with reference solution (a).

*Detection B*: spray with *alcoholic solution of sulfuric acid R*. Heat at 120 °C for 10 min or until the spots appear. Allow to cool. Examine in daylight and in ultraviolet light at 365 nm.

**Results B:** the principal spot in the chromatogram obtained with the test solution is similar in position, colour in daylight, fluorescence in ultraviolet light at 365 nm and size to the principal spot in the chromatogram obtained with reference solution (a).

**System suitability:** reference solution (b):

- the chromatogram shows 2 spots which may, however, not be completely separated.

D. Add about 2 mg to 2 mL of *sulfuric acid R* and shake to dissolve. Within 5 min, a faint reddish-brown colour develops. Add this solution to 10 mL of *water R* and mix; the colour is discharged.

E. Mix about 5 mg with 45 mg of *heavy magnesium oxide R* and ignite in a crucible until an almost white residue is obtained (usually less than 5 min). Allow to cool, add 1 mL of *water R*, 0.05 mL of *phenolphthalein solution R1* and about 1 mL of *dilute hydrochloric acid R* to render the solution colourless. Filter. To a freshly prepared mixture of 0.1 mL of *alizarin S solution R* and 0.1 mL of *zirconyl nitrate solution R*, add 1.0 mL of the filtrate. Mix, allow to stand for 5 min and compare the colour of the solution with that of a blank prepared in the same manner. The test solution is yellow and the blank solution is red.

## TESTS

**Specific optical rotation (2.2.7):** + 86 to + 92 (dried substance).

Dissolve 0.250 g in *anhydrous ethanol R* and dilute to 25.0 mL with the same solvent.

**Related substances.** Liquid chromatography (2.2.29). Carry out the test protected from light.

**Test solution.** Dissolve 25 mg of the substance to be examined in 1.5 mL of *acetonitrile R* and add 5 mL of mobile phase A. Mix with the aid of an ultrasonic bath until complete dissolution, and dilute to 10.0 mL with mobile phase A.

**Reference solution (a).** Dissolve 5 mg of *dexamethasone for system suitability CRS* (containing impurities B, F and G) in 0.5 mL of *acetonitrile R* and add 1 mL of mobile phase A. Mix with the aid of an ultrasonic bath until complete dissolution and dilute to 2.0 mL with mobile phase A.

**Reference solution (b).** Dilute 1.0 mL of the test solution to 100.0 mL with mobile phase A. Dilute 1.0 mL of this solution to 10.0 mL with mobile phase A.

**Column:**

- **size:**  $l = 0.15$  m,  $\varnothing = 4.6$  mm;
- **stationary phase:** octadecylsilyl silica gel for chromatography R (5  $\mu$ m);
- **temperature:** 45 °C.

**Mobile phase:**

- **mobile phase A:** mix 250 mL of *acetonitrile R* with 700 mL of *water R* and allow to equilibrate; dilute to 1000.0 mL with *water R* and mix again;
- **mobile phase B:** *acetonitrile R*;

Time (min)	Mobile phase A (per cent V/V)	Mobile phase B (per cent V/V)
0 - 15	100	0
15 - 40	100 → 0	0 → 100

**Flow rate:** 1.2 mL/min.

**Detection:** spectrophotometer at 254 nm.

**Injection:** 20  $\mu$ L; inject mobile phase A as a blank.

**Identification of impurities:** use the chromatogram supplied with *dexamethasone for system suitability CRS* and the chromatogram obtained with reference solution (a) to identify the peaks due to impurities B, F and G.

**Relative retention** with reference to dexamethasone (retention time = about 15 min): impurity B = about 0.94; impurity F = about 1.5; impurity G = about 1.7.

**System suitability:** reference solution (a):

- **peak-to-valley ratio:** minimum 2.0, where  $H_p$  = height above the baseline of the peak due to impurity B and  $H_v$  = height above the baseline of the lowest point of the curve separating this peak from the peak due to dexamethasone.

**Limits:**

- **impurity G:** not more than 3 times the area of the principal peak in the chromatogram obtained with reference solution (b) (0.3 per cent);
- **impurities B, F:** for each impurity, not more than 1.5 times the area of the principal peak in the chromatogram obtained with reference solution (b) (0.15 per cent);
- **unspecified impurities:** for each impurity, not more than the area of the principal peak in the chromatogram obtained with reference solution (b) (0.10 per cent);
- **total:** not more than 5 times the area of the principal peak in the chromatogram obtained with reference solution (b) (0.5 per cent);
- **disregard limit:** 0.5 times the area of the principal peak in the chromatogram obtained with reference solution (b) (0.05 per cent).

**Loss on drying (2.2.32):** maximum 0.5 per cent, determined on 0.500 g by drying in an oven at 105 °C.

## ASSAY

Dissolve 0.100 g in *ethanol (96 per cent) R* and dilute to 100.0 mL with the same solvent. Dilute 2.0 mL of this solution to 100.0 mL with *ethanol (96 per cent) R*. Measure the absorbance (2.2.25) at the absorption maximum at 238.5 nm.

Calculate the content of  $C_{22}H_{29}FO_5$  taking the specific absorbance to be 394.

## STORAGE

Protected from light.

## IMPURITIES

**Specified impurities:** B, F, G.

**Other detectable impurities** (the following substances would, if present at a sufficient level, be detected by one or other of the tests in the monograph. They are limited by the general acceptance criterion for other/unspecified impurities and/or by the general monograph *Substances for pharmaceutical use (2034)*. It is therefore not necessary to identify these impurities for demonstration of compliance. See also 5.10. *Control of impurities in substances for pharmaceutical use*): A, C, D, E, H.

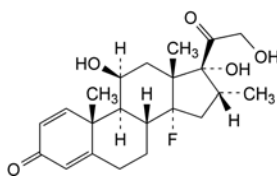

A. 14-fluoro-11 $\beta$ ,17,21-trihydroxy-16 $\alpha$ -methylpregna-1,4-diene-3,20-dione,

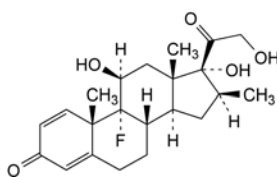

B. 9-fluoro-11 $\beta$ ,17,21-trihydroxy-16 $\beta$ -methylpregna-1,4-diene-3,20-dione (betamethasone),

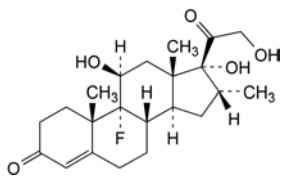

C. 9-fluoro-11 $\beta$ ,17,21-trihydroxy-16 $\alpha$ -methylpregn-4-ene-3,20-dione,

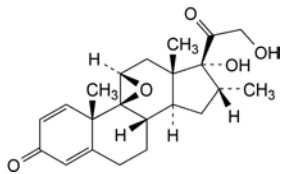

D. 17,21-dihydroxy-16 $\alpha$ -methyl-9 $\beta$ ,11 $\beta$ -epoxypregna-1,4-diene-3,20-dione,

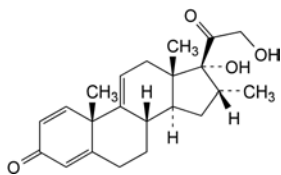

E. 17,21-dihydroxy-16 $\alpha$ -methylpregna-1,4,9(11)-triene-3,20-dione,

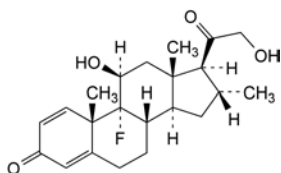

F. 9-fluoro-11 $\beta$ ,21-dihydroxy-16 $\alpha$ -methylpregna-1,4-diene-3,20-dione,

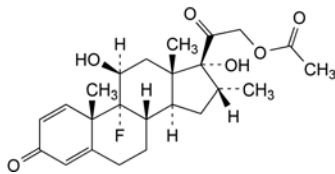

G. 9-fluoro-11 $\beta$ ,17-dihydroxy-16 $\alpha$ -methyl-3,20-dioxopregna-1,4-dien-21-yl acetate (dexamethasone acetate),

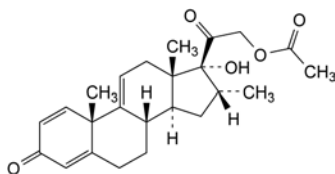

H. 17-hydroxy-16 $\alpha$ -methyl-3,20-dioxopregna-1,4,9(11)-trien-21-yl acetate.

04/2010:0548

## DEXAMETHASONE ACETATE

### Dexamethasoni acetas

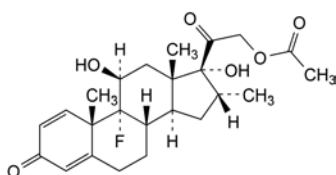

C<sub>24</sub>H<sub>31</sub>FO<sub>6</sub>  
[1177-87-3]

M<sub>r</sub> 434.5

#### DEFINITION

9-Fluoro-11 $\beta$ ,17-dihydroxy-16 $\alpha$ -methyl-3,20-dioxopregna-1,4-dien-21-yl acetate.

*Content*: 97.0 per cent to 103.0 per cent (dried substance).

#### CHARACTERS

*Appearance*: white or almost white, crystalline powder.

*Solubility*: practically insoluble in water, freely soluble in ethanol (96 per cent), slightly soluble in methylene chloride.

It shows polymorphism (5.9).

#### IDENTIFICATION

*First identification*: B, C.

*Second identification*: A, C, D, E, F.

A. Dissolve 10.0 mg in *anhydrous ethanol R* and dilute to 100.0 mL with the same solvent. Place 2.0 mL of this solution in a ground-glass-stoppered tube, add 10.0 mL of *phenylhydrazine-sulfuric acid solution R*, mix and heat in a water-bath at 60 °C for 20 min. Cool immediately. The absorbance (2.2.25) measured at the absorption maximum at 419 nm is not less than 0.35.

B. Infrared absorption spectrophotometry (2.2.24).

*Comparison*: *dexamethasone acetate CRS*.

If the spectra obtained in the solid state show differences, dissolve the substance to be examined and the reference substance separately in *methylene chloride R*, evaporate to dryness and record new spectra using the residues.

C. Thin-layer chromatography (2.2.27).

*Solvent mixture*: *methanol R*, *methylene chloride R* (1:9 V/V).

*Test solution*. Dissolve 10 mg of the substance to be examined in the solvent mixture and dilute to 10 mL with the solvent mixture.

*Reference solution (a)*. Dissolve 20 mg of *dexamethasone acetate CRS* in the solvent mixture and dilute to 20 mL with the solvent mixture.

*Reference solution (b)*. Dissolve 10 mg of *cortisone acetate R* in reference solution (a) and dilute to 10 mL with reference solution (a).

*Plate*: *TLC silica gel F<sub>254</sub> plate R*.

*Mobile phase*: add a mixture of 1.2 volumes of *water R* and 8 volumes of *methanol R* to a mixture of 15 volumes of *ether R* and 77 volumes of *methylene chloride R*.

*Application*: 5  $\mu$ L.

*Development*: over 3/4 of the plate.

*Drying*: in air.

*Detection A*: examine in ultraviolet light at 254 nm.

*Results A*: the principal spot in the chromatogram obtained with the test solution is similar in position and size to the principal spot in the chromatogram obtained with reference solution (a).

*Detection B*: spray with *alcoholic solution of sulfuric acid R*, heat at 120 °C for 10 min or until the spots appear, and allow to cool; examine in daylight and in ultraviolet light at 365 nm.

*Results B*: the principal spot in the chromatogram obtained with the test solution is similar in position, colour in daylight, fluorescence in ultraviolet light at 365 nm and size to the principal spot in the chromatogram obtained with reference solution (a).

*System suitability*: reference solution (b):

– the chromatogram shows 2 clearly separated spots.

D. Add about 2 mg to 2 mL of *sulfuric acid R* and shake to dissolve. Within 5 min, a faint reddish-brown colour develops. Add this solution to 10 mL of *water R* and mix. The colour is discharged and a clear solution remains.

E. Mix about 5 mg with 45 mg of *heavy magnesium oxide R* and ignite in a crucible until an almost white residue is obtained (usually less than 5 min). Allow to cool, add 1 mL of

water R, 0.05 mL of phenolphthalein solution R1 and about 1 mL of dilute hydrochloric acid R to render the solution colourless. Filter. To a freshly prepared mixture of 0.1 mL of alizarin S solution R and 0.1 mL of zirconyl nitrate solution R, add 1.0 mL of the filtrate. Mix, allow to stand for 5 min and compare the colour of the solution with that of a blank prepared in the same manner. The test solution is yellow and the blank is red.

F. About 10 mg gives the reaction of acetyl (2.3.1).

## TESTS

**Specific optical rotation** (2.2.7): + 94 to + 99 (dried substance).

Dissolve 0.250 g in anhydrous ethanol R and dilute to 25.0 mL with the same solvent.

**Related substances.** Liquid chromatography (2.2.29). Carry out the test protected from light.

**Test solution.** Dissolve 25 mg of the substance to be examined in about 4 mL of acetonitrile R and dilute to 10.0 mL with water R.

**Reference solution (a).** Dissolve 2 mg of dexamethasone CRS (impurity A) and 2 mg of betamethasone acetate CRS (impurity D) in 100.0 mL of the mobile phase and sonicate for about 10 min (solution A). Mix 6.0 mL of the test solution and 1.0 mL of solution A and dilute to 10.0 mL with the mobile phase.

**Reference solution (b).** Dilute 1.0 mL of the test solution to 100.0 mL with the mobile phase. Dilute 1.0 mL of this solution to 10.0 mL with the mobile phase.

**Reference solution (c).** Dissolve the contents of a vial of dexamethasone acetate impurity E CRS in 1.0 mL of the mobile phase.

**Column:**

- size:  $l = 0.25$  m,  $\varnothing = 4.6$  mm;
- stationary phase: octadecylsilyl silica gel for chromatography R (5  $\mu$ m).

**Mobile phase:** mix 380 mL of acetonitrile R with 550 mL of water R and allow to equilibrate; dilute to 1000.0 mL with water R and mix again.

**Flow rate:** 1 mL/min.

**Detection:** spectrophotometer at 254 nm.

**Injection:** 20  $\mu$ L.

**Run time:** 2.5 times the retention time of dexamethasone acetate.

**Identification of impurities:** use the chromatogram obtained with reference solution (a) to identify the peaks due to impurities A and D; use the chromatogram obtained with reference solution (c) to identify the peak due to impurity E.

**Relative retention** with reference to dexamethasone acetate (retention time = about 22 min): impurity A = about 0.4; impurity D = about 0.9; impurity E = about 1.2.

**System suitability:** reference solution (a):

- resolution: minimum 3.3 between the peaks due to impurity D and dexamethasone acetate.

**Limits:**

- impurity D: not more than 3 times the area of the principal peak in the chromatogram obtained with reference solution (b) (0.3 per cent);
- impurities A, E: for each impurity, not more than twice the area of the principal peak in the chromatogram obtained with reference solution (b) (0.2 per cent);
- unspecified impurities: for each impurity, not more than the area of the principal peak in the chromatogram obtained with reference solution (b) (0.10 per cent);

- total: not more than 5 times the area of the principal peak in the chromatogram obtained with reference solution (b) (0.5 per cent);
- disregard limit: 0.5 times the area of the principal peak in the chromatogram obtained with reference solution (b) (0.05 per cent).

**Loss on drying** (2.2.32): maximum 0.5 per cent, determined on 0.500 g by drying *in vacuo* in an oven at 105 °C.

## ASSAY

Dissolve 0.100 g in ethanol (96 per cent) R and dilute to 100.0 mL with the same solvent. Dilute 2.0 mL of this solution to 100.0 mL with ethanol (96 per cent) R. Measure the absorbance (2.2.25) at the absorption maximum at 238.5 nm.

Calculate the content of  $C_{24}H_{31}FO_6$  taking the specific absorbance to be 357.

## STORAGE

Protected from light.

## IMPURITIES

**Specified impurities:** A, D, E.

**Other detectable impurities** (the following substances would, if present at a sufficient level, be detected by one or other of the tests in the monograph. They are limited by the general acceptance criterion for other/unspecified impurities and/or by the general monograph *Substances for pharmaceutical use* (2034). It is therefore not necessary to identify these impurities for demonstration of compliance. See also 5.10. *Control of impurities in substances for pharmaceutical use*): B, C, F, G, H.

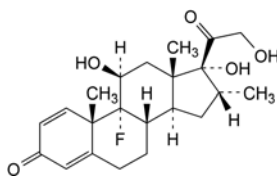

A. 9-fluoro-11 $\beta$ ,17,21-trihydroxy-16 $\alpha$ -methylpregna-1,4-diene-3,20-dione (dexamethasone),

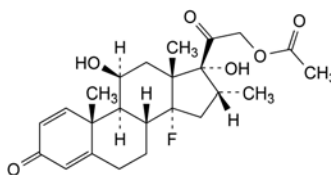

B. 14-fluoro-11 $\beta$ ,17-dihydroxy-16 $\alpha$ -methyl-3,20-dioxopregna-1,4-dien-21-yl acetate,

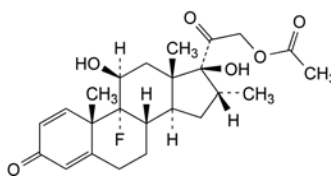

C. 9-fluoro-11 $\beta$ ,17 $\beta$ -dihydroxy-16 $\alpha$ -methyl-3,20-dioxopregna-1,4-dien-21-yl acetate,

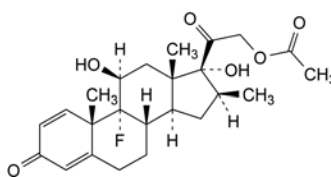

D. 9-fluoro-11 $\beta$ ,17-dihydroxy-16 $\beta$ -methyl-3,20-dioxopregna-1,4-dien-21-yl acetate (betamethasone acetate),

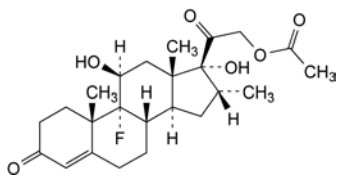

E. 9-fluoro-11 $\beta$ ,17-dihydroxy-16 $\alpha$ -methyl-3,20-dioxopregna-4-en-21-yl acetate,

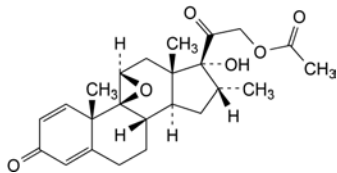

F. 17-hydroxy-16 $\alpha$ -methyl-3,20-dioxo-9 $\beta$ ,11 $\beta$ -epoxypregna-1,4-dien-21-yl acetate,

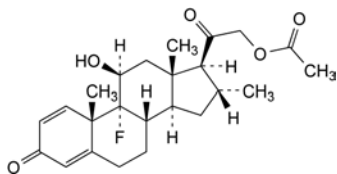

G. 9-fluoro-11 $\beta$ -hydroxy-16 $\alpha$ -methyl-3,20-dioxopregna-1,4-dien-21-yl acetate,

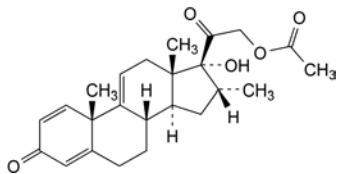

H. 17-hydroxy-16 $\alpha$ -methyl-3,20-dioxopregna-1,4,9(11)-trien-21-yl acetate.

01/2008:2237

## DEXAMETHASONE ISONICOTINATE

### Dexamethasoni isonicotinas

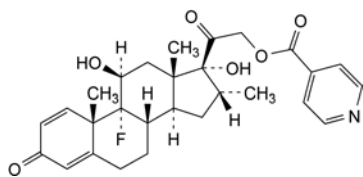

C<sub>28</sub>H<sub>32</sub>FNO<sub>6</sub>  
[2265-64-7]

M<sub>r</sub> 497.6

#### DEFINITION

9-Fluoro-11 $\beta$ ,17-dihydroxy-16 $\alpha$ -methyl-3,20-dioxopregna-1,4-dien-21-yl pyridine-4-carboxylate.

*Content*: 99.0 per cent to 101.0 per cent (dried substance).

#### CHARACTERS

*Appearance*: white or almost white crystalline powder.

*Solubility*: practically insoluble in water, slightly soluble in anhydrous ethanol and in acetone.

#### IDENTIFICATION

Infrared absorption spectrophotometry (2.2.24).

*Comparison*: dexamethasone isonicotinate CRS.

#### TESTS

**Specific optical rotation** (2.2.7): + 142 to + 146 (dried substance).

Suspend 0.200 g in 4.0 mL of *ethyl acetate R* and dilute to 20.0 mL with *ethanol (96 per cent) R*. Treat in an ultrasonic bath until a clear solution is obtained.

**Related substances**. Liquid chromatography (2.2.29). Prepare solutions immediately before use.

*Test solution*. Suspend 50.0 mg in 7 mL of *acetonitrile R* and dilute to 10.0 mL with *water R*. Treat in an ultrasonic bath until a clear solution is obtained.

*Reference solution (a)*. Suspend 5.0 mg of *dexamethasone CRS* and 5.0 mg of *dexamethasone acetate CRS* in 70 mL of *acetonitrile R*, add 1.0 mL of the test solution and dilute to 100.0 mL with *water R*. Treat in an ultrasonic bath until a clear solution is obtained.

*Reference solution (b)*. Dilute 1.0 mL of reference solution (a) to 10.0 mL with *water R*.

*Reference solution (c)*. Suspend 5 mg of *dexamethasone isonicotinate for impurity C identification CRS* in 0.7 mL of *acetonitrile R* and dilute to 1 mL with *water R*. Treat in an ultrasonic bath until a clear solution is obtained.

#### Column:

- size:  $l = 0.125$  m,  $\varnothing = 4.0$  mm,
- stationary phase: octadecylsilyl silica gel for chromatography R (5  $\mu$ m).

#### Mobile phase:

- mobile phase A: *water R*,
- mobile phase B: *acetonitrile R*,

Time (min)	Mobile phase A (per cent V/V)	Mobile phase B (per cent V/V)
0 - 2	68	32
2 - 20	68 → 50	32 → 50
20 - 25	50 → 68	50 → 32
25 - 35	68	32

*Flow rate*: 1.2 mL/min.

*Detection*: spectrophotometer at 240 nm.

*Injection*: 10  $\mu$ L.

*Identification of impurities*: use the chromatogram supplied with *dexamethasone isonicotinate for impurity C identification CRS* and the chromatogram obtained with reference solution (c) to identify the peak due to impurity C.

*Relative retention* with reference to dexamethasone isonicotinate (retention time = about 12 min):  
impurity A = about 0.4; impurity C = about 0.6;  
impurity B = about 0.8.

*System suitability*: reference solution (a):

- *resolution*: minimum 5.0 between the peaks due to impurity B and dexamethasone isonicotinate.

#### Limits:

- *impurity A*: not more than 5 times the area of the corresponding peak in the chromatogram obtained with reference solution (b) (0.5 per cent),
- *impurity B*: not more than 3 times the area of the corresponding peak in the chromatogram obtained with reference solution (b) (0.3 per cent),
- *impurity C*: not more than 3 times the area of the peak due to dexamethasone isonicotinate in the chromatogram obtained with reference solution (b) (0.3 per cent),
- *unspecified impurities*: for each impurity, not more than the area of the peak due to dexamethasone isonicotinate in the chromatogram obtained with reference solution (b) (0.1 per cent),

- *total*: not more than 8 times the area of the peak due to dexamethasone isonicotinate in the chromatogram obtained with reference solution (b) (0.8 per cent),
- *disregard limit*: 0.5 times the area of the peak due to dexamethasone isonicotinate in the chromatogram obtained with reference solution (b) (0.05 per cent).

**Loss on drying** (2.2.32): maximum 1.0 per cent, determined on 1.000 g by drying in an oven at 102 °C under high vacuum for 4 h.

#### ASSAY

Dissolve 0.400 g in a mixture of 5 mL of *anhydrous formic acid R* and 50 mL of *glacial acetic acid R*. Titrate with 0.1 M *perchloric acid*, determining the end-point potentiometrically (2.2.20).

1 mL of 0.1 M *perchloric acid* is equivalent to 49.76 mg of  $C_{28}H_{32}FNO_6$ .

#### IMPURITIES

*Specified impurities: A, B, C.*

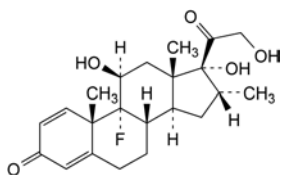

- A. 9-fluoro-11β,17,21-trihydroxy-16α-methylpregna-1,4-diene-3,20-dione (dexamethasone),

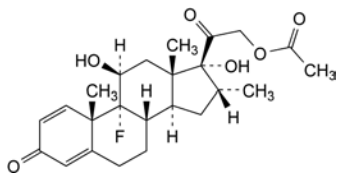

- B. 9-fluoro-11β,17-dihydroxy-16α-methyl-3,20-dioxopregna-1,4-dien-21-yl acetate (dexamethasone acetate),

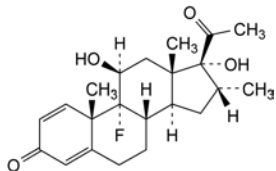

- C. 9-fluoro-11β,17-dihydroxy-16α-methylpregna-1,4-diene-3,20-dione (21-deoxydexamethasone).

01/2008:0549

## DEXAMETHASONE SODIUM PHOSPHATE

Dexamethasoni natrii phosphas

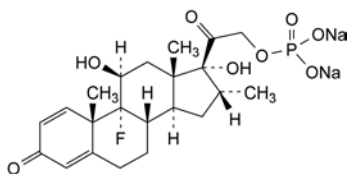

$C_{22}H_{28}FNa_2O_8P$   
[2392-39-4]

$M_r$  516.4

#### DEFINITION

9-Fluoro-11β,17-dihydroxy-16α-methyl-3,20-dioxopregna-1,4-dien-21-yl disodium phosphate.

*Content*: 97.0 per cent to 103.0 per cent (anhydrous substance).

#### CHARACTERS

*Appearance*: white or almost white, very hygroscopic powder.

*Solubility*: freely soluble in water, slightly soluble in ethanol (96 per cent), practically insoluble in methylene chloride.

It shows polymorphism (5.9).

#### IDENTIFICATION

*First identification: B, C.*

*Second identification: A, C, D, E, F.*

A. Dissolve 10.0 mg in 5 mL of *water R* and dilute to 100.0 mL with *anhydrous ethanol R*. Place 2.0 mL of this solution in a ground-glass-stoppered tube, add 10.0 mL of *phenylhydrazine-sulfuric acid solution R*, mix and heat in a water-bath at 60 °C for 20 min. Cool immediately. The absorbance (2.2.25) measured at the absorption maximum at 419 nm is at least 0.20.

B. Infrared absorption spectrophotometry (2.2.24).

*Comparison: dexamethasone sodium phosphate CRS.*

If the spectra obtained in the solid state show differences, dissolve the substance to be examined and the reference substance separately in the minimum volume of *ethanol (96 per cent) R*, evaporate to dryness on a water-bath and record new spectra using the residues.

C. Thin-layer chromatography (2.2.27).

*Test solution.* Dissolve 10 mg of the substance to be examined in *methanol R* and dilute to 10 mL with the same solvent.

*Reference solution (a).* Dissolve 20 mg of *dexamethasone sodium phosphate CRS* in *methanol R* and dilute to 20 mL with the same solvent.

*Reference solution (b).* Dissolve 10 mg of *prednisolone sodium phosphate CRS* in reference solution (a) and dilute to 10 mL with reference solution (a).

*Plate: TLC silica gel F<sub>254</sub> plate R.*

*Mobile phase: glacial acetic acid R, water R, butanol R (20:20:60 V/V/V).*

*Application: 5 μL.*

*Development: over a path of 15 cm.*

*Drying: in air.*

*Detection A: examine in ultraviolet light at 254 nm.*

*Results A: the principal spot in the chromatogram obtained with the test solution is similar in position and size to the principal spot in the chromatogram obtained with reference solution (a).*

*Detection B: spray with alcoholic solution of sulfuric acid R. Heat at 120 °C for 10 min or until the spots appear. Allow to cool. Examine in daylight and in ultraviolet light at 365 nm.*

*Results B: the principal spot in the chromatogram obtained with the test solution is similar in position, colour in daylight, fluorescence in ultraviolet light at 365 nm and size to the principal spot in the chromatogram obtained with reference solution (a).*

*System suitability: reference solution (b):*

- the chromatogram shows 2 spots which may, however, not be completely separated.

D. Add about 2 mg to 2 mL of *sulfuric acid R* and shake to dissolve. Within 5 min, a faint yellowish-brown colour develops. Add this solution to 10 mL of *water R* and mix. The colour fades and a clear solution remains.

E. Mix about 5 mg with 45 mg of *heavy magnesium oxide R* and ignite in a crucible until an almost white residue is obtained (usually less than 5 min). Allow to cool, add 1 mL of *water R*, 0.05 mL of *phenolphthalein solution RI* and about 1 mL of *dilute hydrochloric acid R* to render the solution colourless. Filter. To a freshly prepared mixture of 0.1 mL of *alizarin S solution R* and 0.1 mL of *zirconyl nitrate solution R*, add 1.0 mL of the filtrate. Mix, allow to stand

for 5 min and compare the colour of the solution with that of a blank prepared in the same manner. The test solution is yellow and the blank is red.

- F. To 40 mg add 2 mL of *sulfuric acid R* and heat gently until white fumes are evolved, add *nitric acid R* dropwise, continue the heating until the solution is almost colourless and cool. Add 2 mL of *water R*, heat until white fumes are again evolved, cool, add 10 mL of *water R* and neutralise to *red litmus paper R* with *dilute ammonia RI*. The solution gives reaction (a) of sodium (2.3.1) and reaction (b) of phosphates (2.3.1).

#### TESTS

**Solution S.** Dissolve 1.0 g in *carbon dioxide-free water R* and dilute to 20 mL with the same solvent.

**Appearance of solution.** Solution S is clear (2.2.1) and not more intensely coloured than reference solution B<sub>7</sub> (2.2.2, Method II).

**pH** (2.2.3): 7.5 to 9.5.

Dilute 1 mL of solution S to 5 mL with *carbon dioxide-free water R*.

**Specific optical rotation** (2.2.7): + 75 to + 83 (anhydrous substance).

Dissolve 0.250 g in *water R* and dilute to 25.0 mL with the same solvent.

**Related substances.** Liquid chromatography (2.2.29).

**Test solution.** Dissolve 25.0 mg of the substance to be examined in the mobile phase and dilute to 10.0 mL with the mobile phase.

**Reference solution (a).** Dissolve 2 mg of *dexamethasone sodium phosphate CRS* and 2 mg of *betamethasone sodium phosphate CRS* in the mobile phase, then dilute to 100.0 mL with the mobile phase.

**Reference solution (b).** Dilute 1.0 mL of the test solution to 100.0 mL with the mobile phase.

**Column:**

- size:  $l = 0.25$  m,  $\varnothing = 4.6$  mm;
- stationary phase: *octadecylsilyl silica gel for chromatography R* (5  $\mu$ m).

**Mobile phase:** in a 250 mL conical flask, weigh 1.360 g of *potassium dihydrogen phosphate R* and 0.600 g of *hexylamine R*, mix and allow to stand for 10 min and then dissolve in 182.5 mL of *water R*; add 67.5 mL of *acetonitrile R*, mix and filter (0.45  $\mu$ m).

**Flow rate:** 1 mL/min.

**Detection:** spectrophotometer at 254 nm.

**Equilibration:** with the mobile phase for about 45 min.

**Injection:** 20  $\mu$ L.

**Run time:** twice the retention time of dexamethasone sodium phosphate.

**Retention time:** impurity B = about 12.5 min; dexamethasone sodium phosphate = about 14 min.

**System suitability:** reference solution (a):

- resolution: minimum 2.2 between the peaks due to impurity B and dexamethasone sodium phosphate; if necessary, adjust slightly the concentration of acetonitrile or increase the concentration of water in the mobile phase.

**Limits:**

- impurities A, B: for each impurity, not more than 0.5 times the area of the principal peak in the chromatogram obtained with reference solution (b) (0.5 per cent);
- total: not more than the area of the principal peak in the chromatogram obtained with reference solution (b) (1 per cent);

- disregard limit: 0.05 times the area of the principal peak in the chromatogram obtained with reference solution (b) (0.05 per cent).

**Inorganic phosphates:** maximum 1 per cent.

Dissolve 50 mg in *water R* and dilute to 100 mL with the same solvent. To 10 mL of this solution add 5 mL of *molybdovanadic reagent R*, mix and allow to stand for 5 min. Any yellow colour in the solution is not more intense than that in a standard prepared at the same time in the same manner using 10 mL of *phosphate standard solution (5 ppm PO<sub>4</sub>) R*.

**Ethanol.** Gas chromatography (2.2.28).

**Internal standard solution.** Dilute 1.0 mL of *propanol R* to 100.0 mL with *water R*.

**Test solution.** Dissolve 0.50 g of the substance to be examined in 5.0 mL of the internal standard solution and dilute to 10.0 mL with *water R*.

**Reference solution.** Dilute 1.0 g of *anhydrous ethanol R* to 100.0 mL with *water R*. To 2.0 mL of this solution add 5.0 mL of the internal standard solution and dilute to 10.0 mL with *water R*.

**Column:**

- size:  $l = 1$  m,  $\varnothing = 3.2$  mm;
- stationary phase: *ethylvinylbenzene-divinylbenzene copolymer RI* (150-180  $\mu$ m).

**Carrier gas:** *nitrogen for chromatography R*.

**Flow rate:** 30 mL/min.

**Temperature:**

- column: 150 °C;
- injection port: 250 °C;
- detector: 280 °C.

**Detection:** flame ionisation.

**Injection:** 2  $\mu$ L.

**Limit:**

- ethanol: maximum 3.0 per cent *m/m*.

**Ethanol and water:** maximum 13.0 per cent *m/m* for the sum of the percentage contents.

Determine the water content using 0.200 g (2.5.12). Add the percentage content of water and the percentage content of ethanol obtained in the test for ethanol.

#### ASSAY

Dissolve 0.100 g in *water R* and dilute to 100.0 mL with the same solvent. Dilute 10.0 mL of this solution to 500.0 mL with *water R*. Measure the absorbance (2.2.25) at the absorption maximum at 241.5 nm.

Calculate the content of C<sub>22</sub>H<sub>28</sub>FN<sub>2</sub>O<sub>8</sub>P taking the specific absorbance to be 303.

#### STORAGE

In an airtight container, protected from light.

#### IMPURITIES

**Specified impurities:** A, B.

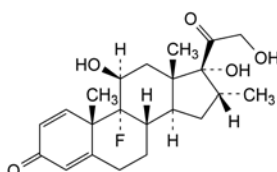

A. 9-fluoro-11 $\beta$ ,17,21-trihydroxy-16 $\alpha$ -methylpregna-1,4-diene-3,20-dione (dexamethasone),

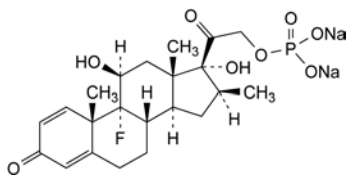

- B. 9-fluoro-11 $\beta$ ,17-dihydroxy-16 $\beta$ -methyl-3,20-dioxopregna-1,4-dien-21-yl disodium phosphate (bethamethasone sodium phosphate).

01/2008:1196  
corrected 6.8

## DEXCHLORPHENIRAMINE MALEATE

### Dexchlorphenirami maleas

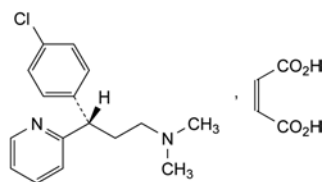

C<sub>20</sub>H<sub>23</sub>ClN<sub>2</sub>O<sub>4</sub>  
[2438-32-6]

M<sub>r</sub> 390.9

#### DEFINITION

(3*S*)-3-(4-Chlorophenyl)-*N,N*-dimethyl-3-(pyridin-2-yl)propan-1-amine (*Z*)-butenedioate.

*Content*: 98.0 per cent to 100.5 per cent (dried substance).

#### CHARACTERS

*Appearance*: white or almost white, crystalline powder.

*Solubility*: very soluble in water, freely soluble in ethanol (96 per cent), in methanol and in methylene chloride.

#### IDENTIFICATION

*First identification*: A, C, E.

*Second identification*: A, B, D, E.

- A. Specific optical rotation (see Tests).  
B. Melting point (2.2.14): 110 °C to 115 °C.  
C. Infrared absorption spectrophotometry (2.2.24).

*Preparation*: discs of *potassium bromide R*.

*Comparison*: *dexchlorpheniramine maleate CRS*.

- D. Thin-layer chromatography (2.2.27).

*Test solution*. Dissolve 0.10 g of the substance to be examined in *methanol R* and dilute to 5.0 mL with the same solvent.

*Reference solution*. Dissolve 56 mg of *maleic acid R* in *methanol R* and dilute to 10 mL with the same solvent.

*Plate*: *TLC silica gel F<sub>254</sub> plate R*.

*Mobile phase*: *water R*, *anhydrous formic acid R*, *methanol R*, *di-isopropyl ether R* (3:7:20:70 V/V/V/V).

*Application*: 5  $\mu$ L.

*Development*: over a path of 12 cm.

*Drying*: in a current of air for a few minutes.

*Detection*: examine in ultraviolet light at 254 nm.

*Results*: the chromatogram obtained with the test solution shows 2 clearly separated spots. The upper spot is similar in position and size to the spot in the chromatogram obtained with the reference solution.

- E. To 0.15 g in a porcelain crucible add 0.5 g of *anhydrous sodium carbonate R*. Heat over an open flame for 10 min. Allow to cool. Take up the residue with 10 mL of *dilute nitric acid R* and filter. To 1 mL of the filtrate add 1 mL of *water R*. The solution gives reaction (a) of chlorides (2.3.1).

#### TESTS

**Solution S**. Dissolve 2.0 g in *water R* and dilute to 20.0 mL with the same solvent.

**Appearance of solution**. Solution S is clear (2.2.1) and not more intensely coloured than reference solution BY<sub>6</sub> (2.2.2, *Method II*).

**pH** (2.2.3): 4.5 to 5.5.

Dissolve 0.20 g in 20 mL of *water R*.

**Specific optical rotation** (2.2.7): + 22 to + 23 (dried substance), determined on solution S.

**Related substances**. Gas chromatography (2.2.28).

*Test solution*. Dissolve 10.0 mg of the substance to be examined in 1.0 mL of *methylene chloride R*.

*Reference solution*. Dissolve 5.0 mg of *brompheniramine maleate CRS* in 0.5 mL of *methylene chloride R* and add 0.5 mL of the test solution. Dilute 0.5 mL of this solution to 50.0 mL with *methylene chloride R*.

*Column*:

- *material*: glass;
- *size*:  $l = 2.3$  m,  $\varnothing = 2$  mm;
- *stationary phase*: acid- and base-washed *silanised diatomaceous earth for gas chromatography R* (135-175  $\mu$ m) impregnated with 3 per cent *m/m* of a mixture of 50 per cent of poly(dimethyl)siloxane and 50 per cent of poly(diphenyl)siloxane.

*Carrier gas*: *nitrogen for chromatography R*.

*Flow rate*: 20 mL/min.

*Temperature*:

- *column*: 205 °C;
- *injection port and detector*: 250 °C.

*Detection*: flame ionisation.

*Injection*: 1  $\mu$ L.

*Run time*: 2.5 times the retention time of dexchlorpheniramine.

*System suitability*: reference solution:

- *resolution*: minimum 1.5 between the peaks due to dexchlorpheniramine and brompheniramine.

*Limits*:

- *impurity A*: not more than 0.8 times the area of the peak due to dexchlorpheniramine in the chromatogram obtained with the reference solution (0.4 per cent);
- *total*: not more than twice the area of the peak due to dexchlorpheniramine in the chromatogram obtained with the reference solution (1 per cent).

**Enantiomeric purity**. Liquid chromatography (2.2.29).

*Test solution*. Dissolve 10.0 mg of the substance to be examined in 3 mL of *water R*. Add a few drops of *concentrated ammonia R* until an alkaline reaction is produced. Shake with 5 mL of *methylene chloride R*. Separate the layers. Evaporate the lower, methylene chloride layer to an oily residue on a water-bath. Dissolve the oily residue in *2-propanol R* and dilute to 10.0 mL with the same solvent.

*Reference solution (a)*. Dissolve 10.0 mg of *dexchlorpheniramine maleate CRS* in 3 mL of *water R*. Add a few drops of *concentrated ammonia R* until an alkaline reaction is produced. Shake with 5 mL of *methylene chloride R*. Separate the layers. Evaporate the lower, methylene chloride layer to an oily residue on a water-bath. Dissolve the oily residue in *2-propanol R* and dilute to 10.0 mL with the same solvent.

*Reference solution (b)*. Dissolve 10.0 mg of *chlorphenamine maleate CRS* in 3 mL of *water R*. Add a few drops of *concentrated ammonia R* until an alkaline reaction is produced. Shake with 5 mL of *methylene chloride R*. Separate the layers. Evaporate the lower, methylene chloride layer to an oily residue on a water-bath. Dissolve the oily residue in *2-propanol R* and dilute to 10.0 mL with the same solvent.



01/2008:0761

**Reference solution (c).** Dilute 1.0 mL of the test solution to 50 mL with 2-propanol R.

**Column:**

- size:  $l = 0.25$  m,  $\varnothing = 4.6$  mm;
- stationary phase: amylose derivative of silica gel for chromatography R.

**Mobile phase:** diethylamine R, 2-propanol R, hexane R (3:20:980 V/V/V).

**Flow rate:** 1 mL/min.

**Detection:** spectrophotometer at 254 nm.

**Injection:** 10  $\mu$ L.

Under these conditions the peak due to the (S)-isomer appears first.

**System suitability:**

- **resolution:** minimum 1.5 between the peaks due to the (R)-enantiomer (impurity B) and the (S)-enantiomer in the chromatogram obtained with reference solution (b);
- the retention times of the principal peaks in the chromatograms obtained with the test solution and reference solution (a) are identical ((S)-enantiomer).

**Limits:**

- (R)-enantiomer (impurity B): not more than the area of the principal peak in the chromatogram obtained with reference solution (c) (2 per cent);
- **unspecified impurities:** for each impurity, not more than 0.25 times the area of the principal peak in the chromatogram obtained with reference solution (c) (0.5 per cent).

**Heavy metals (2.4.8):** maximum 20 ppm.

1.0 g complies with test C. Prepare the reference solution using 2 mL of lead standard solution (10 ppm Pb) R.

**Loss on drying (2.2.32):** maximum 0.5 per cent, determined on 1.000 g by drying in an oven at 65 °C for 4 h.

**Sulfated ash (2.4.14):** maximum 0.1 per cent, determined on 1.0 g.

**ASSAY**

Dissolve 0.150 g in 25 mL of anhydrous acetic acid R. Titrate with 0.1 M perchloric acid, determining the end-point potentiometrically (2.2.20).

1 mL of 0.1 M perchloric acid is equivalent to 19.54 mg of  $C_{20}H_{23}ClN_2O_4$ .

**STORAGE**

Protected from light.

**IMPURITIES**

**Specified impurities:** A, B.

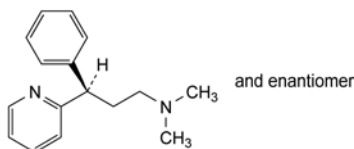

A. (3R)-N,N-dimethyl-3-phenyl-3-(pyridin-2-yl)propan-1-amine,

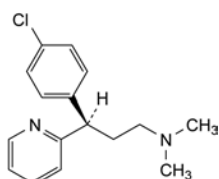

B. (3R)-3-(4-chlorophenyl)-N,N-dimethyl-3-(pyridin-2-yl)propan-1-amine ((R)-enantiomer).

## DEXPANTHENOL

### Dexpanthenolum

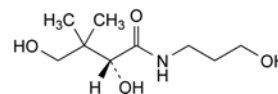

$C_9H_{19}NO_4$   
[81-13-0]

$M_r$  205.3

**DEFINITION**

Dexpanthenol contains not less than 98.0 per cent and not more than the equivalent of 101.0 per cent of (2R)-2,4-dihydroxy-N-(3-hydroxypropyl)-3,3-dimethylbutanamide, calculated with reference to the anhydrous substance.

**CHARACTERS**

A colourless or slightly yellowish, viscous hygroscopic liquid, or a white or almost white, crystalline powder, very soluble in water, freely soluble in ethanol (96 per cent).

**IDENTIFICATION**

**First identification:** A, B.

**Second identification:** A, C, D.

- Specific optical rotation (see Tests).
- Examine by infrared absorption spectrophotometry (2.2.24), comparing with the spectrum obtained with dexpanthenol CRS. Examine the substances using discs prepared as follows: dissolve the substance to be examined and the reference substance separately in 1.0 mL of anhydrous ethanol R to obtain a concentration of 5 mg/mL. Place dropwise 0.5 mL of this solution on a disc of potassium bromide R. Dry the disc at 100-105 °C for 15 min.
- Examine the chromatograms obtained in the test for 3-aminopropanol. The principal spot in the chromatogram obtained with test solution (b) is similar in position, colour and size to the principal spot in the chromatogram obtained with reference solution (a).
- To 1 mL of solution S (see Tests) add 1 mL of dilute sodium hydroxide solution R and 0.1 mL of copper sulfate solution R. A blue colour develops.

**TESTS**

**Solution S.** Dissolve 2.500 g in carbon dioxide-free water R and dilute to 50.0 mL with the same solvent.

**Appearance of solution.** Solution S is clear (2.2.1) and not more intensely coloured than reference solution B<sub>6</sub> (2.2.2, Method II).

**pH (2.2.3).** The pH of solution S is not greater than 10.5.

**Specific optical rotation (2.2.7).** The specific optical rotation is + 29.0 to + 32.0, determined on solution S and calculated with reference to the anhydrous substance.

**3-Aminopropanol.** Examine by thin-layer chromatography (2.2.27), using silica gel G R as the coating substance.

**Test solution (a).** Dissolve 0.25 g of the substance to be examined in anhydrous ethanol R and dilute to 5 mL with the same solvent.

**Test solution (b).** Dilute 1 mL of test solution (a) to 10 mL with anhydrous ethanol R.

**Reference solution (a).** Dissolve the contents of a vial of dexpanthenol CRS in 1.0 mL of anhydrous ethanol R to obtain a concentration of 5 mg/mL.

**Reference solution (b).** Dissolve 25 mg of 3-aminopropanol R in anhydrous ethanol R and dilute to 100 mL with the same solvent.

Apply separately to the plate 10  $\mu$ L of each solution. Develop over a path of 15 cm using a mixture of 20 volumes of concentrated ammonia R, 25 volumes of methanol R and

55 volumes of *butanol R*. Allow the plate to dry in air, spray with a 100 g/L solution of *trichloroacetic acid R* in *methanol R* and heat at 150 °C for 10 min. Spray with a 1 g/L solution of *ninhydrin R* in *methanol R* and heat at 120 °C until a colour appears. Any spot due to 3-aminopropanol in the chromatogram obtained with test solution (a) is not more intense than the spot in the chromatogram obtained with reference solution (b) (0.5 per cent).

**Heavy metals (2.4.8).** 12 mL of solution S complies with limit test A for heavy metals (20 ppm). Prepare the reference solution using *lead standard solution (1 ppm Pb) R*.

**Water (2.5.12).** Not more than 1.0 per cent, determined on 1.000 g.

**Sulfated ash (2.4.14).** Not more than 0.1 per cent, determined on 1.0 g.

#### ASSAY

To 0.400 g add 50.0 mL of 0.1 M *perchloric acid*. Boil under a reflux condenser for 5 h protected from humidity. Allow to cool. Add 50 mL of *dioxan R* by rinsing the condenser, protected from humidity. Add 0.2 mL of *naphtholbenzein solution R* and titrate with 0.1 M *potassium hydrogen phthalate* until the colour changes from green to yellow. Carry out a blank titration.

1 mL of 0.1 M *perchloric acid* is equivalent to 20.53 mg of  $C_9H_{19}NO_4$ .

#### STORAGE

In an airtight container.

01/2009:1506

## DEXTRAN 1 FOR INJECTION

### Dextranum 1 ad iniectabile

#### DEFINITION

Low-molecular-weight fraction of dextran, consisting of a mixture of isomaltooligosaccharides.

*Average relative molecular mass:* about 1000.

#### PRODUCTION

It is obtained by hydrolysis and fractionation of dextrans produced by fermentation of sucrose using *Leuconostoc mesenteroides* strain NRRL B-512 = CIP 78.59 or substrains thereof (for example *L. mesenteroides* B-512 F = NCTC 10817).

It is prepared in conditions designed to minimise the risk of microbial contamination.

#### CHARACTERS

*Appearance:* white or almost white hygroscopic powder.

*Solubility:* very soluble in water, very slightly soluble in ethanol (96 per cent).

#### IDENTIFICATION

A. Dissolve 3.000 g in *water R*, heat on a water-bath and dilute to 100.0 mL with the same solvent. The specific optical rotation (2.2.7) is + 148 to + 164, calculated with reference to the dried substance. Dry an aliquot of the solution first on a water-bath and then to constant weight *in vacuo* at 70 °C. Calculate the dextran content after correction for the content of sodium chloride.

B. Infrared absorption spectrophotometry (2.2.24).

*Preparation:* to 1-2 mg add 1 or a few drops of *water R*. Grind in an agate mortar for 1-2 min. Add about 300 mg of *potassium bromide R* and mix to a slurry but do not grind. Dry *in vacuo* at 40 °C for 15 min. Crush the residue. If it is not dry, dry for another 15 min. Prepare a disc using *potassium bromide R*.

*Comparison:* repeat the operations using *dextran 1 CRS*.

*Blank:* run the infrared spectrum with a blank disc using *potassium bromide R* in the reference beam.

C. Molecular-mass distribution (see Tests).

#### TESTS

**Solution S.** Dissolve 7.5 g in *carbon dioxide-free water R*, heat on a water-bath and dilute to 50 mL with the same solvent.

**Absorbance (2.2.25):** maximum 0.12, determined at 375 nm on solution S.

**Acidity or alkalinity.** To 10 mL of solution S add 0.1 mL of *phenolphthalein solution R*. The solution is colourless. Add 0.2 mL of 0.01 M *sodium hydroxide*. The solution is pink. Add 0.4 mL of 0.01 M *hydrochloric acid*. The solution is colourless. Add 0.1 mL of *methyl red solution R*. The solution is red or orange.

**Nitrogen-containing substances:** maximum 110 ppm of N.

Carry out the determination of nitrogen by sulfuric acid digestion (2.5.9), using 0.200 g and heating for 2 h. Collect the distillate in a mixture of 0.5 mL of *bromocresol green solution R*, 0.5 mL of *methyl red solution R* and 20 mL of *water R*. Titrate with 0.01 M *hydrochloric acid*. Not more than 0.15 mL of 0.01 M *hydrochloric acid* is required to change the colour of the indicator.

**Sodium chloride:** maximum 1.5 per cent.

Accurately weigh 3-5 g and dissolve in 100 mL of *water R*. Add 0.3 mL of *potassium chromate solution R* and titrate with 0.1 M *silver nitrate* until the yellowish-white colour changes to reddish-brown.

1 mL of 0.1 M *silver nitrate* is equivalent to 5.844 mg of NaCl.

**Molecular-mass distribution.** Size-exclusion chromatography (2.2.30).

*Test solution.* Dissolve 6.0-6.5 mg of the substance to be examined in 1.0 mL of the mobile phase.

*Reference solution (a).* Dissolve 6.0-6.5 mg of *dextran 1 CRS* in 1.0 mL of the mobile phase.

*Reference solution (b).* Dissolve the content of an ampoule of *isomaltooligosaccharide CRS* in 1 mL of the mobile phase, and mix. This corresponds to approximately 45 µg of isomaltotriose (3 glucose units), approximately 45 µg of isomaltotetraose (4 glucose units), approximately 45 µg of isomaltopentaose (5 glucose units), and approximately 60 µg of sodium chloride per 100 µL.

*Column:* 2 columns coupled in series:

- *size:*  $l = 0.30$  m,  $\varnothing = 10$  mm;
- *stationary phase:* dextran covalently bound to highly cross-linked porous agarose beads, allowing resolution of oligosaccharides in the molecular mass range of 180 to 3000;
- *temperature:* 20-25 °C.

*Mobile phase:* 2.92 g/L solution of *sodium chloride R*.

*Flow rate:* 0.07-0.08 mL/min maintained constant to  $\pm 1$  per cent.

*Detection:* differential refractometer.

*Injection:* 100 µL.

*Identification of peaks:* use the chromatogram obtained with reference solution (b) to identify the peaks due to isomaltotriose, isomaltotetraose and sodium chloride.

01/2009:0999

Determine the peak areas. Disregard any peak due to sodium chloride. Calculate the average relative molecular mass  $M_w$  and the amount of the fraction with less than 3 and more than 9 glucose units, of *dextran 1 CRS* and of the substance to be examined, using the following expression:

$$M_w = \sum w_i \times m_i$$

$M_w$  = average molecular mass of the dextran;

$m_i$  = molecular mass of oligosaccharide  $i$ ;

$w_i$  = weight proportion of oligosaccharide  $i$ .

Use the following  $m_i$  values for the calculation:

Oligosaccharide $i$	$m_i$
glucose	180
isomaltose	342
isomaltotriose	504
isomaltotetraose	666
isomaltopentaose	828
isomaltohexaose	990
isomaltoheptaose	1152
isomaltooctaose	1314
isomalttonaose	1476
isomaltodecaose	1638
isomaltoundecaose	1800
isomaltododecaose	1962
isomaltotridecaose	2124
isomaltotetradecaose	2286
isomaltopentadecaose	2448
isomaltohexadecaose	2610
isomaltoheptadecaose	2772
isomaltooctadecaose	2934
isomalttonadecaose	3096

*System suitability*: the values obtained for *dextran 1 CRS* are within the values stated on the label.

*Limits*:

- average molecular mass ( $M_w$ ): 850 to 1150;
- fraction with less than 3 glucose units: less than 15 per cent;
- fraction with more than 9 glucose units: less than 20 per cent.

**Heavy metals** (2.4.8): maximum 10 ppm.

Dilute 20 mL of solution S to 30 mL with *water R*. 12 mL of solution complies with test A. Prepare the reference solution using *lead standard solution (1 ppm Pb) R*.

**Loss on drying** (2.2.32): maximum 5.0 per cent, determined on 5.000 g by drying in an oven at 105 °C for 5 h.

**Bacterial endotoxins** (2.6.14): less than 25 IU/g.

**Microbial contamination**

TAMC: acceptance criterion  $10^2$  CFU/g (2.6.12).

## DEXTRAN 40 FOR INJECTION

### Dextranum 40 ad iniectionabile

#### DEFINITION

Mixture of polysaccharides, principally of the  $\alpha$ -1,6-glucan type. *Average relative molecular mass*: about 40 000.

#### PRODUCTION

It is obtained by hydrolysis and fractionation of dextrans produced by fermentation of sucrose using *Leuconostoc mesenteroides* strain NRRL B-512 = CIP 78.59 or substrains thereof (for example *L. mesenteroides* B-512F = NCTC 10817).

It is prepared in conditions designed to minimise the risk of microbial contamination.

#### CHARACTERS

*Appearance*: white or almost white powder.

*Solubility*: very soluble in water, very slightly soluble in ethanol (96 per cent).

#### IDENTIFICATION

A. Specific optical rotation (2.2.7): + 195 to + 201 (dried substance).

Dissolve 1.0 g in *water R*, heating on a water-bath, and dilute to 50.0 mL with the same solvent.

B. Infrared absorption spectrophotometry (2.2.24).

*Comparison*: *dextran CRS*.

C. Molecular-mass distribution (see Tests).

#### TESTS

**Solution S**. Dissolve 5.0 g in *distilled water R*, heating on a water-bath, and dilute to 50 mL with the same solvent.

**Appearance of solution**. Solution S is clear (2.2.1) and colourless (2.2.2, *Method II*).

**Acidity or alkalinity**. To 10 mL of solution S add 0.1 mL of *phenolphthalein solution R*. The solution remains colourless. Add 0.2 mL of 0.01 M *sodium hydroxide*. The solution is red. Add 0.4 mL of 0.01 M *hydrochloric acid*. The solution is colourless. Add 0.1 mL of *methyl red solution R*. The solution is red or orange.

**Nitrogen-containing substances**: maximum 110 ppm N.

Carry out the determination of nitrogen by sulfuric acid digestion (2.5.9), using 0.200 g and heating for 2 h. Collect the distillate in a mixture of 0.5 mL of *bromocresol green solution R*, 0.5 mL of *methyl red solution R* and 20 mL of *water R*. Titrate with 0.01 M *hydrochloric acid*. Not more than 0.15 mL of 0.01 M *hydrochloric acid* is required to change the colour of the indicator.

**Residual solvents**. Gas chromatography (2.2.28).

*Internal standard*: *propanol R*.

*Test solution*. Dissolve 5 g of the substance to be examined in 100 mL of *water R* and distil. Collect the first 45 mL of the distillate, add 1 mL of a 25 g/L solution of *propanol R* and dilute to 50 mL with *water R*.

*Reference solution*. Mix 0.5 mL of a 25 g/L solution of *anhydrous ethanol R*, 0.5 mL of a 25 g/L solution of *propanol R* and 0.5 mL of a 2.5 g/L solution of *methanol R* and dilute to 25.0 mL with *water R*.

*Column*:

- *material*: stainless steel;
- *size*:  $l = 1.8$  m,  $\varnothing = 2$  mm;
- *stationary phase*: *ethylvinylbenzene-divinylbenzene copolymer R* (125-150  $\mu$ m).

*Carrier gas*: *nitrogen for chromatography R*.

*Flow rate*: 25 mL/min.

**Temperature:**

- column: 190 °C;
- injection port: 240 °C;
- detector: 210 °C.

**Detection:** flame ionisation.

**Injection:** the chosen volume of each solution.

**Limits:**

- *ethanol*: not more than the area of the corresponding peak in the chromatogram obtained with the reference solution (0.5 per cent);
- *methanol*: not more than the area of the corresponding peak in the chromatogram obtained with the reference solution (0.05 per cent);
- *sum of solvents other than ethanol, methanol and propanol*: not more than the area of the peak due to the internal standard (0.5 per cent, calculated as propanol).

**Molecular-mass distribution (2.2.39).** The average molecular mass ( $M_w$ ) is 35 000 to 45 000. The average molecular mass of the 10 per cent high fraction is not greater than 110 000. The average molecular mass of the 10 per cent low fraction is not less than 7000.

**Heavy metals (2.4.8):** maximum 10 ppm.

12 mL of solution S complies with test A. Prepare the reference solution using *lead standard solution (1 ppm Pb) R*.

**Loss on drying (2.2.32):** maximum 7.0 per cent, determined on 0.200 g by heating in an oven at  $105 \pm 2$  °C for 5 h.

**Sulfated ash (2.4.14):** maximum 0.3 per cent, determined on 0.50 g.

**Bacterial endotoxins (2.6.14):** less than 10 IU/g.

**Microbial contamination**

TAMC: acceptance criterion  $10^2$  CFU/g (2.6.12).

01/2009:1000

**DEXTRAN 60 FOR INJECTION****Dextranum 60 ad iniectionabile****DEFINITION**

Mixture of polysaccharides, principally of the  $\alpha$ -1,6-glucan type.  
*Average relative molecular mass:* about 60 000.

**PRODUCTION**

It is obtained by hydrolysis and fractionation of dextrans produced by fermentation of sucrose using *Leuconostoc mesenteroides* strain NRRL B-512 = CIP 78.59 or substrains thereof (for example *L. mesenteroides* B-512F = NCTC 10817).

It is prepared in conditions designed to minimise the risk of microbial contamination.

**CHARACTERS**

*Appearance:* white or almost white powder.

*Solubility:* very soluble in water, very slightly soluble in ethanol (96 per cent).

**IDENTIFICATION**

- Specific optical rotation (2.2.7): + 195 to + 201 (dried substance).  
Dissolve 1.0 g in *water R*, heating on a water-bath, and dilute to 50.0 mL with the same solvent.
- Infrared absorption spectrophotometry (2.2.24).  
*Comparison:* *dextran CRS*.
- Molecular-mass distribution (see Tests).

**TESTS**

**Solution S.** Dissolve 5.0 g in *distilled water R*, heating on a water-bath, and dilute to 50 mL with the same solvent.

**Appearance of solution.** Solution S is clear (2.2.1) and colourless (2.2.2, *Method II*).

**Acidity or alkalinity.** To 10 mL of solution S add 0.1 mL of *phenolphthalein solution R*. The solution remains colourless. Add 0.2 mL of 0.01 M *sodium hydroxide*. The solution is red. Add 0.4 mL of 0.01 M *hydrochloric acid*. The solution is colourless. Add 0.1 mL of *methyl red solution R*. The solution is red or orange.

**Nitrogen-containing substances:** maximum 110 ppm of N.

Carry out the determination of nitrogen by sulfuric acid digestion (2.5.9), using 0.200 g and heating for 2 h. Collect the distillate in a mixture of 0.5 mL of *bromocresol green solution R*, 0.5 mL of *methyl red solution R* and 20 mL of *water R*. Titrate with 0.01 M *hydrochloric acid*. Not more than 0.15 mL of 0.01 M *hydrochloric acid* is required to change the colour of the indicator.

**Residual solvents.** Gas chromatography (2.2.28).

*Internal standard:* *propanol R*.

*Test solution.* Dissolve 5 g of the substance to be examined in 100 mL of *water R* and distil. Collect the first 45 mL of the distillate, add 1 mL of a 25 g/L solution of *propanol R* and dilute to 50 mL with *water R*.

*Reference solution.* Mix 0.5 mL of a 25 g/L solution of *anhydrous ethanol R*, 0.5 mL of a 25 g/L solution of *propanol R* and 0.5 mL of a 2.5 g/L solution of *methanol R* and dilute to 25.0 mL with *water R*.

**Column:**

- *material:* stainless steel;
- *size:*  $l = 1.8$  m,  $\varnothing = 2$  mm;
- *stationary phase:* *ethylvinylbenzene-divinylbenzene copolymer R* (125-150  $\mu$ m).

*Carrier gas:* *nitrogen for chromatography R*.

*Flow rate:* 25 mL/min.

**Temperature:**

- column: 190 °C;
- injection port: 240 °C;
- detector: 210 °C.

**Detection:** flame ionisation.

**Injection:** the chosen volume of each solution.

**Limits:**

- *ethanol*: not more than the area of the corresponding peak in the chromatogram obtained with the reference solution (0.5 per cent);
- *methanol*: not more than the area of the corresponding peak in the chromatogram obtained with the reference solution (0.05 per cent);
- *sum of solvents other than ethanol, methanol and propanol*: not more than the area of the peak due to the internal standard (0.5 per cent, calculated as propanol).

**Molecular-mass distribution (2.2.39).** The average molecular mass ( $M_w$ ) is 54 000 to 66 000. The average molecular mass of the 10 per cent high fraction is not greater than 180 000. The average molecular mass of the 10 per cent low fraction is not less than 14 000.

**Heavy metals (2.4.8):** maximum 10 ppm.

12 mL of solution S complies with test A. Prepare the reference solution using *lead standard solution (1 ppm Pb) R*.

**Loss on drying (2.2.32):** maximum 7.0 per cent, determined on 0.200 g by heating in an oven at  $105 \pm 2$  °C for 5 h.

**Sulfated ash (2.4.14):** maximum 0.3 per cent, determined on 0.50 g.

**Bacterial endotoxins (2.6.14):** less than 16 IU/g.

**Microbial contamination**

TAMC: acceptance criterion  $10^2$  CFU/g (2.6.12).

01/2009:1001 Flow rate: 25 mL/min.

**DEXTRAN 70 FOR INJECTION****Dextranum 70 ad iniectionabile****DEFINITION**

Mixture of polysaccharides, principally of the  $\alpha$ -1,6-glucan type.  
Average relative molecular mass: about 70 000.

**PRODUCTION**

It is obtained by hydrolysis and fractionation of dextrans produced by fermentation of sucrose using *Leuconostoc mesenteroides* strain NRRL B-512 = CIP 78.59 or substrains thereof (for example *L. mesenteroides* B-512F = NCTC 10817).

It is prepared in conditions designed to minimise the risk of microbial contamination.

**CHARACTERS**

*Appearance*: white or almost white powder.

*Solubility*: very soluble in water, very slightly soluble in ethanol (96 per cent).

**IDENTIFICATION**

A. Specific optical rotation (2.2.7): + 195 to + 201 (dried substance).

Dissolve 1.0 g in *water R*, heating on a water-bath, and dilute to 50.0 mL with the same solvent.

B. Infrared absorption spectrophotometry (2.2.24).

*Comparison*: dextran CRS.

C. Molecular-mass distribution (see Tests).

**TESTS**

**Solution S.** Dissolve 5.0 g in *distilled water R*, heating on a water-bath, and dilute to 50 mL with the same solvent.

**Appearance of solution.** Solution S is clear (2.2.1) and colourless (2.2.2, *Method II*).

**Acidity or alkalinity.** To 10 mL of solution S add 0.1 mL of *phenolphthalein solution R*. The solution remains colourless. Add 0.2 mL of 0.01 M *sodium hydroxide*. The solution is red. Add 0.4 mL of 0.01 M *hydrochloric acid*. The solution is colourless. Add 0.1 mL of *methyl red solution R*. The solution is red or orange.

**Nitrogen-containing substances:** maximum 110 ppm of N.

Carry out the determination of nitrogen by sulfuric acid digestion (2.5.9), using 0.200 g and heating for 2 h. Collect the distillate in a mixture of 0.5 mL of *bromocresol green solution R*, 0.5 mL of *methyl red solution R* and 20 mL of *water R*. Titrate with 0.01 M *hydrochloric acid*. Not more than 0.15 mL of 0.01 M *hydrochloric acid* is required to change the colour of the indicator.

**Residual solvents.** Gas chromatography (2.2.28).

*Internal standard*: *propanol R*.

*Test solution.* Dissolve 5 g of the substance to be examined in 100 mL of *water R* and distil. Collect the first 45 mL of the distillate, add 1 mL of a 25 g/L solution of *propanol R* and dilute to 50 mL with *water R*.

*Reference solution.* Mix 0.5 mL of a 25 g/L solution of *anhydrous ethanol R*, 0.5 mL of a 25 g/L solution of *propanol R* and 0.5 mL of a 2.5 g/L solution of *methanol R* and dilute to 25.0 mL with *water R*.

*Column*:

- *material*: stainless steel;
- *size*:  $l = 1.8$  m,  $\varnothing = 2$  mm;
- *stationary phase*: *ethylvinylbenzene-divinylbenzene copolymer R* (125-150  $\mu$ m).

*Carrier gas*: *nitrogen for chromatography R*.

*Temperature*:

- *column*: 190 °C;
- *injection port*: 240 °C;
- *detector*: 210 °C.

*Detection*: flame ionisation.

*Injection*: the chosen volume of each solution.

*Limits*:

- *ethanol*: not more than the area of the corresponding peak in the chromatogram obtained with the reference solution (0.5 per cent);
- *methanol*: not more than the area of the corresponding peak in the chromatogram obtained with the reference solution (0.05 per cent);
- *sum of solvents other than ethanol, methanol and propanol*: not more than the area of the peak due to the internal standard (0.5 per cent, calculated as propanol).

**Molecular-mass distribution (2.2.39).** The average molecular mass ( $M_w$ ) is 64 000 to 76 000. The average molecular mass of the 10 per cent high fraction is not greater than 185 000. The average molecular mass of the 10 per cent low fraction is not less than 15 000.

**Heavy metals (2.4.8):** maximum 10 ppm.

12 mL of solution S complies with test A. Prepare the reference solution using *lead standard solution (1 ppm Pb) R*.

**Loss on drying (2.2.32):** maximum 7.0 per cent, determined on 0.200 g by heating in an oven at  $105 \pm 2$  °C for 5 h.

**Sulfated ash (2.4.14):** maximum 0.3 per cent, determined on 0.50 g.

**Bacterial endotoxins (2.6.14):** less than 16 IU/g.

**Microbial contamination**

TAMC: acceptance criterion  $10^2$  CFU/g (2.6.12).

01/2008:2238

**DEXTRANOMER****Dextranomerum**

[56087-11-7]

**DEFINITION**

Three-dimensional network made of dextran chains *O,O'*-cross-linked with 2-hydroxypropane-1,3-diol bridges and *O*-substituted with 2,3-dihydroxypropyl and 2-hydroxy-1-(hydroxymethyl)ethyl groups.

**CHARACTERS**

*Appearance*: white or almost white, spherical beads.

*Solubility*: practically insoluble in water. It swells in water and electrolyte solutions.

**PRODUCTION**

The absorption capacity is determined using a 9.0 g/L solution of *sodium chloride R* containing 20  $\mu$ L/L of *polysorbate 20 R* or another suitable solution, with a suitable, validated method.

The particle size is controlled to a minimum of 80 per cent of the number of dry beads within 100  $\mu$ m to 300  $\mu$ m and a maximum of 7 per cent of their number below 100  $\mu$ m using a suitable, validated method.

**IDENTIFICATION**

A. The substance to be examined is practically insoluble in *water R*. It swells in *water R*.

## B. Infrared absorption spectrophotometry (2.2.24).

*Preparation:* grind the substance to be examined in acetone R. Evaporate the solvent at room temperature and use the residue.

*Comparison:* dextranomer CRS.

## TESTS

**pH** (2.2.3): 5.3 to 7.5.

Introduce 0.50 g to 30 mL of a freshly prepared 74.6 g/L solution of *potassium chloride R*. Allow to stand for 2 min. Determine the pH on the mucilage obtained.

**Boron:** maximum 30 ppm.

Inductively coupled plasma-atomic emission spectroscopy (ICP-AES) (2.2.57).

*Test solution.* Introduce 3.0 g into a platinum dish, moisten with 5 mL of a 32.1 g/L solution of *magnesium nitrate R* in a mixture of equal volumes of *ethanol (96 per cent) R* and *distilled water R*. Evaporate to dryness on a water-bath. Ignite at 550 °C for 5 h. Take up the residue with 5 mL of 6 M *hydrochloric acid R* and transfer to a 50 mL volumetric flask. Add about 20 mL of *distilled water R* and allow to digest for 1 h on a water-bath. Allow to cool and dilute to 50.0 mL with *distilled water R*.

*Standard solutions.* Prepare the standard solutions using a solution of *boric acid R* containing 10 ppm of boron. Proceed as described for the test solution.

*Wavelength:* 249.773 nm.

**Heavy metals** (2.4.8): maximum 30 ppm.

1.0 g complies with test F. Prepare the reference solution using 3 mL of *lead standard solution (10 ppm Pb) R*.

**Loss on drying** (2.2.32): maximum 10.0 per cent.

To 1.000 g, add *distilled water R* dropwise until the sample has completely swollen. Dry in an oven at 105 °C.

**Sulfated ash** (2.4.14): maximum 0.4 per cent, determined on 1.0 g.

**Microbial contamination.** Total aerobic microbial count (TAMC) (2.6.12) not more than 10<sup>2</sup> CFU per gram, determined using the pour-plate method.

## TESTS

**pH** (2.2.3): 2.0 to 8.0.

Disperse 5.0 g in 100 mL of *carbon dioxide-free water R*.

**Chlorides:** maximum 0.2 per cent.

Dissolve 2.5 g in 50 mL of boiling *water R*, dilute to 100 mL with *water R* and filter. Dilute 1 mL of the filtrate to 15 mL, add 1 mL of *dilute nitric acid R*, pour the mixture as a single addition into 1 mL of *silver nitrate solution R2* and allow to stand for 5 min protected from light. When viewed transversely against a black background any opalescence produced is not more intense than that obtained by treating a mixture of 10 mL of *chloride standard solution (5 ppm Cl) R* and 5 mL of *water R*, prepared in the same manner.

**Reducing sugars:** maximum 10 per cent, calculated as glucose C<sub>6</sub>H<sub>12</sub>O<sub>6</sub>.

To a quantity of dextrin equivalent to 2.0 g (dried substance) add 100 mL of *water R*, shake for 30 min, dilute to 200.0 mL with *water R* and filter. To 10.0 mL of alkaline *cupri-tartaric solution R* add 20.0 mL of the filtrate, mix, and heat on a hot plate adjusted to bring the solution to boil within 3 min. Boil for 2 min, and cool immediately. Add 5 mL of a 300 g/L solution of *potassium iodide R* and 10 mL of 1 M *sulfuric acid*, mix, and titrate immediately with 0.1 M *sodium thiosulfate*, using *starch solution R*, added towards the end of the titration, as indicator. Repeat the procedure beginning with "To 10.0 mL of...", using, in place of the filtrate, 20.0 mL of a 1 g/L solution of *glucose R*, accurately prepared. Perform a blank titration. ( $V_B - V_U$ ) is not greater than ( $V_B - V_S$ ), in which  $V_B$ ,  $V_U$  and  $V_S$  are the number of millilitres of 0.1 M *sodium thiosulfate* consumed in the titrations of the blank, the dextrin and the glucose, respectively.

**Heavy metals** (2.4.8): maximum 20 ppm.

1.0 g complies with test C. Prepare the reference solution using 2 mL of *lead standard solution (10 ppm Pb) R*.

**Loss on drying** (2.2.32): maximum 13.0 per cent, determined on 1.000 g by drying at 130-135 °C for 90 min.

**Sulfated ash** (2.4.14): maximum 0.5 per cent, determined on 1.0 g.

## FUNCTIONALITY-RELATED CHARACTERISTICS

*This section provides information on characteristics that are recognised as being relevant control parameters for one or more functions of the substance when used as an excipient (see chapter 5.15). This section is a non-mandatory part of the monograph and it is not necessary to verify the characteristics to demonstrate compliance. Control of these characteristics can however contribute to the quality of a medicinal product by improving the consistency of the manufacturing process and the performance of the medicinal product during use. Where control methods are cited, they are recognised as being suitable for the purpose, but other methods can also be used. Wherever results for a particular characteristic are reported, the control method must be indicated.*

*The following characteristics may be relevant for dextrin used as filler and binder, in tablets and capsules.*

**Particle-size distribution** (2.9.31 or 2.9.38).

**Powder flow** (2.9.36).

*The following characteristic may be relevant for dextrin used as viscosity-increasing agent.*

**Apparent viscosity** (2.2.10): typically 100 mPa·s to 350 mPa·s (dried substance), depending on the grade of dextrin.

In a beaker, prepare a 10-50 per cent slurry so that the viscosity value ranges from 100 mPa·s to 350 mPa·s. The total mass of the sample plus water must be 600 g. Mix with a plastic rod to obtain a homogeneous slurry. Place the beaker in a water-bath at 100 ± 1 °C. Introduce the paddle of a stirrer into the beaker and close the beaker with a lid. Start agitation at 250 r/min as rapidly as possible and carry on for exactly 30 min. Transfer the paste immediately to the beaker to be used for viscosity

04/2009:1507

## DEXTRIN

## Dextrinum

## DEFINITION

Maize, potato or cassava starch partly hydrolysed and modified by heating with or without the presence of acids, alkalis or pH-control agents.

## CHARACTERS

*Appearance:* white or almost white, free-flowing powder.

*Solubility:* very soluble in boiling water forming a mucilaginous solution, slowly soluble in cold water, practically insoluble in ethanol (96 per cent).

## IDENTIFICATION

- Suspend 1 g in 50 mL of *water R*, boil for 1 min and cool. To 1 mL of the solution add 0.05 mL of *iodine solution R1*. A dark blue or reddish-brown colour is produced, which disappears on heating.
- Centrifuge 5 mL of the mucilage obtained in identification test A. To the upper layer add 2 mL of *dilute sodium hydroxide solution R* and, dropwise with shaking, 0.5 mL of *copper sulfate solution R* and boil. A red precipitate is produced.
- It is very soluble in boiling *water R*, forming a mucilaginous solution.

measurement, placed in a water-bath at  $40 \pm 1$  °C. Stir until the temperature in the beaker is  $40 \pm 1$  °C then measure the apparent viscosity using spindle no. 2 and a rotation speed of 100 r/min.

07/2010:0020

## DEXTROMETHORPHAN HYDROBROMIDE

### Dextromethorphan hydrobromidum

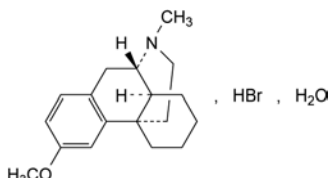

$C_{18}H_{26}BrNO \cdot H_2O$   
[6700-34-1]

$M_r$  370.3

#### DEFINITION

*ent*-3-Methoxy-17-methylmorphinan hydrobromide monohydrate.

*Content*: 99.0 per cent to 101.0 per cent (anhydrous substance).

#### CHARACTERS

*Appearance*: almost white, crystalline powder.

*Solubility*: sparingly soluble in water, freely soluble in ethanol (96 per cent).

mp: about 125 °C, with decomposition.

#### IDENTIFICATION

*First identification*: A, B, D.

*Second identification*: A, C, D.

A. Specific optical rotation (see Tests).

B. Infrared absorption spectrophotometry (2.2.24).

*Comparison*: dextromethorphan hydrobromide CRS.

C. Thin-layer chromatography (2.2.27).

*Test solution*. Dissolve 25 mg of the substance to be examined in *methanol R* and dilute to 10 mL with the same solvent.

*Reference solution*. Dissolve 25 mg of *dextromethorphan hydrobromide CRS* in *methanol R* and dilute to 10 mL with the same solvent.

*Plate*: TLC silica gel G plate R.

*Mobile phase*: concentrated ammonia R, methylene chloride R, methanol R, ethyl acetate R, toluene R (2:10:13:20:55 V/V/V/V).

*Application*: 5 µL.

*Development*: over 2/3 of the plate.

*Drying*: in air.

*Detection*: spray with potassium iodobismuthate solution R2.

*Results*: the principal spot in the chromatogram obtained with the test solution is similar in position and size to the principal spot in the chromatogram obtained with the reference solution.

D. It gives reaction (a) of bromides (2.3.1).

#### TESTS

**Solution S**. Dissolve 1.0 g in *ethanol (96 per cent) R* and dilute to 20 mL with the same solvent.

**Appearance of solution**. Solution S is clear (2.2.1) and colourless (2.2.2, Method II).

**Acidity or alkalinity**. Dissolve 0.4 g in *carbon dioxide-free water R* with gentle heating, cool and dilute to 20 mL with the same solvent. Add 0.1 mL of *methyl red solution R* and 0.2 mL of 0.01 M sodium hydroxide. The solution is yellow. Not more than 0.4 mL of 0.01 M hydrochloric acid is required to change the colour of the indicator to red.

**Specific optical rotation (2.2.7)**: + 28 to + 30 (anhydrous substance).

Dissolve 0.200 g in 0.1 M hydrochloric acid and dilute to 10.0 mL with the same acid.

**Related substances**. Liquid chromatography (2.2.29).

*Test solution*. Dissolve 10.0 mg of the substance to be examined in the mobile phase and dilute to 10.0 mL with the mobile phase.

*Reference solution (a)*. Dissolve 2 mg of *dextromethorphan impurity A CRS* in 2 mL of the test solution and dilute to 25.0 mL with the mobile phase.

*Reference solution (b)*. Dilute 1.0 mL of the test solution to 200.0 mL with the mobile phase.

*Column*:

– *size*:  $l = 0.25$  m,  $\varnothing = 4.6$  mm;

– *stationary phase*: octadecylsilyl silica gel for chromatography R (5 µm).

*Mobile phase*: dissolve 3.11 g of *docosate sodium R* in a mixture of 400 mL of *water R* and 600 mL of *acetonitrile R*, add 0.56 g of *ammonium nitrate R* and adjust to apparent pH 2.0 with *glacial acetic acid R*.

*Flow rate*: 1.0 mL/min.

*Detection*: spectrophotometer at 280 nm.

*Injection*: 20 µL.

*Run time*: twice the retention time of dextromethorphan.

*Relative retention* with reference to dextromethorphan (retention time = about 22 min): impurity B = about 0.4; impurity C = about 0.8; impurity D = about 0.9; impurity A = about 1.1.

*System suitability*: reference solution (a):

– *resolution*: minimum 1.5 between the peaks due to dextromethorphan and impurity A.

*Limits*:

– *correction factor*: for the calculation of content, multiply the peak area of impurity C by 0.2;

– *impurities A, B, C, D*: for each impurity, not more than the area of the principal peak in the chromatogram obtained with reference solution (b) (0.5 per cent), and not more than 1 such peak has an area greater than 0.5 times the area of the principal peak in the chromatogram obtained with reference solution (b) (0.25 per cent);

– *unspecified impurities*: for each impurity, not more than 0.2 times the area of the principal peak in the chromatogram obtained with reference solution (b) (0.10 per cent);

– *total*: not more than twice the area of the principal peak in the chromatogram obtained with reference solution (b) (1.0 per cent);

– *disregard limit*: 0.1 times the area of the principal peak in the chromatogram obtained with reference solution (b) (0.05 per cent).

***N,N*-Dimethylaniline**: maximum 10 ppm.

Dissolve 0.5 g with heating in 20 mL of *water R*. Allow to cool, add 2 mL of *dilute acetic acid R* and 1 mL of a 10 g/L solution of *sodium nitrite R* and dilute to 25 mL with *water R*. The solution is not more intensely coloured than a reference solution prepared at the same time and in the same manner using 20 mL of a 0.25 mg/L solution of *dimethylaniline R*.

**Water (2.5.12)**: 4.0 per cent to 5.5 per cent, determined on 0.200 g.

**Sulfated ash (2.4.14)**: maximum 0.1 per cent, determined on 1.0 g.

## ASSAY

Dissolve 0.300 g in a mixture of 5.0 mL of 0.01 M hydrochloric acid and 20 mL of ethanol (96 per cent) R. Titrate with 0.1 M sodium hydroxide, determining the end-point potentiometrically (2.2.20). Read the volume added between the 2 points of inflexion.

1 mL of 0.1 M sodium hydroxide is equivalent to 35.23 mg of C<sub>18</sub>H<sub>26</sub>BrNO.

## STORAGE

Protected from light.

## IMPURITIES

Specified impurities: A, B, C, D.

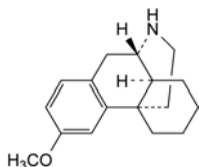

A. *ent*-3-methoxymorphinan,

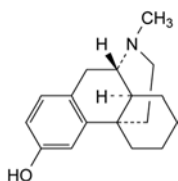

B. *ent*-17-methylmorphinan-3-ol,

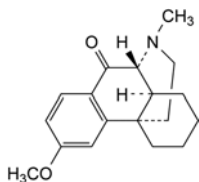

C. *ent*-3-methoxy-17-methylmorphinan-10-one,

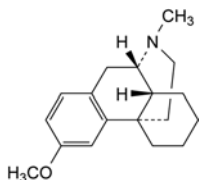

D. *ent*-(14S)-3-methoxy-17-methylmorphinan.

## DEFINITION

Dextromoramide tartrate contains not less than 98.0 per cent and not more than the equivalent of 101.0 per cent of 1-[(3S)-3-methyl-4-(morpholin-4-yl)-2,2-diphenylbutanoyl]pyrrolidine hydrogen (2*R*,3*R*)-2,3-dihydroxybutanedioate, calculated with reference to the dried substance.

## CHARACTERS

A white or almost white, amorphous or crystalline powder, soluble in water, sparingly soluble in alcohol.

It melts at about 190 °C, with slight decomposition.

## IDENTIFICATION

A. Dissolve 75 mg in 1 M hydrochloric acid and dilute to 100.0 mL with the same acid. Examined between 230 nm and 350 nm (2.2.25), the solution shows 3 absorption maxima, at 254 nm, 259 nm and 264 nm. The specific absorbances at the maxima are about 6.9, 7.7 and 6.5, respectively.

B. Dissolve about 50 mg in water R and dilute to 10 mL with the same solvent. To 2 mL of the solution add 3 mL of ammoniacal silver nitrate solution R and heat on a water-bath. A grey or black precipitate is formed.

C. It gives reaction (b) of tartrates (2.3.1).

## TESTS

**pH** (2.2.3). Dissolve 0.2 g in carbon dioxide-free water R and dilute to 20 mL with the same solvent. The pH of the solution is 3.0 to 4.0.

**Specific optical rotation** (2.2.7). Dissolve 0.50 g in 0.1 M hydrochloric acid and dilute to 10.0 mL with the same acid. The specific optical rotation is + 21 to + 23.

**Related substances.** Examine by thin-layer chromatography (2.2.27), using silica gel G R as the coating substance.

**Test solution.** Dissolve 0.2 g of the substance to be examined in methanol R and dilute to 10 mL with the same solvent.

**Reference solution.** Dilute 1 mL of the test solution to 100 mL with methanol R.

Apply separately to the plate 10 µL of each solution. Develop over a path of 15 cm using methanol R. Allow the plate to dry in air and spray with dilute potassium iodobismuthate solution R. Any spot in the chromatogram obtained with the test solution, apart from the principal spot, is not more intense than the spot in the chromatogram obtained with the reference solution (1.0 per cent).

**Loss on drying** (2.2.32). Not more than 0.5 per cent, determined on 1.00 g by drying in an oven at 105 °C.

**Sulfated ash** (2.4.14). Not more than 0.1 per cent, determined on 1.0 g.

## ASSAY

Dissolve 0.250 g in 30 mL of anhydrous acetic acid R. Titrate with 0.05 M perchloric acid using 0.15 mL of naphtholbenzein solution R as indicator.

*M*<sub>r</sub> 542.6 1 mL of 0.05 M perchloric acid is equivalent to 27.13 mg of C<sub>29</sub>H<sub>38</sub>N<sub>2</sub>O<sub>8</sub>.

01/2008:0021  
corrected 6.0

## DEXTRAMORAMIDE TARTRATE

## Dextromoramidi tartras

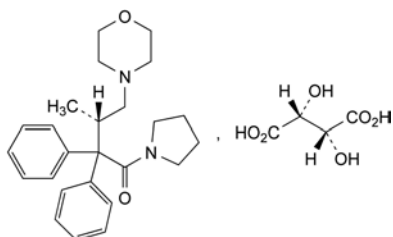

C<sub>29</sub>H<sub>38</sub>N<sub>2</sub>O<sub>8</sub>  
[2922-44-3]



01/2010:0713 *Mobile phase:***DEXTROPROPOXYPHENE  
HYDROCHLORIDE**

## Dextropropoxypheni hydrochloridum

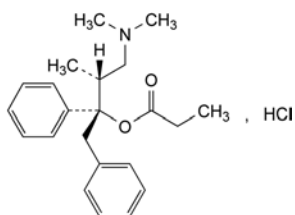
C<sub>22</sub>H<sub>30</sub>ClNO<sub>2</sub>  
[1639-60-7]M<sub>r</sub> 375.9

## DEFINITION

(1*S*,2*R*)-1-Benzyl-3-(dimethylamino)-2-methyl-1-phenylpropyl propanoate hydrochloride.*Content:* 98.5 per cent to 101.5 per cent (dried substance).

## CHARACTERS

*Appearance:* white or almost white, crystalline powder.*Solubility:* very soluble in water, freely soluble in ethanol (96 per cent).

mp: about 165 °C.

## IDENTIFICATION

A. Specific optical rotation (see Tests).

B. Infrared absorption spectrophotometry (2.2.24).

*Comparison:* dextropropoxyphene hydrochloride CRS.

C. Solution S (see Tests) gives reaction (a) of chlorides (2.3.1).

## TESTS

**Solution S.** Dissolve 1.5 g in carbon dioxide-free water R and dilute to 30 mL with the same solvent.**Appearance of solution.** Solution S is clear (2.2.1) and colourless (2.2.2, Method II).**Acidity or alkalinity.** Dilute 10 mL of solution S to 25 mL with carbon dioxide-free water R. To 10 mL of this solution add 0.1 mL of methyl red solution R and 0.2 mL of 0.01 M sodium hydroxide. The solution is yellow. Add 0.4 mL of 0.01 M hydrochloric acid. The solution is red.**Specific optical rotation** (2.2.7): + 52 to + 57.

Dissolve 0.100 g in water R and dilute to 10.0 mL with the same solvent.

**Related substances.** Liquid chromatography (2.2.29).*Solvent mixture:* acetonitrile R, methanol R (50:50 V/V).*Test solution.* Dissolve 0.100 g of the substance to be examined in the solvent mixture and dilute to 50.0 mL with the solvent mixture.*Reference solution (a).* Dilute 1.0 mL of the test solution to 50.0 mL with the solvent mixture. Dilute 1.0 mL of this solution to 20.0 mL with the solvent mixture.*Reference solution (b).* Dissolve 2 mg of dextropropoxyphene for system suitability CRS (containing impurities A, B, C and D) in 1.0 mL of the solvent mixture.*Reference solution (c).* Dilute 1.0 mL of toluene R to 50.0 mL with the solvent mixture. Dilute 1.0 mL of this solution to 10.0 mL with the solvent mixture.*Column:*– size:  $l = 0.15$  m,  $\varnothing = 4.6$  mm;

– stationary phase: octylsilyl silica gel for chromatography R (5 µm).

- mobile phase A: dissolve 2.5 g of ammonium phosphate R in water R, adjust to pH 5.6 with dilute phosphoric acid R and dilute to 1000 mL with the same solvent;
- mobile phase B: acetonitrile R1.

Time (min)	Mobile phase A (per cent V/V)	Mobile phase B (per cent V/V)
0 - 2	85	15
2 - 7	85 → 75	15 → 25
7 - 24	75 → 50	25 → 50
24 - 32	50 → 40	50 → 60

*Flow rate:* 1.5 mL/min.*Detection:* spectrophotometer at 214 nm.*Injection:* 10 µL.*Identification of impurities:* use the chromatogram supplied with dextropropoxyphene for system suitability CRS and the chromatogram obtained with reference solution (b) to identify the peaks due to impurities A, B, C and D. Use the chromatogram obtained with reference solution (c) to identify the peak due to toluene.*Relative retention* with reference to dextropropoxyphene (retention time = about 18 min): impurity A = about 0.8; impurity B = about 0.9; impurity D = about 1.1; impurity C = about 1.2.*System suitability:* reference solution (b):

- peak-to-valley ratio: minimum 5, where  $H_p$  = height above the baseline of the peak due to impurity D and  $H_v$  = height above the baseline of the lowest point of the curve separating this peak from the peak due to dextropropoxyphene.

*Limits:*

- impurities A, B: for each impurity, not more than 5 times the area of the principal peak in the chromatogram obtained with reference solution (a) (0.5 per cent);
- impurities C, D: for each impurity, not more than twice the area of the principal peak in the chromatogram obtained with reference solution (a) (0.2 per cent);
- unspecified impurities: for each impurity, not more than the area of the principal peak in the chromatogram obtained with reference solution (a) (0.10 per cent);
- total: not more than 10 times the area of the principal peak in the chromatogram obtained with reference solution (a) (1.0 per cent);
- disregard limit: 0.5 times the area of the principal peak in the chromatogram obtained with reference solution (a) (0.05 per cent); disregard any peak due to toluene (relative retention = about 1.24).

**Loss on drying** (2.2.32): maximum 1.0 per cent, determined on 1.000 g by drying in an oven at 105 °C for 4 h.**Sulfated ash** (2.4.14): maximum 0.1 per cent, determined on 1.0 g.

## ASSAY

Dissolve 0.270 g in 60 mL of acetic anhydride R. Titrate with 0.1 M perchloric acid, determining the end-point potentiometrically (2.2.20).

1 mL of 0.1 M perchloric acid is equivalent to 37.59 mg of C<sub>22</sub>H<sub>30</sub>ClNO<sub>2</sub>.

## STORAGE

Protected from light.

## IMPURITIES

*Specified impurities:* A, B, C, D.*Other detectable impurities* (the following substances would, if present at a sufficient level, be detected by one or other of the tests in the monograph. They are limited by the general

acceptance criterion for other/unspecified impurities and/or by the general monograph *Substances for pharmaceutical use* (2034). It is therefore not necessary to identify these impurities for demonstration of compliance. See also 5.10. *Control of impurities in substances for pharmaceutical use*): F.

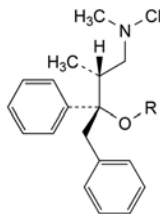

- A. R = H: (2*S*,3*R*)-4-(dimethylamino)-1,2-diphenyl-3-methylbutan-2-ol (oxyphene),  
 B. R = CO-CH<sub>3</sub>: (1*S*,2*R*)-1-benzyl-3-(dimethylamino)-2-methyl-1-phenylpropyl acetate (acetoxyphene),  
 C. R = CO-CH<sub>2</sub>-CH<sub>2</sub>-CH<sub>3</sub>: (1*S*,2*R*)-1-benzyl-3-(dimethylamino)-2-methyl-1-phenylpropyl butanoate (butyroxophene),

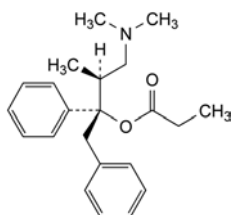

- D. (1*S*,2*S*)-1-benzyl-3-(dimethylamino)-2-methyl-1-phenylpropyl propanoate (isopropoxyphene),

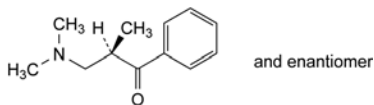

- F. (2*RS*)-3-(dimethylamino)-2-methyl-1-phenylpropan-1-one.

## TESTS

**Related substances.** Liquid chromatography (2.2.29). *Prepare the solutions protected from bright light.*

**Test solution.** Dissolve 25.0 mg of the substance to be examined in 0.5 mL of *acetonitrile R* and dilute to 50.0 mL with the mobile phase.

**Reference solution (a).** Dilute 1.0 mL of the test solution to 100.0 mL with the mobile phase. Dilute 1.0 mL of this solution to 10.0 mL with the mobile phase.

**Reference solution (b).** Dissolve the contents of a vial of *diazepam for system suitability CRS* (containing impurities A, B and E) in 1.0 mL of the mobile phase.

**Column:**

- size:  $l = 0.15$  m,  $\varnothing = 4.6$  mm;
- stationary phase: spherical *end-capped octylsilyl silica gel for chromatography R* (5  $\mu$ m);
- temperature: 30 °C.

**Mobile phase:** mix 22 volumes of *acetonitrile R*, 34 volumes of *methanol R* and 44 volumes of a 3.4 g/L solution of *potassium dihydrogen phosphate R* previously adjusted to pH 5.0 with *dilute sodium hydroxide solution R*.

**Flow rate:** 1.0 mL/min.

**Detection:** spectrophotometer at 254 nm.

**Injection:** 20  $\mu$ L.

**Run time:** about 4 times the retention time of diazepam.

**Identification of impurities:** use the chromatogram supplied with *diazepam for system suitability CRS* and the chromatogram obtained with reference solution (b) to identify the peaks due to impurities A, B and E.

**Relative retention** with reference to diazepam (retention time = about 9 min): impurity E = about 0.7; impurity A = about 0.8; impurity B = about 1.3.

**System suitability:** reference solution (b):

- resolution: minimum 2.5 between the peaks due to impurities E and A and minimum 6.0 between the peaks due to impurity A and diazepam.

**Limits:**

- correction factors: for the calculation of content, multiply the peak areas of the following impurities by the corresponding correction factor: impurity B = 1.3; impurity E = 1.3;
- impurities A, B, E: for each impurity, not more than the area of the principal peak in the chromatogram obtained with reference solution (a) (0.1 per cent);
- unspecified impurities: for each impurity, not more than the area of the principal peak in the chromatogram obtained with reference solution (a) (0.10 per cent);
- total: not more than twice the area of the principal peak in the chromatogram obtained with reference solution (a) (0.2 per cent);
- disregard limit: 0.5 times the area of the principal peak in the chromatogram obtained with reference solution (a) (0.05 per cent).

**Heavy metals** (2.4.8): maximum 20 ppm.

2.0 g complies with test C. Prepare the reference solution using 4 mL of *lead standard solution (10 ppm Pb) R*.

**Loss on drying** (2.2.32): maximum 0.5 per cent, determined on 1.000 g by drying *in vacuo* at 60 °C for 4 h.

**Sulfated ash** (2.4.14): maximum 0.1 per cent, determined on 1.0 g.

## ASSAY

Dissolve 0.200 g in 50 mL of *acetic anhydride R*. Titrate with 0.1 M *perchloric acid*, determining the end-point potentiometrically (2.2.20).

1 mL of 0.1 M *perchloric acid* is equivalent to 28.47 mg of C<sub>16</sub>H<sub>13</sub>ClN<sub>2</sub>O.

01/2008:0022

## DIAZEPAM

## Diazepamum

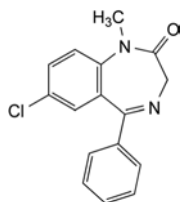

C<sub>16</sub>H<sub>13</sub>ClN<sub>2</sub>O  
[439-14-5]

$M_r$  284.7

## DEFINITION

7-Chloro-1-methyl-5-phenyl-1,3-dihydro-2*H*-1,4-benzodiazepin-2-one.

**Content:** 99.0 per cent to 101.0 per cent (dried substance).

## CHARACTERS

**Appearance:** white or almost white, crystalline powder.

**Solubility:** very slightly soluble in water, soluble in ethanol (96 per cent).

## IDENTIFICATION

Infrared absorption spectrophotometry (2.2.24).

**Comparison:** *diazepam CRS*.

## STORAGE

Protected from light.

01/2008:0550  
corrected 6.0

## IMPURITIES

Specified impurities: A, B, E.

Other detectable impurities (the following substances would, if present at a sufficient level, be detected by one or other of the tests in the monograph. They are limited by the general acceptance criterion for other/unspecified impurities and/or by the general monograph *Substances for pharmaceutical use* (2034). It is therefore not necessary to identify these impurities for demonstration of compliance. See also 5.10. *Control of impurities in substances for pharmaceutical use*): C, D, F.

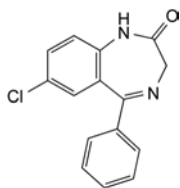

- A. 7-chloro-5-phenyl-1,3-dihydro-2H-1,4-benzodiazepin-2-one (nordazepam),

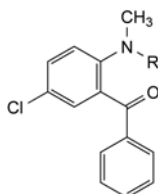

- B. R = CO-CH<sub>2</sub>-Cl: 2-chloro-N-(4-chloro-2-benzoylphenyl)-N-methylacetamide,

- D. R = H: [5-chloro-2-(methylamino)phenyl]phenylmethanone,

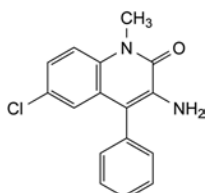

- C. 3-amino-6-chloro-1-methyl-4-phenylquinolin-2(1H)-one,

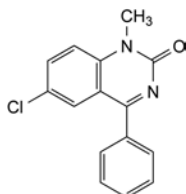

- E. 6-chloro-1-methyl-4-phenylquinazolin-2(1H)-one,

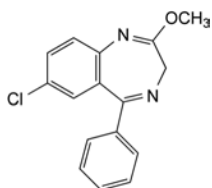

- F. 7-chloro-2-methoxy-5-phenyl-3H-1,4-benzodiazepine.

## DIAZOXIDE

## Diazoxidum

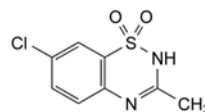

C<sub>8</sub>H<sub>7</sub>ClN<sub>2</sub>O<sub>2</sub>S  
[364-98-7]

M<sub>r</sub> 230.7

## DEFINITION

Diazoxide contains not less than 98.0 per cent and not more than the equivalent of 101.0 per cent of 7-chloro-3-methyl-2H-1,2,4-benzothiadiazine 1,1-dioxide, calculated with reference to the dried substance.

## CHARACTERS

A white or almost white, fine or crystalline powder, practically insoluble in water, freely soluble in dimethylformamide, slightly soluble in alcohol. It is very soluble in dilute solutions of the alkali hydroxides.

## IDENTIFICATION

First identification: B.

Second identification: A, C, D.

- A. Dissolve 50.0 mg in 5 mL of 1 M sodium hydroxide and dilute to 50.0 mL with water R. Dilute 1.0 mL of this solution to 100.0 mL with 0.1 M sodium hydroxide. Examined between 230 nm and 350 nm (2.2.25), the solution shows an absorption maximum at 280 nm and a shoulder at 304 nm. The specific absorbance at the maximum is 570 to 610.
- B. Examine by infrared absorption spectrophotometry (2.2.24), comparing with the spectrum obtained with diazoxide CRS. Examine the substances prepared as discs using potassium bromide R.
- C. Examine the chromatograms obtained in the test for related substances in ultraviolet light at 254 nm. The principal spot in the chromatogram obtained with test solution (b) is similar in position and size to the principal spot in the chromatogram obtained with reference solution (b).
- D. Dissolve about 20 mg in a mixture of 5 mL of hydrochloric acid R and 10 mL of water R. Add 0.1 g of zinc powder R. Boil for 5 min, cool and filter. To the filtrate add 2 mL of a 1 g/L solution of sodium nitrite R and mix. Allow to stand for 1 min and add 1 mL of a 5 g/L solution of naphthylethylenediamine dihydrochloride R. A red or violet-red colour develops.

## TESTS

**Appearance of solution.** Dissolve 0.4 g in 2 mL of 1 M sodium hydroxide and dilute to 20 mL with water R. The solution is clear (2.2.1) and not more intensely coloured than reference solution Y<sub>7</sub> (2.2.2, Method II).

**Acidity or alkalinity.** To 0.5 g of the powdered substance to be examined add 30 mL of carbon dioxide-free water R, shake for 2 min and filter. To 10 mL of the filtrate add 0.2 mL of 0.01 M sodium hydroxide and 0.15 mL of methyl red solution R. The solution is yellow. Not more than 0.4 mL of 0.01 M hydrochloric acid is required to change the colour of the indicator to red.

**Related substances.** Examine by thin-layer chromatography (2.2.27), using silica gel GF<sub>254</sub> R as the coating substance.

**Test solution (a).** Dissolve 0.1 g of the substance to be examined in a mixture of 0.5 mL of 1 M sodium hydroxide and 1 mL of methanol R and dilute to 5 mL with methanol R.

**Test solution (b).** Dilute 1 mL of test solution (a) to 5 mL with a mixture of 1 volume of 1 M sodium hydroxide and 9 volumes of methanol R.

**Reference solution (a).** Dilute 0.5 mL of test solution (a) to 100 mL with a mixture of 1 volume of 1 M sodium hydroxide and 9 volumes of methanol R.

**Reference solution (b).** Dissolve 20 mg of diazoxide CRS in a mixture of 0.5 mL of 1 M sodium hydroxide and 1 mL of methanol R and dilute to 5 mL with methanol R.

Apply separately to the plate 5 µL of each solution. Develop over a path of 15 cm using a mixture of 7 volumes of concentrated ammonia R, 25 volumes of methanol R and 68 volumes of chloroform R. Allow the plate to dry in air and examine in ultraviolet light at 254 nm. Any spot in the chromatogram obtained with test solution (a), apart from the principal spot, is not more intense than the spot in the chromatogram obtained with reference solution (a) (0.5 per cent).

**Loss on drying (2.2.32).** Not more than 0.5 per cent, determined on 1.000 g by drying in an oven at 105 °C for 2 h.

**Sulfated ash (2.4.14).** Not more than 0.1 per cent, determined on 1.0 g.

#### ASSAY

Dissolve 0.200 g with gentle heating in 50 mL of a mixture of 1 volume of water R and 2 volumes of dimethylformamide R. Titrate with 0.1 M sodium hydroxide, determining the end-point potentiometrically (2.2.20). Carry out a blank titration.

1 mL of 0.1 M sodium hydroxide is equivalent to 23.07 mg of C<sub>8</sub>H<sub>7</sub>ClN<sub>2</sub>O<sub>2</sub>S.

01/2008:2300  
corrected 6.0

## DIBROMPROPAMIDINE DISETIONATE

### Dibrompropamidini diisetionas

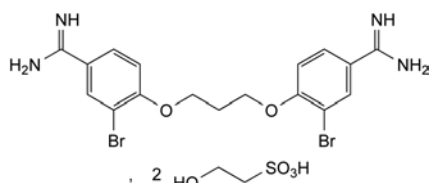

C<sub>21</sub>H<sub>30</sub>Br<sub>2</sub>N<sub>4</sub>O<sub>10</sub>S<sub>2</sub>  
[614-87-9]

M<sub>r</sub> 722

#### DEFINITION

3,3'-Dibromo-4,4'-(propane-1,3-diylbisoxymethyl)dibenzimidamide bis(2-hydroxyethanesulfonate).

**Content:** 99.0 per cent to 101.0 per cent (dried substance).

#### PRODUCTION

The production method must be evaluated to determine the potential for formation of alkyl 2-hydroxyethanesulfonates, which is particularly likely to occur if the reaction medium contains lower alcohols. Where necessary, the production method is validated to demonstrate that alkyl 2-hydroxyethanesulfonates are not detectable in the final product.

#### CHARACTERS

**Appearance:** white or almost white, crystalline powder.

**Solubility:** freely soluble or soluble in water, slightly soluble in ethanol (96 per cent), practically insoluble in methylene chloride.

#### IDENTIFICATION

A. Infrared absorption spectrophotometry (2.2.24).

**Comparison:** dibrompropamidini diisetionate CRS.

B. Mix 0.1 g with 0.5 g of anhydrous sodium carbonate R, ignite and take up the residue with 20 mL of water R. Filter and neutralise the filtrate to blue litmus paper R with nitric acid R. The filtrate gives reaction (a) of bromides (2.3.1).

#### TESTS

**pH (2.2.3):** 5.0 to 6.0.

Dissolve 0.50 g in carbon dioxide-free water R and dilute to 10 mL with the same solvent.

**Related substances.** Liquid chromatography (2.2.29).

**Solvent mixture:** anhydrous formic acid R, methanol R, ethyl acetate R (0.01:8:12 V/V/V).

**Test solution.** To 8 mL of methanol R add 20.0 mg of the substance to be examined and dissolve with the aid of an ultrasonic bath. Add 11 mL of ethyl acetate R then 10 µL of anhydrous formic acid R and mix. Dilute to 20.0 mL with ethyl acetate R.

**Reference solution (a).** Dilute 1.0 mL of the test solution to 100.0 mL with the solvent mixture. Dilute 1.0 mL of this solution to 10.0 mL with the solvent mixture.

**Reference solution (b).** Dissolve 10 mg of dibrompropamidini diisetionate CRS (containing impurities A and B) in 4 mL of methanol R using an ultrasonic bath. Add 5 mL of ethyl acetate R then 5 µL of anhydrous formic acid R and mix. Dilute to 10.0 mL with ethyl acetate R.

**Column:**

- size:  $l = 0.25$  m,  $\varnothing = 4.6$  mm,
- stationary phase: strong cation-exchange silica gel for chromatography R (5 µm).

**Mobile phase:** mix 4 volumes of a 25 g/L solution of ammonium formate R in methanol R and 6 volumes of ethyl acetate R.

**Flow rate:** 1 mL/min.

**Detection:** spectrophotometer at 254 nm.

**Injection:** 40 µL.

**Run time:** 1.5 times the retention time of dibrompropamidini diisetionate CRS.

**Identification of impurities:** use the chromatogram supplied with dibrompropamidini diisetionate CRS and the chromatogram obtained with reference solution (b) to identify the peaks due to impurities A and B.

**Relative retention** with reference to dibrompropamidini diisetionate CRS (retention time = about 20 min): impurity A = about 0.4; impurity B = about 1.1.

**System suitability:** reference solution (b):

- peak-to-valley ratio: minimum 1.5, where  $H_p$  = height above the baseline of the peak due to impurity B and  $H_v$  = height above the baseline of the lowest point of the curve separating this peak from the peak due to dibrompropamidini diisetionate CRS.

**Limits:**

- impurity A: not more than 3 times the area of the principal peak in the chromatogram obtained with reference solution (a) (0.3 per cent);
- impurity B: not more than 5 times the area of the principal peak in the chromatogram obtained with reference solution (a) (0.5 per cent);
- unspecified impurities: for each impurity, not more than the area of the principal peak in the chromatogram obtained with reference solution (a) (0.1 per cent);
- total: not more than 10 times the area of the principal peak in the chromatogram obtained with reference solution (a) (1.0 per cent);
- disregard limit: 0.5 times the area of the principal peak in the chromatogram obtained with reference solution (a) (0.05 per cent).

**Loss on drying (2.2.32):** maximum 2.0 per cent, determined on 1.000 g by drying in an oven at 105 °C.

**Sulfated ash (2.4.14):** maximum 0.1 per cent, determined on 1.0 g.

## ASSAY

Dissolve 0.250 g in 50 mL of *dimethylformamide R*. Titrate with 0.1 M *tetrabutylammonium hydroxide* under a current of *nitrogen R*, determining the end-point potentiometrically (2.2.20).

1 mL of 0.1 M *tetrabutylammonium hydroxide* is equivalent to 36.12 mg of  $C_{21}H_{30}Br_2N_4O_{10}S_2$ .

## IMPURITIES

Specified impurities: A, B.

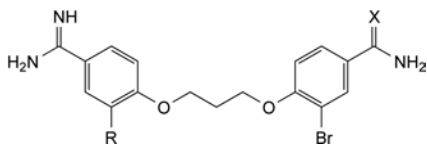

- A. R = Br, X = O: 3-bromo-4-[3-(2-bromo-4-carbamimidoylphenoxy)propoxy]benzamide,  
 B. R = H, X = NH: 3-bromo-4-[3-(4-carbamimidoylphenoxy)propoxy]benzimidamide.

01/2008:0762

## DIBUTYL PHTHALATE

## Dibutylis phthalas

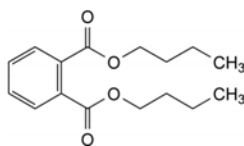

$C_{16}H_{22}O_4$   
 [84-74-2]

 $M_r$  278.3

## DEFINITION

Dibutyl benzene-1,2-dicarboxylate.

Content: 99.0 per cent *m/m* to 101.0 per cent *m/m*.

## CHARACTERS

Appearance: clear, oily liquid, colourless or very slightly yellow.

Solubility: practically insoluble in water, miscible with ethanol (96 per cent).

## IDENTIFICATION

First identification: B, C.

Second identification: A, D, E.

- A. Relative density (2.2.5): 1.043 to 1.048.  
 B. Refractive index (2.2.6): 1.490 to 1.495.  
 C. Infrared absorption spectrophotometry (2.2.24).

Comparison: *dibutyl phthalate CRS*.

D. Thin-layer chromatography (2.2.27).

Test solution. Dissolve 50 mg of the substance to be examined in *ether R* and dilute to 10 mL with the same solvent.

Reference solution. Dissolve 50 mg of *dibutyl phthalate CRS* in *ether R* and dilute to 10 mL with the same solvent.

Plate: *TLC silica gel GF<sub>254</sub> plate R*.

Mobile phase: *heptane R, ether R* (30:70 *V/V*).

Application: 10  $\mu$ L.

Development: over a path of 15 cm.

Drying: in air.

Detection: examine in ultraviolet light at 254 nm.

Results: the principal spot in the chromatogram obtained with the test solution is similar in position and size to the principal spot in the chromatogram obtained with the reference solution.

- E. To about 0.1 mL add 0.25 mL of *sulfuric acid R* and 50 mg of *resorcinol R*. Heat in a water-bath for 5 min. Allow to cool. Add 10 mL of *water R* and 1 mL of *strong sodium hydroxide solution R*. The solution becomes yellow or brownish-yellow and shows a green fluorescence.

## TESTS

Appearance. The substance to be examined is clear (2.2.1) and not more intensely coloured than reference solution  $Y_6$  (2.2.2, *Method II*).

Acidity. Dissolve 20.0 g in 50 mL of *ethanol (96 per cent) R* previously neutralised to *phenolphthalein solution R1*. Add 0.2 mL of *phenolphthalein solution R1*. Not more than 0.50 mL of 0.1 M *sodium hydroxide* is required to change the colour of the indicator.

Related substances. Gas chromatography (2.2.28).

Internal standard solution. Dissolve 60 mg of *bibenzyl R* in *methylene chloride R* and dilute to 20 mL with the same solvent.

Test solution (a). Dissolve 1.0 g of the substance to be examined in *methylene chloride R* and dilute to 20.0 mL with the same solvent.

Test solution (b). Dissolve 1.0 g of the substance to be examined in *methylene chloride R*, add 2.0 mL of the internal standard solution and dilute to 20.0 mL with *methylene chloride R*.

Reference solution. To 1.0 mL of test solution (a) add 10.0 mL of the internal standard solution and dilute to 100.0 mL with *methylene chloride R*.

Column:

- material: glass;
- size:  $l = 1.5$  m,  $\varnothing = 4$  mm;
- stationary phase: *silanised diatomaceous earth for gas chromatography R* (150-180  $\mu$ m) impregnated with 3 per cent *m/m* of *polymethylphenylsiloxane R*.

Carrier gas: *nitrogen for chromatography R*.

Flow rate: 30 mL/min.

Temperature:

- column: 190 °C;
- injection port and detector: 225 °C.

Detection: flame ionisation.

Injection: 1  $\mu$ L.

Run time: 3 times the retention time of dibutyl phthalate.

Elution order: *bibenzyl*, *dibutyl phthalate*.

Retention time: *dibutyl phthalate* = about 12 min.

System suitability:

- resolution: minimum 12 between the peaks due to *bibenzyl* and *dibutyl phthalate* in the chromatogram obtained with the reference solution;
- in the chromatogram obtained with test solution (a), there is no peak with the same retention time as the internal standard.

Limit:

- total: calculate the ratio (*R*) of the area of the peak due to *dibutyl phthalate* to the area of the peak due to the internal standard from the chromatogram obtained with the reference solution; from the chromatogram obtained with test solution (b), calculate the ratio of the sum of the areas of any peaks, apart from the principal peak and the peak due to the internal standard, to the area of the peak due to the internal standard: this ratio is not greater than *R* (1.0 per cent).

Water (2.5.12): maximum 0.2 per cent, determined on 10.00 g.

Sulfated ash (2.4.14): maximum 0.1 per cent, determined on 1.0 g.

## ASSAY

Introduce 0.750 g into a 250 mL borosilicate glass flask. Add 25.0 mL of 0.5 M alcoholic potassium hydroxide and a few glass beads. Heat in a water-bath under a reflux condenser for 1 h. Add 1 mL of phenolphthalein solution R1 and titrate immediately with 0.5 M hydrochloric acid until the colour changes from red to colourless. Carry out a blank titration. Calculate the volume of potassium hydroxide used in the saponification.

1 mL of 0.5 M alcoholic potassium hydroxide is equivalent to 69.59 mg of  $C_{16}H_{22}O_4$ .

## STORAGE

In an airtight container.

– stationary phase: base-deactivated octadecylsilyl silica gel for chromatography R (3 µm),

– temperature: 35 °C.

Mobile phase:

– mobile phase A: mix 10 volumes of a 6.3 g/L solution of ammonium formate R adjusted to pH 4.0 with anhydrous formic acid R, 15 volumes of acetonitrile R and 75 volumes of water R,

– mobile phase B: mix 10 volumes of a 6.3 g/L solution of ammonium formate R adjusted to pH 4.0 with anhydrous formic acid R, 85 volumes of acetonitrile R and 5 volumes of water R,

Time (min)	Mobile phase A (per cent V/V)	Mobile phase B (per cent V/V)
0 - 20	100 → 0	0 → 100
20 - 25	0	100

01/2008:1718  
corrected 7.0

## DICLAZURIL FOR VETERINARY USE

## Diclazurilum ad usum veterinarium

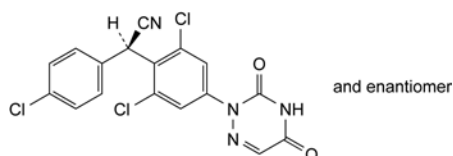

$C_{17}H_9Cl_3N_4O_2$   
[101831-37-2]

$M_r$  407.6

## DEFINITION

(*RS*)-4-Chlorophenyl[2,6-dichloro-4-(3,5-dioxo-4,5-dihydro-1,2,4-triazin-2(3*H*)-yl)phenyl]acetone nitrile.

Content: 99.0 per cent to 101.0 per cent (dried substance).

## CHARACTERS

Appearance: white or light yellow powder.

Solubility: practically insoluble in water, sparingly soluble in dimethylformamide, practically insoluble in alcohol and methylene chloride.

## IDENTIFICATION

Infrared absorption spectrophotometry (2.2.24).

Comparison: Ph. Eur. reference spectrum of diclazuril.

## TESTS

**Related substances.** Liquid chromatography (2.2.29).

**Test solution.** Dissolve 20.0 mg of the substance to be examined in dimethylformamide R and dilute to 20.0 mL with the same solvent.

**Reference solution (a).** Dissolve 5 mg of diclazuril for system suitability CRS in dimethylformamide R and dilute to 5.0 mL with the same solvent.

**Reference solution (b).** Dilute 1.0 mL of the test solution to 100.0 mL with dimethylformamide R. Dilute 5.0 mL of the solution to 20.0 mL with dimethylformamide R.

Column:

– size:  $l = 0.10$  m,  $\varnothing = 4.6$  mm,

Flow rate: 1.0 mL/min.

Detection: spectrophotometer at 230 nm.

Injection: 5 µL.

System suitability: reference solution (a):

– peak-to-valley ratio: minimum of 1.5, where  $H_p$  = height above the baseline of the peak due to impurity D and  $H_v$  = height above the baseline of the lowest point of the curve separating this peak from the peak due to diclazuril.

Limits:

– correction factors: for the calculation of contents, multiply the peak areas of the following impurities by the corresponding correction factor: impurity D = 1.9; impurity H = 1.4,

– impurity D: not more than 0.4 times the area of the principal peak in the chromatogram obtained with reference solution (b) (0.1 per cent),

– any other impurity: not more than the area of the principal peak in the chromatogram obtained with reference solution (b) (0.25 per cent),

– total: not more than 4 times the area of the principal peak in the chromatogram obtained with reference solution (b) (1.0 per cent),

– disregard limit: 0.2 times the area of the principal peak in the chromatogram obtained with reference solution (b) (0.05 per cent).

**Loss on drying** (2.2.32): maximum 0.5 per cent, determined on 1.000 g by drying in an oven at 105 °C for 4 h.

**Sulfated ash** (2.4.14): maximum 0.1 per cent, determined on 1.0 g.

## ASSAY

Dissolve 0.150 g in 75 mL of dimethylformamide R. Carry out a potentiometric titration (2.2.20), using 0.1 M tetrabutylammonium hydroxide. Read the volume added at the second inflexion point. Carry out a blank titration.

1 mL of 0.1 M tetrabutylammonium hydroxide is equivalent to 20.38 mg of  $C_{17}H_9Cl_3N_4O_2$ .

## STORAGE

Protected from light.

## IMPURITIES

Specified impurities: A, B, C, D, E, F, G, H, I.

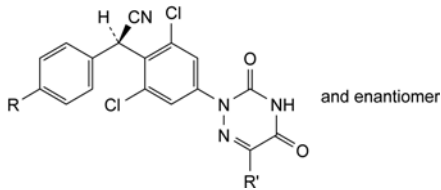

- A. R = Cl, R' = CO<sub>2</sub>H: 2-[3,5-dichloro-4-[(*RS*)-(4-chlorophenyl)cyanomethyl]phenyl]-3,5-dioxo-2,3,4,5-tetrahydro-1,2,4-triazine-6-carboxylic acid,
- B. R = OH, R' = H: (*RS*)-[2,6-dichloro-4-(3,5-dioxo-4,5-dihydro-1,2,4-triazin-2(3*H*)-yl)phenyl](4-hydroxyphenyl)acetonitrile,
- C. R = Cl, R' = CONH<sub>2</sub>: 2-[3,5-dichloro-4-[(*RS*)-(4-chlorophenyl)cyanomethyl]phenyl]-3,5-dioxo-2,3,4,5-tetrahydro-1,2,4-triazine-6-carboxamide,
- G. R = Cl, R' = CO-O-[CH<sub>2</sub>]<sub>3</sub>-CH<sub>3</sub>: butyl 2-[3,5-dichloro-4-[(*RS*)-(4-chlorophenyl)cyanomethyl]phenyl]-3,5-dioxo-2,3,4,5-tetrahydro-1,2,4-triazine-6-carboxylate,

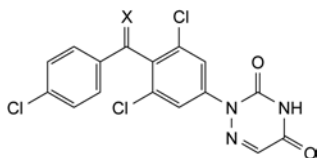

- D. X = O: 2-[3,5-dichloro-4-(4-chlorobenzoyl)phenyl]-1,2,4-triazine-3,5(2*H*,4*H*)-dione,
- F. X = H<sub>2</sub>: 2-[3,5-dichloro-4-(4-chlorobenzyl)phenyl]-1,2,4-triazine-3,5(2*H*,4*H*)-dione,

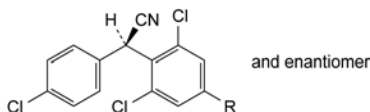

- E. R = NH<sub>2</sub>: (*RS*)-(4-amino-2,6-dichlorophenyl)(4-chlorophenyl)acetonitrile,
- H. R = H: (*RS*)-(4-chlorophenyl)(2,6-dichlorophenyl)acetonitrile,

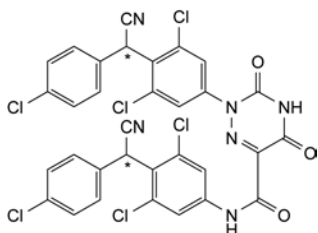

- I. *N*,2-bis[3,5-dichloro-4-[(4-chlorophenyl)cyanomethyl]phenyl]-3,5-dioxo-2,3,4,5-tetrahydro-1,2,4-triazine-6-carboxamide.

01/2008:1508 TESTS

## DICLOFENAC POTASSIUM

## Diclofenacum kalicum

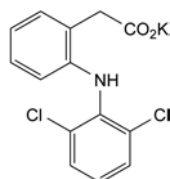

C<sub>14</sub>H<sub>10</sub>Cl<sub>2</sub>KNO<sub>2</sub>  
[15307-81-0]

*M*<sub>r</sub> 334.2

## DEFINITION

Potassium [2-[(2,6-dichlorophenyl)amino]phenyl]acetate.

Content: 99.0 per cent to 101.0 per cent (dried substance).

## CHARACTERS

*Appearance*: white or slightly yellowish, slightly hygroscopic, crystalline powder.

*Solubility*: sparingly soluble in water, freely soluble in methanol, soluble in ethanol (96 per cent), slightly soluble in acetone.

## IDENTIFICATION

*First identification*: A, D.

*Second identification*: B, C, D.

A. Infrared absorption spectrophotometry (2.2.24).

*Preparation*: discs.

*Comparison*: diclofenac potassium CRS.

B. Thin-layer chromatography (2.2.27).

*Test solution*. Dissolve 25 mg of the substance to be examined in *methanol R* and dilute to 5 mL with the same solvent.

*Reference solution (a)*. Dissolve 25 mg of *diclofenac potassium CRS* in *methanol R* and dilute to 5 mL with the same solvent.

*Reference solution (b)*. Dissolve 10 mg of *indometacin R* in reference solution (a) and dilute to 2 mL with the same solution.

*Plate*: TLC silica gel GF<sub>254</sub> plate *R*.

*Mobile phase*: concentrated ammonia *R*, *methanol R*, *ethyl acetate R* (10:10:80 V/V/V).

*Application*: 5 µL.

*Development*: over a path of 10 cm.

*Drying*: in air.

*Detection*: examine in ultraviolet light at 254 nm.

*System suitability*: reference solution (b):

– the chromatogram shows 2 clearly separated spots.

*Results*: the principal spot in the chromatogram obtained with the test solution is similar in position and size to the principal spot in the chromatogram obtained with reference solution (a).

C. Dissolve about 10 mg in 10 mL of *ethanol (96 per cent) R*. To 1 mL of this solution add 0.2 mL of a mixture, prepared immediately before use, of equal volumes of a 6 g/L solution of *potassium ferricyanide R* and a 9 g/L solution of *ferric chloride R*. Allow to stand protected from light for 5 min. Add 3 mL of a 10 g/L solution of *hydrochloric acid R*. Allow to stand protected from light for 15 min. A blue colour develops and a precipitate is formed.

D. Suspend 0.5 g in 10 mL of *water R*. Stir and add *water R* until the substance is dissolved. Add 2 mL of *hydrochloric acid R1*, stir for 1 h and filter with the aid of vacuum. Neutralise with *sodium hydroxide solution R*. The solution gives reaction (b) of potassium (2.3.1).

## TESTS

*Appearance of solution*. The solution is clear (2.2.1) and its absorbance (2.2.25) at 440 nm is not greater than 0.05.

Dissolve 1.25 g in *methanol R* and dilute to 25.0 mL with the same solvent.

*Related substances*. Liquid chromatography (2.2.29).

*Test solution*. Dissolve 50.0 mg of the substance to be examined in *methanol R* and dilute to 50.0 mL with the same solvent.

*Reference solution (a)*. Dilute 2.0 mL of the test solution to 100.0 mL with *methanol R*. Dilute 1.0 mL of this solution to 10.0 mL with *methanol R*.

*Reference solution (b)*. Dilute 1.0 mL of the test solution to 200.0 mL with *methanol R*. In 1.0 mL of this solution dissolve the contents of a vial of *diclofenac impurity A CRS*.

## Column:

- size:  $l = 0.25$  m,  $\varnothing = 4.6$  mm;
- stationary phase: end-capped octylsilyl silica gel for chromatography R (5  $\mu$ m).

Mobile phase: mix 34 volumes of a solution containing 0.5 g/L of phosphoric acid R and 0.8 g/L of sodium dihydrogen phosphate R, adjusted to pH 2.5 with phosphoric acid R, and 66 volumes of methanol R.

Flow rate: 1 mL/min.

Detection: spectrophotometer at 254 nm.

Injection: 20  $\mu$ L.

Run time: 1.5 times the retention time of diclofenac.

Retention time: impurity A = about 12 min; diclofenac = about 25 min.

System suitability: reference solution (b):

- resolution: minimum 6.5 between the peaks due to impurity A and diclofenac.

## Limits:

- impurities A, B, C, D, E: for each impurity, not more than the area of the principal peak in the chromatogram obtained with reference solution (a) (0.2 per cent);
- total: not more than 2.5 times the area of the principal peak in the chromatogram obtained with reference solution (a) (0.5 per cent);
- disregard limit: 0.25 times the area of the principal peak in the chromatogram obtained with reference solution (a) (0.05 per cent).

Heavy metals (2.4.8): maximum 10 ppm.

2.0 g complies with test C. Use a quartz crucible. Prepare the reference solution using 2 mL of lead standard solution (10 ppm Pb) R.

Loss on drying (2.2.32): maximum 0.5 per cent, determined on 1.000 g by drying in an oven at 105 °C for 3 h.

## ASSAY

Dissolve 0.250 g in 30 mL of anhydrous acetic acid R. Titrate with 0.1 M perchloric acid, determining the end-point potentiometrically (2.2.20).

1 mL of 0.1 M perchloric acid is equivalent to 33.42 mg of  $C_{14}H_{10}Cl_2KNO_2$ .

## STORAGE

In an airtight container, protected from light.

## IMPURITIES

Specified impurities: A, B, C, D, E.

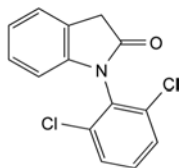

A. 1-(2,6-dichlorophenyl)-1,3-dihydro-2H-indol-2-one,

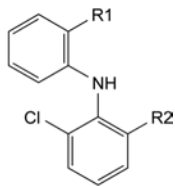

B. R1 = CHO, R2 = Cl: 2-[(2,6-dichlorophenyl)amino]benzaldehyde,

C. R1 = CH<sub>2</sub>OH, R2 = Cl: 2-[(2,6-dichlorophenyl)amino]phenylmethanol,

D. R1 = CH<sub>2</sub>-CO<sub>2</sub>H, R2 = Br: 2-[(2-bromo-6-chlorophenyl)amino]phenylacetic acid,

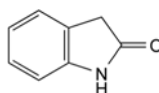

E. 1,3-dihydro-2H-indol-2-one.

01/2008:1002

## DICLOFENAC SODIUM

## Diclofenacum natricum

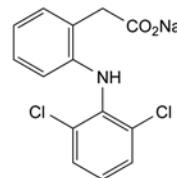

$C_{14}H_{10}Cl_2NNaO_2$   
[15307-79-6]

$M_r$  318.1

## DEFINITION

Sodium 2-[(2,6-dichlorophenyl)amino]phenyl]acetate.

Content: 99.0 per cent to 101.0 per cent (dried substance).

## CHARACTERS

Appearance: white or slightly yellowish, slightly hygroscopic, crystalline powder.

Solubility: sparingly soluble in water, freely soluble in methanol, soluble in ethanol (96 per cent), slightly soluble in acetone.

mp: about 280 °C, with decomposition.

## IDENTIFICATION

First identification: A, D.

Second identification: B, C, D.

A. Infrared absorption spectrophotometry (2.2.24).

Preparation: discs.

Comparison: diclofenac sodium CRS.

B. Thin-layer chromatography (2.2.27).

Test solution. Dissolve 25 mg of the substance to be examined in methanol R and dilute to 5 mL with the same solvent.

Reference solution (a). Dissolve 25 mg of diclofenac sodium CRS in methanol R and dilute to 5 mL with the same solvent.

Reference solution (b). Dissolve 10 mg of indometacin R in reference solution (a) and dilute to 2 mL with the same solution.

Plate: TLC silica gel GF<sub>254</sub> plate R.

Mobile phase: concentrated ammonia R, methanol R, ethyl acetate R (10:10:80 V/V/V).

Application: 5  $\mu$ L.

Development: over a path of 10 cm.

Drying: in air.

Detection: examine in ultraviolet light at 254 nm.

System suitability: reference solution (b):

- the chromatogram shows 2 clearly separated spots.

Results: the principal spot in the chromatogram obtained with the test solution is similar in position and size to the principal spot in the chromatogram obtained with reference solution (a).

C. Dissolve about 10 mg in 10 mL of ethanol (96 per cent) R. To 1 mL of this solution add 0.2 mL of a mixture, prepared immediately before use, of equal volumes of a 6 g/L solution of potassium ferricyanide R and a 9 g/L solution of ferric chloride R. Allow to stand protected from light for 5 min.



Add 3 mL of a 10 g/L solution of *hydrochloric acid R*. Allow to stand, protected from light, for 15 min. A blue colour develops and a precipitate is formed.

D. Dissolve 60 mg in 0.5 mL of *methanol R* and add 0.5 mL of *water R*. The solution gives reaction (b) of sodium (2.3.1).

#### TESTS

**Appearance of solution.** The solution is clear (2.2.1) and its absorbance (2.2.25) at 440 nm is not greater than 0.05.

Dissolve 1.25 g in *methanol R* and dilute to 25.0 mL with the same solvent.

**Related substances.** Liquid chromatography (2.2.29).

*Test solution.* Dissolve 50.0 mg of the substance to be examined in *methanol R* and dilute to 50.0 mL with the same solvent.

*Reference solution (a).* Dilute 2.0 mL of the test solution to 100.0 mL with *methanol R*. Dilute 1.0 mL of this solution to 10.0 mL with *methanol R*.

*Reference solution (b).* Dilute 1.0 mL of the test solution to 200.0 mL with *methanol R*. In 1.0 mL of this solution dissolve the contents of a vial of *diclofenac impurity A CRS*.

*Column:*

- size:  $l = 0.25$  m,  $\varnothing = 4.6$  mm;
- stationary phase: end-capped octylsilyl silica gel for chromatography R (5  $\mu$ m).

*Mobile phase:* mix 34 volumes of a solution containing 0.5 g/L of *phosphoric acid R* and 0.8 g/L of *sodium dihydrogen phosphate R*, adjusted to pH 2.5 with *phosphoric acid R*, and 66 volumes of *methanol R*.

*Flow rate:* 1 mL/min.

*Detection:* spectrophotometer at 254 nm.

*Injection:* 20  $\mu$ L.

*Run time:* 1.5 times the retention time of diclofenac.

*Retention times:* impurity A = about 12 min; diclofenac = about 25 min.

*System suitability:* reference solution (b):

- resolution: minimum 6.5 between the peaks due to impurity A and diclofenac.

*Limits:*

- impurities A, B, C, D, E: for each impurity, not more than the area of the principal peak in the chromatogram obtained with reference solution (a) (0.2 per cent);
- total: not more than 2.5 times the area of the principal peak in the chromatogram obtained with reference solution (a) (0.5 per cent);
- disregard limit: 0.25 times the area of the principal peak in the chromatogram obtained with reference solution (a) (0.05 per cent).

**Heavy metals (2.4.8):** maximum 10 ppm.

2.0 g complies with test C. Use a quartz crucible. Prepare the reference solution using 2 mL of *lead standard solution (10 ppm Pb) R*.

**Loss on drying (2.2.32):** maximum 0.5 per cent, determined on 1.000 g by drying in an oven at 105 °C for 3 h.

#### ASSAY

Dissolve 0.250 g in 30 mL of *anhydrous acetic acid R*. Titrate with 0.1 M *perchloric acid*, determining the end-point potentiometrically (2.2.20).

1 mL of 0.1 M *perchloric acid* is equivalent to 31.81 mg of  $C_{14}H_{10}Cl_2NNaO_2$ .

#### STORAGE

In an airtight container, protected from light.

#### IMPURITIES

*Specified impurities: A, B, C, D, E.*

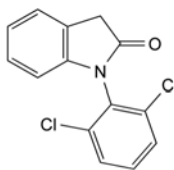

A. 1-(2,6-dichlorophenyl)-1,3-dihydro-2H-indol-2-one,

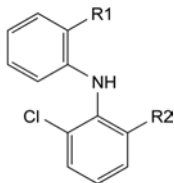

B. R1 = CHO, R2 = Cl: 2-[(2,6-dichlorophenyl)amino]benzaldehyde,

C. R1 = CH<sub>2</sub>OH, R2 = Cl: [2-[(2,6-dichlorophenyl)amino]phenyl]methanol,

D. R1 = CH<sub>2</sub>-CO<sub>2</sub>H, R2 = Br: 2-[2-[(2-bromo-6-chlorophenyl)amino]phenyl]acetic acid,

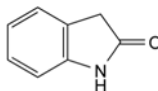

E. 1,3-dihydro-2H-indol-2-one.

01/2008:0663  
corrected 6.0

## DICLOXACILLIN SODIUM

### Dicloxacillinum natriicum

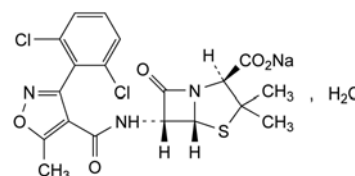

$C_{19}H_{16}Cl_2N_3NaO_5S \cdot H_2O$   
[13412-64-1]

$M_r$  510.3

#### DEFINITION

Sodium (2*S*,5*R*,6*R*)-6-[[[3-(2,6-dichlorophenyl)-5-methylisoxazol-4-yl]carbonyl]amino]-3,3-dimethyl-7-oxo-4-thia-1-azabicyclo[3.2.0]heptane-2-carboxylate monohydrate.

Semi-synthetic product derived from a fermentation product.

*Content:* 95.0 per cent to 102.0 per cent (anhydrous substance).

#### CHARACTERS

*Appearance:* white or almost white, hygroscopic, crystalline powder.

*Solubility:* freely soluble in water, soluble in ethanol (96 per cent) and in methanol.

#### IDENTIFICATION

*First identification:* A, D.

*Second identification:* B, C, D.

A. Infrared absorption spectrophotometry (2.2.24).

*Preparation:* discs.

*Comparison:* dicloxacillin sodium CRS.

B. Thin-layer chromatography (2.2.27).

*Test solution.* Dissolve 25 mg of the substance to be examined in 5 mL of *water R*.

**Reference solution (a).** Dissolve 25 mg of *dicloxacillin sodium CRS* in 5 mL of *water R*.

**Reference solution (b).** Dissolve 25 mg of *cloxacillin sodium CRS*, 25 mg of *dicloxacillin sodium CRS* and 25 mg of *flucloxacillin sodium CRS* in 5 mL of *water R*.

**Plate:** TLC silanised silica gel plate *R*.

**Mobile phase:** mix 30 volumes of *acetone R* and 70 volumes of a 154 g/L solution of *ammonium acetate R* adjusted to pH 5.0 with *glacial acetic acid R*.

**Application:** 1 µL.

**Development:** over a path of 15 cm.

**Drying:** in air.

**Detection:** expose to iodine vapour until the spots appear and examine in daylight.

**System suitability:** reference solution (b):

– the chromatogram shows 3 clearly separated spots.

**Results:** the principal spot in the chromatogram obtained with the test solution is similar in position, colour and size to the principal spot in the chromatogram obtained with reference solution (a).

- C. Place about 2 mg in a test-tube about 150 mm long and about 15 mm in diameter. Moisten with 0.05 mL of *water R* and add 2 mL of *sulfuric acid-formaldehyde reagent R*. Mix the contents of the tube by swirling; the solution is slightly greenish-yellow. Place the test-tube in a water-bath for 1 min; a yellow colour develops.

- D. It gives reaction (a) of sodium (2.3.1).

#### TESTS

**Solution S.** Dissolve 2.50 g in *carbon dioxide-free water R* and dilute to 25.0 mL with the same solvent.

**Appearance of solution.** Solution S is clear (2.2.1) and its absorbance (2.2.25) at 430 nm is not greater than 0.04.

**pH (2.2.3):** 5.0 to 7.0 for solution S.

**Specific optical rotation (2.2.7):** + 128 to + 143 (anhydrous substance).

Dissolve 0.250 g in *water R* and dilute to 25.0 mL with the same solvent.

**Related substances.** Liquid chromatography (2.2.29).

**Test solution (a).** Dissolve 50.0 mg of the substance to be examined in the mobile phase and dilute to 50.0 mL with the mobile phase.

**Test solution (b).** Dilute 5.0 mL of test solution (a) to 50.0 mL with the mobile phase.

**Reference solution (a).** Dissolve 50.0 mg of *dicloxacillin sodium CRS* in the mobile phase and dilute to 50.0 mL with the mobile phase. Dilute 5.0 mL of this solution to 50.0 mL with the mobile phase.

**Reference solution (b).** Dilute 5.0 mL of test solution (b) to 50.0 mL with the mobile phase.

**Reference solution (c).** Dissolve 5 mg of *flucloxacillin sodium CRS* and 5 mg of *dicloxacillin sodium CRS* in the mobile phase, then dilute to 50.0 mL with the mobile phase.

**Column:**

- size:  $l = 0.25$  m,  $\varnothing = 4$  mm;
- stationary phase: *octadecylsilyl silica gel for chromatography R* (5 µm).

**Mobile phase:** mix 25 volumes of *acetonitrile R* and 75 volumes of a 2.7 g/L solution of *potassium dihydrogen phosphate R* adjusted to pH 5.0 with *dilute sodium hydroxide solution R*.

**Flow rate:** 1.0 mL/min.

**Detection:** spectrophotometer at 225 nm.

**Injection:** 20 µL of test solution (a) and reference solutions (b) and (c).

**Run time:** 5 times the retention time of dicloxacillin.

**Retention time:** dicloxacillin = about 10 min.

**System suitability:** reference solution (c):

- **resolution:** minimum 2.5 between the peaks due to flucloxacillin (1<sup>st</sup> peak) and dicloxacillin (2<sup>nd</sup> peak).

**Limits:**

- **any impurity:** for each impurity, not more than the area of the principal peak in the chromatogram obtained with reference solution (b) (1 per cent);
- **total:** not more than 5 times the area of the principal peak in the chromatogram obtained with reference solution (b) (5 per cent);
- **disregard limit:** 0.05 times the area of the principal peak in the chromatogram obtained with reference solution (b) (0.05 per cent).

***N,N*-Dimethylaniline (2.4.26, Method B):** maximum 20 ppm.

**2-Ethylhexanoic acid (2.4.28):** maximum 0.8 per cent *m/m*.

**Water (2.5.12):** 3.0 per cent to 4.5 per cent, determined on 0.300 g.

**Pyrogens (2.6.8).** If intended for use in the manufacture of parenteral preparations without a further appropriate procedure for the removal of pyrogens, it complies with the test for pyrogens. Inject per kilogram of the rabbit's mass 1 mL of a solution in *water for injections R* containing 20 mg of the substance to be examined per millilitre.

#### ASSAY

Liquid chromatography (2.2.29) as described in the test for related substances with the following modifications.

**Injection:** test solution (b) and reference solution (a).

**System suitability:** reference solution (a):

- **repeatability:** maximum relative standard deviation of 1.0 per cent after 6 injections.

#### STORAGE

In an airtight container, at a temperature not exceeding 25 °C. If the substance is sterile, store in a sterile, airtight, tamper-proof container.

#### IMPURITIES

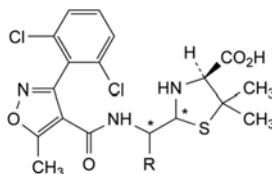

A. R = CO<sub>2</sub>H: (4*S*)-2-[carboxy[[[3-(2,6-dichlorophenyl)-5-methylisoxazol-4-yl]carbonyl]amino]methyl]-5,5-dimethylthiazolidine-4-carboxylic acid (penicilloic acids of dicloxacillin),

B. R = H: (2*R,S*,4*S*)-2-[[[3-(2,6-dichlorophenyl)-5-methylisoxazol-4-yl]carbonyl]amino]methyl]-5,5-dimethylthiazolidine-4-carboxylic acid (penilloic acids of dicloxacillin),

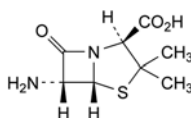

C. (2*S*,5*R*,6*R*)-6-amino-3,3-dimethyl-7-oxo-4-thia-1-azabicyclo[3.2.0]heptane-2-carboxylic acid (6-aminopenicillanic acid),

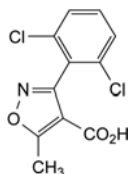

D. 3-(2,6-dichlorophenyl)-5-methylisoxazole-4-carboxylic acid.

01/2008:1197  
corrected 6.0**DICYCLOVERINE HYDROCHLORIDE**

## Dicycloverini hydrochloridum

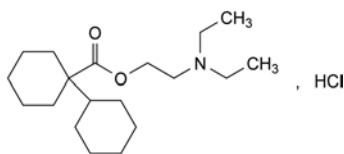
 $C_{19}H_{36}ClNO_2$  $M_r$  346.0**DEFINITION**

Dicycloverine hydrochloride contains not less than 99.0 per cent and not more than the equivalent of 101.0 per cent of 2-(diethylamino)ethyl bicyclohexyl-1-carboxylate hydrochloride, calculated with reference to the dried substance.

**CHARACTERS**

A white or almost white, crystalline powder, soluble in water, freely soluble in alcohol and in methylene chloride.

It shows polymorphism (5.9).

**IDENTIFICATION**

*First identification:* A, D.

*Second identification:* B, C, D.

- A. Examine by infrared absorption spectrophotometry (2.2.24), comparing with the spectrum obtained with *dicycloverine hydrochloride CRS*. Examine the substances prepared as discs using *potassium chloride R*. If the spectra obtained show differences, dissolve the substance to be examined and the reference substance separately in *acetone R*, evaporate to dryness and record new spectra using the residues.
- B. Examine the chromatograms obtained in the test for related substances. The principal spot in the chromatogram obtained with test solution (b) is similar in position, colour and size to the principal spot in the chromatogram obtained with reference solution (b).
- C. To 3 mL of a 1.0 g/L solution of *sodium laurilsulfate R* add 5 mL of *methylene chloride R* and 0.05 mL of a 2.5 g/L solution of *methylene blue R*, mix gently and allow to stand; the lower layer is blue. Add 2 mL of a 20 g/L solution of the substance to be examined, mix gently and allow to stand; the upper layer is blue and the lower layer is colourless.
- D. It gives reaction (a) of chlorides (2.3.1).

**TESTS**

**pH** (2.2.3). Dissolve 0.5 g in *water R* and dilute to 50 mL with the same solvent. The pH of the solution is 5.0 to 5.5.

**Related substances.** Examine by thin-layer chromatography (2.2.27), using a suitable silica gel as the coating substance.

*Test solution (a).* Dissolve 0.25 g to the substance to be examined in *methanol R* and dilute to 5 mL with the same solvent.

*Test solution (b).* Dilute 1 mL of test solution (a) to 50 mL with *methanol R*.

*Reference solution (a).* Dilute 1 mL of test solution (b) to 10 mL with *methanol R*.

*Reference solution (b).* Dissolve 10 mg of *dicycloverine hydrochloride CRS* in *methanol R* and dilute to 10 mL with the same solvent.

*Reference solution (c).* Dissolve 5 mg of *tropicamide CRS* in reference solution (b) and dilute to 5 mL with the same solution.

Apply separately to the plate 10 µL of each solution. Develop over a path of 15 cm using a mixture of 5 volumes of *concentrated ammonia R*, 10 volumes of *ethyl acetate R*, 10 volumes of *water R* and 75 volumes of *propanol R*. Dry the

plate in a current of warm air. Spray with *dilute potassium iodobismuthate solution R*. Any spot in the chromatogram obtained with test solution (a), apart from the principal spot, is not more intense than the spot in the chromatogram obtained with reference solution (a) (0.2 per cent). The test is not valid unless the chromatogram obtained with reference solution (c) shows two clearly separated spots.

**Loss on drying** (2.2.32). Not more than 1.0 per cent, determined on 1.000 g by drying in an oven at 105 °C.

**Sulfated ash** (2.4.14). Not more than 0.1 per cent, determined on 1.0 g.

**ASSAY**

Dissolve 0.300 g in a mixture of 5.0 mL of 0.01 M *hydrochloric acid* and 50 mL of *alcohol R*. Carry out a potentiometric titration (2.2.20), using 0.1 M *sodium hydroxide*. Read the volume added between the two points of inflexion.

1 mL of 0.1 M *sodium hydroxide* is equivalent to 34.60 mg of  $C_{19}H_{36}ClNO_2$ .

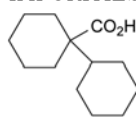
**IMPURITIES**

A. bicyclohexyl-1-carboxylic acid.

01/2008:2200  
corrected 7.0**DIDANOSINE**

## Didanosinum

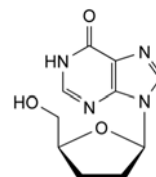
 $C_{10}H_{12}N_4O_3$   
[69655-05-6] $M_r$  236.2**DEFINITION**

9-(2,3-Dideoxy-β-D-glycero-pentofuranosyl)-1,9-dihydro-6H-purin-6-one (2',3'-dideoxyinosine).

*Content:* 98.5 per cent to 101.0 per cent (anhydrous substance).

**CHARACTERS**

*Appearance:* white or almost white, crystalline powder.

*Solubility:* sparingly soluble in water, freely soluble in dimethyl sulfoxide, slightly soluble in methanol and in ethanol (96 per cent).

**IDENTIFICATION**

A. Infrared absorption spectrophotometry (2.2.24).

*Comparison:* *didanosine CRS*.

B. Specific optical rotation (2.2.7): -24.2 to -28.2 (anhydrous substance).

Dissolve 0.100 g in *water R* and dilute to 10.0 mL with the same solvent.

**TESTS**

**Related substances.** Liquid chromatography (2.2.29). Prepare the solutions immediately before use.

*Solvent mixture.* Mix 8 volumes of mobile phase B and 92 volumes of mobile phase A.

*Test solution.* Dissolve 25.0 mg of the substance to be examined in 50.0 mL of the solvent mixture.

**Reference solution (a).** Dilute 1.0 mL of the test solution to 100.0 mL with the solvent mixture. Dilute 1.0 mL of this solution to 10.0 mL with the solvent mixture.

**Reference solution (b).** Dissolve 5.0 mg of *didanosine impurity A CRS* in the solvent mixture and dilute to 100.0 mL with the solvent mixture. Dilute 1.0 mL to 20.0 mL with the solvent mixture.

**Reference solution (c).** Dissolve 5 mg of *didanosine for system suitability CRS* (containing impurities A to F) in the solvent mixture and dilute to 10 mL with the solvent mixture.

**Reference solution (d).** Dissolve 5 mg of *didanosine impurity G CRS* in the solvent mixture and dilute to 100 mL with the solvent mixture. Dilute 1 mL to 20 mL with the solvent mixture.

**Column:**

- size:  $l = 0.25$  m,  $\varnothing = 4.6$  mm;
- stationary phase: base-deactivated octadecylsilyl silica gel for chromatography R (5  $\mu$ m).

**Mobile phase:**

- mobile phase A: mix 8 volumes of *methanol R* and 92 volumes of a 3.86 g/L solution of *ammonium acetate R* adjusted to pH 8.0 with *concentrated ammonia R*;
- mobile phase B: mix 30 volumes of *methanol R* and 70 volumes of a 3.86 g/L solution of *ammonium acetate R* adjusted to pH 8.0 with *concentrated ammonia R*;

Time (min)	Mobile phase A (per cent V/V)	Mobile phase B (per cent V/V)
0 - 18	100	0
18 - 25	100 $\rightarrow$ 0	0 $\rightarrow$ 100
25 - 45	0	100
45 - 50	0 $\rightarrow$ 100	100 $\rightarrow$ 0
50 - 60	100	0

**Flow rate:** 1.0 mL/min.

**Detection:** spectrophotometer at 254 nm.

**Injection:** 20  $\mu$ L.

**Identification of impurities:** use the chromatogram supplied with *didanosine for system suitability CRS* and the chromatogram obtained with reference solution (c) to identify the peaks due to impurities A to F and use the chromatogram obtained with reference solution (d) to identify the peak due to impurity G.

**Relative retention** with reference to didanosine (retention time = about 13-15 min): impurity A = about 0.3; impurity B = about 0.4; impurity C = about 0.44; impurity D = about 0.48; impurity E = about 0.5; impurity F = about 0.8; impurity G = about 1.6.

**System suitability:** reference solution (c):

- resolution: minimum 2.5 between the peaks due to impurity C and impurity D.

**Limits:**

- **impurity A:** not more than the area of the principal peak in the chromatogram obtained with reference solution (b) (0.5 per cent);
- **impurities B, C, D, E, F, G:** for each impurity, not more than twice the area of the principal peak in the chromatogram obtained with reference solution (a) (0.2 per cent);
- **unspecified impurities:** for each impurity, not more than the area of the principal peak in the chromatogram obtained with reference solution (a) (0.10 per cent);
- **total:** not more than 10 times the area of the principal peak in the chromatogram obtained with reference solution (a) (1.0 per cent);
- **disregard limit:** 0.5 times the area of the principal peak in the chromatogram obtained with reference solution (a) (0.05 per cent).

**Heavy metals (2.4.8):** maximum 20 ppm.

1.0 g complies with test F. Prepare the reference solution using 2 mL of *lead standard solution (10 ppm Pb) R*.

**Water (2.5.12):** maximum 2.0 per cent, determined on 0.500 g.

**Sulfated ash (2.4.14):** maximum 0.1 per cent, determined on 1.0 g.

**ASSAY**

Dissolve 0.200 g in 50 mL of *glacial acetic acid R*. Titrate with 0.1 M *perchloric acid*, determining the end-point potentiometrically (2.2.20).

1 mL of 0.1 M *perchloric acid* is equivalent to 23.62 mg of  $C_{10}H_{12}N_4O_3$ .

**IMPURITIES**

**Specified impurities:** A, B, C, D, E, F, G.

**Other detectable impurities** (the following substances would, if present at a sufficient level, be detected by one or other of the tests in the monograph. They are limited by the general acceptance criterion for other/unspecified impurities and/or by the general monograph *Substances for pharmaceutical use (2034)*. It is therefore not necessary to identify these impurities for demonstration of compliance. See also 5.10. *Control of impurities in substances for pharmaceutical use*): H, I.

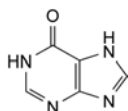

A. 1,7-dihydro-6H-purin-6-one (hypoxanthine),

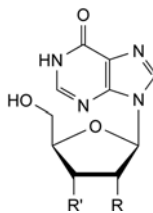

B.  $R = R' = OH$ : 9- $\beta$ -D-ribofuranosyl-1,9-dihydro-6H-purin-6-one (inosine),

C.  $R = H, R' = OH$ : 9-(2-deoxy- $\beta$ -D-erythro-pentofuranosyl)-1,9-dihydro-6H-purin-6-one (2'-deoxyinosine),

D.  $R = OH, R' = H$ : 9-(3-deoxy- $\beta$ -D-erythro-pentofuranosyl)-1,9-dihydro-6H-purin-6-one (3'-deoxyinosine),

E.  $R + R' = O$ : 9-(2,3-anhydro- $\beta$ -D-ribofuranosyl)-1,9-dihydro-6H-purin-6-one (2',3'-anhydroinosine),

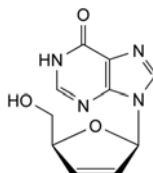

F. 9-(2,3-dideoxy- $\beta$ -D-glycero-pent-2-enofuranosyl)-1,9-dihydro-6H-purin-6-one (2',3'-dideoxy-2',3'-dideoxyinosine),

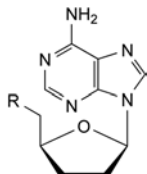

G.  $R = OH$ : 9-(2,3-dideoxy- $\beta$ -D-glycero-pentofuranosyl)-9H-purin-6-amine (2',3'-dideoxyadenosine),

H.  $R = H$ : 9-(2,3,5-trideoxy- $\beta$ -D-glycero-pentofuranosyl)-9H-purin-6-amine (2',3',5'-trideoxyadenosine),

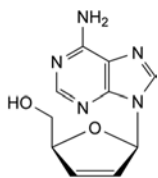

- I. 9-(2,3-dideoxy-β-D-glycero-pent-2-enofuranosyl)-9H-purin-6-amine (2',3'-dideoxy-2',3'-didehydroadenosine).

01/2008:0483  
corrected 6.0

## DIENESTROL

### Dienestrolum

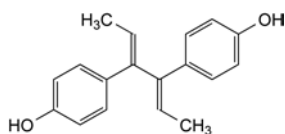

C<sub>18</sub>H<sub>18</sub>O<sub>2</sub>  
[84-17-3]

M<sub>r</sub> 266.3

#### DEFINITION

Dienestrol contains not less than 98.5 per cent and not more than the equivalent of 101.5 per cent of (*E,E*)-4,4'-(1,2-diethylidene-ethylene)diphenol, calculated with reference to the dried substance.

#### CHARACTERS

A white or almost white, crystalline powder, practically insoluble in water, freely soluble in acetone and in alcohol. It dissolves in dilute solutions of the alkali hydroxides.

#### IDENTIFICATION

First identification: A, D.

Second identification: B, C, D.

- Examine by infrared absorption spectrophotometry (2.2.24), comparing with the spectrum obtained with *dienestrol CRS*. Examine the substances prepared as discs.
- Examine the chromatograms obtained in the test for related substances. The principal spot in the chromatogram obtained with test solution (b) is similar in position, colour and size to the spot in the chromatogram obtained with reference solution (a).
- Dissolve about 1 mg in 5 mL of *glacial acetic acid R*, add 1 mL of a 1 per cent V/V solution of *bromine R* in *glacial acetic acid R* and heat in a water-bath for 2 min. Place 0.5 mL of this solution in a dry test-tube, add 0.5 mL of *ethanol R*, mix and add 10 mL of *water R*. A reddish-violet colour is produced. Add 5 mL of *chloroform R*, shake vigorously and allow to separate. The chloroform layer is red and the aqueous layer is almost colourless.
- Dissolve about 0.5 mg in 0.2 mL of *glacial acetic acid R*, add 1 mL of *phosphoric acid R* and heat on a water-bath for 3 min. A reddish-violet colour is produced.

#### TESTS

**Melting range.** Determined by the capillary method (2.2.14), the melting point is 227 °C to 234 °C. The temperature interval between the formation of a definite meniscus in the melt and the disappearance of the last particle does not exceed 3 °C.

**Related substances.** Examine by thin-layer chromatography (2.2.27), using *silica gel G R* as the coating substance.

**Test solution (a).** Dissolve 0.2 g of the substance to be examined in 2 mL of *alcohol R*.

**Test solution (b).** Dilute 1 mL of test solution (a) to 20 mL with *alcohol R*.

**Reference solution (a).** Dissolve 25 mg of *dienestrol CRS* in *alcohol R* and dilute to 5 mL with the same solvent.

**Reference solution (b).** Dilute 1 mL of reference solution (a) to 10 mL with *alcohol R*.

**Reference solution (c).** Dissolve 10 mg of *diethylstilbestrol CRS* in 2 mL of *alcohol R*. To 1 mL of this solution add 1 mL of reference solution (a).

Apply separately to the plate 1 µL of each solution. Develop over a path of 15 cm using a mixture of 10 volumes of *diethylamine R* and 90 volumes of *toluene R*. Allow the plate to dry in air, spray with *alcoholic solution of sulfuric acid R* and heat at 120 °C for 10 min. Any spot in the chromatogram obtained with test solution (a), apart from the principal spot, is not more intense than the spot in the chromatogram obtained with reference solution (b) (0.5 per cent). The test is not valid unless the chromatogram obtained with reference solution (c) shows at least two clearly separated spots having approximately the same intensity.

**Loss on drying (2.2.32).** Not more than 0.5 per cent, determined on 1.000 g by drying in an oven at 105 °C.

**Sulfated ash (2.4.14).** Not more than 0.1 per cent, determined on 1.0 g.

#### ASSAY

Dissolve 25.0 mg in *ethanol R* and dilute to 100.0 mL with the same solvent. To 5.0 mL of this solution add 10 mL of *ethanol R* and dilute to 250.0 mL with 0.1 M *sodium hydroxide*. Prepare a reference solution in the same manner using 25.0 mg of *dienestrol CRS*. Measure the absorbance (2.2.25) of the solutions at the maximum at 245 nm.

Calculate the content of C<sub>18</sub>H<sub>18</sub>O<sub>2</sub> from the measured absorbances and the concentrations of the solutions.

#### STORAGE

Store protected from light.

04/2008:0897

## DIETHYL PHTHALATE

### Diethylis phthalas

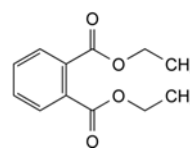

C<sub>12</sub>H<sub>14</sub>O<sub>4</sub>  
[84-66-2]

M<sub>r</sub> 222.2

#### DEFINITION

Diethyl benzene-1,2-dicarboxylate.

**Content:** 99.0 per cent *m/m* to 101.0 per cent *m/m*.

#### CHARACTERS

**Appearance:** clear, colourless or very slightly yellow, oily liquid.

**Solubility:** practically insoluble in water, miscible with ethanol (96 per cent).

#### IDENTIFICATION

First identification: B, C.

Second identification: A, D, E.

A. Relative density (2.2.5): 1.117 to 1.121.

B. Refractive index (2.2.6): 1.500 to 1.505.

C. Infrared absorption spectrophotometry (2.2.24).

**Preparation:** thin films.

**Comparison:** *diethyl phthalate CRS*.

## D. Thin-layer chromatography (2.2.27).

**Test solution.** Dissolve 50 mg of the substance to be examined in ether R and dilute to 10 mL with the same solvent.

**Reference solution.** Dissolve 50 mg of diethyl phthalate CRS in ether R and dilute to 10 mL with the same solvent.

**Plate:** TLC silica gel GF<sub>254</sub> plate R.

**Mobile phase:** heptane R, ether R (30:70 V/V).

**Application:** 10 µL.

**Development:** over 2/3 of the plate.

**Drying:** in air.

**Detection:** examine in ultraviolet light at 254 nm.

**Results:** the principal spot in the chromatogram obtained with the test solution is similar in position and size to the principal spot in the chromatogram obtained with the reference solution.

## E. To about 0.1 mL add 0.25 mL of sulfuric acid R and 50 mg of resorcinol R. Heat on a water-bath for 5 min. Allow to cool. Add 10 mL of water R and 1 mL of strong sodium hydroxide solution R. The solution becomes yellow or brownish-yellow and shows green fluorescence.

## TESTS

**Appearance.** The substance to be examined is clear (2.2.1) and not more intensely coloured than reference solution Y<sub>6</sub> (2.2.2, Method II).

**Acidity.** Dissolve 20.0 g in 50 mL of ethanol (96 per cent) R previously neutralised to phenolphthalein solution R1. Add 0.2 mL of phenolphthalein solution R1. Not more than 0.1 mL of 0.1 M sodium hydroxide is required to change the colour of the indicator to pink.

**Related substances.** Gas chromatography (2.2.28).

**Internal standard solution.** Dissolve 60 mg of naphthalene R in methylene chloride R and dilute to 20 mL with the same solvent.

**Test solution (a).** Dissolve 1.0 g of the substance to be examined in methylene chloride R and dilute to 20.0 mL with the same solvent.

**Test solution (b).** Dissolve 1.0 g of the substance to be examined in methylene chloride R, add 2.0 mL of the internal standard solution and dilute to 20.0 mL with methylene chloride R.

**Reference solution.** To 1.0 mL of test solution (a) add 10.0 mL of the internal standard solution and dilute to 100.0 mL with methylene chloride R.

**Column:**

- material: glass;
- size:  $l = 2$  m,  $\varnothing = 2$  mm;
- stationary phase: silanised diatomaceous earth for gas chromatography R (150-180 µm) impregnated with 3 per cent m/m of polymethylphenylsiloxane R.

**Carrier gas:** nitrogen for chromatography R.

**Flow rate:** 30 mL/min.

**Temperature:**

- column: 150 °C;
- injection port and detector: 225 °C.

**Detection:** flame ionisation.

**Injection:** 1 µL.

**Run time:** 3 times the retention time of diethyl phthalate.

**Elution order:** naphthalene, diethyl phthalate.

**System suitability:**

- resolution: minimum 10 between the peaks due to naphthalene and diethyl phthalate in the chromatogram obtained with the reference solution;
- in the chromatogram obtained with test solution (a), there is no peak with the same retention time as the internal standard.

**Limit:**

- total: calculate the ratio ( $R$ ) of the area of the peak due to diethyl phthalate to the area of the peak due to the internal standard from the chromatogram obtained with the reference solution; from the chromatogram obtained with test solution (b), calculate the ratio of the sum of the areas of any peaks, apart from the principal peak and the peak due to the internal standard, to the area of the peak due to the internal standard: this ratio is not greater than  $R$  (1.0 per cent).

**Water (2.5.12):** maximum 0.2 per cent, determined on 10.0 g.

**Sulfated ash (2.4.14):** maximum 0.1 per cent, determined on 1.0 g.

## ASSAY

Introduce 0.750 g into a 250 mL borosilicate glass flask. Add 25.0 mL of 0.5 M alcoholic potassium hydroxide and a few glass beads. Boil in a water-bath under a reflux condenser for 1 h. Add 1 mL of phenolphthalein solution R1 and titrate immediately with 0.5 M hydrochloric acid. Carry out a blank titration. Calculate the volume of 0.5 M alcoholic potassium hydroxide used in the saponification.

1 mL of 0.5 M alcoholic potassium hydroxide is equivalent to 55.56 mg of C<sub>12</sub>H<sub>14</sub>O<sub>4</sub>.

## STORAGE

In an airtight container.

01/2008:0271

## DIETHYLCARBAMAZINE CITRATE

## Diethylcarbamazini citras

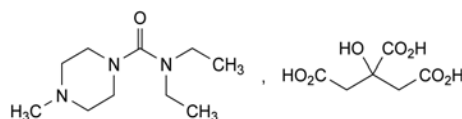

C<sub>16</sub>H<sub>29</sub>N<sub>3</sub>O<sub>8</sub>  
[1642-54-2]

$M_r$  391.4

## DEFINITION

*N,N*-Diethyl-4-methylpiperazine-1-carboxamide dihydrogen 2-hydroxypropane-1,2,3-tricarboxylate.

**Content:** 98.0 per cent to 102.0 per cent (dried substance).

## CHARACTERS

**Appearance:** white or almost white, crystalline powder, slightly hygroscopic.

**Solubility:** very soluble in water, soluble in ethanol (96 per cent), practically insoluble in acetone.

mp: about 138 °C, with decomposition.

## IDENTIFICATION

**First identification:** A, C.

**Second identification:** B, C.

A. Infrared absorption spectrophotometry (2.2.24).

**Comparison:** diethylcarbamazine citrate CRS.

B. Examine the chromatograms obtained in the test for impurities A and B.

**Results:** the principal spot in the chromatogram obtained with the test solution is similar in position, colour and size to the principal spot in the chromatogram obtained with reference solution (a).

C. Dissolve 0.1 g in 5 mL of water R. The solution gives the reaction of citrates (2.3.1).

## TESTS

**Solution S.** Shake 2.5 g with water R until dissolved and dilute to 25 mL with the same solvent.

**Appearance of solution.** Solution S is not more opalescent than reference suspension II (2.2.1) and not more intensely coloured than reference solution BY<sub>6</sub> (2.2.2, Method II).

**Impurities A and B.** Thin-layer chromatography (2.2.27).

**Test solution.** Dissolve 0.5 g of the substance to be examined in methanol R and dilute to 10 mL with the same solvent.

**Reference solution (a).** Dissolve 0.1 g of diethylcarbamazine citrate CRS in methanol R and dilute to 2.0 mL with the same solvent.

**Reference solution (b).** Dissolve 10 mg of methylpiperazine R (impurity A) in methanol R and dilute to 100 mL with the same solvent.

**Reference solution (c).** Dissolve 10 mg of dimethylpiperazine R (impurity B) in methanol R and dilute to 100 mL with the same solvent.

**Plate:** TLC silica gel plate R.

**Mobile phase:** concentrated ammonia R, methyl ethyl ketone R, methanol R (5:30:65 V/V/V).

**Application:** 10 µL.

**Development:** over 2/3 of the plate.

**Drying:** at 100-105 °C.

**Detection:** expose to iodine vapour for 30 min.

**Retardation factors:** impurity A = about 0.2; impurity B = about 0.5.

**Limits:**

- **impurity A:** any spot due to impurity A is not more intense than the corresponding spot in the chromatogram obtained with reference solution (b) (0.2 per cent);
- **impurity B:** any spot due to impurity B is not more intense than the corresponding spot in the chromatogram obtained with reference solution (c) (0.2 per cent).

**Related substances.** Liquid chromatography (2.2.29).

**Solution A.** Dissolve 31.2 g of potassium dihydrogen phosphate R in water R and dilute to 1000 mL with the same solvent.

**Test solution (a).** Suspend 0.30 g of the substance to be examined in solution A and dilute to 100 mL with solution A. Filter or centrifuge and use the clear filtrate or supernatant.

**Test solution (b).** Dissolve 10.0 mg of the substance to be examined in solution A and dilute to 100.0 mL with solution A.

**Reference solution (a).** Dilute 1.0 mL of test solution (a) to 100.0 mL with solution A. Dilute 1.0 mL of this solution to 10.0 mL with solution A.

**Reference solution (b).** Dissolve 10 mg of citric acid R in solution A and dilute to 10 mL with solution A.

**Reference solution (c).** To 3 mL of test solution (a) add 0.5 mL of strong hydrogen peroxide solution R and maintain at 80 °C for 3 h. Dilute to 100 mL with solution A.

**Reference solution (d).** Dissolve 5.0 mg of diethylcarbamazine citrate CRS in solution A and dilute to 50.0 mL with solution A.

**Column:**

- **size:**  $l = 0.15$  m,  $\varnothing = 3.9$  mm;
- **stationary phase:** end-capped octadecylsilyl silica gel for chromatography R (5 µm).

**Mobile phase:** mix 100 volumes of methanol R2 and 900 volumes of a 10 g/L solution of potassium dihydrogen phosphate R.

**Flow rate:** 0.8 mL/min.

**Detection:** spectrophotometer at 220 nm.

**Injection:** 20 µL of test solution (a) and reference solutions (a), (b) and (c).

**Run time:** twice the retention time of diethylcarbamazine.

**Identification of impurities:** use the chromatogram obtained with reference solution (b) to identify the peak due to the citrate.

**Relative retention** with reference to diethylcarbamazine (retention time = about 7 min): citrate = about 0.2; degradation product = about 1.6.

**System suitability:** reference solution (c):

- **resolution:** minimum 5 between the peaks due to diethylcarbamazine and the degradation product.

**Limits:**

- **unspecified impurities:** for each impurity, not more than the area of the principal peak in the chromatogram obtained with reference solution (a) (0.10 per cent);
- **total:** not more than 5 times the area of the principal peak in the chromatogram obtained with reference solution (a) (0.5 per cent);
- **disregard limit:** 0.5 times the area of the principal peak in the chromatogram obtained with reference solution (a) (0.05 per cent); disregard the peak due to the citrate.

**Heavy metals (2.4.8):** maximum 20 ppm.

12 mL of solution S complies with test A. Prepare the reference solution using 10 mL of lead standard solution (2 ppm Pb) R.

**Loss on drying (2.2.32):** maximum 0.5 per cent, determined on 1.000 g by drying *in vacuo* at 60 °C for 4 h.

**Sulfated ash (2.4.14):** maximum 0.1 per cent, determined on 1.0 g.

**ASSAY**

Liquid chromatography (2.2.29) as described in the test for related substances with the following modification.

**Injection:** 20 µL of test solution (b) and reference solution (d). Calculate the percentage content of C<sub>16</sub>H<sub>29</sub>N<sub>3</sub>O<sub>8</sub> from the declared content of diethylcarbamazine citrate CRS.

**STORAGE**

In an airtight container.

**IMPURITIES**

**Specified impurities:** A, B.

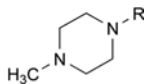

A. R = H: 1-methylpiperazine,

B. R = CH<sub>3</sub>: 1,4-dimethylpiperazine.

01/2008:1198

## DIETHYLENE GLYCOL MONOETHYL ETHER

Diethylenglycoli aether monoethilicus

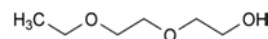

C<sub>6</sub>H<sub>14</sub>O<sub>3</sub>  
[111-90-0]

*M*<sub>r</sub> 134.2

**DEFINITION**

2-(2-Ethoxyethoxy)ethanol, produced by condensation of ethylene oxide and alcohol, followed by distillation.

**CHARACTERS**

**Appearance:** clear, colourless, hygroscopic liquid.

**Solubility:** miscible with water, with acetone and with alcohol, miscible in certain proportions with vegetable oils, not miscible with mineral oils.

**Relative density:** about 0.991.

## IDENTIFICATION

- A. Refractive index (2.2.6): 1.426 to 1.428.  
 B. Infrared absorption spectrophotometry (2.2.24).  
*Comparison: Ph. Eur. reference spectrum of diethylene glycol monoethyl ether.*

## TESTS

**Acid value** (2.5.1): maximum 0.1.

Mix 30.0 mL with 30 mL of *alcohol R* previously neutralised with 0.1 M *potassium hydroxide* using *phenolphthalein solution R* as indicator. Titrate with 0.01 M *alcoholic potassium hydroxide*.

**Peroxide value** (2.5.5): maximum 8.0, determined on 2.00 g.

**Related substances.** Gas chromatography (2.2.28).

**Internal standard solution.** Dilute 1.00 g of *decane R* to 100.0 mL with *methanol R*.

**Test solution.** To 5.00 g of the substance to be examined, add 0.1 mL of the internal standard solution and dilute to 10.0 mL with *methanol R*.

**Reference solution (a).** Dilute 25.0 mg of *ethylene glycol monomethyl ether R*, 80.0 mg of *ethylene glycol monoethyl ether R*, 0.310 g of *ethylene glycol R* and 0.125 g of *diethylene glycol R* to 100.0 mL with *methanol R*. To 1.0 mL of this solution add 0.1 mL of the internal standard solution and dilute to 10.0 mL with *methanol R*.

**Reference solution (b).** Dilute 25.0 mg of *ethylene glycol monoethyl ether R* and 25.0 mg of *ethylene glycol R* to 100.0 mL with *methanol R*. Dilute 1.0 mL of this solution to 5.0 mL with *methanol R*.

**Reference solution (c).** Dilute 1.00 g of the substance to be examined to 100.0 mL with *methanol R*. To 1.0 mL of this solution add 0.1 mL of the internal standard solution and dilute to 10.0 mL with *methanol R*.

**Column:**

- *material*: fused silica,
- *size*:  $l = 30$  m,  $\varnothing = 0.32$  mm,
- *stationary phase*: *poly(cyanopropyl)(7)(phenyl)(7)methyl(86)siloxane R* (film thickness 1  $\mu$ m).

**Carrier gas:** *nitrogen for chromatography R* or *helium for chromatography R*.

**Flow rate:** 2.0 mL/min.

**Split ratio:** 1:80.

**Temperature:**

	Time (min)	Temperature (°C)
Column	0 - 1	120
	1 - 10	120 → 225
	10 - 12	225
Injection port		275
Detector		250

**Detection:** flame ionisation.

**Injection:** 0.5  $\mu$ L.

**Relative retentions** with reference to diethylene glycol monoethyl ether (retention time = about 4 min): ethylene glycol monomethyl ether = about 0.4; ethylene glycol monoethyl ether = about 0.5; ethylene glycol = about 0.55; diethylene glycol = about 1.1.

**System suitability:**

- **resolution:** minimum 3.0 between the peaks due to ethylene glycol monoethyl ether and to ethylene glycol in the chromatogram obtained with reference solution (b),
- **signal-to-noise ratio:** minimum 3.0 for the peak due to ethylene glycol monomethyl ether in the chromatogram obtained with reference solution (a),

**Limits** (take into account the impurity/internal standard peak area ratio):

- *ethylene glycol monomethyl ether*: not more than the area of the corresponding peak in the chromatogram obtained with reference solution (a) (50 ppm),
- *ethylene glycol monoethyl ether*: not more than the area of the corresponding peak in the chromatogram obtained with reference solution (a) (160 ppm),
- *ethylene glycol*: not more than the area of the corresponding peak in the chromatogram obtained with reference solution (a) (620 ppm),
- *diethylene glycol*: not more than the area of the corresponding peak in the chromatogram obtained with reference solution (a) (250 ppm),
- **total**: not more than the area of the principal peak in the chromatogram obtained with reference solution (c) (0.2 per cent).

**Ethylene oxide.** Head-space gas chromatography (2.2.28).

**Test solution.** To 1.00 g of the substance to be examined in a vial, add 50  $\mu$ L of *water R*.

**Reference solution.** To 1.00 g of the substance to be examined in a vial, add 50  $\mu$ L of *ethylene oxide solution R4* and close tightly.

**Column:**

- *material*: fused silica,
- *size*:  $l = 30$  m,  $\varnothing = 0.32$  mm,
- *stationary phase*: *poly(cyanopropyl)(7)(phenyl)(7)methyl(86)siloxane R* (film thickness 1  $\mu$ m).

**Carrier gas:** *helium for chromatography R*.

**Flow rate:** 1.1 mL/min.

**Static head-space conditions which may be used:**

- **equilibration temperature:** 80 °C,
- **equilibration time:** 45 min,
- **transfer line temperature:** 110 °C,
- **pressurisation time:** 2 min,
- **injection time:** 12 s.

**Temperature:**

	Time (min)	Temperature (°C)
Column	0 - 5	40
	5 - 18	40 → 200
Injection port		150
Detector		250

**Detection:** flame ionisation.

**Injection:** 1.0 mL.

The peak due to ethylene oxide is identified by injecting solutions of ethylene oxide of increasing concentration.

Determine the content of ethylene oxide (ppm) in the substance to be examined using the following expression:

$$\frac{S_T \times C}{(S_S \times M_T) - (S_T \times M_S)}$$

$S_T$  = area of the peak corresponding to ethylene oxide in the chromatogram obtained with the test solution,

$S_S$  = area of the peak corresponding to ethylene oxide in the chromatogram obtained with the reference solution,

$M_T$  = mass of the substance to be examined in the test solution, in grams,

$M_S$  = mass of the substance to be examined in the reference solution, in grams,

$C$  = mass of added ethylene oxide in the reference solution, in micrograms.



**Limit:**

– *ethylene oxide*: maximum 1 ppm.

**Water** (2.5.12): maximum 0.1 per cent, determined on 10.0 g.

**STORAGE**

Under an inert gas, in an airtight container.

**LABELLING**

The label states that the substance is stored under an inert gas.

01/2008:1415  
corrected 6.0

## DIETHYLENE GLYCOL PALMITOSTEARATE

### Diethylen glycoli palmitostearas

**DEFINITION**

Mixture of diethylene glycol mono- and diesters of stearic (octadecanoic) and palmitic (hexadecanoic) acids.

It is produced by esterification of diethylene glycol and stearic acid 50 (see *Stearic acid* (1474)) of vegetable or animal origin.

**Content:**

- *monoesters*: 45.0 per cent to 60.0 per cent;
- *diesters*: 35.0 per cent to 55.0 per cent.

**CHARACTERS**

**Appearance:** white or almost white, waxy solid.

**Solubility:** practically insoluble in water, soluble in acetone and in hot ethanol (96 per cent).

**IDENTIFICATION**

- Melting point (see Tests).
- Composition of fatty acids (see Tests).
- It complies with the limit of the assay (monoesters content).

**TESTS**

**Melting point** (2.2.15): 43 °C to 50 °C.

**Acid value** (2.5.1): maximum 4.0.

**Iodine value** (2.5.4, *Method A*): maximum 3.0.

**Saponification value** (2.5.6): 155 to 180, determined on 2.0 g.

**Composition of fatty acids** (2.4.22, *Method A*). Use the mixture of calibrating substances in Table 2.4.22.-1.

**Composition of the fatty acid fraction of the substance:**

- *stearic acid*: 40.0 per cent to 60.0 per cent;
- *sum of contents of palmitic acid and stearic acid*: minimum 90.0 per cent.

**Free diethylene glycol:** maximum 2.5 per cent, determined as described in the assay.

**Total ash** (2.4.16): maximum 0.1 per cent.

**ASSAY**

Size-exclusion chromatography (2.2.30).

**Test solution.** Into a 15 mL flask, weigh 0.200 g (*m*). Add 5.0 mL of *tetrahydrofuran R* and shake to dissolve. Heat gently, if necessary. Reweigh the flask and calculate the total mass of solvent and substance (*M*).

**Reference solutions.** Into four 15 mL flasks, weigh, 2.5 mg, 5.0 mg, 10.0 mg and 20.0 mg respectively of *diethylene glycol R*. Add 5.0 mL of *tetrahydrofuran R*. Weigh the flasks again and calculate the concentration of diethylene glycol in milligrams per gram for each reference solution.

**Column:**

- *size*:  $l = 0.6$  m,  $\varnothing = 7$  mm,
- *stationary phase*: *styrene-divinylbenzene copolymer R* (5  $\mu$ m) with a pore size of 10 nm.

**Mobile phase:** *tetrahydrofuran R*.

**Flow rate:** 1 mL/min.

**Detection:** differential refractometer.

**Injection:** 40  $\mu$ L.

**Relative retention** with reference to diethylene glycol: diesters = about 0.78; monoesters = about 0.84.

**Calculations:**

- *free diethylene glycol*: from the calibration curve obtained with the reference solutions, determine the concentration (*C*) of diethylene glycol in milligrams per gram in the test solution and calculate the percentage content of free diethylene glycol in the substance to be examined using the following expression:

$$\frac{C \times M}{m \times 10}$$

- *monoesters*: calculate the percentage content of monoesters using the following expression:

$$\frac{A}{A + B} \times (100 - D)$$

*A* = area of the peak due to the monoesters,

*B* = area of the peak due to the diesters,

*D* = percentage content of free diethylene glycol + percentage content of free fatty acids.

Calculate the percentage content of free fatty acids using the following expression:

$$\frac{I_A \times 270}{561.1}$$

*I<sub>A</sub>* = acid value.

- *diesters*: calculate the percentage content of diesters using the following expression:

$$\frac{B}{A + B} \times (100 - D)$$

**STORAGE**

Protected from light.

01/2008:0484  
corrected 6.0

## DIETHYLSTILBESTROL

### Diethylstilbestrolum

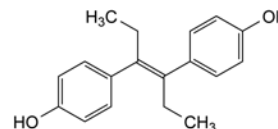

$C_{18}H_{20}O_2$   
[56-53-1]

$M_r$  268.4

**DEFINITION**

Diethylstilbestrol contains not less than 97.0 per cent and not more than the equivalent of 101.0 per cent of (*E*)-4,4'-(1,2-diethylethene-1,2-diyl)diphenol, calculated with reference to the dried substance.

**CHARACTERS**

A white or almost white, crystalline powder, practically insoluble in water, freely soluble in alcohol. It dissolves in solutions of the alkali hydroxides.

It melts at about 172 °C.

## IDENTIFICATION

*First identification: B, D.*

*Second identification: A, C, D.*

- A. Examined between 230 nm and 450 nm (2.2.25), the irradiated solution of the substance to be examined prepared as prescribed in the assay shows two absorption maxima, at 292 nm and 418 nm.
- B. Examine by infrared absorption spectrophotometry (2.2.24), comparing with the spectrum obtained with *diethylstilbestrol CRS*. Examine the substances prepared as discs.
- C. Examine the chromatograms obtained in the test for mono- and dimethyl ethers. The principal spot in the chromatogram obtained with test solution (b) is similar in position, colour and size to the principal spot in the chromatogram obtained with reference solution (a).
- D. Dissolve about 0.5 mg in 0.2 mL of *glacial acetic acid R*, add 1 mL of *phosphoric acid R* and heat on a water-bath for 3 min. A deep-yellow colour develops.

## TESTS

**4,4'-Dihydroxystilbene and related ethers.** Dissolve 0.100 g in *ethanol R* and dilute to 10.0 mL with the same solvent. The absorbance (2.2.25) of the solution measured at 325 nm is not greater than 0.50.

**Mono- and dimethyl ethers.** Examine by thin-layer chromatography (2.2.27), using *silica gel G R* as the coating substance.

*Test solution (a).* Dissolve 0.2 g of the substance to be examined in 2 mL of *alcohol R*.

*Test solution (b).* Dilute 1 mL of test solution (a) to 20 mL with *alcohol R*.

*Reference solution (a).* Dissolve 10 mg of *diethylstilbestrol CRS* in 2 mL of *alcohol R*.

*Reference solution (b).* Dissolve 5 mg of *diethylstilbestrol monomethyl ether CRS* in *alcohol R* and dilute to 10 mL with the same solvent.

*Reference solution (c).* Dissolve 5 mg of *diethylstilbestrol dimethyl ether CRS* in *alcohol R* and dilute to 10 mL with the same solvent.

*Reference solution (d).* Dissolve 10 mg of *dienestrol CRS* in 2 mL of *alcohol R*. To 1 mL of this solution add 1 mL of reference solution (a).

Apply to the plate 1 µL of each solution. Develop over a path of 15 cm using a mixture of 10 volumes of *diethylamine R* and 90 volumes of *toluene R*. Allow the plate to dry in air, spray with *alcoholic solution of sulfuric acid R* and heat at 120 °C for 10 min. In the chromatogram obtained with test solution (a), any spots corresponding to diethylstilbestrol monomethyl ether and diethylstilbestrol dimethyl ether are not more intense than the spots in the chromatograms obtained with reference solutions (b) and (c) respectively (0.5 per cent). Diethylstilbestrol gives one or sometimes two spots. The test is not valid unless the chromatogram obtained with reference solution (d) shows at least two clearly separated spots having approximately the same intensity.

**Loss on drying** (2.2.32). Not more than 0.5 per cent, determined on 1.000 g by drying in an oven at 105 °C.

**Sulfated ash** (2.4.14). Not more than 0.1 per cent, determined on 1.0 g.

## ASSAY

Dissolve 20.0 mg in *ethanol R* and dilute to 100.0 mL with the same solvent. Dilute 10.0 mL of the solution to 100.0 mL with *ethanol R*. To 25.0 mL of the resulting solution add 25.0 mL of a solution of 1 g of *dipotassium hydrogen phosphate R* in 55 mL of *water R*. Prepare in the same manner a reference solution using 20.0 mg of *diethylstilbestrol CRS*. Transfer an equal volume of each solution to separate 1 cm quartz

cells and close the cells; place the two cells about 5 cm from a low-pressure, short-wave 2 W to 20 W mercury lamp and irradiate for about 5 min. Measure the absorbance (2.2.25) of the irradiated solutions at the maximum at 418 nm, using *water R* as the compensation liquid. Continue the irradiation for successive periods of 3 min to 15 min, depending on the power of the lamp, and repeat the measurement of the absorbances at 418 nm until the maximum absorbance (about 0.7) is obtained. If necessary, adjust the geometry of the irradiation apparatus to obtain a maximum, reproducible absorbance at 418 nm.

Calculate the content of C<sub>18</sub>H<sub>20</sub>O<sub>2</sub> from the measured absorbances and the concentrations of the solutions.

## STORAGE

Store protected from light.

04/2009:0818

## DIFLUNISAL

## Diflunisalium

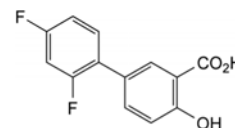

C<sub>13</sub>H<sub>8</sub>F<sub>2</sub>O<sub>3</sub>  
[22494-42-4]

*M<sub>r</sub>* 250.2

## DEFINITION

2',4'-Difluoro-4-hydroxybiphenyl-3-carboxylic acid.

*Content:* 99.0 per cent to 101.0 per cent (dried substance).

## CHARACTERS

*Appearance:* white or almost white, crystalline powder.

*Solubility:* practically insoluble in water, soluble in ethanol (96 per cent). It dissolves in dilute solutions of alkali hydroxides. It shows polymorphism (5.9).

## IDENTIFICATION

*First identification: B.*

*Second identification: A, C, D.*

- A. Ultraviolet and visible absorption spectrophotometry (2.2.25).

*Test solution.* Dissolve 10 mg in a 0.3 per cent V/V solution of *hydrochloric acid R* in *methanol R* and dilute to 100.0 mL with the same solution. Dilute 2.0 mL of this solution to 10.0 mL with a 0.3 per cent V/V solution of *hydrochloric acid R* in *methanol R*.

*Spectral range:* 230-350 nm.

*Absorption maxima:* at 251 nm and 315 nm.

*Absorbance ratio:* A<sub>251</sub> / A<sub>315</sub> = 4.2 to 4.6.

- B. Infrared absorption spectrophotometry (2.2.24).

*Comparison: diflunisal CRS.*

If the spectra obtained show differences, dissolve the substance to be examined and the reference substance separately in *ethanol (96 per cent) R*, evaporate to dryness and record new spectra using the residues.

- C. Dissolve about 2 mg in 10 mL of *ethanol (96 per cent) R* and add 0.1 mL of *ferric chloride solution R1*. A violet-red colour is produced.
- D. Mix about 5 mg with 45 mg of *heavy magnesium oxide R* and ignite in a crucible until an almost white residue is obtained (usually less than 5 min). Allow to cool, add 1 mL of *water R*, 0.05 mL of *phenolphthalein solution R1* and about 1 mL of *dilute hydrochloric acid R* to render the solution colourless. Filter. Add 1.0 mL of the filtrate to a freshly prepared mixture of 0.1 mL of *alizarin S solution R* and 0.1 mL of *zirconyl nitrate solution R*. Mix, allow to stand

for 5 min and compare the colour of the solution with that of a blank prepared in the same manner. The test solution is yellow and the blank is red.

## TESTS

**Appearance of solution.** The solution is clear (2.2.1) and not more intensely coloured than reference solution Y<sub>7</sub> (2.2.2, Method II).

Dissolve 0.5 g in *ethanol* (96 per cent) R and dilute to 50 mL with the same solvent.

**Related substances**

A. Thin-layer chromatography (2.2.27).

**Test solution.** Dissolve 0.20 g of the substance to be examined in *methanol* R and dilute to 10 mL with the same solvent.

**Reference solution (a).** Dissolve 30 mg of *biphenyl-4-ol* R (impurity A) in *methanol* R and dilute to 100 mL with the same solvent. Dilute 1 mL of this solution to 10 mL with *methanol* R.

**Reference solution (b).** Dissolve 20 mg of *biphenyl-4-ol* R (impurity A) in *methanol* R, add 1 mL of the test solution and dilute to 10 mL with *methanol* R.

**Plate:** TLC silica gel GF<sub>254</sub> plate R.

**Mobile phase:** glacial acetic acid R, acetone R, methylene chloride R (10:20:70 V/V/V).

**Application:** 10 µL.

**Development:** over a path of 15 cm.

**Drying:** in a current of warm air.

**Detection:** examine in ultraviolet light at 254 nm.

**System suitability:** reference solution (b):

- the chromatogram shows 2 clearly separated principal spots.

**Limit:**

- **any impurity:** any spot, apart from the principal spot, is not more intense than the principal spot in the chromatogram obtained with reference solution (a) (0.15 per cent).

B. Liquid chromatography (2.2.29).

**Test solution.** Dissolve 50.0 mg of the substance to be examined in the reference solution and dilute to 10.0 mL with the reference solution.

**Reference solution.** Dissolve 55.0 mg of *fluoranthene* R in a mixture of 1 volume of *water* R and 4 volumes of *acetonitrile* R and dilute to 100.0 mL with the same mixture of solvents. Dilute 1.0 mL of this solution to 100.0 mL with a mixture of 1 volume of *water* R and 4 volumes of *acetonitrile* R.

**Column:**

- **size:**  $l = 0.25$  m,  $\varnothing = 4$  mm;
- **stationary phase:** octadecylsilyl silica gel for chromatography R (10 µm).

**Mobile phase:** glacial acetic acid R, *methanol* R, *water* R, *acetonitrile* R (2:25:55:70 V/V/V/V).

**Flow rate:** 2 mL/min.

**Detection:** spectrophotometer at 254 nm.

**Injection:** 20 µL.

**Run time:** 3 times the retention time of *fluoranthene*.

**Limits:**

- **sum of the impurities with a retention time greater than that of *fluoranthene*:** not more than the area of the principal peak in the chromatogram obtained with the reference solution (0.1 per cent);
- **disregard limit:** 0.05 times the area of the principal peak in the chromatogram obtained with the reference solution (0.005 per cent).

**Heavy metals** (2.4.8): maximum 10 ppm.

2.0 g complies with test C. Use a platinum crucible. Prepare the reference solution using 2 mL of *lead standard solution* (10 ppm Pb) R.

**Loss on drying** (2.2.32): maximum 0.3 per cent, determined on 1.000 g by drying at 60 °C at a pressure not exceeding 0.7 kPa for 2 h.

**Sulfated ash** (2.4.14): maximum 0.1 per cent, determined on 1.0 g in a platinum crucible.

## ASSAY

Dissolve 0.200 g in 40 mL of *methanol* R. Add 5 mL of *water* R and 0.2 mL of *phenol red solution* R. Titrate with 0.1 M *sodium hydroxide* until the colour changes from yellow to reddish-violet. 1 mL of 0.1 M *sodium hydroxide* is equivalent to 25.02 mg of C<sub>13</sub>H<sub>8</sub>F<sub>2</sub>O<sub>3</sub>.

## STORAGE

Protected from light.

## IMPURITIES

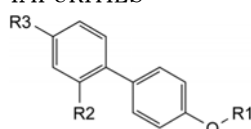

- A. R1 = R2 = R3 = H: biphenyl-4-ol,  
 B. R1 = H, R2 = R3 = F: 2',4'-difluorobiphenyl-4-ol,  
 C. R1 = CO-CH<sub>3</sub>, R2 = R3 = F: 2',4'-difluorobiphenyl-4-yl acetate,  
 D. condensation products.

01/2008:0078  
corrected 6.0

## DIGITOXIN

## Digitoxinum

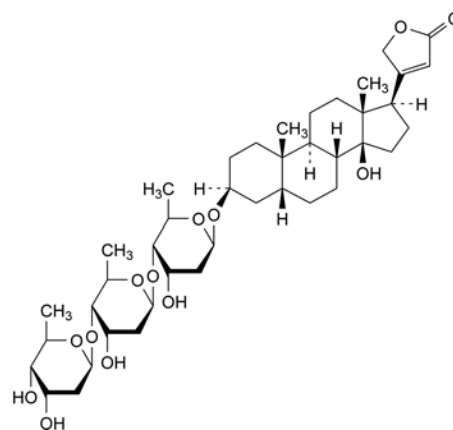

C<sub>41</sub>H<sub>64</sub>O<sub>13</sub>  
[71-63-6]

M<sub>r</sub> 765

## DEFINITION

Digitoxin contains not less than 95.0 per cent and not more than the equivalent of 103.0 per cent of 3β-[(O-2,6-dideoxy-β-D-ribo-hexopyranosyl-(1→4)-O-2,6-dideoxy-β-D-ribo-hexopyranosyl-(1→4)-2,6-dideoxy-β-D-ribo-hexopyranosyl)oxy]-14-hydroxy-5β,14β-card-20(22)-enolide, calculated with reference to the dried substance.

## CHARACTERS

A white or almost white powder, practically insoluble in water, freely soluble in a mixture of equal volumes of methanol and methylene chloride, slightly soluble in alcohol and in methanol.

## IDENTIFICATION

*First identification:* A.

*Second identification:* B, C, D.

- A. Examine by infrared absorption spectrophotometry (2.2.24), comparing with the spectrum obtained with *digitoxin CRS*.
- B. Examine the chromatograms obtained in the test for related substances. The principal spot in the chromatogram obtained with the test solution is similar in position, colour and size to the principal spot in the chromatogram obtained with reference solution (a).
- C. Suspend about 0.5 mg in 0.2 mL of *alcohol (60 per cent V/V) R*. Add 0.1 mL of *dinitrobenzoic acid solution R* and 0.1 mL of *dilute sodium hydroxide solution R*. A violet colour develops.
- D. Dissolve about 0.5 mg in 1 mL of *glacial acetic acid R*, heating gently, allow to cool and add 0.05 mL of *ferric chloride solution R1*. Cautiously add 1 mL of *sulfuric acid R*, avoiding mixing the two liquids. A brown ring develops at the interface and on standing a green, then blue colour passes to the upper layer.

## TESTS

**Appearance of solution.** Dissolve 50 mg in a mixture of equal volumes of *methanol R* and *methylene chloride R* and dilute to 10 mL with the same mixture of solvents. The solution is clear (2.2.1) and colourless (2.2.2, *Method I*).

**Specific optical rotation** (2.2.7). Dissolve 0.25 g in *chloroform R* and dilute to 10.0 mL with the same solvent. The specific optical rotation is + 16.0 to + 18.5.

**Related substances.** Examine by thin-layer chromatography (2.2.27), using a *TLC silica gel G plate R*.

*Test solution.* Dissolve 20 mg of the substance to be examined in a mixture of equal volumes of *methanol R* and *methylene chloride R* and dilute to 2 mL with the same mixture of solvents.

*Reference solution (a).* Dissolve 20 mg of *digitoxin CRS* in a mixture of equal volumes of *methanol R* and *methylene chloride R* and dilute to 2 mL with the same mixture of solvents.

*Reference solution (b).* Dilute 0.5 mL of reference solution (a) to 50 mL with a mixture of equal volumes of *methanol R* and *methylene chloride R*.

*Reference solution (c).* Dissolve 10 mg of *gitoxin CRS* with stirring in a mixture of equal volumes of *methanol R* and *methylene chloride R* and dilute to 50 mL with the same mixture of solvents.

*Reference solution (d).* Dilute 1 mL of reference solution (b) to 2 mL with a mixture of equal volumes of *methanol R* and *methylene chloride R*.

*Reference solution (e).* Mix 1 mL of reference solution (a) and 1 mL of reference solution (c).

Apply to the plate 5 µL of each solution. Develop immediately over a path of 15 cm using a mixture of 15 volumes of *methanol R*, 40 volumes of *cyclohexane R* and 90 volumes of *methylene chloride R*. Dry the plate in a stream of cold air for 5 min. Repeat the development and dry the plate in a stream of cold air for 5 min. Spray with a mixture of 1 volume of *sulfuric acid R* and 9 volumes of *alcohol R* and heat at 130 °C for 15 min. Examine in daylight.

*Gitoxin.* Any spot corresponding to gitoxin in the chromatogram obtained with the test solution is not more intense than the spot in the chromatogram obtained with reference solution (c) (2.0 per cent).

*Other glycosides.* Any spot in the chromatogram obtained with the test solution, apart from the principal spot and the spot corresponding to gitoxin, is not more intense than the spot in the chromatogram obtained with reference solution (b) (1.0 per cent).

The test is not valid unless the chromatogram obtained with reference solution (e) shows clearly separated spots corresponding to digitoxin, gitoxin and other glycosides and the spot in the chromatogram obtained with reference solution (d) is clearly visible.

**Loss on drying** (2.2.32). Not more than 1.5 per cent, determined on 0.500 g by drying in an oven at 105 °C for 2 h.

**Sulfated ash** (2.4.14). Not more than 0.1 per cent, determined on the residue from the test for loss on drying.

## ASSAY

Dissolve 40.0 mg in *alcohol R* and dilute to 50.0 mL with the same solvent. Dilute 5.0 mL of the solution to 100.0 mL with *alcohol R*. Prepare a reference solution in the same manner, using 40.0 mg of *digitoxin CRS*. To 5.0 mL of each solution add 3.0 mL of *alkaline sodium picrate solution R*, allow to stand protected from bright light for 30 min and measure the absorbance (2.2.25) of each solution at the maximum at 495 nm, using as the compensation liquid a mixture of 5.0 mL of *alcohol R* and 3.0 mL of *alkaline sodium picrate solution R* prepared at the same time.

Calculate the content of  $C_{41}H_{64}O_{13}$  from the absorbances measured and the concentrations of the solutions.

## STORAGE

Store protected from light.

01/2008:0079  
corrected 7.0

## DIGOXIN

## Digoxinum

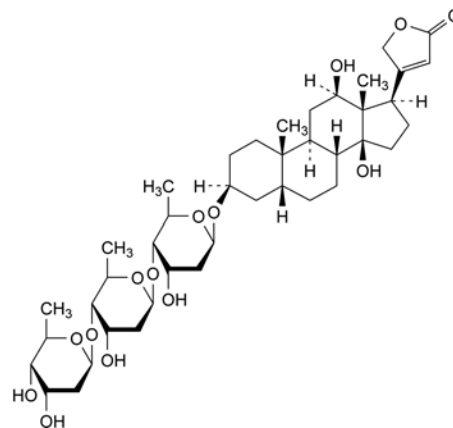

$C_{41}H_{64}O_{14}$   
[20830-75-5]

$M_r$  781

## DEFINITION

3β-[(2,6-Dideoxy-β-D-ribo-hexopyranosyl-(1→4)-2,6-dideoxy-β-D-ribo-hexopyranosyl-(1→4)-2,6-dideoxy-β-D-ribo-hexopyranosyl)oxy]-12β,14-dihydroxy-5β-card-20(22)-enolide.

*Content:* 96.0 per cent to 102.0 per cent (dried substance).

## CHARACTERS

*Appearance:* white or almost white powder, or colourless crystals.

*Solubility:* practically insoluble in water, soluble in a mixture of equal volumes of methanol and methylene chloride, slightly soluble in ethanol (96 per cent).

## IDENTIFICATION

Infrared absorption spectrophotometry (2.2.24).

*Comparison:* *digoxin CRS*.

## TESTS

**Appearance of solution.** The solution is clear (2.2.1) and colourless (2.2.2, Method I).

Dissolve 50 mg in a mixture of equal volumes of *methanol R* and *methylene chloride R* and dilute to 10 mL with the same mixture of solvents.

**Specific optical rotation** (2.2.7): + 13.9 to + 15.9 (dried substance).

Dissolve 0.50 g in a mixture of equal volumes of *methanol R* and *methylene chloride R* and dilute to 25.0 mL with the same mixture of solvents.

**Related substances.** Liquid chromatography (2.2.29).

**Test solution.** Dissolve 50.0 mg of the substance to be examined in 100.0 mL of *methanol R*.

**Reference solution (a).** Dissolve 10.0 mg of *digoxin CRS* in *methanol R* and dilute to 20.0 mL with the same solvent.

**Reference solution (b).** Dilute 1.0 mL of the test solution to 100.0 mL with *methanol R*.

**Reference solution (c).** Dissolve 2.5 mg of *digoxigenin CRS* (impurity C) in *methanol R* and dilute to 5.0 mL with the same solvent. Dilute 1.0 mL of the solution to 50.0 mL with *methanol R*. Dilute 1.0 mL of this solution to 10.0 mL with *methanol R*.

**Reference solution (d).** Dissolve 50.0 mg of *lanatoside C R* (impurity H) in *methanol R* and dilute to 100.0 mL with the same solvent. To 1.0 mL of this solution, add 1.0 mL of the test solution and dilute to 20.0 mL with *methanol R*.

**Reference solution (e).** Dissolve 5.0 mg of *digoxin for peak identification CRS* in *methanol R* and dilute to 10.0 mL with the same solvent.

**Column:**

- size:  $l = 0.15$  m,  $\varnothing = 3.9$  mm;
- stationary phase: octadecylsilyl silica gel for chromatography R (5  $\mu$ m).

**Mobile phase:**

- mobile phase A: acetonitrile R, water R (10:90 V/V);
- mobile phase B: water R, acetonitrile R (10:90 V/V);

Time (min)	Mobile phase A (per cent V/V)	Mobile phase B (per cent V/V)
0 - 5	78	22
5 - 15	78 $\rightarrow$ 30	22 $\rightarrow$ 70

**Flow rate:** 1.5 mL/min.

**Detection:** spectrophotometer at 220 nm.

**Injection:** 10  $\mu$ L of the test solution and reference solutions (b), (c), (d) and (e).

**Identification of impurities:** use the chromatogram supplied with *digoxin for peak identification CRS* and the chromatogram obtained with reference solution (e) to identify the peaks due to impurities A, B, C, E, F, G and K.

**Relative retention** with reference to digoxin (retention time = about 4.3 min): impurity C = about 0.3; impurity E = about 0.5; impurity F = about 0.6; impurity G = about 0.8; impurity L = about 1.4; impurity K = about 1.6; impurity B = about 2.2; impurity A = about 2.6.

**System suitability:** reference solution (d):

- resolution: minimum 1.5 between the peaks due to impurity H and digoxin.

**Limits:**

- impurity F: not more than 2.5 times the area of the principal peak in the chromatogram obtained with reference solution (b) (2.5 per cent);
- impurity C: not more than 5 times the area of the corresponding peak in the chromatogram obtained with reference solution (c) (1.0 per cent);
- impurities E, K: for each impurity, not more than the area of the principal peak in the chromatogram obtained with reference solution (b) (1.0 per cent);
- impurity G: not more than 0.8 times the area of the principal peak in the chromatogram obtained with reference solution (b) (0.8 per cent);
- impurities A, B: for each impurity, not more than 0.5 times the area of the principal peak in the chromatogram obtained with reference solution (b) (0.5 per cent);
- impurity L: not more than 0.3 times the area of the principal peak in the chromatogram obtained with reference solution (b) (0.3 per cent);
- any other impurity: for each impurity, not more than 0.2 times the area of the principal peak in the chromatogram obtained with reference solution (b) (0.2 per cent);
- sum of impurities other than A, B, C, E, F, G, K, L: not more than 0.7 times the area of the principal peak in the chromatogram obtained with reference solution (b) (0.7 per cent);
- total: not more than 3.5 times the area of the principal peak in the chromatogram obtained with reference solution (b) (3.5 per cent);
- disregard limit: 0.05 times the area of the principal peak in the chromatogram obtained with reference solution (b) (0.05 per cent).

The thresholds indicated under Related Substances (Table 2034-1) in the general monograph *Substances for pharmaceutical use (2034)* do not apply.

**Loss on drying** (2.2.32): maximum 1.0 per cent, determined on 0.500 g by drying *in vacuo* in an oven.

**Sulfated ash** (2.4.14): maximum 0.1 per cent, determined on the residue obtained in the test for loss on drying.

## ASSAY

Liquid chromatography (2.2.29) as described in the test for related substances with the following modification.

**Injection:** test solution and reference solution (a).

Calculate the percentage content of  $C_{41}H_{64}O_{14}$  from the declared content of *digoxin CRS*.

## STORAGE

Protected from light.

## IMPURITIES

**Specified impurities:** A, B, C, E, F, G, K, L.

**Other detectable impurities** (the following substances would, if present at a sufficient level, be detected by one or other of the tests in the monograph. They are limited by the general acceptance criterion for other/unspecified impurities. It is therefore not necessary to identify these impurities for demonstration of compliance. See also 5.10. *Control of impurities in substances for pharmaceutical use*): D, H, I, J.

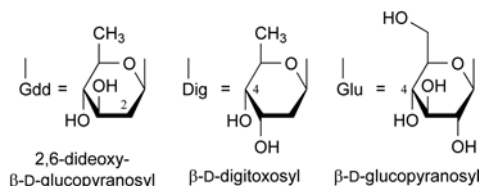

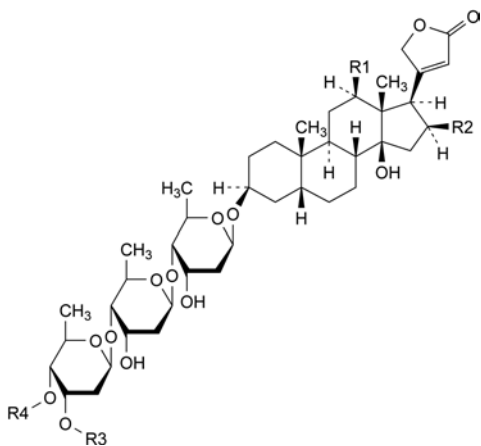

- A. R1 = R2 = R3 = R4 = H: 3β-[(2,6-dideoxy-β-D-*ribo*-hexopyranosyl-(1→4)-2,6-dideoxy-β-D-*ribo*-hexopyranosyl-(1→4)-2,6-dideoxy-β-D-*ribo*-hexopyranosyl)oxy]-14-hydroxy-5β-card-20(22)-enolide (digitoxin),
- B. R1 = R3 = R4 = H, R2 = OH: 3β-[(2,6-dideoxy-β-D-*ribo*-hexopyranosyl-(1→4)-2,6-dideoxy-β-D-*ribo*-hexopyranosyl-(1→4)-2,6-dideoxy-β-D-*ribo*-hexopyranosyl)oxy]-14,16β-dihydroxy-5β-card-20(22)-enolide (gitoxin),
- E. R1 = R2 = OH, R3 = R4 = H: 3β-[(2,6-dideoxy-β-D-*ribo*-hexopyranosyl-(1→4)-2,6-dideoxy-β-D-*ribo*-hexopyranosyl-(1→4)-2,6-dideoxy-β-D-*ribo*-hexopyranosyl)oxy]-12β,14,16β-trihydroxy-5β-card-20(22)-enolide (diginitin),
- H. R1 = OH, R2 = H, R3 = CO-CH<sub>3</sub>, R4 = Glu: 3β-[(β-D-glucopyranosyl-(1→4)-3-*O*-acetyl-2,6-dideoxy-β-D-*ribo*-hexopyranosyl-(1→4)-2,6-dideoxy-β-D-*ribo*-hexopyranosyl-(1→4)-2,6-dideoxy-β-D-*ribo*-hexopyranosyl)oxy]-12β,14-dihydroxy-5β-card-20(22)-enolide (lanatoside C),
- I. R1 = OH, R2 = R4 = H, R3 = CO-CH<sub>3</sub>: 3β-[(3-*O*-acetyl-2,6-dideoxy-β-D-*ribo*-hexopyranosyl-(1→4)-2,6-dideoxy-β-D-*ribo*-hexopyranosyl-(1→4)-2,6-dideoxy-β-D-*ribo*-hexopyranosyl)oxy]-12β,14-dihydroxy-5β-card-20(22)-enolide (α-acetyldigoxin),
- J. R1 = OH, R2 = R3 = H, R4 = CO-CH<sub>3</sub>: 3β-[(4-*O*-acetyl-2,6-dideoxy-β-D-*ribo*-hexopyranosyl-(1→4)-2,6-dideoxy-β-D-*ribo*-hexopyranosyl-(1→4)-2,6-dideoxy-β-D-*ribo*-hexopyranosyl)oxy]-12β,14-dihydroxy-5β-card-20(22)-enolide (β-acetyldigoxin),
- K. R1 = OH, R2 = R3 = H, R4 = Dig: 3β-[(2,6-dideoxy-β-D-*ribo*-hexopyranosyl-(1→4)-2,6-dideoxy-β-D-*ribo*-hexopyranosyl-(1→4)-2,6-dideoxy-β-D-*ribo*-hexopyranosyl-(1→4)-2,6-dideoxy-β-D-*ribo*-hexopyranosyl)oxy]-12β,14-dihydroxy-5β-card-20(22)-enolide (digoxigenin tetrakisdigoxoside),

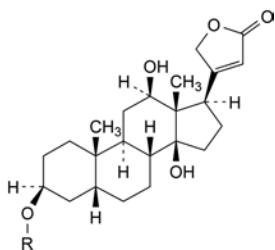

- C. R = H: 3β,12β,14-trihydroxy-5β-card-20(22)-enolide (digoxigenin),
- D. R = Dig: 3β-(2,6-dideoxy-β-D-*ribo*-hexopyranosyloxy)-12β,14-dihydroxy-5β-card-20(22)-enolide (digoxigenin monodigoxoside),
- F. R = Dig-(1→4)-Dig: 3β-[(2,6-dideoxy-β-D-*ribo*-hexopyranosyl-(1→4)-2,6-dideoxy-β-D-*ribo*-hexopyranosyl)oxy]-12β,14-dihydroxy-5β-card-20(22)-enolide (digoxigenin bisdigoxoside),

G. R = Gdd-(1→4)-Dig-(1→4)-Dig: 3β-[(2,6-dideoxy-β-D-*arabino*-hexopyranosyl-(1→4)-2,6-dideoxy-β-D-*ribo*-hexopyranosyl-(1→4)-2,6-dideoxy-β-D-*ribo*-hexopyranosyl)oxy]-12β,14-dihydroxy-5β-card-20(22)-enolide (neodigoxin),

L. unknown structure.

01/2008:1310  
corrected 6.1

## DIHYDRALAZINE SULFATE, HYDRATED

### Dihydralazini sulfas hydricus

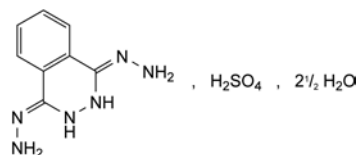

C<sub>8</sub>H<sub>12</sub>N<sub>6</sub>O<sub>4</sub>S<sub>2</sub>·2½H<sub>2</sub>O  
[7327-87-9]

M<sub>r</sub> 333.3

#### DEFINITION

(Phthalazine-1,4(2*H*,3*H*)-diylidene)dihydrazine sulfate 2.5-hydrate.

*Content*: 98.0 per cent to 102.0 per cent (dried substance).

#### CHARACTERS

*Appearance*: white or slightly yellow, crystalline powder.

*Solubility*: slightly soluble in water, practically insoluble in anhydrous ethanol. It dissolves in dilute mineral acids.

#### IDENTIFICATION

A. Infrared absorption spectrophotometry (2.2.24).

*Comparison*: Ph. Eur. reference spectrum of dihydralazine sulfate hydrated.

B. Dissolve about 50 mg in 5 mL of dilute hydrochloric acid R. The solution gives reaction (a) of sulfates (2.3.1).

#### TESTS

**Appearance of solution.** The solution is clear (2.2.1) and not more intensely coloured than reference solution BY<sub>6</sub> (2.2.2, Method II).

Dissolve 0.20 g in dilute nitric acid R and dilute to 10 mL with the same acid.

**Related substances.** Liquid chromatography (2.2.29). Prepare the solutions immediately before use.

*Test solution.* Dissolve 50.0 mg of the substance to be examined in a 6 g/L solution of glacial acetic acid R and dilute to 50.0 mL with the same solution.

*Reference solution (a).* Dilute 1.0 mL of the test solution to 100.0 mL with the mobile phase containing 0.5 g/L of sodium edetate R. Dilute 1.0 mL of this solution to 10.0 mL with the mobile phase containing 0.5 g/L of sodium edetate R.

*Reference solution (b).* Dilute 1.0 mL of the test solution to 50.0 mL with the mobile phase containing 0.5 g/L of sodium edetate R.

*Reference solution (c).* Dissolve 5 mg of dihydralazine for system suitability CRS in a 6 g/L solution of glacial acetic acid R and dilute to 5.0 mL with the same solution.

#### Column:

– size: *l* = 0.25 m, Ø = 4.6 mm;

– stationary phase: nitrile silica gel for chromatography R (5 µm).

*Mobile phase:* mix 22 volumes of acetonitrile R1 and 78 volumes of a solution containing 1.44 g/L of sodium laurilsulfate R and 0.75 g/L of tetrabutylammonium bromide R, then adjust to pH 3.0 with 0.05 M sulfuric acid.

*Flow rate:* 1.5 mL/min.

**Detection:** spectrophotometer at 230 nm.

**Injection:** 20 µL.

**Run time:** twice the retention time of dihydralazine.

**Relative retention** with reference to dihydralazine:  
impurity A = about 0.8.

**System suitability:** reference solution (c):

- the peaks due to impurity A and dihydralazine are baseline separated as in the chromatogram supplied with *dihydralazine for system suitability CRS*.

**Limits:**

- **impurity A:** not more than the area of the principal peak in the chromatogram obtained with reference solution (b) (2 per cent);
- **impurity C:** not more than the area of the principal peak in the chromatogram obtained with reference solution (a) (0.1 per cent);
- **unspecified impurities:** for each impurity, not more than the area of the principal peak in the chromatogram obtained with reference solution (a) (0.10 per cent);
- **sum of impurities other than A:** not more than 5 times the area of the principal peak in the chromatogram obtained with reference solution (a) (0.5 per cent);
- **disregard limit:** 0.1 times the area of the principal peak in the chromatogram obtained with reference solution (a) (0.01 per cent).

**Impurity B.** Liquid chromatography (2.2.29). Prepare the solutions immediately before use.

**Test solution.** Dissolve 40.0 mg of *hydrazine sulfate R* (impurity B) in *water R* and dilute to 100.0 mL with the same solvent. Dilute 1.0 mL of the solution to 25.0 mL with *water R*. To 0.50 mL of this solution, add 0.200 g of the substance to be examined and dissolve in 6 mL of *dilute hydrochloric acid R*, then dilute to 10.0 mL with *water R*. In a centrifuge tube with a ground-glass stopper, place immediately 0.50 mL of this solution and 2.0 mL of a 60 g/L solution of *benzaldehyde R* in a mixture of equal volumes of *methanol R* and *water R*. Shake for 90 s. Add 1.0 mL of *water R* and 5.0 mL of *heptane R*. Shake for 1 min and centrifuge. Use the upper layer.

**Reference solution.** Dissolve 40.0 mg of *hydrazine sulfate R* (impurity B) in *water R* and dilute to 100.0 mL with the same solvent. Dilute 1.0 mL of the solution to 25.0 mL with *water R*. To 0.50 mL of this solution, add 6 mL of *dilute hydrochloric acid R* and dilute to 10.0 mL with *water R*. In a centrifuge tube with a ground-glass stopper, place 0.50 mL of this solution and 2.0 mL of a 60 g/L solution of *benzaldehyde R* in a mixture of equal volumes of *methanol R* and *water R*. Shake for 90 s. Add 1.0 mL of *water R* and 5.0 mL of *heptane R*. Shake for 1 min and centrifuge. Use the upper layer.

**Blank solution.** Prepare in the same manner as for the reference solution but replacing the 0.50 mL of hydrazine sulfate solution by 0.50 mL of *water R*.

**Column:**

- **size:**  $l = 0.25$  m,  $\varnothing = 4.6$  mm;
- **stationary phase:** octadecylsilyl silica gel for chromatography R (5 µm).

**Mobile phase:** 0.3 g/L solution of *sodium edetate R*, *acetonitrile R* (30:70 V/V).

**Flow rate:** 1 mL/min.

**Detection:** spectrophotometer at 305 nm.

**Injection:** 20 µL.

**Relative retention** with reference to benzaldehyde: benzaldehydeazine (benzalazine) corresponding to impurity B = about 1.8.

**Limit:**

- **impurity B:** the area of the peak due to benzaldehydeazine is not greater than twice the area of the corresponding peak in the chromatogram obtained with the reference solution (10 ppm).

**Iron (2.4.9):** maximum 20 ppm.

To the residue obtained in the test for sulfated ash add 0.2 mL of *sulfuric acid R* and heat carefully until the acid is almost completely eliminated. Allow to cool and dissolve the residue with heating in 5.5 mL of *hydrochloric acid R1*. Filter the hot solution through a filter previously washed 3 times with *dilute hydrochloric acid R*. Wash the crucible and the filter with 5 mL of *water R*. Combine the filtrate and the washings and neutralise with about 3.5 mL of *strong sodium hydroxide solution R*. Adjust to pH 3-4 with *acetic acid R* and dilute to 20 mL with *water R*. Prepare the standard with 5 mL of *iron standard solution (2 ppm Fe) R* and 5 mL of *water R*.

**Loss on drying (2.2.32):** 13.0 per cent to 15.0 per cent, determined on 1.000 g by drying in an oven at 50 °C at a pressure not exceeding 0.7 kPa for 5 h.

**Sulfated ash (2.4.14):** maximum 0.1 per cent, determined on 1.0 g.

**ASSAY**

Dissolve 60.0 mg in 25 mL of *water R*. Add 35 mL of *hydrochloric acid R* and titrate slowly with 0.05 M *potassium iodate*, determining the end-point potentiometrically (2.2.20), using a calomel reference electrode and a platinum indicator electrode.

1 mL of 0.05 M *potassium iodate* is equivalent to 7.208 mg of  $C_8H_{12}N_6O_4S$ .

**IMPURITIES**

**Specified impurities:** A, B, C.

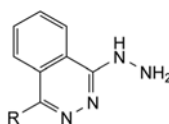

A. R =  $NH_2$ : 4-hydrazinophthalazin-1-amine,

C. R = H: (phthalazin-1-yl)hydrazine (hydralazine),

B.  $H_2N-NH_2$ : hydrazine.

01/2008:1776

## DIHYDROCODEINE HYDROGEN TARTRATE

Dihydrocodeini hydrogenotartras

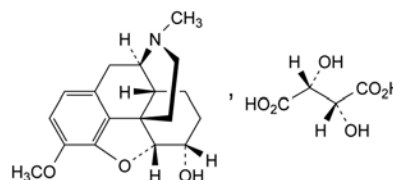

$C_{22}H_{29}NO_9$   
[5965-13-9]

$M_r$  451.5

**DEFINITION**

4,5 $\alpha$ -Epoxy-3-methoxy-17-methylmorphinan-6 $\alpha$ -ol hydrogen (2R,3R)-2,3-dihydroxybutanedioate.

**Content:** 98.5 per cent to 101.0 per cent (anhydrous substance).

**CHARACTERS**

**Appearance:** white or almost white, crystalline powder.

**Solubility:** freely soluble in water, sparingly soluble in alcohol, practically insoluble in cyclohexane.

## IDENTIFICATION

*First identification:* A.

*Second identification:* B, C, D.

A. Infrared absorption spectrophotometry (2.2.24).

*Comparison:* Ph. Eur. reference spectrum of dihydrocodeine hydrogen tartrate.

B. To about 0.1 g add 1 mL of sulfuric acid R and 0.05 mL of ferric chloride solution R1 and heat on a water-bath. A brownish-yellow colour develops. Add 0.05 mL of dilute nitric acid R. The colour does not become red.

C. To 1 mL of solution S (see Tests) add 5 mL of picric acid solution R. Heat on a water-bath until a clear solution is obtained. Allow to cool. A precipitate is formed. Filter, wash with 5 mL of water R and dry at 100-105 °C. The crystals melt (2.2.14) at 220 °C to 223 °C.

D. It gives reaction (b) of tartrates (2.3.1).

## TESTS

**Solution S.** Dissolve 2.50 g in carbon dioxide-free water R and dilute to 25.0 mL with the same solvent.

**Appearance of solution.** Solution S is clear (2.2.1) and not more intensely coloured than reference solution BY<sub>5</sub> (2.2.2, Method II).

**pH** (2.2.3): 3.2 to 4.2 for solution S.

**Specific optical rotation** (2.2.7): -70.5 to -73.5 (anhydrous substance).

Dilute 10.0 mL of solution S to 20.0 mL with water R.

**Related substances.** Liquid chromatography (2.2.29).

*Test solution.* Dissolve 10.0 mg of the substance to be examined in the mobile phase and dilute to 10.0 mL with the mobile phase.

*Reference solution (a).* Dissolve 2.0 mg of codeine phosphate R in 2.0 mL of the test solution and dilute to 25.0 mL with the mobile phase.

*Reference solution (b).* Dilute 1.0 mL of the test solution to 200 mL with the mobile phase.

*Column:*

- size:  $l = 0.25$  m,  $\varnothing = 4.6$  mm,
- stationary phase: octylsilyl silica gel for chromatography R (5  $\mu$ m).

*Mobile phase:* to 1.0 g of sodium heptanesulfonate R, add 10.0 mL of glacial acetic acid R and 4.0 mL of a solution of 5.0 mL of triethylamine R diluted to 25.0 mL with a mixture of equal volumes of water R and acetonitrile R. Add 170 mL of acetonitrile R and dilute to 1000 mL with water R.

*Flow rate:* 1 mL/min.

*Detection:* spectrophotometer at 284 nm.

*Injection:* 20  $\mu$ L.

*Run time:* 5 times the retention time of dihydrocodeine.

*Retention time:* dihydrocodeine = about 14 min.

*System suitability:* reference solution (a):

- resolution: minimum of 2 between the peaks due to dihydrocodeine and to impurity A.

*Limits:*

- *impurity A:* not more than the area of the principal peak in the chromatogram obtained with reference solution (b) (0.5 per cent),
- *any other peak:* not more than 0.6 times the area of the principal peak in the chromatogram obtained with reference solution (b) (0.3 per cent),
- *total:* not more than twice the area of the principal peak in the chromatogram obtained with reference solution (b) (1 per cent); disregard any peak due to tartaric acid (relative retention with reference to dihydrocodeine = about 0.25),
- *disregard limit:* 0.1 times the area of the principal peak in the chromatogram obtained with reference solution (b) (0.05 per cent).

**Water** (2.5.12): maximum 0.7 per cent, determined on 1.00 g.

**Sulfated ash** (2.4.14): maximum 0.1 per cent, determined on 1.0 g.

## ASSAY

Dissolve 0.350 g in 60 mL of anhydrous acetic acid R. Titrate with 0.1 M perchloric acid determining the end-point potentiometrically (2.2.20).

1 mL of 0.1 M perchloric acid is equivalent to 45.15 mg of C<sub>22</sub>H<sub>29</sub>NO<sub>9</sub>.

## STORAGE

Protected from light.

## IMPURITIES

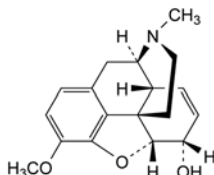

A. 7,8-dihydro-4,5 $\alpha$ -epoxy-3-methoxy-17-methylmorphinan-6 $\alpha$ -ol (codeine),

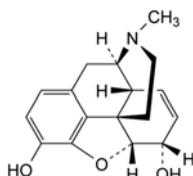

B. 7,8-dihydro-4,5 $\alpha$ -epoxy-17-methylmorphinan-3,6 $\alpha$ -diol (morphine),

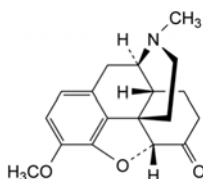

C. 4,5 $\alpha$ -epoxy-3-methoxy-17-methylmorphinan-6-one (hydrocodone),

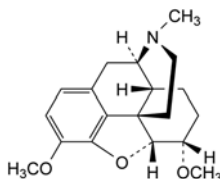

D. 4,5 $\alpha$ -epoxy-3,6 $\alpha$ -dimethoxy-17-methylmorphinan (tetrahydrothebaine).

01/2008:1416  
corrected 7.0

## DIHYDROERGOCRISTINE MESILATE

## Dihydroergocristini mesilas

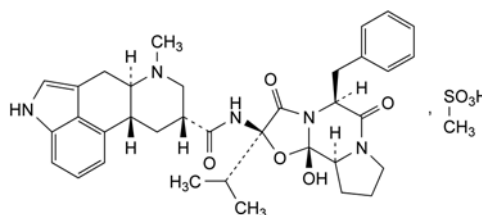

C<sub>36</sub>H<sub>45</sub>N<sub>5</sub>O<sub>8</sub>S  
[24730-10-7]

M<sub>r</sub> 708



## DEFINITION

(6a*R*,9*R*,10a*R*)-*N*[(2*R*,5*S*,10a*S*,10b*S*)-5-Benzyl-10b-hydroxy-2-(1-methylethyl)-3,6-dioxo-octahydro-8*H*-oxazolo[3,2-*a*]pyrrolo[2,1-*c*]pyrazin-2-yl]-7-methyl-4,6,6a,7,8,9,10,10a-octahydroindolo[4,3-*fg*]quinoline-9-carboxamide methanesulfonate.

*Content*: 98.0 per cent to 102.0 per cent (dried substance).

## PRODUCTION

The production method must be evaluated to determine the potential for formation of alkyl mesilates, which is particularly likely to occur if the reaction medium contains lower alcohols. Where necessary, the production method is validated to demonstrate that alkyl mesilates are not detectable in the final product.

## CHARACTERS

*Appearance*: white or almost white, fine crystalline powder.

*Solubility*: slightly soluble in water, soluble in methanol.

## IDENTIFICATION

## A. Infrared absorption spectrophotometry (2.2.24).

*Preparation*: discs.

*Comparison*: dihydroergocristine mesilate CRS.

## B. Thin-layer chromatography (2.2.27).

*Test solution*. Dissolve 0.10 g of the substance to be examined in a mixture of 1 volume of *methanol R* and 9 volumes of *methylene chloride R* and dilute to 5 mL with the same mixture of solvents.

*Reference solution*. Dissolve 0.10 g of *dihydroergocristine mesilate CRS* in a mixture of 1 volume of *methanol R* and 9 volumes of *methylene chloride R* and dilute to 5 mL with the same mixture of solvents.

*Plate*: TLC silica gel  $F_{254}$  plate *R*.

*Mobile phase*: concentrated ammonia *R*, dimethylformamide *R*, ether *R* (2:15:85 V/V/V).

*Application*: 5 µL.

*Development*: over 2/3 of the plate protected from light.

*Drying*: in a current of cold air for 5 min.

*Detection*: spray with dimethylaminobenzaldehyde solution *R7* and dry in a current of hot air for 2 min.

*Results*: the principal spot in the chromatogram obtained with the test solution is similar in position, colour and size to the principal spot in the chromatogram obtained with the reference solution.

## C. Thin-layer chromatography (2.2.27).

*Test solution*. Dissolve 0.20 g of the substance to be examined in a mixture of 1 volume of *methanol R* and 9 volumes of *methylene chloride R* and dilute to 5 mL with the same mixture of solvents.

*Reference solution*. Dissolve 0.20 g of *methanesulfonic acid R* in a mixture of 1 volume of *methanol R* and 9 volumes of *methylene chloride R* and dilute to 5 mL with the same mixture of solvents. Dilute 1 mL of the solution to 10 mL with a mixture of 1 volume of *methanol R* and 9 volumes of *methylene chloride R*.

*Plate*: TLC silica gel  $F_{254}$  plate *R*.

*Mobile phase*: water *R*, concentrated ammonia *R*, butanol *R*, acetone *R* (5:10:20:65 V/V/V/V).

*Application*: 10 µL.

*Development*: over a path of 10 cm protected from light.

*Drying*: in a current of cold air for not more than 1 min.

*Detection*: spray with a 1 g/L solution of *bromocresol purple R* in *methanol R*, adjusting the colour to violet-red with one drop of *dilute ammonia RI* and dry the plate in a current of hot air at 100 °C.

*Results*: the principal spot in the chromatogram obtained with the test solution is similar in position, colour and size to the principal spot in the chromatogram obtained with the reference solution.

## TESTS

**Appearance of solution.** The solution is clear (2.2.1) and not more intensely coloured than reference solution B<sub>7</sub> (2.2.2, *Method II*).

Dissolve 0.50 g in *methanol R* and dilute to 25.0 mL with the same solvent.

**pH (2.2.3)**: 4.0 to 5.0.

Dissolve 0.10 g in *carbon dioxide-free water R* and dilute to 20 mL with the same solvent.

**Specific optical rotation (2.2.7)**: –37 to –43 (dried substance).

Dissolve 0.250 g in *anhydrous pyridine R* and dilute to 25.0 mL with the same solvent.

**Related substances.** Liquid chromatography (2.2.29). Carry out the test and preparation of the solutions protected from bright light.

*Test solution*. Dissolve 75.0 mg of the substance to be examined in 10 mL of *acetonitrile R*. Add 10 mL of a 1.0 g/L solution of *phosphoric acid R* and dilute to 50.0 mL with *water R*.

*Reference solution*. Dissolve 20.0 mg of *codergocrine mesilate CRS* in 10 mL of *acetonitrile R*. Add 10 mL of a 1.0 g/L solution of *phosphoric acid R* and dilute to 50.0 mL with *water R*. Dilute 6.0 mL of the solution to 50.0 mL with a mixture of 20 volumes of *acetonitrile R*, 20 volumes of a 1.0 g/L solution of *phosphoric acid R* and 60 volumes of *water R*.

*Column*:

- size:  $l = 0.25$  m,  $\varnothing = 4.6$  mm,
- stationary phase: octadecylsilyl silica gel for chromatography *R* (5 µm) with a pore size of 10 nm and a carbon loading of 19 per cent.

*Mobile phase*:

- mobile phase A: mix 100 volumes of *acetonitrile R* with 900 volumes of *water R* and add 10 volumes of *triethylamine R*,
- mobile phase B: mix 100 volumes of *water R* with 900 volumes of *acetonitrile R* and add 10 volumes of *triethylamine R*.

Time (min)	Mobile phase A (per cent V/V)	Mobile phase B (per cent V/V)
0 - 5	75	25
5 - 20	75 → 25	25 → 75

*Flow rate*: 1.2 mL/min.

*Detection*: spectrophotometer at 280 nm.

*Injection*: 10 µL.

*Relative retention* with reference to dihydroergocristine (retention time = about 13.7 min): impurity F = about 0.8; impurity H = about 0.9; impurity I = about 1.02.

*System suitability*: reference solution:

- the chromatogram shows 4 peaks,
- resolution: minimum 1 between the peaks corresponding to dihydroergocristine and impurity I.

*Limits*:

- any impurity: not more than the area of the peak corresponding to dihydroergocristine in the chromatogram obtained with the reference solution (1 per cent),
- total: not more than twice the area of the peak corresponding to dihydroergocristine in the chromatogram obtained with the reference solution (2 per cent),

– *disregard limit*: 0.1 times the area of the peak corresponding to dihydroergocristine in the chromatogram obtained with the reference solution (0.1 per cent).

**Loss on drying** (2.2.32): maximum 3.0 per cent, determined on 0.500 g by drying under high vacuum at 80 °C.

#### ASSAY

Dissolve 0.300 g in 60 mL of *pyridine R*. Pass a stream of *nitrogen R* over the surface of the solution and titrate with 0.1 M *tetrabutylammonium hydroxide*, determining the end-point potentiometrically (2.2.20). Note the volume used at the second point of inflexion.

1 mL of 0.1 M *tetrabutylammonium hydroxide* is equivalent to 35.39 mg of  $C_{36}H_{45}N_5O_8S$ .

#### STORAGE

Store protected from light.

#### IMPURITIES

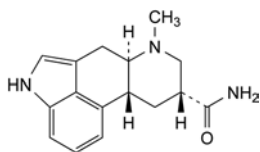

A. (6a*R*,9*R*,10a*R*)-7-methyl-4,6,6a,7,8,9,10,10a-octahydroindolo[4,3-*fg*]quinoline-9-carboxamide (6-methylergoline-8β-carboxamide),

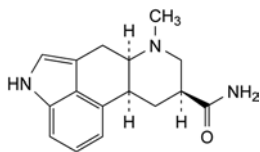

B. (6a*R*,9*S*,10a*S*)-7-methyl-4,6,6a,7,8,9,10,10a-octahydroindolo[4,3-*fg*]quinoline-9-carboxamide (6-methylisoergoline-8α-carboxamide),

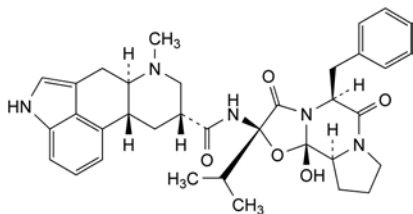

C. (6a*R*,9*R*,10a*R*)-*N*-[(2*S*,5*S*,10a*S*,10b*S*)-5-benzyl-10b-hydroxy-2-(1-methylethyl)-3,6-dioxooctahydro-8*H*-oxazolo[3,2-*a*]pyrrolo[2,1-*c*]pyrazin-2-yl]-7-methyl-4,6,6a,7,8,9,10,10a-octahydroindolo[4,3-*fg*]quinoline-9-carboxamide (2'-epidihydroergocristine),

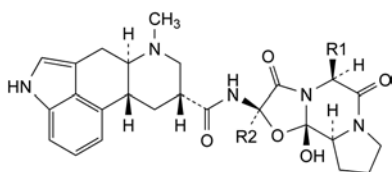

D. R1 = CH(CH<sub>3</sub>)<sub>2</sub>, R2 = CH<sub>3</sub>: (6a*R*,9*R*,10a*R*)-*N*-[(2*R*,5*S*,10a*S*,10b*S*)-10b-hydroxy-2-methyl-5-(1-methylethyl)-3,6-dioxooctahydro-8*H*-oxazolo[3,2-*a*]pyrrolo[2,1-*c*]pyrazin-2-yl]-7-methyl-4,6,6a,7,8,9,10,10a-octahydroindolo[4,3-*fg*]quinoline-9-carboxamide (dihydroergosine),

E. R1 = CH<sub>2</sub>-C<sub>6</sub>H<sub>5</sub>, R2 = CH<sub>3</sub>: (6a*R*,9*R*,10a*R*)-*N*-[(2*R*,5*S*,10a*S*,10b*S*)-5-benzyl-10b-hydroxy-2-methyl-3,6-dioxooctahydro-8*H*-oxazolo[3,2-*a*]pyrrolo[2,1-*c*]pyrazin-2-yl]-7-methyl-4,6,6a,7,8,9,10,10a-octahydroindolo[4,3-*fg*]quinoline-9-carboxamide (dihydroergotamine),

F. R1 = R2 = CH(CH<sub>3</sub>)<sub>2</sub>: (6a*R*,9*R*,10a*R*)-*N*-[(2*R*,5*S*,10a*S*,10b*S*)-10b-hydroxy-2,5-bis(1-methylethyl)-3,6-dioxooctahydro-8*H*-oxazolo[3,2-*a*]pyrrolo[2,1-*c*]pyrazin-2-yl]-7-methyl-4,6,6a,7,8,9,10,10a-octahydroindolo[4,3-*fg*]quinoline-9-carboxamide (dihydroergocornine),

G. R1 = CH<sub>2</sub>-C<sub>6</sub>H<sub>5</sub>, R2 = CH<sub>2</sub>-CH<sub>3</sub>: (6a*R*,9*R*,10a*R*)-*N*-[(2*R*,5*S*,10a*S*,10b*S*)-5-benzyl-2-ethyl-10b-hydroxy-3,6-dioxooctahydro-8*H*-oxazolo[3,2-*a*]pyrrolo[2,1-*c*]pyrazin-2-yl]-7-methyl-4,6,6a,7,8,9,10,10a-octahydroindolo[4,3-*fg*]quinoline-9-carboxamide (dihydroergostine),

H. R1 = CH<sub>2</sub>-CH(CH<sub>3</sub>)<sub>2</sub>, R2 = CH(CH<sub>3</sub>)<sub>2</sub>: (6a*R*,9*R*,10a*R*)-*N*-[(2*R*,5*S*,10a*S*,10b*S*)-10b-hydroxy-2-(1-methylethyl)-5-(2-methylpropyl)-3,6-dioxooctahydro-8*H*-oxazolo[3,2-*a*]pyrrolo[2,1-*c*]pyrazin-2-yl]-7-methyl-4,6,6a,7,8,9,10,10a-octahydroindolo[4,3-*fg*]quinoline-9-carboxamide (α-dihydroergocryptine),

I. R1 = C\*H(CH<sub>3</sub>)-CH<sub>2</sub>-CH<sub>3</sub>, R2 = CH(CH<sub>3</sub>)<sub>2</sub>: (6a*R*,9*R*,10a*R*)-*N*-[(2*R*,5*S*,10a*S*,10b*S*)-10b-hydroxy-2-(1-methylethyl)-5-[(1*RS*-1-methylpropyl)-3,6-dioxooctahydro-8*H*-oxazolo[3,2-*a*]pyrrolo[2,1-*c*]pyrazin-2-yl]-7-methyl-4,6,6a,7,8,9,10,10a-octahydroindolo[4,3-*fg*]quinoline-9-carboxamide (β-dihydroergocryptine or epicriptine),

J. R1 = CH<sub>2</sub>-C<sub>6</sub>H<sub>5</sub>, R2 = C\*H(CH<sub>3</sub>)-CH<sub>2</sub>-CH<sub>3</sub>: (6a*R*,9*R*,10a*R*)-*N*-[(2*R*,5*S*,10a*S*,10b*S*)-5-benzyl-10b-hydroxy-2-[(1*RS*)-1-methylpropyl]-3,6-dioxooctahydro-8*H*-oxazolo[3,2-*a*]pyrrolo[2,1-*c*]pyrazin-2-yl]-7-methyl-4,6,6a,7,8,9,10,10a-octahydroindolo[4,3-*fg*]quinoline-9-carboxamide (dihydroergosedmine),

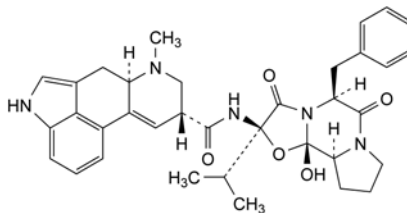

K. (6a*R*,9*R*,10a*R*)-*N*-[(2*R*,5*S*,10a*S*,10b*S*)-5-benzyl-10b-hydroxy-2-(1-methylethyl)-3,6-dioxooctahydro-8*H*-oxazolo[3,2-*a*]pyrrolo[2,1-*c*]pyrazin-2-yl]-7-methyl-4,6,6a,7,8,9-hexahydroindolo[4,3-*fg*]quinoline-9-carboxamide (ergocristine),

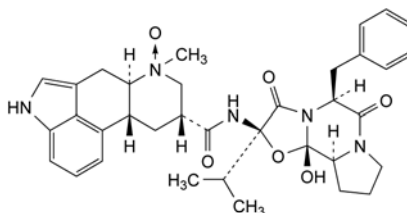

L. (6a*R*,7*RS*,9*R*,10a*R*)-*N*-[(2*R*,5*S*,10a*S*,10b*S*)-5-benzyl-10b-hydroxy-2-(1-methylethyl)-3,6-dioxooctahydro-8*H*-oxazolo[3,2-*a*]pyrrolo[2,1-*c*]pyrazin-2-yl]-7-methyl-4,6,6a,7,8,9,10,10a-octahydroindolo[4,3-*fg*]quinoline-9-carboxamide 7-oxide (dihydroergocristine 6-oxide).

04/2009:0551

## DIHYDROERGOTAMINE MESILATE

## Dihydroergotamini mesilas

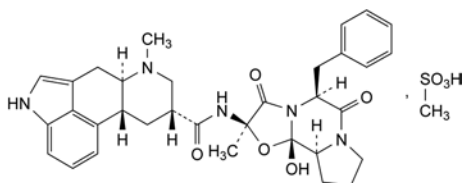

$C_{34}H_{41}N_5O_5S$   
[6190-39-2]

$M_r$  680

## DEFINITION

(6a*R*,9*R*,10a*R*)-*N*-(2*R*,5*S*,10a*S*,10b*S*)-5-Benzyl-10b-hydroxy-2-methyl-3,6-dioxooctahydro-8*H*-oxazolo[3,2-*a*]pyrrolo[2,1-*c*]pyrazin-2-yl]-7-methyl-4,6,6a,7,8,9,10,10a-octahydroindolo[4,3-*fg*]quinoline-9-carboxamide methanesulfonate.

*Content*: 98.0 per cent to 101.0 per cent (dried substance).

## PRODUCTION

The production method must be evaluated to determine the potential for formation of alkyl mesilates, which is particularly likely to occur if the reaction medium contains lower alcohols. Where necessary, the production method is validated to demonstrate that alkyl mesilates are not detectable in the final product.

## CHARACTERS

*Appearance*: white or almost white, crystalline powder or colourless crystals.

*Solubility*: slightly soluble in water, sparingly soluble in methanol, slightly soluble in ethanol (96 per cent).

## IDENTIFICATION

*First identification*: B, C.

*Second identification*: A, C, D.

A. Ultraviolet and visible absorption spectrophotometry (2.2.25).

*Test solution*. Dissolve 5.0 mg in *methanol R* and dilute to 100.0 mL with the same solvent.

*Spectral range*: 250-350 nm.

*Absorption maxima*: at 281 nm and 291 nm.

*Shoulder*: at 275 nm.

*Absorbance*: negligible above 320 nm.

*Specific absorbance at the absorption maximum at 281 nm*: 95 to 105 (dried substance).

B. Infrared absorption spectrophotometry (2.2.24).

*Comparison*: *dihydroergotamine mesilate CRS*.

C. Thin-layer chromatography (2.2.27). Prepare the reference solution and the test solution immediately before use.

*Solvent mixture*: *methanol R*, *methylene chloride R* (10:90 V/V).

*Test solution*. Dissolve 5 mg of the substance to be examined in the solvent mixture and dilute to 2.5 mL with the solvent mixture.

*Reference solution*. Dissolve 5 mg of *dihydroergotamine mesilate CRS* in the solvent mixture and dilute to 2.5 mL with the solvent mixture.

*Plate*: TLC silica gel G plate R.

*Mobile phase*: concentrated ammonia R, *methanol R*, *ethyl acetate R*, *methylene chloride R* (1:6:50:50 V/V/V/V).

*Application*: 5  $\mu$ L.

*Development*: protected from light, over a path of 15 cm; dry in a current of cold air for not longer than 1 min and repeat the development protected from light over a path of 15 cm using a freshly prepared amount of the mobile phase.

*Drying*: in a current of cold air.

*Detection*: spray abundantly with *dimethylaminobenzaldehyde solution R7* and dry in a current of hot air for about 2 min.

*Results*: the principal spot in the chromatogram obtained with the test solution is similar in position, colour and size to the principal spot in the chromatogram obtained with the reference solution.

D. To 0.1 g of the substance to be examined, add 5 mL of *dilute hydrochloric acid R* and shake for about 5 min. Filter, then add 1 mL of *barium chloride solution R1*. The filtrate remains clear. Mix 0.1 g of the substance to be examined with 0.4 g of powdered *sodium hydroxide R*, heat to fusion and continue to heat for 1 min. Cool, add 5 mL of *water R*, boil and filter. Acidify the filtrate with *hydrochloric acid R1* and filter again. The filtrate gives reaction (a) of sulfates (2.3.1).

## TESTS

**Appearance of solution**. The solution is clear (2.2.1) and not more intensely coloured than reference solution Y<sub>7</sub> or BY<sub>7</sub> (2.2.2, Method II).

Dissolve 0.10 g in a mixture of 0.1 mL of a 70 g/L solution of *methanesulfonic acid R* and 50 mL of *water R*.

**pH** (2.2.3): 4.4 to 5.4.

Dissolve 0.10 g in *carbon dioxide-free water R* and dilute to 100 mL with the same solvent.

**Specific optical rotation** (2.2.7): -42 to -47 (dried substance).

Dissolve 0.250 g in *anhydrous pyridine R* and dilute to 25.0 mL with the same solvent.

**Related substances**. Liquid chromatography (2.2.29). Carry out the test protected from light.

*Solvent mixture*: *acetonitrile R*, *water R* (50:50 V/V).

*Test solution*. Dissolve 70 mg of the substance to be examined in the solvent mixture and dilute to 100.0 mL with the solvent mixture.

*Reference solution (a)*. Dilute 1.0 mL of the test solution to 10.0 mL with the solvent mixture. Dilute 1.0 mL of this solution to 100.0 mL with the solvent mixture.

*Reference solution (b)*. Dissolve 7 mg of the substance to be examined and 6.8 mg of *ergotamine tartrate CRS* (impurity A) (equivalent to 7 mg of *ergotamine mesilate*) in the solvent mixture and dilute to 100 mL with the solvent mixture. Dilute 5 mL of this solution to 10 mL with the solvent mixture.

*Reference solution (c)*. Dissolve 5 mg of *dihydroergotamine for peak identification CRS* (containing impurities A, B, C, D and E) in the solvent mixture, add 100  $\mu$ L of *dilute sulfuric acid R* and dilute to 5 mL with the solvent mixture.

*Column*:

– *size*:  $l = 0.15$  m,  $\varnothing = 4.6$  mm;

– *stationary phase*: spherical end-capped octadecylsilyl silica gel for chromatography R (3  $\mu$ m);

– *temperature*: 25 °C.

*Mobile phase*:

– *mobile phase A*: 3 g/L solution of *sodium heptanesulfonate monohydrate R* adjusted to pH 2.0 with *phosphoric acid R*;

– *mobile phase B*: mobile phase A, *acetonitrile R* for chromatography R (20:80 V/V);

Time (min)	Mobile phase A (per cent V/V)	Mobile phase B (per cent V/V)
0 - 15	58 → 40	42 → 60

*Flow rate*: 1.5 mL/min.

*Detection*: spectrophotometer at 220 nm.

Injection: 5 µL.

**Identification of impurities:** use the chromatogram supplied with *dihydroergotamine* for peak identification CRS and the chromatogram obtained with reference solution (c) to identify the peaks due to impurities A, B, C, D and E.

**Relative retention** with reference to dihydroergotamine (retention time = about 6.5 min): impurity D = about 0.7; impurity C = about 0.86; impurity A = about 0.95; impurity B = about 1.2; impurity E = about 1.4.

**System suitability:** reference solution (b):

- **resolution:** minimum 1.5 between the peaks due to impurity A and dihydroergotamine.

**Limits:**

- **correction factors:** for the calculation of content, multiply the peak areas of the following impurities by the corresponding correction factor: impurity A = 1.3; impurity C = 1.3;
- **impurities B, E:** for each impurity, not more than 5 times the area of the principal peak in the chromatogram obtained with reference solution (a) (0.5 per cent);
- **impurity C:** not more than 3 times the area of the principal peak in the chromatogram obtained with reference solution (a) (0.3 per cent);
- **impurities A, D:** for each impurity, not more than 1.5 times the area of the principal peak in the chromatogram obtained with reference solution (a) (0.15 per cent);
- **unspecified impurities:** for each impurity, not more than the area of the principal peak in the chromatogram obtained with reference solution (a) (0.10 per cent);
- **total:** not more than 10 times the area of the principal peak in the chromatogram obtained with reference solution (a) (1.0 per cent);
- **disregard limit:** 0.5 times the area of the principal peak in the chromatogram obtained with reference solution (a) (0.05 per cent).

**Loss on drying** (2.2.32): maximum 4.0 per cent, determined on 0.500 g by drying at 105 °C at a pressure not exceeding 0.1 kPa for 5 h.

ASSAY

Dissolve 0.500 g in a mixture of 10 mL of *anhydrous acetic acid* R and 70 mL of *acetic anhydride* R. Titrate with 0.1 M *perchloric acid*, determining the end-point potentiometrically (2.2.20).

1 mL of 0.1 M *perchloric acid* is equivalent to 68.00 mg of C<sub>34</sub>H<sub>41</sub>N<sub>5</sub>O<sub>8</sub>S.

STORAGE

Protected from light.

IMPURITIES

**Specified impurities:** A, B, C, D, E.

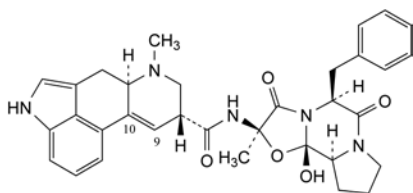

- A. (6aR,9R)-N-[(2R,5S,10aS,10bS)-5-benzyl-10b-hydroxy-2-methyl-3,6-dioxooctahydro-8H-oxazolo[3,2-a]pyrrolo[2,1-c]pyrazin-2-yl]-7-methyl-4,6,6a,7,8,9-hexahydroindolo[4,3-fg]quinoline-9-carboxamide (ergotamine),

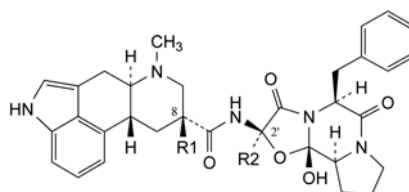

- B. R1 = H, R2 = C<sub>2</sub>H<sub>5</sub>: (6aR,9R,10aR)-N-[(2R,5S,10aS,10bS)-5-benzyl-2-ethyl-10b-hydroxy-3,6-dioxooctahydro-8H-oxazolo[3,2-a]pyrrolo[2,1-c]pyrazin-2-yl]-7-methyl-4,6,6a,7,8,9,10,10a-octahydroindolo[4,3-fg]quinoline-9-carboxamide (9,10-dihydroergostine),

- C. R1 = OH, R2 = CH<sub>3</sub>: (6aR,9S,10aR)-N-[(2R,5S,10aS,10bS)-5-benzyl-10b-hydroxy-2-methyl-3,6-dioxooctahydro-8H-oxazolo[3,2-a]pyrrolo[2,1-c]pyrazin-2-yl]-9-hydroxy-7-methyl-4,6,6a,7,8,9,10,10a-octahydroindolo[4,3-fg]quinoline-9-carboxamide (8-hydroxy-9,10-dihydroergotamine),

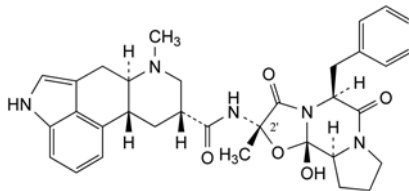

- D. (6aR,9R,10aR)-N-[(2S,5S,10aS,10bS)-5-benzyl-10b-hydroxy-2-methyl-3,6-dioxooctahydro-8H-oxazolo[3,2-a]pyrrolo[2,1-c]pyrazin-2-yl]-7-methyl-4,6,6a,7,8,9,10,10a-octahydroindolo[4,3-fg]quinoline-9-carboxamide (2'-epi-9,10-dihydroergotamine),

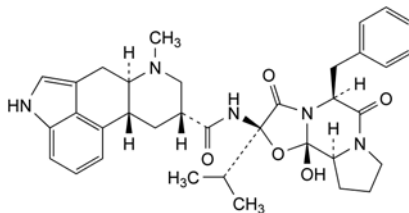

- E. (6aR,9R,10aR)-N-[(2R,5S,10aS,10bS)-5-benzyl-10b-hydroxy-2-(1-methylethyl)-3,6-dioxooctahydro-8H-oxazolo[3,2-a]pyrrolo[2,1-c]pyrazin-2-yl]-7-methyl-4,6,6a,7,8,9,10,10a-octahydroindolo[4,3-fg]quinoline-9-carboxamide (dihydroergocristine).

01/2008:0600  
corrected 6.0

## DIHYDROERGOTAMINE TARTRATE

Dihydroergotamini tartras

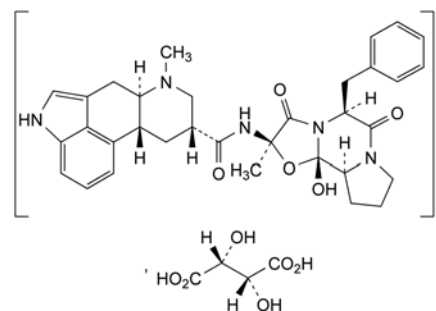

C<sub>70</sub>H<sub>80</sub>N<sub>10</sub>O<sub>16</sub>  
[5989-77-5]

M<sub>r</sub> 1317

## DEFINITION

Bis[(6*aR*,9*R*,10*aR*)-*N*-[(2*R*,5*S*,10*aS*,10*bS*)-5-benzyl-10*b*-hydroxy-2-methyl-3,6-dioxooctahydro-8*H*-oxazolo[3,2-*a*]pyrrolo[2,1-*c*]pyrazin-2-yl]-7-methyl-4,6,6*a*,7,8,9,10,10*a*-octahydroindolo[4,3-*fg*]quinoline-9-carboxamide] (2*R*,3*R*)-2,3-dihydroxybutanedioate.

*Content*: 98.0 per cent to 101.0 per cent (dried substance).

## CHARACTERS

*Appearance*: white or almost white, crystalline powder or colourless crystals.

*Solubility*: very slightly soluble in water, sparingly soluble in alcohol.

## IDENTIFICATION

*First identification*: B, C.

*Second identification*: A, C, D.

A. Dissolve 5.0 mg in *methanol R* and dilute to 100.0 mL with the same solvent. Examined between 250 nm and 350 nm (2.2.25), the solution shows 2 absorption maxima, at 281 nm and 291 nm, and a shoulder at 275 nm. Above 320 nm the absorbance is negligible. The specific absorbance at the maximum at 281 nm is 95 to 115 (dried substance).

B. Infrared absorption spectrophotometry (2.2.24).

*Preparation*: discs.

*Comparison*: dihydroergotamine tartrate CRS.

C. Examine the chromatograms obtained in the test for related substances.

*Results*: the principal spot in the chromatogram obtained with test solution (b) is similar in position, colour and size to the principal spot in the chromatogram obtained with reference solution (a).

D. Suspend about 15 mg in 1 mL of *water R*. 0.1 mL of the suspension gives reaction (b) of tartrates (2.3.1).

## TESTS

**Appearance of solution.** The solution is clear (2.2.1) and not more intensely coloured than reference solution Y<sub>7</sub> or BY<sub>7</sub> (2.2.2, *Method II*).

Dissolve 0.1 g in *alcohol (85 per cent V/V) R* warming carefully in a water-bath at 40 °C and dilute to 50 mL with the same solvent.

**pH** (2.2.3): 4.0 to 5.5 for the clear supernatant.

Suspend 50 mg in 50 mL of *carbon dioxide-free water R* and shake for 10 min. Allow to stand.

**Specific optical rotation** (2.2.7): –52 to –57 (dried substance).

Dissolve 0.250 g in *anhydrous pyridine R* and dilute to 25.0 mL with the same solvent.

**Related substances.** Thin-layer chromatography (2.2.27).

*Prepare the reference solutions and the test solutions immediately before use and in the order indicated.*

*Reference solution (a).* Dissolve 20 mg of dihydroergotamine tartrate CRS in a mixture of 1 volume of *methanol R* and 9 volumes of *chloroform R* and dilute to 10 mL with the same mixture of solvents.

*Reference solution (b).* Dilute 2.5 mL of reference solution (a) to 50 mL with a mixture of 1 volume of *methanol R* and 9 volumes of *chloroform R*.

*Reference solution (c).* Dilute 2 mL of reference solution (b) to 5 mL with a mixture of 1 volume of *methanol R* and 9 volumes of *chloroform R*.

*Test solution (a).* Dissolve 0.10 g of the substance to be examined in a mixture of 1 volume of *methanol R* and 9 volumes of *chloroform R* and dilute to 5 mL with the same mixture of solvents.

*Test solution (b).* Dilute 1 mL of test solution (a) to 10 mL with a mixture of 1 volume of *methanol R* and 9 volumes of *chloroform R*.

*Plate*: TLC silica gel G plate R.

*Mobile phase*: concentrated ammonia R, *methanol R*, *ethyl acetate R*, *methylene chloride R* (1:6:50:50 V/V/V/V).

*Application*: 5 µL.

*Development*: protected from light over a path of 15 cm. Dry the plate in a current of cold air for not longer than 1 min. Repeat the development protected from light over a path of 15 cm using a freshly prepared amount of the mobile phase.

*Drying*: in a current of cold air.

*Detection*: spray the plate abundantly with *dimethylamino-benzaldehyde solution R7* and dry in a current of hot air for about 2 min.

*Limits*: in the chromatogram obtained with test solution (a):

– *any impurity*: any spot, apart from the principal spot, is not more intense than the principal spot in the chromatogram obtained with reference solution (b) (0.5 per cent) and not more than 2 such spots are more intense than the principal spot in the chromatogram obtained with reference solution (c) (0.2 per cent).

**Loss on drying** (2.2.32): maximum 5.0 per cent, determined on 0.200 g by drying in an oven at 105 °C.

## ASSAY

Dissolve 0.250 g in 50 mL of *anhydrous acetic acid R*. Titrate with 0.05 M *perchloric acid*, determining the end-point potentiometrically (2.2.20).

1 mL of 0.05 M *perchloric acid* is equivalent to 32.93 mg of C<sub>70</sub>H<sub>80</sub>N<sub>10</sub>O<sub>16</sub>.

## STORAGE

Protected from light.

04/2010:0485

DIHYDROSTREPTOMYCIN SULFATE  
FOR VETERINARY USE

Dihydrostreptomycini sulfas  
ad usum veterinarium

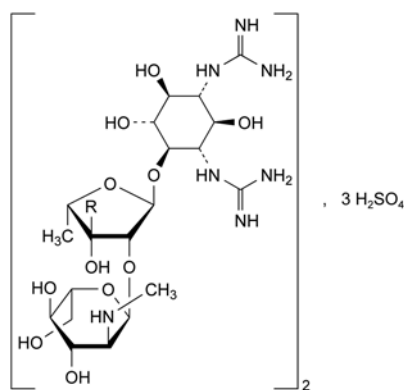

Compound	R	Molec. Formula	M <sub>r</sub>
dihydrostreptomycin sulphate	CH <sub>2</sub> OH	C <sub>42</sub> H <sub>88</sub> N <sub>14</sub> O <sub>36</sub> S <sub>3</sub>	1461
streptomycin sulphate	CHO	C <sub>42</sub> H <sub>84</sub> N <sub>14</sub> O <sub>36</sub> S <sub>3</sub>	1457

[5490-27-7]

## DEFINITION

*Main compound*: bis[*N,N'*-(1*R*,2*R*,3*S*,4*R*,5*R*,6*S*)-4-[[5-deoxy-2-*O*-[2-deoxy-2-(methylamino)-α-*L*-glucopyranosyl]-3-*C*-(hydroxymethyl)-α-*L*-lyxofuranosyl]oxy]-2,5,6-trihydroxycyclohexane-1,3-diyl]diguandine] trisulfate.

Sulfate of a substance obtained by catalytic hydrogenation of streptomycin or by any other means.

Semi-synthetic product derived from a fermentation product.

Stabilisers may be added.

**Content:**

- *sum of the percentage contents of dihydrostreptomycin sulfate and streptomycin sulfate*: 95.0 per cent to 102.0 per cent (dried substance);
- *streptomycin sulfate*: maximum 2.0 per cent (dried substance).

#### PRODUCTION

The method of manufacture is validated to demonstrate that the product, if tested, would comply with the following test.

**Abnormal toxicity** (2.6.9). Inject into each mouse 1 mg dissolved in 0.5 mL of *water for injections R*.

#### CHARACTERS

**Appearance:** white or almost white, hygroscopic powder.

**Solubility:** freely soluble in water, practically insoluble in acetone, in ethanol (96 per cent) and in methanol.

#### IDENTIFICATION

**First identification:** A, E.

**Second identification:** B, C, D, E.

A. Examine the chromatograms obtained in the assay.

**Results:** the principal peak in the chromatogram obtained with the test solution is similar in retention time and size to the principal peak in the chromatogram obtained with reference solution (a).

B. Thin-layer chromatography (2.2.27).

**Test solution.** Dissolve 10 mg of the substance to be examined in *water R* and dilute to 10 mL with the same solvent.

**Reference solution (a).** Dissolve the contents of a vial of *dihydrostreptomycin sulfate CRS* in 5.0 mL of *water R*.

**Reference solution (b).** Dilute 1.0 mL of reference solution (a) to 5.0 mL with *water R*.

**Reference solution (c).** Dissolve 10 mg of *kanamycin monosulfate CRS* and 10 mg of *neomycin sulfate CRS* in *water R*, add 2.0 mL of reference solution (a), mix thoroughly and dilute to 10 mL with *water R*.

**Plate:** TLC silica gel plate R.

**Mobile phase:** 70 g/L solution of *potassium dihydrogen phosphate R*.

**Application:** 10 µL.

**Development:** over 2/3 of the plate.

**Drying:** in a current of warm air.

**Detection:** spray with a mixture of equal volumes of a 2 g/L solution of *1,3-dihydroxynaphthalene R* in *ethanol (96 per cent) R* and a 460 g/L solution of *sulfuric acid R*; heat at 150 °C for 5-10 min.

**System suitability:** reference solution (c):

- the chromatogram shows 3 clearly separated spots.

**Results:** the principal spot in the chromatogram obtained with the test solution is similar in position, colour and size to the principal spot in the chromatogram obtained with reference solution (b).

C. Dissolve 0.1 g in 2 mL of *water R* and add 1 mL of *α-naphthol solution R* and 2 mL of a mixture of equal volumes of *strong sodium hypochlorite solution R* and *water R*. A red colour develops.

D. Dissolve 10 mg in 5 mL of *water R* and add 1 mL of *1 M hydrochloric acid*. Heat in a water-bath for 2 min. Add 2 mL of a 5 g/L solution of *α-naphthol R* in *1 M sodium hydroxide* and heat in a water-bath for 1 min. A violet-pink colour is produced.

E. It gives reaction (a) of sulfates (2.3.1).

#### TESTS

**Solution S.** Dissolve 2.5 g in *carbon dioxide-free water R* and dilute to 10 mL with the same solvent.

**Appearance of solution.** Solution S is not more intensely coloured than intensity 5 of the range of reference solutions of the most appropriate colour (2.2.2, *Method II*). Allow to stand protected from light at about 20 °C for 24 h; solution S is not more opalescent than reference suspension II (2.2.1).

**pH** (2.2.3): 5.0 to 7.0 for solution S.

**Specific optical rotation** (2.2.7): –83.0 to –91.0 (dried substance).

Dissolve 0.200 g in *water R* and dilute to 10.0 mL with the same solvent.

**Related substances.** Liquid chromatography (2.2.29).

**Test solution.** Dissolve 50.0 mg of the substance to be examined in *water R* and dilute to 10.0 mL with the same solvent.

**Reference solution (a).** Dissolve the contents of a vial of *dihydrostreptomycin sulfate CRS* (containing impurities A, B and C) in 5.0 mL of *water R*.

**Reference solution (b).** Dilute 1.0 mL of the test solution to 100.0 mL with *water R*.

**Reference solution (c).** Dilute 5.0 mL of reference solution (b) to 50.0 mL with *water R*.

**Reference solution (d).** Dissolve 10 mg of *streptomycin sulfate CRS* in *water R* and dilute to 20 mL with the same solvent. Mix 0.1 mL of this solution with 1.0 mL of reference solution (a).

**Reference solution (e).** Dilute 1.0 mL of reference solution (a) to 100.0 mL with *water R*.

**Column:**

- *size:*  $l = 0.25$  m,  $\varnothing = 4.6$  mm;
- *stationary phase:* *octadecylsilyl silica gel for chromatography R* (5 µm);
- *temperature:* 45 °C.

**Mobile phase:** solution in *water R* containing 4.6 g/L of *anhydrous sodium sulfate R*, 1.5 g/L of *sodium octanesulfonate R*, 120 mL/L of *acetonitrile R1* and 50 mL/L of a 27.2 g/L solution of *potassium dihydrogen phosphate R* adjusted to pH 3.0 with a 22.5 g/L solution of *phosphoric acid R*.

**Flow rate:** 1.0 mL/min.

**Detection:** spectrophotometer at 205 nm.

**Injection:** 20 µL.

**Run time:** 1.5 times the retention time of dihydrostreptomycin.

**Identification of impurities:** use the chromatogram supplied with *dihydrostreptomycin sulfate CRS* and the chromatogram obtained with reference solution (a) to identify the peaks due to streptomycin and impurities A, B and C.

**Relative retention** with reference to dihydrostreptomycin (retention time = about 57 min): impurity A = about 0.2; impurity B = about 0.8; streptomycin = about 0.9; impurity C = about 0.95.

**System suitability:**

- peak-to-valley ratio (a): minimum 1.1, where  $H_p$  = height above the baseline of the peak due to streptomycin and  $H_v$  = height above the baseline of the lowest point of the curve separating this peak from the peak due to impurity C in the chromatogram obtained with reference solution (d);
- peak-to-valley ratio (b): minimum 5, where  $H_p$  = height above the baseline of the peak due to impurity C and  $H_v$  = height above the baseline of the lowest point of the curve separating this peak from the peak due to dihydrostreptomycin in the chromatogram obtained with reference solution (d);
- the chromatogram obtained with reference solution (a) is similar to the chromatogram supplied with *dihydrostreptomycin sulfate CRS*.

**Limits:**

- **correction factor:** for the calculation of content, multiply the peak area of impurity A by 0.5;
- **impurity C:** not more than twice the area of the principal peak in the chromatogram obtained with reference solution (b) (2.0 per cent);
- **impurities A, B:** for each impurity, not more than the area of the principal peak in the chromatogram obtained with reference solution (b) (1.0 per cent);
- **any other impurity:** for each impurity, not more than the area of the principal peak in the chromatogram obtained with reference solution (b) (1.0 per cent);
- **total:** not more than 5 times the area of the principal peak in the chromatogram obtained with reference solution (b) (5.0 per cent);
- **disregard limit:** the area of the principal peak in the chromatogram obtained with reference solution (c) (0.1 per cent); disregard the peak due to streptomycin.

**Heavy metals (2.4.8):** 20 ppm.

1.0 g complies with test C. Prepare the reference solution using 2 mL of lead standard solution (10 ppm Pb) R.

**Loss on drying (2.2.32):** maximum 5.0 per cent, determined on 1.000 g by drying under high vacuum at 60 °C for 4 h.

**Sulfated ash (2.4.14):** maximum 1.0 per cent, determined on 1.0 g.

**Bacterial endotoxins (2.6.14):** less than 0.50 IU/mg, if intended for use in the manufacture of parenteral preparations without a further appropriate procedure for removal of bacterial endotoxins.

**ASSAY**

Liquid chromatography (2.2.29) as described in the test for related substances with the following modification.

**Injection:** test solution and reference solutions (a) and (e).

Calculate the percentage content of streptomycin sulfate using the chromatogram obtained with reference solution (e) and the declared content of *dihydrostreptomycin sulfate CRS*.

Calculate the percentage content of dihydrostreptomycin sulfate using the chromatogram obtained with reference solution (a) and the declared content of *dihydrostreptomycin sulfate CRS*.

**STORAGE**

In an airtight container, protected from light. If the substance is sterile, store in a sterile, airtight, tamper-proof container.

**IMPURITIES**

**Specified impurities:** A, B, C.

**Other detectable impurities** (the following substances would, if present at a sufficient level, be detected by one or other of the tests in the monograph. They are limited by the general acceptance criterion for other/unspecified impurities and/or by the general monograph *Substances for pharmaceutical use (2034)*. It is therefore not necessary to identify these impurities for demonstration of compliance. See also 5.10. *Control of impurities in substances for pharmaceutical use*): D.

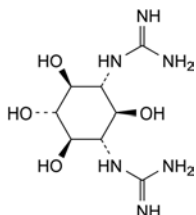

A. *N,N''*-[(1*R*,2*s*,3*S*,4*R*,5*r*,6*S*)-2,4,5,6-tetrahydroxycyclohexane-1,3-diyl]diguanidine (streptidine),

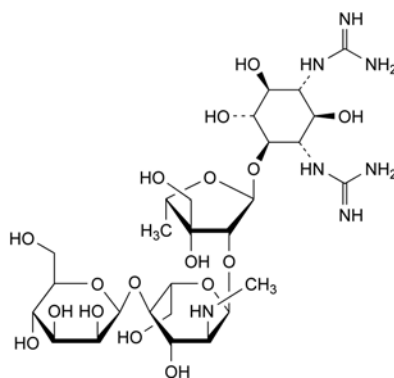

B. *N,N'''*-[(1*S*,2*R*,3*R*,4*S*,5*R*,6*R*)-2,4,5-trihydroxy-6-[[β-D-mannopyranosyl-(1→4)-2-deoxy-2-(methylamino)-α-L-glucopyranosyl-(1→2)-5-deoxy-3-C-(hydroxymethyl)-α-L-lyxofuranosyl]oxy]cyclohexane-1,3-diyl]diguanidine (dihydrostreptomycin B),

C. unknown structure,

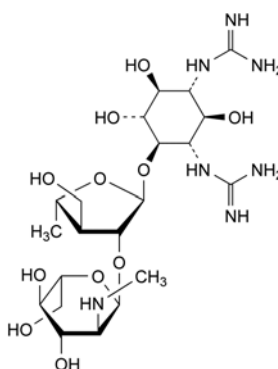

D. *N,N'''*-[(1*R*,2*R*,3*S*,4*R*,5*R*,6*S*)-4-[[3,5-dideoxy-2-*O*-[2-deoxy-2-(methylamino)-α-*L*-glucopyranosyl]-3-(hydroxymethyl)-α-*L*-arabinofuranosyl]oxy]-2,5,6-trihydroxycyclohexane-1,3-diyl]diguanidine (deoxydihydrostreptomycin).

01/2008:2014

**DIHYDROTACHYSTEROL**

## Dihydrostachysterolum

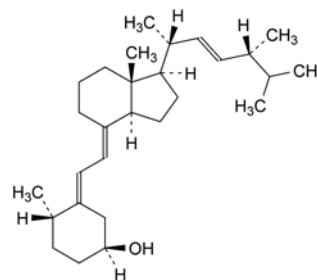

$C_{28}H_{46}O$   
[67-96-9]

$M_r$  398.7

**DEFINITION**

(5*E*,7*E*,22*E*)-9,10-Seco-10α-ergosta-5,7,22-trien-3β-ol.

**Content:** 97.0 per cent to 102.0 per cent.

**CHARACTERS**

**Appearance:** colourless crystals or white or almost white crystalline powder.

**Solubility:** practically insoluble in water, freely soluble in acetone and hexane, sparingly soluble in ethanol (96 per cent). It shows polymorphism (5.9).

## IDENTIFICATION

Infrared absorption spectrophotometry (2.2.24).

Comparison: dihydrotachysterol CRS.

If the spectra obtained in the solid state show differences, record new spectra using the residues after recrystallisation from methanol R.

## TESTS

**Specific optical rotation** (2.2.7): + 99 to + 103.

Dissolve 0.500 g in ethanol (96 per cent) R and dilute to 25.0 mL with the same solvent.

**Related substances.** Liquid chromatography (2.2.29).

**Test solution.** Dissolve 10.00 mg of the substance to be examined in acetonitrile R and dilute to 50.0 mL with the same solvent.

**Reference solution (a).** Dissolve 1.0 mg of dihydrotachysterol for system suitability CRS (containing impurities A, B and C) in acetonitrile R and dilute to 5.0 mL with the same solvent.

**Reference solution (b).** Dissolve 10.00 mg of dihydrotachysterol CRS in acetonitrile R and dilute to 50.0 mL with the same solvent.

**Reference solution (c).** Dilute 5.0 mL of the test solution to 100.0 mL with acetonitrile R. Dilute 5.0 mL of this solution to 50.0 mL with acetonitrile R.

**Column:**

- size:  $l = 0.25$  m,  $\varnothing = 3.0$  mm,
- stationary phase: spherical trifunctional end-capped octadecylsilyl silica gel for chromatography R (4  $\mu$ m),
- temperature: 40 °C.

**Mobile phase:** decanol R, water for chromatography R, acetonitrile for chromatography R (1:25:1000 V/V/V).

**Flow rate:** 0.5 mL/min.

**Detection:** variable-wavelength spectrophotometer capable of operating at 251 nm and at 203 nm.

**Injection:** 5  $\mu$ L of the test solution and reference solutions (a) and (c).

**Run time:** twice the retention time of dihydrotachysterol.

**Identification of impurities:** reference solution (a):

- use the chromatogram obtained at 203 nm and the chromatogram obtained at 251 nm supplied with dihydrotachysterol for system suitability CRS to identify the peak due to impurity A,
- use the chromatogram obtained at 251 nm and the chromatogram obtained at 251 nm supplied with dihydrotachysterol for system suitability CRS to identify the peak due to impurities B and C.

**Relative retention** with reference to dihydrotachysterol (retention time = about 15 min); impurity B = about 0.9; impurity C = about 1.2; impurity A (not visible at 251 nm, detected at 203 nm) = about 1.2.

**System suitability:** reference solution (a):

- peak-to-valley ratio: minimum of 4, where  $H_p$  = height above the baseline of the peak due to impurity B, and  $H_v$  = height above the baseline of the lowest point of the curve separating this peak from the peak due to dihydrotachysterol in the chromatogram obtained at 251 nm.

Examine the chromatogram obtained at 203 nm for impurity A and the chromatogram obtained at 251 nm for the impurities other than A.

**Limits:**

- impurity A: not more than the area of the principal peak in the chromatogram obtained with reference solution (c) (0.5 per cent),
- impurities B, C: for each impurity, not more than the area of the principal peak in the chromatogram obtained with reference solution (c) (0.5 per cent),

- any other impurity: for each impurity, not more than 0.2 times the area of the principal peak in the chromatogram obtained with reference solution (c) (0.1 per cent),
- total (including A): not more than twice the area of the principal peak in the chromatogram obtained with reference solution (c) at 251 nm (1.0 per cent),
- disregard limit: 0.1 times the area of the principal peak in the chromatogram obtained with reference solution (c) (0.05 per cent).

**Water** (2.5.32): maximum 0.1 per cent, determined on 40.0 mg.

## ASSAY

Liquid chromatography (2.2.29) as described in the test for related substances with the following modifications.

**Detection:** spectrophotometer at 251 nm.

**Injection:** test solution and reference solution (b).

Calculate the percentage content of  $C_{28}H_{46}O$  using the chromatograms obtained with the test solution and reference solution (b) and the declared content of dihydrotachysterol CRS.

## STORAGE

Under an inert gas, in an airtight container, at a temperature of 2 °C to 8 °C.

The contents of an opened container are to be used immediately.

## IMPURITIES

Specified impurities: A, B, C.

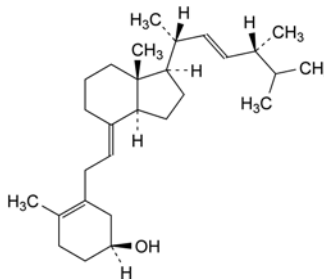

A. (7*E*,22*E*)-9,10-secoergosta-5(10),7,22-trien-3 $\beta$ -ol (dihydrovitamin D<sub>2</sub>-I),

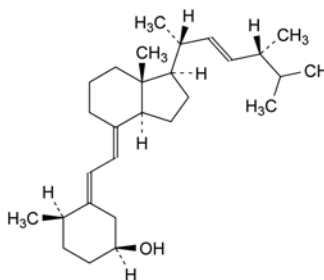

B. (5*E*,7*E*,22*E*)-9,10-secoergosta-5,7,22-trien-3 $\beta$ -ol (dihydrovitamin D<sub>2</sub>-IV),

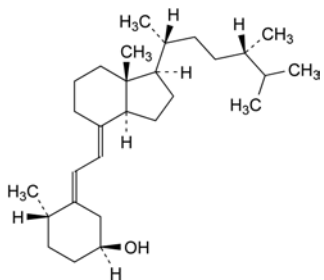

C. (5*E*,7*E*)-9,10-seco-10 $\alpha$ -ergosta-5,7-dien-3 $\beta$ -ol (dihydrotachysterol<sub>4</sub>).



07/2010:1004 **Related substances.** Liquid chromatography (2.2.29).

## DILTIAZEM HYDROCHLORIDE

### Diltiazemi hydrochloridum

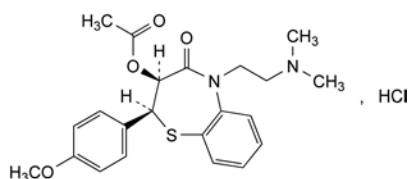

$C_{22}H_{27}ClN_2O_4S$   
[33286-22-5]

$M_r$  451.0

#### DEFINITION

Hydrochloride of (2*S*,3*S*)-5-[2-(dimethylamino)ethyl]-2-(4-methoxyphenyl)-4-oxo-2,3,4,5-tetrahydro-1,5-benzothiazepin-3-yl acetate.

**Content:** 98.5 per cent to 101.0 per cent (dried substance).

#### CHARACTERS

**Appearance:** white or almost white, crystalline powder.

**Solubility:** freely soluble in water, in methanol and in methylene chloride, slightly soluble in anhydrous ethanol.

**mp:** about 213 °C, with decomposition.

#### IDENTIFICATION

**First identification:** A, D.

**Second identification:** B, C, D.

A. Infrared absorption spectrophotometry (2.2.24).

**Comparison:** diltiazem hydrochloride CRS.

B. Thin-layer chromatography (2.2.27).

**Test solution.** Dissolve 50 mg of the substance to be examined in *methylene chloride R* and dilute to 5 mL with the same solvent.

**Reference solution.** Dissolve 50 mg of *diltiazem hydrochloride CRS* in *methylene chloride R* and dilute to 5 mL with the same solvent.

**Plate:** TLC silica gel  $F_{254}$  plate *R*.

**Mobile phase:** acetic acid *R*, water *R*, methylene chloride *R*, anhydrous ethanol *R* (1:3:10:12 V/V/V/V).

**Application:** 10  $\mu$ L.

**Development:** over 2/3 of the plate.

**Drying:** in air.

**Detection:** examine in ultraviolet light at 254 nm.

**Results:** the principal spot in the chromatogram obtained with the test solution is similar in position and size to the principal spot in the chromatogram obtained with the reference solution.

C. Dissolve 50 mg in 5 mL of water *R*. Add 1 mL of ammonium reineckate solution *R*. A pink precipitate is produced.

D. It gives reaction (a) of chlorides (2.3.1).

#### TESTS

**Solution S.** Dissolve 1.00 g in carbon-dioxide free water *R* and dilute to 20.0 mL with the same solvent.

**Appearance of solution.** Solution S is clear (2.2.1) and colourless (2.2.2, Method II).

**pH** (2.2.3): 4.3 to 5.3.

Dilute 2.0 mL of solution S to 10.0 mL with carbon dioxide-free water *R*.

**Specific optical rotation** (2.2.7): + 115 to + 120 (dried substance).

Dilute 5.0 mL of solution S to 25.0 mL with water *R*.

**Test solution.** Dissolve 50 mg of the substance to be examined in the mobile phase and dilute to 200.0 mL with the mobile phase.

**Reference solution (a).** Dissolve 5 mg of *diltiazem for system suitability CRS* (containing impurity A) in the mobile phase and dilute to 20.0 mL with the mobile phase.

**Reference solution (b).** Dilute 0.3 mL of the test solution to 100.0 mL with the mobile phase.

**Column:**

– size:  $l = 0.10$  m,  $\varnothing = 4.6$  mm;

– stationary phase: octadecylsilyl silica gel for chromatography *R* (3  $\mu$ m).

**Mobile phase:** mix 5 volumes of anhydrous ethanol *R*, 25 volumes of acetonitrile *R* and 70 volumes of a solution containing 6.8 g/L of potassium dihydrogen phosphate *R* and 0.1 mL/l of *N,N*-dimethyloctylamine *R*, adjusted to pH 4.5 with dilute phosphoric acid *R*.

**Flow rate:** 1.5 mL/min.

**Detection:** spectrophotometer at 240 nm.

**Injection:** 20  $\mu$ L.

**Run time:** 5 times the retention time of diltiazem.

**Relative retention** with reference to diltiazem (retention time = about 5 min): impurity A = about 0.8.

**System suitability:** reference solution (a):

– resolution: minimum 3.0 between the peaks due to impurity A and diltiazem; if necessary, adjust the concentration of *N,N*-dimethyloctylamine in the mobile phase;

– symmetry factor: maximum 2.0 for the peak due to impurity A; if necessary, adjust the concentration of *N,N*-dimethyloctylamine in the mobile phase.

**Limits:**

– unspecified impurities: for each impurity, not more than 0.33 times the area of the principal peak in the chromatogram obtained with reference solution (b) (0.10 per cent);

– total: not more than the area of the principal peak in the chromatogram obtained with reference solution (b) (0.3 per cent);

– disregard limit: 0.17 times the area of the principal peak in the chromatogram obtained with reference solution (b) (0.05 per cent).

**Heavy metals** (2.4.8): maximum 10 ppm.

Dissolve 2.0 g in water *R* and dilute to 20.0 mL with the same solvent. 12 mL of the solution complies with test A. Prepare the reference solution using lead standard solution (1 ppm Pb) *R*.

**Loss on drying** (2.2.32): maximum 0.5 per cent, determined on 1.000 g by drying in an oven at 105 °C for 2 h.

**Sulfated ash** (2.4.14): maximum 0.1 per cent, determined on 1.0 g.

#### ASSAY

Dissolve 0.400 g in a mixture of 2 mL of anhydrous formic acid *R* and 60 mL of acetic anhydride *R* and titrate with 0.1 M perchloric acid, determining the end-point potentiometrically (2.2.20).

1 mL of 0.1 M perchloric acid is equivalent to 45.1 mg of  $C_{22}H_{27}ClN_2O_4S$ .

#### STORAGE

In an airtight container, protected from light.

#### IMPURITIES

**Other detectable impurities** (the following substances would, if present at a sufficient level, be detected by one or other of the tests in the monograph. They are limited by the general acceptance criterion for other/unspecified impurities and/or by the general monograph *Substances for pharmaceutical use* (2034). It is therefore not necessary to identify these impurities

for demonstration of compliance. See also 5.10. *Control of impurities in substances for pharmaceutical use*: A, B, C, D, E, F.

07/2009:0601

## DIMENHYDRINATE

## Dimenhydrinatum

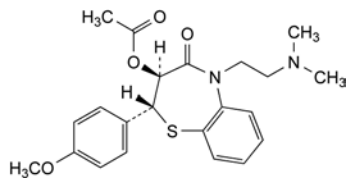

A. (2*R*,3*S*)-5-[2-(dimethylamino)ethyl]-2-(4-methoxyphenyl)-4-oxo-2,3,4,5-tetrahydro-1,5-benzothiazepin-3-yl acetate,

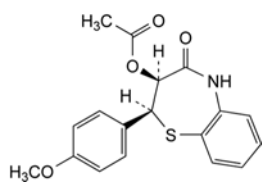

B. (2*S*,3*S*)-2-(4-methoxyphenyl)-4-oxo-2,3,4,5-tetrahydro-1,5-benzothiazepin-3-yl acetate,

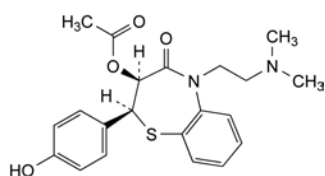

C. (2*S*,3*S*)-5-[2-(dimethylamino)ethyl]-2-(4-hydroxyphenyl)-4-oxo-2,3,4,5-tetrahydro-1,5-benzothiazepin-3-yl acetate,

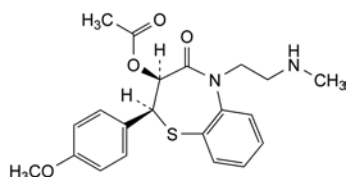

D. (2*S*,3*S*)-2-(4-methoxyphenyl)-5-[2-(methylamino)ethyl]-4-oxo-2,3,4,5-tetrahydro-1,5-benzothiazepin-3-yl acetate,

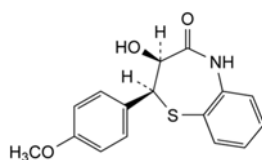

E. (2*S*,3*S*)-3-hydroxy-2-(4-methoxyphenyl)-2,3-dihydro-1,5-benzothiazepin-4(5*H*)-one,

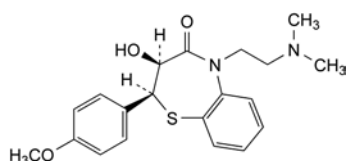

F. (2*S*,3*S*)-5-[2-(dimethylamino)ethyl]-3-hydroxy-2-(4-methoxyphenyl)-2,3-dihydro-1,5-benzothiazepin-4(5*H*)-one.

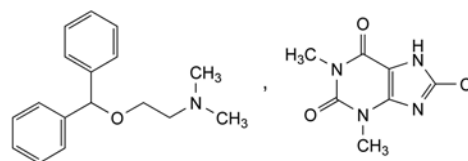

$C_{24}H_{28}ClN_5O_3$   
[523-87-5]

$M_r$  470.0

## DEFINITION

Diphenhydramine [2-(diphenylmethoxy)-*N,N*-dimethylethanamine] 8-chlorotheophylline (8-chloro-1,3-dimethyl-3,7-dihydro-1*H*-purine-2,6-dione).

## Content:

- *diphenhydramine* ( $C_{17}H_{21}NO$ ;  $M_r$  255.4): 53.0 per cent to 55.5 per cent (dried substance);
- *8-chlorotheophylline* ( $C_7H_7ClN_4O_2$ ;  $M_r$  214.6): 44.0 per cent to 46.5 per cent (dried substance).

## CHARACTERS

*Appearance*: white or almost white, crystalline powder or colourless crystals.

*Solubility*: slightly soluble in water, freely soluble in ethanol (96 per cent).

## IDENTIFICATION

*First identification*: C.

*Second identification*: A, B, D.

- A. Melting point (2.2.14): 102 °C to 106 °C.
- B. Dissolve 0.1 g in a mixture of 3 mL of *water R* and 3 mL of *ethanol (96 per cent) R*, add 6 mL of *water R* and 1 mL of *dilute hydrochloric acid R* and cool in iced water for 30 min, scratching the wall of the tube with a glass rod if necessary to initiate crystallisation. Dissolve about 10 mg of the precipitate obtained in 1 mL of *hydrochloric acid R*, add 0.1 g of *potassium chlorate R* and evaporate to dryness in a porcelain dish. A reddish residue is obtained that becomes violet-red when exposed to ammonia vapour.
- C. Infrared absorption spectrophotometry (2.2.24).  
*Comparison*: *dimenhydrinate CRS*.
- D. Dissolve 0.2 g in 10 mL of *ethanol (96 per cent) R*. Add 10 mL of *picric acid solution R* and initiate crystallisation by scratching the wall of the tube with a glass rod. The precipitate, washed with *water R* and dried at 100–105 °C, melts (2.2.14) at 130 °C to 134 °C.

## TESTS

**Appearance of solution.** The solution is clear (2.2.1) and colourless (2.2.2, *Method II*).

Dissolve 1.0 g in *ethanol (96 per cent) R* and dilute to 20 mL with the same solvent.

**pH** (2.2.3): 7.1 to 7.6 for the filtrate.

To 0.4 g add 20 mL of *carbon dioxide-free water R*, shake for 2 min and filter.

**Related substances.** Liquid chromatography (2.2.29).

*Solvent mixture*: *acetonitrile R*, *water R* (18:82 V/V).

*Test solution.* Dissolve 0.100 g of the substance to be examined in the solvent mixture and dilute to 100.0 mL with the solvent mixture.

*Reference solution (a).* Dissolve 57 mg of *diphenhydramine hydrochloride CRS* in the solvent mixture and dilute to 50.0 mL with the solvent mixture.

**Reference solution (b).** Dilute 1.0 mL of reference solution (a) to 100.0 mL with the solvent mixture. Dilute 2.0 mL of this solution to 10.0 mL with the solvent mixture.

**Reference solution (c).** Dissolve 5.0 mg of *diphenhydramine impurity A CRS* (impurity F) in 5.0 mL of reference solution (a) and dilute to 50.0 mL with the solvent mixture.

**Reference solution (d).** Dissolve the contents of a vial of *dimenhydrinate for peak identification CRS* (containing impurities A and E) in 1.0 mL of the solvent mixture.

**Column:**

- size:  $l = 0.25$  m,  $\varnothing = 4.6$  mm;
- stationary phase: end-capped octadecylsilyl silica gel for chromatography R (5  $\mu$ m);
- temperature: 30 °C.

**Mobile phase:**

- mobile phase A: dissolve 10.0 g of *triethylamine R2* in 950 mL of *water R*, adjust to pH 2.5 with *phosphoric acid R* and dilute to 1000 mL with *water R*;
- mobile phase B: *acetonitrile R1*;

Time (min)	Mobile phase A (per cent V/V)	Mobile phase B (per cent V/V)	Flow rate (mL/min)
0 - 2	82	18	1.2
2 - 15	82 → 50	18 → 50	1.2
15 - 20	50 → 20	50 → 80	1.2 → 2.0
20 - 30	20	80	2.0

**Detection:** spectrophotometer at 225 nm.

**Injection:** 10  $\mu$ L.

**Identification of impurities:** use the chromatogram supplied with *dimenhydrinate for peak identification CRS* and the chromatogram obtained with reference solution (d) to identify the peaks due to impurities A and E; use the chromatogram obtained with reference solution (c) to identify impurity F.

**Relative retention** with reference to *diphenhydramine* (retention time = about 13 min): impurity A = about 0.3; impurity E = about 0.7; impurity F = about 0.95.

**System suitability:** reference solution (c):

- resolution: minimum 1.5 between the peaks due to impurity F and *diphenhydramine*.

**Limits:**

- impurities A, F: for each impurity, not more than the area of the principal peak in the chromatogram obtained with reference solution (b) (0.2 per cent);
- impurity E: not more than 0.75 times the area of the principal peak in the chromatogram obtained with reference solution (b) (0.15 per cent);
- unspecified impurities: for each impurity, not more than 0.5 times the area of the principal peak in the chromatogram obtained with reference solution (b) (0.10 per cent);
- total: not more than 2.5 times the area of the principal peak in the chromatogram obtained with reference solution (b) (0.5 per cent);
- disregard limit: 0.25 times the area of the principal peak in the chromatogram obtained with reference solution (b) (0.05 per cent).

**Loss on drying** (2.2.32): maximum 0.5 per cent, determined on 1.000 g by drying *in vacuo*.

**Sulfated ash** (2.4.14): maximum 0.2 per cent, determined on 1.0 g.

**ASSAY**

**Diphenhydramine.** Dissolve 0.200 g in 60 mL of *anhydrous acetic acid R*. Titrate with 0.1 M *perchloric acid*, determining the end-point potentiometrically (2.2.20).

1 mL of 0.1 M *perchloric acid* is equivalent to 25.54 mg of  $C_{17}H_{21}NO$ .

**8-Chlorotheophylline.** To 0.800 g add 50 mL of *water R*, 3 mL of *dilute ammonia R1* and 0.6 g of *ammonium nitrate R* and heat on a water-bath for 5 min. Add 25.0 mL of 0.1 M *silver nitrate* and continue heating on a water-bath for 15 min with frequent swirling. Cool, add 25 mL of *dilute nitric acid R* and dilute to 250.0 mL with *water R*. Filter and discard the first 25 mL of the filtrate. Using 5 mL of *ferric ammonium sulfate solution R2* as indicator, titrate 100.0 mL of the filtrate with 0.1 M *ammonium thiocyanate* until a yellowish-brown colour is obtained.

1 mL of 0.1 M *silver nitrate* is equivalent to 21.46 mg of  $C_7H_7ClN_4O_2$ .

**IMPURITIES**

**Specified impurities:** A, E, F.

**Other detectable impurities** (the following substances would, if present at a sufficient level, be detected by one or other of the tests in the monograph. They are limited by the general acceptance criterion for other/unspecified impurities and/or by the general monograph *Substances for pharmaceutical use (2034)*. It is therefore not necessary to identify these impurities for demonstration of compliance. See also 5.10. *Control of impurities in substances for pharmaceutical use*): C, D, G, H, I, J, K.

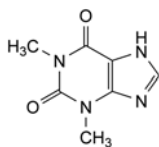

A. 1,3-dimethyl-3,7-dihydro-1H-purine-2,6-dione (theophylline),

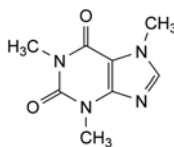

C. 1,3,7-trimethyl-3,7-dihydro-1H-purine-2,6-dione (caffeine),

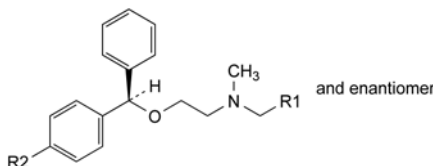

D. R1 =  $CH_2N(CH_3)_2$ , R2 = H: *N*-[2-(diphenylmethoxy)ethyl]-*N,N'*-trimethylethane-1,2-diamine,

G. R1 = H, R2 =  $CH_3$ : *N,N*-dimethyl-2-[(*RS*)-(4-methylphenyl)(phenyl)methoxy]ethanamine (4-methyl diphenhydramine),

H. R1 = H, R2 = Br: 2-[(*RS*)-(4-bromophenyl)(phenyl)methoxy]-*N,N*-dimethylethanamine (4-bromodiphenhydramine),

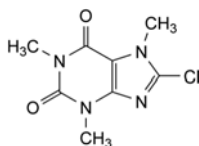

E. 8-chloro-1,3,7-trimethyl-3,7-dihydro-1H-purine-2,6-dione (8-chlorocaffeine),

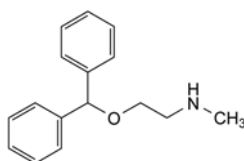

F. 2-(diphenylmethoxy)-*N*-methylethanamine (diphenhydramine impurity A),

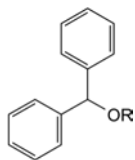

- I. R = H: diphenylmethanol (benzhydrol),  
 K. R = CH(C<sub>6</sub>H<sub>5</sub>)<sub>2</sub>: [oxybis(methanetriyl)]tetrabenzene,

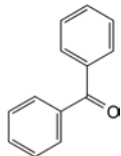

- J. diphenylmethanone (benzophenone).

01/2008:0389

## DIMERCAPROL

### Dimercaprolum

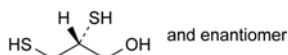

C<sub>3</sub>H<sub>8</sub>OS<sub>2</sub>  
 [59-52-9]

M<sub>r</sub> 124.2

#### DEFINITION

(2*RS*)-2,3-Disulfanylpropan-1-ol.

*Content*: 98.5 per cent to 101.5 per cent.

#### CHARACTERS

*Appearance*: clear, colourless or slightly yellow liquid.

*Solubility*: soluble in water and in arachis oil, miscible with ethanol (96 per cent) and with benzyl benzoate.

#### IDENTIFICATION

- A. Dissolve 0.05 mL in 2 mL of *water R*. Add 1 mL of 0.05 *M iodine*. The colour of the iodine is discharged immediately.
- B. Dissolve 0.1 mL in 5 mL of *water R* and add 2 mL of *copper sulfate solution R*. A bluish-black precipitate is formed which quickly becomes dark grey.
- C. In a ground-glass-stoppered tube, suspend 0.6 g of *sodium bismuthate R*, previously heated to 200 °C for 2 h, in a mixture of 2.8 mL of *dilute phosphoric acid R* and 6 mL of *water R*. Add 0.2 mL of the substance to be examined, mix and allow to stand for 10 min with frequent shaking. To 1 mL of the supernatant liquid add 5 mL of a 4 g/L solution of *chromotropic acid, sodium salt R* in *sulfuric acid R* and mix. Heat in a water-bath for 15 min. A violet-red colour develops.

#### TESTS

**Appearance.** It is clear (2.2.1) and not more intensely coloured than reference solution B<sub>6</sub> or BY<sub>6</sub> (2.2.2, *Method II*).

**Acidity or alkalinity.** Dissolve 0.2 g in *carbon dioxide-free water R* and dilute to 10 mL with the same solvent. Add 0.25 mL of *bromocresol green solution R* and 0.3 mL of 0.01 *M hydrochloric acid*. The solution is yellow. Not more than 0.5 mL of 0.01 *M sodium hydroxide* is required to change the colour of the indicator to blue.

**Refractive index** (2.2.6): 1.568 to 1.574.

**Halides.** To 2.0 g add 25 mL of *alcoholic potassium hydroxide solution R* and boil under a reflux condenser for 2 h. Eliminate the ethanol by evaporation in a stream of hot air. Add 20 mL of *water R* and cool. Add 40 mL of *water R* and 10 mL of *strong hydrogen peroxide solution R*, boil gently for 10 min, cool and filter rapidly. Add 10 mL of *dilute nitric acid R* and 5.0 mL of 0.1 *M silver nitrate*. Using 2 mL of *ferric ammonium sulfate solution R2* as indicator, titrate with 0.1 *M ammonium*

*thiocyanate* until a reddish-yellow colour is obtained. Carry out a blank titration. The difference between the titration volumes is not greater than 1.0 mL.

#### ASSAY

Dissolve 0.100 g in 40 mL of *methanol R*. Add 20 mL of 0.1 *M hydrochloric acid* and 50.0 mL of 0.05 *M iodine*. Allow to stand for 10 min and titrate with 0.1 *M sodium thiosulfate*. Carry out a blank titration.

1 mL of 0.05 *M iodine* is equivalent to 6.21 mg of C<sub>3</sub>H<sub>8</sub>OS<sub>2</sub>.

#### STORAGE

In a well-filled, airtight container, protected from light, at a temperature of 2 °C to 8 °C.

01/2008:0763

## DIMETHYL SULFOXIDE

### Dimethylis sulfoxidum

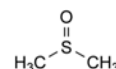

C<sub>2</sub>H<sub>6</sub>OS  
 [67-68-5]

M<sub>r</sub> 78.1

#### DEFINITION

Sulfinylbismethane.

#### CHARACTERS

*Appearance*: colourless liquid or colourless crystals, hygroscopic.

*Solubility*: miscible with water and with ethanol (96 per cent).

#### IDENTIFICATION

*First identification*: C.

*Second identification*: A, B, D.

- A. Relative density (see Tests).  
 B. Refractive index (see Tests).  
 C. Infrared absorption spectrophotometry (2.2.24).  
*Comparison*: *dimethyl sulfoxide CRS*.  
 D. Dissolve 50 mg of *nickel chloride R* in 5 mL of the substance to be examined. The solution is greenish-yellow. Heat in a water-bath at 50 °C. The colour changes to green or bluish-green. Cool. The colour changes to greenish-yellow.

#### TESTS

**Acidity.** Dissolve 50.0 g in 100 mL of *carbon dioxide-free water R*. Add 0.1 mL of *phenolphthalein solution R1*. Not more than 5.0 mL of 0.01 *M sodium hydroxide* is required to produce a pink colour.

**Relative density** (2.2.5): 1.100 to 1.104.

**Refractive index** (2.2.6): 1.478 to 1.479.

**Freezing point** (2.2.18): minimum 18.3 °C.

**Absorbance** (2.2.25). Purge with *nitrogen R* for 15 min. The absorbance, measured using *water R* as the compensation liquid, is not more than 0.30 at 275 nm and not more than 0.20 at both 285 nm and 295 nm. Examined between 270 nm and 350 nm, the substance to be examined shows no absorption maximum.

**Related substances.** Gas chromatography (2.2.28).

*Internal standard solution.* Dissolve 0.125 g of *bibenzyl R* in *acetone R* and dilute to 50 mL with the same solvent.

*Test solution (a).* Dissolve 5.0 g of the substance to be examined in *acetone R* and dilute to 10.0 mL with the same solvent.

*Test solution (b).* Dissolve 5.0 g of the substance to be examined in *acetone R*, add 1.0 mL of the internal standard solution and dilute to 10.0 mL with *acetone R*.

**Reference solution.** Dissolve 50.0 mg of the substance to be examined and 50 mg of *dimethyl sulfone R* in *acetone R*, add 10.0 mL of the internal standard solution and dilute to 100.0 mL with *acetone R*.

**Column:**

- **material:** glass;
- **size:**  $l = 1.5 \text{ m}$ ,  $\varnothing = 4 \text{ mm}$ ;
- **stationary phase:** *diatomaceous earth for gas chromatography R* (125-180  $\mu\text{m}$ ) impregnated with 10 per cent *m/m* of *polyethyleneglycol adipate R*.

**Carrier gas:** *nitrogen for chromatography R*.

**Flow rate:** 30 mL/min.

**Temperature:**

- **column:** 165 °C;
- **injection port and detector:** 190 °C.

**Detection:** flame ionisation.

**Injection:** 1  $\mu\text{L}$ .

**Run time:** 4 times the retention time of dimethyl sulfoxide.

**Elution order:** dimethyl sulfoxide, dimethyl sulfone, bibenzyl.

**Retention time:** dimethyl sulfoxide = about 5 min.

**System suitability:**

- **resolution:** minimum 3 between the peaks due to dimethyl sulfoxide and dimethyl sulfone in the chromatogram obtained with the reference solution;
- in the chromatogram obtained with test solution (a) there is no peak with the same retention time as the internal standard.

**Limit:**

- **total:** calculate the ratio *R* of the area of the peak due to dimethyl sulfoxide to the area of the peak due to the internal standard from the chromatogram obtained with the reference solution; from the chromatogram obtained with test solution (b), calculate the ratio of the sum of the areas of any peaks, apart from the principal peak and the peak due to the internal standard to the area of the peak due to the internal standard: this ratio is not greater than *R* (0.1 per cent).

**Water (2.5.12):** maximum 0.2 per cent, determined on 10.0 g.

**STORAGE**

In an airtight, glass container, protected from light.

01/2008:1667

## DIMETHYLACETAMIDE

### Dimethylacetamidum

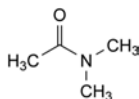

$\text{C}_4\text{H}_9\text{NO}$   
[127-19-5]

$M_r$  87.1

**DEFINITION**

*N,N*-Dimethylacetamide.

**CHARACTERS**

**Appearance:** clear, colourless, slightly hygroscopic liquid.

**Solubility:** miscible with water, with ethanol (96 per cent), and with most common organic solvents.

**bp:** about 165 °C.

**IDENTIFICATION**

**First identification:** C.

**Second identification:** A, B, D.

A. Relative density (2.2.5): 0.941 to 0.944.

B. Refractive index (2.2.6): 1.435 to 1.439.

C. Infrared absorption spectrophotometry (2.2.24).

**Preparation:** films.

**Comparison:** *Ph. Eur. reference spectrum of dimethylacetamide.*

D. Dilute 50 mg with 1 mL of *methanol R*. Add 1 mL of a 15 g/L solution of *hydroxylamine hydrochloride R* and mix. Add 1 mL of *dilute sodium hydroxide solution R*, mix and allow to stand for 30 min. Add 1 mL of *dilute hydrochloric acid R* and add 1 mL of a 100 g/L solution of *ferric chloride R* in 0.1 M *hydrochloric acid*. A reddish-brown colour develops, reaching a maximum intensity after about 5 min.

**TESTS**

**Appearance.** The substance to be examined is clear (2.2.1) and not more intensely coloured than reference solution  $Y_7$  (2.2.2, *Method II*).

**Acidity.** Dilute 50 mL with 50 mL of *water R* previously adjusted with 0.02 M *potassium hydroxide* or 0.02 M *hydrochloric acid* to a bluish-green colour, using 0.5 mL of *bromothymol blue solution R1* as indicator. Not more than 5.0 mL of 0.02 M *potassium hydroxide* is required to restore the initial (bluish-green) colour.

**Alkalinity.** To 50 mL add 50 mL of *water R* previously adjusted with 0.02 M *potassium hydroxide* or 0.02 M *hydrochloric acid* to a yellow colour, using 0.5 mL of *bromothymol blue solution R1* as indicator. Not more than 0.5 mL of 0.02 M *hydrochloric acid* is required to restore the initial (yellow) colour.

**Related substances.** Gas chromatography (2.2.28): use the normalisation procedure.

**Test solution.** The substance to be examined.

**Reference solution (a).** Dilute a mixture of 1 mL of the substance to be examined and 1 mL of *dimethylformamide R* to 20 mL with *methylene chloride R*.

**Reference solution (b).** Dilute 1 mL of the substance to be examined to 20.0 mL with *methylene chloride R*. Dilute 0.1 mL of the solution to 10.0 mL with *methylene chloride R*.

**Column:**

- **material:** fused silica,
  - **size:**  $l = 30 \text{ m}$ ,  $\varnothing = 0.32 \text{ mm}$ ,
  - **stationary phase:** *macrogol 20 000 R* (film thickness 1  $\mu\text{m}$ ).
- Carrier gas:** *nitrogen for chromatography R*.

**Linear velocity:** 30 cm/s.

**Split ratio:** 1:20.

**Temperature:**

	Time (min)	Temperature (°C)
Column	0 - 15	80 → 200
Injection port		250
Detector		250

**Detection:** flame ionisation.

**Injection:** 0.5  $\mu\text{L}$ .

**System suitability:**

- **resolution:** minimum 5.0 between the peaks due to dimethylacetamide and impurity B in the chromatogram obtained with reference solution (a),
- **signal-to-noise ratio:** minimum 10 for the principal peak in the chromatogram obtained with reference solution (b).

**Limits:**

- **any impurity:** maximum 0.1 per cent,
- **total:** maximum 0.3 per cent,
- **disregard limit:** the area of the peak in the chromatogram obtained with reference solution (b) (0.05 per cent).

**Heavy metals** (2.4.8): maximum 10 ppm.

Dilute 4.0 g to 20.0 mL with *water R*. 12 mL of the solution complies with limit test A. Prepare the reference solution using *lead standard solution (2 ppm Pb) R*.

**Non-volatile matter**: maximum 20 ppm.

Evaporate 50 g to dryness using a rotary evaporator at a pressure not exceeding 1 kPa and on a water-bath. Dry the residue in an oven at 170–175 °C. The residue weighs not more than 1 mg.

**Water** (2.5.32): maximum 0.1 per cent, determined on 0.100 g.

#### STORAGE

In an airtight container, protected from light.

#### IMPURITIES

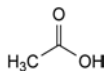

A. acetic acid,

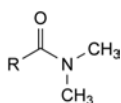

B. R = H: *N,N*-dimethylformamide,

C. R = C<sub>2</sub>H<sub>5</sub>: *N,N*-dimethylpropanamide,

D. R = CH<sub>2</sub>-CH<sub>2</sub>-CH<sub>3</sub>: *N,N*-dimethylbutanamide.

01/2008:0138  
corrected 6.2

## DIMETICONE

### Dimeticonum

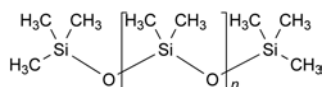

[9006-65-9]

#### DEFINITION

Poly(dimethylsiloxane) obtained by hydrolysis and polycondensation of dichlorodimethylsilane and chlorotrimethylsilane. Different grades of dimeticone exist which are distinguished by a number indicating the nominal kinematic viscosity placed after the name.

Their degree of polymerisation ( $n = 20$  to 400) is such that their kinematic viscosities are nominally between 20 mm<sup>2</sup>·s<sup>-1</sup> and 1300 mm<sup>2</sup>·s<sup>-1</sup>.

*Dimeticones with a nominal viscosity of 50 mm<sup>2</sup>·s<sup>-1</sup> or lower are intended for external use only.*

#### CHARACTERS

**Appearance**: clear, colourless liquid of various viscosities.

**Solubility**: practically insoluble in water, very slightly soluble or practically insoluble in anhydrous ethanol, miscible with ethyl acetate, with methyl ethyl ketone and with toluene.

#### IDENTIFICATION

A. It is identified by its kinematic viscosity at 25 °C (see Tests).

B. Infrared absorption spectrophotometry (2.2.24).

*Comparison: dimeticone CRS.*

The region of the spectrum from 850 cm<sup>-1</sup> to 750 cm<sup>-1</sup> is not taken into account.

C. Heat 0.5 g in a test-tube over a small flame until white fumes begin to appear. Invert the tube over a 2<sup>nd</sup> tube containing 1 mL of a 1 g/L solution of *chromotropic acid, sodium*

*salt R* in *sulfuric acid R* so that the fumes reach the solution. Shake the 2<sup>nd</sup> tube for about 10 s and heat on a water-bath for 5 min. The solution is violet.

D. In a platinum crucible, prepare the sulfated ash (2.4.14) using 50 mg. The residue is a white powder that gives the reaction of silicates (2.3.1).

#### TESTS

**Acidity**. To 2.0 g add 25 mL of a mixture of equal volumes of *anhydrous ethanol R* and *ether R*, previously neutralised to 0.2 mL of *bromothymol blue solution R1* and shake. Not more than 0.15 mL of 0.01 M *sodium hydroxide* is required to change the colour of the solution to blue.

**Viscosity** (2.2.9): 90 per cent to 110 per cent of the nominal kinematic viscosity stated on the label, determined at 25 °C.

**Mineral oils**. Place 2 g in a test-tube and examine in ultraviolet light at 365 nm. The fluorescence is not more intense than that of a solution containing 0.1 ppm of *quinine sulfate R* in 0.005 M *sulfuric acid* examined in the same conditions.

**Phenylated compounds**. Dissolve 5.0 g with shaking in 10 mL of *cyclohexane R*. At wavelengths from 250 nm to 270 nm, the absorbance (2.2.25) of the solution is not greater than 0.2.

**Heavy metals**: maximum 5 ppm.

Mix 1.0 g with *methylene chloride R* and dilute to 20 mL with the same solvent. Add 1.0 mL of a freshly prepared 0.02 g/L solution of *dithizone R* in *methylene chloride R*, 0.5 mL of *water R* and 0.5 mL of a mixture of 1 volume of *dilute ammonia R2* and 9 volumes of a 2 g/L solution of *hydroxylamine hydrochloride R*. At the same time, prepare a reference solution as follows: to 20 mL of *methylene chloride R* add 1.0 mL of a freshly prepared 0.02 g/L solution of *dithizone R* in *methylene chloride R*, 0.5 mL of *lead standard solution (10 ppm Pb) R* and 0.5 mL of a mixture of 1 volume of *dilute ammonia R2* and 9 volumes of a 2 g/L solution of *hydroxylamine hydrochloride R*. Immediately shake each solution vigorously for 1 min. Any red colour in the test solution is not more intense than that in the reference solution.

**Volatile matter**: maximum 0.3 per cent, for dimeticones with a nominal viscosity greater than 50 mm<sup>2</sup>·s<sup>-1</sup>, determined on 1.00 g by heating in an oven at 150 °C for 2 h. Carry out the test using a dish 60 mm in diameter and 10 mm deep.

#### LABELLING

The label states:

- the nominal kinematic viscosity by a number placed after the name of the product,
- where applicable, that the product is intended for external use.

01/2008:1417  
corrected 6.0

## DIMETINDENE MALEATE

### Dimetindeneni maleas

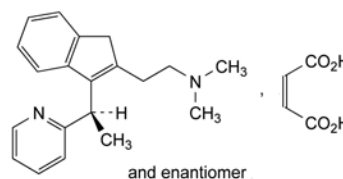

C<sub>24</sub>H<sub>28</sub>N<sub>2</sub>O<sub>4</sub>  
[3614-69-5]

M<sub>r</sub> 408.5

#### DEFINITION

*N,N*-Dimethyl-2-[3-[(*RS*)-1-(pyridin-2-yl)ethyl]-1*H*-inden-2-yl]ethanamine (*Z*)-butenedioate.

**Content**: 99.0 per cent to 101.0 per cent (dried substance).

## CHARACTERS

**Appearance:** white or almost white, crystalline powder.

**Solubility:** slightly soluble in water, soluble in methanol.

## IDENTIFICATION

Infrared absorption spectrophotometry (2.2.24).

**Preparation:** discs.

**Comparison:** dimetindene maleate CRS.

## TESTS

**Solution S.** Dissolve 0.20 g in methanol R and dilute to 20.0 mL with the same solvent.

**Appearance of solution.** Solution S is clear (2.2.1) and not more intensely coloured than Y<sub>6</sub> (2.2.2, Method II).

**Optical rotation** (2.2.7):  $-0.10^\circ$  to  $+0.10^\circ$ , determined on solution S.

**Related substances.** Gas chromatography (2.2.28).

**Solvent mixture:** acetone R, methylene chloride R (50:50 V/V).

**Test solution.** Dissolve 50.0 mg of the substance to be examined in the solvent mixture and dilute to 5.0 mL with the solvent mixture.

**Reference solution (a).** Dilute 1 mL of the test solution to 100.0 mL with the solvent mixture.

**Reference solution (b).** Dissolve 5.0 mg of 2-ethylpyridine R (impurity A) in the solvent mixture and dilute to 50.0 mL with the solvent mixture. Dilute 10.0 mL of this solution to 100.0 mL with the solvent mixture.

**Column:**

- **material:** fused silica;
- **size:**  $l = 30$  m,  $\varnothing = 0.32$  mm;
- **stationary phase:** polymethylphenylsiloxane R (film thickness 0.25  $\mu$ m).

**Carrier gas:** helium for chromatography R.

**Linear velocity:** about 30 cm/s.

**Temperature:**

	Time (min)	Temperature (°C)
Column	0 - 1	60
	1 - 34.3	60 → 260
	34.3 - 46.3	260
Injection port		240
Detector		260

**Detection:** flame ionisation.

**Injection:** 2  $\mu$ L; inject via a split injector with a split flow of 30 mL/min.

**Run time:** 1.3 times the retention time of dimetindene.

**Elution order:** impurity A and maleic acid appear during the first 8 min.

**System suitability:** reference solution (a):

- **symmetry factor:** maximum 1.3 for the principal peak.

**Limits:**

- **impurity A:** not more than the area of the corresponding peak in the chromatogram obtained with reference solution (b) (0.1 per cent);
- **impurities B, C, D, E, F, G, H, I:** for each impurity, not more than 0.2 times the area of the principal peak in the chromatogram obtained with reference solution (a) (0.2 per cent);
- **sum of impurities other than A:** not more than 0.5 times the area of the principal peak in the chromatogram obtained with reference solution (a) (0.5 per cent);

- **disregard limit:** 0.05 times the area of the principal peak in the chromatogram obtained with reference solution (a) (0.05 per cent); disregard the peak due to maleic acid.

**Loss on drying** (2.2.32): maximum 0.1 per cent, determined on 1.000 g by drying in an oven at 105 °C for 2 h.

**Sulfated ash** (2.4.14): maximum 0.1 per cent, determined on 1.0 g.

## ASSAY

Dissolve 0.150 g in 80 mL of anhydrous acetic acid R. Titrate with 0.1 M perchloric acid, determining the end-point potentiometrically (2.2.20).

1 mL of 0.1 M perchloric acid is equivalent to 20.43 mg of C<sub>24</sub>H<sub>28</sub>N<sub>2</sub>O<sub>4</sub>.

## STORAGE

Protected from light.

## IMPURITIES

**Specified impurities:** A, B, C, D, E, F, G, H, I.

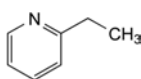

A. 2-ethylpyridine,

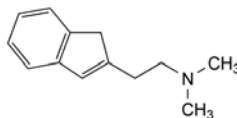

B. 2-(1H-inden-2-yl)-N,N-dimethylethanamine,

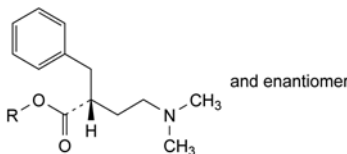

C. R = C<sub>2</sub>H<sub>5</sub>: ethyl (2RS)-2-benzyl-4-(dimethylamino)butanoate,

D. R = H: (2RS)-2-benzyl-4-(dimethylamino)butanoic acid,

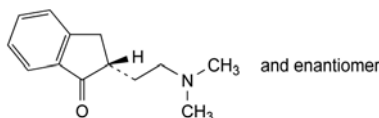

E. (2RS)-2-[2-(dimethylamino)ethyl]indan-1-one,

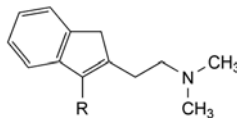

F. R = [CH<sub>2</sub>]<sub>3</sub>-CH<sub>3</sub>: 2-(3-butyl-1H-inden-2-yl)-N,N-dimethylethanamine,

G. R = C<sub>6</sub>H<sub>5</sub>: N,N-dimethyl-2-(3-phenyl-1H-inden-2-yl)ethanamine,

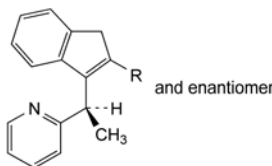

H. R = CH = CH<sub>2</sub>: 2-[(1RS)-1-(2-ethenyl-1H-inden-3-yl)ethyl]pyridine,

I. R = CH<sub>2</sub>-CH<sub>2</sub>-NH-CH<sub>3</sub>: N-methyl-2-[3-[(1RS)-1-(pyridin-2-yl)ethyl]-1H-inden-2-yl]ethanamine.

01/2008:1312 – *symmetry factor*: maximum 1.2 for the peaks due to impurities A and B.

## DINOPROST TROMETAMOL

### Dinoprostum trometamololum

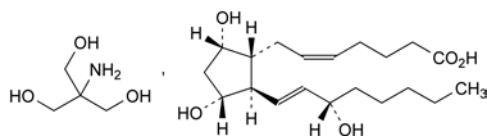

$C_{24}H_{45}NO_8$   
[38562-01-5]

$M_r$  475.6

#### DEFINITION

Trometamol (*Z*)-7-[(1*R*,2*R*,3*R*,5*S*)-3,5-dihydroxy-2-[(*E*)-(3*S*)-3-hydroxyoct-1-enyl]cyclopentyl]hept-5-enoate (PGF<sub>2α</sub>).

*Content*: 96.0 per cent to 102.0 per cent (anhydrous substance).

#### CHARACTERS

*Appearance*: white or almost white powder.

*Solubility*: very soluble in water, freely soluble in ethanol (96 per cent), practically insoluble in acetonitrile.

#### IDENTIFICATION

A. Specific optical rotation (2.2.7): + 19 to + 26 (anhydrous substance).

Dissolve 0.100 g in *ethanol* (96 per cent) *R* and dilute to 10.0 mL with the same solvent.

B. Infrared absorption spectrophotometry (2.2.24).

*Comparison*: *dinoprost trometamol CRS*.

#### TESTS

**Related substances.** Liquid chromatography (2.2.29).

*Solvent mixture*: *acetonitrile R*, *water R* (23:77 *V/V*).

*Test solution.* Dissolve 10.0 mg of the substance to be examined in the solvent mixture and dilute to 10.0 mL with the solvent mixture.

*Reference solution (a). Degradation of dinoprost trometamol to impurity B.* Dissolve 1 mg of the substance to be examined in 1 mL of the mobile phase and heat the solution on a water-bath at 85 °C for 5 min and cool.

*Reference solution (b).* Dilute 2.0 mL of the test solution to 20.0 mL with the solvent mixture. Dilute 2.0 mL of this solution to 20.0 mL with the solvent mixture.

*Column*:

- *size*:  $l = 0.15$  m,  $\varnothing = 3.9$  mm;
- *stationary phase*: octadecylsilyl silica gel for chromatography *R1* (5 μm) with a pore size of 10 nm and a carbon loading of 19 per cent.

*Mobile phase*: dissolve 2.44 g of *sodium dihydrogen phosphate R* in *water R* and dilute to 1000 mL with *water R*; adjust to pH 2.5 with *phosphoric acid R* (about 0.6 mL); mix 770 mL of this solution with 230 mL of *acetonitrile R1*.

*Flow rate*: 1 mL/min.

*Detection*: spectrophotometer at 200 nm.

*Injection*: 20 μL.

*Run time*: 2.5 times the retention time of the principal peak (to elute degradation products formed during heating) for reference solution (a) and 10 min after the elution of dinoprost for the test solution and reference solution (b).

*Retention time*: impurity B = about 55 min; impurity A = about 60 min; dinoprost = about 66 min.

*System suitability*: reference solution (a):

- *resolution*: minimum 1.5 between the peaks due to impurities B and A and minimum 2.0 between the peaks due to impurity A and dinoprost; if necessary, adjust the composition of the mobile phase by increasing the concentration of acetonitrile to decrease the retention times;

#### Limits:

- *impurity A*: not more than twice the area of the principal peak obtained with reference solution (b) (2 per cent);
  - *impurities B, C, D*: for each impurity, not more than 1.5 times the area of the principal peak obtained with reference solution (b) (1.5 per cent) and not more than one such peak has an area greater than 0.5 times the area of the principal peak obtained with reference solution (b) (0.5 per cent);
  - *sum of impurities other than A*: not more than twice the area of the principal peak obtained with reference solution (b) (2 per cent);
  - *disregard limit*: 0.05 times the area of the principal peak obtained with reference solution (b) (0.05 per cent); disregard any peak due to trometamol (retention time = about 1.5 min).
- Water** (2.5.12): maximum 1.0 per cent, determined on 0.500 g.

#### ASSAY

Liquid chromatography (2.2.29).

*Solvent mixture*: *acetonitrile R*, *water R* (23:77 *V/V*).

*Test solution.* Dissolve 10.0 mg of the substance to be examined in the solvent mixture and dilute to 10.0 mL with the solvent mixture.

*Reference solution.* Dissolve 10.0 mg of *dinoprost trometamol CRS* in the solvent mixture and dilute to 10.0 mL with the solvent mixture.

*Column*:

- *size*:  $l = 0.15$  m,  $\varnothing = 3.9$  mm;
- *stationary phase*: octadecylsilyl silica gel for chromatography *R1* (5 μm) with a pore size of 10 nm and a carbon loading of 19 per cent.

*Mobile phase*: dissolve 2.44 g of *sodium dihydrogen phosphate R* in *water R* and dilute to 1000 mL with *water R*; adjust to pH 2.5 with *phosphoric acid R* (about 0.6 mL); mix 730 mL of this solution with 270 mL of *acetonitrile R1*.

*Flow rate*: 1 mL/min.

*Detection*: spectrophotometer at 200 nm.

*Injection*: 20 μL.

*Retention time*: dinoprost = about 23 min.

*System suitability*: reference solution:

- *repeatability*: maximum relative standard deviation of 2.0 per cent for the peak due to dinoprost after 6 injections.

Calculate the percentage of dinoprost trometamol from the declared content of *dinoprost trometamol CRS*.

#### IMPURITIES

*Specified impurities*: A, B, C, D.

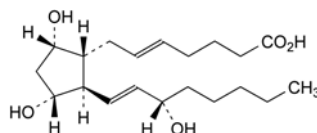

A. (*E*)-7-[(1*R*,2*R*,3*R*,5*S*)-3,5-dihydroxy-2-[(*E*)-(3*S*)-3-hydroxyoct-1-enyl]cyclopentyl]hept-5-enoic acid ((5*E*)-PGF<sub>2α</sub>; 5,6-*trans*-PGF<sub>2α</sub>),

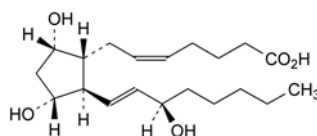

B. (*Z*)-7-[(1*R*,2*R*,3*R*,5*S*)-3,5-dihydroxy-2-[(*E*)-(3*R*)-3-hydroxyoct-1-enyl]cyclopentyl]hept-5-enoic acid ((15*R*)-PGF<sub>2α</sub>; 15-*epi*PGF<sub>2α</sub>),



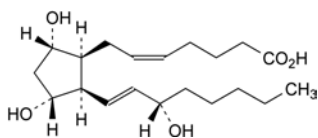

- C. (*Z*)-7-[(1*S*,2*R*,3*R*,5*S*)-3,5-dihydroxy-2-[(*E*)-(3*S*)-3-hydroxyoct-1-enyl]cyclopentyl]hept-5-enoic acid ((8*S*)-PGF<sub>2α</sub>; 8-epiPGF<sub>2α</sub>),

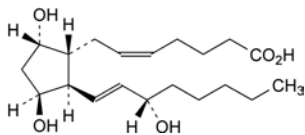

- D. (*Z*)-7-[(1*R*,2*R*,3*S*,5*S*)-3,5-dihydroxy-2-[(*E*)-(3*S*)-3-hydroxyoct-1-enyl]cyclopentyl]hept-5-enoic acid (11β-PGF<sub>2α</sub>; 11-epiPGF<sub>2α</sub>).

01/2008:1311

## DINOPROSTONE

### Dinoprostonum

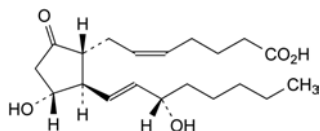

C<sub>20</sub>H<sub>32</sub>O<sub>5</sub>  
[363-24-6]

M<sub>r</sub> 352.5

#### DEFINITION

(*Z*)-7-[(1*R*,2*R*,3*R*)-3-hydroxy-2-[(*E*)-(3*S*)-3-hydroxyoct-1-enyl]-5-oxocyclopentyl]hept-5-enoic acid (PGE<sub>2</sub>).

*Content*: 95.0 per cent to 102.0 per cent (anhydrous substance).

#### CHARACTERS

*Appearance*: white or almost white, crystalline powder or colourless crystals.

*Solubility*: practically insoluble in water, very soluble in methanol, freely soluble in alcohol.

The substance degrades at room temperature.

#### IDENTIFICATION

- A. Specific optical rotation (2.2.7): –82 to –90 (anhydrous substance).

Immediately before use, dissolve 50.0 mg in *alcohol R* and dilute to 10.0 mL with the same solvent.

- B. Infrared absorption spectrophotometry (2.2.24).

*Comparison*: *dinoprostone CRS*.

#### TESTS

*Prepare the solutions immediately before use.*

**Related substances.** Liquid chromatography (2.2.29).

*Test solution (a)*. Dissolve 10.0 mg of the substance to be examined in a 58 per cent *V/V* solution of *methanol R2* and dilute to 2.0 mL with the same solvent.

*Test solution (b)*. Dissolve 20.0 mg of the substance to be examined in a 58 per cent *V/V* solution of *methanol R2* and dilute to 20.0 mL with the same solvent.

*Reference solution (a)*. Dissolve 1 mg of *dinoprostone CRS* and 1 mg of *dinoprostone impurity C CRS* in a 58 per cent *V/V* solution of *methanol R2* and dilute to 10.0 mL with the same solvent. Dilute 4.0 mL of the solution to 10.0 mL with a 58 per cent *V/V* solution of *methanol R2*.

*Reference solution (b)*. Dilute 0.5 mL of test solution (a) to 10.0 mL with a 58 per cent *V/V* solution of *methanol R2*. Dilute 1.0 mL of the solution to 10.0 mL with a 58 per cent *V/V* solution of *methanol R2*.

*Reference solution (c)*. In order to prepare *in situ* the degradation compounds (impurity D and impurity E), dissolve 1 mg of the substance to be examined in 100 μL of 1 *M sodium hydroxide* (the solution becomes brownish-red), wait 4 min, add 150 μL of 1 *M acetic acid* (yellowish-white opalescent solution) and dilute to 5.0 mL with a 58 per cent *V/V* solution of *methanol R2*.

*Reference solution (d)*. Dissolve 20 mg of *dinoprostone CRS* in a 58 per cent *V/V* solution of *methanol R2* and dilute to 20.0 mL with the same solvent.

#### Column:

- *size*: *l* = 0.25 m, Ø = 4.6 mm,
- *stationary phase*: *end-capped octadecylsilyl silica gel for chromatography R*,
- *temperature*: 30 °C.

*Mobile phase*: mix 42 volumes of a 0.2 per cent *V/V* solution of *acetic acid R* and 58 volumes of *methanol R2*.

*Flow rate*: 1.0 mL/min.

*Detection*: spectrophotometer at 210 nm.

*Injection*: 20 μL; inject test solution (a) and reference solutions (a), (b) and (c).

*Relative retention* with reference to dinoprostone (retention time = about 18 min): impurity C = about 1.2; impurity D = about 1.8; impurity E = about 2.0.

*System suitability*: reference solution (a):

- *resolution*: minimum of 3.8 between the peaks due to dinoprostone and to impurity C. If necessary adjust the concentration of the acetic acid solution and/or methanol (increase the concentration of the acetic acid solution to increase the retention time for dinoprostone and impurity C and increase the concentration of methanol to decrease the retention time for both compounds).

#### Limits:

- *correction factors*: for the calculation of contents, multiply the peak areas of the following impurities by the corresponding correction factor: impurity D = 0.2; impurity E = 0.7,
- *impurity C*: not more than 3 times the area of the principal peak in the chromatogram obtained with reference solution (b) (1.5 per cent),
- *impurity D*: not more than twice the area of the principal peak in the chromatogram obtained with reference solution (b) (1 per cent),
- *impurity E*: not more than the area of the principal peak in the chromatogram obtained with reference solution (b) (0.5 per cent),
- *any other impurity*: not more than the area of the principal peak in the chromatogram obtained with reference solution (b) (0.5 per cent),
- *total of other impurities*: not more than twice the area of the principal peak in the chromatogram obtained with reference solution (b) (1 per cent),
- *disregard limit*: 0.1 times the area of the principal peak in the chromatogram obtained with reference solution (b) (0.05 per cent).

If any peak with a relative retention to dinoprostone of about 0.8 is greater than 0.5 per cent or if the total of other impurities is greater than 1.0 per cent, record the chromatogram of test solution (a) with a detector set at 230 nm. If the area of the peak at 230 nm is twice the area of the peak at 210 nm, multiply the area at 210 nm by 0.2 (correction factor for impurity F).

**Water (2.5.12)**: maximum 0.5 per cent, determined on 0.50 g.

## ASSAY

01/2008:1611

Prepare the solutions immediately before use.

Liquid chromatography (2.2.29) as described in the test for related substances.

*Injection*: test solution (b) and reference solution (d).

Calculate the percentage content of  $C_{20}H_{32}O_5$ .

## STORAGE

At a temperature not exceeding - 15 °C.

## IMPURITIES

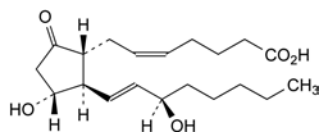

- A. (Z)-7-[(1R,2R,3R)-3-hydroxy-2-[(E)-(3R)-3-hydroxyoct-1-enyl]-5-oxocyclopentyl]hept-5-enoic acid (15-epiPGE<sub>2</sub>; (15R)-PGE<sub>2</sub>),

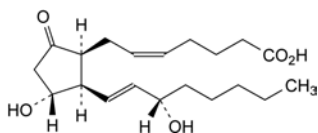

- B. (Z)-7-[(1S,2R,3R)-3-hydroxy-2-[(E)-(3S)-3-hydroxyoct-1-enyl]-5-oxocyclopentyl]hept-5-enoic acid (8-epiPGE<sub>2</sub>; (8S)-PGE<sub>2</sub>),

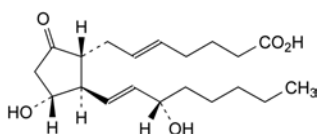

- C. (E)-7-[(1R,2R,3R)-3-hydroxy-2-[(E)-(3S)-3-hydroxyoct-1-enyl]-5-oxocyclopentyl]hept-5-enoic acid (5-*trans*-PGE<sub>2</sub>; (5*E*)-PGE<sub>2</sub>),

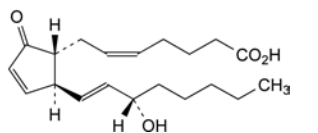

- D. (Z)-7-[(1R,2S)-2-[(E)-(3S)-3-hydroxyoct-1-enyl]-5-oxocyclopent-3-enyl]hept-5-enoic acid (PGA<sub>2</sub>),

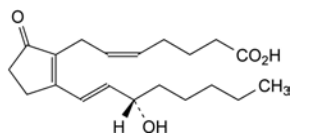

- E. (Z)-7-[2-[(E)-(3S)-3-hydroxyoct-1-enyl]-5-oxocyclopent-1-enyl]hept-5-enoic acid (PGB<sub>2</sub>),

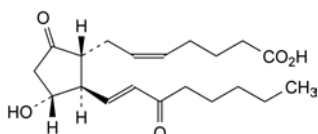

- F. (Z)-7-[(1R,2R,3R)-3-hydroxy-2-[(E)-3-oxo-oct-1-enyl]-5-oxocyclopentyl]hept-5-enoic acid (15-oxo-PGE<sub>2</sub>; 15-keto-PGE<sub>2</sub>),

## DIOSMIN

## Diosminum

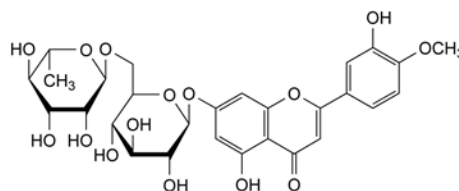

$C_{28}H_{32}O_{15}$   
[520-27-4]

$M_r$  609

## DEFINITION

7-[[6-*O*-(6-Deoxy- $\alpha$ -L-mannopyranosyl)- $\beta$ -D-glucopyranosyl]oxy]-5-hydroxy-2-(3-hydroxy-4-methoxyphenyl)-4*H*-1-benzopyran-4-one.

Substance obtained through iodine-assisted oxidation of (2*S*)-7-[[6-*O*-(6-deoxy- $\alpha$ -L-mannopyranosyl)- $\beta$ -D-glucopyranosyl]oxy]-5-hydroxy-2-(3-hydroxy-4-methoxyphenyl)-2,3-dihydro-4*H*-1-benzopyran-4-one (hesperidin) of natural origin.

*Content*: 90.0 per cent to 102.0 per cent (anhydrous substance).

## CHARACTERS

*Appearance*: greyish-yellow or light yellow hygroscopic powder.

*Solubility*: practically insoluble in water, soluble in dimethyl sulfoxide, practically insoluble in alcohol. It dissolves in dilute solutions of alkali hydroxides.

## IDENTIFICATION

- A. Infrared absorption spectrophotometry (2.2.24).

*Comparison*: *diosmin CRS*.

- B. Examine the chromatograms obtained in the assay.

*Results*: the principal peak in the chromatogram obtained with the test solution is similar in retention time and size to the principal peak in the chromatogram obtained with reference solution (a).

## TESTS

**Iodine**: maximum 0.1 per cent.

Determine the total content of iodine by potentiometry, using an iodide-selective electrode (2.2.36), after oxygen combustion (2.5.10).

*Test solution*. Wrap 0.100 g of the substance to be examined in a piece of filter paper and place it in a sample carrier. Introduce into the flask 50 mL of a 0.2 g/L solution of *hydrazine R*. Flush the flask with oxygen for 10 min. Ignite the filter paper. Stir the contents of the flask immediately after the end of the combustion to dissolve completely the combustion products. Continue stirring for 1 h.

*Reference solution*. Dilute 2.0 mL of a 16.6 g/L solution of *potassium iodide R* to 100.0 mL with *water R*. Dilute 10.0 mL of the solution to 100.0 mL with *water R*.

Introduce into a beaker 30 mL of a 200 g/L solution of *potassium nitrate R* in 0.1 *M nitric acid*. Immerse the electrodes and stir for 10 min. The potential of the solution ( $nT_1$ ) must remain stable. Add 1 mL of the test solution and measure the potential ( $nT_2$ ).

Introduce into a beaker 30 mL of a 200 g/L solution of *potassium nitrate R* in 0.1 *M nitric acid*. Immerse the electrodes and stir for 10 min. The potential of the solution must remain stable ( $nR_1$ ). Add 80  $\mu$ L of the reference solution and measure the potential ( $nR_2$ ).

The absolute value  $|nT_2 - nT_1|$  is not higher than the absolute value  $|nR_2 - nR_1|$ .

**Related substances.** Liquid chromatography (2.2.29).

**Test solution.** Dissolve 25.0 mg of the substance to be examined in *dimethyl sulfoxide R* and dilute to 25.0 mL with the same solvent.

**Reference solution (a).** Dissolve 25.0 mg of *diosmin CRS* in *dimethyl sulfoxide R* and dilute to 25.0 mL with the same solvent.

**Reference solution (b).** Dilute 5.0 mL of reference solution (a) to 100.0 mL with *dimethyl sulfoxide R*.

**Reference solution (c).** Dissolve 5.0 mg of *diosmin for system suitability CRS* in *dimethyl sulfoxide R* and dilute to 5.0 mL with the same solvent.

**Column:**

- *size*:  $l = 0.10$  m,  $\varnothing = 4.6$  mm,
- *stationary phase*: *octadecylsilyl silica gel for chromatography R* (3  $\mu$ m),
- *temperature*: 40 °C.

**Mobile phase:** *acetonitrile R*, *glacial acetic acid R*, *methanol R*, *water R* (2:6:28:66 V/V/V/V).

**Flow rate:** 1.5 mL/min.

**Detection:** spectrophotometer at 275 nm.

**Injection:** 10  $\mu$ L loop injector; inject the test solution and reference solutions (b) and (c).

**Run time:** 6 times the retention time of diosmin.

**Relative retention** with reference to diosmin (retention time = about 4.6 min): impurity A = about 0.5, impurity B = about 0.6, impurity C = about 0.8, impurity D = about 2.2, impurity E = about 2.6, impurity F = about 4.5.

**System suitability:** reference solution (c):

- *resolution*: minimum of 2.5 between the peaks due to impurities B and C.

**Limits:**

- *correction factors*: for the calculation of contents, multiply the peak areas of the following impurities by the corresponding correction factor: impurity A = 0.38; impurity F = 0.61,
- *impurity A*: not more than 0.2 times the area of the principal peak in the chromatogram obtained with reference solution (b) (1 per cent),
- *impurity B*: not more than the area of the principal peak in the chromatogram obtained with reference solution (b) (5 per cent),
- *impurity C*: not more than 0.6 times the area of the principal peak in the chromatogram obtained with reference solution (b) (3 per cent),
- *impurity E*: not more than 0.6 times the area of the principal peak in the chromatogram obtained with reference solution (b) (3 per cent),
- *impurity F*: not more than 0.6 times the area of the principal peak in the chromatogram obtained with reference solution (b) (3 per cent),
- *any other impurity*: not more than 0.2 times the area of the principal peak in the chromatogram obtained with reference solution (b) (1 per cent),
- *total of other impurities and impurity A*: not more than 0.2 times the area of the principal peak in the chromatogram obtained with reference solution (b) (1 per cent),
- *total*: not more than twice the area of the principal peak in the chromatogram obtained with reference solution (b) (10 per cent),
- *disregard limit*: 0.02 times the area of the principal peak in the chromatogram obtained with reference solution (b) (0.1 per cent).

**Heavy metals** (2.4.8): maximum 20 ppm.

2.0 g complies with limit test C. Prepare the standard using 4.0 mL of *lead standard solution (10 ppm Pb) R*.

**Water** (2.5.12): maximum 6.0 per cent, determined on 0.300 g.

**Sulfated ash** (2.4.14): maximum 0.2 per cent, determined on 1.0 g.

**ASSAY**

Liquid chromatography (2.2.29), as described in the test for related substances.

**Injection:** test solution and reference solution (a).

**STORAGE**

In an airtight container.

**IMPURITIES**

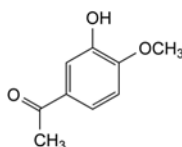

A. 1-(3-hydroxy-4-methoxyphenyl)ethanone (acetoisovanillone),

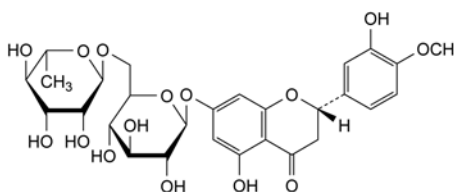

B. (2S)-7-[[6-O-(6-deoxy- $\alpha$ -L-mannopyranosyl)- $\beta$ -D-glucopyranosyl]oxy]-5-hydroxy-2-(3-hydroxy-4-methoxyphenyl)-2,3-dihydro-4H-1-benzopyran-4-one (hesperidin),

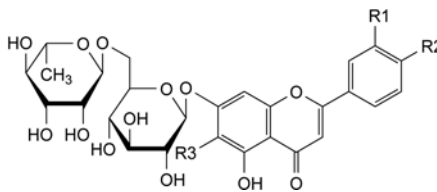

C. R1 = R3 = H, R2 = OH: 7-[[6-O-(6-deoxy- $\alpha$ -L-mannopyranosyl)- $\beta$ -D-glucopyranosyl]oxy]-5-hydroxy-2-(4-hydroxyphenyl)-4H-1-benzopyran-4-one (isorhoifolin),

D. R1 = OH, R2 = OCH<sub>3</sub>, R3 = I: 7-[[6-O-(6-deoxy- $\alpha$ -L-mannopyranosyl)- $\beta$ -D-glucopyranosyl]oxy]-5-hydroxy-2-(3-hydroxy-4-methoxyphenyl)-6-iodo-4H-1-benzopyran-4-one (6-iododiosmin),

E. R1 = R3 = H, R2 = OCH<sub>3</sub>: 7-[[6-O-(6-deoxy- $\alpha$ -L-mannopyranosyl)- $\beta$ -D-glucopyranosyl]oxy]-5-hydroxy-2-(4-methoxyphenyl)-4H-1-benzopyran-4-one (linarin),

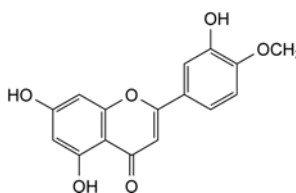

F. 5,7-dihydroxy-2-(3-hydroxy-4-methoxyphenyl)-4H-1-benzopyran-4-one (diosmetin).

01/2008:0023  
corrected 6.0

## DIPHENHYDRAMINE HYDROCHLORIDE

## Diphenhydramini hydrochloridum

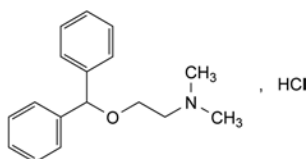
C<sub>17</sub>H<sub>22</sub>ClNO  
[147-24-0]M<sub>r</sub> 291.8

## DEFINITION

2-(Diphenylmethoxy)-*N,N*-dimethylethanamine hydrochloride.*Content*: 99.0 per cent to 101.0 per cent (dried substance).

## CHARACTERS

*Appearance*: white or almost white, crystalline powder.*Solubility*: very soluble in water, freely soluble in alcohol.

## IDENTIFICATION

*First identification*: C, D.*Second identification*: A, B, D.

A. Melting point (2.2.14): 168 °C to 172 °C.

B. Dissolve 50 mg in *alcohol R* and dilute to 100.0 mL with the same solvent. Examined between 230 nm and 350 nm, the solution shows 3 absorption maxima (2.2.25), at 253 nm, 258 nm and 264 nm. The ratio of the absorbance measured at the maximum at 258 nm to that measured at the maximum at 253 nm is 1.1 to 1.3. The ratio of the absorbance measured at the maximum at 258 nm to that measured at the maximum at 264 nm is 1.2 to 1.4.

C. Infrared absorption spectrophotometry (2.2.24).

*Preparation*: discs.*Comparison*: diphenhydramine hydrochloride CRS.

D. It gives the reactions of chlorides (2.3.1).

## TESTS

**Solution S.** Dissolve 1.0 g in *carbon dioxide-free water R* and dilute to 20 mL with the same solvent.**Appearance of solution.** Solution S and a fivefold dilution of solution S are clear (2.2.1). Solution S is not more intensely coloured than reference solution BY<sub>6</sub> (2.2.2, *Method II*).**Acidity or alkalinity.** To 10 mL of solution S add 0.15 mL of *methyl red solution R* and 0.25 mL of 0.01 M hydrochloric acid. The solution is pink. Not more than 0.5 mL of 0.01 M sodium hydroxide is required to change the colour of the indicator to yellow.**Related substances.** Liquid chromatography (2.2.29).**Test solution.** Dissolve 70 mg of the substance to be examined in the mobile phase and dilute to 20.0 mL with the mobile phase. Dilute 2.0 mL of the solution to 10.0 mL with the mobile phase.**Reference solution (a).** Dilute 1.0 mL of the test solution to 10.0 mL with the mobile phase. Dilute 1.0 mL of this solution to 20.0 mL with the mobile phase.**Reference solution (b).** Dissolve 5 mg of *diphenhydramine impurity A CRS* and 5 mg of *diphenylmethanol R* in the mobile phase and dilute to 10.0 mL with the mobile phase. To 2.0 mL of this solution add 1.5 mL of the test solution and dilute to 10.0 mL with the mobile phase.**Column**:– *size*: *l* = 0.25 m, Ø = 4.6 mm,– *stationary phase*: base-deactivated octylsilyl silica gel for chromatography R (5 µm).**Mobile phase**: mix 35 volumes of *acetonitrile R* and 65 volumes of a 5.4 g/L solution of *potassium dihydrogen phosphate R* adjusted to pH 3.0 using *phosphoric acid R*.**Flow rate**: 1.2 mL/min.**Detection**: spectrophotometer at 220 nm.**Injection**: 10 µL.**Run time**: 7 times the retention time of diphenhydramine.**Relative retention** with reference to diphenhydramine (retention time = about 6 min): impurity A = about 0.9; impurity B = about 1.5; impurity C = about 1.8; impurity D = about 2.6; impurity E = about 5.1.**System suitability**: reference solution (b):– **resolution**: minimum 2.0 between the peaks due to diphenhydramine and to impurity A.**Limits**:– **correction factor**: for the calculation of content, multiply the peak area of impurity D by 0.7,– **impurity A**: not more than the area of the principal peak in the chromatogram obtained with reference solution (a) (0.5 per cent),– **any other impurity**: not more than 0.6 times the area of the principal peak in the chromatogram obtained with reference solution (a) (0.3 per cent),– **total**: not more than twice the area of the principal peak in the chromatogram obtained with reference solution (a) (1.0 per cent),– **disregard limit**: 0.1 times the area of the principal peak in the chromatogram obtained with reference solution (a) (0.05 per cent).**Loss on drying** (2.2.32): maximum 0.5 per cent, determined on 1.000 g by drying in an oven at 105 °C.**Sulfated ash** (2.4.14): maximum 0.1 per cent, determined on 1.0 g.

## ASSAY

Dissolve 0.250 g in 50 mL of *alcohol R* and add 5.0 mL of 0.01 M hydrochloric acid. Carry out a potentiometric titration (2.2.20), using 0.1 M sodium hydroxide. Read the volume added between the 2 points of inflexion.1 mL of 0.1 M sodium hydroxide is equivalent to 29.18 mg of C<sub>17</sub>H<sub>22</sub>ClNO.

## STORAGE

Protected from light.

## IMPURITIES

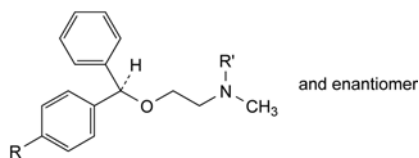
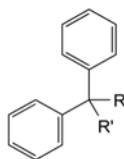
**Specified impurities**: A, B, C, D, E.A. R = R' = H: 2-(diphenylmethoxy)-*N*-methylethanamine,B. R = R' = CH<sub>3</sub>: 2-[(*RS*)-(4-methylphenyl)phenylmethoxy]-*N,N*-dimethylethanamine,C. R = Br, R' = CH<sub>3</sub>: 2-[(*RS*)-(4-bromophenyl)phenylmethoxy]-*N,N*-dimethylethanamine,

D. R = OH, R' = H: diphenylmethanol (benzhydrol),

E. R + R' = O: diphenylmethanone (benzophenone).

01/2008:0819  
corrected 6.0

## DIPHENOXYLATE HYDROCHLORIDE

## Diphenoxylati hydrochloridum

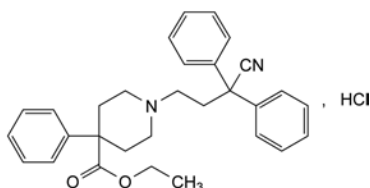
C<sub>30</sub>H<sub>33</sub>ClN<sub>2</sub>O<sub>2</sub>  
[3810-80-8]M<sub>r</sub> 489.1

## DEFINITION

Diphenoxylate hydrochloride contains not less than 98.0 per cent and not more than the equivalent of 102.0 per cent of ethyl 1-(3-cyano-3,3-diphenylpropyl)-4-phenylpiperidine-4-carboxylate hydrochloride, calculated with reference to the dried substance.

## CHARACTERS

A white or almost white, crystalline powder, very slightly soluble in water, freely soluble in methylene chloride, sparingly soluble in alcohol.

It melts at about 220 °C, with decomposition.

## IDENTIFICATION

- A. Examine by infrared absorption spectrophotometry (2.2.24), comparing with the *Ph. Eur. reference spectrum of diphenoxylate hydrochloride*.
- B. Dissolve about 30 mg in 5 mL of *methanol R*. Add 0.25 mL of *nitric acid R* and 0.4 mL of *silver nitrate solution R1*. Shake and allow to stand. A curdled precipitate is formed. Centrifuge and rinse the precipitate with three quantities, each of 2 mL, of *methanol R*. Carry out this operation rapidly and protected from bright light. Suspend the precipitate in 2 mL of *water R* and add 1.5 mL of *ammonia R*. The precipitate dissolves easily.

## TESTS

**Appearance of solution.** Dissolve 1.0 g in *methylene chloride R* and dilute to 10 mL with the same solvent. The solution is clear (2.2.1) and not more intensely coloured than reference solution Y<sub>6</sub> (2.2.2, *Method II*).

**Related substances.** Examine by thin-layer chromatography (2.2.27), using a plate coated with a suitable octadecylsilyl silica gel (5 µm) with a fluorescent indicator having an optimal intensity at 254 nm.

**Test solution.** Dissolve 1.0 g in a mixture of 1 volume of *methanol R* and 2 volumes of *methylene chloride R* and dilute to 20 mL with the same mixture of solvents.

**Reference solution (a).** Dilute 0.5 mL of the test solution to 100 mL with a mixture of 1 volume of *methanol R* and 2 volumes of *methylene chloride R*.

**Reference solution (b).** Dissolve 0.50 g of the substance to be examined in 25 mL of a 15 g/L solution of *potassium hydroxide R* in *methanol R* and add 1 mL of *water R*. Heat on a water-bath under a reflux condenser for 4 h. Cool and add 25 mL of 0.5 M *hydrochloric acid*. Shake with 100 mL of *methylene chloride R*. Evaporate the lower layer to dryness on a water-bath. Dissolve the residue in 10 mL of a mixture of 1 volume of *methanol R* and 2 volumes of *methylene chloride R*, add 10 mL of the test solution and dilute to 25 mL with a mixture of 1 volume of *methanol R* and 2 volumes of *methylene chloride R*.

Apply separately to a plate (100 mm square) 1 µL of each solution. Develop in an unsaturated tank over a path of 7 cm using a mixture of 10 volumes of *methanol R*, 30 volumes

of a 59 g/L solution of *sodium chloride R* and 60 volumes of *dioxan R*. Allow the plate to dry in an oven at 160 °C for 15 min and place the hot plate in a closed tank containing about 20 mL of *fuming nitric acid R* for 30 min. Remove the plate and heat it again at 160 °C for 15 min. Allow to cool and examine immediately in ultraviolet light at 254 nm. Any spot in the chromatogram obtained with the test solution, apart from the principal spot, is not more intense than the spot in the chromatogram obtained with reference solution (a) (0.5 per cent). The test is not valid unless the chromatogram obtained with reference solution (b) shows two clearly separated principal spots.

**Loss on drying** (2.2.32). Not more than 0.5 per cent, determined on 1.000 g by drying in an oven at 105 °C.

**Sulfated ash** (2.4.14). Not more than 0.1 per cent, determined on 1.0 g.

## ASSAY

Dissolve 0.400 g in 40 mL of *alcohol R* and add 5.0 mL of 0.01 M *hydrochloric acid*. Carry out a potentiometric titration (2.2.20), using 0.1 M *ethanolic sodium hydroxide*. Read the volume added between the two points of inflexion.

1 mL of 0.1 M *ethanolic sodium hydroxide* is equivalent to 48.91 mg of C<sub>30</sub>H<sub>33</sub>ClN<sub>2</sub>O<sub>2</sub>.

## STORAGE

Store protected from light.

01/2008:1719  
corrected 7.0

## DIPIVEFRINE HYDROCHLORIDE

## Dipivefrini hydrochloridum

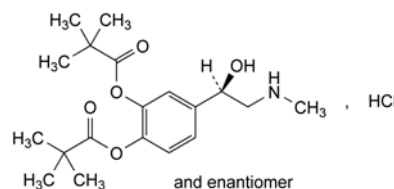
C<sub>19</sub>H<sub>30</sub>ClNO<sub>5</sub>  
[64019-93-8]M<sub>r</sub> 387.9

## DEFINITION

Hydrochloride of 4-[(1*S*)-1-hydroxy-2-(methylamino)ethyl]-1,2-phenylene bis(2,2-dimethylpropanoate).

*Content*: 97.5 per cent to 102.0 per cent (dried substance).

## CHARACTERS

*Appearance*: white or almost white, crystalline powder.

*Solubility*: freely soluble in water, very soluble in methanol, freely soluble in ethanol (96 per cent) and in methylene chloride.

mp: about 160 °C.

## IDENTIFICATION

- A. Infrared absorption spectrophotometry (2.2.24).

*Preparation*: discs.

*Comparison*: *dipivefrine hydrochloride CRS*.

- B. It gives reaction (a) of chlorides (2.3.1).

## TESTS

**Impurities A and B.** Liquid chromatography (2.2.29).

**Test solution.** Dissolve 0.100 g of the substance to be examined in 0.01 M *hydrochloric acid* and dilute to 10.0 mL with the same acid.

**Reference solution.** Dissolve 10.0 mg of *adrenaline R* and 10.0 mg of *adrenalone hydrochloride R* in 0.01 M hydrochloric acid and dilute to 100.0 mL with the same acid. Dilute 1.0 mL of this solution to 10.0 mL with 0.01 M hydrochloric acid.

Protect this solution from light.

**Column:**

- size:  $l = 0.15$  m,  $\varnothing = 4.6$  mm;
- stationary phase: end-capped polar-embedded octadecylsilyl amorphous organosilica polymer R (5  $\mu$ m).

**Mobile phase:**

- mobile phase A: 0.1 per cent V/V solution of anhydrous formic acid R;
- mobile phase B: methanol R2, acetonitrile R (40:60 V/V);

Time (min)	Mobile phase A (per cent V/V)	Mobile phase B (per cent V/V)
0 - 3	100	0
3 - 5	100 → 40	0 → 60
5 - 10	40	60

**Flow rate:** 1 mL/min.

**Detection:** spectrophotometer at 260 nm.

**Injection:** 10  $\mu$ L.

**Retention times:** impurity A = about 2.2 min; impurity B = about 3.2 min.

**System suitability:** reference solution:

- resolution: minimum 2.0 between the peaks due to impurity A and impurity B.

**Limits:**

- impurities A, B: for each impurity, not more than the area of the corresponding peak in the chromatogram obtained with the reference solution (0.1 per cent).

**Related substances.** Liquid chromatography (2.2.29).

**Solvent mixture.** Mix 40 volumes of methanol R2 and 60 volumes of acetonitrile R. Mix 55 volumes of this mixture and 45 volumes of 0.01 M hydrochloric acid.

**Test solution.** Dissolve 50.0 mg of the substance to be examined in the solvent mixture and dilute to 5.0 mL with the solvent mixture.

**Reference solution (a).** Dilute 1.0 mL of the test solution to 100.0 mL with the solvent mixture.

**Reference solution (b).** Dissolve 5 mg of dipivefrine for system suitability CRS (containing impurities C, D and E) in the solvent mixture and dilute to 2.0 mL with the solvent mixture.

**Reference solution (c).** Dissolve 5.0 mg of dipivefrine hydrochloride CRS in the solvent mixture and dilute to 2.0 mL with the solvent mixture. Dilute 1.0 mL of this solution to 25.0 mL with the solvent mixture.

**Column:**

- size:  $l = 0.15$  m,  $\varnothing = 4.6$  mm;
- stationary phase: end-capped polar-embedded octadecylsilyl amorphous organosilica polymer R (5  $\mu$ m).

**Mobile phase:** mix 45 volumes of a 2.7 g/L solution of concentrated ammonia R adjusted to pH 10.0 with dilute acetic acid R and 55 volumes of a mixture of 40 volumes of methanol R2 and 60 volumes of acetonitrile R.

**Flow rate:** 1 mL/min.

**Detection:** spectrophotometer at 260 nm.

**Injection:** 10  $\mu$ L.

**Run time:** 2.5 times the retention time of dipivefrine.

**Relative retention** with reference to dipivefrine (retention time = about 7 min): impurities C and D = about 0.4; impurity E = about 1.3; impurity F = about 2.0.

**System suitability:** reference solution (b):

- resolution: minimum 3.0 between the peaks due to dipivefrine and impurity E.

**Limits:**

- correction factors: for the calculation of content, multiply the peak areas of the following impurities by the corresponding correction factor: impurities C and D = 0.5; impurity E = 0.06;
- sum of impurities C and D: not more than 0.3 times the area of the principal peak in the chromatogram obtained with reference solution (a) (0.3 per cent);
- impurities E, F: for each impurity, not more than 0.1 times the area of the principal peak in the chromatogram obtained with reference solution (a) (0.1 per cent);
- unspecified impurities: for each impurity, not more than 0.1 times the area of the principal peak in the chromatogram obtained with reference solution (a) (0.10 per cent);
- total: not more than 0.5 times the area of the principal peak in the chromatogram obtained with reference solution (a) (0.5 per cent);
- disregard limit: 0.05 times the area of the principal peak in the chromatogram obtained with reference solution (a) (0.05 per cent); disregard any peak with a mass distribution ratio less than 0.5.

**Loss on drying** (2.2.32): maximum 1.0 per cent, determined on 1.000 g by drying *in vacuo* at 60 °C for 6 h.

**Sulfated ash** (2.4.14): maximum 0.1 per cent, determined on 1.0 g.

#### ASSAY

Liquid chromatography (2.2.29) as described in the test for related substances with the following modification.

**Injection:** 20  $\mu$ L of reference solutions (a) and (c).

**System suitability:** reference solution (c):

- symmetry factor: maximum 2.0 for the peak due to dipivefrine.

Calculate the percentage content of C<sub>19</sub>H<sub>30</sub>ClNO<sub>5</sub> using the chromatograms obtained with reference solutions (a) and (c) and the declared content of dipivefrine hydrochloride CRS.

#### IMPURITIES

**Specified impurities:** A, B, C, D, E, F.

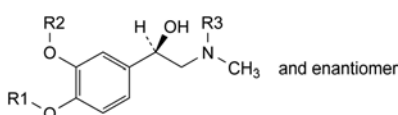

- A. R1 = R2 = R3 = H: 4-[(1*R,S*)-1-hydroxy-2-(methylamino)ethyl]benzene-1,2-diol ((±)-adrenaline),
- C. R1 = R3 = H, R2 = CO-C(CH<sub>3</sub>)<sub>3</sub>: 2-hydroxy-5-[(1*R,S*)-1-hydroxy-2-(methylamino)ethyl]phenyl 2,2-dimethylpropanoate,
- D. R1 = CO-C(CH<sub>3</sub>)<sub>3</sub>, R2 = R3 = H: 2-hydroxy-4-[(1*R,S*)-1-hydroxy-2-(methylamino)ethyl]phenyl 2,2-dimethylpropanoate,
- F. R1 = R2 = CO-C(CH<sub>3</sub>)<sub>3</sub>, R3 = C<sub>2</sub>H<sub>5</sub>: 4-[(1*R,S*)-2-(ethylmethylamino)-1-hydroxyethyl]-1,2-phenylene bis(2,2-dimethylpropanoate),

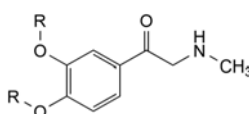

- B. R = H: 1-(3,4-dihydroxyphenyl)-2-(methylamino)ethanone (adrenalone),
- E. R = CO-C(CH<sub>3</sub>)<sub>3</sub>: 4-[(methylamino)acetyl]-1,2-phenylene bis(2,2-dimethylpropanoate) (adrenalone dipivalate ester).

01/2008:0898

## DIPOTASSIUM CLORAZEPATE

## Dikalii clorazepas

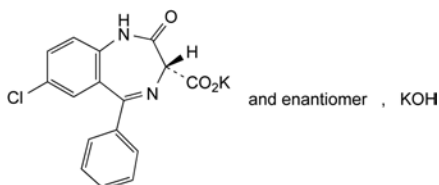

$C_{16}H_{11}ClK_2N_2O_4$   
[57109-90-7]

$M_r$  408.9

## DEFINITION

Potassium (3*RS*)-7-chloro-2-oxo-5-phenyl-2,3-dihydro-1*H*-1,4-benzodiazepine-3-carboxylate compound with potassium hydroxide (1:1).

*Content*: 99.0 per cent to 101.0 per cent (dried substance).

## CHARACTERS

*Appearance*: white or light yellow, crystalline powder.

*Solubility*: freely soluble to very soluble in water, very slightly soluble in alcohol, practically insoluble in methylene chloride.

Solutions in water and in alcohol are unstable and are to be used immediately.

## IDENTIFICATION

*First identification*: B, E.

*Second identification*: A, C, D, E.

- A. Dissolve 10.0 mg in a 0.3 g/L solution of *potassium carbonate R* and dilute to 100.0 mL with the same solution (solution A). Dilute 10.0 mL of solution A to 100.0 mL with a 0.3 g/L solution of *potassium carbonate R* (solution B). Examined between 280 nm and 350 nm (2.2.25), solution A shows a broad absorption maximum at about 315 nm. The specific absorbance at the absorption maximum at 315 nm is 49 to 56. Examined between 220 nm and 280 nm (2.2.25), solution B shows an absorption maximum at 230 nm. The specific absorbance at the absorption maximum at 230 nm is 800 to 870.

- B. Infrared absorption spectrophotometry (2.2.24).

*Preparation*: discs.

*Comparison*: *Ph. Eur. reference spectrum of dipotassium clorazepate*.

- C. Dissolve about 20 mg in 2 mL of *sulfuric acid R*. Observed in ultraviolet light at 365 nm, the solution shows yellow fluorescence.
- D. Dissolve 0.5 g in 5 mL of *water R*. Add 0.1 mL of *thymol blue solution R*. The solution is violet-blue.
- E. Place 1.0 g in a crucible and add 2 mL of *dilute sulfuric acid R*. Heat at first on a water-bath, then ignite until all black particles have disappeared. Allow to cool. Take up the residue with *water R* and dilute to 20 mL with the same solvent. The solution gives reaction (b) of potassium (2.3.1).

## TESTS

**Appearance of solution.** The solution is clear (2.2.1) and not more intensely coloured than reference solution GY<sub>5</sub> (2.2.2, *Method II*).

Rapidly dissolve 2.0 g with shaking in *water R* and dilute to 20.0 mL with the same solvent. Observe immediately.

**Related substances.** Thin-layer chromatography (2.2.27).

*Prepare the solutions immediately before use and carry out the test protected from light.*

*Test solution.* Dissolve 0.20 g of the substance to be examined in *water R* and dilute to 5.0 mL with the same solvent. Shake

immediately with 2 quantities, each of 5.0 mL, of *methylene chloride R*. Combine the organic layers and dilute to 10.0 mL with *methylene chloride R*.

*Reference solution (a).* Dissolve 10 mg of *aminochlorobenzophenone R* in *methylene chloride R* and dilute to 100.0 mL with the same solvent. Dilute 5.0 mL of the solution to 25.0 mL with *methylene chloride R*.

*Reference solution (b).* Dissolve 5 mg of *nordazepam CRS* in *methylene chloride R* and dilute to 25.0 mL with the same solvent. Dilute 5.0 mL of the solution to 25.0 mL with *methylene chloride R*.

*Reference solution (c).* Dilute 10.0 mL of reference solution (b) to 20.0 mL with *methylene chloride R*.

*Reference solution (d).* Dissolve 5 mg of *nordazepam CRS* and 5 mg of *nitrazepam CRS* in *methylene chloride R* and dilute to 25 mL with the same solvent.

*Plate*: TLC silica gel F<sub>254</sub> plate R.

*Mobile phase*: *acetone R*, *methylene chloride R* (15:85 V/V).

*Application*: 5 µL.

*Development*: over 2/3 of the plate.

*Drying*: in air.

*Detection A*: examine in ultraviolet light at 254 nm.

*System suitability*: the chromatogram obtained with reference solution (d) shows 2 clearly separated spots.

*Limits A*:

- *impurity B*: any spot due to impurity B is not more intense than the spot in the chromatogram obtained with reference solution (b) (0.2 per cent),
- *any other impurity*: any spot, apart from any spot due to impurity B, is not more intense than the spot in the chromatogram obtained with reference solution (c) (0.1 per cent).

*Detection B*: spray with a freshly prepared 10 g/L solution of *sodium nitrite R* in *dilute hydrochloric acid R*. Dry in a current of warm air and spray with a 4 g/L solution of *naphthylethylenediamine dihydrochloride R* in *alcohol R*.

*Limits B*:

- *impurity A*: any spot due to impurity A is not more intense than the spot in the chromatogram obtained with reference solution (a) (0.1 per cent).

**Loss on drying** (2.2.32): maximum 0.5 per cent, determined on 1.000 g by drying *in vacuo* at 60 °C for 4 h.

## ASSAY

Dissolve 0.130 g in 10 mL of *anhydrous acetic acid R*. Add 30 mL of *methylene chloride R*. Titrate with 0.1 M *perchloric acid*, determining the 2 points of inflexion by potentiometry (2.2.20).

At the 2<sup>nd</sup> point of inflexion, 1 mL of 0.1 M *perchloric acid* is equivalent to 13.63 mg of  $C_{16}H_{11}ClK_2N_2O_4$ .

## STORAGE

In an airtight container, protected from light.

## IMPURITIES

*Specified impurities*: A, B.

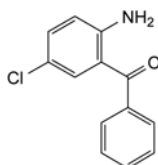

- A. (2-amino-5-chlorophenyl)phenylmethanone (aminochlorobenzophenone),

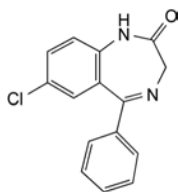

- B. 7-chloro-5-phenyl-1,3-dihydro-2H-1,4-benzodiazepin-2-one (nordazepam).

01/2008:1003  
corrected 7.0

## DIPOTASSIUM PHOSPHATE

### Dikalii fosphas

$K_2HPO_4$   
[7758-11-4]

$M_r$  174.2

#### DEFINITION

*Content*: 98.0 per cent to 101.0 per cent (dried substance).

#### CHARACTERS

*Appearance*: white or almost white powder or colourless crystals, very hygroscopic.

*Solubility*: very soluble in water, very slightly soluble in ethanol (96 per cent).

#### IDENTIFICATION

- A. Solution S (see Tests) is slightly alkaline (2.2.4).  
B. Solution S gives reaction (b) of phosphates (2.3.1).  
C. Solution S gives reaction (a) of potassium (2.3.1).

#### TESTS

**Solution S.** Dissolve 5.0 g in *distilled water R* and dilute to 50 mL with the same solvent.

**Appearance of solution.** Solution S is clear (2.2.1) and colourless (2.2.2, *Method II*).

**Reducing substances.** To 5 mL of solution S add 5 mL of *dilute sulfuric acid R* and 0.25 mL of 0.02 M *potassium permanganate* and heat on a water-bath for 5 min. The solution remains faintly pink.

**Monopotassium phosphate:** maximum 2.5 per cent.

From the volume of 1 M *hydrochloric acid* (10.0 mL) and of 1 M *sodium hydroxide* ( $n_1$  mL and  $n_2$  mL) used in the assay, calculate the following ratio:

$$\frac{n_2 - 10}{10 - n_1}$$

This ratio is not greater than 0.025.

**Chlorides** (2.4.4): maximum 200 ppm.

To 2.5 mL of solution S add 10 mL of *dilute nitric acid R* and dilute to 15 mL with *water R*.

**Sulfates** (2.4.13): maximum 0.1 per cent.

To 1.5 mL of solution S add 2 mL of *dilute hydrochloric acid R* and dilute to 15 mL with *distilled water R*.

**Arsenic** (2.4.2, *Method A*): maximum 2 ppm, determined on 5 mL of solution S.

**Iron** (2.4.9): maximum 10 ppm, determined on solution S.

**Heavy metals** (2.4.8): maximum 10 ppm.

Dissolve 2.0 g in 8 mL of *water R*. Acidify with about 6 mL of *dilute hydrochloric acid R* (pH 3-4) and dilute to 20 mL with

*water R*. 12 mL of this solution complies with test A. Prepare the reference solution using *lead standard solution (1 ppm Pb) R*.

**Sodium:** maximum 0.1 per cent, if intended for use in the manufacture of parenteral preparations.

Atomic emission spectrometry (2.2.22, *Method I*).

*Test solution.* Dissolve 1.00 g in *water R* and dilute to 100.0 mL with the same solvent.

*Reference solutions.* Prepare the reference solutions using *sodium standard solution (200 ppm Na) R*, diluted as necessary with *water R*.

*Wavelength:* 589 nm.

**Loss on drying** (2.2.32): maximum 2.0 per cent, determined on 1.000 g by drying in an oven at 125-130 °C.

**Bacterial endotoxins** (2.6.14): less than 1.1 IU/mg, if intended for use in the manufacture of parenteral preparations without a further appropriate procedure for the removal of bacterial endotoxins.

#### ASSAY

Dissolve 0.800 g ( $m$ ) in 40 mL of *carbon dioxide-free water R* and add 10.0 mL of 1 M *hydrochloric acid*. Carry out a potentiometric titration (2.2.20) using 1 M *sodium hydroxide*. Read the volume added at the 1<sup>st</sup> inflexion point ( $n_1$  mL). Continue the titration to the 2<sup>nd</sup> inflexion point (total volume of 1 M *sodium hydroxide* required,  $n_2$  mL).

Calculate the percentage content of  $K_2HPO_4$  from the following expression:

$$\frac{1742(10 - n_1)}{m(100 - d)}$$

$d$  = percentage loss on drying.

#### STORAGE

In an airtight container.

#### LABELLING

The label states, where applicable, that the substance is suitable for use in the manufacture of parenteral preparations.

01/2008:0486  
corrected 6.0

## DIPROPHYLLINE

### Diprophyllinum

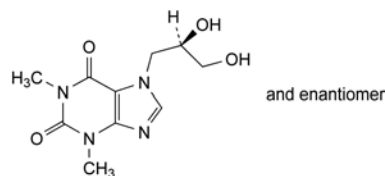

$C_{10}H_{14}N_4O_4$   
[479-18-5]

$M_r$  254.2

#### DEFINITION

Diprophylline contains not less than 98.5 per cent and not more than the equivalent of 101.0 per cent of 7-[(2RS)-2,3-dihydroxypropyl]-1,3-dimethyl-3,7-dihydro-1H-purine-2,6-dione, calculated with reference to the dried substance.

#### CHARACTERS

A white or almost white, crystalline powder, freely soluble in water, slightly soluble in alcohol.



## IDENTIFICATION

First identification: B, C.

Second identification: A, C, D.

- A. Melting point (2.2.14): 160 °C to 165 °C.
- B. Examine by infrared absorption spectrophotometry (2.2.24), comparing with the spectrum obtained with *diprophylline CRS*. Examine the substances as discs prepared using 0.5 mg to 1 mg of the substance to be examined in 0.3 g of *potassium bromide R*.
- C. Dissolve 1 g in 5 mL of *acetic anhydride R* and boil under a reflux condenser for 15 min. Allow to cool and add 100 mL of a mixture of 20 volumes of *ether R* and 80 volumes of *light petroleum R*. Cool in iced water for at least 20 min, shaking from time to time. Filter, wash the precipitate with a mixture of 20 volumes of *ether R* and 80 volumes of *light petroleum R*, recrystallise from *alcohol R* and dry *in vacuo*. The crystals melt (2.2.14) at 142 °C to 148 °C.
- D. It gives the reaction of xanthenes (2.3.1).

## TESTS

**Solution S.** Dissolve 2.5 g in *carbon dioxide-free water R* and dilute to 50 mL with the same solvent.

**Appearance of solution.** Solution S is clear (2.2.1) and colourless (2.2.2, *Method II*).

**Acidity or alkalinity.** To 10 mL of solution S add 0.25 mL of *bromothymol blue solution RI*. The solution is yellow or green. Not more than 0.4 mL of 0.01 M *sodium hydroxide* is required to change the colour of the indicator to blue.

**Related substances.** Examine by thin-layer chromatography (2.2.27), using *silica gel HF<sub>254</sub> R* as the coating substance.

**Test solution.** Dissolve 0.3 g of the substance to be examined in a mixture of 20 volumes of *water R* and 30 volumes of *methanol R* and dilute to 10 mL with the same mixture of solvents. *Prepare immediately before use.*

**Reference solution (a).** Dilute 1 mL of the test solution to 100 mL with *methanol R*.

**Reference solution (b).** Dilute 0.2 mL of the test solution to 100 mL with *methanol R*.

**Reference solution (c).** Dissolve 10 mg of *theophylline R* in *methanol R*, add 0.3 mL of the test solution and dilute to 10 mL with *methanol R*.

Apply to the plate 10 µL of each solution. Develop over a path of 15 cm using a mixture of 1 volume of *concentrated ammonia R*, 10 volumes of *ethanol R* and 90 volumes of *chloroform R*. Allow the plate to dry in air and examine in ultraviolet light at 254 nm. Any spot in the chromatogram obtained with the test solution, apart from the principal spot, is not more intense than the spot in the chromatogram obtained with reference solution (a) (1 per cent) and at most one such spot is more intense than the spot in the chromatogram obtained with reference solution (b) (0.2 per cent). The test is not valid unless the chromatogram obtained with reference solution (c) shows two clearly separated spots.

**Chlorides (2.4.4).** Dilute 2.5 mL of solution S to 15 mL with *water R*. The solution complies with the limit test for chlorides (400 ppm).

**Heavy metals (2.4.8).** 12 mL of solution S complies with limit test A for heavy metals (20 ppm). Prepare the standard using *lead standard solution (1 ppm Pb) R*.

**Loss on drying (2.2.32).** Not more than 0.5 per cent, determined on 1.000 g by drying in an oven at 105 °C.

**Sulfated ash (2.4.14).** Not more than 0.1 per cent, determined on 1.0 g.

## ASSAY

*In order to avoid overheating in the reaction medium, mix thoroughly throughout and stop the titration immediately after the end-point has been reached.*

Dissolve 0.200 g in 3.0 mL of *anhydrous formic acid R* and add 50.0 mL of *acetic anhydride R*. Titrate with 0.1 M *perchloric acid*, determining the end-point potentiometrically (2.2.20).

1 mL of 0.1 M *perchloric acid* is equivalent to 25.42 mg of C<sub>24</sub>H<sub>40</sub>N<sub>8</sub>O<sub>4</sub>.

## STORAGE

Store protected from light.

01/2008:1199

## DIPYRIDAMOLE

## Dipyridamolum

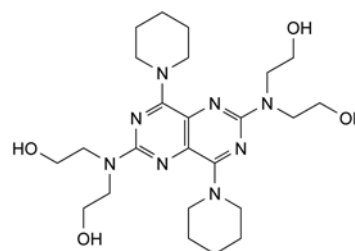

C<sub>24</sub>H<sub>40</sub>N<sub>8</sub>O<sub>4</sub>  
[58-32-2]

*M*, 504.6

## DEFINITION

2,2',2'',2'''-[4,8-Di(piperidin-1-yl)pyrimido[5,4-*d*]pyrimidine-2,6-diyl]dinitrilo]tetraethanol.

*Content*: 98.5 per cent to 101.5 per cent (dried substance).

## CHARACTERS

*Appearance*: bright yellow, crystalline powder.

*Solubility*: practically insoluble in water, freely soluble in acetone, soluble in anhydrous ethanol. It dissolves in dilute mineral acids.

## IDENTIFICATION

Infrared absorption spectrophotometry (2.2.24).

*Preparation*: discs of *potassium bromide R*.

*Comparison*: *dipyridamole CRS*.

## TESTS

**Related substances.** Liquid chromatography (2.2.29). *Prepare the solutions immediately before use.*

**Test solution.** Dissolve 0.100 g of the substance to be examined in *methanol R* and dilute to 50 mL with the same solvent.

**Reference solution (a).** Dilute 1.0 mL of the test solution to 100.0 mL with *methanol R*. Dilute 1.0 mL of this solution to 10.0 mL with *methanol R*.

**Reference solution (b).** Dissolve the contents of a vial of *dipyridamole for peak identification CRS* (containing impurities A, B, C, D, E and F) in 1 mL of *methanol R*.

*Column*:

- *size*: *l* = 0.10 m, Ø = 4.0 mm;
- *stationary phase*: spherical *end-capped octadecylsilyl silica gel for chromatography R* (5 µm);
- *temperature*: 45 °C.

*Mobile phase*:

- *mobile phase A*: dissolve 1.0 g of *potassium dihydrogen phosphate R* in 900 mL of *water R*, adjust to pH 7.0 with 0.5 M *sodium hydroxide* and dilute to 1000 mL with *water R*;

– mobile phase B: methanol R;

Time (min)	Mobile phase A (per cent V/V)	Mobile phase B (per cent V/V)
0 - 5	40	60
5 - 19	40 → 5	60 → 95
19 - 24	5 → 40	95 → 60
24 - 29	40	60

Flow rate: 1.2 mL/min.

Detection: spectrophotometer at 295 nm.

Injection: 5 µL.

Identification of impurities: use the chromatogram supplied with dipyridamole for peak identification CRS and the chromatogram obtained with reference solution (b) to identify the peaks due to impurities A, B, C, D, E and F.

Relative retention with reference to dipyridamole (retention time = about 8 min): impurity B = about 0.2; impurity F = about 0.3; impurity D = about 0.9; impurity E = about 1.3; impurity C = about 1.6; impurity A = about 2.2.

System suitability: reference solution (b):

- resolution: minimum 2.0 between the peaks due to impurity D and dipyridamole;
- peak-to-valley ratio: minimum 4, where  $H_p$  = height above the baseline of the peak due to impurity B and  $H_v$  = height above the baseline of the lowest point of the curve separating this peak from the peak due to impurity F.

Limits:

- correction factor: for the calculation of content, multiply the peak area of impurity B by 1.7;
- impurities A, B, C: for each impurity, not more than 5 times the area of the principal peak in the chromatogram obtained with reference solution (a) (0.5 per cent);
- impurities D, E: for each impurity, not more than twice the area of the principal peak in the chromatogram obtained with reference solution (a) (0.2 per cent);
- unspecified impurities: for each impurity, not more than the area of the principal peak in the chromatogram obtained with reference solution (a) (0.10 per cent);
- total: not more than 10 times the area of the principal peak in the chromatogram obtained with reference solution (a) (1.0 per cent);
- disregard limit: 0.5 times the area of the principal peak in the chromatogram obtained with reference solution (a) (0.05 per cent).

Chlorides (2.4.4): maximum 200 ppm.

To 0.250 g add 10 mL of water R and shake vigorously. Filter, rinse the filter with 5 mL of water R and dilute to 15 mL with water R.

Loss on drying (2.2.32): maximum 0.5 per cent, determined on 1.000 g by drying in an oven at 105 °C.

Sulfated ash (2.4.14): maximum 0.1 per cent, determined on 1.0 g.

#### ASSAY

Dissolve 0.400 g in 70 mL of methanol R. Titrate with 0.1 M perchloric acid, determining the end-point potentiometrically (2.2.20).

1 mL of 0.1 M perchloric acid is equivalent to 50.46 mg of  $C_{24}H_{40}N_8O_4$ .

#### STORAGE

Protected from light.

#### IMPURITIES

Specified impurities: A, B, C, D, E.

Other detectable impurities (the following substances would, if present at a sufficient level, be detected by one or other of the tests in the monograph. They are limited by the general acceptance criterion for other/unspecified impurities and/or by the general monograph *Substances for pharmaceutical use* (2034). It is therefore not necessary to identify these impurities for demonstration of compliance. See also 5.10. *Control of impurities in substances for pharmaceutical use*): F, G.

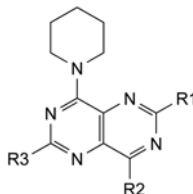

- A. R1 = N(CH<sub>2</sub>-CH<sub>2</sub>-OH)<sub>2</sub>, R2 = R3 = NC<sub>5</sub>H<sub>10</sub>:  
2,2'-[[4,6,8-tri(piperidin-1-yl)pyrimido[5,4-d]pyrimidin-2-yl]nitrilo]diethanol,
- B. R1 = R2 = R3 = N(CH<sub>2</sub>-CH<sub>2</sub>-OH)<sub>2</sub>: 2,2',2'',2''',2''''-[[8-(piperidin-1-yl)pyrimido[5,4-d]pyrimidine-2,4,6-triyl]trinitrilo]hexaethanol,
- C. R1 = N(CH<sub>2</sub>-CH<sub>2</sub>-OH)<sub>2</sub>, R2 = NC<sub>5</sub>H<sub>10</sub>, R3 = Cl:  
2,2'-[[6-chloro-4,8-di(piperidin-1-yl)pyrimido[5,4-d]pyrimidin-2-yl]nitrilo]diethanol,
- D. R1 = N(CH<sub>2</sub>-CH<sub>2</sub>-OH)<sub>2</sub>, R2 = NC<sub>5</sub>H<sub>10</sub>, R3 = NH-CH<sub>2</sub>-CH<sub>2</sub>-OH:  
2,2'-[[6-[(2-hydroxyethyl)amino]-4,8-di(piperidin-1-yl)pyrimido[5,4-d]pyrimidin-2-yl]nitrilo]diethanol,
- E. R1 = R2 = N(CH<sub>2</sub>-CH<sub>2</sub>-OH)<sub>2</sub>, R3 = NC<sub>5</sub>H<sub>10</sub>:  
2,2',2'',2'''-[[6,8-di(piperidin-1-yl)pyrimido[5,4-d]pyrimidine-2,4-diyl]dinitrilo]tetraethanol,
- F. R1 = R3 = N(CH<sub>2</sub>-CH<sub>2</sub>-OH)<sub>2</sub>, R2 = NH-CH<sub>2</sub>-CH<sub>2</sub>-OH:  
2,2',2'',2'''-[[4-[(2-hydroxyethyl)amino]-8-(piperidin-1-yl)pyrimido[5,4-d]pyrimidine-2,6-diyl]dinitrilo]tetraethanol,
- G. R1 = R3 = Cl, R2 = NC<sub>5</sub>H<sub>10</sub>: 2,6-dichloro-4,8-di(piperidin-1-yl)pyrimido[5,4-d]pyrimidine.

01/2008:1313  
corrected 6.1

## DIRITHROMYCIN

### Dirithromycinum

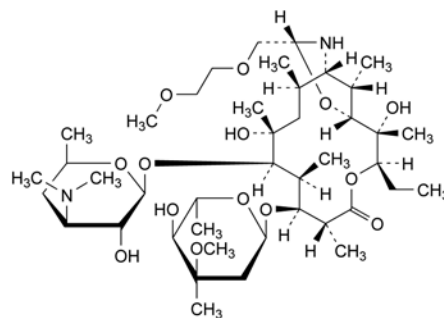

$C_{42}H_{78}N_2O_{14}$   
[62013-04-1]

$M_r$  835

#### DEFINITION

(1R,2S,3R,6R,7S,8S,9R,10R,12R,13S,15R,17S)-9-[[3-(Dimethylamino)-3,4,6-trideoxy-β-D-xyllohexopyranosyl]oxy]-3-ethyl-2,10-dihydroxy-15-[(2-methoxyethoxy)methyl]-2,

6,8,10,12,17-hexamethyl-7-[(3-*C*-methyl-3-*O*-methyl-2,6-dideoxy- $\alpha$ -*L*-ribo-hexopyranosyl)oxy]-4,16-dioxo-14-azabicyclo[11.3.1]heptadecan-5-one (or (9*S*)-9,11-[imino[(1*R*)-2-(2-methoxyethoxy)ethylidene]oxy]-9-deoxo-11-deoxyerythromycin).

Semi-synthetic product derived from a fermentation product.

**Content:** 96.0 per cent to 102.0 per cent for the sum of the percentage contents of C<sub>42</sub>H<sub>78</sub>N<sub>2</sub>O<sub>14</sub> and dirithromycin 15*S*-epimer (anhydrous substance).

#### CHARACTERS

**Appearance:** white or almost white powder.

**Solubility:** very slightly soluble in water, very soluble in methanol and in methylene chloride.

It shows polymorphism (5.9).

#### IDENTIFICATION

A. Infrared absorption spectrophotometry (2.2.24).

**Comparison:** dirithromycin CRS.

B. Examine the chromatograms obtained in the assay.

**Results:** the principal peak in the chromatogram obtained with test solution (a) is similar in retention time and size to the principal peak in the chromatogram obtained with reference solution (a).

#### TESTS

**Related substances.** Liquid chromatography (2.2.29).

**Solvent mixture:** methanol R, acetonitrile R1 (30:70 V/V).

**Test solution (a).** Dissolve 20.0 mg of the substance to be examined in the solvent mixture and dilute to 10.0 mL with the solvent mixture.

**Test solution (b).** Dissolve 0.10 g of the substance to be examined in the solvent mixture and dilute to 10.0 mL with the solvent mixture.

**Reference solution (a).** Dissolve 20.0 mg of dirithromycin CRS in the solvent mixture and dilute to 10.0 mL with the solvent mixture.

**Reference solution (b).** Dilute 5.0 mL of reference solution (a) to 50.0 mL with the solvent mixture.

**Reference solution (c).** Dissolve 20 mg of dirithromycin CRS in the mobile phase and dilute to 10 mL with the mobile phase. Allow to stand for 24 h before use.

**Column:**

- size:  $l = 0.25$  m,  $\varnothing = 4.6$  mm;
- stationary phase: octadecylsilyl silica gel for chromatography R (5  $\mu$ m);
- temperature: 40 °C.

**Mobile phase:** mix 9 volumes of water R, 19 volumes of methanol R, 28 volumes of a solution containing 1.9 g/L of potassium dihydrogen phosphate R and 9.1 g/L of dipotassium hydrogen phosphate R adjusted to pH 7.5 if necessary with a 100 g/L solution of potassium hydroxide R, and 44 volumes of acetonitrile R1.

**Flow rate:** 2.0 mL/min.

**Detection:** spectrophotometer at 205 nm.

**Injection:** 10  $\mu$ L of test solution (b) and reference solutions (b) and (c).

**Run time:** 3 times the retention time of dirithromycin.

**Relative retention** with reference to dirithromycin: impurity A = about 0.7; 15*S*-epimer = about 1.1.

**System suitability:** reference solution (c):

- resolution: minimum 2.0 between the peaks due to dirithromycin and its 15*S*-epimer; if necessary, adjust the concentration of the organic modifiers in the mobile phase.

**Limits:**

- **impurity A:** not more than 0.75 times the area of the principal peak in the chromatogram obtained with reference solution (b) (1.5 per cent);
- **any other impurity:** for each impurity, not more than 0.5 times the area of the principal peak in the chromatogram obtained with reference solution (b) (1 per cent);
- **disregard limit:** disregard the peak due to the 15*S*-epimer.

**Dirithromycin 15*S*-epimer.** Liquid chromatography (2.2.29) as described in the test for related substances with the following modifications.

**Injection:** test solution (b) and reference solution (b).

**System suitability:** reference solution (b):

- **repeatability:** maximum relative standard deviation of 5.0 per cent after 6 injections.

**Limit:**

- 15*S*-epimer: maximum 1.5 per cent.

**Acetonitrile (2.4.24, System A):** maximum 0.1 per cent.

Prepare the solutions using dimethylformamide R instead of water R.

**Sample solution.** Dissolve 0.200 g of the substance to be examined in dimethylformamide R and dilute to 20.0 mL with the same solvent.

**Static head-space injection conditions that may be used:**

- equilibration temperature: 120 °C;
- equilibration time: 60 min;
- transfer-line temperature: 125 °C.

**Heavy metals (2.4.8):** maximum 20 ppm.

Dissolve 1.0 g in 20 mL of a mixture of equal volumes of methanol R and water R. 12 mL of the solution complies with test B. Prepare the reference solution using lead standard solution (1 ppm Pb) obtained by diluting lead standard solution (100 ppm Pb) R with a mixture of equal volumes of methanol R and water R.

**Water (2.5.12):** maximum 1.0 per cent, determined on 1.00 g.

**Sulfated ash (2.4.14):** maximum 0.1 per cent, determined on 1.0 g.

#### ASSAY

Liquid chromatography (2.2.29) as described in the test for related substances with the following modifications.

**Injection:** test solution (a) and reference solution (a).

**System suitability:** reference solution (a):

- **repeatability:** maximum relative standard deviation of 1.0 per cent after 6 injections.

#### IMPURITIES

**Specified impurities:** A.

**Other detectable impurities** (the following substances would, if present at a sufficient level, be detected by one or other of the tests in the monograph. They are limited by the general acceptance criterion for other/unspecified impurities and/or by the general monograph *Substances for pharmaceutical use (2034)*. It is therefore not necessary to identify these impurities for demonstration of compliance. See also 5.10. *Control of impurities in substances for pharmaceutical use*): B, C, D, E.

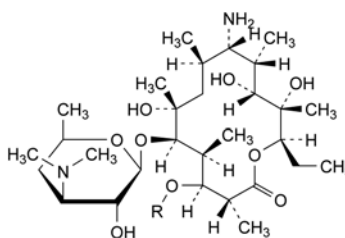

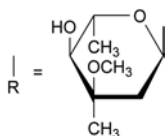

- A. (9S)-9-amino-9-deoxyerythromycin,  
 B. R = H: (9S)-9-amino-3-de(2,6-dideoxy-3-C-methyl-3-O-methyl- $\alpha$ -L-ribo-hexopyranosyl)-9-deoxyerythromycin,

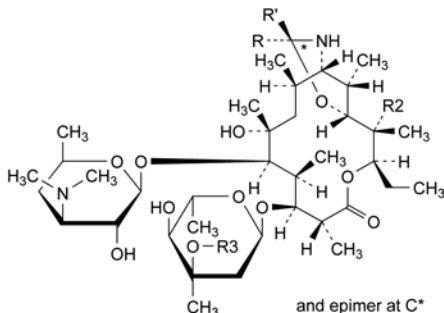

- C. R = CH<sub>2</sub>-O-CH<sub>2</sub>-CH<sub>2</sub>-O-CH<sub>3</sub>, R' = H, R<sub>2</sub> = H, R<sub>3</sub> = CH<sub>3</sub>: (9S)-9,11-[imino[(1RS)-2-(2-methoxyethoxy)ethylidene]oxy]-9-deoxy-11,12-dideoxyerythromycin (dirithromycin B),  
 D. R = CH<sub>2</sub>-O-CH<sub>2</sub>-CH<sub>2</sub>-O-CH<sub>3</sub>, R' = H, R<sub>2</sub> = OH, R<sub>3</sub> = H: (9S)-9,11-[imino[(1RS)-2-(2-methoxyethoxy)ethylidene]oxy]-3'-O-demethyl-9-deoxy-11-deoxyerythromycin (dirithromycin C),  
 E. R = CH<sub>3</sub>, R' = CH<sub>3</sub>, R<sub>2</sub> = OH, R<sub>3</sub> = CH<sub>3</sub>: 9,11-[imino(1-methylethylidene)oxy]-9-deoxy-11-deoxyerythromycin.

- C. Dissolve 0.5 g in 10 mL of *water R* and add 0.5 mL of *calcium chloride solution R*. Make alkaline to *red litmus paper R* by the addition of *dilute ammonia R2* and add 3 mL of *ammonium oxalate solution R*. No precipitate is formed.  
 D. It gives the reactions of sodium (2.3.1).

## TESTS

**Solution S.** Dissolve 5.0 g in *carbon dioxide-free water R* and dilute to 100 mL with the same solvent.

**Appearance of solution.** Solution S is clear (2.2.1) and colourless (2.2.2, *Method II*).

**pH (2.2.3):** 4.0 to 5.5 for solution S.

**Impurity A.** Liquid chromatography (2.2.29). Carry out the test protected from light.

**Solvent mixture.** Dissolve 10.0 g of *ferric sulfate pentahydrate R* in 20 mL of 0.5 M *sulfuric acid* and add 780 mL of *water R*. Adjust to pH 2.0 with 1 M *sodium hydroxide* and dilute to 1000 mL with *water R*.

**Test solution.** Dissolve 0.100 g of the substance to be examined in the solvent mixture and dilute to 25.0 mL with the solvent mixture.

**Reference solution.** Dissolve 40.0 mg of *nitrilotriacetic acid R* in the solvent mixture and dilute to 100.0 mL with the solvent mixture. To 1.0 mL of the solution add 0.1 mL of the test solution and dilute to 100.0 mL with the solvent mixture.

## Column:

- size:  $l = 0.10$  m,  $\varnothing = 4.6$  mm,
- stationary phase: spherical *graphitised carbon for chromatography R1* (5  $\mu\text{m}$ ) with a specific surface area of 120 m<sup>2</sup>/g and a pore size of 25 nm.

**Mobile phase:** dissolve 50.0 mg of *ferric sulfate pentahydrate R* in 50 mL of 0.5 M *sulfuric acid* and add 750 mL of *water R*. Adjust to pH 1.5 with 0.5 M *sulfuric acid* or 1 M *sodium hydroxide*, add 20 mL of *ethylene glycol R* and dilute to 1000 mL with *water R*.

**Flow rate:** 1 mL/min.

**Detection:** spectrophotometer at 273 nm.

**Injection:** 20  $\mu\text{L}$ ; filter the solutions and inject immediately.

**Run time:** 4 times the retention time of the iron complex of impurity A.

**Retention times:** iron complex of impurity A = about 5 min; iron complex of edetic acid = about 10 min.

**System suitability:** reference solution:

- resolution: minimum 7 between the peaks due to the iron complex of impurity A and the iron complex of edetic acid,
- signal-to-noise ratio: minimum 50 for the peak due to impurity A.

## Limit:

- impurity A: not more than the area of the corresponding peak in the chromatogram obtained with the reference solution (0.1 per cent).

**Iron (2.4.9):** maximum 80 ppm.

Dilute 2.5 mL of solution S to 10 mL with *water R*. Add 0.25 g of *calcium chloride R* to the test solution and the standard before the addition of the *thioglycollic acid R*.

**Heavy metals (2.4.8):** maximum 20 ppm.

1.0 g complies with test F. Prepare the reference solution using 2 mL of *lead standard solution (10 ppm Pb) R*.

## ASSAY

Dissolve 0.300 g in *water R* and dilute to 300 mL with the same solvent. Add 2 g of *hexamethylenetetramine R* and 2 mL of *dilute hydrochloric acid R*. Titrate with 0.1 M *lead nitrate*, using about 50 mg of *xylene orange triturate R* as indicator.

1 mL of 0.1 M *lead nitrate* is equivalent to 37.22 mg of C<sub>10</sub>H<sub>14</sub>N<sub>2</sub>Na<sub>2</sub>O<sub>8</sub>·2H<sub>2</sub>O.

01/2008:0232

## DISODIUM EDETATE

## Dinatrii edetas

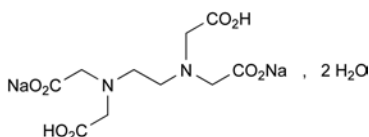
C<sub>10</sub>H<sub>14</sub>N<sub>2</sub>Na<sub>2</sub>O<sub>8</sub>·2H<sub>2</sub>OM<sub>r</sub> 372.2

## DEFINITION

Disodium dihydrogen (ethylenedinitrilo)tetraacetate dihydrate.

**Content:** 98.5 per cent to 101.0 per cent.

## CHARACTERS

**Appearance:** white or almost white, crystalline powder.

**Solubility:** soluble in water, practically insoluble in ethanol (96 per cent).

## IDENTIFICATION

**First identification:** A, B, D.

**Second identification:** B, C, D.

A. Infrared absorption spectrophotometry (2.2.24).

**Preparation:** discs.

**Comparison:** *disodium edetate CRS*.

- B. Dissolve 2 g in 25 mL of *water R*, add 6 mL of *lead nitrate solution R*, shake and add 3 mL of *potassium iodide solution R*. No yellow precipitate is formed. Make alkaline to *red litmus paper R* by the addition of *dilute ammonia R2*. Add 3 mL of *ammonium oxalate solution R*. No precipitate is formed.

## STORAGE

Protected from light.

## IMPURITIES

Specified impurities: A.

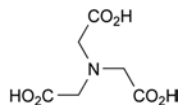

A. nitrilotriacetic acid.

01/2008:1509  
corrected 6.3

## DISODIUM PHOSPHATE, ANHYDROUS

Dinatrii phosphas anhydricus

$\text{Na}_2\text{HPO}_4$   
[7558-79-4]

$M_r$  142.0

## DEFINITION

Content: 98.0 per cent to 101.0 per cent (dried substance).

## CHARACTERS

Appearance: white or almost white powder, hygroscopic.

Solubility: soluble in water, practically insoluble in ethanol (96 per cent).

## IDENTIFICATION

- Solution S (see Tests) is slightly alkaline (2.2.4).
- Loss on drying (see Tests).
- Solution S gives reaction (b) of phosphates (2.3.1).
- Solution S gives reaction (a) of sodium (2.3.1).

## TESTS

**Solution S.** Dissolve 5.0 g in *distilled water R* and dilute to 100.0 mL with the same solvent.

**Appearance of solution.** Solution S is clear (2.2.1) and colourless (2.2.2, *Method II*).

**Reducing substances.** To 10 mL of solution S add 5 mL of *dilute sulfuric acid R* and 0.25 mL of 0.02 M *potassium permanganate* and heat on a water-bath for 5 min. The solution retains a slight red colour.

**Monosodium phosphate:** maximum 2.5 per cent.

From the volume of 1 M *hydrochloric acid* (25 mL) and of 1 M *sodium hydroxide* ( $n_1$  mL and  $n_2$  mL) used in the assay, calculate the following ratio:

$$\frac{n_2 - 25}{25 - n_1}$$

This ratio is not greater than 0.025.

**Chlorides** (2.4.4): maximum 200 ppm.

Dilute 5 mL of solution S to 15 mL with *dilute nitric acid R*.

**Sulfates** (2.4.13): maximum 500 ppm.

To 6 mL of solution S add 2 mL of *dilute hydrochloric acid R* and dilute to 15 mL with *distilled water R*.

**Arsenic** (2.4.2, *Method A*): maximum 2 ppm, determined on 10 mL of solution S.

**Iron** (2.4.9): maximum 20 ppm, determined on solution S.

**Heavy metals** (2.4.8): maximum 10 ppm.

12 mL of solution S complies with test A. Prepare the reference solution using 5 mL of *lead standard solution (1 ppm Pb) R* and 5 mL of *water R*.

**Loss on drying** (2.2.32): maximum 1.0 per cent, determined on 1.000 g by drying in an oven at 105 °C for 4 h.

## ASSAY

Dissolve 1.600 g ( $m$ ) in 25.0 mL of *carbon dioxide-free water R* and add 25.0 mL of 1 M *hydrochloric acid*. Carry out a potentiometric titration (2.2.20) using 1 M *sodium hydroxide*. Read the volume added at the 1<sup>st</sup> inflexion point ( $n_1$  mL). Continue the titration to the 2<sup>nd</sup> inflexion point (total volume of 1 M *sodium hydroxide* required,  $n_2$  mL).

Calculate the percentage content of  $\text{Na}_2\text{HPO}_4$  from the following expression:

$$\frac{1420 (25 - n_1)}{m (100 - d)}$$

$d$  = percentage loss on drying.

## STORAGE

In an airtight container.

01/2008:0602

## DISODIUM PHOSPHATE DIHYDRATE

Dinatrii phosphas dihydricus

$\text{Na}_2\text{HPO}_4 \cdot 2\text{H}_2\text{O}$   
[10028-24-7]

$M_r$  178.0

## DEFINITION

Content: 98.0 per cent to 101.0 per cent (dried substance).

## CHARACTERS

Appearance: white or almost white powder or colourless crystals.

Solubility: soluble in water, practically insoluble in ethanol (96 per cent).

## IDENTIFICATION

- Solution S (see Tests) is slightly alkaline (2.2.4).
- Loss on drying (see Tests).
- Solution S gives reaction (b) of phosphates (2.3.1).
- Solution S gives reaction (a) of sodium (2.3.1).

## TESTS

**Solution S.** Dissolve 5.0 g in *distilled water R* and dilute to 100 mL with the same solvent.

**Appearance of solution.** Solution S is clear (2.2.1) and colourless (2.2.2, *Method II*).

**Reducing substances.** To 5 mL of solution S add 5 mL of *dilute sulfuric acid R* and 0.25 mL of 0.02 M *potassium permanganate* and heat on a water-bath for 5 min. The solution retains a slight red colour.

**Monosodium phosphate:** maximum 2.5 per cent.

From the volume of 1 M *hydrochloric acid* (25 mL) and of 1 M *sodium hydroxide* ( $n_1$  mL and  $n_2$  mL) used in the assay, calculate the following ratio:

$$\frac{n_2 - 25}{25 - n_1}$$

This ratio is not greater than 0.025.

**Chlorides** (2.4.4): maximum 400 ppm.

To 2.5 mL of solution S add 10 mL of *dilute nitric acid R* and dilute to 15 mL with *water R*.

**Sulfates** (2.4.13): maximum 0.1 per cent.

To 3 mL of solution S add 2 mL of *dilute hydrochloric acid R* and dilute to 15 mL with *distilled water R*.

**Arsenic** (2.4.2, *Method A*): maximum 4 ppm, determined on 5 mL of solution S.

**Iron (2.4.9):** maximum 40 ppm

Dilute 5 mL of solution S to 10 mL with *water R*.

**Heavy metals (2.4.8):** maximum 20 ppm.

12 mL of solution S complies with test A. Prepare the reference solution using *lead standard solution (1 ppm Pb) R*.

**Loss on drying (2.2.32):** 19.5 per cent to 21.0 per cent, determined on 1.000 g by drying in an oven at 130 °C.

#### ASSAY

Dissolve 2.000 g (*m*) in 50 mL of *water R* and add 25.0 mL of 1 M *hydrochloric acid*. Carry out a potentiometric titration (2.2.20) using 1 M *sodium hydroxide*. Read the volume added at the 1<sup>st</sup> inflexion point ( $n_1$  mL). Continue the titration to the 2<sup>nd</sup> inflexion point (total volume of 1 M *sodium hydroxide* required,  $n_2$  mL).

Calculate the percentage content of  $\text{Na}_2\text{HPO}_4$  from the following expression:

$$\frac{1420(25 - n_1)}{m(100 - d)}$$

$d$  = percentage loss on drying.

04/2008:0118

## DISODIUM PHOSPHATE DODECAHYDRATE

Dinatrii phosphas dodecahydricus

$\text{Na}_2\text{HPO}_4 \cdot 12\text{H}_2\text{O}$   
[10039-32-4]

$M_r$  358.1

#### DEFINITION

**Content:** 98.5 per cent to 102.5 per cent.

#### CHARACTERS

**Appearance:** colourless, transparent crystals, very efflorescent.  
**Solubility:** very soluble in water, practically insoluble in ethanol (96 per cent).

#### IDENTIFICATION

- Solution S (see Tests) is slightly alkaline (2.2.4).
- Water (see Tests).
- Solution S gives reaction (b) of phosphates (2.3.1).
- Solution S gives reaction (a) of sodium (2.3.1).

#### TESTS

**Solution S.** Dissolve 5.0 g in *distilled water R* and dilute to 50 mL with the same solvent.

**Appearance of solution.** Solution S is clear (2.2.1) and colourless (2.2.2, *Method II*).

**Reducing substances.** To 5 mL of solution S add 5 mL of *dilute sulfuric acid R* and 0.25 mL of 0.02 M *potassium permanganate* and heat on a water-bath for 5 min. The solution retains a slight red colour.

**Monosodium phosphate:** maximum 2.5 per cent.

From the volume of 1 M *hydrochloric acid* (25 mL) and of 1 M *sodium hydroxide* ( $n_1$  mL and  $n_2$  mL) used in the assay, calculate the following ratio:

$$\frac{n_2 - 25}{25 - n_1}$$

This ratio is not greater than 0.025.

**Chlorides (2.4.4):** maximum 200 ppm.

To 2.5 mL of solution S add 10 mL of *dilute nitric acid R* and dilute to 15 mL with *water R*.

**Sulfates (2.4.13):** maximum 500 ppm.

To 3 mL of solution S add 2 mL of *dilute hydrochloric acid R* and dilute to 15 mL with *distilled water R*.

**Arsenic (2.4.2, Method A):** maximum 2 ppm, determined on 5 mL of solution S.

**Iron (2.4.9):** maximum 20 ppm.

Dilute 5 mL of solution S to 10 mL with *water R*.

**Heavy metals (2.4.8):** maximum 10 ppm.

12 mL of solution S complies with test A. Prepare the reference solution using *lead standard solution (1 ppm Pb) R*.

**Water (2.5.12):** 57.0 per cent to 61.0 per cent, determined on 50.0 mg. Use a mixture of 10 volumes of *anhydrous methanol R* and 40 volumes of *formamide R1* as solvent.

#### ASSAY

Dissolve 4.00 g (*m*) in 25 mL of *water R* and add 25.0 mL of 1 M *hydrochloric acid*. Carry out a potentiometric titration (2.2.20) using 1 M *sodium hydroxide*. Read the volume added at the 1<sup>st</sup> inflexion point ( $n_1$  mL). Continue the titration to the 2<sup>nd</sup> inflexion point (total volume of 1 M *sodium hydroxide* required,  $n_2$  mL).

Calculate the percentage content of  $\text{Na}_2\text{HPO}_4 \cdot 12\text{H}_2\text{O}$  from the following expression:

$$\frac{3581(25 - n_1)}{m \times 100}$$

01/2008:1006

## DISOPYRAMIDE

Disopyramidum

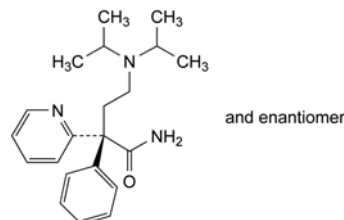

$\text{C}_{21}\text{H}_{29}\text{N}_3\text{O}$   
[3737-09-5]

$M_r$  339.5

#### DEFINITION

Disopyramide contains not less than 98.5 per cent and not more than the equivalent of 101.5 per cent of (2*R*)-4-[bis(1-methylethyl)amino]-2-phenyl-2-(pyridin-2-yl)butanamide, calculated with reference to the dried substance.

#### CHARACTERS

A white or almost white powder, slightly soluble in water, freely soluble in methylene chloride, soluble in alcohol.

#### IDENTIFICATION

**First identification:** B.

**Second identification:** A, C.

- Dissolve 40.0 mg in a 5 g/L solution of *sulfuric acid R* in *methanol R* and dilute to 100.0 mL with the same solution. Dilute 5.0 mL of this solution to 50.0 mL with a 5 g/L solution of *sulfuric acid R* in *methanol R*. Examined between 240 nm and 350 nm (2.2.25), the solution shows an absorption maximum at 269 nm and a shoulder at 263 nm. The specific absorbance at the maximum is 190 to 210.
- Examine by infrared absorption spectrophotometry (2.2.24), comparing with the spectrum obtained with *disopyramide CRS*. Examine the substances as discs

prepared by placing 50 µL of a 50 g/L solution in *methylene chloride R* on a disc of *potassium bromide R*. Dry the discs at 60 °C for 1 h before use.

- C. Examine the chromatograms obtained in the test for related substances in ultraviolet light at 254 nm. The principal spot in the chromatogram obtained with test solution (b) is similar in position and size to the principal spot in the chromatogram obtained with reference solution (a). Spray with *dilute potassium iodobismuthate solution R*. Examine in daylight. The principal spot in the chromatogram obtained with test solution (b) is similar in position, colour and size to the principal spot in the chromatogram obtained with reference solution (a).

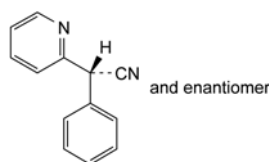

- D. *(RS)*-phenyl(pyridin-2-yl)acetonitrile (pyronitrile).

01/2008:1005  
corrected 6.0

## TESTS

**Related substances.** Examine by thin-layer chromatography (2.2.27), using *silica gel GF<sub>254</sub> R* as the coating substance.

**Test solution (a).** Dissolve 0.20 g of the substance to be examined in *methanol R* and dilute to 10 mL with the same solvent.

**Test solution (b).** Dilute 1 mL of test solution (a) to 10 mL with *methanol R*.

**Reference solution (a).** Dissolve 20 mg of *disopyramide CRS* in *methanol R* and dilute to 10 mL with the same solvent.

**Reference solution (b).** Dilute 0.5 mL of test solution (b) to 20 mL with *methanol R*.

Apply to the plate 10 µL of each solution. Develop over a path of 15 cm using a mixture of 1 volume of *concentrated ammonia R*, 30 volumes of *acetone R* and 30 volumes of *cyclohexane R*. Dry the plate in a current of warm air and examine in ultraviolet light at 254 nm. Any spot in the chromatogram obtained with test solution (a), apart from the principal spot, is not more intense than the spot in the chromatogram obtained with reference solution (b) (0.25 per cent).

**Heavy metals (2.4.8).** 2.0 g complies with limit test C for heavy metals (10 ppm). Prepare the standard using 2 mL of *lead standard solution (10 ppm Pb) R*.

**Loss on drying (2.2.32).** Not more than 0.5 per cent, determined on 1.000 g by drying at 80 °C over *diphosphorus pentoxide R* at a pressure not exceeding 0.7 kPa for 2 h.

**Sulfated ash (2.4.14).** Not more than 0.2 per cent, determined on 1.0 g.

## ASSAY

Dissolve 0.130 g in 30 mL of *anhydrous acetic acid R*. Add 0.2 mL of *naphtholbenzein solution R*. Titrate with 0.1 M *perchloric acid* until the colour changes from yellow to green.

1 mL of 0.1 M *perchloric acid* is equivalent to 16.97 mg of  $C_{21}H_{29}N_3O_5$ .

## STORAGE

Store protected from light.

## IMPURITIES

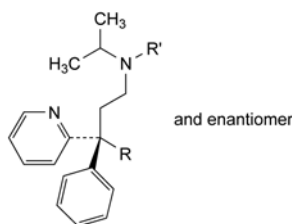

- A. R = CN, R' = CH(CH<sub>3</sub>)<sub>2</sub>: *(2RS)*-4-[bis(1-methylethyl)amino]-2-phenyl-2-(pyridin-2-yl)butanenitrile (di-isopyronitrile),
- B. R = H, R' = CH(CH<sub>3</sub>)<sub>2</sub>: *(3RS)*-*N,N*-bis(1-methylethyl)-3-phenyl-3-(pyridin-2-yl)propan-1-amine,
- C. R = CO-NH<sub>2</sub>, R' = H: *(2RS)*-4-[(1-methylethyl)amino]-2-phenyl-2-(pyridin-2-yl)butanamide,

## DISOPYRAMIDE PHOSPHATE

### Disopyramidi phosphas

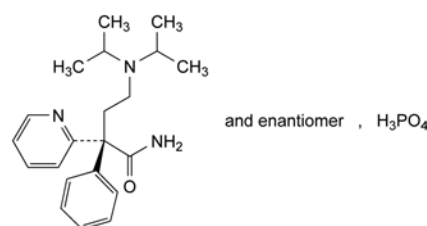

$C_{21}H_{32}N_3O_5P$   
[22059-60-5]

$M_r$  437.5

## DEFINITION

Disopyramide phosphate contains not less than 98.0 per cent and not more than the equivalent of 102.0 per cent of *(2RS)*-4-[bis(1-methylethyl)amino]-2-phenyl-2-(pyridin-2-yl)butanamide dihydrogen phosphate, calculated with reference to the dried substance.

## CHARACTERS

A white or almost white powder, soluble in water, sparingly soluble in alcohol, practically insoluble in methylene chloride.

## IDENTIFICATION

**First identification: B.**

**Second identification: A, C, D.**

- A. Dissolve 50.0 mg in a 5 g/L solution of *sulfuric acid R* in *methanol R* and dilute to 100.0 mL with the same solution. Dilute 5.0 mL of this solution to 50.0 mL with a 5 g/L solution of *sulfuric acid R* in *methanol R*. Examined between 240 nm and 350 nm (2.2.25), the solution shows an absorption maximum at 269 nm and a shoulder at 263 nm. The specific absorbance at the maximum is 147 to 163.
- B. Examine by infrared absorption spectrophotometry (2.2.24), comparing with the spectrum obtained with *disopyramide phosphate CRS*. Examine the substances prepared as discs.
- C. Examine the chromatograms obtained in the test for related substances in ultraviolet light at 254 nm. The principal spot in the chromatogram obtained with test solution (b) is similar in position and size to the principal spot in the chromatogram obtained with reference solution (a). Spray with *dilute potassium iodobismuthate solution R*. Examine in daylight. The principal spot in the chromatogram obtained with test solution (b) is similar in position, colour and size to the principal spot in the chromatogram obtained with reference solution (a).
- D. Solution S (see Tests) gives reaction (a) of phosphates (2.3.1).

## TESTS

**Solution S.** Dissolve 1.0 g in *carbon dioxide-free water R* and dilute to 20 mL with the same solvent.

**Appearance of solution.** Solution S is clear (2.2.1) and colourless (2.2.2, *Method II*).

**pH (2.2.3).** The pH of solution S is 4.0 to 5.0.

layer is not more intense than that of a standard prepared at the same time using 0.2 mL of a freshly prepared 0.15 g/L solution of *sodium diethyldithiocarbamate R* (150 ppm).

**Heavy metals** (2.4.8). 1.0 g complies with limit test C for heavy metals (20 ppm). Prepare the standard using 2 mL of *lead standard solution (10 ppm Pb) R*.

**Loss on drying** (2.2.32). Not more than 0.5 per cent, determined on 1.000 g by drying *in vacuo* at 50 °C.

**Sulfated ash** (2.4.14). Not more than 0.1 per cent, determined on 1.0 g.

#### ASSAY

Dissolve 0.450 g in 80 mL of *acetone R* and add 20 mL of a 20 g/L solution of *potassium nitrate R*. Titrate with 0.1 M *silver nitrate*. Determine the end-point potentiometrically (2.2.20), using a silver electrode and a silver-silver chloride double-junction electrode saturated with potassium nitrate.

1 mL of 0.1 M *silver nitrate* is equivalent to 59.30 mg of  $C_{10}H_{20}N_2S_4$ .

#### STORAGE

Store protected from light.

#### IMPURITIES

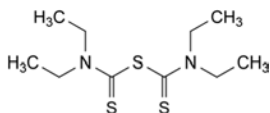

A. diethylthiocarbamic thioanhydride (sulfiram),

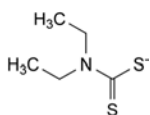

B. diethyldithiocarbamate.

01/2008:1007  
corrected 6.0

## DITHRANOL

### Dithranolum

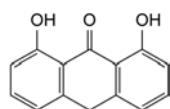

$C_{14}H_{10}O_3$   
[1143-38-0]

$M_r$  226.2

#### DEFINITION

1,8-Dihydroxyanthracen-9(10H)-one.

*Content*: 98.5 per cent to 101.0 per cent (dried substance).

#### CHARACTERS

*Appearance*: yellow or brownish-yellow, crystalline powder.

*Solubility*: practically insoluble in water, soluble in methylene chloride, sparingly soluble in acetone, slightly soluble in ethanol (96 per cent). It dissolves in dilute solutions of alkali hydroxides.

*Carry out all tests protected from bright light and use freshly prepared solutions.*

#### IDENTIFICATION

*First identification*: A, B.

*Second identification*: A, C, D.

A. Melting point (2.2.14): 178 °C to 182 °C.

B. Infrared absorption spectrophotometry (2.2.24).

*Comparison*: *dithranol CRS*.

C. Thin-layer chromatography (2.2.27).

*Test solution*. Dissolve 10 mg of the substance to be examined in *methylene chloride R* and dilute to 10 mL with the same solvent.

*Reference solution (a)*. Dissolve 10 mg of *dithranol CRS* in *methylene chloride R* and dilute to 10 mL with the same solvent.

*Reference solution (b)*. Dissolve about 5 mg of *dantron R* in 5 mL of reference solution (a).

*Plate*: *TLC silica gel plate R*.

*Mobile phase*: *hexane R, methylene chloride R (50:50 V/V)*.

*Application*: 10 µL.

*Development*: over a path of 12 cm.

*Drying*: in air.

*Detection*: place the plate in a tank saturated with ammonia vapour until the spots appear. Examine in daylight.

*System suitability*: reference solution (b):

– the chromatogram shows 2 clearly separated spots.

*Results*: the principal spot in the chromatogram obtained with the test solution is similar in position, colour and size to the principal spot in the chromatogram obtained with reference solution (a).

D. To 5 mg add 0.1 g of *anhydrous sodium acetate R* and 1 mL of *acetic anhydride R*. Boil for 30 s. Add 20 mL of *ethanol (96 per cent) R*. Examined in ultraviolet light at 365 nm, the solution shows a blue fluorescence.

#### TESTS

##### Related substances

A. Liquid chromatography (2.2.29).

*Test solution*. Dissolve 0.200 g of the substance to be examined in 20 mL of *methylene chloride R*, add 1.0 mL of *glacial acetic acid R* and dilute to 100.0 mL with *hexane R*.

*Reference solution*. Dissolve 5.0 mg of *anthrone R* (impurity A), 5.0 mg of *dantron R* (impurity B), 5.0 mg of *dithranol impurity C CRS* and 5.0 mg of *dithranol CRS* in *methylene chloride R* and dilute to 5.0 mL with the same solvent. To 1.0 mL of this solution, add 19.0 mL of *methylene chloride R* and 1.0 mL of *glacial acetic acid R*, and dilute to 50.0 mL with *hexane R*.

*Column*:

– *size*:  $l = 0.25$  m,  $\varnothing = 4.6$  mm;

– *stationary phase*: *silica gel for chromatography R* (5 µm).

*Mobile phase*: *glacial acetic acid R, methylene chloride R, hexane R (1:5:82 V/V/V)*.

*Flow rate*: 2 mL/min.

*Detection*: spectrophotometer at 260 nm.

*Injection*: 20 µL.

*Run time*: 1.5 times the retention time of impurity C.

*Elution order*: dithranol, impurity B, impurity A, impurity C.

*System suitability*: reference solution:

– *resolution*: minimum 2.0 between the peaks due to dithranol and impurity B.

*Limits*:

– *impurities A, B, C*: for each impurity, not more than the area of the corresponding peak in the chromatogram obtained with the reference solution (1 per cent).

B. Liquid chromatography (2.2.29).

*Test solution*. Dissolve 25.0 mg of the substance to be examined in 5 mL of *tetrahydrofuran R* and dilute to 25.0 mL with the mobile phase.

*Reference solution*. Dissolve 5.0 mg of *dithranol impurity D CRS* and 5.0 mg of *dithranol CRS* in 5 mL of *tetrahydrofuran R* and dilute to 10.0 mL with the mobile phase. Dilute 1.0 mL of this solution to 20.0 mL with the mobile phase.



## Column:

- size:  $l = 0.20$  m,  $\varnothing = 4.6$  mm;
- stationary phase: octadecylsilyl silica gel for chromatography R (5  $\mu$ m).

Mobile phase: glacial acetic acid R, tetrahydrofuran R, water R (2.5:40:60 V/V/V).

Flow rate: 0.9 mL/min.

Detection: spectrophotometer at 254 nm.

Injection: 20  $\mu$ L.

Run time: 3 times the retention time of dithranol.

System suitability: reference solution:

- resolution: minimum 2.5 between the peaks due to impurity D and dithranol.

## Limit:

- impurity D: not more than the area of the corresponding peak in the chromatogram obtained with the reference solution (2.5 per cent).

Total (tests A + B): maximum 3.0 per cent for the sum of the contents of all impurities.

Chlorides (2.4.4): maximum 100 ppm.

Shake 1.0 g with 20 mL of water R for 1 min and filter. Dilute 10 mL of the filtrate to 15 mL with water R.

Loss on drying (2.2.32): maximum 0.5 per cent, determined on 1.000 g by drying in an oven at 105 °C.

Sulfated ash (2.4.14): maximum 0.1 per cent, determined on 1.0 g.

## ASSAY

Dissolve 0.200 g in 50 mL of anhydrous pyridine R. Titrate with 0.1 M tetrabutylammonium hydroxide under nitrogen R. Determine the end-point potentiometrically (2.2.20), using a glass indicator electrode and a calomel reference electrode containing, as the electrolyte, a saturated solution of potassium chloride R in methanol R.

1 mL of 0.1 M tetrabutylammonium hydroxide is equivalent to 22.62 mg of  $C_{18}H_{24}O_3$ .

## STORAGE

Protected from light.

## IMPURITIES

Specified impurities: A, B, C, D.

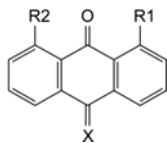

- A.  $R_1 = R_2 = H$ ,  $X = H_2$ : anthracen-9(10H)-one (anthrone),
- B.  $R_1 = R_2 = OH$ ,  $X = O$ : 1,8-dihydroxyanthracene-9,10-dione (dantron),
- D.  $R_1 = OH$ ,  $R_2 = H$ ,  $X = H_2$ : 1-hydroxyanthracen-9(10H)-one,



- C. 4,4',5,5'-tetrahydroxy-9,9'-bianthracenyl-10,10'(9H,9'H)-dione.

07/2010:1200

## DOBUTAMINE HYDROCHLORIDE

## Dobutamini hydrochloridum

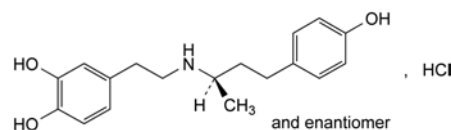

$C_{18}H_{24}ClNO_3$   
[49745-95-1]

$M_r$  337.9

## DEFINITION

(RS)-4-[2-[[3-(4-Hydroxyphenyl)-1-methylpropyl]amino]ethyl]-benzene-1,2-diol hydrochloride.

Content: 98.5 per cent to 101.0 per cent (dried substance).

## CHARACTERS

Appearance: white or almost white, crystalline powder.

Solubility: sparingly soluble in water, soluble in methanol, sparingly soluble in ethanol (96 per cent).

## IDENTIFICATION

First identification: C, E.

Second identification: A, B, D, E.

A. Melting point (2.2.14): 189 °C to 192 °C.

B. Ultraviolet and visible absorption spectrophotometry (2.2.25).

Test solution. Dissolve 20.0 mg in methanol R and dilute to 100.0 mL with the same solvent. Dilute 10.0 mL of this solution to 100.0 mL with methanol R.

Spectral range: 220-300 nm.

Absorption maxima: at 223 nm and 281 nm.

Absorbance ratio:  $A_{281} / A_{223} = 0.34$  to 0.36.

C. Infrared absorption spectrophotometry (2.2.24).

Comparison: dobutamine hydrochloride CRS.

D. Thin-layer chromatography (2.2.27).

Solvent mixture: glacial acetic acid R, methanol R (50:50 V/V).

Test solution. Dissolve 10 mg of the substance to be examined in the solvent mixture and dilute to 10 mL with the solvent mixture.

Reference solution (a). Dissolve 10.0 mg of dobutamine hydrochloride CRS in the solvent mixture and dilute to 10 mL with the solvent mixture.

Reference solution (b). Dissolve 5.0 mg of dopamine hydrochloride CRS in 5 mL of the test solution.

Plate: TLC silica gel G plate R.

Mobile phase: water R, glacial acetic acid R, ether R, butanol R (5:15:30:45 V/V/V/V).

Application: 10  $\mu$ L.

Development: over 2/3 of the plate.

Drying: in air.

Detection: spray with a 1 g/L solution of potassium permanganate R.

System suitability: reference solution (b):

- the chromatogram shows 2 clearly separated spots.

Results: the principal spot in the chromatogram obtained with the test solution is similar in position, colour and size to the principal spot in the chromatogram obtained with reference solution (a).

E. It gives reaction (a) of chlorides (2.3.1) using a mixture of equal volumes of methanol R and water R.

## TESTS

**Acidity or alkalinity.** Dissolve 0.1 g in *water R* with gentle heating and dilute to 10 mL with the same solvent. Add 0.1 mL of *methyl red solution R* and 0.2 mL of 0.01 M *sodium hydroxide*. The solution is yellow. Add 0.4 mL of 0.01 M *hydrochloric acid*. The solution is red.

**Optical rotation (2.2.7):**  $-0.05^\circ$  to  $+0.05^\circ$ .

Dissolve 0.50 g in *methanol R* and dilute to 10.0 mL with the same solvent.

**Absorbance (2.2.25):** maximum 0.04 at 480 nm.

Dissolve 0.5 g in a mixture of equal volumes of *methanol R* and of *water R* with heating, if necessary, at 30-35 °C and dilute to 25 mL with the same mixture of solvents. Cool quickly. Examine immediately.

**Related substances.** Liquid chromatography (2.2.29).

*Solvent mixture:* mobile phase B, mobile phase A (35:65 V/V).

*Test solution.* Dissolve 0.10 g of the substance to be examined in the solvent mixture and dilute to 20.0 mL with the solvent mixture.

*Reference solution (a).* Dilute 4.0 mL of the test solution to 100.0 mL with a 0.05 g/L solution of *anisaldehyde R* in the solvent mixture. Dilute 1.0 mL of this solution to 10.0 mL with the solvent mixture.

*Reference solution (b).* Dilute 5.0 mL of the test solution to 100.0 mL with the solvent mixture. Dilute 1.0 mL of this solution to 10.0 mL with the solvent mixture.

*Reference solution (c).* Dissolve the contents of a vial of *dobutamine impurity mixture CRS* (impurities A, B and C) in 1.0 mL of the solvent mixture.

*Column:*

- *size:*  $l = 0.15$  m,  $\varnothing = 4.6$  mm;
- *stationary phase:* *octadecylsilyl silica gel for chromatography R* (5  $\mu$ m).

*Mobile phase:*

- *mobile phase A:* dissolve 2.60 g of *sodium octanesulfonate R* in 1000 mL of *water R*, add 3 mL of *triethylamine R* and adjust to pH 2.5 with *phosphoric acid R*;
- *mobile phase B:* *acetonitrile R*, *methanol R* (18:82 V/V);

Time (min)	Mobile phase A (per cent V/V)	Mobile phase B (per cent V/V)
0 - 5	65	35
5 - 20	65 → 20	35 → 80
20 - 25	20	80

*Flow rate:* 1 mL/min.

*Detection:* spectrophotometer at 280 nm.

*Injection:* 20  $\mu$ L.

*Identification of impurities:* use the chromatogram supplied with *dobutamine impurity mixture CRS* and the chromatogram obtained with reference solution (c) to identify the peaks due to impurities A, B and C.

*Relative retention* with reference to *dobutamine* (retention time = about 12 min): impurity A = about 0.3; impurity B = about 0.5; impurity C = about 1.4.

*System suitability:* reference solution (a):

- *resolution:* minimum 4.0 between the peaks due to *dobutamine* and *anisaldehyde*.

*Limits:*

- *correction factor:* for the calculation of content, multiply the peak area of impurity B by 1.4;
- *impurities A, B, C:* for each impurity, not more than the area of the principal peak in the chromatogram obtained with reference solution (b) (0.5 per cent);
- *unspecified impurities:* for each impurity, not more than 0.2 times the area of the principal peak in the chromatogram obtained with reference solution (b) (0.10 per cent);

- *total:* not more than twice the area of the principal peak in the chromatogram obtained with the reference solution (b) (1 per cent);
- *disregard limit:* 0.1 times the area of the principal peak in the chromatogram obtained with reference solution (b) (0.05 per cent).

**Heavy metals (2.4.8):** maximum 10 ppm.

2.0 g complies with test C. Prepare the reference solution using 2 mL of *lead standard solution (10 ppm Pb) R*.

**Loss on drying (2.2.32):** maximum 0.5 per cent, determined on 1.000 g by drying in an oven at 105 °C.

**Sulfated ash (2.4.14):** maximum 0.1 per cent, determined on 1.0 g.

## ASSAY

*In order to avoid overheating in the reaction medium, mix thoroughly throughout and stop the titration immediately after the end-point has been reached.*

Dissolve 0.250 g in 10 mL of *anhydrous formic acid R*. Add 50 mL of *acetic anhydride R*. Titrate with 0.1 M *perchloric acid*, determining the end-point potentiometrically (2.2.20).

1 mL of 0.1 M *perchloric acid* is equivalent to 33.79 mg of  $C_{18}H_{24}ClNO_3$ .

## STORAGE

Protected from light.

## IMPURITIES

*Specified impurities:* A, B, C.

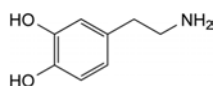

A. 4-(2-aminoethyl)benzene-1,2-diol (*dopamine*),

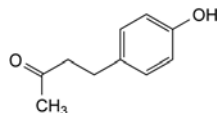

B. 4-(4-hydroxyphenyl)butan-2-one,

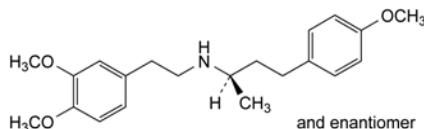

C. (2*RS*)-*N*[2-(3,4-dimethoxyphenyl)ethyl]-4-(4-methoxyphenyl)butan-2-amine.

01/2010:2449

## DOCETAXEL TRIHYDRATE

Docetaxelum trihydricum

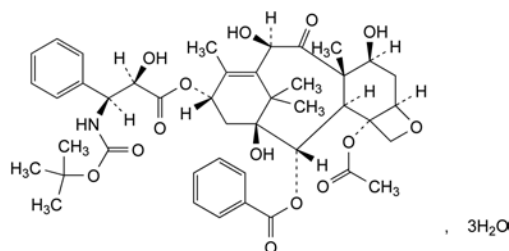

$C_{43}H_{53}NO_{14} \cdot 3H_2O$   
[148408-66-6]

$M_r$  862

## DEFINITION

1,7 $\beta$ ,10 $\beta$ -Trihydroxy-9-oxo-5 $\beta$ ,20-epoxytax-11-ene-2 $\alpha$ ,4,13 $\alpha$ -triyl 4-acetate 2-benzoate 13-[(2*R*,3*S*)-3-[[1,1-dimethylethoxy]carbonyl]amino]-2-hydroxy-3-phenylpropanoate], trihydrate.

*Content*: 97.5 per cent to 102.0 per cent (anhydrous substance).

## CHARACTERS

*Appearance*: white or almost white crystalline powder.

*Solubility*: practically insoluble in water, freely soluble in anhydrous ethanol, soluble in methylene chloride.

## IDENTIFICATION

A. Specific optical rotation (see Tests).

B. Infrared absorption spectrophotometry (2.2.24).

*Comparison*: docetaxel trihydrate CRS.

## TESTS

**Appearance of solution.** The solution is not more opalescent than reference suspension II (2.2.1) and not more intensely coloured than reference solution B5 (2.2.2, Method I).

Dissolve 1.0 g in *anhydrous ethanol R* and dilute to 20 mL with the same solvent.

**Specific optical rotation** (2.2.7): –38.5 to –41.5 (anhydrous substance).

Dissolve 0.250 g in *methanol R* and dilute to 25.0 mL with the same solvent.

**Related substances.** Liquid chromatography (2.2.29).

*Solvent mixture*: acetic acid R, acetonitrile R1, water R (0.05:50:50 V/V/V).

*Test solution.* Dissolve 50.0 mg of the substance to be examined in 2.5 mL of *anhydrous ethanol R* and dilute to 50.0 mL with the solvent mixture.

*Reference solution (a).* Dissolve 50.0 mg of *docetaxel trihydrate CRS* in 2.5 mL of *anhydrous ethanol R* and dilute to 50.0 mL with the solvent mixture.

*Reference solution (b).* Dilute 1.0 mL of the test solution to 100.0 mL with the solvent mixture. Dilute 1.0 mL of this solution to 10.0 mL with the solvent mixture.

*Reference solution (c).* Dissolve 5 mg of *docetaxel for system suitability CRS* (containing impurities A, B and C) in 0.25 mL of *anhydrous ethanol R* and dilute to 5.0 mL with the solvent mixture.

*Column*:

- *size*:  $l = 0.15$  m,  $\varnothing = 4.6$  mm;
- *stationary phase*: end-capped octadecylsilyl silica gel for chromatography R (3.5  $\mu$ m);
- *temperature*: 45 °C.

*Mobile phase*:

- *mobile phase A*: water R;
- *mobile phase B*: acetonitrile R1;

Time (min)	Mobile phase A (per cent V/V)	Mobile phase B (per cent V/V)
0 - 9	72	28
9 → 39	72 → 28	28 → 72

*Flow rate*: 1.2 mL/min.

*Detection*: spectrophotometer at 232 nm.

*Injection*: 10  $\mu$ L of the test solution and reference solutions (b) and (c).

*Identification of impurities*: use the chromatogram supplied with *docetaxel for system suitability CRS* and the chromatogram obtained with reference solution (c) to identify the peaks due to impurities A, B and C.

*Relative retention* with reference to docetaxel (retention time = about 27 min): impurity A = about 0.97; impurity B = about 1.08; impurity C = about 1.13.

*System suitability*: reference solution (c):

- *resolution*: minimum 4.0 between the peaks due to impurity A and docetaxel.

*Limits*:

- *correction factor*: for the calculation of content, multiply the peak area of impurity A by 1.6;
- *impurity A*: not more than 5 times the area of the principal peak in the chromatogram obtained with reference solution (b) (0.5 per cent);
- *impurities B, C*: for each impurity, not more than 3 times the area of the principal peak in the chromatogram obtained with reference solution (b) (0.3 per cent);
- *unspecified impurities*: for each impurity, not more than the area of the principal peak in the chromatogram obtained with reference solution (b) (0.10 per cent);
- *total*: not more than 10 times the area of the principal peak in the chromatogram obtained with reference solution (b) (1.0 per cent);
- *disregard limit*: 0.5 times the area of the principal peak in the chromatogram obtained with reference solution (b) (0.05 per cent).

**Heavy metals** (2.4.8): maximum 20 ppm.

Dissolve, using sonication, 1.0 g in a mixture of 15 volumes of *water R* and 85 volumes of *dimethylformamide R* and dilute to 20 mL with the same mixture of solvents. 12 mL of the solution complies with test B. Prepare the reference solution using lead standard solution (1 ppm Pb) obtained by diluting *lead standard solution (100 ppm Pb) R* with a mixture of 15 volumes of *water R* and 85 volumes of *dimethylformamide R*.

**Water** (2.5.32): 5.0 per cent to 7.0 per cent.

Inject 200  $\mu$ L of a 100 mg/mL solution of the substance to be examined in *dimethylformamide R*.

**Sulfated ash** (2.4.14): maximum 0.1 per cent, determined on 1.0 g.

**Bacterial endotoxins** (2.6.14): less than 0.3 IU/mg, if intended for use in the manufacture of parenteral preparations without a further appropriate procedure for the removal of bacterial endotoxins.

## ASSAY

Liquid chromatography (2.2.29) as described in the test for related substances with the following modifications.

*Injection*: 10  $\mu$ L of the test solution and reference solution (a).

Calculate the percentage content of C<sub>43</sub>H<sub>53</sub>NO<sub>14</sub> from the declared content of *docetaxel trihydrate CRS*.

## STORAGE

Protected from light.

## IMPURITIES

*Specified impurities*: A, B, C.

*Other detectable impurities* (the following substances would, if present at a sufficient level, be detected by one or other of the tests in the monograph. They are limited by the general acceptance criterion for other/unspecified impurities and/or by the general monograph *Substances for pharmaceutical use (2034)*. It is therefore not necessary to identify these impurities for demonstration of compliance. See also 5.10. *Control of impurities in substances for pharmaceutical use*): D.

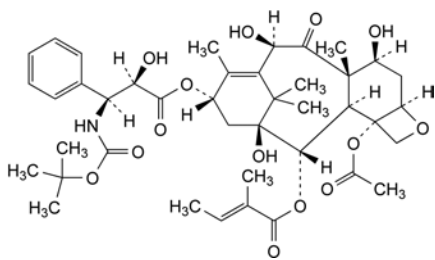

- A. 1,7 $\beta$ ,10 $\beta$ -trihydroxy-9-oxo-5 $\beta$ ,20-epoxytax-11-ene-2 $\alpha$ ,4,13 $\alpha$ -triyl 4-acetate 13-[(2*R*,3*S*)-3-[[1,1-dimethylethoxy)carbonyl]amino]-2-hydroxy-3-phenylpropanoate] 2-[(2*E*)-2-methylbut-2-enoate] (2-*O*-desbenzoyl-2-*O*-tiglyldocetaxel),

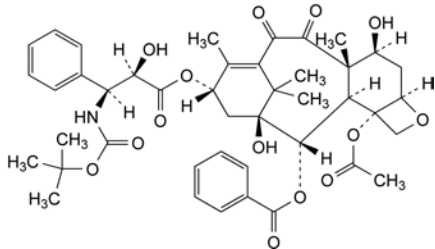

- B. 1,7 $\beta$ -dihydroxy-9,10-dioxo-5 $\beta$ ,20-epoxytax-11-ene-2 $\alpha$ ,4,13 $\alpha$ -triyl 4-acetate 2-benzoate 13-[(2*R*,3*S*)-3-[[1,1-dimethylethoxy)carbonyl]amino]-2-hydroxy-3-phenylpropanoate] (10-dehydroxy-10-oxodocetaxel),

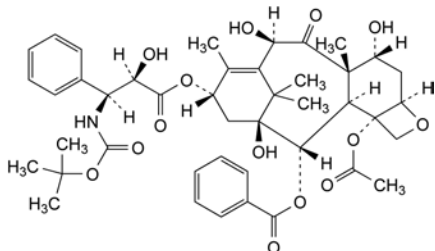

- C. 1,7 $\alpha$ ,10 $\beta$ -trihydroxy-9-oxo-5 $\beta$ ,20-epoxytax-11-ene-2 $\alpha$ ,4,13 $\alpha$ -triyl 4-acetate 2-benzoate 13-[(2*R*,3*S*)-3-[[1,1-dimethylethoxy)carbonyl]amino]-2-hydroxy-3-phenylpropanoate] (7-*epi*-docetaxel),

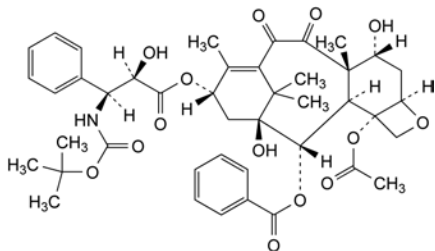

- D. 1,7 $\alpha$ -dihydroxy-9,10-dioxo-5 $\beta$ ,20-epoxytax-11-ene-2 $\alpha$ ,4,13 $\alpha$ -triyl 4-acetate 2-benzoate 13-[(2*R*,3*S*)-3-[[1,1-dimethylethoxy)carbonyl]amino]-2-hydroxy-3-phenylpropanoate] (10-dehydroxy-10-oxo-7-*epi*-docetaxel).

01/2008:1418

## DOCUSATE SODIUM

### Natrii docusas

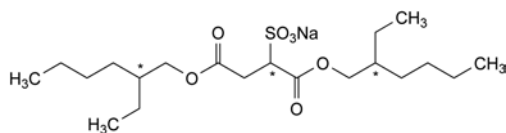

$C_{20}H_{37}NaO_7S$   
[577-11-7]

$M_r$  444.6

#### DEFINITION

Sodium 1,4-bis[(2-ethylhexyl)oxy]-1,4-dioxobutane-2-sulfonate.  
*Content*: 98.0 to 101.0 per cent (anhydrous substance).

#### CHARACTERS

*Appearance*: white or almost white, waxy masses or flakes, hygroscopic.

*Solubility*: sparingly soluble in water, freely soluble in ethanol (96 per cent) and in methylene chloride.

#### IDENTIFICATION

- A. Infrared absorption spectrophotometry (2.2.24).

*Preparation*: place about 3 mg of the substance to be examined on a sodium chloride plate, add 0.05 mL of *acetone R* and immediately cover with another sodium chloride plate. Rub the plates together to dissolve the substance to be examined, slide the plates apart and allow the acetone to evaporate.

*Comparison*: *Ph. Eur. reference spectrum of docusate sodium*.

- B. In a crucible, ignite 0.75 g in the presence of *dilute sulfuric acid R*, until an almost white residue is obtained. Allow to cool and take up the residue with 5 mL of *water R*. Filter. 2 mL of the filtrate gives reaction (a) of sodium (2.3.1).

#### TESTS

**Alkalinity.** Dissolve 1.0 g in 100 mL of a mixture of equal volumes of *methanol R* and *water R*, previously neutralised to *methyl red solution R*. Add 0.1 mL of *methyl red solution R*. Not more than 0.2 mL of 0.1 M *hydrochloric acid* is required to change the colour of the indicator to red.

**Related non-ionic substances.** Gas chromatography (2.2.28).

*Internal standard solution.* Dissolve 10 mg of *methyl behenate R* in *hexane R* and dilute to 50 mL with the same solvent.

*Test solution (a).* Dissolve 0.10 g of the substance to be examined in 2.0 mL of the internal standard solution and dilute to 5.0 mL with *hexane R*. Pass the solution, at a rate of about 1.5 mL/min, through a column 10 mm in internal diameter, packed with 5 g of *basic aluminium oxide R* and previously washed with 25 mL of *hexane R*. Elute with 5 mL of *hexane R* and discard the eluate. Elute with 20 mL of a mixture of equal volumes of *ether R* and *hexane R*. Evaporate the eluate to dryness and dissolve the residue in 2.0 mL of *hexane R*.

*Test solution (b).* Prepare as described for test solution (a) but dissolving 0.10 g of the substance to be examined in *hexane R*, diluting to 5.0 mL with the same solvent, and using a new column.

*Reference solution.* Dilute 2.0 mL of the internal standard solution to 5.0 mL with *hexane R*.

*Column*:

- *material*: glass,
- *size*:  $l = 2$  m,  $\varnothing = 2$  mm,
- *stationary phase*: *silanised diatomaceous earth for gas chromatography R* impregnated with 3 per cent *m/m* of *polymethylphenylsiloxane R*.

*Carrier gas*: *nitrogen for chromatography R*.

*Flow rate*: 30 mL/min.

*Temperature*:

- *column*: 230 °C,
- *injection port and detector*: 280 °C.

*Detection*: flame ionisation.

*Injection*: 1  $\mu$ L.

*Run time*: 2.5 times the retention time of the internal standard.

*System suitability*: there is no peak with the same retention time as the internal standard in the chromatogram obtained with test solution (b).

**Limits:** test solution (a):

- *any impurity:* for each impurity, not more than the area of the peak due to the internal standard (0.4 per cent).

**Chlorides:** maximum 350 ppm.

Dissolve 5.0 g in 50 mL of *ethanol (50 per cent V/V) R* and add 0.1 mL of *potassium dichromate solution R*. Not more than 0.5 mL of 0.1 M *silver nitrate* is required to change the colour of the indicator from yellow to orange.

**Sodium sulfate:** maximum 2 per cent.

Dissolve 0.25 g in 40 mL of a mixture of 20 volumes of *water R* and 80 volumes of *2-propanol R*. Adjust to pH between 2.5 and 4.0 using *perchloric acid solution R*. Add 0.4 mL of *naphtharson solution R* and 0.1 mL of a 0.125 g/L solution of *methylene blue R*. Not more than 1.5 mL of 0.025 M *barium perchlorate* is required to change the colour of the indicator from yellowish-green to yellowish-pink.

**Heavy metals (2.4.8):** maximum 10 ppm.

Dissolve 4.0 g in *ethanol (80 per cent V/V) R* and dilute to 20 mL with the same solvent. 12 mL of the solution complies with test B. Prepare the reference solution using lead standard solution (2 ppm Pb) obtained by diluting *lead standard solution (100 ppm Pb) R* with *ethanol (80 per cent V/V) R*.

**Water (2.5.12):** maximum 3.0 per cent, determined on 0.250 g.

#### ASSAY

To 1.000 g in a 250 mL conical flask fitted with a reflux condenser add 25.0 mL of 0.5 M *alcoholic potassium hydroxide* and heat on a water-bath under reflux for 45 min. Allow to cool. Add 0.25 mL of *phenolphthalein solution R1* and titrate with 0.5 M *hydrochloric acid* until the red colour disappears. Carry out a blank titration.

1 mL of 0.5 M *alcoholic potassium hydroxide* is equivalent to 0.1112 g of  $C_{20}H_{37}NaO_7S$ .

#### STORAGE

In an airtight container.

01/2008:2078

## DODECYL GALLATE

Dodecylis gallas

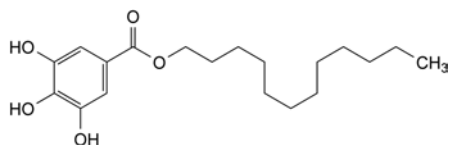

$C_{19}H_{30}O_5$   
[1166-52-5]

$M_r$  338.4

#### DEFINITION

Dodecyl 3,4,5-trihydroxybenzoate.

**Content:** 97.0 per cent to 103.0 per cent (dried substance).

#### CHARACTERS

**Appearance:** white or almost white, crystalline powder.

**Solubility:** very slightly soluble or practically insoluble in water, freely soluble in ethanol (96 per cent), slightly soluble in methylene chloride.

#### IDENTIFICATION

A. Determine the melting point (2.2.14) of the substance to be examined. Mix equal parts of the substance to be examined and *dodecyl gallate CRS* and determine the melting point of the mixture. The difference between the melting points (which are about 96 °C) is not greater than 2 °C.

B. Examine the chromatograms obtained in the test for impurity A.

**Results:** the principal spot in the chromatogram obtained with test solution (b) is similar in position, colour and size to the principal spot in the chromatogram obtained with reference solution (a).

#### TESTS

**Impurity A.** Thin-layer chromatography (2.2.27).

**Test solution (a).** Dissolve 0.20 g of the substance to be examined in *acetone R* and dilute to 10 mL with the same solvent.

**Test solution (b).** Dilute 1.0 mL of test solution (a) to 20 mL with *acetone R*.

**Reference solution (a).** Dissolve 10 mg of *dodecyl gallate CRS* in *acetone R* and dilute to 10 mL with the same solvent.

**Reference solution (b).** Dissolve 20 mg of *gallic acid R* in *acetone R* and dilute to 20 mL with the same solvent.

**Reference solution (c).** Dilute 1.0 mL of reference solution (b) to 10 mL with *acetone R*.

**Reference solution (d).** Dilute 1.0 mL of reference solution (b) to 5 mL with test solution (a).

**Plate:** *TLC silica gel plate R*.

**Mobile phase:** *anhydrous formic acid R, ethyl formate R, toluene R (10:40:50 V/V/V)*.

**Application:** 5 µL of test solutions (a) and (b) and reference solutions (a), (c) and (d).

**Development:** over 2/3 of the plate.

**Drying:** in air for 10 min.

**Detection:** spray with a mixture of 1 volume of *ferric chloride solution R1* and 9 volumes of *ethanol (96 per cent) R*.

**System suitability:** reference solution (d):

- the chromatogram shows 2 clearly separated principal spots.

**Limit:** test solution (a):

- *impurity A:* any spot due to impurity A is not more intense than the spot in the chromatogram obtained with reference solution (c) (0.5 per cent).

**Chlorides (2.4.4):** maximum 100 ppm.

To 1.65 g add 50 mL of *water R*. Shake for 5 min. Filter. 15 mL of the filtrate complies with the test.

**Heavy metals (2.4.8):** maximum 10 ppm.

2.0 g complies with limit test C. Prepare the reference solution using 2 mL of *lead standard solution (10 ppm Pb) R*.

**Loss on drying (2.2.32):** maximum 0.5 per cent, determined on 1.000 g by drying in an oven at 70 °C.

**Sulfated ash (2.4.14):** maximum 0.1 per cent, determined on 1.0 g.

#### ASSAY

Dissolve 0.100 g in *methanol R* and dilute to 250.0 mL with the same solvent. Dilute 5.0 mL of the solution to 200.0 mL with *methanol R*. Measure the absorbance (2.2.25) at the absorption maximum at 275 nm.

Calculate the content of  $C_{19}H_{30}O_5$  taking the specific absorbance to be 321.

#### STORAGE

In a non-metallic container, protected from light.

#### IMPURITIES

**Specified impurities:** A.

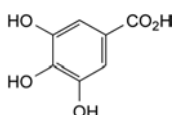

A. 3,4,5-trihydroxybenzoic acid (gallic acid).

**01/2008:1009 corrected 6.0** **Related substances.** Liquid chromatography (2.2.29). Prepare the solutions immediately before use.

## DOMPERIDONE

### Domperidonum

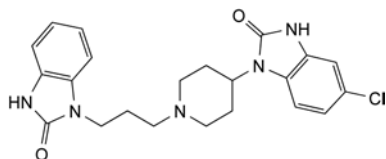

C<sub>22</sub>H<sub>24</sub>ClN<sub>5</sub>O<sub>2</sub>  
[57808-66-9]

M<sub>r</sub> 425.9

#### DEFINITION

5-Chloro-1-[1-[3-(2-oxo-2,3-dihydro-1H-benzimidazol-1-yl)propyl]piperidin-4-yl]-1,3-dihydro-2H-benzimidazol-2-one.

Content: 99.0 per cent to 101.0 per cent (dried substance).

#### CHARACTERS

**Appearance:** white or almost white powder.

**Solubility:** practically insoluble in water, soluble in dimethylformamide, slightly soluble in ethanol (96 per cent) and in methanol.

#### IDENTIFICATION

**First identification:** A, B.

**Second identification:** A, C, D.

A. Melting point (2.2.14): 244 °C to 248 °C.

B. Infrared absorption spectrophotometry (2.2.24).

*Preparation:* discs.

*Comparison:* domperidone CRS.

C. Thin-layer chromatography (2.2.27).

**Test solution.** Dissolve 20 mg of the substance to be examined in methanol R and dilute to 10 mL with the same solvent.

**Reference solution (a).** Dissolve 20 mg of domperidone CRS in methanol R and dilute to 10 mL with the same solvent.

**Reference solution (b).** Dissolve 20 mg of domperidone CRS and 20 mg of droperidol CRS in methanol R and dilute to 10 mL with the same solvent.

**Plate:** TLC octadecylsilyl silica gel plate R.

**Mobile phase:** ammonium acetate solution R, dioxan R, methanol R (20:40:40 V/V/V).

**Application:** 5 µL.

**Development:** over a path of 15 cm.

**Drying:** in a current of warm air for 15 min.

**Detection:** expose to iodine vapour until the spots appear. Examine in daylight.

**System suitability:** reference solution (b):

– the chromatogram shows 2 clearly separated spots.

**Results:** the principal spot in the chromatogram obtained with the test solution is similar in position and size to the principal spot in the chromatogram obtained with reference solution (a).

D. It gives the reaction of non-nitrogen substituted barbiturates (2.3.1).

#### TESTS

**Appearance of solution.** The solution is clear (2.2.1) and not more intensely coloured than reference solution Y<sub>6</sub> (2.2.2, Method II).

Dissolve 0.20 g in dimethylformamide R and dilute to 20.0 mL with the same solvent.

**Test solution.** Dissolve 0.10 g of the substance to be examined in dimethylformamide R and dilute to 10.0 mL with the same solvent.

**Reference solution (a).** Dissolve 10.0 mg of domperidone CRS and 15.0 mg of droperidol CRS in dimethylformamide R and dilute to 100.0 mL with the same solvent.

**Reference solution (b).** Dilute 1.0 mL of the test solution to 100.0 mL with dimethylformamide R. Dilute 5.0 mL of this solution to 20.0 mL with dimethylformamide R.

**Column:**

– size: *l* = 0.1 m, Ø = 4.6 mm;

– stationary phase: base-deactivated octadecylsilyl silica gel for chromatography R (3 µm).

**Mobile phase:**

– mobile phase A: 5 g/L solution of ammonium acetate R;

– mobile phase B: methanol R;

Time (min)	Mobile phase A (per cent V/V)	Mobile phase B (per cent V/V)
0 - 10	70 → 0	30 → 100
10 - 12	0	100

**Flow rate:** 1.5 mL/min.

**Detection:** spectrophotometer at 280 nm.

**Equilibration:** with methanol R for at least 30 min and then with the mobile phase at the initial composition for at least 5 min.

**Injection:** 10 µL; inject dimethylformamide R as a blank.

**Retention time:** domperidone = about 6.5 min; droperidol = about 7 min.

**System suitability:** reference solution (a):

– resolution: minimum 2.0 between the peaks due to domperidone and droperidol; if necessary, adjust the concentration of methanol in the mobile phase or adjust the time programme for the linear gradient.

**Limits:**

– impurities A, B, C, D, E, F: for each impurity, not more than the area of the principal peak in the chromatogram obtained with reference solution (b) (0.25 per cent);

– total: not more than twice the area of the principal peak in the chromatogram obtained with reference solution (b) (0.5 per cent);

– disregard limit: 0.2 times the area of the principal peak in the chromatogram obtained with reference solution (b) (0.05 per cent); disregard any peak due to the blank.

**Heavy metals (2.4.8):** maximum 20 ppm.

1.0 g complies with test D. Prepare the reference solution using 2 mL of lead standard solution (10 ppm Pb) R.

**Loss on drying (2.2.32):** maximum 0.5 per cent, determined on 1.000 g by drying in an oven at 105 °C.

**Sulfated ash (2.4.14):** maximum 0.1 per cent, determined on 1.0 g.

#### ASSAY

Dissolve 0.300 g in 50 mL of a mixture of 1 volume of anhydrous acetic acid R and 7 volumes of methyl ethyl ketone R. Titrate with 0.1 M perchloric acid until the colour changes from orange-yellow to green using 0.2 mL of naphtholbenzein solution R as indicator.

1 mL of 0.1 M perchloric acid is equivalent to 42.59 mg of C<sub>22</sub>H<sub>24</sub>ClN<sub>5</sub>O<sub>2</sub>.

#### STORAGE

Protected from light.

## IMPURITIES

Specified impurities: A, B, C, D, E, F.

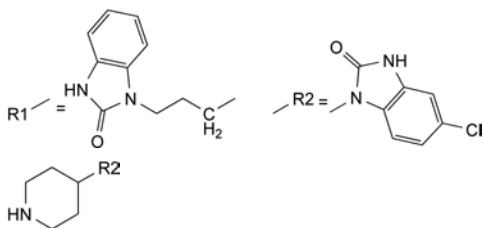

A. 5-chloro-1-(piperidin-4-yl)-1,3-dihydro-2H-benzimidazol-2-one,

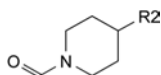

B. 4-(5-chloro-2-oxo-2,3-dihydro-1H-benzimidazol-1-yl)-1-formylpiperidine,

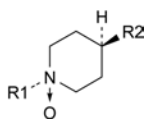

C. *cis*-4-(5-chloro-2-oxo-2,3-dihydro-1H-benzimidazol-1-yl)-1-(3-(2-oxo-2,3-dihydro-1H-benzimidazol-1-yl)propyl)piperidine 1-oxide,

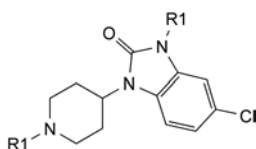

D. 5-chloro-3-[3-(2-oxo-2,3-dihydro-1H-benzimidazol-1-yl)propyl]-1-[1-[3-(2-oxo-2,3-dihydro-1H-benzimidazol-1-yl)propyl]piperidin-4-yl]-1,3-dihydro-2H-benzimidazol-2-one,

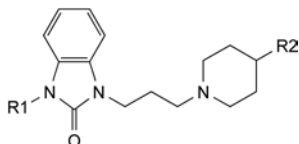

E. 1-[3-[4-(5-chloro-2-oxo-2,3-dihydro-1H-benzimidazol-1-yl)piperidin-1-yl]propyl]-3-[3-(2-oxo-2,3-dihydro-1H-benzimidazol-1-yl)propyl]-1,3-dihydro-2H-benzimidazol-2-one,

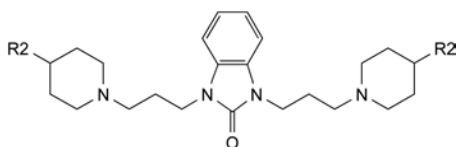

F. 1,3-bis[3-[4-(5-chloro-2-oxo-2,3-dihydro-1H-benzimidazol-1-yl)piperidin-1-yl]propyl]-1,3-dihydro-2H-benzimidazol-2-one.

01/2008:1008  
corrected 6.0

## DOMPERIDONE MALEATE

## Domperidoni maleas

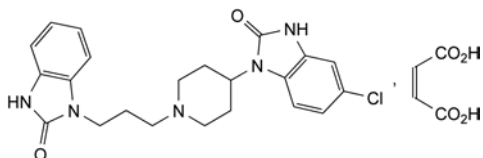

$C_{26}H_{28}ClN_5O_6$   
[83898-65-1]

$M_r$  542.0

## DEFINITION

5-Chloro-1-[1-[3-(2-oxo-2,3-dihydro-1H-benzimidazol-1-yl)propyl]piperidin-4-yl]-1,3-dihydro-2H-benzimidazol-2-one hydrogen (*Z*)-butenedioate.

Content: 99.0 per cent to 101.0 per cent (dried substance).

## CHARACTERS

Appearance: white or almost white powder.

Solubility: very slightly soluble in water, sparingly soluble in dimethylformamide, slightly soluble in methanol, very slightly soluble in ethanol (96 per cent).

It shows polymorphism (5.9).

## IDENTIFICATION

First identification: A.

Second identification: B, C.

A. Infrared absorption spectrophotometry (2.2.24).

Preparation: discs.

Comparison: domperidone maleate CRS.

If the spectra obtained show differences, dissolve the substance to be examined and the reference substance separately in the minimum volume of 2-propanol R, evaporate to dryness on a water-bath and record new spectra using the residues.

B. Thin-layer chromatography (2.2.27).

Test solution. Dissolve 20 mg of the substance to be examined in methanol R and dilute to 10 mL with the same solvent.

Reference solution (a). Dissolve 20 mg of domperidone maleate CRS in methanol R and dilute to 10 mL with the same solvent.

Reference solution (b). Dissolve 20 mg of domperidone maleate CRS and 20 mg of droperidol CRS in methanol R and dilute to 10 mL with the same solvent.

Plate: TLC octadecylsilyl silica gel plate R.

Mobile phase: ammonium acetate solution R, dioxan R, methanol R (20:40:40 V/V/V).

Application: 5  $\mu$ L.

Development: over a path of 15 cm.

Drying: in a current of warm air for 15 min.

Detection: expose to iodine vapour until the spots appear. Examine in daylight.

System suitability: reference solution (b):

– the chromatogram shows 2 clearly separated spots.

Results: the principal spot in the chromatogram obtained with the test solution is similar in position and size to the principal spot in the chromatogram obtained with reference solution (a).

C. Triturate 0.1 g with a mixture of 1 mL of strong sodium hydroxide solution R and 3 mL of water R. Shake with 3 quantities, each of 5 mL, of ether R. To 0.1 mL of the aqueous layer add a solution of 10 mg of resorcinol R in 3 mL of sulfuric acid R. Heat on a water-bath for 15 min. No colour develops. To the remainder of the aqueous layer add 2 mL of bromine solution R. Heat on a water-bath for 15 min and then heat to boiling. Cool. To 0.1 mL of this solution add a solution of 10 mg of resorcinol R in 3 mL of sulfuric acid R. Heat on a water-bath for 15 min. A violet colour develops.

## TESTS

Appearance of solution. The solution is clear (2.2.1) and not more intensely coloured than reference solution Y<sub>6</sub> (2.2.2, Method II).

Dissolve 0.20 g in dimethylformamide R and dilute to 20.0 mL with the same solvent.

**Related substances.** Liquid chromatography (2.2.29). Prepare the solutions immediately before use.

**Test solution.** Dissolve 0.10 g of the substance to be examined in dimethylformamide R and dilute to 10.0 mL with the same solvent.

**Reference solution (a).** Dissolve 10.0 mg of domperidone maleate CRS and 15.0 mg of droperidol CRS in dimethylformamide R and dilute to 100.0 mL with the same solvent.

**Reference solution (b).** Dilute 1.0 mL of the test solution to 100.0 mL with dimethylformamide R. Dilute 5.0 mL of this solution to 20.0 mL with dimethylformamide R.

**Column:**

- size:  $l = 0.1$  m,  $\emptyset = 4.6$  mm;
- stationary phase: base-deactivated octadecylsilyl silica gel for chromatography R (3  $\mu$ m).

**Mobile phase:**

- mobile phase A: 5 g/L solution of ammonium acetate R;
- mobile phase B: methanol R;

Time (min)	Mobile phase A (per cent V/V)	Mobile phase B (per cent V/V)
0 - 10	70 → 0	30 → 100
10 - 12	0	100

**Flow rate:** 1.5 mL/min.

**Detection:** spectrophotometer at 280 nm.

**Equilibration:** with methanol R for at least 30 min and then with the mobile phase at the initial composition for at least 5 min.

**Injection:** 10  $\mu$ L; inject dimethylformamide R as a blank.

**Retention time:** domperidone = about 6.5 min; droperidol = about 7 min.

**System suitability:** reference solution (a):

- resolution: minimum 2.0 between the peaks due to domperidone and droperidol; if necessary, adjust the concentration of methanol in the mobile phase or adjust the time programme for the linear gradient.

**Limits:**

- impurities A, B, C, D, E, F: for each impurity, not more than the area of the principal peak in the chromatogram obtained with reference solution (b) (0.25 per cent);
- total: not more than twice the area of the principal peak in the chromatogram obtained with reference solution (b) (0.5 per cent);
- disregard limit: 0.2 times the area of the principal peak in the chromatogram obtained with reference solution (b) (0.05 per cent); disregard any peak due to the blank and any peak due to maleic acid at the beginning of the chromatogram.

**Heavy metals** (2.4.8): maximum 20 ppm.

1.0 g complies with test D. Prepare the reference solution using 2 mL of lead standard solution (10 ppm Pb) R.

**Loss on drying** (2.2.32): maximum 0.5 per cent, determined on 1.000 g by drying in an oven at 105 °C.

**Sulfated ash** (2.4.14): maximum 0.1 per cent, determined on 1.0 g.

**ASSAY**

Dissolve 0.400 g in 50 mL of anhydrous acetic acid R. Using 0.2 mL of naphtholbenzein solution R as indicator, titrate with 0.1 M perchloric acid until the colour changes from orange-yellow to green.

1 mL of 0.1 M perchloric acid is equivalent to 54.20 mg of C<sub>26</sub>H<sub>28</sub>ClN<sub>5</sub>O<sub>6</sub>.

**STORAGE**

Protected from light.

**IMPURITIES**

Specified impurities: A, B, C, D, E, F.

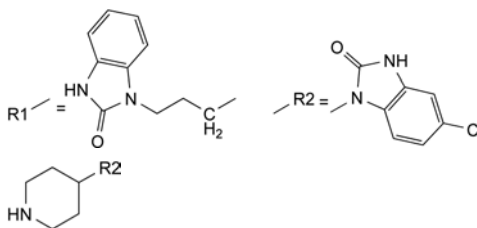

A. 5-chloro-1-(piperidin-4-yl)-1,3-dihydro-2H-benzimidazol-2-one,

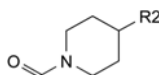

B. 4-(5-chloro-2-oxo-2,3-dihydro-1H-benzimidazol-1-yl)-1-formylpiperidine,

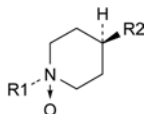

C. cis-4-(5-chloro-2-oxo-2,3-dihydro-1H-benzimidazol-1-yl)-1-[3-(2-oxo-2,3-dihydro-1H-benzimidazol-1-yl)propyl]piperidine 1-oxide,

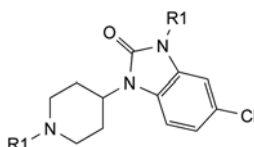

D. 5-chloro-3-[3-(2-oxo-2,3-dihydro-1H-benzimidazol-1-yl)propyl]-1-[1-[3-(2-oxo-2,3-dihydro-1H-benzimidazol-1-yl)propyl]piperidin-4-yl]-1,3-dihydro-2H-benzimidazol-2-one,

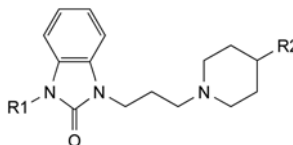

E. 1-[3-[4-(5-chloro-2-oxo-2,3-dihydro-1H-benzimidazol-1-yl)piperidin-1-yl]propyl]-3-[3-(2-oxo-2,3-dihydro-1H-benzimidazol-1-yl)propyl]-1,3-dihydro-2H-benzimidazol-2-one,

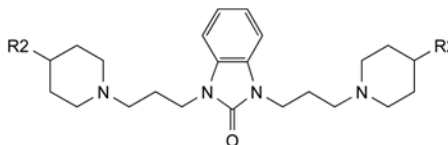

F. 1,3-bis[3-[4-(5-chloro-2-oxo-2,3-dihydro-1H-benzimidazol-1-yl)piperidin-1-yl]propyl]-1,3-dihydro-2H-benzimidazol-2-one.

01/2008:0664

## DOPAMINE HYDROCHLORIDE

Dopamini hydrochloridum

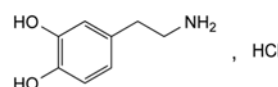

C<sub>8</sub>H<sub>12</sub>ClNO<sub>2</sub>  
[62-31-7]

M<sub>r</sub> 189.6

**DEFINITION**

4-(2-Aminoethyl)benzene-1,2-diol hydrochloride.

**Content:** 99.0 per cent to 101.0 per cent (dried substance).



## CHARACTERS

**Appearance:** white or almost white, crystalline powder.

**Solubility:** freely soluble in water, soluble in ethanol (96 per cent), sparingly soluble in acetone and in methylene chloride.

## IDENTIFICATION

**First identification:** B, E.

**Second identification:** A, C, D, E.

A. Ultraviolet and visible absorption spectrophotometry (2.2.25).

**Test solution.** Dissolve 40.0 mg in 0.1 M hydrochloric acid and dilute to 100.0 mL with the same acid. Dilute 10.0 mL of this solution to 100.0 mL with 0.1 M hydrochloric acid.

**Spectral range:** 230-350 nm.

**Absorption maximum:** at 280 nm.

**Specific absorbance at the absorption maximum:** 136 to 150.

B. Infrared absorption spectrophotometry (2.2.24).

**Comparison:** dopamine hydrochloride CRS.

C. Dissolve about 5 mg in a mixture of 5 mL of 1 M hydrochloric acid and 5 mL of water R. Add 0.1 mL of sodium nitrite solution R containing 100 g/L of ammonium molybdate R. A yellow colour develops which becomes red on the addition of strong sodium hydroxide solution R.

D. Dissolve about 2 mg in 2 mL of water R and add 0.2 mL of ferric chloride solution R2. A green colour develops which changes to bluish-violet on the addition of 0.1 g of hexamethylenetetramine R.

E. It gives reaction (a) of chlorides (2.3.1).

## TESTS

**Appearance of solution.** The solution is clear (2.2.1) and not more intensely coloured than reference solution B<sub>6</sub> or Y<sub>6</sub> (2.2.2, Method II).

Dissolve 0.4 g in water R and dilute to 10 mL with the same solvent.

**Acidity or alkalinity.** Dissolve 0.5 g in carbon dioxide-free water R and dilute to 10 mL with the same solvent. Add 0.1 mL of methyl red solution R and 0.75 mL of 0.01 M sodium hydroxide. The solution is yellow. Add 1.5 mL of 0.01 M hydrochloric acid. The solution is red.

**Related substances.** Liquid chromatography (2.2.29). Protect the solutions from light.

**Buffer solution.** Dissolve 21 g of citric acid R in 200 mL of 1 M sodium hydroxide and dilute to 1000 mL with water R. To 600 mL of this solution add 400 mL of 0.1 M hydrochloric acid.

**Test solution.** Dissolve 50 mg of the substance to be examined in mobile phase A and dilute to 25 mL with mobile phase A.

**Reference solution (a).** Dilute 1.0 mL of the test solution to 100.0 mL with mobile phase A. Dilute 1.0 mL of this solution to 10.0 mL with mobile phase A.

**Reference solution (b).** Dissolve 10 mg of 3-O-methyldopamine hydrochloride R (impurity B) and 10 mg of 4-O-methyldopamine hydrochloride R (impurity A) in mobile phase A and dilute to 100 mL with mobile phase A. Dilute 6 mL of this solution to 25 mL with mobile phase A.

**Column:**

- size:  $l = 0.15$  m,  $\varnothing = 3.9$  mm;
- stationary phase: spherical end-capped octadecylsilyl silica gel for chromatography R (4  $\mu$ m).

**Mobile phase:**

- mobile phase A: dissolve 1.08 g of sodium octanesulfonate R in 880 mL of the buffer solution and add 50 mL of methanol R and 70 mL of acetonitrile R;

- mobile phase B: dissolve 1.08 g of sodium octanesulfonate R in 700 mL of the buffer solution and add 100 mL of methanol R and 200 mL of acetonitrile R;

Time (min)	Mobile phase A (per cent V/V)	Mobile phase B (per cent V/V)
0 - 5	90	10
5 - 20	90 → 40	10 → 60
20 - 25	40	60

**Flow rate:** 1.0 mL/min.

**Detection:** spectrophotometer at 280 nm.

**Injection:** 10  $\mu$ L.

**Retention time:** dopamine = about 5 min.

**System suitability:** reference solution (b):

- resolution: minimum 5.0 between the peaks due to impurities B and A.

**Limits:**

- unspecified impurities: for each impurity, not more than the area of the principal peak in the chromatogram obtained with reference solution (a) (0.10 per cent);
- total: not more than twice the area of the principal peak in the chromatogram obtained with reference solution (a) (0.2 per cent);
- disregard limit: 0.5 times the area of the principal peak in the chromatogram obtained with reference solution (a) (0.05 per cent).

**Heavy metals (2.4.8):** maximum 20 ppm.

1.0 g complies with test C. Prepare the reference solution using 2 mL of lead standard solution (10 ppm Pb) R.

**Loss on drying (2.2.32):** maximum 0.5 per cent, determined on 1.000 g by drying in an oven at 105 °C for 2 h.

**Sulfated ash (2.4.14):** maximum 0.1 per cent, determined on 1.0 g.

## ASSAY

In order to avoid overheating in the reaction medium, mix thoroughly throughout the titration and stop the titration immediately after the end-point has been reached.

Dissolve 0.150 g in 10 mL of anhydrous formic acid R. Add 50 mL of acetic anhydride R. Titrate with 0.1 M perchloric acid, determining the end-point potentiometrically (2.2.20).

1 mL of 0.1 M perchloric acid is equivalent to 18.96 mg of C<sub>8</sub>H<sub>12</sub>ClNO<sub>2</sub>.

## STORAGE

In an airtight container, under nitrogen, protected from light.

## IMPURITIES

**Other detectable impurities** (the following substances would, if present at a sufficient level, be detected by one or other of the tests in the monograph. They are limited by the general acceptance criterion for other/unspecified impurities and/or by the general monograph *Substances for pharmaceutical use (2034)*. It is therefore not necessary to identify these impurities for demonstration of compliance. See also 5.10. *Control of impurities in substances for pharmaceutical use*): A, B, C.

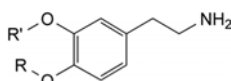

- A. R = CH<sub>3</sub>, R' = H: 5-(2-aminoethyl)-2-methoxyphenol (4-O-methyldopamine),
- B. R = H, R' = CH<sub>3</sub>: 4-(2-aminoethyl)-2-methoxyphenol (3-O-methyldopamine),
- C. R = R' = CH<sub>3</sub>: 2-(3,4-dimethoxyphenyl)ethanamine.

01/2008:1748  
corrected 7.0

## DOPEXAMINE DIHYDROCHLORIDE

## Dopexamini dihydrochloridum

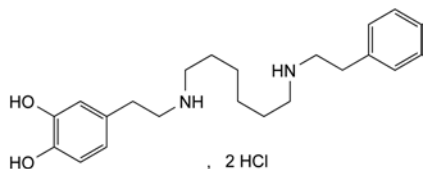
 $C_{22}H_{34}Cl_2N_2O_2$   
[86484-91-5]
 $M_r$  429.4

## DEFINITION

4-[2-[[6-[(2-Phenylethyl)amino]hexyl]amino]ethyl]benzene-1,2-diol dihydrochloride.

Content: 98.5 per cent to 101.0 per cent (anhydrous substance).

## CHARACTERS

Appearance: white or almost white, crystalline powder.

Solubility: soluble in water, sparingly soluble in ethanol (96 per cent) and in methanol, practically insoluble in acetone.

## IDENTIFICATION

A. Infrared absorption spectrophotometry (2.2.24).

Comparison: dopexamine dihydrochloride CRS.

B. It gives reaction (a) of chlorides (2.3.1).

## TESTS

**Appearance of solution.** The solution is clear (2.2.1) and not more intensely coloured than reference solution BY<sub>7</sub> (2.2.2, Method II).

Dissolve 0.10 g in 0.1 M hydrochloric acid and dilute to 10 mL with the same acid.

pH (2.2.3): 3.7 to 5.7.

Dissolve 0.20 g in carbon dioxide-free water R and dilute to 20 mL with the same solvent.

**Related substances.** Liquid chromatography (2.2.29).**Test solution.** Dissolve 0.100 g of the substance to be examined in mobile phase A and dilute to 10.0 mL with mobile phase A.**Reference solution (a).** Dilute 1.0 mL of the test solution to 100.0 mL with mobile phase A. Dilute 1.0 mL of this solution to 10.0 mL with mobile phase A.**Reference solution (b).** Dissolve 5 mg of the substance to be examined and 5 mg of dopexamine impurity B CRS in mobile phase A and dilute to 10.0 mL with mobile phase A.**Reference solution (c).** Dissolve 5 mg of dopexamine impurity F CRS in mobile phase A and dilute to 100 mL with mobile phase A.

Column:

- size:  $l = 0.15$  m,  $\varnothing = 4.6$  mm;
- stationary phase: octadecylsilyl silica gel for chromatography R (5  $\mu$ m);
- temperature: 45 °C.

Mobile phase:

- mobile phase A: mix 5 volumes of buffer solution pH 2.5 R and 95 volumes of water R;
- mobile phase B: mix 5 volumes of buffer solution pH 2.5 R and 95 volumes of a 60 per cent V/V solution of acetonitrile R;

Time (min)	Mobile phase A (per cent V/V)	Mobile phase B (per cent V/V)
0 - 10	81 → 77	19 → 23
10 - 25	77 → 50	23 → 50
25 - 30	50	50

Flow rate: 1 mL/min.

Detection: spectrophotometer at 280 nm.

Preconditioning of the column: rinse for 5 min with a mixture of 19 volumes of mobile phase B and 81 volumes of mobile phase A.

Injection: 20  $\mu$ L.

Relative retention with reference to dopexamine (retention time = about 5 min): impurity A = about 0.5; impurity B = about 2.0; impurity C = about 2.3; impurity D = about 2.8; impurity E = about 2.9; impurity F = about 3.0; impurity I = about 3.6; impurity J = about 5.0; impurity K = about 5.9.

System suitability: reference solution (b):

- resolution: minimum 2 between the peaks due to dopexamine and impurity B.

Limits:

- correction factors: for the calculation of content, multiply the peak areas of the following impurities by the corresponding correction factor: impurity A = 1.4; impurity F = 0.7;
- impurities A, B, C, D, E, F, I, K: for each impurity, not more than the area of the principal peak in the chromatogram obtained with reference solution (a) (0.1 per cent);
- unspecified impurities: for each impurity, not more than the area of the principal peak in the chromatogram obtained with reference solution (a) (0.10 per cent);
- total: not more than 5 times the area of the principal peak in the chromatogram obtained with reference solution (a) (0.5 per cent);
- disregard limit: 0.5 times the area of the principal peak in the chromatogram obtained with reference solution (a) (0.05 per cent).

**Impurity J.** Liquid chromatography (2.2.29) as described in the test for related substances with the following modification.

Detection: spectrophotometer at 210 nm.

Limit:

- impurity J: not more than the area of the principal peak in the chromatogram obtained with reference solution (a) (0.1 per cent).

**Heavy metals (2.4.8):** maximum 10 ppm.Dissolve 0.50 g in water R and dilute to 20 mL with the same solvent. 12 mL of the solution complies with test A. Prepare the reference solution using lead standard solution (0.25 ppm Pb) R. For the evaluation of the results, filter the solutions through a membrane filter (nominal pore size 0.45  $\mu$ m).**Water (2.5.12):** maximum 0.5 per cent, determined on 1.00 g.**Sulfated ash (2.4.14):** maximum 0.1 per cent, determined on 1.0 g.**Bacterial endotoxins (2.6.14):** less than 10 IU/mg.

## ASSAY

Carry out the titration immediately after preparation of the test solution. In order to avoid overheating in the reaction medium, mix thoroughly throughout and stop the titration immediately after the end-point has been reached.

Dissolve 0.150 g in 10 mL of anhydrous formic acid R. Add 50 mL of acetic anhydride R. Titrate with 0.1 M perchloric acid, determining the end-point potentiometrically (2.2.20). 1 mL of 0.1 M perchloric acid is equivalent to 21.47 mg of  $C_{22}H_{34}Cl_2N_2O_2$ .

## STORAGE

Protected from light.

## IMPURITIES

Specified impurities: A, B, C, D, E, F, I, J, K.

Other detectable impurities (the following substances would, if present at a sufficient level, be detected by one or other of the tests in the monograph. They are limited by the general acceptance criterion for other/unspecified impurities and/or by the general monograph *Substances for pharmaceutical use* (2034). It is therefore not necessary to identify these impurities for demonstration of compliance. See also 5.10. *Control of impurities in substances for pharmaceutical use*): G, H.

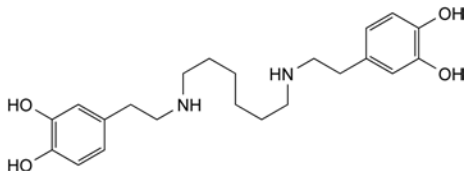

A. 4,4'-[hexane-1,6-diylbis(iminoethylene)]dibenzene-1,2-diol,

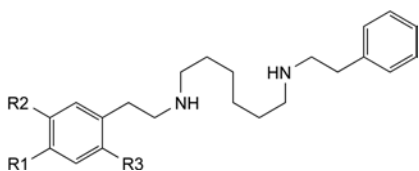

B. R1 = OH, R2 = OCH<sub>3</sub>, R3 = H: 2-methoxy-4-[2-[[6-[(2-phenylethyl)amino]hexyl]amino]ethyl]phenol,

C. R1 = OCH<sub>3</sub>, R2 = OH, R3 = H: 2-methoxy-5-[2-[[6-[(2-phenylethyl)amino]hexyl]amino]ethyl]phenol,

F. R1 = R2 = OH, R3 = Cl: 4-chloro-5-[2-[[6-[(2-phenylethyl)amino]hexyl]amino]ethyl]benzene-1,2-diol,

H. R1 = R2 = OCH<sub>3</sub>, R3 = H: *N*-[2-(3,4-dimethoxyphenyl)ethyl]-*N'*-(2-phenylethyl)hexane-1,6-diamine,

J. R1 = R2 = R3 = H: *N,N'*-bis(2-phenylethyl)hexane-1,6-diamine,

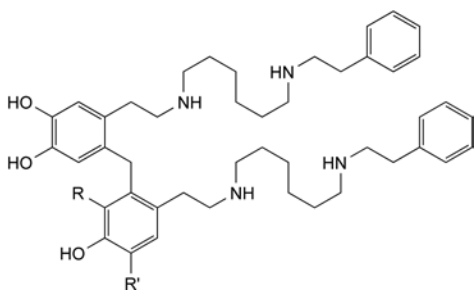

D. R = H, R' = OH: 4,4'-methylenebis[5-[2-[[6-[(2-phenylethyl)amino]hexyl]amino]ethyl]benzene-1,2-diol],

E. R = OH, R' = H: 3-[4,5-dihydroxy-2-[2-[[6-[(2-phenylethyl)amino]hexyl]amino]ethyl]benzyl]-4-[2-[[6-[(2-phenylethyl)amino]hexyl]amino]ethyl]benzene-1,2-diol,

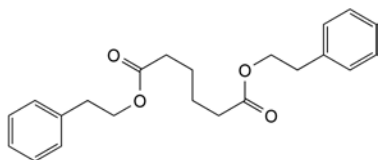

G. bis(2-phenylethyl) hexanedioate,

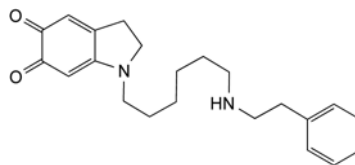

I. 1-[6-[(2-phenylethyl)amino]hexyl]-2,3-dihydro-1H-indole-5,6-dione (dopexamine aminochrome),

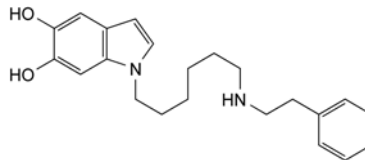

K. 1-[6-[(2-phenylethyl)amino]hexyl]-1H-indole-5,6-diol.

01/2008:2359

## DORZOLAMIDE HYDROCHLORIDE

## Dorzolamidi hydrochloridum

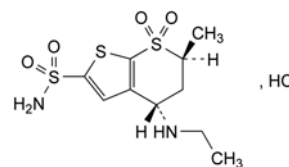

C<sub>10</sub>H<sub>17</sub>ClN<sub>2</sub>O<sub>3</sub>S<sub>3</sub>  
[130693-82-2]

*M*<sub>r</sub> 360.9

## DEFINITION

(4*S*,6*S*)-4-(Ethylamino)-6-methyl-5,6-dihydro-4*H*-thieno[2,3-*b*]thiopyran-2-sulfonamide 7,7-dioxide hydrochloride.

*Content*: 99.0 per cent to 101.0 per cent (dried substance).

## CHARACTERS

*Appearance*: white or almost white, crystalline powder.

*Solubility*: soluble in water, slightly soluble in methanol, very slightly soluble in anhydrous ethanol.

It shows polymorphism (5.9).

## IDENTIFICATION

A. Infrared absorption spectrophotometry (2.2.24).

*Comparison*: dorzolamide hydrochloride CRS.

If the spectra obtained in the solid state show differences, dissolve the substance to be examined and the reference substance separately in *methanol R*, evaporate to dryness and record new spectra using the residues.

B. It complies with the test for impurity A (see Tests).

C. It gives reaction (a) of chlorides (2.3.1).

## TESTS

**Impurity A.** Liquid chromatography (2.2.29).

*Solvent mixture*: acetonitrile *R*, glacial acetic acid *R*, 1,1-dimethylethyl methyl ether *R* (3:10:87 V/V/V).

*Test solution*. In a centrifuge tube, dissolve 20.0 mg of the substance to be examined in 4 mL of dilute ammonia *R*4, add 4 mL of ethyl acetate *R*, and mix. Separate the organic layer and transfer it to a separate centrifuge tube. Add 4 mL of ethyl acetate *R* to the aqueous layer, mix, separate the organic layer, and combine it with the 1<sup>st</sup> extract. Evaporate the combined organic layers to dryness in a water-bath at 50 °C under a stream of nitrogen *R*. Dissolve the residue in 3 mL of acetonitrile *R*, add 0.06 mL of (*S*)-(-)- $\alpha$ -methylbenzyl isocyanate *R*, and heat in a water-bath at 50 °C for 5 min. Evaporate to dryness in a water-bath at 50 °C under a stream of nitrogen *R*. Dissolve the residue in 10 mL of the solvent mixture.

**Reference solution.** In a centrifuge tube, dissolve 18.0 mg of dorzolamide hydrochloride CRS and 2.0 mg of dorzolamide impurity A CRS in 4 mL of dilute ammonia R4, and proceed as indicated for the test solution beginning with “add 4 mL of ethyl acetate R, and mix”.

**Column:**

- size:  $l = 0.25$  m,  $\varnothing = 4.6$  mm;
- stationary phase: silica gel for chromatography R (5  $\mu$ m).

**Mobile phase:** water R, acetonitrile R, heptane R, 1,1-dimethylethyl methyl ether R (0.2:2:35:63 V/V/V/V).

**Flow rate:** 2 mL/min.

**Detection:** spectrophotometer at 254 nm.

**Injection:** 10  $\mu$ L.

**Run time:** 3 times the retention time of dorzolamide.

**Relative retention** with reference to dorzolamide (retention time = about 10 min): impurity A = about 1.4.

**System suitability:** reference solution:

- resolution: minimum 4.0 between the peaks due to dorzolamide and impurity A.

Calculate the percentage content of impurity A using the following expression:

$$\frac{A}{A + B} \times 100$$

A = area of the peak due to impurity A in the chromatogram obtained with the test solution;

B = area of the peak due to dorzolamide in the chromatogram obtained with the test solution.

**Limit:**

- impurity A: maximum 0.5 per cent.

**Related substances.** Liquid chromatography (2.2.29).

**Test solution.** Dissolve 30.0 mg of the substance to be examined in mobile phase A and dilute to 50.0 mL with mobile phase A.

**Reference solution (a).** Dissolve 1.0 mL of the test solution to 100.0 mL with mobile phase A. Dilute 1.0 mL of this solution to 10.0 mL with mobile phase A.

**Reference solution (b).** Dissolve 2 mg of dorzolamide for system suitability CRS (containing impurity C) in 2 mL of mobile phase A.

**Column:**

- size:  $l = 0.25$  m,  $\varnothing = 4.6$  mm;
- stationary phase: end-capped octadecylsilyl silica gel for chromatography R (5  $\mu$ m);
- temperature: 35 °C.

**Mobile phase:**

- mobile phase A: mix 65 mL of acetonitrile R and 935 mL of a 3.7 g/L solution of potassium dihydrogen phosphate R;
- mobile phase B: acetonitrile R;

Time (min)	Mobile phase A (per cent V/V)	Mobile phase B (per cent V/V)
0 - 15	100	0
15 - 30	100 → 50	0 → 50
30 - 37	50 → 100	50 → 0
37 - 44	100	0

**Flow rate:** 1.5 mL/min.

**Detection:** spectrophotometer at 254 nm.

**Injection:** 10  $\mu$ L.

**Identification of impurities:** use the chromatogram supplied with dorzolamide for system suitability CRS and the chromatogram obtained with reference solution (b) to identify the peak due to impurity C.

**Relative retention** with reference to dorzolamide (retention time = about 11 min): impurity C = about 0.9.

**System suitability:** reference solution (b):

- resolution: minimum 2.0 between the peaks due to impurity C and dorzolamide.

**Limits:**

- impurity C: not more than 1.5 times the area of the principal peak in the chromatogram obtained with reference solution (a) (0.15 per cent);
- unspecified impurities: for each impurity, not more than the area of the principal peak in the chromatogram obtained with reference solution (a) (0.10 per cent);
- total: not more than 3 times the area of the principal peak in the chromatogram obtained with reference solution (a) (0.3 per cent);
- disregard limit: 0.5 times the area of the principal peak in the chromatogram obtained with reference solution (a) (0.05 per cent).

**Loss on drying** (2.2.32): maximum 0.5 per cent, determined on 1.000 g by drying in an oven at 105 °C.

**Sulfated ash** (2.4.14): maximum 0.1 per cent, determined on 1.0 g.

**ASSAY**

Dissolve 0.150 g in a mixture of 5.0 mL of 0.01 M hydrochloric acid and 50 mL of ethanol (96 per cent) R, using sonication if necessary. Carry out a potentiometric titration (2.2.20), using 0.1 M sodium hydroxide. Read the volume added between the 1<sup>st</sup> and the 3<sup>rd</sup> points of inflexion.

1 mL of 0.1 M sodium hydroxide is equivalent to 18.05 mg of C<sub>10</sub>H<sub>17</sub>N<sub>2</sub>O<sub>4</sub>S<sub>3</sub>Cl.

**IMPURITIES**

**Specified impurities:** A, C.

**Other detectable impurities** (the following substances would, if present at a sufficient level, be detected by one or other of the tests in the monograph. They are limited by the general acceptance criterion for other/unspecified impurities and/or by the general monograph *Substances for pharmaceutical use* (2034). It is therefore not necessary to identify these impurities for demonstration of compliance. See also 5.10. *Control of impurities in substances for pharmaceutical use*): B, D.

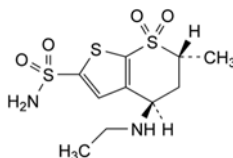

A. (4*R*,6*R*)-4-(ethylamino)-6-methyl-5,6-dihydro-4*H*-thieno[2,3-*b*]thiopyran-2-sulfonamide 7,7-dioxide,

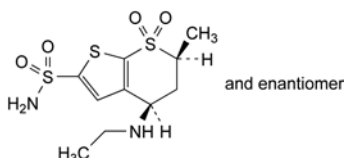

B. (4*RS*,6*SR*)-4-(ethylamino)-6-methyl-5,6-dihydro-4*H*-thieno[2,3-*b*]thiopyran-2-sulfonamide 7,7-dioxide,

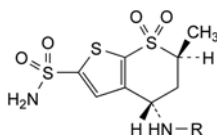

C. R = CH<sub>2</sub>-CH<sub>2</sub>-B(OH)<sub>2</sub>; [2-[[[(4*S*,6*S*)-6-methyl-7,7-dioxo-2-sulfamoyl-4,5,6,7-tetrahydro-7λ<sup>6</sup>-thieno[2,3-*b*]thiopyran-4-yl]amino]ethyl]boronic acid,

D. R = H: (4*S*,6*S*)-4-amino-6-methyl-5,6-dihydro-4*H*-thieno[2,3-*b*]thiopyran-2-sulfonamide 7,7-dioxide.

01/2008:1314 *Column:*  
corrected 6.0

## DOSULEPIN HYDROCHLORIDE

### Dosulepini hydrochloridum

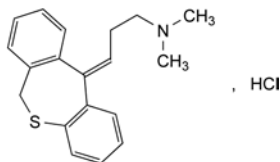

C<sub>19</sub>H<sub>22</sub>ClNS  
[897-15-4]

M<sub>r</sub> 331.9

#### DEFINITION

(*E*)-3-(Dibenzo[*b,e*]thiepin-11(6*H*)-ylidene)-*N,N*-dimethylpropan-1-amine hydrochloride.

*Content*: 98.0 per cent to 101.0 per cent (dried substance).

#### CHARACTERS

*Appearance*: white or faintly yellow, crystalline powder.

*Solubility*: freely soluble in water, in alcohol and in methylene chloride.

#### IDENTIFICATION

*First identification*: B, D.

*Second identification*: A, C, D.

A. Dissolve 25.0 mg in a 1 g/L solution of *hydrochloric acid R* in *methanol R* and dilute to 100.0 mL with the same solution. Dilute 2.0 mL to 50.0 mL with a 1 g/L solution of *hydrochloric acid R* in *methanol R*. Examined between 220 nm and 350 nm (2.2.25), the solution shows 2 absorption maxima at 231 nm and 306 nm and a shoulder at about 260 nm. The specific absorbance at the maximum at 231 nm is 660 to 730.

B. Infrared absorption spectrophotometry (2.2.24).

*Preparation*: discs.

*Comparison*: *dosulepin hydrochloride CRS*.

C. Dissolve about 1 mg in 5 mL of *sulfuric acid R*. A dark red colour is produced.

D. It gives reaction (b) of chlorides (2.3.1).

#### TESTS

**Appearance of solution.** The solution is clear (2.2.1) and not more intensely coloured than reference solution Y<sub>5</sub> (2.2.2, *Method II*).

Dissolve 1 g in *water R* and dilute to 20 mL with the same solvent.

**pH** (2.2.3): 4.2 to 5.2.

Dissolve 1 g in *carbon dioxide-free water R* and dilute to 10 mL with the same solvent.

**Impurity E and related substances.** Liquid chromatography (2.2.29). Prepare the solutions immediately before use and protect from light.

*Test solution.* Dissolve 50.0 mg of the substance to be examined in 5 mL of *methanol R* and dilute to 100.0 mL with the mobile phase.

*Reference solution (a).* Dissolve 12.5 mg of *dosulepin impurity A CRS* in 5 mL of *methanol R* and dilute to 50.0 mL with the mobile phase. Dilute 0.5 mL to 100.0 mL with the mobile phase.

*Reference solution (b).* Dissolve 10.0 mg of *dosulepin hydrochloride CRS* in 5 mL of *methanol R* and dilute to 20.0 mL with the mobile phase.

- *size*:  $l = 0.25$  m,  $\varnothing = 4.6$  mm,
- *stationary phase*: nitrile silica gel for chromatography R1 (5 μm),
- *temperature*: 35 °C.

*Mobile phase*: 0.83 per cent V/V solution of *perchloric acid R*, *propanol R*, *methanol R*, *water R* (1:10:30:60 V/V/V/V).

*Flow rate*: 1 mL/min.

*Detection*: spectrophotometer at 229 nm.

*Injection*: 5 μL.

*Run time*: 2.5 times the retention time of *dosulepin (E-isomer)*.

*Relative retention* with reference to *dosulepin (E-isomer)*; retention time = about 25 min): *impurity E* = about 0.9.

*System suitability*: reference solution (b):

- *peak-to-valley ratio*: minimum 4, where  $H_p$  = height above the baseline of the peak due to *impurity E* and  $H_v$  = height above the baseline of the lowest point of the curve separating this peak from the peak due to *dosulepin (E-isomer)*.

#### Limits:

- *impurity E*: not more than 5 per cent of the sum of the areas of the peak due to *impurity E* and the principal peak in the chromatogram obtained with the test solution,
- *impurity A*: not more than the area of the principal peak in the chromatogram obtained with reference solution (a) (0.25 per cent),
- *any other impurity*: not more than 0.4 times the area of the principal peak in the chromatogram obtained with reference solution (a) (0.1 per cent),
- *total of other impurities and impurity A*: not more than twice the area of the principal peak in the chromatogram obtained with reference solution (a) (0.5 per cent),
- *disregard limit*: 0.2 times the area of the principal peak in the chromatogram obtained with reference solution (a) (0.05 per cent).

**Heavy metals** (2.4.8): maximum 20 ppm.

1.0 g complies with limit test C. Prepare the standard using 2 mL of *lead standard solution (10 ppm Pb) R*.

**Loss on drying** (2.2.32): maximum 0.5 per cent, determined on 1.000 g by drying in an oven at 105 °C.

**Sulfated ash** (2.4.14): maximum 0.1 per cent, determined on 1.0 g.

#### ASSAY

Dissolve 0.250 g in a mixture of 5 mL of *anhydrous acetic acid R* and 35 mL of *acetic anhydride R*. Titrate with 0.1 M *perchloric acid*, determining the end-point potentiometrically (2.2.20).

1 mL of 0.1 M *perchloric acid* is equivalent to 33.19 mg of C<sub>19</sub>H<sub>22</sub>ClNS.

#### STORAGE

Protected from light.

#### IMPURITIES

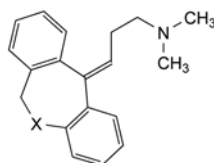

- A. X = SO: (*E*)-3-(5-oxo-5λ<sup>4</sup>-dibenzo[*b,e*]thiepin-11(6*H*)-ylidene)-*N,N*-dimethylpropan-1-amine,
- D. X = SO<sub>2</sub>: (*E*)-3-(5,5-dioxo-5λ<sup>6</sup>-dibenzo[*b,e*]thiepin-11(6*H*)-ylidene)-*N,N*-dimethylpropan-1-amine,

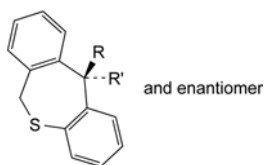

B.  $R + R' = O$ : dibenzo[*b,e*]thiepin-11(6*H*)-one,

C.  $R = OH$ ,  $R' = [CH_2]_3-N(CH_3)_2$ : (11*RS*)-11-[3-(dimethylamino)propyl]-6,11-dihydrodibenzo[*b,e*]thiepin-11-ol,

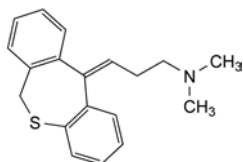

E. (*Z*)-3-(dibenzo[*b,e*]thiepin-11(6*H*)-ylidene)-*N,N*-dimethylpropan-1-amine.

01/2008:1201  
corrected 6.0

## DOXAPRAM HYDROCHLORIDE

### Doxaprami hydrochloridum

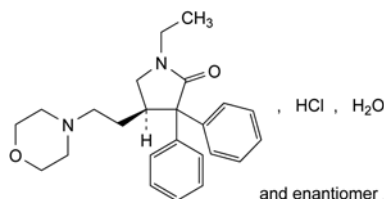

C<sub>24</sub>H<sub>31</sub>ClN<sub>2</sub>O<sub>2</sub>·H<sub>2</sub>O  
[7081-53-0]

*M*<sub>r</sub> 433.0

#### DEFINITION

(4*RS*)-1-Ethyl-4-[2-(morpholin-4-yl)ethyl]-3,3-diphenylpyrrolidin-2-one hydrochloride.

*Content*: 98.0 per cent to 100.5 per cent (dried substance).

#### CHARACTERS

*Appearance*: white or almost white, crystalline powder.

*Solubility*: soluble in water, in alcohol and in methylene chloride.

#### IDENTIFICATION

*First identification*: A, C.

*Second identification*: B, C.

A. Infrared absorption spectrophotometry (2.2.24).

*Preparation*: discs.

*Comparison*: doxapram hydrochloride CRS.

B. Thin-layer chromatography (2.2.27).

*Test solution*. Dissolve 10 mg of the substance to be examined in *methanol R* and dilute to 10 mL with the same solvent.

*Reference solution*. Dissolve 10 mg of *doxapram hydrochloride CRS* in *methanol R* and dilute to 10 mL with the same solvent.

*Plate*: TLC silica gel plate *R*.

*Mobile phase*: solution of *ammonia R* containing 17 g/L of NH<sub>3</sub>, *2-propanol R*, *2-methylpropanol R* (10:10:80 V/V/V).

*Application*: 10 µL.

*Development*: over a path of 15 cm.

*Drying*: in air.

*Detection*: spray with *dilute potassium iodobismuthate solution R* and examine immediately.

*Results*: the principal spot in the chromatogram obtained with the test solution is similar in position, colour and size to the principal spot in the chromatogram obtained with the reference solution.

C. It gives reaction (a) of chlorides (2.3.1).

#### TESTS

**Solution S**. Dissolve 2.500 g in *carbon dioxide-free water R* and dilute to 50.0 mL with the same solvent.

**Appearance of solution**. The solution is clear (2.2.1) and colourless (2.2.2, *Method II*).

Dilute 10 mL of solution S to 25 mL with *water R*.

**pH** (2.2.3): 3.5 to 5.0.

Dilute 5 mL of solution S to 25 mL with *carbon dioxide-free water R*.

**Optical rotation** (2.2.7):  $-0.10^\circ$  to  $+0.10^\circ$ , determined on solution S.

**Related substances**. Liquid chromatography (2.2.29). Prepare the solutions immediately before use.

*Test solution*. Dissolve 10.0 mg of the substance to be examined in the mobile phase and dilute to 10.0 mL with the mobile phase.

*Reference solution (a)*. Dilute 1.0 mL of the test solution to 100.0 mL with the mobile phase.

*Reference solution (b)*. Dilute 1.0 mL of reference solution (a) to 5.0 mL with the mobile phase.

*Reference solution (c)*. Dissolve 5 mg of *doxapram impurity B CRS* in the mobile phase and dilute to 5.0 mL with the mobile phase. To 1.0 mL of the solution, add 1.0 mL of the test solution and dilute to 100.0 mL with the mobile phase.

*Column*:

– *size*:  $l = 0.25$  m,  $\varnothing = 4.6$  mm,

– *stationary phase*: spherical *end-capped octadecylsilyl silica gel for chromatography R* (5 µm) with a carbon loading of 14 per cent, a specific surface area of 350 m<sup>2</sup>/g and a pore size of 10 nm.

*Mobile phase*: mix 50 volumes of *acetonitrile R* and 50 volumes of a 0.82 g/L solution of *sodium acetate R* adjusted to pH 4.5 with *glacial acetic acid R*.

*Flow rate*: 1.5 mL/min.

*Detection*: spectrophotometer at 214 nm.

*Injection*: 20 µL.

*Run time*: 4 times the retention time of doxapram.

*Retention time*: doxapram = about 6 min.

*System suitability*: reference solution (c):

– *resolution*: minimum of 3.0 between the peaks corresponding to doxapram and to impurity B.

*Limits*:

– *any impurity*: not more than the area of the principal peak in the chromatogram obtained with reference solution (b) (0.2 per cent),

– *total*: not more than the area of the principal peak in the chromatogram obtained with reference solution (a) (1.0 per cent),

– *disregard limit*: 0.05 times the area of the principal peak in the chromatogram obtained with reference solution (a) (0.05 per cent).

**Heavy metals** (2.4.8): maximum 20 ppm.

Dissolve 2.0 g in a mixture of 15 volumes of *water R* and 85 volumes of *methanol R* and dilute to 20 mL with the same mixture of solvents. 12 mL of the solution complies with limit test B. Prepare the standard using lead standard solution (2 ppm Pb) obtained by diluting *lead standard solution (100 ppm Pb) R* with a mixture of 15 volumes of *water R* and 85 volumes of *methanol R*.

**Loss on drying** (2.2.32): 3.0 per cent to 4.5 per cent, determined on 1.000 g by drying in an oven at 105 °C.

**Sulfated ash** (2.4.14): maximum 0.1 per cent, determined on 1.0 g.

#### ASSAY

Dissolve 0.300 g in a mixture of 10 mL of 0.01 M hydrochloric acid and 50 mL of alcohol R. Carry out a potentiometric titration (2.2.20) using 0.1 M sodium hydroxide. Read the volume added between the 2 points of inflexion.

1 mL of 0.1 M sodium hydroxide is equivalent to 41.50 mg of  $C_{24}H_{31}ClN_2O_2$ .

#### IMPURITIES

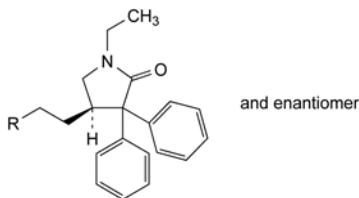

A. R = Cl: (4*RS*)-4-(2-chloroethyl)-1-ethyl-3,3-diphenylpyrrolidin-2-one,

B. R = NH-CH<sub>2</sub>-CH<sub>2</sub>-OH: (4*RS*)-1-ethyl-4-[2-[(2-hydroxyethyl)amino]ethyl]-3,3-diphenylpyrrolidin-2-one.

01/2008:2125  
corrected 7.0

## DOXAZOSIN MESILATE

### Doxazosini mesilas

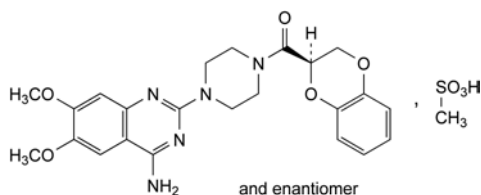

$C_{24}H_{29}N_5O_8S$   
[77883-43-3]

$M_r$  547.6

#### DEFINITION

1-(4-Amino-6,7-dimethoxyquinazolin-2-yl)-4-[(2*RS*)-2,3-dihydro-1,4-benzodioxin-2-ylcarbonyl]piperazine methanesulfonate.

**Content:** 98.0 per cent to 102.0 per cent (anhydrous substance).

#### PRODUCTION

The production method must be evaluated to determine the potential for formation of alkyl mesilates, which is particularly likely to occur if the reaction medium contains lower alcohols. Where necessary, the production method is validated to demonstrate that alkyl mesilates are not detectable in the final product.

#### CHARACTERS

**Appearance:** white or almost white crystalline powder.

**Solubility:** slightly soluble in water, soluble in a mixture of 15 volumes of water and 35 volumes of tetrahydrofuran, slightly soluble in methanol, practically insoluble in acetone.

It shows polymorphism (5.9), some forms may be hygroscopic.

#### IDENTIFICATION

Infrared absorption spectrophotometry (2.2.24).

**Comparison:** doxazosin mesilate CRS.

If the spectra obtained in the solid state show differences, mix 1 part of the substance to be examined and 1 part of the reference substance separately with 10 parts of anhydrous ethanol R and

heat to boiling. Continue heating the suspension under a reflux condenser for about 3 h. Cool and filter. Record new spectra using the previously dried residues on the filters.

#### TESTS

**Appearance of solution.** The solution is clear (2.2.1) and not more intensely coloured than reference solution BY<sub>6</sub> (2.2.2, Method II).

Dissolve 1.0 g in a mixture of 15 mL of water R and 35 mL of tetrahydrofuran R.

**Related substances.** Liquid chromatography (2.2.29).

**Test solution.** Dissolve 25.0 mg of the substance to be examined in 5 mL of mobile phase B, adding water R, and dilute to 50.0 mL with water R.

**Reference solution (a).** Dilute 5.0 mL of the test solution to 100.0 mL with water R. Dilute 2.0 mL of this solution to 100.0 mL with water R.

**Reference solution (b).** Dissolve 5 mg of doxazosin impurity D CRS and 5 mg of doxazosin impurity F CRS in 5 mL of mobile phase B, adding water R, and dilute to 50.0 mL with water R. Dilute 10.0 mL of this solution to 50.0 mL with water R.

**Reference solution (c).** Dilute 5.0 mL of reference solution (a) to 10.0 mL with water R.

**Reference solution (d).** Dissolve 25.0 mg of doxazosin mesilate CRS in 5 mL of mobile phase B, adding water R, and dilute to 50.0 mL with water R.

**Column:**

- size:  $l = 0.25$  m,  $\varnothing = 4.0$  mm;
- stationary phase: base-deactivated octylsilyl silica gel for chromatography R (5  $\mu$ m);
- temperature: 35 °C.

**Mobile phase:**

- mobile phase A: 10 g/L solution of phosphoric acid R;
- mobile phase B: 10 g/L solution of phosphoric acid R in acetonitrile R1;

Time (min)	Mobile phase A (per cent V/V)	Mobile phase B (per cent V/V)
0 - 5	90	10
5 - 40	90 → 50	10 → 50
40 - 45	50	50

**Flow rate:** 0.8 mL/min.

**Detection:** spectrophotometer at 210 nm.

**Injection:** 10  $\mu$ L of the test solution and reference solutions (a), (b) and (c).

**Relative retention** with reference to doxazosin (retention time = about 30 min): impurity D = about 0.5; impurity F = about 0.6.

**System suitability:** reference solution (b):

- resolution: minimum 4.5 between the peaks due to impurities D and F.

**Limits:**

- unspecified impurities: for each impurity, not more than the area of the principal peak in the chromatogram obtained with reference solution (a) (0.10 per cent);
- total: not more than 3 times the area of the principal peak in the chromatogram obtained with reference solution (a) (0.3 per cent);
- disregard limit: the area of the principal peak in the chromatogram obtained with reference solution (c) (0.05 per cent).

**Water** (2.5.12): maximum 1.5 per cent, determined on 0.500 g.

**Sulfated ash** (2.4.14): maximum 0.1 per cent, determined on 1.0 g.

## ASSAY

Liquid chromatography (2.2.29) as described in the test for related substances with the following modification.

*Injection*: test solution and reference solution (d).

Calculate the percentage content of  $C_{24}H_{29}N_5O_8S$  using the chromatogram obtained with reference solution (d) and the declared content of *doxazosin mesilate CRS*.

## STORAGE

In an airtight container.

## IMPURITIES

*Other detectable impurities* (the following substances would, if present at a sufficient level, be detected by one or other of the tests in the monograph. They are limited by the general acceptance criterion for other/unspecified impurities and/or by the general monograph *Substances for pharmaceutical use (2034)*. It is therefore not necessary to identify these impurities for demonstration of compliance. See also 5.10. *Control of impurities in substances for pharmaceutical use*): A, B, C, D, E, F, G, H.

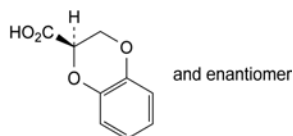

A. (2*RS*)-2,3-dihydro-1,4-benzodioxine-2-carboxylic acid,

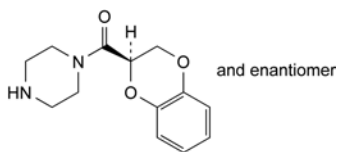

B. 1-[(2*RS*)-2,3-dihydro-1,4-benzodioxin-2-ylcarbonyl]piperazine,

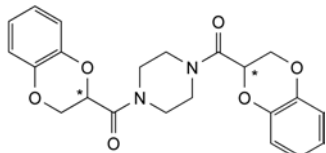

C. 1,4-bis[(2*RS*)-2,3-dihydro-1,4-benzodioxin-2-ylcarbonyl]piperazine,

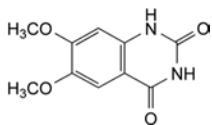

D. 6,7-dimethoxyquinazolin-2,4(1*H*,3*H*)-dione,

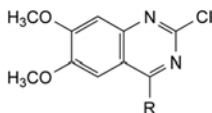

E. R = Cl: 2,4-dichloro-6,7-dimethoxyquinazolin-4-amine,

F. R = NH<sub>2</sub>: 2-chloro-6,7-dimethoxyquinazolin-4-amine,

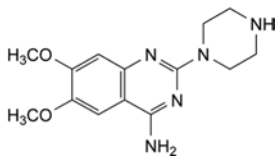

G. 6,7-dimethoxy-2-(piperazin-1-yl)quinazolin-4-amine,

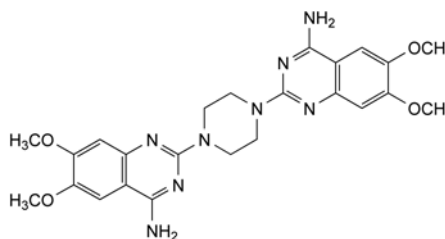

H. 2,2'-(piperazine-1,4-diyl)bis(6,7-dimethoxyquinazolin-4-amine).

04/2009:1096

## DOXEPIN HYDROCHLORIDE

## Doxepini hydrochloridum

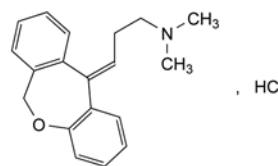

$C_{19}H_{22}ClNO$   
[1229-29-4]

$M_r$  315.8

## DEFINITION

(*E*)-3-(Dibenzo[*b,e*]oxepin-11(6*H*)-ylidene)-*N,N*-dimethylpropan-1-amine hydrochloride.

*Content*: 98.0 per cent to 101.0 per cent of  $C_{19}H_{22}ClNO$  (dried substance).

## CHARACTERS

*Appearance*: white or almost white, crystalline powder.

*Solubility*: freely soluble in water, in ethanol (96 per cent) and in methylene chloride.

## IDENTIFICATION

*First identification*: C, E.

*Second identification*: A, B, D, E.

A. Melting point (2.2.14): 185 °C to 191 °C.

B. Ultraviolet and visible absorption spectrophotometry (2.2.25).

*Test solution*. Dissolve 50.0 mg in a 1 g/L solution of *hydrochloric acid R* in *methanol R* and dilute to 100.0 mL with the same acid solution. Dilute 5.0 mL to 50.0 mL with a 1 g/L solution of *hydrochloric acid R* in *methanol R*.

*Spectral range*: 230-350 nm.

*Absorption maximum*: at 297 nm.

*Specific absorbance at the absorption maximum*: 128 to 142.

C. Infrared absorption spectrophotometry (2.2.24).

*Comparison*: *doxepin hydrochloride CRS*.

D. Dissolve about 5 mg in 2 mL of *sulfuric acid R*. A dark red colour is produced.

E. Solution S (see Tests) gives reaction (a) of chlorides (2.3.1).

## TESTS

**Solution S**. Dissolve 1.5 g in *carbon dioxide-free water R* and dilute to 30 mL with the same solvent.

**Appearance of solution**. Dilute 10 mL of solution S to 25 mL with *water R*. The solution is clear (2.2.1) and colourless (2.2.2, *Method II*).

**Acidity**. To 10 mL of solution S add 0.1 mL of *methyl red solution R*. Not more than 0.1 mL of 0.1 M *sodium hydroxide* is required to change the colour of the indicator to yellow.



**Related substances.** Liquid chromatography (2.2.29). Prepare the solutions immediately before use and protect them from light.

**Phosphate buffer solution.** Dissolve 1.42 g of anhydrous disodium hydrogen phosphate R in water R, adjust to pH 7.7 with dilute phosphoric acid R and dilute to 1000 mL with water R.

**Solvent mixture.** Mix 1 volume of 1 M sodium hydroxide and 250 volumes of the mobile phase.

**Test solution.** Dissolve 50 mg of the substance to be examined in the solvent mixture and dilute to 50.0 mL with the solvent mixture.

**Reference solution (a).** Dilute 1.0 mL of the test solution to 100.0 mL with the solvent mixture. Dilute 1.0 mL of this solution to 10.0 mL with the solvent mixture.

**Reference solution (b).** Dissolve the contents of a vial of doxepin for system suitability CRS (containing impurities A, B and C) in 1.0 mL of mobile phase.

**Column:**

- size:  $l = 0.25$  m,  $\varnothing = 4.6$  mm;
- stationary phase: end-capped octadecylsilyl silica gel for chromatography R ( $5 \mu\text{m}$ );
- temperature:  $30^\circ\text{C}$ .

**Mobile phase:** acetonitrile R1, phosphate buffer solution, methanol R1 (20:30:50 V/V/V).

**Flow rate:** 1.0 mL/min.

**Detection:** spectrophotometer at 215 nm.

**Injection:** 20  $\mu\text{L}$ .

**Run time:** 1.5 times the retention time of doxepin.

**Identification of impurities:** use the chromatogram supplied with doxepin for system suitability CRS and the chromatogram obtained with reference solution (b) to identify the peaks due to impurities A, B and C.

**Relative retention** with reference to doxepin (retention time = about 18 min): impurity A = about 0.5; impurity B = about 0.6; impurity C = about 0.7; the peak due to doxepin might show a shoulder caused by the (Z)-isomer (impurity D).

**System suitability:** reference solution (b):

- resolution: minimum 1.5 between the peaks due to impurities A and C, and minimum 1.5 between the peaks due to impurities C and B;
- the chromatogram obtained is similar to the chromatogram supplied with doxepin for system suitability CRS.

**Limits:**

- correction factor: for the calculation of content, multiply the peak area of impurity B by 1.7;
- impurities A, B: for each impurity, not more than the area of the principal peak in the chromatogram obtained with reference solution (a) (0.1 per cent);
- impurity C: not more than twice the area of the principal peak in the chromatogram obtained with reference solution (a) (0.2 per cent);
- unspecified impurities: for each impurity, not more than the area of the principal peak in the chromatogram obtained with reference solution (a) (0.10 per cent);
- total: not more than 3 times the area of the principal peak in the chromatogram obtained with reference solution (a) (0.3 per cent);
- disregard limit: 0.5 times the area of the principal peak in the chromatogram obtained with reference solution (a) (0.05 per cent).

**(Z)-Isomer.** Liquid chromatography (2.2.29).

**Test solution.** Dissolve 20.0 mg of the substance to be examined in the mobile phase and dilute to 20.0 mL with the mobile phase. Dilute 1.0 mL of this solution to 10.0 mL with the mobile phase.

**Column:**

- size:  $l = 0.12$  m,  $\varnothing = 4$  mm;
- stationary phase: spherical octylsilyl silica gel for chromatography R ( $5 \mu\text{m}$ ) with a specific surface area of  $220 \text{ m}^2/\text{g}$  and a pore size of 80 nm;
- temperature:  $50^\circ\text{C}$ .

**Mobile phase:** mix 30 volumes of methanol R and 70 volumes of a 30 g/L solution of sodium dihydrogen phosphate R previously adjusted to pH 2.5 with phosphoric acid R.

**Flow rate:** 1 mL/min.

**Detection:** spectrophotometer at 254 nm.

**Injection:** 20  $\mu\text{L}$ .

**System suitability:**

- resolution: minimum 1.5 between the peaks due to the (E)-isomer (1<sup>st</sup> peak) and to the (Z)-isomer (2<sup>nd</sup> peak).

**Results:**

- calculate the ratio of the area of the peak due to the (E)-isomer to the area of the peak due to the (Z)-isomer: this ratio is 4.4 to 6.7 (13.0 per cent to 18.5 per cent of the (Z)-isomer).

**Heavy metals (2.4.8):** maximum 20 ppm.

Dissolve 2.0 g in water R and dilute to 20 mL with the same solvent. 12 mL of the solution complies with test A. Prepare the reference solution using lead standard solution (2 ppm Pb) R.

**Loss on drying (2.2.32):** maximum 0.5 per cent, determined on 1.000 g by drying in an oven at  $105^\circ\text{C}$ .

**Sulfated ash (2.4.14):** maximum 0.1 per cent, determined on 1.0 g.

## ASSAY

Dissolve 0.250 g in a mixture of 5 mL of anhydrous acetic acid R and 35 mL of acetic anhydride R. Using 0.2 mL of crystal violet solution R as indicator, titrate with 0.1 M perchloric acid until the colour changes from blue to green.

1 mL of 0.1 M perchloric acid is equivalent to 31.58 mg of  $\text{C}_{19}\text{H}_{22}\text{ClNO}$ .

## STORAGE

Protected from light.

## IMPURITIES

**Specified impurities:** A, B, C, D.

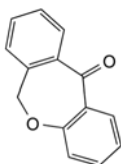

A. dibenzo[b,e]oxepin-11(6H)-one (doxepinone),

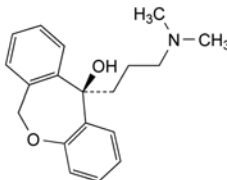

and enantiomer

B. (11R)-11-[3-(dimethylamino)propyl]-6,11-dihydrodibenzo[b,e]oxepin-11-ol (doxepinol),

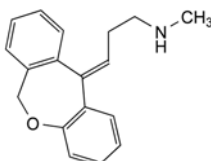

C. (E)-3-(dibenzo[b,e]oxepin-11(6H)-ylidene)-N-methylpropan-1-amine (desmethyldoxepin),

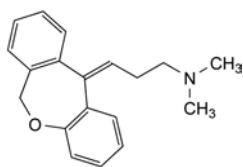

D. (Z)-3-(dibenzo[*b,e*]oxepin-11(6*H*)-ylidene)-*N,N*-dimethylpropan-1-amine.

01/2008:0714

## DOXORUBICIN HYDROCHLORIDE

### Doxorubicini hydrochloridum

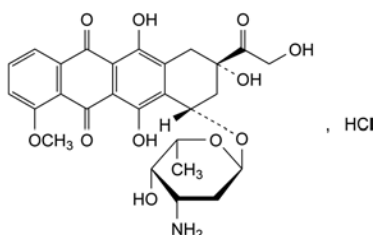

$C_{27}H_{30}ClNO_{11}$   
[25316-40-9]

$M_r$  580.0

#### DEFINITION

(8*S*,10*S*)-10-[(3-Amino-2,3,6-trideoxy- $\alpha$ -*L*-lyxo-hexopyranosyl)oxy]-6,8,11-trihydroxy-8-(hydroxyacetyl)-1-methoxy-7,8,9,10-tetrahydrotetracene-5,12-dione hydrochloride.

Substance produced by certain strains of *Streptomyces coeruleorubidus* or *Streptomyces peucetius* or obtained by any other means.

*Content*: 98.0 per cent to 102.0 per cent (anhydrous substance).

#### CHARACTERS

*Appearance*: orange-red, crystalline powder, hygroscopic.

*Solubility*: soluble in water, slightly soluble in methanol.

#### IDENTIFICATION

A. Infrared absorption spectrophotometry (2.2.24).

*Comparison*: doxorubicin hydrochloride CRS.

B. Dissolve about 10 mg in 0.5 mL of *nitric acid R*, add 0.5 mL of *water R* and heat over a flame for 2 min. Allow to cool and add 0.5 mL of *silver nitrate solution RI*. A white precipitate is formed.

#### TESTS

**pH** (2.2.3): 4.0 to 5.5.

Dissolve 50 mg in *carbon dioxide-free water R* and dilute to 10 mL with the same solvent.

**Related substances**. Liquid chromatography (2.2.29). Prepare the solutions immediately before use.

*Test solution (a)*. Dissolve 50.0 mg of the substance to be examined in the mobile phase and dilute to 50.0 mL with the mobile phase.

*Test solution (b)*. Dilute 10.0 mL of test solution (a) to 100.0 mL with the mobile phase.

*Reference solution (a)*. Dissolve 10.0 mg of *doxorubicin hydrochloride CRS* and 10 mg of *epirubicin hydrochloride CRS* in the mobile phase and dilute to 50.0 mL with the mobile phase. Dilute 10.0 mL of the solution to 100.0 mL with the mobile phase.

*Reference solution (b)*. Dilute 5.0 mL of reference solution (a) to 20.0 mL with the mobile phase.

*Reference solution (c)*. Dissolve 50.0 mg of *doxorubicin hydrochloride CRS* in the mobile phase and dilute to 50.0 mL with the mobile phase. Dilute 10.0 mL of the solution to 100.0 mL with the mobile phase.

#### Column:

– *size*:  $l = 0.25$  m,  $\varnothing = 4.0$  mm,

– *stationary phase*: end-capped octadecylsilyl silica gel for chromatography *R* (5  $\mu$ m).

*Mobile phase*: mix equal volumes of *acetonitrile R* and a solution containing 2.88 g/L of *sodium laurilsulfate R* and 2.25 g/L of *phosphoric acid R*.

*Flow rate*: 1 mL/min.

*Detection*: spectrophotometer at 254 nm.

*Injection*: 5  $\mu$ L; inject test solution (a) and reference solutions (a) and (b).

*Run time*: 3.5 times the retention time of doxorubicin.

*Retention time*: doxorubicin = about 8 min.

*System suitability*: reference solution (a):

– *resolution*: minimum of 2.0 between the peaks due to doxorubicin and to epirubicin.

#### Limits:

– *any impurity*: not more than the area of the peak corresponding to doxorubicin in the chromatogram obtained with reference solution (b) (0.5 per cent),

– *disregard limit*: 0.1 times the area of the peak corresponding to doxorubicin in the chromatogram obtained with reference solution (b) (0.05 per cent).

**Ethanol** (2.4.24, *System B*): maximum 1.0 per cent.

**Water** (2.5.12): maximum 4.0 per cent, determined on 0.100 g.

**Bacterial endotoxins** (2.6.14): less than 2.2 IU/mg, if intended for use in the manufacture of parenteral preparations without a further appropriate procedure for the removal of bacterial endotoxins.

#### ASSAY

Liquid chromatography (2.2.29) as described in the test for related substances.

*Injection*: test solution (b) and reference solution (c).

Calculate the percentage content of  $C_{27}H_{30}ClNO_{11}$ .

#### STORAGE

In an airtight container. If the substance is sterile, store in a sterile, airtight, tamper-proof container.

#### IMPURITIES

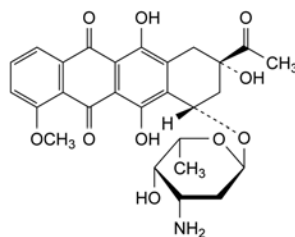

A. (8*S*,10*S*)-8-acetyl-10-[(3-amino-2,3,6-trideoxy- $\alpha$ -*L*-lyxohexopyranosyl)oxy]-6,8,11-trihydroxy-1-methoxy-7,8,9,10-tetrahydrotetracene-5,12-dione (daunorubicin),

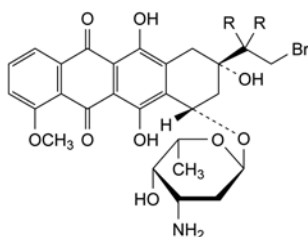

- B. R = OCH<sub>3</sub>: (8S,10S)-10[(3-amino-2,3,6-trideoxy- $\alpha$ -L-lyxohexopyranosyl)oxy]-8-(2-bromo-1,1-dimethoxyethyl)-6,8,11-trihydroxy-1-methoxy-7,8,9,10-tetrahydrotetracene-5,12-dione,
- C. R + R = O: (8S,10S)-10[(3-amino-2,3,6-trideoxy- $\alpha$ -L-lyxohexopyranosyl)oxy]-8-(bromoacetyl)-6,8,11-trihydroxy-1-methoxy-7,8,9,10-tetrahydrotetracene-5,12-dione,

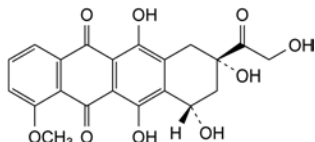

- D. (8S,10S)-6,8,10,11-tetrahydroxy-8-(hydroxyacetyl)-1-methoxy-7,8,9,10-tetrahydrotetracene-5,12-dione (doxorubicin aglycone, doxorubicinone).

01/2008:0272  
corrected 6.0

## DOXYCYCLINE HYCLATE

### Doxycyclini hyclas

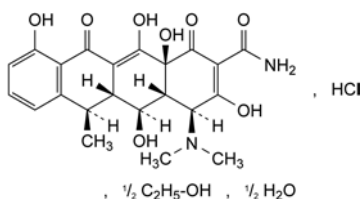

(C<sub>22</sub>H<sub>25</sub>ClN<sub>2</sub>O<sub>8</sub>), 1/2 C<sub>2</sub>H<sub>6</sub>O, 1/2 H<sub>2</sub>O  
[24390-14-5]

M<sub>r</sub> 512.9

#### DEFINITION

Hydrochloride hemimethanol hemihydrate of (4S,4aR,5S,5aR,6R,12aS)-4-(dimethylamino)-3,5,10,12,12a-pentahydroxy-6-methyl-1,11-dioxo-1,4,4a,5,5a,6,11,12a-octahydrotetracene-2-carboxamide.

Substance obtained from oxytetracycline or metacycline or by any other means.

Semi-synthetic product derived from a fermentation product.

**Content:** 95.0 per cent to 102.0 per cent of C<sub>22</sub>H<sub>25</sub>ClN<sub>2</sub>O<sub>8</sub> (anhydrous substance).

#### CHARACTERS

**Appearance:** yellow, crystalline powder, hygroscopic.

**Solubility:** freely soluble in water and in methanol, sparingly soluble in ethanol (96 per cent). It dissolves in solutions of alkali hydroxides and carbonates.

#### IDENTIFICATION

A. Examine the chromatograms obtained in the assay.

**Results:** the principal peak in the chromatogram obtained with the test solution is similar in retention time and size to the principal peak in the chromatogram obtained with reference solution (a).

B. To about 2 mg add 5 mL of *sulfuric acid R*. A yellow colour develops.

C. It gives reaction (a) of chlorides (2.3.1).

#### TESTS

**pH** (2.2.3): 2.0 to 3.0.

Dissolve 0.1 g in *carbon dioxide-free water R* and dilute to 10 mL with the same solvent.

**Specific optical rotation** (2.2.7): –105 to –120 (anhydrous substance).

Dissolve 0.250 g in a mixture of 1 volume of 1 M *hydrochloric acid* and 99 volumes of *methanol R* and dilute to 25.0 mL with the same mixture of solvents. Carry out the measurement within 5 min of preparing the solution.

**Specific absorbance** (2.2.25): 300 to 335, determined at the absorption maximum at 349 nm (anhydrous substance).

Dissolve 25.0 mg in a mixture of 1 volume of 1 M *hydrochloric acid* and 99 volumes of *methanol R* and dilute to 25.0 mL with the same mixture of solvents. Dilute 1.0 mL of the solution to 100.0 mL with a mixture of 1 volume of 1 M *hydrochloric acid* and 99 volumes of *methanol R*. Carry out the measurement within 1 h of preparing the solution.

**Light-absorbing impurities.** The absorbance (2.2.25), determined at 490 nm is not greater than 0.07 (anhydrous and ethanol-free substance).

Dissolve 0.10 g in a mixture of 1 volume of 1 M *hydrochloric acid* and 99 volumes of *methanol R* and dilute to 10.0 mL with the same mixture of solvents. Carry out the measurement within 1 h of preparing the solution.

**Related substances.** Liquid chromatography (2.2.29). Prepare the solutions immediately before use.

**Test solution.** Dissolve 20.0 mg of the substance to be examined in 0.01 M *hydrochloric acid* and dilute to 25.0 mL with the same acid.

**Reference solution (a).** Dissolve 20.0 mg of *doxycycline hyclate CRS* in 0.01 M *hydrochloric acid* and dilute to 25.0 mL with the same acid.

**Reference solution (b).** Dissolve 20.0 mg of *6-epidoxycycline hydrochloride CRS* in 0.01 M *hydrochloric acid* and dilute to 25.0 mL with the same acid.

**Reference solution (c).** Dissolve 20.0 mg of *metacycline hydrochloride CRS* in 0.01 M *hydrochloric acid* and dilute to 25.0 mL with the same acid.

**Reference solution (d).** Mix 4.0 mL of reference solution (a), 1.5 mL of reference solution (b) and 1.0 mL of reference solution (c) and dilute to 25.0 mL with 0.01 M *hydrochloric acid*.

**Reference solution (e).** Mix 2.0 mL of reference solution (b) and 2.0 mL of reference solution (c) and dilute to 100.0 mL with 0.01 M *hydrochloric acid*.

#### Column:

– size:  $l = 0.25$  m,  $\varnothing = 4.6$  mm,

– stationary phase: *styrene-divinylbenzene copolymer R* (8  $\mu$ m),

– temperature: 60 °C.

**Mobile phase:** weigh 60.0 g of *2-methyl-2-propanol R* and transfer to a 1000 mL volumetric flask with the aid of 200 mL of *water R*; add 400 mL of *buffer solution pH 8.0 R*, 50 mL of a 10 g/L solution of *tetrabutylammonium hydrogen sulfate R* adjusted to pH 8.0 with *dilute sodium hydroxide solution R* and 10 mL of a 40 g/L solution of *sodium edetate R* adjusted to pH 8.0 with *dilute sodium hydroxide solution R*; dilute to 1000.0 mL with *water R*.

**Flow rate:** 1.0 mL/min.

**Detection:** spectrophotometer at 254 nm.

**Injection:** 20  $\mu$ L of the test solution and reference solutions (d) and (e).

**Relative retention** with reference to doxycycline: impurity E = about 0.2; impurity D = about 0.3; impurity C = about 0.5; impurity F = about 1.2.

**System suitability:** reference solution (d):

- **resolution:** minimum 1.25 between the peaks due to impurity B (1<sup>st</sup> peak) and impurity A (2<sup>nd</sup> peak) and minimum 2.0 between the peaks due to impurity A and doxycycline (3<sup>rd</sup> peak); if necessary, adjust the 2-methyl-2-propanol content in the mobile phase;
- **symmetry factor:** maximum 1.25 for the peak due to doxycycline.

**Limits:**

- **impurity A:** not more than the area of the corresponding peak in the chromatogram obtained with reference solution (e) (2.0 per cent),
- **impurity B:** not more than the area of the corresponding peak in the chromatogram obtained with reference solution (e) (2.0 per cent),
- **impurities C, D, E, F:** for each impurity, not more than 0.25 times the area of the peak due to impurity A in the chromatogram obtained with reference solution (e) (0.5 per cent),
- **any other impurity:** for each impurity, not more than 0.25 times the area of the peak due to impurity A in the chromatogram obtained with reference solution (e) (0.5 per cent),
- **disregard limit:** 0.05 times the area of the peak due to impurity A in the chromatogram obtained with reference solution (e) (0.1 per cent).

**Ethanol.** Gas chromatography (2.2.28).

**Internal standard solution.** Dilute 0.50 mL of *propanol R* to 1000.0 mL with *water R*.

**Test solution (a).** Dissolve 0.10 g of the substance to be examined in *water R* and dilute to 10.0 mL with the same solvent.

**Test solution (b).** Dissolve 0.10 g of the substance to be examined in the internal standard solution and dilute to 10.0 mL with the same solution.

**Reference solution.** Dilute 0.50 mL of *ethanol R* to 100.0 mL with the internal standard solution. Dilute 1.0 mL of this solution to 10.0 mL with the internal standard solution.

**Column:**

- **size:**  $l = 1.5$  m,  $\varnothing = 4.0$  mm,
- **stationary phase:** *ethylvinylbenzene-divinylbenzene copolymer R* (150-180  $\mu$ m).

**Carrier gas:** *nitrogen for chromatography R*.

**Temperature:**

- **column:** 135 °C,
- **injection port and detector:** 150 °C.

**Detection:** flame ionisation.

Calculate the content of ethanol taking the density (2.2.5) at 20 °C to be 0.790 g/mL.

**Limit:**

- **ethanol:** 4.3 per cent to 6.0 per cent.

**Heavy metals** (2.4.8): maximum 50 ppm.

0.5 g complies with limit test C. Prepare the reference solution using 2.5 mL of *lead standard solution (10 ppm Pb) R*.

**Water** (2.5.12): 1.4 per cent to 2.8 per cent, determined on 1.20 g.

**Sulfated ash** (2.4.14): maximum 0.4 per cent, determined on 1.0 g.

**Bacterial endotoxins** (2.6.14): less than 1.14 IU/mg, if intended for use in the manufacture of parenteral preparations without a further appropriate procedure for the removal of bacterial endotoxins.

**ASSAY**

Liquid chromatography (2.2.29) as described in the test for related substances with the following modification.

**Injection:** test solution and reference solution (a).

Calculate the percentage content of  $C_{22}H_{25}ClN_2O_8$  ( $M_r = 480.9$ ).

**STORAGE**

In an airtight container, protected from light. If the substance is sterile, store in a sterile, airtight, tamper-proof container.

**IMPURITIES**

**Specified impurities:** A, B, C, D, E, F.

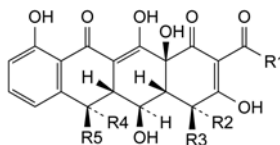

- A.  $R_1 = NH_2$ ,  $R_2 = R_5 = H$ ,  $R_3 = N(CH_3)_2$ ,  $R_4 = CH_3$ :  
(4*S*,4*aR*,5*S*,5*aR*,6*S*,12*aS*)-4-(dimethylamino)-3,5,10,12,12*a*-pentahydroxy-6-methyl-1,11-dioxo-1,4,4*a*,5,5*a*,6,11,12*a*-octahydrotetracene-2-carboxamide (6-epidoxycycline),
- B.  $R_1 = NH_2$ ,  $R_2 = H$ ,  $R_3 = N(CH_3)_2$ ,  $R_4 + R_5 = CH_2$ :  
(4*S*,4*aR*,5*S*,5*aR*,12*aS*)-4-(dimethylamino)-3,5,10,12,12*a*-pentahydroxy-6-methylene-1,11-dioxo-1,4,4*a*,5,5*a*,6,11,12*a*-octahydrotetracene-2-carboxamide (metacycline),
- C.  $R_1 = NH_2$ ,  $R_2 = N(CH_3)_2$ ,  $R_3 = R_4 = H$ ,  $R_5 = CH_3$ :  
(4*R*,4*aR*,5*S*,5*aR*,6*R*,12*aS*)-4-(dimethylamino)-3,5,10,12,12*a*-pentahydroxy-6-methyl-1,11-dioxo-1,4,4*a*,5,5*a*,6,11,12*a*-octahydrotetracene-2-carboxamide (4-epidoxycycline),
- D.  $R_1 = NH_2$ ,  $R_2 = N(CH_3)_2$ ,  $R_3 = R_5 = H$ ,  $R_4 = CH_3$ :  
(4*R*,4*aR*,5*S*,5*aR*,6*S*,12*aS*)-4-(dimethylamino)-3,5,10,12,12*a*-pentahydroxy-6-methyl-1,11-dioxo-1,4,4*a*,5,5*a*,6,11,12*a*-octahydrotetracene-2-carboxamide (4-epi-6-epidoxycycline),
- E.  $R_1 = NH_2$ ,  $R_2 = H$ ,  $R_3 = N(CH_3)_2$ ,  $R_4 = OH$ ,  $R_5 = CH_3$ :  
oxytetracycline,
- F.  $R_1 = CH_3$ ,  $R_2 = R_4 = H$ ,  $R_3 = N(CH_3)_2$ ,  $R_5 = CH_3$ :  
(4*S*,4*aR*,5*S*,5*aR*,6*R*,12*aS*)-2-acetyl-4-(dimethylamino)-3,5,10,12,12*a*-pentahydroxy-6-methyl-4*a*,5*a*,6,12*a*-tetrahydrotetracene-1,11(4*H*,5*H*)-dione (2-acetyl-2-decarbamoilydoxycycline).

01/2008:0820  
corrected 6.0

## DOXYCYCLINE MONOHYDRATE

Doxycyclinum monohydricum

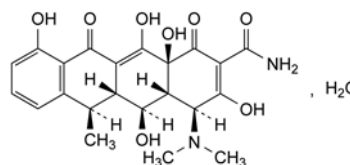

$C_{22}H_{24}N_2O_8 \cdot H_2O$   
[17086-28-1]

$M_r$  462.5

**DEFINITION**

(4*S*,4*aR*,5*S*,5*aR*,6*R*,12*aS*)-4-(Dimethylamino)-3,5,10,12,12*a*-pentahydroxy-6-methyl-1,11-dioxo-1,4,4*a*,5,5*a*,6,11,12*a*-octahydrotetracene-2-carboxamide monohydrate.

Substance obtained from oxytetracycline or metacycline or by any other means.

Semi-synthetic product derived from a fermentation product.

**Content:** 95.0 per cent to 102.0 per cent (anhydrous substance).

**CHARACTERS**

**Appearance:** yellow, crystalline powder.

**Solubility:** very slightly soluble in water and in alcohol. It dissolves in dilute solutions of mineral acids and in solutions of alkali hydroxides and carbonates.

## IDENTIFICATION

A. Examine the chromatograms obtained in the assay.

*Results:* the principal peak in the chromatogram obtained with the test solution is similar in retention time and size to the principal peak in the chromatogram obtained with reference solution (a).

B. To about 2 mg add 5 mL of *sulfuric acid R*. A yellow colour develops.

C. Dissolve 25 mg in a mixture of 0.2 mL of *dilute nitric acid R* and 1.8 mL of *water R*. The solution does not give reaction (a) of chlorides (2.3.1).

## TESTS

**pH** (2.2.3): 5.0 to 6.5.

Suspend 0.1 g in *carbon dioxide-free water R* and dilute to 10 mL with the same solvent.

**Specific optical rotation** (2.2.7): –113 to –130 (anhydrous substance).

Dissolve 0.250 g in a mixture of 0.5 volumes of *hydrochloric acid R* and 99.5 volumes of *methanol R* and dilute to 25.0 mL with the same mixture of solvents. Carry out the measurement within 5 min of preparing the solution.

**Specific absorbance** (2.2.25): 325 to 363 determined at the maximum at 349 nm (anhydrous substance).

Dissolve 25.0 mg in a mixture of 0.5 volumes of *hydrochloric acid R* and 99.5 volumes of *methanol R* and dilute to 50.0 mL with the same mixture of solvents. Dilute 2.0 mL of the solution to 100.0 mL with a mixture of 0.5 volumes of *1 M hydrochloric acid* and 99.5 volumes of *methanol R*. Carry out the measurement within 1 h of preparing the solution.

**Light-absorbing impurities.** The absorbance (2.2.25) determined at 490 nm has a maximum of 0.07 (anhydrous substance).

Dissolve 0.10 g in a mixture of 0.5 volumes of *hydrochloric acid R* and 99.5 volumes of *methanol R* and dilute to 10.0 mL with the same mixture of solvents. Carry out the measurement within 1 h of preparing the solution.

**Related substances.** Liquid chromatography (2.2.29). Prepare the solutions immediately before use.

*Test solution.* Dissolve 20.0 mg of the substance to be examined in 0.01 M *hydrochloric acid* and dilute to 25.0 mL with the same acid.

*Reference solution (a).* Dissolve 20.0 mg of *doxycycline hyclate CRS* in 0.01 M *hydrochloric acid* and dilute to 25.0 mL with the same acid.

*Reference solution (b).* Dissolve 20.0 mg of *6-epidoxycycline hydrochloride CRS* in 0.01 M *hydrochloric acid* and dilute to 25.0 mL with the same acid.

*Reference solution (c).* Dissolve 20.0 mg of *metacycline hydrochloride CRS* in 0.01 M *hydrochloric acid* and dilute to 25.0 mL with the same acid.

*Reference solution (d).* Mix 4.0 mL of reference solution (a), 1.5 mL of reference solution (b) and 1.0 mL of reference solution (c) and dilute to 25.0 mL with 0.01 M *hydrochloric acid*.

*Reference solution (e).* Mix 2.0 mL of reference solution (b) and 2.0 mL of reference solution (c) and dilute to 100.0 mL with 0.01 M *hydrochloric acid*.

*Column:*

– *size:*  $l = 0.25$  m,  $\varnothing = 4.6$  mm,

– *stationary phase:* *styrene-divinylbenzene copolymer R* (8  $\mu$ m),

– *temperature:* 60 °C.

*Mobile phase:* weigh 60.0 g of *2-methyl-2-propanol R* and transfer into a 1000 mL volumetric flask with the aid of 200 mL of *water R*; add 400 mL of *buffer solution pH 8.0 R*, 50 mL of a 10 g/L solution of *tetrabutylammonium hydrogen sulfate R* adjusted to pH 8.0 with *dilute sodium hydroxide solution R* and 10 mL of a 40 g/L solution of *sodium edetate R* adjusted to pH 8.0 with *dilute sodium hydroxide solution R*; dilute to 1000.0 mL with *water R*.

*Flow rate:* 1.0 mL/min.

*Detection:* spectrophotometer at 254 nm.

*Injection:* 20  $\mu$ L; inject the test solution and reference solutions (d) and (e).

*Relative retention* with reference to doxycycline: impurity E = about 0.2; impurity D = about 0.3; impurity C = about 0.5; impurity F = about 1.2.

*System suitability:* reference solution (d):

– *resolution:* minimum 1.25 between the peaks due to impurity B (1<sup>st</sup> peak) and impurity A (2<sup>nd</sup> peak) and minimum 2.0 between the peaks due to impurity A and doxycycline (3<sup>rd</sup> peak); if necessary, adjust the 2-methyl-2-propanol content in the mobile phase,

– *symmetry factor:* maximum 1.25 for the peak due to doxycycline.

*Limits:*

– *impurity A:* not more than the area of the corresponding peak in the chromatogram obtained with reference solution (e) (2.0 per cent),

– *impurity B:* not more than the area of the corresponding peak in the chromatogram obtained with reference solution (e) (2.0 per cent),

– *any other impurity:* not more than 0.25 times the area of the peak due to impurity A in the chromatogram obtained with reference solution (e) (0.5 per cent),

– *disregard limit:* 0.05 times the area of the peak due to impurity A in the chromatogram obtained with reference solution (e) (0.1 per cent).

**Heavy metals** (2.4.8): maximum 50 ppm.

0.5 g complies with limit test C. Prepare the standard using 2.5 mL of *lead standard solution (10 ppm Pb) R*.

**Water** (2.5.12): 3.6 per cent to 4.6 per cent, determined on 0.200 g.

**Sulfated ash** (2.4.14): maximum 0.4 per cent, determined on 1.0 g.

## ASSAY

Liquid chromatography (2.2.29) as described in the test for related substances with the following modification.

*Injection:* test solution and reference solution (a).

Calculate the percentage content of  $C_{22}H_{24}N_2O_8$ .

## STORAGE

Protected from light.

## IMPURITIES

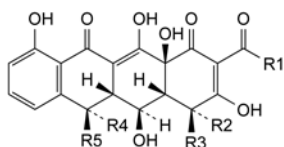

- A. R1 = NH<sub>2</sub>, R2 = R5 = H, R3 = N(CH<sub>3</sub>)<sub>2</sub>, R4 = CH<sub>3</sub>:  
(4*S*,4*aR*,5*S*,5*aR*,6*S*,12*aS*)-4-(dimethylamino)-3,5,10,12,12a-pentahydroxy-6-methyl-1,11-dioxo-1,4,4a,5,5a,6,11,12a-octahydrotetracene-2-carboxamide (6-epidoxycycline),
- B. R1 = NH<sub>2</sub>, R2 = H, R3 = N(CH<sub>3</sub>)<sub>2</sub>, R4 + R5 = CH<sub>2</sub>:  
(4*S*,4*aR*,5*S*,5*aR*,12*aS*)-4-(dimethylamino)-3,5,10,12,12a-pentahydroxy-6-methylene-1,11-dioxo-1,4,4a,5,5a,6,11,12a-octahydrotetracene-2-carboxamide (metacycline),
- C. R1 = NH<sub>2</sub>, R2 = N(CH<sub>3</sub>)<sub>2</sub>, R3 = R4 = H, R5 = CH<sub>3</sub>:  
(4*R*,4*aR*,5*S*,5*aR*,6*R*,12*aS*)-4-(dimethylamino)-3,5,10,12,12a-pentahydroxy-6-methyl-1,11-dioxo-1,4,4a,5,5a,6,11,12a-octahydrotetracene-2-carboxamide (4-epidoxycycline),
- D. R1 = NH<sub>2</sub>, R2 = N(CH<sub>3</sub>)<sub>2</sub>, R3 = R5 = H, R4 = CH<sub>3</sub>:  
(4*R*,4*aR*,5*S*,5*aR*,6*S*,12*aS*)-4-(dimethylamino)-3,5,10,12,12a-pentahydroxy-6-methyl-1,11-dioxo-1,4,4a,5,5a,6,11,12a-octahydrotetracene-2-carboxamide (4-epi-6-epidoxycycline),
- E. R1 = NH<sub>2</sub>, R2 = H, R3 = N(CH<sub>3</sub>)<sub>2</sub>, R4 = OH, R5 = CH<sub>3</sub>:  
oxytetracycline,
- F. R1 = CH<sub>3</sub>, R2 = R4 = H, R3 = N(CH<sub>3</sub>)<sub>2</sub>, R5 = CH<sub>3</sub>:  
(4*S*,4*aR*,5*S*,5*aR*,6*R*,12*aS*)-2-acetyl-4-(dimethylamino)-3,5,10,12,12a-pentahydroxy-6-methyl-4a,5a,6,12a-tetrahydrotetracene-1,11-(4*H*,5*H*)-dione (2-acetyl-2-decarbamoylepidoxycycline).

01/2008:1589  
corrected 6.1

## DOXYLAMINE HYDROGEN SUCCINATE

## Doxylamini hydrogenosuccinas

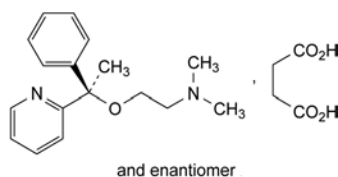

C<sub>21</sub>H<sub>28</sub>N<sub>2</sub>O<sub>5</sub>  
[562-10-7]

M<sub>r</sub> 388.5

## DEFINITION

*N,N*-dimethyl-2-[(1*R,S*)-1-phenyl-1-(pyridin-2-yl)ethoxy](ethanamine hydrogen butanedioate).

*Content*: 99.0 per cent to 101.0 per cent (anhydrous substance).

## CHARACTERS

*Appearance*: a white or almost white powder.

*Solubility*: very soluble in water, freely soluble in ethanol (96 per cent).

## IDENTIFICATION

*First identification*: C.

*Second identification*: A, B.

A. Melting point (2.2.14): 103 °C to 108 °C.

B. Dissolve 0.200 g in 0.1 M hydrochloric acid and dilute to 100.0 mL with the same solvent. Dilute 1.0 mL of this solution to 100.0 mL with 0.1 M hydrochloric acid.

Examined between 230 nm and 350 nm (2.2.25), the solution shows an absorption maximum at 262 nm. The specific absorbance at the maximum is 229 to 243 (anhydrous substance).

C. Infrared absorption spectrophotometry (2.2.24).

*Comparison*: Ph. Eur. reference spectrum of doxylamine hydrogen succinate.

## TESTS

**Appearance of solution.** The solution is clear (2.2.1) and colourless (2.2.2, *Method II*).

Dissolve 0.4 g of the substance to be examined in *water R* and dilute to 20 mL with the same solvent.

**Optical rotation** (2.2.7): - 0.10° to + 0.10°.

Dissolve 2.50 g of the substance to be examined in *water R* and dilute to 25.0 mL with the same solvent.

**Related substances.** Gas chromatography (2.2.28).

*Test solution.* Dissolve 0.650 g of the substance to be examined in 20 mL of 0.1 M hydrochloric acid. Add 3 mL of a 100 g/L solution of sodium hydroxide *R* and extract with 3 quantities, each of 25 mL, of methylene chloride *R*. Combine the methylene chloride extracts and filter using hydrophobic phase-separation filter paper. Rinse the filter with 10 mL of methylene chloride *R* and combine the rinsings with the methylene chloride extracts. Evaporate the solvent under reduced pressure at a temperature not exceeding 40 °C. Dissolve the residue in 20.0 mL of anhydrous ethanol *R*.

*Reference solution (a).* Dilute 1.0 mL of the test solution to 200.0 mL with anhydrous ethanol *R*.

*Reference solution (b).* Dissolve 4 mg of doxylamine impurity A CRS and 4 mg of 2-benzoylpyridine *R* in anhydrous ethanol *R* and dilute to 40 mL with the same solvent.

*Column*:

- *material*: fused silica;
- *size*: *l* = 30 m, Ø = 0.53 mm;
- *stationary phase*: poly(dimethyl)(diphenyl)siloxane *R* (film thickness 1.5 µm).

*Carrier gas*: helium for chromatography *R*.

*Flow rate*: 7 mL/min.

*Temperature*:

	Time (min)	Temperature (°C)
Column	0 - 12	160 → 220
	12 - 27	220
Injection port		250
Detector		250

*Detection*: flame ionisation.

*Injection*: 1 µL.

*System suitability*: reference solution (b):

- *resolution*: minimum 1.5 between the peaks due to impurities A and D.

*Limits*:

- *any impurity*: not more than the area of the principal peak in the chromatogram obtained with reference solution (a) (0.5 per cent);
- *total*: not more than twice the area of the principal peak in the chromatogram obtained with reference solution (a) (1 per cent);
- *disregard limit*: 0.1 times the area of the principal peak in the chromatogram obtained with reference solution (a) (0.05 per cent).

**Water** (2.5.12): maximum 0.5 per cent, determined on 2.00 g.

**Sulfated ash** (2.4.14): maximum 0.1 per cent, determined on 1.0 g.

## ASSAY

Dissolve 0.150 g in 50 mL of *anhydrous acetic acid R*. Titrate with 0.1 M *perchloric acid*, determining the end-point potentiometrically (2.2.20).

1 mL of 0.1 M *perchloric acid* is equivalent to 19.43 mg of  $C_{21}H_{28}N_2O_5$ .

## IMPURITIES

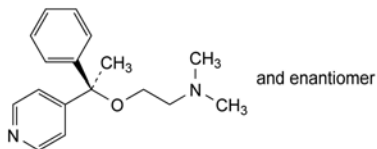

A. *N,N*-dimethyl-2-[1(*RS*)-1-phenyl-1-(pyridin-4-yl)ethoxy]ethanamine,

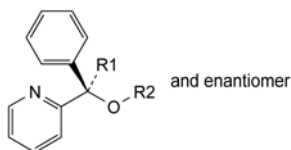

B. R1 = CH<sub>3</sub>, R2 = H: (1*RS*)-1-phenyl-1-(pyridin-2-yl)ethanol,

C. R1 = H, R2 = CH<sub>2</sub>-CH<sub>2</sub>-N(CH<sub>3</sub>)<sub>2</sub>: *N,N*-dimethyl-2-[(*RS*)-1-phenyl(pyridin-2-yl)methoxy]ethanamine,

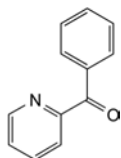

D. phenyl(pyridin-2-yl)methanone (2-benzoylpyridine).

01/2008:1010  
corrected 6.0

## DROPERIDOL

## Droperidolum

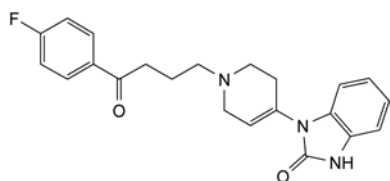

$C_{22}H_{22}FN_3O_2$   
[548-73-2]

$M_r$  379.4

## DEFINITION

1-[1-[4-(4-Fluorophenyl)-4-oxobutyl]-1,2,3,6-tetrahydropyridin-4-yl]-1,3-dihydro-2*H*-benzimidazol-2-one.

*Content*: 99.0 per cent to 101.0 per cent (dried substance).

## CHARACTERS

*Appearance*: white or almost white powder.

*Solubility*: practically insoluble in water, freely soluble in dimethylformamide and in methylene chloride, sparingly soluble in ethanol (96 per cent).

It shows polymorphism (5.9).

## IDENTIFICATION

*First identification*: A.

*Second identification*: B, C, D.

A. Infrared absorption spectrophotometry (2.2.24).

*Preparation*: discs.

*Comparison*: droperidol CRS.

If the spectra obtained show differences, dissolve the substance to be examined and the reference substance separately in the minimum volume of *acetone R*, evaporate to dryness on a water-bath and record new spectra using the residues.

B. Thin-layer chromatography (2.2.27).

*Test solution*. Dissolve 30 mg of the substance to be examined in the mobile phase and dilute to 10 mL with the mobile phase.

*Reference solution (a)*. Dissolve 30 mg of droperidol CRS in the mobile phase and dilute to 10 mL with the mobile phase.

*Reference solution (b)*. Dissolve 30 mg of droperidol CRS and 30 mg of benperidol CRS in the mobile phase, then dilute to 10 mL with the mobile phase.

*Plate*: TLC silica gel GF<sub>254</sub> plate R.

*Mobile phase*: acetone R, methanol R (1:9 V/V).

*Application*: 10 µL.

*Development*: over a path of 15 cm.

*Drying*: in air.

*Detection*: examine in ultraviolet light at 254 nm.

*System suitability*: reference solution (b):

– the chromatogram shows 2 clearly separated spots.

*Results*: the principal spot in the chromatogram obtained with the test solution is similar in position and size to the principal spot in the chromatogram obtained with reference solution (a).

C. Dissolve about 10 mg in 5 mL of *anhydrous ethanol R*.

Add 0.5 mL of *dinitrobenzene solution R* and 0.5 mL of 2 M *alcoholic potassium hydroxide R*. A violet colour is produced and becomes brownish-red after 20 min.

D. Mix about 5 mg with 45 mg of *heavy magnesium oxide R* and ignite in a crucible until an almost white residue is obtained (usually less than 5 min). Allow to cool, add 1 mL of *water R*, 0.05 mL of *phenolphthalein solution R1* and about 1 mL of *dilute hydrochloric acid R* to render the solution colourless. Filter. To a freshly prepared mixture of 0.1 mL of *alizarin S solution R* and 0.1 mL of *zirconyl nitrate solution R*, add 1.0 mL of the filtrate. Mix, allow to stand for 5 min and compare the colour of the solution with that of a blank prepared in the same manner. The test solution is yellow and the blank is red.

## TESTS

**Appearance of solution.** The solution is clear (2.2.1) and not more intensely coloured than reference solution BY<sub>5</sub> (2.2.2, Method II).

Dissolve 0.20 g in *methylene chloride R* and dilute to 20.0 mL with the same solvent.

**Related substances.** Liquid chromatography (2.2.29). Prepare the solutions immediately before use.

*Test solution.* Dissolve 0.10 g of the substance to be examined in *dimethylformamide R* and dilute to 10.0 mL with the same solvent.

*Reference solution (a).* Dissolve 2.5 mg of droperidol CRS and 2.5 mg of benperidol CRS in *dimethylformamide R*, then dilute to 100.0 mL with the same solvent.

*Reference solution (b).* Dilute 1.0 mL of the test solution to 100.0 mL with *dimethylformamide R*. Dilute 5.0 mL of this solution to 20.0 mL with *dimethylformamide R*.

*Column*:

– size:  $l = 0.10$  m,  $\varnothing = 4.6$  mm;

– stationary phase: base-deactivated octadecylsilyl silica gel for chromatography R (3 µm).

Mobile phase:

- mobile phase A: acetonitrile R;
- mobile phase B: 10 g/L solution of tetrabutylammonium hydrogen sulfate R1;

Time (min)	Mobile phase A (per cent V/V)	Mobile phase B (per cent V/V)
0 - 15	0 → 40	100 → 60
15 - 20	40	60
20 - 25	40 → 0	60 → 100

Flow rate: 1.5 mL/min.

Detection: spectrophotometer at 275 nm.

Injection: 10 µL; inject dimethylformamide R as a blank.

Retention time: benperidol = about 6.5 min; droperidol = about 7 min.

System suitability: reference solution (a):

- resolution: minimum 2.0 between the peaks due to benperidol and droperidol; if necessary, adjust the final concentration of acetonitrile in the mobile phase or adjust the time programme for the linear gradient.

Limits:

- impurities A, B, C, D, E: for each impurity, not more than the area of the principal peak in the chromatogram obtained with reference solution (b) (0.25 per cent);
- total: not more than twice the area of the principal peak in the chromatogram obtained with reference solution (b) (0.5 per cent);
- disregard limit: 0.2 times the area of the principal peak in the chromatogram obtained with reference solution (b) (0.05 per cent).

Heavy metals (2.4.8): maximum 20 ppm.

1.0 g complies with test D. Prepare the reference solution using 2 mL of lead standard solution (10 ppm Pb) R.

Loss on drying (2.2.32): maximum 0.5 per cent, determined on 1.000 g by drying in an oven at 105 °C.

Sulfated ash (2.4.14): maximum 0.1 per cent, determined on 1.0 g.

ASSAY

Dissolve 0.300 g in 50 mL of a mixture of 1 volume of anhydrous acetic acid R and 7 volumes of methyl ethyl ketone R. Using 0.2 mL of naphtholbenzein solution R, titrate with 0.1 M perchloric acid until the colour changes from orange-yellow to green.

1 mL of 0.1 M perchloric acid is equivalent to 37.94 mg of C<sub>22</sub>H<sub>22</sub>FN<sub>3</sub>O<sub>2</sub>.

STORAGE

Protected from light.

IMPURITIES

Specified impurities: A, B, C, D, E.

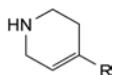
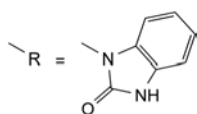

- A. 1-(1,2,3,6-tetrahydropyridin-4-yl)-1,3-dihydro-2H-benzimidazol-2-one,

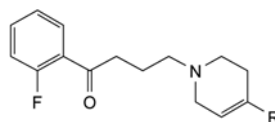

- B. 1-[1-[4-(2-fluorophenyl)-4-oxobutyl]-1,2,3,6-tetrahydropyridin-4-yl]-1,3-dihydro-2H-benzimidazol-2-one,

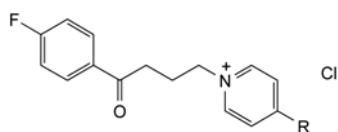

- C. 1-[4-(4-fluorophenyl)-4-oxobutyl]-4-(2-oxo-2,3-dihydro-1H-benzimidazol-1-yl)pyridinium chloride,

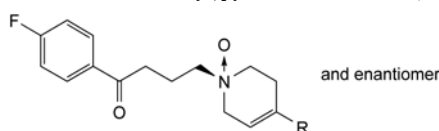

- D. (1RS)-1-[4-(4-fluorophenyl)-4-oxobutyl]-4-(2-oxo-2,3-dihydro-1H-benzimidazol-1-yl)-1,2,3,6-tetrahydropyridine 1-oxide,

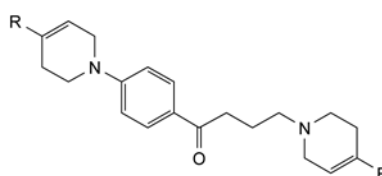

- E. 1-[1-[4-[4-(2-oxo-2,3-dihydro-1H-benzimidazol-1-yl)-3,6-dihydropyridin-1(2H)-yl]-1-oxobutyl]phenyl]-1,2,3,6-tetrahydropyridin-4-yl]-1,3-dihydro-2H-benzimidazol-2-one.

07/2009:2404

## DROSPIRENONE

### Drospirenonum

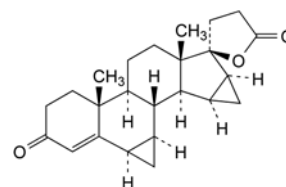

C<sub>24</sub>H<sub>30</sub>O<sub>3</sub>  
[67392-87-4]

M<sub>r</sub> 366.5

DEFINITION

3-Oxo-6α,7α,15α,16α-tetrahydro-3′H,3″H-dicyclopropa-[6,7:15,16]-17α-pregn-4-en-21,17-carbolactone.

Content: 98.0 per cent to 102.0 per cent (dried substance).

CHARACTERS

Appearance: white or almost white powder.

Solubility: practically insoluble in water, freely soluble in methylene chloride, soluble in methanol, sparingly soluble in ethanol (96 per cent).

IDENTIFICATION

A. Specific optical rotation (see Tests).

B. Infrared absorption spectrophotometry (2.2.24).

Comparison: drospirenone CRS.

TESTS

Specific optical rotation (2.2.7): –187 to –193 (dried substance).

Dissolve 0.100 g in methanol R and dilute to 10.0 mL with the same solvent.



**Related substances.** Liquid chromatography (2.2.29).

**Solvent mixture:** acetonitrile R, water R (50:50 V/V).

**Test solution.** Dissolve 30.0 mg of the substance to be examined in the solvent mixture and dilute to 50.0 mL with the solvent mixture.

**Reference solution (a).** Dilute 1.0 mL of the test solution to 10.0 mL with the solvent mixture. Use 1.0 mL of this solution to dissolve the contents of a vial of *drospirenone impurity E CRS*.

**Reference solution (b).** Dilute 1.0 mL of the test solution to 100.0 mL with the solvent mixture. Dilute 1.0 mL of this solution to 10.0 mL with the solvent mixture.

**Reference solution (c).** Dissolve 30.0 mg of *drospirenone CRS* in the solvent mixture and dilute to 50.0 mL with the solvent mixture.

**Column:**

- size:  $l = 0.25$  m,  $\varnothing = 4.6$  mm;
- stationary phase: spherical end-capped octadecylsilyl silica gel for chromatography R (3  $\mu$ m);
- temperature: 35 °C.

**Mobile phase:**

- mobile phase A: water R;
- mobile phase B: acetonitrile R;

Time (min)	Mobile phase A (per cent V/V)	Mobile phase B (per cent V/V)
0 - 2	63	37
2 - 16	63 → 52	37 → 48
16 - 23	52	48
23 - 31	52 → 20	48 → 80
31 - 39	20	80

**Flow rate:** 1.0 mL/min.

**Detection:** spectrophotometer at 245 nm.

**Injection:** 10  $\mu$ L of the test solution and reference solutions (a) and (b).

**Relative retention** with reference to drospirenone (retention time = about 22 min): impurity E = about 1.1.

**System suitability:** reference solution (a):

- resolution: minimum 5.0 between the peaks due to drospirenone and impurity E.

**Limits:**

- **unspecified impurities:** for each impurity, not more than the area of the principal peak in the chromatogram obtained with reference solution (b) (0.10 per cent);
- **total:** not more than 3 times the area of the principal peak in the chromatogram obtained with reference solution (b) (0.3 per cent);
- **disregard limit:** 0.5 times the area of the principal peak in the chromatogram obtained with reference solution (b) (0.05 per cent).

**Loss on drying** (2.2.32): maximum 0.5 per cent, determined on 1.000 g by drying in an oven at 105 °C for 3 h.

**ASSAY**

Liquid chromatography (2.2.29) as described in the test for related substances with the following modification.

**Injection:** 10  $\mu$ L of the test solution and reference solution (c). Calculate the percentage content of  $C_{24}H_{30}O_3$  from the declared content of *drospirenone CRS*.

**IMPURITIES**

**Other detectable impurities** (the following substances would, if present at a sufficient level, be detected by one or other of the tests in the monograph. They are limited by the general acceptance criterion for other/unspecified impurities and/or by the general monograph *Substances for pharmaceutical use* (2034). It is therefore not necessary to identify these impurities

for demonstration of compliance. See also 5.10. *Control of impurities in substances for pharmaceutical use*): A, B, C, D, E, F, G, H, I, K.

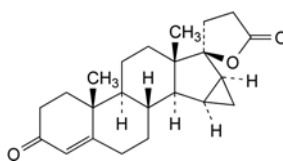

A. 3-oxo-15 $\alpha$ ,16 $\alpha$ -dihydro-3'*H*-cyclopropa[15,16]-17 $\alpha$ -pregn-4-ene-21,17-carbolactone (6,7-desmethylenedrospirenone),

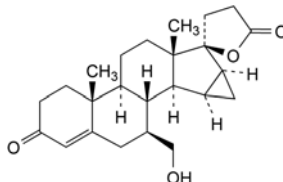

B. 7 $\beta$ -(hydroxymethyl)-3-oxo-15 $\alpha$ ,16 $\alpha$ -dihydro-3'*H*-cyclopropa[15,16]-17 $\alpha$ -pregn-4-ene-21,17-carbolactone (7 $\beta$ -hydroxymethyl derivative),

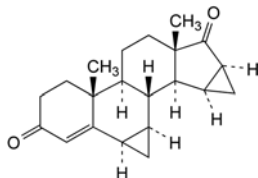

C. 6 $\alpha$ ,7 $\alpha$ ,15 $\alpha$ ,16 $\alpha$ -tetrahydro-3'*H*,3''*H*-dicyclopropa[6,7:15,16]androst-4-ene-3,17-dione (17-keto derivative),

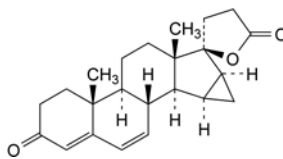

D. 3-oxo-15 $\alpha$ ,16 $\alpha$ -dihydro-3'*H*-cyclopropa[15,16]-17 $\alpha$ -pregna-4,6-diene-21,17-carbolactone ( $\Delta$ 6-drospirenone),

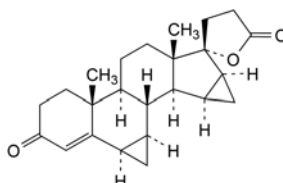

E. 3-oxo-6 $\alpha$ ,7 $\alpha$ ,15 $\alpha$ ,16 $\alpha$ -tetrahydro-3'*H*,3''*H*-dicyclopropa[6,7:15,16]pregn-4-ene-21,17-carbolactone (17-epidrospirenone),

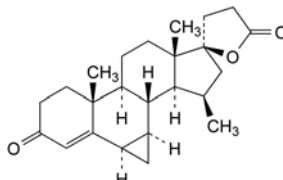

F. 15 $\beta$ -methyl-3-oxo-6 $\alpha$ ,7 $\alpha$ -dihydro-3'*H*-cyclopropa[6,7]-17 $\alpha$ -pregn-4-ene-21,17-carbolactone (3''-16-secodrospirenone),

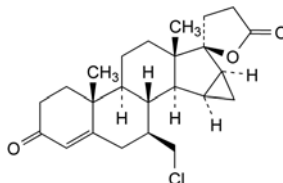

G. 7 $\beta$ -(chloromethyl)-3-oxo-15 $\alpha$ ,16 $\alpha$ -dihydro-3'*H*-cyclopropa[15,16]-17 $\alpha$ -pregn-4-ene-21,17-carbolactone (3'-chloro-3',6-secodrospirenone),

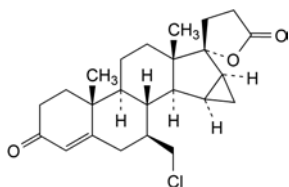

- H. 7β-(chloromethyl)-3-oxo-15α,16α-dihydro-3'H-cyclopropa[15,16]pregn-4-ene-21,17-carbolactone (3'-chloro-3',6-seco-17-epidrosiprenone),

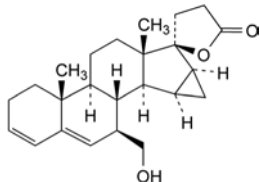

- I. 7β-(hydroxymethyl)-15α,16α-dihydro-3'H-cyclopropa[15,16]-17α-pregna-3,5-diene-21,17-carbolactone (7β-hydroxymethyl diene derivative),

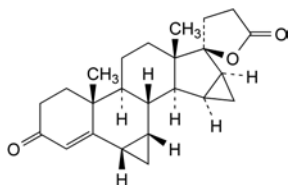

- K. 3-oxo-6β,7β,15α,16α-tetrahydro-3'H,3''H-dicyclopropa[6,7:15,16]-17α-pregna-4-ene-21,17-carbolactone (6α,7α-drosiprenone).

01/2009:2357

## DYDROGESTERONE

### Dydrogesteronum

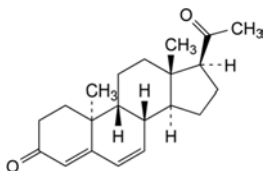

$C_{21}H_{28}O_2$   
[152-62-5]

$M_r$  312.5

#### DEFINITION

9β,10α-Pregna-4,6-diene-3,20-dione.

*Content*: 98.0 per cent to 102.0 per cent (dried substance).

#### CHARACTERS

*Appearance*: white or almost white, crystalline powder.

*Solubility*: practically insoluble in water, soluble in acetone, sparingly soluble in ethanol (96 per cent).

#### IDENTIFICATION

Infrared absorption spectrophotometry (2.2.24).

*Comparison*: dydrogesterone CRS.

#### TESTS

**Specific optical rotation** (2.2.7): –469 to –485 (dried substance), measured at 25 °C.

Dissolve 0.100 g in *methylene chloride R* and dilute to 20.0 mL with the same solvent.

**Related substances**. Liquid chromatography (2.2.29).

*Test solution (a)*. Dissolve 50.0 mg of the substance to be examined in the mobile phase and dilute to 100.0 mL with the mobile phase.

*Test solution (b)*. Dissolve 20.0 mg of the substance to be examined in the mobile phase and dilute to 100.0 mL with the mobile phase.

*Reference solution (a)*. Dissolve 3.0 mg of *dydrogesterone impurity A CRS* in the mobile phase and dilute to 20.0 mL with the mobile phase. Dilute 1.0 mL of this solution to 100.0 mL with the mobile phase.

*Reference solution (b)*. Dilute 1.0 mL of test solution (a) to 100.0 mL with the mobile phase. Dilute 1.0 mL of this solution to 10.0 mL with the mobile phase.

*Reference solution (c)*. Dissolve 10 mg of the substance to be examined in 10 mL of reference solution (a).

*Reference solution (d)*. Dissolve 10 mg of the substance to be examined in 30 mL of *ethanol (96 per cent) R*. Add 1 mL of a 8.4 g/L solution of *sodium hydroxide R* and heat at 85 °C for 10 min. Cool to room temperature, add 1 mL of a 20.6 g/L solution of *hydrochloric acid R*, add 20 mL of *acetonitrile R*, 2 mg of *dydrogesterone impurity B CRS*, dilute to 100 mL with *water R* and mix. This solution contains dydrogesterone and impurities B and C.

*Reference solution (e)*. Dissolve 20.0 mg of *dydrogesterone CRS* in the mobile phase and dilute to 100.0 mL with the mobile phase.

#### Column:

- *size*:  $l = 0.15$  m,  $\varnothing = 4.6$  mm;
- *stationary phase*: spherical *end-capped octadecylsilyl silica gel for chromatography R* (3 μm);
- *temperature*: 40 °C.

*Mobile phase*: *acetonitrile R*, *ethanol (96 per cent) R*, *water R* (21:25:54 V/V/V).

*Flow rate*: 1.0 mL/min.

*Detection*: spectrophotometer at 280 nm and at 385 nm.

*Injection*: 10 μL of test solution (a) and reference solutions (a), (b), (c) and (d).

*Run time*: twice the retention time of dydrogesterone.

*Relative retention at 385 nm* with reference to dydrogesterone (retention time = about 13 min): impurity A = about 0.9.

*Relative retention at 280 nm* with reference to dydrogesterone (retention time = about 13 min): impurity B = about 1.1; impurity C = about 1.2.

#### System suitability:

- *resolution at 385 nm*: minimum 1.1 between the peaks due to impurity A and dydrogesterone in the chromatogram obtained with reference solution (c);
- *resolution at 280 nm*: minimum 4.5 between the peaks due to dydrogesterone and impurity B and minimum 1.5 between the peaks due to impurity B and impurity C in the chromatogram obtained with reference solution (d).

#### Limits:

- *impurity A at 385 nm*: not more than the area of the corresponding peak in the chromatogram obtained with reference solution (a) (0.3 per cent);
- *impurity B at 280 nm*: not more than 1.5 times the area of the principal peak in the chromatogram obtained with reference solution (b) (0.15 per cent);
- *impurity C at 280 nm*: not more than 3 times the area of the principal peak in the chromatogram obtained with reference solution (b) (0.3 per cent);
- *unspecified impurities at 280 nm*: for each impurity, not more than the area of the principal peak in the chromatogram obtained with reference solution (b) (0.10 per cent);
- *total at 280 nm*: not more than 5 times the area of the principal peak in the chromatogram obtained with reference solution (b) (0.5 per cent);
- *disregard limit at 280 nm*: 0.5 times the area of the principal peak in the chromatogram obtained with reference solution (b) (0.05 per cent).

**Loss on drying** (2.2.32): maximum 0.5 per cent, determined on 1.000 g by drying in an oven at 105 °C for 3 h.

**Sulfated ash** (2.4.14): maximum 0.1 per cent, determined on 1.0 g.

**ASSAY**

Liquid chromatography (2.2.29) as described in the test for related substances with the following modifications.

*Detection*: spectrophotometer at 280 nm.

*Injection*: test solution (b) and reference solution (e).

Calculate the percentage content of  $C_{21}H_{28}O_2$  from the declared content of *dydrogesterone CRS*.

**IMPURITIES**

*Specified impurities*: A, B, C.

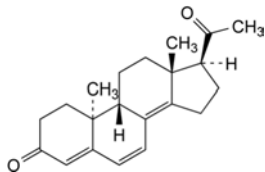

A. 9β,10α-pregna-4,6,8(14)-triene-3,20-dione,

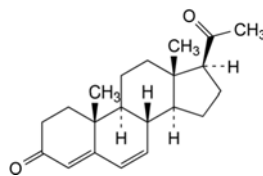

B. pregna-4,6-diene-3,20-dione,

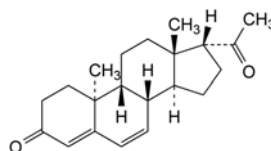

C. 9β,10α,17α-pregna-4,6-diene-3,20-dione.

## EBASTINE

## Ebastinum

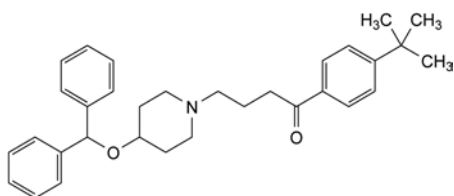

$C_{32}H_{39}NO_2$   
[90729-43-4]

$M_r$  469.7

## DEFINITION

1-[4-(1,1-Dimethylethyl)phenyl]-4-[4-(diphenylmethoxy)piperidin-1-yl]butan-1-one.

Content: 99.0 per cent to 101.0 per cent (anhydrous substance).

## CHARACTERS

Appearance: white or almost white, crystalline powder.

Solubility: practically insoluble in water, very soluble in methylene chloride, sparingly soluble in methanol.

mp: about 86 °C.

## IDENTIFICATION

Infrared absorption spectrophotometry (2.2.24).

Comparison: Ph. Eur. reference spectrum of ebastine.

## TESTS

**Related substances.** Liquid chromatography (2.2.29). Keep the solutions protected from light.

**Solution A.** Mix 65 volumes of acetonitrile R and 35 volumes of a 1.1 g/L solution of phosphoric acid R adjusted to pH 5.0 with a 40 g/L solution of sodium hydroxide R.

**Test solution.** Dissolve 0.125 g of the substance to be examined in solution A and dilute to 50.0 mL with the same solution.

**Reference solution (a).** Dissolve 5.0 mg of ebastine impurity C CRS and 5.0 mg of ebastine impurity D CRS in solution A and dilute to 20.0 mL with the same solution. Dilute 1.0 mL of the solution to 100.0 mL with solution A.

**Reference solution (b).** Dilute 1.0 mL of the test solution to 100.0 mL with solution A. Dilute 1.0 mL of this solution to 10.0 mL with solution A.

## Column:

- size:  $l = 0.25$  m,  $\emptyset = 4.6$  mm,
- stationary phase: nitrile silica gel for chromatography R (5  $\mu$ m).

**Mobile phase:** mix 35 volumes of acetonitrile R and 65 volumes of a 1.1 g/L solution of phosphoric acid R adjusted to pH 5.0 with a 40 g/L solution of sodium hydroxide R. Adjust the percentage of acetonitrile to between 30 per cent V/V and 40 per cent V/V so that the retention time of ebastine is about 110 min.

Flow rate: 1 mL/min.

Detection: spectrophotometer at 210 nm.

Injection: 10  $\mu$ L.

Run time: 1.4 times the retention time of ebastine.

Relative retention with reference to ebastine: impurity A = about 0.04; impurity B = about 0.05; impurity D = about 0.20; impurity C = about 0.22; impurity F = about 0.42; impurity G = about 0.57; impurity E = about 1.14.

System suitability: reference solution (a):

- resolution: minimum 2.0 between the peaks due to impurity D and impurity C.

## 01/2008:2015 Limits:

- impurities A, B, C, D, E, F, G: for each impurity, not more than the area of the principal peak in the chromatogram obtained with reference solution (b) (0.1 per cent),
- any other impurity: for each impurity, not more than the area of the principal peak in the chromatogram obtained with reference solution (b) (0.1 per cent),
- total: not more than 4 times the area of the principal peak in the chromatogram obtained with reference solution (b) (0.4 per cent),
- disregard limit: 0.5 times the area of the principal peak in the chromatogram obtained with reference solution (b) (0.05 per cent).

**Sulfates (2.4.13):** maximum 100 ppm.

Suspend 2.5 g in 25 mL of dilute nitric acid R. Boil under a reflux condenser for 10 min. Cool and filter. 15 mL of the filtrate complies with the limit test for sulfates.

**Water (2.5.12):** maximum 0.5 per cent, determined on 0.500 g.

**Sulfated ash (2.4.14):** maximum 0.1 per cent, determined on 1.0 g.

## ASSAY

Dissolve 0.350 g in 50 mL of anhydrous acetic acid R. Titrate with 0.1 M perchloric acid, determining the end-point potentiometrically (2.2.20).

1 mL of 0.1 M perchloric acid is equivalent to 46.97 mg of  $C_{32}H_{39}NO_2$ .

## STORAGE

Protected from light.

## IMPURITIES

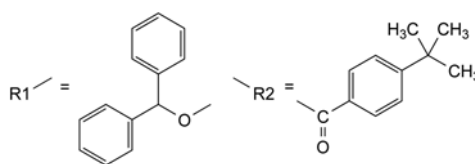

- A. R1-H: diphenylmethanol (benzhydrol),  
B. R2-CH<sub>3</sub>: 1-[4-(1,1-dimethylethyl)phenyl]ethanone,

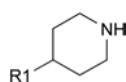

- C. 4-(diphenylmethoxy)piperidine,

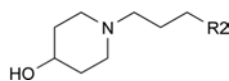

- D. 1-[4-(1,1-dimethylethyl)phenyl]-4-(4-hydroxypiperidin-1-yl)butan-1-one,

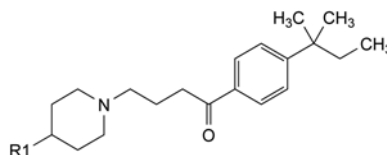

- E. 1-[4-(1,1-dimethylpropyl)phenyl]-4-[4-(diphenylmethoxy)piperidin-1-yl]butan-1-one,

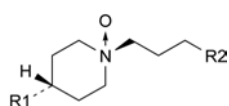

- F. 1-[4-(1,1-dimethylethyl)phenyl]-4-[cis-4-(diphenylmethoxy)-1-oxopiperidin-1-yl]butan-1-one,

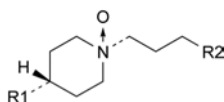

- G. 1-[4-(1,1-dimethylethyl)phenyl]-4-[*trans*-4-(diphenylmethoxy)-1-oxidopiperidin-1-yl]butan-1-one.

07/2010:2049  
corrected 7.0

## ECONAZOLE

### Econazolium

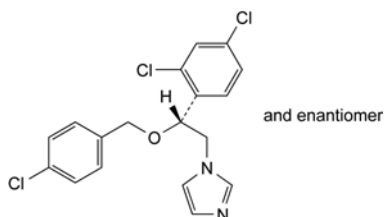

$C_{18}H_{15}Cl_3N_2O$   
[27220-47-9]

$M_r$  381.7

#### DEFINITION

1-[(2*RS*)-2-[(4-chlorobenzyl)oxy]-2-(2,4-dichlorophenyl)ethyl]-1*H*-imidazole.

*Content*: 99.0 per cent to 101.0 per cent (dried substance).

#### CHARACTERS

*Appearance*: white or almost white powder.

*Solubility*: practically insoluble in water, very soluble in ethanol (96 per cent) and in methylene chloride.

#### IDENTIFICATION

A. Melting point (2.2.14): 88 °C to 92 °C.

B. Infrared absorption spectrophotometry (2.2.24).

*Comparison*: econazole CRS.

#### TESTS

**Related substances.** Liquid chromatography (2.2.29).

*Test solution.* Dissolve 0.100 g of the substance to be examined in *methanol R* and dilute to 10.0 mL with the same solvent.

*Reference solution (a).* Dissolve 10 mg of *econazole for system suitability CRS* (containing impurities A, B and C) in *methanol R* and dilute to 1.0 mL with the same solvent.

*Reference solution (b).* Dilute 1.0 mL of the test solution to 20.0 mL with *methanol R*. Dilute 1.0 mL of this solution to 25.0 mL with *methanol R*.

*Column*:

- *size*:  $l = 0.10$  m,  $\varnothing = 4.6$  mm;
- *stationary phase*: base-deactivated octadecylsilyl silica gel for chromatography *R* (3  $\mu$ m);
- *temperature*: 35 °C.

*Mobile phase*:

- *mobile phase A*: *methanol R*, 0.77 g/L solution of ammonium acetate *R* (20:80 V/V);
- *mobile phase B*: *methanol R*, acetonitrile *R* (40:60 V/V);

Time (min)	Mobile phase A (per cent V/V)	Mobile phase B (per cent V/V)
0 - 25	60 → 10	40 → 90
25 - 27	10	90

*Flow rate*: 1.5 mL/min.

*Detection*: spectrophotometer at 225 nm.

*Injection*: 10  $\mu$ L.

*Identification of impurities*: use the chromatogram supplied with *econazole for system suitability CRS* and the chromatogram obtained with reference solution (a) to identify the peaks due to impurities A, B and C.

*Relative retention* with reference to econazole (retention time = about 15 min): impurity A = about 0.2; impurity B = about 0.6; impurity C = about 1.1.

*System suitability*: reference solution (a):

- *peak-to-valley ratio*: minimum 1.5, where  $H_p$  = height above the baseline of the peak due to impurity C and  $H_v$  = height above the baseline of the lowest point of the curve separating this peak from the peak due to econazole.

*Limits*:

- *correction factor*: for the calculation of content, multiply the peak area of impurity A by 1.4;
- *impurities A, B, C*: for each impurity, not more than the area of the principal peak in the chromatogram obtained with reference solution (b) (0.2 per cent);
- *unspecified impurities*: for each impurity, not more than 0.5 times the area of the principal peak in the chromatogram obtained with reference solution (b) (0.10 per cent);
- *total*: not more than 1.5 times the area of the principal peak in the chromatogram obtained with reference solution (b) (0.3 per cent);
- *disregard limit*: 0.25 times the area of the principal peak in the chromatogram obtained with reference solution (b) (0.05 per cent).

**Loss on drying** (2.2.32): maximum 0.5 per cent, determined on 1.000 g by drying *in vacuo* at 60 °C for 4 h.

**Sulfated ash** (2.4.14): maximum 0.1 per cent, determined on 1.0 g.

#### ASSAY

Dissolve 0.300 g in 75 mL of *anhydrous acetic acid R*. Titrate with 0.1 *M perchloric acid*, determining the end-point potentiometrically (2.2.20). Carry out a blank titration.

1 mL of 0.1 *M perchloric acid* is equivalent to 38.17 mg of  $C_{18}H_{15}Cl_3N_2O$ .

#### STORAGE

Protected from light.

#### IMPURITIES

*Specified impurities*: A, B, C.

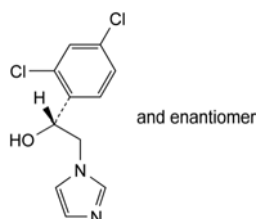

- A. (1*RS*)-1-(2,4-dichlorophenyl)-2-(1*H*-imidazol-1-yl)ethanol,

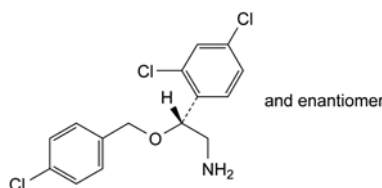

- B. (2*RS*)-2-[(4-chlorobenzyl)oxy]-2-(2,4-dichlorophenyl)ethanamine,

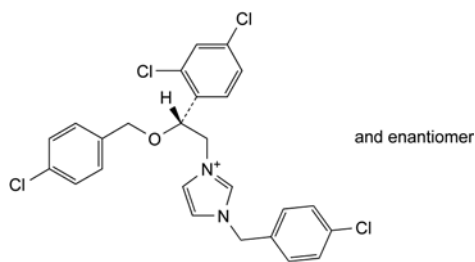

C. 1-(4-chlorobenzyl)-3-[(2RS)-2-[(4-chlorobenzyl)oxy]-2-(2,4-dichlorophenyl)ethyl]imidazolium.

07/2010:0665  
corrected 7.0

## ECONAZOLE NITRATE

### Econazoli nitras

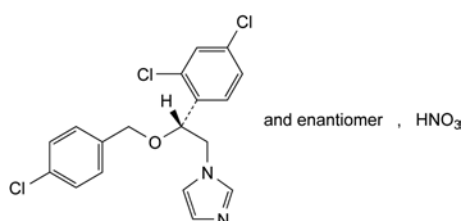

$C_{18}H_{16}Cl_3N_3O_4$   
[24169-02-6]

$M_r$  444.7

#### DEFINITION

1-[(2RS)-2-[(4-Chlorobenzyl)oxy]-2-(2,4-dichlorophenyl)ethyl]-1H-imidazole nitrate.

*Content*: 99.0 per cent to 101.0 per cent (dried substance).

#### CHARACTERS

*Appearance*: white or almost white, crystalline powder.

*Solubility*: very slightly soluble in water, soluble in methanol, sparingly soluble in methylene chloride, slightly soluble in ethanol (96 per cent).

mp: about 165 °C, with decomposition.

#### IDENTIFICATION

Infrared absorption spectrophotometry (2.2.24).

*Comparison*: econazole nitrate CRS.

#### TESTS

**Related substances.** Liquid chromatography (2.2.29).

*Test solution.* Dissolve 0.100 g of the substance to be examined in methanol R and dilute to 10.0 mL with the same solvent.

*Reference solution (a).* Dissolve 10 mg of econazole for system suitability CRS (containing impurities A, B and C) in methanol R and dilute to 1.0 mL with the same solvent.

*Reference solution (b).* Dilute 1.0 mL of the test solution to 20.0 mL with methanol R. Dilute 1.0 mL of this solution to 25.0 mL with methanol R.

*Column*:

- size:  $l = 0.10$  m,  $\varnothing = 4.6$  mm;
- stationary phase: base-deactivated octadecylsilyl silica gel for chromatography R (3  $\mu$ m);
- temperature: 35 °C.

*Mobile phase*:

- mobile phase A: methanol R, 0.77 g/L solution of ammonium acetate R (20:80 V/V);
- mobile phase B: methanol R, acetonitrile R (40:60 V/V);

Time (min)	Mobile phase A (per cent V/V)	Mobile phase B (per cent V/V)
0 - 25	60 → 10	40 → 90
25 - 27	10	90

*Flow rate*: 1.5 mL/min.

*Detection*: spectrophotometer at 225 nm.

*Injection*: 10  $\mu$ L.

*Identification of impurities*: use the chromatogram supplied with econazole for system suitability CRS and the chromatogram obtained with reference solution (a) to identify the peaks due to impurities A, B and C.

*Relative retention* with reference to econazole (retention time = about 15 min): impurity A = about 0.2; impurity B = about 0.6; impurity C = about 1.1.

*System suitability*: reference solution (a):

- peak-to-valley ratio: minimum 1.5, where  $H_p$  = height above the baseline of the peak due to impurity C and  $H_v$  = height above the baseline of the lowest point of the curve separating this peak from the peak due to econazole.

*Limits*:

- correction factor: for the calculation of content, multiply the peak area of impurity A by 1.4;
- impurities A, B, C: for each impurity, not more than the area of the principal peak in the chromatogram obtained with reference solution (b) (0.2 per cent);
- unspecified impurities: for each impurity, not more than 0.5 times the area of the principal peak in the chromatogram obtained with reference solution (b) (0.10 per cent);
- total: not more than 1.5 times the area of the principal peak in the chromatogram obtained with reference solution (b) (0.3 per cent);
- disregard limit: 0.25 times the area of the principal peak in the chromatogram obtained with reference solution (b) (0.05 per cent); disregard the peak due to the nitrate ion at the beginning of the chromatogram.

**Loss on drying** (2.2.32): maximum 0.5 per cent, determined on 1.000 g by drying in an oven at 105 °C for 4 h.

**Sulfated ash** (2.4.14): maximum 0.1 per cent, determined on 1.0 g.

#### ASSAY

Dissolve 0.400 g in 50 mL of anhydrous acetic acid R. Titrate with 0.1 M perchloric acid, determining the end-point potentiometrically (2.2.20). Carry out a blank titration.

1 mL of 0.1 M perchloric acid is equivalent to 44.47 mg of  $C_{18}H_{16}Cl_3N_3O_4$ .

#### STORAGE

Protected from light.

#### IMPURITIES

*Specified impurities*: A, B, C.

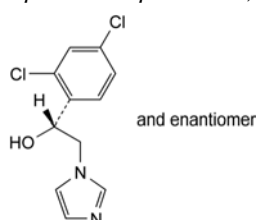

A. (1RS)-1-(2,4-dichlorophenyl)-2-(1H-imidazol-1-yl)ethanol,

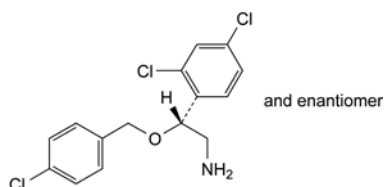

B. (2RS)-2-[(4-chlorobenzyl)oxy]-2-(2,4-dichlorophenyl)ethanamine,

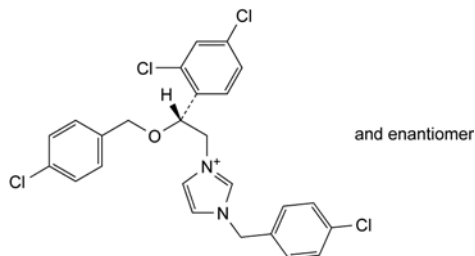

C. 1-(4-chlorobenzyl)-3-[(2RS)-2-[(4-chlorobenzyl)oxy]-2-(2,4-dichlorophenyl)ethyl]imidazolium.

01/2008:1612

## EDETIC ACID

### Acidum edeticum

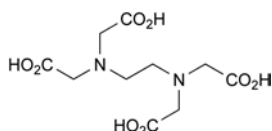

$C_{10}H_{16}N_2O_8$   
[60-00-4]

$M_r$  292.2

#### DEFINITION

(Ethylenedinitrilo)tetraacetic acid.

*Content*: 98.0 per cent to 101.0 per cent.

#### CHARACTERS

*Appearance*: white or almost white, crystalline powder or colourless crystals.

*Solubility*: practically insoluble in water and in ethanol (96 per cent). It dissolves in dilute solutions of alkali hydroxides.

#### IDENTIFICATION

*First identification*: A.

*Second identification*: B, C.

A. Infrared absorption spectrophotometry (2.2.24).

*Preparation*: discs, after drying the substance to be examined in an oven at 100-105 °C for 2 h.

*Comparison*: sodium edetate R, treated as follows: dissolve 0.25 g of sodium edetate R in 5 mL of water R, add 1.0 mL of dilute hydrochloric acid R. Filter, wash the residue with 2 quantities, each of 5 mL, of water R and dry the residue in an oven at 100-105 °C for 2 h.

B. To 5 mL of water R add 0.1 mL of ammonium thiocyanate solution R and 0.1 mL of ferric chloride solution R1 and mix. The solution is red. Add 0.5 mL of solution S (see Tests). The solution becomes yellowish.

C. To 10 mL of solution S add 0.5 mL of calcium chloride solution R. Make alkaline to red litmus paper R by the addition of dilute ammonia R2 and add 3 mL of ammonium oxalate solution R. No precipitate is formed.

#### TESTS

**Solution S**. Dissolve 5.0 g in 20 mL of dilute sodium hydroxide solution R and dilute to 100 mL with water R.

**Appearance of solution**. Solution S is clear (2.2.1) and colourless (2.2.2, Method II).

**Impurity A**. Liquid chromatography (2.2.29). Carry out the test protected from light.

*Solvent mixture*. Dissolve 10.0 g of ferric sulfate pentahydrate R in 20 mL of 0.5 M sulfuric acid and add 780 mL of water R. Adjust to pH 2.0 with 1 M sodium hydroxide and dilute to 1000 mL with water R.

*Test solution*. Dissolve 0.100 g of the substance to be examined in 1.0 mL of 1 M sodium hydroxide and dilute to 25.0 mL with the solvent mixture.

*Reference solution*. Dissolve 40.0 mg of nitrilotriacetic acid R in the solvent mixture and dilute to 100.0 mL with the solvent mixture. To 1.0 mL of the solution add 0.1 mL of the test solution and dilute to 100.0 mL with the solvent mixture.

*Column*:

- *size*:  $l = 0.10$  m,  $\varnothing = 4.6$  mm,
- *stationary phase*: spherical graphitised carbon for chromatography R1 (5  $\mu$ m) with a specific surface area of 120 m<sup>2</sup>/g and a pore size of 25 nm.

*Mobile phase*: dissolve 50.0 mg of ferric sulfate pentahydrate R in 50 mL of 0.5 M sulfuric acid and add 750 mL of water R. Adjust to pH 1.5 with 0.5 M sulfuric acid or 1 M sodium hydroxide, add 20 mL of ethylene glycol R and dilute to 1000 mL with water R.

*Flow rate*: 1 mL/min.

*Detection*: spectrophotometer at 273 nm.

*Injection*: 20  $\mu$ L; filter the solutions and inject immediately.

*Run time*: 4 times the retention time of the iron complex of impurity A.

*Retention time*: iron complex of impurity A = about 5 min; iron complex of edetic acid = about 10 min.

*System suitability*: reference solution:

- *resolution*: minimum 7 between the peaks due to the iron complex of impurity A and the iron complex of edetic acid,
- *signal-to-noise ratio*: minimum 50 for the peak due to impurity A.

*Limit*:

- *impurity A*: not more than the area of the corresponding peak in the chromatogram obtained with the reference solution (0.1 per cent).

**Chlorides** (2.4.4): maximum 200 ppm.

To 10 mL of solution S add 8 mL of nitric acid R and stir for 10 min. A precipitate is formed. Filter and wash the filter with water R. Collect the filtrate and the washings and dilute to 20 mL with water R. Dilute 10 mL of this solution to 15 mL with water R.

**Iron** (2.4.9): maximum 80 ppm.

Dilute 2.5 mL of solution S to 10 mL with water R and add 0.25 g of calcium chloride R before adding the thioglycollic acid R. Allow to stand for 5 min. Also add 0.25 g of calcium chloride R to the standard.

**Heavy metals** (2.4.8): maximum 20 ppm.

1.0 g complies with test F. Prepare the reference solution using 2 mL of lead standard solution (10 ppm Pb) R.

**Sulfated ash** (2.4.14): maximum 0.2 per cent, determined on 1.0 g.

#### ASSAY

Dissolve 0.250 g in 2.0 mL of dilute sodium hydroxide solution R and dilute to 300 mL with water R. Add 2 g of hexamethylenetetramine R and 2 mL of dilute hydrochloric acid R. Titrate with 0.1 M zinc sulfate using about 50 mg of xylene orange triturate R as indicator.

1 mL of 0.1 M zinc sulfate corresponds to 29.22 mg of  $C_{10}H_{16}N_2O_8$ .

## STORAGE

Protected from light.

## IMPURITIES

Specified impurities: A.

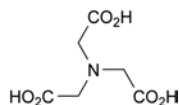

A. nitrotriacetic acid.

01/2008:2106

## EDROPHONIUM CHLORIDE

## Edrophonii chloridum

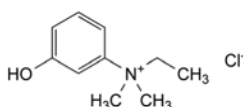

$C_{10}H_{16}ClNO$   
[116-38-1]

$M_r$  201.7

## DEFINITION

*N*-Ethyl-3-hydroxy-*N,N*-dimethylanilinium chloride.

Content: 99.0 per cent to 101.0 per cent (dried substance).

## CHARACTERS

Appearance: white or almost white, crystalline powder.

Solubility: very soluble in water, freely soluble in ethanol (96 per cent), practically insoluble in methylene chloride.

## IDENTIFICATION

A. Infrared absorption spectrophotometry (2.2.24).

Comparison: edrophonium chloride CRS.

B. It gives reaction (a) of chlorides (2.3.1).

## TESTS

Appearance of solution. The solution is clear (2.2.1) and colourless (2.2.2, Method II).

Dissolve 0.5 g in water *R* and dilute to 25 mL with the same solvent.

pH (2.2.3): 4.0 to 5.0.

Dissolve 1.0 g in carbon dioxide-free water *R* and dilute to 10.0 mL with the same solvent.

Related substances. Liquid chromatography (2.2.29).

Test solution. Dissolve 50.0 mg in water *R* and dilute to 50.0 mL with the same solvent.

Reference solution (a). Dissolve 10.0 mg of 3-dimethylamino-phenol *R* in acetonitrile *R* and dilute to 10.0 mL with the same solvent.

Reference solution (b). Mix 1.0 mL of the test solution and 1.0 mL of reference solution (a) and dilute to 100.0 mL with water *R*. Dilute 10.0 mL of this solution to 100.0 mL with water *R*.

Column:

– size:  $l = 0.25$  m,  $\varnothing = 4.6$  mm,

– stationary phase: styrene-divinylbenzene copolymer *R* (8–10  $\mu$ m).

Mobile phase: mix 10 volumes of acetonitrile *R* and 90 volumes of a 7.7 g/L solution of tetramethylammonium bromide *R* previously adjusted to pH 3.0 with phosphoric acid *R*.

Flow rate: 1 mL/min.

Detection: spectrophotometer at 281 nm.

Injection: 20  $\mu$ L.

Run time: twice the retention time of edrophonium.

Relative retention with reference to edrophonium (retention time = about 3.8 min): impurity A = about 1.3.

System suitability: reference solution (b):

– resolution: minimum 2.0 between the peaks due to edrophonium and impurity A.

Limits:

– impurity A: not more than the area of the corresponding peak in the chromatogram obtained with reference solution (b) (0.1 per cent),

– any other impurity: for each impurity, not more than the area of the peak due to edrophonium in the chromatogram obtained with reference solution (b) (0.1 per cent),

– total: not more than 5 times the area of the peak due to edrophonium in the chromatogram obtained with reference solution (b) (0.5 per cent),

– disregard limit: 0.5 times the area of the peak due to edrophonium in the chromatogram obtained with reference solution (b) (0.05 per cent).

Loss on drying (2.2.32): maximum 0.5 per cent, determined on 1.000 g by drying in a desiccator over diphosphorus pentoxide *R* at a pressure not exceeding 0.7 kPa for 24 h.

Sulfated ash (2.4.14): maximum 0.1 per cent, determined on 1.0 g.

Bacterial endotoxins (2.6.14): less than 8.3 IU/mg.

## ASSAY

Dissolve 0.150 g in 60 mL of a mixture of equal volumes of acetic anhydride *R* and anhydrous acetic acid *R*. Titrate with 0.1 *M* perchloric acid, determining the end-point potentiometrically (2.2.20).

1 mL of 0.1 *M* perchloric acid is equivalent to 20.17 mg of  $C_{10}H_{16}ClNO$ .

## STORAGE

Protected from light.

## IMPURITIES

Specified impurities: A.

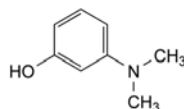

A. 3-(dimethylamino)phenol.

01/2008:2242

## EMEDASTINE DIFUMARATE

## Emedastini difumaras

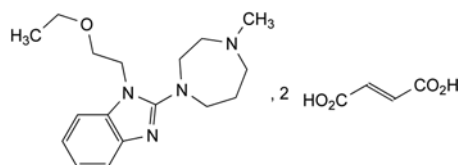

$C_{25}H_{34}N_4O_9$   
[87233-62-3]

$M_r$  534.6

## DEFINITION

1-(2-Ethoxyethyl)-2-(4-methylhexahydro-1*H*-1,4-diazepin-1-yl)-1*H*-benzimidazole bis[hydrogen (2*E*)-butenedioate].

Content: 99.0 per cent to 101.0 per cent (dried substance).

## CHARACTERS

Appearance: white or yellowish powder.

Solubility: soluble in water, sparingly soluble in anhydrous ethanol, very slightly soluble in acetone.

It shows polymorphism (5.9).



## IDENTIFICATION

Infrared absorption spectrophotometry (2.2.24).

Comparison: emedastine difumarate CRS.

If the spectra obtained in the solid state show differences, dissolve the substance to be examined and the reference substance separately in *anhydrous ethanol R*, evaporate to dryness and record new spectra using the residues.

## TESTS

**Appearance of solution.** The solution is clear (2.2.1) and not more intensely coloured than reference solution Y<sub>5</sub> (2.2.2, Method II).

Dissolve 2.50 g in *water R* and dilute to 50 mL with the same solvent.

**pH** (2.2.3): 3.0 to 4.5.

Dissolve 0.20 g in 100 mL of *carbon dioxide-free water R*.

**Related substances.** Liquid chromatography (2.2.29).

**Test solution.** Dissolve 10 mg of the substance to be examined in the mobile phase and dilute to 10 mL with the mobile phase.

**Reference solution (a).** Dissolve 5 mg of *emedastine impurity E CRS* in the mobile phase and dilute to 25 mL with the mobile phase.

**Reference solution (b).** Dissolve 10 mg of the substance to be examined in the mobile phase. Add 0.5 mL of reference solution (a) and dilute to 10 mL with the mobile phase.

**Reference solution (c).** Dilute 5.0 mL of the test solution to 50.0 mL with the mobile phase. Dilute 1.0 mL of this solution to 100.0 mL with the mobile phase.

**Column:**

- size:  $l = 0.15$  m,  $\varnothing = 4.6$  mm;
- stationary phase: *octadecylsilyl silica gel for chromatography R* (5  $\mu$ m).

**Mobile phase:** dissolve 3.9 g of *disodium hydrogen phosphate R* and 2.5 g of *sodium dodecyl sulfate R* in *water R* and dilute to 1000.0 mL with the same solvent. Adjust to pH 2.4 with *phosphoric acid R*. Mix 550 volumes of this solution with 450 volumes of *acetonitrile R*.

**Flow rate:** 1.0 mL/min.

**Detection:** spectrophotometer at 280 nm.

**Injection:** 10  $\mu$ L of the test solution and reference solutions (b) and (c).

**Run time:** twice the retention time of emedastine.

**Relative retention** with reference to emedastine (retention time = about 18 min): fumaric acid = about 0.1; impurity A = about 0.2; impurity B = about 0.3; impurity C = about 0.5; impurity D = about 0.7; impurity E = about 0.9; impurity F = about 1.4.

**System suitability:** reference solution (b):

- **peak-to-valley ratio:** minimum 4, where  $H_p$  = height above the baseline of the peak due to impurity E and  $H_v$  = height above the baseline of the lowest point of the curve separating this peak from the peak due to emedastine.

**Limits:**

- **impurities A, B, C, D, E, F:** for each impurity, not more than the area of the principal peak in the chromatogram obtained with reference solution (c) (0.1 per cent);
- **unspecified impurities:** for each impurity, not more than the area of the principal peak in the chromatogram obtained with reference solution (c) (0.1 per cent);
- **total:** not more than twice the area of the principal peak in the chromatogram obtained with reference solution (c) (0.2 per cent);
- **disregard limit:** 0.5 times the area of the principal peak in the chromatogram obtained with reference solution (c) (0.05 per cent); disregard the peak due to fumaric acid.

**Loss on drying** (2.2.32): maximum 0.5 per cent, determined on 1.000 g by drying in an oven at 105 °C for 3 h.

**Sulfated ash** (2.4.14): maximum 0.1 per cent, determined on 1.0 g.

## ASSAY

Dissolve 0.200 g in 50 mL of *glacial acetic acid R*. Titrate with 0.1 M *perchloric acid*, determining the end-point potentiometrically (2.2.20).

1 mL of 0.1 M *perchloric acid* is equivalent to 26.73 mg of C<sub>25</sub>H<sub>34</sub>N<sub>4</sub>O<sub>9</sub>.

## STORAGE

Protected from light.

## IMPURITIES

**Specified impurities:** A, B, C, D, E, F.

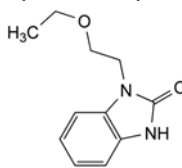

A. 1-(2-ethoxyethyl)-1,3-dihydro-2H-benzimidazol-2-one,

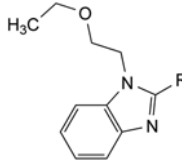

B. R = Cl: 2-chloro-1-(2-ethoxyethyl)-1H-benzimidazole,

F. R = NH-[CH<sub>2</sub>]<sub>3</sub>-NH-CH<sub>3</sub>: *N*-[1-(2-ethoxyethyl)-1H-benzimidazol-2-yl]-*N'*-methylpropane-1,3-diamine,

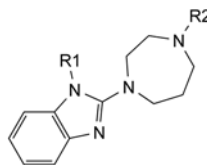

C. R<sub>1</sub> = CH<sub>2</sub>-CH<sub>2</sub>OH, R<sub>2</sub> = CH<sub>3</sub>: 2-[2-(4-methylhexahydro-1H-1,4-diazepin-1-yl)-1H-benzimidazol-1-yl]ethanol,

D. R<sub>1</sub> = CH=CH<sub>2</sub>, R<sub>2</sub> = CH<sub>3</sub>: 1-ethenyl-2-(4-methylhexahydro-1H-1,4-diazepin-1-yl)-1H-benzimidazole,

E. R<sub>1</sub> = CH<sub>2</sub>-CH<sub>2</sub>-O-C<sub>2</sub>H<sub>5</sub>, R<sub>2</sub> = H: 1-(2-ethoxyethyl)-2-(hexahydro-1H-1,4-diazepin-1-yl)-1H-benzimidazole.

01/2008:0080  
corrected 6.0

EMETINE HYDROCHLORIDE  
HEPTAHYDRATE

Emetini hydrochloridum heptahydricum

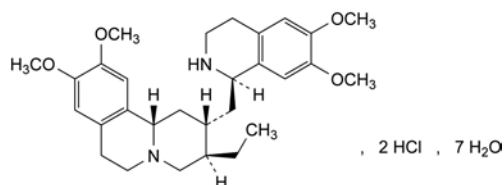

C<sub>29</sub>H<sub>42</sub>Cl<sub>2</sub>N<sub>2</sub>O<sub>4</sub>·7H<sub>2</sub>O

$M_r$  680

## DEFINITION

Emetine hydrochloride heptahydrate contains not less than 98.0 per cent and not more than the equivalent of 102.0 per cent of (2*S*,3*R*,11*bS*)-2-[[1*R*]-6,7-dimethoxy-1,2,3,4-tetrahydroisoquinolin-1-yl]methyl]-3-ethyl-9,10-

dimethoxy-1,3,4,6,7,11b-hexahydro-2*H*-benzo[*a*]quinolizine dihydrochloride, calculated with reference to the dried substance.

#### CHARACTERS

A white or slightly yellowish, crystalline powder, freely soluble in water and in alcohol.

#### IDENTIFICATION

*First identification: A, E.*

*Second identification: B, C, D, E.*

- A. Examine by infrared absorption spectrophotometry (2.2.24), comparing with the spectrum obtained with *emetine hydrochloride CRS*.
- B. Examine the chromatograms obtained in the test for related substances in ultraviolet light at 365 nm. The principal spot in the chromatogram obtained with the test solution is similar in position, fluorescence and size to the spot in the chromatogram obtained with reference solution (a).
- C. Dissolve about 10 mg in 2 mL of *dilute hydrogen peroxide solution R*, add 1 mL of *hydrochloric acid R* and heat. An orange colour develops.
- D. Sprinkle about 5 mg on the surface of 1 mL of *sulfomolybdic reagent R2*. A bright-green colour develops.
- E. It gives reaction (a) of chlorides (2.3.1).

#### TESTS

**Solution S.** Dissolve 1.25 g in *carbon dioxide-free water R* and dilute to 25 mL with the same solvent.

**Appearance of solution.** Solution S is clear (2.2.1) and not more intensely coloured than reference solution Y<sub>5</sub> or BY<sub>5</sub> (2.2.2, *Method II*).

**pH** (2.2.3). Dilute 4 mL of solution S to 10 mL with *carbon dioxide-free water R*. The pH of the solution is 4.0 to 6.0.

**Specific optical rotation** (2.2.7). Dissolve in *water R* a quantity of the substance to be examined corresponding to 1.250 g of dried substance and dilute to 25.0 mL with the same solvent. The specific optical rotation is + 16 to + 19, calculated with reference to the dried substance.

**Related substances.** Examine by thin-layer chromatography (2.2.27), using a *TLC silica gel G plate R*. Prepare the solutions immediately before use.

**Test solution.** Dissolve 50 mg of the substance to be examined in *methanol R* containing 1 per cent V/V of *dilute ammonia R2* and dilute to 100 mL with the same solvent.

**Reference solution (a).** Dissolve 50 mg of *emetine hydrochloride CRS* in *methanol R* containing 1 per cent V/V of *dilute ammonia R2* and dilute to 100 mL with the same solvent.

**Reference solution (b).** Dissolve 10 mg of *isoemetine hydrobromide CRS* in *methanol R* containing 1 per cent V/V of *dilute ammonia R2* and dilute to 100 mL with the same solvent. Dilute 5 mL of this solution to 50 mL with *methanol R* containing 1 per cent V/V of *dilute ammonia R2*.

**Reference solution (c).** Dissolve 10 mg of *cephaeline hydrochloride CRS* in *methanol R* containing 1 per cent V/V of *dilute ammonia R2* and dilute to 100 mL with the same solvent. Dilute 5 mL of this solution to 50 mL with *methanol R* containing 1 per cent V/V of *dilute ammonia R2*.

**Reference solution (d).** Dilute 1 mL of reference solution (a) to 100 mL with *methanol R* containing 1 per cent V/V of *dilute ammonia R2*.

**Reference solution (e).** To 1 mL of reference solution (a) add 1 mL of reference solution (b) and 1 mL of reference solution (c). Apply to the plate 10 µL of the test solution and each of reference solutions (a), (b), (c) and (d) and 30 µL of reference solution (e). Develop over a path of 15 cm using a mixture of 0.5 volumes of *diethylamine R*, 2 volumes of *water R*, 5 volumes of *methanol R*, 20 volumes of *ethylene glycol monomethyl ether R* and 100 volumes of *chloroform R*. Allow

the plate to dry in air until the solvent has evaporated. Spray in a well ventilated fume-cupboard with *chloroformic solution of iodine R* and heat at 60 °C for 15 min. Examine in ultraviolet light at 365 nm. In the chromatogram obtained with the test solution, any spots corresponding to isoemetine and cephaeline are not more intense than the spots in the chromatograms obtained with reference solutions (b) and (c) respectively (2.0 per cent); any spot, apart from the principal spot and the spots corresponding to isoemetine and cephaeline, is not more intense than the spot in the chromatogram obtained with reference solution (d) (1.0 per cent). The test is not valid unless the chromatogram obtained with reference solution (e) shows three clearly separated spots.

**Loss on drying** (2.2.32). 15.0 per cent to 19.0 per cent, determined on 1.00 g by drying in an oven at 105 °C for 3 h.

**Sulfated ash** (2.4.14). Not more than 0.1 per cent, determined on 1.0 g.

#### ASSAY

Dissolve 0.200 g in a mixture of 5.0 mL of 0.01 *M hydrochloric acid* and 50 mL of *alcohol R*. Carry out a potentiometric titration (2.2.20), using 0.1 *M sodium hydroxide*. Read the volume added between the 2 points of inflexion.

1 mL of 0.1 *M sodium hydroxide* is equivalent to 27.68 mg of C<sub>29</sub>H<sub>42</sub>Cl<sub>2</sub>N<sub>2</sub>O<sub>4</sub>.

#### STORAGE

Store protected from light.

01/2008:0081  
corrected 6.0

## EMETINE HYDROCHLORIDE PENTAHYDRATE

### Emetini hydrochloridum pentahydricum

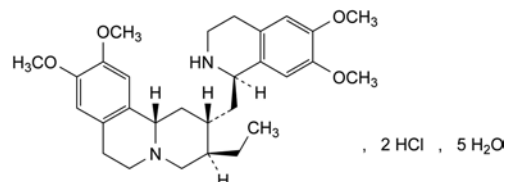

C<sub>29</sub>H<sub>42</sub>Cl<sub>2</sub>N<sub>2</sub>O<sub>4</sub>·5H<sub>2</sub>O

*M*, 644

#### DEFINITION

Emetine hydrochloride pentahydrate contains not less than 98.0 per cent and not more than the equivalent of 102.0 per cent of (2*S*,3*R*,11*B**S*)-2-[[*(1R)*-6,7-dimethoxy-1,2,3,4-tetrahydroisoquinolin-1-yl]methyl]-3-ethyl-9,10-dimethoxy-1,3,4,6,7,11*b*-hexahydro-2*H*-benzo[*a*]quinolizine dihydrochloride, calculated with reference to the dried substance.

#### CHARACTERS

A white or slightly yellowish, crystalline powder, freely soluble in water and in alcohol.

#### IDENTIFICATION

*First identification: A, E.*

*Second identification: B, C, D, E.*

A. Examine by infrared absorption spectrophotometry (2.2.24), comparing with the spectrum obtained with *emetine hydrochloride CRS*.

B. Examine the chromatograms obtained in the test for related substances in ultraviolet light at 365 nm. The principal spot in the chromatogram obtained with the test solution is similar in position, fluorescence and size to the spot in the chromatogram obtained with reference solution (a).

- C. Dissolve about 10 mg in 2 mL of *dilute hydrogen peroxide solution R*, add 1 mL of *hydrochloric acid R* and heat. An orange colour develops.
- D. Sprinkle about 5 mg on the surface of 1 mL of *sulfomolybdic reagent R2*. A bright-green colour develops.
- E. It gives reaction (a) of chlorides (2.3.1).

## TESTS

**Solution S.** Dissolve 1.25 g in *carbon dioxide-free water R* and dilute to 25 mL with the same solvent.

**Appearance of solution.** Solution S is clear (2.2.1) and not more intensely coloured than reference solution Y<sub>5</sub> or BY<sub>5</sub> (2.2.2, *Method II*).

**pH (2.2.3).** Dilute 4 mL of solution S to 10 mL with *carbon dioxide-free water R*. The pH of the solution is 4.0 to 6.0.

**Specific optical rotation (2.2.7).** Dissolve in *water R* a quantity of the substance to be examined corresponding to 1.250 g of dried substance and dilute to 25.0 mL with the same solvent. The specific optical rotation is + 16 to + 19, calculated with reference to the dried substance.

**Related substances.** Examine by thin-layer chromatography (2.2.27), using a *TLC silica gel G plate R*. Prepare the solutions immediately before use.

**Test solution.** Dissolve 50 mg of the substance to be examined in *methanol R* containing 1 per cent V/V of *dilute ammonia R2* and dilute to 100 mL with the same solvent.

**Reference solution (a).** Dissolve 50 mg of *emetine hydrochloride CRS* in *methanol R* containing 1 per cent V/V of *dilute ammonia R2* and dilute to 100 mL with the same solvent.

**Reference solution (b).** Dissolve 10 mg of *isoemetine hydrobromide CRS* in *methanol R* containing 1 per cent V/V of *dilute ammonia R2* and dilute to 100 mL with the same solvent. Dilute 5 mL of this solution to 50 mL with *methanol R* containing 1 per cent V/V of *dilute ammonia R2*.

**Reference solution (c).** Dissolve 10 mg of *cephaeline hydrochloride CRS* in *methanol R* containing 1 per cent V/V of *dilute ammonia R2* and dilute to 100 mL with the same solvent. Dilute 5 mL of this solution to 50 mL with *methanol R* containing 1 per cent V/V of *dilute ammonia R2*.

**Reference solution (d).** Dilute 1 mL of reference solution (a) to 100 mL with *methanol R* containing 1 per cent V/V of *dilute ammonia R2*.

**Reference solution (e).** To 1 mL of reference solution (a) add 1 mL of reference solution (b) and 1 mL of reference solution (c).

Apply to the plate 10 µL of the test solution and each of reference solutions (a), (b), (c) and (d) and 30 µL of reference solution (e). Develop over a path of 15 cm using a mixture of 0.5 volumes of *diethylamine R*, 2 volumes of *water R*, 5 volumes of *methanol R*, 20 volumes of *ethylene glycol monomethyl ether R* and 100 volumes of *chloroform R*. Allow the plate to dry in air until the solvent has evaporated. Spray in a well ventilated fume-cupboard with *chloroformic solution of iodine R* and heat at 60 °C for 15 min. Examine in ultraviolet light at 365 nm. In the chromatogram obtained with the test solution, any spots corresponding to isoemetine and cephaeline are not more intense than the spots in the chromatograms obtained with reference solutions (b) and (c) respectively (2.0 per cent); any spot, apart from the principal spot and the spots corresponding to isoemetine and cephaeline, is not more intense than the spot in the chromatogram obtained with reference solution (d) (1.0 per cent). The test is not valid unless the chromatogram obtained with reference solution (e) shows three clearly separated spots.

**Loss on drying (2.2.32).** 11.0 per cent to 15.0 per cent, determined on 1.00 g by drying in an oven at 105 °C for 3 h.

**Sulfated ash (2.4.14).** Not more than 0.1 per cent, determined on 1.0 g.

## ASSAY

Dissolve 0.200 g in a mixture of 5.0 mL of 0.01 M *hydrochloric acid* and 50 mL of *alcohol R*. Carry out a potentiometric titration (2.2.20), using 0.1 M *sodium hydroxide*. Read the volume added between the two points of inflexion.

1 mL of 0.1 M *sodium hydroxide* is equivalent to 27.68 mg of C<sub>29</sub>H<sub>42</sub>Cl<sub>2</sub>N<sub>2</sub>O<sub>4</sub>.

## STORAGE

Store protected from light.

07/2010:1420

## ENALAPRIL MALEATE

## Enalaprili maleas

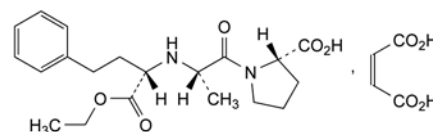

C<sub>24</sub>H<sub>32</sub>N<sub>2</sub>O<sub>9</sub>  
[76095-16-4]

M<sub>r</sub> 492.5

## DEFINITION

(2S)-1-[(2S)-2-[[[(1S)-1-(Ethoxycarbonyl)-3-phenylpropyl]-amino]propanoyl]pyrrolidine-2-carboxylic acid (Z)-butenedioate.

**Content:** 98.5 per cent to 101.5 per cent (dried substance).

## CHARACTERS

**Appearance:** white or almost white, crystalline powder.

**Solubility:** sparingly soluble in water, freely soluble in methanol, practically insoluble in methylene chloride. It dissolves in dilute solutions of alkali hydroxides.

mp: about 144 °C.

## IDENTIFICATION

Infrared absorption spectrophotometry (2.2.24).

**Comparison:** *enalapril maleate CRS*.

## TESTS

**Solution S.** Dissolve 0.25 g in *carbon dioxide-free water R* and dilute to 25.0 mL with the same solvent.

**Appearance of solution.** Solution S is clear (2.2.1) and colourless (2.2.2, *Method II*).

**pH (2.2.3):** 2.4 to 2.9 for solution S.

**Specific optical rotation (2.2.7):** – 48 to – 51 (dried substance), determined on solution S.

**Related substances.** Liquid chromatography (2.2.29).

**Buffer solution A.** Dissolve 2.8 g of *sodium dihydrogen phosphate monohydrate R* in 950 mL of *water R*. Adjust to pH 2.5 with *phosphoric acid R* and dilute to 1000 mL with *water R*.

**Buffer solution B.** Dissolve 2.8 g of *sodium dihydrogen phosphate monohydrate R* in 950 mL of *water R*. Adjust to pH 6.8 with *strong sodium hydroxide solution R* and dilute to 1000 mL with *water R*.

**Dissolution mixture.** Mix 50 mL of *acetonitrile R1* and 950 mL of buffer solution A.

**Test solution.** Dissolve 30 mg of the substance to be examined in the dissolution mixture and dilute to 100.0 mL with the dissolution mixture.

**Reference solution (a).** Dilute 1.0 mL of the test solution to 100.0 mL with the dissolution mixture.

**Reference solution (b).** Dissolve 3 mg of *enalapril for system suitability CRS* (containing impurity A) in the dissolution mixture and dilute to 10.0 mL with the dissolution mixture.

**Reference solution (c).** Dissolve the contents of a vial of *enalapril impurity mixture CRS* (impurities B, C, D, E and H) in 1.0 mL of the dissolution mixture.

**Column:**

- **size:**  $l = 0.15$  m,  $\varnothing = 4.1$  mm;
- **stationary phase:** *styrene-divinylbenzene copolymer R* (5  $\mu$ m);
- **temperature:** 70 °C.

**Mobile phase:**

- **mobile phase A:** mix 50 mL of *acetonitrile R1* and 950 mL of buffer solution B;
- **mobile phase B:** mix 340 mL of buffer solution B and 660 mL of *acetonitrile R1*;

Time (min)	Mobile phase A (per cent V/V)	Mobile phase B (per cent V/V)
0 - 20	95 → 40	5 → 60
20 - 25	40	60

**Flow rate:** 1.0 mL/min.

**Detection:** spectrophotometer at 215 nm.

**Injection:** 50  $\mu$ L.

**Identification of impurities:**

- use the chromatogram supplied with *enalapril impurity mixture CRS* and the chromatogram obtained with reference solution (c) to identify the peaks due to impurities B, C, D, E and H;
- use the chromatogram obtained with reference solution (b) to identify the peak due to impurity A.

**Relative retention** with reference to enalapril (retention time = about 11 min): impurity C = about 0.2; impurity B = about 0.8; impurity A = about 1.1; impurity H = about 1.3; impurity E = about 1.5; impurity D = about 2.1.

**System suitability:** reference solution (b):

- **peak-to-valley ratio:** minimum 10, where  $H_p$  = height above the baseline of the peak due to impurity A and  $H_v$  = height above the baseline of the lowest point of the curve separating this peak from the peak due to enalapril.

**Limits:**

- **impurity A:** not more than the area of the principal peak in the chromatogram obtained with reference solution (a) (1.0 per cent);
- **impurities B, C, D, E, H:** for each impurity, not more than 0.3 times the area of the principal peak in the chromatogram obtained with reference solution (a) (0.3 per cent);
- **unspecified impurities:** for each impurity, not more than 0.1 times the area of the principal peak in the chromatogram obtained with reference solution (a) (0.10 per cent);
- **sum of impurities other than A:** not more than the area of the principal peak in the chromatogram obtained with reference solution (a) (1.0 per cent);
- **disregard limit:** 0.05 times the area of the principal peak in the chromatogram obtained with reference solution (a) (0.05 per cent); disregard the peak due to maleic acid.

**Heavy metals (2.4.8):** maximum 10 ppm.

2.0 g complies with test C. Prepare the reference solution using 2 mL of *lead standard solution (10 ppm Pb) R*.

**Loss on drying (2.2.32):** maximum 1.0 per cent, determined on 1.000 g by drying in an oven at 105 °C for 3 h.

**Sulfated ash (2.4.14):** maximum 0.1 per cent, determined on 1.0 g.

**ASSAY**

Dissolve 0.100 g in *carbon dioxide-free water R* and dilute to 30 mL with the same solvent. Titrate with 0.1 M *sodium hydroxide* determining the end-point potentiometrically (2.2.20). Titrate to the 2<sup>nd</sup> point of inflexion.

1 mL of 0.1 M *sodium hydroxide* is equivalent to 16.42 mg of  $C_{24}H_{32}N_2O_9$ .

**STORAGE**

Protected from light.

**IMPURITIES**

**Specified impurities:** A, B, C, D, E, H.

**Other detectable impurities** (the following substances would, if present at a sufficient level, be detected by one or other of the tests in the monograph. They are limited by the general acceptance criterion for other/unspecified impurities and/or by the general monograph *Substances for pharmaceutical use (2034)*. It is therefore not necessary to identify these impurities for demonstration of compliance. See also 5.10. *Control of impurities in substances for pharmaceutical use*): F, G, I.

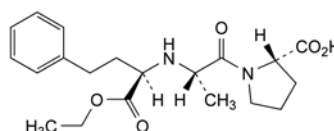

A. (2S)-1-[(2S)-2-[[[(1R)-1-(ethoxycarbonyl)-3-phenylpropyl]-amino]propanoyl]pyrrolidine-2-carboxylic acid,

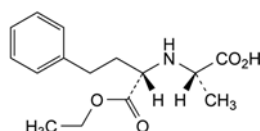

B. (2S)-2-[[[(1S)-1-(ethoxycarbonyl)-3-phenylpropyl]-amino]propanoic acid,

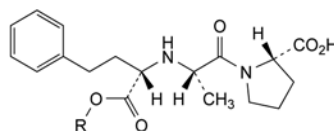

C. R = H: (2S)-1-[(2S)-2-[[[(1S)-1-carboxy-3-phenylpropyl]-amino]propanoyl]pyrrolidine-2-carboxylic acid,

E. R =  $CH_2-CH_2-C_6H_5$ : (2S)-1-[(2S)-2-[[[(1S)-3-phenyl-1-[(2-phenylethoxy)carbonyl]propyl]amino]propanoyl]pyrrolidine-2-carboxylic acid,

F. R =  $C_4H_9$ : (2S)-1-[(2S)-2-[[[(1S)-1-(butoxycarbonyl)-3-phenylpropyl]amino]propanoyl]pyrrolidine-2-carboxylic acid,

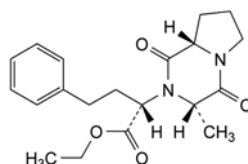

D. ethyl (2S)-2-[(3S,8aS)-3-methyl-1,4-dioxo-octahydropyrrolo[1,2-a]pyrazin-2-yl]-4-phenylbutanoate,

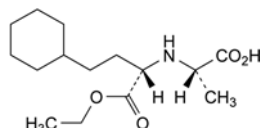

G. (2S)-2-[[[(1S)-3-cyclohexyl-1-(ethoxycarbonyl)propyl]-amino]propanoic acid,

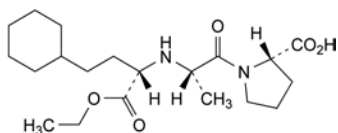

H. (2S)-1-[(2S)-2-[(1S)-3-cyclohexyl-1-(ethoxycarbonyl)propyl]amino]propanoyl]pyrrolidine-2-carboxylic acid,



I. 1*H*-imidazole.

01/2008:1749  
corrected 7.0

## ENALAPRILAT DIHYDRATE

### Enalaprilatum dihydricum

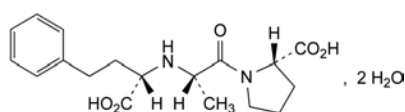

$C_{18}H_{24}N_2O_5 \cdot 2H_2O$   
[84680-54-6]

$M_r$  384.4

#### DEFINITION

(2S)-1-[(2S)-2-[(1S)-1-Carboxy-3-phenylpropyl]amino]propanoyl]pyrrolidine-2-carboxylic acid dihydrate.

*Content*: 98.5 per cent to 101.5 per cent (anhydrous substance).

#### CHARACTERS

*Appearance*: white or almost white, hygroscopic, crystalline powder.

*Solubility*: very slightly soluble or slightly soluble in water, sparingly soluble in methanol, practically insoluble in acetonitrile.

It shows pseudopolymorphism (5.9).

#### IDENTIFICATION

A. Specific optical rotation (see Tests).

B. Infrared absorption spectrophotometry (2.2.24).

*Preparation*: mulls in liquid paraffin *R*.

*Comparison*: enalaprilat dihydrate CRS.

If the spectra obtained show differences, expose the substance to be examined and the reference substance to a 98 per cent relative humidity for 3 days using a chamber conditioned with a saturated solution of calcium sulfate *R*. Record new spectra.

#### TESTS

**Appearance of solution.** The solution is clear (2.2.1) and colourless (2.2.2, Method II).

Dissolve 0.10 g in water *R* and dilute to 100.0 mL with the same solvent.

**Specific optical rotation** (2.2.7):  $-53.0$  to  $-56.0$  (anhydrous substance).

Dissolve 0.200 g in methanol *R* and dilute to 20.0 mL with the same solvent.

**Related substances.** Liquid chromatography (2.2.29). Use freshly prepared solutions.

**Buffer solution.** Dissolve 1.36 g of potassium dihydrogen phosphate *R* in 950 mL of water *R*. Adjust to pH 3.0 with phosphoric acid *R* and dilute to 1000 mL with water *R*.

**Solvent mixture.** Buffer solution, acetonitrile *R1*, methanol *R1* (1:2:2 V/V/V).

**Dissolution mixture.** Solvent mixture, buffer solution (8:92 V/V).

**Test solution.** Dissolve 25.0 mg of the substance to be examined in 2.5 mL of methanol *R1* and dilute to 25.0 mL with the dissolution mixture.

**Reference solution (a).** Dilute 1.0 mL of the test solution to 100.0 mL with the dissolution mixture. Dilute 5.0 mL of this solution to 10.0 mL with the dissolution mixture.

**Reference solution (b).** Dissolve 5 mg of enalaprilat for system suitability CRS (containing impurity C) in 0.5 mL of methanol *R1* and dilute to 5 mL with the dissolution mixture.

**Reference solution (c).** Dissolve the contents of a vial of enalaprilat impurity G CRS in 1 mL of the test solution.

**Column:**

– size:  $l = 0.25$  m,  $\varnothing = 4.6$  mm;

– stationary phase: end-capped octadecylsilyl silica gel for chromatography *R* (5  $\mu$ m);

– temperature: 70 °C.

**Mobile phase:**

– mobile phase A: solvent mixture, buffer solution (10:90 V/V);

– mobile phase B: acetonitrile *R1*;

Time (min)	Mobile phase A (per cent V/V)	Mobile phase B (per cent V/V)
0 - 25	100	0
25 - 50	100 → 90	0 → 10
50 - 80	90	10

**Flow rate:** 2.0 mL/min.

**Detection:** spectrophotometer at 210 nm.

**Injection:** 20  $\mu$ L.

**Identification of impurities:** use the chromatogram supplied with enalaprilat for system suitability CRS and the chromatogram obtained with reference solution (b) to identify the peak due to impurity C; use the chromatogram obtained with reference solution (c) to identify the peak due to impurity G.

**Relative retention** with reference to enalaprilat (retention time = about 21 min): impurity C = about 1.2; impurity G = about 2.9.

**System suitability:** reference solution (b):

– **peak-to-valley ratio:** minimum 2.0, where  $H_p$  = height above the baseline of the peak due to impurity C and  $H_v$  = height above the baseline of the lowest point of the curve separating this peak from the peak due to enalaprilat.

**Limits:**

- **impurities C, G:** for each impurity, not more than the area of the principal peak in the chromatogram obtained with reference solution (a) (0.5 per cent);
- **unspecified impurities:** for each impurity, not more than 0.2 times the area of the principal peak in the chromatogram obtained with reference solution (a) (0.10 per cent);
- **total:** not more than twice the area of the principal peak in the chromatogram obtained with reference solution (a) (1.0 per cent);
- **disregard limit:** 0.1 times the area of the principal peak in the chromatogram obtained with reference solution (a) (0.05 per cent).

**Heavy metals** (2.4.8): maximum 10 ppm.

2.0 g complies with test G. Prepare the reference solution using 2 mL of lead standard solution (10 ppm Pb) *R*.

**Water** (2.5.12): 7.0 per cent to 11.0 per cent, determined on 0.100 g.

**Sulfated ash** (2.4.14): maximum 0.1 per cent, determined on 1.0 g.

**Bacterial endotoxins** (2.6.14): less than 0.1 IU/mg.

07/2010:1720

## ASSAY

Dissolve 0.300 g in *glacial acetic acid R* and dilute to 50 mL with the same solvent. Titrate with 0.1 M *perchloric acid*, determining the end point potentiometrically (2.2.20).

1 mL of 0.1 M *perchloric acid* is equivalent to 34.84 mg of  $C_{18}H_{24}N_2O_5$ .

## STORAGE

In an airtight container.

## IMPURITIES

*Specified impurities: C, G.*

*Other detectable impurities* (the following substances would, if present at a sufficient level, be detected by one or other of the tests in the monograph. They are limited by the general acceptance criterion for other/unspecified impurities and/or by the general monograph *Substances for pharmaceutical use (2034)*. It is therefore not necessary to identify these impurities for demonstration of compliance. See also 5.10. *Control of impurities in substances for pharmaceutical use*): A, B, D, E, F.

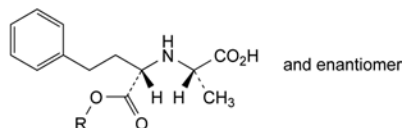

A. R = H: (2SR)-2-[(1SR)-1-carboxyethyl]amino]-4-phenylbutanoic acid,

F. R =  $C_2H_5$ : (2SR)-2-[(1SR)-1-(ethoxycarbonyl)-3-phenylpropyl]amino]propanoic acid,

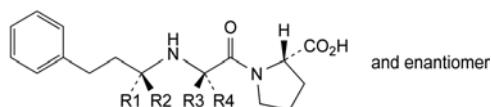

B. R1 = R4 = H, R2 =  $CO_2H$ , R3 =  $CH_3$ : (2SR)-1-[(2RS)-2-[(1RS)-1-carboxy-3-phenylpropyl]amino]propanoyl]pyrrolidine-2-carboxylic acid,

C. R1 = R3 = H, R2 =  $CO_2H$ , R4 =  $CH_3$ : (2SR)-1-[(2SR)-2-[(1RS)-1-carboxy-3-phenylpropyl]amino]propanoyl]pyrrolidine-2-carboxylic acid,

D. R1 =  $CO_2H$ , R2 = R4 = H, R3 =  $CH_3$ : (2SR)-1-[(2RS)-2-[(1SR)-1-carboxy-3-phenylpropyl]amino]propanoyl]pyrrolidine-2-carboxylic acid,

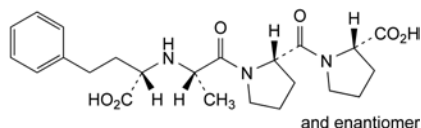

E. (2SR)-1-[(2SR)-1-[(2SR)-2-[(1SR)-1-carboxy-3-phenylpropyl]amino]propanoyl]pyrrolidin-2-yl]carbonyl]pyrrolidine-2-carboxylic acid,

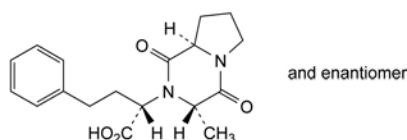

G. (2SR)-2-[(3SR,8aRS)-3-methyl-1,4-dioxohexahydro-pyrrolo[1,2-a]pyrazin-2(1H)-yl]-4-phenylbutanoic acid.

## ENILCONAZOLE FOR VETERINARY USE

## Enilconazolium ad usum veterinarium

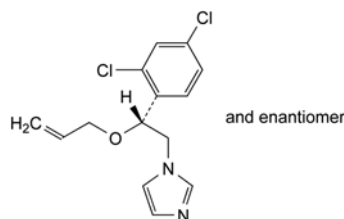

$C_{14}H_{14}Cl_2N_2O$   
[35554-44-0]

$M_r$  297.2

## DEFINITION

1-[(2RS)-2-(2,4-Dichlorophenyl)-2-(prop-2-enyloxy)ethyl]-1H-imidazole.

*Content*: 98.5 per cent to 101.5 per cent (dried substance).

## CHARACTERS

*Appearance*: clear, yellowish, oily liquid or solid mass.

*Solubility*: very slightly soluble in water, freely soluble in ethanol (96 per cent), in methanol and in toluene.

## IDENTIFICATION

Infrared absorption spectrophotometry (2.2.24).

*Comparison*: enilconazole CRS.

## TESTS

**Optical rotation** (2.2.7):  $-0.10^\circ$  to  $+0.10^\circ$ .

Dissolve 0.1 g in *methanol R* and dilute to 10 mL with the same solvent.

**Related substances**. Gas chromatography (2.2.28). Prepare the solutions immediately before use and protect from light.

*Test solution*. Dissolve 0.100 g of the substance to be examined in *toluene R* and dilute to 100.0 mL with the same solvent.

*Reference solution (a)*. Dissolve 10.0 mg of enilconazole CRS and 10.0 mg of enilconazole impurity E CRS in *toluene R* and dilute to 100.0 mL with the same solvent.

*Reference solution (b)*. Dilute 5.0 mL of the test solution to 100.0 mL with *toluene R*. Dilute 1.0 mL of this solution to 10.0 mL with *toluene R*.

*Column*:

- *material*: fused silica;
- *size*:  $l = 25$  m,  $\varnothing = 0.32$  mm;
- *stationary phase*: chemically bonded poly(dimethyl)(diphenyl)siloxane R (film thickness 0.52  $\mu$ m).

*Carrier gas*: helium for chromatography R.

*Flow rate*: 1.3 mL/min.

*Split ratio*: 1:38.

*Temperature*:

	Time (min)	Temperature ( $^\circ$ C)
Column	0 - 6.4	100 $\rightarrow$ 260
	6.4 - 14	260
Injection port		250
Detector		300

*Detection*: flame ionisation.

*Injection*: 2  $\mu$ L.

*Identification of impurities*: use the chromatogram obtained with reference solution (a) to identify the peak due to impurity E.

*Relative retention* with reference to enilconazole (retention time = about 10 min): impurity A = about 0.6; impurity B = about 0.7; impurity C = about 0.8; impurity D = about 0.9; impurity E = about 1.03; impurity F = about 1.1.

*System suitability*: reference solution (a):

- *resolution*: minimum 2.5 between the peaks due to enilconazole and impurity E.

*Limits*:

- *impurities A, B, C, D, E, F*: for each impurity, not more than twice the area of the principal peak in the chromatogram obtained with reference solution (b) (1.0 per cent), and not more than 1 such peak has an area greater than the area of the principal peak in the chromatogram obtained with reference solution (b) (0.5 per cent);
- *unspecified impurities*: for each impurity, not more than 0.4 times the area of the principal peak in the chromatogram obtained with reference solution (b) (0.20 per cent);
- *total*: not more than 4 times the area of the principal peak in the chromatogram obtained with reference solution (b) (2.0 per cent);
- *disregard limit*: 0.1 times the area of the principal peak in the chromatogram obtained with reference solution (b) (0.05 per cent).

**Loss on drying** (2.2.32): maximum 0.5 per cent, determined on 1.000 g by drying *in vacuo* at 40 °C for 4 h.

**Sulfated ash** (2.4.14): maximum 0.1 per cent, determined on 1.0 g.

#### ASSAY

Dissolve 0.230 g in 50 mL of a mixture of 1 volume of *anhydrous acetic acid R* and 7 volumes of *methyl ethyl ketone R*. Titrate with 0.1 M perchloric acid using 0.2 mL of *naphtholbenzein solution R* as indicator.

1 mL of 0.1 M perchloric acid is equivalent to 29.72 mg of C<sub>14</sub>H<sub>14</sub>Cl<sub>2</sub>N<sub>2</sub>O.

#### STORAGE

In an airtight container, protected from light.

#### IMPURITIES

*Specified impurities*: A, B, C, D, E, F.

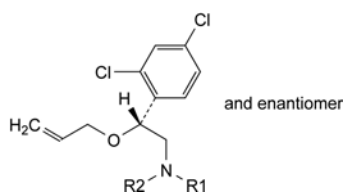

- A. R<sub>1</sub> = R<sub>2</sub> = H: (2*RS*)-2-(2,4-dichlorophenyl)-2-(prop-2-enyloxy)ethanamine,
- B. R<sub>1</sub> = H, R<sub>2</sub> = CH<sub>2</sub>-CH=CH<sub>2</sub>: *N*-[(2*RS*)-2-(2,4-dichlorophenyl)-2-(prop-2-enyloxy)ethyl]prop-2-en-1-amine,
- C. R<sub>1</sub> = CHO, R<sub>2</sub> = H: *N*-[(2*RS*)-2-(2,4-dichlorophenyl)-2-(prop-2-enyloxy)ethyl]formamide,
- D. R<sub>1</sub> = CHO, R<sub>2</sub> = CH<sub>2</sub>-CH=CH<sub>2</sub>: *N*-[(2*RS*)-2-(2,4-dichlorophenyl)-2-(prop-2-enyloxy)ethyl]-*N*-(prop-2-enyl)formamide,

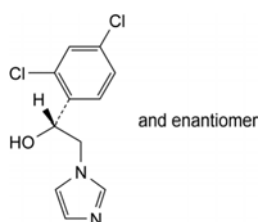

- E. (1*RS*)-1-(2,4-dichlorophenyl)-2-(1*H*-imidazol-1-yl)ethanol,

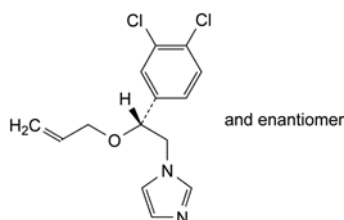

- F. 1-[(2*RS*)-2-(3,4-dichlorophenyl)-2-(prop-2-enyloxy)ethyl]-1*H*-imidazole.

01/2008:1097

## ENOXAPARIN SODIUM

### Enoxaparinum natrium

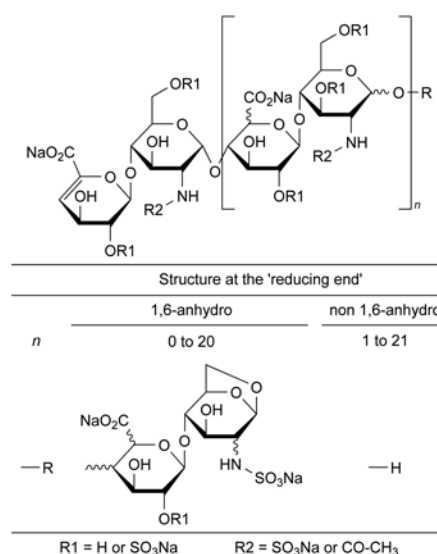

#### DEFINITION

Enoxaparin sodium is the sodium salt of a low-molecular-mass heparin that is obtained by alkaline depolymerisation of the benzyl ester derivative of heparin from porcine intestinal mucosa. Enoxaparin consists of a complex set of oligosaccharides that have not yet been completely characterised. Based on current knowledge, the majority of the components have a 4-enopyranose uronate structure at the non-reducing end of their chain. 15 per cent to 25 per cent of the components have a 1,6-anhydro structure at the reducing end of their chain.

*Enoxaparin sodium complies with the monograph Low-molecular-mass heparins (0828) with the modifications and additional requirements below.*

The mass-average relative molecular mass ranges between 3800 and 5000, with a characteristic value of about 4500.

The degree of sulfatation is about 2 per disaccharide unit.

The potency is not less than 90 IU and not more than 125 IU of anti-factor Xa activity per milligram, calculated with reference to the dried substance. The anti-factor IIa activity is not less than 20.0 IU and not more than 35.0 IU per milligram, calculated with reference to the dried substance. The ratio of anti-factor Xa activity to anti-factor IIa activity is between 3.3 and 5.3.

#### PRODUCTION

Enoxaparin is produced by alkaline depolymerisation of benzyl ester derivatives of heparin from porcine intestinal mucosa under conditions that yield a product complying with the structural requirements stated under Definition.

01/2008:1511  
corrected 6.0

## IDENTIFICATION

Carry out identification test A as described in the monograph *Low-molecular-mass heparins (0828)* using *enoxaparin sodium CRS*.

Carry out identification test C as described in the monograph *Low-molecular-mass heparins (0828)*. The following requirements apply.

The mass-average relative molecular mass ranges between 3800 and 5000. The mass percentage of chains lower than 2000 ranges between 12.0 per cent and 20.0 per cent. The mass percentage of chains between 2000 and 8000 ranges between 68.0 per cent and 82.0 per cent.

## TESTS

**Appearance of solution.** The solution is clear (2.2.1) and not more intensely coloured than intensity 6 of the range of reference solutions of the most appropriate colour (2.2.2, Method II).

Dissolve 1.0 g in 10 mL of *water R*.

**pH (2.2.3):** 6.2 to 7.7.

Dissolve 1.0 g in *carbon dioxide-free water R* and dilute to 10.0 mL with the same solvent.

**Specific absorbance (2.2.25):** 14.0 to 20.0 (dried substance), determined at 231 nm.

Dissolve 50.0 mg in 100 mL of 0.01 M *hydrochloric acid*.

**Benzyl alcohol.** Liquid chromatography (2.2.29).

**Internal standard solution:** 1 g/L solution of 3,4-dimethylphenol *R* in *methanol R*.

**Test solution.** Dissolve about 0.500 g of the substance to be examined in 5.0 mL of 1 M *sodium hydroxide*. Allow to stand for 1 h. Add 1.0 mL of *glacial acetic acid R* and 1.0 mL of the internal standard solution and dilute to 10.0 mL with *water R*.

**Reference solution.** Prepare a 0.25 g/L solution of *benzyl alcohol R* in *water R*. Mix 0.50 mL of this solution with 1.0 mL of the internal standard solution and dilute to 10.0 mL with *water R*.

**Precolumn:**

- size:  $l = 0.02$  m,  $\emptyset = 4.6$  mm;
- stationary phase: *octylsilyl silica gel for chromatography R* (5  $\mu$ m).

**Column:**

- size:  $l = 0.15$  m,  $\emptyset = 4.6$  mm;
- stationary phase: *octylsilyl silica gel for chromatography R* (5  $\mu$ m).

**Mobile phase:** *methanol R*, *acetonitrile R*, *water R* (5:15:80 V/V/V).

**Flow rate:** 1 mL/min.

**Detection:** spectrophotometer at 256 nm.

From the chromatogram obtained with the reference solution, calculate the ratio ( $R_1$ ) of the height of the peak due to benzyl alcohol to the height of the peak due to the internal standard. From the chromatogram obtained with the test solution, calculate the ratio ( $R_2$ ) of the height of the peak due to benzyl alcohol to the height of the peak due to the internal standard. Calculate the percentage content ( $m/m$ ) of benzyl alcohol using the following expression:

$$\frac{0.0125 \times R_2}{m \times R_1}$$

$m$  = mass of the substance to be examined, in grams.

**Limit:**

- *benzyl alcohol*: maximum 0.1 per cent  $m/m$ .

**Sodium (2.2.23, Method I):** 11.3 per cent to 13.5 per cent (dried substance).

## ENOXOLONE

## Enoxolonum

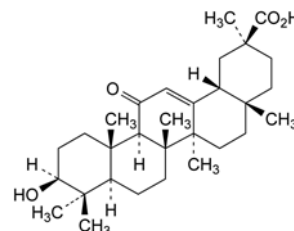

$C_{30}H_{46}O_4$   
[471-53-4]

$M_r$  470.7

## DEFINITION

(20 $\beta$ )-3 $\beta$ -Hydroxy-11-oxo-olean-12-en-29-oic acid.

**Content:** 98.0 per cent to 101.0 per cent (dried substance).

## CHARACTERS

**Appearance:** white or almost white crystalline powder.

**Solubility:** practically insoluble in water, soluble in ethanol, sparingly soluble in methylene chloride.

It shows polymorphism (5.9).

## IDENTIFICATION

**First identification:** A.

**Second identification:** B, C.

A. Examine by infrared absorption spectrophotometry (2.2.24).

**Comparison:** *enoxolone CRS*.

If the spectra obtained in the solid state show differences, dissolve 0.2 g of the substance to be examined and 0.2 g of the reference substance separately in 6 mL of *ethanol R*. Boil under a reflux condenser for 1 h and add 6 mL of *water R*. A precipitate is formed. Cool to about 10 °C and filter with the aid of vacuum. Wash the precipitate with 10 mL of *alcohol R*, dry in an oven at 80 °C and record new spectra.

B. Thin-layer chromatography (2.2.27).

**Test solution.** Dissolve 10 mg of the substance to be examined in *methylene chloride R* and dilute to 10 mL with the same solvent.

**Reference solution.** Dissolve 10 mg of *enoxolone CRS* in *methylene chloride R* and dilute to 10 mL with the same solvent.

**Plate:** *TLC silica gel plate R*.

**Mobile phase:** *glacial acetic acid R*, *acetone R*, *methylene chloride R* (5:10:90 V/V/V).

**Application:** 5  $\mu$ L.

**Development:** over 2/3 of the plate.

**Drying:** in air for 5 min.

**Detection:** spray with *anisaldehyde solution R* and heat at 100-105 °C for 10 min.

**Results:** the principal spot in the chromatogram obtained with the test solution is similar in position, colour and size to the principal spot in the chromatogram obtained with the reference solution.

C. Dissolve 50 mg in 10 mL of *methylene chloride R*. To 2 mL of this solution, add 1 mL of *acetic anhydride R* and 0.3 mL of *sulfuric acid R*. A pink colour is produced.



## TESTS

**Appearance of solution.** The solution is clear (2.2.1) and not more intensely coloured than reference solution Y<sub>6</sub> (2.2.2, Method II).

Dissolve 0.1 g in *ethanol R* and dilute to 10 mL with the same solvent.

**Specific optical rotation** (2.2.7): + 145 to + 154 (dried substance).

Dissolve 0.50 g in *dioxan R* and dilute to 50.0 mL with the same solvent.

**Related substances.** Liquid chromatography (2.2.29).

**Test solution.** Dissolve 0.10 g of the substance to be examined in the mobile phase and dilute to 100.0 mL with the mobile phase.

**Reference solution (a).** Dilute 2.0 mL of the test solution to 100.0 mL with the mobile phase.

**Reference solution (b).** Dilute 5.0 mL of reference solution (a) to 100.0 mL with the mobile phase.

**Reference solution (c).** Dissolve 0.1 g of *18 $\alpha$ -glycyrrhetic acid R* in *tetrahydrofuran R* and dilute to 100.0 mL with the same solvent. To 2.0 mL of the solution, add 2.0 mL of the test solution and dilute to 100.0 mL with the mobile phase.

**Column:**

- size:  $l = 0.25$  m,  $\varnothing = 4.6$  mm,
- stationary phase: octadecylsilyl silica gel for chromatography R (5  $\mu$ m),
- temperature: 30 °C.

**Mobile phase:** mix 430 volumes of *tetrahydrofuran R* and 570 volumes of a 1.36 g/L solution of *sodium acetate R* adjusted to pH 4.8 with *glacial acetic acid R*.

**Flow rate:** 0.8 mL/min.

**Detection:** spectrophotometer at 250 nm.

**Injection:** 20  $\mu$ L loop injector; inject the test solution and the reference solutions.

**Run time:** 4 times the retention time of enoxolone.

**System suitability:**

- resolution: minimum of 2.0 between the peaks due to enoxolone and to *18 $\alpha$ -glycyrrhetic acid* in the chromatogram obtained with reference solution (c).

**Limits:**

- any impurity: not more than 7 times the area of the principal peak in the chromatogram obtained with reference solution (b) (0.7 per cent),
- total: not more than the area of the principal peak in the chromatogram obtained with reference solution (a) (2.0 per cent),
- disregard limit: 0.5 times the area of the principal peak in the chromatogram obtained with reference solution (b) (0.05 per cent).

**Heavy metals** (2.4.8): maximum 20 ppm.

1.0 g complies with limit test F. Prepare the standard using 2 mL of *lead standard solution (10 ppm Pb) R*.

**Loss on drying** (2.2.32): maximum 0.5 per cent, determined on 1.000 g by drying in an oven at 105 °C for 4 h.

**Sulfated ash** (2.4.14): maximum 0.2 per cent, determined on 1.0 g.

## ASSAY

Dissolve 0.330 g in 40 mL of *dimethylformamide R*. Titrate with 0.1 M *tetrabutylammonium hydroxide*, determining the end-point potentiometrically (2.2.20). Carry out a blank titration.

1 mL of 0.1 M *tetrabutylammonium hydroxide* is equivalent to 47.07 mg of C<sub>30</sub>H<sub>46</sub>O<sub>4</sub>.

## STORAGE

Protected from light.

## IMPURITIES

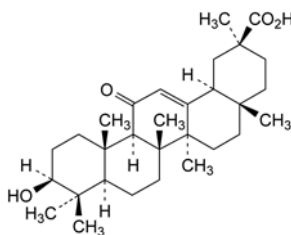

A. (20 $\beta$ )-3 $\beta$ -hydroxy-11-oxo-18 $\alpha$ -olean-12-en-29-oic acid,

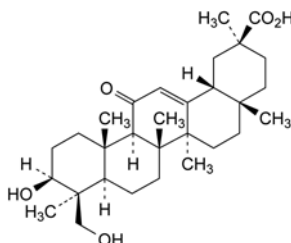

B. (4 $\beta$ ,20 $\beta$ )-3 $\beta$ ,23-dihydroxy-11-oxo-olean-12-en-29-oic acid.

04/2010:2229  
corrected 7.0

## ENROFLOXACIN FOR VETERINARY USE

## Enrofloxacinum ad usum veterinarium

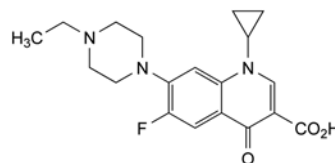

C<sub>19</sub>H<sub>22</sub>FN<sub>3</sub>O<sub>3</sub>  
[93106-60-6]

$M_r$  359.4

## DEFINITION

1-Cyclopropyl-7-(4-ethylpiperazin-1-yl)-6-fluoro-4-oxo-1,4-dihydroquinoline-3-carboxylic acid.

**Content:** 98.5 per cent to 101.5 per cent (dried substance).

## CHARACTERS

**Appearance:** pale yellowish or light yellow, crystalline powder.

**Solubility:** practically insoluble in water, freely soluble in methylene chloride, slightly soluble in methanol.

## IDENTIFICATION

Infrared absorption spectrophotometry (2.2.24).

**Comparison:** *enrofloxacin CRS*.

## TEST

**Appearance of solution.** The solution is not more opalescent than reference suspension II (2.2.1) and not more intensely coloured than reference solution GY<sub>4</sub> (2.2.2, Method II).

To 1.0 g of the substance to be examined add about 0.25 g of *potassium hydroxide R* and 7 mL of *water R*. Sonicate to dissolve and dilute to 10.0 mL with *water R*.

**Impurity A.** Thin-layer chromatography (2.2.27). Prepare the solutions immediately before use.

**Solvent mixture:** *methanol R*, *methylene chloride R* (50:50 V/V).

**Test solution.** Dissolve 0.100 g of the substance to be examined in the solvent mixture and dilute to 5.0 mL with the solvent mixture.

**Reference solution.** Dissolve 5.0 mg of *ciprofloxacin impurity A CRS* (enrofloxacin impurity A) in the solvent mixture and dilute to 50.0 mL with the solvent mixture. Dilute 4.0 mL of this solution to 10.0 mL with the solvent mixture.

**Plate:** TLC silica gel  $F_{254}$  plate R (2-10  $\mu\text{m}$ ).

**Mobile phase:** butanol R, water R, anhydrous acetic acid R, ethyl acetate R (15:15:20:50 V/V/V/V).

**Application:** 10  $\mu\text{L}$ .

**Development:** over 3/4 of the plate.

**Drying:** in air.

**Detection:** examine in ultraviolet light at 254 nm.

**Results:**

- **impurity A:** any spot due to impurity A is not more intense than the spot in the chromatogram obtained with the reference solution (0.2 per cent).

**Related substances.** Liquid chromatography (2.2.29).

**Test solution.** Dissolve 50 mg of the substance to be examined in the mobile phase and dilute to 50.0 mL with the mobile phase.

**Reference solution (a).** Dissolve 10 mg of *enrofloxacin for system suitability CRS* (containing impurities B and C) and dilute to 10 mL with the mobile phase.

**Reference solution (b).** Dilute 1.0 mL of the test solution to 50.0 mL with the mobile phase. Dilute 1.0 mL of this solution to 10.0 mL with the mobile phase.

**Column:**

- **size:**  $l = 0.15$  m,  $\varnothing = 4.6$  mm;
- **stationary phase:** base-deactivated end-capped octadecylsilyl silica gel for chromatography R (5  $\mu\text{m}$ );
- **temperature:** 40 °C.

**Mobile phase:** mix 15 volumes of *methanol R* and 85 volumes of a 2.9 g/L solution of *phosphoric acid R*, previously adjusted to pH 2.3 with *triethylamine R*.

**Flow rate:** 1.5 mL/min.

**Detection:** spectrophotometer at 270 nm.

**Injection:** 10  $\mu\text{L}$ .

**Run time:** 3 times the retention time of enrofloxacin.

**Identification of impurities:** use the chromatogram supplied with *enrofloxacin for system suitability CRS* and the chromatogram obtained with reference solution (a) to identify the peaks due to impurities B and C.

**Relative retention** with reference to enrofloxacin (retention time = about 16 min): impurity C = about 0.6; impurity B = about 0.8.

**System suitability:** reference solution (a):

- **resolution:** minimum 2.0 between the peaks due to impurity B and enrofloxacin.

**Limits:**

- **impurity B:** not more than 2.5 times the area of the principal peak in the chromatogram obtained with reference solution (b) (0.5 per cent);
- **impurity C:** not more than the area of the principal peak in the chromatogram obtained with reference solution (b) (0.2 per cent);
- **unspecified impurities:** for each impurity, not more than the area of the principal peak in the chromatogram obtained with reference solution (b) (0.20 per cent);
- **total:** not more than 5 times the area of the principal peak in the chromatogram obtained with reference solution (b) (1.0 per cent);
- **disregard limit:** 0.5 times the area of the principal peak in the chromatogram obtained with reference solution (b) (0.1 per cent).

**Heavy metals** (2.4.8): maximum 20 ppm.

Dissolve 1.5 g in a mixture of 5 mL of 2 M *acetic acid* and 10 mL of *water R*. Filter. 12 mL of the filtrate after adding 2 mL

of *water R* (instead of buffer solution) complies with test E. Prepare the reference solution using 12 mL of *lead standard solution* (2 ppm Pb) R.

**Loss on drying** (2.2.32): maximum 1.0 per cent, determined on 2.000 g by drying under high vacuum at 120 °C for 6 h.

**Sulfated ash** (2.4.14): maximum 0.1 per cent, determined on 1.0 g.

**ASSAY**

Dissolve 0.250 g in 100 mL of *anhydrous acetic acid R* and titrate with 0.1 M *perchloric acid* determining the end-point potentiometrically (2.2.20).

1 mL of 0.1 M *perchloric acid* is equivalent to 35.94 mg of  $\text{C}_{19}\text{H}_{22}\text{FN}_3\text{O}_3$ .

**STORAGE**

Protected from light.

**IMPURITIES**

**Specified impurities:** A, B, C.

**Other detectable impurities** (the following substances would, if present at a sufficient level, be detected by one or other of the tests in the monograph. They are limited by the general acceptance criterion for other/unspecified impurities and/or by the general monograph *Substances for pharmaceutical use* (2034). It is therefore not necessary to identify these impurities for demonstration of compliance. See also 5.10. *Control of impurities in substances for pharmaceutical use*): E, F, G.

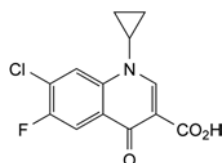

A. 7-chloro-1-cyclopropyl-6-fluoro-4-oxo-1,4-dihydroquinoline-3-carboxylic acid,

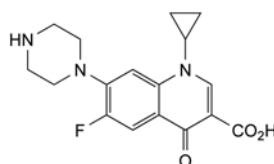

B. ciprofloxacin,

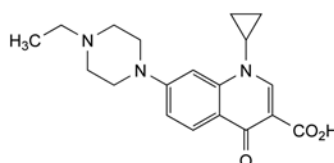

C. 1-cyclopropyl-7-(4-ethylpiperazin-1-yl)-4-oxo-1,4-dihydroquinoline-3-carboxylic acid,

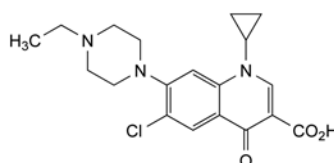

E. 6-chloro-1-cyclopropyl-7-(4-ethylpiperazin-1-yl)-4-oxo-1,4-dihydroquinoline-3-carboxylic acid,

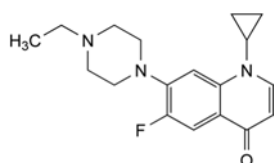

F. 1-cyclopropyl-7-(4-ethylpiperazin-1-yl)-6-fluoroquinolin-4(1H)-one,

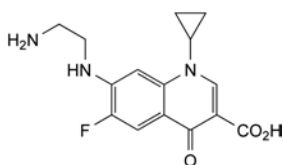

- G. 7-[(2-aminoethyl)amino]-1-cyclopropyl-6-fluoro-4-oxo-1,4-dihydroquinoline-3-carboxylic acid.

01/2011:2574

## ENTACAPONE

### Entacaponum

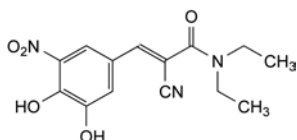

$C_{14}H_{15}N_3O_5$   
[130929-57-6]

$M_r$  305.3

#### DEFINITION

(2*E*)-2-Cyano-3-(3,4-dihydroxy-5-nitrophenyl)-*N,N*-diethylprop-2-enamide.

*Content*: 98.0 per cent to 102.0 per cent (dried substance).

#### CHARACTERS

*Appearance*: greenish-yellow or yellow powder.

*Solubility*: practically insoluble in water, soluble or sparingly soluble in acetone, slightly soluble in anhydrous ethanol.

It shows polymorphism (5.9).

#### IDENTIFICATION

Infrared absorption spectrophotometry (2.2.24).

*Comparison*: entacaponum CRS.

If the spectra obtained in the solid state show differences, dissolve the substance to be examined and the reference substance separately in *acetone R*, evaporate to dryness and record new spectra using the residues.

#### TESTS

**Related substances.** Liquid chromatography (2.2.29). Use freshly prepared solutions.

*Solvent mixture*: tetrahydrofuran *R*, methanol *R* (30:70 *V/V*).

*Test solution (a)*. Dissolve 50.0 mg of the substance to be examined in the solvent mixture and dilute to 50.0 mL with the solvent mixture.

*Test solution (b)*. Dilute 5.0 mL of test solution (a) to 50.0 mL with the solvent mixture.

*Reference solution (a)*. Dissolve 5 mg of entacaponum impurity A CRS in the solvent mixture, add 5.0 mL of test solution (a) and dilute to 25.0 mL with the solvent mixture. Dilute 1.0 mL of the solution to 20.0 mL with the solvent mixture. Dilute 1.0 mL of this solution to 10.0 mL with the solvent mixture.

*Reference solution (b)*. Dilute 1.0 mL of test solution (b) to 100.0 mL with the solvent mixture.

*Reference solution (c)*. Dissolve 50.0 mg of entacaponum CRS in the solvent mixture and dilute to 50.0 mL with the solvent mixture. Dilute 5.0 mL of the solution to 50.0 mL with the solvent mixture.

*Column*:

- *size*:  $l = 0.25$  m,  $\varnothing = 4.6$  mm;
- *stationary phase*: end-capped polar-embedded propyl-2-phenylsilyl amorphous organosilica polymer *R* (5  $\mu$ m).

*Mobile phase*: mix 2 volumes of tetrahydrofuran *R*, 44 volumes of methanol *R* and 54 volumes of a 2.34 g/L solution of sodium dihydrogen phosphate *R* previously adjusted to pH 2.1 with phosphoric acid *R*.

*Flow rate*: 1.0 mL/min.

*Detection*: spectrophotometer at 300 nm.

*Injection*: 10  $\mu$ L of test solution (a) and reference solutions (a) and (b).

*Run time*: 2.5 times the retention time of entacaponum.

*Relative retention* with reference to entacaponum (retention time = about 17 min): impurity A = about 0.8.

*System suitability*: reference solution (a):

- *resolution*: minimum 3.0 between the peaks due to impurity A and entacaponum.

*Limits*:

- *impurity A*: not more than 1.5 times the area of the principal peak in the chromatogram obtained with reference solution (b) (0.15 per cent);
- *unspecified impurities*: for each impurity, not more than the area of the principal peak in the chromatogram obtained with reference solution (b) (0.10 per cent);
- *sum of impurities other than A*: not more than twice the area of the principal peak in the chromatogram obtained with reference solution (b) (0.2 per cent);
- *disregard limit*: 0.5 times the area of the principal peak in the chromatogram obtained with reference solution (b) (0.05 per cent).

**Heavy metals** (2.4.8): maximum 10 ppm.

*Solvent mixture*: dimethylformamide *R*, methanol *R* (25:75 *V/V*).

1.00 g complies with test H. Prepare the reference solution using 1.0 mL of lead standard solution (10 ppm Pb) *R*.

After filtration, rinse the membrane filter with at least 20 mL of methanol *R*.

**Loss on drying** (2.2.32): maximum 0.5 per cent, determined on 1.000 g by drying *in vacuo* at 60 °C.

**Sulfated ash** (2.4.14): maximum 0.1 per cent, determined on 1.0 g.

#### ASSAY

Liquid chromatography (2.2.29) as described in the test for related substances with the following modification.

*Injection*: test solution (b) and reference solution (c).

Calculate the percentage content of  $C_{14}H_{15}N_3O_5$  from the declared content of entacaponum CRS.

#### STORAGE

Protected from light.

#### IMPURITIES

*Specified impurities*: A.

*Other detectable impurities* (the following substances would, if present at a sufficient level, be detected by one or other of the tests in the monograph. They are limited by the general acceptance criterion for other/unspecified impurities and/or by the general monograph *Substances for pharmaceutical use* (2034). It is therefore not necessary to identify these impurities for demonstration of compliance. See also 5.10. *Control of impurities in substances for pharmaceutical use*): B, C, D, E, F, G, H, I.

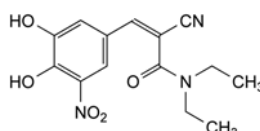

- A. (2*Z*)-2-cyano-3-(3,4-dihydroxy-5-nitrophenyl)-*N,N*-diethylprop-2-enamide,

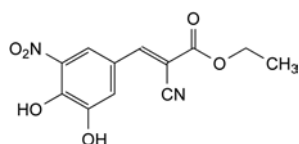
01/2008:0488  
corrected 6.0

B. ethyl (2*E*)-2-cyano-3-(3,4-dihydroxy-5-nitrophenyl)prop-2-enoate,

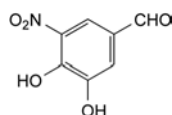

C. 3,4-dihydroxy-5-nitrobenzaldehyde,

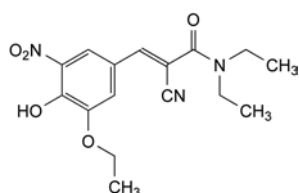

D. (2*E*)-2-cyano-3-(3-ethoxy-4-hydroxy-5-nitrophenyl)-*N,N*-diethylprop-2-enamide,

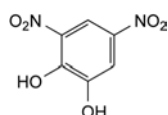

E. 3,5-dinitrobenzene-1,2-diol,

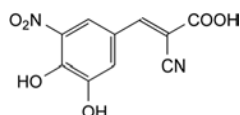

F. (2*E*)-2-cyano-3-(3,4-dihydroxy-5-nitrophenyl)prop-2-enoic acid,

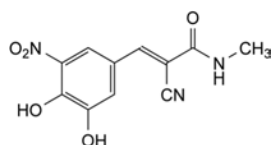

G. (2*E*)-2-cyano-3-(3,4-dihydroxy-5-nitrophenyl)-*N*-methylprop-2-enamide,

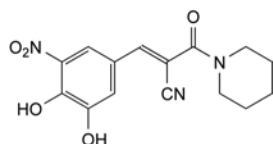

H. (2*E*)-3-(3,4-dihydroxy-5-nitrophenyl)-2-(piperidin-1-ylcarbonyl)prop-2-enitrile,

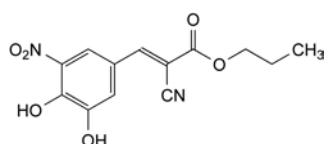

I. propyl (2*E*)-2-cyano-3-(3,4-dihydroxy-5-nitrophenyl)prop-2-enoate.

## EPHEDRINE, ANHYDROUS

### Ephedrinum anhydricum

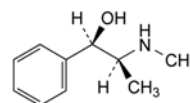

$C_{10}H_{15}NO$   
[299-42-3]

$M_r$  165.2

#### DEFINITION

Anhydrous ephedrine contains not less than 99.0 per cent and not more than the equivalent of 101.0 per cent of (1*R*,2*S*)-2-methylamino-1-phenylpropan-1-ol, calculated with reference to the anhydrous substance.

#### CHARACTERS

A white or almost white, crystalline powder or colourless crystals, soluble in water, very soluble in alcohol.

It melts at about 36 °C.

#### IDENTIFICATION

*First identification:* B, D.

*Second identification:* A, C, D, E.

- Specific optical rotation (see Tests).
- Examine by infrared absorption spectrophotometry (2.2.24), comparing with the spectrum obtained with the base isolated from *ephedrine hydrochloride CRS*. Examine the substances in discs prepared as follows: dissolve 40 mg of the substance to be examined in 1 mL of *water R*, add 1 mL of *dilute sodium hydroxide solution R* and 4 mL of *chloroform R* and shake; dry the organic layer over 0.2 g of *anhydrous sodium sulfate R*; prepare a blank disc using about 0.3 g of *potassium bromide R*; apply dropwise to the disc 0.1 mL of the organic layer, allowing the solvent to evaporate between applications; dry the disc at 50 °C for 2 min. Repeat the operations using 50 mg of *ephedrine hydrochloride CRS*.
- Examine the chromatograms obtained in the test for related substances. The principal spot in the chromatogram obtained with test solution (b) is similar in position, colour and size to the principal spot in the chromatogram obtained with reference solution (a).
- Dissolve about 10 mg in 1 mL of *water R*. Add 0.2 mL of *strong sodium hydroxide solution R* and 0.2 mL of *copper sulfate solution R*. A violet colour is produced. Add 2 mL of *ether R* and shake. The ether layer is purple and the aqueous layer blue.
- Water (see Tests).

#### TESTS

**Appearance of solution.** Dissolve 0.25 g in *water R* and dilute to 10 mL with the same solvent. The solution is clear (2.2.1) and colourless (2.2.2, *Method II*).

**Specific optical rotation** (2.2.7). Dissolve 2.25 g in 15 mL of *dilute hydrochloric acid R* and dilute to 50.0 mL with *water R*. The specific optical rotation is –41 to –43, calculated with reference to the anhydrous substance.

**Related substances.** Examine by thin-layer chromatography (2.2.27), using *silica gel G R* as the coating substance.

*Test solution (a).* Dissolve 0.2 g of the substance to be examined in *methanol R* and dilute to 10 mL with the same solvent.

*Test solution (b).* Dilute 1 mL of test solution (a) to 10 mL with *methanol R*.

*Reference solution (a).* Dissolve 25 mg of *ephedrine hydrochloride CRS* in *methanol R* and dilute to 10 mL with the same solvent.

*Reference solution (b)*. Dilute 1.0 mL of test solution (a) to 200 mL with *methanol R*.

Apply separately to the plate 10 µL of each solution. Develop over a path of 15 cm using a mixture of 5 volumes of *chloroform R*, 15 volumes of *concentrated ammonia R* and 80 volumes of *2-propanol R*. Allow the plate to dry in air and spray with *ninhydrin solution R*. Heat at 110 °C for 5 min. Any spot in the chromatogram obtained with test solution (a), apart from the principal spot, is not more intense than the spot in the chromatogram obtained with reference solution (b) (0.5 per cent). Disregard any spot of lighter colour than the background.

**Chlorides**. Dissolve 0.17 g in 10 mL of *water R*. Add 5 mL of *dilute nitric acid R* and 0.5 mL of *silver nitrate solution R1*. Allow to stand for 2 min, protected from bright light. Any opalescence in the solution is not more intense than that in a standard prepared at the same time and in the same manner using 10 mL of *chloride standard solution (5 ppm Cl) R*, 5 mL of *dilute nitric acid R* and 0.5 mL of *silver nitrate solution R1* (290 ppm).

**Water (2.5.12)**. Not more than 0.5 per cent, determined on 2.000 g by the semi-micro determination of water.

**Sulfated ash (2.4.14)**. Not more than 0.1 per cent, determined on 1.0 g.

#### ASSAY

Dissolve 0.200 g in 5 mL of *alcohol R* and add 20.0 mL of *0.1 M hydrochloric acid*. Using 0.05 mL of *methyl red solution R* as indicator, titrate with *0.1 M sodium hydroxide* until a yellow colour is obtained.

1 mL of *0.1 M hydrochloric acid* is equivalent to 16.52 mg of C<sub>10</sub>H<sub>15</sub>NO.

#### STORAGE

Store protected from light.

and shake; dry the organic layer over 0.2 g of *anhydrous sodium sulfate R*; prepare a blank disc using about 0.3 g of *potassium bromide R*; apply dropwise to the disc 0.1 mL of the organic layer, allowing the solvent to evaporate between applications; dry the disc at 50 °C for 2 min. Repeat the operations using 50 mg of *ephedrine hydrochloride CRS*.

C. Examine the chromatograms obtained in the test for related substances. The principal spot in the chromatogram obtained with test solution (b) is similar in position, colour and size to the principal spot in the chromatogram obtained with reference solution (a).

D. Dissolve about 10 mg in 1 mL of *water R*. Add 0.2 mL of *strong sodium hydroxide solution R* and 0.2 mL of *copper sulfate solution R*. A violet colour is produced. Add 2 mL of *ether R* and shake. The ether layer is purple and the aqueous layer blue.

E. Water (see Tests).

#### TESTS

**Appearance of solution**. Dissolve 0.25 g in *water R* and dilute to 10 mL with the same solvent. The solution is clear (2.2.1) and colourless (2.2.2, *Method II*).

**Specific optical rotation (2.2.7)**. Dissolve 2.25 g in 15 mL of *dilute hydrochloric acid R* and dilute to 50.0 mL with *water R*. The specific optical rotation is –41 to –43, calculated with reference to the anhydrous substance.

**Related substances**. Examine by thin-layer chromatography (2.2.27), using *silica gel G R* as the coating substance.

*Test solution (a)*. Dissolve 0.2 g of the substance to be examined in *methanol R* and dilute to 10 mL with the same solvent.

*Test solution (b)*. Dilute 1 mL of test solution (a) to 10 mL with *methanol R*.

*Reference solution (a)*. Dissolve 25 mg of *ephedrine hydrochloride CRS* in *methanol R* and dilute to 10 mL with the same solvent.

*Reference solution (b)*. Dilute 1.0 mL of test solution (a) to 200 mL with *methanol R*.

Apply separately to the plate 10 µL of each solution. Develop over a path of 15 cm using a mixture of 5 volumes of *chloroform R*, 15 volumes of *concentrated ammonia R* and 80 volumes of *2-propanol R*. Allow the plate to dry in air and spray with *ninhydrin solution R*. Heat at 110 °C for 5 min. Any spot in the chromatogram obtained with test solution (a), apart from the principal spot, is not more intense than the spot in the chromatogram obtained with reference solution (b) (0.5 per cent). Disregard any spot of lighter colour than the background.

**Chlorides**. Dissolve 0.18 g in 10 mL of *water R*. Add 5 mL of *dilute nitric acid R* and 0.5 mL of *silver nitrate solution R1*. Allow to stand for 2 min, protected from bright light. Any opalescence in the solution is not more intense than that in a standard prepared at the same time and in the same manner using 10 mL of *chloride standard solution (5 ppm Cl) R*, 5 mL of *dilute nitric acid R* and 0.5 mL of *silver nitrate solution R1* (280 ppm).

**Water (2.5.12)**: 4.5 per cent to 5.5 per cent, determined on 0.300 g by the semi-micro determination of water.

**Sulfated ash (2.4.14)**. Not more than 0.1 per cent, determined on 1.0 g.

#### ASSAY

Dissolve 0.200 g in 5 mL of *alcohol R* and add 20.0 mL of *0.1 M hydrochloric acid*. Using 0.05 mL of *methyl red solution R* as indicator, titrate with *0.1 M sodium hydroxide* until a yellow colour is obtained.

1 mL of *0.1 M hydrochloric acid* is equivalent to 16.52 mg of C<sub>10</sub>H<sub>15</sub>NO.

#### STORAGE

Store protected from light.

01/2008:0489  
corrected 6.0

## EPHEDRINE HEMIHYDRATE

### Ephedrinum hemihydricum

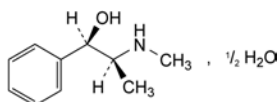

C<sub>10</sub>H<sub>15</sub>NO, 1/2 H<sub>2</sub>O  
[50906-05-3]

M<sub>r</sub> 174.2

#### DEFINITION

Ephedrine hemihydrate contains not less than 99.0 per cent and not more than the equivalent of 101.0 per cent of (1*R*,2*S*)-2-(methylamino)-1-phenylpropan-1-ol, calculated with reference to the anhydrous substance.

#### CHARACTERS

A white or almost white, crystalline powder or colourless crystals, soluble in water, very soluble in alcohol.

It melts at about 42 °C, determined without previous drying.

#### IDENTIFICATION

*First identification: B, D.*

*Second identification: A, C, D, E.*

A. Specific optical rotation (see Tests).

B. Examine by infrared absorption spectrophotometry (2.2.24), comparing with the spectrum obtained with the base isolated from *ephedrine hydrochloride CRS*. Examine the substances in discs prepared as follows: dissolve 40 mg of the substance to be examined in 1 mL of *water R*, add 1 mL of *dilute sodium hydroxide solution R* and 4 mL of *chloroform R*

01/2008:0487  
corrected 6.0

## EPHEDRINE HYDROCHLORIDE

## Ephedrini hydrochloridum

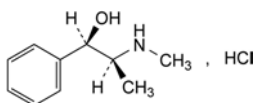
C<sub>10</sub>H<sub>16</sub>ClNO  
[50-98-6]M<sub>r</sub> 201.7

## DEFINITION

(1*R*,2*S*)-2-(Methylamino)-1-phenylpropan-1-ol hydrochloride.  
Content: 99.0 per cent to 101.0 per cent (dried substance).

## CHARACTERS

*Appearance*: white or almost white, crystalline powder or colourless crystals.

*Solubility*: freely soluble in water, soluble in ethanol (96 per cent).

mp: about 219 °C.

## IDENTIFICATION

*First identification*: B, E.

*Second identification*: A, C, D, E.

A. Specific optical rotation (see Tests).

B. Infrared absorption spectrophotometry (2.2.24).

*Comparison*: ephedrine hydrochloride CRS.

C. Thin-layer chromatography (2.2.27).

*Test solution*. Dissolve 20 mg of the substance to be examined in *methanol R* and dilute to 10 mL with the same solvent.

*Reference solution*. Dissolve 10 mg of *ephedrine hydrochloride CRS* in *methanol R* and dilute to 5 mL with the same solvent.

*Plate*: TLC silica gel plate R.

*Mobile phase*: *methylene chloride R*, *concentrated ammonia R*, *2-propanol R* (5:15:80 V/V/V).

*Application*: 10 µL.

*Development*: over 2/3 of the plate.

*Drying*: in air.

*Detection*: spray with *ninhydrin solution R*; heat at 110 °C for 5 min.

*Results*: the principal spot in the chromatogram obtained with the test solution is similar in position, colour and size to the principal spot in the chromatogram obtained with the reference solution.

D. To 0.1 mL of solution S (see Tests) add 1 mL of *water R*, 0.2 mL of *copper sulfate solution R* and 1 mL of *strong sodium hydroxide solution R*. A violet colour is produced. Add 2 mL of *methylene chloride R* and shake. The lower (organic) layer is dark grey and the upper (aqueous) layer is blue.

E. To 5 mL of solution S (see Tests) add 5 mL of *water R*. The solution gives reaction (a) of chlorides (2.3.1).

## TESTS

**Solution S**. Dissolve 5.00 g in *distilled water R* and dilute to 50.0 mL with the same solvent.

**Appearance of solution**. Solution S is clear (2.2.1) and colourless (2.2.2, *Method II*).

**Acidity or alkalinity**. To 10 mL of solution S add 0.1 mL of *methyl red solution R* and 0.2 mL of 0.01 M *sodium hydroxide*. The solution is yellow. Add 0.4 mL of 0.01 M *hydrochloric acid*. The solution is red.

**Specific optical rotation** (2.2.7): –33.5 to –35.5 (dried substance).

Dilute 12.5 mL of solution S to 25.0 mL with *water R*.

**Related substances**. Liquid chromatography (2.2.29).

*Test solution*. Dissolve 75 mg of the substance to be examined in the mobile phase and dilute to 10 mL with the mobile phase.

*Reference solution (a)*. Dilute 2.0 mL of the test solution to 100.0 mL with the mobile phase. Dilute 1.0 mL of this solution to 10.0 mL with the mobile phase.

*Reference solution (b)*. Dissolve 5 mg of the substance to be examined and 5 mg of *pseudoephedrine hydrochloride CRS* in the mobile phase and dilute to 50 mL with the mobile phase.

**Column**:

– *size*:  $l = 0.15$  m,  $\varnothing = 4.6$  mm;

– *stationary phase*: spherical *phenylsilyl silica gel for chromatography R* (3 µm).

*Mobile phase*: mix 6 volumes of *methanol R* and 94 volumes of a 11.6 g/L solution of *ammonium acetate R* adjusted to pH 4.0 with *glacial acetic acid R*.

*Flow rate*: 1.0 mL/min.

*Detection*: spectrophotometer at 257 nm.

*Injection*: 20 µL.

*Run time*: 2.5 times the retention time of ephedrine.

*Relative retention* with reference to ephedrine (retention time = about 8 min): impurity B = about 1.1; impurity A = about 1.4.

*System suitability*: reference solution (b):

– *resolution*: minimum 2.0 between the peaks due to ephedrine and impurity B.

**Limits**:

– *correction factor*: for the calculation of content, multiply the peak area of impurity A by 0.4;

– *impurity A*: not more than the area of the principal peak in the chromatogram obtained with reference solution (a) (0.2 per cent);

– *unspecified impurities*: for each impurity, not more than 0.5 times the area of the principal peak in the chromatogram obtained with reference solution (a) (0.1 per cent);

– *sum of impurities other than A*: not more than 2.5 times the area of the principal peak in the chromatogram obtained with reference solution (a) (0.5 per cent);

– *disregard limit*: 0.25 times the area of the principal peak in the chromatogram obtained with reference solution (a) (0.05 per cent).

**Sulfates** (2.4.13): maximum 100 ppm, determined on solution S.

**Loss on drying** (2.2.32): maximum 0.5 per cent, determined on 1.000 g by drying in an oven at 105 °C.

**Sulfated ash** (2.4.14): maximum 0.1 per cent, determined on 1.0 g.

## ASSAY

Dissolve 0.150 g in 50 mL of *ethanol (96 per cent) R* and add 5.0 mL of 0.01 M *hydrochloric acid*. Carry out a potentiometric titration (2.2.20), using 0.1 M *sodium hydroxide*. Read the volume added between the 2 points of inflexion.

1 mL of 0.1 M *sodium hydroxide* is equivalent to 20.17 mg of C<sub>10</sub>H<sub>16</sub>ClNO.

## STORAGE

Protected from light.

## IMPURITIES

*Specified impurities*: A.

*Other detectable impurities* (the following substances would, if present at a sufficient level, be detected by one or other of the tests in the monograph. They are limited by the general acceptance criterion for other/unspecified impurities and/or

by the general monograph *Substances for pharmaceutical use (2034)*. It is therefore not necessary to identify these impurities for demonstration of compliance. See also 5.10. *Control of impurities in substances for pharmaceutical use*): B.

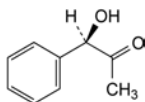

A. (-)-(1*R*)-1-hydroxy-1-phenylpropan-2-one,

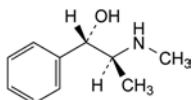

B. (1*S*,2*S*)-2-(methylamino)-1-phenylpropan-1-ol (pseudoephedrine).

01/2008:0715  
corrected 6.0

## EPHEDRINE HYDROCHLORIDE, RACEMIC

Ephedrini racemici hydrochloridum

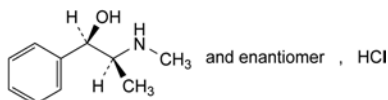

$C_{10}H_{16}ClNO$   
[134-71-4]

$M_r$  201.7

### DEFINITION

Racemic ephedrine hydrochloride contains not less than 99.0 per cent and not more than the equivalent of 101.0 per cent of (1*R,S*,2*S,R*)-2-(methylamino)-1-phenylpropan-1-ol hydrochloride, calculated with reference to the dried substance.

### CHARACTERS

A white or almost white, crystalline powder or colourless crystals, freely soluble in water, soluble in ethanol (96 per cent). It melts at about 188 °C.

### IDENTIFICATION

*First identification:* B, E.

*Second identification:* A, C, D, E.

- Optical rotation (see Tests).
- Examine by infrared absorption spectrophotometry (2.2.24), comparing with the spectrum obtained with *racemic ephedrine hydrochloride CRS*. Examine the substances prepared as discs.
- Examine the chromatograms obtained in the test for related substances. The principal spot in the chromatogram obtained with test solution (b) is similar in position, colour and size to the principal spot in the chromatogram obtained with reference solution (a).
- To 0.1 mL of solution S (see Tests) add 1 mL of *water R*, 0.2 mL of *copper sulfate solution R* and 1 mL of *strong sodium hydroxide solution R*. A violet colour is produced. Add 2 mL of *ether R* and shake. The ether layer is purple and the aqueous layer is blue.
- To 5 mL of solution S add 5 mL of *water R*. The solution gives reaction (a) of chlorides (2.3.1).

### TESTS

**Solution S.** Dissolve 5.00 g in *distilled water R* and dilute to 50.0 mL with the same solvent.

**Appearance of solution.** Solution S is clear (2.2.1) and colourless (2.2.2, *Method II*).

**Acidity or alkalinity.** To 10 mL of solution S add 0.1 mL of *methyl red solution R* and 0.1 mL of 0.01 *M sodium hydroxide*; the solution is yellow. Add 0.2 mL of 0.01 *M hydrochloric acid*; the solution is red.

**Optical rotation (2.2.7):** + 0.2° to -0.2°, determined on solution S.

**Related substances.** Examine by thin-layer chromatography (2.2.27), using *silica gel G R* as the coating substance.

**Test solution (a).** Dissolve 0.20 g of the substance to be examined in *methanol R* and dilute to 10 mL with the same solvent.

**Test solution (b).** Dilute 1 mL of test solution (a) to 10 mL with *methanol R*.

**Reference solution (a).** Dissolve 20 mg of *racemic ephedrine hydrochloride CRS* in *methanol R* and dilute to 10 mL with the same solvent.

**Reference solution (b).** Dilute 1 mL of test solution (a) to 200 mL with *methanol R*.

Apply separately to the plate 10 µL of each solution. Develop over a path of 15 cm using a mixture of 5 volumes of *chloroform R*, 15 volumes of *concentrated ammonia R* and 80 volumes of *2-propanol R*. Allow the plate to dry in air. Spray with *ninhydrin solution R* and heat at 110 °C for 5 min. Any spot in the chromatogram obtained with test solution (a), apart from the principal spot, is not more intense than the spot in the chromatogram obtained with reference solution (b) (0.5 per cent). Disregard any spot of lighter colour than the background.

**Sulfates (2.4.13).** 15 mL of solution S complies with the limit test for sulfates (100 ppm).

**Loss on drying (2.2.32).** Not more than 0.5 per cent, determined on 1.000 g by drying in an oven at 105 °C.

**Sulfated ash (2.4.14).** Not more than 0.1 per cent, determined on 1.0 g.

### ASSAY

Dissolve 0.170 g in 30 mL of *ethanol (96 per cent) R*. Add 5.0 mL of 0.01 *M hydrochloric acid*. Carry out a potentiometric titration (2.2.20), using 0.1 *M sodium hydroxide*. Read the volume added between the two points of inflexion.

1 mL of 0.1 *M sodium hydroxide* corresponds to 20.17 mg of  $C_{10}H_{16}ClNO$ .

### STORAGE

Store protected from light.

01/2010:2411  
corrected 7.0

## EPINASTINE HYDROCHLORIDE

Epinastini hydrochloridum

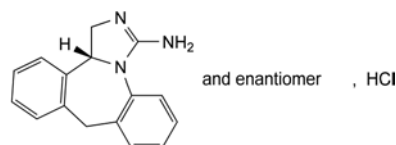

$C_{16}H_{16}ClN_3$   
[108929-04-0]

$M_r$  285.8

### DEFINITION

(13*bRS*)-9,13*b*-Dihydro-1*H*-dibenzo[*c,f*]imidazo[1,5-*a*]azepin-3-amine hydrochloride.

**Content:** 99.0 per cent to 101.0 per cent (dried substance).

### CHARACTERS

**Appearance:** white or almost white, hygroscopic, crystalline powder.

**Solubility:** freely soluble in water and in methanol, sparingly soluble in methylene chloride, slightly soluble in acetonitrile.

#### IDENTIFICATION

A. Infrared absorption spectrophotometry (2.2.24).

Comparison: *epinastine hydrochloride CRS*.

B. It gives reaction (a) of chlorides (2.3.1).

#### TESTS

**Acidity or alkalinity.** Dissolve 1.0 g in *carbon dioxide-free water R* and dilute to 10 mL with the same solvent. Add 0.1 mL of *methyl red mixed solution R* and 0.25 mL of 0.01 M *sodium hydroxide*. The solution is green. Add 0.5 mL of 0.01 M *hydrochloric acid*. The solution is reddish-violet.

**Related substances.** Liquid chromatography (2.2.29).

**Buffer solution pH 4.4.** Dissolve 3.8 g of *sodium pentanesulfonate monohydrate R* and 4.0 g of *potassium dihydrogen phosphate R* in *water R*, adjust to pH 4.4 with *phosphoric acid R* and dilute to 1000.0 mL with *water R*.

**Solvent mixture:** mobile phase B, mobile phase A (25:75 V/V).

**Test solution.** Dissolve 50 mg of the substance to be examined in the solvent mixture and dilute to 100.0 mL with the solvent mixture.

**Reference solution (a).** Dilute 10.0 mL of the test solution to 100.0 mL with the solvent mixture. Dilute 1.0 mL of this solution to 100.0 mL with the solvent mixture.

**Reference solution (b).** Dissolve 5 mg of *epinastine for system suitability CRS* (containing impurities A and B) in 10.0 mL of the solvent mixture.

**Column:**

- size:  $l = 0.10$  m,  $\varnothing = 3.0$  mm;
- stationary phase: end-capped octadecylsilyl silica gel for chromatography R (3  $\mu$ m);
- temperature: 50 °C.

**Mobile phase :**

- mobile phase A: *methanol R2*, buffer solution pH 4.4 (15:85 V/V);
- mobile phase B: *methanol R2*, *acetonitrile R1* (15:85 V/V);

Time (min)	Mobile phase A (per cent V/V)	Mobile phase B (per cent V/V)
0 - 4	80	20
4 - 13	80 → 30	20 → 70

**Flow rate:** 1.4 mL/min.

**Detection:** spectrophotometer at 220 nm.

**Injection:** 10  $\mu$ L.

**Identification of impurities:** use the chromatogram supplied with *epinastine for system suitability CRS* and the chromatogram obtained with reference solution (b) to identify the peaks due to impurities A and B.

**Relative retention** with reference to *epinastine* (retention time = about 4 min): impurity A = about 1.2; impurity B = about 2.0.

**System suitability:** reference solution (b):

- **peak-to-valley ratio:** minimum 2.0, where  $H_p$  = height above the baseline of the peak due to impurity A and  $H_v$  = height above the baseline of the lowest point of the curve separating this peak from the peak due to *epinastine*.

**Limits:**

- **impurity B:** not more than 3 times the area of the principal peak in the chromatogram obtained with reference solution (a) (0.3 per cent);
- **impurity A:** not more than twice the area of the principal peak in the chromatogram obtained with reference solution (a) (0.2 per cent);

- **unspecified impurities:** for each impurity, not more than the area of the principal peak in the chromatogram obtained with reference solution (a) (0.10 per cent);
- **total:** not more than 7 times the area of the principal peak in the chromatogram obtained with reference solution (a) (0.7 per cent);
- **disregard limit:** 0.5 times the area of the principal peak in the chromatogram obtained with reference solution (a) (0.05 per cent).

**Heavy metals** (2.4.8): maximum 20 ppm.

**Solvent:** *water R*.

0.250 g complies with test H. Prepare the reference solution using 0.5 mL of *lead standard solution (10 ppm Pb) R*.

**Loss on drying** (2.2.32): maximum 1.0 per cent, determined on 1.000 g by drying in an oven at 105 °C.

**Sulfated ash** (2.4.14): maximum 0.1 per cent, determined on 1.0 g.

#### ASSAY

Dissolve 0.200 g in 100 mL of a mixture of 1 volume of *anhydrous acetic acid R* and 2 volumes of *acetic anhydride R*. Titrate with 0.1 M *perchloric acid*, determining the end-point potentiometrically (2.2.20).

1 mL of 0.1 M *perchloric acid* is equivalent to 28.58 mg of  $C_{16}H_{16}ClN_3$ .

#### STORAGE

In an airtight container.

#### IMPURITIES

**Specified impurities:** A, B.

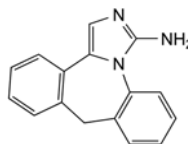

A. 9H-dibenzo[*c,f*]imidazo[1,5-*a*]azepin-3-amine,

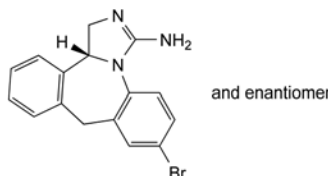

B. (13*bRS*)-7-bromo-9,13*b*-dihydro-1*H*-dibenzo[*c,f*]imidazo[1,5-*a*]azepin-3-amine.

01/2008:1590

## EPIRUBICIN HYDROCHLORIDE

### Epirubicini hydrochloridum

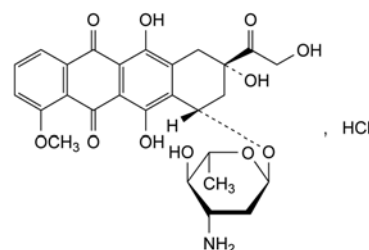

$C_{27}H_{30}ClNO_{11}$   
[56390-09-1]

$M_r$  580.0

#### DEFINITION

(8*S*,10*S*)-10-[(3-Amino-2,3,6-trideoxy- $\alpha$ -L-arabino-hexopyranosyl)oxy]-6,8,11-trihydroxy-8-(hydroxyacetyl)-1-methoxy-7,8,9,10-tetrahydrotetracene-5,12-dione hydrochloride.



Substance obtained by chemical transformation of a substance produced by certain strains of *Streptomyces peucetius*.

Content: 97.0 per cent to 102.0 per cent (anhydrous substance).

#### CHARACTERS

**Appearance:** orange-red powder.

**Solubility:** soluble in water and in methanol, slightly soluble in anhydrous ethanol, practically insoluble in acetone.

#### IDENTIFICATION

A. Infrared absorption spectrophotometry (2.2.24).

**Comparison:** epirubicin hydrochloride CRS.

B. Examine the chromatograms obtained in the assay.

**Results:** the principal peak in the chromatogram obtained with the test solution is similar in retention time to the principal peak in the chromatogram obtained with reference solution (a).

C. Dissolve about 10 mg in 0.5 mL of *nitric acid R*, add 0.5 mL of *water R* and heat over a flame for 2 min. Allow to cool and add 0.5 mL of *silver nitrate solution R1*. A white precipitate is formed.

#### TESTS

**pH** (2.2.3): 4.0 to 5.5.

Dissolve 50 mg in *carbon dioxide-free water R* and dilute to 10 mL with the same solvent.

**Related substances.** Liquid chromatography (2.2.29). Allow the solutions to stand for 3 h before use.

**Test solution.** Dissolve 25.0 mg of the substance to be examined in the mobile phase and dilute to 25.0 mL with the mobile phase.

**Reference solution (a).** Dissolve 25.0 mg of *epirubicin hydrochloride CRS* in the mobile phase and dilute to 25.0 mL with the mobile phase.

**Reference solution (b).** Dissolve 10 mg of *epirubicin hydrochloride CRS* and 10 mg of *doxorubicin hydrochloride CRS* in the mobile phase and dilute to 100 mL with the mobile phase.

**Reference solution (c).** Dissolve 10 mg of *doxorubicin hydrochloride CRS* in a mixture of 5 mL of *water R* and 5 mL of *phosphoric acid R*. Allow to stand for 30 min. Adjust to pH 2.6 with an 80 g/L solution of *sodium hydroxide R*. Add 15 mL of *acetonitrile R* and 10 mL of *methanol R*. Mix.

**Reference solution (d).** Dilute 1.0 mL of the test solution to 100.0 mL with the mobile phase.

**Column:**

- size:  $l = 0.25$  m,  $\varnothing = 4.6$  mm;
- stationary phase: trimethylsilyl silica gel for chromatography R (6  $\mu$ m);
- temperature: 35 °C.

**Mobile phase:** mix 17 volumes of *methanol R*, 29 volumes of *acetonitrile R* and 54 volumes of a solution containing 3.7 g/L of *sodium laurilsulfate R* and 2.8 per cent V/V of *dilute phosphoric acid R*.

**Flow rate:** 2.5 mL/min.

**Detection:** spectrophotometer at 254 nm.

**Injection:** 10  $\mu$ L of the test solution and reference solutions (b), (c) and (d).

**Run time:** 3.5 times the retention time of epirubicin.

**Identification of impurities:** use the 2<sup>nd</sup> most abundant peak present in the chromatogram obtained with reference solution (c) to identify impurity A.

**Relative retention** with reference to epirubicin (retention time = about 9.5 min): impurity A = about 0.3; impurity B = about 0.4; impurity C = about 0.8; impurity E = about 1.1; impurity D = about 1.5; impurity F = about 1.7; impurity G = about 2.1.

**System suitability:** reference solution (b):

- resolution: minimum 2.0 between the peaks due to impurity C and epirubicin.

**Limits:**

- correction factor: for the calculation of content, multiply the peak area of impurity A by 0.7;
- impurity A: not more than the area of the principal peak in the chromatogram obtained with reference solution (d) (1.0 per cent);
- impurity C: not more than the area of the principal peak in the chromatogram obtained with reference solution (d) (1.0 per cent);
- any other impurity: for each impurity, not more than 0.5 times the area of the principal peak in the chromatogram obtained with reference solution (d) (0.5 per cent);
- total: not more than twice the area of the principal peak in the chromatogram obtained with reference solution (d) (2.0 per cent);
- disregard limit: 0.05 times the area of the principal peak in the chromatogram obtained with reference solution (d) (0.05 per cent).

**Acetone** (2.4.24): maximum 1.5 per cent.

**Water** (2.5.12): maximum 4.0 per cent, determined on 0.100 g.

**Bacterial endotoxins** (2.6.14): less than 1.1 IU/mg, if intended for use in the manufacture of parenteral preparations without a further appropriate procedure for removal of bacterial endotoxins.

#### ASSAY

Liquid chromatography (2.2.29) as described in the test for related substances with the following modification.

**Injection:** test solution and reference solution (a).

Calculate the percentage content of  $C_{27}H_{30}ClNO_{11}$ .

#### STORAGE

In an airtight container, protected from light, at a temperature of 2 °C to 8 °C. If the substance is sterile, store in a sterile, airtight, tamper-proof container.

#### IMPURITIES

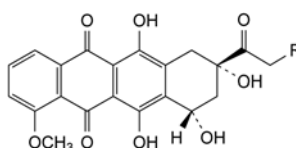

A. R = OH: (8S,10S)-6,8,10,11-tetrahydroxy-8-(hydroxyacetyl)-1-methoxy-7,8,9,10-tetrahydrotetracene-5,12-dione (doxorubicinone),

B. R = H: (8S,10S)-8-acetyl-6,8,10,11-tetrahydroxy-1-methoxy-7,8,9,10-tetrahydrotetracene-5,12-dione (daunorubicinone),

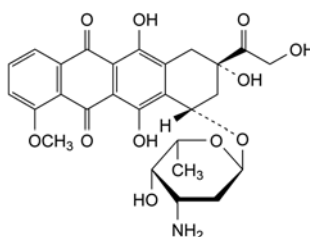

C. (8S,10S)-10-[(3-amino-2,3,6-trideoxy- $\alpha$ -L-lyxo-hexopyranosyl)oxy]-6,8,11-trihydroxy-8-(hydroxyacetyl)-1-methoxy-7,8,9,10-tetrahydrotetracene-5,12-dione (doxorubicin),

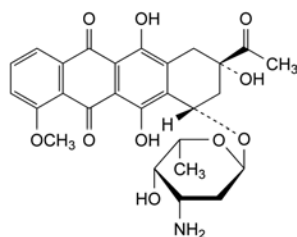
01/2008:0082  
corrected 6.3

- D. (8*S*,10*S*)-8-acetyl-10-[(3-amino-2,3,6-trideoxy- $\alpha$ -*L*-lyxohexopyranosyl)oxy]-6,8,11-trihydroxy-1-methoxy-7,8,9,10-tetrahydrotetracene-5,12-dione (daunorubicin),

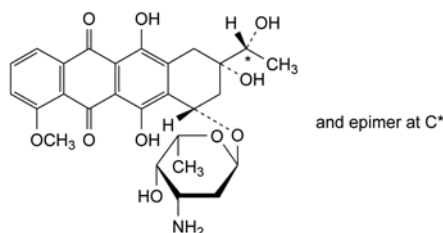

- E. (8*S*,10*S*)-10-[(3-amino-2,3,6-trideoxy- $\alpha$ -*L*-lyxohexopyranosyl)oxy]-6,8,11-trihydroxy-8-[(1*R**S*)-1-hydroxyethyl]-1-methoxy-7,8,9,10-tetrahydrotetracene-5,12-dione (dihydrodaunorubicin),

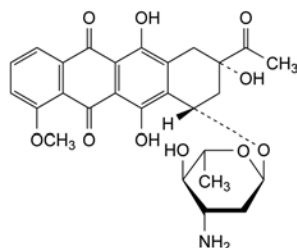

- F. (8*S*,10*S*)-8-acetyl-10-[(3-amino-2,3,6-trideoxy- $\alpha$ -*L*-arabinohexopyranosyl)oxy]-6,8,11-trihydroxy-1-methoxy-7,8,9,10-tetrahydrotetracene-5,12-dione (*epi*-daunorubicin),

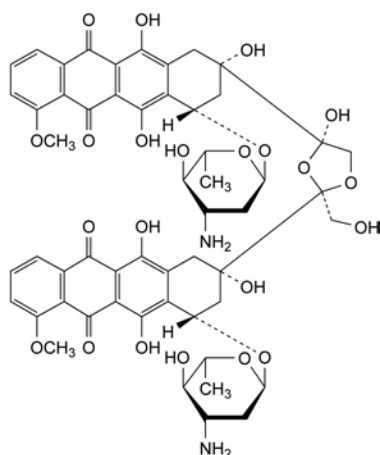

- G. 8,8'-[(2*R*,4*R*)-4-hydroxy-2-(hydroxymethyl)-1,3-dioxolan-2,4-diyl]bis[(8*S*,10*S*)-10-[(3-amino-2,3,6-trideoxy- $\alpha$ -*L*-arabinohexopyranosyl)oxy]-6,8,11-trihydroxy-1-methoxy-7,8,9,10-tetrahydrotetracene-5,12-dione] (epirubicin dimer).

## ERGOCALCIFEROL

### Ergocalciferolum

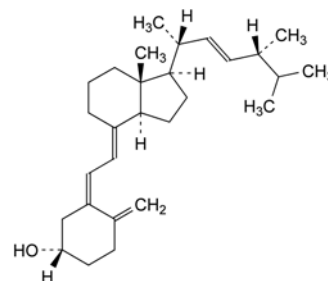

$C_{28}H_{44}O$   
[50-14-6]

$M_r$  396.7

#### DEFINITION

Ergocalciferol contains not less than 97.0 per cent and not more than the equivalent of 103.0 per cent of (5*Z*,7*E*,22*E*)-9,10-secoergosta-5,7,10(19),22-tetraen-3 $\beta$ -ol.

1 mg of ergocalciferol is equivalent to 40 000 IU of antirachitic activity (vitamin D) in rats.

#### CHARACTERS

A white or slightly yellowish, crystalline powder or white or almost white crystals, practically insoluble in water, freely soluble in alcohol, soluble in fatty oils. It is sensitive to air, heat and light. Solutions in volatile solvents are unstable and are to be used immediately.

A reversible isomerisation to pre-ergocalciferol takes place in solution, depending on temperature and time. The activity is due to both compounds.

#### IDENTIFICATION

Examine by infrared absorption spectrophotometry (2.2.24), comparing with the spectrum obtained with *ergocalciferol CRS*. Examine the substances prepared as discs.

#### TESTS

**Specific optical rotation** (2.2.7). Dissolve 0.200 g rapidly and without heating in *aldehyde-free alcohol R* and dilute to 25.0 mL with the same solvent. The specific optical rotation, determined within 30 min of preparing the solution, is + 103 to + 107.

**Reducing substances.** Dissolve 0.1 g in *aldehyde-free alcohol R* and dilute to 10.0 mL with the same solvent. Add 0.5 mL of a 5 g/L solution of *tetrazolium blue R* in *aldehyde-free alcohol R* and 0.5 mL of *dilute tetramethylammonium hydroxide solution R*. Allow to stand for exactly 5 min and add 1.0 mL of *glacial acetic acid R*. Prepare a reference solution at the same time and in the same manner using 10.0 mL of a solution containing 0.2  $\mu$ g/mL of *hydroquinone R* in *aldehyde-free alcohol R*. Measure the absorbance (2.2.25) of the two solutions at 525 nm using as the compensation liquid 10.0 mL of *aldehyde-free alcohol R* treated in the same manner. The absorbance of the test solution is not greater than that of the reference solution (20 ppm).

**Ergosterol.** Examine by thin-layer chromatography (2.2.27), using a *TLC silica gel G plate R*.

**Test solution.** Dissolve 0.25 g of the substance to be examined in *ethylene chloride R* containing 10 g/L of *squalane R* and 0.1 g/L of *butylhydroxytoluene R* and dilute to 5 mL with the same solvent. Prepare immediately before use.

**Reference solution (a).** Dissolve 0.10 g of *ergocalciferol CRS* in *ethylene chloride R* containing 10 g/L of *squalane R* and 0.1 g/L of *butylhydroxytoluene R* and dilute to 2 mL with the same solvent. Prepare immediately before use.

**Reference solution (b).** Dissolve 5 mg of *ergosterol CRS* in *ethylene chloride R* containing 10 g/L of *squalane R* and 0.1 g/L of *butylhydroxytoluene R* and dilute to 50 mL with the same solvent. Prepare immediately before use.

**Reference solution (c).** Mix equal volumes of reference solution (a) and reference solution (b). Prepare immediately before use.

Apply to the plate 10 µL of the test solution, 10 µL of reference solution (a), 10 µL of reference solution (b) and 20 µL of reference solution (c). Develop immediately, protected from light, over a path of 15 cm using a mixture of equal volumes of *cyclohexane R* and *peroxide-free ether R*, the mixture containing 0.1 g/L of *butylhydroxytoluene R*. Allow the plate to dry in air and spray three times with *antimony trichloride solution RI*. Examine the chromatograms for 3 min to 4 min after spraying. The principal spot in the chromatogram obtained with the test solution is initially orange-yellow and then becomes brown. In the chromatogram obtained with the test solution, any slowly appearing violet spot (corresponding to ergosterol) immediately below the principal spot is not more intense than the spot in the chromatogram obtained with reference solution (b) (0.2 per cent). There is no spot in the chromatogram obtained with the test solution that does not correspond to one of the spots in the chromatograms obtained with reference solutions (a) and (b). The test is not valid unless the chromatogram obtained with reference solution (c) shows two clearly separated spots.

#### ASSAY

Carry out the operations as rapidly as possible, avoiding exposure to actinic light and air.

Examine by liquid chromatography (2.2.29).

**Test solution.** Dissolve 10.0 mg of the substance to be examined without heating in 10.0 mL of *toluene R* and dilute to 100.0 mL with the mobile phase.

**Reference solution (a).** Dissolve 10.0 mg of *ergocalciferol CRS* without heating in 10.0 mL of *toluene R* and dilute to 100.0 mL with the mobile phase.

**Reference solution (b).** Dilute 1.0 mL of *cholecalciferol for system suitability CRS* to 5.0 mL with the mobile phase. Heat in a water-bath at 90 °C under a reflux condenser for 45 min and cool.

The chromatographic procedure may be carried out using:

- a stainless steel column 0.25 m long and 4.6 mm in internal diameter packed with a suitable silica gel (5 µm),
- as mobile phase at a flow rate of 2 mL/min a mixture of 3 volumes of *pentanol R* and 997 volumes of *hexane R*,
- as detector a spectrophotometer set at 254 nm.

An automatic injection device or a sample loop is recommended. Inject a suitable volume of reference solution (b). Adjust the sensitivity of the system so that the height of the principal peak is at least 50 per cent of the full scale of the recorder. Inject reference solution (b) 6 times. When the chromatograms are recorded in the prescribed conditions, the approximate relative retention times with reference to cholecalciferol are 0.4 for pre-cholecalciferol and 0.5 for *trans*-cholecalciferol. The relative standard deviation of the response for cholecalciferol is not greater than 1 per cent and the resolution between the peaks corresponding to pre-cholecalciferol and *trans*-cholecalciferol is not less than 1.0. If necessary adjust the proportions of the constituents and the flow rate of the mobile phase to obtain this resolution.

Inject a suitable volume of reference solution (a). Adjust the sensitivity of the system so that the height of the principal peak is at least 50 per cent of the full scale of the recorder. Inject the same volume of the test solution and record the chromatogram in the same manner.

Calculate the percentage content of ergocalciferol from the expression:

$$\frac{m'}{m} \times \frac{S_D}{S'_D} \times 100$$

- $m$  = mass of the substance to be examined in the test solution, in milligrams;
- $m'$  = mass of *ergocalciferol CRS* in reference solution (a), in milligrams;
- $S_D$  = area (or height) of the peak due to ergocalciferol in the chromatogram obtained with the test solution;
- $S'_D$  = area (or height) of the peak due to ergocalciferol in the chromatogram obtained with reference solution (a).

#### STORAGE

Store in an airtight container, under nitrogen, protected from light, at a temperature between 2 °C and 8 °C.

The contents of an opened container are to be used immediately.

#### IMPURITIES

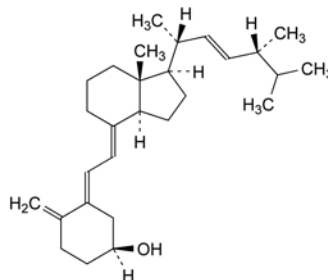

- A. (5*E*,7*E*,22*E*)-9,10-secoergosta-5,7,10(19),22-tetraen-3β-ol (*trans*-vitamin D<sub>2</sub>),

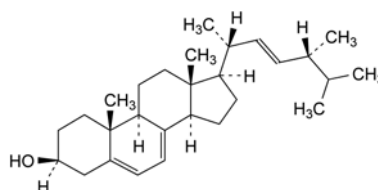

- B. (22*E*)-ergosta-5,7,22-trien-3β-ol (ergosterol),

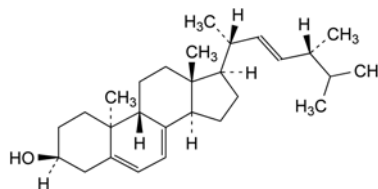

- C. (9β,10α,22*E*)-ergosta-5,7,22-trien-3β-ol (lumisterol<sub>2</sub>),

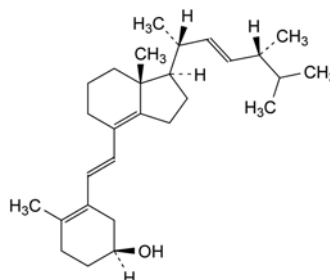

- D. (6*E*,22*E*)-9,10-secoergosta-5(10),6,8(14),22-tetraen-3β-ol (iso-tachysterol<sub>2</sub>),

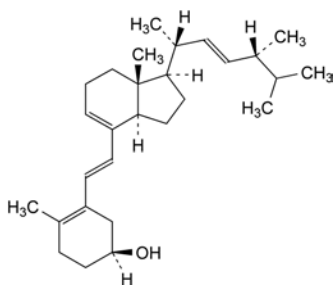

- E. (6*E*,22*E*)-9,10-secoergosta-5(10),6,8,22-tetraen-3β-ol (tachysterol<sub>2</sub>).

01/2008:0223  
corrected 6.0

## ERGOMETRINE MALEATE

### Ergometrini maleas

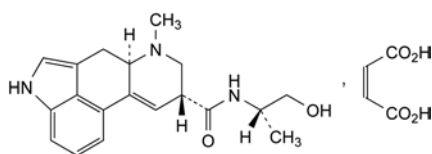

C<sub>23</sub>H<sub>27</sub>N<sub>3</sub>O<sub>6</sub>  
[129-51-1]

M<sub>r</sub> 441.5

#### DEFINITION

Ergometrine maleate contains not less than 98.0 per cent and not more than the equivalent of 101.0 per cent of (6*aR*,9*R*)-*N*[(*S*)-2-hydroxy-1-methylethyl]-7-methyl-4,6,6*a*,7,8,9-hexahydro-indolo[4,3-*fg*]quinoline-9-carboxamide (*Z*)-butenedioate, calculated with reference to the dried substance.

#### CHARACTERS

A white or almost white or slightly coloured, crystalline powder, sparingly soluble in water, slightly soluble in alcohol.

#### IDENTIFICATION

*First identification:* B, C.

*Second identification:* A, C, D, E.

- Dissolve 30 mg in 0.01 *M* hydrochloric acid and dilute to 100.0 mL with the same acid. Dilute 10.0 mL of the solution to 100.0 mL with 0.01 *M* hydrochloric acid. Examined between 250 nm and 360 nm (2.2.25), the solution shows an absorption maximum at 311 nm and a minimum at 265 nm to 272 nm. The specific absorbance at the maximum is 175 to 195.
- Examine by infrared absorption spectrophotometry (2.2.24), comparing with the spectrum obtained with *ergometrine maleate CRS*. Examine the substances prepared as discs.
- Examine the chromatograms obtained in the test for related substances. The principal spot in the chromatogram obtained with test solution (b) is similar in position, colour and size to the principal spot in the chromatogram obtained with reference solution (a).
- To 0.1 mL of solution S (see Tests) add 1 mL of *glacial acetic acid R*, 0.05 mL of *ferric chloride solution R1* and 1 mL of *phosphoric acid R* and heat in a water-bath at 80 °C. After about 10 min, a blue or violet colour develops which becomes more intense on standing.
- Dissolve 0.1 g in a mixture of 0.5 mL of *dilute sulfuric acid R* and 2.5 mL of *water R*. Add 5 mL of *ether R* and 1 mL of *strong sodium hydroxide solution R* and shake. Separate

the aqueous layer and shake with two quantities, each of 5 mL, of *ether R*. To 0.1 mL of the aqueous layer add a solution of 10 mg of *resorcinol R* in 3 mL of *sulfuric acid R*. Heat on a water-bath for 15 min. No colour develops. To the rest of the aqueous layer add 1 mL of *bromine water R*. Heat on a water-bath for 10 min, then heat to boiling and cool. To 0.2 mL of this solution add a solution of 10 mg of *resorcinol R* in 3 mL of *sulfuric acid R*. Heat on a water-bath for 15 min. A pinkish-violet colour develops.

#### TESTS

**Solution S.** Dissolve 0.100 g, without heating and protected from light, in 9 mL of *carbon dioxide-free water R* and dilute to 10.0 mL with the same solvent.

**Appearance of solution.** Solution S is clear (2.2.1) and not more intensely coloured than reference solution Y<sub>5</sub> or BY<sub>5</sub> (2.2.2, *Method II*).

**pH (2.2.3).** The pH of solution S is 3.6 to 4.4.

**Specific optical rotation (2.2.7):** + 50 to + 56, determined on solution S and calculated with reference to the dried substance.

**Related substances.** Examine by thin-layer chromatography (2.2.27), using *silica gel G R* as the coating substance. Carry out all operations as rapidly as possible, protected from light. Prepare the test and reference solutions immediately before use.

**Test solution (a).** Dissolve 50 mg of the substance to be examined in a mixture of 1 volume of *concentrated ammonia R* and 9 volumes of *alcohol (80 per cent V/V) R* and dilute to 5.0 mL with the same mixture of solvents.

**Test solution (b).** Dilute 1.0 mL of test solution (a) to 10.0 mL with a mixture of 1 volume of *concentrated ammonia R* and 9 volumes of *alcohol (80 per cent V/V) R*.

**Reference solution (a).** Dissolve 10 mg of *ergometrine maleate CRS* in a mixture of 1 volume of *concentrated ammonia R* and 9 volumes of *alcohol (80 per cent V/V) R* and dilute to 10.0 mL with the same mixture of solvents.

**Reference solution (b).** Dilute 5.0 mL of reference solution (a) to 50.0 mL with a mixture of 1 volume of *concentrated ammonia R* and 9 volumes of *alcohol (80 per cent V/V) R*.

**Reference solution (c).** To 2.0 mL of reference solution (b) add 2.0 mL of a mixture of 1 volume of *concentrated ammonia R* and 9 volumes of *alcohol (80 per cent V/V) R*.

Apply separately to the plate 5 µL of each solution. Develop immediately over a path of 14 cm using a mixture of 3 volumes of *water R*, 25 volumes of *methanol R* and 75 volumes of *chloroform R*. Dry the plate in a current of cold air and spray with *dimethylaminobenzaldehyde solution R7*. Dry the plate in a current of warm air for about 2 min. Any spot in the chromatogram obtained with test solution (a), apart from the principal spot, is not more intense than the principal spot in the chromatogram obtained with reference solution (b) (1.0 per cent) and at most one such spot is more intense than the principal spot in the chromatogram obtained with reference solution (c) (0.5 per cent).

**Loss on drying (2.2.32).** Not more than 2.0 per cent, determined on 0.20 g by drying over *diphosphorus pentoxide R* at 80 °C at a pressure not exceeding 2.7 kPa for 2 h.

#### ASSAY

Dissolve 0.150 g in 40 mL of *anhydrous acetic acid R*. Titrate with 0.05 *M perchloric acid*, determining the end-point potentiometrically (2.2.20).

1 mL of 0.05 *M perchloric acid* is equivalent to 22.07 mg of C<sub>23</sub>H<sub>27</sub>N<sub>3</sub>O<sub>6</sub>.

#### STORAGE

Store in an airtight, glass container, protected from light, at a temperature of 2 °C to 8 °C.

- 01/2008:0224 E. Dissolve about 10 mg in 1.0 mL of 0.1 M sodium hydroxide. Transfer to a separating funnel and shake with 5 mL of methylene chloride R. Discard the organic layer. Neutralise the aqueous layer with a few drops of dilute hydrochloric acid R. 0.1 mL of this solution gives reaction (b) of tartrates (2.3.1). Pour the reaction mixture into 1 mL of water R to observe the colour change to red or brownish-red.

## ERGOTAMINE TARTRATE

### Ergotamini tartras

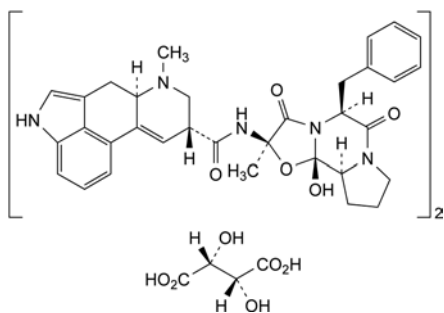

$C_{70}H_{76}N_{10}O_{16}$   
[379-79-3]

$M_r$  1313

#### DEFINITION

Ergotamine tartrate contains not less than 98.0 per cent and not more than the equivalent of 101.0 per cent of bis[(6aR,9R)-N-[(2R,5S,10aS,10bS)-5-benzyl-10b-hydroxy-2-methyl-3,6-dioxo-octahydro-8H-oxazolo[3,2-a]pyrrolo[2,1-c]pyrazin-2-yl]-7-methyl-4,6,6a,7,8,9-hexahydroindolo[4,3-fg]quinoline-9-carboxamide] tartrate, calculated with reference to the dried substance. It may contain two molecules of methanol of crystallisation.

#### CHARACTERS

A white or almost white, crystalline powder or colourless crystals, slightly hygroscopic, slightly soluble in alcohol. Aqueous solutions slowly become cloudy owing to hydrolysis; this may be prevented by the addition of tartaric acid.

#### IDENTIFICATION

First identification: B, C.

Second identification: A, C, D, E.

- A. Dissolve 50 mg in 0.01 M hydrochloric acid and dilute to 100.0 mL with the same acid. Dilute 10.0 mL of the solution to 100.0 mL with 0.01 M hydrochloric acid. Examined between 250 nm and 360 nm (2.2.25), the solution shows an absorption maximum at 311 nm to 321 nm and a minimum at 265 nm to 275 nm. The specific absorbance at the maximum is 118 to 128, calculated with reference to the dried substance.
- B. Examine by infrared absorption spectrophotometry (2.2.24), comparing with the spectrum obtained with ergotamine tartrate CRS. Examine the substances as discs prepared as follows: triturate the substance to be examined and the reference substance separately with 0.2 mL of methanol R and then with potassium bromide R as prescribed in the general method.
- C. Examine for not more than 1 min in ultraviolet light at 365 nm the chromatograms obtained in the test for related substances. The principal spot in the chromatogram obtained with test solution (b) is similar in position and fluorescence to the principal spot in the chromatogram obtained with reference solution (a). After spraying with dimethylaminobenzaldehyde solution R7, examine in daylight. The principal spot in the chromatogram obtained with test solution (b) is similar in position, colour and size to the principal spot in the chromatogram obtained with reference solution (a).
- D. To 0.1 mL of solution S (see Tests) add 1 mL of glacial acetic acid R, 0.05 mL of ferric chloride solution R1 and 1 mL of phosphoric acid R and heat in a water-bath at 80 °C. After about 10 min, a blue or violet colour develops which becomes more intense on standing.
- E. Dissolve about 10 mg in 1.0 mL of 0.1 M sodium hydroxide. Transfer to a separating funnel and shake with 5 mL of methylene chloride R. Discard the organic layer. Neutralise the aqueous layer with a few drops of dilute hydrochloric acid R. 0.1 mL of this solution gives reaction (b) of tartrates (2.3.1). Pour the reaction mixture into 1 mL of water R to observe the colour change to red or brownish-red.

#### TESTS

Carry out all operations as rapidly as possible, protected from light.

**Solution S.** Triturate 30 mg finely with about 15 mg of tartaric acid R and dissolve with shaking in 6 mL of water R.

**Appearance of solution.** Solution S is clear (2.2.1) and not more intensely coloured than reference solution Y<sub>6</sub> (2.2.2, Method II).

**pH (2.2.3).** Shake 10 mg, finely powdered, with 4 mL of carbon dioxide-free water R. The pH of the suspension is 4.0 to 5.5.

**Specific optical rotation (2.2.7).** Dissolve 0.40 g in 40 mL of a 10 g/L solution of tartaric acid R. Add 0.5 g of sodium hydrogen carbonate R cautiously in several portions and mix thoroughly. Shake with four quantities, each of 10 mL, of chloroform R previously washed with five quantities of water R, each of 50 mL per 100 mL of chloroform R. Combine the organic layers. Filter through a small filter moistened with chloroform R previously washed as described above. Dilute the filtrate to 50.0 mL with chloroform R previously washed as described above. Measure the angle of rotation.

Determine the amount of ergotamine base in the chloroformic solution as follows: to 25.0 mL of the solution add 50 mL of anhydrous acetic acid R and titrate with 0.05 M perchloric acid, determining the end-point potentiometrically (2.2.20).

1 mL of 0.05 M perchloric acid is equivalent to 29.08 mg of  $C_{33}H_{35}N_5O_5$ .

The specific optical rotation is –154 to –165, calculated from the angle of rotation and the concentration of ergotamine base.

**Related substances.** Examine by thin-layer chromatography (2.2.27), using a TLC silica gel G plate R. Prepare the reference solutions and the test solutions immediately before use and in the order indicated below.

**Reference solution (a).** Dissolve 10 mg of ergotamine tartrate CRS in a mixture of 1 volume of methanol R and 9 volumes of methylene chloride R and dilute to 10.0 mL with the same mixture of solvents.

**Reference solution (b).** Dilute 7.5 mL of reference solution (a) to 50.0 mL with a mixture of 1 volume of methanol R and 9 volumes of methylene chloride R.

**Reference solution (c).** To 2.0 mL of reference solution (b) add 4.0 mL of a mixture of 1 volume of methanol R and 9 volumes of methylene chloride R.

**Test solution (a).** Dissolve 50 mg of the substance to be examined in a mixture of 1 volume of methanol R and 9 volumes of methylene chloride R and dilute to 5.0 mL with the same mixture of solvents.

**Test solution (b).** Dilute 1.0 mL of test solution (a) to 10.0 mL with a mixture of 1 volume of methanol R and 9 volumes of methylene chloride R.

Apply immediately to the plate 5 µL of each reference solution and then 5 µL of each test solution. Expose the points of application immediately to ammonia vapour and for exactly 20 s by moving the line of application from side to side above a beaker 55 mm high and 45 mm in diameter containing about 20 mL of concentrated ammonia R. Dry the line of application in a current of cold air for exactly 20 s. Develop immediately over a path of 17 cm using a mixture of 5 volumes of ethanol R, 10 volumes of methylene chloride R, 15 volumes of dimethylformamide R and 70 volumes of ether R. Dry the plate in a current of cold air for about 2 min. Examine for not more than 1 min in ultraviolet light at 365 nm for the identification. Spray the plate abundantly with dimethylaminobenzaldehyde

solution R7 and dry in a current of warm air for about 2 min. Any spot in the chromatogram obtained with test solution (a), apart from the principal spot, is not more intense than the principal spot in the chromatogram obtained with reference solution (b) (1.5 per cent) and at most one such spot is more intense than the principal spot in the chromatogram obtained with reference solution (c) (0.5 per cent).

**Loss on drying** (2.2.32). Not more than 6.0 per cent, determined on 0.100 g by drying *in vacuo* at 95 °C for 6 h.

#### ASSAY

Dissolve 0.200 g in 40 mL of *anhydrous acetic acid R*. Titrate with 0.05 M *perchloric acid*, determining the end-point potentiometrically (2.2.20).

1 mL of 0.05 M *perchloric acid* is equivalent to 32.84 mg of C<sub>70</sub>H<sub>76</sub>N<sub>10</sub>O<sub>16</sub>.

#### STORAGE

Store in an airtight, glass container, protected from light, at a temperature of 2 °C to 8 °C.

01/2009:1803

## ERYTHRITOL

### Erythritolum

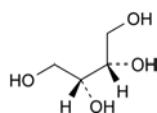

C<sub>4</sub>H<sub>10</sub>O<sub>4</sub>  
[149-32-6]

M<sub>r</sub> 122.1

#### DEFINITION

(2*R*,3*S*)-Butane-1,2,3,4-tetrol (*meso*-erythritol).

**Content:** 96.0 per cent to 102.0 per cent (anhydrous substance).

#### CHARACTERS

**Appearance:** white or almost white, crystalline powder or free-flowing granules.

**Solubility:** freely soluble in water, very slightly soluble in ethanol (96 per cent).

#### IDENTIFICATION

A. Melting point (2.2.14): 119 °C to 122 °C.

B. Infrared absorption spectrophotometry (2.2.24).

*Comparison: erythritol CRS.*

#### TESTS

**Appearance of solution.** The solution is clear (2.2.1) and colourless (2.2.2, *Method II*).

Dissolve 5.0 g in *water R* and dilute to 50 mL with the same solvent.

**Conductivity** (2.2.38): maximum 20 µS·cm<sup>-1</sup>.

Dissolve 20.0 g in *carbon dioxide-free water R* prepared from *distilled water R* and dilute to 100.0 mL with the same solvent. Measure the conductivity of the solution, while gently stirring with a magnetic stirrer.

**Related substances.** Liquid chromatography (2.2.29).

**Test solution.** Dissolve 0.50 g of the substance to be examined in *water R* and dilute to 10.0 mL with the same solvent.

**Reference solution (a).** Dissolve 0.50 g of *erythritol CRS* in *water R* and dilute to 10.0 mL with the same solvent.

**Reference solution (b).** Dilute 2.0 mL of the test solution to 100.0 mL with *water R*.

**Reference solution (c).** Dilute 5.0 mL of reference solution (b) to 100.0 mL with *water R*.

**Reference solution (d).** Dissolve 1.0 g of *erythritol R* and 1.0 g of *glycerol R* in *water R* and dilute to 20.0 mL with the same solvent.

#### Column:

– **size:** *l* = 0.3 m, Ø = 7.8 mm;

– **stationary phase:** cation-exchange resin R (9 µm);

– **temperature:** 70 °C.

**Mobile phase:** 0.01 per cent V/V solution of *sulfuric acid R*.

**Flow rate:** 0.8 mL/min.

**Detection:** refractometer maintained at a constant temperature.

**Injection:** 20 µL; inject the test solution and reference solutions (b), (c) and (d).

**Run time:** 3 times the retention time of erythritol.

**Relative retention** with reference to erythritol (retention time = about 11 min): impurity A = about 0.77; impurity B = about 0.90; impurity C = about 0.94; impurity D = about 1.10.

**System suitability:** reference solution (d):

– **resolution:** minimum 2 between the peaks due to erythritol and impurity D.

#### Limits:

– **any impurity:** not more than the area of the principal peak in the chromatogram obtained with reference solution (b) (2.0 per cent);

– **total:** not more than the area of the principal peak in the chromatogram obtained with reference solution (b) (2.0 per cent);

– **disregard limit:** area of the principal peak in the chromatogram obtained with reference solution (c) (0.1 per cent).

**Lead** (2.4.10): maximum 0.5 ppm.

**Water** (2.5.12): maximum 0.5 per cent, determined on 1.00 g.

#### Microbial contamination

If intended for use in the manufacture of parenteral preparations:

– TAMC: acceptance criterion 10<sup>2</sup> CFU/g (2.6.12).

If not intended for use in the manufacture of parenteral preparations:

– TAMC: acceptance criterion 10<sup>3</sup> CFU/g (2.6.12);

– TYMC: acceptance criterion 10<sup>2</sup> CFU/g (2.6.12);

– absence of *Escherichia coli* (2.6.13);

– absence of *Salmonella* (2.6.13).

**Bacterial endotoxins** (2.6.14). If intended for use in the manufacture of parenteral preparations without a further appropriate procedure for the removal of bacterial endotoxins:

– less than 4 IU/g for parenteral preparations having a concentration of 100 g/L or less of erythritol;

– less than 2.5 IU/g for parenteral preparations having a concentration of more than 100 g/L of erythritol.

#### ASSAY

Liquid chromatography (2.2.29) as described in the test for related substances with the following modification.

**Injection:** test solution and reference solution (a).

Calculate the percentage content of erythritol using the chromatogram obtained with reference solution (a) and the declared content of *erythritol CRS*.

#### LABELLING

The label states where applicable, that the substance is suitable for use in the manufacture of parenteral preparations.

## IMPURITIES

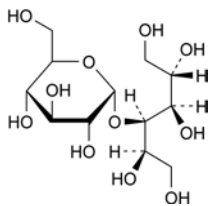

A. 4-O-α-D-glucopyranosyl-D-glucitol (D-maltitol),

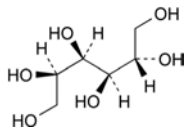

B. D-glucitol (D-sorbitol),

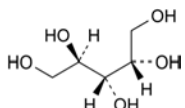

C. (2R,3S,4S)-pentane-1,2,3,4,5-pentol (*meso*-ribitol),

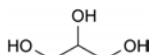

D. propane-1,2,3-triol (glycerol).

01/2008:0179  
corrected 6.0

## ERYTHROMYCIN

## Erythromycinum

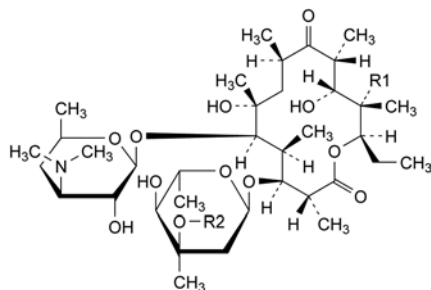

Erythromycin	Mol. Formula	M <sub>r</sub>	R1	R2
A	C <sub>37</sub> H <sub>67</sub> NO <sub>13</sub>	734	OH	CH <sub>3</sub>
B	C <sub>37</sub> H <sub>67</sub> NO <sub>12</sub>	718	H	CH <sub>3</sub>
C	C <sub>36</sub> H <sub>65</sub> NO <sub>13</sub>	720	OH	H

## DEFINITION

Mixture of macrolide antibiotics produced by a strain of *Streptomyces erythreus*, the main component being (3R,4S,5S,6R,7R,9R,11R,12R,13S,14R)-4-[(2,6-dideoxy-3-C-methyl-3-O-methyl-α-L-ribo-hexopyranosyl)oxy]-14-ethyl-7,12,13-trihydroxy-3,5,7,9,11,13-hexamethyl-6-[(3,4,6-trideoxy-3-dimethylamino-β-D-xylo-hexopyranosyl)oxy]oxacyclotetradecane-2,10-dione (erythromycin A).

## Content:

- sum of the contents of erythromycin A, erythromycin B and erythromycin C: 93.0 per cent to 102.0 per cent (anhydrous substance);
- erythromycin B: maximum 5.0 per cent;
- erythromycin C: maximum 5.0 per cent.

## CHARACTERS

*Appearance*: white or slightly yellow powder or colourless or slightly yellow crystals, slightly hygroscopic.

*Solubility*: slightly soluble in water (the solubility decreases as the temperature rises), freely soluble in alcohol, soluble in methanol.

## IDENTIFICATION

*First identification*: A.

*Second identification*: B, C, D.

A. Infrared absorption spectrophotometry (2.2.24).

*Comparison*: erythromycin A CRS.

Disregard any band in the region from 1980 cm<sup>-1</sup> to 2050 cm<sup>-1</sup>.

If the spectra obtained show differences, dissolve 50 mg of the substance to be examined and of the reference substance separately in 1.0 mL of *methylene chloride R*, dry at 60 °C at a pressure not exceeding 670 Pa for 3 h and record new spectra using the residues.

B. Thin-layer chromatography (2.2.27).

*Test solution*. Dissolve 10 mg of the substance to be examined in *methanol R* and dilute to 10 mL with the same solvent.

*Reference solution (a)*. Dissolve 10 mg of *erythromycin A CRS* in *methanol R* and dilute to 10 mL with the same solvent.

*Reference solution (b)*. Dissolve 20 mg of *spiramycin CRS* in *methanol R* and dilute to 10 mL with the same solvent.

*Plate*: TLC silica gel G plate R.

*Mobile phase*: mix 4 volumes of *2-propanol R*, 8 volumes of a 150 g/L solution of *ammonium acetate R* previously adjusted to pH 9.6 with *ammonia R* and 9 volumes of *ethyl acetate R*. Allow to settle and use the upper layer.

*Application*: 10 µL.

*Development*: over 2/3 of the plate.

*Drying*: in air.

*Detection*: spray with *anisaldehyde solution R1* and heat at 110 °C for 5 min.

*Results*: the principal spot in the chromatogram obtained with the test solution is similar in position, colour and size to the principal spot in the chromatogram obtained with reference solution (a) and its position and colour are different from those of the spots in the chromatogram obtained with reference solution (b).

C. To about 5 mg add 5 mL of a 0.2 g/L solution of *xanthydrol R* in a mixture of 1 volume of *hydrochloric acid R* and 99 volumes of *acetic acid R* and heat on a water-bath. A red colour develops.

D. Dissolve about 10 mg in 5 mL of *hydrochloric acid R1* and allow to stand for 10-20 min. A yellow colour develops.

## TESTS

**Specific optical rotation** (2.2.7): –71 to –78 (anhydrous substance).

Dissolve 1.00 g in *ethanol R* and dilute to 50.0 mL with the same solvent. The specific optical rotation is determined at least 30 min after preparing the solution.

**Related substances**. Liquid chromatography (2.2.29).

*Test solution*. Dissolve 40.0 mg of the substance to be examined in a mixture of 1 volume of *methanol R* and 3 volumes of *phosphate buffer solution pH 7.0 R1* and dilute to 10.0 mL with the same mixture of solvents.

*Reference solution (a)*. Dissolve 40.0 mg of *erythromycin A CRS* in a mixture of 1 volume of *methanol R* and 3 volumes of *phosphate buffer solution pH 7.0 R1* and dilute to 10.0 mL with the same mixture of solvents.

*Reference solution (b)*. Dissolve 10.0 mg of *erythromycin B CRS* and 10.0 mg of *erythromycin C CRS* in a mixture of 1 volume of *methanol R* and 3 volumes of *phosphate buffer solution pH 7.0 R1* and dilute to 50.0 mL with the same mixture of solvents.

**Reference solution (c).** Dissolve 5 mg of *N*-demethylerythromycin A CRS in reference solution (b). Add 1.0 mL of reference solution (a) and dilute to 25 mL with reference solution (b).

**Reference solution (d).** Dilute 3.0 mL of reference solution (a) to 100.0 mL with a mixture of 1 volume of *methanol R* and 3 volumes of *phosphate buffer solution pH 7.0 R1*.

**Reference solution (e).** Transfer 40 mg of erythromycin A CRS to a glass vial and spread evenly such that it forms a layer not more than about 1 mm thick. Heat at 130 °C for 4 h. Allow to cool and dissolve in a mixture of 1 volume of *methanol R* and 3 volumes of *phosphate buffer solution pH 7.0 R1* and dilute to 10 mL with the same mixture of solvents.

**Column:**

- **size:**  $l = 0.25$  m,  $\varnothing = 4.6$  mm;
- **stationary phase:** *styrene-divinylbenzene copolymer R* (8  $\mu$ m) with a pore size of 100 nm;
- **temperature:** 70 °C using a water-bath for the column and at least one-third of the tubing preceding the column.

**Mobile phase:** to 50 mL of a 35 g/L solution of *dipotassium hydrogen phosphate R* adjusted to pH 9.0  $\pm$  0.05 with *dilute phosphoric acid R*, add 400 mL of *water R*, 165 mL of *2-methyl-2-propanol R* and 30 mL of *acetonitrile R*, and dilute to 1000 mL with *water R*.

**Flow rate:** 2.0 mL/min.

**Detection:** spectrophotometer at 215 nm.

**Injection:** 100  $\mu$ L; inject the test solution and reference solutions (c), (d) and (e).

**Run time:** 5 times the retention time of erythromycin A.

**Relative retention** with reference to erythromycin A (retention time = about 15 min): impurity A = about 0.3; impurity B = about 0.45; erythromycin C = about 0.5; impurity C = about 0.9; impurity D = about 1.4; impurity F = about 1.5; erythromycin B = about 1.8; impurity E = about 4.3.

**System suitability:** reference solution (c):

- **resolution:** minimum 0.8 between the peaks due to impurity B and erythromycin C and minimum 5.5 between the peaks due to impurity B and erythromycin A. If necessary, adjust the concentration of 2-methyl-2-propanol in the mobile phase or reduce the flow rate to 1.5 mL or 1.0 mL/min.

**Limits:**

- **correction factors:** for the calculation of contents, multiply the peak areas of the following impurities (use the chromatogram obtained with reference solution (e) to identify them) by the corresponding correction factor: impurity E = 0.09; impurity F = 0.15;
- **any impurity:** not more than the area of the principal peak in the chromatogram obtained with reference solution (d) (3.0 per cent);
- **total:** not more than 2.3 times the area of the principal peak in the chromatogram obtained with reference solution (d) (7.0 per cent);
- **disregard limit:** 0.02 times the area of the principal peak in the chromatogram obtained with reference solution (d) (0.06 per cent); disregard the peaks due to erythromycin B and erythromycin C.

**Thiocyanate:** maximum 0.3 per cent.

**Prepare the solutions immediately before use and protect from actinic light.**

**Compensation liquid.** Dilute 1.0 mL of a 90 g/L solution of *ferric chloride R* to 50.0 mL with *methanol R*.

**Test solution.** Dissolve 0.100 g ( $m$  g) of the substance to be examined in 20 mL of *methanol R*, add 1.0 mL of a 90 g/L solution of *ferric chloride R* and dilute to 50.0 mL with *methanol R*.

**Prepare 2 independent reference solutions.**

**Reference solution.** Dissolve 0.100 g of *potassium thiocyanate R*, previously dried at 105 °C for 1 h, in *methanol R* and dilute to 50.0 mL with the same solvent. Dilute 5.0 mL to 50.0 mL with *methanol R*. To 5.0 mL of this solution, add 1.0 mL of a 90 g/L solution of *ferric chloride R* and dilute to 50.0 mL with *methanol R*.

Measure the absorbances (2.2.25) of each reference solution ( $A_1$ ,  $A_2$ ) and of the test solution ( $A$ ) at the maximum (about 492 nm).

**Suitability value:**

$$S = \frac{m_2 \times A_1}{m_1 \times A_2}$$

$m_1$ ,  $m_2$  = mass of the potassium thiocyanate used to prepare the respective reference solutions, in grams.

The test is not valid unless  $S$  is not less than 0.985 and not more than 1.015.

Calculate the percentage content of thiocyanate from the expression:

$$\frac{A \times 58.08 \times 0.5}{m \times 97.18} \times \left( \frac{m_1}{A_1} + \frac{m_2}{A_2} \right)$$

58.08 = relative molecular mass of the thiocyanate moiety;

97.18 = relative molecular mass of potassium thiocyanate.

**Water (2.5.12):** maximum 6.5 per cent, determined on 0.200 g.

Use a 100 g/L solution of *imidazole R* in *anhydrous methanol R* as the solvent.

**Sulfated ash (2.4.14):** maximum 0.2 per cent, determined on 1.0 g.

#### ASSAY

Liquid chromatography (2.2.29) as described in the test for related substances with the following modifications.

**Injection:** test solution and reference solutions (a) and (b).

**System suitability:** reference solution (a):

- **repeatability:** maximum relative standard deviation of 1.2 per cent for 6 replicate injections.

Calculate the percentage content of erythromycin A using the chromatogram obtained with reference solution (a). Calculate the percentage contents of erythromycin B and erythromycin C using the chromatogram obtained with reference solution (b).

#### STORAGE

Protected from light.

#### IMPURITIES

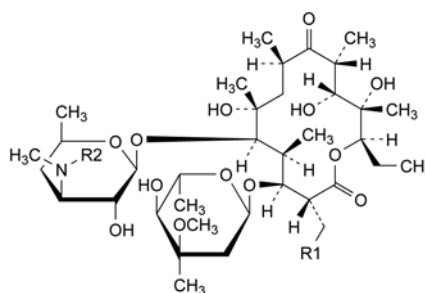

A. R1 = OH, R2 = CH<sub>3</sub>: erythromycin F,

B. R1 = R2 = H: *N*-demethylerythromycin A,



01/2008:0552

## ERYTHROMYCIN ESTOLATE

## Erythromycini estolas

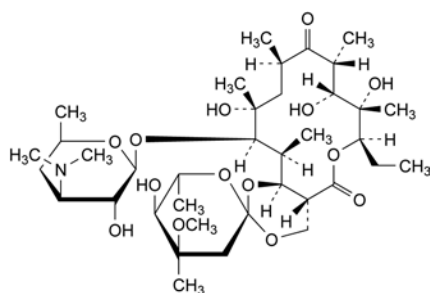

C. erythromycin E,

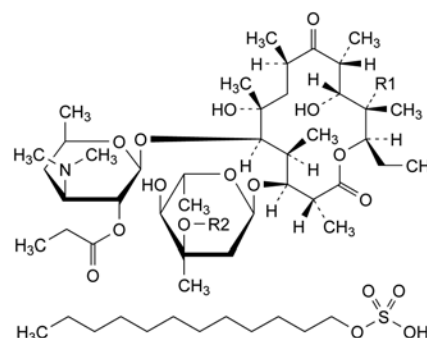

Erythromycin (estolate)	Mol. Formula	M <sub>r</sub>	R1	R2
A	C <sub>52</sub> H <sub>97</sub> NO <sub>16</sub> S	1056	OH	CH <sub>3</sub>
B	C <sub>52</sub> H <sub>97</sub> NO <sub>17</sub> S	1040	H	CH <sub>3</sub>
C	C <sub>51</sub> H <sub>95</sub> NO <sub>18</sub> S	1042	OH	H

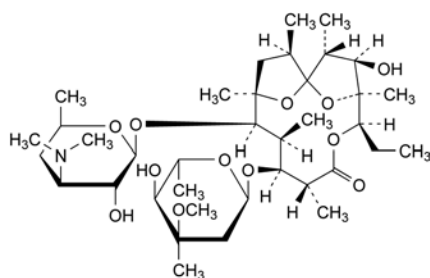

D. anhydroerythromycin A,

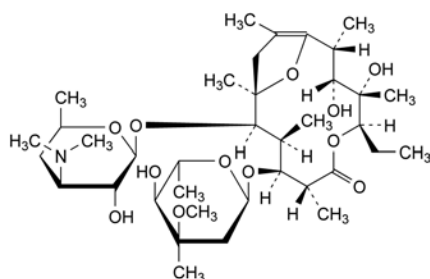

E. erythromycin A enol ether,

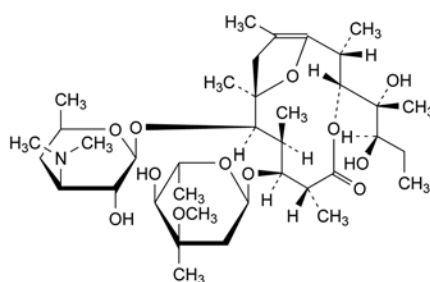

F. pseudoerythromycin A enol ether.

## DEFINITION

**Main component:** (3*R*,4*S*,5*S*,6*R*,7*R*,9*R*,11*R*,12*R*,13*S*,14*R*)-4-[(2,6-Dideoxy-3-*C*-methyl-3-*O*-methyl- $\alpha$ -*L*-ribo-hexopyranosyl)-oxy]-14-ethyl-7,12,13-trihydroxy-3,5,7,9,11,13-hexamethyl-6-[[3,4,6-trideoxy-3-(dimethylamino)-2-*O*-propionyl- $\beta$ -*D*-xylo-hexopyranosyl]oxy]oxacyclotetradecane-2,10-dione dodecyl sulfate (erythromycin A 2''-propionate dodecyl sulfate).

Semi-synthetic product derived from a fermentation product.

**Content:**

- *erythromycin estolate*: 86.0 per cent to 102.0 per cent (anhydrous substance);
- *erythromycin B*: maximum 5.0 per cent (anhydrous substance);
- *erythromycin C*: maximum 5.0 per cent (anhydrous substance).

## CHARACTERS

**Appearance:** white or almost white, crystalline powder.

**Solubility:** practically insoluble in water, freely soluble in ethanol (96 per cent), soluble in acetone. It is practically insoluble in dilute hydrochloric acid.

## IDENTIFICATION

Infrared absorption spectrophotometry (2.2.24).

**Comparison:** *erythromycin estolate CRS*.

## TESTS

**Related substances.** Liquid chromatography (2.2.29).

**Hydrolysis solution.** A 20 g/L solution of *dipotassium hydrogen phosphate R* adjusted to pH 8.0 with *phosphoric acid R*.

**Test solution.** Dissolve 0.150 g of the substance to be examined in 25 mL of *methanol R*. Add 20 mL of the hydrolysis solution, mix and allow to stand at room temperature for at least 12 h. Dilute to 50.0 mL with the hydrolysis solution.

**Reference solution (a).** Dissolve 40.0 mg of *erythromycin A CRS* in 10 mL of *methanol R* and dilute to 20.0 mL with the hydrolysis solution.

**Reference solution (b).** Dissolve 10.0 mg of *erythromycin B CRS* and 10.0 mg of *erythromycin C CRS* in 50.0 mL of *methanol R*. Add 5.0 mL of reference solution (a) and dilute to 100.0 mL with the hydrolysis solution.

**Reference solution (c).** Dissolve 2 mg of *N-demethylerythromycin A CRS* in 20 mL of reference solution (b).

**Reference solution (d).** Dilute 3.0 mL of reference solution (a) to 100.0 mL with a mixture of equal volumes of *methanol R* and the hydrolysis solution.

**Reference solution (e).** Dissolve 40 mg of *erythromycin A CRS*, previously heated at 130 °C for 3 h, in 10 mL of *methanol R* and dilute to 20 mL with the hydrolysis solution (*in situ* preparation of impurities E and F).

**Reference solution (f).** Dissolve 2 mg of *erythromycin A CRS* in 10 mL of 0.01 M hydrochloric acid. Allow to stand at room temperature for 30 min. Dilute to 20 mL with the hydrolysis solution (*in situ* preparation of impurity D).

**Column:**

- size:  $l = 0.25$  m,  $\emptyset = 4.6$  mm;
- stationary phase: *styrene-divinylbenzene copolymer R* (8  $\mu$ m) with a pore size of 100 nm;
- temperature: 70 °C using a water-bath for the column and at least one third of the tubing preceding the column.

**Mobile phase:** to 50 mL of a 35 g/L solution of *dipotassium hydrogen phosphate R* adjusted to pH 8.0 with *dilute phosphoric acid R*, add 400 mL of *water R*, 165 mL of *2-methyl-2-propanol R* and 30 mL of *acetonitrile R*, and dilute to 1000 mL with *water R*.

**Flow rate:** 2.0 mL/min.

**Detection:** spectrophotometer at 215 nm.

**Injection:** 200  $\mu$ L of the test solution and reference solutions (c), (d), (e) and (f).

**Run time:** 5 times the retention time of erythromycin A; begin integration after the hydrolysis peak.

**Identification of impurities:** use the chromatogram obtained with reference solution (e) to identify the peaks due to impurities E and F.

**Relative retention** with reference to erythromycin A (retention time = about 15 min): hydrolysis peak = less than 0.3; impurity A = about 0.3; impurity B = about 0.45; erythromycin C = about 0.5; impurity C = about 0.9; impurity G = about 1.3; impurity D = about 1.4; impurity F = about 1.5; erythromycin B = about 1.8; impurity E = about 4.3.

**System suitability:** reference solution (c):

- resolution: minimum 0.8 between the peaks due to impurity B and erythromycin C and minimum 5.5 between the peaks due to impurity B and erythromycin A.

**Limits:**

- correction factors: for the calculation of content, multiply the peak areas of the following impurities by the corresponding correction factor: impurity E = 0.09; impurity F = 0.15; impurity G = 0.14;
- impurities A, B, C, D, E, F, G: for each impurity, not more than the area of the principal peak in the chromatogram obtained with reference solution (d) (3.0 per cent);
- any other impurity: for each impurity, not more than 0.067 times the area of the principal peak in the chromatogram obtained with reference solution (d) (0.2 per cent);
- total: not more than 1.67 times the area of the principal peak in the chromatogram obtained with reference solution (d) (5.0 per cent);
- disregard limit: 0.02 times the area of the principal peak in the chromatogram obtained with reference solution (d) (0.06 per cent).

**Free erythromycin.** Liquid chromatography (2.2.29). Prepare the solutions immediately before use.

**Test solution.** Dissolve 0.250 g of the substance to be examined in the mobile phase and dilute to 50.0 mL with the mobile phase.

**Reference solution.** Dissolve 75.0 mg of *erythromycin A CRS* in the mobile phase and dilute to 50.0 mL with the mobile phase. Dilute 5.0 mL of the solution to 25.0 mL with *acetonitrile R*.

**Column:**

- size:  $l = 0.25$  m,  $\emptyset = 4.6$  mm;
- stationary phase: *octylsilyl silica gel for chromatography R* (5  $\mu$ m);
- temperature: 30 °C.

**Mobile phase:** mix 35 volumes of *acetonitrile R1* and 65 volumes of a solution containing 3.4 g/L of *potassium dihydrogen phosphate R* and 2.75 mL/L of *triethylamine R*, adjusted to pH 3.0 with *dilute phosphoric acid R*.

**Flow rate:** 1 mL/min.

**Detection:** spectrophotometer at 195 nm.

**Injection:** 20  $\mu$ L.

**Run time:** twice the retention time of erythromycin A for the reference solution and 4.5 times the retention time of the 1<sup>st</sup> peak of erythromycin propionate for the test solution.

**Retention time:** erythromycin A = about 5 min; 1<sup>st</sup> peak of erythromycin propionate = about 10 min.

**Limit:**

- free erythromycin: not more than the area of the principal peak in the chromatogram obtained with the reference solution (6.0 per cent).

**Dodecyl sulfate:** 23.0 per cent to 25.5 per cent of  $C_{12}H_{26}O_4S$  (anhydrous substance).

Dissolve 0.500 g in 25 mL of *dimethylformamide R*. Titrate with 0.1 M *sodium methoxide* using 0.05 mL of a 3 g/L solution of *thymol blue R* in *methanol R* as indicator.

1 mL of 0.1 M *sodium methoxide* is equivalent to 26.64 mg of  $C_{12}H_{26}O_4S$ .

**Water (2.5.12):** maximum 4.0 per cent, determined on 0.300 g.

Use a 100 g/L solution of *imidazole R* in *anhydrous methanol R* as the solvent.

**Sulfated ash (2.4.14):** maximum 0.5 per cent, determined on 0.5 g.

**ASSAY**

Liquid chromatography (2.2.29) as described in the test for related substances with the following modifications.

**Injection:** test solution and reference solutions (a) and (b).

**System suitability:**

- repeatability: maximum relative standard deviation of 1.2 per cent after 6 injections of reference solution (a).

Calculate the percentage content of erythromycin A using the chromatogram obtained with reference solution (a). Express the result as erythromycin A estolate by multiplying the percentage content of erythromycin A by 1.4387.

Calculate the percentage contents of erythromycin B and erythromycin C using the chromatogram obtained with reference solution (b). Express the result as erythromycin B estolate and as erythromycin C estolate by multiplying by 1.4387.

For the calculation of content of erythromycin estolate use the sum of erythromycins A, B and C expressed as estolate as described above.

**STORAGE**

Protected from light.

**IMPURITIES**

**Specified impurities:** A, B, C, D, E, F, G.

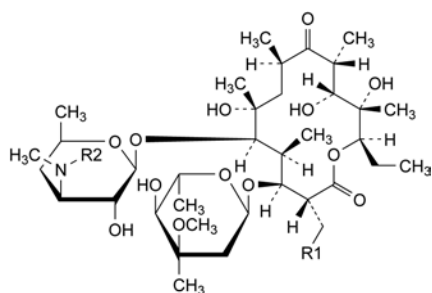
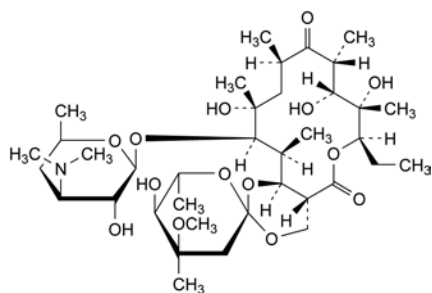
01/2008:0274  
corrected 6.0A. R1 = OH, R2 = CH<sub>3</sub>: erythromycin F,B. R1 = R2 = H: *N*-demethylerythromycin A,G. R1 = H, R2 = CO-C<sub>2</sub>H<sub>5</sub>: *N*-demethyl-*N*-propanoyl-erythromycin A,

C. erythromycin E,

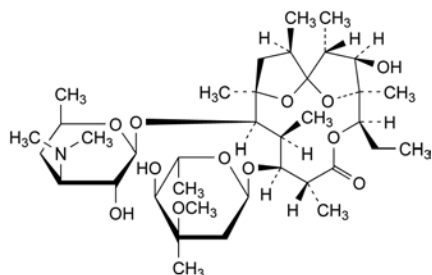

D. anhydroerythromycin A,

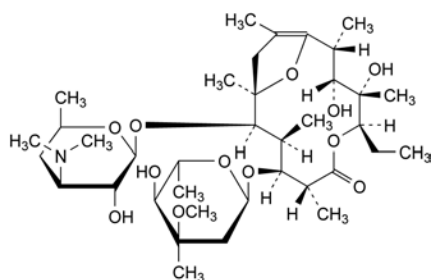

E. erythromycin A enol ether,

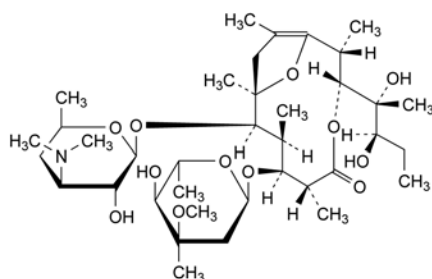

F. pseudoerythromycin A enol ether.

## ERYTHROMYCIN ETHYLSUCCINATE

## Erythromycini ethylsuccinas

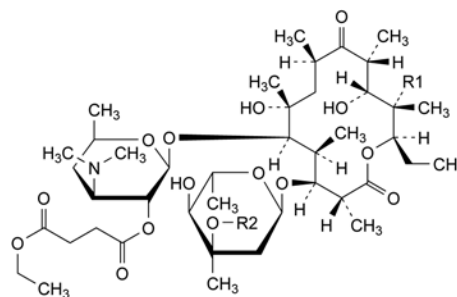

Ethylsuccinate compound	Mol. Formula	<i>M</i> <sub>r</sub>	R1	R2
Erythromycin A	C <sub>43</sub> H <sub>75</sub> NO <sub>16</sub>	862	OH	CH <sub>3</sub>
Erythromycin B	C <sub>43</sub> H <sub>75</sub> NO <sub>15</sub>	846	H	CH <sub>3</sub>
Erythromycin C	C <sub>42</sub> H <sub>73</sub> NO <sub>16</sub>	848	OH	H

## DEFINITION

**Main component:** (3*R*,4*S*,5*S*,6*R*,7*R*,9*R*,11*R*,12*R*,13*S*,14*R*)-4-[(2,6-dideoxy-3-*C*-methyl-3-*O*-methyl- $\alpha$ -*L*-ribo-hexopyranosyl)oxy]-14-ethyl-7,12,13-trihydroxy-3,5,7,9,11,13-hexamethyl-6-[[3,4,6-trideoxy-3-(dimethylamino)-2-*O*-(4-ethoxy-4-oxobutanoyl)- $\beta$ -*D*-xylo-hexopyranosyl]oxy]oxacyclotetradecane-2,10-dione (erythromycin A ethylsuccinate).

Semi-synthetic product derived from a fermentation product.

**Content:**

- sum of erythromycin A, erythromycin B and erythromycin C: minimum 78.0 per cent (anhydrous substance);
- erythromycin B: maximum 5.0 per cent (anhydrous substance);
- erythromycin C: maximum 5.0 per cent (anhydrous substance).

## CHARACTERS

**Appearance:** white or almost white, crystalline powder, hygroscopic.

**Solubility:** practically insoluble in water, freely soluble in acetone, in ethanol and in methanol.

## IDENTIFICATION

Infrared absorption spectrophotometry (2.2.24).

**Comparison:** erythromycin ethylsuccinate CRS.

## TESTS

**Specific optical rotation** (2.2.7): –70 to –82 (anhydrous substance).

Dissolve 0.100 g in *acetone R* and dilute to 10.0 mL with the same solvent. Measure the angle of rotation at least 30 min after preparing the solution.

**Related substances.** Liquid chromatography (2.2.29).

**Hydrolysis solution.** A 20 g/L solution of *dipotassium hydrogen phosphate R* adjusted to pH 8.0 with *phosphoric acid R*.

**Test solution.** Dissolve 0.115 g of the substance to be examined in 25 mL of *methanol R*. Add 20 mL of the hydrolysis solution, mix and allow to stand at room temperature for at least 12 h. Dilute to 50.0 mL with the hydrolysis solution.

**Reference solution (a).** Dissolve 40.0 mg of *erythromycin A CRS* in 10 mL of *methanol R* and dilute to 20.0 mL with the hydrolysis solution.

**Reference solution (b).** Dissolve 10.0 mg of erythromycin B CRS and 10.0 mg of erythromycin C CRS in 50 mL of methanol R. Add 5.0 mL of reference solution (a) and dilute to 100.0 mL with the hydrolysis solution.

**Reference solution (c).** Dissolve 2 mg of *N*-demethylerythromycin A CRS in 20 mL of reference solution (b).

**Reference solution (d).** Dilute 3.0 mL of reference solution (a) to 100.0 mL with a mixture of equal volumes of methanol R and the hydrolysis solution.

**Reference solution (e).** Dissolve 40 mg of erythromycin A CRS, previously heated at 130 °C for 3 h, in 10 mL of methanol R and dilute to 20 mL with the hydrolysis solution.

**Column:**

- size:  $l = 0.25$  m,  $\varnothing = 4.6$  mm;
- stationary phase: styrene-divinylbenzene copolymer R (8  $\mu$ m) with a pore size of 100 nm;
- temperature: 70 °C using a water-bath for the column and at least one third of the tubing preceding the column.

**Mobile phase:** to 50 mL of a 35 g/L solution of dipotassium hydrogen phosphate R adjusted to pH 8.0 with dilute phosphoric acid R, add 400 mL of water R, 165 mL of 2-methyl-2-propanol R and 30 mL of acetonitrile R, and dilute to 1000 mL with water R.

**Flow rate:** 2.0 mL/min.

**Detection:** spectrophotometer at 215 nm.

**Injection:** 200  $\mu$ L; inject the test solution and reference solutions (a), (c), (d) and (e).

**Run time:** 5 times the retention time of erythromycin A; begin integration after the hydrolysis peak.

**Relative retention** with reference to erythromycin A (retention time = about 15 min): hydrolysis peak = less than 0.3; impurity B = about 0.45; erythromycin C = about 0.5; impurity C = about 0.9; impurity G = about 1.3; impurity D = about 1.4; impurity F = about 1.5; erythromycin B = about 1.8; impurity E = about 4.3.

**System suitability:** reference solution (c):

- resolution: minimum 0.8 between the peaks due to impurity B and to erythromycin C and minimum 5.5 between the peaks due to impurity B and to erythromycin A.

**Limits:**

- correction factors: for the calculation of contents, multiply the peak areas of the following impurities by the corresponding correction factor: impurity E = 0.09; impurity F = 0.15; impurity G = 0.14; use the chromatogram obtained with reference solution (e) to identify the peaks due to impurities E and F;
- any impurity: not more than the area of the principal peak in the chromatogram obtained with reference solution (d) (3.0 per cent);
- total: not more than 1.67 times the area of the principal peak in the chromatogram obtained with reference solution (d) (5.0 per cent);
- disregard limit: 0.02 times the area of the principal peak in the chromatogram obtained with reference solution (d) (0.06 per cent).

**Free erythromycin.** Liquid chromatography (2.2.29).

**Test solution.** Dissolve 0.250 g of the substance to be examined in acetonitrile R and dilute to 50.0 mL with the same solvent.

**Reference solution.** Dissolve 75.0 mg of erythromycin A CRS in acetonitrile R and dilute to 50.0 mL with the same solvent. Dilute 5.0 mL of the solution to 25.0 mL with acetonitrile R.

**Column:**

- size:  $l = 0.25$  m,  $\varnothing = 4.6$  mm;

– stationary phase: octylsilyl silica gel for chromatography R (5  $\mu$ m).

**Mobile phase:** mix 35 volumes of acetonitrile R and 65 volumes of a solution containing 3.4 g/L of potassium dihydrogen phosphate R and 2.0 g/L of triethylamine R, adjusted to pH 3.0 with dilute phosphoric acid R.

**Flow rate:** 1 mL/min.

**Detection:** spectrophotometer at 195 nm.

**Injection:** 20  $\mu$ L.

**Run time:** twice the retention time of erythromycin A (retention time = about 8 min) for the reference solution and twice the retention time of erythromycin ethylsuccinate (retention time = about 24 min) for the test solution.

**Limit:**

- free erythromycin: not more than the area of the principal peak in the chromatogram obtained with the reference solution (6.0 per cent).

**Water (2.5.12):** maximum 3.0 per cent, determined on 0.30 g.

Use a 100 g/L solution of imidazole R in anhydrous methanol R as the solvent.

**Sulfated ash (2.4.14):** maximum 0.3 per cent, determined on 1.0 g.

**ASSAY**

Liquid chromatography (2.2.29) as described in the test for related substances.

**Injection:** inject the test solution and reference solutions (a) and (b).

**System suitability:** reference solution (a):

- relative standard deviation: maximum 1.2 per cent for 6 replicate injections.

Calculate the percentage content of erythromycin A using the chromatogram obtained with reference solution (a). Calculate the percentage contents of erythromycin B and erythromycin C using the chromatogram obtained with reference solution (b).

**STORAGE**

In an airtight container, protected from light.

**IMPURITIES**

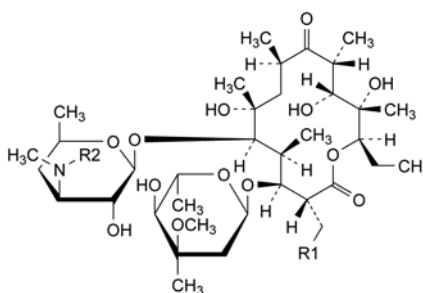

A. R1 = OH, R2 = CH<sub>3</sub>: erythromycin B,

B. R1 = R2 = H: *N*-demethylerythromycin A,

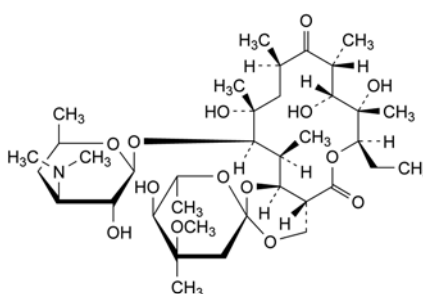

C. erythromycin E,

01/2008:1098

## ERYTHROMYCIN LACTOBIONATE

## Erythromycini lactobionas

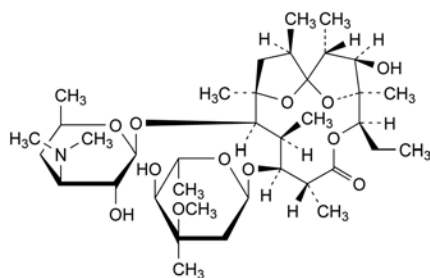

D. anhydroerythromycin A,

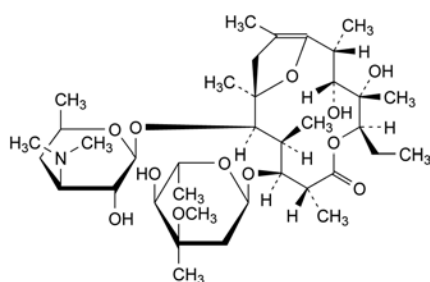

E. erythromycin A enol ether,

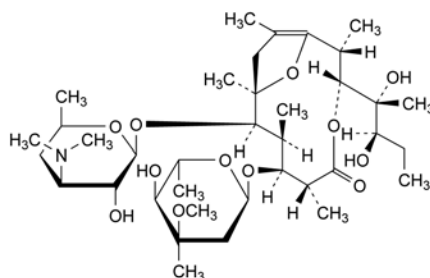

F. pseudoerythromycin A enol ether,

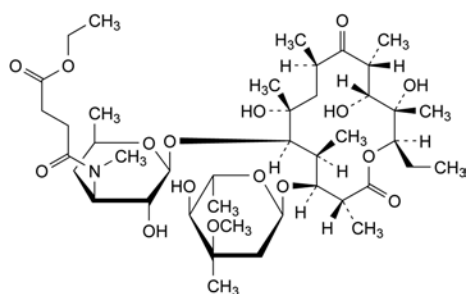

G. erythromycin N-ethylsuccinate.

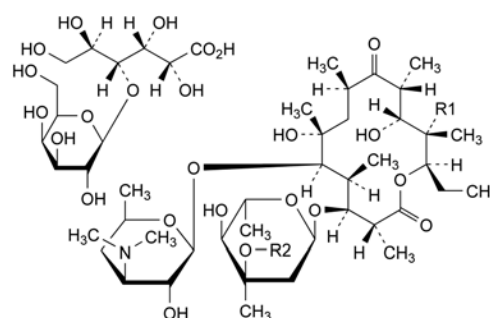

Erythromycin (lactobionate)	Mol. Formula	$M_r$	R1	R2
A	$C_{49}H_{89}NO_{25}$	1092	OH	$CH_3$
B	$C_{49}H_{89}NO_{24}$	1076	H	$CH_3$
C	$C_{48}H_{87}NO_{25}$	1078	OH	H

## DEFINITION

**Main component:** (3*R*,4*S*,5*S*,6*R*,7*R*,9*R*,11*R*,12*R*,13*S*,14*R*)-4-[(2,6-dideoxy-3-*C*-methyl-3-*O*-methyl- $\alpha$ -*L*-ribo-hexopyranosyl)-oxy]-14-ethyl-7,12,13-trihydroxy-3,5,7,9,11,13-hexamethyl-6-[[3,4,6-trideoxy-3-(dimethylamino)- $\beta$ -*D*-xylo-hexopyranosyl]-oxy]oxacyclotetradecane-2,10-dione 4-*O*- $\beta$ -*D*-galactopyranosyl-*D*-gluconate (erythromycin A lactobionate).

Salt of a product obtained by fermentation using a strain of *Streptomyces erythreus*.

**Content:**

- sum of erythromycin A lactobionate, erythromycin B lactobionate and erythromycin C lactobionate: 93.0 per cent to 102.0 per cent (anhydrous substance);
- erythromycin B lactobionate: maximum 5.0 per cent (anhydrous substance);
- erythromycin C lactobionate: maximum 5.0 per cent (anhydrous substance).

## CHARACTERS

**Appearance:** white or slightly yellow hygroscopic, powder.

**Solubility:** soluble in water, freely soluble in anhydrous ethanol and in methanol, very slightly soluble in acetone and in methylene chloride.

## IDENTIFICATION

A. Thin-layer chromatography (2.2.27).

**Test solution.** Dissolve 30 mg of the substance to be examined in methanol R and dilute to 10 mL with the same solvent.

**Reference solution (a).** Dissolve 20 mg of erythromycin A CRS in methanol R and dilute to 10 mL with the same solvent.

**Reference solution (b).** Dissolve 10 mg of lactobionic acid R in water R and dilute to 10 mL with the same solvent.

**Plate:** TLC silica gel plate R.

**Mobile phase:** glacial acetic acid R, water R, methanol R (3:10:90 V/V/V).

**Application:** 5  $\mu$ L.

**Development:** over 3/4 of the plate.

**Drying:** in air.

**Detection:** spray with a 5 g/L solution of potassium permanganate R in 1 M sodium hydroxide and heat at 110 °C for 5 min.

**Results:** the 2 spots in the chromatogram obtained with the test solution are similar in position, colour and size, one to the principal spot in the chromatogram obtained with reference solution (a) and the other to the principal spot in the chromatogram obtained with reference solution (b).

- B. To about 5 mg add 5 mL of a 0.2 g/L solution of *xanthidrol R* in a mixture of 1 volume of *hydrochloric acid R* and 99 volumes of *acetic acid R*. A red colour develops.
- C. Dissolve about 10 mg in 5 mL of *hydrochloric acid R1*. A yellowish-green colour develops.

#### TESTS

**Appearance of solution.** The solution is clear (2.2.1) and colourless (2.2.2, Method II).

Dissolve 1.0 g in 20 mL of *water R*.

**pH** (2.2.3): 6.5 to 7.5.

Dissolve 0.50 g in *carbon dioxide-free water R* and dilute to 25 mL with the same solvent.

**Related substances.** Liquid chromatography (2.2.29). *The test solution and the reference solutions can be used within 24 h if stored at 2-8 °C.*

**Solvent mixture:** *methanol R*, *phosphate buffer solution pH 7.0 R* (25:75 V/V).

**Test solution.** Dissolve 60.0 mg of the substance to be examined in the solvent mixture and dilute to 10.0 mL with the solvent mixture.

**Reference solution (a).** Dissolve 40.0 mg of *erythromycin A CRS* in the solvent mixture and dilute to 10.0 mL with the solvent mixture.

**Reference solution (b).** Dissolve 10.0 mg of *erythromycin B CRS* and 10.0 mg of *erythromycin C CRS* in the solvent mixture and dilute to 50.0 mL with the solvent mixture.

**Reference solution (c).** Dissolve 5 mg of *N-demethylerythromycin A CRS* (impurity B) in reference solution (b). Add 1.0 mL of reference solution (a) and dilute to 25 mL with reference solution (b).

**Reference solution (d).** Dilute 3.0 mL of reference solution (a) to 100.0 mL with the solvent mixture.

**Reference solution (e).** Dissolve 40 mg of *erythromycin A CRS*, previously heated at 130 °C for 4 h, in the solvent mixture and dilute to 10 mL with the solvent mixture (*in situ* preparation of impurities E and F).

**Reference solution (f).** Dissolve 2 mg of *erythromycin A CRS* in 5 mL of 0.01 M *hydrochloric acid*. Allow to stand at room temperature for 30 min. Dilute to 10 mL with the solvent mixture (*in situ* preparation of impurity D).

**Column:**

- **size:**  $l = 0.25$  m,  $\varnothing = 4.6$  mm;
- **stationary phase:** *styrene-divinylbenzene copolymer R* (8  $\mu$ m) with a pore size of 100 nm;
- **temperature:** 70 °C using a water-bath for the column and at least 1/3 of the tubing preceding the column.

**Mobile phase:** to 50 mL of a 35 g/L solution of *dipotassium hydrogen phosphate R* adjusted to pH 9.0 with *dilute phosphoric acid R*, add 400 mL of *water R*, 165 mL of *2-methyl-2-propanol R* and 30 mL of *acetonitrile R1*, and dilute to 1000 mL with *water R*.

**Flow rate:** 2.0 mL/min.

**Detection:** spectrophotometer at 215 nm.

**Injection:** 100  $\mu$ L of the test solution and reference solutions (a), (c), (d), (e) and (f).

**Run time:** 5 times the retention time of erythromycin A.

**Identification of impurities:** use the chromatogram obtained with reference solution (c) to identify the peak due to impurity B, with reference solution (e) to identify the peaks due to impurities E and F, and with reference solution (f) to identify the peak due to impurity D.

**Relative retention** with reference to erythromycin A (retention time = about 15 min): impurity A = about 0.3; impurity B = about 0.45; erythromycin C = about 0.5; impurity C = about 0.9; impurity D = about 1.4; impurity F = about 1.5; erythromycin B = about 1.8; impurity E = about 4.3.

**System suitability:** reference solution (c):

- **resolution:** minimum 0.8 between the peaks due to impurity B and erythromycin C and minimum 5.5 between the peaks due to impurity B and erythromycin A. If necessary adjust the concentration of 2-methyl-2-propanol in the mobile phase or reduce the flow rate to 1.5 mL/min or 1.0 mL/min.

**Limits:**

- **correction factors:** for the calculation of content, multiply the peak areas of the following impurities by the corresponding correction factor: impurity E = 0.09; impurity F = 0.15;
- **impurities A, B, C, D, E, F:** for each impurity, not more than the area of the principal peak in the chromatogram obtained with reference solution (d) (3.0 per cent);
- **any other impurity:** for each impurity, not more than 0.067 times the area of the principal peak in the chromatogram obtained with reference solution (d) (0.2 per cent);
- **total:** not more than twice the area of the principal peak in the chromatogram obtained with reference solution (d) (6.0 per cent);
- **disregard limit:** 0.02 times the area of the principal peak in the chromatogram obtained with reference solution (d) (0.06 per cent).

**Free lactobionic acid:** maximum 1.0 per cent of  $C_{12}H_{22}O_{12}$  (anhydrous substance).

Dissolve 0.400 g in 50 mL of *water R*. Titrate with 0.1 M *sodium hydroxide*, determining the end-point potentiometrically (2.2.20). Calculate the volume of 0.1 M *sodium hydroxide* required per gram of the substance to be examined ( $n_1$  mL). Dissolve 0.500 g in 40 mL of *anhydrous acetic acid R* and titrate with 0.1 M *perchloric acid*, determining the end-point potentiometrically (2.2.20). Calculate the volume of 0.1 M *perchloric acid* required per gram of the substance to be examined ( $n_2$  mL).

Calculate the percentage content of  $C_{12}H_{22}O_{12}$  using the following expression:

$$3.580 (n_1 - n_2)$$

**Water** (2.5.12): maximum 5.0 per cent, determined on 0.200 g.

Use a 100 g/L solution of *imidazole R* in *anhydrous methanol R* as the solvent.

**Sulfated ash** (2.4.14): maximum 0.5 per cent, determined on 1.0 g.

**Bacterial endotoxins** (2.6.14): less than 0.35 IU/mg of erythromycin, if intended for use in the manufacture of parenteral preparations without a further appropriate procedure for the removal of bacterial endotoxins.

#### ASSAY

Liquid chromatography (2.2.29) as described in the test for related substances with the following modifications.

**Injection:** test solution and reference solutions (a) and (b).

**System suitability:**

- **repeatability:** maximum relative standard deviation of 2.0 per cent after 6 injections of reference solution (a).

Calculate the percentage content of erythromycin A using the chromatogram obtained with reference solution (a). Express the result as erythromycin A lactobionate by multiplying the percentage content of erythromycin A by 1.4877. Calculate the percentage contents of erythromycin B and erythromycin C

using the chromatogram obtained with reference solution (b). Express the result as erythromycin B lactobionate and as erythromycin C lactobionate by multiplying by 1.4877.

#### STORAGE

In an airtight container. If the substance is sterile, store in a sterile, airtight, tamper-proof container.

#### IMPURITIES

Specified impurities: A, B, C, D, E, F.

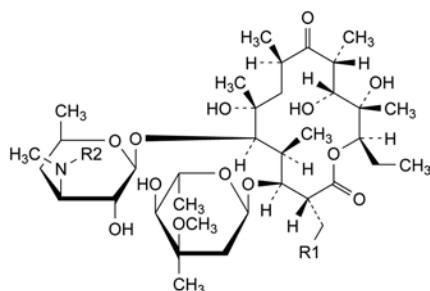

A. R1 = OH, R2 = CH<sub>3</sub>: erythromycin F,

B. R1 = R2 = H: *N*-demethylerythromycin A,

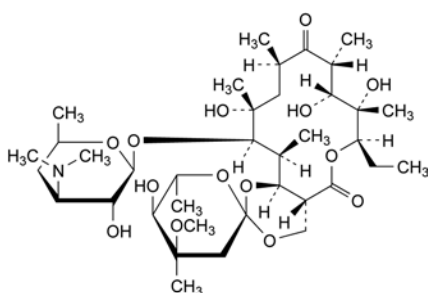

C. erythromycin E,

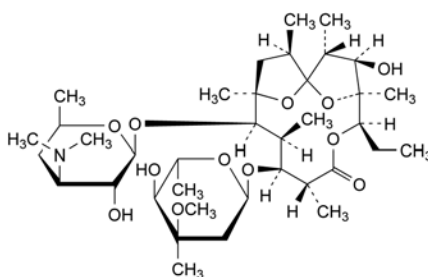

D. anhydroerythromycin A,

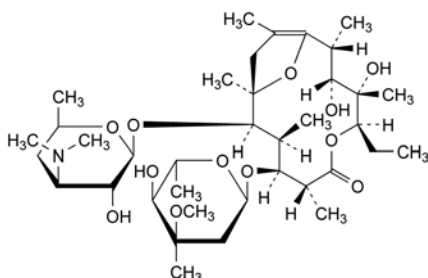

E. erythromycin A enol ether,

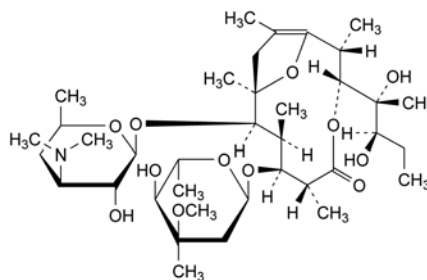

F. pseudoerythromycin A enol ether.

01/2008:0490  
corrected 6.0

## ERYTHROMYCIN STEARATE

### Erythromycini stearas

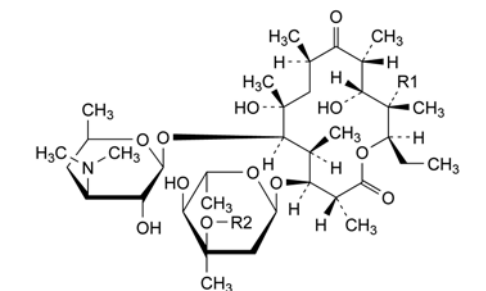

Erythromycin	Mol. Formula	R1	R2
A	C <sub>55</sub> H <sub>103</sub> NO <sub>15</sub>	OH	CH <sub>3</sub>
B	C <sub>55</sub> H <sub>103</sub> NO <sub>14</sub>	H	CH <sub>3</sub>
C	C <sub>54</sub> H <sub>101</sub> NO <sub>15</sub>	OH	H

C<sub>55</sub>H<sub>103</sub>NO<sub>15</sub>

M<sub>r</sub> 1018

#### DEFINITION

A mixture of the stearates of erythromycin and stearic acid. The main component is the octadecanoate of (3*R*,4*S*,5*S*,6*R*,7*R*,9*R*,11*R*,12*R*,13*S*,14*R*)-4-[(2,6-dideoxy-3-*C*-methyl-3-*O*-methyl- $\alpha$ -*L*-ribo-hexopyranosyl)oxy]-14-ethyl-7,12,13-trihydroxy-3,5,7,9,11,13-hexamethyl-6-[[3,4,6-trideoxy-3-(dimethylamino)- $\beta$ -*D*-xylo-hexopyranosyl]oxy]oxacyclotetradecane-2,10-dione (erythromycin A stearate).

Fermentation product.

#### Content:

- sum of the contents of erythromycin A, erythromycin B and erythromycin C: minimum 60.5 per cent (anhydrous substance);
- erythromycin B: maximum 5.0 per cent;
- erythromycin C: maximum 5.0 per cent.

#### CHARACTERS

**Appearance:** white or almost white, crystalline powder.

**Solubility:** practically insoluble in water, soluble in acetone and in methanol.

Solutions may be opalescent.

#### IDENTIFICATION

A. Infrared absorption spectrophotometry (2.2.24).

*Comparison:* erythromycin stearate CRS.

B. Thin-layer chromatography (2.2.27).

*Test solution.* Dissolve 28 mg of the substance to be examined in *methanol R* and dilute to 10 mL with the same solvent.

*Reference solution (a).* Dissolve 20 mg of erythromycin A CRS in *methanol R* and dilute to 10 mL with the same solvent.

**Reference solution (b).** Dissolve 10 mg of *stearic acid R* in *methanol R* and dilute to 10 mL with the same solvent.

**Plate:** TLC silica gel G plate *R*.

**Mobile phase:** mix 4 volumes of *2-propanol R*, 8 volumes of a 150 g/L solution of *ammonium acetate R* previously adjusted to pH 9.6 with *ammonia R* and 9 volumes of *ethyl acetate R*. Allow to settle and use the upper layer.

**Application:** 5 µL.

**Development:** over 2/3 of the plate.

**Drying:** in air.

**Detection A:** spray with a solution containing 0.2 g/L of *dichlorofluorescein R* and 0.1 g/L of *rhodamine B R* in *alcohol R*. Maintain the plate for a few seconds in the vapour above a water-bath. Examine in ultraviolet light at 365 nm.

**Results A:** the chromatogram obtained with the test solution shows 2 spots, one of which corresponds in position to the principal spot in the chromatogram obtained with reference solution (a) and the other to the principal spot in the chromatogram obtained with reference solution (b).

**Detection B:** spray the plate with *anisaldehyde solution R1*. Heat at 110 °C for 5 min and examine in daylight.

**Results B:** the spot in the chromatogram obtained with the test solution corresponds in position, colour and size to the principal spot in the chromatogram obtained with reference solution (a).

## TESTS

**Free stearic acid:** maximum 14.0 per cent (anhydrous substance) of C<sub>18</sub>H<sub>36</sub>O<sub>2</sub>.

Dissolve 0.400 g in 50 mL of *methanol R*. Titrate with 0.1 M *sodium hydroxide*, determining the end-point potentiometrically (2.2.20). Calculate the volume of 0.1 M *sodium hydroxide* required per gram of the substance to be examined (n<sub>1</sub> mL). Dissolve 0.500 g in 30 mL of *methylene chloride R*. If the solution is opalescent, filter and shake the residue with 3 quantities, each of 25 mL, of *methylene chloride R*. Filter, if necessary, and rinse the filter with *methylene chloride R*. Reduce the volume of the combined filtrate and rinsings to 30 mL by evaporation on a water-bath. Add 50 mL of *glacial acetic acid R* and titrate with 0.1 M *perchloric acid*, determining the end-point potentiometrically (2.2.20). Calculate the volume of 0.1 M *perchloric acid* required per gram of the substance to be examined (n<sub>2</sub> mL).

Calculate the percentage content of C<sub>18</sub>H<sub>36</sub>O<sub>2</sub> from the expression:

$$2.845 (n_1 - n_2) \times \frac{100}{100 - h}$$

*h* = percentage water content.

**Related substances.** Liquid chromatography (2.2.29).

**Test solution.** Dissolve 55.0 mg of the substance to be examined in 5.0 mL of *methanol R* and dilute to 10.0 mL with *buffer solution pH 8.0 R1*. Centrifuge and use the clear solution.

**Reference solution (a).** Dissolve 40.0 mg of *erythromycin A CRS* in 5.0 mL of *methanol R* and dilute to 10.0 mL with *buffer solution pH 8.0 R1*.

**Reference solution (b).** Dissolve 10.0 mg of *erythromycin B CRS* and 10.0 mg of *erythromycin C CRS* in 25.0 mL of *methanol R* and dilute to 50.0 mL with *buffer solution pH 8.0 R1*.

**Reference solution (c).** Dissolve 5 mg of *N-demethylerythromycin A CRS* in reference solution (b). Add 1.0 mL of reference solution (a) and dilute to 25 mL with reference solution (b).

**Reference solution (d).** Dilute 3.0 mL of reference solution (a) to 100.0 mL with a mixture of equal volumes of *methanol R* and *buffer solution pH 8.0 R1*.

**Reference solution (e).** Transfer 40 mg of *erythromycin A CRS* to a glass vial and spread evenly such that it forms a layer not more than about 1 mm thick. Heat at 130 °C for 4 h. Allow to

cool and dissolve in a mixture of 1 volume of *methanol R* and 3 volumes of *buffer solution pH 8.0 R1* and dilute to 10 mL with the same mixture of solvents.

**Column:**

– *size:* *l* = 0.25 m, Ø = 4.6 mm;

– *stationary phase:* *styrene-divinylbenzene copolymer R* (8 µm) with a pore size of 100 nm;

– *temperature:* 70 °C using a water-bath for the column and at least one third of the tubing preceding the column.

**Mobile phase:** to 50 mL of a 35 g/L solution of *dipotassium hydrogen phosphate R* adjusted to pH 9.0 ± 0.05 with *dilute phosphoric acid R*, add 400 mL of *water R*, 165 mL of *2-methyl-2-propanol R* and 30 mL of *acetonitrile R*, and dilute to 1000 mL with *water R*.

**Flow rate:** 2.0 mL/min.

**Detection:** spectrophotometer at 215 nm.

**Injection:** 100 µL; inject the test solution and reference solutions (c), (d) and (e).

**Run time:** 5 times the retention time of erythromycin A.

**Relative retention** with reference to erythromycin A (retention time = about 15 min): impurity A = about 0.3; impurity B = about 0.45; erythromycin C = about 0.5; impurity C = about 0.9; impurity D = about 1.4; impurity F = about 1.5; erythromycin B = about 1.8; impurity E = about 4.3.

**System suitability:** reference solution (c):

– *resolution:* minimum 0.8 between the peaks due to impurity B and to erythromycin C and minimum 5.5 between the peaks due to impurity B and to erythromycin A. If necessary, adjust the concentration of 2-methyl-2-propanol in the mobile phase or reduce the flow rate to 1.5 mL/min or 1.0 mL/min.

**Limits:**

– *correction factors:* for the calculation of contents, multiply the peak areas of the following impurities (use the chromatogram obtained with reference solution (e) to identify them) by the corresponding correction factor: impurity E = 0.09; impurity F = 0.15;

– *any impurity:* not more than the area of the principal peak in the chromatogram obtained with reference solution (d) (3 per cent);

– *total:* not more than twice the area of the principal peak in the chromatogram obtained with reference solution (d) (6 per cent);

– *disregard limit:* 0.02 times the area of the principal peak in the chromatogram obtained with reference solution (d) (0.06 per cent); disregard the peaks due to erythromycin B and to erythromycin C.

**Water (2.5.12):** maximum 4.0 per cent, determined on 0.300 g. Use a 100 g/L solution of *imidazole R* in *anhydrous methanol R* as the solvent.

**Sulfated ash (2.4.14):** maximum 0.5 per cent, determined on 1.0 g.

## ASSAY

Liquid chromatography (2.2.29) as described in the test for related substances with the following modifications.

**Injection:** test solution and reference solutions (a) and (b).

**System suitability:** reference solution (a):

– *repeatability:* maximum relative standard deviation of 1.2 per cent for 6 replicate injections.

Calculate the percentage content of erythromycin A using the chromatogram obtained with reference solution (a). Calculate the percentage contents of erythromycin B and erythromycin C using the chromatogram obtained with reference solution (b).



## IMPURITIES

01/2008:1316

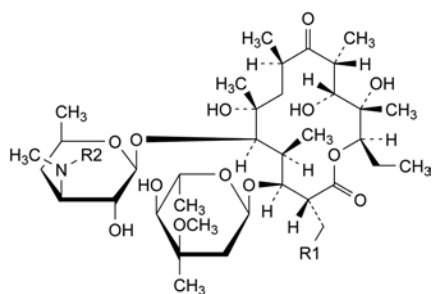
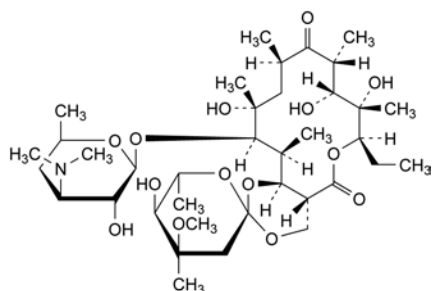
A. R1 = OH, R2 = CH<sub>3</sub>: erythromycin F,B. R1 = R2 = H: *N*-demethylerythromycin A,

C. erythromycin E,

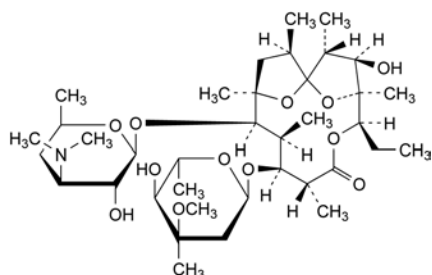

D. anhydroerythromycin A,

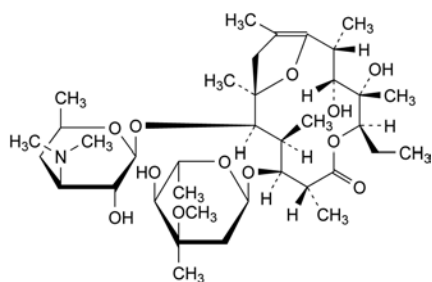

E. erythromycin A enol ether,

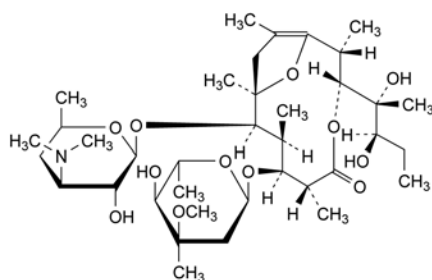

F. pseudoerythromycin A enol ether.

## ERYTHROPOIETIN CONCENTRATED SOLUTION

## Erythropoietini solutio concentrata

APPRLICDSR	VLERYLLEAK	EAENITTGCA
EHCSLNENIT	VPDTKVNIFYA	WKRMEVGGQA
VEVWQGLALL	SEAVLRGQAL	LVNSSQPWEP
LQLHVDKAVS	GLRSLTLLR	ALGAQKEAIS
PPDAASAPL	RTITADTRK	LFRVYSNFLR
GKCLKYTGEA	CRTGD	

 $M_r$  approx. 30 600

## DEFINITION

Erythropoietin concentrated solution is a solution containing a family of closely-related glycoproteins which are indistinguishable from the naturally occurring human erythropoietin (urinary erythropoietin) in terms of amino acid sequence (165 amino acids) and average glycosylation pattern, at a concentration of 0.5-10 mg/mL. It may also contain buffer salts and other excipients. It has a potency of not less than 100 000 IU/mg of active substance determined using the conditions described under Assay and in the test for protein.

## PRODUCTION

Erythropoietin is produced in rodent cells *in vitro* by a method based on recombinant DNA technology.

Prior to batch release, the following tests are carried out on each batch of the final product, unless exemption has been granted by the competent authority.

**Host cell-derived proteins:** the limit is approved by the competent authority.

**Host cell- and vector-derived DNA:** the limit is approved by the competent authority.

## CHARACTERS

**Appearance:** clear or slightly turbid, colourless solution.

## IDENTIFICATION

A. It gives the appropriate response when examined using the conditions described under Assay.

B. Capillary zone electrophoresis (2.2.47).

**Test solution.** Dilute the preparation to be examined with *water R* to obtain a concentration of 1 mg/mL. Desalt 0.25 mL of the solution by passage through a micro-concentrator cartridge provided with a membrane with a molecular mass cut-off of not more than 10 000 Da. Add 0.2 mL of *water R* to the sample and desalt again. Repeat the desalting procedure once more. Dilute the sample with *water R*, determine its protein concentration as described under Tests and adjust to a concentration of approximately 1 mg/mL with *water R*.

**Reference solution.** Dissolve the contents of a vial of *erythropoietin BRP* in 0.25 mL of *water R*. Proceed with desalting as described for the test solution.

**Capillary:**

- **material:** uncoated fused silica;
- **size:** effective length = about 100 cm,  $\varnothing$  = 50  $\mu$ m.

**Temperature:** 35 °C.

**CZE buffer concentrate (0.1 M sodium chloride, 0.1 M tricine, 0.1 M sodium acetate).** Dissolve 0.584 g of *sodium chloride R*, 1.792 g of *tricine R* and 0.820 g of *anhydrous sodium acetate R* in *water R* and dilute to 100.0 mL with the same solvent.

**1 M putrescine solution.** Dissolve 0.882 g of *putrescine R* in 10 mL of *water R*. Distribute in 0.5 mL aliquots.

**CZE buffer (0.01 M tricine, 0.01 M sodium chloride, 0.01 M sodium acetate, 7 M urea, 2.5 mM putrescine).** Dissolve 21.0 g of *urea R* in 25 mL of *water R* by warming in a water-bath at 30 °C. Add 5.0 mL of CZE buffer concentrate and 125 µL of 1 M putrescine solution. Dilute to 50.0 mL with *water R*. Using *dilute acetic acid R*, adjust to pH 5.55 at 30 °C and filter through a membrane filter (nominal pore size 0.45 µm).

**Detection:** spectrophotometer at 214 nm.

**Set the autosampler to store the samples at 4 °C during analysis.**

**Preconditioning of the capillary:** rinse the capillary for 60 min with 0.1 M sodium hydroxide filtered through a membrane filter (nominal pore size 0.45 µm) and for 60 min with CZE buffer. Apply voltage for 12 h (20 kV).

**Between-run rinsing:** rinse the capillary for 10 min with *water R*, for 5 min with 0.1 M sodium hydroxide filtered through a membrane filter (nominal pore size 0.45 µm) and for 10 min with CZE buffer.

**Injection:** under pressure or vacuum.

**Migration:** apply a field strength of 143 V/cm (15.4 kV for capillaries of 107 cm total length) for 80 min, using CZE buffer as the electrolyte in both buffer reservoirs.

**System suitability:** in the electropherogram obtained with the reference solution, a pattern of well separated peaks corresponding to the peaks in the electropherogram of erythropoietin supplied with *erythropoietin BRP* is seen, and the largest peak is at least 50 times greater than the baseline noise. If necessary, adjust the sample load to give peaks of sufficient height. Identify the peaks due to isoforms 1 to 8. Isoform 1 may not be visible. The peak due to isoform 8 is detected and the resolution between the peaks due to isoforms 5 and 6 is not less than 1. Repeat the separation at least 3 times. The baseline is stable, showing little drift, and the distribution of peaks is qualitatively and quantitatively similar to the distribution of peaks in the electropherogram of erythropoietin supplied with *erythropoietin BRP*. The relative standard deviation of the migration time of the peak due to isoform 2 is less than 2 per cent.

**Limits:** identify the peaks due to isoforms 1 to 8 in the electropherogram obtained with the test solution by comparison with the electropherogram obtained with the reference solution. Calculate the percentage content of each isoform from the corresponding peak area. The percentages are within the following ranges:

Isoform	Content (per cent)
1	0 - 15
2	0 - 15
3	1 - 20
4	10 - 35
5	15 - 40
6	10 - 35
7	5 - 25
8	0 - 15

C. Polyacrylamide gel electrophoresis and immunoblotting.

(a) Polyacrylamide gel electrophoresis (2.2.31)

**Gel dimensions:** 0.75 mm thick, about 16 cm square.

**Resolving gel:** 12 per cent acrylamide.

**Sample buffer:** SDS-PAGE sample buffer (concentrated) *R*.

**Test solution (a).** Dilute the preparation to be examined in *water R* to obtain a concentration of 1.0 mg/mL. To 1 volume of this solution add 1 volume of sample buffer.

**Test solution (b).** Dilute the preparation to be examined in *water R* to obtain a concentration of 0.1 mg/mL. To 1 volume of this solution add 1 volume of sample buffer.

**Reference solution (a).** Dissolve the contents of a vial of *erythropoietin BRP* in 0.25 mL of *water R*. To 1 volume of this solution add 1 volume of sample buffer.

**Reference solution (b).** Dissolve the contents of a vial of *erythropoietin BRP* in *water R* and dilute with the same solvent to obtain a concentration of 0.1 mg/mL. To 1 volume of this solution add 1 volume of sample buffer.

**Reference solution (c).** A solution of molecular mass markers suitable for calibrating SDS-polyacrylamide gels in the range of 10-70 kDa.

**Reference solution (d).** A solution of pre-stained molecular mass markers suitable for calibrating SDS-polyacrylamide gels in the range of 10-70 kDa and suitable for the electrotransfer to an appropriate membrane.

**Sample treatment:** boil for 2 min.

**Application:** 20 µL, in the following order: reference solution (c), reference solution (a), test solution (a), empty well, reference solution (b), test solution (b), reference solution (d).

At the end of the separation, remove the gel-cassette from the apparatus and cut the gel into 2 parts: the first part containing reference solution (c), reference solution (a) and test solution (a); the second part containing reference solution (b), test solution (b) and reference solution (d).

**Detection:** by Coomassie staining on the first part of the gel.

**System suitability:** reference solution (c):

– the validation criteria are met.

**Results:** the electropherogram obtained with test solution (a) shows a single diffuse band corresponding in position and intensity to the single band seen in the electropherogram obtained with reference solution (a).

(b) Immunoblotting

Transfer the second part of the gel onto a membrane suitable for the immobilisation of proteins, using commercially available electrotransfer equipment and following the manufacturer's instructions. After electrotransfer, incubate the membrane in a neutral isotonic buffer containing a suitable blocking agent (for example, 50 g/L of dried milk or 10 per cent V/V foetal calf serum), for 1-2 h, followed by incubation for 1-14 h in the same blocking solution with a suitable dilution of either a polyclonal or monoclonal anti-erythropoietin antibody. Detect erythropoietin-bound antibody using a suitable enzyme- or radiolabelled antibody (for example, an alkaline phosphatase-conjugated second antibody). The precise details of blocking agents, concentrations and incubation times should be optimised using the principles set out in *Immunochemical methods* (2.7.1).

**System suitability:** in the electropherogram obtained with reference solution (d), the molecular mass markers are resolved on the membrane into discrete bands, with a linear relationship between distance migrated and  $\log_{10}$  of the molecular mass.

**Results:** the electropherogram obtained with test solution (b) shows a single broad band corresponding in position and intensity to the single band seen in the electropherogram obtained with reference solution (b).

D. Peptide mapping (2.2.55). Liquid chromatography (2.2.29).

**Test solution.** Dilute the preparation to be examined in *tris-acetate buffer solution pH 8.5 R* to a concentration of 1.0 mg/mL. Equilibrate the solution in *tris-acetate buffer solution pH 8.5 R* using a suitable procedure (dialysis against *tris-acetate buffer solution pH 8.5 R*, or membrane filtration using the procedure described under Identification B, but reconstituting the desalted sample with *tris-acetate buffer solution pH 8.5 R*, are suitable). Transfer

the dialysed solution to a polypropylene centrifuge tube. Freshly prepare a solution of *trypsin for peptide mapping R* at a concentration of 1 mg/mL in *water R*, and add 5 µL to 0.25 mL of the dialysed solution. Cap the tube and place in a water-bath at 37 °C for 18 h. Remove the sample from the water-bath and stop the reaction immediately by freezing.

**Reference solution.** Dissolve the contents of a vial of *erythropoietin BRP* in 0.25 mL of *water R*. Prepare as for the test solution, ensuring that all procedures are carried out simultaneously, and under identical conditions.

**Column:**

- size:  $l = 0.25$  m,  $\varnothing = 4.6$  mm;
- stationary phase: *butylsilyl silica gel for chromatography R* (5–10 µm).

**Mobile phase:**

- mobile phase A: 0.06 per cent V/V solution of *trifluoroacetic acid R*;
- mobile phase B: to 100 mL of *water R* add 0.6 mL of *trifluoroacetic acid R* and dilute to 1000 mL with *acetonitrile for chromatography R*;

Time (min)	Flow rate (mL/min)	Mobile phase A (per cent V/V)	Mobile phase B (per cent V/V)
0 - 10	0.75	100	0
10 - 125	0.75	100 → 39	0 → 61
125 - 135	1.25	39 → 17	61 → 83
135 - 145	1.25	17 → 0	83 → 100
145 - 150	1.25	100	0

**Detection:** spectrophotometer at 214 nm.

**Equilibration:** at initial conditions for at least 15 min. Carry out a blank run using the above-mentioned gradient.

**Injection:** 50 µL.

**System suitability:** the chromatograms obtained with the test solution and the reference solution are qualitatively similar to the chromatogram of erythropoietin digest supplied with *erythropoietin BRP*.

**Results:** the profile of the chromatogram obtained with the test solution corresponds to that of the chromatogram obtained with the reference solution.

#### E. N-terminal sequence analysis.

The first 15 amino acids are: Ala - Pro - Pro - Arg - Leu - Ile - (no recovered peak) - Asp - Ser - Arg - Val - Leu - Glu - Arg - Tyr. Perform the Edman degradation using an automated solid-phase sequencer, operated in accordance with the manufacturer's instructions.

Desalt the equivalent of 50 µg of erythropoietin. For example, dilute a volume of the preparation to be examined equivalent to 50 µg of the active substance in 1 mL of a 0.1 per cent V/V solution of *trifluoroacetic acid R*. Pre-wash a C18 reverse-phase sample preparation cartridge according to the instructions supplied and equilibrate the cartridge in a 0.1 per cent V/V solution of *trifluoroacetic acid R*. Apply the sample to the cartridge, and wash successively with a 0.1 per cent V/V solution of *trifluoroacetic acid R* containing 0 per cent, 10 per cent and 50 per cent V/V of *acetonitrile R* according to the manufacturer's instructions. Lyophilise the 50 per cent V/V *acetonitrile R* eluate.

Redissolve the desalted sample in 50 µL of a 0.1 per cent V/V solution of *trifluoroacetic acid R* and couple to a sequencing cartridge using the protocol provided by the manufacturer. Run 15 sequencing cycles, using the reaction conditions for proline when running the 2<sup>nd</sup> and 3<sup>rd</sup> cycles.

Identify the phenylthiohydantoin (PTH)-amino acids released at each sequencing cycle by reverse-phase liquid chromatography. The procedure may be carried out using

the column and reagents recommended by the manufacturer of the sequencing equipment for the separation of PTH-amino-acids.

The separation procedure is calibrated using:

- the mixture of PTH-amino acids provided by the manufacturer of the sequencer, with the gradient conditions adjusted as indicated to achieve optimum resolution of all amino acids;
- a sample obtained from a blank sequencing cycle obtained as recommended by the equipment manufacturer.

#### TESTS

**Protein (2.5.33, Method I):** 80 per cent to 120 per cent of the stated concentration.

**Test solution.** Dilute the preparation to be examined in a 4 g/L solution of *ammonium hydrogen carbonate R*.

Record the absorbance spectrum between 250 nm and 400 nm. Measure the value at the absorbance maximum (276–280 nm), after correction for any light scattering, measured up to 400 nm. Calculate the concentration of erythropoietin taking the specific absorbance to be 7.43.

**Dimers and related substances of higher molecular mass.** Size-exclusion chromatography (2.2.30).

**Test solution.** Dilute the preparation to be examined in the mobile phase to obtain a concentration of 0.2 mg/mL.

**Reference solution.** To 0.02 mL of the test solution add 0.98 mL of the mobile phase.

**Column:**

- size:  $l = 0.6$  m,  $\varnothing = 7.5$  mm;
- stationary phase: *hydrophilic silica gel for chromatography R*, of a grade suitable for fractionation of globular proteins in the relative molecular mass range of 20 000 to 200 000.

**Mobile phase:** dissolve 1.15 g of *anhydrous disodium hydrogen phosphate R*, 0.2 g of *potassium dihydrogen phosphate R* and 23.4 g of *sodium chloride R* in 1 litre of *water R* (1.5 mM potassium dihydrogen phosphate, 8.1 mM disodium hydrogen phosphate, 0.4 M sodium chloride, pH 7.4); adjust to pH 7.4 if necessary.

**Flow rate:** 0.5 mL/min.

**Detection:** spectrophotometer at 214 nm.

**Injection:** 100 µL.

**Run time:** minimum 1 h.

**System suitability:** the area of the principal peak in the chromatogram obtained with the reference solution is 1.5 per cent to 2.5 per cent of the area of the principal peak in the chromatogram obtained with the test solution.

**Limits:**

- total of any peaks eluted before the principal peak: not more than the area of the principal peak in the chromatogram obtained with the reference solution (2 per cent).

**Sialic acids:** minimum 10 mol of sialic acids (calculated as *N-acetylneuraminic acid*) per mole of erythropoietin.

**Test solution (a).** Dilute the preparation to be examined in the mobile phase used in the test for dimers and related substances of higher molecular mass to obtain a concentration of 0.3 mg/mL.

**Test solution (b).** To 0.5 mL of test solution (a) add 0.5 mL of the mobile phase used in the test for dimers and related substances of higher molecular mass.

**Reference solution (a).** Dissolve a suitable amount of *N-acetylneuraminic acid R* in *water R* to obtain a concentration of 0.1 mg/mL.

**Reference solution (b).** To 0.8 mL of reference solution (a) add 0.2 mL of *water R*.

**Reference solution (c).** To 0.6 mL of reference solution (a) add 0.4 mL of *water R*.

*Reference solution (d).* To 0.4 mL of reference solution (a) add 0.6 mL of *water R*.

*Reference solution (e).* To 0.2 mL of reference solution (a) add 0.8 mL of *water R*.

*Reference solution (f).* Use *water R*.

Carry out the test in triplicate. Transfer 100 µL of each of the test and reference solutions to 10 mL glass test tubes. To each tube add 1.0 mL of *resorcinol reagent R*. Stopper the tubes and incubate at 100 °C for 30 min. Cool on ice. To each tube, add 2.0 mL of a mixture of 12 volumes of *butanol R* and 48 volumes of *butyl acetate R*. Mix vigorously, and allow the 2 phases to separate. Ensuring that the upper phase is completely clear, remove the upper phase, taking care to exclude completely any of the lower phase. Measure the absorbance (2.2.25) of all samples at 580 nm. Using the calibration curve generated by the reference solutions, determine the content of sialic acids in test solutions (a) and (b) and calculate the mean. Calculate the number of moles of sialic acids per mole of erythropoietin assuming that the relative molecular mass of erythropoietin is 30 600 and that the relative molecular mass of *N*-acetylneuraminic acid is 309.

*System suitability:*

- the individual replicates agree to within ± 10 per cent of each other;
- the value obtained from reference solution (a) is between 1.5 and 3.3 times that obtained with test solution (a).

**Bacterial endotoxins (2.6.14):** less than 20 IU in the volume that contains 100 000 IU of erythropoietin.

#### ASSAY

The activity of the preparation is compared with that of *erythropoietin BRP* and expressed in International Units (IU).

The estimated potency is not less than 80 per cent and not more than 125 per cent of the stated potency. The confidence limits of the estimated potency ( $P = 0.95$ ) are not less than 64 per cent and not more than 156 per cent of the stated potency.

Carry out the determination of potency by Method A or B.

##### A. In polycythaemic mice

The activity of the preparation is estimated by examining, under given conditions, its effect in stimulating the incorporation of  $^{59}\text{Fe}$  into circulating red blood cells of mice made polycythaemic by exposure to reduced atmospheric pressure.

The following schedule, using treatment in a hypobaric chamber, has been found to be suitable.

Induce polycythaemia in female mice of the same strain, weighing 16–18 g. Place the mice in a hypoxic chamber and reduce the pressure to 0.6 atmospheres. After 3 days at 0.6 atmospheres, further reduce the pressure to 0.4–0.5 atmospheres and maintain the animals at this pressure for a further 11 days (the partial vacuum is interrupted daily for a maximum of 1 h at about 11:00 a.m., in order to clean the cages and feed the animals). At the end of the specified period, return the mice to normal atmospheric conditions. Randomly distribute the mice into cages, each containing 6 animals, and mark them.

*Test solution (a).* Dilute the substance to be examined in *phosphate-albumin buffered saline pH 7.2 R1* to obtain a concentration of 0.2 IU/mL.

*Test solution (b).* Mix equal volumes of test solution (a) and *phosphate-albumin buffered saline pH 7.2 R1*.

*Test solution (c).* Mix equal volumes of test solution (b) and *phosphate-albumin buffered saline pH 7.2 R1*.

*Reference solution (a).* Dissolve *erythropoietin BRP* in *phosphate-albumin buffered saline pH 7.2 R1* to obtain a concentration of 0.2 IU/mL.

*Reference solution (b).* Mix equal volumes of reference solution (a) and *phosphate-albumin buffered saline pH 7.2 R1*.

*Reference solution (c).* Mix equal volumes of reference solution (b) and *phosphate-albumin buffered saline pH 7.2 R1*.

*Radiolabelled ferric [ $^{59}\text{Fe}$ ] chloride solution, concentrated.* Use a commercially available solution of [ $^{59}\text{Fe}$ ]ferric chloride (approximate specific activity: 100–1000 MBq/mg of Fe).

*Radiolabelled [ $^{59}\text{Fe}$ ]ferric chloride solution.* Dilute the concentrated radiolabelled [ $^{59}\text{Fe}$ ]ferric chloride solution in *sodium citrate buffer solution pH 7.8 R* to obtain a solution with an activity of  $3.7 \times 10^4$  Bq/mL.

The concentrations of the test solutions and reference solutions may need to be modified, based on the response range of the animals used.

3 days after returning the animals to atmospheric pressure, inject each animal subcutaneously with 0.2 mL of one of the solutions. The 6 animals in each cage must each receive one of the 6 different treatments (3 test solutions and 3 reference solutions), and the order of injection must be separately randomised for each cage. A minimum of 8 cages is recommended. 2 days after injection of the test or reference solution, inject each animal intraperitoneally with 0.2 mL of radiolabelled [ $^{59}\text{Fe}$ ]ferric chloride solution. The order of the injections must be the same as that of the erythropoietin injections, and the time interval between administration of the erythropoietin and the radiolabelled ferric chloride solution must be the same for each animal. After a further 48 h, anaesthetise each animal by injection of a suitable anaesthetic, record body weights and withdraw blood samples (0.65 mL) into haematocrit capillaries from the bifurcation of the aorta. After determining the packed cell volume for each sample, measure the radioactivity.

Calculate the response (percentage of iron-59 in total circulating blood) for each mouse using the expression:

$$\frac{A_s \times M \times 7.5}{A_t \times V_s}$$

$A_s$  = radioactivity in the sample;

$A_t$  = total radioactivity injected;

7.5 = total blood volume as per cent body weight;

$M$  = body weight, in grams;

$V_s$  = sample volume.

Calculate the potency by the usual statistical methods for a parallel line assay. Eliminate from the calculation any animal where the packed cell volume is less than 54 per cent, or where the body weight is more than 24 g.

##### B. In normocythaemic mice

The assay is based on the measurement of stimulation of reticulocyte production in normocythaemic mice.

The assay may be carried out using the following procedure:

*Test solution (a).* Dilute the preparation to be examined in *phosphate-albumin buffered saline pH 7.2 R1* to obtain a concentration of 80 IU/mL.

*Test solution (b).* Mix equal volumes of test solution (a) and *phosphate-albumin buffered saline pH 7.2 R1*.

*Test solution (c).* Mix equal volumes of test solution (b) and *phosphate-albumin buffered saline pH 7.2 R1*.

*Reference solution (a).* Dissolve *erythropoietin BRP* in *phosphate-albumin buffered saline pH 7.2 R1* to obtain a concentration of 80 IU/mL.

*Reference solution (b).* Mix equal volumes of reference solution (a) and *phosphate-albumin buffered saline pH 7.2 R1*.

*Reference solution (c).* Mix equal volumes of reference solution (b) and *phosphate-albumin buffered saline pH 7.2 R1*.

The exact concentrations of the test solutions and reference solutions may need to be modified, based on the response range of the animals used.

At the beginning of the assay procedure, randomly distribute mice of a suitable age and strain (8-week old B6D2F1 mice are suitable) into 6 cages. A minimum of 8 mice per cage is

recommended. Inject each animal subcutaneously with 0.5 mL of the appropriate treatment (one solution per cage) and put the animal in a new cage. Combine the mice in such a way that each cage housing the treated mice contains one mouse out of the 6 different treatments (3 test solutions and 3 reference solutions, 6 mice per cage). 4 days after the injections, collect blood samples from the animals and determine the number of reticulocytes using a suitable procedure.

The following method may be employed:

*The volume of blood, dilution procedure and fluorescent reagent may need to be modified to ensure maximum development and stability of fluorescence.*

*Colorant solution, concentrated.* Use a solution of thiazole orange suitable for the determination of reticulocytes. Prepare at a concentration twice that necessary for the analysis.

Proceed with the following dilution steps. Dilute whole blood 500-fold in the buffer used to prepare the colorant solution. Dilute this solution 2-fold in the concentrated colorant solution. After staining for 3-10 min, determine the reticulocyte count microfluorometrically in a flow cytometer. The percentage of reticulocytes is determined using a biparametric histogram: number of cells/red fluorescence (620 nm).

Calculate the potency by the usual statistical methods for a parallel line assay.

#### STORAGE

In an airtight container at a temperature below  $-20\text{ }^{\circ}\text{C}$ . Avoid repeated freezing and thawing.

#### LABELLING

The label states:

- the erythropoietin content in milligrams per millilitre;
- the activity in International Units per millilitre;
- the name and the concentration of any other excipients.

01/2008:1742  
corrected 6.0

## ESKETAMINE HYDROCHLORIDE

### Esketamini hydrochloridum

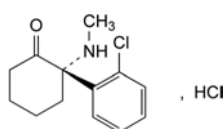

$\text{C}_{13}\text{H}_{17}\text{Cl}_2\text{NO}$   
[33795-24-3]

$M_r$  274.2

#### DEFINITION

(2S)-2-(2-Chlorophenyl)-2-(methylamino)cyclohexanone hydrochloride.

*Content:* 99.0 per cent to 101.0 per cent.

#### CHARACTERS

*Appearance:* white or almost white, crystalline powder.

*Solubility:* freely soluble in water and in methanol, soluble in alcohol.

#### IDENTIFICATION

A. Specific optical rotation (2.2.7):  $+85.0$  to  $+95.0$ .

Dilute 12.5 mL of solution S (see Tests) to 40.0 mL with water R.

B. Infrared absorption spectrophotometry (2.2.24).

*Comparison:* Ph. Eur. reference spectrum of esketamine hydrochloride.

C. It gives reaction (a) of chlorides (2.3.1).

#### TESTS

**Solution S.** Dissolve 8.0 g in carbon dioxide-free water R and dilute to 50.0 mL with the same solvent.

**Appearance of solution.** Solution S is clear (2.2.1) and colourless (2.2.2, Method II).

**pH (2.2.3):** 3.5 to 4.5.

Dilute 12.5 mL of solution S to 20 mL with carbon dioxide-free water R.

**Impurity D.** Liquid chromatography (2.2.29).

*Test solution.* Dissolve 25.0 mg of the substance to be examined in water R and dilute to 100.0 mL with the same solvent.

*Reference solution (a).* Dissolve 5 mg of esketamine impurity D CRS in water R, add 20 mL of the test solution and dilute to 50 mL with water R. Dilute 10 mL of this solution to 100 mL with water R.

*Reference solution (b).* Dilute 5.0 mL of the test solution to 25.0 mL with water R. Dilute 5.0 mL of this solution to 50.0 mL with water R.

*Reference solution (c).* Dilute 2.5 mL of reference solution (b) to 10.0 mL with water R. Dilute 1.0 mL of this solution to 10.0 mL with water R.

*Precolumn:*

- size:  $l = 0.01$  m,  $\varnothing = 3.0$  mm,
- stationary phase: silica gel AGP for chiral chromatography R (5  $\mu\text{m}$ ),
- temperature:  $30\text{ }^{\circ}\text{C}$ .

*Column:*

- size:  $l = 0.125$  m,  $\varnothing = 4.6$  mm,
- stationary phase: silica gel AGP for chiral chromatography R (5  $\mu\text{m}$ ),
- temperature:  $30\text{ }^{\circ}\text{C}$ .

*Mobile phase:* mix 16 volumes of methanol R and 84 volumes of a 6.8 g/L solution of potassium dihydrogen phosphate R previously adjusted to pH 7.0 with potassium hydroxide R.

*Flow rate:* 0.8 mL/min.

*Detection:* spectrophotometer at 215 nm.

*Injection:* 20  $\mu\text{L}$ .

*Run time:* 20 min.

*Relative retention* with reference to esketamine (retention time = about 10 min): impurity D = about 1.3.

*System suitability:*

- resolution: minimum 2.0 between the peaks due to esketamine and impurity D in the chromatogram obtained with reference solution (a),
- signal-to-noise ratio: minimum 3 for the principal peak in the chromatogram obtained with reference solution (c).

*Limit:*

- impurity D: not more than the area of the principal peak in the chromatogram obtained with reference solution (b) (2.0 per cent).

**Related substances.** Liquid chromatography (2.2.29).

*Test solution.* Dissolve 50.0 mg of the substance to be examined in the mobile phase and dilute to 50.0 mL with the mobile phase.

*Reference solution (a).* Dissolve 5 mg of ketamine impurity A CRS in the mobile phase (using ultrasound, if necessary) and dilute to 10 mL with the mobile phase. To 1 mL of the solution add 0.5 mL of the test solution and dilute to 100 mL with the mobile phase. Prepare immediately before use.

*Reference solution (b).* Dilute 1.0 mL of the test solution to 10.0 mL with the mobile phase. Dilute 1.0 mL of this solution to 20.0 mL with the mobile phase.

*Column:*

- size:  $l = 0.125$  m,  $\varnothing = 4.0$  mm,
- stationary phase: spherical octadecylsilyl silica gel for chromatography R (5  $\mu\text{m}$ ).

01/2009:2372  
corrected 6.7

**Mobile phase:** dissolve 0.95 g of *sodium hexanesulfonate R* in 1000 mL of a mixture of 25 volumes of *acetonitrile R* and 75 volumes of *water R* and add 4 mL of *acetic acid R*.

**Flow rate:** 1.0 mL/min.

**Detection:** spectrophotometer at 215 nm.

**Injection:** 20 µL.

**Run time:** 10 times the retention time of esketamine.

**Relative retention** with reference to esketamine:  
impurity A = about 1.6; impurity B = about 3.3;  
impurity C = about 4.6.

**System suitability:** reference solution (a):

- **retention time:** esketamine = 3.0 min to 4.5 min,
- **resolution:** minimum 1.5 between the peaks due to impurity A and esketamine.

**Limits:**

- **impurities A, B, C:** for each impurity, not more than 0.4 times the area of the principal peak in the chromatogram obtained with reference solution (b) (0.2 per cent),
- **any other impurity:** for each impurity, not more than 0.2 times the area of the principal peak in the chromatogram obtained with reference solution (b) (0.1 per cent),
- **total:** not more than the area of the principal peak in the chromatogram obtained with reference solution (b) (0.5 per cent),
- **disregard limit:** 0.2 times the area of the principal peak in the chromatogram obtained with reference solution (b) (0.1 per cent).

**Heavy metals (2.4.8):** maximum 20 ppm.

Dilute 12.5 mL of solution S to 20 mL with *water R*. 12 mL of the solution complies with limit test A. Prepare the standard using *lead standard solution (2 ppm Pb) R*.

**Sulfated ash (2.4.14):** maximum 0.1 per cent, determined on 1.0 g.

**ASSAY**

Dissolve 0.200 g in 50 mL of *methanol R* and add 1.0 mL of 0.1 M *hydrochloric acid*. Carry out a potentiometric titration (2.2.20), using 0.1 M *sodium hydroxide*. Read the volume added between the 2 points of inflexion.

1 mL of 0.1 M *sodium hydroxide* is equivalent to 27.42 mg of  $C_{34}H_{36}MgN_6O_6S_2 \cdot 3H_2O$ .

**STORAGE**

Protected from light.

**IMPURITIES**

**Specified impurities:** A, B, C, D.

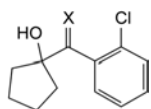

A. X = N-CH<sub>3</sub>: 1-[(2-chlorophenyl)(methylimino)methyl]cyclopentanol,

C. X = O: (2-chlorophenyl)(1-hydroxycyclopentyl)methanone,

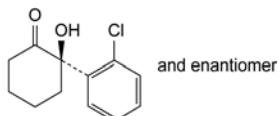

B. (2R)-2-(2-chlorophenyl)-2-hydroxycyclohexanone,

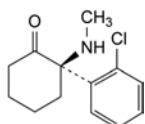

D. (2R)-2-(2-chlorophenyl)-2-(methylamino)cyclohexanone ((R)-ketamine).

## ESOMEPRAZOLE MAGNESIUM TRIHYDRATE

Esomeprazolium magnesium trihydricum

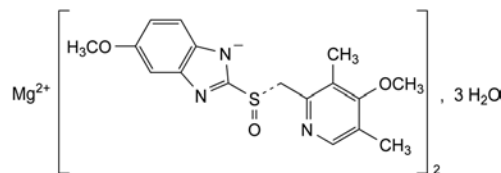

$C_{34}H_{36}MgN_6O_6S_2 \cdot 3H_2O$   
[217087-09-7]

$M_r$  767.2

**DEFINITION**

Magnesium bis[5-methoxy-2-[(S)-[(4-methoxy-3,5-dimethylpyridin-2-yl)methyl]sulfinyl]-1H-benzimidazol-1-ide] trihydrate.

**Content:** 98.0 per cent to 102.0 per cent (anhydrous substance).

**CHARACTERS**

**Appearance:** white or slightly coloured powder, slightly hygroscopic.

**Solubility:** slightly soluble in water, soluble in methanol, practically insoluble in heptane.

**IDENTIFICATION**

Carry out either tests A, B, C or A, B, E or B, C, D or B, D, E.

A. **Specific optical rotation (2.2.7):** – 137 to – 155.

Dissolve 0.250 g in *methanol R* and dilute to 25.0 mL with the same solvent.

B. **Infrared absorption spectrophotometry (2.2.24).**

**Comparison:** *esomeprazole magnesium trihydrate CRS*.

C. **Atomic absorption spectrometry (2.2.23)** as described in the test for magnesium.

The test solution shows the absorption maximum at 285.2 nm.

D. **Enantiomeric purity** (see Tests).

E. Ignite about 0.5 g of the substance to be examined according to the procedure for the sulfated ash test (2.4.14). Dissolve the residue in 10 mL of *water R*. 2 mL of this solution gives the reaction of magnesium (2.3.1).

**TESTS**

**Absorbance (2.2.25):** maximum 0.20 at 440 nm.

Dissolve 0.500 g in *methanol R* and dilute to 25.0 mL with the same solvent. Filter the solution through a membrane filter (nominal pore size 0.45 µm).

**Related substances.** Liquid chromatography (2.2.29). Use the normalisation procedure. *Use freshly prepared solutions.*

**Test solution.** Dissolve 3.5 mg of the substance to be examined in the mobile phase and dilute to 25.0 mL with the mobile phase.

**Reference solution (a).** Dissolve 1 mg of *omeprazole CRS* and 1 mg of *omeprazole impurity D CRS* in the mobile phase and dilute to 10.0 mL with the mobile phase.

**Reference solution (b).** Dissolve 3 mg of the *omeprazole for peak identification CRS* (containing impurity E) in the mobile phase and dilute to 20.0 mL with the mobile phase.

**Reference solution (c).** Dilute 1.0 mL of the test solution to 100.0 mL with the mobile phase. Dilute 1.0 mL of this solution to 10.0 mL with the mobile phase.

**Column:**

- size:  $l = 0.125$  m,  $\emptyset = 4.6$  mm;
- stationary phase: octylsilyl silica gel for chromatography R (5  $\mu$ m).

**Mobile phase:** mix 27 volumes of acetonitrile R and 73 volumes of a 1.4 g/L solution of disodium hydrogen phosphate R previously adjusted to pH 7.6 with phosphoric acid R.

**Flow rate:** 1 mL/min.

**Detection:** spectrophotometer at 280 nm.

**Injection:** 40  $\mu$ L.

**Run time:** 5 times the retention time of esomeprazole.

**Identification of impurities:**

- use the chromatogram supplied with omeprazole for peak identification CRS and the chromatogram obtained with reference solution (b) to identify the peak due to impurity E;
- use the chromatogram obtained with reference solution (a) to identify the peak due to impurity D.

**Relative retention** with reference to esomeprazole (retention time = about 9 min): impurity E = about 0.6; impurity D = about 0.8.

**System suitability:** reference solution (a):

- resolution: minimum 3.0 between the peaks due to impurity D and omeprazole. If necessary, adjust the pH of the aqueous part of the mobile phase or its proportion of acetonitrile; an increase in the pH will improve the resolution.

**Limits:**

- impurity D: maximum 0.2 per cent;
- impurity E: maximum 0.1 per cent;
- unspecified impurities: for each impurity, maximum 0.10 per cent;
- total: maximum 0.5 per cent;
- disregard limit: 0.5 times the area of the principal peak in the chromatogram obtained with reference solution (c) (0.05 per cent).

**Enantiomeric purity.** Liquid chromatography (2.2.29).

**Buffer solution pH 6.0.** Mix 70 mL of a 156.0 g/L solution of sodium dihydrogen phosphate R with 20 mL of a 179.1 g/L solution of disodium hydrogen phosphate R. Dilute to 1000 mL with water R, then dilute 250 mL of this solution to 1000.0 mL with water R.

**Buffer solution pH 11.0.** Mix 11 mL of a 95.0 g/L solution of trisodium phosphate dodecahydrate R with 22 mL of a 179.1 g/L solution of disodium hydrogen phosphate R, then dilute to 1000.0 mL with water R.

**Test solution.** Dissolve 40 mg of the substance to be examined in 5 mL of methanol R and dilute to 25 mL with buffer solution pH 11.0. Dilute 1.0 mL of this solution to 50.0 mL with buffer solution pH 11.0.

**Reference solution (a).** Dissolve 2 mg of omeprazole CRS in buffer solution pH 11.0 and dilute to 10.0 mL with the same buffer solution. Dilute 1.0 mL of this solution to 50.0 mL with buffer solution pH 11.0.

**Reference solution (b).** Dilute 1.0 mL of reference solution (a) to 50.0 mL with buffer solution pH 11.0.

**Column:**

- size:  $l = 0.1$  m,  $\emptyset = 4.0$  mm;
- stationary phase: silica gel AGP for chiral chromatography R (5  $\mu$ m).

**Mobile phase:** acetonitrile R, buffer solution pH 6.0 (65:435 V/V).

**Flow rate:** 0.6 mL/min.

**Detection:** spectrophotometer at 302 nm.

**Injection:** 20  $\mu$ L.

**Elution order:** impurity F, esomeprazole.

**Retention time:** esomeprazole = about 4 min.

**System suitability:**

- resolution: minimum 3.0 between the peaks due to impurity F and esomeprazole in the chromatogram obtained with reference solution (a);
- signal-to-noise ratio: minimum 10 for the peak due to impurity F in the chromatogram obtained with reference solution (b).

Calculate the percentage content of impurity F using the following expression:

$$100 \left( \frac{r_i}{r_s} \right)$$

- $r_i$  = area of the peak due to impurity F in the chromatogram obtained with the test solution;
- $r_s$  = sum of the areas of the peaks due to esomeprazole and impurity F in the chromatogram obtained with the test solution.

**Limits:**

- impurity F: maximum 0.2 per cent.

**Magnesium:** 3.30 per cent to 3.55 per cent (anhydrous substance).

Atomic absorption spectrometry (2.2.23, Method I).

**Test solution.** Dissolve 0.250 g in 20 mL of a 103 g/L solution of hydrochloric acid R, adding the acid slowly, and dilute to 100.0 mL with water R. Dilute 10.0 mL of this solution to 200.0 mL with water R. To 10.0 mL of the solution obtained add 4 mL of lanthanum chloride solution R and dilute to 100.0 mL with water R.

**Reference solutions.** Prepare the reference solutions using magnesium standard solution (1000 ppm Mg) R, diluted as necessary with a mixture of 1 mL of a 103 g/L solution of hydrochloric acid R in 1000.0 mL of water R.

**Wavelength:** 285.2 nm.

**Water (2.5.12):** 6.0 per cent to 8.0 per cent, determined on 0.200 g.

**ASSAY**

Liquid chromatography (2.2.29).

**Buffer solution pH 11.0.** Mix 11 mL of a 95.0 g/L solution of trisodium phosphate dodecahydrate R with 22 mL of a 179.1 g/L solution of disodium hydrogen phosphate R, and dilute to 100.0 mL with water R.

**Test solution.** Dissolve 10.0 mg of the substance to be examined in about 10 mL of methanol R, add 10 mL of buffer solution pH 11.0 and dilute to 200.0 mL with water R.

**Reference solution.** Dissolve 10.0 mg of omeprazole CRS in about 10 mL of methanol R, add 10 mL of buffer solution pH 11.0 and dilute to 200.0 mL with water R.

**Column:**

- size:  $l = 0.125$  m,  $\emptyset = 4$  mm;
- stationary phase: octylsilyl silica gel for chromatography R (5  $\mu$ m).

**Mobile phase:** mix 35 volumes of acetonitrile R with 65 volumes of a 1.4 g/L solution of disodium hydrogen phosphate R previously adjusted to pH 7.6 with phosphoric acid R.

**Flow rate:** 1 mL/min.

**Detection:** spectrophotometer at 280 nm.

**Injection:** 20  $\mu$ L.

**Run time:** 1.5 times the retention time of esomeprazole.

**Retention time:** esomeprazole = about 4 min.

Calculate the percentage content of  $C_{34}H_{36}MgN_6O_6S_2$  from the declared content of omeprazole CRS.

1 g of omeprazole is equivalent to 1.032 g of esomeprazole magnesium.

## STORAGE

In an airtight container, protected from light.

## IMPURITIES

Specified impurities: D, E, F.

Other detectable impurities (the following substances would, if present at a sufficient level, be detected by one or other of the tests in the monograph. They are limited by the general acceptance criterion for other/unspecified impurities and/or by the general monograph *Substances for pharmaceutical use (2034)*. It is therefore not necessary to identify these impurities for demonstration of compliance. See also 5.10. *Control of impurities in substances for pharmaceutical use*): A, B, C.

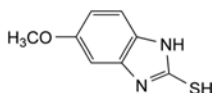

A. 5-methoxy-1*H*-benzimidazole-2-thiol,

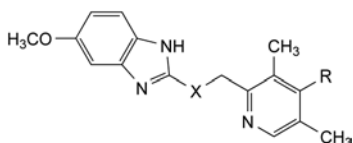

B. R = H, X = SO: 2-[(*RS*)-(3,5-dimethylpyridin-2-yl)methyl]sulfinyl]-5-methoxy-1*H*-benzimidazole,

C. R = OCH<sub>3</sub>, X = S: 5-methoxy-2-[(4-methoxy-3,5-dimethylpyridin-2-yl)methyl]sulfanyl]-1*H*-benzimidazole (ufiprazole),

D. R = OCH<sub>3</sub>, X = SO<sub>2</sub>: 5-methoxy-2-[(4-methoxy-3,5-dimethylpyridin-2-yl)methyl]sulfonyl]-1*H*-benzimidazole (omeprazole sulfone),

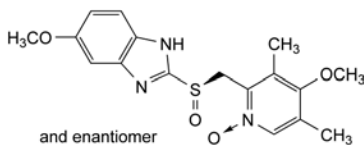

E. 4-methoxy-2-[(*RS*)-(5-methoxy-1*H*-benzimidazol-2-yl)sulfinyl]methyl]-3,5-dimethylpyridine 1-oxide.

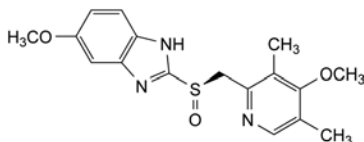

F. 5-methoxy-2-[(*R*)-(4-methoxy-3,5-dimethylpyridin-2-yl)methyl]sulfinyl]-1*H*-benzimidazole(*R*)-omeprazole).

04/2008:0139

## ESTRADIOL BENZOATE

## Estradioli benzoas

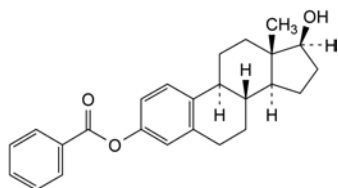

C<sub>25</sub>H<sub>28</sub>O<sub>3</sub>  
[50-50-0]

M<sub>r</sub> 376.5

## DEFINITION

17β-Hydroxyestra-1,3,5(10)-trien-3-yl benzoate.

Content: 97.0 per cent to 103.0 per cent (dried substance).

## CHARACTERS

Appearance: almost white, crystalline powder or colourless crystals.

Solubility: practically insoluble in water, freely soluble in methylene chloride, sparingly soluble in acetone, slightly soluble in methanol.

It shows polymorphism (5.9).

## IDENTIFICATION

Infrared absorption spectrophotometry (2.2.24).

Comparison: estradiol benzoate CRS.

If the spectra obtained in the solid state show differences, dissolve the substance to be examined and the reference substance separately in *acetone R*, evaporate to dryness and record new spectra using the residues.

## TESTS

Specific optical rotation (2.2.7): + 55.0 to + 59.0 (dried substance).

Dissolve 0.250 g in *acetone R* and dilute to 25.0 mL with the same solvent.

Related substances. Liquid chromatography (2.2.29).

Test solution. Dissolve 20 mg of the substance to be examined in *acetonitrile R1* and dilute to 10.0 mL with the same solvent.

Reference solution (a). Dissolve 5 mg of *estradiol benzoate for system suitability CRS* (containing impurities A, B, C, E and G) in *acetonitrile R1* and dilute to 2.5 mL with the same solvent.

Reference solution (b). Dilute 0.5 mL of the test solution to 100.0 mL with *acetonitrile R1*.

Column:

- size: *l* = 0.25 m, Ø = 4.6 mm;
- stationary phase: end-capped octylsilyl silica gel for chromatography R (5 µm).

Mobile phase:

- mobile phase A: water R, *acetonitrile R1* (40:60 V/V);
- mobile phase B: *acetonitrile R1*;

Time (min)	Mobile phase A (per cent V/V)	Mobile phase B (per cent V/V)
0 - 20	100	0
20 - 21	100 → 10	0 → 90
21 - 31	10	90

Flow rate: 1.0 mL/min.

Detection: spectrophotometer at 230 nm.

Injection: 10 µL.

Identification of impurities: use the chromatogram supplied with *estradiol benzoate for system suitability CRS* and the chromatogram obtained with reference solution (a) to identify the peaks due to impurities A, B, C, E and G.

Relative retention with reference to estradiol benzoate (retention time = about 19 min): impurity A = about 0.3; impurity E = about 1.1; impurity B = about 1.2; impurity G = about 1.3; impurity C = about 1.5.

System suitability: reference solution (a):

- peak-to-valley ratio: minimum 2.0, where *H<sub>p</sub>* = height above the baseline of the peak due to impurity E and *H<sub>v</sub>* = height above the baseline of the lowest point of the curve separating this peak from the peak due to estradiol benzoate.

Limits:

- correction factors: for the calculation of content, multiply the peak areas of the following impurities by the corresponding correction factor: impurity A = 3.3; impurity C = 0.7;
- impurity C: not more than the area of the principal peak in the chromatogram obtained with reference solution (b) (0.5 per cent);



- *impurities B, E, G*: for each impurity, not more than 0.6 times the area of the principal peak in the chromatogram obtained with reference solution (b) (0.3 per cent);
- *impurity A*: not more than 0.4 times the area of the principal peak in the chromatogram obtained with reference solution (b) (0.2 per cent);
- *unspecified impurities*: for each impurity, not more than 0.2 times the area of the principal peak in the chromatogram obtained with reference solution (b) (0.10 per cent);
- *total*: not more than twice the area of the principal peak in the chromatogram obtained with reference solution (b) (1.0 per cent);
- *disregard limit*: 0.1 times the area of the principal peak in the chromatogram obtained with reference solution (b) (0.05 per cent).

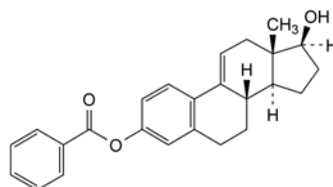

F. 17β-hydroxyestra-1,3,5(10),9(11)-tetraen-3-yl benzoate.

01/2008:0821

**ESTRADIOL HEMIHYDRATE**

## Estradiolum hemihydricum

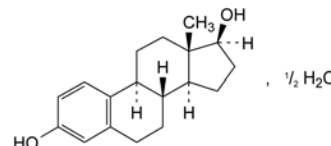
 $C_{18}H_{24}O_2 \cdot \frac{1}{2}H_2O$  $M_r$  281.4

## DEFINITION

Estra-1,3,5(10)-triene-3,17β-diol hemihydrate.

*Content*: 97.0 per cent to 103.0 per cent (anhydrous substance).

## CHARACTERS

*Appearance*: white or almost white, crystalline powder or colourless crystals.*Solubility*: practically insoluble in water, soluble in acetone, sparingly soluble in ethanol (96 per cent), slightly soluble in methylene chloride.

## IDENTIFICATION

*First identification*: B.*Second identification*: A, C, D, E.

A. Melting point (2.2.14): 175 °C to 180 °C.

B. Infrared absorption spectrophotometry (2.2.24).

*Comparison*: estradiol hemihydrate CRS.

C. Thin-layer chromatography (2.2.27).

*Test solution*. Dissolve 50 mg of the substance to be examined in *methanol R* and dilute to 50 mL with the same solvent.*Reference solution (a)*. Dissolve 50 mg of *estradiol hemihydrate CRS* in *methanol R* and dilute to 50 mL with the same solvent.*Reference solution (b)*. Dissolve 25 mg of *ethinylestradiol CRS* in reference solution (a) and dilute to 25 mL with reference solution (a).*Plate*: TLC silica gel plate R.*Mobile phase*: ethanol (96 per cent) R, toluene R (20:80 V/V).*Application*: 5 µL.*Development*: over 3/4 of the plate.*Drying*: in air until the solvent has evaporated.*Detection*: heat at 110 °C for 10 min. Spray the hot plate with *alcoholic solution of sulfuric acid R*. Heat again at 110 °C for 10 min. Allow to cool. Examine in daylight and in ultraviolet light at 365 nm.*System suitability*: the chromatogram obtained with reference solution (b) shows 2 spots which may however not be completely separated.*Results*: the principal spot in the chromatogram obtained with the test solution is similar in position, colour in daylight, fluorescence in ultraviolet light at 365 nm and size to the principal spot in the chromatogram obtained with reference solution (a).**Loss on drying** (2.2.32): maximum 0.5 per cent, determined on 1.000 g by drying in an oven at 105 °C for 3 h.

## ASSAY

Dissolve 25.0 mg in *anhydrous ethanol R* and dilute to 250.0 mL with the same solvent. Dilute 10.0 mL of this solution to 100.0 mL with *anhydrous ethanol R*. Measure the absorbance (2.2.25) at the absorption maximum at 231 nm.Calculate the content of  $C_{25}H_{28}O_3$  taking the specific absorbance to be 500.

## IMPURITIES

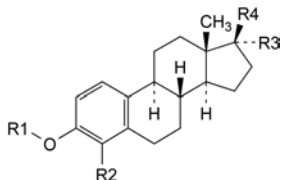
*Specified impurities*: A, B, C, E, G.*Other detectable impurities* (the following substances would, if present at a sufficient level, be detected by one or other of the tests in the monograph. They are limited by the general acceptance criterion for other/unspecified impurities and/or by the general monograph *Substances for pharmaceutical use (2034)*. It is therefore not necessary to identify these impurities for demonstration of compliance. See also 5.10. *Control of impurities in substances for pharmaceutical use*): D, F, H.

- A.  $R_1 = R_2 = R_3 = H, R_4 = OH$ : estradiol,
- B.  $R_1 = CO-C_6H_5, R_2 = CH_3, R_3 = H, R_4 = OH$ :  
17β-hydroxy-4-methylestra-1,3,5(10)-trien-3-yl benzoate,
- C.  $R_1 = CO-C_6H_5, R_2 = R_3 = H, R_4 = O-CO-C_6H_5$ :  
estra-1,3,5(10)-triene-3,17β-diyl dibenzoate,
- E.  $R_1 = CO-C_6H_5, R_2 = R_4 = H, R_3 = OH$ : 17α-hydroxyestra-1,3,5(10)-trien-3-yl benzoate,
- G.  $R_1 = CO-C_6H_5, R_2 = H, R_3 + R_4 = O$ : 17-oxoestra-1,3,5(10)-trien-3-yl benzoate (estrone benzoate),

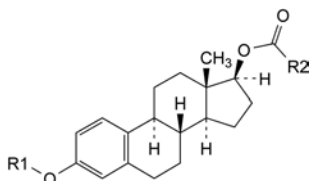

- D.  $R_1 = H, R_2 = C_6H_5$ : 3-hydroxyestra-1,3,5(10)-trien-17β-yl benzoate,
- H.  $R_1 = CO-C_6H_5, R_2 = CH_3$ : estra-1,3,5(10)-triene-3,17β-diyl 17-acetate 3-benzoate,

D. To about 1 mg add 0.5 mL of freshly prepared *sulfomolybdic reagent R2*. A blue colour develops which in ultraviolet light at 365 nm has an intense green fluorescence. Add 1 mL of *sulfuric acid R* and 9 mL of *water R*. The colour becomes pink with a yellowish fluorescence.

E. Water (see Tests).

#### TESTS

**Specific optical rotation** (2.2.7): + 76.0 to + 83.0 (anhydrous substance).

Dissolve 0.250 g in *ethanol (96 per cent) R* and dilute to 25.0 mL with the same solvent.

**Related substances.** Liquid chromatography (2.2.29).

**Test solution.** Dissolve 25.0 mg of the substance to be examined in 10 mL of *acetonitrile R* and dilute to 25.0 mL with *methanol R2*.

**Reference solution (a).** Dilute 1.0 mL of the test solution to 100.0 mL with the mobile phase. Dilute 2.0 mL of the solution to 10.0 mL with the mobile phase.

**Reference solution (b).** Dissolve 2 mg of *17 $\alpha$ -estradiol R* in 5.0 mL of *acetonitrile R*. Mix 2.0 mL of this solution with 1.0 mL of the test solution and dilute to 5.0 mL with the mobile phase.

**Reference solution (c).** Mix equal volumes of a 1 mg/mL solution of the substance to be examined in *methanol R2* and of a 1 mg/mL solution of *2,3-dichloro-5,6-dicyanobenzoquinone R* in *methanol R2*. Allow to stand for 30 min before injection.

**Reference solution (d).** Dissolve 5 mg of *estradiol for peak identification CRS* (estradiol hemihydrate spiked with impurities A, B and C at about 0.5 per cent) in 2 mL of *acetonitrile R* and dilute to 5 mL with *methanol R2*.

**Column:**

- size:  $l = 0.25$  m,  $\varnothing = 4.6$  mm;
- stationary phase: *end-capped octadecylsilyl silica gel for chromatography R* (5  $\mu$ m).

**Mobile phase:** to 400 mL of *acetonitrile R* add 50 mL of *methanol R2* and 400 mL of *water R*; allow to stand for 10 min, dilute to 1000 mL with *water R* and mix again.

**Flow rate:** 1 mL/min.

**Detection:** spectrophotometer at 280 nm.

**Equilibration:** about 60 min.

**Injection:** 20  $\mu$ L.

**Run time:** twice the retention time of the principal peak.

**Identification of impurities:** use the chromatogram supplied with *estradiol for peak identification CRS* and the chromatogram obtained with reference solution (d) to identify the peaks due to impurities A, B and C. Use the chromatogram obtained with reference solution (c) to identify the peak due to impurity D.

**Relative retention** with reference to estradiol (retention time = about 13 min): impurity D = about 0.9; impurity B = about 1.1; impurity A = about 1.4; impurity C = about 1.9.

**System suitability:** reference solution (b):

- **resolution:** minimum 2.5 between the peaks due to estradiol and impurity B.

**Limits:**

- **correction factor:** for the calculation of content, multiply the peak area of impurity D by 0.4;
- **impurities A, B, C, D:** for each impurity, not more than 1.5 times the area of the principal peak obtained with reference solution (a) (0.3 per cent);
- **unspecified impurities:** for each impurity, not more than 0.5 times the area of the principal peak obtained with reference solution (a) (0.10 per cent);
- **total:** not more than 2.5 times the area of the principal peak in the chromatogram obtained with reference solution (a) (0.5 per cent);

- **disregard limit:** 0.25 times the area of the principal peak in the chromatogram obtained with reference solution (a) (0.05 per cent).

**Water** (2.5.12): 2.9 per cent to 3.5 per cent, determined on 0.500 g.

#### ASSAY

Dissolve 20.0 mg in *ethanol (96 per cent) R* and dilute to 100.0 mL with the same solvent. Dilute 5.0 mL of the solution to 50.0 mL with *0.1 M sodium hydroxide*. Allow to cool to room temperature. Measure the absorbance (2.2.25) of the solution at the maximum at 238 nm.

Calculate the content of  $C_{18}H_{24}O_2$  taking the specific absorbance to be 335.

#### IMPURITIES

**Specified impurities:** A, B, C, D.

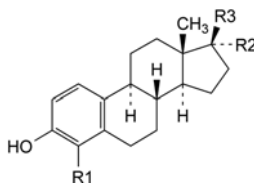

- A. R1 = H, R2 + R3 = O: 3-hydroxyestra-1,3,5(10)-trien-17-one (estrone),  
 B. R1 = R3 = H, R2 = OH: estra-1,3,5(10)-triene-3,17 $\alpha$ -diol (17 $\alpha$ -estradiol),  
 C. R1 = CH<sub>3</sub>, R2 = H, R3 = OH: 4-methylestra-1,3,5(10)-triene-3,17 $\beta$ -diol,  
 D. estra-1,3,5(10),9(11)-tetraene-3,17 $\beta$ -diol.

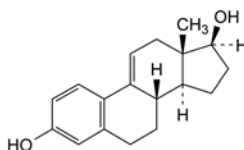

- D. estra-1,3,5(10),9(11)-tetraene-3,17 $\beta$ -diol.

01/2008:1614  
corrected 6.0

## ESTRADIOL VALERATE

### Estradioli valeras

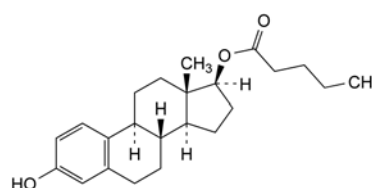

$C_{23}H_{32}O_3$   
[979-32-8]

$M_r$  356.5

#### DEFINITION

3-Hydroxyestra-1,3,5(10)-trien-17 $\beta$ -yl pentanoate.

**Content:** 97.0 per cent to 103.0 per cent (dried substance).

#### CHARACTERS

**Appearance:** white or almost white, crystalline powder or colourless crystals.

**Solubility:** practically insoluble in water, soluble in alcohol.  
mp: about 145 °C.

#### IDENTIFICATION

Infrared absorption spectrophotometry (2.2.24).

**Comparison:** *estradiol valerate CRS*.

## TESTS

**Solution S.** Dissolve 0.500 g in *methanol R* and dilute to 20.0 mL with the same solvent.

**Appearance of solution.** Solution S is clear (2.2.1) and colourless (2.2.2, *Method II*).

**Specific optical rotation** (2.2.7): + 41 to + 47 (dried substance), determined on solution S.

**Related substances.** Liquid chromatography (2.2.29).

**Solvent mixture.** Mix 15 volumes of *water R* and 135 volumes of *acetonitrile R*.

**Test solution.** Dissolve 0.100 g of the substance to be examined in the solvent mixture and dilute to 10.0 mL with the solvent mixture.

**Reference solution (a).** Dissolve 2 mg of *estradiol valerate CRS* and 2 mg of *estradiol butyrate CRS* in the solvent mixture and dilute to 10 mL with the solvent mixture.

**Reference solution (b).** Dilute 0.5 mL of the test solution to 100.0 mL with the solvent mixture.

**Column:**

- size:  $l = 0.25$  m,  $\varnothing = 4.6$  mm,
- stationary phase: octadecylsilyl silica gel for chromatography R (5  $\mu$ m),
- temperature: 40 °C.

**Mobile phase:**

- mobile phase A: *water R*,
- mobile phase B: *acetonitrile R*,

Time (min)	Mobile phase A (per cent V/V)	Mobile phase B (per cent V/V)
0 - 15	40 → 0	60 → 100
15 - 25	0	100
25 - 30	40	60
30 = 0	40	60

**Flow rate:** 1.0 mL/min.

**Detection:** spectrophotometer at 220 nm.

**Injection:** 10  $\mu$ L.

**Relative retention** with reference to estradiol valerate (retention time = about 12 min): impurity F = about 0.9.

**System suitability:** reference solution (a):

- resolution: minimum of 5.0 between the peaks due to impurity F and to estradiol valerate.

**Limits:**

- any impurity: not more than the area of the principal peak in the chromatogram obtained with reference solution (b) (0.5 per cent),
- total: not more than twice the area of the principal peak in the chromatogram obtained with reference solution (b) (1.0 per cent),
- disregard limit: 0.1 times the area of the principal peak in the chromatogram obtained with reference solution (b) (0.05 per cent).

**Loss on drying** (2.2.32): maximum 1.0 per cent, determined on 0.500 g by drying in an oven at 105 °C for 3 h.

## ASSAY

Dissolve 25.0 mg in *alcohol R* and dilute to 250.0 mL with the same solvent. Measure the absorbance (2.2.25) at the maximum at 280 nm.

Calculate the content of  $C_{23}H_{32}O_3$  taking the specific absorbance to be 58.0.

## STORAGE

Protected from light.

## IMPURITIES

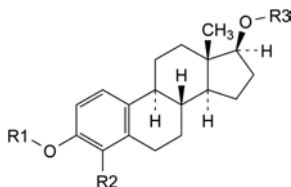

- A. R1 = R2 = R3 = H: estradiol,
- B. R1 = CO-[CH<sub>2</sub>]<sub>3</sub>-CH<sub>3</sub>, R2 = R3 = H: 17 $\beta$ -hydroxyestra-1,3,5(10)-trien-3-yl pentanoate,
- D. R1 = H, R2 = CH<sub>3</sub>, R3 = CO-[CH<sub>2</sub>]<sub>3</sub>-CH<sub>3</sub>: 3-hydroxy-4-methylestra-1,3,5(10)-trien-17 $\beta$ -yl pentanoate,
- E. R1 = R3 = CO-[CH<sub>2</sub>]<sub>3</sub>-CH<sub>3</sub>, R2 = H: estra-1,3,5(10)-trien-3,17 $\beta$ -diyl dipentanoate,
- F. R1 = R2 = H, R3 = CO-[CH<sub>2</sub>]<sub>2</sub>-CH<sub>3</sub>: 3-hydroxyestra-1,3,5(10)-trien-17 $\beta$ -yl butanoate (estradiol butyrate),

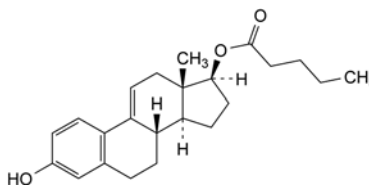

- C. 3-hydroxyestra-1,3,5(10),9(11)-tetraen-17 $\beta$ -yl pentanoate.

01/2008:1203  
corrected 6.0

## ESTRIOL

## Estriolum

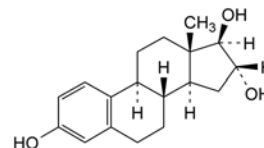

$C_{18}H_{24}O_3$   
[50-27-1]

$M_r$  288.4

## DEFINITION

Estra-1,3,5(10)-triene-3,16 $\alpha$ ,17 $\beta$ -triol.

**Content:** 97.0 per cent to 103.0 per cent (dried substance).

## CHARACTERS

**Appearance:** white or almost white, crystalline powder.

**Solubility:** practically insoluble in water, sparingly soluble in ethanol (96 per cent).

mp: about 282 °C.

## IDENTIFICATION

- A. Infrared absorption spectrophotometry (2.2.24).

**Comparison:** *estriol CRS*.

- B. Thin-layer chromatography (2.2.27).

**Test solution.** Dissolve 10 mg of the substance to be examined in *methanol R* and dilute to 10 mL with the same solvent.

**Reference solution (a).** Dissolve 10 mg of *estriol CRS* in *methanol R* and dilute to 10 mL with the same solvent.

**Reference solution (b).** Dissolve 5 mg of *estradiol hemihydrate CRS* in reference solution (a) and dilute to 5 mL with reference solution (a).

**Plate:** TLC silica gel plate R.

**Mobile phase:** *ethanol (96 per cent) R*, *toluene R* (20:80 V/V).

**Application:** 5  $\mu$ L.

*Development:* over a path of 15 cm.

*Drying:* in air.

*Detection:* spray with *alcoholic solution of sulfuric acid R*. Heat at 100 °C for 10 min or until the spots appear. Allow to cool. Examine in daylight and ultraviolet light at 365 nm.

*System suitability:* reference solution (b):

- the chromatogram shows 2 clearly separated spots.

*Results:* the principal spot in the chromatogram obtained with the test solution is similar in position, colour in daylight, fluorescence in ultraviolet light at 365 nm and size to the principal spot in the chromatogram obtained with the reference solution (a).

## TESTS

**Specific optical rotation (2.2.7):** + 60 to + 65 (dried substance).

Dissolve 80 mg in *anhydrous ethanol R* and dilute to 10 mL with the same solvent.

**Related substances.** Liquid chromatography (2.2.29).

*Solvent mixture:* 2-propanol R1, heptane R (20:80 V/V).

*Test solution.* Dissolve 20.0 mg of the substance to be examined in 5 mL of 2-propanol R1 and dilute to 20.0 mL with the solvent mixture.

*Reference solution (a).* Dissolve 5 mg of *estriol CRS* and 2.0 mg of *estriol impurity A CRS* in 5 mL of 2-propanol R1, then dilute to 10.0 mL with the solvent mixture. Dilute 1.0 mL of this solution to 20.0 mL with the solvent mixture.

*Reference solution (b).* Dilute 1.0 mL of the test solution to 10.0 mL with the solvent mixture. Dilute 1.0 mL of this solution to 10.0 mL with the solvent mixture.

*Column:*

- size:  $l = 0.15$  m,  $\varnothing = 4.0$  mm;
- stationary phase: *diol silica gel for chromatography R* (5  $\mu$ m);
- temperature: 40 °C.

*Mobile phase:*

- mobile phase A: *heptane R*;
- mobile phase B: 2-propanol R1;

Time (min)	Mobile phase A (per cent V/V)	Mobile phase B (per cent V/V)
0 - 10	95 → 88	5 → 12
10 - 20	88	12
20 - 30	88 → 95	12 → 5
30 - 35	95	5

*Flow rate:* 1.2 mL/min.

*Detection:* spectrophotometer at 280 nm.

*Equilibration:* with the solvent mixture until a stable baseline is obtained.

*Injection:* 20  $\mu$ L; inject the solvent mixture as a blank.

*Retention time:* *estriol* = about 19 min; *impurity A* = about 21 min; if the retention times increase, wash the column first with *acetone R* and then with *heptane R*.

*System suitability:* reference solution (a):

- resolution: minimum 2.2 between the peaks due to *estriol* and *impurity A*; if the resolution decreases, wash the column first with *acetone R* and then with *heptane R*.

*Limits:*

- *impurity A*: not more than 0.5 times the area of the corresponding peak in the chromatogram obtained with reference solution (a) (0.5 per cent);
- *impurities B, C, D, E, F, G*: for each impurity, not more than 0.5 times the area of the principal peak in the chromatogram obtained with reference solution (b) (0.5 per cent);

- *sum of impurities other than A*: not more than the area of the principal peak in the chromatogram obtained with reference solution (b) (1 per cent);
- *disregard limit*: 0.05 times the area of the principal peak in the chromatogram obtained with reference solution (b) (0.05 per cent).

**Loss on drying (2.2.32):** maximum 0.5 per cent, determined on 1.000 g by drying in an oven at 105 °C for 3 h.

## ASSAY

Dissolve 25.0 mg in *ethanol (96 per cent) R* and dilute to 50.0 mL with the same solvent. Dilute 10.0 mL of this solution to 50.0 mL with *ethanol (96 per cent) R*. Measure the absorbance (2.2.25) at the absorption maximum at 281 nm.

Calculate the content of  $C_{18}H_{24}O_3$  taking the specific absorbance to be 72.5.

## IMPURITIES

*Specified impurities:* A, B, C, D, E, F, G.

*Other detectable impurities* (the following substances would, if present at a sufficient level, be detected by one or other of the tests in the monograph. They are limited by the general acceptance criterion for other/unspecified impurities and/or by the general monograph *Substances for pharmaceutical use (2034)*. It is therefore not necessary to identify these impurities for demonstration of compliance. See also 5.10. *Control of impurities in substances for pharmaceutical use*): H, I.

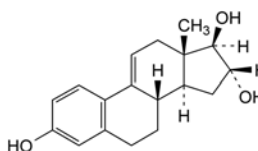

A. estra-1,3,5(10),9(11)-tetraene-3,16 $\alpha$ ,17 $\beta$ -triol (9,11-didehydroestriol),

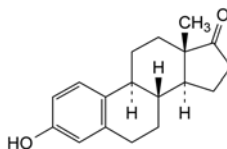

B. 3-hydroxyestra-1,3,5(10)-trien-17-one (estrone),

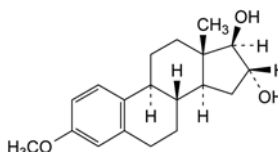

C. 3-methoxyestra-1,3,5(10)-triene-16 $\alpha$ ,17 $\beta$ -diol (estriol 3-methyl ether),

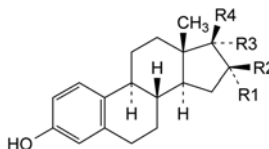

- D. R1 = R2 = R3 = H, R4 = OH: estradiol,  
 E. R1 = R3 = OH, R2 = R4 = H: estra-1,3,5(10)-triene-3,16 $\alpha$ ,17 $\alpha$ -triol (17-epi-estriol),  
 F. R1 = R3 = H, R2 = R4 = OH: estra-1,3,5(10)-triene-3,16 $\beta$ ,17 $\beta$ -triol (16-epi-estriol),  
 G. R1 = R4 = H, R2 = R3 = OH: estra-1,3,5(10)-triene-3,16 $\beta$ ,17 $\alpha$ -triol (16,17-epi-estriol),  
 H. R1 = OH, R2 = H, R3 + R4 = O: 3,16 $\alpha$ -dihydroxyestra-1,3,5(10)-trien-17-one,

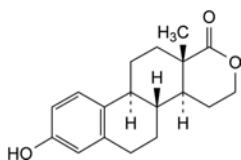
I. 3-hydroxy-17-oxa-*D*-homoestra-1,3,5(10)-trien-17a-one.

01/2008:1512

## ESTROGENS, CONJUGATED

## Estrogeni coniuncti

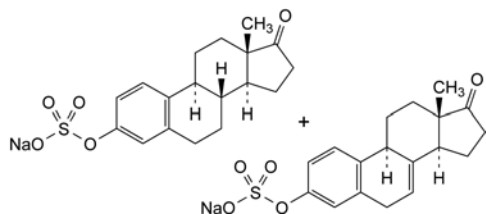
 $C_{18}H_{21}O_5NaS + C_{18}H_{19}O_5NaS$  $M_r 372.4 + 370.4$ 

## DEFINITION

Mixture of various conjugated forms of estrogens obtained from the urine of pregnant mares or by synthesis, dispersed in a suitable powdered diluent.

The 2 principal components are 17-oxoestra-1,3,5(10)-trien-3-yl sodium sulfate (sodium estrone sulfate) and 17-oxoestra-1,3,5(10),7-tetraen-3-yl sodium sulfate (sodium equilin sulfate). Concomitants are sodium 17 $\alpha$ -estradiol sulfate, sodium 17 $\alpha$ -dihydroequilin sulfate and sodium 17 $\beta$ -dihydroequilin sulfate.

*Content* (percentages related to the labelled content):

- sodium estrone sulfate: 52.5 per cent to 61.5 per cent;
- sodium equilin sulfate: 22.5 per cent to 30.5 per cent;
- sodium 17 $\alpha$ -estradiol sulfate: 2.5 per cent to 9.5 per cent;
- sodium 17 $\alpha$ -dihydroequilin sulfate: 13.5 per cent to 19.5 per cent;
- sodium 17 $\beta$ -dihydroequilin sulfate: 0.5 per cent to 4.0 per cent;
- sum of sodium estrone sulfate and sodium equilin sulfate: 79.5 per cent to 88.0 per cent.

## CHARACTERS

*Appearance*: almost white or brownish, amorphous powder.

## IDENTIFICATION

A. Examine the chromatograms obtained in the assay.

*Results*: the 2 principal peaks due to estrone and equilin in the chromatogram obtained with test solution (a) are similar in retention time and size to the 2 principal peaks in the chromatogram obtained with reference solution (a).

B. Examine the chromatogram obtained in the test for chromatographic profile.

*Results*: the chromatogram obtained with test solution (b) exhibits additional peaks due to 17 $\alpha$ -estradiol, 17 $\alpha$ -dihydroequilin and 17 $\beta$ -dihydroequilin, at relative retentions with reference to 3-*O*-methylestrone (internal standard) of about 0.24, 0.30 and 0.35 respectively.

## TESTS

**Chromatographic profile.** Gas chromatography (2.2.28).

*Internal standard solution.* Dissolve 8 mg of 3-*O*-methylestrone *R* in 10.0 mL of anhydrous ethanol *R*. Dilute 2.0 mL of this solution to 10.0 mL with anhydrous ethanol *R*.

*Acetate buffer solution pH 5.2.* Dissolve 10 g of sodium acetate *R* in 100 mL of water *R* and add 10 mL of dilute acetic acid *R*. Dilute to 500 mL with water *R* and adjust to pH 5.2  $\pm$  0.1.

*Test solution (a).* Considering the labelled content, transfer an accurately weighed quantity corresponding to about 2 mg of conjugated estrogens to a 50 mL centrifuge tube containing 15 mL of the acetate buffer solution pH 5.2 and 1 g of barium chloride *R*. Cap the tube tightly and shake for 30 min. If necessary, adjust to pH 5.0  $\pm$  0.5 with acetic acid *R* or a 120 g/L solution of sodium acetate *R*. Sonicate for 30 s, then shake for 30 min. Add a suitable sulfatase preparation equivalent to 2500 units and shake mechanically for 10 min in a water-bath at 50  $\pm$  1  $^{\circ}$ C. Swirl the tube by hand, then shake mechanically for 10 min in the water-bath. Allow to cool. Add 15.0 mL of ethylene chloride *R* to the mixture, immediately cap the tube tightly and shake for 15 min. Centrifuge for 10 min or until the lower layer is clear. Draw out the organic layer to a screw-cap tube, add 5 g of anhydrous sodium sulfate *R* and shake. Allow the solution to stand until clear. Protect the solution from any loss due to evaporation. Transfer 3.0 mL of the clear solution to a suitable centrifuge tube fitted with a screw cap. Add 1.0 mL of the internal standard solution. Evaporate the mixture to dryness with the aid of a stream of nitrogen *R*, maintaining the temperature below 50  $^{\circ}$ C. To the dry residue add 15  $\mu$ L of anhydrous pyridine *R* and 65  $\mu$ L of *N,O*-bis(trimethylsilyl)trifluoroacetamide *R* containing 1 per cent of chlorotrimethylsilane *R*. Immediately cap the tube tightly, mix thoroughly and allow to stand for 15 min. Add 0.5 mL of toluene *R* and mix mechanically.

*Test solution (b).* Prepare as described in test solution (a), but do not add the sulfatase and use 6.0 mL of the upper layer instead of 3.0 mL. Prepare a blank in the same manner.

*Reference solution (a).* Dissolve separately 8 mg of estrone *CRS*, 7 mg of equilin *CRS* and 5 mg of 17 $\alpha$ -dihydroequilin *CRS* in 10.0 mL of anhydrous ethanol *R*. Dilute together 2.0 mL, 1.0 mL and 1.0 mL respectively of these solutions to 10.0 mL with anhydrous ethanol *R*. Transfer 1.0 mL of this solution and 1.0 mL of the internal standard solution to a centrifuge tube fitted with a screw cap. Evaporate the mixture to dryness with the aid of a stream of nitrogen *R*, maintaining the temperature below 50  $^{\circ}$ C. To the dry residue add 15  $\mu$ L of anhydrous pyridine *R* and 65  $\mu$ L of *N,O*-bis(trimethylsilyl)trifluoroacetamide *R* containing 1 per cent of chlorotrimethylsilane *R*. Immediately cap the tube tightly, mix and allow to stand for 15 min. Add 0.5 mL of toluene *R*.

*Reference solution (b).* Prepare as described in reference solution (a), but dilute tenfold with anhydrous ethanol *R* before adding the internal standard.

*Column*:

- material: fused silica;
- size:  $l = 15$  m,  $\varnothing = 0.25$  mm;
- stationary phase: poly[(cyanopropyl)(methyl)][(phenyl)(methyl)siloxane *R* (film thickness 0.25  $\mu$ m).

*Carrier gas*: hydrogen for chromatography *R*.

*Flow rate*: 2 mL/min.

*Split ratio*: 1:20 to 1:30.

*Temperature*:

- column: 220  $^{\circ}$ C;
- injection port and detector: 260  $^{\circ}$ C.

*Detection*: flame ionisation.

*Injection*: 1  $\mu$ L.

*Relative retention* with reference to 3-*O*-methylestrone: 17 $\alpha$ -dihydroequilin = about 0.30; estrone = about 0.80; equilin = about 0.87.

*System suitability*: reference solution (a):

- resolution: minimum 1.2 between the peaks due to estrone and equilin; if necessary, adjust the temperature and the flow rate of the carrier gas.

In the chromatogram obtained with reference solution (a), measure the areas of the peaks due to 17 $\alpha$ -dihydroequilin, estrone and 3-*O*-methylestrone.

In the chromatogram obtained with test solution (a), locate the peaks with relative retentions with reference to 3-*O*-methylestrone of 1 and about 0.24, 0.29, 0.30, 0.35, 0.56, 0.64, 0.90 and 1.3 and measure their areas.

Calculate the percentage content of the components occurring as sodium sulfate salts using expression (1) below.

In the chromatogram obtained with reference solution (b), measure the areas of the peaks due to estrone and 3-*O*-methylestrone.

In the chromatogram obtained with test solution (b), locate the peaks with relative retentions with reference to 3-*O*-methylestrone of about 0.30, 0.80 and 0.87 and measure the sum of the areas.

Calculate the percentage content of 17 $\alpha$ -dihydroequilin, estrone and equilin occurring as free steroids using expression (2) below.

$$\frac{S'_A \times S_I \times m_R \times 137.8 \times 1000}{S_R \times S'_I \times m \times LC} \quad (1)$$

$$\frac{S'_{FS} \times S_I \times m_E \times 100 \times 1000}{S_E \times S'_I \times m \times LC} \quad (2)$$

$S_I$  = area of the peak due to the internal standard in the chromatogram obtained with the corresponding reference solution;

$S'_I$  = area of the peak due to the internal standard in the chromatogram obtained with the corresponding test solution;

$S_R$  = area of the peak due to the reference substance (Table 1512.-1) in the chromatogram obtained with the corresponding reference solution;

$S'_A$  = area of the peak due to the analyte in the chromatogram obtained with the corresponding test solution;

$m_R$  = mass of the reference substance (Table 1512.-1) in the corresponding reference solution, in milligrams;

$m$  = mass of the substance to be examined in the corresponding test solution, in milligrams;

$S'_{FS}$  = sum of the areas of the peaks due to 17 $\alpha$ -dihydroequilin, estrone and equilin in the chromatogram obtained with the corresponding test solution;

$S_E$  = area of the peak due to *estrone CRS* in the chromatogram obtained with the corresponding reference solution;

$m_E$  = mass of *estrone CRS* in the corresponding reference solution, in milligrams;

$LC$  = labelled content, in milligrams per gram.

The percentages are within the following ranges:

- sodium 17 $\alpha$ -estradiol sulfate: 2.5 per cent to 9.5 per cent;
- sodium 17 $\alpha$ -dihydroequilin sulfate: 13.5 per cent to 19.5 per cent;
- sodium 17 $\beta$ -dihydroequilin sulfate: 0.5 per cent to 4.0 per cent;
- sodium 17 $\beta$ -estradiol sulfate: maximum 2.25 per cent;
- sodium 17 $\alpha$ -dihydroequilenin sulfate: maximum 3.25 per cent;
- sodium 17 $\beta$ -dihydroequilenin sulfate: maximum 2.75 per cent;
- sodium 8,9-didehydroestrone sulfate: maximum 6.25 per cent;
- sodium equilenin sulfate: maximum 5.5 per cent;
- sum of estrone, equilin and 17 $\alpha$ -dihydroequilin: maximum 1.3 per cent.

#### ASSAY

Gas chromatography (2.2.28) as described in the test for chromatographic profile with the following modifications.

*Injection*: test solution (a) and reference solution (a).

*System suitability*: reference solution (a):

- *repeatability*: maximum relative standard deviation of 2.0 per cent for the ratio of the area of the peak due to estrone to that due to the internal standard after at least 6 injections.

In the chromatogram obtained with reference solution (a), measure the areas of the peaks due to estrone or equilin and 3-*O*-methylestrone. In the chromatogram obtained with test solution (a), measure the areas of the peaks due to estrone, equilin and 3-*O*-methylestrone.

Calculate the percentage content of sodium estrone sulfate and sodium equilin sulfate using expression (1).

#### LABELLING

The label states:

- the name of the substance;
- the content of the substance;
- the nature of the diluent.

Table 1512.-1

Relative retention (to 3- <i>O</i> -methylestrone)	Analyte	Quantified with reference to CRS	Present as
0.24	17 $\alpha$ -estradiol	17 $\alpha$ -dihydroequilin CRS	sodium sulfate
0.29	17 $\beta$ -estradiol	<i>estrone CRS</i>	sodium sulfate
0.30	17 $\alpha$ -dihydroequilin	17 $\alpha$ -dihydroequilin CRS	free steroid, sodium sulfate (assay)
0.35	17 $\beta$ -dihydroequilin	17 $\alpha$ -dihydroequilin CRS	sodium sulfate
0.56	17 $\alpha$ -dihydroequilenin	<i>estrone CRS</i>	sodium sulfate
0.64	17 $\beta$ -dihydroequilenin	<i>estrone CRS</i>	sodium sulfate
0.80	estrone	<i>estrone CRS</i>	free steroid, sodium sulfate (assay)
0.87	equilin	<i>equilin CRS</i>	free steroid, sodium sulfate (assay)
0.90	8,9-didehydroestrone	<i>estrone CRS</i>	sodium sulfate
1	3- <i>O</i> -methylestrone	(internal standard)	
1.3	equilenin	<i>estrone CRS</i>	sodium sulfate

## IMPURITIES AND CONCOMITANTS

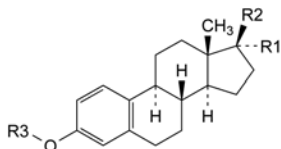

- A. R1 = OH, R2 = H, R3 = SO<sub>3</sub>Na: 17 $\alpha$ -hydroxyestra-1,3,5(10)-trien-3-yl sodium sulfate (sodium 17 $\alpha$ -estradiol sulfate),
- D. R1 = H, R2 = OH, R3 = SO<sub>3</sub>Na: 17 $\beta$ -hydroxyestra-1,3,5(10)-trien-3-yl sodium sulfate (sodium 17 $\beta$ -estradiol sulfate),
- I. R1 + R2 = O, R3 = H: 3-hydroxyestra-1,3,5(10)-trien-17-one (estrone),

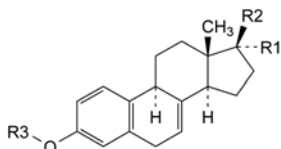

- B. R1 = OH, R2 = H, R3 = SO<sub>3</sub>Na: 17 $\alpha$ -hydroxyestra-1,3,5(10),7-tetraen-3-yl sodium sulfate (sodium 17 $\alpha$ -dihydroequilin sulfate),
- C. R1 = H, R2 = OH, R3 = SO<sub>3</sub>Na: 17 $\beta$ -hydroxyestra-1,3,5(10),7-tetraen-3-yl sodium sulfate (sodium 17 $\beta$ -dihydroequilin sulfate),
- J. R1 + R2 = O, R3 = H: 3-hydroxyestra-1,3,5(10),7-tetraen-17-one (equilin),
- K. R1 = OH, R2 = R3 = H: estra-1,3,5(10),7-tetraene-3,17 $\alpha$ -diol (17 $\alpha$ -dihydroequilin),

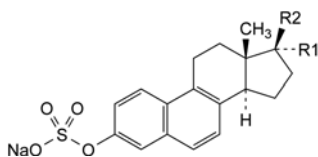

- E. R1 = OH, R2 = H: 17 $\alpha$ -hydroxyestra-1,3,5(10),6,8-pentaen-3-yl sodium sulfate (sodium 17 $\alpha$ -dihydroequilenin sulfate),
- F. R1 = H, R2 = OH: 17 $\beta$ -hydroxyestra-1,3,5(10),6,8-pentaen-3-yl sodium sulfate (sodium 17 $\beta$ -dihydroequilenin sulfate),
- H. R1 + R2 = O: 17-oxoestra-1,3,5(10),6,8-pentaen-3-yl sodium sulfate (sodium equilenin sulfate),

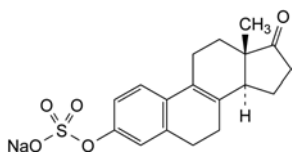

- G. 17-oxoestra-1,3,5(10),8-tetraen-3-yl sodium sulfate (sodium 8,9-didehydroestrone sulfate).

07/2009:0457

## ETACRYNIC ACID

## Acidum etacrynicum

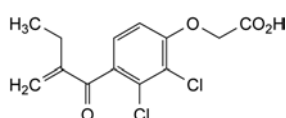

C<sub>13</sub>H<sub>12</sub>Cl<sub>2</sub>O<sub>4</sub>  
[58-54-8]

M<sub>r</sub> 303.1

## DEFINITION

[2,3-Dichloro-4-(2-methylenebutanoyl)phenoxy]acetic acid  
*Content*: 98.0 per cent to 102.0 per cent (dried substance).

## CHARACTERS

*Appearance*: white or almost white, crystalline powder.

*Solubility*: very slightly soluble in water, freely soluble in ethanol (96 per cent). It dissolves in ammonia and in dilute solutions of alkali hydroxides and carbonates.

## IDENTIFICATION

*First identification*: C.

*Second identification*: A, B, D, E.

A. Melting point (2.2.14): 121 °C to 124 °C.

B. Ultraviolet and visible absorption spectrophotometry (2.2.25).

*Solvent mixture*: 103 g/L solution of hydrochloric acid R, methanol R (1:99 V/V).

*Test solution*: Dissolve 50.0 mg in the solvent mixture and dilute to 100.0 mL with the solvent mixture. Dilute 10.0 mL of this solution to 100.0 mL with the solvent mixture.

*Spectral range*: 230-350 nm.

*Absorption maximum*: at 270 nm.

*Shoulder*: at about 285 nm.

*Specific absorbance at the absorption maximum*: 110 to 120.

C. Infrared absorption spectrophotometry (2.2.24).

*Comparison*: etacrynic acid CRS.

D. Dissolve about 30 mg in 2 mL of aldehyde-free alcohol R. Dissolve 70 mg of hydroxylamine hydrochloride R in 0.1 mL of water R, add 7 mL of alcoholic potassium hydroxide solution R and dilute to 10 mL with aldehyde-free alcohol R. Allow to stand and add 1 mL of the supernatant liquid to the solution of the substance to be examined. Heat the mixture on a water-bath for 3 min. After cooling, add 3 mL of water R and 0.15 mL of hydrochloric acid R. Examine in ultraviolet light at 254 nm, the mixture shows an intense blue fluorescence.

E. Dissolve about 25 mg in 2 mL of a 42 g/L solution of sodium hydroxide R and heat in a water-bath for 5 min. Cool and add 0.25 mL of a mixture of equal volumes of sulfuric acid R and water R. Add 0.5 mL of a 100 g/L solution of chromotropic acid, sodium salt R and, carefully, 2 mL of sulfuric acid R. An intense violet colour is produced.

## TESTS

**Related substances.** Liquid chromatography (2.2.29).

*Solvent mixture*: acetonitrile R, water R (40:60 V/V).

*Test solution.* Dissolve 25 mg of the substance to be examined in the solvent mixture and dilute to 25.0 mL with the solvent mixture.

*Reference solution (a).* Dilute 1.0 mL of the test solution to 100.0 mL with the solvent mixture. Dilute 1.0 mL of this solution to 10.0 mL with the solvent mixture.

*Reference solution (b).* Dissolve 5 mg of etacrynic acid for system suitability CRS (containing impurities A, B and C) in 5.0 mL of the solvent mixture.

*Column*:

– size:  $l = 0.25$  m,  $\varnothing = 4.0$  mm;

– stationary phase: end-capped octadecylsilyl silica gel for chromatography R (5  $\mu$ m);

– temperature: 25 °C.

*Mobile phase*:

– mobile phase A: 1 per cent V/V solution of triethylamine R adjusted to pH 6.8 with phosphoric acid R;

– mobile phase B: acetonitrile R;

Time (min)	Mobile phase A (per cent V/V)	Mobile phase B (per cent V/V)
0-2.5	70	30
2.5-3	70→65	30→35
3-6	65	35
6-7	65→45	35→55
7-22	45	55

Flow rate: 0.8 mL/min.

Detection: spectrophotometer at 280 nm.

Injection: 10 µL.

Identification of impurities: use the chromatogram supplied with *etacrynic acid* for system suitability CRS and the chromatogram obtained with reference solution (b) to identify the peaks due to impurities A, B and C.

Relative retention with reference to etacrynic acid (retention time = about 9 min): impurity A = about 0.8; impurity B = about 1.3; impurity C = about 1.7.

System suitability: reference solution (b):

- resolution: minimum 4.0 between the peaks due to impurity A and etacrynic acid.

Limits:

- correction factors: for the calculation of contents, multiply the peak areas of the following impurities by the corresponding correction factor: impurity A = 0.6; impurity B = 0.6; impurity C = 1.3;
- impurity C: not more than 3 times the area of the principal peak in the chromatogram obtained with reference solution (a) (0.3 per cent);
- impurities A, B: for each impurity, not more than 1.5 times the area of the principal peak in the chromatogram obtained with reference solution (a) (0.15 per cent);
- unspecified impurities: for each impurity, not more than the area of the principal peak in the chromatogram obtained with reference solution (a) (0.10 per cent);
- total: not more than 8 times the area of the principal peak in the chromatogram obtained with reference solution (a) (0.8 per cent);
- disregard limit: 0.5 times the area of the principal peak in the chromatogram obtained with reference solution (a) (0.05 per cent).

Heavy metals (2.4.8): maximum 20 ppm.

1.0 g complies with test F. Prepare the reference solution using 2 mL of lead standard solution (10 ppm Pb) R.

Loss on drying (2.2.32): maximum 0.5 per cent, determined on 2.000 g by drying at 60 °C over diphosphorus pentoxide R at a pressure of 0.1-0.5 kPa.

Sulfated ash (2.4.14): maximum 0.1 per cent, determined on 1.0 g.

#### ASSAY

Dissolve 0.250 g in 100 mL of methanol R and add 5 mL of water R. Titrate with 0.1 M sodium hydroxide, determining the end-point potentiometrically (2.2.20).

1 mL of 0.1 M sodium hydroxide is equivalent to 30.31 mg of C<sub>13</sub>H<sub>12</sub>Cl<sub>2</sub>O<sub>4</sub>.

#### IMPURITIES

Specified impurities: A, B, C.

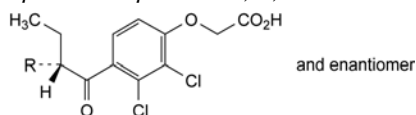

- A. R = H: (4-butanoyl-2,3-dichlorophenoxy)acetic acid,  
 B. R = CH<sub>2</sub>Cl: [2,3-dichloro-4-[2-(chloromethyl)butanoyl]-phenoxy]acetic acid,

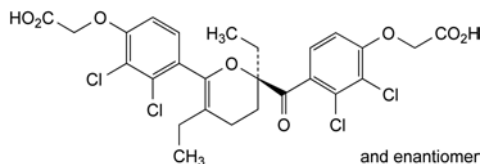

- C. [4-[2-[4-(carboxymethoxy)-2,3-dichlorobenzoyl]-2,5-diethyl-3,4-dihydro-2H-pyran-6-yl]-2,3-dichlorophenoxy]acetic acid.

07/2008:1204

## ETAMSYLATE

### Etamsylatum

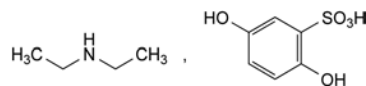

C<sub>10</sub>H<sub>17</sub>NO<sub>5</sub>S  
 [2624-44-4]

M<sub>r</sub> 263.3

#### DEFINITION

N-Ethylethanamine 2,5-dihydroxybenzenesulfonate.

Content: 99.0 per cent to 101.0 per cent (dried substance).

#### CHARACTERS

Appearance: white or almost white, crystalline powder.

Solubility: very soluble in water, freely soluble in methanol, soluble in anhydrous ethanol, practically insoluble in methylene chloride.

It shows polymorphism (5.9).

#### IDENTIFICATION

First identification: B.

Second identification: A, C, D.

- A. Melting point (2.2.14): 127 °C to 134 °C.  
 B. Infrared absorption spectrophotometry (2.2.24).  
 Comparison: *etamsylate* CRS.  
 C. Ultraviolet and visible absorption spectrophotometry (2.2.25).

Test solution. Dissolve 0.100 g in water R and dilute to 200.0 mL with the same solvent. Dilute 5.0 mL of this solution to 100.0 mL with water R. Examine immediately.

Spectral range: 210-350 nm.

Absorption maxima: at 221 nm and 301 nm.

Specific absorbance at the absorption maximum at 301 nm: 145 to 151.

- D. Into a test-tube, introduce 2 mL of freshly prepared solution S (see Tests) and 0.5 g of sodium hydroxide R. Warm the mixture and place a wet strip of red litmus paper R near the open end of the tube. The colour of the paper becomes blue.

#### TESTS

Solution S. Dissolve 10.0 g in carbon dioxide-free water R and dilute to 100 mL with the same solvent.

Appearance of solution. Solution S, when freshly prepared, is clear (2.2.1) and colourless (2.2.2, Method II).

pH (2.2.3): 4.5 to 5.6 for solution S.

Related substances. Liquid chromatography (2.2.29). Keep all solutions at 2-8 °C.

Buffer solution. Dissolve 1.2 g of anhydrous sodium dihydrogen phosphate R in 900 mL of water for chromatography R. Adjust to pH 6.5 with disodium hydrogen phosphate solution R and dilute to 1000 mL with water for chromatography R.

Test solution. Dissolve 0.100 g of the substance to be examined in water R and dilute to 10.0 mL with the same solvent.



01/2008:1591  
corrected 6.3

**Reference solution (a).** Dilute 1.0 mL of the test solution to 100.0 mL with *water R*. Dilute 1.0 mL of this solution to 10.0 mL with *water R*.

**Reference solution (b).** Dissolve 10 mg of the substance to be examined and 10 mg of *hydroquinone R* (impurity A) in *water R* and dilute to 10 mL with the same solvent. Dilute 1 mL of this solution to 100 mL with *water R*.

**Column:**

- **size:**  $l = 0.25$  m,  $\varnothing = 4.6$  mm;
- **stationary phase:** spherical *end-capped octadecylsilyl silica gel for chromatography R* (5  $\mu$ m).

**Mobile phase:** *acetonitrile R1*, buffer solution (10:90 V/V).

**Flow rate:** 0.8 mL/min.

**Detection:** spectrophotometer at 220 nm.

**Injection:** 10  $\mu$ L.

**Run time:** 2.5 times the retention time of etamsylate.

**Relative retention** with reference to etamsylate (retention time = about 6 min): impurity A = about 1.7.

**System suitability:** reference solution (b):

- **resolution:** minimum 8.0 between the peaks due to etamsylate and impurity A.

**Limits:**

- **correction factor:** for the calculation of content, multiply the peak area of impurity A by 0.5;
- **impurity A:** not more than the area of the principal peak in the chromatogram obtained with reference solution (a) (0.1 per cent);
- **unspecified impurities:** for each impurity, not more than the area of the principal peak in the chromatogram obtained with reference solution (a) (0.10 per cent);
- **total:** not more than twice the area of principal peak in the chromatogram obtained with reference solution (a) (0.2 per cent);
- **disregard limit:** 0.5 times the area of the principal peak in the chromatogram obtained with reference solution (a) (0.05 per cent).

**Iron (2.4.9):** maximum 10 ppm, determined on solution S.

**Heavy metals (2.4.8):** maximum 15 ppm.

1.0 g complies with test C. Prepare the reference solution using 1.5 mL of *lead standard solution (10 ppm Pb) R*.

**Loss on drying (2.2.32):** maximum 0.5 per cent, determined on 1.000 g by drying *in vacuo* in an oven at 60 °C.

**Sulfated ash (2.4.14):** maximum 0.1 per cent, determined on 1.0 g.

**ASSAY**

Dissolve 0.200 g in a mixture of 10 mL of *water R* and 40 mL of *dilute sulfuric acid R*. Titrate with 0.1 M *cerium sulfate*, determining the end-point potentiometrically (2.2.20).

1 mL of 0.1 M *cerium sulfate* is equivalent to 13.16 mg of  $C_{10}H_{17}NO_5S$ .

**STORAGE**

In an airtight container, protected from light.

**IMPURITIES**

**Specified impurities:** A.

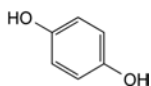

A. benzene-1,4-diol (hydroquinone).

## ETHACRIDINE LACTATE MONOHYDRATE

Ethacridini lactas monohydricus

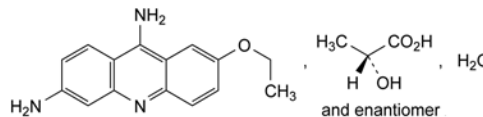

$C_{18}H_{21}N_3O_4 \cdot H_2O$   
[6402-23-9]

$M_r$  361.4

**DEFINITION**

7-Ethoxyacridine-3,9-diamine (2*RS*)-2-hydroxypropanoate monohydrate.

**Content:** 99.0 per cent to 101.0 per cent (dried substance).

**CHARACTERS**

**Appearance:** yellow crystalline powder.

**Solubility:** sparingly soluble in water, very slightly soluble in ethanol (96 per cent), practically insoluble in methylene chloride.

**IDENTIFICATION**

**First identification:** A.

**Second identification:** B, C, D.

A. Infrared absorption spectrophotometry (2.2.24).

**Comparison:** *ethacridine lactate monohydrate CRS*.

B. Mix 0.1 mL of solution S (see Tests) and 100 mL of *water R*. The solution is greenish-yellow and shows a strong green fluorescence in ultraviolet light at 365 nm. Add 5 mL of 1 M *hydrochloric acid*. The fluorescence remains.

C. To 0.5 mL of solution S add 1.0 mL of *water R*, 0.1 mL of a 10 g/L solution of *cobalt chloride R* and 0.1 mL of a 50 g/L solution of *potassium ferrocyanide R*. The solution is green.

D. To 50 mL of solution S add 10 mL of *dilute sodium hydroxide solution R*. Filter. To 5 mL of the filtrate, add 1 mL of *dilute sulfuric acid R*. 5 mL of the solution obtained gives the reaction of lactates (2.3.1).

**TESTS**

**Solution S.** Dissolve 2.0 g in *carbon dioxide-free water R* and dilute to 100.0 mL with the same solvent.

**pH (2.2.3):** 5.5 to 7.0 for solution S.

**Related substances.** Liquid chromatography (2.2.29).

**Test solution.** Dissolve 10.0 mg of the substance to be examined in the mobile phase and dilute to 25.0 mL with the mobile phase.

**Reference solution (a).** Dilute 1.0 mL of test solution to 100.0 mL with the mobile phase.

**Reference solution (b).** Dilute 1.0 mL of reference solution (a) to 10.0 mL with the mobile phase.

**Column:**

- **size:**  $l = 0.25$  m,  $\varnothing = 4.6$  mm,
- **stationary phase:** *octadecylsilyl silica gel for chromatography R* (5  $\mu$ m).

**Mobile phase:** dissolve 1.0 g of *sodium octanesulfonate R* in a mixture of 300 mL of *acetonitrile R* and 700 mL of *phosphate buffer solution pH 2.8 R*.

**Flow rate:** 1 mL/min.

**Detection:** spectrophotometer at 268 nm.

**Injection:** 10  $\mu$ L.

**Run time:** 3 times the retention time of ethacridine.

**Retention time:** ethacridine = about 15 min.

**Limits:**

- *any impurity*: not more than 3 times the area of the principal peak in the chromatogram obtained with reference solution (b) (0.3 per cent),
- *total*: not more than the area of the principal peak in the chromatogram obtained with reference solution (a) (1 per cent),
- *disregard limit*: 0.5 times the area of the principal peak in the chromatogram obtained with reference solution (b) (0.05 per cent).

**Heavy metals** (2.4.8): maximum 50 ppm.

1.0 g complies with test F. Prepare the reference solution using 5.0 mL of *lead standard solution* (10 ppm Pb) R.

**Loss on drying** (2.2.32): 4.5 per cent to 5.5 per cent, determined on 1.000 g by drying in an oven *in vacuo* at 105 °C.

**Sulfated ash** (2.4.14): maximum 0.1 per cent, determined on 1.0 g.

**ASSAY**

Dissolve 0.270 g in 5.0 mL of *anhydrous formic acid* R. Add 60.0 mL of *acetic anhydride* R and titrate with 0.1 M *perchloric acid*, determining the end-point potentiometrically (2.2.20).

1 mL of 0.1 M *perchloric acid* is equivalent to 34.34 mg of C<sub>18</sub>H<sub>21</sub>N<sub>3</sub>O<sub>4</sub>.

**STORAGE**

Protected from light.

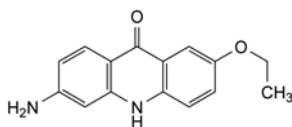
**IMPURITIES**

A. 6-amino-2-ethoxyacridin-9(10H)-one,

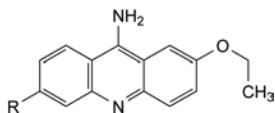

B. R = Cl: 6-chloro-2-ethoxyacridin-9-amine,

C. R = O-CH<sub>2</sub>-CH<sub>2</sub>-OH: 2-[(9-amino-7-ethoxyacridin-3-yl)oxy]ethanol.

04/2008:0553

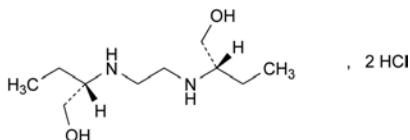
**ETHAMBUTOL HYDROCHLORIDE****Ethambutoli hydrochloridum**

C<sub>10</sub>H<sub>26</sub>Cl<sub>2</sub>N<sub>2</sub>O<sub>2</sub>  
[1070-11-7]

M<sub>r</sub> 277.2

**DEFINITION**

(2*S*,2'*S*)-2,2'-(Ethylenediimino)dibutan-1-ol dihydrochloride.

*Content*: 99.0 per cent to 101.0 per cent (dried substance).

**CHARACTERS**

*Appearance*: white or almost white, crystalline powder, hygroscopic.

*Solubility*: freely soluble in water, soluble in ethanol (96 per cent).

**IDENTIFICATION**

*First identification*: A, D, E.

*Second identification*: B, C, D.

A. Infrared absorption spectrophotometry (2.2.24).

*Comparison*: *ethambutol hydrochloride CRS*.

B. Examine the chromatograms obtained in the test for impurity A.

*Results*: the principal spot in the chromatogram obtained with test solution (b) is similar in position, colour and size to the principal spot in the chromatogram obtained with reference solution (b).

C. Dissolve 0.1 g in 10 mL of *water R*. Add 0.2 mL of *copper sulfate solution R* and 0.5 mL of *dilute sodium hydroxide solution R*; a blue colour is produced.

D. It gives reaction (a) of chlorides (2.3.1).

E. Related substances (see Tests).

**TESTS**

**pH** (2.2.3): 3.7 to 4.0.

Dissolve 0.2 g in 10 mL of *carbon dioxide-free water R*.

**Impurity A**. Thin-layer chromatography (2.2.27).

*Test solution (a)*. Dissolve 0.50 g of the substance to be examined in *methanol R* and dilute to 10 mL with the same solvent.

*Test solution (b)*. Dilute 1 mL of test solution (a) to 10 mL with *methanol R*.

*Reference solution (a)*. Dissolve 50.0 mg of *2-aminobutanol R* (impurity A) in *methanol R* and dilute to 10.0 mL with the same solvent. Dilute 1.0 mL of this solution to 10.0 mL with *methanol R*.

*Reference solution (b)*. Dissolve 50 mg of *ethambutol hydrochloride CRS* and 5 mg of *2-aminobutanol R* in *methanol R* and dilute to 10 mL with the same solvent.

*Plate*: *TLC silica gel plate R*.

*Mobile phase*: *concentrated ammonia R, water R, methanol R* (10:15:75 V/V/V).

*Application*: 2 µL.

*Development*: over 2/3 of the plate.

*Drying*: in air; heat at 110 °C for 10 min.

*Detection*: cool then spray with *ninhydrin solution R1*; heat at 110 °C for 5 min.

*System suitability*: reference solution (b):

- the chromatogram shows 2 clearly separated spots.

*Limit*:

- *impurity A*: any spot due to impurity A in the chromatogram obtained with test solution (a) is not more intense than the spot in the chromatogram obtained with reference solution (a) (1.0 per cent).

**Related substances**. Liquid chromatography (2.2.29). *Prepare the solutions immediately before use.*

*Test solution*. Suspend 4.0 mg of the substance to be examined in 4.0 mL of *acetonitrile R1* and add 100 µL of *triethylamine R*. Sonicate the mixture for 5 min. Add 15 µL of (*R*)-(+)-*α*-methylbenzyl isocyanate R and heat at 70 °C for 20 min.

*Reference solution (a)*. Dilute 0.50 mL of the test solution to 100.0 mL with *acetonitrile R1*.

*Reference solution (b)*. Treat 4.0 mg of *ethambutol for system suitability CRS* (containing impurity B) as described for the test solution.

*Column*:

- *size*: *l* = 0.10 m, Ø = 4.6 mm;
- *stationary phase*: *end-capped octadecylsilyl silica gel for chromatography R* (3 µm);
- *temperature*: 40 °C.

## Mobile phase:

- mobile phase A: methanol R, water R (50:50 V/V);
- mobile phase B: methanol R;

Time (min)	Mobile phase A (per cent V/V)	Mobile phase B (per cent V/V)
0 - 30	71	29
30 - 35	71 → 0	29 → 100
35 - 37	0	100
37 - 38	0 → 71	100 → 29

Flow rate: 1.0 mL/min.

Detection: spectrophotometer at 215 nm.

Injection: 10 µL.

Relative retention with reference to ethambutol (retention time = about 14 min): impurity B = about 1.3.

System suitability: reference solution (b):

- resolution: minimum 4.0 between the peaks due to ethambutol and impurity B.

## Limits:

- impurity B: not more than twice the area of the principal peak in the chromatogram obtained with reference solution (a) (1.0 per cent);
- unspecified impurities with a relative retention of 0.75 to 1.5 with reference to ethambutol: for each impurity, not more than 0.2 times the area of the peak due to ethambutol in the chromatogram obtained with reference solution (a) (0.10 per cent);
- total (impurity B and unspecified impurities with a relative retention of 0.75 to 1.5 with reference to ethambutol): not more than twice the area of the principal peak in the chromatogram obtained with reference solution (a) (1.0 per cent);
- disregard limit: 0.1 times the area of the peak due to ethambutol in the chromatogram obtained with reference solution (a) (0.05 per cent).

**Impurity D (1,2-dichloroethane) (2.4.24):** maximum 5 ppm.**Heavy metals (2.4.8):** maximum 10 ppm.

Dissolve 2.0 g in water R and dilute to 20 mL with the same solvent. 12 mL of the solution complies with test A. Prepare the reference solution using 10 mL of lead standard solution (1 ppm Pb) R.

**Loss on drying (2.2.32):** maximum 0.5 per cent, determined on 0.500 g by drying in an oven at 105 °C for 3 h.**Sulfated ash (2.4.14):** maximum 0.1 per cent, determined on 1.0 g.

## ASSAY

Dissolve 0.200 g in 50 mL of water R and add 1.0 mL of 0.1 M hydrochloric acid. Carry out a potentiometric titration (2.2.20), using 0.1 M sodium hydroxide. Read the volume added between the 2 points of inflexion.

1 mL of 0.1 M sodium hydroxide is equivalent to 27.72 mg of C<sub>10</sub>H<sub>26</sub>Cl<sub>2</sub>N<sub>2</sub>O<sub>2</sub>.

## STORAGE

In an airtight container.

## IMPURITIES

Specified impurities: A, B, D.

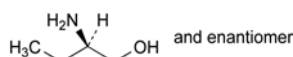
Other detectable impurities (the following substances would, if present at a sufficient level, be detected by one or other of the tests in the monograph. They are limited by the general acceptance criterion for other/unspecified impurities and/or by the general monograph *Substances for pharmaceutical use (2034)*. It is therefore not necessary to identify these impurities for demonstration of compliance. See also 5.10. *Control of impurities in substances for pharmaceutical use*): C.

A. 2-aminobutan-1-ol,

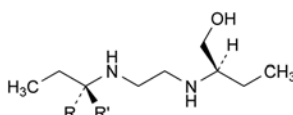
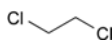
B. R = CH<sub>2</sub>-OH, R' = H: (2*R*,2'*S*)-2,2'-(ethylenediimino)-dibutan-1-ol (meso-ethambutol),C. R = H, R' = CH<sub>2</sub>-OH: (2*R*,2'*R*)-2,2'-(ethylenediimino)dibutan-1-ol ((*R,R*)-ethambutol),

D. 1,2-dichloroethane (ethylene chloride).

01/2008:1317

## ETHANOL (96 PER CENT)

## Ethanolum (96 per centum)

## DEFINITION

## Content:

- ethanol (C<sub>2</sub>H<sub>6</sub>O; M<sub>r</sub> 46.07): 95.1 per cent V/V (92.6 per cent m/m) to 96.9 per cent V/V (95.2 per cent m/m) at 20 °C, calculated from the relative density using the alcoholimetric tables (5.5);
- water.

## CHARACTERS

**Appearance:** colourless, clear, volatile, flammable liquid, hygroscopic.**Solubility:** miscible with water and with methylene chloride.

It burns with a blue, smokeless flame.

bp: about 78 °C.

## IDENTIFICATION

**First identification:** A, B.**Second identification:** A, C, D.

A. Relative density (see Tests).

B. Infrared absorption spectrophotometry (2.2.24).

**Comparison:** Ph. Eur. reference spectrum ethanol (96 per cent).

C. Mix 0.1 mL with 1 mL of a 10 g/L solution of potassium permanganate R and 0.2 mL of dilute sulfuric acid R in a test-tube. Cover immediately with a filter paper moistened with a freshly prepared solution containing 0.1 g of sodium nitroprusside R and 0.5 g of piperazine hydrate R in 5 mL of water R. After a few minutes, an intense blue colour appears on the paper and becomes paler after 10-15 min.

D. To 0.5 mL add 5 mL of water R, 2 mL of dilute sodium hydroxide solution R, then slowly add 2 mL of 0.05 M iodine. A yellow precipitate is formed within 30 min.

## TESTS

**Appearance.** It is clear (2.2.1) and colourless (2.2.2, Method II) when compared with water R. Dilute 1.0 mL to 20 mL with water R. After standing for 5 min, the dilution remains clear (2.2.1) when compared with water R.**Acidity or alkalinity.** To 20 mL add 20 mL of carbon dioxide-free water R and 0.1 mL of phenolphthalein solution R. The solution is colourless. Add 1.0 mL of 0.01 M sodium hydroxide. The solution is pink (30 ppm, expressed as acetic acid).**Relative density (2.2.5):** 0.805 to 0.812.

**Absorbance** (2.2.25): maximum 0.40 at 240 nm, 0.30 between 250 nm and 260 nm and 0.10 between 270 nm and 340 nm. The absorption curve is smooth.

Examine between 235 nm and 340 nm, in a 5 cm cell using *water R* as the compensation liquid.

**Volatile impurities.** Gas chromatography (2.2.28).

*Test solution (a).* The substance to be examined.

*Test solution (b).* Add 150 µL of *4-methylpentan-2-ol R* to 500.0 mL of the substance to be examined.

*Reference solution (a).* Dilute 100 µL of *anhydrous methanol R* to 50.0 mL with the substance to be examined. Dilute 5.0 mL of the solution to 50.0 mL with the substance to be examined.

*Reference solution (b).* Dilute 50 µL of *anhydrous methanol R* and 50 µL of *acetaldehyde R* to 50.0 mL with the substance to be examined. Dilute 100 µL of the solution to 10.0 mL with the substance to be examined.

*Reference solution (c).* Dilute 150 µL of *acetal R* to 50.0 mL with the substance to be examined. Dilute 100 µL of the solution to 10.0 mL with the substance to be examined.

*Reference solution (d).* Dilute 100 µL of *benzene R* to 100.0 mL with the substance to be examined. Dilute 100 µL of the solution to 50.0 mL with the substance to be examined.

**Column:**

- *material:* fused silica;
- *size:*  $l = 30$  m,  $\varnothing = 0.32$  mm;
- *stationary phase:* poly[(cyanopropyl)(phenyl)]dimethylsiloxane *R* (film thickness 1.8 µm).

*Carrier gas:* helium for chromatography *R*.

*Linear velocity:* 35 cm/s.

*Split ratio:* 1:20.

**Temperature:**

	Time (min)	Temperature (°C)
Column	0 - 12	40
	12 - 32	40 → 240
	32 - 42	240
Injection port		200
Detector		280

**Detection:** flame ionisation.

**Injection:** 1 µL.

**System suitability:** reference solution (b):

- *resolution:* minimum 1.5 between the first peak (acetaldehyde) and the second peak (methanol).

**Limits:**

- *methanol* in the chromatogram obtained with test solution (a): not more than half the area of the corresponding peak in the chromatogram obtained with reference solution (a) (200 ppm  $V/V$ );
- *acetaldehyde + acetal:* maximum 10 ppm  $V/V$ , expressed as acetaldehyde.

Calculate the sum of the contents of acetaldehyde and acetal in parts per million ( $V/V$ ) using the following expression:

$$\frac{10 \times A_E}{A_T - A_E} + \frac{30 \times C_E}{C_T - C_E}$$

- $A_E$  = area of the acetaldehyde peak in the chromatogram obtained with test solution (a),
- $A_T$  = area of the acetaldehyde peak in the chromatogram obtained with reference solution (b),
- $C_E$  = area of the acetal peak in the chromatogram obtained with test solution (a),
- $C_T$  = area of the acetal peak in the chromatogram obtained with reference solution (c).

- *benzene:* maximum 2 ppm  $V/V$ .

Calculate the content of benzene in parts per million ( $V/V$ ) using the following expression:

$$\frac{2B_E}{B_T - B_E}$$

- $B_E$  = area of the benzene peak in the chromatogram obtained with the test solution (a),
- $B_T$  = area of the benzene peak in the chromatogram obtained with reference solution (d).

If necessary, the identity of benzene can be confirmed using another suitable chromatographic system (stationary phase with a different polarity).

- *total of other impurities* in the chromatogram obtained with test solution (b): not more than the area of the peak due to 4-methylpentan-2-ol in the chromatogram obtained with test solution (b) (300 ppm),
- *disregard limit:* 0.03 times the area of the peak corresponding to 4-methylpentan-2-ol in the chromatogram obtained with test solution (b) (9 ppm).

**Residue on evaporation:** maximum 25 ppm  $m/V$ .

Evaporate 100 mL to dryness on a water-bath and dry at 100-105 °C for 1 h. The residue weighs a maximum of 2.5 mg.

**STORAGE**

Protected from light.

**IMPURITIES**

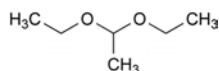

A. 1,1-diethoxyethane (acetal),



B. acetaldehyde,

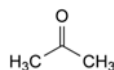

C. propan-2-one (acetone),



D. benzene,



E. cyclohexane,



F. methanol,

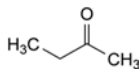

G. butan-2-one (methyl ethyl ketone),

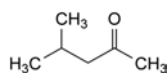

H. 4-methylpentan-2-one (methyl isobutyl ketone),

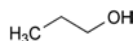

I. propan-1-ol (propanol),

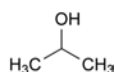

J. propan-2-ol (isopropyl alcohol),

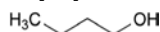

K. butan-1-ol (butanol),

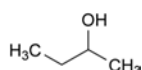

L. butan-2-ol,

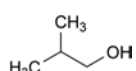

M. 2-methylpropan-1-ol (isobutanol),

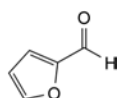

N. furane-2-carbaldehyde (furfural),

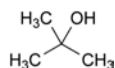

O. 2-methylpropan-2-ol (1,1-dimethylethyl alcohol),

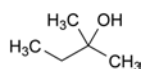

P. 2-methylbutan-2-ol,

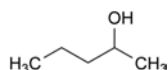

Q. pentan-2-ol,

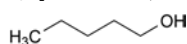

R. pentan-1-ol (pentanol),



S. hexan-1-ol (hexanol),

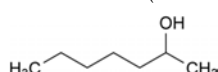

T. heptan-2-ol,

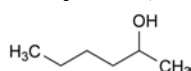

U. hexan-2-ol,

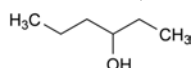

V. hexan-3-ol.

01/2008:1318

## ETHANOL, ANHYDROUS

### Ethanolum anhydricum

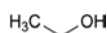

C<sub>2</sub>H<sub>6</sub>O  
[64-17-5]

M<sub>r</sub> 46.07

#### DEFINITION

*Content*: not less than 99.5 per cent V/V of C<sub>2</sub>H<sub>6</sub>O (99.2 per cent m/m), at 20 °C, calculated from the relative density using the alcoholimetric tables (5.5).

#### CHARACTERS

*Appearance*: colourless, clear, volatile, flammable liquid, hygroscopic.

*Solubility*: miscible with water and with methylene chloride.

It burns with a blue, smokeless flame.

bp: about 78 °C.

#### IDENTIFICATION

*First identification*: A, B.

*Second identification*: A, C, D.

A. Relative density (see Tests).

B. Infrared absorption spectrophotometry (2.2.24).

*Comparison*: Ph. Eur. reference spectrum of anhydrous ethanol.

C. Mix 0.1 mL with 1 mL of a 10 g/L solution of *potassium permanganate R* and 0.2 mL of *dilute sulfuric acid R* in a test-tube. Cover immediately with a filter paper moistened with a freshly prepared solution containing 0.1 g of *sodium nitroprusside R* and 0.5 g of *piperazine hydrate R* in 5 mL of *water R*. After a few minutes, an intense blue colour appears on the paper and becomes paler after 10-15 min.

D. To 0.5 mL add 5 mL of *water R*, 2 mL of *dilute sodium hydroxide solution R*, then slowly add 2 mL of 0.05 M *iodine*. A yellow precipitate is formed within 30 min.

#### TESTS

**Appearance.** It is clear (2.2.1) and colourless (2.2.2, *Method II*) when compared with *water R*. Dilute 1.0 mL to 20 mL with *water R*. After standing for 5 min, the dilution remains clear (2.2.1) when compared with *water R*.

**Acidity or alkalinity.** To 20 mL add 20 mL of *carbon dioxide-free water R* and 0.1 mL of *phenolphthalein solution R*. The solution is colourless. Add 1.0 mL of 0.01 M *sodium hydroxide*. The solution is pink (30 ppm, expressed as acetic acid).

**Relative density** (2.2.5): 0.790 to 0.793.

**Absorbance** (2.2.25): maximum 0.40 at 240 nm, 0.30 between 250 nm and 260 nm, and 0.10 between 270 nm and 340 nm. The absorption curve is smooth.

Examined between 235 nm and 340 nm in a 5 cm cell using *water R* as the compensation liquid.

**Volatile impurities.** Gas chromatography (2.2.28).

*Test solution (a).* The substance to be examined.

*Test solution (b).* Add 150 µL of 4-methylpentan-2-ol R to 500.0 mL of the substance to be examined.

*Reference solution (a).* Dilute 100 µL of *anhydrous methanol R* to 50.0 mL with the substance to be examined. Dilute 5.0 mL of the solution to 50.0 mL with the substance to be examined.

*Reference solution (b).* Dilute 50 µL of *anhydrous methanol R* and 50 µL of *acetaldehyde R* to 50.0 mL with the substance to be examined. Dilute 100 µL of the solution to 10.0 mL with the substance to be examined.

*Reference solution (c).* Dilute 150 µL of *acetal R* to 50.0 mL with the substance to be examined. Dilute 100 µL of the solution to 10.0 mL with the substance to be examined.

*Reference solution (d).* Dilute 100 µL of *benzene R* to 100.0 mL with the substance to be examined. Dilute 100 µL of the solution to 50.0 mL with the substance to be examined.

*Column*:

– *material*: fused silica;

– *size*: *l* = 30 m, Ø = 0.32;

– *stationary phase*: poly[(cyanopropyl)(phenyl)][dimethylsiloxane R (film thickness 1.8 µm).

Carrier gas: helium for chromatography R.

Linear velocity: 35 cm/s.

Split ratio: 1:20.

Temperature:

	Time (min)	Temperature (°C)
Column	0 - 12	40
	12 - 32	40 → 240
	32 - 42	240
Injection port		200
Detector		280

Detection: flame ionisation.

Injection: 1 µL.

System suitability: reference solution (b):

- resolution: minimum 1.5 between the first peak (acetaldehyde) and the second peak (methanol).

Limits:

- methanol: in the chromatogram obtained with test solution (a): not more than half the area of the corresponding peak in the chromatogram obtained with reference solution (a) (200 ppm V/V);

- acetaldehyde + acetal: maximum of 10 ppm V/V, expressed as acetaldehyde.

Calculate the sum of the contents of acetaldehyde and acetal in parts per million (V/V) using the following expression:

$$\frac{10 \times A_E}{A_T - A_E} + \frac{30 \times C_E}{C_T - C_E}$$

$A_E$  = area of the acetaldehyde peak in the chromatogram obtained with test solution (a),

$A_T$  = area of the acetaldehyde peak in the chromatogram obtained with reference solution (b),

$C_E$  = area of the acetal peak in the chromatogram obtained with test solution (a),

$C_T$  = area of the acetal peak in the chromatogram obtained with reference solution (c).

- benzene: maximum 2 ppm V/V.

Calculate the content of benzene in parts per million (V/V) using the following expression:

$$\frac{2B_E}{B_T - B_E}$$

$B_E$  = area of the benzene peak in the chromatogram obtained with the test solution (a),

$B_T$  = area of the benzene peak in the chromatogram obtained with reference solution (d).

If necessary, the identity of benzene can be confirmed using another suitable chromatographic system (stationary phase with a different polarity).

- total of other impurities in the chromatogram obtained with test solution (b): not more than the area of the peak due to 4-methylpentan-2-ol in the chromatogram obtained with test solution (b) (300 ppm);
- disregard limit: 0.03 times the area of the peak corresponding to 4-methylpentan-2-ol in the chromatogram obtained with test solution (b) (9 ppm).

Residue on evaporation: maximum 25 ppm m/V.

Evaporate 100 mL to dryness on a water-bath and dry at 100-105 °C for 1 h. The residue weighs a maximum of 2.5 mg.

STORAGE

Protected from light.

## IMPURITIES

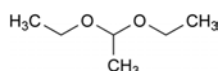

A. 1,1-diethoxyethane (acetal),



B. acetaldehyde,

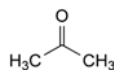

C. propan-2-one (acetone),



D. benzene,



E. cyclohexane,



F. methanol,

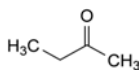

G. butan-2-one (methyl ethyl ketone),

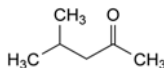

H. 4-methylpentan-2-one (methyl isobutyl ketone),

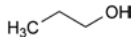

I. propan-1-ol (propanol),

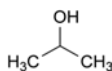

J. propan-2-ol (isopropyl alcohol),



K. butan-1-ol (butanol),

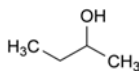

L. butan-2-ol,

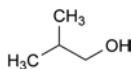

M. 2-methylpropan-1-ol (isobutanol),

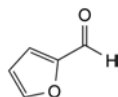

N. furane-2-carbaldehyde (furfural),

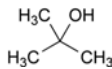

O. 2-methylpropan-2-ol (1,1-dimethylethyl alcohol),

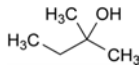

P. 2-methylbutan-2-ol,

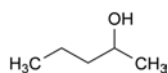

Q. pentan-2-ol,

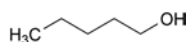

R. pentan-1-ol (pentanol),



S. hexan-1-ol (hexanol),

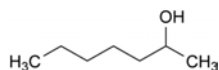

T. heptan-2-ol,

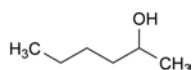

U. hexan-2-ol,

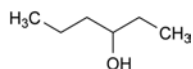

V. hexan-3-ol.

**Peroxides.** Place 8 mL of *potassium iodide and starch solution R* in a 12 mL ground-glass-stoppered cylinder about 15 mm in diameter. Fill completely with the substance to be examined, mix and allow to stand protected from light for 5 min. No colour develops.

**Non-volatile matter:** maximum 20 mg/L.

*After ensuring that the substance to be examined complies with the test for peroxides*, evaporate 50 mL to dryness on a water-bath and dry the residue in an oven at 100-105 °C. The residue weighs a maximum of 1 mg.

**Substances with a foreign odour.** Moisten a disc of filter paper 80 mm in diameter with 5 mL of the substance to be examined and allow to evaporate. No foreign odour is perceptible immediately after the evaporation.

**Water (2.5.12):** maximum 2 g/L, determined on 20 mL.

#### STORAGE

In an airtight container, protected from light, at a temperature of 8 °C to 15 °C.

01/2008:0367

## ETHER, ANAESTHETIC

### Aether anaestheticus

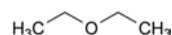

$C_4H_{10}O$   
[60-29-7]

$M_r$  74.1

#### DEFINITION

Diethyl ether.

It may contain a suitable non-volatile antioxidant at an appropriate concentration.

#### CHARACTERS

*Appearance:* clear, colourless liquid, volatile, very mobile.

*Solubility:* soluble in 15 parts of water, miscible with ethanol (96 per cent) and with fatty oils.

It is highly flammable.

#### IDENTIFICATION

A. Relative density (see Tests).

B. Distillation range (see Tests).

#### TESTS

**Acidity.** To 20 mL of *ethanol (96 per cent) R* add 0.25 mL of *bromothymol blue solution R1* and, dropwise, 0.02 M sodium hydroxide until a blue colour persists for 30 s. Add 25 mL of the substance to be examined, shake and add, dropwise, 0.02 M sodium hydroxide until the blue colour reappears and persists for 30 s. Not more than 0.4 mL of 0.02 M sodium hydroxide is required.

**Relative density (2.2.5):** 0.714 to 0.716.

**Distillation range (2.2.11).** *Do not distil if the substance to be examined does not comply with the test for peroxides.* It distils completely between 34.0 °C and 35.0 °C. Carry out the test using a suitable heating device and taking care to avoid directly heating the flask above the level of the liquid.

**Acetone and aldehydes.** To 10.0 mL in a ground-glass-stoppered cylinder add 1 mL of *alkaline potassium tetra-iodomercurate solution R* and shake for 10 s. Allow to stand for 5 min, protected from light. The lower layer shows only a slight opalescence.

If the substance to be examined does not comply with the test, distil 40 mL, *after ensuring that the substance to be examined complies with the test for peroxides*, until only 5 mL remains. Collect the distillate in a receiver cooled in a bath of iced

01/2008:0650

## ETHER

### Aether

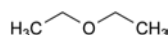

$C_4H_{10}O$   
[60-29-7]

$M_r$  74.1

#### DEFINITION

Diethyl ether.

It may contain a suitable non-volatile antioxidant at a suitable concentration.

#### CHARACTERS

*Appearance:* clear, colourless liquid, volatile.

*Solubility:* soluble in water, miscible with ethanol (96 per cent), with methylene chloride and with fatty oils.

It is highly flammable.

#### IDENTIFICATION

A. Relative density (see Tests).

B. Distillation range (see Tests).

#### TESTS

**Acidity.** To 20 mL of *ethanol (96 per cent) R* add 0.25 mL of *bromothymol blue solution R1* and, dropwise, 0.02 M sodium hydroxide until a blue colour persists for 30 s. Add 25 mL of the substance to be examined, shake and add, dropwise, 0.02 M sodium hydroxide until the blue colour reappears and persists for 30 s. Not more than 0.4 mL of 0.02 M sodium hydroxide is required.

**Relative density (2.2.5):** 0.714 to 0.716.

**Distillation range (2.2.11).** *Do not distil if the substance to be examined does not comply with the test for peroxides.* It distils completely between 34.0 °C and 35.0 °C. Carry out the test using a suitable heating device and taking care to avoid directly heating the flask above the level of the liquid.

**Aldehydes.** To 10.0 mL in a ground-glass-stoppered cylinder add 1 mL of *alkaline potassium tetraiodomercurate solution R* and shake for 10 s. Allow to stand for 5 min, protected from light. The lower layer may show a yellow or reddish-brown opalescence but not a grey or black opalescence.

water and repeat the test described above using 10.0 mL of the distillate.

**Peroxides.** Place 8 mL of *potassium iodide and starch solution R* in a 12 mL ground-glass-stoppered cylinder about 15 mm in diameter. Fill completely with the substance to be examined, shake vigorously and allow to stand protected from light for 30 min. No colour develops.

**Non-volatile matter:** maximum 20 mg/L.

After ensuring that the substance to be examined complies with the test for peroxides, evaporate 50 mL to dryness on a water-bath and dry the residue in an oven at 100-105 °C. The residue weighs a maximum of 1 mg.

**Substances with a foreign odour.** Moisten a disc of filter paper 80 mm in diameter with 5 mL of the substance to be examined and allow to evaporate. No foreign odour is perceptible immediately after the evaporation.

**Water (2.5.12):** maximum 2 g/L, determined on 20 mL.

#### STORAGE

In an airtight container, protected from light, at a temperature of 8 °C to 15 °C. The contents of a partly filled container may deteriorate rapidly.

04/2010:0140

## ETHINYLESTRADIOL

### Ethinylestradiolum

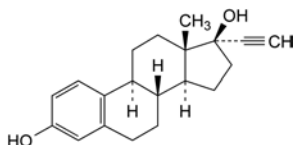

C<sub>20</sub>H<sub>24</sub>O<sub>2</sub>  
[57-63-6]

M<sub>r</sub> 296.4

#### DEFINITION

19-Nor-17 $\alpha$ -pregna-1,3,5(10)-trien-20-yne-3,17-diol.

**Content:** 97.0 per cent to 102.0 per cent (dried substance).

#### CHARACTERS

**Appearance:** white or slightly yellowish-white, crystalline powder.

**Solubility:** practically insoluble in water, freely soluble in ethanol (96 per cent). It dissolves in dilute alkaline solutions. It shows polymorphism (5.9).

#### IDENTIFICATION

##### A. Infrared absorption spectrophotometry (2.2.24).

**Comparison:** *ethinylestradiol CRS*.

If the spectra obtained in the solid state show differences, dissolve the substance to be examined and the reference substance separately in *methanol R*, evaporate to dryness and record new spectra using the residues.

##### B. Thin-layer chromatography (2.2.27).

**Solvent mixture:** *methanol R*, *methylene chloride R* (10:90 V/V).

**Test solution.** Dissolve 25 mg of the substance to be examined in the solvent mixture and dilute to 25 mL with the solvent mixture.

**Reference solution.** Dissolve 25 mg of *ethinylestradiol CRS* in the solvent mixture and dilute to 25 mL with the solvent mixture.

**Plate:** *TLC silica gel G plate R*.

**Mobile phase:** *ethanol (96 per cent) R*, *toluene R* (10:90 V/V).

**Application:** 5  $\mu$ L.

**Development:** over 2/3 of the plate.

**Drying:** in air until the solvent has evaporated.

**Detection:** heat at 110 °C for 10 min, spray the hot plate with *alcoholic solution of sulfuric acid R* and heat again at 110 °C for 10 min. Examine in daylight and in ultraviolet light at 365 nm.

**Results:** the principal spot in the chromatogram obtained with the test solution is similar in position, colour, fluorescence and size to the principal spot in the chromatogram obtained with the reference solution.

#### TESTS

**Related substances.** Liquid chromatography (2.2.29).

**Solvent mixture:** *water R*, *acetonitrile R1* (40:60 V/V).

**Test solution.** Dissolve 10 mg of the substance to be examined in 6 mL of *acetonitrile R1* and dilute to 10.0 mL with *water R*.

**Reference solution (a).** Dilute 1.0 mL of the test solution to 100.0 mL with the solvent mixture. Dilute 1.0 mL of this solution to 10.0 mL with the solvent mixture.

**Reference solution (b).** Dissolve 2 mg of *estrone CRS* (impurity C) in 10.0 mL of the solvent mixture. Dilute 1.0 mL of this solution to 100.0 mL with the solvent mixture. Use 1.0 mL of this solution to dissolve the contents of a vial of *ethinylestradiol for system suitability CRS* (containing impurities B, F, H, I and K).

**Column:**

- size:  $l = 0.25$  m,  $\varnothing = 4.6$  mm;
- stationary phase: end-capped butylsilyl silica gel for chromatography R (5  $\mu$ m);
- temperature: 30 °C.

**Mobile phase:**

- mobile phase A: *water R*;
- mobile phase B: *acetonitrile R1*;

Time (min)	Mobile phase A (per cent V/V)	Mobile phase B (per cent V/V)
0 - 35	70	30
35 - 65	70 $\rightarrow$ 25	30 $\rightarrow$ 75

**Flow rate:** 1.5 mL/min.

**Detection:** spectrophotometer at 220 nm.

**Injection:** 30  $\mu$ L.

**Identification of impurities:** use the chromatogram supplied with *ethinylestradiol for system suitability CRS* and the chromatogram obtained with reference solution (b) to identify the peaks due to impurities B, C, F, H, I and K.

**Relative retention** with reference to *ethinylestradiol* (retention time = about 35 min): impurity F = about 0.2; impurity H = about 0.5; impurity I = about 0.8; impurity B = about 0.88; impurity C = about 0.92; impurity K = about 1.3.

**System suitability:** reference solution (b):

- resolution: minimum 1.2 between the peaks due to impurities I and B.

**Limits:**

- correction factors: for the calculation of content, multiply the peak areas of the following impurities by the corresponding correction factor: impurity B = 0.7; impurity I = 0.4;
- impurity B: not more than 5 times the area of the corresponding peak in the chromatogram obtained with reference solution (a) (0.5 per cent);
- impurities H, I, K: for each impurity, not more than twice the area of the principal peak in the chromatogram obtained with reference solution (a) (0.2 per cent);
- impurities C, F: for each impurity, not more than 1.5 times the area of the principal peak in the chromatogram obtained with reference solution (a) (0.15 per cent);
- unspecified impurities: for each impurity, not more than the area of the principal peak in the chromatogram obtained with reference solution (a) (0.10 per cent);



- *total*: not more than 8 times the area of the principal peak in the chromatogram obtained with reference solution (a) (0.8 per cent);
- *disregard limit*: 0.5 times the area of the principal peak in the chromatogram obtained with reference solution (a) (0.05 per cent).

**Loss on drying** (2.2.32): maximum 1.0 per cent, determined on 0.500 g by drying in an oven at 105 °C for 3 h.

#### ASSAY

Dissolve 0.200 g in 40 mL of *tetrahydrofuran R* and add 5 mL of a 100 g/L solution of *silver nitrate R*. Titrate with 0.1 M *sodium hydroxide*, determining the end-point potentiometrically (2.2.20). Carry out a blank titration. Wash the electrode with *acetone R* after each titration.

1 mL of 0.1 M *sodium hydroxide* is equivalent to 29.64 mg of  $C_{20}H_{24}O_2$ .

#### STORAGE

Protected from light.

#### IMPURITIES

*Specified impurities*: B, C, F, H, I, K.

*Other detectable impurities* (the following substances would, if present at a sufficient level, be detected by one or other of the tests in the monograph. They are limited by the general acceptance criterion for other/unspecified impurities and/or by the general monograph *Substances for pharmaceutical use* (2034). It is therefore not necessary to identify these impurities for demonstration of compliance. See also 5.10. *Control of impurities in substances for pharmaceutical use*): A, D, E, G, J, L, M.

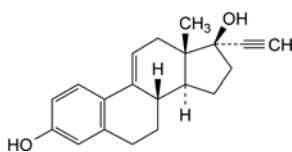

B. 19-nor-17 $\alpha$ -pregna-1,3,5(10),9(11)-tetraen-20-yne-3,17-diol,

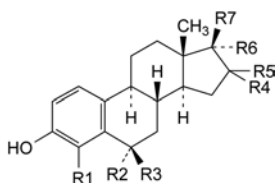

C. R1 = R2 = R3 = R4 = R5 = H, R6 + R7 = O:  
3-hydroxyestra-1,3,5(10)-trien-17-one (estrone),

F. R1 = R2 = R4 = R5 = H, R3 = R7 = OH, R6 = C $\equiv$ CH:  
19-nor-17 $\alpha$ -pregna-1,3,5(10)-trien-20-yne-3,6 $\beta$ ,17-triol  
(6 $\beta$ -hydroxy-ethinylestradiol),

H. R1 = R2 = R3 = H, R4 + R5 = O, R6 = C $\equiv$ CH, R7 = OH: 3,17-dihydroxy-19-nor-17 $\alpha$ -pregna-1,3,5(10)-trien-20-yn-16-one  
(16-oxo-ethinylestradiol),

K. R1 = CH<sub>3</sub>, R2 = R3 = R4 = R5 = H, R6 = C $\equiv$ CH, R7 = OH:  
4-methyl-19-nor-17 $\alpha$ -pregna-1,3,5(10)-trien-20-yne-3,17-diol  
(4-methyl-ethinylestradiol),

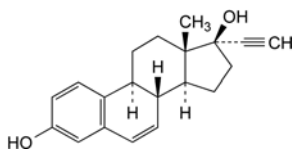

I. 19-nor-17 $\alpha$ -pregna-1,3,5(10),6-tetraen-20-yne-3,17-diol,

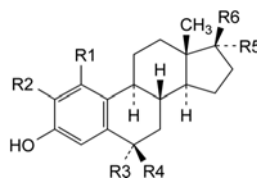

- A. R1 = R2 = R3 = R4 = H, R5 = OH, R6 = C $\equiv$ CH:  
19-norpregna-1,3,5(10)-trien-20-yne-3,17-diol  
(17 $\beta$ -ethinylestradiol),
- D. R1 = R2 = R3 = R4 = R5 = H, R6 = OH: estradiol,
- E. R1 = R2 = R4 = H, R3 = R6 = OH, R5 = C $\equiv$ CH:  
19-nor-17 $\alpha$ -pregna-1,3,5(10)-trien-20-yne-3,6 $\alpha$ ,17-triol  
(6 $\alpha$ -hydroxy-ethinylestradiol),
- G. R1 = R2 = H, R3 + R4 = O, R5 = C $\equiv$ CH, R6 = OH:  
3,17-dihydroxy-19-nor-17 $\alpha$ -pregna-1,3,5(10)-trien-20-yn-6-one  
(6-oxo-ethinylestradiol),
- J. R1 = CH<sub>3</sub>, R2 = R3 = R4 = H, R5 = C $\equiv$ CH, R6 = OH:  
1-methyl-19-nor-17 $\alpha$ -pregna-1,3,5(10)-trien-20-yne-3,17-diol  
(1-methyl-ethinylestradiol),
- L. R1 = R2 = R3 = R4 = R6 = H, R5 = OH: estra-1,3,5(10)-triene-3,17 $\alpha$ -diol (17 $\alpha$ -estradiol),
- M. R1 = R3 = R4 = H, R2 = CH<sub>3</sub>, R5 = C $\equiv$ CH, R6 = OH:  
2-methyl-19-nor-17 $\alpha$ -pregna-1,3,5(10)-trien-20-yne-3,17-diol  
(2-methyl-ethinylestradiol).

01/2008:0141  
corrected 6.0

## ETHIONAMIDE

### Ethionamidum

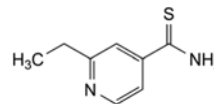

$C_8H_{10}N_2S$   
[536-33-4]

$M_r$  166.2

#### DEFINITION

Ethionamide contains not less than 98.5 per cent and not more than the equivalent of 101.0 per cent of 2-ethylpyridine-4-carbothioamide, calculated with reference to the dried substance.

#### CHARACTERS

A yellow, crystalline powder or small, yellow crystals, practically insoluble in water, soluble in methanol, sparingly soluble in alcohol.

#### IDENTIFICATION

*First identification*: A, C.

*Second identification*: A, B, D.

- A. Melting point (2.2.14): 158 °C to 164 °C.
- B. Dissolve 10.0 mg in *methanol R* and dilute to 100.0 mL with the same solvent. Dilute 10.0 mL of the solution to 100.0 mL with *methanol R*. Examined between 230 nm and 350 nm (2.2.25), the solution shows an absorption maximum at 290 nm. The specific absorbance at the maximum is 380 to 440.
- C. Examine by infrared absorption spectrophotometry (2.2.24), comparing with the spectrum obtained with *ethionamide CRS*.
- D. Dissolve about 10 mg in 5 mL of *methanol R*. Add 5 mL of *silver nitrate solution R2*. A dark-brown precipitate is formed.

## TESTS

**Appearance of solution.** Dissolve 0.5 g in 10 mL of *methanol R*, heating to about 50 °C. Allow to cool to room temperature. The solution is not more opalescent than reference suspension II (2.2.1).

**Acidity.** Dissolve 2.0 g in 20 mL of *methanol R*, heating to about 50 °C, and add 20 mL of *water R*. Cool slightly while shaking until crystallisation begins and then allow to cool to room temperature. Add 60 mL of *water R* and 0.2 mL of *cresol red solution R*. Not more than 0.2 mL of 0.1 M *sodium hydroxide* is required to change the colour of the indicator to red.

**Related substances.** Examine by thin-layer chromatography (2.2.27), using *silica gel GF<sub>254</sub> R* as the coating substance.

**Test solution.** Dissolve 0.2 g of the substance to be examined in *acetone R* and dilute to 10 mL with the same solvent.

**Reference solution (a).** Dilute 0.5 mL of the test solution to 100 mL with *acetone R*.

**Reference solution (b).** Dilute 0.2 mL of the test solution to 100 mL with *acetone R*.

Apply separately to the plate 10 µL of each solution. Develop over a path of 15 cm using a mixture of 10 volumes of *methanol R* and 90 volumes of *chloroform R*. Allow the plate to dry in air. Examine in ultraviolet light at 254 nm. Any spot in the chromatogram obtained with the test solution, apart from the principal spot, is not more intense than the spot in the chromatogram obtained with reference solution (a) (0.5 per cent) and at most 1 such spot is more intense than the spot in the chromatogram obtained with reference solution (b) (0.2 per cent).

**Heavy metals (2.4.8).** 1.0 g complies with limit test D for heavy metals (20 ppm). Prepare the standard using 2 mL of *lead standard solution (10 ppm Pb) R*.

**Loss on drying (2.2.32).** Not more than 0.5 per cent, determined on 1.00 g by drying in an oven at 105 °C for 3 h.

**Sulfated ash (2.4.14).** Not more than 0.1 per cent, determined on 1.0 g.

## ASSAY

Dissolve 0.150 g in 50 mL of *anhydrous acetic acid R*. Titrate with 0.1 M *perchloric acid*, determining the end-point potentiometrically (2.2.20).

1 mL of 0.1 M *perchloric acid* is equivalent to 16.62 mg of C<sub>8</sub>H<sub>10</sub>N<sub>2</sub>S.

01/2008:0764

## ETHOSUXIMIDE

## Ethosuximidum

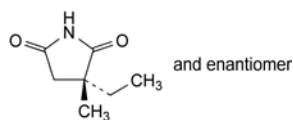

C<sub>7</sub>H<sub>11</sub>NO<sub>2</sub>  
[77-67-8]

M<sub>r</sub> 141.2

## DEFINITION

(*RS*)-3-Ethyl-3-methylpyrrolidine-2,5-dione.

**Content:** 99.0 per cent to 101.0 per cent (anhydrous substance).

## CHARACTERS

**Appearance:** white or almost white, powder or waxy solid.

**Solubility:** freely soluble in water, very soluble in ethanol (96 per cent) and in methylene chloride.

It shows polymorphism (5.9).

## IDENTIFICATION

**First identification:** A, C.

**Second identification:** A, B, D, E.

A. Melting point (2.2.14): 45 °C to 50 °C.

B. Dissolve 50.0 mg in *ethanol (96 per cent) R* and dilute to 50.0 mL with the same solvent. Examined between 230 nm and 300 nm (2.2.25), the solution shows an absorption maximum at 248 nm. The specific absorbance at the absorption maximum is 8 to 9.

C. Infrared absorption spectrophotometry (2.2.24).

**Preparation:** discs of *potassium bromide R*.

**Comparison:** *ethosuximide CRS*.

If the spectra obtained in the solid state show differences, dissolve the substance to be examined and the reference substance separately in *methylene chloride R*, evaporate to dryness and record new spectra using the residues.

D. Dissolve 0.1 g in 3 mL of *methanol R*. Add 0.05 mL of a 100 g/L solution of *cobalt chloride R* and 0.05 mL of a 100 g/L solution of *calcium chloride R* and add 0.1 mL of *dilute sodium hydroxide solution R*. A purple colour develops and no precipitate is formed.

E. To about 10 mg add 10 mg of *resorcinol R* and 0.2 mL of *sulfuric acid R*. Heat at 140 °C for 5 min and cool. Add 5 mL of *water R* and 2 mL of *concentrated ammonia R1*. A brown colour is produced. Add about 100 mL of *water R*. A green fluorescence is produced.

## TESTS

**Solution S.** Dissolve 2.5 g in *water R* and dilute to 25 mL with the same solvent.

**Appearance of solution.** Solution S is clear (2.2.1) and colourless (2.2.2, *Method II*).

**Cyanide.** Liquid chromatography (2.2.29).

**Test solution.** Dissolve 0.50 g of the substance to be examined in *water R* and dilute to 10.0 mL with the same solvent.

**Reference solution (a).** Dissolve 0.125 g of *potassium cyanide R* in *water R* and dilute to 50.0 mL with the same solvent. Dilute 1.0 mL of the solution to 100.0 mL with *water R*. Dilute 0.5 mL of this solution to 10.0 mL with *water R*.

**Reference solution (b).** Dissolve 0.50 g of the substance to be examined in *water R*, add 0.5 mL of reference solution (a) and dilute to 10.0 mL with *water R*.

**Column:**

– size:  $l = 0.075$  m,  $\varnothing = 7.5$  mm,

– stationary phase: spherical *weak anion exchange resin R* (10 µm).

**Mobile phase:** dissolve 2.1 g of *lithium hydroxide R* and 85 mg of *sodium edetate R* in *water for chromatography R* and dilute to 1000.0 mL with the same solvent.

**Flow rate:** 2.0 mL/min.

**Detection:** electrochemical detector (direct amperometry) with a silver working electrode, a silver-silver chloride reference electrode, held at + 0.05 V oxidation potential, and a detector sensitivity of 20 nA full scale.

**Injection:** 20 µL of the test solution and reference solution (b).

**System suitability:** reference solution (b):

– **peak-to-valley ratio:** minimum 3, where  $H_p$  = height above the baseline of the peak due to cyanide and  $H_v$  = height above the baseline of the lowest point of the curve separating this peak from the peak due to ethosuximide.

**Limit:**

– **cyanide:** not more than 0.5 times the height of the corresponding peak in the chromatogram obtained with reference solution (b) (0.5 ppm).

**Related substances.** Gas chromatography (2.2.28).

**Internal standard solution.** Dissolve 20 mg of *myristyl alcohol R* in *anhydrous ethanol R* and dilute to 10.0 mL with the same solvent.

**Test solution.** Dissolve 1.00 g of the substance to be examined in *anhydrous ethanol R* add 1.0 mL of the internal standard solution and dilute to 20.0 mL with *anhydrous ethanol R*.

**Reference solution (a).** Dissolve 10.0 mg of *ethosuximide impurity A CRS* in *anhydrous ethanol R* and dilute to 5.0 mL with the same solvent. To 0.5 mL of the solution add 1.0 mL of the internal standard solution and dilute to 20.0 mL with *anhydrous ethanol R*.

**Reference solution (b).** Dissolve 0.500 g of the substance to be examined in *anhydrous ethanol R* and dilute to 10.0 mL with the same solvent. Dilute 1.0 mL of the solution to 50.0 mL with *anhydrous ethanol R*. To 2.0 mL of this solution add 1.0 mL of the internal standard solution and dilute to 20.0 mL with *anhydrous ethanol R*.

**Column:**

- **material:** fused silica,
- **size:**  $l = 30$  m,  $\varnothing = 0.25$  mm,
- **stationary phase:** *poly(cyanopropyl)(phenylmethyl) siloxane R* (film thickness 0.25  $\mu$ m).

**Carrier gas:** *helium for chromatography R*.

**Flow rate:** 1 mL/min.

**Split ratio:** 1:67.

**Temperature:**

- **column:** 175 °C,
- **injection port and detector:** 240 °C.

**Detection:** flame ionisation.

**Injection:** 1  $\mu$ L.

**Run time:** 1.5 times the retention time of *ethosuximide*.

**Relative retention** with reference to the internal standard (retention time = about 8 min): *impurity A* = about 0.7; *ethosuximide* = about 1.1.

**System suitability:** reference solution (b):

- **resolution:** minimum 5 between the peaks due to the internal standard and *ethosuximide*.

**Limits:**

- **impurity A:** calculate the ratio (*R*) of the area of the peak due to *impurity A* to the area of the peak due to the internal standard from the chromatogram obtained with reference solution (a); from the chromatogram obtained with the test solution, calculate the ratio of the area of any peak due to *impurity A* to the area of the peak due to the internal standard: this ratio is not greater than *R* (0.1 per cent);
- **any other impurity:** calculate the ratio (*R*) of half the area of the peak due to *ethosuximide* to the area of the peak due to the internal standard from the chromatogram obtained with reference solution (b); from the chromatogram obtained with the test solution, calculate the ratio of the area of any peak, apart from the principal peak and the peaks due to *impurity A* and to the internal standard, to the area of the peak due to the internal standard: this ratio is not greater than *R* (0.1 per cent);
- **total:** calculate the ratio (*R*) of the area of the peak due to *ethosuximide* to the area of the peak due to the internal standard from the chromatogram obtained with reference solution (b); from the chromatogram obtained with the test solution, calculate the ratio of the sum of the areas of any peaks, apart from the principal peak and the peak due to the internal standard, to the area of the peak due to the internal standard: this ratio is not greater than *R* (0.2 per cent);
- **disregard limit:** calculate the ratio (*R*) of 0.25 times the area of the peak due to *impurity A* to the area of the peak due to the internal standard from the chromatogram obtained with reference solution (a); from the chromatogram obtained with the test solution, calculate the ratio of the area of any peak, apart from the principal peak and the peak due to the internal standard, to the area of the peak due to the internal standard: disregard any peak which has a ratio less than *R* (0.025 per cent).

**Heavy metals (2.4.8):** maximum 10 ppm.

12 mL of solution S complies with test A. Prepare the reference solution using *lead standard solution (1 ppm Pb) R*.

**Water (2.5.12):** maximum 0.5 per cent, determined on 1.00 g.

**Sulfated ash (2.4.14):** maximum 0.1 per cent, determined on 1.0 g.

**ASSAY**

Dissolve 0.120 g in 20 mL of *dimethylformamide R* and carry out a potentiometric titration (2.2.20) using *0.1 M tetrabutylammonium hydroxide*. Protect the solution from atmospheric carbon dioxide throughout the titration. Carry out a blank titration.

1 mL of *0.1 M tetrabutylammonium hydroxide* is equivalent to 14.12 mg of  $C_7H_{11}NO_2$ .

**STORAGE**

Protected from light.

**IMPURITIES**

**Specified impurities:** A.

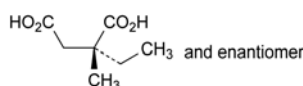

A. (2*RS*)-2-ethyl-2-methylbutanedioic acid.

01/2008:0899

## ETHYL ACETATE

### Ethylis acetas

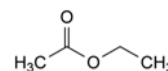

$C_4H_8O_2$   
[141-78-6]

$M_r$  88.1

**DEFINITION**

Ethyl ethanoate.

**CHARACTERS**

**Appearance:** clear, colourless, volatile liquid.

**Solubility:** soluble in water, miscible with acetone, with ethanol (96 per cent) and with methylene chloride.

**IDENTIFICATION**

**First identification:** B.

**Second identification:** A, C, D.

A. Boiling point (2.2.12): 76 °C to 78 °C.

B. Infrared absorption spectrophotometry (2.2.24).

*Comparison:* Ph. Eur. reference spectrum of *ethyl acetate*.

C. It gives the reaction of acetyl (2.3.1).

D. It gives the reaction of esters (2.3.1).

**TESTS**

**Appearance of solution.** The solution is clear (2.2.1) and colourless (2.2.2, *Method II*).

Mix 1 mL of the substance to be examined and 15 mL of *water R*.

**Acidity.** To 10 mL of *ethanol (96 per cent) R* add 0.1 mL of *phenolphthalein solution R* and *0.01 M sodium hydroxide* until the colour changes to pink. Add 5.5 mL of the substance to be examined and 0.25 mL of *0.02 M sodium hydroxide*. The solution remains pink for not less than 15 s.

**Relative density (2.2.5):** 0.898 to 0.902.

**Refractive index (2.2.6):** 1.370 to 1.373.

**Reaction with sulfuric acid.** Carefully add 2 mL to 10 mL of *sulfuric acid R*. After 15 min, the interface between the 2 liquids is not coloured.

**Related substances.** Gas chromatography (2.2.28).

**Test solution.** The substance to be examined.

**Column:**

- *material:* glass;
- *size:*  $l = 2$  m,  $\varnothing = 2$  mm;
- *stationary phase:* ethylvinylbenzene-divinylbenzene copolymer R (136-173  $\mu\text{m}$ ).

**Carrier gas:** nitrogen for chromatography R.

**Flow rate:** 30 mL/min.

**Temperature:**

	Time (min)	Temperature (°C)
Column	0 - 18.8	90 → 240
	18.8 - 26.8	240
Injection port		240
Detector		240

**Detection:** flame ionisation.

**Injection:** 1  $\mu\text{L}$ .

**Limit:**

- *total:* not more than 0.2 per cent of the area of the principal peak.

**Residue on evaporation:** maximum 30 ppm.

Evaporate 100.0 g to dryness on a water-bath and dry in an oven at 100-105 °C. The residue weighs not more than 3 mg.

**Water (2.5.12):** maximum 0.1 per cent, determined on 10.0 mL.

**STORAGE**

Protected from light, at a temperature not exceeding 30 °C.

**IMPURITIES**

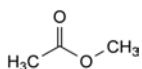

A. methyl ethanoate (methyl acetate),

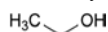

B. ethanol,



C. methanol.

01/2008:1319

## ETHYL OLEATE

### Ethylis oleas

**DEFINITION**

Mixture consisting of the ethyl esters of fatty acids, mainly oleic (*cis*-9-octadecenoic) acid.

A suitable antioxidant may be added.

**CHARACTERS**

**Appearance:** clear, pale yellow or colourless liquid.

**Solubility:** practically insoluble in water, miscible with ethanol (96 per cent), with methylene chloride and with light petroleum (bp: 40-60 °C).

**IDENTIFICATION**

- A. Relative density (see Tests).
- B. Saponification value (see Tests).
- C. Oleic acid (see Tests).

**TESTS**

**Relative density (2.2.5):** 0.866 to 0.874.

**Acid value (2.5.1):** maximum 0.5, determined on 10.0 g.

**Iodine value (2.5.4, Method A):** 75 to 90.

**Peroxide value (2.5.5, Method A):** maximum 10.0.

**Saponification value (2.5.6):** 177 to 188, determined on 2.0 g.

**Oleic acid (2.4.22, Method A):** minimum 60.0 per cent in the fatty acid fraction of the substance to be examined.

**Water (2.5.12):** maximum 1.0 per cent, determined on 1.00 g.

**Total ash (2.4.16):** maximum 0.1 per cent, determined on 2.0 g.

**STORAGE**

Protected from light.

07/2010:0900

## ETHYL PARAHYDROXYBENZOATE

### Ethylis parahydroxybenzoas

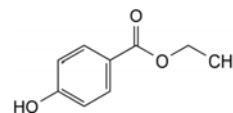

$\text{C}_9\text{H}_{10}\text{O}_3$   
[120-47-8]

$M_r$  166.2

**DEFINITION**

Ethyl 4-hydroxybenzoate.

**Content:** 98.0 per cent to 102.0 per cent.

**CHARACTERS**

**Appearance:** white or almost white, crystalline powder or colourless crystals.

**Solubility:** very slightly soluble in water, freely soluble in ethanol (96 per cent) and in methanol.

**IDENTIFICATION**

**First identification:** A, B.

**Second identification:** A, C.

A. Melting point (2.2.14): 115 °C to 118 °C.

B. Infrared absorption spectrophotometry (2.2.24).

*Comparison:* ethyl parahydroxybenzoate CRS.

C. Thin-layer chromatography (2.2.27).

**Test solution (a).** Dissolve 0.10 g of the substance to be examined in *acetone R* and dilute to 10 mL with the same solvent.

**Test solution (b).** Dilute 1 mL of test solution (a) to 10 mL with *acetone R*.

**Reference solution (a).** Dissolve 10 mg of ethyl parahydroxybenzoate CRS in *acetone R* and dilute to 10 mL with the same solvent.

**Reference solution (b).** Dissolve 10 mg of methyl parahydroxybenzoate R in 1 mL of test solution (a) and dilute to 10 mL with *acetone R*.

**Plate:** TLC octadecylsilyl silica gel  $F_{254}$  plate R.

**Mobile phase:** glacial acetic acid R, water R, methanol R (1:30:70 V/V/V).

**Application:** 2  $\mu\text{L}$  of test solution (b) and reference solutions (a) and (b).

**Development:** over 2/3 of the plate.

**Drying:** in air.

**Detection:** examine in ultraviolet light at 254 nm.

**System suitability:** reference solution (b):

- the chromatogram shows 2 clearly separated principal spots.

**Results:** the principal spot in the chromatogram obtained with test solution (b) is similar in position and size to the principal spot in the chromatogram obtained with reference solution (a).

## TESTS

**Solution S.** Dissolve 1.0 g in *ethanol (96 per cent) R* and dilute to 10 mL with the same solvent.

**Appearance of solution.** Solution S is clear (2.2.1) and not more intensely coloured than reference solution BY<sub>6</sub> (2.2.2, Method II).

**Acidity.** To 2 mL of solution S add 3 mL of *ethanol (96 per cent) R*, 5 mL of *carbon dioxide-free water R* and 0.1 mL of *bromocresol green solution R*. Not more than 0.1 mL of 0.1 M *sodium hydroxide* is required to change the colour of the indicator to blue.

**Related substances.** Liquid chromatography (2.2.29).

**Test solution.** Dissolve 50.0 mg of the substance to be examined in 2.5 mL of *methanol R* and dilute to 50.0 mL with the mobile phase. Dilute 10.0 mL of this solution to 100.0 mL with the mobile phase.

**Reference solution (a).** Dissolve 5 mg of *4-hydroxybenzoic acid R* (impurity A), 5 mg of *methyl parahydroxybenzoate R* (impurity B) and 5 mg of the substance to be examined in the mobile phase and dilute to 100.0 mL with the mobile phase. Dilute 1.0 mL of this solution to 10.0 mL with the mobile phase.

**Reference solution (b).** Dissolve 50.0 mg of *ethyl parahydroxybenzoate CRS* in 2.5 mL of *methanol R* and dilute to 50.0 mL with the mobile phase. Dilute 10.0 mL of this solution to 100.0 mL with the mobile phase.

**Reference solution (c).** Dilute 1.0 mL of the test solution to 20.0 mL with the mobile phase. Dilute 1.0 mL of this solution to 10.0 mL with the mobile phase.

**Column:**

- size:  $l = 0.15$  m,  $\varnothing = 4.6$  mm;
- stationary phase: end-capped octadecylsilyl silica gel for chromatography R (5  $\mu$ m).

**Mobile phase:** 6.8 g/L solution of *potassium dihydrogen phosphate R*, *methanol R* (35:65 V/V).

**Flow rate:** 1.3 mL/min.

**Detection:** spectrophotometer at 272 nm.

**Injection:** 10  $\mu$ L of the test solution and reference solutions (a) and (c).

**Run time:** 4 times the retention time of ethyl parahydroxybenzoate.

**Relative retention** with reference to ethyl parahydroxybenzoate (retention time = about 3.0 min): impurity A = about 0.5; impurity B = about 0.8.

**System suitability:** reference solution (a):

- resolution: minimum 2.0 between the peaks due to impurity B and ethyl parahydroxybenzoate.

**Limits:**

- correction factor: for the calculation of content, multiply the peak area of impurity A by 1.4;
- impurity A: not more than the area of the principal peak in the chromatogram obtained with reference solution (c) (0.5 per cent);
- unspecified impurities: for each impurity, not more than the area of the principal peak in the chromatogram obtained with reference solution (c) (0.5 per cent);
- total: not more than twice the area of the principal peak in the chromatogram obtained with reference solution (c) (1.0 per cent);
- disregard limit: 0.2 times the area of the principal peak in the chromatogram obtained with reference solution (c) (0.1 per cent).

**Sulfated ash (2.4.14):** maximum 0.1 per cent, determined on 1.0 g.

## ASSAY

Liquid chromatography (2.2.29) as described in the test for related substances with the following modification.

**Injection:** test solution and reference solution (b).

Calculate the percentage content of C<sub>9</sub>H<sub>10</sub>O<sub>3</sub> from the declared content of *ethyl parahydroxybenzoate CRS*.

## IMPURITIES

**Specified impurities: A.**

**Other detectable impurities** (the following substances would, if present at a sufficient level, be detected by one or other of the tests in the monograph. They are limited by the general acceptance criterion for other/unspecified impurities and/or by the general monograph *Substances for pharmaceutical use (2034)*. It is therefore not necessary to identify these impurities for demonstration of compliance. See also 5.10. *Control of impurities in substances for pharmaceutical use*): B, C, D.

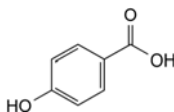

A. 4-hydroxybenzoic acid,

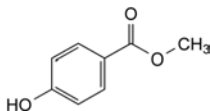

B. methyl 4-hydroxybenzoate (methyl parahydroxybenzoate),

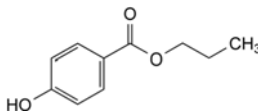

C. propyl 4-hydroxybenzoate (propyl parahydroxybenzoate),

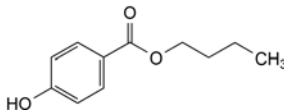

D. butyl 4-hydroxybenzoate (butyl parahydroxybenzoate).

01/2008:2134

## ETHYL PARAHYDROXYBENZOATE SODIUM

Ethylis parahydroxybenzoas natricus

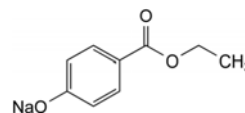

C<sub>9</sub>H<sub>9</sub>NaO<sub>3</sub>  
[35285-68-8]

$M_r$  188.2

## DEFINITION

Sodium 4-(ethoxycarbonyl)phenolate.

**Content:** 99.0 per cent to 103.0 per cent (anhydrous substance).

## CHARACTERS

**Appearance:** white or almost white, hygroscopic, crystalline powder.

**Solubility:** freely soluble in water, soluble in anhydrous ethanol, practically insoluble in methylene chloride.

## IDENTIFICATION

**First identification:** A, B, E.

Second identification: A, C, D, E.

- A. Dissolve 0.5 g in 50 mL of *water R*. Immediately add 5 mL of *hydrochloric acid RI*. Filter and wash the precipitate with *water R*. Dry *in vacuo* at 80 °C for 2 h. It melts (2.2.14) at 115 °C to 118 °C.
- B. Infrared absorption spectrophotometry (2.2.24).  
*Preparation*: the precipitate obtained in identification A.  
*Comparison*: *ethyl parahydroxybenzoate CRS*.
- C. Examine the chromatograms obtained in the test for related substances.  
*Results*: the principal spot in the chromatogram obtained with test solution (b) is similar in position and size to the principal spot in the chromatogram obtained with reference solution (c).
- D. To about 10 mg in a test-tube add 1 mL of *sodium carbonate solution R*, boil for 30 s and cool. Add 5 mL of *aminopyrazolone solution R* and 1 mL of *potassium ferricyanide solution R* and mix. An orange or red colour develops.
- E. To 1 mL of solution S (see Tests) add 1 mL of *water R*. The solution gives reaction (a) of sodium (2.3.1).

#### TESTS

**Solution S.** Dissolve 5.0 g in *carbon dioxide-free water R* prepared from *distilled water R* and dilute to 50 mL with the same solvent.

**Appearance of solution.** Solution S examined immediately after preparation is clear (2.2.1) and not more intensely coloured than reference solution BY<sub>6</sub> (2.2.2, Method II).

**pH** (2.2.3): 9.5 to 10.5.

Dilute 1 mL of solution S to 100 mL with *carbon dioxide-free water R*.

**Related substances.** Thin-layer chromatography (2.2.27).

*Test solution (a).* Dissolve 0.100 g of the substance to be examined in 10 mL of *water R*. Immediately add 2 mL of *hydrochloric acid R* and shake with 50 mL of *methylene chloride R*. Evaporate the lower layer to dryness and take up the residue with 10 mL of *acetone R*.

*Test solution (b).* Dilute 1 mL of test solution (a) to 10 mL with *acetone R*.

*Reference solution (a).* Dissolve 34.3 mg of *4-hydroxybenzoic acid R* (impurity A) in *acetone R* and dilute to 100 mL with the same solvent.

*Reference solution (b).* Dilute 0.5 mL of test solution (a) to 100 mL with *acetone R*.

*Reference solution (c).* Dissolve 5 mg of *ethyl parahydroxybenzoate CRS* in *acetone R* and dilute to 5 mL with the same solvent.

*Reference solution (d).* Dissolve 5 mg of *methyl parahydroxybenzoate CRS* (impurity B) in 0.5 mL of test solution (a) and dilute to 5 mL with *acetone R*.

*Plate*: TLC octadecylsilyl silica gel F<sub>254</sub> plate R.

*Mobile phase*: *glacial acetic acid R*, *water R*, *methanol R* (1:30:70 V/V/V).

*Application*: 5 µL.

*Development*: over 2/3 of the plate.

*Drying*: in air.

*Detection*: examine in ultraviolet light at 254 nm.

*System suitability*: reference solution (d):

- the chromatogram shows 2 clearly separated principal spots.

*Limits*: test solution (a):

- *impurity A*: any spot due to impurity A is not more intense than the spot in the chromatogram obtained with reference solution (a) (4 per cent);
- *any other impurity*: any spot is not more intense than the spot in the chromatogram obtained with reference solution (b) (0.5 per cent).

**Chlorides** (2.4.4): maximum 350 ppm.

To 10 mL of solution S add 30 mL of *water R* and 1 mL of *nitric acid R* and dilute to 50 mL with *water R*. Shake and filter. Dilute 10 mL of the filtrate to 15 mL with *water R*. The solution complies with the test. Prepare the standard using a mixture of 1 mL of *water R* and 14 mL of *chloride standard solution (5 ppm Cl) R*.

**Sulfates** (2.4.13): maximum 300 ppm.

To 25 mL of solution S add 5 mL of *distilled water R* and 10 mL of *hydrochloric acid R* and dilute to 50 mL with *distilled water R*. Shake and filter. Dilute 10 mL of the filtrate to 15 mL with *distilled water R*.

**Heavy metals** (2.4.8): maximum 10 ppm.

Dissolve 2.0 g in *water R* and dilute to 20.0 mL with the same solvent. 12 mL of the solution complies with test A. Prepare the reference solution using 1 mL of *lead standard solution (10 ppm Pb) R*.

After the addition of *buffer solution pH 3.5 R*, the substance precipitates. Dilute each solution to 40 mL with *anhydrous ethanol R*: the substance dissolves completely. Continue the test as described for Method A. Filter the solutions through a membrane filter (nominal pore size 0.45 µm) to evaluate the result.

**Water** (2.5.12): maximum 5.0 per cent, determined on 0.500 g.

#### ASSAY

Dissolve 0.150 g in 50 mL of *anhydrous acetic acid R*. Titrate with 0.1 M *perchloric acid*, determining the end-point potentiometrically (2.2.20).

1 mL of 0.1 M *perchloric acid* is equivalent to 18.82 mg of C<sub>9</sub>H<sub>9</sub>NaO<sub>3</sub>.

#### STORAGE

In an airtight container.

#### IMPURITIES

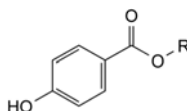

- A. R = H: 4-hydroxybenzoic acid,  
B. R = CH<sub>3</sub>: methyl 4-hydroxybenzoate,  
C. R = CH<sub>2</sub>-CH<sub>2</sub>-CH<sub>3</sub>: propyl 4-hydroxybenzoate,  
D. R = CH<sub>2</sub>-CH<sub>2</sub>-CH<sub>2</sub>-CH<sub>3</sub>: butyl 4-hydroxybenzoate.

01/2008:0822  
corrected 6.0

## ETHYLCELLULOSE

### Ethylcellulosum

#### DEFINITION

Partly *O*-ethylated cellulose.

*Content*: 44.0 per cent to 51.0 per cent of ethoxy (-OC<sub>2</sub>H<sub>5</sub>) groups (dried substance).

#### CHARACTERS

*Appearance*: white or yellowish-white powder or granular powder, odourless or almost odourless.

*Solubility*: practically insoluble in water, soluble in methylene chloride and in a mixture of 20 g of ethanol (96 per cent) and 80 g of toluene, slightly soluble in ethyl acetate and in methanol, practically insoluble in glycerol (85 per cent) and in propylene glycol. The solutions may show a slight opalescence.

## IDENTIFICATION

A. Infrared absorption spectrophotometry (2.2.24).

*Comparison: Ph. Eur. reference spectrum of ethylcellulose.*

B. It complies with the limits of the assay.

## TESTS

**Acidity or alkalinity.** To 0.5 g add 25 mL of *carbon dioxide-free water R* and shake for 15 min. Filter through a sintered-glass filter (40) (2.1.2). To 10 mL of the solution add 0.1 mL of *phenolphthalein solution R* and 0.5 mL of 0.01 M *sodium hydroxide*. The solution is pink. To 10 mL of the solution add 0.1 mL of *methyl red solution R* and 0.5 mL of 0.01 M *hydrochloric acid*. The solution is red.

**Viscosity (2.2.9):** 80.0 per cent to 120.0 per cent of that stated on the label for a nominal viscosity greater than 6 mPas; 75.0 per cent to 140.0 per cent of that stated on the label for a nominal viscosity not greater than 6 mPas.

Shake a quantity of the substance to be examined equivalent to 5.00 g of the dried substance with 95 g of a mixture of 20 g of *ethanol (96 per cent) R* and 80 g of *toluene R* until the substance is dissolved. Determine the viscosity in mPas at 25 °C using a capillary viscometer.

**Acetaldehyde:** maximum 100 ppm.

Introduce 3.0 g into a 250 mL conical flask with a ground-glass stopper, add 10 mL of *water R* and stir mechanically for 1 h. Allow to stand for 24 h, filter and dilute the filtrate to 100.0 mL with *water R*. Transfer 5.0 mL of the filtrate to a 25 mL volumetric flask, add 5 mL of a 0.5 g/L solution of *methylbenzothiazolone hydrazone hydrochloride R* and heat in a water-bath at 60 °C for 5 min. Add 2 mL of *ferric chloride-sulfamic acid reagent R* and heat again in a water-bath at 60 °C for 5 min. Cool and dilute to 25.0 mL with *water R*. The solution is not more intensely coloured than a standard prepared at the same time and in the same manner using instead of the 5.0 mL of filtrate, 5.0 mL of a reference solution prepared by diluting 3.0 mL of *acetaldehyde standard solution (100 ppm C<sub>2</sub>H<sub>4</sub>O) RI* to 100.0 mL with *water R*.

**Chlorides (2.4.4):** maximum 0.1 per cent.

Disperse 0.250 g in 50 mL of *water R*, heat to boiling and allow to cool, shaking occasionally. Filter and discard the first 10 mL of the filtrate. Dilute 10 mL of the filtrate to 15 mL with *water R*.

**Heavy metals (2.4.8):** maximum 20 ppm.

1.0 g complies with test C. Prepare the reference solution using 2 mL of *lead standard solution (10 ppm Pb) R*.

**Loss on drying (2.2.32):** maximum 3.0 per cent, determined on 1.000 g by drying in an oven at 105 °C for 2 h.

**Sulfated ash (2.4.14):** maximum 0.5 per cent, determined on 1.0 g.

## ASSAY

Gas chromatography (2.2.28).

**CAUTION:** *hydriodic acid and its reaction by-products are highly toxic. Perform all steps for preparation of the test and reference solutions in a properly functioning hood.*

**Internal standard solution.** Dilute 120 µL of *toluene R* to 10 mL with *o-xylene R*.

**Test solution.** Transfer 50.0 mg of the substance to be examined, 50.0 mg of *adipic acid R* and 2.0 mL of the internal standard solution into a suitable 5 mL thick-walled reaction vial with a pressure-tight septum-type closure. Cautiously add 2.0 mL of *hydriodic acid R*, immediately close the vial tightly and weigh the contents and the vial accurately. Shake the vial for 30 s, heat to 125 °C for 10 min, allow to cool for 2 min, shake again for 30 s and heat to 125 °C for 10 min. Afterwards allow to cool for 2 min and repeat shaking and heating for a 3<sup>rd</sup> time. Allow the vial to cool for 45 min and reweigh. If the loss is greater than 10 mg, discard the mixture and prepare another. Use the upper layer.

**Reference solution.** Transfer 100.0 mg of *adipic acid R*, 4.0 mL of the internal standard solution and 4.0 mL of *hydriodic acid R* into a suitable 10 mL thick-walled reaction vial with a pressure-tight septum-type closure. Close the vial tightly and weigh the vial and contents accurately. Afterwards inject 50 µL of *iodoethane R* through the septum with a syringe, weigh the vial again and calculate the mass of iodoethane added, by difference. Shake well and allow the layers to separate. Use the upper layer.

**Column:**

- *material:* stainless steel,
- *size:*  $l = 5.0$  m,  $\varnothing = 2$  mm,
- *stationary phase:* *diatomaceous earth for gas chromatography R* (150-180 µm) impregnated with 3 per cent *m/m* of *poly(dimethyl)siloxane R*.

**Carrier gas:** *nitrogen for chromatography R*.

**Flow rate:** 15 mL/min.

**Temperature:**

- *column:* 80 °C,
- *injection port and detector:* 200 °C.

**Detection:** flame ionisation.

**Injection:** 1 µL.

**Relative retention** with reference to toluene: iodoethane = about 0.6; *o*-xylene = about 2.3.

**System suitability:** reference solution:

- **resolution:** minimum 2.0 between the peaks due to iodoethane and toluene.

Calculate the percentage content of ethoxy groups using the following expression:

$$\frac{Q_1 \times m_2 \times 45.1 \times 100 \times 100}{2 \times Q_2 \times m_1 \times 156.0 \times (100 - d)}$$

$Q_1$  = ratio of iodoethane peak area to toluene peak area in the chromatogram obtained with the test solution,

$Q_2$  = ratio of iodoethane peak area to toluene peak area in the chromatogram obtained with the reference solution,

$m_1$  = mass of the substance to be examined used in the test solution, in milligrams,

$m_2$  = mass of iodoethane used in the reference solution, in milligrams,

$d$  = percentage loss on drying.

## LABELLING

The label states the nominal viscosity in millipascal seconds for a 5 per cent *m/m* solution.

01/2008:1421

## ETHYLENE GLYCOL MONOPALMITOSTEARATE

### Ethylenglycoli monopalmitostearas

## DEFINITION

Mixture of ethylene glycol mono- and diesters of stearic (octadecanoic) and palmitic (hexadecanoic) acids, produced from the condensation of ethylene glycol and stearic acid 50 of vegetable or animal origin (see *Stearic acid (1474)*).

**Content:** minimum of 50.0 per cent of monoesters.

## CHARACTERS

**Appearance:** white or almost white, waxy solid.

**Solubility:** practically insoluble in water, soluble in acetone and in hot alcohol.

01/2008:0716

## IDENTIFICATION

- A. Melting point (see Tests).  
 B. Composition of fatty acids (see Tests).  
 C. It complies with the assay (monoesters content).

## TESTS

**Melting point** (2.2.15): 54 °C to 60 °C.

**Acid value** (2.5.1): maximum 3.0, determined on 10.0 g.

**Iodine value** (2.5.4): maximum 3.0.

**Saponification value** (2.5.6): 170 to 195, determined on 2.0 g.

**Composition of fatty acids** (2.4.22, Method A). The fatty acid fraction has the following composition:

- *stearic acid*: 40.0 per cent to 60.0 per cent,
- *sum of contents of palmitic acid and stearic acid*: minimum 90.0 per cent.

**Free ethylene glycol**: maximum 5.0 per cent, determined as prescribed under Assay.

**Total ash** (2.4.16): maximum 0.1 per cent, determined on 1.0 g.

## ASSAY

Size-exclusion chromatography (2.2.30).

**Test solution.** Into a 15 mL flask, weigh about 0.2 g (*m*), to the nearest 0.1 mg. Add 5.0 mL of *tetrahydrofuran R* and shake to dissolve. Heat gently, if necessary. Reweigh the flask and calculate the total mass of solvent and substance (*M*).

**Reference solutions.** Into four 15 mL flasks, weigh, to the nearest 0.1 mg, about 2.5 mg, 5.0 mg, 10.0 mg and 20.0 mg of *ethylene glycol R*. Add 5.0 mL of *tetrahydrofuran R* and shake to dissolve. Weigh the flasks again and calculate the concentration of ethylene glycol in milligrams per gram for each reference solution.

**Column:**

- *size*:  $l = 0.6$  m,  $\emptyset = 7$  mm,
- *stationary phase*: *styrene-divinylbenzene copolymer R* (particle diameter 5  $\mu$ m and pore size 10 nm).

**Mobile phase:** *tetrahydrofuran R*.

**Flow rate:** 1 mL/min.

**Detection:** differential refractometer.

**Injection:** 40  $\mu$ L.

**Relative retention** with reference to ethylene glycol: diesters = about 0.76, monoesters = about 0.83.

**Limits:**

- *free ethylene glycol*: from the calibration curve obtained with the reference solutions, determine the concentration (*C*) in milligrams per gram in the test solution and calculate the percentage content in the substance to be examined using the following expression:

$$\frac{C \times M}{m \times 10}$$

- *monoesters*: calculate the percentage content of monoesters using the following expression:

$$\frac{A}{A + B} \times (100 - D)$$

*A* = area of the peak due to the monoesters,

*B* = area of the peak due to the diesters,

*D* = percentage content of free ethylene glycol + percentage content of free fatty acids which may be determined using the following expression:  $\frac{I_A \times 270}{561.1}$

*I<sub>A</sub>* = acid value.

## STORAGE

Protected from light.

## ETHYLENEDIAMINE

## Ethylenediaminum

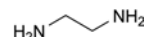

$C_2H_8N_2$   
 [107-15-3]

$M_r$  60.1

## DEFINITION

Ethane-1,2-diamine.

**Content:** 98.0 per cent to 101.0 per cent.

## CHARACTERS

**Appearance:** clear, colourless or slightly yellow liquid, hygroscopic.

**Solubility:** miscible with water and with anhydrous ethanol. On exposure to air, white fumes are evolved. On heating, it evaporates completely.

## IDENTIFICATION

A. Relative density (2.2.5): 0.895 to 0.905.

B. Boiling point (2.2.12): 116 °C to 118 °C.

C. To 0.2 mL add 0.5 mL of *acetic anhydride R*. Boil. A crystalline mass forms after cooling, which dissolves in 5 mL of *2-propanol R* with heating. Cool the solution and add 5 mL of *ether R*. If necessary, initiate crystallisation by scratching the walls of the test-tube with a glass rod. Filter through a sintered-glass filter (2.1.2), wash with several portions of *ether R* and dry at 100-105 °C. The residue melts (2.2.14) at 173 °C to 177 °C.

## TESTS

**Solution S.** Mix 10 g with *carbon dioxide-free water R* and dilute to 100 mL with the same solvent.

**Appearance of solution.** Solution S is clear (2.2.1) and not more intensely coloured than the reference solution BY<sub>6</sub> (2.2.2, Method II).

**Carbonate.** A mixture of 4 mL of solution S and 6 mL of *calcium hydroxide solution R* is not more opalescent than reference suspension II (2.2.1).

**Chlorides** (2.4.4): maximum 100 ppm.

To 5 mL of solution S add 5 mL of *dilute nitric acid R* and dilute to 15 mL with *water R*.

**Ammonia and other bases.** Dissolve 1.2 g in 20 mL of *ethanol (96 per cent) R* and add, dropwise with stirring, 4.5 mL of *hydrochloric acid R*. Evaporate to dryness on a water-bath, breaking up any resulting cake with a glass rod, and dry at 100-105 °C for 1 h. 1 g of the residue is equivalent to 0.4518 g of  $C_2H_8N_2$ . Calculate the percentage content of  $C_2H_8N_2$ ; it does not vary by more than 0.5 from the percentage content determined in the assay.

**Iron** (2.4.9): maximum 10 ppm, determined on solution S.

**Heavy metals** (2.4.8): maximum 10 ppm.

12 mL of solution S complies with test A. Prepare the reference solution using *lead standard solution (1 ppm Pb) R*.

**Residue on evaporation:** maximum 0.3 per cent.

Evaporate 5.00 g to dryness on a water-bath and dry at 100-105 °C for 1 h. The residue weighs a maximum of 15 mg.

## ASSAY

Place 25.0 mL of *1 M hydrochloric acid* and 0.2 mL of *methyl red mixed solution R* in a flask. Add 0.600 g of the substance to be examined. Titrate with *1 M sodium hydroxide* until the colour changes from violet-red to green.

1 mL of *1 M hydrochloric acid* is equivalent to 30.05 mg of  $C_2H_8N_2$ .



## STORAGE

In an airtight container, protected from light.

01/2008:0491

## ETHYLMORPHINE HYDROCHLORIDE

## Ethylmorphini hydrochloridum

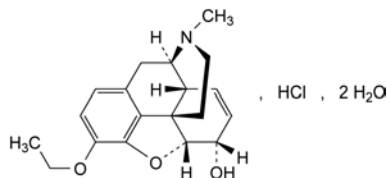
 $C_{19}H_{24}ClNO_3 \cdot 2H_2O$ 
 $M_r$  385.9

## DEFINITION

7,8-Didehydro-4,5 $\alpha$ -epoxy-3-ethoxy-17-methylmorphinan-6 $\alpha$ -ol hydrochloride dihydrate.

Content: 99.0 per cent to 101.0 per cent (anhydrous substance).

## CHARACTERS

Appearance: white or almost white, crystalline powder.

Solubility: soluble in water and in alcohol, insoluble in cyclohexane.

## IDENTIFICATION

First identification: A, D.

Second identification: B, C, D.

A. Infrared absorption spectrophotometry (2.2.24).

Comparison: Ph. Eur. reference spectrum of ethylmorphine hydrochloride.

B. In a test-tube, dissolve 0.5 g in 6 mL of water R and add 15 mL of 0.1 M sodium hydroxide. Scratch the wall of the tube with a glass rod. A white, crystalline precipitate is formed. Collect the precipitate, wash and dissolve in 20 mL of water R heated to 80 °C. Filter and cool in iced water. The crystals, after drying *in vacuo* for 12 h, melt (2.2.14) at 85 °C to 89 °C.

C. To about 10 mg add 1 mL of sulfuric acid R and 0.05 mL of ferric chloride solution R2. Heat on a water-bath. A blue colour develops. Add 0.05 mL of nitric acid R. The colour becomes red.

D. Solution S (see Tests) gives reaction (a) of chlorides (2.3.1).

## TESTS

**Solution S.** Dissolve 0.500 g in carbon dioxide-free water R and dilute to 25.0 mL with the same solvent.

**Appearance of solution.** Solution S is clear (2.2.1) and not more intensely coloured than reference solution BY<sub>6</sub> (2.2.2, Method II).

**Acidity or alkalinity.** To 10 mL of solution S add 0.05 mL of methyl red solution R and 0.2 mL of 0.02 M hydrochloric acid, the solution is red. Add 0.4 mL of 0.02 M sodium hydroxide, the solution becomes yellow.

**Specific optical rotation** (2.2.7): –102 to –105 (anhydrous substance), determined on solution S.

**Related substances.** Liquid chromatography (2.2.29).

**Test solution.** Dissolve 50.0 mg of the substance to be examined in the mobile phase and dilute to 20.0 mL with the mobile phase.

**Reference solution (a).** Dilute 1.0 mL of the test solution to 25.0 mL with the mobile phase. Dilute 1.0 mL of this solution to 20.0 mL with the mobile phase.

**Reference solution (b).** Dissolve 12.5 mg of codeine R in the mobile phase and dilute to 5.0 mL with the mobile phase.

**Reference solution (c).** Dilute 0.5 mL of reference solution (b) to 100.0 mL with the mobile phase.

**Reference solution (d).** To 1.0 mL of the test solution, add 1.0 mL of reference solution (b) and dilute to 50.0 mL with the mobile phase.

## Column:

– size:  $l = 0.25$  m,  $\varnothing = 4.6$  mm,

– stationary phase: octylsilyl silica gel for chromatography R (5  $\mu$ m),

– temperature: 30 °C.

**Mobile phase:** add 1.25 g of sodium heptanesulfonate R to a mixture of 12.5 mL of glacial acetic acid R and 5 mL of a 20 per cent V/V solution of triethylamine R in a mixture of equal volumes of methanol R and water R. Dilute to 1000 mL with water R. To 550 mL of this solution add 450 mL of methanol R.

Flow rate: 1 mL/min.

Detection: spectrophotometer at 230 nm.

Injection: 10  $\mu$ L.

Run time: 4 times the retention time of ethylmorphine.

**Relative retention** with reference to ethylmorphine (retention time = about 6.2 min): impurity B = about 0.7; impurity C = about 0.8; impurity D = about 1.3; impurity A = about 2.5.

**System suitability:** reference solution (d):

– resolution: minimum 5 between the peaks due to ethylmorphine and impurity C.

## Limits:

– correction factor: for the calculation of content, multiply the peak area of impurity D by 0.4,

– impurities A, B, D: for each impurity, not more than the area of the principal peak in the chromatogram obtained with reference solution (a) (0.2 per cent),

– impurity C: not more than the area of the principal peak in the chromatogram obtained with reference solution (c) (0.5 per cent),

– any other impurity: for each impurity, not more than 0.5 times the area of the principal peak in the chromatogram obtained with reference solution (a) (0.1 per cent),

– total of impurities other than C: not more than 2.5 times the area of the principal peak in the chromatogram obtained with reference solution (a) (0.5 per cent),

– disregard limit: 0.25 times the area of the principal peak in the chromatogram obtained with reference solution (a) (0.05 per cent).

**Water** (2.5.12): 8.0 per cent to 10.0 per cent, determined on 0.250 g.

**Sulfated ash** (2.4.14): maximum 0.1 per cent, determined on 1.0 g.

## ASSAY

Dissolve 0.300 g in a mixture of 5 mL of 0.01 M hydrochloric acid and 30 mL of alcohol R. Carry out a potentiometric titration (2.2.20), using 0.1 M sodium hydroxide. Read the volume added between the 2 points of inflexion.

1 mL of 0.1 M sodium hydroxide is equivalent to 34.99 mg of  $C_{19}H_{24}ClNO_3$ .

## STORAGE

Protected from light.

## IMPURITIES

Specified impurities: A, B, C, D.

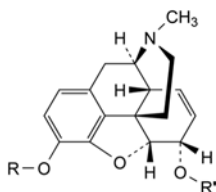

- A. R = R' = C<sub>2</sub>H<sub>5</sub>: 7,8-didehydro-4,5α-epoxy-3,6α-diethoxy-17-methylmorphinan,  
 B. R = R' = H: 7,8-didehydro-4,5α-epoxy-17-methylmorphinan-3,6α-diol (morphine),  
 C. R = CH<sub>3</sub>, R' = H: 7,8-didehydro-4,5α-epoxy-3-methoxy-17-methylmorphinan-6α-ol (codeine),

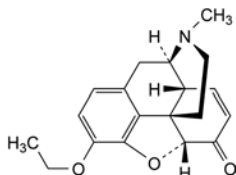

- D. 7,8-didehydro-4,5α-epoxy-3-ethoxy-17-methylmorphinan-6-one (ethylmorphine).

01/2008:1778

## ETIDRONATE DISODIUM

### Dinatrii etidronas

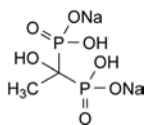

C<sub>2</sub>H<sub>6</sub>Na<sub>2</sub>O<sub>7</sub>P<sub>2</sub>  
 [7414-83-7]

M<sub>r</sub> 250.0

#### DEFINITION

Disodium dihydrogen (1-hydroxyethylidene)bisphosphonate.  
*Content*: 98.0 per cent to 102.0 per cent (anhydrous substance).

#### CHARACTERS

*Appearance*: white or yellowish, hygroscopic powder.  
*Solubility*: freely soluble in water, practically insoluble in acetone and in ethanol (96 per cent).

#### IDENTIFICATION

- A. Infrared absorption spectrophotometry (2.2.24).  
*Comparison*: etidronate disodium CRS.  
 The transmittance at about 2000 cm<sup>-1</sup> (5 μm) is not less than 40 per cent without compensation.  
 B. It gives reaction (a) of sodium (2.3.1).

#### TESTS

**pH** (2.2.3): 4.2 to 5.2.

Dissolve 1.0 g in carbon dioxide-free water R and dilute to 100 mL with the same solvent.

**Impurities A and B.** Liquid chromatography (2.2.29).  
*Test solution.* Dissolve 20.0 mg of the substance to be examined in water R and dilute to 10.0 mL with the same solvent.  
*Reference solution.* To 2.0 mL of a 0.3 g/L solution of phosphoric acid R add 2.0 mL of a 0.25 g/L solution of phosphorous acid R and dilute to 50.0 mL with water R.  
*Column*:

- size:  $l = 0.15$  m,  $\varnothing = 4.6$  mm;
- stationary phase: anion exchange resin R (5 μm);
- temperature: 35 °C.

*Mobile phase*: mix 0.2 mL of anhydrous formic acid R and 1000 mL of water R; adjust to pH 3.5 with an 80 g/L solution of sodium hydroxide R.

*Flow rate*: 1.0 mL/min.

*Detection*: differential refractometer.

*Injection*: 100 μL.

*System suitability*: reference solution:

- *resolution*: minimum 2.5 between the peaks due to impurity A and impurity B.

*Limits*:

- *impurities A, B*: for each impurity, not more than the area of the corresponding peak in the chromatogram obtained with the reference solution (0.5 per cent).

**Heavy metals** (2.4.8): maximum 20 ppm.

1.0 g complies with test F. Prepare the reference solution using 2 mL of lead standard solution (10 ppm Pb) R.

**Water** (2.5.32): maximum 5.0 per cent.

Dissolve 50.0 mg in a mixture of equal volumes of anhydrous acetic acid R and formamide R and dilute to 5.0 mL with the same mixture of solvents. Use 1.0 mL of the solution.

#### ASSAY

Dissolve 0.100 g in 2 mL of formic acid R and dilute to 50 mL with glacial acetic acid R. Titrate with 0.1 M perchloric acid, determining the end-point potentiometrically (2.2.20).

1 mL of 0.1 M perchloric acid is equivalent to 12.50 mg of C<sub>2</sub>H<sub>6</sub>Na<sub>2</sub>O<sub>7</sub>P<sub>2</sub>.

#### STORAGE

In an airtight container.

#### IMPURITIES

*Specified impurities*: A, B.

- A. H<sub>3</sub>PO<sub>4</sub>: phosphoric acid,  
 B. H<sub>3</sub>PO<sub>3</sub>: phosphorous acid.

01/2008:1205  
corrected 6.0

## ETILEFRINE HYDROCHLORIDE

### Etilefrini hydrochloridum

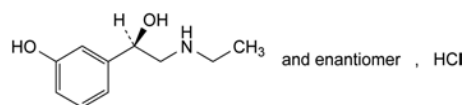

C<sub>10</sub>H<sub>16</sub>ClNO<sub>2</sub>  
 [943-17-9]

M<sub>r</sub> 217.7

#### DEFINITION

(1*S*)-2-(Ethylamino)-1-(3-hydroxyphenyl)ethanol hydrochloride.  
*Content*: 98.0 per cent to 101.0 per cent (dried substance).

#### CHARACTERS

*Appearance*: white or almost white, crystalline powder or colourless crystals.  
*Solubility*: freely soluble in water, soluble in ethanol (96 per cent), practically insoluble in methylene chloride.

#### IDENTIFICATION

- First identification*: B, E.  
*Second identification*: A, C, D, E.  
 A. Melting point (2.2.14): 118 °C to 122 °C.  
 B. Infrared absorption spectrophotometry (2.2.24).  
*Preparation*: discs of potassium chloride R.  
*Comparison*: etilefrine hydrochloride CRS.

## C. Thin-layer chromatography (2.2.27).

Prepare the solutions protected from bright light and develop the chromatograms protected from light.

**Test solution.** Dissolve 25 mg of the substance to be examined in *methanol R* and dilute to 5 mL with the same solvent.

**Reference solution (a).** Dissolve 25 mg of *etilefrine hydrochloride CRS* in *methanol R* and dilute to 5 mL with the same solvent.

**Reference solution (b).** Dissolve 10 mg of *phenylephrine hydrochloride CRS* in 2 mL of reference solution (a) and dilute to 10 mL with *methanol R*.

**Plate:** TLC silica gel plate *R*.

**Mobile phase:** concentrated ammonia *R*, *methanol R*, *methylene chloride R* (5:25:70 V/V/V).

**Application:** 5 µL.

**Development:** over a path of 15 cm.

**Drying:** in a current of warm air.

**Detection:** spray with a 10 g/L solution of *potassium permanganate R*; examine in daylight after 15 min.

**System suitability:** reference solution (b):

- the chromatogram shows 2 clearly separated spots.

**Results:** the principal spot in the chromatogram obtained with the test solution is similar in position, colour and size to the principal spot in the chromatogram obtained with reference solution (a).

D. To 0.2 mL of solution S (see Tests), add 1 mL of *water R*, 0.1 mL of *copper sulfate solution R* and 1 mL of *strong sodium hydroxide solution R*. A blue colour is produced. Add 2 mL of *ether R* and shake. The upper layer is colourless.E. Dilute 1 mL of solution S to 10 mL with *water R*. The solution gives reaction (a) of chlorides (2.3.1).

## TESTS

**Solution S.** Dissolve 2.50 g in *carbon dioxide-free water R* prepared from *distilled water R* and dilute to 50.0 mL with the same solvent.

**Appearance of solution.** Solution S is clear (2.2.1) and colourless (2.2.2, *Method II*).

**Acidity or alkalinity.** Dilute 4 mL of solution S to 10 mL with *carbon dioxide-free water R*. Add 0.1 mL of *methyl red solution R* and 0.2 mL of 0.01 M *sodium hydroxide*. The solution is yellow. Not more than 0.4 mL of 0.01 M *hydrochloric acid* is required to change the colour of the indicator to red.

**Optical rotation (2.2.7):**  $-0.10^\circ$  to  $+0.10^\circ$ , determined on solution S.

**Related substances.** Liquid chromatography (2.2.29). Prepare the solutions immediately before use.

**Test solution.** Dissolve 50.0 mg of the substance to be examined in *water R* and dilute to 50.0 mL with the same solvent.

**Reference solution (a).** Dilute 1.0 mL of the test solution to 10.0 mL with *water R*. Dilute 1.0 mL of this solution to 50.0 mL with *water R*.

**Reference solution (b).** Dissolve 10.0 mg of *etilefrine impurity A CRS* in *water R* and dilute to 50.0 mL with the same solvent. Dilute 1.0 mL of the solution to 50.0 mL with *water R*.

**Reference solution (c).** To 10.0 mL of reference solution (a) add 5.0 mL of reference solution (b) and dilute to 20.0 mL with *water R*.

**Column:**

- size:  $l = 0.25$  m,  $\varnothing = 4.6$  mm,
- stationary phase: octylsilyl silica gel for chromatography *R* (5 µm).

**Mobile phase:** mix 35 volumes of *acetonitrile R* and 65 volumes of a 1.1 g/L solution of *sodium laurilsulfate R* adjusted to pH 2.3 with *phosphoric acid R*.

**Flow rate:** 1 mL/min.

**Detection:** spectrophotometer at 220 nm.

**Injection:** 20 µL.

**Run time:** 5 times the retention time of etilefrine.

**Relative retention** with reference to etilefrine (retention time = about 9 min): impurity E = about 0.5; impurity C = about 0.8; impurity B = about 0.9; impurity A = about 1.2; impurity F = about 1.7; impurity D = about 4.5.

**System suitability:** reference solution (c):

- resolution: minimum 2.5 between the peaks due to etilefrine and impurity A.

**Limits:**

- impurity A: not more than the area of the principal peak in the chromatogram obtained with reference solution (b) (0.4 per cent),
- impurities B, C, D, E: for each impurity, not more than the area of the principal peak in the chromatogram obtained with reference solution (a) (0.2 per cent),
- any other impurity: for each impurity, not more than 0.5 times the area of the principal peak in the chromatogram obtained with reference solution (a) (0.1 per cent),
- sum of impurities other than A: not more than 5 times the area of the principal peak in the chromatogram obtained with reference solution (a) (1 per cent),
- disregard limit: 0.1 times the area of the principal peak in the chromatogram obtained with reference solution (a) (0.02 per cent); disregard any peak due to the solvent.

**Sulfates (2.4.13):** maximum 200 ppm, determined on 15 mL of solution S.

**Heavy metals (2.4.8):** maximum 20 ppm.

Dissolve 2.0 g in 20 mL of *water R*. 12 mL of the solution complies with limit test A. Prepare the reference solution using *lead standard solution (2 ppm Pb) R*.

**Loss on drying (2.2.32):** maximum 0.5 per cent, determined on 1.000 g by drying in an oven at 105 °C.

**Sulfated ash (2.4.14):** maximum 0.1 per cent, determined on 1.0 g.

## ASSAY

Dissolve 0.150 g in a mixture of 20 mL of *anhydrous acetic acid R* and 50 mL of *acetic anhydride R*. Titrate with 0.1 M *perchloric acid*, determining the end-point potentiometrically (2.2.20).

1 mL of 0.1 M *perchloric acid* is equivalent to 21.77 mg of  $C_{10}H_{16}ClNO_2$ .

## STORAGE

In an airtight container, protected from light.

## IMPURITIES

**Specified impurities:** A, B, C, D, E.

**Other detectable impurities** (the following substances would, if present at a sufficient level, be detected by one or other of the tests in the monograph. They are limited by the general acceptance criterion for other/unspecified impurities and/or by the general monograph *Substances for pharmaceutical use (2034)*. It is therefore not necessary to identify these impurities for demonstration of compliance. See also 5.10. *Control of impurities in substances for pharmaceutical use*): F.

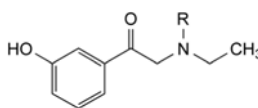

A. R = H: 2-(ethylamino)-1-(3-hydroxyphenyl)ethanone (etilefrine),

D. R =  $CH_2-C_6H_5$ : 2-(benzylethylamino)-1-(3-hydroxyphenyl)ethanone (benzyletilefrine),

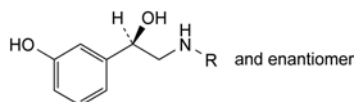

B. R = CH<sub>3</sub>: (1*RS*)-1-(3-hydroxyphenyl)-2-(methylamino)ethanol (phenylephrine),

C. R = H: (1*RS*)-2-amino-1-(3-hydroxyphenyl)ethanol (norfenefrine),

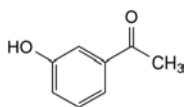

E. 1-(3-hydroxyphenyl)ethanone (3-hydroxyacetophenone),

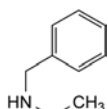

F. *N*-benzylethanamine (benzylethylamine).

Place the plate in an unsaturated tank containing a mixture of 20 volumes of a 25 g/L solution of *ascorbic acid R* and 80 volumes of *methanol R*. Allow the solution to ascend 1 cm above the line of application on the plate, remove the plate and allow it to dry for at least 30 min.

*Mobile phase*: glacial acetic acid *R*, anhydrous ethanol *R*, toluene *R* (0.5:30:70 V/V/V).

*Application*: 10 µL.

*Development*: 2/3 of the plate.

*Drying*: in air.

*Detection*: examine in ultraviolet light at 254 nm.

*Results*: the principal spot in the chromatogram obtained with the test solution is similar in position and size to the principal spot in the chromatogram obtained with the reference solution.

## TESTS

**Related substances.** Liquid chromatography (2.2.29).

*Test solution.* Dissolve 20.0 mg of the substance to be examined in *acetonitrile R1* and dilute to 50.0 mL with the same solvent.

*Reference solution (a).* Dilute 1.0 mL of the test solution to 50.0 mL with *acetonitrile R1*. Dilute 1.0 mL of this solution to 20.0 mL with *acetonitrile R1*.

*Reference solution (b).* Dissolve 4 mg of *etodolac impurity H CRS* in the test solution and dilute to 10 mL with the same solution. Dilute 0.5 mL of this solution to 50 mL with *acetonitrile R1*.

*Reference solution (c).* Dissolve 4 mg of *etodolac for peak identification CRS* (containing impurities A, B, C, D, E, F, G, H, I and K) in 10 mL of *acetonitrile R1*.

*Column*:

- size:  $l = 0.15$  m,  $\varnothing = 4.6$  mm;
- stationary phase: end-capped butylsilyl silica gel for chromatography *R* (3.5 µm);
- temperature: 35 °C.

*Mobile phase*:

- mobile phase A: 0.77 g/L solution of ammonium acetate *R*;
- mobile phase B: mobile phase A, *acetonitrile R1* (10:90 V/V);

Time (min)	Mobile phase A (per cent V/V)	Mobile phase B (per cent V/V)
0 - 25	80 → 50	20 → 50
25 - 42	50	50
42 - 48	50 → 80	50 → 20

*Flow rate*: 1 mL/min.

*Detection*: spectrophotometer at 225 nm.

*Injection*: 5 µL.

*Identification of impurities*: use the chromatogram supplied with *etodolac for peak identification CRS* and the chromatogram obtained with reference solution (c) to identify the peaks due to impurities A, B, C, D, E, F, G, H, I and K.

*Relative retention* with reference to etodolac (retention time = about 16.7 min): impurity A = about 0.68; impurity B = about 0.83; impurity C = about 0.85; impurity H = about 1.09; impurity D = about 1.17; impurity G = about 1.19; impurity E = about 1.20; impurity F = about 1.22; impurity I = about 1.50; impurity K = about 2.37.

*System suitability*: reference solution (b):

- resolution: minimum 5.0 between the peaks due to etodolac and impurity H.

01/2008:1422

## ETODOLAC

### Etodolacum

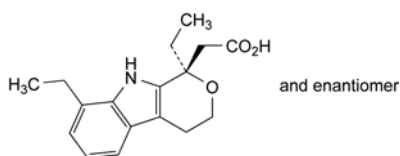

C<sub>17</sub>H<sub>21</sub>NO<sub>3</sub>  
[41340-25-4]

*M<sub>r</sub>* 287.4

## DEFINITION

2-[(1*RS*)-1,8-Diethyl-1,3,4,9-tetrahydropyrano[3,4-*b*]indol-1-yl]acetic acid.

*Content*: 98.0 per cent to 102.0 per cent (anhydrous substance).

## CHARACTERS

*Appearance*: white or almost white, crystalline powder.

*Solubility*: practically insoluble in water, freely soluble in acetone and in ethanol (96 per cent).

## IDENTIFICATION

*First identification*: B.

*Second identification*: A, C.

A. Melting point (2.2.14): 144 °C to 150 °C.

B. Infrared absorption spectrophotometry (2.2.24).

*Comparison*: etodolac CRS.

C. Thin-layer chromatography (2.2.27).

*Test solution.* Dissolve 10 mg of the substance to be examined in *acetone R* and dilute to 10 mL with the same solvent.

*Reference solution.* Dissolve 10 mg of *etodolac CRS* in *acetone R* and dilute to 10 mL with the same solvent.

*Plate*: TLC silica gel GF<sub>254</sub> plate *R* previously activated by heating at 105 °C for 1 h.

**Limits:**

- *impurity C*: not more than 5 times the area of the principal peak in the chromatogram obtained with reference solution (a) (0.5 per cent);
- *impurities A, B, D, E, F, G, H, I, K*: for each impurity, not more than twice the area of the principal peak in the chromatogram obtained with reference solution (a) (0.2 per cent);
- *unspecified impurities*: for each impurity, not more than the area of the principal peak in the chromatogram obtained with reference solution (a) (0.10 per cent);
- *total*: not more than 10 times the area of the principal peak in the chromatogram obtained with reference solution (a) (1.0 per cent);
- *disregard limit*: 0.5 times the area of the principal peak in the chromatogram obtained with reference solution (a) (0.05 per cent).

**Chlorides:** maximum 300 ppm.

Dissolve 1.0 g of the substance to be examined in 60 mL of *methanol R*, add 10 mL of *water R* and 20 mL of *dilute nitric acid R*. Titrate with 0.01 M *silver nitrate*, determining the end-point potentiometrically (2.2.20).

1 mL of 0.01 M *silver nitrate* is equivalent to 0.3545 mg of Cl.

**Heavy metals (2.4.8):** maximum 10 ppm.

2.0 g complies with test C. Prepare the reference solution using 2 mL of *lead standard solution (10 ppm Pb) R*.

**Water (2.5.12):** maximum 0.5 per cent, determined on 1.00 g.

**Sulfated ash (2.4.14):** maximum 0.1 per cent, determined on 1.0 g.

**ASSAY**

Dissolve 0.250 g in 60 mL of *methanol R*. Titrate with 0.1 M *tetrabutylammonium hydroxide* determining the end-point potentiometrically (2.2.20). Carry out a blank titration.

1 mL of 0.1 M *tetrabutylammonium hydroxide* is equivalent to 28.74 mg of C<sub>17</sub>H<sub>21</sub>NO<sub>3</sub>.

**IMPURITIES**

*Specified impurities: A, B, C, D, E, F, G, H, I, K.*

*Other detectable impurities* (the following substances would, if present at a sufficient level, be detected by one or other of the tests in the monograph. They are limited by the general acceptance criterion for other/unspecified impurities and/or by the general monograph *Substances for pharmaceutical use (2034)*. It is therefore not necessary to identify these impurities for demonstration of compliance. See also 5.10. *Control of impurities in substances for pharmaceutical use*): *J, L.*

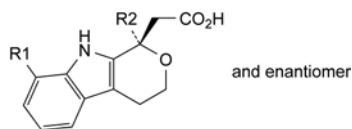

- A. R1 = H, R2 = CH<sub>2</sub>-CH<sub>3</sub>: 2-[(1*RS*)-1-ethyl-1,3,4,9-tetrahydropyrano[3,4-*b*]indol-1-yl]acetic acid (8-desethyl etodolac),
- B. R1 = CH<sub>3</sub>, R2 = CH<sub>2</sub>-CH<sub>3</sub>: 2-[(1*RS*)-1-ethyl-8-methyl-1,3,4,9-tetrahydropyrano[3,4-*b*]indol-1-yl]acetic acid (8-methyl etodolac),
- C. R1 = CH<sub>2</sub>-CH<sub>3</sub>, R2 = CH<sub>3</sub>: 2-[(1*RS*)-8-ethyl-1-methyl-1,3,4,9-tetrahydropyrano[3,4-*b*]indol-1-yl]acetic acid (1-methyl etodolac),
- D. R1 = CH(CH<sub>3</sub>)<sub>2</sub>, R2 = CH<sub>2</sub>-CH<sub>3</sub>: 2-[(1*RS*)-1-ethyl-8-(1-methylethyl)-1,3,4,9-tetrahydropyrano[3,4-*b*]indol-1-yl]acetic acid (8-isopropyl etodolac),
- E. R1 = CH<sub>2</sub>-CH<sub>2</sub>-CH<sub>3</sub>, R2 = CH<sub>2</sub>-CH<sub>3</sub>: 2-[(1*RS*)-1-ethyl-8-propyl-1,3,4,9-tetrahydropyrano[3,4-*b*]indol-1-yl]acetic acid (8-propyl etodolac),

F. R1 = CH<sub>2</sub>-CH<sub>3</sub>, R2 = CH(CH<sub>3</sub>)<sub>2</sub>: 2-[(1*RS*)-8-ethyl-1-(1-methylethyl)-1,3,4,9-tetrahydropyrano[3,4-*b*]indol-1-yl]acetic acid (1-isopropyl etodolac),

G. R1 = CH<sub>2</sub>-CH<sub>3</sub>, R2 = CH<sub>2</sub>-CH<sub>2</sub>-CH<sub>3</sub>: 2-[(1*RS*)-8-ethyl-1-propyl-1,3,4,9-tetrahydropyrano[3,4-*b*]indol-1-yl]acetic acid (1-propyl etodolac),

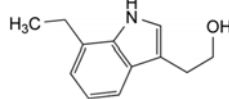

H. 2-(7-ethyl-1*H*-indol-3-yl)ethanol,

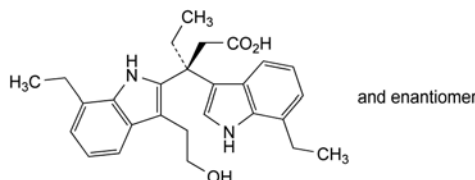

I. (3*RS*)-3-[7-ethyl-3-(2-hydroxyethyl)-1*H*-indol-2-yl]-3-(7-ethyl-1*H*-indol-3-yl)pentanoic acid (etodolac dimer),

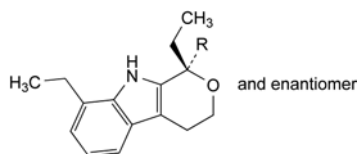

J. R = CH<sub>3</sub>: (1*RS*)-1,8-diethyl-1-methyl-1,3,4,9-tetrahydropyrano[3,4-*b*]indole (decarboxy etodolac),

K. R = CH<sub>2</sub>-CO-O-CH<sub>3</sub>: methyl 2-[(1*RS*)-1,8-diethyl-1,3,4,9-tetrahydropyrano[3,4-*b*]indol-1-yl]acetate (etodolac methyl ester),

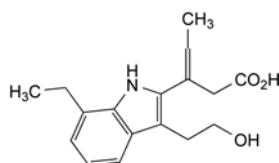

L. (*EZ*)-3-[7-ethyl-3-(2-hydroxyethyl)-1*H*-indol-2-yl]pent-3-enoic acid.

01/2008:1513

**ETOFENAMATE**

## Etofenamatum

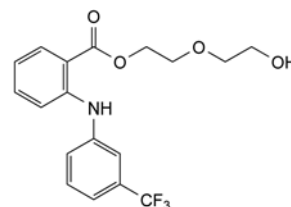

C<sub>18</sub>H<sub>18</sub>F<sub>3</sub>NO<sub>4</sub>  
[30544-47-9]

*M<sub>r</sub>* 369.4

**DEFINITION**

2-(2-Hydroxyethoxy)ethyl 2-[[3-(trifluoromethyl)phenyl]amino]-benzoate.

*Content*: 98.5 per cent to 101.5 per cent (anhydrous substance).

**CHARACTERS**

*Appearance*: yellowish viscous liquid.

*Solubility*: practically insoluble in water, miscible with alcohol and with ethyl acetate.

## IDENTIFICATION

Infrared absorption spectrophotometry (2.2.24).

Comparison: etofenamate CRS.

Preparation: films.

## TESTS

**Appearance.** The substance to be examined is clear (2.2.1) and not more intensely coloured than reference solution GY<sub>1</sub> (2.2.2, Method II).

**Impurity F.** Gas chromatography (2.2.28).

Internal standard: tetradecane R.

**Solution A.** Dissolve 6.0 mg of tetradecane R in hexane R and dilute to 10.0 mL with the same solvent.

**Solution B.** To 6.0 mg of diethylene glycol R in a 10 mL volumetric flask add 3 mL of *N*-methyltrimethylsilyl-trifluoroacetamide R and heat for 30 min at 50 °C. After cooling dilute to 10.0 mL with *N*-methyltrimethylsilyl-trifluoroacetamide R.

**Test solution.** To 0.200 g of the substance to be examined add 10 µL of solution A. Add 2 mL of *N*-methyltrimethylsilyl-trifluoroacetamide R and heat for 30 min at 50 °C.

**Reference solution.** To 2.0 mL of *N*-methyltrimethylsilyl-trifluoroacetamide R add 10 µL of solution A and 10 µL of solution B.

Column:

- size:  $l = 25$  m,  $\varnothing = 0.20$  mm,
- stationary phase: poly(dimethyl)(diphenyl)siloxane R (film thickness 0.33 µm).

Carrier gas: hydrogen for chromatography R.

Flow rate: 0.9 mL/min.

Temperature:

	Time (min)	Temperature (°C)	Rate (°C/min)
Column	0 - 13	60 → 150	7
	13 - 19	150 → 300	25
	19 - 34	300	
Injection port		150	
Detector		300	

Detection: flame ionisation.

Injection: 0.2 µL.

Limit:

- impurity F: maximum 0.1 per cent.

**Related substances.** Liquid chromatography (2.2.29).

**Test solution.** Dissolve 50.0 mg of the substance to be examined in 30 mL of methanol R and dilute to 50.0 mL with water R.

**Reference solution (a).** Dissolve 10.0 mg of etofenamate impurity G CRS in methanol R and dilute to 20.0 mL with the same solvent. Dilute 0.2 mL of the solution to 50.0 mL with a mixture of 40 volumes of water R and 60 volumes of methanol R.

**Reference solution (b).** Dilute 0.2 mL of the test solution to 100.0 mL with a mixture of 40 volumes of water R and 60 volumes of methanol R.

**Reference solution (c).** To 5.0 mL of reference solution (a), add 5.0 mL of reference solution (b).

**Reference solution (d).** Dissolve 10.0 mg of etofenamate for peak identification CRS (contains etofenamate spiked with about 1 per cent of impurities A, B, C, D and E) in 6.0 mL of methanol R and dilute to 10.0 mL with water R.

Column:

- size:  $l = 0.10$  m,  $\varnothing = 4.0$  mm,

– stationary phase: octadecylsilyl silica gel for chromatography R (3 µm),

– temperature: 40 °C.

Mobile phase:

– mobile phase A: dissolve 1.3 g of ammonium phosphate R and 4.0 g of tetrabutylammonium hydroxide R in 900 mL of water R. Adjust the pH to 8.0 with dilute phosphoric acid R and dilute to 1000 mL with water R,

– mobile phase B: methanol R,

Time	Mobile phase A (per cent V/V)	Mobile phase B (per cent V/V)
0 - 13	40	60
13 - 20	40 → 10	60 → 90
20 - 25	10	90
25 - 26	10 → 40	90 → 60
26 - 31	40	60

Flow rate: 1.2 mL/min.

Detection: spectrophotometer at 286 nm.

Injection: 20 µL.

**Relative retention** with reference to etofenamate (retention time = about 13 min): impurity A = about 0.2; impurity C = about 0.7; impurity G = about 0.85; impurity E = about 1.5; impurity B = about 1.6; impurity D = about 1.7.

**System suitability:** reference solution (c):

- resolution: minimum of 2.3 between the peaks due to impurity G and to etofenamate.

Limits:

- correction factors: for the calculation of contents, multiply the peak areas of the following impurities by the corresponding correction factor: impurity A = 0.62; impurity C = 0.45; impurity D = 0.77,
- impurity A: not more than 1.25 times the area of the principal peak in the chromatogram obtained with reference solution (b) (0.25 per cent),
- impurity B: not more than the area of the principal peak in the chromatogram obtained with reference solution (b) (0.2 per cent),
- impurity C: not more than the area of the principal peak in the chromatogram obtained with reference solution (b) (0.2 per cent),
- impurity D: not more than 2.5 times the area of the principal peak in the chromatogram obtained with reference solution (b) (0.5 per cent),
- impurity E: not more than the area of the principal peak in the chromatogram obtained with reference solution (b) (0.2 per cent),
- impurity G: not more than the area of the principal peak in the chromatogram obtained with reference solution (a) (0.2 per cent),
- any other impurity: not more than half the area of the principal peak in the chromatogram obtained with reference solution (b) (0.1 per cent),
- total: not more than 6 times the area of the principal peak in the chromatogram obtained with reference solution (b) (1.2 per cent),
- disregard limit: 0.25 times the area of the principal peak in the chromatogram obtained with reference solution (b) (0.05 per cent).

**Heavy metals (2.4.8):** maximum 10 ppm.

2.0 g complies with limit test C. Prepare the standard using 2 mL of lead standard solution (10 ppm Pb) R.

**Water (2.5.12):** maximum 0.5 per cent, determined on 1.00 g.

**Sulfated ash (2.4.14):** maximum 0.1 per cent, determined on 1.0 g.

## ASSAY

To 3.000 g add 20 mL of *2-propanol R* and 20.0 mL of 1 M *sodium hydroxide* and heat under reflux for 2 h. Add 0.1 mL of *bromothymol blue solution R1*. Titrate after cooling with 1 M *hydrochloric acid* until the colour disappears. Carry out a blank titration.

1 mL of 1 M *sodium hydroxide* is equivalent to 0.3694 g of  $C_{18}H_{18}F_3NO_4$ .

## IMPURITIES

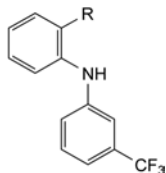

- A. R = CO<sub>2</sub>H: 2-[[3-(trifluoromethyl)phenyl]amino]benzoic acid (flufenamic acid),  
 B. R = CO-O-C<sub>4</sub>H<sub>9</sub>: butyl 2-[[3-(trifluoromethyl)phenyl]amino]benzoate (butyl flufenamate),  
 C. R = H: *N*-phenyl-3-(trifluoromethyl)aniline,  
 E. R = CO-[O-CH<sub>2</sub>-CH<sub>2</sub>]<sub>3</sub>-CH<sub>2</sub>-CH<sub>3</sub>: 2-(2-butoxyethoxy)ethyl 2-[[3-(trifluoromethyl)phenyl]amino]benzoate,  
 G. R = CO-O-CH<sub>2</sub>-CH<sub>2</sub>-OH: 2-hydroxyethyl 2-[[3-(trifluoromethyl)phenyl]amino]benzoate,

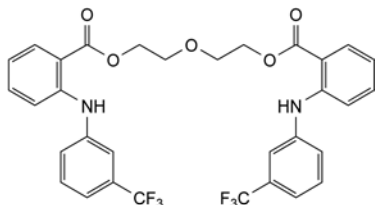

- D. 2,2'-oxybis(ethylene) bis[2-[[3-(trifluoromethyl)phenyl]amino]benzoate],

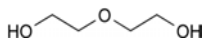

- F. 2,2'-oxydiethanol.

B. Examine by infrared absorption spectrophotometry (2.2.24), comparing with the spectrum obtained with *etofylline CRS*. Examine the substances as discs prepared using 0.5 mg to 1 mg of the substance to be examined in 0.3 g of *potassium bromide R*.

C. Dissolve 1 g in 5 mL of *acetic anhydride R* and boil under a reflux condenser for 15 min. Allow to cool and add 100 mL of a mixture of 20 volumes of *ether R* and 80 volumes of *light petroleum R*. Cool in iced water for at least 20 min, shaking from time to time. Filter, wash the precipitate with a mixture of 20 volumes of *ether R* and 80 volumes of *light petroleum R*, recrystallise from *alcohol R* and dry *in vacuo*. The crystals melt (2.2.14) at 101 °C to 105 °C.

D. It gives the reaction of xanthines (2.3.1).

## TESTS

**Solution S.** Dissolve 2.5 g in *carbon dioxide-free water R* and dilute to 50 mL with the same solvent.

**Appearance of solution.** Solution S is clear (2.2.1) and colourless (2.2.2, *Method II*).

**Acidity or alkalinity.** To 10 mL of solution S add 0.25 mL of *bromothymol blue solution R1*. The solution is yellow or green. Not more than 0.4 mL of 0.01 M *sodium hydroxide* is required to change the colour of the indicator to blue.

**Related substances.** Examine by thin-layer chromatography (2.2.27), using *silica gel HF<sub>254</sub> R* as the coating substance.

**Test solution.** Dissolve 0.3 g of the substance to be examined in a mixture of 20 volumes of *water R* and 30 volumes of *methanol R* and dilute to 10 mL with the same mixture of solvents. Prepare immediately before use.

**Reference solution (a).** Dilute 1 mL of the test solution to 100 mL with *methanol R*.

**Reference solution (b).** Dilute 0.2 mL of the test solution to 100 mL with *methanol R*.

**Reference solution (c).** Dissolve 10 mg of *theophylline R* in *methanol R*, add 0.3 mL of the test solution and dilute to 10 mL with *methanol R*.

Apply to the plate 10 µL of each solution. Develop over a path of 15 cm using a mixture of 1 volume of *concentrated ammonia R*, 10 volumes of *ethanol R* and 90 volumes of *chloroform R*. Allow the plate to dry in air and examine in ultraviolet light at 254 nm. Any spot in the chromatogram obtained with the test solution, apart from the principal spot, is not more intense than the spot in the chromatogram obtained with reference solution (a) (1 per cent) and at most one such spot is more intense than the spot in the chromatogram obtained with reference solution (b) (0.2 per cent). The test is not valid unless the chromatogram obtained with reference solution (c) shows two clearly separated spots.

**Chlorides** (2.4.4). Dilute 2.5 mL of solution S to 15 mL with *water R*. The solution complies with the limit test for chlorides (400 ppm).

**Heavy metals** (2.4.8). 12 mL of solution S complies with limit test A for heavy metals (20 ppm). Prepare the standard using *lead standard solution (1 ppm Pb) R*.

**Loss on drying** (2.2.32). Not more than 0.5 per cent, determined on 1.000 g by drying in an oven at 105 °C.

**Sulfated ash** (2.4.14). Not more than 0.1 per cent, determined on 1.0 g.

## ASSAY

*In order to avoid overheating in the reaction medium, mix thoroughly throughout and stop the titration immediately after the end-point has been reached.*

Dissolve 0.200 g in 3.0 mL of *anhydrous formic acid R* and add 50.0 mL of *acetic anhydride R*. Titrate with 0.1 M *perchloric acid*, determining the end-point potentiometrically (2.2.20).

1 mL of 0.1 M *perchloric acid* is equivalent to 22.42 mg of  $C_9H_{12}N_4O_3$ .

01/2008:0492  
corrected 6.0

## ETOFYLLINE

## Etofyllinum

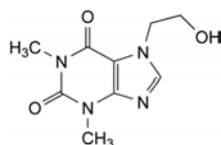

$C_9H_{12}N_4O_3$   
[519-37-9]

$M_r$  224.2

## DEFINITION

Etofylline contains not less than 98.5 per cent and not more than the equivalent of 101.0 per cent of 7-(2-hydroxyethyl)-1,3-dimethyl-3,7-dihydro-1*H*-purine-2,6-dione, calculated with reference to the dried substance.

## CHARACTERS

A white or almost white, crystalline powder, soluble in water, slightly soluble in alcohol.

## IDENTIFICATION

*First identification:* B, C.

*Second identification:* A, C, D.

A. Melting point (2.2.14): 161 °C to 166 °C.

## STORAGE

Store protected from light.

01/2008:1514  
corrected 7.0

## ETOMIDATE

## Etomidatum

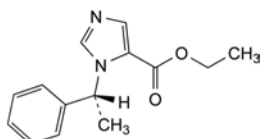

$C_{14}H_{16}N_2O_2$   
[33125-97-2]

$M_r$  244.3

## DEFINITION

Ethyl 1-[(1R)-1-phenylethyl]-1H-imidazole-5-carboxylate.

Content: 99.0 per cent to 101.0 per cent (dried substance).

## CHARACTERS

Appearance: white or almost white powder.

Solubility: very slightly soluble in water, freely soluble in ethanol (96 per cent) and in methylene chloride.

mp: about 68 °C.

## IDENTIFICATION

A. Infrared absorption spectrophotometry (2.2.24).

Comparison: etomidate CRS.

B. Specific optical rotation (see Tests).

## TESTS

**Solution S.** Dissolve 0.25 g in *anhydrous ethanol R* and dilute to 25.0 mL with the same solvent.

**Appearance of solution.** Solution S is clear (2.2.1) and colourless (2.2.2, Method II).

**Specific optical rotation** (2.2.7): + 67 to + 70 (dried substance), determined on solution S.

**Related substances.** Liquid chromatography (2.2.29).

*Solvent mixture: anhydrous ethanol R, water R (50:50 V/V).*

*Test solution.* Dissolve 0.100 g of the substance to be examined in the solvent mixture and dilute to 10.0 mL with the solvent mixture.

*Reference solution (a).* Dissolve 5.0 mg of *etomidate CRS* and 5.0 mg of *etomidate impurity B CRS* in the solvent mixture, then dilute to 250.0 mL with the solvent mixture.

*Reference solution (b).* Dilute 1.0 mL of the test solution to 100.0 mL with the solvent mixture. Dilute 5.0 mL of this solution to 25.0 mL with the solvent mixture.

*Column:*

- size:  $l = 0.1$  m,  $\emptyset = 4.6$  mm;
- stationary phase: octadecylsilyl silica gel for chromatography R (3  $\mu$ m).

*Mobile phase:*

- mobile phase A: 5 g/L solution of ammonium carbonate R;

- mobile phase B: acetonitrile R;

Time (min)	Mobile phase A (per cent V/V)	Mobile phase B (per cent V/V)
0 - 5	90 → 30	10 → 70
5 - 6	30 → 10	70 → 90
6 - 10	10	90

Flow rate: 2.0 mL/min.

Detection: spectrophotometer at 235 nm.

Injection: 10  $\mu$ L.

Retention time: impurity B = about 4.5 min; etomidate = about 5.0 min.

System suitability: reference solution (a):

- resolution: minimum 5.0 between the peaks due to impurity B and etomidate; if necessary, adjust the concentration of ammonium carbonate in the mobile phase or the time programme of the linear gradient.

Limits:

- impurities A, B, C: for each impurity, not more than the area of the principal peak in the chromatogram obtained with reference solution (b) (0.2 per cent);
- total: not more than 1.5 times the area of the principal peak in the chromatogram obtained with reference solution (b) (0.3 per cent);
- disregard limit: 0.25 times the area of the principal peak in the chromatogram obtained with reference solution (b) (0.05 per cent).

**Loss on drying** (2.2.32): maximum 0.5 per cent, determined on 1.000 g by drying *in vacuo* at 40 °C for 4 h.

**Sulfated ash** (2.4.14): maximum 0.1 per cent, determined on 1.0 g.

## ASSAY

Dissolve 0.200 g in 50 mL of a mixture of 1 volume of *anhydrous acetic acid R* and 7 volumes of *methyl ethyl ketone R*. Titrate with 0.1 M perchloric acid using 0.2 mL of *naphtholbenzein solution R* as indicator.

1 mL of 0.1 M perchloric acid is equivalent to 24.43 mg of  $C_{14}H_{16}N_2O_2$ .

## STORAGE

Protected from light.

## IMPURITIES

Specified impurities: A, B, C.

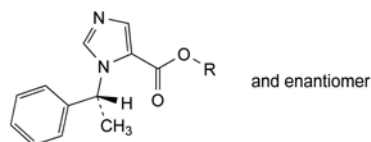

- A. R = H: 1-[(1R)-1-phenylethyl]-1H-imidazole-5-carboxylic acid,
- B. R = CH<sub>3</sub>: methyl 1-[(1R)-1-phenylethyl]-1H-imidazole-5-carboxylate (metomidate),
- C. R = CH(CH<sub>3</sub>)<sub>2</sub>: 1-methylethyl 1-[(1R)-1-phenylethyl]-1H-imidazole-5-carboxylate.



01/2008:0823 TESTS

**ETOPOSIDE**

## Etoposidum

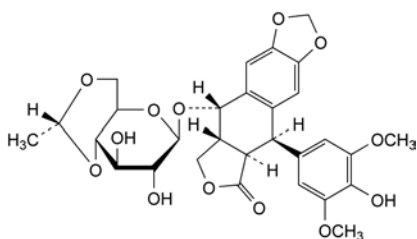

$C_{29}H_{32}O_{13}$   
[33419-42-0]

$M_r$  588.6

**DEFINITION**

(5*R*,5*aR*,8*aR*,9*S*)-9-[[4,6-*O*-(*R*)-Ethylidene]- $\beta$ -D-glucopyranosyl]oxy]-5-(4-hydroxy-3,5-dimethoxyphenyl)-5,8,8*a*,9-tetrahydroisobenzofuro[5,6-*f*][1,3]benzodioxol-6(5*aH*)-one.

*Content*: 98.0 per cent to 101.0 per cent (anhydrous substance).

**CHARACTERS**

*Appearance*: white or almost white crystalline powder.

*Solubility*: practically insoluble in water, sparingly soluble in methanol, slightly soluble in alcohol and in methylene chloride.

**IDENTIFICATION**

*First identification*: A, B.

*Second identification*: C, D.

A. Specific optical rotation (see Tests).

B. Infrared absorption spectrophotometry (2.2.24).

*Comparison*: etoposide CRS.

C. Thin-layer chromatography (2.2.27).

*Test solution*. Dissolve 10 mg of the substance to be examined in a mixture of 1 volume of *methanol R* and 9 volumes of *methylene chloride R* and dilute to 2 mL with the same mixture of solvents.

*Reference solution*. Dissolve 10 mg of *etoposide CRS* in a mixture of 1 volume of *methanol R* and 9 volumes of *methylene chloride R* and dilute to 2 mL with the same mixture of solvents.

*Plate*: plate with *silica gel H R* as coating substance.

*Mobile phase*: *water R*, *glacial acetic acid R*, *acetone R*, *methylene chloride R* (1.5:8:20:100 V/V/V/V).

*Application*: 5  $\mu$ L as 10 mm bands.

*Development*: immediately, over a path of 17 cm.

*Drying*: in a current of warm air for 5 min.

*Detection*: spray with a mixture of 1 volume of *sulfuric acid R* and 9 volumes of *alcohol R* and heat at 140 °C for 15 min. Cover the plate immediately with a glass plate of the same size. Examine in daylight.

*Results*: the principal band in the chromatogram obtained with the test solution is similar in position, colour and size to the principal band in the chromatogram obtained with the reference solution.

D. In a test-tube dissolve about 5 mg in 5 mL of *glacial acetic acid R* and add 0.05 mL of *ferric chloride solution RI*. Mix and cautiously add 2 mL of *sulfuric acid R*. Avoid mixing the 2 layers. Allow to stand for about 30 min; a pink to reddish-brown ring develops at the interface and the upper layer is yellow.

**Appearance of solution**. The solution is clear (2.2.1) and not more intensely coloured than reference solution  $Y_6$  or  $BY_6$  (2.2.2, *Method II*).

Dissolve 0.6 g in a mixture of 1 volume of *methanol R* and 9 volumes of *methylene chloride R* and dilute to 20 mL with the same mixture of solvents.

**Specific optical rotation** (2.2.7): –106 to –114 (anhydrous substance).

Dissolve 50 mg in a mixture of 1 volume of *methanol R* and 9 volumes of *methylene chloride R* and dilute to 10.0 mL with the same mixture of solvents.

**Related substances**. Liquid chromatography (2.2.29).

*Test solution (a)*. Dissolve 40 mg of the substance to be examined in a mixture of equal volumes of mobile phase A and mobile phase B and dilute to 10.0 mL with the same mixture of mobile phases.

*Test solution (b)*. Dissolve 50.0 mg of the substance to be examined in a mixture of equal volumes of mobile phase A and mobile phase B and dilute to 50.0 mL with the same mixture of mobile phases.

*Reference solution (a)*. Dilute 1.0 mL of test solution (a) to 10.0 mL with a mixture of equal volumes of mobile phase A and mobile phase B. Dilute 1.0 mL of this solution to 20.0 mL with a mixture of equal volumes of mobile phase A and mobile phase B.

*Reference solution (b)*. Dilute 4.0 mL of reference solution (a) to 10.0 mL with a mixture of equal volumes of mobile phase A and mobile phase B.

*Reference solution (c)*. Dissolve 50.0 mg of *etoposide CRS* in a mixture of equal volumes of mobile phase A and mobile phase B and dilute to 50.0 mL with the same mixture of mobile phases.

*Reference solution (d)*. To 10 mL of test solution (b), add 0.1 mL of a 4 per cent V/V solution of *glacial acetic acid R* and 0.1 mL of *phenolphthalein solution R*. Add 1 M *sodium hydroxide* until the solution becomes faintly pink (about 0.15 mL). After 15 min, add 0.1 mL of a 4 per cent V/V solution of *glacial acetic acid R*.

*Column*:

- *size*:  $l = 0.125$  m,  $\emptyset = 4.6$  mm,
- *stationary phase*: *octadecylsilyl silica gel for chromatography R* (5  $\mu$ m),
- *temperature*: 40 °C.

*Mobile phase*:

- *mobile phase A*: *triethylamine R*, *anhydrous formic acid R*, *water R* (1:1:998 V/V/V),
- *mobile phase B*: *triethylamine R*, *anhydrous formic acid R*, *acetonitrile R* (1:1:998 V/V/V),

Time (min)	Mobile phase A (per cent V/V)	Mobile phase B (per cent V/V)
0 - 7	75	25
7 - 23	75 $\rightarrow$ 27	25 $\rightarrow$ 73
23 - 25	27 $\rightarrow$ 75	73 $\rightarrow$ 25
25 - 40	75	25

*Flow rate*: 1 mL/min.

*Detection*: spectrophotometer at 285 nm.

*Injection*: 10  $\mu$ L; inject test solution (a) and reference solutions (a), (b) and (d).

*Retention times*: the retention times and the elution order of the peaks are similar to those shown in the chromatogram (Figure 0823-1).

*System suitability*: reference solution (d): continue the chromatography until the peak due to phenolphthalein is eluted.

- the chromatogram shows 2 principal peaks corresponding to etoposide and to impurity B. Disregard any peak due to phenolphthalein.

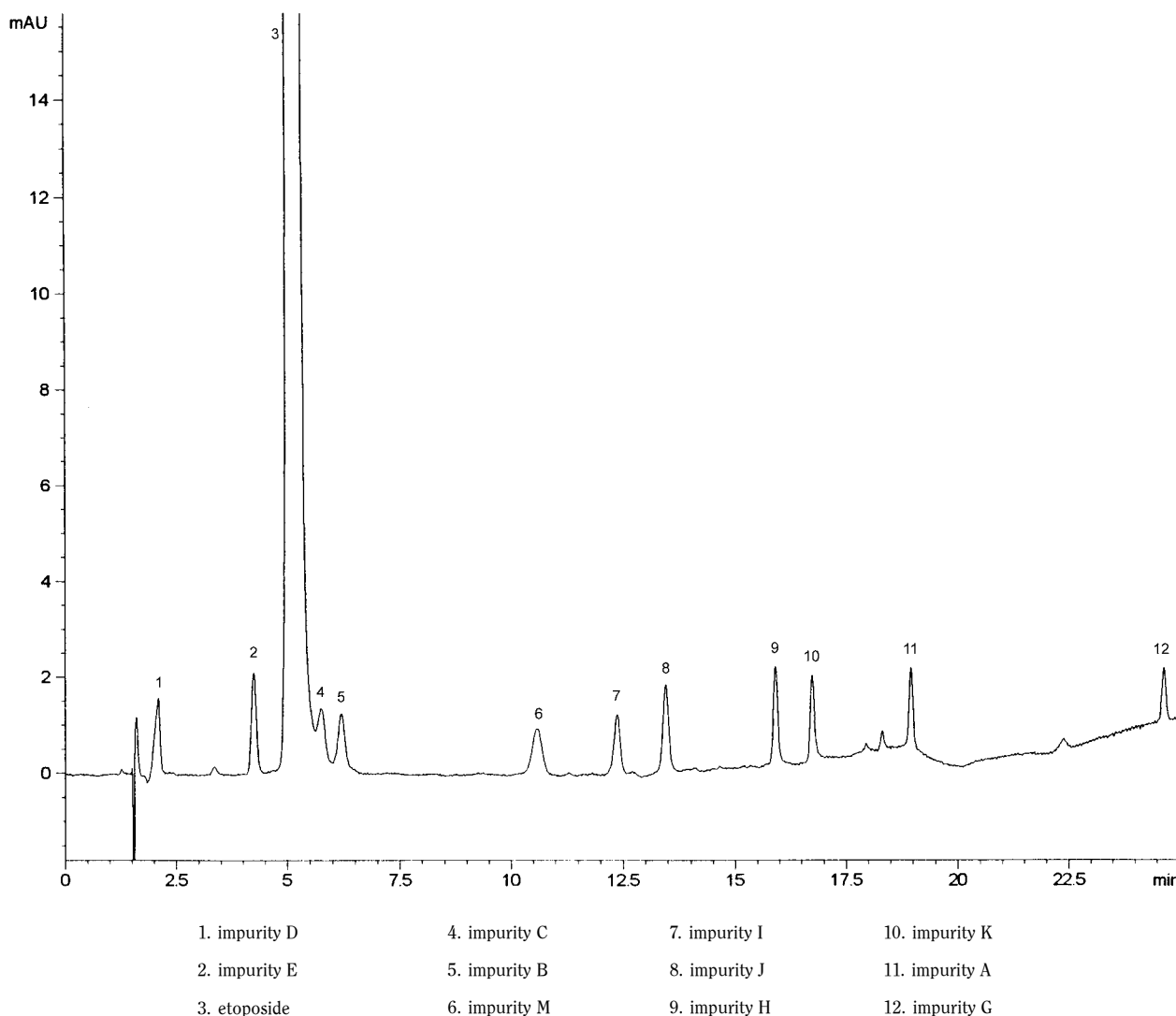

Figure 0823-1. – Chromatogram for the test for related substances of etoposide

– **resolution**: minimum 3.0 between the peaks due to etoposide and to impurity B.

If necessary, increase slightly the proportion of mobile phase A during the isocratic phase of the gradient. When the chromatograms are recorded under the prescribed conditions, the retention times of the peaks in the chromatogram obtained with reference solution (d) are similar to those shown in the chromatogram (Figure 0823-2).

**Limits:**

– **any impurity**: not more than the area of the principal peak in the chromatogram obtained with reference solution (a) (0.5 per cent) and not more than 2 such peaks have an area greater than the area of the principal peak in the chromatogram obtained with reference solution (b) (0.2 per cent),

– **total**: not more than twice the area of the principal peak in the chromatogram obtained with reference solution (a) (1 per cent),

– **disregard limit**: 0.1 times the area of the principal peak in the chromatogram obtained with reference solution (a). Disregard any peak due to the solvent.

**Heavy metals** (2.4.8): maximum 20 ppm.

1.0 g complies with limit test C. Prepare the reference solution using 2 mL of lead standard solution (10 ppm Pb) R.

**Water** (2.5.12): maximum 6.0 per cent, determined on 0.250 g.

**Sulfated ash** (2.4.14): maximum 0.1 per cent, determined on 1.0 g.

**ASSAY**

Liquid chromatography (2.2.29) as described in the test for related substances with the following modifications.

**Injection**: test solution (b) and reference solution (c).

**System suitability:**

– **repeatability**: maximum relative standard deviation of 1.0 per cent after 6 injections of reference solution (c).

Calculate the percentage content of  $C_{29}H_{32}O_{13}$  from the areas of the peaks and the declared content of etoposide CRS.

**STORAGE**

In an airtight container.

**IMPURITIES**

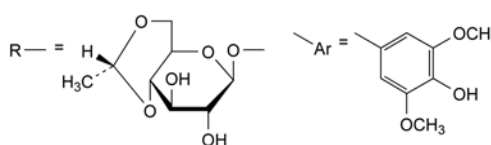

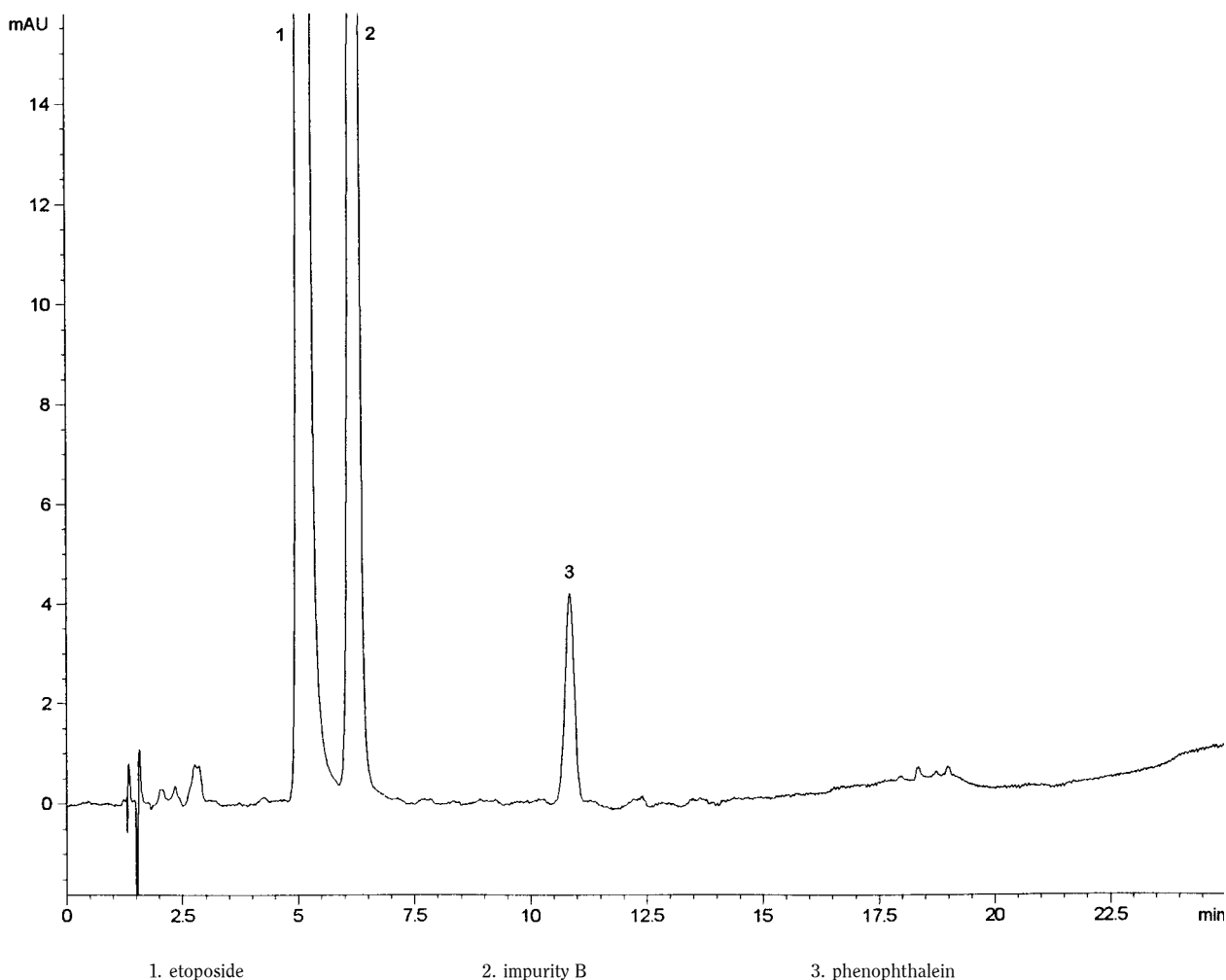
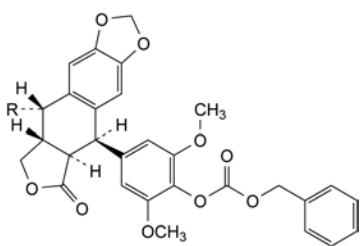
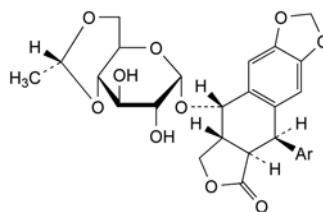

Figure 0823.-2. - Chromatogram for the test for related substances of etoposide: reference solution (d)



A. (5R,5aR,8aR,9S)-9-[4-[[benzyloxy]carbonyloxy]-3,5-dimethoxyphenyl]-9-[[4,6-O-[(R)-ethylidene]-β-D-glucopyranosyl]oxy]-5,8,8a,9-tetrahydroisobenzofuro[5,6-f][1,3]benzodioxol-6(5aH)-one (4'-carbobenzoyloxyethylidene-lignan P),



C. (5R,5aR,8aR,9S)-9-[[4,6-O-[(R)-ethylidene]-α-D-glucopyranosyl]oxy]-5-(4-hydroxy-3,5-dimethoxyphenyl)-5,8,8a,9-tetrahydroisobenzofuro[5,6-f][1,3]benzodioxol-6(5aH)-one (α-etoposide),

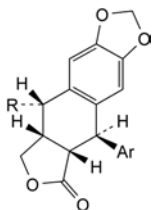

B. (5R,5aS,8aR,9S)-9-[[4,6-O-[(R)-ethylidene]-β-D-glucopyranosyl]oxy]-5-(4-hydroxy-3,5-dimethoxyphenyl)-5,8,8a,9-tetrahydroisobenzofuro[5,6-f][1,3]benzodioxol-6(5aH)-one (picroethylidene-lignan P; cis-etoposide),

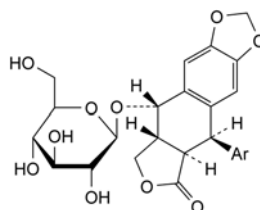

D. (5R,5aR,8aR,9S)-9-(β-D-glucopyranosyloxy)-5-(4-hydroxy-3,5-dimethoxyphenyl)-5,8,8a,9-tetrahydroisobenzofuro[5,6-f][1,3]benzodioxol-6(5aH)-one (lignan P),

## EUGENOL

## Eugenolum

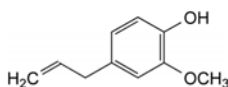

C<sub>10</sub>H<sub>12</sub>O<sub>2</sub>  
[97-53-0]

M<sub>r</sub> 164.2

## DEFINITION

2-Methoxy-4-(prop-2-enyl)phenol.

## CHARACTERS

**Appearance:** colourless or pale yellow, clear liquid, darkening on exposure to air.

It has a strong odour of clove.

**Solubility:** practically insoluble in water, freely soluble in ethanol (70 per cent V/V), practically insoluble in glycerol, miscible with ethanol (96 per cent), with glacial acetic acid, with methylene chloride and with fatty oils.

## IDENTIFICATION

**First identification:** B.

**Second identification:** A, C, D.

A. Refractive index (see Tests).

B. Infrared absorption spectrophotometry (2.2.24).

*Comparison: eugenol CRS.*

C. Thin-layer chromatography (2.2.27).

**Test solution.** Dissolve 50 µL of the substance to be examined in *ethanol (96 per cent) R* and dilute to 25 mL with the same solvent.

**Reference solution.** Dissolve 50 µL of *eugenol CRS* in *ethanol (96 per cent) R* and dilute to 25 mL with the same solvent.

**Plate:** TLC silica gel F<sub>254</sub> plate R.

**Mobile phase:** *ethyl acetate R, toluene R* (10:90 V/V).

**Application:** 5 µL.

**Development:** over a path of 15 cm.

**Drying:** in a current of cold air.

**Detection A:** examine in ultraviolet light at 254 nm.

**Results A:** the principal spot in the chromatogram obtained with the test solution is similar in position and size to the principal spot in the chromatogram obtained with the reference solution.

**Detection B:** spray with *anisaldehyde solution R* and heat at 100-105 °C for 10 min.

**Results B:** the principal spot in the chromatogram obtained with the test solution is similar in position, colour and size to the principal spot in the chromatogram obtained with the reference solution.

D. Dissolve 0.05 mL in 2 mL of *ethanol (96 per cent) R* and add 0.1 mL of *ferric chloride solution R1*. A dark green colour is produced which changes to yellowish-green within 10 min.

## TESTS

**Relative density** (2.2.5): 1.066 to 1.070.

**Refractive index** (2.2.6): 1.540 to 1.542.

**Dimeric and oligomeric compounds.** Dissolve 0.150 g in *anhydrous ethanol R* and dilute to 100.0 mL with the same solvent. The absorbance (2.2.25) of the solution at 330 nm is not greater than 0.25.

**01/2008:1100 Related substances.** Gas chromatography (2.2.28): use the normalisation procedure.

**Test solution.** Dissolve 1.00 g of the substance to be examined in *anhydrous ethanol R* and dilute to 5.0 mL with the same solvent.

**Reference solution (a).** Dilute 1.0 mL of the test solution to 100.0 mL with *anhydrous ethanol R*.

**Reference solution (b).** Dissolve 50 mg of *vanillin R* (impurity H) in 1 mL of the test solution and dilute to 5 mL with *anhydrous ethanol R*.

**Column:**

- **material:** fused silica;
- **size:** *l* = 30 m, Ø = 0.25 mm;
- **stationary phase:** *polymethylphenylsiloxane R* (film thickness 0.25 µm).

**Carrier gas:** *helium for chromatography R*.

**Flow rate:** 1 mL/min.

**Split ratio:** 1:40.

**Temperature:**

	Time (min)	Temperature (°C)
Column	0 - 2	80
	2 - 27	80 → 280
	27 - 47	280
Injection port		250
Detector		280

**Detection:** flame ionisation.

**Injection:** 1 µL.

**System suitability:** reference solution (b):

- **relative retention** with reference to eugenol: impurity H = minimum 1.1.

**Limits:**

- **any impurity:** for each impurity, maximum 0.5 per cent;
- **sum of impurities with a relative retention greater than 2.0 with reference to eugenol:** maximum 1.0 per cent;
- **total:** maximum 3.0 per cent;
- **disregard limit:** 0.05 times the area of the principal peak in the chromatogram obtained with reference solution (a) (0.05 per cent).

**Hydrocarbons.** Dissolve 1 mL in 5 mL of *dilute sodium hydroxide solution R* and add 30 mL of *water R* in a stoppered test-tube. Examined immediately, the solution is yellow and clear (2.2.1).

**Sulfated ash** (2.4.14): maximum 0.1 per cent, determined on 1.0 g.

## STORAGE

In a well-filled container, protected from light.

## IMPURITIES

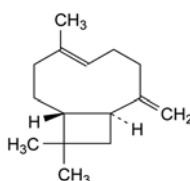

A. (1*R*,4*E*,9*S*)-4,11,11-trimethyl-8-methylenebicyclo[7.2.0]-undec-4-ene ( $\beta$ -caryophyllene),

01/2010:2104

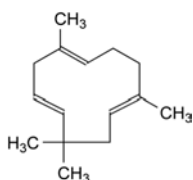

- B. (1*E*,4*E*,8*E*)-2,6,6,9-tetramethylcycloundeca-1,4,8-triene ( $\alpha$ -humulene,  $\alpha$ -caryophyllene),

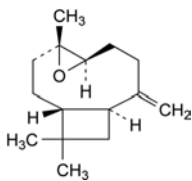

- C. (1*R*,4*R*,6*R*,10*S*)-4,12,12-trimethyl-9-methylene-5-oxatricyclo[8.2.0.0<sup>4,6</sup>]dodecane ( $\beta$ -caryophyllene oxide),

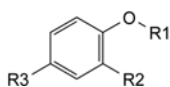

- D. R1 = H, R2 = H, R3 = CH<sub>2</sub>-CH=CH<sub>2</sub>: 4-(prop-2-enyl)phenol,  
 E. R1 = CH<sub>3</sub>, R2 = OCH<sub>3</sub>, R3 = CH<sub>2</sub>-CH=CH<sub>2</sub>: 1,2-dimethoxy-4-(prop-2-enyl)benzene (eugenol methyl ether),  
 F. R1 = H, R2 = OCH<sub>3</sub>, R3 = CH=CH-CH<sub>3</sub> (*cis*): 2-methoxy-4-[(*Z*)-prop-1-enyl]phenol (*cis*-isoeugenol),  
 G. R1 = H, R2 = OCH<sub>3</sub>, R3 = CH=CH-CH<sub>3</sub> (*trans*): 2-methoxy-4-[(*E*)-prop-1-enyl]phenol (*trans*-isoeugenol),  
 H. R1 = H, R2 = OCH<sub>3</sub>, R3 = CHO: 4-hydroxy-3-methoxybenzaldehyde (vanillin),  
 I. R1 = CO-CH<sub>3</sub>, R2 = OCH<sub>3</sub>, R3 = CH<sub>2</sub>-CH=CH<sub>2</sub>: 2-methoxy-4-(prop-2-enyl)phenyl acetate (acetyleneugenol),  
 J. R1 = H, R2 = OCH<sub>3</sub>, R3 = CO-CH=CH<sub>2</sub>: 1-(4-hydroxy-3-methoxyphenyl)prop-2-enone,  
 K. R1 = H, R2 = OCH<sub>3</sub>, R3 = CH=CH-CHO: (*E*)-3-(4-hydroxy-3-methoxyphenyl)prop-2-enal (*trans*-coniferyl aldehyde),

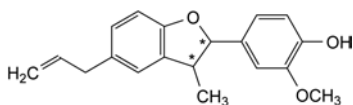

- L. 2-methoxy-4-[3-methyl-5-(prop-2-enyl)-2,3-dihydrobenzofuran-2-yl]phenol (dehydrodi-isoeugenol),

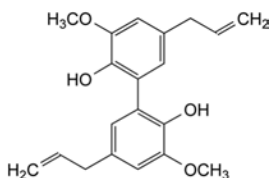

- M. 3,3'-dimethoxy-5,5'-bis(prop-2-enyl)biphenyl-2,2'-diol (dehydrodieugenol),

- N. O. 2 further unknown dimeric compounds,

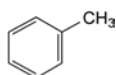

- P. toluene.

## EVENING PRIMROSE OIL, REFINED

### Oenotherae oleum raffinatum

#### DEFINITION

Fatty oil obtained from seeds of *Oenothera biennis* L. or *Oenothera lamarckiana* L. by extraction and/or expression. It is then refined. A suitable antioxidant may be added.

#### CHARACTERS

*Appearance*: clear, light yellow or yellow liquid.

*Solubility*: practically insoluble in water and in ethanol (96 per cent), miscible with light petroleum (bp: 40-60 °C).

*Relative density*: about 0.923.

*Refractive index*: about 1.478.

#### IDENTIFICATION

*First identification*: B.

*Second identification*: A.

- A. Identification of fatty oils by thin-layer chromatography (2.3.2).

*Results*: the chromatogram obtained is similar to the corresponding chromatogram shown in Figure 2.3.2.-1.

- B. Composition of fatty acids (see Tests).

#### TESTS

**Acid value** (2.5.1): maximum 0.5, or maximum 0.3 if intended for use in the manufacture of parenteral preparations.

**Peroxide value** (2.5.5, Method A): maximum 10.0, or maximum 5.0 if intended for use in the manufacture of parenteral preparations.

**Unsaponifiable matter** (2.5.7): maximum 2.5 per cent, determined on 5.0 g.

**Alkaline impurities** (2.4.19). It complies with the test.

**Composition of fatty acids** (2.4.22, Method A). Use the mixture of calibrating substances in Table 2.4.22.-3.

*Composition of the fatty-acid fraction of the oil*:

- saturated fatty acids of chain length less than C<sub>16</sub>: maximum 0.3 per cent;
- palmitic acid: 4.0 per cent to 10.0 per cent;
- stearic acid: 1.0 per cent to 4.0 per cent;
- oleic acid: 5.0 per cent to 12.0 per cent;
- linoleic acid: 65.0 per cent to 85.0 per cent;
- gamma-linolenic acid: 7.0 per cent to 14.0 per cent;
- alpha-linolenic acid: maximum 0.5 per cent.

**Brassicasterol** (2.4.23): maximum 0.3 per cent in the sterol fraction of the oil.

**Water** (2.5.32): maximum 0.1 per cent, determined on 1.00 g.

#### STORAGE

Under an inert gas, in a well-filled, airtight container, protected from light.

#### LABELLING

The label states, where applicable, that the oil is suitable for use in the manufacture of parenteral preparations.

## FAMOTIDINE

## Famotidinum

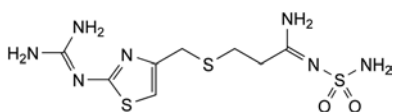

$C_8H_{15}N_7O_2S_3$   
[76824-35-6]

$M_r$  337.5

## DEFINITION

3-[[[2-[(Diaminomethylene)amino]thiazol-4-yl]methyl]sulfanyl]-*N'*-sulfamoylpropanimidamide.

*Content*: 98.5 per cent to 101.5 per cent (dried substance).

## CHARACTERS

*Appearance*: white or yellowish-white, crystalline powder or crystals.

*Solubility*: very slightly soluble in water, freely soluble in glacial acetic acid, very slightly soluble in anhydrous ethanol, practically insoluble in ethyl acetate. It dissolves in dilute mineral acids.

It shows polymorphism (5.9).

## IDENTIFICATION

Infrared absorption spectrophotometry (2.2.24).

*Preparation*: discs.

*Comparison*: famotidine CRS.

If the spectra obtained show differences, suspend 0.10 g of the substance to be examined and 0.10 g of the reference substance separately in 5 mL of *water R*. Heat to boiling and allow to cool, scratching the wall of the tube with a glass rod to initiate crystallisation. Filter, wash the crystals with 2 mL of iced *water R* and dry in an oven at 80 °C at a pressure not exceeding 670 Pa for 1 h. Record new spectra using the residues.

## TESTS

**Appearance of solution.** Dissolve 0.20 g in a 50 g/L solution of *hydrochloric acid R*, heating to 40 °C if necessary, and dilute to 20 mL with the same acid. The solution is clear (2.2.1) and not more intensely coloured than reference solution BY<sub>7</sub> (2.2.2, Method II).

**Related substances.** Liquid chromatography (2.2.29).

*Test solution.* Dissolve 12.5 mg of the substance to be examined in mobile phase A and dilute to 25.0 mL with mobile phase A.

*Reference solution (a).* Dilute 1.0 mL of the test solution to 10.0 mL with mobile phase A. Dilute 1.0 mL of this solution to 100.0 mL with mobile phase A.

*Reference solution (b).* Dissolve 2.5 mg of *famotidine impurity D CRS* in *methanol R* and dilute to 10.0 mL with the same solvent. To 1.0 mL of the solution add 0.50 mL of the test solution and dilute to 100.0 mL with mobile phase A.

*Reference solution (c).* Dissolve 5.0 mg of *famotidine for system suitability CRS* (famotidine containing impurities A, B, C, D, E, F, G) in mobile phase A and dilute to 10.0 mL with mobile phase A.

*Column*:

- *size*:  $l = 0.25$  m,  $\varnothing = 4.6$  mm,
- *stationary phase*: end-capped octadecylsilyl silica gel for chromatography R (5  $\mu$ m),
- *temperature*: 50 °C.

01/2008:1012 *Mobile phase*:

- *mobile phase A*: mix 6 volumes of *methanol R*, 94 volumes of *acetonitrile R* and 900 volumes of a 1.882 g/L solution of *sodium hexanesulfonate R* previously adjusted to pH 3.5 with *acetic acid R*,
- *mobile phase B*: *acetonitrile R*,

Time (min)	Mobile phase A (per cent V/V)	Mobile phase B (per cent V/V)	Flow rate (mL/min)
0 - 23	100 → 96	0 → 4	1
23 - 27	96	4	1 → 2
27 - 47	96 → 78	4 → 22	2
47 - 48	78 → 100	22 → 0	2
48 - 54	100	0	2 → 1

*Detection*: spectrophotometer at 265 nm.

*Injection*: 20  $\mu$ L.

*Relative retention* with reference to famotidine (retention time = about 21 min): impurity D = about 1.1; impurity C = about 1.2; impurity G = about 1.4; impurity F = about 1.5; impurity A = about 1.6; impurity B = about 2.0; impurity E = about 2.1.

*System suitability*:

- the chromatogram obtained with reference solution (c) is similar to the chromatogram supplied with *famotidine for system suitability CRS*;
- *retention time*: famotidine = 19-23 min in all the chromatograms; impurity E = maximum 48 min in the chromatogram obtained with reference solution (c);
- *resolution*: minimum 3.5 between the peaks due to famotidine and impurity D in the chromatogram obtained with reference solution (b).

*Limits*:

- *correction factors*: for the calculation of contents, multiply the peak areas of the following impurities by the corresponding correction factor: impurity A = 1.9; impurity B = 2.5; impurity C = 1.9; impurity F = 1.7; impurity G = 1.4;
- *impurities A, G*: for each impurity, not more than twice the area of the principal peak in the chromatogram obtained with reference solution (a) (0.2 per cent);
- *impurities B, C, D, E*: for each impurity, not more than 3 times the area of the principal peak in the chromatogram obtained with reference solution (a) (0.3 per cent), and not more than 3 such peaks have an area greater than the area of the principal peak in the chromatogram obtained with reference solution (a) (0.1 per cent);
- *impurity F*: not more than the area of the principal peak in the chromatogram obtained with reference solution (a) (0.1 per cent);
- *any other impurity*: for each impurity, not more than the area of the principal peak in the chromatogram obtained with reference solution (a) for the peaks eluting by 25 min, and not more than 0.5 times the area of the principal peak in the chromatogram obtained with reference solution (a) for the peaks eluting after 25 min (0.1 per cent);
- *total*: not more than 10 times the area of the principal peak in the chromatogram obtained with reference solution (a) (1.0 per cent);
- *disregard limit*: 0.2 times the area of the principal peak in the chromatogram obtained with reference solution (a).

**Heavy metals** (2.4.8): maximum 10 ppm.

2.0 g complies with limit test D. Prepare the reference solution using 2 mL of *lead standard solution (10 ppm Pb) R*.

**Loss on drying** (2.2.32): maximum 0.5 per cent, determined on 1.000 g by drying in an oven at 80 °C at a pressure not exceeding 670 Pa for 5 h.

**Sulfated ash (2.4.14):** maximum 0.1 per cent, determined on 1.0 g.

#### ASSAY

Dissolve 0.120 g in 60 mL of *anhydrous acetic acid R*. Titrate with 0.1 M *perchloric acid*, determining the end-point potentiometrically (2.2.20).

1 mL of 0.1 M *perchloric acid* is equivalent to 16.87 mg of  $C_8H_{15}N_7O_2S_3$ .

#### STORAGE

Protected from light.

#### IMPURITIES

*Specified impurities: A, B, C, D, E, F, G.*

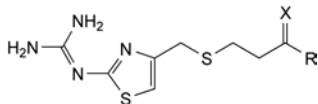

- A. R = NH<sub>2</sub>, X = NH: 3-[[[2-[(diaminomethylene)amino]thiazol-4-yl]methyl]sulfanyl]propanimidamide,  
 C. R = NH-SO<sub>2</sub>-NH<sub>2</sub>, X = O: 3-[[[2-[(diaminomethylene)amino]thiazol-4-yl]methyl]sulfanyl]-*N*-sulfamoylpropanamide,  
 D. R = NH<sub>2</sub>, X = O: 3-[[[2-[(diaminomethylene)amino]thiazol-4-yl]methyl]sulfanyl]propanamide,  
 F. R = OH, X = O: 3-[[[2-[(diaminomethylene)amino]thiazol-4-yl]methyl]sulfanyl]propanoic acid,  
 G. R = NH-CN, X = NH: *N*-cyano-3-[[[2-[(diaminomethylene)amino]thiazol-4-yl]methyl]sulfanyl]propanimidamide,

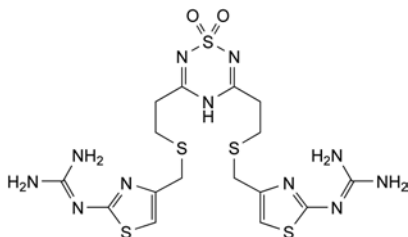

- B. 3,5-bis[2-[[[2-[(diaminomethylene)amino]thiazol-4-yl]methyl]sulfanyl]ethyl]-4H-1,2,4,6-thiazine 1,1-dioxide,

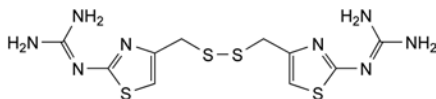

- E. 2,2'-[disulfanediy]bis(methylenethiazole-4,2-diyl)diguanidine.

01/2008:2176  
corrected 6.0

## FEBANTEL FOR VETERINARY USE

### Febantelum ad usum veterinarium

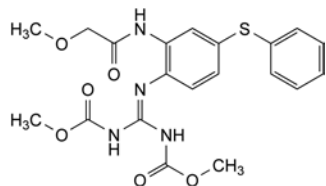

$C_{20}H_{22}N_4O_6S$   
[58306-30-2]

$M_r$  446.5

#### DEFINITION

Dimethyl *N,N'*-[[[2-[(methoxyacetyl)amino]-4-(phenylsulfanyl)phenyl]imino]methylene]dicarbamate.

*Content:* 97.5 per cent to 102.0 per cent (dried substance).

#### CHARACTERS

*Appearance:* white or almost white, crystalline powder.

*Solubility:* practically insoluble in water, soluble in acetone, slightly soluble in anhydrous ethanol.

It shows polymorphism (5.9).

#### IDENTIFICATION

Infrared absorption spectrophotometry (2.2.24).

*Comparison:* *febantel CRS*.

If the spectra obtained in the solid state show differences, dissolve the substance to be examined and the reference substance separately in *acetone R*, evaporate to dryness and record new spectra using the residues.

#### TESTS

**Related substances.** Liquid chromatography (2.2.29).

*Solvent mixture:* *acetonitrile R*, *tetrahydrofuran R* (50:50 V/V).

*Test solution (a).* Dissolve 0.100 g of the substance to be examined in the solvent mixture and dilute to 10.0 mL with the solvent mixture.

*Test solution (b).* Dilute 5.0 mL of test solution (a) to 100.0 mL with the solvent mixture.

*Reference solution (a).* Dilute 1.0 mL of test solution (a) to 100.0 mL with the solvent mixture. Dilute 1.0 mL of this solution to 10.0 mL with the solvent mixture.

*Reference solution (b).* Dissolve 50.0 mg of *febantel CRS* in the solvent mixture and dilute to 10.0 mL with the solvent mixture. Dilute 5.0 mL of this solution to 50.0 mL with the solvent mixture.

*Reference solution (c).* Dissolve 5 mg of *febantel for system suitability CRS* (containing impurities A, B and C) in 1.0 mL of the solvent mixture.

*Column:*

– *size:*  $l = 0.15$  m,  $\varnothing = 4.0$  mm;

– *stationary phase:* spherical *end-capped octadecylsilyl silica gel for chromatography R1* (5  $\mu$ m).

*Mobile phase:* dissolve 6.8 g of *potassium dihydrogen phosphate R* in 1000 mL of *water for chromatography R*. Mix 350 mL of *acetonitrile R* with 650 mL of this solution.

*Flow rate:* 1.0 mL/min.

*Detection:* spectrophotometer at 280 nm.

*Injection:* 10  $\mu$ L of test solution (a) and reference solutions (a) and (c).

*Run time:* 1.5 times the retention time of febantel.

*Elution order:* impurity A, impurity B, impurity C, febantel.

*Retention time:* febantel = about 32 min.

*System suitability:* reference solution (c):

– *resolution:* minimum 3.0 between the peaks due to impurities A and B and minimum 4.0 between the peaks due to impurities B and C.

*Limits:*

– *impurities A, B, C:* for each impurity, not more than the area of the principal peak in the chromatogram obtained with reference solution (a) (0.1 per cent);

– *unspecified impurities:* for each impurity, not more than twice the area of the principal peak in the chromatogram obtained with reference solution (a) (0.20 per cent);

– *total:* not more than 5 times the area of the principal peak in the chromatogram obtained with reference solution (a) (0.5 per cent);

– *disregard limit:* 0.5 times the area of the principal peak in the chromatogram obtained with reference solution (a) (0.05 per cent).

**Heavy metals (2.4.8):** maximum 20 ppm.

1.0 g complies with test F. Prepare the reference solution using 2 mL of *lead standard solution (10 ppm Pb) R*.

**Loss on drying** (2.2.32): maximum 0.5 per cent, determined on 1.000 g by drying in an oven at 105 °C for 2 h.

**Sulfated ash** (2.4.14): maximum 0.1 per cent, determined on 1.0 g.

#### ASSAY

Liquid chromatography (2.2.29) as described in the test for related substances with the following modification.

**Injection:** test solution (b) and reference solution (b).

Calculate the percentage content of  $C_{20}H_{22}N_4O_6S$  from the declared content of *felbantel* CRS.

#### IMPURITIES

**Specified impurities:** A, B, C.

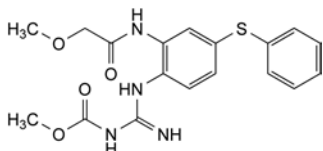

A. methyl [[2-[(methoxyacetyl)amino]-4-(phenylsulfanyl)phenyl]phenyl]carbamidoyl]carbamate,

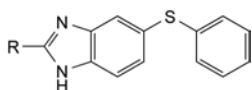

B. R =  $CH_2-OCH_3$ : 2-(methoxymethyl)-5-(phenylsulfanyl)-1*H*-benzimidazole,

C. R =  $NH-CO-OCH_3$ : methyl [5-(phenylsulfanyl)-1*H*-benzimidazol-2-yl]carbamate (*fenbendazole*).

01/2008:2304

## FELBINAC

### Felbinacum

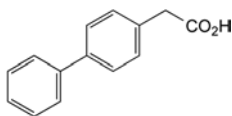

$C_{14}H_{12}O_2$   
[5728-52-9]

$M_r$  212.2

#### DEFINITION

(Biphenyl-4-yl)acetic acid.

**Content:** 99.0 per cent to 101.0 per cent (dried substance).

#### CHARACTERS

**Appearance:** white or almost white, crystalline powder.

**Solubility:** practically insoluble in water, soluble in methanol, sparingly soluble in ethanol (96 per cent).

mp: about 164 °C.

#### IDENTIFICATION

Infrared absorption spectrophotometry (2.2.24).

**Comparison:** *felbinac* CRS.

#### TESTS

**Related substances.** Liquid chromatography (2.2.29).

Protect the solutions from light and inject within 20 min of preparation.

**Test solution.** Dissolve 0.100 g of the substance to be examined in *methanol R* and dilute to 10.0 mL with the same solvent.

**Reference solution.** Dissolve 5.0 mg of *felbinac impurity A* CRS and 5.0 mg of *biphenyl R* (impurity B) in *methanol R*, add 0.5 mL of the test solution and dilute to 50.0 mL with *methanol R*. Dilute 1.0 mL of this solution to 10.0 mL with *methanol R*.

**Column:**

– **size:**  $l = 0.15$  m,  $\varnothing = 4.6$  mm;

– **stationary phase:** *octadecylsilyl silica gel for chromatography R* (5  $\mu$ m).

**Mobile phase:** mix 45 volumes of a 0.1 per cent *V/V* solution of *glacial acetic acid R* and 55 volumes of *methanol R*.

**Flow rate:** 2 mL/min.

**Detection:** spectrophotometer at 254 nm.

**Injection:** 20  $\mu$ L.

**Run time:** 3.5 times the retention time of *felbinac*.

**Relative retention** with reference to *felbinac* (retention time = about 15 min): *impurity A* = about 1.3; *impurity B* = about 2.8.

**System suitability:** reference solution:

– **resolution:** minimum 3.0 between the peaks due to *felbinac* and *impurity A*.

**Limits:**

– **impurity A:** not more than the area of the corresponding peak in the chromatogram obtained with the reference solution (0.1 per cent);

– **impurity B:** not more than the area of the peak due to *felbinac* in the chromatogram obtained with the reference solution (0.1 per cent);

– **unspecified impurities:** for each impurity, not more than the area of the peak due to *felbinac* in the chromatogram obtained with the reference solution (0.10 per cent);

– **total:** not more than twice the area of the peak due to *felbinac* in the chromatogram obtained with the reference solution (0.2 per cent);

– **disregard limit:** 0.5 times the area of the peak due to *felbinac* in the chromatogram obtained with the reference solution (0.05 per cent).

**Chlorides:** maximum 110 ppm.

Dissolve 1.0 g in 40 mL of *acetone R*, add 6 mL of a 10 per cent *V/V* solution of *nitric acid R*, dilute to 50.0 mL with *water R* and mix. Pour 15.0 mL of this solution as a single addition into 1 mL of 0.1 *M* *silver nitrate* and allow to stand for 5 min protected from light. When viewed horizontally against a black background, any opalescence produced is not more intense than that obtained by treating in the same manner 15.0 mL of a mixture of 1.5 mL of 0.002 *M* *hydrochloric acid*, 40 mL of *acetone R*, 6 mL of 10 per cent *V/V* solution of *nitric acid R*, diluted to 50.0 mL with *water R*.

**Sulfates:** maximum 130 ppm.

Dissolve 1.5 g in 40 mL of *dimethylformamide R*, add 1 mL of a 10 per cent *V/V* solution of *hydrochloric acid R*, dilute to 50.0 mL with *dimethylformamide R* and mix. To 15.0 mL of this solution add 2.0 mL of a 120 g/L solution of *barium chloride R* and allow to stand for 5 min. Any opalescence produced is not more intense than that of a standard prepared in the same manner but using 2.0 mL of 0.001 *M* *sulfuric acid* instead of the substance to be examined.

**Loss on drying** (2.2.32) : maximum 0.5 per cent, determined on 1.000 g by drying in an oven at 105 °C for 3 h.

**Sulfated ash** (2.4.14): maximum 0.1 per cent, determined on 1.0 g.

#### ASSAY

Dissolve 0.160 g in 50 mL of *methanol R*. Titrate with 0.1 *M* *alcoholic potassium hydroxide* determining the end-point potentiometrically (2.2.20).

1 mL of 0.1 *M* *alcoholic potassium hydroxide* is equivalent to 21.23 mg of  $C_{14}H_{12}O_2$ .



## IMPURITIES

Specified impurities: A, B.

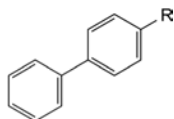

A. R = CO-CH<sub>3</sub>: 4-acetyl biphenyl,

B. R = H: biphenyl.

01/2008:1013  
corrected 6.0

## FELODIPINE

## Felodipinum

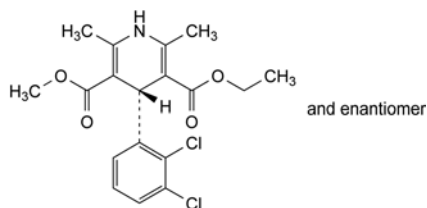

C<sub>18</sub>H<sub>19</sub>Cl<sub>2</sub>NO<sub>4</sub>  
[72509-76-3]

M<sub>r</sub> 384.3

## DEFINITION

Ethyl methyl (4*RS*)-4-(2,3-dichlorophenyl)-2,6-dimethyl-1,4-dihydropyridine-3,5-dicarboxylate.

Content: 99.0 per cent to 101.0 per cent (dried substance).

## CHARACTERS

Appearance: white or light yellow, crystalline powder.

Solubility: practically insoluble in water, freely soluble in acetone, in anhydrous ethanol, in methanol and in methylene chloride.

## IDENTIFICATION

First identification: B.

Second identification: A, C, D.

A. Ultraviolet and visible absorption spectrophotometry (2.2.25).

Test solution. Dissolve 50 mg in methanol R and dilute to 100 mL with the same solvent. Dilute 3 mL of this solution to 100 mL with methanol R.

Spectral range: 220-400 nm.

Absorption maxima: at 238 nm and 361 nm.

Absorbance ratio:  $A_{361} / A_{238} = 0.34$  to 0.36.

B. Infrared absorption spectrophotometry (2.2.24).

Preparation: discs.

Comparison: felodipine CRS.

C. Thin-layer chromatography (2.2.27).

Test solution. Dissolve 10 mg of the substance to be examined in methanol R and dilute to 10 mL with the same solvent.

Reference solution (a). Dissolve 10 mg of felodipine CRS in methanol R and dilute to 10 mL with the same solvent.

Reference solution (b). Dissolve 5 mg of nifedipine CRS in reference solution (a) and dilute to 5 mL with reference solution (a).

Plate: TLC silica gel F<sub>254</sub> plate R.

Mobile phase: ethyl acetate R, cyclohexane R (40:60 V/V).

Application: 5 µL.

Development: over a path of 15 cm.

Drying: in air.

Detection: examine in ultraviolet light at 254 nm.

System suitability: reference solution (b):

– the chromatogram shows 2 clearly separated spots.

Results: the principal spot in the chromatogram obtained with the test solution is similar in position, fluorescence and size to the principal spot in the chromatogram obtained with reference solution (a).

D. Ultraviolet and visible absorption spectrophotometry (2.2.25).

Test solution. Dissolve 0.150 g in a mixture of 25 mL of 2-methyl-2-propanol R and 25 mL of perchloric acid solution R. Add 10 mL of 0.1 M cerium sulfate, allow to stand for 15 min, add 3.5 mL of strong sodium hydroxide solution R and neutralise with dilute sodium hydroxide solution R. Shake with 25 mL of methylene chloride R. Evaporate the lower layer to dryness on a water-bath under nitrogen (the residue is also used in the test for related substances). Dissolve about 20 mg of the residue in methanol R and dilute to 50 mL with the same solvent. Dilute 2 mL of this solution to 50 mL with methanol R.

Spectral range: 220-400 nm.

Absorption maximum: at 273 nm.

## TESTS

Solution S. Dissolve 1.00 g in methanol R and dilute to 20.0 mL with the same solvent.

Appearance of solution. Solution S is clear (2.2.1).

Absorbance (2.2.25): maximum 0.10, determined at 440 nm on solution S.

Related substances. Liquid chromatography (2.2.29).

Test solution. Dissolve 25.0 mg of the substance to be examined in the mobile phase and dilute to 50.0 mL with the mobile phase.

Reference solution (a). Dilute 1.0 mL of the test solution to 100.0 mL with the mobile phase.

Reference solution (b). Dilute 1.0 mL of reference solution (a) to 10.0 mL with the mobile phase.

Reference solution (c). Dissolve 50.0 mg of the residue obtained in identification test D (impurity A) and 25.0 mg of felodipine CRS in the mobile phase, then dilute to 50.0 mL with the mobile phase. Dilute 1.0 mL of this solution to 100.0 mL with the mobile phase. Dilute 1.0 mL of the solution to 10.0 mL with the mobile phase.

Column:

– size:  $l = 0.125$ -0.15 m,  $\varnothing = 4$  mm;

– stationary phase: octadecylsilyl silica gel for chromatography R (5 µm).

Mobile phase: mix 20 volumes of methanol R, 40 volumes of acetonitrile R and 40 volumes of a phosphate buffer solution pH 3.0 containing 0.8 g/L of phosphoric acid R and 8 g/L of sodium dihydrogen phosphate R.

Flow rate: 1 mL/min.

Detection: spectrophotometer at 254 nm.

Injection: 20 µL.

Run time: twice the retention time of felodipine.

Elution order: impurity B, impurity A, felodipine, impurity C.

Retention time: felodipine = about 12 min.

System suitability: reference solution (c):

– resolution: minimum 2.5 between the peaks due to impurity A and felodipine.

Limits:

– sum of impurities B and C: not more than the area of the principal peak in the chromatogram obtained with reference solution (a) (1.0 per cent);

– unspecified impurities: for each impurity, not more than the area of the principal peak in the chromatogram obtained with reference solution (b) (0.10 per cent);

- *sum of impurities other than B and C*: not more than 3 times the area of the principal peak in the chromatogram obtained with reference solution (b) (0.3 per cent);
- *disregard limit*: 0.2 times the area of the principal peak in the chromatogram obtained with reference solution (b) (0.02 per cent).

**Loss on drying** (2.2.32): maximum 0.5 per cent, determined on 1.000 g by drying in an oven at 105 °C for 3 h.

**Sulfated ash** (2.4.14): maximum 0.1 per cent, determined on 1.0 g.

#### ASSAY

Dissolve 0.160 g in a mixture of 25 mL of 2-methyl-2-propanol R and 25 mL of perchloric acid solution R. Add 0.05 mL of ferroin R. Titrate with 0.1 M cerium sulfate until the pink colour disappears. Titrate slowly towards the end of the titration.

1 mL of 0.1 M cerium sulfate is equivalent to 19.21 mg of C<sub>18</sub>H<sub>19</sub>Cl<sub>2</sub>NO<sub>4</sub>.

#### STORAGE

Protected from light.

#### IMPURITIES

*Specified impurities*: B, C.

*Other detectable impurities* (the following substances would, if present at a sufficient level, be detected by one or other of the tests in the monograph. They are limited by the general acceptance criterion for other/unspecified impurities and/or by the general monograph *Substances for pharmaceutical use* (2034). It is therefore not necessary to identify these impurities for demonstration of compliance. See also 5.10. *Control of impurities in substances for pharmaceutical use*): A.

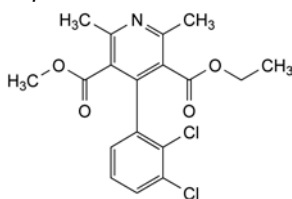

- A. ethyl methyl 4-(2,3-dichlorophenyl)-2,6-dimethylpyridine-3,5-dicarboxylate,

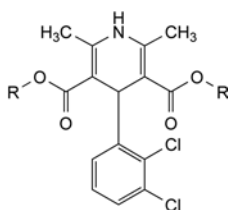

- B. R = CH<sub>3</sub>: dimethyl 4-(2,3-dichlorophenyl)-2,6-dimethyl-1,4-dihydropyridine-3,5-dicarboxylate,  
 C. R = C<sub>2</sub>H<sub>5</sub>: diethyl 4-(2,3-dichlorophenyl)-2,6-dimethyl-1,4-dihydropyridine-3,5-dicarboxylate.

01/2008:1634  
corrected 7.0

## FELYPRESSIN

### Felypressinum

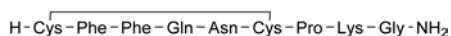

C<sub>46</sub>H<sub>65</sub>N<sub>13</sub>O<sub>11</sub>S<sub>2</sub>  
[56-59-7]

M<sub>r</sub> 1039

#### DEFINITION

L-Cysteinyl-L-phenylalanyl-L-phenylalanyl-L-glutaminy-L-asparaginy-L-cysteinyl-L-prolyl-L-lysylglycinamide cyclic (1,6)-disulfide.

Synthetic nonapeptide having a vasoconstricting activity. It is available as an acetate.

**Content**: 95.0 per cent to 102.0 per cent (anhydrous and acetic acid-free substance).

#### CHARACTERS

**Appearance**: white or almost white, powder or flakes.

**Solubility**: freely soluble in water, practically insoluble in acetone and ethanol (96 per cent). It dissolves in dilute solutions of alkali hydroxides.

#### IDENTIFICATION

- A. Examine the chromatograms obtained in the assay.

**Results**: the principal peak in the chromatogram obtained with test solution (b) is similar in retention time and size to the principal peak in the chromatogram obtained with the reference solution.

- B. Amino acid analysis (2.2.56). For hydrolysis use Method 1 and for analysis use Method 1.

Express the content of each amino acid in moles. Calculate the relative proportions of amino acids, taking one-seventh of the sum of the number of moles of glutamic acid, aspartic acid, proline, lysine, glycine and phenylalanine as equal to one. The values fall within the following limits: aspartic acid: 0.9 to 1.1; glutamic acid: 0.9 to 1.1; proline: 0.9 to 1.1; glycine: 0.9 to 1.1; phenylalanine: 1.8 to 2.2; half-cystine: 1.8 to 2.2; lysine: 0.9 to 1.1.

#### TESTS

**Specific optical rotation** (2.2.7): –35 to –29, determined at 25 °C (anhydrous and acetic acid-free substance).

Dissolve 20.0 mg in a 1 per cent V/V solution of glacial acetic acid R and dilute to 10.0 mL with the same solution.

**Related substances**. Liquid chromatography (2.2.29); use the normalisation procedure. *The solutions are stable for 24 h at room temperature or for 1 week at 2-8 °C.*

**Test solution (a)**. Dissolve 5.0 mg of the substance to be examined in 5.0 mL of mobile phase A.

**Test solution (b)**. Dilute 1.0 mL of test solution (a) to 5.0 mL with mobile phase A.

**Reference solution**. Dissolve the contents of a vial of felypressin CRS in mobile phase A to obtain a concentration of 0.2 mg/mL.

**Column**:

- *size*:  $l = 0.15$  m,  $\varnothing = 3.9$  mm,
- *stationary phase*: octadecylsilyl silica gel for chromatography R (5 µm),
- *temperature*: 50 °C.

**Mobile phase**:

- *mobile phase A*: dissolve 3.62 g of tetramethylammonium hydroxide R in 900 mL water R; adjust to pH 2.5 with phosphoric acid R and dilute to 1000 mL with water R;
- *mobile phase B*: dissolve 1.81 g of tetramethylammonium hydroxide R in 450 mL of a 50 per cent V/V solution of acetonitrile for chromatography R; adjust to pH 2.5 with phosphoric acid R and dilute to 500 mL with a 50 per cent V/V solution of acetonitrile for chromatography R;

Time (min)	Mobile phase A (per cent V/V)	Mobile phase B (per cent V/V)
0 - 20	80 → 50	20 → 50
20 - 25	50	50

**Flow rate**: 1.0 mL/min.

**Detection**: spectrophotometer at 210 nm.

**Injection**: 10 µL of test solution (a) and 50 µL of the reference solution.

**Identification of impurities:** use the chromatogram supplied with *felypressin CRS* to identify the peaks due to impurities A to F.

**Relative retention** with reference to *felypressin*: impurity A = about 0.9; impurity B = about 1.1; impurity F = about 1.2; impurity C = about 1.3; impurity D = about 1.4; impurity E = about 2.1.

**System suitability:** reference solution:

- **retention time:** *felypressin* = about 7.5 min;
- **resolution:** minimum 1.5 between the peaks due to impurity C and impurity D.

**Limits:**

- **impurities A, B, C, D, E, F:** for each impurity, maximum 0.5 per cent,
- **any other impurity:** for each impurity, maximum 0.1 per cent,
- **total:** maximum 3.0 per cent,
- **disregard limit:** 0.05 per cent.

**Acetic acid (2.5.34):** 9.0 per cent to 13.0 per cent.

**Test solution.** Dissolve 10.0 mg of the substance to be examined in a mixture of 5 volumes of mobile phase B and 95 volumes of mobile phase A and dilute to 10.0 mL with the same mixture of mobile phases.

**Water (2.5.32):** maximum 7.0 per cent.

**Bacterial endotoxins (2.6.14):** less than 100 IU/mg, if intended for use in the manufacture of parenteral preparations without a further appropriate procedure for the removal of bacterial endotoxins.

#### ASSAY

Liquid chromatography (2.2.29) as described in the test for related substances with the following modification.

**Injection:** 10 µL of test solution (b) and of the reference solution.

Calculate the content of *felypressin* ( $C_{46}H_{65}N_{13}O_{11}S_2$ ) from the areas of the peaks and the declared content of  $C_{46}H_{65}N_{13}O_{11}S_2$  in *felypressin CRS*.

#### STORAGE

In an airtight container, protected from light, at a temperature of 2 °C to 8 °C. If the substance is sterile, store in a sterile, airtight, tamper-proof container.

#### LABELLING

The label states the mass of peptide in the container.

#### IMPURITIES

**Specified impurities:** A, B, C, D, E, F.

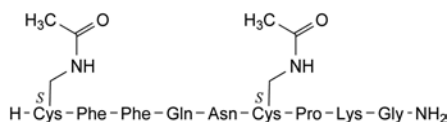

A.  $S^1, S^6$ -bis[(acetylamino)methyl]-(reduced *felypressin*),

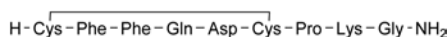

B. [5-aspartic acid]*felypressin*,

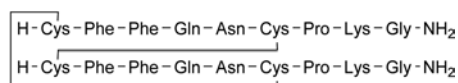

C. bis(reduced *felypressin*) (1,6'),(1',6)-bis(disulfide),



D. bis(reduced *felypressin*) (1,1'),(6,6')-bis(disulfide),

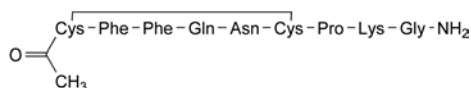

E.  $N^1$ -acetylfelypressin,

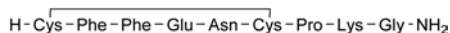

F. [4-glutamic acid]*felypressin*.

01/2008:1208  
corrected 7.0

## FENBENDAZOLE FOR VETERINARY USE

### Fenbendazolium ad usum veterinarium

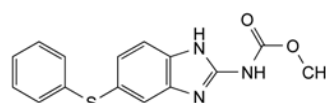

$C_{15}H_{13}N_3O_2S$   
[43210-67-9]

$M_r$  299.4

#### DEFINITION

Methyl [5-(phenylsulfanyl)-1*H*-benzimidazol-2-yl]carbamate.

**Content:** 98.0 per cent to 101.0 per cent (dried substance).

#### CHARACTERS

**Appearance:** white or almost white powder.

**Solubility:** practically insoluble in water, sparingly soluble in dimethylformamide, very slightly soluble in methanol.

#### IDENTIFICATION

Infrared absorption spectrophotometry (2.2.24).

**Preparation:** discs.

**Comparison:** *fenbendazole CRS*.

#### TESTS

**Related substances.** Liquid chromatography (2.2.29).

**Test solution.** Dissolve 50.0 mg of the substance to be examined in 10.0 mL of *hydrochloric methanol R*.

**Reference solution (a).** Dissolve 50.0 mg of *fenbendazole CRS* in 10.0 mL of *hydrochloric methanol R*. Dilute 1.0 mL of this solution to 200.0 mL with *methanol R*. Dilute 5.0 mL of the solution to 10.0 mL with *hydrochloric methanol R*.

**Reference solution (b).** Dissolve 10.0 mg of *fenbendazole impurity A CRS* in 100.0 mL of *methanol R*. Dilute 1.0 mL of this solution to 10.0 mL with *hydrochloric methanol R*.

**Reference solution (c).** Dissolve 10.0 mg of *fenbendazole impurity B CRS* in 100.0 mL of *methanol R*. Dilute 1.0 mL of this solution to 10.0 mL with *hydrochloric methanol R*.

**Reference solution (d).** Dissolve 10.0 mg of *fenbendazole CRS* and 10.0 mg of *mebendazole CRS* in 100.0 mL of *methanol R*. Dilute 1.0 mL of this solution to 10.0 mL with *hydrochloric methanol R*.

**Column:**

- **size:**  $l = 0.25$  m,  $\varnothing = 4.6$  mm;
- **stationary phase:** octadecylsilyl silica gel for chromatography R (5 µm).

**Mobile phase:**

- **mobile phase A:** anhydrous acetic acid R, *methanol R*, water R (1:30:70 V/V/V);

– mobile phase B: anhydrous acetic acid R, water R, methanol R (1:30:70 V/V/V);

01/2008:1209  
corrected 7.0

Time (min)	Mobile phase A (per cent V/V)	Mobile phase B (per cent V/V)
0 - 10	100 → 0	0 → 100
10 - 40	0	100

Flow rate: 1 mL/min.

Detection: spectrophotometer at 280 nm.

Injection: 10 µL.

Retention time: fenbendazole = about 19 min.

System suitability: reference solution (d):

– resolution: minimum 1.5 between the peaks due to fenbendazole and mebendazole.

Limits:

- impurity A: not more than 2.5 times the area of the corresponding peak in the chromatogram obtained with reference solution (b) (0.5 per cent);
- impurity B: not more than 2.5 times the area of the corresponding peak in the chromatogram obtained with reference solution (c) (0.5 per cent);
- any other impurity: for each impurity, not more than twice the area of the principal peak in the chromatogram obtained with reference solution (a) (0.5 per cent);
- total: not more than 4 times the area of the principal peak in the chromatogram obtained with reference solution (a) (1 per cent);
- disregard limit: 0.2 times the area of the principal peak in the chromatogram obtained with reference solution (a) (0.05 per cent).

Heavy metals (2.4.8): maximum 20 ppm.

1.0 g complies with test C. Prepare the reference solution using 2 mL of lead standard solution (10 ppm Pb) R.

Loss on drying (2.2.32): maximum 1.0 per cent, determined on 1.000 g by drying in an oven at 105 °C for 3 h.

Sulfated ash (2.4.14): maximum 0.3 per cent, determined on 1.0 g.

#### ASSAY

Dissolve 0.200 g in 30 mL of anhydrous acetic acid R, warming gently if necessary. Cool and titrate with 0.1 M perchloric acid, determining the end-point potentiometrically (2.2.20).

1 mL of 0.1 M perchloric acid is equivalent to 29.94 mg of C<sub>15</sub>H<sub>13</sub>N<sub>3</sub>O<sub>2</sub>S.

#### STORAGE

Protected from light.

#### IMPURITIES

Specified impurities: A, B.

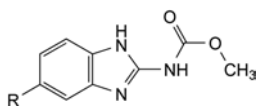

A. R = H: methyl (1H-benzimidazol-2-yl)carbamate,

B. R = Cl: methyl (5-chloro-1H-benzimidazol-2-yl)carbamate.

## FENBUFEN

### Fenbufenum

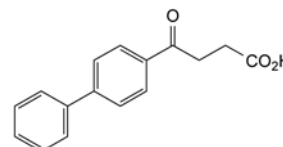

C<sub>16</sub>H<sub>14</sub>O<sub>3</sub>  
[36330-85-5]

M<sub>r</sub> 254.3

#### DEFINITION

4-(Biphenyl-4-yl)-4-oxobutanoic acid.

Content: 98.5 per cent to 101.0 per cent (dried substance).

#### CHARACTERS

Appearance: white or almost white, fine, crystalline powder.

Solubility: very slightly soluble in water, slightly soluble in acetone, in ethanol (96 per cent) and in methylene chloride.

#### IDENTIFICATION

First identification: B.

Second identification: A, C.

A. Melting point (2.2.14): 186 °C to 189 °C.

B. Infrared absorption spectrophotometry (2.2.24).

Comparison: fenbufen CRS.

C. Thin-layer chromatography (2.2.27).

Test solution. Dissolve 10 mg of the substance to be examined in methylene chloride R and dilute to 10 mL with the same solvent.

Reference solution (a). Dissolve 10 mg of fenbufen CRS in methylene chloride R and dilute to 10 mL with the same solvent.

Reference solution (b). Dissolve 10 mg of ketoprofen CRS in methylene chloride R and dilute to 10 mL with the same solvent. To 5 mL of this solution, add 5 mL of reference solution (a).

Plate: TLC silica gel F<sub>254</sub> plate R.

Mobile phase: anhydrous acetic acid R, ethyl acetate R, hexane R (5:25:75 V/V/V).

Application: 10 µL.

Development: over a path of 15 cm.

Drying: in air.

Detection: examine in ultraviolet light at 254 nm.

System suitability: reference solution (b):

– the chromatogram shows 2 clearly separated spots.

Results: the principal spot in the chromatogram obtained with the test solution is similar in position and size to the principal spot in the chromatogram obtained with reference solution (a).

#### TESTS

Related substances. Liquid chromatography (2.2.29).

Solvent mixture: dimethylformamide R, mobile phase A (40:60 V/V).

Test solution. Dissolve 50.0 mg of the substance to be examined in the solvent mixture and dilute to 10.0 mL with the solvent mixture.

Reference solution (a). Dilute 0.5 mL of the test solution to 50.0 mL with the solvent mixture. Dilute 1.0 mL of this solution to 10.0 mL with the solvent mixture.

*Reference solution (b).* Dissolve 25 mg of *fenbufen CRS* and 6 mg of *ketoprofen CRS* in the solvent mixture and dilute to 10 mL with the solvent mixture. Dilute 1 mL of this solution to 100 mL with the solvent mixture.

*Column:*

- *size:*  $l = 0.125$  m,  $\varnothing = 4.0$  mm;
- *stationary phase:* octadecylsilyl silica gel for chromatography R (5  $\mu$ m).

*Mobile phase:*

- *mobile phase A:* mix 32 volumes of *acetonitrile R* and 68 volumes of a mixture of 1 volume of *glacial acetic acid R* and 55 volumes of *water R*;
- *mobile phase B:* mix 45 volumes of *acetonitrile R* and 55 volumes of a mixture of 1 volume of *glacial acetic acid R* and 55 volumes of *water R*;

Time (min)	Mobile phase A (per cent V/V)	Mobile phase B (per cent V/V)
0 – 15	100	0
15 – 20	100 → 0	0 → 100
20 – 35	0	100

*Flow rate:* 2 mL/min.

*Detection:* spectrophotometer at 254 nm.

*Injection:* 20  $\mu$ L.

*System suitability:* reference solution (b):

- *resolution:* minimum 5.0 between the peaks due to ketoprofen and fenbufen.

*Limits:*

- *any impurity:* for each impurity, not more than the area of the principal peak in the chromatogram obtained with reference solution (a) (0.1 per cent);
- *total:* not more than 5 times the area of the principal peak in the chromatogram obtained with reference solution (a) (0.5 per cent);
- *disregard limit:* 0.2 times the area of the principal peak in the chromatogram obtained with reference solution (a) (0.02 per cent).

**Heavy metals (2.4.8):** maximum 20 ppm.

1.0 g complies with test C. Prepare the reference solution using 2 mL of *lead standard solution (10 ppm Pb) R*.

**Loss on drying (2.2.32):** maximum 0.5 per cent, determined on 1.000 g by drying in an oven at 105 °C for 3 h.

**Sulfated ash (2.4.14):** maximum 0.1 per cent, determined on 1.0 g.

**ASSAY**

Dissolve 0.200 g in 75 mL of *acetone R* previously neutralised with *phenolphthalein solution RI* and add 50 mL of *water R*. Add 0.2 mL of *phenolphthalein solution RI* and titrate with 0.1 M *sodium hydroxide*. Carry out a blank titration.

1 mL of 0.1 M *sodium hydroxide* is equivalent to 25.43 mg of  $C_{16}H_{14}O_3$ .

**IMPURITIES**

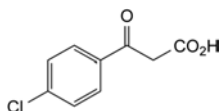

A. 3-(4-chlorophenyl)-3-oxopropanoic acid,

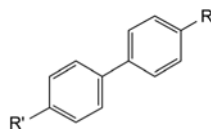

- B. R = CO-CH=CH-CO<sub>2</sub>H, R' = H: 4-(biphenyl-4-yl)-4-oxobut-2-enoic acid,  
 C. R = R' = H: biphenyl,  
 D. R = CO-CH<sub>2</sub>-CH<sub>2</sub>-CO<sub>2</sub>H, R' = OH: 4-(4'-hydroxybiphenyl-4-yl)-4-oxobutanoic acid.

01/2008:1322

## FENOFIBRATE

### Fenofibratum

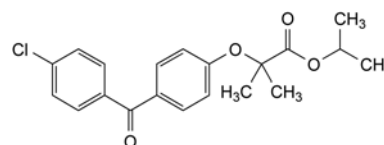

$C_{20}H_{21}ClO_4$   
 [49562-28-9]

$M_r$  360.8

**DEFINITION**

1-Methylethyl 2-[4-(4-chlorobenzoyl)phenoxy]-2-methylpropanoate.

*Content:* 98.0 per cent to 102.0 per cent (dried substance).

**CHARACTERS**

*Appearance:* white or almost white, crystalline powder.

*Solubility:* practically insoluble in water, very soluble in methylene chloride, slightly soluble in ethanol (96 per cent).

**IDENTIFICATION**

A. Melting point (2.2.14): 79 °C to 82 °C.

B. Infrared absorption spectrophotometry (2.2.24).

*Preparation:* discs.

*Comparison:* fenofibrate CRS.

**TESTS**

**Solution S.** To 5.0 g, add 25 mL of *distilled water R* and heat at 50 °C for 10 min. Cool and dilute to 50.0 mL with the same solvent. Filter. Use the filtrate as solution S.

**Appearance of solution.** The solution is clear (2.2.1) and not more intensely coloured than reference solution BY<sub>6</sub> (2.2.2, *Method II*).

Dissolve 0.50 g in *acetone R* and dilute to 10.0 mL with the same solvent.

**Acidity.** Dissolve 1.0 g in 50 mL of *ethanol (96 per cent) R* previously neutralised using 0.2 mL of *phenolphthalein solution RI*. Not more than 0.2 mL of 0.1 M *sodium hydroxide* is required to change the colour of the indicator to pink.

**Related substances.** Liquid chromatography (2.2.29).

*Test solution.* Dissolve 0.100 g of the substance to be examined in the mobile phase and dilute to 100.0 mL with the mobile phase.

*Reference solution (a).* Dissolve 25.0 mg of *fenofibrate CRS* in the mobile phase and dilute to 25.0 mL with the mobile phase.

*Reference solution (b).* Dissolve 5.0 mg of *fenofibrate CRS*, 5.0 mg of *fenofibrate impurity A CRS*, 5.0 mg of *fenofibrate impurity B CRS* and 10.0 mg of *fenofibrate impurity G CRS* in the mobile phase and dilute to 100.0 mL with the mobile phase. Dilute 1.0 mL of this solution to 50.0 mL with the mobile phase.

*Column:*

- *size:*  $l = 0.25$  m,  $\varnothing = 4.0$  mm;

– *stationary phase*: octadecylsilyl silica gel for chromatography R (5 µm).

*Mobile phase*: mix 30 volumes of *water R* acidified to pH 2.5 with *phosphoric acid R* and 70 volumes of *acetonitrile R*.

*Flow rate*: 1 mL/min.

*Detection*: spectrophotometer at 286 nm.

*Injection*: 20 µL of the test solution and reference solution (b).

*Run time*: twice the retention time of fenofibrate.

*Relative retention* with reference to fenofibrate: impurity A = about 0.34; impurity B = about 0.36; impurity C = about 0.50; impurity D = about 0.65; impurity E = about 0.80, impurity F = about 0.85; impurity G = about 1.35.

*System suitability*: reference solution (b):

– *resolution*: minimum 1.5 between the peaks due to impurities A and B.

*Limits*:

– *impurities A, B*: for each impurity, not more than the area of the corresponding peak in the chromatogram obtained with reference solution (b) (0.1 per cent);

– *impurity G*: not more than the area of the corresponding peak in the chromatogram obtained with reference solution (b) (0.2 per cent);

– *unspecified impurities*: for each impurity, not more than the area of the peak due to fenofibrate in the chromatogram obtained with reference solution (b) (0.10 per cent);

– *total*: not more than 5 times the area of the peak due to fenofibrate in the chromatogram obtained with reference solution (b) (0.5 per cent);

– *disregard limit*: 0.1 times the area of the peak due to fenofibrate in the chromatogram obtained with reference solution (b) (0.01 per cent).

**Halides expressed as chlorides (2.4.4)**: maximum 100 ppm.

To 5 mL of solution S add 10 mL of *distilled water R*.

**Sulfates (2.4.13)**: maximum 100 ppm, determined on solution S.

**Heavy metals (2.4.8)**: maximum 20 ppm.

1.0 g complies with test C. Prepare the reference solution using 2 mL of *lead standard solution (10 ppm Pb) R*.

**Loss on drying (2.2.32)**: maximum 0.5 per cent, determined on 1.000 g by drying *in vacuo* at 60 °C.

**Sulfated ash (2.4.14)**: maximum 0.1 per cent, determined on 1.0 g.

#### ASSAY

Liquid chromatography (2.2.29) as described in the test for related substances with the following modifications.

*Injection*: 5 µL of the test solution and reference solution (a).

*System suitability*: reference solution (a):

– *repeatability*: maximum relative standard deviation of 1.0 per cent after 6 injections.

#### STORAGE

Protected from light.

#### IMPURITIES

*Specified impurities*: A, B, G.

*Other detectable impurities* (the following substances would, if present at a sufficient level, be detected by one or other of the tests in the monograph. They are limited by the general acceptance criterion for other/unspecified impurities and/or by the general monograph *Substances for pharmaceutical use (2034)*. It is therefore not necessary to identify these impurities for demonstration of compliance. See also 5.10. *Control of impurities in substances for pharmaceutical use*): C, D, E, F.

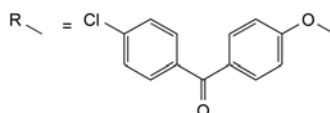

A. R-H: (4-chlorophenyl)(4-hydroxyphenyl)methanone,

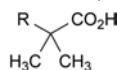

B. 2-[4-(4-chlorobenzoyl)phenoxy]-2-methylpropanoic acid (fenofibric acid),

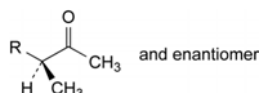

C. (3*RS*)-3-[4-(4-chlorobenzoyl)phenoxy]butan-2-one,

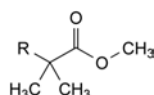

D. methyl 2-[4-(4-chlorobenzoyl)phenoxy]-2-methylpropanoate,

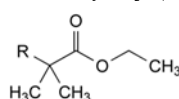

E. ethyl 2-[4-(4-chlorobenzoyl)phenoxy]-2-methylpropanoate,



F. (4-chlorophenyl)[4-(1-methylethoxy)phenyl]methanone,

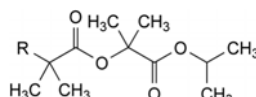

G. 1-methylethyl 2-[[2-[4-(4-chlorobenzoyl)phenoxy]-2-methylpropanoyl]oxy]-2-methylpropanoate.

01/2008:0901

## FENOTEROL HYDROBROMIDE

### Fenoteroli hydrobromidum

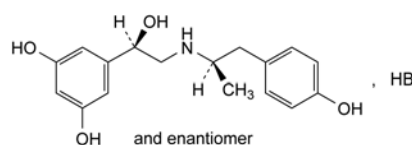

C<sub>17</sub>H<sub>22</sub>BrNO<sub>4</sub>  
[1944-12-3]

M<sub>r</sub> 384.3

#### DEFINITION

(1*RS*)-1-(3,5-Dihydroxyphenyl)-2-[[1*RS*]-2-(4-hydroxyphenyl)-1-methylethyl]amino]ethanol hydrobromide.

*Content*: 99.0 per cent to 101.0 per cent (dried substance).

#### CHARACTERS

*Appearance*: white or almost white, crystalline powder.

*Solubility*: soluble in water and in ethanol (96 per cent).

#### IDENTIFICATION

*First identification*: B, E.

*Second identification*: A, C, D, E.

A. Ultraviolet and visible absorption spectrophotometry (2.2.25).

*Test solution*. Dissolve 50.0 mg in *dilute hydrochloric acid R1* and dilute to 50.0 mL with the same acid. Dilute 5.0 mL of this solution to 50.0 mL with *dilute hydrochloric acid R1*.

*Spectral range:* 230-350 nm.

*Absorption maximum:* at 275 nm.

*Shoulder:* at about 280 nm.

*Specific absorbance at the absorption maximum:* 80 to 86.

B. Infrared absorption spectrophotometry (2.2.24).

*Comparison:* fenoterol hydrobromide CRS.

C. Thin-layer chromatography (2.2.27).

*Test solution.* Dissolve 10 mg of the substance to be examined in *ethanol (96 per cent) R* and dilute to 10 mL with the same solvent.

*Reference solution.* Dissolve 10 mg of *fenoterol hydrobromide CRS* in *ethanol (96 per cent) R* and dilute to 10 mL with the same solvent.

*Plate:* TLC silica gel G plate R.

*Mobile phase:* concentrated ammonia R, water R, aldehyde-free methanol R (1.5:10:90 V/V/V).

*Application:* 2 µL.

*Development:* over a path of 15 cm.

*Drying:* in air.

*Detection:* spray with a 10 g/L solution of *potassium permanganate R*.

*Results:* the principal spot in the chromatogram obtained with the test solution is similar in position, colour and size to the principal spot in the chromatogram obtained with the reference solution.

D. Dissolve about 10 mg in a 20 g/L solution of *disodium tetraborate R* and dilute to 50 mL with the same solution. Add 1 mL of a 10 g/L solution of *aminopyrazolone R*, 10 mL of a 2 g/L solution of *potassium ferricyanide R* and 10 mL of *methylene chloride R*. Shake and allow to separate. A reddish-brown colour develops in the lower layer.

E. It gives reaction (a) of bromides (2.3.1).

TESTS

**Solution S.** Dissolve 2.00 g in *carbon dioxide-free water R* and dilute to 50.0 mL with the same solvent.

**Appearance of solution.** Solution S is clear (2.2.1) and not more intensely coloured than reference solution Y<sub>7</sub> (2.2.2, Method II).

**pH** (2.2.3): 4.2 to 5.2 for solution S.

**Related substances.** Liquid chromatography (2.2.29). Prepare the solutions immediately before use.

*Test solution.* Dissolve 24.0 mg of the substance to be examined in *water R* and dilute to 20.0 mL with the same solvent.

*Reference solution (a).* Dissolve 24.0 mg of *fenoterol hydrobromide CRS* (containing impurity A) in *water R* and dilute to 20.0 mL with the same solvent.

*Reference solution (b).* Dissolve the contents of a vial of *fenoterol for peak identification CRS* (containing impurities B and C) in 1.0 mL of *water R*.

*Reference solution (c).* Dilute 10.0 mL of the test solution to 50.0 mL with *water R*. Dilute 1.0 mL of this solution to 100.0 mL with *water R*.

*Column:*

- size:  $l = 0.15$  m,  $\varnothing = 4.6$  mm;
- stationary phase: octadecylsilyl silica gel for chromatography R (5 µm).

*Mobile phase.* Dissolve 24 g of *disodium hydrogen phosphate R* in 1000 mL of *water R*. Mix 69 volumes of this solution with 1 volume of a 9 g/L solution of *potassium of hydrogen phosphate R*, adjust to pH 8.5 with *phosphoric acid R* and add 35 volumes of *methanol R2*.

*Flow rate:* 1 mL/min.

*Detection:* spectrophotometer at 215 nm.

*Injection:* 20 µL.

*Run time:* 3 times the retention time of fenoterol.

*Relative retention* with reference to fenoterol (retention time = about 7 min): impurity A = about 1.3; impurity B = about 2.0; impurity C = about 2.2.

*System suitability:*

- resolution:
  - minimum 3 between the peaks due to fenoterol and impurity A in the chromatogram obtained with reference solution (a);
  - minimum 1.5 between the peaks due to impurities B and C in the chromatogram obtained with reference solution (b).

*Limits:*

- *correction factor:* for the calculation of content, multiply the peak area of impurity B by 0.6;
- *impurity A:* maximum 4.0 per cent, calculated from the area of the corresponding peak in the chromatogram obtained with reference solution (a) and taking into account the declared content of impurity A in *fenoterol hydrobromide CRS*;
- *impurity C:* not more than 1.5 times the area of the principal peak in the chromatogram obtained with reference solution (c) (0.3 per cent);
- *impurity B:* not more than the area of the principal peak in the chromatogram obtained with reference solution (c) (0.2 per cent);
- *unspecified impurities:* for each impurity, not more than 0.5 times the area of the principal peak in the chromatogram obtained with reference solution (c) (0.10 per cent);
- *sum of impurities other than A:* not more than 1.5 times the area of the principal peak in the chromatogram obtained with reference solution (c) (0.3 per cent);
- *disregard limit:* 0.25 times the area of the principal peak in the chromatogram obtained with reference solution (c) (0.05 per cent).

**Iron** (2.4.9): maximum 10 ppm.

Dissolve the residue obtained in the test for sulfated ash in 2.5 mL of *dilute hydrochloric acid R* and dilute to 10 mL with *water R*.

**Loss on drying** (2.2.32): maximum 0.5 per cent, determined on 1.000 g by drying in an oven at 105 °C.

**Sulfated ash** (2.4.14): maximum 0.1 per cent, determined on 1.0 g.

ASSAY

Dissolve 0.600 g in 50 mL of *water R* and add 5 mL of *dilute nitric acid R*, 25.0 mL of 0.1 M *silver nitrate* and 2 mL of *ferric ammonium sulfate solution R2*. Shake and titrate with 0.1 M *ammonium thiocyanate* until an orange colour is obtained. Carry out a blank titration.

1 mL of 0.1 M *silver nitrate* is equivalent to 38.43 mg of C<sub>17</sub>H<sub>22</sub>BrNO<sub>4</sub>.

STORAGE

Protected from light.

## IMPURITIES

Specified impurities: A, B, C.

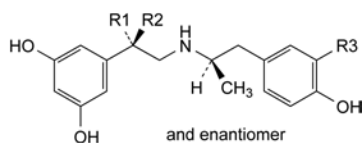

- A. R1 = OH, R2 = R3 = H: (1*RS*)-1-(3,5-dihydroxyphenyl)-2-[[[(1*SR*)-2-(4-hydroxyphenyl)-1-methylethyl]amino]ethanol,
- B. R1 + R2 = O, R3 = H: 1-(3,5-dihydroxyphenyl)-2-[[[(1*RS*)-2-(4-hydroxyphenyl)-1-methylethyl]amino]ethanone,
- C. R1 = H, R2 = OH, R3 = CH<sub>3</sub>: (1*RS*)-1-(3,5-dihydroxyphenyl)-2-[[[(1*RS*)-2-(4-hydroxy-3-methylphenyl)-1-methylethyl]amino]ethanol.

01/2008:1210  
corrected 6.0

## FENTANYL

## Fentanylum

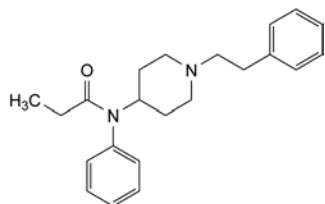

C<sub>22</sub>H<sub>28</sub>N<sub>2</sub>O  
[437-38-7]

M<sub>r</sub> 336.5

## DEFINITION

*N*-Phenyl-*N*-[1-(2-phenylethyl)piperidin-4-yl]propanamide.

Content: 99.0 per cent to 101.0 per cent (dried substance).

## CHARACTERS

Appearance: white or almost white powder.

Solubility: practically insoluble in water, freely soluble in ethanol (96 per cent) and in methanol.

It shows polymorphism (5.9).

## IDENTIFICATION

Infrared absorption spectrophotometry (2.2.24).

Comparison: Ph. Eur. reference spectrum of fentanyl.

If the spectrum obtained in the solid state shows differences, dissolve the substance to be examined in the minimum volume of anhydrous ethanol R, evaporate to dryness at room temperature under an air-stream and record the spectrum again using the residue.

## TESTS

**Related substances.** Liquid chromatography (2.2.29).

**Test solution.** Dissolve 0.100 g of the substance to be examined in methanol R and dilute to 10.0 mL with the same solvent.

**Reference solution (a).** In order to prepare the *in situ* degradation compound (impurity D), dissolve 10 mg of the substance to be examined in 10.0 mL of dilute hydrochloric acid R. Heat on a water-bath under a reflux condenser for 4 h. Neutralise with 10.0 mL of dilute sodium hydroxide solution R. Evaporate to dryness on a water-bath. Cool and take up the residue in 10 mL of methanol R. Filter.

**Reference solution (b).** Dilute 1.0 mL of the test solution to 100.0 mL with methanol R. Dilute 5.0 mL of this solution to 20.0 mL with methanol R.

## Column:

- size:  $l = 0.1$  m,  $\varnothing = 4.6$  mm;
- stationary phase: octadecylsilyl silica gel for chromatography R (3  $\mu$ m).

## Mobile phase:

- mobile phase A: 5 g/L solution of ammonium carbonate R in a mixture of 10 volumes of tetrahydrofuran R and 90 volumes of water R;
- mobile phase B: acetonitrile R1;

Time (min)	Mobile phase A (per cent V/V)	Mobile phase B (per cent V/V)
0 - 15	90 → 40	10 → 60
15 - 20	40	60

Flow rate: 1.5 mL/min.

Detection: spectrophotometer at 220 nm.

Equilibration: with acetonitrile R for at least 30 min and then with the mobile phase at the initial composition for at least 5 min.

Injection: 10  $\mu$ L; inject methanol R as a blank.

Retention time: fentanyl = about 10 min; impurity D = about 12 min.

System suitability: reference solution (a):

- resolution: minimum 8.0 between the peaks due to fentanyl and impurity D; if necessary, adjust the concentration of acetonitrile in the mobile phase or adjust the time programme for the linear gradient elution.

## Limits:

- impurities A, B, C, D: for each impurity, not more than the area of the principal peak in the chromatogram obtained with reference solution (b) (0.25 per cent);
- total: not more than twice the area of the principal peak in the chromatogram obtained with reference solution (b) (0.5 per cent);
- disregard limit: 0.2 times the area of the principal peak in the chromatogram obtained with reference solution (b) (0.05 per cent).

**Loss on drying** (2.2.32): maximum 0.5 per cent, determined on 1.000 g by drying *in vacuo* at 50 °C.

## ASSAY

Dissolve 0.200 g in 50 mL of a mixture of 1 volume of anhydrous acetic acid R and 7 volumes of methyl ethyl ketone R and titrate with 0.1 M perchloric acid, using 0.2 mL of naphtholbenzene solution R as indicator.

1 mL of 0.1 M perchloric acid is equivalent to 33.65 mg of C<sub>22</sub>H<sub>28</sub>N<sub>2</sub>O.

## STORAGE

Protected from light.

## IMPURITIES

Specified impurities: A, B, C, D.

Other detectable impurities (the following substances would, if present at a sufficient level, be detected by one or other of the tests in the monograph. They are limited by the general acceptance criterion for other/unspecified impurities and/or by the general monograph *Substances for pharmaceutical use* (2034). It is therefore not necessary to identify these impurities for demonstration of compliance. See also 5.10. *Control of impurities in substances for pharmaceutical use*): E, F, G.



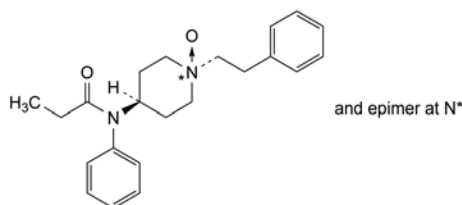

A. *N*-phenyl-*N*-[*cis,trans*-1-oxido-1-(2-phenylethyl)piperidin-4-yl]propanamide,

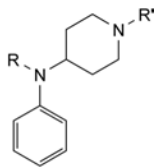

B. R = CO-C<sub>2</sub>H<sub>5</sub>, R' = H: *N*-phenyl-*N*-(piperidin-4-yl)propanamide,

C. R = CO-CH<sub>3</sub>, R' = CH<sub>2</sub>-CH<sub>2</sub>-C<sub>6</sub>H<sub>5</sub>: *N*-phenyl-*N*-[1-(2-phenylethyl)piperidin-4-yl]acetamide,

D. R = H, R' = CH<sub>2</sub>-CH<sub>2</sub>-C<sub>6</sub>H<sub>5</sub>: *N*-phenyl-1-(2-phenylethyl)piperidin-4-amine,

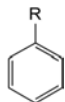

E. R = CHO: benzaldehyde,

F. R = NH<sub>2</sub>: aniline (phenylamine),

G. R = NH-CO-C<sub>2</sub>H<sub>5</sub>: *N*-phenylpropanamide.

01/2008:1103  
corrected 6.0

## FENTANYL CITRATE

### Fentanyli citras

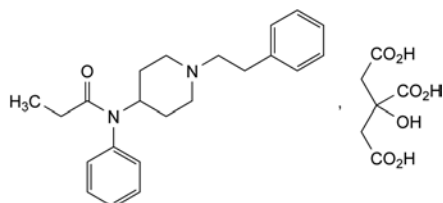

C<sub>28</sub>H<sub>36</sub>N<sub>2</sub>O<sub>8</sub>  
[990-73-8]

*M<sub>r</sub>* 528.6

#### DEFINITION

*N*-Phenyl-*N*-[1-(2-phenylethyl)piperidin-4-yl]propanamide dihydrogen 2-hydroxypropane-1,2,3-tricarboxylate.

*Content*: 99.0 per cent to 101.0 per cent (dried substance).

#### CHARACTERS

*Appearance*: white or almost white powder.

*Solubility*: soluble in water, freely soluble in methanol, sparingly soluble in ethanol (96 per cent).

mp: about 152 °C, with decomposition.

#### IDENTIFICATION

Infrared absorption spectrophotometry (2.2.24).

*Comparison*: Ph. Eur. reference spectrum of fentanyl citrate.

#### TESTS

**Appearance of solution.** The solution is clear (2.2.1) and colourless (2.2.2, Method II).

Dissolve 0.2 g of the substance to be examined in *water R* and dilute to 20 mL with the same solvent.

**Related substances.** Liquid chromatography (2.2.29).

**Test solution.** Dissolve 0.100 g of the substance to be examined in *methanol R* and dilute to 10.0 mL with the same solvent.

**Reference solution (a).** In order to prepare the *in situ* degradation compound (impurity D), dissolve 10 mg of the substance to be examined in 10.0 mL of *dilute hydrochloric acid R*. Heat on a water-bath under a reflux condenser for 4 h. Neutralise with 10.0 mL of *dilute sodium hydroxide solution R*. Evaporate to dryness on a water-bath. Cool and take up the residue in 10 mL of *methanol R*. Filter.

**Reference solution (b).** Dilute 1.0 mL of the test solution to 100.0 mL with *methanol R*. Dilute 5.0 mL of this solution to 20.0 mL with *methanol R*.

**Column:**

– *size*: *l* = 0.1 m, Ø = 4.6 mm;

– *stationary phase*: octadecylsilyl silica gel for chromatography R (3 µm).

**Mobile phase:**

– *mobile phase A*: 5 g/L solution of ammonium carbonate R in a mixture of 10 volumes of tetrahydrofuran R and 90 volumes of water R;

– *mobile phase B*: acetonitrile R1;

Time (min)	Mobile phase A (per cent V/V)	Mobile phase B (per cent V/V)
0 - 15	90 → 40	10 → 60
15 - 20	40	60

**Flow rate:** 1.5 mL/min.

**Detection:** spectrophotometer at 220 nm.

**Equilibration:** with acetonitrile R for at least 30 min, and then with the mobile phase at the initial composition for at least 5 min.

**Injection:** 10 µL; inject *methanol R* as a blank.

**Retention time:** fentanyl = about 10 min; impurity D = about 12 min.

**System suitability:** reference solution (a):

– *resolution*: minimum 8.0 between the peaks due to fentanyl and impurity D; if necessary, adjust the concentration of acetonitrile in the mobile phase or adjust the time programme for the linear gradient elution.

**Limits:**

– *impurities A, B, C, D*: for each impurity, not more than the area of the principal peak in the chromatogram obtained with reference solution (b) (0.25 per cent);

– *total*: not more than twice the area of the principal peak in the chromatogram obtained with reference solution (b) (0.5 per cent);

– *disregard limit*: 0.2 times the area of the principal peak in the chromatogram obtained with reference solution (b) (0.05 per cent); disregard any peak with a retention time relative to the principal peak of 0.05 or less.

**Loss on drying** (2.2.32): maximum 0.5 per cent, determined on 1.000 g by drying *in vacuo* at 60 °C.

#### ASSAY

Dissolve 0.300 g in 50 mL of a mixture of 1 volume of *anhydrous acetic acid R* and 7 volumes of *methyl ethyl ketone R*. Titrate with 0.1 M perchloric acid using 0.2 mL of *naphtholbenzein solution R* as indicator.

1 mL of 0.1 M perchloric acid is equivalent to 52.86 mg of C<sub>28</sub>H<sub>36</sub>N<sub>2</sub>O<sub>8</sub>.

#### STORAGE

Protected from light.

## IMPURITIES

Specified impurities: A, B, C, D.

Other detectable impurities (the following substances would, if present at a sufficient level, be detected by one or other of the tests in the monograph. They are limited by the general acceptance criterion for other/unspecified impurities and/or by the general monograph *Substances for pharmaceutical use* (2034). It is therefore not necessary to identify these impurities for demonstration of compliance. See also 5.10. *Control of impurities in substances for pharmaceutical use*): E.

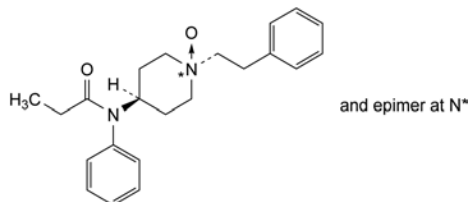

A. *N*-phenyl-*N*-[*cis,trans*-1-oxido-1-(2-phenylethyl)piperidin-4-yl]propanamide,

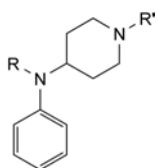

B. R = CO-C<sub>2</sub>H<sub>5</sub>, R' = H: *N*-phenyl-*N*-(piperidin-4-yl)propanamide,

C. R = CO-CH<sub>3</sub>, R' = CH<sub>2</sub>-CH<sub>2</sub>-C<sub>6</sub>H<sub>5</sub>: *N*-phenyl-*N*-[1-(2-phenylethyl)piperidin-4-yl]acetamide,

D. R = H, R' = CH<sub>2</sub>-CH<sub>2</sub>-C<sub>6</sub>H<sub>5</sub>: *N*-phenyl-1-(2-phenylethyl)piperidin-4-amine,

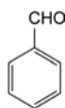

E. benzaldehyde.

## IDENTIFICATION

First identification: C, D.

Second identification: A, B, D.

A. Melting point (2.2.14): 134 °C to 137 °C.

B. Ultraviolet and visible absorption spectrophotometry (2.2.25).

*Test solution.* Dissolve 20.0 mg in *anhydrous ethanol R* and dilute to 100.0 mL with the same solvent. Dilute 1.0 mL of this solution to 10.0 mL with *anhydrous ethanol R*.

*Spectral range:* 230-350 nm.

*Absorption maximum:* at 252 nm.

*Shoulder:* at about 270 nm.

*Absorption minimum:* at 236 nm.

*Specific absorbance at the absorption maximum:* 260 to 280.

C. Infrared absorption spectrophotometry (2.2.24).

*Comparison:* fenticonazole nitrate CRS.

D. It gives the reaction of nitrates (2.3.1).

## TESTS

**Optical rotation** (2.2.7):  $-0.10^\circ$  to  $+0.10^\circ$ .

Dissolve 0.10 g in *methanol R* and dilute to 10.0 mL with the same solvent.

**Related substances.** Liquid chromatography (2.2.29).

*Test solution.* Dissolve 25.0 mg of the substance to be examined in the mobile phase and dilute to 25.0 mL with the mobile phase.

*Reference solution (a).* Dilute 1.0 mL of the test solution to 200.0 mL with the mobile phase.

*Reference solution (b).* Dilute 10.0 mL of reference solution (a) to 25.0 mL with the mobile phase.

*Reference solution (c).* Dilute 1.0 mL of reference solution (a) to 10.0 mL with the mobile phase.

*Reference solution (d).* To 5 mL of the test solution add 5.0 mg of *fenticonazole impurity D CRS*, dissolve in the mobile phase and dilute to 100.0 mL with the mobile phase. Dilute 2.0 mL of this solution to 10.0 mL with the mobile phase.

*Column:*

– size:  $l = 0.25$  m,  $\varnothing = 4$  mm;

– stationary phase: octadecylsilyl silica gel for chromatography R (5-10  $\mu$ m).

*Mobile phase:* mix 70 volumes of *acetonitrile R1* and 30 volumes of a phosphate buffer solution prepared by dissolving 3.4 g of *potassium dihydrogen phosphate R* in 900 mL of *water R*, adjusting to pH 3.0 with *phosphoric acid R* and diluting to 1000 mL with *water R*.

*Flow rate:* 1.0 mL/min.

*Detection:* spectrophotometer at 229 nm.

*Injection:* 10  $\mu$ L.

*Run time:* 5.5 times the retention time of fenticonazole.

*System suitability:*

– *resolution:* minimum 2.0 between the peaks due to impurity D and fenticonazole in the chromatogram obtained with reference solution (d);

– *signal-to-noise ratio:* minimum 5 for the principal peak in the chromatogram obtained with reference solution (c).

*Limits:*

– *impurities A, B, C, D, E:* for each impurity, not more than the area of the principal peak in the chromatogram obtained with reference solution (b) (0.2 per cent);

– *total:* not more than the area of the principal peak in the chromatogram obtained with reference solution (a) (0.5 per cent);

– *disregard limit:* the area of the principal peak in the chromatogram obtained with reference solution (c) (0.05 per cent); disregard the peak due to the nitric ion (which corresponds to the dead volume of the column).

01/2008:1211  
corrected 6.0

## FENTICONAZOLE NITRATE

## Fenticonazoli nitras

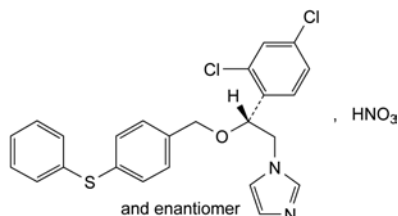

C<sub>24</sub>H<sub>21</sub>Cl<sub>2</sub>N<sub>3</sub>O<sub>4</sub>S  
[73151-29-8]

M<sub>r</sub> 518.4

## DEFINITION

1-[(2*RS*)-2-(2,4-Dichlorophenyl)-2-[[4-(phenylsulfanyl)benzyl]oxy]ethyl]-1*H*-imidazole nitrate.

*Content:* 99.0 per cent to 101.0 per cent (dried substance).

## CHARACTERS

*Appearance:* white or almost white, crystalline powder.

*Solubility:* practically insoluble in water, freely soluble in dimethylformamide and in methanol, sparingly soluble in anhydrous ethanol.

**Toluene.** Head-space gas chromatography (2.2.28): use the standard additions method.

**Test solution.** Disperse 0.2 g of the substance to be examined in a 10 mL vial with 5 mL of *water R*.

**Reference solution.** Mix 4 mg of *toluene R* with *water R* and dilute to 1000 mL with the same solvent. Place 5 mL of this solution in a 10 mL vial.

**Column:**

- size:  $l = 25$  m,  $\varnothing = 0.32$  mm;
- stationary phase: poly(cyanopropyl)(7)(phenyl)(7)-(methyl)(86)siloxane *R R* (film thickness 1.2  $\mu$ m).

**Carrier gas:** helium for chromatography *R*.

**Split ratio:** 1:25.

**Column head pressure:** 40 kPa.

**Static head-space conditions which may be used:**

- equilibration temperature: 90 °C;
- equilibration time: 1 h.

**Temperature:**

- column: 80 °C;
- injection port: 180 °C;
- detector: 220 °C.

**Detection:** flame ionisation.

**Injection:** 1 mL of the gaseous phase.

**Limit:**

- *toluene*: maximum 100 ppm.

**Loss on drying** (2.2.32): maximum 0.5 per cent, determined on 1.000 g by drying *in vacuo* at 60 °C.

**Sulfated ash** (2.4.14): maximum 0.1 per cent, determined on 1.0 g.

**ASSAY**

Dissolve 0.450 g in 50 mL of a mixture of equal volumes of *anhydrous acetic acid R* and *methyl ethyl ketone R*. Titrate with 0.1 M *perchloric acid*, determining the end-point potentiometrically (2.2.20).

1 mL of 0.1 M *perchloric acid* is equivalent to 51.84 mg of  $C_{24}H_{21}Cl_2N_3O_4S$ .

**STORAGE**

Protected from light.

**IMPURITIES**

*Specified impurities: A, B, C, D, E.*

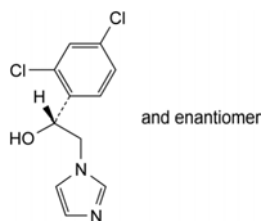

A. (RS)-1-(2,4-dichlorophenyl)-2-(1H-imidazol-1-yl)ethanol,

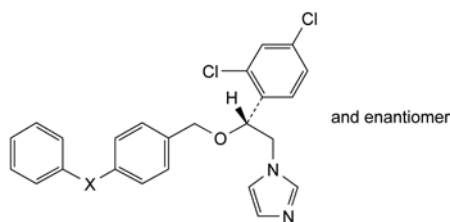

B. X = SO: 1-[(2RS)-2-(2,4-dichlorophenyl)-2-[[4-(phenylsulfinyl)benzyl]oxy]ethyl]-1H-imidazole,

C. X = SO<sub>2</sub>: 1-[(2RS)-2-(2,4-dichlorophenyl)-2-[[4-(phenylsulfonyl)benzyl]oxy]ethyl]-1H-imidazole,

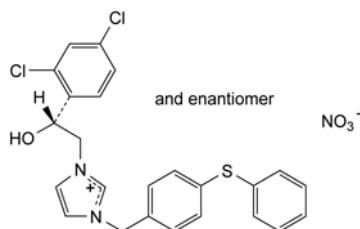

D. (RS)-1-[2-(2,4-dichlorophenyl)-2-hydroxyethyl]-3-[4-(phenylsulfonyl)benzyl]imidazolium nitrate,

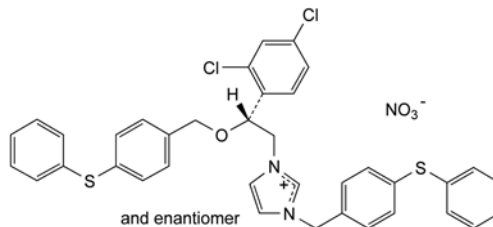

E. (RS)-1-[2-(2,4-dichlorophenyl)-2-[4-(phenylsulfonyl)benzyloxy]ethyl]-3-[4-(phenylsulfonyl)benzyl]imidazolium nitrate.

01/2008:1515

**FERRIC CHLORIDE HEXAHYDRATE**

**Ferri chloridum hexahydricum**

$FeCl_3 \cdot 6H_2O$   
[10025-77-1]

$M_r$  270.3

**DEFINITION**

*Content:* 98.0 per cent to 102.0 per cent.

**CHARACTERS**

*Appearance:* crystalline mass or orange-yellow or brownish-yellow crystals, very hygroscopic.

*Solubility:* very soluble in water and in ethanol (96 per cent), freely soluble in glycerol.

**IDENTIFICATION**

- A. It gives reaction (a) of chlorides (2.3.1).
- B. It gives reaction (c) of iron (2.3.1).

**TESTS**

**Solution S.** Dissolve 10 g in *distilled water R* and dilute to 100 mL with the same solvent.

**Acidity.** In a suitable polyethylene container, dissolve 3.0 g of *potassium fluoride R* in 15 mL of *water R*. Titrate with 0.1 M *sodium hydroxide* using 0.1 mL of *phenolphthalein solution R* as indicator until a pink colour is obtained. Add 10 mL of solution S and allow to stand for 3 h. Filter and use 12.5 mL of the filtrate. Not more than 0.30 mL of 0.1 M *sodium hydroxide* is required to change the colour of the indicator to pink.

**Free chlorine.** Heat 5 mL of solution S. The vapour does not turn *starch iodide paper R* blue.

**Sulfates** (2.4.13): maximum 100 ppm.

Heat 15 mL of solution S on a water-bath and add 5 mL of *strong sodium hydroxide solution R*. Allow to cool and filter. Neutralise the filtrate to *blue litmus paper R* using *hydrochloric acid R1* and evaporate to 15 mL.

**Ferrous ions:** maximum 50 ppm.

To 10 mL of solution S, add 1 mL of *water R*, and 0.05 mL of *potassium ferricyanide solution R* followed by 4 mL of *phosphoric acid R*. After 10 min, any blue colour in the solution is not more intense than that in a standard prepared at the same time and in the same manner using 10 mL of *water R* and 1 mL of a freshly prepared 0.250 g/L solution of *ferrous sulfate R*.

**Heavy metals** (2.4.8): maximum 50 ppm.

Dissolve 1.0 g in 10 mL of *hydrochloric acid R1*. Add 2 mL of *strong hydrogen peroxide solution R*, then evaporate to 5 mL. Allow to cool and dilute to 20 mL with *hydrochloric acid R1* and transfer the solution to a separating funnel. Shake 3 times, for 3 min each time, with 20 mL of *methyl isobutyl ketone R1*. Separate the lower phase, reduce to half its volume by evaporation and dilute to 25 mL with *water R*. Neutralise 10 mL of the solution with *dilute ammonia R1* to *red litmus paper R* and dilute to 20 mL with *water R*. 12 mL of the solution complies with test A. Prepare the reference solution using *lead standard solution (1 ppm Pb) R*.

#### ASSAY

In a conical flask with a ground-glass stopper, dissolve 0.200 g in 20 mL of *water R*. Add 10 mL of *dilute hydrochloric acid R* and 2 g of *potassium iodide R*. Allow the stoppered flask to stand for 1 h protected from light. Titrate with *0.1 M sodium thiosulfate*, adding 5 mL of *starch solution R* towards the end of the titration.

1 mL of *0.1 M sodium thiosulfate* is equivalent to 27.03 mg of  $\text{FeCl}_3 \cdot 6\text{H}_2\text{O}$ .

#### STORAGE

In an airtight container, protected from light.

01/2008:0902  
corrected 7.0

## FERROUS FUMARATE

Ferrosi fumaras

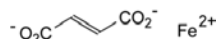

$\text{C}_4\text{H}_2\text{FeO}_4$   
[141-01-5]

$M_r$  169.9

#### DEFINITION

Iron(II) (*E*)-butenedioate.

*Content*: 93.0 per cent to 101.0 per cent (dried substance).

#### CHARACTERS

*Appearance*: fine, reddish-orange or reddish-brown powder.

*Solubility*: slightly soluble in water, very slightly soluble in ethanol (96 per cent).

#### IDENTIFICATION

A. Thin-layer chromatography (2.2.27).

*Test solution*. To 1.0 g add 25 mL of a mixture of equal volumes of *hydrochloric acid R* and *water R* and heat on a water-bath for 15 min. Cool and filter. Use the filtrate for identification test C. Wash the residue with 50 mL of a mixture of 1 volume of *dilute hydrochloric acid R* and 9 volumes of *water R* and discard the washings. Dry the residue at 100-105 °C. Dissolve 20 mg of the residue in *acetone R* and dilute to 10 mL with the same solvent.

*Reference solution*. Dissolve 20 mg of *fumaric acid CRS* in *acetone R* and dilute to 10 mL with the same solvent.

*Plate*: TLC silica gel  $F_{254}$  plate *R*.

*Mobile phase*: *anhydrous formic acid R*, *methylene chloride R*, *butanol R*, *heptane R* (12:16:32:44 V/V/V/V).

*Application*: 5 µL.

*Development*: in an unsaturated tank, over a path of 10 cm.

*Drying*: at 105 °C for 15 min.

*Detection*: examine in ultraviolet light at 254 nm.

*Results*: the principal spot in the chromatogram obtained with the test solution is similar in position and size to the principal spot in the chromatogram obtained with the reference solution.

B. Mix 0.5 g with 1 g of *resorcinol R*. To 0.5 g of the mixture in a crucible add 0.15 mL of *sulfuric acid R* and heat gently. A dark red semi-solid mass is formed. Add the mass, with care, to 100 mL of *water R*. An orange-yellow colour develops and the solution shows no fluorescence.

C. The filtrate obtained during preparation of the test solution in identification test A gives reaction (a) of iron (2.3.1).

#### TESTS

**Solution S**. Dissolve 2.0 g in a mixture of 10 mL of *lead-free hydrochloric acid R* and 80 mL of *water R*, heating slightly if necessary. Allow to cool, filter if necessary and dilute to 100 mL with *water R*.

**Sulfates** (2.4.13): maximum 0.2 per cent.

Heat 0.15 g with 8 mL of *dilute hydrochloric acid R* and 20 mL of *distilled water R*. Cool in iced water, filter and dilute to 30 mL with *distilled water R*.

**Arsenic** (2.4.2, *Method A*): maximum 5 ppm.

Mix 1.0 g with 15 mL of *water R* and 15 mL of *sulfuric acid R*. Warm to precipitate the fumaric acid completely. Cool and add 30 mL of *water R*. Filter. Wash the precipitate with *water R*. Dilute the combined filtrate and washings to 125 mL with *water R*. 25 mL of the solution complies with the test.

**Ferric ion**: maximum 2.0 per cent.

In a flask with a ground-glass stopper, dissolve 3.0 g in a mixture of 10 mL of *hydrochloric acid R* and 100 mL of *water R* by heating rapidly to boiling. Boil for 15 s. Cool rapidly, add 3 g of *potassium iodide R*, stopper the flask and allow to stand protected from light for 15 min. Add 2 mL of *starch solution R* as indicator. Titrate the liberated iodine with *0.1 M sodium thiosulfate*. Carry out a blank test. The difference between the volumes used in the 2 titrations corresponds to the amount of iodine liberated by ferric ion.

1 mL of *0.1 M sodium thiosulfate* is equivalent to 5.585 mg of ferric ion.

**Cadmium**: maximum 10 ppm.

Atomic absorption spectrometry (2.2.23, *Method I*).

*Test solution*. Solution S.

*Reference solutions*. Prepare the reference solutions using *cadmium standard solution (0.1 per cent Cd) R* and diluting with a 10 per cent V/V solution of *lead-free hydrochloric acid R*.

*Source*: cadmium hollow-cathode lamp.

*Wavelength*: 228.8 nm.

*Atomisation device*: air-acetylene flame.

**Chromium**: maximum 200 ppm.

Atomic absorption spectrometry (2.2.23, *Method I*).

*Test solution*. Solution S.

*Reference solutions*. Prepare the reference solutions using *chromium standard solution (0.1 per cent Cr) R* and diluting with a 10 per cent V/V solution of *lead-free hydrochloric acid R*.

*Source*: chromium hollow-cathode lamp.

*Wavelength*: 357.9 nm.

*Atomisation device*: air-acetylene flame.

**Lead**: maximum 20 ppm.

Atomic absorption spectrometry (2.2.23, *Method I*).

*Test solution*. Solution S.

*Reference solutions*. Prepare the reference solutions using *lead standard solution (10 ppm Pb) R* and diluting with a 10 per cent V/V solution of *lead-free hydrochloric acid R*.

*Source*: lead hollow-cathode lamp.

*Wavelength*: 283.3 nm.

*Atomisation device*: air-acetylene flame.

**Mercury**: maximum 1 ppm.

Atomic absorption spectrometry (2.2.23, *Method I*).

*Test solution*. Solution S.

**Reference solutions.** Prepare the reference solutions using *mercury standard solution (10 ppm Hg) R* and diluting with a 25 per cent V/V solution of *lead-free hydrochloric acid R*.

**Source:** mercury hollow-cathode lamp.

**Wavelength:** 253.7 nm.

Following the recommendations of the manufacturer, introduce 5 mL of solution S or 5 mL of the reference solutions into the reaction vessel of the cold-vapour mercury assay accessory, add 10 mL of *water R* and 1 mL of *stannous chloride solution R1*.

**Nickel:** maximum 200 ppm.

Atomic absorption spectrometry (2.2.23, Method I).

**Test solution.** Solution S.

**Reference solutions.** Prepare the reference solutions using *nickel standard solution (10 ppm Ni) R* and diluting with a 10 per cent V/V solution of *lead-free hydrochloric acid R*.

**Source:** nickel hollow-cathode lamp.

**Wavelength:** 232 nm.

**Atomisation device:** air-acetylene flame.

**Zinc:** maximum 500 ppm.

Atomic absorption spectrometry (2.2.23, Method I).

**Test solution.** Solution S diluted to 10 volumes.

**Reference solutions.** Prepare the reference solutions using *zinc standard solution (10 ppm Zn) R* and diluting with a 1 per cent V/V solution of *lead-free hydrochloric acid R*.

**Source:** zinc hollow-cathode lamp.

**Wavelength:** 213.9 nm.

**Atomisation device:** air-acetylene flame.

**Loss on drying (2.2.32):** maximum 1.0 per cent, determined on 1.000 g by drying in an oven at 105 °C.

#### ASSAY

Dissolve with slight heating 0.150 g in 7.5 mL of *dilute sulfuric acid R*. Cool and add 25 mL of *water R*. Add 0.1 mL of *ferroin R*. Titrate immediately with 0.1 M *cerium sulfate* until the colour changes from orange to light bluish-green.

1 mL of 0.1 M *cerium sulfate* is equivalent to 16.99 mg of  $C_4H_2FeO_4$ .

#### STORAGE

In an airtight container, protected from light.

01/2009:0493

## FERROUS GLUCONATE

### Ferrosi gluconas

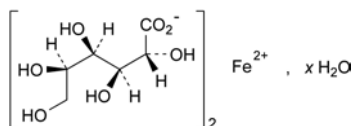

$C_{12}H_{22}FeO_{14} \cdot xH_2O$

$M_r$  446.1 (anhydrous substance)

#### DEFINITION

Iron(II) di(D-gluconate).

**Content:** 11.8 per cent to 12.5 per cent of iron(II) (dried substance). It contains a variable amount of water.

#### CHARACTERS

**Appearance:** greenish-yellow or grey powder or granules.

**Solubility:** freely but slowly soluble in water giving a greenish-brown solution, more readily soluble in hot water, practically insoluble in ethanol (96 per cent).

#### IDENTIFICATION

A. Thin-layer chromatography (2.2.27).

**Test solution.** Dissolve 20 mg of the substance to be examined in 2 mL of *water R*, heating if necessary in a water-bath at 60 °C.

**Reference solution.** Dissolve 20 mg of *ferrous gluconate CRS* in 2 mL of *water R*, heating if necessary in a water-bath at 60 °C.

**Plate:** TLC silica gel G plate R.

**Mobile phase:** concentrated ammonia R, ethyl acetate R, water R, ethanol (96 per cent) R (10:10:30:50 V/V/V/V).

**Application:** 5 µL.

**Development:** over a path of 10 cm.

**Drying:** at 100-105 °C for 20 min.

**Detection:** allow to cool and spray with a 50 g/L solution of *potassium dichromate R* in a 40 per cent m/m solution of *sulfuric acid R*.

**Results:** after 5 min, the principal spot in the chromatogram obtained with the test solution is similar in position, colour and size to the principal spot in the chromatogram obtained with the reference solution.

B. 1 mL of solution S (see Tests) gives reaction (a) of iron (2.3.1).

#### TESTS

**Solution S.** Dissolve 5.0 g in *carbon dioxide-free water R* prepared from *distilled water R* and heated to about 60 °C, allow to cool and dilute to 50 mL with *carbon dioxide-free water R* prepared from *distilled water R*.

**Appearance of solution.** The solution is clear (2.2.1).

Dilute 2 mL of solution S to 10 mL with *water R*. Examine the solution against the light.

**pH (2.2.3):** 4.0 to 5.5 for solution S, measured 3-4 h after preparation.

**Sucrose and reducing sugars.** Dissolve 0.5 g in 10 mL of warm *water R* and add 1 mL of *dilute ammonia R1*. Pass *hydrogen sulfide R* through the solution and allow to stand for 30 min. Filter and wash the precipitate with 2 quantities, each of 5 mL, of *water R*. Acidify the combined filtrate and washings to *blue litmus paper R* with *dilute hydrochloric acid R* and add 2 mL in excess. Boil until the vapour no longer darkens *lead acetate paper R* and continue boiling, if necessary, until the volume is reduced to about 10 mL. Cool, add 15 mL of *sodium carbonate solution R*, allow to stand for 5 min and filter. Dilute the filtrate to 100 mL with *water R*. To 5 mL of this solution add 2 mL of *cupri-tartaric solution R* and boil for 1 min. Allow to stand for 1 min. No red precipitate is formed.

**Chlorides (2.4.4):** maximum 0.06 per cent.

Dilute 0.8 mL of solution S to 15 mL with *water R*.

**Oxalates.** Dissolve 5.0 g in a mixture of 10 mL of *dilute sulfuric acid R* and 40 mL of *water R*. Shake the solution with 50 mL of *ether R* for 5 min. Separate the aqueous layer and shake it with 20 mL of *ether R* for 5 min. Combine the ether layers, evaporate to dryness and dissolve the residue in 15 mL of *water R*. Filter, boil the filtrate until the volume is reduced to 5 mL and add 1 mL of *dilute acetic acid R* and 1.5 mL of *calcium chloride solution R*. Allow to stand for 30 min. No precipitate is formed.

**Sulfates (2.4.13):** maximum 500 ppm.

To 3.0 mL of solution S add 3 mL of *acetic acid R* and dilute to 15 mL with *distilled water R*. Examine the solutions against the light.

**Arsenic (2.4.2, Method A):** maximum 2 ppm, determined on 0.5 g.

**Barium.** Dilute 10 mL of solution S to 50 mL with *distilled water R* and add 5 mL of *dilute sulfuric acid R*. Allow to stand for 5 min. Any opalescence in the solution is not more intense than that in a mixture of 10 mL of solution S and 45 mL of *distilled water R*.

**Ferric ion:** maximum 1.0 per cent.

In a ground-glass-stoppered flask, dissolve 5.00 g in a mixture of 10 mL of *hydrochloric acid R* and 100 mL of *carbon dioxide-free water R*. Add 3 g of *potassium iodide R*, close the flask and allow to stand protected from light for 5 min. Titrate with 0.1 M *sodium thiosulfate*, using 0.5 mL of *starch solution R*, added towards the end of the titration, as indicator. Carry out a blank titration. Not more than 9.0 mL of 0.1 M *sodium thiosulfate* is used.

**Heavy metals (2.4.8):** maximum 20 ppm.

Thoroughly mix 2.5 g with 0.5 g of *magnesium oxide R1* in a silica crucible. Ignite to dull redness until a homogeneous mass is obtained. Heat at  $800 \pm 50$  °C for about 1 h, allow to cool and take up the residue in 20 mL of hot *hydrochloric acid R*. Allow to cool. Transfer the liquid to a separating funnel and shake for 3 min with 3 quantities, each of 20 mL, of methyl isobutyl ketone saturated with hydrochloric acid (prepared by shaking 100 mL of freshly distilled *methyl isobutyl ketone R* with 1 mL of *hydrochloric acid R*). Allow to stand, separate the aqueous layer, reduce to half its volume by boiling, allow to cool and dilute to 25 mL with *water R*. Neutralise 10 mL of this solution to *red litmus paper R* using *dilute ammonia R1* and dilute to 20 mL with *water R*. 12 mL of the solution complies with test A. Prepare the reference solution using *lead standard solution (1 ppm Pb) R*.

**Loss on drying (2.2.32):** 5.0 per cent to 10.5 per cent, determined on 0.500 g by drying in an oven at 105 °C for 5 h.

#### Microbial contamination

TAMC: acceptance criterion  $10^3$  CFU/g (2.6.12).

TYMC: acceptance criterion  $10^2$  CFU/g (2.6.12).

#### ASSAY

Dissolve 0.5 g of *sodium hydrogen carbonate R* in a mixture of 30 mL of *dilute sulfuric acid R* and 70 mL of *water R*. When the effervescence stops, dissolve 1.00 g of the substance to be examined with gentle shaking. Using 0.1 mL of *ferroin R* as indicator, titrate with 0.1 M *ammonium and cerium nitrate* until the red colour disappears.

1 mL of 0.1 M *ammonium and cerium nitrate* is equivalent to 5.585 mg of iron(II).

#### STORAGE

Protected from light.

01/2008:2340  
corrected 7.0

## FERROUS SULFATE, DRIED

### Ferrosi sulfas desiccatus

FeSO<sub>4</sub>

*M<sub>r</sub>* 151.9

#### DEFINITION

Hydrated ferrous sulfate from which part of the water of hydration has been removed by drying.

**Content:** 86.0 per cent to 90.0 per cent.

#### CHARACTERS

**Appearance:** greyish-white powder.

**Solubility:** slowly but freely soluble in water, very soluble in boiling water, practically insoluble in ethanol (96 per cent).

It is oxidised in moist air, becoming brown.

#### IDENTIFICATION

A. It gives the reactions of sulfates (2.3.1).

B. It gives reaction (a) of iron (2.3.1).

C. It complies with the limits of the assay.

#### TESTS

**Solution S.** Dissolve 2.00 g in a 5 per cent V/V solution of *lead-free nitric acid R* and dilute to 100.0 mL with the same acid.

**pH (2.2.3):** 3.0 to 4.0.

Dissolve 1.0 g in *carbon dioxide-free water R* and dilute to 20 mL with the same solvent.

**Chlorides (2.4.4):** maximum 300 ppm.

Dissolve 2.5 g in *water R*, add 0.5 mL of *dilute sulfuric acid R* and dilute to 50 mL with *water R*. Dilute 3.3 mL of this solution to 10 mL with *water R* and add 5 mL of *dilute nitric acid R*. Prepare the standard using a mixture of 10 mL of *chloride standard solution (5 ppm Cl) R* and 5 mL of *dilute nitric acid R*. Use 0.15 mL of *silver nitrate solution R2* in this test.

**Chromium:** maximum 100 ppm.

Atomic absorption spectrometry (2.2.23, *Method I*).

**Test solution.** Solution S.

**Reference solutions.** Prepare the reference solutions using *chromium standard solution (100 ppm Cr) R*, diluted as necessary with a 5 per cent V/V solution of *lead-free nitric acid R*.

**Source:** chromium hollow-cathode lamp using a transmission band preferably of 1 nm.

**Wavelength:** 357.9 nm.

**Atomisation device:** air-acetylene flame.

**Copper:** maximum 50 ppm.

Atomic absorption spectrometry (2.2.23, *Method II*).

**Test solution.** Solution S.

**Reference solutions.** Prepare the reference solutions using *copper standard solution (0.1 per cent Cu) R*, diluted as necessary with a 5 per cent V/V solution of *lead-free nitric acid R*.

**Source:** copper hollow-cathode lamp using a transmission band preferably of 1 nm.

**Wavelength:** 324.7 nm.

**Atomisation device:** air-acetylene flame.

**Ferric ions:** maximum 0.5 per cent.

In a ground-glass-stoppered flask, dissolve 5.00 g in a mixture of 10 mL of *hydrochloric acid R* and 100 mL of *carbon dioxide-free water R*. Add 3 g of *potassium iodide R*, close the flask and allow to stand in the dark for 5 min. Titrate the liberated iodine with 0.1 M *sodium thiosulfate*, using 0.5 mL of *starch solution R*, added towards the end of titration, as indicator. Carry out a blank test in the same conditions. Not more than 4.5 mL of 0.1 M *sodium thiosulfate* is used.

**Manganese:** maximum 0.1 per cent.

Atomic absorption spectrometry (2.2.23, *Method II*).

**Test solution.** Dilute 1.0 mL of solution S to 20.0 mL with a 5 per cent V/V solution of *lead-free nitric acid R*.

**Reference solutions.** Prepare the reference solutions using *manganese standard solution (1000 ppm Mn) R*, diluted as necessary with a 5 per cent V/V solution of *lead-free nitric acid R*.

**Source:** manganese hollow-cathode lamp using a transmission band preferably of 1 nm.

**Wavelength:** 279.5 nm.

**Atomisation device:** air-acetylene flame.

**Nickel:** maximum 100 ppm.

Atomic absorption spectrometry (2.2.23, *Method I*).

**Test solution.** Solution S.

**Reference solutions.** Prepare the reference solutions using *nickel standard solution (10 ppm Ni) R*, diluted as necessary with a 5 per cent V/V solution of *lead-free nitric acid R*.

**Source:** nickel hollow-cathode lamp using a transmission band preferably of 1 nm.

*Wavelength*: 232.0 nm.

*Atomisation device*: air-acetylene flame.

**Zinc**: maximum 100 ppm.

Atomic absorption spectrometry (2.2.23, *Method II*).

*Test solution*. Solution S.

*Reference solutions*. Prepare the reference solutions using *zinc standard solution (100 ppm Zn) R*, diluted as necessary with a 5 per cent V/V solution of *lead-free nitric acid R*.

*Source*: zinc hollow-cathode lamp using a transmission band preferably of 1 nm.

*Wavelength*: 213.9 nm.

*Atomisation device*: air-acetylene flame.

#### ASSAY

Dissolve 2.5 g of *sodium hydrogen carbonate R* in a mixture of 150 mL of *water R* and 10 mL of *sulfuric acid R*. When the effervescence ceases, add to the solution 0.140 g of the substance to be examined and dissolve with gentle shaking. Add 0.1 mL of *ferroin R* and titrate with 0.1 M *ammonium and cerium nitrate* until the red colour disappears.

1 mL of 0.1 M *ammonium and cerium nitrate* is equivalent to 15.19 mg of  $\text{FeSO}_4$ .

#### STORAGE

In an airtight container.

01/2010:0083

## FERROUS SULFATE HEPTAHYDRATE

### Ferrosi sulfas heptahydricus

$\text{FeSO}_4 \cdot 7\text{H}_2\text{O}$   
[7782-63-0]

$M_r$  278.0

#### DEFINITION

*Content*: 98.0 per cent to 105.0 per cent.

#### CHARACTERS

*Appearance*: light green, crystalline powder or bluish-green crystals, efflorescent in air.

*Solubility*: freely soluble in water, very soluble in boiling water, practically insoluble in ethanol (96 per cent).

Ferrous sulfate heptahydrate is oxidised in moist air, becoming brown.

#### IDENTIFICATION

- It gives the reactions of sulfates (2.3.1).
- It gives reaction (a) of iron (2.3.1).
- It complies with the limits of the assay.

#### TESTS

**Solution S**. Dissolve 4.0 g in a 5 per cent V/V solution of *lead-free nitric acid R* and dilute to 100.0 mL with the same solution.

**pH** (2.2.3): 3.0 to 4.0.

Dissolve 1.0 g in *carbon dioxide-free water R* and dilute to 20 mL with the same solvent.

**Chlorides** (2.4.4): maximum 200 ppm.

Dilute 5 mL of solution S to 10 mL with *water R* and add 5 mL of *dilute nitric acid R*. Prepare the standard with a mixture of 2 mL of *water R*, 5 mL of *dilute nitric acid R* and 8 mL of *chloride standard solution (5 ppm Cl) R*. Use 0.15 mL of *silver nitrate solution R2* in this test.

**Chromium**: maximum 50 ppm.

Atomic absorption spectrometry (2.2.23, *Method I*).

*Test solution*. Solution S.

*Reference solutions*. Prepare the reference solutions using *chromium standard solution (100 ppm Cr) R*, diluting with a 5 per cent V/V solution of *lead-free nitric acid R*.

*Source*: chromium hollow-cathode lamp using a transmission band preferably of 1 nm.

*Wavelength*: 357.9 nm.

*Atomisation device*: air-acetylene flame.

**Copper**: maximum 50 ppm.

Atomic absorption spectrometry (2.2.23, *Method II*).

*Test solution*. Solution S.

*Reference solutions*. Prepare the reference solutions using *copper standard solution (0.1 per cent Cu) R*, diluting with a 5 per cent V/V solution of *lead-free nitric acid R*.

*Source*: copper hollow-cathode lamp using a transmission band preferably of 1 nm.

*Wavelength*: 324.7 nm.

*Atomisation device*: air-acetylene flame.

**Ferric ions**: maximum 0.3 per cent.

In a ground-glass-stoppered flask, dissolve 5.00 g in a mixture of 10 mL of *hydrochloric acid R* and 100 mL of *carbon dioxide-free water R*. Add 3 g of *potassium iodide R*, close the flask and allow to stand in the dark for 5 min. Titrate the liberated iodine with 0.1 M *sodium thiosulfate*, using 0.5 mL of *starch solution R*, added towards the end of the titration, as indicator. Carry out a blank test in the same conditions. Not more than 2.7 mL of 0.1 M *sodium thiosulfate* is used, taking into account the blank titration.

**Manganese**: maximum 0.1 per cent.

Atomic absorption spectrometry (2.2.23, *Method II*).

*Test solution*. Dilute 1.0 mL of solution S to 20.0 mL with a 5 per cent V/V solution of *lead-free nitric acid R*.

*Reference solutions*. Prepare the reference solutions using *manganese standard solution (1000 ppm Mn) R*, diluting with a 5 per cent V/V solution of *lead-free nitric acid R*.

*Source*: manganese hollow-cathode lamp using a transmission band preferably of 1 nm.

*Wavelength*: 279.5 nm.

*Atomisation device*: air-acetylene flame.

**Nickel**: maximum 50 ppm.

Atomic absorption spectrometry (2.2.23, *Method II*).

*Test solution*. Solution S.

*Reference solutions*. Prepare the reference solutions using *nickel standard solution (10 ppm Ni) R*, diluting with a 5 per cent V/V solution of *lead-free nitric acid R*.

*Source*: nickel hollow-cathode lamp using a transmission band preferably of 1 nm.

*Wavelength*: 232.0 nm.

*Atomisation device*: air-acetylene flame.

**Zinc**: maximum 50 ppm.

Atomic absorption spectrometry (2.2.23, *Method II*).

*Test solution*. Solution S.

*Reference solutions*. Prepare the reference solutions using *zinc standard solution (100 ppm Zn) R*, diluting with a 5 per cent V/V solution of *lead-free nitric acid R*.

*Source*: zinc hollow-cathode lamp using a transmission band preferably of 1 nm.

*Wavelength*: 213.9 nm.

*Atomisation device*: air-acetylene flame.

#### ASSAY

Dissolve 2.5 g of *sodium hydrogen carbonate R* in a mixture of 150 mL of *water R* and 10 mL of *sulfuric acid R*. When the effervescence ceases add to the solution 0.500 g of the substance to be examined and dissolve with gentle swirling. Add 0.1 mL of *ferroin R* and titrate with 0.1 M *ammonium and cerium nitrate* until the red colour disappears.

1 mL of 0.1 M ammonium and cerium nitrate is equivalent to 27.80 mg of  $\text{FeSO}_4 \cdot 7\text{H}_2\text{O}$ .

#### STORAGE

In an airtight container.

01/2008:2280

## FEXOFENADINE HYDROCHLORIDE

### Fexofenadini hydrochloridum

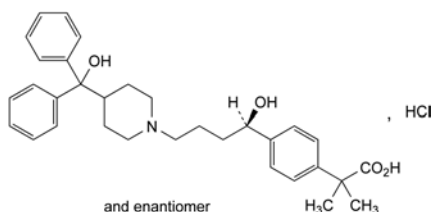

$\text{C}_{32}\text{H}_{40}\text{ClNO}_4$   
[153439-40-8]

$M_r$  538.1

#### DEFINITION

2-[4-[(1*RS*)-1-hydroxy-4-[4-(hydroxydiphenylmethyl)piperidin-1-yl]butyl]phenyl]-2-methylpropanoic acid hydrochloride.

*Content*: 98.0 per cent to 102.0 per cent (anhydrous substance).

#### CHARACTERS

*Appearance*: white or almost white powder.

*Solubility*: slightly soluble in water, freely soluble in methanol, very slightly soluble in acetone.

It shows polymorphism (5.9).

#### IDENTIFICATION

A. Infrared absorption spectrophotometry (2.2.24).

*Comparison*: fexofenadine hydrochloride CRS.

It the spectra obtained in the solid state show differences, dissolve the substance to be examined and the reference substance separately in *methanol R*, evaporate to dryness and record new spectra using the residues.

B. Dissolve 30 mg of the substance to be examined in a mixture of equal volumes of *methanol R* and *water R*; sonicate if necessary and dilute to 2 mL with the same mixture of solvents. The solution gives reaction (a) of chlorides (2.3.1).

#### TESTS

**Impurity B.** Liquid chromatography (2.2.29).

*Test solution.* Dissolve 50.0 mg of the substance to be examined in the mobile phase and dilute to 100.0 mL with the mobile phase.

*Reference solution (a).* Dissolve the contents of a vial of *fexofenadine impurity B CRS* in the test solution and dilute to 2.0 mL with the test solution.

*Reference solution (b).* Dilute 1.0 mL of the test solution to 100.0 mL with the mobile phase. Dilute 1.0 mL of this solution to 10.0 mL with the mobile phase.

*Column*:

- *size*:  $l = 0.25$  m,  $\varnothing = 4.6$  mm;
- *stationary phase*: silica gel BC for chiral chromatography R1 (5  $\mu\text{m}$ ).

*Mobile phase*: mix 20 volumes of *acetonitrile for chromatography R* and 80 volumes of a buffer solution prepared as follows: to 1.15 mL of *glacial acetic acid R* add *water for chromatography R*, adjust to pH  $4.0 \pm 0.1$  with *dilute ammonia R1* and dilute to 1000 mL with *water for chromatography R*.

*Flow rate*: 0.5 mL/min.

*Detection*: spectrophotometer at 220 nm.

*Injection*: 20  $\mu\text{L}$ .

*Run time*: 1.2 times the retention time of fexofenadine.

*Relative retention* with reference to fexofenadine (retention time = about 20 min): impurity B = about 0.7.

*System suitability*: reference solution (a):

- *resolution*: minimum 3.0 between the peaks due to fexofenadine and impurity B.

*Limits*:

- *correction factor*: for the calculation of content, multiply the peak area of impurity B by 1.3;
- *impurity B*: not more than the area of the principal peak in the chromatogram obtained with reference solution (b) (0.1 per cent).

**Related substances.** Liquid chromatography (2.2.29).

*Buffer solution.* Dissolve 6.64 g of *sodium dihydrogen phosphate monohydrate R* and 0.84 g of *sodium perchlorate R* in *water for chromatography R*, adjust to pH  $2.0 \pm 0.1$  with *phosphoric acid R* and dilute to 1000 mL with *water for chromatography R*.

*Solvent mixture.* Mix equal volumes of *acetonitrile for chromatography R* and the buffer solution.

*Test solution (a).* Dissolve 25.0 mg of the substance to be examined in 25.0 mL of the solvent mixture.

*Test solution (b).* Dilute 3.0 mL of test solution (a) to 50.0 mL with the mobile phase.

*Reference solution (a).* Dissolve 25.0 mg of *fexofenadine hydrochloride CRS* in the solvent mixture and dilute to 25.0 mL with the solvent mixture. Dilute 3.0 mL of this solution to 50.0 mL with the mobile phase.

*Reference solution (b).* Dilute 1.0 mL of test solution (a) to 100.0 mL with the mobile phase. Dilute 1.0 mL of this solution to 10.0 mL with the mobile phase.

*Reference solution (c).* Dissolve 1 mg each of *fexofenadine impurity A CRS* and *fexofenadine impurity C CRS* in 20 mL of reference solution (a) and dilute to 200.0 mL with the mobile phase.

*Column*:

- *size*:  $l = 0.25$  m,  $\varnothing = 4.6$  mm;
- *stationary phase*: phenylsilyl silica gel for chromatography R (5  $\mu\text{m}$ ).

*Mobile phase*: mix 350 volumes of *acetonitrile for chromatography R* and 650 volumes of the buffer solution; add 3 volumes of *triethylamine R* and mix.

*Flow rate*: 1.5 mL/min.

*Detection*: spectrophotometer at 220 nm.

*Injection*: 20  $\mu\text{L}$  of test solution (a) and reference solutions (b) and (c).

*Relative retention* with reference to fexofenadine (retention time = about 9 min): impurity A = about 1.7; impurity D = about 2.3; impurity C = about 3.2.

*Run time*: 6 times the retention time of fexofenadine for test solution (a) and reference solution (c), twice the retention time of fexofenadine for reference solution (b).

*System suitability*: reference solution (c):

- *resolution*: minimum 10 between the peaks due to fexofenadine and impurity A.

*Limits*:

- *correction factor*: for the calculation of content, multiply the peak area of impurity A by 1.4;
- *impurities A, C, D*: not more than the area of the principal peak in the chromatogram obtained with reference solution (b) (0.1 per cent);
- *unspecified impurities*: for each impurity, not more than the area of the principal peak in the chromatogram obtained with reference solution (b) (0.10 per cent);



- *total*: not more than 3 times the area of the principal peak in the chromatogram obtained with reference solution (b) (0.3 per cent);
- *disregard limit*: 0.5 times the area of the principal peak in the chromatogram obtained with reference solution (b) (0.05 per cent).

**Heavy metals** (2.4.8): maximum 10 ppm.

Dissolve 1.0 g in a mixture of 15 volumes of *water R* and 85 volumes of *methanol R* and dilute to 20 mL with the same mixture of solvents. 12 mL of the solution complies with test B. Prepare the reference solution using 5 mL of *lead standard solution (1 ppm Pb) R*.

**Water** (2.5.32): maximum 0.5 per cent.

Dissolve 1.000 g in *anhydrous methanol R* and dilute to 5.0 mL with the same solvent. Use 1.0 mL of this solution.

**Sulfated ash** (2.4.14): maximum 0.1 per cent, determined on 1.0 g.

#### ASSAY

Liquid chromatography (2.2.29) as described in the test for related substances with the following modifications.

*Injection*: test solution (b) and reference solution (a).

*Run time*: twice the retention time of fexofenadine.

Calculate the percentage content of fexofenadine hydrochloride from the declared content of *fexofenadine hydrochloride CRS*.

#### IMPURITIES

*Specified impurities*: A, B, C, D.

*Other detectable impurities* (the following substances would, if present at a sufficient level, be detected by one or other of the tests in the monograph. They are limited by the general acceptance criterion for other/unspecified impurities and/or by the general monograph *Substances for pharmaceutical use (2034)*. It is therefore not necessary to identify these impurities for demonstration of compliance. See also 5.10. *Control of impurities in substances for pharmaceutical use*): E, F, G.

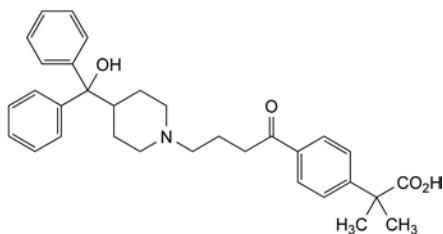

A. 2-[4-[4-(hydroxydiphenylmethyl)piperidin-1-yl]butanoyl]phenyl]-2-methylpropanoic acid,

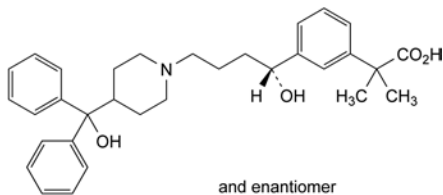

B. 2-[3-[(1RS)-1-hydroxy-4-[4-(hydroxydiphenylmethyl)piperidin-1-yl]butyl]phenyl]-2-methylpropanoic acid,

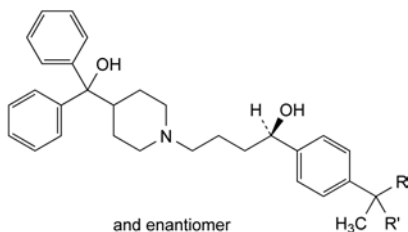

C. R = H, R' = CH<sub>3</sub>: (1RS)-4-[4-(hydroxydiphenylmethyl)piperidin-1-yl]-1-[4-(1-methylethyl)phenyl]butan-1-ol,

D. R = CO-OCH<sub>3</sub>, R' = CH<sub>3</sub>: methyl 2-[4-[(1RS)-1-hydroxy-4-[4-(hydroxydiphenylmethyl)piperidin-1-yl]butyl]phenyl]-2-methylpropanoate,

F. R = CO<sub>2</sub>H, R' = H: 2-[4-[1-hydroxy-4-[4-(hydroxydiphenylmethyl)piperidin-1-yl]butyl]phenyl]propanoic acid,

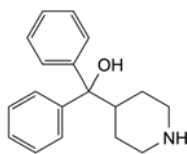

E. diphenyl(piperidin-4-yl)methanol,

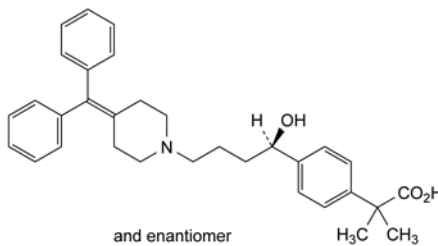

G. 2-[4-[(1RS)-4-[4-(diphenylmethylidene)piperidin-1-yl]-1-hydroxybutyl]phenyl]-2-methylpropanoic acid.

01/2008:0903

## FIBRIN SEALANT KIT

### Fibrini glutinum

#### DEFINITION

Fibrin sealant kit is essentially composed of 2 components, namely fibrinogen concentrate (component 1), a protein fraction containing human fibrinogen and a preparation containing human thrombin (component 2). A fibrin clot is rapidly formed when the 2 thawed or reconstituted components are mixed. Other ingredients (for example, human coagulation factor XIII, a fibrinolysis inhibitor or calcium ions) and stabilisers (for example, *Human albumin solution (0255)*) may be added. No antimicrobial preservative is added.

Human constituents are obtained from plasma that complies with the requirements of the monograph on *Human plasma for fractionation (0853)*. No antibiotic is added to the plasma used.

When thawed or reconstituted as stated on the label, component 1 contains not less than 40 g/L of clottable protein; the thrombin activity of component 2 varies over a wide range (approximately 4-1000 IU/mL).

#### PRODUCTION

The method of preparation includes a step or steps that have been shown to remove or to inactivate known agents of infection; if substances are used for inactivation of viruses during production, the subsequent purification procedure must be validated to demonstrate that the concentration of these substances is reduced to a suitable level and any residues are such as not to compromise the safety of the preparation for patients.

Constituents or mixtures of constituents are passed through a bacteria-retentive filter and distributed aseptically into sterile containers. Containers of freeze-dried constituents are closed under vacuum or filled with oxygen-free nitrogen or other suitable inert gas before being closed. In either case, they are closed so as to exclude micro-organisms.

If the human coagulation factor XIII content in component 1 is greater than 10 units/mL, the assay of factor XIII is carried out.

## CHARACTERS

Freeze-dried constituents are hygroscopic, white or pale yellow powders or friable solids. Frozen constituents are colourless or pale yellow, opaque solids. Liquid constituents are colourless or pale yellow.

*For the freeze-dried or frozen constituents, reconstitute or thaw as stated on the label immediately before carrying out the identification and the tests, except those for solubility and water.*

## Component 1 (fibrinogen concentrate)

## IDENTIFICATION

- A. It complies with the limits of the assay of fibrinogen.  
B. It complies with the limits of the assay of factor XIII (where applicable).

## TESTS

**pH** (2.2.3): 6.5 to 8.0.

**Solubility.** Freeze-dried concentrates dissolve within 20 min in the volume of solvent for reconstitution and at the temperature stated on the label, forming an almost colourless, clear or slightly turbid solution.

**Stability of solution.** No gel formation appears at room temperature during 120 min following thawing or reconstitution.

**Water.** Determined by a suitable method, such as the semi-micro determination (2.5.12), loss on drying (2.2.32) or near infrared spectrophotometry (2.2.40), the water content is within the limits approved by the competent authority.

**Sterility** (2.6.1). It complies with the test for sterility.

## ASSAY

**Fibrinogen (clottable protein).** The estimated content in milligrams of clottable protein is not less than 70 per cent and not more than 130 per cent of the content stated on the label.

Mix 0.2 mL of the reconstituted preparation with 2 mL of a suitable buffer solution (pH 6.6-7.4) containing sufficient *human thrombin R* (approximately 3 IU/mL) and calcium (0.05 mol/L). Maintain at 37 °C for 20 min, separate the precipitate by centrifugation (5000 *g*, 20 min), wash thoroughly with a 9 g/L solution of *sodium chloride R* and determine the protein as nitrogen by sulfuric acid digestion (2.5.9). Calculate the protein content by multiplying the result by 6.0. If for a particular preparation this method cannot be applied, use another validated method for determination of fibrinogen.

**Factor XIII.** Where the label indicates that the human coagulation factor XIII activity is greater than 10 units/mL, the estimated activity is not less than 80 per cent and not more than 120 per cent of the activity stated on the label.

Make at least 3 suitable dilutions of thawed or reconstituted component 1 and of human normal plasma (reference preparation) using as diluent coagulation factor XIII deficient plasma or another suitable diluent. Add to each dilution suitable amounts of the following reagents:

- activator reagent, containing bovine or human thrombin, a suitable buffer, calcium chloride and a suitable inhibitor such as Gly-Pro-Arg-Pro-Ala-NH<sub>2</sub> which inhibits clotting of the sample but does not prevent coagulation factor XIII activation by thrombin,
- detection reagent, containing a suitable factor XIIIa-specific peptide substrate, such as Leu-Gly-Pro-Gly-Glu-Ser-Lys-Val-Ile-Gly-NH<sub>2</sub> and glycine ethyl ester as 2<sup>nd</sup> substrate in a suitable buffer solution,
- NADH reagent, containing glutamate dehydrogenase, α-ketoglutarate and NADH in a suitable buffer solution.

After mixing, the absorbance changes ( $\Delta A/\text{min}$ ) are measured at a wavelength of 340 nm, after the linear phase of the reaction is reached.

1 unit of factor XIII is equal to the activity of 1 mL of human normal plasma.

Calculate the activity of the test preparation by the usual statistical methods (5.3, for example). The confidence limits ( $P = 0.95$ ) are not less than 80 per cent and not more than 125 per cent of the estimated activity.

## Component 2 (thrombin preparation)

## IDENTIFICATION

It complies with the limits of the assay of thrombin.

## TESTS

**pH** (2.2.3): 5.0 to 8.0.

**Solubility.** Freeze-dried preparations dissolve within 5 min in the volume of solvent for reconstitution stated on the label, forming a colourless, clear or slightly turbid solution.

**Water.** Determined by a suitable method, such as the semi-micro determination (2.5.12), loss on drying (2.2.32) or near infrared spectrophotometry (2.2.40), the water content is within the limits approved by the competent authority.

**Sterility** (2.6.1). It complies with the test for sterility.

## ASSAY

**Thrombin.** The estimated activity is not less than 80 per cent and not more than 125 per cent of the activity stated on the label.

If necessary, dilute the reconstituted preparation to be examined to approximately 2-20 IU of thrombin per millilitre using as diluent a suitable buffer pH 7.3-7.5, such as *imidazole buffer solution pH 7.3 R* containing 10 g/L of *human albumin R* or *bovine albumin R*. To a suitable volume of the dilution, add a suitable volume of fibrinogen solution (1 g/L of clottable protein) warmed to 37 °C and start measurement of the clotting time immediately. Repeat the procedure with each of at least 3 dilutions, in the range stated above, of a reference preparation of thrombin, calibrated in International Units. Calculate the activity of the test preparation by the usual statistical methods (5.3, for example). The confidence limits ( $P = 0.95$ ) are not less than 80 per cent and not more than 125 per cent of the estimated activity.

## STORAGE

Protected from light and, for freeze-dried components, in an airtight container.

## LABELLING

The label states:

- the amount of fibrinogen (milligrams of clottable protein), thrombin (International Units) per container, and coagulation factor XIII, if this is greater than 10 units/mL,
- where applicable, the name and volume of solvent to be used to reconstitute the components.

07/2010:2206  
corrected 7.0

## FILGRASTIM CONCENTRATED SOLUTION

## Filgrastimi solutio concentrata

MTPLGPASSL PQSFLKCLE QVRKIQGDGA ALQEKLCATY  
KLCHPEELVL LGHSLGIPWA PLSSCPSQAL QLAGLSQLH  
SGLFLYQGLL QALEGISPEL GPTLDTLQLD VADFATTIWQ  
QMEELGMAPA LQPTQGAMPA FASAFQRRAG GVLVASHLQS  
FLEVSYRVLR HLAQP

C<sub>845</sub>H<sub>1339</sub>N<sub>223</sub>O<sub>243</sub>S<sub>9</sub>  
[121181-53-1]

*M<sub>r</sub>* 18 799

## DEFINITION

Solution of a protein having the primary structure of the granulocyte colony-stimulating factor plus 1 additional amino acid, an *N*-terminal methionine (*r*-met HU G-CSF). In contrast to its natural counterpart, the protein is not glycosylated. Human G-CSF is produced and secreted by endothelium, monocytes and other immune cells. The protein stimulates the differentiation and proliferation of leucocyte stem cells into mature granulocytes.

*Content*: minimum 0.9 mg of protein per millilitre.

*Potency*: minimum  $1.0 \times 10^8$  IU per milligram of protein.

## PRODUCTION

Filgrastim concentrated solution is produced by a method based on recombinant DNA (rDNA) technology, using bacteria as host cells.

Prior to release, the following tests are carried out on each batch of the final bulk product, unless exemption has been granted by the competent authority.

**Host-cell-derived proteins**: the limit is approved by the competent authority.

**Host-cell- or vector-derived DNA**: the limit is approved by the competent authority.

## CHARACTERS

*Appearance*: clear, colourless or slightly yellowish liquid.

## IDENTIFICATION

A. It complies with the requirements described under Assay.

B. Examine the electropherograms obtained in the test for impurities with charges differing from that of filgrastim.

*Results*: the principal band in the electropherogram obtained with the test solution is similar in position to the principal band in the electropherogram obtained with reference solution (a).

C. Examine the chromatograms obtained in the test for impurities with molecular masses higher than that of filgrastim.

*Results*: the principal peak in the chromatogram obtained with the test solution is similar in retention time to the principal peak in the chromatogram obtained with the reference solution.

D. Examine the electropherograms obtained under both reducing and non-reducing conditions in the test for impurities with molecular masses differing from that of filgrastim.

*Results*: the principal band in the electropherogram obtained with test solution (a) is similar in position to the principal band obtained with reference solution (b).

E. Peptide mapping (2.2.55).

## SELECTIVE CLEAVAGE OF THE PEPTIDE BONDS

*Test solution*. Introduce 50 µL of 0.02 M sodium phosphate buffer solution pH 8.0 R into a polypropylene tube and add a volume of the substance to be examined corresponding to 25 µg of protein. Add 25 µL of a 0.1 mg/mL solution of glutamyl endopeptidase for peptide mapping R, dilute to 1 mL with water R, stopper the tube and incubate at about 37 °C for 18 h. Add 125 µL of a 764 g/L (8 M) solution of guanidine hydrochloride R and mix well; add 10 µL of a 154.2 g/L (1 M) solution of dithiothreitol R and mix well. Place the capped tube in boiling water for 1 min, then allow to cool to room temperature.

*Reference solution*. Prepare at the same time and in the same manner as for the test solution but using filgrastim CRS instead of the preparation to be examined.

**CHROMATOGRAPHIC SEPARATION**. Liquid chromatography (2.2.29).

*Column*:

– size:  $l = 0.10$  m,  $\emptyset = 2.1$  mm;

– stationary phase: octadecylsilyl silica gel for chromatography R (5 µm) with a pore size of 20 nm;

– temperature: 60 °C.

*Mobile phase*:

– mobile phase A: dilute 0.5 mL of trifluoroacetic acid R in 950 mL of water R, add 50 mL of acetonitrile for chromatography R and mix;

– mobile phase B: dilute 0.5 mL of trifluoroacetic acid R in 50 mL of water R, add 950 mL of acetonitrile for chromatography R and mix;

Time (min)	Mobile phase A (per cent V/V)	Mobile phase B (per cent V/V)
0 - 8	97 → 94	3 → 6
8 - 25	94 → 66	6 → 34
25 - 40	66 → 10	34 → 90
40 - 45	10	90

*Flow rate*: 0.2 mL/min.

*Detection*: spectrophotometer at 215 nm.

*Injection*: 10 µL.

*System suitability*: the chromatogram obtained with the reference solution is similar to the chromatogram of filgrastim digest supplied with filgrastim CRS.

*Results*: the profile of the chromatogram obtained with the test solution corresponds to that of the chromatogram obtained with the reference solution.

## TESTS

**Impurities with molecular masses higher than that of filgrastim**. Size-exclusion chromatography (2.2.30): use the normalisation procedure.

*Solution A*. Dissolve 4.1 g of sodium acetate R in 400 mL of water R, adjust to pH 4.0 with acetic acid R and dilute to 500 mL with water R.

*Test solution*. Dilute the preparation to be examined with solution A to obtain a concentration of 0.4 mg/mL.

*Reference solution*. Dilute filgrastim CRS with solution A to obtain a concentration of 0.4 mg/mL.

*Resolution solution*. Mix a sample of the reference solution for about 30 s using a vortex mixer.

*Column*:

– size:  $l = 0.3$  m,  $\emptyset = 7.8$  mm;

– stationary phase: hydrophilic silica gel for chromatography R (5 µm), of a grade suitable for fractionation of globular proteins in the relative molecular mass range of 10 000 to 500 000;

– temperature: 30 °C.

*Mobile phase*. Dissolve 7.9 g of ammonium hydrogen carbonate R in 1000 mL of water R and adjust to pH 7.0 with phosphoric acid R; dilute to 2000 mL with water R.

*Flow rate*: 0.5 mL/min.

*Detection*: spectrophotometer at 215 nm.

*Injection*: 20 µL.

*Relative retention* with reference to the filgrastim monomer (retention time = about 19 min): aggregates = about 0.60; filgrastim oligomer 1 = about 0.75; filgrastim oligomer 2 = about 0.80; filgrastim dimer = about 0.85.

*System suitability*: resolution solution:

– retention time: filgrastim monomer = 17 min to 20 min;

– resolution: minimum 3 between the peaks due to the filgrastim dimer and the filgrastim monomer.

Calculate the percentage content of the dimer, oligomers and aggregates.

**Limit:**

- total of the peaks with retention times less than that of the principal peak: maximum 2 per cent.

**Impurities with molecular masses differing from that of filgrastim.** Polyacrylamide gel electrophoresis (2.2.31) under both reducing and non-reducing conditions.

**Gel dimensions:** 1 mm thick.

**Resolving gel:** 13 per cent acrylamide.

**Sample buffer (non-reducing conditions).** Mix equal volumes of water R and concentrated SDS-PAGE sample buffer R.

**Sample buffer (reducing conditions).** Mix equal volumes of water R and concentrated SDS-PAGE sample buffer for reducing conditions R containing 2-mercaptoethanol as the reducing agent.

**Test solution (a).** Dilute the preparation to be examined with sample buffer to obtain a concentration of 100 µg/mL.

**Test solution (b).** To 0.20 mL of test solution (a) add 0.20 mL of sample buffer.

**Test solution (c).** Dilute 0.20 mL of test solution (b) to 1 mL with sample buffer.

**Test solution (d).** Dilute 0.20 mL of test solution (c) to 1 mL with sample buffer.

**Test solution (e).** To 0.20 mL of test solution (d) add 0.20 mL of sample buffer.

**Reference solution (a).** Solution of molecular mass markers suitable for calibrating SDS-polyacrylamide gels in the range of 14.4-94 kDa.

**Reference solution (b).** Dilute filgrastim CRS with sample buffer to obtain a concentration of 100 µg/mL.

**Sample treatment:** boil for 5 min.

**Application:** 20 µL.

**Detection:** by silver staining.

**System suitability:**

- reference solution (a): the validation criteria are met;
- a band is seen in the electropherogram obtained with test solution (e);
- a gradation of intensity of staining is seen in the electropherograms obtained with test solutions (a) to (e).

**Limit:** test solution (a):

- impurities with molecular masses lower or higher than that of filgrastim: no band is more intense than the principal band in the electropherogram obtained with test solution (d) (2.0 per cent).

**Impurities with charges differing from that of filgrastim.** Isoelectric focusing (2.2.54).

**Test solution.** Dilute the preparation to be examined with water R to obtain a concentration of 0.3 mg/mL.

**Reference solution (a).** Dilute filgrastim CRS with water R to obtain a concentration of 0.3 mg/mL.

**Reference solution (b).** Dilute filgrastim CRS with water R to obtain a concentration of 0.03 mg/mL.

**Reference solution (c).** Use an isoelectric point (pI) calibration solution, in the pI range of 2.5-6.5, prepared according to the manufacturer's instructions.

**Focusing:**

- pH gradient: 4.5-8.0;
- catholyte: 1 M solution of sodium hydroxide R;
- anolyte: 0.04 M solution of glutamic acid R in a 0.0025 per cent V/V solution of phosphoric acid R;
- application: 20 µL.

**Detection:** as described in 2.2.54.

**System suitability:**

- in the electropherogram obtained with reference solution (c), the relevant isoelectric point markers are distributed along the entire length of the gel;
- in the electropherogram obtained with reference solution (a), the pI of the principal band is 5.7 to 6.3.

**Limit:**

- any impurity: no band is more intense than the principal band in the electropherogram obtained with reference solution (b) (10 per cent).

**Related proteins.** Liquid chromatography (2.2.29): use the normalisation procedure.

**Solution A.** A 0.1 M sodium acetate buffer solution pH 4.0, containing 0.1 mg/mL of polysorbate 80 R and 50 mg/mL of sorbitol CRS.

**Test solution.** Dilute the preparation to be examined with solution A to obtain a concentration of 0.2 mg/mL.

**Reference solution (a).** Dilute filgrastim CRS with solution A to obtain a concentration of 0.2 mg/mL.

**Reference solution (b).** To 500 µL of reference solution (a) add 2.0 µL of a 4.5 g/L solution of hydrogen peroxide. Mix and incubate at 25 °C for 30 min, then add 1.5 mg of L-methionine R.

**Column:**

- size:  $l = 0.25$  m,  $\varnothing = 4.6$  mm;
- stationary phase: butylsilyl silica gel for chromatography R (5 µm) with a pore size of 30 nm;
- temperature: 60 °C.

**Mobile phase:**

- mobile phase A: dilute 1.0 mL of trifluoroacetic acid R to 900 mL with water R, then add 100 mL of acetonitrile R;
- mobile phase B: dilute 1.0 mL of trifluoroacetic acid R to 200 mL with water R, then add 800 mL of acetonitrile R;

Time (min)	Mobile phase A (per cent V/V)	Mobile phase B (per cent V/V)
0 - 35	34 → 27	66 → 73
35 - 50	27 → 10	73 → 90
50 - 60	10 → 34	90 → 66

**Flow rate:** 0.6 mL/min.

**Detection:** spectrophotometer at 215 nm.

**Injection:** 50 µL.

**Relative retention** with reference to filgrastim (retention time = about 28 min): oxidised form 1 = about 0.85; oxidised form 2 = about 0.95; deamidated forms = about 1.1.

**System suitability:** reference solution (b):

- resolution: minimum 1.5 between the peaks due to oxidised form 1 and oxidised form 2.

**Limits:**

- any impurity: for each impurity, maximum 2.0 per cent;
- total: maximum 3.5 per cent.

**Bacterial endotoxins (2.6.14):** less than 2 IU in the volume that contains 1.0 mg of protein.

**ASSAY**

**Protein.** Liquid chromatography (2.2.29) as described in the test for related proteins with the following modification.

**Injection:** test solution and reference solution (a).

Calculate the content of filgrastim ( $C_{845}H_{1339}N_{223}O_{243}S_9$ ) from the declared content of  $C_{845}H_{1339}N_{223}O_{243}S_9$  in filgrastim CRS.

**Potency.** The potency of the preparation to be examined is determined by comparison of the dilutions of the test preparation with the dilutions of the International Standard of filgrastim or with a reference preparation calibrated in International Units.

The International Unit is the activity contained in a stated amount of the appropriate International Standard. The equivalence in International Units of the International Standard is stated by the World Health Organisation.

Carry out the assay using a suitable method such as the following, which uses the conversion of a tetrazolium salt (MTS) as a staining method. Alternative methods of quantifying cell proliferation, such as measurement of intracellular ATP by luciferase bioluminescence, have also been found suitable, and may be used as the assay readout, subject to appropriate validation. The assay conditions (for example, cell concentration, incubation time and dilution steps) are then adapted accordingly. Use an established cell line responsive to filgrastim. M-NFS-60 cells (ATCC No. CRL-1838) have been found suitable. Incubate with varying dilutions of test and reference preparations of filgrastim. Then incubate with a solution of *tetrazolium salt R*. This cytochemical stain is converted by cellular dehydrogenases to a coloured formazan product. The formazan is then measured spectrophotometrically.

Add 50 µL of dilution medium to all wells of a 96-well microtitre plate. Add an additional 50 µL of this solution to the wells designed for the blanks. Add 50 µL of each solution to be tested in triplicate (test preparation and reference preparation at a concentration of about 800 IU/mL, plus a series of 10 twofold dilutions to obtain a standard curve). Prepare a suspension of M-NFS-60 cells containing  $7 \times 10^5$  cells per millilitre. Immediately before use, add 2-mercaptoethanol to a final concentration of 0.1 mM, and add 50 µL of the prepared cell suspension to each well, maintaining the cells in a uniform suspension during addition.

Incubate the plate at 36.0-38.0 °C for 44-48 h in a humidified incubator using  $6 \pm 1$  per cent CO<sub>2</sub>. Add 20 µL of a 5.0 g/L sterile solution of *tetrazolium salt R* to each well and reincubate for 4 h. Estimate the quantity of formazan produced using a microtitre well plate reader at 490 nm.

Calculate the potency of the preparation to be examined using a suitable statistical method, for example the parallel line assay (5.3).

The estimated potency is not less than 80 per cent and not more than 125 per cent of the stated potency. The confidence limits ( $P = 0.95$ ) are not less than 74 per cent and not more than 136 per cent of the estimated potency.

#### LABELLING

The label states:

- the content, in milligrams of protein per millilitre;
- the potency, in International Units per milligram of protein.

01/2008:1615  
corrected 6.0

## FINASTERIDE

### Finasteridum

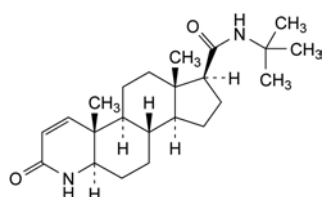

C<sub>23</sub>H<sub>36</sub>N<sub>2</sub>O<sub>2</sub>  
[98319-26-7]

M<sub>r</sub> 372.6

#### DEFINITION

*N*-(1,1-Dimethylethyl)-3-oxo-4-aza-5 $\alpha$ -androst-1-ene-17 $\beta$ -carboxamide.

*Content:* 98.0 per cent to 102.0 per cent (dried substance).

#### CHARACTERS

*Appearance:* white or almost white, crystalline powder.

*Solubility:* practically insoluble in water, freely soluble in ethanol and in methylene chloride.

It shows polymorphism (5.9).

#### IDENTIFICATION

Infrared absorption spectrophotometry (2.2.24).

*Comparison:* *finasteride CRS*.

If the spectra obtained in the solid state show differences, dissolve the substance to be examined and the reference substance separately in *methanol R*, evaporate to dryness and record new spectra using the residues.

#### TESTS

**Specific optical rotation (2.2.7):** + 12.0 to + 14.0 (dried substance).

Dissolve 0.250 g in *methanol R* and dilute to 25.0 mL with the same solvent.

**Related substances.** Liquid chromatography (2.2.29).

*Test solution (a).* Dissolve 25.0 mg of the substance to be examined in a mixture of equal volumes of *acetonitrile R* and *water R* and dilute to 50.0 mL with the same mixture of solvents.

*Test solution (b).* Dissolve 0.100 g of the substance to be examined in a mixture of equal volumes of *acetonitrile R* and *water R* and dilute to 10.0 mL with the same mixture of solvents.

*Reference solution (a).* Dissolve 25.0 mg of *finasteride CRS* in a mixture of equal volumes of *acetonitrile R* and *water R* and dilute to 50.0 mL with the same mixture of solvents.

*Reference solution (b).* Dissolve 50.0 mg of *finasteride for system suitability CRS* in a mixture of equal volumes of *acetonitrile R* and *water R* and dilute to 5.0 mL with the same mixture of solvents.

*Reference solution (c).* Dilute 2.0 mL of test solution (b) to 100.0 mL in a mixture of equal volumes of *acetonitrile R* and *water R*. Dilute 1.0 mL of this solution to 10.0 mL with a mixture of equal volumes of *acetonitrile R* and *water R*.

*Column:*

– *size:*  $l = 0.25$  m,  $\varnothing = 4.0$  mm,

– *stationary phase:* *end-capped octadecylsilyl silica gel for chromatography R* (5 µm) with a ratio of specific surface area (m<sup>2</sup>g<sup>-1</sup>)/carbon-percentage less than 20,

– *temperature:* 60 °C.

*Mobile phase:* *acetonitrile R*, *tetrahydrofuran R*, *water R* (10:10:80 V/V/V).

*Flow rate:* 1.5 mL/min.

*Detection:* spectrophotometer at 210 nm.

*Injection:* 15 µL; inject test solution (b) and reference solutions (b) and (c).

*Run time:* twice the retention time of finasteride.

*Relative retention* with reference to finasteride (retention time = about 28 min): impurity A = about 0.94; impurity B = about 1.22; impurity C = about 1.36.

*System suitability:* reference solution (b):

– *peak-to-valley ratio:* minimum 2.5, where  $H_p$  = height above the baseline of the peak due to impurity A, and  $H_v$  = height above the baseline of the lowest point of the curve separating this peak from the peak due to finasteride.

## Limits:

01/2011:1912

- *impurity A*: maximum 0.3 per cent, calculated from the area of the corresponding peak in the chromatogram obtained with reference solution (b) and taking into account the assigned value of impurity A in *finasteride for system suitability CRS*,
- *impurity B*: not more than 1.5 times the area of the principal peak in the chromatogram obtained with reference solution (c) (0.3 per cent),
- *impurity C*: not more than 1.5 times the area of the principal peak in the chromatogram obtained with reference solution (c) (0.3 per cent),
- *unspecified impurities*: for each impurity, not more than 0.5 times the area of the principal peak in the chromatogram obtained with reference solution (c) (0.10 per cent),
- *total*: not more than 3 times the area of the principal peak in the chromatogram obtained with reference solution (c) (0.6 per cent),
- *disregard limit*: 0.25 times the area of the principal peak in the chromatogram obtained with reference solution (c) (0.05 per cent).

**Loss on drying** (2.2.32): maximum 0.5 per cent, determined on 1.000 g by drying in an oven at 105 °C.

## ASSAY

Liquid chromatography (2.2.29) as described in the test for related substances.

*Injection*: test solution (a) and reference solution (a).

Calculate the percentage content of  $C_{23}H_{36}N_2O_2$ .

## STORAGE

Protected from light.

## IMPURITIES

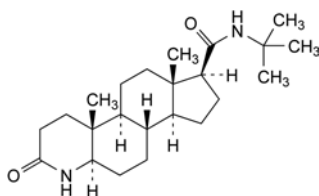

- A. *N*-(1,1-dimethylethyl)-3-oxo-4-aza-5 $\alpha$ -androstane-17 $\beta$ -carboxamide (dihydrofinasteride),

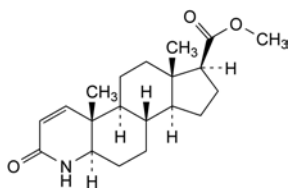

- B. methyl 3-oxo-4-aza-5 $\alpha$ -androst-1-ene-17 $\beta$ -carboxylate ( $\Delta$ -1-aza ester),

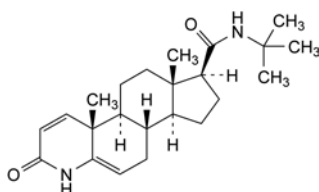

- C. *N*-(1,1-dimethylethyl)-3-oxo-4-azaandrost-1,5-diene-17 $\beta$ -carboxamide ( $\Delta$ -1,5-aza amide).

## FISH OIL, RICH IN OMEGA-3 ACIDS

## Piscis oleum omega-3 acidis abundans

## DEFINITION

Purified, winterised and deodorised fatty oil obtained from fish of families such as *Engraulidae*, *Carangidae*, *Clupeidae*, *Osmeridae*, *Scombridae* (except the genera *Thunnus* and *Sarda*) and *Ammodytidae* (type I) or from the genera *Thunnus* and *Sarda* within the family *Scombridae* (type II). The omega-3 acids are defined as the following acids: *alpha*-linolenic acid (C18:3 n-3), morotic acid (C18:4 n-3), eicosatetraenoic acid (C20:4 n-3), timnodonic (eicosapentaenoic) acid (C20:5 n-3; EPA), heneicosapentaenoic acid (C21:5 n-3), clupanodonic acid (C22:5 n-3) and cervonic (docosahexaenoic) acid (C22:6 n-3; DHA).

## Content:

	Type I	Type II
<i>EPA, expressed as triglycerides</i>	minimum 13 per cent	4 per cent to 8 per cent
<i>DHA, expressed as triglycerides</i>	minimum 9 per cent	minimum 20 per cent
<i>Total omega-3 acids, expressed as triglycerides</i>	minimum 28 per cent	minimum 28 per cent

Authorised antioxidants in concentrations not exceeding the levels specified by the competent authorities may be added.

## CHARACTERS

*Appearance*: pale yellow liquid.

*Solubility*: practically insoluble in water, very soluble in acetone and in heptane, slightly soluble in anhydrous ethanol.

## IDENTIFICATION

- A. Examine the chromatograms obtained in the assay for EPA and DHA.

*Results*: the peaks due to eicosapentaenoic acid methyl ester and docosahexaenoic acid methyl ester in the chromatogram obtained with test solution (b) are similar in retention time to the corresponding peaks in the chromatogram obtained with reference solution (a).

- B. It complies with the limits of the assay for EPA (type I or II).

## TESTS

**Appearance**. The substance to be examined is not more intensely coloured than a reference solution prepared as follows: to 3.0 mL of red primary solution add 25.0 mL of yellow primary solution and dilute to 50.0 mL with a 10 g/L solution of *hydrochloric acid R* (2.2.2, *Method II*).

**Absorbance** (2.2.25): maximum 0.70 (type I) or maximum 0.50 (type II), at 233 nm.

Dilute 0.300 g of the substance to be examined to 50.0 mL with *trimethylpentane R*. Dilute 2.0 mL of this solution to 50.0 mL with *trimethylpentane R*.

**Acid value** (2.5.1): maximum 0.5, determined on 20.0 g.

**Anisidine value** (2.5.36): maximum 30.0 (type I) or maximum 15.0 (type II).

**Peroxide value** (2.5.5, *Method A*): maximum 10.0 (type I) or maximum 5.0 (type II).

**Unsaponifiable matter** (2.5.7): maximum 1.5 per cent, determined on 5.0 g.

**Stearin**. 10 mL remains clear after cooling at 0 °C for 3 h.

**Oligomers.** Size-exclusion chromatography (2.2.30).

**Test solution.** Dilute 50.0 mg of the substance to be examined to 10.0 mL with *tetrahydrofuran R*.

**Reference solution.** In a 100 mL volumetric flask dissolve 20 mg of *tridocosahexaenoin R*, 30 mg of *didocosahexaenoin R* and 50 mg of *monodocosahexaenoin R* in *tetrahydrofuran R* and dilute to 100.0 mL with the same solvent.

**Column 1:**

- size:  $l = 0.3$  m,  $\varnothing = 7.8$  mm;
- stationary phase: *styrene-divinylbenzene copolymer R* (7  $\mu$ m) with a pore size of 10 nm.

**Columns 2 and 3,** placed closest to the injector:

- size:  $l = 0.3$  m,  $\varnothing = 7.8$  mm;
- stationary phase: *styrene-divinylbenzene copolymer R* (7  $\mu$ m) with a pore size of 50 nm.

**Mobile phase:** *tetrahydrofuran R*.

**Flow rate:** 0.8 mL/min.

**Detection:** differential refractometer.

**Injection:** 40  $\mu$ L.

**System suitability:** reference solution:

- **elution order:** tridocosahexaenoin, didocosahexaenoin, monodocosahexaenoin;
- **resolution:** minimum 2.0 between the peaks due to didocosahexaenoin and monodocosahexaenoin and minimum 1.0 between the peaks due to tridocosahexaenoin and didocosahexaenoin.

Identify the peaks from the chromatogram (Figure 1912.-1). Calculate the percentage content of oligomers using the following expression:

$$\frac{B}{A} \times 100$$

$A$  = sum of the areas of all the peaks in the chromatogram;

$B$  = area of the peak with a retention time less than the retention time of the triglyceride peak.

**Limit:**

- **oligomers:** maximum 1.5 per cent.

**ASSAY**

**EPA and DHA (2.4.29).** For identification of the peaks, see Figure 1912.-2.

**Total omega-3 acids (2.4.29).** See Figure 1912.-2.

**STORAGE**

Under an inert gas, in a well-filled, airtight container, protected from light.

**LABELLING**

The label states:

- the concentration of EPA, DHA and total omega-3 acids, expressed as triglycerides;
- the type of fish oil rich in omega-3 acids (type I or II).

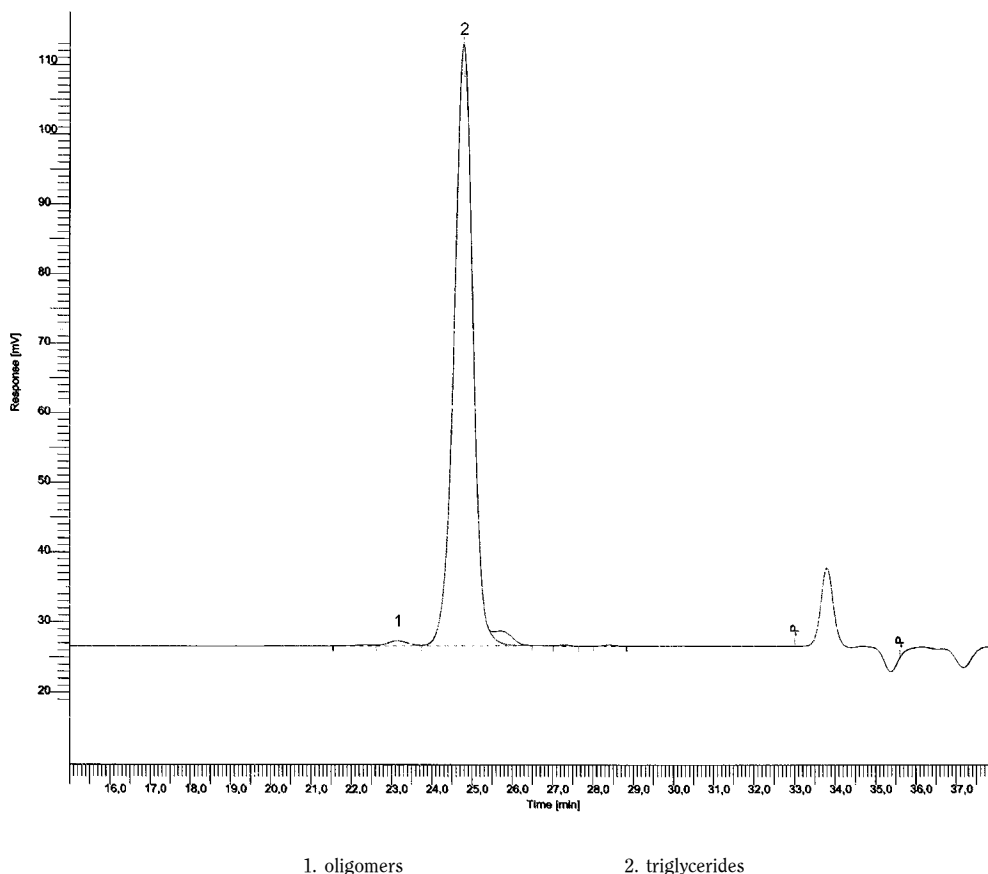
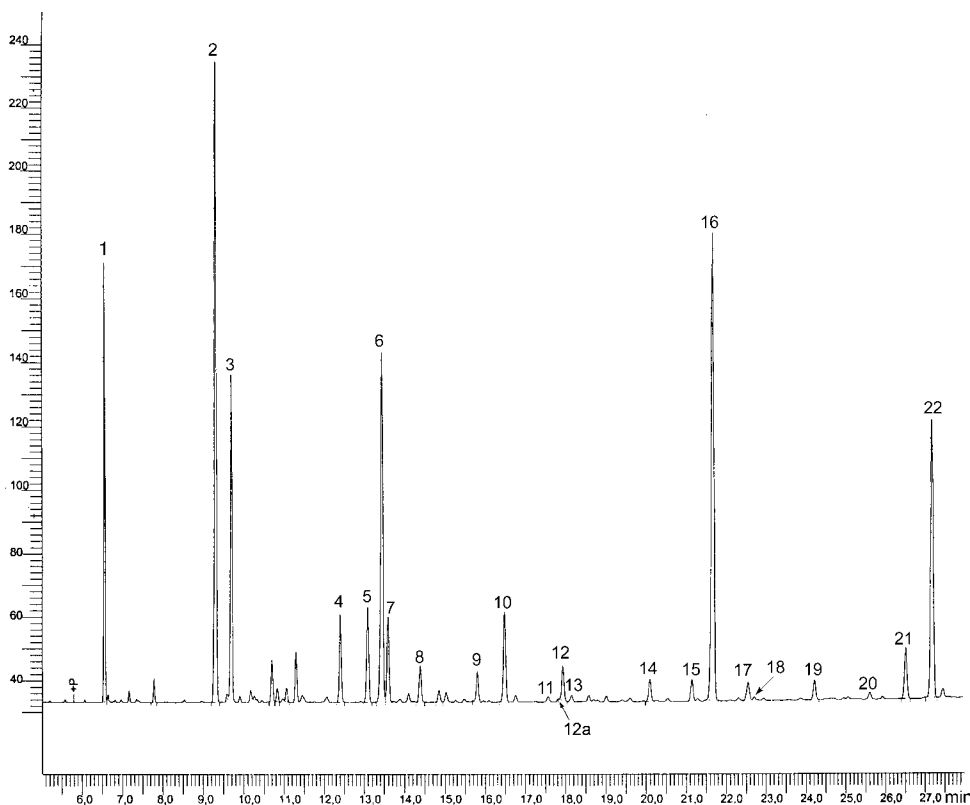

Figure 1912.-1. – Chromatogram for the test for oligomers in fish oil rich in omega-3 acids



1. C14:0	6. C18:1 n-9	11. C20:0	15. C20:4 n-3	20. C22:5 n-6
2. C16:0	7. C18:1 n-7	12. C20:1 n-9	16. C20:5 n-3	21. C22:5 n-3
3. C16:1 n-7	8. C18:2 n-6	12a. C20:1 n-11	17. C22:1 n-11	22. C22:6 n-3
4. C16:4 n-1	9. C18:3 n-3	13. C20:1 n-7	18. C22:1 n-9	
5. C18:0	10. C18:4 n-3	14. C20:4 n-6	19. C21:5 n-3	

Figure 1912.-2. – Chromatogram for the assay of total omega-3 acids in fish oil rich in omega-3 acids

01/2008:1692 B. It gives reaction (a) of chlorides (2.3.1).

## FLAVOXATE HYDROCHLORIDE

Flavoxati hydrochloridum

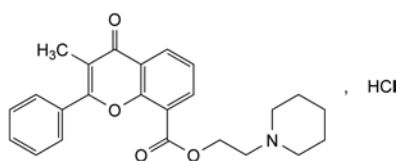

C<sub>24</sub>H<sub>26</sub>ClNO<sub>4</sub>  
[3717-88-2]

M<sub>r</sub> 427.9

### DEFINITION

2-(Piperidin-1-yl)ethyl 3-methyl-4-oxo-2-phenyl-4H-1-benzopyran-8-carboxylate hydrochloride.

Content: 99.0 per cent to 101.0 per cent (dried substance).

### CHARACTERS

Appearance: white or almost white, crystalline powder.

Solubility: slightly soluble in water, sparingly soluble in methylene chloride, slightly soluble in ethanol (96 per cent).

### IDENTIFICATION

A. Infrared absorption spectrophotometry (2.2.24).

Comparison: flavoxate hydrochloride CRS.

### TESTS

**Related substances.** Liquid chromatography (2.2.29). Use freshly prepared solutions.

**Solvent mixture.** Mix 20 volumes of a 0.4 g/L solution of potassium dihydrogen phosphate R adjusted to pH 3.0 with phosphoric acid R and 80 volumes of acetonitrile R.

**Test solution.** Dissolve 10.0 mg of the substance to be examined in the solvent mixture and dilute to 10.0 mL with the solvent mixture.

**Reference solution (a).** Dilute 1.0 mL of the test solution to 100.0 mL with the solvent mixture.

**Reference solution (b).** Dilute 1.0 mL of reference solution (a) to 10.0 mL with the solvent mixture.

**Reference solution (c).** Dissolve 6.0 mg of flavoxate impurity A CRS and 3.0 mg of flavoxate impurity B CRS in the solvent mixture, add 2.0 mL of the test solution and dilute to 100.0 mL with the solvent mixture. Dilute 1.0 mL of this solution to 20.0 mL with the solvent mixture.

### Column:

- size: l = 0.25 m, Ø = 4.6 mm;
- stationary phase: spherical end-capped octadecylsilyl silica gel for chromatography R (5 µm).

### Mobile phase:

- mobile phase A: 0.435 g/L solution of dipotassium hydrogen phosphate R adjusted to pH 7.5 with phosphoric acid R;



– mobile phase B: acetonitrile R;

Time (min)	Mobile phase A (per cent V/V)	Mobile phase B (per cent V/V)
0 - 10	20	80
10 - 20	20 → 10	80 → 90
20 - 25	10	90

Flow rate: 0.8 mL/min.

Detection: spectrophotometer at 254 nm.

Injection: 10 µL.

Relative retention with reference to flavoxate (retention time = about 10 min): impurity A = about 0.2; impurity B = about 0.8.

System suitability: reference solution (c):

– resolution: minimum 4.0 between the peaks due to impurity B and flavoxate.

Limits:

- impurity A: not more than the area of the corresponding peak in the chromatogram obtained with reference solution (c) (0.3 per cent);
- impurity B: not more than the area of the corresponding peak in the chromatogram obtained with reference solution (c) (0.15 per cent);
- unspecified impurities: for each impurity, not more than the area of the principal peak in the chromatogram obtained with reference solution (b) (0.10 per cent);
- total of unspecified impurities: not more than 0.5 times the area of the principal peak in the chromatogram obtained with reference solution (a) (0.5 per cent);
- disregard limit: 0.5 times the area of the principal peak in the chromatogram obtained with reference solution (b) (0.05 per cent).

Heavy metals (2.4.8): maximum 10 ppm.

2.0 g complies with test F. Prepare the reference solution using 2 mL of lead standard solution (10 ppm Pb) R.

Loss on drying (2.2.32): maximum 0.5 per cent, determined on 1.000 g by drying in an oven at 105 °C.

Sulfated ash (2.4.14): maximum 0.1 per cent, determined on 1.0 g.

#### ASSAY

In order to avoid overheating in the reaction medium, mix thoroughly throughout and stop the titration immediately after the end-point has been reached.

Dissolve 0.350 g in 10 mL of anhydrous formic acid R and add 40 mL of acetic anhydride R. Titrate with 0.1 M perchloric acid, determining the end-point potentiometrically (2.2.20).

1 mL of 0.1 M perchloric acid is equivalent to 42.79 mg of C<sub>24</sub>H<sub>26</sub>ClNO<sub>4</sub>.

#### STORAGE

Protected from light.

#### IMPURITIES

Specified impurities: A, B.

Other detectable impurities (the following substances would, if present at a sufficient level, be detected by one or other of the tests in the monograph. They are limited by the general acceptance criterion for other/unspecified impurities and/or by the general monograph Substances for pharmaceutical use (2034). It is therefore not necessary to identify these impurities for demonstration of compliance. See also 5.10. Control of impurities in substances for pharmaceutical use): C.

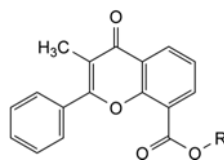

- A. R = H: 3-methyl-4-oxo-2-phenyl-4H-1-benzopyran-8-carboxylic acid,
- B. R = C<sub>2</sub>H<sub>5</sub>: ethyl 3-methyl-4-oxo-2-phenyl-4H-1-benzopyran-8-carboxylate,
- C. R = CH(CH<sub>3</sub>)<sub>2</sub>: 1-methylethyl 3-methyl-4-oxo-2-phenyl-4H-1-benzopyran-8-carboxylate.

01/2008:1324

## FLECAINIDE ACETATE

### Flecainidi acetat

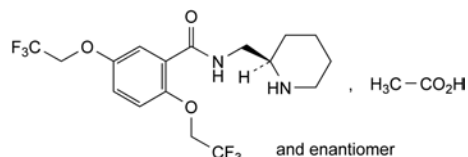

C<sub>19</sub>H<sub>24</sub>F<sub>6</sub>N<sub>2</sub>O<sub>5</sub>  
[54143-56-5]

M<sub>r</sub> 474.4

#### DEFINITION

N-[(RS)-(Piperidin-2-ylmethyl)]-2,5-bis(2,2,2-trifluoroethoxy)-benzamide acetate.

Content: 98.0 per cent to 101.0 per cent (dried substance).

#### CHARACTERS

Appearance: white or almost white, very hygroscopic, crystalline powder.

Solubility: soluble in water and in anhydrous ethanol. It is freely soluble in dilute acetic acid and practically insoluble in dilute hydrochloric acid.

#### IDENTIFICATION

First identification: A, C.

Second identification: A, B, D.

A. Melting point (2.2.14): 146 °C to 152 °C, with a melting range not greater than 3 °C.

B. Ultraviolet and visible absorption spectrophotometry (2.2.25).

Test solution. Dissolve 50 mg in ethanol (96 per cent) R and dilute to 50.0 mL with the same solvent. Dilute 5.0 mL of this solution to 50.0 mL with ethanol (96 per cent) R.

Spectral range: 230-350 nm.

Absorption maximum: at 298 nm.

Specific absorbance at the absorption maximum: 61 to 65.

C. Infrared absorption spectrophotometry (2.2.24).

Comparison: flecainide acetate CRS.

D. It gives reaction (b) of acetates (2.3.1).

#### TESTS

Appearance of solution. The solution is clear (2.2.1) and colourless (2.2.2, Method II).

Dissolve 0.25 g in water R, add 0.05 mL of glacial acetic acid R and dilute to 10 mL with water R.

pH (2.2.3): 6.7 to 7.1.

Dissolve 0.25 g in carbon dioxide-free water R and dilute to 10 mL with the same solvent.

Impurity B. Thin-layer chromatography (2.2.27).

Test solution. Dissolve 0.10 g of the substance to be examined in methanol R and dilute to 2 mL with the same solvent.

**Reference solution.** Dissolve 10 mg of flecainide impurity B CRS in methanol R and dilute to 100 mL with the same solvent (solution A). Dissolve 0.10 g of flecainide acetate CRS in solution A and dilute to 2 mL with the same solution.

**Plate:** TLC silica gel  $F_{254}$  plate R.

**Mobile phase:** freshly prepared mixture of 5 volumes of concentrated ammonia R and 95 volumes of acetone R.

**Application:** 5  $\mu$ L.

**Development:** over a path of 10 cm.

**Drying:** at 100-105 °C until the ammonia has evaporated.

**Detection:** examine in ultraviolet light at 254 nm to establish the position of the flecainide spot, then spray with a freshly prepared 2 g/L solution of ninhydrin R in methanol R and heat at 100-110 °C for 2-5 min; examine in daylight.

**System suitability:** reference solution:

- the chromatogram shows 2 clearly separated spots.

**Limit:**

- **impurity B:** any spot due to impurity B is not more intense than the corresponding spot in the chromatogram obtained with the reference solution (0.2 per cent).

**Related substances.** Liquid chromatography (2.2.29).

**Test solution.** Dissolve 0.25 g of the substance to be examined in methanol R and dilute to 25.0 mL with the same solvent.

**Reference solution (a).** Dilute 5.0 mL of the test solution to 100.0 mL with methanol R. Dilute 1.0 mL of this solution to 10.0 mL with methanol R.

**Reference solution (b).** Dissolve 25 mg of flecainide acetate CRS and 25 mg of flecainide impurity A CRS in methanol R and dilute to 25.0 mL with the same solvent.

**Column:**

- **size:**  $l = 0.15$  m,  $\varnothing = 4.6$  mm;
- **stationary phase:** octylsilyl silica gel for chromatography R (5  $\mu$ m).

**Mobile phase:**

- **mobile phase A:** mix 2 mL of concentrated ammonia R, 4 mL of triethylamine R and 985 mL of water R; add 6 mL of phosphoric acid R and adjust to pH 2.8 with concentrated ammonia R;
- **mobile phase B:** acetonitrile R;

Time (min)	Mobile phase A (per cent V/V)	Mobile phase B (per cent V/V)
0 - 12	90 → 30	10 → 70
12 - 17	30	70
17 - 19	30 → 90	70 → 10
19 - 21	90	10

If a suitable baseline cannot be obtained, use another grade of triethylamine.

**Flow rate:** 2 mL/min.

**Detection:** spectrophotometer at 300 nm.

**Injection:** 20  $\mu$ L.

**System suitability:** reference solution (b):

- **resolution:** minimum 4 between the peaks due to flecainide and impurity A.

**Limits:**

- **impurities A, C, D, E:** for each impurity, not more than 0.4 times the area of the principal peak in the chromatogram obtained with reference solution (a) (0.2 per cent);

- **total:** not more than the area of the principal peak in the chromatogram obtained with reference solution (a) (0.5 per cent);
- **disregard limit:** 0.02 times the area of the principal peak in the chromatogram obtained with reference solution (a) (0.01 per cent).

**Heavy metals** (2.4.8): maximum 20 ppm.

1.0 g complies with test C. Prepare the reference solution using 2 mL of lead standard solution (10 ppm Pb) R.

**Loss on drying** (2.2.32): maximum 0.5 per cent, determined on 1.000 g by drying in an oven at 60 °C under a pressure not exceeding 0.6 kPa for 2 h.

**Sulfated ash** (2.4.14): maximum 0.1 per cent, determined on 1.0 g in a platinum crucible.

#### ASSAY

Dissolve 0.400 g in 25 mL of anhydrous acetic acid R. Titrate with 0.1 M perchloric acid, determining the end-point potentiometrically (2.2.20).

1 mL of 0.1 M perchloric acid is equivalent to 47.44 mg of  $C_{19}H_{24}F_6N_2O_5$ .

#### STORAGE

Protected from light.

#### IMPURITIES

**Specified impurities:** A, B, C, D, E.

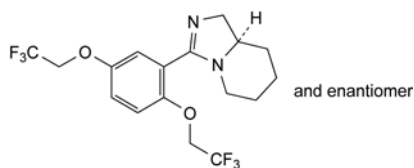

A. (8a*RS*)-3-[2,5-bis(2,2,2-trifluoroethoxy)phenyl]-1,5,6,7,8,8a-hexahydroimidazo[1,5-*a*]pyridine,

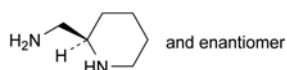

B. (*RS*)-(piperidin-2-yl)methanamine,

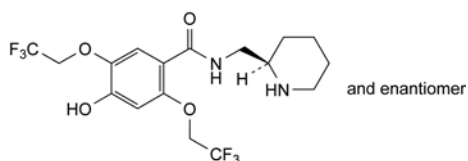

C. (*RS*)-4-hydroxy-*N*-(piperidin-2-ylmethyl)-2,5-bis(2,2,2-trifluoroethoxy)benzamide,

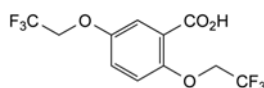

D. 2,5-bis(2,2,2-trifluoroethoxy)benzoic acid,

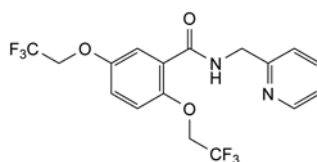

E. *N*-(pyridin-2-ylmethyl)-2,5-bis(2,2,2-trifluoroethoxy)benzamide.

## FLUBENDAZOLE

## Flubendazolium

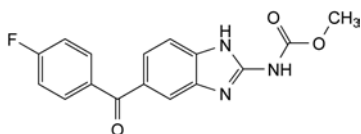

$C_{16}H_{12}FN_3O_3$   
[31430-15-6]

$M_r$  313.3

## DEFINITION

Methyl [5-(4-fluorobenzoyl)-1H-benzimidazol-2-yl]carbamate

Content: 99.0 per cent to 101.0 per cent (dried substance).

## CHARACTERS

Appearance: white or almost white powder.

Solubility: practically insoluble in water, in alcohol and in methylene chloride.

It shows polymorphism (5.9).

## IDENTIFICATION

Infrared absorption spectrophotometry (2.2.24), without recrystallisation.

Comparison: flubendazole CRS.

## TESTS

**Related substances.** Liquid chromatography (2.2.29).

**Test solution.** Dissolve 0.100 g of the substance to be examined in dimethylformamide R and dilute to 100.0 mL with the same solvent.

**Reference solution (a).** Dissolve 5 mg of flubendazole for system suitability CRS in dimethylformamide R and dilute to 5.0 mL with the same solvent.

**Reference solution (b).** Dilute 1.0 mL of the test solution to 100.0 mL with dimethylformamide R. Dilute 5.0 mL of this solution to 20.0 mL with dimethylformamide R.

Column:

- size:  $l = 0.10$  m,  $\varnothing = 4.6$  mm,
- stationary phase: base-deactivated octadecylsilyl silica gel for chromatography R (3  $\mu$ m),
- temperature: 40 °C.

Mobile phase:

- mobile phase A: 7.5 g/L solution of ammonium acetate R,
- mobile phase B: acetonitrile R,

Time (min)	Mobile phase A (per cent V/V)	Mobile phase B (per cent V/V)
0 - 15	90 → 75	10 → 25
15 - 30	75 → 45	25 → 55
30 - 32	45 → 10	55 → 90
32 - 37	10	90

Flow rate: 1.2 mL/min.

Detection: spectrophotometer at 250 nm.

Injection: 10  $\mu$ L.

System suitability: reference solution (a):

- the chromatogram obtained is similar to the chromatogram supplied with flubendazole for system suitability CRS.

## 01/2008:1721 Limits:

corrected 7.0

- correction factors: for the calculation of contents, multiply the peak areas of the following impurities by the corresponding correction factor: impurity A = 1.4; impurity C = 1.3; impurity D = 1.3; impurity G = 1.4,
- impurities A, B, C, D, E, G: for each impurity, not more than the area of the principal peak in the chromatogram obtained with reference solution (b) (0.25 per cent),
- impurity F: not more than twice the area of the principal peak in the chromatogram obtained with reference solution (b) (0.5 per cent),
- any other impurity with a relative retention between 1.2 and 1.3: not more than the area of the principal peak in the chromatogram obtained with reference solution (b) (0.25 per cent),
- total: not more than 6 times the area of the principal peak in the chromatogram obtained with reference solution (b) (1.5 per cent),
- disregard limit: 0.2 times the area of the principal peak in the chromatogram obtained with reference solution (b) (0.05 per cent).

**Loss on drying** (2.2.32): maximum 0.5 per cent, determined on 1.000 g by drying in an oven at 105 °C, for 4 h.

**Sulfated ash** (2.4.14): maximum 0.1 per cent, determined on 1.0 g.

## ASSAY

Dissolve 0.250 g in 3 mL of anhydrous formic acid R and add 50 mL of a mixture of 1 volume of anhydrous acetic acid R and 7 volumes of methyl ethyl ketone R. Titrate with 0.1 M perchloric acid, determining the end-point potentiometrically (2.2.20).

1 mL of 0.1 M perchloric acid is equivalent to 31.33 mg of  $C_{16}H_{12}FN_3O_3$ .

## STORAGE

Protected from light.

## IMPURITIES

Specified impurities: A, B, C, D, E, F, G.

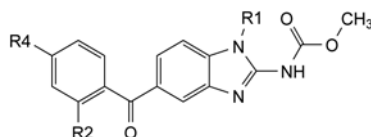

- A. R1 = R2 = H, R4 = NH-CHO: methyl [5-[4-(formylamino)benzoyl]-1H-benzimidazol-2-yl]carbamate,
- E. R1 = R4 = H, R2 = F: methyl [5-(2-fluorobenzoyl)-1H-benzimidazol-2-yl]carbamate,
- F. R1 = CH<sub>3</sub>, R2 = H, R4 = F: methyl [5-(4-fluorobenzoyl)-1-methyl-1H-benzimidazol-2-yl]carbamate,
- G. R1 = R2 = H, R4 = O-CH(CH<sub>3</sub>)<sub>2</sub>: methyl [5-[4-(1-methylethoxy)benzoyl]-1H-benzimidazol-2-yl]carbamate,

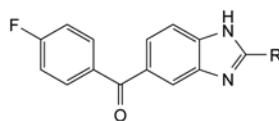

- B. R = NH<sub>2</sub>: (2-amino-1H-benzimidazol-5-yl)(4-fluorophenyl)methanone,
- C. R = OH: (4-fluorophenyl)(2-hydroxy-1H-benzimidazol-5-yl)methanone,
- D. R = H: (1H-benzimidazol-5-yl)(4-fluorophenyl)methanone.

07/2008:2346 **Specific optical rotation** (2.2.7): + 163 to + 175 (anhydrous substance).

## FLUCLOXACILLIN MAGNESIUM OCTAHYDRATE

Flucloxacillinum magnesicum octahydricum

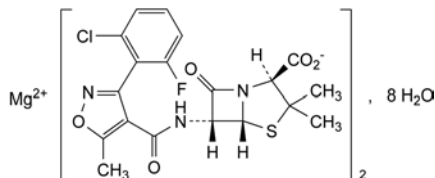

$C_{38}H_{32}Cl_2F_2MgN_6O_{10}S_2 \cdot 8H_2O$   
[58486-36-5]

$M_r$  1074

### DEFINITION

Magnesium bis[(2*S*,5*R*,6*R*)-6-[[[3-(2-chloro-6-fluorophenyl)-5-methylisoxazol-4-yl]carbonyl]amino]-3,3-dimethyl-7-oxo-4-thia-1-azabicyclo[3.2.0]heptane-2-carboxylate] octahydrate.

Semi-synthetic product derived from a fermentation product.

*Content*: 95.0 per cent to 102.0 per cent (anhydrous substance).

### CHARACTERS

*Appearance*: white or almost white, crystalline powder.

*Solubility*: slightly soluble in water, freely soluble in methanol.

### IDENTIFICATION

*First identification*: A, C.

*Second identification*: B, C.

A. Infrared absorption spectrophotometry (2.2.24).

*Comparison*: flucloxacillin magnesium octahydrate CRS.

B. Thin-layer chromatography (2.2.27).

*Test solution*. Dissolve 25 mg of the substance to be examined in 5 mL of *water R*.

*Reference solution (a)*. Dissolve 25 mg of flucloxacillin sodium CRS in 5 mL of *water R*.

*Reference solution (b)*. Dissolve 25 mg of cloxacillin sodium CRS, 25 mg of dicloxacillin sodium CRS and 25 mg of flucloxacillin sodium CRS in 5 mL of *water R*.

*Plate*: TLC silanised silica gel plate R.

*Mobile phase*: mix 30 volumes of acetone R and 70 volumes of a 154 g/L solution of ammonium acetate R previously adjusted to pH 5.0 with glacial acetic acid R.

*Application*: 1 µL.

*Development*: over 2/3 of the plate.

*Drying*: in air.

*Detection*: expose the plate to iodine vapour until the spots appear.

*System suitability*: reference solution (b):

– the chromatogram shows 3 clearly separated spots.

*Results*: the principal spot in the chromatogram obtained with the test solution is similar in position, colour and size to the principal spot in the chromatogram obtained with reference solution (a).

C. It gives the reaction of magnesium (2.3.1).

### TESTS

**pH** (2.2.3): 4.5 to 6.5.

Dissolve 0.25 g in carbon dioxide-free water R and dilute to 50 mL with the same solvent.

Dissolve 0.250 g in *water R* and dilute to 50.0 mL with the same solvent.

**Related substances**. Liquid chromatography (2.2.29). Prepare the solutions immediately before use.

*Test solution (a)*. Dissolve 50.0 mg of the substance to be examined in the mobile phase and dilute to 50.0 mL with the mobile phase.

*Test solution (b)*. Dilute 5.0 mL of test solution (a) to 50.0 mL with the mobile phase.

*Reference solution (a)*. Dissolve 50.0 mg of flucloxacillin sodium CRS in the mobile phase and dilute to 50.0 mL with the mobile phase. Dilute 5.0 mL of this solution to 50.0 mL with the mobile phase.

*Reference solution (b)*. Dilute 5.0 mL of test solution (b) to 50.0 mL with the mobile phase.

*Reference solution (c)*. In order to prepare impurity A *in situ*, add 1 mL of sodium carbonate solution R to 10 mg of the substance to be examined, dilute to 25 mL with *water R* and place in an oven at 70 °C for 20 min.

*Reference solution (d)*. Dilute 1 mL of reference solution (c) to 10 mL with a 27 g/L solution of dipotassium hydrogen phosphate R previously adjusted to pH 3.5 with dilute phosphoric acid R.

*Reference solution (e)*. In order to prepare impurity B *in situ*, add 5 mL of dilute hydrochloric acid R to 10 mL of reference solution (c), dilute to 25 mL with *water R* and place in an oven at 70 °C for 1 h. Dilute 1 mL of this solution to 5 mL with a 27 g/L solution of dipotassium hydrogen phosphate R previously adjusted to pH 7.0 with phosphoric acid R.

*Reference solution (f)*. Dilute 2 mL of reference solution (a) to 10 mL with reference solution (e).

*Reference solution (g)*. Dissolve 1.5 mg of flucloxacillin impurity C CRS in 1 mL of the mobile phase and dilute to 50 mL with the mobile phase.

*Reference solution (h)*. Dissolve 1 mg of flucloxacillin impurity D CRS in 100 mL of the mobile phase.

*Reference solution (i)*. Dissolve 1 mg of flucloxacillin impurity E CRS in 100 mL of the mobile phase.

*Column*:

- size:  $l = 0.25$  m,  $\varnothing = 4$  mm;
- stationary phase: octadecylsilyl silica gel for chromatography R (5 µm);
- temperature: 40 °C.

*Mobile phase*: mix 25 volumes of acetonitrile R1 and 75 volumes of a 2.7 g/L solution of potassium dihydrogen phosphate R previously adjusted to pH 5.0 with dilute sodium hydroxide solution R.

*Flow rate*: 1 mL/min.

*Detection*: spectrophotometer at 225 nm.

*Injection*: 20 µL of test solution (a) and reference solutions (b), (d), (e), (f), (g), (h) and (i).

*Run time*: 7 times the retention time of flucloxacillin.

*Identification of impurities*: use the chromatograms obtained with reference solutions (d), (e), (g), (h) and (i) to identify the peaks due to impurities A, B, C, D and E respectively.

*Relative retention* with reference to flucloxacillin (retention time = about 8 min): impurity C = about 0.2; impurity A (isomer 1) = about 0.3; impurity A (isomer 2) = about 0.5; impurity D = about 0.6; impurity B (isomer 1) = about 0.8; impurity B (isomer 2) = about 0.9; impurity E = about 6.

*System suitability*: reference solution (f):

- resolution: minimum 2.0 between the 2<sup>nd</sup> peak due to impurity B (isomer 2) and the peak due to flucloxacillin.

**Limits:**

- *correction factor*: for the calculation of content, multiply the peak area of impurity C by 3.3;
- *impurity A* (sum of the 2 isomers): the sum of the areas of the 2 peaks is not more than twice the area of the principal peak in the chromatogram obtained with reference solution (b) (2.0 per cent);
- *impurity B* (sum of the 2 isomers): the sum of the areas of the 2 peaks is not more than the area of the principal peak in the chromatogram obtained with reference solution (b) (1.0 per cent);
- *impurity C*: not more than the area of the principal peak in the chromatogram obtained with reference solution (b) (1.0 per cent);
- *impurities D, E*: for each impurity, not more than 0.3 times the area of the principal peak in the chromatogram obtained with reference solution (b) (0.3 per cent);
- *any other impurity*: for each impurity, not more than 0.3 times the area of the principal peak in the chromatogram obtained with reference solution (b) (0.3 per cent);
- *total*: not more than 3 times the area of the principal peak in the chromatogram obtained with reference solution (b) (3.0 per cent);
- *disregard limit*: 0.05 times the area of the principal peak in the chromatogram obtained with reference solution (b) (0.05 per cent).

**2-Ethylhexanoic acid (2.4.28)**: maximum 0.8 per cent *m/m*.

**Water (2.5.12)**: 12.0 per cent to 15.0 per cent, determined on 0.100 g.

**ASSAY**

Liquid chromatography (2.2.29) as described in the test for related substances with the following modifications.

**Injection**: test solution (b) and reference solution (a).

Calculate the percentage content of  $C_{38}H_{32}Cl_2F_2MgN_6O_{10}S_2$  from the declared content of *flucloxacillin sodium CRS*, multiplying by 0.9773.

**IMPURITIES**

**Specified impurities: A, B, C, D, E.**

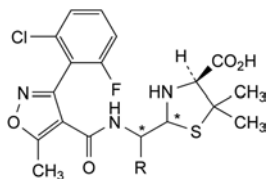

- A. R = CO<sub>2</sub>H: (4*S*)-2-[carboxy[[[3-(2-chloro-6-fluorophenyl)-5-methylisoxazol-4-yl]carbonyl]amino]methyl]-5,5-dimethylthiazolidine-4-carboxylic acid (penicilloic acids of flucloxacillin),
- B. R = H: (2*R*,4*S*)-2-[[[3-(2-chloro-6-fluorophenyl)-5-methylisoxazol-4-yl]carbonyl]amino]methyl]-5,5-dimethylthiazolidine-4-carboxylic acid (penilloic acids of flucloxacillin),

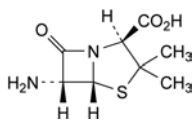

- C. (2*S*,5*R*,6*R*)-6-amino-3,3-dimethyl-7-oxo-4-thia-1-azabicyclo[3.2.0]heptane-2-carboxylic acid (6-aminopenicillanic acid),

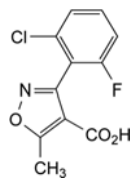

- D. 3-(2-chloro-6-fluorophenyl)-5-methylisoxazole-4-carboxylic acid,

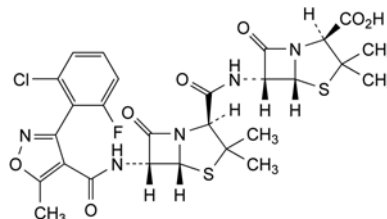

- E. (2*S*,5*R*,6*R*)-6-[[[3-(2-chloro-6-fluorophenyl)-5-methylisoxazol-4-yl]carbonyl]amino]-3,3-dimethyl-7-oxo-4-thia-1-azabicyclo[3.2.0]heptane-2-carboxylic acid (6-APA flucloxacillin amide).

01/2008:0668  
corrected 6.0

**FLUCLOXACILLIN SODIUM**

## Flucloxacillinum natricum

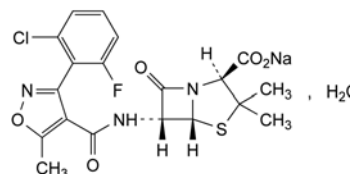

$C_{19}H_{16}ClFN_3NaO_5S_2H_2O$

$M_r$  493.9

**DEFINITION**

Sodium (2*S*,5*R*,6*R*)-6-[[[3-(2-chloro-6-fluorophenyl)-5-methylisoxazol-4-yl]carbonyl]amino]-3,3-dimethyl-7-oxo-4-thia-1-azabicyclo[3.2.0]heptane-2-carboxylate monohydrate.

Semi-synthetic product derived from a fermentation product.

**Content**: 95.0 per cent to 102.0 per cent (anhydrous substance).

**CHARACTERS**

**Appearance**: white or almost white, hygroscopic, crystalline powder.

**Solubility**: freely soluble in water and in methanol, soluble in ethanol (96 per cent).

**IDENTIFICATION**

**First identification: A, D.**

**Second identification: B, C, D.**

A. Infrared absorption spectrophotometry (2.2.24).

*Comparison: flucloxacillin sodium CRS.*

B. Thin-layer chromatography (2.2.27).

*Test solution.* Dissolve 25 mg of the substance to be examined in 5 mL of *water R*.

*Reference solution (a).* Dissolve 25 mg of *flucloxacillin sodium CRS* in 5 mL of *water R*.

*Reference solution (b).* Dissolve 25 mg of *cloxacillin sodium CRS*, 25 mg of *dicloxacillin sodium CRS* and 25 mg of *flucloxacillin sodium CRS* in 5 mL of *water R*.

*Plate: TLC silanised silica gel plate R.*

*Mobile phase:* mix 30 volumes of *acetone R* and 70 volumes of a 154 g/L solution of *ammonium acetate R* adjusted to pH 5.0 with *glacial acetic acid R*.

**Application:** 1 µL.

**Development:** over a path of 15 cm.

**Drying:** in air.

**Detection:** expose to iodine vapour until the spots appear and examine in daylight.

**System suitability:** reference solution (b):

- the chromatogram shows 3 clearly separated spots.

**Results:** the principal spot in the chromatogram obtained with the test solution is similar in position, colour and size to the principal spot in the chromatogram obtained with reference solution (a).

- C. Place about 2 mg in a test-tube about 150 mm long and 15 mm in diameter. Moisten with 0.05 mL of *water R* and add 2 mL of *sulfuric acid-formaldehyde reagent R*. Mix the contents of the tube by swirling; the colour of the solution is slightly greenish-yellow. Place the test-tube in a water-bath for 1 min; the solution becomes yellow.
- D. It gives reaction (a) of sodium (2.3.1).

## TESTS

**Solution S.** Dissolve 2.50 g in *carbon dioxide-free water R* and dilute to 25.0 mL with the same solvent.

**Appearance of solution.** Solution S is clear (2.2.1) and its absorbance (2.2.25) at 430 nm is not greater than 0.04.

**pH** (2.2.3): 5.0 to 7.0 for solution S.

**Specific optical rotation** (2.2.7): + 158 to + 168 (anhydrous substance).

Dissolve 0.250 g in *water R* and dilute to 25.0 mL with the same solvent.

**Related substances.** Liquid chromatography (2.2.29).

**Test solution (a).** Dissolve 50.0 mg of the substance to be examined in the mobile phase and dilute to 50.0 mL with the mobile phase.

**Test solution (b).** Dilute 5.0 mL of test solution (a) to 50.0 mL with the mobile phase.

**Reference solution (a).** Dissolve 50.0 mg of *flucloxacillin sodium CRS* in the mobile phase and dilute to 50.0 mL with the mobile phase. Dilute 5.0 mL of this solution to 50.0 mL with the mobile phase.

**Reference solution (b).** Dilute 5.0 mL of reference solution (a) to 50.0 mL with the mobile phase.

**Reference solution (c).** Dissolve 5 mg of *flucloxacillin sodium CRS* and 5 mg of *cloxacillin sodium CRS* in the mobile phase, then dilute to 50.0 mL with the mobile phase.

**Column:**

- **size:**  $l = 0.25$  m,  $\varnothing = 4$  mm;
- **stationary phase:** octadecylsilyl silica gel for chromatography R (5 µm).

**Mobile phase:** mix 25 volumes of *acetonitrile R1* and 75 volumes of a 2.7 g/L solution of *potassium dihydrogen phosphate R* adjusted to pH 5.0 with *dilute sodium hydroxide solution R*.

**Flow rate:** 1 mL/min.

**Detection:** spectrophotometer at 225 nm.

**Injection:** 20 µL of test solution (a) and reference solutions (b) and (c).

**Run time:** 6 times the retention time of flucloxacillin.

**System suitability:** reference solution (c):

- **resolution:** minimum 2.5 between the peaks due to cloxacillin (1<sup>st</sup> peak) and flucloxacillin (2<sup>nd</sup> peak).

**Limits:**

- **impurities A, B, C, D, E:** for each impurity, not more than the area of the principal peak in the chromatogram obtained with reference solution (b) (1 per cent);

- **total:** not more than 5 times the area of the principal peak in the chromatogram obtained with reference solution (b) (5 per cent);
- **disregard limit:** 0.05 times the area of the principal peak in the chromatogram obtained with reference solution (b) (0.05 per cent).

***N,N*-Dimethylaniline** (2.4.26, *Method B*): maximum 20 ppm.

**2-Ethylhexanoic acid** (2.4.28): maximum 0.8 per cent *m/m*.

**Water** (2.5.12): 3.0 per cent to 4.5 per cent, determined on 0.300 g.

**Pyrogens** (2.6.8). If intended for use in the manufacture of parenteral preparations without a further appropriate procedure for the removal of pyrogens, it complies with the test. Inject per kilogram of the rabbit's mass 1 mL of a solution in *water for injections R* containing 20 mg of the substance to be examined per millilitre.

## ASSAY

Liquid chromatography (2.2.29) as described in the test for related substances with the following modifications.

**Injection:** test solution (b) and reference solution (a).

**System suitability:** reference solution (a):

- **repeatability:** maximum relative standard deviation of 1.0 per cent after 6 injections.

Calculate the percentage content of  $C_{19}H_{16}ClFN_3NaO_5S$  from the declared content of *flucloxacillin sodium CRS*.

## STORAGE

In an airtight container, at a temperature not exceeding 25 °C. If the substance is sterile, store in a sterile, airtight, tamper-proof container.

## IMPURITIES

**Specified impurities:** A, B, C, D, E.

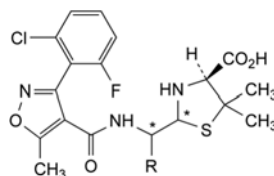

A. R = CO<sub>2</sub>H: (4*S*)-2-[carboxy[[[3-(2-chloro-6-fluorophenyl)-5-methylisoxazol-4-yl]carbonyl]amino]methyl]-5,5-dimethylthiazolidine-4-carboxylic acid (penicilloic acids of flucloxacillin),

B. R = H: (2*RS*,4*S*)-2-[[[3-(2-chloro-6-fluorophenyl)-5-methylisoxazol-4-yl]carbonyl]amino]methyl]-5,5-dimethylthiazolidine-4-carboxylic acid (penicilloic acids of flucloxacillin),

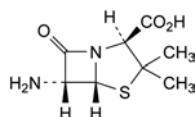

C. (2*S*,5*R*,6*R*)-6-amino-3,3-dimethyl-7-oxo-4-thia-1-azabicyclo[3.2.0]heptane-2-carboxylic acid (6-aminopenicillanic acid),

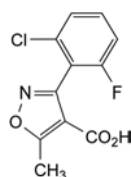

D. 3-(2-chloro-6-fluorophenyl)-5-methylisoxazole-4-carboxylic acid,

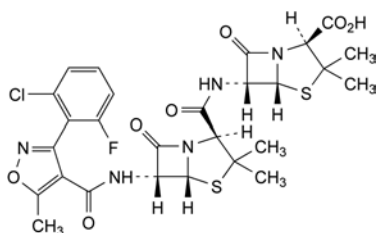

E. (2*S*,5*R*,6*R*)-6-[[[(2*S*,5*R*,6*R*)-[[[3-(2-chloro-6-fluorophenyl)-5-methylisoxazol-4-yl]carbonyl]amino]-3,3-dimethyl-7-oxo-4-thia-1-azabicyclo[3.2.0]hept-2-yl]carbonyl]amino]-3,3-dimethyl-7-oxo-4-thia-1-azabicyclo[3.2.0]heptane-2-carboxylic acid.

01/2008:2287  
corrected 6.0

## FLUCONAZOLE

### Fluconazolium

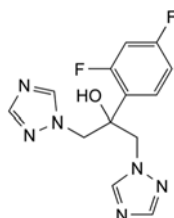

$C_{13}H_{12}F_2N_6O$   
[86386-73-4]

$M_r$  306.3

#### DEFINITION

2-(2,4-Difluorophenyl)-1,3-bis(1*H*-1,2,4-triazol-1-yl)propan-2-ol.

*Content*: 99.0 per cent to 101.0 per cent (dried substance).

#### CHARACTERS

*Appearance*: white or almost white, hygroscopic, crystalline powder.

*Solubility*: slightly soluble in water, freely soluble in methanol, soluble in acetone.

It shows polymorphism (5.9).

#### IDENTIFICATION

Infrared absorption spectrophotometry (2.2.24).

*Comparison*: fluconazole CRS.

If the spectra obtained in the solid state show differences, dissolve the substance to be examined and the reference substance separately in the minimum volume of *methylene chloride R*, evaporate to dryness on a water-bath and record new spectra using the residues.

#### TESTS

**Appearance of solution.** The solution is clear (2.2.1) and colourless (2.2.2, *Method II*).

Dissolve 1.0 g in *methanol R* and dilute to 20 mL with the same solvent.

**Related substances.** Liquid chromatography (2.2.29).

*Test solution.* Dissolve 0.100 g of the substance to be examined in the mobile phase, sonicate if necessary, and dilute to 10.0 mL with the mobile phase.

*Reference solution (a).* Dilute 5.0 mL of the test solution to 100.0 mL with the mobile phase. Dilute 1.0 mL of this solution to 10.0 mL with the mobile phase.

*Reference solution (b).* Dissolve 5 mg of *fluconazole for peak identification CRS* (containing impurity A) in the mobile phase, sonicate if necessary, and dilute to 10 mL with the mobile phase.

*Reference solution (c).* Dissolve 3.0 mg of *fluconazole impurity B CRS* in the mobile phase, sonicate if necessary and, dilute to 100.0 mL with the mobile phase.

*Reference solution (d).* Dissolve 2.0 mg of *fluconazole impurity C CRS* in the mobile phase and dilute to 20.0 mL with the mobile phase. To 1.0 mL of this solution add 1.0 mL of the test solution and dilute to 10.0 mL with the mobile phase.

#### Column:

- *size*:  $l = 0.15$  m,  $\varnothing = 4.6$  mm;
- *stationary phase*: octadecylsilyl silica gel for chromatography R1 (5  $\mu$ m);
- *temperature*: 40 °C.

*Mobile phase*: acetonitrile R, 0.63 g/L solution of ammonium formate R (14:86 V/V).

*Flow rate*: 1.0 mL/min.

*Detection*: spectrophotometer at 260 nm.

*Injection*: 20  $\mu$ L.

*Run time*: 3.5 times the retention time of fluconazole.

*Identification of impurities*: use the chromatogram supplied with *fluconazole for peak identification CRS* and the chromatogram obtained with reference solution (b) to identify the peak due to impurity A; use the chromatogram obtained with reference solution (c) to identify the peak due to impurity B and the chromatogram obtained with reference solution (d) to identify the peak due to impurity C.

*Relative retention* with reference to fluconazole (retention time = about 11 min): impurity B = about 0.4; impurity A = about 0.5; impurity C = about 0.8.

*System suitability*: reference solution (d):

- *resolution*: minimum 3.0 between the peaks due to impurity C and fluconazole.

#### Limits:

- *impurity A*: not more than 0.8 times the area of the principal peak in the chromatogram obtained with reference solution (a) (0.4 per cent);
- *impurity B*: not more than the area of the principal peak in the chromatogram obtained with reference solution (c) (0.3 per cent);
- *impurity C*: not more than the area of the corresponding peak in the chromatogram obtained with reference solution (d) (0.1 per cent);
- *unspecified impurities*: for each impurity, not more than 0.2 times the area of the principal peak in the chromatogram obtained with reference solution (a) (0.10 per cent);
- *total*: not more than 1.2 times the area of the principal peak in the chromatogram obtained with reference solution (a) (0.6 per cent);
- *disregard limit*: 0.1 times the area of the principal peak in the chromatogram obtained with reference solution (a) (0.05 per cent).

**Heavy metals** (2.4.8): maximum 10 ppm.

Dissolve 2.0 g in a mixture of 15 volumes of *water R* and 85 volumes of *methanol R* and dilute to 20.0 mL with the same mixture of solvents. 12 mL of the solution complies with test B. Prepare the reference solution using *lead standard solution (1 ppm Pb) R*.

**Loss on drying** (2.2.32): maximum 0.5 per cent, determined on 1.000 g by drying in an oven at 105 °C.

**Sulfated ash** (2.4.14): maximum 0.1 per cent, determined on 1.0 g.

#### ASSAY

Dissolve 0.125 g in 60 mL of *anhydrous acetic acid R*. Titrate with 0.1 *M perchloric acid*, determining the end-point potentiometrically (2.2.20).

1 mL of 0.1 *M perchloric acid* is equivalent to 15.32 mg of  $C_{13}H_{12}F_2N_6O$ .

## STORAGE

In an airtight container.

## IMPURITIES

Specified impurities: A, B, C.

Other detectable impurities (the following substances would, if present at a sufficient level, be detected by one or other of the tests in the monograph. They are limited by the general acceptance criterion for other/unspecified impurities and/or by the general monograph *Substances for pharmaceutical use (2034)*. It is therefore not necessary to identify these impurities for demonstration of compliance. See also 5.10. *Control of impurities in substances for pharmaceutical use*): D, E, F, G, H, I.

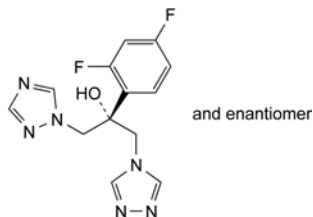

A. (2*RS*)-2-(2,4-difluorophenyl)-1-(1*H*-1,2,4-triazol-1-yl)-3-(4*H*-1,2,4-triazol-4-yl)propan-2-ol,

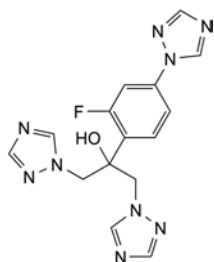

B. 2-[2-fluoro-4-(1*H*-1,2,4-triazol-1-yl)phenyl]-1,3-bis(1*H*-1,2,4-triazol-1-yl)propan-2-ol,

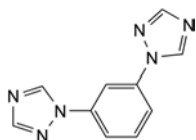

C. 1,1'-(1,3-phenylene)di-1*H*-1,2,4-triazole,

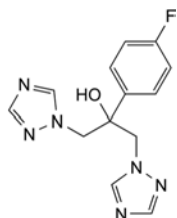

D. 2-(4-fluorophenyl)-1,3-bis(1*H*-1,2,4-triazol-1-yl)propan-2-ol,

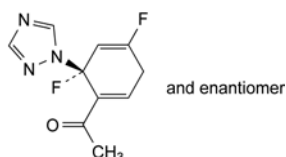

E. 1-[(6*RS*)-4,6-difluoro-6-(1*H*-1,2,4-triazol-1-yl)cyclohexa-1,4-dienyl]ethanone,

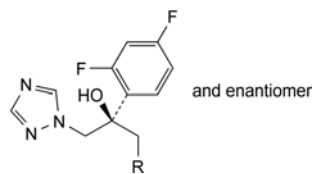

F. R = OH: (2*RS*)-2-(2,4-difluorophenyl)-3-(1*H*-1,2,4-triazol-1-yl)propane-1,2-diol,

H. R = Br: (2*RS*)-1-bromo-2-(2,4-difluorophenyl)-3-(1*H*-1,2,4-triazol-1-yl)propan-2-ol,

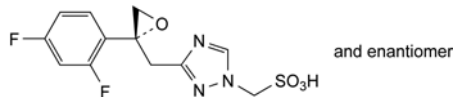

G. [3-[(2*RS*)-2-(2,4-difluorophenyl)oxiran-2-yl]methyl]-1*H*-1,2,4-triazol-1-yl]methanesulfonic acid,

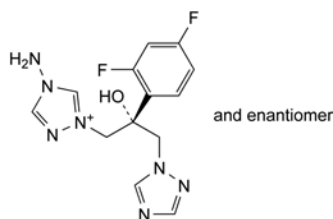

I. 4-amino-1-[(2*RS*)-2-(2,4-difluorophenyl)-2-hydroxy-3-(1*H*-1,2,4-triazol-1-yl)propyl]-4*H*-1,2,4-triazolium.

01/2011:0766

## FLUCYTOSINE

## Flucytosinum

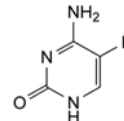

C<sub>4</sub>H<sub>4</sub>FN<sub>3</sub>O  
[2022-85-7]

M<sub>r</sub> 129.1

## DEFINITION

4-Amino-5-fluoropyrimidin-2(1*H*)-one.

*Content*: 99.0 per cent to 101.0 per cent (dried substance).

## CHARACTERS

*Appearance*: white or almost white, crystalline powder.

*Solubility*: sparingly soluble in water, slightly soluble in ethanol (96 per cent).

## IDENTIFICATION

*First identification*: A.

*Second identification*: B, C, D.

A. Infrared absorption spectrophotometry (2.2.24).

*Comparison*: flucytosine CRS.

B. Thin-layer chromatography (2.2.27).

*Solvent mixture*: water R, methanol R (10:15 V/V).

*Test solution*. Dissolve 10 mg of the substance to be examined in the solvent mixture and dilute to 10 mL with the solvent mixture.

*Reference solution*. Dissolve 10 mg of flucytosine CRS in the solvent mixture and dilute to 10 mL with the solvent mixture.

*Plate*: TLC silica gel F<sub>254</sub> plate R.

*Mobile phase*: anhydrous formic acid R, water R, methanol R, ethyl acetate R (1:15:25:60 V/V/V/V).

*Application*: 10 µL.



**Development:** over 2/3 of the plate in an unsaturated tank with the mobile phase. Then allow the solvents to evaporate.

**Detection:** at the bottom of a chromatography tank place an evaporating dish containing a mixture of 1 volume of hydrochloric acid R1, 1 volume of water R and 2 volumes of a 15 g/L solution of potassium permanganate R. Close the tank and allow to stand for 15 min. Place the dried plate in the tank and close the tank. Leave the plate in contact with the chlorine vapour for 5 min. Withdraw the plate and place it in a current of cold air until the excess of chlorine is removed and an area of the coating below the points of application does not give a blue colour with a drop of potassium iodide and starch solution R. Spray with potassium iodide and starch solution R. Examine in daylight.

**Results:** the principal spot in the chromatogram obtained with the test solution is similar in position and size to the principal spot in the chromatogram obtained with the reference solution.

- C. Mix about 5 mg with 45 mg of heavy magnesium oxide R and ignite in a crucible until an almost white residue is obtained (usually less than 5 min). Allow to cool, add 1 mL of water R, 0.05 mL of phenolphthalein solution R1 and about 1 mL of dilute hydrochloric acid R to render the solution colourless. Filter and add to the filtrate a freshly prepared mixture of 0.1 mL of alizarin S solution R and 0.1 mL of zirconyl nitrate solution R. Mix, allow to stand for 5 min and compare the colour of the solution with that of a blank prepared in the same manner. The colour of the solution changes from red to yellow.
- D. To 5 mL of solution S (see Tests) add 0.15 mL of bromine water R and shake. The colour of the solution is discharged.

#### TESTS

**Solution S.** Dissolve 0.5 g in carbon dioxide-free water R and dilute to 50 mL with the same solvent.

**Appearance of solution.** Solution S is clear (2.2.1) and not more intensely coloured than reference solution BY<sub>7</sub> or Y<sub>7</sub> (2.2.2, Method II).

**Related substances.** Liquid chromatography (2.2.29).

**Solvent mixture.** Dissolve 13.6 g of potassium dihydrogen phosphate R in 950 mL of water R. Add 50 mL of methanol R. Mix thoroughly.

**Test solution.** Dissolve 15.0 mg of the substance to be examined in the solvent mixture and dilute to 50.0 mL with the solvent mixture. Mix well. Sonicate for 5 min. Mix thoroughly. Sonicate the solution for 5 min. Mix thoroughly.

**Reference solution (a).** Dilute 1.0 mL of the test solution to 100.0 mL with the solvent mixture. Dilute 1.0 mL of this solution to 10.0 mL with the solvent mixture.

**Reference solution (b).** Dissolve 15.0 mg of fluorouracil CRS (impurity A) in the solvent mixture and dilute to 50.0 mL with the solvent mixture. Mix well. Sonicate for 5 min. Mix thoroughly. Sonicate the solution for 5 min. Mix thoroughly. Dilute 1.0 mL of this solution to 10.0 mL with the solvent mixture. Dilute 2.0 mL of this solution to 100.0 mL with the solvent mixture.

**Reference solution (c).** Dissolve the contents of a vial of flucytosine for system suitability CRS (containing impurity B) in 0.5 mL of the solvent mixture and add 0.5 mL of reference solution (b).

**Column:**

- size:  $l = 0.25$  m,  $\varnothing = 4.0$  mm;
- stationary phase: end-capped octadecylsilyl silica gel for chromatography R (5  $\mu$ m).

**Mobile phase:** dissolve 13.6 g of potassium dihydrogen phosphate R in 950 mL of water R. Filter through a membrane filter (nominal pore size 0.45  $\mu$ m). Adjust to pH 2.0 by adding phosphoric acid R and add 50 mL of methanol R. Mix thoroughly.

**Flow rate:** 1.1 mL/min.

**Detection:** spectrophotometer at 260 nm.

**Injection:** 20  $\mu$ L of the test solution and reference solutions (a) and (c).

**Run time:** 15 times the retention time of flucytosine.

**Identification of impurities:** use the chromatogram obtained with reference solution (c) to identify the peaks due to impurities A and B.

**Relative retention** with reference to flucytosine (retention time = about 2 min): impurity A = about 1.7; impurity B = about 13.3.

**System suitability:**

- resolution: minimum 5.0 between the peaks due to flucytosine and impurity A in the chromatogram obtained with reference solution (c);
- signal-to-noise ratio: minimum 50 for the peak due to impurity B in the chromatogram obtained with reference solution (c);
- symmetry factor: maximum 2.0 for the peak due to flucytosine in the chromatogram obtained with reference solution (a).

**Limits:**

- correction factor: for the calculation of content, multiply the peak area of impurity B by 0.6;
- impurity A: not more than 1.5 times the area of the corresponding peak in the chromatogram obtained with reference solution (c) (0.15 per cent);
- impurity B: not more than 1.5 times the area of the principal peak in the chromatogram obtained with reference solution (a) (0.15 per cent);
- unspecified impurities: for each impurity, not more than 0.5 times the area of the principal peak in the chromatogram obtained with reference solution (a) (0.05 per cent);
- total: not more than 3 times the area of the principal peak in the chromatogram obtained with reference solution (a) (0.3 per cent);
- disregard limit: 0.3 times the area of the principal peak in the chromatogram obtained with reference solution (a) (0.03 per cent).

**Fluorides:** maximum 200 ppm.

Potentiometry (2.2.36, Method I). Prepare and store all solutions in plastic containers.

**Buffer solution.** Dissolve 58 g of sodium chloride R in 500 mL of water R. Add 57 mL of glacial acetic acid R and 200 mL of a 100 g/L solution of cyclohexylenedinitrilotetra-acetic acid R in 1 M sodium hydroxide. Adjust the pH to 5.0-5.5 with a 200 g/L solution of sodium hydroxide R and dilute to 1000.0 mL with water R.

**Test solution.** Dissolve 1.00 g of the substance to be examined in water R and dilute to 100.0 mL with the same solvent.

**Reference solutions.** Dissolve 4.42 g of sodium fluoride R, previously dried at 120 °C for 2 h, in 300 mL of water R and dilute to 1000.0 mL with the same solvent (solution (a): 1.9 g/L of fluoride). Prepare 3 reference solutions by dilution of solution (a) 1 in 100, 1 in 1000 and 1 in 10 000 respectively.

**Indicator electrode:** fluoride selective.

**Reference electrode:** silver-silver chloride.

To 20.0 mL of each reference solution, add 10.0 mL of the buffer solution and stir with a magnetic stirrer. Introduce the electrodes into the solution and allow to stand for 5 min with constant stirring.

Calculate the concentration of fluorides using the calibration curve.

**Heavy metals** (2.4.8): maximum 20 ppm.

1.0 g complies with test C. Use a platinum crucible. Prepare the reference solution using 2 mL of *lead standard solution* (10 ppm Pb) R.

**Loss on drying** (2.2.32): maximum 1.0 per cent, determined on 1.000 g by drying in an oven at 105 °C.

**Sulfated ash** (2.4.14): maximum 0.1 per cent, determined on 1.0 g in a platinum crucible.

#### ASSAY

Dissolve 0.100 g in 40 mL of *anhydrous acetic acid* R and add 100 mL of *acetic anhydride* R. Titrate with 0.1 M *perchloric acid* determining the end-point potentiometrically (2.2.20).

1 mL of 0.1 M *perchloric acid* is equivalent to 12.91 mg of C<sub>4</sub>H<sub>4</sub>FN<sub>3</sub>O.

#### STORAGE

Protected from light.

#### IMPURITIES

*Specified impurities: A, B.*

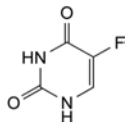

A. 5-fluoropyrimidine-2,4(1*H*,3*H*)-dione (fluorouracil),

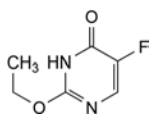

B. 2-ethoxy-5-fluoropyrimidin-4(3*H*)-one.

**Solubility:** slightly soluble in water, freely soluble in dimethylformamide, very slightly soluble in anhydrous ethanol.

#### IDENTIFICATION

Infrared absorption spectrophotometry (2.2.24).

*Comparison: fludarabine phosphate CRS.*

#### TESTS

**Appearance of solution.** The solution is clear (2.2.1) and not more intensely coloured than reference solution BY<sub>5</sub> (2.2.2, *Method II*).

Dissolve 50 mg in 5.0 mL of *dimethylformamide* R with the aid of ultrasound.

**Specific optical rotation** (2.2.7): + 10.0 to + 14.0 (anhydrous substance).

Dissolve 0.100 g in *water* R and dilute to 20.0 mL with the same solvent with the aid of ultrasound.

**Related substances.** Liquid chromatography (2.2.29): use the normalisation procedure. *Prepare the solutions immediately before use.*

**Test solution.** With the aid of ultrasound, dissolve 20 mg of the substance to be examined in 50 mL of *water* R and dilute to 100.0 mL with the same solvent.

**Reference solution (a).** With the aid of ultrasound, dissolve 20 mg of *fludarabine phosphate CRS* in 50 mL of *water* R and dilute to 100.0 mL with the same solvent.

**Reference solution (b).** With the aid of ultrasound, dissolve 20 mg of the substance to be examined in 20 mL of 0.1 M *hydrochloric acid*. Heat in a water-bath at 80 °C for 15 min, cool to room temperature, mix and dilute to 100.0 mL with *water* R.

**Reference solution (c).** Dilute 1.0 mL of reference solution (a) to 100.0 mL with *water* R. Dilute 1.0 mL of this solution to 20.0 mL with *water* R.

**Blank solution:** 0.02 M *hydrochloric acid*.

A. Early eluting impurities.

**Column:**

– size:  $l = 0.15$  m,  $\varnothing = 4.6$  mm,

– stationary phase: end-capped octadecylsilyl silica gel for chromatography R (5  $\mu$ m).

**Mobile phase:** mix 60 volumes of *methanol* R and 940 volumes of a 1.36 g/L solution of *potassium dihydrogen phosphate* R.

**Flow rate:** 1 mL/min.

**Detection:** spectrophotometer at 260 nm and 292 nm.

**Injection:** 10  $\mu$ L; inject the solutions and record the chromatograms at 260 nm.

**Run time:** 4.5 times the retention time of the principal peak in the chromatogram obtained with the test solution.

**Identification of impurities:** identify the impurity peaks in the chromatogram obtained with reference solution (a) and in the chromatogram obtained with the test solution by comparison with Figure 1781-1. Additionally, inject the test solution and reference solution (a) and record the chromatograms at 292 nm to identify impurities A and B, the response of which is much higher than that at 260 nm.

**Relative retention** with reference to fludarabine phosphate (retention time = about 9 min): impurity A = about 0.26; impurity B = about 0.34; impurity C = about 0.42.

**System suitability:** reference solution (b) at 292 nm:

– resolution: minimum 2.0 between the peaks due to impurities A and B.

01/2008:1781

## FLUDARABINE PHOSPHATE

### Fludarabini fosphas

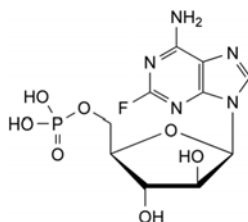

C<sub>10</sub>H<sub>13</sub>FN<sub>5</sub>O<sub>7</sub>P  
[75607-67-9]

$M_r$  365.2

#### DEFINITION

2-Fluoro-9-(5-*O*-phosphono- $\beta$ -D-arabinofuranosyl)-9*H*-purin-6-amine.

**Content:** 97.0 per cent to 102.0 per cent (anhydrous substance).

#### CHARACTERS

**Appearance:** white or almost white, crystalline powder, hygroscopic.

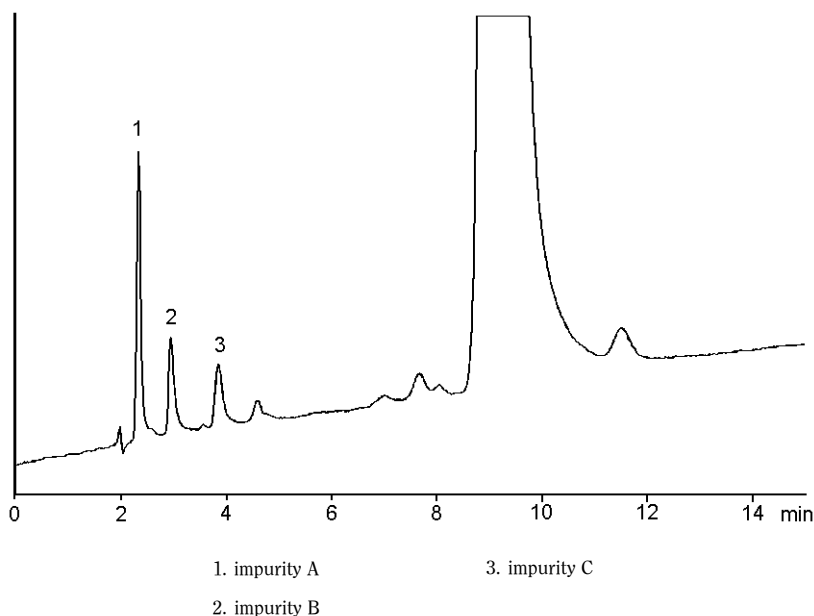

Figure 1781.-1. – Chromatogram for test A for related substances of fludarabine phosphate: reference solution (a) at 260 nm

Limits: at 260 nm:

- *correction factors*: for the calculation of contents, multiply the peak areas of the following impurities by the corresponding correction factor: impurity A = 4.0; impurity B = 2.5; impurity C = 1.9;
- *impurity A*: maximum 0.8 per cent;
- *impurity B*: maximum 0.2 per cent;
- *impurity C*: maximum 0.4 per cent;
- *any other impurity preceding fludarabine phosphate*: maximum 0.1 per cent;
- *disregard limit*: the area of the principal peak in the chromatogram obtained with reference solution (c) (0.05 per cent), and any peak eluting after fludarabine phosphate.

#### B. Late eluting impurities.

Conditions as described under Test A with the following modifications.

**Mobile phase**: mix 200 volumes of *methanol R* and 800 volumes of a 1.36 g/L solution of *potassium dihydrogen phosphate R*.

**Detection**: spectrophotometer at 260 nm.

**Injection**: 10  $\mu$ L.

**Run time**: 8 times the retention time of the principal peak in the chromatogram obtained with the test solution.

**Identification of impurities**: identify the impurity peaks in the chromatogram obtained with reference solution (a) and in the chromatogram obtained with the test solution by comparison with Figure 1781.-2.

**Relative retention** with reference to fludarabine phosphate (retention time = about 2.5 min): impurity D = about 1.5; impurity E = about 1.9; impurity G = about 2.2; impurity H = about 2.4; impurity F = about 2.5.

**System suitability**: reference solution (a):

- *peak-to-valley ratio*: minimum 2.0, where  $H_p$  = height above the baseline of the peak due to impurity G and  $H_v$  = height above the baseline of the lowest point of the curve separating this peak from the peak due to impurity H.

Limits:

- *correction factors*: for the calculation of contents, multiply the peak areas of the following impurities by the corresponding correction factor: impurity D = 0.5; impurity E = 0.6; impurity F = 1.8;

- *impurity D*: maximum 0.1 per cent;
- *impurity E*: maximum 0.2 per cent;
- *impurity F*: maximum 0.2 per cent;
- *any other impurity eluting after fludarabine phosphate*: maximum 0.1 per cent;
- *disregard limit*: the area of the principal peak in the chromatogram obtained with reference solution (c) (0.05 per cent), and any peak eluting before fludarabine phosphate.

**Total of impurities eluting before fludarabine phosphate in test A, apart from impurities A, B and C, and of impurities eluting after fludarabine phosphate in test B, apart from impurities D, E and F**: maximum 0.5 per cent.

**Total of all impurities eluting before fludarabine phosphate in test A and after fludarabine phosphate in test B**: maximum 2.0 per cent.

**Ethanol (2.4.24, System A)**: maximum 1.0 per cent.

**Heavy metals (2.4.8)**: maximum 20 ppm.

Dissolve 1.0 g by heating in 10 mL of *water R*. Allow to cool. Add *ammonia R* until the litmus paper reaction is slightly alkaline. Adjust to pH 3.0-4.0 with *dilute acetic acid R* and dilute to 20 mL with *water R*. 12 mL of the solution complies with limit test A. Prepare the reference solution using *lead standard solution (1 ppm Pb) R*.

**Water (2.5.12)**: maximum 3.0 per cent, determined on 0.200 g (ground to a very fine powder). Stir the substance in 15 mL of *anhydrous methanol R* for about 15 s before titrating.

#### ASSAY

Liquid chromatography (2.2.29) as described in test A for related substances with the following modifications.

**Test solution**. With the aid of ultrasound, dissolve 24.0 mg of the substance to be examined in 50 mL of *water R* and dilute to 100.0 mL with the same solvent. Dilute 25.0 mL of the solution to 100.0 mL with the mobile phase.

**Reference solution**. With the aid of ultrasound, dissolve 24.0 mg of *fludarabine phosphate CRS* in 50 mL of *water R* and dilute to 100.0 mL with the same solvent. Dilute 25.0 mL of the solution to 100.0 mL with the mobile phase.

**Detection**: spectrophotometer at 260 nm.

**Injection**: 10  $\mu$ L.

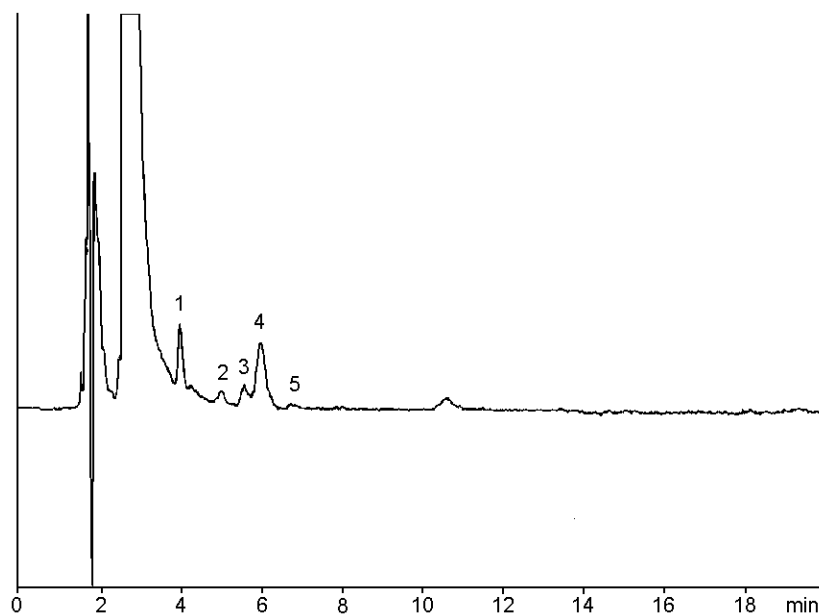

- |               |               |
|---------------|---------------|
| 1. impurity D | 4. impurity H |
| 2. impurity E | 5. impurity F |
| 3. impurity G |               |

Figure 1781.-2. – Chromatogram for test B for related substances of fludarabine phosphate: reference solution (a) at 260 nm.

Calculate the percentage content of  $C_{10}H_{13}FN_5O_7P$  using the chromatograms obtained with the test solution and the reference solution, and the declared content of *fludarabine phosphate CRS*.

#### STORAGE

In an airtight container, protected from light, at a temperature of 2 °C to 8 °C.

#### IMPURITIES

*Specified impurities: A, B, C, D, E, F, G.*

*Other detectable impurities* (the following substances would, if present at a sufficient level, be detected by one or other of the tests in the monograph. They are limited by the general acceptance criterion for other/unspecified impurities and/or by the general monograph *Substances for pharmaceutical use (2034)*. It is therefore not necessary to identify these impurities for demonstration of compliance. See also 5.10. *Control of impurities in substances for pharmaceutical use*): *H, I, J.*

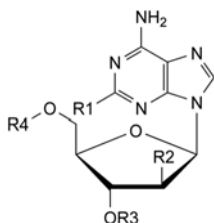

- A. R1 = R2 = OH, R3 = H, R4 =  $PO_3H_2$ : 6-amino-9-(5-*O*-phosphono- $\beta$ -D-arabinofuranosyl)-9*H*-purin-2-ol,  
 C. R1 = F, R2 = OH, R3 = R4 =  $PO_3H_2$ : 9-(3,5-di-*O*-phosphono- $\beta$ -D-arabinofuranosyl)-2-fluoro-9*H*-purin-6-amine,  
 E. R1 = F, R2 = OH, R3 = R4 = H: 9- $\beta$ -D-arabinofuranosyl-2-fluoro-9*H*-purin-6-amine,  
 F. R1 =  $O-C_2H_5$ , R2 = OH, R3 = H, R4 =  $PO_3H_2$ : 2-ethoxy-9-(5-*O*-phosphono- $\beta$ -D-arabinofuranosyl)-9*H*-purin-6-amine,  
 G. R1 = F, R2 = Cl, R3 = H, R4 =  $PO_3H_2$ : 9-(2-chloro-2-deoxy-5-*O*-phosphono- $\beta$ -D-arabinofuranosyl)-2-fluoro-9*H*-purin-6-amine,  
 I. R1 =  $NH_2$ , R2 = OH, R3 = H, R4 =  $PO_3H_2$ : 9-(5-*O*-phosphono- $\beta$ -D-arabinofuranosyl)-9*H*-purine-2,6-diamine,

- J. R1 =  $OCH_3$ , R2 = OH, R3 = H, R4 =  $PO_3H_2$ : 2-methoxy-9-(5-*O*-phosphono- $\beta$ -D-arabinofuranosyl)-9*H*-purin-6-amine,

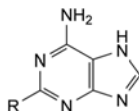

- B. R = OH: 6-amino-7*H*-purin-2-ol,  
 D. R = F: 2-fluoro-7*H*-purin-6-amine,

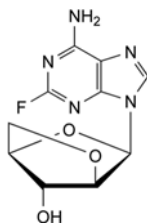

- H. 9-(2,5-anhydro- $\beta$ -D-arabinofuranosyl)-2-fluoro-9*H*-purin-6-amine.

01/2008:0767  
corrected 6.0

## FLUDROCORTISONE ACETATE

### Fludrocortisoni acetat

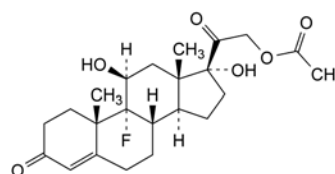

$C_{23}H_{31}FO_6$   
[514-36-3]

$M_r$  422.5

#### DEFINITION

9-Fluoro-11 $\beta$ ,17-dihydroxy-3,20-dioxopregn-4-en-21-yl acetate.  
*Content*: 97.0 per cent to 103.0 per cent (dried substance).

## CHARACTERS

*Appearance*: white or almost white, crystalline powder.

*Solubility*: practically insoluble in water, sparingly soluble in anhydrous ethanol.

## IDENTIFICATION

*First identification*: A, B.

*Second identification*: C, D, E.

## A. Infrared absorption spectrophotometry (2.2.24).

*Comparison*: fludrocortisone acetate CRS.

If the spectra obtained in the solid state show differences, dissolve the substance to be examined and the reference substance separately in the minimum volume of acetone R, evaporate to dryness and record new spectra using the residues.

## B. Thin-layer chromatography (2.2.27).

*Solvent mixture*: methanol R, methylene chloride R (1:9 V/V).

*Test solution*. Dissolve 10 mg of the substance to be examined in the solvent mixture and dilute to 10 mL with the solvent mixture.

*Reference solution (a)*. Dissolve 10 mg of fludrocortisone acetate CRS in the solvent mixture and dilute to 10 mL with the solvent mixture.

*Reference solution (b)*. Dissolve 5 mg of cortisone acetate CRS in 5 mL of reference solution (a).

*Plate*: TLC silica gel F<sub>254</sub> plate R.

*Mobile phase*: add a mixture of 1.2 volumes of water R and 8 volumes of methanol R to a mixture of 15 volumes of ether R and 77 volumes of methylene chloride R.

*Application*: 5 µL.

*Development*: over a path of 15 cm.

*Drying*: in air.

*Detection A*: examine in ultraviolet light at 254 nm.

*Results A*: the principal spot in the chromatogram obtained with the test solution is similar in position and size to the principal spot in the chromatogram obtained with reference solution (a).

*Detection B*: spray with alcoholic solution of sulfuric acid R. Heat at 120 °C for 10 min or until the spots appear. Allow to cool. Examine in daylight and in ultraviolet light at 365 nm.

*Results B*: the principal spot in the chromatogram obtained with the test solution is similar in position, colour in daylight, fluorescence in ultraviolet light at 365 nm and size to the principal spot in the chromatogram obtained with reference solution (a).

*System suitability*: reference solution (b):

– the chromatogram shows 2 clearly separated spots.

## C. Thin-layer chromatography (2.2.27).

*Test solution (a)*. Dissolve 25 mg of the substance to be examined in methanol R and dilute to 5 mL with the same solvent (solution A). Dilute 2 mL of this solution to 10 mL with methylene chloride R.

*Test solution (b)*. Transfer 2 mL of solution A to a 15 mL glass tube with a ground-glass stopper or a polytetrafluoroethylene cap. Add 10 mL of saturated methanolic potassium hydrogen carbonate solution R and immediately pass a stream of nitrogen R through the solution for 5 min. Stopper the tube. Heat on a water-bath at 45 °C protected from light for 2 h 30 min. Allow to cool.

*Reference solution (a)*. Dissolve 25 mg of fludrocortisone acetate CRS in methanol R and dilute to 5 mL with the same solvent (solution B). Dilute 2 mL of this solution to 10 mL with methylene chloride R.

*Reference solution (b)*. Transfer 2 mL of solution B to a 15 mL glass tube with a ground-glass stopper or a polytetrafluoroethylene cap. Add 10 mL of saturated

methanolic potassium hydrogen carbonate solution R and immediately pass a stream of nitrogen R through the solution for 5 min. Stopper the tube. Heat on a water bath at 45 °C protected from light for 2 h 30 min. Allow to cool.

*Plate*: TLC silica gel F<sub>254</sub> plate R.

*Mobile phase*: add a mixture of 1.2 volumes of water R and 8 volumes of methanol R to a mixture of 15 volumes of ether R and 77 volumes of methylene chloride R.

*Application*: 5 µL.

*Development*: over a path of 15 cm.

*Drying*: in air.

*Detection A*: examine in ultraviolet light at 254 nm.

*Results A*: the principal spot in each of the chromatograms obtained with the test solutions is similar in position and size to the principal spot in the chromatogram obtained with the corresponding reference solution.

*Detection B*: spray with alcoholic solution of sulfuric acid R. Heat at 120 °C for 10 min or until the spots appear. Allow to cool. Examine in daylight and in ultraviolet light at 365 nm.

*Results B*: the principal spot in each of the chromatograms obtained with the test solutions is similar in position, colour in daylight, fluorescence in ultraviolet light at 365 nm and size to the principal spot in the chromatogram obtained with the corresponding reference solution. The principal spots in the chromatograms obtained with test solution (b) and reference solution (b) have  $R_F$  values distinctly lower than those of the principal spots in the chromatograms obtained with test solution (a) and reference solution (a).

## D. Mix about 5 mg with 45 mg of heavy magnesium oxide R and ignite in a crucible until an almost white residue is obtained (usually less than 5 min). Allow to cool, add 1 mL of water R, 0.05 mL of phenolphthalein solution RI and about 1 mL of dilute hydrochloric acid R to render the solution colourless. Filter and add to the filtrate a freshly prepared mixture of 0.1 mL of alizarin S solution R and 0.1 mL of zirconyl nitrate solution R. Mix, allow to stand for 5 min and compare the colour of the solution with that of a blank prepared in the same manner. The colour of the solution to be examined changes from red to yellow.

## E. About 10 mg gives the reaction of acetyl (2.3.1).

## TESTS

**Specific optical rotation** (2.2.7): + 148 to + 156 (dried substance).

Dissolve 0.250 g in dioxan R and dilute to 25.0 mL with the same solvent.

**Related substances**. Liquid chromatography (2.2.29).

*Test solution*. Dissolve 20.0 mg of the substance to be examined in the mobile phase and dilute to 10.0 mL with the mobile phase.

*Reference solution (a)*. Dissolve 2.0 mg of fludrocortisone acetate CRS and 2.0 mg of hydrocortisone acetate CRS in the mobile phase, then dilute to 50.0 mL with the mobile phase.

*Reference solution (b)*. Dilute 1.0 mL of the test solution to 50.0 mL with the mobile phase.

*Column*:

– size:  $l = 0.2$  m,  $\varnothing = 4.6$  mm;

– stationary phase: octadecylsilyl silica gel for chromatography R.

*Mobile phase*: tetrahydrofuran R, water R (35:65 V/V).

*Flow rate*: 1 mL/min.

*Detection*: spectrophotometer at 254 nm.

*Equilibration*: with the mobile phase for about 30 min.

*Injection*: 20 µL.

*Run time*: twice the retention time of fludrocortisone acetate.

*Retention time*: hydrocortisone acetate = about 8.5 min; fludrocortisone acetate = about 10 min.

*System suitability*: reference solution (a):

- *resolution*: minimum 1.0 between the peaks due to hydrocortisone acetate and fludrocortisone acetate; if necessary, adjust slightly the concentration of tetrahydrofuran in the mobile phase (an increase in the concentration of tetrahydrofuran reduces the retention times).

*Limits*:

- *any impurity*: for each impurity, not more than 0.5 times the area of the principal peak in the chromatogram obtained with reference solution (b) (1.0 per cent);
- *total*: not more than 0.75 times the area of the principal peak in the chromatogram obtained with reference solution (b) (1.5 per cent);
- *disregard limit*: 0.025 times the area of the principal peak in the chromatogram obtained with reference solution (b) (0.05 per cent).

**Loss on drying** (2.2.32): maximum 1.0 per cent, determined on 0.500 g by drying in an oven at 105 °C.

#### ASSAY

Dissolve 10.0 mg in *ethanol* (96 per cent) *R* and dilute to 100.0 mL with the same solvent. Dilute 5.0 mL of this solution to 50.0 mL with *ethanol* (96 per cent) *R*. Measure the absorbance (2.2.25) at the absorption maximum at 238 nm.

Calculate the content of C<sub>23</sub>H<sub>31</sub>FN<sub>3</sub>O<sub>3</sub> taking the specific absorbance to be 405.

01/2008:1326  
corrected 6.0

## FLUMAZENIL

### Flumazenilum

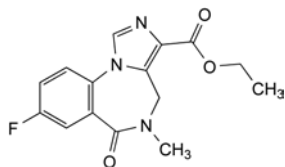

C<sub>15</sub>H<sub>14</sub>FN<sub>3</sub>O<sub>3</sub>  
[78755-81-4]

*M*<sub>r</sub> 303.3

#### DEFINITION

Ethyl 8-fluoro-5-methyl-6-oxo-5,6-dihydro-4*H*-imidazo[1,5-*a*][1,4]benzodiazepine-3-carboxylate.

*Content*: 99.0 per cent to 101.0 per cent (dried substance).

#### CHARACTERS

*Appearance*: white or almost white, crystalline powder.

*Solubility*: very slightly soluble in water, freely soluble in methylene chloride, sparingly soluble in methanol.

mp: 198 °C to 202 °C.

#### IDENTIFICATION

Infrared absorption spectrophotometry (2.2.24).

*Comparison*: Ph. Eur. reference spectrum of flumazenil.

#### TESTS

**Appearance of solution.** The solution is clear (2.2.1) and is not more intensely coloured than reference solution BY<sub>7</sub> (2.2.2, Method II).

Dissolve 0.10 g in *methanol* *R* and dilute to 10 mL with the same solvent.

**Impurity C:** maximum 1 per cent.

Dissolve 0.10 g in 0.5 mL of *methylene chloride* *R* and dilute to 10 mL with *butanol* *R*. To 5.0 mL of this solution add 2.0 mL

of *ninhydrin solution* *R* and heat in a water-bath at 95 °C for 15 min. Any blue-purple colour in the solution is not more intense than that in a standard prepared at the same time and in the same manner using 5.0 mL of a 0.1 g/L solution of *dimethylformamide diethylacetal* *R* in *butanol* *R*.

**Related substances.** Liquid chromatography (2.2.29).

*Test solution.* Dissolve 50.0 mg of the substance to be examined in 5 mL of *methanol* *R* and dilute to 25.0 mL with the mobile phase.

*Reference solution (a).* Dissolve 2.0 mg of *flumazenil impurity B* CRS and 2.0 mg of the substance to be examined in the mobile phase and dilute to 25.0 mL with the mobile phase. Dilute 2.0 mL of this solution to 25.0 mL with the mobile phase.

*Reference solution (b).* Dilute 10.0 mL of the test solution to 100.0 mL with the mobile phase. Dilute 1.0 mL of this solution to 100.0 mL with the mobile phase.

*Column*:

- *size*: *l* = 0.25 m,  $\varnothing$  = 4.6 mm,
- *stationary phase*: end-capped octadecylsilyl silica gel for chromatography *R* (5  $\mu$ m).

*Mobile phase*: to 800 mL of *water* *R* adjusted to pH 2.0 with *phosphoric acid* *R*, add 130 mL of *methanol* *R* and 70 mL of *tetrahydrofuran* *R* and mix.

*Flow rate*: 1 mL/min.

*Detection*: spectrophotometer at 230 nm.

*Injection*: 20  $\mu$ L.

*Run time*: 3 times the retention time of flumazenil.

*Relative retention* with reference to flumazenil (retention time = about 14 min): impurity A = about 0.4; impurity D = about 0.5; impurity E = about 0.6; impurity B = about 0.7; impurity F = about 2.4.

*System suitability*: reference solution (a):

- *resolution*: minimum 3.0 between the peaks due to impurity B and flumazenil.

*Limits*:

- *impurity B*: not more than twice the area of the principal peak in the chromatogram obtained with reference solution (b) (0.2 per cent),
- *unspecified impurities*: for each impurity, not more than the area of the principal peak in the chromatogram obtained with reference solution (b) (0.10 per cent),
- *total*: not more than twice the area of the principal peak in the chromatogram obtained with reference solution (b) (0.2 per cent),
- *disregard limit*: 0.5 times the area of the principal peak in the chromatogram obtained with reference solution (b) (0.05 per cent).

**Loss on drying** (2.2.32): maximum 0.5 per cent, determined on 1.000 g by drying in an oven at 105 °C.

**Sulfated ash** (2.4.14): maximum 0.1 per cent, determined on 1.0 g in a platinum crucible.

#### ASSAY

Dissolve 0.250 g in 50 mL of a mixture of 2 volumes of *acetic anhydride* *R* and 3 volumes of *anhydrous acetic acid* *R*. Titrate with 0.1 *M perchloric acid*, determining the end-point potentiometrically (2.2.20).

1 mL of 0.1 *M perchloric acid* is equivalent to 30.33 mg of C<sub>15</sub>H<sub>14</sub>FN<sub>3</sub>O<sub>3</sub>.

#### IMPURITIES

*Specified impurities*: B, C.

*Other detectable impurities* (the following substances would, if present at a sufficient level, be detected by one or other of the tests in the monograph. They are limited by the general acceptance criterion for other/unspecified impurities and/or by the general monograph *Substances for pharmaceutical use*

(2034). It is therefore not necessary to identify these impurities for demonstration of compliance. See also 5.10. *Control of impurities in substances for pharmaceutical use*): A, D, E, F.

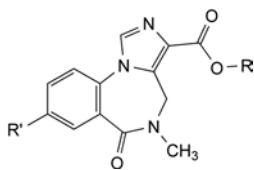

- A. R = H, R' = F: 8-fluoro-5-methyl-6-oxo-5,6-dihydro-4*H*-imidazo[1,5-*a*][1,4]benzodiazepine-3-carboxylic acid,  
 B. R = C<sub>2</sub>H<sub>5</sub>, R' = OH: ethyl 8-hydroxy-5-methyl-6-oxo-5,6-dihydro-4*H*-imidazo[1,5-*a*][1,4]benzodiazepine-3-carboxylate,  
 E. R = C<sub>2</sub>H<sub>5</sub>, R' = H: ethyl 5-methyl-6-oxo-5,6-dihydro-4*H*-imidazo[1,5-*a*][1,4]benzodiazepine-3-carboxylate,  
 F. R = C<sub>2</sub>H<sub>5</sub>, R' = Cl: ethyl 8-chloro-5-methyl-6-oxo-5,6-dihydro-4*H*-imidazo[1,5-*a*][1,4]benzodiazepine-3-carboxylate,

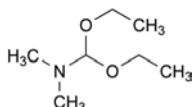

- C. diethoxy-*N,N*-dimethylmethanamine,

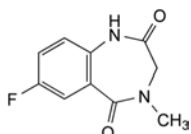

- D. 7-fluoro-4-methyl-3,4-dihydro-1*H*-1,4-benzodiazepine-2,5-dione.

07/2010:1517

## FLUMEQUINE

### Flumequinum

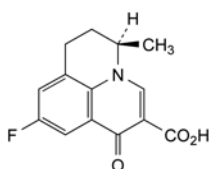

and enantiomer

C<sub>14</sub>H<sub>12</sub>FNO<sub>3</sub>  
[42835-25-6]

M<sub>r</sub> 261.3

#### DEFINITION

(*RS*)-9-Fluoro-5-methyl-1-oxo-6,7-dihydro-1*H*,5*H*-benzo[*i,j*]quinolizine-2-carboxylic acid.

*Content*: 99.0 per cent to 101.0 per cent (dried substance).

#### CHARACTERS

*Appearance*: white or almost white, microcrystalline powder.

*Solubility*: practically insoluble in water, sparingly soluble in methylene chloride, very slightly soluble in methanol. It is freely soluble in dilute solutions of alkali hydroxides.

#### IDENTIFICATION

*First identification*: A, B.

*Second identification*: B, C, D.

- A. Infrared absorption spectrophotometry (2.2.24).

*Comparison*: flumequine CRS.

- B. Optical rotation (see Tests).

- C. Thin-layer chromatography (2.2.27).

*Test solution*. Dissolve 5 mg of the substance to be examined in 10 mL of methylene chloride R.

*Reference solution*. Dissolve 5 mg of flumequine CRS in 10 mL of methylene chloride R.

*Plate*: TLC silica gel F<sub>254</sub> plate R.

*Mobile phase*: ammonia R, water R, ethanol (96 per cent) R (10:10:90 V/V/V).

*Application*: 5 µL.

*Development*: over 2/3 of the plate.

*Drying*: in air.

*Detection*: examine in ultraviolet light at 254 nm.

*Results*: the principal spot in the chromatogram obtained with the test solution is similar in position and size to the principal spot in the chromatogram obtained with the reference solution.

- D. Mix about 5 mg with 45 mg of heavy magnesium oxide R and ignite in a crucible until an almost white residue is obtained (usually less than 5 min). Allow to cool, add 1 mL of water R, 0.05 mL of phenolphthalein solution R1 and about 2 mL of dilute hydrochloric acid R to render the solution colourless. Filter and add to the filtrate a freshly prepared mixture of 0.1 mL of alizarin S solution R and 0.1 mL of zirconyl nitrate solution R. Mix, allow to stand for 5 min and compare the colour of the solution with that of a blank prepared in the same manner. The test solution changes from red to yellow and the blank remains red.

#### TESTS

**Solution S**. Dissolve 5.00 g in 0.5 M sodium hydroxide and dilute to 50.0 mL with the same solvent.

**Appearance of solution**. Solution S is clear (2.2.1) and not more intensely coloured than reference solution BY<sub>5</sub> (2.2.2, Method II).

**Optical rotation** (2.2.7): −0.10° to +0.10°, determined on solution S.

**Related substances**. Liquid chromatography (2.2.29).

*Test solution*. Dissolve 35.0 mg of the substance to be examined in dimethylformamide R and dilute to 100.0 mL with the same solvent.

*Reference solution (a)*. Dissolve the contents of a vial of flumequine impurity B CRS in 2.0 mL of a 50 µg/mL solution of flumequine CRS in dimethylformamide R.

*Reference solution (b)*. Dilute 1.0 mL of the test solution to 200.0 mL with dimethylformamide R.

*Column*:

- *size*: *l* = 0.15 m, Ø = 4.6 mm;
- *stationary phase*: octadecylsilyl silica gel for chromatography R (5 µm).

*Mobile phase*: methanol R, 1.36 g/L solution of potassium dihydrogen phosphate R (49:51 V/V).

*Flow rate*: 0.8 mL/min.

*Detection*: spectrophotometer at 313 nm.

*Injection*: 10 µL; inject dimethylformamide R as a blank.

*Run time*: 3 times the retention time of flumequine.

*Relative retention* with reference to flumequine (retention time = about 13 min): impurity A = about 0.67; impurity B = about 0.85.

*System suitability*: reference solution (a):

- *resolution*: minimum 2.0 between the peaks due to impurity B and flumequine.

*Limits*:

- *impurities A, B*: for each impurity, not more than the area of the principal peak in the chromatogram obtained with reference solution (b) (0.5 per cent);
- *unspecified impurities*: for each impurity, not more than 0.2 times the area of the principal peak in the chromatogram obtained with reference solution (b) (0.10 per cent);

- *total*: not more than twice the area of the principal peak in the chromatogram obtained with reference solution (b) (1.0 per cent);
- *disregard limit*: 0.1 times the area of the principal peak in the chromatogram obtained with reference solution (b) (0.05 per cent).

**Heavy metals** (2.4.8): maximum 10 ppm.

2.0 g complies with test C. Prepare the reference solution using 2 mL of *lead standard solution* (10 ppm Pb) R.

**Loss on drying** (2.2.32): maximum 0.5 per cent, determined on 1.000 g by drying in an oven at 105 °C for 3 h.

**Sulfated ash** (2.4.14): maximum 0.1 per cent, determined on 1.0 g in a platinum crucible.

#### ASSAY

Dissolve 0.500 g in 50 mL of *dimethylformamide* R. Titrate with 0.1 M *tetrabutylammonium hydroxide*, determining the end-point potentiometrically (2.2.20).

1 mL of 0.1 M *tetrabutylammonium hydroxide* is equivalent to 26.13 mg of C<sub>14</sub>H<sub>12</sub>FNO<sub>3</sub>.

#### IMPURITIES

*Specified impurities*: A, B.

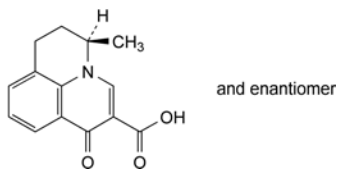

- A. (RS)-5-methyl-1-oxo-6,7-dihydro-1H,5H-benzo-*[i,j]*quinolizine-2-carboxylic acid (defluoroflumequine),

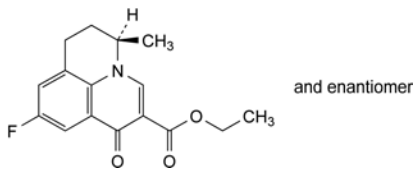

- B. ethyl (RS)-9-fluoro-5-methyl-1-oxo-6,7-dihydro-1H,5H-benzo-*[i,j]*quinolizine-2-carboxylate (flumequine ethyl ester).

01/2008:1327  
corrected 6.0

## FLUMETASONE PIVALATE

### Flumetasoni pivalas

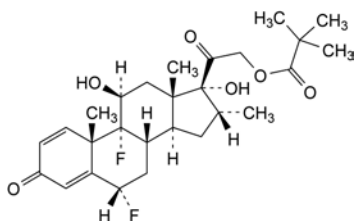

C<sub>27</sub>H<sub>36</sub>F<sub>2</sub>O<sub>6</sub>  
[2002-29-1]

M<sub>r</sub> 494.6

#### DEFINITION

6α,9-Difluoro-11β,17-dihydroxy-16α-methyl-3,20-dioxopregna-1,4-dien-21-yl 2,2-dimethylpropanoate.

*Content*: 97.0 per cent to 103.0 per cent (dried substance).

#### CHARACTERS

*Appearance*: white or almost white, crystalline powder.

*Solubility*: practically insoluble in water, sparingly soluble in acetone, slightly soluble in ethanol (96 per cent) and in methylene chloride.

It shows polymorphism (5.9).

#### IDENTIFICATION

*First identification*: A, B.

*Second identification*: B, C, D.

A. Infrared absorption spectrophotometry (2.2.24).

*Comparison*: *flumetasone pivalate* CRS.

If the spectra obtained in the solid state show differences, dissolve the substance to be examined and the reference substance separately in *acetone* R, evaporate to dryness on a water-bath and record new spectra using the residues.

B. Thin-layer chromatography (2.2.27).

*Test solution*. Dissolve 10 mg of the substance to be examined in *acetone* R and dilute to 10 mL with the same solvent.

*Reference solution (a)*. Dissolve 10 mg of *flumetasone pivalate* CRS in *acetone* R and dilute to 10 mL with the same solvent.

*Reference solution (b)*. Dissolve 10 mg of *desoxycortone acetate* CRS in *acetone* R and dilute to 10 mL with the same solvent. Dilute 5 mL of this solution to 10 mL with reference solution (a).

*Plate*: TLC silica gel F<sub>254</sub> plate R.

*Mobile phase*: add a mixture of 1.2 volumes of *water* R and 8 volumes of *methanol* R to a mixture of 15 volumes of *ether* R and 77 volumes of *methylene chloride* R.

*Application*: 5 µL.

*Development*: over a path of 15 cm.

*Drying*: in air.

*Detection A*: examine in ultraviolet light at 254 nm.

*Results A*: the principal spot in the chromatogram obtained with the test solution is similar in position and size to the principal spot in the chromatogram obtained with reference solution (a).

*Detection B*: spray with *alcoholic solution of sulfuric acid* R. Heat at 120 °C for 10 min or until the spots appear. Allow to cool. Examine in daylight and in ultraviolet light at 365 nm.

*Results B*: the principal spot in the chromatogram obtained with the test solution is similar in position, colour in daylight, fluorescence in ultraviolet light at 365 nm and size to the principal spot in the chromatogram obtained with reference solution (a).

*System suitability*: reference solution (b):

- the chromatogram shows 2 clearly separated spots.

C. Add about 2 mg to 2 mL of a mixture of 0.5 mL of *water* R and 1.5 mL of *sulfuric acid* R and shake to dissolve. Within 5 min, a pink colour develops. Add this solution to 10 mL of *water* R and mix. The colour fades and a clear solution remains.

D. Mix about 5 mg with 45 mg of *heavy magnesium oxide* R and ignite in a crucible until an almost white residue is obtained (usually less than 5 min). Allow to cool, add 1 mL of *water* R, 0.05 mL of *phenolphthalein solution* R1 and about 1 mL of *dilute hydrochloric acid* R to render the solution colourless. Filter. To a freshly prepared mixture of 0.1 mL of *alizarin S solution* R and 0.1 mL of *zirconyl nitrate solution* R add 1.0 mL of the filtrate. Mix, allow to stand for 5 min and compare the colour of the solution with that of a blank prepared in the same manner. The test solution is yellow and the blank is red.

#### TESTS

**Solution S**. Dissolve 0.50 g in *acetone* R and dilute to 25.0 mL with the same solvent.

**Appearance of solution**. Solution S is clear (2.2.1) and not more intensely coloured than reference solution BY<sub>6</sub> (2.2.2, *Method II*).



**Specific optical rotation** (2.2.7): + 69 to + 77 (dried substance), determined on solution S.

**Related substances.** Liquid chromatography (2.2.29).

**Test solution.** Dissolve 25.0 mg of the substance to be examined in the mobile phase and dilute to 25.0 mL with the mobile phase. Dilute 5.0 mL of this solution to 50.0 mL with the mobile phase.

**Reference solution (a).** Dissolve 10 mg of *dexamethasone pivalate CRS* in the mobile phase and dilute to 100.0 mL with the mobile phase. To 5.0 mL of this solution, add 5.0 mL of the test solution, mix and dilute to 50.0 mL with the mobile phase.

**Reference solution (b).** Dilute 2.0 mL of the test solution to 100.0 mL with the mobile phase.

**Column:**

- size:  $l = 0.25$  m,  $\varnothing = 4.6$  mm;
- stationary phase: octadecylsilyl silica gel for chromatography R (5  $\mu$ m).

**Mobile phase:** tetrahydrofuran R, acetonitrile R, water R, methanol R (5:30:30:35 V/V/V/V).

**Flow rate:** 0.6 mL/min.

**Detection:** spectrophotometer at 254 nm.

**Injection:** 20  $\mu$ L.

**Run time:** 1.5 times the retention time of flumetasone pivalate.

**Relative retention** with reference to flumetasone pivalate: impurity C = about 1.1.

**System suitability:** reference solution (a):

- resolution: minimum 2.8 between the peaks due to flumetasone pivalate and impurity C; if necessary, adjust the concentration of tetrahydrofuran in the mobile phase.

**Limits:**

- impurities A, B, C, D: for each impurity, not more than 0.75 times the area of the principal peak in the chromatogram obtained with reference solution (b) (1.5 per cent);
- total: not more than the area of the principal peak in the chromatogram obtained with reference solution (b) (2 per cent);
- disregard limit: 0.025 times the area of the principal peak in the chromatogram obtained with reference solution (b) (0.05 per cent).

**Loss on drying** (2.2.32): maximum 1.0 per cent, determined on 0.500 g by drying in an oven at 105 °C for 4 h.

#### ASSAY

Dissolve 50.0 mg in *ethanol (96 per cent) R* and dilute to 100.0 mL with the same solvent. Dilute 2.0 mL of this solution to 100.0 mL with *ethanol (96 per cent) R*. Measure the absorbance (2.2.25) at the absorption maximum at 239 nm.

Calculate the content of  $C_{27}H_{36}F_2O_6$  taking the specific absorbance to be 336.

#### STORAGE

Protected from light.

#### IMPURITIES

**Specified impurities:** A, B, C, D.

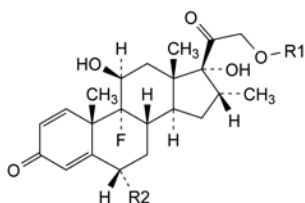

- A. R1 = H, R2 = F: 6 $\alpha$ ,9-difluoro-11 $\beta$ ,17,21-trihydroxy-16 $\alpha$ -methylpregna-1,4-diene-3,20-dione (flumetasone),
- B. R1 = CO-CH<sub>3</sub>, R2 = F: 6 $\alpha$ ,9-difluoro-11 $\beta$ ,17-dihydroxy-16 $\alpha$ -methyl-3,20-dioxopregna-1,4-dien-21-yl acetate (flumetasone acetate),

- C. R1 = CO-C(CH<sub>3</sub>)<sub>3</sub>, R2 = H: 9-fluoro-11 $\beta$ ,17-dihydroxy-16 $\alpha$ -methyl-3,20-dioxopregna-1,4-dien-21-yl 2,2-dimethylpropanoate (dexamethasone pivalate),
- D. R1 = CO-C(CH<sub>3</sub>)<sub>3</sub>, R2 = Cl: 6 $\alpha$ -chloro-9-fluoro-11 $\beta$ ,17-dihydroxy-16 $\alpha$ -methyl-3,20-dioxopregna-1,4-dien-21-yl 2,2-dimethylpropanoate (chlorodexamethasone pivalate).

01/2008:1722  
corrected 7.0

## FLUNARIZINE DIHYDROCHLORIDE

### Flunarizini dihydrochloridum

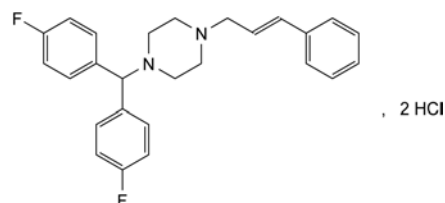

$C_{26}H_{28}Cl_2F_2N_2$   
[30484-77-6]

$M_r$  477.4

#### DEFINITION

1-[Bis(4-fluorophenyl)methyl]-4-[(2E)-3-phenylprop-2-enyl]piperazine dihydrochloride.

**Content:** 99.0 per cent to 101.5 per cent (dried substance).

#### CHARACTERS

**Appearance:** white or almost white powder, hygroscopic.

**Solubility:** slightly soluble in water, sparingly soluble in methanol, slightly soluble in alcohol and in methylene chloride. mp: about 208 °C, with decomposition.

#### IDENTIFICATION

A. Infrared absorption spectrophotometry (2.2.24).

**Comparison:** Ph. Eur. reference spectrum of flunarizine dihydrochloride.

B. Dissolve 25 mg in 2 mL of *methanol R* and add 0.5 mL of *water R*. The solution gives reaction (a) of chlorides (2.3.1).

#### TESTS

**Related substances.** Liquid chromatography (2.2.29). Prepare the solutions immediately before use and protect from light.

**Test solution.** Dissolve 0.100 g of the substance to be examined in *methanol R* and dilute to 10.0 mL with the same solvent.

**Reference solution (a).** Dissolve 10 mg of *flunarizine dihydrochloride for system suitability CRS* in *methanol R* and dilute to 1.0 mL with the same solvent.

**Reference solution (b).** Dilute 1.0 mL of the test solution to 100.0 mL with *methanol R*. Dilute 5.0 mL of this solution to 20.0 mL with *methanol R*.

**Column:**

- size:  $l = 0.10$  m,  $\varnothing = 4.6$  mm,
- stationary phase: base-deactivated octadecylsilyl silica gel for chromatography R (3  $\mu$ m).

**Mobile phase:**

- mobile phase A: solution containing 23.8 g/L of *tetrabutylammonium hydrogen sulfate R* and 7 g/L of *ammonium acetate R*,
- mobile phase B: *acetonitrile R*,

Time (min)	Mobile phase A (per cent V/V)	Mobile phase B (per cent V/V)
0 - 12	80 → 40	20 → 60
12 - 15	40	60

Flow rate: 1.5 mL/min.

Detection: spectrophotometer at 230 nm.

Injection: 10 µL.

System suitability: reference solution (a):

- *peak-to-valley ratio*: minimum 1.5, where  $H_p$  = height above the baseline of the peak due to impurity C and  $H_v$  = height above the baseline of the lowest point of the curve separating this peak from the peak due to flunarizine,
- the chromatogram obtained is concordant with the chromatogram supplied with *flunarizine dihydrochloride for system suitability CRS*.

Limits:

- *correction factor*: for the calculation of content, multiply the peak area of impurity A by 1.5,
- *impurities A, D*: for each impurity, not more than 0.4 times the area of the principal peak in the chromatogram obtained with reference solution (b) (0.1 per cent),
- *impurity B*: not more than twice the area of the principal peak in the chromatogram obtained with reference solution (b) (0.5 per cent),
- *impurity C*: not more than the area of the principal peak in the chromatogram obtained with reference solution (b) (0.25 per cent),
- *any other impurity*: for each impurity, not more than 0.4 times the area of the principal peak in the chromatogram obtained with reference solution (b) (0.1 per cent),
- *total*: not more than 4 times the area of the principal peak in the chromatogram obtained with reference solution (b) (1.0 per cent),
- *disregard limit*: 0.2 times the area of the principal peak in the chromatogram obtained with reference solution (b) (0.05 per cent).

**Loss on drying** (2.2.32): maximum 5.0 per cent, determined on 1.000 g by drying in an oven at 105 °C for 4 h.

**Sulfated ash** (2.4.14): maximum 0.1 per cent, determined on 1.0 g in a platinum crucible.

#### ASSAY

Dissolve 0.200 g in 70 mL of *alcohol R*. Carry out a potentiometric titration (2.2.20), using 0.1 M *sodium hydroxide*. Read the volume added at the second point of inflexion. Carry out a blank titration.

1 mL of 0.1 M *sodium hydroxide* is equivalent to 23.87 mg of  $C_{16}H_{12}FN_3O_3$ .

#### STORAGE

In an airtight container, protected from light.

#### IMPURITIES

*Specified impurities: A, B, C, D.*

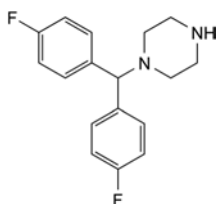

A. 1-[bis(4-fluorophenyl)methyl]piperazine,

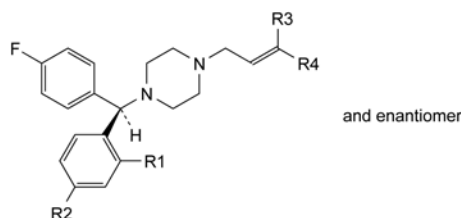

- B. R1 = R2 = R3 = H, R4 = C<sub>6</sub>H<sub>5</sub>: 1-[(*RS*)-(4-fluorophenyl)phenylmethyl]-4-[(*2E*)-3-phenylprop-2-enyl]piperazine,
- C. R1 = F, R2 = R3 = H, R4 = C<sub>6</sub>H<sub>5</sub>: 1-[(*RS*)-(2-fluorophenyl)(4-fluorophenyl)methyl]-4-[(*2E*)-3-phenylprop-2-enyl]piperazine,
- D. R1 = R4 = H, R2 = F, R3 = C<sub>6</sub>H<sub>5</sub>: 1-[bis(4-fluorophenyl)methyl]-4-[(*2Z*)-3-phenylprop-2-enyl]piperazine.

01/2008:0717  
corrected 6.0

## FLUNITRAZEPAM

### Flunitrazepamum

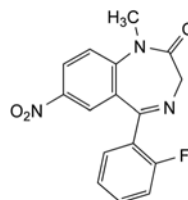

$C_{16}H_{12}FN_3O_3$   
[1622-62-4]

$M_r$  313.3

#### DEFINITION

5-(2-Fluorophenyl)-1-methyl-7-nitro-1,3-dihydro-2*H*-1,4-benzodiazepin-2-one.

*Content*: 99.0 per cent to 101.0 per cent (dried substance).

#### CHARACTERS

*Appearance*: white or yellowish, crystalline powder.

*Solubility*: practically insoluble in water, soluble in acetone, slightly soluble in alcohol.

#### IDENTIFICATION

Infrared absorption spectrophotometry (2.2.24).

*Comparison*: Ph. Eur. reference spectrum of flunitrazepam.

#### TESTS

**Related substances.** Liquid chromatography (2.2.29). Prepare the solutions immediately before use.

*Test solution.* Dissolve 100.0 mg of the substance to be examined in 10 mL of *acetonitrile R* and dilute to 50.0 mL with the mobile phase.

*Reference solution (a).* Dilute 1.0 mL of the test solution to 100.0 mL with the mobile phase. Dilute 5.0 mL of this solution to 50.0 mL with the mobile phase.

*Reference solution (b).* Dissolve 4 mg of the substance to be examined and 4 mg of *nitrazepam R* in 5 mL of *acetonitrile R* and dilute to 20.0 mL with the mobile phase. Dilute 1.0 mL of the solution to 20.0 mL with the mobile phase.

*Column*:

- *size*:  $l = 0.15$  m,  $\varnothing = 4.6$  mm,
- *stationary phase*: octadecylsilyl silica gel for chromatography R (5 µm).

*Mobile phase*: *methanol R*, *acetonitrile R*, *water R* (50:305:645 V/V/V).

*Flow rate*: 1.0 mL/min.

*Detection*: spectrophotometer at 254 nm.

**Injection:** 20 µL.

**Run time:** 6 times the retention time of flunitrazepam.

**Relative retention** with reference to flunitrazepam (retention time = about 11 min): impurity A = about 0.2; impurity B = about 0.6; impurity C = about 2.3; impurity D = about 4.0.

**System suitability:** reference solution (b):

– **resolution:** minimum 4.0 between the peaks due to nitrazepam and flunitrazepam.

**Limits:**

- **correction factor:** for the calculation of content, multiply the peak area of impurity C by 2.44,
- **any impurity:** not more than the area of the principal peak in the chromatogram obtained with reference solution (a) (0.1 per cent),
- **total:** not more than 3 times the area of the principal peak in the chromatogram obtained with reference solution (a) (0.3 per cent),
- **disregard limit:** 0.5 times the area of the principal peak in the chromatogram obtained with reference solution (a) (0.05 per cent).

**Loss on drying** (2.2.32): maximum 0.5 per cent, determined on 1.000 g by drying in an oven at 105 °C.

**Sulfated ash** (2.4.14): maximum 0.1 per cent, determined on 1.0 g.

#### ASSAY

Dissolve 0.250 g in 20 mL of *anhydrous acetic acid R* and add 50 mL of *acetic anhydride R*. Titrate with 0.1 M *perchloric acid*, determining the end-point potentiometrically (2.2.20).

1 mL of 0.1 M *perchloric acid* is equivalent to 31.33 mg of C<sub>16</sub>H<sub>12</sub>FN<sub>3</sub>O<sub>3</sub>.

#### STORAGE

Protected from light.

#### IMPURITIES

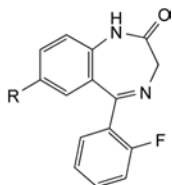

- A. R = NH<sub>2</sub>: 7-amino-5-(2-fluorophenyl)-1,3-dihydro-2H-1,4-benzodiazepin-2-one (7-aminodemethylflunitrazepam),
- B. R = NO<sub>2</sub>: 5-(2-fluorophenyl)-7-nitro-1,3-dihydro-2H-1,4-benzodiazepin-2-one (demethylflunitrazepam),

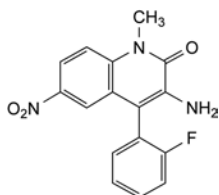

- C. 3-amino-4-(2-fluorophenyl)-1-methyl-6-nitroquinolin-2(1H)-one,

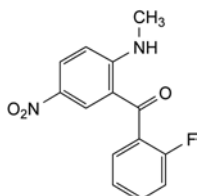

- D. (2-fluorophenyl)[2-(methylamino)-5-nitrophenyl]methanone.

01/2008:1696  
corrected 6.0

## FLUNIXIN MEGLUMINE FOR VETERINARY USE

### Flunixini megluminum ad usum veterinarium

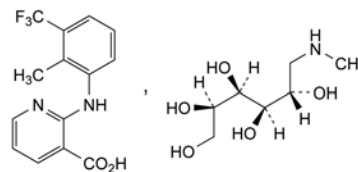

C<sub>21</sub>H<sub>28</sub>F<sub>3</sub>N<sub>3</sub>O<sub>7</sub>  
[42461-84-7]

M<sub>r</sub> 491.5

#### DEFINITION

2-[[2-Methyl-3-(trifluoromethyl)phenyl]amino]pyridine-3-carboxylic acid, 1-deoxy-1-(methylamino)-D-glucitol.

**Content:** 99.0 per cent to 101.0 per cent (dried substance).

#### CHARACTERS

**Appearance:** white or almost white, crystalline powder.

**Solubility:** freely soluble in water and in methanol, practically insoluble in acetone.

#### IDENTIFICATION

- A. Specific optical rotation (2.2.7): –9.0 to –12.0 (dried substance), determined on solution S (see Tests).
- B. Infrared absorption spectrophotometry (2.2.24).

**Comparison:** *flunixin meglumine CRS*.

#### TESTS

**Solution S.** Dissolve 2.50 g in *carbon dioxide-free water R* and dilute to 50.0 mL with the same solvent.

**Appearance of solution.** Solution S is clear (2.2.1) and not more intensely coloured than reference solution Y<sub>7</sub> (2.2.2, *Method II*).

**pH** (2.2.3): 7.0 to 9.0 for solution S.

**Related substances.** Liquid chromatography (2.2.29).

**Test solution.** Dissolve 50.0 mg of the substance to be examined in the mobile phase and dilute to 10.0 mL with the mobile phase.

**Reference solution (a).** Dissolve 5.0 mg of *flunixin impurity B CRS* in 1.0 mL of the test solution and dilute to 50.0 mL with the mobile phase.

**Reference solution (b).** Dissolve 5.0 mg of *2-chloronicotinic acid R* (impurity A) in the mobile phase and dilute to 50.0 mL with the mobile phase. To 2.0 mL of this solution add 2.0 mL of reference solution (a) and dilute to 20.0 mL with the mobile phase.

**Reference solution (c).** Dissolve 50 mg of *flunixin impurity C CRS* in the mobile phase and dilute to 100 mL with the mobile phase.

**Column:**

- **size:** *l* = 0.125 m, Ø = 4.0 mm,
- **stationary phase:** *octadecylsilyl silica gel for chromatography R* (5 µm).

**Mobile phase:** mix 300 volumes of *water R* and 700 volumes of *acetonitrile R*, and add 0.25 volumes of *phosphoric acid R*.

**Flow rate:** 1.0 mL/min.

**Detection:** spectrophotometer at 254 nm.

**Injection:** 10 µL.

**Run time:** 5 times the retention time of flunixin.

**Relative retention** with reference to flunixin (retention time = about 3.1 min): impurity A = about 0.4; impurity C = about 0.6; impurity B = about 0.7; impurity D = about 4.2.

*System suitability*: reference solution (a):

- *resolution*: minimum 3.5 between the peaks due to impurity B and flunixin.

*Limits*:

- *correction factor*: for the calculation of content, multiply the peak area of impurity C by 1.9,
- *impurity A*: not more than the area of the corresponding peak in the chromatogram obtained with reference solution (b) (0.2 per cent),
- *impurity B*: not more than the area of the corresponding peak in the chromatogram obtained with reference solution (b) (0.2 per cent),
- *impurities C, D*: for each impurity, not more than the area of the peak due to flunixin in the chromatogram obtained with reference solution (b) (0.2 per cent),
- *any other impurity*: for each impurity, not more than the area of the peak due to flunixin in the chromatogram obtained with reference solution (b) (0.2 per cent),
- *total*: not more than 2.5 times the area of the peak due to flunixin in the chromatogram obtained with reference solution (b) (0.5 per cent),
- *disregard limit*: 0.25 times the area of the peak due to flunixin in the chromatogram obtained with reference solution (b) (0.05 per cent).

**Loss on drying** (2.2.32): maximum 0.5 per cent, determined on 1.000 g by drying in an oven at 105 °C for 4 h.

**Sulfated ash** (2.4.14): maximum 0.1 per cent, determined on 1.0 g.

#### ASSAY

Dissolve 0.175 g in 50 mL of *anhydrous acetic acid R*. Titrate with 0.1 M *perchloric acid*, determining the end-point potentiometrically (2.2.20).

1 mL of 0.1 M *perchloric acid* is equivalent to 24.57 mg of  $C_{21}H_{28}F_3N_3O_7$ .

#### IMPURITIES

*Specified impurities: A, B, C, D.*

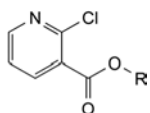

A. R = H: 2-chloropyridine-3-carboxylic acid,

C. R =  $C_2H_5$ : ethyl 2-chloropyridine-3-carboxylate,

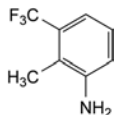

B. 2-methyl-3-(trifluoromethyl)aniline,

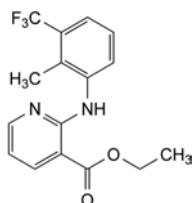

D. ethyl 2-[[2-methyl-3-(trifluoromethyl)phenyl]amino]pyridine-3-carboxylate.

01/2008:0494  
corrected 6.0

## FLUOCINOLONE ACETONIDE

### Fluocinoloni acetonidum

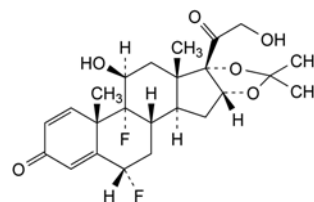

$C_{24}H_{30}F_2O_6$   
[67-73-2]

$M_r$  452.5

#### DEFINITION

6 $\alpha$ ,9-Difluoro-11 $\beta$ ,21-dihydroxy-16 $\alpha$ ,17-(1-methylethylidene-dioxy)pregna-1,4-diene-3,20-dione.

*Content*: 97.0 per cent to 103.0 per cent (dried substance).

#### CHARACTERS

*Appearance*: white or almost white, crystalline powder.

*Solubility*: practically insoluble in water, soluble in acetone and in ethanol.

It shows polymorphism (5.9).

#### IDENTIFICATION

A. Infrared absorption spectrophotometry (2.2.24).

*Comparison*: fluocinolone acetonide CRS.

If the spectra obtained in the solid state show differences, dissolve the substance to be examined and the reference substance separately in *ethanol R*, evaporate to dryness and record new spectra using the residues.

B. Examine the chromatograms obtained in the test for related substances.

*Results*: the principal peak in the chromatogram obtained with the reference solution (b) is similar in retention time to the peak due to *fluocinolone acetonide CRS* in the chromatogram obtained with the reference solution (a).

#### TESTS

**Specific optical rotation** (2.2.7): + 100 to + 104 (dried substance).

Dissolve 0.100 g in *ethanol R* and dilute to 10.0 mL with the same solvent.

**Related substances**. Liquid chromatography (2.2.29). *Carry out the test protected from light.*

*Test solution*. Dissolve 25.0 mg of the substance to be examined in *acetonitrile R* and dilute to 10.0 mL with the same solvent.

*Reference solution (a)*. Dissolve 2.5 mg of *fluocinolone acetonide CRS* and 2.5 mg of *triamcinolone acetonide R* in 45 mL of *acetonitrile R* and dilute to 100.0 mL with *water R*.

*Reference solution (b)*. Dilute 1.0 mL of the test solution to 100.0 mL with *acetonitrile R*.

*Column*:

- *size*:  $l = 0.25$  m,  $\emptyset = 4.6$  mm,
- *stationary phase*: base-deactivated end-capped octadecylsilyl silica gel for chromatography R (5  $\mu$ m).

*Mobile phase*: mix 450 mL of *acetonitrile R* with 500 mL of *water R* and allow to equilibrate; adjust the volume to 1000.0 mL with *water R* and mix again.

*Flow rate*: 1 mL/min.

*Detection*: spectrophotometer at 238 nm.

*Injection*: 20  $\mu$ L.

*Run time*: 4 times the retention time of fluocinolone acetonide.

*Retention times:* triamcinolone acetonide = about 8.5 min;  
flucinolone acetonide = about 10 min.

*System suitability:*

- *resolution:* minimum of 3.0 between the peaks due to triamcinolone acetonide and flucinolone acetonide in the chromatogram obtained with reference solution (a).

*Limits:*

- *any impurity:* not more than the area of the principal peak in the chromatogram obtained with reference solution (b) (1 per cent) and not more than 1 such peak has an area greater than half the area of the principal peak in the chromatogram obtained with reference solution (b) (0.5 per cent),
- *total:* not more than 2.5 times the area of the principal peak in the chromatogram obtained with reference solution (b) (2.5 per cent),
- *disregard limit:* 0.05 times the area of the principal peak in the chromatogram obtained with reference solution (b) (0.05 per cent).

**Loss on drying (2.2.32):** maximum 1.0 per cent, determined on 1.000 g by drying in an oven at 105 °C for 3 h.

#### ASSAY

*Protect the solutions from light throughout the assay.*

Dissolve 50.0 mg in *alcohol R* and dilute to 50.0 mL with the same solvent. Dilute 2.0 mL of this solution to 100.0 mL with *alcohol R*. Measure the absorbance (2.2.25) at the maximum at 238 nm.

Calculate the content of  $C_{24}H_{30}F_2O_6$  taking the specific absorbance to be 355.

#### STORAGE

Protected from light.

#### IMPURITIES

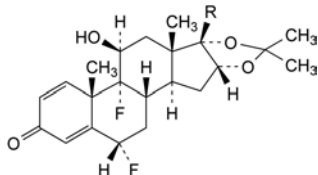

- A. R = CO-CO<sub>2</sub>H: 6 $\alpha$ ,9-difluoro-11 $\beta$ -hydroxy-16 $\alpha$ ,17-(1-methylethylidenedioxy)-3,20-dioxopregna-1,4-dien-21-oic acid,
- B. R = CO<sub>2</sub>H: 6 $\alpha$ ,9-difluoro-11 $\beta$ -hydroxy-16 $\alpha$ ,17-(1-methylethylidenedioxy)-3-oxoandrosta-1,4-diene-17 $\beta$ -carboxylic acid,
- D. R = CO-CH=O: 6 $\alpha$ ,9-difluoro-11 $\beta$ -hydroxy-16 $\alpha$ ,17-(1-methylethylidenedioxy)-3,20-dioxopregna-1,4-dien-21-al,

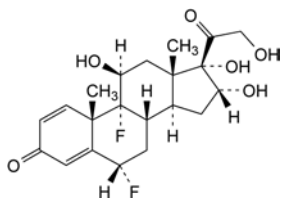

- C. 6 $\alpha$ ,9-difluoro-11 $\beta$ ,16 $\alpha$ ,17,21-tetrahydroxypregna-1,4-diene-3,20-dione (flucinolone),

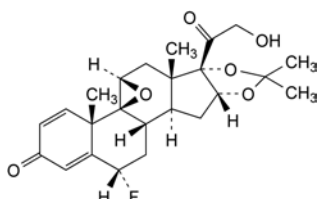

- E. 9,11 $\beta$ -epoxy-6 $\alpha$ -fluoro-21-hydroxy-16 $\alpha$ ,17-(1-methylethylidenedioxy)-9 $\beta$ -pregna-1,4-diene-3,20-dione,

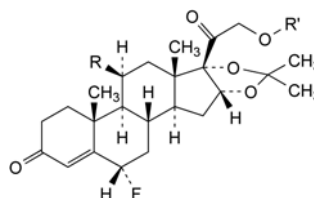

- F. R = R' = H: 6 $\alpha$ -fluoro-21-hydroxy-16 $\alpha$ ,17-(1-methylethylidenedioxy)pregn-4-ene-3,20-dione,
- G. R = OH, R' = CO-CH<sub>3</sub>: 6 $\alpha$ -fluoro-11 $\beta$ -hydroxy-16 $\alpha$ ,17-(1-methylethylidenedioxy)-3,20-dioxopregna-4-en-21-yl acetate.

01/2008:1212  
corrected 6.0

## FLUCORTOLONE PIVALATE

### Fluocortoloni pivalas

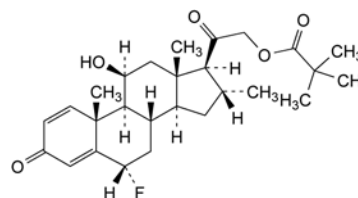

$C_{27}H_{37}FO_5$   
[29205-06-9]

$M_r$  460.6

#### DEFINITION

6 $\alpha$ -Fluoro-11 $\beta$ -hydroxy-16 $\alpha$ -methyl-3,20-dioxopregna-1,4-dien-21-yl 2,2-dimethylpropanoate.

*Content:* 97.0 per cent to 103.0 per cent (dried substance).

#### CHARACTERS

*Appearance:* white or almost white, crystalline powder.

*Solubility:* practically insoluble in water, freely soluble in methylene chloride and in dioxan, sparingly soluble in ethanol (96 per cent).

#### IDENTIFICATION

*First identification:* A, B.

*Second identification:* B, C, D.

A. Infrared absorption spectrophotometry (2.2.24).

*Comparison:* fluocortolone pivalate CRS.

B. Thin-layer chromatography (2.2.27).

*Solvent mixture:* methanol R, methylene chloride R (1:9 V/V).

*Test solution.* Dissolve 10 mg of the substance to be examined in the solvent mixture and dilute to 10 mL with the solvent mixture.

*Reference solution (a).* Dissolve 20 mg of fluocortolone pivalate CRS in the solvent mixture and dilute to 20 mL with the solvent mixture.

*Reference solution (b).* Dissolve 10 mg of norethisterone CRS in reference solution (a) and dilute to 10 mL with reference solution (a).

*Plate:* TLC silica gel F<sub>254</sub> plate R.

*Mobile phase:* add a mixture of 1.2 volumes of water R and 8 volumes of methanol R to a mixture of 15 volumes of ether R and 77 volumes of methylene chloride R.

*Application:* 5  $\mu$ L.

*Development:* over a path of 15 cm.

*Drying:* in air.

*Detection A:* examine in ultraviolet light at 254 nm.

**Results A:** the principal spot in the chromatogram obtained with the test solution is similar in position and size to the principal spot in the chromatogram obtained with reference solution (a).

**Detection B:** spray with *alcoholic solution of sulfuric acid R*. Heat at 120 °C for 10 min or until the spots appear. Allow to cool. Examine in daylight and in ultraviolet light at 365 nm.

**Results B:** the principal spot in the chromatogram obtained with the test solution is similar in position, colour in daylight, fluorescence in ultraviolet light at 365 nm and size to the principal spot in the chromatogram obtained with reference solution (a).

**System suitability:** reference solution (b):

– the chromatogram shows 2 clearly separated spots.

C. To about 1 mg add 2 mL of a mixture of 2 volumes of *glacial acetic acid R* and 3 volumes of *sulfuric acid R* and heat for 1 min on a water-bath. A red colour is produced. Add 5 mL of *water R*, the colour changes to violet-red.

D. Mix about 5 mg with 45 mg of *heavy magnesium oxide R* and ignite in a crucible until an almost white residue is obtained (usually less than 5 min). Allow to cool, add 1 mL of *water R*, 0.05 mL of *phenolphthalein solution R1* and about 1 mL of *dilute hydrochloric acid R* to render the solution colourless. Filter and add to the filtrate a freshly prepared mixture of 0.1 mL of *alizarin S solution R* and 0.1 mL of *zirconyl nitrate solution R*. Mix, allow to stand for 5 min and compare the colour of the solution with that of a blank prepared in the same manner. The test solution is yellow and the blank is red.

## TESTS

**Specific optical rotation (2.2.7):** + 100 to + 105 (dried substance).

Dissolve 0.25 g in *dioxan R* and dilute to 25.0 mL with the same solvent.

**Related substances.** Liquid chromatography (2.2.29).

**Test solution.** Dissolve 10.0 mg of the substance to be examined in *acetonitrile R* and dilute to 10.0 mL with the same solvent.

**Reference solution (a).** Dilute 1.0 mL of the test solution to 100.0 mL with *acetonitrile R*.

**Reference solution (b).** Dissolve 2 mg of *fluocortolone pivalate CRS* and 2 mg of *prednisolone hexanoate CRS* in *acetonitrile R*, then dilute to 100 mL with the same solvent.

**Column:**

– *size:*  $l = 0.25$  m,  $\varnothing = 4.6$  mm;

– *stationary phase:* *octadecylsilyl silica gel for chromatography R* (5  $\mu$ m).

**Mobile phase:** *methanol R*, *acetonitrile R*, *water R* (25:30:32 V/V/V).

**Flow rate:** 1.5 mL/min.

**Detection:** spectrophotometer at 243 nm.

**Injection:** 20  $\mu$ L.

**Run time:** twice the retention time of fluocortolone pivalate.

**System suitability:** reference solution (b):

– *resolution:* minimum 5.0 between the peaks due to fluocortolone pivalate and prednisolone hexanoate.

**Limits:**

– *impurities A, B, C, D:* for each impurity, not more than the area of the principal peak in the chromatogram obtained with reference solution (a) (1 per cent);

– *total:* not more than twice the area of the principal peak in the chromatogram obtained with reference solution (a) (2 per cent);

– *disregard limit:* 0.025 times the area of the principal peak in the chromatogram obtained with reference solution (a) (0.025 per cent).

**Loss on drying (2.2.32):** maximum 1.0 per cent, determined on 1.000 g by drying in an oven at 105 °C.

**Sulfated ash (2.4.14):** maximum 0.1 per cent, determined on 1.0 g.

## ASSAY

Dissolve 30.0 mg in *anhydrous ethanol R* and dilute to 100.0 mL with the same solvent. Dilute 5.0 mL of this solution to 100.0 mL with *anhydrous ethanol R*. Measure the absorbance (2.2.25) at the absorption maximum at 242 nm.

Calculate the content of  $C_{27}H_{37}FO_5$  taking the specific absorbance to be 350.

## STORAGE

Protected from light.

## IMPURITIES

*Specified impurities: A, B, C, D.*

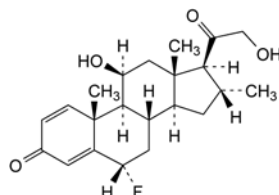

A. 6 $\alpha$ -fluoro-11 $\beta$ ,21-dihydroxy-16 $\alpha$ -methylpregna-1,4-diene-3,20-dione (fluocortolone),

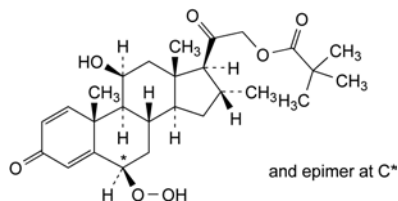

B. 6-hydroperoxy-11 $\beta$ -hydroxy-16 $\alpha$ -methyl-3,20-dioxopregna-1,4-dien-21-yl 2,2-dimethylpropanoate,

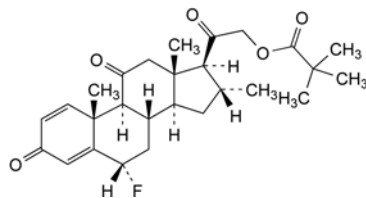

C. 6 $\alpha$ -fluoro-16 $\alpha$ -methyl-3,11,20-trioxopregna-1,4-dien-21-yl 2,2-dimethylpropanoate,

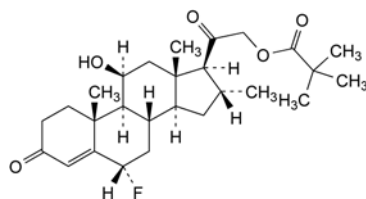

D. 6 $\alpha$ -fluoro-11 $\beta$ -hydroxy-16 $\alpha$ -methyl-3,20-dioxopregna-4-en-21-yl 2,2-dimethylpropanoate.

01/2008:2348  
corrected 7.0

## FLUORESCEIN

## Fluoresceinum

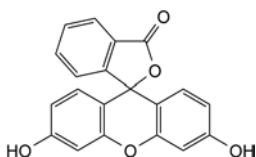
C<sub>20</sub>H<sub>12</sub>O<sub>5</sub>  
[2321-07-5]M<sub>r</sub> 332.3

## DEFINITION

3',6'-Dihydroxy-3H-spiro[isobenzofuran-1,9'-xanthen]-3-one.

Content: 97.0 per cent to 102.0 per cent (dried substance).

## CHARACTERS

Appearance: orange-red, fine powder.

Solubility: practically insoluble in water, soluble in hot ethanol (96 per cent). It dissolves in dilute solutions of alkali hydroxides.

## IDENTIFICATION

First identification: A, D.

Second identification: B, C, D.

A. Infrared absorption spectrophotometry (2.2.24).

Comparison: fluorescein CRS.

Dissolve the substance to be examined and the reference substance separately in the minimum volume of ethanol (96 per cent) R, evaporate to dryness and record the spectra using the residues.

B. Dilute 0.1 mL of solution S (see Tests) to 10 mL with water R. The solution shows a yellowish-green fluorescence. The fluorescence disappears on addition of 0.1 mL of dilute hydrochloric acid R and reappears on addition of 0.2 mL of dilute sodium hydroxide solution R.

C. The absorption by a piece of filter paper of 0.05 mL of the solution prepared for identification B (before the addition of dilute hydrochloric acid R) colours the paper yellow. On exposing the moist paper to bromine vapour for 1 min and then to ammonia vapour, the colour becomes deep pink.

D. Suspend 0.5 g in 50 mL of water R and shake for 10 min. The substance does not completely dissolve.

## TESTS

**Solution S.** Suspend 1.0 g in 35.0 mL of water R and add dropwise with shaking 4.5 mL of 1 M sodium hydroxide. Adjust to pH 8.5-9.0 with 1 M sodium hydroxide and dilute to 50.0 mL with water R to obtain a clear solution.**Appearance of solution.** Solution S is clear (2.2.1) and orange-yellow with yellowish-green fluorescence.**Related substances.** Liquid chromatography (2.2.29).

Solvent mixture: acetonitrile for chromatography R, mobile phase A (30:70 V/V).

Test solution (a). Disperse 50.0 mg of the substance to be examined in 15.0 mL of ethanol (96 per cent) R. Sonicate and dilute to 50.0 mL with the solvent mixture.

Test solution (b). Dilute 5.0 mL of test solution (a) to 250.0 mL with the solvent mixture.

Reference solution (a). Disperse 50.0 mg of fluorescein CRS in 15.0 mL of ethanol (96 per cent) R. Sonicate and dilute to 50.0 mL with water R. Dilute 5.0 mL of this solution to 250.0 mL with the solvent mixture.

Reference solution (b). Dissolve 10.0 mg of phthalic acid CRS (impurity B) and 10.0 mg of resorcinol CRS (impurity A) in the solvent mixture and dilute to 100.0 mL with the solvent mixture. Dilute 1.0 mL of this solution to 100.0 mL with the solvent mixture.

Reference solution (c). Dilute 5.0 mL of test solution (b) to 20.0 mL with the solvent mixture.

Reference solution (d). Dilute 10.0 mL of reference solution (c) to 100.0 mL with the solvent mixture.

Reference solution (e). Dissolve the contents of a vial of fluorescein impurity C CRS in 1 mL of the solvent mixture.

Column:

- size:  $l = 0.25$  m,  $\varnothing = 4.6$  mm;
- stationary phase: octylsilyl silica gel for chromatography R3 (5  $\mu$ m);
- temperature: 35 °C.

Mobile phase:

- mobile phase A: dissolve 0.610 g of potassium dihydrogen phosphate R in water for chromatography R, adjust to pH 2.0 with phosphoric acid R and dilute to 1000.0 mL with water for chromatography R;
- mobile phase B: acetonitrile for chromatography R;

Time (min)	Mobile phase A (per cent V/V)	Mobile phase B (per cent V/V)
0 - 20	85 → 20	15 → 80
20 - 29	20	80

Flow rate: 1.0 mL/min.

Detection: spectrophotometer at 220 nm.

Injection: 20  $\mu$ L of test solution (a) and reference solutions (b), (c), (d) and (e).

Identification of impurity C: use the chromatogram obtained with reference solution (e) to identify the peak due to impurity C.

Relative retention with reference to fluorescein (retention time = about 15 min): impurity A = about 0.42; impurity B = about 0.48; impurity C = about 0.86.

System suitability: reference solution (b):

- resolution: minimum 2.0 between the peaks due to impurities A and B.

Limits:

- correction factor: for the calculation of content, multiply the peak area of impurity C by 1.9;
- impurity C: not more than 1.2 times the area of the principal peak in the chromatogram obtained with reference solution (c) (0.6 per cent);
- impurities A, B: for each impurity, not more than the area of the corresponding peak in the chromatogram obtained with reference solution (b) (0.1 per cent);
- unspecified impurities: for each impurity, not more than 0.2 times the area of the principal peak in the chromatogram obtained with reference solution (c) (0.10 per cent);
- sum of impurities other than A, B and C: not more than 0.4 times the area of the principal peak in the chromatogram obtained with reference solution (c) (0.2 per cent);
- disregard limit: the area of the principal peak in the chromatogram obtained with reference solution (d) (0.05 per cent).

**Chlorides** (2.4.4): maximum 0.25 per cent.

To 10.0 mL of solution S add 90.0 mL of water R and 3.0 mL of dilute nitric acid R, wait for at least 30 min and filter. Dilute 10.0 mL of the filtrate to 15.0 mL with water R.

**Loss on drying** (2.2.32): maximum 1.0 per cent, determined on 1.000 g by drying in an oven at 105 °C.

## ASSAY

Liquid chromatography (2.2.29) as described in the test for related substances with the following modification.

*Injection*: test solution (b) and reference solution (a).

Calculate the percentage content of  $C_{20}H_{12}O_5$  from the declared content of *fluorescein CRS*.

## STORAGE

Protected from light.

## IMPURITIES

*Specified impurities*: A, B, C.

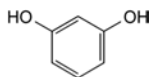

A. benzene-1,3-diol (resorcinol),

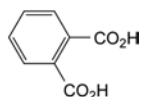

B. benzene-1,2-dicarboxylic acid (phthalic acid),

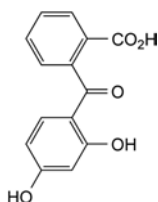

C. 2-(2,4-dihydroxybenzoyl)benzoic acid.

01/2008:1213  
corrected 6.0

## FLUORESC EIN SODIUM

## Fluoresceinum natricum

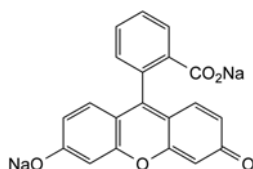

$C_{20}H_{10}Na_2O_5$   
[518-47-8]

$M_r$  376.3

## DEFINITION

Disodium 2-(6-oxido-3-oxo-3*H*-xanthen-9-yl)benzoate.

*Content*: 95.0 per cent to 103.0 per cent (dried substance).

## CHARACTERS

*Appearance*: orange-red, fine powder, hygroscopic.

*Solubility*: freely soluble in water, soluble in ethanol (96 per cent), practically insoluble in hexane and in methylene chloride.

## IDENTIFICATION

*First identification*: B, D.

*Second identification*: A, C, D.

A. Dilute 0.1 mL of solution S (see Tests) to 10 mL with *water R*. The solution shows yellowish-green fluorescence. The fluorescence disappears on addition of 0.1 mL of *dilute hydrochloric acid R* and reappears on addition of 0.2 mL of *dilute sodium hydroxide solution R*.

B. Infrared absorption spectrophotometry (2.2.24).

*Preparation*: discs.

*Comparison*: Ph. Eur. reference spectrum of *fluorescein sodium*.

C. The absorption by a piece of filter paper of 0.05 mL of the solution prepared for identification A (before the addition of *dilute hydrochloric acid R*) colours the paper yellow. On exposing the moist paper to bromine vapour for 1 min and then to ammonia vapour, the colour becomes deep pink.

D. Ignite 0.1 g in a porcelain crucible. Dissolve the residue in 5 mL of *water R* and filter. 2 mL of the filtrate gives reaction (a) of sodium (2.3.1).

## TESTS

**Solution S.** Dissolve 1.0 g in *carbon dioxide-free water R* prepared from *distilled water R* and dilute to 50 mL with the same solvent.

**Appearance of solution.** Solution S is clear (2.2.1) and orange-yellow with yellowish-green fluorescence.

**pH** (2.2.3): 7.0 to 9.0 for solution S.

**Related substances.** Liquid chromatography (2.2.29).

*Test solution (a).* Dissolve 0.100 g of the substance to be examined in a mixture of 30 volumes of *acetonitrile R* and 70 volumes of mobile phase A and dilute to 100.0 mL with the same mixture of solvents.

*Test solution (b).* Dilute 5.0 mL of test solution (a) to 250.0 mL with a mixture of 30 volumes of *acetonitrile R* and 70 volumes of mobile phase A.

*Reference solution (a).* Dissolve 55.0 mg of *diacetylfluorescein CRS* in a mixture of 1 mL of 2.5 *M sodium hydroxide* and 5 mL of *ethanol (96 per cent) R*, heat on a water-bath for 20 min mixing frequently, cool and dilute to 50.0 mL with *water R*. Dilute 5.0 mL of the solution to 250.0 mL with a mixture of 30 volumes of *acetonitrile R* and 70 volumes of mobile phase A.

*Reference solution (b).* Dissolve 10.0 mg of *phthalic acid R* (impurity B) and 10.0 mg of *resorcinol R* (impurity A) in a mixture of 30 volumes of *acetonitrile R* and 70 volumes of mobile phase A and dilute to 100.0 mL with the same mixture of solvents. Dilute 5.0 mL of the solution to 100.0 mL with a mixture of 30 volumes of *acetonitrile R* and 70 volumes of mobile phase A.

*Reference solution (c).* Dilute 5.0 mL of test solution (b) to 20.0 mL with a mixture of 30 volumes of *acetonitrile R* and 70 volumes of mobile phase A.

*Column*:

- *size*:  $l = 0.25$  m,  $\varnothing = 4.6$  mm;
- *stationary phase*: *octylsilyl silica gel for chromatography R* (5  $\mu$ m);
- *temperature*: 35 °C.

*Mobile phase*:

- *mobile phase A*: dissolve 0.610 g of *potassium dihydrogen phosphate R* in *water R* and dilute to 1000 mL with the same solvent; adjust to pH 2.0 with *phosphoric acid R*;
- *mobile phase B*: *acetonitrile for chromatography R*;

Time (min)	Mobile phase A (per cent V/V)	Mobile phase B (per cent V/V)
0 - 20	85 → 20	15 → 80
20 - 29	20	80
29 - 30	20 → 85	80 → 15
30 - 35	85	15

*Flow rate*: 1.0 mL/min.

*Detection*: spectrophotometer at 220 nm.

*Injection*: 20  $\mu$ L of test solution (a) and reference solutions (b) and (c).

*Relative retention* with reference to fluorescein (retention time = about 15 min): impurity A = about 0.4; impurity B = about 0.5; impurity C = about 0.9.



*System suitability*: reference solution (b):

- *resolution*: minimum 1.5 between the peaks due to impurity A and impurity B.

*Limits*:

- *correction factor*: for the calculation of content, multiply the peak area of impurity C by 1.6;
- *impurities A, B*: for each impurity, not more than the area of the corresponding peak in the chromatogram obtained with reference solution (b) (0.5 per cent);
- *impurity C*: not more than the area of the principal peak in the chromatogram obtained with reference solution (c) (0.5 per cent);
- *unspecified impurities*: for each impurity, not more than 0.2 times the area of the principal peak in the chromatogram obtained with reference solution (c) (0.10 per cent);
- *sum of impurities other than A, B, C*: not more than the area of the principal peak in the chromatogram obtained with reference solution (c) (0.5 per cent);
- *disregard limit*: 0.1 times the area of the principal peak in the chromatogram obtained with reference solution (c) (0.05 per cent).

**Chlorides** (2.4.4): maximum 0.25 per cent.

To 10 mL of solution S add 90 mL of *water R* and 1 mL of *dilute nitric acid R*, wait for at least 10 min and filter. Dilute 10 mL of the filtrate to 15 mL with *water R*.

**Sulfates** (2.4.13): maximum 1.0 per cent.

To 5 mL of solution S add 90 mL of *distilled water R*, 2.5 mL of *dilute hydrochloric acid R* and dilute to 100 mL with *distilled water R*. Filter.

**Zinc**. Dilute 5 mL of solution S to 10 mL with *water R*. Add 2 mL of *hydrochloric acid R1*, filter and add 0.1 mL of *potassium ferrocyanide solution R*. No turbidity or precipitate is formed immediately.

**Loss on drying** (2.2.32): maximum 10.0 per cent, determined on 1.000 g by drying in an oven at 105 °C.

#### ASSAY

Liquid chromatography (2.2.29) as described in the test for related substances with the following modification.

*Injection*: test solution (b) and reference solution (a).

Calculate the percentage content of  $C_{20}H_{10}Na_2O_5$  using the chromatogram obtained with reference solution (a) and the declared content of *diacetylfluorescein CRS*.

1 mg of *diacetylfluorescein CRS* is equivalent to 0.9037 mg of  $C_{20}H_{10}Na_2O_5$ .

#### STORAGE

In an airtight container, protected from light.

#### IMPURITIES

*Specified impurities*: A, B, C.

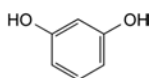

A. benzene-1,3-diol (resorcinol),

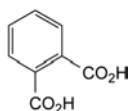

B. benzene-1,2-dicarboxylic acid (phthalic acid),

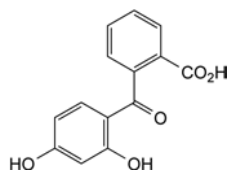

C. 2-(2,4-dihydroxybenzoyl)benzoic acid.

01/2008:0611

## FLUOROURACIL

### Fluorouracilum

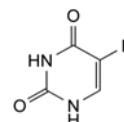

$C_4H_3FN_2O_2$   
[51-21-8]

$M_r$  130.1

#### DEFINITION

5-Fluoropyrimidine-2,4(1*H*,3*H*)-dione.

*Content*: 98.5 per cent to 101.0 per cent (dried substance).

#### CHARACTERS

*Appearance*: white or almost white, crystalline powder.

*Solubility*: sparingly soluble in water, slightly soluble in ethanol (96 per cent).

#### IDENTIFICATION

Infrared absorption spectrophotometry (2.2.24).

*Comparison*: *fluorouracil CRS*.

#### TESTS

**Solution S**. Dissolve 0.5 g in *carbon dioxide-free water R* and dilute to 50 mL with the same solvent.

**Appearance of solution**. Solution S is clear (2.2.1) and not more intensely coloured than reference solution BY<sub>7</sub> or Y<sub>7</sub> (2.2.2, *Method II*).

**pH** (2.2.3): 4.5 to 5.0 for solution S.

**Impurities F and G**. Thin-layer chromatography (2.2.27).

*Test solution*. Dissolve 0.10 g of the substance to be examined in a mixture of equal volumes of *methanol R* and *water R* and dilute to 10.0 mL with the same mixture of solvents.

*Reference solution (a)*. Dissolve 5.0 mg of *fluorouracil impurity F CRS* in a mixture of equal volumes of *methanol R* and *water R* and dilute to 200.0 mL with the same mixture of solvents.

*Reference solution (b)*. Dissolve 20.0 mg of *urea R* (impurity G) in *methanol R* and dilute to 10.0 mL with the same solvent. Dilute 1.0 mL of this solution to 100.0 mL with *methanol R*.

*Plate*: TLC silica gel F<sub>254</sub> plate R.

*Mobile phase*: *methanol R*, *water R*, *ethyl acetate R* (15:15:70 V/V/V).

*Application*: 10 µL.

*Development*: over a path of 2/3 of the plate.

*Drying*: in air.

*Detection*:

- *impurity F*: examine in ultraviolet light at 254 nm;
- *impurity G*: spray with a mixture of 200 mL of a 10 g/L solution of *dimethylaminobenzaldehyde R* in *anhydrous ethanol R* and 20 mL of *hydrochloric acid R*; dry in an oven at 80 °C for 3-4 min, then examine in daylight (impurity G produces a yellow spot and fluorouracil is not detected by the spray).

**System suitability:** the chromatogram shows 2 clearly separated spots after both detections.

**Limits:**

- **impurity F:** any spot due to impurity F is not more intense than the spot in the chromatogram obtained with reference solution (a) (0.25 per cent);
- **impurity G:** any spot due to impurity G is not more intense than the spot in the chromatogram obtained with reference solution (b) (0.2 per cent).

**Related substances.** Liquid chromatography (2.2.29). Carry out the test protected from light.

**Test solution.** Dissolve 50.0 mg of the substance to be examined in the mobile phase and dilute to 50.0 mL with the mobile phase. Dilute 5.0 mL of this solution to 50.0 mL with the mobile phase.

**Reference solution (a).** Dissolve 5.0 mg of *fluorouracil impurity C CRS* in the mobile phase and dilute to 50.0 mL with the mobile phase.

**Reference solution (b).** Dilute 1.0 mL of reference solution (a) to 100.0 mL with the mobile phase. Dilute 1.0 mL of this solution to 10.0 mL with the mobile phase.

**Reference solution (c).** Dissolve 5.0 mg of *fluorouracil impurity A CRS* in the mobile phase and dilute to 50.0 mL with the mobile phase. Dilute 1.0 mL of the solution to 100.0 mL with the mobile phase. Dilute 1.0 mL of this solution to 10.0 mL with the mobile phase.

**Reference solution (d).** Dissolve 5.0 mg of *fluorouracil impurity B CRS* in the mobile phase and dilute to 50.0 mL with the mobile phase. Dilute 1.0 mL of the solution to 100.0 mL with the mobile phase. Dilute 1.0 mL of this solution to 10.0 mL with the mobile phase.

**Reference solution (e).** Dilute 1.0 mL of the test solution to 100.0 mL with the mobile phase. Dilute 1.0 mL of this solution to 10.0 mL with the mobile phase.

**Reference solution (f).** To 1 mL of reference solution (a) add 1 mL of the test solution and dilute to 10 mL with the mobile phase.

**Reference solution (g).** Dissolve the contents of a vial of *fluorouracil impurity mixture CRS* (containing impurities D and E) in 1.0 mL of the mobile phase.

**Column:**

- **size:**  $l = 0.25$  m,  $\varnothing = 4.6$  mm;
- **stationary phase:** octadecylsilyl silica gel for chromatography R (5  $\mu$ m).

**Mobile phase:** 6.805 g/L solution of *potassium dihydrogen phosphate R* adjusted to pH  $5.7 \pm 0.1$  with 5 M *potassium hydroxide*.

**Flow rate:** 1.0 mL/min.

**Detection:** spectrophotometer at 266 nm.

**Injection:** 20  $\mu$ L.

**Run time:** 3 times the retention time of fluorouracil.

**Identification of impurities:** use the chromatogram supplied with *fluorouracil impurity mixture CRS* and the chromatogram obtained with reference solution (g) to identify the peaks due to impurities D and E.

**Relative retention** with reference to fluorouracil (retention time = about 6 min): impurity A = about 0.5; impurity B = about 0.7; impurity C = about 0.9; impurity D = about 1.6; impurity E = about 1.9.

**System suitability:** reference solution (f):

- **resolution:** minimum 2 between the peaks due to impurity C and fluorouracil.

**Limits:**

- **correction factors:** for the calculation of content, multiply the peak areas of the following impurities by the corresponding correction factor: impurity D = 1.5; impurity E = 1.3;

- **impurity A:** not more than the area of the corresponding peak in the chromatogram obtained with reference solution (c) (0.1 per cent);
- **impurity B:** not more than the area of the corresponding peak in the chromatogram obtained with reference solution (d) (0.1 per cent);
- **impurity C:** not more than the area of the corresponding peak in the chromatogram obtained with reference solution (b) (0.1 per cent);
- **impurities D, E:** for each impurity, not more than the area of the principal peak in the chromatogram obtained with reference solution (e) (0.1 per cent);
- **unspecified impurities:** for each impurity, not more than the area of the principal peak in the chromatogram obtained with reference solution (e) (0.10 per cent);
- **total:** not more than 5 times the area of the principal peak in the chromatogram obtained with reference solution (e) (0.5 per cent);
- **disregard limit:** 0.5 times the area of the principal peak in the chromatogram obtained with reference solution (e) (0.05 per cent).

**Heavy metals (2.4.8):** maximum 20 ppm.

1.0 g complies with test C. Use a platinum crucible. Prepare the reference solution using 2 mL of *lead standard solution (10 ppm Pb) R*.

**Loss on drying (2.2.32):** maximum 0.5 per cent, determined on 1.000 g by drying *in vacuo* at 80 °C for 4 h.

**Sulfated ash (2.4.14):** maximum 0.1 per cent, determined on 1.0 g in a platinum crucible.

#### ASSAY

Dissolve 0.100 g in 80 mL of *dimethylformamide R*, warming gently. Cool and titrate with 0.1 M *tetrabutylammonium hydroxide*, using 0.25 mL of a 10 g/L solution of *thymol blue R* in *dimethylformamide R* as indicator. Carry out a blank titration.

1 mL of 0.1 M *tetrabutylammonium hydroxide* is equivalent to 13.01 mg of  $C_4H_3FN_2O_2$ .

#### STORAGE

Protected from light.

#### IMPURITIES

**Specified impurities:** A, B, C, D, E, F, G.

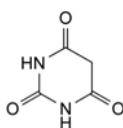

A. pyrimidine-2,4,6(1H,3H,5H)-trione (barbituric acid),

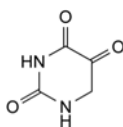

B. dihydropyrimidine-2,4,5(3H)-trione (isobarbituric acid or 5-hydroxyuracil),

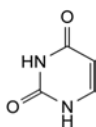

C. pyrimidine-2,4(1H,3H)-dione (uracil),

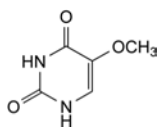

D. 5-methoxypyrimidine-2,4(1H,3H)-dione (5-methoxyuracil),

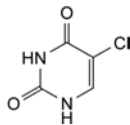

E. 5-chloropyrimidine-2,4(1H,3H)-dione (5-chlorouracil),

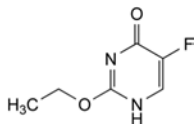

F. 2-ethoxy-5-fluoropyrimidin-4(1H)-one (2-ethoxy-5-fluorouracil),

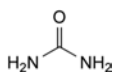

G. carbamide (urea).

01/2011:1104

## FLUOXETINE HYDROCHLORIDE

### Fluoxetini hydrochloridum

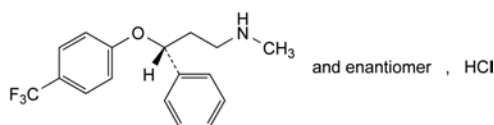

$C_{17}H_{19}ClF_3NO$   
[56296-78-7]

$M_r$  345.8

#### DEFINITION

(3*RS*)-*N*-Methyl-3-phenyl-3-[4-(trifluoromethyl)phenoxy]propan-1-amine hydrochloride.

*Content*: 98.0 per cent to 102.0 per cent (anhydrous substance).

#### CHARACTERS

*Appearance*: white or almost white, crystalline powder.

*Solubility*: sparingly soluble in water, freely soluble in methanol, sparingly soluble in methylene chloride.

#### IDENTIFICATION

A. Infrared absorption spectrophotometry (2.2.24).

*Comparison*: fluoxetine hydrochloride CRS.

B. It gives reaction (a) of chlorides (2.3.1).

#### TESTS

**Solution S.** Dissolve 2.0 g in a mixture of 15 volumes of *water R* and 85 volumes of *methanol R*, then dilute to 100.0 mL with the same mixture of solvents.

**Appearance of solution.** Solution S is clear (2.2.1) and colourless (2.2.2, *Method II*).

**pH** (2.2.3): 4.5 to 6.5.

Dissolve 0.20 g in *carbon dioxide-free water R* and dilute to 20 mL with the same solvent.

**Optical rotation** (2.2.7):  $-0.05^\circ$  to  $+0.05^\circ$ , determined on solution S.

**Related substances.** Liquid chromatography (2.2.29).

**Test solution (a).** Dissolve 55 mg of the substance to be examined in the mobile phase and dilute to 10.0 mL with the mobile phase.

**Test solution (b).** Dilute 2.0 mL of test solution (a) to 10.0 mL with the mobile phase.

**Reference solution.** Dissolve 22 mg of *fluoxetine hydrochloride CRS* in 10.0 mL of 0.5 *M sulfuric acid*. Heat at about 85 °C for 3 h. Allow to cool. The resulting solution contains considerable quantities of impurity A and usually also contains 4-trifluoromethylphenol. To 0.4 mL of this solution add 28.0 mg of *fluoxetine hydrochloride CRS*, about 1 mg of *fluoxetine impurity B CRS* and about 1 mg of *fluoxetine impurity C CRS*, then dilute to 25.0 mL with the mobile phase.

#### Column:

- size:  $l = 0.25$  m,  $\varnothing = 4.6$  mm;
- stationary phase: octylsilyl silica gel for chromatography *R* (5  $\mu$ m).

**Mobile phase:** mix 8 volumes of *methanol R*, 30 volumes of *tetrahydrofuran R* and 62 volumes of a solution of *triethylamine R* prepared as follows: to 10 mL of *triethylamine R*, add 980 mL of *water R*, mix and adjust to pH 6.0 with *phosphoric acid R* (about 4.5 mL) and dilute to 1000 mL with *water R*.

**Flow rate:** 1 mL/min.

**Detection:** spectrophotometer at 215 nm.

**Injection:** 10  $\mu$ L.

**Run time:** 3 times the retention time of fluoxetine.

**Identification of impurities:** use the chromatogram obtained with the reference solution to identify the peaks due to impurities A, B and C.

**Relative retention** with reference to fluoxetine: impurity A = about 0.24; impurity B = about 0.27; impurity C = about 0.9.

**System suitability:** reference solution:

- retention time: fluoxetine = 10 min to 18 min; 4-trifluoromethylphenol: maximum 35 min; if no peak due to 4-trifluoromethylphenol is observed, inject a 0.02 per cent solution of 4-trifluoromethylphenol *R* in the mobile phase;
- peak-to-valley ratio: minimum 11, where  $H_p$  = height above the baseline of the peak due to impurity C and  $H_v$  = height above the baseline of the lowest point of the curve separating this peak from the peak due to fluoxetine. If necessary, reduce the volume of methanol and increase the volume of the solution of triethylamine in the mobile phase.

**Limit:** test solution (b):

- impurity C: not more than 0.0015 times the area of the principal peak (0.15 per cent).

**Limits:** test solution (a):

- impurities A, B: for each impurity, not more than 0.0125 times the area of the principal peak in the chromatogram obtained with test solution (b) (0.25 per cent);
- unspecified impurities: for each impurity, not more than 0.005 times the area of the principal peak in the chromatogram obtained with test solution (b) (0.10 per cent);
- total: not more than 0.025 times the area of the principal peak in the chromatogram obtained with test solution (b) (0.5 per cent);
- disregard limit: 0.0025 times the area of the principal peak in the chromatogram obtained with test solution (b) (0.05 per cent).

**Acetonitrile.** Gas chromatography (2.2.28).

**Test solution.** Dissolve 50 mg of the substance to be examined in *dimethylformamide R* and dilute to 5.0 mL with the same solvent.

**Reference solution.** To 1.0 g of *acetonitrile R*, add *dimethylformamide R*, mix and dilute to 100.0 mL with the same solvent. Dilute 1.0 mL of this solution to 1000.0 mL with *dimethylformamide R*.

**Column:**

- *material*: fused silica;
  - *size*:  $l = 30$  m,  $\varnothing = 0.53$  mm;
  - *stationary phase*: macrogol 20 000 R (film thickness 1  $\mu$ m).
- Carrier gas*: helium for chromatography R.  
*Flow rate*: 10 mL/min.

**Temperature:**

	Time (min)	Temperature (°C)
Column	0 - 2	35
	2 - 14.33	35 → 220
	14.33 - 24.33	220
Injection port		250
Detector		250

**Detection:** flame ionisation.**Injection:** 1  $\mu$ L; inject *dimethylformamide R* as a blank.

In the chromatogram obtained with *dimethylformamide R*, verify that there is no peak with the same retention time as acetonitrile.

**Limit:**

- *acetonitrile*: not more than the area of the corresponding peak in the chromatogram obtained with the reference solution (0.1 per cent).

**Heavy metals (2.4.8):** maximum 20 ppm.

1.0 g complies with test C. Prepare the reference solution using 2 mL of *lead standard solution (10 ppm Pb) R*.

**Water (2.5.12):** maximum 0.5 per cent, determined on 1.00 g.**Sulfated ash (2.4.14):** maximum 0.1 per cent, determined on 1.0 g.**ASSAY**

Liquid chromatography (2.2.29) as described in the test for related substances with the following modifications.

**Test solution.** Dissolve 55.0 mg of the substance to be examined in the mobile phase and dilute to 50.0 mL with the mobile phase. Dilute 10.0 mL of this solution to 100.0 mL with the mobile phase.

**Reference solution.** Dissolve 55.0 mg of *fluoxetine hydrochloride CRS* in the mobile phase and dilute to 50.0 mL with the mobile phase. Dilute 10.0 mL of this solution to 100.0 mL with the mobile phase.

**Detection:** spectrophotometer at 227 nm.

**Retention time:** fluoxetine = 10 min to 18 min; if necessary, adjust the volumes of methanol and of the solution of triethylamine in the mobile phase.

**System suitability:** reference solution:

- *symmetry factor*: maximum 2.0 calculated at 10 per cent of the height of the peak due to fluoxetine.

Calculate the content of  $C_{17}H_{19}ClF_3NO$  from the declared content of *fluoxetine hydrochloride CRS*.

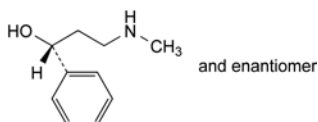
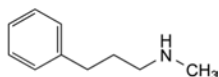
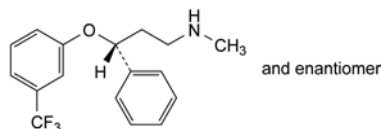
**IMPURITIES****Specified impurities:** A, B, C.A. (1*RS*)-3-(methylamino)-1-phenylpropan-1-ol,B. *N*-methyl-3-phenylpropan-1-amine,C. (3*RS*)-*N*-methyl-3-phenyl-3-[3-(trifluoromethyl)phenoxy]propan-1-amine.01/2008:1693  
corrected 6.0**FLUPENTIXOL DIHYDROCHLORIDE**

## Flupentixoli dihydrochloridum

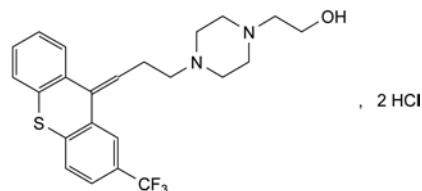
 $C_{23}H_{27}Cl_2F_3N_2OS$   
[2413-38-9] $M_r$  507.4**DEFINITION**

2-[4-[3-[(*EZ*)-2-(trifluoromethyl)-9*H*-thioxanthen-9-ylidene]propyl]piperazin-1-yl]ethanol dihydrochloride.

**Content:**

- flupentixol dihydrochloride: 98.0 per cent to 101.5 per cent (dried substance),
- *Z*-isomer: 42.0 per cent to 52.0 per cent.

**CHARACTERS****Appearance:** white or almost white powder.**Solubility:** very soluble in water, soluble in alcohol, practically insoluble in methylene chloride.**IDENTIFICATION****First identification:** A, D.**Second identification:** B, C, D.

A. Infrared absorption spectrophotometry (2.2.24).

*Comparison:* flupentixol dihydrochloride CRS.

B. Thin-layer chromatography (2.2.27).

**Test solution.** Dissolve 20 mg of the substance to be examined in *methanol R* and dilute to 10 mL with the same solvent.

**Reference solution.** Dissolve 20 mg of *flupentixol dihydrochloride CRS* in *methanol R* and dilute to 10 mL with the same solvent.

**Plate:** TLC silica gel  $F_{254}$  plate R.**Mobile phase:** water R, diethylamine R, methyl ethyl ketone R (1:4:95 V/V/V).**Application:** 2  $\mu$ L.**Development:** twice over a path of 15 cm.**Drying:** in air.**Detection A:** examine in ultraviolet light at 254 nm.

**Results A:** the principal spot in the chromatogram obtained with the test solution is similar in position and size to the principal spot in the chromatogram obtained with the reference solution. Doubling of the spot may be observed in both chromatograms.

**Detection B:** spray with *alcoholic solution of sulfuric acid R*; heat at 110 °C for 5 min and allow to cool; examine in ultraviolet light at 365 nm.

**Results B:** the principal spot in the chromatogram obtained with the test solution is similar in position and size to the principal spot in the chromatogram obtained with the reference solution. Doubling of the spot may be observed in both chromatograms.

- C. Mix about 5 mg with 45 mg of *heavy magnesium oxide R* and ignite in a crucible until an almost white residue is obtained (usually less than 5 min). Allow to cool, add 1 mL of *water R*, 0.05 mL of *phenolphthalein solution R1* and about 1 mL of *dilute hydrochloric acid R* to render the solution colourless. Filter and add to the filtrate a freshly prepared mixture of 0.1 mL of *alizarin S solution R* and 0.1 mL of *zirconyl nitrate solution R*. Mix, allow to stand for 5 min and compare the colour of the solution with that of a blank prepared in the same manner. The test solution is yellow. The blank is red.
- D. It gives reaction (a) of chlorides (2.3.1).

#### TESTS

**Appearance of solution.** The solution is clear (2.2.1) and not more intensely coloured than reference solution GY<sub>6</sub> (2.2.2, Method II).

Dissolve 2.0 g of the substance to be examined in *water R* and dilute to 20 mL with the same solvent.

**pH** (2.2.3): 2.0 to 3.0.

Dissolve 0.5 g in *carbon dioxide-free water R* and dilute to 50 mL with the same solvent.

**Related substances.** Thin-layer chromatography (2.2.27). Carry out the test protected from light and prepare the solutions immediately before use.

**Test solution (a).** Dissolve 0.40 g of the substance to be examined in *alcohol R* and dilute to 20 mL with the same solvent.

**Test solution (b).** Dilute 2.0 mL of test solution (a) to 20.0 mL with *alcohol R*.

**Reference solution (a).** Dilute 1.0 mL of test solution (b) to 50.0 mL with *alcohol R*.

**Reference solution (b).** Dilute 2.0 mL of reference solution (a) to 20.0 mL with *alcohol R*.

**Reference solution (c).** Dissolve 10 mg of *flupentixol impurity D CRS* in *alcohol R*, add 0.5 mL of test solution (a) and dilute to 20.0 mL with *alcohol R*.

**Plate:** TLC silica gel F<sub>254</sub> plate R.

**Mobile phase:** diethylamine R, toluene R, ethyl acetate R (10:20:70 V/V/V).

**Application:** 5 µL.

**Development:** in an unsaturated tank over a path of 10 cm.

**Drying:** in air.

**Detection:** spray with *alcoholic solution of sulfuric acid R*, heat at 110 °C for 5 min and allow to cool; examine in ultraviolet light at 365 nm. Doubling of the spot due to flupentixol may be observed.

**System suitability:** the chromatogram obtained with reference solution (c) shows 2 clearly separated spots.

**Limits:**

- in the chromatogram obtained with test solution (a): any spots, apart from the principal spot, are not more intense than the spot, or spots in the chromatogram obtained with reference solution (a) (0.2 per cent),
- in the chromatogram obtained with test solution (b): any spots, apart from the principal spot, are not more intense than the spot or spots in the chromatogram obtained with reference solution (b) (0.2 per cent).

**Impurity F.** Liquid chromatography (2.2.29). Carry out the test protected from light and prepare the solutions immediately before use.

**Test solution.** Dissolve 20.0 mg of the substance to be examined in the mobile phase and dilute to 20.0 mL with the mobile phase.

**Reference solution.** Dissolve 10.0 mg of *flupentixol dihydrochloride CRS* and 10.0 mg of *flupentixol impurity F CRS* in the mobile phase and dilute to 100.0 mL with the mobile phase. Dilute 1.0 mL of the solution to 20.0 mL with the mobile phase.

**Column:**

- size:  $l = 0.125$  m,  $\emptyset = 4.6$  mm,
- stationary phase: octylsilyl silica gel for chromatography R (3 µm)

**Mobile phase:** mix 10 volumes of *acetonitrile R*, 55 volumes of *methanol R* and 35 volumes of a solution containing 8.72 g/L of *potassium dihydrogen phosphate R*, 0.37 g/L of *anhydrous disodium hydrogen phosphate R* and 0.77 g/L of *dodecyltrimethylammonium bromide R*.

**Flow rate:** 1.0 mL/min.

**Detection:** spectrophotometer at 270 nm.

**Injection:** 20 µL.

**System suitability:** reference solution:

- resolution: minimum 2.0 between the 2<sup>nd</sup> of the peaks due to impurity F and the 1<sup>st</sup> of the peaks due to flupentixol. Peak splitting may not always occur.

**Limit:**

- impurity F: not more than the area of the corresponding peak or peaks in the chromatogram obtained with the reference solution (0.5 per cent).

**Heavy metals** (2.4.8): maximum 20 ppm.

1.0 g complies with limit test C. Prepare the standard using 2 mL of *lead standard solution (10 ppm Pb) R*.

**Loss on drying** (2.2.32): maximum 2.0 per cent, determined on 1.000 g by drying in an oven at 105 °C.

**Sulfated ash** (2.4.14): maximum 0.1 per cent, determined on 1.0 g in a platinum crucible.

#### ASSAY

**Flupentixol dihydrochloride.** Dissolve 0.200 g in 30 mL of *alcohol R*. Carry out a potentiometric titration (2.2.20), using 0.1 M *sodium hydroxide*. Read the volume added between the 2 points of inflexion.

1 mL of 0.1 M *sodium hydroxide* is equivalent to 50.74 mg of C<sub>23</sub>H<sub>27</sub>Cl<sub>2</sub>F<sub>3</sub>N<sub>2</sub>OS.

**Z-Isomer.** Liquid chromatography (2.2.29).

**Test solution.** Dissolve 20.0 mg of the substance to be examined in the mobile phase and dilute to 50.0 mL with the mobile phase.

**Reference solution.** Dissolve 20.0 mg of *flupentixol dihydrochloride CRS* in the mobile phase and dilute to 50.0 mL with the mobile phase.

**Column:**

- size:  $l = 0.25$  m,  $\emptyset = 4.0$  mm,
- stationary phase: silica gel for chromatography R (5 µm).

**Mobile phase:** *water R*, concentrated ammonia R, 2-propanol R, heptane R (2:4:150:850 V/V/V/V).

**Flow rate:** 1.5 mL/min.

**Detection:** spectrophotometer at 254 nm.

**Injection:** 20 µL.

**System suitability:** reference solution:

- resolution: minimum 3.0 between the peaks due to Z-isomer (1<sup>st</sup> peak) and to E-isomer (2<sup>nd</sup> peak).

**Results:**

- calculate the percentage content of Z-isomer taking into account the assigned content of Z-isomer in *flupentixol dihydrochloride CRS*,
- calculate the ratio of the area of the peak due to the E-isomer to the area of the peak due to the Z-isomer: this ratio is 0.9 to 1.4.

## STORAGE

Protected from light.

01/2008:1014  
corrected 7.0

## IMPURITIES

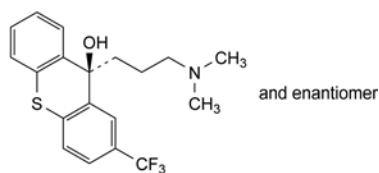

- A. (9*RS*)-9-[3-(dimethylamino)propyl]-2-(trifluoromethyl)-9*H*-thioxanthen-9-ol,

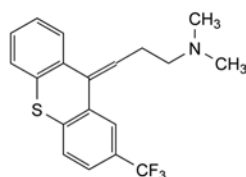

- B. *N,N*-dimethyl-3-[(*EZ*)-2-(trifluoromethyl)-9*H*-thioxanthen-9-ylidene]propan-1-amine,

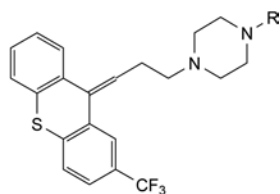

- C. R = H: 1-[3-[(*EZ*)-2-(trifluoromethyl)-9*H*-thioxanthen-9-ylidene]propyl]piperazine,

- D. R = CH<sub>2</sub>-CH<sub>2</sub>-O-CH<sub>2</sub>-CH<sub>2</sub>-OH: 2-[2-[4-[3-[(*EZ*)-2-(trifluoromethyl)-9*H*-thioxanthen-9-ylidene]propyl]piperazin-1-yl]ethoxy]ethanol,

- E. R = CH<sub>2</sub>-CH<sub>2</sub>-O-CO-CH<sub>3</sub>: 2-[4-[3-[(*EZ*)-2-(trifluoromethyl)-9*H*-thioxanthen-9-ylidene]propyl]piperazin-1-yl]ethyl acetate,

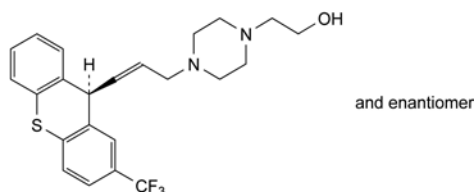

- F. 2-[4-[(*EZ*)-3-[(9*RS*)-2-(trifluoromethyl)-9*H*-thioxanthen-9-yl]prop-2-enyl]piperazin-1-yl]ethanol,

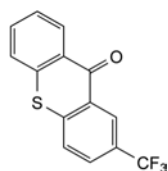

- G. 2-(trifluoromethyl)-9*H*-thioxanthen-9-one.

## FLUPHENAZINE DECANOATE

## Fluphenazine decanoate

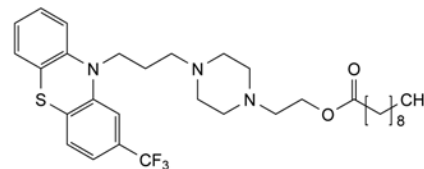

C<sub>32</sub>H<sub>44</sub>F<sub>3</sub>N<sub>3</sub>O<sub>2</sub>S  
[5002-47-1]

*M<sub>r</sub>* 591.8

## DEFINITION

2-[4-[3-[2-(Trifluoromethyl)-10*H*-phenothiazin-10-yl]propyl]piperazin-1-yl]ethyl decanoate.

*Content*: 98.5 per cent to 101.5 per cent (dried substance).

## CHARACTERS

*Appearance*: pale yellow, viscous liquid or yellow solid.

*Solubility*: practically insoluble in water, very soluble in ethanol and in methylene chloride, freely soluble in methanol.

## IDENTIFICATION

*First identification*: B, C.

*Second identification*: A, C.

- A. Dissolve 50.0 mg in *methanol R* and dilute to 100.0 mL with the same solvent. Dilute 1.0 mL to 50.0 mL with *methanol R*. Examined between 230 nm and 350 nm (2.2.25), the solution shows an absorption maximum at 260 nm and a broad absorption maximum at about 310 nm. The specific absorbance at the maximum at 260 nm is 570 to 630.

- B. Infrared absorption spectrophotometry (2.2.24).

*Preparation*: apply 50 µL of a 25 g/L solution in *methylene chloride R* to a disc of *potassium bromide R*. Dry the discs at 60 °C for 1 h before use.

*Comparison*: *fluphenazine decanoate CRS*.

- C. Thin-layer chromatography (2.2.27).

*Test solution*. Dissolve 10 mg of the substance to be examined in *methanol R* and dilute to 10 mL with the same solvent.

*Reference solution (a)*. Dissolve 10 mg of *fluphenazine decanoate CRS* in *methanol R* and dilute to 10 mL with the same solvent.

*Reference solution (b)*. Dissolve 5 mg of *fluphenazine enantate CRS* in reference solution (a) and dilute to 5 mL with the same solution.

*Plate*: TLC octadecylsilyl silica gel F<sub>254</sub> plate R.

*Mobile phase*: concentrated ammonia R1, water R, *methanol R* (1:4:95 V/V/V).

*Application*: 2 µL.

*Development*: over a path of 8 cm.

*Detection*: examine in ultraviolet light at 254 nm.

*System suitability*: the chromatogram obtained with reference solution (b) shows 2 clearly separated spots.

*Results*: the principal spot in the chromatogram obtained with the test solution is similar in position and size to the principal spot in the chromatogram obtained with reference solution (a).

## TESTS

**Related substances.** Liquid chromatography (2.2.29). Carry out the test protected from light and prepare the solutions immediately before use.

**Test solution.** Dissolve 10.0 mg of the substance to be examined in acetonitrile R and dilute to 50.0 mL with the same solvent.

**Reference solution (a).** Dissolve 5 mg of fluphenazine octanoate CRS and 5 mg of fluphenazine enantate CRS in acetonitrile R and dilute to 50 mL with the same solvent.

**Reference solution (b).** Dilute 5.0 mL of the test solution to 100.0 mL with a mixture of 5 volumes of mobile phase A and 95 volumes of mobile phase B. Dilute 1.0 mL of this solution to 10.0 mL with a mixture of 5 volumes of mobile phase A and 95 volumes of mobile phase B.

**Reference solution (c).** Dissolve 11.7 mg of fluphenazine dihydrochloride CRS and 5.0 mg of fluphenazine sulfoxide CRS in a mixture of 5 volumes of water R and 95 volumes of acetonitrile R and dilute to 100.0 mL with the same mixture of solvents. Dilute 1.0 mL to 50.0 mL with a mixture of 5 volumes of water R and 95 volumes of acetonitrile R.

**Column:**

- size:  $l = 0.25$  m,  $\varnothing = 4.6$  mm,
- stationary phase: spherical octadecylsilyl silica gel for chromatography R (5  $\mu$ m).

**Mobile phase:**

- mobile phase A: 10 g/L solution of ammonium carbonate R adjusted to pH 7.5 with dilute hydrochloric acid R,
- mobile phase B: mobile phase A, acetonitrile R, methanol R (7.5:45:45 V/V/V),

Time (min)	Mobile phase A (per cent V/V)	Mobile phase B (per cent V/V)
0 - 7	20	80
7 - 17	20 $\rightarrow$ 0	80 $\rightarrow$ 100
17 - 80	0	100

**Flow rate:** 1.0 mL/min.

**Detection:** spectrophotometer at 260 nm.

**Injection:** 10  $\mu$ L.

**Relative retention** with reference to fluphenazine decanoate (retention time = about 34 min): impurity A = about 0.13; impurity B = about 0.33; impurity C = about 0.76; impurity D = about 0.82.

**System suitability:** reference solution (a):

- resolution: minimum 6 between the peaks due to impurity C and impurity D.

**Limits:**

- impurity A: not more than the area of the corresponding peak in the chromatogram obtained with reference solution (c) (0.5 per cent),
- impurity B: not more than the area of the corresponding peak in the chromatogram obtained with reference solution (c) (1.0 per cent),
- any other impurity: not more than the area of the principal peak in the chromatogram obtained with reference solution (b) (0.5 per cent),
- total: not more than 2.0 per cent,
- disregard limit for any other impurity: 0.1 times the area of the principal peak in the chromatogram obtained with reference solution (b) (0.05 per cent).

**Heavy metals** (2.4.8): maximum 20 ppm.

1.0 g complies with limit test C. Prepare the standard using 2 mL of lead standard solution (10 ppm Pb) R.

**Loss on drying** (2.2.32): maximum 1.0 per cent, determined on 1.000 g by drying in an oven at 60 °C at a pressure not exceeding 0.7 kPa for 3 h.

**Sulfated ash** (2.4.14): maximum 0.1 per cent, determined on 1.0 g in a platinum crucible.

## ASSAY

Dissolve 0.250 g in 30 mL of glacial acetic acid R. Using 0.05 mL of crystal violet solution R as indicator, titrate with 0.1 M perchloric acid until the colour changes from violet to green.

1 mL of 0.1 M perchloric acid is equivalent to 29.59 mg of  $C_{32}H_{44}F_3N_3O_2S$ .

## STORAGE

Protected from light.

## IMPURITIES

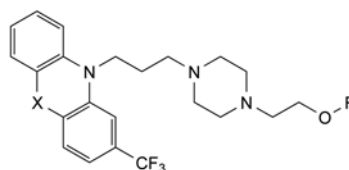

- A. X = SO, R = H: fluphenazine S-oxide,  
 B. X = S, R = H: fluphenazine,  
 C. X = S, R = CO-[CH<sub>2</sub>]<sub>5</sub>-CH<sub>3</sub>: fluphenazine enantate,  
 D. X = S, R = CO-[CH<sub>2</sub>]<sub>6</sub>-CH<sub>3</sub>: fluphenazine octanoate,  
 E. X = S, R = CO-[CH<sub>2</sub>]<sub>7</sub>-CH<sub>3</sub>: fluphenazine nonanoate,  
 F. X = S, R = CO-[CH<sub>2</sub>]<sub>9</sub>-CH<sub>3</sub>: fluphenazine undecanoate,  
 G. X = S, R = CO-[CH<sub>2</sub>]<sub>10</sub>-CH<sub>3</sub>: fluphenazine dodecanoate.

01/2008:0904

## FLUPHENAZINE DIHYDROCHLORIDE

## Fluphenazini dihydrochloridum

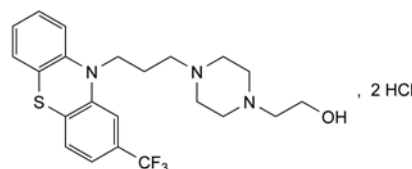

$C_{22}H_{28}Cl_2F_3N_3OS$   
 [146-56-5]

$M_r$  510.4

## DEFINITION

2-[4-[3-[2-(Trifluoromethyl)-10H-phenothiazin-10-yl]-propyl]piperazin-1-yl]ethanol dihydrochloride.

**Content:** 98.5 per cent to 101.5 per cent (dried substance).

## CHARACTERS

**Appearance:** white or almost white, crystalline powder.

**Solubility:** freely soluble in water, slightly soluble in ethanol (96 per cent) and in methylene chloride.

## IDENTIFICATION

**First identification:** B, D.

**Second identification:** A, C, D.

- A. Ultraviolet and visible absorption spectrophotometry (2.2.25).

**Test solution.** Dissolve 50.0 mg in methanol R and dilute to 100.0 mL with the same solvent. Dilute 2.0 mL of this solution to 100.0 mL with methanol R.

**Spectral range:** 230-350 nm.

*Absorption maxima*: at 260 nm and at about 310 nm (broad band).

*Specific absorbance at the absorption maximum at 260 nm*: 630 to 700.

B. Infrared absorption spectrophotometry (2.2.24).

*Comparison*: fluphenazine dihydrochloride CRS.

C. Thin-layer chromatography (2.2.27).

*Test solution*. Dissolve 10 mg of the substance to be examined in *methanol R* and dilute to 10 mL with the same solvent.

*Reference solution (a)*. Dissolve 10 mg of *fluphenazine dihydrochloride CRS* in *methanol R* and dilute to 10 mL with the same solvent.

*Reference solution (b)*. Dissolve 5 mg of *perphenazine CRS* in reference solution (a) and dilute to 5 mL with reference solution (a).

*Plate*: TLC octadecylsilyl silica gel  $F_{254}$  plate R.

*Mobile phase*: concentrated ammonia R1, water R, methanol R (1:4:95 V/V/V).

*Application*: 2  $\mu$ L.

*Development*: over 2/3 of the plate.

*Detection*: examine in ultraviolet light at 254 nm.

*System suitability*: reference solution (b):

– the chromatogram shows 2 clearly separated principal spots.

*Results*: the principal spot in the chromatogram obtained with the test solution is similar in position and size to the principal spot in the chromatogram obtained with reference solution (a).

D. It gives reaction (a) of chlorides (2.3.1).

TESTS

**pH** (2.2.3): 1.9 to 2.4.

Dissolve 0.5 g in 10 mL of *water R*.

**Related substances**. Liquid chromatography (2.2.29). Carry out the test protected from light and prepare the solutions immediately before use.

*Test solution*. Dissolve 25.0 mg of the substance to be examined in mobile phase B and dilute to 50.0 mL with mobile phase B.

*Reference solution (a)*. Dilute 1.0 mL of the test solution to 100.0 mL with mobile phase B.

*Reference solution (b)*. Dilute 5.0 mL of reference solution (a) to 25.0 mL with mobile phase B.

*Reference solution (c)*. Dissolve the contents of a vial of *fluphenazine impurity mixture CRS* (containing impurities A, B, C and D) in 1 mL of the test solution.

*Reference solution (d)*. Dissolve 5.0 mg of *fluphenazine sulfoxide CRS* (impurity A) in mobile phase B and dilute to 50.0 mL with mobile phase B. Dilute 1.0 mL of this solution to 100.0 mL with mobile phase B.

*Column*:

– size:  $l = 0.25$  m,  $\emptyset = 4.6$  mm;

– stationary phase: spherical octadecylsilyl silica gel for chromatography R (5  $\mu$ m).

*Mobile phase*:

– mobile phase A: 10 g/L solution of ammonium carbonate R adjusted to pH 7.5 with dilute hydrochloric acid R;

– mobile phase B: mobile phase A, acetonitrile R, methanol R (7.5:45:45 V/V/V);

Time (min)	Mobile phase A (per cent V/V)	Mobile phase B (per cent V/V)
0 - 7	25	75
7 - 17	25 $\rightarrow$ 0	75 $\rightarrow$ 100
17 - 50	0	100
50 - 51	0 $\rightarrow$ 25	100 $\rightarrow$ 75

*Flow rate*: 1.0 mL/min.

*Detection*: spectrophotometer at 260 nm and at 274 nm.

*Injection*: 10  $\mu$ L of the test solution and reference solutions (b), (c) and (d).

*Identification of impurities*: use the chromatogram supplied with *fluphenazine impurity mixture CRS* and the chromatogram obtained with reference solution (c) to identify the peaks due to impurities A, B, C and D.

*Relative retention* with reference to fluphenazine (retention time = about 14.5 min): impurity A = about 0.3; impurity B = about 0.4; impurity C = about 1.8; impurity D = about 2.2.

*System suitability*: reference solution (c):

– resolution: minimum 2.5 between the peaks due to impurities A and B.

*Limits*:

– correction factors: for the calculation of content, multiply the peak areas of the following impurities by the corresponding correction factor: impurity B = 0.3; impurity C = 0.6;

– impurity A at 274 nm: not more than the area of the corresponding peak in the chromatogram obtained with reference solution (d) (0.2 per cent);

– impurity B at 274 nm: not more than the area of the principal peak in the chromatogram obtained with reference solution (b) (0.2 per cent);

– impurities C, D at 260 nm: for each impurity, not more than the area of the principal peak in the chromatogram obtained with reference solution (b) (0.2 per cent);

– unspecified impurities at 260 nm: for each impurity, not more than 0.5 times the area of the principal peak in the chromatogram obtained with reference solution (b) (0.10 per cent);

– sum of the impurities at 260 nm and impurities A and B at 274 nm: maximum 1.0 per cent;

– disregard limit at 260 nm: 0.25 times the area of the principal peak in the chromatogram obtained with reference solution (b) (0.05 per cent).

**Heavy metals** (2.4.8): maximum 20 ppm.

1.0 g complies with test C. Prepare the reference solution using 2 mL of lead standard solution (10 ppm Pb) R.

**Loss on drying** (2.2.32): maximum 1.0 per cent, determined on 0.500 g by drying in an oven at 65 °C for 3 h.

**Sulfated ash** (2.4.14): maximum 0.1 per cent, determined on 1.0 g in a platinum crucible.

ASSAY

*In order to avoid overheating during the titration, mix thoroughly throughout and stop the titration immediately after the end-point has been reached.*

Dissolve 0.220 g in a mixture of 10 mL of *anhydrous formic acid R* and 40 mL of *acetic anhydride R*. Titrate with 0.1 M perchloric acid, determining the end-point potentiometrically (2.2.20).

1 mL of 0.1 M perchloric acid is equivalent to 25.52 mg of  $C_{22}H_{28}Cl_2F_3N_3OS$ .

STORAGE

Protected from light.



## IMPURITIES

Specified impurities: A, B, C, D.

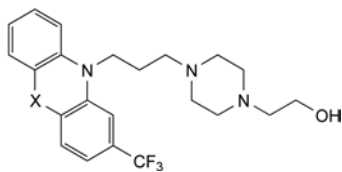

A. X = SO: 2-[4-[3-[5-oxo-2-(trifluoromethyl)-10H-5<sup>4</sup>-phenothiazin-10-yl]propyl]piperazin-1-yl]ethanol (fluphenazine S-oxide),

B. X = SO<sub>2</sub>: 2-[4-[3-[5,5-dioxo-2-(trifluoromethyl)-10H-5<sup>6</sup>-phenothiazin-10-yl]propyl]piperazin-1-yl]ethanol (fluphenazine S,S-dioxide),

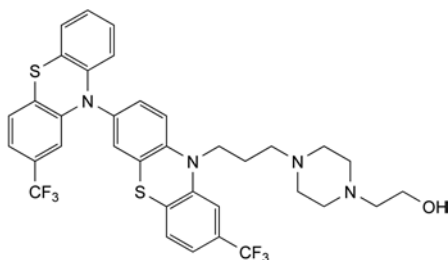

C. 2-[4-[3-[2',8-bis(trifluoromethyl)-10H-3,10'-biphenothiazin-10-yl]propyl]piperazin-1-yl]ethanol,

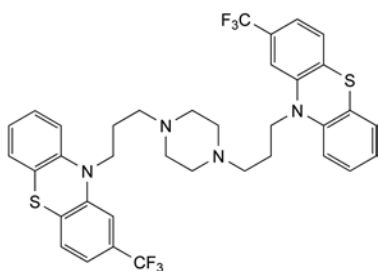

D. 10,10'-[piperazine-1,4-diylbis(propane-3,1-diyl)]bis[2-(trifluoromethyl)-10H-phenothiazine].

**Solubility:** practically insoluble in water, very soluble in ethanol and in methylene chloride, freely soluble in methanol.

## IDENTIFICATION

First identification: B, C.

Second identification: A, C.

A. Dissolve 50.0 mg in *methanol R* and dilute to 100.0 mL with the same solvent. Dilute 1.0 mL to 50.0 mL with *methanol R*. Examined between 230 nm and 350 nm (2.2.25), the solution shows an absorption maximum at 260 nm and a broad absorption maximum at about 310 nm. The specific absorbance at the maximum at 260 nm is 610 to 670.

B. Infrared absorption spectrophotometry (2.2.24).

**Preparation:** apply 50 µL of a 25 g/L solution in *methylene chloride R* to a disc of *potassium bromide R*. Dry the discs at 60 °C for 1 h before use.

**Comparison:** *fluphenazine enantate CRS*.

C. Thin-layer chromatography (2.2.27).

**Test solution.** Dissolve 10 mg of the substance to be examined in *methanol R* and dilute to 10 mL with the same solvent.

**Reference solution (a).** Dissolve 10 mg of *fluphenazine enantate CRS* in *methanol R* and dilute to 10 mL with the same solvent.

**Reference solution (b).** Dissolve 5 mg of *fluphenazine decanoate CRS* in reference solution (a) and dilute to 5 mL with the same solution.

**Plate:** TLC octadecylsilyl silica gel F<sub>254</sub> plate R.

**Mobile phase:** concentrated ammonia R1, water R, *methanol R* (1:4:95 V/V/V).

**Application:** 2 µL.

**Development:** over a path of 8 cm.

**Detection:** examine in ultraviolet light at 254 nm.

**System suitability:** the chromatogram obtained with reference solution (b) shows 2 clearly separated spots.

**Results:** the principal spot in the chromatogram obtained with the test solution is similar in position and size to the principal spot in the chromatogram obtained with reference solution (a).

## TESTS

01/2008:1015  
corrected 7.0

**Related substances.** Liquid chromatography (2.2.29). Carry out the test protected from light and prepare the solutions immediately before use.

**Test solution.** Dissolve 10.0 mg of the substance to be examined in *acetonitrile R* and dilute to 50.0 mL with the same solvent.

**Reference solution (a).** Dissolve 5 mg of *fluphenazine octanoate CRS* and 5 mg of *fluphenazine enantate CRS* in *acetonitrile R* and dilute to 50 mL with the same solvent.

**Reference solution (b).** Dilute 5.0 mL of the test solution to 100.0 mL with a mixture of 5 volumes of mobile phase A and 95 volumes of mobile phase B. Dilute 1.0 mL of this solution to 10.0 mL with a mixture of 5 volumes of mobile phase A and 95 volumes of mobile phase B.

**Reference solution (c).** Dissolve 5.0 mg of *fluphenazine sulfoxide CRS* in *acetonitrile R* and dilute to 100.0 mL with the same solvent. Dilute 1.0 mL to 50.0 mL with *acetonitrile R*.

**Column:**

– size: *l* = 0.25 m, Ø = 4.6 mm,

– stationary phase: spherical octadecylsilyl silica gel for chromatography R (5 µm).

**Mobile phase:**

– mobile phase A: 10 g/L solution of ammonium carbonate R adjusted to pH 7.5 with dilute hydrochloric acid R,

## FLUPHENAZINE ENANTATE

## Fluphenazini enantas

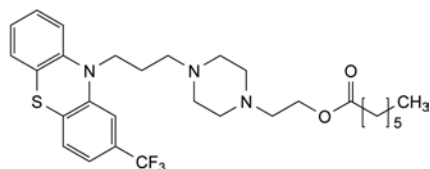

C<sub>29</sub>H<sub>38</sub>F<sub>3</sub>N<sub>3</sub>O<sub>2</sub>S  
[2746-81-8]

M<sub>r</sub> 549.7

## DEFINITION

2-[4-[3-[2-(Trifluoromethyl)-10H-phenothiazin-10-yl]propyl]piperazin-1-yl]ethyl heptanoate.

**Content:** 98.5 per cent to 101.5 per cent (dried substance).

## CHARACTERS

**Appearance:** pale yellow, viscous liquid or yellow solid.

– *mobile phase B*: mobile phase A, acetonitrile R, methanol R (7.5:45:45 V/V/V),

01/2008:0905  
corrected 6.0

Time (min)	Mobile phase A (per cent V/V)	Mobile phase B (per cent V/V)
0 - 7	20	80
7 - 17	20 → 0	80 → 100
17 - 80	0	100

*Flow rate*: 1.0 mL/min.

*Detection*: spectrophotometer at 260 nm.

*Injection*: 10 µL.

*Relative retention* with reference to fluphenazine enantate (retention time = about 25 min): impurity A = about 0.2; impurity D = about 1.1.

*System suitability*: reference solution (a):

– *resolution*: minimum 6 between the peaks due to fluphenazine enantate and impurity D.

*Limits*:

- *impurity A*: not more than the area of the principal peak in the chromatogram obtained with reference solution (c) (0.5 per cent),
- *any other impurity*: not more than the area of the principal peak in the chromatogram obtained with reference solution (b) (0.5 per cent),
- *total*: not more than 1.6 per cent,
- *disregard limit for any other impurity*: 0.1 times the area of the principal peak in the chromatogram obtained with reference solution (b) (0.05 per cent).

**Heavy metals** (2.4.8): maximum 20 ppm.

1.0 g complies with limit test C. Prepare the standard using 2 mL of *lead standard solution* (10 ppm Pb) R.

**Loss on drying** (2.2.32): maximum 1.0 per cent, determined on 1.000 g by drying in an oven at 60 °C at a pressure not exceeding 0.7 kPa for 3 h.

**Sulfated ash** (2.4.14): maximum 0.1 per cent, determined on 1.0 g in a platinum crucible.

#### ASSAY

Dissolve 0.250 g in 30 mL of *glacial acetic acid* R. Using 0.05 mL of *crystal violet solution* R as indicator titrate with 0.1 M *perchloric acid* until the colour changes from violet to green.

1 mL of 0.1 M *perchloric acid* is equivalent to 27.49 mg of C<sub>29</sub>H<sub>38</sub>F<sub>3</sub>N<sub>3</sub>O<sub>2</sub>S.

#### STORAGE

Protected from light.

#### IMPURITIES

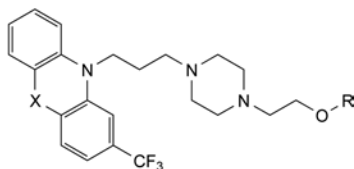

- A. X = SO, R = H: fluphenazine S-oxide,
- B. X = S, R = H: fluphenazine,
- C. X = S, R = CO-[CH<sub>2</sub>]<sub>8</sub>-CH<sub>3</sub>: fluphenazine decanoate,
- D. X = S, R = CO-[CH<sub>2</sub>]<sub>6</sub>-CH<sub>3</sub>: fluphenazine octanoate,
- E. X = S, R = CO-[CH<sub>2</sub>]<sub>7</sub>-CH<sub>3</sub>: fluphenazine nonanoate,
- F. X = S, R = CO-[CH<sub>2</sub>]<sub>9</sub>-CH<sub>3</sub>: fluphenazine undecanoate,
- G. X = S, R = CO-[CH<sub>2</sub>]<sub>10</sub>-CH<sub>3</sub>: fluphenazine dodecanoate.

## FLURAZEPAM MONOHYDROCHLORIDE

### Flurazepami monohydrochloridum

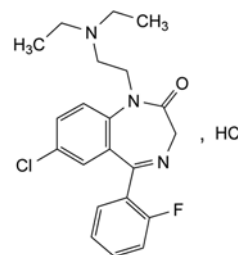

C<sub>21</sub>H<sub>24</sub>Cl<sub>2</sub>FN<sub>3</sub>O  
[36105-20-1]

M<sub>r</sub> 424.3

#### DEFINITION

7-Chloro-1-[2-(diethylamino)ethyl]-5-(2-fluorophenyl)-1,3-dihydro-2H-1,4-benzodiazepin-2-one monohydrochloride.

*Content*: 99.0 per cent to 101.0 per cent (dried substance).

#### CHARACTERS

*Appearance*: white or almost white, crystalline powder.

*Solubility*: very soluble in water, freely soluble in alcohol.

#### IDENTIFICATION

A. Infrared absorption spectrophotometry (2.2.24).

*Comparison*: Ph. Eur. reference spectrum of flurazepam monohydrochloride.

B. It gives reaction (a) of chlorides (2.3.1).

#### TESTS

**pH** (2.2.3): 5.0 to 6.0.

Dissolve 0.50 g in *carbon dioxide-free water* R and dilute to 10 mL with the same solvent.

**Related substances**. Liquid chromatography (2.2.29). Prepare the solutions immediately before use.

*Test solution*. Dissolve 50.0 mg of the substance to be examined in the mobile phase and dilute to 50.0 mL with the mobile phase.

*Reference solution (a)*. Dilute 1.0 mL of the test solution to 100.0 mL with the mobile phase. Dilute 5.0 mL of this solution to 50.0 mL with the mobile phase.

*Reference solution (b)*. Dissolve 5 mg of the substance to be examined and 5 mg of *oxazepam* R in 10 mL of *acetonitrile* R and dilute to 50.0 mL with the mobile phase.

*Column*:

- *size*: l = 0.15 m, Ø = 4.6 mm,
- *stationary phase*: base-deactivated octylsilyl silica gel for chromatography R (5 µm).

*Mobile phase*: mix 350 volumes of *acetonitrile* R and 650 volumes of a 10.5 g/L solution of *potassium dihydrogen phosphate* R and adjust to pH 6.1 with a 40 g/L solution of *sodium hydroxide* R.

*Flow rate*: 1.0 mL/min.

*Detection*: spectrophotometer at 239 nm.

*Injection*: 20 µL.

Run time: 6 times the retention time of flurazepam.

*Relative retention* with reference to flurazepam (retention time = about 7 min): impurity C = about 1.5; impurity B = about 1.9; impurity A = about 2.4.

*System suitability*: reference solution (b):

- *resolution*: minimum of 4.5 between the peaks due to flurazepam and to oxazepam.

## Limits:

- *correction factors*: for the calculation of contents, multiply the peak areas of the following impurities by the corresponding correction factor: impurity B = 0.61; impurity C = 0.65,
- *any impurity*: not more than the area of the principal peak in the chromatogram obtained with reference solution (a) (0.1 per cent),
- *total*: not more than 3 times the area of the principal peak in the chromatogram obtained with reference solution (a) (0.3 per cent),
- *disregard limit*: 0.5 times the area of the principal peak in the chromatogram obtained with reference solution (a) (0.05 per cent).

**Fluorides** (2.4.5): maximum 500 ppm.

0.10 g complies with the limit test for fluorides.

**Loss on drying** (2.2.32): maximum 0.5 per cent, determined on 1.000 g by drying in an oven at 105 °C for 4 h.

**Sulfated ash** (2.4.14): maximum 0.1 per cent, determined on 1.0 g.

## ASSAY

Dissolve 0.350 g in a mixture of 1.0 mL of 0.1 M hydrochloric acid and 50 mL of alcohol R. Carry out a potentiometric titration (2.2.20), using 0.1 M sodium hydroxide. Read the volume added between the 2 points of inflexion.

1 mL of 0.1 M sodium hydroxide is equivalent to 42.43 mg of C<sub>21</sub>H<sub>24</sub>Cl<sub>2</sub>FN<sub>3</sub>O.

## STORAGE

Protected from light.

## IMPURITIES

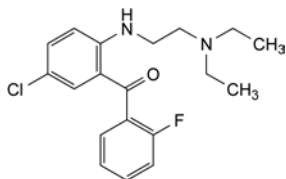

- A. [5-chloro-2-[[2-(diethylamino)ethyl]amino]phenyl](2-fluorophenyl)methanone,

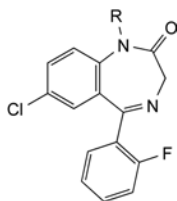

- B. R = H: 7-chloro-5-(2-fluorophenyl)-1,3-dihydro-2H-1,4-benzodiazepin-2-one,  
 C. R = CHOH-CH<sub>3</sub>: 7-chloro-5-(2-fluorophenyl)-1-[(1R)-1-hydroxyethyl]-1,3-dihydro-2H-1,4-benzodiazepin-2-one.

01/2008:1519  
corrected 6.5

## FLURBIPROFEN

## Flurbiprofenum

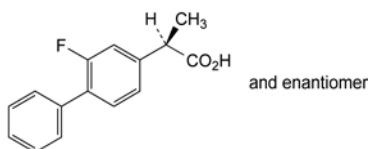

C<sub>15</sub>H<sub>13</sub>FO<sub>2</sub>  
[5104-49-4]

M<sub>r</sub> 244.3

## DEFINITION

(2*RS*)-2-(2-Fluorobiphenyl-4-yl)propanoic acid.

*Content*: 99.0 per cent to 101.0 per cent (dried substance).

## CHARACTERS

*Appearance*: white or almost white, crystalline powder.

*Solubility*: practically insoluble in water, freely soluble in ethanol (96 per cent) and in methylene chloride. It dissolves in aqueous solutions of alkali hydroxides and carbonates.

## IDENTIFICATION

*First identification*: C, D.

*Second identification*: A, B, D.

A. Melting point (2.2.14): 114 °C to 117 °C.

B. Ultraviolet and visible absorption spectrophotometry (2.2.25).

*Test solution*. Dissolve 0.10 g in 0.1 M sodium hydroxide and dilute to 100.0 mL with the same alkaline solution.

Dilute 1.0 mL of this solution to 100.0 mL with 0.1 M sodium hydroxide.

*Spectral range*: 230-350 nm.

*Absorption maximum*: at 247 nm.

*Specific absorbance at the absorption maximum*: 780 to 820.

C. Infrared absorption spectrophotometry (2.2.24).

*Comparison*: flurbiprofen CRS.

D. Mix about 5 mg with 45 mg of heavy magnesium oxide R and ignite in a crucible until an almost white residue is obtained (usually less than 5 min). Allow to cool, add 1 mL of water R, 0.05 mL of phenolphthalein solution R1 and about 1 mL of dilute hydrochloric acid R to render the solution colourless. Filter. To a freshly prepared mixture of 0.1 mL of alizarin S solution R and 0.1 mL of zirconyl nitrate solution R add 1.0 mL of the filtrate. Mix, allow to stand for 5 min and compare the colour of the solution with that of a blank prepared in the same manner. The test solution is yellow and the blank is red.

## TESTS

**Appearance of solution**. The solution is clear (2.2.1) and colourless (2.2.2, Method I).

Dissolve 1.0 g in methanol R and dilute to 10 mL with the same solvent.

**Optical rotation** (2.2.7): –0.1° to +0.1°.

Dissolve 0.50 g in methanol R and dilute to 20.0 mL with the same solvent.

**Related substances**. Liquid chromatography (2.2.29).

*Solvent mixture*: acetonitrile R, water R (45:55 V/V).

*Test solution*. Dissolve 0.20 g of the substance to be examined in the solvent mixture and dilute to 100.0 mL with the solvent mixture.

*Reference solution (a)*. Dilute 1.0 mL of the test solution to 50.0 mL with the solvent mixture. Dilute 1.0 mL of this solution to 10.0 mL with the solvent mixture.

*Reference solution (b)*. Dissolve 10.0 mg of flurbiprofen impurity A CRS in the solvent mixture and dilute to 100.0 mL with the solvent mixture. Dilute 10.0 mL of this solution to 100.0 mL with the solvent mixture.

*Reference solution (c)*. Dissolve 10 mg of the substance to be examined in the solvent mixture and dilute to 100.0 mL with the solvent mixture. Dilute 1.0 mL of this solution to 10.0 mL with reference solution (b).

*Column*:

– *size*: *l* = 0.15 m,  $\emptyset$  = 3.9 mm;

– *stationary phase*: octadecylsilyl silica gel for chromatography R (5  $\mu$ m).

*Mobile phase*: glacial acetic acid R, acetonitrile R, water R (5:35:60 V/V/V).

01/2011:1723

Flow rate: 1 mL/min.

Detection: spectrophotometer at 254 nm.

Injection: 10 µL.

Run time: twice the retention time of flurbiprofen.

System suitability: reference solution (c):

- resolution: minimum 1.5 between the peaks due to impurity A and flurbiprofen.

Limits:

- impurity A: not more than the area of the corresponding peak in the chromatogram obtained with reference solution (b) (0.5 per cent);
- impurities B, C, D, E: for each impurity, not more than the area of the principal peak in the chromatogram obtained with reference solution (a) (0.2 per cent);
- sum of impurities other than A: not more than 5 times the area of the principal peak in the chromatogram obtained with reference solution (a) (1.0 per cent);
- disregard limit: 0.1 times the area of the principal peak in the chromatogram obtained with reference solution (a) (0.02 per cent).

**Heavy metals** (2.4.8): maximum 10 ppm.

Dissolve 2.0 g in a mixture of 10 volumes of *water R* and 90 volumes of *methanol R* and dilute to 20 mL with the same mixture of solvents. 12 mL of the solution complies with test B. Prepare the reference solution using lead standard solution (1 ppm Pb) obtained by diluting *lead standard solution (100 ppm Pb) R* with a mixture of 10 volumes of *water R* and 90 volumes of *methanol R*.

**Loss on drying** (2.2.32): maximum 0.5 per cent, determined on 1.000 g by drying at 60 °C at a pressure not exceeding 0.7 kPa for 3 h.

**Sulfated ash** (2.4.14): maximum 0.1 per cent, determined on 1.0 g in a platinum crucible.

**ASSAY**

Dissolve 0.200 g in 50 mL of *ethanol (96 per cent) R*. Titrate with 0.1 M *sodium hydroxide*, determining the end-point potentiometrically (2.2.20).

1 mL of 0.1 M *sodium hydroxide* is equivalent to 24.43 mg of C<sub>15</sub>H<sub>13</sub>FO<sub>2</sub>.

**IMPURITIES**

Specified impurities: A, B, C, D, E.

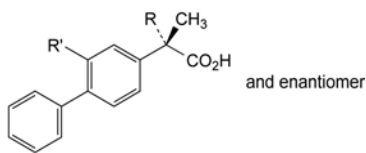
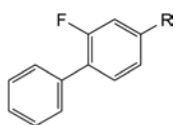
A. R = R' = H: (2*RS*)-2-(biphenyl-4-yl)propanoic acid,B. R = CH(CH<sub>3</sub>)-CO<sub>2</sub>H, R' = F: 2-(2-fluorobiphenyl-4-yl)-2,3-dimethylbutanedioic acid,C. R = OH, R' = F: (2*RS*)-2-(2-fluorobiphenyl-4-yl)-2-hydroxypropanoic acid,D. R = CO-CH<sub>3</sub>: 1-(2-fluorobiphenyl-4-yl)ethanone,E. R = CO<sub>2</sub>H: 2-fluorobiphenyl-4-carboxylic acid.**FLUSPIRILENE**

## Fluspirilenum

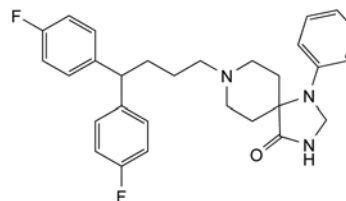
C<sub>29</sub>H<sub>31</sub>F<sub>2</sub>N<sub>3</sub>O  
[1841-19-6]M<sub>r</sub> 475.6**DEFINITION**

8-[4,4-bis(4-Fluorophenyl)butyl]-1-phenyl-1,3,8-triazaspiro[4.5]decan-4-one.

Content: 99.0 per cent to 101.0 per cent (dried substance).

**CHARACTERS***Appearance*: white or almost white powder.*Solubility*: practically insoluble in water, soluble in methylene chloride, slightly soluble in ethanol (96 per cent).

It shows polymorphism (5.9).

**IDENTIFICATION**

Infrared absorption spectrophotometry (2.2.24).

*Comparison*: fluspirilene CRS.

If the spectra obtained show differences, dissolve the substance to be examined and the reference substance separately in *methylene chloride R*, gently evaporate to dryness and record new spectra using the residues.

**TESTS****Appearance of solution.** The solution is clear (2.2.1) and colourless (2.2.2, *Method II*).Dissolve 0.25 g in 25 mL of *methylene chloride R*.**Related substances.** Liquid chromatography (2.2.29).*Test solution.* Dissolve 0.100 g of the substance to be examined in *dimethylformamide R* and dilute to 10.0 mL with the same solvent.*Reference solution (a).* Dissolve 5.0 mg of *fluspirilene impurity C CRS* in *dimethylformamide R*, add 0.5 mL of the test solution and dilute to 100.0 mL with *dimethylformamide R*.*Reference solution (b).* Dilute 1.0 mL of the test solution to 20.0 mL with *dimethylformamide R*. Dilute 1.0 mL of this solution to 25.0 mL with *dimethylformamide R*.*Column*:– size: *l* = 0.15 m, Ø = 4.6 mm,

– stationary phase: octadecylsilyl silica gel for chromatography R (3 µm).

*Mobile phase*:

– mobile phase A: 13.6 g/L solution of tetrabutylammonium hydrogen sulfate R,

– mobile phase B: acetonitrile R,

Time (min)	Mobile phase A (per cent V/V)	Mobile phase B (per cent V/V)
0 - 15	75 → 70	25 → 30
15 - 20	70	30
20 - 22	70 → 0	30 → 100
22 - 30	0	100

Flow rate: 1.2 mL/min.

**Detection:** spectrophotometer at 250 nm.

**Injection:** 10 µL.

**Identification of impurities:** use the chromatogram obtained with reference solution (a) to identify the peak due to impurity C.

**Relative retention** with reference to fluspirilene (retention time = about 15 min): impurity A = about 0.8; impurity B = about 0.93; impurity C = about 0.97.

**System suitability:** reference solution (a):

- **resolution:** minimum 2.2 between the peaks due to impurity C and fluspirilene.

**Limits:**

- **impurities A, B, C:** for each impurity, not more than 1.5 times the area of the principal peak in the chromatogram obtained with reference solution (b) (0.3 per cent),
- **unspecified impurities:** for each impurity, not more than 0.5 times the area of the principal peak in the chromatogram obtained with reference solution (b) (0.10 per cent),
- **total:** not more than 3 times the area of the principal peak in the chromatogram obtained with reference solution (b) (0.6 per cent),
- **disregard limit:** 0.25 times the area of the principal peak in the chromatogram obtained with reference solution (b) (0.05 per cent).

**Loss on drying** (2.2.32): maximum 0.5 per cent, determined on 1.000 g by drying in an oven at 105 °C for 4 h.

**Sulfated ash** (2.4.14): maximum 0.1 per cent, determined on 1.0 g in a platinum crucible.

#### ASSAY

Dissolve 0.350 g in 50 mL of a mixture of 1 volume of *anhydrous acetic acid R* and 7 volumes of *methyl ethyl ketone R*.

Titrate with 0.1 M *perchloric acid*, determining the end-point potentiometrically (2.2.20). Carry out a blank titration.

1 mL of 0.1 M *perchloric acid* is equivalent to 47.56 mg of C<sub>29</sub>H<sub>31</sub>F<sub>2</sub>N<sub>3</sub>O.

#### STORAGE

Protected from light.

#### IMPURITIES

**Specified impurities:** A, B, C.

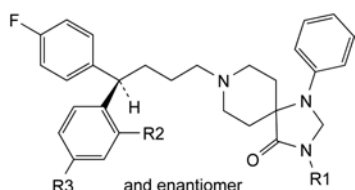

- A. R1 = R2 = R3 = H: 8-[(4*RS*)-4-(4-fluorophenyl)-4-phenylbutyl]-1-phenyl-1,3,8-triazaspiro[4.5]decan-4-one,
- B. R1 = R3 = H, R2 = F: 8-[(4*RS*)-4-(2-fluorophenyl)-4-(4-fluorophenyl)butyl]-1-phenyl-1,3,8-triazaspiro[4.5]decan-4-one,
- C. R1 = CH<sub>2</sub>OH, R2 = H, R3 = F: 8-[4,4-bis(4-fluorophenyl)butyl]-3-(hydroxymethyl)-1-phenyl-1,3,8-triazaspiro[4.5]decan-4-one.

01/2008:1423

## FLUTAMIDE

### Flutamidum

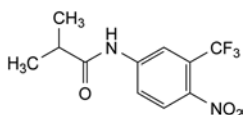

C<sub>11</sub>H<sub>11</sub>F<sub>3</sub>N<sub>2</sub>O<sub>3</sub>  
[13311-84-7]

*M<sub>r</sub>* 276.2

#### DEFINITION

2-Methyl-*N*-[4-nitro-3-(trifluoromethyl)phenyl]propanamide.

**Content:** 97.0 per cent to 103.0 per cent (dried substance).

#### CHARACTERS

**Appearance:** pale yellow, crystalline powder.

**Solubility:** practically insoluble in water, freely soluble in acetone and in ethanol (96 per cent).

mp: about 112 °C.

#### IDENTIFICATION

Infrared absorption spectrophotometry (2.2.24).

**Comparison:** flutamide CRS.

#### TESTS

**Related substances.** Liquid chromatography (2.2.29).

**Test solution.** Dissolve 20.0 mg of the substance to be examined in the mobile phase and dilute to 20.0 mL with the mobile phase.

**Reference solution (a).** Dissolve 2 mg of flutamide CRS and 2 mg of flutamide impurity C CRS in the mobile phase, then dilute to 50.0 mL with the mobile phase. Dilute 1.0 mL of this solution to 20.0 mL with the mobile phase.

**Reference solution (b).** Dilute 1.0 mL of the test solution to 50.0 mL with the mobile phase. Dilute 2.0 mL of this solution to 20.0 mL with the mobile phase.

**Column:**

- **size:** *l* = 0.25 m, Ø = 4.0 mm;
- **stationary phase:** octadecylsilyl silica gel for chromatography R (5 µm).

**Mobile phase:** acetonitrile R, water R (50:50 V/V).

**Flow rate:** 0.5 mL/min.

**Detection:** spectrophotometer at 240 nm.

**Injection:** 20 µL.

**Run time:** 1.5 times the retention time of flutamide.

**Retention time:** impurity C = about 14 min; flutamide = about 19 min.

**Relative retention** with reference to flutamide: impurity C = about 0.72.

**System suitability:** reference solution (a):

- **resolution:** minimum 10.5 between the peaks due to impurity C and flutamide.

**Limits:**

- **impurity C:** not more than 1.5 times the area of the principal peak in the chromatogram obtained with reference solution (b) (0.3 per cent);
- **impurities A, B, D, E, F:** for each impurity, not more than the area of the principal peak in the chromatogram obtained with reference solution (b) (0.2 per cent);
- **total:** not more than 2.5 times the area of the principal peak in the chromatogram obtained with reference solution (b) (0.5 per cent);
- **disregard limit:** 0.25 times the area of the principal peak in the chromatogram obtained with reference solution (b) (0.05 per cent).

**Heavy metals** (2.4.8): maximum 20 ppm.

1.0 g complies with test C. Prepare the reference solution using 2 mL of lead standard solution (10 ppm Pb) R.

**Loss on drying** (2.2.32): maximum 0.5 per cent, determined on 1.000 g by drying *in vacuo* at 60 °C for 3 h.

**Sulfated ash** (2.4.14): maximum 0.1 per cent, determined on 1.0 g.

#### ASSAY

Dissolve 25.0 mg in *methanol R* and dilute to 25.0 mL with the same solvent. Dilute 2.0 mL of this solution to 100.0 mL with *methanol R*. Measure the absorbance (2.2.25) at the absorption maximum at 295 nm.

Calculate the content of  $C_{11}H_{11}F_3N_2O_3$  taking the specific absorbance to be 295.

#### STORAGE

Protected from light.

#### IMPURITIES

Specified impurities: A, B, C, D, E, F.

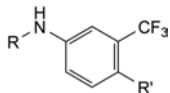

- A. R = H, R' = NO<sub>2</sub>: 4-nitro-3-(trifluoromethyl)aniline,  
 B. R = CO-CH<sub>3</sub>, R' = NO<sub>2</sub>: *N*-[4-nitro-3-(trifluoromethyl)phenyl]acetamide,  
 C. R = CO-CH<sub>2</sub>-CH<sub>3</sub>, R' = NO<sub>2</sub>: *N*-[4-nitro-3-(trifluoromethyl)phenyl]propanamide,  
 D. R = R' = H: 3-(trifluoromethyl)aniline,

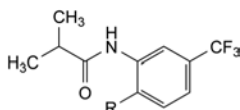

- E. R = H: 2-methyl-*N*-[3-(trifluoromethyl)phenyl]propanamide,  
 F. R = NO<sub>2</sub>: 2-methyl-*N*-[2-nitro-5-(trifluoromethyl)phenyl]propanamide.

01/2008:1750

## FLUTICASONE PROPIONATE

### Fluticasoni propionas

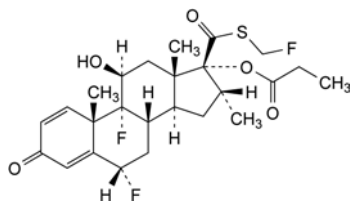

$C_{25}H_{31}F_3O_5S$   
 [80474-14-2]

$M_r$  500.6

#### DEFINITION

6 $\alpha$ ,9-Difluoro-17-[[[(fluoromethyl)sulfanyl]carbonyl]-11 $\beta$ -hydroxy-16 $\alpha$ -methyl-3-oxoandrosta-1,4-dien-17 $\alpha$ -yl]propanoate.

Content: 97.0 per cent to 102.0 per cent (anhydrous substance).

#### CHARACTERS

*Appearance*: white or almost white powder.

*Solubility*: practically insoluble in water, sparingly soluble in methylene chloride, slightly soluble in alcohol.

#### IDENTIFICATION

A. Infrared absorption spectrophotometry (2.2.24).

*Comparison*: fluticasone propionate CRS.

B. Examine the chromatograms obtained in the assay.

*Results*: the principal peak in the chromatogram obtained with the test solution is similar in retention time to the principal peak in the chromatogram obtained with reference solution (b).

#### TESTS

**Specific optical rotation** (2.2.7): + 32 to + 36 (anhydrous substance).

Dissolve 0.25 g in *methylene chloride R* and dilute to 50.0 mL with the same solvent.

**Related substances.** Liquid chromatography (2.2.29): use the normalisation procedure.

*Test solution.* Dissolve 20 mg of the substance to be examined in a mixture of equal volumes of mobile phase A and mobile phase B and dilute to 100.0 mL with the same mixture of mobile phases.

*Reference solution (a).* Dissolve 4 mg of *fluticasone impurity D CRS* in a mixture of equal volumes of mobile phase A and mobile phase B and dilute to 100.0 mL with the same mixture of mobile phases.

*Reference solution (b).* Dissolve 20 mg of *fluticasone propionate CRS* in a mixture of equal volumes of mobile phase A and mobile phase B, add 1.0 mL of reference solution (a) and dilute to 100.0 mL with a mixture of equal volumes of mobile phase A and mobile phase B.

#### Column:

- size:  $l = 0.25$  m,  $\varnothing = 4.6$  mm,
- stationary phase: octadecylsilyl silica gel for chromatography R (5  $\mu$ m),
- temperature: 40 °C.

#### Mobile phase:

- mobile phase A: a solution containing 0.05 per cent V/V of phosphoric acid R and 3.0 per cent V/V of methanol R in acetonitrile R,
- mobile phase B: a solution containing 0.05 per cent V/V of phosphoric acid R and 3.0 per cent V/V of methanol R in water R,

Time (min)	Mobile phase A (per cent V/V)	Mobile phase B (per cent V/V)
0 - 40	43 → 55	57 → 45
40 - 60	55 → 90	45 → 10
60 - 70	90	10
70 - 75	90 → 43	10 → 57

*Flow rate*: 1 mL/min.

*Detection*: spectrophotometer at 239 nm.

*Injection*: 50  $\mu$ L; inject the test solution and reference solution (b).

*Relative retention* with reference to fluticasone propionate (retention time = about 30 min): impurity A = about 0.38; impurity B = about 0.46; impurity C = about 0.76; impurity D = about 0.95; impurity E = about 1.12; impurity F = about 1.18; impurity G = about 1.33; impurity H = about 1.93; impurity I = about 2.01.

*System suitability*: reference solution (b):

- resolution: minimum 1.5 between the peaks due to impurity D and to fluticasone propionate.

#### Limits:

- impurities D, G: for each impurity, maximum 0.3 per cent,
- impurities A, B, C, E, F, H, I: for each impurity, maximum 0.2 per cent,
- impurity with relative retention at about 1.23: maximum 0.2 per cent,
- any other impurity: maximum 0.1 per cent,
- total: maximum 1.2 per cent,
- disregard limit: 0.05 per cent.

**Acetone.** Gas chromatography (2.2.28).

*Internal standard solution.* Dilute 0.5 mL of tetrahydrofuran R to 1000 mL with dimethylformamide R.

*Test solution.* Dissolve 0.50 g of the substance to be examined in the internal standard solution and dilute to 10.0 mL with the same solution.

*Reference solution.* Dilute 0.40 g of acetone R to 100.0 mL with the internal standard solution. Dilute 1.0 mL to 10.0 mL with the internal standard solution.

## Column:

- material: fused silica,
- size:  $l = 25$  m,  $\varnothing = 0.53$  mm,
- stationary phase: cross-linked *macrogol 20 000 R* (film thickness 2  $\mu$ m).

Carrier gas: nitrogen for chromatography R.

Flow rate: 5.5 mL/min.

Temperature:

	Time (min)	Temperature (°C)
Column	0 - 3.5	60
	3.5 - 7.5	60 → 180
	7.5 - 10.5	180
Injection port		150
Detector		250

Detection: flame ionisation.

Injection: 0.1  $\mu$ L.

Limit:

- acetone: maximum 1.0 per cent *m/m*.

**Water** (2.5.12): maximum 0.5 per cent determined on 0.250 g.Use as solvent a mixture of equal volumes of *chloroform R* and *methanol R*.

## ASSAY

Liquid chromatography (2.2.29).

**Test solution.** Dissolve 20.0 mg of the substance to be examined in the mobile phase and dilute to 50.0 mL with the mobile phase. Dilute 1.0 mL to 10.0 mL with the mobile phase.

**Reference solution (a).** Dissolve 20.0 mg of *fluticasone propionate CRS* in the mobile phase and dilute to 50.0 mL with the mobile phase.

**Reference solution (b).** Dilute 1.0 mL of reference solution (a) to 10.0 mL with the mobile phase.

**Reference solution (c).** Dissolve 4.0 mg of *fluticasone impurity D CRS* in the mobile phase and dilute to 50.0 mL with the mobile phase. To 1.0 mL of this solution, add 1.0 mL of reference solution (a) and dilute to 10.0 mL with the mobile phase.

Column:

- size:  $l = 0.25$  m,  $\varnothing = 4.6$  mm,
- stationary phase: *octadecylsilyl silica gel for chromatography R* (5  $\mu$ m),
- temperature: 40 °C.

**Mobile phase:** mix 15 volumes of *acetonitrile R*, 35 volumes of a 1.15 g/L solution of *ammonium dihydrogen phosphate R* adjusted to pH 3.5 and 50 volumes of *methanol R*.

Flow rate: 1.5 mL/min.

Detection: spectrophotometer at 239 nm.

**Injection:** 20  $\mu$ L; inject the test solution and reference solutions (b) and (c).

System suitability: reference solution (c):

- resolution: minimum 1.5 between the peaks due to impurity D and to fluticasone propionate.

If necessary, adjust the ratio of acetonitrile to methanol in the mobile phase.

Calculate the percentage content of  $C_{25}H_{31}F_3O_5S$  using the chromatograms obtained with the test solution and reference solution (b), and the declared content of *fluticasone propionate CRS*.

## STORAGE

Protected from light.

## IMPURITIES

Specified impurities: A, B, C, D, E, F, G, H, I.

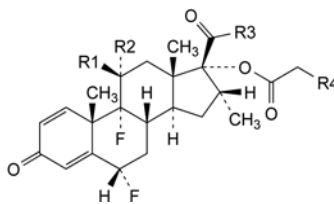

- A.  $R_1 = R_3 = OH$ ,  $R_2 = H$ ,  $R_4 = CH_3$ : 6 $\alpha$ ,9-difluoro-11 $\beta$ -hydroxy-16 $\alpha$ -methyl-3-oxo-17-(propanoyloxy)androsta-1,4-diene-17 $\beta$ -carboxylic acid,
- B.  $R_1 = OH$ ,  $R_2 = H$ ,  $R_3 = S-OH$ ,  $R_4 = CH_3$ : [[6 $\alpha$ ,9-difluoro-11 $\beta$ -hydroxy-16 $\alpha$ -methyl-3-oxo-17-(propanoyloxy)androsta-1,4-dien-17 $\beta$ -yl]carbonyl]sulfenic acid,
- C.  $R_1 = OH$ ,  $R_2 = R_4 = H$ ,  $R_3 = S-CH_2-F$ : 6 $\alpha$ ,9-difluoro-17-[(fluoromethyl)sulfanyl]carbonyl]-11 $\beta$ -hydroxy-16 $\alpha$ -methyl-3-oxoandrosta-1,4-dien-17 $\alpha$ -yl acetate,
- D.  $R_1 = OH$ ,  $R_2 = H$ ,  $R_3 = S-CH_3$ ,  $R_4 = CH_3$ : 6 $\alpha$ ,9-difluoro-17-[(methylsulfanyl)carbonyl]-11 $\beta$ -hydroxy-16 $\alpha$ -methyl-3-oxoandrosta-1,4-dien-17 $\alpha$ -yl propanoate,
- F.  $R_1 + R_2 = O$ ,  $R_3 = S-CH_2-F$ ,  $R_4 = CH_3$ : 6 $\alpha$ ,9-difluoro-17-[(fluoromethyl)sulfanyl]carbonyl]-16 $\alpha$ -methyl-3,11-dioxoandrosta-1,4-dien-17 $\alpha$ -yl propanoate,

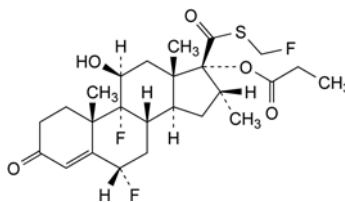

- E. 6 $\alpha$ ,9-difluoro-17-[(fluoromethyl)sulfanyl]carbonyl]-11 $\beta$ -hydroxy-16 $\alpha$ -methyl-3-oxoandrosta-1,4-dien-17 $\alpha$ -yl propanoate,

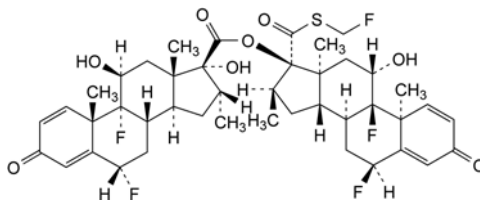

- G. 6 $\alpha$ ,9-difluoro-17-[(fluoromethyl)sulfanyl]carbonyl]-11 $\beta$ -hydroxy-16 $\alpha$ -methyl-3-oxoandrosta-1,4-dien-17 $\alpha$ -yl 6 $\alpha$ ,9-difluoro-11 $\beta$ ,17-dihydroxy-16 $\alpha$ -methyl-3-oxoandrosta-1,4-diene-17 $\beta$ -carboxylate,

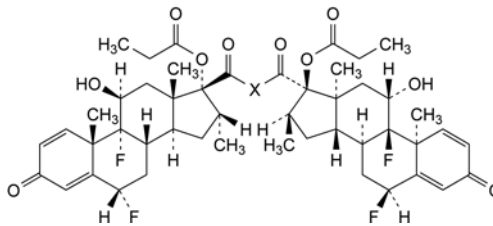

- H.  $X = S-S$ : 17,17'-(disulfaneyldicarbonyl)bis(6 $\alpha$ ,9-difluoro-11 $\beta$ -hydroxy-16 $\alpha$ -methyl-3-oxoandrosta-1,4-dien-17 $\alpha$ -yl) dipropanoate,
- I.  $X = S-S-S$ : 17,17'-(trisulfaneyldicarbonyl)bis(6 $\alpha$ ,9-difluoro-11 $\beta$ -hydroxy-16 $\alpha$ -methyl-3-oxoandrosta-1,4-dien-17 $\alpha$ -yl) dipropanoate.

01/2008:1424 TESTS

corrected 6.0

## FLUTRIMAZOLE

## Flutrimazolum

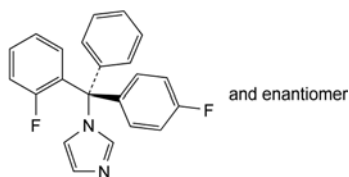

$C_{22}H_{16}F_2N_2$   
[119006-77-8]

 $M_r$  346.4

## DEFINITION

(*RS*)-1-[(2-Fluorophenyl)(4-fluorophenyl)phenylmethyl]-1*H*-imidazole.

*Content*: 99.0 per cent to 101.0 per cent (dried substance).

## CHARACTERS

*Appearance*: white or almost white powder.

*Solubility*: practically insoluble in water, freely soluble in tetrahydrofuran, soluble in methanol.

## IDENTIFICATION

*First identification*: B.

*Second identification*: A, C, D.

A. Melting point (2.2.14): 161 °C to 166 °C.

B. Infrared absorption spectrophotometry (2.2.24).

*Preparation*: discs.

*Comparison*: flutrimazole CRS.

C. Thin-layer chromatography (2.2.27).

*Test solution*. Dissolve 20 mg of the substance to be examined in *acetone R* and dilute to 10 mL with the same solvent.

*Reference solution (a)*. Dissolve 20 mg of flutrimazole CRS in *acetone R* and dilute to 10 mL with the same solvent.

*Reference solution (b)*. Dissolve 20 mg of flutrimazole CRS and 10 mg of *metronidazole benzoate CRS* in *acetone R* and dilute to 10 mL with the same solvent.

*Plate*: TLC silica gel  $F_{254}$  plate *R*.

*Pretreatment*: heat the plate at 110 °C for 1 h.

*Mobile phase*: 2-propanol *R*, ethyl acetate *R* (10:90 *V/V*).

*Application*: 10 µL.

*Development*: over 2/3 of the plate.

*Drying*: in air.

*Detection*: examine in ultraviolet light at 254 nm.

*System suitability*: reference solution (b):

– the chromatogram shows 2 clearly separated spots.

*Results*: the principal spot in the chromatogram obtained with the test solution is similar in position and size to the principal spot in the chromatogram obtained with reference solution (a).

D. Mix about 5 mg with 45 mg of *heavy magnesium oxide R* and ignite in a crucible until an almost white residue is obtained (usually less than 5 min). Allow to cool, add 1 mL of *water R*, 0.05 mL of *phenolphthalein solution R1* and about 1 mL of *dilute hydrochloric acid R* to render the solution colourless. Filter. Add 1.0 mL of the filtrate to a freshly prepared mixture of 0.1 mL of *alizarin S solution R* and 0.1 mL of *zirconyl nitrate solution R*. Mix, allow to stand for 5 min and compare the colour of the solution with that of a blank prepared in the same manner. The test solution is yellow and the blank is red.

**Solution S**. Dissolve 1.00 g in *methanol R* and dilute to 50.0 mL with the same solvent.

**Appearance of solution**. Solution S is not more opalescent than reference suspension II (2.2.7) and not more intensely coloured than reference solution  $Y_7$  (2.2.2, *Method II*).

**Optical rotation** (2.2.7):  $-0.05^\circ$  to  $+0.05^\circ$ , determined on solution S.

**Related substances**. Liquid chromatography (2.2.29).

*Test solution*. Dissolve 40.0 mg of the substance to be examined in the mobile phase and dilute to 50.0 mL with the mobile phase.

*Reference solution (a)*. Dissolve 25.0 mg of *imidazole CRS* (impurity A) in the mobile phase and dilute to 50.0 mL with the mobile phase. Dilute 10.0 mL of this solution to 50.0 mL with the mobile phase.

*Reference solution (b)*. Dissolve 30.0 mg of *flutrimazole impurity B CRS* in the mobile phase and dilute to 100.0 mL with the mobile phase.

*Reference solution (c)*. Mix 2.0 mL of reference solution (a) and 2.0 mL of reference solution (b) and dilute to 50.0 mL with the mobile phase.

*Reference solution (d)*. Dilute 10.0 mL of reference solution (c) to 50.0 mL with the mobile phase.

*Reference solution (e)*. Mix 2.0 mL of the test solution and 10.0 mL of reference solution (c) and dilute to 50.0 mL with the mobile phase.

*Reference solution (f)*. Dilute 1.0 mL of the test solution to 100.0 mL with the mobile phase. Dilute 1.0 mL of this solution to 10.0 mL with the mobile phase.

*Column*:

– *size*:  $l = 0.2$  m,  $\varnothing = 4.6$  mm;

– *stationary phase*: octylsilyl silica gel for chromatography *R* (5 µm).

*Mobile phase*: 0.03 *M* phosphate buffer solution pH 7.0 *R*, acetonitrile *R* (40:60 *V/V*).

*Flow rate*: 1.3 mL/min.

*Detection*: spectrophotometer at 220 nm.

*Injection*: 20 µL.

*Run time*: 2.5 times the retention time of flutrimazole.

*System suitability*: reference solution (e):

– *resolution*: minimum 2.0 between the peaks due to impurity A (1<sup>st</sup> peak) and impurity B (2<sup>nd</sup> peak); minimum 1.5 between the peaks due to impurity B and flutrimazole (3<sup>rd</sup> peak);

– *symmetry factors*: maximum 2.0 for the peaks due to impurities A and B.

*Limits*:

– *impurity A*: not more than the area of the corresponding peak in the chromatogram obtained with reference solution (d) (0.1 per cent);

– *impurity B*: not more than the area of the corresponding peak in the chromatogram obtained with reference solution (d) (0.3 per cent);

– *unspecified impurities*: for each impurity, not more than the area of the principal peak in the chromatogram obtained with reference solution (f) (0.10 per cent);

– *sum of impurities other than B*: not more than 3 times the area of the principal peak in the chromatogram obtained with reference solution (f) (0.3 per cent);

– *disregard limit*: 0.5 times the area of the principal peak in the chromatogram obtained with reference solution (f) (0.05 per cent).

**Heavy metals** (2.4.8): maximum 10 ppm.

2.0 g complies with test F. Use a platinum crucible. Prepare the reference solution using 2 mL of *lead standard solution* (10 ppm *Pb*) *R*.



**Loss on drying** (2.2.32): maximum 0.5 per cent, determined on 1.000 g by drying in an oven at 105 °C.

**Sulfated ash** (2.4.14): maximum 0.1 per cent, determined on 1.0 g in a platinum crucible.

#### ASSAY

Dissolve 0.300 g in 50 mL of *anhydrous acetic acid R*. Titrate with 0.1 M *perchloric acid*, determining the end-point potentiometrically (2.2.20).

1 mL of 0.1 M *perchloric acid* is equivalent to 34.64 mg of  $C_{22}H_{16}F_2N_2$ .

#### STORAGE

Protected from light.

#### IMPURITIES

*Specified impurities: A, B.*

*Other detectable impurities* (the following substances would, if present at a sufficient level, be detected by one or other of the tests in the monograph. They are limited by the general acceptance criterion for other/unspecified impurities and/or by the general monograph *Substances for pharmaceutical use* (2034). It is therefore not necessary to identify these impurities for demonstration of compliance. See also 5.10. *Control of impurities in substances for pharmaceutical use*): C.



A. imidazole,

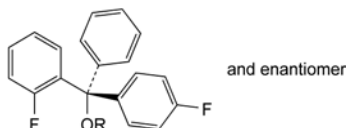

B. R = H: (RS)-(2-fluorophenyl)(4-fluorophenyl)phenylmethanol,

C. R = CH<sub>3</sub>: (RS)-(2-fluorophenyl)(4-fluorophenyl)methoxyphenylmethane.

04/2009:2333

## FLUVASTATIN SODIUM

### Fluvastatinum natrium

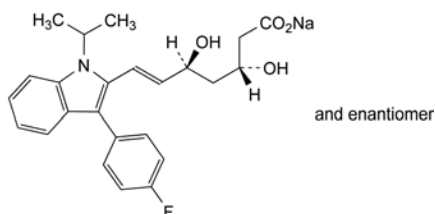

$C_{24}H_{25}FNNaO_4$   
[93957-55-2]

$M_r$  433.5

#### DEFINITION

Sodium (3RS,5SR,6E)-7-[3-(4-fluorophenyl)-1-(1-methylethyl)-1H-indol-2-yl]-3,5-dihydroxyhept-6-enoate.

*Content*: 98.5 per cent to 101.5 per cent (dried substance).

#### CHARACTERS

*Appearance*: white or almost white, or pale yellow to pale reddish-yellow, very hygroscopic, crystalline powder.

*Solubility*: soluble in water, freely soluble in methanol, practically insoluble in acetonitrile.

It shows polymorphism (5.9).

#### IDENTIFICATION

A. Infrared absorption spectrophotometry (2.2.24).

*Comparison*: fluvastatin sodium CRS.

If the spectra obtained in the solid state show differences, dissolve the substance to be examined and the reference substance separately in *methanol R*, evaporate to dryness and record new spectra using the residues.

B. 0.5 mL of solution S (see Tests) gives reaction (a) of sodium (2.3.1).

#### TESTS

**Solution S.** Dissolve 1.0 g in *carbon dioxide-free water R* and dilute to 20.0 mL with the same solvent.

**pH** (2.2.3): 8.0 to 10.0 for solution S.

**Related substances.** Liquid chromatography (2.2.29). *Carry out the test protected from light.*

*Test solution.* Dissolve 25 mg of the substance to be examined in 20 mL of mobile phase B and dilute to 50.0 mL with mobile phase A.

*Reference solution (a).* Dilute 1.0 mL of the test solution to 10.0 mL with mobile phase A. Dilute 1.0 mL of this solution to 50.0 mL with mobile phase A.

*Reference solution (b).* Dissolve the contents of a vial of *fluvastatin for system suitability CRS* (containing impurities A, B and D) in 1.0 mL of a mixture of equal volumes of mobile phase A and mobile phase B.

*Column*:

- *size*:  $l = 0.10$  m,  $\varnothing = 4.6$  mm;
- *stationary phase*: end-capped octadecylsilyl silica gel for chromatography R (3  $\mu$ m);
- *temperature*: 40 °C.

*Mobile phase*:

- *mobile phase A*: to 880 mL of *water R* add 20 mL of a 250 g/L solution of *tetramethylammonium hydroxide R* and adjust quickly to pH 7.2 with *phosphoric acid R*; mix with 100 mL of a mixture of 40 volumes of *acetonitrile R* and 60 volumes of *methanol R*;
- *mobile phase B*: to 80 mL of *water R* add 20 mL of a 250 g/L solution of *tetramethylammonium hydroxide R* and adjust quickly to pH 7.2 with *phosphoric acid R*; mix with 900 mL of a mixture of 40 volumes of *acetonitrile R* and 60 volumes of *methanol R*;

Time (min)	Mobile phase A (per cent V/V)	Mobile phase B (per cent V/V)
0 - 3	70	30
3 - 23	70 → 10	30 → 90

*Flow rate*: 2.0 mL/min.

*Detection*: spectrophotometer at 305 nm and at 365 nm.

*Injection*: 20  $\mu$ L.

*Identification of impurities*: use the chromatogram supplied with *fluvastatin for system suitability CRS* and the chromatogram obtained with reference solution (b) to identify the peaks due to impurities A, B and D.

*Relative retention* with reference to fluvastatin (retention time = about 14 min); impurity A = about 1.05; impurity D = about 1.1; impurity B = about 1.6.

*System suitability*: reference solution (b) at 305 nm:

- *peak-to-valley ratio*: minimum 5, where  $H_p$  = height above the baseline of the peak due to impurity A and  $H_v$  = height above the baseline of the lowest point of the curve separating this peak from the peak due to fluvastatin.

*Limits*:

- *impurity A at 305 nm*: not more than 4 times the area of the principal peak in the chromatogram obtained with reference solution (a) (0.8 per cent);
- *impurity B at 305 nm*: not more than the area of the principal peak in the chromatogram obtained with reference solution (a) (0.2 per cent);

- *impurity D at 365 nm*: not more than 0.75 times the area of the principal peak in the chromatogram obtained with reference solution (a) at 305 nm (0.15 per cent);
- *unspecified impurities at 305 nm*: not more than 0.5 times the area of the principal peak in the chromatogram obtained with reference solution (a) (0.10 per cent);
- *sum of impurities at 305 nm*: not more than 5 times the area of the principal peak in the chromatogram obtained with reference solution (a) (1.0 per cent);
- *disregard limit at 305 nm*: 0.25 times the area of the principal peak in the chromatogram obtained with reference solution (a) (0.05 per cent).

**Heavy metals (2.4.8)**: maximum 20 ppm.

Dissolve 1.0 g in a mixture of 15 volumes of *water R* and 85 volumes of *methanol R* and dilute to 20 mL with the same mixture of solvents. 12 mL of the solution complies with test B. Prepare the reference solution using lead standard solution (1 ppm Pb) obtained by diluting *lead standard solution (100 ppm Pb) R* with a mixture of 15 volumes of *water R* and 85 volumes of *methanol R*. For the evaluation of the results, filter the solutions through a membrane filter (nominal pore size 0.45 µm).

**Loss on drying (2.2.32)**: maximum 4.0 per cent, determined on 1.000 g by drying in an oven at 105 °C.

#### ASSAY

Dissolve 0.325 g in 50 mL of *glacial acetic acid R*. Titrate with 0.1 M *perchloric acid*, determining the end-point potentiometrically (2.2.20).

1 mL of 0.1 M *perchloric acid* is equivalent to 43.35 mg of C<sub>24</sub>H<sub>25</sub>FNNaO<sub>4</sub>.

#### STORAGE

In an airtight container, protected from light.

#### IMPURITIES

*Specified impurities: A, B, D.*

*Other detectable impurities* (the following substances would, if present at a sufficient level, be detected by one or other of the tests in the monograph. They are limited by the general acceptance criterion for other/unspecified impurities and/or by the general monograph *Substances for pharmaceutical use (2034)*. It is therefore not necessary to identify these impurities for demonstration of compliance. See also 5.10. *Control of impurities in substances for pharmaceutical use*): C, E, F, G.

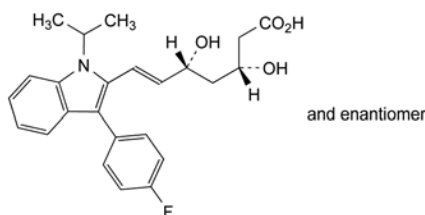

- A. (3*RS*,5*RS*,6*E*)-7-[3-(4-fluorophenyl)-1-(1-methylethyl)-1*H*-indol-2-yl]-3,5-dihydroxyhept-6-enoic acid,

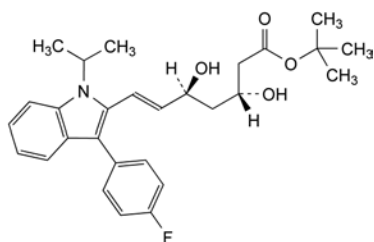

- B. 1,1-dimethylethyl (3*R*,5*S*,6*E*)-7-[3-(4-fluorophenyl)-1-(1-methylethyl)-1*H*-indol-2-yl]-3,5-dihydroxyhept-6-enoate,

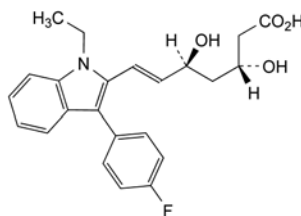

- C. (3*R*,5*S*,6*E*)-7-[1-ethyl-3-(4-fluorophenyl)-1*H*-indol-2-yl]-3,5-dihydroxyhept-6-enoic acid,

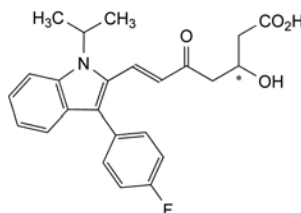

- D. (6*E*)-7-[3-(4-fluorophenyl)-1-(1-methylethyl)-1*H*-indol-2-yl]-3-hydroxy-5-oxohept-6-enoic acid,

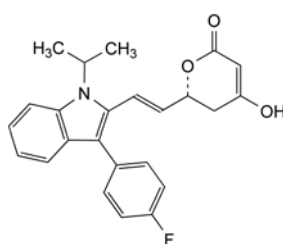

- E. (6*R*)-6-[(*E*)-2-[3-(4-fluorophenyl)-1-(1-methylethyl)-1*H*-indol-2-yl]ethenyl]-4-hydroxy-5,6-dihydro-2*H*-pyran-2-one,

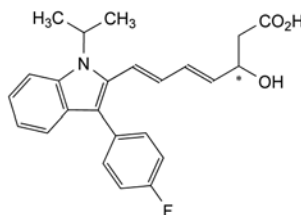

- F. (4*E*,6*E*)-7-[3-(4-fluorophenyl)-1-(1-methylethyl)-1*H*-indol-2-yl]-3-hydroxyhepta-4,6-dienoic acid,

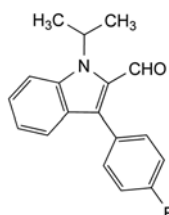

- G. 3-(4-fluorophenyl)-1-(1-methylethyl)-1*H*-indole-2-carbaldehyde.

07/2008:1977  
corrected 6.3

## FLUVOXAMINE MALEATE

### Fluvoxamini maleas

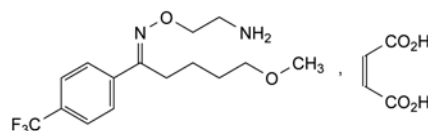

C<sub>19</sub>H<sub>25</sub>F<sub>3</sub>N<sub>2</sub>O<sub>6</sub>  
[61718-82-9]

M<sub>r</sub> 434.4

## DEFINITION

2-[[[(1*E*)-5-Methoxy-1-[4-(trifluoromethyl)phenyl]pentylidene]amino]oxy]ethanamine (*Z*)-butenedioate.

*Content*: 99.0 per cent to 101.0 per cent (dried substance).

## PRODUCTION

The production method must be evaluated to determine the potential for formation of aziridine. Where necessary, a validated test for the substance is carried out or the production method is validated to demonstrate acceptable clearance.

## CHARACTERS

*Appearance*: white or almost white, crystalline powder.

*Solubility*: sparingly soluble in water, freely soluble in ethanol (96 per cent) and in methanol.

## IDENTIFICATION

Infrared absorption spectrophotometry (2.2.24).

*Comparison*: fluvoxamine maleate CRS.

## TESTS

**Related substances.** Liquid chromatography (2.2.29). Prepare the test solution immediately before use.

*Test solution.* Dissolve 50 mg of the substance to be examined in the mobile phase and dilute to 25 mL with the mobile phase.

*Reference solution (a).* Dilute 1.0 mL of the test solution to 10.0 mL with the mobile phase. Dilute 1.0 mL of this solution to 100.0 mL with the mobile phase.

*Reference solution (b).* Dissolve the contents of a vial of fluvoxamine for system suitability CRS (containing impurities A, B, C and F) in 1.0 mL of the mobile phase.

*Reference solution (c).* Dissolve 3.0 mg of fluvoxamine impurity D CRS in 5 mL of the mobile phase and dilute to 10.0 mL with the mobile phase. Dilute 1.0 mL of this solution to 100.0 mL with the mobile phase.

*Column*:

- *size*:  $l = 0.25$  m,  $\varnothing = 4.6$  mm;
- *stationary phase*: octylsilyl silica gel for chromatography R (5  $\mu$ m).

*Mobile phase*: mix 370 volumes of acetonitrile R1 and 630 volumes of a buffer solution containing 1.1 g/L of potassium dihydrogen phosphate R and 1.9 g/L of sodium pentanesulfonate R in water R, previously adjusted to pH 3.0 with phosphoric acid R.

*Flow rate*: 1.2 mL/min.

*Detection*: spectrophotometer at 234 nm.

*Injection*: 20  $\mu$ L.

*Run time*: 6 times the retention time of fluvoxamine.

*Identification of impurities*: use the chromatogram supplied with fluvoxamine for system suitability CRS and the chromatogram obtained with reference solution (b) to identify the peaks due to impurities A, B, C and F.

*Relative retention* with reference to fluvoxamine (retention time = about 15 min): maleic acid = about 0.15; impurities F and G = about 0.5; impurity C = about 0.6; impurity B = about 0.8; impurity A = about 2.5; impurity D = about 5.4.

*System suitability*: reference solution (b):

- *resolution*: minimum 1.5 between the peaks due to impurities F and C.

*Limits*:

- *impurity B*: not more than 5 times the area of the principal peak in the chromatogram obtained with reference solution (a) (0.5 per cent);
- *impurity C*: not more than 3 times the area of the principal peak in the chromatogram obtained with reference solution (a) (0.3 per cent);

- *impurity A*: not more than twice the area of the principal peak in the chromatogram obtained with reference solution (a) (0.2 per cent);
- *impurity D*: not more than the area of the corresponding peak in the chromatogram obtained with reference solution (c) (0.15 per cent);
- *sum of impurities F and G*: not more than 3 times the area of the principal peak in the chromatogram obtained with reference solution (a) (0.3 per cent);
- *unspecified impurities*: for each impurity, not more than the area of the principal peak in the chromatogram obtained with reference solution (a) (0.10 per cent);
- *total*: not more than 10 times the area of the principal peak in the chromatogram obtained with reference solution (a) (1.0 per cent);
- *disregard limit*: 0.5 times the area of the principal peak in the chromatogram obtained with reference solution (a) (0.05 per cent); disregard the peak due to maleic acid.

**Heavy metals** (2.4.8): maximum 20 ppm.

1.0 g complies with test B. Prepare the reference solution using 2 mL of lead standard solution (10 ppm Pb) R.

**Loss on drying** (2.2.32): maximum 0.5 per cent, determined on 1.000 g by drying *in vacuo* at 80 °C for 2 h.

**Sulfated ash** (2.4.14): maximum 0.1 per cent, determined on 1.0 g in a platinum crucible.

## ASSAY

Dissolve 0.350 g in 50 mL of anhydrous acetic acid R. Titrate with 0.1 M perchloric acid, determining the end-point potentiometrically (2.2.20).

1 mL of 0.1 M perchloric acid is equivalent to 43.44 mg of C<sub>19</sub>H<sub>25</sub>F<sub>3</sub>N<sub>2</sub>O<sub>6</sub>.

## IMPURITIES

*Specified impurities*: A, B, C, D, F, G.

*Other detectable impurities* (the following substances would, if present at a sufficient level, be detected by one or other of the tests in the monograph. They are limited by the general acceptance criterion for other/unspecified impurities and/or by the general monograph *Substances for pharmaceutical use* (2034). It is therefore not necessary to identify these impurities for demonstration of compliance. See also 5.10. *Control of impurities in substances for pharmaceutical use*): E, I, J.

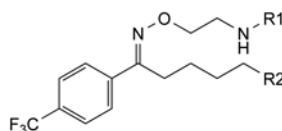

A. R1 = R2 = H: 2-[[[(1*E*)-1-[4-(trifluoromethyl)phenyl]pentylidene]amino]oxy]ethanamine,

F. R1 = CH<sub>2</sub>-CH<sub>2</sub>-NH<sub>2</sub>, R2 = OCH<sub>3</sub>: *N*-[2-[[[(1*E*)-5-methoxy-1-[4-(trifluoromethyl)phenyl]pentylidene]amino]oxy]ethyl]ethane-1,2-diamine,

G. R1 = H, R2 = OH: (5*E*)-5-[(2-aminoethoxy)imino]-5-[4-(trifluoromethyl)phenyl]pentan-1-ol,

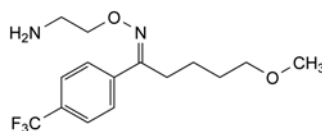

B. 2-[[[(1*Z*)-5-methoxy-1-[4-(trifluoromethyl)phenyl]pentylidene]amino]oxy]ethanamine,

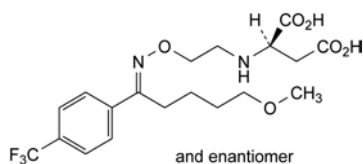

C. (2*RS*)-2-[[2-[[[(1*E*)-5-methoxy-1-[4-(trifluoromethyl)phenyl]pentylidene]amino]oxy]ethyl]amino]butanedioic acid,

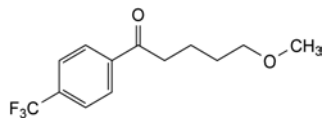

D. 5-methoxy-1-[4-(trifluoromethyl)phenyl]pentan-1-one,

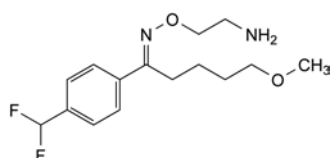

E. 2-[[[(1*E*)-1-[4-(difluoromethyl)phenyl]-5-methoxypentylidene]amino]oxy]ethanamine,

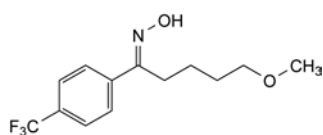

I. (*E*)-*N*-[5-methoxy-1-[4-(trifluoromethyl)phenyl]pentylidene]hydroxylamine,

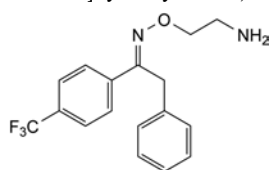

J. 2-[[[(1*E*)-2-phenyl-1-[4-(trifluoromethyl)phenyl]ethylidene]amino]oxy]ethanamine.

07/2010:0067

## FOLIC ACID

### Acidum folicum

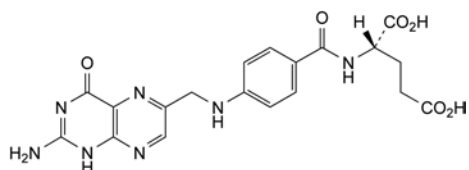

$C_{19}H_{19}N_7O_6$   
[59-30-3]

$M_r$  441.4

#### DEFINITION

(2*S*)-2-[[4-[[[(2-Amino-4-oxo-1,4-dihydropteridin-6-yl)methyl]amino]benzoyl]amino]pentanedioic acid.

*Content*: 96.0 per cent to 102.0 per cent (anhydrous substance).

#### CHARACTERS

*Appearance*: yellowish or orange, crystalline powder.

*Solubility*: practically insoluble in water and in most organic solvents. It dissolves in dilute acids and in alkaline solutions.

#### IDENTIFICATION

*First identification*: A, B.

*Second identification*: A, C.

A. Specific optical rotation (2.2.7): + 18 to + 22 (anhydrous substance).

Dissolve 0.25 g in 0.1 *M* sodium hydroxide and dilute to 25.0 mL with the same solvent.

B. Examine the chromatograms obtained in the assay.

*Results*: the principal peak in the chromatogram obtained with the test solution is similar in retention time to the principal peak in the chromatogram obtained with reference solution (a).

C. Thin-layer chromatography (2.2.27).

*Test solution*. Dissolve 50 mg of the substance to be examined in a mixture of 2 volumes of concentrated ammonia *R* and 9 volumes of methanol *R* and dilute to 100 mL with the same mixture of solvents.

*Reference solution*. Dissolve 50 mg of folic acid *CRS* in a mixture of 2 volumes of concentrated ammonia *R* and 9 volumes of methanol *R* and dilute to 100 mL with the same mixture of solvents.

*Plate*: TLC silica gel *G* plate *R*.

*Mobile phase*: concentrated ammonia *R*, propanol *R*, ethanol (96 per cent) *R* (20:20:60 *V/V/V*).

*Application*: 2  $\mu$ L.

*Development*: over 3/4 of the plate.

*Drying*: in air.

*Detection*: examine in ultraviolet light at 365 nm.

*Results*: the principal spot in the chromatogram obtained with the test solution is similar in position, fluorescence and size to the principal spot in the chromatogram obtained with the reference solution.

#### TESTS

**Related substances.** Liquid chromatography (2.2.29).

*Test solution*. Dissolve 0.100 g of the substance to be examined in 5 mL of a 28.6 g/L solution of sodium carbonate *R* and dilute to 100.0 mL with the mobile phase. Dilute 2.0 mL of this solution to 10.0 mL with the mobile phase.

*Reference solution (a)*. Dissolve 0.100 g of folic acid *CRS* in 5 mL of a 28.6 g/L solution of sodium carbonate *R* and dilute to 100.0 mL with the mobile phase. Dilute 2.0 mL of this solution to 10.0 mL with the mobile phase.

*Reference solution (b)*. To 20 mg of folic acid impurity *D* *CRS* add 5 mL of a 28.6 g/L solution of sodium carbonate *R*, dilute to 100.0 mL with the same solution and mix until completely dissolved. Mix 1.0 mL of this solution with 1.0 mL of reference solution (a) and dilute to 100.0 mL with the mobile phase.

*Reference solution (c)*. Dilute 2.0 mL of the test solution to 20.0 mL with the mobile phase. Dilute 1.0 mL of this solution to 20.0 mL with the mobile phase.

*Reference solution (d)*. Dissolve 10.0 mg of folic acid impurity *A* *CRS* in 1 mL of a 28.6 g/L solution of sodium carbonate *R* and dilute to 100.0 mL with the mobile phase. Dilute 1.0 mL of this solution to 100.0 mL with the mobile phase.

*Reference solution (e)*. To 12.0 mg of folic acid impurity *D* *CRS* add 1 mL of a 28.6 g/L solution of sodium carbonate *R*, dilute to 100.0 mL with the same solution and mix until completely dissolved. Dilute 1.0 mL of this solution to 100.0 mL with the mobile phase.

*Column*:

– *size*:  $l = 0.25$  m,  $\varnothing = 4.0$  mm;

– *stationary phase*: spherical octylsilyl silica gel for chromatography *R* (5  $\mu$ m) with a specific surface area of 350 m<sup>2</sup>/g, a pore size of 10 nm and a carbon loading of 12.5 per cent.

*Mobile phase*: mix 12 volumes of methanol *R* and 88 volumes of a solution containing 11.16 g/L of potassium dihydrogen phosphate *R* and 5.50 g/L of dipotassium hydrogen phosphate *R*.

*Flow rate*: 0.6 mL/min.

*Detection*: spectrophotometer at 280 nm.

**Injection:** 5 µL of the test solution and reference solutions (b), (c), (d) and (e).

**Run time:** 3 times the retention time of folic acid.

**Relative retention** with reference to folic acid (retention time = about 8.5 min): impurity A = about 0.5; impurity B = about 0.6; impurity C = about 0.9; impurity E = about 1.27; impurity D = about 1.33; impurity F = about 2.2.

**System suitability:** reference solution (b):

- **resolution:** minimum 4.0 between the peaks due to folic acid and impurity D.

**Limits:**

- **impurity D:** not more than the area of the principal peak in the chromatogram obtained with reference solution (e) (0.6 per cent);
- **impurity A:** not more than the area of the principal peak in the chromatogram obtained with reference solution (d) (0.5 per cent);
- **any other impurity:** not more than the area of the principal peak in the chromatogram obtained with reference solution (c) (0.5 per cent);
- **total of other impurities:** not more than twice the area of the principal peak in the chromatogram obtained with reference solution (c) (1.0 per cent);
- **disregard limit:** 0.1 times the area of the principal peak in the chromatogram obtained with reference solution (c) (0.05 per cent).

**Water (2.5.12):** 5.0 per cent to 8.5 per cent, determined on 0.150 g.

**Sulfated ash (2.4.14):** maximum 0.2 per cent, determined on 1.0 g.

#### ASSAY

Liquid chromatography (2.2.29) as described in the test for related substances with the following modification.

**Injection:** test solution and reference solution (a).

#### STORAGE

Protected from light.

#### IMPURITIES

**Specified impurities:** A, B, C, D, E, F.

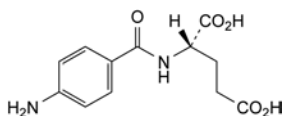

- A. (2S)-2-[(4-aminobenzoyl)amino]pentanedioic acid (N-(4-aminobenzoyl)-L-glutamic acid),

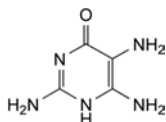

- B. 2,5,6-triaminopyrimidin-4(1H)-one,

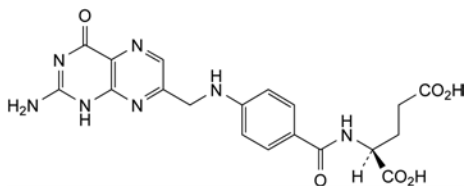

- C. (2S)-2-[[4-[(2-amino-4-oxo-1,4-dihydropteridin-7-yl)methyl]amino]benzoyl]amino]pentanedioic acid (isofolic acid),

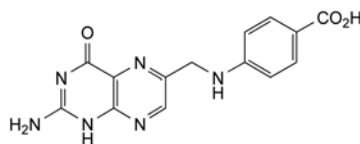

- D. 4-[[[(2-amino-4-oxo-1,4-dihydropteridin-6-yl)methyl]amino]benzoyl]amino]benzoic acid (pterioic acid),

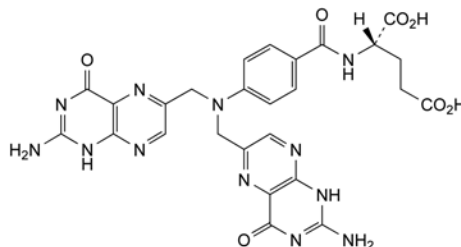

- E. (2S)-2-[[4-bis[(2-amino-4-oxo-1,4-dihydropteridin-6-yl)methyl]amino]benzoyl]amino]pentanedioic acid (6-pterinylfolic acid),

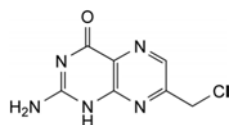

- F. 2-amino-7-(chloromethyl)pteridin-4(1H)-one.

01/2008:0826

## FORMALDEHYDE SOLUTION (35 PER CENT)

### Formaldehydi solutio (35 per centum)

[50-00-0]

#### DEFINITION

**Content:** 34.5 per cent *m/m* to 38.0 per cent *m/m* of formaldehyde (CH<sub>2</sub>O; *M<sub>r</sub>* 30.03).

It contains methanol as stabiliser.

#### CHARACTERS

**Appearance:** clear, colourless liquid.

**Solubility:** miscible with water and with ethanol (96 per cent).

It may be cloudy after storage.

#### IDENTIFICATION

- Dilute 1 mL of solution S (see Tests) to 10 mL with *water R*. To 0.05 mL of the solution add 1 mL of a 15 g/L solution of *chromotropic acid sodium salt R*, 2 mL of *water R* and 8 mL of *sulfuric acid R*. A violet-blue or violet-red colour develops within 5 min.
- To 0.1 mL of solution S add 10 mL of *water R*. Add 2 mL of a 10 g/L solution of *phenylhydrazine hydrochloride R*, prepared immediately before use, 1 mL of *potassium ferricyanide solution R* and 5 mL of *hydrochloric acid R*. An intense red colour is formed.
- Mix 0.5 mL with 2 mL of *water R* and 2 mL of *silver nitrate solution R2* in a test-tube. Add *dilute ammonia R2* until slightly alkaline. Heat on a water-bath. A grey precipitate or a silver mirror is formed.
- It complies with the limits of the assay.

#### TESTS

**Solution S.** Dilute 10 mL, filtered if necessary, to 50 mL with *carbon dioxide-free water R*.

**Appearance of solution.** Solution S is colourless (2.2.2, *Method II*).

**Acidity.** To 10 mL of solution S add 1 mL of *phenolphthalein solution R*. Not more than 0.4 mL of 0.1 M sodium hydroxide is required to change the colour of the indicator to red.

**Methanol.** Gas chromatography (2.2.28).

**Internal standard solution.** Dilute 10 mL of *ethanol R1* to 100 mL with *water R*.

**Test solution.** To 10.0 mL of the solution to be examined add 10.0 mL of the internal standard solution and dilute to 100.0 mL with *water R*.

**Reference solution.** To 1.0 mL of *methanol R* add 10.0 mL of the internal standard solution and dilute to 100.0 mL with *water R*.

**Column:**

- *material:* glass,
- *size:*  $l = 1.5\text{--}2.0$  m,  $\varnothing = 2\text{--}4$  mm,
- *stationary phase:* ethylvinylbenzene-divinylbenzene copolymer R (150–180  $\mu\text{m}$ ).

**Carrier gas:** nitrogen for chromatography R.

**Flow rate:** 30–40 mL/min.

**Temperature:**

- *column:* 120 °C,
- *injection port and detector:* 150 °C.

**Detection:** flame ionisation.

**Injection:** 1  $\mu\text{L}$  of the test solution and the reference solution.

**System suitability:** reference solution:

- *resolution:* minimum 2.0 between the peaks due to methanol and ethanol.

**Limit:**

- *methanol:* 9.0 per cent V/V to 15.0 per cent V/V.

**Sulfated ash (2.4.14):** maximum 0.1 per cent, determined on 1.0 g.

#### ASSAY

Into a 100 mL volumetric flask containing 2.5 mL of *water R* and 1 mL of *dilute sodium hydroxide solution R*, introduce 1.000 g of the solution to be examined, shake and dilute to 100.0 mL with *water R*. To 10.0 mL of the solution add 30.0 mL of 0.05 M iodine. Mix and add 10 mL of *dilute sodium hydroxide solution R*. After 15 min, add 25 mL of *dilute sulfuric acid R* and 2 mL of *starch solution R*. Titrate with 0.1 M sodium thiosulfate.

1 mL of 0.05 M iodine is equivalent to 1.501 mg of  $\text{CH}_2\text{O}$ .

#### STORAGE

Protected from light, at a temperature of 15 °C to 25 °C.

01/2008:1724  
corrected 7.0

## FORMOTEROL FUMARATE DIHYDRATE

### Formoteroli fumaras dihidricus

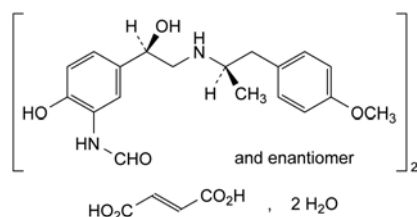

$\text{C}_{42}\text{H}_{52}\text{N}_4\text{O}_{12} \cdot 2\text{H}_2\text{O}$

$M_r$  841

#### DEFINITION

*N*-[2-Hydroxy-5-[(1*R,S*)-1-hydroxy-2-[(1*R,S*)-2-(4-methoxyphenyl)-1-methylethylamino]ethyl]phenyl]formamide (*E*)-butenedioate dihydrate.

**Content:** 98.5 per cent to 101.5 per cent (anhydrous substance).

#### CHARACTERS

**Appearance:** white or almost white or slightly yellow powder.

**Solubility:** slightly soluble in water, soluble in methanol, slightly soluble in 2-propanol, practically insoluble in acetonitrile.

#### IDENTIFICATION

Infrared absorption spectrophotometry (2.2.24).

**Comparison:** formoterol fumarate dihydrate CRS.

#### TESTS

**pH (2.2.3):** 5.5 to 6.5.

Dissolve 20 mg in *carbon dioxide-free water R* while heating to about 40 °C, allow to cool and dilute to 20 mL with the same solvent.

**Optical rotation (2.2.7):**  $-0.10^\circ$  to  $+0.10^\circ$ .

Dissolve 0.25 g in *methanol R* and dilute to 25.0 mL with the same solvent.

**Related substances.** Liquid chromatography (2.2.29).

**Solution A.** Dissolve 6.10 g of *sodium dihydrogen phosphate monohydrate R* and 1.03 g of *disodium hydrogen phosphate dihydrate R* in *water R* and dilute to 1000 mL with the same solvent. The pH is  $6.0 \pm 0.1$ .

**Solvent mixture:** acetonitrile R, solution A (16:84 V/V).

**Test solution.** Dissolve 20.0 mg of the substance to be examined in the solvent mixture and dilute to 100.0 mL with the solvent mixture. Inject within 4 h of preparation, or within 24 h if stored protected from light at 4 °C.

**Reference solution (a).** Dissolve 5 mg of *formoterol fumarate for system suitability CRS* (containing impurities A, B, C, D, E, F and G) in the solvent mixture and dilute to 25.0 mL with the solvent mixture.

**Reference solution (b).** Dilute 1.0 mL of the test solution to 25.0 mL with the solvent mixture. Dilute 1.0 mL of this solution to 20.0 mL with the solvent mixture.

**Column:**

- *size:*  $l = 0.15$  m,  $\varnothing = 4.6$  mm;
- *stationary phase:* spherical octylsilyl silica gel for chromatography R3 (5  $\mu\text{m}$ ) with a pore size of 8 nm.

**Mobile phase:**

- *mobile phase A:* acetonitrile R1;
- *mobile phase B:* dissolve 3.73 g of *sodium dihydrogen phosphate monohydrate R* and 0.35 g of *phosphoric acid R* in *water R* and dilute to 1000 mL with the same solvent; the pH is  $3.1 \pm 0.1$ ;

Time (min)	Mobile phase A (per cent V/V)	Mobile phase B (per cent V/V)
0 - 10	16	84
10 - 37	16 → 70	84 → 30

**Flow rate:** 1.0 mL/min.

**Detection:** spectrophotometer at 214 nm.

**Injection:** 20  $\mu\text{L}$ ; inject the solvent mixture until a repeatable profile is obtained.

**Identification of impurities:** use the chromatogram obtained with reference solution (a) and the chromatogram supplied with *formoterol for system suitability CRS* to identify the peaks.

**Relative retention** with reference to formoterol (retention time = about 12 min): impurity G = about 0.4; impurity A = about 0.5; impurity B = about 0.7; impurity C = about 1.2; impurity D = about 1.3; impurity E = about 1.8; impurity F = about 2.0; impurity H = about 2.2.

**System suitability:** reference solution (a):

- *resolution:* minimum 1.5 between the peaks due to impurity G and impurity A.

- *peak-to-valley ratio*: minimum 2.5, where  $H_p$  = height above the baseline of the peak due to impurity C and  $H_v$  = height above the baseline of the lowest point of the curve separating this peak from the peak due to formoterol.

**Limits:**

- *correction factor*: for the calculation of content, multiply the peak area of impurity A by 1.75;
- *impurity A*: not more than 1.5 times the area of the principal peak in the chromatogram obtained with reference solution (b) (0.3 per cent);
- *impurities B, C, D, F*: for each impurity, not more than the area of the principal peak in the chromatogram obtained with reference solution (b) (0.2 per cent);
- *impurity E*: not more than 0.5 times the area of the principal peak in the chromatogram obtained with reference solution (b) (0.1 per cent);
- *unspecified impurities*: for each impurity, not more than 0.5 times the area of the principal peak in the chromatogram obtained with reference solution (b) (0.10 per cent);
- *total*: not more than 2.5 times the area of the principal peak in the chromatogram obtained with reference solution (b) (0.5 per cent);
- *disregard limit*: 0.25 times the area of the principal peak in the chromatogram obtained with reference solution (b) (0.05 per cent).

**Impurity I.** Liquid chromatography (2.2.29).

**Test solution.** Dissolve 5.0 mg of the substance to be examined in water R and dilute to 50.0 mL with the same solvent. Sonicate if necessary.

**Reference solution (a).** Dissolve 5.0 mg of formoterol for impurity I identification CRS in water R and dilute to 50.0 mL with the same solvent. Sonicate if necessary.

**Reference solution (b).** Dilute 1.0 mL of the test solution to 20.0 mL with water R. Dilute 1.0 mL of this solution to 25.0 mL with water R.

**Column:**

- *size*:  $l = 0.15$  m,  $\varnothing = 4.6$  mm;
- *stationary phase*: octadecyl vinyl polymer for chromatography R.

**Mobile phase:** mix 12 volumes of acetonitrile R1 with 88 volumes of a 5.3 g/L solution of tripotassium phosphate trihydrate R previously adjusted to pH  $12.0 \pm 0.1$  with a 280 g/L solution of potassium hydroxide R or phosphoric acid R.

**Flow rate:** 0.5 mL/min.

**Detection:** spectrophotometer at 225 nm.

**Injection:** 20  $\mu$ L.

**Elution order:** formoterol, impurity I.

**System suitability:** reference solution (a):

- *peak-to-valley ratio*: minimum 2.5, where  $H_p$  = height above the baseline of the peak due to impurity I and  $H_v$  = height above the baseline of the lowest point of the curve separating this peak from the peak due to formoterol.

**Limit:**

- *impurity I*: not more than 1.5 times the area of the principal peak in the chromatogram obtained with reference solution (b) (0.3 per cent).

**Water (2.5.12):** 4.0 per cent to 5.0 per cent, determined on 0.100 g.

**ASSAY**

Dissolve 0.350 g in 50 mL of anhydrous acetic acid R. Titrate with 0.1 M perchloric acid, determining the end-point potentiometrically (2.2.20).

1 mL of 0.1 M perchloric acid is equivalent to 40.24 mg of  $C_{42}H_{52}N_4O_{12}$ .

**STORAGE**

Protected from light.

**IMPURITIES**

**Specified impurities:** A, B, C, D, E, F, I.

**Other detectable impurities** (the following substances would, if present at a sufficient level, be detected by one or other of the tests in the monograph. They are limited by the general acceptance criterion for other/unspecified impurities and/or by the general monograph *Substances for pharmaceutical use (2034)*. It is therefore not necessary to identify these impurities for demonstration of compliance. See also 5.10. *Control of impurities in substances for pharmaceutical use*): G, H.

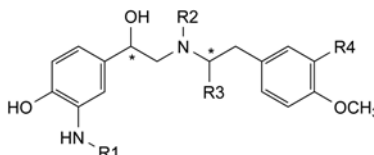

- A. R1 = R2 = R4 = H, R3 = CH<sub>3</sub>: 1-(3-amino-4-hydroxyphenyl)-2-[[2-(4-methoxyphenyl)-1-methylethyl]amino]ethanol,
- B. R1 = CHO, R2 = R3 = R4 = H: *N*-[2-hydroxy-5-[(1*RS*)-1-hydroxy-2-[[2-(4-methoxyphenyl)ethyl]amino]ethyl]phenyl]formamide,
- C. R1 = CO-CH<sub>3</sub>, R2 = R4 = H, R3 = CH<sub>3</sub>: *N*-[2-hydroxy-5-[1-hydroxy-2-[[2-(4-methoxyphenyl)-1-methylethyl]amino]ethyl]phenyl]acetamide,
- D. R1 = CHO, R2 = R3 = CH<sub>3</sub>, R4 = H: *N*-[2-hydroxy-5-[1-hydroxy-2-[methyl[2-(4-methoxyphenyl)-1-methylethyl]amino]ethyl]phenyl]formamide,
- E. R1 = CHO, R2 = H, R3 = R4 = CH<sub>3</sub>: *N*-[2-hydroxy-5-[1-hydroxy-2-[[2-(4-methoxy-3-methylphenyl)-1-methylethyl]amino]ethyl]phenyl]formamide,

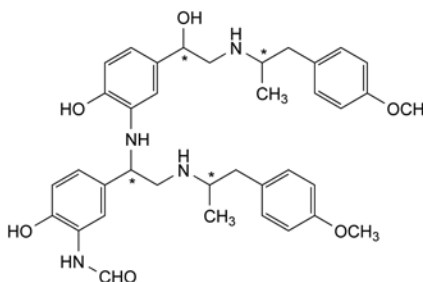

- F. *N*-[2-hydroxy-5-[1-[[2-hydroxy-5-[1-hydroxy-2-[[2-(4-methoxyphenyl)-1-methylethyl]amino]ethyl]phenyl]amino]-2-[[2-(4-methoxyphenyl)-1-methylethyl]amino]ethyl]phenyl]formamide,

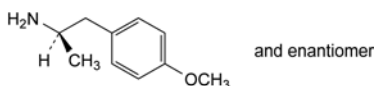

- G. (2*RS*)-1-(4-methoxyphenyl)propan-2-amine,

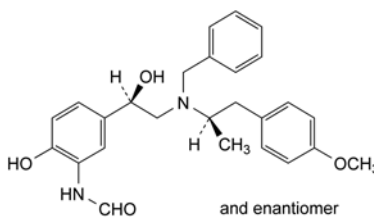

- H. *N*-[5-[(1*RS*)-2-[benzyl[(1*RS*)-2-(4-methoxyphenyl)-1-methylethyl]amino]-1-hydroxyethyl]-2-hydroxyphenyl]formamide (monobenzyl analogue),

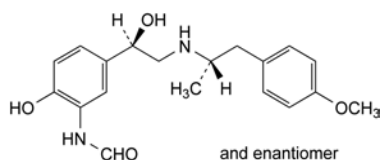

- I. *N*-[2-hydroxy-5-[(1*RS*)-1-hydroxy-2-[(1*SR*)-2-(4-methoxyphenyl)-1-methylethyl]amino]ethyl]phenyl]formamide (diastereoisomer).

07/2010:1520

## FOSCARNET SODIUM HEXAHYDRATE

### Foscarnetum natricum hexahydricum

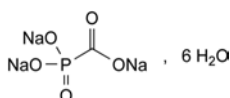

$\text{CNa}_3\text{O}_5\text{P}_6\text{H}_2\text{O}$   
[34156-56-4]

 $M_r$  300.0

#### DEFINITION

Trisodium phosphonatoformate hexahydrate.

*Content*: 98.5 per cent to 101.0 per cent (dried substance).

#### CHARACTERS

*Appearance*: white or almost white, crystalline powder.

*Solubility*: soluble in water, practically insoluble in ethanol (96 per cent).

#### IDENTIFICATION

A. Infrared absorption spectrophotometry (2.2.24).

*Comparison*: foscarnet sodium hexahydrate CRS.

B. It gives reaction (a) of sodium (2.3.1).

#### TESTS

**Solution S.** Dissolve 0.5 g in carbon dioxide-free water R and dilute to 25 mL with the same solvent.

**Appearance of solution.** Solution S is not more opalescent than reference suspension I (2.2.1) and is colourless (2.2.2, Method II).

**pH** (2.2.3): 9.0 to 11.0 for solution S.

**Impurity D.** Gas chromatography (2.2.28).

*Test solution.* Dissolve 0.250 g of the substance to be examined in 9.0 mL of 0.1 M acetic acid using a magnetic stirrer. Add 1.0 mL of anhydrous ethanol R and mix.

*Reference solution.* Dissolve 25.0 mg of foscarnet impurity D CRS in anhydrous ethanol R and dilute to 100.0 mL with the same solvent. Dilute 1.0 mL of this solution to 10.0 mL with anhydrous ethanol R.

*Column*:

- *material*: fused silica;
- *size*:  $l = 25$  m,  $\varnothing = 0.31$  mm;
- *stationary phase*: poly(dimethyl)(diphenyl)(divinyl)siloxane R (film thickness 0.5  $\mu\text{m}$ ).

*Carrier gas*: helium for chromatography R.

*Split ratio*: 1:20.

*Temperature*:

	Time (min)	Temperature (°C)
Column	0 - 8	100 → 180
Injection port		200
Detector		250

*Detection*: flame ionisation.

*Injection*: 3  $\mu\text{L}$

*Limit*:

- *impurity D*: not more than the area of the principal peak in the chromatogram obtained with the reference solution (0.1 per cent).

**Related substances.** Liquid chromatography (2.2.29).

*Test solution.* Dissolve 25 mg of the substance to be examined in the mobile phase and dilute to 10.0 mL with the mobile phase.

*Reference solution (a).* Dilute 1.0 mL of the test solution to 50.0 mL with the mobile phase. Dilute 1.0 mL of this solution to 10.0 mL with the mobile phase.

*Reference solution (b).* Dissolve 5 mg of foscarnet impurity B CRS in the mobile phase, add 2.0 mL of the test solution and dilute to 50.0 mL with the mobile phase.

*Reference solution (c).* Dissolve the contents of a vial of foscarnet impurity mixture CRS (impurities A and C) in 1.0 mL of mobile phase.

*Column*:

- *size*:  $l = 0.10$  m,  $\varnothing = 4.6$  mm;
- *stationary phase*: octadecylsilyl silica gel for chromatography R (3  $\mu\text{m}$ ).

*Mobile phase:* dissolve 3.22 g of sodium sulfate decahydrate R in water R, add 3 mL of glacial acetic acid R and 6 mL of a 44.61 g/L solution of sodium pyrophosphate R and dilute to 1000 mL with water R (solution A); dissolve 3.22 g of sodium sulfate decahydrate R in water R, add 6.8 g of sodium acetate R and 6 mL of a 44.61 g/L solution of sodium pyrophosphate R and dilute to 1000 mL with water R (solution B). Mix about 700 mL of solution A and about 300 mL of solution B to obtain a solution of pH 4.4. To 1000 mL of this solution, add 0.25 g of tetrahexylammonium hydrogen sulfate R and 100 mL of methanol R.

*Flow rate*: 1.0 mL/min.

*Detection*: spectrophotometer at 230 nm.

*Injection*: 40  $\mu\text{L}$ .

*Run time*: 2.5 times the retention time of foscarnet.

*Identification of impurities:* use the chromatogram supplied with foscarnet impurity mixture CRS and the chromatogram obtained with reference solution (c) to identify the peaks due to impurities A and C; use the chromatogram obtained with reference solution (b) to identify the peak due to impurity B.

*Relative retention* with reference to foscarnet (retention time = about 5 min): impurity A = about 0.7; impurity B = about 1.5; impurity C = about 2.0.

*System suitability:* reference solution (b):

- *resolution*: minimum 7.0 between the peaks due to foscarnet and impurity B.

*Limits*:

- *impurities A, B, C*: for each impurity, not more than the area of the principal peak in the chromatogram obtained with reference solution (a) (0.2 per cent);
- *unspecified impurities*: for each impurity, not more than 0.25 times the area of the principal peak in the chromatogram obtained with reference solution (a) (0.05 per cent);
- *total*: not more than twice the area of the principal peak in the chromatogram obtained with reference solution (a) (0.4 per cent);
- *disregard limit*: 0.2 times the area of the principal peak in the chromatogram obtained with reference solution (a) (0.04 per cent); disregard any peak with a relative retention time less than 0.6.

**Phosphate and phosphite.** Liquid chromatography (2.2.29).

*Test solution.* Dissolve 60.0 mg of the substance to be examined in water R and dilute to 25.0 mL with the same solvent.

*Reference solution (a).* Dissolve 28 mg of sodium dihydrogen phosphate monohydrate R in water R and dilute to 100 mL with the same solvent.



*Reference solution (b).* Dissolve 43 mg of *sodium phosphite pentahydrate R* in *water R* and dilute to 100 mL with the same solvent.

*Reference solution (c).* Dilute 1.0 mL of reference solution (a) and 1.0 mL of reference solution (b) to 25 mL with *water R*.

*Reference solution (d).* Dilute 3 mL of reference solution (a) and 3 mL of reference solution (b) to 25 mL with *water R*.

*Column:*

– *size:*  $l = 0.05$  m,  $\emptyset = 4.6$  mm;

– *stationary phase:* anion exchange resin *R*.

*Mobile phase:* dissolve 0.102 g of *potassium hydrogen phthalate R* in *water R*, add 2.5 mL of 1 M *nitric acid* and dilute to 1000 mL with *water R*.

*Flow rate:* 1.4 mL/min.

*Detection:* spectrophotometer at 290 nm (indirect detection).

*Injection:* 20  $\mu$ L of the test solution and reference solutions (c) and (d).

*System suitability:* reference solution (d):

- *resolution:* minimum 2.0 between the peaks due to phosphate (1<sup>st</sup> peak) and phosphite;
- *signal-to-noise ratio:* minimum 10 for the principal peak.

*Limits:*

- *phosphate:* not more than the area of the corresponding peak in the chromatogram obtained with reference solution (c) (0.3 per cent);
- *phosphite:* not more than the area of the corresponding peak in the chromatogram obtained with reference solution (c) (0.3 per cent).

**Heavy metals:** maximum 10 ppm.

Dissolve 1.25 g in 12.5 mL of 1 M *hydrochloric acid*. Warm on a water-bath for 3 min and cool to room temperature. Transfer to a beaker, adjust to about pH 3.5 with *dilute ammonia R1* and dilute to 25 mL with *water R* (solution A). To 12 mL of solution A, add 2.0 mL of *buffer solution pH 3.5 R*. Rapidly pour the mixture into a test tube containing 1 drop of *sodium sulfide solution R*. The solution is not more intensely coloured than a reference solution prepared simultaneously and in the same manner by pouring a mixture of 5.0 mL of *lead standard solution (1 ppm Pb) R*, 5.0 mL of *water R*, 2.0 mL of solution A and 2.0 mL of *buffer solution pH 3.5 R* into a test tube containing 1 drop of *sodium sulfide solution R*.

**Loss on drying (2.2.32):** 35.0 per cent to 37.0 per cent, determined on 1.000 g by drying in an oven at 150 °C.

**Bacterial endotoxins (2.6.14):** less than 83.3 IU/g, if intended for use in the manufacture of parenteral preparations without a further appropriate procedure for the removal of bacterial endotoxins.

ASSAY

Dissolve 0.200 g in 50 mL of *water R*. Titrate with 0.05 M *sulfuric acid*, determining the end-point potentiometrically (2.2.20) at the 1<sup>st</sup> point of inflexion.

1 mL of 0.05 M *sulfuric acid* is equivalent to 19.20 mg of  $\text{C}_3\text{H}_5\text{CaO}_4\text{P}\cdot\text{H}_2\text{O}$ .

STORAGE

Protected from light.

IMPURITIES

*Specified impurities:* A, B, C, D.

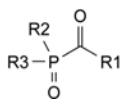

A.  $\text{R}_1 = \text{OC}_2\text{H}_5$ ,  $\text{R}_2 = \text{R}_3 = \text{ONa}$ : disodium (ethoxycarbonyl)phosphonate,

B.  $\text{R}_1 = \text{R}_2 = \text{ONa}$ ,  $\text{R}_3 = \text{OC}_2\text{H}_5$ : disodium (ethoxyoxydophosphanyl)formate,

C.  $\text{R}_1 = \text{R}_2 = \text{OC}_2\text{H}_5$ ,  $\text{R}_3 = \text{ONa}$ : ethyl sodium (ethoxycarbonyl)phosphonate,

D.  $\text{R}_1 = \text{R}_2 = \text{R}_3 = \text{OC}_2\text{H}_5$ : ethyl (diethoxyphosphoryl)formate.

01/2011:1328

## FOSFOMYCIN CALCIUM

### Fosfomycinum calcicum

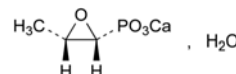

$\text{C}_3\text{H}_5\text{CaO}_4\text{P}\cdot\text{H}_2\text{O}$   
[26016-98-8]

$M_r$  194.1

DEFINITION

Calcium (2*R*,3*S*)-(3-methyloxiran-2-yl)phosphonate monohydrate.

Substance produced by certain strains of *Streptomyces fradiae* or obtained by any other means.

*Content:* 95.0 per cent to 101.0 per cent (anhydrous substance).

CHARACTERS

*Appearance:* white or almost white powder.

*Solubility:* slightly soluble in water, practically insoluble in acetone, in methanol and in methylene chloride.

IDENTIFICATION

*First identification:* A, D.

*Second identification:* B, C, D.

A. Infrared absorption spectrophotometry (2.2.24).

*Comparison:* fosfomycin calcium CRS.

B. Dissolve about 0.1 g in 3 mL of a 25 per cent V/V solution of *perchloric acid R*. Add 1 mL of 0.1 M *sodium periodate* and heat on a water-bath for 30 min. Allow to cool and add 50 mL of *water R*. Neutralise with a saturated solution of *sodium hydrogen carbonate R* and add 1 mL of a freshly prepared 400 g/L solution of *potassium iodide R*. Prepare a blank at the same time and in the same manner. The test solution remains colourless and the blank is orange.

C. To about 8 mg add 2 mL of *water R*, 1 mL of *perchloric acid R* and 2 mL of 0.1 M *sodium periodate*. Heat on a water-bath for 10 min and add, without cooling, 1 mL of *ammonium molybdate solution R5* and 1 mL of *aminohydroxynaphthalenesulfonic acid solution R*. Allow to stand for 30 min. A blue colour develops.

D. It gives reaction (a) of calcium (2.3.1).

TESTS

**pH (2.2.3):** 8.1 to 9.6.

Dissolve 20 mg in *carbon dioxide-free water R* and dilute to 20.0 mL with the same solvent.

**Specific optical rotation (2.2.7):** –11.0 to –13.0 (anhydrous substance).

Dissolve 2.5 g in a 125 g/L solution of *sodium edetate R* previously adjusted to pH 8.5 with *strong sodium hydroxide solution R*, and dilute to 50.0 mL with the same solution. Measure at 405 nm using a mercury lamp.

**Impurity A:** maximum 1.5 per cent.

In a glass-stoppered flask, dissolve 0.200 g in 100.0 mL of *water R*. Add 50 mL of 0.5 M *phthalate buffer solution pH 6.4 R* and 5.0 mL of 0.005 M *sodium periodate*, close and shake. Allow to stand protected from light for 90 min. Add 10 mL of a freshly prepared 400 g/L solution of *potassium iodide R*, close and shake for 2 min. Titrate with 0.0025 M *sodium arsenite* until the yellow colour almost disappears. Add 2 mL of *starch solution R* and slowly continue the titration until the colour is completely discharged. Carry out a blank test under the same

conditions. Calculate the percentage content of  $C_3H_7CaO_5P$  using the following expression:

$$\frac{(n_1 - n_2) \times c \times 97}{m(100 - H)} \times 100$$

- $m$  = mass of the substance to be examined, in milligrams;  
 $n_1$  = volume of 0.0025 M sodium arsenite used in the blank titration;  
 $n_2$  = volume of 0.0025 M sodium arsenite used in the titration of the test solution;  
 $c$  = molarity of the sodium arsenite solution;  
 $H$  = percentage content of water.

**Chlorides** (2.4.4): maximum 0.2 per cent.

Dissolve 0.500 g in *water R*, add 2 mL of *nitric acid R* and dilute to 50 mL with the same acid. To 2.5 mL of this solution add 12.5 mL of *water R*.

**Heavy metals** (2.4.8): maximum 20 ppm.

Dissolve 2.5 g in 6 mL of *glacial acetic acid R* and dilute to 25.0 mL with *water R*. 12 mL of the solution complies with test A. Prepare the reference solution using *lead standard solution (2 ppm Pb) R*.

**Water** (2.5.12): 8.5 per cent to 11.5 per cent, determined on 0.250 g. Use as the solvent a mixture of 1 volume of *pyridine R* and 3 volumes of *ethylene glycol R*.

#### ASSAY

In a glass-stoppered flask, dissolve 0.120 g in 20.0 mL of 0.1 M *sodium periodate*. Add 5 mL of a 50 per cent V/V solution of *perchloric acid R* and shake. Heat in a water-bath at 37 °C for 105 min. Add 50 mL of *water R* and immediately adjust to pH 6.4 with a saturated solution of *sodium hydrogen carbonate R*. Add 10 mL of a freshly prepared 400 g/L solution of *potassium iodide R*, close and allow to stand for 2 min. Titrate with 0.1 M *sodium arsenite* until the yellow colour almost disappears. Add 2 mL of *starch solution R* and slowly continue the titration until the colour is completely discharged. Carry out a blank test under the same conditions.

Calculate the percentage content of  $C_3H_5CaO_4P$  using the following expression:

$$\frac{(n_1 - n_2) \times c \times 88 \times 100}{m(100 - H)} \times 100 - G$$

- $m$  = mass of the substance to be examined, in milligrams;  
 $n_1$  = volume of 0.1 M *sodium arsenite* used in the blank titration;  
 $n_2$  = volume of 0.1 M *sodium arsenite* used in the titration of the test solution;  
 $c$  = molarity of the sodium arsenite solution;  
 $G$  = percentage content of impurity A;  
 $H$  = percentage content of water.

#### STORAGE

In an airtight container, protected from light.

#### IMPURITIES

*Specified impurities: A.*

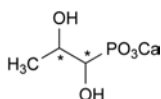

A. calcium (1,2-dihydroxypropyl)phosphonate.

01/2008:1329  
corrected 6.0

## FOSFOMYCIN SODIUM

### Fosfomicinum natricum



$C_3H_5Na_2O_4P$   
[26016-99-9]

$M_r$  182.0

#### DEFINITION

Disodium (2*R*,3*S*)-(3-methyloxiran-2-yl)phosphonate.

Substance produced by certain strains of *Streptomyces fradiae* or obtained by any other means.

*Content*: 95.0 per cent to 101.0 per cent (anhydrous substance).

#### CHARACTERS

*Appearance*: white or almost white, very hygroscopic powder.

*Solubility*: very soluble in water, sparingly soluble in methanol, practically insoluble in ethanol (96 per cent) and in methylene chloride.

#### IDENTIFICATION

*First identification: A, D.*

*Second identification: B, C, D.*

A. Infrared absorption spectrophotometry (2.2.24).

*Preparation*: discs of *potassium bromide R*.

*Comparison: Ph. Eur. reference spectrum of fosfomicin sodium.*

B. Dissolve about 0.1 g in 3 mL of a 25 per cent V/V solution of *perchloric acid R*. Add 1 mL of 0.1 M *sodium periodate* and heat on a water-bath for 30 min. Allow to cool and add 50 mL of *water R*. Neutralise with a saturated solution of *sodium hydrogen carbonate R* and add 1 mL of a freshly prepared 400 g/L solution of *potassium iodide R*. Prepare a blank at the same time and in the same manner. The test solution remains colourless and the blank is orange.

C. To about 8 mg add 2 mL of *water R*, 1 mL of *perchloric acid R* and 2 mL of 0.1 M *sodium periodate*. Heat on a water-bath for 10 min and add, without cooling, 1 mL of *ammonium molybdate solution R5* and 1 mL of *aminohydroxynaphthalenesulfonic acid solution R*. Allow to stand for 30 min. A blue colour develops.

D. It gives reaction (a) of sodium (2.3.1).

#### TESTS

**Solution S.** Dissolve 5.0 g in *carbon dioxide-free water R* and dilute to 50.0 mL with the same solvent.

**Appearance of solution.** Solution S is clear (2.2.1) and not more intensely coloured than reference solution B<sub>9</sub> (2.2.2, *Method II*).

**pH** (2.2.3): 9.0 to 10.5.

Dilute 10 mL of solution S to 20 mL with *carbon dioxide-free water R*.

**Specific optical rotation** (2.2.7): –13.0 to –15.0 (anhydrous substance).

Dissolve 2.5 g in *water R* and dilute to 50.0 mL with the same solvent. Measure at 405 nm using a mercury lamp.

**Impurity A:** maximum 1.0 per cent.

In a glass-stoppered flask, dissolve 0.200 g in 100.0 mL of *water R*. Add 50 mL of 0.5 M *phthalate buffer solution pH 6.4 R* and 5.0 mL of 0.005 M *sodium periodate*, close and shake. Allow to stand protected from light for 90 min. Add 10 mL of a freshly prepared 400 g/L solution of *potassium iodide R*, close and shake for 2 min. Titrate with 0.0025 M *sodium arsenite* until the yellow colour almost disappears. Add 2 mL of *starch solution R* and slowly continue the titration until the colour is

01/2008:1425

completely discharged. Carry out a blank test under the same conditions.

Calculate the percentage content of  $C_3H_7Na_2O_5P$  using the following expression:

$$\frac{(n_1 - n_2) \times c \times 100}{m(100 - H)} \times 100$$

- $m$  = mass of the substance to be examined, in milligrams;  
 $n_1$  = volume of 0.0025 M sodium arsenite used in the blank titration;  
 $n_2$  = volume of 0.0025 M sodium arsenite used in the titration of the test solution;  
 $c$  = molarity of the sodium arsenite solution;  
 $H$  = percentage content of water.

**Heavy metals** (2.4.8): maximum 20 ppm.

12 mL of solution S complies with test A. Prepare the reference solution using lead standard solution (2 ppm Pb) R.

**Water** (2.5.12): maximum 1.0 per cent, determined on 0.50 g. Use as the solvent a mixture of 1 volume of pyridine R and 3 volumes of ethylene glycol R.

**Bacterial endotoxins** (2.6.14): less than 0.083 IU/mg, if intended for use in the manufacture of parenteral preparations without a further appropriate procedure for removal of bacterial endotoxins.

#### ASSAY

In a glass-stoppered flask, dissolve 0.120 g in 20.0 mL of 0.1 M sodium periodate. Add 5 mL of a 50 per cent V/V solution of perchloric acid R and shake. Heat on a water-bath at 37 °C for 105 min. Add 50 mL of water R and immediately adjust to pH 6.4 with a saturated solution of sodium hydrogen carbonate R. Add 10 mL of a freshly prepared 400 g/L solution of potassium iodide R, close and allow to stand for 2 min. Titrate with 0.1 M sodium arsenite until the yellow colour almost disappears. Add 2 mL of starch solution R and slowly continue the titration until the colour is completely discharged. Carry out a blank test under the same conditions.

Calculate the percentage content of  $C_3H_5Na_2O_4P$  using the following expression:

$$\frac{(n_1 - n_2) \times c \times 91 \times 100}{m(100 - H)} \times 100 - G$$

- $m$  = mass of the substance to be examined, in milligrams;  
 $n_1$  = volume of 0.1 M sodium arsenite used in the blank titration;  
 $n_2$  = volume of 0.1 M sodium arsenite used in the titration of the test solution;  
 $c$  = molarity of the sodium arsenite solution;  
 $G$  = percentage content of impurity A;  
 $H$  = percentage content of water.

#### STORAGE

In an airtight container, protected from light. If the substance is sterile, store in a sterile, airtight, tamper-proof container.

#### IMPURITIES

*Specified impurities:* A.

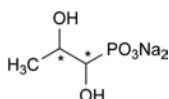

- A. disodium (1,2-dihydroxypropyl)phosphonate.

## FOSFOMYCIN TROMETAMOL

### Fosfomicinum trometamololum

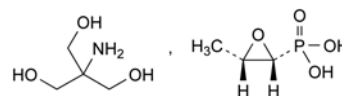

$C_7H_{18}NO_7P$   
[78964-85-9]

$M_r$  259.2

#### DEFINITION

2-Amino-2-(hydroxymethyl)propane-1,3-diol hydrogen (2R,3S)-(3-methyloxiran-2-yl)phosphonate.

*Content:* 98.0 per cent to 102.0 per cent (anhydrous substance).

#### CHARACTERS

*Appearance:* white or almost white, hygroscopic powder.

*Solubility:* very soluble in water, slightly soluble in ethanol (96 per cent) and in methanol, practically insoluble in acetone.

#### IDENTIFICATION

*First identification:* A.

*Second identification:* B, C.

A. Infrared absorption spectrophotometry (2.2.24).

*Comparison:* fosfomicin trometamol CRS.

B. Thin-layer chromatography (2.2.27).

*Test solution.* Dissolve 50 mg of the substance to be examined in water R and dilute to 10 mL with the same solvent.

*Reference solution.* Dissolve 50 mg of fosfomicin trometamol CRS in water R and dilute to 10 mL with the same solvent.

*Plate:* cellulose for chromatography R as the coating substance.

*Mobile phase:* concentrated ammonia R, water R, 2-propanol R (10:20:70 V/V/V).

*Application:* 10 µL.

*Development:* over 3/4 of the plate.

*Drying:* in a current of warm air.

*Detection:* expose to iodine vapour until the spots appear.

*Results:* the principal spot in the chromatogram obtained with the test solution is similar in position, colour and size to the principal spot in the chromatogram obtained with the reference solution.

C. To about 15 mg add 2 mL of water R, 1 mL of perchloric acid R and 2 mL of 0.1 M sodium periodate. Heat on a water-bath for 10 min and add, without cooling, 1 mL of ammonium molybdate solution R5 and 1 mL of aminohydroxynaphthalenesulfonic acid solution R. Allow to stand for 30 min. A blue colour develops.

#### TESTS

**Solution S.** Dissolve 1.00 g in carbon dioxide-free water R and dilute to 20.0 mL with the same solvent.

**pH** (2.2.3): 3.5 to 5.5 for solution S.

**Specific optical rotation** (2.2.7): –13.5 to –12.5 (anhydrous substance), determined on solution S at 365 nm using a mercury lamp.

**Related substances.** Liquid chromatography (2.2.29). Prepare the solutions immediately before use.

*Test solution.* Dissolve 0.600 g of the substance to be examined in the mobile phase and dilute to 5.0 mL with the mobile phase.

*Reference solution (a).* Dissolve 0.600 g of fosfomicin trometamol CRS in the mobile phase and dilute to 5.0 mL with the mobile phase.

**Reference solution (b).** Dilute 1.0 mL of the test solution to 100.0 mL with the mobile phase. Dilute 3.0 mL of this solution to 10.0 mL with the mobile phase.

**Reference solution (c).** Wet 0.3 g of the substance to be examined with 60 µL of *water R* and heat in an oven at 60 °C for 24 h. Dissolve the residue in the mobile phase and dilute to 20.0 mL with the mobile phase (solution A). Dissolve 0.6 g of the substance to be examined in solution A and dilute to 5.0 mL with the same solution (*in situ* degradation to obtain impurities A, B, C and D).

**Blank solution.** The mobile phase.

**Column:**

- size:  $l = 0.25$  m,  $\varnothing = 4.6$  mm,
- stationary phase: aminopropylsilyl silica gel for chromatography R (5 µm).

**Mobile phase:** 10.89 g/L solution of potassium dihydrogen phosphate R in *water for chromatography R*.

**Flow rate:** 1.0 mL/min.

**Detection:** differential refractometer at 35 °C.

**Injection:** 10 µL of the blank solution, the test solution and reference solutions (b) and (c).

**Run time:** twice the retention time of fosfomycin.

**Relative retention** with reference to fosfomycin (retention time = about 9 min): trometamol (2 peaks) = about 0.3; impurity B = about 0.48; impurity C = about 0.54; impurity A = about 0.88; impurity D = about 1.27.

**System suitability:** reference solution (c):

- resolution: minimum 1.5 between the peaks due to impurity A and fosfomycin,
- peak-to-valley ratio: minimum 1.5, where  $H_p$  = height above the baseline of the peak due to impurity C and  $H_v$  = height above the baseline of the lowest point of the curve separating this peak from the peak due to impurity B.

**Limits:**

- impurities A, B: for each impurity, not more than the area of the peak due to fosfomycin in the chromatogram obtained with reference solution (b) (0.3 per cent),
- impurities C, D: for each impurity, not more than 0.33 times the area of the peak due to fosfomycin in the chromatogram obtained with reference solution (b) (0.1 per cent),
- unspecified impurities: for each impurity, not more than 0.33 times the area of the peak due to fosfomycin in the chromatogram obtained with reference solution (b) (0.1 per cent),
- total: not more than 1.67 times the area of the peak due to fosfomycin in the chromatogram obtained with reference solution (b) (0.5 per cent);
- disregard limit: 0.17 times the area of the peak due to fosfomycin in the chromatogram obtained with reference solution (b) (0.05 per cent); disregard the 2 peaks due to trometamol and any peak due to the blank.

**Phosphates:** maximum 500 ppm.

Dissolve 0.1 g in 3 mL of *dilute nitric acid R* and dilute to 10 mL with *water R*. To 5 mL of this solution add 5 mL of *water R* and 5 mL of *molybdovanadic reagent R*. Shake vigorously. After 5 min, any colour in the test solution is not more intense than that in a standard prepared at the same time in the same manner, using 5 mL of *phosphate standard solution (5 ppm PO<sub>4</sub>) R*.

**Heavy metals (2.4.8):** maximum 10 ppm.

Dissolve 2.0 g in *water R* and dilute to 20 mL with the same solvent. 12 mL of the solution complies with test A. Prepare the reference solution using *lead standard solution (1 ppm Pb) R*.

**Water (2.5.12):** maximum 0.5 per cent, determined on 0.500 g.

**ASSAY**

Liquid chromatography (2.2.29) as described in the test for related substances with the following modification.

**Injection:** 5 µL of the test solution and reference solution (a).

Calculate the percentage content of C<sub>7</sub>H<sub>18</sub>NO<sub>7</sub>P from the areas of the peaks due to fosfomycin and the declared content of *fosfomycin trometamol CRS*.

**STORAGE**

In an airtight container.

**IMPURITIES**

**Specified impurities:** A, B, C, D.

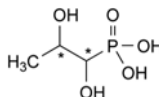

A. (1,2-dihydroxypropyl)phosphonic acid,

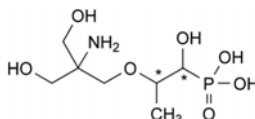

B. [2-[2-amino-3-hydroxy-2-(hydroxymethyl)propoxy]-1-hydroxypropyl]phosphonic acid,

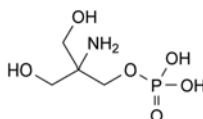

C. 2-amino-3-hydroxy-2-(hydroxymethyl)propyl dihydrogen phosphate (trometamol phosphoric acid monoester),

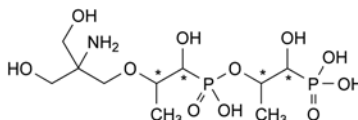

D. [2-[[[2-[2-amino-3-hydroxy-2-(hydroxymethyl)propoxy]-1-hydroxypropyl]hydroxyphosphoryl]oxy]-1-hydroxypropyl]phosphonic acid (trometamoyloxy fosfomycin dimer).

01/2011:1751

## FOSINOPRIL SODIUM

### Fosinoprilum natriicum

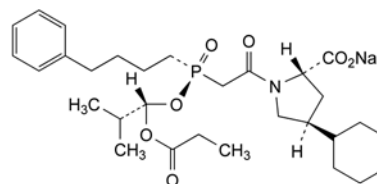

C<sub>30</sub>H<sub>45</sub>NNaO<sub>7</sub>P  
[88889-14-9]

$M_r$  585.7

**DEFINITION**

Sodium (2S,4S)-4-cyclohexyl-1-[[*(R)*]-[(1S)-2-methyl-1-(1-oxo-propoxy)propoxy]](4-phenylbutyl)phosphoryl]acetyl]pyrrolidine-2-carboxylate.

**Content:** 99.0 per cent to 101.0 per cent (anhydrous substance).

**CHARACTERS**

**Appearance:** white or almost white, crystalline powder.

**Solubility:** freely soluble in water, sparingly soluble in anhydrous ethanol, practically insoluble in hexane.

It shows polymorphism (5.9).

## IDENTIFICATION

A. Specific optical rotation (2.2.7):  $-4.7$  to  $-6.7$  (anhydrous substance).

Dissolve 0.500 g in *methanol R* and dilute to 25.0 mL with the same solvent.

B. Infrared absorption spectrophotometry (2.2.24).

*Comparison: fosinopril sodium CRS.*

If the spectra obtained show differences, dissolve the substance to be examined and the reference substance separately in a 2 per cent *V/V* solution of *water R* in *methanol R*, evaporate to dryness and record new spectra using the residues.

C. It gives reaction (a) of sodium (2.3.1).

## TESTS

## Related substances

A. Liquid chromatography (2.2.29).

*Test solution.* Dissolve 25 mg of the substance to be examined in the mobile phase and dilute to 50.0 mL with the mobile phase. Sonicate until dissolution is complete.

*Reference solution (a).* Dissolve 2 mg of the substance to be examined, 2 mg of *fosinopril impurity A CRS*, 2 mg of *fosinopril impurity B CRS*, 2 mg of *fosinopril impurity I CRS* and 2 mg of *fosinopril impurity K CRS* in the mobile phase and dilute to 50.0 mL with the mobile phase. Dilute 1.0 mL of the solution to 50.0 mL with the mobile phase.

*Reference solution (b).* Dilute 1.0 mL of the test solution to 50.0 mL with the mobile phase. Dilute 1.0 mL of this solution to 20.0 mL with the mobile phase.

*Reference solution (c).* Dilute 5.0 mL of reference solution (b) to 10.0 mL with the mobile phase.

*Column:*

- *size:*  $l = 0.15$  m,  $\emptyset = 3.9$  mm;
- *stationary phase:* *silica gel for chromatography R* (5  $\mu$ m);
- *temperature:* 33 °C.

*Mobile phase:* *phosphoric acid R, water R, acetonitrile R1* (0.5:3.5:1000 *V/V/V*).

*Flow rate:* 1.2 mL/min.

*Detection:* spectrophotometer at 214 nm.

*Injection:* 20  $\mu$ L.

*Run time:* 4 times the retention time of fosinopril.

*Identification of impurities:* use the chromatogram obtained with reference solution (a) to identify the peaks due to impurities A, B, I and K.

*Relative retention* with reference to fosinopril (retention time = about 5 min): impurity K = about 0.3; impurity I = about 0.5; impurities B, E and H = about 0.7; impurity A = about 2.0.

*System suitability:*

- *resolution:* minimum 2.0 between the peaks due to impurity B and fosinopril in the chromatogram obtained with reference solution (a);
- *signal-to-noise ratio:* minimum 40 for the principal peak in the chromatogram obtained with reference solution (c).

*Limits:*

- *correction factor:* for the calculation of content, multiply the peak area of impurity I by 1.3;
- *sum of impurities B, E and H:* not more than 10 times the area of the principal peak in the chromatogram obtained with reference solution (b) (1.0 per cent);
- *impurity A:* not more than 5 times the area of the principal peak in the chromatogram obtained with reference solution (b) (0.5 per cent);
- *impurities I, K:* for each impurity, not more than 3 times the area of the principal peak in the chromatogram obtained with reference solution (b) (0.3 per cent);

- *unspecified impurities:* for each impurity, not more than the area of the principal peak in the chromatogram obtained with reference solution (b) (0.10 per cent).

B. Impurities C and D. Liquid chromatography (2.2.29).

*Test solution.* Dissolve 25.0 mg of the substance to be examined in the mobile phase and dilute to 50.0 mL with the mobile phase. Sonicate until dissolution is complete.

*Reference solution (a).* Dissolve 5 mg of the substance to be examined and 5.0 mg of *fosinopril impurity C CRS* in the mobile phase and dilute to 100.0 mL with the mobile phase. Dilute 10.0 mL of the solution to 50.0 mL with the mobile phase.

*Reference solution (b).* Dilute 5.0 mL of reference solution (a) to 50.0 mL with the mobile phase.

*Reference solution (c).* Dissolve 5.0 mg of *fosinopril impurity D CRS* in the mobile phase and dilute to 100.0 mL with the mobile phase. Dilute 10.0 mL of the solution to 50.0 mL with the mobile phase. Dilute 5.0 mL of this solution to 50.0 mL with the mobile phase.

*Column:*

- *size:*  $l = 0.25$  m,  $\emptyset = 4.6$  mm;
- *stationary phase:* *strongly basic anion exchange resin for chromatography R* (5  $\mu$ m);
- *temperature:* 45 °C.

*Mobile phase:* *phosphoric acid R, water R, acetonitrile R1* (0.2:1.5:400 *V/V/V*).

*Flow rate:* 0.9 mL/min.

*Detection:* spectrophotometer at 214 nm.

*Injection:* 20  $\mu$ L.

*Run time:* twice the retention time of fosinopril.

*Identification of impurities:* use the chromatogram obtained with reference solution (a) to identify the peak due to impurity C and the chromatogram obtained with reference solution (c) to identify the peak due to impurity D.

*Relative retention* with reference to fosinopril (retention time = about 10 min): impurity C = about 1.2; impurity D = about 1.3.

*System suitability:* reference solution (a):

- *resolution:* minimum 1.5 between the peaks due to fosinopril and impurity C.

*Limits:*

- *impurity C:* not more than 1.5 times the area of the corresponding peak in the chromatogram obtained with reference solution (b) (0.3 per cent);
- *impurity D:* not more than 1.5 times the area of the corresponding peak in the chromatogram obtained with reference solution (c) (0.3 per cent).

C. Impurities E and F. Liquid chromatography (2.2.29).

*Test solution.* Dissolve 25 mg of the substance to be examined in the mobile phase and dilute to 50.0 mL with the mobile phase.

*Reference solution (a).* Dilute 1.0 mL of the test solution to 50.0 mL with the mobile phase.

*Reference solution (b).* Dilute 1.0 mL of reference solution (a) to 20.0 mL with the mobile phase.

*Reference solution (c).* Dissolve the contents of a vial of *fosinopril impurity mixture CRS* (containing impurities E and F) in 1.0 mL of reference solution (a).

*Column:*

- *size:*  $l = 0.25$  m,  $\emptyset = 4.6$  mm;
- *stationary phase:* *phenylsilyl silica gel for chromatography R* (5  $\mu$ m);
- *temperature:* 45 °C.

*Mobile phase:* 0.2 per cent *V/V* solution of *phosphoric acid R, acetonitrile R1* (44:56 *V/V*).

*Flow rate:* 1.0 mL/min.

**Detection:** spectrophotometer at 205 nm.

**Injection:** 20 µL of the test solution and reference solutions (b) and (c).

**Run time:** 3 times the retention time of fosinopril.

**Identification of impurities:** use the chromatogram supplied with *fosinopril impurity mixture CRS* and the chromatogram obtained with reference solution (c) to identify the peaks due to impurities E and F.

**Relative retention** with reference to fosinopril (retention time = about 8 min): impurity E = about 0.8; impurity F = about 0.9.

**System suitability:** reference solution (c):

- **resolution:** minimum 1.5 between the peaks due to impurity F and fosinopril.

**Limits:**

- **correction factor:** for the calculation of content, multiply the peak area of impurity E by 0.7;
- **impurity F:** not more than 3 times the area of the principal peak in the chromatogram obtained with reference solution (b) (0.3 per cent);
- **impurity E:** not more than twice the area of the principal peak in the chromatogram obtained with reference solution (b) (0.2 per cent).

**2-Ethylhexanoic acid (2.4.28):** maximum 0.2 per cent *m/m*.

**Heavy metals (2.4.8):** maximum 20 ppm.

**Solvent mixture:** ethanol (96 per cent) *R*, water *R* (20:80 *V/V*). 0.50 g complies with test H. Prepare the reference solution using 1 mL of lead standard solution (10 ppm *Pb*) *R*.

**Water (2.5.12):** maximum 0.2 per cent, determined on 1.00 g.

#### ASSAY

Dissolve 0.450 g in 50 mL of water *R*. Titrate with 0.1 *M* hydrochloric acid, determining the end-point potentiometrically (2.2.20).

1 mL of 0.1 *M* hydrochloric acid is equivalent to 58.57 mg of  $C_{30}H_{45}NNaO_7P$ .

#### IMPURITIES

**Specified impurities:** A, B, C, D, E, F, H, I, K.

**Other detectable impurities** (the following substances would, if present at a sufficient level, be detected by one or other of the tests in the monograph. They are limited by the general acceptance criterion for other/unspecified impurities and/or by the general monograph *Substances for pharmaceutical use (2034)*. It is therefore not necessary to identify these impurities for demonstration of compliance. See also 5.10. **Control of impurities in substances for pharmaceutical use):** N.

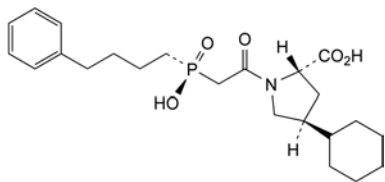

A. (2*S*,4*S*)-4-cyclohexyl-1-[[*R*]-hydroxy(4-phenylbutyl)phosphoryl]acetyl]pyrrolidine-2-carboxylic acid,

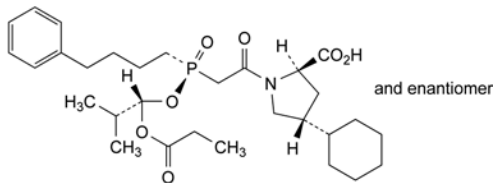

B. (2*RS*,4*RS*)-4-cyclohexyl-1-[[*RS*]-[(1*SR*)-2-methyl-1-(1-oxopropoxy)propoxy](4-phenylbutyl)phosphoryl]acetyl]pyrrolidine-2-carboxylic acid,

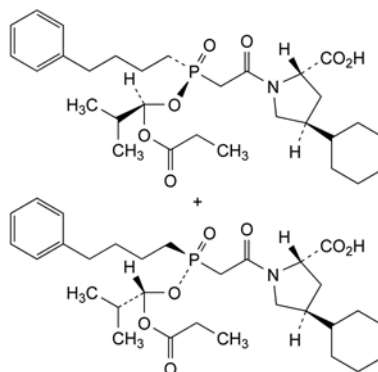

C. mixture of (2*S*,4*S*)-4-cyclohexyl-1-[[*S*]-[(1*S*)-2-methyl-1-(1-oxopropoxy)propoxy](4-phenylbutyl)phosphoryl]acetyl]pyrrolidine-2-carboxylic acid and (2*S*,4*S*)-4-cyclohexyl-1-[[*R*]-[(1*R*)-2-methyl-1-(1-oxopropoxy)propoxy](4-phenylbutyl)phosphoryl]acetyl]pyrrolidine-2-carboxylic acid,

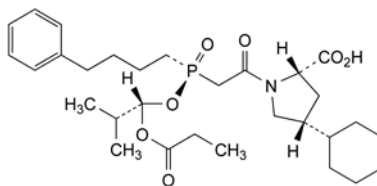

D. (2*S*,4*R*)-4-cyclohexyl-1-[[*R*]-[(1*S*)-2-methyl-1-(1-oxopropoxy)propoxy](4-phenylbutyl)phosphoryl]acetyl]pyrrolidine-2-carboxylic acid,

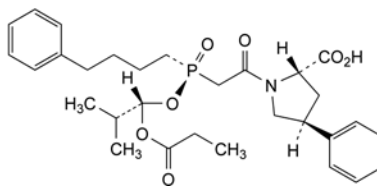

E. (2*S*,4*S*)-1-[[*R*]-[(1*S*)-2-methyl-1-(1-oxopropoxy)propoxy](4-phenylbutyl)phosphoryl]acetyl]-4-phenylpyrrolidine-2-carboxylic acid (phenylfosinopril),

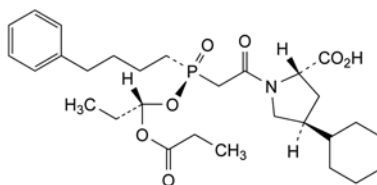

F. (2*S*,4*S*)-4-cyclohexyl-1-[[*R*]-[(4-phenylbutyl)[(1*S*)-1-(1-oxopropoxy)propoxy]phosphoryl]acetyl]pyrrolidine-2-carboxylic acid,

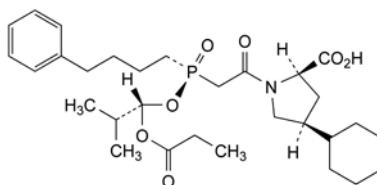

H. (2*R*,4*S*)-4-cyclohexyl-1-[[*R*]-[(1*S*)-2-methyl-1-(1-oxopropoxy)propoxy](4-phenylbutyl)phosphoryl]acetyl]pyrrolidine-2-carboxylic acid,

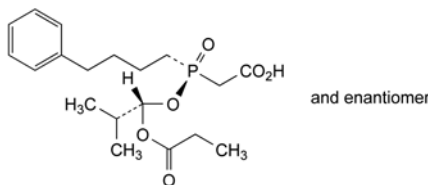

I. [[*RS*]-[(1*SR*)-2-methyl-1-(1-oxopropoxy)propoxy](4-phenylbutyl)phosphoryl]acetic acid,

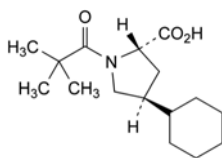

K. (2*S*,4*S*)-4-cyclohexyl-1-(2,2-dimethyl-1-oxopropyl)pyrrolidine-2-carboxylic acid,

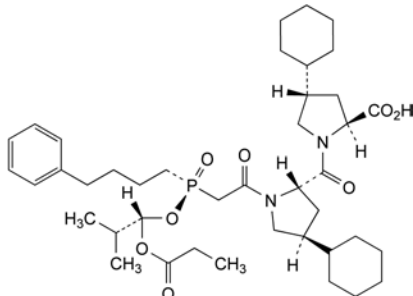

N. (2*S*,4*S*)-4-cyclohexyl-1-[[[(2*S*,4*S*)-4-cyclohexyl-1-[[[(*R*)-[(1*S*)-2-methyl-1-(1-oxopropoxy)propoxy][4-phenylbutyl]phosphoryl]acetyl]pyrrolidin-2-yl]-carbonyl]pyrrolidine-2-carboxylic acid.

01/2008:0180

## FRAMYCETIN SULFATE

### Framycetini sulfas

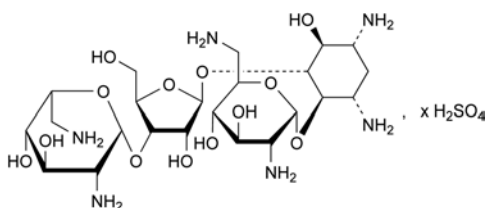

$C_{23}H_{46}N_6O_{13} \cdot xH_2SO_4$   
[4146-30-9]

$M_r$  615 (base)

#### DEFINITION

Sulfate of 2-deoxy-4-*O*-(2,6-diamino-2,6-dideoxy- $\alpha$ -D-glucopyranosyl)-5-*O*-[3-*O*-(2,6-diamino-2,6-dideoxy- $\beta$ -L-idopyranosyl)- $\beta$ -D-ribofuranosyl]-D-streptomycin (neomycin B).

Substance produced by the growth of selected strains of *Streptomyces fradiae* or *Streptomyces decaris* or obtained by any other means.

**Content:** minimum of 630 IU/mg (dried substance).

#### CHARACTERS

**Appearance:** white or yellowish-white powder, hygroscopic.

**Solubility:** freely soluble in water, very slightly soluble in alcohol, practically insoluble in acetone.

#### IDENTIFICATION

A. Examine the chromatograms obtained in the test for related substances.

**Results:**

- the retention time of the principal peak in the chromatogram obtained with the test solution is approximately the same as that of the principal peak in the chromatogram obtained with reference solution (a),
- it complies with the limit given for impurity C.

B. It gives reaction (a) of sulfates (2.3.1).

#### TESTS

**pH** (2.2.3): 6.0 to 7.0.

Dissolve 0.1 g in *carbon dioxide-free water R* and dilute to 10 mL with the same solvent.

**Specific optical rotation** (2.2.7): + 52.5 to + 55.5 (dried substance).

Dissolve 1.00 g in *water R* and dilute to 10.0 mL with the same solvent

**Related substances.** Liquid chromatography (2.2.29).

**Test solution.** Dissolve 25.0 mg of the substance to be examined in the mobile phase and dilute to 50.0 mL with the mobile phase.

**Reference solution (a).** Dissolve the contents of a vial of *framycetin sulfate CRS* in the mobile phase and dilute with the mobile phase to obtain a solution containing 0.5 mg/mL.

**Reference solution (b).** Dilute 3.0 mL of reference solution (a) to 100.0 mL with the mobile phase.

**Reference solution (c).** Dilute 1.0 mL of reference solution (a) to 100.0 mL with the mobile phase.

**Reference solution (d).** Dissolve the contents of a vial of *neamine CRS* (corresponding to 0.5 mg) in the mobile phase and dilute to 100.0 mL with the mobile phase.

**Reference solution (e).** Dissolve 10 mg of *neomycin sulfate CRS* in the mobile phase and dilute to 100.0 mL with the mobile phase.

**Column:**

- **size:**  $l = 0.25$  m,  $\varnothing = 4.6$  mm,
- **stationary phase:** base-deactivated octadecylsilyl silica gel for chromatography R (5  $\mu$ m),
- **temperature:** 25 °C.

**Mobile phase:** mix 20.0 mL of *trifluoroacetic acid R*, 6.0 mL of *carbonate-free sodium hydroxide solution R* and 500 mL of *water R*, allow to equilibrate, dilute to 1000 mL with *water R* and degas.

**Flow rate:** 0.7 mL/min.

**Post-column solution:** *carbonate-free sodium hydroxide solution R* diluted 1 in 25 previously degassed, which is added pulse-less to the column effluent using a 375  $\mu$ L polymeric mixing coil.

**Flow rate:** 0.5 mL/min.

**Detection:** pulsed amperometric detector with a gold working electrode, a silver-silver chloride reference electrode and a stainless steel auxiliary electrode which is the cell body, held at respectively 0.00 V detection, + 0.80 V oxidation and – 0.60 V reduction potentials, with pulse durations according to the instrument used.

**Injection:** 10  $\mu$ L.

**Run time:** 1.5 times the retention time of neomycin B.

**Relative retention** with reference to neomycin B (retention time = about 10 min): impurity A = about 0.65; impurity C = about 0.9; impurity G = about 1.1.

**System suitability:**

- **resolution:** minimum 2.0 between the peaks due to impurity C and to neomycin B in the chromatogram obtained with reference solution (e); if necessary, adjust the volume of the carbonate-free sodium hydroxide solution in the mobile phase,
- **signal-to-noise ratio:** minimum 10 for the principal peak in the chromatogram obtained with reference solution (c).

**Limits:**

- **impurity A:** not more than the area of the principal peak in the chromatogram obtained with reference solution (d) and taking into account the declared content of *neamine CRS* (1.0 per cent),
- **impurity C:** not more than the area of the principal peak in the chromatogram obtained with reference solution (b) (3.0 per cent),

- *total of other impurities*: not more than the area of the principal peak in the chromatogram obtained with reference solution (b) (3.0 per cent),
- *disregard limit*: area of the principal peak in the chromatogram obtained with reference solution (c) (1.0 per cent).

**Sulfate**: 27.0 per cent to 31.0 per cent (dried substance).

Dissolve 0.250 g in 100 mL of *water R* and adjust the solution to pH 11 using *concentrated ammonia R*. Add 10.0 mL of 0.1 M *barium chloride* and about 0.5 mg of *phthalein purple R*. Titrate with 0.1 M *sodium edetate* adding 50 mL of *alcohol R* when the colour of the solution begins to change and continuing the titration until the violet-blue colour disappears.

1 mL of 0.1 M *barium chloride* is equivalent to 9.606 mg of  $\text{SO}_4$ .

**Loss on drying** (2.2.32): maximum 8.0 per cent, determined on 1.000 g by drying at 60 °C over *diphosphorus pentoxide R* at a pressure not exceeding 0.7 kPa for 3 h.

**Sulfated ash** (2.4.14): maximum 1.0 per cent, determined on 1.0 g.

**Sterility** (2.6.1). If intended for introduction into body cavities without a further appropriate sterilisation procedure, it complies with the test for sterility.

**Bacterial endotoxins** (2.6.14, *Method D*): less than 1.3 IU/mg if intended for introduction into body cavities without a further appropriate procedure for the removal of bacterial endotoxins.

#### ASSAY

Carry out the microbiological assay of antibiotics (2.7.2). Use *framycetin sulfate CRS* as the reference substance.

#### STORAGE

In an airtight container, protected from light. If the substance is intended for introduction into body cavities, store in a sterile, tamper-proof container.

#### IMPURITIES

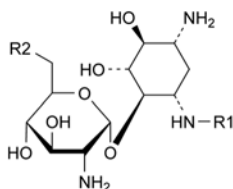

- A. R1 = H, R2 =  $\text{NH}_2$ : 2-deoxy-4-*O*-(2,6-diamino-2,6-dideoxy- $\alpha$ -D-glucopyranosyl)-D-streptomine (neamine or neomycin A-LP),
- B. R1 =  $\text{CO-CH}_3$ , R2 =  $\text{NH}_2$ : 3-*N*-acetyl-2-deoxy-4-*O*-(2,6-diamino-2,6-dideoxy- $\alpha$ -D-glucopyranosyl)-D-streptomine (3-acetylneamine),
- D. R1 = H, R2 = OH: 4-*O*-(2-amino-2-deoxy- $\alpha$ -D-glucopyranosyl)-2-deoxy-D-streptomine (paromamine or neomycin D),

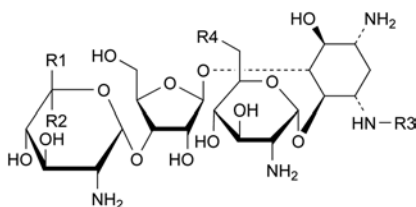

- C. R1 =  $\text{CH}_2\text{-NH}_2$ , R2 = R3 = H, R4 =  $\text{NH}_2$ : 2-deoxy-4-*O*-(2,6-diamino-2,6-dideoxy- $\alpha$ -D-glucopyranosyl)-5-*O*-[3-*O*-(2,6-diamino-2,6-dideoxy- $\alpha$ -D-glucopyranosyl)- $\beta$ -D-ribofuranosyl]-D-streptomine (neomycin C),
- E. R1 = R3 = H, R2 =  $\text{CH}_2\text{-NH}_2$ , R4 = OH: 4-*O*-(2-amino-2-deoxy- $\alpha$ -D-glucopyranosyl)-2-deoxy-5-*O*-[3-*O*-(2,6-diamino-2,6-dideoxy- $\beta$ -L-idopyranosyl)- $\beta$ -D-ribofuranosyl]-D-streptomine (paromomycin I or neomycin E),

- F. R1 =  $\text{CH}_2\text{-NH}_2$ , R2 = R3 = H, R4 = OH: 4-*O*-(2-amino-2-deoxy- $\alpha$ -D-glucopyranosyl)-2-deoxy-5-*O*-[3-*O*-(2,6-diamino-2,6-dideoxy- $\alpha$ -D-glucopyranosyl)- $\beta$ -D-ribofuranosyl]-D-streptomine (paromomycin II or neomycin F),
- G. R1 = H, R2 =  $\text{CH}_2\text{-NH}_2$ , R3 =  $\text{CO-CH}_3$ , R4 =  $\text{NH}_2$ : 3-*N*-acetyl-2-deoxy-4-*O*-(2,6-diamino-2,6-dideoxy- $\alpha$ -D-glucopyranosyl)-5-*O*-[3-*O*-(2,6-diamino-2,6-dideoxy- $\beta$ -L-idopyranosyl)- $\beta$ -D-ribofuranosyl]-D-streptomine (neomycin B-LP).

01/2008:0188  
corrected 6.0

## FRUCTOSE

### Fructosum

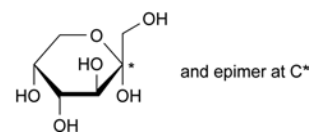

$\text{C}_6\text{H}_{12}\text{O}_6$   
[57-48-7]

$M_r$  180.2

#### DEFINITION

(-)-D-Arabino-hex-2-ulopyranose.

The substance described in this monograph is not necessarily suitable for parenteral administration.

#### CHARACTERS

*Appearance*: white or almost white, crystalline powder.

It has a very sweet taste.

*Solubility*: very soluble in water, soluble in ethanol (96 per cent).

#### IDENTIFICATION

A. Thin-layer chromatography (2.2.27).

*Solvent mixture*: water R, methanol R (2:3 V/V).

*Test solution*. Dissolve 10 mg of the substance to be examined in the solvent mixture and dilute to 20 mL with the solvent mixture.

*Reference solution (a)*. Dissolve 10 mg of *fructose CRS* in the solvent mixture and dilute to 20 mL with the solvent mixture.

*Reference solution (b)*. Dissolve 10 mg each of *fructose CRS*, *glucose CRS*, *lactose CRS* and *sucrose CRS* in the solvent mixture and dilute to 20 mL with the solvent mixture.

*Plate*: TLC silica gel G plate R.

*Mobile phase*: water R, methanol R, anhydrous acetic acid R, ethylene chloride R (10:15:25:50 V/V/V/V). Measure the volumes accurately since a slight excess of water produces cloudiness.

*Application*: 2  $\mu\text{L}$ ; thoroughly dry the points of application.

*Development A*: over a path of 15 cm.

*Drying A*: in a current of warm air.

*Development B*: immediately, over a path of 15 cm, after renewing the mobile phase.

*Drying B*: in a current of warm air.

*Detection*: spray with a solution of 0.5 g of *thymol R* in a mixture of 5 mL of *sulfuric acid R* and 95 mL of *ethanol (96 per cent) R*. Heat at 130 °C for 10 min.

*System suitability*: reference solution (b):

– the chromatogram shows 4 clearly separated spots.

*Results*: the principal spot in the chromatogram obtained with the test solution is similar in position, colour and size to the principal spot in the chromatogram obtained with reference solution (a).



- B. Dissolve 0.1 g in 10 mL of *water R*. Add 3 mL of *cupri-tartaric solution R* and heat. A red precipitate is formed.
- C. To 1 mL of solution S (see Tests) add 9 mL of *water R*. To 1 mL of the solution add 5 mL of *hydrochloric acid R* and heat to 70 °C. A brown colour develops.
- D. Dissolve 5 g in *water R* and dilute to 10 mL with the same solvent. To 0.5 mL of the solution add 0.2 g of *resorcinol R* and 9 mL of *dilute hydrochloric acid R* and heat on a water-bath for 2 min. A red colour develops.

## TESTS

**Solution S.** Dissolve 10.0 g in *distilled water R* and dilute to 100 mL with the same solvent.

**Appearance of solution.** Dissolve 5.0 g in *water R* and dilute to 10 mL with the same solvent. The solution is clear (2.2.1). Add 10 mL of *water R*. The solution is colourless (2.2.2, *Method II*).

**Acidity or alkalinity.** Dissolve 6.0 g in 25 mL of *carbon dioxide-free water R* and add 0.3 mL of *phenolphthalein solution R*. The solution is colourless. Not more than 0.15 mL of 0.1 M *sodium hydroxide* is required to change the colour of the indicator to pink.

**Specific optical rotation** (2.2.7): –91.0 to –93.5 (anhydrous substance).

Dissolve 10.0 g in 80 mL of *water R*, add 0.2 mL of *dilute ammonia RI*, allow to stand for 30 min and dilute to 100.0 mL with *water R*.

**Foreign sugars.** Dissolve 5.0 g in *water R* and dilute to 10 mL with the same solvent. To 1 mL of the solution add 9 mL of *ethanol (96 per cent) R*. Any opalescence in the solution is not more intense than that in a mixture of 1 mL of the initial solution and 9 mL of *water R*.

**5-Hydroxymethylfurfural and related compounds.** To 5 mL of solution S add 5 mL of *water R*. The absorbance (2.2.25) measured at 284 nm is not greater than 0.32.

**Barium.** To 10 mL of solution S add 1 mL of *dilute sulfuric acid R*. When examined immediately and after 1 h, any opalescence in the solution is not more intense than that in a mixture of 1 mL of *distilled water R* and 10 mL of solution S.

**Lead** (2.4.10): maximum 0.5 ppm.

**Water** (2.5.12): maximum 0.5 per cent, determined on 1.00 g.

**Sulfated ash** : maximum 0.1 per cent.

Dissolve 5.0 g in 10 mL of *water R*, add 2 mL of *sulfuric acid R*, evaporate to dryness on a water-bath and ignite to constant mass.

**Solubility:** practically insoluble in water, soluble in acetone, sparingly soluble in ethanol (96 per cent), practically insoluble in methylene chloride. It dissolves in dilute solutions of alkali hydroxides.

mp: about 210 °C, with decomposition.

## IDENTIFICATION

**First identification:** B.

**Second identification:** A, C.

A. Ultraviolet and visible absorption spectrophotometry (2.2.25).

**Test solution.** Dissolve 50 mg in a 4 g/L solution of *sodium hydroxide R* and dilute to 100 mL with the same solution. Dilute 1 mL of this solution to 100 mL with a 4 g/L solution of *sodium hydroxide R*.

**Spectral range:** 220-350 nm.

**Absorption maxima:** at 228 nm, 270 nm and 333 nm.

**Absorbance ratio:**  $A_{270} / A_{228} = 0.52$  to 0.57.

B. Infrared absorption spectrophotometry (2.2.24).

**Comparison:** *furosemide CRS*.

C. Dissolve about 25 mg in 10 mL of *ethanol (96 per cent) R*. To 5 mL of this solution add 10 mL of *water R*. To 0.2 mL of the solution add 10 mL of *dilute hydrochloric acid R* and heat under a reflux condenser for 15 min. Allow to cool and add 18 mL of 1 M *sodium hydroxide* and 1 mL of a 5 g/L solution of *sodium nitrite R*. Allow to stand for 3 min, add 2 mL of a 25 g/L solution of *sulfamic acid R* and mix. Add 1 mL of a 5 g/L solution of *naphthylethylenediamine dihydrochloride R*. A violet-red colour develops.

## TESTS

**Related substances.** Liquid chromatography (2.2.29). *Prepare the solutions immediately before use and protect from light.*

**Test solution.** Dissolve 50.0 mg of the substance to be examined in the mobile phase and dilute to 50.0 mL with the mobile phase.

**Reference solution (a).** Dissolve 2.0 mg of *furosemide impurity A CRS* in the mobile phase and dilute to 2.0 mL with the mobile phase.

**Reference solution (b).** Dilute a mixture of 1.0 mL of the test solution and 1.0 mL of reference solution (a) to 20.0 mL with the mobile phase. Dilute 1.0 mL of this solution to 20.0 mL with the mobile phase.

**Column:**

– size:  $l = 0.25$  m,  $\varnothing = 4.6$  mm;

– stationary phase: *octylsilyl silica gel for chromatography R* (5  $\mu$ m).

**Mobile phase:** dissolve 0.2 g of *potassium dihydrogen phosphate R* and 0.25 g of *cetrimide R* in 70 mL of *water R*; adjust to pH 7.0 with *ammonia R* and add 30 mL of *propanol R*.

**Flow rate:** 1 mL/min.

**Detection:** spectrophotometer at 238 nm.

**Injection:** 20  $\mu$ L of the test solution and reference solution (b).

**Run time:** 3 times the retention time of furosemide.

**System suitability:** reference solution (b):

– resolution: minimum 4 between the peaks due to impurity A (1<sup>st</sup> peak) and furosemide (2<sup>nd</sup> peak).

**Limits:**

– impurities A, B, C, D, E: for each impurity, not more than the area of the peak due to impurity A in the chromatogram obtained with reference solution (b) (0.25 per cent);

– total: not more than twice the area of the peak due to impurity A in the chromatogram obtained with reference solution (b) (0.5 per cent);

– disregard limit: 0.1 times the area of the peak due to impurity A in the chromatogram obtained with reference solution (b) (0.025 per cent).

01/2008:0391  
corrected 6.0

## FUROSEMIDE

## Furosemidum

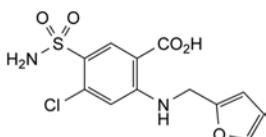

$C_{12}H_{11}ClN_2O_5S$   
[54-31-9]

$M_r$  330.7

## DEFINITION

4-Chloro-2-[(furan-2-ylmethyl)amino]-5-sulfamoylbenzoic acid.

**Content:** 98.5 per cent to 101.0 per cent (dried substance).

## CHARACTERS

**Appearance:** white or almost white, crystalline powder.

**Chlorides** (2.4.4): maximum 200 ppm.

To 0.5 g add a mixture of 0.2 mL of *nitric acid R* and 30 mL of *water R* and shake for 5 min. Allow to stand for 15 min and filter.

**Sulfates** (2.4.13): maximum 300 ppm.

To 1.0 g add a mixture of 0.2 mL of *acetic acid R* and 30 mL of *distilled water R* and shake for 5 min. Allow to stand for 15 min and filter.

**Heavy metals** (2.4.8): maximum 20 ppm.

1.0 g complies with test C. Prepare the reference solution using 2 mL of *lead standard solution (10 ppm Pb) R*.

**Loss on drying** (2.2.32): maximum 0.5 per cent, determined on 1.000 g by drying in an oven at 105 °C.

**Sulfated ash** (2.4.14): maximum 0.1 per cent, determined on 1.0 g.

#### ASSAY

Dissolve 0.250 g in 20 mL of *dimethylformamide R*. Titrate with 0.1 M *sodium hydroxide* using 0.2 mL of *bromothymol blue solution R2*. Carry out a blank titration.

1 mL of 0.1 M *sodium hydroxide* is equivalent to 33.07 mg of C<sub>12</sub>H<sub>11</sub>ClN<sub>2</sub>O<sub>5</sub>S.

#### STORAGE

Protected from light.

#### IMPURITIES

*Specified impurities: A, B, C, D, E.*

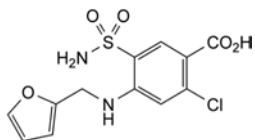

A. 2-chloro-4-((furan-2-ylmethyl)amino)-5-sulfamoylbenzoic acid,

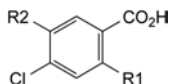

B. R<sub>1</sub> = Cl, R<sub>2</sub> = SO<sub>2</sub>NH<sub>2</sub>: 2,4-dichloro-5-sulfamoylbenzoic acid,

C. R<sub>1</sub> = NH<sub>2</sub>, R<sub>2</sub> = SO<sub>2</sub>NH<sub>2</sub>: 2-amino-4-chloro-5-sulfamoylbenzoic acid,

E. R<sub>1</sub> = Cl, R<sub>2</sub> = H: 2,4-dichlorobenzoic acid,

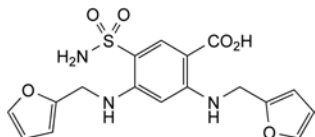

D. 2,4-bis((furan-2-ylmethyl)amino)-5-sulfamoylbenzoic acid.

01/2008:0798

## FUSIDIC ACID

### Acidum fusidicum

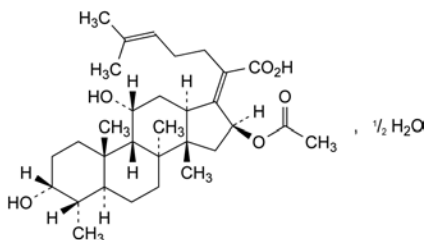

C<sub>31</sub>H<sub>48</sub>O<sub>6</sub> · 1/2 H<sub>2</sub>O

*M*<sub>r</sub> 525.7

#### DEFINITION

*ent*-(17*Z*)-16α-(Acetyloxy)-3β,11β-dihydroxy-4β,8,14-trimethyl-18-nor-5β,10α-cholesta-17(20),24-dien-21-oic acid hemihydrate.

Antimicrobial substance produced by the growth of certain strains of *Fusidium coccineum* or by any other means.

*Content*: 97.5 per cent to 101.0 per cent (anhydrous substance).

#### CHARACTERS

*Appearance*: white or almost white, crystalline powder.

*Solubility*: practically insoluble in water, freely soluble in ethanol (96 per cent).

#### IDENTIFICATION

A. Infrared absorption spectrophotometry (2.2.24).

*Comparison*: *Ph. Eur. reference spectrum of fusidic acid*.

B. Thin-layer chromatography (2.2.27).

*Test solution*. Dissolve 20 mg of the substance to be examined in *methanol R* and dilute to 10 mL with the same solvent.

*Reference solution*. Dissolve 24 mg of *diethanolamine fusidate CRS* in *methanol R* and dilute to 10 mL with the same solvent.

*Plate*: *TLC silica gel F<sub>254</sub> plate R*.

*Mobile phase*: *methanol R, cyclohexane R, glacial acetic acid R, chloroform R* (2.5:10:10:80 V/V/V/V).

*Application*: 10 µL.

*Development*: over a path of 15 cm.

*Drying*: in a current of warm air.

*Detection*: examine in ultraviolet light at 254 nm.

*Results*: the principal spot in the chromatogram obtained with the test solution is similar in position and size to the principal spot in the chromatogram obtained with the reference solution.

#### TESTS

**Related substances.** Liquid chromatography (2.2.29).

*Test solution*. Dissolve 50 mg of the substance to be examined in the mobile phase and dilute to 10.0 mL with the mobile phase.

*Reference solution (a)*. Dissolve 5 mg of *3-ketofusidic acid CRS* in 5 mL of the mobile phase. To 1.0 mL of this solution add 0.20 mL of the test solution and dilute to 20.0 mL with the mobile phase.

*Reference solution (b)*. Dilute 20 µL of the test solution to 100.0 mL with the mobile phase.

*Column*:

– *size*: *l* = 0.125-0.15 m, Ø = 4-5 mm;

– *stationary phase*: *octadecylsilyl silica gel for chromatography R* (5 µm).

*Mobile phase*: *methanol R*, 10 g/L solution of *phosphoric acid R*, *water R*, *acetonitrile R* (10:20:20:50 V/V/V/V).

*Flow rate*: 2 mL/min.

*Detection*: spectrophotometer at 235 nm.

*Injection*: 20 µL.

*Run time*: 3.5 times the retention time of fusidic acid.

*System suitability*:

– *resolution*: minimum 2.5 between the peaks due to 3-ketofusidic acid and fusidic acid in the chromatogram obtained with reference solution (a);

– *signal-to-noise ratio*: minimum 3 for the principal peak in the chromatogram obtained with reference solution (b).

*Limits*:

– *total*: not more than twice the area of the peak due to fusidic acid in the chromatogram obtained with reference solution (a) (2.0 per cent);

– *disregard limit*: the area of the principal peak in the chromatogram obtained with reference solution (b) (0.02 per cent).

**Water** (2.5.12): 1.4 per cent to 2.0 per cent, determined on 0.50 g.

**Sulfated ash** (2.4.14): maximum 0.2 per cent, determined on 1.0 g.

**ASSAY**

Dissolve 0.500 g in 10 mL of *ethanol (96 per cent) R*. Add 0.5 mL of *phenolphthalein solution R*. Titrate with 0.1 M *sodium hydroxide* until a pink colour is obtained.

1 mL of 0.1 M *sodium hydroxide* is equivalent to 51.67 mg of  $C_{31}H_{48}O_6$ .

**STORAGE**

Protected from light, at a temperature of 2 °C to 8 °C.

## GALACTOSE

## Galactosum

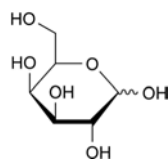

$C_6H_{12}O_6$   
[59-23-4]

$M_r$  180.2

## DEFINITION

D-Galactopyranose.

## CHARACTERS

**Appearance:** white or almost white, crystalline or finely granulated powder.

**Solubility:** freely soluble or soluble in water, very slightly soluble in ethanol (96 per cent).

## IDENTIFICATION

**First identification:** A.

**Second identification:** B, C.

A. Infrared absorption spectrophotometry (2.2.24).

**Preparation:** discs.

**Comparison:** galactose CRS.

B. Thin-layer chromatography (2.2.27).

**Test solution.** Dissolve 10 mg of the substance to be examined in a mixture of 2 volumes of *water R* and 3 volumes of *methanol R* and dilute to 20 mL with the same mixture of solvents.

**Reference solution (a).** Dissolve 10 mg of *galactose CRS* in a mixture of 2 volumes of *water R* and 3 volumes of *methanol R* and dilute to 20 mL with the same mixture of solvents.

**Reference solution (b).** Dissolve 10 mg of *galactose CRS*, 10 mg of *glucose CRS* and 10 mg of *lactose CRS* in a mixture of 2 volumes of *water R* and 3 volumes of *methanol R* and dilute to 20 mL with the same mixture of solvents.

**Plate:** suitable silica gel as the coating substance.

**Mobile phase:** *water R*, *propanol R* (15:85 V/V).

**Application:** 2  $\mu$ L; thoroughly dry the points of application.

**Development:** in an unsaturated tank over a path of 15 cm.

**Drying:** in a current of warm air.

**Detection:** spray with a solution of 0.5 g of *thymol R* in a mixture of 5 mL of *sulfuric acid R* and 95 mL of *ethanol (96 per cent) R*. Heat in an oven at 130 °C for 10 min.

**System suitability:** reference solution (b):

– the chromatogram shows 3 clearly separated spots.

**Results:** the principal spot in the chromatogram obtained with the test solution is similar in position, colour and size to the principal spot in the chromatogram obtained with reference solution (a).

C. Dissolve 0.1 g in 10 mL of *water R*. Add 3 mL of *cupri-tartaric solution R* and heat. An orange or red precipitate is formed.

## TESTS

**Solution S.** Dissolve, with heating in a water-bath at 50 °C, 10.0 g in *carbon dioxide-free water R* prepared from *distilled water R* and dilute to 50 mL with the same solvent.

**Appearance of solution.** Solution S is clear (2.2.1) and not more intensely coloured than reference solution B<sub>8</sub> (2.2.2, *Method II*).

**01/2009:1215 Acidity or alkalinity.** To 30 mL of solution S add 0.3 mL of *phenolphthalein solution R*. The solution is colourless. Not more than 1.5 mL of 0.01 M *sodium hydroxide* is required to change the colour of the indicator to pink.

**Specific optical rotation (2.2.7):** + 78.0 to + 81.5 (anhydrous substance).

Dissolve 10.00 g in 80 mL of *water R* and add 0.2 mL of *dilute ammonia R1*. Allow to stand for 30 min and dilute to 100.0 mL with *water R*.

**Barium.** Dilute 5 mL of solution S to 10 mL with *distilled water R*. Add 1 mL of *dilute sulfuric acid R*. When examined immediately and after 1 h, any opalescence in the solution is not more intense than that in a mixture of 5 mL of solution S and 6 mL of *distilled water R*.

**Lead (2.4.10):** maximum 0.5 ppm.

**Water (2.5.12):** maximum 1.0 per cent, determined on 1.00 g.

**Sulfated ash:** maximum 0.1 per cent.

To 5 mL of solution S add 2 mL of *sulfuric acid R*, evaporate to dryness on a water-bath and ignite to constant mass. The residue weighs a maximum of 1 mg.

## Microbial contamination

TAMC: acceptance criterion 10<sup>2</sup> CFU/g (2.6.12).

07/2010:2366  
corrected 7.0

## GALANTAMINE HYDROBROMIDE

## Galantamini hydrobromidum

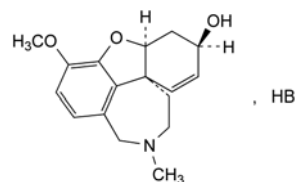

$C_{17}H_{22}BrNO_3$   
[1953-04-4]

$M_r$  368.3

## DEFINITION

(4a*S*,6*R*,8a*S*)-3-Methoxy-11-methyl-5,6,9,10,11,12-hexahydro-4a*H*-[1]benzofuro[3a,3,2-*ef*][2]benzazepin-6-ol hydrobromide. It is isolated from natural sources or produced by a synthetic process.

**Content:** 99.0 per cent to 101.0 per cent (dried substance).

## CHARACTERS

**Appearance:** white or almost white, crystalline or amorphous powder.

**Solubility:** sparingly soluble in water, very slightly soluble in anhydrous ethanol. It dissolves in dilute solutions of alkali hydroxides.

## IDENTIFICATION

A. Infrared absorption spectrophotometry (2.2.24).

**Comparison:** *galantamine hydrobromide CRS*.

B. Specific optical rotation or enantiomeric purity (see Tests).

C. It gives reaction (a) of bromides (2.3.1).

## TESTS

**Solution S.** Dissolve 0.60 g in *carbon dioxide-free water R* and dilute to 30.0 mL with the same solvent.

**pH (2.2.3):** 4.0 to 5.5 for solution S.

**Specific optical rotation (2.2.7)** for galantamine from natural sources: – 90 to – 100 (dried substance), determined on Solution S.

**Enantiomeric purity** for galantamine produced by a synthetic process. Capillary electrophoresis (2.2.47). Prepare the solutions immediately before use.

**Buffer electrolyte:** 8.9 g/L solution of disodium hydrogen phosphate dihydrate R.

**Test solution.** Dissolve 25.0 mg of the substance to be examined in 50.0 mL of water R and filter through a membrane filter (nominal pore size 0.22 µm).

**Reference solution (a).** Dissolve 5 mg of galantamine racemic mixture CRS in 10.0 mL of water R. Dilute 1.0 mL of this solution to 100.0 mL with water R. Filter through a membrane filter (nominal pore size 0.22 µm).

**Reference solution (b).** Dilute 1.0 mL of the test solution to 100.0 mL with water R. Dilute 1.0 mL of this solution to 10.0 mL with water R. Filter through a membrane filter (nominal pore size 0.22 µm).

**Blank solution.** Filter water R through a membrane filter (nominal pore size 0.22 µm).

**Capillary:**

- material: uncoated fused silica;
- size: effective length = about 0.50 m, Ø = 75 µm.

**Temperature:** 20 °C.

**CZE buffer.** Dissolve 0.196 g of α-cyclodextrin R in 10.0 mL of buffer electrolyte and filter through a membrane filter (nominal pore size 0.22 µm).

**Detection:** spectrophotometer at 214 nm.

**Preconditioning of the capillary:** at 137.9 kPa, rinse the capillary for 5 min with water R and for 5 min with CZE buffer.

**Injection:** under pressure (3.45 kPa) for 4 s.

**Migration:** a voltage of 15kV.

**Run time:** 35 min.

**Relative migration times** with reference to galantamine (retention time = about 18 min): impurity F = about 1.05.

**System suitability:** reference solution (a):

- resolution: minimum 2.5 between the peaks due to galantamine and to impurity F.

**Limit:**

- impurity F: not more than 1.5 times the area of the principal peak in the electropherogram obtained with reference solution (b) (0.15 per cent).

**Related substances.** Liquid chromatography (2.2.29).

A. Galantamine from natural sources

**Solvent mixture:** mobile phase B, mobile phase A (10:90 V/V).

**Test solution.** Dissolve 12 mg of the substance to be examined in the solvent mixture and dilute to 10.0 mL with the same solvent mixture.

**Reference solution (a).** Dilute 1.0 mL of the test solution to 100.0 mL with the solvent mixture. Dilute 1.0 mL of this solution to 10.0 mL with the solvent mixture.

**Reference solution (b).** Dissolve 5 mg of galantamine natural for system suitability CRS (containing impurities A and E) in the solvent mixture and dilute to 5.0 mL with the solvent mixture.

**Column:**

- size:  $l = 0.25$  m, Ø = 4.6 mm;
- stationary phase: octylsilyl silica gel for chromatography R (5 µm);
- temperature: 30 °C.

**Mobile phase:**

- mobile phase A: dissolve 3.15 g of ammonium formate R in 900 mL of water R, adjust to pH 3.8 with anhydrous formic acid R and dilute to 1000 mL with water R;
- mobile phase B: acetonitrile R;

Time (min)	Mobile phase A (per cent V/V)	Mobile phase B (per cent V/V)
0 - 5	95	5
5 - 20	95 → 80	5 → 20
20 - 23	80 → 50	20 → 50
23 - 31	50 → 20	50 → 80
31 - 35	20	80

**Flow rate:** 1.0 mL/min.

**Detection:** spectrophotometer at 287 nm.

**Injection:** 10 µL.

**Identification of impurities:** use the chromatogram supplied with galantamine natural for system suitability CRS and the chromatogram obtained with reference solution (b) to identify the peaks due to impurities A and E.

**Relative retention** with reference to galantamine (retention time = about 12 min): impurity E = about 0.8; impurity A = about 1.5.

**System suitability:** reference solution (b):

- resolution: minimum 5.0 between the peaks due to impurity E and galantamine.

**Limits:**

- impurity E: not more than 6 times the area of the principal peak in the chromatogram obtained with reference solution (a) (0.6 per cent);
- impurity A: not more than 1.5 times the area of the principal peak in the chromatogram obtained with reference solution (a) (0.15 per cent);
- unspecified impurities: for each impurity, not more than the area of the principal peak in the chromatogram obtained with reference solution (a) (0.10 per cent);
- total: not more than 8 times the area of the principal peak in the chromatogram obtained with reference solution (a) (0.8 per cent);
- disregard limit: 0.5 times the area of the principal peak in the chromatogram obtained with reference solution (a) (0.05 per cent).

B. Galantamine produced by a synthetic process

**Solvent mixture.** Dilute 50 mL of methanol R to 1000 mL with water R.

**Test solution.** Dissolve 0.10 g of the substance to be examined in 50.0 mL of the solvent mixture and dilute to 100.0 mL with the solvent mixture.

**Reference solution (a).** Dilute 1.0 mL of the test solution to 100.0 mL with the solvent mixture. Dilute 5.0 mL of this solution to 10.0 mL with the solvent mixture.

**Reference solution (b).** Dissolve 2.5 mg of galantamine synthetic for system suitability CRS (containing impurities C and D) in the solvent mixture and dilute to 5.0 mL with the solvent mixture.

**Column:**

- size:  $l = 0.10$  m, Ø = 4.6 mm;
- stationary phase: octadecylsilyl silica gel for chromatography R (3.5 µm);
- temperature: 55 °C.

**Mobile phase:**

- **mobile phase A:** dissolve 0.79 g of *disodium hydrogen phosphate dihydrate R* and 2.46 g of *sodium dihydrogen phosphate R* in *water R* and dilute to 1000 mL with *water R*; to 950 mL of this solution, add 50 mL of *methanol R*;
- **mobile phase B:** *acetonitrile R*;

Time (min)	Mobile phase A (per cent V/V)	Mobile phase B (per cent V/V)
0 - 6	100	0
6 - 20	100 → 95	0 → 5
20 - 35	95 → 85	5 → 15
35 - 50	85 → 80	15 → 20

**Flow rate:** 1.5 mL/min.

**Detection:** spectrophotometer at 230 nm.

**Injection:** 20 µL.

**Identification of impurities:** use the chromatogram supplied with *galantamine synthetic for system suitability CRS* and the chromatogram obtained with reference solution (b) to identify the peaks due to impurities C and D.

**Relative retention** with reference to galantamine (retention time = about 16 min): impurity C = about 0.8; impurity D = about 2.1.

**System suitability:** reference solution (b):

- **resolution:** minimum 4.5 between the peak due to impurity C and galantamine.

**Limits:**

- **impurities C, D:** for each impurity, not more than 0.8 times the area of the principal peak in the chromatogram obtained with reference solution (a) (0.4 per cent);
- **unspecified impurities:** for each impurity, not more than 0.2 times the area of the principal peak in the chromatogram obtained with reference solution (a) (0.10 per cent);
- **total:** not more than twice the area of the principal peak in the chromatogram obtained with reference solution (a) (1.0 per cent);
- **disregard limit:** 0.1 times the area of the principal peak in the chromatogram obtained with reference solution (a) (0.05 per cent).

**Palladium:** maximum 10 ppm for galantamine produced by a synthetic process.

Atomic absorption spectrometry (2.2.23, *Method D*).

**Test solution.** Transfer 1.000 g into an appropriate digestion system and digest using *nitric acid R*. After digestion, heat to dryness. Add 0.125 mL of *nitric acid R*, 0.375 mL of *hydrochloric acid R* and 2 mL of *water R*. Warm gently to dissolve any residue and allow to cool. Transfer quantitatively, by rinsing with several millilitres of *water R*, and dilute to 10.0 mL with *water R*.

**Reference solution.** Use solutions containing 0.2 µg, 1.0 µg and 2.0 µg of palladium per millilitre, freshly prepared by dilution of *palladium standard solution (20 ppm Pd) R* with a mixture of 0.25 volumes of *nitric acid R*, 0.75 volumes of *hydrochloric acid R* and 25.0 volumes of *water R*.

**Source:** palladium hollow cathode lamp.

**Wavelength:** 247.6 nm.

**Heavy metals (2.4.8):** maximum 20 ppm.

0.250 g complies with test G. Prepare the reference solution using 0.5 mL of *lead standard solution (10 ppm Pb) R*.

**Loss on drying (2.2.32):** maximum 1.0 per cent, determined on 1.000 g in an oven at 105 °C for 4 h.

**Sulfated ash (2.4.14):** maximum 0.1 per cent, determined on 2.0 g.

**ASSAY**

Dissolve 0.275 g in 40 mL of *water R*. Add 40 mL of *ethanol (96 per cent) R*. Add 5 mL of 0.01 M *hydrochloric acid*. Titrate with 0.1 M *sodium hydroxide* determining the end-point potentiometrically. Read the volume between the 2 points of inflection.

1 mL of 0.1 M *sodium hydroxide* is equivalent to 36.83 mg of C<sub>17</sub>H<sub>22</sub>BrNO<sub>3</sub>.

**LABELLING**

The label states the origin of the substance:

- isolated from natural sources;
- produced by a synthetic process.

**IMPURITIES****Specified impurities:**

- galantamine from natural sources: *A, E*,
- galantamine produced by a synthetic process: *C, D, F*.

**Other detectable impurities** (the following substances would, if present at a sufficient level, be detected by one or other of the tests in the monograph. They are limited by the general acceptance criterion for other/unspecified impurities and/or by the general monograph *Substances for pharmaceutical use (2034)*. It is therefore not necessary to identify these impurities for demonstration of compliance. See also 5.10. *Control of impurities in substances for pharmaceutical use*):

- galantamine from natural sources: *B*,
- galantamine produced by a synthetic process: *A, B, E*.

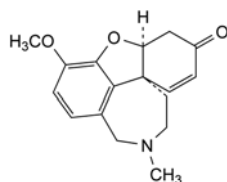

A. (4aS,8aS)-3-methoxy-11-methyl-4a,5,9,10,11,12-hexahydro-6H-[1]benzofuro[3a,3,2-ef][2]benzazepin-6-one (narwedine),

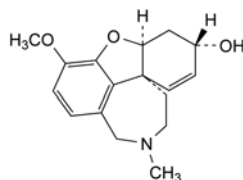

B. (4aS,6S,8aS)-3-methoxy-11-methyl-5,6,9,10,11,12-hexahydro-4aH-[1]benzofuro[3a,3,2-ef][2]benzazepin-6-ol (*epi*-galantamine),

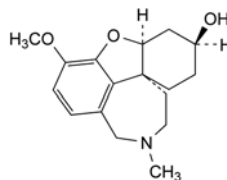

C. (4aS,6S,8aR)-3-methoxy-11-methyl-5,6,7,8,9,10,11,12-octahydro-4aH-[1]benzofuro[3a,3,2-ef][2]benzazepin-6-ol (dihydrogalantamine),

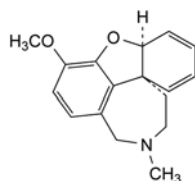

D. (4aS,8aS)-3-methoxy-11-methyl-9,10,11,12-tetrahydro-4aH-[1]benzofuro[3a,3,2-ef][2]benzazepine (anhydrogalantamine),

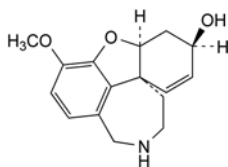

- E. (4a*S*,6*R*,8a*S*)-3-methoxy-5,6,9,10,11,12-hexahydro-4a*H*-[1]benzofuro[3a,3,2-*ef*][2]benzazepin-6-ol (*N*-desmethylgalantamine).

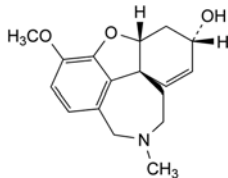

- F. (4a*R*,6*S*,8a*R*)-3-methoxy-11-methyl-5,6,9,10,11,12-hexahydro-4a*H*-[1]benzofuro[3a,3,2-*ef*][2]benzazepin-6-ol (*ent*-galantamine).

01/2011:1752

## GANCICLOVIR

### Ganciclovirum

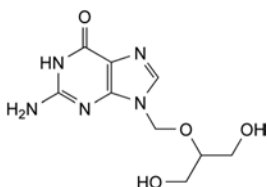

$C_9H_{13}N_5O_4$   
[82410-32-0]

$M_r$  255.2

#### DEFINITION

2-Amino-9-[[2-hydroxy-1-(hydroxymethyl)ethoxy]methyl]-1,9-dihydro-6*H*-purin-6-one.

*Content*: 99.0 per cent to 101.0 per cent (anhydrous substance).

#### CHARACTERS

*Appearance*: white or almost white, hygroscopic, crystalline powder.

*Solubility*: slightly soluble in water, very slightly soluble in ethanol (96 per cent). It dissolves in dilute solutions of mineral acids and alkali hydroxides.

It shows polymorphism (5.9).

#### IDENTIFICATION

Infrared absorption spectrophotometry (2.2.24).

*Comparison*: ganciclovir CRS.

If the spectra obtained in the solid state show differences, dissolve 0.10 g of the substance to be examined and the reference substance separately in about 3.6 mL of *water R* at 80 °C. Allow to cool in an ice-bath and filter the precipitate. Dry in an oven at 105 °C for 3 h and record new spectra using the residues.

#### TESTS

**Appearance of solution.** The solution is clear (2.2.1) and not more intensely coloured than reference solution  $Y_5$  (2.2.2, *Method II*).

Dissolve 1.25 g in a 40 g/L solution of *sodium hydroxide R* and dilute to 25 mL with the same solution.

**Related substances.** Liquid chromatography (2.2.29).

*Test solution.* Dissolve 30 mg of the substance to be examined in the mobile phase with the aid of ultrasound and dilute to 50.0 mL with the mobile phase.

*Reference solution (a).* Dilute 1.0 mL of the test solution to 100.0 mL with the mobile phase. Dilute 1.0 mL of this solution to 10.0 mL with the mobile phase.

*Reference solution (b).* Dissolve 3 mg of *ganciclovir CRS* in the mobile phase with the aid of ultrasound and dilute to 5.0 mL with the mobile phase.

*Reference solution (c).* Dissolve the contents of a vial of *ganciclovir impurity mixture CRS* (impurities A, B, C, D, E and F) in 1.0 mL of reference solution (b).

#### Column:

- *size*:  $l = 0.25$  m,  $\varnothing = 4.6$  mm;
- *stationary phase*: strong cation-exchange silica gel for chromatography *R* (10  $\mu$ m);
- *temperature*: 40 °C.

*Mobile phase*: mix equal volumes of *acetonitrile R* and a 0.05 per cent *V/V* solution of *trifluoroacetic acid R*.

*Flow rate*: 1.5 mL/min.

*Detection*: spectrophotometer at 254 nm.

*Injection*: 20  $\mu$ L.

*Run time*: 2.5 times the retention time of ganciclovir.

*Identification of impurities*: use the chromatogram supplied with *ganciclovir impurity mixture CRS* and the chromatogram obtained with reference solution (c) to identify the peaks due to impurities A, B, C, D, E and F.

*Relative retention* with reference to ganciclovir (retention time = about 14 min): impurity A = about 0.6; impurity B = about 0.67; impurity C = about 0.71; impurity D = about 0.8; impurity E = about 0.9; impurity F = about 2.0.

*System suitability*: reference solution (c):

- *peak-to-valley ratio*: minimum 5, where  $H_p$  = height above the baseline of the peak due to impurity E and  $H_v$  = height above the baseline of the lowest point of the curve separating this peak from the peak due to ganciclovir.

#### Limits:

- *correction factors*: for the calculation of content, multiply the peak areas of the following impurities by the corresponding correction factor: impurity B = 1.3; impurity F = 0.7;
- *impurity F*: not more than 4 times the area of the principal peak in the chromatogram obtained with reference solution (a) (0.4 per cent);
- *impurity B*: not more than twice the area of the principal peak in the chromatogram obtained with reference solution (a) (0.2 per cent);
- *impurities A, C, D, E*: for each impurity, not more than 1.5 times the area of the principal peak in the chromatogram obtained with reference solution (a) (0.15 per cent);
- *unspecified impurities*: for each impurity, not more than 0.5 times the area of the principal peak in the chromatogram obtained with reference solution (a) (0.05 per cent);
- *total*: not more than 6 times the area of the principal peak in the chromatogram obtained with reference solution (a) (0.6 per cent);
- *disregard limit*: 0.3 times the area of the principal peak in the chromatogram obtained with reference solution (a) (0.03 per cent).

**Heavy metals** (2.4.8): maximum 10 ppm.

0.5 g complies with test F, modified as follows: prepare the test solution using 10 mL of *nitric acid R* instead of the mixture of *sulfuric acid R* and *nitric acid R*; judge the result based only on the visual comparison of the spots obtained with the different solutions on membrane filters (nominal pore size 0.45  $\mu$ m). Prepare the reference solution using 0.5 mL of *lead standard solution (10 ppm Pb) R*.

**Water (2.5.12):** maximum 4.0 per cent, determined on 0.300 g. Use *methanol R* as solvent. The substance to be examined has limited solubility in methanol. The sample will appear as a slurry. Replace the solvent after each titration.

**Sulfated ash (2.4.14):** maximum 0.1 per cent, determined on 1.0 g.

**Bacterial endotoxins (2.6.14):** less than 0.84 IU/mg, if intended for use in the manufacture of parenteral preparations without a further appropriate procedure for the removal of bacterial endotoxins.

#### ASSAY

Dissolve 0.200 g in 10 mL of *anhydrous formic acid R* and dilute to 60 mL with *glacial acetic acid R*. Titrate with 0.1 M *perchloric acid*, determining the end point potentiometrically (2.2.20).

1 mL of 0.1 M *perchloric acid* is equivalent to 25.52 mg of  $C_9H_{13}N_5O_4$ .

#### STORAGE

In an airtight container.

#### IMPURITIES

*Specified impurities: A, B, C, D, E, F.*

*Other detectable impurities* (the following substances would, if present at a sufficient level, be detected by one or other of the tests in the monograph. They are limited by the general acceptance criterion for other/unspecified impurities and/or by the general monograph *Substances for pharmaceutical use (2034)*. It is therefore not necessary to identify these impurities for demonstration of compliance. See also 5.10. *Control of impurities in substances for pharmaceutical use*): *H, I, J.*

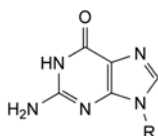

A. R =  $CH_2-O-CH_2-CCl=CH_2$ : 2-amino-9-[(2-chloroprop-2-en-1-yl)oxy]methyl]-1,9-dihydro-6*H*-purin-6-one,

D. R =  $CH_2-O-CH_2-O-CH(CH_2OH)_2$ : 2-amino-9-[[[2-hydroxy-1-(hydroxymethyl)ethoxy]methoxy]methyl]-1,9-dihydro-6*H*-purin-6-one,

F. R = H: 2-amino-1,9-dihydro-6*H*-purin-6-one (guanine),

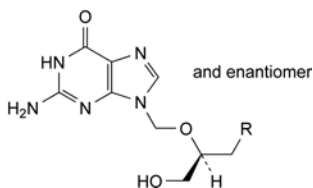

B. R =  $O-CO-CH_2-CH_3$ : (2*RS*)-2-[(2-amino-6-oxo-1,6-dihydro-9*H*-purin-9-yl)methoxy]-3-hydroxypropyl propionate,

C. R = Cl: 2-amino-9-[(1*RS*)-2-chloro-1-(hydroxymethyl)ethoxy]methyl]-1,9-dihydro-6*H*-purin-6-one,

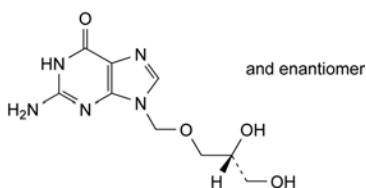

E. 2-amino-9-[[[(2*RS*)-2,3-dihydroxypropoxy]methyl]-1,9-dihydro-6*H*-purin-6-one,

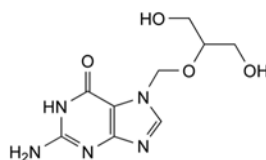

H. 2-amino-7-[[[2-hydroxy-1-(hydroxymethyl)ethoxy]methyl]-1,7-dihydro-6*H*-purin-6-one,

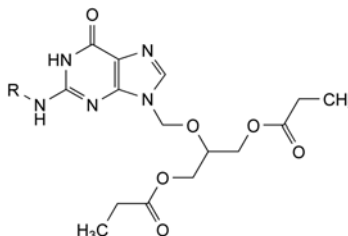

I. R = H: 2-[(2-amino-6-oxo-1,6-dihydro-9*H*-purin-9-yl)methoxy]propane-1,3-diyl dipropionate,

J. R =  $CO-CH_2-CH_3$ : 2-[2-(propanoylamino)-6-oxo-1,6-dihydro-9*H*-purin-9-yl]methoxy]propane-1,3-diyl dipropionate.

01/2009:0330  
corrected 7.0

## GELATIN

### Gelatina

#### DEFINITION

Purified protein obtained either by partial acid hydrolysis (type A), partial alkaline hydrolysis (type B) or enzymatic hydrolysis of collagen from animals (including fish and poultry); it may also be a mixture of different types.

The hydrolysis leads to gelling or non-gelling product grades. Both product grades are covered by this monograph.

Gelatin described in this monograph is not suitable for parenteral administration or for other special purposes.

#### CHARACTERS

**Appearance:** faintly yellow or light yellowish-brown, solid, usually occurring as translucent sheets, shreds, granules or powder.

**Solubility:** practically insoluble in common organic solvents; gelling grades swell in cold water and give on heating a colloidal solution which on cooling forms a more or less firm gel.

The isoelectric point is a relevant quality parameter for use of gelatin in different applications: for type A gelatin it is typically between pH 6.0 and pH 9.5 and for type B gelatin is typically between pH 4.7 and pH 5.6. These ranges cover a variety of different gelatins and for specific applications a narrower tolerance is usually applied.

Different gelatins form aqueous solutions that vary in clarity and colour. For a particular application, a suitable specification for clarity and colour is usually applied.

#### IDENTIFICATION

A. To 2 mL of solution S (see Tests) add 0.05 mL of *copper sulfate solution R*. Mix and add 0.5 mL of *dilute sodium hydroxide solution R*. A violet colour is produced.

B. To 0.5 g in a test-tube add 10 mL of *water R*. Allow to stand for 10 min, heat at 60 °C for 15 min and keep the tube upright at 0 °C for 6 h. Invert the tube; the contents immediately flow out for non-gelling grades and do not flow out immediately for gelling grades.

#### TESTS

**Solution S.** Dissolve 1.00 g in *carbon dioxide-free water R* at about 55 °C, dilute to 100 mL with the same solvent and keep the solution at this temperature to carry out the tests.



**pH** (2.2.3): 3.8 to 7.6 for solution S.

**Conductivity** (2.2.38): maximum  $1 \text{ mS}\cdot\text{cm}^{-1}$ , determined on a 1.0 per cent solution at  $30 \pm 1.0 \text{ }^\circ\text{C}$ .

**Sulfur dioxide** (2.5.29): maximum 50 ppm.

**Peroxides**: maximum 10 ppm, determined using *peroxide test strips R*.

Peroxidase transfers oxygen from peroxides to an organic redox indicator which is converted to a blue oxidation product. The intensity of the colour obtained is proportional to the quantity of peroxide and can be compared with a colour scale provided with the test strips, to determine the peroxide concentration.

**Suitability test.** Dip a test strip for 1 s into *hydrogen peroxide standard solution (10 ppm  $\text{H}_2\text{O}_2$ ) R*, such that the reaction zone is properly wetted. Remove the test strip, shake off excess liquid and compare the reaction zone after 15 s with the colour scale provided with the test strips used. The colour must match that of the 10 ppm concentration, otherwise the test is invalid.

**Test.** Weigh  $20.0 \pm 0.1 \text{ g}$  of the substance to be tested in a beaker and add  $80.0 \pm 0.2 \text{ mL}$  of *water R*. Stir to moisten all gelatin and allow the sample to stand at room temperature for 1-3 h. Cover the beaker with a watch-glass. Place the beaker for  $20 \pm 5 \text{ min}$  in a water bath at  $65 \pm 2 \text{ }^\circ\text{C}$  to dissolve the sample. Stir the contents of the beaker with a glass rod to achieve a homogeneous solution. Dip a test strip for 1 s into the test solution, such that the reaction zone is properly wetted. Remove the test strip, shake off excess liquid and compare the reaction zone after 15 s with the colour scale provided with the test strips used. Multiply the concentration read from the colour scale by a factor of 5 to calculate the concentration in parts per million of peroxide in the test substance.

**Gel strength (Bloom value)**: 80 to 120 per cent of the labelled nominal value.

The gel strength is expressed as the mass in grams necessary to produce the force which, applied to a plunger 12.7 mm in diameter, makes a depression 4 mm deep in a gel having a concentration of 6.67 per cent *m/m* and matured at  $10 \text{ }^\circ\text{C}$ .

**Apparatus.** Texture analyser or gelometer with:

- a cylindrical piston  $12.7 \pm 0.1 \text{ mm}$  in diameter with a plane pressure surface with a sharp bottom edge,
- a bottle  $59 \pm 1 \text{ mm}$  in internal diameter and 85 mm high.

Adjust the apparatus according to the manufacturer's manual. Settings are: distance 4 mm, test speed 0.5 mm/s.

**Method.** Perform the test in duplicate. Place 7.5 g of the substance to be tested in each bottle. Add 105 mL of *water R*, place a watch-glass over each bottle and allow to stand for 1-4 h. Heat in a water-bath at  $65 \pm 2 \text{ }^\circ\text{C}$  for 15 min. While heating, gently stir with a glass rod. Ensure that the solution is uniform and that any condensed water on the inner walls of the bottle is incorporated. Allow to cool at room temperature for 15 min and transfer the bottles to a thermostatically controlled bath at  $10.0 \pm 0.1 \text{ }^\circ\text{C}$ , and fitted with a device to ensure that the platform on which the bottles stand is perfectly horizontal. Close the bottles with a rubber stopper and allow to stand for  $17 \pm 1 \text{ h}$ . Remove the sample bottles from the bath and quickly wipe the water from the exterior of the bottle. Centre consecutively the 2 bottles on the platform of the apparatus so that the plunger contacts the sample as nearly at its midpoint as possible and start the measurement. Report the result as the average of the 2 measurements.

**Iron**: maximum 30 ppm.

Atomic absorption spectrometry (2.2.23, *Method I*).

**Test solution.** To 5.00 g of the substance to be examined, in a conical flask, add 10 mL of *hydrochloric acid R*. Close the flask and place in a water-bath at  $75\text{--}80 \text{ }^\circ\text{C}$  for 2 h. Allow to cool and adjust the content of the flask to 100.0 g with *water R*.

**Reference solutions.** Prepare the reference solutions using *iron standard solution (8 ppm Fe) R*, diluted as necessary with *water R*.

**Wavelength**: 248.3 nm.

**Chromium**: maximum 10 ppm.

Atomic absorption spectrometry (2.2.23, *Method I*).

**Test solution.** Test solution described in the test for iron.

**Reference solutions.** Prepare the reference solutions using *chromium standard solution (100 ppm Cr) R*, diluted if necessary with *water R*.

**Wavelength**: 357.9 nm.

**Zinc**: maximum 30 ppm.

Atomic absorption spectrometry (2.2.23, *Method I*).

**Test solution.** Test solution described in the test for iron.

**Reference solutions.** Prepare the reference solutions using *zinc standard solution (10 ppm Zn) R*, diluted if necessary with *water R*.

**Wavelength**: 213.9 nm.

**Loss on drying** (2.2.32): maximum 15.0 per cent, determined on 1.000 g, by drying in an oven at  $105 \text{ }^\circ\text{C}$ .

#### Microbial contamination

TAMC: acceptance criterion  $10^3 \text{ CFU/g}$  (2.6.12).

TYMC: acceptance criterion  $10^2 \text{ CFU/g}$  (2.6.12).

Absence of *Escherichia coli* (2.6.13).

Absence of *Salmonella* (2.6.13).

#### STORAGE

Protect from heat and moisture.

#### LABELLING

The label states the gel strength (Bloom value) or that it is a non-gelling grade.

01/2008:2306

## GEMCITABINE HYDROCHLORIDE

### Gemcitabini hydrochloridum

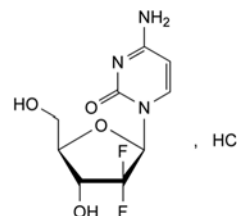

$\text{C}_9\text{H}_{12}\text{ClF}_2\text{N}_3\text{O}_4$   
[122111-03-9]

$M_r$  299.7

#### DEFINITION

4-Amino-1-(2-deoxy-2,2-difluoro-β-D-erythro-pentofuranosyl)pyrimidin-2(1H)-one hydrochloride.

**Content**: 98.0 per cent to 102.0 per cent.

#### CHARACTERS

**Appearance**: white or almost white powder.

**Solubility**: soluble in water, slightly soluble in methanol, practically insoluble in acetone.

#### IDENTIFICATION

A. Infrared absorption spectrophotometry (2.2.24).

**Comparison**: *gemcitabine hydrochloride CRS*.

B. It gives reaction (a) of chlorides (2.3.1).

#### TESTS

**Solution S.** Dissolve 1.00 g in *carbon dioxide-free water R* and dilute to 100.0 mL with the same solvent.

**Appearance of solution.** Solution S is clear (2.2.1) and not more intensely coloured than reference solution BY<sub>7</sub> (2.2.2, *Method II*).

**pH (2.2.3):** 2.0 to 3.0 for solution S.

**Specific optical rotation (2.2.7):** + 43.0 to + 50.0, determined on solution S.

**Related substances.** Liquid chromatography (2.2.29).

**Test solution (a).** Dissolve 50.0 mg of the substance to be examined in *water R* and dilute to 25.0 mL with the same solvent.

**Test solution (b).** Dissolve 20.0 mg of the substance to be examined in *water R* and dilute to 200.0 mL with the same solvent.

**Reference solution (a).** Dissolve 10.0 mg of the substance to be examined and 10.0 mg of *gemcitabine impurity A CRS* in *water R* and dilute to 50.0 mL with the same solvent. Dilute 2.0 mL of this solution to 200.0 mL with *water R*.

**Reference solution (b).** Dissolve 20.0 mg of *gemcitabine hydrochloride CRS* in *water R* and dilute to 200.0 mL with the same solvent.

**Reference solution (c).** Place 10 mg of the substance to be examined in a small vial. Add 4 mL of a 168 g/L solution of *potassium hydroxide R* in *methanol R*, sonicate for 5 min then seal with a cap. The mixture may be cloudy. Heat at 55 °C for a minimum of 6 h to produce impurity B. Allow to cool, then transfer the entire contents of the vial to a 100 mL volumetric flask by successively washing with a 1 per cent V/V solution of *phosphoric acid R*. Dilute to 100 mL with a 1 per cent V/V solution of *phosphoric acid R* and mix.

**Column:**

- **size:**  $l = 0.25$  m,  $\varnothing = 4.6$  mm;
- **stationary phase:** *octylsilyl silica gel for chromatography R* (5  $\mu$ m).

**Mobile phase:**

- **mobile phase A:** 13.8 g/L solution of *sodium dihydrogen phosphate monohydrate R* adjusted to pH  $2.5 \pm 0.1$  with *phosphoric acid R*;
- **mobile phase B:** *methanol R*;

Time (min)	Mobile phase A (per cent V/V)	Mobile phase B (per cent V/V)
0 - 8	97	3
8 - 13	97 → 50	3 → 50
13 - 20	50	50

**Flow rate:** 1.2 mL/min.

**Detection:** spectrophotometer at 275 nm.

**Injection:** 20  $\mu$ L of test solution (a) and reference solutions (a) and (c).

**Relative retention** with reference to gemcitabine (retention time = about 8 min): impurity A = about 0.4; impurity B = about 0.7.

**System suitability:** reference solution (c):

- **resolution:** minimum 8.0 between the peaks due to impurity B and gemcitabine.

**Limits:**

- **impurity A:** not more than the area of the corresponding peak in the chromatogram obtained with reference solution (a) (0.1 per cent);
- **unspecified impurities:** for each impurity, not more than the area of the peak due to gemcitabine in the chromatogram obtained with reference solution (a) (0.10 per cent);
- **total:** not more than twice the area of the peak due to gemcitabine in the chromatogram obtained with reference solution (a) (0.2 per cent);

- **disregard limit:** 0.5 times the area of the peak due to gemcitabine in the chromatogram obtained with reference solution (a) (0.05 per cent).

**Heavy metals (2.4.8):** maximum 10 ppm.

Dissolve 1.0 g in *water R* and dilute to 20 mL with the same solvent. 12 mL of the solution complies with test A. Prepare the reference solution using 5 mL of *lead standard solution (1 ppm Pb) R*, 5 mL of *water R* and 2 mL of the aqueous solution to be examined. If necessary, filter the solutions and compare the spots on the membrane filter.

**Sulfated ash (2.4.14):** maximum 0.1 per cent, determined on 1.0 g in a platinum crucible.

**Bacterial endotoxins (2.6.14):** less than 0.05 IU/mg, if intended for use in the manufacture of parenteral preparations without a further appropriate procedure for the removal of bacterial endotoxins.

**ASSAY**

Liquid chromatography (2.2.29) as described in the test for related substances with the following modifications.

**Mobile phase:** mobile phase A.

**Injection:** test solution (b) and reference solutions (b) and (c).

**Relative retention** with reference to gemcitabine (retention time = about 10 min): impurity B = about 0.5.

**System suitability:** reference solution (c):

- **resolution:** minimum 8.0 between the peaks due to impurity B and gemcitabine.

Calculate the percentage content of  $C_8H_{12}ClF_2N_3O_4$  from the declared content of *gemcitabine hydrochloride CRS*.

**STORAGE**

If the substance is sterile, store in a sterile, airtight, tamper-proof container.

**IMPURITIES**

**Specified impurities:** A.

**Other detectable impurities** (the following substances would, if present at a sufficient level, be detected by one or other of the tests in the monograph. They are limited by the general acceptance criterion for other/unspecified impurities and/or by the general monograph *Substances for pharmaceutical use (2034)*. It is therefore not necessary to identify these impurities for demonstration of compliance. See also 5.10. *Control of impurities in substances for pharmaceutical use*): B.

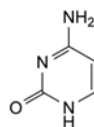

A. 4-aminopyrimidin-2(1H)-one (cytosine),

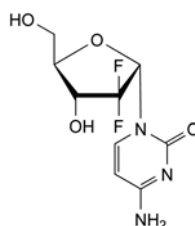

B. 4-amino-1-(2-deoxy-2,2-difluoro- $\alpha$ -D-erythro-pentofuranosyl)pyrimidin-2(1H)-one (gemcitabine  $\alpha$ -anomer).

04/2010:1694  
corrected 7.0

## GEMFIBROZIL

## Gemfibrozilum

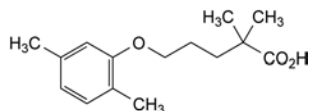
C<sub>15</sub>H<sub>22</sub>O<sub>3</sub>  
[25812-30-0]M<sub>r</sub> 250.3

## DEFINITION

5-(2,5-Dimethylphenoxy)-2,2-dimethylpentanoic acid.

Content: 99.0 per cent to 101.0 per cent (anhydrous substance).

## CHARACTERS

*Appearance*: white or almost white, waxy, crystalline powder.*Solubility*: practically insoluble in water, very soluble in methylene chloride, freely soluble in anhydrous ethanol and in methanol.

## IDENTIFICATION

A. Melting point (2.2.14): 58 °C to 61 °C.

B. Infrared absorption spectrophotometry (2.2.24).

*Comparison*: gemfibrozil CRS.

## TESTS

**Related substances.** Liquid chromatography (2.2.29).*Test solution.* Dissolve 40 mg of the substance to be examined in mobile phase A and dilute to 10.0 mL with mobile phase A.*Reference solution (a).* Dissolve the contents of a vial of gemfibrozil for system suitability CRS (containing impurities C, D and E) in 2 mL of acetonitrile R.*Reference solution (b).* Dilute 1.0 mL of test solution to 100.0 mL with mobile phase A. Dilute 1.0 mL of this solution to 10.0 mL with mobile phase A.*Reference solution (c).* Dissolve 5 mg of 2,5-dimethylphenol R (impurity A) in mobile phase A and dilute to 10 mL with mobile phase A.*Column*:

- size:  $l = 0.250$  m,  $\varnothing = 4.0$  mm;
- stationary phase: end-capped octadecylsilyl silica gel for chromatography R (5  $\mu$ m).

*Mobile phase*:

- mobile phase A: dissolve 0.49 g of potassium acetate R in 400 mL of water R, adjust to pH 4.0 with phosphoric acid R and add 600 mL of acetonitrile R;
- mobile phase B: acetonitrile R;

Time (min)	Mobile phase A (per cent V/V)	Mobile phase B (per cent V/V)
0 - 5	100	0
5 - 20	100 → 0	0 → 100
20 - 25	0	100

*Flow rate*: 1.5 mL/min.*Detection*: spectrophotometer at 276 nm.*Injection*: 20  $\mu$ L.

*Identification of impurities*: use the chromatogram supplied with gemfibrozil for system suitability CRS and the chromatogram obtained with reference solution (a) to identify the peaks due to impurities C, D and E. Use the chromatogram obtained with reference solution (c) to identify the peak due to impurity A.

*Relative retention* with reference to gemfibrozil (retention time = about 7 min): impurity A = about 0.4; impurity C = about 1.3; impurity D = about 1.5; impurity E = about 1.7; impurity I = about 2.0; impurity H = about 2.9.

*System suitability*: reference solution (a):

- resolution: minimum 6.0 between the peaks due to gemfibrozil and impurity C, and minimum 2.0 between the peaks due to impurity D and impurity E.

*Limits*:

- correction factors: for the calculations of content multiply the peak areas of the following impurities by the corresponding correction factor: impurity A = 0.5; impurity D = 1.8; impurity E = 0.2; impurity H = 0.6;
- impurities E, I: for each impurity, not more than twice the area of the principal peak in the chromatogram obtained with reference solution (b) (0.2 per cent);
- impurities A, D, H: for each impurity, not more than the area of the principal peak in the chromatogram obtained with reference solution (b) (0.1 per cent);
- unspecified impurities: for each impurity, not more than the area of the principal peak in the chromatogram obtained with reference solution (b) (0.10 per cent);
- total: not more than 5 times the area of the principal peak in the chromatogram obtained with reference solution (b) (0.5 per cent);
- disregard limit: 0.5 times the area of the principal peak in the chromatogram obtained with reference solution (b) (0.05 per cent).

**Heavy metals** (2.4.8): maximum 20 ppm.

1.0 g complies with test F. Prepare the reference solution using 2 mL of lead standard solution (10 ppm Pb) R.

**Water** (2.5.12): maximum 0.25 per cent, determined on 2.000 g.**Sulfated ash** (2.4.14): maximum 0.1 per cent, determined on 2.0 g. Allow to stand for 1 h after the first moistening before heating.

## ASSAY

Dissolve 0.200 g in 25 mL of methanol R. Add 25 mL of water R and 1 mL of 0.1 M hydrochloric acid. Carry out a potentiometric titration (2.2.20) using 0.1 M sodium hydroxide. Read the volume added between the 2 points of inflexion.

1 mL of 0.1 M sodium hydroxide is equivalent to 25.03 mg of C<sub>15</sub>H<sub>22</sub>O<sub>3</sub>.

## STORAGE

Protected from light.

## IMPURITIES

*Specified impurities*: A, D, E, H, I.

*Other detectable impurities* (the following substances would, if present at a sufficient level, be detected by one or other of the tests in the monograph. They are limited by the general acceptance criterion for other/unspecified impurities and/or by the general monograph *Substances for pharmaceutical use* (2034). It is therefore not necessary to identify these impurities for demonstration of compliance. See also 5.10. *Control of impurities in substances for pharmaceutical use*): B, C, F, G.

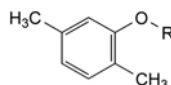
A. R = H: 2,5-dimethylphenol (*p*-xylenol),C. R = [CH<sub>2</sub>]<sub>13</sub>-O-[CH<sub>2</sub>]<sub>2</sub>-O-C<sub>2</sub>H<sub>5</sub>: 2-[3-(2-ethoxyethoxy)propoxy]-1,4-dimethylbenzene,F. R = [CH<sub>2</sub>]<sub>4</sub>-C<sub>6</sub>H<sub>5</sub>: 1,4-dimethyl-2-(4-phenylbutoxy)benzene,G. R = CH<sub>2</sub>-CH=CH<sub>2</sub>: 1,4-dimethyl-2-(prop-2-enyloxy)benzene,

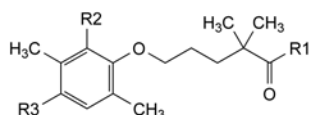

- B. R1 = NH<sub>2</sub>, R2 = R3 = H: 5-(2,5-dimethylphenoxy)-2,2-dimethylpentanamide,  
 D. R1 = OH, R2 = CH=CH-CH<sub>3</sub>, R3 = H: 5-[3,6-dimethyl-2-(prop-1-enyl)phenoxy]-2,2-dimethylpentanoic acid,  
 E. R1 = OH, R2 = H, R3 = CH=CH-CH<sub>3</sub>: 5-[2,5-dimethyl-4-(prop-1-enyl)phenoxy]-2,2-dimethylpentanoic acid,  
 I. R1 = OCH<sub>3</sub>, R2 = R3 = H: methyl 5-(2,5-dimethylphenoxy)-2,2-dimethylpentanoate,

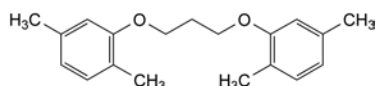

- H. 1,3-bis(2,5-dimethylphenoxy)propane.

01/2008:0331  
corrected 6.0

## GENTAMICIN SULFATE

### Gentamicini sulfas

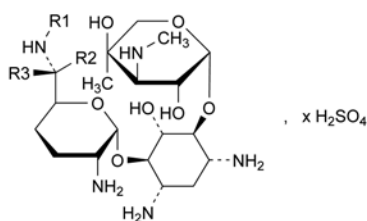

Gentamicin	Mol. Formula	R1	R2	R3
C1	C <sub>21</sub> H <sub>43</sub> N <sub>5</sub> O <sub>7</sub>	CH <sub>3</sub>	CH <sub>3</sub>	H
C1a	C <sub>19</sub> H <sub>39</sub> N <sub>5</sub> O <sub>7</sub>	H	H	H
C2	C <sub>20</sub> H <sub>41</sub> N <sub>5</sub> O <sub>7</sub>	H	CH <sub>3</sub>	H
C2a	C <sub>20</sub> H <sub>41</sub> N <sub>5</sub> O <sub>7</sub>	H	H	CH <sub>3</sub>
C2b	C <sub>20</sub> H <sub>41</sub> N <sub>5</sub> O <sub>7</sub>	CH <sub>3</sub>	H	H

#### DEFINITION

Mixture of the sulfates of antimicrobial substances produced by *Micromonospora purpurea*, the main components being gentamicins C1, C1a, C2, C2a and C2b.

*Content*: minimum 590 IU/mg (anhydrous substance).

#### CHARACTERS

*Appearance*: white or almost white, hygroscopic powder.

*Solubility*: freely soluble in water, practically insoluble in ethanol (96 per cent).

#### IDENTIFICATION

*First identification*: C, D.

*Second identification*: A, B, D.

- A. Dissolve about 10 mg in 1 mL of *water R* and add 5 mL of a 400 g/L solution of *sulfuric acid R*. Heat on a water-bath for 100 min, cool and dilute to 25 mL with *water R*. Examined between 240 nm and 330 nm (2.2.25), the solution shows no absorption maximum.

- B. Thin-layer chromatography (2.2.27).

*Test solution*. Dissolve 25 mg of the substance to be examined in *water R* and dilute to 5 mL with the same solvent.

*Reference solution*. Dissolve the contents of a vial of *gentamicin sulfate CRS* in *water R* and dilute to 5 mL with the same solvent.

*Plate*: TLC silica gel plate R.

*Mobile phase*: the lower layer of a mixture of equal volumes of concentrated ammonia R, methanol R and methylene chloride R.

*Application*: 10 µL.

*Development*: over 2/3 of the plate.

*Drying*: in air.

*Detection*: spray with *ninhydrin solution R1* and heat at 110 °C for 5 min.

*Results*: the 3 principal spots in the chromatogram obtained with the test solution are similar in position, colour and size to the 3 principal spots in the chromatogram obtained with the reference solution.

- C. Examine the chromatograms obtained in the test for composition.

*Results*: the chromatogram obtained with the test solution shows 5 principal peaks having the same retention times as the 5 principal peaks in the chromatogram obtained with reference solution (a).

- D. It gives reaction (a) of sulfates (2.3.1).

#### TESTS

**Solution S**. Dissolve 0.8 g in *carbon dioxide-free water R* and dilute to 20 mL with the same solvent.

**Appearance of solution**. Solution S is clear (2.2.1) and not more intensely coloured than intensity 6 of the range of reference solutions of the most appropriate colour (2.2.2, *Method II*).

**pH** (2.2.3): 3.5 to 5.5 for solution S.

**Specific optical rotation** (2.2.7): + 107 to + 121 (anhydrous substance).

Dissolve 2.5 g in *water R* and dilute to 25.0 mL with the same solvent.

**Composition**. Liquid chromatography (2.2.29): use the normalisation procedure taking into account only the peaks due to gentamicins C1, C1a, C2, C2a and C2b; use the chromatogram supplied with *gentamicin sulfate CRS* to identify the corresponding peaks.

*Test solution*. Dissolve 50 mg of the substance to be examined in the mobile phase and dilute to 100.0 mL with the mobile phase.

*Reference solution (a)*. Dissolve the contents of a vial of *gentamicin sulfate CRS* in the mobile phase and dilute with the mobile phase to obtain a solution containing 0.5 mg/mL.

*Reference solution (b)*. Dilute 5.0 mL of reference solution (a) to 100.0 mL with the mobile phase.

*Column*:

– *size*:  $l = 0.25$  m,  $\varnothing = 4.6$  mm;

– *stationary phase*: styrene-divinylbenzene copolymer R (8 µm) with a pore size of 100 nm;

– *temperature*: 55 °C.

*Mobile phase*: a mixture prepared with *carbon dioxide-free water R* containing 60 g/L of *anhydrous sodium sulfate R*, 1.75 g/L of *sodium octanesulfonate R*, 8 mL/L of *tetrahydrofuran R*, 50 mL/L of 0.2 M *potassium dihydrogen phosphate R* previously adjusted to pH 3.0 with *dilute phosphoric acid R* and degassed.

*Flow rate*: 1.0 mL/min.

*Post-column solution*: a *carbonate-free sodium hydroxide solution R* diluted 1 to 25, previously degassed, which is added pulse-less to the column effluent using a 375 µL polymeric mixing coil.

*Flow rate*: 0.3 mL/min.

*Detection*: pulsed amperometric detector or equivalent with a gold indicator electrode, a silver-silver chloride reference electrode, and a stainless steel auxiliary electrode which is the cell body, held at respectively + 0.05 V detection, + 0.75 V oxidation and – 0.15 V reduction potentials, with pulse durations according to the instrument used.

**Injection:** 20 µL.

**Run time:** 1.2 times the retention time of gentamicin C1.

**System suitability:** reference solution (a):

- **peak-to-valley ratio:** minimum 2.0 where  $H_p$  = height above the baseline of the peak due to gentamicin C2a, and  $H_v$  = height above the baseline of the lowest point of the curve separating this peak from the peak due to gentamicin C2.

**Limits:**

- **gentamicin C1:** 20.0 per cent to 40.0 per cent;
- **gentamicin C1a:** 10.0 per cent to 30.0 per cent;
- **sum of gentamicins C2, C2a, and C2b:** 40.0 per cent to 60.0 per cent;
- **disregard limit:** the area of the peak due to gentamicin C1a in the chromatogram obtained with reference solution (b).

**Related substances.** Liquid chromatography (2.2.29) as described in the test for composition.

**Limits** (for related substances eluting before gentamicin C1a):

- **any impurity:** maximum 3.0 per cent;
- **total:** maximum 10.0 per cent.

**Methanol** (2.4.24, System B): maximum 1.0 per cent.

**Sulfate:** 32.0 per cent to 35.0 per cent (anhydrous substance).

Dissolve 0.250 g in 100 mL of *distilled water R* and adjust the solution to pH 11 using *concentrated ammonia R*. Add 10.0 mL of 0.1 M *barium chloride* and about 0.5 mg of *phthalein purple R*. Titrate with 0.1 M *sodium edetate*, adding 50 mL of *ethanol (96 per cent) R* when the colour of the solution begins to change and continue the titration until the violet-blue colour disappears.

1 mL of 0.1 M *barium chloride* is equivalent to 9.606 mg of  $\text{SO}_4$ .

**Water** (2.5.12): maximum 15.0 per cent, determined on 0.300 g.

**Sulfated ash** (2.4.14): maximum 1.0 per cent, determined on 0.50 g.

**Bacterial endotoxins** (2.6.14): less than 0.71 IU/mg, if intended for use in the manufacture of parenteral preparations without a further appropriate procedure for the removal of bacterial endotoxins.

#### ASSAY

Carry out the microbiological assay of antibiotics (2.7.2).

#### STORAGE

In an airtight container. If the substance is sterile, store in a sterile, airtight, tamper-proof container.

#### IMPURITIES

**Specified impurities:** A, B, C.

**Other detectable impurities** (the following substances would, if present at a sufficient level, be detected by one or other of the tests in the monograph. They are limited by the general acceptance criterion for other/unspecified impurities and/or by the general monograph *Substances for pharmaceutical use* (2034). It is therefore not necessary to identify these impurities for demonstration of compliance. See also 5.10. *Control of impurities in substances for pharmaceutical use*): D, E.

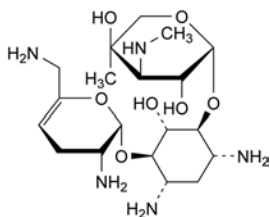

- A. 2-deoxy-4-O-[3-deoxy-4-C-methyl-3-(methylamino)-β-L-arabinopyranosyl]-6-O-(2,6-diamino-2,3,4,6-tetra-deoxy-α-D-glycero-hex-4-enopyranosyl)-L-streptomycin (sisomicin),

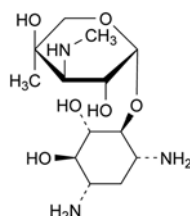

- B. 2-deoxy-4-O-[3-deoxy-4-C-methyl-3-(methylamino)-β-L-arabinopyranosyl]-L-streptomycin (garamine),

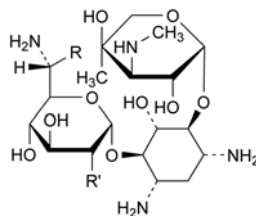

- C. R =  $\text{CH}_3$ , R' = OH: 4-O-(6-amino-6,7-dideoxy-D-glycero-α-D-gluco-heptopyranosyl)-2-deoxy-6-O-[3-deoxy-4-C-methyl-3-(methylamino)-β-L-arabinopyranosyl]-D-streptomycin (gentamicin B<sub>1</sub>),

- D. R = H, R' =  $\text{NH}_2$ : 2-deoxy-4-O-[3-deoxy-4-C-methyl-3-(methylamino)-β-L-arabinopyranosyl]-6-O-(2,6-diamino-2,6-dideoxy-α-D-gluco-hexopyranosyl)-L-streptomycin,

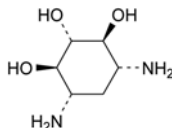

- E. 2-deoxystreptomycin.

07/2009:1726  
corrected 6.8

## GESTODENE

### Gestodenum

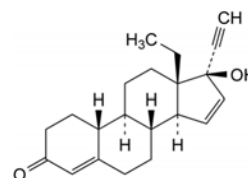

$\text{C}_{21}\text{H}_{26}\text{O}_2$   
[60282-87-3]

$M_r$  310.4

#### DEFINITION

13-Ethyl-17-hydroxy-18,19-dinor-17α-pregna-4,15-dien-20-yn-3-one.

**Content:** 97.5 per cent to 102.0 per cent (dried substance).

#### CHARACTERS

**Appearance:** white or yellowish, crystalline powder.

**Solubility:** practically insoluble in water, freely soluble in methylene chloride, soluble in methanol, sparingly soluble in ethanol (96 per cent).

It shows polymorphism (5.9).

#### IDENTIFICATION

A. Specific optical rotation (see Tests).

B. Infrared absorption spectrophotometry (2.2.24).

**Comparison:** *gestodene CRS*.

If the spectra obtained in the solid state show differences, dissolve the substance to be examined and the reference substance separately in *acetone R*, evaporate to dryness and record new spectra using the residues.

## TESTS

**Specific optical rotation** (2.2.7): –188 to –198 (dried substance).

Dissolve 0.100 g in *methanol R* and dilute to 10.0 mL with the same solvent.

**Related substances.** Liquid chromatography (2.2.29).

*Solvent mixture: acetonitrile R1, water R (50:50 V/V).*

*Test solution (a).* Dissolve 30.0 mg of the substance to be examined in 5 mL of *acetonitrile R1* and dilute to 10.0 mL with *water R*.

*Test solution (b).* Dilute 1.0 mL of test solution (a) to 10.0 mL with the solvent mixture.

*Reference solution (a).* Dissolve 3 mg of *gestodene for system suitability CRS* (containing impurities A, B, C and L) in 0.5 mL of *acetonitrile R1* and dilute to 1.0 mL with *water R*.

*Reference solution (b).* Dilute 1.0 mL of test solution (a) to 100.0 mL with the solvent mixture. Dilute 1.0 mL of this solution to 10.0 mL with the solvent mixture.

*Reference solution (c).* Dissolve 30.0 mg of *gestodene CRS* in 5 mL of *acetonitrile R1* and dilute to 10.0 mL with *water R*. Dilute 1.0 mL of this solution to 10.0 mL with the solvent mixture.

*Reference solution (d).* Dissolve the contents of a vial of *gestodene impurity I CRS* in 1.0 mL of the solvent mixture.

*Column:*

- size:  $l = 0.15$  m,  $\varnothing = 4.6$  mm;
- stationary phase: spherical *end-capped octylsilyl silica gel for chromatography R* (3.5  $\mu$ m).

*Mobile phase:*

- mobile phase A: *water R*;
- mobile phase B: *acetonitrile R1*;

Time (min)	Mobile phase A (per cent V/V)	Mobile phase B (per cent V/V)
0 - 2	62	38
2 - 20	62 → 58	38 → 42
20 - 24	58 → 30	42 → 70
24 - 32	30	70

*Flow rate:* 1.0 mL/min.

*Detection:* spectrophotometer at 205 nm and at 254 nm.

*Injection:* 10  $\mu$ L of test solution (a) and reference solutions (a), (b) and (d).

*Identification of impurities:* use the chromatogram supplied with *gestodene for system suitability CRS* and the chromatogram obtained with reference solution (a) to identify the peaks due to impurities A, B, C and L; use the chromatogram obtained with reference solution (d) to identify the peak due to impurity I.

*Relative retention* with reference to *gestodene* (retention time = about 12.5 min): impurity A = about 0.9; impurity C = about 1.1; impurity I = about 1.2; impurity L = about 1.46; impurity B = about 1.53.

*System suitability:* reference solution (a):

- resolution: minimum 2.0 between the peaks due to impurity A and *gestodene*.

*Limits:*

- correction factors: for the calculation of content, multiply the peak areas of the following impurities by the corresponding correction factor: impurity A = 2.2; impurity I = 1.3;
- impurity A at 254 nm: not more than 3 times the area of the principal peak in the chromatogram obtained with reference solution (b) (0.3 per cent);
- impurity B at 205 nm: not more than twice the area of the principal peak in the chromatogram obtained with reference solution (b) (0.2 per cent);

- impurity C at 254 nm: not more than twice the area of the principal peak in the chromatogram obtained with reference solution (b) (0.2 per cent);
- impurities I, L at 205 nm: for each impurity, not more than 1.5 times the area of the principal peak in the chromatogram obtained with reference solution (b) (0.15 per cent);
- unspecified impurities at 254 nm: for each impurity, not more than the area of the principal peak in the chromatogram obtained with reference solution (b) (0.10 per cent);
- total at 254 nm: not more than 5 times the area of the principal peak in the chromatogram obtained with reference solution (b) (0.5 per cent);
- disregard limit at 254 nm: 0.5 times the area of the principal peak in the chromatogram obtained with reference solution (b) (0.05 per cent).

**Loss on drying** (2.2.32): maximum 0.5 per cent, determined on 1.000 g by drying in an oven at 105 °C for 3 h.

## ASSAY

Liquid chromatography (2.2.29) as described in the test for related substances with the following modifications.

*Injection:* test solution (b) and reference solution (c).

*Detection:* spectrophotometer at 254 nm.

Calculate the percentage content of  $C_{21}H_{26}O_2$  from the declared content of *gestodene CRS*.

## IMPURITIES

*Specified impurities: A, B, C, I, L.*

*Other detectable impurities* (the following substances would, if present at a sufficient level, be detected by one or other of the tests in the monograph. They are limited by the general acceptance criterion for other/unspecified impurities and/or by the general monograph *Substances for pharmaceutical use* (2034). It is therefore not necessary to identify these impurities for demonstration of compliance. See also 5.10. *Control of impurities in substances for pharmaceutical use*):

- at 205 nm: G, J, K;
- at 254 nm: D, E, F, H.

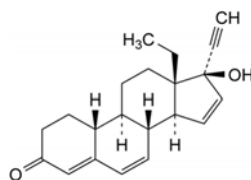

A. 13-ethyl-17-hydroxy-18,19-dinor-17 $\alpha$ -pregna-4,6,15-trien-20-yn-3-one ( $\Delta^6$ -gestodene),

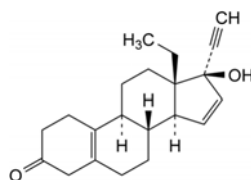

B. 13-ethyl-17-hydroxy-18,19-dinor-17 $\alpha$ -pregna-5(10),15-dien-20-yn-3-one ( $\Delta^5(10)$ -gestodene),

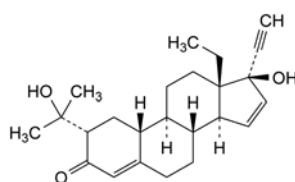

C. 13-ethyl-17-hydroxy-2 $\alpha$ -(1-hydroxy-1-methylethyl)-18,19-dinor-17 $\alpha$ -pregna-4,15-dien-20-yn-3-one (2-isopropanol-gestodene),

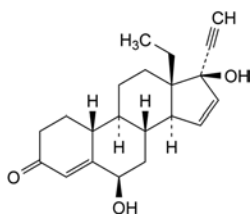

D. 13-ethyl-6β,17-dihydroxy-18,19-dinor-17α-pregna-4,15-dien-20-yn-3-one (6β-hydroxy-gestodene),

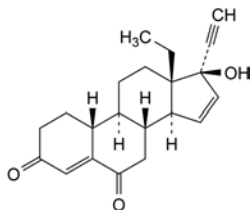

E. 13-ethyl-17-hydroxy-18,19-dinor-17α-pregna-4,15-dien-20-yn-3,6-dione (6-keto-gestodene),

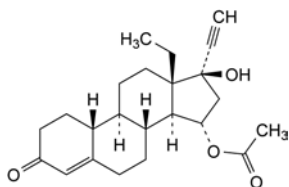

F. 13-ethyl-17-hydroxy-3-oxo-18,19-dinor-17α-pregna-4-en-20-yn-15α-yl acetate (15α-acetoxy-gestodene),

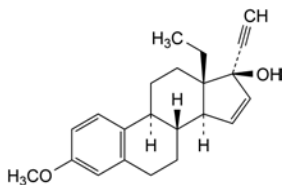

G. 13-ethyl-3-methoxy-18,19-dinor-17α-pregna-1,3,5(10),15-tetraen-20-yn-17-o1 (A-aromatic-gestodene),

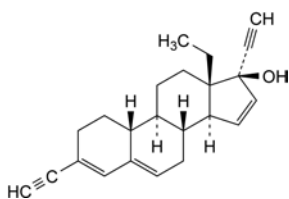

H. 13-ethyl-3-ethynyl-18,19-dinor-17α-pregna-3,5,15-trien-20-yn-17-o1 (diethynyl-gestodene),

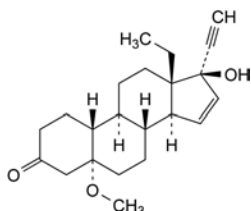

I. 13-ethyl-17-hydroxy-5-methoxy-18,19-dinor-5α,17α-pregna-15-en-20-yn-3-one (5-methoxy-gestodene),

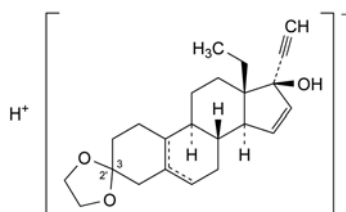

J. 13-ethylspiro(18,19-dinor-17α-pregna-5,15-dien-20-yn-3,2'-[1,3]dioxolan)-17-ol and 13-ethylspiro(18,19-dinor-17α-pregna-5(10),15-dien-20-yn-3,2'-[1,3]dioxolan)-17-ol (gestodene ketal),

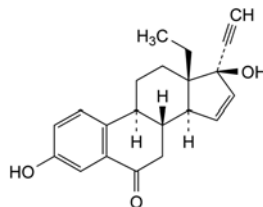

K. 13-ethyl-3,17-dihydroxy-18,19-dinor-17α-pregna-1,3,5(10),15-tetraen-20-yn-6-one (aromatic 6-keto-gestodene),

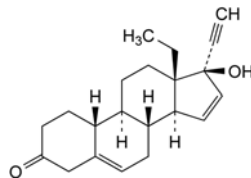

L. 13-ethyl-17-hydroxy-18,19-dinor-17α-pregna-5,15-dien-20-yn-3-one (Δ5(6)-gestodene).

01/2008:0718  
corrected 7.0

## GLIBENCLAMIDE

### Glibenclamidum

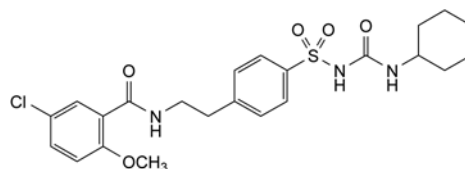

C<sub>23</sub>H<sub>28</sub>ClN<sub>3</sub>O<sub>5</sub>S  
[10238-21-8]

M<sub>r</sub> 494.0

#### DEFINITION

1-[[4-[2-[(5-Chloro-2-methoxybenzoyl)amino]ethyl]phenyl]sulfonyl]-3-cyclohexylurea.

*Content*: 99.0 per cent to 101.0 per cent (dried substance).

#### CHARACTERS

*Appearance*: white or almost white, crystalline powder.

*Solubility*: practically insoluble in water, sparingly soluble in methylene chloride, slightly soluble in alcohol and in methanol.

#### IDENTIFICATION

*First identification*: A, C.

*Second identification*: A, B, D, E.

A. Melting point (2.2.14): 169 °C to 174 °C.

B. Dissolve 50.0 mg in *methanol R*, with the aid of ultrasound if necessary, and dilute to 50.0 mL with the same solvent. To 10.0 mL of the solution add 1.0 mL of a 103 g/L solution of *hydrochloric acid R* and dilute to 100.0 mL with *methanol R*. Examined between 230 nm and 350 nm (2.2.25), the solution shows an absorption maximum at 300 nm and a less intense maximum at 275 nm. The specific absorbances at the maxima are 61 to 65 and 27 to 32, respectively.

## C. Infrared absorption spectrophotometry (2.2.24).

*Preparation:* discs of *potassium bromide R*.

*Comparison:* *glibenclamide CRS*.

If the spectra obtained show differences, moisten separately the substance to be examined and the reference substance with *methanol R*, triturate, dry at 100-105 °C and record the spectra again.

## D. Thin-layer chromatography (2.2.27).

*Test solution.* Dissolve 10 mg of the substance to be examined in a mixture of equal volumes of *methanol R* and *methylene chloride R* and dilute to 10 mL with the same mixture of solvents.

*Reference solution.* Dissolve 10 mg of *glibenclamide CRS* in a mixture of equal volumes of *methanol R* and *methylene chloride R* and dilute to 10 mL with the same mixture of solvents.

*Plate:* *TLC silica gel GF<sub>254</sub> plate R*.

*Mobile phase:* *alcohol R, glacial acetic acid R, cyclohexane R, methylene chloride R* (5:5:45:45 V/V/V/V).

*Application:* 10 µL.

*Development:* over a path of 10 cm.

*Drying:* in air.

*Detection:* examine in ultraviolet light at 254 nm.

*Results:* the principal spot in the chromatogram obtained with the test solution is similar in position and size to the principal spot in the chromatogram obtained with the reference solution.

- E. Dissolve 20 mg in 2 mL of *sulfuric acid R*. The solution is colourless and shows blue fluorescence in ultraviolet light at 365 nm. Dissolve 0.1 g of *chloral hydrate R* in the solution. Within about 5 min, the colour changes to deep yellow and, after about 20 min, develops a brownish tinge.

## TESTS

**Related substances.** Liquid chromatography (2.2.29).

*Test solution.* Dissolve 25.0 mg of the substance to be examined in *methanol R* and dilute to 10.0 mL with the same solvent. Prepare immediately before use.

*Reference solution (a).* Dissolve 5.0 mg of *glibenclamide impurity A CRS* and 5.0 mg of *glibenclamide impurity B CRS* in *methanol R* and dilute to 100.0 mL with the same solvent. Dilute 5.0 mL of the solution to 20.0 mL with *methanol R*.

*Reference solution (b).* Dilute 2.0 mL of the test solution to 100.0 mL with *methanol R*. Dilute 5.0 mL of this solution to 50.0 mL with *methanol R*.

*Reference solution (c).* Dissolve 5 mg of *gliclazide CRS* in *methanol R*, add 2 mL of the test solution and dilute to 100 mL with *methanol R*. Dilute 1 mL of this solution to 10 mL with *methanol R*.

*Column:*

- *size:*  $l = 0.10$  m,  $\varnothing = 4.6$  mm,
- *stationary phase:* spherical base-deactivated end-capped octadecylsilyl silica gel for chromatography R (3 µm),
- *temperature:* 35 °C.

*Mobile phase:*

- *mobile phase A:* mix 20 mL of a 101.8 g/L solution of freshly distilled *triethylamine R* adjusted to pH 3.0 using *phosphoric acid R*, and 50 mL of *acetonitrile R*; dilute to 1000 mL with *water R*,
- *mobile phase B:* mobile phase A, *water R*, *acetonitrile R* (20:65:915 V/V/V),

Time (min)	Mobile phase A (per cent V/V)	Mobile phase B (per cent V/V)
0 - 15	45	55
15 - 30	45 → 5	55 → 95
30 - 40	5	95

*Flow rate:* 0.8 mL/min.

*Detection:* spectrophotometer at 230 nm.

*Injection:* 10 µL.

*Relative retention* with reference to *glibenclamide* (retention time = about 5 min): impurity A = about 0.5; impurity B = about 0.6.

*System suitability:* reference solution (c):

- *resolution:* minimum 5.0 between the peaks due to *glibenclamide* and *gliclazide*.

*Limits:*

- *impurity A:* not more than the area of the corresponding peak in the chromatogram obtained with reference solution (a) (0.5 per cent),
- *impurity B:* not more than the area of the corresponding peak in the chromatogram obtained with reference solution (a) (0.5 per cent),
- *any other impurity:* not more than the area of the principal peak in the chromatogram obtained with reference solution (b) (0.2 per cent), and not more than 2 such peaks have an area greater than half the area of the principal peak in the chromatogram obtained with reference solution (b) (0.1 per cent),
- *total of other impurities:* not more than 2.5 times the area of the principal peak in the chromatogram obtained with reference solution (b) (0.5 per cent),
- *disregard limit:* 0.25 times the area of the principal peak in the chromatogram obtained with reference solution (b) (0.05 per cent).

**Heavy metals** (2.4.8): maximum 20 ppm.

1.0 g complies with limit test D. Prepare the standard using 2 mL of *lead standard solution (10 ppm Pb) R*.

**Loss on drying** (2.2.32): maximum 1.0 per cent, determined on 1.000 g by drying in an oven at 105 °C.

**Sulfated ash** (2.4.14): maximum 0.1 per cent, determined on 1.0 g.

## ASSAY

Dissolve 0.400 g with heating in 100 mL of *alcohol R*. Titrate with 0.1 M *sodium hydroxide*, using 1.0 mL of *phenolphthalein solution R* as indicator, until a pink colour is obtained.

1 mL of 0.1 M *sodium hydroxide* is equivalent to 49.40 mg of  $C_{23}H_{28}ClN_3O_5S$ .

## IMPURITIES

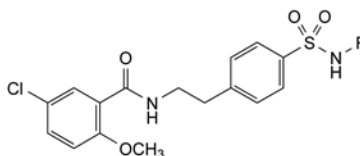

A. R = H: 5-chloro-2-methoxy-*N*-[2-(4-sulfamoylphenyl)ethyl]benzamide,

B. R = CO-OCH<sub>3</sub>: methyl [[4-[2-[(5-chloro-2-methoxybenzoyl)amino]ethyl]phenyl]sulfonyl]carbamate.



01/2008:1524 *Limits:*

corrected 6.0

## GLICLAZIDE

## Gliclazidum

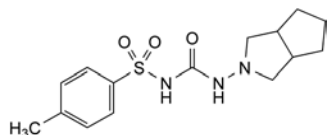
C<sub>15</sub>H<sub>21</sub>N<sub>3</sub>O<sub>3</sub>S  
[21187-98-4]M<sub>r</sub> 323.4

## DEFINITION

1-(Hexahydrocyclopenta[c]pyrrol-2(1H)-yl)-3-[(4-methylphenyl)sulfonyl]urea.

*Content:* 99.0 per cent to 101.0 per cent (dried substance).

## CHARACTERS

*Appearance:* white or almost white powder.*Solubility:* practically insoluble in water, freely soluble in methylene chloride, sparingly soluble in acetone, slightly soluble in ethanol (96 per cent).

## IDENTIFICATION

Infrared absorption spectrophotometry (2.2.24).

*Preparation:* discs.*Comparison:* gliclazide CRS.

## TESTS

**Related substances.** Liquid chromatography (2.2.29). Prepare the solutions immediately before use.*Solvent mixture:* acetonitrile R, water R (45:55 V/V).*Test solution.* Dissolve 50.0 mg of the substance to be examined in 23 mL of acetonitrile R and dilute to 50.0 mL with water R.*Reference solution (a).* Dilute 1.0 mL of the test solution to 100.0 mL with the solvent mixture. Dilute 10.0 mL of this solution to 100.0 mL with the solvent mixture.*Reference solution (b).* Dissolve 5 mg of the substance to be examined and 15 mg of gliclazide impurity F CRS in 23 mL of acetonitrile R and dilute to 50 mL with water R. Dilute 1 mL of this solution to 20 mL with the solvent mixture.*Reference solution (c).* Dissolve 10.0 mg of gliclazide impurity F CRS in 45 mL of acetonitrile R and dilute to 100.0 mL with water R. Dilute 1.0 mL of this solution to 100.0 mL with the solvent mixture.*Column:*

- size:  $l = 0.25$  m,  $\varnothing = 4$  mm;
- stationary phase: octylsilyl silica gel for chromatography R (5  $\mu$ m).

*Mobile phase:* triethylamine R, trifluoroacetic acid R, acetonitrile R, water R (0.1:0.1:45:55 V/V/V/V).*Flow rate:* 0.9 mL/min.*Detection:* spectrophotometer at 235 nm.*Injection:* 20  $\mu$ L.*Run time:* twice the retention time of gliclazide.*Relative retention* with reference to gliclazide (retention time = about 16 min): impurity F = about 0.9.*System suitability:* reference solution (b):

- resolution: minimum 1.8 between the peaks due to impurity F and gliclazide.

- *impurity F:* not more than the area of the corresponding peak in the chromatogram obtained with reference solution (c) (0.1 per cent);
- *unspecified impurities:* for each impurity, not more than the area of the principal peak in the chromatogram obtained with reference solution (a) (0.10 per cent);
- *sum of impurities other than F:* not more than twice the area of the principal peak in the chromatogram obtained with reference solution (a) (0.2 per cent);
- *disregard limit:* 0.2 times the area of the principal peak in the chromatogram obtained with reference solution (a) (0.02 per cent).

**Impurity B.** Liquid chromatography (2.2.29) as described in the test for related substances with the following modifications.*Test solution.* Dissolve 0.400 g of the substance to be examined in 2.5 mL of dimethyl sulfoxide R and dilute to 10.0 mL with water R. Stir for 10 min, store at 4 °C for 30 min and filter.*Reference solution.* Dissolve 20.0 mg of gliclazide impurity B CRS in dimethyl sulfoxide R and dilute to 100.0 mL with the same solvent. To 1.0 mL of the solution, add 12 mL of dimethyl sulfoxide R and dilute to 50.0 mL with water R. To 1.0 mL of this solution, add 12 mL of dimethyl sulfoxide R and dilute to 50.0 mL with water R.*Injection:* 50  $\mu$ L.*Retention time:* impurity B = about 8 min.*Limit:*

- *impurity B:* not more than the area of the corresponding peak in the chromatogram obtained with the reference solution (2 ppm).

**Heavy metals** (2.4.8): maximum 10 ppm.

1.5 g complies with test F. Prepare the reference solution using 1.5 mL of lead standard solution (10 ppm Pb) R.

**Loss on drying** (2.2.32): maximum 0.25 per cent, determined on 1.000 g by drying in an oven at 105 °C for 2 h.**Sulfated ash** (2.4.14): maximum 0.1 per cent, determined on 1.0 g.

## ASSAY

Dissolve 0.250 g in 50 mL of anhydrous acetic acid R. Titrate with 0.1 M perchloric acid, determining the end-point potentiometrically (2.2.20).

1 mL of 0.1 M perchloric acid is equivalent to 32.34 mg of C<sub>15</sub>H<sub>21</sub>N<sub>3</sub>O<sub>3</sub>S.

## IMPURITIES

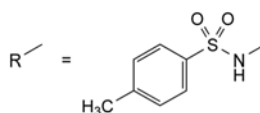
*Specified impurities:* B, F.*Other detectable impurities* (the following substances would, if present at a sufficient level, be detected by one or other of the tests in the monograph. They are limited by the general acceptance criterion for other/unspecified impurities and/or by the general monograph *Substances for pharmaceutical use* (2034). It is therefore not necessary to identify these impurities for demonstration of compliance. See also 5.10. *Control of impurities in substances for pharmaceutical use*): A, C, D, E, G.

A. R-H: 4-methylbenzenesulfonamide,

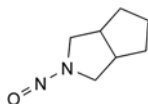

B. 2-nitroso-octahydrocyclopenta[c]pyrrole,

C. R-CO-O-C<sub>2</sub>H<sub>5</sub>: ethyl [(4-methylphenyl)sulfonyl]carbamate,

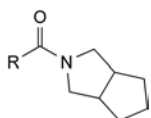

D. *N*-[(4-methylphenyl)sulfonyl]hexahydrocyclopenta[*c*]pyrrol-2(1*H*)-carboxamide,

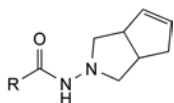

E. 1-[(4-methylphenyl)sulfonyl]-3-(3,3a,4,6a-tetrahydrocyclopenta[*c*]pyrrol-2(1*H*)-yl)urea,

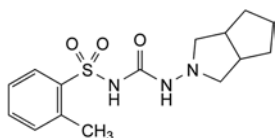

F. 1-(hexahydrocyclopenta[*c*]pyrrol-2(1*H*)-yl)-3-[(2-methylphenyl)sulfonyl]urea,

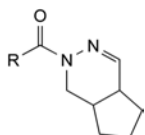

G. *N*-[(4-methylphenyl)sulfonyl]-1,4a,5,6,7,7a-hexahydro-2*H*-cyclopenta[*d*]pyridazine-2-carboxamide.

01/2008:2223

## GLIMEPIRIDE

### Glimepiridum

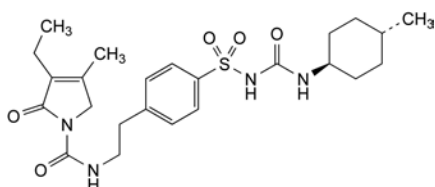

$C_{24}H_{34}N_4O_5S$   
[93479-97-1]

$M_r$  490.6

#### DEFINITION

1-[[4-[2-(3-Ethyl-4-methyl-2-oxo-3-pyrroline-1-carboxamido)ethyl]phenyl]sulfonyl]-3-*trans*-(4-methylcyclohexyl)urea.

*Content*: 97.0 per cent to 102.0 per cent (anhydrous substance).

#### CHARACTERS

*Appearance*: white or almost white powder.

*Solubility*: practically insoluble in water, soluble in dimethylformamide, slightly soluble in methylene chloride, very slightly soluble in methanol.

It shows polymorphism (5.9).

#### IDENTIFICATION

Infrared absorption spectrophotometry (2.2.24).

*Comparison*: glimepiride CRS.

If the spectra obtained in the solid state show differences, dissolve the substance to be examined and the reference substance separately in *dimethylformamide R*, evaporate to dryness and record new spectra using the residues.

#### TESTS

**Related substances.** Liquid chromatography (2.2.29). Store the solutions at a temperature not exceeding 12 °C and for not more than 15 h.

*Solvent mixture*: water for chromatography *R*, acetonitrile for chromatography *R* (1:4 V/V).

*Test solution*. Dissolve 20.0 mg of the substance to be examined in the solvent mixture and dilute to 100.0 mL with the solvent mixture.

*Reference solution (a)*. Dissolve the contents of a vial of *glimepiride for system suitability CRS* (containing impurities B, C and D) in 2.0 mL of the test solution.

*Reference solution (b)*. Dilute 1.0 mL of the test solution to 100.0 mL with the solvent mixture. Dilute 1.0 mL of this solution to 10.0 mL with the solvent mixture.

*Reference solution (c)*. Dissolve 20.0 mg of *glimepiride CRS* in the solvent mixture and dilute to 100.0 mL with the solvent mixture.

#### Column:

- size:  $l = 0.25$  m,  $\emptyset = 4$  mm,
- stationary phase: end-capped octadecylsilyl silica gel for chromatography *R* (4  $\mu$ m).

*Mobile phase*: dissolve 0.5 g of *sodium dihydrogen phosphate R* in 500 mL of *water for chromatography R* and adjust to pH 2.5 with *phosphoric acid R*. Add 500 mL of *acetonitrile for chromatography R*.

*Flow rate*: 1.0 mL/min.

*Detection*: spectrophotometer at 228 nm.

*Injection*: 20  $\mu$ L of the test solution and reference solutions (a) and (b).

*Run time*: 2.5 times the retention time of glimepiride.

*Relative retention* with reference to glimepiride (retention time = about 17 min): impurity B = about 0.2; impurity C = about 0.3; impurity D = about 1.1.

*System suitability*: reference solution (a):

- resolution: minimum 4.0 between the peaks due to impurity B and impurity C.

#### Limits:

- impurity B: not more than 4 times the area of the principal peak in the chromatogram obtained with reference solution (b) (0.4 per cent),
- impurity D: not more than twice the area of the principal peak in the chromatogram obtained with reference solution (b) (0.2 per cent),
- unspecified impurities: for each impurity, not more than the area of the principal peak in the chromatogram obtained with reference solution (b) (0.1 per cent),
- sum of impurities other than B: not more than 5 times the area of the principal peak in the chromatogram obtained with reference solution (b) (0.5 per cent),
- disregard limit: 0.5 times the area of the principal peak in the chromatogram obtained with reference solution (b) (0.05 per cent).

**Impurity A.** Liquid chromatography (2.2.29). Prepare the solutions immediately before use.

*Test solution*. Dissolve 10.0 mg of the substance to be examined in 5 mL of *methylene chloride R* and dilute to 20.0 mL with the mobile phase.

*Reference solution (a)*. Dilute 0.8 mL of the test solution to 100.0 mL with the mobile phase.

*Reference solution (b)*. Dissolve 2.0 mg of *glimepiride CRS* (containing impurity A) in 1 mL of *methylene chloride R* and dilute to 4.0 mL with the mobile phase.

#### Column:

- size:  $l = 0.15$  m,  $\emptyset = 4$  mm,
- stationary phase: diol silica gel for chromatography *R* (5  $\mu$ m).

Mobile phase: anhydrous acetic acid R, 2-propanol R, heptane R (1:100:899 V/V/V).

Flow rate: 0.5 mL/min.

Detection: spectrophotometer at 228 nm.

Injection: 10 µL.

Run time: 1.5 times the retention time of glimepiride.

Identification of impurities: use the chromatogram supplied with *glimepiride CRS* and the chromatogram obtained with reference solution (b) to identify the peak due to impurity A.

Relative retention with reference to glimepiride (retention time = about 14 min): impurity A = about 0.9.

System suitability: reference solution (b):

- peak-to-valley ratio: minimum 2.0, where  $H_p$  = height above the baseline of the peak due to impurity A and  $H_v$  = height above the baseline of the lowest point of the curve separating this peak from the peak due to glimepiride.

Limit:

- impurity A: not more than the area of the principal peak in the chromatogram obtained with reference solution (a) (0.8 per cent).

Water (2.5.32): maximum 0.5 per cent.

Dissolve 0.250 g in *dimethylformamide R* and dilute to 5.0 mL with the same solvent. Carry out the test on 1.0 mL of solution. Carry out a blank test.

Sulfated ash (2.4.14): maximum 0.1 per cent, determined on 1.0 g.

ASSAY

Liquid chromatography (2.2.29) as described in the test for related substances with the following modification.

Injection: test solution and reference solution (c).

Calculate the percentage content of  $C_{24}H_{34}N_4O_5S$  from the areas of the peaks and the declared content of *glimepiride CRS*.

IMPURITIES

Specified impurities: A, B, D.

Other detectable impurities (the following substances would, if present at a sufficient level, be detected by one or other of the tests in the monograph. They are limited by the general acceptance criterion for other/unspecified impurities and/or by the general monograph *Substances for pharmaceutical use (2034)*. It is therefore not necessary to identify these impurities for demonstration of compliance. See also 5.10. *Control of impurities in substances for pharmaceutical use*): C, E, F, G, H, I, J.

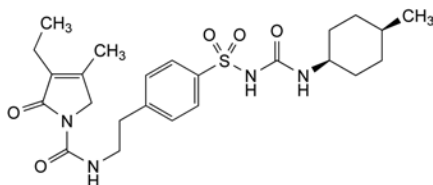

- A. 1-[[4-[2-[[[(3-ethyl-4-methyl-2-oxo-2,3-dihydro-1H-pyrrol-1-yl)carbonyl]amino]ethyl]phenyl]sulfonyl]-3-(*cis*-4-methylcyclohexyl)urea,

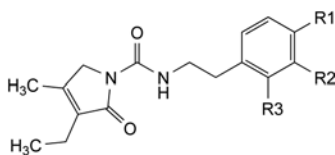

- B. R1 = SO<sub>2</sub>-NH<sub>2</sub>, R2 = R3 = H: 3-ethyl-4-methyl-2-oxo-N-[2-(4-sulfamoylphenyl)ethyl]-2,3-dihydro-1H-pyrrole-1-carboxamide,  
 C. R1 = SO<sub>2</sub>-NH-CO-OCH<sub>3</sub>, R2 = R3 = H: methyl [[4-[2-[[[(3-ethyl-4-methyl-2-oxo-2,3-dihydro-1H-pyrrol-1-yl)carbonyl]amino]ethyl]phenyl]sulfonyl]carbamate,

- E. R1 = R3 = H, R2 = SO<sub>2</sub>-NH<sub>2</sub>: 3-ethyl-4-methyl-2-oxo-N-[2-(3-sulfamoylphenyl)ethyl]-2,3-dihydro-1H-pyrrole-1-carboxamide,  
 F. R1 = R2 = H, R3 = SO<sub>2</sub>-NH-CO-OCH<sub>3</sub>: methyl [[2-[2-[[[(3-ethyl-4-methyl-2-oxo-2,3-dihydro-1H-pyrrol-1-yl)carbonyl]amino]ethyl]phenyl]sulfonyl]carbamate,  
 G. R1 = SO<sub>2</sub>-N(CH<sub>3</sub>)-CO-OCH<sub>3</sub>, R2 = R3 = H: methyl [[4-[2-[[[(3-ethyl-4-methyl-2-oxo-2,3-dihydro-1H-pyrrol-1-yl)carbonyl]amino]ethyl]phenyl]sulfonyl]methylcarbamate,  
 H. R1 = SO<sub>2</sub>-NH-CO-NH-C<sub>6</sub>H<sub>4</sub>-CH<sub>3</sub>, R2 = R3 = H: 1-[[4-[2-[[[(3-ethyl-4-methyl-2-oxo-2,3-dihydro-1H-pyrrol-1-yl)carbonyl]amino]ethyl]phenyl]sulfonyl]-3-(4-methylphenyl)urea,

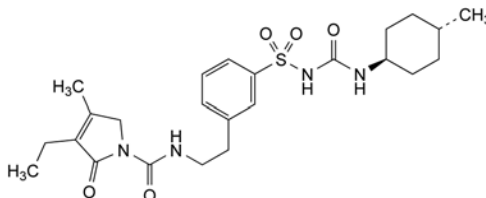

- D. 1-[[3-[2-[[[(3-ethyl-4-methyl-2-oxo-2,3-dihydro-1H-pyrrol-1-yl)carbonyl]amino]ethyl]phenyl]sulfonyl]-3-(*trans*-4-methylcyclohexyl)urea,

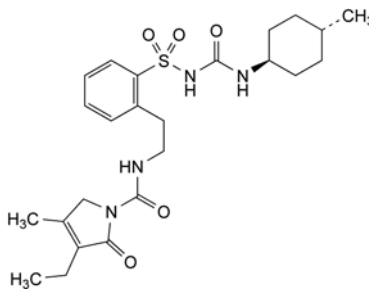

- I. 1-[[2-[2-[[[(3-ethyl-4-methyl-2-oxo-2,3-dihydro-1H-pyrrol-1-yl)carbonyl]amino]ethyl]phenyl]sulfonyl]-3-(*trans*-4-methylcyclohexyl)urea,

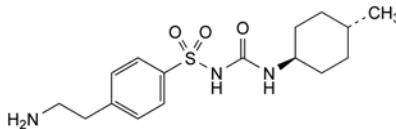

- J. 1-[[4-(2-aminoethyl)phenyl]sulfonyl]-3-(*trans*-4-methylcyclohexyl)urea.

01/2010:0906

## GLIPIZIDE

### Glipizidum

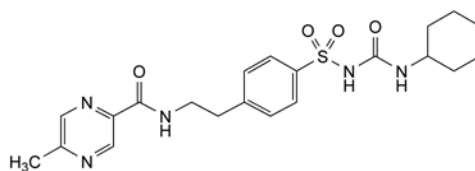

C<sub>21</sub>H<sub>27</sub>N<sub>3</sub>O<sub>4</sub>S  
[29094-61-9]

M<sub>r</sub> 445.5

DEFINITION

1-Cyclohexyl-3-[[4-[2-[[[(5-methylpyrazin-2-yl)carbonyl]amino]ethyl]phenyl]sulfonyl]urea.

Content: 98.0 per cent to 102.0 per cent (dried substance).

CHARACTERS

Appearance: white or almost white, crystalline powder.

**Solubility:** practically insoluble in water, very slightly soluble in methylene chloride and in acetone, practically insoluble in ethanol (96 per cent). It dissolves in dilute solutions of alkali hydroxides.

#### IDENTIFICATION

**First identification:** B.

**Second identification:** A, C.

**A. Ultraviolet and visible absorption spectrophotometry (2.2.25).**

**Test solution.** Dissolve about 2 mg in *methanol R* and dilute to 100 mL with the same solvent.

**Spectral range:** 220-350 nm.

**Absorption maxima:** at 226 nm and 274 nm.

**Absorbance ratio:**  $A_{226}/A_{274} = 2.0$  to 2.4.

**B. Infrared absorption spectrophotometry (2.2.24).**

**Comparison:** *glipizide CRS*.

**C. Thin-layer chromatography (2.2.27).**

**Test solution.** Dissolve 10 mg of the substance to be examined in a mixture of equal volumes of *methanol R* and *methylene chloride R* and dilute to 10 mL with the same mixture of solvents.

**Reference solution.** Dissolve 10 mg of *glipizide CRS* in a mixture of equal volumes of *methanol R* and *methylene chloride R* and dilute to 10 mL with the same mixture of solvents.

**Plate:** TLC silica gel GF<sub>254</sub> plate R.

**Mobile phase:** *anhydrous formic acid R*, *ethyl acetate R*, *methylene chloride R* (25:25:50 V/V/V).

**Application:** 10 µL.

**Development:** over 2/3 of the plate.

**Drying:** in air.

**Detection:** examine in ultraviolet light at 254 nm.

**Results:** the principal spot in the chromatogram obtained with the test solution is similar in position and size to the principal spot in the chromatogram obtained with the reference solution.

#### TESTS

**Related substances.** Liquid chromatography (2.2.29).

**Solvent mixture.** Mix 40 volumes of *acetonitrile R1* and 60 volumes of *water for chromatography R* previously adjusted to pH 3.5 with *acetic acid R*.

**Test solution.** Dissolve 20.0 mg of the substance to be examined in 20.0 mL of *methanol R* using sonication and dilute to 50.0 mL with the solvent mixture.

**Reference solution (a).** Dilute 1.0 mL of test solution to 100.0 mL with the solvent mixture. Dilute 1.0 mL of this solution to 10.0 mL with the solvent mixture.

**Reference solution (b).** Dissolve the contents of a vial of *glipizide impurity mixture CRS* (impurities F, G, H and I) in 1.0 mL of solvent mixture.

**Reference solution (c).** Dissolve 6.0 mg of *glipizide impurity A CRS*, 2 mg of *glipizide impurity C CRS* and 2 mg of *glipizide impurity D CRS* in the solvent mixture and dilute to 100.0 mL with the solvent mixture. Dilute 1.0 mL to 50.0 mL with the solvent mixture.

**Column:**

- size:  $l = 0.25$  m,  $\varnothing = 4.6$  mm;
- stationary phase: base-deactivated end-capped octadecylsilyl silica gel for chromatography R (5 µm).

**Mobile phase:**

- mobile phase A: *water for chromatography R* adjusted to pH 3.5 with *acetic acid R*;
- mobile phase B: *acetonitrile R1*;

Time (min)	Mobile phase A (per cent V/V)	Mobile phase B (per cent V/V)
0 - 5	75	25
5 - 12	75 → 65	25 → 35
12 - 20	65	35
20 - 25	65 → 50	35 → 50

**Flow rate:** 1.0 mL/min.

**Detection:** spectrophotometer at 225 nm.

**Injection:** 50 µL.

**Identification of impurities:** use the chromatogram supplied with *glipizide impurity mixture CRS* and the chromatogram obtained with reference solution (b) to identify the peaks due to impurities F, G, H and I; use the chromatogram obtained with reference solution (c) to identify the peaks due to impurities A, C and D.

**Relative retention** with reference to *glipizide* (retention time = about 22 min): impurity A = about 0.25; impurity D = about 0.27; impurity F = about 0.32; impurity G = about 0.4; impurity H = about 0.6; impurity C = about 1.2; impurity I = about 1.3.

**System suitability:** reference solution (c):

- peak to valley ratio: minimum 2.0, where  $H_p$  = height above the baseline of the peak due to impurity D and  $H_v$  = height above the baseline of the lowest point of the curve separating this peak from the peak due to impurity A.

**Limits:**

- correction factors: for the calculation of content, multiply the peak areas of the following impurities by the corresponding correction factor: impurity C = 1.7; impurity H = 1.3; impurity I = 2.1;
- impurity A: not more than the area of the corresponding peak in the chromatogram obtained with reference solution (c) (0.3 per cent);
- impurities C, D, F, G, H, I: for each impurity, not more than 1.5 times the area of the peak due to *glipizide* in the chromatogram obtained with reference solution (a) (0.15 per cent);
- unspecified impurities: for each impurity, not more than the area of the peak due to *glipizide* in the chromatogram obtained with reference solution (a) (0.10 per cent);
- total: not more than 5 times the area of the peak due to *glipizide* in the chromatogram obtained with reference solution (a) (0.5 per cent);
- disregard limit: 0.5 times the area of the peak due to *glipizide* in the chromatogram obtained with reference solution (a) (0.05 per cent).

**Impurity B.** Gas chromatography (2.2.28).

**Internal standard solution.** Dissolve 25 mg of *decane R* in *methylene chloride R* and dilute to 100 mL with the same solvent. Dilute 5 mL of this solution to 100 mL with *methylene chloride R*.

**Test solution (a).** Dissolve 1.0 g of the substance to be examined in 50 mL of a 12 g/L solution of *sodium hydroxide R* and shake with 2 quantities, each of 5.0 mL, of *methylene chloride R*. Use the combined lower layers.

**Test solution (b).** Dissolve 1.0 g of the substance to be examined in 50 mL of a 12 g/L solution of *sodium hydroxide R* and shake with 2 quantities, each of 5.0 mL, of the internal standard solution. Use the combined lower layers.

**Reference solution.** Dissolve 10.0 mg of *cyclohexylamine R* (impurity B) in a 17.5 g/L solution of *hydrochloric acid R* and dilute to 100.0 mL with the same acid. To 1.0 mL of this solution add 50 mL of a 12 g/L solution of *sodium hydroxide R* and shake with 2 quantities, each of 5.0 mL, of the internal standard solution. Use the combined lower layers.

**Column:**

- *material*: fused silica;
- *size*:  $l = 25$  m,  $\varnothing = 0.32$  mm;
- *stationary phase*: poly(dimethyl)(diphenyl)siloxane R (film thickness 0.5  $\mu$ m).

*Carrier gas*: helium for chromatography R.

*Flow rate*: 1.8 mL/min.

*Split ratio*: 1:11.

*Temperature*:

	Time (min)	Temperature (°C)
Column	0 - 4	40
	4 - 20	40 → 200
	20 - 25	200
Injection port		250
Detector		270

*Detection*: flame ionisation.

*Injection*: 1  $\mu$ L.

*Elution order*: impurity B, decane.

*System suitability*:

- *resolution*: minimum 7 between the peaks due to impurity B and the internal standard in the chromatogram obtained with the reference solution;
- there is no peak with the same retention time as that of the internal standard in the chromatogram obtained with test solution (a).

Calculate the ratio (*R*) of the area of the peak due to impurity B to the area of the peak due to the internal standard from the chromatogram obtained with the reference solution; from the chromatogram obtained with test solution (b), calculate the ratio of the area of any peak due to impurity B to the area of the peak due to the internal standard.

*Limit*:

- *impurity B*: not more than *R* (100 ppm).

**Loss on drying** (2.2.32): maximum 0.5 per cent, determined on 1.000 g by drying in an oven at 105 °C.

**Sulfated ash** (2.4.14): maximum 0.2 per cent, determined on 1.0 g.

**ASSAY**

Dissolve 0.400 g in 50 mL of dimethylformamide R. Add 0.2 mL of quinaldine red solution R. Titrate with 0.1 M lithium methoxide until the colour changes from red to colourless.

1 mL of 0.1 M lithium methoxide is equivalent to 44.55 mg of C<sub>21</sub>H<sub>27</sub>N<sub>5</sub>O<sub>4</sub>S.

**IMPURITIES**

*Specified impurities*: A, B, C, D, F, G, H, I.

*Other detectable impurities* (the following substances would, if present at a sufficient level, be detected by one or other of the tests in the monograph. They are limited by the general acceptance criterion for other/unspecified impurities and/or by the general monograph *Substances for pharmaceutical use* (2034). It is therefore not necessary to identify these impurities for demonstration of compliance. See also 5.10. *Control of impurities in substances for pharmaceutical use*): E.

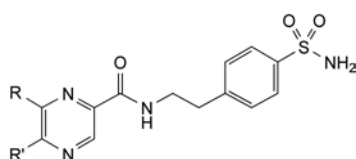

A. R = H, R' = CH<sub>3</sub>: 5-methyl-*N*-[2-(4-sulfamoylphenyl)ethyl]pyrazine-2-carboxamide,

D. R = CH<sub>3</sub>, R' = H: 6-methyl-*N*-[2-(4-sulfamoylphenyl)ethyl]pyrazine-2-carboxamide,

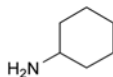

B. cyclohexanamine,

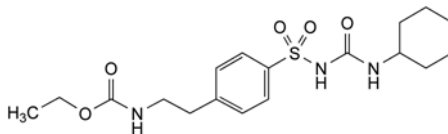

C. ethyl 2-[4-[(cyclohexylcarbamoyl)sulfamoyl]phenyl]ethylcarbamate,

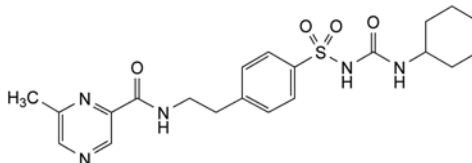

E. 1-cyclohexyl-3-[[4-[2-[(6-methylpyrazin-2-yl)carbonyl]amino]ethyl]phenyl]sulfonyl]urea,

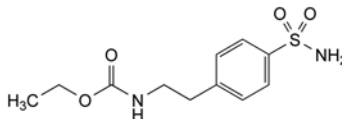

F. ethyl 2-(4-sulfamoylphenyl)ethylcarbamate,

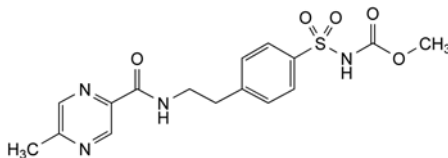

G. methyl [[4-[2-[(5-methylpyrazin-2-yl)carbonyl]amino]ethyl]phenyl]sulfonyl]carbamate,

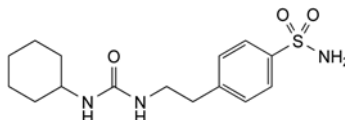

H. 4-[2-[(cyclohexylcarbamoyl)amino]ethyl]benzenesulfonamide,

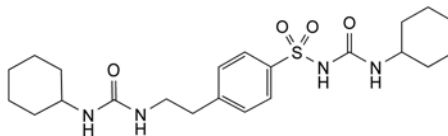

I. *N*-(cyclohexylcarbamoyl)-4-[2-[(cyclohexylcarbamoyl)amino]ethyl]benzenesulfonamide.

01/2008:1635

**GLUCAGON, HUMAN**

## Glucagonum humanum

H - His - Ser - Gln - Gly - Thr - Phe - Thr - Ser - Asp - Tyr -  
 10  
 Ser - Lys - Tyr - Leu - Asp - Ser - Arg - Arg - Ala - Gln -  
 20  
 Asp - Phe - Val - Gln - Trp - Leu - Met - Asn - Thr - OH

C<sub>153</sub>H<sub>225</sub>N<sub>43</sub>O<sub>49</sub>S

*M*<sub>r</sub> 3483

## DEFINITION

Polypeptide having the same structure (29 amino acids) as the hormone produced by the  $\alpha$ -cells of the human pancreas, which increases the blood-glucose concentration by promoting rapid breakdown of liver glycogen.

*Content*: 92.5 per cent to 105.0 per cent (anhydrous substance).

## PRODUCTION

Human glucagon is produced by a method based on recombinant DNA (rDNA) technology. During the course of product development it must be demonstrated that the manufacturing process produces a product having a biological activity of not less than 1 IU/mg using a suitable validated bioassay.

**Host-cell-derived proteins.** The limit is approved by the competent authority.

**Host-cell- and vector-derived DNA.** The limit is approved by the competent authority.

## CHARACTERS

*Appearance*: white or almost white powder.

*Solubility*: practically insoluble in water and in most organic solvents. It is soluble in dilute mineral acids and in dilute solutions of alkali hydroxides.

## IDENTIFICATION

## A. Peptide mapping. Liquid chromatography (2.2.29).

*Test solution.* Prepare a 5 mg/mL solution of the substance to be examined in 0.01 M hydrochloric acid. Mix 200  $\mu$ L of this solution with 800  $\mu$ L of 0.1 M ammonium carbonate buffer solution pH 10.3 R (diluted stock solution). Prepare a 2 mg/mL solution of  $\alpha$ -chymotrypsin for peptide mapping R in 0.1 M ammonium carbonate buffer solution pH 10.3 R and add 25  $\mu$ L of this solution to the diluted stock solution. Place the solution in a closed vial at 37 °C for 2 h. Remove the vial and stop the reaction immediately by adding 120  $\mu$ L of glacial acetic acid R.

*Reference solution.* Prepare a 1 mg/mL solution of human glucagon CRS in 0.1 M ammonium carbonate buffer solution pH 10.3 R (diluted stock solution) and continue as described for the test solution.

*Column*:

- size:  $l = 0.05$  m,  $\varnothing = 4$  mm;
- stationary phase: octadecylsilyl silica gel for chromatography R (5  $\mu$ m).

*Mobile phase*:

- mobile phase A: mix 500  $\mu$ L of trifluoroacetic acid R and 1000 mL of water R;
- mobile phase B: mix 500  $\mu$ L of trifluoroacetic acid R with 600 mL of anhydrous ethanol R and add 400 mL of water R;

Time (min)	Mobile phase A (per cent V/V)	Mobile phase B (per cent V/V)
0 - 35	100 $\rightarrow$ 53	0 $\rightarrow$ 47
35 - 45	53 $\rightarrow$ 0	47 $\rightarrow$ 100
45 - 46	0 $\rightarrow$ 100	100 $\rightarrow$ 0
46 - 75	100	0

*Flow rate*: 1.0 mL/min.

*Detection*: spectrophotometer at 215 nm.

*Equilibration*: with mobile phase A for at least 15 min.

*Injection*: 20  $\mu$ L.

*Results*: the profile of the chromatogram obtained with the test solution corresponds to that of the chromatogram obtained with the reference solution.

## B. Examine the chromatograms obtained in the assay.

*Results*: the principal peak in the chromatogram obtained with the test solution is similar in retention time to the principal peak in the chromatogram obtained with the reference solution.

## TESTS

**Deamidated glucagon.** Liquid chromatography (2.2.29): use the normalisation procedure.

*Test solution.* Dissolve the substance to be examined in 0.01 M hydrochloric acid to obtain a concentration of 1.0 mg/mL.

*Resolution solution.* Dissolve the substance to be examined in 0.1 M hydrochloric acid to obtain a concentration of 1.0 mg/mL. Incubate in an oven at 60 °C for 2 h. Immediately after degradation, adjust to pH 2.5 with 1 M sodium hydroxide.

*Column*:

- material: glass;
- size:  $l = 0.05$  m,  $\varnothing = 5$  mm;
- stationary phase: anion exchange resin R2.

*Mobile phase*:

- mobile phase A: mix 1000 mL of tris-hydrochloride buffer solution pH 8.3 R and 1000 mL of anhydrous ethanol R;
- mobile phase B: dissolve 29.2 g of sodium chloride R in 1000 mL of tris-hydrochloride buffer solution pH 8.3 R; add 1000 mL of anhydrous ethanol R;

Time (min)	Mobile phase A (per cent V/V)	Mobile phase B (per cent V/V)
0 - 4	100	0
4 - 30	100 $\rightarrow$ 78	0 $\rightarrow$ 22
30 - 34	78 $\rightarrow$ 45	22 $\rightarrow$ 55
34 - 38	45 $\rightarrow$ 20	55 $\rightarrow$ 80
38 - 40	20 $\rightarrow$ 100	80 $\rightarrow$ 0
40 - 60	100	0

*Flow rate*: 0.6 mL/min.

*Detection*: spectrophotometer at 230 nm.

*Equilibration*: with mobile phase A for at least 15 min.

*Injection*: 60  $\mu$ L.

*System suitability*: resolution solution:

- retention time: glucagon = about 10 min; 4 deamidated forms: between 15 min and 40 min;
- resolution: baseline separation of the 4 deamidated forms and glucagon.

*Limit*:

- sum of the 4 deamidated forms: maximum 0.5 per cent, calculated from the peaks eluting between 15 min and 40 min.

**Related proteins.** Liquid chromatography (2.2.29): use the normalisation procedure.

*2.8 M urea solution.* Dissolve 16.8 g of urea R in 100 mL of water R.

*Test solution.* Dissolve the substance to be examined in 0.01 M hydrochloric acid to obtain a concentration of 0.5 mg/mL. Maintain the solution at 2-8 °C.

*Reference solution.* Dissolve the contents of a vial of human glucagon CRS in 0.01 M hydrochloric acid to obtain a concentration of 0.5 mg/mL. Maintain the solution at 2-8 °C.

*Resolution solution.* Dissolve 10 mg of the substance to be examined in 20 mL of the 2.8 M urea solution. Heat at 50 °C for 2 h. Cool and adjust to pH 2.2 with 1 M hydrochloric acid. Maintain the solution at 2-8 °C and use within 2 h, or maintain the solution below -15 °C and then thaw and filter through a 0.22  $\mu$ m filter before use.

*Column*:

- size:  $l = 0.25$  m,  $\varnothing = 4.6$  mm;

- stationary phase: octadecylsilyl silica gel for chromatography R (5 µm) with a pore size of 30 nm;
- temperature: 45 °C.

Mobile phase:

- mobile phase A: dissolve 13.6 g of potassium dihydrogen phosphate R in 400 mL of water R, adjust to pH 2.5 with phosphoric acid R, and add 100 mL of acetonitrile for chromatography R;
- mobile phase B: acetonitrile for chromatography R, water R (40:60 V/V);

Time (min)	Mobile phase A (per cent V/V)	Mobile phase B (per cent V/V)
0 - 23	57	43
23 - 29	57 → 10	43 → 90
29 - 30	10	90
30 - 31	10 → 57	90 → 43
31 - 75	57	43

Flow rate: 1.0 mL/min.

Detection: spectrophotometer at 214 nm.

Injection: 50 µL of the test solution and the resolution solution.

Relative retention with reference to glucagon (retention time = about 20 min): carbamoylglucagon = about 1.1.

System suitability: resolution solution:

- resolution: minimum 2.0 between the peaks due to glucagon and carbamoylglucagon.

Limit:

- total: maximum 2.5 per cent.

Water (2.5.12): maximum 10 per cent, determined on 50 mg.

Bacterial endotoxins (2.6.14): less than 10 IU/mg.

ASSAY

Liquid chromatography (2.2.29) as described in the test for related proteins with the following modification.

Injection: test solution and reference solution.

Calculate the content of human glucagon (C<sub>153</sub>H<sub>225</sub>N<sub>43</sub>O<sub>49</sub>S) from the declared content of C<sub>153</sub>H<sub>225</sub>N<sub>43</sub>O<sub>49</sub>S in human glucagon CRS.

STORAGE

In an airtight container, protected from light, at a temperature lower than – 15 °C.

01/2008:0177  
corrected 6.3

## GLUCOSE, ANHYDROUS

Glucosum anhydricum

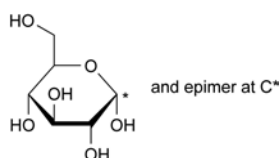

C<sub>6</sub>H<sub>12</sub>O<sub>6</sub>  
[50-99-7]

M<sub>r</sub> 180.2

DEFINITION

(+)-D-Glucopyranose.

CHARACTERS

Appearance: white or almost white, crystalline powder.

It has a sweet taste.

Solubility: freely soluble in water, sparingly soluble in ethanol (96 per cent).

IDENTIFICATION

A. Specific optical rotation (see Tests).

B. Thin-layer chromatography (2.2.27).

Solvent mixture: water R, methanol R (2:3 V/V).

Test solution. Dissolve 10 mg of the substance to be examined in the solvent mixture and dilute to 20 mL with the solvent mixture.

Reference solution (a). Dissolve 10 mg of glucose CRS in the solvent mixture and dilute to 20 mL with the solvent mixture.

Reference solution (b). Dissolve 10 mg each of fructose CRS, glucose CRS, lactose CRS and sucrose CRS in the solvent mixture and dilute to 20 mL with the solvent mixture.

Plate: TLC silica gel G plate R.

Mobile phase: water R, methanol R, anhydrous acetic acid R, ethylene chloride R (10:15:25:50 V/V/V/V); measure the volumes accurately since a slight excess of water produces cloudiness.

Application: 2 µL; thoroughly dry the points of application.

Development A: over a path of 15 cm.

Drying A: in a current of warm air.

Development B: immediately, over a path of 15 cm, after renewing the mobile phase.

Drying B: in a current of warm air.

Detection: spray with a solution of 0.5 g of thymol R in a mixture of 5 mL of sulfuric acid R and 95 mL of ethanol (96 per cent) R. Heat at 130 °C for 10 min.

System suitability: reference solution (b):

- the chromatogram shows 4 clearly separated spots.

Results: the principal spot in the chromatogram obtained with the test solution is similar in position, colour and size to the principal spot in the chromatogram obtained with reference solution (a).

C. Dissolve 0.1 g in 10 mL of water R. Add 3 mL of cupri-tartaric solution R and heat. A red precipitate is formed.

TESTS

Solution S. Dissolve 10.0 g in distilled water R and dilute to 100 mL with the same solvent.

Appearance of solution. The solution is clear (2.2.1) and not more intensely coloured than reference solution BY<sub>7</sub> (2.2.2, Method II).

Dissolve 10.0 g in 15 mL of water R.

Acidity or alkalinity. Dissolve 6.0 g in 25 mL of carbon dioxide-free water R and add 0.3 mL of phenolphthalein solution R. The solution is colourless. Not more than 0.15 mL of 0.1 M sodium hydroxide is required to change the colour of the indicator to pink.

Specific optical rotation (2.2.7): + 52.5 to + 53.3 (anhydrous substance).

Dissolve 10.0 g in 80 mL of water R, add 0.2 mL of dilute ammonia RI, allow to stand for 30 min and dilute to 100.0 mL with water R.

Foreign sugars, soluble starch, dextrans. Dissolve 1.0 g by boiling in 30 mL of ethanol (90 per cent V/V) R. Cool; the appearance of the solution shows no change.

Sulfites: maximum 15 ppm, expressed as SO<sub>2</sub>.

Test solution. Dissolve 5.0 g in 40 mL of water R, add 2.0 mL of 0.1 M sodium hydroxide and dilute to 50.0 mL with water R. To 10.0 mL of the solution, add 1 mL of a 310 g/L solution of hydrochloric acid R, 2.0 mL of decolorised fuchsin solution RI and 2.0 mL of a 0.5 per cent V/V solution of formaldehyde R. Allow to stand for 30 min.

Reference solution. Dissolve 76 mg of sodium metabisulfite R in water R and dilute to 50.0 mL with the same solvent. Dilute 5.0 mL of this solution to 100.0 mL with water R. To 3.0 mL of this solution add 4.0 mL of 0.1 M sodium hydroxide and dilute to 100.0 mL with water R. Immediately add to 10.0 mL of this

## CHARACTERS

*Appearance*: white or almost white, slightly hygroscopic powder or granules.

*Solubility*: freely soluble in water.

## IDENTIFICATION

- A. Dissolve 0.1 g in 2.5 mL of *water R* and heat with 2.5 mL of *cupri-tartaric solution R*. A red precipitate is formed.
- B. Dip, for 1 s, a suitable stick with a reactive pad containing glucose-oxidase, peroxidase and a hydrogen-donating substance, such as tetramethylbenzidine, in a 5 g/L solution of the substance to be examined. Observe the colour of the reactive pad; within 60 s the colour changes from yellow to green or blue.
- C. It is a powder or granules.
- D. Dextrose equivalent (see Tests).

## TESTS

**Solution S.** Dissolve 12.5 g in *carbon dioxide-free water R* and dilute to 50.0 mL with the same solvent.

**pH (2.2.3)**: 4.0 to 7.0.

Mix 1 mL of a 223.6 g/L solution of *potassium chloride R* and 30 mL of solution S.

**Sulfur dioxide (2.5.29)**: maximum 20 ppm.

**Heavy metals (2.4.8)**: maximum 10 ppm.

Dilute 4 mL of solution S to 30 mL with *water R*. The solution complies with test E. Prepare the reference solution using 10 mL of *lead standard solution (1 ppm Pb) R*.

**Loss on drying (2.2.32)**: maximum 6.0 per cent, determined on 10.00 g by drying in an oven at 105 °C.

**Sulfated ash (2.4.14)**: maximum 0.5 per cent, determined on 1.0 g.

**Dextrose equivalent (DE)**: within 10 per cent of the nominal value.

Weigh an amount of the substance to be examined equivalent to 2.85-3.15 g of reducing carbohydrates, calculated as dextrose equivalent, into a 500 mL volumetric flask. Dissolve in *water R* and dilute to 500.0 mL with the same solvent. Transfer the solution to a 50 mL burette.

Pipette 25.0 mL of *cupri-tartaric solution R* into a 250 mL flask and add 18.5 mL of the test solution from the burette, mix and add a few glass beads. Place the flask on a hot plate, previously adjusted so that the solution begins to boil after 2 min ± 15 s. Allow to boil for exactly 120 s, add 1 mL of a 1 g/L solution of *methylene blue R* and titrate with the test solution ( $V_1$ ) until the blue colour disappears. Maintain the solution at boiling throughout the titration.

Standardise the cupri-tartaric solution using a 6.00 g/L solution of *glucose R* ( $V_0$ ).

Calculate the dextrose equivalent using the following expression:

$$\frac{300 \times V_0 \times 100}{V_1 \times M \times D}$$

$V_0$  = total volume of glucose standard solution, in millilitres;

$V_1$  = total volume of test solution, in millilitres;

$M$  = mass of the sample, in grams;

$D$  = percentage content of dry matter in the substance.

## Microbial contamination

TAMC: acceptance criterion 10<sup>3</sup> CFU/g (2.6.12).

TYMC: acceptance criterion 10<sup>2</sup> CFU/g (2.6.12).

Absence of *Escherichia coli* (2.6.13).

Absence of *Salmonella* (2.6.13).

## LABELLING

The label states the dextrose equivalent (DE) (= nominal value).

## FUNCTIONALITY-RELATED CHARACTERISTICS

*This section provides information on characteristics that are recognised as being relevant control parameters for one or more functions of the substance when used as an excipient (see chapter 5.15). This section is a non-mandatory part of the monograph and it is not necessary to verify the characteristics to demonstrate compliance. Control of these characteristics can however contribute to the quality of a medicinal product by improving the consistency of the manufacturing process and the performance of the medicinal product during use. Where control methods are cited, they are recognised as being suitable for the purpose, but other methods can also be used. Wherever results for a particular characteristic are reported, the control method must be indicated.*

*The following characteristics may be relevant for spray-dried liquid glucose used as filler or binder for wet granulation.*

**Dextrose equivalent** (see Tests).

**Particle-size distribution (2.9.31 or 2.9.38).**

01/2008:0178  
corrected 6.3

## GLUCOSE MONOHYDRATE

## Glucosum monohydricum

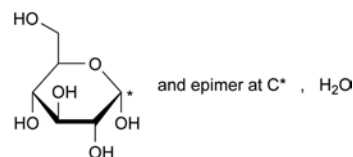

C<sub>6</sub>H<sub>12</sub>O<sub>6</sub>·H<sub>2</sub>O  
[5996-10-1]

$M_r$  198.2

## DEFINITION

(+)-D-Glucopyranose monohydrate.

## CHARACTERS

*Appearance*: white or almost white, crystalline powder.

It has a sweet taste.

*Solubility*: freely soluble in water, sparingly soluble in ethanol (96 per cent).

## IDENTIFICATION

A. Specific optical rotation (see Tests).

B. Thin-layer chromatography (2.2.27).

*Solvent mixture*: *water R*, *methanol R* (2:3 V/V).

*Test solution.* Dissolve 10 mg of the substance to be examined in the solvent mixture and dilute to 20 mL with the solvent mixture.

*Reference solution (a).* Dissolve 10 mg of *glucose CRS* in the solvent mixture and dilute to 20 mL with the solvent mixture.

*Reference solution (b).* Dissolve 10 mg each of *fructose CRS*, *glucose CRS*, *lactose CRS* and *sucrose CRS* in the solvent mixture and dilute to 20 mL with the solvent mixture.

*Plate*: TLC silica gel G plate R.

*Mobile phase*: *water R*, *methanol R*, *anhydrous acetic acid R*, *ethylene chloride R* (10:15:25:50 V/V/V/V); measure the volumes accurately since a slight excess of water produces cloudiness.

*Application*: 2 µL; thoroughly dry the points of application.

*Development A*: over a path of 15 cm.

*Drying A*: in a current of warm air.

*Development B*: immediately, over a path of 15 cm, after renewing the mobile phase.



**Drying B:** in a current of warm air.

**Detection:** spray with a solution of 0.5 g of *thymol R* in a mixture of 5 mL of *sulfuric acid R* and 95 mL of *ethanol (96 per cent) R*; heat at 130 °C for 10 min.

**System suitability:** reference solution (b):

– the chromatogram shows 4 clearly separated spots.

**Results:** the principal spot in the chromatogram obtained with the test solution is similar in position, colour and size to the principal spot in the chromatogram obtained with reference solution (a).

C. Dissolve 0.1 g in 10 mL of *water R*. Add 3 mL of *cupri-tartaric solution R* and heat. A red precipitate is formed.

#### TESTS

**Solution S.** Dissolve 10.0 g in *distilled water R* and dilute to 100 mL with the same solvent.

**Appearance of solution.** The solution is clear (2.2.1) and not more intensely coloured than reference solution BY<sub>7</sub> (2.2.2, Method II).

Dissolve 10.0 g in 15 mL of *water R*.

**Acidity or alkalinity.** Dissolve 6.0 g in 25 mL of *carbon dioxide-free water R* and add 0.3 mL of *phenolphthalein solution R*. The solution is colourless. Not more than 0.15 mL of 0.1 M *sodium hydroxide* is required to change the colour of the indicator to pink.

**Specific optical rotation (2.2.7):** + 52.5 to + 53.3 (anhydrous substance).

Dissolve 10.0 g in 80 mL of *water R*, add 0.2 mL of *dilute ammonia R1*, allow to stand for 30 min and dilute to 100.0 mL with *water R*.

**Foreign sugars, soluble starch, dextrans.** Dissolve 1.0 g by boiling in 30 mL of *ethanol (90 per cent V/V) R*. Cool; the appearance of the solution shows no change.

**Sulfites:** maximum 15 ppm, expressed as SO<sub>2</sub>.

**Test solution.** Dissolve 5.0 g in 40 mL of *water R*, add 2.0 mL of 0.1 M *sodium hydroxide* and dilute to 50.0 mL with *water R*. To 10.0 mL of the solution, add 1 mL of a 310 g/L solution of *hydrochloric acid R*, 2.0 mL of *decolorised fuchsin solution R1* and 2.0 mL of a 0.5 per cent V/V solution of *formaldehyde R*. Allow to stand for 30 min.

**Reference solution.** Dissolve 76 mg of *sodium metabisulfite R* in *water R* and dilute to 50.0 mL with the same solvent. Dilute 5.0 mL of this solution to 100.0 mL with *water R*. To 3.0 mL of this solution add 4.0 mL of 0.1 M *sodium hydroxide* and dilute to 100.0 mL with *water R*. Immediately add to 10.0 mL of this solution 1 mL of a 310 g/L solution of *hydrochloric acid R*, 2.0 mL of *decolorised fuchsin solution R1* and 2.0 mL of a 0.5 per cent V/V solution of *formaldehyde R*. Allow to stand for 30 min.

Measure the absorbance (2.2.25) of the 2 solutions at the absorption maximum at 583 nm using for both measurements a solution prepared in the same manner using 10.0 mL of *water R* as the compensation liquid. The absorbance of the test solution is not greater than that of the reference solution.

**Chlorides (2.4.4):** maximum 125 ppm.

Dilute 4 mL of solution S to 15 mL with *water R*.

**Sulfates (2.4.13):** maximum 200 ppm.

Dilute 7.5 mL of solution S to 15 mL with *distilled water R*.

**Arsenic (2.4.2, Method A):** maximum 1 ppm, determined on 1.0 g.

**Barium.** To 10 mL of solution S add 1 mL of *dilute sulfuric acid R*. When examined immediately and after 1 h, any opalescence in the solution is not more intense than that in a mixture of 1 mL of *distilled water R* and 10 mL of solution S.

**Calcium (2.4.3):** maximum 200 ppm.

Dilute 5 mL of solution S to 15 mL with *distilled water R*.

**Lead (2.4.10):** maximum 0.5 ppm.

**Water (2.5.12):** 7.0 per cent to 9.5 per cent, determined on 0.50 g.

**Sulfated ash:** maximum 0.1 per cent.

Dissolve 5.0 g in 5 mL of *water R*, add 2 mL of *sulfuric acid R*, evaporate to dryness on a water-bath and ignite to constant mass. If necessary, repeat the heating with *sulfuric acid R*.

**Pyrogens (2.6.8).** If intended for use in the manufacture of large-volume parenteral preparations without a further appropriate procedure for the removal of pyrogens, the competent authority may require that it comply with the test for pyrogens. Inject per kilogram of the rabbit's mass 10 mL of a solution in *water for injections R* containing 55 mg of the substance to be examined per millilitre.

01/2008:0750  
corrected 6.0

## GLUTAMIC ACID

### Acidum glutamicum

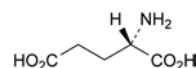

C<sub>5</sub>H<sub>9</sub>NO<sub>4</sub>  
[56-86-0]

M<sub>r</sub> 147.1

#### DEFINITION

Glutamic acid contains not less than 98.5 per cent and not more than the equivalent of 100.5 per cent of (2S)-2-aminopentanedioic acid, calculated with reference to the dried substance.

#### CHARACTERS

A white or almost white, crystalline powder or colourless crystals, freely soluble in boiling water, slightly soluble in cold water, practically insoluble in acetic acid, in acetone and in alcohol.

#### IDENTIFICATION

**First identification:** A, B.

**Second identification:** A, C, D.

A. Specific optical rotation (see Tests).

B. Examine by infrared absorption spectrophotometry (2.2.24), comparing with the spectrum obtained with *glutamic acid CRS*. Examine the substances prepared as discs. If the spectra obtained show differences, dissolve the substance to be examined and the reference substance separately in the minimum quantity of *water R*, evaporate to dryness at 60 °C and record new spectra using the residues.

C. Examine the chromatograms obtained in the test for ninhydrin-positive substances. The principal spot in the chromatogram obtained with test solution (b) is similar in position, colour and size to the principal spot in the chromatogram obtained with reference solution (a).

D. To 2.0 mL of solution S (see Tests) add 0.1 mL of *phenolphthalein solution R* and 3.0 mL to 3.5 mL of 1 M *sodium hydroxide* to change the colour of the indicator to red. Add a mixture of 3 mL of *formaldehyde solution R*, 3 mL of *carbon dioxide-free water R* and 0.1 mL of *phenolphthalein solution R*, to which sufficient 1 M *sodium hydroxide* has been added to produce a pink colour. The solution is decolourised. Add 1 M *sodium hydroxide* until a red colour is produced. The total volume of 1 M *sodium hydroxide* used is 4.0 mL to 4.7 mL.

#### TESTS

**Solution S.** Dissolve 5.00 g in 1 M *hydrochloric acid* with gentle heating, and dilute to 50.0 mL with the same acid.

04/2008:1670

**Appearance of solution.** Solution S is clear (2.2.1) and colourless (Method II, 2.2.2).

**Specific optical rotation** (2.2.7): + 30.5 to + 32.5, determined on solution S and calculated with reference to the dried substance.

**Ninhydrin-positive substances.** Examine by thin-layer chromatography (2.2.27), using a *TLC silica gel plate R*.

**Test solution (a).** Dissolve 0.10 g of the substance to be examined in 5 mL of *dilute ammonia R2* and dilute to 10 mL with *water R*.

**Test solution (b).** Dilute 1 mL of test solution (a) to 50 mL with *water R*.

**Reference solution (a).** Dissolve 10 mg of *glutamic acid CRS* in *water R* and dilute to 50 mL with the same solvent.

**Reference solution (b).** Dilute 5 mL of test solution (b) to 20 mL with *water R*.

**Reference solution (c).** Dissolve 10 mg of *glutamic acid CRS* and 10 mg of *aspartic acid CRS* in *water R* and dilute to 25 mL with the same solvent.

Apply to the plate 5 µL of each solution. Dry the plate in a current of air for 15 min. Develop over a path of 15 cm using a mixture of 20 volumes of *glacial acetic acid R*, 20 volumes of *water R* and 60 volumes of *butanol R*. Allow the plate to dry in air, spray with *ninhydrin solution R* and heat at 100-105 °C for 15 min. Any spot in the chromatogram obtained with test solution (a), apart from the principal spot, is not more intense than the spot in the chromatogram obtained with reference solution (b) (0.5 per cent). The test is not valid unless the chromatogram obtained with reference solution (c) shows 2 clearly separated spots.

**Chlorides** (2.4.4). Dissolve 0.25 g in 3 mL of *dilute nitric acid R* and dilute to 15 mL with *water R*. The solution, to which 1 mL of *water R* is added instead of *dilute nitric acid R*, complies with the limit test for chlorides (200 ppm).

**Sulfates** (2.4.13). Dilute 5 mL of solution S to 15 mL with *distilled water R*. The solution complies with the limit test for sulfates (300 ppm).

**Ammonium** (2.4.1). 50 mg complies with limit test B for ammonium (200 ppm). Prepare the standard using 0.1 mL of *ammonium standard solution (100 ppm NH<sub>4</sub>) R*.

**Iron** (2.4.9). In a separating funnel, dissolve 1.0 g in 10 mL of *dilute hydrochloric acid R*. Shake with 3 quantities, each of 10 mL, of *methyl isobutyl ketone R1*, shaking for 3 min each time. To the combined organic layers add 10 mL of *water R* and shake for 3 min. The aqueous layer complies with the limit test for iron (10 ppm).

**Heavy metals** (2.4.8). 2.0 g complies with limit test D for heavy metals (10 ppm). Prepare the standard using 2 mL of *lead standard solution (10 ppm Pb) R*.

**Loss on drying** (2.2.32). Not more than 0.5 per cent, determined on 1.000 g by drying in an oven at 105 °C.

**Sulfated ash** (2.4.14). Not more than 0.1 per cent, determined on 1.0 g.

#### ASSAY

Dissolve 0.130 g in 50 mL of *carbon dioxide-free water R* with gentle heating. Cool. Using 0.1 mL of *bromothymol blue solution R1* as indicator, titrate with 0.1 M *sodium hydroxide* until the colour changes from yellow to blue.

1 mL of 0.1 M *sodium hydroxide* is equivalent to 14.71 mg of C<sub>5</sub>H<sub>9</sub>NO<sub>4</sub>.

#### STORAGE

Protected from light.

## GLUTATHIONE

### Glutathionum

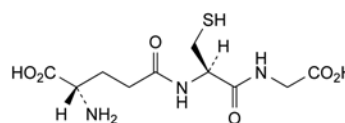

C<sub>10</sub>H<sub>17</sub>N<sub>3</sub>O<sub>6</sub>S  
[70-18-8]

M<sub>r</sub> 307.3

#### DEFINITION

L-γ-Glutamyl-L-cysteinylglycine.

Fermentation product.

**Content:** 98.0 per cent to 101.0 per cent (dried substance).

#### CHARACTERS

**Appearance:** white or almost white, crystalline powder or colourless crystals.

**Solubility:** freely soluble in water, very slightly soluble in ethanol (96 per cent) and in methylene chloride.

#### IDENTIFICATION

A. Specific optical rotation (see Tests).

B. Infrared absorption spectrophotometry (2.2.24).

*Comparison:* glutathione CRS.

#### TESTS

**Solution S.** Dissolve 5.0 g in *distilled water R* and dilute to 50 mL with the same solvent.

**Appearance of solution.** Solution S is clear (2.2.1) and colourless (2.2.2, Method II).

**Specific optical rotation** (2.2.7): – 15.5 to – 17.5 (dried substance).

Dissolve 1.0 g in *water R* and dilute to 25.0 mL with the same solvent.

**Related substances.** Capillary electrophoresis (2.2.47). Prepare the solutions immediately before use.

**Internal standard solution (a).** Dissolve 0.100 g of *phenylalanine R* in the electrolyte solution and dilute to 50.0 mL with the same solution.

**Internal standard solution (b).** Dilute 10.0 mL of internal standard solution (a) to 100.0 mL with the electrolyte solution.

**Test solution (a).** Dissolve 0.200 g of the substance to be examined in the electrolyte solution and dilute to 10.0 mL with the same solution.

**Test solution (b).** Dissolve 0.200 g of the substance to be examined in internal standard solution (b) and dilute to 10.0 mL with the same solution.

**Reference solution (a).** Dissolve 20.0 mg of the substance to be examined in internal standard solution (a) and dilute to 10.0 mL with the same solution.

**Reference solution (b).** Dilute 5.0 mL of reference solution (a) to 50.0 mL with the electrolyte solution.

**Reference solution (c).** Dissolve 0.200 g of the substance to be examined in 5 mL of the electrolyte solution. Add 1.0 mL of internal standard solution (a), 0.5 mL of a 2 mg/mL solution of *L-cysteine R* (impurity B) in the electrolyte solution, 0.5 mL of a 2 mg/mL solution of *oxidised L-glutathione R* (impurity C) in the electrolyte solution and 0.5 mL of a 2 mg/mL solution of *L-γ-glutamyl-L-cysteine R* (impurity D) in the electrolyte solution. Dilute to 10.0 mL with the electrolyte solution.

#### Capillary:

– *material:* uncoated fused silica;

– *size:* length to the detector cell = 0.5 m; total length = 0.6 m; Ø = 75 µm.

Temperature: 25 °C.

**Electrolyte solution.** Dissolve 1.50 g of *anhydrous sodium dihydrogen phosphate R* in 230 mL of *water R* and adjust to pH 1.80 with *phosphoric acid R*. Dilute to 250.0 mL with *water R*. Check the pH and, if necessary, adjust with *phosphoric acid R* or *dilute sodium hydroxide solution R*.

**Detection:** spectrophotometer at 200 nm.

**Preconditioning of a new capillary:** rinse the new capillary before the first injection with 0.1 M *hydrochloric acid* at 138 kPa for 20 min and with *water R* at 138 kPa for 10 min; for complete equilibration, condition the capillary with the electrolyte solution at 350 kPa for 40 min, and subsequently at a voltage of 20 kV for 60 min.

**Preconditioning of the capillary:** rinse the capillary with the electrolyte solution at 138 kPa for 40 min.

**Between-run rinsing:** rinse the capillary with *water R* at 138 kPa for 1 min, with 0.1 M *sodium hydroxide* at 138 kPa for 2 min, with *water R* at 138 kPa for 1 min, with 0.1 M *hydrochloric acid* at 138 kPa for 3 min and with the electrolyte solution at 138 kPa for 10 min.

**Injection:** test solutions (a) and (b), reference solutions (b) and (c) and the electrolyte solution (blank): under pressure (3.45 kPa) for 5 s.

**Migration:** apply a voltage of 20 kV.

**Run time:** 45 min.

**Relative migration** with reference to the internal standard (about 14 min): impurity A = about 0.77; impurity B = about 1.04; impurity E = about 1.2; impurity C = about 1.26; impurity D = about 1.3.

**System suitability:**

- **resolution:** minimum 1.5 between the peaks due to the internal standard and impurity B in the chromatogram obtained with reference solution (c); if necessary, increase the pH with *dilute sodium hydroxide solution R*;
- **peak-to-valley ratio:** minimum 2.5, where  $H_p$  = height above the baseline of the peak due to impurity D and  $H_v$  = height above the baseline of the lowest point of the curve separating this peak from the peak due to glutathione in the chromatogram obtained with reference solution (c); if necessary, lower the pH with *phosphoric acid R*;
- check that in the electropherogram obtained with test solution (a) there is no peak with the same migration time as the internal standard (in such case correct the area of the phenylalanine peak).

**Limits:** test solution (b):

- **corrected areas:** divide all the peak areas by the corresponding migration times;
- **correction factors:** for the calculation of content, multiply the ratio of time-corrected peak areas of impurity and the internal standard by the corresponding correction factor: impurity B = 3.0; impurity D = 1.4;
- **impurity C:** not more than 1.5 times the ratio of the area of the peak due to glutathione to the area of the peak due to the internal standard in the electropherogram obtained with reference solution (b) (1.5 per cent);
- **impurity D:** not more than the ratio of the area of the peak due to glutathione to the area of the peak due to the internal standard in the electropherogram obtained with reference solution (b) (1.0 per cent);
- **impurities A, B, E:** for each impurity, not more than 0.5 times the ratio of the area of the peak due to glutathione to the area of the peak due to the internal standard in the electropherogram obtained with reference solution (b) (0.5 per cent);

- **any other impurity:** for each impurity, not more than 0.2 times the ratio of the area of the peak due to glutathione to the area of the peak due to the internal standard in the electropherogram obtained with reference solution (b) (0.2 per cent);
- **total:** not more than 2.5 times the ratio of the area of the peak due to glutathione to the area of the peak due to the internal standard in the electropherogram obtained with reference solution (b) (2.5 per cent);
- **disregard limit:** 0.05 times the ratio of the area of the peak due to glutathione to the area of the peak due to the internal standard in the electropherogram obtained with reference solution (b) (0.05 per cent).

**Chlorides (2.4.4):** maximum 200 ppm.

Dilute 2.5 mL of solution S to 15 mL with *water R*.

**Sulfates (2.4.13):** maximum 300 ppm.

Dilute 5 mL of solution S to 15 mL with *distilled water R*.

**Ammonium (2.4.1, Method B):** maximum 200 ppm, determined on 50 mg.

Prepare the standard using 0.1 mL of *ammonium standard solution (100 ppm NH<sub>4</sub>) R*.

**Iron (2.4.9):** maximum 10 ppm.

In a separating funnel, dissolve 1.0 g in 10 mL of *dilute hydrochloric acid R*. Shake with 3 quantities, each of 10 mL, of *methyl isobutyl ketone RI*, shaking for 3 min each time. To the combined organic layers, add 10 mL of *water R* and shake for 3 min. The aqueous layer complies with the test.

**Heavy metals (2.4.8):** maximum 10 ppm.

12 mL of solution S complies with test A. Prepare the reference solution using *lead standard solution (1 ppm Pb) R*.

**Loss on drying (2.2.32):** maximum 0.5 per cent, determined on 1.000 g by drying in an oven at 105 °C for 3 h.

**Sulfated ash (2.4.14):** maximum 0.1 per cent, determined on 1.0 g.

#### ASSAY

In a ground-glass-stoppered flask, dissolve 0.500 g of the substance to be examined and 2 g of *potassium iodide R* in 50 mL of *water R*. Cool the solution in iced water and add 10 mL of *hydrochloric acid RI* and 20.0 mL of 0.05 M *iodine*. Stopper the flask and allow to stand in the dark for 15 min. Titrate with 0.1 M *sodium thiosulfate* using 1 mL of *starch solution R*, added towards the end of the titration, as indicator. Carry out a blank titration.

1 mL of 0.05 M *iodine* is equivalent to 30.73 mg of C<sub>10</sub>H<sub>17</sub>N<sub>3</sub>O<sub>6</sub>S.

#### STORAGE

Protected from light.

#### IMPURITIES

**Specified impurities:** A, B, C, D, E.

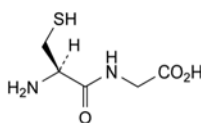

A. L-cysteinylglycine,

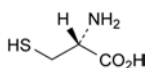

B. (2R)-2-amino-3-sulfanylpropanoic acid (cysteine),

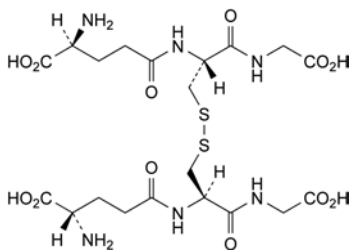

C. bis(L-γ-glutamyl-L-cysteinylglycine) disulfide (L-glutathione oxidised),

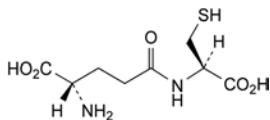

D. L-γ-glutamyl-L-cysteine,

E. unknown structure (product of degradation).

01/2008:0496

## GLYCEROL

### Glycerolum

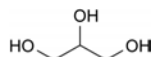

$C_3H_8O_3$   
[56-81-5]

$M_r$  92.1

#### DEFINITION

Propane-1,2,3-triol.

**Content:** 98.0 per cent *m/m* to 101.0 per cent *m/m* (anhydrous substance).

#### CHARACTERS

**Aspect:** syrupy liquid, unctuous to the touch, colourless or almost colourless, clear, very hygroscopic.

**Solubility:** miscible with water and with ethanol (96 per cent), slightly soluble in acetone, practically insoluble in fatty oils and in essential oils.

#### IDENTIFICATION

**First identification:** A, B.

**Second identification:** A, C, D.

A. Refractive index (see Tests).

B. Infrared absorption spectrophotometry (2.2.24).

**Preparation:** to 5 mL add 1 mL of *water R* and mix carefully.

**Comparison:** *Ph. Eur. reference spectrum of glycerol (85 per cent)*.

C. Mix 1 mL with 0.5 mL of *nitric acid R*. Superimpose 0.5 mL of *potassium dichromate solution R*. A blue ring develops at the interface of the liquids. Within 10 min, the blue colour does not diffuse into the lower layer.

D. Heat 1 mL with 2 g of *potassium hydrogen sulfate R* in an evaporating dish. Vapours (acrolein) are evolved which blacken filter paper impregnated with *alkaline potassium tetraiodomercurate solution R*.

#### TESTS

**Solution S.** Dilute 100.0 g to 200.0 mL with *carbon dioxide-free water R*.

**Appearance of solution.** Solution S is clear (2.2.1). Dilute 10 mL of solution S to 25 mL with *water R*. The solution is colourless (2.2.2, *Method II*).

**Acidity or alkalinity.** To 50 mL of solution S add 0.5 mL of *phenolphthalein solution R*. The solution is colourless. Not more than 0.2 mL of 0.1 M *sodium hydroxide* is required to change the colour of the indicator to pink.

**Refractive index (2.2.6):** 1.470 to 1.475.

**Aldehydes:** maximum 10 ppm.

Place 7.5 mL of solution S in a ground-glass-stoppered flask and add 7.5 mL of *water R* and 1.0 mL of *decolorised pararosaniline solution R*. Close the flask and allow to stand for 1 h at a temperature of  $25 \pm 1$  °C. The absorbance (2.2.25) of the solution measured at 552 nm is not greater than that of a standard prepared at the same time and in the same manner using 7.5 mL of *formaldehyde standard solution (5 ppm CH<sub>2</sub>O) R* and 7.5 mL of *water R*. The test is not valid unless the standard is pink.

**Esters.** Add 10.0 mL of 0.1 M *sodium hydroxide* to the final solution obtained in the test for acidity or alkalinity. Boil under a reflux condenser for 5 min. Cool. Add 0.5 mL of *phenolphthalein solution R* and titrate with 0.1 M *hydrochloric acid*. Not less than 8.0 mL of 0.1 M *hydrochloric acid* is required to change the colour of the indicator.

**Impurity A and related substances.** Gas chromatography (2.2.28).

**Test solution.** Dilute 10.0 mL of solution S to 100.0 mL with *water R*.

**Reference solution (a).** Dilute 10.0 g of *glycerol R1* to 20.0 mL with *water R*. Dilute 10.0 mL of the solution to 100.0 mL with *water R*.

**Reference solution (b).** Dissolve 1.000 g of *diethylene glycol R* in *water R* and dilute to 100.0 mL with the same solvent.

**Reference solution (c).** Dilute 1.0 mL of reference solution (b) to 10.0 mL with reference solution (a). Dilute 1.0 mL of this solution to 20.0 mL with reference solution (a).

**Reference solution (d).** Mix 1.0 mL of the test solution and 5.0 mL of reference solution (b) and dilute to 100.0 mL with *water R*. Dilute 1.0 mL of this solution to 10.0 mL with *water R*.

**Reference solution (e).** Dilute 5.0 mL of reference solution (b) to 100.0 mL with *water R*.

**Column:**

– *size:*  $l = 30$  m,  $\varnothing = 0.53$  mm;

– *stationary phase:* 6 per cent polycyanopropylphenyl siloxane and 94 per cent of polydimethylsiloxane.

**Carrier gas:** *helium for chromatography R*.

**Split ratio:** 1:10.

**Linear velocity:** 38 cm/s.

**Temperature:**

	Time (min)	Temperature (°C)
Column	0	100
	0 - 16	100 → 220
	16 - 20	220
Injection port		220
Detector		250

**Detection:** flame ionisation.

**Injection:** 0.5 µL.

**Elution order:** impurity A, glycerol.

**System suitability:** reference solution (d):

– *resolution:* minimum 7.0 between the peaks due to impurity A and glycerol.

**Limits:**

– *impurity A:* not more than the area of the corresponding peak in the chromatogram obtained with reference solution (c) (0.1 per cent);

- any other impurity with a retention time less than the retention time of glycerol: not more than the area of the peak due to impurity A in the chromatogram obtained with reference solution (c) (0.1 per cent);
- total of all impurities with retention times greater than the retention time of glycerol: not more than 5 times the area of the peak due to impurity A in the chromatogram obtained with reference solution (c) (0.5 per cent);
- disregard limit: 0.05 times the area of the peak due to impurity A in the chromatogram obtained with reference solution (e) (0.05 per cent).

**Halogenated compounds:** maximum 35 ppm.

To 10 mL of solution S add 1 mL of dilute sodium hydroxide solution R, 5 mL of water R and 50 mg of halogen-free nickel-aluminium alloy R. Heat on a water-bath for 10 min, allow to cool and filter. Rinse the flask and the filter with water R until 25 mL of filtrate is obtained. To 5 mL of the filtrate add 4 mL of ethanol (96 per cent) R, 2.5 mL of water R, 0.5 mL of nitric acid R and 0.05 mL of silver nitrate solution R2 and mix. Allow to stand for 2 min. Any opalescence in the solution is not more intense than that in a standard prepared at the same time by mixing 7.0 mL of chloride standard solution (5 ppm Cl) R, 4 mL of ethanol (96 per cent) R, 0.5 mL of water R, 0.5 mL of nitric acid R and 0.05 mL of silver nitrate solution R2.

**Sugars.** To 10 mL of solution S add 1 mL of dilute sulfuric acid R and heat on a water-bath for 5 min. Add 3 mL of carbonate-free dilute sodium hydroxide solution R (prepared by the method described for carbonate-free 1 M sodium hydroxide (4.2.2)), mix and add dropwise 1 mL of freshly prepared copper sulfate solution R. The solution is clear and blue. Continue heating on the water-bath for 5 min. The solution remains blue and no precipitate is formed.

**Chlorides (2.4.4):** maximum 10 ppm.

1 mL of solution S diluted to 15 mL with water R complies with the limit test for chlorides. Prepare the standard using 1 mL of chloride standard solution (5 ppm Cl) R diluted to 15 mL with water R.

**Heavy metals (2.4.8):** maximum 5 ppm.

Dilute 8 mL of solution S to 20 mL with water R. 12 mL of the solution complies with test A. Prepare the reference solution using lead standard solution (1 ppm Pb) R.

**Water (2.5.12):** maximum 2.0 per cent, determined on 1.000 g.

**Sulfated ash (2.4.14):** maximum 0.01 per cent, determined on 5.0 g after heating to boiling and ignition.

#### ASSAY

Thoroughly mix 0.075 g with 45 mL of water R. Add 25.0 mL of a mixture of 1 volume of 0.1 M sulfuric acid and 20 volumes of 0.1 M sodium periodate. Allow to stand protected from light for 15 min. Add 5.0 mL of a 500 g/L solution of ethylene glycol R and allow to stand protected from light for 20 min. Using 0.5 mL of phenolphthalein solution R as indicator, titrate with 0.1 M sodium hydroxide. Carry out a blank titration.

1 mL of 0.1 M sodium hydroxide is equivalent to 9.21 mg of C<sub>3</sub>H<sub>8</sub>O<sub>3</sub>.

#### STORAGE

In an airtight container.

#### IMPURITIES

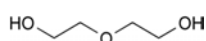

A. 2,2'-oxydiethanol (diethylene glycol),

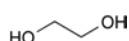

B. ethane-1,2-diol (ethylene glycol),

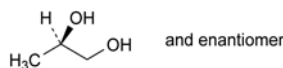

C. (R,S)-propane-1,2-diol (propylene glycol).

01/2008:0497

## GLYCEROL (85 PER CENT)

### Glycerolum (85 per centum)

#### DEFINITION

Aqueous solution of propane-1,2,3-triol.

**Content:** 83.5 per cent *m/m* to 88.5 per cent *m/m* of propane-1,2,3-triol (C<sub>3</sub>H<sub>8</sub>O<sub>3</sub>; *M<sub>r</sub>* 92.1).

#### CHARACTERS

**Aspect:** syrupy liquid, unctuous to the touch, colourless or almost colourless, clear, very hygroscopic.

**Solubility:** miscible with water and with ethanol (96 per cent), slightly soluble in acetone, practically insoluble in fatty oils and in essential oils.

#### IDENTIFICATION

**First identification:** A, B.

**Second identification:** A, C, D.

A. Refractive index (see Tests).

B. Infrared absorption spectrophotometry (2.2.24).

**Comparison:** Ph. Eur. reference spectrum of glycerol (85 per cent).

C. Mix 1 mL with 0.5 mL of nitric acid R. Superimpose 0.5 mL of potassium dichromate solution R. A blue ring develops at the interface of the liquids. Within 10 min, the blue colour does not diffuse into the lower layer.

D. Heat 1 mL with 2 g of potassium hydrogen sulfate R in an evaporating dish. Vapours (acrolein) are evolved which blacken filter paper impregnated with alkaline potassium tetraiodomercurate solution R.

#### TESTS

**Solution S.** Dilute 117.6 g to 200.0 mL with carbon dioxide-free water R.

**Appearance of solution.** Solution S is clear (2.2.1). Dilute 10 mL of solution S to 25 mL with water R. The solution is colourless (2.2.2, Method II).

**Acidity or alkalinity.** To 50 mL of solution S add 0.5 mL of phenolphthalein solution R. The solution is colourless. Not more than 0.2 mL of 0.1 M sodium hydroxide is required to change the colour of the indicator to pink.

**Refractive index (2.2.6):** 1.449 to 1.455.

**Aldehydes:** maximum 10 ppm.

Place 7.5 mL of solution S in a ground-glass-stoppered flask and add 7.5 mL of water R and 1.0 mL of decolorised pararosaniline solution R. Close the flask and allow to stand for 1 h at a temperature of 25 ± 1 °C. The absorbance (2.2.25) of the solution measured at 552 nm is not greater than that of a standard prepared at the same time and in the same manner using 7.5 mL of formaldehyde standard solution (5 ppm CH<sub>2</sub>O) R and 7.5 mL of water R. The test is not valid unless the standard is pink.

**Esters.** Add 10.0 mL of 0.1 M sodium hydroxide to the final solution obtained in the test for acidity or alkalinity. Boil under a reflux condenser for 5 min. Cool. Add 0.5 mL of phenolphthalein solution R and titrate with 0.1 M hydrochloric acid. Not less than 8.0 mL of 0.1 M hydrochloric acid is required to change the colour of the indicator.

**Impurity A and related substances.** Gas chromatography (2.2.28).

**Test solution.** Dilute 10.0 mL of solution S to 100.0 mL with water R.

**Reference solution (a).** Dilute 11.8 g of glycerol (85 per cent) R1 to 20.0 mL with water R. Dilute 10.0 mL of the solution to 100.0 mL with water R.

**Reference solution (b).** Dissolve 1.000 g of diethylene glycol R in water R and dilute to 100.0 mL with the same solvent.

**Reference solution (c).** Dilute 1.0 mL of reference solution (b) to 10.0 mL with reference solution (a). Dilute 1.0 mL of this solution to 20.0 mL with reference solution (a).

**Reference solution (d).** Mix 1.0 mL of the test solution and 5.0 mL of reference solution (b) and dilute to 100.0 mL with water R. Dilute 1.0 mL of this solution to 10.0 mL with water R.

**Reference solution (e).** Dilute 5.0 mL of reference solution (b) to 100.0 mL with water R.

**Column:**

- size:  $l = 30$  m,  $\varnothing = 0.53$  mm;
- stationary phase: 6 per cent polycyanolpropylphenyl siloxane and 94 per cent of polydimethylsiloxane.

**Carrier gas:** helium for chromatography R.

**Split ratio:** 1:10.

**Linear velocity:** 38 cm/s.

**Temperature:**

	Time (min)	Temperature (°C)
Column	0	100
	0 - 16	100 → 220
	16 - 20	220
Injection port		220
Detector		250

**Detection:** flame ionisation.

**Injection:** 0.5 µL.

**Elution order:** impurity A, glycerol.

**System suitability:** reference solution (d):

- resolution: minimum 7.0 between the peaks due to impurity A and glycerol.

**Limits:**

- impurity A: not more than the area of the corresponding peak in the chromatogram obtained with reference solution (c) (0.1 per cent);
- any other impurity with a retention time less than the retention time of glycerol: not more than the area of the peak due to impurity A in the chromatogram obtained with reference solution (c) (0.1 per cent);
- total of all impurities with retention times greater than the retention time of glycerol: not more than 5 times the area of the peak due to impurity A in the chromatogram obtained with reference solution (c) (0.5 per cent);
- disregard limit: 0.05 times the area of the peak due to impurity A in the chromatogram obtained with reference solution (e) (0.05 per cent).

**Halogenated compounds:** maximum 30 ppm.

To 10 mL of solution S add 1 mL of dilute sodium hydroxide solution R, 5 mL of water R and 50 mg of halogen-free nickel-aluminium alloy R. Heat on a water-bath for 10 min, allow to cool and filter. Rinse the flask and the filter with water R until 25 mL of filtrate is obtained. To 5 mL of the filtrate add 4 mL of ethanol (96 per cent) R, 2.5 mL of water R, 0.5 mL of nitric acid R and 0.05 mL of silver nitrate solution R2 and mix. Allow to stand for 2 min. Any opalescence in the solution is not more intense than that in a standard prepared at the same time by mixing 7.0 mL of chloride standard solution (5 ppm Cl) R, 4 mL of ethanol (96 per cent) R, 0.5 mL of

water R, 0.5 mL of nitric acid R and 0.05 mL of silver nitrate solution R2.

**Sugars.** To 10 mL of solution S add 1 mL of dilute sulfuric acid R and heat on a water-bath for 5 min. Add 3 mL of carbonate-free dilute sodium hydroxide solution R (prepared by the method described for carbonate-free 1 M sodium hydroxide (4.2.2)), mix and add dropwise 1 mL of freshly prepared copper sulfate solution R. The solution is clear and blue. Continue heating on the water-bath for 5 min. The solution remains blue and no precipitate is formed.

**Chlorides (2.4.4):** maximum 10 ppm.

1 mL of solution S diluted to 15 mL with water R complies with the limit test for chlorides. Prepare the standard using 1 mL of chloride standard solution (5 ppm Cl) R diluted to 15 mL with water R.

**Heavy metals (2.4.8):** maximum 5 ppm.

Dilute 8 mL of solution S to 20 mL with water R. 12 mL of the solution complies with test A. Prepare the reference solution using lead standard solution (1 ppm Pb) R.

**Water (2.5.12):** 12.0 per cent to 16.0 per cent, determined on 0.200 g.

**Sulfated ash (2.4.14):** maximum 0.01 per cent, determined on 5.0 g after heating to boiling and ignition.

**ASSAY**

Thoroughly mix 0.075 g with 45 mL of water R. Add 25.0 mL of a mixture of 1 volume of 0.1 M sulfuric acid and 20 volumes of 0.1 M sodium periodate. Allow to stand protected from light for 15 min. Add 5.0 mL of a 500 g/L solution of ethylene glycol R and allow to stand protected from light for 20 min. Using 0.5 mL of phenolphthalein solution R as indicator, titrate with 0.1 M sodium hydroxide. Carry out a blank titration. 1 mL of 0.1 M sodium hydroxide is equivalent to 9.21 mg of C<sub>3</sub>H<sub>8</sub>O<sub>3</sub>.

**STORAGE**

In an airtight container.

**IMPURITIES**

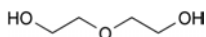

A. 2,2'-oxydiethanol (diethylene glycol),

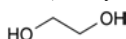

B. ethane-1,2-diol (ethylene glycol),

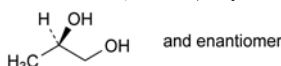

C. (RS)-propane-1,2-diol (propylene glycol).

01/2008:1427

## GLYCEROL DIBEHENATE

### Glyceroli dibehenas

**DEFINITION**

Mixture of diacylglycerols, mainly dibehenylglycerol, together with variable quantities of mono- and triacylglycerols, obtained by esterification of glycerol (0496) with behenic (docosanoic) acid.

**Content:**

- monoacylglycerols: 15.0 per cent to 23.0 per cent,
- diacylglycerols: 40.0 per cent to 60.0 per cent,
- triacylglycerols: 21.0 per cent to 35.0 per cent.

**CHARACTERS**

**Appearance:** hard, waxy mass or powder or white or almost white, unctuous flakes.

**Solubility:** practically insoluble in water, soluble in methylene chloride, partly soluble in hot ethanol (96 per cent).

#### IDENTIFICATION

A. Melting point (2.2.14): 65 °C to 77 °C.

B. Thin-layer chromatography (2.2.27).

**Test solution.** Dissolve 1.0 g of the substance to be examined in *toluene R* with gentle heating and dilute to 20 mL with the same solvent.

**Reference solution.** Dissolve 1.0 g of *glycerol dibehenate CRS* in *toluene R* with gentle heating and dilute to 20 mL with the same solvent.

**Plate:** TLC silica gel plate R.

**Mobile phase:** hexane R, ether R (30:70 V/V).

**Application:** 10 µL.

**Development:** over a path of 15 cm.

**Drying:** in air.

**Detection:** spray with a 0.1 g/L solution of *rhodamine B R* in *ethanol (96 per cent) R*; examine in ultraviolet light at 365 nm.

**Results:** the spots in the chromatogram obtained with the test solution are similar in position to the spots in the chromatogram obtained with the reference solution.

C. Composition of fatty acids (see Tests).

#### TESTS

**Acid value (2.5.1):** maximum 4.0, determined on 1.0 g, using a mixture of equal volumes of *ethanol (96 per cent) R* and *toluene R* as solvent and with gentle heating.

**Iodine value (2.5.4, Method A):** maximum 3.0.

**Saponification value (2.5.6):** 145 to 165.

Carry out the titration with heating.

**Free glycerol:** maximum 1.0 per cent, determined as described under Assay.

**Composition of fatty acids (2.4.22, Method C).** Raise the temperature of the column to 240 °C and use the mixture of calibrating substances in Table 2.4.22-3.

**Composition of the fatty acid fraction of the substance:**

- *palmitic acid:* maximum 3.0 per cent;
- *stearic acid:* maximum 5.0 per cent;
- *arachidic acid:* maximum 10.0 per cent;
- *behenic acid:* minimum 83.0 per cent;
- *erucic acid:* maximum 3.0 per cent;
- *lignoceric acid:* maximum 3.0 per cent.

**Nickel (2.4.31):** maximum 1 ppm.

**Water (2.5.12):** maximum 1.0 per cent, determined on 1.00 g. Use *pyridine R* as the solvent.

**Total ash (2.4.16):** maximum 0.1 per cent, determined on 1.00 g.

#### ASSAY

Size-exclusion chromatography (2.2.30).

**Stock solution.** Place 0.100 g of *glycerol R* in a flask and dilute to 25.0 mL with *tetrahydrofuran R*.

**Test solution.** In a 15 mL flask, weigh 0.2 g (*m*) of the substance to be examined. Add 5.0 mL of *tetrahydrofuran R* and shake to dissolve. Heat gently, at about 35 °C. Reweigh the flask and calculate the total mass of solvent and substance (*M*).

**Reference solutions.** Into four 15 mL flasks, introduce respectively 0.25 mL, 0.5 mL, 1.0 mL and 2.5 mL of the stock solution and add 5.0 mL of *tetrahydrofuran R*. Weigh each flask and calculate the concentration of glycerol in milligrams per gram of each reference solution.

**Column:**

- *size:*  $l = 0.6$  m,  $\emptyset = 7$  mm;
- *stationary phase:* styrene-divinylbenzene copolymer R (5 µm) with a pore size of 10 nm.

**Mobile phase:** tetrahydrofuran R.

**Flow rate:** 1 mL/min.

**Detection:** differential refractive index.

**Injection:** 40 µL; when injecting the test solution, maintain the flask at about 35 °C to avoid precipitation.

**Relative retention** with reference to glycerol (retention time = about 15 min): triacylglycerols = about 0.73; diacylglycerols = about 0.76; monoacylglycerols = about 0.82.

**Calculations:**

- **free glycerol:** from the calibration curve obtained with the reference solutions, determine the concentration (*C*) in milligrams per gram in the test solution and calculate the percentage content in the substance to be examined using the following expression:

$$\frac{C \times M}{m \times 10}$$

- **monoacylglycerols:** calculate the percentage content of monoacylglycerols using the following expression:

$$A - D$$

- A* = percentage content of monoacylglycerols determined by the normalisation procedure,  
*D* = percentage content of free fatty acids.

Calculate the percentage content of free fatty acids using the following expression:

$$\frac{I_A \times 340}{561.1}$$

*I<sub>A</sub>* = acid value.

- **diacylglycerols, triacylglycerols:** determine the percentage content of each by the normalisation procedure.

01/2008:1428

## GLYCEROL DISTEARATE

### Glyceroli distearas

#### DEFINITION

Mixture of diacylglycerols, mainly distearoylglycerol, together with variable quantities of mono- and triacylglycerols. It is obtained by partial glycerolysis of vegetable oils containing triacylglycerols of palmitic (hexadecanoic) or stearic (octadecanoic) acid or by esterification of glycerol with stearic acid. The fatty acids may be of vegetable or animal origin.

**Content:**

- **monoacylglycerols:** 8.0 per cent to 22.0 per cent;
- **diacylglycerols:** 40.0 per cent to 60.0 per cent;
- **triacylglycerols:** 25.0 per cent to 35.0 per cent.

#### CHARACTERS

**Appearance:** hard, waxy mass or powder, or white or almost white, unctuous flakes.

**Solubility:** practically insoluble in water, soluble in methylene chloride, partly soluble in hot ethanol (96 per cent).

#### IDENTIFICATION

**First identification:** C, D.

**Second identification:** A, B.

A. Melting point (2.2.14): 50 °C to 60 °C (types I and II), 50 °C to 70 °C (type III).

B. Thin-layer chromatography (2.2.27).

**Test solution.** Dissolve 0.5 g of the substance to be examined in *methylene chloride R*, with gentle heating, and dilute to 10 mL with the same solvent.

**Reference solution.** Dissolve 0.5 g of *glycerol distearate CRS* in *methylene chloride R*, with gentle heating, and dilute to 10 mL with the same solvent.

**Plate:** *TLC silica gel plate R*.

**Mobile phase:** *hexane R, ether R* (30:70 V/V).

**Application:** 10 µL.

**Development:** over a path of 15 cm.

**Detection:** spray with a 0.1 g/L solution of *rhodamine B R* in *ethanol (96 per cent) R* and examine in ultraviolet light at 365 nm.

**System suitability:** reference solution:

– the chromatogram shows 4 clearly separated spots.

**Results:** the spots in the chromatogram obtained with the test solution are similar in position to those in the chromatogram obtained with the reference solution.

C. Composition of fatty acids (see Tests) according to the type stated on the label.

D. It complies with the limits of the assay (diacylglycerol content).

#### TESTS

**Acid value (2.5.1):** maximum 6.0, determined on 1.0 g.

Use a mixture of equal volumes of *ethanol (96 per cent) R* and *toluene R* as solvent and heat gently.

**Iodine value (2.5.4, Method A):** maximum 3.0.

**Saponification value (2.5.6):** 165 to 195, determined on 2.0 g. Carry out the titration with heating.

**Free glycerol:** maximum 1.0 per cent, determined as described under Assay.

**Composition of fatty acids (2.4.22, Method C).** Use the mixture of calibrating substances in Table 2.4.22.-1.

**Composition of the fatty-acid fraction of the substance:**

Glycerol distearate	Composition of fatty acids
Type I	<i>Stearic acid:</i> 40.0 per cent to 60.0 per cent <i>Sum of the contents of palmitic and stearic acids:</i> minimum 90.0 per cent
Type II	<i>Stearic acid:</i> 60.0 per cent to 80.0 per cent <i>Sum of the contents of palmitic and stearic acids:</i> minimum 90.0 per cent
Type III	<i>Stearic acid:</i> 80.0 per cent to 99.0 per cent <i>Sum of the contents of palmitic and stearic acids:</i> minimum 96.0 per cent

**Nickel (2.4.31):** maximum 1 ppm.

**Water (2.5.12):** maximum 1.0 per cent, determined on 1.00 g. Use *pyridine R* as the solvent.

**Total ash (2.4.16):** maximum 0.1 per cent.

#### ASSAY

Size-exclusion chromatography (2.2.30).

**Test solution.** Into a 15 mL flask, weigh 0.200 g (*m*). Add 5.0 mL of *tetrahydrofuran R* and shake to dissolve. Reweigh the flask and calculate the total mass of solvent and substance (*M*).

**Reference solutions.** Into three 15 mL flasks, respectively weigh 2.0 mg, 5.0 mg and 10.0 mg of *glycerol R* and add 5.0 mL of *tetrahydrofuran R* to each flask. Into a 4<sup>th</sup> flask, weigh about 2.0 mg of *glycerol R* and add 10.0 mL of *tetrahydrofuran R*. Weigh the flasks again and calculate the concentration of glycerol in milligrams per gram for each reference solution.

**Column:**

– *size:* *l* = 0.6 m,  $\emptyset$  = 7 mm;

– *stationary phase:* *styrene-divinylbenzene copolymer R* (5 µm) with a pore size of 10 nm.

**Mobile phase:** *tetrahydrofuran R*.

**Flow rate:** 1 mL/min.

**Detection:** differential refractometer.

**Injection:** 40 µL.

**Relative retention** with reference to glycerol (retention time = about 15 min): triacylglycerols = about 0.75; diacylglycerols = about 0.80; monoacylglycerols = about 0.85.

**Calculations:**

– **free glycerol:** from the calibration curve obtained with the reference solutions, determine the concentration (*C*) in milligrams per gram in the test solution and calculate the percentage content in the substance to be examined using the following expression:

$$\frac{C \times M}{m \times 10}$$

– **mono-, di- and triacylglycerols:** calculate the percentage contents by the normalisation procedure.

#### LABELLING

The label states the type of glycerol distearate.

01/2008:2213

## GLYCEROL MONOCAPRYLATE

### Glyceroli monocaprylas

#### DEFINITION

Mixture of monoacylglycerols, mainly mono-*O*-octanoylglycerol, containing variable quantities of di- and triacylglycerols, obtained by direct esterification of glycerol with caprylic (octanoic) acid, followed by a distillation step in the case of glycerol monocaprylate (type II).

**Content:**

- **glycerol monocaprylate (type I):**
  - *monoacylglycerols:* 45.0 per cent to 75.0 per cent;
  - *diacylglycerols:* 20.0 per cent to 50.0 per cent;
  - *triacylglycerols:* maximum 10.0 per cent;
- **glycerol monocaprylate (type II):**
  - *monoacylglycerols:* minimum 80.0 per cent;
  - *diacylglycerols:* maximum 20.0 per cent;
  - *triacylglycerols:* maximum 5.0 per cent.

#### CHARACTERS

**Appearance:** colourless or slightly yellow, oily liquid or soft mass.

**Solubility:** practically insoluble in water, very soluble in ethanol (96 per cent) and freely soluble in methylene chloride.

#### IDENTIFICATION

A. Composition of fatty acids (see Tests).

B. It complies with the limits of the assay (monoacylglycerols).

#### TESTS

**Acid value (2.5.1):** maximum 3.0.

**Composition of fatty acids (2.4.22, Method C).** Use the mixture of calibrating substances in Table 2.4.22.-2.

**Composition of the fatty acid fraction of the substance:**

- *caproic acid:* maximum 1.0 per cent;
- *caprylic acid:* minimum 90.0 per cent;
- *capric acid:* maximum 10.0 per cent;
- *lauric acid:* maximum 1.0 per cent;
- *myristic acid:* maximum 0.5 per cent.

**Free glycerol:** maximum 3.0 per cent.

Dissolve 1.20 g in 25.0 mL of *methylene chloride R*. Heat to about 50 °C then allow to cool. Add 100 mL of *water R*. Shake and add 25.0 mL of *periodic acetic acid solution R*. Shake again and allow to stand for 30 min. Add 40 mL of a 75 g/L solution of *potassium iodide R* and allow to stand for 1 min. Add 1 mL of *starch solution R*. Titrate with 0.1 M sodium



*thiosulfate* until the aqueous phase becomes colourless. Carry out a blank titration.

1 mL of 0.1 M sodium thiosulfate is equivalent to 2.3 mg of glycerol.

**Water** (2.5.12): maximum 1.0 per cent, determined on 1.00 g.

**Total ash** (2.4.16): maximum 0.5 per cent.

#### ASSAY

Gas chromatography (2.2.28): use the normalisation procedure.

**Test solution.** To 0.25 g of the substance to be examined, add 5.0 mL of tetrahydrofuran R and shake to dissolve.

**Reference solution (a).** To 0.25 g of glycerol monocaprylate CRS, add 5.0 mL of tetrahydrofuran R and shake to dissolve.

**Reference solution (b).** To 50 mg of glycerol 1-octanoate R and 50 mg of glycerol 1-decanoate R, add 2.5 mL of tetrahydrofuran R and shake to dissolve.

**Column:**

- size:  $l = 10$  m,  $\varnothing = 0.32$  mm;
- stationary phase: poly(dimethyl)(diphenyl)siloxane R (film thickness 0.1  $\mu$ m).

**Carrier gas:** helium for chromatography R.

**Flow rate:** 2.3 mL/min.

**Split ratio:** 1:50.

**Temperature:**

	Time (min)	Temperature (°C)
Column	0 - 3	60
	3 - 38	60 → 340
	38 - 50	340
Injection port		350
Detector		370

**Detection:** flame ionisation.

**Injection:** 1  $\mu$ L.

**Identification of peaks:** use the chromatogram supplied with glycerol monocaprylate CRS and the chromatogram obtained with reference solution (a) to identify the peaks due to mono-, di- and triacylglycerols.

**System suitability:** reference solution (b):

- resolution: minimum 5 between the peaks due to glycerol 1-octanoate and glycerol 1-decanoate.

For the calculation of the contents of mono-, di- and triacylglycerols, disregard the peaks with a retention time less than that of the monoacylglycerols, which are due to impurities of the solvent and to the free fatty acids.

Calculate the percentage content of free fatty acids (C) using the following expression:

$$\frac{I_A \times 144}{561.1}$$

$I_A$  = acid value of glycerol monocaprylate.

Calculate the content of mono-, di- and triacylglycerols using the following equations:

$$\text{Monoacylglycerols content} = \frac{X \times (100 - A - B - C)}{100}$$

$$\text{Diacylglycerols content} = \frac{Y \times (100 - A - B - C)}{100}$$

$$\text{Triacylglycerols content} = \frac{Z \times (100 - A - B - C)}{100}$$

A = percentage content of free glycerol (see Tests);

B = percentage content of water;

X = monoacylglycerols content obtained by normalisation;

Y = diacylglycerols content obtained by normalisation;

Z = triacylglycerols content obtained by normalisation.

#### LABELLING

The label states the type of glycerol monocaprylate (type I or II).

01/2011:2392

## GLYCEROL MONOCAPRYLOCAPRATE

### Glyceroli monocaprylocapras

#### DEFINITION

Mixture of monoacylglycerols, mainly mono-*O*-octanoylglycerol and mono-*O*-decanoylglycerol, containing variable quantities of di- and triacylglycerols, obtained by direct esterification of glycerol with caprylic (octanoic) and capric (decanoic) acids, followed by a distillation step in the case of glycerol monocaprylocaprate (type II).

**Content:**

- glycerol monocaprylocaprate (type I):
  - monoacylglycerols: 45.0 per cent to 75.0 per cent;
  - diacylglycerols: 20.0 per cent to 50.0 per cent;
  - triacylglycerols: maximum 10.0 per cent;
- glycerol monocaprylocaprate (type II):
  - monoacylglycerols: minimum 80.0 per cent;
  - diacylglycerols: maximum 20.0 per cent;
  - triacylglycerols: maximum 5.0 per cent.

#### CHARACTERS

**Appearance:** colourless or slightly yellow, oily liquid or soft mass.

**Solubility:** practically insoluble in water, very soluble in ethanol (96 per cent) and freely soluble in methylene chloride.

#### IDENTIFICATION

A. Composition of fatty acids (see Tests).

B. It complies with the limits of the assay (monoacylglycerols).

#### TESTS

**Acid value** (2.5.1): maximum 3.0.

**Composition of fatty acids** (2.4.22, Method C). Use the mixture of calibrating substances in Table 2.4.22.-2.

**Composition of the fatty acid fraction of the substance:**

- caproic acid: maximum 3.0 per cent;
- caprylic acid: 50.0 per cent to 90.0 per cent;
- capric acid: 10.0 per cent to 50.0 per cent;
- lauric acid: maximum 3.0 per cent;
- myristic acid: maximum 1.0 per cent.

**Free glycerol:** maximum 3.0 per cent.

Dissolve 1.20 g in 25.0 mL of methylene chloride R. Heat to about 50 °C and allow to cool. Add 100 mL of water R, shake and add 25.0 mL of periodic acetic acid solution R. Shake again and allow to stand for 30 min. Add 40 mL of a 75 g/L solution of potassium iodide R and allow to stand for 1 min. Add 1 mL of starch solution R. Titrate with 0.1 M sodium thiosulfate until the aqueous phase becomes colourless. Carry out a blank titration.

1 mL of 0.1 M sodium thiosulfate is equivalent to 2.3 mg of glycerol.

**Water** (2.5.12): maximum 0.5 per cent, determined on 1.00 g.

**Total ash** (2.4.16): maximum 0.5 per cent.

## ASSAY

Gas chromatography (2.2.28): use the normalisation procedure.

*Test solution.* To 0.25 g of the substance to be examined, add 5.0 mL of *tetrahydrofuran R* and shake to dissolve.

*Reference solution (a).* To 0.25 g of *glycerol monocaprylocaprate CRS*, add 5.0 mL of *tetrahydrofuran R* and shake to dissolve.

*Reference solution (b).* To 50 mg of *glycerol 1-octanoate R* and 50 mg of *glycerol 1-decanoate R*, add 2.5 mL of *tetrahydrofuran R* and shake to dissolve.

*Column:*

- size:  $l = 10$  m,  $\varnothing = 0.32$  mm;
- stationary phase: *poly(dimethyl)(diphenyl)siloxane R* (film thickness 0.1  $\mu$ m).

*Carrier gas:* helium for chromatography *R*.

*Flow rate:* 2.3 mL/min.

*Split ratio:* 1:50.

*Temperature:*

	Time (min)	Temperature (°C)
Column	0 - 3	60
	3 - 38	60 → 340
	38 - 50	340
Injection port		350
Detector		370

*Detection:* flame ionisation.

*Injection:* 1  $\mu$ L.

*Identification of peaks:* use the chromatogram supplied with *glycerol monocaprylocaprate CRS* and the chromatogram obtained with reference solution (a) to identify the peaks due to mono-, di- and triacylglycerols.

*System suitability:* reference solution (b):

- resolution: minimum 5 between the peaks due to glycerol 1-octanoate and glycerol 1-decanoate.

For the calculation of the contents of mono-, di- and triacylglycerols, disregard the peaks with a retention time less than that of the monoacylglycerols, which are due to the impurities of the solvent and to the free fatty acids.

Calculate the percentage content of free fatty acids (*C*) using the following equations:

$$\frac{I_A \times 144}{561.1}$$

$I_A$  = acid value of the glycerol monocaprylocaprate.

Calculate the content of mono-, di- and triacylglycerols using the following equations:

$$\text{Monoacylglycerols content} = \frac{X \times (100 - A - B - C)}{X + Y + Z}$$

$$\text{Diacylglycerols content} = \frac{Y \times (100 - A - B - C)}{X + Y + Z}$$

$$\text{Triacylglycerols content} = \frac{Z \times (100 - A - B - C)}{X + Y + Z}$$

*A* = percentage content of free glycerol (see Tests);

*B* = percentage content of water;

*X* = area of the peak due to monoacylglycerols;

*Y* = area of the peak due to diacylglycerols;

*Z* = area of the peak due to triacylglycerols.

## LABELLING

The labelling states the type of glycerol monocaprylocaprate (type I or II).

01/2008:1429  
corrected 6.0

## GLYCEROL MONOLINOLEATE

## Glyceroli monolinoleas

## DEFINITION

Mixture of monoacylglycerols, mainly mono-oleoyl- and monolinoleoylglycerol, together with variable quantities of di- and triacylglycerols, obtained by partial glycerolysis of vegetable oils mainly containing triacylglycerols of linoleic (*cis,cis*-9,12-octadecadienoic) acid. A suitable antioxidant may be added.

*Content:*

- monoacylglycerols: 32.0 per cent to 52.0 per cent;
- diacylglycerols: 40.0 per cent to 55.0 per cent;
- triacylglycerols: 5.0 per cent to 20.0 per cent.

## CHARACTERS

*Appearance:* amber, oily liquid which may be partially solidified at room temperature.

*Solubility:* practically insoluble in water, freely soluble in methylene chloride.

## IDENTIFICATION

A. Iodine value (see Tests).

B. Thin-layer chromatography (2.2.27).

*Test solution.* Dissolve 1.0 g of the substance to be examined in *methylene chloride R* and dilute to 20 mL with the same solvent.

*Reference solution.* Dissolve 1.0 g of *glycerol monolinoleate CRS* in *methylene chloride R* and dilute to 20 mL with the same solvent.

*Plate:* TLC silica gel plate *R*.

*Mobile phase:* hexane *R*, ether *R* (30:70 V/V).

*Application:* 10  $\mu$ L.

*Development:* over a path of 15 cm.

*Drying:* in air.

*Detection:* spray with a 0.1 g/L solution of *rhodamine B R* in *ethanol (96 per cent) R* and examine in ultraviolet light at 365 nm.

*Results:* the spots in the chromatogram obtained with the test solution are similar in position to those in the chromatogram obtained with the reference solution.

C. Composition of fatty acids (see Tests).

## TESTS

**Acid value (2.5.1):** maximum 6.0, determined on 1.0 g.

**Iodine value (2.5.4, Method A):** 100 to 140.

**Peroxide value (2.5.5, Method A):** maximum 12.0, determined on 2.0 g.

**Saponification value (2.5.6):** 160 to 180, determined on 2.0 g.

**Free glycerol:** maximum 6.0 per cent, determined as described in the assay.

**Composition of fatty acids (2.4.22, Method C).**

*Composition of the fatty acid fraction of the substance:*

- palmitic acid: 4.0 per cent to 20.0 per cent;
- stearic acid: maximum 6.0 per cent;
- oleic acid: 10.0 per cent to 35.0 per cent;
- linoleic acid: minimum 50.0 per cent;
- linolenic acid: maximum 2.0 per cent;

- *arachidic acid*: maximum 1.0 per cent;
- *eicosenoic acid*: maximum 1.0 per cent.

**Water** (2.5.12): maximum 1.0 per cent, determined on 1.00 g. Use as the solvent a mixture of equal volumes of *anhydrous methanol R* and *methylene chloride R*.

**Total ash** (2.4.16): maximum 0.1 per cent.

#### ASSAY

Size-exclusion chromatography (2.2.30).

**Test solution.** Into a 15 mL flask, weigh about 0.2 g (*m*), to the nearest 0.1 mg. Add 5 mL of *tetrahydrofuran R* and shake to dissolve. Reweigh the flask and calculate the total mass of solvent and substance (*M*).

**Reference solutions.** Into four 15 mL flasks, respectively weigh, to the nearest 0.1 mg, about 2.5 mg, 5 mg, 10 mg and 20 mg of *glycerol R*. Add 5 mL of *tetrahydrofuran R* and shake until well mixed. Weigh the flasks again and calculate the concentration of glycerol in milligrams per gram for each reference solution.

**Column:**

- *size*:  $l = 0.6$  m,  $\emptyset = 7$  mm,
- *stationary phase*: *styrene-divinylbenzene copolymer R* (5  $\mu$ m) with a pore size of 10 nm.

**Mobile phase:** *tetrahydrofuran R*.

**Flow rate:** 1 mL/min.

**Detection:** differential refractometer.

**Injection:** 40  $\mu$ L.

**Relative retention** with reference to glycerol (retention time = about 15.6 min): triacylglycerols = about 0.76; diacylglycerols = about 0.80; monoacylglycerols = about 0.86.

**Calculations:**

- *free glycerol*: from the calibration curve obtained with the reference solutions, determine the concentration (*C*) of glycerol in milligrams per gram in the test solution and calculate the percentage content of free glycerol in the substance to be examined using the following expression:

$$\frac{C \times M}{m \times 10}$$

- *mono-, di- and triacylglycerols*: calculate the percentage content of mono-, di- and triacylglycerols using the normalisation procedure.

#### STORAGE

In an airtight container, protected from light.

01/2008:1430  
corrected 6.3

## GLYCEROL MONO-OLEATE

### Glyceroli mono-oleas

#### DEFINITION

Mixture of monoacylglycerols, mainly mono-oleoylglycerol, together with variable quantities of di- and triacylglycerols. It is defined by the nominal content of monoacylglycerols and obtained by partial glycerolysis of vegetable oils mainly containing triacylglycerols of oleic (*cis*-9-octadecenoic) acid or by esterification of glycerol by oleic acid, this fatty acid being of vegetable or animal origin. A suitable antioxidant may be added.

**Content:**

	Nominal content of acylglycerol (per cent)		
	40	60	90
Monoacylglycerols	32.0 - 52.0	55.0 - 65.0	90.0 - 101.0
Diacylglycerols	30.0 - 50.0	15.0 - 35.0	< 10.0
Triacylglycerols	5.0 - 20.0	2.0 - 10.0	< 2.0

#### CHARACTERS

**Appearance:** amber, oily liquid which may be partially solidified at room temperature.

**Solubility:** practically insoluble in water, freely soluble in methylene chloride.

#### IDENTIFICATION

A. Iodine value (see Tests).

B. Thin-layer chromatography (2.2.27).

**Test solution.** Dissolve 1.0 g of the substance to be examined in *methylene chloride R* and dilute to 20 mL with the same solvent.

**Reference solution.** Dissolve 1.0 g of *glycerol mono-oleate CRS* in *methylene chloride R* and dilute to 20 mL with the same solvent.

**Plate:** *TLC silica gel plate R*.

**Mobile phase:** *hexane R, ether R* (30:70 V/V).

**Application:** 10  $\mu$ L.

**Development:** over a path of 15 cm.

**Drying:** in air.

**Detection:** spray with a 0.1 g/L solution of *rhodamine B R* in *ethanol (96 per cent) R* and examine in ultraviolet light at 365 nm.

**Results:** the spots in the chromatogram obtained with the test solution are similar in position to those in the chromatogram obtained with the reference solution.

C. It complies with the limits of the assay (monoacylglycerol content).

#### TESTS

**Acid value** (2.5.1): maximum 6.0, determined on 1.0 g.

**Iodine value** (2.5.4, *Method A*): 65.0 to 95.0.

**Peroxide value** (2.5.5, *Method A*): maximum 12.0, determined on 2.0 g.

**Saponification value** (2.5.6): 150 to 175, determined on 2.0 g.

**Free glycerol:** maximum 6.0 per cent, determined as described in the assay.

**Composition of fatty acids** (2.4.22, *Method C*).

**Composition of the fatty acid fraction of the substance:**

- *palmitic acid*: maximum 12.0 per cent,
- *stearic acid*: maximum 6.0 per cent,
- *oleic acid*: minimum 60.0 per cent,
- *linoleic acid*: maximum 35.0 per cent,
- *linolenic acid*: maximum 2.0 per cent,
- *arachidic acid*: maximum 2.0 per cent,
- *eicosenoic acid*: maximum 2.0 per cent.

**Water** (2.5.12): maximum 1.0 per cent, determined on 1.00 g. Use as the solvent a mixture of equal volumes of *anhydrous methanol R* and *methylene chloride R*.

**Total ash** (2.4.16): maximum 0.1 per cent.

#### ASSAY

Size-exclusion chromatography (2.2.30).

**Test solution.** Into a 15 mL flask, weigh about 0.2 g (*m*), to the nearest 0.1 mg. Add 5 mL of *tetrahydrofuran R* and shake to dissolve. Reweigh the flask and calculate the total mass of solvent and substance (*M*).

**Reference solutions.** Into four 15 mL flasks, respectively weigh, to the nearest 0.1 mg, about 2.5 mg, 5 mg, 10 mg and 20 mg of *glycerol R*. Add 5 mL of *tetrahydrofuran R* and shake until well mixed. Weigh the flasks again and calculate the concentration of glycerol in milligrams per gram for each reference solution.

**Column:**

- *size*:  $l = 0.6$  m,  $\emptyset = 7$  mm;
- *stationary phase*: *styrene-divinylbenzene copolymer R* (5  $\mu$ m) with a pore size of 10 nm.

*Mobile phase:* tetrahydrofuran R.

*Flow rate:* 1 mL/min.

*Detection:* differential refractometer.

*Injection:* 40 µL.

*Relative retention* with reference to glycerol (retention time = about 15.6 min): triacylglycerols = about 0.76; diacylglycerols = about 0.79; monoacylglycerols = about 0.85.

*Calculations:*

- *free glycerol:* from the calibration curve obtained with the reference solutions determine the concentration (C) of glycerol in milligrams per gram in the test solution and calculate the percentage content of free glycerol in the substance to be examined using the following expression:

$$\frac{C \times M}{m \times 10}$$

- *mono-, di- and triacylglycerols:* calculate the percentage content of mono-, di- and triacylglycerols using the normalisation procedure.

#### STORAGE

In an airtight container, protected from light.

#### LABELLING

The label states the nominal content of monoacylglycerol.

*Application:* 10 µL.

*Development:* over a path of 15 cm.

*Detection:* spray with a 0.1 g/L solution of *rhodamine B R* in *ethanol (96 per cent) R* and examine in ultraviolet light at 365 nm.

*Suitability system:* reference solution:

- the chromatogram shows 4 clearly separated spots.

*Results:* the spots in the chromatogram obtained with the test solution are similar in position to those in the chromatogram obtained with the reference solution.

- C. Composition of fatty acids (see Tests) according to the type stated on the label.
- D. It complies with the limits of the assay (monoacylglycerol content).

#### TESTS

**Acid value (2.5.1):** maximum 3.0, determined on 1.0 g.

Use a mixture of equal volumes of *ethanol (96 per cent) R* and *toluene R* as solvent and heat gently.

**Iodine value (2.5.4, Method A):** maximum 3.0.

**Saponification value (2.5.6):** 158 to 177, determined on 2.0 g. Carry out the titration with heating.

**Free glycerol:** maximum 6.0 per cent, determined as described under Assay.

**Composition of fatty acids (2.4.22, Method C).** Use the mixture of calibrating substances in Table 2.4.22.-1.

*Composition of the fatty-acid fraction of the substance:*

Glycerol monostearate 40-55	Composition of fatty acids
Type I	<i>Stearic acid:</i> 40.0 per cent to 60.0 per cent <i>Sum of the contents of palmitic and stearic acids:</i> minimum 90.0 per cent
Type II	<i>Stearic acid:</i> 60.0 per cent to 80.0 per cent <i>Sum of the contents of palmitic and stearic acids:</i> minimum 90.0 per cent
Type III	<i>Stearic acid:</i> 80.0 per cent to 99.0 per cent <i>Sum of the contents of palmitic and stearic acids:</i> minimum 96.0 per cent

**Nickel (2.4.31):** maximum 1 ppm.

**Water (2.5.12):** maximum 1.0 per cent, determined on 1.00 g. Use *pyridine R* as the solvent and heat gently.

**Total ash (2.4.16):** maximum 0.1 per cent.

#### ASSAY

Size-exclusion chromatography (2.2.30).

*Test solution.* Into a 15 mL flask, weigh 0.200 g (m). Add 5.0 mL of *tetrahydrofuran R* and shake to dissolve. Reweigh the flask and calculate the total mass of solvent and substance (M).

*Reference solutions.* Into four 15 mL flasks, respectively weigh 2.5 mg, 5.0 mg, 10.0 mg and 20.0 mg of *glycerol R*, and add 5.0 mL of *tetrahydrofuran R* to each flask. Weigh the flasks again and calculate the concentration of glycerol in milligrams per gram for each reference solution.

*Column:*

- *size:* l = 0.6 m, Ø = 7 mm;
- *stationary phase:* styrene-divinylbenzene copolymer R (5 µm) with a pore size of 10 nm.

*Mobile phase:* tetrahydrofuran R.

*Flow rate:* 1 mL/min.

*Detection:* differential refractometer.

*Injection:* 40 µL.

*Relative retention* with reference to glycerol (retention time = about 15 min): triacylglycerols = about 0.75; diacylglycerols = about 0.80; monoacylglycerols = about 0.85.

01/2008:0495

## GLYCEROL MONOSTEARATE 40-55

### Glyceroli monostearas 40-55

#### DEFINITION

Mixture of monoacylglycerols, mainly monostearoylglycerol, together with variable quantities of di- and triacylglycerols. It is obtained by partial glycerolysis of vegetable oils mainly containing triacylglycerols of palmitic (hexadecanoic) or stearic (octadecanoic) acid or by esterification of glycerol with stearic acid. The fatty acids may be of vegetable or animal origin.

*Content:*

- *monoacylglycerols:* 40.0 per cent to 55.0 per cent;
- *diacylglycerols:* 30.0 per cent to 45.0 per cent;
- *triacylglycerols:* 5.0 per cent to 15.0 per cent.

#### CHARACTERS

*Appearance:* hard, waxy mass or unctuous powder or flakes, white or almost white.

*Solubility:* practically insoluble in water, soluble in ethanol (96 per cent) at 60 °C.

#### IDENTIFICATION

*First identification:* C, D.

*Second identification:* A, B.

A. Melting point (2.2.15): 54 °C to 66 °C.

Introduce the melted substance into the capillary tubes and allow to stand for 24 h in a well-closed container.

B. Thin-layer chromatography (2.2.27).

*Test solution.* Dissolve 0.5 g of the substance to be examined in *methylene chloride R*, with gentle heating, and dilute to 10 mL with the same solvent.

*Reference solution.* Dissolve 0.5 g of *glycerol monostearate 40-55 CRS* in *methylene chloride R*, with gentle heating, and dilute to 10 mL with the same solvent.

*Plate:* TLC silica gel plate R.

*Mobile phase:* hexane R, ether R (30:70 V/V).

**Calculations:**

- *free glycerol*: from the calibration curve obtained with the reference solutions, determine the concentration (C) in milligrams per gram in the test solution and calculate the percentage content in the substance to be examined using the following expression:

$$\frac{C \times M}{m \times 10}$$

- *mono-, di- and triacylglycerols*: calculate the percentage contents by the normalisation procedure.

**LABELLING**

The label states the type of glycerol monostearate 40-55.

01/2008:1331  
corrected 6.4

**GLYCERYL TRINITRATE SOLUTION**

## Glyceroli trinitratis solutio

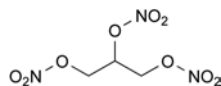

C<sub>3</sub>H<sub>5</sub>N<sub>3</sub>O<sub>9</sub>

M<sub>r</sub> 227.1

**DEFINITION**

Ethanol solution of glyceryl trinitrate.

*Content*: 1 per cent m/m to 10 per cent m/m of propane-1,2,3-triyl trinitrate and 96.5 per cent to 102.5 per cent of the declared content of glyceryl trinitrate stated on the label.

**CHARACTERS**

*Appearance*: clear, colourless or slightly yellow solution.

*Solubility*: miscible with acetone and with anhydrous ethanol.

*Solubility of pure glyceryl trinitrate*: practically insoluble in water, freely soluble in anhydrous ethanol, miscible with acetone.

**IDENTIFICATION**

*First identification*: A, C.

*Second identification*: B, C.

*Upon diluting glyceryl trinitrate solution, care must be taken to always use anhydrous ethanol, otherwise droplets of pure glyceryl trinitrate may precipitate from the solution.*

*After examination, the residues and the solutions obtained in both the identification and the test sections must be heated on a water-bath for 5 min with dilute sodium hydroxide solution R.*

**A. Infrared absorption spectrophotometry (2.2.24).**

*Preparation*: place 50 µL of a solution diluted, if necessary, with *anhydrous ethanol R*, to contain 10 g/L of glyceryl trinitrate, on a disc of *potassium bromide R* and evaporate the solvent *in vacuo*.

*Comparison*: Ph. Eur. reference spectrum of glyceryl trinitrate.

**B. Thin-layer chromatography (2.2.27).**

*Test solution*. Dilute a quantity of the substance to be examined corresponding to 50 mg of glyceryl trinitrate in *acetone R* and dilute to 100 mL with the same solvent.

*Reference solution*. Dilute 0.05 mL of *glyceryl trinitrate solution CRS* to 1 mL with *acetone R*.

*Plate*: TLC silica gel G plate R.

*Mobile phase*: *ethyl acetate R*, *toluene R* (20:80 V/V).

*Application*: 5 µL.

*Development*: over 2/3 of the plate.

*Drying*: in air.

*Detection*: spray with freshly prepared *potassium iodide and starch solution R*; expose to ultraviolet light at 254 nm for 15 min and examine in daylight.

*Results*: the principal spot in the chromatogram obtained with the test solution is similar in position, colour and size to the principal spot in the chromatogram obtained with the reference solution.

C. It complies with the limits of the assay.

**TESTS**

*Upon diluting glyceryl trinitrate solution, care must be taken always to use anhydrous ethanol, otherwise droplets of pure glyceryl trinitrate may precipitate from the solution.*

*After examination, the residues and the solutions obtained in both the identification and the test sections must be heated on a water-bath for 5 min with dilute sodium hydroxide solution R.*

**Appearance of solution.** If necessary dilute the solution to be examined to a concentration of 10 g/L with *anhydrous ethanol R*. The solution is not more intensely coloured than reference solution Y<sub>7</sub> (2.2.2, Method II).

**Inorganic nitrates.** Thin-layer chromatography (2.2.27).

*Test solution.* If necessary dilute the solution to be examined to a concentration of 10 g/L with *anhydrous ethanol R*.

*Reference solution.* Dissolve 5 mg of *potassium nitrate R* in 1 mL of *water R* and dilute to 100 mL with *ethanol (96 per cent) R*.

*Plate*: TLC silica gel plate R.

*Mobile phase*: *glacial acetic acid R*, *acetone R*, *toluene R* (15:30:60 V/V/V).

*Application*: 10 µL.

*Development*: over 2/3 of the plate.

*Drying*: in a current of air until the acetic acid is completely removed.

*Detection*: spray intensively with freshly prepared *potassium iodide and starch solution R*; expose to ultraviolet light at 254 nm for 15 min and examine in daylight.

*Limit*:

- *nitrate ion*: any spot due to the nitrate ion in the chromatogram obtained with the test solution is not more intense than the spot in the chromatogram obtained with the reference solution (0.5 per cent of the content of glyceryl trinitrate calculated as potassium nitrate).

**Related substances.** Liquid chromatography (2.2.29).

*Test solution.* Dissolve a quantity of the substance to be examined equivalent to 2 mg of glyceryl trinitrate in the mobile phase and dilute to 20.0 mL with the mobile phase.

*Reference solution (a).* Dissolve 0.10 g of *glyceryl trinitrate solution CRS* and a quantity of *diluted pentaerythrityl tetranitrate CRS* equivalent to 1.0 mg of pentaerythrityl tetranitrate in the mobile phase and dilute to 100.0 mL with the mobile phase. Sonicate and filter if necessary.

*Reference solution (b).* Dilute 1.0 mL of the test solution to 100.0 mL with the mobile phase.

*Column*:

– *size*: l = 0.25 m, Ø = 4.6 mm;

– *stationary phase*: *octadecylsilyl silica gel for chromatography R* (5 µm).

*Mobile phase*: *acetonitrile R*, *water R* (50:50 V/V).

*Flow rate*: 1 mL/min.

*Detection*: spectrophotometer at 210 nm.

*Injection*: 20 µL.

*Run time*: 3 times the retention time of the principal peak.

*System suitability*: reference solution (a):

- *resolution*: minimum 2.0 between the peaks due to glyceryl trinitrate and to pentaerythrityl tetranitrate.

01/2008:0614  
corrected 6.0

## Limits:

- *any impurity*: not more than the area of the principal peak in the chromatogram obtained with reference solution (b) (1 per cent, expressed as glyceryl trinitrate);
- *total*: not more than 3 times the area of the principal peak in the chromatogram obtained with reference solution (b) (3 per cent, expressed as glyceryl trinitrate);
- *disregard limit*: 0.1 times the area of the principal peak in the chromatogram obtained with reference solution (b) (0.1 per cent).

## ASSAY

**Test solution.** Prepare a solution containing 1.0 mg of glyceryl trinitrate in 250.0 mL of *methanol R*.

**Reference solution.** Dissolve 70.0 mg of *sodium nitrite R* in *methanol R* and dilute to 250.0 mL with the same solvent. Dilute 5.0 mL of the solution to 500.0 mL with *methanol R*.

Into three 50 mL volumetric flasks introduce 10.0 mL of the test solution, 10.0 mL of the reference solution and 10 mL of *methanol R* as a blank. To each flask add 5 mL of *dilute sodium hydroxide solution R*, close the flask, mix and allow to stand at room temperature for 30 min. Add 10 mL of *sulfanilic acid solution R* and 10 mL of *dilute hydrochloric acid R* and mix. After exactly 4 min, add 10 mL of *naphthylethylenediamine dihydrochloride solution R*, dilute to volume with *water R* and mix. After 10 min read the absorbance (2.2.25) of the test solution and the reference solution at 540 nm using the blank solution as the compensation liquid.

Calculate the percentage content of glyceryl trinitrate using the following expression:

$$\frac{A_T \times m_S \times C}{A_R \times m_T \times 60.8}$$

- $A_T$  = absorption of the test solution;  
 $m_T$  = mass of the substance to be examined, in milligrams;  
 $C$  = percentage content of sodium nitrite used as reference;  
 $A_R$  = absorption of the reference solution;  
 $m_S$  = mass of sodium nitrite, in milligrams.

## STORAGE

Store the diluted solutions (10 g/L) protected from light, at a temperature of 2 °C to 15 °C.

Store more concentrated solutions protected from light, at a temperature of 15 °C to 20 °C.

## LABELLING

The label states the declared content of glyceryl trinitrate.

## IMPURITIES

A. inorganic nitrates,

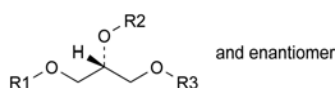

- B. R1 = NO<sub>2</sub>, R2 = R3 = H: (2*RS*)-2,3-dihydroxypropyl nitrate,  
 C. R1 = R3 = H, R2 = NO<sub>2</sub>: 2-hydroxy-1-(hydroxymethyl)ethyl nitrate,  
 D. R1 = R2 = NO<sub>2</sub>, R3 = H: (2*RS*)-3-hydroxypropane-1,2-diyl dinitrate,  
 E. R1 = R3 = NO<sub>2</sub>, R2 = H: 2-hydroxypropane-1,3-diyl dinitrate.

## GLYCINE

## Glycinum



C<sub>2</sub>H<sub>5</sub>NO<sub>2</sub>  
[56-40-6]

$M_r$  75.1

## DEFINITION

2-Aminoacetic acid.

**Content:** 98.5 per cent to 101.0 per cent (dried substance).

## CHARACTERS

**Appearance:** white or almost white, crystalline powder.

**Solubility:** freely soluble in water, very slightly soluble in ethanol (96 per cent).

It shows polymorphism (5.9).

## IDENTIFICATION

**First identification:** A.

**Second identification:** B, C.

A. Infrared absorption spectrophotometry (2.2.24).

**Comparison:** *glycine CRS*.

If the spectra obtained in the solid state show differences, dissolve the substance to be examined and the reference substance separately in the minimum volume of *ethanol (60 per cent V/V) R*, evaporate to dryness and record the spectra again.

B. Examine the chromatograms obtained in the test for ninhydrin-positive substances.

**Results:** the principal spot in the chromatogram obtained with test solution (b) is similar in position, colour and size to the principal spot in the chromatogram obtained with reference solution (a).

C. Dissolve 50 mg in 5 mL of *water R*, add 1 mL of *strong sodium hypochlorite solution R* and boil for 2 min. Add 1 mL of *hydrochloric acid R* and boil for 4-5 min. Add 2 mL of *hydrochloric acid R* and 1 mL of a 20 g/L solution of *resorcinol R*, boil for 1 min and cool. Add 10 mL of *water R* and mix. To 5 mL of the solution add 6 mL of *dilute sodium hydroxide solution R*. The solution is violet with greenish-yellow fluorescence. After a few minutes, the colour becomes orange and then yellow and an intense fluorescence remains.

## TESTS

**Solution S.** Dissolve 5.0 g in *carbon dioxide-free water R* and dilute to 50 mL with the same solvent.

**Appearance of solution.** Solution S is clear (2.2.1) and not more intensely coloured than reference solution Y<sub>7</sub> (2.2.2, *Method II*).

**pH** (2.2.3): 5.9 to 6.4.

Dilute 10 mL of solution S to 20 mL with *carbon dioxide-free water R*.

**Ninhydrin-positive substances.** Thin-layer chromatography (2.2.27).

**Test solution (a).** Dissolve 0.10 g of the substance to be examined in *water R* and dilute to 10.0 mL with the same solvent.

**Test solution (b).** Dilute 1.0 mL of test solution (a) to 10.0 mL with *water R*.

**Reference solution (a).** Dissolve 10 mg of *glycine CRS* in *water R* and dilute to 10.0 mL with the same solvent.

**Reference solution (b).** Dilute 1.0 mL of test solution (a) to 200 mL with *water R*.

**Reference solution (c).** Dissolve 10 mg of *glycine CRS* and 10 mg of *alanine CRS* in *water R* and dilute to 25 mL with the same solvent.

**Plate:** *cellulose for chromatography R* as the coating substance.

**Mobile phase:** *glacial acetic acid R, water R, butanol R* (20:20:60 V/V/V).

**Application:** 5 µL.

**Development:** over 2/3 of the plate.

**Drying:** at 80 °C for 30 min.

**Detection:** spray with *ninhydrin solution R* and dry at 100-105 °C for 15 min.

**System suitability:** the chromatogram obtained with reference solution (c) shows 2 clearly separated spots.

**Limits:** in the chromatogram obtained with test solution (a):

- **any impurity:** any spots, apart from the principal spot, are not more intense than the principal spot in the chromatogram obtained with reference solution (b) (0.5 per cent).

**Chlorides (2.4.4):** maximum 75 ppm.

Dissolve 0.67 g in *water R* and dilute to 15 mL with the same solvent.

**Heavy metals (2.4.8):** maximum 10 ppm.

12 mL of solution S complies with test A. Prepare the reference solution using *lead standard solution (1 ppm Pb) R*.

**Loss on drying (2.2.32):** maximum 0.5 per cent, determined on 1.000 g by drying in an oven at 105 °C for 2 h.

**Sulfated ash (2.4.14):** maximum 0.1 per cent, determined on 1.0 g.

#### ASSAY

Dissolve 70.0 mg in 3 mL of *anhydrous formic acid R* and add 30 mL of *anhydrous acetic acid R*. Immediately after dissolution, titrate with 0.1 M *perchloric acid*, determining the end-point potentiometrically (2.2.20).

1 mL of 0.1 M *perchloric acid* is equivalent to 7.51 mg of C<sub>2</sub>H<sub>5</sub>NO<sub>2</sub>.

01/2008:0827  
corrected 7.0

## GONADORELIN ACETATE

### Gonadorelini acetat

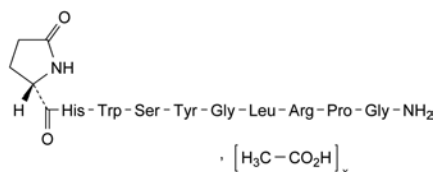

C<sub>55</sub>H<sub>75</sub>N<sub>17</sub>O<sub>13</sub> · xC<sub>2</sub>H<sub>4</sub>O<sub>2</sub>  
[34973-08-5]

M<sub>r</sub> 1182 (C<sub>55</sub>H<sub>75</sub>N<sub>17</sub>O<sub>13</sub>)

#### DEFINITION

Gonadorelin acetate is the acetate form of a hypothalamic peptide that stimulates the release of follicle-stimulating hormone and luteinising hormone from the pituitary gland. It contains not less than 95.0 per cent and not more than the equivalent of 102.0 per cent of the peptide C<sub>55</sub>H<sub>75</sub>N<sub>17</sub>O<sub>13</sub>, calculated with reference to the anhydrous, acetic acid-free substance. It is obtained by chemical synthesis.

#### CHARACTERS

A white or slightly yellowish powder, soluble in water and in a 1 per cent V/V solution of glacial acetic acid, sparingly soluble in methanol.

#### IDENTIFICATION

- Examine the chromatograms obtained in the assay. The retention time and size of the principal peak in the chromatogram obtained with the test solution are approximately the same as those of the principal peak in the chromatogram obtained with reference solution (a).
- Examine by thin-layer chromatography (2.2.27), using a *TLC silica gel G plate R*.

Use the test solution and reference solution (a) prepared under Assay.

Apply to the plate 10 µL of each solution. Develop over a path of 15 cm using a mixture of 6 volumes of *glacial acetic acid R*, 14 volumes of *water R*, 45 volumes of *methanol R* and 60 volumes of *methylene chloride R*. Allow the plate to dry in air for 5 min. At the bottom of a chromatographic tank, place an evaporating dish containing a mixture of 10 mL of a 50 g/L solution of *potassium permanganate R* and 3 mL of *hydrochloric acid R*, close the tank and allow to stand. Place the dried plate in the tank and close the tank. Leave the plate in contact with the chlorine vapour for 2 min. Withdraw the plate and place it in a current of cold air until the excess of chlorine is removed and an area of coating below the points of application no longer gives a blue colour with 0.05 mL of *potassium iodide and starch solution R*. Spray with *potassium iodide and starch solution R*. The principal spot in the chromatogram obtained with the test solution corresponds in position and size to the principal spot in the chromatogram obtained with reference solution (a).

#### TESTS

**Appearance of solution.** A 10 g/L solution is clear (2.2.1) and not more intensely coloured than reference solution Y<sub>5</sub> (2.2.2, *Method II*).

**Specific optical rotation (2.2.7).** Dissolve 10.0 mg in 1.0 mL of a 1 per cent V/V solution of *glacial acetic acid R*. The specific optical rotation is –54 to –66, calculated on the basis of the peptide content as determined in the assay.

**Absorbance (2.2.25).** Dissolve 10.0 mg in *water R* and dilute to 100.0 mL with the same solvent. The absorbance, determined at the maximum at 278 nm, corrected to a 10 mg/100 mL solution on the basis of the peptide content determined in the assay, is 0.55 to 0.61.

**Amino acids.** Examine by means of an amino-acid analyser. Standardise the apparatus with a mixture containing equimolar amounts of ammonia, glycine and the L-form of the following amino acids:

lysine	threonine	alanine	leucine
histidine	serine	valine	tyrosine
arginine	glutamic acid	methionine	phenylalanine
aspartic acid	proline	isoleucine	

together with half the equimolar amount of L-cystine. For the validation of the method, an appropriate internal standard, such as *DL-norleucine R*, is used.

**Test solution.** Place 1.0 mg of the substance to be examined in a rigorously cleaned hard-glass tube 100 mm long and 6 mm in internal diameter. Add a suitable amount of a 50 per cent V/V solution of *hydrochloric acid R*. Immerse the tube in a freezing mixture at –5 °C, reduce the pressure to below 133 Pa and seal. Heat at 110 °C to 115 °C for 16 h. Cool, open the tube, transfer the contents to a 10 mL flask with the aid of five quantities, each of 0.2 mL, of *water R* and evaporate to dryness over *potassium hydroxide R* under reduced pressure. Take up the residue in *water R* and evaporate to dryness over *potassium hydroxide R* under reduced pressure; repeat these operations once. Take up the residue in a buffer solution suitable for

the amino-acid analyser used and dilute to a suitable volume with the same buffer solution. Apply a suitable volume to the amino-acid analyser.

Express the content of each amino acid in moles. Calculate the relative proportions of the amino acids, taking one-eighth of the sum of the number of moles of histidine, glutamic acid, leucine, proline, glycine, tyrosine and arginine as equal to one. The values fall within the following limits: serine 0.7 to 1.05; glutamic acid 0.95 to 1.05; proline 0.95 to 1.05; glycine 1.9 to 2.1; leucine 0.9 to 1.1; tyrosine 0.7 to 1.05; histidine 0.95 to 1.05 and arginine 0.95 to 1.05. Lysine and isoleucine are absent; not more than traces of other amino acids are present, with the exception of tryptophan.

**Related substances.** Examine by liquid chromatography (2.2.29) as described under Assay.

Inject 20 µL of reference solution (b). Adjust the sensitivity of the system so that the height of the principal peak in the chromatogram obtained is at least 50 per cent of the full scale of the recorder.

Inject 20 µL of the test solution. Continue the chromatography for twice the retention time of gonadorelin. In the chromatogram obtained with the test solution: the area of any peak apart from the principal peak, is not greater than twice the area of the principal peak in the chromatogram obtained with reference solution (b) (2 per cent); the sum of the areas of the peaks, apart from the principal peak, is not greater than 5 times the area of the principal peak in the chromatogram obtained with reference solution (b) (5 per cent). Disregard any peak with an area less than 0.05 times that of the principal peak in the chromatogram obtained with reference solution (b) (0.05 per cent).

**Acetic acid** (2.5.34): 4.0 per cent to 7.5 per cent.

**Test solution.** Dissolve 10.0 mg of the substance to be examined in a mixture of 5 volumes of mobile phase B and 95 volumes of mobile phase A and dilute to 10.0 mL with the same mixture of solvents.

**Water** (2.5.12). Not more than 7.0 per cent, determined on 0.200 g by the semi-micro determination of water.

**Bacterial endotoxins** (2.6.14): less than 70 IU/mg, if intended for use in the manufacture of parenteral preparations without a further appropriate procedure for the removal of bacterial endotoxins.

#### ASSAY

Examine by liquid chromatography (2.2.29).

**Test solution.** Dissolve 5.0 mg of the substance to be examined in *water R* and dilute to 10.0 mL with the same solvent.

**Reference solution (a).** Dissolve the contents of a vial of *gonadorelin CRS* in *water R* to obtain a concentration of 0.5 mg/mL.

**Reference solution (b).** Dilute 1.0 mL of the test solution to 100.0 mL with *water R*.

**Reference solution (c).** Dissolve 2.5 mg of the substance to be examined in 1 mL of 0.1 M hydrochloric acid and heat in a water-bath at 65 °C for 4 h. Add 1 mL of 0.1 M sodium hydroxide and dilute to 5.0 mL with *water R*.

The chromatographic procedure may be carried out using:

- a stainless steel column 0.12 m long and 4.0 mm in internal diameter packed with *octadecylsilyl silica gel for chromatography R* (5 µm),
- as mobile phase at a flow rate of 1.5 mL/min a mixture of 13 volumes of *acetonitrile R* and 87 volumes of a 1.18 per cent V/V solution of *phosphoric acid R* (adjusted to pH 2.3 with *triethylamine R*),
- as detector a spectrophotometer set at 215 nm.

Inject 20 µL of reference solution (c). The test is not valid unless the resolution between the first and second peaks is at least 2.0.

Inject 20 µL of the test solution and 20 µL of reference solution (a).

Calculate the content of gonadorelin (C<sub>55</sub>H<sub>75</sub>N<sub>17</sub>O<sub>13</sub>) from the peak areas in the chromatograms obtained with the test solution and reference solution (a) and the declared content of C<sub>55</sub>H<sub>75</sub>N<sub>17</sub>O<sub>13</sub> in *gonadorelin CRS*.

#### STORAGE

Store in an airtight container, protected from light at a temperature of 2 °C to 8 °C. If the substance is sterile, store in a sterile, airtight, tamper-proof container.

#### LABELLING

The label states the mass of peptide in the container.

01/2011:0498

## GONADOTROPHIN, CHORIONIC

### Gonadotropinum chorionicum

#### DEFINITION

Chorionic gonadotrophin is a dry preparation of placental glycoproteins which have luteinising activity. It is extracted from the urine of pregnant women. The potency is not less than 2500 IU/mg.

#### PRODUCTION

Chorionic gonadotrophin is extracted using a suitable fractionation procedure. It is either dried under reduced pressure or freeze-dried.

#### CHARACTERS

**Appearance:** white or yellowish-white, amorphous powder.

**Solubility:** soluble in water.

#### IDENTIFICATION

When administered to immature rats as prescribed in the assay, it causes an increase in the mass of the seminal vesicles and of the prostate gland.

#### TESTS

**Water** (2.5.32): maximum 5.0 per cent.

**Bacterial endotoxins** (2.6.14): less than 0.02 IU per IU of chorionic gonadotrophin, if intended for use in the manufacture of parenteral preparations without a further appropriate procedure for the removal of bacterial endotoxins.

#### ASSAY

The potency of chorionic gonadotrophin is estimated by comparing under given conditions its effect of increasing the mass of the seminal vesicles (or the prostate gland) of immature rats with the same effect of the International Standard of chorionic gonadotrophin or of a reference preparation calibrated in International Units.

The International Unit is the activity contained in a stated amount of the International Standard, which consists of a mixture of a freeze-dried extract of chorionic gonadotrophin from the urine of pregnant women with lactose. The equivalence in International Units of the International Standard is stated by the World Health Organisation.

Use immature male rats of the same strain, 19 to 28 days old, differing in age by not more than 3 days and having body masses such that the difference between the heaviest and the lightest rat is not more than 10 g. Assign the rats at random to 6 equal groups of at least 5 animals. If sets of 6 litter mates are available, assign one litter mate from each set to each group and mark according to litter.

Choose 3 doses of the reference preparation and 3 doses of the preparation to be examined such that the smallest dose is sufficient to produce a positive response in some of the rats and the largest dose does not produce a maximal response in all the rats. Use doses in geometric progression and as an initial



approximation total doses of 4 IU, 8 IU and 16 IU may be tried although the dose will depend on the sensitivity of the animals used, which may vary widely.

Dissolve separately the total quantities of the preparation to be examined and of the reference preparation corresponding to the daily doses to be used in sufficient *phosphate-albumin buffered saline pH 7.2 R* such that the daily dose is administered in a volume of about 0.5 mL. Add a suitable antimicrobial preservative such as 4 g/L of phenol or 0.02 g/L of thiomersal. Store the solutions at  $5 \pm 3$  °C.

Inject subcutaneously into each rat the daily dose allocated to its group, on 4 consecutive days at the same time each day. On the 5<sup>th</sup> day, about 24 h after the last injection, euthanise the rats and remove the seminal vesicles. Remove any extraneous fluid and tissue and weigh the vesicles immediately. Calculate the results by the usual statistical methods, using the mass of the vesicles as the response. (The precision of the assay may be improved by a suitable correction of the organ mass with reference to the body mass of the animal from which it was taken; an analysis of covariance may be used).

The estimated potency is not less than 80 per cent and not more than 125 per cent of the stated potency. The confidence limits ( $P = 0.95$ ) of the estimated potency are not less than 64 per cent and not more than 156 per cent of the stated potency.

#### STORAGE

In an airtight, tamper-proof container, protected from light at a temperature of 2 °C to 8 °C. If the substance is sterile, store in a sterile, airtight, tamper-proof container.

#### LABELLING

The label states:

- the number of International Units per container,
- the potency in International Units per milligram.

01/2008:0719

## GONADOTROPHIN, EQUINE SERUM, FOR VETERINARY USE

### Gonadotropinum sericum equinum ad usum veterinarium

#### DEFINITION

Equine serum gonadotrophin for veterinary use is a dry preparation of a glycoprotein fraction obtained from the serum or plasma of pregnant mares. It has follicle-stimulating and luteinising activities. The potency is not less than 1000 IU of gonadotrophin activity per milligram, calculated with reference to the anhydrous substance.

#### PRODUCTION

Equine serum gonadotrophin may be prepared by precipitation with alcohol (70 per cent *V/V*) and further purification by a suitable form of chromatography. It is prepared in conditions designed to minimise microbial contamination.

#### CHARACTERS

*Appearance*: white or pale grey, amorphous powder.

*Solubility*: soluble in water.

#### IDENTIFICATION

When administered as prescribed in the assay it causes an increase in the mass of the ovaries of immature female rats.

#### TESTS

**Water** (2.5.12): maximum 10.0 per cent, determined on 80 mg.

**Bacterial endotoxins** (2.6.14, method C): less than 0.035 IU per IU of equine serum gonadotrophin, if intended for use in the manufacture of parenteral preparations without a further appropriate procedure for the removal of bacterial endotoxins.

#### ASSAY

The potency of equine serum gonadotrophin is estimated by comparing under given conditions its effect of increasing the mass of the ovaries of immature female rats with the same effect of the International Standard of equine serum gonadotrophin or of a reference preparation calibrated in International Units.

The International Unit is the activity contained in a stated amount of the International Standard, which consists of a mixture of a freeze-dried extract of equine serum gonadotrophin from the serum of pregnant mares with lactose. The equivalence in International Units of the International Standard is stated by the World Health Organisation.

Use immature female rats of the same strain, 21 to 28 days old, differing in age by not more than 3 days and having masses such that the difference between the heaviest and the lightest rat is not more than 10 g. Assign the rats at random to 6 equal groups of not fewer than 5 animals. If sets of 6 litter mates are available, assign one litter mate from each set to each group and mark according to litter.

Choose 3 doses of the reference preparation and 3 doses of the preparation to be examined such that the smallest dose is sufficient to produce a positive response in some of the rats and the largest dose does not produce a maximal response in all the rats. Use doses in geometric progression: as an initial approximation total doses of 8 IU, 12 IU and 18 IU may be tried, although the dose will depend on the sensitivity of the animals used and may vary widely.

Dissolve separately the total quantities of the preparation to be examined and of the reference preparation corresponding to the doses to be used in sufficient of a sterile 9 g/L solution of *sodium chloride R* containing 1 mg/mL of *bovine albumin R* such that each single dose is administered in a volume of about 0.2 mL. Store the solutions at  $5 \pm 3$  °C.

Inject subcutaneously into each rat the dose allocated to its group. Repeat the injections 18 h, 21 h, 24 h, 42 h and 48 h after the first injection. Not less than 40 h and not more than 72 h after the last injection, euthanise the rats and remove the ovaries. Remove any extraneous fluid and tissue and weigh the 2 ovaries immediately. Calculate the results by the usual statistical methods, using the combined mass of the 2 ovaries of each animal as the response.

The estimated potency is not less than 80 per cent and not more than 125 per cent of the stated potency. The confidence limits ( $P = 0.95$ ) of the estimated potency are not less than 64 per cent and not more than 156 per cent of the stated potency.

#### STORAGE

In an airtight container, protected from light, at a temperature not exceeding 8 °C. If the substance is sterile, store in a sterile, airtight, tamper-proof container.

#### LABELLING

The label states the potency in International Units per milligram.

01/2008:1636

## GOSERELIN

### Goserelinum

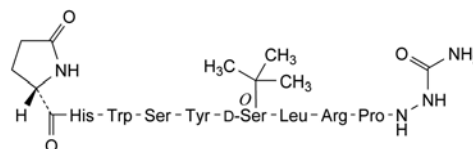

$C_{59}H_{84}N_{18}O_{14}$   
[65807-02-5]

$M_r$  1269

## DEFINITION

1-Carbamoyl-2-[5-oxo-L-prolyl-L-histidyl-L-tryptophyl-L-seryl-L-tyrosyl-O-(1,1-dimethylethyl)-D-seryl-L-leucyl-L-arginyl-L-prolyl]diazane.

Synthetic nonapeptide analogue of the hypothalamic decapeptide, gonadorelin. It is obtained by chemical synthesis and is available as an acetate.

*Content:* 94.5 per cent to 103.0 per cent of the peptide  $C_{59}H_{84}N_{18}O_{14}$  (anhydrous and acetic-acid free substance).

## CHARACTERS

*Appearance:* white or almost white powder.

*Solubility:* soluble in water, freely soluble in glacial acetic acid. It dissolves in dilute solutions of mineral acids and alkali hydroxides.

## IDENTIFICATION

## A. Nuclear magnetic resonance spectrometry (2.2.33).

*Preparation:* 40 mg/mL solution of the substance to be examined in *deuterium oxide R* adjusted to pH 4.0 with *deuterated acetic acid R*.

*Results:* the  $^{13}C$ , proton decoupled NMR spectrum obtained is qualitatively similar to the *Ph. Eur. reference spectrum of goserelin*.

## B. Examine the chromatograms obtained in the assay.

*Results:* the principal peak in the chromatogram obtained with the test solution is similar in retention time and size to the principal peak in the chromatogram obtained with reference solution (a).

## C. Amino acid analysis (2.2.56). For protein hydrolysis use Method 1 and for analysis use Method 1.

Express the content of each amino acid in moles. Calculate the relative proportions of the amino acids taking one sixth of the sum of the number of moles of glutamic acid, histidine, tyrosine, leucine, arginine, proline as equal to 1. The values fall within the following limits: glutamic acid, histidine, tyrosine, leucine, arginine and proline 0.9 to 1.1; serine 1.6 to 2.2. Not more than traces of other amino acids are present, with the exception of tryptophan.

## TESTS

**Specific optical rotation (2.2.7):**  $-52$  to  $-56$  (anhydrous and acetic-acid free substance).

Dissolve the substance to be examined in *water R* to obtain a concentration of 2 mg/mL.

**Related substances.** Liquid chromatography (2.2.29).

*Test solution.* Dissolve the substance to be examined in *water R* to obtain a concentration of 1.0 mg/mL.

*Reference solution (a).* Dissolve the contents of a vial of *goserelin CRS* in *water R* to obtain a concentration of 1.0 mg/mL.

*Reference solution (b).* Dilute 1.0 mL of the test solution to 100 mL with *water R*.

*Reference solution (c).* Dilute 1.0 mL of the test solution to 10.0 mL with *water R*.

*Resolution solution (a).* Dissolve the contents of a vial of *4-D-Ser-goserelin CRS* in *water R* to obtain a concentration of 0.1 mg/mL. Mix equal volumes of this solution and of reference solution (c).

*Resolution solution (b).* Dissolve the contents of a vial of *goserelin validation mixture CRS* with 1.0 mL of *water R*.

*Column:*

- *size:*  $l = 0.15$  m,  $\emptyset = 4.6$  mm,
- *stationary phase:* octadecylsilyl amorphous organosilica polymer *R* (3.5  $\mu$ m) with a pore size of 12.5 nm,
- *temperature:* 50-55 °C.

*Mobile phase:* trifluoroacetic acid *R*, acetonitrile for chromatography *R*, water *R* (0.5:200:800 V/V/V).

*Flow rate:* 0.7-1.2 mL/min.

*Detection:* spectrophotometer at 220 nm.

*Injection:* 10  $\mu$ L of the test solution, reference solution (b) and the resolution solutions.

*Run time:* 90 min.

*Relative retention* with reference to goserelin:

impurity A = about 0.67; impurity C = about 0.78; impurity B = about 0.79; impurity D = about 0.85; impurity E = about 0.89; impurity F = about 0.92; impurity G = about 0.94; impurity H = about 0.98; impurity I = about 1.43; impurity J = about 1.53; impurity K = about 1.67; impurity L = about 1.77.

*System suitability:*

- *retention time:* goserelin = 40 min to 50 min in the chromatogram obtained with resolution solution (b); adjust the flow rate of the mobile phase if necessary; if adjusting the flow rate does not result in a correct retention time of the principal peak, change the composition of acetonitrile in the mobile phase to obtain the requested retention time for goserelin;
- *resolution:* minimum 7.0 between the peaks due to impurity A and goserelin in the chromatogram obtained with resolution solution (a);
- *symmetry factor:* 0.8 to 2.5 for the peaks due to impurity A and goserelin in the chromatogram obtained with resolution solution (a);
- the chromatogram obtained with resolution solution (b) is similar to the chromatogram supplied with *goserelin validation mixture CRS*. 2 peaks eluting prior to the principal peak and corresponding to impurity E and impurity G, are clearly visible. 3 peaks eluting after the principal peak are clearly visible.

*Limits:*

- *impurity E:* not more than the area of the principal peak in the chromatogram obtained with reference solution (b) (1.0 per cent),
- *any other impurity:* for each impurity, not more than 0.5 times the area of the principal peak in the chromatogram obtained with reference solution (b) (0.5 per cent),
- *total:* not more than 2.5 times the area of the principal peak in the chromatogram obtained with reference solution (b) (2.5 per cent),
- *disregard limit:* 0.05 times the area of the principal peak in the chromatogram obtained with reference solution (b) (0.05 per cent).

**Acetic acid (2.5.34):** 4.5 per cent to 15.0 per cent.

*Test solution.* Dissolve 10.0 mg of the substance to be examined in a mixture of 5 volumes of mobile phase B and 95 volumes of mobile phase A and dilute to 10.0 mL with the same mixture of mobile phases.

**Water (2.5.32):** maximum 10.0 per cent.

**Bacterial endotoxins (2.6.14):** less than 16 IU/mg, if intended for use in the manufacture of parenteral preparations without a further appropriate procedure for the removal of bacterial endotoxins.

## ASSAY

Liquid chromatography (2.2.29) as described in the test for related substances with the following modifications.

*Injection:* test solution and reference solution (a).

*Run time:* 60 min.

Calculate the content of goserelin ( $C_{59}H_{84}N_{18}O_{14}$ ) using the chromatograms obtained with the test solution and reference solution (a) and the declared content of  $C_{59}H_{84}N_{18}O_{14}$  in *goserelin CRS*.

## STORAGE

In an airtight container, protected from light, at a temperature of 2 °C to 8 °C.

## LABELLING

The label states the mass of peptide in the container.

## IMPURITIES

Specified impurities: A, B, C, D, E, F, G, H, I, J, K, L.

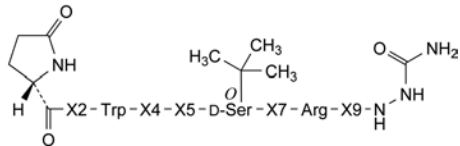

- A. X2 = L-His, X4 = D-Ser, X5 = L-Tyr, X7 = L-Leu, X9 = L-Pro: [4-D-serine]goserelin,  
 C. X2 = L-His, X4 = L-Ser, X5 = L-Tyr, X7 = L-Leu, X9 = D-Pro: [9-D-proline]goserelin,  
 F. X2 = L-His, X4 = L-Ser, X5 = D-Tyr, X7 = L-Leu, X9 = L-Pro: [5-D-tyrosine]goserelin,  
 G. X2 = D-His, X4 = L-Ser, X5 = L-Tyr, X7 = L-Leu, X9 = L-Pro: [2-D-histidine]goserelin,  
 L. X2 = L-His, X4 = L-Ser, X5 = L-Tyr, X7 = D-Leu, X9 = L-Pro: [7-D-leucine]goserelin,

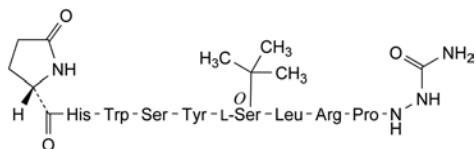

- B. [6-[O-(1,1-dimethylethyl)-L-serine]]goserelin,

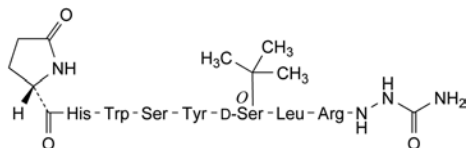

- D. 1-carbamoyl-2-[5-oxo-L-prolyl-L-histidyl-L-tryptophyl-L-seryl-L-tyrosyl-O-(1,1-dimethylethyl)-D-seryl-L-leucyl-L-arginyl]diazane,

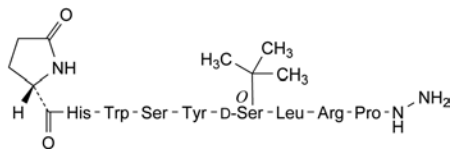

- E. 5-oxo-L-prolyl-L-histidyl-L-tryptophyl-L-seryl-L-tyrosyl-O-(1,1-dimethylethyl)-D-seryl-L-leucyl-L-arginyl-L-prolinohydrazide,

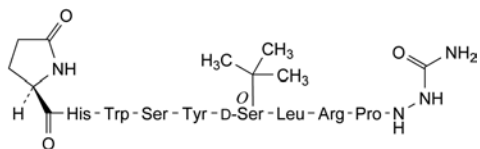

- H. [1-(5-oxo-D-proline)]goserelin,

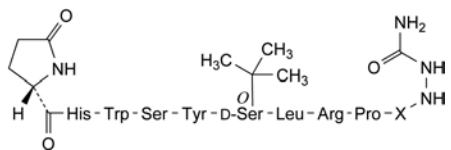

- I. X = Pro-Pro: endo-8a,8b-di-L-proline-goserelin,  
 J. X = Pro: endo-8a-L-proline-goserelin,

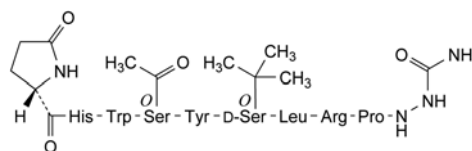

- K. O<sup>4</sup>-acetyl-goserelin.

01/2008:0907

## GRAMICIDIN

## Gramicidinum

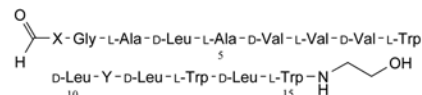

Gramicidin	X	Y	Mol. formula	M <sub>r</sub>
A1	L-Val	L-Trp	C <sub>99</sub> H <sub>140</sub> N <sub>20</sub> O <sub>17</sub>	1882
A2	L-Ile	L-Trp	C <sub>100</sub> H <sub>142</sub> N <sub>20</sub> O <sub>17</sub>	1896
B1	L-Val	L-Phe	C <sub>97</sub> H <sub>139</sub> N <sub>19</sub> O <sub>17</sub>	1843
C1	L-Val	L-Tyr	C <sub>97</sub> H <sub>139</sub> N <sub>19</sub> O <sub>18</sub>	1859
C2	L-Ile	L-Tyr	C <sub>98</sub> H <sub>141</sub> N <sub>19</sub> O <sub>18</sub>	1873

## DEFINITION

Gramicidin consists of a family of antimicrobial linear polypeptides, usually obtained by extraction from tyrothricin, the complex isolated from the fermentation broth of *Brevibacillus brevis* Dubos. The main component is gramicidin A1, together with gramicidins A2, B1, C1 and C2 in particular.

Content: minimum 900 IU/mg (dried substance).

## CHARACTERS

Appearance: white or almost white, crystalline powder, slightly hygroscopic.

Solubility: practically insoluble in water, soluble in methanol, sparingly soluble in alcohol.

mp: about 230 °C.

## IDENTIFICATION

First identification: A, C.

Second identification: A, B.

- A. Dissolve 0.100 g in alcohol R and dilute to 100.0 mL with the same solvent. Dilute 5.0 mL of this solution to 100.0 mL with alcohol R. Examined between 240 nm and 320 nm (2.2.25), the solution shows 2 absorption maxima, at 282 nm and 290 nm, a shoulder at about 275 nm and an absorption minimum at 247 nm. The specific absorbance at the maximum at 282 nm is 105 to 125.  
 B. Thin-layer chromatography (2.2.27).

Test solution. Dissolve 5 mg of the substance to be examined in 6.0 mL of alcohol R.

Reference solution (a). Dissolve 5 mg of gramicidin CRS in 6.0 mL of alcohol R.

Reference solution (b). Dissolve 5 mg of tyrothricin CRS in 6.0 mL of alcohol R.

Plate: TLC silica gel plate R.

Mobile phase: methanol R, butanol R, water R, glacial acetic acid R, butyl acetate R (3:9:15:24:49 V/V/V/V/V).

Application: 1 µL.

Development: over 2/3 of the plate.

Drying: in air.

Detection: dip the plate into dimethylaminobenzaldehyde solution R2. Heat at 90 °C until the spots appear.

**System suitability:** the chromatogram obtained with reference solution (b) shows 2 clearly separated spots or 2 clearly separated groups of spots.

**Results:** the principal spot or group of principal spots in the chromatogram obtained with the test solution is similar in position, colour and size to the principal spot or group of principal spots in the chromatogram obtained with reference solution (a) and to the spot or group of spots with the highest  $R_f$  value in the chromatogram obtained with reference solution (b).

- C. Examine the chromatograms obtained in the test for composition.

**Results:** the 3 principal peaks in the chromatogram obtained with the test solution are similar in retention time to the 3 principal peaks in the chromatogram obtained with reference solution (a).

## TESTS

**Composition.** Liquid chromatography (2.2.29): use the normalisation procedure.

**Test solution.** Dissolve 25 mg of the substance to be examined in 10 mL of *methanol R* and dilute to 25 mL with the mobile phase.

**Reference solution (a).** Dissolve 25 mg of *gramicidin CRS* in 10 mL of *methanol R* and dilute to 25 mL with the mobile phase.

**Reference solution (b).** Dilute 1.0 mL of reference solution (a) to 50.0 mL with the mobile phase. Dilute 1.0 mL of this solution to 10.0 mL with the mobile phase.

**Column:**

- size:  $l = 0.25$  m,  $\varnothing = 4.6$  mm,
- stationary phase: base-deactivated end-capped octadecylsilyl silica gel for chromatography *R* (5  $\mu$ m),
- temperature: 50 °C.

**Mobile phase:** water *R*, *methanol R* (29:71 V/V).

**Flow rate:** 1.0 mL/min.

**Detection:** spectrophotometer at 282 nm.

**Injection:** 20  $\mu$ L.

**Run time:** 2.5 times the retention time of *gramicidin A1*.

**Relative retention** with reference to *gramicidin A1* (retention time = about 22 min): *gramicidin C1* = about 0.7; *gramicidin C2* = about 0.8; *gramicidin A2* = about 1.2; *gramicidin B1* = about 1.9.

**System suitability:** reference solution (a):

- resolution: minimum 1.5 between the peaks due to *gramicidin A1* and *gramicidin A2*,
- the chromatogram obtained is concordant with the chromatogram supplied with *gramicidin CRS*.

**Composition:**

- sum of the contents of *gramicidins A1, A2, B1, C1* and *C2*: minimum 95.0 per cent,
- ratio of the content of *gramicidin A1* to the sum of the contents of *gramicidins A1, A2, B1, C1* and *C2*: minimum 60.0 per cent,
- disregard limit: the area of the peak due to *gramicidin A1* in the chromatogram obtained with reference solution (b).

**Related substances.** Liquid chromatography (2.2.29) as described in the test for composition.

**Limit:**

- any impurity: maximum 2.0 per cent and not more than 1 peak is more than 1.0 per cent; disregard the peaks due to *gramicidins A1, A2, B1, C1* and *C2*.

**Loss on drying** (2.2.32): maximum 3.0 per cent, determined on 1.000 g by drying over *diphosphorus pentoxide R* at 60 °C at a pressure not exceeding 0.1 kPa for 3 h.

**Sulfated ash** (2.4.14): maximum 1.0 per cent, determined on 1.0 g.

## ASSAY

Carry out the microbiological assay of antibiotics (2.7.2), using the turbidimetric method. Use *gramicidin CRS* as the reference substance.

## STORAGE

In an airtight container, protected from light.

## IMPURITIES

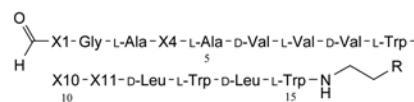

Impurity	X1	X4	X10	X11	R
A	L-Val	Met	D-Leu	L-Trp	OH
B	L-Val	D-Leu	D-Leu	L-Trp	CH <sub>2</sub> -OH
C	L-Ile	D-Leu	D-Leu	L-Phe	OH
D	L-Val	D-Leu	Met	L-Tyr	OH
E	L-Ile	D-Leu	D-Leu	L-Trp	CH <sub>2</sub> -OH

- A. [4-methionine]gramicidin A1,  
 B. *gramicidin A1* 3-hydroxypropyl,  
 C. *gramicidin B2*,  
 D. [10-methionine]gramicidin C1,  
 E. *gramicidin A2* 3-hydroxypropyl.

01/2008:1695  
corrected 6.3

# GRANISETRON HYDROCHLORIDE

## Granisetroni hydrochloridum

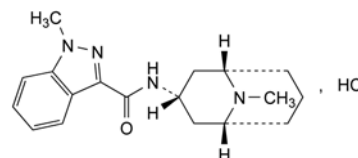

$C_{18}H_{25}ClN_4O$   
[107007-99-8]

$M_r$  348.9

## DEFINITION

1-Methyl-*N*-[(1*R*,3*r*,5*S*)-9-methyl-9-azabicyclo[3.3.1]non-3-yl]-1*H*-indazole-3-carboxamide hydrochloride.

**Content:** 97.0 per cent to 102.0 per cent (dried substance).

## CHARACTERS

**Appearance:** white or almost white powder.

**Solubility:** freely soluble in water, sparingly soluble in methylene chloride, slightly soluble in methanol.

## IDENTIFICATION

A. Infrared absorption spectrophotometry (2.2.24).

**Comparison:** *granisetron hydrochloride CRS*.

B. It gives reaction (a) of chlorides (2.3.1).

## TESTS

**Solution S.** Dissolve 0.2 g in *carbon dioxide-free water R* and dilute to 20 mL with the same solvent.

**Appearance of solution.** Solution S is clear (2.2.1) and colourless (2.2.2, *Method II*).

**pH** (2.2.3): 4.0 to 6.5 for solution S.

**Impurity E.** Thin-layer chromatography (2.2.27).

**Solvent mixture:** water *R*, *acetonitrile R* (20:80 V/V).

**Test solution.** Dissolve 0.25 g of the substance to be examined in the solvent mixture and dilute to 5 mL with the solvent mixture.

**Reference solution.** Dissolve 5.0 mg of *granisetron impurity E CRS* in the solvent mixture and dilute to 20.0 mL with the solvent mixture.

**Plate:** TLC silica gel  $F_{254}$  plate R.

**Mobile phase:** concentrated ammonia R, 2-propanol R, ethyl acetate R (6.5:30:50 V/V/V).

**Application:** 2  $\mu$ L.

**Development:** over half of the plate.

**Drying:** in air.

**Detection:** expose to iodine vapour for 30 min.

**Limit:**

- **impurity E:** any spot due to impurity E is not more intense than the principal spot in the chromatogram obtained with the reference solution (0.5 per cent).

**Related substances.** Liquid chromatography (2.2.29). Carry out the test protected from light.

**Test solution.** Dissolve 50.0 mg of the substance to be examined in the mobile phase and dilute to 50.0 mL with the mobile phase.

**Reference solution (a).** Dilute 1.0 mL of the test solution to 50.0 mL with the mobile phase. Dilute 5.0 mL of this solution to 20.0 mL with the mobile phase.

**Reference solution (b).** Transfer 2 mL of the test solution to a colourless glass vial, stopper and expose the solution either to sunlight for 4 h or under a UV lamp for 16 h (partial degradation of granisetron to impurity C). A degradation of at least about 0.3 per cent of granisetron to impurity C must be obtained as shown by appearance of a corresponding peak in the chromatogram. If not, expose the solution once again to sunlight or under a UV lamp.

**Reference solution (c).** Dissolve 50.0 mg of *granisetron hydrochloride CRS* in the mobile phase and dilute to 50.0 mL with the mobile phase.

**Reference solution (d).** Dissolve the contents of a vial of *granisetron impurity A CRS* in 1 mL of the mobile phase.

**Reference solution (e).** Dissolve the contents of a vial of *granisetron impurity B CRS* in 1 mL of the mobile phase.

**Column:**

- **size:**  $l = 0.25$  m,  $\varnothing = 4.6$  mm;
- **stationary phase:** spherical base-deactivated end-capped octadecylsilyl silica gel for chromatography R (5  $\mu$ m);
- **temperature:** 40 °C.

**Mobile phase:** dilute 1.6 mL of phosphoric acid R to 800 mL with water R, add 200 mL of acetonitrile R and mix. Add 1.0 mL of hexylamine R and mix. Adjust to pH 7.5  $\pm$  0.05 with freshly distilled triethylamine R (about 4 mL).

**Flow rate:** 1.5 mL/min.

**Detection:** spectrophotometer at 305 nm.

**Injection:** 10  $\mu$ L of the test solution and reference solutions (a), (b), (d) and (e).

**Run time:** twice the retention time of granisetron.

**Relative retention** with reference to granisetron (retention time = about 7 min): impurity D = about 0.4; impurity B = about 0.5; impurity A = about 0.7; impurity C = about 0.8.

**System suitability:**

- **resolution:** minimum 3.5 between the peaks due to impurity C and granisetron in the chromatogram obtained with reference solution (b);
- **symmetry factor:** maximum 2.0 for the peak due to granisetron.

**Limits:**

- **correction factor:** for the calculation of content, multiply the peak area of impurity B by 1.7;
- **impurity B:** not more than the area of the principal peak in the chromatogram obtained with reference solution (a) (0.5 per cent);

- **impurity C:** not more than 0.4 times the area of the principal peak in the chromatogram obtained with reference solution (a) (0.2 per cent);
- **impurity A:** not more than twice the area of the principal peak in the chromatogram obtained with reference solution (a) (1.0 per cent);
- **impurity D:** not more than 0.2 times the area of the principal peak in the chromatogram obtained with reference solution (a) (0.1 per cent);
- **any other impurity:** for each impurity, not more than 0.2 times the area of the principal peak in the chromatogram obtained with reference solution (a) (0.1 per cent);
- **total:** not more than twice the area of the principal peak in the chromatogram obtained with reference solution (a) (1.0 per cent);
- **disregard limit:** 0.1 times the area of the principal peak in the chromatogram obtained with reference solution (a) (0.05 per cent); disregard any peak due to the blank.

**Loss on drying (2.2.32):** maximum 0.5 per cent, determined on 1.000 g by drying in an oven at 105 °C for 4 h.

**Sulfated ash (2.4.14):** maximum 0.1 per cent, determined on 1.0 g.

#### ASSAY

Liquid chromatography (2.2.29) as described in the test for related substances with the following modification.

**Injection:** test solution and reference solution (c).

Calculate the percentage content of  $C_{18}H_{25}ClN_4O$  using the declared content of *granisetron hydrochloride CRS*.

#### IMPURITIES

**Specified impurities:** A, B, C, D, E.

**Other detectable impurities** (the following substances would, if present at a sufficient level, be detected by one or other of the tests in the monograph. They are limited by the general acceptance criterion for other/unspecified impurities and/or by the general monograph *Substances for pharmaceutical use (2034)*. It is therefore not necessary to identify these impurities for demonstration of compliance. See also 5.10. *Control of impurities in substances for pharmaceutical use*): F, G, H, I.

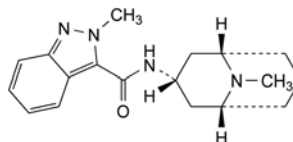

A. 2-methyl-*N*-[(1*R*,3*r*,5*S*)-9-methyl-9-azabicyclo[3.3.1]non-3-yl]-2*H*-indazole-3-carboxamide,

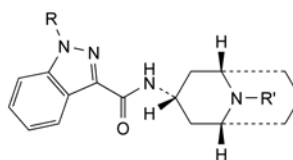

B. R = H, R' = CH<sub>3</sub>: *N*-[(1*R*,3*r*,5*S*)-9-methyl-9-azabicyclo[3.3.1]non-3-yl]-1*H*-indazole-3-carboxamide,

C. R = CH<sub>3</sub>, R' = H: *N*-[(1*R*,3*r*,5*S*)-9-azabicyclo[3.3.1]non-3-yl]-1-methyl-1*H*-indazole-3-carboxamide,

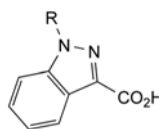

D. R = CH<sub>3</sub>: 1-methyl-1*H*-indazole-3-carboxylic acid,

H. R = H: 1*H*-indazole-3-carboxylic acid,

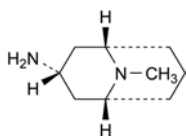

E. (1*R*,3*r*,5*S*)-9-methyl-9-azabicyclo[3.3.1]nonan-3-amine,

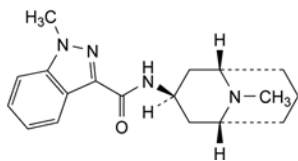

F. 1-methyl-*N*-[(1*R*,3*s*,5*S*)-9-methyl-9-azabicyclo[3.3.1]non-3-yl]-1*H*-indazole-3-carboxamide (*exo*-granisetron),

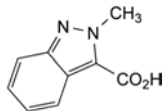

G. 2-methyl-2*H*-indazole-3-carboxylic acid,

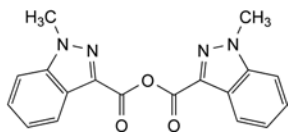

I. 1-methyl-1*H*-indazole-3-carboxylic anhydride.

01/2008:0182  
corrected 6.0

## GRISEOFULVIN

### Griseofulvinum

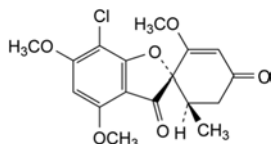

C<sub>17</sub>H<sub>17</sub>ClO<sub>6</sub>  
[126-07-8]

*M*<sub>r</sub> 352.8

#### DEFINITION

(1'*S*,3-6'*R*)-7-Chloro-2',4,6-trimethoxy-6'-methylspiro[benzofuran-2(3*H*),1'-[2]cyclohexene]-3,4'-dione.

Substance produced by the growth of certain strains of *Penicillium griseofulvum* or obtained by any other means.

*Content*: 97.0 per cent to 102.0 per cent (dried substance).

#### PRODUCTION

The method of manufacture is validated to demonstrate that the product if tested would comply with the following test.

**Abnormal toxicity.** To each of 5 healthy mice, each weighing 17-22 g, administer orally a suspension of 0.1 g of the substance to be examined in 0.5-1 mL of *water R*. None of the mice dies within 48 h.

#### CHARACTERS

**Appearance:** white or yellowish-white, microfine powder, the particles of which generally have a maximum dimension of up to 5 µm, although larger particles that may exceed 30 µm may occasionally be present.

**Solubility:** practically insoluble in water, freely soluble in dimethylformamide and in tetrachloroethane, slightly soluble in anhydrous ethanol and in methanol.

*mp*: about 220 °C.

#### IDENTIFICATION

A. Infrared absorption spectrophotometry (2.2.24).

*Comparison: griseofulvin CRS.*

B. Dissolve about 5 mg in 1 mL of *sulfuric acid R* and add about 5 mg of powdered *potassium dichromate R*. A dark red colour develops.

#### TESTS

**Appearance of solution.** The solution is clear (2.2.1) and not more intensely coloured than reference solution Y<sub>4</sub> (2.2.2, *Method II*).

Dissolve 0.75 g in *dimethylformamide R* and dilute to 10 mL with the same solvent.

**Acidity.** Suspend 0.25 g in 20 mL of *ethanol (96 per cent) R* and add 0.1 mL of *phenolphthalein solution R*. Not more than 1.0 mL of 0.02 *M sodium hydroxide* is required to change the colour of the indicator.

**Specific optical rotation** (2.2.7): + 354 to + 364 (dried substance).

Dissolve 0.250 g in *dimethylformamide R* and dilute to 25.0 mL with the same solvent.

**Related substances.** Gas chromatography (2.2.28).

**Internal standard solution.** Dissolve 0.2 g of *diphenylanthracene R* in *acetone R* and dilute to 100.0 mL with the same solvent.

**Test solution (a).** Dissolve 0.10 g of the substance to be examined in *acetone R* and dilute to 10.0 mL with the same solvent.

**Test solution (b).** Dissolve 0.10 g of the substance to be examined in *acetone R*, add 1.0 mL of the internal standard solution and dilute to 10.0 mL with *acetone R*.

**Reference solution.** Dissolve 5.0 mg of *griseofulvin CRS* in *acetone R*, add 1.0 mL of the internal standard solution and dilute to 10.0 mL with *acetone R*.

**Column:**

- *material*: glass;
- *size*: *l* = 1 m, Ø = 4 mm;
- *stationary phase*: *diatomaceous earth for gas chromatography R* impregnated with 1 per cent *m/m of poly[(cyanopropyl)(methyl)][(phenyl)(methyl)siloxane R*.

**Carrier gas:** *nitrogen for chromatography R*.

**Flow rate:** 50-60 mL/min.

**Temperature:**

- *column*: 250 °C;
- *injection port*: 270 °C;
- *detector*: 300 °C.

**Detection:** flame ionisation.

**Run time:** 3 times the retention time of griseofulvin.

**Relative retention** with reference to griseofulvin (retention time = about 11 min): dechloro-griseofulvin = about 0.6; dehydrogriseofulvin = about 1.4.

Calculate the ratio (*R*) of the area of the peak due to griseofulvin to the area of the peak due to the internal standard in the chromatogram obtained with the reference solution.

**Limits:**

- *dechloro-griseofulvin*: calculate the ratio of the area of the peak due to dechloro-griseofulvin to the area of the peak due to the internal standard in the chromatogram obtained with test solution (b): this ratio is not greater than 0.6 *R* (3.0 per cent);
- *dehydrogriseofulvin*: calculate the ratio of the area of the peak due to dehydrogriseofulvin to the area of the peak due to the internal standard in the chromatogram obtained with test solution (b): this ratio is not greater than 0.15 *R* (0.75 per cent).

**Substances soluble in light petroleum:** maximum 0.2 per cent.

Shake 1.0 g with 20 mL of *light petroleum R*. Boil under a reflux condenser for 10 min. Cool, filter and wash with 3 quantities,

each of 15 mL, of *light petroleum R*. Combine the filtrate and washings, evaporate to dryness on a water-bath and dry at 100-105 °C for 1 h. The residue weighs not more than 2 mg.

**Loss on drying** (2.2.32): maximum 1.0 per cent, determined on 1.00 g by drying in an oven at 105 °C.

**Sulfated ash** (2.4.14): maximum 0.2 per cent, determined on 1.0 g.

#### ASSAY

Dissolve 80.0 mg in *anhydrous ethanol R* and dilute to 200.0 mL with the same solvent. Dilute 2.0 mL of this solution to 100.0 mL with *anhydrous ethanol R*. Measure the absorbance (2.2.25) at the absorption maximum at 291 nm.

Calculate the content of C<sub>7</sub>H<sub>8</sub>O<sub>2</sub>, taking the specific absorbance to be 686.

07/2009:1978

## GUAIACOL

### Guaiacolum

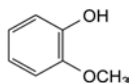

C<sub>7</sub>H<sub>8</sub>O<sub>2</sub>  
[90-05-1]

M<sub>r</sub> 124.1

#### DEFINITION

2-Methoxyphenol.

**Content:** 97.0 per cent to 102.0 per cent (anhydrous substance).

#### CHARACTERS

**Appearance:** crystalline mass or colourless or yellowish liquid, hygroscopic.

**Solubility:** sparingly soluble in water, very soluble in methylene chloride, freely soluble in ethanol (96 per cent).

mp: about 28 °C.

#### IDENTIFICATION

**First identification:** A.

**Second identification:** B.

A. Infrared absorption spectrophotometry (2.2.24).

**Comparison:** *guaiacol CRS*.

B. Thin-layer chromatography (2.2.27).

**Test solution.** Dissolve 0.5 g of the substance to be examined in *methanol R* and dilute to 25 mL with the same solvent.

**Reference solution.** Dissolve 0.5 g of *guaiacol CRS* in *methanol R* and dilute to 25 mL with the same solvent.

**Plate:** *TLC silica gel plate R*.

**Mobile phase:** *anhydrous acetic acid R, methanol R, toluene R* (6:14:80 V/V/V).

**Application:** 5 µL.

**Development:** over 2/3 of the plate.

**Drying:** in air.

**Detection:** spray with *ferric chloride solution R1*.

**Results:** the principal spot in the chromatogram obtained with the test solution is similar in position, colour and size to the principal spot in the chromatogram obtained with the reference solution.

#### TESTS

**Solution S.** Dissolve 1.00 g in *ethanol (96 per cent) R* and dilute to 10.0 mL with the same solvent.

**Appearance of solution.** Solution S is clear (2.2.1) and not more intensely coloured than reference solution BY<sub>6</sub> (2.2.2, *Method I*).

**Acidity or alkalinity.** To 5.0 mL of solution S, add 10 mL of *carbon dioxide-free water R* and 0.1 mL of *methyl red mixed solution R*. Not more than 0.05 mL of 0.1 M *hydrochloric acid* or 0.1 M *sodium hydroxide* is required to change the colour of the indicator.

**Impurity A.** Liquid chromatography (2.2.29).

**Solvent mixture:** *phosphoric acid R, water R, methanol R* (1:499:500 V/V/V).

**Test solution (a).** Dissolve 1.0 g of the substance to be examined in the solvent mixture and dilute to 25.0 mL with the solvent mixture.

**Test solution (b).** Dissolve 20.0 mg of the substance to be examined in the solvent mixture and dilute to 100.0 mL with the solvent mixture.

**Reference solution (a).** Dilute 1.0 mL of test solution (a) to 100.0 mL with the solvent mixture. Dilute 1.0 mL of this solution to 20.0 mL with the solvent mixture.

**Reference solution (b).** Dissolve 0.20 g of *pyrocatechol R* (impurity A) and 0.20 g of *phenol R* (impurity B) in the solvent mixture and dilute to 100 mL with the solvent mixture. Dilute 1 mL of this solution to 10 mL with the solvent mixture.

**Reference solution (c).** Dissolve 20.0 mg of *guaiacol CRS* in the solvent mixture and dilute to 100.0 mL with the solvent mixture.

**Column:**

- size:  $l = 0.15$  m,  $\varnothing = 4.6$  mm;
- stationary phase: *octadecylsilyl silica gel for chromatography R* (5 µm).

**Mobile phase:**

- mobile phase A: *phosphoric acid R, methanol R, water R* (1:150:849 V/V/V);
- mobile phase B: *methanol R*;

Time (min)	Mobile phase A (per cent V/V)	Mobile phase B (per cent V/V)
0 - 28	100	0
28 - 30	100 → 35	0 → 65
30 - 40	35	65

**Flow rate:** 1 mL/min.

**Detection:** spectrophotometer at 270 nm.

**Injection:** 20 µL of test solution (a) and reference solutions (a) and (b).

**Retention time:** *guaiacol* = about 20 min.

**System suitability:** reference solution (b):

- resolution: minimum 5.0 between the peaks due to impurities A (1<sup>st</sup> peak) and B (2<sup>nd</sup> peak).

**Limit:**

- impurity A: not more than the area of the principal peak in the chromatogram obtained with reference solution (a) (0.05 per cent).

**Related substances.** Gas chromatography (2.2.28): use the normalisation procedure.

**Test solution.** Dissolve 1.00 g of the substance to be examined in *acetonitrile R* and dilute to 10.0 mL with the same solvent.

**Reference solution (a).** Dissolve 0.20 g of *phenol R* (impurity B) and 0.40 g of *methyl benzoate R* (impurity E) in *acetonitrile R* and dilute to 50 mL with the same solvent. Dilute 1 mL of this solution to 20 mL with *acetonitrile R*.

**Reference solution (b).** Dilute 0.5 mL of the test solution to 100.0 mL with *acetonitrile R*. Dilute 1.0 mL of this solution to 10.0 mL with *acetonitrile R*.

**Reference solution (c).** Dissolve 10 mg of *veratrole R* (impurity C) in *acetonitrile R* and dilute to 10 mL with the same solvent.

**Column:**

- material: fused silica;
- size:  $l = 25$  m,  $\varnothing = 0.53$  mm;

– stationary phase: poly(cyanopropyl)(7)(phenyl)-  
(7)(methyl)(86)siloxane R (film thickness 2 µm).

Carrier gas: helium for chromatography R.

Flow rate: 5 mL/min.

Split ratio: 1:5.

Temperature:

	Time (min)	Temperature (°C)
Column	0 - 15	90
	15 - 45	90 → 180
Injection port		200
Detector		220

Detection: flame ionisation.

Injection: 1 µL.

Relative retention with reference to guaiacol (retention time = about 25 min): impurity E = about 0.88; impurity B = about 0.92; impurity C = about 1.1.

System suitability: reference solution (a):

– resolution: minimum 2.0 between the peaks due to impurities E (1<sup>st</sup> peak) and B (2<sup>nd</sup> peak).

Limits:

- impurity C: maximum 0.4 per cent;
- impurity E: maximum 0.2 per cent;
- impurity B: maximum 0.15 per cent;
- unspecified impurities: for each impurity, maximum 0.10 per cent;
- total: maximum 1.0 per cent;
- disregard limit: the area of the principal peak in the chromatogram obtained with reference solution (b) (0.05 per cent).

Water (2.5.12): maximum 0.5 per cent, determined on 2.000 g.

#### ASSAY

Liquid chromatography (2.2.29) as described in the test for impurity A with the following modification.

Injection: test solution (b) and reference solution (c).

Calculate the percentage content of C<sub>7</sub>H<sub>8</sub>O<sub>2</sub> from the declared content of guaiacol CRS.

#### STORAGE

In an airtight container, protected from light.

#### IMPURITIES

Specified impurities: A, B, C, E.

Other detectable impurities (the following substances would, if present at a sufficient level, be detected by one or other of the tests in the monograph. They are limited by the general acceptance criterion for other/unspecified impurities and/or by the general monograph *Substances for pharmaceutical use* (2034). It is therefore not necessary to identify these impurities for demonstration of compliance. See also 5.10. *Control of impurities in substances for pharmaceutical use*): D, F, G, H.

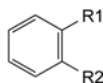

- A. R1 = R2 = OH: benzene-1,2-diol (pyrocatechol),
- B. R1 = OH, R2 = H: phenol,
- C. R1 = R2 = OCH<sub>3</sub>: 1,2-dimethoxybenzene (veratrole),
- E. R1 = CO-O-CH<sub>3</sub>, R2 = H: methyl benzoate,

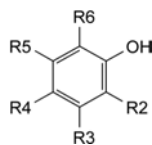

- D. R2 = R5 = OCH<sub>3</sub>, R3 = R4 = R6 = H: 2,5-dimethoxyphenol,
- F. R2 = OCH<sub>3</sub>, R3 = R4 = R5 = H, R6 = CH<sub>3</sub>: 2-methoxy-6-methylphenol (6-methylguaiaicol),
- G. R2 = R3 = R5 = R6 = H, R4 = OCH<sub>3</sub>: 4-methoxyphenol,
- H. R2 = R4 = R5 = R6 = H, R3 = OCH<sub>3</sub>: 3-methoxyphenol.

01/2008:0615  
corrected 7.0

## GUAIFENESIN

### Guaifenesinum

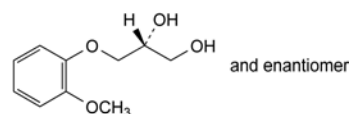

C<sub>10</sub>H<sub>14</sub>O<sub>4</sub>  
[93-14-1]

M<sub>r</sub> 198.2

#### DEFINITION

(2*RS*)-3-(2-Methoxyphenoxy)propane-1,2-diol.

Content: 98.0 per cent to 102.0 per cent (dried substance).

#### CHARACTERS

Appearance: white or almost white, crystalline powder.

Solubility: sparingly soluble in water, soluble in alcohol.

#### IDENTIFICATION

First identification: B.

Second identification: A, C.

A. Melting point (2.2.14): 79 °C to 83 °C.

B. Infrared absorption spectrophotometry (2.2.24).

Comparison: guaiifenesin CRS.

C. Thin-layer chromatography (2.2.27).

Test solution. Dissolve 30 mg of the substance to be examined in methanol R and dilute to 10 mL with the same solvent.

Reference solution. Dissolve 30 mg of guaiifenesin CRS in methanol R and dilute to 10 mL with the same solvent.

Plate: TLC silica gel G plate R.

Mobile phase: methylene chloride R, propanol R (20:80 V/V).

Application: 5 µL.

Development: over 2/3 of the plate.

Drying: in air.

Detection: spray with a mixture of equal volumes of a 10 g/L solution of potassium ferricyanide R, a 200 g/L solution of ferric chloride R and alcohol R.

Results: the principal spot in the chromatogram obtained with the test solution is similar in position, colour and size to the principal spot in the chromatogram obtained with the reference solution.

#### TESTS

**Solution S.** Dissolve 1.0 g in carbon dioxide-free water R, heating gently if necessary, and dilute to 50 mL with the same solvent.

**Appearance of solution.** Solution S is clear (2.2.1) and colourless (2.2.2, Method II).



**Acidity or alkalinity.** To 10 mL of solution S add 0.05 mL of *phenolphthalein solution R1*. Not more than 0.1 mL of 0.01 M sodium hydroxide is required to change the colour of the indicator. To 10 mL of solution S add 0.15 mL of *methyl red solution R*. Not more than 0.1 mL of 0.01 M hydrochloric acid is required to change the colour of the indicator to red.

**Related substances.** Liquid chromatography (2.2.29).

**Test solution.** Dissolve 0.100 g of the substance to be examined in *acetonitrile R* and dilute to 50.0 mL with the same solvent.

**Reference solution (a).** Dilute 1.0 mL of the test solution to 20.0 mL with *acetonitrile R*. Dilute 1.0 mL of this solution to 10.0 mL with *acetonitrile R*.

**Reference solution (b).** Dissolve 10.0 mg of *guaiacol R* in *acetonitrile R* and dilute to 50.0 mL with the same solvent. Dilute 0.5 mL of this solution to 50.0 mL with *acetonitrile R*.

**Reference solution (c).** Dissolve 50.0 mg of *guaiacol R* in *acetonitrile R* and dilute to 50.0 mL with the same solvent. Dilute 5.0 mL of this solution to 10.0 mL with the test solution.

**Column:**

- size:  $l = 0.25$  m,  $\varnothing = 4.6$  mm,
- stationary phase: octadecylsilyl silica gel for chromatography R (5  $\mu$ m).

**Mobile phase:**

- mobile phase A: glacial acetic acid R, water R (10:990 V/V),
- mobile phase B: *acetonitrile R*,

Time (min)	Mobile phase A (per cent V/V)	Mobile phase B (per cent V/V)
0 - 32	80 → 50	20 → 50

**Flow rate:** 1 mL/min.

**Detection:** spectrophotometer at 276 nm.

**Injection:** 10  $\mu$ L.

**Relative retention** with reference to *guaifenesin* (retention time = about 8 min): impurity B = about 0.9; impurity A = about 1.4; impurity C = about 3.1; impurity D = about 3.7.

**System suitability:** reference solution (c):

- resolution: minimum 3.0 between the peaks due to *guaifenesin* and impurity A.

**Limits:**

- impurity A: not more than the area of the principal peak in the chromatogram obtained with reference solution (b) (0.1 per cent),
- impurity B: not more than twice the area of the principal peak in the chromatogram obtained with reference solution (a) (1.0 per cent),
- any other impurity: not more than the area of the principal peak in the chromatogram obtained with reference solution (a) (0.5 per cent),
- total (excluding impurity B): not more than twice the area of the principal peak in the chromatogram obtained with reference solution (a) (1.0 per cent),
- disregard level: 0.1 times the area of the principal peak in the chromatogram obtained with reference solution (a) (0.05 per cent).

**Chlorides and monochlorhydrins:** maximum of 250 ppm.

To 10 mL of solution S add 2 mL of *dilute sodium hydroxide solution R* and heat on a water-bath for 5 min. Cool and add 3 mL of *dilute nitric acid R*. The resulting solution complies with the limit test for chlorides (2.4.4).

**Heavy metals (2.4.8):** maximum of 25 ppm.

Dissolve 2.0 g in a mixture of 1 volume of *water R* and 9 volumes of *alcohol R* and dilute to 25 mL with the same mixture of solvents. 12 mL of the solution complies with limit test B. Prepare the standard using lead standard solution (2 ppm Pb)

prepared by diluting *lead standard solution (100 ppm Pb) R* with a mixture of 1 volume of *water R* and 9 volumes of *alcohol R*.

**Loss on drying (2.2.32):** maximum 0.5 per cent, determined on 1.000 g by drying *in vacuo* at 60 °C for 3 h.

**Sulfated ash (2.4.14):** maximum 0.1 per cent, determined on 1.0 g.

**ASSAY**

To 0.500 g ( $m$  g) add 10.0 mL of a freshly prepared mixture of 1 volume of *acetic anhydride R* and 7 volumes of *pyridine R*. Boil under a reflux condenser for 45 min. Cool and add 25 mL of *water R*. Using 0.25 mL of *phenolphthalein solution R* as indicator, titrate with 1 M sodium hydroxide ( $n_1$  mL). Carry out a blank titration ( $n_2$  mL).

Calculate the percentage content of  $C_{10}H_{14}O_4$  from the expression:

$$\frac{19.82 (n_2 - n_1)}{2m}$$

**IMPURITIES**

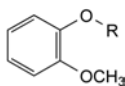

A. R = H: 2-methoxyphenol (*guaiacol*),

B. R =  $CH(CH_2OH)_2$ : 2-(2-methoxyphenoxy)propane-1,3-diol (B-isomer),

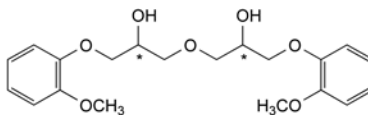

C. 1,1'-oxybis[3-(2-methoxyphenoxy)propan-2-ol] (bisether),

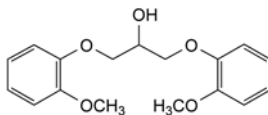

D. 1,3-bis(2-methoxyphenoxy)propan-2-ol.

01/2008:0027  
corrected 6.0

## GUANETHIDINE MONOSULFATE

### Guanethidini monosulfas

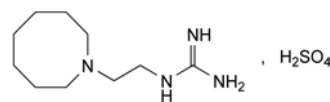

$C_{10}H_{24}N_4O_4S$   
[645-43-2]

$M_r$  296.4

**DEFINITION**

1-[2-(Hexahydroazocin-1(2*H*)-yl)ethyl]guanidine monosulfate.

**Content:** 99.0 per cent to 101.0 per cent (dried substance).

**CHARACTERS**

**Appearance:** colourless, crystalline powder.

**Solubility:** freely soluble in water, practically insoluble in ethanol (96 per cent).

mp: about 250 °C, with decomposition.

**IDENTIFICATION**

A. Dissolve about 25 mg in 25 mL of *water R*, add 20 mL of *picric acid solution R* and filter. The precipitate, washed with *water R* and dried at 100-105 °C, melts (2.2.14) at about 154 °C.

- B. Dissolve about 25 mg in 5 mL of *water R*. Add 1 mL of *strong sodium hydroxide solution R*, 1 mL of *α-naphthol solution R* and, dropwise with shaking, 0.5 mL of *strong sodium hypochlorite solution R*. A bright pink precipitate is formed and becomes violet-red on standing.
- C. It gives the reactions of sulfates (2.3.1).

## TESTS

**Solution S.** Dissolve 0.4 g in *carbon dioxide-free water R* and dilute to 20 mL with the same solvent.

**Appearance of solution.** Solution S is not more intensely coloured than reference solution GY<sub>6</sub> (2.2.2, *Method II*).

**pH (2.2.3):** 4.7 to 5.5 for solution S.

**Oxidisable substances.** In a conical, ground-glass-stoppered flask, dissolve 1.0 g in 25 mL of *water R* and add 25 mL of *dilute sodium hydroxide solution R*. Allow to stand for 10 min and add 1 g of *potassium bromide R* and 1 mL of 0.0083 M *potassium bromate*. Acidify with 30 mL of *dilute hydrochloric acid R*. Mix and allow to stand in the dark for 5 min. Add 2 g of *potassium iodide R* and shake. Allow to stand for 2 min and titrate the liberated iodine with 0.05 M *sodium thiosulfate*, using *starch solution R* as indicator. Not less than 0.3 mL of 0.05 M *sodium thiosulfate* is required to decolorise the solution.

**Heavy metals (2.4.8):** maximum 10 ppm.

2.0 g complies with test C. Prepare the reference solution using 2 mL of *lead standard solution (10 ppm Pb) R*.

**Loss on drying (2.2.32):** maximum 0.5 per cent, determined on 1.00 g by drying in an oven at 105 °C.

**Sulfated ash (2.4.14):** maximum 0.1 per cent, determined on 1.0 g.

## ASSAY

Dissolve 0.250 g, warming if necessary, in 30 mL of *anhydrous acetic acid R* and add 15 mL of *acetic anhydride R*. Titrate with 0.1 M *perchloric acid*, determining the end-point potentiometrically (2.2.20).

1 mL of 0.1 M *perchloric acid* is equivalent to 29.64 mg of C<sub>10</sub>H<sub>24</sub>N<sub>4</sub>O<sub>4</sub>S.

## STORAGE

Protected from light.

01/2010:0908

## GUAR GALACTOMANNAN

## Guar galactomannanum

## DEFINITION

Guar galactomannan is obtained from the seeds of *Cyamopsis tetragonolobus* (L.) Taub. by grinding of the endosperms and subsequent partial hydrolysis. The main components are polysaccharides composed of D-galactose and D-mannose at molar ratios of 1:1.4 to 1:2. The molecules consist of a linear main chain of β-(1→4)-glycosidically linked mannopyranoses and single α-(1→6)-glycosidically linked galactopyranoses.

## CHARACTERS

**Appearance:** yellowish-white powder.

**Solubility:** soluble in cold water and in hot water, practically insoluble in organic solvents.

## IDENTIFICATION

- A. Mix 5 g of solution S (see Tests) with 0.5 mL of a 10 g/L solution of *disodium tetraborate R*. A gel forms within a short time.
- B. Heat 20 g of solution S in a water-bath for 10 min. Allow to cool and adjust to the original mass with *water R*. The solution does not gel.

- C. Thin-layer chromatography (2.2.27).

**Test solution.** To 10 mg of the substance to be examined in a thick-walled centrifuge tube add 2 mL of a 230 g/L solution of *trifluoroacetic acid R*, shake vigorously to dissolve the forming gel, stopper the tube and heat the mixture at 120 °C for 1 h. Centrifuge the hydrolysate, transfer the clear supernatant liquid carefully into a 50 mL flask, add 10 mL of *water R* and evaporate the solution to dryness under reduced pressure. Take up the residue in 10 mL of *water R* and evaporate again to dryness under reduced pressure. To the resulting clear film, which has no odour of acetic acid, add 0.1 mL of *water R* and 1 mL of *methanol R*. Centrifuge to separate the amorphous precipitate. Dilute the supernatant liquid, if necessary, to 1 mL with *methanol R*.

**Reference solution.** Dissolve 10 mg of *galactose R* and 10 mg of *mannose R* in 2 mL of *water R* and dilute to 10 mL with *methanol R*.

**Plate:** TLC silica gel G plate R.

**Mobile phase:** *water R*, *acetonitrile R* (15:85 V/V).

**Application:** 5 µL, as bands of 20 mm by 3 mm.

**Development:** over a path of 15 cm.

**Detection:** spray with *aminohippuric acid reagent R* and heat at 120 °C for 5 min.

**Results:** the chromatogram obtained with the reference solution shows in the lower part 2 clearly separated brownish zones due to galactose and mannose in order of increasing R<sub>f</sub> value; the chromatogram obtained with the test solution shows 2 zones due to galactose and mannose.

## TESTS

**Solution S.** Moisten 1.0 g with 2 mL of *2-propanol R*. While stirring, dilute to 100 g with *water R* and stir until the substance is uniformly dispersed. Allow to stand for at least 1 h. If the apparent viscosity is below 200 mPas, use 3.0 g of substance instead of 1.0 g.

**pH (2.2.3):** 5.5 to 7.5 for solution S.

**Apparent viscosity (2.2.10):** 75 per cent to 140 per cent of the value stated on the label.

Moisten a quantity of the substance to be examined equivalent to 2.00 g of the dried substance with 2.5 mL of *2-propanol R* and, while stirring, dilute to 100.0 mL with *water R*. After 1 h, determine the viscosity at 20 °C using a rotating viscometer and a shear rate of 100 s<sup>-1</sup>.

**Insoluble matter:** maximum 7.0 per cent.

In a 250 mL flask disperse, while stirring, 1.50 g in a mixture of 1.6 mL of *sulfuric acid R* and 150 mL of *water R* and weigh. Immerse the flask in a water-bath and heat under a reflux condenser for 6 h. Adjust to the original mass with *water R*. Filter the hot solution through a tared, sintered-glass filter (160) (2.1.2). Rinse the filter with hot *water R* and dry at 100-105 °C. The residue weighs a maximum of 105 mg.

**Protein:** maximum 5.0 per cent.

Carry out the determination of nitrogen by sulfuric acid digestion (2.5.9), using 0.400 g. Multiply the result by 6.25.

**Tragacanth, sterculia gum, agar, alginates and carrageenan.**

To a small amount of the substance to be examined add 0.2 mL of freshly prepared *ruthenium red solution R*. Examined under a microscope, none of the structures are red.

**Loss on drying (2.2.32):** maximum 15.0 per cent, determined on 1.000 g by drying in an oven at 105 °C for 5 h.

**Total ash (2.4.16):** maximum 1.8 per cent, determined on 1.00 g after wetting with 10 mL of *water R*.

## Microbial contamination

TAMC: acceptance criterion 10<sup>3</sup> CFU/g (2.6.12).

TYMC: acceptance criterion 10<sup>2</sup> CFU/g (2.6.12).

Absence of *Escherichia coli* (2.6.13).

Absence of *Salmonella* (2.6.13).

**LABELLING**

The label states the apparent viscosity in millipascal seconds for a 20 g/L solution.

**FUNCTIONALITY-RELATED CHARACTERISTICS**

*This section provides information on characteristics that are recognised as being relevant control parameters for one or more functions of the substance when used as an excipient (see chapter 5.15). This section is a non-mandatory part of the monograph and it is not necessary to verify the characteristics to demonstrate compliance. Control of these characteristics*

*can however contribute to the quality of a medicinal product by improving the consistency of the manufacturing process and the performance of the medicinal product during use. Where control methods are cited, they are recognised as being suitable for the purpose, but other methods can also be used. Wherever results for a particular characteristic are reported, the control method must be indicated.*

*The following characteristic may be relevant for guar galactomannan used as viscosity-increasing agent or binder.*

**Apparent viscosity:** see Tests.

01/2009:1167  
corrected 7.0**HAEMODIALYSIS SOLUTIONS,  
CONCENTRATED, WATER FOR  
DILUTING****Aqua ad dilutionem solutionum  
concentratarum ad haemodialysim**

The following monograph is given for information.

The analytical methods described and the limits proposed are intended to be used for validating the procedure for obtaining the water.

**DEFINITION**

Water for diluting concentrated haemodialysis solutions is obtained from potable water by distillation, by reverse osmosis, by ion exchange or by any other suitable method. The conditions of preparation, transfer and storage are designed to minimise the risk of chemical and microbial contamination.

When water obtained by one of the methods described above is not available, potable water may be used for home dialysis. Because the chemical composition of potable water varies considerably from one locality to another, consideration must be given to its chemical composition to enable adjustments to be made to the content of ions so that the concentrations in the diluted solution correspond to the intended use.

Attention has also to be paid to the possible presence of residues from water treatment (for example, chloramines) and volatile halogenated hydrocarbons.

For the surveillance of the quality of water for diluting concentrated haemodialysis solutions, the following methods may be used to determine the chemical composition and/or to detect the presence of possible contaminants together with suggested limits to be obtained.

**CHARACTERS**

Clear, colourless, liquid.

**TESTS**

**Acidity or alkalinity.** To 10 mL of the water to be examined, freshly boiled and cooled in a borosilicate glass flask, add 0.05 mL of *methyl red solution R*. The solution is not red. To 10 mL of the water to be examined add 0.1 mL of *bromothymol blue solution R1*. The solution is not blue.

**Oxidisable substances.** To 100 mL of the water to be examined add 10 mL of *dilute sulfuric acid R* and 0.1 mL of *0.02 M potassium permanganate* and boil for 5 min. The solution remains faintly pink.

**Total available chlorine:** maximum 0.1 ppm.

In a 125 mL test-tube (A), place successively 5 mL of *buffer solution pH 6.5 R*, 5 mL of *diethylphenylenediamine sulfate solution R* and 1 g of *potassium iodide R*. In a second 125 mL test-tube (B), place successively 5 mL of *buffer solution pH 6.5 R* and 5 mL of *diethylphenylenediamine sulfate solution R*. Add as simultaneously as possible to tube A 100 mL of the water to be examined and to tube B a reference solution prepared as follows: to 1 mL of a 10 mg/L solution of *potassium iodate R*, add 1 g of *potassium iodide R* and 1 mL of *dilute sulfuric acid R*; allow to stand for 1 min, add 1 mL of *dilute sodium hydroxide solution R* and dilute to 100 mL with *water R*. Any colour in the mixture obtained with the water to be examined is not more intense than that in the mixture obtained with the reference solution.

**Chlorides (2.4.4):** maximum 50 ppm.

Dilute 1 mL of the water to be examined to 15 mL with *water R*. The solution complies with the limit test for chlorides.

**Fluorides:** maximum 0.2 ppm.

Potentiometry (2.2.36, *Method I*): use as indicator electrode a fluoride-selective solid-membrane electrode and as reference electrode a silver-silver chloride electrode.

*Test solution.* The water to be examined.

*Reference solutions.* Dilute 2.0 mL, 4.0 mL and 10.0 mL of *fluoride standard solution (1 ppm F) R* respectively to 20.0 mL with *total-ionic-strength-adjustment buffer R1*.

Carry out the measurement of each solution.

**Nitrates:** maximum 2 ppm.

Dilute 2 mL of the water to be examined to 100 mL with *nitrate-free water R*. Place 5 mL of the dilution in a test-tube immersed in iced water, add 0.4 mL of a 100 g/L solution of *potassium chloride R* and 0.1 mL of *diphenylamine solution R* and then, dropwise and with shaking, 5 mL of *sulfuric acid R*. Transfer the tube to a water-bath at 50 °C. Allow to stand for 15 min. Any blue colour in the solution is not more intense than that in a standard prepared at the same time and in the same manner using a mixture of 0.1 mL of *nitrate standard solution (2 ppm NO<sub>3</sub>) R* and 4.9 mL of *nitrate-free water R*.

**Sulfates (2.4.13):** maximum 50 ppm.

Dilute 3 mL of the water to be examined to 15 mL with *distilled water R*. The solution complies with the limit test for sulfates.

**Aluminium (2.4.17):** maximum 10 µg/L.

*Prescribed solution.* To 400 mL of the water to be examined add 10 mL of *acetate buffer solution pH 6.0 R* and 100 mL of *water R*.

*Reference solution.* Mix 2 mL of *aluminium standard solution (2 ppm Al) R*, 10 mL of *acetate buffer solution pH 6.0 R* and 98 mL of *water R*.

*Blank solution.* Mix 10 mL of *acetate buffer solution pH 6.0 R* and 100 mL of *water R*.

**Ammonium:** maximum 0.2 ppm.

To 20 mL of the water to be examined in a flat-bottomed and transparent tube, add 1 mL of *alkaline potassium tetraiodomercurate solution R*. Allow to stand for 5 min. The solution is not more intensely coloured than a standard prepared at the same time and in the same manner using a mixture of 4 mL of *ammonium standard solution (1 ppm NH<sub>4</sub>) R* and 16 mL of *ammonium-free water R*. Examine the solutions along the vertical axis of the tube.

**Calcium:** maximum 2 ppm.

Atomic absorption spectrometry (2.2.23, *Method I*).

*Test solution.* The water to be examined.

*Reference solutions.* Prepare reference solutions (1 ppm to 5 ppm) using *calcium standard solution (400 ppm Ca) R*.

*Source:* calcium hollow-cathode lamp.

*Wavelength:* 422.7 nm.

*Atomisation device:* oxidising air-acetylene flame.

**Magnesium:** maximum 2 ppm.

Atomic absorption spectrometry (2.2.23, *Method I*).

*Test solution.* Dilute 10 mL of the water to be examined to 100 mL with *distilled water R*.

*Reference solutions.* Prepare reference solutions (0.1 ppm to 0.5 ppm) using *magnesium standard solution (100 ppm Mg) R*.

*Source:* magnesium hollow-cathode lamp.

*Wavelength:* 285.2 nm.

*Atomisation device:* oxidising air-acetylene flame.

**Mercury:** maximum 0.001 ppm.

Atomic absorption spectrometry (2.2.23, *Method I*).

*Test solution.* Add 5 mL of *nitric acid R* per litre of the water to be examined. In a 50 mL borosilicate glass flask with a ground-glass-stopper, place 20 mL of the water to be examined and add 1 mL of *dilute nitric acid R* and shake. Add 0.3 mL of *bromine water R1*. Stopper the flask, shake and heat the stoppered flask at 45 °C for 4 h. Allow to cool. If the solution

does not become yellow, add 0.3 mL of *bromine water R1* and re-heat at 45 °C for 4 h. Add 0.5 mL of a freshly prepared 10 g/L solution of *hydroxylamine hydrochloride R*. Shake. Allow to stand for 20 min.

**Reference solutions.** Use freshly prepared reference solutions (0.0005 ppm to 0.002 ppm) obtained by diluting *mercury standard solution (1000 ppm Hg) R* with a 5 per cent V/V solution of *dilute nitric acid R* and treat as described for the test solution.

To a volume of solution suitable for the instrument to be used, add *stannous chloride solution R2* equal to 1/5 of this volume. Fit immediately the device for the entrainment of the mercury vapour. Wait 20 s and pass through the device a stream of *nitrogen R* as the carrier gas.

**Source:** mercury hollow-cathode tube or a discharge lamp.

**Wavelength:** 253.7 nm.

**Atomisation device:** flameless system whereby the mercury can be entrained in the form of cold vapour.

**Potassium:** maximum 2 ppm.

Atomic emission spectrometry (2.2.22, *Method I*).

**Test solution (a).** Dilute 50.0 mL of the water to be examined to 100 mL with *distilled water R*. Carry out a determination using this solution. If the potassium content is more than 0.75 mg/L, further dilute the water to be examined with *distilled water R*.

**Test solution (b).** Take 50.0 mL of the water to be examined or, if necessary, the water to be examined diluted as described in the preparation of test solution (a). Add 1.25 mL of *potassium standard solution (20 ppm K) R* and dilute to 100.0 mL with *distilled water R*.

**Reference solutions.** Prepare reference solutions (0 ppm; 0.25 ppm; 0.50 ppm; 0.75 ppm; 1 ppm) using *potassium standard solution (20 ppm K) R*.

**Wavelength:** 766.5 nm.

Calculate the potassium content of the water to be examined in parts per million from the expression:

$$\frac{p \times n_1 \times 0.5}{n_2 - n_1}$$

$p$  = dilution factor used for the preparation of test solution (a);

$n_1$  = measured value of test solution (a);

$n_2$  = measured value of test solution (b).

**Sodium:** maximum 50 ppm.

Atomic emission spectrometry (2.2.22, *Method I*).

**Test solution.** The water to be examined. If the sodium content is more than 10 mg/L, dilute with *distilled water R* to obtain a concentration suitable for the apparatus used.

**Reference solutions.** Prepare reference solutions (0 ppm; 2.5 ppm; 5.0 ppm; 7.5 ppm; 10 ppm) using *sodium standard solution (200 ppm Na) R*.

**Wavelength:** 589 nm.

**Zinc:** maximum 0.1 ppm.

Atomic absorption spectrometry (2.2.23, *Method I*): use sampling and analytical equipment free from zinc or not liable to yield zinc under the conditions of use.

**Test solution.** The water to be examined.

**Reference solutions.** Prepare reference solutions (0.05 ppm to 0.15 ppm) using *zinc standard solution (100 ppm Zn) R*.

**Source:** zinc hollow-cathode lamp.

**Wavelength:** 213.9 nm.

**Atomisation device:** oxidising air-acetylene flame.

**Heavy metals (2.4.8):** maximum 0.1 ppm.

Heat 200 mL of the water to be examined in a glass evaporating dish on a water-bath until the volume is reduced to 20 mL.

12 mL of the solution complies with limit test A. Prepare the standard using *lead standard solution (1 ppm Pb) R*.

**Microbial contamination**

TAMC: acceptance criterion 10<sup>2</sup> CFU/g (2.6.12).

**Bacterial endotoxins (2.6.14):** less than 0.25 IU/mL.

01/2011:0128

## HAEMODIALYSIS, SOLUTIONS FOR

### Solutiones ad haemodialysim

#### DEFINITION

Solutions of electrolytes with a concentration close to the electrolytic composition of plasma. Glucose may be included in the formulation.

Because of the large volumes used, haemodialysis solutions are usually prepared by diluting a concentrated solution with water of suitable quality (see the monograph *Haemodialysis solutions, concentrated, water for diluting (1167)*), using for example an automatic dosing device.

#### Concentrated solutions for haemodialysis

Concentrated haemodialysis solutions are prepared and stored using materials and methods designed to produce solutions having as low a degree of microbial contamination as possible. In certain circumstances, it may be necessary to use sterile solutions.

During dilution and use, precautions are taken to avoid microbial contamination. Diluted solutions are to be used immediately after preparation.

Concentrated solutions for haemodialysis are supplied in:

- rigid, semi-rigid or flexible plastic containers;
- glass containers.

Three types of concentrated solutions are used:

##### 1. Concentrated solutions with acetate or lactate

Several formulations of concentrated solutions are used. The concentrations of the components in the solutions are such that after dilution to the stated volume the concentrations of the components per litre are usually in the following ranges (see Table 0128.-1):

Table 0128.-1.

	Concentration in mmol/L	Concentration in mEq/L
Sodium	130 - 145	130 - 145
Potassium	0 - 3.0	0 - 3.0
Calcium	0 - 2.0	0 - 4.0
Magnesium	0 - 1.2	0 - 2.4
Acetate or lactate	32 - 45	32 - 45
Chloride	90 - 120	90 - 120
Glucose	0 - 12.0	

Concentrated solutions with acetate or lactate are diluted before use.

##### 2. Concentrated acid solutions

Several formulations of concentrated solutions are used. The concentrations of the components in the solutions are such that after dilution to the stated volume and before neutralisation with sodium hydrogen carbonate the concentrations of the components per litre are usually in the following ranges (see Table 0128.-2):

Table 0128.-2.

	Concentration in mmol/L	Concentration in mEq/L
Sodium	80 - 110	80 - 110
Potassium	0 - 3.0	0 - 3.0
Calcium	0 - 2.0	0 - 4.0
Magnesium	0 - 1.2	0 - 2.4
Acetic acid	2.5 - 10	2.5 - 10
Chloride	90 - 120	90 - 120
Glucose	0 - 12.0	

Sodium hydrogen carbonate must be added immediately before use to a final concentration of not more than 45 mmol/L. The concentrated solution of sodium hydrogen carbonate is supplied in a separate container. The concentrated acid solutions and the concentrated solutions of sodium hydrogen carbonate are diluted and mixed immediately before use using a suitable device. Alternatively, solid sodium hydrogen carbonate may be used to prepare the solution.

### 3. Concentrated solutions without buffer

Several formulations of concentrated solutions without buffer are used. The concentrations of the components in the solutions are such that after dilution to the stated volume, the concentrations of the components per litre are usually in the following ranges (see Table 0128.-3):

Table 0128.-3.

	Concentration in mmol/L	Concentration in mEq/L
Sodium	130 - 145	130 - 145
Potassium	0 - 3.0	0 - 3.0
Calcium	0 - 2.0	0 - 4.0
Magnesium	0 - 1.2	0 - 2.4
Chloride	130 - 155	130 - 155
Glucose	0 - 12.0	

Concentrated solutions without buffer are used together with parenteral administration of suitable hydrogen carbonate solutions.

### IDENTIFICATION

According to the stated composition, the solution to be examined gives the following identification reactions (2.3.1):

- potassium: reaction (b);
- calcium: reaction (a);
- sodium: reaction (b);
- chlorides: reaction (a);
- lactates;
- carbonates and hydrogen carbonates;
- acetates:
  - if the solution is free from glucose, use reaction (b);
  - if the solution contains glucose, use the following method: to 5 mL of the solution to be examined add 1 mL of *hydrochloric acid R* in a test-tube fitted with a stopper and a bent tube, heat and collect a few millilitres of distillate; carry out reaction (b) of acetates on the distillate;
- magnesium: to 0.1 mL of *titan yellow solution R* add 10 mL of *water R*, 2 mL of the solution to be examined and 1 mL of a 4.2 g/L solution of *sodium hydroxide R*; a pink colour is produced;
- glucose: to 5 mL of the solution to be examined, add 2 mL of *dilute sodium hydroxide solution R* and 0.05 mL of *copper sulfate solution R*; the solution is blue and clear; heat to boiling; an abundant red precipitate is formed.

### TESTS

**Appearance of solution.** The solution to be examined is clear (2.2.1). If it does not contain glucose, it is colourless (2.2.2, *Method I*). If it contains glucose, it is not more intensely coloured than reference solution Y<sub>7</sub> (2.2.2, *Method I*).

**Aluminium (2.4.17):** maximum 0.1 mg/L.

**Prescribed solution.** Take 20 mL of the solution to be examined, adjust to pH 6.0 using 0.1 M *hydrochloric acid* or 0.1 M *sodium hydroxide* and add 10 mL of *acetate buffer solution pH 6.0 R*.

**Reference solution.** Mix 1 mL of *aluminium standard solution (2 ppm Al) R*, 10 mL of *acetate buffer solution pH 6.0 R* and 9 mL of *water R*.

**Blank solution.** Mix 10 mL of *acetate buffer solution pH 6.0 R* and 10 mL of *water R*.

**Extractable volume (2.9.17).** The volume measured is not less than the nominal volume stated on the label.

**Sterility (2.6.1).** If the label states that the concentrated haemodialysis solution is sterile, it complies with the test for sterility.

**Bacterial endotoxins (2.6.14):** less than 0.5 IU/mL in the solution diluted for use.

**Pyrogens (2.6.8).** Solutions for which a validated test for bacterial endotoxins cannot be carried out comply with the test for pyrogens. Dilute the solution to be examined with *water for injections R* to the concentration prescribed for use. Inject 10 mL of the solution per kilogram of the rabbit's mass.

### ASSAY

**Determine the density (2.2.5) of the concentrated solution and calculate the content in grams per litre and in millimoles per litre.**

**Sodium:** 97.5 per cent to 102.5 per cent of the content of sodium (Na) stated on the label.

Atomic emission spectrometry (2.2.22, *Method I*).

**Test solution.** If necessary, dilute the solution to be examined with *water R* to a concentration suitable for the instrument to be used.

**Reference solutions.** Prepare the reference solutions using *sodium standard solution (200 ppm Na) R*.

**Wavelengths:** 589.0 nm or 589.6 nm (sodium emits as a doublet).

**Potassium:** 95.0 per cent to 105.0 per cent of the content of potassium (K) stated on the label.

Atomic absorption spectrometry (2.2.23, *Method I*).

**Test solution.** Dilute with *water R* an accurately weighed quantity of the solution to be examined to a concentration suitable for the instrument to be used. To 100 mL of this solution add 10 mL of a 22 g/L solution of *sodium chloride R*.

**Reference solutions.** Prepare the reference solutions using *potassium standard solution (100 ppm K) R*. To 100 mL of each reference solution add 10 mL of a 22 g/L solution of *sodium chloride R*.

**Source:** potassium hollow-cathode lamp.

**Wavelength:** 766.5 nm.

**Atomisation device:** air-acetylene flame.

**Calcium:** 95.0 per cent to 105.0 per cent of the content of calcium (Ca) stated on the label.

Atomic absorption spectrometry (2.2.23, *Method I*).

**Test solution.** Dilute 5.0 mL of the solution to be examined to 100.0 mL with *water R*. To 3.0 mL of this solution add 5 mL of *lanthanum chloride solution R* and dilute to 50.0 mL with *water R*.

**Reference solutions.** Into 4 identical volumetric flasks each containing 5 mL of *lanthanum chloride solution R*, introduce respectively 2.5 mL, 5.0 mL, 7.0 mL and 10.0 mL of *calcium standard solution (10 ppm Ca) R* and dilute to 50.0 mL with *water R*.

Source: calcium hollow-cathode lamp.

Wavelength: 422.7 nm.

Atomisation device: air-acetylene flame.

**Magnesium:** 95.0 per cent to 105.0 per cent of the content of magnesium (Mg) stated on the label.

Atomic absorption spectrometry (2.2.23, Method I).

**Test solution.** Dilute 5.0 mL of the solution to be examined to 100.0 mL with *water R*. To 2.0 mL of this solution add 5 mL of *lanthanum chloride solution R* and dilute to 50.0 mL with *water R*.

**Reference solutions.** Into 4 identical volumetric flasks each containing 5 mL of *lanthanum chloride solution R*, introduce respectively 1.0 mL, 2.0 mL, 3.0 mL and 4.0 mL of *magnesium standard solution (10 ppm Mg) R* and dilute to 50.0 mL with *water R*.

Source: magnesium hollow-cathode lamp.

Wavelength: 285.2 nm.

Atomisation device: air-acetylene flame.

**Total chloride:** 95.0 per cent to 105.0 per cent of the content of chloride (Cl) stated on the label.

Dilute to 50 mL with *water R* an accurately measured volume of the solution to be examined containing the equivalent of about 60 mg of chloride. Add 5 mL of *dilute nitric acid R*, 25.0 mL of *0.1 M silver nitrate* and 2 mL of *dibutyl phthalate R*. Shake. Using 2 mL of *ferric ammonium sulfate solution R2* as indicator, titrate with *0.1 M ammonium thiocyanate* until a reddish-yellow colour is obtained.

1 mL of *0.1 M silver nitrate* is equivalent to 3.545 mg of Cl.

**Acetate:** 95.0 per cent to 105.0 per cent of the content of acetate stated on the label.

To a volume of the solution to be examined, corresponding to about 0.7 mmol of acetate, add 10.0 mL of *0.1 M hydrochloric acid*. Carry out a potentiometric titration (2.2.20), using *0.1 M sodium hydroxide*. Read the volume added between the 2 points of inflexion.

1 mL of *0.1 M sodium hydroxide* is equivalent to 0.1 mmol of acetate.

**Lactate:** 95.0 per cent to 105.0 per cent of the content of lactate stated on the label.

To a volume of the solution to be examined, corresponding to about 0.7 mmol of lactate, add 10.0 mL of *0.1 M hydrochloric acid*. Then add 50 mL of *acetonitrile R*. Carry out a potentiometric titration (2.2.20), using *0.1 M sodium hydroxide*. Read the volume added between the 2 points of inflexion.

1 mL of *0.1 M sodium hydroxide* is equivalent to 0.1 mmol of lactate.

**Sodium hydrogen carbonate:** 95.0 per cent to 105.0 per cent of the content of sodium hydrogen carbonate stated on the label.

Titrate with *0.1 M hydrochloric acid* a volume of the solution to be examined corresponding to about 0.1 g of sodium hydrogen carbonate, determining the end-point potentiometrically (2.2.20).

1 mL of *0.1 M hydrochloric acid* is equivalent to 8.40 mg of  $\text{NaHCO}_3$ .

**Reducing sugars** (expressed as anhydrous glucose): 95.0 per cent to 105.0 per cent of the content of glucose stated on the label.

Transfer a volume of the solution to be examined containing the equivalent of 25 mg of glucose to a 250 mL conical flask with a ground-glass neck and add 25.0 mL of *cupri-citric solution R*. Add a few grains of pumice, fit a reflux condenser, heat so that boiling occurs within 2 min and maintain boiling for exactly 10 min. Cool and add 3 g of *potassium iodide R* dissolved in 3 mL of *water R*. Carefully add, in small amounts, 25 mL of a 25 per cent *m/m* solution of *sulfuric acid R*. Titrate with *0.1 M sodium thiosulfate* using *starch solution R*, added towards the

end of the titration, as indicator. Carry out a blank titration using 25.0 mL of *water R*.

Calculate the content of reducing sugars, expressed as anhydrous glucose ( $\text{C}_6\text{H}_{12}\text{O}_6$ ), using Table 0128.4.

Table 0128.4.

Volume of 0.1 M sodium thiosulfate in mL	Anhydrous glucose in mg
8	19.8
9	22.4
10	25.0
11	27.6
12	30.3
13	33.0
14	35.7
15	38.5
16	41.3

#### STORAGE

At a temperature not lower than 4 °C.

#### LABELLING

The label states:

- the formula of the concentrated solution for haemodialysis expressed in grams per litre and in millimoles per litre;
- the nominal volume of the solution in the container;
- where applicable, that the concentrated solution is sterile;
- the storage conditions;
- that the concentrated solution is to be diluted immediately before use;
- the dilution to be made;
- that the volume taken for use is to be measured accurately;
- the ionic formula for the diluted solution ready for use in millimoles per litre;
- that any unused portion of solution is to be discarded;
- where applicable, that sodium hydrogen carbonate is to be added before use.

01/2011:0861

## HAEMOFILTRATION AND HAEMODIAFILTRATION, SOLUTIONS FOR

### Solutiones ad haemocolaturam haemodiocolaturamque

#### DEFINITION

Preparations for parenteral administration containing electrolytes with a concentration close to the electrolytic composition of plasma. Glucose may be included in the formulation.

Solutions for haemofiltration and haemodiafiltration are supplied in:

- rigid or semi-rigid plastic containers;
- flexible plastic containers inside closed protective envelopes;
- glass containers.

The containers and closures comply with the requirements for containers for preparations for parenteral administration (3.2).

In haemofiltration and haemodiafiltration, the following formulations are used. The concentrations of the components per litre of solution are usually in the following range (see Table 0861.1):

Table 0861-1.

	Concentration in mmol/L	Concentration in mEq/L
Sodium	125 - 150	125 - 150
Potassium	0 - 4.5	0 - 4.5
Calcium	1.0 - 2.5	2.0 - 5.0
Magnesium	0.25 - 1.5	0.50 - 3.0
Acetate and/or lactate and/or hydrogen carbonate	30 - 60	30 - 60
Chloride	90 - 120	90 - 120
Glucose	0 - 25	

When hydrogen carbonate is present, the solution of sodium hydrogen carbonate is supplied in a container or a separate compartment and is added to the electrolyte solution immediately before use.

In haemofiltration and haemodiafiltration, the following formulations may also be used (see Table 0861-2):

Table 0861-2.

	Concentration in mmol/L	Concentration in mEq/L
Sodium	130 - 167	130 - 167
Potassium	0 - 4.0	0 - 4.0
Hydrogen carbonate	20 - 167	20 - 167
Chloride	0 - 147	0 - 147

Antioxidants are not added to the solutions.

#### IDENTIFICATION

According to the stated composition, the solution to be examined gives the following identification reactions (2.3.1):

- potassium: reaction (b);
- calcium: reaction (a);
- sodium: reaction (b);
- chlorides: reaction (a);
- acetates:
  - if the solution is free from glucose, use reaction (b);
  - if the solution contains glucose, use the following method: to 5 mL of the solution to be examined add 1 mL of *hydrochloric acid R* in a test-tube fitted with a stopper and a bent tube, heat and collect a few millilitres of distillate; carry out reaction (b) of acetates on the distillate;
- lactates;
- carbonates and hydrogen carbonates;
- magnesium: to 0.1 mL of *titan yellow solution R* add 10 mL of *water R*, 2 mL of the solution to be examined and 1 mL of 1 M *sodium hydroxide*; a pink colour is produced;
- glucose: to 5 mL of the solution to be examined, add 2 mL of *dilute sodium hydroxide solution R* and 0.05 mL of *copper sulfate solution R*; the solution is blue and clear; heat to boiling; an abundant red precipitate is formed.

#### TESTS

**Appearance of solution.** The solution is clear (2.2.1). If it does not contain glucose, it is colourless (2.2.2, *Method I*). If it contains glucose, it is not more intensely coloured than reference solution Y<sub>7</sub> (2.2.2, *Method I*).

**pH (2.2.3):** 5.0 to 7.5. If the solution contains glucose, the pH is 4.5 to 6.5. If the solution contains hydrogen carbonate, the pH is 7.0 to 8.5.

**Hydroxymethylfurfural.** Carry out the test only if glucose is added to the preparation. To a volume of the solution to be examined containing the equivalent of 25 mg of glucose, add 5.0 mL of a 100 g/L solution of *p-toluidine R* in *2-propanol R*

containing 10 per cent *V/V* of *glacial acetic acid R*, then add 1.0 mL of a 5 g/L solution of *barbituric acid R*. The absorbance (2.2.25), determined at 550 nm after allowing the mixture to stand for 2-3 min, is not greater than that of a standard prepared at the same time and in the same manner using a solution containing 10 µg of *hydroxymethylfurfural R* in the same volume as the solution to be examined (400 ppm expressed with reference to the glucose concentration). If the solution contains hydrogen carbonate, use as the standard a solution containing 20 µg of *hydroxymethylfurfural R* (800 ppm expressed with reference to the glucose concentration).

**Aluminium (2.4.17):** maximum 10 µg/L.

**Prescribed solution.** Take 200 mL of the solution to be examined, adjust to pH 6.0 using 0.1 M *hydrochloric acid* or 0.1 M *sodium hydroxide* and add 10 mL of *acetate buffer solution pH 6.0 R*.

**Reference solution.** Mix 1 mL of *aluminium standard solution (2 ppm Al) R*, 10 mL of *acetate buffer solution pH 6.0 R* and 9 mL of *water R*.

**Blank solution.** Mix 10 mL of *acetate buffer solution pH 6.0 R* and 10 mL of *water R*.

**Particulate contamination (2.9.19, Method I).** Use 50 mL of the solution to be examined.

**Extractable volume (2.9.17).** The solution complies with the test prescribed for parenteral infusions.

**Sterility (2.6.1).** The solution complies with the test for sterility.

**Bacterial endotoxins (2.6.14):** less than 0.25 IU/mL.

**Pyrogens (2.6.8).** Solutions for which a validated test for bacterial endotoxins cannot be carried out comply with the test for pyrogens. Inject per kilogram of the rabbit's mass 10 mL of the solution.

#### ASSAY

**Sodium:** 97.5 per cent to 102.5 per cent of the content of sodium (Na) stated on the label.

Atomic emission spectrometry (2.2.22, *Method I*).

**Test solution.** If necessary, dilute the solution to be examined with *water R* to a concentration suitable for the instrument to be used.

**Reference solutions.** Prepare the reference solutions using *sodium standard solution (200 ppm Na) R*.

**Wavelengths:** 589.0 nm or 589.6 nm (sodium emits as a doublet).

**Potassium:** 95.0 per cent to 105.0 per cent of the content of potassium (K) stated on the label.

Atomic absorption spectrometry (2.2.23, *Method I*).

**Test solution.** If necessary, dilute the solution to be examined with *water R* to a concentration suitable for the instrument to be used. To 100 mL of the solution add 10 mL of a 22 g/L solution of *sodium chloride R*.

**Reference solutions.** Prepare the reference solutions using *potassium standard solution (100 ppm K) R*. To 100 mL of each reference solution add 10 mL of a 22 g/L solution of *sodium chloride R*.

**Source:** potassium hollow-cathode lamp.

**Wavelength:** 766.5 nm.

**Atomisation device:** air-propane or air-acetylene flame.

**Calcium:** 95.0 per cent to 105.0 per cent of the content of calcium (Ca) stated on the label.

Atomic absorption spectrometry (2.2.23, *Method I*).

**Test solution.** If necessary, dilute the solution to be examined with *water R* to a concentration suitable for the instrument to be used.

**Reference solutions.** Prepare the reference solutions using *calcium standard solution (400 ppm Ca) R*.

**Source:** calcium hollow-cathode lamp.



Wavelength: 422.7 nm.

Atomisation device: air-propane or air-acetylene flame.

**Magnesium:** 95.0 per cent to 105.0 per cent of the content of magnesium (Mg) stated on the label.

Atomic absorption spectrometry (2.2.23, Method I).

**Test solution.** If necessary, dilute the solution to be examined with *water R* to a concentration suitable for the instrument to be used.

**Reference solutions.** Prepare the reference solutions using *magnesium standard solution (100 ppm Mg) R*.

**Source:** magnesium hollow-cathode lamp.

Wavelength: 285.2 nm.

Atomisation device: air-propane or air-acetylene flame.

**Total chloride:** 95.0 per cent to 105.0 per cent of the content of chloride (Cl) stated on the label.

Dilute to 50 mL with *water R* an accurately measured volume of the solution to be examined containing the equivalent of about 60 mg of chloride. Add 5 mL of *dilute nitric acid R*, 25.0 mL of *0.1 M silver nitrate* and 2 mL of *dibutyl phthalate R*. Shake. Using 2 mL of *ferric ammonium sulfate solution R2* as indicator, titrate with *0.1 M ammonium thiocyanate* until a reddish-yellow colour is obtained.

1 mL of *0.1 M silver nitrate* is equivalent to 3.545 mg of Cl.

**Acetate:** 95.0 per cent to 105.0 per cent of the content of acetate stated on the label.

To a volume of the solution to be examined, corresponding to about 0.7 mmol of acetate, add 10.0 mL of *0.1 M hydrochloric acid*. Carry out a potentiometric titration (2.2.20), using *0.1 M sodium hydroxide*. Read the volume added between the 2 points of inflexion.

1 mL of *0.1 M sodium hydroxide* is equivalent to 0.1 mmol of acetate.

**Lactate:** 95.0 per cent to 105.0 per cent of the content of lactate stated on the label.

To a volume of the solution to be examined, corresponding to about 0.7 mmol of lactate, add 10.0 mL of *0.1 M hydrochloric acid*. Add 50 mL of *acetonitrile R*. Carry out a potentiometric titration (2.2.20), using *0.1 M sodium hydroxide*. Read the volume added between the 2 points of inflexion.

1 mL of *0.1 M sodium hydroxide* is equivalent to 0.1 mmol of lactate.

**Sodium hydrogen carbonate:** 95.0 per cent to 105.0 per cent of the content of sodium hydrogen carbonate stated on the label.

Titrate with *0.1 M hydrochloric acid*, a volume of the solution to be examined corresponding to about 0.1 g of sodium hydrogen carbonate, determining the end-point potentiometrically (2.2.20).

1 mL of *0.1 M hydrochloric acid* is equivalent to 8.40 mg of  $\text{NaHCO}_3$ .

**Lactate and hydrogen carbonate:** 95.0 per cent to 105.0 per cent of the content of lactates and hydrogen carbonates stated on the label.

Liquid chromatography (2.2.29).

**Test solution.** The solution to be examined.

**Reference solution.** Dissolve in 100 mL of *water for chromatography R* quantities of lactates and hydrogen carbonates, accurately weighed, in order to obtain solutions having concentrations representing about 90 per cent, 100 per cent and 110 per cent of the concentrations stated on the label.

**Column:**

– size:  $l = 0.30$  m,  $\varnothing = 7.8$  mm;

– stationary phase: cation exchange resin *R* (9  $\mu\text{m}$ );

– temperature: 60 °C.

**Mobile phase:** 0.005 M sulfuric acid previously degassed with *helium R*.

**Flow rate:** 0.6 mL/min.

**Detection:** differential refractometer.

**Injection:** 20  $\mu\text{L}$ , twice.

**Order of elution:** lactates, hydrogen carbonates.

Determine the concentration of lactates and hydrogen carbonates in the test solution by interpolating the peak area for lactate and the peak height for hydrogen carbonate from the linear regression curve obtained with the reference solutions.

**Reducing sugars** (expressed as anhydrous glucose): 95.0 per cent to 105.0 per cent of the content of glucose stated on the label.

Transfer a volume of the solution to be examined containing the equivalent of 25 mg of glucose to a 250 mL conical flask with a ground-glass neck and add 25.0 mL of *cupri-citric solution R*. Add a few grains of pumice, fit a reflux condenser, heat so that boiling occurs within 2 min and boil for exactly 10 min. Cool and add 3 g of *potassium iodide R* dissolved in 3 mL of *water R*. Carefully add, in small amounts, 25 mL of a 25 per cent *m/m* solution of *sulfuric acid R*. Titrate with *0.1 M sodium thiosulfate* using *starch solution R*, added towards the end of the titration, as indicator. Carry out a blank titration using 25.0 mL of *water R*.

Calculate the content of reducing sugars expressed as anhydrous glucose ( $\text{C}_6\text{H}_{12}\text{O}_6$ ), using Table 0861-3.

Table 0861-3.

Volume of <i>0.1 M sodium thiosulfate</i> in mL	Anhydrous glucose in mg
8	19.8
9	22.4
10	25.0
11	27.6
12	30.3
13	33.0
14	35.7
15	38.5
16	41.3

#### STORAGE

At a temperature not below 4 °C.

#### LABELLING

The label states:

- the formula of the solution for haemofiltration or haemodiafiltration, expressed in grams per litre and in millimoles per litre;
- the calculated osmolarity, expressed in milliosmoles per litre;
- the nominal volume of the solution for haemofiltration or haemodiafiltration in the container;
- that the solution is free from bacterial endotoxins, or where applicable, that it is apyrogenic;
- the storage conditions;
- that any unused portion of solution is to be discarded.

01/2008:1979 *Column:*  
corrected 6.0

## HALOFANTRINE HYDROCHLORIDE

### Halofantrini hydrochloridum

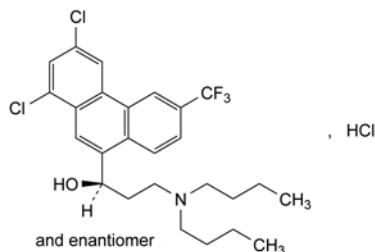

C<sub>26</sub>H<sub>31</sub>Cl<sub>3</sub>F<sub>3</sub>NO  
[36167-63-2]

M<sub>r</sub> 536.9

#### DEFINITION

(1*RS*)-3-(Dibutylamino)-1-[1,3-dichloro-6-(trifluoromethyl)phenanthren-9-yl]propan-1-ol hydrochloride.

*Content:* 97.5 per cent to 102.0 per cent (dried substance).

#### CHARACTERS

*Appearance:* white or almost white powder.

*Solubility:* practically insoluble in water, freely soluble in methanol, sparingly soluble in alcohol.

It shows polymorphism (5.9).

#### IDENTIFICATION

A. Infrared absorption spectrophotometry (2.2.24).

*Comparison:* halofantrine hydrochloride CRS.

If the spectra obtained in the solid state show differences, dissolve the substance to be examined and the reference substance separately in *methyl ethyl ketone R*, evaporate to dryness and record new spectra using the residues.

B. It gives reaction (b) of chlorides (2.3.1).

#### TESTS

**Optical rotation** (2.2.7):  $-0.10^\circ$  to  $+0.10^\circ$ .

Dissolve 1.00 g in *alcohol R* and dilute to 100.0 mL with the same solvent.

**Absorbance** (2.2.25): maximum 0.085 at 450 nm.

Dissolve 0.200 g in *methanol R* and dilute to 10.0 mL with the same solvent.

**Related substances.** Liquid chromatography (2.2.29).

*Test solution (a).* Dissolve 40.0 mg of the substance to be examined in the mobile phase and dilute to 100.0 mL with the mobile phase.

*Test solution (b).* Dilute 5.0 mL of test solution (a) to 50.0 mL with the mobile phase.

*Reference solution (a).* Dissolve 40.0 mg of *halofantrine hydrochloride CRS* in the mobile phase and dilute to 100.0 mL with the mobile phase.

*Reference solution (b).* Dilute 5.0 mL of reference solution (a) to 50.0 mL with the mobile phase.

*Reference solution (c).* Dilute 1.0 mL of test solution (a) to 100.0 mL with the mobile phase. Dilute 5.0 mL of the solution to 50.0 mL with the mobile phase.

*Reference solution (d).* Dissolve 10.0 mg of *halofantrine impurity C CRS* in the mobile phase and dilute to 25 mL with the mobile phase. To 5.0 mL of the solution, add 5.0 mL of reference solution (a) and dilute to 50.0 mL with the mobile phase.

– *size:*  $l = 0.30$  m,  $\varnothing = 3.9$  mm,  
– *stationary phase:* octadecylsilyl silica gel for chromatography *R* (10  $\mu$ m) of irregular type, with a specific surface of 330 m<sup>2</sup>/g, a pore size of 12.5 nm and a carbon loading of 9.8 per cent.

*Mobile phase:* mix 250 mL of a 2.0 g/L solution of *sodium hydroxide R*, previously adjusted to pH 2.5 with *perchloric acid R* and 750 mL of *acetonitrile R*.

*Flow rate:* 1 mL/min.

*Detection:* spectrophotometer at 260 nm.

*Injection:* 20  $\mu$ L; inject the test solution (a) and reference solutions (c) and (d).

*Run time:* 5 times the retention time of halofantrine which is about 6 min.

#### System suitability:

– *resolution:* minimum 3.3 between the peaks due to halofantrine and impurity C in the chromatogram obtained with reference solution (d).

#### Limits:

– *any impurity:* not more than twice the area of the principal peak in the chromatogram obtained with reference solution (c) (0.2 per cent),

– *total:* not more than 5 times the area of the principal peak in the chromatogram obtained with reference solution (c) (0.5 per cent),

– *disregard limit:* 0.5 times the area of the principal peak in the chromatogram obtained with reference solution (c) (0.05 per cent).

**Heavy metals** (2.4.8): maximum 20 ppm.

1.0 g complies with limit test C. Prepare the standard using 2 mL of *lead standard solution (10 ppm Pb) R*.

**Loss on drying** (2.2.32): maximum 0.5 per cent, determined on 1.000 g by drying in an oven at 105 °C for 4 h.

**Sulfated ash** (2.4.14): maximum 0.1 per cent, determined on 1.0 g.

#### ASSAY

Liquid chromatography (2.2.29) as described in the test for related substances.

*Injection:* test solution (b) and reference solution (b).

Calculate the percentage content of halofantrine hydrochloride.

#### STORAGE

Protected from light.

#### IMPURITIES

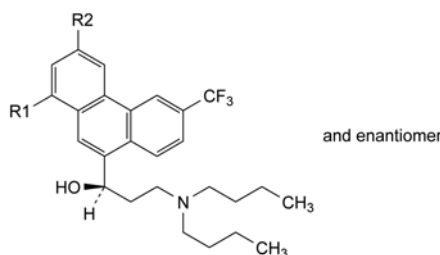

A. R<sub>1</sub> = H, R<sub>2</sub> = Cl: (1*RS*)-1-[3-chloro-6-(trifluoromethyl)phenanthren-9-yl]-3-(dibutylamino)propan-1-ol (1-dechlorohalofantrine),

B. R<sub>1</sub> = Cl, R<sub>2</sub> = H: (1*RS*)-1-[1-chloro-6-(trifluoromethyl)phenanthren-9-yl]-3-(dibutylamino)propan-1-ol (3-dechlorohalofantrine),

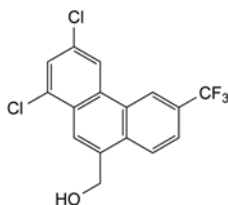

C. [1,3-dichloro-6-(trifluoromethyl)phenanthren-9-yl]methanol.

01/2008:0616  
corrected 6.0

## HALOPERIDOL

### Haloperidolum

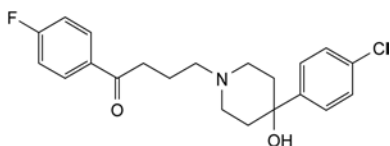

C<sub>21</sub>H<sub>23</sub>ClFNO<sub>2</sub>  
[52-86-8]

M<sub>r</sub> 375.9

#### DEFINITION

4-[4-(4-Chlorophenyl)-4-hydroxypiperidin-1-yl]-1-(4-fluorophenyl)butan-1-one.

*Content*: 99.0 per cent to 101.0 per cent (dried substance).

#### CHARACTERS

*Appearance*: white or almost white powder.

*Solubility*: practically insoluble in water, slightly soluble in ethanol (96 per cent), in methanol and in methylene chloride.

#### IDENTIFICATION

*First identification*: B, E.

*Second identification*: A, C, D, E.

A. Melting point (2.2.14): 150 °C to 153 °C.

B. Infrared absorption spectrophotometry (2.2.24).

*Preparation*: discs.

*Comparison*: haloperidol CRS.

C. Thin-layer chromatography (2.2.27).

*Test solution*. Dissolve 10 mg of the substance to be examined in methanol R and dilute to 10 mL with the same solvent.

*Reference solution (a)*. Dissolve 10 mg of haloperidol CRS in methanol R and dilute to 10 mL with the same solvent.

*Reference solution (b)*. Dissolve 10 mg of haloperidol CRS and 10 mg of bromperidol CRS in methanol R and dilute to 10 mL with the same solvent.

*Plate*: TLC octadecylsilyl silica gel plate R.

*Mobile phase*: tetrahydrofuran R, methanol R, 58 g/L solution of sodium chloride R (10:45:45 V/V/V).

*Application*: 1 µL.

*Development*: in an unsaturated tank, over a path of 15 cm.

*Drying*: in air.

*Detection*: examine in ultraviolet light at 254 nm.

*System suitability*: reference solution (b):

- the chromatogram shows 2 spots which may, however, not be completely separated.

*Results*: the principal spot in the chromatogram obtained with the test solution is similar in position and size to the principal spot in the chromatogram obtained with reference solution (a).

D. Dissolve about 10 mg in 5 mL of anhydrous ethanol R. Add 0.5 mL of dinitrobenzene solution R and 0.5 mL of 2 M alcoholic potassium hydroxide R. A violet colour is produced and becomes brownish-red after 20 min.

E. To 0.1 g in a porcelain crucible add 0.5 g of anhydrous sodium carbonate R. Heat over an open flame for 10 min. Allow to cool. Take up the residue with 5 mL of dilute nitric acid R and filter. To 1 mL of the filtrate add 1 mL of water R. The solution gives reaction (a) of chlorides (2.3.1).

#### TESTS

**Appearance of solution**. The solution is clear (2.2.1) and not more intensely coloured than reference solution Y<sub>7</sub> (2.2.2, Method II).

Dissolve 0.2 g in 20 mL of a 1 per cent V/V solution of lactic acid R.

**Related substances**. Liquid chromatography (2.2.29). Prepare the solutions immediately before use and protect from light.

*Test solution*. Dissolve 0.100 g of the substance to be examined in methanol R and dilute to 10.0 mL with the same solvent.

*Reference solution (a)*. Dissolve 5.0 mg of haloperidol CRS and 2.5 mg of bromperidol CRS in methanol R and dilute to 50.0 mL with the same solvent.

*Reference solution (b)*. Dilute 5.0 mL of the test solution to 100.0 mL with methanol R. Dilute 1.0 mL of this solution to 10.0 mL with methanol R.

*Column*:

- size: *l* = 0.1 m, Ø = 4.6 mm;
- stationary phase: base-deactivated octadecylsilyl silica gel for chromatography R (3 µm).

*Mobile phase*:

- mobile phase A: 17 g/L solution of tetrabutylammonium hydrogen sulfate R1;
- mobile phase B: acetonitrile R;

Time (min)	Mobile phase A (per cent V/V)	Mobile phase B (per cent V/V)
0 - 15	90 → 50	10 → 50
15 - 20	50	50
20 - 25	90	10

*Flow rate*: 1.5 mL/min.

*Detection*: spectrophotometer at 230 nm.

*Injection*: 10 µL; inject methanol R as a blank.

*Retention time*: haloperidol = about 5.5 min; bromperidol = about 6 min.

*System suitability*: reference solution (a):

- resolution: minimum 3.0 between the peaks due to haloperidol and bromperidol; if necessary, adjust the concentration of acetonitrile in the mobile phase or adjust the time programme for the linear-gradient elution.

*Limits*:

- impurities A, B, C, D, E, F: for each impurity, not more than the area of the principal peak in the chromatogram obtained with reference solution (b) (0.5 per cent);
- total: not more than twice the area of the principal peak in the chromatogram obtained with reference solution (b) (1 per cent);
- disregard limit: 0.1 times the area of the principal peak in the chromatogram obtained with reference solution (b) (0.05 per cent).

**Loss on drying** (2.2.32): maximum 0.5 per cent, determined on 1.000 g by drying in an oven at 105 °C.

**Sulfated ash** (2.4.14): maximum 0.1 per cent, determined on 1.0 g using a platinum crucible.

## ASSAY

Dissolve 0.300 g in 50 mL of a mixture of 1 volume of *anhydrous acetic acid R* and 7 volumes of *methyl ethyl ketone R*. Titrate with 0.1 M *perchloric acid*, using 0.2 mL of *naphtholbenzein solution R* as indicator.

1 mL of 0.1 M *perchloric acid* is equivalent to 37.59 mg of  $C_{21}H_{23}ClFNO_2$ .

## STORAGE

Protected from light.

## IMPURITIES

Specified impurities: A, B, C, D, E, F.

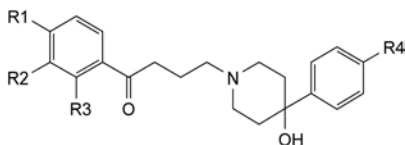

- A. R1 = F, R2 = R3 = R4 = H: 1-(4-fluorophenyl)-4-(4-hydroxy-4-phenylpiperidin-1-yl)butan-1-one,  
 B. R1 = R2 = H, R3 = F, R4 = Cl: 4-[4-(4-chlorophenyl)-4-hydroxypiperidin-1-yl]-1-(2-fluorophenyl)butan-1-one,  
 C. R1 = F, R2 =  $C_2H_5$ , R3 = H, R4 = Cl: 4-[4-(4-chlorophenyl)-4-hydroxypiperidin-1-yl]-1-(3-ethyl-4-fluorophenyl)butan-1-one,

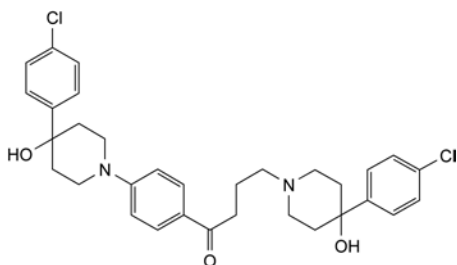

- D. 4-[4-(4-chlorophenyl)-4-hydroxypiperidin-1-yl]-1-[4-(4-chlorophenyl)-4-hydroxypiperidin-1-yl]phenyl]butan-1-one,

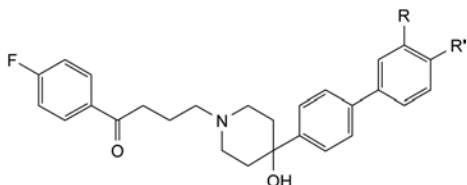

- E. R = H, R' = Cl: 4-[4-(4'-chlorobiphenyl-4-yl)-4-hydroxypiperidin-1-yl]-1-(4-fluorophenyl)butan-1-one,  
 F. R = Cl, R' = H: 4-[4-(3'-chlorobiphenyl-4-yl)-4-hydroxypiperidin-1-yl]-1-(4-fluorophenyl)butan-1-one.

01/2008:1431

## HALOPERIDOL DECANOATE

## Haloperidoli decanoas

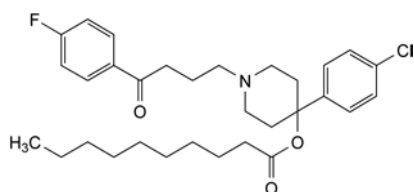

$C_{31}H_{41}ClFNO_3$   
[74050-97-8]

$M_r$  530.1

## DEFINITION

4-(4-Chlorophenyl)-1-[4-(4-fluorophenyl)-4-oxobutyl]piperidin-4-yl decanoate.

Content: 98.5 per cent to 101.0 per cent (dried substance).

## CHARACTERS

Appearance: white or almost white powder.

Solubility: practically insoluble in water, very soluble in ethanol (96 per cent), in methanol and in methylene chloride.

mp: about 42 °C.

## IDENTIFICATION

- A. Infrared absorption spectrophotometry (2.2.24).

Preparation: mulls in *liquid paraffin R*.

Comparison: *haloperidol decanoate CRS*.

- B. To 0.1 g in a porcelain crucible add 0.5 g of *anhydrous sodium carbonate R*. Heat over an open flame for 10 min. Allow to cool. Take up the residue with 5 mL of *dilute nitric acid R* and filter. To 1 mL of the filtrate add 1 mL of *water R*. The solution gives reaction (a) of chlorides (2.3.1).

## TESTS

Appearance of solution. The solution is clear (2.2.1) and not more intensely coloured than reference solution B<sub>5</sub> (2.2.2, Method II).

Dissolve 2.0 g in *methylene chloride R* and dilute to 20 mL with the same solvent.

Related substances. Liquid chromatography (2.2.29). Prepare the solutions immediately before use and protect from light.

Test solution. Dissolve 0.100 g of the substance to be examined in *methanol R* and dilute to 10.0 mL with the same solvent.

Reference solution (a). Dissolve 2.5 mg of *bromperidol decanoate CRS* and 2.5 mg of *haloperidol decanoate CRS* in *methanol R*, then dilute to 50.0 mL with the same solvent.

Reference solution (b). Dilute 5.0 mL of the test solution to 100.0 mL with *methanol R*. Dilute 1.0 mL of this solution to 10.0 mL with *methanol R*.

Column:

- size:  $l = 0.1$  m,  $\varnothing = 4.0$  mm;
- stationary phase: base-deactivated octadecylsilyl silica gel for chromatography R (3  $\mu$ m).

Mobile phase:

- mobile phase A: 27 g/L solution of *tetrabutylammonium hydrogen sulfate R*;
- mobile phase B: *acetonitrile R*;

Time (min)	Mobile phase A (per cent V/V)	Mobile phase B (per cent V/V)
0 - 30	80 → 40	20 → 60
30 - 35	40	60
35 - 40	40 → 80	60 → 20

Flow rate: 1.5 mL/min.

Detection: spectrophotometer at 230 nm.

Equilibration: with *acetonitrile R* for at least 30 min and then with the mobile phase at the initial composition for at least 5 min.

Injection: 10  $\mu$ L; inject *methanol R* as a blank.

Retention time: haloperidol decanoate = about 24 min; bromperidol decanoate = about 24.5 min.

System suitability: reference solution (a):

- resolution: minimum 1.5 between the peaks due to haloperidol decanoate and bromperidol decanoate; if necessary, adjust the gradient or the time programme for the linear gradient elution.

## Limits:

- *impurities A, B, C, D, E, F, G, H, I, J, K*: for each impurity, not more than the area of the principal peak in the chromatogram obtained with reference solution (b) (0.5 per cent);
- *total*: not more than 3 times the area of the principal peak in the chromatogram obtained with reference solution (b) (1.5 per cent);
- *disregard limit*: 0.1 times the area of the principal peak in the chromatogram obtained with reference solution (b) (0.05 per cent).

**Loss on drying** (2.2.32): maximum 0.5 per cent, determined on 1.000 g by drying *in vacuo* at 30 °C.

**Sulfated ash** (2.4.14): maximum 0.1 per cent, determined on 1.0 g in a platinum crucible.

## ASSAY

Dissolve 0.425 g in 50 mL of a mixture of 1 volume of *anhydrous acetic acid R* and 7 volumes of *methyl ethyl ketone R*. Titrate with 0.1 M *perchloric acid* using 0.2 mL of *naphtholbenzein solution R* as indicator.

1 mL of 0.1 M *perchloric acid* is equivalent to 53.01 mg of C<sub>31</sub>H<sub>41</sub>ClFNO<sub>3</sub>.

## STORAGE

Protected from light, at a temperature below 25 °C.

## IMPURITIES

*Specified impurities: A, B, C, D, E, F, G, H, I, J, K.*

*Other detectable impurities* (the following substances would, if present at a sufficient level, be detected by one or other of the tests in the monograph. They are limited by the general acceptance criterion for other/unspecified impurities and/or by the general monograph *Substances for pharmaceutical use (2034)*. It is therefore not necessary to identify these impurities for demonstration of compliance. See also 5.10. *Control of impurities in substances for pharmaceutical use*): L.

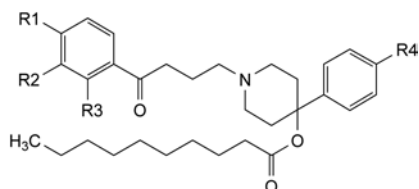

- A. R1 = F, R2 = R3 = R4 = H: 1-[4-(4-fluorophenyl)-4-oxobutyl]-4-phenylpiperidin-4-yl decanoate,
- B. R1 = R2 = H, R3 = F, R4 = Cl: 4-(4-chlorophenyl)-1-[4-(2-fluorophenyl)-4-oxobutyl]piperidin-4-yl decanoate,
- C. R1 = F, R2 = C<sub>2</sub>H<sub>5</sub>, R3 = H, R4 = Cl: 4-(4-chlorophenyl)-1-[4-(3-ethyl-4-fluorophenyl)-4-oxobutyl]piperidin-4-yl decanoate,

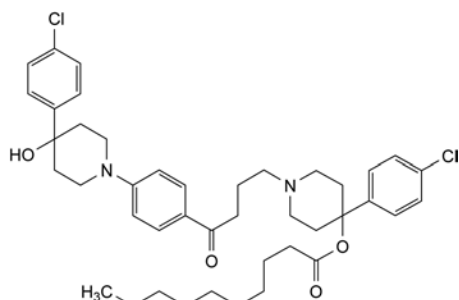

- D. 4-(4-chlorophenyl)-1-[4-[4-(4-chlorophenyl)-4-hydroxypiperidin-1-yl]phenyl]-4-oxobutyl]piperidin-4-yl decanoate,

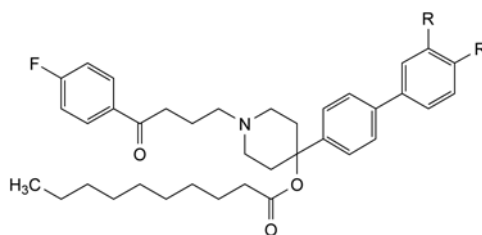

- E. R = H, R' = Cl: 4-(4'-chlorobiphenyl-4-yl)-1-[4-(4-fluorophenyl)-4-oxobutyl]piperidin-4-yl decanoate,

- F. R = Cl, R' = H: 4-(3'-chlorobiphenyl-4-yl)-1-[4-(4-fluorophenyl)-4-oxobutyl]piperidin-4-yl decanoate,

G. haloperidol,

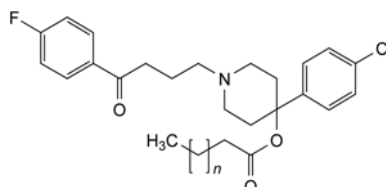

- H. n = 5: 4-(4-chlorophenyl)-1-[4-(4-fluorophenyl)-4-oxobutyl]piperidin-4-yl octanoate,

- I. n = 6: 4-(4-chlorophenyl)-1-[4-(4-fluorophenyl)-4-oxobutyl]piperidin-4-yl nonanoate,

- J. n = 8: 4-(4-chlorophenyl)-1-[4-(4-fluorophenyl)-4-oxobutyl]piperidin-4-yl undecanoate,

- K. n = 9: 4-(4-chlorophenyl)-1-[4-(4-fluorophenyl)-4-oxobutyl]piperidin-4-yl dodecanoate,

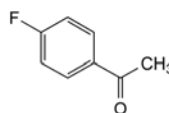

- L. 1-(4-fluorophenyl)ethanone.

01/2008:0393

## HALOTHANE

## Halothanum

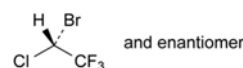

C<sub>2</sub>HBrClF<sub>3</sub>  
[151-67-7]

M<sub>r</sub> 197.4

## DEFINITION

(*RS*)-2-Bromo-2-chloro-1,1,1-trifluoroethane to which 0.01 per cent *m/m* of thymol has been added.

## CHARACTERS

*Appearance*: clear, colourless, mobile, heavy, non-flammable liquid.

*Solubility*: slightly soluble in water, miscible with anhydrous ethanol and with trichloroethylene.

## IDENTIFICATION

*First identification: B.*

*Second identification: A, C.*

A. Distillation range (see Tests).

B. Infrared absorption spectrophotometry (2.2.24).

*Preparation*: examine the substance in a 0.1 mm cell.

*Comparison: Ph. Eur. reference spectrum of halothane.*

C. Add 0.1 mL to 2 mL of 2-methyl-2-propanol *R* in a test-tube. Add 1 mL of copper edetate solution *R*, 0.5 mL of concentrated ammonia *R* and a mixture of 0.4 mL of strong hydrogen peroxide solution *R* and 1.6 mL of water *R*

(solution A). Prepare a blank at the same time (solution B). Place both tubes in a water-bath at 50 °C for 15 min, cool and add 0.3 mL of *glacial acetic acid R*. To 1 mL of each of solutions A and B add 0.5 mL of a mixture of equal volumes of freshly prepared *alizarin S solution R* and *zirconyl nitrate solution R*. Solution A is yellow and solution B is red.

To 1 mL of each of solutions A and B add 1 mL of *buffer solution pH 5.2 R*, 1 mL of *phenol red solution R* diluted 1 to 10 with *water R* and 0.1 mL of *chloramine solution R*. Solution A is bluish-violet and solution B is yellow.

To 2 mL of each of solutions A and B add 0.5 mL of a mixture of 25 volumes of *sulfuric acid R* and 75 volumes of *water R*, 0.5 mL of *acetone R* and 0.2 mL of a 50 g/L solution of *potassium bromate R* and shake. Warm the tubes in a water-bath at 50 °C for 2 min, cool and add 0.5 mL of a mixture of equal volumes of *nitric acid R* and *water R* and 0.5 mL of *silver nitrate solution R2*. Solution A is opalescent and a white precipitate is formed after a few minutes; solution B remains clear.

## TESTS

**Acidity or alkalinity.** To 20 mL add 20 mL of *carbon dioxide-free water R*, shake for 3 min and allow to stand. Separate the aqueous layer and add 0.2 mL of *bromocresol purple solution R*. Not more than 0.1 mL of 0.01 M *sodium hydroxide* or 0.6 mL of 0.01 M *hydrochloric acid* is required to change the colour of the indicator.

**Relative density (2.2.5):** 1.872 to 1.877.

**Distillation range (2.2.11):** it distils completely between 49.0 °C and 51.0 °C and 95 per cent distills within a range of 1.0 °C.

**Volatile related substances.** Gas chromatography (2.2.28).

*Internal standard: trichlorotrifluoroethane CRS.*

*Test solution (a).* The substance to be examined.

*Test solution (b).* Dilute 5.0 mL of *trichlorotrifluoroethane CRS* to 100.0 mL with the substance to be examined. Dilute 1.0 mL of the solution to 100.0 mL with the substance to be examined. Dilute 1.0 mL of this solution to 10.0 mL with the substance to be examined.

**Column:**

- size:  $l = 2.75$  m,  $\varnothing = 5$  mm;
- stationary phase: *silanised diatomaceous earth for gas chromatography R1* (180-250  $\mu\text{m}$ ), the first 1.8 m being impregnated with 30 per cent *m/m* of *macrogol 400 R* and the remainder with 30 per cent *m/m* of *dinonyl phthalate R*;
- temperature: 50 °C.

*Carrier gas: nitrogen for chromatography R.*

*Flow rate:* 30 mL/min.

*Detection:* flame ionisation.

*Injection:* 5  $\mu\text{L}$ .

**Limit:** test solution (b):

- total: not more than the area of the peak due to the internal standard, corrected if necessary for any impurity with the same retention time as the internal standard (0.005 per cent).

**Thymol.** Gas chromatography (2.2.28).

*Internal standard solution.* Dissolve 0.10 g of *menthol R* in *methylene chloride R* and dilute to 100.0 mL with the same solvent.

*Test solution.* To 20.0 mL of the substance to be examined add 5.0 mL of the internal standard solution.

*Reference solution.* Dissolve 20.0 mg of *thymol R* in *methylene chloride R* and dilute to 100.0 mL with the same solvent. To 20.0 mL of this solution, add 5.0 mL of the internal standard solution.

**Column:**

- material: fused silica;
- size:  $l = 15$  m,  $\varnothing = 0.53$  mm;

- stationary phase: *poly(dimethyl)siloxane R* (film thickness 1.5  $\mu\text{m}$ ).

*Carrier gas: nitrogen for chromatography R.*

*Flow rate:* 15 mL/min.

**Temperature:**

- column: 150 °C;
- injection port: 170 °C;
- detector: 200 °C.

*Detection:* flame ionisation.

*Injection:* 1.0  $\mu\text{L}$ .

**Limit:**

- *thymol*: 0.75 times to 1.15 times the area of the corresponding peak in the chromatogram obtained with the reference solution (0.008 per cent *m/m* to 0.012 per cent *m/m*).

**Bromides and chlorides.** To 10 mL add 20 mL of *water R* and shake for 3 min. To 5 mL of the aqueous layer add 5 mL of *water R*, 0.05 mL of *nitric acid R* and 0.2 mL of *silver nitrate solution R1*. The solution is not more opalescent than a mixture of 5 mL of the aqueous layer and 5 mL of *water R*.

**Bromine and chlorine.** To 10 mL of the aqueous layer obtained in the test for bromides and chlorides add 1 mL of *potassium iodide and starch solution R*. No blue colour is produced.

**Non-volatile matter:** maximum 20 mg/L.

Evaporate 50 mL to dryness on a water-bath and dry the residue in an oven at 100-105 °C for 2 h. The residue weighs a maximum of 1 mg.

## STORAGE

In an airtight container, protected from light, at a temperature not exceeding 25 °C. The choice of material for the container is made taking into account the particular reactivity of halothane with certain metals.

## IMPURITIES

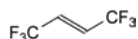

A. (*E*)-1,1,1,4,4,4-hexafluorobut-2-ene,

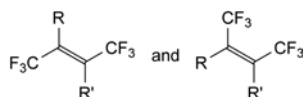

B. R = Cl, R' = H: (*EZ*)-2-chloro-1,1,1,4,4,4-hexafluorobut-2-ene (*cis* and *trans*),

C. R = R' = Cl: (*EZ*)-2,3-dichloro-1,1,1,4,4,4-hexafluorobut-2-ene (*cis* and *trans*),

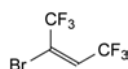

D. (*E*)-2-bromo-1,1,1,4,4,4-hexafluorobut-2-ene,



E. 2-chloro-1,1,1-trifluoroethane,

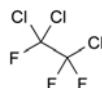

F. 1,1,2-trichloro-1,2,2-trifluoroethane,

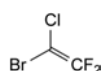

G. 1-bromo-1-chloro-2,2-difluoroethene,

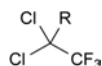

H. R = H: 2,2-dichloro-1,1,1-trifluoroethane,

I. R = Br: 1-bromo-1,1-dichloro-2,2,2-trifluoroethane,



J. 1,2-dichloro-1,1-difluoroethane.

01/2009:0462

## HARD FAT

### Adeps solidus

#### DEFINITION

Mixture of triglycerides, diglycerides and monoglycerides, which may be obtained either by esterification of fatty acids of natural origin with glycerol or by transesterification of natural fats.

Each type of hard fat is characterised by its melting point, its hydroxyl value and its saponification value.

It contains no added substances.

#### CHARACTERS

*Appearance*: white or almost white, waxy, brittle mass.

*Solubility*: practically insoluble in water, slightly soluble in anhydrous ethanol.

When heated to 50 °C, it melts giving a colourless or slightly yellowish liquid.

#### IDENTIFICATION

Thin-layer chromatography (2.2.27).

*Test solution*. Dissolve 1.0 g of the substance to be examined in ethylene chloride R and dilute to 10 mL with the same solvent.

*Plate*: TLC silica gel G plate R.

*Mobile phase*: ether R, ethylene chloride R (10:90 V/V).

*Application*: 2 µL.

*Development*: over a path of 12 cm.

*Drying*: in air.

*Detection*: expose to iodine vapour until the spots appear and examine in daylight.

*Results*: the chromatogram shows a spot with an  $R_f$  value of about 0.6 due to triglycerides ( $R_{st}$  1) and may show spots due to 1,3-diglycerides ( $R_{st}$  0.5), to 1,2-diglycerides ( $R_{st}$  0.3) and to 1-monoglycerides ( $R_{st}$  0.05). If spots due to partial glycerides are not detectable the tests for melting point and for hydroxyl value (see Tests) are carried out in addition to confirm identification.

#### TESTS

**Alkaline impurities**. Dissolve 2.00 g in a mixture of 1.5 mL of ethanol (96 per cent) R and 3.0 mL of ether R. Add 0.05 mL of bromophenol blue solution R. Not more than 0.15 mL of 0.01 M hydrochloric acid is required to change the colour of the indicator to yellow.

**Melting point** (2.2.15): 30 °C to 45 °C, and within 2 °C of the nominal value.

Introduce the melted substance into the capillary tube and allow to stand at a temperature below 10 °C for 24 h.

**Acid value** (2.5.1): maximum 0.5.

Dissolve 5.0 g in 50 mL of the prescribed mixture of solvents.

**Hydroxyl value** (2.5.3, Method A): maximum 50, and within 5 units of the nominal value; maximum 5 if the nominal value is less than 5.

**Iodine value** (2.5.4, Method A): maximum 3.

**Peroxide value** (2.5.5, Method A): maximum 3.

**Saponification value** (2.5.6): 210 to 260, and within 5 per cent of the nominal value, determined on 2.0 g.

**Unsaponifiable matter** (2.5.7): maximum 0.6 per cent, determined on 5.0 g.

**Heavy metals** (2.4.8): maximum 10 ppm.

2.0 g complies with test D. Prepare the reference solution using 2 mL of lead standard solution (10 ppm Pb) R.

**Total ash** (2.4.16): maximum 0.05 per cent, determined on 2.00 g.

#### STORAGE

Protected from light and heat.

#### LABELLING

The label states:

- the nominal melting point;
- the nominal hydroxyl value;
- the nominal saponification value.

01/2008:2155

## HELIUM

### Helium

He

$A_r$  4.00

#### DEFINITION

*Content*: minimum 99.5 per cent V/V of He.

This monograph applies to helium obtained by separation from natural gas and intended for medicinal use.

#### CHARACTERS

*Appearance*: colourless, inert gas.

#### IDENTIFICATION

Examine the chromatograms obtained in the assay. The retention time of the principal peak in the chromatogram obtained with the substance to be examined is approximately the same as that of the principal peak in the chromatogram obtained with the reference gas.

#### TESTS

**Methane**: maximum 50.0 ppm V/V.

Infrared analyser.

*Gas to be examined*. The substance to be examined. It must be filtered to avoid stray light phenomena (3 µm filter).

*Reference gas (a)*: helium for chromatography R.

*Reference gas (b)*: mixture containing 50.0 ppm V/V of methane R in helium for chromatography R.

The infrared analyser generally comprises an infrared source emitting broadband infrared radiation, an optical device, a sample cell, a detector and in some analysers a reference cell. The optical device may be positioned either before or after the sample cell. It consists of one or more optical filters, through which the broadband radiation is passed. The optical device is selected for methane determination. The measurement light beam passes through the sample cell and may also pass through a reference cell if the analyser integrates such a feature. When methane is present in the sample cell, absorption of energy in the measurement light beam will occur according to the Beer-Lambert law, and this produces a change in the detector signal. This measurement signal is compared to a reference signal to generate an output related to the concentration of methane. The generated signal is linearised in order to determine the methane content.

Calibrate the apparatus and set the sensitivity using reference gases (a) and (b). Measure the methane content in the gas to be examined.

**Oxygen**: maximum 50.0 ppm V/V, determined using an oxygen analyser equipped with an electrochemical cell and a detector scale ranging from 0-100 ppm V/V.

The gas to be examined passes through a detection cell containing an aqueous solution of an electrolyte, generally

potassium hydroxide. The presence of oxygen in the gas to be examined produces a variation in the electric signal recorded at the outlet of the cell that is proportional to the oxygen content. Calibrate the analyser according to the instructions of the manufacturer. Pass the gas to be examined through the analyser using a suitable pressure regulator and airtight metal tubes and operating at the prescribed flow rates until constant readings are obtained.

**Water** (2.5.28): maximum 67 ppm *V/V*.

#### ASSAY

Gas chromatography (2.2.28).

*Gas to be examined.* The substance to be examined.

*Reference gas:* helium for chromatography R.

*Column:*

- size:  $l = 2$  m,  $\varnothing = 4.5$  mm;
- stationary phase: molecular sieve for chromatography R (0.5 nm).

*Carrier gas:* argon for chromatography R.

*Flow rate:* 60 mL/min.

*Temperature:*

- column: 50 °C;
- detector: 150 °C.

*Detection:* thermal conductivity.

*Injection:* 0.5 mL.

Inject the reference gas. Adjust the injected volumes and operating conditions so that the height of the peak due to helium in the chromatogram obtained is at least 35 per cent of the full scale of the recorder.

*System suitability:* reference gas:

- symmetry factor: minimum 0.6.

Calculate the content of He in the gas to be examined.

#### STORAGE

As compressed gas or liquid at cryogenic temperature, in appropriate containers, complying with the legal regulations.

#### IMPURITIES

*Specified impurities:* A, B, C.

- A. CH<sub>4</sub>: methane,
- B. O<sub>2</sub>: oxygen,
- C. H<sub>2</sub>O: water.

08/2010:0332

## HEPARIN CALCIUM

### Heparinum calcicum

#### DEFINITION

Preparation containing the calcium salt of a sulfated glycosaminoglycan present in mammalian tissues. It is prepared either from the lungs of cattle or from the intestinal mucosae of pigs, cattle or sheep. On complete hydrolysis, it liberates D-glucosamine, D-glucuronic acid, L-iduronic acid, acetic acid and sulfuric acid. It has the property of delaying the clotting of blood.

*Potency:* minimum 180 IU/mg (dried substance).

#### PRODUCTION

The animals from which heparin calcium is derived must fulfil the requirements for the health of animals suitable for human consumption. All stages of production and sourcing are subjected to a suitable quality management system. The identity of the source species and the absence of material from the other species is verified by appropriate testing during production.

It is produced by methods of manufacturing designed to minimise or eliminate substances lowering blood pressure.

#### CHARACTERS

*Appearance:* white or almost white, hygroscopic powder.

*Solubility:* freely soluble in water.

#### IDENTIFICATION

A. It delays the clotting of recalcified citrated sheep plasma (see Assay).

B. Nuclear magnetic resonance spectrometry (2.2.33).

*Preparation:* dissolve 20 mg of the substance to be examined in 0.7 mL of a 20 µg/mL solution of *deuterated sodium trimethylsilylpropionate R* in *deuterium oxide R*.

*Comparison:* dissolve 20 mg of *heparin calcium for NMR identification CRS* in 0.7 mL of a 20 µg/mL solution of *deuterated sodium trimethylsilylpropionate R* in *deuterium oxide R*.

*Apparatus:* spectrometer operating at minimum 300 MHz.

*Acquisition of <sup>1</sup>H-NMR spectra:*

- number of transients: minimum 16; it is adjusted until the signal-to-noise ratio is at least 1000:1 for the heparin methyl signal at 2.04 ppm;
- temperature: about 25 °C; test sample and reference spectra have to be obtained at the same temperature;
- acquisition time: minimum 2 s;
- repetition time (acquisition time plus delay): minimum 4 s;
- spectral width: 10-12 ppm, centred at around 4.5 ppm;
- pulse width: to give a flip angle between 30° and 90°.

*Processing:*

- exponential line-broadening window function: 0.3 Hz;
- Fourier transformation;
- trimethylsilylpropionate reference signal set at 0.00 ppm.

*Results:*

- the large heparin calcium signals must be present: 2.05 ppm, 3.29 ppm (doublet), 4.37 ppm, 5.35 ppm and 5.43 ppm, all within ± 0.03 ppm;
- the <sup>1</sup>H-NMR spectrum obtained with the test sample and that obtained with *heparin calcium for NMR identification CRS* are compared qualitatively after the 2 spectra have been normalised so as to have a similar intensity; dermatan sulfate with a methyl signal at 2.08 ± 0.02 ppm may be observed; no unidentified signals larger than 4 per cent compared to the height of the heparin signal at 5.43 ppm are present in the ranges 0.10-2.00 ppm, 2.10-3.10 ppm and 5.70-8.00 ppm; signals from the solvent or process-related substances may be present and have to be identified to be accepted.

C. Liquid chromatography (2.2.29) as described in the test for related substances with the following modifications.

*Injection:* test solution (a) and reference solution (c).

*Relative retention* with reference to heparin (retention time = about 26 min): dermatan sulfate and chondroitin sulfate = about 0.9; over-sulfated chondroitin sulfate = about 1.3.

*System suitability:* reference solution (c):

- peak-to-valley ratio: minimum 1.3, where  $H_p$  = height above the baseline of the peak due to dermatan sulfate + chondroitin sulfate and  $H_v$  = height above the baseline of the lowest point of the curve separating this peak from the peak due to heparin.

*Results:* the principal peak in the chromatogram obtained with test solution (a) is similar in retention time and shape to the principal peak in the chromatogram obtained with reference solution (c).

D. It gives the reactions of calcium (2.3.1).



## TESTS

**Appearance of solution.** The solution is clear (2.2.1) and not more intensely coloured than intensity 5 of the range of reference solutions of the most appropriate colour (2.2.2, Method II).

Dissolve a quantity equivalent to 50 000 IU in water R and dilute to 10 mL with the same solvent.

**pH** (2.2.3): 5.5 to 8.0.

Dissolve 0.1 g in carbon dioxide-free water R and dilute to 10 mL with the same solvent.

**Nucleotidic impurities.** Dissolve 40 mg in 10 mL of water R. The absorbance (2.2.25) measured at 260 nm is not greater than 0.15.

**Protein:** maximum 0.5 per cent (dried substance).

**Solution A.** Mix 2 volumes of a 10 g/L solution of sodium hydroxide R and 2 volumes of a 50 g/L solution of sodium carbonate R and dilute to 5 volumes with water R.

**Solution B.** Mix 2 volumes of a 12.5 g/L solution of copper sulfate R and 2 volumes of a 29.8 g/L solution of sodium tartrate R and dilute to 5 volumes with water R.

**Solution C.** Mix 1 volume of solution B and 50 volumes of solution A.

**Solution D.** Dilute a phosphomolybdotungstic reagent 2- to 4-fold in water R. Suitable dilutions produce solutions of pH 10.25 ± 0.25 after addition of solutions C and D to the test and reference solutions.

**Test solution.** Dissolve the substance to be examined in water R to obtain a concentration of 5 mg/mL.

**Reference solutions.** Dissolve bovine albumin R in water R to obtain a concentration of 100 mg/mL. Prepare dilutions of the solution in water R as prescribed in general chapter 2.5.33, method 2.

**Blank:** water R.

**Procedure.** To 1 mL of each reference solution, of the test solution and of the blank, add 5 mL of solution C. Allow to stand for 10 min. Add 0.5 mL of solution D, mix and allow to stand at room temperature for 30 min. Determine the absorbances (2.2.25) of the solutions at 750 nm, using the solution prepared from the blank as compensation liquid.

**Calculations.** As prescribed in general chapter 2.5.33, method 2.

**Related substances.** Liquid chromatography (2.2.29).

Reference solutions are stable at room temperature for 24 h.

**Test solution (a).** Dissolve an accurately weighed quantity of about 50 mg of the substance to be examined in 5.0 mL of water for chromatography R. Mix using a vortex mixer until dissolution is complete.

**Test solution (b).** Dissolve an accurately weighed quantity of about 0.1 g of the substance to be examined in 1.0 mL of water for chromatography R. Mix using a vortex mixer until dissolution is complete. Mix 500 µL of the solution and 250 µL of 1 M hydrochloric acid, then add 50 µL of a 250 mg/mL solution of sodium nitrite R. Mix gently and allow to stand at room temperature for 40 min before adding 200 µL of 1 M sodium hydroxide to stop the reaction.

**Reference solution (a).** Dissolve 250 mg of heparin for physico-chemical analysis CRS in water for chromatography R and dilute to 2.0 mL with the same solvent. Mix using a vortex mixer until dissolution is complete.

**Reference solution (b).** Add 1200 µL of reference solution (a) to 300 µL of dermatan sulfate and over-sulfated chondroitin sulfate CRS. Mix using a vortex mixer to homogenise.

**Reference solution (c).** Add 100 µL of reference solution (b) to 900 µL of water for chromatography R. Mix using a vortex mixer to homogenise.

**Reference solution (d).** Add 400 µL of reference solution (a) to 100 µL of water for chromatography R and mix using a vortex mixer. Add 250 µL of 1 M hydrochloric acid, then add 50 µL

of a 250 mg/mL solution of sodium nitrite R. Mix gently and allow to stand at room temperature for 40 min before adding 200 µL of 1 M sodium hydroxide to stop the reaction.

**Reference solution (e).** To 500 µL of reference solution (b), add 250 µL of 1 M hydrochloric acid, then add 50 µL of a 250 mg/mL solution of sodium nitrite R. Mix gently and allow to stand at room temperature for 40 min before adding 200 µL of 1 M sodium hydroxide to stop the reaction.

**Precolumnn:**

- size:  $l = 0.05$  m,  $\varnothing = 2$  mm;
- stationary phase: anion exchange resin R (13 µm).

**Column:**

- size:  $l = 0.25$  m,  $\varnothing = 2$  mm;
- stationary phase: anion exchange resin R (9 µm);
- temperature: 40 °C.

**Mobile phase:**

- mobile phase A: dissolve 0.40 g of sodium dihydrogen phosphate R in 1 L of water for chromatography R and adjust to pH 3.0 with dilute phosphoric acid R;
- mobile phase B: dissolve 0.40 g of sodium dihydrogen phosphate R in 1 L of water for chromatography R, add 140 g of sodium perchlorate R and adjust to pH 3.0 with dilute phosphoric acid R; filter and degas;

Time (min)	Mobile phase A (per cent V/V)	Mobile phase B (per cent V/V)
0 - 10	75	25
10 - 35	75 → 0	25 → 100
35 - 40	0	100

**Flow rate:** 0.22 mL/min.

**Detection:** spectrophotometer at 202 nm.

**Equilibration:** at least 15 min.

**Injection:** 20 µL of test solution (b) and reference solutions (d) and (e).

**Relative retention** with reference to heparin (retention time = about 26 min): dermatan sulfate and chondroitin sulfate = about 0.9; over-sulfated chondroitin sulfate = about 1.3.

**System suitability:**

- the chromatogram obtained with reference solution (d) shows no peak at the retention time of heparin;
- resolution: minimum 3.0 between the peaks due to dermatan sulfate + chondroitin sulfate and over-sulfated chondroitin sulfate in the chromatogram obtained with reference solution (e).

**Limits:**

- sum of dermatan sulfate and chondroitin sulfate: not more than the area of the corresponding peak in the chromatogram obtained with reference solution (e) (2.0 per cent);
- any other impurity: no peaks other than the peak due to dermatan sulfate + chondroitin sulfate are detected.

**Nitrogen** (2.5.9): 1.5 per cent to 2.5 per cent (dried substance), determined on 0.100 g.

**Calcium:** 9.5 per cent to 11.5 per cent (dried substance), determined on 0.200 g by complexometric titration (2.5.11).

**Heavy metals** (2.4.8): maximum 30 ppm.

1.0 g complies with test F. Prepare the reference solution using 3.0 mL of lead standard solution (10 ppm Pb) R.

**Loss on drying** (2.2.32): maximum 8.0 per cent, determined on 1.000 g by drying at 60 °C over diphosphorus pentoxide R at a pressure not exceeding 670 Pa for 3 h.

**Bacterial endotoxins** (2.6.14): less than 0.01 IU per International Unit of heparin, if intended for use in the manufacture of parenteral preparations without a further

appropriate procedure for the removal of bacterial endotoxins. The addition of divalent cations may be necessary in order to fulfil the validation criteria.

#### ASSAY

Carry out the assay of heparin (2.7.5). The estimated potency is not less than 90 per cent and not more than 111 per cent of the stated potency. The confidence limits of the estimated potency ( $P = 0.95$ ) are not less than 80 per cent and not more than 125 per cent of the stated potency.

#### STORAGE

In an airtight container. If the substance is sterile, store in a sterile, airtight, tamper-proof container.

#### LABELLING

The label states:

- the number of International Units per milligram;
- the animal species of origin;
- where applicable, that the substance is suitable for use in the manufacture of parenteral preparations.

08/2010:0333

## HEPARIN SODIUM

### Heparinum natricum

#### DEFINITION

Preparation containing the sodium salt of a sulfated glycosaminoglycan present in mammalian tissues. It is prepared either from the lungs of cattle or from the intestinal mucosae of pigs, cattle or sheep. On complete hydrolysis, it liberates D-glucosamine, D-glucuronic acid, L-iduronic acid, acetic acid and sulfuric acid. It has the property of delaying the clotting of blood.

*Potency*: minimum 180 IU/mg (dried substance).

#### PRODUCTION

The animals from which heparin sodium is derived must fulfil the requirements for the health of animals suitable for human consumption. All stages of production and sourcing are subjected to a suitable quality management system. The identity of the source species and the absence of material from the other species is verified by appropriate testing during production.

It is produced by methods of manufacturing designed to minimise or eliminate substances lowering blood pressure.

#### CHARACTERS

*Appearance*: white or almost white, hygroscopic powder.

*Solubility*: freely soluble in water.

#### IDENTIFICATION

A. It delays the clotting of recalcified citrated sheep plasma (see Assay).

B. Nuclear magnetic resonance spectrometry (2.2.33).

*Solution A*. A solution in *deuterium oxide R* containing 20 µg/mL of *deuterated sodium trimethylsilylpropionate R* and if the signal at 5.22 ppm is smaller than 80 per cent of the signal at 5.44 ppm, 12 µg/mL of *sodium edetate R*.

*Preparation*: dissolve 20 mg of the substance to be examined in 0.7 mL of solution A.

*Comparison*: dissolve 20 mg of *heparin sodium for NMR identification CRS* in 0.7 mL of solution A.

*If stored, the sodium edetate and deuterated sodium trimethylsilylpropionate solutions must be kept in high-density, natural polyethylene bottles.*

*Apparatus*: spectrometer operating at minimum 300 MHz.

*Acquisition of <sup>1</sup>H-NMR spectra*:

- *number of transients*: minimum 16; it is adjusted until the signal-to-noise ratio is at least 1000:1 for the heparin methyl signal at 2.04 ppm;
- *temperature*: about 25 °C; test sample and reference spectra have to be obtained at the same temperature;
- *acquisition time*: minimum 2 s;
- *repetition time* (acquisition time plus delay): minimum 4 s;
- *spectral width*: 10-12 ppm, centred at around 4.5 ppm;
- *pulse width*: to give a flip angle between 30° and 90°.

*Processing*:

- *exponential line-broadening window function*: 0.3 Hz;
- Fourier transformation;
- trimethylsilylpropionate reference signal set at 0.00 ppm.

*Results*:

- the large heparin sodium signals must be present: 2.04 ppm, 3.27 ppm (doublet), 4.34 ppm, 5.22 ppm and 5.42 ppm, all within ± 0.03 ppm;
- the <sup>1</sup>H-NMR spectrum obtained with the test sample and that obtained with *heparin sodium for NMR identification CRS* are compared qualitatively after the 2 spectra have been normalised so as to have a similar intensity; dermatan sulfate with a methyl signal at 2.08 ± 0.02 ppm may be observed; no unidentified signals larger than 4 per cent compared to the height of the heparin signal at 5.42 ppm are present in the ranges 0.10-2.00 ppm, 2.10-3.10 ppm and 5.70-8.00 ppm; signals from the solvent or process-related substances may be present and have to be identified to be accepted; variations in the intensity of some signal regions of the spectrum of heparin may occur: the intensity-variable regions are between 3.35 ppm and 4.55 ppm, where the signal pattern is approximately kept but intensity varies.

C. Liquid chromatography (2.2.29) as described in the test for related substances with the following modifications.

*Injection*: test solution (a) and reference solution (c).

*Relative retention* with reference to heparin (retention time = about 26 min): dermatan sulfate and chondroitin sulfate = about 0.9; over-sulfated chondroitin sulfate = about 1.3.

*System suitability*: reference solution (c):

- *peak-to-valley ratio*: minimum 1.3, where  $H_p$  = height above the baseline of the peak due to dermatan sulfate + chondroitin sulfate and  $H_v$  = height above the baseline of the lowest point of the curve separating this peak from the peak due to heparin.

*Results*: the principal peak in the chromatogram obtained with test solution (a) is similar in retention time and shape to the principal peak in the chromatogram obtained with reference solution (c).

D. It complies with the test for sodium (see Tests).

#### TESTS

**Appearance of solution.** The solution is clear (2.2.1) and not more intensely coloured than intensity 5 of the range of reference solutions of the most appropriate colour (2.2.2, Method II).

Dissolve a quantity equivalent to 50 000 IU in *water R* and dilute to 10 mL with the same solvent.

**pH** (2.2.3): 5.5 to 8.0.

Dissolve 0.1 g in *carbon dioxide-free water R* and dilute to 10 mL with the same solvent.

**Nucleotidic impurities.** Dissolve 40 mg in 10 mL of *water R*. The absorbance (2.2.25) measured at 260 nm is not greater than 0.15.

**Protein:** maximum 0.5 per cent (dried substance).

**Solution A.** Mix 2 volumes of a 10 g/L solution of *sodium hydroxide R* and 2 volumes of a 50 g/L solution of *sodium carbonate R* and dilute to 5 volumes with *water R*.

**Solution B.** Mix 2 volumes of a 12.5 g/L solution of *copper sulfate R* and 2 volumes of a 29.8 g/L solution of *sodium tartrate R* and dilute to 5 volumes with *water R*.

**Solution C.** Mix 1 volume of solution B and 50 volumes of solution A.

**Solution D.** Dilute a phosphomolybdotungstic reagent 2- to 4-fold in *water R*. Suitable dilutions produce solutions of pH 10.25 ± 0.25 after addition of solutions C and D to the test and reference solutions.

**Test solution.** Dissolve the substance to be examined in *water R* to obtain a concentration of 5 mg/mL.

**Reference solutions.** Dissolve *bovine albumin R* in *water R* to obtain a concentration of 100 mg/mL. Prepare dilutions of the solution in *water R* as prescribed in general chapter 2.5.33, method 2.

**Blank:** *water R*.

**Procedure.** To 1 mL of each reference solution, of the test solution and of the blank, add 5 mL of solution C. Allow to stand for 10 min. Add 0.5 mL of solution D, mix and allow to stand at room temperature for 30 min. Determine the absorbances (2.2.25) of the solutions at 750 nm, using the solution prepared from the blank as compensation liquid.

**Calculations.** As prescribed in general chapter 2.5.33, method 2.

**Related substances.** Liquid chromatography (2.2.29).

*Reference solutions are stable at room temperature for 24 h.*

**Test solution (a).** Dissolve an accurately weighed quantity of about 50 mg of the substance to be examined in 5.0 mL of *water for chromatography R*. Mix using a vortex mixer until dissolution is complete.

**Test solution (b).** Dissolve an accurately weighed quantity of about 0.1 g of the substance to be examined in 1.0 mL of *water for chromatography R*. Mix using a vortex mixer until dissolution is complete. Mix 500 µL of the solution and 250 µL of 1 M *hydrochloric acid*, then add 50 µL of a 250 mg/mL solution of *sodium nitrite R*. Mix gently and allow to stand at room temperature for 40 min before adding 200 µL of 1 M *sodium hydroxide* to stop the reaction.

**Reference solution (a).** Dissolve 250 mg of *heparin for physico-chemical analysis CRS* in *water for chromatography R* and dilute to 2.0 mL with the same solvent. Mix using a vortex mixer until dissolution is complete.

**Reference solution (b).** Add 1200 µL of reference solution (a) to 300 µL of *dermatan sulfate and over-sulfated chondroitin sulfate CRS*. Mix using a vortex mixer to homogenise.

**Reference solution (c).** Add 100 µL of reference solution (b) to 900 µL of *water for chromatography R*. Mix using a vortex mixer to homogenise.

**Reference solution (d).** Add 400 µL of reference solution (a) to 100 µL of *water for chromatography R* and mix using a vortex mixer. Add 250 µL of 1 M *hydrochloric acid*, then add 50 µL of a 250 mg/mL solution of *sodium nitrite R*. Mix gently and allow to stand at room temperature for 40 min before adding 200 µL of 1 M *sodium hydroxide* to stop the reaction.

**Reference solution (e).** To 500 µL of reference solution (b), add 250 µL of 1 M *hydrochloric acid*, then add 50 µL of a 250 mg/mL solution of *sodium nitrite R*. Mix gently and allow to stand at room temperature for 40 min before adding 200 µL of 1 M *sodium hydroxide* to stop the reaction.

**Precolumn:**

- size:  $l = 0.05$  m,  $\emptyset = 2$  mm;
- stationary phase: anion exchange resin R (13 µm).

**Column:**

- size:  $l = 0.25$  m,  $\emptyset = 2$  mm;

– stationary phase: anion exchange resin R (9 µm);

– temperature: 40 °C.

**Mobile phase:**

– mobile phase A: dissolve 0.40 g of *sodium dihydrogen phosphate R* in 1 L of *water for chromatography R* and adjust to pH 3.0 with *dilute phosphoric acid R*;

– mobile phase B: dissolve 0.40 g of *sodium dihydrogen phosphate R* in 1 L of *water for chromatography R*, add 140 g of *sodium perchlorate R* and adjust to pH 3.0 with *dilute phosphoric acid R*; filter and degas;

Time (min)	Mobile phase A (per cent V/V)	Mobile phase B (per cent V/V)
0 - 10	75	25
10 - 35	75 → 0	25 → 100
35 - 40	0	100

**Flow rate:** 0.22 mL/min.

**Detection:** spectrophotometer at 202 nm.

**Equilibration:** at least 15 min.

**Injection:** 20 µL of test solution (b) and reference solutions (d) and (e).

**Relative retention** with reference to heparin (retention time = about 26 min): dermatan sulfate and chondroitin sulfate = about 0.9; over-sulfated chondroitin sulfate = about 1.3.

**System suitability:**

- the chromatogram obtained with reference solution (d) shows no peak at the retention time of heparin;
- resolution: minimum 3.0 between the peaks due to dermatan sulfate + chondroitin sulfate and over-sulfated chondroitin sulfate in the chromatogram obtained with reference solution (e).

**Limits:**

- sum of dermatan sulfate and chondroitin sulfate: not more than the area of the corresponding peak in the chromatogram obtained with reference solution (e) (2.0 per cent);
- any other impurity: no peaks other than the peak due to dermatan sulfate + chondroitin sulfate are detected.

**Nitrogen** (2.5.9): 1.5 per cent to 2.5 per cent (dried substance), determined on 0.100 g.

**Sodium:** 9.5 per cent to 12.5 per cent (dried substance).

Atomic absorption spectrometry (2.2.23, Method I).

**Test solution.** Dissolve 50 mg of the substance to be examined in a 1.27 mg/mL solution of *caesium chloride R* in 0.1 M *hydrochloric acid* and dilute to 100.0 mL with the same solvent.

**Reference solutions.** Prepare reference solutions containing 25 ppm, 50 ppm and 75 ppm of Na, using *sodium standard solution (200 ppm Na) R* diluted with a 1.27 mg/mL solution of *caesium chloride R* in 0.1 M *hydrochloric acid*.

**Source:** sodium hollow-cathode lamp.

**Wavelength:** 330.3 nm.

**Atomisation device:** flame of suitable composition (for example 11 L of air and 2 L of acetylene per minute).

**Heavy metals** (2.4.8): maximum 30 ppm.

1.0 g complies with test F. Prepare the reference solution using 3.0 mL of *lead standard solution (10 ppm Pb) R*.

**Loss on drying** (2.2.32): maximum 8.0 per cent, determined on 1.000 g by drying at 60 °C over *diphosphorus pentoxide R* at a pressure not exceeding 670 Pa for 3 h.

**Bacterial endotoxins** (2.6.14): less than 0.01 IU per International Unit of heparin, if intended for use in the manufacture of parenteral preparations without a further appropriate procedure for the removal of bacterial endotoxins.

## ASSAY

Carry out the assay of heparin (2.7.5). The estimated potency is not less than 90 per cent and not more than 111 per cent of the stated potency. The confidence limits of the estimated potency ( $P = 0.95$ ) are not less than 80 per cent and not more than 125 per cent of the stated potency.

## STORAGE

In an airtight container. If the substance is sterile, store in a sterile, airtight, tamper-proof container.

## LABELLING

The label states:

- the number of International Units per milligram;
- the animal species of origin;
- where applicable, that the substance is suitable for use in the manufacture of parenteral preparations.

01/2008:0828

## HEPARINS, LOW-MOLECULAR-MASS

## Heparina massae molecularis minoris

## DEFINITION

Salts of sulfated glucosaminoglycans having a mass-average relative molecular mass less than 8000 and for which at least 60 per cent of the total mass has a relative molecular mass less than 8000. Low-molecular-mass heparins display different chemical structures at the reducing, or the non-reducing end of the polysaccharide chains.

The potency is not less than 70 IU of anti-factor Xa activity per milligram, calculated with reference to the dried substance. The ratio of anti-factor Xa activity to anti-factor IIa activity, determined as described under Assay, is not less than 1.5.

## PRODUCTION

Low-molecular-mass heparins are obtained by fractionation or depolymerisation of heparin of natural origin that complies with the monograph on *Heparin sodium* (0333) or *Heparin calcium* (0332), whichever is appropriate, for parenteral administration, unless otherwise justified and authorised. For each type of low-molecular-mass heparin the batch-to-batch consistency is ensured by demonstrating, for example, that the mass-average relative molecular mass and the mass percentage within defined relative molecular-mass ranges lower than 8000 are not less than 75 per cent and not more than 125 per cent of the mean value stated as type specification. The same limits apply also to the ratio of anti-factor Xa activity to anti-factor IIa activity.

**Nucleotide and protein impurities of the source material.**

Dissolve 40 mg of the source material before fractionation in 10 mL of water R. The absorbance (2.2.25) measured at 260 nm and 280 nm is not greater than 0.20 and 0.15, respectively.

## CHARACTERS

*Appearance*: white or almost white powder, hygroscopic.

*Solubility*: freely soluble in water.

## IDENTIFICATION

## A. Nuclear magnetic resonance spectrometry (2.2.33).

*Preparation*: dissolve 0.200 g of the substance to be examined in a mixture of 0.2 mL of deuterium oxide R and 0.8 mL of water R.

*Comparison*: dissolve 0.200 g of the appropriate specific low-molecular-mass heparin reference standard in a mixture of 0.2 mL of deuterium oxide R and 0.8 mL of water R.

*Operating conditions*: use a pulsed (Fourier transform) spectrometer operating at 75 MHz for  $^{13}\text{C}$ . Record the spectra at 40 °C, using cells 5 mm in diameter. Use deuterated methanol R as internal reference at  $\delta = 50.0$  ppm.

*Results*: the spectrum obtained is similar to the appropriate specific low-molecular-mass heparin reference standard.

- B. The ratio of anti-factor Xa activity to anti-factor IIa activity, determined as described under Assay, is not less than 1.5.
- C. Size-exclusion chromatography (2.2.30).

*Test solution*. Dissolve 20 mg of the substance to be examined in 2 mL of the mobile phase.

*Reference solution*. Dissolve 20 mg of heparin low-molecular-mass for calibration CRS in 2 mL of the mobile phase.

*Column*:

- *size*:  $l = 0.30$  m,  $\varnothing = 7.5$  mm;
- *stationary phase*: appropriate porous silica beads (5  $\mu\text{m}$ ) with a fractionation range for proteins of approximately 15 000 to 100 000;
- *number of theoretical plates*: minimum of 20 000 per metre.

*Mobile phase*: 28.4 g/L solution of anhydrous sodium sulfate R adjusted to pH 5.0 using dilute sulfuric acid R.

*Flow rate*: 0.5 mL/min.

*Detection*: differential refractometer.

*Injection*: 25  $\mu\text{L}$ .

*Calibration*. For detection, use a differential refractometer (RI) detector connected in series to a ultraviolet spectrophotometer (UV) set at 234 nm such that the UV monitor is connected to the column outlet, and the RI detector to the UV-monitor outlet.

It is necessary to measure the time lapse between the 2 detectors accurately, so that their chromatograms can be aligned correctly. The retention times used in the calibration must be those from the RI detector.

The normalisation factor used to calculate the relative molecular mass from the RI/UV ratio is obtained as follows: calculate the total area under the UV<sub>234</sub> ( $\sum\text{UV}_{234}$ ) and the RI ( $\sum\text{RI}$ ) curves by numerical integration over the range of interest (i.e. excluding salt and solvent peaks at the end of the chromatogram). Calculate the ratio  $r$  using the following expression:

$$\frac{\sum \text{RI}}{\sum \text{UV}_{234}}$$

Calculate the factor  $f$  using the following expression:

$$\frac{M_{na}}{r}$$

$M_{na}$  = assigned number-average relative molecular mass of the Heparin low-molecular-mass for calibration CRS found in the leaflet supplied with the CRS.

Provided the UV<sub>234</sub> and the RI responses are aligned, the relative molecular mass  $M$  at any point is calculated using the following expression:

$$f \frac{\text{RI}}{\text{UV}_{234}}$$

The resulting table of retention times and relative molecular masses may be used to derive a calibration for the chromatographic system by fitting a suitable mathematical relationship to the data. A polynomial of the 3<sup>rd</sup> degree is recommended. *It must be stressed that the extrapolation of this fitted calibration curve to higher molecular masses is not valid.*

Inject 25  $\mu\text{L}$  of the test solution and record the chromatogram for a period of time, ensuring complete elution of sample and solvent peaks.

The mass-average relative molecular mass is defined by the following expression:

$$\frac{\sum (RI_i M_i)}{\sum RI_i}$$

- $RI_i$  = mass of substance eluting in the fraction  $i$ ;  
 $M_i$  = relative molecular mass corresponding to fraction  $i$ .

Any low-molecular-mass heparin covered by a specific monograph complies with the requirements for identification C prescribed in the corresponding monograph.

Where no specific monograph exists for the low-molecular-mass heparin to be examined, the mass-average relative molecular mass is not greater than 8000 and at least 60 per cent of the total mass has a relative molecular mass lower than 8000. In addition, the molecular mass parameters (mass-average molecular mass and mass percentages of chains comprised between specified values) correspond to that of the manufacturer's reference preparation.

- D. It gives reaction (a) of sodium or the reactions of calcium (as appropriate) (2.3.1).

#### TESTS

**pH** (2.2.3): 5.5 to 8.0.

Dissolve 0.1 g in *carbon dioxide-free water R* and dilute to 10 mL with the same solvent.

**Nitrogen** (2.5.9): 1.5 per cent to 2.5 per cent (dried substance).

**Calcium** (2.5.11): 9.5 per cent to 11.5 per cent (dried substance), if prepared from heparin complying with the monograph on *Heparin calcium* (0332). Use 0.200 g.

**Sodium**: 9.5 per cent to 12.5 per cent (dried substance), if prepared from heparin complying with the monograph on *Heparin sodium* (0333).

Atomic absorption spectrometry (2.2.23, *Method I*).

**Test solution.** Dissolve 50 mg in 0.1 M *hydrochloric acid* containing 1.27 mg of *caesium chloride R* per millilitre and dilute to 100.0 mL with the same solvent.

**Reference solutions.** Prepare reference solutions (25 ppm, 50 ppm and 75 ppm) using *sodium standard solution* (200 ppm Na) *R* diluted with 0.1 M *hydrochloric acid* containing 1.27 mg of *caesium chloride R* per millilitre.

**Source:** sodium hollow-cathode lamp.

**Wavelength:** 330.3 nm.

**Atomisation device:** flame of suitable composition (for example, 11 L of air and 2 L of acetylene per minute).

**Molar ratio of sulfate ions to carboxylate ions** (2.2.38): minimum 1.8.

*The sample of heparin used in this titration must be free from ionisable impurities, particularly salts.*

Weigh 0.100 g of the substance to be examined taking the necessary measures to avoid the problems linked to hygroscopicity.

Take up into about 20 mL of double-glass-distilled *water R*. Cool to 4 °C and apply 2.0 mL of this solution to a pre-cooled column (approximately 10 × 1 cm), packed with a suitable *cation exchange resin R*. Wash through with double-glass-distilled *water R* into the titration vessel up to a final volume of about 10-15 mL (*the titration vessel must be just large enough to hold the electrodes from the conductivity meter, a small stirrer bar and a fine flexible tube from the outlet of a 2 mL burette*). Stir magnetically. When the conductivity reading is constant, note it and titrate with 0.05 M *sodium hydroxide* added in approximately 50 µL portions. Record the burette level and the conductivity meter reading a few seconds after each addition until the end-point is reached.

For each measured figure, calculate the number of milliequivalents of sodium hydroxide added from the volume and the known concentration of the sodium hydroxide solution. Plot on a graph the figures for conductivity (as  $y$ -axis) against the figures of milliequivalent of sodium hydroxide (as  $x$ -axis). The graph will have 3, approximately linear sections: an initial steep downward slope, a middle slight rise and a final steep rise. Estimate the best straight lines through these 3 parts of the graph. At the points where the 1<sup>st</sup> and 2<sup>nd</sup> lines intersect, and where the 2<sup>nd</sup> and 3<sup>rd</sup> lines intersect, draw perpendiculars to the  $x$ -axis to estimate the milliequivalents of sodium hydroxide taken up by the sample at those points. The point where the 1<sup>st</sup> and 2<sup>nd</sup> lines intersect will give the number of milliequivalents of sodium hydroxide taken up by the sulfate groups, and the point where the 2<sup>nd</sup> and 3<sup>rd</sup> lines intersect will give the number of milliequivalents taken up by the sulfate and carboxylate groups together. The difference between the 2 will therefore give the number of milliequivalents taken up by the carboxylate groups.

**Heavy metals** (2.4.8): maximum 30 ppm.

0.5 g complies with test C. Prepare the reference solution using 1.5 mL of *lead standard solution* (10 ppm Pb) *R*.

**Loss on drying** (2.2.32): maximum 10.0 per cent, determined on 1.000 g by drying at 60 °C over *diphosphorus pentoxide R* at a pressure not exceeding 0.67 kPa for 3 h.

**Bacterial endotoxins** (2.6.14): less than 0.01 IU per International Unit of anti-Xa activity, if intended for use in the manufacture of parenteral preparations without a further appropriate procedure for the removal of bacterial endotoxins. The addition of divalent cations may be necessary to fulfil the validation criteria.

#### ASSAY

The anticoagulant activity of low-molecular-mass heparins is determined *in vitro* by 2 assays which determine its ability to accelerate the inhibition of factor Xa (anti-Xa assay) and thrombin, factor IIa (anti-IIa assay), by antithrombin III.

The International Units for anti-Xa and anti-IIa activity are the activities contained in a stated amount of the International Standard for low-molecular-mass heparin.

*Heparin low-molecular-mass for assay BRP*, calibrated in International Units by comparison with the International Standard using the 2 assays given below, is used as reference preparation.

#### ANTI-FACTOR Xa ACTIVITY

##### Reference and test solutions

Prepare 4 independent series of 4 dilutions each, of the substance to be examined and of the reference preparation of low-molecular-mass heparin in *tris(hydroxymethyl)aminomethane sodium chloride buffer solution pH 7.4 R*; the concentration range should be within 0.025 IU to 0.2 IU of anti-factor Xa activity per millilitre and the dilutions chosen should give a linear response when results are plotted as absorbance against log concentration.

##### Procedure

Label 16 tubes in duplicate: T<sub>1</sub>, T<sub>2</sub>, T<sub>3</sub>, T<sub>4</sub> for the dilutions of the substance to be examined and S<sub>1</sub>, S<sub>2</sub>, S<sub>3</sub>, S<sub>4</sub> for the dilutions of the reference preparation. To each tube add 50 µL of *antithrombin III solution R1* and 50 µL of the appropriate dilution of the substance to be examined, or the reference preparation. After each addition, mix but do not allow bubbles to form. Treating the tubes in the order S<sub>1</sub>, S<sub>2</sub>, S<sub>3</sub>, S<sub>4</sub>, T<sub>1</sub>, T<sub>2</sub>, T<sub>3</sub>, T<sub>4</sub>, T<sub>1</sub>, T<sub>2</sub>, T<sub>3</sub>, T<sub>4</sub>, S<sub>1</sub>, S<sub>2</sub>, S<sub>3</sub>, S<sub>4</sub>, allow to equilibrate at 37 °C (water-bath or heating block) for 1 min and add to each tube 100 µL of *bovine factor Xa solution R*. Incubate for exactly 1 min and add 250 µL of *chromogenic substrate R1*. Stop the reaction after exactly 4 min by adding 375 µL of *acetic acid R*. Transfer the mixtures to semi-micro cuvettes and measure the absorbance (2.2.25) at 405 nm using a suitable reading device. Determine the blank amidolytic activity at the beginning and at the end of the procedure in a similar manner, using

01/2008:1980  
corrected 6.0

*tris(hydroxymethyl)aminomethane sodium chloride buffer solution pH 7.4 R* instead of the reference and test solutions; the 2 blank values do not differ significantly. Calculate the regression of the absorbance on log concentrations of the solutions of the substance to be examined and of the reference preparation of low-molecular-mass heparins and calculate the potency of the substance to be examined in International Units of anti-factor Xa activity per millilitre using the usual statistical methods for parallel-line assays.

**ANTI-FACTOR IIa ACTIVITY****Reference and test solutions**

Prepare 4 independent series of 4 dilutions each, of the substance to be examined and of the reference preparation of low molecular-mass heparin in *tris(hydroxymethyl)aminomethane sodium chloride buffer solution pH 7.4 R*; the concentration range should be within 0.015 IU to 0.075 IU of anti-factor IIa activity per millilitre and the dilutions chosen should give a linear response when results are plotted as absorbance against log concentration.

**Procedure**

Label 16 tubes in duplicate: T<sub>1</sub>, T<sub>2</sub>, T<sub>3</sub>, T<sub>4</sub> for the dilutions of the substance to be examined and S<sub>1</sub>, S<sub>2</sub>, S<sub>3</sub>, S<sub>4</sub> for the dilutions of the reference preparation. To each tube add 50 µL of *antithrombin III solution R2* and 50 µL of the appropriate dilution of the substance to be examined or the reference preparation. After each addition, mix but do not allow bubbles to form. Treating the tubes in the order S<sub>1</sub>, S<sub>2</sub>, S<sub>3</sub>, S<sub>4</sub>, T<sub>1</sub>, T<sub>2</sub>, T<sub>3</sub>, T<sub>4</sub>, T<sub>1</sub>, T<sub>2</sub>, T<sub>3</sub>, T<sub>4</sub>, S<sub>1</sub>, S<sub>2</sub>, S<sub>3</sub>, S<sub>4</sub>, allow to equilibrate at 37 °C (water-bath or heating block) for 1 min and add to each tube 100 µL of *human thrombin solution R*. Incubate for exactly 1 min and add 250 µL of *chromogenic substrate R2*. Stop the reaction after exactly 4 min by adding 375 µL of *acetic acid R*. Transfer the mixtures to semi-micro cuvettes and measure the absorbance (2.2.25) at 405 nm using a suitable reading device. Determine the blank amidolytic activity at the beginning and at the end of the procedure in a similar manner, using *tris(hydroxymethyl)aminomethane sodium chloride buffer solution pH 7.4 R* instead of the reference and test solutions; the 2 blank values do not differ significantly. Calculate the regression of the absorbance on log concentrations of the solutions of the substance to be examined and of the reference preparation of low-molecular-mass heparins, and calculate the potency of the substance to be examined in International Units of anti-factor IIa activity per millilitre using the usual statistical methods for parallel-line assays.

**LABELLING**

The label states:

- the number of International Units of anti-factor Xa activity per milligram;
- the number of International Units of anti-factor IIa activity per milligram;
- the mass-average molecular mass and the percentage of molecules within defined molecular mass ranges;
- where applicable, that the contents are the sodium salt;
- where applicable, that the contents are the calcium salt.

**STORAGE**

In an airtight tamper-proof container. If the product is sterile and free of bacterial endotoxins, store in a sterile and apyrogenic container.

**HEPTAMINOL HYDROCHLORIDE**

## Heptaminoli hydrochloridum

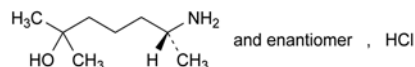
C<sub>8</sub>H<sub>20</sub>ClNO  
[543-15-7]M<sub>r</sub> 181.7**DEFINITION**

(6RS)-6-Amino-2-methylheptan-2-ol hydrochloride.

*Content*: 99.0 per cent to 101.0 per cent (dried substance).

**CHARACTERS**

*Appearance*: white or almost white, crystalline powder.

*Solubility*: freely soluble in water, soluble in alcohol, practically insoluble in methylene chloride.

**IDENTIFICATION**

*First identification*: B, D.

*Second identification*: A, C, D.

A. To 1 mL of solution S (see Tests) add 4 mL of *water R* and 2 mL of a 200 g/L solution of *ammonium and cerium nitrate R* in 4 M *nitric acid*. An orange-brown colour develops.

B. Infrared absorption spectrophotometry (2.2.24).

*Comparison*: *heptaminol hydrochloride CRS*.

C. Examine the chromatograms obtained in the test for related substances.

*Detection*: examine in daylight.

*Results*: the principal spot in the chromatogram obtained with test solution (b) is similar in position, colour and size to the principal spot in the chromatogram obtained with reference solution (b).

D. It gives reaction (a) of chlorides (2.3.1).

**TESTS**

**Solution S**. Dissolve 5.0 g in *carbon dioxide-free water R* and dilute to 50 mL with the same solvent.

**Appearance of solution**. Solution S is clear (2.2.1) and not more intensely coloured than reference solution BY<sub>6</sub> (2.2.2, *Method II*).

**Acidity or alkalinity**. To 10 mL of solution S add 0.1 mL of *methyl red solution R* and 0.3 mL of 0.01 M *hydrochloric acid*. The solution is red. Add 0.6 mL of 0.01 M *sodium hydroxide*. The solution is yellow.

**Related substances**. Thin-layer chromatography (2.2.27).

*Test solution (a)*. Dissolve 0.50 g of the substance to be examined in *methanol R* and dilute to 5.0 mL with the same solvent.

*Test solution (b)*. Dilute 1.0 mL of test solution (a) to 10 mL with *methanol R*.

*Reference solution (a)*. Dilute 3.0 mL of test solution (a) to 10.0 mL with *methanol R*. Dilute 1.0 mL of this solution to 50.0 mL with *methanol R*.

*Reference solution (b)*. Dissolve 0.10 g of *heptaminol hydrochloride CRS* in *methanol R* and dilute to 10 mL with the same solvent.

*Reference solution (c)*. Dissolve 10.0 mg of *heptaminol impurity A CRS* in *methanol R* and dilute to 5.0 mL with the same solvent.

*Reference solution (d)*. Dilute 1.0 mL of reference solution (c) to 10.0 mL with *methanol R*.

*Reference solution (e).* To 2.5 mL of reference solution (c) add 0.5 mL of test solution (b) and dilute to 5 mL with *methanol R*.

*Plate:* TLC silica gel G plate *R*.

*Mobile phase:* concentrated ammonia *R*, dioxan *R*, 2-propanol *R* (10:50:50 V/V/V).

*Application:* 10 µL; apply test solutions (a) and (b) and reference solutions (a), (b), (d) and (e).

*Development:* over 2/3 of the plate.

*Drying:* in air.

*Detection:* expose the plate to iodine vapour for at least 15 h.

*System suitability:* the chromatogram obtained with reference solution (e) shows 2 clearly separated principal spots and the chromatogram obtained with reference solution (a) shows a single principal spot.

*Limits:* in the chromatogram obtained with test solution (a):

- *impurity A:* any spot corresponding to impurity A is not more intense than the spot in the chromatogram obtained with reference solution (d) (0.2 per cent),
- *any other impurity:* any spot, apart from the principal spot and any spot corresponding to impurity A is not more intense than the spot in the chromatogram obtained with reference solution (a) (0.6 per cent).

**Heavy metals (2.4.8):** maximum 10 ppm.

12 mL of solution S complies with limit test A. Prepare the standard using *lead standard solution (1 ppm Pb) R*.

**Loss on drying (2.2.32):** maximum 0.5 per cent, determined on 1.000 g by drying in an oven at 105 °C for 4 h.

**Sulfated ash (2.4.14):** maximum 0.1 per cent, determined on 1.0 g.

#### ASSAY

Dissolve 0.140 g in 50 mL of *alcohol R* and add 5.0 mL of 0.01 M hydrochloric acid. Carry out a potentiometric titration (2.2.20), using 0.1 M sodium hydroxide. Read the volume added between the 2 points of inflexion.

1 mL of 0.1 M sodium hydroxide is equivalent to 18.17 mg of C<sub>8</sub>H<sub>20</sub>ClNO.

#### IMPURITIES

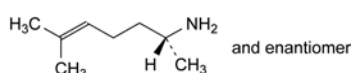

A. (2*RS*)-6-methylhept-5-en-2-amine.

01/2008:1436  
corrected 6.0

## HEXAMIDINE DISETIONATE

Hexamidini diisetionas

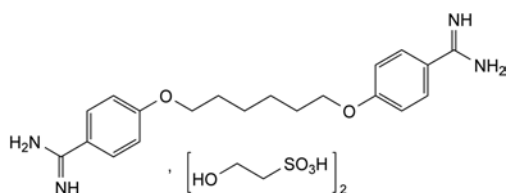

C<sub>24</sub>H<sub>38</sub>N<sub>4</sub>O<sub>10</sub>S<sub>2</sub>  
[659-40-5]

*M*<sub>r</sub> 607

#### DEFINITION

4,4'-(Hexane-1,6-diylbis(oxy)dibenzimidamide bis(2-hydroxyethanesulfonate).

*Content:* 98.5 per cent to 101.5 per cent (dried substance).

#### PRODUCTION

The production method must be evaluated to determine the potential for formation of alkyl isetonates, which is particularly likely to occur if the reaction medium contains lower alcohols. Where necessary, the production method is validated to demonstrate that alkyl isetonates are not detectable in the final product.

#### CHARACTERS

*Appearance:* white or slightly yellow powder, hygroscopic.

*Solubility:* sparingly soluble in water, slightly soluble in ethanol (96 per cent), practically insoluble in methylene chloride.

#### IDENTIFICATION

A. Infrared absorption spectrophotometry (2.2.24).

*Comparison:* hexamidine diisetonate CRS.

B. Dissolve about 40 mg in 5 mL of *water R* and add dropwise with shaking 1 mL of a 100 g/L solution of *sodium chloride R*. Allow to stand for 5 min. An abundant, shimmering white precipitate is slowly formed.

#### TESTS

**Appearance of solution.** Dissolve 0.50 g in *carbon dioxide-free water R*, heating at about 70 °C and dilute to 10 mL with the same solvent. Allow to cool to room temperature for 10-15 min. The solution is not more opalescent than reference suspension II (2.2.1) and not more intensely coloured than intensity 6 of the range of reference solutions of the most appropriate colour (2.2.2, Method II).

**Acidity or alkalinity.** Dissolve 2.0 g in *water R* heating at about 50 °C and dilute to 20 mL with *water R* heating at about 50 °C. Allow to cool to about 35 °C, add 0.1 mL of *methyl red solution R*. Not more than 0.25 mL of 0.05 M hydrochloric acid or 0.05 M sodium hydroxide is required to change the colour of the indicator.

**Related substances.** Liquid chromatography (2.2.29).

*Test solution.* Dissolve 20.0 mg of the substance to be examined in mobile phase A and dilute to 100.0 mL with mobile phase A.

*Reference solution (a).* Dilute 1.0 mL of the test solution to 100.0 mL with mobile phase A.

*Reference solution (b).* Dilute 1.0 mL of reference solution (a) to 10.0 mL with mobile phase A.

*Reference solution (c).* Dissolve 5 mg of the substance to be examined and 5 mg of *pentamidine diisetonate CRS* in mobile phase A and dilute to 100 mL with mobile phase A. Dilute 2 mL of the solution to 5 mL with mobile phase A.

*Column:*

- *size:* *l* = 0.25 m, Ø = 4.6 mm,
- *stationary phase:* styrene-divinylbenzene copolymer *R* (8 µm).

*Mobile phase:*

- *mobile phase A:* mix 20 volumes of *acetonitrile R* and 80 volumes of a 6.8 g/L solution of *potassium dihydrogen phosphate R* previously adjusted to pH 3.0 using *phosphoric acid R*,
- *mobile phase B:* mix equal volumes of *acetonitrile R* and of a 6.8 g/L solution of *potassium dihydrogen phosphate R* previously adjusted to pH 3.0 using *phosphoric acid R*,

Time (min)	Mobile phase A (per cent V/V)	Mobile phase B (per cent V/V)
0 - 30	100 → 0	0 → 100
30 - 35	0	100
35 - 40	0 → 100	100 → 0

*Flow rate:* 1 mL/min.

*Detection:* spectrophotometer at 263 nm.

*Injection:* 20 µL.

01/2008:1221

*Relative retention* with reference to hexamidine (retention time = about 6 min): impurity B = about 1.7; impurity A = about 2.0; impurity C = about 3.7; impurity D = about 4.7.

*System suitability*: reference solution (c):

- *resolution*: minimum 5.0 between the peaks due to hexamidine and pentamidine.

*Limits*:

- *impurity A*: not more than the area of the principal peak in the chromatogram obtained with reference solution (a) (1.0 per cent),
- *impurity B*: not more than 3 times the area of the principal peak in the chromatogram obtained with reference solution (b) (0.3 per cent),
- *impurities C, D*: for each impurity, not more than the area of the principal peak in the chromatogram obtained with reference solution (b) (0.1 per cent),
- *any other impurities*: for each impurity, not more than the area of the principal peak in the chromatogram obtained with reference solution (b) (0.1 per cent),
- *total*: not more than 1.5 times the area of the principal peak in the chromatogram obtained with reference solution (a) (1.5 per cent),
- *disregard limit*: 0.5 times the area of the principal peak in the chromatogram obtained with reference solution (b) (0.05 per cent).

**Loss on drying** (2.2.32): maximum 0.5 per cent, determined on 1.000 g by drying in an oven at 105 °C.

**Sulfated ash** (2.4.14): maximum 0.1 per cent, determined on 1.0 g.

#### ASSAY

Dissolve 0.250 g in 50 mL of *dimethylformamide R*. Titrate with 0.1 M *tetrabutylammonium hydroxide* under a current of *nitrogen R*, determining the end-point potentiometrically (2.2.20).

1 mL of 0.1 M *tetrabutylammonium hydroxide* is equivalent to 30.35 mg of  $C_{24}H_{38}N_4O_{10}S_2$ .

#### STORAGE

In an airtight container.

#### IMPURITIES

*Specified impurities: A, B, C, D.*

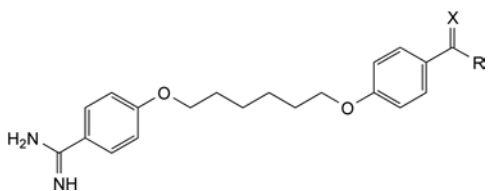

- A. X = O, R = NH<sub>2</sub>: 4-[[6-(4-carbamimidoylphenoxy)hexyl]oxy]benzamide,
- B. X = NH, R = OC<sub>2</sub>H<sub>5</sub>: ethyl 4-[[6-(4-carbamimidoylphenoxy)hexyl]oxy]benzimidate,
- D. X = O, R = OC<sub>2</sub>H<sub>5</sub>: ethyl 4-[[6-(4-carbamimidoylphenoxy)hexyl]oxy]benzoate,

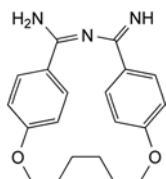

- C. 4-imino-9,16-dioxo-3-azatricyclo[15.2.2.2<sup>5,8</sup>]tricoso-1(19),2,5,7,17,20,22-heptaen-2-amine.

## HEXETIDINE

### Hexetidinum

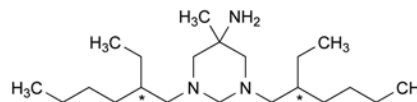

$C_{21}H_{45}N_3$   
[141-94-6]

$M_r$  339.6

#### DEFINITION

Hexetidine contains not less than 98.0 per cent and not more than the equivalent of 102.0 per cent of 1,3-bis(2-ethylhexyl)-5-methylhexahydropyrimidin-5-amine.

#### CHARACTERS

An oily liquid, colourless or slightly yellow, very slightly soluble in water, very soluble in acetone, in alcohol and in methylene chloride. It dissolves in dilute mineral acids.

#### IDENTIFICATION

*First identification: A.*

*Second identification: B, C, D.*

- A. Examine by infrared absorption spectrophotometry (2.2.24), comparing with the spectrum obtained with *hexetidine CRS*.
- B. Examine the chromatograms obtained in the test for related substances. The principal spot in the chromatogram obtained with test solution (b) is similar in position, colour and size to the principal spot in the chromatogram obtained with reference solution (a).
- C. To 0.2 mL add 2 mL of *sulfuric acid R* and 2 mg of *chromotropic acid, sodium salt R*. Heat in a water-bath at 60 °C. A violet colour develops.
- D. Dissolve 0.2 mL in 1 mL of *methylene chloride R*. Add 0.5 mL of *copper sulfate solution R*, 0.05 mL of 0.25 M *alcoholic sulfuric acid R* and 5 mL of *water R*. Shake, then allow to stand. The lower layer becomes deep blue.

#### TESTS

**Appearance.** The substance to be examined is clear (2.2.1) and not more intensely coloured than reference solution Y<sub>5</sub> or reference solution GY<sub>5</sub> (2.2.2, *Method II*).

**Relative density** (2.2.5): 0.864 to 0.870.

**Refractive index** (2.2.6): 1.461 to 1.467.

**Optical rotation** (2.2.7). Dissolve 1.0 g in *ethanol R* and dilute to 10.0 mL with the same solvent. The angle of optical rotation is –0.10° to +0.10°.

**Absorbance** (2.2.25). Dissolve 0.50 g in *heptane R* and dilute to 50.0 mL with the same solvent. At wavelengths from 270 nm to 350 nm, the absorbance of the solution is not greater than 0.1.

**Related substances.** Examine by thin-layer chromatography (2.2.27), using *silica gel H R* as the coating substance. *Prepare the solutions immediately before use.*

*Test solution (a).* Dissolve 2.0 g of the substance to be examined in *heptane R* and dilute to 20 mL with the same solvent.

*Test solution (b).* Dilute 1 mL of test solution (a) to 10 mL with *heptane R*.

*Reference solution (a).* Dissolve 20 mg of *hexetidine CRS* in *heptane R* and dilute to 2 mL with the same solvent.

*Reference solution (b).* Dilute 1 mL of test solution (a) to 100 mL with *heptane R*.

*Reference solution (c).* Dilute 5 mL of reference solution (b) to 10 mL with *heptane R*.

*Reference solution (d).* Dissolve 10 mg of *dehydrohexetidine CRS* in test solution (a) and dilute to 10 mL with the same solution.



01/2008:0183  
corrected 6.0

Apply separately to the plate 1 µL of each solution. At the bottom of a chromatographic tank, place an evaporating dish containing *concentrated ammonia R1*. Place the dried plate in the tank and close the tank. Leave the plate in contact with the ammonia vapour for 15 min. Withdraw the plate and place it in a current of air to remove the ammonia vapour. Develop over a path of 15 cm using a mixture of 20 volumes of *methanol R* and 80 volumes of *toluene R*. Allow the plate to dry in air. Expose the plate to iodine vapour for 30 min. Any spot in the chromatogram obtained with test solution (a), apart from the principal spot, is not more intense than the spot in the chromatogram obtained with reference solution (b) (1 per cent) and at most two such spots are more intense than the spot in the chromatogram obtained with reference solution (c) (0.5 per cent). The test is not valid unless the chromatogram obtained with reference solution (d) shows two clearly separated spots.

**Heavy metals (2.4.8).** Dissolve 2.0 g in a mixture of 15 volumes of *water R* and 85 volumes of *acetone R* and dilute to 20 mL with the same mixture of solvents. 12 mL of the solution complies with limit test B for heavy metals (10 ppm). Prepare the standard using lead standard solution (1 ppm Pb) obtained by diluting *lead standard solution (100 ppm Pb) R* with a mixture of 15 volumes of *water R* and 85 volumes of *acetone R*.

**Sulfated ash (2.4.14).** Not more than 0.1 per cent, determined on 1.0 g.

#### ASSAY

Dissolve 0.150 g in 80 mL of *anhydrous acetic acid R*. Titrate with 0.1 M *perchloric acid*, determining the end-point potentiometrically (2.2.20).

1 mL of 0.1 M *perchloric acid* is equivalent to 16.98 mg of  $C_{12}H_{16}N_2O_3$ .

#### STORAGE

Store protected from light.

#### IMPURITIES

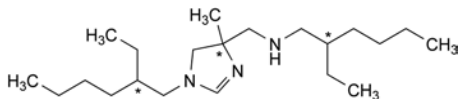

- A. 2-ethyl-N-[[1-(2-ethylhexyl)-4-methyl-4,5-dihydro-1H-imidazol-4-yl]methyl]hexan-1-amine (dehydrohexetidine),

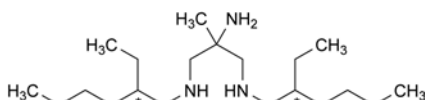

- B. *N*<sup>7</sup>,*N*<sup>3</sup>-bis(2-ethylhexyl)-2-methylpropane-1,2,3-triamine (triamine),

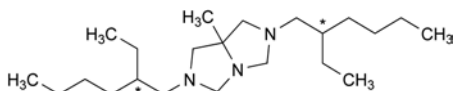

- C. 2,6-bis(2-ethylhexyl)-7a-methylhexahydro-1H-imidazo[1,5-c]imidazole (hexedine),

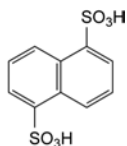

- D. naphthalene-1,5-disulfonic acid.

## HEXOBARBITAL

### Hexobarbitalum

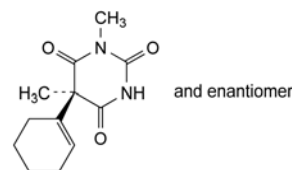

$C_{12}H_{16}N_2O_3$   
[56-29-1]

$M_r$  236.3

#### DEFINITION

Hexobarbital contains not less than 99.0 per cent and not more than the equivalent of 101.0 per cent of (5*RS*)-5-(cyclohex-1-enyl)-1,5-dimethylpyrimidine-2,4,6(1*H*,3*H*,5*H*)-trione, calculated with reference to the dried substance.

#### CHARACTERS

A white or almost white, crystalline powder, very slightly soluble in water, sparingly soluble in alcohol. It forms water-soluble compounds with alkali hydroxides and carbonates and with ammonia.

#### IDENTIFICATION

*First identification: A, B.*

*Second identification: A, C, D.*

- A. Determine the melting point (2.2.14) of the substance to be examined. Mix equal parts of the substance to be examined and *hexobarbital CRS* and determine the melting point of the mixture. The difference between the melting points (which are about 146 °C) is not greater than 2 °C.
- B. Examine by infrared absorption spectrophotometry (2.2.24), comparing with the spectrum obtained with *hexobarbital CRS*.
- C. Examine by thin-layer chromatography (2.2.27), using *silica gel GF<sub>254</sub> R* as the coating substance.

*Test solution.* Dissolve 0.1 g of the substance to be examined in *chloroform R* and dilute to 100 mL with the same solvent.

*Reference solution.* Dissolve 0.1 g of *hexobarbital CRS* in *chloroform R* and dilute to 100 mL with the same solvent.

Apply separately to the plate 10 µL of each solution. Develop over a path of 18 cm using the lower layer of a mixture of 5 volumes of *concentrated ammonia R*, 15 volumes of *alcohol R* and 80 volumes of *chloroform R*. Examine immediately in ultraviolet light at 254 nm. The principal spot in the chromatogram obtained with the test solution is similar in position and size to the principal spot in the chromatogram obtained with the reference solution.

- D. To about 10 mg add 1.0 mL of a 10 g/L solution of *vanillin R* in *alcohol R* and 2 mL of a cooled mixture of 1 volume of *water R* and 2 volumes of *sulfuric acid R*. Shake and allow to stand for 5 min. A greenish-yellow colour develops. Heat on a water-bath for 10 min. The colour becomes dark red.

#### TESTS

**Appearance of solution.** Dissolve 1.0 g in a mixture of 4 mL of *dilute sodium hydroxide solution R* and 6 mL of *water R*. The solution is clear (2.2.1) and not more intensely coloured than reference solution  $Y_6$  (2.2.2, *Method II*).

**Acidity.** Boil 1.0 g with 50 mL of *water R* for 2 min, allow to cool and filter. To 10 mL of the filtrate add 0.15 mL of *methyl red solution R*. The solution is orange-yellow. Not more than 0.1 mL of 0.1 M *sodium hydroxide* is required to produce a pure yellow colour.

**Related substances.** Examine by thin-layer chromatography (2.2.27), using *silica gel GF<sub>254</sub> R* as the coating substance.

**Test solution.** Dissolve 1.0 g of the substance to be examined in *chloroform R* and dilute to 100 mL with the same solvent.

**Reference solution.** Dilute 0.5 mL of the test solution to 100 mL with *chloroform R*.

Apply separately to the plate 20 µL of each solution. Develop over a path of 15 cm using the lower layer of a mixture of 5 volumes of *concentrated ammonia R*, 15 volumes of *alcohol R* and 80 volumes of *chloroform R*. Examine immediately in ultraviolet light at 254 nm. Any spot in the chromatogram obtained with the test solution, apart from the principal spot, is not more intense than the spot in the chromatogram obtained with the reference solution (0.5 per cent).

**Loss on drying (2.2.32).** Not more than 0.5 per cent, determined on 1.00 g by drying in an oven at 105 °C.

**Sulfated ash (2.4.14).** Not more than 0.1 per cent, determined on 1.0 g.

#### ASSAY

Dissolve 0.200 g in 5 mL of *pyridine R*. Add 0.5 mL of *thymolphthalein solution R* and 10 mL of *silver nitrate solution in pyridine R*. Titrate with 0.1 M *ethanolic sodium hydroxide* until a pure blue colour is obtained. Carry out a blank titration.

1 mL of 0.1 M *ethanolic sodium hydroxide* is equivalent to 23.63 mg of C<sub>12</sub>H<sub>18</sub>O<sub>2</sub>.

01/2008:1437

## HEXYLRESORCINOL

### Hexylresorcinolum

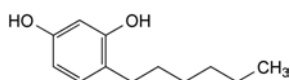

C<sub>12</sub>H<sub>18</sub>O<sub>2</sub>  
[136-77-6]

M<sub>r</sub> 194.3

#### DEFINITION

4-Hexylbenzene-1,3-diol.

**Content:** 98.0 per cent to 101.0 per cent (anhydrous substance).

#### CHARACTERS

**Appearance:** colourless, yellowish or reddish, crystalline powder or needles, turning brownish-pink on exposure to light or air.

**Solubility:** very slightly soluble in water, freely soluble in ethanol (96 per cent) and in methylene chloride.

It shows polymorphism (5.9).

#### IDENTIFICATION

**First identification:** B.

**Second identification:** A, C, D.

A. Melting point (2.2.14): 66 °C to 68 °C, melting may occur at about 60 °C, followed by solidification and a second melting between 66 °C and 68 °C.

B. Infrared absorption spectrophotometry (2.2.24).

**Comparison:** *hexylresorcinol CRS*.

If the spectra obtained in the solid state show differences, dissolve the substance to be examined and the reference substance separately in *methanol R*, evaporate to dryness and record new spectra using the residues.

C. Thin-layer chromatography (2.2.27).

**Test solution.** Dilute 0.1 mL of solution S (see Tests) to 10 mL with *ethanol (96 per cent) R*.

**Reference solution (a).** Dissolve 10 mg of *hexylresorcinol CRS* in *ethanol (96 per cent) R* and dilute to 10 mL with the same solvent.

**Reference solution (b).** Dissolve 10 mg of *hexylresorcinol CRS* and 10 mg of *resorcinol R* in *ethanol (96 per cent) R*, then dilute to 10 mL with the same solvent.

**Plate:** *TLC silica gel G plate R*.

**Mobile phase:** *methyl ethyl ketone R, pentane R* (50:50 V/V).

**Application:** 10 µL.

**Development:** over 2/3 of the plate.

**Drying:** in air for 5 min.

**Detection:** spray with 3 mL of *anisaldehyde solution R* and heat at 100-105 °C for 5 min.

**System suitability:** reference solution (b):

– the chromatogram shows 2 clearly separated principal spots.

**Results:** the principal spot in the chromatogram obtained with the test solution is similar in position, colour and size to the principal spot in the chromatogram obtained with reference solution (a).

D. Dissolve 0.1 g in 1 mL of *ethanol (96 per cent) R*. Add one drop of *ferric chloride solution R1*. A green colour is produced. Add *dilute ammonia R1*. The solution becomes brown.

#### TESTS

**Solution S.** Dissolve 1.0 g in *ethanol (96 per cent) R* and dilute to 10.0 mL with the same solvent.

**Appearance of solution.** Solution S is clear (2.2.1).

**Acidity.** Dissolve 0.5 g in a mixture of 25 mL of *carbon dioxide-free water R* and 25 mL of *ether R* previously neutralised to *phenolphthalein solution R1* and titrate with 0.1 M *sodium hydroxide*, shaking vigorously after each addition. Not more than 0.4 mL is required to change the colour of the solution.

**Related substances.** Liquid chromatography (2.2.29).

**Test solution.** Dissolve 0.1 g of the substance to be examined in the mobile phase and dilute to 10.0 mL with the mobile phase.

**Reference solution (a).** Dilute 1.0 mL of the test solution to 200.0 mL with the mobile phase.

**Reference solution (b).** Dissolve 20.0 mg of *phenol R* (impurity A) in the mobile phase and dilute to 100.0 mL with the mobile phase.

**Reference solution (c).** Dissolve 20.0 mg of *resorcinol R* (impurity B) in the mobile phase and dilute to 100.0 mL with the mobile phase.

**Reference solution (d).** To 8.0 mL of reference solution (a) add 2.0 mL of reference solution (b), 2.0 mL of reference solution (c) and dilute to 20.0 mL with the mobile phase.

**Column:**

– **size:** *l* = 0.25 m, Ø = 4.6 mm;

– **stationary phase:** *octadecylsilyl silica gel for chromatography R* (5 µm).

**Mobile phase:** mix 25 volumes of a 3.0 g/L solution of *glacial acetic acid R* adjusted to pH 5.9 with *dilute ammonia R1*, and 75 volumes of *methanol R*.

**Flow rate:** 1 mL/min.

**Detection:** spectrophotometer at 281 nm.

**Injection:** 20 µL.

**Run time:** twice the retention time of hexylresorcinol.

**System suitability:** reference solution (d):

– **resolution:** minimum 5.0 between the peaks due to impurity A (2<sup>nd</sup> peak) and hexylresorcinol (3<sup>rd</sup> peak).

**Limits:**

– **impurities A, B:** for each impurity, not more than the area of the corresponding peak in the chromatogram obtained with reference solution (d) (0.2 per cent);

- *any other impurity*: for each impurity, not more than the area of the principal peak in the chromatogram obtained with reference solution (a) (0.5 per cent);
- *total*: not more than twice the area of the principal peak in the chromatogram obtained with reference solution (a) (1 per cent);
- *disregard limit*: 0.1 times the area of the principal peak in the chromatogram obtained with reference solution (a) (0.05 per cent).

**Water** (2.5.12): maximum 0.5 per cent, determined on 1.000 g.

**Sulfated ash** (2.4.14): maximum 0.1 per cent, determined on 1.0 g.

#### ASSAY

Dissolve 0.100 g in 10 mL of *methanol R* in a ground-glass-stoppered flask, add 30.0 mL of 0.0167 M *potassium bromate R* and 2 g of *potassium bromide R*. Shake to dissolve the substance and add 15 mL of *dilute sulfuric acid R*. Stopper the flask, shake and allow to stand in the dark for 15 min, stirring continuously. Add 5 mL of *methylene chloride R* and a solution of 1 g of *potassium iodide R* in 10 mL of *water R*, allow to stand in the dark for 15 min, stirring continuously. Titrate with 0.1 M *sodium thiosulfate*, using 1 mL of *starch solution R*, shaking thoroughly. Carry out a blank titration under the same conditions.

1 mL of 0.0167 M *potassium bromate* is equivalent to 4.857 mg of  $C_{12}H_{18}O_2$ .

#### STORAGE

In an airtight container, protected from light.

#### IMPURITIES

*Specified impurities*: A, B.

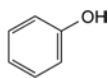

A. phenol,

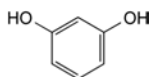

B. benzene-1,3-diol (resorcinol).

01/2008:0143  
corrected 6.0

## HISTAMINE DIHYDROCHLORIDE

### Histamini dihydrochloridum

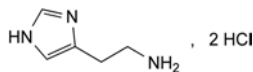

$C_5H_{11}Cl_2N_3$   
[56-92-8]

$M_r$  184.1

#### DEFINITION

Histamine dihydrochloride contains not less than 98.5 per cent and not more than the equivalent of 101.0 per cent of 2-(1*H*-imidazol-4-yl)ethanamine dihydrochloride, calculated with reference to the dried substance.

#### CHARACTERS

A white or almost white, crystalline powder or colourless crystals, hygroscopic, very soluble in water, soluble in alcohol.

#### IDENTIFICATION

*First identification*: A, D.

*Second identification*: B, C, D.

- Examine by infrared absorption spectrophotometry (2.2.24), comparing with the spectrum obtained with *histamine dihydrochloride CRS*. Examine as discs prepared using 1 mg of substance.
- Examine the chromatograms obtained in the test for histidine. The principal spot in the chromatogram obtained with test solution (b) is similar in position, colour and size to the principal spot in the chromatogram obtained with reference solution (a).
- Dissolve 0.1 g in 7 mL of *water R* and add 3 mL of a 200 g/L solution of *sodium hydroxide R*. Dissolve 50 mg of *sulfanilic acid R* in a mixture of 0.1 mL of *hydrochloric acid R* and 10 mL of *water R* and add 0.1 mL of *sodium nitrite solution R*. Add the second solution to the first and mix. A red colour is produced.
- It gives reaction (a) of chlorides (2.3.1).

#### TESTS

**Solution S**. Dissolve 0.5 g in *carbon dioxide-free water R* prepared from *distilled water R* and dilute to 10 mL with the same solvent.

**Appearance of solution**. Solution S is clear (2.2.1) and not more intensely coloured than reference solution Y<sub>7</sub> (2.2.2, *Method II*).

**pH** (2.2.3). The pH of solution S is 2.85 to 3.60.

**Histidine**. Examine by thin-layer chromatography (2.2.27), using a *TLC silica gel G plate R*.

*Test solution (a)*. Dissolve 0.5 g of the substance to be examined in *water R* and dilute to 10 mL with the same solvent.

*Test solution (b)*. Dilute 2 mL of test solution (a) to 10 mL with *water R*.

*Reference solution (a)*. Dissolve 0.1 g of *histamine dihydrochloride CRS* in *water R* and dilute to 10 mL with the same solvent.

*Reference solution (b)*. Dissolve 50 mg of *histidine monohydrochloride R* in *water R* and dilute to 100 mL with the same solvent.

*Reference solution (c)*. Mix 1 mL of test solution (a) and 1 mL of reference solution (b).

Apply to the plate 1 µL of test solution (a), 1 µL of test solution (b), 1 µL of reference solution (a), 1 µL of reference solution (b) and 2 µL of reference solution (c). Develop over a path of 15 cm using a mixture of 5 volumes of *concentrated ammonia R*, 20 volumes of *water R* and 75 volumes of *acetonitrile R*. Dry the plate in a current of air. Repeat the development in the same direction, dry the plate in a current of air and spray with *ninhydrin solution RI*. Heat the plate at 110 °C for 10 min. Any spot corresponding to histidine in the chromatogram obtained with test solution (a) is not more intense than the spot in the chromatogram obtained with reference solution (b) (1 per cent). The test is not valid unless the chromatogram obtained with reference solution (c) shows 2 clearly separated spots.

**Sulfates** (2.4.13). 3 mL of solution S diluted to 15 mL with *distilled water R* complies with the limit test for sulfates (0.1 per cent).

**Loss on drying** (2.2.32). Not more than 0.5 per cent, determined on 0.20 g by drying in an oven at 105 °C.

**Sulfated ash** (2.4.14). Not more than 0.1 per cent, determined on 0.5 g.

#### ASSAY

Dissolve 0.080 g in a mixture of 5.0 mL of 0.01 M *hydrochloric acid* and 50 mL of *alcohol R*. Carry out a potentiometric titration (2.2.20), using 0.1 M *sodium hydroxide*. Read the volume added between the first and third points of inflexion.

1 mL of 0.1 M *sodium hydroxide* is equivalent to 9.203 mg of  $C_5H_{11}Cl_2N_3$ .

## STORAGE

Store in an airtight container, protected from light.

01/2008:0144

## HISTAMINE PHOSPHATE

## Histamini fosphas

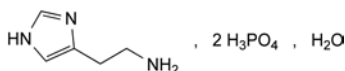
 $C_5H_{15}N_3O_8P_2 \cdot H_2O$ 
 $M_r$  325.2

## DEFINITION

Histamine phosphate contains not less than 98.0 per cent and not more than the equivalent of 101.0 per cent of 2-(1*H*-imidazol-4-yl)ethanamine diphosphate, calculated with reference to the anhydrous substance.

## CHARACTERS

Colourless, long prismatic crystals, freely soluble in water, slightly soluble in alcohol.

## IDENTIFICATION

First identification: A, D.

Second identification: B, C, D.

- A. Examine by infrared absorption spectrophotometry (2.2.24), comparing with the spectrum obtained with *histamine phosphate CRS*. Examine as discs prepared using 1 mg of substance.
- B. Examine the chromatograms obtained in the test for histidine. The principal spot in the chromatogram obtained with test solution (b) is similar in position, colour and size to the principal spot in the chromatogram obtained with reference solution (a).
- C. Dissolve 0.1 g in 7 mL of *water R* and add 3 mL of a 200 g/L solution of *sodium hydroxide R*. Dissolve 50 mg of *sulfanilic acid R* in a mixture of 0.1 mL of *hydrochloric acid R* and 10 mL of *water R* and add 0.1 mL of *sodium nitrite solution R*. Add the second solution to the first and mix. A red colour is produced.
- D. It gives reaction (a) of phosphates (2.3.1).

## TESTS

**Solution S.** Dissolve 0.5 g in *carbon dioxide-free water R* prepared from *distilled water R* and dilute to 10 mL with the same solvent.

**Appearance of solution.** Solution S is clear (2.2.1) and not more intensely coloured than reference solution BY<sub>7</sub> (2.2.2, Method II).

**pH (2.2.3).** The pH of solution S is 3.75 to 3.95.

**Histidine.** Examine by thin-layer chromatography (2.2.27), using *silica gel G R* as the coating substance.

**Test solution (a).** Dissolve 0.5 g of the substance to be examined in *water R* and dilute to 10 mL with the same solvent.

**Test solution (b).** Dilute 2 mL of test solution (a) to 10 mL with *water R*.

**Reference solution (a).** Dissolve 0.1 g of *histamine phosphate CRS* in *water R* and dilute to 10 mL with the same solvent.

**Reference solution (b).** Dissolve 50 mg of *histidine monohydrochloride R* in *water R* and dilute to 100 mL with the same solvent.

**Reference solution (c).** Mix 1 mL of test solution (a) and 1 mL of reference solution (b).

Apply separately to the plate 1 µL of test solution (a), 1 µL of test solution (b), 1 µL of reference solution (a), 1 µL of reference solution (b) and 2 µL of reference solution (c).

Develop over a path of 15 cm using a mixture of 5 volumes of *concentrated ammonia R*, 20 volumes of *water R* and 75 volumes of *acetonitrile R*. Dry the plate in a current of air. Repeat the development in the same direction, dry the plate in a current of air and spray with *ninhydrin solution R1*. Heat at 110 °C for 10 min. Any spot corresponding to histidine in the chromatogram obtained with test solution (a) is not more intense than the spot in the chromatogram obtained with reference solution (b) (1 per cent). The test is not valid unless the chromatogram obtained with reference solution (c) shows 2 clearly separated spots.

**Sulfates (2.4.13).** 3 mL of solution S diluted to 15 mL with *distilled water R* complies with the limit test for sulfates (0.1 per cent).

**Water (2.5.12).** 5.0 per cent to 6.2 per cent, determined on 0.30 g by the semi-micro determination of water.

## ASSAY

Dissolve 0.140 g in 5 mL of *anhydrous formic acid R* and add 20 mL of *anhydrous acetic acid R*. Titrate with 0.1 M *perchloric acid*, determining the end-point potentiometrically (2.2.20). Carry out a blank titration.

1 mL of 0.1 M *perchloric acid* is equivalent to 15.36 mg of  $C_5H_{15}N_3O_8P_2$ .

## STORAGE

Store protected from light.

01/2008:0911  
corrected 6.0

## HISTIDINE

## Histidinum

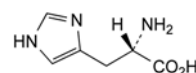
 $C_6H_9N_3O_2$   
[71-00-1]

 $M_r$  155.2

## DEFINITION

(*S*)-2-Amino-3-(imidazol-4-yl)propanoic acid.

**Content:** 98.5 per cent to 101.0 per cent (dried substance).

## CHARACTERS

**Appearance:** white or almost white, crystalline powder or colourless crystals.

**Solubility:** soluble in water, very slightly soluble in ethanol (96 per cent).

## IDENTIFICATION

First identification: A, B.

Second identification: A, C, D.

A. Specific optical rotation (see Tests).

B. Infrared absorption spectrophotometry (2.2.24).

**Preparation:** discs.

**Comparison:** *histidine CRS*.

If the spectra obtained show differences, dissolve the substance to be examined and the reference substance separately in the minimum volume of *water R*, evaporate to dryness at 60 °C and record new spectra using the residues.

- C. Examine the chromatograms obtained in the test for ninhydrin-positive substances. The principal spot in the chromatogram obtained with test solution (b) is similar in position, colour and size to the principal spot in the chromatogram obtained with reference solution (a).
- D. Dissolve 0.1 g in 7 mL of *water R* and add 3 mL of a 200 g/L solution of *sodium hydroxide R*. Dissolve 50 mg of *sulfanilic acid R* in a mixture of 0.1 mL of *hydrochloric acid R*

and 10 mL of *water R* and add 0.1 mL of *sodium nitrite solution R*. Add the second solution to the first and mix. An orange-red colour develops.

## TESTS

**Solution S.** Dissolve 2.5 g in *distilled water R*, heating in a water-bath and dilute to 50 mL with the same solvent.

**Appearance of solution.** Solution S is clear (2.2.1) and not more intensely coloured than reference solution BY<sub>7</sub> (2.2.2, Method II).

**Specific optical rotation** (2.2.7): + 11.4 to + 12.4 (dried substance).

Dissolve 2.75 g in 12.0 mL of *hydrochloric acid R1* and dilute to 25.0 mL with *water R*.

**Ninhydrin-positive substances.** Thin-layer chromatography (2.2.27).

*Test solution (a).* Dissolve 0.10 g of the substance to be examined in *water R* and dilute to 10 mL with the same solvent.

*Test solution (b).* Dilute 1 mL of test solution (a) to 50 mL with *water R*.

*Reference solution (a).* Dissolve 10 mg of *histidine CRS* in *water R* and dilute to 50 mL with the same solvent.

*Reference solution (b).* Dilute 5 mL of test solution (b) to 20 mL with *water R*.

*Reference solution (c).* Dissolve 10 mg of *histidine CRS* and 10 mg of *proline CRS* in *water R* and dilute to 25 mL with the same solvent.

*Plate:* TLC silica gel plate R.

*Mobile phase:* glacial acetic acid R, *water R*, *butanol R* (20:20:60 V/V/V).

*Application:* 5 µL.

*Development:* over 2/3 of the plate.

*Drying:* in air.

*Detection:* spray with *ninhydrin solution R* and heat at 100-105 °C for 15 min.

*System suitability:* the chromatogram obtained with reference solution (c) shows 2 clearly separated spots.

*Limits:*

- *any impurity:* any spots in the chromatogram obtained with test solution (a), apart from the principal spot, are not more intense than the spot in the chromatogram obtained with reference solution (b) (0.5 per cent).

**Chlorides** (2.4.4): maximum 200 ppm.

Dilute 5 mL of solution S to 15 mL with *water R*.

**Sulfates** (2.4.13): maximum 300 ppm.

Dilute 10 mL of solution S to 15 mL with *distilled water R*.

**Ammonium** (2.4.1, Method B): maximum 200 ppm, determined on 50 mg.

Prepare the standard using 0.1 mL of *ammonium standard solution (100 ppm NH<sub>4</sub>) R*.

**Iron** (2.4.9): maximum 10 ppm.

In a separating funnel, dissolve 1.0 g in 10 mL of *dilute hydrochloric acid R*. Shake with 3 quantities, each of 10 mL, of *methyl isobutyl ketone R1*, shaking for 3 min each time. To the combined organic layers add 10 mL of *water R* and shake for 3 min. The aqueous layer complies with the limit test for iron.

**Heavy metals** (2.4.8): maximum 10 ppm.

Dissolve 2.0 g in a mixture of 3 mL of *dilute hydrochloric acid R* and 15 mL of *water R*, with gentle warming if necessary, and dilute to 20 mL with *water R*. 12 mL of the solution complies with test A. Prepare the reference solution using *lead standard solution (1 ppm Pb) R*.

**Loss on drying** (2.2.32): maximum 0.5 per cent, determined on 1.000 g by drying in an oven at 105 °C.

**Sulfated ash** (2.4.14): maximum 0.1 per cent, determined on 1.0 g.

## ASSAY

Dissolve 0.130 g in 50 mL of *water R*. Titrate with 0.1 M *hydrochloric acid*, determining the end-point potentiometrically (2.2.20).

1 mL of 0.1 M *hydrochloric acid* is equivalent to 15.52 mg of C<sub>6</sub>H<sub>9</sub>N<sub>3</sub>O<sub>2</sub>.

## STORAGE

Protected from light.

01/2008:0910  
corrected 6.0

## HISTIDINE HYDROCHLORIDE MONOHYDRATE

### Histidini hydrochloridum monohydricum

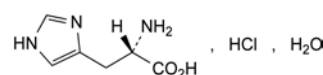

C<sub>6</sub>H<sub>10</sub>ClN<sub>3</sub>O<sub>2</sub>·H<sub>2</sub>O  
[5934-29-2]

M<sub>r</sub> 209.6

## DEFINITION

Histidine hydrochloride monohydrate contains not less than 98.5 per cent and not more than the equivalent of 101.0 per cent of the hydrochloride of (S)-2-amino-3-(imidazol-4-yl)propanoic acid, calculated with reference to the dried substance.

## CHARACTERS

A white or almost white, crystalline powder or colourless crystals, freely soluble in water, slightly soluble in alcohol.

## IDENTIFICATION

*First identification:* A, B, C, F.

*Second identification:* A, B, D, E, F.

- Specific optical rotation (see Tests).
- pH (see Tests).
- Examine by infrared absorption spectrophotometry (2.2.24), comparing with the spectrum obtained with *histidine hydrochloride monohydrate CRS*. Examine the substances prepared as discs.
- Examine the chromatograms obtained in the test for ninhydrin-positive substances. The principal spot in the chromatogram obtained with test solution (b) is similar in position, colour and size to the principal spot in the chromatogram obtained with reference solution (a).
- Dissolve 0.1 g in 7 mL of *water R* and add 3 mL of a 200 g/L solution of *sodium hydroxide R*. Dissolve 50 mg of *sulfanilic acid R* in a mixture of 0.1 mL of *hydrochloric acid R* and 10 mL of *water R* and add 0.1 mL of *sodium nitrite solution R*. Add the second solution to the first and mix. An orange-red colour develops.
- About 20 mg gives reaction (a) of chlorides (2.3.1).

## TESTS

**Solution S.** Dissolve 2.5 g in *carbon dioxide-free water R* prepared from *distilled water R* and dilute to 50 mL with the same solvent.

**Appearance of solution.** Solution S is clear (2.2.1) and not more intensely coloured than reference solution BY<sub>6</sub> (2.2.2, Method II).

**pH** (2.2.3). The pH of solution S is 3.0 to 5.0.

01/2008:0500  
corrected 6.0

**Specific optical rotation** (2.2.7). Dissolve 2.75 g in 12.0 mL of *hydrochloric acid R1* and dilute to 25.0 mL with *water R*. The specific optical rotation is + 9.2 to + 10.6, calculated with reference to the dried substance.

**Ninhydrin-positive substances.** Examine by thin-layer chromatography (2.2.27), using a *TLC silica gel plate R*.

**Test solution (a).** Dissolve 0.10 g of the substance to be examined in *water R* and dilute to 10 mL with the same solvent.

**Test solution (b).** Dilute 1 mL of test solution (a) to 50 mL with *water R*.

**Reference solution (a).** Dissolve 10 mg of *histidine hydrochloride monohydrate CRS* in *water R* and dilute to 50 mL with the same solvent.

**Reference solution (b).** Dilute 5 mL of test solution (b) to 20 mL with *water R*.

**Reference solution (c).** Dissolve 10 mg of *histidine hydrochloride monohydrate CRS* and 10 mg of *proline CRS* in *water R* and dilute to 25 mL with the same solvent.

Apply separately to the plate 5 µL of each solution. Dry the plate in a current of air. Develop over a path of 15 cm using a mixture of 20 volumes of *glacial acetic acid R*, 20 volumes of *water R* and 60 volumes of *butanol R*. Allow the plate to dry in air. Spray with *ninhydrin solution R* and heat at 100 °C to 105 °C for 15 min. Any spot in the chromatogram obtained with test solution (a), apart from the principal spot, is not more intense than the spot in the chromatogram obtained with reference solution (b) (0.5 per cent). The test is not valid unless the chromatogram obtained with reference solution (c) shows two clearly separated principal spots.

**Sulfates** (2.4.13). Dilute 10 mL of solution S to 15 mL with *distilled water R*. The solution complies with the limit test for sulfates (300 ppm).

**Ammonium** (2.4.1). 50 mg complies with limit test B for ammonium (200 ppm). Prepare the standard using 0.1 mL of *ammonium standard solution (100 ppm NH<sub>4</sub>) R*.

**Iron** (2.4.9). In a separating funnel, dissolve 1.0 g in 10 mL of *dilute hydrochloric acid R*. Shake with three quantities, each of 10 mL, of *methyl isobutyl ketone R1*, shaking for 3 min each time. To the combined organic layers add 10 mL of *water R* and shake for 3 min. The aqueous layer complies with the limit test for iron (10 ppm).

**Heavy metals** (2.4.8). Dissolve 2.0 g in *water R* and dilute to 20 mL with the same solvent. 12 mL of the solution complies with limit test A for heavy metals (10 ppm). Prepare the standard using *lead standard solution (1 ppm Pb) R*.

**Loss on drying** (2.2.32): 7.0 per cent to 10.0 per cent, determined on 1.000 g by drying in an oven at 145 °C to 150 °C.

**Sulfated ash** (2.4.14). Not more than 0.1 per cent, determined on 1.0 g.

## ASSAY

Dissolve 0.160 g in 50 mL of *carbon dioxide-free water R*. Titrate with 0.1 M *sodium hydroxide*, determining the end-point potentiometrically (2.2.20).

1 mL of 0.1 M *sodium hydroxide* is equivalent to 19.16 mg of C<sub>16</sub>H<sub>22</sub>NBrO<sub>3</sub>.

## STORAGE

Store protected from light.

## HOMATROPINE HYDROBROMIDE

### Homatropini hydrobromidum

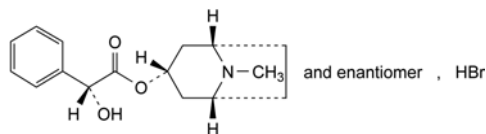

C<sub>16</sub>H<sub>22</sub>BrNO<sub>3</sub>  
[51-56-9]

M<sub>r</sub> 356.3

## DEFINITION

(1*R*,3*r*,5*S*)-8-Methyl-8-azabicyclo[3.2.1]oct-3-yl (2*RS*)-2-hydroxy-2-phenylacetate hydrobromide.

**Content:** 99.0 per cent to 101.0 per cent (dried substance).

## CHARACTERS

**Appearance:** white or almost white, crystalline powder or colourless crystals.

**Solubility:** freely soluble in water, sparingly soluble in alcohol. mp: about 215 °C, with decomposition.

## IDENTIFICATION

**First identification:** A, C.

**Second identification:** B, C.

A. Infrared absorption spectrophotometry (2.2.24).

**Comparison:** *homatropine hydrobromide CRS*.

B. Dissolve 50 mg in 1 mL of *water R* and add 2 mL of *dilute acetic acid R*. Heat and add 4 mL of *picric acid solution R*. Allow to cool, shaking occasionally. Collect the crystals, wash with 2 quantities, each of 3 mL, of iced *water R* and dry at 100-105 °C. The crystals melt (2.2.14) at 182 °C to 186 °C.

C. It gives reaction (a) of bromides (2.3.1).

## TESTS

**Solution S.** Dissolve 1.25 g in *carbon dioxide-free water R* and dilute to 25 mL with the same solvent.

**Appearance of solution.** Solution S is clear (2.2.1) and colourless (2.2.2, *Method II*).

**pH** (2.2.3): 5.0 to 6.5 for solution S.

**Related substances.** Liquid chromatography (2.2.29).

**Test solution.** Dissolve 50.0 mg of the substance to be examined in the mobile phase and dilute to 25.0 mL with the mobile phase.

**Reference solution (a).** Dilute 5.0 mL of the test solution to 100.0 mL with the mobile phase. Dilute 5.0 mL of this solution to 50.0 mL with the mobile phase.

**Reference solution (b).** Dilute 5.0 mL of reference solution (a) to 25.0 mL with the mobile phase.

**Reference solution (c).** Dissolve 5.0 mg of *hyoscine hydrobromide CRS* in the mobile phase and dilute to 50.0 mL with the mobile phase. To 10.0 mL of this solution add 0.5 mL of the test solution and dilute to 100.0 mL with the mobile phase.

**Column:**

- **size:** *l* = 0.1 m, Ø = 4.6 mm,
- **stationary phase:** *octadecylsilyl silica gel for chromatography R* (3 µm),
- **temperature:** 40 °C.

**Mobile phase:** mix 33 volumes of *methanol R2* and 67 volumes of a solution prepared as follows: dissolve 6.8 g of *potassium dihydrogen phosphate R* and 7.0 g of *sodium heptanesulfonate monohydrate R* in 1000 mL of *water R* and adjust to pH 2.7 with a 330 g/L solution of *phosphoric acid R*.

**Flow rate:** 1.5 mL/min.

**Detection:** spectrophotometer at 210 nm.

**Injection:** 10 µL.

**Run time:** 3 times the retention time of homatropine.

**Relative retention** with reference to homatropine (retention time = about 6.8 min): impurity C = about 0.2; impurity A = about 0.9; impurity B = about 1.1; impurity D = about 1.9.

**System suitability:** reference solution (c):

- **resolution:** minimum 1.5 between the peaks due to homatropine and impurity B,
- **symmetry factor:** maximum 2.5 for the peak due to homatropine.

**Limits:**

- **impurity A:** not more than the area of the principal peak in the chromatogram obtained with reference solution (a) (0.5 per cent),
- **impurities B, C, D:** for each impurity, not more than the area of the principal peak in the chromatogram obtained with reference solution (b) (0.1 per cent),
- **any other impurity:** for each impurity, not more than the area of the principal peak in the chromatogram obtained with reference solution (b) (0.1 per cent),
- **total:** not more than twice the area of the principal peak in the chromatogram obtained with reference solution (a) (1.0 per cent); disregard the peak due to the bromide ion which appears close to the peak due to the solvent,
- **disregard limit:** 0.5 times the area of the principal peak in the chromatogram obtained with reference solution (b) (0.05 per cent).

**Loss on drying** (2.2.32): maximum 0.5 per cent, determined on 1.000 g by drying in an oven at 105 °C.

**Sulfated ash** (2.4.14): maximum 0.1 per cent, determined on 1.0 g.

#### ASSAY

Dissolve 0.300 g in a mixture of 5.0 mL of 0.01 M hydrochloric acid and 50 mL of alcohol R. Carry out a potentiometric titration (2.2.20), using 0.1 M sodium hydroxide. Read the volume added between the 2 points of inflexion.

1 mL of 0.1 M sodium hydroxide is equivalent to 35.63 mg of C<sub>16</sub>H<sub>22</sub>BrNO<sub>3</sub>.

#### STORAGE

Protected from light.

#### IMPURITIES

**Specified impurities:** A, B, C, D.

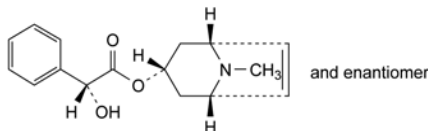

- A. (1R,3s,5S)-8-methyl-8-azabicyclo[3.2.1]oct-6-en-3-yl (2RS)-2-hydroxy-2-phenylacetate (dehydrohomatropine),

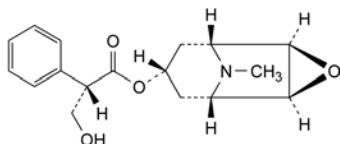

- B. (1R,2R,4S,5S,7s)-9-methyl-3-oxa-9-azatricyclo[3.3.1.0<sup>2,4</sup>]non-7-yl (2S)-3-hydroxy-2-phenylpropanoate (hyoscine),

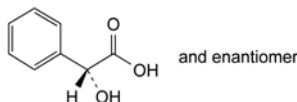

- C. (2RS)-2-hydroxy-2-phenylacetic acid (mandelic acid),

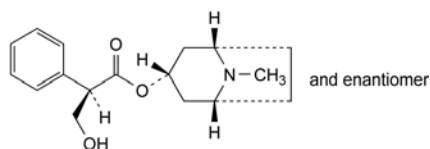

- D. (1R,3r,5S)-8-methyl-8-azabicyclo[3.2.1]oct-3-yl (2RS)-3-hydroxy-2-phenylpropanoate (atropine).

01/2008:0720

corrected 6.0

## HOMATROPINE METHYLBROMIDE

### Homatropini methylbromidum

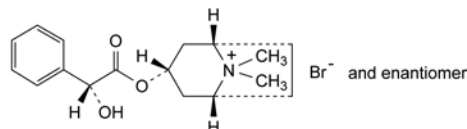

C<sub>17</sub>H<sub>24</sub>BrNO<sub>3</sub>  
[80-49-9]

M<sub>r</sub> 370.3

#### DEFINITION

(1R,3r,5S)-3-[[ (2RS)-2-hydroxy-2-phenylacetyl]oxy]-8,8-dimethyl-8-azoniabicyclo[3.2.1]octane bromide.

**Content:** 98.5 per cent to 101.0 per cent (dried substance).

#### CHARACTERS

**Appearance:** white or almost white, crystalline powder or colourless crystals.

**Solubility:** freely soluble in water, soluble in alcohol.  
mp: about 190 °C.

#### IDENTIFICATION

**First identification:** A, C.

**Second identification:** B, C.

A. Infrared absorption spectrophotometry (2.2.24),

*Comparison:* homatropine methylbromide CRS.

B. Dissolve 50 mg in 1 mL of water R and add 2 mL of dilute acetic acid R. Heat and add 4 mL of picric acid solution R. Allow to cool, shaking occasionally. The crystals, washed with 2 quantities, each of 3 mL, of iced water R and dried at 100-105 °C melt (2.2.14) at 132 °C to 138 °C.

C. It gives reaction (a) of bromides (2.3.1).

#### TESTS

**Solution S.** Dissolve 1.25 g in carbon dioxide-free water R and dilute to 25 mL with the same solvent.

**Appearance of solution.** Solution S is clear (2.2.1) and colourless (2.2.2, Method II).

**pH** (2.2.3): 4.5 to 6.5 for solution S.

**Related substances.** Liquid chromatography (2.2.29).

**Solvent mixture:** acetonitrile R, mobile phase A (9:41 V/V).

**Test solution.** Dissolve 50.0 mg of the substance to be examined in the solvent mixture and dilute to 25.0 mL with the solvent mixture.

**Reference solution (a).** Dilute 5.0 mL of the test solution to 100.0 mL with the solvent mixture. Dilute 5.0 mL of the solution to 50.0 mL with the solvent mixture.

**Reference solution (b).** Dilute 5.0 mL of reference solution (a) to 25.0 mL with the solvent mixture.

**Reference solution (c).** Dissolve 5.0 mg of homatropine hydrobromide CRS in the solvent mixture and dilute to 50.0 mL with the solvent mixture. To 10.0 mL of the solution add 0.5 mL of the test solution and dilute to 100.0 mL with the solvent mixture.

**Column:**

- size:  $l = 0.15$  m,  $\varnothing = 4.6$  mm,
- stationary phase: octadecylsilyl silica gel for chromatography R (3  $\mu$ m),
- temperature: 25 °C.

**Mobile phase:**

- mobile phase A: dissolve 3.4 g of potassium dihydrogen phosphate R and 5.0 g of sodium heptanesulfonate monohydrate R in 1000 mL of water R, and adjust to pH 3.0 with a 330 g/L solution of phosphoric acid R,
- mobile phase B: mix 400 mL of mobile phase A and 600 mL of acetonitrile R,

Time (min)	Mobile phase A (per cent V/V)	Mobile phase B (per cent V/V)
0 - 2	70	30
2 - 15	70 → 30	30 → 70
15 - 20	30 → 70	70 → 30

Flow rate: 1.4 mL/min.

Detection: spectrophotometer at 210 nm.

Injection: 10  $\mu$ L.

Relative retention with reference to homatropine methylbromide (retention time = about 4.8 min): impurity C = about 0.7; impurity A = about 0.9; impurity B = about 1.2; impurity D = about 1.3; impurity E = about 1.4; impurity F = about 1.7.

System suitability: reference solution (c):

- resolution: minimum 2.5 between the peaks due to homatropine methylbromide and impurity B,
- symmetry factor: maximum 2.5 for the peak due to homatropine methylbromide.

**Limits:**

- impurities A, B: for each impurity, not more than the area of the principal peak in the chromatogram obtained with reference solution (a) (0.5 per cent),
- impurities C, D, E, F: for each impurity, not more than the area of the principal peak in the chromatogram obtained with reference solution (b) (0.1 per cent),
- any other impurity: for each impurity, not more than the area of the principal peak in the chromatogram obtained with reference solution (b) (0.1 per cent),
- total: not more than twice the area of the principal peak in the chromatogram obtained with reference solution (a) (1.0 per cent); disregard the peak due to the bromide ion which appears close to the peak due to the solvent,
- disregard limit: 0.5 times the area of the principal peak in the chromatogram obtained with reference solution (b) (0.05 per cent).

**Loss on drying (2.2.32):** maximum 0.5 per cent, determined on 1.000 g by drying in an oven at 105 °C.

**Sulfated ash (2.4.14):** maximum 0.1 per cent, determined on 1.0 g.

**ASSAY**

Dissolve 0.300 g in 10 mL of water R. Titrate with 0.1 M silver nitrate. Determine the end-point potentiometrically (2.2.20), using a silver indicator electrode and a silver-silver chloride reference electrode.

1 mL of 0.1 M silver nitrate is equivalent to 37.03 mg of  $C_{17}H_{24}BrNO_3$ .

**STORAGE**

Protected from light.

**IMPURITIES**

Specified impurities: A, B, C, D, E, F.

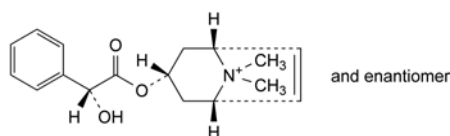

A. (1*R*,3*S*,5*S*)-3-[[[(2*RS*)-2-hydroxy-2-phenylacetyl]oxy]-8,8-dimethyl-8-azoniabicyclo[3.2.1]oct-6-ene (methyldehydrohomatropine),

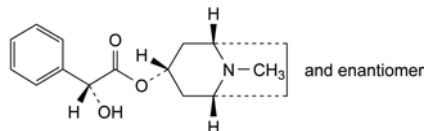

B. (1*R*,3*r*,5*S*)-8-methyl-8-azabicyclo[3.2.1]oct-3-yl (2*RS*)-2-hydroxy-2-phenylacetate (homatropine),

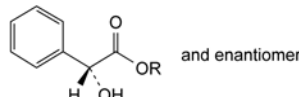

C. R = H: (2*RS*)-2-hydroxy-2-phenylacetic acid (mandelic acid),

F. R = CH<sub>3</sub>: methyl (2*RS*)-2-hydroxy-2-phenylacetate (methyl mandelate),

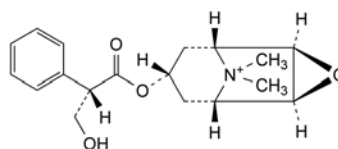

D. (1*R*,2*R*,4*S*,5*S*,7*s*)-7-[[[(2*S*)-3-hydroxy-2-phenylpropanoyl]oxy]-9,9-dimethyl-3-oxa-9-azoniatricyclo[3.3.1.0<sup>2,4</sup>]nonane (methylhyoscyne),

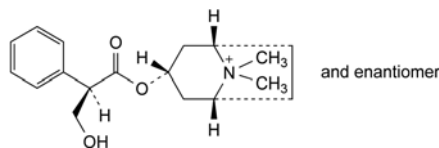

E. (1*R*,3*r*,5*S*)-3-[[[(2*RS*)-3-hydroxy-2-phenylpropanoyl]oxy]-8,8-dimethyl-8-azoniabicyclo[3.2.1]octane (methylatropine).

01/2008:2051

**HONEY****Mel****DEFINITION**

Honey is produced by bees (*Apis mellifera* L.) from the nectar of plants or from secretions of living parts of plants which the bees collect, transform by combining with specific substances of their own, deposit, dehydrate, store and leave in the honey comb to ripen and mature.

**PRODUCTION**

If the bee has been exposed to treatment to prevent or cure diseases or to any substance intended for preventing, destroying or controlling any pest, unwanted species of plants or animals, appropriate steps are taken to ensure that the levels of residues are as low as possible.

**CHARACTERS**

**Appearance:** viscous liquid which may be partly crystalline, almost white to dark brown.

**IDENTIFICATION**

Thin-layer chromatography (2.2.27).

**Test solution.** Dissolve 0.6 g of the substance to be examined in 50 mL of ethanol (30 per cent V/V) R.



**Reference solution.** Dissolve 0.5 g of fructose R, 0.5 g of glucose R and 0.1 g of sucrose R in 100 mL of ethanol (30 per cent V/V) R.

**Plate:** TLC silica gel plate R.

**Mobile phase:** water R, acetonitrile R (13:87 V/V).

**Application:** 5 µL as bands.

**Development:** 3 times over a path of 15 cm.

**Drying:** in warm air.

**Detection:** spray with a solution prepared as follows: dissolve 2 g of diphenylamine R and 2 mL of aniline R in 100 mL of acetone R. Add a 850 g/L solution of phosphoric acid R until the precipitate formed dissolves again (about 15-20 mL). Examine in daylight after heating at 100-105 °C for 5-10 min.

**Results:** see below the sequence of the zones present in the chromatograms obtained with the reference solution and the test solution. Furthermore, the weak brown zone due to sucrose in the chromatogram obtained with the reference solution may be present in the chromatogram obtained with the test solution. One or more other weak zones may be present in the chromatogram obtained with the test solution.

Top of the plate	
Fructose: an intense brown zone	An intense brown zone (fructose)
Glucose: an intense greyish-blue zone	An intense greyish-blue zone (glucose)
Sucrose: a brown zone	2 to 3 brownish-grey zones
<b>Reference solution</b>	<b>Test solution</b>

## TESTS

**Refractive index (2.2.6):** minimum 1.487 (equivalent to a maximum water content of 20 per cent).

Homogenise 100 g and transfer into a flask. Close tightly and place in a water-bath at  $50 \pm 0.2$  °C until all sugar crystals have dissolved. Cool the solution to 20 °C and rehomogenise. Immediately after rehomogenisation, cover the surface of the refractometer prism evenly with the sample. Determine the refractive index after 2 min if using an Abbe refractometer and after 4 min if using a digital refractometer. Use the average value of 2 determinations.

**Conductivity (2.2.38):** maximum 800 µS·cm<sup>-1</sup>.

Using the value obtained for the refractive index, determine the water content of the substance to be examined from Table 2051.-1. Using this information, dissolve an amount of the substance to be examined equivalent to 20.0 g of honey dry solids, in water R to produce 100.0 mL.

**Optical rotation (2.2.7):** maximum + 0.6°.

Using the value obtained for the refractive index, determine the water content of the substance to be examined from Table 2051.-1. Using this information, dissolve an amount of the substance to be examined, equivalent to 20.0 g of honey dry solids, in 50 mL of water R. Add 0.2 mL of concentrated ammonia R and dilute to 100.0 mL with water R. If necessary decolourise the solution with activated charcoal R.

Table 2051.-1. – Relationship of water content of honey to refractive index

Water content (per cent m/m)	Refractive index at 20 °C
15.0	1.4992
15.2	1.4987
15.4	1.4982
15.6	1.4976
15.8	1.4971
16.0	1.4966
16.2	1.4961
16.4	1.4956
16.6	1.4951
16.8	1.4946
17.0	1.4940
17.2	1.4935
17.4	1.4930
17.6	1.4925
17.8	1.4920
18.0	1.4915
18.2	1.4910
18.4	1.4905
18.6	1.4900
18.8	1.4895
19.0	1.4890
19.2	1.4885
19.4	1.4880
19.6	1.4875
19.8	1.4870
20.0	1.4865

**5-Hydroxymethylfurfural:** maximum 80 ppm, calculated on dry solids.

Using the value obtained for the refractive index, determine the water content of the substance to be examined from Table 2051.-1. Using this information, dissolve an amount of the substance to be examined, equivalent to 5.0 g of honey dry solids, in 25 mL of water R and transfer to a 50.0 mL volumetric flask with the same solvent. Add 0.5 mL of a 150 g/L solution of potassium ferrocyanide R and mix. Add 0.5 mL of a 300 g/L solution of zinc acetate R, mix and dilute to 50.0 mL with water R (a drop of anhydrous ethanol R may be added to avoid foaming). Filter. Transfer 5.0 mL of the filtered solution into each of 2 tubes. To one tube add 5.0 mL of water R (test solution). To the other tube add 5.0 mL of a 2.0 g/L solution of sodium hydrogensulfite R (reference solution). Determine the absorbance (2.2.25) of the test solution against the reference solution at 284 nm and 336 nm within 60 min. If the absorbance at 284 nm is greater than 0.8, dilute to the same extent the test solution with water R and the reference solution with a 2.0 g/L solution of sodium hydrogensulfite R so as to obtain an absorbance of less than 0.8.

Calculate the content of 5-hydroxymethylfurfural from the expression:

$$(A_1 - A_2) \times D \times 149.7$$

- $A_1$  = absorbance at 284 nm,  
 $A_2$  = absorbance at 336 nm,  
 $D$  = dilution factor, where applicable.

**Chlorides** (2.4.4): maximum 350 ppm, determined on 15 mL of a 10 g/L solution.

**Sulfates** (2.4.13): maximum 250 ppm, determined on 15 mL of a 40 g/L solution.

01/2010:0255  
corrected 7.0

## HUMAN ALBUMIN SOLUTION

### Albumini humani solutio

#### DEFINITION

Human albumin solution is an aqueous solution of protein obtained from plasma that complies with the requirements of the monograph *Human plasma for fractionation* (0853).

#### PRODUCTION

Separation of the albumin is carried out under controlled conditions, particularly of pH, ionic strength and temperature so that in the final product not less than 95 per cent of the total protein is albumin. Human albumin solution is prepared as a concentrated solution containing 150-250 g/L of total protein or as an isotonic solution containing 35-50 g/L of total protein. A suitable stabiliser against the effects of heat, such as sodium caprylate (sodium octanoate) or *N*-acetyltryptophan or a combination of these 2, at a suitable concentration, may be added but no antimicrobial preservative is added at any stage during preparation. The solution is passed through a bacteria-retentive filter and distributed aseptically into sterile containers which are then closed so as to prevent contamination. The solution in its final container is heated to  $60 \pm 1.0$  °C and maintained at this temperature for not less than 10 h. The containers are then incubated at 30-32 °C for not less than 14 days or at 20-25 °C for not less than 4 weeks and examined visually for evidence of microbial contamination.

#### CHARACTERS

A clear, slightly viscous liquid; it is almost colourless, yellow, amber or green.

#### IDENTIFICATION

Examine by a suitable immunoelectrophoresis technique. Using antiserum to normal human serum, compare normal human serum and the preparation to be examined, both diluted to contain 10 g/L of protein. The main component of the preparation to be examined corresponds to the main component of normal human serum. The preparation may show the presence of small quantities of other plasma proteins.

#### TESTS

**pH** (2.2.3): 6.7 to 7.3.

Dilute the preparation to be examined with a 9 g/L solution of *sodium chloride R* to obtain a solution containing 10 g/L of protein.

**Total protein.** Dilute the preparation to be examined with a 9 g/L solution of *sodium chloride R* to obtain a solution containing about 15 mg of protein in 2 mL. To 2.0 mL of this solution in a round-bottomed centrifuge tube add 2 mL of a 75 g/L solution of *sodium molybdate R* and 2 mL of a mixture of 1 volume of *nitrogen-free sulfuric acid R* and 30 volumes of *water R*. Shake, centrifuge for 5 min, decant the supernatant liquid and allow the inverted tube to drain on filter paper. Determine the nitrogen in the residue by the method of sulfuric acid digestion (2.5.9) and calculate the quantity of protein by

multiplying by 6.25. The preparation contains not less than 95 per cent and not more than 105 per cent of the quantity of protein stated on the label.

**Protein composition.** Zone electrophoresis (2.2.31).

Use strips of suitable cellulose acetate gel or agarose gel as the supporting medium and *barbital buffer solution pH 8.6 R1* as the electrolyte solution.

If cellulose acetate is the supporting material, the method described below can be used. If agarose gels are used, and because they are normally part of an automated system, the manufacturer's instructions are followed instead.

**Test solution.** Dilute the preparation to be examined with a 9 g/L solution of *sodium chloride R* to a protein concentration of 20 g/L.

**Reference solution.** Dilute *human albumin for electrophoresis BRP* with a 9 g/L solution of *sodium chloride R* to a protein concentration of 20 g/L.

To a strip apply 2.5 µL of the test solution as a 10 mm band or apply 0.25 µL per millimetre if a narrower strip is used. To another strip, apply in the same manner the same volume of the reference solution. Apply a suitable electric field such that the most rapid band migrates at least 30 mm. Treat the strips with *amido black 10B solution R* for 5 min. Decolorise with a mixture of 10 volumes of *glacial acetic acid R* and 90 volumes of *methanol R* until the background is just free of colour. Develop the transparency of the strips with a mixture of 19 volumes of *glacial acetic acid R* and 81 volumes of *methanol R*. Measure the absorbance of the bands at 600 nm in an instrument having a linear response over the range of measurement. Calculate the result as the mean of 3 measurements of each strip.

**System suitability:** in the electropherogram obtained with the reference solution on cellulose acetate or on agarose gels, the proportion of protein in the principal band is within the limits stated in the leaflet accompanying the reference preparation.

**Results:** in the electropherogram obtained with the test solution on cellulose acetate or on agarose gels, not more than 5 per cent of the protein has a mobility different from that of the principal band.

**Molecular size distribution.** Liquid chromatography (2.2.29).

**Test solution.** Dilute the preparation to be examined with a 9 g/L solution of *sodium chloride R* to a concentration suitable for the chromatographic system used. A concentration in the range of 4-12 g/L and injection of 50-600 µg of protein are usually suitable.

**Column:**

- size:  $l = 0.6$  m,  $\emptyset = 7.5$  mm, or  $l = 0.3$  m,  $\emptyset = 7.8$  mm;
- stationary phase: *hydrophilic silica gel for chromatography R*, of a grade suitable for fractionation of globular proteins with relative molecular masses in the range 10 000 to 500 000.

**Mobile phase:** dissolve 4.873 g of *disodium hydrogen phosphate dihydrate R*, 1.741 g of *sodium dihydrogen phosphate monohydrate R*, 11.688 g of *sodium chloride R* and 50 mg of *sodium azide R* in 1 litre of *water R*.

**Flow rate:** 0.5 mL/min.

**Detection:** spectrophotometer at 280 nm.

The peak due to polymers and aggregates is located in the part of the chromatogram representing the void volume. Disregard the peak due to the stabiliser. The area of the peak due to polymers and aggregates is not greater than 10 per cent of the total area of the chromatogram (corresponding to about 5 per cent of polymers and aggregates).

**Haem.** Dilute the preparation to be examined using a 9 g/L solution of *sodium chloride R* to obtain a solution containing 10 g/L of protein. The absorbance (2.2.25) of the solution measured at 403 nm using *water R* as the compensation liquid is not greater than 0.15.

**Prekallikrein activator** (2.6.15): maximum 35 IU/mL.

**Aluminium:** maximum 200 µg/L.

Atomic absorption spectrometry (2.2.23, *Method I or II*).

Use a furnace as atomic generator.

Use plastic containers for preparation of the solutions and use plastic equipment where possible. Wash glassware (or equipment) in nitric acid (200 g/L HNO<sub>3</sub>) before use.

**Test solution.** Use the preparation to be examined, diluted if necessary.

**Reference solutions.** Prepare at least 3 reference solutions in a range spanning the expected aluminium concentration of the preparation to be examined, for example by diluting *aluminium standard solution (10 ppm Al) R* with a 1 g/L solution of *octoxinol 10 R*.

**Monitor solution.** Add *aluminium standard solution (10 ppm Al) R* or a suitable certified reference material to the test solution in a sufficient amount to increase the aluminium concentration by 20 µg/L.

**Blank solution.** 1 g/L solution of *octoxinol 10 R*.

**Wavelength:** 309.3 nm or other suitable wavelength.

**Slit width:** 0.5 nm.

**Tube:** pyrolytically coated, with integrated platform.

**Background corrector:** off.

**Atomisation device:** furnace; fire between readings.

The operating conditions in Table 0255-1 are cited as an example of conditions found suitable for a given apparatus; they may be modified to obtain optimum conditions.

Table 0255-1. – *Operating conditions found suitable, cited as an example*

Step	Final temperature (°C)	Ramp time (s)	Hold time (s)	Gas
1	120	10	80	argon
2	200	5	20	argon
3	650	5	10	argon
4	1300	5	10	argon
5	1300	1	10	no gas
6	2500	0.7	4	no gas
7	2600	0.5	3	argon
8	20	12.9	3	no gas

**Injection:** each of the following solutions 3 times: blank solution, reference solutions, test solution and monitor solution.

**System suitability:**

- the recovery of aluminium added in preparation of the monitor solution is within the range 80-120 per cent.

Prepare a calibration curve from the mean of the readings obtained with the reference solutions and determine the aluminium content of the preparation to be examined using the calibration curve.

**Potassium:** maximum 0.05 mmol of K per gram of protein.

Atomic emission spectrometry (2.2.22, *Method I*).

**Wavelength:** 766.5 nm.

**Sodium:** maximum 160 mmol/L and 95 per cent to 105 per cent of the content of Na stated on the label.

Atomic emission spectrometry (2.2.22, *Method I*).

**Wavelength:** 589 nm.

**Sterility (2.6.1).** It complies with the test for sterility.

**Pyrogens (2.6.8) or Bacterial endotoxins (2.6.14).** It complies with the test for pyrogens or, preferably and where justified and authorised, with a validated *in vitro* test such as the bacterial endotoxin test.

For the pyrogen test, for a solution with a protein content of 35-50 g/L, inject 10 mL per kilogram of the rabbit's mass; for a

solution with a protein content of 150-250 g/L, inject 5 mL per kilogram of the rabbit's mass.

Where the bacterial endotoxin test is used, the preparation to be examined contains less than 0.5 IU of endotoxin per millilitre for solutions with a protein content not greater than 50 g/L, less than 1.3 IU of endotoxin per millilitre for solutions with a protein content greater than 50 g/L but not greater than 200 g/L, and less than 1.7 IU of endotoxin per millilitre for solutions with a protein content greater than 200 g/L but not greater than 250 g/L.

**STORAGE**

Protected from light.

**LABELLING**

The label states:

- the name of the preparation;
- the volume of the preparation;
- the content of protein expressed in grams per litre;
- the content of sodium expressed in millimoles per litre;
- that the product is not to be used if it is cloudy or if a deposit has formed;
- the name and concentration of any added substance (for example stabiliser).

07/2008:0557

## HUMAN ANTI-D IMMUNOGLOBULIN

### Immunoglobulinum humanum anti-D

**DEFINITION**

Human anti-D immunoglobulin is a liquid or freeze-dried preparation containing immunoglobulins, mainly immunoglobulin G. The preparation is intended for intramuscular administration. It contains specific antibodies against erythrocyte D-antigen and may also contain small quantities of other blood-group antibodies. *Human normal immunoglobulin (0338)* and/or *Human albumin solution (0255)* may be added.

It complies with the monograph *Human normal immunoglobulin (0338)*, except for the minimum number of donors and the minimum total protein content.

The test for anti-D antibodies (2.6.26) prescribed in the monograph *Human normal immunoglobulin (0338)* is not carried out, since it is replaced by the assay of human anti-D immunoglobulin (2.7.13) as prescribed below under Potency.

For products prepared by a method that eliminates immunoglobulins with specificities other than anti-D, where authorised, the test for antibodies to hepatitis B surface antigen is not required.

**PRODUCTION**

Human anti-D immunoglobulin is preferably obtained from the plasma of donors with a sufficient titre of previously acquired anti-D antibodies. Where necessary, in order to ensure an adequate supply of human anti-D immunoglobulin, it is obtained from plasma derived from donors immunised with D-positive erythrocytes that are compatible in relevant blood group systems in order to avoid formation of undesirable antibodies.

**ERYTHROCYTE DONORS**

Erythrocyte donors comply with the requirements for donors prescribed in the monograph *Human plasma for fractionation (0853)*.

**IMMUNISATION**

Immunisation of the plasma donor is carried out under proper medical supervision. Recommendations concerning donor immunisation, including testing of erythrocyte donors, have been formulated by the World Health Organisation (*Requirements for the collection, processing and quality*

**Plasmin inhibitor ( $\alpha_2$ -antiplasmin).** Carry out the assay of human plasmin inhibitor (2.7.25) using a reference plasma calibrated against human normal plasma.

1 unit of human plasmin inhibitor is equal to the activity of 1 mL of human normal plasma. Human normal plasma is prepared by pooling plasma units from not fewer than 30 donors and storing at  $-30\text{ }^\circ\text{C}$  or lower.

The estimated potency is not less than 0.2 units/mL. The confidence limits ( $P = 0.95$ ) are not less than 80 per cent and not more than 120 per cent of the estimated potency.

#### LABELLING

The label states:

- the ABO blood group;
- the method used for virus inactivation.

07/2008:2387

## HUMAN $\alpha$ -1-PROTEINASE INHIBITOR

### $\alpha$ -1-Proteinase inhibitor humanum

#### DEFINITION

Human  $\alpha$ -1-proteinase inhibitor is a plasma protein fraction containing mainly human  $\alpha$ -1-proteinase inhibitor (also known as human  $\alpha$ -1-antitrypsin or  $\alpha$ -1-antiproteinase). Human  $\alpha$ -1-proteinase inhibitor is a glycoprotein existing in isoforms with different isoelectric points and is the most abundant multifunctional serine proteinase inhibitor in human plasma. It is obtained from human plasma that complies with the monograph *Human plasma for fractionation (0853)*, using a suitable fractionation process and further purification steps. Other plasma proteins may be present.

#### PRODUCTION

##### GENERAL PROVISIONS

The method of preparation includes steps that have been shown to remove or to inactivate known agents of infection. The subsequent purification procedure must be validated to demonstrate that the concentration of any substances used for inactivation of viruses during production is reduced to a suitable level and that any residues are such as not to compromise the safety of the preparation for patients.

The specific activity is not less than 0.35 mg of active human  $\alpha$ -1-proteinase inhibitor per milligram of total protein. Ratio of human  $\alpha$ -1 proteinase inhibitor activity to human  $\alpha$ -1-proteinase inhibitor antigen is not less than 0.7.

Buffering and other auxiliary substances such as a stabiliser may be included. No antimicrobial preservative is added. The solution is passed through a bacteria-retentive filter and distributed aseptically into the final containers. The product may be freeze-dried.

##### CONSISTENCY OF THE METHOD OF PRODUCTION

The consistency of the method of production, including demonstration that the manufacturing process yields a product with a consistent composition and maintains the functional integrity of human  $\alpha$ -1-proteinase inhibitor, is evaluated by suitable analytical procedures that are determined during process development, and which include:

- assay of human  $\alpha$ -1-proteinase inhibitor activity;
- determination of specific human  $\alpha$ -1-proteinase inhibitor activity, expressed as the ratio of active human  $\alpha$ -1-proteinase inhibitor to total protein;
- characterisation of isoform composition and protein structure by suitable methods such as isoelectric focusing (2.2.54), spectrometric methods (for example, mass spectrometry) or capillary electrophoresis (2.2.47);
- determination of the ratio of human  $\alpha$ -1-proteinase inhibitor activity to human  $\alpha$ -1-proteinase inhibitor antigen;

- characterisation of accompanying plasma proteins that might be present, by a set of suitable methods such as SDS-PAGE, cellulose acetate electrophoresis or capillary zone electrophoresis (2.2.31) and quantitative determination of relevant accompanying plasma proteins;
- determination of molecular-size distribution, used to quantify the polymeric forms of human  $\alpha$ -1-proteinase inhibitor; consideration is given to the potential presence of accompanying proteins that might affect the results.

#### CHARACTERS

*Appearance:* freeze-dried products are hygroscopic, white or pale yellow or pale brown powders or friable solids; liquid products are clear or slightly opalescent, colourless or pale yellow or pale green or pale brown.

*If the preparation to be examined is freeze-dried, reconstitute it as stated on the label immediately before carrying out the identification, tests (except those for solubility and water) and assay.*

#### IDENTIFICATION

The assay of human  $\alpha$ -1-proteinase inhibitor activity serves to identify the preparation.

#### TESTS

**pH (2.2.3):** 6.5 to 7.8.

**Solubility.** To a container of the preparation to be examined add the volume of the liquid stated on the label at room temperature. The preparation dissolves completely when reconstituted according to the instructions for use, giving a clear, colourless or pale green or pale yellow or pale brown solution.

**Osmolality (2.2.35):** minimum 210 mosmol/kg.

**Total protein.** Dilute the preparation to be examined with a 9 g/L solution of *sodium chloride R* to obtain a solution containing about 15 mg of protein in 2 mL. To 2.0 mL of this solution in a round-bottomed centrifuge tube add 2 mL of a 75 g/L solution of *sodium molybdate R* and 2 mL of a mixture of 1 volume of *nitrogen-free sulfuric acid R* and 30 volumes of *water R*. Shake, centrifuge for 5 min, decant the supernatant and allow the inverted tube to drain on filter paper. Determine the nitrogen in the residue by the method of sulfuric acid digestion (2.5.9) and calculate the protein content by multiplying by 6.25.

**Water.** Determined by a suitable method, such as the semi-micro determination of water (2.5.12), loss on drying (2.2.32) or near-infrared spectrophotometry (2.2.40), the water content is within the limits approved by the competent authority.

**Sterility (2.6.1).** It complies with the test.

**Pyrogens (2.6.8).** It complies with the test. Inject per kilogram of the rabbit's mass a volume equivalent to not less than 60 mg of human  $\alpha$ -1-proteinase inhibitor.

#### ASSAY

Carry out the assay of human  $\alpha$ -1-proteinase inhibitor (2.7.32). The estimated potency is not less than 80 per cent and not more than 120 per cent of the stated potency. The confidence limits ( $P = 0.95$ ) are not less than 80 per cent and not more than 120 per cent of the estimated potency.

#### STORAGE

Unless otherwise justified and authorised, in an airtight and sterile container, at a temperature not exceeding  $25\text{ }^\circ\text{C}$ .

#### LABELLING

The label states:

- the potency of active (functional) human  $\alpha$ -1-proteinase inhibitor per container;
- the name and quantity of any added substances;
- the quantity of protein per container;

- where applicable, the name and volume of the liquid to be used for reconstitution;
- that the transmission of infectious agents cannot be totally excluded when medicinal products prepared from human blood or plasma are administered.

01/2011:0554

## HUMAN PROTHROMBIN COMPLEX

### Prothrombinum multiplex humanum

#### DEFINITION

Human prothrombin complex is a plasma protein fraction containing blood coagulation factor IX together with variable amounts of coagulation factors II, VII and X; the presence and proportion of these additional factors depends on the method of fractionation. It is obtained from human plasma that complies with the monograph *Human plasma for fractionation (0853)*.

The potency of the preparation, reconstituted as stated on the label, is not less than 20 IU of factor IX per millilitre.

If the content of any of the factors is stated as a single value, the estimated potency is not less than 80 per cent and not more than 125 per cent of the stated potency; if the content of any of the factors is stated as a range, the estimated potency is not less than the lower limit and not greater than the upper limit of the stated range.

#### PRODUCTION

The method of preparation is designed to minimise activation of any coagulation factor (to minimise potential thrombogenicity) and includes a step or steps that have been shown to remove or to inactivate known agents of infection; if substances are used for inactivation of viruses during production, the subsequent purification procedure must be validated to demonstrate that the concentration of these substances is reduced to a suitable level and that any residues are such as not to compromise the safety of the preparation for patients.

The specific activity is not less than 0.6 IU of factor IX per milligram of total protein, before the addition of any protein stabiliser.

The prothrombin complex fraction is dissolved in a suitable liquid. Heparin, antithrombin and other auxiliary substances such as a stabiliser may be added. No antimicrobial preservative is added. The solution is passed through a bacteria-retentive filter, distributed aseptically into the final containers and immediately frozen. It is subsequently freeze-dried and the containers are closed under vacuum or under an inert gas.

#### CHARACTERS

A white or slightly coloured powder or friable solid, very hygroscopic.

*Reconstitute the preparation to be examined as stated on the label immediately before carrying out the identification, tests (except those for solubility and water) and assay.*

#### IDENTIFICATION

It complies with the limits of the assays for factor IX and for factor II and, where applicable, those for factors VII and X.

#### TESTS

**Solubility.** To a container of the preparation to be examined add the volume of the liquid stated on the label at the recommended temperature. The preparation dissolves completely with gentle swirling within 10 min, giving a clear solution that may be coloured.

**pH (2.2.3):** 6.5 to 7.5.

**Osmolality (2.2.35):** minimum 240 mosmol/kg.

**Total protein.** If necessary, dilute an accurately measured volume of the reconstituted preparation with a 9 g/L solution of *sodium chloride R* to obtain a solution expected to contain about 15 mg of protein in 2 mL. To 2.0 mL of the solution in a round-bottomed centrifuge tube add 2 mL of a 75 g/L solution of *sodium molybdate R* and 2 mL of a mixture of 1 volume of *nitrogen-free sulfuric acid R* and 30 volumes of *water R*. Shake, centrifuge for 5 min, decant the supernatant and allow the inverted tube to drain on filter paper. Determine the nitrogen in the residue by the method of sulfuric acid digestion (2.5.9) and calculate the amount of protein by multiplying the result by 6.25.

**Activated coagulation factors (2.6.22).** If necessary, dilute the preparation to be examined to contain 20 IU of factor IX per millilitre. For each of the dilutions, the coagulation time is not less than 150 s.

**Heparin.** If heparin has been added during preparation, determine the amount present by the assay of heparin in coagulation factor concentrates (2.7.12). The preparation to be examined contains not more than the amount of heparin stated on the label and in all cases not more than 0.5 IU of heparin per International Unit of factor IX.

**Thrombin.** If the preparation to be examined contains heparin, determine the amount present as described in the test for heparin and neutralise it by addition of *protamine sulfate R* (10 µg of protamine sulfate neutralises 1 IU of heparin). In each of 2 test-tubes, mix equal volumes of the reconstituted preparation and a 3 g/L solution of *fibrinogen R*. Keep one of the tubes at 37 °C for 6 h and the other at room temperature for 24 h. In a 3<sup>rd</sup> tube, mix a volume of the fibrinogen solution with an equal volume of a solution of *human thrombin R* (1 IU/mL) and place the tube in a water-bath at 37 °C. No coagulation occurs in the tubes containing the preparation to be examined. Coagulation occurs within 30 s in the tube containing thrombin.

**Water.** Determined by a suitable method, such as the semi-micro determination of water (2.5.12), loss on drying (2.2.32) or near-infrared spectrometry (2.2.40), the water content is within the limits approved by the competent authority.

**Sterility (2.6.1).** It complies with the test.

**Pyrogens (2.6.8) or Bacterial endotoxins (2.6.14).** It complies with the test for pyrogens or, preferably and where justified and authorised, with a validated *in vitro* test such as the bacterial endotoxin test.

For the pyrogen test, inject per kilogram of the rabbit's mass a volume equivalent to not less than 30 IU of factor IX.

Where the bacterial endotoxin test is used, the preparation to be examined contains less than 0.05 IU of endotoxin per International Unit of factor IX.

#### ASSAY

**Factor IX.** Carry out the assay of human coagulation factor IX (2.7.11).

The estimated potency is not less than 80 per cent and not more than 125 per cent of the stated potency. The confidence interval ( $P = 0.95$ ) of the estimated potency is not greater than 80 per cent to 125 per cent.

**Factor II.** Carry out the assay of human coagulation factor II (2.7.18).

The estimated potency is not less than 80 per cent and not more than 125 per cent of the stated potency. The confidence interval ( $P = 0.95$ ) of the estimated potency is not greater than 90 per cent to 111 per cent.

The estimated factor II potency is not less than 70 per cent and not more than 165 per cent of the estimated factor IX potency.

**Factor VII.** If the label states that the preparation contains factor VII, carry out the assay of human coagulation factor VII (2.7.10).

The estimated potency is not less than 80 per cent and not more than 125 per cent of the stated potency. The confidence interval

control of blood, blood components and plasma derivatives, WHO Technical Report Series, No. 840, 1994 or subsequent revision).

#### POOLED PLASMA

To limit the potential B19 virus burden in plasma pools used for the manufacture of anti-D immunoglobulin, the plasma pool is tested for B19 virus using validated nucleic acid amplification techniques (2.6.21).

**B19 virus DNA:** maximum 10.0 IU/ $\mu$ L.

A positive control with 10.0 IU of B19 virus DNA per microlitre and, to test for inhibitors, an internal control prepared by addition of a suitable marker to a sample of the plasma pool are included in the test. The test is invalid if the positive control is non-reactive or if the result obtained with the internal control indicates the presence of inhibitors.

*B19 virus DNA for NAT testing BRP* is suitable for use as a positive control.

If *Human normal immunoglobulin (0338)* and/or *Human albumin solution (0255)* are added to the preparation, the plasma pool or pools from which they are derived comply with the above requirement for B19 virus DNA.

#### POTENCY

Carry out the assay of human anti-D immunoglobulin (2.7.13, Method A). The estimated potency is not less than 90 per cent of the stated potency. The confidence limits ( $P = 0.95$ ) are not less than 80 per cent and not more than 120 per cent of the estimated potency.

Method B or C (2.7.13) may be used for potency determination if a satisfactory correlation with the results obtained by Method A has been established for the particular product.

#### STORAGE

See *Human normal immunoglobulin (0338)*.

#### LABELLING

See *Human normal immunoglobulin (0338)*.

The label states the number of International Units per container.

01/2008:1527

## HUMAN ANTI-D IMMUNOGLOBULIN FOR INTRAVENOUS ADMINISTRATION

### Immunoglobulinum humanum anti-D ad usum intravenosum

#### DEFINITION

Human anti-D immunoglobulin for intravenous administration is a liquid or freeze-dried preparation containing immunoglobulins, mainly immunoglobulin G. It contains specific antibodies against erythrocyte D-antigen and may also contain small quantities of other blood-group antibodies. *Human normal immunoglobulin for intravenous administration (0918)* and/or *Human albumin solution (0255)* may be added.

It complies with the monograph *Human normal immunoglobulin for intravenous administration (0918)*, except for the minimum number of donors, the minimum total protein content, the limit for osmolality and the limit for prekallikrein activator.

The test for anti-D antibodies (2.6.26) prescribed in the monograph *Human normal immunoglobulin for intravenous administration (0918)* is not carried out, since it is replaced by the assay of human anti-D immunoglobulin (2.7.13) as prescribed below under Potency.

For products prepared by a method that eliminates immunoglobulins with specificities other than anti-D: where authorised, the test for antibodies to hepatitis B surface antigen is not required; a suitable test for Fc function is carried out instead of that described in chapter 2.7.9, which is not applicable to such a product.

#### PRODUCTION

Human anti-D immunoglobulin is preferably obtained from the plasma of donors with a sufficient titre of previously acquired anti-D antibodies. Where necessary, in order to ensure an adequate supply of human anti-D immunoglobulin, it is obtained from plasma derived from donors immunised with D-positive erythrocytes that are compatible in relevant blood group systems in order to avoid formation of undesirable antibodies.

#### ERYTHROCYTE DONORS

Erythrocyte donors comply with the requirements for donors prescribed in the monograph *Human plasma for fractionation (0853)*.

#### IMMUNISATION

Immunisation of the plasma donor is carried out under proper medical supervision. Recommendations concerning donor immunisation, including testing of erythrocyte donors, have been formulated by the World Health Organisation (*Requirements for the collection, processing and quality control of blood, blood components and plasma derivatives*, WHO Technical Report Series, No. 840, 1994 or subsequent revision).

#### POOLED PLASMA

To limit the potential B19 virus burden in plasma pools used for the manufacture of anti-D immunoglobulin, the plasma pool is tested for B19 virus using validated nucleic acid amplification techniques (2.6.21).

**B19 virus DNA:** maximum 10.0 IU/ $\mu$ L.

A positive control with 10.0 IU of B19 virus DNA per microlitre and, to test for inhibitors, an internal control prepared by addition of a suitable marker to a sample of the plasma pool are included in the test. The test is invalid if the positive control is non-reactive or if the result obtained with the internal control indicates the presence of inhibitors.

*B19 virus DNA for NAT testing BRP* is suitable for use as a positive control.

If *Human normal immunoglobulin for intravenous administration (0918)* and/or *Human albumin solution (0255)* are added to the preparation, the plasma pool or pools from which they are derived comply with the above requirement for B19 virus DNA.

#### POTENCY

Carry out the assay of human anti-D immunoglobulin (2.7.13, Method A). The estimated potency is not less than 90 per cent of the stated potency. The confidence limits ( $P = 0.95$ ) are not less than 80 per cent and not more than 120 per cent of the estimated potency.

Method B or C (2.7.13) may be used for potency determination if a satisfactory correlation with the results obtained by Method A has been established for the particular product.

#### STORAGE

See *Human normal immunoglobulin for intravenous administration (0918)*.

#### LABELLING

See *Human normal immunoglobulin for intravenous administration (0918)*.

The label states the number of International Units per container.

01/2011:0878

## HUMAN ANTITHROMBIN III CONCENTRATE

### Antithrombinum III humanum densatum

#### DEFINITION

Human antithrombin III concentrate is a preparation of a glycoprotein fraction obtained from human plasma that inactivates thrombin in the presence of an excess of heparin. It is obtained from plasma that complies with the requirements of the monograph *Human plasma for fractionation (0853)*.

When reconstituted in the volume of solvent stated on the label, the potency is not less than 25 IU of antithrombin III per millilitre.

#### PRODUCTION

The method of preparation includes a step or steps that have been shown to remove or to inactivate known agents of infection; if substances are used for inactivation of viruses during production, the subsequent purification procedure must be validated to demonstrate that the concentration of these substances is reduced to a suitable level and any residues are such as not to compromise the safety of the preparation for patients.

The antithrombin III is purified and concentrated and a suitable stabiliser may be added. The specific activity is not less than 3 IU of antithrombin III per milligram of total protein, excluding albumin. The antithrombin III concentrate is passed through a bacteria-retentive filter, distributed aseptically into its final, sterile containers and immediately frozen. It is then freeze-dried and the containers are closed under vacuum or in an atmosphere of inert gas. No antimicrobial preservative is added at any stage of production.

#### VALIDATION TEST

It shall be demonstrated that the manufacturing process yields a product that consistently complies with the following test.

**Heparin-binding fraction.** Examine by agarose gel electrophoresis (2.2.31). Prepare a 10 g/L solution of *agarose for electrophoresis R* containing 15 IU of *heparin R* per millilitre in *barbital buffer solution pH 8.4 R*. Pour 5 mL of this solution onto a glass plate 5 cm square. Cool at 4 °C for 30 min. Cut 2 wells 2 mm in diameter 1 cm and 4 cm from the side of the plate and 1 cm from the cathode. Introduce into one well 5 µL of the preparation to be examined, diluted to an activity of about 1 IU of antithrombin III per millilitre. Introduce into the other well 5 µL of a solution of a marker dye such as *bromophenol blue R*. Allow the electrophoresis to proceed at 4 °C, using a constant electric field of 7 V/cm, until the dye reaches the anode.

Cut across the agarose gel 1.5 cm from that side of the plate on which the preparation to be examined was applied and remove the larger portion of the gel leaving a band 1.5 cm wide containing the material to be examined. Replace the removed portion with an even layer consisting of 3.5 mL of a 10 g/L solution of *agarose for electrophoresis R* in *barbital buffer solution pH 8.4 R*, containing a rabbit anti-human antithrombin III antiserum at a suitable concentration, previously determined, to give adequate peak heights of at least 1.5 cm. Place the plate with the original gel at the cathode so that a 2<sup>nd</sup> electrophoretic migration can occur at right angles to the 1<sup>st</sup>. Allow this 2<sup>nd</sup> electrophoresis to proceed using a constant electric field of 2 V/cm for 16 h. Cover the plates with filter paper and several layers of thick lint soaked in a 9 g/L solution of *sodium chloride R* and compress for 2 h, renewing the saline several times. Rinse with *water R*, dry the plates and stain with *acid blue 92 solution R*.

Calculate the fraction of antithrombin III bound to heparin, which is the peak closest to the anode, with respect to the total amount of antithrombin III, by measuring the area defined by the 2 precipitation peaks.

The fraction of antithrombin III able to bind to heparin is not less than 60 per cent.

#### CHARACTERS

A white or almost white, hygroscopic, friable solid or a powder.

*Reconstitute the preparation to be examined as stated on the label immediately before carrying out the identification, tests (except those for solubility, total protein and water) and assay.*

#### IDENTIFICATION

It complies with the limits of the assay.

#### TESTS

**Solubility.** It dissolves completely under gentle swirling within 10 min in the volume of the solvent stated on the label, forming a clear or slightly turbid, colourless solution.

**pH (2.2.3):** 6.0 to 7.5.

**Osmolality (2.2.35):** minimum 240 mosmol/kg.

**Total protein.** If necessary, dilute an accurately measured volume of the preparation to be examined with *water R* to obtain a solution containing about 15 mg of protein in 2 mL. To 2.0 mL of the solution in a round-bottomed centrifuge tube add 2 mL of a 75 g/L solution of *sodium molybdate R* and 2 mL of a mixture of 1 volume of *nitrogen-free sulfuric acid R* and 30 volumes of *water R*. Shake, centrifuge for 5 min, decant the supernatant and allow the inverted tube to drain on filter paper. Determine the nitrogen in the residue by the method of sulfuric acid digestion (2.5.9) and calculate the amount of protein by multiplying the result by 6.25.

**Heparin (2.7.5):** maximum 0.1 IU of heparin activity per International Unit of antithrombin III activity. It is necessary to validate the method for assay of heparin for each specific preparation to be examined to allow for interference by antithrombin III.

**Water.** Determined by a suitable method, such as the semi-micro determination of water (2.5.12), loss on drying (2.2.32) or near-infrared spectrophotometry (2.2.40), the water content is within the limits approved by the competent authority.

**Sterility (2.6.1).** It complies with the test.

**Pyrogens (2.6.8) or Bacterial endotoxins (2.6.14).** It complies with the test for pyrogens or, preferably and where justified and authorised, with a validated *in vitro* test such as the bacterial endotoxin test.

For the pyrogen test, inject per kilogram of the rabbit's mass a volume equivalent to 50 IU of antithrombin III.

Where the bacterial endotoxin test is used, the preparation to be examined contains less than 0.1 IU of endotoxin per International Unit of antithrombin III.

#### ASSAY

Assay of human antithrombin III (2.7.17).

The estimated potency is not less than 80 per cent and not more than 120 per cent of the potency stated on the label. The confidence limits ( $P = 0.95$ ) are not less than 90 per cent and not more than 110 per cent of the estimated potency.

#### STORAGE

Protected from light, in an airtight container.

#### LABELLING

The label states:

- the content of antithrombin III expressed in International Units per container;
- the name and volume of the solvent to be used to reconstitute the preparation;

- where applicable, the amount of albumin present as a stabiliser.

01/2011:1224

## HUMAN COAGULATION FACTOR VII

### Factor VII coagulationis humanus

#### DEFINITION

Human coagulation factor VII is a plasma protein fraction that contains the single-chain glycoprotein factor VII and may also contain small amounts of the activated form, the two-chain derivative factor VIIa. It may also contain coagulation factors II, IX and X and protein C and protein S. It is obtained from human plasma that complies with the monograph *Human plasma for fractionation (0853)*.

The potency of the preparation, reconstituted as stated on the label, is not less than 15 IU of factor VII per millilitre.

#### PRODUCTION

The method of preparation is designed to minimise activation of any coagulation factor (to minimise potential thrombogenicity) and includes a step or steps that have been shown to remove or to inactivate known agents of infection; if substances are used for inactivation of viruses during production, the subsequent purification procedure must be validated to demonstrate that the concentration of these substances is reduced to a suitable level and that any residues are such as not to compromise the safety of the preparation for patients.

The specific activity is not less than 2 IU of factor VII per milligram of total protein, before the addition of any protein stabiliser.

The factor VII fraction is dissolved in a suitable liquid. Heparin, antithrombin and other auxiliary substances such as a stabiliser may be added. No antimicrobial preservative is added. The solution is passed through a bacteria-retentive filter, distributed aseptically into the final containers and immediately frozen. It is subsequently freeze-dried and the containers are closed under vacuum or under an inert gas.

#### CONSISTENCY OF THE METHOD OF PRODUCTION

The consistency of the method of production with respect to the activities of factors II, IX and X of the preparation, expressed in International Units relative to the activity of factor VII, shall be demonstrated.

The consistency of the method of production with respect to the activity of factor VIIa of the preparation shall be demonstrated. The activity of factor VIIa may be determined, for example, using a recombinant soluble tissue factor that does not activate factor VII but possesses a cofactor function specific for factor VIIa; after incubation of a mixture of the recombinant soluble tissue factor with phospholipids reagent and the dilution of the test sample in factor VII-deficient plasma, calcium chloride is added and the clotting time determined; the clotting time is inversely related to the factor VIIa activity of the test sample.

#### CHARACTERS

A hygroscopic powder or friable solid that may be white or almost white, pale yellow, green or blue.

*Reconstitute the preparation to be examined as stated on the label immediately before carrying out the identification, tests (except those for solubility and water) and assay.*

#### IDENTIFICATION

It complies with the limits of the assay.

#### TESTS

**Solubility.** To a container of the preparation to be examined add the volume of liquid stated on the label at the recommended temperature. The preparation dissolves completely with gentle swirling within 10 min, giving a clear or slightly opalescent solution that may be coloured.

**pH (2.2.3):** 6.5 to 7.5.

**Osmolality (2.2.35):** minimum 240 mosmol/kg.

**Total protein.** If necessary, dilute an accurately measured volume of the reconstituted preparation with a 9 g/L solution of *sodium chloride R* to obtain a solution expected to contain about 15 mg of protein in 2 mL. To 2.0 mL of the solution in a round-bottomed centrifuge tube add 2 mL of a 75 g/L solution of *sodium molybdate R* and 2 mL of a mixture of 1 volume of *nitrogen-free sulfuric acid R* and 30 volumes of *water R*. Shake, centrifuge for 5 min, decant the supernatant and allow the inverted tube to drain on filter paper. Determine the nitrogen in the residue by the method of sulfuric acid digestion (2.5.9) and calculate the amount of protein by multiplying the result by 6.25.

**Activated coagulation factors (2.6.22).** For each of the dilutions, the coagulation time is not less than 150 s.

**Heparin.** If heparin has been added during preparation, determine the amount present by the assay of heparin in coagulation factor concentrates (2.7.12). The preparation to be examined contains not more than the amount of heparin stated on the label and in any case not more than 0.5 IU of heparin per International Unit of factor VII.

**Thrombin.** If the preparation to be examined contains heparin, determine the amount present as described in the test for heparin and neutralise the heparin by addition of *protamine sulfate R* (10 µg of protamine sulfate neutralises 1 IU of heparin). In each of 2 test-tubes, mix equal volumes of the reconstituted preparation and a 3 g/L solution of *fibrinogen R*. Keep one of the tubes at 37 °C for 6 h and the other at room temperature for 24 h. In a 3<sup>rd</sup> tube, mix a volume of the fibrinogen solution with an equal volume of a solution of *human thrombin R* (1 IU/mL) and place the tube in a water-bath at 37 °C. No coagulation occurs in the tubes containing the preparation to be examined. Coagulation occurs within 30 s in the tube containing thrombin.

**Factor II.** Carry out the assay of human coagulation factor II (2.7.18).

The estimated content is not more than 125 per cent of the stated content. The confidence limits ( $P = 0.95$ ) are not less than 90 per cent and not more than 111 per cent of the estimated potency.

**Factor IX.** Carry out the assay of human coagulation factor IX (2.7.11).

The estimated content is not more than 125 per cent of the stated content. The confidence limits ( $P = 0.95$ ) are not less than 80 per cent and not more than 125 per cent of the estimated potency.

**Factor X.** Carry out the assay of human coagulation factor X (2.7.19).

The estimated content is not more than 125 per cent of the stated content. The confidence limits ( $P = 0.95$ ) are not less than 90 per cent and not more than 111 per cent of the estimated potency.

**Water.** Determined by a suitable method, such as the semi-micro determination of water (2.5.12), loss on drying (2.2.32) or near-infrared spectrometry (2.2.40), the water content is within the limits approved by the competent authority.

**Sterility (2.6.1).** It complies with the test.



## CHARACTERS

*Appearance*: white or slightly yellow powder or friable mass.

## IDENTIFICATION

- A. It complies with the limits of the assay.  
 B. The distribution of characteristic peptide bands corresponds with that of the manufacturer's reference preparation (SDS-PAGE or Western blot).

## TESTS

*Reconstitute the preparation as stated on the label immediately before carrying out the tests (except those for solubility and water) and assay.*

**Solubility.** It dissolves within 5 min at 20-25 °C, giving a clear or slightly opalescent solution.

**pH (2.2.3):** 6.5 to 7.5.

**Osmolality (2.2.35):** minimum 240 mosmol/kg.

**Water.** Determined by a suitable method, such as the semi-micro determination of water (2.5.12), loss on drying (2.2.32) or near infrared spectrophotometry (2.2.40), the water content is within the limits approved by the competent authority.

**Sterility (2.6.1).** It complies with the test for sterility.

**Bacterial endotoxins (2.6.14):** less than 3 IU in the volume that contains 100 IU of factor VIII activity.

## ASSAY

Carry out the assay of human coagulation factor VIII (2.7.4).

The estimated potency is not less than 80 per cent and not more than 125 per cent of the stated potency. The confidence limits ( $P = 0.95$ ) are not less than 80 per cent and not more than 120 per cent of the estimated potency.

## STORAGE

Protected from light.

## LABELLING

The label states:

- the factor VIII content in International Units,
- the name and amount of any excipient,
- the composition and volume of the liquid to be used for reconstitution.

01/2011:1223

## HUMAN COAGULATION FACTOR IX

## Factor IX coagulationis humanus

## DEFINITION

Human coagulation factor IX is a plasma protein fraction containing coagulation factor IX, prepared by a method that effectively separates factor IX from other prothrombin complex factors (factors II, VII and X). It is obtained from human plasma that complies with the monograph *Human plasma for fractionation (0853)*.

The potency of the preparation, reconstituted as stated on the label, is not less than 20 IU of factor IX per millilitre.

## PRODUCTION

The method of preparation is designed to maintain functional integrity of factor IX, to minimise activation of any coagulation factor (to minimise potential thrombogenicity) and includes a step or steps that have been shown to remove or to inactivate known agents of infection; if substances are used for inactivation of viruses during production, the subsequent purification procedure must be validated to demonstrate that the concentration of these substances is reduced to a suitable level and that any residues are such as not to compromise the safety of the preparation for patients.

The specific activity is not less than 50 IU of factor IX per milligram of total protein, before the addition of any protein stabiliser.

The factor IX fraction is dissolved in a suitable liquid. Heparin, antithrombin and other auxiliary substances such as a stabiliser may be included. No antimicrobial preservative is added. The solution is passed through a bacteria-retentive filter, distributed aseptically into the final containers and immediately frozen. It is subsequently freeze-dried and the containers are closed under vacuum or under an inert gas.

## CONSISTENCY OF THE METHOD OF PRODUCTION

The consistency of the method of production is evaluated by suitable analytical procedures that are determined during process development and that normally include:

- assay of factor IX;
- determination of activated coagulation factors;
- determination of activities of factors II, VII and X, which shall be shown to be not more than 5 per cent of the activity of factor IX.

## CHARACTERS

A white or pale yellow, hygroscopic powder or friable solid.

*Reconstitute the preparation to be examined as stated on the label immediately before carrying out the identification, tests (except those for solubility and water) and assay.*

## IDENTIFICATION

It complies with the limits of the assay.

## TESTS

**Solubility.** To a container of the preparation to be examined add the volume of the liquid stated on the label at the recommended temperature. The preparation dissolves completely with gentle swirling within 10 min, giving a clear or slightly opalescent, colourless solution.

**pH (2.2.3):** 6.5 to 7.5.

**Osmolality (2.2.35):** minimum 240 mosmol/kg.

**Total protein.** If necessary, dilute an accurately measured volume of the preparation to be examined with a 9 g/L solution of *sodium chloride R* to obtain a solution expected to contain about 15 mg of protein in 2 mL. To 2.0 mL of the solution in a round-bottomed centrifuge tube add 2 mL of a 75 g/L solution of *sodium molybdate R* and 2 mL of a mixture of 1 volume of *nitrogen-free sulfuric acid R* and 30 volumes of *water R*. Shake, centrifuge for 5 min, decant the supernatant and allow the inverted tube to drain on filter paper. Determine the nitrogen in the residue by the method of sulfuric acid digestion (2.5.9) and calculate the amount of protein by multiplying the result by 6.25.

*For some products, especially those without a protein stabiliser such as albumin, this method may not be applicable. Another validated method for protein determination must therefore be performed.*

**Activated coagulation factors (2.6.22).** If necessary, dilute the preparation to be examined to contain 20 IU of factor IX per millilitre. For each of the dilutions, the coagulation time is not less than 150 s.

**Heparin.** If heparin has been added during preparation, determine the amount by the assay of heparin in coagulation factor concentrates (2.7.12). The preparation to be examined contains not more than the amount of heparin stated on the label and in all cases not more than 0.5 IU of heparin per International Unit of factor IX.

**Water.** Determined by a suitable method, such as the semi-micro determination of water (2.5.12), loss on drying (2.2.32) or near-infrared spectrophotometry (2.2.40), the water content is within the limits approved by the competent authority.

**Sterility (2.6.1).** It complies with the test.

**Pyrogens (2.6.8) or Bacterial endotoxins (2.6.14).** It complies with the test for pyrogens or, preferably and where justified and authorised, with a validated *in vitro* test such as the bacterial endotoxin test.

For the pyrogen test, inject per kilogram of the rabbit's mass a volume equivalent to not less than 50 IU of factor IX.

Where the bacterial endotoxin test is used, the preparation to be examined contains less than 0.03 IU of endotoxin per International Unit of factor IX.

#### ASSAY

Carry out the assay of human coagulation factor IX (2.7.11).

The estimated potency is not less than 80 per cent and not more than 125 per cent of the stated potency. The confidence limits ( $P = 0.95$ ) are not less than 80 per cent and not more than 125 per cent of the estimated potency.

#### STORAGE

In an airtight container, protected from light.

#### LABELLING

The label states:

- the number of International Units of factor IX per container;
- the amount of protein per container;
- the name and quantity of any added substances including, where applicable, heparin;
- the name and volume of the liquid to be used for reconstitution;
- that the transmission of infectious agents cannot be totally excluded when medicinal products prepared from human blood or plasma are administered.

01/2011:1644

## HUMAN COAGULATION FACTOR XI

### Factor XI coagulationis humanus

#### DEFINITION

Human coagulation factor XI is a plasma protein fraction containing coagulation factor XI. It is obtained from *Human plasma for fractionation (0853)*.

When reconstituted as stated on the label, the potency is not less than 50 units of factor XI per millilitre.

#### PRODUCTION

The method of preparation includes a step or steps that have been shown to remove or to inactivate known agents of infection; if substances are used for inactivation of viruses during production, the subsequent purification procedure must be validated to demonstrate that the concentration of these substances is reduced to a suitable level and any residues are such as not to compromise the safety of the preparation for patients.

After preparation, the factor XI fraction is dissolved in a suitable liquid. Heparin, C<sub>1</sub>-esterase inhibitor and antithrombin III may be added. No antimicrobial preservative is added. The solution is distributed into the final containers and immediately frozen. It is subsequently freeze-dried and the containers are closed under vacuum or under nitrogen.

#### CHARACTERS

A white or almost white powder or friable solid.

*Reconstitute the preparation to be examined as stated on the label immediately before carrying out the identification, tests (except those for solubility and water) and assay.*

#### IDENTIFICATION

The assay serves also to identify the preparation.

#### TESTS

**Solubility.** To a container of the preparation to be examined, add the volume of liquid stated on the label at room temperature. The preparation dissolves completely with gentle swirling within 10 min.

**pH (2.2.3):** 6.8 to 7.4.

**Osmolality (2.2.35):** minimum 240 mosmol/kg.

**Total protein.** If necessary, dilute an accurately measured volume of the preparation to be examined with a 9 g/L solution of *sodium chloride R* to obtain a solution expected to contain about 15 mg of protein in 2 mL. To 2.0 mL of the solution in a round-bottomed centrifuge tube add 2 mL of a 75 g/L solution of *sodium molybdate R* and 2 mL of a mixture of 1 volume of *nitrogen-free sulfuric acid R* and 30 volumes of *water R*. Shake, centrifuge for 5 min, decant the supernatant and allow the inverted tube to drain on filter paper. Determine the nitrogen in the residue by the method of sulfuric acid digestion (2.5.9) and calculate the amount of protein by multiplying the result by 6.25.

**Activated coagulation factors (2.6.22).** For each of the dilutions, the coagulation time is not less than 150 s.

**Heparin (2.7.12).** If heparin has been added, the preparation to be examined contains not more than the amount of heparin stated on the label and in all cases not more than 0.5 IU of heparin per unit of factor XI.

**Antithrombin III (2.7.17).** If antithrombin III has been added, the preparation to be examined contains not more than the amount of antithrombin III stated on the label.

**C<sub>1</sub>-esterase inhibitor.** If C<sub>1</sub>-esterase inhibitor has been added, the preparation to be examined contains not more than the amount of C<sub>1</sub>-esterase inhibitor stated on the label.

The C<sub>1</sub>-esterase inhibitor content of the preparation to be examined is determined by comparing its ability to inhibit C<sub>1</sub>-esterase with the same ability of a reference preparation consisting of human normal plasma. 1 unit of C<sub>1</sub>-esterase is equal to the activity of 1 mL of human normal plasma. Varying quantities of the preparation to be examined are mixed with an excess of C<sub>1</sub>-esterase and the remaining C<sub>1</sub>-esterase activity is determined using a suitable chromogenic substrate.

**Method.** Reconstitute the preparation as stated on the label. Prepare an appropriate series of 3 or 4 independent dilutions from 1 unit/mL of factor XI, for both the preparation to be examined and the reference preparation, using a solution containing 9 g/L of *sodium chloride R* and either 10 g/L of *human albumin R* or 10 g/L of *bovine albumin R*. Warm all solutions to 37 °C in a water-bath for 1-2 min before use. Place a suitable amount of C<sub>1</sub>-esterase solution in tubes or in microtitre plate wells and incubate at 37 °C. Add a suitable amount of one of the dilutions of the reference preparation or of the preparation to be examined and incubate at 37 °C for 5 min. Add a suitable amount of a suitable chromogenic substrate such as methoxycarbonyl-L-lysyl(ε-benzyloxycarbonyl)-glycyl-L-arginine 4-nitroanilide. Read the rate of increase of absorbance (ΔA/min) at 405 nm. Carry out a blank test using *tris(hydroxymethyl)aminomethane sodium chloride buffer solution pH 7.4 R* instead of the C<sub>1</sub>-esterase and the substrate.

Calculate the C<sub>1</sub>-esterase inhibitor content using the usual statistical methods (for example, 5.3).

**Anti-A and anti-B haemagglutinins (2.6.20).** The 1 to 64 dilutions do not show agglutination.

**Water.** Determined by a suitable method, such as the semi-micro determination of water (2.5.12), loss on drying (2.2.32) or near-infrared spectrophotometry (2.2.40), the water content is within the limits approved by the competent authority.

**Sterility (2.6.1).** The reconstituted preparation complies with the test.

**Pyrogens (2.6.8) or Bacterial endotoxins (2.6.14).** It complies with the test for pyrogens or, preferably and where justified and authorised, with a validated *in vitro* test such as the bacterial endotoxin test.

For the pyrogen test, inject per kilogram of the rabbit's mass a volume equivalent to not less than 30 IU of factor VII.

Where the bacterial endotoxin test is used, the preparation to be examined contains less than 0.1 IU of endotoxin per International Unit of factor VII.

#### ASSAY

Assay of human coagulation factor VII (2.7.10).

The estimated potency is not less than 80 per cent and not more than 125 per cent of the stated potency. The confidence limits ( $P = 0.95$ ) are not less than 80 per cent and not more than 125 per cent of the estimated potency.

#### STORAGE

In an airtight container, protected from light.

#### LABELLING

The label states:

- the number of International Units of factor VII per container;
- the maximum content of International Units of factor II, factor IX and factor X per container;
- the amount of protein per container;
- the name and quantity of any added substances, including, where applicable, heparin;
- the name and volume of the liquid to be used for reconstitution;
- that the transmission of infectious agents cannot be totally excluded when medicinal products prepared from human blood or plasma are administered.

01/2010:0275

## HUMAN COAGULATION FACTOR VIII

### Factor VIII coagulationis humanus

#### DEFINITION

Human coagulation factor VIII is a preparation of a plasma protein fraction that contains the glycoprotein coagulation factor VIII together with varying amounts of von Willebrand factor, depending on the method of preparation. It is prepared from human plasma that complies with the monograph *Human plasma for fractionation (0853)*.

The potency of the preparation, reconstituted as stated on the label, is not less than 20 IU of factor VIII:C per millilitre.

#### PRODUCTION

The method of preparation includes a step or steps that have been shown to remove or to inactivate known agents of infection; if substances are used for the inactivation of viruses, the subsequent purification procedure must be validated to demonstrate that the concentration of these substances is reduced to a suitable level and that any residues are such as not to compromise the safety of the preparation for patients.

The specific activity is not less than 1 IU of factor VIII:C per milligram of total protein before the addition of any protein stabiliser.

The factor VIII fraction is dissolved in a suitable liquid. Excipients such as a stabiliser may be added. No antimicrobial preservative is added. The solution is passed through a bacteria-retentive filter, distributed aseptically into the final containers and immediately frozen. It is subsequently freeze-dried and the containers are closed under vacuum or under an inert gas.

#### VALIDATION STUDIES

*Products stated to have von Willebrand factor activity.* For products intended for treatment of von Willebrand's disease it shall be demonstrated that the manufacturing process yields a product with a consistent composition with respect to von Willebrand factor. This composition may be characterised in a number of ways. For example, the number and the relative amount of the different multimers may be determined by sodium dodecyl sulfate (SDS) agarose gel electrophoresis (about 1 per cent agarose) with or without Western blot analysis, using a normal human plasma pool as reference; visualisation of the multimeric pattern may be performed using an immunoenzymatic technique and quantitative evaluation may be carried out by densitometric analysis or by other suitable methods.

*Products that show flakes or particles after reconstitution for use.* If a few small flakes or particles remain when the preparation is reconstituted, it shall be demonstrated during validation studies that the potency is not significantly affected after passage of the preparation through the filter provided.

#### CHARACTERS

*Appearance:* white or pale yellow, hygroscopic powder or friable solid.

*Reconstitute the preparation to be examined as stated on the label immediately before carrying out the identification, tests (except those for solubility and water) and assay.*

#### IDENTIFICATION

It complies with the limits of the assay.

#### TESTS

**Solubility.** To a container of the preparation to be examined add the volume of the solvent stated on the label at the recommended temperature. The preparation dissolves completely with gentle swirling within 10 min, giving a clear or slightly opalescent, colourless or slightly yellow solution.

Where the label states that the product may show a few small flakes or particles after reconstitution, reconstitute the preparation as described on the label and pass it through the filter provided: the filtered solution is clear or slightly opalescent.

**pH (2.2.3):** 6.5 to 7.5.

**Osmolality (2.2.35):** minimum 240 mosmol/kg.

**Total protein.** If necessary, dilute an accurately measured volume of the preparation to be examined with a 9 g/L solution of *sodium chloride R* to obtain a solution containing about 15 mg of protein in 2 mL. Place 2.0 mL of this solution in a round-bottomed centrifuge tube and add 2 mL of a 75 g/L solution of *sodium molybdate R* and 2 mL of a mixture of 1 volume of *nitrogen-free sulfuric acid R* and 30 volumes of *water R*. Shake, centrifuge for 5 min, decant the supernatant liquid and allow the inverted tube to drain on filter paper. Determine the nitrogen in the residue by the method of sulfuric acid digestion (2.5.9) and calculate the amount of protein by multiplying the result by 6.25. *For some products, especially those without a protein stabiliser such as albumin, this method may not be applicable and another validated method for protein determination must therefore be performed.*

**Anti-A and anti-B haemagglutinins (2.6.20).** Dilute the preparation to be examined with a 9 g/L solution of *sodium chloride R* to contain 3 IU of factor VIII:C per millilitre. The 1 to 64 dilutions do not show agglutination.

**Water.** Determined by a suitable method, such as the semi-micro determination of water (2.5.12), loss on drying (2.2.32) or near infrared spectrophotometry (2.2.40), the water content is within the limits approved by the competent authority.

**Sterility (2.6.1).** It complies with the test for sterility.

**Pyrogens (2.6.8) or Bacterial endotoxins (2.6.14).** It complies with the test for pyrogens or, preferably and where justified and authorised, with a validated *in vitro* test such as the bacterial endotoxin test.

For the pyrogen test, inject per kilogram of the rabbit's mass a volume equivalent to not less than 50 IU of factor VIII:C.

Where the bacterial endotoxin test is used, the preparation to be examined contains less than 0.03 IU of endotoxin per International Unit of factor VIII:C.

#### ASSAY

**Factor VIII (2.7.4).** The estimated potency is not less than 80 per cent and not more than 120 per cent of the stated potency. The confidence limits ( $P = 0.95$ ) are not less than 80 per cent and not more than 120 per cent of the estimated potency.

**von Willebrand factor (2.7.21).** Carry out the assay of human von Willebrand factor for preparations intended for the treatment of von Willebrand's disease.

The estimated potency is not less than 60 per cent and not more than 140 per cent of the stated potency.

*Pending the availability of an International Standard for von Willebrand factor concentrate calibrated for use in the collagen-binding assay, only the ristocetin cofactor assay may be used.*

#### STORAGE

In an airtight container, protected from light.

#### LABELLING

The label states:

- the number of International Units of factor VIII:C and, where applicable, of von Willebrand factor in the container;
- the amount of protein in the container;
- the name and quantity of any added substance;
- the name and volume of the liquid to be used for reconstitution;
- where applicable, that the preparation may show the presence of a few small flakes or particles after reconstitution;
- that the transmission of infectious agents cannot be totally excluded when medicinal products prepared from human blood or plasma are administered.

01/2008:1643

## HUMAN COAGULATION FACTOR VIII (rDNA)

### Factor VIII coagulationis humanus (ADNr)

#### DEFINITION

Human coagulation factor VIII (rDNA) is a freeze-dried preparation of glycoproteins having the same activity as coagulation factor VIII in human plasma. It acts as a cofactor of the activation of factor X in the presence of factor IXa, phospholipids and calcium ions.

Human coagulation factor VIII circulates in plasma mainly as a two-chain glycosylated protein with 1 heavy (relative molecular mass of about 200 000) and 1 light (relative molecular mass 80 000) chain held together by divalent metal ions. Human coagulation factor VIII (rDNA) is prepared as full-length factor VIII (octocog alfa), or as a shortened two-chain structure (relative molecular mass 90 000 and 80 000), in which the B-domain has been deleted from the heavy chain (morocotocog alfa).

Full-length human rDNA coagulation factor VIII contains 25 potential *N*-glycosylation sites, 19 in the B domain of the heavy chain, 3 in the remaining part of the heavy chain (relative molecular mass 90 000) and 3 in the light chain

(relative molecular mass 80 000). The different products are characterised by their molecular size and post-translational modification and/or other modifications.

#### PRODUCTION

Human coagulation factor VIII (rDNA) is produced by recombinant DNA technology in mammalian cell culture. It is produced under conditions designed to minimise microbial contamination.

Purified bulk factor VIII (rDNA) may contain added human albumin and/or other stabilising agents, as well as other auxiliary substances to provide, for example, correct pH and osmolality.

The specific activity is not less than 2000 IU of factor VIII:C per milligram of total protein before the addition of any protein stabiliser, and varies depending on purity and the type of modification of molecular structure of factor VIII.

The quality of the bulk preparation is controlled using one or more manufacturer's reference preparations as reference.

#### MANUFACTURER'S REFERENCE PREPARATIONS

During development, reference preparations are established for subsequent verification of batch consistency during production, and for control of bulk and final preparation. They are derived from representative batches of purified bulk factor VIII (rDNA) that are extensively characterised by tests including those described below and whose procoagulant and other relevant functional properties have been ascertained and compared, wherever possible, with the International Standard for factor VIII concentrate. The reference preparations are suitably characterised for their intended purpose and are stored in suitably sized aliquots under conditions ensuring their stability.

#### PURIFIED BULK FACTOR VIII (rDNA)

*The purified bulk complies with a suitable combination of the following tests for characterisation of integrity of the factor VIII (rDNA). Where any substance added during preparation of the purified bulk interferes with a test, the test is carried out before addition of that substance. Where applicable, the characterisation tests may alternatively be carried out on the finished product.*

**Specific biological activity or ratio of factor VIII activity to factor VIII antigen.** Carry out the assay of human coagulation factor VIII (2.7.4). The protein content, or where a protein stabiliser is present, the factor VIII antigen content, is determined by a suitable method and the specific biological activity or the ratio of factor VIII activity to factor VIII antigen is calculated.

**Protein composition.** The protein composition is determined by a selection of appropriate characterisation techniques which may include peptide mapping, Western blots, HPLC, gel electrophoresis, capillary electrophoresis, mass spectrometry or other techniques to monitor integrity and purity. The protein composition is comparable to that of the manufacturer's reference preparation.

**Molecular size distribution.** Using size-exclusion chromatography (2.2.30), the molecular size distribution is comparable to that of the manufacturer's reference preparation.

**Peptide mapping (2.2.55).** There is no significant difference between the test protein and the manufacturer's reference preparation.

**Carbohydrates/sialic acid.** To monitor batch-to-batch consistency, the monosaccharide content and the degree of sialylation or the oligosaccharide profile are monitored and correspond to those of the manufacturer's reference preparation.

#### FINAL LOT

It complies with the requirements under Identification, Tests and Assay.

**Excipients:** 80 per cent to 120 per cent of the stated content, determined by a suitable method, where applicable.

## CHARACTERS

*Appearance*: white or slightly yellow powder or friable mass.

## IDENTIFICATION

- A. It complies with the limits of the assay.  
 B. The distribution of characteristic peptide bands corresponds with that of the manufacturer's reference preparation (SDS-PAGE or Western blot).

## TESTS

*Reconstitute the preparation as stated on the label immediately before carrying out the tests (except those for solubility and water) and assay.*

**Solubility.** It dissolves within 5 min at 20-25 °C, giving a clear or slightly opalescent solution.

**pH (2.2.3):** 6.5 to 7.5.

**Osmolality (2.2.35):** minimum 240 mosmol/kg.

**Water.** Determined by a suitable method, such as the semi-micro determination of water (2.5.12), loss on drying (2.2.32) or near infrared spectrophotometry (2.2.40), the water content is within the limits approved by the competent authority.

**Sterility (2.6.1).** It complies with the test for sterility.

**Bacterial endotoxins (2.6.14):** less than 3 IU in the volume that contains 100 IU of factor VIII activity.

## ASSAY

Carry out the assay of human coagulation factor VIII (2.7.4).

The estimated potency is not less than 80 per cent and not more than 125 per cent of the stated potency. The confidence limits ( $P = 0.95$ ) are not less than 80 per cent and not more than 120 per cent of the estimated potency.

## STORAGE

Protected from light.

## LABELLING

The label states:

- the factor VIII content in International Units,
- the name and amount of any excipient,
- the composition and volume of the liquid to be used for reconstitution.

01/2011:1223

## HUMAN COAGULATION FACTOR IX

## Factor IX coagulationis humanus

## DEFINITION

Human coagulation factor IX is a plasma protein fraction containing coagulation factor IX, prepared by a method that effectively separates factor IX from other prothrombin complex factors (factors II, VII and X). It is obtained from human plasma that complies with the monograph *Human plasma for fractionation (0853)*.

The potency of the preparation, reconstituted as stated on the label, is not less than 20 IU of factor IX per millilitre.

## PRODUCTION

The method of preparation is designed to maintain functional integrity of factor IX, to minimise activation of any coagulation factor (to minimise potential thrombogenicity) and includes a step or steps that have been shown to remove or to inactivate known agents of infection; if substances are used for inactivation of viruses during production, the subsequent purification procedure must be validated to demonstrate that the concentration of these substances is reduced to a suitable level and that any residues are such as not to compromise the safety of the preparation for patients.

The specific activity is not less than 50 IU of factor IX per milligram of total protein, before the addition of any protein stabiliser.

The factor IX fraction is dissolved in a suitable liquid. Heparin, antithrombin and other auxiliary substances such as a stabiliser may be included. No antimicrobial preservative is added. The solution is passed through a bacteria-retentive filter, distributed aseptically into the final containers and immediately frozen. It is subsequently freeze-dried and the containers are closed under vacuum or under an inert gas.

## CONSISTENCY OF THE METHOD OF PRODUCTION

The consistency of the method of production is evaluated by suitable analytical procedures that are determined during process development and that normally include:

- assay of factor IX;
- determination of activated coagulation factors;
- determination of activities of factors II, VII and X, which shall be shown to be not more than 5 per cent of the activity of factor IX.

## CHARACTERS

A white or pale yellow, hygroscopic powder or friable solid.

*Reconstitute the preparation to be examined as stated on the label immediately before carrying out the identification, tests (except those for solubility and water) and assay.*

## IDENTIFICATION

It complies with the limits of the assay.

## TESTS

**Solubility.** To a container of the preparation to be examined add the volume of the liquid stated on the label at the recommended temperature. The preparation dissolves completely with gentle swirling within 10 min, giving a clear or slightly opalescent, colourless solution.

**pH (2.2.3):** 6.5 to 7.5.

**Osmolality (2.2.35):** minimum 240 mosmol/kg.

**Total protein.** If necessary, dilute an accurately measured volume of the preparation to be examined with a 9 g/L solution of *sodium chloride R* to obtain a solution expected to contain about 15 mg of protein in 2 mL. To 2.0 mL of the solution in a round-bottomed centrifuge tube add 2 mL of a 75 g/L solution of *sodium molybdate R* and 2 mL of a mixture of 1 volume of *nitrogen-free sulfuric acid R* and 30 volumes of *water R*. Shake, centrifuge for 5 min, decant the supernatant and allow the inverted tube to drain on filter paper. Determine the nitrogen in the residue by the method of sulfuric acid digestion (2.5.9) and calculate the amount of protein by multiplying the result by 6.25.

*For some products, especially those without a protein stabiliser such as albumin, this method may not be applicable. Another validated method for protein determination must therefore be performed.*

**Activated coagulation factors (2.6.22).** If necessary, dilute the preparation to be examined to contain 20 IU of factor IX per millilitre. For each of the dilutions, the coagulation time is not less than 150 s.

**Heparin.** If heparin has been added during preparation, determine the amount by the assay of heparin in coagulation factor concentrates (2.7.12). The preparation to be examined contains not more than the amount of heparin stated on the label and in all cases not more than 0.5 IU of heparin per International Unit of factor IX.

**Water.** Determined by a suitable method, such as the semi-micro determination of water (2.5.12), loss on drying (2.2.32) or near-infrared spectrophotometry (2.2.40), the water content is within the limits approved by the competent authority.

**Sterility (2.6.1).** It complies with the test.

**Pyrogens (2.6.8) or Bacterial endotoxins (2.6.14).** It complies with the test for pyrogens or, preferably and where justified and authorised, with a validated *in vitro* test such as the bacterial endotoxin test.

For the pyrogen test, inject per kilogram of the rabbit's mass a volume equivalent to not less than 50 IU of factor IX.

Where the bacterial endotoxin test is used, the preparation to be examined contains less than 0.03 IU of endotoxin per International Unit of factor IX.

#### ASSAY

Carry out the assay of human coagulation factor IX (2.7.11).

The estimated potency is not less than 80 per cent and not more than 125 per cent of the stated potency. The confidence limits ( $P = 0.95$ ) are not less than 80 per cent and not more than 125 per cent of the estimated potency.

#### STORAGE

In an airtight container, protected from light.

#### LABELLING

The label states:

- the number of International Units of factor IX per container;
- the amount of protein per container;
- the name and quantity of any added substances including, where applicable, heparin;
- the name and volume of the liquid to be used for reconstitution;
- that the transmission of infectious agents cannot be totally excluded when medicinal products prepared from human blood or plasma are administered.

01/2011:1644

## HUMAN COAGULATION FACTOR XI

### Factor XI coagulationis humanus

#### DEFINITION

Human coagulation factor XI is a plasma protein fraction containing coagulation factor XI. It is obtained from *Human plasma for fractionation (0853)*.

When reconstituted as stated on the label, the potency is not less than 50 units of factor XI per millilitre.

#### PRODUCTION

The method of preparation includes a step or steps that have been shown to remove or to inactivate known agents of infection; if substances are used for inactivation of viruses during production, the subsequent purification procedure must be validated to demonstrate that the concentration of these substances is reduced to a suitable level and any residues are such as not to compromise the safety of the preparation for patients.

After preparation, the factor XI fraction is dissolved in a suitable liquid. Heparin, C<sub>1</sub>-esterase inhibitor and antithrombin III may be added. No antimicrobial preservative is added. The solution is distributed into the final containers and immediately frozen. It is subsequently freeze-dried and the containers are closed under vacuum or under nitrogen.

#### CHARACTERS

A white or almost white powder or friable solid.

*Reconstitute the preparation to be examined as stated on the label immediately before carrying out the identification, tests (except those for solubility and water) and assay.*

#### IDENTIFICATION

The assay serves also to identify the preparation.

#### TESTS

**Solubility.** To a container of the preparation to be examined, add the volume of liquid stated on the label at room temperature. The preparation dissolves completely with gentle swirling within 10 min.

**pH (2.2.3):** 6.8 to 7.4.

**Osmolality (2.2.35):** minimum 240 mosmol/kg.

**Total protein.** If necessary, dilute an accurately measured volume of the preparation to be examined with a 9 g/L solution of *sodium chloride R* to obtain a solution expected to contain about 15 mg of protein in 2 mL. To 2.0 mL of the solution in a round-bottomed centrifuge tube add 2 mL of a 75 g/L solution of *sodium molybdate R* and 2 mL of a mixture of 1 volume of *nitrogen-free sulfuric acid R* and 30 volumes of *water R*. Shake, centrifuge for 5 min, decant the supernatant and allow the inverted tube to drain on filter paper. Determine the nitrogen in the residue by the method of sulfuric acid digestion (2.5.9) and calculate the amount of protein by multiplying the result by 6.25.

**Activated coagulation factors (2.6.22).** For each of the dilutions, the coagulation time is not less than 150 s.

**Heparin (2.7.12).** If heparin has been added, the preparation to be examined contains not more than the amount of heparin stated on the label and in all cases not more than 0.5 IU of heparin per unit of factor XI.

**Antithrombin III (2.7.17).** If antithrombin III has been added, the preparation to be examined contains not more than the amount of antithrombin III stated on the label.

**C<sub>1</sub>-esterase inhibitor.** If C<sub>1</sub>-esterase inhibitor has been added, the preparation to be examined contains not more than the amount of C<sub>1</sub>-esterase inhibitor stated on the label.

The C<sub>1</sub>-esterase inhibitor content of the preparation to be examined is determined by comparing its ability to inhibit C<sub>1</sub>-esterase with the same ability of a reference preparation consisting of human normal plasma. 1 unit of C<sub>1</sub>-esterase is equal to the activity of 1 mL of human normal plasma. Varying quantities of the preparation to be examined are mixed with an excess of C<sub>1</sub>-esterase and the remaining C<sub>1</sub>-esterase activity is determined using a suitable chromogenic substrate.

**Method.** Reconstitute the preparation as stated on the label. Prepare an appropriate series of 3 or 4 independent dilutions from 1 unit/mL of factor XI, for both the preparation to be examined and the reference preparation, using a solution containing 9 g/L of *sodium chloride R* and either 10 g/L of *human albumin R* or 10 g/L of *bovine albumin R*. Warm all solutions to 37 °C in a water-bath for 1-2 min before use. Place a suitable amount of C<sub>1</sub>-esterase solution in tubes or in microtitre plate wells and incubate at 37 °C. Add a suitable amount of one of the dilutions of the reference preparation or of the preparation to be examined and incubate at 37 °C for 5 min. Add a suitable amount of a suitable chromogenic substrate such as methoxycarbonyl-L-lysyl(ε-benzyloxycarbonyl)-glycyl-L-arginine 4-nitroanilide. Read the rate of increase of absorbance (ΔA/min) at 405 nm. Carry out a blank test using *tris(hydroxymethyl)aminomethane sodium chloride buffer solution pH 7.4 R* instead of the C<sub>1</sub>-esterase and the substrate.

Calculate the C<sub>1</sub>-esterase inhibitor content using the usual statistical methods (for example, 5.3).

**Anti-A and anti-B haemagglutinins (2.6.20).** The 1 to 64 dilutions do not show agglutination.

**Water.** Determined by a suitable method, such as the semi-micro determination of water (2.5.12), loss on drying (2.2.32) or near-infrared spectrophotometry (2.2.40), the water content is within the limits approved by the competent authority.

**Sterility (2.6.1).** The reconstituted preparation complies with the test.

**Pyrogens (2.6.8) or Bacterial endotoxins (2.6.14).** It complies with the test for pyrogens or, preferably and where justified and authorised, with a validated *in vitro* test such as the bacterial endotoxin test.

For the pyrogen test, inject per kilogram of the rabbit's mass a volume equivalent to 100 IU of factor XI.

Where the bacterial endotoxin test is used, the preparation to be examined contains less than 0.1 IU of endotoxin per International Unit of factor XI.

#### ASSAY

Carry out the assay of human coagulation factor XI (2.7.22).

The estimated potency is not less than 80 per cent and not more than 120 per cent of the stated potency. The confidence limits ( $P = 0.95$ ) are not less than 80 per cent and not more than 125 per cent of the estimated potency.

#### STORAGE

Protected from light, at a temperature of 2 °C to 8 °C.

#### LABELLING

The label states:

- the number of units per container;
- the maximum amount of protein per container;
- where applicable, the amount of heparin per container;
- where applicable, the amount of antithrombin III per container;
- where applicable, the amount of C<sub>1</sub>-esterase inhibitor per container;
- the name and volume of the liquid to be used for reconstitution.

method such as that described under Total protein in *Human albumin solution (0255)*. If a protein stabiliser (for example, human albumin) is added to the preparation, the requirement for specific activity applies to the fibrinogen before addition of the stabiliser. Albumin may also be obtained with fibrinogen during fractionation, in which case a specific determination of albumin is carried out by a suitable immunochemical method (2.7.1) and the quantity of albumin determined is subtracted from the total protein content for the calculation of the specific activity.

#### CHARACTERS

A white or pale yellow, hygroscopic powder or friable solid.

#### IDENTIFICATION

It complies with the limits of the assay.

#### TESTS

**Solubility.** Add the volume of solvent stated on the label to the contents of one container. The preparation dissolves within 30 min at 20-25 °C, forming an almost colourless, slightly opalescent solution.

**pH (2.2.3):** 6.5 to 7.5.

**Osmolality (2.2.35):** minimum 240 mosmol/kg.

**Stability of solution.** Allow the reconstituted solution to stand at 20-25 °C. No gel formation appears within 60 min of reconstitution.

**Water.** Determined by a suitable method, such as the semi-micro determination of water (2.5.12), loss on drying (2.2.32) or near-infrared spectrophotometry (2.2.40), the water content is within the limits approved by the competent authority.

**Sterility (2.6.1).** The reconstituted preparation complies with the test.

**Pyrogens (2.6.8) or Bacterial endotoxins (2.6.14).** It complies with the test for pyrogens or, preferably and where justified and authorised, with a validated *in vitro* test such as the bacterial endotoxin test.

For the pyrogen test, inject per kilogram of the rabbit's mass a volume equivalent to not less than 30 mg of fibrinogen.

Where the bacterial endotoxin test is used, the preparation to be examined contains less than 0.03 IU of endotoxin per milligram of fibrinogen.

#### ASSAY

Mix 0.2 mL of the reconstituted preparation with 2 mL of a suitable buffer solution (pH 6.6-6.8) containing sufficient thrombin (approximately 3 IU/mL) and calcium (0.05 mol/L). Maintain at 37 °C for 20 min, separate the precipitate by centrifugation (5000 g, 20 min) and wash thoroughly with a 9 g/L solution of *sodium chloride R*. Determine the nitrogen content by sulfuric acid digestion (2.5.9) and calculate the fibrinogen (clottable protein) content by multiplying the result by 6.0. The content is not less than 70 per cent and not more than 130 per cent of the amount of fibrinogen stated on the label.

#### STORAGE

In an airtight container, protected from light.

#### LABELLING

The label states:

- the amount of fibrinogen in the container;
- the name and volume of the solvent to be used to reconstitute the preparation;
- where applicable, the name and quantity of protein stabiliser in the preparation.

01/2011:0024

## HUMAN FIBRINOGEN

### Fibrinogenum humanum

#### DEFINITION

Human fibrinogen contains the soluble constituent of human plasma that is transformed to fibrin on the addition of thrombin. It is obtained from *Human plasma for fractionation (0853)*. The preparation may contain excipients such as salts, buffers and stabilisers.

When dissolved in the volume of the solvent stated on the label, the solution contains not less than 10 g/L of fibrinogen.

#### PRODUCTION

The method of preparation includes a step or steps that have been shown to remove or to inactivate known agents of infection; if substances are used for inactivation of viruses during production, the subsequent purification procedure must be validated to demonstrate that the concentration of these substances is reduced to a suitable level and any residues are such as not to compromise the safety of the preparation for patients.

No antibiotic is added to the plasma used and no antimicrobial preservative is included in the preparation. The preparation is freeze-dried.

The method of preparation is such as to obtain fibrinogen with a specific activity (fibrinogen content with respect to total protein content) not less than 80 per cent. The fibrinogen content is determined by a suitable method such as that described under Assay, and the total protein content is determined by a suitable

01/2008:2323  
corrected 6.3

## HUMAN HAEMATOPOIETIC STEM CELLS

### Cellulae stirpes haematopoieticae humanae

*This monograph provides a standard for the preparation and control of human haematopoietic stem cells for use in therapy. It does not exclude the use of alternative preparation and control methods that are acceptable to the competent authority.*

#### DEFINITION

Human haematopoietic stem cells are primitive multipotent cells capable of self-renewal as well as differentiation and maturation into all haematopoietic lineages. They are found in small numbers in bone marrow, in the mononuclear cell fraction of circulating blood and in umbilical cord blood. The preparation also contains haematopoietic progenitor cells, which are capable of differentiation but not self-renewal. The numbers of haematopoietic stem cells and haematopoietic progenitor cells are correlated.

This monograph applies to haematopoietic stem cells that have not undergone expansion or genetic modification, and that are intended to provide a successful engraftment leading to a permanent restoration of all lineages of blood cell production to a sufficient level and function in a recipient whose haematopoiesis has been compromised by, for example, disease or high doses of chemotherapy and/or radiation therapy, or has to be replaced in certain congenital diseases. The infused haematopoietic stem cells can originate from the recipient (autologous) or from another individual (allogeneic).

Haematopoietic stem cells are recognised by their ability to reconstitute human haematopoiesis *in vivo*. They also have the capacity to differentiate into colony-forming cells, which are able to give rise to colonies in the presence of various growth factors. The membrane marker CD34 is commonly used for the successful isolation/purification of haematopoietic stem cells from crude preparations and as an indicator of haematopoietic stem cell content in routine quality control.

#### PRODUCTION

##### DONORS

Where allogeneic cells are used, they are derived from carefully selected donors in accordance with donor selection criteria. Directive 2004/23/EC of the European Union deals with the criteria for donor selection.

##### COLLECTION

**Peripheral blood stem cells.** These are collected by cytapheresis after mobilisation from the bone marrow by administration of growth factors and/or treatment of autologous donors with cytotoxic substances. The cells may be processed to select a population of interest and may be cryopreserved.

**Bone marrow.** Bone marrow is harvested by aspirating the cells from the cavities of hollow bones, then removing bone fragments by filtration and, if necessary, separating the buffy coat cells after centrifugation or with commercial kits based on the cytapheresis principle. The cells may be processed to select a population of interest and may be cryopreserved.

**Umbilical cord blood.** Placental blood haematopoietic cells are collected from placentae via the vein of the umbilical cord. The cells are then cryopreserved.

##### CRYOPRESERVATION

Cryopreservation allows storage for long periods. The cells are suspended in a validated medium containing a suitable cryoprotectant (for example, dimethyl sulfoxide) and macromolecules (for example, autologous plasma/albumin) and are frozen in cryobags in a manner designed to maintain viability of the cells by controlled cooling according to a

validated method. They are stored at a temperature of  $-140\text{ }^{\circ}\text{C}$  or lower. Where cryobags are stored under other conditions of temperature and duration, the functionality of the preparation must be validated. Cryobags from donors that test positive for any infectious disease marker must be stored in such a way as to avoid cross-contamination.

#### SUBSTANCES USED IN PRODUCTION

The quality of substances used in production may be critical with respect to the quality, safety and efficacy of the final product, particularly for substances of biological origin. This is of particular importance for:

- proteins, including enzymes and antibodies;
- cryopreservation reagents;
- purification reagents.

**Quality assurance.** All substances must be produced within a recognised quality management system using suitable production facilities.

**Quality specifications.** A suitable quality specification must be presented for each substance, including notably:

- identity;
- potency (where applicable);
- purity;
- determination of bacterial endotoxins (2.6.14) (where applicable);
- microbiological quality (total viable count, tests for specified micro-organisms);
- sterility (2.6.1) (where applicable).

**Viral safety.** The requirements of chapter 5.1.7 apply.

**Transmissible spongiform encephalopathies.** A risk assessment of the product with respect to transmissible spongiform encephalopathies is carried out, and suitable measures are taken to minimise any such risk (5.2.8).

**Water.** Water used in the preparation of cellular products complies with the relevant monograph (*Water for injections (0169)*, *Water, highly purified (1927)*, *Purified water (0008)*). Water incorporated into the final product complies with the section on Water for injections in bulk in the monograph *Water for injections (0169)*, and in addition is sterile.

#### TESTS

*Target specifications are established for the different tests, but these are not used as rigid acceptance criteria.*

Tests carried out include the following (further tests, such as purging, cell depletion, allogeneic application, may be necessary depending on any treatment applied to the cells and on the intended recipient):

**Nucleated cell count (2.7.29).**

**Viability (2.7.29).** Viability is assessed for products that are not infused within 24 h of collection.

**CD34+ cell count.** For peripheral blood stem cells, CD34+ cell count is determined using a validated automated apparatus to analyse cells labelled with anti-CD34 antibodies. The apparatus and method employed must be able to determine the number of CD34+ cells with a sensitivity, accuracy and reproducibility comparable with those of immunophenotyping (2.7.23), where cells are labelled using anti-CD34 and anti-CD45 antibodies conjugated to a fluorochrome and analysed by flow cytometry (2.7.24).

**Colony-forming cell (CFC) assay (2.7.28).** Proliferative capacity is established by a suitable assay. The test is not necessarily carried out on each unit. The correlation between the dose of CD34 and the number of CFCs in a given situation (pathology, packaging, mobilisation) is determined. The CFC assay is carried out periodically; whenever a change that could affect the quality of CD34+ cells is made to the protocol for packaging or mobilisation, it is carried out on a suitable number of units.



**Microbiological control.** Examine as prescribed in general method 2.6.27. *Microbiological control of cellular products.* Where justified, the product may be released before completion of the test.

01/2008:0769

## HUMAN HEPATITIS A IMMUNOGLOBULIN

### Immunoglobulinum humanum hepatitis A

#### DEFINITION

Human hepatitis A immunoglobulin is a liquid or freeze-dried preparation containing immunoglobulins, mainly immunoglobulin G. The preparation is intended for intramuscular administration. It is obtained from plasma from selected donors having antibodies against hepatitis A virus. *Human normal immunoglobulin (0338)* may be added.

It complies with the monograph on *Human normal immunoglobulin (0338)*, except for the minimum number of donors and the minimum total protein content.

#### POTENCY

The potency is determined by comparing the antibody titre of the immunoglobulin to be examined with that of a reference preparation calibrated in International Units, using an immunoassay of suitable sensitivity and specificity (2.7.1).

The International Unit is the activity contained in a stated amount of the International Standard for anti-hepatitis A immunoglobulin. The equivalence in International Units of the International Standard is stated by the World Health Organisation.

*Human hepatitis A immunoglobulin BRP* is calibrated in International Units by comparison with the International Standard.

The stated potency is not less than 600 IU/mL. The estimated potency is not less than the stated potency. The confidence limits ( $P = 0.95$ ) of the estimated potency are not less than 80 per cent and not more than 125 per cent.

#### STORAGE

See *Human normal immunoglobulin (0338)*.

#### LABELLING

See *Human normal immunoglobulin (0338)*.

The label states the number of International Units per container.

01/2008:0722

## HUMAN HEPATITIS B IMMUNOGLOBULIN

### Immunoglobulinum humanum hepatitis B

#### DEFINITION

Human hepatitis B immunoglobulin is a liquid or freeze-dried preparation containing immunoglobulins, mainly immunoglobulin G. The preparation is intended for intramuscular administration. It is obtained from plasma from selected and/or immunised donors having antibodies against hepatitis B surface antigen. *Human normal immunoglobulin (0338)* may be added.

It complies with the monograph on *Human normal immunoglobulin (0338)*, except for the minimum number of donors and the minimum total protein content.

#### POTENCY

The potency is determined by comparing the antibody titre of the immunoglobulin to be examined with that of a reference preparation calibrated in International Units, using an immunoassay of suitable sensitivity and specificity (2.7.1).

The International Unit is the activity contained in a stated amount of the International Reference Preparation of hepatitis B immunoglobulin. The equivalence in International Units of the International Reference Preparation is stated by the World Health Organisation.

The stated potency is not less than 100 IU/mL. The estimated potency is not less than the stated potency. The confidence limits ( $P = 0.95$ ) of the estimated potency are not less than 80 per cent and not more than 125 per cent.

#### STORAGE

See *Human normal immunoglobulin (0338)*.

#### LABELLING

See *Human normal immunoglobulin (0338)*.

The label states the number of International Units per container.

01/2008:1016

## HUMAN HEPATITIS B IMMUNOGLOBULIN FOR INTRAVENOUS ADMINISTRATION

### Immunoglobulinum humanum hepatitis B ad usum intravenosum

#### DEFINITION

Human hepatitis B immunoglobulin for intravenous administration is a liquid or freeze-dried preparation containing immunoglobulins, mainly immunoglobulin G. It is obtained from plasma from selected and/or immunised donors having antibodies against hepatitis B surface antigen. *Human normal immunoglobulin for intravenous administration (0918)* may be added.

It complies with the monograph on *Human normal immunoglobulin for intravenous administration (0918)*, except for the minimum number of donors, the minimum total protein content and the limit for osmolality.

#### POTENCY

The potency is determined by comparing the antibody titre of the immunoglobulin to be examined with that of a reference preparation calibrated in International Units, using an immunoassay (2.7.1) of suitable sensitivity and specificity.

The International Unit is the activity contained in a stated amount of the International Reference Preparation of hepatitis B immunoglobulin. The equivalence in International Units of the International Reference Preparation is stated by the World Health Organisation.

The stated potency is not less than 50 IU/mL. The estimated potency is not less than the stated potency. The confidence limits ( $P = 0.95$ ) are not less than 80 per cent and not more than 120 per cent of the estimated potency.

#### STORAGE

See *Human normal immunoglobulin for intravenous administration (0918)*.

#### LABELLING

See *Human normal immunoglobulin for intravenous administration (0918)*.

The label states the minimum number of International Units of hepatitis B immunoglobulin per container.

**01/2008:0397** Human normal immunoglobulin is obtained from plasma that complies with the requirements of the monograph *Human plasma for fractionation (0853)*. No antibiotic is added to the plasma used.

## HUMAN MEASLES IMMUNOGLOBULIN

### Immunoglobulinum humanum morbillicum

#### DEFINITION

Human measles immunoglobulin is a liquid or freeze-dried preparation containing immunoglobulins, mainly immunoglobulin G. The preparation is intended for intramuscular administration. It is obtained from plasma containing specific antibodies against the measles virus. *Human normal immunoglobulin (0338)* may be added.

It complies with the monograph on *Human normal immunoglobulin (0338)*, except for the minimum number of donors and the minimum total protein content.

#### POTENCY

The potency of the liquid preparation and of the freeze-dried preparation after reconstitution as stated on the label is not less than 50 IU per millilitre of neutralising antibody against measles virus.

The potency is determined by comparing the antibody titres of the immunoglobulin to be examined and of a reference preparation calibrated in International Units, using a challenge dose of measles virus in a suitable cell culture system. A method of equal sensitivity and precision may be used providing that the competent authority is satisfied that it correlates with neutralising activity for the measles virus by comparison with the reference preparation.

The International Unit is the specific neutralising activity for measles virus contained in a stated amount of the International Standard for human anti-measles serum. The equivalence in International Units of the International Reference Preparation is stated by the World Health Organisation.

Prepare serial two-fold dilutions of the immunoglobulin to be examined and of the reference preparation. Mix each dilution with an equal volume of a suspension of measles virus containing about 100 CCID<sub>50</sub> in 0.1 mL and incubate protected from light at 37 °C for 2 h. Using not fewer than six cell cultures per mixture, inoculate 0.2 mL of each mixture into each of the cell cultures allocated to that mixture and incubate for not less than 10 days. Examine the cultures for viral activity and compare the dilution containing the smallest quantity of the immunoglobulin which neutralises the virus with that of the corresponding dilution of the reference preparation.

Calculate the potency of the immunoglobulin to be examined in International Units per millilitre of neutralising antibody against measles virus.

#### STORAGE

See *Human normal immunoglobulin (0338)*.

#### LABELLING

See *Human normal immunoglobulin (0338)*.

The label states the number of International Units per container.

**01/2011:0338**

## HUMAN NORMAL IMMUNOGLOBULIN

### Immunoglobulinum humanum normale

#### DEFINITION

Human normal immunoglobulin is a liquid or freeze-dried preparation containing immunoglobulins, mainly immunoglobulin G (IgG). Other proteins may be present. Human normal immunoglobulin contains the IgG antibodies of normal subjects. It is intended for intramuscular or subcutaneous administration.

#### PRODUCTION

The method of preparation includes a step or steps that have been shown to remove or to inactivate known agents of infection; if substances are used for inactivation of viruses, it shall have been shown that any residues present in the final product have no adverse effects on the patients treated with the immunoglobulin.

The product shall have been shown, by suitable tests in animals and evaluation during clinical trials, to be well tolerated when administered intramuscularly or subcutaneously.

Human normal immunoglobulin is prepared from pooled material from at least 1000 donors by a method that has been shown to yield a product that:

- does not transmit infection;
- at a protein concentration of 160 g/L, contains antibodies for at least 2 of which (1 viral and 1 bacterial) an International Standard or Reference Preparation is available, the concentration of such antibodies being at least 10 times that in the initial pooled material.

If the human normal immunoglobulin is intended for subcutaneous administration, the production method shall have been shown to consistently yield products that comply with the test for Fc function of immunoglobulin (2.7.9).

Human normal immunoglobulin is prepared as a stabilised solution, for example in a 9 g/L solution of sodium chloride, a 22.5 g/L solution of glycine or, if the preparation is to be freeze-dried, a 60 g/L solution of glycine. Multidose preparations contain an antimicrobial preservative. Single-dose preparations do not contain an antimicrobial preservative. Any antimicrobial preservative or stabilising agent used shall have been shown to have no deleterious effect on the final product in the amount present. The solution is passed through a bacteria-retentive filter. The preparation may subsequently be freeze-dried and the containers closed under vacuum or under an inert gas.

The stability of the preparation is demonstrated by suitable tests carried out during development studies.

#### CHARACTERS

The liquid preparation is clear and pale-yellow or light-brown; during storage it may show formation of slight turbidity or a small amount of particulate matter. The freeze-dried preparation is a hygroscopic, white or slightly yellow powder or solid, friable mass.

*For the freeze-dried preparation, reconstitute as stated on the label immediately before carrying out the identification and the tests, except those for solubility and water.*

#### IDENTIFICATION

Examine by a suitable immunoelectrophoresis technique. Using antiserum to normal human serum, compare normal human serum and the preparation to be examined, both diluted to a protein concentration of 10 g/L. The main component of the preparation to be examined corresponds to the IgG component of normal human serum. The solution may show the presence of small quantities of other plasma proteins.

#### TESTS

**Solubility.** For the freeze-dried preparation, add the volume of the liquid stated on the label. The preparation dissolves completely within 20 min at 20-25 °C.

**pH (2.2.3):** 5.0 to 7.2.

Dilute the preparation to be examined with a 9 g/L solution of *sodium chloride R* to a protein concentration of 10 g/L.

**Total protein.** Dilute the preparation to be examined with a 9 g/L solution of *sodium chloride R* to obtain a solution containing about 15 mg of protein in 2 mL. To 2.0 mL of this solution in a round-bottomed centrifuge tube add 2 mL of a 75 g/L solution of *sodium molybdate R* and 2 mL of a mixture of 1 volume of *nitrogen-free sulfuric acid R* and 30 volumes of *water R*. Shake, centrifuge for 5 min, decant the supernatant liquid and allow the inverted tube to drain on filter paper. Determine the nitrogen in the residue by the method of sulfuric acid digestion (2.5.9) and calculate the content of protein by multiplying the result by 6.25. The preparation has a protein concentration of not less than 100 g/L and not more than 180 g/L and contains not less than 90 per cent and not more than 110 per cent of the quantity of protein stated on the label.

**Protein composition.** Examine by zone electrophoresis (2.2.31).

Use strips of suitable cellulose acetate gel or suitable agarose gel as the supporting medium and *barbital buffer solution pH 8.6 R1* as the electrolyte solution.

If cellulose acetate is the supporting material, the method described below can be used. If agarose gels are used, and because they are normally part of an automated system, the manufacturer's instructions are followed instead.

**Test solution.** Dilute the preparation to be examined with a 9 g/L solution of *sodium chloride R* to a protein concentration of 50 g/L.

**Reference solution.** Reconstitute *human immunoglobulin for electrophoresis BRP* and dilute with a 9 g/L solution of *sodium chloride R* to a protein concentration of 50 g/L.

To a strip apply 2.5 µL of the test solution as a 10 mm band or apply 0.25 µL per millimetre if a narrower strip is used. To another strip apply in the same manner the same volume of the reference solution. Apply a suitable electric field such that the albumin band of normal human serum applied on a control strip migrates at least 30 mm. Stain the strip with *amido black 10B solution R* for 5 min. Decolourise with a mixture of 10 volumes of *glacial acetic acid R* and 90 volumes of *methanol R* so that the background is just free of colour. Develop the transparency of the strips with a mixture of 19 volumes of *glacial acetic acid R* and 81 volumes of *methanol R*. Measure the absorbance of the bands at 600 nm in an instrument having a linear response over the range of measurement. Calculate the result as the mean of 3 measurements of each strip.

**System suitability:** in the electropherogram obtained with the reference solution on cellulose acetate or on agarose gels, the proportion of protein in the principal band is within the limits stated in the leaflet accompanying the reference preparation.

**Results:** in the electropherogram obtained with the test solution on cellulose acetate or on agarose gels, not more than 10 per cent of protein has a mobility different from that of the principal band.

**Distribution of molecular size.** Liquid chromatography (2.2.29).

**Test solution.** Dilute the preparation to be examined with a 9 g/L solution of *sodium chloride R* to a concentration suitable for the chromatographic system used. A concentration in the range of 4-12 g/L and injection of 50-600 µg of protein are usually suitable.

**Reference solution.** Dilute *human immunoglobulin (molecular size) BRP* with a 9 g/L solution of *sodium chloride R* to the same protein concentration as the test solution.

**Column:**

- size:  $l = 0.6$  m,  $\emptyset = 7.5$  mm [or  $l = 0.3$  m,  $\emptyset = 7.8$  mm];
- stationary phase: *hydrophilic silica gel for chromatography R*, of a grade suitable for fractionation of globular proteins with relative molecular masses in the range 10 000 to 500 000.

**Mobile phase:** dissolve 4.873 g of *disodium hydrogen phosphate dihydrate R*, 1.741 g of *sodium dihydrogen phosphate monohydrate R*, 11.688 g of *sodium chloride R* and 50 mg of *sodium azide R* in 1 litre of *water R*.

**Flow rate:** 0.5 mL/min.

**Detection:** spectrophotometer at 280 nm.

In the chromatogram obtained with the reference solution, the principal peak corresponds to the IgG monomer and there is a peak corresponding to the dimer with a relative retention to the principal peak of about 0.85. Identify the peaks in the chromatogram obtained with the test solution by comparison with the chromatogram obtained with the reference solution; any peak with a retention time shorter than that of the dimer corresponds to polymers and aggregates. The preparation to be examined complies with the test if, in the chromatogram obtained with the test solution:

- **retention time:** for the monomer and for the dimer, the retention time relative to the corresponding peak in the chromatogram obtained with the reference solution is  $1 \pm 0.02$ ;
- **peak area:** the sum of the peak areas of the monomer and the dimer represent not less than 85 per cent of the total area of the chromatogram and the sum of the peak areas of polymers and aggregates represents not more than 10 per cent of the total area of the chromatogram.

**Anti-A and anti-B haemagglutinins (2.6.20).** If human normal immunoglobulin is intended for subcutaneous administration, carry out the tests for anti-A and anti-B haemagglutinins. Dilute the preparation to be examined to an immunoglobulin concentration of 30 g/L before preparing the dilutions to be used in the test. The 64-fold dilutions do not show agglutination.

**Anti-D antibodies (2.6.26).** If human normal immunoglobulin is intended for subcutaneous administration, it complies with the test for anti-D antibodies in human immunoglobulin for intravenous administration.

**Antibody to hepatitis B surface antigen.** Not less than 0.5 IU/g of immunoglobulin, determined by a suitable immunochemical method (2.7.1).

**Antibody to hepatitis A virus.** If intended for use in the prophylaxis of hepatitis A, it complies with the following additional requirement. Determine the antibody content by comparison with a reference preparation calibrated in International Units, using an immunoassay of suitable sensitivity and specificity (2.7.1).

The International Unit is the activity contained in a stated amount of the International Standard for anti-hepatitis A immunoglobulin. The equivalence in International Units of the International Standard is stated by the World Health Organisation.

*Human hepatitis A immunoglobulin BRP* is calibrated in International Units by comparison with the International Standard.

The stated potency is not less than 100 IU/mL. The estimated potency is not less than the stated potency. The confidence limits ( $P = 0.95$ ) of the estimated potency are not less than 80 per cent and not more than 125 per cent.

**Immunoglobulin A.** As determined by a suitable immunochemical method (2.7.1), the content of immunoglobulin A is not greater than the maximum content stated on the label.

**Water.** Determined by a suitable method, such as the semi-micro determination of water (2.5.12), loss on drying (2.2.32) or near infrared spectrophotometry (2.2.40), the water content is within the limits approved by the competent authority.

**Sterility (2.6.1).** It complies with the test.

**Pyrogens (2.6.8) or Bacterial endotoxins (2.6.14).** It complies with the test for pyrogens or, preferably and where justified and authorised, with a validated *in vitro* test such as the bacterial endotoxin test.

For the pyrogen test, inject 1 mL per kilogram of the rabbit's mass.

Where the bacterial endotoxin test is used, the product contains less than 5 IU of endotoxin per millilitre.

#### STORAGE

For the liquid preparation, in a colourless glass container, protected from light. For the freeze-dried preparation, in an airtight colourless glass container, protected from light.

#### LABELLING

The label states:

- for liquid preparations, the volume of the preparation in the container and the protein content expressed in grams per litre;
- for freeze-dried preparations, the quantity of protein in the container;
- the route of administration;
- for freeze-dried preparations, the name or composition and the volume of the reconstituting liquid to be added;
- where applicable, that the preparation is suitable for use in the prophylaxis of hepatitis A infection;
- where applicable, the anti-hepatitis A virus activity in International Units per millilitre;
- where applicable, the name and amount of antimicrobial preservative in the preparation;
- the maximum content of immunoglobulin A.

01/2010:0918  
corrected 6.7

## HUMAN NORMAL IMMUNOGLOBULIN FOR INTRAVENOUS ADMINISTRATION

### Immunoglobulinum humanum normale ad usum intravenosum

#### DEFINITION

Human normal immunoglobulin for intravenous administration is a liquid or freeze-dried preparation containing immunoglobulins, mainly immunoglobulin G (IgG). Other proteins may be present. Human normal immunoglobulin for intravenous administration contains the IgG antibodies of normal subjects. This monograph does not apply to products intentionally prepared to contain fragments or chemically modified IgG.

Human normal immunoglobulin for intravenous administration is obtained from plasma that complies with the requirements of the monograph *Human plasma for fractionation (0853)*. No antibiotic is added to the plasma used.

#### PRODUCTION

The method of preparation includes a step or steps that have been shown to remove or to inactivate known agents of infection; if substances are used for inactivation of viruses, it shall have been shown that any residues present in the final product have no adverse effects on the patients treated with the immunoglobulin.

The product shall have been shown, by suitable tests in animals and evaluation during clinical trials, to be well tolerated when administered intravenously.

Human normal immunoglobulin for intravenous administration is prepared from pooled material from not fewer than 1000 donors by a method that has been shown to yield a product that:

- does not transmit infection;
- at an immunoglobulin concentration of 50 g/L, contains antibodies for at least 2 of which (1 viral and 1 bacterial) an International Standard or Reference Preparation is available, the concentration of such antibodies being at least 3 times that in the initial pooled material;
- has a defined distribution of immunoglobulin G subclasses;
- complies with the test for Fc function of immunoglobulin (2.7.9).

Human normal immunoglobulin for intravenous administration is prepared as a stabilised solution or as a freeze-dried preparation. A stabiliser may be added. In both cases the preparation is passed through a bacteria-retentive filter. The preparation may subsequently be freeze-dried and the containers closed under vacuum or under an inert gas. No antimicrobial preservative is added either during fractionation or at the stage of the final bulk solution.

The stability of the preparation is demonstrated by suitable tests carried out during development studies.

#### CHARACTERS

The liquid preparation is clear or slightly opalescent and colourless or pale yellow. The freeze-dried preparation is a hygroscopic, white or slightly yellow powder or solid friable mass.

*For the freeze-dried preparation, reconstitute as stated on the label immediately before carrying out the identification and the tests, except those for solubility and water.*

#### IDENTIFICATION

Examine by a suitable immunoelectrophoresis technique. Using antiserum to normal human serum, compare normal human serum and the preparation to be examined, both diluted to contain 10 g/L of protein. The main component of the preparation to be examined corresponds to the IgG component of normal human serum. The preparation to be examined may show the presence of small quantities of other plasma proteins; if human albumin has been added as a stabiliser, it may be seen as a major component.

#### TESTS

**Solubility.** For the freeze-dried preparation, add the volume of the liquid stated on the label. The preparation dissolves completely within 30 min at 20-25 °C.

**pH (2.2.3):** 4.0 to 7.4.

Dilute the preparation to be examined with a 9 g/L solution of *sodium chloride R* to obtain a solution containing 10 g/L of protein.

**Osmolality (2.2.35):** minimum 240 mosmol/kg.

**Total protein:** minimum 30 g/L and between 90 per cent and 110 per cent of the quantity of protein stated on the label.

Dilute the preparation to be examined with a 9 g/L solution of *sodium chloride R* to obtain a solution containing about 15 mg of protein in 2 mL. To 2.0 mL of this solution in a round-bottomed centrifuge tube add 2 mL of a 75 g/L solution of *sodium molybdate R* and 2 mL of a mixture of 1 volume of *nitrogen-free sulfuric acid R* and 30 volumes of *water R*. Shake, centrifuge for 5 min, decant the supernatant liquid and allow the inverted tube to drain on filter paper. Determine the nitrogen in the centrifugation residue by the method of sulfuric acid digestion (2.5.9) and calculate the content of protein by multiplying the result by 6.25.

**Protein composition.** Zone electrophoresis (2.2.31).

Use strips of suitable cellulose acetate gel or suitable agarose gel as the supporting medium and *barbital buffer solution pH 8.6 R1* as the electrolyte solution.

If cellulose acetate is the supporting material, the method described below can be used. If agarose gels are used, and because they are normally part of an automated system, the manufacturer's instructions are followed instead.

**Test solution.** Dilute the preparation to be examined with a 9 g/L solution of *sodium chloride R* to an immunoglobulin concentration of 30 g/L.

**Reference solution.** Reconstitute *human immunoglobulin for electrophoresis BRP* and dilute with a 9 g/L solution of *sodium chloride R* to a protein concentration of 30 g/L.

To a strip apply 4.0 µL of the test solution as a 10 mm band or apply 0.4 µL per millimetre if a narrower strip is used. To another strip apply in the same manner the same volume of the reference solution. Apply a suitable electric field such that the albumin band of normal human serum applied on a control strip migrates at least 30 mm. Stain the strips with *amido black 10B solution R* for 5 min. Decolourise with a mixture of 10 volumes of *glacial acetic acid R* and 90 volumes of *methanol R* so that the background is just free of colour. Develop the transparency of the strips with a mixture of 19 volumes of *glacial acetic acid R* and 81 volumes of *methanol R*. Measure the absorbance of the bands at 600 nm in an instrument having a linear response over the range of measurement. Calculate the result as the mean of 3 measurements of each strip.

**System suitability:** in the electropherogram obtained with the reference solution on cellulose acetate or on agarose gels, the proportion of protein in the principal band is within the limits stated in the leaflet accompanying the reference preparation.

**Results:** in the electropherogram obtained with the test solution on cellulose acetate or on agarose gels, not more than 5 per cent of protein has a mobility different from that of the principal band. This limit is not applicable if albumin has been added to the preparation as a stabiliser; for such preparations, a test for protein composition is carried out during manufacture before addition of the stabiliser.

**Distribution of molecular size.** Liquid chromatography (2.2.29).

**Test solution.** Dilute the preparation to be examined with a 9 g/L solution of *sodium chloride R* to a concentration suitable for the chromatographic system used. A concentration in the range of 4-12 g/L and injection of 50-600 µg of protein are usually suitable.

**Reference solution.** Dilute *human immunoglobulin (molecular size) BRP* with a 9 g/L solution of *sodium chloride R* to the same protein concentration as the test solution.

**Column:**

- size:  $l = 0.6$  m,  $\emptyset = 7.5$  mm, or  $l = 0.3$  m,  $\emptyset = 7.8$  mm;
- stationary phase: *hydrophilic silica gel for chromatography R* of a grade suitable for fractionation of globular proteins with relative molecular masses in the range 10 000 to 500 000.

**Mobile phase:** dissolve 4.873 g of *disodium hydrogen phosphate dihydrate R*, 1.741 g of *sodium dihydrogen phosphate monohydrate R*, 11.688 g of *sodium chloride R* and 50 mg of *sodium azide R* in 1 litre of *water R*.

**Flow rate:** 0.5 mL/min.

**Detection:** spectrophotometer at 280 nm.

In the chromatogram obtained with the reference solution, the principal peak corresponds to the IgG monomer and there is a peak corresponding to the dimer with a relative retention to the principal peak of about 0.85. Identify the peaks in the chromatogram obtained with the test solution by comparison with the chromatogram obtained with the reference solution; any peak with a retention time shorter than that of the dimer corresponds to polymers and aggregates.

**Results:** in the chromatogram obtained with the test solution:

- retention time: for the monomer and for the dimer, the retention time relative to the corresponding peak in the chromatogram obtained with the reference solution is  $1 \pm 0.02$ ;
- peak area: the sum of the peak areas of the monomer and the dimer represent not less than 90 per cent of the total area of the chromatogram and the sum of the peak areas

of polymers and aggregates represents not more than 3 per cent of the total area of the chromatogram. This requirement does not apply to products where albumin has been added as a stabiliser; for products stabilised with albumin, a test for distribution of molecular size is carried out during manufacture before addition of the stabiliser.

**Anticomplementary activity (2.6.17).** The consumption of complement is not greater than 50 per cent (1 CH<sub>50</sub> per milligram of immunoglobulin).

**Prekallikrein activator (2.6.15):** maximum 35 IU/mL, calculated with reference to a dilution of the preparation to be examined containing 30 g/L of immunoglobulin.

**Anti-A and anti-B haemagglutinins (2.6.20).** Carry out the tests for anti-A and anti-B haemagglutinins. If the preparation to be examined contains more than 30 g/L of immunoglobulin, dilute to this concentration before preparing the dilutions to be used in the test. The 1 to 64 dilutions do not show agglutination.

**Anti-D antibodies (2.6.26).** It complies with the test for anti-D antibodies in human immunoglobulin for intravenous administration.

**Antibody to hepatitis B surface antigen:** minimum 0.5 IU/g of immunoglobulin, determined by a suitable immunochemical method (2.7.1).

**Immunoglobulin A.** As determined by a suitable immunochemical method (2.7.1), the content of immunoglobulin A is not greater than the maximum content stated on the label.

**Water.** Determined by a suitable method, such as the semi-micro determination of water (2.5.12), loss on drying (2.2.32) or near infrared spectrophotometry (2.2.40), the water content is within the limits approved by the competent authority.

**Sterility (2.6.1).** It complies with the test for sterility.

**Pyrogens (2.6.8) or Bacterial endotoxins (2.6.14).** It complies with the test for pyrogens or, preferably and where justified and authorised, with a validated *in vitro* test such as the bacterial endotoxin test.

For the pyrogen test, inject per kilogram of the rabbit's mass a volume equivalent to 0.5 g of the preparation to be examined, but not more than 10 mL per kilogram of the rabbit's mass.

Where the bacterial endotoxin test is used, the preparation to be examined contains less than 0.5 IU of endotoxin per millilitre for solutions with a protein content not greater than 50 g/L, and less than 1.0 IU of endotoxin per millilitre for solutions with a protein content greater than 50 g/L but not greater than 100 g/L.

#### STORAGE

For the liquid preparation, store in a colourless glass container, protected from light, at the temperature stated on the label. For the freeze-dried preparation, store in an airtight colourless glass container, protected from light, at a temperature not exceeding 25 °C.

#### LABELLING

The label states:

- for liquid preparations, the volume of the preparation in the container and the protein content expressed in grams per litre;
- for freeze-dried preparations, the quantity of protein in the container;
- the amount of immunoglobulin in the container;
- the route of administration;
- for freeze-dried preparations, the name or composition and the volume of the reconstituting liquid to be added;
- the distribution of subclasses of immunoglobulin G present in the preparation;

- where applicable, the amount of albumin added as a stabiliser;
- the maximum content of immunoglobulin A.

07/2008:0853

## HUMAN PLASMA FOR FRACTIONATION

### Plasma humanum ad separationem

#### DEFINITION

Human plasma for fractionation is the liquid part of human blood remaining after separation of the cellular elements from blood collected in a receptacle containing an anticoagulant, or separated by continuous filtration or centrifugation of anticoagulated blood in an apheresis procedure; it is intended for the manufacture of plasma-derived products.

#### PRODUCTION

##### DONORS

Only a carefully selected, healthy donor who, as far as can be ascertained after medical examination, laboratory blood tests and a study of the donor's medical history, is free from detectable agents of infection transmissible by plasma-derived products may be used. Recommendations in this field are made by the Council of Europe [*Recommendation No. R (95) 15 on the preparation, use and quality assurance of blood components, or subsequent revision*]; a directive of the European Union also deals with the matter: *Commission Directive 2004/33/EC of 22 March 2004 implementing Directive 2002/98/EC of the European Parliament and of the Council as regards certain technical requirements for blood and blood components*.

**Immunisation of donors.** Immunisation of donors to obtain immunoglobulins with specific activities may be carried out when sufficient supplies of material of suitable quality cannot be obtained from naturally immunised donors. Recommendations for such immunisations are formulated by the World Health Organisation (*Requirements for the collection, processing and quality control of blood, blood components and plasma derivatives*, WHO Technical Report Series, No. 840, 1994 or subsequent revision).

**Records.** Records of donors and donations made are kept in such a way that, while maintaining the required degree of confidentiality concerning the donor's identity, the origin of each donation in a plasma pool and the results of the corresponding acceptance procedures and laboratory tests can be traced.

**Laboratory tests.** Laboratory tests are carried out for each donation to detect the following viral markers:

1. antibodies against human immunodeficiency virus 1 (anti-HIV-1);
2. antibodies against human immunodeficiency virus 2 (anti-HIV-2);
3. hepatitis B surface antigen (HBsAg);
4. antibodies against hepatitis C virus (anti-HCV).

The test methods used are of suitable sensitivity and specificity and comply with the regulations in force. If a repeat-reactive result is found in any of these tests, the donation is not accepted.

##### INDIVIDUAL PLASMA UNITS

The plasma is prepared by a method that removes cells and cell debris as completely as possible. Whether prepared from whole blood or by plasmapheresis, the plasma is separated from the cells by a method designed to prevent the introduction of

micro-organisms. No antibacterial or antifungal agent is added to the plasma. The containers comply with the requirements for glass containers (3.2.1) or for plastic containers for blood and blood components (3.2.3). The containers are closed so as to prevent any possibility of contamination.

If 2 or more units are pooled prior to freezing, the operations are carried out using sterile connecting devices or under aseptic conditions and using containers that have not previously been used.

When obtained by plasmapheresis or from whole blood (after separation from cellular elements), plasma intended for the recovery of proteins that are labile in plasma is frozen within 24 h of collection by cooling rapidly in conditions validated to ensure that a temperature of  $-25\text{ }^{\circ}\text{C}$  or below is attained at the core of each plasma unit within 12 h of placing in the freezing apparatus.

When obtained by plasmapheresis, plasma intended solely for the recovery of proteins that are not labile in plasma is frozen by cooling rapidly in a chamber at  $-20\text{ }^{\circ}\text{C}$  or below as soon as possible and at the latest within 24 h of collection.

When obtained from whole blood, plasma intended solely for the recovery of proteins that are not labile in plasma is separated from cellular elements and frozen in a chamber at  $-20\text{ }^{\circ}\text{C}$  or below as soon as possible and at the latest within 72 h of collection.

*It is not intended that the determination of total protein and factor VIII shown below be carried out on each unit of plasma. They are rather given as guidelines for good manufacturing practice, the test for factor VIII being relevant for plasma intended for use in the preparation of concentrates of labile proteins.*

*The total protein content of a unit of plasma depends on the serum protein content of the donor and the degree of dilution inherent in the donation procedure. When plasma is obtained from a suitable donor and using the intended proportion of anticoagulant solution, a total protein content complying with the limit of 50 g/L is obtained. If a volume of blood or plasma smaller than intended is collected into the anticoagulant solution, the resulting plasma is not necessarily unsuitable for pooling for fractionation. The aim of good manufacturing practice must be to achieve the prescribed limit for all normal donations.*

*Preservation of factor VIII in the donation depends on the collection procedure and the subsequent handling of the blood and plasma. With good practice, 0.7 IU/mL can usually be achieved, but units of plasma with a lower activity may still be suitable for use in the production of coagulation factor concentrates. The aim of good manufacturing practice is to conserve labile proteins as much as possible.*

**Total protein.** Carry out the test using a pool of not fewer than 10 units. Dilute the pool with a 9 g/L solution of sodium chloride R to obtain a solution containing about 15 mg of protein in 2 mL. To 2.0 mL of this solution in a round-bottomed centrifuge tube add 2 mL of a 75 g/L solution of sodium molybdate R and 2 mL of a mixture of 1 volume of nitrogen-free sulfuric acid R and 30 volumes of water R. Shake, centrifuge for 5 min, decant the supernatant liquid and allow the inverted tube to drain on filter paper. Determine the nitrogen in the residue by the method of sulfuric acid digestion (2.5.9) and calculate the protein content by multiplying the quantity of nitrogen by 6.25. The total protein content is not less than 50 g/L.

**Factor VIII.** Carry out the test using a pool of not fewer than 10 units. Thaw the samples to be examined, if necessary, at  $37\text{ }^{\circ}\text{C}$ . Carry out the assay of factor VIII (2.7.4), using a reference plasma calibrated against the International Standard for human coagulation factor VIII in plasma. The activity is not less than 0.7 IU/mL.

**STORAGE AND TRANSPORT**

Frozen plasma is stored and transported in conditions designed to maintain the temperature at or below  $-20\text{ }^{\circ}\text{C}$ ; for accidental reasons, the storage temperature may rise above  $-20\text{ }^{\circ}\text{C}$  on one or more occasions during storage and transport but the plasma is nevertheless considered suitable for fractionation if all the following conditions are fulfilled:

- the total period of time during which the temperature exceeds  $-20\text{ }^{\circ}\text{C}$  does not exceed 72 h;
- the temperature does not exceed  $-15\text{ }^{\circ}\text{C}$  on more than one occasion;
- the temperature at no time exceeds  $-5\text{ }^{\circ}\text{C}$ .

**POOLED PLASMA**

During the manufacture of plasma products, the first homogeneous pool of plasma (for example, after removal of cryoprecipitate) is tested for HBsAg and for HIV antibodies using test methods of suitable sensitivity and specificity; the pool must give negative results in these tests.

The plasma pool is also tested for hepatitis C virus RNA using a validated nucleic acid amplification technique (2.6.21). A positive control with 100 IU/mL of hepatitis C virus RNA and, to test for inhibitors, an internal control prepared by addition of a suitable marker to a sample of the plasma pool are included in the test. The test is invalid if the positive control is non-reactive or if the result obtained with the internal control indicates the presence of inhibitors. The plasma pool complies with the test if it is found non-reactive for hepatitis C virus RNA.

*Hepatitis C virus RNA for NAT testing BRP* is suitable for use as a positive control.

**CHARACTERS**

Before freezing, a clear to slightly turbid liquid without visible signs of haemolysis; it may vary in colour from light yellow to green.

**LABELLING**

The label enables each individual unit to be traced to a specific donor.

01/2011:1646

## HUMAN PLASMA (POOLED AND TREATED FOR VIRUS INACTIVATION)

### Plasma humanum coagmentatum conditumque ad exstinguendum virum

**DEFINITION**

Human plasma (pooled and treated for virus inactivation) is a frozen or freeze-dried, sterile, non-pyrogenic preparation obtained from human plasma derived from donors belonging to the same ABO blood group. The preparation is thawed or reconstituted before use to give a solution for infusion.

The human plasma used complies with the monograph *Human plasma for fractionation (0853)*.

**PRODUCTION**

The units of plasma to be used are cooled to  $-30\text{ }^{\circ}\text{C}$  or lower within 6 h of separation of cells and always within 24 h of collection.

The pool is prepared by mixing units of plasma belonging to the same ABO blood group.

The pool of plasma is tested for hepatitis B surface antigen (HBsAg) and for HIV antibodies using test methods of suitable sensitivity and specificity; the pool must give negative results in these tests.

**Hepatitis A virus RNA.** The plasma pool is tested using a validated nucleic acid amplification technique (2.6.21). A positive control with  $1.0 \times 10^2$  IU of hepatitis A virus RNA per

millilitre and, to test for inhibitors, an internal control prepared by addition of a suitable marker to a sample of the plasma pool are included in the test. The test is invalid if the positive control is non-reactive or if the result obtained with the internal control indicates the presence of inhibitors. The pool complies with the test if it is found non-reactive for hepatitis A virus RNA.

**Hepatitis C virus RNA.** The plasma pool is tested using a validated nucleic acid amplification technique (2.6.21). A positive control with  $1.0 \times 10^2$  IU of hepatitis C virus RNA per millilitre and, to test for inhibitors, an internal control prepared by addition of a suitable marker to a sample of the plasma pool are included in the test. The test is invalid if the positive control is non-reactive or if the result obtained with the internal control indicates the presence of inhibitors. The pool complies with the test if it is found non-reactive for hepatitis C virus RNA.

*Hepatitis C virus RNA for NAT testing BRP* is suitable for use as a positive control.

To limit the potential burden of B19 virus in plasma pools, the plasma pool is also tested for B19 virus using a validated nucleic acid amplification technique (2.6.21).

**B19 virus DNA.** The plasma pool contains not more than 10.0 IU/ $\mu\text{L}$ .

A positive control with 10.0 IU of B19 virus DNA per microlitre and, to test for inhibitors, an internal control prepared by addition of a suitable marker to a sample of the plasma pool are included in the test. The test is invalid if the positive control is non-reactive or if the result obtained with the internal control indicates the presence of inhibitors.

*B19 virus DNA for NAT testing BRP* is suitable for use as a positive control.

The method of preparation is designed to minimise activation of any coagulation factor (to minimise potential thrombogenicity) and includes a step or steps that have been shown to inactivate known agents of infection; if substances are used for the inactivation of viruses during production, the subsequent purification procedure must be validated to demonstrate that the concentration of these substances is reduced to a suitable level and that any residues are such as not to compromise the safety of the preparation for patients.

**Inactivation process.** The solvent-detergent process, which is one of the methods used to inactivate enveloped viruses, uses treatment with a combination of tributyl phosphate and octoxinol 10; these reagents are subsequently removed by oil extraction or by solid phase extraction so that the amount in the final product is less than  $2\text{ }\mu\text{g/mL}$  for tributyl phosphate and less than  $5\text{ }\mu\text{g/mL}$  for octoxinol 10.

No antimicrobial preservative is added.

The solution is passed through a bacteria-retentive filter, distributed aseptically into the final containers and immediately frozen; it may subsequently be freeze-dried.

Plastic containers comply with the requirements for sterile plastic containers for human blood and blood components (3.2.3).

Glass containers comply with the requirements for glass containers for pharmaceutical use (3.2.1).

**CHARACTERS**

The frozen preparation, after thawing, is a clear or slightly opalescent liquid free from solid and gelatinous particles. The freeze-dried preparation is an almost white or slightly yellow powder or friable solid.

*Thaw or reconstitute the preparation to be examined as stated on the label immediately before carrying out the identification, tests and assay.*

**IDENTIFICATION**

A. Examine by electrophoresis (2.2.31) comparing with normal human plasma. The electropherograms show the same bands.

B. It complies with the test for anti-A and anti-B haemagglutinins (see Tests).

#### TESTS

**pH** (2.2.3): 6.5 to 7.6.

**Osmolality** (2.2.35): minimum 240 mosmol/kg.

**Total protein**: minimum 45 g/L.

Dilute with a 9 g/L solution of *sodium chloride R* to obtain a solution containing about 15 mg of protein in 2 mL. Place 2.0 mL of this solution in a round-bottomed centrifuge tube and add 2 mL of a 75 g/L solution of *sodium molybdate R* and 2 mL of a mixture of 1 volume of *nitrogen-free sulfuric acid R* and 30 volumes of *water R*. Shake, centrifuge for 5 min, decant the supernatant and allow the inverted tube to drain on filter paper. Determine the nitrogen in the residue by the method of sulfuric acid digestion (2.5.9) and calculate the quantity of protein by multiplying the result by 6.25.

**Activated coagulation factors** (2.6.22). It complies with the test for activated coagulation factors. Carry out the test with 0.1 mL of the preparation to be examined instead of 10-fold and 100-fold dilutions. The coagulation time for the preparation to be examined is not less than 150 s.

**Anti-A and anti-B haemagglutinins** (2.6.20). The presence of haemagglutinins (anti-A or anti-B) corresponds to the blood group stated on the label.

**Hepatitis A virus antibodies**: minimum 1.0 IU/mL, determined by a suitable immunochemical method (2.7.1).

*Human hepatitis A immunoglobulin BRP* is suitable for use as a reference preparation.

**Irregular erythrocyte antibodies**. The preparation to be examined does not show the presence of irregular erythrocyte antibodies when examined without dilution by an indirect antiglobulin test.

**Citrate**. Liquid chromatography (2.2.29).

**Test solution**. Dilute the preparation to be examined with an equal volume of a 9 g/L solution of *sodium chloride R*. Filter the solution using a filter with 0.45 µm pores.

**Reference solution**. Dissolve 0.300 g of *sodium citrate R* in *water R* and dilute to 100.0 mL with the same solvent.

**Column**:

- size:  $l = 0.3$  m,  $\emptyset = 7.8$  mm;
- stationary phase: cation exchange resin R (9 µm).

**Mobile phase**: 0.51 g/L solution of *sulfuric acid R*.

**Flow rate**: 0.5 mL/min.

**Detection**: spectrophotometer at 215 nm.

**Equilibration**: 15 min.

**Injection**: 10 µL.

**Retention time**: citrate = about 10 min.

**Limit**:

- citrate: maximum 25 mmol/L.

**Calcium**: maximum 5.0 mmol/L.

Atomic absorption spectrometry (2.2.23, Method I).

**Source**: calcium hollow-cathode lamp using a transmission band preferably of 0.5 nm.

**Wavelength**: 622 nm.

**Atomisation device**: air-acetylene or acetylene-propane flame.

**Potassium**: maximum 5.0 mmol/L.

Atomic emission spectrometry (2.2.22, Method I).

**Wavelength**: 766.5 nm.

**Sodium**: maximum 200 mmol/L.

Atomic emission spectrometry (2.2.22, Method I).

**Wavelength**: 589 nm.

**Water**: determined by a suitable method, such as the semi-micro determination of water (2.5.12), loss on drying (2.2.32) or near-infrared spectrometry (2.2.40), the water content is within the limits approved by the competent authority (freeze-dried product).

**Sterility** (2.6.1). It complies with the test.

**Pyrogens (2.6.8) or Bacterial endotoxins (2.6.14)**. It complies with the test for pyrogens or, preferably and where justified and authorised, with a validated *in vitro* test such as the bacterial endotoxin test.

For the pyrogen test, inject 3 mL per kilogram of the rabbit's mass.

Where the bacterial endotoxin test is used, the preparation to be examined contains less than 0.1 IU of endotoxin per millilitre.

#### ASSAY

**Factor VIII**. Carry out the assay of human coagulation factor VIII (2.7.4) using a reference plasma calibrated against the International Standard for blood coagulation factor VIII in plasma.

The estimated potency is not less than 0.5 IU/mL. The confidence limits ( $P = 0.95$ ) are not less than 80 per cent and not more than 120 per cent of the estimated potency.

**Factor V**. Carry out the assay of human coagulation factor V described below using a reference plasma calibrated against the International Standard for blood coagulation factor V in plasma.

Using *imidazole buffer solution pH 7.3 R*, prepare at least 3 two-fold dilutions of the preparation to be examined, preferably in duplicate, from 1 in 10 to 1 in 40. Test each dilution as follows: mix 1 volume of *plasma substrate deficient in factor VR*, 1 volume of the dilution to be examined, 1 volume of *thromboplastin R* and 1 volume of a 3.5 g/L solution of *calcium chloride R*; measure the coagulation times, i.e. the interval between the moment at which the calcium chloride solution is added and the 1<sup>st</sup> indication of the formation of fibrin, which may be observed visually or by means of a suitable apparatus.

In the same manner, determine the coagulation time of 4 twofold dilutions (1 in 10 to 1 in 80) of human normal plasma in *imidazole buffer solution pH 7.3 R*.

Check the validity of the assay and calculate the potency of the test preparation by the usual statistical methods (for example, 5.3).

The estimated potency is not less than 0.5 IU/mL. The confidence limits ( $P = 0.95$ ) are not less than 80 per cent and not more than 120 per cent of the estimated potency.

**Factor XI**. Carry out the assay of human coagulation factor XI (2.7.22) using a reference plasma calibrated against the International Standard for blood coagulation factor XI in plasma.

The estimated potency is not less than 0.5 IU/mL. The confidence limits ( $P = 0.95$ ) are not less than 80 per cent and not more than 125 per cent of the estimated potency.

**Protein C**. Carry out the assay of human protein C (2.7.30) using a reference plasma calibrated against the International Standard for human protein C in plasma.

The estimated potency is not less than 0.7 IU/mL. The confidence limits ( $P = 0.95$ ) are not less than 80 per cent and not more than 120 per cent of the estimated potency.

**Protein S**. Carry out the assay of human protein S (2.7.31) using a reference plasma calibrated against the International Standard for human protein S in plasma.

The estimated potency is within the limits approved for the particular product. The confidence limits ( $P = 0.95$ ) are not less than 80 per cent and not more than 120 per cent of the estimated potency.



**Plasmin inhibitor ( $\alpha_2$ -antiplasmin).** Carry out the assay of human plasmin inhibitor (2.7.25) using a reference plasma calibrated against human normal plasma.

1 unit of human plasmin inhibitor is equal to the activity of 1 mL of human normal plasma. Human normal plasma is prepared by pooling plasma units from not fewer than 30 donors and storing at  $-30\text{ }^\circ\text{C}$  or lower.

The estimated potency is not less than 0.2 units/mL. The confidence limits ( $P = 0.95$ ) are not less than 80 per cent and not more than 120 per cent of the estimated potency.

#### LABELLING

The label states:

- the ABO blood group;
- the method used for virus inactivation.

07/2008:2387

## HUMAN $\alpha$ -1-PROTEINASE INHIBITOR

### $\alpha$ -1-Proteinase inhibitor humanum

#### DEFINITION

Human  $\alpha$ -1-proteinase inhibitor is a plasma protein fraction containing mainly human  $\alpha$ -1-proteinase inhibitor (also known as human  $\alpha$ -1-antitrypsin or  $\alpha$ -1-antiproteinase). Human  $\alpha$ -1-proteinase inhibitor is a glycoprotein existing in isoforms with different isoelectric points and is the most abundant multifunctional serine proteinase inhibitor in human plasma. It is obtained from human plasma that complies with the monograph *Human plasma for fractionation (0853)*, using a suitable fractionation process and further purification steps. Other plasma proteins may be present.

#### PRODUCTION

##### GENERAL PROVISIONS

The method of preparation includes steps that have been shown to remove or to inactivate known agents of infection. The subsequent purification procedure must be validated to demonstrate that the concentration of any substances used for inactivation of viruses during production is reduced to a suitable level and that any residues are such as not to compromise the safety of the preparation for patients.

The specific activity is not less than 0.35 mg of active human  $\alpha$ -1-proteinase inhibitor per milligram of total protein. Ratio of human  $\alpha$ -1 proteinase inhibitor activity to human  $\alpha$ -1-proteinase inhibitor antigen is not less than 0.7.

Buffering and other auxiliary substances such as a stabiliser may be included. No antimicrobial preservative is added. The solution is passed through a bacteria-retentive filter and distributed aseptically into the final containers. The product may be freeze-dried.

##### CONSISTENCY OF THE METHOD OF PRODUCTION

The consistency of the method of production, including demonstration that the manufacturing process yields a product with a consistent composition and maintains the functional integrity of human  $\alpha$ -1-proteinase inhibitor, is evaluated by suitable analytical procedures that are determined during process development, and which include:

- assay of human  $\alpha$ -1-proteinase inhibitor activity;
- determination of specific human  $\alpha$ -1-proteinase inhibitor activity, expressed as the ratio of active human  $\alpha$ -1-proteinase inhibitor to total protein;
- characterisation of isoform composition and protein structure by suitable methods such as isoelectric focusing (2.2.54), spectrometric methods (for example, mass spectrometry) or capillary electrophoresis (2.2.47);
- determination of the ratio of human  $\alpha$ -1-proteinase inhibitor activity to human  $\alpha$ -1-proteinase inhibitor antigen;

- characterisation of accompanying plasma proteins that might be present, by a set of suitable methods such as SDS-PAGE, cellulose acetate electrophoresis or capillary zone electrophoresis (2.2.31) and quantitative determination of relevant accompanying plasma proteins;
- determination of molecular-size distribution, used to quantify the polymeric forms of human  $\alpha$ -1-proteinase inhibitor; consideration is given to the potential presence of accompanying proteins that might affect the results.

#### CHARACTERS

*Appearance:* freeze-dried products are hygroscopic, white or pale yellow or pale brown powders or friable solids; liquid products are clear or slightly opalescent, colourless or pale yellow or pale green or pale brown.

*If the preparation to be examined is freeze-dried, reconstitute it as stated on the label immediately before carrying out the identification, tests (except those for solubility and water) and assay.*

#### IDENTIFICATION

The assay of human  $\alpha$ -1-proteinase inhibitor activity serves to identify the preparation.

#### TESTS

**pH (2.2.3):** 6.5 to 7.8.

**Solubility.** To a container of the preparation to be examined add the volume of the liquid stated on the label at room temperature. The preparation dissolves completely when reconstituted according to the instructions for use, giving a clear, colourless or pale green or pale yellow or pale brown solution.

**Osmolality (2.2.35):** minimum 210 mosmol/kg.

**Total protein.** Dilute the preparation to be examined with a 9 g/L solution of *sodium chloride R* to obtain a solution containing about 15 mg of protein in 2 mL. To 2.0 mL of this solution in a round-bottomed centrifuge tube add 2 mL of a 75 g/L solution of *sodium molybdate R* and 2 mL of a mixture of 1 volume of *nitrogen-free sulfuric acid R* and 30 volumes of *water R*. Shake, centrifuge for 5 min, decant the supernatant and allow the inverted tube to drain on filter paper. Determine the nitrogen in the residue by the method of sulfuric acid digestion (2.5.9) and calculate the protein content by multiplying by 6.25.

**Water.** Determined by a suitable method, such as the semi-micro determination of water (2.5.12), loss on drying (2.2.32) or near-infrared spectrophotometry (2.2.40), the water content is within the limits approved by the competent authority.

**Sterility (2.6.1).** It complies with the test.

**Pyrogens (2.6.8).** It complies with the test. Inject per kilogram of the rabbit's mass a volume equivalent to not less than 60 mg of human  $\alpha$ -1-proteinase inhibitor.

#### ASSAY

Carry out the assay of human  $\alpha$ -1-proteinase inhibitor (2.7.32). The estimated potency is not less than 80 per cent and not more than 120 per cent of the stated potency. The confidence limits ( $P = 0.95$ ) are not less than 80 per cent and not more than 120 per cent of the estimated potency.

#### STORAGE

Unless otherwise justified and authorised, in an airtight and sterile container, at a temperature not exceeding  $25\text{ }^\circ\text{C}$ .

#### LABELLING

The label states:

- the potency of active (functional) human  $\alpha$ -1-proteinase inhibitor per container;
- the name and quantity of any added substances;
- the quantity of protein per container;

- where applicable, the name and volume of the liquid to be used for reconstitution;
- that the transmission of infectious agents cannot be totally excluded when medicinal products prepared from human blood or plasma are administered.

01/2011:0554

## HUMAN PROTHROMBIN COMPLEX

### Prothrombinum multiplex humanum

#### DEFINITION

Human prothrombin complex is a plasma protein fraction containing blood coagulation factor IX together with variable amounts of coagulation factors II, VII and X; the presence and proportion of these additional factors depends on the method of fractionation. It is obtained from human plasma that complies with the monograph *Human plasma for fractionation (0853)*.

The potency of the preparation, reconstituted as stated on the label, is not less than 20 IU of factor IX per millilitre.

If the content of any of the factors is stated as a single value, the estimated potency is not less than 80 per cent and not more than 125 per cent of the stated potency; if the content of any of the factors is stated as a range, the estimated potency is not less than the lower limit and not greater than the upper limit of the stated range.

#### PRODUCTION

The method of preparation is designed to minimise activation of any coagulation factor (to minimise potential thrombogenicity) and includes a step or steps that have been shown to remove or to inactivate known agents of infection; if substances are used for inactivation of viruses during production, the subsequent purification procedure must be validated to demonstrate that the concentration of these substances is reduced to a suitable level and that any residues are such as not to compromise the safety of the preparation for patients.

The specific activity is not less than 0.6 IU of factor IX per milligram of total protein, before the addition of any protein stabiliser.

The prothrombin complex fraction is dissolved in a suitable liquid. Heparin, antithrombin and other auxiliary substances such as a stabiliser may be added. No antimicrobial preservative is added. The solution is passed through a bacteria-retentive filter, distributed aseptically into the final containers and immediately frozen. It is subsequently freeze-dried and the containers are closed under vacuum or under an inert gas.

#### CHARACTERS

A white or slightly coloured powder or friable solid, very hygroscopic.

*Reconstitute the preparation to be examined as stated on the label immediately before carrying out the identification, tests (except those for solubility and water) and assay.*

#### IDENTIFICATION

It complies with the limits of the assays for factor IX and for factor II and, where applicable, those for factors VII and X.

#### TESTS

**Solubility.** To a container of the preparation to be examined add the volume of the liquid stated on the label at the recommended temperature. The preparation dissolves completely with gentle swirling within 10 min, giving a clear solution that may be coloured.

**pH (2.2.3):** 6.5 to 7.5.

**Osmolality (2.2.35):** minimum 240 mosmol/kg.

**Total protein.** If necessary, dilute an accurately measured volume of the reconstituted preparation with a 9 g/L solution of *sodium chloride R* to obtain a solution expected to contain about 15 mg of protein in 2 mL. To 2.0 mL of the solution in a round-bottomed centrifuge tube add 2 mL of a 75 g/L solution of *sodium molybdate R* and 2 mL of a mixture of 1 volume of *nitrogen-free sulfuric acid R* and 30 volumes of *water R*. Shake, centrifuge for 5 min, decant the supernatant and allow the inverted tube to drain on filter paper. Determine the nitrogen in the residue by the method of sulfuric acid digestion (2.5.9) and calculate the amount of protein by multiplying the result by 6.25.

**Activated coagulation factors (2.6.22).** If necessary, dilute the preparation to be examined to contain 20 IU of factor IX per millilitre. For each of the dilutions, the coagulation time is not less than 150 s.

**Heparin.** If heparin has been added during preparation, determine the amount present by the assay of heparin in coagulation factor concentrates (2.7.12). The preparation to be examined contains not more than the amount of heparin stated on the label and in all cases not more than 0.5 IU of heparin per International Unit of factor IX.

**Thrombin.** If the preparation to be examined contains heparin, determine the amount present as described in the test for heparin and neutralise it by addition of *protamine sulfate R* (10 µg of protamine sulfate neutralises 1 IU of heparin). In each of 2 test-tubes, mix equal volumes of the reconstituted preparation and a 3 g/L solution of *fibrinogen R*. Keep one of the tubes at 37 °C for 6 h and the other at room temperature for 24 h. In a 3<sup>rd</sup> tube, mix a volume of the fibrinogen solution with an equal volume of a solution of *human thrombin R* (1 IU/mL) and place the tube in a water-bath at 37 °C. No coagulation occurs in the tubes containing the preparation to be examined. Coagulation occurs within 30 s in the tube containing thrombin.

**Water.** Determined by a suitable method, such as the semi-micro determination of water (2.5.12), loss on drying (2.2.32) or near-infrared spectrometry (2.2.40), the water content is within the limits approved by the competent authority.

**Sterility (2.6.1).** It complies with the test.

**Pyrogens (2.6.8) or Bacterial endotoxins (2.6.14).** It complies with the test for pyrogens or, preferably and where justified and authorised, with a validated *in vitro* test such as the bacterial endotoxin test.

For the pyrogen test, inject per kilogram of the rabbit's mass a volume equivalent to not less than 30 IU of factor IX.

Where the bacterial endotoxin test is used, the preparation to be examined contains less than 0.05 IU of endotoxin per International Unit of factor IX.

#### ASSAY

**Factor IX.** Carry out the assay of human coagulation factor IX (2.7.11).

The estimated potency is not less than 80 per cent and not more than 125 per cent of the stated potency. The confidence interval ( $P = 0.95$ ) of the estimated potency is not greater than 80 per cent to 125 per cent.

**Factor II.** Carry out the assay of human coagulation factor II (2.7.18).

The estimated potency is not less than 80 per cent and not more than 125 per cent of the stated potency. The confidence interval ( $P = 0.95$ ) of the estimated potency is not greater than 90 per cent to 111 per cent.

The estimated factor II potency is not less than 70 per cent and not more than 165 per cent of the estimated factor IX potency.

**Factor VII.** If the label states that the preparation contains factor VII, carry out the assay of human coagulation factor VII (2.7.10).

The estimated potency is not less than 80 per cent and not more than 125 per cent of the stated potency. The confidence interval

( $P = 0.95$ ) of the estimated potency is not greater than 80 per cent to 125 per cent.

**Factor X.** If the label states that the preparation contains factor X, carry out the assay of human coagulation factor X (2.7.19).

The estimated potency is not less than 80 per cent and not more than 125 per cent of the stated potency. The confidence interval ( $P = 0.95$ ) of the estimated potency is not greater than 90 per cent to 111 per cent.

#### STORAGE

In an airtight container, protected from light.

#### LABELLING

The label states:

- the number of International Units of factor IX, and the number or range of International Units of factor II per container;
- where applicable, the number or range of International Units of factor VII and factor X per container;
- the amount of protein per container;
- the name and quantity of any added substances, including, where applicable, heparin and antithrombin;
- the name and quantity of the liquid to be used for reconstitution;
- that the transmission of infectious agents cannot be totally excluded when medicinal products prepared from human blood or plasma are administered.

01/2008:0723

## HUMAN RABIES IMMUNOGLOBULIN

### Immunoglobulinum humanum rabicum

#### DEFINITION

Human rabies immunoglobulin is a liquid or freeze-dried preparation containing immunoglobulins, mainly immunoglobulin G. The preparation is intended for intramuscular administration. It is obtained from plasma from donors immunised against rabies. It contains specific antibodies neutralising the rabies virus. *Human normal immunoglobulin (0338)* may be added.

It complies with the monograph on *Human normal immunoglobulin (0338)*, except for the minimum number of donors and the minimum total protein content.

#### POTENCY

The potency is determined by comparing the dose of immunoglobulin required to neutralise the infectivity of a rabies virus suspension with the dose of a reference preparation, calibrated in International Units, required to produce the same degree of neutralisation (2.7.1). The test is performed in sensitive cell cultures and the presence of unneutralised virus is revealed by immunofluorescence.

The International Unit is the specific neutralising activity for rabies virus in a stated amount of the International Standard for anti-rabies immunoglobulin. The equivalence in International Units of the International Standard is stated by the World Health Organisation.

*Human rabies immunoglobulin BRP* is calibrated in International Units by comparison with the International Standard.

Carry out the test in suitable sensitive cells. It is usual to use the BHK 21 cell line, grown in the medium described below, between the 18th and 30th passage levels counted from the

ATCC seed lot. Harvest the cells after 2 to 4 days of growth, treat with trypsin and prepare a suspension containing 500 000 cells per millilitre (cell suspension). 10 min before using this suspension add 10 µg of *diethylamino-ethyl-dextran R* per millilitre, if necessary, to increase the sensitivity of the cells.

Use a fixed virus strain grown in sensitive cells, such as the CVS strain of rabies virus adapted to growth in the BHK 21 cell line (seed virus suspension). Estimate the titre of the seed virus suspension as follows.

Prepare a series of dilutions of the viral suspension. In the chambers of cell-culture slides (8 chambers per slide), place 0.1 mL of each dilution and 0.1 mL of medium and add 0.2 mL of the cell suspension. Incubate in an atmosphere of carbon dioxide at 37 °C for 24 h. Carry out fixation, immunofluorescence staining and evaluation as described below. Determine the end-point titre of the seed virus suspension and prepare the working virus dilution corresponding to 100 CCID<sub>50</sub> per 0.1 mL.

For each assay, check the amount of virus used by performing a control titration: from the dilution corresponding to 100 CCID<sub>50</sub> per 0.1 mL, make three tenfold dilutions. Add 0.1 mL of each dilution to four chambers containing 0.1 mL of medium and add 0.2 mL of the cell suspension. The test is not valid unless the titre lies between 30 CCID<sub>50</sub> and 300 CCID<sub>50</sub>.

Dilute the reference preparation to a concentration of 2 IU/mL using non-supplemented culture medium (stock reference dilution, stored below –80 °C). Prepare two suitable predilutions (1:8 and 1:10) of the stock reference dilution so that the dilution of the reference preparation that reduces the number of fluorescent fields by 50 per cent lies within the four dilutions of the cell-culture slide. Add 0.1 mL of the medium to each chamber, except the first in each of two rows, to which add respectively 0.2 mL of the two predilutions of the stock reference dilution transferring successively 0.1 mL to the other chambers.

Dilute the preparation to be examined 1 in 100 using non-supplemented medium (stock immunoglobulin dilution) - to reduce to a minimum errors due to viscosity of the undiluted preparation - and make three suitable predilutions so that the dilution of the preparation to be examined that reduces the number of fluorescent fields by 50 per cent lies within the four dilutions of the cell-culture slide. Add 0.1 mL of the medium to all the chambers except the first in each of three rows, to which add respectively 0.2 mL of the three predilutions of the stock immunoglobulin dilution. Prepare a series of twofold dilutions transferring successively 0.1 mL to the other chambers.

To all the chambers containing the dilutions of the reference preparation and the dilutions of the preparation to be examined, add 0.1 mL of the virus suspension corresponding to 100 CCID<sub>50</sub> per 0.1 mL (working virus dilution), shake manually, allow to stand in an atmosphere of carbon dioxide at 37 °C for 90 min, add 0.2 mL of the cell suspension, shake manually and allow to stand in an atmosphere of carbon dioxide at 37 °C for 24 h.

After 24 h, discard the medium and remove the plastic walls. Wash the cell monolayer with *phosphate buffered saline pH 7.4 R* and then with a mixture of 20 volumes of *water R* and 80 volumes of *acetone R* and fix in a mixture of 20 volumes of *water R* and 80 volumes of *acetone R* at –20 °C for 3 min. Spread on the slides *fluorescein-conjugated rabies antiserum R* ready for use. Allow to stand in an atmosphere with a high level of moisture at 37 °C for 30 min. Wash with *phosphate buffered saline pH 7.4 R* and dry. Examine twenty fields in each chamber at a magnification of 250 ×, using a microscope equipped for fluorescence readings. Note the number of fields with at least one fluorescent cell. Check the test dose used in the virus titration slide and determine the dilution of the reference preparation and the dilution of the preparation to be examined that reduce the number of fluorescent fields by 50 per cent, calculating the two or three dilutions together using probit analysis. The test is not valid unless the statistical analysis shows a significant slope of the dose-response curve and no evidence of deviation from linearity or parallelism.

01/2008:0617

The stated potency is not less than 150 IU/mL. The estimated potency is not less than the stated potency and is not greater than twice the stated potency. The confidence limits ( $P = 0.95$ ) of the estimated potency are not less than 80 per cent and not more than 125 per cent.

**CULTURE MEDIUM FOR GROWTH OF BHK 21 CELLS**

*Commercially available media that have a slightly different composition from that shown below may also be used.*

Sodium chloride	6.4 g
Potassium chloride	0.40 g
Calcium chloride, anhydrous	0.20 g
Magnesium sulfate, heptahydrate	0.20 g
Sodium dihydrogen phosphate, monohydrate	0.124 g
Glucose monohydrate	4.5 g
Ferric nitrate, nonahydrate	0.10 mg
L-Arginine hydrochloride	42.0 mg
L-Cystine	24.0 mg
L-Histidine	16.0 mg
L-Isoleucine	52.0 mg
L-Leucine	52.0 mg
L-Lysine hydrochloride	74.0 mg
L-Phenylalanine	33.0 mg
L-Threonine	48.0 mg
L-Tryptophan	8.0 mg
L-Tyrosine	36.0 mg
L-Valine	47.0 mg
L-Methionine	15.0 mg
L-Glutamine	0.292 g
<i>l</i> -Inositol	3.60 mg
Choline chloride	2.0 mg
Folic acid	2.0 mg
Nicotinamide	2.0 mg
Calcium pantothenate	2.0 mg
Pyridoxal hydrochloride	2.0 mg
Thiamine hydrochloride	2.0 mg
Riboflavin	0.2 mg
Phenol red	15.0 mg
Sodium hydrogen carbonate	2.75 g
Water	to 1000 mL

The medium is supplemented with:

Foetal calf serum (heated at 56 °C for 30 min)	10 per cent
Tryptose phosphate broth	10 per cent
Benzylpenicillin sodium	60 mg/L
Streptomycin	0.1 g/L

**STORAGE**

See *Human normal immunoglobulin (0338)*.

**LABELLING**

See *Human normal immunoglobulin (0338)*.

The label states the number of International Units per container.

**HUMAN RUBELLA IMMUNOGLOBULIN****Immunoglobulinum humanum rubellae****DEFINITION**

Human rubella immunoglobulin is a liquid or freeze-dried preparation containing immunoglobulins, mainly immunoglobulin G. The preparation is intended for intramuscular administration. It is obtained from plasma containing specific antibodies against rubella virus. *Human normal immunoglobulin (0338)* may be added.

It complies with the monograph on *Human normal immunoglobulin (0338)*, except for the minimum number of donors and the minimum total protein content.

**POTENCY**

The potency is determined by comparing the activity of the preparation to be examined in a suitable haemagglutination-inhibition test with that of a reference preparation calibrated in International Units.

The International Unit is the activity contained in a stated amount of the International Standard for anti-rubella immunoglobulin. The equivalence in International Units of the International Reference Preparation is stated by the World Health Organisation.

The estimated potency is not less than 4500 IU/mL. The confidence limits ( $P = 0.95$ ) of the estimate of potency are not less than 50 per cent and not more than 200 per cent of the stated potency.

**STORAGE**

See *Human normal immunoglobulin (0338)*.

**LABELLING**

See *Human normal immunoglobulin (0338)*.

The label states the number of International Units per millilitre.

01/2008:0398

**HUMAN TETANUS IMMUNOGLOBULIN****Immunoglobulinum humanum tetanicum****DEFINITION**

Human tetanus immunoglobulin is a liquid or freeze-dried preparation containing immunoglobulins, mainly immunoglobulin G. The preparation is intended for intramuscular administration. It is obtained from plasma containing specific antibodies against the toxin of *Clostridium tetani*. *Human normal immunoglobulin (0338)* may be added.

It complies with the monograph on *Human normal immunoglobulin (0338)*, except for the minimum number of donors and the minimum total protein content.

**PRODUCTION**

During development, a satisfactory relationship shall be established between the potency determined by immunoassay as described under Potency and that determined by means of the following test for toxin-neutralising capacity in mice.

*Toxin-neutralising capacity in mice.* The potency is determined by comparing the quantity necessary to protect mice against the paralytic effects of a fixed quantity of tetanus toxin with the quantity of a reference preparation of human tetanus immunoglobulin, calibrated in International Units, necessary to give the same protection.

The International Unit of antitoxin is the specific neutralising activity for tetanus toxin contained in a stated amount of the International Standard, which consists of freeze-dried human

immunoglobulin. The equivalence in International Units of the International Standard is stated by the World Health Organisation.

*Human tetanus immunoglobulin BRP* is calibrated in International Units by comparison with the International Standard.

*Selection of animals.* Use mice weighing 16 g to 20 g.

*Preparation of the test toxin.* Prepare the test toxin by a suitable method from the sterile filtrate of a culture in liquid medium of *C. tetani*. The two methods shown below are given as examples and any other suitable method may be used.

(1) To the filtrate of an approximately 9-day culture add 1 to 2 volumes of *glycerol R* and store the mixture in the liquid state at a temperature slightly below 0 °C.

(2) Precipitate the toxin by addition to the filtrate of *ammonium sulfate R*, dry the precipitate *in vacuo* over *diphosphorus pentoxide R*, reduce to a powder and store dry, either in sealed ampoules or *in vacuo* over *diphosphorus pentoxide R*.

*Determination of test dose of toxin (Lp/10 dose).* Prepare a solution of the reference preparation in a suitable liquid such that it contains 0.5 IU of antitoxin per millilitre. If the test toxin is stored dry, reconstitute it using a suitable liquid. Prepare mixtures of the solution of the reference preparation and the test toxin such that each contains 2.0 mL of the solution of the reference preparation, one of a graded series of volumes of the test toxin and sufficient of a suitable liquid to bring the volume to 5.0 mL. Allow the mixtures to stand, protected from light, for 60 min. Using six mice for each mixture, inject a dose of 0.5 mL subcutaneously into each mouse. Observe the mice for 96 h. Mice that become paralysed may be euthanised. The test dose of toxin is the quantity in 0.5 mL of the mixture made with the smallest amount of toxin capable of causing, despite partial neutralisation by the reference preparation, paralysis in all six mice injected with the mixture, within the observation period.

*Determination of potency of the immunoglobulin.* Prepare a solution of the reference preparation in a suitable liquid such that it contains 0.5 IU of antitoxin per millilitre. Prepare a solution of the test toxin in a suitable liquid such that it contains five test doses per millilitre. Prepare mixtures of the solution of the test toxin and the immunoglobulin to be examined such that each contains 2.0 mL of the solution of the test toxin, one of a graded series of volumes of the immunoglobulin to be examined and sufficient of a suitable liquid to bring the total volume to 5.0 mL. Also prepare mixtures of the solution of the test toxin and the solution of the reference preparation such that each contains 2.0 mL of the solution of the test toxin, one of a graded series of volumes of the solution of the reference preparation centred on that volume (2.0 mL) that contains 1 IU and sufficient of a suitable liquid to bring the total volume to 5.0 mL. Allow the mixtures to stand, protected from light, for 60 min. Using six mice for each mixture, inject subcutaneously a dose of 0.5 mL into each mouse. Observe the mice for 96 h. Mice that become paralysed may be euthanised. The mixture that contains the largest volume of immunoglobulin that fails to protect the mice from paralysis contains 1 IU. This quantity is used to calculate the potency of the immunoglobulin in International Units per millilitre.

The test is not valid unless all the mice injected with mixtures containing 2.0 mL or less of the solution of the reference preparation show paralysis and all those injected with mixtures containing more do not.

#### POTENCY

The potency is determined by comparing the antibody titre of the immunoglobulin to be examined with that of a reference preparation calibrated in International Units, using an immunoassay of suitable sensitivity and specificity (2.7.1).

The International Unit is the activity contained in a stated amount of the International Standard for anti-tetanus immunoglobulin. The equivalence in International Units of the International Standard is stated by the World Health Organisation.

*Human tetanus immunoglobulin BRP* is calibrated in International Units by comparison with the International Standard.

The stated potency is not less than 100 IU of tetanus antitoxin per millilitre. The estimated potency is not less than the stated potency. The confidence limits ( $P = 0.95$ ) of the estimated potency are not less than 80 per cent and not more than 125 per cent.

#### STORAGE

See *Human normal immunoglobulin (0338)*.

#### LABELLING

See *Human normal immunoglobulin (0338)*.

The label states the number of International Units per container.

01/2008:0724

## HUMAN VARICELLA IMMUNOGLOBULIN

### Immunoglobulinum humanum varicellae

#### DEFINITION

Human varicella immunoglobulin is a liquid or freeze-dried preparation containing immunoglobulins, mainly immunoglobulin G. The preparation is intended for intramuscular administration. It is obtained from plasma from selected donors having antibodies against *Herpesvirus varicellae*. *Human normal immunoglobulin (0338)* may be added.

It complies with the monograph on *Human normal immunoglobulin (0338)* except for the minimum number of donors, the minimum total protein content and, where authorised, the test for antibody to hepatitis B surface antigen.

#### POTENCY

The potency is determined by comparing the antibody titre of the immunoglobulin to be examined with that of a reference preparation calibrated in International Units, using an immunoassay of suitable sensitivity and specificity (2.7.1).

The International Unit is the activity contained in a stated amount of the International Standard for anti varicella-zoster. The equivalence in International Units of the International Standard is stated by the World Health Organisation.

The stated potency is not less than 100 IU/mL. The estimated potency is not less than the stated potency. The confidence limits ( $P = 0.95$ ) of the estimated potency are not less than 80 per cent and not more than 125 per cent.

#### STORAGE

See *Human normal immunoglobulin (0338)*.

#### LABELLING

See *Human normal immunoglobulin (0338)*.

The label states the number of International Units per container.

01/2008:1528

## HUMAN VARICELLA IMMUNOGLOBULIN FOR INTRAVENOUS ADMINISTRATION

### Immunoglobulinum humanum varicellae ad usum intravenosum

#### DEFINITION

Human varicella immunoglobulin for intravenous administration is a liquid or freeze-dried preparation containing immunoglobulins, mainly immunoglobulin G. It is obtained from plasma from selected donors having antibodies against human herpesvirus 3 (varicella-zoster virus 1). *Human normal immunoglobulin for intravenous administration (0918)* may be added.

It complies with the monograph on *Human normal immunoglobulin for intravenous administration (0918)*, except for the minimum number of donors, the minimum total protein content and the limit for osmolality.

#### POTENCY

The potency is determined by comparing the antibody titre of the immunoglobulin to be examined with that of a reference preparation calibrated in International Units, using an immunoassay of suitable sensitivity and specificity (2.7.1).

The International Unit is the activity contained in a stated amount of the International Standard for anti varicella-zoster immunoglobulin. The equivalence in International Units of the International Standard is stated by the World Health Organisation.

The stated potency is not less than 25 IU/mL. The estimated potency is not less than the stated potency. The confidence limits ( $P = 0.95$ ) of the estimated potency are not less than 80 per cent and not more than 125 per cent.

#### STORAGE

See *Human normal immunoglobulin for intravenous administration (0918)*.

#### LABELLING

See *Human normal immunoglobulin for intravenous administration (0918)*.

The label states the number of International Units per container.

01/2011:2298

## HUMAN VON WILLEBRAND FACTOR

### Factor humanus von Willebrandi

#### DEFINITION

Human von Willebrand factor is a preparation of a plasma protein fraction that contains the glycoprotein von Willebrand factor with varying amounts of coagulation factor VIII, depending on the method of preparation. It is prepared from human plasma that complies with the monograph *Human plasma for fractionation (0853)*.

This monograph applies to preparations formulated according to the von Willebrand factor activity.

The potency of the preparation, reconstituted as stated on the label, is not less than 20 IU of von Willebrand factor per millilitre.

#### PRODUCTION

The method of preparation includes steps that have been shown to remove or to inactivate known agents of infection; if substances are used for the inactivation of viruses, the subsequent purification procedure must be validated to

demonstrate that the concentration of these substances is reduced to a suitable level and that any residues are such as not to compromise the safety of the preparation for patients.

The specific activity is not less than 1 IU of von Willebrand factor per milligram of total protein, before the addition of any protein stabiliser.

The von Willebrand factor fraction is dissolved in a suitable liquid. Excipients such as a stabiliser may be added. No antimicrobial preservative is added. The solution is passed through a bacteria-retentive filter, distributed aseptically into the final containers and immediately frozen. It is subsequently freeze-dried and the containers are closed under vacuum or under an inert gas.

#### VALIDATION STUDIES

**COMPOSITION.** It shall be demonstrated that the manufacturing process yields a product having a consistent composition with respect to von Willebrand factor, factor VIII and the proportions of von Willebrand factor and factor VIII.

**von Willebrand factor multimers.** The distribution of the different von Willebrand factor multimers is determined by a suitable method such as sodium dodecyl sulfate (SDS) agarose gel electrophoresis with or without Western blot analysis, using a suitable normal human plasma as standard. Visualisation of the multimeric pattern may be performed using, for example, an immunoenzymatic technique and quantitative evaluation may be carried out by densitometric analysis.

**von Willebrand factor activity (2.7.21).** The von Willebrand factor activity is estimated by determining the ristocetin cofactor activity and by one or more other suitable assays such as determination of collagen-binding activity using a suitable reference preparation.

**von Willebrand factor activity/antigen ratio.** Consistency of the manufacturing process with respect to the ratio of von Willebrand factor activity to von Willebrand factor antigen content is demonstrated.

**PRODUCTS THAT SHOW PARTICLES AFTER RECONSTITUTION.** If a few particles remain when the preparation is reconstituted, it shall be demonstrated during validation studies that the potency is not significantly affected after passage of the preparation through the filter to be provided with the preparation.

#### CHARACTERS

**Appearance:** white or pale yellow, hygroscopic powder or friable solid.

**Reconstitute the preparation to be examined as stated on the label immediately before carrying out the identification, tests (except those for solubility and water) and assay.**

#### IDENTIFICATION

The assay for von Willebrand factor serves also to identify the preparation.

#### TESTS

**Solubility.** To a container of the preparation to be examined add the volume of the solvent stated on the label at the recommended temperature. The preparation dissolves completely with gentle swirling within 10 min, giving a clear or slightly opalescent, colourless or slightly yellow solution.

In addition, where the label states that the product may show a few particles after reconstitution, reconstitute the preparation as described on the label and pass it through the filter provided: the filtered solution is clear or slightly opalescent.

**pH (2.2.3):** 6.5 to 7.5.

**Osmolality (2.2.35):** minimum 240 mosmol/kg.

**Total protein.** If necessary, dilute an accurately measured volume of the preparation to be examined with a 9 g/L solution of *sodium chloride R* to obtain a solution expected to contain about 15 mg of protein in 2 mL. To 2.0 mL of the solution in a round-bottomed centrifuge tube add 2 mL of a 75 g/L solution

01/2008:0912

of *sodium molybdate R* and 2 mL of a mixture of 1 volume of *nitrogen-free sulfuric acid R* and 30 volumes of *water R*. Shake, centrifuge for 5 min, decant the supernatant and allow the inverted tube to drain on filter paper. Determine the nitrogen in the residue by the method of sulfuric acid digestion (2.5.9) and calculate the amount of protein by multiplying the result by 6.25.

For some products, especially those without a protein stabiliser, this method may not be applicable. Another validated method for protein determination must therefore be performed.

**Anti-A and anti-B haemagglutinins (2.6.20).** Dilute the preparation to be examined with a 9 g/L solution of *sodium chloride R* to contain 6 IU of von Willebrand factor activity per millilitre. The 1 to 64 dilutions do not show agglutination.

**Water.** Determined by a suitable method, such as the semi-micro determination of water (2.5.12), loss on drying (2.2.32) or near-infrared spectrophotometry (2.2.40), the water content is within the limits approved by the competent authority.

**Sterility (2.6.1).** It complies with the test.

**Pyrogens (2.6.8) or Bacterial endotoxins (2.6.14).** It complies with the test for pyrogens or, preferably and where justified and authorised, with a validated *in vitro* test such as the bacterial endotoxin test.

For the pyrogen test, inject per kilogram of the rabbit's mass a volume of the preparation to be examined equivalent to not less than 100 IU of von Willebrand factor.

Where the bacterial endotoxin test is used, the preparation to be examined contains less than 0.05 IU of endotoxin per International Unit of von Willebrand factor.

#### ASSAY

**von Willebrand factor (2.7.21).** The estimated potency is not less than 80 per cent and not more than 120 per cent of the stated potency. The confidence limits ( $P = 0.95$ ) are not less than 80 per cent and not more than 120 per cent of the estimated potency.

*Pending the availability of an International Standard for von Willebrand factor concentrate calibrated for use in the collagen-binding assay, only the ristocetin cofactor assay may be used.*

**Factor VIII (2.7.4).** The assay is carried out where the factor VIII content is greater than 10 IU of factor VIII per 100 IU of von Willebrand factor activity. The estimated potency is not less than 60 per cent and not more than 140 per cent of the stated potency. The confidence limits ( $P = 0.95$ ) are not less than 80 per cent and not more than 120 per cent of the estimated potency.

#### STORAGE

In an airtight container, protected from light.

#### LABELLING

The label states:

- the number of International Units of von Willebrand factor in the container;
- the number of International Units of factor VIII in the container, or that the content of factor VIII is less than or equal to 10 IU of factor VIII per 100 IU of von Willebrand factor activity;
- the amount of protein in the container;
- the name and quantity of any added substance;
- the name and volume of the liquid to be used for reconstitution;
- where applicable, that the preparation may show the presence of a few particles after reconstitution;
- that the transmission of infectious agents cannot be totally excluded when medicinal products prepared from human blood or plasma are administered.

## HYALURONIDASE

### Hyaluronidasum

[9001-54-1]

#### DEFINITION

Enzyme extracted from mammalian testes (for example bovine testes) and capable of hydrolysing mucopolysaccharides of the hyaluronic acid type. It may contain a suitable stabiliser.

**Potency:** minimum 300 IU of hyaluronidase activity per milligram (dried substance).

#### PRODUCTION

The animals from which hyaluronidase is derived must fulfil the requirements for the health of animals suitable for human consumption.

#### CHARACTERS

**Appearance:** white or yellowish-white, amorphous powder.

**Solubility:** soluble in water, practically insoluble in acetone and in anhydrous ethanol.

#### IDENTIFICATION

A solution containing the equivalent of 100 IU of hyaluronidase in 1 mL of a 9 g/L solution of *sodium chloride R* depolymerises an equal volume of a 10 g/L solution of *sodium hyaluronate BRP* in 1 min at 20 °C as shown by a pronounced decrease in viscosity. This action is destroyed by heating the hyaluronidase at 100 °C for 30 min.

#### TESTS

**Appearance of solution.** The solution is clear (2.2.1).

Dissolve 0.10 g in *water R* and dilute to 10 mL with the same solvent.

**pH (2.2.3):** 4.5 to 7.5.

Dissolve 30 mg in *carbon dioxide-free water R* and dilute to 10 mL with the same solvent.

**Loss on drying (2.2.32):** maximum 5.0 per cent, determined on 0.500 g by drying at 60 °C at a pressure not exceeding 670 Pa for 2 h.

**Bacterial endotoxins (2.6.14):** less than 0.2 IU per IU of hyaluronidase.

#### ASSAY

The activity of hyaluronidase is determined by comparing the rate at which it hydrolyses *sodium hyaluronate BRP* with the rate obtained with the International Standard, or a reference preparation calibrated in International Units, using a slope-ratio assay.

**Substrate solution.** To 0.10 g of *sodium hyaluronate BRP* in a 25 mL conical flask add slowly 20.0 mL of *water R* at 4 °C. The rate of addition must be slow enough to allow the substrate particles to swell (about 5 min). Maintain at 4 °C and stir for at least 12 h. Store at 4 °C and use within 4 days.

*For the test solution and the reference solution, prepare the solution and carry out the dilution at 0 °C to 4 °C.*

**Test solution.** Dissolve a suitable amount of the substance to be examined in *hyaluronidase diluent R* so as to obtain a solution containing  $0.6 \pm 0.3$  IU of hyaluronidase per millilitre.

**Reference solution.** Dissolve a suitable amount of *hyaluronidase BRP* in *hyaluronidase diluent R* so as to obtain a solution containing 0.6 IU of hyaluronidase per millilitre.

In a reaction vessel, mix 1.50 mL of *phosphate buffer solution pH 6.4 R* and 1.0 mL of the substrate solution and equilibrate at  $37 \pm 0.1$  °C. At time  $t_1 = 0$  (first chronometer) add 0.50 mL of the test solution containing  $E_t$  mg of the enzyme to be examined, mix, measure the viscosity of the solution using a suitable

viscometer maintained at  $37 \pm 0.1$  °C and record the outflow time  $t_2$  using a second chronometer (graduated in 0.1 second intervals), several times during about 20 min (read on the first chronometer). The following viscometer has been found suitable: Ubbelohde microviscometer (DIN 51 562, Part 2), capillary type MII, viscometer constant about  $0.1 \text{ mm}^2/\text{s}^2$ .

Repeat the procedure using 0.50 mL of the reference solution containing  $E_r$  mg of *hyaluronidase BRP*.

Calculate the viscosity ratio from the expression:

$$\eta_r = \frac{k \times t_2}{0.6915}$$

$k$  = the viscometer constant in  $\text{mm}^2/\text{s}^2$  (indicated on the viscometer);

$t_2$  = the outflow time (in seconds) of the solution;

0.6915 = the kinematic viscosity in  $\text{mm}^2/\text{s}$  of the buffer solution at 37 °C.

Since the enzymatic reaction continues during the outflow time measurements, the real reaction time equals  $t_1 + t_2/2$ , half of the outflow time ( $t_2/2$ ) for which a certain measurement is valid being added to the time  $t_1$  at which the measurement is started. Plot  $(\ln \eta_r)^{-1}$  as a function of the reaction time ( $t_1 + t_2/2$ ) in seconds. A linear relationship is obtained. Calculate the slope for the substance to be examined ( $b_t$ ) and the reference preparation ( $b_r$ ).

Calculate the specific activity in International Units per milligram from the expression:

$$\frac{b_t}{b_r} \times \frac{E_r}{E_t} \times A$$

$A$  = the specific activity of *hyaluronidase BRP* in International Units per milligram.

Carry out the complete procedure at least three times and calculate the average activity of the substance to be examined.

#### STORAGE

Store in an airtight container, at a temperature of 2 °C to 8 °C. If the substance is sterile, store in a sterile, tamper-proof container.

#### LABELLING

The label states the activity in International Units per milligram.

01/2008:0829

## HYDRALAZINE HYDROCHLORIDE

### Hydralazini hydrochloridum

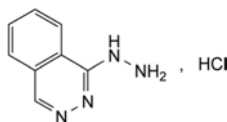

$\text{C}_8\text{H}_9\text{ClN}_4$   
[304-20-1]

$M_r$  196.6

#### DEFINITION

1-Hydrazinophthalazine hydrochloride.

*Content*: 98.5 per cent to 101.0 per cent (dried substance).

#### CHARACTERS

*Appearance*: white or almost white, crystalline powder.

*Solubility*: soluble in water, slightly soluble in ethanol (96 per cent), very slightly soluble in methylene chloride.

mp: about 275 °C, with decomposition.

#### IDENTIFICATION

*First identification*: B, E.

*Second identification*: A, C, D, E.

A. Ultraviolet and visible absorption spectrophotometry (2.2.25).

*Test solution*. Dissolve 50 mg in *water R* and dilute to 100 mL with the same solvent. Dilute 2 mL of this solution to 100 mL with *water R*.

*Spectral range*: 220-350 nm.

*Absorption maxima*: at 240 nm, 260 nm, 303 nm and 315 nm.

*Absorbance ratio*:  $A_{240}/A_{303} = 2.0$  to 2.2.

B. Infrared absorption spectrophotometry (2.2.24).

*Preparation*: discs.

*Comparison*: *hydralazine hydrochloride CRS*.

C. Dissolve 0.5 g in a mixture of 8 mL of *dilute hydrochloric acid R* and 100 mL of *water R*. Add 2 mL of *sodium nitrite solution R*, allow to stand for 10 min and filter. The precipitate, washed with *water R* and dried at 100-105 °C, melts (2.2.14) at 209 °C to 212 °C.

D. Dissolve about 10 mg in 2 mL of *water R*. Add 2 mL of a 20 g/L solution of *nitrobenzaldehyde R* in *ethanol (96 per cent) R*. An orange precipitate is formed.

E. It gives reaction (a) of chlorides (2.3.1).

#### TESTS

**Solution S**. Dissolve 0.5 g in *carbon dioxide-free water R* and dilute to 25 mL with the same solvent.

**Appearance of solution**. The solution is clear (2.2.1) and not more intensely coloured than reference solution GY<sub>6</sub> (2.2.2, *Method II*).

Dilute 4 mL of solution S to 20 mL with *water R*.

**pH** (2.2.3): 3.5 to 4.2 for solution S.

**Hydrazine**. Thin-layer chromatography (2.2.27).

*Test solution*. Dissolve 0.12 g of the substance to be examined in 4 mL of *water R* and add 4 mL of a 150 g/L solution of *salicylaldehyde R* in *methanol R* and 0.2 mL of *hydrochloric acid R*. Mix and keep at a temperature not exceeding 25 °C for 2-4 h, until the precipitate formed has sedimented. Add 4 mL of *toluene R*, shake vigorously and centrifuge. Transfer the clear supernatant liquid to a 100 mL separating funnel and shake vigorously, each time for 3 min, with 2 quantities, each of 20 mL, of a 200 g/L solution of *sodium metabisulfite R* and with 2 quantities, each of 50 mL, of *water R*. Separate the upper toluene layer which is the test solution.

*Reference solution (a)*. Dissolve 12 mg of *hydrazine sulfate R* in *dilute hydrochloric acid R* and dilute to 100.0 mL with the same acid. Dilute 1.0 mL of this solution to 100.0 mL with *dilute hydrochloric acid R*.

*Reference solution (b)*. Prepare the solution at the same time and in the same manner as for the test solution, using 1.0 mL of reference solution (a) and 3 mL of *water R*.

*Plate*: TLC silica gel G plate R.

*Mobile phase*: *ethanol (96 per cent) R*, *toluene R* (10:90 V/V).

*Application*: 20 µL of the test solution and reference solution (b).

*Development*: over a path of 10 cm.

*Drying*: in air.

*Detection*: examine in ultraviolet light at 365 nm.

*Limit*:

– *hydrazine*: any yellow fluorescent spot due to hydrazine is not more intense than the corresponding spot in the chromatogram obtained with reference solution (b) (10 ppm).

**Related substances**. Liquid chromatography (2.2.29). *The solutions must be injected within one working day*.

*Test solution*. Dissolve 25.0 mg of the substance to be examined in the mobile phase and dilute to 50.0 mL with the mobile phase.



*Reference solution (a).* Dilute 1.0 mL of the test solution to 100.0 mL with the mobile phase.

*Reference solution (b).* Dilute 10.0 mL of reference solution (a) to 50.0 mL with the mobile phase.

*Reference solution (c).* Dissolve 25.0 mg of *phthalazine R* in the mobile phase and dilute to 50.0 mL with the mobile phase. Dilute 4.0 mL of this solution to 100.0 mL with the mobile phase.

*Reference solution (d).* Dilute a mixture of 4.0 mL of the test solution and 10.0 mL of reference solution (c) to 100.0 mL with the mobile phase.

*Column:*

- size:  $l = 0.25$  m,  $\varnothing = 4.6$  mm;
- stationary phase: nitrile silica gel for chromatography R1 (10  $\mu$ m).

*Mobile phase:* mix 22 volumes of *acetonitrile R* and 78 volumes of a solution containing 1.44 g/L of *sodium laurilsulfate R* and 0.75 g/L of *tetrabutylammonium bromide R*, then adjust to pH 3.0 with 0.05 M *sulfuric acid*.

*Flow rate:* 1 mL/min.

*Detection:* spectrophotometer at 230 nm.

*Injection:* 20  $\mu$ L.

*Run time:* 3 times the retention time of *hydralazine*.

*Retention time:* *hydralazine* = about 10 min to 12 min; if necessary, adjust the concentration of *acetonitrile* in the mobile phase.

*System suitability:*

- the chromatogram obtained with reference solution (d) shows 2 principal peaks;
- resolution: minimum 2.5 between the peaks due to *hydralazine* and *phthalazine* in the chromatogram obtained with reference solution (d);
- signal-to-noise ratio: minimum 3 for the principal peak in the chromatogram obtained with reference solution (b).

*Limit:*

- any impurity: for each impurity, not more than the area of the principal peak in the chromatogram obtained with reference solution (b) (0.2 per cent).

**Heavy metals (2.4.8):** maximum 20 ppm.

1.0 g complies with test C. Prepare the reference solution using 2 mL of *lead standard solution (10 ppm Pb) R*.

**Loss on drying (2.2.32):** maximum 0.5 per cent, determined on 1.000 g by drying *in vacuo*.

**Sulfated ash (2.4.14):** maximum 0.1 per cent, determined on 1.0 g.

ASSAY

Dissolve 80.0 mg in 25 mL of *water R*. Add 35 mL of *hydrochloric acid R* and titrate with 0.05 M *potassium iodate*, determining the end-point potentiometrically (2.2.20), using a calomel reference electrode and a platinum indicator electrode.

1 mL of 0.05 M *potassium iodate* is equivalent to 9.832 mg of  $C_8H_9ClN_4$ .

STORAGE

Protected from light.

01/2008:0002

## HYDROCHLORIC ACID, CONCENTRATED

Acidum hydrochloridum concentratum

HCl  
[7647-01-0]

$M_r$  36.46

DEFINITION

*Content:* 35.0 per cent *m/m* to 39.0 per cent *m/m*.

CHARACTERS

*Appearance:* clear, colourless, fuming liquid.

*Solubility:* miscible with water.

*Relative density:* about 1.18.

IDENTIFICATION

A. Dilute with *water R*. The solution is strongly acid (2.2.4).

B. It gives the reactions of chlorides (2.3.1).

C. It complies with the limits of the assay.

TESTS

**Appearance of solution.** To 2 mL add 8 mL of *water R*. The solution is clear (2.2.1) and colourless (2.2.2, *Method II*).

**Free chlorine:** maximum 4 ppm.

To 15 mL add 100 mL of *carbon dioxide-free water R*, 1 mL of a 100 g/L solution of *potassium iodide R* and 0.5 mL of *iodide-free starch solution R*. Allow to stand in the dark for 2 min. Any blue colour disappears on the addition of 0.2 mL of 0.01 M *sodium thiosulfate*.

**Sulfates (2.4.13):** maximum 20 ppm.

To 6.4 mL add 10 mg of *sodium hydrogen carbonate R* and evaporate to dryness on a water-bath. Dissolve the residue in 15 mL of *distilled water R*.

**Heavy metals (2.4.8):** maximum 2 ppm.

Dissolve the residue obtained in the test for residue on evaporation in 1 mL of *dilute hydrochloric acid R* and dilute to 25 mL with *water R*. Dilute 5 mL of this solution to 20 mL with *water R*. 12 mL of the solution complies with test A. Prepare the reference solution using *lead standard solution (2 ppm Pb) R*.

**Residue on evaporation:** maximum 0.01 per cent.

Evaporate 100.0 g to dryness on a water-bath and dry at 100-105 °C. The residue weighs a maximum of 10 mg.

ASSAY

Weigh accurately a ground-glass-stoppered flask containing 30 mL of *water R*. Introduce 1.5 mL of the acid to be examined and weigh again. Titrate with 1 M *sodium hydroxide*, using *methyl red solution R* as indicator.

1 mL of 1 M *sodium hydroxide* is equivalent to 36.46 mg of HCl.

STORAGE

In a stoppered container made of glass or another inert material, at a temperature not exceeding 30 °C.

01/2008:0003

## HYDROCHLORIC ACID, DILUTE

Acidum hydrochloridum dilutum

DEFINITION

*Content:* 9.5 per cent *m/m* to 10.5 per cent *m/m* of HCl ( $M_r$  36.46).

PREPARATION

To 726 g of *water R* add 274 g of concentrated hydrochloric acid and mix.

IDENTIFICATION

A. It is strongly acid (2.2.4).

B. It gives the reactions of chlorides (2.3.1).

C. It complies with the limits of the assay.

TESTS

**Appearance.** It is clear (2.2.1) and colourless (2.2.2, *Method II*).

**Free chlorine:** maximum 1 ppm.

To 60 mL add 50 mL of *carbon dioxide-free water R*, 1 mL of a 100 g/L solution of *potassium iodide R* and 0.5 mL of *iodide-free starch solution R*. Allow to stand in the dark for 2 min. Any blue colour disappears on the addition of 0.2 mL of 0.01 M *sodium thiosulfate*.

**Sulfates (2.4.13):** maximum 5 ppm.

To 26 mL add 10 mg of *sodium hydrogen carbonate R* and evaporate to dryness on a water-bath. Dissolve the residue in 15 mL of *distilled water R*.

**Heavy metals (2.4.8):** maximum 2 ppm.

Dissolve the residue obtained in the test for residue on evaporation in 1 mL of *dilute hydrochloric acid R* and dilute to 25 mL with *water R*. Dilute 5 mL of this solution to 20 mL with *water R*. 12 mL of the solution complies with test A. Prepare the reference solution using *lead standard solution (2 ppm Pb) R*.

**Residue on evaporation:** maximum 0.01 per cent.

Evaporate 100.0 g to dryness on a water-bath and dry at 100-105 °C. The residue weighs a maximum of 10 mg.

#### ASSAY

To 6.00 g add 30 mL of *water R*. Titrate with 1 M *sodium hydroxide*, using *methyl red solution R* as indicator.

1 mL of 1 M *sodium hydroxide* is equivalent to 36.46 mg of HCl.

04/2009:0394

## HYDROCHLOROTHIAZIDE

### Hydrochlorothiazidum

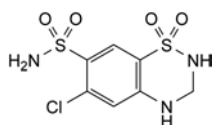

C<sub>7</sub>H<sub>8</sub>ClN<sub>3</sub>O<sub>4</sub>S<sub>2</sub>  
[58-93-5]

M<sub>r</sub> 297.7

#### DEFINITION

6-Chloro-3,4-dihydro-2H-1,2,4-benzothiadiazine-7-sulfonamide 1,1-dioxide.

*Content:* 98.0 per cent to 102.0 per cent (dried substance).

#### CHARACTERS

*Appearance:* white or almost white, crystalline powder.

*Solubility:* very slightly soluble in water, soluble in acetone, sparingly soluble in ethanol (96 per cent). It dissolves in dilute solutions of alkali hydroxides.

It shows polymorphism (5.9).

#### IDENTIFICATION

*First identification:* B.

*Second identification:* A, C, D.

A. Ultraviolet and visible absorption spectrophotometry (2.2.25).

*Test solution.* Dissolve 50.0 mg in 10 mL of 0.1 M *sodium hydroxide* and dilute to 100.0 mL with *water R*. Dilute 2.0 mL of this solution to 100.0 mL with 0.01 M *sodium hydroxide*.

*Spectral range:* 250-350 nm.

*Absorption maxima:* at 273 nm and 323 nm.

*Absorbance ratio:* A<sub>273</sub>/A<sub>323</sub> = 5.4 to 5.7.

B. Infrared absorption spectrophotometry (2.2.24).

*Comparison:* *hydrochlorothiazide CRS*.

If the spectra obtained in the solid state show differences, dissolve the substance to be examined and the reference substance separately in the minimum volume of *ethanol R1*, evaporate to dryness and record new spectra using the residues.

C. Thin-layer chromatography (2.2.27).

*Test solution.* Dissolve 50 mg of the substance to be examined in *acetone R* and dilute to 10 mL with the same solvent.

*Reference solution (a).* Dissolve 50 mg of *hydrochlorothiazide CRS* in *acetone R* and dilute to 10 mL with the same solvent.

*Reference solution (b).* Dissolve 25 mg of *chlorothiazide R* in reference solution (a) and dilute to 5 mL with reference solution (a).

*Plate:* TLC silica gel F<sub>254</sub> plate R.

*Mobile phase:* ethyl acetate R.

*Application:* 2 µL.

*Development:* over a path of 10 cm.

*Drying:* in a current of air.

*Detection:* examine in ultraviolet light at 254 nm.

*System suitability:* reference solution (b):

– the chromatogram shows 2 clearly separated spots.

*Results:* the principal spot in the chromatogram obtained with the test solution is similar in position and size to the principal spot in the chromatogram obtained with reference solution (a).

D. Gently heat about 1 mg with 2 mL of a freshly prepared 0.5 g/L solution of *chromotropic acid, sodium salt R* in a cooled mixture of 35 volumes of *water R* and 65 volumes of *sulfuric acid R*. A violet colour develops.

#### TESTS

**Acidity or alkalinity.** Shake 0.5 g of the powdered substance to be examined with 25 mL of *water R* for 2 min and filter. To 10 mL of the filtrate, add 0.2 mL of 0.01 M *sodium hydroxide* and 0.15 mL of *methyl red solution R*. The solution is yellow. Not more than 0.4 mL of 0.01 M *hydrochloric acid* is required to change the colour of the indicator to red.

**Related substances.** Liquid chromatography (2.2.29).

*Solvent mixture.* Dilute 50.0 mL of a mixture of equal volumes of *acetonitrile R* and *methanol R* to 200.0 mL with *phosphate buffer solution pH 3.2 R1*.

*Test solution.* Dissolve 30.0 mg of the substance to be examined in 5 mL of a mixture of equal volumes of *acetonitrile R* and *methanol R*, using sonication if necessary, and dilute to 20.0 mL with *phosphate buffer solution pH 3.2 R1*.

*Reference solution (a).* Dissolve 15 mg of *hydrochlorothiazide CRS* and 15 mg of *chlorothiazide CRS* (impurity A) in 25 mL of a mixture of equal volumes of *acetonitrile R* and *methanol R*, using sonication if necessary, and dilute to 100 mL with *phosphate buffer solution pH 3.2 R1*. Dilute 5 mL of this solution to 100 mL with the solvent mixture.

*Reference solution (b).* Dilute 1.0 mL of the test solution to 50.0 mL with the solvent mixture. Dilute 5.0 mL of this solution to 20.0 mL with the solvent mixture.

*Column:*

– *size:* l = 0.1 m, Ø = 4.6 mm;

– *stationary phase:* octadecylsilyl silica gel for chromatography R (3 µm).

*Mobile phase:*

– *mobile phase A:* to 940 mL of *phosphate buffer solution pH 3.2 R1* add 60.0 mL of *methanol R* and 10.0 mL of *tetrahydrofuran R* and mix;

– *mobile phase B:* to a mixture of 500 mL of *methanol R* and 500 mL of *phosphate buffer solution pH 3.2 R1* add 50.0 mL of *tetrahydrofuran R* and mix;

Time (min)	Mobile phase A (per cent V/V)	Mobile phase B (per cent V/V)
0 - 17	100 → 55	0 → 45
17 - 30	55	45
30 - 35	55 → 100	45 → 0
35 - 50	100	0

Flow rate: 0.8 mL/min.

Detection: spectrophotometer at 224 nm.

Equilibration: with mobile phase A for at least 20 min.

Injection: 10 µL; inject the solvent mixture as a blank.

Retention time: impurity A = about 7 min; hydrochlorothiazide = about 8 min.

System suitability: reference solution (a):

- resolution: minimum 2.5 between the peaks due to impurity A and hydrochlorothiazide; if necessary, adjust slightly the composition of the mobile phase or the time programme of the linear gradient.

Limits:

- impurities A, B, C: for each impurity, not more than the area of the principal peak in the chromatogram obtained with reference solution (b) (0.5 per cent);
- total: not more than twice the area of the principal peak in the chromatogram obtained with reference solution (b) (1 per cent);
- disregard limit: 0.1 times the area of the principal peak in the chromatogram obtained with reference solution (b) (0.05 per cent).

Chlorides (2.4.4): maximum 100 ppm.

Dissolve 1.0 g in 25 mL of acetone R and dilute to 30 mL with water R. Prepare the standard using 5 mL of acetone R containing 15 per cent V/V of water R and 10 mL of chloride standard solution (5 ppm Cl) R.

Loss on drying (2.2.32): maximum 0.5 per cent, determined on 1.000 g by drying in an oven at 105 °C.

Sulfated ash (2.4.14): maximum 0.1 per cent, determined on 1.0 g.

#### ASSAY

Dissolve 0.120 g in 50 mL of dimethyl sulfoxide R. Titrate with 0.1 M tetrabutylammonium hydroxide in 2-propanol, determining the end-point potentiometrically (2.2.20) at the 2<sup>nd</sup> point of inflexion. Carry out a blank titration.

1 mL of 0.1 M tetrabutylammonium hydroxide in 2-propanol is equivalent to 14.88 mg of C<sub>7</sub>H<sub>8</sub>ClN<sub>3</sub>O<sub>4</sub>S<sub>2</sub>.

#### IMPURITIES

Specified impurities: A, B, C.

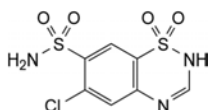

- A. 6-chloro-2H-1,2,4-benzothiadiazine-7-sulfonamide 1,1-dioxide (chlorothiazide),

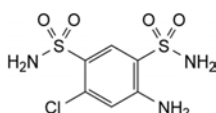

- B. 4-amino-6-chlorobenzene-1,3-disulfonamide (salamide),

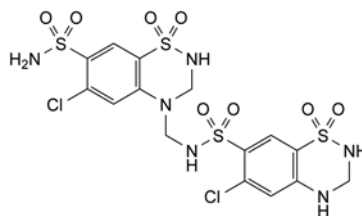

- C. 6-chloro-N-[(6-chloro-7-sulfamoyl-2,3-dihydro-4H-1,2,4-benzothiadiazin-4-yl 1,1-dioxide)methyl]-3,4-dihydro-2H-1,2,4-benzothiadiazine-7-sulfonamide 1,1-dioxide.

04/2009:1784  
corrected 7.0

## HYDROCODONE HYDROGEN TARTRATE 2.5-HYDRATE

### Hydrocodoni hydrogenotartras 2.5-hydricus

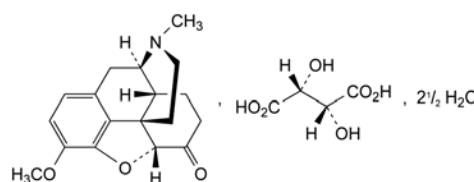

C<sub>22</sub>H<sub>27</sub>NO<sub>9</sub>·2.5H<sub>2</sub>O

M<sub>r</sub> 494.5

#### DEFINITION

4,5α-Epoxy-3-methoxy-17-methylmorphinan-6-one hydrogen (2R,3R)-2,3-dihydroxybutanedioate 2.5-hydrate.

Content: 99.0 per cent to 101.0 per cent (anhydrous substance).

#### CHARACTERS

Appearance: white or almost white, hygroscopic, crystalline powder.

Solubility: freely soluble or soluble in water, sparingly soluble in ethanol (96 per cent), practically insoluble in cyclohexane.

#### IDENTIFICATION

Infrared absorption spectrophotometry (2.2.24).

Comparison: hydrocodone hydrogen tartrate 2.5-hydrate CRS. If the spectra obtained in the solid state show differences, dry the substance to be examined and the reference substance at 105 °C and record new spectra using the residues.

#### TESTS

Appearance of solution. The solution is clear (2.2.1) and not more intensely coloured than reference solution Y<sub>5</sub> (2.2.2, Method II).

Dissolve 0.5 g in water R and dilute to 10 mL with the same solvent.

pH (2.2.3): 3.2 to 3.8.

Dissolve 1.0 g in carbon dioxide-free water R and dilute to 50.0 mL with the same solvent.

Specific optical rotation (2.2.7): –87 to –91 (anhydrous substance).

Dissolve 2.50 g in carbon dioxide-free water R and dilute to 50.0 mL with the same solvent.

Related substances. Liquid chromatography (2.2.29).

Test solution. Dissolve 0.100 g of the substance to be examined in mobile phase A and dilute to 10.0 mL with mobile phase A.

Reference solution (a). Dissolve 5 mg of oxycodone hydrochloride CRS (impurity D) in mobile phase A, add 0.5 mL of the test solution and dilute to 5.0 mL with mobile phase A.

Reference solution (b). Dilute 1.0 mL of the test solution to 100.0 mL with mobile phase A. Dilute 1.0 mL of this solution to 10.0 mL with mobile phase A.

**Reference solution (c).** Dissolve 20 mg of *benzophenone CRS* (impurity H) in 50.0 mL of *methanol R*. Dilute 1.0 mL of this solution to 20.0 mL with mobile phase A.

**Reference solution (d).** Dissolve the contents of a vial of *hydrocodone for peak identification CRS* (containing impurities B, C, D, E, F and I) in 1.0 mL of mobile phase A.

**Reference solution (e).** Dissolve 5 mg of *morphine sulfate CRS* (impurity A) in 5 mL of mobile phase A.

**Column:**

- size:  $l = 0.25$  m,  $\varnothing = 4.6$  mm;
- stationary phase: *octadecylsilyl silica gel for chromatography end-capped R* (5  $\mu$ m);
- temperature: 40 °C.

**Mobile phase:**

- mobile phase A: dissolve 1.08 g of *sodium octanesulfonate R* in *water R*, adjust to pH 2.0 with *phosphoric acid R* and dilute to 1000 mL with *water R*;
- mobile phase B: *acetonitrile R*;

Time (min)	Mobile phase A (per cent V/V)	Mobile phase B (per cent V/V)
0 - 15	80	20
15 - 30	80 → 70	20 → 30
30 - 40	70 → 40	30 → 60
40 - 42	40	60

**Flow rate:** 1.5 mL/min.

**Detection:** spectrophotometer at 283 nm.

**Injection:** 10  $\mu$ L.

**Identification of impurities:** use the chromatogram supplied with *hydrocodone for peak identification CRS* and the chromatogram obtained with reference solution (d) to identify the peaks due to impurities B, C, D, E, F and I; use the chromatogram obtained with reference solution (e) to identify the peak due to impurity A.

**Relative retention** with reference to hydrocodone (retention time = about 14 min): impurity A = about 0.3; impurity K = about 0.43; impurity B = about 0.57; impurity C = about 0.61; impurity D = about 0.9; impurity E = about 1.1; impurity F = about 1.5; impurity I = about 2.0; impurity H = about 2.9.

**System suitability:** reference solution (a):

- resolution: minimum 3.0 between the peaks due to impurity D and hydrocodone.

**Limits:**

- correction factor: for the calculation of content, multiply the peak area of impurity I by 0.2;
- impurity I: not more than the area of the principal peak in the chromatogram obtained with reference solution (b) (0.1 per cent);
- impurity H: not more than 0.5 times the area of the corresponding peak in the chromatogram obtained with reference solution (c) (0.1 per cent);
- impurities A, B, C, D, E, F, K: for each impurity, not more than twice the area of the principal peak in the chromatogram obtained with reference solution (b) (0.2 per cent);
- unspecified impurities: for each impurity, not more than the area of the principal peak in the chromatogram obtained with reference solution (b) (0.10 per cent);
- total: not more than 10 times the area of the principal peak in the chromatogram obtained with reference solution (b) (1.0 per cent);
- disregard limit: 0.5 times the area of the principal peak in the chromatogram obtained with reference solution (b) (0.05 per cent).

**Water (2.5.12):** 7.0 per cent to 12.0 per cent, determined on 0.100 g.

**Sulfated ash (2.4.14):** maximum 0.1 per cent, determined on 1.0 g.

**ASSAY**

Dissolve 0.350 g in 60 mL of *anhydrous acetic acid R*. Titrate with 0.1 M *perchloric acid*, determining the end-point potentiometrically (2.2.20).

1 mL of 0.1 M *perchloric acid* is equivalent to 44.95 mg of  $C_{22}H_{27}NO_9$ .

**STORAGE**

In an airtight container, protected from light.

**IMPURITIES**

**Specified impurities:** A, B, C, D, E, F, H, I, K.

**Other detectable impurities** (the following substances would, if present at a sufficient level, be detected by one or other of the tests in the monograph. They are limited by the general acceptance criterion for other/unspecified impurities and/or by the general monograph *Substances for pharmaceutical use (2034)*. It is therefore not necessary to identify these impurities for demonstration of compliance. See also 5.10. *Control of impurities in substances for pharmaceutical use*): G, J.

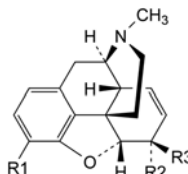

A. R1 = R2 = OH, R3 = H: morphine,

C. R1 = OCH<sub>3</sub>, R2 = OH, R3 = H: codeine,

E. R1 = OCH<sub>3</sub>, R2 + R3 = O: 7,8-didehydro-4,5 $\alpha$ -epoxy-3-methoxy-17-methylmorphinan-6-one (codeinone),

F. R1 = R2 = OCH<sub>3</sub>, R3 = H: 7,8-didehydro-4,5 $\alpha$ -epoxy-3,6 $\alpha$ -dimethoxy-17-methylmorphinan (methylcodeine),

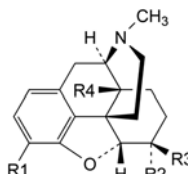

B. R1 = OCH<sub>3</sub>, R2 = OH, R3 = R4 = H: 4,5 $\alpha$ -epoxy-3-methoxy-17-methylmorphinan-6 $\alpha$ -ol (dihydrocodeine),

D. R1 = OCH<sub>3</sub>, R2 + R3 = O, R4 = OH: 4,5 $\alpha$ -epoxy-14-hydroxy-3-methoxy-17-methylmorphinan-6-one (oxycodone),

K. R1 = OH, R2 + R3 = O, R4 = H: 4,5 $\alpha$ -epoxy-3-hydroxy-17-methylmorphinan-6-one,

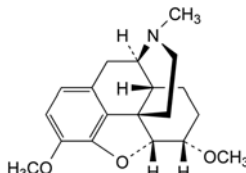

G. 4,5 $\alpha$ -epoxy-3,6 $\alpha$ -dimethoxy-17-methylmorphinan (tetrahydrothebaine),

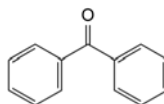

H. diphenylmethanone (benzophenone),

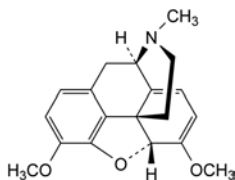

- I. 6,7,8,14-tetrahydro-4,5 $\alpha$ -epoxy-3,6-dimethoxy-17-methylmorphinan (thebaine),

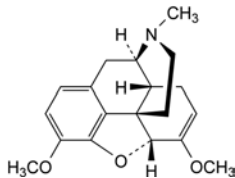

- J. 6,7-didehydro-4,5 $\alpha$ -epoxy-3,6-dimethoxy-17-methylmorphinan.

01/2011:0335

## HYDROCORTISONE

### Hydrocortisonum

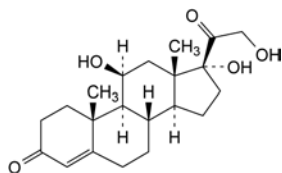

C<sub>21</sub>H<sub>30</sub>O<sub>5</sub>  
[50-23-7]

M<sub>r</sub> 362.5

#### DEFINITION

11 $\beta$ ,17,21-Trihydroxypregn-4-ene-3,20-dione.

*Content*: 97.0 per cent to 103.0 per cent (dried substance).

#### CHARACTERS

*Appearance*: white or almost white, crystalline powder.

*Solubility*: practically insoluble in water, sparingly soluble in acetone and in ethanol (96 per cent), slightly soluble in methylene chloride.

It shows polymorphism (5.9).

#### IDENTIFICATION

*First identification*: A, B.

*Second identification*: C, D.

- A. Infrared absorption spectrophotometry (2.2.24).

*Comparison*: hydrocortisone CRS.

If the spectra obtained in the solid state show differences, dissolve the substance to be examined and the reference substance separately in the minimum volume of *acetone R*, evaporate to dryness on a water-bath and record new spectra using the residues.

- B. Liquid chromatography (2.2.29) as described in the test for related substances with the following modification.

*Injection*: test solution and reference solution (c).

*Results*: the principal peak in the chromatogram obtained with the test solution is similar in retention time and size to the principal peak in the chromatogram obtained with reference solution (c).

- C. Thin-layer chromatography (2.2.27).

*Solution A*. Dissolve 25 mg of the substance to be examined in *methanol R* and dilute to 5 mL with the same solvent.

*Solution B*. Dissolve 25 mg of *hydrocortisone CRS* in *methanol R* and dilute to 5 mL with the same solvent.

*Test solution (a)*. Dilute 2 mL of solution A to 10 mL with *methylene chloride R*.

*Test solution (b)*. Transfer 0.4 mL of solution A to a glass tube 100 mm long and 20 mm in diameter and fitted with a ground-glass stopper or a polytetrafluoroethylene cap. Evaporate the solvent with gentle heating under a stream of *nitrogen R*. Add 2 mL of a 15 per cent V/V solution of *glacial acetic acid R* and 50 mg of *sodium bismuthate R*. Stopper the tube and shake the suspension in a mechanical shaker, protected from light, for 1 h. Add 2 mL of a 15 per cent V/V solution of *glacial acetic acid R* and filter into a 50 mL separating funnel, washing the filter with 2 quantities, each of 5 mL, of *water R*. Shake the clear filtrate with 10 mL of *methylene chloride R*. Wash the organic layer with 5 mL of 1 M *sodium hydroxide* and then with 2 quantities, each of 5 mL, of *water R*. Dry over *anhydrous sodium sulfate R*.

*Reference solution (a)*. Dilute 2 mL of solution B to 10 mL with *methylene chloride R*.

*Reference solution (b)*. Transfer 0.4 mL of solution B to a glass tube 100 mm long and 20 mm in diameter and fitted with a ground-glass stopper or a polytetrafluoroethylene cap. Evaporate the solvent with gentle heating under a stream of *nitrogen R*. Add 2 mL of a 15 per cent V/V solution of *glacial acetic acid R* and 50 mg of *sodium bismuthate R*. Stopper the tube and shake the suspension in a mechanical shaker, protected from light, for 1 h. Add 2 mL of a 15 per cent V/V solution of *glacial acetic acid R* and filter into a 50 mL separating funnel, washing the filter with 2 quantities, each of 5 mL, of *water R*. Shake the clear filtrate with 10 mL of *methylene chloride R*. Wash the organic layer with 5 mL of 1 M *sodium hydroxide* and then with 2 quantities, each of 5 mL, of *water R*. Dry over *anhydrous sodium sulfate R*.

*Plate*: TLC silica gel F<sub>254</sub> plate R.

*Mobile phase A*: add a mixture of 1.2 volumes of *water R* and 8 volumes of *methanol R* to a mixture of 15 volumes of *ether R* and 77 volumes of *methylene chloride R*.

*Mobile phase B*: *butanol R* saturated with *water R*, *toluene R*, *ether R* (5:15:80 V/V/V).

*Application*: 5  $\mu$ L of test solution (a) and reference solution (a), 25  $\mu$ L of test solution (b) and reference solution (b), applying the latter 2 in small quantities to obtain small spots.

*Development*: over a path of 15 cm with mobile phase A, and then over a path of 15 cm with mobile phase B.

*Drying*: in air.

*Detection A*: examine in ultraviolet light at 254 nm.

*Results A*: the principal spot in each of the chromatograms obtained with test solutions (a) and (b) is similar in position and size to the principal spot in the chromatogram obtained with the corresponding reference solution.

*Detection B*: spray with *alcoholic solution of sulfuric acid R* and heat at 120 °C for 10 min or until the spots appear; allow to cool, and examine in daylight and in ultraviolet light at 365 nm.

*Results B*: the principal spot in each of the chromatograms obtained with test solutions (a) and (b) is similar in position, colour in daylight, fluorescence in ultraviolet light at 365 nm and size to the principal spot in the chromatogram obtained with the corresponding reference solution; the principal spots in the chromatograms obtained with test solution (b) and reference solution (b) have an *R<sub>f</sub>* value distinctly higher than that of the principal spots in the chromatograms obtained with test solution (a) and reference solution (a).

- D. Add about 2 mg to 2 mL of *sulfuric acid R* and shake to dissolve. Within 5 min, an intense brownish-red colour develops with a green fluorescence that is particularly intense when examined in ultraviolet light at 365 nm. Add the solution to 10 mL of *water R* and mix. The colour fades and a clear solution remains. The fluorescence in ultraviolet light does not disappear.

## TESTS

**Specific optical rotation** (2.2.7): + 162 to + 168 (dried substance).

Dissolve 0.200 g in *methanol R*, dilute to 25.0 mL with the same solvent and sonicate for 10 min.

**Related substances.** Liquid chromatography (2.2.29).

**Solvent mixture:** acetonitrile *R*, water *R* (40:60 V/V).

**Test solution.** Dissolve 20 mg of the substance to be examined in the solvent mixture, dilute to 10.0 mL with the solvent mixture and sonicate for 10 min.

**Reference solution (a).** Dissolve 4 mg of *prednisolone CRS* (impurity A), 2 mg of *cortisone R* (impurity B), 8 mg of *hydrocortisone acetate CRS* (impurity C) and 6 mg of *Reichstein's substance S R* (impurity F) in 40 mL of *acetonitrile R* and dilute to 100.0 mL with *water R*. Dilute 0.5 mL of the solution to 5.0 mL with the test solution.

**Reference solution (b).** Dilute 1.0 mL of the test solution to 100.0 mL with the solvent mixture. Dilute 1.0 mL of this solution to 10.0 mL with the solvent mixture.

**Reference solution (c).** Dissolve 2 mg of *hydrocortisone CRS* in 1.0 mL of the solvent mixture and sonicate for 10 min.

**Reference solution (d).** Dissolve 2 mg of *hydrocortisone for peak identification CRS* (containing impurities D, E, G, H, I and N) in 1.0 mL of the solvent mixture and sonicate for 10 min.

**Column:**

- size:  $l = 0.25$  m,  $\varnothing = 4.6$  mm;
- stationary phase: base-deactivated end-capped octadecylsilyl silica gel for chromatography *R* (5  $\mu$ m).

**Mobile phase:**

- mobile phase A: water *R*;
- mobile phase B: acetonitrile *R*;

Time (min)	Mobile phase A (per cent V/V)	Mobile phase B (per cent V/V)
0 - 18	74	26
18 - 32	74 → 55	26 → 45
32 - 48	55 → 30	45 → 70

**Flow rate:** 0.8 mL/min.

**Detection:** spectrophotometer at 254 nm.

**Injection:** 10  $\mu$ L of the test solution and reference solutions (a), (b) and (d).

**Identification of impurities:** use the chromatogram supplied with *hydrocortisone for peak identification CRS* and the chromatogram obtained with reference solution (d) to identify the peaks due to impurities D, E, G, H, I and N; use the chromatogram obtained with reference solution (a) to identify the peaks due to impurities A, B, C and F.

**Relative retention** with reference to hydrocortisone (retention time = about 24 min): impurity D = about 0.2; impurity H = about 0.3; impurity I = about 0.5; impurity G = about 0.8; impurity E = about 0.86; impurity A = about 0.96; impurity B = about 1.1; impurity F = about 1.4; impurity C = about 1.5; impurity N = about 1.7.

**System suitability:** reference solution (a):

- peak-to-valley ratio: minimum 3.0, where  $H_p$  = height above the baseline of the peak due to impurity A and  $H_v$  = height above the baseline of the lowest point of the curve separating this peak from the peak due to hydrocortisone.

**Limits:**

- correction factors: for the calculation of content, multiply the peak areas of the following impurities by the corresponding correction factor: impurity D = 1.8; impurity E = 2.7;

- impurities C, D, E, I: for each impurity, not more than 5 times the area of the principal peak in the chromatogram obtained with reference solution (b) (0.5 per cent);
- impurity G: not more than 4 times the area of the principal peak in the chromatogram obtained with reference solution (b) (0.4 per cent);
- impurity F: not more than 3 times the area of the principal peak in the chromatogram obtained with reference solution (b) (0.3 per cent);
- impurities A, B: for each impurity, not more than twice the area of the principal peak in the chromatogram obtained with reference solution (b) (0.2 per cent);
- impurities H, N: for each impurity, not more than 1.5 times the area of the principal peak in the chromatogram obtained with reference solution (b) (0.15 per cent);
- unspecified impurities: for each impurity, not more than the area of the principal peak in the chromatogram obtained with reference solution (b) (0.10 per cent);
- total: not more than 20 times the area of the principal peak in the chromatogram obtained with reference solution (b) (2.0 per cent);
- disregard limit: 0.5 times the area of the principal peak in the chromatogram obtained with reference solution (b) (0.05 per cent).

**Loss on drying** (2.2.32): maximum 1.0 per cent, determined on 1.000 g by drying in an oven at 105 °C.

## ASSAY

Dissolve 0.100 g in *ethanol (96 per cent) R* and dilute to 100.0 mL with the same solvent. Dilute 2.0 mL of the solution to 100.0 mL with *ethanol (96 per cent) R*. Measure the absorbance (2.2.25) at the absorption maximum at 241.5 nm.

Calculate the content of  $C_{21}H_{30}O_5$  taking the specific absorbance to be 440.

## STORAGE

Protected from light.

## IMPURITIES

**Specified impurities:** A, B, C, D, E, F, G, H, I, N.

**Other detectable impurities** (the following substances would, if present at a sufficient level, be detected by one or other of the tests in the monograph. They are limited by the general acceptance criterion for other/unspecified impurities and/or by the general monograph *Substances for pharmaceutical use* (2034). It is therefore not necessary to identify these impurities for demonstration of compliance. See also 5.10. *Control of impurities in substances for pharmaceutical use*): J, K, L, M, O.

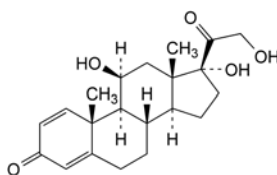

A. 11 $\beta$ ,17,21-trihydroxypregna-1,4-diene-3,20-dione (prednisolone),

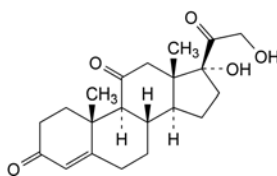

B. 17,21-dihydroxypregna-4-ene-3,11,20-trione (cortisone),

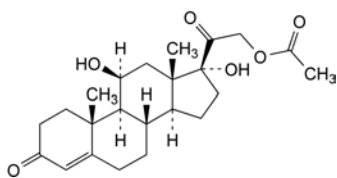

- C. 11β,17-dihydroxy-3,20-dioxopregn-4-en-21-yl acetate (hydrocortisone acetate),

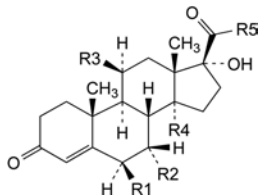

- D. R1 = R3 = OH, R2 = R4 = H, R5 = CH<sub>2</sub>OH: 6β,11β,17,21-tetrahydroxypregn-4-ene-3,20-dione (6β-hydroxyhydrocortisone),
- F. R1 = R2 = R3 = R4 = H, R5 = CH<sub>2</sub>OH: 17,21-dihydroxypregn-4-ene-3,20-dione (Reichstein's substance S),
- G. R1 = R2 = R4 = H, R3 = OH, R5 = CHO: 11β,17-dihydroxy-3,20-dioxopregn-4-en-21-al (hydrocortisone-21-aldehyde),
- H. R1 = R4 = H, R2 = R3 = OH, R5 = CH<sub>2</sub>OH: 7α,11β,17,21-tetrahydroxypregn-4-ene-3,20-dione (7α-hydroxyhydrocortisone),
- I. R1 = R2 = H, R3 = R4 = OH, R5 = CH<sub>2</sub>OH: 11β,14,17,21-tetrahydroxypregn-4-ene-3,20-dione (14α-hydroxyhydrocortisone),
- K. R1 = R2 = R3 = R4 = H, R5 = CH<sub>2</sub>-O-CO-CH<sub>3</sub>: 17-hydroxy-3,20-dioxopregn-4-en-21-yl acetate (Reichstein's substance S-21-acetate),

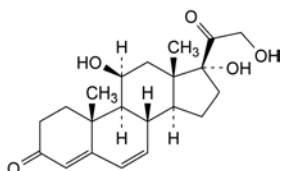

- E. 11β,17,21-trihydroxypregna-4,6-diene-3,20-dione (Δ6-hydrocortisone),

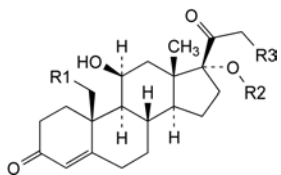

- J. R1 = H, R2 = CO-CH<sub>3</sub>, R3 = OH: 11β,21-dihydroxy-3,20-dioxopregn-4-en-17-yl acetate (hydrocortisone-17-acetate),
- L. R1 = R2 = R3 = H: 11β,17-dihydroxypregn-4-ene-3,20-dione (oxenol),
- O. R1 = R3 = OH, R2 = H: 11β,17,19,21-tetrahydroxypregn-4-ene-3,20-dione (19-hydroxyhydrocortisone),

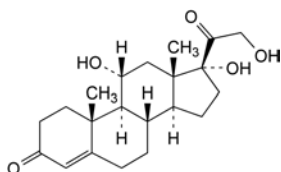

- M. 11α,17,21-trihydroxypregn-4-ene-3,20-dione (epi-hydrocortisone),

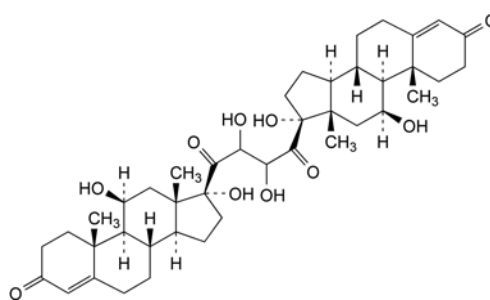

- N. 11β,17,21-trihydroxy-21-(11β,17,21-trihydroxy-3,20-dioxopregn-4-en-21-yl)pregn-4-ene-3,20-dione (hydrocortisone dimer).

01/2008:0334  
corrected 6.0

## HYDROCORTISONE ACETATE

### Hydrocortisoni acetas

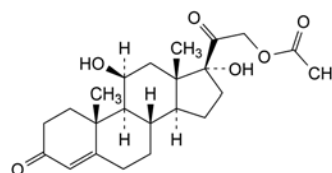

C<sub>23</sub>H<sub>32</sub>O<sub>6</sub>  
[50-03-3]

M<sub>r</sub> 404.5

#### DEFINITION

11β,17-Dihydroxy-3,20-dioxopregn-4-en-21-yl acetate.

*Content*: 97.0 per cent to 103.0 per cent (dried substance).

#### CHARACTERS

*Appearance*: white or almost white, crystalline powder.

*Solubility*: practically insoluble in water, slightly soluble in anhydrous ethanol and in methylene chloride.

mp: about 220 °C, with decomposition.

#### IDENTIFICATION

*First identification*: A, B.

*Second identification*: C, D, E.

A. Infrared absorption spectrophotometry (2.2.24).

*Comparison*: hydrocortisone acetate CRS.

B. Thin-layer chromatography (2.2.27).

*Solvent mixture*: methanol R, methylene chloride R (1:9 V/V).

*Test solution*. Dissolve 10 mg of the substance to be examined in the solvent mixture and dilute to 10 mL with the solvent mixture.

*Reference solution (a)*. Dissolve 20 mg of hydrocortisone acetate CRS in the solvent mixture and dilute to 20 mL with the solvent mixture.

*Reference solution (b)*. Dissolve 10 mg of cortisone acetate R in reference solution (a) and dilute to 10 mL with reference solution (a).

*Plate*: TLC silica gel F<sub>254</sub> plate R.

*Mobile phase*: add a mixture of 1.2 volumes of water R and 8 volumes of methanol R to a mixture of 15 volumes of ether R and 77 volumes of methylene chloride R.

*Application*: 5 µL.

*Development*: over a path of 15 cm.

*Drying*: in air.

*Detection A*: examine in ultraviolet light at 254 nm.

**Results A:** the principal spot in the chromatogram obtained with the test solution is similar in position and size to the principal spot in the chromatogram obtained with reference solution (a).

**Detection B:** spray with *alcoholic solution of sulfuric acid R*. Heat at 120 °C for 10 min or until the spots appear and allow to cool; examine in daylight and in ultraviolet light at 365 nm.

**Results B:** the principal spot in the chromatogram obtained with the test solution is similar in position, colour in daylight, fluorescence in ultraviolet light at 365 nm and size to the principal spot in the chromatogram obtained with reference solution (a).

**System suitability:** reference solution (b):

- the chromatogram shows 2 clearly separated spots.

C. Thin-layer chromatography (2.2.27).

**Test solution (a).** Dissolve 25 mg of the substance to be examined in *methanol R* and dilute to 5 mL with the same solvent (solution A). Dilute 2 mL of this solution to 10 mL with *methylene chloride R*.

**Test solution (b).** Transfer 2 mL of solution A to a 15 mL glass tube with a ground-glass stopper or a polytetrafluoroethylene cap. Add 10 mL of *saturated methanolic potassium hydrogen carbonate solution R* and immediately pass a stream of *nitrogen R* briskly through the solution for 5 min. Stopper the tube. Heat in a water-bath at 45 °C protected from light for 2 h 30 min. Allow to cool.

**Reference solution (a).** Dissolve 25 mg of *hydrocortisone acetate CRS* in *methanol R* and dilute to 5 mL with the same solvent (solution B). Dilute 2 mL of this solution to 10 mL with *methylene chloride R*.

**Reference solution (b).** Transfer 2 mL of solution B to a 15 mL glass tube with a ground-glass stopper or a polytetrafluoroethylene cap. Add 10 mL of *saturated methanolic potassium hydrogen carbonate solution R* and immediately pass a stream of *nitrogen R* briskly through the solution for 5 min. Stopper the tube. Heat in a water-bath at 45 °C protected from light for 2 h 30 min. Allow to cool.

**Plate:** *TLC silica gel F<sub>254</sub> plate R*.

**Mobile phase:** add a mixture of 1.2 volumes of *water R* and 8 volumes of *methanol R* to a mixture of 15 volumes of *ether R* and 77 volumes of *methylene chloride R*.

**Application:** 5 µL.

**Development:** over a path of 15 cm.

**Drying:** in air.

**Detection A:** examine in ultraviolet light at 254 nm.

**Results A:** the principal spot in each of the chromatograms obtained with the test solutions is similar in position and size to the principal spot in the chromatogram obtained with the corresponding reference solution.

**Detection B:** spray with *alcoholic solution of sulfuric acid R* and heat at 120 °C for 10 min or until the spots appear and allow to cool; examine in daylight and in ultraviolet light at 365 nm.

**Results B:** the principal spot in each of the chromatograms obtained with the test solutions is similar in position, colour in daylight, fluorescence in ultraviolet light at 365 nm and size to the principal spot in the chromatogram obtained with the corresponding reference solution. The principal spots in the chromatograms obtained with test solution (b) and reference solution (b) have an  $R_f$  value distinctly lower than that of the principal spots in the chromatograms obtained with test solution (a) and reference solution (a).

D. Add about 2 mg to 2 mL of *sulfuric acid R* and shake to dissolve. Within 5 min an intense brownish-red colour develops with a green fluorescence which is particularly

intense when viewed in ultraviolet light at 365 nm. Add this solution to 10 mL of *water R* and mix. The colour fades and the fluorescence in ultraviolet light does not disappear.

E. About 10 mg gives the reaction of acetyl (2.3.1).

TESTS

**Specific optical rotation (2.2.7):** + 158 to + 167 (dried substance).

Dissolve 0.250 g in *dioxan R* and dilute to 25.0 mL with the same solvent.

**Related substances.** Liquid chromatography (2.2.29).

**Test solution.** Dissolve 25.0 mg of the substance to be examined in *methanol R* and dilute to 10.0 mL with the same solvent.

**Reference solution (a).** Dissolve 2 mg of *hydrocortisone acetate CRS* and 2 mg of *cortisone acetate R* in the mobile phase, then dilute to 100.0 mL with the mobile phase.

**Reference solution (b).** Dilute 1.0 mL of the test solution to 100.0 mL with the mobile phase.

**Column:**

- size:  $l = 0.25$  m,  $\varnothing = 4.6$  mm;
- stationary phase: *octadecylsilyl silica gel for chromatography R* (5 µm).

**Mobile phase:** in a 1000 mL volumetric flask mix 400 mL of *acetonitrile R* with 550 mL of *water R* and allow to equilibrate; dilute to 1000 mL with *water R* and mix again.

**Flow rate:** 1 mL/min.

**Detection:** spectrophotometer at 254 nm.

**Equilibration:** with the mobile phase for about 30 min.

**Injection:** 20 µL.

**Run time:** 2.5 times the retention time of hydrocortisone acetate.

**Retention time:** hydrocortisone acetate = about 10 min; cortisone acetate = about 12 min.

**System suitability:** reference solution (a):

- resolution: minimum 4.2 between the peaks due to hydrocortisone acetate and cortisone acetate; if necessary, adjust the concentration of acetonitrile in the mobile phase.

**Limits:**

- any impurity: for each impurity, not more than the area of the principal peak in the chromatogram obtained with reference solution (b) (1.0 per cent), and not more than one such peak has an area greater than 0.5 times the area of the principal peak in the chromatogram obtained with reference solution (b) (0.5 per cent);
- total: not more than 1.5 times the area of the principal peak in the chromatogram obtained with reference solution (b) (1.5 per cent);
- disregard limit: 0.05 times the area of the principal peak in the chromatogram obtained with reference solution (b) (0.05 per cent).

**Loss on drying (2.2.32):** maximum 0.5 per cent, determined on 0.500 g by drying in an oven at 105 °C.

ASSAY

Dissolve 0.100 g in *ethanol (96 per cent) R* and dilute to 100.0 mL with the same solvent. Dilute 2.0 mL of this solution to 100.0 mL with *ethanol (96 per cent) R*. Measure the absorbance (2.2.25) at the absorption maximum at 241.5 nm.

Calculate the content of  $C_{23}H_{32}O_6$  taking the specific absorbance to be 395.

STORAGE

Protected from light.



01/2008:0768  
corrected 6.0**HYDROCORTISONE HYDROGEN  
SUCCINATE**

Hydrocortisoni hydrogenosuccinas

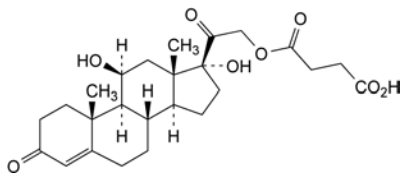
C<sub>25</sub>H<sub>34</sub>O<sub>8</sub>  
[2203-97-6]M<sub>r</sub> 462.5**DEFINITION**

11β,17-Dihydroxy-3,20-dioxopregn-4-en-21-yl hydrogen butanedioate.

*Content*: 97.0 per cent to 103.0 per cent (dried substance).**CHARACTERS***Appearance*: white or almost white, hygroscopic powder.*Solubility*: practically insoluble in water, freely soluble in acetone and in anhydrous ethanol. It dissolves in dilute solutions of alkali carbonates and alkali hydroxides.**IDENTIFICATION***First identification*: A, B.*Second identification*: C, D.

A. Infrared absorption spectrophotometry (2.2.24).

*Preparation*: dry the substances before use at 100-105 °C for 3 h.*Comparison*: hydrocortisone hydrogen succinate CRS.

B. Thin-layer chromatography (2.2.27).

*Solvent mixture*: methanol R, methylene chloride R (1:9 V/V).*Test solution*. Dissolve 10 mg of the substance to be examined in the solvent mixture and dilute to 10 mL with the solvent mixture.*Reference solution (a)*. Dissolve 20 mg of hydrocortisone hydrogen succinate CRS in the solvent mixture and dilute to 20 mL with the solvent mixture.*Reference solution (b)*. Dissolve 10 mg of methylprednisolone hydrogen succinate CRS in reference solution (a) and dilute to 10 mL with reference solution (a).*Plate*: TLC silica gel F<sub>254</sub> plate R.*Mobile phase*: anhydrous formic acid R, anhydrous ethanol R, methylene chloride R (0.1:1:15 V/V/V).*Application*: 5 µL.*Development*: over a path of 15 cm.*Drying*: in air.*Detection A*: examine in ultraviolet light at 254 nm.*Results A*: the principal spot in the chromatogram obtained with the test solution is similar in position and size to the principal spot in the chromatogram obtained with reference solution (a).*Detection B*: spray with alcoholic solution of sulfuric acid R. Heat at 120 °C for 10 min or until the spots appear. Allow to cool. Examine in daylight and in ultraviolet light at 365 nm.*Results B*: the principal spot in the chromatogram obtained with the test solution is similar in position, colour in daylight, fluorescence in ultraviolet light at 365 nm and size to the principal spot in the chromatogram obtained with reference solution (a).*System suitability*: reference solution (b):

– the chromatogram shows 2 spots which may, however, not be completely separated.

C. Thin-layer chromatography (2.2.27).

*Test solution (a)*. Dissolve 25 mg of the substance to be examined in methanol R with gentle heating and dilute to 5 mL with the same solvent (solution A). Dilute 2 mL of this solution to 10 mL with methylene chloride R.*Test solution (b)*. Transfer 2 mL of solution A to a 15 mL glass tube with a ground-glass stopper or a polytetrafluoroethylene cap. Add 10 mL of a 0.8 g/L solution of sodium hydroxide R in methanol R and immediately pass a stream of nitrogen R briskly through the solution for 5 min. Stopper the tube. Heat in a water-bath at 45 °C, protected from light, for 30 min. Allow to cool.*Reference solution (a)*. Dissolve 25 mg of hydrocortisone hydrogen succinate CRS in methanol R with gentle heating and dilute to 5 mL with the same solvent (solution B). Dilute 2 mL of this solution to 10 mL with methylene chloride R.*Reference solution (b)*. Transfer 2 mL of solution B to a 15 mL glass tube with a ground-glass stopper or a polytetrafluoroethylene cap. Add 10 mL of a 0.8 g/L solution of sodium hydroxide R in methanol R and immediately pass a stream of nitrogen R briskly through the solution for 5 min. Stopper the tube. Heat in a water-bath at 45 °C, protected from light, for 30 min. Allow to cool.*Plate*: TLC silica gel F<sub>254</sub> plate R.*Mobile phase*: add a mixture of 1.2 volumes of water R and 8 volumes of methanol R to a mixture of 15 volumes of ether R and 77 volumes of methylene chloride R.*Application*: 5 µL.*Development*: over a path of 15 cm.*Drying*: in air.*Detection A*: examine in ultraviolet light at 254 nm.*Results A*: the principal spot in each of the chromatograms obtained with the test solutions is similar in position and size to the principal spot in the chromatogram obtained with the corresponding reference solution.*Detection B*: spray with alcoholic solution of sulfuric acid R. Heat at 120 °C for 10 min or until the spots appear. Allow to cool. Examine in daylight and in ultraviolet light at 365 nm.*Results B*: the principal spot in each of the chromatograms obtained with the test solutions is similar in position, colour in daylight, fluorescence in ultraviolet light at 365 nm and size to the principal spot in the chromatogram obtained with the corresponding reference solution. The principal spot in each of the chromatograms obtained with test solution (b) and reference solution (b) has an R<sub>f</sub> value distinctly higher than that of the principal spot in each of the chromatograms obtained with test solution (a) and reference solution (a).

D. Add about 2 mg to 2 mL of sulfuric acid R and shake to dissolve. Within 5 min, an intense brownish-red colour develops with a green fluorescence which is particularly intense when viewed in ultraviolet light at 365 nm. Add this solution to 10 mL of water R and mix. The colour fades and a clear solution remains. The fluorescence in ultraviolet light does not disappear.

**TESTS****Appearance of solution**. The solution is clear (2.2.1).

Dissolve 0.10 g in 5 mL of sodium hydrogen carbonate solution R.

**Specific optical rotation** (2.2.7): + 147 to + 153 (dried substance).

Dissolve 0.250 g in anhydrous ethanol R and dilute to 25.0 mL with the same solvent.

**Related substances.** Liquid chromatography (2.2.29).

**Test solution.** Dissolve 25.0 mg of the substance to be examined in a mixture of equal volumes of *acetonitrile R* and *water R* and dilute to 10.0 mL with the same mixture of solvents.

**Reference solution (a).** Dissolve 2 mg of *hydrocortisone hydrogen succinate CRS* and 2 mg of *dexamethasone CRS* in 50 mL of *acetonitrile R*, then dilute to 100.0 mL with *water R*.

**Reference solution (b).** Dilute 1.0 mL of the test solution to 100.0 mL with a mixture of equal volumes of *acetonitrile R* and *water R*.

**Column:**

- size:  $l = 0.25$  m,  $\varnothing = 4.6$  mm;
- stationary phase: octadecylsilyl silica gel for chromatography R (5  $\mu$ m).

**Mobile phase:** in a 1000 mL volumetric flask mix 330 mL of *acetonitrile R* with 600 mL of *water R* and 1.0 mL of *phosphoric acid R*, then allow to equilibrate; dilute to 1000 mL with *water R* and mix again.

**Flow rate:** 1 mL/min.

**Detection:** spectrophotometer at 254 nm.

**Equilibration:** with the mobile phase for about 30 min.

**Injection:** 20  $\mu$ L.

**Run time:** twice the retention time of hydrocortisone hydrogen succinate.

**Retention time:** dexamethasone = about 12.5 min; hydrocortisone hydrogen succinate = about 15 min.

**System suitability:** reference solution (a):

- resolution: minimum 5.0 between the peaks due to dexamethasone and hydrocortisone hydrogen succinate; if necessary, adjust the concentration of acetonitrile in the mobile phase.

**Limits:**

- impurities A, B: for each impurity, not more than 0.5 times the area of the principal peak in the chromatogram obtained with reference solution (b) (0.5 per cent);
- total: not more than 0.75 times the area of the principal peak in the chromatogram obtained with reference solution (b) (0.75 per cent);
- disregard limit: 0.05 times the area of the principal peak in the chromatogram obtained with reference solution (b) (0.05 per cent).

**Loss on drying (2.2.32):** maximum 4.0 per cent, determined on 1.000 g by drying in an oven at 105 °C.

**Sulfated ash (2.4.14):** maximum 0.1 per cent, determined on 1.0 g.

#### ASSAY

Dissolve 0.100 g in *ethanol (96 per cent) R* and dilute to 100.0 mL with the same solvent. Dilute 2.0 mL of this solution to 100.0 mL with *ethanol (96 per cent) R*. Measure the absorbance (2.2.25) at the absorption maximum at 241.5 nm.

Calculate the content of  $C_{25}H_{34}O_8$  taking the specific absorbance to be 353.

#### STORAGE

In an airtight container, protected from light.

#### IMPURITIES

**Specified impurities:** A, B.

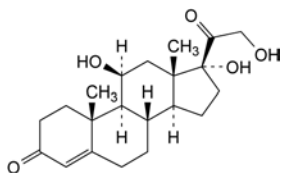

A. 11 $\beta$ ,17,21-trihydroxypregn-4-ene-3,20-dione (hydrocortisone),

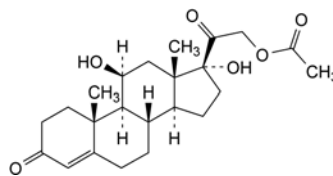

B. 11 $\beta$ ,17-dihydroxy-3,20-dioxopregn-4-en-21-yl acetate (hydrocortisone acetate).

01/2008:0395

## HYDROGEN PEROXIDE SOLUTION (3 PER CENT)

### Hydrogenii peroxidum 3 per centum

#### DEFINITION

**Content:** 2.5 per cent *m/m* to 3.5 per cent *m/m* of  $H_2O_2$  ( $M_r$  34.01).

1 volume of hydrogen peroxide solution (3 per cent) corresponds to about 10 times its volume of oxygen. A suitable stabiliser may be added.

#### CHARACTERS

**Appearance:** colourless, clear liquid.

#### IDENTIFICATION

- To 2 mL add 0.2 mL of *dilute sulfuric acid R* and 0.2 mL of 0.02 M *potassium permanganate*. The solution becomes colourless or slightly pink within 2 min.
- To 0.5 mL add 1 mL of *dilute sulfuric acid R*, 2 mL of *ether R* and 0.1 mL of *potassium chromate solution R* and shake. The ether layer is blue.
- It complies with the requirement for the content of  $H_2O_2$ .

#### TESTS

**Acidity.** To 10 mL add 20 mL of *water R* and 0.25 mL of *methyl red solution R*. Not less than 0.05 mL and not more than 1.0 mL of 0.1 M *sodium hydroxide* is required to change the colour of the indicator.

**Organic stabilisers:** maximum 250 ppm.

Shake 20 mL with 10 mL of *chloroform R* and then with 2 quantities, each of 5 mL, of *chloroform R*. Evaporate the combined chloroform layers under reduced pressure at a temperature not exceeding 25 °C and dry in a desiccator. The residue weighs a maximum of 5 mg.

**Non-volatile residue:** maximum 2 g/L.

Allow 10 mL to stand in a platinum dish until all effervescence has ceased. Evaporate to dryness on a water-bath and dry at 100–105 °C. The residue weighs a maximum of 20 mg.

#### ASSAY

Dilute 10.0 g to 100.0 mL with *water R*. To 10.0 mL of this solution add 20 mL of *dilute sulfuric acid R*. Titrate with 0.02 M *potassium permanganate* until a pink colour is obtained.

1 mL of 0.02 M *potassium permanganate* is equivalent to 1.701 mg of  $H_2O_2$  or 0.56 mL of oxygen.

#### STORAGE

Protected from light, and if the solution does not contain a stabiliser, at a temperature below 15 °C.

#### LABELLING

If the solution contains a stabiliser, the label states that the contents are stabilised. The competent authority may require that the name of the stabiliser be stated on the label.

#### CAUTION

It decomposes in contact with oxidisable organic matter and with certain metals and if allowed to become alkaline.

01/2008:0396

01/2008:2099  
corrected 6.0**HYDROGEN PEROXIDE SOLUTION  
(30 PER CENT)**

Hydrogenii peroxidum 30 per centum

[7722-84-1]

**DEFINITION**

*Content:* 29.0 per cent *m/m* to 31.0 per cent *m/m* of H<sub>2</sub>O<sub>2</sub> (*M<sub>r</sub>* 34.01).

1 volume of hydrogen peroxyde solution (30 per cent) corresponds to about 110 times its volume of oxygen. A suitable stabiliser may be added.

**CHARACTERS**

*Appearance:* colourless, clear liquid.

**IDENTIFICATION**

- A. To 1 mL add 0.2 mL of *dilute sulfuric acid R* and 0.25 mL of 0.02 *M* *potassium permanganate*. The solution becomes colourless with evolution of gas.
- B. To 0.05 mL add 2 mL of *dilute sulfuric acid R*, 2 mL of *ether R* and 0.05 mL of *potassium chromate solution R* and shake. The ether layer is blue.
- C. It complies with the requirement for the content of H<sub>2</sub>O<sub>2</sub>.

**TESTS**

**Acidity.** To 10 mL add 100 mL of *water R* and 0.25 mL of *methyl red solution R*. Not less than 0.05 mL and not more than 0.5 mL of 0.1 *M* *sodium hydroxide* is required to change the colour of the indicator.

**Organic stabilisers:** maximum 500 ppm.

Shake 20 mL with 10 mL of *chloroform R* and then with 2 quantities, each of 5 mL, of *chloroform R*. Evaporate the combined chloroform layers under reduced pressure at a temperature not exceeding 25 °C and dry in a desiccator. The residue weighs a maximum of 10 mg.

**Non-volatile residue:** maximum 2 g/L.

Allow 10 mL to stand in a platinum dish until all effervescence has ceased, cooling if necessary. Evaporate to dryness on a water-bath and dry at 100-105 °C. The residue weighs a maximum of 20 mg.

**ASSAY**

Dilute 1.00 g to 100.0 mL with *water R*. To 10.0 mL of this solution add 20 mL of *dilute sulfuric acid R*. Titrate with 0.02 *M* *potassium permanganate* until a pink colour is obtained.

1 mL of 0.02 *M* *potassium permanganate* is equivalent to 1.701 mg of H<sub>2</sub>O<sub>2</sub> or 0.56 mL of oxygen.

**STORAGE**

Protected from light, and if the solution does not contain a stabiliser, at a temperature below 15 °C.

**LABELLING**

If the solution contains a stabiliser, the label states that the contents are stabilised. The competent authority may require that the name of the stabiliser be stated on the label.

**CAUTION**

It decomposes vigorously in contact with oxidisable organic matter and with certain metals and if allowed to become alkaline.

**HYDROMORPHONE HYDROCHLORIDE**

Hydromorphoni hydrochloridum

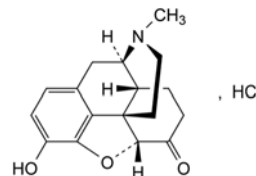

C<sub>17</sub>H<sub>20</sub>ClNO<sub>3</sub>  
[71-68-1]

*M<sub>r</sub>* 321.8

**DEFINITION**

4,5 $\alpha$ -Epoxy-3-hydroxy-17-methylmorphinan-6-one hydrochloride.

*Content:* 99.0 per cent to 101.0 per cent (dried substance).

**CHARACTERS**

*Appearance:* white or almost white, crystalline powder.

*Solubility:* freely soluble in water, very slightly soluble in ethanol (96 per cent), practically insoluble in methylene chloride.

**IDENTIFICATION**

A. Infrared absorption spectrophotometry (2.2.24).

*Comparison:* *hydromorphone hydrochloride CRS*.

B. It gives reaction (a) of chlorides (2.3.1).

**TESTS**

**Solution S.** Dissolve 1.250 g in *carbon dioxide-free water R* and dilute to 25.0 mL with the same solvent.

**Appearance of solution.** Solution S is clear (2.2.1) and not more intensely coloured than reference solution BY<sub>5</sub> (2.2.2, *Method II*).

**Acidity or alkalinity.** To 2 mL of solution S add 0.1 mL of *methyl red solution R*. The solution is not yellow. To 2 mL of solution S add 0.05 mL of *bromocresol green solution R*. The solution is not yellow.

**Specific optical rotation (2.2.7):** –136 to –140 (dried substance), determined on solution S.

**Related substances.** Liquid chromatography (2.2.29).

*Test solution.* Dissolve 0.100 g of the substance to be examined in *water R*, sonicating if necessary and dilute to 100.0 mL with the same solvent.

*Reference solution (a).* Dilute 1.0 mL of the test solution to 100.0 mL with *water R*. Dilute 1.0 mL of this solution to 10.0 mL with *water R*.

*Reference solution (b).* To 5 mL of the test solution add 5 mg of *naloxone hydrochloride dihydrate CRS* and dilute to 50 mL with *water R*.

*Column:*

– *size:* *l* = 0.25 m,  $\varnothing$  = 4.6 mm;

– *stationary phase:* *base-deactivated end-capped octadecylsilyl silica gel for chromatography R* (5  $\mu$ m).

*Mobile phase:* dissolve 18.29 g of *diethylamine R* and 2.88 g of *sodium laurilsulfate R* in *water R* and dilute to 1000 mL with the same solvent. Adjust 800 mL of this solution to pH 3.0 with *phosphoric acid R*. Add 100 mL of *acetonitrile R* and 100 mL of *methanol R*.

*Flow rate:* 1 mL/min.

*Detection:* spectrophotometer at 284 nm.

*Injection:* 20  $\mu$ L.

*Run time:* 4 times the retention time of hydromorphone.

*Relative retention* with reference to hydromorphone (retention time = about 9 min): impurity D = about 0.72; impurity B = about 0.77; impurity C = about 0.82; impurity A = about 3.2.

*System suitability*: reference solution (b):

- *resolution*: minimum 4.0 between the peaks due to hydromorphone and naloxone.

*Limits*:

- *impurity A*: not more than 3 times the area of the principal peak in the chromatogram obtained with reference solution (a) (0.3 per cent);
- *impurities B, C, D*: for each impurity, not more than twice the area of the principal peak in the chromatogram obtained with reference solution (a) (0.2 per cent);
- *unspecified impurities*: for each impurity, not more than the area of the principal peak in the chromatogram obtained with reference solution (a) (0.10 per cent);
- *total*: not more than 5 times the area of the principal peak in the chromatogram obtained with reference solution (a) (0.5 per cent);
- *disregard limit*: 0.5 times the area of the principal peak in the chromatogram obtained with reference solution (a) (0.05 per cent).

**Loss on drying** (2.2.32): maximum 0.5 per cent, determined on 1.000 g by drying in an oven at 105 °C.

**Sulfated ash** (2.4.14): maximum 0.1 per cent, determined on the residue obtained in the test for loss on drying.

#### ASSAY

Dissolve 0.250 g in 50 mL of *ethanol (96 per cent) R* and add 5.0 mL of 0.01 M *hydrochloric acid*. Carry out a potentiometric titration (2.2.20), using 0.1 M *sodium hydroxide*. Read the volume added between the 2 points of inflexion.

1 mL of 0.1 M *sodium hydroxide* is equivalent to 32.18 mg of  $C_{17}H_{20}ClNO_3$ .

#### STORAGE

Protected from light.

#### IMPURITIES

*Specified impurities: A, B, C, D.*

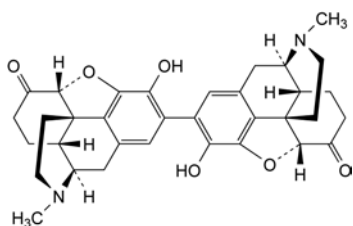

- A. 4,5α:4',5'α-diepoxy-3,3'-dihydroxy-17,17'-dimethyl-2,2'-bimorphinan-6,6'-dione (pseudohydromorphone),

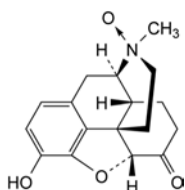

- B. 4,5α-epoxy-3-hydroxy-17-methylmorphinan-6-one 17-oxide (hydromorphone *N*-oxide),

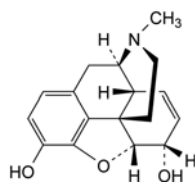

- C. 7,8-didehydro-4,5α-epoxy-17-methylmorphinan-3,6α-diol (morphine),

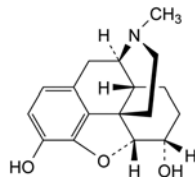

- D. 4,5α-epoxy-17-methylmorphinan-3,6α-diol (dihydromorphone).

01/2008:0913  
corrected 6.0

## HYDROXOCOBALAMIN ACETATE

### Hydroxocobalamini acetas

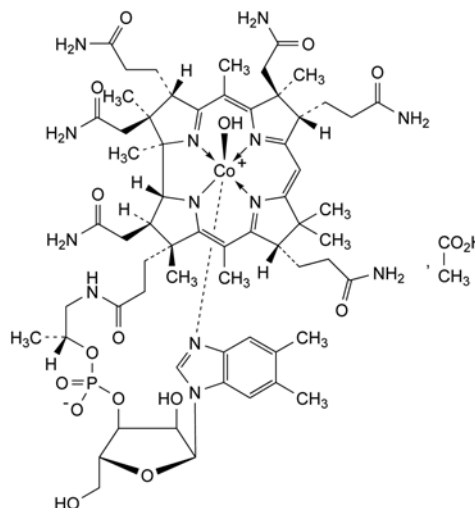

$C_{64}H_{93}CoN_{13}O_{17}P$   
[22465-48-1]

$M_r$  1406

#### DEFINITION

$Co\alpha$ -[ $\alpha$ -(5,6-dimethylbenzimidazolyl)]- $Co\beta$ -hydroxocobamide acetate.

*Content*: 96.0 per cent to 102.0 per cent (dried substance).

This monograph applies to hydroxocobalamin acetate produced by fermentation.

#### CHARACTERS

*Appearance*: dark red, crystalline powder or dark red crystals, very hygroscopic.

*Solubility*: soluble in water.

Some decomposition may occur on drying.

#### IDENTIFICATION

- A. Ultraviolet and visible absorption spectrophotometry (2.2.25).

*Test solution*. Dissolve 2.5 mg in a solution containing 0.8 per cent *V/V* of *glacial acetic acid R* and 10.9 g/L of *sodium acetate R*, then dilute to 100 mL with the same solution.

*Spectral range*: 260-610 nm.

*Absorption maxima*: at 274 nm, 351 nm and 525 nm.

**Absorbance ratio:**

- $A_{274}/A_{351} = 0.75$  to  $0.83$ ;
- $A_{525}/A_{351} = 0.31$  to  $0.35$ .

**B. Thin-layer chromatography (2.2.27). Carry out the test protected from light.**

**Test solution.** Dissolve 2 mg of the substance to be examined in 1 mL of a mixture of equal volumes of *ethanol 96 per cent R* and *water R*.

**Reference solution.** Dissolve 2 mg of *hydroxocobalamin CRS* in 1 mL of a mixture of equal volumes of *ethanol 96 per cent R* and *water R*.

**Plate:** *TLC silica gel G plate R*.

**Mobile phase:** *dilute ammonia R1, methanol R* (25:75 V/V).

**Application:** 10 µL.

**Development:** in an unlined tank, over a path of 12 cm.

**Drying:** in air.

**Detection:** examine in daylight.

**Results:** the principal spot in the chromatogram obtained with the test solution is similar in position, colour and size to the principal spot in the chromatogram obtained with the reference solution.

**C. It gives reaction (a) of acetates (2.3.1).****TESTS**

**Related substances.** Liquid chromatography (2.2.29). Use freshly prepared solutions and protect them from bright light.

**Test solution.** Dissolve 10.0 mg of the substance to be examined in the mobile phase and dilute to 10.0 mL with the mobile phase.

**Reference solution (a).** Dilute 5.0 mL of the test solution to 100.0 mL with the mobile phase.

**Reference solution (b).** Dilute 1.0 mL of the test solution to 10.0 mL with the mobile phase. Dilute 1.0 mL of this solution to 100.0 mL with the mobile phase.

**Reference solution (c).** Dissolve 25 mg of the substance to be examined in 10 mL of *water R*, warming if necessary. Allow to cool and add 1 mL of a 20 g/L solution of *chloramine R* and 0.5 mL of 0.05 M *hydrochloric acid*. Dilute this solution to 25 mL with *water R*. Shake and allow to stand for 5 min. Inject immediately.

**Column:**

- **size:**  $l = 0.25$  m,  $\varnothing = 4$  mm;
- **stationary phase:** *octylsilyl silica gel for chromatography R* (5 µm).

**Mobile phase:** mix 19.5 volumes of *methanol R* and 80.5 volumes of a solution containing 15 g/L of *citric acid R* and 8.1 g/L of *disodium hydrogen phosphate R*.

**Flow rate:** 1.5 mL/min.

**Detection:** spectrophotometer at 351 nm.

**Injection:** 20 µL.

**Run time:** 4 times the retention time of hydroxocobalamin.

**System suitability:**

- the chromatogram obtained with reference solution (c) shows 3 principal peaks;
- **resolution:** minimum 3.0 between each pair of adjacent peaks in the chromatogram obtained with reference solution (c);
- **signal-to-noise ratio:** minimum 5 for the principal peak in the chromatogram obtained with reference solution (b).

**Limits:**

- **total:** not more than the area of the principal peak in the chromatogram obtained with reference solution (a) (5 per cent);
- **disregard limit:** the area of the principal peak in the chromatogram obtained with reference solution (b) (0.1 per cent).

**Loss on drying (2.2.32):** 8.0 per cent to 12.0 per cent, determined on 0.400 g by drying at 105 °C at a pressure not exceeding 0.7 kPa.

**ASSAY**

**Protect the solutions from light throughout the assay.** Dissolve 25.0 mg in a solution containing 0.8 per cent V/V of *glacial acetic acid R* and 10.9 g/L of *sodium acetate R*, then dilute to 1000.0 mL with the same solution. Measure the absorbance (2.2.25) at the absorption maximum at 351 nm.

Calculate the content of  $C_{64}H_{93}CoN_{13}O_{17}P$  taking the specific absorbance to be 187.

**STORAGE**

In an airtight container, protected from light, at a temperature of 2 °C to 8 °C.

01/2008:0914  
corrected 6.0

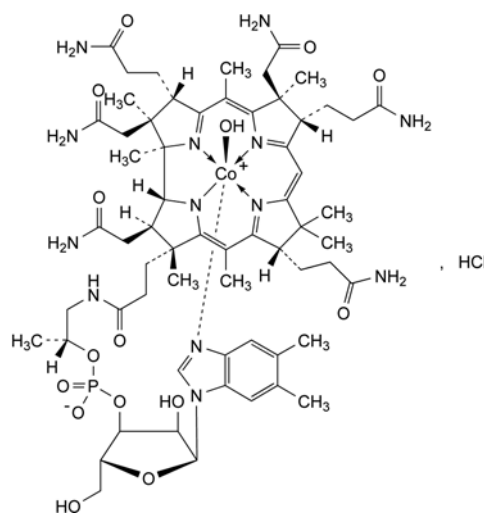
**HYDROXOCOBALAMIN CHLORIDE****Hydroxocobalamini chloridum**

$C_{62}H_{90}ClCoN_{13}O_{15}P$   
[58288-50-9]

$M_r$  1383

**DEFINITION**

Co $\alpha$ -[ $\alpha$ -(5,6-dimethylbenzimidazolyl)]-Co $\beta$ -hydroxocobamide chloride.

Fermentation product.

**Content:** 96.0 per cent to 102.0 per cent (dried substance).

**CHARACTERS**

**Appearance:** dark red crystalline powder or dark red crystals, very hygroscopic.

**Solubility:** soluble in water.

Some decomposition may occur on drying.

**IDENTIFICATION****A. Ultraviolet and visible absorption spectrophotometry (2.2.25).**

**Test solution.** Dissolve 2.5 mg in a solution containing 0.8 per cent V/V of *glacial acetic acid R* and 10.9 g/L of *sodium acetate R*, then dilute to 100 mL with the same solution.

**Spectral range:** 260-610 nm.

**Absorption maxima:** at 274 nm, 351 nm and 525 nm.

**Absorbance ratio:**

- $A_{274}/A_{351} = 0.75$  to  $0.83$ ;
- $A_{525}/A_{351} = 0.31$  to  $0.35$ .

B. Thin-layer chromatography (2.2.27). Carry out the identification test protected from light.

**Test solution.** Dissolve 2 mg of the substance to be examined in 1 mL of a mixture of equal volumes of *ethanol 96 per cent R* and *water R*.

**Reference solution.** Dissolve 2 mg of *hydroxocobalamin CRS* in 1 mL of a mixture of equal volumes of *ethanol 96 per cent R* and *water R*.

**Plate:** TLC silica gel G plate R.

**Mobile phase:** dilute ammonia R1, methanol R (25:75 V/V).

**Application:** 10 µL.

**Development:** in an unlined tank, over a path of 12 cm.

**Drying:** in air.

**Detection:** examine in daylight.

**Results:** the principal spot in the chromatogram obtained with the test solution is similar in position, colour and size to the principal spot in the chromatogram obtained with the reference solution.

C. It gives reaction (a) of chlorides (2.3.1).

## TESTS

**Related substances.** Liquid chromatography (2.2.29). Use freshly prepared solutions and protect them from bright light.

**Test solution.** Dissolve 10.0 mg of the substance to be examined in the mobile phase and dilute to 10.0 mL with the mobile phase.

**Reference solution (a).** Dilute 5.0 mL of the test solution to 100.0 mL with the mobile phase.

**Reference solution (b).** Dilute 1.0 mL of the test solution to 10.0 mL with the mobile phase. Dilute 1.0 mL of this solution to 100.0 mL with the mobile phase.

**Reference solution (c).** Dissolve 25 mg of the substance to be examined in 10 mL of *water R*, warming if necessary. Allow to cool and add 1 mL of a 20 g/L solution of *chloramine R* and 0.5 mL of 0.05 M *hydrochloric acid*. Dilute to 25 mL with *water R*. Shake and allow to stand for 5 min. Inject immediately.

**Column:**

- size:  $l = 0.25$  m,  $\varnothing = 4$  mm;
- stationary phase: octylsilyl silica gel for chromatography R (5 µm).

**Mobile phase:** mix 19.5 volumes of *methanol R* and 80.5 volumes of a solution containing 15 g/L of *citric acid R* and 8.1 g/L of *disodium hydrogen phosphate R*.

**Flow rate:** 1.5 mL/min.

**Detection:** spectrophotometer at 351 nm.

**Injection:** 20 µL.

**Run time:** 4 times the retention time of hydroxocobalamin.

**System suitability:**

- the chromatogram obtained with reference solution (c) shows 3 principal peaks;
- resolution: minimum 3.0 between each pair of adjacent peaks in the chromatogram obtained with reference solution (c);
- signal-to-noise ratio: minimum 5 for the principal peak in the chromatogram obtained with reference solution (b).

**Limits:**

- total: not more than the area of the principal peak in the chromatogram obtained with reference solution (a) (5.0 per cent);
- disregard limit: the area of the principal peak in the chromatogram obtained with reference solution (b) (0.1 per cent).

**Loss on drying** (2.2.32): 8.0 per cent to 12.0 per cent, determined on 0.400 g by drying at 105 °C at a pressure not exceeding 0.7 kPa.

## ASSAY

Protect the solutions from light throughout the assay. Dissolve 25.0 mg in a solution containing 0.8 per cent V/V of *glacial acetic acid R* and 10.9 g/L of *sodium acetate R*, then dilute to 1000.0 mL with the same solution. Measure the absorbance (2.2.25) at the absorption maximum at 351 nm.

Calculate the content of  $C_{62}H_{90}ClCoN_{13}O_{15}P$  taking the specific absorbance to be 190.

## STORAGE

In an airtight container protected from light, at a temperature of 2 °C to 8 °C.

01/2008:0915  
corrected 6.0

## HYDROXOCOBALAMIN SULFATE

### Hydroxocobalamini sulfas

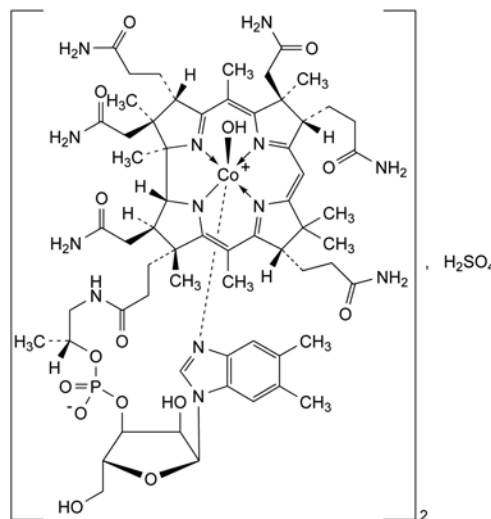

$C_{124}H_{180}Co_2N_{26}O_{34}P_2S$

$M_r$  2791

## DEFINITION

Di-(Coc- $[\alpha$ -(5,6-dimethylbenzimidazolyl)]-Co $\beta$ -hydroxocobamide) sulfate.

Fermentation product.

**Content:** 96.0 per cent to 102.0 per cent (dried substance).

## CHARACTERS

**Appearance:** dark red crystalline powder or dark red crystals, very hygroscopic.

**Solubility:** soluble in water.

Some decomposition may occur on drying.

## IDENTIFICATION

A. Ultraviolet and visible absorption spectrophotometry (2.2.25).

**Test solution.** Dissolve 2.5 mg in a solution containing 0.8 per cent V/V of *glacial acetic acid R* and 10.9 g/L of *sodium acetate R*, then dilute to 100 mL with the same solution.

**Spectral range:** 260-610 nm.

**Absorption maxima:** at 274 nm, 351 nm and 525 nm.

**Absorbance ratios:**

- $A_{274}/A_{351} = 0.75$  to 0.83;
- $A_{525}/A_{351} = 0.31$  to 0.35.

B. Thin-layer chromatography (2.2.27). Carry out the test protected from light.

**Test solution.** Dissolve 2 mg of the substance to be examined in 1 mL of a mixture of equal volumes of *ethanol 96 per cent R* and *water R*.

**Reference solution.** Dissolve 2 mg of *hydroxocobalamin CRS* in 1 mL of a mixture of equal volumes of *ethanol 96 per cent R* and *water R*.

**Plate:** TLC silica gel G plate R.

**Mobile phase:** dilute ammonia R1, methanol R (25:75 V/V).

**Application:** 10 µL.

**Development:** in an unlined tank, over a path of 12 cm.

**Drying:** in air.

**Detection:** examine in daylight.

**Results:** the principal spot in the chromatogram obtained with the test solution is similar in position, colour and size to the principal spot in the chromatogram obtained with the reference solution.

C. It gives reaction (a) of sulfates (2.3.1).

#### TESTS

**Related substances.** Liquid chromatography (2.2.29). Use freshly prepared solutions and protect them from bright light.

**Test solution.** Dissolve 10.0 mg of the substance to be examined in the mobile phase and dilute to 10.0 mL with the mobile phase.

**Reference solution (a).** Dilute 5.0 mL of the test solution to 100.0 mL with the mobile phase.

**Reference solution (b).** Dilute 1.0 mL of the test solution to 10.0 mL with the mobile phase. Dilute 1.0 mL of this solution to 100.0 mL with the mobile phase.

**Reference solution (c).** Dissolve 25 mg of the substance to be examined in 10 mL of *water R*, warming if necessary. Allow to cool and add 1 mL of a 20 g/L solution of *chloramine R* and 0.5 mL of 0.05 M *hydrochloric acid*. Dilute to 25 mL with *water R*. Shake and allow to stand for 5 min. Inject immediately.

**Column:**

- size:  $l = 0.25$  m,  $\varnothing = 4$  mm;
- stationary phase: octylsilyl silica gel for chromatography R (5 µm).

**Mobile phase:** mix 19.5 volumes of *methanol R* and 80.5 volumes of a solution containing 15 g/L of *citric acid R* and 8.1 g/L of *disodium hydrogen phosphate R*.

**Flow rate:** 1.5 mL/min.

**Detection:** spectrophotometer at 351 nm.

**Injection:** 20 µL.

**Run time:** 4 times the retention time of hydroxocobalamin.

**System suitability:**

- the chromatogram obtained with reference solution (c) shows 3 principal peaks;
- resolution: minimum 3.0 between each pair of adjacent peaks in the chromatogram obtained with reference solution (c);
- signal-to-noise ratio: minimum 5 for the principal peak in the chromatogram obtained with reference solution (b).

**Limits:**

- total: not more than the area of the principal peak in the chromatogram obtained with reference solution (a) (5.0 per cent);
- disregard limit: the area of the principal peak in the chromatogram obtained with reference solution (b) (0.1 per cent).

**Loss on drying** (2.2.32): 8.0 per cent to 16.0 per cent, determined on 0.400 g by drying at 105 °C at a pressure not exceeding 0.7 kPa.

#### ASSAY

Protect the solutions from light throughout the assay. Dissolve 25.0 mg in a solution containing 0.8 per cent V/V of *glacial acetic acid R* and 10.9 g/L of *sodium acetate R* and dilute to 1000.0 mL with the same solution. Measure the absorbance (2.2.25) at the absorption maximum at 351 nm.

Calculate the content of  $C_{124}H_{180}Co_2N_{26}O_{34}P_2S$  taking the specific absorbance to be 188.

#### STORAGE

In an airtight container protected from light, at a temperature of 2 °C to 8 °C.

01/2008:1616

## HYDROXYCARBAMIDE

### Hydroxycarbamidum

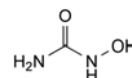

$CH_4N_2O_2$   
[127-07-1]

$M_r$  76.1

#### DEFINITION

*N*-Hydroxyurea.

**Content:** 97.5 per cent to 102.0 per cent (anhydrous substance).

#### CHARACTERS

**Appearance:** white or almost white, crystalline powder, hygroscopic.

**Solubility:** freely soluble in water, practically insoluble in alcohol.

It shows polymorphism (5.9).

#### IDENTIFICATION

A. Infrared absorption spectrophotometry (2.2.24).

**Comparison:** *hydroxycarbamide CRS*.

If the spectra obtained in the solid state show differences dissolve the substance to be examined and the reference substance separately in *alcohol R*, evaporate to dryness and record new spectra using the residues.

B. Examine the chromatograms obtained in the test for urea.

**Results:** the principal spot in the chromatogram obtained with the test solution is similar in position and size to the principal spot in the chromatogram obtained with reference solution (c).

#### TESTS

**Urea.** Thin-layer chromatography (2.2.27).

**Test solution.** Dissolve 50 mg of the substance to be examined in *water R* and dilute to 1.0 mL with the same solvent.

**Reference solution (a).** Dissolve 12.5 mg of *urea R* in *water R* and dilute to 50 mL with the same solvent.

**Reference solution (b).** Dissolve 5 mg of the substance to be examined and 5 mg of *urea R* in *water R* and dilute to 20 mL with the same solvent.

**Reference solution (c).** Dissolve 50 mg of *hydroxycarbamide CRS* in *water R* and dilute to 1 mL with the same solvent.

**Plate:** TLC silica gel plate R.

**Mobile phase:** pyridine R, water R, ethyl acetate R (2:2:10 V/V/V).

**Application:** 10 µL.

**Development:** over 2/3 of the plate.

**Drying:** in air.

**Detection:** spray with a 10 g/L solution of *dimethylaminobenzaldehyde R* in 1 M *hydrochloric acid*.

**System suitability:** the test is not valid unless the chromatogram obtained with reference solution (b) shows 2 clearly separated spots.

**Limit:**

- *urea*: any spot corresponding to urea in the chromatogram obtained with the test solution is not more intense than the spot in the chromatogram obtained with the reference solution (a) (0.5 per cent).

**Related substances.** Liquid chromatography (2.2.29).

**Test solution (a).** Dissolve 0.100 g of the substance to be examined in the mobile phase and dilute to 10.0 mL with the same mobile phase.

**Test solution (b).** Dilute 5.0 mL of test solution (a) to 50.0 mL with the mobile phase.

**Reference solution (a).** Dissolve 0.100 g of *hydroxylamine hydrochloride R* and 5 mg of the substance to be examined in the mobile phase and dilute to 10.0 mL with the mobile phase. Prepare immediately before use.

**Reference solution (b).** Dilute 0.1 mL of test solution (a) to 100.0 mL with the mobile phase.

**Reference solution (c).** Dissolve 0.100 g of *hydroxycarbamide CRS* in the mobile phase and dilute to 10.0 mL with the same solvent. Dilute 5.0 mL to 50.0 mL with the mobile phase.

**Column:**

- *size*:  $l = 0.25$  m,  $\varnothing = 4.6$  mm,
- *stationary phase*: *octadecylsilyl silica gel for chromatography R* (5  $\mu$ m).

**Mobile phase:** *methanol R*, *water R* (5:95 V/V).

**Flow rate:** 0.5 mL/min.

**Detection:** spectrophotometer at 214 nm.

**Injection:** 20  $\mu$ L; inject test solution (a) and reference solutions (a) and (b).

**Run time:** 3 times the retention time of hydroxycarbamide which is about 5 min.

**System suitability:** reference solution (a):

- *resolution*: minimum of 1.0 between the peaks due to impurity A and to hydroxycarbamide.

**Limits:**

- *any impurity*: not more than the area of the principal peak in the chromatogram obtained with reference solution (b) (0.1 per cent),
- *total*: not more than 2 times the area of the principal peak in the chromatogram obtained with reference solution (b) (0.2 per cent),
- *disregard limit*: 0.2 times the area of the principal peak in the chromatogram obtained with reference solution (b) (0.02 per cent).

**Chlorides (2.4.4):** maximum 50 ppm.

Dissolve 1.0 g in *water R* and dilute to 15 mL with the same solvent. The solution complies with the limit test for chlorides.

**Heavy metals (2.4.8):** maximum 10 ppm.

Dissolve 2.0 g in *water R* and dilute to 20 mL with the same solvent. 12 mL of the solution complies with limit test A. Prepare the standard using *lead standard solution (1 ppm Pb) R*.

**Water (2.5.12):** maximum 0.5 per cent, determined on 2.00 g.

**Sulfated ash (2.4.14):** maximum 0.1 per cent, determined on 1.0 g.

**ASSAY**

Liquid chromatography (2.2.29) as described in the test for related substances.

**Injection:** test solution (b) and reference solution (c).

**STORAGE**

In an airtight container, protected from light.

**IMPURITIES**

A.  $\text{H}_2\text{N-OH}$ : hydroxylamine.

01/2008:1225

## HYDROXYETHYL SALICYLATE

Hydroxyethylis salicylas

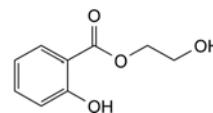

$\text{C}_9\text{H}_{10}\text{O}_4$   
[87-28-5]

$M_r$  182.2

**DEFINITION**

2-Hydroxyethyl 2-hydroxybenzoate.

**Content:** 98.0 per cent to 102.0 per cent.

**CHARACTERS**

**Appearance:** oily, colourless or almost colourless liquid, or colourless crystals.

**Solubility:** sparingly soluble in water, very soluble in acetone and in methylene chloride, freely soluble in ethanol (96 per cent).

**Mp:** about 21 °C.

**IDENTIFICATION**

**First identification:** A, B.

**Second identification:** A, C, D, E.

A. Refractive index (see Tests).

B. Infrared absorption spectrophotometry (2.2.24).

**Preparation:** thin films.

**Comparison:** *hydroxyethyl salicylate CRS*.

C. Examine the chromatograms obtained in the test for related substances.

**Results:** the principal spot in the chromatogram obtained with test solution (b) is similar in position and size to the principal spot in the chromatogram obtained with reference solution (a).

D. To 1 mL of solution S (see Tests), add 1 mL of *water R* and 0.2 mL of *ferric chloride solution R2*. A violet-red colour appears which disappears immediately after the addition of 2 mL of *dilute acetic acid R*. A very faint violet colour may remain.

E. In a test tube 160 mm long, mix 1.0 g with 2.0 g of finely powdered *manganese sulfate R*. Insert 2 cm into the test-tube a strip of filter paper impregnated with a freshly prepared mixture of 1 volume of a 20 per cent V/V solution of *diethanolamine R* and 11 volumes of a 50 g/L solution of *sodium nitroprusside R* adjusted to pH 9.8 with *1 M hydrochloric acid*. Heat the test-tube over a naked flame for 1-2 min. The filter paper becomes blue.

**TESTS**

**Solution S.** Dissolve 2.5 g in 40 mL of *ethanol (96 per cent) R* and dilute to 50 mL with *distilled water R*.

**Appearance of solution.** Solution S is clear (2.2.1) and colourless (2.2.2, *Method II*).

**Acidity or alkalinity.** To 2 mL of solution S add 0.1 mL of *methyl red solution R* and 0.2 mL of 0.01 M *sodium hydroxide*. The solution is yellow. Add 0.3 mL of 0.01 M *hydrochloric acid*. The solution is red.

**Relative density (2.2.5):** 1.252 to 1.257.

**Refractive index (2.2.6):** 1.548 to 1.551.



**Related substances.** Thin-layer chromatography (2.2.27).

**Test solution (a).** Dissolve 0.50 g of the substance to be examined in *methanol R* and dilute to 10 mL with the same solvent.

**Test solution (b).** Dilute 2 mL of test solution (a) to 50 mL with *methanol R*.

**Reference solution (a).** Dissolve 50.0 mg of *hydroxyethyl salicylate CRS* in *methanol R* and dilute to 25 mL with the same solvent.

**Reference solution (b).** Dilute 2.5 mL of test solution (b) to 10 mL with *methanol R*.

**Reference solution (c).** Dissolve 0.10 g of *ethylene glycol R* in *methanol R* and dilute to 50 mL with the same solvent. Dilute 1.25 mL of the solution to 10 mL with *methanol R*.

**Plate:** TLC silica gel  $F_{254}$  plate *R*.

**Mobile phase:** *ethyl acetate R*, *glacial acetic acid R*, *cyclohexane R* (20:20:60 V/V/V).

**Application:** 10  $\mu$ L.

**Development:** over a path of 15 cm.

**Drying:** in a current of cold air.

**Detection A:** in ultraviolet light at 254 nm.

**Limits A:**

- **any impurity:** any spot in the chromatogram obtained with test solution (a), apart from the principal spot, is not more intense than the spot in the chromatogram obtained with reference solution (b) (1 per cent).

**Detection B:** spray the plate with *ammonium vanadate solution R* and heat at 100 °C for 10 min. Allow to cool for 10 min and examine in daylight.

**Limits B:** in the chromatogram obtained with test solution (a):

- **impurity B:** any spot corresponding to impurity B is not more intense than the spot in the chromatogram obtained with reference solution (c) (0.5 per cent);
- **any other impurity:** any spot, apart from the principal spot and any spot corresponding to impurity B is not more intense than the spot in the chromatogram obtained with reference solution (b) (1 per cent).

**System suitability:** the chromatogram obtained with reference solution (c) shows a clearly visible spot.

**Chlorides (2.4.4):** maximum 100 ppm.

Dilute 10 mL of solution S to 15 mL with *water R*. The solution complies with the limit test for chlorides.

**Sulfates (2.4.13):** maximum 250 ppm.

Dilute 12 mL of solution S to 15 mL with *distilled water R*. The solution complies with the limit test for sulfates.

**Sulfated ash (2.4.14):** maximum 0.1 per cent, determined on 1.0 g.

#### ASSAY

In a flask with a ground-glass stopper, dissolve 0.125 g in 30 mL of *glacial acetic acid R*. Add 10 mL of *dilute sulfuric acid R*, 1.5 g of *potassium bromide R* and 50.0 mL of 0.0167 M *potassium bromate*. Immediately close the flask and allow to stand protected from light for 15 min. Add 1.5 g of *potassium iodide R* immediately after removing the stopper and titrate with 0.1 M *sodium thiosulfate*, adding 1 mL of *starch solution R* towards the end of the titration. Carry out a blank titration.

1 mL of 0.0167 M *potassium bromate* is equivalent to 4.555 mg of  $C_9H_{10}O_4$ .

#### STORAGE

Protected from light.

#### IMPURITIES

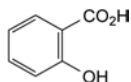

A. 2-hydroxybenzenecarboxylic acid (salicylic acid),

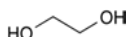

B. ethane-1,2-diol (ethylene glycol).

01/2008:0336  
corrected 6.0

## HYDROXYETHYLCELLULOSE

### Hydroxyethylcellulosum

[9004-62-0]

#### DEFINITION

Partly *O*-(2-hydroxyethylated) cellulose.

#### CHARACTERS

**Appearance:** white, yellowish-white or greyish-white powder or granules.

**Solubility:** soluble in hot and cold water giving a colloidal solution, practically insoluble in acetone, in ethanol (96 per cent) and in toluene.

#### IDENTIFICATION

- Heat 10 mL of solution S (see Tests) to boiling. The solution remains clear.
- To 10 mL of solution S add 0.3 mL of *dilute acetic acid R* and 2.5 mL of a 100 g/L solution of *tannic acid R*. A yellowish-white, flocculent precipitate is formed which dissolves in *dilute ammonia R1*.
- In a test-tube about 160 mm in length, thoroughly mix 1 g with 2 g of finely powdered *manganese sulfate R*. Introduce to a depth of 2 cm into the upper part of the tube a strip of filter paper impregnated with a freshly prepared mixture of 1 volume of a 200 g/L solution of *diethanolamine R* and 11 volumes of a 50 g/L solution of *sodium nitroprusside R*, adjusted to about pH 9.8 with 1 M *hydrochloric acid*. Insert the tube 8 cm into a silicone-oil bath and heat at 190-200 °C. The filter paper becomes blue within 10 min. Carry out a blank test.
- Dissolve 0.2 g completely, without heating, in 15 mL of a 700 g/L solution of *sulfuric acid R*. Pour the solution with stirring into 100 mL of iced *water R* and dilute to 250 mL with iced *water R*. In a test-tube, mix thoroughly while cooling in iced water 1 mL of the solution with 8 mL of *sulfuric acid R*, added dropwise. Heat on a water-bath for exactly 3 min and immediately cool in iced water. While the mixture is cold, carefully add 0.6 mL of *ninhydrin solution R2* and mix well. Allow to stand at 25 °C. A pink colour is produced immediately and does not become violet within 100 min.

#### TESTS

**Solution S.** Disperse a quantity of the substance to be examined equivalent to 1.0 g of the dried substance in 50 mL of *carbon dioxide-free water R*. After 10 min, dilute to 100 mL with *carbon dioxide-free water R* and stir until dissolution is complete.

**pH (2.2.3):** 5.5 to 8.5 for solution S.

**Apparent viscosity (2.2.10):** 75 per cent to 140 per cent of the value stated on the label.

While stirring, introduce a quantity of the substance to be examined equivalent to 2.00 g of the dried substance into 50 g of *water R*. Dilute to 100.0 g with *water R* and stir until dissolution is complete. Determine the viscosity using a rotating viscometer at 25 °C and at a shear rate of 100 s<sup>-1</sup> for substances

with an expected viscosity up to 100 mPas, at a shear rate of  $10 \text{ s}^{-1}$  for substances with an expected viscosity between 100 mPas and 20 000 mPas and at a shear rate of  $1 \text{ s}^{-1}$  for substances with an expected viscosity above 20 000 mPas. If it is impossible to obtain a shear rate of exactly  $1 \text{ s}^{-1}$ ,  $10 \text{ s}^{-1}$  or  $100 \text{ s}^{-1}$  respectively, use a rate slightly higher and a rate slightly lower and interpolate.

**Chlorides (2.4.4):** maximum 1.0 per cent.

Dilute 1 mL of solution S to 30 mL with *water R*. 15 mL of the solution complies with the limit test for chlorides.

**Nitrates:** maximum 3.0 per cent (dried substance), if hydroxyethylcellulose has an apparent viscosity of 1000 mPas or less and maximum 0.2 per cent (dried substance), if hydroxyethylcellulose has an apparent viscosity of more than 1000 mPas.

Determine potentiometrically (2.2.36, *Method I*) using as indicator a nitrate selective electrode and a silver-silver chloride electrode with a 13.2 g/L solution of *ammonium sulfate R* as reference electrolyte.

*Prepare the solutions immediately before use.*

**Buffer solution.** To a mixture of 50 mL of 1 M *sulfuric acid* and 800 mL of *water R*, add 135 g of *potassium dihydrogen phosphate R* and dilute to 1000 mL with *water R*.

**Buffered water.** Dilute 80 mL of buffer solution to 2000 mL with *water R*.

**Nitrate standard solution (500 ppm  $\text{NO}_3$ ).** Dissolve 0.8154 g of *potassium nitrate R* in 500 mL of buffered water and dilute to 1000.0 mL with the same solvent.

**Test solution.** Dissolve 0.50 g of the substance to be examined in buffered water and dilute to 100.0 mL with the same solvent.

**Reference solutions.** If hydroxyethylcellulose has an apparent viscosity of 1000 mPas or less, dilute 10.0 mL, 20.0 mL and 40.0 mL of nitrate standard solution (500 ppm  $\text{NO}_3$ ) to 100.0 mL with buffered water and mix.

If hydroxyethylcellulose has an apparent viscosity of more than 1000 mPas, dilute 1.0 mL, 2.0 mL and 4.0 mL of nitrate standard solution (500 ppm  $\text{NO}_3$ ) to 100.0 mL with buffered water and mix.

Carry out the measurements for each solution. Calculate the concentration of nitrates using the calibration curve.

**Glyoxal:** maximum 20 ppm.

Introduce 1.0 g into a test-tube with a ground-glass stopper and add 10.0 mL of *anhydrous ethanol R*. Stopper the tube and stir mechanically for 30 min. Centrifuge. To 2.0 mL of the supernatant liquid add 5.0 mL of a 4 g/L solution of *methylbenzothiazolone hydrazone hydrochloride R* in an 80 per cent V/V solution of *glacial acetic acid R* in *water R*. Shake to homogenise. After 2 h, the solution is not more intensely coloured than a standard prepared at the same time and in the same manner using 2.0 mL of *glyoxal standard solution (2 ppm  $\text{C}_2\text{H}_2\text{O}_2$ ) R* instead of the 2.0 mL of supernatant liquid.

**Ethylene oxide.** Head-space gas chromatography (2.4.25).

**Test preparation.** Place 1.00 g of the substance to be examined in a 5 mL vial (other sizes may be used depending on the operating conditions) and add 1 mL of *water R*. It swells in water but does not dissolve.

**Reference preparation (a).** Place 1.00 g of the substance to be examined in an identical 5 mL vial. Add 0.1 mL of cooled *ethylene oxide solution R2* and 0.9 mL of *water R*. It swells in water but does not dissolve.

**Reference preparation (b).** To 0.1 mL of *ethylene oxide solution R2* in a 5 mL vial add 0.1 mL of a freshly prepared 10 mg/L solution of *acetaldehyde R*.

*Close the vials immediately with a butyl rubber membrane stopper, coated with aluminium or polytetrafluoroethylene and secured with an aluminium crimped cap.*

**Limit:**

– *ethylene oxide:* maximum 1 ppm.

**2-Chloroethanol.** Head-space gas chromatography (2.2.28).

**Test preparation.** To 50 mg of the substance to be examined in a 10 mL vial (other sizes may be used depending on the operating conditions), add 2  $\mu\text{L}$  of *2-propanol R*. Seal the flask and mix.

**Reference preparation (a).** Dissolve 0.125 g of *2-chloroethanol R* and dilute to 50.0 mL with *2-propanol R*. Dilute 1.0 mL of the solution to 10.0 mL with *2-propanol R*.

**Reference preparation (b).** To 50 mg of the substance to be examined in an identical 10 mL vial, add 2  $\mu\text{L}$  of reference solution (a). Seal the flask and mix.

*Close the vials immediately with a butyl rubber membrane stopper, coated with aluminium or polytetrafluoroethylene and secured with an aluminium crimped cap.*

**Column:**

– *size:*  $l = 50 \text{ m}$ ,  $\varnothing = 0.32 \text{ mm}$ ,

– *stationary phase:* *poly(dimethyl)siloxane R* (1.2  $\mu\text{m}$ ).

*Carrier gas:* *helium for chromatography R*.

*Flow rate:* 25-35 cm/s.

*Split ratio:* 1:10.

*Static head-space conditions which may be used:*

– *equilibration temperature:* 110 °C,

– *equilibration time:* 20 min,

– *temperature of injection system:* 115 °C.

**Temperature:**

	Time (min)	Temperature (°C)
Column	0 - 6	60
	6 - 16	60 → 110
	16 - 31	110 → 230
	31 - 36	230
Injection port		150
Detector		250

**Detection:** flame ionisation.

**Injection:** 2 mL.

**Retention time:** 2-chloroethanol = about 7.8 min.

**Limit:**

– *2-chloroethanol:* not more than 0.5 times the area of the peak due to 2-chloroethanol in the chromatogram obtained with reference solution (b) (10 ppm).

**Heavy metals (2.4.8):** maximum 20 ppm.

1.0 g complies with limit test C. Prepare the reference solution using 2 mL of *lead standard solution (10 ppm Pb) R*.

**Loss on drying (2.2.32):** maximum 10.0 per cent, determined on 1.000 g by drying in an oven at 105 °C for 3 h.

**Sulfated ash (2.4.14):** maximum 4.0 per cent, determined on 1.0 g.

**LABELLING**

The label states the apparent viscosity, in millipascal seconds for a 2 per cent *m/m* solution.

01/2009:1804 Column:

**HYDROXYPROPYLBETADEX**

## Hydroxypropylbetadexum

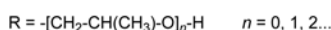
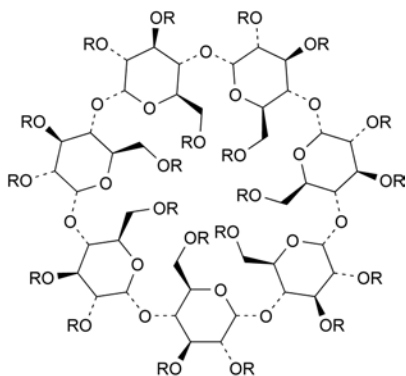
 $C_{42}H_{70}O_{35}(C_3H_6O)_x$  with  $x = 7 MS$ 
**DEFINITION**

Hydroxypropylbetadex ( $\beta$ -cyclodextrin, 2-hydroxypropyl ether) is a partially substituted poly(hydroxypropyl) ether of betadex. The number of hydroxypropyl groups per anhydroglucose unit, expressed as molar substitution (*MS*), is not less than 0.40 and not more than 1.50 and is within 10 per cent of the value stated on the label.

**CHARACTERS**

*Appearance*: white or almost white, amorphous or crystalline powder.

*Solubility*: freely soluble in water and in propylene glycol.

**IDENTIFICATION**

A. Infrared absorption spectrophotometry (2.2.24).

*Comparison*: hydroxypropylbetadex CRS.

*Results*: the spectrum obtained with the substance to be examined shows the same absorption bands as the spectrum obtained with hydroxypropylbetadex CRS. Due to the difference in the substitution of the substance, the intensity of some absorption bands can vary.

B. Appearance of solution (see Tests).

**TESTS**

**Solution S.** Dissolve 5.0 g in carbon dioxide-free water *R* prepared from distilled water *R* and dilute to 50.0 mL with the same solvent.

**Appearance of solution.** The solution is clear (2.2.1) and colourless (2.2.2, Method II), and remains so after cooling to room temperature.

Dissolve 1.0 g in 2.0 mL of water *R*, with heating.

**Conductivity** (2.2.38): maximum 200  $\mu\text{S}\cdot\text{cm}^{-1}$ .

Measure the conductivity of solution S, while gently stirring with a magnetic stirrer.

**Related substances.** Liquid chromatography (2.2.29).

*Test solution.* Dissolve 2.50 g of the substance to be examined in water *R* with heating, cool, and dilute to 25.0 mL with the same solvent.

*Reference solution (a).* Dissolve 0.15 g of betadex CRS and 0.25 g of propylene glycol *R* in water *R* and dilute to 10.0 mL with the same solvent.

*Reference solution (b).* Dilute 5.0 mL of reference solution (a) to 50.0 mL with water *R*.

*Precolumn*:

– *stationary phase*: phenylsilyl silica gel for chromatography *R*.

– *size*:  $l = 0.30$  m,  $\varnothing = 3.9$  mm;

– *stationary phase*: phenylsilyl silica gel for chromatography *R*;

– *temperature*: 40 °C.

*Mobile phase*: water for chromatography *R*.

*Flow rate*: 1.5 mL/min.

*Detection*: differential refractometer, at 40 °C.

*Injection*: 20  $\mu\text{L}$ .

*Run time*: 6 times the retention time of impurity A.

*Relative retention* with reference to impurity B (retention time = about 2.5 min): impurity A = about 4.2; hydroxypropylbetadex = about 6 for the beginning of the elution.

Hydroxypropylbetadex elutes as a very wide peak or several peaks.

*System suitability*: reference solution (a):

– *resolution*: minimum 4 between the peaks due to impurities A and B.

*Limits*:

– *impurity A*: not more than the area of the corresponding peak in the chromatogram obtained with reference solution (b) (1.5 per cent);

– *impurity B*: not more than the area of the corresponding peak in the chromatogram obtained with reference solution (b) (2.5 per cent);

– *any other impurity*: for each impurity, not more than 0.04 times the area of the peak due to impurity B in the chromatogram obtained with reference solution (b) (0.1 per cent);

– *sum of impurities other than A and B*: not more than 0.4 times the area of the peak due to impurity B in the chromatogram obtained with reference solution (b) (1.0 per cent);

– *disregard limit*: 0.02 times the area of the peak due to impurity B in the chromatogram obtained with reference solution (b) (0.05 per cent); disregard any peak eluting before impurity B or after impurity A.

**Heavy metals** (2.4.8): maximum 20 ppm.

12 mL of solution S complies with test A. Prepare the reference solution using lead standard solution (2 ppm Pb) *R*.

**Loss on drying** (2.2.32): maximum 10.0 per cent, determined on 1.000 g by drying in an oven at 120 °C for 2 h.

**Molar substitution.** Nuclear magnetic resonance spectrometry (2.2.33).

The molar substitution (*MS*) is calculated from the ratio between the signal from the 3 protons of the methyl group that is part of the hydroxypropyl group and the signal from the proton attached to the C1 carbon (glycosidic proton) of the anhydroglucose units.

Use a Fourier transform nuclear magnetic resonance spectrometer of minimum frequency 250 MHz, suited to record a proton spectrum and to carry out quantitative analysis, at a temperature of at least 25 °C.

Introduce not less than the equivalent of 10.0 mg of the substance to be examined (dried substance) into a 5 mm NMR tube, equipped with a spinner in order to record the spectrum in rotation. Add approximately 0.75 mL of deuterium oxide *R1*. Cap the tube, mix thoroughly and adapt the spinner.

Make the appropriate instrument settings (frequency, gain, digital resolution, sample rotation, shims, probe tuning, resolution/data point, receiver gain etc.) so as to obtain a suitable spectrum for quantitative analysis (good FID (Free Induction Decay), no distortion of the spectrum after Fourier transform and phase corrections). The relaxation delay must be

adapted to the pulse angle in order to have sufficient relaxation of the protons concerned between 2 pulses (for example: 10 s for a 90° pulse).

Record the FID, with at least 8 scans, so as to obtain a spectral window comprised, at least, between 0 ppm and 6.2 ppm, referring to the signal of exchangeable protons (solvent) at 4.8 ppm (25 °C).

Make a zero filling of at least 3-fold in size relative to the acquisition data file and transform the FID to the spectrum without any correction of Gaussian broadening factor (GB = 0) and with a line broadening factor not greater than 0.2 (LB ≤ 0.2). Call the integration sub-routine after phase corrections and baseline correction between 0.5 ppm and 6.2 ppm.

Measure the peak areas of the doublet from the methyl groups at 1.2 ppm ( $A_1$ ), and of the signals of the glycosidic protons between 5 ppm and 5.4 ppm ( $A_2$ ).

The molar substitution is obtained using the following equation:

$$MS = \frac{A_1}{(3 \times A_2)}$$

- $A_1$  = area of the signal due to the 3 protons of the methyl groups that are part of the hydroxypropyl groups;  
 $A_2$  = area of the signals due to the glycosidic protons.

The degree of substitution is the number of hydroxypropyl groups per molecule of  $\beta$ -cyclodextrin and is obtained by multiplying the  $MS$  by 7.

#### Microbial contamination

If intended for use in the manufacture of parenteral preparations:

- TAMC: acceptance criterion  $10^3$  CFU/g (2.6.12).

If not intended for use in the manufacture of parenteral preparations:

- TAMC: acceptance criterion  $10^3$  CFU/g (2.6.12);
- TYMC: acceptance criterion  $10^2$  CFU/g (2.6.12);
- absence of *Escherichia coli* (2.6.13);
- absence of *Salmonella* (2.6.13).

**Bacterial endotoxins** (2.6.14): less than 10 IU/g, if intended for use in the manufacture of parenteral preparations without a further appropriate procedure for the removal of bacterial endotoxins.

#### LABELLING

The label states:

- the molar substitution ( $MS$ );
- where applicable, that the substance is suitable for use in the manufacture of parenteral preparations.

#### IMPURITIES

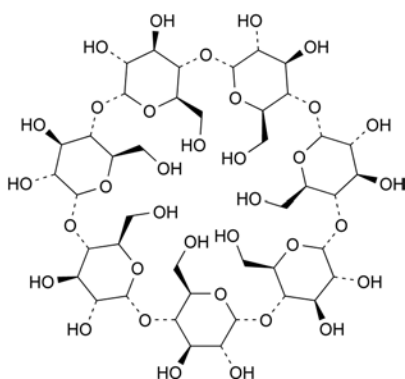

- A. cycloheptakis-(1→4)-( $\alpha$ -D-glucopyranosyl) (betadex or cyclomaltoheptaose or  $\beta$ -cyclodextrin),

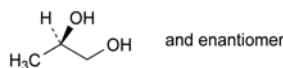

- B. (*RS*)-propane-1,2-diol (propylene glycol).

01/2008:0337  
corrected 6.0

## HYDROXYPROPYLCELLULOSE

### Hydroxypropylcellulosum

[9004-64-2]

#### DEFINITION

Partly *O*-(2-hydroxypropylated) cellulose.

It may contain maximum 0.6 per cent of silica ( $\text{SiO}_2$ ).

#### CHARACTERS

**Appearance:** white or yellowish-white powder or granules, hygroscopic after drying.

**Solubility:** soluble in cold water, in glacial acetic acid, in anhydrous ethanol, in methanol and in propylene glycol and in a mixture of 10 parts of methanol and 90 parts of methylene chloride giving colloidal solutions, sparingly soluble or slightly soluble in acetone depending on the degree of substitution, practically insoluble in hot water, in ethylene glycol and in toluene.

#### IDENTIFICATION

- A. Heat 10 mL of solution S (see Tests) in a water-bath while stirring. At a temperature above 40 °C the solution becomes cloudy or a flocculent precipitate is formed. The solution becomes clear again on cooling.
- B. To 10 mL of solution S add 0.3 mL of *dilute acetic acid R* and 2.5 mL of a 100 g/L solution of *tannic acid R*. A yellowish-white flocculent precipitate is formed which dissolves in *dilute ammonia R1*.
- C. In a test-tube about 160 mm long, thoroughly mix 1 g with 2 g of finely powdered *manganese sulfate R*. Introduce to a depth of 2 cm into the upper part of the tube a strip of filter paper impregnated with a freshly prepared mixture of 1 volume of a 20 per cent *V/V* solution of *diethanolamine R* and 11 volumes of a 50 g/L solution of *sodium nitroprusside R*, adjusted to about pH 9.8 with *1 M hydrochloric acid*. Insert the tube 8 cm into a silicone-oil bath at 190-200 °C. The filter paper becomes blue within 10 min. Carry out a blank test.
- D. Dissolve completely 0.2 g without heating in 15 mL of a 70 per cent *m/m* solution of *sulfuric acid R*. Pour the solution with stirring into 100 mL of iced *water R* and dilute to 250 mL with iced *water R*. In a test-tube, mix thoroughly while cooling in iced water 1 mL of this solution with 8 mL of *sulfuric acid R* added dropwise. Heat in a water-bath for exactly 3 min and immediately cool in iced water. While the mixture is cold, carefully add 0.6 mL of *ninhydrin solution R2* and mix well. Allow to stand at 25 °C. A pink colour is produced immediately and becomes violet within 100 min.
- E. Place 1 mL of solution S on a glass plate. After evaporation of the water a thin film is formed.
- F. 0.2 g does not dissolve in 10 mL of *toluene R* but dissolves completely in 10 mL of *anhydrous ethanol R*.

#### TESTS

**Solution S.** While stirring, introduce a quantity of the substance to be examined equivalent to 1.0 g of the dried substance into 50 g of *carbon dioxide-free water R* heated to 90 °C. Allow to cool, adjust the mass of the solution to 100 g with *carbon dioxide-free water R* and stir until dissolution is complete.

**Appearance of solution.** Solution S is not more opalescent than reference suspension III (2.2.1) and not more intensely coloured than reference solution Y<sub>6</sub> (2.2.2, Method II).

**pH** (2.2.3): 5.0 to 8.5 for solution S.

**Apparent viscosity** (2.2.10): 75 per cent to 140 per cent of the value stated on the label.

While stirring, introduce a quantity of the substance to be examined equivalent to 6.00 g of the dried substance into 150 g of water R heated to 90 °C. Stir with a propeller-type stirrer for 10 min, place the flask in a bath of iced water, continue the stirring and allow to remain in the bath of iced water for 40 min to ensure that dissolution is complete. Adjust the mass of the solution to 300 g and centrifuge the solution to expel any entrapped air. Adjust the temperature of the solution to 20 ± 0.1 °C. Determine the viscosity with a rotating viscometer at 20 °C and a shear rate of 10 s<sup>-1</sup>.

For a product of low viscosity, use a quantity of the substance to be examined sufficient to prepare a solution of the concentration stated on the label.

**Silica:** maximum 0.6 per cent.

To the residue obtained in the test for sulfated ash add sufficient ethanol (96 per cent) R to moisten the residue completely. Add 6 mL of hydrofluoric acid R in small portions. Evaporate to dryness at 95-105 °C, taking care to avoid loss from sputtering. Cool and rinse the wall of the platinum crucible with 6 mL of hydrofluoric acid R. Add 0.5 mL of sulfuric acid R and evaporate to dryness. Progressively increase the temperature, ignite at 900 ± 50 °C, allow to cool in a desiccator and weigh. The difference between the mass of the residue obtained in the test for sulfated ash and the mass of the final residue is equal to the amount of silica in the substance to be examined.

**Chlorides** (2.4.4): maximum 0.5 per cent.

Dilute 1 mL of solution S to 15 mL with water R.

**Heavy metals** (2.4.8): maximum 20 ppm.

1.0 g complies with test C. Prepare the reference solution using 2 mL of lead standard solution (10 ppm Pb) R.

**Loss on drying** (2.2.32): maximum 7.0 per cent, determined on 1.000 g by drying in an oven at 105 °C.

**Sulfated ash** (2.4.14): maximum 1.6 per cent, determined on 1.0 g using a platinum crucible.

#### LABELLING

The label states:

- the apparent viscosity in millipascal seconds for a 2 per cent *m/m* solution,
- for a product of low viscosity, the concentration of the solution to be used and the apparent viscosity in millipascal seconds,
- where applicable, that the substance contains silica.

01/2008:0916  
corrected 6.0

## HYDROXYZINE HYDROCHLORIDE

### Hydroxyzini hydrochloridum

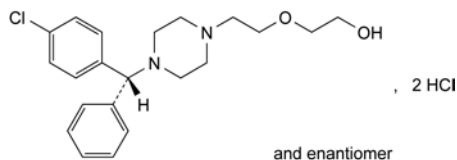

C<sub>21</sub>H<sub>29</sub>Cl<sub>3</sub>N<sub>2</sub>O<sub>2</sub>  
[2192-20-3]

M<sub>r</sub> 447.8

#### DEFINITION

(*RS*)-2-[2-[4-[(4-Chlorophenyl)phenylmethyl]piperazin-1-yl]ethoxy]ethanol dihydrochloride.

**Content:** 99.0 per cent to 101.0 per cent (dried substance).

#### CHARACTERS

**Appearance:** white or almost white, hygroscopic, crystalline powder.

**Solubility:** freely soluble in water and in ethanol (96 per cent), very slightly soluble in acetone.

**mp:** about 200 °C, with decomposition.

#### IDENTIFICATION

**First identification:** A, D.

**Second identification:** B, C, D.

A. Infrared absorption spectrophotometry (2.2.24).

**Preparation:** discs.

**Comparison:** hydroxyzine hydrochloride CRS.

B. Thin-layer chromatography (2.2.27).

**Solvent mixture:** methanol R, methylene chloride R (50:50 V/V).

**Test solution.** Dissolve 0.50 g of the substance to be examined in the solvent mixture and dilute to 10 mL with the solvent mixture.

**Reference solution (a).** Dissolve 0.50 g of hydroxyzine hydrochloride CRS in the solvent mixture and dilute to 10 mL with the solvent mixture.

**Reference solution (b).** Dissolve 0.50 g of meclozine dihydrochloride R in the solvent mixture and dilute to 10 mL with the solvent mixture. Dilute 1 mL of this solution to 2 mL with reference solution (a).

**Plate:** TLC silica gel G plate R.

**Mobile phase:** concentrated ammonia R, ethanol (96 per cent) R, toluene R (1:24:75 V/V/V).

**Application:** 2 µL.

**Development:** over a path of 15 cm.

**Drying:** in air.

**Detection:** spray with potassium iodobismuthate solution R2.

**System suitability:** reference solution (b):

- the chromatogram shows 2 clearly separated principal spots.

**Results:** the principal spot in the chromatogram obtained with the test solution is similar in position, colour and size to the principal spot in the chromatogram obtained with reference solution (a).

C. Dissolve 0.1 g in ethanol (96 per cent) R and dilute to 15 mL with the same solvent. Add 15 mL of a saturated solution of picric acid R in ethanol (96 per cent) R. Allow to stand for 15 min. A precipitate is formed. Filter. Recrystallise from ethanol (96 per cent) R. Initiate crystallisation, if necessary, by scratching the wall of the tube with a glass rod. The crystals melt (2.2.14) at 189 °C to 192 °C.

D. It gives reaction (a) of chlorides (2.3.1).

#### TESTS

**Solution S.** Dissolve 2.0 g in water R and dilute to 20.0 mL with the same solvent.

**Appearance of solution.** Solution S is clear (2.2.1) and not more intensely coloured than reference solution Y<sub>7</sub> (2.2.2, Method II).

**Optical rotation** (2.2.7): –0.10° to +0.10°, determined on solution S.

**Related substances.** Liquid chromatography (2.2.29).

**Test solution.** Dissolve 10.0 mg of the substance to be examined in the mobile phase and dilute to 10.0 mL with the mobile phase.

01/2008:1786  
corrected 6.0

**Reference solution (a).** Dissolve 10.0 mg of *hydroxyzine hydrochloride CRS* in the mobile phase and dilute to 10.0 mL with the mobile phase.

**Reference solution (b).** Dilute 3.0 mL of the test solution to 200.0 mL with the mobile phase. Dilute 5.0 mL of this solution to 25.0 mL with the mobile phase.

**Column:**

- size:  $l = 0.15$  m,  $\varnothing = 4.6$  mm;
- stationary phase: base-deactivated octadecylsilyl silica gel for chromatography R (3  $\mu$ m).

**Mobile phase:** dissolve 0.5 g of sodium methanesulfonate R in a mixture of 14 mL of triethylamine R, 300 mL of acetonitrile R and 686 mL of water R, then adjust to pH 2.7 with sulfuric acid R.

**Flow rate:** 1 mL/min.

**Detection:** spectrophotometer at 230 nm.

**Injection:** 20  $\mu$ L.

**Run time:** 2.5 times the retention time of hydroxyzine.

**System suitability:** reference solution (a):

- peak-to-valley ratio: minimum 10, where  $H_p$  = height above the baseline of the peak immediately before the peak due to hydroxyzine and  $H_v$  = height above the baseline of the lowest point of the curve separating this peak from the peak due to hydroxyzine.

**Limits:**

- any impurity: for each impurity, not more than 1/3 of the area of the principal peak in the chromatogram obtained with reference solution (b) (0.1 per cent);
- total: not more than the area of the principal peak in the chromatogram obtained with reference solution (b) (0.3 per cent);
- disregard limit: 0.1 times the area of the principal peak in the chromatogram obtained with reference solution (b) (0.03 per cent).

**Heavy metals (2.4.8):** maximum 10 ppm.

12 mL of solution S complies with test A. Prepare the reference solution using lead standard solution (1 ppm Pb) R.

**Loss on drying (2.2.32):** maximum 5.0 per cent, determined on 1.000 g by drying in an oven at 105 °C.

**Sulfated ash (2.4.14):** maximum 0.1 per cent, determined on 1.0 g.

## ASSAY

Dissolve 0.200 g in 10 mL of anhydrous acetic acid R. Add 40 mL of acetic anhydride R. Titrate with 0.1 M perchloric acid, determining the end-point potentiometrically (2.2.20).

1 mL of 0.1 M perchloric acid is equivalent to 22.39 mg of  $C_{21}H_{29}Cl_3N_2O_2$ .

## STORAGE

In an airtight container, protected from light.

## IMPURITIES

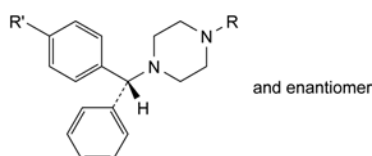

A. R = H, R' = Cl: (RS)-1-[(4-chlorophenyl)phenylmethyl]-piperazine,

B. R =  $CH_2-CH_2-O-CH_2-CH_2-OH$ , R' = H: 2-[2-[4-(diphenylmethyl)piperazin-1-yl]ethoxy]ethanol (declozixine).

# HYMECROMONE

## Hymecromonum

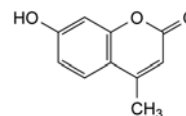

$C_{10}H_8O_3$   
[90-33-5]

$M_r$  176.2

## DEFINITION

7-Hydroxy-4-methyl-2H-1-benzopyran-2-one.

**Content:** 99.0 per cent to 101.0 per cent (dried substance).

## CHARACTERS

**Appearance:** almost white crystalline powder.

**Solubility:** very slightly soluble in water, sparingly soluble in methanol, slightly soluble in methylene chloride. It dissolves in dilute solutions of ammonia.

## IDENTIFICATION

Infrared absorption spectrophotometry (2.2.24).

**Comparison:** hymecromone CRS.

## TESTS

**Absorbance (2.2.25).** Dissolve 50 mg in 10 mL of ammonium chloride buffer solution pH 10.4 R and dilute to 100.0 mL with water R. To 1.0 mL of the solution, add 10 mL of ammonium chloride buffer solution pH 10.4 R and dilute to 100.0 mL with water R. Examined between 200 nm and 400 nm, the solution shows 2 absorption maxima, at 229 nm and 360 nm, and an absorption minimum at 276 nm. The specific absorbance at the maximum at 360 nm is 1020 to 1120.

**Related substances.** Liquid chromatography (2.2.29).

**Buffer solution.** To 280 mL of a 1.56 g/L solution of sodium dihydrogen phosphate R, add 720 mL of a 3.58 g/L solution of disodium hydrogen phosphate R. Adjust to pH 7 with a 100 g/L solution of phosphoric acid R.

**Test solution.** Dissolve 10 mg of the substance to be examined in the mobile phase and dilute to 10.0 mL with the mobile phase.

**Reference solution (a).** Dissolve 20 mg of hymecromone CRS, 10 mg of hymecromone impurity A CRS and 10 mg of hymecromone impurity B CRS in the mobile phase and dilute to 100.0 mL with the mobile phase.

**Reference solution (b).** Dilute 1.0 mL of reference solution (a) to 200.0 mL with the mobile phase.

**Column:**

- size:  $l = 0.25$  m,  $\varnothing = 4$  mm,
- stationary phase: spherical octadecylsilyl silica gel for chromatography R (10  $\mu$ m).

**Mobile phase:** methanol R, buffer solution (465:535 V/V).

**Flow rate:** 1.0 mL/min.

**Detection:** spectrophotometer at 270 nm.

**Injection:** 20  $\mu$ L.

**Run time:** 1.5 times the retention time of hymecromone.

**Relative retention** with reference to hymecromone (retention time = about 6 min): impurity A = about 0.5; impurity B = about 0.7.

**System suitability:** reference solution (a):

- resolution: minimum of 2 between the peaks due to impurity A and to impurity B and minimum of 3 between the peaks due to impurity B and to hymecromone.

**Limits:**

- *impurity A*: not more than the area of the corresponding peak in the chromatogram obtained with reference solution (b) (0.05 per cent),
- *impurity B*: not more than the area of the corresponding peak in the chromatogram obtained with reference solution (b) (0.05 per cent),
- *unspecified impurities*: for each impurity, not more than the area of the peak due to hymecromone in the chromatogram obtained with reference solution (b) (0.10 per cent),
- *total*: not more than twice the area of the peak due to hymecromone in the chromatogram obtained with reference solution (b) (0.2 per cent),
- *disregard limit*: 0.1 times the area of the peak due to hymecromone in the chromatogram obtained with reference solution (b) (0.01 per cent).

**Heavy metals** (2.4.8): maximum 10 ppm.

Dissolve 1.5 g in a mixture of 15 volumes of *water R* and 85 volumes of *dimethylformamide R* and dilute to 18 mL with the same mixture of solvents. The solution complies with test B. Prepare the reference solution using a lead standard solution (1 ppm Pb) obtained by diluting *lead standard solution (100 ppm Pb) R* with a mixture of 15 volumes of *water R* and 85 volumes of *dimethylformamide R*.

**Loss on drying** (2.2.32): maximum 0.5 per cent, determined on 1.000 g by drying in an oven at 105 °C for 4 h.

**Sulfated ash** (2.4.14): maximum 0.1 per cent, determined on 1.0 g.

**ASSAY**

Dissolve 0.100 g in 80 mL of *2-propanol R*. Titrate with 0.1 M *tetrabutylammonium hydroxide in 2-propanol* determining the end-point potentiometrically (2.2.20). Carry out a blank titration.

1 mL of 0.1 M *tetrabutylammonium hydroxide in 2-propanol* is equivalent to 17.62 mg of C<sub>10</sub>H<sub>8</sub>O<sub>3</sub>.

**STORAGE**

Protected from light.

**IMPURITIES**

*Specified impurities: A, B.*

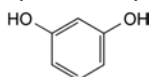

A. benzene-1,3-diol (resorcinol),

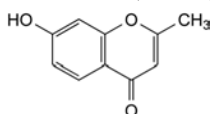

B. 7-hydroxy-2-methyl-4H-1-benzopyran-4-one.

01/2008:2167

**HYOSCINE**

Hyoscinum

Scopolaminum

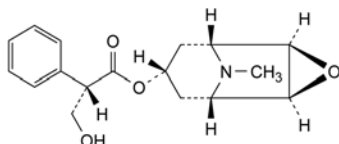

C<sub>17</sub>H<sub>21</sub>NO<sub>4</sub>  
[51-34-3]

M<sub>r</sub> 303.4

**DEFINITION**

(1*R*,2*R*,4*S*,5*S*,7*S*)-9-Methyl-3-oxa-9-azatricyclo[3.3.1.0<sup>2,4</sup>]non-7-yl (2*S*)-3-hydroxy-2-phenylpropanoate.

*Content*: 98.5 per cent to 101.0 per cent (anhydrous substance).

**CHARACTERS**

*Appearance*: white or almost white, crystalline powder or colourless crystals.

*Solubility*: soluble in water, freely soluble in ethanol (96 per cent).

mp: 66 °C to 70 °C.

**IDENTIFICATION**

A. Specific optical rotation (see Tests).

B. Infrared absorption spectrophotometry (2.2.24).

*Comparison: hyoscine CRS.*

**TESTS**

**Specific optical rotation** (2.2.7): –33 to –39 (anhydrous substance).

Dissolve 1.00 g in *dilute hydrochloric acid R* and dilute to 25.0 mL with the same acid.

**Related substances.** Liquid chromatography (2.2.29).

*Test solution.* Dissolve 25.0 mg of the substance to be examined in the mobile phase and dilute to 25.0 mL with the mobile phase.

*Reference solution (a).* Dilute 1.0 mL of the test solution to 10.0 mL with the mobile phase. Dilute 1.0 mL of this solution to 100.0 mL with the mobile phase.

*Reference solution (b).* Dissolve 5.0 mg of *hyoscine impurity A CRS* in the mobile phase and dilute to 10.0 mL with the mobile phase.

*Reference solution (c).* Dilute 5.0 mL of reference solution (b) to 25.0 mL with the mobile phase. Dilute 5.0 mL of this solution to 50.0 mL with the mobile phase.

*Reference solution (d).* Mix 2.0 mL of reference solution (b) and 1.0 mL of the test solution and dilute to 10.0 mL with the mobile phase.

*Column:*

– *size*: *l* = 0.125 m, Ø = 4.0 mm,

– *stationary phase*: *octylsilyl silica gel for chromatography R* (3 µm).

*Mobile phase*: mix 33 volumes of *acetonitrile R* and 67 volumes of a 2.5 g/L solution of *sodium dodecyl sulfate R* previously adjusted to pH 2.5 with a 346 g/L solution of *phosphoric acid R*.

*Flow rate*: 1.5 mL/min.

*Detection*: spectrophotometer at 210 nm.

*Injection*: 5 µL.

*Run time*: 3 times the retention time of hyoscine.

*Relative retention* with reference to hyoscine (retention time = about 5 min): *impurity C* = about 0.2; *impurity A* = about 0.9; *impurity D* = about 1.3; *impurity B* = about 2.5.

*System suitability*: reference solution (d):

– *resolution*: minimum 1.5 between the peaks due to *impurity A* and hyoscine.

*Limits:*

– *correction factors*: for the calculation of content, multiply the peak areas of the following impurities by the corresponding correction factor: *impurity B* = 0.6; *impurity C* = 0.3;

– *impurity A*: not more than 0.5 times the area of the principal peak in the chromatogram obtained with reference solution (c) (0.5 per cent);

– *impurities B, C, D*: for each impurity, not more than the area of the principal peak in the chromatogram obtained with reference solution (a) (0.1 per cent);

- *any other impurity*: for each impurity, not more than the area of the principal peak in the chromatogram obtained with reference solution (a) (0.1 per cent);
- *total*: not more than 5 times the area of the principal peak in the chromatogram obtained with reference solution (a) (0.5 per cent);
- *disregard limit*: 0.5 times the area of the principal peak in the chromatogram obtained with reference solution (a) (0.05 per cent).

**Water** (2.5.12): maximum 0.5 per cent, determined on 1.000 g.

**Sulfated ash** (2.4.14): maximum 0.1 per cent, determined on 1.0 g.

#### ASSAY

Dissolve 0.250 g in 60 mL of *anhydrous acetic acid R*. Titrate with 0.1 M *perchloric acid*, determining the end-point potentiometrically (2.2.20).

1 mL of 0.1 M *perchloric acid* is equivalent to 30.34 mg of  $C_{17}H_{21}NO_4$ .

#### IMPURITIES

*Specified impurities: A, B, C, D.*

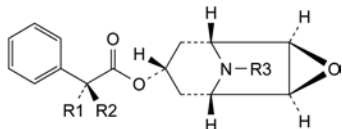

- A.  $R_1 = CH_2OH$ ,  $R_2 = R_3 = H$ : (1*R*,2*R*,4*S*,5*S*,7*S*)-3-oxa-9-azatricyclo[3.3.1.0<sup>2,4</sup>]non-7-yl (2*S*)-3-hydroxy-2-phenylpropanoate (norhyoscine),
- B.  $R_1 + R_2 = CH_2$ ,  $R_3 = CH_3$ : (1*R*,2*R*,4*S*,5*S*,7*S*)-9-methyl-3-oxa-9-azatricyclo[3.3.1.0<sup>2,4</sup>]non-7-yl 2-phenylprop-2-enoate (apohyoscine),

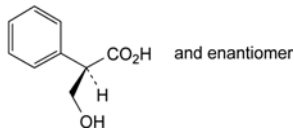

- C. (2*R*)-3-hydroxy-2-phenylpropanoic acid (DL-tropic acid),

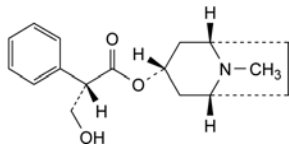

- D. (1*R*,3*r*,5*S*)-8-methyl-8-azabicyclo[3.2.1]oct-3-yl (2*S*)-3-hydroxy-2-phenylpropanoate (hyoscyamine).

01/2008:0737  
corrected 6.0

## HYOSCINE BUTYLBROMIDE

Hyoscini butylbromidum

Scopolamini butylbromidum

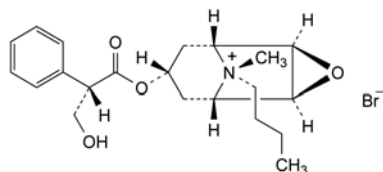

$C_{21}H_{30}BrNO_4$   
[149-64-4]

$M_r$  440.4

#### DEFINITION

(1*R*,2*R*,4*S*,5*S*,7*S*,9*r*)-Butyl-7-[[[(2*S*)-3-hydroxy-2-phenylpropanoyl]oxy]-9-methyl-3-oxa-9-azoniatricyclo[3.3.1.0<sup>2,4</sup>]nonane bromide.

*Content*: 98.0 per cent to 101.0 per cent (dried substance).

#### CHARACTERS

*Appearance*: white or almost white, crystalline powder.

*Solubility*: freely soluble in water and in methylene chloride, sparingly soluble in anhydrous ethanol.

#### IDENTIFICATION

*First identification: A, C, F.*

*Second identification: A, B, D, E, F.*

- A. Specific optical rotation (see Tests).  
B. Melting point (2.2.14): 139 °C to 141 °C.  
C. Infrared absorption spectrophotometry (2.2.24).

*Comparison: hyoscine butylbromide CRS.*

- D. To about 1 mg add 0.2 mL of *nitric acid R* and evaporate to dryness on a water-bath. Dissolve the residue in 2 mL of *acetone R* and add 0.1 mL of a 30 g/L solution of *potassium hydroxide R* in *methanol R*. A violet colour develops.  
E. To 5 mL of solution S (see Tests) add 2 mL of *dilute sodium hydroxide solution R*. No precipitate is formed.  
F. It gives reaction (a) of bromides (2.3.1).

#### TESTS

**Solution S.** Dissolve 1.25 g in *carbon dioxide-free water R* and dilute to 25.0 mL with the same solvent.

**Appearance of solution.** Solution S is clear (2.2.1) and colourless (2.2.2, *Method II*).

**pH** (2.2.3): 5.5 to 6.5 for solution S.

**Specific optical rotation** (2.2.7): – 18 to – 20 (dried substance), determined on solution S.

**Related substances.** Liquid chromatography (2.2.29).

*Test solution.* Dissolve 50.0 mg of the substance to be examined in the mobile phase and dilute to 10.0 mL with the mobile phase.

*Reference solution (a).* Dilute 1.0 mL of the test solution to 50.0 mL with the mobile phase. Dilute 5.0 mL of this solution to 50.0 mL with the mobile phase.

*Reference solution (b).* Dilute 10.0 mL of reference solution (a) to 20.0 mL with the mobile phase.

*Reference solution (c).* Dissolve 5.0 mg of *hyoscine butylbromide impurity E CRS* in the mobile phase, add 1.0 mL of the test solution and dilute to 10.0 mL with the mobile phase. Dilute 5.0 mL of this solution to 50.0 mL with the mobile phase.

*Column:*

- *size*:  $l = 0.125$  m,  $\emptyset = 4.0$  mm;
- *stationary phase*: octylsilyl silica gel for chromatography R (4  $\mu$ m);
- *temperature*:  $25 \pm 1$  °C.

*Mobile phase:* dissolve 5.8 g of *sodium dodecyl sulfate R* in a mixture of 410 mL of *acetonitrile R* and 605 mL of a 7.0 g/L solution of *potassium dihydrogen phosphate R* previously adjusted to pH 3.3 with 0.05 M *phosphoric acid*.

*Flow rate*: 2.0 mL/min.

*Detection*: spectrophotometer at 210 nm.

*Injection*: 10  $\mu$ L.

*Run time*: 3.5 times the retention time of butylhyoscine.

*Relative retention* with reference to butylhyoscine (retention time = about 7.0 min): impurity B = about 0.1; impurity A = about 0.36; impurity C = about 0.40; impurity D = about 0.7; impurity E = about 0.8; impurity F = about 0.9; impurity G = about 3.0.



*System suitability*: reference solution (c):

- *resolution*: minimum 1.5 between the peaks due to impurity E and butylhyoscine;
- *symmetry factor*: maximum 2.5 for the peak due to butylhyoscine.

*Limits*:

- *correction factors*: for the calculation of contents, multiply the peak areas of the following impurities by the corresponding correction factor: impurity B = 0.3; impurity G = 0.6;
- *impurities B, C, D, E, F, G*: for each impurity, not more than the area of the principal peak in the chromatogram obtained with reference solution (a) (0.2 per cent);
- *impurity A*: not more than the area of the principal peak in the chromatogram obtained with reference solution (b) (0.1 per cent);
- *any other impurity*: for each impurity, not more than the area of the principal peak in the chromatogram obtained with reference solution (b) (0.1 per cent);
- *total*: not more than twice the area of the principal peak in the chromatogram obtained with reference solution (a) (0.4 per cent); disregard any peak due to the bromide ion which appears close to the solvent peak;
- *disregard limit*: 0.5 times the area of the principal peak in the chromatogram obtained with reference solution (b) (0.05 per cent).

**Loss on drying** (2.2.32): maximum 2.5 per cent, determined on 0.500 g by drying in an oven at 105 °C.

**Sulfated ash** (2.4.14): maximum 0.1 per cent, determined on 0.5 g.

#### ASSAY

Dissolve 0.400 g in 50 mL of *water R*. Titrate with 0.1 M *silver nitrate*, determining the end-point potentiometrically (2.2.20) using a silver indicator electrode and a silver-silver chloride reference electrode.

1 mL of 0.1 M *silver nitrate* is equivalent to 44.04 mg of  $C_{21}H_{30}BrNO_4$ .

#### IMPURITIES

*Specified impurities*: A, B, C, D, E, F, G.

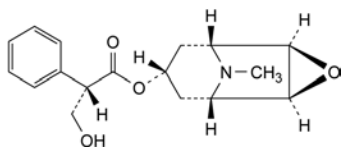

A. (1*R*,2*R*,4*S*,5*S*,7*s*)-9-methyl-3-oxa-9-azatricyclo[3.3.1.0<sup>2,4</sup>]non-7-yl (2*S*)-3-hydroxy-2-phenylpropanoate (hyoscine),

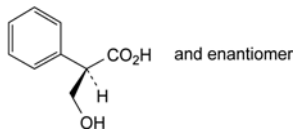

B. (2*RS*)-3-hydroxy-2-phenylpropanoic acid (DL-tropic acid),

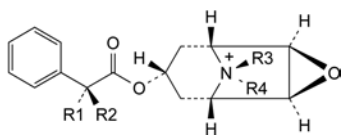

C. R1 = CH<sub>2</sub>OH, R2 = H, R3 = R4 = CH<sub>3</sub>: (1*R*,2*R*,4*S*,5*S*,7*s*)-7-[[[(2*S*)-3-hydroxy-2-phenylpropanoyl]oxy]-9,9-dimethyl-3-oxa-9-azoniatricyclo[3.3.1.0<sup>2,4</sup>]nonane (methylhyoscine),

D. R1 = CH<sub>2</sub>OH, R2 = H, R3 = CH<sub>3</sub>, R4 = CH<sub>2</sub>-CH<sub>2</sub>-CH<sub>3</sub>: (1*R*,2*R*,4*S*,5*S*,7*s*,9*r*)-7-[[[(2*S*)-3-hydroxy-2-phenylpropanoyl]oxy]-9-methyl-9-propyl-3-oxa-9-azoniatricyclo[3.3.1.0<sup>2,4</sup>]nonane (propylhyoscine),

F. R1 = CH<sub>2</sub>OH, R2 = H, R3 = CH<sub>2</sub>-CH<sub>2</sub>-CH<sub>2</sub>-CH<sub>3</sub>, R4 = CH<sub>3</sub>: (1*R*,2*R*,4*S*,5*S*,7*s*,9*s*)-9-butyl-7-[[[(2*S*)-3-hydroxy-2-phenylpropanoyl]oxy]-9-methyl-3-oxa-9-azoniatricyclo[3.3.1.0<sup>2,4</sup>]nonane (pseudo-isomer),

G. R1 + R2 = CH<sub>2</sub>, R3 = CH<sub>3</sub>, R4 = CH<sub>2</sub>-CH<sub>2</sub>-CH<sub>2</sub>-CH<sub>3</sub>: (1*R*,2*R*,4*S*,5*S*,7*s*,9*r*)-9-butyl-9-methyl-7-[(2-phenylprop-2-enyl)oxy]-3-oxa-9-azoniatricyclo[3.3.1.0<sup>2,4</sup>]nonane (apo-*N*-butylhyoscine);

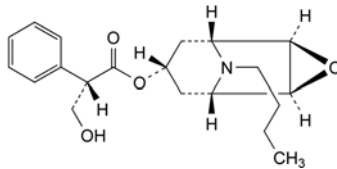

E. (1*R*,2*R*,4*S*,5*S*,7*s*)-9-butyl-3-oxa-9-azatricyclo[3.3.1.0<sup>2,4</sup>]nonan-7-yl (2*S*)-3-hydroxy-2-phenylpropanoate (*N*-butylhyoscine).

01/2008:0106

## HYOSCINE HYDROBROMIDE

### Hyoscini hydrobromidum

### Scopolamini hydrobromidum

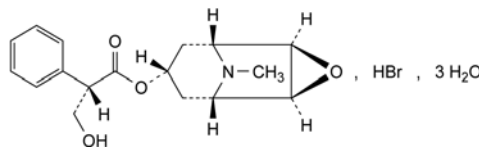

$C_{17}H_{22}BrNO_4 \cdot 3H_2O$   
[6533-68-2]

$M_r$  438.3

#### DEFINITION

(1*R*,2*R*,4*S*,5*S*,7*s*)-9-Methyl-3-oxa-9-azatricyclo[3.3.1.0<sup>2,4</sup>]non-7-yl (2*S*)-3-hydroxy-2-phenylpropanoate hydrobromide trihydrate.

*Content*: 99.0 per cent to 101.0 per cent (anhydrous substance).

#### CHARACTERS

*Appearance*: white or almost white, crystalline powder or colourless crystals, efflorescent.

*Solubility*: freely soluble in water, soluble in ethanol (96 per cent).

#### IDENTIFICATION

*First identification*: B, E.

*Second identification*: A, C, D, E.

A. Specific optical rotation (see Tests).

B. Infrared absorption spectrophotometry (2.2.24).

*Comparison*: *hyoscine hydrobromide CRS*.

If the spectra obtained in the solid state show differences, proceed as follows: dissolve 3 mg of the substance to be examined in 1 mL of *ethanol (96 per cent) R* and evaporate to dryness on a water-bath; dissolve the residue in 0.5 mL of *methylene chloride R* and add 0.2 g of *potassium bromide R* and 15 mL of *ether R*; allow to stand for 5 min shaking frequently; decant; dry the residue on a water-bath until the solvents have evaporated; using the residue prepare a disc and dry at 100-105 °C for 3 h. Repeat the procedure with *hyoscine hydrobromide CRS* and record the spectra.

C. Dissolve about 50 mg in 5 mL of *water R* and add 5 mL of *picric acid solution R* dropwise and with shaking. The precipitate, washed with *water R* and dried at 100-105 °C for 2 h, melts (2.2.14) at 188 °C to 193 °C.

D. To about 1 mg add 0.2 mL of *fuming nitric acid R* and evaporate to dryness on a water-bath. Dissolve the residue in 2 mL of *acetone R* and add 0.1 mL of a 30 g/L solution of *potassium hydroxide R* in *methanol R*. A violet colour develops.

E. It gives reaction (a) of bromides (2.3.1).

#### TESTS

**Solution S.** Dissolve 2.50 g in *carbon dioxide-free water R* and dilute to 50.0 mL with the same solvent.

**pH (2.2.3):** 4.0 to 5.5 for solution S.

**Specific optical rotation (2.2.7):** –24 to –27 (anhydrous substance), determined on solution S.

**Related substances.** Liquid chromatography (2.2.29).

**Test solution.** Dissolve 70.0 mg of the substance to be examined in the mobile phase and dilute to 50.0 mL with the mobile phase.

**Reference solution (a).** Dilute 2.0 mL of the test solution to 100.0 mL with the mobile phase. Dilute 5.0 mL of this solution to 20.0 mL with the mobile phase.

**Reference solution (b).** Dilute 5.0 mL of reference solution (a) to 25.0 mL with the mobile phase.

**Reference solution (c).** Dissolve 5.0 mg of *hyoscyine hydrobromide impurity B CRS* in the mobile phase, add 5.0 mL of the test solution and dilute to 50.0 mL with the mobile phase. Dilute 1.0 mL of this solution to 10.0 mL with the mobile phase.

**Column:**

- size:  $l = 0.125$  m,  $\varnothing = 4.0$  mm,
- stationary phase: *octylsilyl silica gel for chromatography R* (3  $\mu$ m),
- temperature:  $25 \pm 1$  °C.

**Mobile phase:** mix 330 mL of *acetonitrile R* with 670 mL of a 2.5 g/L solution of *sodium dodecyl sulfate R* previously adjusted to pH 2.5 with 3 M *phosphoric acid*.

**Flow rate:** 1.5 mL/min.

**Detection:** spectrophotometer at 210 nm.

**Injection:** 5  $\mu$ L.

**Run time:** 3 times the retention time of hyoscyine.

**Relative retention** with reference to hyoscyine (retention time = about 5.0 min): impurity D = about 0.2; impurity B = about 0.9; impurity A = about 1.3; impurity C = about 2.4.

**System suitability:** reference solution (c):

- resolution: minimum 1.5 between the peaks due to impurity B and hyoscyine,
- symmetry factor: maximum 2.5 for the peak due to hyoscyine.

**Limits:**

- correction factors: for the calculation of contents, multiply the peak areas of the following impurities by the corresponding correction factor: impurity D = 0.3; impurity C = 0.6;
- impurity B: not more than the area of the principal peak in the chromatogram obtained with reference solution (a) (0.5 per cent);
- impurities A, C, D: for each impurity, not more than the area of the principal peak in the chromatogram obtained with reference solution (b) (0.1 per cent);
- any other impurity: for each impurity, not more than the area of the principal peak in the chromatogram obtained with reference solution (b) (0.1 per cent);
- total: not more than 1.4 times the area of the principal peak in the chromatogram obtained with reference solution (a) (0.7 per cent); disregard any peak due to the bromide ion which appears close to the solvent peak;
- disregard limit: 0.5 times the area of the principal peak in the chromatogram obtained with reference solution (b) (0.05 per cent).

**Water (2.5.12):** 10.0 per cent to 13.0 per cent, determined on 0.20 g.

**Sulfated ash (2.4.14):** maximum 0.1 per cent, determined on 1.0 g.

#### ASSAY

Dissolve 0.300 g in a mixture of 5.0 mL of 0.01 M *hydrochloric acid* and 50 mL of *ethanol (96 per cent) R*. Carry out a potentiometric titration (2.2.20), using 0.1 M *sodium hydroxide* free from carbonate. Read the volume added between the 2 points of inflexion.

1 mL of 0.1 M *sodium hydroxide* is equivalent to 38.43 mg of  $C_{17}H_{22}BrNO_4$ .

#### STORAGE

In a well-filled, airtight container of small capacity, protected from light.

#### IMPURITIES

**Specified impurities: A, B, C, D.**

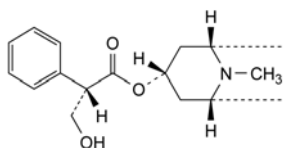

A. (1*R*,3*r*,5*S*)-8-methyl-8-azabicyclo[3.2.1]oct-3-yl (2*S*)-3-hydroxy-2-phenylpropanoate (hyoscyamine),

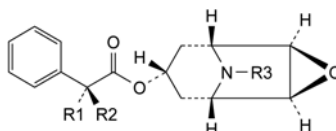

B. R1 = CH<sub>2</sub>OH, R2 = R3 = H: (1*R*,2*R*,4*S*,5*S*,7*s*)-3-oxa-9-azatricyclo[3.3.1.0<sup>2,4</sup>]non-7-yl (2*S*)-3-hydroxy-2-phenylpropanoate (norhyoscyine),

C. R1 + R2 = CH<sub>2</sub>, R3 = CH<sub>3</sub>: (1*R*,2*R*,4*S*,5*S*,7*s*)-9-methyl-3-oxa-9-azatricyclo[3.3.1.0<sup>2,4</sup>]non-7-yl 2-phenylprop-2-enoate (apohyoscyine),

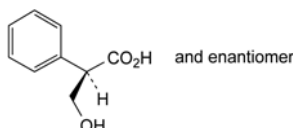

D. (2*RS*)-3-hydroxy-2-phenylpropanoic acid (DL-tropic acid).

01/2008:0501

## HYOSCYAMINE SULFATE

### Hyoscyamini sulfas

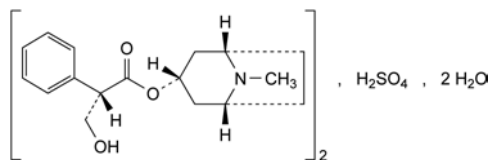

$C_{34}H_{48}N_2O_{10}S_2 \cdot 2H_2O$   
[620-61-1]

$M_r$  713

#### DEFINITION

Bis[(1*R*,3*r*,5*S*)-8-methyl-8-azabicyclo[3.2.1]oct-3-yl (2*S*)-3-hydroxy-2-phenylpropanoate] sulfate dihydrate.

**Content:** 98.0 per cent to 101.0 per cent (anhydrous substance).

#### CHARACTERS

**Appearance:** white or almost white, crystalline powder or colourless needles.

**Solubility:** very soluble in water, sparingly soluble or soluble in ethanol (96 per cent).

#### IDENTIFICATION

**First identification:** A, B, E.

**Second identification:** C, D, E.

A. Specific optical rotation (see Tests).

B. Infrared absorption spectrophotometry (2.2.24).

*Comparison: hyoscyamine sulfate CRS.*

C. To 0.5 mL of solution S (see Tests) add 2 mL of dilute acetic acid R and heat. To the hot solution add 4 mL of picric acid solution R. Allow to cool, shaking occasionally. Collect the crystals, wash with 2 quantities, each of 3 mL, of iced water R and dry at 100–105 °C. The crystals melt (2.2.14) at 164 °C to 168 °C.

D. To about 1 mg add 0.2 mL of fuming nitric acid R and evaporate to dryness on a water-bath. Dissolve the residue in 2 mL of acetone R and add 0.2 mL of a 30 g/L solution of potassium hydroxide R in methanol R. A violet colour develops.

E. It gives reaction (a) of sulfates (2.3.1).

#### TESTS

**Solution S.** Dissolve 2.50 g in water R and dilute to 50.0 mL with the same solvent.

**Appearance of solution.** Solution S is not more intensely coloured than reference solution BY<sub>6</sub> (2.2.2, Method II).

**pH (2.2.3):** 4.5 to 6.2.

Dissolve 0.5 g in carbon dioxide-free water R and dilute to 25 mL with the same solvent.

**Specific optical rotation (2.2.7):** –24 to –29 (anhydrous substance), determined on solution S.

**Related substances.** Liquid chromatography (2.2.29).

**Test solution.** Dissolve 60.0 mg of the substance to be examined in mobile phase A and dilute to 50.0 mL with mobile phase A. Dilute 10.0 mL of the solution to 50.0 mL with mobile phase A.

**Reference solution (a).** Dilute 5.0 mL of the test solution to 100.0 mL with mobile phase A. Dilute 5.0 mL of this solution to 50.0 mL with mobile phase A.

**Reference solution (b).** Dilute 5.0 mL of reference solution (a) to 25.0 mL with mobile phase A.

**Reference solution (c).** Dissolve 5.0 mg of hyoscyamine impurity E CRS in the test solution and dilute to 20.0 mL with the test solution. Dilute 5.0 mL of this solution to 25.0 mL with mobile phase A.

**Column:**

- size:  $l = 0.10$  m,  $\varnothing = 4.6$  mm;
- stationary phase: octadecylsilyl silica gel for chromatography R (3  $\mu$ m);
- temperature:  $25 \pm 1$  °C.

**Mobile phase:**

- mobile phase A: dissolve 3.5 g of sodium dodecyl sulfate R in 606 mL of a 7.0 g/L solution of potassium dihydrogen phosphate R previously adjusted to pH 3.3 with 0.05 M phosphoric acid and mix with 320 mL of acetonitrile R;
- mobile phase B: acetonitrile R;

Time (min)	Mobile phase A (per cent V/V)	Mobile phase B (per cent V/V)
0 - 2.0	95	5
2.0 - 20.0	95 → 70	5 → 30
20.0 - 20.1	70 → 95	30 → 5
20.1 - 25.0	95	5

**Flow rate:** 1.0 mL/min.

**Detection:** spectrophotometer at 210 nm.

**Injection:** 10  $\mu$ L.

**Relative retention** with reference to hyoscyamine (retention time = about 10.5 min): impurity A = about 0.2; impurity B = about 0.67; impurity C = about 0.72; impurity D = about 0.8; impurity E = about 0.9; impurity F = about 1.1; impurity G = about 1.8.

**System suitability:** reference solution (c):

- resolution: minimum 2.5 between the peaks due to hyoscyamine and impurity E;
- symmetry factor: maximum 2.5 for the peak due to hyoscyamine.

**Limits:**

- correction factors: for the calculation of contents, multiply the peak areas of the following impurities by the corresponding correction factor: impurity A = 0.3; impurity G = 0.6;
- impurity E: not more than 3 times the area of the principal peak in the chromatogram obtained with reference solution (b) (0.3 per cent);
- impurities A, B, C, D, F, G: for each impurity, not more than twice the area of the principal peak in the chromatogram obtained with reference solution (b) (0.2 per cent);
- unspecified impurities: for each impurity, not more than the area of the principal peak in the chromatogram obtained with reference solution (b) (0.10 per cent);
- total: not more than the area of the principal peak in the chromatogram obtained with reference solution (a) (0.5 per cent);
- disregard limit: 0.1 times the area of the principal peak in the chromatogram obtained with reference solution (a) (0.05 per cent).

**Water (2.5.12):** 2.0 per cent to 5.5 per cent, determined on 0.500 g.

**Sulfated ash (2.4.14):** maximum 0.1 per cent, determined on 1.0 g.

#### ASSAY

Dissolve 0.500 g in 25 mL of anhydrous acetic acid R. Titrate with 0.1 M perchloric acid, determining the end-point potentiometrically (2.2.20).

1 mL of 0.1 M perchloric acid is equivalent to 67.7 mg of C<sub>34</sub>H<sub>48</sub>N<sub>2</sub>O<sub>10</sub>S.

#### STORAGE

In an airtight container, protected from light.

#### IMPURITIES

**Specified impurities:** A, B, C, D, E, F, G.

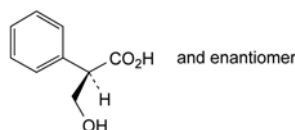

A. (2RS)-3-hydroxy-2-phenylpropanoic acid (DL-tropic acid),

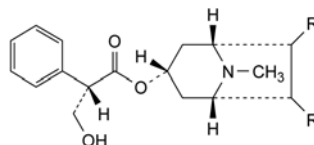

B. R = OH, R' = H: (1R,3S,5R,6RS)-6-hydroxy-8-methyl-8-azabicyclo[3.2.1]oct-3-yl (2S)-3-hydroxy-2-phenylpropanoate (7-hydroxyhyoscyamine),

C. R = H, R' = OH: (1S,3R,5S,6RS)-6-hydroxy-8-methyl-8-azabicyclo[3.2.1]oct-3-yl (2S)-3-hydroxy-2-phenylpropanoate (6-hydroxyhyoscyamine),

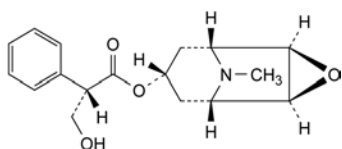

- D. (1*R*,2*R*,4*S*,5*S*,7*s*)-9-methyl-3-oxa-9-azatricyclo[3.3.1.0<sup>2,4</sup>]non-7-yl (2*S*)-3-hydroxy-2-phenylpropanoate (hyoscyne),

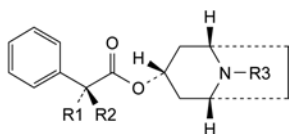

- E. R1 = CH<sub>2</sub>OH, R2 = R3 = H: (1*R*,3*r*,5*S*)-8-azabicyclo[3.2.1]oct-3-yl (2*S*)-3-hydroxy-2-phenylpropanoate (norhyoscyamine),  
 G. R1 + R2 = CH<sub>2</sub>, R3 = CH<sub>3</sub>: (1*R*,3*r*,5*S*)-8-methyl-8-azabicyclo[3.2.1]oct-3-yl 2-phenylprop-2-enoate (apoatropine),

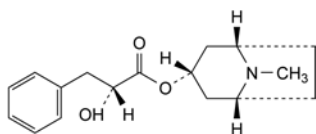

- F. (1*R*,3*r*,5*S*)-8-methyl-8-azabicyclo[3.2.1]oct-3-yl (2*R*)-2-hydroxy-3-phenylpropanoate (littorine).

01/2008:0348  
corrected 6.3

## HYPROMELLOSE

### Hypromellosum

[9004-65-3]

#### DEFINITION

Hydroxypropylmethylcellulose.

Partly *O*-methylated and *O*-(2-hydroxypropylated) cellulose.

#### CHARACTERS

**Appearance:** white, yellowish-white or greyish-white powder or granules, hygroscopic after drying.

**Solubility:** practically insoluble in hot water, in acetone, in anhydrous ethanol and in toluene. It dissolves in cold water giving a colloidal solution.

#### IDENTIFICATION

- Evenly distribute 1.0 g on the surface of 100 mL of *water R* in a beaker, tapping the top of the beaker, gently if necessary to ensure a uniform layer on the surface. Allow to stand for 1-2 min: the powdered material aggregates on the surface.
- Evenly distribute 1.0 g into 100 mL of boiling *water R*, and stir the mixture using a magnetic stirrer with a bar 25 mm long: a slurry is formed and the particles do not dissolve. Allow the slurry to cool to 10 °C and stir using a magnetic stirrer: a clear or slightly turbid solution occurs with its thickness dependent on the viscosity grade.
- To 0.1 mL of the solution obtained in identification B add 9 mL of a 90 per cent *V/V* solution of *sulfuric acid R*, shake, heat on a water-bath for exactly 3 min, immediately cool in an ice-bath, carefully add 0.6 mL of a 20 g/L solution of *ninhydrin R*, shake and allow to stand at 25 °C: a red colour develops at first and changes to purple within 100 min.
- Place 2-3 mL of the solution obtained in identification B onto a glass slide as a thin film and allow the water to evaporate: a coherent, clear film forms on the glass slide.
- Add exactly 50 mL of the solution obtained in identification B to exactly 50 mL of *water R* in a beaker. Insert a thermometer into the solution. Stir the solution on a magnetic stirrer/hot plate and begin heating, increasing the temperature at a rate of 2-5 °C per minute. Determine the temperature at

which a turbidity increase begins to occur and designate the temperature as the flocculation temperature: the flocculation temperature is higher than 50 °C.

#### TESTS

**Solution S.** While stirring, introduce a quantity of the substance to be examined equivalent to 1.0 g of the dried substance into 50 g of *carbon dioxide-free water R* heated to 90 °C. Allow to cool, adjust the mass of the solution to 100 g with *carbon dioxide-free water R* and stir until dissolution is complete.

**Appearance of solution.** Solution S is not more opalescent than reference suspension III (2.2.1) and not more intensely coloured than reference solution Y<sub>6</sub> (2.2.2, *Method II*).

**pH (2.2.3):** 5.0 to 8.0 for the solution prepared as described under Apparent viscosity.

Carry out the test at 20 ± 2 °C and read the indicated pH value after the probe has been immersed for 5 ± 0.5 min.

**Heavy metals (2.4.8):** maximum 20 ppm.

1.0 g complies with test F. Prepare the reference solution using 2 mL of *lead standard solution (10 ppm Pb) R*.

**Loss on drying (2.2.32):** maximum 5.0 per cent, determined on 1.000 g by drying in an oven at 105 °C for 1 h.

**Sulfated ash (2.4.14):** maximum 1.5 per cent, determined on 1.0 g.

#### FUNCTIONALITY-RELATED CHARACTERISTICS

*This section provides information on characteristics that are recognised as being relevant control parameters for one or more functions of the substance when used as an excipient (see chapter 5.15). This section is a non-mandatory part of the monograph and it is not necessary to verify the characteristics to demonstrate compliance. Control of these characteristics can however contribute to the quality of a medicinal product by improving the consistency of the manufacturing process and the performance of the medicinal product during use. Where control methods are cited, they are recognised as being suitable for the purpose, but other methods can also be used. Wherever results for a particular characteristic are reported, the control method must be indicated.*

*The following characteristics may be relevant for hypromellose used as binder, viscosity-increasing agent or film former.*

**Apparent viscosity:** minimum 80 per cent and maximum 120 per cent of the nominal value for samples with a viscosity less than 600 mPa·s (Method 1); minimum 75 per cent and maximum 140 per cent of the nominal value for samples with a viscosity of 600 mPa·s or higher (Method 2).

*Method 1, to be applied to samples with a viscosity of less than 600 mPa·s.* Weigh accurately a quantity of the substance to be examined equivalent to 4.000 g of the dried substance. Transfer into a wide-mouthed bottle, and adjust the mass to 200.0 g with hot *water R*. Capping the bottle, stir by mechanical means at 400 ± 50 r/min for 10-20 min until the particles are thoroughly dispersed and wetted. Scrape down the insides of the bottle with a spatula if necessary, to ensure that there is no undissolved material on the sides of the bottle, and continue the stirring in a cooling water-bath maintained at a temperature below 10 °C for another 20-40 min. Adjust the solution mass if necessary to 200.0 g using cold *water R*. Centrifuge the solution if necessary to expel any entrapped air bubbles. Using a spatula, remove any foam, if present. Determine the viscosity of this solution using the capillary viscometer method (2.2.9) to obtain the kinematic viscosity ( $\nu$ ). Separately, determine the density ( $\rho$ ) (2.2.5) of the solution and calculate the dynamic viscosity ( $\eta$ ), as  $\eta = \rho\nu$ .

*Method 2, to be applied to samples with a viscosity of 600 mPa·s or higher.* Weigh accurately a quantity of the substance to be examined equivalent to 10.00 g of the dried substance. Transfer into a wide-mouthed bottle, and adjust the mass to 500.0 g with hot *water R*. Capping the bottle, stir by mechanical means at 400 ± 50 r/min for 10-20 min until the particles are thoroughly dispersed and wetted. Scrape down the insides of the bottle with

a spatula if necessary, to ensure that there is no undissolved material on the sides of the bottle, and continue the stirring in a cooling water-bath maintained at a temperature below 10 °C for another 20-40 min. Adjust the solution mass if necessary to 500.0 g using cold *water R*. Centrifuge the solution if necessary to expel any entrapped air bubbles. Using a spatula, remove any foam, if present. Determine the viscosity (2.2.10) of this solution at 20 ± 0.1 °C using a rotating viscometer.

**Apparatus:** single-cylinder type spindle viscometer.

**Rotor number, revolution and calculation multiplier:** apply the conditions specified in Table 0348-1.

Allow the spindle to rotate for 2 min before taking the measurement. Allow a rest period of 2 min between subsequent measurements. Repeat the measurement twice and determine the mean of the 3 readings.

Table 0348-1.

Labelled viscosity* (mPa·s)	Rotor number	Revolution (r/min)	Calculation multiplier
600 to less than 1400	3	60	20
1400 to less than 3500	3	12	100
3500 to less than 9500	4	60	100
9500 to less than 99 500	4	6	1000
99 500 or more	4	3	2000

\* the nominal viscosity is based on the manufacturer's specifications.

**Degree of substitution.** Gas chromatography (2.2.28).

**Apparatus:**

- **reaction vial:** a 5 mL pressure-tight vial, 50 mm in height, 20 mm in external diameter and 13 mm in internal diameter at the mouth, equipped with a pressure-tight butyl rubber membrane stopper coated with polytetrafluoroethylene and secured with an aluminium crimped cap or another sealing system providing a sufficient air-tightness;
- **heater:** a heating module with a square aluminium block having holes 20 mm in diameter and 32 mm in depth, so that the reaction vials fit; mixing of the contents of the vial is effected using a magnetic stirrer equipped in the heating module or using a reciprocal shaker that performs approximately 100 cycles/min.

**Internal standard solution:** 30 g/L solution of *octane R* in *xylene R*.

**Test solution.** Weigh 65.0 mg of the substance to be examined, place in a reaction vial, add 0.06-0.10 g of *adipic acid R*, 2.0 mL of the internal standard solution and 2.0 mL of *hydriodic acid R*, immediately cap and seal the vial, and weigh accurately. Mix the contents of the vial continuously for 60 min while heating the block so that the temperature of the contents is maintained at 130 ± 2 °C. If a reciprocal shaker or magnetic stirrer cannot be used, shake the vial well by hand at 5-minute intervals during the initial 30 min of the heating time. Allow the vial to cool, and again weigh accurately. If the loss of mass is less than 0.50 per cent of the contents and there is no evidence of a leak, use the upper layer of the mixture as the test solution.

**Reference solution.** Place 0.06-0.10 g of *adipic acid R*, 2.0 mL of the internal standard solution and 2.0 mL of *hydriodic acid R* in another reaction vial, cap and seal the vial, and weigh accurately. Add 15-22 µL of *isopropyl iodide R* through the

septum with a syringe, weigh accurately, add 45 µL of *methyl iodide R* in the same manner, and weigh accurately. Shake the reaction vial well, and use the upper layer as the reference solution.

**Column:**

- **size:**  $l = 1.8-3$  m,  $\varnothing = 3-4$  mm;
- **stationary phase:** *diatomaceous earth for gas chromatography R* impregnated with 10-20 per cent of *poly(dimethyl)(75)(diphenyl)(25)siloxane R* (film thickness 125-150 µm);
- **temperature:** 100 °C.

**Carrier gas:** *helium for chromatography R* (thermal conductivity); *helium for chromatography R* or *nitrogen for chromatography R* (flame ionisation).

**Flow rate:** adjusted so that the retention time of the internal standard is about 10 min.

**Detection:** flame ionisation or thermal conductivity.

**Injection:** 1-2 µL.

**System suitability:** reference solution:

- **resolution:** well resolved peaks of methyl iodide (1<sup>st</sup> peak), isopropyl iodide (2<sup>nd</sup> peak) and internal standard (3<sup>rd</sup> peak).

**Calculation:**

- **methoxy and hydroxypropoxy groups:** calculate the ratios ( $Q_1$  and  $Q_2$ ) of the areas of the peaks due to methyl iodide and isopropyl iodide to the area of the peak due to the internal standard in the chromatogram obtained with the test solution, and the ratios ( $Q_3$  and  $Q_4$ ) of the areas of the peaks due to methyl iodide and isopropyl iodide to the area of the peak due to the internal standard in the chromatogram obtained with the reference solution.

Calculate the percentage content of methoxy groups using the following expression:

$$\frac{Q_1}{Q_3} \times \frac{m_1}{m} \times 21.864$$

Calculate the percentage content of hydroxypropoxy groups using the following expression:

$$\frac{Q_2}{Q_4} \times \frac{m_2}{m} \times 44.17$$

- $m_1$  = mass of methyl iodide in the reference solution, in milligrams;
- $m_2$  = mass of isopropyl iodide in the reference solution, in milligrams;
- $m$  = mass of the sample (dried substance), in milligrams.

Substitution type	Methoxy (per cent)	Hydroxypropoxy (per cent)
1828	16.5 to 20.0	23.0 to 32.0
2208	19.0 to 24.0	4.0 to 12.0
2906	27.0 to 30.0	4.0 to 7.5
2910	28.0 to 30.0	7.0 to 12.0

The following characteristics may be relevant for hypromellose used as matrix former in prolonged-release tablets.

**Apparent viscosity:** see test above.

**Degree of substitution:** see test above.

**Molecular mass distribution (2.2.30).**

**Particle-size distribution (2.9.31 or 2.9.38).**

**Powder flow (2.9.36).**

04/2008:0347  
corrected 6.3

## HYPROMELLOSE PHTHALATE

## Hypromellosi phthalas

## DEFINITION

Hydroxypropylmethylcellulose phthalate.

Monophthalic acid ester of hypromellose, containing methoxy (-OCH<sub>3</sub>), 2-hydroxypropoxy (-OCH<sub>2</sub>CHOHCH<sub>3</sub>) and phthaloyl (o-carboxybenzoyl C<sub>8</sub>H<sub>5</sub>O<sub>3</sub>) groups.

## CHARACTERS

*Appearance*: white or almost white, free-flowing flakes or granular powder.

*Solubility*: practically insoluble in water, soluble in a mixture of equal volumes of acetone and methanol and in a mixture of equal volumes of methanol and methylene chloride, very slightly soluble in acetone and in toluene, practically insoluble in anhydrous ethanol.

## IDENTIFICATION

Infrared absorption spectrophotometry (2.2.24).

*Preparation*: dissolve 40 mg in 1 mL of a mixture of equal volumes of *methanol R* and *methylene chloride R*; spread 2 drops of this solution between 2 sodium chloride plates, then remove one of the plates to evaporate the solvent.

*Comparison*: *hypromellose phthalate CRS*.

## TESTS

**Free phthalic acid.** Liquid chromatography (2.2.29).

*Test solution.* Dissolve 0.20 g of the substance to be examined in about 50 mL of *acetonitrile R* with the aid of ultrasound. Add 10 mL of *water R*, cool to room temperature, dilute to 100.0 mL with *acetonitrile R* and mix.

*Reference solution.* Dissolve 12.5 mg of *phthalic acid R* in 125 mL of *acetonitrile R*. Add 25 mL of *water R*, dilute to 250.0 mL with *acetonitrile R* and mix.

*Column*:

- *size*:  $l = 0.25$  m,  $\varnothing = 4.6$  mm;
- *stationary phase*: *octadecylsilyl silica gel for chromatography R* (5–10  $\mu$ m).

*Mobile phase*: *acetonitrile R*, 1 g/L solution of *trifluoroacetic acid R* (1:9 V/V).

*Flow rate*: 2.0 mL/min.

*Detection*: spectrophotometer at 235 nm.

*Injection*: 10  $\mu$ L.

*System suitability*: reference solution:

- *repeatability*: maximum relative standard deviation of 1.0 per cent after 2 injections.

*Limit*:

- *phthalic acid*: not more than 0.4 times the area of the corresponding peak in the chromatogram obtained with the reference solution (1.0 per cent).

**Chlorides**: maximum 0.07 per cent.

Dissolve 1.0 g in 40 mL of 0.2 M *sodium hydroxide*, add 0.05 mL of *phenolphthalein solution R* and add *dilute nitric acid R* dropwise, with stirring, until the red colour disappears. Add an additional 20 mL of *dilute nitric acid R* with stirring. Heat on

a water-bath with stirring until the gel-like precipitate formed becomes granular. Cool and centrifuge. Separate the liquid phase and wash the residue with 3 quantities, each of 20 mL, of *water R*, separating the washings by centrifugation. Combine the liquid phases, dilute to 200 mL with *water R*, mix and filter. To 50 mL of this solution, add 1 mL of 0.1 M *silver nitrate*. The solution is not more opalescent than a standard prepared by mixing 0.5 mL of 0.01 M *hydrochloric acid* with 10 mL of 0.2 M *sodium hydroxide*, adding 7 mL of *dilute nitric acid R* and 1 mL of 0.1 M *silver nitrate*, and diluting to 50 mL with *water R*.

**Heavy metals** (2.4.8): maximum 10 ppm.

2.0 g complies with test C. Prepare the reference solution using 2 mL of *lead standard solution* (10 ppm Pb) R.

**Water** (2.5.12): maximum 5.0 per cent, determined on 0.500 g.

**Sulfated ash** (2.4.14): maximum 0.2 per cent, determined on 1.0 g.

## STORAGE

In an airtight container.

## FUNCTIONALITY-RELATED CHARACTERISTICS

*This section provides information on characteristics that are recognised as being relevant control parameters for one or more functions of the substance when used as an excipient (see chapter 5.15). This section is a non-mandatory part of the monograph and it is not necessary to verify the characteristics to demonstrate compliance. Control of these characteristics can however contribute to the quality of a medicinal product by improving the consistency of the manufacturing process and the performance of the medicinal product during use. Where control methods are cited, they are recognised as being suitable for the purpose, but other methods can also be used. Wherever results for a particular characteristic are reported, the control method must be indicated.*

*The following characteristics may be relevant for hypromellose phthalate used as a gastro-resistant coating agent.*

**Apparent viscosity** (2.2.9): 80 per cent to 120 per cent of the nominal value.

Dissolve 10 g, previously dried at 105 °C for 1 h, in 90 g of a mixture of equal masses of *methanol R* and *methylene chloride R* by mixing and shaking.

**Solubility.** 0.2 g does not dissolve in 0.1 M *hydrochloric acid* but dissolves quickly and completely in 100 mL of *phosphate buffer solution pH 6.8 R* with stirring.

**Phthaloyl groups**: typically 21.0 per cent to 35.0 per cent (anhydrous substance).

Dissolve 1.000 g in 50 mL of a mixture of 1 volume of *water R*, 2 volumes of *acetone R* and 2 volumes of *ethanol (96 per cent) R*. Add 0.1 mL of *phenolphthalein solution R* and titrate with 0.1 M *sodium hydroxide* until a faint pink colour is obtained. Carry out a blank titration.

Calculate the percentage content of phthaloyl groups using the following expression:

$$\frac{149n}{(100 - a)m} - 1.795S$$

$a$  = percentage content of water;

$m$  = mass of the substance to be examined, in grams;

$n$  = volume of 0.1 M *sodium hydroxide* used, in millilitres;

$S$  = percentage content of free phthalic acid (see Tests).

04/2008:0721  
corrected 7.0

## IBUPROFEN

## Ibuprofenum

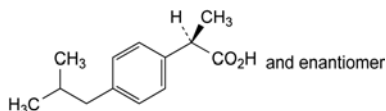
C<sub>13</sub>H<sub>18</sub>O<sub>2</sub>  
[15687-27-1]M<sub>r</sub> 206.3

## DEFINITION

(2*RS*)-2-[4-(2-Methylpropyl)phenyl]propanoic acid.*Content*: 98.5 per cent to 101.0 per cent (dried substance).

## CHARACTERS

*Appearance*: white or almost white, crystalline powder or colourless crystals.*Solubility*: practically insoluble in water, freely soluble in acetone, in methanol and in methylene chloride. It dissolves in dilute solutions of alkali hydroxides and carbonates.

## IDENTIFICATION

*First identification*: A, C.*Second identification*: A, B, D.

A. Melting point (2.2.14): 75 °C to 78 °C.

B. Ultraviolet and visible absorption spectrophotometry (2.2.25).

*Test solution*. Dissolve 50.0 mg in a 4 g/L solution of sodium hydroxide R and dilute to 100.0 mL with the same alkaline solution.*Spectral range*: 240-300 nm, using a spectrophotometer with a band width of 1.0 nm and a scan speed of not more than 50 nm/min.*Absorption maxima*: at 264 nm and 272 nm.*Shoulder*: at 258 nm.*Absorbance ratio*:–  $A_{264} / A_{258} = 1.20$  to 1.30;–  $A_{272} / A_{258} = 1.00$  to 1.10.

C. Infrared absorption spectrophotometry (2.2.24).

*Comparison*: *ibuprofen CRS*.

D. Thin-layer chromatography (2.2.27).

*Test solution*. Dissolve 50 mg of the substance to be examined in methylene chloride R and dilute to 10 mL with the same solvent.*Reference solution*. Dissolve 50 mg of *ibuprofen CRS* in methylene chloride R and dilute to 10 mL with the same solvent.*Plate*: TLC silica gel plate R.*Mobile phase*: anhydrous acetic acid R, ethyl acetate R, hexane R (5:24:71 V/V/V).*Application*: 5 µL.*Development*: over a path of 10 cm.*Drying*: at 120 °C for 30 min.*Detection*: lightly spray with a 10 g/L solution of potassium permanganate R in dilute sulfuric acid R and heat at 120 °C for 20 min; examine in ultraviolet light at 365 nm.*Results*: the principal spot in the chromatogram obtained with the test solution is similar in position, colour and size to the principal spot in the chromatogram obtained with the reference solution.

## TESTS

**Solution S**. Dissolve 2.0 g in methanol R and dilute to 20 mL with the same solvent.**Appearance of solution**. Solution S is clear (2.2.1) and colourless (2.2.2, Method II).**Optical rotation** (2.2.7): –0.05° to +0.05°.

Dissolve 0.50 g in methanol R and dilute to 20.0 mL with the same solvent.

**Related substances**. Liquid chromatography (2.2.29).*Test solution*. Dissolve 20 mg of the substance to be examined in 2 mL of acetonitrile R1 and dilute to 10.0 mL with mobile phase A.*Reference solution (a)*. Dilute 1.0 mL of the test solution to 100.0 mL with mobile phase A. Dilute 1.0 mL of this solution to 10.0 mL with mobile phase A.*Reference solution (b)*. Dilute 1.0 mL of *ibuprofen impurity B CRS* to 10.0 mL with acetonitrile R1 (solution A). Dissolve 20 mg of *ibuprofen CRS* in 2 mL of acetonitrile R1, add 1.0 mL of solution A and dilute to 10.0 mL with mobile phase A.*Reference solution (c)*. Dissolve the contents of a vial of *ibuprofen for peak identification CRS* (mixture of impurities A, J and N) in 1 mL of acetonitrile R1 and dilute to 5 mL with mobile phase A.*Column*:– *size*:  $l = 0.15$  m,  $\varnothing = 4.6$  mm;– *stationary phase*: octadecylsilyl silica gel for chromatography R (5 µm).*Mobile phase*:

- *mobile phase A*: mix 0.5 volumes of phosphoric acid R, 340 volumes of acetonitrile R1 and 600 volumes of water R; allow to equilibrate and dilute to 1000 volumes with water R;
- *mobile phase B*: acetonitrile R1;

Time (min)	Mobile phase A (per cent V/V)	Mobile phase B (per cent V/V)
0 - 25	100	0
25 - 55	100 → 15	0 → 85
55 - 70	15	85

*Flow rate*: 2 mL/min.*Detection*: spectrophotometer at 214 nm.*Injection*: 20 µL.*Identification of impurities*: use the chromatogram supplied with *ibuprofen for peak identification CRS* and the chromatogram obtained with reference solution (c) to identify the peaks due to impurities A, J and N.*Relative retention* with reference to *ibuprofen* (retention time = about 21 min): impurity J = about 0.2; impurity N = about 0.3; impurity A = about 0.9; impurity B = about 1.1.*System suitability*: reference solution (b):

- *peak-to-valley ratio*: minimum 1.5, where  $H_p$  = height above the baseline of the peak due to impurity B, and  $H_v$  = height above the baseline of the lowest point of the curve separating this peak from the peak due to *ibuprofen*. If necessary, adjust the concentration of acetonitrile in mobile phase A.

*Limits*:

- *impurities A, J, N*: for each impurity, not more than 1.5 times the area of the principal peak in the chromatogram obtained with reference solution (a) (0.15 per cent);
- *unspecified impurities*: for each impurity, not more than 0.5 times the area of the principal peak in the chromatogram obtained with reference solution (a) (0.05 per cent);
- *total*: not more than twice the area of the principal peak in the chromatogram obtained with reference solution (a) (0.2 per cent);
- *disregard limit*: 0.3 times the area of the principal peak in the chromatogram obtained with reference solution (a) (0.03 per cent).

**Impurity F.** Gas chromatography (2.2.28): use the normalisation procedure.

**Methylating solution.** Dilute 1 mL of *N,N*-dimethylformamide dimethylacetal *R* and 1 mL of pyridine *R* to 10 mL with ethyl acetate *R*.

**Test solution.** Weigh about 50.0 mg of the substance to be examined into a sealable vial, dissolve in 1.0 mL of ethyl acetate *R*, add 1 mL of the methylating solution, seal and heat at 100 °C in a block heater for 20 min. Allow to cool. Remove the reagents under a stream of nitrogen at room temperature. Dissolve the residue in 5 mL of ethyl acetate *R*.

**Reference solution (a).** Dissolve 0.5 mg of *ibuprofen impurity F CRS* in ethyl acetate *R* and dilute to 10.0 mL with the same solvent.

**Reference solution (b).** Weigh about 50.0 mg of *ibuprofen CRS* into a sealable vial, dissolve in 1.0 mL of reference solution (a), add 1 mL of the methylating solution, seal and heat at 100 °C in a block heater for 20 min. Allow to cool. Remove the reagents under a stream of nitrogen at room temperature. Dissolve the residue in 5 mL of ethyl acetate *R*.

**Column:**

- **material:** fused silica;
  - **size:**  $l = 25$  m,  $\varnothing = 0.53$  mm;
  - **stationary phase:** macrogol 20 000 *R* (film thickness 2  $\mu$ m).
- Carrier gas:** helium for chromatography *R*.

**Flow rate:** 5.0 mL/min.

**Temperature:**

- **column:** 150 °C;
- **injection port:** 200 °C;
- **detector:** 250 °C.

**Detection:** flame ionisation.

**Injection:** 1  $\mu$ L of the test solution and reference solution (b).

**Run time:** twice the retention time of ibuprofen.

**System suitability:**

- **relative retention** with reference to ibuprofen (retention time = about 17 min): impurity F = about 1.5.

**Limit:**

- **impurity F:** maximum 0.1 per cent.

**Heavy metals (2.4.8):** maximum 10 ppm.

12 mL of solution S complies with test B. Prepare the reference solution using lead standard solution (1 ppm Pb) obtained by diluting lead standard solution (100 ppm Pb) *R* with methanol *R*.

**Loss on drying (2.2.32):** maximum 0.5 per cent, determined on 1.000 g by drying *in vacuo*.

**Sulfated ash (2.4.14):** maximum 0.1 per cent, determined on 1.0 g.

**ASSAY**

Dissolve 0.450 g in 50 mL of methanol *R*. Add 0.4 mL of phenolphthalein solution *R1*. Titrate with 0.1 M sodium hydroxide until a red colour is obtained. Carry out a blank titration.

1 mL of 0.1 M sodium hydroxide is equivalent to 20.63 mg of  $C_{13}H_{18}O_2$ .

**IMPURITIES**

**Specified impurities:** A, F, J, N.

**Other detectable impurities** (the following substances would, if present at a sufficient level, be detected by one or other of the tests in the monograph. They are limited by the general acceptance criterion for other/unspecified impurities and/or by the general monograph *Substances for pharmaceutical use (2034)*. It is therefore not necessary to identify these impurities for demonstration of compliance. See also 5.10. *Control of impurities in substances for pharmaceutical use*): B, C, D, E, G, H, I, K, L, M, O, P, Q, R.

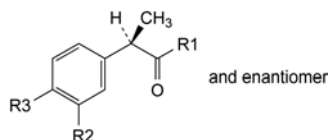

- A. R1 = OH, R2 =  $CH_2-CH(CH_3)_2$ , R3 = H: (2*RS*)-2-[3-(2-methylpropyl)phenyl]propanoic acid,
- B. R1 = OH, R2 = H, R3 =  $[CH_2]_3-CH_3$ : (2*RS*)-2-(4-butylphenyl)propanoic acid,
- C. R1 =  $NH_2$ , R2 = H, R3 =  $CH_2-CH(CH_3)_2$ : (2*RS*)-2-[4-(2-methylpropyl)phenyl]propanamide,
- D. R1 = OH, R2 = H, R3 =  $CH_3$ : (2*RS*)-2-(4-methylphenyl)propanoic acid,

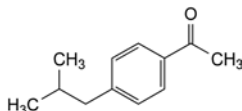

- E. 1-[4-(2-methylpropyl)phenyl]ethanone,

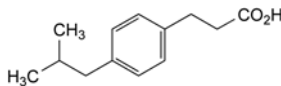

- F. 3-[4-(2-methylpropyl)phenyl]propanoic acid,

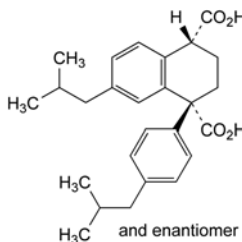

- G. (1*RS*,4*RS*)-7-(2-methylpropyl)-1-[4-(2-methylpropyl)phenyl]-1,2,3,4-tetrahydronaphthalene-1,4-dicarboxylic acid,

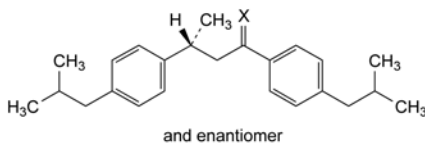

- H. X = O: (3*RS*)-1,3-bis[4-(2-methylpropyl)phenyl]butan-1-one,
- I. X =  $H_2$ : 1-(2-methylpropyl)-4-[(3*RS*)-3-[4-(2-methylpropyl)phenyl]butyl]benzene,

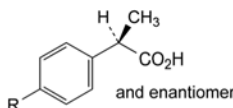

- J. R =  $CO-CH(CH_3)_2$ : (2*RS*)-2-[4-(2-methylpropyl)phenyl]propanoic acid,
- N. R =  $C_2H_5$ : (2*RS*)-2-(4-ethylphenyl)propanoic acid,

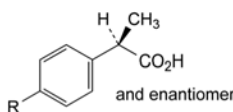

- K. R = CHO: (2*RS*)-2-(4-formylphenyl)propanoic acid,
- L. R =  $CHOH-CH(CH_3)_2$ : 2-[4-(1-hydroxy-2-methylpropyl)phenyl]propanoic acid,
- O. R =  $CH(CH_3)-C_2H_5$ : 2-[4-(1-methylpropyl)phenyl]propanoic acid,



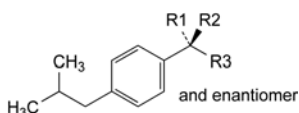

- M. R<sub>1</sub> = OH, R<sub>2</sub> = CH<sub>3</sub>, R<sub>3</sub> = CO<sub>2</sub>H: (2*RS*)-2-hydroxy-2-[4-(2-methylpropyl)phenyl]propanoic acid,  
 P. R<sub>1</sub> = H, R<sub>2</sub> = CH<sub>3</sub>, R<sub>3</sub> = CH<sub>2</sub>OH: (2*RS*)-2-[4-(2-methylpropyl)phenyl]propan-1-ol,  
 Q. R<sub>1</sub> = R<sub>2</sub> = H, R<sub>3</sub> = CH<sub>2</sub>OH: 2-[4-(2-methylpropyl)phenyl]ethanol,

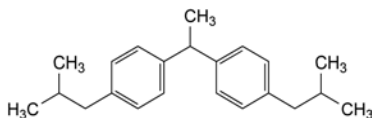

- R. 1,1'-(ethane-1,1-diyl)-4,4'-(2-methylpropyl)dibenzene.

01/2008:0917  
corrected 6.3

## ICHTHAMMOL

### Ichthammolum

#### DEFINITION

Ichthammol is obtained by distillation from certain bituminous schists, sulfonation of the distillate and neutralisation of the product with ammonia.

#### Content:

- *dry matter*: 50.0 per cent *m/m* to 56.0 per cent *m/m*;
- *total ammonia* (NH<sub>3</sub>; *M<sub>r</sub>* 17.03): 4.5 per cent *m/m* to 7.0 per cent *m/m* (dried substance);
- *organically combined sulfur*: minimum 10.5 per cent *m/m* (dried substance);
- *sulfur in the form of sulfate*: maximum 20.0 per cent *m/m* of the total sulfur.

#### CHARACTERS

*Appearance*: dense, blackish-brown liquid.

*Solubility*: miscible with water and with glycerol, slightly soluble in ethanol (96 per cent), in fatty oils and in liquid paraffin. It forms homogeneous mixtures with wool fat and soft paraffin.

#### IDENTIFICATION

- A. Dissolve 1.5 g in 15 mL of *water R* (solution A). To 2 mL of solution A add 2 mL of *hydrochloric acid R*. A resinous precipitate is formed. Decant the supernatant liquid. The precipitate is partly soluble in *ether R*.
- B. 2 mL of solution A, obtained in identification test A, gives the reaction of ammonium salts and salts of volatile bases (2.3.1).
- C. Evaporate and ignite the mixture of solution A and *dilute sodium hydroxide solution R* obtained in identification test B. Take up the residue with 5 mL of *dilute hydrochloric acid R*. Gas is evolved which turns *lead acetate paper R* brown or black. Filter the solution. The filtrate gives reaction (a) of sulfates (2.3.1).

#### TESTS

**Acidity or alkalinity.** To 10.0 mL of the clear filtrate obtained in the assay of total ammonia add 0.05 mL of *methyl red solution R*. Not more than 0.2 mL of 0.02 *M hydrochloric acid* or 0.02 *M sodium hydroxide* is required to change the colour of the indicator.

**Relative density** (2.2.5): 1.040 to 1.085, determined on a mixture of equal volumes of the substance to be examined and *water R*.

**Sulfated ash** (2.4.14): maximum 0.3 per cent, determined on 1.00 g.

#### ASSAY

**Dry matter.** Weigh 1.000 g in a tared flask containing 2 g of *sand R*, previously dried to constant mass, and a small glass rod. Heat on a water-bath for 2 h with frequent stirring and dry in an oven at 100-105 °C until 2 consecutive weighings do not differ by more than 2.0 mg; the 2<sup>nd</sup> weighing is carried out after drying again for 1 h.

**Total ammonia.** Dissolve 2.50 g in 25 mL of warm *water R*. Rinse the solution into a 250 mL volumetric flask, add 200 mL of *sodium chloride solution R* and dilute to 250.0 mL with *water R*. Filter the solution, discarding the first 20 mL of filtrate. To 100.0 mL of the clear filtrate add 25 mL of *formaldehyde solution R*, neutralised to *phenolphthalein solution R1*. Titrate with 0.1 *M sodium hydroxide* until a faint pink colour is obtained.

1 mL of 0.1 *M sodium hydroxide* is equivalent to 1.703 mg of NH<sub>3</sub>.

**Organically combined sulfur.** Mix 0.500 g with 4 g of *anhydrous sodium carbonate R* and 3 mL of *methylene chloride R* in a porcelain crucible of about 50 mL capacity, warm and stir until all the methylene chloride has evaporated. Add 10 g of coarsely powdered *copper nitrate R*, mix thoroughly and heat the mixture very gently using a small flame. When the initial reaction has subsided, increase the temperature slightly until most of the material has blackened. Cool, place the crucible in a large beaker, add 20 mL of *hydrochloric acid R* and, when the reaction has ceased, add 100 mL of *water R* and boil until all the copper oxide has dissolved. Filter the solution, add 400 mL of *water R*, heat to boiling and add 20 mL of *barium chloride solution R1*. Allow to stand for 2 h, filter, wash with *water R*, dry and ignite at about 600 ± 50 °C until 2 successive weighings do not differ by more than 0.2 per cent of the mass of the residue.

1 g of residue is equivalent to 0.1374 g of total sulfur.

Calculate the percentage content of total sulfur and subtract the percentage content of sulfur in the form of sulfate.

**Sulfur in the form of sulfate.** Dissolve 2.000 g in 100 mL of *water R*, add 2 g of *cupric chloride R* dissolved in 80 mL of *water R* and dilute to 200.0 mL with *water R*. Shake and filter. Heat 100.0 mL of the filtrate almost to boiling, add 1 mL of *hydrochloric acid R* and 5 mL of *barium chloride solution R1* dropwise and heat on a water-bath. Filter, wash the precipitate with *water R*, dry and ignite at about 600 ± 50 °C until 2 successive weighings do not differ by more than 0.2 per cent of the mass of the residue.

1 g of residue is equivalent to 0.1374 g of sulfur present in the form of sulfate.

Calculate the percentage content of sulfur in the form of sulfate.

01/2008:0669

## IDOXURIDINE

### Idoxuridinum

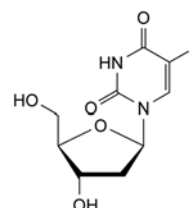

C<sub>9</sub>H<sub>11</sub>IN<sub>2</sub>O<sub>5</sub>  
[54-42-2]

*M<sub>r</sub>* 354.1

## DEFINITION

Ifoxuridine contains not less than 98.0 per cent and not more than the equivalent of 101.0 per cent of 5-iodo-1-(2-deoxy-β-D-erythro-pentofuranosyl)pyrimidine-2,4(1*H*,3*H*)-dione, calculated with reference to the dried substance.

## CHARACTERS

A white or almost white, crystalline powder, slightly soluble in water and in ethanol (96 per cent). It dissolves in dilute solutions of alkali hydroxides.

It melts at about 180 °C, with decomposition.

## IDENTIFICATION

*First identification:* A.

*Second identification:* B, C, D.

- Examine by infrared absorption spectrophotometry (2.2.24), comparing with the spectrum obtained with *idoxuridine CRS*. Examine the substances as discs prepared using 1 mg of the substance to be examined and of the reference substance each in 0.3 g of *potassium bromide R*.
- Examine the chromatograms obtained in the test for related substances. The principal spot in the chromatogram obtained with test solution (b) is similar in position and size to the principal spot in the chromatogram obtained with reference solution (c).
- Heat about 5 mg in a test-tube over a naked flame. Violet vapour is evolved.
- Disperse about 2 mg in 1 mL of *water R* and add 2 mL of *diphenylamine solution R2*. Heat in a water-bath for 10 min. A persistent light-blue colour develops.

## TESTS

**Solution S.** Dissolve 0.500 g in 1 *M sodium hydroxide* and dilute to 50.0 mL with the same solvent.

**Appearance of solution.** Solution S is clear (2.2.1) and colourless (2.2.2, *Method II*).

**pH (2.2.3).** Dissolve 0.10 g in *carbon dioxide-free water R* and dilute to 100 mL with the same solvent. The pH of the solution is 5.5 to 6.5.

**Specific optical rotation (2.2.7):** + 28 to + 32, determined on solution S and calculated with reference to the dried substance.

**Related substances.** Examine by thin-layer chromatography (2.2.27), using as coating substance a suitable silica gel with a fluorescent indicator having an optimal intensity at 254 nm.

**Test solution (a).** Dissolve 0.20 g of the substance to be examined in a mixture of 1 volume of *concentrated ammonia R* and 5 volumes of *methanol R* and dilute to 5 mL with the same mixture of solvents.

**Test solution (b).** Dilute 1 mL of test solution (a) to 10 mL with a mixture of 1 volume of *concentrated ammonia R* and 5 volumes of *methanol R*.

**Reference solution (a).** Dissolve 20 mg of *5-iodouracil R*, 20 mg of *2'-deoxyuridine R* and 20 mg of *5-bromo-2'-deoxyuridine R* in a mixture of 1 volume of *concentrated ammonia R* and 5 volumes of *methanol R* and dilute to 100 mL with the same mixture of solvents.

**Reference solution (b).** Dissolve 0.20 g of the substance to be examined in 5 mL of reference solution (a).

**Reference solution (c).** Dissolve 20 mg of *idoxuridine CRS* in a mixture of 1 volume of *concentrated ammonia R* and 5 volumes of *methanol R* and dilute to 5 mL with the same mixture of solvents.

**Reference solution (d).** Dilute 1 mL of test solution (b) to 20 mL with a mixture of 1 volume of *concentrated ammonia R* and 5 volumes of *methanol R*.

Apply separately to the plate 5 µL of each solution. Develop twice over a path of 15 cm using a mixture of 10 volumes of *concentrated ammonia R*, 40 volumes of *chloroform R* and 50 volumes of *2-propanol R*, drying the plate in a current of

cold air after each development. Examine in ultraviolet light at 254 nm. In the chromatogram obtained with test solution (a): any spots corresponding to 5-iodouracil, 2'-deoxyuridine and 5-bromo-2'-deoxyuridine are not more intense than the corresponding spots in the chromatogram obtained with reference solution (a) (0.5 per cent); any spot, apart from the principal spot and the spots corresponding to 5-iodouracil, 2'-deoxyuridine and 5-bromo-2'-deoxyuridine, is not more intense than the spot in the chromatogram obtained with reference solution (d) (0.5 per cent). The test is not valid unless the chromatogram obtained with reference solution (b) shows four clearly separated spots.

**Iodide.** Dissolve 0.25 g in 25 mL of 0.1 *M sodium hydroxide*, add 5 mL of *dilute hydrochloric acid R* and dilute to 50 mL with *water R*. Allow to stand for 10 min and filter. To 25 mL of the filtrate add 5 mL of *dilute hydrogen peroxide solution R* and 10 mL of *chloroform R* and shake. Any pink colour in the organic layer is not more intense than that in a standard prepared at the same time in the same manner using 1 mL of a 0.33 g/L solution of *potassium iodide R* instead of the substance to be examined (0.1 per cent).

**Loss on drying (2.2.32).** Not more than 1.0 per cent, determined on 1.000 g by drying *in vacuo* at 60 °C.

**Sulfated ash (2.4.14).** Not more than 0.1 per cent, determined on 1.0 g.

## ASSAY

Dissolve 0.3000 g in 20 mL of *dimethylformamide R*. Titrate with 0.1 *M tetrabutylammonium hydroxide*, determining the end-point potentiometrically (2.2.20).

1 mL of 0.1 *M tetrabutylammonium hydroxide* is equivalent to 35.41 mg of C<sub>9</sub>H<sub>11</sub>N<sub>2</sub>O<sub>5</sub>.

## STORAGE

Store protected from light.

01/2008:1529

## IFOSFAMIDE

## Ifosfamidum

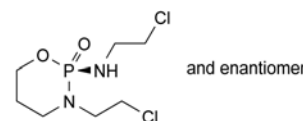

C<sub>9</sub>H<sub>15</sub>Cl<sub>2</sub>N<sub>2</sub>O<sub>2</sub>P  
[3778-73-2]

*M<sub>r</sub>*, 261.1

## DEFINITION

Ifosfamide contains not less than 98.0 per cent and not more than the equivalent of 102.0 per cent of (RS)-N,3-bis(2-chloroethyl)-1,3,2-oxazaphosphinan-2-amine 2-oxide, calculated with reference to the anhydrous substance.

## CHARACTERS

A white or almost white, fine, crystalline powder, hygroscopic, soluble in water, freely soluble in methylene chloride.

## IDENTIFICATION

Examine by infrared absorption spectrophotometry (2.2.24), comparing with the *Ph. Eur. reference spectrum of ifosfamide*. Examine the substance prepared as a disc.

## TESTS

**Solution S.** Dissolve 5.0 g in *carbon dioxide-free water R* and dilute to 50.0 mL with the same solvent.

**Appearance of solution.** Solution S is clear (2.2.1) and not more intensely coloured than reference solution Y<sub>7</sub> (2.2.2, *Method II*).

**Acidity or alkalinity.** Dilute 5 mL of solution S to 50 mL with carbon dioxide-free water R. To 10 mL of this solution add 0.1 mL of methyl red solution R. Not more than 0.1 mL of 0.01 M hydrochloric acid is required to change the colour of the indicator to red. To another 10 mL of the solution add 0.1 mL of phenolphthalein solution R. Not more than 0.3 mL of 0.01 M sodium hydroxide is required to change the colour of the indicator to pink.

**Optical rotation (2.2.7).** The angle of optical rotation, determined on solution S, is  $-0.10^\circ$  to  $+0.10^\circ$ .

#### Related substances

A. Examine by thin-layer chromatography (2.2.27), using a TLC silica gel plate R.

**Test solution.** Dissolve 1.00 g of the substance to be examined in a mixture of equal volumes of methanol R and water R and dilute to 10 mL with the same mixture of solvents.

**Reference solution (a).** Dissolve 25 mg of ifosfamide impurity A CRS and 25 mg of chloroethylamine hydrochloride R (impurity C) in a mixture of equal volumes of methanol R and water R and dilute to 100 mL with the same mixture of solvents.

**Reference solution (b).** Dissolve 15 mg of ifosfamide impurity B CRS in a mixture of equal volumes of methanol R and water R and dilute to 100 mL with the same mixture of solvents.

**Reference solution (c).** Dissolve 5 mg of ethanolamine R (impurity D), 20 mg of ifosfamide impurity A CRS and 80 mg of chloroethylamine hydrochloride R (impurity C) in a mixture of equal volumes of methanol R and water R and dilute to 100 mL with the same mixture of solvents.

Apply to the plate 10  $\mu$ L of each solution. Develop over a path of 15 cm using a mixture of 10 volumes of water R, 15 volumes of methanol R, 25 volumes of anhydrous acetic acid R and 50 volumes of methylene chloride R. Dry the plate at 115 °C for 45 min. At the bottom of a chromatographic tank, place an evaporating dish containing a 3.2 g/L solution of potassium permanganate R and add an equal volume of dilute hydrochloric acid R, close the tank and allow to stand for 10 min. Place the plate whilst still hot in the tank, avoiding contact of the stationary phase with the solution, and close the tank. Leave the plate in contact with the chlorine vapour for 20 min. Withdraw the plate and place it in a current of cold air until the excess of chlorine is removed (about 20 min) and an area of coating below the points of application does not give a blue colour with a drop of potassium iodide and starch solution R. Avoid prolonged exposure to cold air. Immerse the plate in a 1 g/L solution of tetramethylbenzidine R in alcohol R for 5 s. Allow the plate to dry and examine. In the chromatogram obtained with the test solution: any spot corresponding to impurity A or impurity C is not more intense than the corresponding spot in the chromatogram obtained with reference solution (a) (0.25 per cent); any spot corresponding to impurity B is not more intense than the corresponding spot in the chromatogram obtained with reference solution (b) (0.15 per cent); any other spot is not more intense than the principal spot in the chromatogram obtained with reference solution (b) (0.15 per cent). The test is not valid unless the chromatogram obtained with reference solution (c) shows 3 clearly separated spots.

B. Examine by thin-layer chromatography (2.2.27), using a TLC silica gel plate R.

**Test solution.** Dissolve 0.200 g of the substance to be examined in a mixture of equal volumes of methanol R and methylene chloride R and dilute to 10 mL with the same mixture of solvents.

**Reference solution (a).** Dissolve 5 mg of ifosfamide impurity E CRS and 5 mg of ifosfamide impurity F CRS in a mixture of equal volumes of methanol R and methylene chloride R and dilute to 100 mL with the same mixture of solvents.

**Reference solution (b).** Dissolve 10 mg of ifosfamide impurity E CRS and 10 mg of ifosfamide CRS in a mixture of equal volumes of methanol R and methylene chloride R and dilute to 100 mL with the same mixture of solvents.

Apply to the plate 5  $\mu$ L of each solution. Develop over a path of 15 cm using a mixture of 1 volume of methylene chloride R and 10 volumes of acetone R. Dry the plate at 115 °C for 45 min. Proceed as described in Related substances test A. Any spot corresponding to impurity E or impurity F in the chromatogram obtained with the test solution is not more intense than the corresponding spot in the chromatogram obtained with reference solution (a) (0.25 per cent). The test is not valid unless the chromatogram obtained with reference solution (b) shows 2 clearly separated spots.

**Chlorides (2.4.4).** Dilute 5 mL of solution S to 15 mL with water R. The freshly prepared solution complies with the limit test for chlorides (100 ppm).

**Heavy metals (2.4.8).** 12 mL of solution S complies with limit test A for heavy metals (10 ppm). Prepare the standard using lead standard solution (1 ppm Pb) R.

**Water (2.5.12).** Not more than 0.5 per cent, determined on 1.00 g by the semi-micro determination of water.

#### ASSAY

Examine by liquid chromatography (2.2.29). Use the solutions within 24 h.

**Solution A.** Dissolve 50.0 mg of ethyl parahydroxybenzoate R in 25 mL of alcohol R, dilute to 100.0 mL with water R and mix.

**Test solution.** To 0.150 g of the substance to be examined add 10.0 mL of solution A and dilute to 250.0 mL with water R.

**Reference solution.** To 15.0 mg of ifosfamide CRS add 1.0 mL of solution A and dilute to 25.0 mL with water R.

The chromatography may be carried out using:

- a stainless steel column 0.25 m long and 4.6 mm in internal diameter packed with octadecylsilyl silica gel for chromatography R (5  $\mu$ m),
- as mobile phase at a flow rate of 1.5 mL/min a mixture of 30 volumes of acetonitrile R and 70 volumes of water R,
- as detector a spectrophotometer set at 195 nm.

Inject 1  $\mu$ L of the reference solution six times. The assay is not valid unless the resolution between the peaks due to ifosfamide and to ethyl parahydroxybenzoate is not less than 6.0 and the relative standard deviation of the peak area for ifosfamide is at most 2.0 per cent.

Inject 1  $\mu$ L of the test solution. Calculate the percentage content of  $C_7H_{15}Cl_2N_2O_2P$  from the area of the corresponding peak in the chromatogram obtained and the declared content of ifosfamide CRS.

#### STORAGE

Store in an airtight container.

#### IMPURITIES

**Specified impurities:** A, B, C, E, F.

**Other detectable impurities** (the following substances would, if present at a sufficient level, be detected by one or other of the tests in the monograph. They are limited by the general acceptance criterion for other/unspecified impurities and/or by the general monograph *Substances for pharmaceutical use* (2034). It is therefore not necessary to identify these impurities for demonstration of compliance. See also 5.10. *Control of impurities in substances for pharmaceutical use*): D.

**Related substances test A**

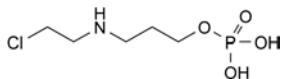

A. 3-[(2-chloroethyl)amino]propyl dihydrogen phosphate,

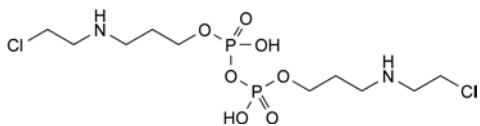

B. bis[3-[(2-chloroethyl)amino]propyl] dihydrogen diphosphate,

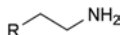

C. R = Cl: 2-chloroethanamine,

D. R = OH: 2-aminoethanol.

**Related substances test B**

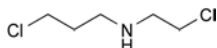

E. 3-chloro-*N*-(2-chloroethyl)propan-1-amine,

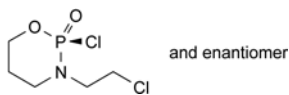

F. (*RS*)-2-chloro-3-(2-chloroethyl)-1,3,2-oxazaphosphinane 2-oxide.

**Specific optical rotation (2.2.7):** + 84 to + 89 (anhydrous substance), measured at 25 °C.

Dissolve 0.125 g in *phosphate buffer solution pH 7.0 R3* and dilute to 25.0 mL with the same solution.

**Related substances.** Liquid chromatography (2.2.29). *Keep the solutions in an ice-bath and use within 8 h of preparation.*

**Solvent mixture.** Mix 0.7 volumes of *acetonitrile R* and 99.3 volumes of a 0.135 g/L solution of *dipotassium hydrogen phosphate R* adjusted to pH 6.8 with *dilute phosphoric acid R*.

**Test solution.** Dissolve 40.0 mg of the substance to be examined in the solvent mixture and dilute to 100.0 mL with the solvent mixture.

**Reference solution (a).** Dissolve 40.0 mg of *imipenem CRS* in the solvent mixture and dilute to 100.0 mL with the solvent mixture.

**Reference solution (b).** Dilute 1.0 mL of the test solution to 100.0 mL with the solvent mixture.

**Reference solution (c).** Heat 20 mL of the test solution, previously adjusted to pH 10 with *sodium hydroxide solution R*, at 80 °C for 5 min (*in situ* preparation of impurity A).

**Column:**

- size: *l* = 0.25 m, Ø = 4.6 mm;
- stationary phase: *octadecylsilyl silica gel for chromatography R* (5 µm).

**Mobile phase:** mix 0.7 volumes of *acetonitrile R* and 99.3 volumes of a 8.7 g/L solution of *dipotassium hydrogen phosphate R* adjusted to pH 7.3 with *dilute phosphoric acid R*.

**Flow rate:** 1.0 mL/min.

**Detection:** spectrophotometer at 254 nm.

**Injection:** 20 µL of the test solution and reference solutions (b) and (c).

**Run time:** twice the retention time of imipenem.

**Relative retention** with reference to imipenem (retention time = about 9 min): impurity A = about 0.8.

**System suitability:** reference solution (c):

- resolution: minimum 3.5 between the peaks due to impurity A and imipenem.

**Limits:**

- *impurity A*: not more than the area of the principal peak in the chromatogram obtained with reference solution (b) (1 per cent);
- *any other impurity*: for each impurity, not more than 0.3 times the area of the principal peak in the chromatogram obtained with reference solution (b) (0.3 per cent);
- *sum of impurities other than A*: not more than the area of the principal peak in the chromatogram obtained with reference solution (b) (1 per cent);
- *disregard limit*: 0.1 times the area of the principal peak in the chromatogram obtained with reference solution (b) (0.1 per cent).

**Water (2.5.12):** 5.0 per cent to 8.0 per cent, determined on 0.200 g. Use an iodosulfurous reagent containing imidazole instead of pyridine and a clean container for each determination.

**Sulfated ash (2.4.14):** maximum 0.2 per cent, determined on 1.0 g.

**Bacterial endotoxins (2.6.14):** less than 0.17 IU/mg, if intended for use in the manufacture of parenteral preparations without a further appropriate procedure for removal of bacterial endotoxins.

**ASSAY**

Liquid chromatography (2.2.29) as described in the test for related substances with the following modifications.

**Injection:** test solution and reference solution (a).

**System suitability:** reference solution (a):

- *repeatability*: maximum relative standard deviation of 1.0 per cent after 6 injections.

01/2008:1226  
corrected 6.0

**IMIPENEM**

Imipenemum

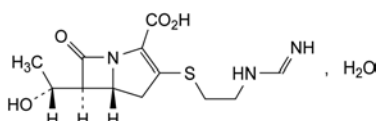

C<sub>12</sub>H<sub>17</sub>N<sub>3</sub>O<sub>4</sub>S·H<sub>2</sub>O

M<sub>r</sub> 317.4

**DEFINITION**

(5*R*,6*S*)-6-[(*R*)-1-Hydroxyethyl]-3-[[2-[(iminomethyl)amino]ethyl]sulfanyl]-7-oxo-1-azabicyclo[3.2.0]hept-2-ene-2-carboxylic acid monohydrate.

Semi-synthetic product derived from a fermentation product.

**Content:** 98.0 per cent to 102.0 per cent (anhydrous substance).

**CHARACTERS**

**Appearance:** white or almost white or pale yellow powder.

**Solubility:** sparingly soluble in water, slightly soluble in methanol.

**IDENTIFICATION**

Infrared absorption spectrophotometry (2.2.24).

**Comparison:** *imipenem CRS*.

**TESTS**

**Appearance of solution.** The solution is not more opalescent than reference suspension II (2.2.1) and not more intensely coloured than intensity 6 of the range of the reference solutions of the most appropriate colour (2.2.2, *Method II*).

Dissolve 0.500 g in *phosphate buffer solution pH 7.0 R3* and dilute to 50 mL with the same solution.

**pH (2.2.3):** 4.5 to 7.0.

Dissolve 0.500 g in *carbon dioxide-free water R* and dilute to 100.0 mL with the same solvent.

## STORAGE

In an airtight container, at a temperature of 2 °C to 8 °C. If the substance is sterile, store in a sterile, airtight, tamper-proof container.

## IMPURITIES

Specified impurities: A.

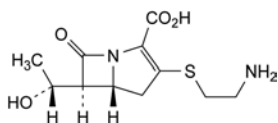

- A. (5*R*,6*S*)-3-[(2-aminoethyl)sulfanyl]-6-[(*R*)-1-hydroxyethyl]-7-oxo-1-azabicyclo[3.2.0]hept-2-ene-2-carboxylic acid (thienamycin).

07/2008:0029  
corrected 7.0

## IMIPRAMINE HYDROCHLORIDE

## Imipramini hydrochloridum

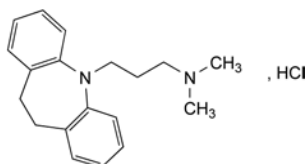

$C_{19}H_{25}ClN_2$   
[113-52-0]

$M_r$  316.9

## DEFINITION

3-(10,11-Dihydro-5*H*-dibenzo[*b,f*]azepin-5-yl)-*N,N*-dimethylpropan-1-amine hydrochloride.

Content: 98.5 per cent to 101.0 per cent (dried substance).

## CHARACTERS

Appearance: white or slightly yellow, crystalline powder.

Solubility: freely soluble in water and in ethanol (96 per cent).

## IDENTIFICATION

First identification: B, D.

Second identification: A, C, D.

A. Melting point (2.2.14): 170 °C to 174 °C.

B. Infrared absorption spectrophotometry (2.2.24).

Comparison: imipramine hydrochloride CRS.

C. Dissolve about 5 mg in 2 mL of nitric acid R. An intense blue colour develops.

D. About 20 mg gives reaction (a) of chlorides (2.3.1).

## TESTS

**Solution S.** To 3.0 g add 20 mL of carbon dioxide-free water R, dissolve rapidly by shaking and triturating with a glass rod and dilute to 30 mL with the same solvent.

**Appearance of solution.** Solution S is clear (2.2.1). Immediately after preparation, dilute solution S with an equal volume of water R. This solution is not more intensely coloured than reference solution BY<sub>6</sub> (2.2.2, Method II).

**pH** (2.2.3): 3.6 to 5.0 for solution S, measured immediately after preparation.

**Related substances.** Liquid chromatography (2.2.29).

**Test solution.** Dissolve 50.0 mg of the substance to be examined in the mobile phase and dilute to 50.0 mL with the mobile phase.

**Reference solution (a).** Dissolve 5.0 mg of imipramine for system suitability CRS (containing impurity B) in the mobile phase and dilute to 5.0 mL with the mobile phase.

**Reference solution (b).** Dilute 1.0 mL of the test solution to 100.0 mL with the mobile phase. Dilute 1.0 mL of this solution to 10.0 mL with the mobile phase.

Column:

– size:  $l = 0.15$  m,  $\varnothing = 4.6$  mm;

– stationary phase: end-capped polar-embedded octadecylsilyl amorphous organosilica polymer R (5  $\mu$ m);

– temperature: 40 °C.

**Mobile phase:** mix 40 volumes of acetonitrile R1 with 60 volumes of a 5.2 g/L solution of dipotassium hydrogen phosphate R previously adjusted to pH 7.0 with phosphoric acid R.

**Flow rate:** 1.0 mL/min.

**Detection:** spectrophotometer at 220 nm.

**Injection:** 10  $\mu$ L.

**Run time:** 2.5 times the retention time of imipramine.

**Relative retention** with reference to imipramine (retention time = about 7 min): impurity B = about 0.7.

**System suitability:** reference solution (a):

– resolution: minimum 5.0 between the peaks due to impurity B and imipramine.

**Limits:**

– impurity B: not more than the area of the corresponding peak in the chromatogram obtained with reference solution (a) (0.1 per cent);

– unspecified impurities: for each impurity, not more than the area of the peak due to imipramine in the chromatogram obtained with reference solution (b) (0.10 per cent);

– total: not more than 3 times the area of the peak due to imipramine in the chromatogram obtained with reference solution (b) (0.3 per cent);

– disregard limit: 0.5 times the area of the peak due to imipramine in the chromatogram obtained with reference solution (b) (0.05 per cent).

**Heavy metals** (2.4.8): maximum 20 ppm.

**Solvent:** water R.

0.500 g complies with test H. Prepare the reference solution using 1 mL of lead standard solution (10 ppm Pb) R.

**Loss on drying** (2.2.32): maximum 0.5 per cent, determined on 1.000 g by drying in an oven at 105 °C.

**Sulfated ash** (2.4.14): maximum 0.1 per cent, determined on 1.0 g.

## ASSAY

Dissolve 0.250 g in 50 mL of ethanol (96 per cent) R and add 5.0 mL of 0.01 M hydrochloric acid. Carry out a potentiometric titration (2.2.20), using 0.1 M sodium hydroxide. Read the volume added between the 2 points of inflexion.

1 mL of 0.1 M sodium hydroxide is equivalent to 31.69 mg of  $C_{19}H_{25}ClN_2$ .

## STORAGE

Protected from light.

## IMPURITIES

Specified impurities: B.

**Other detectable impurities** (the following substances would, if present at a sufficient level, be detected by one or other of the tests in the monograph. They are limited by the general acceptance criterion for other/unspecified impurities and/or by the general monograph *Substances for pharmaceutical use* (2034). It is therefore not necessary to identify these impurities for demonstration of compliance. See also 5.10. *Control of impurities in substances for pharmaceutical use*): A, C.

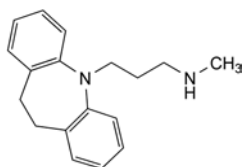

A. 3-(10,11-dihydro-5H-dibenzo[b,f]azepin-5-yl)-N-methylpropan-1-amine (desipramine),

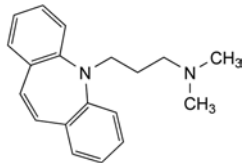

B. 3-(5H-dibenzo[b,f]azepin-5-yl)-N,N-dimethylpropan-1-amine (depramine),

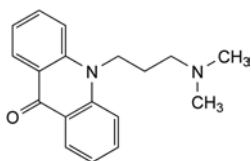

C. 10-[3-(dimethylamino)propyl]acridin-9(10H)-one.

01/2008:1108  
corrected 6.0

## INDAPAMIDE

### Indapamidum

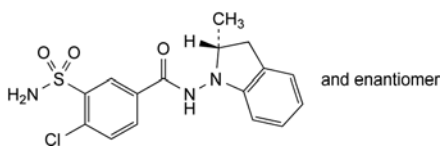

$C_{16}H_{16}ClN_3O_3S$   
[26807-65-8]

$M_r$  365.8

#### DEFINITION

4-Chloro-N-[(2*RS*)-2-methyl-2,3-dihydro-1*H*-indol-1-yl]-3-sulfamoylbenzamide.

*Content*: 98.0 per cent to 102.0 per cent (anhydrous substance).

#### CHARACTERS

*Appearance*: white or almost white powder.

*Solubility*: practically insoluble in water, soluble in ethanol (96 per cent).

#### IDENTIFICATION

*First identification*: B.

*Second identification*: A, C.

A. Ultraviolet and visible absorption spectrophotometry (2.2.25).

*Test solution*. Dissolve 50.0 mg in ethanol (96 per cent) *R* and dilute to 100.0 mL with the same solvent. Dilute 2.0 mL of this solution to 100.0 mL with ethanol (96 per cent) *R*.

*Spectral range*: 220-350 nm.

*Absorption maximum*: at 242 nm.

*Shoulders*: at 279 nm and 287 nm.

*Specific absorbance at the absorption maximum*: 590 to 630.

B. Infrared absorption spectrophotometry (2.2.24).

*Preparation*: discs of potassium bromide *R*.

*Comparison*: indapamide CRS.

C. Thin-layer chromatography (2.2.27).

*Test solution*. Dissolve 20 mg of the substance to be examined in ethanol (96 per cent) *R* and dilute to 10 mL with the same solvent.

*Reference solution (a)*. Dissolve 20 mg of indapamide CRS in ethanol (96 per cent) *R* and dilute to 10 mL with the same solvent.

*Reference solution (b)*. Dissolve 10 mg of indometacin *R* in 5 mL of reference solution (a) and dilute to 10 mL with ethanol (96 per cent) *R*.

*Plate*: TLC silica gel GF<sub>254</sub> plate *R*.

*Mobile phase*: glacial acetic acid *R*, acetone *R*, toluene *R* (1:20:79 V/V/V).

*Application*: 10 µL.

*Development*: over a path of 15 cm.

*Drying*: in air.

*Detection*: examine in ultraviolet light at 254 nm.

*System suitability*: reference solution (b):

– the chromatogram shows 2 clearly separated spots.

*Results*: the principal spot in the chromatogram obtained with the test solution is similar in position and size to the principal spot in the chromatogram obtained with reference solution (a).

#### TESTS

**Optical rotation** (2.2.7):  $-0.02^\circ$  to  $+0.02^\circ$ .

Dissolve 0.250 g in anhydrous ethanol *R* and dilute to 25.0 mL with the same solvent.

**Related substances**. Liquid chromatography (2.2.29). Carry out the test protected from light and prepare the solutions immediately before use or maintain them at 4 °C.

*Test solution*. Dissolve 20.0 mg of the substance to be examined in 7 mL of a mixture of equal volumes of acetonitrile *R* and methanol *R* and dilute to 20.0 mL with a 0.2 g/L solution of sodium edetate *R*.

*Reference solution (a)*. Dissolve 3.0 mg of indapamide impurity B CRS in 3.5 mL of a mixture of equal volumes of acetonitrile *R* and methanol *R* and dilute to 10.0 mL with a 0.2 g/L solution of sodium edetate *R*. To 1.0 mL of this solution, add 35 mL of a mixture of equal volumes of acetonitrile *R* and methanol *R* and dilute to 100.0 mL with a 0.2 g/L solution of sodium edetate *R*.

*Reference solution (b)*. Dilute 1.0 mL of the test solution to 50.0 mL with a mixture of 17.5 volumes of acetonitrile *R*, 17.5 volumes of methanol *R* and 65 volumes of a 0.2 g/L solution of sodium edetate *R*. Dilute 1.0 mL of this solution to 20.0 mL with a mixture of 17.5 volumes of acetonitrile *R*, 17.5 volumes of methanol *R* and 65 volumes of a 0.2 g/L solution of sodium edetate *R*.

*Reference solution (c)*. Dissolve 20.0 mg of indapamide CRS in 7 mL of a mixture of equal volumes of acetonitrile *R* and methanol *R* and dilute to 20.0 mL with a 0.2 g/L solution of sodium edetate *R*.

*Reference solution (d)*. Dissolve 25.0 mg of indapamide CRS and 45.0 mg of methylnitrosoindoline CRS (impurity A) in 17.5 mL of a mixture of equal volumes of acetonitrile *R* and methanol *R* and dilute to 50.0 mL with a 0.2 g/L solution of sodium edetate *R*.

*Column*:

– size:  $l = 0.20$  m,  $\varnothing = 4.6$  mm;

– stationary phase: octadecylsilyl silica gel for chromatography *R* (5 µm);

– temperature: 40 °C.

*Mobile phase*: glacial acetic acid *R*, acetonitrile *R*, methanol *R*, 0.2 g/L solution of sodium edetate *R* (0.1:17.5:17.5:65 V/V/V/V).

*Flow rate*: 2 mL/min.

*Detection*: spectrophotometer at 254 nm.

*Injection*: 10 µL.

**Run time:** 2.5 times the retention time of indapamide.

**Retention time:** indapamide = about 11 min.

**System suitability:**

- **resolution:** minimum 4.0 between the peaks due to indapamide and impurity A in the chromatogram obtained with reference solution (d);
- **signal-to-noise ratio:** minimum 6 for the principal peak in the chromatogram obtained with reference solution (b).

**Limits:**

- **impurity B:** not more than the area of the principal peak in the chromatogram obtained with reference solution (a) (0.3 per cent);
- **unspecified impurities:** for each impurity, not more than the area of the principal peak in the chromatogram obtained with reference solution (b) (0.10 per cent);
- **total:** not more than 5 times the area of the principal peak in the chromatogram obtained with reference solution (b) (0.5 per cent);
- **disregard limit:** 0.5 times the area of the principal peak in the chromatogram obtained with reference solution (b) (0.05 per cent).

**Impurity A.** Liquid chromatography (2.2.29). Carry out the test protected from light.

**Test solution.** Dissolve 25.0 mg of the substance to be examined in 1 mL of *acetonitrile R* and dilute to 10.0 mL with *water R*. Shake for 15 min. Allow to stand at 4 °C for 1 h and filter.

**Reference solution.** Dissolve 25.0 mg of the substance to be examined in 1.0 mL of a 0.125 mg/L solution of *methylnitrosoindoline CRS* (impurity A) in *acetonitrile R* and dilute to 10.0 mL with *water R*. Shake for 15 min. Allow to stand at 4 °C for 1 h and filter.

**Column:**

- **size:**  $l = 0.15$  m,  $\varnothing = 4.6$  mm;
- **stationary phase:** octadecylsilyl silica gel for chromatography R (5  $\mu$ m);
- **temperature:** 30 °C.

**Mobile phase:** mix 7 volumes of *acetonitrile R*, 20 volumes of *tetrahydrofuran R* and 73 volumes of a 1.5 g/L solution of *triethylamine R* adjusted to pH 2.8 with *phosphoric acid R*.

**Flow rate:** 1.4 mL/min.

**Detection:** spectrophotometer at 305 nm.

**Injection:** 0.1 mL.

**System suitability:** reference solution:

- **signal-to-noise ratio:** minimum 3 for the peak due to impurity A appearing just before the peak due to indapamide;
- **peak-to-valley-ratio:** minimum 6.7, where  $H_p$  = height above the baseline of the peak due to impurity A and  $H_v$  = height above the baseline of the lowest point of the curve separating this peak from the peak due to indapamide.

**Limit:**

- **impurity A:** not more than the difference between the areas of the peaks due to impurity A in the chromatograms obtained with the reference solution and the test solution (5 ppm).

**Heavy metals (2.4.8):** maximum 10 ppm.

2.0 g complies with test C. Prepare the reference solution using 2 mL of *lead standard solution (10 ppm Pb) R*.

**Water (2.5.12):** maximum 3.0 per cent, determined on 0.100 g.

**Sulfated ash (2.4.14):** maximum 0.1 per cent, determined on 1.0 g.

**ASSAY**

Liquid chromatography (2.2.29) as described in the test for related substances with the following modifications.

**Injection:** the test solution and reference solution (c).

**System suitability:** reference solution (c):

- **repeatability:** maximum relative standard deviation of 1.0 per cent after 6 injections; if necessary, adjust the integrator parameters.

Calculate the percentage content of  $C_{36}H_{49}N_5O_8S_2$  from the declared content of *indapamide CRS*.

**STORAGE**

Protected from light.

**IMPURITIES**

**Specified impurities:** A, B.

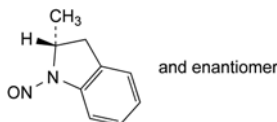

A. (2RS)-2-methyl-1-nitroso-2,3-dihydro-1H-indole,

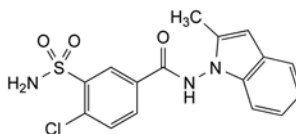

B. 4-chloro-N-(2-methyl-1H-indol-1-yl)-3-sulfamoylbenzamide.

01/2008:2214

## INDINAVIR SULFATE

### Indinaviri sulfas

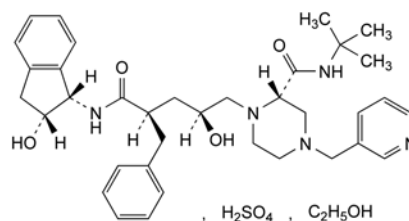

$C_{36}H_{49}N_5O_8S_2 \cdot C_2H_6O$   
[157810-81-6]

$M_r$  758

**DEFINITION**

(2S)-1-[(2S,4R)-4-Benzyl-2-hydroxy-5-[[[(1S,2R)-2-hydroxy-2,3-dihydro-1H-inden-1-yl]amino]-5-oxopentyl]-N-(1,1-dimethylethyl)-4-(pyridin-3-ylmethyl)piperazine-2-carboxamide sulfate ethanolate.

**Content:** 98.0 per cent to 102.0 per cent (anhydrous and ethanol-free substance).

**PRODUCTION**

A test for enantiomeric purity is carried out unless it has been demonstrated that the manufacturing process is enantioselective for the substance.

**CHARACTERS**

**Appearance:** white or almost white, hygroscopic powder.

**Solubility:** freely soluble in water, soluble in methanol, practically insoluble in heptane.

**IDENTIFICATION**

A. Specific optical rotation (2.2.7): + 122 to + 129 (anhydrous and ethanol-free substance), determined at 365 nm and at 25 °C.

Dissolve 0.500 g in *water R* and dilute to 50.0 mL with the same solvent.

B. Infrared absorption spectrophotometry (2.2.24).

**Comparison:** Ph. Eur. reference spectrum of *indinavir sulfate*.

C. It gives reaction (a) of sulfates (2.3.1).

D. Ethanol (see Tests).

## TESTS

**Related substances.** Liquid chromatography (2.2.29).

**Solution A.** Thoroughly mix equal volumes of mobile phase A and acetonitrile R1.

**Test solution.** Dissolve 50.0 mg of the substance to be examined in solution A and dilute to 100.0 mL with the same solution.

**Reference solution (a).** Dissolve 4 mg of indinavir for system suitability CRS (containing impurities B, C and E) in solution A and dilute to 10 mL with the same solution.

**Reference solution (b).** Dilute 1.0 mL of the test solution to 100.0 mL with solution A. Dilute 1.0 mL of this solution to 10.0 mL with solution A.

**Reference solution (c).** Dissolve 5.0 mg of cis-aminoindanol R (impurity A) in solution A and dilute to 10.0 mL with the same solution. Dilute 1.0 mL of the solution to 100.0 mL with solution A. Dilute 1.0 mL of this solution to 10.0 mL with solution A.

**Reference solution (d).** To 30 mg of the substance to be examined add 0.25 mL of 2 M hydrochloric acid R and allow to stand at room temperature for 1 h. Dilute to 100 mL with a mixture of 2 volumes of acetonitrile R1 and 3 volumes of mobile phase A and mix (*in situ* degradation to obtain impurity D).

**Column:**

- size:  $l = 0.25$  m,  $\varnothing = 4.6$  mm;
- stationary phase: octadecylsilyl silica gel for chromatography R (5  $\mu$ m).

**Mobile phase:**

- mobile phase A: solution containing 0.27 g/L of potassium dihydrogen phosphate R and 1.40 g/L of dipotassium hydrogen phosphate R; filter and degas;
- mobile phase B: acetonitrile R1;

Time (min)	Mobile phase A (per cent V/V)	Mobile phase B (per cent V/V)
0 - 5	80	20
5 - 40	80 → 30	20 → 70
40 - 45	30	70
45 - 47	30 → 80	70 → 20
47 - 52	80	20

**Flow rate:** 1.0 mL/min.

**Detection:** spectrophotometer at 220 nm.

**Injection:** 20  $\mu$ L.

**Identification of impurities:** use the chromatogram supplied with indinavir for system suitability CRS and the chromatogram obtained with reference solution (a) to identify the peaks due to impurities B, C and E; use the chromatogram obtained with reference solution (d) to identify the peak due to impurity D.

**Relative retention** with reference to indinavir (retention time = about 25 min): impurity A = about 0.2; impurity B = about 0.8; impurity C = about 0.98; impurity D = about 1.1; impurity E = about 1.3.

**System suitability:** reference solution (a):

- resolution: minimum 1.8 between the peaks due to impurity C and indinavir.

**Limits:**

- correction factor: for the calculation of content, multiply the peak area of impurity D by 1.8;
- impurity A: not more than the area of the principal peak in the chromatogram obtained with reference solution (c) (0.1 per cent);

- impurity D: not more than twice the area of the principal peak in the chromatogram obtained with reference solution (b) (0.2 per cent);
- impurities B, C, E: for each impurity, not more than the area of the principal peak in the chromatogram obtained with reference solution (b) (0.1 per cent);
- unspecified impurities: for each impurity, not more than 0.5 times the area of the principal peak in the chromatogram obtained with reference solution (b) (0.05 per cent);
- total: not more than 5 times the area of the principal peak in the chromatogram obtained with reference solution (b) (0.5 per cent);
- disregard limit: 0.3 times the area of the principal peak in the chromatogram obtained with reference solution (b) (0.03 per cent).

**Ethanol.** Gas chromatography (2.2.28).

**Internal standard solution.** Dilute 1.0 mL of propanol R to 200.0 mL with water R.

**Test solution.** Dissolve 0.400 g of the substance to be examined in 50.0 mL of water R, add 8.0 mL of the internal standard solution and dilute to 100.0 mL with water R.

**Reference solution.** Dilute 1.0 mL of anhydrous ethanol R to 200.0 mL. Dilute 2.0 mL of this solution and 2.0 mL of the internal standard solution to 25.0 mL with water R.

**Column:**

- material: fused silica;
- size:  $l = 30$  m,  $\varnothing = 0.53$  mm;
- stationary phase: macrogol 20 000 R (film thickness 1.0  $\mu$ m).

**Carrier gas:** helium for chromatography R.

**Flow rate:** 10 mL/min.

**Split ratio:** 1:10.

**Temperature:**

- column: 35 °C;
- injection port: 140 °C;
- detector: 220 °C.

**Detection:** flame ionisation.

**Injection:** 1.0  $\mu$ L.

**System suitability:** reference solution:

- retention time: ethanol = 2 min to 4 min;
- resolution: minimum 5.0 between the peaks due to ethanol and propanol.

Calculate the percentage content of ethanol taking the density (2.2.5) to be 0.790 g/mL.

**Limit:**

- ethanol: 5.0 per cent to 8.0 per cent (*m/m*).

**Heavy metals** (2.4.8): maximum 10 ppm.

Dissolve 2.0 g in water R and dilute to 20 mL with the same solvent. 12 mL of the solution complies with test A. Prepare the reference solution using lead standard solution (1 ppm Pb) R.

**Water** (2.5.12): maximum 1.5 per cent, determined on 0.500 g.

**Sulfated ash** (2.4.14): maximum 0.1 per cent, determined on 1.0 g.

## ASSAY

Liquid chromatography (2.2.29).

**Solution B.** Add 20 mL of dibutylammonium phosphate for ion-pairing R to 1000 mL of water R. Adjust to pH 6.5 with 1 M sodium hydroxide.

**Test solution.** Dissolve 60.0 mg of the substance to be examined in the mobile phase and dilute to 100.0 mL with the mobile phase.

**Reference solution.** Dissolve 50.0 mg of indinavir CRS in the mobile phase and dilute to 100.0 mL with the mobile phase.



## Column:

- size:  $l = 0.25$  m,  $\varnothing = 4.6$  mm;
- stationary phase: base-deactivated octylsilyl silica gel for chromatography R (5  $\mu$ m);
- temperature: 40 °C.

Mobile phase: acetonitrile R, solution B (45:55 V/V).

Flow rate: 1.0 mL/min.

Detection: spectrophotometer at 260 nm.

Injection: 10  $\mu$ L.

Run time: twice the retention time of indinavir.

Retention time: indinavir = about 10 min.

Calculate the percentage content of  $C_{36}H_{49}N_5O_8S$  using the declared content of *indinavir CRS* and multiplying by a correction factor of 1.1598.

## STORAGE

In an airtight container, protected from light.

## IMPURITIES

Specified impurities: A, B, C, D, E.

Other detectable impurities (the following substances would, if present at a sufficient level, be detected by one or other of the tests in the monograph. They are limited by the general acceptance criterion for other/unspecified impurities and/or by the general monograph *Substances for pharmaceutical use (2034)*. It is therefore not necessary to identify these impurities for demonstration of compliance. See also 5.10. *Control of impurities in substances for pharmaceutical use*): F.

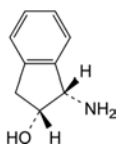

- A. (1*S*,2*R*)-1-amino-2,3-dihydro-1*H*-inden-2-ol (*cis*-aminoindanol),

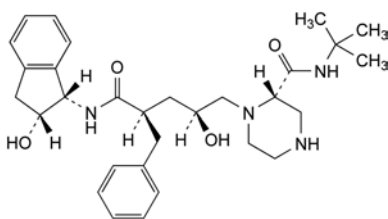

- B. (2*S*)-1-[(2*S*,4*R*)-4-benzyl-2-hydroxy-5-[(1*S*,2*R*)-2-hydroxy-2,3-dihydro-1*H*-inden-1-yl]amino]-5-oxopentyl]-*N*-(1,1-dimethylethyl)piperazine-2-carboxamide,

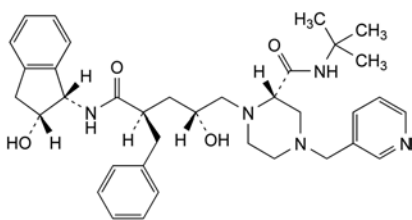

- C. (2*S*)-1-[(2*R*,4*R*)-4-benzyl-2-hydroxy-5-[(1*S*,2*R*)-2-hydroxy-2,3-dihydro-1*H*-inden-1-yl]amino]-5-oxopentyl]-*N*-(1,1-dimethylethyl)-4-(pyridin-3-ylmethyl)piperazine-2-carboxamide,

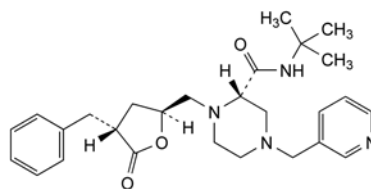

- D. (3*R*,5*S*)-3-benzyl-5-[(2*S*)-2-[(1,1-dimethylethyl)carbamoyl]-4-(pyridin-3-ylmethyl)piperazin-1-yl]methyl]-4,5-dihydrofuran-2(3*H*)-one,

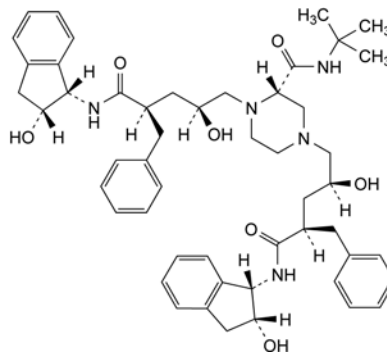

- E. (2*S*)-1,4-bis[(2*S*,4*R*)-4-benzyl-2-hydroxy-5-[(1*S*,2*R*)-2-hydroxy-2,3-dihydro-1*H*-inden-1-yl]amino]-5-oxopentyl]-*N*-(1,1-dimethylethyl)piperazine-2-carboxamide,

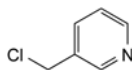

- F. 3-(chloromethyl)pyridine (nicotiny chloride).

01/2008:0092  
corrected 6.0

## INDOMETACIN

## Indometacinum

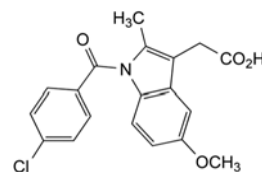

$C_{19}H_{16}ClNO_4$   
[53-86-1]

$M_r$  357.8

## DEFINITION

Indometacin contains not less than 98.5 per cent and not more than the equivalent of 100.5 per cent of [1-(4-chlorobenzoyl)-5-methoxy-2-methylindol-3-yl]acetic acid, calculated with reference to the dried substance.

## CHARACTERS

A white or yellow, crystalline powder, practically insoluble in water, sparingly soluble in alcohol.

## IDENTIFICATION

First identification: A, C.

Second identification: A, B, D, E.

- A. Melting point (2.2.14): 158 °C to 162 °C.
- B. Dissolve 25 mg in a mixture of 1 volume of 1 *M* hydrochloric acid and 9 volumes of methanol R and dilute to 100.0 mL with the same mixture of solvents. Dilute 10.0 mL of the solution to 100.0 mL with a mixture of 1 volume of 1 *M* hydrochloric acid and 9 volumes of methanol R. Examined between 300 nm and 350 nm (2.2.25), the solution shows an absorption maximum at 318 nm. The specific absorbance at the maximum is 170 to 190.

01/2008:1805  
corrected 7.0

- C. Examine by infrared absorption spectrophotometry (2.2.24), comparing with the spectrum obtained with *indometacin CRS*. Examine the substances in the solid state without recrystallisation.
- D. Dissolve 0.1 g in 10 mL of *alcohol R*, heating slightly if necessary. To 0.1 mL of the solution add 2 mL of a freshly prepared mixture of 1 volume of a 250 g/L solution of *hydroxylamine hydrochloride R* and 3 volumes of *dilute sodium hydroxide solution R*. Add 2 mL of *dilute hydrochloric acid R* and 1 mL of *ferric chloride solution R2* and mix. A violet-pink colour develops.
- E. To 0.5 mL of the solution in alcohol prepared in identification test D, add 0.5 mL of *dimethylaminobenzaldehyde solution R2*. A precipitate is formed that dissolves on shaking. Heat on a water-bath. A bluish-green colour is produced. Continue to heat for 5 min and cool in iced water for 2 min. A precipitate is formed and the colour changes to light greyish-green. Add 3 mL of *alcohol R*. The solution is clear and violet-pink in colour.

## TESTS

**Related substances.** Examine by thin-layer chromatography (2.2.27), using *silica gel HF<sub>254</sub> R* as the coating substance. Prepare the slurry using a 46.8 g/L solution of *sodium dihydrogen phosphate R*.

**Test solution.** Dissolve 0.2 g of the substance to be examined in *methanol R* and dilute to 10 mL with the same solvent. Prepare immediately before use.

**Reference solution.** Dilute 1 mL of the test solution to 200 mL with *methanol R*.

Apply separately to the plate 10 µL of each solution. Develop over a path of 15 cm using a mixture of 30 volumes of *light petroleum R* and 70 volumes of *ether R*. Allow the plate to dry in air and examine in ultraviolet light at 254 nm. Any spot in the chromatogram obtained with the test solution, apart from the principal spot, is not more intense than the spot in the chromatogram obtained with the reference solution (0.5 per cent).

**Heavy metals (2.4.8).** 2.0 g complies with limit test C for heavy metals (20 ppm). Prepare the standard using 4 mL of *lead standard solution (10 ppm Pb) R*.

**Loss on drying (2.2.32).** Not more than 0.5 per cent, determined on 1.000 g by drying in an oven at 105 °C.

**Sulfated ash (2.4.14).** Not more than 0.1 per cent, determined on 1.0 g.

## ASSAY

Dissolve 0.300 g in 75 mL of *acetone R*, through which *nitrogen R*, free from carbon dioxide, has been passed for 15 min. Maintain a constant stream of nitrogen through the solution. Add 0.1 mL of *phenolphthalein solution R*. Titrate with 0.1 M *sodium hydroxide*. Carry out a blank titration.

1 mL of 0.1 M *sodium hydroxide* is equivalent to 35.78 mg of C<sub>19</sub>H<sub>16</sub>ClNO<sub>4</sub>.

## STORAGE

Store protected from light.

## IMPURITIES

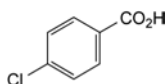

- A. 4-chlorobenzoic acid.

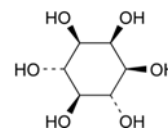
**myo-INOSITOL***myo*-InositolumC<sub>6</sub>H<sub>12</sub>O<sub>6</sub>  
[87-89-8]M<sub>r</sub> 180.2

## DEFINITION

Cyclohexane-1,2,3,5/4,6-hexol.

**Content:** 97.0 per cent to 102.0 per cent (anhydrous substance).

## CHARACTERS

**Appearance:** white or almost white, crystalline powder.

**Solubility:** very soluble in water, practically insoluble in ethanol (96 per cent).

## IDENTIFICATION

- A. Infrared absorption spectrophotometry (2.2.24).

**Comparison:** *myo-inositol CRS*.

- B. Examine the chromatograms obtained in the assay.

**Results:** the principal peak in the chromatogram obtained with the test solution is similar in retention time and size to the principal peak in the chromatogram obtained with reference solution (a).

## TESTS

**Solution S.** Dissolve 10.0 g in *distilled water R* and dilute to 100.0 mL with the same solvent.

**Appearance of solution.** Solution S is clear (2.2.1) and colourless (2.2.2, *Method II*).

**Conductivity (2.2.38):** maximum 30 µS·cm<sup>-1</sup>.

Dissolve 10.0 g in *carbon dioxide-free water R* prepared from *distilled water R*, with gentle warming if necessary, and dilute to 50.0 mL with the same solvent. Measure the conductivity of the solution while gently stirring with a magnetic stirrer.

**Related substances.** Liquid chromatography (2.2.29).

**Test solution.** Dissolve 0.500 g of the substance to be examined in *water R* and dilute to 10.0 mL with the same solvent.

**Reference solution (a).** Dissolve 0.500 g of *myo-inositol CRS* in *water R* and dilute to 10.0 mL with the same solvent.

**Reference solution (b).** Dilute 2.0 mL of the test solution to 100.0 mL with *water R*. Dilute 5.0 mL of this solution to 100.0 mL with *water R*.

**Reference solution (c).** Dissolve 0.5 g of *myo-inositol R* and 0.5 g of *mannitol R* in *water R* and dilute to 10 mL with the same solvent.

**Column:**

- size: *l* = 0.3 m, Ø = 7.8 mm;
- stationary phase: strong cation exchange resin (calcium form) *R* (9 µm);
- temperature: 85 °C.

**Mobile phase:** *water R*.

**Flow rate:** 0.5 mL/min.

**Detection:** refractometer maintained at a constant temperature (at about 30-35 °C for example).

**Injection:** 20 µL of the test solution and reference solutions (b) and (c).

**Run time:** twice the retention time of *myo-inositol*.

*Relative retention* with reference to *myo*-inositol (retention time = about 17.5 min): impurity A = about 1.3; impurity B = about 1.4.

*System suitability*: reference solution (c):

- *resolution*: minimum 4 between the peaks due to *myo*-inositol and impurity A.

*Limits*:

- *impurities A, B*: for each impurity, not more than 3 times the area of the principal peak in the chromatogram obtained with reference solution (b) (0.3 per cent);
- *unspecified impurities*: for each impurity, not more than the area of the principal peak in the chromatogram obtained with reference solution (b) (0.10 per cent);
- *total*: not more than 10 times the area of the principal peak in the chromatogram obtained with reference solution (b) (1.0 per cent);
- *disregard limit*: 0.5 times the area of the principal peak in the chromatogram obtained with reference solution (b) (0.05 per cent).

**Barium.** To 10 mL of solution S add 1 mL of *dilute sulfuric acid R*. When examined immediately, and after 1 h, any opalescence in the solution is not more intense than that in a mixture of 1 mL of *distilled water R* and 10 mL of solution S.

**Lead (2.4.10):** maximum 0.5 ppm.

Prepare the test solution by dissolving 20.0 g of the substance to be examined in 100 mL of *water R*, heating if necessary, and diluting to 200.0 mL with *dilute acetic acid R*.

**Water (2.5.12):** maximum 0.5 per cent, determined on 1.00 g.

#### ASSAY

Liquid chromatography (2.2.29) as described in the test for related substances with the following modification.

*Injection*: test solution and reference solution (a).

Calculate the percentage content of  $C_6H_{12}O_6$  from the declared content of *myo*-inositol CRS.

#### IMPURITIES

*Specified impurities*: A, B.

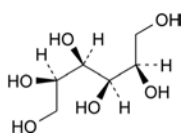

A. D-mannitol,

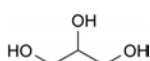

B. propane-1,2,3-triol (glycerol).

01/2008:2084  
corrected 6.0

## INSULIN ASPART

### Insulinum aspartum

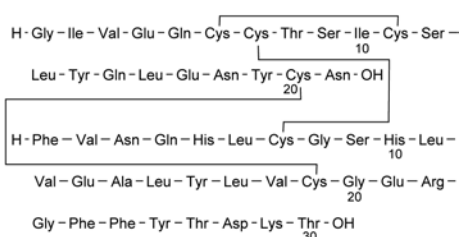

$C_{256}H_{381}N_{65}O_{79}S_6$

$M_r$  5826

#### DEFINITION

28<sup>B</sup>-L-Aspartate insulin (human).

Insulin aspart is a 2-chain peptide containing 51 amino acids. The A-chain is composed of 21 amino acids and the B-chain is composed of 30 amino acids. It is identical in primary structure to human insulin, except that it has aspartic acid instead of proline at position 28 of the B-chain. As in human insulin, insulin aspart contains 2 interchain disulfide bonds and 1 intrachain disulfide bond.

**Content:** 90.0 per cent to 104.0 per cent of insulin aspart  $C_{256}H_{381}N_{65}O_{79}S_6$  plus A21Asp insulin aspart, B3Asp insulin aspart, B3isoAsp insulin aspart and B28isoAsp insulin aspart (dried substance).

By convention, for the purpose of labelling insulin aspart preparations, 0.0350 mg of insulin aspart is equivalent to 1 unit.

#### PRODUCTION

Insulin aspart is produced by a method based on recombinant DNA (rDNA) technology under conditions designed to minimise the degree of microbial contamination.

Prior to release the following tests are carried out on each batch of the final bulk product, unless exemption has been granted by the competent authority.

**Host-cell-derived proteins.** The limit is approved by the competent authority.

**Single-chain precursor.** The limit is approved by the competent authority. Use a suitably sensitive method.

#### CHARACTERS

*Appearance*: white or almost white powder.

*Solubility*: practically insoluble in ethanol (96 per cent), in methanol and in aqueous solutions with a pH around 5.1. In aqueous solutions below pH 3.5 or above pH 6.5, the solubility is greater than or equal to 25 mg/mL.

#### IDENTIFICATION

A. Examine the chromatograms obtained in the assay.

*Results*: the principal peak in the chromatogram obtained with the test solution is similar in retention time to the principal peak in the chromatogram obtained with reference solution (a).

B. Peptide mapping (2.2.55).

##### SELECTIVE CLEAVAGE OF THE PEPTIDE BONDS

*Test solution.* Prepare a 2.0 mg/mL solution of the substance to be examined in 0.01 M hydrochloric acid and transfer 25 µL of this solution to a clean tube. Add 100 µL of HEPES buffer solution pH 7.5 R and 20 µL of a 1 mg/mL solution of *Staphylococcus aureus strain V8 protease, type XVII-B R*. Cap the tube and incubate at 25 °C for 6 h. Stop the reaction by adding 145 µL of sulfate buffer solution pH 2.0 R.

*Reference solution.* Prepare at the same time and in the same manner as for the test solution, but using *insulin aspart CRS* instead of the substance to be examined.

*CHROMATOGRAPHIC SEPARATION.* Liquid chromatography (2.2.29).

*Column*:

- *size*:  $l = 0.10$  m,  $\emptyset = 4.6$  mm,
- *stationary phase*: octadecylsilyl silica gel for chromatography R (3 µm) with a pore size of 8 nm,
- *temperature*: 40 °C.

*Mobile phase*:

- *mobile phase A*: mix 100 mL of acetonitrile for chromatography R, 200 mL of sulfate buffer solution pH 2.0 R and 700 mL of water R; filter and degas;
- *mobile phase B*: mix 200 mL of sulfate buffer solution pH 2.0 R, 400 mL of acetonitrile for chromatography R and 400 mL of water R; filter and degas;

Time (min)	Mobile phase A (per cent V/V)	Mobile phase B (per cent V/V)
0 - 60	90 → 30	10 → 70
60 - 65	30 → 0	70 → 100
65 - 70	0	100

*Flow rate:* 1 mL/min.

*Detection:* spectrophotometer at 214 nm.

*Equilibration:* at initial conditions for at least 15 min. Carry out a blank run using the above-mentioned gradient.

*Injection:* 50 µL.

*System suitability:*

- the chromatograms obtained with the test solution and the reference solution are qualitatively similar to the chromatogram of insulin aspart digest supplied with *insulin aspart CRS*,
- in the chromatogram obtained with the reference solution, identify the peaks due to digest fragments I, II and III:  
*symmetry factor:* maximum 1.5, for the peaks due to fragments II and III,  
*resolution* minimum 8.0, between the peaks due to fragments II and III.

*Results:* the profile of the chromatogram obtained with the test solution corresponds to that of the chromatogram obtained with the reference solution.

*NOTE:* the retention times of fragments I, II and IV are the same as for human insulin. The retention time of fragment III differs from human insulin due to substitution of proline by aspartic acid.

## TESTS

**Impurities with molecular masses greater than that of insulin aspart.** Size-exclusion chromatography (2.2.30): use the normalisation procedure.

*Test solution.* Prepare a solution containing 4 mg/mL of the substance to be examined in 0.01 M hydrochloric acid. Maintain the solution at 2-8 °C and use within 48 h.

*Resolution solution.* Use a solution of insulin (about 4 mg/mL), containing more than 0.4 per cent of high molecular mass proteins. An injectable insulin preparation, whether a solution or a suspension, that has been clarified with a sufficient amount of 6 M hydrochloric acid R, containing the indicated percentage of high molecular mass proteins, or a solution prepared from insulin, dissolved in 0.01 M hydrochloric acid may be used. Insulin containing the indicated percentage of high molecular mass proteins may be prepared by allowing insulin powder to stand at room temperature for about 10 days. Maintain the solution at 2-8 °C and use within 7 days.

*Column:*

- *size:*  $l = 0.3$  m,  $\emptyset = 7.8$  mm,
- *stationary phase:* hydrophilic silica gel for chromatography R (5-10 µm) with a pore size of 12-12.5 nm, of a grade suitable for the separation of insulin monomer from dimer and polymers.

*Mobile phase:* mix 15 volumes of glacial acetic acid R, 20 volumes of acetonitrile for chromatography R and 65 volumes of a 1.0 g/L solution of arginine R; filter and degas.

*Flow rate:* 0.5 mL/min.

*Detection:* spectrophotometer at 276 nm.

*Equilibration:* at least 3 injections of the resolution solution; the column is equilibrated when repeatable results are obtained from 2 subsequent injections.

*Injection:* 100 µL.

*Run time:* about 35 min.

*Retention time:* insulin aspart polymers = 13-17 min; insulin aspart dimer = about 17.5 min; insulin aspart monomer = about 20 min; salts = about 22 min.

*System suitability:* resolution solution:

- *peak-to-valley ratio:* minimum 2.0, where  $H_p$  = height above the baseline of the peak due to the dimer and  $H_v$  = height above the baseline of the lowest point of the curve separating this peak from the peak due to the monomer.

*Limits:* the sum of the areas of the peaks with a retention time less than that of the principal peak is not more than 0.5 per cent of the total area of the peaks. Disregard any peak with a retention time greater than that of the peak due to insulin aspart monomer.

**Related proteins.** Liquid chromatography (2.2.29) as described under Assay: use the normalisation procedure.

*Limits:*

- *B28isoAsp insulin aspart:* maximum 1.0 per cent,
- *total of the peaks due to A21Asp insulin aspart, B3Asp insulin aspart and B3isoAsp insulin aspart:* maximum 2.0 per cent,
- *total of other impurities:* maximum 1.5 per cent.

**Loss on drying** (2.2.32): maximum 10.0 per cent, determined on 0.200 g by drying in an oven at 105 °C for 24 h.

**Sulfated ash** (2.4.14): maximum 6.0 per cent, determined on 0.200 g (dried substance).

**Bacterial endotoxins** (2.6.14): less than 10 IU/mg, if intended for use in the manufacture of parenteral preparations without a further appropriate procedure for the removal of bacterial endotoxins.

## ASSAY

Liquid chromatography (2.2.29).

*Test solution.* Dissolve the substance to be examined in 0.01 M hydrochloric acid to obtain a concentration of 4.0 mg/mL. Maintain the solution at 2-8 °C and use within 24 h.

*Reference solution.* Dissolve the contents of a vial of *insulin aspart CRS* in 0.01 M hydrochloric acid to obtain a concentration of 4.0 mg/mL. Maintain the solution at 2-8 °C and use within 48 h.

*Resolution solution.* Use an appropriate solution with a content of B3Asp insulin aspart and A21Asp insulin aspart of not less than 1 per cent. This may be achieved by storing reference solution at room temperature for about 1-3 days. Maintain the solution at 2-8 °C and use within 72 h.

*Column:*

- *size:*  $l = 0.25$  m,  $\emptyset = 4$  mm,
- *stationary phase:* octadecylsilyl silica gel for chromatography R (5 µm),
- *temperature:* 40 °C.

*Mobile phase:*

- *mobile phase A:* dissolve 142.0 g of anhydrous sodium sulfate R in water R; add 13.5 mL of phosphoric acid R and dilute to 5000 mL with water R; adjust to pH 3.6, if necessary, with strong sodium hydroxide solution R; filter and degas; mix 9 volumes of the solution with 1 volume of acetonitrile for chromatography R; filter and degas;
- *mobile phase B:* mix equal volumes of water R and acetonitrile for chromatography R; filter and degas;

Time (min)	Mobile phase A (per cent V/V)	Mobile phase B (per cent V/V)
0 - 35	58	42
35 - 40	58 → 20	42 → 80
40 - 45	20	80
45 - 46	20 → 58	80 → 42
46 - 60	58	42

*Flow rate:* 1 mL/min.

*Detection:* spectrophotometer at 214 nm.

*Injection:* 10 µL.

*Relative retention* with reference to insulin aspart (retention time = 20-24 min): B28isoAsp insulin aspart = about 0.9; B3Asp insulin aspart plus A21Asp insulin aspart (generally coeluted) = about 1.3; B3isoAsp insulin aspart = about 1.5.

*System suitability*: resolution solution:

- *resolution*: minimum 2.0 between the peak due to insulin aspart and the peak due to A21Asp insulin aspart and to B3Asp insulin aspart.

Calculate the content of insulin aspart  $C_{256}H_{381}N_{65}O_{79}S_6$ , plus B28isoAsp insulin aspart, A21Asp insulin aspart, B3Asp insulin aspart and B3isoAsp insulin aspart using the areas of the corresponding peaks in the chromatograms obtained with the test solution and reference solution and the declared content of insulin aspart plus B28isoAsp insulin aspart, A21Asp insulin aspart, B3Asp insulin aspart and B3isoAsp insulin aspart in *insulin aspart CRS*.

#### STORAGE

In an airtight container, protected from light, at or below  $-18\text{ }^{\circ}\text{C}$  until released by the manufacturer. When thawed, insulin aspart is stored at  $5 \pm 3\text{ }^{\circ}\text{C}$  and used for manufacturing preparations within a short period of time. To avoid absorption of humidity from the air during weighing, insulin aspart must be at room temperature before opening the container.

01/2008:1637

## INSULIN, BOVINE

### Insulinum bovinum

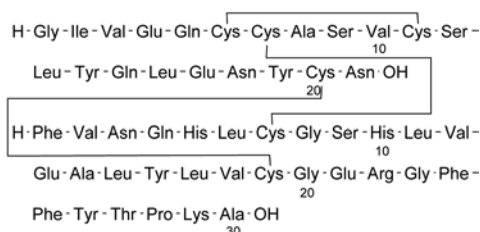
 $C_{254}H_{377}N_{65}O_{75}S_6$ 
 $M_r$  5734

#### DEFINITION

Bovine insulin is the natural antidiabetic principle obtained from beef pancreas and purified.

*Content*:

- *sum of bovine insulin* ( $C_{254}H_{377}N_{65}O_{75}S_6$ ) and *A21 desamido bovine insulin*: 93.0 per cent to 105.0 per cent (dried substance).

By convention, for the purpose of labelling insulin preparations, 0.0342 mg of bovine insulin is equivalent to 1 IU of insulin.

#### PRODUCTION

The animals from which bovine insulin is derived must fulfil the requirements for the health of animals suitable for human consumption.

#### CHARACTERS

*Appearance*: white or almost white powder.

*Solubility*: practically insoluble in water and in ethanol. It dissolves in dilute mineral acids and with decomposition in dilute solutions of alkali hydroxides.

#### IDENTIFICATION

- A. Examine the chromatograms obtained in the assay.

*Results*: the retention time of the principal peak in the chromatogram obtained with the test solution corresponds to that of the principal peak in the chromatogram obtained with reference solution (c).

- B. Peptide mapping.

*Test solution*. Prepare a 2.0 mg/mL solution of the substance to be examined in 0.01 M hydrochloric acid and transfer 500  $\mu\text{L}$  of this solution to a clean tube. Add 2.0 mL of HEPES buffer solution pH 7.5 R and 400  $\mu\text{L}$  of a 1 mg/mL solution of *Staphylococcus aureus strain V8 protease, type XVII-B R*. Cap the tube and incubate at  $25\text{ }^{\circ}\text{C}$  for 6 h. Stop the reaction by adding 2.9 mL of sulfate buffer solution pH 2.0 R.

*Reference solution*. Prepare at the same time and in the same manner as for the test solution but using *bovine insulin CRS* instead of the substance to be examined.

Examine the digests by liquid chromatography (2.2.29).

*Column*:

- *size*:  $l = 0.10\text{ m}$ ,  $\varnothing = 4.6\text{ mm}$ ;
- *stationary phase*: octadecylsilyl silica gel for chromatography R ( $3\text{ }\mu\text{m}$ );
- *temperature*:  $40\text{ }^{\circ}\text{C}$ .

*Mobile phase*:

- *mobile phase A*: mix 100 mL of acetonitrile for chromatography R, 700 mL of water R and 200 mL of sulfate buffer solution pH 2.0 R; filter and degas;
- *mobile phase B*: mix 400 mL of acetonitrile for chromatography R, 400 mL of water R and 200 mL of sulfate buffer solution pH 2.0 R; filter and degas;

Time (min)	Mobile phase A (per cent V/V)	Mobile phase B (per cent V/V)
0 - 60	90 $\rightarrow$ 30	10 $\rightarrow$ 70
60 - 65	30 $\rightarrow$ 0	70 $\rightarrow$ 100
65 - 70	0	100

*Flow rate*: 1 mL/min.

*Detection*: spectrophotometer at 214 nm.

*Equilibration*: at initial conditions for at least 15 min. Carry out a blank run using the above-mentioned gradient.

*Injection*: 50  $\mu\text{L}$ .

*System suitability*: the chromatograms obtained with the test solution and the reference solution are qualitatively similar to the chromatogram of bovine insulin digest supplied with *bovine insulin CRS*. In the chromatogram obtained with the reference solution, identify the peaks due to digest fragments I, II and III. The symmetry factor of the peaks due to fragments II and III is not greater than 1.5, and the resolution between the 2 peaks is at least 1.9.

*Results*: the profile of the chromatogram obtained with the test solution corresponds to that of the chromatogram obtained with the reference solution.

*NOTE*: The retention time of fragment I is the same for porcine insulin and for human insulin. The retention times of fragments II and IV are the same for all insulins. The retention time of fragment III is the same for bovine insulin and for porcine insulin.

## TESTS

**Impurities with molecular masses greater than that of insulin.**

Size-exclusion chromatography (2.2.30): use the normalisation procedure. Maintain the solutions at 2-10 °C and use within 7 days. If an automatic injector is used, maintain the temperature at 2-10 °C.

**Test solution.** Dissolve 4 mg of the substance to be examined in 1.0 mL of 0.01 M hydrochloric acid.

**Resolution solution.** Use a solution of insulin (approximately 4 mg/mL), containing more than 0.4 per cent of high molecular mass proteins. An injectable insulin preparation, whether a solution or a suspension, that has been clarified with a sufficient amount of 6 M hydrochloric acid R, containing the indicated percentage of high molecular mass proteins, or a solution prepared from insulin, dissolved in 0.01 M hydrochloric acid, may be used. Insulin containing the indicated percentage of high molecular mass proteins may be prepared by allowing insulin powder to stand at room temperature for about 10 days.

**Column:**

- size:  $l = 0.3$  m,  $\emptyset =$  at least 7.5 mm;
- stationary phase: hydrophilic silica gel for chromatography R (5-10  $\mu$ m), of a grade suitable for the separation of insulin monomer from dimer and polymers.

**Mobile phase:** mix of 15 volumes of glacial acetic acid R, 20 volumes of acetonitrile R and 65 volumes of a 1.0 g/L solution of arginine R; filter and degas.

**Flow rate:** 0.5 mL/min.

**Detection:** spectrophotometer at 276 nm.

**Equilibration:** before using a new column for chromatographic analysis, equilibrate by repeated injections of an insulin solution containing high molecular mass proteins. This can be done by at least 3 injections of the resolution solution. The column is equilibrated when repeatable results are obtained from 2 subsequent injections.

**Injection:** 100  $\mu$ L.

**Run time:** about 35 min.

**Retention times:** polymeric insulin complexes = 13 min to 17 min; covalent insulin dimer = about 17.5 min; insulin monomer = about 20 min; salts = about 22 min.

**System suitability:** resolution solution:

- peak-to-valley ratio: minimum 2.0, where  $H_p$  = height above the baseline of the peak due to the dimer and  $H_v$  = height above the baseline of the lowest point of the curve separating this peak from the peak due to the monomer.

**Limits:** the sum of the areas of any peaks with a retention time less than that of the principal peak is not greater than 1.0 per cent of the total area of the peaks; disregard any peak with a retention time greater than that of the insulin peak.

**Related proteins.** Liquid chromatography (2.2.29) as described under Assay, following the elution conditions as described in the table below.

Time (min)	Mobile phase A (per cent V/V)	Mobile phase B (per cent V/V)
0 - 30	42	58
30 - 44	42 → 11	58 → 89
44 - 50	11	89

Maintain the solutions at 2-10 °C and use within 24 h. Perform a system suitability test (resolution, linearity) as described under Assay. If necessary, the relative proportions of the mobile phases may be adjusted to ensure complete elution of A21 desamido porcine insulin before commencement of the gradient. The profile of the gradient may also be adjusted to ensure complete elution of all insulin related impurities.

Inject 20  $\mu$ L of reference solution (c) and 20  $\mu$ L of the test solution. If necessary, adjust the injection volume to between 10  $\mu$ L and 20  $\mu$ L in accordance with the results obtained in the test for linearity as described under Assay. Record the

chromatograms for approximately 50 min. In the chromatogram obtained with reference solution (c), A21 desamido bovine insulin appears as a small peak after the principal peak and has a relative retention of about 1.3 with reference to the principal peak. In the chromatogram obtained with the test solution, the area of the peak due to A21 desamido bovine insulin is not greater than 3.0 per cent of the total area of the peaks; the sum of the areas of all the peaks, apart from those due to bovine insulin and A21 desamido bovine insulin, is not greater than 3.0 per cent of the total area of the peaks.

**Bovine proinsulin-like immunoreactivity (PLI):** maximum 10 ppm (dried substance).

Use a suitably sensitive immunochemical method (2.7.1) such as radio-immunoassay, using the International Reference Reagent for bovine proinsulin to calibrate the method.

**Zinc:** maximum 1.0 per cent (dried substance).

Atomic absorption spectrometry (2.2.23, Method I).

**Test solution.** Dissolve 50.0 mg of the substance to be examined in 0.01 M hydrochloric acid and dilute to 25.0 mL with the same acid. Dilute if necessary to a suitable concentration (for example, 0.4  $\mu$ g to 1.6  $\mu$ g of Zn per millilitre) with 0.01 M hydrochloric acid.

**Reference solutions.** Use solutions containing 0.40  $\mu$ g, 0.80  $\mu$ g, 1.00  $\mu$ g, 1.20  $\mu$ g and 1.60  $\mu$ g of Zn per millilitre, freshly prepared by diluting zinc standard solution (5 mg/mL Zn) R with 0.01 M hydrochloric acid.

**Source:** zinc hollow-cathode lamp.

**Wavelength:** 213.9 nm.

**Flame:** air-acetylene flame of suitable composition (for example, 11 L of air and 2 L of acetylene per minute).

**Loss on drying (2.2.32):** maximum 10.0 per cent, determined on 0.200 g by drying in an oven at 105 °C for 24 h.

**Sulfated ash (2.4.14):** maximum 2.5 per cent (dried substance), determined on 0.200 g.

**Bacterial endotoxins (2.6.14):** less than 10 IU/mg, if intended for use in the manufacture of parenteral preparations without a further appropriate procedure for the removal of bacterial endotoxins.

## ASSAY

Liquid chromatography (2.2.29).

**Test solution.** Dissolve a suitable amount of the substance to be examined in 0.01 M hydrochloric acid to obtain a concentration of 4.0 mg/mL.

**Reference solution (a).** Dissolve the contents of a vial of human insulin CRS in 0.01 M hydrochloric acid to obtain a concentration of 4.0 mg/mL.

**Reference solution (b).** Dissolve the contents of a vial of porcine insulin CRS in 0.01 M hydrochloric acid to obtain a concentration of 4.0 mg/mL.

**Reference solution (c).** Dissolve the contents of a vial of bovine insulin CRS in 0.01 M hydrochloric acid to obtain a concentration of 4.0 mg/mL.

**Reference solution (d).** Dilute 1.0 mL of reference solution (c) to 10.0 mL with 0.01 M hydrochloric acid.

**Resolution solution.** Mix 1.0 mL of reference solution (a) and 1.0 mL of reference solution (b).

Maintain the solutions at 2-10 °C and use within 48 h. If an automatic injector is used, maintain the temperature at 2-10 °C.

**Column:**

- size:  $l = 0.25$  m,  $\emptyset = 4.6$  mm;
- stationary phase: octadecylsilyl silica gel for chromatography R (5  $\mu$ m);
- temperature: 40 °C.

**Mobile phase:** mix 42 volumes of mobile phase A and 58 volumes of mobile phase B, adjusting the composition of the mixture if necessary.

Prepare and maintain the following solutions at a temperature of at least 20 °C:

- *mobile phase A*: dissolve 28.4 g of *anhydrous sodium sulfate R* in *water R* and dilute to 1000 mL with the same solvent; add 2.7 mL of *phosphoric acid R*; adjust to pH 2.3, if necessary, with *ethanolamine R*; filter and degas;
- *mobile phase B*: mix 550 mL of mobile phase A with 450 mL of *acetonitrile R*. Warm the solution to a temperature of at least 20 °C in order to avoid precipitation (mixing of mobile phase A with acetonitrile is endothermic); filter and degas.

*Flow rate*: 1 mL/min.

*Detection*: spectrophotometer at 214 nm.

*System suitability*:

- *resolution*: inject 20 µL of the resolution solution and 20 µL of reference solution (b). Record the chromatogram of the resolution solution until the peak corresponding to the principal peak in the chromatogram obtained with reference solution (b) is clearly visible. In the chromatogram obtained with the resolution solution, identify the peaks due to porcine insulin and human insulin. The test is not valid unless the resolution between the peaks corresponding to human insulin and porcine insulin is at least 1.2. If necessary, adjust the concentration of acetonitrile in the mobile phase until this resolution is achieved;
- *linearity*: inject 20 µL each of reference solutions (c) and (d). The test is not valid unless the area of the principal peak in the chromatogram obtained with reference solution (c) is 10 ± 0.5 times the area of the principal peak in the chromatogram obtained with reference solution (d). If this test fails, adjust the injection volume to between 10 µL and 20 µL, in order that the responses are within the linearity range of the detector.

*Injection*: 20 µL of the test solution.

Calculate the content of bovine insulin  $C_{254}H_{377}N_{65}O_{75}S_6$  plus A21 desamido bovine insulin from the area of the principal peak and the area of the peak corresponding to A21 desamido bovine insulin in the chromatograms obtained with the test solution and reference solution (c) and the declared content of bovine insulin plus A21 desamido bovine insulin in *bovine insulin CRS*.

#### STORAGE

In an airtight container, protected from light, at –20 °C until released by the manufacturer. When thawed, insulin may be stored at 5 ± 3 °C and used for manufacturing preparations within a short period of time. To avoid absorption of humidity from the air during weighing, the insulin must be at room temperature.

01/2011:0838

## INSULIN, HUMAN

### Insulinum humanum

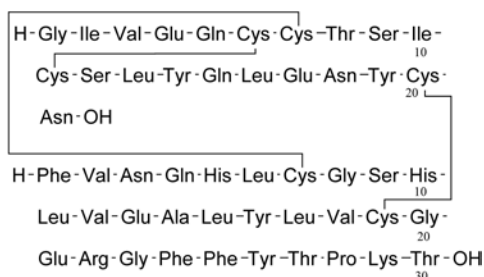

$C_{257}H_{383}N_{65}O_{77}S_6$

$M_r$  5808

#### DEFINITION

Human insulin is a 2-chain peptide having the structure of the antidiabetic hormone produced by the human pancreas.

*Content*: 95.0 per cent to 105.0 per cent of human insulin  $C_{257}H_{383}N_{65}O_{77}S_6$  plus A21 desamido human insulin (dried substance).

By convention, for the purpose of labelling insulin preparations, 0.0347 mg of human insulin is equivalent to 1 IU of insulin.

#### PRODUCTION

Human insulin is produced either by enzymatic modification and suitable purification of insulin obtained from the pancreas of the pig or by a method based on recombinant DNA (rDNA) technology.

Where applicable, the animals from which human insulin is derived must fulfil the requirements for the health of animals suitable for human consumption.

Human insulin is produced under conditions designed to minimise the degree of microbial contamination.

For human insulin produced by enzymatic modification of insulin obtained from the pancreas of the pig, the manufacturing process is validated to demonstrate removal of any residual proteolytic activity. The competent authority may require additional tests.

For human insulin produced by a method based on rDNA technology, prior to release the following tests are carried out on each batch of the final bulk product, unless exemption has been granted by the competent authority.

**Host-cell-derived proteins.** The limit is approved by the competent authority.

**Single chain precursor.** The limit is approved by the competent authority. Use a suitably sensitive method.

#### CHARACTERS

*Appearance*: white or almost white powder.

*Solubility*: practically insoluble in water and in ethanol (96 per cent). It dissolves in dilute mineral acids and with decomposition in dilute solutions of alkali hydroxides.

#### IDENTIFICATION

A. Examine the chromatograms obtained in the assay.

*Results*: the principal peak in the chromatogram obtained with the test solution is similar in retention time to the principal peak in the chromatogram obtained with reference solution (a).

B. Peptide mapping (2.2.55).

##### SELECTIVE CLEAVAGE OF THE PEPTIDE BONDS

*Test solution.* Prepare a 2.0 mg/mL solution of the substance to be examined in 0.01 M hydrochloric acid and transfer 500 µL of this solution to a clean tube. Add 2.0 mL of HEPES buffer solution pH 7.5 R and 400 µL of a 1 mg/mL solution of *Staphylococcus aureus strain V8 protease, type XVII-B R*. Cap the tube and incubate at 25 °C for 6 h. Stop the reaction by adding 2.9 mL of sulfate buffer solution pH 2.0 R.

*Reference solution.* Prepare at the same time and in the same manner as for the test solution but using *human insulin CRS* instead of the substance to be examined.

**CHROMATOGRAPHIC SEPARATION.** Liquid chromatography (2.2.29).

*Column*:

- *size*:  $l = 0.10$  m,  $\varnothing = 4.6$  mm,
- *stationary phase*: octadecylsilyl silica gel for chromatography R (3 µm) with a pore size of 8 nm,
- *temperature*: 40 °C.

*Mobile phase*:

- *mobile phase A*: mix 100 mL of acetonitrile for chromatography R, 200 mL of sulfate buffer solution pH 2.0 R and 700 mL of water R; filter and degas;
- *mobile phase B*: mix 200 mL of sulfate buffer solution pH 2.0 R, 400 mL of acetonitrile for chromatography R and 400 mL of water R; filter and degas;

Time (min)	Mobile phase A (per cent V/V)	Mobile phase B (per cent V/V)
0 - 60	90 → 30	10 → 70
60 - 65	30 → 0	70 → 100
65 - 70	0	100

*Flow rate:* 1 mL/min.

*Detection:* spectrophotometer at 214 nm.

*Equilibration:* at initial conditions for at least 15 min. Carry out a blank run using the above-mentioned gradient.

*Injection:* 50 µL.

*System suitability:*

- the chromatograms obtained with the test solution and the reference solution are qualitatively similar to the chromatogram of human insulin digest supplied with *human insulin CRS*,
- in the chromatogram obtained with the reference solution, identify the peaks due to digest fragments I, II and III:  
*symmetry factor:* maximum 1.5 for the peaks due to fragments II and III,  
*resolution:* minimum 3.4 between the peaks due to fragments II and III.

*Results:* the profile of the chromatogram obtained with the test solution corresponds to that of the chromatogram obtained with the reference solution.

*NOTE:* the retention time of fragment I is the same for porcine insulin and for human insulin. The retention times of fragments II and IV are the same for all insulins. The retention time of fragment III is the same for bovine insulin and for porcine insulin.

## TESTS

### Impurities with molecular masses greater than that of insulin.

Size-exclusion chromatography (2.2.30): use the normalisation procedure.

*Test solution.* Prepare a solution containing 4 mg/mL of the substance to be examined in 0.01 M hydrochloric acid.

*Resolution solution.* Use a solution of insulin (about 4 mg/mL), containing more than 0.4 per cent of high molecular mass proteins. An injectable insulin preparation, whether a solution or a suspension, that has been clarified with a sufficient amount of 6 M hydrochloric acid R, containing the indicated percentage of high molecular mass proteins, or a solution prepared from insulin, dissolved in 0.01 M hydrochloric acid, may be used. Insulin containing the indicated percentage of high molecular mass proteins may be prepared by allowing insulin powder to stand at room temperature for about 10 days.

Maintain the solutions at 2-8 °C and use within 7 days. If an automatic injector is used, maintain the temperature at 2-8 °C.

*Column:*

- *size:*  $l = 0.3$  m,  $\emptyset =$  minimum 7.5 mm,
- *stationary phase:* hydrophilic silica gel for chromatography R (5-10 µm) with a pore size of 12-12.5 nm, of a grade suitable for the separation of insulin monomer from dimer and polymers.

*Mobile phase:* mix 15 volumes of glacial acetic acid R, 20 volumes of acetonitrile R and 65 volumes of a 1.0 g/L solution of arginine R; filter and degas.

*Flow rate:* 0.5 mL/min.

*Detection:* spectrophotometer at 276 nm.

*Equilibration:* before using a new column for chromatographic analysis, equilibrate by repeated injections of an insulin solution containing high molecular mass proteins. This can be done by at least 3 injections of the resolution solution. The column is equilibrated when repeatable results are obtained from 2 subsequent injections.

*Injection:* 100 µL.

*Run time:* about 35 min.

*Retention time:* polymeric insulin complexes = 13-17 min; covalent insulin dimer = about 17.5 min; insulin monomer = about 20 min; salts = about 22 min.

*System suitability:* resolution solution:

- *peak-to-valley ratio:* minimum 2.0, where  $H_p$  = height above the baseline of the peak due to the dimer and  $H_v$  = height above the baseline of the lowest point of the curve separating this peak from the peak due to the monomer.

*Limits:* the sum of the areas of any peaks with a retention time less than that of the principal peak is not greater than 1.0 per cent of the total area of the peaks. Disregard any peak with a retention time greater than that of the peak due to insulin.

**Related proteins.** Liquid chromatography (2.2.29) as described under Assay, following the elution conditions as described below:

Time (min)	Mobile phase A (per cent V/V)	Mobile phase B (per cent V/V)
0 - 30	42	58
30 - 44	42 → 11	58 → 89
44 - 50	11	89

Maintain the solutions at 2-8 °C and use within 24 h. Perform a system suitability test (resolution, linearity) as described in the assay. If necessary, the relative proportions of the mobile phases may be adjusted to ensure complete elution of A21 desamido porcine insulin before commencement of the gradient. The profile of the gradient may also be adjusted to ensure complete elution of all insulin related impurities.

Inject 20 µL of reference solution (a), 20 µL of reference solution (b), 20 µL of reference solution (c) and 20 µL of the test solution. If necessary, adjust the injection volume to a volume between 10 µL and 20 µL in accordance with the results obtained in the test for linearity as described in the assay. Record the chromatograms for approximately 50 min. In the chromatogram obtained with reference solution (a), A21 desamido human insulin appears as a small peak after the principal peak and has a retention time of about 1.3 relative to the principal peak. In the chromatogram obtained with the test solution, the area of the peak due to A21 desamido human insulin is not greater than 2.0 per cent of the total area of the peaks; the sum of the areas of all peaks, apart from those due to human insulin and that due to A21 desamido human insulin, is not greater than 2.0 per cent of the total area of the peaks. For semisynthetic human insulin only: in the chromatogram obtained with the test solution, the area of any peak corresponding to the principal peak in the chromatogram obtained with reference solution (b) is not greater than the area of the corresponding peak in the chromatogram obtained with reference solution (c) (1.0 per cent of porcine insulin in human insulin).

*The following test applies only to human insulin produced by enzymatic modification of porcine insulin.*

**Proinsulin-like immunoreactivity (PLI):** maximum 10 ppm, calculated with reference to the dried substance and determined by a suitably sensitive immunochemical method (2.7.1) such as radio-immunoassay. Use the International Reference Reagent for porcine proinsulin to calibrate the method.

**Zinc:** maximum 1.0 per cent (dried substance).

Atomic absorption spectrometry (2.2.23, Method I).

*Test solution.* Dissolve 50.0 mg of the substance to be examined in 0.01 M hydrochloric acid and dilute to 25.0 mL with the same acid. Dilute if necessary to a suitable concentration (for example, 0.4-1.6 µg of Zn per millilitre) with 0.01 M hydrochloric acid.

*Reference solutions.* Use solutions containing 0.40 µg, 0.80 µg, 1.00 µg, 1.20 µg and 1.60 µg of Zn per millilitre, freshly prepared by diluting zinc standard solution (5 mg/mL Zn) R with 0.01 M hydrochloric acid.

*Source:* zinc hollow-cathode lamp.



*Wavelength*: 213.9 nm.

*Atomisation device*: air-acetylene flame of suitable composition (for example, 11 L of air and 2 L of acetylene per minute).

**Loss on drying** (2.2.32): maximum 10.0 per cent, determined on 0.200 g by drying in an oven at 105 °C for 24 h.

**Sulfated ash** (2.4.14): maximum 2.5 per cent, determined on 0.200 g (dried substance).

**Bacterial endotoxins** (2.6.14): less than 10 IU/mg, if intended for use in the manufacture of parenteral preparations without a further appropriate procedure for removal of bacterial endotoxins.

#### ASSAY

Liquid chromatography (2.2.29).

*Test solution*. Dissolve 40.0 mg of the substance to be examined in 0.01 M hydrochloric acid and dilute to 10.0 mL with the same solvent.

*Reference solution (a)*. Dissolve the contents of a vial of human insulin CRS in 0.01 M hydrochloric acid to obtain a concentration of 4.0 mg/mL.

*Reference solution (b)*. Dissolve the contents of a vial of porcine insulin CRS in 0.01 M hydrochloric acid to obtain a concentration of 4.0 mg/mL.

*Reference solution (c)*. Dilute 1.0 mL of reference solution (b) to 50.0 mL with 0.01 M hydrochloric acid. To 1.0 mL of this solution add 1.0 mL of reference solution (a).

*Reference solution (d)*. Dilute 1.0 mL of reference solution (a) to 10.0 mL with 0.01 M hydrochloric acid.

*Resolution solution*. Mix 1.0 mL of reference solution (a) and 1.0 mL of reference solution (b).

Maintain the solutions at 2-8 °C and use within 48 h. If an automatic injector is used, maintain at 2-8 °C.

*Column*:

- size:  $l = 0.25$ ,  $\varnothing = 4.6$  mm,
- stationary phase: octadecylsilyl silica gel for chromatography R (5  $\mu\text{m}$ ),
- temperature: 40 °C.

*Mobile phase*: mix 42 volumes of mobile phase A and 58 volumes of mobile phase B, adjusting the composition of the mixture if necessary.

Prepare and maintain the following solutions at a temperature of at least 20 °C:

- *mobile phase A*: dissolve 28.4 g of anhydrous sodium sulfate R in water R and dilute to 1000 mL with the same solvent; add 2.7 mL of phosphoric acid R; adjust to pH 2.3, if necessary, with ethanolamine R; filter and degas;
- *mobile phase B*: mix 550 mL of mobile phase A with 450 mL of acetonitrile R. Warm the solution to a temperature of at least 20 °C in order to avoid precipitation (mixing of mobile phase A with acetonitrile is endothermic); filter and degas.

*Flow rate*: 1 mL/min.

*Detection*: spectrophotometer at 214 nm.

*System suitability*:

- *resolution*: inject 20  $\mu\text{L}$  of the resolution solution and 20  $\mu\text{L}$  of reference solution (b). Record the chromatogram of the resolution solution until the peak corresponding to the principal peak in the chromatogram obtained with reference solution (b) is clearly visible. In the chromatogram obtained with the resolution solution, identify the peaks due to porcine insulin and human insulin. The test is not valid unless the resolution between the peaks due to human insulin and porcine insulin is at least 1.2. If necessary, adjust the concentration of acetonitrile in the mobile phase until this resolution is achieved.

- *linearity*: inject 20  $\mu\text{L}$  each of reference solutions (a) and (d). The test is not valid unless the area of the principal peak in the chromatogram obtained with reference solution (a) is  $10 \pm 0.5$  times the area of the principal peak in the chromatogram obtained with reference solution (d). If this test fails, adjust the injection volume to between 10  $\mu\text{L}$  and 20  $\mu\text{L}$ , in order that the responses are within the linearity range of the detector.

*Injection*: 20  $\mu\text{L}$  of the test solution and reference solution (a). Calculate the content of human insulin  $\text{C}_{257}\text{H}_{383}\text{N}_{65}\text{O}_{77}\text{S}_6$  plus A21 desamido human insulin using the areas of the corresponding peaks in the chromatograms obtained with the test solution and reference solution (a) and the declared content of human insulin plus A21 desamido human insulin in human insulin CRS.

#### STORAGE

In an airtight container, protected from light, at  $-18$  °C or below, until released by the manufacturer. When thawed, insulin is stored at  $5 \pm 3$  °C and used for manufacturing preparations within a short period of time. To avoid absorption of humidity from the air during weighing, the insulin must be at room temperature.

#### LABELLING

The label states whether the substance is produced by enzymatic modification of porcine insulin or by rDNA technology.

01/2008:0831  
corrected 6.0

## INSULIN INJECTION, BIPHASIC

### Insulinum biphasicum iniectionabile

*Biphasic insulin injection complies with the monograph on Insulin preparations, injectable (0854) with the amendments prescribed below.*

#### DEFINITION

Biphasic insulin injection is a sterile suspension of crystals containing bovine insulin in a solution of porcine insulin.

#### CHARACTERS

A white or almost white suspension. When examined under a microscope, the majority of the particles are seen to be rhombohedral crystals, with a maximum dimension measured from corner to corner through the crystal greater than 10  $\mu\text{m}$  but rarely exceeding 40  $\mu\text{m}$ .

#### IDENTIFICATION

Examine the chromatograms obtained in the assay. The position of the peaks due to the two insulins in the chromatogram obtained with the test solution correspond to those of the principal peaks in the chromatogram obtained with the appropriate reference solution.

#### TESTS

**pH** (2.2.3). The pH of the suspension to be examined is 6.6 to 7.2.

**Insulin in the supernatant**: 22.0 per cent to 28.0 per cent of insulin in solution. Determine by the method described in the test for insulin in the supernatant in the monograph on *Insulin preparations, injectable (0854)*.

**Total zinc**: 26.0  $\mu\text{g}$  to 37.5  $\mu\text{g}$  per 100 IU of insulin. Determine by the method described in the monograph on *Insulin preparations, injectable (0854)*.

01/2008:0832  
corrected 6.0

## INSULIN INJECTION, BIPHASIC ISOPHANE

### Insulinum isophanum biphasicum iniectionabile

*Biphasic isophane insulin injection complies with the monograph on Insulin preparations, injectable (0854) with the exception of the test for Insulin in the supernatant and with the amendments prescribed below for the other tests.*

#### DEFINITION

Biphasic isophane insulin injection is a sterile buffered suspension of either porcine or human insulin, complexed with protamine sulfate or another suitable protamine, in a solution of insulin of the same species.

#### PRODUCTION

Biphasic isophane insulin injection is prepared by carrying out the procedures described in the monograph on *Insulin preparations, injectable (0854)*.

Biphasic isophane insulin injection is produced by mixing, in defined ratios, soluble insulin injection and isophane insulin injection. The defined ratios shall be demonstrated by a test method which has been approved by the competent authority to comply with the label claim.

#### CHARACTERS

A white or almost white suspension which on standing deposits a white or almost white sediment and leaves a colourless or almost colourless supernatant liquid; the sediment is readily resuspended by gently shaking. When examined under a microscope, the particles are seen to be rod-shaped crystals, the majority with a maximum dimension greater than 1 µm but rarely exceeding 60 µm, free from large aggregates.

#### IDENTIFICATION

Examine the chromatograms obtained in the Assay. The position of the peak due to insulin in the chromatogram obtained with the test solution corresponds to that of the principal peak obtained with the appropriate reference solution.

#### TESTS

**Total zinc.** Not more than 40.0 µg per 100 IU of insulin, determined as described in the monograph on *Insulin preparations, injectable (0854)*.

#### LABELLING

The label states in addition to the indications mentioned in the monograph on *Insulin preparations, injectable (0854)* the ratio of soluble insulin injection to isophane insulin injection used in the manufacturing process of biphasic isophane insulin injection.

01/2008:0833  
corrected 6.0

## INSULIN INJECTION, ISOPHANE

### Insulinum isophanum iniectionabile

*Isophane insulin injection complies with the monograph on Insulin preparations, injectable (0854) with the modifications prescribed below.*

#### DEFINITION

Isophane insulin injection is a sterile suspension of bovine, porcine or human insulin, complexed with protamine sulfate or another suitable protamine.

#### PRODUCTION

Isophane insulin injection is prepared by carrying out the procedures described in the monograph on *Insulin preparations, injectable (0854)*.

The amount of protamine is based on the known isophane ratio and is not less than the equivalent of 0.3 mg and not more than the equivalent of 0.6 mg of protamine sulfate for each 100 IU of insulin in the insulin-protamine complex.

#### CHARACTERS

A white or almost white suspension which on standing deposits a white or almost white sediment and leaves a colourless or almost colourless supernatant liquid; the sediment is readily resuspended by gently shaking. When examined under a microscope, the particles are seen to be rod-shaped crystals, the majority with a maximum dimension greater than 1 µm but rarely exceeding 60 µm, free from large aggregates.

#### IDENTIFICATION

Examine the chromatograms obtained in the Assay. The position of the peak due to insulin in the chromatogram obtained with the test solution corresponds to that of the principal peak in the chromatogram obtained with the appropriate reference solution.

#### TESTS

**Total zinc.** Not more than 40.0 µg per 100 IU of insulin, determined as described in the monograph on *Insulin preparations, injectable (0854)*.

01/2008:0834

## INSULIN INJECTION, SOLUBLE

### Insulinum solubile iniectionabile

*Soluble insulin injection complies with the monograph on Insulin preparations, injectable (0854) with the amendments prescribed below.*

#### DEFINITION

Soluble insulin injection is a neutral, sterile solution of bovine, porcine or human insulin.

#### CHARACTERS

A colourless liquid, free from turbidity and foreign matter; during storage, traces of a very fine sediment may be deposited.

#### IDENTIFICATION

Examine the chromatograms obtained in the assay. The position of the peak due to insulin in the chromatogram obtained with the test solution corresponds to that of the principal peak obtained with the appropriate reference solution.

#### TESTS

**Total zinc.** Not more than 40.0 µg per 100 IU of insulin.

Determine by the method described in the monograph on *Insulin preparations, injectable (0854)*.

*Use the following test solution.*

**Test solution.** Dilute a volume of the gently shaken preparation containing 200 IU to 25.0 mL with *water R*. Dilute if necessary to a suitable concentration (for example, 0.4 µg to 1.6 µg of Zn per millilitre) with *water R*.

01/2008:2085  
corrected 6.0

## INSULIN LISPRO

## Insulinum lisprum

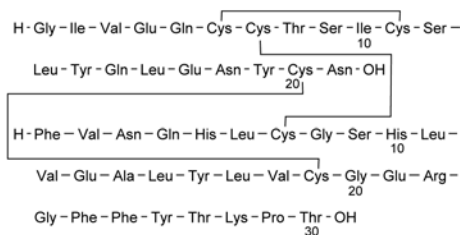
 $C_{257}H_{383}N_{65}O_{77}S_6$  $M_r$  5808

## DEFINITION

28<sup>B</sup>-L-Lysine-29<sup>B</sup>-L-proline insulin (human).

Insulin lispro is a 2-chain peptide containing 51 amino acids. The A-chain is composed of 21 amino acids and the B-chain is composed of 30 amino acids. It is identical in primary structure to human insulin, only differing in amino acid sequence at positions 28 and 29 of the B-chain. Human insulin is Pro(B28), Lys(B29), whereas insulin lispro is Lys(B28), Pro(B29). As in human insulin, insulin lispro contains 2 interchain disulfide bonds and 1 intrachain disulfide bond.

**Content:** 94.0 per cent to 104.0 per cent (dried substance).

By convention, for the purpose of labelling insulin lispro preparations, 0.0347 mg of insulin lispro is equivalent to 1 unit.

## PRODUCTION

Insulin lispro is produced by a method based on recombinant DNA (rDNA) technology under conditions designed to minimise the degree of microbial contamination.

Prior to release the following tests are carried out on each batch of final bulk product, unless exemption has been granted by the competent authority.

**Host-cell-derived proteins.** The limit is approved by the competent authority.

**Single-chain precursor.** The limit is approved by the competent authority. Use a suitably sensitive method.

## CHARACTERS

**Appearance:** white or almost white powder.

**Solubility:** practically insoluble in water and in ethanol (96 per cent). It dissolves in dilute mineral acids and with decomposition in dilute solutions of alkali hydroxides.

## IDENTIFICATION

A. Examine the chromatograms obtained in the assay.

**Results:** the principal peak in the chromatogram obtained with the test solution is similar in retention time to the principal peak in the chromatogram obtained with the reference solution.

B. Peptide mapping (2.2.55).

## SELECTIVE CLEAVAGE OF THE PEPTIDE BONDS

**Test solution.** Prepare a 2.0 mg/mL solution of the substance to be examined in 0.01 M hydrochloric acid and transfer 500 µL of this solution to a clean tube. Add 2.0 mL of HEPES buffer solution pH 7.5 R and 400 µL of a 1 mg/mL solution of *Staphylococcus aureus* strain V8 protease, type XVII-B R. Cap the tube and incubate at 25 °C for 6 h. Stop the reaction by adding 2.9 mL of sulfate buffer solution pH 2.0 R.

**Reference solution.** Prepare at the same time and in the same manner as for the test solution but using insulin lispro CRS instead of the substance to be examined.

**CHROMATOGRAPHIC SEPARATION.** Liquid chromatography (2.2.29).

**Column:**

- size:  $l = 0.10$  m,  $\varnothing = 4.6$  mm,
- stationary phase: octadecylsilyl silica gel for chromatography R (3 µm) with a pore size of 8 nm,
- temperature: 40 °C.

**Mobile phase:**

- mobile phase A: mix 100 mL of acetonitrile for chromatography R, 200 mL of sulfate buffer solution pH 2.0 R and 700 mL of water R; filter and degas;
- mobile phase B: mix 200 mL of sulfate buffer solution pH 2.0 R, 400 mL of acetonitrile for chromatography R and 400 mL of water R; filter and degas;

Time (min)	Mobile phase A (per cent V/V)	Mobile phase B (per cent V/V)
0 - 60	90 → 30	10 → 70
60 - 65	30 → 0	70 → 100
65 - 70	0	100

**Flow rate:** 1 mL/min.

**Detection:** spectrophotometer at 214 nm.

**Equilibration:** at initial conditions for at least 15 min. Carry out a blank run using the above-mentioned gradient.

**Injection:** 50 µL.

**System suitability:**

- the chromatograms obtained with the test solution and the reference solution are qualitatively similar to the chromatogram of insulin lispro digest supplied with insulin lispro CRS,
- in the chromatogram obtained with the reference solution, identify the peaks due to digest fragments I, II and III:
  - symmetry factor:** maximum 1.5 for the peaks due to fragments II and III,
  - resolution:** minimum 8.0 between the peaks due to fragments II and III.

**Results:** the profile of the chromatogram obtained with the test solution corresponds to that of the chromatogram obtained with the reference solution.

**NOTE:** the retention times of fragments I, II and IV are the same as for human insulin. The retention time of fragment III differs from human insulin due to differences in sequence at positions 28 and 29 of the B-chain.

## TESTS

**Impurities with molecular masses greater than that of insulin lispro.** Size-exclusion chromatography (2.2.30): use the normalisation procedure.

**Test solution.** Prepare a solution containing 4 mg/mL of the substance to be examined in 0.01 M hydrochloric acid. Maintain the solution at 2-8 °C and use within 48 h.

**Resolution solution.** Use a solution of insulin (about 4 mg/mL), containing more than 0.4 per cent of high molecular mass proteins. An injectable insulin preparation, whether a solution or a suspension, that has been clarified with a sufficient amount of 6 M hydrochloric acid R, containing the indicated percentage of high molecular mass proteins, or a solution prepared from insulin, dissolved in 0.01 M hydrochloric acid, may be used. Insulin containing the indicated percentage of high molecular mass proteins may be prepared by allowing insulin powder to stand at room temperature for about 10 days. Maintain the solution at 2-8 °C and use within 8 days.

**Column:**

- size:  $l = 0.30$  m,  $\varnothing = 7.8$  mm,

- *stationary phase: hydrophilic silica gel for chromatography R* (5-10 µm) with a pore size of 12-12.5 nm, of a grade suitable for the separation of insulin monomer from dimer and polymers.

*Mobile phase:* mix 15 volumes of *glacial acetic acid R*, 20 volumes of *acetonitrile for chromatography R* and 65 volumes of a 1.0 g/L solution of *arginine R*; filter and degas.

*Flow rate:* 0.5 mL/min.

*Detection:* spectrophotometer at 276 nm.

*Equilibration:* at least 3 injections of the resolution solution; the column is equilibrated when repeatable results are obtained for 2 subsequent injections.

*Injection:* 100 µL.

*Run time:* about 35 min.

*Retention time:* insulin lispro polymers = 13-17 min; insulin lispro dimer = about 17.5 min; insulin lispro monomer = about 20 min; salts = about 22 min.

*System suitability:* resolution solution:

- *peak-to-valley ratio:* minimum 2.0, where  $H_p$  = height above the baseline of the peak due to the dimer and  $H_v$  = height above the baseline of the lowest point of the curve separating this peak from the peak due to the monomer,
- *symmetry factor:* maximum 2.0 for the peak due to insulin lispro.

*Limits:* the sum of the areas of the peaks with a retention time less than that of the principal peak is not more than 0.25 per cent of the total area of the peaks. Disregard any peak with a retention time greater than that of the peak due to insulin lispro monomer.

**Related proteins.** Liquid chromatography (2.2.29): use the normalisation procedure.

*Test solution.* Dissolve 3.5 mg of the substance to be examined in 1.0 mL of 0.01 M hydrochloric acid. Maintain the solution at 2-8 °C and use within 56 h.

*Resolution solution.* Dissolve 3.5 mg of the substance to be examined in 1.0 mL of 0.01 M hydrochloric acid. Allow to stand at room temperature to obtain a solution containing between 0.8 per cent and 11 per cent of A21 desamido insulin lispro.

*Column:*

- *size:*  $l = 0.25$  m,  $\emptyset = 4.6$  mm,
- *stationary phase: octadecylsilyl silica gel for chromatography R* (5 µm) with a pore size of 30 nm,
- *temperature:* 40 °C.

*Mobile phase:*

- *mobile phase A:* mix 82 volumes of a 28.4 g/L solution of *anhydrous sodium sulfate R* adjusted to pH 2.3 with *phosphoric acid R* and 18 volumes of *acetonitrile for chromatography R*; filter and degas;
- *mobile phase B:* mix equal volumes of a 28.4 g/L solution of *anhydrous sodium sulfate R* adjusted to pH 2.3 with *phosphoric acid R* and *acetonitrile for chromatography R*; filter and degas;

Time (min)	Mobile phase A (per cent V/V)	Mobile phase B (per cent V/V)
0 - 60	81	19
60 - 83	81 → 51	19 → 49
83 - 84	51 → 81	49 → 19
84 - 94	81	19

*Flow rate:* 1 mL/min.

*Detection:* spectrophotometer at 214 nm.

*Injection:* 20 µL.

*Retention time:* adjust the mobile phase composition to obtain a retention time of about 41 min for insulin lispro; A21 desamido insulin lispro elutes near the start of the gradient elution.

*System suitability:* resolution solution:

- *resolution:* minimum 1.5 between the 1<sup>st</sup> peak (insulin lispro) and the 2<sup>nd</sup> peak (A21 desamido insulin lispro),
- *symmetry factor:* maximum 2.0 for the peak due to insulin lispro.

*Limits:*

- *A21 desamido insulin lispro:* maximum 1.0 per cent,
- *any other impurity:* maximum 0.50 per cent,
- *total (excluding A21):* maximum 2.0 per cent.

**Zinc:** maximum 1.0 per cent (dried substance).

Atomic absorption spectrometry (2.2.23, Method I).

*Test solution.* Dissolve at least 50 mg of the substance to be examined in 0.01 M hydrochloric acid and dilute to 25 mL with the same acid. Dilute if necessary to a suitable concentration (for example 0.4-0.6 µg of Zn per millilitre) with 0.01 M hydrochloric acid.

*Reference solutions.* Use solutions of concentrations which bracket the expected zinc concentration of the samples, for example, 0.2-0.8 µg of Zn per millilitre, freshly prepared by diluting zinc standard solution (5 mg/mL Zn) R with 0.01 M hydrochloric acid.

*Source:* zinc hollow-cathode lamp.

*Wavelength:* 213.9 nm.

*Atomisation device:* air-acetylene flame of suitable composition (for example, 11 L of air and 2 L of acetylene per minute).

**Loss on drying (2.2.32):** maximum 10.0 per cent, determined on 0.200 g by drying in an oven at 105 °C for 16 h.

**Sulfated ash (2.4.14):** maximum 2.5 per cent, determined on 0.200 g (dried substance).

**Bacterial endotoxins (2.6.14, Method D):** less than 10 IU/mg, if intended for use in the manufacture of parenteral preparations without a further appropriate procedure for the removal of bacterial endotoxins.

#### ASSAY

Liquid chromatography (2.2.29).

*Test solution.* Dissolve the substance to be examined in 0.01 M hydrochloric acid to obtain a concentration of 0.8 mg/mL. Maintain the solution at 2-8 °C and use within 48 h.

*Reference solution.* Dissolve the contents of a vial of *insulin lispro CRS* in 0.01 M hydrochloric acid to obtain a concentration of 0.8 mg/mL. Maintain the solution at 2-8 °C and use within 48 h.

*Resolution solution.* Dissolve about 10 mg of the substance to be examined in 10 mL of 0.01 M hydrochloric acid. Allow to stand at room temperature to obtain a solution containing between 0.8 per cent and 11 per cent of A21 desamido insulin lispro. Maintain the solution at 2-8 °C and use within 14 days.

*Column:*

- *size:*  $l = 0.10$  m,  $\emptyset = 4.6$  mm,
- *stationary phase: octadecylsilyl silica gel for chromatography R* (3 µm) with a pore size of 8 nm,
- *temperature:* 40 °C.

*Mobile phase:* mix 745 volumes of a 28.4 g/L solution of *anhydrous sodium sulfate R* adjusted to pH 2.3 with *phosphoric acid R* and 255 volumes of *acetonitrile for chromatography R*; filter and degas.

*Flow rate:* 0.8 mL/min.

*Detection:* spectrophotometer at 214 nm.

*Injection:* 20 µL.

*Retention time:* insulin lispro = about 24 min.

*System suitability:*

- *resolution:* minimum 1.8 between the 1<sup>st</sup> peak (insulin lispro) and the 2<sup>nd</sup> peak (A21 desamido insulin lispro), in the chromatogram obtained with the resolution solution,
- *repeatability:* maximum relative standard deviation of 1.1 per cent after 3 injections of the reference solution.

Calculate the content of insulin lispro  $C_{257}H_{383}N_{65}O_{77}S_6$  using the chromatograms obtained with the test solution and the reference solution and the declared content of  $C_{257}H_{383}N_{65}O_{77}S_6$  in *insulin lispro CRS*.

#### STORAGE

In an airtight container, protected from light, at or below  $-18\text{ }^{\circ}\text{C}$ . When thawed, insulin lispro is stored and weighed under conditions defined by the manufacturer to maintain the quality attributes of the drug substance and is used for manufacturing preparations within a short period of time. To avoid absorption of humidity from the air during weighing, insulin lispro must be at room temperature before opening the container.

01/2008:1638

## INSULIN, PORCINE

### Insulinum porcinum

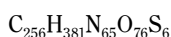
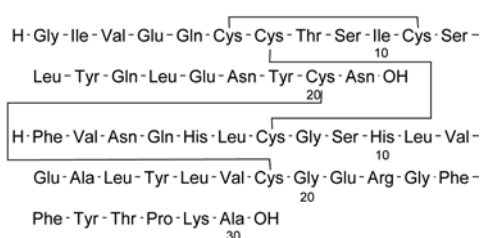
 $M_r$  5778

#### DEFINITION

Porcine insulin is the natural antidiabetic principle obtained from pork pancreas and purified.

#### Content:

- *sum of porcine insulin* ( $C_{256}H_{381}N_{65}O_{76}S_6$ ) and *A21 desamido porcine insulin*: 95.0 per cent to 105.0 per cent (dried substance).

By convention, for the purpose of labelling insulin preparations, 0.0345 mg of porcine insulin is equivalent to 1 IU of insulin.

#### PRODUCTION

The animals from which porcine insulin is derived must fulfil the requirements for the health of animals suitable for human consumption.

#### CHARACTERS

*Appearance*: white or almost white powder.

*Solubility*: practically insoluble in water and in ethanol. It dissolves in dilute mineral acids and with decomposition in dilute solutions of alkali hydroxides.

#### IDENTIFICATION

- A. Examine the chromatograms obtained in the assay.

*Results*: the retention time of the principal peak in the chromatogram obtained with the test solution corresponds to that of the principal peak in the chromatogram obtained with reference solution (b).

- B. Peptide mapping.

*Test solution*. Prepare a 2.0 mg/mL solution of the substance to be examined in 0.01 M hydrochloric acid and transfer 500  $\mu\text{L}$  of this solution to a clean tube. Add 2.0 mL of HEPES buffer solution pH 7.5 R and 400  $\mu\text{L}$  of a 1 mg/mL solution of *Staphylococcus aureus strain V8 protease, type XVII-B R*. Cap the tube and incubate at 25  $^{\circ}\text{C}$  for 6 h. Stop the reaction by adding 2.9 mL of sulfate buffer solution pH 2.0 R.

*Reference solution*. Prepare at the same time and in the same manner as for the test solution but using *porcine insulin CRS* instead of the substance to be examined.

Examine the digests by liquid chromatography (2.2.29).

#### Column:

- *size*:  $l = 0.10\text{ m}$ ,  $\varnothing = 4.6\text{ mm}$ ;
- *stationary phase*: octadecylsilyl silica gel for chromatography R (3  $\mu\text{m}$ );
- *temperature*: 40  $^{\circ}\text{C}$ .

#### Mobile phase:

- *mobile phase A*: mix 100 mL of acetonitrile for chromatography R, 700 mL of water R and 200 mL of sulfate buffer solution pH 2.0 R; filter and degas;
- *mobile phase B*: mix 400 mL of acetonitrile for chromatography R, 400 mL of water R and 200 mL of sulfate buffer solution pH 2.0 R; filter and degas;

Time (min)	Mobile phase A (per cent V/V)	Mobile phase B (per cent V/V)
0 - 60	90 $\rightarrow$ 30	10 $\rightarrow$ 70
60 - 65	30 $\rightarrow$ 0	70 $\rightarrow$ 100
65 - 70	0	100

*Flow rate*: 1 mL/min.

*Detection*: spectrophotometer at 214 nm.

*Equilibration*: at initial conditions for at least 15 min. Carry out a blank run using the above-mentioned gradient.

*Injection*: 50  $\mu\text{L}$ .

*System suitability*: the chromatograms obtained with the test solution and the reference solution are qualitatively similar to the chromatogram of porcine insulin digest supplied with *porcine insulin CRS*. In the chromatogram obtained with the reference solution, identify the peaks due to digest fragments I, II and III. The symmetry factor of the peaks due to fragments II and III is not greater than 1.5, and the resolution between the 2 peaks is at least 1.9.

*Results*: the profile of the chromatogram obtained with the test solution corresponds to that of the chromatogram obtained with the reference solution.

*NOTE*: the retention time of fragment I is the same for porcine insulin and for human insulin. The retention times of fragments II and IV are the same for all insulins. The retention time of fragment III is the same for bovine insulin and for porcine insulin.

#### TESTS

##### Impurities with molecular masses greater than that of insulin.

Size-exclusion chromatography (2.2.30): use the normalisation procedure. Maintain the solutions at 2-10  $^{\circ}\text{C}$  and use within 7 days. If an automatic injector is used, maintain the temperature at 2-10  $^{\circ}\text{C}$ .

*Test solution*. Dissolve 4 mg of the substance to be examined in 1.0 mL of 0.01 M hydrochloric acid.

*Resolution solution*. Use a solution of insulin (approximately 4 mg/mL), containing more than 0.4 per cent of high molecular mass proteins. An injectable insulin preparation, whether a solution or a suspension, that has been clarified with a sufficient amount of 6 M hydrochloric acid R, containing the indicated percentage of high molecular mass proteins, or a solution prepared from insulin, dissolved in 0.01 M hydrochloric acid, may be used. Insulin containing the indicated percentage of high molecular mass proteins may be prepared by allowing insulin powder to stand at room temperature for about 10 days.

#### Column:

- *size*:  $l = 0.3\text{ m}$ ,  $\varnothing =$  at least 7.5 mm;
- *stationary phase*: hydrophilic silica gel for chromatography R (5-10  $\mu\text{m}$ ), of a grade suitable for the separation of insulin monomer from dimer and polymers.

*Mobile phase*: mix 15 volumes of glacial acetic acid R, 20 volumes of acetonitrile R and 65 volumes of a 1.0 g/L solution of arginine R; filter and degas.

*Flow rate*: 0.5 mL/min.

*Detection*: spectrophotometer at 276 nm.

*Equilibration*: before using a new column for chromatographic analysis, equilibrate by repeated injections of an insulin solution containing high molecular mass proteins. This can be done by at least 3 injections of the resolution solution. The column is equilibrated when repeatable results are obtained from 2 subsequent injections.

*Injection*: 100 µL.

*Run time*: about 35 min.

*Retention times*: polymeric insulin complexes = 13 min to 17 min; covalent insulin dimer = about 17.5 min; insulin monomer = about 20 min; salts = about 22 min.

*System suitability*: resolution solution:

- *peak-to-valley ratio*: minimum 2.0, where  $H_p$  = height above the baseline of the peak due to the dimer and  $H_v$  = height above the baseline of the lowest point of the curve separating this peak from the peak due to the monomer.

*Limits*: the sum of the areas of any peaks with a retention time less than that of the principal peak is not greater than 1.0 per cent of the total area of the peaks; disregard any peak with a retention time greater than that of the insulin peak.

**Related proteins.** Liquid chromatography (2.2.29) as described under Assay, following the elution conditions as described in the table below.

Time (min)	Mobile phase A (per cent V/V)	Mobile phase B (per cent V/V)
0 - 30	42	58
30 - 44	42 → 11	58 → 89
44 - 50	11	89

Maintain the solutions at 2-10 °C and use within 24 h.

Perform a system suitability test (resolution, linearity) as described under Assay. If necessary, the relative proportions of the mobile phases may be adjusted to ensure complete elution of A21 desamido porcine insulin before commencement of the gradient. The profile of the gradient may also be adjusted to ensure complete elution of all insulin related impurities.

Inject 20 µL of reference solution (b) and 20 µL of the test solution. If necessary, adjust the injection volume to between 10 µL and 20 µL in accordance with the results obtained in the test for linearity as described under Assay. Record the chromatograms for approximately 50 min. In the chromatogram obtained with reference solution (b), A21 desamido porcine insulin appears as a small peak after the principal peak and has a relative retention of about 1.3 with reference to the principal peak. In the chromatogram obtained with the test solution, the area of the peak due to A21 desamido porcine insulin is not greater than 2.0 per cent of the total area of the peaks; the sum of the areas of all the peaks, apart from those due to porcine insulin and A21 desamido porcine insulin, is not greater than 2.0 per cent of the total area of the peaks.

**Porcine proinsulin-like immunoreactivity (PLI)**: maximum 10 ppm (dried substance).

Use a suitably sensitive immunochemical method (2.7.1) such as radio-immunoassay, using the International Reference Reagent for porcine proinsulin to calibrate the method.

**Zinc**: maximum 1.0 per cent (dried substance).

Atomic absorption spectrometry (2.2.23, Method D).

*Test solution.* Dissolve 50.0 mg of the substance to be examined in 0.01 M hydrochloric acid and dilute to 25.0 mL with the same acid. Dilute if necessary to a suitable concentration (for example, 0.4 µg to 1.6 µg of Zn per millilitre) with 0.01 M hydrochloric acid.

*Reference solutions.* Use solutions containing 0.40 µg, 0.80 µg, 1.00 µg, 1.20 µg and 1.60 µg of Zn per millilitre, freshly prepared by diluting zinc standard solution (5 mg/mL Zn) R with 0.01 M hydrochloric acid.

*Source*: zinc hollow-cathode lamp.

*Wavelength*: 213.9 nm.

*Flame*: air-acetylene flame of suitable composition (for example, 11 L of air and 2 L of acetylene per minute).

**Loss on drying** (2.2.32): maximum 10.0 per cent, determined on 0.200 g by drying in an oven at 105 °C for 24 h.

**Sulfated ash** (2.4.14): maximum 2.5 per cent (dried substance), determined on 0.200 g.

**Bacterial endotoxins** (2.6.14): less than 10 IU/mg, if intended for use in the manufacture of parenteral preparations without a further appropriate procedure for the removal of bacterial endotoxins.

#### ASSAY

Liquid chromatography (2.2.29).

*Test solution.* Dissolve 40.0 mg of the substance to be examined in 0.01 M hydrochloric acid and dilute to 10.0 mL with the same solvent.

*Reference solution (a).* Dissolve the contents of a vial of human insulin CRS in 0.01 M hydrochloric acid to obtain a concentration of 4.0 mg/mL.

*Reference solution (b).* Dissolve the contents of a vial of porcine insulin CRS in 0.01 M hydrochloric acid to obtain a concentration of 4.0 mg/mL.

*Reference solution (c).* Dilute 1.0 mL of reference solution (b) to 10.0 mL with 0.01 M hydrochloric acid.

*Resolution solution.* Mix 1.0 mL of reference solution (a) and 1.0 mL of reference solution (b).

Maintain the solutions at 2-10 °C and use within 48 h. If an automatic injector is used, maintain the temperature at 2-10 °C.

*Column*:

- *size*:  $l = 0.25$ ,  $\emptyset = 4.6$  mm;
- *stationary phase*: octadecylsilyl silica gel for chromatography R (5 µm);
- *temperature*: 40 °C.

*Mobile phase*: mix 42 volumes of mobile phase A and 58 volumes of mobile phase B, adjusting the composition of the mixture if necessary.

Prepare and maintain the following solutions at a temperature of at least 20 °C:

- *mobile phase A*: dissolve 28.4 g of anhydrous sodium sulfate R in water R and dilute to 1000 mL with the same solvent; add 2.7 mL of phosphoric acid R; adjust to pH 2.3, if necessary, with ethanalamine R; filter and degas;
- *mobile phase B*: mix 550 mL of mobile phase A with 450 mL of acetonitrile R. Warm the solution to a temperature of at least 20 °C in order to avoid precipitation (mixing of mobile phase A with acetonitrile is endothermic); filter and degas.

*Flow rate*: 1 mL/min.

*Detection*: spectrophotometer at 214 nm.

*System suitability*:

- *resolution*: inject 20 µL of the resolution solution and 20 µL of reference solution (b). Record the chromatogram of the resolution solution until the peak corresponding to the principal peak in the chromatogram obtained with reference solution (b) is clearly visible. In the chromatogram obtained with the resolution solution, identify the peaks due to porcine insulin and human insulin. The test is not valid unless the resolution between the peaks corresponding to human insulin and porcine insulin is at least 1.2. If necessary, adjust the concentration of acetonitrile in the mobile phase until this resolution is achieved.
- *linearity*: inject 20 µL each of reference solutions (b) and (c). The test is not valid unless the area of the principal peak in the chromatogram obtained with reference solution (b) is  $10 \pm 0.5$  times the area of the principal peak in the chromatogram obtained with reference solution (c). If this

test fails, adjust the injection volume to between 10 µL and 20 µL, in order that the responses are within the linearity range of the detector.

**Injection:** 20 µL of the test solution.

Calculate the content of porcine insulin  $C_{256}H_{381}N_{65}O_{76}S_6$  plus A21 desamido porcine insulin from the area of the principal peak and the area of the peak corresponding to A21 desamido porcine insulin in the chromatograms obtained with the test solution and reference solution (b) and the declared content of porcine insulin plus A21 desamido porcine insulin in *porcine insulin CRS*.

#### STORAGE

In an airtight container, protected from light, at  $-20\text{ }^{\circ}\text{C}$  until released by the manufacturer. When thawed, insulin may be stored at  $5 \pm 3\text{ }^{\circ}\text{C}$  and used for manufacturing preparations within a short period of time. To avoid absorption of humidity from the air during weighing, the insulin must be at room temperature.

01/2008:0854

## INSULIN PREPARATIONS, INJECTABLE

### Praeparationes insulini iniectionabiles

*Injectable insulin preparations comply with the requirements for Injections prescribed in the monograph on Parenteral preparations (0520).*

#### DEFINITION

Injectable insulin preparations are sterile preparations of *Insulin, human (0838)*, *Insulin, bovine (1637)* or *Insulin, porcine (1638)*. They contain not less than 90.0 per cent and not more than the equivalent of 110.0 per cent of the amount of insulin stated on the label. They are either solutions or suspensions or they are prepared by combining solutions and suspensions.

#### PRODUCTION

The methods of preparation are designed to confer suitable properties with respect to the onset and duration of therapeutic action.

The following procedures are carried out in a suitable sequence, depending on the method of preparation:

- addition of suitable antimicrobial preservatives;
- addition of a suitable substance or substances to render the preparation isotonic with blood;
- addition of a suitable substance or substances to adjust the pH to the appropriate value;
- determination of the strength of the insulin-containing component or components followed, where necessary, by adjustment so that the final preparation contains the requisite number of International Units per millilitre;
- sterilisation by filtration of the insulin-containing component or components; once this procedure has been carried out all subsequent procedures are carried out aseptically using materials that have been sterilised by a suitable method.

In addition, where appropriate, suitable excipients are added and suitable procedures carried out to confer the appropriate physical form on the insulin-containing component or components. The final preparation is distributed aseptically into sterile containers which are closed so as to exclude microbial contamination.

#### TESTS

**pH (2.2.3).** The pH of the solution or suspension is 6.9 to 7.8, unless otherwise prescribed in the specific monograph.

**Insulin in the supernatant.** For injectable insulin preparations that are suspensions, not more than 2.5 per cent of the total insulin content, unless otherwise stated. Centrifuge 10 mL of

the suspension at 1500 g for 10 min and carefully separate the supernatant liquid and the residue. Determine the insulin content of the supernatant liquid (S) by a suitable method, for example using the chromatographic conditions described under Assay. Calculate the percentage of the insulin in solution from the expression:

$$\frac{100S}{T}$$

where *T* is the total insulin content determined as described under the Assay.

**Impurities with molecular masses greater than that of insulin.** Examine by size-exclusion chromatography (2.2.30).

**Test solution.** Add 4 µL of 6 M hydrochloric acid R per millilitre of the preparation to be examined, whether a suspension or a solution, to obtain a clear acid insulin solution. When sampling a suspension, agitate the material prior to sampling in order to obtain a homogeneous sample. If a suspension does not turn clear within 5 min of the initial addition of hydrochloric acid, add small aliquots of acid (less than 4 µL per millilitre) until a solution is obtained. Preparations with concentrations higher than 100 IU/mL need to be diluted with 0.01 M hydrochloric acid to avoid overloading the column with insulin monomer.

**Resolution solution.** Use a solution of insulin (approximately 4 mg/mL), containing more than 0.4 per cent of high molecular mass proteins. An injectable insulin preparation, whether a solution or a suspension, that has been clarified with a sufficient amount of 6 M hydrochloric acid R, containing the indicated percentage of high molecular mass proteins, or a solution prepared from insulin, dissolved in 0.01 M hydrochloric acid, may be used. Insulin containing the indicated percentage of high molecular mass proteins may be prepared by allowing insulin powder to stand at room temperature for about ten days.

Maintain the solutions at 2 °C to 10 °C and use within 30 h (soluble insulin injection) or 7 days (other insulin preparations). If an automatic injector is used, maintain the temperature at 2 °C to 10 °C.

The chromatographic procedure may be carried out using:

- a column 0.3 m long and at least 7.5 mm in internal diameter packed with *hydrophilic silica gel for chromatography R* (5 µm to 10 µm), of a grade suitable for the separation of insulin monomer from dimers and polymers;
- as mobile phase at a flow rate of 0.5 mL/min a mixture consisting of 15 volumes of *glacial acetic acid R*, 20 volumes of *acetonitrile R* and 65 volumes of a 1.0 g/L solution of *arginine R*; filter and degas;
- as detector a spectrophotometer set at 276 nm.

**Equilibration of the column.** Before using a new column for chromatographic analysis, equilibrate by repeated injections of an insulin solution containing high molecular mass proteins. This can be done by at least three injections of the resolution solution. The column is equilibrated when repeatable results are obtained from two subsequent injections. If protamine-containing samples are to be analysed, the equilibration of the column is performed using a solution containing protamine.

Inject 100 µL of the resolution solution. When the chromatograms are recorded under the prescribed conditions, the retention times are: polymerised insulin complexes or covalent insulin-protamine complex: about 13 min to 17 min, covalent insulin dimer: about 17.5 min, insulin monomer: about 20 min, salts: about 22 min. If the sample solution contains preservatives, for example methyl paraben, *m*-cresol or phenol, these compounds elute later. The test is not valid unless the resolution, defined by the ratio of the height of the dimer peak to the height above the baseline of the valley separating the monomer and dimer peaks, is at least 2.0.

Inject 100 µL of the test solution. Record the chromatogram for approximately 35 min. In the chromatogram obtained, the sum of the areas of any peak with a retention time less

than that of the insulin peak is not greater than 3.0 per cent (protamine containing preparations) or 2.0 per cent (non-protamine containing preparations) of the total area of the peaks. Disregard any peak with a retention time greater than that of the insulin peak.

**Related proteins.** Examine by liquid chromatography (2.2.29) as described under Assay, following the elution conditions as described in the table below:

Time (min)	Mobile phase A (per cent V/V)	Mobile phase B (per cent V/V)	Comment
0 - 30	42	58	isocratic
30 - 44	42 → 11	58 → 89	linear gradient
44 - 50	11	89	isocratic

Maintain the solutions at 2 °C to 10 °C and use within 24 h. Perform a system suitability check (resolution, linearity) as described under Assay. If necessary, the relative proportions of the mobile phases may be adjusted to ensure complete elution of A21 desamido porcine insulin before commencement of the gradient. The profile of the gradient may also be adjusted to ensure complete elution of all insulin related impurities.

Inject 20 µL of the test solution and 20 µL of either reference solution (a), for insulin preparations containing 100 IU/mL, or reference solution (b), for insulin preparations containing 40 IU/mL. If necessary, adjust the injection volume to a volume between 10 µL and 20 µL in accordance with the results obtained in the test for linearity as described under Assay. Record the chromatograms for approximately 50 min. If necessary, make further adjustments to the mobile phase in order to ensure that the antimicrobial preservatives present in the test solution are well separated from the insulin and show a shorter retention time. A small reduction in the concentration of acetonitrile increases the retention time of the insulin peaks relatively more than those of the preservatives. In the chromatogram obtained with either reference solution (a), or reference solution (b), as appropriate, A21 desamido insulin appears as a small peak after the principal peak and has a retention time of about 1.3 relative to the principal peak, due to insulin. In the chromatogram obtained with the test solution the area of the peak due to A21 desamido insulin is not greater than 5.0 per cent of the total area of the peaks; the sum of the areas of any other peaks, apart from those due to insulin and A21 desamido insulin is not greater than 6.0 per cent of the total area of the peaks. Disregard the peaks due to the preservatives and protamine (early eluting peaks).

**Total zinc.** Not more than the amount stated in the individual monograph, determined by atomic absorption spectrometry (2.2.23, Method I).

Use the following method, unless otherwise prescribed in the specific monograph.

**Test solution.** Shake the preparation gently and dilute a volume containing 200 IU of insulin to 25.0 mL with 0.01 M hydrochloric acid. Dilute if necessary to a suitable concentration of zinc (for example 0.4 µg to 1.6 µg of Zn per millilitre) with 0.01 M hydrochloric acid.

**Reference solutions.** Use solutions containing 0.40 µg, 0.80 µg, 1.00 µg, 1.20 µg and 1.60 µg of Zn per millilitre, freshly prepared by diluting zinc standard solution (5 mg/mL Zn) R with 0.01 M hydrochloric acid.

Measure the absorbance at 213.9 nm using a zinc hollow-cathode lamp as source of radiation and an air-acetylene flame of suitable composition (for example 11 L of air and 2 L of acetylene per minute).

**Zinc in solution.** Where applicable, not more than the amount stated in the individual monograph, determined by atomic absorption spectrometry (2.2.23, Method I).

**Test solution.** Centrifuge the preparation to be examined and dilute 1 mL of the clear supernatant liquid obtained to 25.0 mL

with water R. Dilute if necessary to a suitable concentration of zinc (for example 0.4 µg to 1.6 µg of Zn per millilitre) with water R.

**Reference solutions.** Use solutions containing 0.40 µg, 0.80 µg, 1.00 µg, 1.20 µg and 1.60 µg of Zn per millilitre, freshly prepared by diluting zinc standard solution (5 mg/mL Zn) R with 0.01 M hydrochloric acid.

Measure the absorbance at 213.9 nm using a zinc hollow-cathode lamp as source of radiation and an air-acetylene flame of suitable composition (for example 11 L of air and 2 L of acetylene per minute).

**Bacterial endotoxins (2.6.14):** less than 80 IU per 100 IU of insulin.

#### ASSAY

Examine by liquid chromatography (2.2.29).

**Test solution.** Add 4 µL of 6 M hydrochloric acid R per millilitre of the preparation to be examined, whether a suspension or a solution, to obtain a clear solution. When sampling a suspension, shake the material prior to sampling in order to obtain a homogeneous sample. If a suspension does not turn clear within 5 min of the initial addition of acid, add small aliquots of acid (less than 4 µL per millilitre) until a solution is obtained. For a preparation containing more than 100 IU/mL, an additional dilution with 0.01 M hydrochloric acid is necessary to avoid overloading the column.

**Reference solution (a).** For a preparation containing a single species of insulin, dissolve in 0.01 M hydrochloric acid, as appropriate, the contents of a vial of human insulin CRS, porcine insulin CRS or bovine insulin CRS to obtain a concentration of 4.0 mg/mL. For a preparation containing both bovine and porcine insulins, mix 1.0 mL of a solution containing 4.0 mg of bovine insulin CRS per millilitre of 0.01 M hydrochloric acid and 1.0 mL of a solution containing 4.0 mg of porcine insulin CRS per millilitre of 0.01 M hydrochloric acid. Reference solution (a) is used for the assay of insulin preparations containing 100 IU/mL.

**Reference solution (b).** Dilute 4.0 mL of reference solution (a) to 10.0 mL with 0.01 M hydrochloric acid. Reference solution (b) is used for the assay of insulin preparations containing 40 IU/mL.

**Reference solution (c).** Dissolve the contents of a vial of human insulin CRS in 0.01 M hydrochloric acid to obtain a concentration of 4.0 mg/mL.

**Reference solution (d).** Dissolve the contents of a vial of porcine insulin CRS in 0.01 M hydrochloric acid to obtain a concentration of 4.0 mg/mL.

**Reference solution (e).** Dilute 1.0 mL of reference solution (a) to 10.0 mL with 0.01 M hydrochloric acid.

**Reference solution (f).** Dilute 1.0 mL of reference solution (b) to 10.0 mL with 0.01 M hydrochloric acid.

**Resolution solution.** Mix 1.0 mL of reference solution (c) and 1.0 mL of reference solution (d).

Maintain the solutions at 2 °C to 10 °C and use within 48 h. If an automatic injector is used, maintain the temperature at 2 °C to 10 °C.

The chromatographic procedure may be carried out using:

- a stainless steel column 0.25 m long and 4.6 mm in internal diameter packed with octadecylsilyl silica gel for chromatography R (5 µm);
- as mobile phase at a flow rate of 1 mL/min the following solutions prepared and maintained at a temperature not lower than 20 °C:

**Mobile phase A.** Dissolve 28.4 g of anhydrous sodium sulfate R in water R and dilute to 1000 mL with the same solvent; add 2.7 mL of phosphoric acid R; adjust the pH to 2.3, if necessary, with ethanamine R; filter and degas;



*Mobile phase B.* Mix 550 mL of mobile phase A with 450 mL of *acetonitrile R*. Warm the solution to a temperature not lower than 20 °C in order to avoid precipitation (mixing of mobile phase A with acetonitrile is endothermic); filter and degas;

– as detector a spectrophotometer set at 214 nm; maintaining the temperature of the column at 40 °C.

Elute with a mixture of 42 volumes of mobile phase A and 58 volumes of mobile phase B, adjusted if necessary.

Inject 20 µL of the resolution solution and 20 µL of reference solution (d). Record the chromatogram of the resolution solution until the peak corresponding to the principal peak in the chromatogram obtained with reference solution (d) is clearly visible. In the chromatogram obtained with the resolution solution, identify the peaks due to porcine insulin and human insulin. The test is not valid unless the resolution between the peaks due to human insulin and porcine insulin is at least 1.2. If necessary, adjust the concentration of acetonitrile in the mobile phase until this resolution is achieved.

Inject 20 µL of the test solution and 20 µL of either reference solutions (a) and (e), for insulin preparations containing 100 IU/mL, or 20 µL of reference solutions (b) and (f), for insulin preparations containing 40 IU/mL. If necessary, make further adjustments of the mobile phase in order to ensure that the antimicrobial preservatives present in the test solution are well separated from the insulin and show shorter retention times. A small reduction in the concentration of acetonitrile increases the retention time of the insulin peaks relatively more than those of the preservatives. If necessary, after having carried out the chromatography of a solution wash the column with a mixture of equal volumes of *acetonitrile R* and *water R* for a sufficient time to ensure elution of any interfering substances before injecting the next solution. The test is not valid unless the area of the principal peak in the chromatogram obtained with reference solution (a) or (b) is  $10 \pm 0.5$  times the area of the principal peak in the chromatogram obtained with reference solution (e) or (f). If this test fails, adjust the injection volume between 10 µL and 20 µL, in order to be in the linearity range of the detector.

Calculate the content of insulin plus A21 desamido insulin from the area of the peak due to the bovine, porcine or human insulin and that of any peak due to the A21 desamido insulin, using the declared content of insulin plus A21 desamido insulin in *bovine insulin CRS*, *porcine insulin CRS* or *human insulin CRS*, as appropriate. For preparations containing both bovine and porcine insulin use the sum of the areas of both the bovine and porcine insulin peaks and of the peaks due to the A21 desamido insulin<sup>(1)</sup> derivatives.

#### STORAGE

Unless otherwise prescribed, store in a sterile, airtight, tamper-proof container, protected from light, at a temperature of 2 °C to 8 °C. Insulin preparations are not to be frozen.

#### LABELLING

The label states:

- the potency in International Units per millilitre;
- the concentration in terms of the number of milligrams of insulin per millilitre (for preparations containing both bovine insulin and porcine insulin the concentration is stated as the combined amount of both insulins);
- where applicable, that the substance is produced by enzymatic modification of porcine insulin;
- where applicable, that the substance is produced by recombinant DNA technology;
- where applicable, the animal species of origin;
- that the preparation must not be frozen;

– where applicable, that the preparation must be resuspended before use.

01/2008:0837  
corrected 6.0

## INSULIN ZINC INJECTABLE SUSPENSION

### Insulini zinci suspensio iniectionabilis

*Insulin zinc injectable suspension complies with the monograph on Insulin preparations, injectable (0854) with the amendments prescribed below.*

#### DEFINITION

Insulin zinc injectable suspension is a sterile neutral suspension of bovine insulin and/or porcine insulin or of human insulin with a suitable zinc salt; the insulin is in a form which is practically insoluble in water.

#### PRODUCTION

Insulin zinc injectable suspension is prepared by carrying out the procedures described in the monograph on *Insulin preparations, injectable (0854)*.

Insulin zinc injectable suspension is produced by mixing insulin zinc injectable suspension (crystalline) and insulin zinc injectable suspension (amorphous) in a ratio of 7 to 3.

#### CHARACTERS

A white or almost white suspension which on standing deposits a white or almost white sediment and leaves a colourless or almost colourless supernatant liquid; the sediment is readily resuspended by gently shaking. When examined under a microscope, the majority of the particles are seen to be rhombohedral crystals with a maximum dimension when measured from corner to corner through the crystal greater than 10 µm but rarely exceeding 40 µm; a considerable proportion of the particles are seen to have no uniform shape and a maximum dimension rarely exceeding 2 µm.

#### IDENTIFICATION

Examine the chromatograms obtained in the Assay.

For preparations made from a single species of insulin (bovine, porcine or human), the position of the peak due to insulin in the chromatogram obtained with the test solution corresponds to that of the principal peak in the chromatogram obtained with the appropriate reference solution. For preparations made from a mixture of bovine and porcine insulin, the positions of the peaks due to the two insulins in the chromatogram obtained with the test solution correspond to those of the principal peaks in the chromatogram obtained with the appropriate reference solution.

#### TESTS

**Insulin not extractable with buffered acetone solution:** 63 per cent to 77 per cent of the total insulin content. Centrifuge a volume of the substance to be examined containing 200 IU of insulin and discard the supernatant liquid. Suspend the residue in 1.65 mL of *water R*, add 3.3 mL of *buffered acetone solution R*, stir for 3 min, again centrifuge, discard the supernatant liquid and repeat all the operations with the residue. Dissolve the residue using a suitable procedure, for example dissolve in 0.1 M *hydrochloric acid* to give a final volume of 2.0 mL. Determine the insulin content of the residue (*R*) and determine the total insulin content (*T*) of an equal volume of the suspension by a suitable method. Calculate the percentage of insulin not extractable with buffered acetone solution from the expression:

$$\frac{100R}{T}$$

(1) 100 IU are equivalent to 3.47 mg of human insulin, to 3.45 mg of porcine insulin and to 3.42 mg of bovine insulin.

**Total zinc:** 0.12 mg to 0.25 mg per 100 IU of insulin, determined as described in the monograph on *Insulin preparations, injectable (0854)*.

**Zinc in solution:** 20 per cent to 65 per cent of the total zinc is in the form of zinc in solution. Determine by the method described in the monograph on *Insulin preparations, injectable (0854)*.

01/2008:0835  
corrected 6.0

### INSULIN ZINC INJECTABLE SUSPENSION (AMORPHOUS)

#### Insulini zinci amorphi suspensio iniectionabilis

*Insulin zinc injectable suspension (amorphous) complies with the monograph on Insulin preparations, injectable (0854) with the amendments prescribed below.*

**DEFINITION**

Insulin zinc injectable suspension (amorphous) is a sterile neutral suspension of bovine, porcine or human insulin complexed with a suitable zinc salt; the insulin is in a form which is practically insoluble in water.

**CHARACTERS**

A white or almost white suspension which on standing deposits a white or almost white sediment and leaves a colourless or almost colourless supernatant liquid; the sediment is readily resuspended by gently shaking. When examined under a microscope, the particles are seen to have no uniform shape and a maximum dimension rarely exceeding 2 µm.

**IDENTIFICATION**

Examine the chromatograms obtained in the Assay. The position of the peak due to insulin in the chromatogram obtained with the test solution corresponds to that of the principal peak in the chromatogram obtained with the appropriate reference solution.

**TESTS**

**Total zinc.** 0.12 mg to 0.25 mg per 100 IU of insulin, determined as described in the monograph on *Insulin preparations, injectable (0854)*.

**Zinc in solution.** 20 per cent to 65 per cent of the total zinc is in the form of zinc in solution. Determine by the method described in the monograph on *Insulin preparations, injectable (0854)*.

01/2008:0836  
corrected 6.0

### INSULIN ZINC INJECTABLE SUSPENSION (CRYSTALLINE)

#### Insulini zinci cristallini suspensio iniectionabilis

*Insulin zinc injectable suspension (crystalline) complies with the monograph on Insulin preparations, injectable (0854) with the amendments prescribed below.*

**DEFINITION**

Insulin zinc injectable suspension (crystalline) is a sterile neutral suspension of bovine, porcine or human insulin, complexed with a suitable zinc salt; the insulin is in a form which is practically insoluble in water.

**CHARACTERS**

A white or almost white suspension which on standing deposits a white or almost white sediment and leaves a colourless or almost colourless supernatant liquid; the sediment is readily resuspended by gently shaking. When examined under a

microscope, the particles are seen to be rhombohedral crystals, the majority having a maximum dimension when measured from corner to corner through the crystal greater than 10 µm but rarely exceeding 40 µm.

**IDENTIFICATION**

Examine the chromatograms obtained in the Assay. The position of the peak due to insulin in the chromatogram obtained with the test solution corresponds to that of the principal peak in the chromatogram obtained with the appropriate reference solution.

**TESTS**

**Insulin not extractable with buffered acetone solution.** Not less than 90 per cent of the total insulin content. Centrifuge a volume of the substance to be examined containing 200 IU of insulin and discard the supernatant liquid. Suspend the residue in 1.65 mL of *water R*, add 3.3 mL of *buffered acetone solution R*, stir for 3 min, again centrifuge, discard the supernatant liquid and repeat all the operations with the residue. Dissolve the residue using a suitable procedure, for example dissolve in 0.1 M *hydrochloric acid* to give a final volume of 2.0 mL. Determine the insulin content of the residue (*R*) and determine the total insulin content (*T*) of an equal volume of the suspension by a suitable method. Calculate the percentage of insulin not extractable with buffered acetone solution from the expression:

$$\frac{100R}{T}$$

**Total zinc:** 0.12 mg to 0.25 mg per 100 IU of insulin, determined as described in the monograph on *Insulin preparations, injectable (0854)*.

**Zinc in solution:** 20 per cent to 65 per cent of the total zinc is in the form of zinc in solution. Determine by the method described in the monograph on *Insulin preparations, injectable (0854)*.

01/2008:1110

### INTERFERON ALFA-2 CONCENTRATED SOLUTION

#### Interferoni alfa-2 solutio concentrata

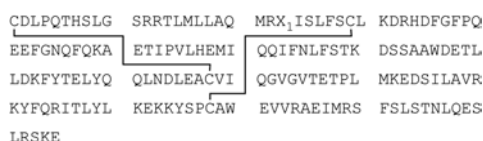

**DEFINITION**

Interferon alfa-2 concentrated solution is a solution of a protein that is produced according to the information coded by the alfa-2 sub-species of interferon alfa gene and that exerts non-specific antiviral activity, at least in homologous cells, through cellular metabolic processes involving synthesis of both ribonucleic acid and protein. Interferon alfa-2 concentrated solution also exerts antiproliferative activity. Different types of alfa-2 interferon, varying in the amino acid residue at position 23, are designated by a letter in lower case.

Designation	Residue at position 23 (X <sub>1</sub> )
alfa-2a	Lys
alfa-2b	Arg

This monograph applies to interferon alfa-2a and -2b concentrated solutions.

The potency of interferon alfa-2 concentrated solution is not less than 1.4 × 10<sup>8</sup> IU per milligram of protein. Interferon alfa-2 concentrated solution contains not less than 2 × 10<sup>8</sup> IU of interferon alfa-2 per millilitre.

Monographs  
I-L

## PRODUCTION

Interferon alfa-2 concentrated solution is produced by a method based on recombinant DNA (rDNA) technology using bacteria as host cells. It is produced under conditions designed to minimise microbial contamination of the product.

Interferon alfa-2 concentrated solution complies with the following additional requirements.

**Host-cell-derived proteins.** The limit is approved by the competent authority.

**Host-cell- or vector-derived DNA.** The limit is approved by the competent authority.

## CHARACTERS

A clear, colourless or slightly yellowish liquid.

## IDENTIFICATION

A. It shows the expected biological activity (see Assay).

B. Examine by isoelectric focusing.

*Test solution.* Dilute the preparation to be examined with *water R* to a protein concentration of 1 mg/mL.

*Reference solution.* Prepare a 1 mg/mL solution of the appropriate *interferon alfa-2 CRS* in *water R*.

*Isoelectric point calibration solution pI range 3.0 to 10.0.* Prepare and use according to the manufacturer's instructions.

Use a suitable apparatus connected with a recirculating temperature controlled water-bath set at 10 °C and gels for isoelectric focusing with a pH gradient from 3.5 to 9.5. Operate the apparatus in accordance with the manufacturer's instructions. Use as the anode solution *phosphoric acid R* (98 g/L H<sub>3</sub>PO<sub>4</sub>) and as the cathode solution *1 M sodium hydroxide*. Samples are applied to the gel by filter papers. Place sample application filters on the gel close to the cathode.

Apply 15 µL of the test solution and 15 µL of the reference solution. Start the isoelectric focusing at 1500 V and 50 mA. Turn off the power after 30 min, remove the application filters and reconnect the power supply for 1 h. Keep the power constant during the focusing process. After focusing, immerse the gel in a suitable volume of a solution containing 115 g/L of *trichloroacetic acid R* and 34.5 g/L of *sulfosalicylic acid R* in *water R* and agitate the container gently for 60 min. Transfer the gel to a mixture of 32 volumes of *glacial acetic acid R*, 100 volumes of *anhydrous ethanol R* and 268 volumes of *water R*, and soak for 5 min. Immerse the gel for 10 min in a staining solution prewarmed to 60 °C in which 1.2 g/L of *acid blue 83 R* has been added to the previous mixture of glacial acetic acid, ethanol and water. Wash the gel in several containers with the previous mixture of glacial acetic acid, ethanol and water and keep the gel in this mixture until the background is clear (12 h to 24 h). After adequate destaining, soak the gel for 1 h in a 10 per cent V/V solution of *glycerol R* in the previous mixture of glacial acetic acid, ethanol and water.

The principal bands of the electropherogram obtained with the test solution correspond in position to the principal bands of the electropherogram obtained with the reference solution. Plot the migration distances of the isoelectric point markers versus their isoelectric points and determine the isoelectric points of the principal components of the test solution and the reference solution. They do not differ by more than 0.2 pI units. The test is not valid unless the isoelectric point markers are distributed along the entire length of the gel and the isoelectric points of the principal bands in the electropherogram obtained with the reference solution are between 5.8 and 6.3.

C. Examine the electropherograms obtained under reducing conditions in the test for impurities of molecular masses differing from that of interferon alfa-2. The principal band

in the electropherogram obtained with test solution (a) corresponds in position to the principal band in the electropherogram obtained with reference solution (a).

D. Examine by peptide mapping.

*Test solution.* Dilute the preparation to be examined in *water R* to a protein concentration of 1.5 mg/mL. Transfer 25 µL to a polypropylene or glass tube of 1.5 mL capacity. Add 1.6 µL of *1 M phosphate buffer solution pH 8.0 R*, 2.8 µL of a freshly prepared 1.0 mg/mL solution of *trypsin for peptide mapping R* in *water R* and 3.6 µL of *water R* and mix vigorously. Cap the tube and place it in a water-bath at 37 °C for 18 h, then add 100 µL of a 573 g/L solution of *guanidine hydrochloride R* and mix well. Add 7 µL of 154.2 g/L solution of *dithiothreitol R* and mix well. Place the capped tube in boiling water for 1 min. Cool to room temperature.

*Reference solution.* Prepare at the same time and in the same manner as for the test solution but use a 1.5 mg/mL solution of the appropriate *interferon alfa-2 CRS* in *water R*. Examine by liquid chromatography (2.2.29).

The chromatographic procedure may be carried out using:

- a stainless steel column 0.10 m long and 4.6 mm in internal diameter packed with *octadecylsilyl silica gel for chromatography R* (5 µm) with a pore size of 30 nm,
- as mobile phase at a flow rate of 1.0 mL/min:

*Mobile phase A.* Dilute 1 mL of *trifluoroacetic acid R* to 1000 mL with *water R*,

*Mobile phase B.* To 100 mL of *water R* add 1 mL of *trifluoroacetic acid R* and dilute to 1000 mL with *acetonitrile for chromatography R*,

Time (min)	Mobile phase A (per cent V/V)	Mobile phase B (per cent V/V)	Comment
0 - 8	100	0	isocratic
8 - 68	100 → 40	0 → 60	linear gradient
68 - 72	40	60	isocratic
72 - 75	40 → 100	60 → 0	linear gradient
75 - 80	100	0	re-equilibration

- as detector a spectrophotometer set at 214 nm, maintaining the temperature of the column at 30 °C.

Equilibrate the column with mobile phase A for at least 15 min.

Inject 100 µL of the test solution and 100 µL of the reference solution. The test is not valid unless the chromatogram obtained with each solution is qualitatively similar to the chromatogram of interferon alfa-2 digest supplied with the appropriate *interferon alfa-2 CRS*. The profile of the chromatogram obtained with the test solution corresponds to that of the chromatogram obtained with the reference solution.

## TESTS

**Impurities of molecular masses differing from that of interferon alfa-2.** Examine by SDS polyacrylamide gel electrophoresis (2.2.31). The test is performed under both reducing and non-reducing conditions, using resolving gels of 14 per cent acrylamide and silver staining as the detection method.

*Sample buffer (non-reducing conditions).* Mix equal volumes of *water R* and *concentrated SDS PAGE sample buffer R*.

*Sample buffer (reducing conditions).* Mix equal volumes of *water R* and *concentrated SDS PAGE sample buffer for reducing conditions R* containing 2-mercaptoethanol as the reducing agent.

*Test solution (a).* Dilute the preparation to be examined in sample buffer to a protein concentration of 0.5 mg/mL.

**Test solution (b).** Dilute 0.20 mL of test solution (a) to 1 mL with sample buffer.

**Reference solution (a).** Prepare a 0.625 mg/mL solution of the appropriate *interferon alfa-2 CRS* in sample buffer.

**Reference solution (b).** Dilute 0.20 mL of reference solution (a) to 1 mL with sample buffer.

**Reference solution (c).** Dilute 0.20 mL of reference solution (b) to 1 mL with sample buffer.

**Reference solution (d).** Dilute 0.20 mL of reference solution (c) to 1 mL with sample buffer.

**Reference solution (e).** Dilute 0.20 mL of reference solution (d) to 1 mL with sample buffer.

**Reference solution (f).** Use a solution of molecular mass standards suitable for calibrating SDS-PAGE gels in the range 15 kDa to 67 kDa.

Place test and reference solutions, contained in covered test-tubes, on a water-bath for 2 min.

Apply 10 µL of reference solution (f) and 50 µL of each of the other solutions to the stacking gel wells. Perform the electrophoresis under the conditions recommended by the manufacturer of the equipment. Detect proteins in the gel by silver staining.

The test is not valid unless: the validation criteria are met (2.2.31); a band is seen in the electropherogram obtained with reference solution (e); and a gradation of intensity of staining is seen in the electropherograms obtained, respectively, with test solution (a) and test solution (b) and with reference solutions (a) to (e).

The electropherogram obtained with test solution (a) under reducing conditions may show, in addition to the principal band, less intense bands with molecular masses lower than the principal band. No such band is more intense than the principal band in the electropherogram obtained with reference solution (d) (1.0 per cent) and not more than 3 such bands are more intense than the principal band in the electropherogram obtained with reference solution (e) (0.2 per cent).

The electropherogram obtained with test solution (a) under non-reducing conditions may show, in addition to the principal band, less intense bands with molecular masses higher than the principal band. No such band is more intense than the principal band in the electropherogram obtained with reference solution (d) (1.0 per cent) and not more than 3 such bands are more intense than the principal band in the electropherogram obtained with reference solution (e) (0.2 per cent).

**Related proteins.** Examine by liquid chromatography (2.2.29).

**Test solution.** Dilute the preparation to be examined with *water R* to a protein concentration of 1 mg/mL.

**0.25 per cent m/m hydrogen peroxide solution.** Dilute dilute hydrogen peroxide solution *R* in *water R* in order to obtain a 0.25 per cent m/m solution.

**Reference solution.** To a volume of the test solution, add a suitable volume of 0.25 per cent m/m hydrogen peroxide solution to give a final hydrogen peroxide concentration of 0.005 per cent m/m, and allow to stand at room temperature for 1 h, or for the length of time that will generate about 5 per cent oxidised interferon. Add 12.5 mg of *L-methionine R* per millilitre of solution. Allow to stand at room temperature for 1 h. Store the solutions for not longer than 24 h at a temperature of 2-8 °C.

The chromatographic procedure may be carried out using:

- a stainless steel column 0.25 m long and 4.6 mm in internal diameter packed with *octadecylsilyl silica gel for chromatography R* (5 µm) with a pore size of 30 nm,
- as mobile phase at a flow rate of 1.0 mL/min:

**Mobile phase A.** To 700 mL of *water R* add 2 mL of *trifluoroacetic acid R* and 300 mL of *acetonitrile for chromatography R*,

**Mobile phase B.** To 200 mL of *water R* add 2 mL of *trifluoroacetic acid R* and 800 mL of *acetonitrile for chromatography R*,

Time (min)	Mobile phase A (per cent V/V)	Mobile phase B (per cent V/V)	Comment
0 - 1	72	28	isocratic
1 - 5	72 → 67	28 → 33	linear gradient
5 - 20	67 → 63	33 → 37	linear gradient
20 - 30	63 → 57	37 → 43	linear gradient
30 - 40	57 → 40	43 → 60	linear gradient
40 - 42	40	60	isocratic
42 - 50	40 → 72	60 → 28	linear gradient
50 - 60	72	28	re-equilibration

– as detector a spectrophotometer set at 210 nm.

Equilibrate the column with the mobile phases in the initial gradient ratio for at least 15 min. Inject 50 µL of each solution.

In the chromatograms obtained, interferon alfa-2 elutes at a retention time of about 20 min. In the chromatogram obtained with the reference solution a peak related to oxidised interferon appears at a retention time of about 0.9 relative to the principal peak. The test is not valid unless the resolution between the peaks corresponding to oxidised interferon and interferon is at least 1.0. Consider only the peaks whose retention time is 0.7 to 1.4 relative to that of the principal peak. In the chromatogram obtained with the test solution, the area of any peak, apart from the principal peak, is not greater than 3.0 per cent of the total area of all of the peaks. The sum of the areas of any peaks other than the principal peak is not greater than 5.0 per cent of the total area of all of the peaks.

**Bacterial endotoxins (2.6.14):** less than 100 IU in the volume that contains 1.0 mg of protein.

## ASSAY

### Protein

**Test solution.** Dilute the preparation to be examined with *water R* to obtain a concentration of about 0.5 mg/mL of interferon alfa-2.

**Reference solutions.** Prepare a stock solution of 0.5 mg/mL of *bovine albumin R*. Prepare 8 dilutions of the stock solution containing between 3 µg/mL and 30 µg/mL of *bovine albumin R*.

Prepare 30-fold and 50-fold dilutions of the test solution. Add 1.25 mL of a mixture prepared the same day by combining 2.0 mL of a 20 g/L solution of *copper sulfate R* in *water R*, 2.0 mL of a 40 g/L solution of *sodium tartrate R* in *water R* and 96.0 mL of a 40 g/L solution of *sodium carbonate R* in 0.2 M *sodium hydroxide* to test-tubes containing 1.5 mL of *water R* (blank), 1.5 mL of the different dilutions of the test solution or 1.5 mL of the reference solutions. Mix after each addition. After approximately 10 min, add to each test-tube 0.25 mL of a mixture of equal volumes of *water R* and *phosphomolybdotungstic reagent R*. Mix after each addition. After approximately 30 min, measure the absorbance (2.2.25) of each solution at 750 nm using the blank as the compensation liquid. Draw a calibration curve from the absorbances of the 8 reference solutions and the corresponding protein contents and read from the curve the content of protein in the test solution.

### Potency

The potency of interferon alfa-2 is estimated by comparing its effect to protect cells against a viral cytopathic effect with the same effect of the appropriate International Standard of human recombinant interferon alfa-2 or of a reference preparation calibrated in International Units.

The International Unit is the activity contained in a stated amount of the appropriate International Standard. The equivalence in International Units of the International Standard is stated by the World Health Organisation.

Carry out the assay by a suitable method, based on the following design.

Use, in standard culture conditions, an established cell line sensitive to the cytopathic effect of a suitable virus (a human diploid fibroblast cell line, free of microbial contamination, responsive to interferon and sensitive to encephalomyocarditis virus, is suitable).

The following cell cultures and virus have been shown to be suitable: MDBK cells (ATCC No. CCL22), or Mouse L cells (NCTC clone 929; ATCC No. CCL 1) as the cell culture and vesicular stomatitis virus VSV, Indiana strain (ATCC No. VR-158) as the infective agent; or A-549 cells (ATCC No. CCL-185) responsive to interferon as the cell culture, and encephalomyocarditis virus (ATCC No. VR-129B) as the infective agent.

Incubate in at least 4 series, cells with 3 or more different concentrations of the preparation to be examined and the reference preparation in a microtitre plate and include in each series appropriate controls of untreated cells. Choose the concentrations of the preparations such that the lowest concentration produces some protection and the largest concentration produces less than maximal protection against the viral cytopathic effect. Add at a suitable time the cytopathic virus to all wells with the exception of a sufficient number of wells in all series, which are left with uninfected control cells. Determine the cytopathic effect of virus quantitatively with a suitable method. Calculate the potency of the preparation to be examined by the usual statistical methods for a parallel line assay.

The estimated potency is not less than 80 per cent and not more than 125 per cent of the stated potency. The confidence limits of the estimated potency ( $P = 0.95$ ) are not less than 64 per cent and not more than 156 per cent of the stated potency.

#### STORAGE

Store in an airtight container, protected from light, at or below  $-20^{\circ}\text{C}$ .

#### LABELLING

The label states:

- the type of interferon (alfa-2a or alfa-2b),
- the type of production.

01/2009:1639  
corrected 6.5

## INTERFERON BETA-1a CONCENTRATED SOLUTION

### Interferoni beta-1a solutio concentrata

```

MSYNLLGFLQ  RSSNFQCQKL  LWQLNGRLEY  CLKDRMNFDI
PEEIKQLQOF  QKEDAALTIY  EMLQNIFAIF  RQDSSSTGWN
ETIVENLLAN  VYHQINHLKT  VLEEKLEKED  FTRGKLMSSL
HLKRYGRIL  HYLKKEYSH  CAWTIVRVEI  LRFYFIFNRL
TGYLRN
  
```

\* glycosylation site

$\text{C}_{908}\text{H}_{1406}\text{N}_{246}\text{O}_{252}\text{S}_7$

$M_r$  approx. 22 500

#### DEFINITION

Solution of a glycosylated protein having the same amino acid sequence and disulfide bridge and a similar glycosylation pattern as interferon beta produced by human diploid fibroblasts in response to viral infections and various other inducers. It exerts antiviral, antiproliferative and immunomodulatory activity.

*Content*: minimum 0.20 mg of protein per millilitre.

*Potency*: minimum  $1.5 \times 10^8$  IU per milligram of protein.

It may contain buffer salts.

#### PRODUCTION

Interferon beta-1a concentrated solution is produced by a method based on recombinant DNA (rdDNA) technology, using mammalian cells in culture.

Prior to release, the following tests are carried out on each batch of the final bulk product, unless exemption has been granted by the competent authority.

**Host-cell-derived proteins.** The limit is approved by the competent authority.

**Host-cell or vector-derived DNA.** The limit is approved by the competent authority.

**N-terminal truncated forms.** Examination for specific N-terminal truncated forms should be performed using a suitable technique such as N-terminal sequence determination. The limits are approved by the competent authority.

**Dimer and related substances of higher molecular mass:** not more than the amount approved by the competent authority, using an appropriate validated liquid chromatography method.

#### CHARACTERS

*Appearance*: clear or slightly opalescent, colourless or slightly yellowish liquid.

#### IDENTIFICATION

A. It shows the expected biological activity (see Assay).

B. Isoform distribution. Mass spectrometry (2.2.43).

*Introduction of the sample*: direct inflow of a desalted preparation to be examined or liquid chromatography-mass spectrometry combination.

*Mode of ionisation*: electrospray.

*Signal acquisition*: complete spectrum mode from 1100 to 2400.

*Calibration*: use myoglobin in the  $m/z$  range of 600-2400; set the instrument within validated instrumental settings and analyse the sample; the deviation of the measured mass does not exceed 0.02 per cent of the reported mass.

*Interpretation of results*: a typical spectrum consists of 6 major glycoforms (A to F), which differ in their degree of sialylation and/or antennarity type as shown in Table 1639-1.

Table 1639-1.

MS peak	Glycoform*	Expected $M_r$	Sialylation level
A	2A2S1F	22 375	Disialylated
B	2A1S1F	22 084	Monosialylated
C	3A2S1F and/or 2A2S1F + 1 HexNacHex repeat	22 739	Disialylated
D	3A3S1F	23 031	Trisialylated
E	4A3S1F and/or 3A3S1F + 1 HexNacHex repeat	23 400	Trisialylated
F	2A0S1F	21 793	Non-sialylated

\* 2A = biantennary complex type oligosaccharide; 3A = triantennary complex type oligosaccharide; 4A = tetraantennary complex type oligosaccharide; 0S = non-sialylated; 1S = monosialylated; 2S = disialylated; 3S = trisialylated; 1F = fucosylated.

*Results*: the mass spectrum obtained with the preparation to be examined corresponds, with respect to the 6 major peaks, to the mass spectrum obtained with *interferon beta-1a CRS*.

C. Peptide mapping (2.2.55) and liquid chromatography (2.2.29).

*Test solution*. Add 5  $\mu\text{L}$  of a 242 g/L solution of *tris(hydroxymethyl)aminomethane R* and a volume of the preparation to be examined containing 20  $\mu\text{g}$  of protein

to a polypropylene tube of 0.5 mL capacity. Add 4 µL of a 1 mg/mL solution of *endoprotease LysC R* in 0.05 M *tris-hydrochloride buffer solution pH 9.0 R*. Mix gently and incubate at 30 °C for 2 h. Add 10 µL of a 15.4 g/L solution of *dithiothreitol R*. Dilute the solution with the same volume of a 573 g/L solution of *guanidine hydrochloride R*. Incubate at 4 °C for 3-4 h.

**Reference solution.** Prepare at the same time and in the same manner as for the test solution but using *interferon beta-1a CRS* instead of the preparation to be examined.

**Precolumn:**

- size:  $l = 0.02$  m,  $\emptyset = 2.1$  mm;
- stationary phase: spherical octadecylsilyl silica gel for chromatography R (5 µm) with a pore size of 30 nm.

**Column:**

- size:  $l = 0.25$  m,  $\emptyset = 2.1$  mm;
- stationary phase: spherical octadecylsilyl silica gel for chromatography R (5 µm) with a pore size of 30 nm.

**Mobile phase:**

- mobile phase A: dilute 1 mL of *trifluoroacetic acid R* to 1000 mL with *water R*;
- mobile phase B: dilute 1 mL of *trifluoroacetic acid R* in 700 mL of *acetonitrile for chromatography R*, then dilute to 1000 mL with *water R*;

Time (min)	Mobile phase A (per cent V/V)	Mobile phase B (per cent V/V)
0 - 30	100 → 64	0 → 36
30 - 45	64 → 55	36 → 45
45 - 50	55 → 40	45 → 60
50 - 70	40 → 0	60 → 100
70 - 83	0	100
83 - 85	0 → 100	100 → 0

**Flow rate:** 0.2 mL/min.

**Detection:** spectrophotometer at 214 nm.

**Injection:** volume that contains 20 µg of digested protein.

**System suitability:** the chromatogram obtained with the reference solution is qualitatively similar to the chromatogram of interferon beta-1a digest supplied with *interferon beta-1a CRS*.

**Results:** the profile of the chromatogram obtained with the test solution corresponds to that of the chromatogram obtained with the reference solution.

## TESTS

**Impurities of molecular masses differing from that of interferon beta-1a.** Polyacrylamide gel electrophoresis (2.2.31) under reducing conditions.

**Resolving gel:** 12 per cent acrylamide.

**Concentrated sample buffer:** concentrated SDS-PAGE sample buffer for reducing conditions R containing 2-mercaptoethanol as the reducing agent.

**Sample buffer:** mixture of equal volumes of concentrated SDS-PAGE sample buffer for reducing conditions R and *water R*.

**Test solution (a).** Concentrate the preparation to be examined using a suitable method to obtain a protein concentration of 1.5 mg/mL.

**Test solution (b):** mixture of equal volumes of test solution (a) and the concentrated sample buffer.

**Test solution (c).** Dilute test solution (a) to obtain a protein concentration of 0.6 mg/mL. Mix equal volumes of this solution and the concentrated sample buffer.

**Test solution (d).** Mix 8 µL of test solution (c) and 40 µL of the sample buffer.

**Test solution (e).** Mix 15 µL of test solution (d) and 35 µL of the sample buffer.

**Test solution (f).** Mix 18 µL of test solution (e) and 18 µL of the sample buffer.

**Test solution (g).** Mix 12 µL of test solution (f) and 12 µL of the sample buffer.

**Reference solution (a).** Solution of relative molecular mass markers suitable for calibrating SDS-PAGE gels in the range of 15-67 kDa. Dissolve in the sample buffer.

**Reference solution (b):** 0.75 mg/mL solution of *interferon beta-1a CRS* in sample buffer.

**Sample treatment:** boil for 3 min.

**Application:** 20 µL of test solutions (b) to (g) and reference solutions (a) and (b).

**Detection:** Coomassie staining, carried out as follows: immerse the gel in *Coomassie staining solution R1* at 33-37 °C for 90 min with gentle shaking, then remove the staining solution; destain the gel with a large excess of a mixture of 1 volume of *glacial acetic acid R*, 1 volume of *2-propanol R* and 8 volumes of *water R*.

**Apparent molecular masses:** interferon beta-1a = about 23 000; underglycosylated interferon beta-1a = about 21 000; deglycosylated interferon beta-1a = about 20 000; interferon beta-1a dimer = about 46 000.

**Identification of bands:** use the electropherogram provided with *interferon beta-1a CRS*.

**System suitability:**

- the validation criteria are met (2.2.31);
- a band is seen in the electropherogram obtained with test solution (g);
- a gradation of intensity of staining is seen in the electropherograms obtained with test solutions (b) to (g).

**Limits:**

- in the electropherogram obtained with test solution (c), the band corresponding to underglycosylated interferon beta-1a is not more intense than the principal band in the electropherogram obtained with test solution (e) (5 per cent);
- in the electropherogram obtained with test solution (b), the band corresponding to deglycosylated interferon beta-1a is not more intense than the principal band in the electropherogram obtained with test solution (e) (2 per cent); any other band corresponding to an impurity of a molecular mass lower than that of interferon beta-1a, apart from the band corresponding to underglycosylated interferon beta-1a is not more intense than the principal band in the electropherogram obtained with test solution (f) (1 per cent).

**Oxidised interferon beta-1a:** maximum 6 per cent.

Use the chromatogram obtained with the test solution in identification C. Locate the peaks due to the peptide fragment comprising amino acids 34-45 and its oxidised form using the chromatogram of oxidised interferon beta-1a digest supplied with *interferon beta-1a CRS*.

Calculate the percentage of oxidation of interferon beta-1a using the following expression:

$$\frac{A_{34-45ox}}{A_{34-45} + A_{34-45ox}} \times 100$$

$A_{34-45ox}$  = area of the peak corresponding to the oxidised peptide fragment 34-45;

$A_{34-45}$  = area of the peak corresponding to the peptide fragment 34-45.

**Bacterial endotoxins (2.6.14):** less than 0.7 IU in the volume that contains  $1 \times 10^6$  IU of interferon beta-1a, if intended for use in the manufacture of parenteral preparations without a further appropriate procedure for removal of bacterial endotoxins.

## ASSAY

**Protein.** Liquid chromatography (2.2.29). Prepare 3 independent dilutions for each solution.

**Test solution.** Dilute the preparation to be examined to obtain a concentration of 100 µg/mL.

**Reference solution.** Dissolve the contents of a vial of *interferon beta-1a CRS* to obtain a concentration of 100 µg/mL.

**Precolumn:**

- size:  $l = 0.02$  m,  $\varnothing = 2.1$  mm;
- stationary phase: *butylsilyl silica gel for chromatography R* (5 µm) with a pore size of 30 nm.

**Column:**

- size:  $l = 0.25$  m,  $\varnothing = 2.1$  mm;
- stationary phase: *butylsilyl silica gel for chromatography R* (5 µm) with a pore size of 30 nm.

**Mobile phase:**

- mobile phase A: 0.1 per cent *V/V* solution of *trifluoroacetic acid R*;
- mobile phase B: to 300 mL of *water R*, add 1 mL of *trifluoroacetic acid R* and dilute to 1000 mL with *acetonitrile for chromatography R*;

Time (min)	Mobile phase A (per cent <i>V/V</i> )	Mobile phase B (per cent <i>V/V</i> )
0 - 20	100 → 0	0 → 100
20 - 25	0	100
25 - 26	0 → 100	100 → 0
26 - 40	100	0

**Flow rate:** 0.2 mL/min.

**Detection:** spectrophotometer at 214 nm.

**Injection:** 50 µL.

**Retention time:** interferon beta-1a = about 20 min.

**System suitability:** reference solution:

- **symmetry factor:** 0.8 to 2.0 for the peak due to interferon beta-1a;
- **repeatability:** maximum relative standard deviation of 3.0 per cent between the peak areas obtained after injection of the 3 independent dilutions.

Calculate the content of interferon beta-1a ( $C_{908}H_{1406}N_{246}O_{252}S_7$ ) from the declared content of  $C_{908}H_{1406}N_{246}O_{252}S_7$  in *interferon beta-1a CRS*.

**Potency**

The potency of interferon beta-1a is estimated by comparing its ability to protect cells against a viral cytopathic effect with the same ability of the appropriate International Standard of human recombinant interferon beta-1a or of a reference preparation calibrated in International Units.

The International Unit is the activity contained in a stated amount of the appropriate International Standard. The equivalence in International Units of the International Standard is stated by the World Health Organisation.

Carry out the assay using a suitable method, based on the following design.

Use, in standard culture conditions, an established cell line sensitive to the cytopathic effect of a suitable virus and responsive to interferon. The cell cultures and viruses that have been shown to be suitable include the following:

- WISH cells (ATCC No. CCL-25) and vesicular stomatitis virus VSV, Indiana strain (ATCC No. VR-158) as infective agent;
- A549 cells (ATCC No. CCL-185) and encephalomyocarditis virus EMC (ATCC No. VR-129B) as infective agent.

Incubate in at least 4 series, cells with 3 or more different concentrations of the preparation to be examined and the reference preparation in a microtitre plate and include in

each series appropriate controls of untreated cells. Choose the concentrations of the preparations such that the lowest concentration produces some protection and the largest concentration produces less than maximal protection against the viral cytopathic effect. Add at a suitable time the cytopathic virus to all wells with the exception of a sufficient number of wells in all series, which are left with uninfected control cells. Determine the cytopathic effect of the virus quantitatively with a suitable method. Calculate the potency of the preparation to be examined by the usual statistical methods (for example, 5.3). The estimated potency is not less than 80 per cent and not more than 125 per cent of the stated potency. The confidence limits ( $P = 0.95$ ) are not less than 64 per cent and not more than 156 per cent of the estimated potency.

## STORAGE

In an airtight container, protected from light, at a temperature below  $-70$  °C. If the substance is sterile, store in a sterile, airtight, tamper-proof container.

## LABELLING

The label states:

- the interferon beta-1a content, in milligrams per millilitre;
- the antiviral activity, in International Units per millilitre;
- where applicable, that the substance is suitable for use in the manufacture of parenteral preparations.

01/2008:1440  
corrected 7.0

## INTERFERON GAMMA-1b CONCENTRATED SOLUTION

### Interferoni gamma-1b solutio concentrata

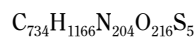

$$M_r 16\ 465$$

## DEFINITION

Interferon gamma-1b concentrated solution is a solution of the *N*-terminal methionyl form of interferon gamma, a protein which is produced and secreted by human antigen-stimulated T lymphocytes in response to viral infections and various other inducers. It has specific immunomodulatory properties, such as potent phagocyte-activating effects. The protein consists of non-covalent dimers of two identical monomers. The formula of the monomer is as follows:

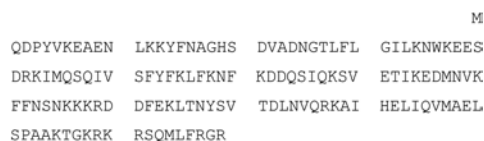

The potency of interferon gamma-1b is not less than  $20 \times 10^6$  IU per milligram of protein. Interferon gamma-1b concentrated solution contains not less than  $30 \times 10^6$  IU of interferon gamma-1b per millilitre.

## PRODUCTION

Interferon gamma-1b concentrated solution is produced by a method based on recombinant DNA technology, using bacteria as host-cells. It is produced under conditions designed to minimise microbial contamination.

Interferon gamma-1b concentrated solution complies with the following additional requirements.

**Host-cell derived proteins.** The limit is approved by the competent authority.

**Host-cell- and vector-derived DNA.** The limit is approved by the competent authority.

## CHARACTERS

A clear, colourless or slightly yellowish liquid.

## IDENTIFICATION

- A. It shows the expected biological activity when tested as prescribed in the assay.
- B. Examine the electropherograms obtained in the test for impurities of molecular masses differing from that of interferon gamma-1b. The principal bands in the electropherogram obtained with the test solution correspond in position to the principal bands in the electropherogram obtained with reference solution (a).
- C. Examine by peptide mapping.

**Solution A.** Prepare a solution containing 1.2 g/L of *tris(hydroxymethyl)aminomethane R*, 8.2 g/L of *anhydrous sodium acetate R*, 0.02 g/L of *calcium chloride R* and adjust to pH 8.3 with *dilute acetic acid R*. Add *polysorbate 20 R* to a concentration of 0.1 per cent V/V.

**Test solution.** Desalt a volume of the preparation to be examined containing 1 mg of protein by a suitable procedure. For example, filter in a microcentrifuge tube and reconstitute with 500 µL of solution A. Add 10 µL of a freshly prepared 1 mg/mL solution of *trypsin for peptide mapping R* in *water R* and mix gently by inversion. Incubate at 30 °C to 37 °C for 24 h, add 100 µL of *phosphoric acid R* per millilitre of digested sample and mix by inversion.

**Reference solution.** Dilute *interferon gamma-1b CRS* in *water R* to obtain a concentration of 1 mg/mL. Prepare as for the test solution, ensuring that all procedures are carried out simultaneously and under identical conditions.

Examine by liquid chromatography (2.2.29).

The chromatographic procedure may be carried out using:

- a stainless steel column, 0.15 m long and 4.6 mm in internal diameter packed with *octadecylsilyl silica gel for chromatography R* (10 µm),
- as mobile phase at a flow rate of 1.0 mL/min:

**Mobile phase A (0.05 M sodium phosphate buffer solution pH 3.3).** Solution I: dissolve 7.80 g of *sodium dihydrogen phosphate R* in *water R* and dilute to 1000.0 mL with the same solvent. Solution II: dilute 0.33 mL of *phosphoric acid R* to 100.0 mL with *water R*. Mix 920 mL of solution I and 80 mL of solution II. Adjust the pH if necessary,

**Mobile phase B. Acetonitrile for chromatography R**, with the following elution conditions (if necessary, the gradient may be modified to improve the separation of the digest):

Time (min)	Mobile phase A (per cent V/V)	Mobile phase B (per cent V/V)
0 - 30	100 → 80	0 → 20
30 - 50	80 → 60	20 → 40
50 - 51	60 → 30	40 → 70
51 - 59	30	70

- as detector a spectrophotometer set at 214 nm, maintaining the temperature of the column at 40 °C.

Equilibrate the column for at least 15 min at the initial elution composition. Carry out a blank run using the above-mentioned gradient.

Inject 100 µL of the test solution and 100 µL of the reference solution. The test is not valid unless the chromatogram obtained with each solution is qualitatively similar to the chromatogram of interferon gamma-1b digest supplied with *interferon gamma-1b CRS*. The profile of the chromatogram obtained with the test solution corresponds to that of the chromatogram obtained with the reference solution.

- D. Examine by N-terminal sequence analysis.

Use an automated solid-phase sequencer, operated in accordance with the manufacturer's instructions.

Equilibrate by a suitable procedure the equivalent of 100 µg of interferon gamma-1b in a 10 g/L solution of *ammonium hydrogen carbonate R*, pH 9.0.

Identify the phenylthiohydantoin (PTH)-amino acids released at each sequencing cycle by reverse-phase liquid chromatography. The procedure may be carried out using the column and reagents recommended by the manufacturer of the sequencing equipment for the separation of PTH-amino acids.

The separation procedure is calibrated using:

- the mixture of PTH-amino acids provided by the manufacturer, with the gradient conditions adjusted as indicated to achieve optimum resolution of all amino acids,
- a sample from a blank sequencing cycle, obtained as recommended by the equipment manufacturer.

The first fifteen amino acids are:

Met-Gln-Asp-Pro-Tyr-Val-Lys-Glu-Ala-Glu-Asn-Leu-Lys-Lys-Tyr.

## TESTS

**Appearance.** The preparation to be examined is clear (2.2.1) and not more intensely coloured than reference solution Y<sub>7</sub> (2.2.2, Method II).

**pH (2.2.3).** The pH of the preparation to be examined is 4.5 to 5.5.

**Covalent dimers and oligomers.** Not greater than 2 per cent, determined by size-exclusion chromatography (2.2.30).

**Test solution.** Dilute the preparation to be examined with the mobile phase to a protein concentration of 0.1 mg/mL.

**Reference solution (a).** Dilute *interferon gamma-1b CRS* with the mobile phase to a protein concentration of 0.1 mg/mL.

**Reference solution (b).** Prepare a mixture of the following molecular mass standards: bovine albumin, ovalbumin, trypsinogen, lysozyme, at a concentration of 0.1 mg/mL to 0.2 mg/mL for each standard.

The chromatographic procedure may be carried out using:

- a stainless steel column 0.3 m long and 7.8 mm in internal diameter packed with *hydrophilic silica gel for chromatography R*, of a grade suitable for fractionation of globular proteins in the molecular weight range of 10 000 to 500 000 (5 µm),
- as mobile phase at a flow rate of 1.0 mL/min a mixture prepared as follows (0.2 M sodium phosphate buffer solution pH 6.8). Solution I: dissolve 31.2 g of *sodium dihydrogen phosphate R* and 1.0 g of *sodium dodecyl sulfate R* in *water R* and dilute to 1000.0 mL with the same solvent. Solution II: dissolve 28.4 g of *anhydrous disodium hydrogen phosphate R* and 1.0 g of *sodium dodecyl sulfate R* in *water R* and dilute to 1000.0 mL with the same solvent. Mix 450 mL of solution I and 550 mL of solution II. Adjust the pH if necessary,
- as detector a spectrophotometer set at 210 nm to 214 nm.

Inject 200 µL of each solution. The test is not valid unless: the molecular mass standards in reference solution (b) are well separated; the retention time of the principal peak in the chromatogram obtained with reference solution (a) is between the retention time of trypsinogen and lysozyme in the chromatogram obtained with reference solution (b).

Compare the chromatograms obtained with the test solution and with reference solution (a). There are no additional shoulders or peaks in the chromatogram obtained with the test solution compared with the chromatogram obtained with reference solution (a).

Calculate the percentage content of covalent dimers and oligomers.



**Monomer and aggregates.** Examine by size-exclusion chromatography (2.2.30). The content of monomer and aggregates is not greater than 2 per cent.

**Solution A.** Prepare a solution of the following composition: 0.59 g/L of *succinic acid R* and 40 g/L of *mannitol R*, adjusted to pH 5.0 with *sodium hydroxide solution R*.

**Test solution.** Dilute the preparation to be examined with solution A to a protein concentration of 1 mg/mL.

**Reference solution.** Dilute *interferon gamma-1b CRS* with solution A to a protein concentration of 1 mg/mL.

**Resolution solution.** Prepare 500 µL of a mixture consisting of 0.04 mg/mL of *bovine albumin R* and 0.2 mg/mL of *interferon gamma-1b CRS* in solution A. Use this solution within 24 h of preparation.

The chromatographic procedure may be carried out using:

- a stainless steel column 0.3 m long and 7.8 mm in internal diameter packed with *hydrophilic silica gel for chromatography R*, of a grade suitable for fractionation of globular proteins in the molecular weight range of 10 000 - 300 000 (5 µm),
- as mobile phase at a flow rate of 0.8 mL/min a 89.5 g/L solution of *potassium chloride R* (1.2 M),
- as detector a spectrophotometer set at 214 nm.

Inject 20 µL of the resolution solution. In the chromatogram obtained, the retention time of the principal peak, corresponding to the native interferon gamma-1b dimer, is about 10 min. bovine albumin elutes at a relative retention time of about 0.85, relative to the main peak. The test is not valid unless the resolution between the peaks corresponding to bovine albumin and interferon gamma-1b is at least 1.5.

Inject 20 µL of the test solution and 20 µL of the reference solution. The chromatograms obtained show principal peaks with identical retention times. Calculate the percentage content of monomer and aggregates from the peak area of the monomer peak and of peaks which elute prior to the native interferon gamma-1b peak in the chromatogram obtained with the test solution, by the normalisation procedure, disregarding any peak due to the solvent.

**Deamidated and oxidised forms and heterodimers.** Examine by liquid chromatography (2.2.29). The content of deamidated and oxidised forms is not greater than 10 per cent. The content of heterodimers is not greater than 3 per cent.

**Test solution.** Dilute the preparation to be examined with *water R* to a protein concentration of 1 mg/mL.

**Reference solution.** Dilute *interferon gamma-1b CRS* with *water R* to a protein concentration of 1 mg/mL.

**Resolution solution.** Use *interferon gamma-1b validation solution CRS*.

The chromatographic procedure may be carried out using:

- a stainless steel column 0.075 m long and 7.5 mm in internal diameter packed with an appropriate hydrophilic polymethacrylate, strong cation exchange gel (10 µm, 100 nm),
- as mobile phase at a flow rate of 1.2 mL/min:

**Mobile phase A (0.05 M ammonium acetate buffer pH 6.5).** A 3.86 g/L solution of *ammonium acetate R*, adjusted to pH 6.5 with *dilute acetic acid R*,

**Mobile phase B (1.2 M ammonium acetate buffer pH 6.5).** A 92.5 g/L solution of *ammonium acetate R*, adjusted to pH 6.5 with *dilute acetic acid R*,

with the following elution conditions (if necessary, the slope of the gradient may be modified to improve the separation).

Time (min)	Mobile phase A (per cent V/V)	Mobile phase B (per cent V/V)
0 - 1	100	0
2 - 30	100 → 0	0 → 100
31 - 35	0	100

– as detector a spectrophotometer set at 280 nm, maintaining the temperature of the column at 35 °C.

Inject 25 µL of the resolution solution. In the chromatogram obtained, the retention time of the principal peak is about 26 min. Deamidated and oxidised forms co-elute at a relative retention time of about 0.95, relative to the principal peak. The test is not valid unless the resolution, defined by the ratio of the height of the peak corresponding to the deamidated and oxidised forms to the height above the baseline of the valley separating the two peaks, is at least 1.2.

Inject 25 µL of the test solution and 25 µL of the reference solution. The chromatograms obtained show principal peaks with identical retention times. Calculate the percentage content of deamidated and oxidised interferon gamma-1b as a percentage of the area of the main peak. Heterodimers have relative retention times of 0.7 and 0.85 relative to the main peak. Calculate the percentage of heterodimers as a percentage of the sum of the areas of all peaks.

**Impurities of molecular masses differing from that of interferon gamma-1b.** Examine by polyacrylamide gel electrophoresis (2.2.31). The test is performed under both reducing and non-reducing conditions, using resolving gels of 15 per cent acrylamide and silver staining as the detection method.

**Sample buffer (non-reducing conditions).** Dissolve 3.78 g of *tris(hydroxymethyl)aminomethane R*, 10.0 g of *sodium dodecyl sulfate R* and 0.100 g of *bromophenol blue R* in *water R*. Add 50.0 mL of *glycerol R* and dilute to 80 mL with *water R*. Adjust the pH to 6.8 with *hydrochloric acid R* and dilute to 100 mL with *water R*.

**Sample buffer (reducing conditions).** Dissolve 3.78 g of *tris(hydroxymethyl)aminomethane R*, 10.0 g of *sodium dodecyl sulfate R* and 0.100 g of *bromophenol blue R* in *water R*. Add 50.0 mL of *glycerol R* and dilute to 80 mL with *water R*. Adjust the pH to 6.8 with *hydrochloric acid R* and dilute to 100 mL with *water R*. Immediately before use, add *dithiothreitol R* to a final concentration of 250 mM.

**Test solution.** Dilute the preparation to be examined in *water R* to a protein concentration of 1 mg/mL. Dilute 150 µL of the solution with 38 µL of sample buffer.

**Reference solution (a).** Prepare in the same manner as for the test solution, but using *interferon gamma-1b CRS* instead of the preparation to be examined.

**Reference solution (b) (5 ng control).** Mix 50 µL of a 0.01 mg/mL solution of *bovine albumin R* with 2000 µL of *water R* and 450 µL of sample buffer.

**Reference solution (c) (2 ng control).** Mix 20 µL of a 0.01 mg/mL solution of *bovine albumin R* with 2000 µL of *water R* and 450 µL of sample buffer.

**Reference solution (d).** Use a solution of molecular mass standards suitable for calibrating SDS-polyacrylamide gels in the range of 10 kDa to 70 kDa.

Leave each solution, contained in a test tube, at ambient temperature for 15 min, then store on ice.

Apply 25 µL of each solution to the stacking gel wells. Perform the electrophoresis under the conditions recommended by the manufacturer of the equipment. Detect proteins in the gel by silver staining.

The test is not valid unless: the validation criteria are met (2.2.31); a band is seen in the electropherograms obtained with reference solutions (b) and (c).

The principal band in the electropherogram obtained with the test solution is similar in intensity to the principal band in the electropherogram obtained with reference solution (a). In the electropherogram obtained with the test solution, no significant bands are observed that are not present in the electropherogram obtained with reference solution (a) (0.01 per cent). A significant band is defined as any band whose intensity is greater than or equal to that of the band in the electropherogram obtained with reference solution (c).

**Norleucine.** Not more than 0.2 mole of norleucine per mole of interferon gamma-1b, determined by amino acid analysis.

**Test solution.** Add 2.5 mL of the preparation to be examined onto a column suitable for the desalting of proteins previously equilibrated with 25 mL of a 10 per cent *V/V* solution of *acetic acid R*. Elute the sample with another 2.5 mL of a 10 per cent *V/V* solution of *acetic acid R*. Determine the protein content by measuring the absorbance of this solution as described under Protein, in the Assay section. Pipette a volume containing the equivalent of 100 µg of interferon gamma-1b into each of three reaction vials. Evaporate to dryness under reduced pressure.

Perform the hydrolysis of the three samples as follows. Add to each reaction vial 200 µL of a 50 per cent *V/V* solution of *hydrochloric acid R* containing 1 per cent *V/V* of *phenol R*, evacuate the samples, purge with nitrogen and hydrolyse in the gas phase. Heat the reaction vials at 110 °C for 22 h. After hydrolysis evaporate to dryness under reduced pressure.

Perform the derivatisation of the samples as follows. Prepare immediately before use a mixture consisting of two volumes of *ethanol R*, one volume of *water R* and one volume of *triethylamine R*. Add 50 µL of this solution to each reaction vial and shake lightly. Evaporate to dryness under reduced pressure. Add to each vial 50 µL of a mixture consisting of 7 volumes of *ethanol R*, one volume of *water R*, one volume of *triethylamine R* and one volume of *phenyl isothiocyanate R*. Shake lightly and allow to stand at room temperature for about 15 min. Evaporate to dryness under reduced pressure. Reconstitute the samples in 250 µL of mobile phase A.

**Norleucine stock solution.** Prepare a 250 nmol/mL solution of *DL-norleucine R* in 0.01 *M* *hydrochloric acid*. This solution may be kept for two months at 4 °C.

**Leucine stock solution.** Prepare a 250 nmol/mL solution of *leucine R* in 0.01 *M* *hydrochloric acid*. This solution may be kept at 4 °C for two months.

**Reference solution.** Mix 10 µL of norleucine stock solution with 100 µL of leucine stock solution in each of the three reaction vials. Evaporate to dryness under reduced pressure. Perform the derivatisation of the samples as described for the preparation of the test solution.

Examine by liquid chromatography (2.2.29).

The chromatographic procedure may be carried out using:

- a stainless steel column 0.15 m long and 3.9 mm in diameter packed with *octadecylsilyl silica gel for chromatography R* (4 µm),
- as mobile phase at a flow rate of 1.0 mL/min:

**Mobile phase A.** Mix 70 volumes of a 19 g/L solution of *sodium acetate R* containing 0.05 per cent *V/V* of *triethylamine R* and adjusted to pH 6.4 with *dilute acetic acid R* and 30 volumes of mobile phase B,

**Mobile phase B.** Mix 40 volumes of *water R* and 60 volumes of *acetonitrile R*,

Time (min)	Mobile phase A (per cent <i>V/V</i> )	Mobile phase B (per cent <i>V/V</i> )	Comment
0 - 7	100	0	isocratic
7 - 7.1	100 → 0	0 → 100	linear gradient
7.1 - 10	0	100	washing step
10 - 10.1	0 → 100	100 → 0	linear gradient
10.1 - 15	100	0	re-equilibration

– as detector a spectrophotometer set at 254 nm, maintaining the temperature of the column at 43 °C.

Inject 50 µL of each solution.

In the chromatograms obtained with the test solution, identify the peaks corresponding to leucine and norleucine. The retention time of norleucine is 6.2 min to 7 min.

Calculate the content of norleucine (in moles of norleucine per mole of interferon gamma-1b) from the peak areas of leucine and norleucine in the chromatograms obtained with the reference and test solutions, considering that there are 10 moles of leucine per mole of interferon gamma-1b.

**Bacterial endotoxins (2.6.14):** less than 5 IU in the volume that contains  $20 \times 10^6$  IU of interferon gamma-1b.

#### ASSAY

**Protein (2.2.25).** Dilute the substance to be examined in *water R* to obtain a concentration of 1 mg/mL. Record the absorbance spectrum between 220 nm and 340 nm. Measure the value at the absorbance maximum of 280 nm, after correction for any light scattering due to turbidity measured at 316 nm. Calculate the concentration of interferon gamma-1b using a specific absorbance value of 7.5.

**Potency.** The potency of interferon gamma-1b is estimated by evaluating the increase of the expression of human-leukocyte-antigen-DR (HLA-DR) due to the interferon gamma-1b present in test solutions during cultivation of the cells, and comparing this increase with the same effect of the appropriate International Standard of human recombinant interferon gamma or of a reference preparation calibrated in International Units.

The International Unit is the activity contained in a stated amount of the appropriate International Standard. The equivalence in International Units of the International Standard is stated by the World Health Organisation.

Carry out the assay by a suitable method, based on the following design.

Use COLO 205 cells under standard culture conditions. Trypsinise a 3- to 5-day-old flask of COLO 205 cells and prepare a cell suspension at a concentration of  $1.0 \times 10^6$  cells/mL.

Add 100 µL of the dilution medium to all wells of a 96-well microtitre plate. Add an additional 100 µL of this solution to the wells designed for the blanks. Add 100 µL of each solution to be tested onto the plate and carry out a series of twofold dilution steps in order to obtain a standard curve. Then add 100 µL of the cell suspension to all wells and incubate the plate under appropriate conditions for cell cultivation.

After cultivation remove the growth medium and wash and fix cells to the plate. Add an antibody able to detect HLA-DR expressed due to the presence of interferon gamma-1b and incubate under appropriate conditions. After washing the plate, incubate with an antibody conjugated to a marker enzyme which is able to detect the anti-HLA-DR antibody. After this incubation step, wash the plate and add an appropriate substrate solution. Stop the reaction. Measure the absorbance of the solution and calculate the potency of the preparation to be examined by the usual statistical methods.

The estimated specific activity is not less than 80 per cent and not more than 125 per cent of the stated potency. The confidence limits ( $P = 0.95$ ) are not less than 70 per cent and not more than 140 per cent of the estimated potency.

## STORAGE

07/2010:2215

Store in an airtight container, protected from light and at a temperature of  $-70\text{ }^{\circ}\text{C}$ .

## IODIXANOL

## Iodixanolum

01/2008:0031

## IODINE

## Iodum

$\text{I}_2$   
[7553-56-2]

 $M_r$  253.8

## DEFINITION

*Content*: 99.5 per cent to 100.5 per cent of I.

## CHARACTERS

*Appearance*: greyish-violet, brittle plates or fine crystals with a metallic sheen.

*Solubility*: very slightly soluble in water, very soluble in concentrated solutions of iodides, soluble in ethanol (96 per cent), slightly soluble in glycerol.

It volatilises slowly at room temperature.

## IDENTIFICATION

- A. Heat a few fragments in a test-tube. Violet vapour is evolved and a bluish-black crystalline sublimate is formed.
- B. To a saturated solution add *starch solution R*. A blue colour is produced. Heat until decolourised. On cooling, the colour reappears.

## TESTS

**Solution S.** Triturate 3.0 g with 20 mL of *water R*, filter, wash the filter with *water R* and dilute the filtrate to 30 mL with the same solvent. To the solution add 1 g of *zinc powder R*. When the solution is decolourised, filter, wash the filter with *water R* and dilute to 40 mL with the same solvent.

**Bromides and chlorides:** maximum 250 ppm.

To 10 mL of solution S add 3 mL of *ammonia R* and 6 mL of *silver nitrate solution R2*. Filter, wash the filter with *water R* and dilute the filtrate to 20 mL with the same solvent. To 10 mL of the solution add 1.5 mL of *nitric acid R*. After 1 min, any opalescence in the solution is not more intense than that in a standard prepared at the same time by mixing 10.75 mL of *water R*, 0.25 mL of 0.01 M *hydrochloric acid*, 0.2 mL of *dilute nitric acid R* and 0.3 mL of *silver nitrate solution R2*.

**Non-volatile substances:** maximum 0.1 per cent.

Heat 1.00 g in a porcelain dish on a water-bath until the iodine has volatilised. Dry the residue at  $100\text{--}105\text{ }^{\circ}\text{C}$ . The residue weighs a maximum of 1 mg.

## ASSAY

Introduce 0.200 g into a flask containing 1 g of *potassium iodide R* and 2 mL of *water R* and add 1 mL of *dilute acetic acid R*. When dissolution is complete, add 50 mL of *water R* and titrate with 0.1 M *sodium thiosulfate*, using *starch solution R* as indicator.

1 mL of 0.1 M *sodium thiosulfate* is equivalent to 12.69 mg of I.

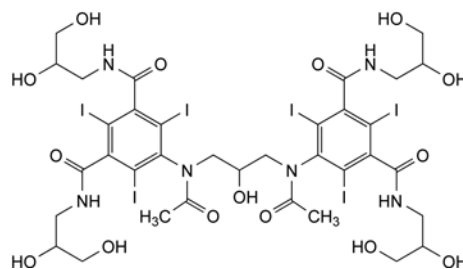

$\text{C}_{35}\text{H}_{44}\text{I}_6\text{N}_6\text{O}_{15}$   
[92339-11-2]

 $M_r$  1550

## DEFINITION

Mixture of stereoisomers of 5,5'-(2-hydroxypropane-1,3-diyl)bis(acetylimino)]bis[*N,N'*-bis(2,3-dihydroxypropyl)-2,4,6-triiodobenzene-1,3-dicarboxamide].

*Content*: 98.5 per cent to 101.0 per cent (anhydrous substance).

## CHARACTERS

*Appearance*: white or almost white powder, hygroscopic.

*Solubility*: freely soluble in water, sparingly soluble in methanol, practically insoluble in methylene chloride.

## IDENTIFICATION

- A. Infrared absorption spectrophotometry (2.2.24).

*Comparison*: *iodixanol CRS*.

- B. Liquid chromatography (2.2.29) as described in the test for related substances with the following modifications.

*Injection*: test solution and reference solution (b).

*Results*: the 3 principal peaks in the chromatogram obtained with the test solution are similar in retention time to the 3 principal peaks in the chromatogram obtained with reference solution (b).

## TESTS

**Solution S.** Dissolve 5.0 g in *water R* and dilute to 50.0 mL with the same solvent.

**Appearance of solution.** Heat solution S at about  $98\text{ }^{\circ}\text{C}$  for 30 min without boiling then allow to cool to room temperature. The solution is clear (2.2.1) and not more intensely coloured than reference solution  $Y_7$  (2.2.2, *Method II*).

**Impurities E and H.** Liquid chromatography (2.2.29).

*Test solution.* Dissolve 0.250 g of the substance to be examined in *water R* and dilute to 100.0 mL with the same solvent.

*Reference solution (a).* Dilute 1.0 mL of the test solution to 100.0 mL with *water R*.

*Reference solution (b).* Dissolve 5 mg of *iodixanol impurity E CRS* and 5 mg of *iodixanol impurity H CRS* in *water R* and dilute to 20.0 mL with the same solvent.

*Reference solution (c).* Mix 5.0 mL of the test solution with 5.0 mL of reference solution (b) and dilute to 50.0 mL with *water R*.

*Column*:

- size:  $l = 0.25\text{ m}$ ,  $\varnothing = 4.6\text{ mm}$ ;
- stationary phase: aminopropylsilyl silica gel for chromatography R (5  $\mu\text{m}$ ).

*Mobile phase*:

- mobile phase A: acetonitrile R, *water R* (50:50 V/V);
- mobile phase B: acetonitrile R;

Time (min)	Mobile phase A (per cent V/V)	Mobile phase B (per cent V/V)
0 - 2	30	70
2 - 27	30 → 68	70 → 32

Flow rate: 1.7 mL/min.

Detection: spectrophotometer at 254 nm.

Injection: 10 µL of the test solution and reference solutions (a) and (c).

Identification of impurities: use the chromatogram obtained with reference solution (c) to identify the peaks due to impurities E and H.

Relative retention with reference to iodixanol (1<sup>st</sup> peak) (retention time = about 16 min): impurity E (1<sup>st</sup> peak) = about 0.7; impurity E (2<sup>nd</sup> peak) = about 0.8; impurity H = about 1.4.

System suitability: reference solution (c):

- resolution: minimum 5.0 between the 1<sup>st</sup> peak due to impurity E and the 1<sup>st</sup> peak due to iodixanol.

Limits:

- correction factor: for the calculation of total content of impurity E, multiply the peak area of the 1<sup>st</sup> peak due to impurity E by 1.7;
- impurity H: not more than 0.6 times the sum of the areas of the 2 principal peaks in the chromatogram obtained with reference solution (a) (0.6 per cent);
- impurity E: not more than 0.3 times the sum of the areas of the 2 principal peaks in the chromatogram obtained with reference solution (a) (0.3 per cent).

Related substances. Liquid chromatography (2.2.29).

Test solution. Dissolve 0.250 g of the substance to be examined in water R and dilute to 100.0 mL with the same solvent.

Reference solution (a). Dilute 1.0 mL of the test solution to 100.0 mL with water R.

Reference solution (b). Dissolve 25 mg of iodixanol CRS in water R and dilute to 10.0 mL with the same solvent.

Reference solution (c). Dissolve 5 mg of iodixanol impurity C CRS and 5 mg of iopentol CRS in water R and dilute to 10.0 mL with the same solvent. Dilute 5.0 mL of this solution to 100.0 mL with water R.

Reference solution (d). Mix 5.0 mL of the test solution with 5.0 mL of reference solution (c) and dilute to 50.0 mL with water R.

Column:

- size:  $l = 0.25$  m,  $\varnothing = 4.6$  mm;
- stationary phase: octadecylsilyl silica gel for chromatography R (5 µm).

Mobile phase:

- mobile phase A: water R;
- mobile phase B: acetonitrile R, water R (50:50 V/V);

Time (min)	Mobile phase A (per cent V/V)	Mobile phase B (per cent V/V)
0 - 2	94	6
2 - 32	94 → 80	6 → 20
32 - 72	80 → 0	20 → 100
72 - 82	0	100

Flow rate: 1 mL/min.

Detection: spectrophotometer at 254 nm.

Injection: 10 µL of the test solution and reference solutions (a), (c) and (d).

Identification of impurities: use the chromatogram obtained with reference solution (c) to identify the peaks due to impurity C and iopentol.

Relative retention with reference to iodixanol (1<sup>st</sup> peak) (retention time = about 27 min): iopentol (1<sup>st</sup> peak) = about 0.8; iopentol (2<sup>nd</sup> peak) = about 0.9; impurity C (1<sup>st</sup> peak) = about 1.04; overalkylated impurities (a group of peaks) = 1.33-1.70.

System suitability: reference solution (d):

- resolution: baseline separation between the 2 peaks due to iopentol;
- peak-to-valley ratio: minimum 1.3, where  $H_p$  = height above the baseline of the 1<sup>st</sup> peak due to impurity C and  $H_v$  = height above the baseline of the lowest point of the curve separating this peak from the 1<sup>st</sup> peak due to iodixanol.

Limits:

- correction factor: for the calculation of total content of impurity C, multiply the peak area of the 1<sup>st</sup> peak due to impurity C by 1.3;
- impurity C: not more than 0.4 times the sum of the areas of the 2 principal peaks in the chromatogram obtained with reference solution (a) (0.4 per cent);
- overalkylated impurities (such as impurity I): not more than the sum of the areas of the 2 principal peaks in the chromatogram obtained with reference solution (a) (1.0 per cent);
- unspecified impurities: for each impurity, not more than 0.1 times the sum of the areas of the 2 principal peaks in the chromatogram obtained with reference solution (a) (0.10 per cent);
- total: not more than 1.5 times the sum of the areas of the 2 principal peaks in the chromatogram obtained with reference solution (a) (1.5 per cent);
- disregard limit: 0.05 times the sum of the areas of the 2 principal peaks in the chromatogram obtained with reference solution (a) (0.05 per cent).

The thresholds indicated under Related substances (Table 2034-1) in the general monograph Substances for pharmaceutical use (2034) do not apply.

Free aromatic amine: maximum 500 ppm.

Test solution. Transfer 0.200 g of the substance to be examined to a 25 mL volumetric flask and dissolve in 15.0 mL of water R.

Reference solution. Dissolve 5.0 mg of iohexol impurity J CRS in water R and dilute to 5.0 mL with the same solvent. Dilute 1.0 mL of this solution to 100.0 mL with water R. Mix 10.0 mL of this solution with 5.0 mL of water R in a 25 mL volumetric flask.

Blank solution. Transfer 15.0 mL of water R to a 25 mL volumetric flask.

In conducting the following steps, keep the flasks in iced water and protected as much as possible from light until all the reagents have been added.

Place the 3 flasks containing respectively the test solution, the reference solution and the blank solution in iced water, protected from light, for 5 min. Add 1.5 mL of hydrochloric acid R1 and mix by swirling. Add 1.0 mL of a 20 g/L solution of sodium nitrite R, mix and allow to stand for 4 min. Add 1.0 mL of a 40 g/L solution of sulfamic acid R, swirl gently until gas liberation has ceased and allow to stand for 1 min. (CAUTION: considerable pressure is produced). Add 1.0 mL of a freshly prepared 3 g/L solution of naphthylethylenediamine dihydrochloride R in a mixture of 30 volumes of water R and 70 volumes of propylene glycol R and mix. Remove the flasks from the iced water, dilute to 25.0 mL with water R, mix and examine the solutions after 5 min. The solution obtained from the test solution is less coloured than the solution obtained from the reference solution. If the solution obtained from the test solution is about the same colour or darker than the solution obtained from the reference solution, proceed as follows. Concomitantly determine the absorbance (2.2.25) at 495 nm of the solution obtained from the test solution and the reference solution in 5 cm cells, using the blank solution as the

compensation liquid. The absorbance of the solution obtained from the test solution is not greater than that of the solution obtained from the reference solution.

**Free iodine.** Transfer 2.0 g to a glass-stoppered tube, add 20 mL of *water R*, 5 mL of *toluene R* and 5 mL of *dilute sulfuric acid R*, shake vigorously and allow the phases to separate: the toluene layer shows no red or pink colour.

**Iodide:** maximum 10 ppm.

Dissolve 5.000 g in *water R* and dilute to 20.0 mL with the same solvent. Titrate with 0.001 M *silver nitrate*. Determine the end-point potentiometrically (2.2.20) using a silver indicator electrode and an appropriate reference electrode.

1 mL of 0.001 M *silver nitrate* is equivalent to 126.9 µg of iodide.

**Ionic compounds** (2.2.38): maximum 0.02 per cent *m/m* calculated as sodium chloride.

*Rinse all glassware with distilled water R 5 times before use.*

**Test solution.** Dissolve 1.0 g of the substance to be examined in *water R* and dilute to 50.0 mL with the same solvent.

**Reference solution.** Dissolve 20.0 mg of *sodium chloride R* in *water R* and dilute to 50.0 mL with the same solvent. Dilute 1.0 mL of this solution to 100.0 mL with *water R*.

Measure the specific conductivity of the test solution and the reference solution using a suitable conductivity meter. The specific conductivity of the test solution is not greater than that of the reference solution.

**Heavy metals** (2.4.8): maximum 10 ppm.

12 mL of solution S complies with test A. Prepare the reference solution using *lead standard solution (1 ppm Pb) R*.

**Water** (2.5.12): maximum 4.0 per cent, determined on 0.500 g.

#### ASSAY

In a 125 mL round-bottomed flask, dissolve 0.200 g in 25 mL of a 50 g/L solution of *sodium hydroxide R*, add 0.5 g of *zinc powder R* and a few glass beads. Boil under a reflux condenser for 1 h. Allow to cool and rinse the condenser with 20 mL of *water R*, adding the rinsings to the flask. Filter through a sintered-glass filter (40) (2.1.2) and wash the filter with several quantities of *water R*. Collect the filtrate and washings. Add 5 mL of *glacial acetic acid R* and titrate immediately with 0.1 M *silver nitrate*. Determine the end-point potentiometrically (2.2.20).

1 mL of 0.1 M *silver nitrate* is equivalent to 25.84 mg of  $C_{35}H_{44}I_6N_6O_{15}$ .

#### STORAGE

In an airtight container, protected from light.

#### IMPURITIES

*Specified impurities: C, E, H, overalkylated impurities.*

*Other detectable impurities* (the following substances would, if present at a sufficient level, be detected by one or other of the tests in the monograph. They are limited by the general acceptance criterion for other/unspecified impurities. It is therefore not necessary to identify these impurities for demonstration of compliance. See also 5.10. *Control of impurities in substances for pharmaceutical use*): A, B, F, G.

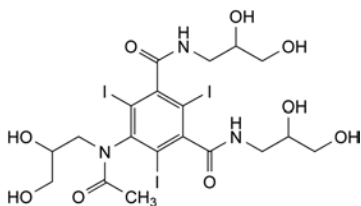

A. 5-[acetyl(2,3-dihydroxypropyl)amino]-*N,N'*-bis(2,3-dihydroxypropyl)-2,4,6-triiodobenzene-1,3-dicarboxamide (iohexol),

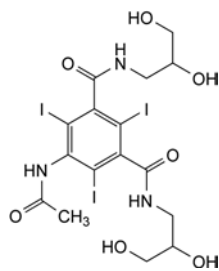

B. 5-acetamido-*N,N'*-bis(2,3-dihydroxypropyl)-2,4,6-triiodobenzene-1,3-dicarboxamide,

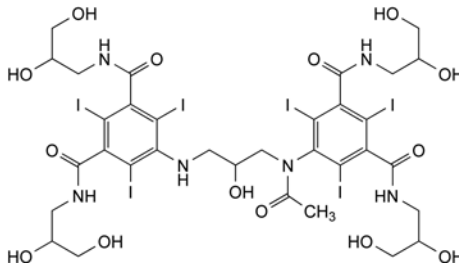

C. 5-[acetyl[3-[[3,5-bis((2,3-dihydroxypropyl)carbamoyl)-2,4,6-triiodophenyl]amino]-2-hydroxypropyl]amino]-*N,N'*-bis(2,3-dihydroxypropyl)-2,4,6-triiodobenzene-1,3-dicarboxamide,

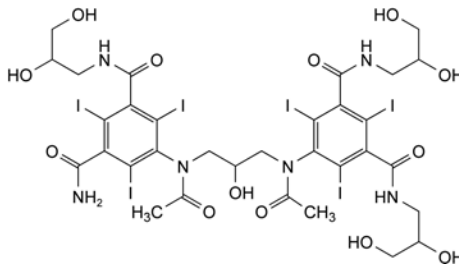

E. 5-[acetyl[3-[acetyl[3-carbamoyl-5-((2,3-dihydroxypropyl)carbamoyl)-2,4,6-triiodophenyl]amino]-2-hydroxypropyl]amino]-*N,N'*-bis(2,3-dihydroxypropyl)-2,4,6-triiodobenzene-1,3-dicarboxamide,

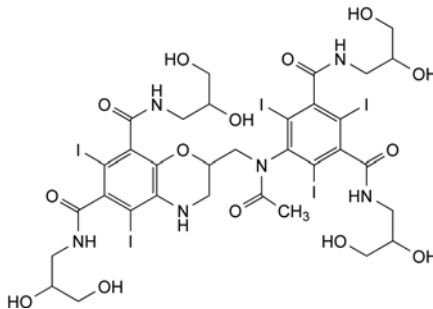

F. 2-[[acetyl[3,5-bis((2,3-dihydroxypropyl)carbamoyl)-2,4,6-triiodophenyl]amino]methyl]-*N,N'*-bis(2,3-dihydroxypropyl)-5,7-diiodo-3,4-dihydro-2*H*-1,4-benzoxazine-6,8-dicarboxamide,

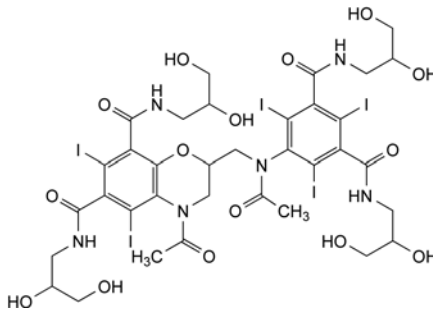

G. 4-acetyl-2-[[acetyl[3,5-bis((2,3-dihydroxypropyl)carbamoyl)-2,4,6-triiodophenyl]amino]methyl]-*N,N'*-bis(2,3-dihydroxypropyl)-5,7-diiodo-3,4-dihydro-2*H*-1,4-benzoxazine-6,8-dicarboxamide,

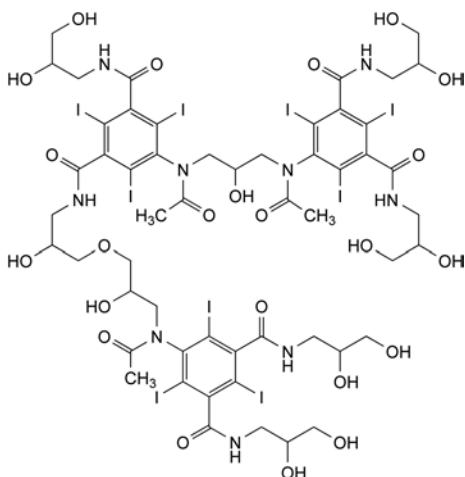

- H. 5-[acetyl[3-[acetyl[3-[3-[3-[acetyl[3,5-bis(2,3-dihydroxypropyl)carbamoyl]-2,4,6-triodophenyl]amino]-2-hydroxypropoxy]-2-hydroxypropyl]carbamoyl]-5-[(2,3-dihydroxypropyl)carbamoyl]-2,4,6-triodophenyl]amino]-2-hydroxypropyl]amino]-*N,N'*-bis(2,3-dihydroxypropyl)-2,4,6-triiodobenzene-1,3-dicarboxamide.

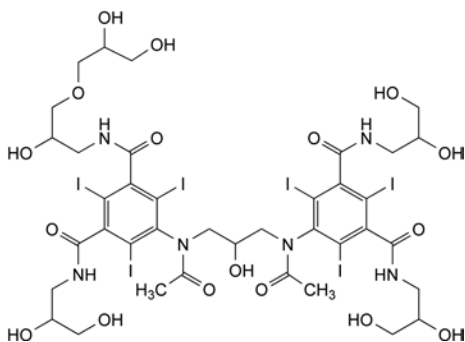

- I. overalkylated impurities (an example): 5-[acetyl[3-[acetyl[3,5-bis(2,3-dihydroxypropyl)carbamoyl]-2,4,6-triiodophenyl]amino]-2-hydroxypropyl]amino]-*N*-[3-(2,3-dihydroxypropoxy)-2-hydroxypropyl]-*N'*-(2,3-dihydroxypropyl)-2,4,6-triiodobenzene-1,3-dicarboxamide.

01/2008:1114

## IOHEXOL

## Iohexolum

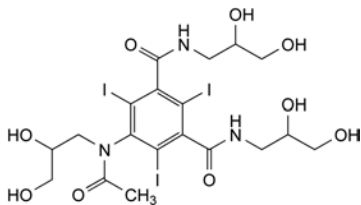

$C_{19}H_{26}I_3N_3O_9$   
[66108-95-0]

 $M_r$  821

## DEFINITION

5-[Acetyl(2,3-dihydroxypropyl)amino]-*N,N'*-bis(2,3-dihydroxypropyl)-2,4,6-triiodobenzene-1,3-dicarboxamide.

The substance is a mixture of diastereoisomers and atropisomers.

*Content*: 98.0 per cent to 101.0 per cent (anhydrous substance).

## CHARACTERS

*Appearance*: white or greyish-white, hygroscopic powder.

*Solubility*: very soluble in water, freely soluble in methanol, practically insoluble in methylene chloride.

## IDENTIFICATION

- A. Infrared absorption spectrophotometry (2.2.24).

*Comparison*: iohexol CRS.

- B. Examine the chromatograms obtained in test A for related substances (see Tests).

*Results*: the principal peaks in the chromatogram obtained with reference solution (b) are similar in retention time and size to the peaks due to iohexol in the chromatogram obtained with reference solution (a).

## TESTS

**Solution S.** Dissolve 5.0 g in *water R* and dilute to 50.0 mL with the same solvent.

**Appearance of solution.** Solution S is clear (2.2.1) and not more intensely coloured than reference solution Y<sub>7</sub> (2.2.2, *Method II*).

## Related substances

- A. Liquid chromatography (2.2.29).

*NOTE*: iohexol gives rise to 2 non-resolved peaks in the chromatogram due to *endo-exo* isomerism. In addition, a small peak (also due to iohexol) usually appears at the leading edge of the 1<sup>st</sup> principal peak. This small peak has a retention time about 1.2 min less than the 1<sup>st</sup> principal peak.

*Test solution.* Dissolve 0.150 g of the substance to be examined in *water R* and dilute to 100.0 mL with the same solvent.

*Reference solution (a).* Dissolve 15.0 mg of iohexol CRS and 15.0 mg of iohexol impurity A CRS in a mixture of 1-2 drops of dilute sodium hydroxide solution R and 10 mL of *water R* and dilute to 100.0 mL with *water R*. Dilute 1.0 mL of this solution to 10.0 mL with *water R*.

*Reference solution (b).* Dilute 1.0 mL of the test solution to 100.0 mL with *water R*.

*Reference solution (c).* Dissolve 5.0 mg of iohexol for peak identification CRS (containing impurities B, C, D and E) in *water R* and dilute to 5.0 mL with the same solvent.

*Blank solution*: *water R*.

*Column*:

- size:  $l = 0.25$  m,  $\varnothing = 4.6$  mm,
- stationary phase: octadecylsilyl silica gel for chromatography R (5  $\mu$ m).

*Mobile phase*:

- mobile phase A: *water R*;
- mobile phase B: acetonitrile R;

Time (min)	Mobile phase A (per cent V/V)	Mobile phase B (per cent V/V)
0 - 60	99 → 87	1 → 13
60 - 65	87 → 99	13 → 1

*Flow rate*: 1 mL/min.

*Detection*: spectrophotometer at 254 nm.

*Equilibration*: at the initial eluent composition for at least 10 min.

*Injection*: 10  $\mu$ L.

*Retention times*: impurity A and impurity H = about 17 min; iohexol (peaks corresponding to *endo-exo* isomerism) = about 20 min.

*System suitability*: reference solution (a):

- resolution: minimum 5.0 between the peak due to impurity A and the 2<sup>nd</sup> and greater peak due to iohexol.

*Limits*:

- sum of impurities B, C, D and E (relative retention with reference to the 2<sup>nd</sup> and greater peak due to iohexol between 1.1 and 1.4): not more than 0.6 times the total area of the principal peaks in the chromatogram

obtained with reference solution (b) (0.6 per cent); use the chromatogram obtained with reference solution (c) to identify the corresponding peaks;

- *sum of impurities A and H*: not more than 0.5 times the total area of the principal peaks in the chromatogram obtained with reference solution (b) (0.5 per cent);
- *impurities M, N, O, P, Q*: for each impurity, not more than 0.1 times the total area of the principal peaks in the chromatogram obtained with reference solution (b) (0.1 per cent);
- *any other impurity*: for each impurity, not more than 0.1 times the total area of the principal peaks in the chromatogram obtained with reference solution (b) (0.1 per cent);
- *total*: not more than 1.5 times the total area of the principal peaks in the chromatogram obtained with reference solution (b) (1.5 per cent);
- *disregard limit*: 0.03 times the total area of the principal peaks in the chromatogram obtained with reference solution (b) (0.03 per cent); disregard any peak observed with the blank.

#### B. Thin-layer chromatography (2.2.27).

**Test solution.** Dissolve 1.0 g of the substance to be examined in *water R* and dilute to 10.0 mL with the same solvent.

**Reference solution (a).** Dissolve 50 mg of *iohexol impurity J CRS* and 50 mg of *iohexol CRS* in *water R* and dilute to 10.0 mL with the same solvent.

**Reference solution (b).** Dilute 1.0 mL of the test solution to 10.0 mL with *water R*. Dilute 1.0 mL of this solution to 50.0 mL with *water R*.

**Plate:** TLC silica gel  $F_{254}$  plate *R*.

**Preconditioning:** wash the plate with the mobile phase, dry at room temperature for 30 min, then at 90 °C for 1 h.

**Mobile phase:** concentrated ammonia *R*, methanol *R*, 2-propanol *R*, acetone *R* (16:16:28:40 V/V/V/V).

**Application:** 10 µL.

**Development:** over half of the plate.

**Drying:** in air.

**Detection:** examine in ultraviolet light at 254 nm.

**System suitability:** reference solution (a):

- the chromatogram shows 2 clearly separated spots.

**Limits:**

- *any impurity*: any spot in the chromatogram obtained with the test solution, apart from the principal spot, is not more intense than the spot in the chromatogram obtained with reference solution (b) (0.2 per cent).

#### 3-Chloropropane-1,2-diol. Gas chromatography (2.2.28).

**Test solution.** Dissolve 1.0 g of the substance to be examined in 1.0 mL of *water R*. Shake with 4 quantities, each of 2 mL, of *methyl acetate R*. Dry the combined upper layers over *anhydrous sodium sulfate R*. Filter and concentrate to about 0.7 mL using a warm water bath at 60 °C and a stream of nitrogen and dilute to 1.0 mL with *methyl acetate R*.

**Reference solution.** Dissolve 0.25 g of *3-chloropropane-1,2-diol R* in 100.0 mL of *methyl acetate R*. Dilute 1.0 mL of this solution with 100.0 mL of *methyl acetate R*.

**Column:**

- *material*: fused silica,
- *size*:  $l = 25$  m,  $\varnothing = 0.33$  mm,
- *stationary phase*: *polymethylphenylsiloxane R* (film thickness 1 µm).

**Carrier gas:** helium for chromatography *R*.

**Flow rate:** 1 mL/min.

**Temperature:**

	Time (min)	Temperature (°C)
Column	0 - 2	80
	2 - 8	80 → 170
	8 - 10	170
Injection port		230
Detector		250

**Detection:** flame ionisation.

**Injection:** 2 µL (splitless for 30 s).

**System suitability:** reference solution:

- *retention time*: 3-chloropropane-1,2-diol = about 8 min.

**Limit:**

- *3-chloropropane-1,2-diol*: not more than the area of the principal peak in the chromatogram obtained with the reference solution (25 ppm).

**Free aromatic amine:** maximum 500 ppm.

**Test solution.** Transfer 0.200 g of the substance to be examined to a 25 mL volumetric flask and dissolve in 15.0 mL of *water R*.

**Reference solution.** Dissolve 5.0 mg of *iohexol impurity J CRS* in *water R* and dilute to 5.0 mL with *water R*. Dilute 1.0 mL of this solution to 100.0 mL with *water R*. Mix 10.0 mL of this solution with 5.0 mL of *water R* in a 25 mL volumetric flask.

**Blank solution.** Transfer 15.0 mL of *water R* to a 25 mL volumetric flask.

*In conducting the following steps, keep the flasks in iced water and protected as much as possible from light until all of the reagents have been added.*

Place the 3 flasks containing respectively the test solution, the reference solution and the blank solution in iced water, protected from light, for 5 min. Add 1.5 mL of *hydrochloric acid R1* and mix by swirling. Add 1.0 mL of a 20 g/L solution of *sodium nitrite R*, mix and allow to stand for 4 min. Add 1.0 mL of a 40 g/L solution of *sulfamic acid R*, swirl gently until gas liberation has ceased and allow to stand for 1 min. (**CAUTION: considerable pressure is produced**). Add 1.0 mL of a freshly prepared 3 g/L solution of *naphthylethylenediamine dihydrochloride R* in a mixture of 30 volumes of *water R* and 70 volumes of *propylene glycol R* and mix. Remove the flasks from the iced water, dilute to 25.0 mL with *water R*, mix and allow to stand for 5 min. Simultaneously determine the absorbance (2.2.25) at 495 nm of the solutions obtained from the test solution and the reference solution in 5 cm cells, using the blank as the compensation liquid. The absorbance of the test solution is not greater than that of the reference solution.

**Iodide:** maximum 10 ppm.

Dissolve 6.000 g in *water R* and dilute to 20 mL with the same solvent. Add 2.0 mL of 0.001 M *potassium iodide*. Titrate with 0.001 M *silver nitrate*. Determine the end-point potentiometrically (2.2.20), using a silver indicator electrode and an appropriate reference electrode. Subtract the volume of titrant corresponding to the 2.0 mL of 0.001 M *potassium iodide*, determined by titrating a blank to which is added 2.0 mL of 0.001 M *potassium iodide* and use the residual value to calculate the iodide content.

1 mL of 0.001 M *silver nitrate* is equivalent to 126.9 µg of I<sup>-</sup>.

**Ionic compounds (2.2.38):** maximum 0.01 per cent *m/m* calculated as sodium chloride.

*Rinse all glassware with distilled water R 5 times before use.*

**Test solution.** Dissolve 1.0 g of the substance to be examined in *water R* and dilute to 50.0 mL with the same solvent.

**Reference solution.** Dissolve 20.0 mg of *sodium chloride R* in *water R* and dilute to 100.0 mL with the same solvent. Dilute 1.0 mL of this solution to 100.0 mL with *water R*.

Measure the conductivity of the test solution and the reference solution using a suitable conductivity meter. The conductivity of the test solution is not greater than that of the reference solution.

**Heavy metals** (2.4.8): maximum 10 ppm.

12 mL of solution S complies with limit test A. Prepare the reference solution using *lead standard solution* (1 ppm Pb) R.

**Water** (2.5.12): maximum 4.0 per cent, determined on 1.00 g.

#### ASSAY

To 0.500 g in a 125 mL round-bottomed flask add 25 mL of a 50 g/L solution of *sodium hydroxide* R, 0.5 g of *zinc powder* R and a few glass beads. Boil under a reflux condenser for 30 min. Allow to cool and rinse the condenser with 20 mL of *water* R, adding the rinsings to the flask. Filter through a sintered-glass filter (2.1.2) and wash the filter with several quantities of *water* R. Collect the filtrate and washings. Add 5 mL of *glacial acetic acid* R and titrate immediately with 0.1 M *silver nitrate*. Determine the end-point potentiometrically (2.2.20).

1 mL of 0.1 M *silver nitrate* is equivalent to 27.37 mg of  $C_{19}H_{26}I_3N_3O_9$ .

#### STORAGE

In an airtight container, protected from light and moisture.

#### IMPURITIES

*Specified impurities: A, B, C, D, E, F, G, H, I, J, K, L, M, N, O, P, Q.*

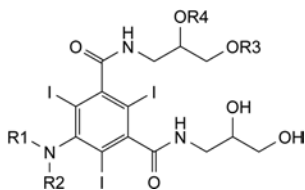

A. R1 = CO-CH<sub>3</sub>, R2 = R3 = R4 = H: 5-(acetylamino)-*N,N'*-bis(2,3-dihydroxypropyl)-2,4,6-triiodobenzene-1,3-dicarboxamide,

J. R1 = R2 = R3 = R4 = H: 5-amino-*N,N'*-bis(2,3-dihydroxypropyl)-2,4,6-triiodobenzene-1,3-dicarboxamide,

P. R1 = R2 = CO-CH<sub>3</sub>, R3 = CH<sub>2</sub>-CHOH-CH<sub>2</sub>OH, R4 = H: 5-(diacetylamino)-*N*-[3-(2,3-dihydroxypropoxy)-2-hydroxypropyl]-*N'*-(2,3-dihydroxypropyl)-2,4,6-triiodobenzene-1,3-dicarboxamide,

Q. R1 = R2 = CO-CH<sub>3</sub>, R3 = H, R4 = CH<sub>2</sub>-CHOH-CH<sub>2</sub>OH: 5-(diacetylamino)-*N*-[2-(2,3-dihydroxypropoxy)-3-hydroxypropyl]-*N'*-(2,3-dihydroxypropyl)-2,4,6-triiodobenzene-1,3-dicarboxamide,

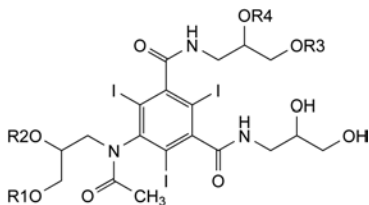

B. R1 = CH<sub>2</sub>-CHOH-CH<sub>2</sub>OH, R2 = R3 = R4 = H: 5-[acetyl[3-(2,3-dihydroxypropoxy)-2-hydroxypropyl]amino]-*N,N'*-bis(2,3-dihydroxypropyl)-2,4,6-triiodobenzene-1,3-dicarboxamide,

C. R2 = CH<sub>2</sub>-CHOH-CH<sub>2</sub>OH, R1 = R3 = R4 = H: 5-[acetyl[2-(2,3-dihydroxypropoxy)-3-hydroxypropyl]amino]-*N,N'*-bis(2,3-dihydroxypropyl)-2,4,6-triiodobenzene-1,3-dicarboxamide,

D. R3 = CH<sub>2</sub>-CHOH-CH<sub>2</sub>OH, R1 = R2 = R4 = H: 5-[acetyl(2,3-dihydroxypropyl)amino]-*N*-[3-(2,3-dihydroxypropoxy)-2-hydroxypropyl]-*N'*-(2,3-dihydroxypropyl)-2,4,6-triiodobenzene-1,3-dicarboxamide,

E. R4 = CH<sub>2</sub>-CHOH-CH<sub>2</sub>OH, R1 = R2 = R3 = H: 5-[acetyl(2,3-dihydroxypropyl)amino]-*N*-[2-(2,3-dihydroxypropoxy)-3-hydroxypropyl]-*N'*-(2,3-dihydroxypropyl)-2,4,6-triiodobenzene-1,3-dicarboxamide,

N. R4 = CO-CH<sub>3</sub>, R1 = R2 = R3 = H: 5-[acetyl(2,3-dihydroxypropyl)amino]-*N*-[2-(acetyloxy)-3-hydroxypropyl]-*N'*-(2,3-dihydroxypropyl)-2,4,6-triiodobenzene-1,3-dicarboxamide,

O. R3 = CO-CH<sub>3</sub>, R1 = R2 = R4 = H: 5-[acetyl(2,3-dihydroxypropyl)amino]-*N*-[3-(acetyloxy)-2-hydroxypropyl]-*N'*-(2,3-dihydroxypropyl)-2,4,6-triiodobenzene-1,3-dicarboxamide,

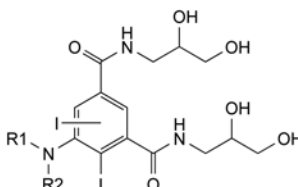

F. R1 = R2 = H: 5-amino-*N,N'*-bis(2,3-dihydroxypropyl)diiodobenzene-1,3-dicarboxamide,

G. R1 = H, R2 = CO-CH<sub>3</sub>: 5-(acetylamino)-*N,N'*-bis(2,3-dihydroxypropyl)diiodobenzene-1,3-dicarboxamide,

H. R1 = CH<sub>2</sub>-CHOH-CH<sub>2</sub>OH, R2 = CO-CH<sub>3</sub>: 5-[acetyl(2,3-dihydroxypropyl)amino]-*N,N'*-bis(2,3-dihydroxypropyl)diiodobenzene-1,3-dicarboxamide,

M. R1 = CH<sub>2</sub>-CHOH-CH<sub>2</sub>OH, R2 = H: *N,N'*-bis(2,3-dihydroxypropyl)-5-[(2,3-dihydroxypropyl)amino]diiodobenzene-1,3-dicarboxamide,

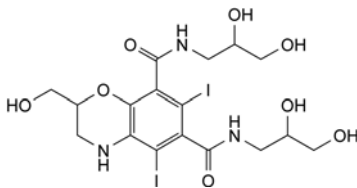

I. *N,N'*-bis(2,3-dihydroxypropyl)-2-(hydroxymethyl)-5,7-diiodo-3,4-dihydro-2*H*-1,4-benzoxazine-6,8-dicarboxamide,

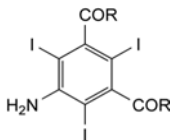

K. R = OH: 5-amino-2,4,6-triiodobenzene-1,3-dicarboxylic acid,

L. R = Cl: 5-amino-2,4,6-triiodobenzene-1,3-dicarbonyl dichloride.

01/2008:1115  
corrected 6.0

## IOPAMIDOL

### Iopamidolum

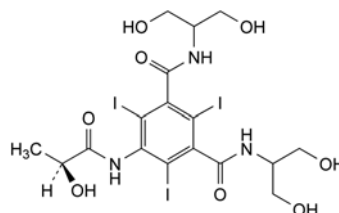

$C_{17}H_{22}I_3N_3O_8$   
[60166-93-0]

$M_r$  777



## DEFINITION

*N,N'*-Bis[2-hydroxy-1-(hydroxymethyl)ethyl]-5-[[2*S*]-2-hydroxypropanoyl]amino]-2,4,6-triiodobenzene-1,3-dicarboxamide.

*Content*: 98.5 per cent to 101.0 per cent (dried substance).

## CHARACTERS

*Appearance*: white or almost white powder.

*Solubility*: freely soluble in water, very slightly soluble in methanol, practically insoluble in ethanol (96 per cent) and in methylene chloride.

## IDENTIFICATION

A. Infrared absorption spectrophotometry (2.2.24).

*Comparison*: iopamidol CRS.

B. Loss on drying (see Tests).

C. Specific optical rotation (see Tests).

## TESTS

**Appearance of solution.** The solution is clear (2.2.1) and colourless (2.2.2, Method II).

Dissolve 1 g in *water R* and dilute to 50 mL with the same solvent.

**Acidity or alkalinity.** Dissolve 10.0 g in *carbon dioxide-free water R* and dilute to 100 mL with the same solvent. Not more than 0.75 mL of 0.01 *M* hydrochloric acid or 1.4 mL of 0.01 *M* sodium hydroxide is required to adjust to pH 7.0 (2.2.3).

**Specific optical rotation** (2.2.7): –4.6 to –5.2 (dried substance), determined at 436 nm.

Dissolve 10.0 g, with heating if necessary, in *water R* and dilute to 25.0 mL with the same solvent.

**Related substances.** Liquid chromatography (2.2.29).

*Test solution.* Dissolve 0.50 g of the substance to be examined in *water R* and dilute to 50.0 mL with the same solvent.

*Reference solution (a).* Dissolve 5.0 mg of iopamidol impurity H CRS in *water R* and dilute to 100.0 mL with the same solvent.

*Reference solution (b).* Dilute 2.0 mL of the test solution to 20.0 mL with *water R*. Dilute 1.0 mL of this solution to 50.0 mL with *water R*.

*Reference solution (c).* Add 0.1 mL of the test solution to 20 mL of reference solution (a) and dilute to 50 mL with *water R*.

*Column*: 2 columns coupled in series,

- *size*:  $l = 0.25$  m,  $\varnothing = 4.6$  mm,
- *stationary phase*: phenylsilyl silica gel for chromatography R (5  $\mu$ m),
- *temperature*: 60 °C.

*Mobile phase*:

- *mobile phase A*: *water R*,
- *mobile phase B*: acetonitrile R, *water R* (50:50 V/V),

Time (min)	Mobile phase A (per cent V/V)	Mobile phase B (per cent V/V)
0 - 18	100	0
18 - 40	100 - 62	0 - 38
40 - 45	62 - 50	38 - 50
45 - 50	50 - 100	50 - 0
50 - 60	100	0

*Flow rate*: 2.0 mL/min.

*Detection*: spectrophotometer at 240 nm.

*Injection*: 20  $\mu$ L.

*Relative retention* with reference to iopamidol (retention time = about 14.6 min): impurity D = about 0.1; impurity B = about 0.6; impurities I and H = about 0.9;

impurity G = about 1.1; impurity K = about 1.2; impurity C = about 1.3; impurity J = about 1.5; impurity A = about 1.8; impurity E = about 2.2; impurity F = about 2.3.

*System suitability*: reference solution (c):

- *resolution*: minimum 2.0 between the peaks due to impurity H and iopamidol.

*Limits*:

- *sum of impurities H and I*: not more than the area of the principal peak in the chromatogram obtained with reference solution (a) (0.5 per cent),
- *impurities A, B, C, D, E, F, G, J, K*: for each impurity, not more than 0.5 times the area of the principal peak in the chromatogram obtained with reference solution (b) (0.1 per cent),
- *any other impurity*: for each impurity, not more than 0.5 times the area of the principal peak in the chromatogram obtained with reference solution (b) (0.1 per cent),
- *sum of impurities other than H and I*: not more than the area of the principal peak in the chromatogram obtained with reference solution (b) (0.2 per cent),
- *disregard limit*: 0.05 times the area of the principal peak in the chromatogram obtained with reference solution (b) (0.01 per cent).

**Free aromatic amines**: maximum 200 ppm.

*Keep the solutions and reagents in iced water, protected from bright light.*

*Test solution.* In a 25 mL volumetric flask, dissolve 0.500 g of the substance to be examined in 20.0 mL of *water R*.

*Reference solution.* In a 25 mL volumetric flask, mix 4.0 mL of a 25.0 mg/L solution of iopamidol impurity A CRS with 16.0 mL of *water R*.

*Blank solution.* Place 20.0 mL of *water R* in a 25 mL volumetric flask.

Place the flasks in iced water, protected from light, for 5 min. Add 1.0 mL of *hydrochloric acid R* to each flask, mix and allow to stand for 5 min. Add 1.0 mL of a 20 g/L solution of *sodium nitrite R* prepared immediately before use, mix and allow to stand for 5 min. Add 1.0 mL of a 120 g/L solution of *ammonium sulfamate R*, swirl gently until gas liberation has ceased, and allow to stand for 5 min. (CAUTION: considerable pressure is produced). Add 1.0 mL of a freshly prepared 1 g/L solution of *naphthylethylenediamine dihydrochloride R* and mix. Remove the flasks from the iced water and allow to stand for 10 min. Dilute to 25.0 mL with *water R* and mix. Measure immediately the absorbance (2.2.25) at 500 nm of the solutions obtained from the test solution and the reference solution using, as the compensation liquid, the solution obtained from the blank solution.

The absorbance of the test solution is not greater than that of the reference solution.

**Free iodine**: maximum 10 ppm.

Dissolve 2.0 g in 25 mL of *water R* in a ground-glass stoppered centrifuge tube. Add 5 mL of *toluene R* and 5 mL of *diluted sulfuric acid R*. Shake and centrifuge. Any red colour of the upper layer is not more intense than that of the upper phase obtained in the same way from 22 mL of *water R*, 2 mL of *iodide standard solution (10 ppm I) R*, 5 mL of *dilute sulfuric acid R*, 1 mL of *concentrated hydrogen peroxide solution R* and 5 mL of *toluene R*.

**Iodide**: maximum 10 ppm.

Dissolve 6.000 g in *water R* and dilute to 20 mL with the same solvent. Add 2.0 mL of 0.001 *M* *potassium iodide*. Carry out a potentiometric titration (2.2.20) with 0.001 *M* *silver nitrate* using a silver indicator electrode and an appropriate reference electrode. Subtract the volume of titrant corresponding to the 2.0 mL of 0.001 *M* *potassium iodide*, determined by titrating a blank to which is added 2.0 mL of 0.001 *M* *potassium iodide* and use the residual value to calculate the iodide content.

1 mL of 0.001 M silver nitrate is equivalent to 126.9 µg of iodide.

**Heavy metals** (2.4.8): maximum 10 ppm.

2.0 g complies with limit test C. Prepare the reference solution using 2 mL of lead standard solution (10 ppm Pb) R.

**Loss on drying** (2.2.32): maximum 0.5 per cent, determined on 1.000 g by drying in an oven at 105 °C.

**Sulfated ash** (2.4.14): maximum 0.1 per cent, determined on 1.0 g.

**Bacterial endotoxins** (2.6.14): less than 1.4 IU/g, if intended for use in the manufacture of parenteral preparations without a further appropriate procedure for the removal of bacterial endotoxins.

#### ASSAY

To 0.300 g in a 250 mL round-bottomed flask add 5 mL of strong sodium hydroxide solution R, 20 mL of water R, 1 g of zinc powder R and a few glass beads. Boil under a reflux condenser for 30 min. Allow to cool and rinse the condenser with 20 mL of water R, adding the rinsings to the flask. Filter through a sintered-glass filter (2.1.2) and wash the filter with several quantities of water R. Collect the filtrate and washings. Add 5 mL of glacial acetic acid R and titrate immediately with 0.1 M silver nitrate. Determine the end-point potentiometrically (2.2.20) using a suitable electrode system such as silver-silver chloride.

1 mL of 0.1 M silver nitrate is equivalent to 25.90 mg of  $C_{17}H_{22}I_3N_3O_8$ .

#### STORAGE

Protected from light. If the substance is sterile, store in a sterile, airtight, tamper-proof container.

#### IMPURITIES

Specified impurities: A, B, C, D, E, F, G, H, I, J, K.

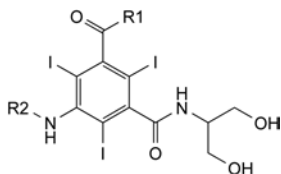

- A. R1 = NH-CH(CH<sub>2</sub>OH)<sub>2</sub>, R2 = H: 5-amino-*N,N'*-bis[2-hydroxy-1-(hydroxymethyl)ethyl]-2,4,6-triiodobenzene-1,3-dicarboxamide,
- B. R1 = NH-CH(CH<sub>2</sub>OH)<sub>2</sub>, R2 = CO-CH<sub>2</sub>OH: 5-[(hydroxyacetyl)amino]-*N,N'*-bis[2-hydroxy-1-(hydroxymethyl)ethyl]-2,4,6-triiodobenzene-1,3-dicarboxamide,
- C. R1 = NH-CH(CH<sub>2</sub>OH)<sub>2</sub>, R2 = CO-CH<sub>3</sub>: 5-(acetylamino)-*N,N'*-bis[2-hydroxy-1-(hydroxymethyl)ethyl]-2,4,6-triiodobenzene-1,3-dicarboxamide,
- D. R1 = OH, R2 = CO-CHOH-CH<sub>3</sub>: 3-[[2-hydroxy-1-(hydroxymethyl)ethyl]carbamoyl]-5-[(2*S*)-2-hydroxypropanoyl]amino]-2,4,6-triiodobenzoic acid,
- E. R1 = NH-CH(CH<sub>2</sub>OH)<sub>2</sub>, R2 = CO-CH(CH<sub>3</sub>)-O-CO-CH<sub>3</sub>: (1*S*)-2-[[3,5-bis[[2-hydroxy-1-(hydroxymethyl)ethyl]carbamoyl]-2,4,6-triiodophenyl]amino]-1-methyl-2-oxoethyl acetate,
- F. R1 = N(CH<sub>3</sub>)<sub>2</sub>, R2 = CO-CHOH-CH<sub>3</sub>: *N'*-[2-hydroxy-1-(hydroxymethyl)ethyl]-5-[[[(2*S*)-2-hydroxypropanoyl]amino]-2,4,6-triiodo-*N,N*-dimethylbenzene-1,3-dicarboxamide,
- G. R1 = NH-CH<sub>2</sub>-CHOH-CH<sub>2</sub>OH, R2 = CO-CHOH-CH<sub>3</sub>: *N*-(2,3-dihydroxypropyl)-*N'*-[2-hydroxy-1-(hydroxymethyl)ethyl]-5-[[[(2*S*)-2-hydroxypropanoyl]amino]-2,4,6-triiodobenzene-1,3-dicarboxamide,
- J. R1 = NH-CH<sub>2</sub>-CH<sub>2</sub>OH, R2 = CO-CHOH-CH<sub>3</sub>: *N*-(2-hydroxyethyl)-*N'*-[2-hydroxy-1-(hydroxymethyl)ethyl]-5-[[[(2*S*)-2-hydroxypropanoyl]amino]-2,4,6-triiodobenzene-1,3-dicarboxamide,

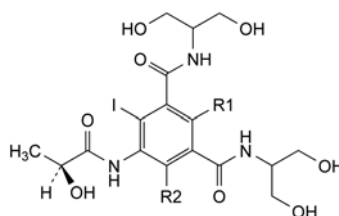

- H. R1 = I, R2 = Cl: 4-chloro-*N,N'*-bis[2-hydroxy-1-(hydroxymethyl)ethyl]-5-[[[(2*S*)-2-hydroxypropanoyl]amino]-2,6-diiodobenzene-1,3-dicarboxamide,
- I. R1 = Cl, R2 = I: 2-chloro-*N,N'*-bis[2-hydroxy-1-(hydroxymethyl)ethyl]-5-[[[(2*S*)-2-hydroxypropanoyl]amino]-4,6-diiodobenzene-1,3-dicarboxamide,
- K. R1 = I, R2 = H: *N,N'*-bis[2-hydroxy-1-(hydroxymethyl)ethyl]-5-[[[(2*S*)-2-hydroxypropanoyl]amino]-2,4-diiodobenzene-1,3-dicarboxamide.

01/2008:0700  
corrected 6.0

## IOPANOIC ACID

### Acidum iopanoicum

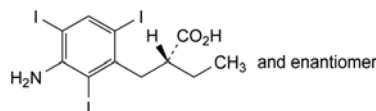

$C_{11}H_{12}I_3NO_2$   
[96-83-3]

*M*, 571

#### DEFINITION

Iopanoic acid contains not less than 98.5 per cent and not more than the equivalent of 101.0 per cent of (*RS*)-2-(3-amino-2,4,6-triiodobenzyl)butanoic acid, calculated with reference to the dried substance.

#### CHARACTERS

A white or yellowish-white powder, practically insoluble in water, soluble in ethanol and in methanol. It dissolves in dilute solutions of alkali hydroxides.

#### IDENTIFICATION

*First identification: B.*

*Second identification: A, C, D.*

- A. Melting point (2.2.14): about 155 °C, with decomposition.
- B. Examine by infrared absorption spectrophotometry (2.2.24), comparing with the spectrum obtained with *iopanoic acid CRS*.
- C. Examine the chromatograms obtained in the test for related substances (see Tests). Spray the plate with a 1 g/L solution of 4-dimethylaminocinnamaldehyde R in a mixture of 1 volume of hydrochloric acid R and 99 volumes of alcohol R. The principal spot in the chromatogram obtained with test solution (b) is similar in position, colour and size to the principal spot in the chromatogram obtained with reference solution (a).
- D. Heat 50 mg carefully in a small porcelain dish over a flame. Violet vapour is evolved.

#### TESTS

**Appearance of solution.** Dissolve 1.0 g in 1 M sodium hydroxide and dilute to 20 mL with the same solvent. The solution is clear (2.2.1) and not more intensely coloured than reference solution Y<sub>3</sub> (2.2.2, Method II).

**Related substances.** Examine by thin-layer chromatography (2.2.27), using silica gel GF<sub>254</sub> R as the coating substance.

**Test solution (a).** Dissolve 1.0 g of the substance to be examined in a mixture of 3 volumes of ammonia R and 97 volumes of

*methanol R* and dilute to 10 mL with the same mixture of solvents.

**Test solution (b).** Dilute 1 mL of test solution (a) to 10 mL with a mixture of 3 volumes of *ammonia R* and 97 volumes of *methanol R*.

**Reference solution (a).** Dissolve 50 mg of *iopanoic acid CRS* in a mixture of 3 volumes of *ammonia R* and 97 volumes of *methanol R* and dilute to 5 mL with the same mixture of solvents.

**Reference solution (b).** Dilute 1 mL of test solution (b) to 50 mL with a mixture of 3 volumes of *ammonia R* and 97 volumes of *methanol R*.

Apply separately to the plate 5 µL of each solution. Develop over a path of 10 cm using a mixture of 10 volumes of *concentrated ammonia R*, 20 volumes of *methanol R*, 20 volumes of *toluene R* and 50 volumes of *dioxan R*. Examine in ultraviolet light at 254 nm. Any spot in the chromatogram obtained with test solution (a), apart from the principal spot, is not more intense than the spot in the chromatogram obtained with reference solution (b) (0.2 per cent).

**Halides.** To 0.46 g add 10 mL of *nitric acid R* and 15 mL of *water R*. Shake for 5 min and filter. 15 mL of the filtrate complies with the limit test for chlorides (2.4.4) (180 ppm, expressed as chloride).

**Loss on drying (2.2.32).** Not more than 0.5 per cent, determined on 1.000 g by drying in an oven at 105 °C for 1 h.

**Sulfated ash (2.4.14).** Not more than 0.1 per cent, determined on 1.0 g.

#### ASSAY

To 0.150 g in a 250 mL round-bottomed flask add 5 mL of *strong sodium hydroxide solution R*, 20 mL of *water R*, 1 g of *zinc powder R* and a few glass beads. Boil under a reflux condenser for 60 min. Allow to cool and rinse the condenser with 20 mL of *water R*, adding the rinsings to the flask. Filter through a sintered-glass filter (2.1.2) and wash the filter with several quantities of *water R*. Collect the filtrate and washings. Add 40 mL of *dilute sulfuric acid R* and titrate immediately with 0.1 M *silver nitrate*. Determine the end-point potentiometrically (2.2.20), using a suitable electrode system such as silver-mercurous sulfate.

1 mL of 0.1 M *silver nitrate* is equivalent to 19.03 mg of C<sub>11</sub>H<sub>12</sub>I<sub>3</sub>NO<sub>2</sub>.

#### STORAGE

Store protected from light.

Mixture of diastereoisomers and atropisomers.

**Content:** 97.0 per cent to 102.0 per cent (anhydrous substance).

#### CHARACTERS

**Appearance:** white or slightly yellowish powder.

**Solubility:** freely soluble in water and in dimethyl sulfoxide, practically insoluble in ethanol (96 per cent) and in acetone.

#### IDENTIFICATION

Infrared absorption spectrophotometry (2.2.24).

**Comparison:** *iopromide CRS*.

#### TESTS

**Appearance of solution.** The solution is clear (2.2.1) and not more intensely coloured than reference solutions BY<sub>6</sub>, B<sub>6</sub> and Y<sub>6</sub> (2.2.2, Method I).

Dissolve 16.5 g in 20 mL of *carbon dioxide-free water R* while heating on a water-bath at a temperature not exceeding 70 °C. Allow to cool to room temperature.

**Conductivity (2.2.38):** maximum 50 µS·cm<sup>-1</sup>.

Dissolve 1.000 g in *water R* and dilute to 50.0 mL with the same solvent.

**Impurity A and related primary aromatic amines:** maximum 0.01 per cent.

*Protect the solutions from light throughout the test. All given times are critical for the test results. The test solution, reference solution and blank solution must be processed in parallel.*

**Test solution.** Dissolve 0.500 g of the substance to be examined in 20.0 mL of *water R* in a 25 mL volumetric flask.

**Reference solution.** Dissolve the contents of a vial of *iopromide impurity A CRS* in 5.0 mL of *water R*. Transfer 2.0 mL of this solution to a 25 mL volumetric flask and add 18.0 mL of *water R*.

**Blank solution.** Place 20.0 mL of *water R* in a 25 mL volumetric flask.

Cool the test solution, reference solution and blank solution in a bath of iced water for 5 min. Add 1.0 mL of *hydrochloric acid R1* to each solution and cool again for 5 min in a bath of iced water. Add 1.0 mL of a 20 g/L solution of *sodium nitrite R*, shake vigorously and cool for another 5 min in a bath of iced water. To each solution add 0.50 mL of an 80 g/L solution of *sulfamic acid R*. Over the next 5 min, shake vigorously several times, raising the stoppers to vent the gas that evolves. Afterwards, add to each solution 1.0 mL of a 1 g/L solution of *naphthylethylenediamine dihydrochloride R* in a mixture of 300 volumes of *water R* and 700 volumes of *propylene glycol R*, shake, allow to cool to room temperature for 10 min and dilute to 25.0 mL with *water R*. Degas the solutions in an ultrasonic bath for 1 min and measure the absorbance (2.2.25) of the test solution and the reference solution at 495 nm against the blank, within 5 min. The test is not valid unless the absorbance of the reference solution is at least 0.08. The absorbance of the test solution is not greater than the absorbance of the reference solution.

**Impurity B.** Liquid chromatography (2.2.29).

**Solvent mixture:** *methanol R*, *water R* (50:50 V/V).

**Test solution.** Dissolve 40.0 mg of the substance to be examined in the solvent mixture and dilute to 25.0 mL with the solvent mixture.

**Reference solution (a).** Dissolve 40.0 mg of *iopromide CRS* in the solvent mixture and dilute to 25.0 mL with the solvent mixture.

**Reference solution (b).** Introduce several millilitres of reference solution (a) into a vial sealed with a crimp-top. Heat at 121 °C for 15 min.

**Reference solution (c).** Dilute 1.5 mL of the test solution to 100.0 mL with the solvent mixture.

07/2009:1753

## IOPROMIDE

### Iopromidum

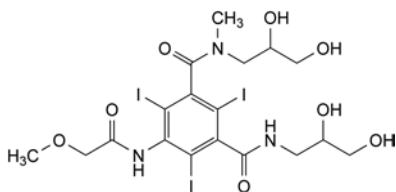

C<sub>18</sub>H<sub>24</sub>I<sub>3</sub>N<sub>3</sub>O<sub>8</sub>  
[73334-07-3]

M<sub>r</sub> 791

#### DEFINITION

*N,N'*-Bis(2,3-dihydroxypropyl)-2,4,6-triiodo-5-[(methoxyacetyl)amino]-*N*-methylbenzene-1,3-dicarboxamide.

**Column:**

- size:  $l = 0.25$  m,  $\varnothing = 4.6$  mm;
- stationary phase: end-capped octadecylsilyl silica gel for chromatography R (5  $\mu$ m);
- temperature: 20 °C.

**Mobile phase:** mix 6 g of chloroform R with 59 g of methanol R. Add 900 g of water for chromatography R in small portions to the chloroform/methanol mixture and stir for at least 2 h to obtain a homogeneous solution.

**Flow rate:** 1.2 mL/min.

**Detection:** spectrophotometer at 254 nm.

**Injection:** 10  $\mu$ L of the test solution and reference solutions (a) and (c).

**Run time:** 50 min.

**Identification of impurities:** use the chromatogram supplied with iopromide CRS and the chromatogram obtained with reference solution (a) to identify the peaks due to impurity B isomers  $Y_1$  and  $Y_2$ .

**Relative retention** with reference to iopromide isomer  $Z_2$  (retention time = about 34 min): impurity B isomer  $Y_1$  = about 0.28; impurity B isomer  $Y_2$  = about 0.31.

**System suitability:** reference solution (a):

- the chromatogram obtained shows 2 peaks due to impurity B isomers  $Y_1$  and  $Y_2$ .

**Limit:**

- sum of impurity B isomers  $Y_1$  and  $Y_2$ : not more than the sum of the areas of the 2 principal peaks due to the iopromide in the chromatogram obtained with reference solution (c) (1.5 per cent).

**Related substances.** Thin-layer chromatography (2.2.27).

**Solvent mixture:** methanol R, water R (50:50 V/V).

**Test solution.** Dissolve 1.0 g of the substance to be examined in the solvent mixture and dilute to 10.0 mL with the solvent mixture.

**Reference solution (a).** Dilute 1.0 mL of the test solution to 100.0 mL with the solvent mixture.

**Reference solution (b).** Dilute 5.0 mL of reference solution (a) to 10.0 mL with the solvent mixture.

**Reference solution (c).** Dilute 2.0 mL of reference solution (a) to 10.0 mL with the solvent mixture.

**Reference solution (d).** Dilute 1.0 mL of reference solution (a) to 10.0 mL with the solvent mixture.

**Reference solution (e).** Dissolve the contents of a vial of iopromide for system suitability 1 CRS (containing impurities B and E) in 50  $\mu$ L of the solvent mixture.

**Reference solution (f).** Dissolve the contents of a vial of iopromide for system suitability 2 CRS (containing impurities B, C, D and F) in 50  $\mu$ L of the solvent mixture.

**Plates:** TLC silica gel F<sub>254</sub> plate R (2 plates).

**A. Mobile phase:** concentrated ammonia R, water R, dioxan R (4:15:85 V/V/V).

**Application:** 2  $\mu$ L of the test solution and reference solutions (b), (d) and (e).

**Development:** over 3/4 of the plate.

**Drying:** in a current of air, until complete evaporation of the solvents, then at 120 °C for 30 min.

**Detection:** examine immediately in ultraviolet light at 254 nm; expose to ultraviolet light for 2-5 min until the principal spots appear clearly as yellow spots, then spray with ferric chloride-ferricyanide-arsenite reagent R and examine immediately in daylight.

**Retardation factors:** impurity B = about 0.26; iopromide = about 0.34; impurity E = about 0.41.

**System suitability:** reference solution (e):

- the chromatogram shows 3 clearly separated spots.

**Limits:**

- impurity E: any spot due to impurity E is not more intense than the principal spot in the chromatogram obtained with reference solution (b) (0.5 per cent);
- unspecified impurities: any other spot is not more intense than the principal spot in the chromatogram obtained with reference solution (d) (0.10 per cent); disregard any spot due to impurity B.

**B. Mobile phase:** anhydrous formic acid R, water R, methanol R, chloroform R (2:6:32:62 V/V/V/V).

**Application:** 2  $\mu$ L of the test solution and reference solutions (a), (b), (c), (d) and (f).

**Development:** over 3/4 of the plate.

**Drying:** in a current of air, until complete evaporation of the solvents, then at 120 °C for 30 min.

**Detection:** examine immediately in ultraviolet light at 254 nm; expose to an ammonia vapour for 30 min, dry in a current of air for 10 min, then expose to ultraviolet light for 2-5 min until the principal spots appear clearly as yellow spots, then spray with ferric chloride-ferricyanide-arsenite reagent R and examine immediately in daylight.

**Retardation factors:** impurity C = about 0.23; impurity D = about 0.29; impurity B = about 0.36; iopromide = about 0.43; impurity F = about 0.71.

**System suitability:** reference solution (f):

- the chromatogram shows 5 clearly separated spots.

**Limits:**

- impurity D: any spot due to impurity D is not more intense than the principal spot in the chromatogram obtained with reference solution (a) (1.0 per cent);
- impurity C: any spot due to impurity C is not more intense than the principal spot in the chromatogram obtained with reference solution (b) (0.5 per cent);
- impurity F: any spot due to impurity F is not more intense than the principal spot in the chromatogram obtained with reference solution (c) (0.2 per cent);
- unspecified impurities: any other spot is not more intense than the principal spot in the chromatogram obtained with reference solution (d) (0.10 per cent); disregard any spot due to impurity B.

**Isomer distribution.** Liquid chromatography (2.2.29) as described in the test for impurity B with the following modifications.

Calculate the percentage content of the isomer groups with reference to the total area of all the peaks due to the 4 iopromide isomers, using the chromatogram obtained with the test solution.

**Limits:**

- sum of iopromide isomers  $E_1$  and  $Z_1$ : 40.0 per cent to 51.0 per cent;
- sum of iopromide isomers  $E_2$  and  $Z_2$ : 49.0 per cent to 60.0 per cent.

**Free iodine.** Dissolve 2.0 g in 20 mL of water R in a glass-stoppered test tube. Add 2 mL of dilute sulfuric acid R and 2 mL of toluene R, close and shake vigorously. The upper layer remains colourless (2.2.2, Method II).

**Iodide:** maximum 2 ppm.

Dissolve 10.0 g in 50 mL of carbon dioxide-free water R. Adjust to pH 3-4 adding about 0.15 mL of 0.1 M sulfuric acid. Titrate with 0.001 M silver nitrate. Determine the end-point potentiometrically (2.2.20) using a combined metal electrode. Not more than 0.15 mL of 0.001 M silver nitrate is required to reach the end-point.

**Heavy metals (2.4.8):** maximum 10 ppm.

Dissolve 2.0 g in water R and dilute to 20 mL with the same solvent. 12 mL of the solution complies with test A. Prepare the reference solution using lead standard solution (1 ppm Pb) R.

**Water** (2.5.12): maximum 1.5 per cent, determined on 1.00 g.

**Sulfated ash** (2.4.14): maximum 0.1 per cent, determined on 1.0 g.

**Bacterial endotoxins** (2.6.14): less than 1.0 IU/g.

#### ASSAY

Liquid chromatography (2.2.29) as described in the test for impurity B with the following modifications.

**Injection:** test solution and reference solutions (a) and (b).

**Identification of the isomers:** the 2 principal peaks in the chromatogram obtained with reference solution (a) are due to iopromide isomers  $Z_1$  and  $Z_2$ . The 2 peaks that have an increased size in the chromatogram obtained with reference solution (b) in comparison to the chromatogram obtained with reference solution (a), are due to iopromide isomers  $E_1$  and  $E_2$ .

**Relative retention** with reference to iopromide isomer  $Z_2$  (retention time = about 34 min): iopromide isomer  $E_1$  = about 0.70; iopromide isomer  $E_2$  = about 0.75; iopromide isomer  $Z_1$  = about 0.85.

**System suitability:** reference solution (a):

- **resolution:** minimum 2.0 between the peaks due to iopromide isomers  $Z_1$  and  $Z_2$ .

Calculate the percentage content of iopromide from the declared content of *iopromide CRS* and from the sum of the areas of all of the peaks due to isomer groups E and Z.

#### STORAGE

Protected from light.

#### IMPURITIES

**Specified impurities:** A, B, C, D, E, F.

**Other detectable impurities** (the following substances would, if present at a sufficient level, be detected by one or other of the tests in the monograph. They are limited by the general acceptance criterion for other/unspecified impurities and/or by the general monograph *Substances for pharmaceutical use* (2034). It is therefore not necessary to identify these impurities for demonstration of compliance. See also 5.10. *Control of impurities in substances for pharmaceutical use*): G, H.

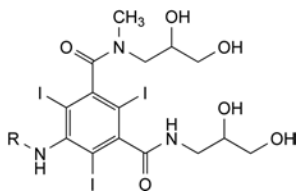

A. R = H: 5-amino-*N,N'*-bis(2,3-dihydroxypropyl)-2,4,6-triiodo-*N*-methylbenzene-1,3-dicarboxamide,

B. R = CO-CH<sub>3</sub>: 5-(acetylamino)-*N,N'*-bis(2,3-dihydroxypropyl)-2,4,6-triiodo-*N*-methylbenzene-1,3-dicarboxamide,

C. R = CO-CH<sub>2</sub>OH: *N,N'*-bis(2,3-dihydroxypropyl)-5-[(hydroxyacetyl)amino]-2,4,6-triiodo-*N*-methylbenzene-1,3-dicarboxamide,

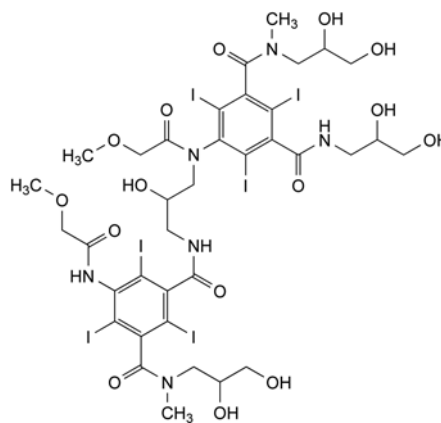

D. *N*-(2,3-dihydroxypropyl)-*N'*-[3-[[3-[(2,3-dihydroxypropyl)carbamoyl]-5-[(2,3-dihydroxypropyl)methylcarbamoyl]-2,4,6-triiodophenyl](methoxyacetyl)amino]-2-hydroxypropyl]-2,4,6-triiodo-5-[(methoxyacetyl)amino]-*N*-methylbenzene-1,3-dicarboxamide,

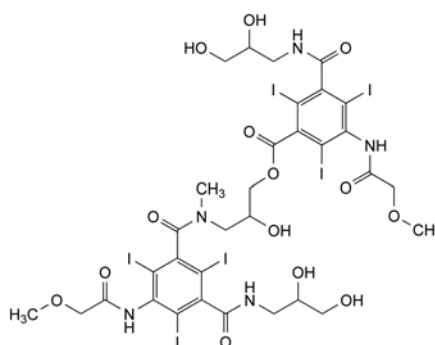

E. 3-[[3-[(2,3-dihydroxypropyl)carbamoyl]-2,4,6-triiodo-5-[(methoxyacetyl)amino]benzoyl]methylamino]-2-hydroxypropyl 3-[(2,3-dihydroxypropyl)carbamoyl]-2,4,6-triiodo-5-[(methoxyacetyl)amino]benzoate,

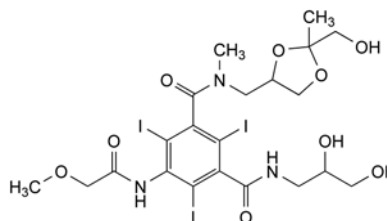

F. *N*-(2,3-dihydroxypropyl)-*N'*-[[2-(hydroxymethyl)-2-methyl-1,3-dioxolan-4-yl]methyl]-2,4,6-triiodo-5-[(methoxyacetyl)amino]-*N*-methylbenzene-1,3-dicarboxamide,

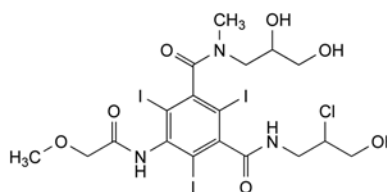

G. *N'*-(2-chloro-3-hydroxypropyl)-*N*-(2,3-dihydroxypropyl)-2,4,6-triiodo-5-[(methoxyacetyl)amino]-*N*-methylbenzene-1,3-dicarboxamide,

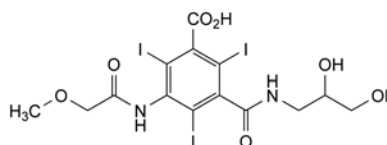

H. 3-[(2,3-dihydroxypropyl)carbamoyl]-2,4,6-triiodo-5-[(methoxyacetyl)amino]benzoic acid.

01/2008:0751  
corrected 6.0**IOTALAMIC ACID**

## Acidum iotalamicum

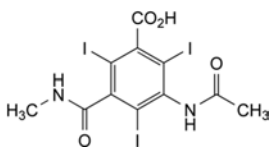
C<sub>11</sub>H<sub>9</sub>I<sub>3</sub>N<sub>2</sub>O<sub>4</sub>  
[2276-90-6]M<sub>r</sub> 614

## DEFINITION

Iotalamic acid contains not less than 98.5 per cent and not more than the equivalent of 101.0 per cent of 3-(acetylaminio)-2,4,6-tri-iodo-5-(methylcarbamoyl)benzoic acid, calculated with reference to the dried substance.

## CHARACTERS

A white or almost white powder, slightly soluble in water and in alcohol. It dissolves in dilute solutions of alkali hydroxides.

## IDENTIFICATION

First identification: A.

Second identification: B, C.

A. Examine by infrared absorption spectrophotometry (2.2.24), comparing with the spectrum obtained with *iotalamic acid CRS*.

B. Examine by thin-layer chromatography (2.2.27), using a *TLC silica gel GF<sub>254</sub> plate R*.

*Test solution.* Dissolve 50 mg of the substance to be examined in *methanol R* containing 3 per cent *V/V* of *ammonia R* and dilute to 5 mL with the same solvent.

*Reference solution.* Dissolve 50 mg of *iotalamic acid CRS* in *methanol R* containing 3 per cent *V/V* of *ammonia R* and dilute to 5 mL with the same solvent.

Apply separately to the plate 5 µL of each solution. Develop over a path of 15 cm using a mixture of 20 volumes of *anhydrous formic acid R*, 25 volumes of *methyl ethyl ketone R* and 60 volumes of *toluene R*. Allow the plate to dry until the solvents have evaporated and examine in ultraviolet light at 254 nm. The principal spot in the chromatogram obtained with the test solution is similar in position and size to the principal spot in the chromatogram obtained with the reference solution.

C. Heat 50 mg gently in a small porcelain dish over a flame. Violet vapour is evolved.

## TESTS

**Appearance of solution.** Dissolve 1.0 g in 1 M *sodium hydroxide* and dilute to 20 mL with the same solvent. The solution is clear (2.2.1) and colourless (2.2.2, *Method II*).

**Related substances.** Examine by thin-layer chromatography (2.2.27), using a *TLC silica gel GF<sub>254</sub> plate R*.

*Test solution.* Dissolve 1.0 g of the substance to be examined in *methanol R* containing 3 per cent *V/V* of *ammonia R* and dilute to 10 mL with the same solvent.

*Reference solution (a).* Dilute 1 mL of the test solution to 50 mL with *water R*. Dilute 1 mL of the solution to 10 mL with *water R*.

*Reference solution (b).* Dissolve 1 mg of *iotalamic acid impurity A CRS* in 5 mL of reference solution (a).

Apply to the plate 5 µL of each solution. Develop over a path of 10 cm using a mixture of 1 volume of *glacial acetic acid R*, 1 volume of *anhydrous formic acid R*, 1 volume of *methanol R*, 5 volumes of *ether R* and 10 volumes of *methylene chloride R*. Allow the plate to dry until the solvents have

evaporated. Examine in ultraviolet light at 254 nm. Any spot in the chromatogram obtained with the test solution, apart from the principal spot, is not more intense than the spot in the chromatogram obtained with reference solution (a) (0.2 per cent). The test is not valid unless the chromatogram obtained with reference solution (b) shows two clearly separated principal spots.

**Halides.** Dissolve 0.55 g in a mixture of 4 mL of *dilute sodium hydroxide solution R* and 15 mL of *water R*. Add 6 mL of *dilute nitric acid R* and filter. 15 mL of the filtrate complies with the limit test for chlorides (2.4.4) (150 ppm, expressed as chloride).

**Impurity A.** Not more than 0.05 per cent *m/m* determined by absorption spectrophotometry (2.2.25).

*Test solution.* Transfer 0.500 g of the substance to be examined to a 50 mL volumetric flask, add 14 mL of *water R*, shake and add 1 mL of *dilute sodium hydroxide solution R*.

*Reference solution.* Prepare the reference solution by mixing 10.0 mL of a 8.5 g/L solution of *sodium hydroxide R* containing 25 µg/mL of *iotalamic acid impurity A CRS* with 5 mL of *water R* in a 50 mL volumetric flask.

*Blank solution.* Transfer 14 mL of *water R* and 1 mL of *dilute sodium hydroxide solution R* to a 50 mL volumetric flask.

*In conducting the following steps, keep the flasks in iced water and protected as far as possible from light until all of the reagents have been added.*

Place all three of the flasks containing the test solution, the reference solution and the blank solution in iced water, protected from light. Add 5 mL of a 5 g/L solution of *sodium nitrite R* and 12 mL of *dilute hydrochloric acid R*. Shake gently and allow to stand for exactly 2 min after adding the hydrochloric acid. Add 10 mL of a 20 g/L solution of *ammonium sulfamate R*. Allow to stand for 5 min shaking frequently (*CAUTION: considerable pressure is produced*), and add 0.15 mL of a 100 g/L solution of *α-naphthol R* in *alcohol R*. Shake and allow to stand for 5 min. Add 3.5 mL of *buffer solution pH 10.9 R*, mix and dilute to 50.0 mL with *water R*. Concomitantly and within 20 min determine the absorbance at 485 nm of the solutions obtained from the test solution and the reference solution in 5 cm cells, using the blank as the compensation liquid.

Calculate the content of impurity A.

**Iodide.** Not more than 20 ppm, determined by potentiometric titration (2.2.20). Dissolve 6.000 g in 20 mL of 1 M *sodium hydroxide*, add 10 mL of *water R* and adjust to pH 4.5 to 5.5 with *acetic acid R*. Add 2.0 mL of 0.001 M *potassium iodide*. Titrate with 0.001 M *silver nitrate* using a silver indicator electrode and an appropriate reference electrode. Subtract the volume of titrant corresponding to the 2.0 mL of 0.001 M *potassium iodide*, determined by titrating a blank to which is added 2.0 mL of 0.001 M *potassium iodide* and use the residual value to calculate the iodide content.

1 mL of 0.001 M *silver nitrate* is equivalent to 126.9 µg of iodide.

**Heavy metals (2.4.8).** Dissolve 2.0 g in 4 mL of *dilute sodium hydroxide solution R* and dilute to 20 mL with *water R*. 12 mL of this solution complies with limit test A for heavy metals (20 ppm). Prepare the standard using *lead standard solution (2 ppm Pb) R*.

**Loss on drying (2.2.32).** Not more than 0.5 per cent, determined on 0.300 g by drying in an oven at 105 °C.

**Sulfated ash (2.4.14).** Not more than 0.1 per cent, determined on 1.0 g.

## ASSAY

To 0.150 g in a 250 mL round-bottomed flask add 5 mL of *strong sodium hydroxide solution R*, 20 mL of *water R*, 1 g of *zinc powder R* and a few glass beads. Boil under a reflux condenser for 30 min. Allow to cool and rinse the condenser with 20 mL of *water R*, adding the rinsings to the flask. Filter through a sintered-glass filter (2.1.2) and wash the filter

with several quantities of *water R*. Collect the filtrate and washings. Add 40 mL of *dilute sulfuric acid R* and titrate immediately with 0.1 M *silver nitrate*. Determine the end-point potentiometrically (2.2.20), using a suitable electrode system such as silver-mercurous sulfate.

1 mL of 0.1 M *silver nitrate* is equivalent to 20.47 mg of  $C_{11}H_9I_3N_2O_4$ .

#### STORAGE

Store protected from light.

#### IMPURITIES

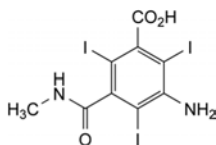

A. 3-amino-2,4,6-triiodo-5-(methylcarbamoyl)benzoic acid.

01/2008:1754

## IOTROLAN

### Iotrolanum

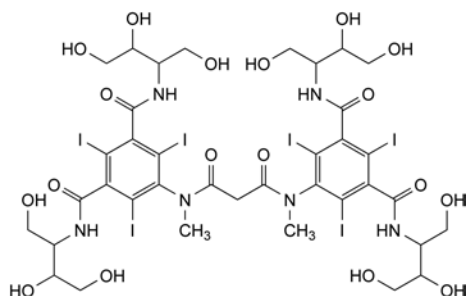

$C_{37}H_{48}I_6N_6O_{18}$   
[79770-24-4]

$M_r$  1626

#### DEFINITION

Mixture of stereoisomers of 5,5'-[propanedioylbis(methyl-imino)]bis[*N,N'*-bis[2,3-dihydroxy-1-(hydroxymethyl)propyl]-2,4,6-triiodobenzene-1,3-dicarboxamide].

*Content*: 98.0 per cent to 102.0 per cent (anhydrous substance).

#### CHARACTERS

*Appearance*: white or yellowish-white powder, hygroscopic.

*Solubility*: very soluble in water, freely soluble in dimethyl sulfoxide, practically insoluble in ethanol (96 per cent).

#### IDENTIFICATION

Infrared absorption spectrophotometry (2.2.24).

*Comparison*: *iotrolan CRS*.

#### TESTS

**Appearance of solution.** The solution is clear (2.2.1) and not more intensely coloured than reference solution BY<sub>6</sub> (2.2.2, Method II).

Dissolve 18.0 g in *carbon dioxide-free water R* and dilute to 20.0 mL with the same solvent.

**Conductivity** (2.2.28): maximum 25  $\mu\text{S}\cdot\text{cm}^{-1}$ .

Dissolve 1.000 g in *water R* and dilute to 50.0 mL with the same solvent.

**Primary aromatic amines.** *Protect the solutions from light throughout the test. All given times are critical for the test results. The test solution, the reference solution and the blank solution must be processed in parallel.*

*Test solution.* Dissolve 0.500 g of the substance to be examined in 20.0 mL of *water R* in a 25 mL volumetric flask.

*Reference solution.* Dissolve 5.0 mg of *iopamidol impurity A CRS* in *water R* and dilute to 20.0 mL with the same solvent. Transfer 1.0 mL of this solution to a 25 mL volumetric flask and add 19.0 mL of *water R*.

*Blank solution.* Place 20.0 mL of *water R* in a 25 mL volumetric flask.

*Procedure.* Cool the test solution, reference solution and blank solution in a bath of iced water for 5 min. Add 1.0 mL of *hydrochloric acid R1* to each solution and cool again for 5 min in a bath of iced water. Add 1.0 mL of a 20 g/L solution of *sodium nitrite R*, shake vigorously and cool for another 5 min in a bath of iced water. To each solution add 0.50 mL of an 80 g/L solution of *sulfamic acid R*. Over the next 5 min, shake vigorously several times, raising the stoppers to vent the gas that evolves. Afterwards add to each solution 1.0 mL of a 1 g/L solution of *naphthylethylenediamine dihydrochloride R* in a mixture of 300 volumes of *water R* and 700 volumes of *propylene glycol R*, shake, allow to cool to room temperature for 10 min and dilute to 25.0 mL with *water R*. Degas the solutions in an ultrasonic bath for 1 min and measure the absorbance (2.2.25) of the test solution and the reference solution at 495 nm against the blank, within 5 min.

*System suitability*:

– *absorbance of the reference solution*: minimum 0.40.

*Limit*:

– *absorbance of the test solution*: not more than the absorbance of the reference solution (0.05 per cent).

**Related substances.** Thin-layer chromatography (2.2.27). *Prepare the solutions immediately before use.*

*Test solution.* Dissolve 1.0 g of the substance to be examined in a mixture of equal volumes of *methanol R* and *water R* and dilute to 10.0 mL with the same mixture of solvents.

*Reference solution (a).* Dilute 1.0 mL of the test solution to 200.0 mL with a mixture of equal volumes of *methanol R* and *water R*.

*Reference solution (b).* Dilute 2.0 mL of reference solution (a) to 10.0 mL with a mixture of equal volumes of *methanol R* and *water R*.

*Reference solution (c).* Dissolve the contents of a vial of *iotrolan for system suitability CRS* (containing about 0.05 per cent of each of impurities A and B) in 50  $\mu\text{L}$  of a mixture of equal volumes of *methanol R* and *water R*.

*Plate*: TLC silica gel F<sub>254</sub> plate R.

*Pretreatment*: over 3/4 of the plate with *methylene chloride R*.

*Mobile phase*: concentrated ammonia R, *water R*, dioxan R (4:20:80 V/V/V).

*Application*: 2  $\mu\text{L}$ .

*Development*: over 3/4 of the plate.

*Drying*: in a current of air until the solvents have evaporated.

*Detection*: examine in ultraviolet light at 254 nm. Expose the plate to the ultraviolet light for 2-5 min until the principal spots appear clearly as yellow spots. Spray with *ferric chloride-ferricyanide-arsenite reagent R* and examine in daylight.

*R<sub>F</sub> values*: *iotrolan* = about 0.25; *impurity A* = about 0.4; *impurity B* = about 0.5.

*System suitability*: reference solution (c):

– the chromatogram shows 3 clearly separated spots.

*Limits*:

– *impurities A, B*: any spot due to impurity A or B is not more intense than the principal spot in the chromatogram obtained with reference solution (a) (0.5 per cent);

– *unspecified impurities*: any other spot is not more intense than the principal spot in the chromatogram obtained with reference solution (b) (0.10 per cent).

**Isomer distribution.** Liquid chromatography (2.2.29) as described under Assay. Use the normalisation procedure.

**Identification of peaks:** use the chromatogram supplied with *iotrolan CRS* and the chromatogram obtained with the reference solution to identify the peaks due to the 3 isomer groups.

Calculate the percentage content of each of the isomer groups G1, G2 and G3, with reference to the total area of all of the peaks due to the 3 isomer groups, using the chromatogram obtained with the test solution.

**Limits:**

- isomer group G1: 53.0 per cent to 70.0 per cent;
- isomer group G2: 3.0 per cent to 11.0 per cent;
- isomer group G3: 25.0 per cent to 39.0 per cent.

**Free iodine.** Dissolve 0.20 g in 1 mL of *water R* in a glass-stoppered test tube. Add 4 mL of a 370 g/L solution of *sulfuric acid R* and 5 mL of *toluene R*, close and shake vigorously. The upper layer remains colourless (2.2.2, *Method II*).

**Iodide:** maximum 20 ppm.

Dissolve 10.0 g in 50 mL of *carbon dioxide-free water R*. Adjust to pH 3-4 adding about 0.15 mL of *dilute sulfuric acid R*. Titrate with 0.001 M *silver nitrate*, determining the end-point potentiometrically (2.2.20). Not more than 1.5 mL of 0.001 M *silver nitrate* is required to reach the end-point.

**Heavy metals (2.4.8):** maximum 10 ppm.

Dissolve 2.0 g in *water R* and dilute to 20 mL with the same solvent. 12 mL of the solution complies with test A. Prepare the reference solution using *lead standard solution (1 ppm Pb) R*.

**Water (2.5.12):** maximum 3.5 per cent, determined on 0.250 g.

**Sulfated ash (2.4.14):** maximum 0.1 per cent, determined on 1.0 g.

**Bacterial endotoxins (2.6.14):** less than 0.7 IU/g.

#### ASSAY

Liquid chromatography (2.2.29).

**Test solution.** Dissolve 40.0 mg of the substance to be examined in *water R* and dilute to 25.0 mL with the same solvent.

**Reference solution.** Dissolve 40.0 mg of *iotrolan CRS* in *water R* and dilute to 25.0 mL with the same solvent.

**Column:**

- size:  $l = 0.25$  m,  $\varnothing = 4.6$  mm;
- stationary phase: end-capped octadecylsilyl silica gel for chromatography R (5  $\mu$ m);
- temperature: 40 °C.

**Mobile phase:** *methanol R*, *water for chromatography R* (10:90 V/V).

**Flow rate:** 0.5 mL/min.

**Detection:** spectrophotometer at 254 nm.

**Injection:** 10  $\mu$ L.

**Run time:** 40 min.

**Retention time:** isomer group G1 = about 8 min to 12 min; isomer group G2 = about 15 min to 22 min; isomer group G3 = about 22 min to 32 min.

**System suitability:** reference solution:

- the chromatogram obtained is similar to the chromatogram supplied with *iotrolan CRS*.

Calculate the percentage content of iotrolan from the total area of all of the peaks of the 3 isomer groups G1, G2 and G3 and the declared content of *iotrolan CRS*.

#### STORAGE

In an airtight container, protected from light.

#### IMPURITIES

**Specified impurities:** A, B.

**Other detectable impurities** (the following substances would, if present at a sufficient level, be detected by one or other of the tests in the monograph. They are limited by the general acceptance criterion for other/unspecified impurities and/or by the general monograph *Substances for pharmaceutical use (2034)*. It is therefore not necessary to identify these impurities for demonstration of compliance. See also 5.10. *Control of impurities in substances for pharmaceutical use*): C, D, E, F, G, H, I, J.

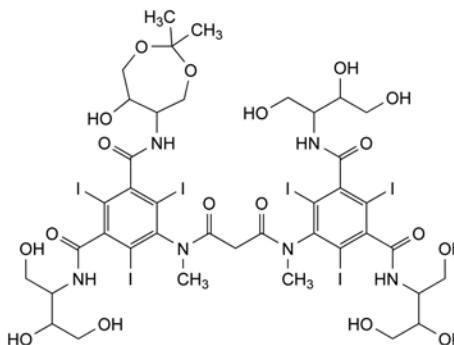

- A. *N,N'*-bis[2,3-dihydroxy-1-(hydroxymethyl)propyl]-5-[[3-[[2,3-dihydroxy-1-(hydroxymethyl)propyl]carbamoyl]-5-[(6-hydroxy-2,2-dimethyl-1,3-dioxepan-5-yl)carbamoyl]-2,4,6-triiodophenyl]methylamino]-3-oxopropanoyl]methylamino]-2,4,6-triiodobenzene-1,3-dicarboxamide,

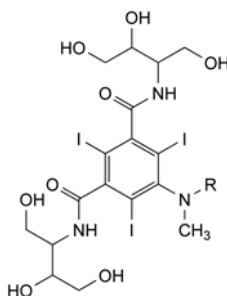

- B. R = CO-CH<sub>3</sub>: 5-(acetylmethylamino)-*N,N'*-bis[2,3-dihydroxy-1-(hydroxymethyl)propyl]-2,4,6-triiodobenzene-1,3-dicarboxamide,
- C. R = CO-CH<sub>2</sub>-CO<sub>2</sub>H: 3-[[3,5-bis[[2,3-dihydroxy-1-(hydroxymethyl)propyl]carbamoyl]-2,4,6-triiodophenyl]methylamino]-3-oxopropanoic acid,
- E. R = H: *N,N'*-bis[2,3-dihydroxy-1-(hydroxymethyl)propyl]-2,4,6-triiodo-5-(methylamino)benzene-1,3-dicarboxamide,

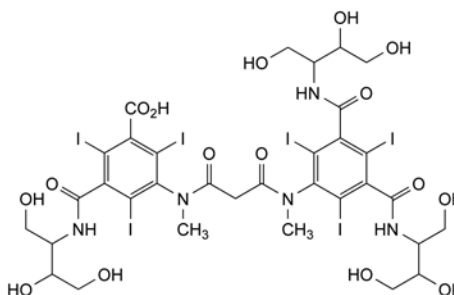

- D. 3-[[3-[[3,5-bis[[2,3-dihydroxy-1-(hydroxymethyl)propyl]carbamoyl]-2,4,6-triiodophenyl]methylamino]-3-oxopropanoyl]methylamino]-5-[[2,3-dihydroxy-1-(hydroxymethyl)propyl]carbamoyl]-2,4,6-triiodobenzoic acid,



01/2011:2009

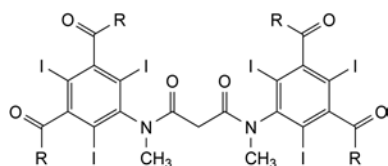

F. R = OH: 5,5'-[propanedioylbis(methylimino)]bis[2,4,6-triiodobenzene-1,3-dicarboxylic] acid,

G. R = Cl: 5,5'-[propanedioylbis(methylimino)]bis[2,4,6-triiodobenzene-1,3-dicarbonyl] tetrachloride,

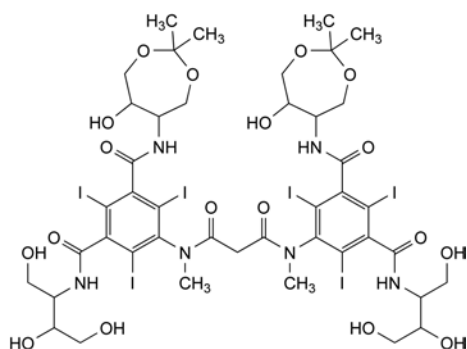

H. 5,5'-[propanedioylbis(methylimino)]bis[*N*-[2,3-dihydroxy-1-(hydroxymethyl)propyl]-*N'*-(6-hydroxy-2,2-dimethyl-1,3-dioxepan-5-yl)-2,4,6-triiodobenzene-1,3-dicarboxamide],

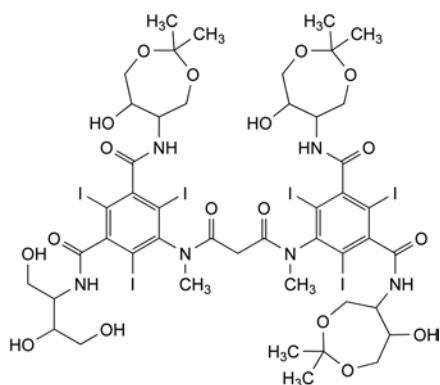

I. 5-[[3-[[3-[[2,3-dihydroxy-1-(hydroxymethyl)propyl]-carbamoyl]-5-[(6-hydroxy-2,2-dimethyl-1,3-dioxepan-5-yl)carbamoyl]-2,4,6-triiodophenyl]methylamino]-3-oxopropanoyl]methylamino]-*N,N'*-bis(6-hydroxy-2,2-dimethyl-1,3-dioxepan-5-yl)-2,4,6-triiodobenzene-1,3-dicarboxamide,

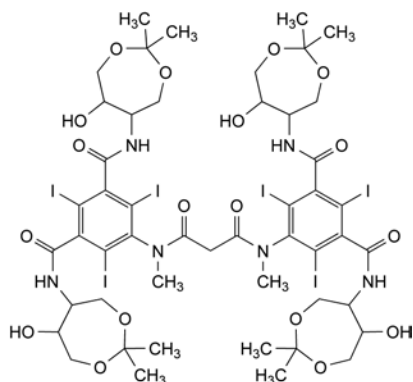

J. 5,5'-[propanedioylbis(methylimino)]bis[*N,N'*-bis(6-hydroxy-2,2-dimethyl-1,3-dioxepan-5-yl)-2,4,6-triiodobenzene-1,3-dicarboxamide].

## IOXAGLIC ACID

### Acidum ioxaglicum

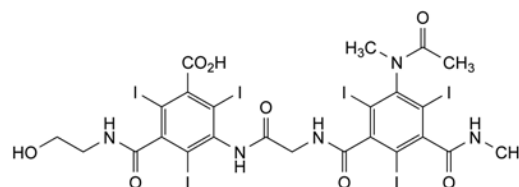

$C_{24}H_{21}I_6N_5O_8$   
[59017-64-0]

$M_r$  1269

#### DEFINITION

3-[[[3-(Acetylmethylamino)-2,4,6-triiodo-5-(methylcarbamoyl)benzoyl]amino]acetyl]amino]-5-[(2-hydroxyethyl)carbamoyl]-2,4,6-triiodobenzoic acid.

*Content*: 98.5 per cent to 101.5 per cent (anhydrous substance).

#### CHARACTERS

*Appearance*: white or almost white, hygroscopic powder.

*Solubility*: very slightly soluble in water, slightly soluble in ethanol (96 per cent), very slightly soluble in methylene chloride. It dissolves in dilute solutions of alkali hydroxides.

#### IDENTIFICATION

Infrared absorption spectrophotometry (2.2.24).

*Comparison*: ioxaglic acid CRS.

#### TESTS

**Appearance of solution.** The solution is clear (2.2.1).

Dissolve 1.0 g in a 40 g/L solution of *sodium hydroxide R* and dilute to 20 mL with the same solution.

**Absorbance** (2.2.25): maximum 0.18, calculated for a solution containing 40 per cent of anhydrous ioxaglic acid.

Dissolve 10.0 g in about 8 mL of a 40 g/L solution of *sodium hydroxide R*. Adjust to pH 7.2-7.6 with a 40 g/L solution of *sodium hydroxide R* or 1 M *hydrochloric acid*. Dilute to 25 mL with *water R*. Filter through a membrane filter (nominal pore size 0.45 µm). Measure the absorbance at 450 nm using *water R* as the compensation liquid.

**Related substances.** Liquid chromatography (2.2.29): use the normalisation procedure.

*Solvent mixture*: acetonitrile *R*, *water R* (5:95 V/V).

*Test solution.* Dissolve 0.10 g of the substance to be examined in about 40 mL of the solvent mixture. Add  $0.5 \pm 0.1$  mL of a 4 g/L solution of *sodium hydroxide R* and dilute to 50.0 mL with the solvent mixture. Shake until dissolution is complete (using ultrasound, if necessary).

*Reference solution (a).* Dissolve 0.10 g of *ioxaglic acid CRS* in about 40 mL of the solvent mixture. Add  $0.5 \pm 0.1$  mL of a 4 g/L solution of *sodium hydroxide R* and dilute to 50.0 mL with the solvent mixture. Shake until dissolution is complete (using ultrasound, if necessary).

*Reference solution (b).* Dissolve 5 mg of *ioxaglic acid impurity A CRS* in the solvent mixture and dilute to 50.0 mL with the solvent mixture. Dilute 1.0 mL of the solution to 50.0 mL with the solvent mixture.

#### Column:

- *size*:  $l = 0.25$  m,  $\varnothing = 4.6$  mm;
- *stationary phase*: spherical end-capped *octylsilyl silica gel for chromatography R* (5 µm) with a specific surface area of not less than 335 m<sup>2</sup>/g, a pore size of 10 nm and a carbon loading of not less than 12 per cent;
- *temperature*: 25 °C.

**Mobile phase:**

- mobile phase A: 0.136 g/L solution of *potassium dihydrogen phosphate R* adjusted to pH 3.0 with *phosphoric acid R*;
- mobile phase B: *acetonitrile R*;

Time (min)	Mobile phase A (per cent V/V)	Mobile phase B (per cent V/V)
0 - 5	95 → 90	5 → 10
5 - 40	90	10
40 - 85	90 → 70	10 → 30
85 - 115	70	30
115 - 120	70 → 50	30 → 50
120 - 125	50	50

**Flow rate:** 0.8 mL/min.

**Detection:** spectrophotometer at 242 nm.

**Injection:** 10 µL.

**Identification of impurities:** use the chromatogram supplied with *ioxaglic acid CRS* and the chromatogram obtained with reference solution (a) to identify the peaks due to impurities A, B, C, D1, D2, D3, D4, E and F.

**Relative retention** with reference to *ioxaglic acid* (retention time = about 65 min): impurity A = about 0.3; impurity B = about 0.7; impurity C = about 0.9; impurity D1 = about 1.09; impurity E = about 1.12; impurity D2 = about 1.20; impurity D3 = about 1.26; impurity D4 = about 1.28; impurity F = about 1.6.

**System suitability:**

- **peak-to-valley ratio:** minimum 1.3, where  $H_p$  = height above the baseline of the peak due to impurity C and  $H_v$  = height above the baseline of the lowest point of the curve separating this peak from the peak due to *ioxaglic acid* in the chromatogram obtained with reference solution (a).

**Limits:**

- **impurity D** (sum of the peaks due to impurities D1, D2, D3 and D4): not more than 0.7 per cent;
- **impurity E:** not more than 0.7 per cent;
- **impurity F:** not more than 0.4 per cent;
- **impurity B:** not more than 0.3 per cent;
- **impurity C:** not more than 0.3 per cent;
- **impurity A:** not more than 0.1 per cent;
- **any other impurity:** not more than 0.2 per cent;
- **total:** not more than 2 per cent;
- **disregard limit:** 0.05 per cent; disregard any peak with a retention time greater than 125 min.

**Iodides:** maximum 50 ppm.

Disperse 10.0 g in 50 mL of *water R*. Add 8 mL of 1 M *sodium hydroxide*. After dissolution and homogenisation, add 1.0 mL of *glacial acetic acid R*. Immediately titrate with 0.001 M *silver nitrate*, determining the end-point potentiometrically (2.2.20), using a silver indicator electrode and a suitable reference electrode.

1 mL of 0.001 M *silver nitrate* is equivalent to 0.1269 mg of iodides.

**Heavy metals** (2.4.8): maximum 10 ppm.

Dissolve 2.0 g in 4 mL of a 40 g/L solution of *sodium hydroxide R* and dilute to 20 mL with *water R*. 12 mL of the solution complies with test A. Prepare the reference solution using 1 mL of *lead standard solution (10 ppm Pb) R*.

**Water** (2.5.12): maximum 5.0 per cent, determined on 0.100 g.

**Sulfated ash** (2.4.14): maximum 0.1 per cent, determined on 1.0 g.

**ASSAY**

In a round-bottomed flask place 0.100 g of the substance to be examined and add 5 mL of *strong sodium hydroxide solution R*, 20 mL of *water R*, 1 g of *zinc powder R* and a few glass beads. Fit the flask with a reflux condenser and boil for 30 min. Cool and rinse the condenser with 20 mL of *water R*. Add the rinsings to the contents of the flask. Filter, wash the filter with 3 quantities, each of 15 mL, of *water R* and add the washings to the filtrate. Add 40 mL of *dilute sulfuric acid R* and titrate immediately with 0.05 M *silver nitrate*. Determine the end-point potentiometrically (2.2.20), using a suitable electrode combination such as the silver/mercurous sulfate system.

1 mL of 0.05 M *silver nitrate* is equivalent to 10.58 mg of  $C_{24}H_{21}I_6N_5O_8$ .

**STORAGE**

In an airtight container, protected from light.

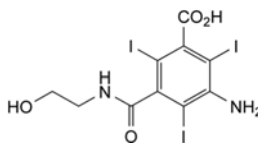
**IMPURITIES**

A. 3-amino-5-[(2-hydroxyethyl)carbamoyl]-2,4,6-triodobenzoic acid,

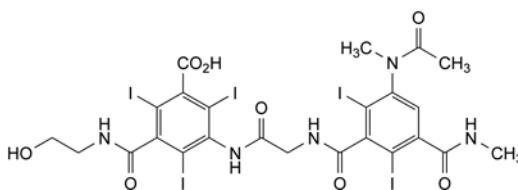

B. 3-[[[3-(acetylmethylamino)-2,6-diiodo-5-(methylcarbamoyl)benzoyl]amino]acetyl]amino]-5-[(2-hydroxyethyl)carbamoyl]-2,4,6-triodobenzoic acid,

C. specified impurity whose structure is unknown,

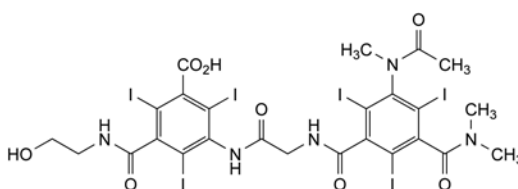

D. D1, D2, D3 and D4: 3-[[[3-(acetylmethylamino)-5-(dimethylcarbamoyl)-2,4,6-triodobenzoyl]amino]acetyl]amino]-5-[(2-hydroxyethyl)carbamoyl]-2,4,6-triodobenzoic acid,

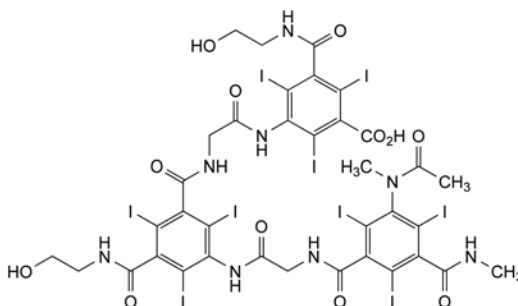

E. 3-[[[3-[[[3-(acetylmethylamino)-2,4,6-triodo-5-(methylcarbamoyl)benzoyl]amino]acetyl]amino]-5-[(2-hydroxyethyl)carbamoyl]-2,4,6-triodobenzoyl]amino]acetyl]amino]-5-[(2-hydroxyethyl)carbamoyl]-2,4,6-triodobenzoic acid,

F. specified impurity whose structure is unknown,

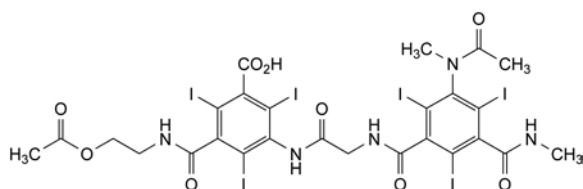

- G. 3-[[[3-(acetylmethylamino)-2,4,6-triiodo-5-(methylcarbamoyl)-benzoyl]amino]acetyl]amino]-5-[[2-(acetyloxy)ethyl]carbamoyl]-2,4,6-triiodobenzoic acid,

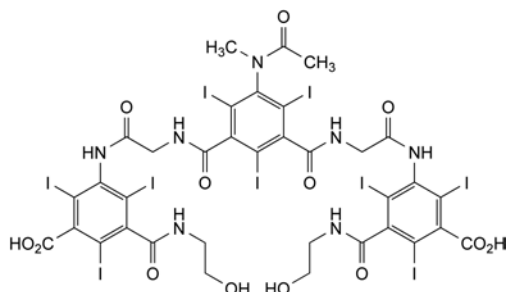

- H. 3,3'-[[5-(acetylmethylamino)-2,4,6-triiodo-1,3-phenylene]bis(carbonyliminomethylenecarbonylimino)]bis[5-[(2-hydroxyethyl)carbamoyl]-2,4,6-triiodobenzoic] acid.

01/2008:0919  
corrected 6.2

## IPRATROPIUM BROMIDE

### Ipratropii bromidum

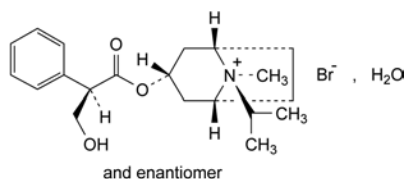

$C_{20}H_{30}BrNO_3 \cdot H_2O$   
[66985-17-9]

$M_r$  430.4

#### DEFINITION

(1*R*,3*r*,5*S*,8*r*)-3-[[*(2R,S)*-3-Hydroxy-2-phenylpropanoyl]oxy]-8-methyl-8-(1-methylethyl)-8-azoniabicyclo[3.2.1]octane bromide monohydrate.

*Content*: 99.0 per cent to 100.5 per cent (anhydrous substance).

#### CHARACTERS

*Appearance*: white or almost white, crystalline powder.

*Solubility*: soluble in water, freely soluble in methanol, slightly soluble in ethanol (96 per cent).

mp: about 230 °C, with decomposition.

#### IDENTIFICATION

*First identification*: A, E.

*Second identification*: B, C, D, E.

A. Infrared absorption spectrophotometry (2.2.24).

*Comparison*: ipratropium bromide CRS.

B. Examine the chromatograms obtained in the test for impurity A.

*Results*: the principal spot in the chromatogram obtained with the test solution is similar in position, colour and size to the principal spot in the chromatogram obtained with reference solution (a).

C. To 5 mL of solution S (see Tests), add 2 mL of dilute sodium hydroxide solution R. No precipitate is formed.

D. To about 1 mg add 0.2 mL of nitric acid R and evaporate to dryness on a water-bath. Dissolve the residue in 2 mL of acetone R and add 0.1 mL of a 30 g/L solution of potassium hydroxide R in methanol R. A violet colour develops.

E. It gives reaction (a) of bromides (2.3.1).

#### TESTS

**Solution S.** Dissolve 0.50 g in carbon dioxide-free water R and dilute to 50.0 mL with the same solvent.

**Appearance of solution.** Solution S is clear (2.2.1) and not more intensely coloured than reference solution GY<sub>7</sub> (2.2.2, Method II).

**pH** (2.2.3): 5.0 to 7.5 for solution S.

**Impurity A.** Thin-layer chromatography (2.2.27).

*Test solution.* Dissolve 20 mg of the substance to be examined in methanol R and dilute to 1.0 mL with the same solvent.

*Reference solution (a).* Dissolve 20 mg of ipratropium bromide CRS in methanol R and dilute to 1.0 mL with the same solvent.

*Reference solution (b).* Dissolve 20 mg of methylatropine bromide CRS in 1.0 mL of reference solution (a).

*Reference solution (c).* Dissolve 5 mg of ipratropium impurity A CRS in 100.0 mL of methanol R. Dilute 2.0 mL of the solution to 5.0 mL with methanol R.

*Plate*: TLC silica gel plate R (2-10 µm).

*Mobile phase*: anhydrous formic acid R, water R, ethanol (96 per cent) R, methylene chloride R (1:3:18:18 V/V/V/V).

*Application*: 1 µL.

*Development*: over a path of 6 cm.

*Drying*: at 60 °C for 15 min.

*Detection*: spray with potassium iodobismuthate solution R, allow the plate to dry in air, spray with a 50 g/L solution of sodium nitrite R and protect immediately with a sheet of glass.

*System suitability*: the chromatogram obtained with reference solution (b) shows 2 clearly separated principal spots.

*Limit*:

- *impurity A*: any spot due to impurity A is not more intense than the principal spot in the chromatogram obtained with reference solution (c) (0.1 per cent).

**Related substances.** Liquid chromatography (2.2.29).

*Test solution.* Dissolve 0.200 g of the substance to be examined in the mobile phase and dilute to 20.0 mL with the mobile phase.

*Reference solution (a).* Dissolve 10.0 mg of ipratropium bromide CRS in the mobile phase and dilute to 20.0 mL with the mobile phase. Dilute 1.0 mL of the solution to 50.0 mL with the mobile phase.

*Reference solution (b).* Dissolve 5 mg of ipratropium bromide CRS and 5 mg of ipratropium impurity B CRS in 1 mL of methanol R and dilute to 25.0 mL with the mobile phase. Dilute 1.0 mL of the solution to 20.0 mL with the mobile phase.

*Column*:

- *size*:  $l = 0.15$  m,  $\emptyset = 3.9$  mm;
- *stationary phase*: octadecylsilyl silica gel for chromatography R (5 µm);
- *temperature*: 30 °C.

*Mobile phase*: dissolve 12.4 g of sodium dihydrogen phosphate R and 1.7 g of tetrapropylammonium chloride R in 870 mL of water R; adjust to pH 5.5 with a 180 g/L solution of disodium hydrogen phosphate R and add 130 mL of methanol R.

*Flow rate*: 1.5 mL/min.

*Detection*: spectrophotometer at 220 nm.

*Injection*: 5 µL.

*Run time*: 6 times the retention time of ipratropium.

*Relative retention* with reference to ipratropium (retention time = about 4.9 min): impurity C = about 0.7; impurity B = about 1.2; impurity D = about 1.8; impurity E = about 2.3; impurity F = about 5.1.

*System suitability*: reference solution (b):

- *resolution*: minimum 3.0 between the peaks due to impurity B and ipratropium;
- *symmetry factor*: maximum 2.5 for the principal peak.

*Limits*:

- *correction factors*: for the calculation of content, multiply the peak areas of the following impurities by the corresponding correction factor: impurity C = 0.3; impurity D = 0.2; impurity F = 0.5;
- *impurity D*: not more than 0.5 times the area of the principal peak in the chromatogram obtained with reference solution (a) (0.05 per cent);
- *impurities B, C*: for each impurity, not more than the area of the principal peak in the chromatogram obtained with reference solution (a) (0.1 per cent);
- *unspecified impurities*: for each impurity, not more than the area of the principal peak in the chromatogram obtained with reference solution (a) (0.10 per cent);
- *total*: not more than 2.5 times the area of the principal peak in the chromatogram obtained with reference solution (a) (0.25 per cent);
- *disregard limit*: one-third of the area of the principal peak in the chromatogram obtained with reference solution (a) (0.03 per cent); disregard the peak due to the bromide ion.

**Water** (2.5.12): 3.9 per cent to 4.4 per cent, determined on 0.50 g.

**Sulfated ash** (2.4.14): maximum 0.1 per cent, determined on 1.0 g.

**ASSAY**

Dissolve 0.350 g in 50 mL of *water R* and add 3 mL of *dilute nitric acid R*. Titrate with 0.1 M *silver nitrate*, determining the end-point potentiometrically (2.2.20).

1 mL of 0.1 M *silver nitrate* is equivalent to 41.24 mg of C<sub>20</sub>H<sub>30</sub>BrNO<sub>3</sub>.

**IMPURITIES**

*Specified impurities: A, B, C, D.*

*Other detectable impurities* (the following substances would, if present at a sufficient level, be detected by one or other of the tests in the monograph. They are limited by the general acceptance criterion for other/unspecified impurities and/or by the general monograph *Substances for pharmaceutical use* (2034). It is therefore not necessary to identify these impurities for demonstration of compliance. See also 5.10. *Control of impurities in substances for pharmaceutical use*): E, F.

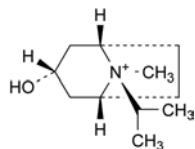

A. (1R,3r,5S,8r)-3-hydroxy-8-methyl-8-(1-methylethyl)-8-azoniabicyclo[3.2.1]octane,

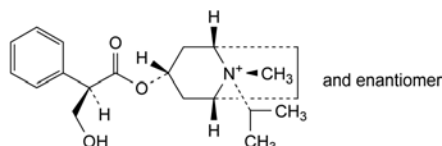

B. (1R,3r,5S,8s)-3-[(2RS)-3-hydroxy-2-phenylpropanoyl]oxy-8-methyl-8-(1-methylethyl)-8-azoniabicyclo[3.2.1]octane,

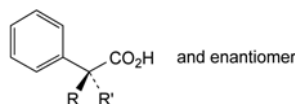

C. R = CH<sub>2</sub>-OH, R' = H: (2RS)-3-hydroxy-2-phenylpropanoic acid (DL-tropic acid),

D. R + R' = CH<sub>2</sub>: 2-phenylpropenoic acid (atropic acid),

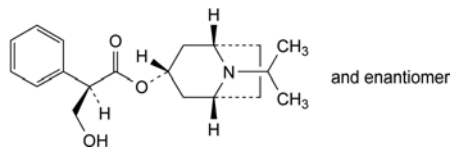

E. (1R,3r,5S)-8-(1-methylethyl)-8-azoniabicyclo[3.2.1]oct-3-yl (2RS)-3-hydroxy-2-phenylpropanoate,

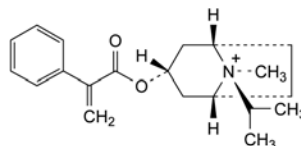

F. (1R,3r,5S,8r)-8-methyl-8-(1-methylethyl)-3-[(2-phenylpropenoyl)oxy]-8-azoniabicyclo[3.2.1]octane.

04/2010:2465 corrected 7.0

**IRBESARTAN**

**Irbesartanum**

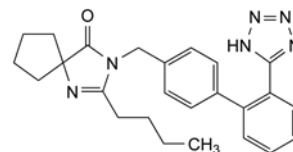

C<sub>25</sub>H<sub>28</sub>N<sub>6</sub>O  
[138402-11-6]

M<sub>r</sub> 428.5

**DEFINITION**

2-Butyl-3-[[2'-(1H-tetrazol-5-yl)biphenyl-4-yl]methyl]-1,3-diazaspiro[4.4]non-1-en-4-one.

*Content*: 99.0 per cent to 101.0 per cent (anhydrous substance).

**CHARACTERS**

*Appearance*: white or almost white, crystalline powder.

*Solubility*: practically insoluble in water, sparingly soluble in methanol, slightly soluble in methylene chloride.

It shows polymorphism (5.9).

**IDENTIFICATION**

Infrared absorption spectrophotometry (2.2.24).

*Comparison*: *irbesartan CRS*.

If the spectra obtained in the solid state show differences, dissolve the substance to be examined and the reference substance separately in *methanol R*, evaporate to dryness at 60 °C and record new spectra using the residues.

**TESTS**

**Appearance of solution.** The solution is clear (2.2.1) and not more intensely colored than reference solution B<sub>7</sub> (2.2.2, *Method II*).

Dissolve 0.50 g in a mixture of 1 volume of 2 M *sodium hydroxide R* and 9 volumes of *methanol R2* and dilute to 10 mL with the same mixture of solvents.

**Impurity B.** Liquid chromatography (2.2.29).

*Test solution.* Dissolve 0.100 g of the substance to be examined in the mobile phase and dilute to 5.0 mL with the mobile phase.

**Reference solution.** Dissolve 25.0 mg of *sodium azide R* (sodium salt of impurity B) in the mobile phase and dilute to 100.0 mL with the mobile phase. Dilute 0.25 mL of this solution to 200.0 mL with the mobile phase.

**Column:**

- *size:*  $l = 0.25$  m,  $\varnothing = 4$  mm;
- *stationary phase:* strongly basic anion-exchange resin for chromatography R (8.5  $\mu$ m).

**Mobile phase:** 4.2 g/L solution of *sodium hydroxide R* in carbon dioxide-free water R.

**Flow rate:** 1.0 mL/min.

**Detection:** conductivity detector with a sensitivity of 3  $\mu$ S; use a self-regenerating anion suppressor.

**Neutralisation of the eluent:** either chemical or electrochemical:

- *chemical:* by continuous countercurrent circulation in a neutralising micromembrane, performed before detection:
  - *neutralising solvent:* 0.025 M sulfuric acid;
  - *flow rate:* 10 mL/min;
  - *pressure:* corresponding to about 100 kPa.
- *electrochemical:* 300 mA (for example).

**Injection:** 200  $\mu$ L.

**Run time:** 25 min.

**Retention time:** impurity B = about 14 min.

**System suitability:** reference solution:

- *signal-to-noise ratio:* minimum 10 for the peak due to impurity B.

**Limit:**

- *impurity B:* not more than the area of the corresponding peak in the chromatogram obtained with the reference solution (10 ppm).

**Related substances.** Liquid chromatography (2.2.29).

**Buffer solution pH 3.2.** Mix 5.5 mL of *phosphoric acid R* and 950 mL of *water R* and adjust to pH 3.2 with *triethylamine R*.

**Test solution.** Dissolve 50 mg of the substance to be examined in *methanol R2* and dilute to 50.0 mL with the same solvent.

**Reference solution (a).** Dilute 1.0 mL of the test solution to 20.0 mL with *methanol R2*. Dilute 1.0 mL of this solution to 50.0 mL with *methanol R2*.

**Reference solution (b).** Dissolve 5 mg of the substance to be examined and 5 mg of *irbesartan impurity A CRS* in *methanol R2* and dilute to 10.0 mL with the same solvent. Dilute 1.0 mL of this solution to 10.0 mL with *methanol R2*.

**Column:**

- *size:*  $l = 0.25$  m,  $\varnothing = 4$  mm;
- *stationary phase:* end-capped octadecylsilyl silica gel for chromatography R (5  $\mu$ m).

**Mobile phase:** *acetonitrile R1*, buffer solution pH 3.2 (33:67 V/V).

**Flow rate:** 1.0 mL/min.

**Detection:** spectrophotometer at 220 nm.

**Injection:** 10  $\mu$ L.

**Run time:** 1.4 times the retention time of irbesartan.

**Identification of impurities:** use the chromatogram obtained with reference solution (b) to identify the peak due to impurity A.

**Relative retention** with reference to irbesartan (retention time = about 23 min): impurity A = about 0.7.

**System suitability:** reference solution (b):

- *resolution:* minimum 3.0 between the peaks due to impurity A and irbesartan.

**Limits:**

- *impurity A:* not more than 1.5 times the area of the principal peak in the chromatogram obtained with reference solution (a) (0.15 per cent);

- *unspecified impurities:* for each impurity, not more than the area of the principal peak in the chromatogram obtained with reference solution (a) (0.10 per cent);
- *total:* not more than twice the area of the principal peak in the chromatogram obtained with reference solution (a) (0.2 per cent);
- *disregard limit:* 0.5 times the area of the principal peak in the chromatogram obtained with reference solution (a) (0.05 per cent).

**Heavy metals** (2.4.8): maximum 20 ppm.

**Solvent mixture:** *acetone R*, *methanol R* (20:80 V/V).

0.25 g complies with test H. Prepare the reference solution using 0.5 mL of *lead standard solution (10 ppm Pb) R*.

**Water** (2.5.12): maximum 0.5 per cent, determined on 1.00 g.

**Sulfated ash** (2.4.14): maximum 0.1 per cent, determined on 1.0 g.

**ASSAY**

Dissolve 0.300 g in 50 mL of *anhydrous acetic acid R*. Titrate with 0.1 M *perchloric acid*, determining the end-point potentiometrically (2.2.20).

1 mL of 0.1 M *perchloric acid* is equivalent to 42.85 mg of  $C_{25}H_{28}N_6O$ .

**IMPURITIES**

**Specified impurities:** A, B.

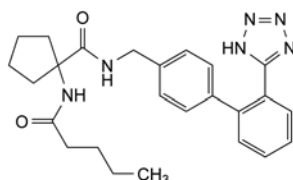

A. 1-(pentanoylamino)-N-[[2'-(1H-tetrazol-5-yl)biphenyl-4-yl]-methyl]cyclopentanecarboxamide,

$N_3^-$

B. trinitride (azide).

01/2008:1018  
corrected 6.0

## ISOCONAZOLE

Isoconazolium

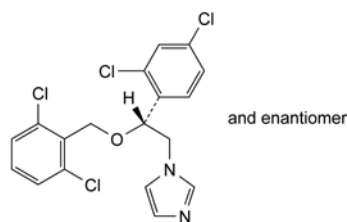

$C_{18}H_{14}Cl_4N_2O$   
[27523-40-6]

$M_r$  416.1

**DEFINITION**

1-[(2R,3S)-2-[(2,6-Dichlorobenzyl)oxy]-2-(2,4-dichlorophenyl)ethyl]-1H-imidazole.

**Content:** 99.0 per cent to 101.0 per cent (dried substance).

**CHARACTERS**

**Appearance:** white or almost white powder.

**Solubility:** practically insoluble in water, very soluble in methanol, freely soluble in ethanol (96 per cent).

**IDENTIFICATION**

**First identification:** A, B.

Second identification: A, C, D.

- A. Melting point (2.2.14): 111 °C to 115 °C.  
 B. Infrared absorption spectrophotometry (2.2.24).

Preparation: discs.

Comparison: isoconazole CRS.

- C. Thin-layer chromatography (2.2.27).

Test solution. Dissolve 30 mg of the substance to be examined in methanol R and dilute to 5 mL with the same solvent.

Reference solution (a). Dissolve 30 mg of isoconazole CRS in methanol R and dilute to 5 mL with the same solvent.

Reference solution (b). Dissolve 30 mg of isoconazole CRS and 30 mg of econazole nitrate CRS in methanol R, then dilute to 5 mL with the same solvent.

Plate: TLC octadecylsilyl silica gel plate R.

Mobile phase: ammonium acetate solution R, dioxan R, methanol R (20:40:40 V/V/V).

Application: 5 µL.

Development: over a path of 15 cm.

Drying: in a current of warm air for 15 min.

Detection: expose to iodine vapour until the spots appear and examine in daylight.

System suitability: reference solution (b):

- the chromatogram shows 2 clearly separated spots.

Results: the principal spot in the chromatogram obtained with the test solution is similar in position, colour and size to the principal spot in the chromatogram obtained with reference solution (a).

- D. To about 30 mg in a porcelain crucible add 0.3 g of anhydrous sodium carbonate R. Heat over an open flame for 10 min. Allow to cool. Take up the residue with 5 mL of dilute nitric acid R and filter. To 1 mL of the filtrate add 1 mL of water R. The solution gives reaction (a) of chlorides (2.3.1).

#### TESTS

**Solution S.** Dissolve 0.20 g in methanol R and dilute to 20.0 mL with the same solvent.

**Appearance of solution.** Solution S is clear (2.2.1) and not more intensely coloured than reference solution Y<sub>6</sub> (2.2.2, Method II).

**Optical rotation** (2.2.7): –0.10° to +0.10°, determined on solution S.

**Related substances.** Liquid chromatography (2.2.29).

Test solution. Dissolve 0.100 g of the substance to be examined in 3.2 mL of methanol R. Add 3.0 mL of acetonitrile R and dilute to 10.0 mL with a solution of ammonium acetate R (6.0 g in 380 mL of water R).

Reference solution (a). Dissolve 2.5 mg of isoconazole CRS and 2.5 mg of econazole nitrate CRS in the mobile phase, then dilute to 100.0 mL with the mobile phase.

Reference solution (b). Dilute 1.0 mL of the test solution to 100.0 mL with the mobile phase. Dilute 5.0 mL of this solution to 20.0 mL with the mobile phase.

Column:

- size:  $l = 0.1$  m,  $\emptyset = 4.6$  mm;
- stationary phase: octadecylsilyl silica gel for chromatography R (3 µm).

Mobile phase: dissolve 6.0 g of ammonium acetate R in a mixture of 300 mL of acetonitrile R, 320 mL of methanol R and 380 mL of water R.

Flow rate: 2 mL/min.

Detection: spectrophotometer at 235 nm.

Equilibration: with the mobile phase for about 30 min.

Injection: 10 µL.

Run time: 1.5 times the retention time of isoconazole.

Retention time: econazole = about 10 min; isoconazole = about 14 min.

System suitability: reference solution (a):

- resolution: minimum 5.0 between the peaks due to econazole and isoconazole; if necessary, adjust the composition of the mobile phase.

Limits:

- impurities B, C, D: for each impurity, not more than the area of the principal peak in the chromatogram obtained with reference solution (b) (0.25 per cent);
- total: not more than twice the area of the principal peak in the chromatogram obtained with reference solution (b) (0.5 per cent);
- disregard limit: 0.2 times the area of the principal peak in the chromatogram obtained with reference solution (b) (0.05 per cent).

**Loss on drying** (2.2.32): maximum 0.5 per cent, determined on 1.000 g by drying in an oven at 105 °C for 2 h.

**Sulfated ash** (2.4.14): maximum 0.1 per cent, determined on 1.0 g.

#### ASSAY

Dissolve 0.300 g in 50 mL of a mixture of 1 volume of anhydrous acetic acid R and 7 volumes of methyl ethyl ketone R. Using 0.2 mL of naphtholbenzein solution R as indicator, titrate with 0.1 M perchloric acid until the colour changes from orange-yellow to green.

1 mL of 0.1 M perchloric acid is equivalent to 41.61 mg of C<sub>18</sub>H<sub>14</sub>Cl<sub>4</sub>N<sub>2</sub>O.

#### STORAGE

Protected from light.

#### IMPURITIES

Specified impurities: B, C, D.

A. deleted,

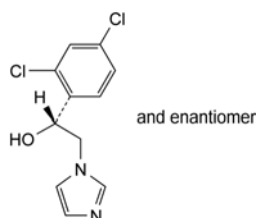

B. (1R)-1-(2,4-dichlorophenyl)-2-(1H-imidazol-1-yl)ethanol,

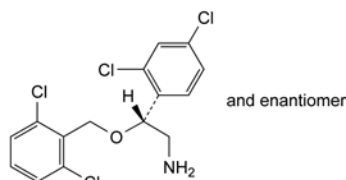

C. (2R)-2-[(2,6-dichlorobenzyl)oxy]-2-(2,4-dichlorophenyl)ethanamine,

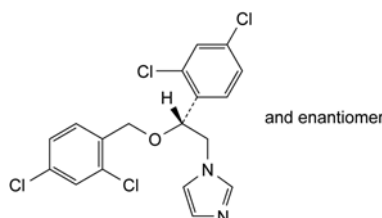

D. 1-[(2R)-2-[(2,4-dichlorobenzyl)oxy]-2-(2,4-dichlorophenyl)ethyl]-1H-imidazole.

01/2008:1017  
corrected 6.7**Optical rotation** (2.2.7):  $-0.10^{\circ}$  to  $+0.10^{\circ}$ , determined on solution S.**ISOCONAZOLE NITRATE**

## Isoconazoli nitras

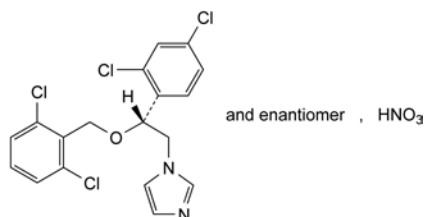
C<sub>18</sub>H<sub>15</sub>Cl<sub>4</sub>N<sub>3</sub>O<sub>4</sub>  
[24168-96-5]M<sub>r</sub> 479.1**DEFINITION**1-[(2*RS*)-2-[(2,6-Dichlorobenzyl)oxy]-2-(2,4-dichlorophenyl)-ethyl]-1*H*-imidazole nitrate.**Content:** 99.0 per cent to 101.0 per cent (dried substance).**CHARACTERS****Appearance:** white or almost white powder.**Solubility:** very slightly soluble in water, soluble in methanol, slightly soluble in ethanol (96 per cent).**IDENTIFICATION****First identification:** A, B.**Second identification:** A, C, D.

A. Melting point (2.2.14): 178 °C to 182 °C.

B. Infrared absorption spectrophotometry (2.2.24).

**Preparation:** discs.**Comparison:** isoconazole nitrate CRS.

C. Thin-layer chromatography (2.2.27).

**Test solution.** Dissolve 30 mg of the substance to be examined in methanol R and dilute to 5 mL with the same solvent.**Reference solution (a).** Dissolve 30 mg of isoconazole nitrate CRS in methanol R and dilute to 5 mL with the same solvent.**Reference solution (b).** Dissolve 30 mg of isoconazole nitrate CRS and 30 mg of econazole nitrate CRS in methanol R, then dilute to 5 mL with the same solvent.**Plate:** TLC octadecylsilyl silica gel plate R.**Mobile phase:** ammonium acetate solution R, dioxan R, methanol R (20:40:40 V/V/V).**Application:** 5 µL.**Development:** over a path of 15 cm.**Drying:** in a current of warm air for 15 min.**Detection:** expose to iodine vapour until the spots appear and examine in daylight.**System suitability:** reference solution (b):

– the chromatogram shows 2 clearly separated spots.

**Results:** the principal spot in the chromatogram obtained with the test solution is similar in position, colour and size to the principal spot in the chromatogram obtained with reference solution (a).

D. It gives the reaction of nitrates (2.3.1).

**TESTS****Solution S.** Dissolve 0.20 g in methanol R and dilute to 20.0 mL with the same solvent.**Appearance of solution.** Solution S is clear (2.2.1) and not more intensely coloured than reference solution Y<sub>7</sub> (2.2.2, Method II).**Related substances.** Liquid chromatography (2.2.29).**Test solution.** Dissolve 0.100 g of the substance to be examined in the mobile phase and dilute to 10.0 mL with the mobile phase.**Reference solution (a).** Dissolve 2.5 mg of isoconazole nitrate CRS and 2.5 mg of econazole nitrate CRS in the mobile phase, then dilute to 100.0 mL with the mobile phase.**Reference solution (b).** Dilute 1.0 mL of the test solution to 100.0 mL with the mobile phase. Dilute 5.0 mL of this solution to 20.0 mL with the mobile phase.**Column:**– size:  $l = 0.1$  m,  $\varnothing = 4.6$  mm;

– stationary phase: octadecylsilyl silica gel for chromatography R (3 µm).

**Mobile phase:** dissolve 6.0 g of ammonium acetate R in a mixture of 300 mL of acetonitrile R, 320 mL of methanol R and 380 mL of water R.**Flow rate:** 2 mL/min.**Detection:** spectrophotometer at 235 nm.**Equilibration:** with the mobile phase for about 30 min.**Injection:** 10 µL.**Run time:** 1.5 times the retention time of isoconazole.**Retention time:** econazole = about 10 min; isoconazole = about 14 min.**System suitability:** reference solution (a):

– resolution: minimum 5.0 between the peaks due to econazole and isoconazole; if necessary, adjust the composition of the mobile phase.

**Limits:**

– impurities A, B, C: for each impurity, not more than the area of the principal peak in the chromatogram obtained with reference solution (b) (0.25 per cent);

– total: not more than twice the area of the principal peak in the chromatogram obtained with reference solution (b) (0.5 per cent);

– disregard limit: 0.2 times the area of the principal peak in the chromatogram obtained with reference solution (b) (0.05 per cent); disregard the peak due to the nitrate ion.

**Loss on drying** (2.2.32): maximum 0.5 per cent, determined on 1.000 g by drying in an oven at 105 °C for 2 h.**Sulfated ash** (2.4.14): maximum 0.1 per cent, determined on 1.0 g.**ASSAY**

Dissolve 0.350 g in 75 mL of a mixture of 1 volume of anhydrous acetic acid R and 7 volumes of methyl ethyl ketone R. Titrate with 0.1 M perchloric acid, determining the end-point potentiometrically (2.2.20).

1 mL of 0.1 M perchloric acid is equivalent to 47.91 mg of C<sub>18</sub>H<sub>15</sub>Cl<sub>4</sub>N<sub>3</sub>O<sub>4</sub>.**STORAGE**

Protected from light.

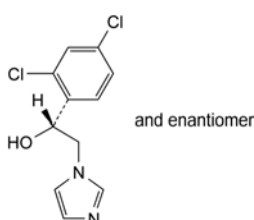
**IMPURITIES****Specified impurities:** A, B, C.A. (1*RS*)-1-(2,4-dichlorophenyl)-2-(1*H*-imidazol-1-yl)ethanol,

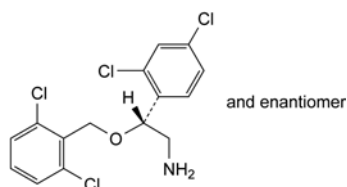

B. (2*R*)-2-[(2,6-dichlorobenzyl)oxy]-2-(2,4-dichlorophenyl)ethanamine,

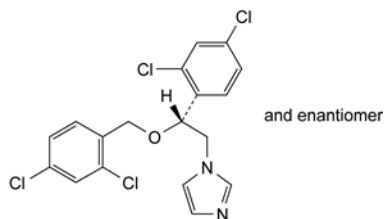

C. 1-[(2*R*)-2-[(2,4-dichlorobenzyl)oxy]-2-(2,4-dichlorophenyl)ethyl]-1*H*-imidazole.

01/2008:1673

## ISOFLURANE

### Isofluranum

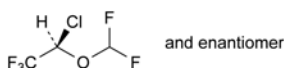

$C_3H_2ClF_5O$   
[26675-46-7]

$M_r$  184.5

#### DEFINITION

(2*R*)-2-Chloro-2-(difluoromethoxy)-1,1,1-trifluoroethane.

#### CHARACTERS

*Appearance*: clear, colourless, mobile, heavy liquid.

*Solubility*: practically insoluble in water, miscible with ethanol and trichloroethylene.

bp: about 48 °C.

It is non-flammable.

#### IDENTIFICATION

Infrared absorption spectrophotometry (2.2.24).

*Preparation*: examine the substance in the gaseous state.

*Comparison*: Ph. Eur. reference spectrum of isoflurane.

#### TESTS

**Acidity or alkalinity.** To 20 mL add 20 mL of carbon dioxide-free water R, shake for 3 min and allow to stand. Collect the upper layer and add 0.2 mL of bromocresol purple solution R. Not more than 0.1 mL of 0.01 M sodium hydroxide or 0.6 mL of 0.01 M hydrochloric acid is required to change the colour of the indicator.

**Related substances.** Gas chromatography (2.2.28).

*Test solution.* The substance to be examined.

*Reference solution.* To 80 mL of ethanol R, add 1.0 mL of the substance to be examined and 1.0 mL of acetone R, avoiding loss by evaporation. Dilute to 100.0 mL with ethanol R. Dilute 1.0 mL of the solution to 100.0 mL with ethanol R.

*Column*:

- *material*: fused silica,
- *size*:  $l = 30$  m,  $\varnothing = 0.32$  mm,
- *stationary phase*: macrogol 20 000 R (film thickness 0.25  $\mu$ m).

*Carrier gas*: helium for chromatography R.

*Flow rate*: 1.0 mL/min.

*Split ratio*: 1:25.

*Temperature*:

- *column*: 35 °C,
- *injection port*: 150 °C,
- *detector*: 250 °C.

*Detection*: flame ionisation.

*Injection*: 1.0  $\mu$ L of each solution and 1.0  $\mu$ L of ethanol R as a blank.

*Run time*: until elution of the ethanol peak in the chromatogram obtained with the reference solution.

*Relative retention* with reference to isoflurane (retention time = about 3.8 min): acetone = about 0.75.

*System suitability*: reference solution:

- *resolution*: minimum of 5 between the peaks due to acetone and to isoflurane,
- *repeatability*: maximum relative standard deviation 15.0 per cent for the peak due to isoflurane after 3 injections.

*Limits*:

- *acetone*: not more than the area of the corresponding peak in the chromatogram obtained with the reference solution (0.01 per cent),
- *any other impurity*: not more than the area of the peak due to isoflurane in the chromatogram obtained with the reference solution (0.01 per cent),
- *total*: not more than 3 times the area of the peak due to isoflurane in the chromatogram obtained with the reference solution (0.03 per cent),
- *disregard limit*: 0.1 times the area of the peak due to isoflurane in the chromatogram obtained with the reference solution (0.001 per cent).

**Chlorides** (2.4.4): maximum 10 ppm.

To 10 mL add 10 mL of 0.01 M sodium hydroxide and shake for 3 min. To 5 mL of the upper layer add 10 mL of water R. The solution complies with the limit test for chlorides.

**Fluorides**: maximum 10 ppm.

Determine by potentiometry (2.2.36, Method I) using a fluoride-selective indicator-electrode and a silver-silver chloride reference electrode.

*Test solution.* To 10.0 mL in a separating funnel, add 10 mL of a mixture of 30.0 mL of dilute ammonia R2 and 70.0 mL of distilled water R. Shake for 1 min and collect the upper layer. Repeat this extraction procedure twice collecting the upper layer each time. Adjust the combined upper layers to pH 5.2 using dilute hydrochloric acid R. Add 5.0 mL of fluoride standard solution (1 ppm F) R and dilute to 50.0 mL with distilled water R. To 20.0 mL of the solution add 20.0 mL of total-ionic-strength-adjustment buffer R and dilute to 50.0 mL with distilled water R.

*Reference solutions.* To each of 5.0 mL, 4.0 mL, 3.0 mL, 2.0 mL and 1.0 mL of fluoride standard solution (10 ppm F) R add 20.0 mL of total-ionic-strength-adjustment buffer R and dilute to 50.0 mL with distilled water R.

Carry out the measurements on 20 mL of each solution. Calculate the concentration of fluorides using the calibration curve, taking into account the addition of fluoride to the test solution.

**Non-volatile matter**: maximum 200 mg/L.

Evaporate 10.0 mL to dryness with the aid of a stream of cold air and dry the residue at 50 °C for 2 h. The residue weighs a maximum of 2.0 mg.

**Water** (2.5.12): maximum 1.0 mg/mL, determined on 10.0 mL.

#### STORAGE

In an airtight container, protected from light.



## IMPURITIES

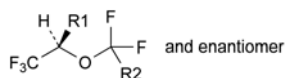

- A. R1 = H, R2 = Cl: 2-(chlorodifluoromethoxy)-1,1,1-trifluoroethane,
- B. R1 = R2 = H: 2-(difluoromethoxy)-1,1,1-trifluoroethane,
- C. R1 = R2 = Cl: (2RS)-2-chloro-2-(chlorodifluoromethoxy)-1,1,1-trifluoroethane,

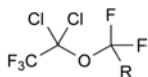

- D. R = H: 1,1-dichloro-1-(difluoromethoxy)-2,2,2-trifluoroethane,
- E. R = Cl: 1,1-dichloro-1-(chlorodifluoromethoxy)-2,2,2-trifluoroethane,

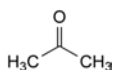

- F. propanone (acetone).

01/2008:0770  
corrected 6.0

## ISOLEUCINE

## Isoleucinum

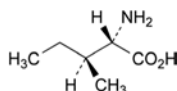

$C_6H_{13}NO_2$   
[73-32-5]

$M_r$  131.2

## DEFINITION

Isoleucine contains not less than 98.5 per cent and not more than the equivalent of 101.0 per cent of (2S,3S)-2-amino-3-methylpentanoic acid, calculated with reference to the dried substance.

## CHARACTERS

White or almost white, crystalline powder or flakes, sparingly soluble in water, slightly soluble in alcohol. It dissolves in dilute mineral acids and in dilute solutions of alkali hydroxides.

## IDENTIFICATION

First identification: A, C.

Second identification: A, B, D.

- A. Specific optical rotation (see Tests).
- B. Dissolve 0.5 g in *water R* and dilute to 25 mL with the same solvent. The solution is dextrorotatory.
- C. Examine by infrared absorption spectrophotometry (2.2.24), comparing with the spectrum obtained with *isoleucine CRS*. Examine the substances prepared as discs.
- D. Examine the chromatograms obtained in the test for ninhydrin-positive substances. The principal spot in the chromatogram obtained with test solution (b) is similar in position, colour and size to the principal spot in the chromatogram obtained with reference solution (a).

## TESTS

**Appearance of solution.** Dissolve 0.5 g in 1 M *hydrochloric acid* and dilute to 10 mL with the same acid. The solution is clear (2.2.1) and not more intensely coloured than reference solution BY<sub>6</sub> (2.2.2, *Method II*).

**Specific optical rotation** (2.2.7). Dissolve 1.00 g in *hydrochloric acid R1* and dilute to 25.0 mL with the same acid. The specific optical rotation is + 40.0 to + 43.0, calculated with reference to the dried substance.

**Ninhydrin-positive substances.** Examine by thin-layer chromatography (2.2.27), using a *TLC silica gel plate R*.

*Test solution (a).* Dissolve 0.10 g of the substance to be examined in 0.1 M *hydrochloric acid* and dilute to 10 mL with the same acid.

*Test solution (b).* Dilute 1 mL of test solution (a) to 50 mL with *water R*.

*Reference solution (a).* Dissolve 10 mg of *isoleucine CRS* in 0.1 M *hydrochloric acid* and dilute to 50 mL with the same acid.

*Reference solution (b).* Dilute 5 mL of test solution (b) to 20 mL with *water R*.

*Reference solution (c).* Dissolve 10 mg of *isoleucine CRS* and 10 mg of *valine CRS* in 0.1 M *hydrochloric acid* and dilute to 25 mL with the same acid.

Apply separately to the plate 5 µL of each solution. Develop over a path of 15 cm using a mixture of 20 volumes of *glacial acetic acid R*, 20 volumes of *water R* and 60 volumes of *butanol R*. Allow the plate to dry in air, spray with *ninhydrin solution R* and heat at 100-105 °C for 15 min. Any spot in the chromatogram obtained with test solution (a), apart from the principal spot, is not more intense than the spot in the chromatogram obtained with reference solution (b) (0.5 per cent). The test is not valid unless the chromatogram obtained with reference solution (c) shows 2 clearly separated spots.

**Chlorides** (2.4.4). Dissolve 0.25 g in *water R* and dilute to 15 mL with the same solvent. The solution complies with the limit test for chlorides (200 ppm).

**Sulfates** (2.4.13). Dissolve 0.5 g in 3 mL of *dilute hydrochloric acid R* and dilute to 15 mL with *distilled water R*. The solution complies with the limit test for sulfates (300 ppm).

**Ammonium** (2.4.1). 50 mg complies with limit test B for ammonium (200 ppm). Prepare the standard using 0.1 mL of *ammonium standard solution (100 ppm NH<sub>4</sub>) R*.

**Iron** (2.4.9). In a separating funnel, dissolve 1.0 g in 10 mL of *dilute hydrochloric acid R*. Shake with 3 quantities, each of 10 mL, of *methyl isobutyl ketone R1*, shaking for 3 min each time. To the combined organic layers add 10 mL of *water R* and shake for 3 min. The aqueous layer complies with the limit test for iron (10 ppm).

**Heavy metals** (2.4.8). 2.0 g complies with limit test D for heavy metals (10 ppm). Prepare the standard using 2 mL of *lead standard solution (10 ppm Pb) R*.

**Loss on drying** (2.2.32). Not more than 0.5 per cent, determined on 1.000 g by drying in an oven at 105 °C.

**Sulfated ash** (2.4.14). Not more than 0.1 per cent, determined on 1.0 g.

## ASSAY

Dissolve 0.100 g in 3 mL of *anhydrous formic acid R*. Add 30 mL of *anhydrous acetic acid R*. Using 0.1 mL of *naphtholbenzein solution R* as indicator, titrate with 0.1 M *perchloric acid* until the colour changes from brownish-yellow to green.

1 mL of 0.1 M *perchloric acid* is equivalent to 13.12 mg of  $C_6H_{13}NO_2$ .

## STORAGE

Store protected from light.

- 01/2008:1531 C. To 3 mL of a freshly prepared 100 g/L solution of *pyrocatechol R* add 6 mL of *sulfuric acid R* while cooling in iced water. To 3 mL of the cooled mixture add 0.3 mL of a 100 g/L solution of the substance to be examined. Heat gently over a naked flame for about 30 s. A pink colour develops.

## ISOMALT

### Isomaltum

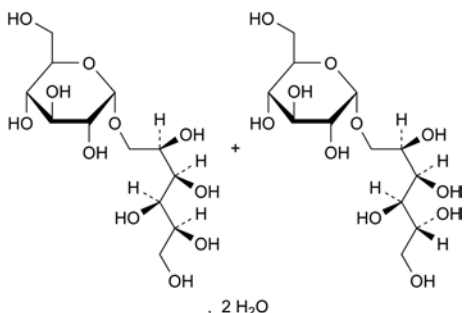

$C_{12}H_{24}O_{11}$

$M_r$  344.3

$C_{12}H_{24}O_{11} \cdot 2H_2O$

$M_r$  380.3

#### DEFINITION

Mixture of 6-*O*- $\alpha$ -D-glucopyranosyl-D-glucitol (6-*O*- $\alpha$ -D-glucopyranosyl-D-sorbitol; 1,6-GPS) and 1-*O*- $\alpha$ -D-glucopyranosyl-D-mannitol (1,1-GPM).

*Content*: 98.0 per cent to 102.0 per cent for the mixture of 1,6-GPS and 1,1-GPM and neither of the 2 components is less than 3.0 per cent (anhydrous substance).

#### CHARACTERS

*Appearance*: white or almost white powder or granules.

*Solubility*: freely soluble in water, practically insoluble in anhydrous ethanol.

#### IDENTIFICATION

*First identification*: A.

*Second identification*: B, C.

A. Examine the chromatograms obtained in the assay.

*Results*: the 2 principal peaks in the chromatogram obtained with the test solution are similar in retention time to the 2 principal peaks in the chromatogram obtained with reference solution (a).

B. Thin-layer chromatography (2.2.27).

*Test solution*. Dissolve 50 mg of the substance to be examined in *water R* and dilute to 10 mL with the same solvent.

*Reference solution*. Dissolve 50 mg of *isomalt CRS* in *water R* and dilute to 10 mL with the same solvent.

*Plate*: TLC silica gel  $F_{254}$  plate *R*.

*Mobile phase*: *acetic acid R*, *propionic acid R*, *water R*, *ethyl acetate R*, *pyridine R* (5:5:10:50:50 V/V/V/V).

*Application*: 1  $\mu$ L; thoroughly dry the points of application in warm air.

*Development*: over a path of 10 cm.

*Drying*: in a current of warm air.

*Detection*: dip for 3 s in a 1 g/L solution of *sodium periodate R* and dry in a current of hot air; dip for 3 s in a mixture of 1 volume of *acetic acid R*, 1 volume of *anisaldehyde R*, 5 volumes of *sulfuric acid R* and 90 volumes of *anhydrous ethanol R*; dry in a current of hot air until coloured spots become visible; the background colour may be brightened in warm steam; examine in daylight.

*Results*: the chromatogram obtained with the reference solution shows 2 blue-grey spots with  $R_f$  values of about 0.13 (1,6-GPS) and 0.16 (1,1-GPM). The chromatogram obtained with the test solution shows principal spots similar in position and colour to the principal spots in the chromatogram obtained with the reference solution.

#### TESTS

**Conductivity** (2.2.38): maximum 20  $\mu$ S $\cdot$ cm $^{-1}$ .

Dissolve 20.0 g in *carbon dioxide-free water R* prepared from *distilled water R* and dilute to 100.0 mL with the same solvent. Measure the conductivity of the solution while gently stirring with a magnetic stirrer.

**Reducing sugars**: maximum 0.3 per cent, expressed as glucose equivalent.

Dissolve 3.3 g in 10 mL of *water R* with the aid of gentle heat. Cool and add 20 mL of *cupri-citric solution R* and a few glass beads. Heat so that the boiling begins after 4 min and maintain boiling for 3 min. Cool rapidly and add 100 mL of a 2.4 per cent V/V solution of *glacial acetic acid R* and 20.0 mL of 0.025 M *iodine*. With continuous shaking, add 25 mL of a mixture of 6 volumes of *hydrochloric acid R* and 94 volumes of *water R*. When the precipitate has dissolved, titrate the excess of iodine with 0.05 M *sodium thiosulfate* using 1 mL of *starch solution R* as indicator, added towards the end of the titration. Not less than 12.8 mL of 0.05 M *sodium thiosulfate* is required.

**Related substances**. Liquid chromatography (2.2.29).

*Test solution*. Dissolve 1.00 g of the substance to be examined in 20 mL of *water R* and dilute to 50.0 mL with the same solvent.

*Reference solution (a)*. Dissolve 1.00 g of *isomalt CRS* in 20 mL of *water R* and dilute to 50.0 mL with the same solvent.

*Reference solution (b)*. Dissolve 10.0 mg of *sorbitol CRS* (impurity C) and 10.0 mg of *mannitol CRS* (impurity B) in 20 mL of *water R* and dilute to 100.0 mL with the same solvent.

*Precolumn*:

- *size*:  $l = 30$  mm,  $\varnothing = 4.6$  mm;
- *stationary phase*: strong cation-exchange resin (calcium form) *R* (9  $\mu$ m);
- *temperature*:  $80 \pm 1$  °C.

*Column*:

- *size*:  $l = 0.3$  m,  $\varnothing = 7.8$  mm;
- *stationary phase*: strong cation-exchange resin (calcium form) *R* (9  $\mu$ m);
- *temperature*:  $80 \pm 1$  °C.

*Mobile phase*: degassed *water R*.

*Flow rate*: 0.5 mL/min.

*Detection*: differential refractometer maintained at a constant temperature.

*Injection*: 20  $\mu$ L of the test solution and reference solution (b).

*Run time*: until impurity C is completely eluted (about 25 min).

*Relative retention* with reference to 1,1-GPM (retention time = about 12.3 min): impurity A = about 0.8; 1,6-GPS = about 1.2; impurity B = about 1.6; impurity C = about 2.0.

*Limits*:

- *impurities B, C*: for each impurity, not more than the area of the corresponding peak in the chromatogram obtained with reference solution (b) (0.5 per cent);
- *any other impurity*: for each impurity, not more than the area of the peak due to impurity C in the chromatogram obtained with reference solution (b) (0.5 per cent);
- *total*: not more than 4 times the area of the peak due to impurity C in the chromatogram obtained with reference solution (b) (2 per cent);
- *disregard limit*: 0.2 times the area of the peak due to impurity C in the chromatogram obtained with reference solution (b) (0.1 per cent).

01/2008:0146  
corrected 6.0**Lead (2.4.10):** maximum 0.5 ppm.**Nickel (2.4.15):** maximum 1 ppm.**Water (2.5.12):** maximum 7.0 per cent, determined on 0.3 g. As solvent, use a mixture of 20 mL of *anhydrous methanol R* and 20 mL of *formamide R* at 50 ± 5 °C.

## ASSAY

Liquid chromatography (2.2.29) as described in the test for related substances with the following modification.

**Injection:** test solution and reference solution (a).Calculate the percentage content of isomalt (1,1-GPM and 1,6-GPS) from the declared content of 1,1-GPM and 1,6-GPS in *isomalt CRS*.

## LABELLING

The label states the percentage content of 1,6-GPS and 1,1-GPM.

## IMPURITIES

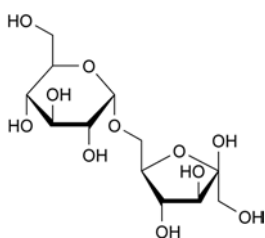
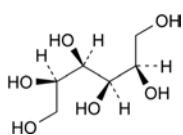
**Specified impurities:** B, C.**Other detectable impurities** (the following substances would, if present at a sufficient level, be detected by one or other of the tests in the monograph. They are limited by the general acceptance criterion for other/unspecified impurities and/or by the general monograph *Substances for pharmaceutical use (2034)*. It is therefore not necessary to identify these impurities for demonstration of compliance. See also 5.10. *Control of impurities in substances for pharmaceutical use*): A, D.A. 6-*O*-α-D-glucopyranosyl-β-D-arabino-hex-2-ulofuranose (isomaltulose),

B. D-mannitol,

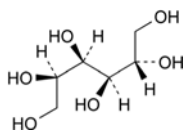

C. D-glucitol (D-sorbitol),

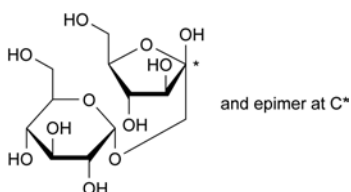
D. 1-*O*-α-D-glucopyranosyl-D-arabino-hex-2-ulofuranose (trehalulose).

## ISONIAZID

## Isoniazidum

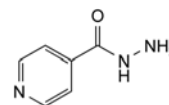
 $C_6H_7N_3O$   
[54-85-3] $M_r$  137.1

## DEFINITION

Isoniazid contains not less than 99.0 per cent and not more than the equivalent of 101.0 per cent of pyridine-4-carbohydrazide, calculated with reference to the dried substance.

## CHARACTERS

A white or almost white, crystalline powder or colourless crystals, freely soluble in water, sparingly soluble in alcohol.

## IDENTIFICATION

**First identification:** A, B.**Second identification:** A, C.

- A. Melting point (2.2.14): 170 °C to 174 °C.
- B. Examine by infrared absorption spectrophotometry (2.2.24), comparing with the spectrum obtained with *isoniazid CRS*.
- C. Dissolve 0.1 g in 2 mL of *water R* and add 10 mL of a warm 10 g/L solution of *vanillin R*. Allow to stand and scratch the wall of the test tube with a glass rod. A yellow precipitate is formed, which, after recrystallisation from 5 mL of *alcohol (70 per cent V/V) R* and drying at 100 °C to 105 °C, melts (2.2.14) at 226 °C to 231 °C.

## TESTS

**Solution S.** Dissolve 2.5 g in *carbon dioxide-free water R* and dilute to 50 mL with the same solvent.**Appearance of solution.** Solution S is clear (2.2.1) and not more intensely coloured than reference solution BY<sub>7</sub> (2.2.2, *Method II*).**pH (2.2.3).** The pH of solution S is 6.0 to 8.0.**Hydrazine and related substances.** Examine by thin-layer chromatography (2.2.27), using *silica gel GF<sub>254</sub> R* as the coating substance.**Test solution.** Dissolve 1.0 g of the substance to be examined in a mixture of equal volumes of *acetone R* and *water R* and dilute to 10.0 mL with the same mixture of solvents.**Reference solution.** Dissolve 50.0 mg of *hydrazine sulfate R* in 50 mL of *water R* and dilute to 100.0 mL with *acetone R*. To 10.0 mL of this solution add 0.2 mL of the test solution and dilute to 100.0 mL with a mixture of equal volumes of *acetone R* and *water R*.Apply separately to the plate 5 µL of each solution and develop over a path of 15 cm using a mixture of 10 volumes of *water R*, 20 volumes of *acetone R*, 20 volumes of *methanol R* and 50 volumes of *ethyl acetate R*. Allow the plate to dry in air and examine in ultraviolet light at 254 nm. Any spot in the chromatogram obtained with the test solution, apart from the principal spot, is not more intense than the spot in the chromatogram obtained with the reference solution (0.2 per cent). Spray the plate with *dimethylaminobenzaldehyde solution RI*. Examine in daylight. An additional spot, corresponding to hydrazine, appears in the chromatogram obtained with the reference solution. Any corresponding spot in the chromatogram obtained with the test solution is not more intense than the spot corresponding to hydrazine in the chromatogram obtained with the reference solution (0.05 per cent).

**Heavy metals** (2.4.8). 2.0 g complies with limit test C for heavy metals (10 ppm). Prepare the standard using 2 mL of *lead standard solution* (10 ppm Pb) R.

**Loss on drying** (2.2.32). Not more than 0.5 per cent, determined on 1.00 g by drying in an oven at 105 °C.

**Sulfated ash** (2.4.14). Not more than 0.1 per cent, determined on 1.0 g.

#### ASSAY

Dissolve 0.250 g in *water R* and dilute to 100.0 mL with the same solvent. To 20.0 mL of the solution add 100 mL of *water R*, 20 mL of *hydrochloric acid R*, 0.2 g of *potassium bromide R* and 0.05 mL of *methyl red solution R*. Titrate dropwise with 0.0167 M *potassium bromate*, shaking continuously, until the red colour disappears.

1 mL of 0.0167 M *potassium bromate* is equivalent to 3.429 mg of C<sub>11</sub>H<sub>18</sub>N<sub>3</sub>O.

**Optical rotation** (2.2.7): -0.10° to +0.10°, determined on solution S.

**Related substances.** Liquid chromatography (2.2.29).

**Test solution.** Dissolve 50.0 mg of the substance to be examined in the mobile phase and dilute to 10.0 mL with the mobile phase.

**Reference solution (a).** Dilute 1.0 mL of the test solution to 100.0 mL with the mobile phase. Dilute 5.0 mL of this solution to 10.0 mL with the mobile phase.

**Reference solution (b).** Dissolve 2.5 mg of *orciprenaline sulfate CRS* in the mobile phase and dilute to 100.0 mL with the mobile phase.

**Reference solution (c).** To 5.0 mL of reference solution (a) add 5.0 mL of reference solution (b).

**Column:**

- size:  $l = 0.125$  m,  $\varnothing = 4.0$  mm;
- stationary phase: *octadecylsilyl silica gel for chromatography R* (5 µm).

**Mobile phase:** *methanol R*, 11.5 g/L solution of *phosphoric acid R* (5:95 V/V).

**Flow rate:** 1.0 mL/min.

**Detection:** spectrophotometer at 280 nm.

**Injection:** 20 µL of the test solution and reference solutions (a) and (c).

**Run time:** 7 times the retention time of isoprenaline.

**Relative retention** with reference to isoprenaline (retention time = about 3 min): *orciprenaline* = about 1.5; *impurity A* = about 1.8. If necessary, adjust the concentration of *methanol* in the mobile phase.

**System suitability:** reference solution (c):

- resolution: minimum 3.0 between the peaks due to isoprenaline and *orciprenaline*.

**Limits:**

- *impurity A*: not more than the area of the principal peak in the chromatogram obtained with reference solution (a) (0.5 per cent);
- *unspecified impurities*: for each impurity, not more than 0.2 times the area of the principal peak in the chromatogram obtained with reference solution (a) (0.10 per cent);
- *total*: not more than twice the area of the principal peak in the chromatogram obtained with reference solution (a) (1.0 per cent);
- *disregard limit*: 0.1 times the area of the principal peak in the chromatogram obtained with reference solution (a) (0.05 per cent).

**Loss on drying** (2.2.32): maximum 1.0 per cent, determined on 1.000 g by drying *in vacuo* at 15-25 °C for 4 h.

**Sulfated ash** (2.4.14): maximum 0.1 per cent, determined on 1.0 g.

#### ASSAY

*In order to avoid overheating in the reaction medium, mix thoroughly throughout and stop the titration immediately after the end-point has been reached.*

Dissolve 0.150 g in 10 mL of *anhydrous formic acid R* and add 50 mL of *acetic anhydride R*. Titrate with 0.1 M *perchloric acid*, determining the end-point potentiometrically (2.2.20).

1 mL of 0.1 M *perchloric acid* is equivalent to 24.77 mg of C<sub>11</sub>H<sub>18</sub>N<sub>3</sub>O.

#### STORAGE

In an airtight container, protected from light.

#### IMPURITIES

**Specified impurities:** A.

01/2011:1332

## ISOPRENALINE HYDROCHLORIDE

### Isoprenalini hydrochloridum

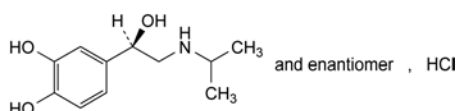

C<sub>11</sub>H<sub>18</sub>ClNO<sub>3</sub>  
[51-30-9]

$M_r$  247.7

#### DEFINITION

(1*R,S*)-1-(3,4-Dihydroxyphenyl)-2-[(1-methylethyl)amino]ethanol hydrochloride.

**Content:** 98.0 per cent to 101.5 per cent (dried substance).

#### CHARACTERS

**Appearance:** white or almost white, crystalline powder.

**Solubility:** freely soluble in water, sparingly soluble in ethanol (96 per cent), practically insoluble in methylene chloride.

#### IDENTIFICATION

**First identification:** B, C, E.

**Second identification:** A, C, D, E.

A. Melting point (2.2.14): 165 °C to 170 °C, with decomposition.

B. Infrared absorption spectrophotometry (2.2.24).

*Comparison:* *isoprenaline hydrochloride CRS*.

C. Optical rotation (see Tests).

D. To 0.1 mL of solution S (see Tests) add 0.05 mL of *ferric chloride solution R1* and 0.9 mL of *water R*. A green colour is produced. Add dropwise *sodium hydrogen carbonate solution R*. The colour becomes blue then red.

E. To 0.5 mL of solution S add 1.5 mL of *water R*. The solution gives reaction (a) of chlorides (2.3.1).

#### TESTS

*Prepare the solutions immediately before use.*

**Solution S.** Dissolve 2.5 g in *carbon dioxide-free water R* and dilute to 25.0 mL with the same solvent.

**Appearance of solution.** Solution S is clear (2.2.1) and not more intensely coloured than reference solution B<sub>7</sub> or BY<sub>7</sub> (2.2.2, *Method II*).

**pH** (2.2.3): 4.3 to 5.5.

Mix 5 mL of solution S and 5 mL of *carbon dioxide-free water R*.

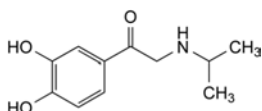

A. 1-(3,4-dihydroxyphenyl)-2-[(1-methylethyl)amino]ethanone.

01/2008:0502

## ISOPRENALINE SULFATE

### Isoprenalini sulfas

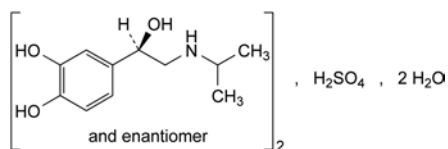

$C_{22}H_{36}N_2O_{10}S \cdot 2H_2O$   
[6700-39-6]

$M_r$  556.6

#### DEFINITION

Bis[(1*R,S*)-1-(3,4-dihydroxyphenyl)-2-[(1-methylethyl)amino]ethanol] sulfate dihydrate.

*Content*: 98.0 per cent to 102.0 per cent (anhydrous substance).

#### CHARACTERS

*Appearance*: white or almost white, crystalline powder.

*Solubility*: freely soluble in water, very slightly soluble in ethanol (96 per cent).

mp: about 128 °C, with decomposition.

#### IDENTIFICATION

*First identification*: A, D.

*Second identification*: B, C, D.

A. Infrared absorption spectrophotometry (2.2.24).

Dissolve 0.5 g in 1.5 mL of *water R* and add 3.5 mL of *2-propanol R*. Scratch the wall of the tube with a glass rod to initiate crystallisation. Collect the crystals and dry *in vacuo* at 60 °C over *diphosphorus pentoxide R*.

*Comparison*: repeat the operations using 0.5 g of *isoprenaline sulfate CRS*.

B. To 0.1 mL of solution S (see Tests) add 0.9 mL of *water R* and 0.05 mL of *ferric chloride solution R1*. A green colour is produced. Add dropwise *sodium hydrogen carbonate solution R*. The colour becomes blue and then red.

C. Dilute 1 mL of solution S to 10 mL with *water R* and add 0.25 mL of *silver nitrate solution R1*. A shining, grey, fine precipitate is formed within 10 min and the solution becomes pink.

D. Solution S gives reaction (a) of sulfates (2.3.1).

#### TESTS

**Solution S.** Dissolve 5.0 g in *carbon dioxide-free water R* and dilute to 50 mL with the same solvent. Use within 2 h of preparation.

**Appearance of solution.** Solution S is clear (2.2.1) and not more intensely coloured than reference solution  $Y_6$  (2.2.2, *Method II*).

**pH** (2.2.3): 4.3 to 5.5.

Dilute 5 mL of solution S to 10 mL with *carbon dioxide-free water R*.

**Isoprenalone:** the absorbance (2.2.25) is not greater than 0.20 at 310 nm.

Dissolve 0.20 g in 0.005 M *sulfuric acid* and dilute to 100.0 mL with the same acid.

**Water** (2.5.12): 5.0 per cent to 7.5 per cent, determined on 0.200 g.

**Sulfated ash** (2.4.14): maximum 0.1 per cent, determined on 1.0 g.

#### ASSAY

Dissolve 0.400 g in 20 mL of *anhydrous acetic acid R*, warming gently if necessary and add 20 mL of *methyl isobutyl ketone R*. Titrate with 0.1 M *perchloric acid* determining the end-point potentiometrically (2.2.20).

1 mL of 0.1 M *perchloric acid* is equivalent to 52.06 mg of  $C_{22}H_{36}N_2O_{10}S$ .

#### STORAGE

In an airtight container, protected from light.

01/2008:0970

## ISOPROPYL ALCOHOL

### Alcohol isopropylicus

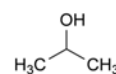

$C_3H_8O$   
[67-63-0]

$M_r$  60.1

#### DEFINITION

Propan-2-ol.

#### CHARACTERS

*Appearance*: clear, colourless liquid.

*Solubility*: miscible with water and with alcohol.

#### IDENTIFICATION

A. Relative density (2.2.5): 0.785 to 0.789.

B. Refractive index (2.2.6): 1.376 to 1.379.

C. To 1 mL add 2 mL of *potassium dichromate solution R* and 1 mL of *dilute sulfuric acid R*. Boil. Vapour is produced which changes the colour of a piece of filter paper impregnated with *nitrobenzaldehyde solution R* to green. Moisten the filter paper with *dilute hydrochloric acid R*. The colour changes to blue.

#### TESTS

**Appearance.** The substance to be examined is clear (2.2.1) and colourless (2.2.2, *Method II*). Dilute 1 mL to 20 mL with *water R*. After 5 min, the solution is clear (2.2.1).

**Acidity or alkalinity.** Gently boil 25 mL for 5 min. Add 25 mL of *carbon dioxide-free water R* and allow to cool protected from carbon dioxide in the air. Add 0.1 mL of *phenolphthalein solution R*. The solution is colourless. Not more than 0.6 mL of 0.01 M *sodium hydroxide* is required to change the colour of the indicator to pale pink.

**Absorbance** (2.2.25): maximum 0.30 at 230 nm, 0.10 at 250 nm, 0.03 at 270 nm, 0.02 at 290 nm and 0.01 at 310 nm.

The absorbance is measured between 230 nm and 310 nm using *water R* as the compensation liquid. The absorption curve is smooth.

**Benzene and related substances.** Gas chromatography (2.2.28).

*Test solution (a).* The substance to be examined.

*Test solution (b).* Dilute 1.0 mL of *2-butanol R1* to 50.0 mL with test solution (a). Dilute 5.0 mL of the solution to 100.0 mL with test solution (a).

*Reference solution (a).* Dilute 0.5 mL of *2-butanol R1* and 0.5 mL of *propanol R* to 50.0 mL with test solution (a). Dilute 5.0 mL of the solution to 50.0 mL with test solution (a).

*Reference solution (b).* Dilute 100 µL of *benzene R* to 100.0 mL with test solution (a). Dilute 0.20 mL of the solution to 100.0 mL with test solution (a).

## Column:

- material: fused silica,
- size:  $l = 30$  m,  $\varnothing = 0.32$  mm,
- stationary phase: poly[(cyanopropyl)(phenyl)]dimethylsiloxane *R* (film thickness 1.8  $\mu$ m).

Carrier gas: helium for chromatography *R*.

Auxiliary gas: nitrogen for chromatography *R* or helium for chromatography *R*.

Linear velocity: 35 cm/s.

Split ratio: 1:5.

Temperature:

	Time (min)	Temperature (°C)
Column	0 - 12	40
	12 - 32	40 → 240
	32 - 42	240
Injection port		280
Detector		280

Detection: flame ionisation.

Injection: 1  $\mu$ L.

Retention time: benzene = about 10 min.

System suitability: reference solution (a):

- resolution: minimum of 10 between the first peak (propanol) and the second peak (2-butanol).

Limits:

- benzene (test solution (a)): not more than half of the area of the corresponding peak in the chromatogram obtained with reference solution (b) (2 ppm), after the sensitivity has been adjusted so that the height of the peak due to benzene in the chromatogram obtained with reference solution (b) represents at least 10 per cent of the full scale of the recorder.
- total of impurities apart from 2-butanol (test solution (b)): not more than 3 times the area of the peak due to 2-butanol in the chromatogram obtained with test solution (b) (0.3 per cent), after the sensitivity has been adjusted so that the height of the 2 peaks following the principal peak in the chromatogram obtained with reference solution (a) represents at least 50 per cent of the full scale of the recorder.

**Peroxides.** In a 12 mL test-tube with a ground-glass stopper and a diameter of about 15 mm, introduce 8 mL of *potassium iodide and starch solution R*. Fill completely with the substance to be examined. Shake vigorously and allow to stand protected from light for 30 min. No colour develops.

**Non-volatile substances:** maximum 20 ppm.

Evaporate 100 g to dryness on a water-bath after having verified that it complies with the test for peroxides and dry in an oven at 100-105 °C. The residue weighs a maximum of 2 mg.

**Water (2.5.12):** maximum 0.5 per cent, determined on 5.0 g.

## STORAGE

Protected from light.

## IMPURITIES

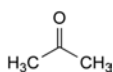

A. propanone (acetone),



B. benzene,

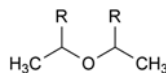

C.  $R = CH_3$ : 2-(1-methylethoxy)propane (diisopropyl ether),

D.  $R = H$ : ethoxyethane (diethyl ether),

E.  $CH_3-OH$ : methanol,

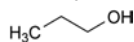

F. propan-1-ol (*n*-propanol).

01/2008:0725

## ISOPROPYL MYRISTATE

## Isopropylis myristas

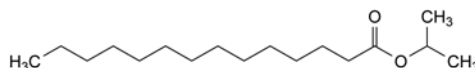

$C_{17}H_{34}O_2$

$M_r$  270.5

## DEFINITION

1-Methylethyl tetradecanoate together with variable amounts of other fatty acid isopropyl esters.

Content: minimum 90.0 per cent of  $C_{17}H_{34}O_2$ .

## CHARACTERS

Appearance: clear, colourless, oily liquid.

Solubility: immiscible with water, miscible with ethanol (96 per cent), with methylene chloride, with fatty oils and with liquid paraffin.

Relative density: about 0.853.

## IDENTIFICATION

First identification: *B*.

Second identification: *A, C*.

A. Saponification value (see Tests).

B. Examine the chromatograms obtained in the assay.

Results: the principal peak in the chromatogram obtained with the test solution is similar in retention time to the principal peak in the chromatogram obtained with the reference solution.

C. Superpose 2 mL of a 1 g/L solution in ethanol (96 per cent) *R* on a freshly prepared solution of 20 mg of dimethylaminobenzaldehyde *R* in 2 mL of sulfuric acid *R*. After 2 min, a yellowish-red colour appears at the junction of the 2 liquids and gradually becomes red.

## TESTS

**Appearance of solution.** The solution is clear (2.2.1) and not more intensely coloured than reference solution  $Y_7$  (2.2.2, Method II).

Dissolve 2.0 g in methanol *R* and dilute to 20 mL with the same solvent.

**Refractive index (2.2.6):** 1.434 to 1.437.

**Viscosity (2.2.9):** 5 mPas to 6 mPas.

**Acid value (2.5.1):** maximum 1.0.

**Iodine value (2.5.4):** maximum 1.0.

**Saponification value (2.5.6):** 202 to 212.

**Water (2.5.12):** maximum 0.1 per cent, determined on 5.0 g.

**Total ash (2.4.16):** maximum 0.1 per cent, determined on 1.0 g.

## ASSAY

Gas chromatography (2.2.28).

Internal standard solution. Dissolve 50.0 mg of tricosane *R* in heptane *R* and dilute to 250.0 mL with the same solvent.

**Test solution.** Dissolve 20.0 mg of the substance to be examined in the internal standard solution and dilute to 100.0 mL with the same solution.

**Reference solution.** Dissolve 20.0 mg of *isopropyl tetradecanoate CRS* in the internal standard solution and dilute to 100.0 mL with the same solution.

**Column:**

- *material:* fused silica,
- *size:*  $l = 50$  m,  $\varnothing = 0.2$  mm,
- *stationary phase:* *poly(cyanopropyl)siloxane R* (film thickness 0.2  $\mu\text{m}$ ).

**Carrier gas:** *helium for chromatography R*.

**Flow rate:** 1 mL/min.

**Split ratio:** 1:40.

**Temperature:**

	Time (min)	Temperature (°C)
Column	0 - 6	125 → 185
	6 - 16	185
Injection port		250
Detector		250

**Detection:** flame ionisation.

**Injection:** 2  $\mu\text{L}$ .

Calculate the percentage content of  $\text{C}_{17}\text{H}_{34}\text{O}_2$  in the substance to be examined.

**STORAGE**

Protected from light.

01/2008:0839

## ISOPROPYL PALMITATE

### Isopropylis palmitas

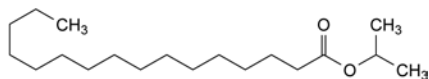

$\text{C}_{19}\text{H}_{38}\text{O}_2$

$M_r$  298.5

**DEFINITION**

1-Methylethyl hexadecanoate together with varying amounts of other fatty acid isopropyl esters.

**Content:** minimum 90.0 per cent of  $\text{C}_{19}\text{H}_{38}\text{O}_2$ .

**CHARACTERS**

**Appearance:** clear, colourless, oily liquid.

**Solubility:** immiscible with water, miscible with ethanol (96 per cent), with methylene chloride, with fatty oils and with liquid paraffin.

**Relative density:** about 0.854.

**IDENTIFICATION**

**First identification:** B.

**Second identification:** A, C.

A. Saponification value (see Tests).

B. Examine the chromatograms obtained in the assay.

**Results:** the principal peak in the chromatogram obtained with the test solution is similar in retention time to the principal peak in the chromatogram obtained with the reference solution.

C. Superpose 2 mL of a 1 g/L solution in *ethanol (96 per cent) R* on a freshly prepared solution of 20 mg of *dimethylaminobenzaldehyde R* in 2 mL of *sulfuric acid R*. After 2 min, a yellowish-red colour appears at the junction of the 2 liquids which gradually becomes red.

**TESTS**

**Appearance of solution.** The solution is clear (2.2.1) and not more intensely coloured than reference solution  $Y_7$  (2.2.2, *Method II*).

Dissolve 2.0 g in *methanol R* and dilute to 20 mL with the same solvent.

**Refractive index (2.2.6):** 1.436 to 1.440.

**Viscosity (2.2.9):** 5 mPas to 10 mPas.

**Acid value (2.5.1):** maximum 1.0.

**Iodine value (2.5.4):** maximum 1.0.

**Saponification value (2.5.6):** 183 to 193.

**Water (2.5.12):** maximum 0.1 per cent, determined on 5.0 g.

**Total ash (2.4.16):** maximum 0.1 per cent, determined on 1.0 g.

**ASSAY**

Gas chromatography (2.2.28).

**Internal standard solution.** Dissolve 50.0 mg of *tricosane R* in *heptane R* and dilute to 250.0 mL with the same solvent.

**Test solution.** Dissolve 20.0 mg of the substance to be examined in the internal standard solution and dilute to 100.0 mL with the same solution.

**Reference solution.** Dissolve 20.0 mg of *isopropyl hexadecanoate CRS* in the internal standard solution and dilute to 100.0 mL with the same solution.

**Column:**

- *material:* fused silica,
- *size:*  $l = 50$  m,  $\varnothing = 0.2$  mm,
- *stationary phase:* *poly(cyanopropyl)siloxane R* (film thickness 0.2  $\mu\text{m}$ ).

**Carrier gas:** *helium for chromatography R*.

**Flow rate:** 1 mL/min.

**Split ratio:** 1:40.

**Temperature:**

	Time (min)	Temperature (°C)
Column	0 - 6	125 → 185
	6 - 16	185
Injection port		250
Detector		250

**Detection:** flame ionisation.

**Injection:** 2  $\mu\text{L}$ .

Calculate the percentage content of  $\text{C}_{19}\text{H}_{38}\text{O}_2$  in the substance to be examined.

**STORAGE**

Protected from light.

01/2008:1117  
corrected 6.0

## ISOSORBIDE DINITRATE, DILUTED

### Isosorbidi dinitras dilutus

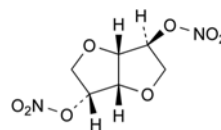

$\text{C}_6\text{H}_8\text{N}_2\text{O}_8$

$M_r$  236.1

**DEFINITION**

Dry mixture of isosorbide dinitrate and *Lactose monohydrate (0187)* or *Mannitol (0559)*.

**Content:** 95.0 per cent *m/m* to 105.0 per cent *m/m* of the content of 1,4:3,6-dianhydro-D-glucitol 2,5-dinitrate stated on the label.

**CAUTION:** undiluted isosorbide dinitrate may explode if subjected to percussion or excessive heat. Appropriate precautions must be taken and only very small quantities handled.

#### CHARACTERS

**Appearance:** undiluted isosorbide dinitrate is a fine, white or almost white, crystalline powder.

**Solubility:** undiluted isosorbide dinitrate is very slightly soluble in water, very soluble in acetone, sparingly soluble in ethanol (96 per cent).

The solubility of the diluted product depends on the diluent and its concentration.

#### IDENTIFICATION

**First identification:** A, C, D.

**Second identification:** B, C, D.

##### A. Infrared absorption spectrophotometry (2.2.24).

**Preparation:** discs prepared with the residue obtained in identification test D.

**Comparison:** isosorbide dinitrate CRS.

##### B. Thin-layer chromatography (2.2.27).

**Test solution.** Shake a quantity of the substance to be examined corresponding to 10 mg of isosorbide dinitrate with 10 mL of ethanol (96 per cent) R for 5 min and filter.

**Reference solution.** Shake a quantity of isosorbide dinitrate CRS corresponding to 10 mg of isosorbide dinitrate with 10 mL of ethanol (96 per cent) R for 5 min and filter.

**Plate:** TLC silica gel G plate R.

**Mobile phase:** methanol R, methylene chloride R (5:95 V/V).

**Application:** 10 µL.

**Development:** over a path of 15 cm.

**Drying:** in a current of air.

**Detection:** spray with freshly prepared potassium iodide and starch solution R; expose to ultraviolet light at 254 nm for 15 min and examine in daylight.

**Results:** the principal spot in the chromatogram obtained with the test solution is similar in position, colour and size to the principal spot in the chromatogram obtained with the reference solution.

##### C. Thin-layer chromatography (2.2.27).

**Test solution.** Shake a quantity of the substance to be examined corresponding to 0.10 g of lactose or mannitol with 10 mL of water R. Filter if necessary.

**Reference solution (a).** Dissolve 0.10 g of lactose R in water R and dilute to 10 mL with the same solvent.

**Reference solution (b).** Dissolve 0.10 g of mannitol R in water R and dilute to 10 mL with the same solvent.

**Reference solution (c).** Mix equal volumes of reference solutions (a) and (b).

**Plate:** TLC silica gel G plate R.

**Mobile phase:** water R, methanol R, anhydrous acetic acid R, ethylene chloride R (10:15:25:50 V/V/V/V); measure the volumes accurately since a slight excess of water produces cloudiness.

**Application:** 1 µL; thoroughly dry the points of application.

**Development A:** over a path of 15 cm.

**Drying A:** in a current of warm air.

**Development B:** immediately, over a path of 15 cm, after renewing the mobile phase.

**Drying B:** in a current of warm air.

**Detection:** spray with 4-aminobenzoic acid solution R, dry in a current of cold air until the acetone is removed, then heat at 100 °C for 15 min; allow to cool, spray with a 2 g/L solution of sodium periodate R, dry in a current of cold air, and heat at 100 °C for 15 min.

**System suitability:** reference solution (c):

– the chromatogram shows 2 clearly separated spots.

**Results:** the principal spot in the chromatogram obtained with the test solution is similar in position, colour and size to the principal spot in the chromatogram obtained with reference solution (a) for lactose or to the principal spot in the chromatogram obtained with reference solution (b) for mannitol.

##### D. Shake a quantity of the substance to be examined corresponding to 25 mg of isosorbide dinitrate with 10 mL of acetone R for 5 min. Filter, evaporate to dryness at a temperature below 40 °C and dry the residue over diphosphorus pentoxide R at a pressure of 0.7 kPa for 16 h. The melting point (2.2.14) of the residue is 69 °C to 72 °C.

#### TESTS

##### Impurity A. Thin-layer chromatography (2.2.27).

**Test solution.** Shake a quantity of the substance to be examined corresponding to 0.10 g of isosorbide dinitrate with 5 mL of ethanol (96 per cent) R and filter.

**Reference solution.** Dissolve 10 mg of potassium nitrate R in 1 mL of water R and dilute to 100 mL with ethanol (96 per cent) R.

**Plate:** TLC silica gel plate R.

**Mobile phase:** glacial acetic acid R, acetone R, toluene R (15:30:60 V/V/V).

**Application:** 10 µL.

**Development:** over a path of 15 cm.

**Drying:** in a current of air until the acetic acid is completely removed.

**Detection:** spray copiously with freshly prepared potassium iodide and starch solution R; expose to ultraviolet light at 254 nm for 15 min and examine in daylight.

**Limit:**

– **impurity A:** any spot due to impurity A is not more intense than the principal spot in the chromatogram obtained with the reference solution (0.5 per cent, calculated as potassium nitrate).

##### Impurities B and C. Liquid chromatography (2.2.29).

**Test solution (a).** Sonicate a quantity of the substance to be examined corresponding to 25.0 mg of isosorbide dinitrate with 20 mL of the mobile phase for 15 min and dilute to 25.0 mL with the mobile phase. Filter the solution through a suitable membrane filter.

**Test solution (b).** Dilute 1.0 mL of test solution (a) to 10.0 mL with the mobile phase.

**Reference solution (a).** Sonicate a quantity of isosorbide dinitrate CRS corresponding to 25.0 mg of isosorbide dinitrate with 20 mL of the mobile phase for 15 min and dilute to 25.0 mL with the mobile phase. Filter the solution through a suitable membrane filter.

**Reference solution (b).** Dilute 1.0 mL of reference solution (a) to 10.0 mL with the mobile phase.

**Reference solution (c).** Dissolve 10.0 mg of isosorbide 2-nitrate CRS (impurity B) in the mobile phase and dilute to 10.0 mL with the mobile phase. Dilute 0.1 mL of this solution to 20.0 mL with the mobile phase.

**Reference solution (d).** Dissolve 10.0 mg of isosorbide mononitrate CRS (impurity C) in the mobile phase and dilute to 10.0 mL with the mobile phase. Dilute 0.1 mL of this solution to 20.0 mL with the mobile phase.



01/2008:1118  
corrected 6.0

**Reference solution (e).** Dissolve 5 mg of *isosorbide 2-nitrate CRS* (impurity B) in the mobile phase and dilute to 10 mL with the mobile phase. To 1 mL of this solution add 0.5 mL of reference solution (a) and dilute to 10 mL with the mobile phase.

**Column:**

- size:  $l = 0.25$  m,  $\varnothing = 4.6$  mm;
- stationary phase: *aminopropylmethylsilyl silica gel for chromatography R* (10  $\mu$ m).

**Mobile phase:** *anhydrous ethanol R, trimethylpentane R* (15:85 V/V).

**Flow rate:** 1 mL/min.

**Detection:** spectrophotometer at 210-215 nm.

**Injection:** 10  $\mu$ L of test solution (a) and reference solutions (c), (d) and (e).

**Retention time:** isosorbide dinitrate = about 5 min; impurity B = about 8 min; impurity C = about 11 min.

**System suitability:** reference solution (e):

- resolution: minimum 6.0 between the peaks due to isosorbide dinitrate and impurity B.

**Limits:**

- **impurity B:** not more than the area of the principal peak in the chromatogram obtained with reference solution (c) (0.5 per cent);
- **impurity C:** not more than the area of the principal peak in the chromatogram obtained with reference solution (d) (0.5 per cent).

#### ASSAY

Liquid chromatography (2.2.29) as described in the test for impurities B and C with the following modifications.

**Detection:** spectrophotometer at 230 nm.

**Injection:** 20  $\mu$ L of test solution (b) and reference solution (b).

If the areas of the peaks from 2 successive injections of reference solution (b) do not agree to within 1.0 per cent, then inject a further 4 times and calculate, for the 6 injections, the relative standard deviation.

**System suitability:** reference solution (b):

- **repeatability:** maximum relative standard deviation of 2.0 per cent after 6 injections.

Calculate the content of isosorbide dinitrate as a percentage of the declared content.

#### STORAGE

Protected from light.

#### LABELLING

The label states the percentage content of isosorbide dinitrate.

#### IMPURITIES

**Specified impurities:** A, B, C.

A. inorganic nitrates,

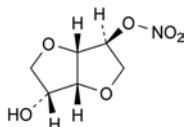

B. 1,4:3,6-dianhydro-D-glucitol 2-nitrate (isosorbide 2-nitrate),

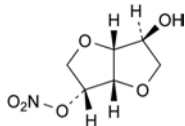

C. 1,4:3,6-dianhydro-D-glucitol 5-nitrate (isosorbide 5-nitrate, isosorbide mononitrate).

## ISOSORBIDE MONONITRATE, DILUTED

### Isosorbidi mononitratas dilutus

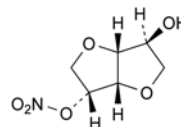

$C_6H_9NO_6$

$M_r$  191.1

#### DEFINITION

Dry mixture of isosorbide mononitrate and *Lactose monohydrate (0187)* or *Mannitol (0559)*.

**Content:** 95.0 per cent *m/m* to 105.0 per cent *m/m* of the content of 1,4:3,6-dianhydro-D-glucitol 5-nitrate stated on the label.

#### CHARACTERS

**Appearance:** undiluted isosorbide mononitrate is a white or almost white, crystalline powder.

**Solubility:** undiluted isosorbide mononitrate is freely soluble in water, in acetone, in ethanol (96 per cent) and in methylene chloride.

The solubility of the diluted product depends on the diluent and its concentration.

#### IDENTIFICATION

**First identification:** A, C, D.

**Second identification:** B, C, D.

A. Infrared absorption spectrophotometry (2.2.24).

**Preparation:** discs prepared with the residue obtained in identification test D.

**Comparison:** *isosorbide mononitrate CRS*.

B. Thin-layer chromatography (2.2.27).

**Test solution.** Shake a quantity of the substance to be examined corresponding to 10 mg of isosorbide mononitrate with 10 mL of *ethanol (96 per cent) R* for 5 min and filter.

**Reference solution.** Dissolve 10 mg of *isosorbide mononitrate CRS* in *ethanol (96 per cent) R* and dilute to 10 mL with the same solvent.

**Plate:** *TLC silica gel G plate R*.

**Mobile phase:** *methanol R, methylene chloride R* (5:95 V/V).

**Application:** 10  $\mu$ L.

**Development:** over a path of 15 cm.

**Drying:** in a current of air.

**Detection:** spray with freshly prepared *potassium iodide and starch solution R*. Expose to ultraviolet light at 254 nm for 15 min and examine in daylight.

**Results:** the principal spot in the chromatogram obtained with the test solution is similar in position, colour and size to the principal spot in the chromatogram obtained with the reference solution.

C. Thin-layer chromatography (2.2.27).

**Test solution.** Shake a quantity of the substance to be examined corresponding to 0.10 g of lactose or mannitol with 10 mL of *water R*; filter if necessary.

**Reference solution (a).** Dissolve 0.10 g of *lactose R* in *water R* and dilute to 10 mL with the same solvent.

**Reference solution (b).** Dissolve 0.10 g of *mannitol R* in *water R* and dilute to 10 mL with the same solvent.

**Reference solution (c).** Mix equal volumes of reference solutions (a) and (b).

**Plate:** *TLC silica gel G plate R*.

*Mobile phase:* water R, methanol R, anhydrous acetic acid R, ethylene chloride R (10:15:25:50 V/V/V/V); measure the volumes accurately since a slight excess of water produces cloudiness.

*Application:* 1 µL; thoroughly dry the points of application.

*Development A:* over a path of 15 cm.

*Drying A:* in a current of warm air.

*Development B:* immediately, over a path of 15 cm, after renewing the mobile phase.

*Drying B:* in a current of warm air.

*Detection:* spray with 4-aminobenzoic acid solution R and dry in a current of cold air until the acetone is removed; heat at 100 °C for 15 min and allow to cool; spray with a 2 g/L solution of sodium periodate R and dry in a current of cold air; heat at 100 °C for 15 min.

*System suitability:* reference solution (c):

– the chromatogram shows 2 clearly separated spots.

*Results:* the principal spot in the chromatogram obtained with the test solution is similar in position, colour and size to the principal spot in the chromatogram obtained with reference solution (a) for lactose or to the principal spot in the chromatogram obtained with reference solution (b) for mannitol.

- D. Shake a quantity of the substance to be examined corresponding to 25 mg of isosorbide mononitrate with 10 mL of acetone R for 5 min. Filter, evaporate to dryness at a temperature below 40 °C and dry the residue over diphosphorus pentoxide R at a pressure of 0.7 kPa for 16 h. The melting point (2.2.14) of the residue is 89 °C to 91 °C.

## TESTS

### Impurity A. Thin-layer chromatography (2.2.27).

*Test solution.* Shake a quantity of the substance to be examined corresponding to 0.10 g of isosorbide mononitrate with 5 mL of ethanol (96 per cent) R and filter.

*Reference solution.* Dissolve 10 mg of potassium nitrate R in 1 mL of water R and dilute to 100 mL with ethanol (96 per cent) R.

*Plate:* TLC silica gel plate R.

*Mobile phase:* glacial acetic acid R, acetone R, toluene R (15:30:60 V/V/V).

*Application:* 10 µL.

*Development:* over a path of 15 cm.

*Drying:* in a current of air until the acetic acid is completely removed.

*Detection:* spray copiously with freshly prepared potassium iodide and starch solution R; expose to ultraviolet light at 254 nm for 15 min and examine in daylight.

*Limit:*

– *impurity A:* any spot due to impurity A is not more intense than the principal spot in the chromatogram obtained with the reference solution (0.5 per cent, calculated as potassium nitrate).

### Impurities B and C. Liquid chromatography (2.2.29).

*Test solution (a).* Sonicate a quantity of the substance to be examined corresponding to 25.0 mg of isosorbide mononitrate with 20 mL of the mobile phase for 15 min and dilute to 25.0 mL with the mobile phase. Filter the solution through a suitable membrane filter.

*Test solution (b).* Dilute 1.0 mL of test solution (a) to 10.0 mL with the mobile phase.

*Reference solution (a).* Dissolve 25.0 mg of isosorbide mononitrate CRS in the mobile phase and dilute to 25.0 mL with the mobile phase. Dilute 1.0 mL of this solution to 10.0 mL with the mobile phase.

*Reference solution (b).* Dissolve 10.0 mg of isosorbide-2-nitrate CRS (impurity C) in the mobile phase and dilute to 10.0 mL with the mobile phase. Dilute 0.1 mL of this solution to 20.0 mL with the mobile phase.

*Reference solution (c).* Sonicate a quantity of isosorbide dinitrate CRS (impurity B) corresponding to 10.0 mg of isosorbide dinitrate in 15 mL of the mobile phase for 15 min and dilute to 20.0 mL with the mobile phase. Filter the solution through a suitable membrane filter. Dilute 0.1 mL of this solution to 10.0 mL with the mobile phase.

*Reference solution (d).* Dissolve 5 mg of isosorbide mononitrate CRS and 5 mg of isosorbide-2-nitrate CRS (impurity C) in the mobile phase and dilute to 10 mL with the mobile phase. Dilute 1 mL of this solution to 10 mL with the mobile phase.

*Column:*

– *size:*  $l = 0.25$  m,  $\varnothing = 4.6$  mm;

– *stationary phase:* aminopropylmethylsilyl silica gel for chromatography R (10 µm).

*Mobile phase:* anhydrous ethanol R, trimethylpentane R (15:85 V/V).

*Flow rate:* 1 mL/min.

*Detection:* spectrophotometer at 210-215 nm.

*Injection:* 10 µL of test solution (a) and reference solutions (b), (c) and (d).

*Retention time:* impurity B = about 5 min; impurity C = about 8 min; isosorbide 5-nitrate = about 11 min.

*System suitability:* reference solution (d):

– *resolution:* minimum 4.0 between the peaks due to impurity C and isosorbide 5-nitrate.

*Limits:*

– *impurity B:* not more than the area of the principal peak in the chromatogram obtained with reference solution (c) (0.5 per cent);

– *impurity C:* not more than the area of the principal peak in the chromatogram obtained with reference solution (b) (0.5 per cent).

## ASSAY

Liquid chromatography (2.2.29) as described in the test for impurities B and C with the following modifications.

*Detection:* spectrophotometer at 230 nm.

*Injection:* 20 µL of test solution (b) and reference solution (a).

If the areas of the peaks from 2 successive injections of reference solution (a) do not agree to within 1.0 per cent, then inject a further 4 times and calculate, for the 6 injections, the relative standard deviation.

*System suitability:* reference solution (a):

– *repeatability:* maximum relative standard deviation of 2.0 per cent after 6 injections.

Calculate the content of isosorbide mononitrate as a percentage of the declared content.

## STORAGE

Protected from light.

## LABELLING

The label states the percentage content of isosorbide mononitrate.

## IMPURITIES

*Specified impurities:* A, B, C.

A. inorganic nitrates,

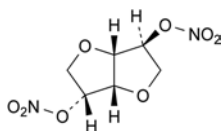

- B. 1,4:3,6-dianhydro-D-glucitol 2,5-dinitrate (isosorbide dinitrate),

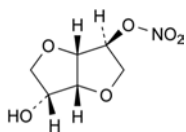

- C. 1,4:3,6-dianhydro-D-glucitol 2-nitrate (isosorbide 2-nitrate).

01/2011:1019

## ISOTRETINOIN

### Isotretinoinum

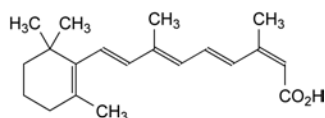

$C_{20}H_{28}O_2$   
[4759-48-2]

$M_r$  300.4

#### DEFINITION

(2*Z*,4*E*,6*E*,8*E*)-3,7-Dimethyl-9-(2,6,6-trimethylcyclohex-1-enyl)nona-2,4,6,8-tetraenoic acid.

*Content*: 98.0 per cent to 102.0 per cent (dried substance).

#### CHARACTERS

*Appearance*: yellow or light orange, crystalline powder.

*Solubility*: practically insoluble in water, soluble in methylene chloride, slightly soluble in ethanol (96 per cent).

It is sensitive to air, heat and light, especially in solution.

*Carry out all operations as rapidly as possible and avoid exposure to actinic light; use freshly prepared solutions.*

#### IDENTIFICATION

*First identification*: A.

*Second identification*: B, C.

- A. Infrared absorption spectrophotometry (2.2.24).

*Comparison*: isotretinoin CRS.

- B. Thin-layer chromatography (2.2.27).

*Test solution*. Dissolve 10 mg of the substance to be examined in *methylene chloride R* and dilute to 10 mL with the same solvent.

*Reference solution (a)*. Dissolve 10 mg of isotretinoin CRS in *methylene chloride R* and dilute to 10 mL with the same solvent.

*Reference solution (b)*. Dissolve 10 mg of isotretinoin CRS and 10 mg of tretinoin CRS in *methylene chloride R* and dilute to 10 mL with the same solvent.

*Plate*: TLC silica gel GF<sub>254</sub> plate R.

*Mobile phase*: glacial acetic acid R, acetone R, peroxide-free ether R, cyclohexane R (2:4:40:54 V/V/V/V).

*Application*: 5 µL.

*Development*: over 3/4 of the plate.

*Drying*: in air.

*Detection*: examine in ultraviolet light at 254 nm.

*System suitability*: reference solution (b):

- the chromatogram shows 2 clearly separated principal spots.

*Results*: the principal spot in the chromatogram obtained with the test solution is similar in position and size to the principal spot in the chromatogram obtained with reference solution (a).

- C. Dissolve about 5 mg in 2 mL of *antimony trichloride solution R*. An intense red colour develops and later becomes violet.

#### TESTS

**Related substances.** Liquid chromatography (2.2.29).

*Test solution*. Dissolve 0.100 g of the substance to be examined in *methanol R* and dilute to 50.0 mL with the same solvent.

*Reference solution (a)*. Dissolve 10.0 mg of tretinoin CRS (impurity A) in *methanol R* and dilute to 10.0 mL with the same solvent.

*Reference solution (b)*. Mix 1.0 mL of reference solution (a) with 0.5 mL of the test solution and dilute to 25.0 mL with *methanol R*.

*Reference solution (c)*. Dilute 0.5 mL of the test solution to 100.0 mL with *methanol R*.

*Reference solution (d)*. Dissolve 5 mg of isotretinoin for peak identification CRS (containing impurities H and I) in 2.5 mL of *methanol R*.

*Column*:

- *size*:  $l = 0.15$  m,  $\varnothing = 4.6$  mm;
- *stationary phase*: octadecylsilyl silica gel for chromatography R (3 µm).

*Mobile phase*: glacial acetic acid R, water R, *methanol R* (5:225:770 V/V/V).

*Flow rate*: 1.0 mL/min.

*Detection*: spectrophotometer at 355 nm.

*Injection*: 10 µL.

*Run time*: 1.6 times the retention time of isotretinoin.

*Identification of impurities*: use the chromatogram supplied with isotretinoin for peak identification CRS and the chromatogram obtained with reference solution (d) to identify the peaks due to impurities H and I. Use the chromatogram obtained with reference solution (a) to identify the peak due to impurity A.

*Relative retention* with reference to isotretinoin (retention time = about 26 min): impurity H = about 0.2; impurity I = about 0.3; impurity A = about 1.34.

*System suitability*:

- *resolution*: minimum 5.0 between the peaks due to isotretinoin and impurity A in the chromatogram obtained with reference solution (b);
- *resolution*: minimum 1.5 between the peaks due to impurities H and I in the chromatogram obtained with reference solution (d).

*Limits*:

- *impurity A*: not more than the area of the principal peak in the chromatogram obtained with reference solution (c) (0.5 per cent);
- *impurities H, I*: for each impurity, not more than 0.6 times the area of the principal peak in the chromatogram obtained with reference solution (c) (0.3 per cent);
- *unspecified impurities*: for each impurity, not more than 0.4 times the area of the principal peak in the chromatogram obtained with reference solution (c) (0.2 per cent);
- *total of impurities eluting before the principal peak*: not more than 1.4 times the area of the principal peak in the chromatogram obtained with reference solution (c) (0.7 per cent);
- *total of impurities eluting after the principal peak*: not more than twice the area of the principal peak in the chromatogram obtained with reference solution (c) (1.0 per cent);

- *disregard limit*: 0.1 times the area of the principal peak in the chromatogram obtained with reference solution (c) (0.05 per cent).

The thresholds indicated under Related substances (Table 2034.-1) in the general monograph *Substances for pharmaceutical use (2034)* do not apply.

**Heavy metals (2.4.8)**: maximum 20 ppm.

0.5 g complies with test D. Prepare the reference solution using 1 mL of *lead standard solution (10 ppm Pb) R*.

**Loss on drying (2.2.32)**: maximum 0.5 per cent, determined on 1.000 g by drying *in vacuo* for 16 h.

**Sulfated ash (2.4.14)**: maximum 0.1 per cent, determined on 1.0 g.

#### ASSAY

Dissolve 0.200 g in 70 mL of *acetone R*. Titrate with 0.1 M *tetrabutylammonium hydroxide in 2-propanol*, determining the end-point potentiometrically (2.2.20).

1 mL of 0.1 M *tetrabutylammonium hydroxide in 2-propanol* is equivalent to 30.04 mg of C<sub>20</sub>H<sub>28</sub>O<sub>2</sub>.

#### STORAGE

Under an inert gas, in an airtight container, protected from light.

It is recommended that the contents of an opened container be used as soon as possible and any unused part be protected by an atmosphere of inert gas.

#### IMPURITIES

*Specified impurities: A, H, I.*

*Other detectable impurities* (the following substances would, if present at a sufficient level, be detected by one or other of the tests in the monograph. They are limited by the general acceptance criterion for other/unspecified impurities. It is therefore not necessary to identify these impurities for demonstration of compliance. See also 5.10. *Control of impurities in substances for pharmaceutical use*): B, C, D, F, G.

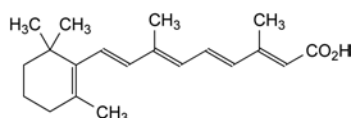

- A. (2*E*,4*E*,6*E*,8*E*)-3,7-dimethyl-9-(2,6,6-trimethylcyclohex-1-en-1-yl)nona-2,4,6,8-tetraenoic acid (tretinoin),

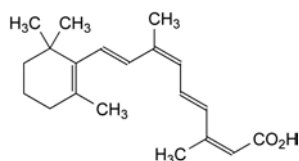

- B. (2*Z*,4*E*,6*Z*,8*E*)-3,7-dimethyl-9-(2,6,6-trimethylcyclohex-1-en-1-yl)nona-2,4,6,8-tetraenoic acid (9,13-dicis-retinoic acid),

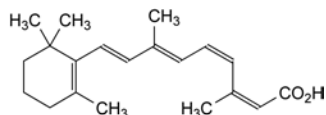

- C. (2*Z*,4*Z*,6*E*,8*E*)-3,7-dimethyl-9-(2,6,6-trimethylcyclohex-1-en-1-yl)nona-2,4,6,8-tetraenoic acid (11,13-dicis-retinoic acid),

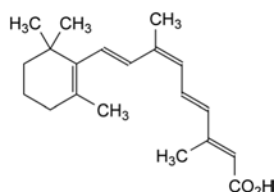

- D. (2*E*,4*E*,6*Z*,8*E*)-3,7-dimethyl-9-(2,6,6-trimethylcyclohex-1-en-1-yl)nona-2,4,6,8-tetraenoic acid (9-cis-retinoic acid),

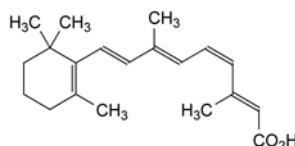

- F. (2*E*,4*Z*,6*E*,8*E*)-3,7-dimethyl-9-(2,6,6-trimethylcyclohex-1-en-1-yl)nona-2,4,6,8-tetraenoic acid (11-cis-retinoic acid),

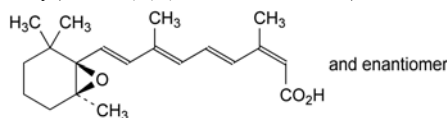

- G. (2*Z*,4*E*,6*E*,8*E*)-3,7-dimethyl-9-[(1*R*,6*S*)-2,2,6-trimethyl-7-oxabicyclo[4.1.0]hept-1-yl]nona-2,4,6,8-tetraenoic acid (13-cis-5,6-dihydro-5,6-epoxyretinoic acid),

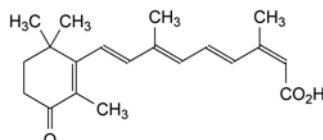

- H. (2*Z*,4*E*,6*E*,8*E*)-3,7-dimethyl-9-(2,6,6-trimethyl-3-oxocyclohex-1-en-1-yl)nona-2,4,6,8-tetraenoic acid (13-cis-4-oxoretinoic acid),

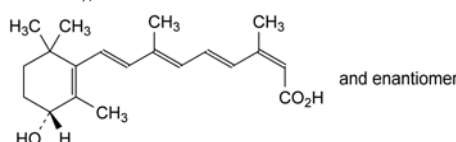

- I. (2*Z*,4*E*,6*E*,8*E*)-9-[(3*R*)-3-hydroxy-2,6,6-trimethylcyclohex-1-en-1-yl]-3,7-dimethylnona-2,4,6,8-tetraenoic acid (13-cis-4-hydroxyretinoic acid).

01/2008:1119  
corrected 6.0

## ISOXSUPRINE HYDROCHLORIDE

### Isoxsuprini hydrochloridum

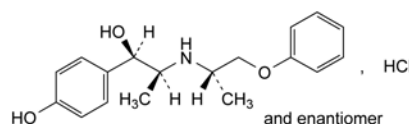

C<sub>18</sub>H<sub>24</sub>ClNO<sub>3</sub>  
[579-56-6]

M<sub>r</sub> 337.8

#### DEFINITION

(1*R*S,2*S*R)-1-(4-Hydroxyphenyl)-2-[[1*S*R]-1-methyl-2-phenoxyethyl]amino]propan-1-ol hydrochloride.

*Content*: 99.0 per cent to 101.0 per cent (dried substance).

#### CHARACTERS

*Appearance*: white or almost white, crystalline powder.

*Solubility*: sparingly soluble in water and in ethanol (96 per cent), practically insoluble in methylene chloride.

mp: about 205 °C, with decomposition.

#### IDENTIFICATION

*First identification: B, E.*

*Second identification: A, C, D, E.*

- A. Ultraviolet and visible absorption spectrophotometry (2.2.25).

*Test solution*. Dissolve 50.0 mg in 0.1 M *hydrochloric acid* and dilute to 50.0 mL with the same acid. Dilute 10.0 mL of this solution to 100.0 mL with 0.1 M *hydrochloric acid*.

*Spectral range*: 230-350 nm.

*Absorption maxima*: at 269 nm and 275 nm.

**Resolution (2.2.25):** minimum 1.7 for the absorbance ratio.

**Specific absorbance at the absorption maxima:**

- at 269 nm: 71 to 74;
- at 275 nm: 70 to 73.

**B. Infrared absorption spectrophotometry (2.2.24).**

**Preparation:** discs.

**Comparison:** isosuprine hydrochloride CRS.

If the spectra obtained show differences, dissolve 50 mg of the substance to be examined and of the reference substance separately in 2 mL of *methanol R*, add 15 mL of *methylene chloride R*, evaporate to dryness and record new spectra using the residues.

**C. Thin-layer chromatography (2.2.27).**

**Test solution.** Dissolve 20 mg of the substance to be examined in *methanol R* and dilute to 10 mL with the same solvent.

**Reference solution.** Dissolve 20 mg of *isosuprine hydrochloride CRS* in *methanol R* and dilute to 10 mL with the same solvent.

**Plate:** TLC silica gel G plate *R*.

**Mobile phase:** concentrated ammonia *R*, *methanol R*, *methylene chloride R* (0.25:15:85 V/V/V).

**Application:** 10 µL.

**Development:** over a path of 12 cm.

**Drying:** in a current of warm air.

**Detection:** spray with a 10 g/L solution of *potassium permanganate R*.

**Results:** the principal spot in the chromatogram obtained with the test solution is similar in position, colour and size to the principal spot in the chromatogram obtained with the reference solution.

**D. To 1 mL of solution S (see Tests) add 0.05 mL of copper sulfate solution R and 0.5 mL of strong sodium hydroxide solution R. The solution becomes blue. Add 1 mL of ether R and shake. Allow to separate. The upper layer remains colourless.**

**E. 2 mL of solution S gives reaction (a) of chlorides (2.3.1).**

**TESTS**

**Solution S.** Dissolve 0.50 g, with gentle heating if necessary, in *carbon dioxide-free water R*, cool and dilute to 50.0 mL with the same solvent.

**Appearance of solution.** Solution S is clear (2.2.1) and colourless (2.2.2, *Method II*).

**pH (2.2.3):** 4.5 to 6.0 for solution S.

**Optical rotation (2.2.7):**  $-0.05^\circ$  to  $+0.05^\circ$ , determined on solution S.

**Phenones:** maximum 1.0 per cent, calculated as impurity B.

Dissolve 10.0 mg in *water R* and dilute to 100.0 mL with the same solvent. The absorbance (2.2.25) of the solution measured at the absorption maximum at 310 nm is not greater than 0.10.

**Related substances.** Gas chromatography (2.2.28). Prepare the solutions immediately before use.

**Internal standard solution (a).** Dissolve 0.1 g of *hexacosane R* in *trimethylpentane R* and dilute to 20 mL with the same solvent.

**Internal standard solution (b).** Dilute 1 mL of internal standard solution (a) to 50 mL with *trimethylpentane R*.

**Test solution.** To 10.0 mg of the substance to be examined, add 0.5 mL of *N-trimethylsilylimidazole R*. Heat to 65 °C for 10 min. Allow to cool, then add 2.0 mL of the internal standard solution (b) and 2.0 mL of *water R*. Shake. Use the upper layer.

**Reference solution (a).** To 10.0 mg of the substance to be examined, add 0.5 mL of *N-trimethylsilylimidazole R*. Heat to 65 °C for 10 min. Allow to cool, then add 2.0 mL of the internal standard solution (a) and 2.0 mL of *water R*. Shake. Dilute 1.0 mL of the upper layer to 50.0 mL with *trimethylpentane R*.

**Reference solution (b).** To 10.0 mg of the substance to be examined, add 0.5 mL of *N-trimethylsilylimidazole R*. Heat to 65 °C for 10 min. Allow to cool, then add 2.0 mL of *trimethylpentane R* and 2.0 mL of *water R*. Shake. Use the upper layer.

**Column:**

- **material:** glass;
- **size:**  $l = 1.5$  m,  $\varnothing = 4$  mm;
- **stationary phase:** silanised diatomaceous earth for gas chromatography *R* (125-135 µm) impregnated with 3 per cent m/m of poly(dimethyl)siloxane *R*.

**Carrier gas:** nitrogen for chromatography *R*.

**Flow rate:** 30 mL/min.

**Temperature:**

	Time (min)	Temperature (°C)
Column	0 - 25	195
	25 - 29	195 → 215
	29 - 39	215
Injection port		225
Detector		225

**Detection:** flame ionisation.

**Injection:** 1 µL.

**Elution order:** isosuprine, hexacosane.

**System suitability:**

- **resolution:** minimum 5.0 between the peaks due to isosuprine and hexacosane in the chromatogram obtained with reference solution (a);
- in the chromatogram obtained with reference solution (b), there is no peak with the same retention time as the internal standard.

**Limit:**

- **total:** calculate the ratio (*R*) of the area of the peak due to the trimethylsilyl derivative of isosuprine to the area of the peak due to the internal standard from the chromatogram obtained with reference solution (a); from the chromatogram obtained with the test solution, calculate the ratio of the sum of the areas of any peaks, apart from the principal peak and the peak due to the internal standard, to the area of the peak due to the internal standard: this ratio is not greater than *R* (2.0 per cent).

**Heavy metals (2.4.8):** maximum 20 ppm.

1.0 g complies with test C. Prepare the reference solution using 2 mL of *lead standard solution (10 ppm Pb) R*.

**Loss on drying (2.2.32):** maximum 0.5 per cent, determined on 1.000 g by drying in an oven at 105 °C.

**Sulfated ash (2.4.14):** maximum 0.1 per cent, determined on 1.0 g.

**ASSAY**

Dissolve 0.250 g in 80 mL of *ethanol (96 per cent) R* and add 1.0 mL of 0.1 M *hydrochloric acid*. Carry out a potentiometric titration (2.2.20), using 0.1 M *sodium hydroxide*. Read the volume added between the 2 points of inflexion.

1 mL of 0.1 M *sodium hydroxide* is equivalent to 33.78 mg of  $C_{18}H_{34}ClNO_3$ .

**STORAGE**

Protected from light.

## IMPURITIES

Specified impurities: B.

Other detectable impurities (the following substances would, if present at a sufficient level, be detected by one or other of the tests in the monograph. They are limited by the general acceptance criterion for other/unspecified impurities and/or by the general monograph *Substances for pharmaceutical use (2034)*. It is therefore not necessary to identify these impurities for demonstration of compliance. See also 5.10. *Control of impurities in substances for pharmaceutical use*): A.

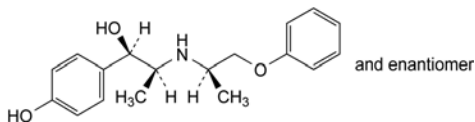

A. (1*R*,2*S*)-1-(4-hydroxyphenyl)-2-[(1*R*)-1-methyl-2-phenoxyethyl]amino]propan-1-ol,

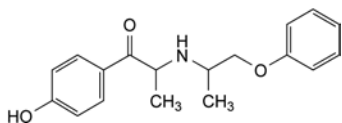

B. 1-(4-hydroxyphenyl)-2-[(1-methyl-2-phenoxyethyl)amino]propan-1-one.

01/2008:2110  
corrected 6.0

## ISRADIPINE

## Isradipinum

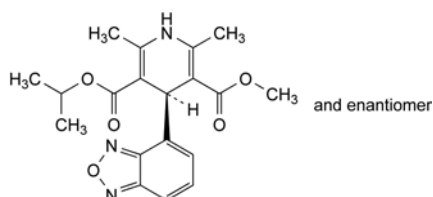

$C_{19}H_{21}N_3O_5$   
[75695-93-1]

$M_r$  371.4

## DEFINITION

Methyl 1-methylethyl (4*R*)-4-(2,1,3-benzoxadiazol-4-yl)-2,6-dimethyl-1,4-dihydropyridine-3,5-dicarboxylate.

*Content*: 97.0 per cent to 102.0 per cent (dried substance).

## CHARACTERS

*Appearance*: yellow, crystalline powder.

*Solubility*: practically insoluble in water, freely soluble in acetone, soluble in methanol.

mp: about 168 °C.

## IDENTIFICATION

Infrared absorption spectrophotometry (2.2.24).

*Comparison*: isradipine CRS.

## TESTS

**Related substances.** Liquid chromatography (2.2.29).

*Test solution (a)*. Dissolve 50.0 mg of the substance to be examined in 1 mL of *methanol R*, using an ultrasonic bath if necessary, and dilute to 25.0 mL with the mobile phase.

*Test solution (b)*. Dissolve 50.0 mg of the substance to be examined in 2 mL of *methanol R* and dilute to 250.0 mL with the mobile phase.

*Reference solution (a)*. Dilute 1.0 mL of test solution (a) to 100.0 mL with the mobile phase. Dilute 1.0 mL of this solution to 10.0 mL with the mobile phase.

*Reference solution (b)*. Dissolve 2 mg of the substance to be examined and 2 mg of *isradipine impurity D CRS* in the mobile phase and dilute to 10.0 mL with the mobile phase. Dilute 1.0 mL of this solution to 10.0 mL with the mobile phase.

*Reference solution (c)*. Dissolve 50.0 mg of *isradipine CRS* in 2 mL of *methanol R* and dilute to 250.0 mL with the mobile phase.

*Column*:

– *size*:  $l = 0.10$  m,  $\varnothing = 4.6$  mm,

– *stationary phase*: octadecylsilyl silica gel for chromatography R (5  $\mu$ m).

*Mobile phase*: acetonitrile R, tetrahydrofuran R, water R (125:270:625 V/V/V).

*Flow rate*: 1.2 mL/min.

*Detection*: spectrophotometer at 230 nm.

*Injection*: 20  $\mu$ L of test solution (a) and reference solutions (a) and (b).

*Run time*: 5 times the retention time of isradipine.

*Identification of impurities*: use the chromatogram supplied with *isradipine CRS* to identify the peaks due to impurities A and B.

*Relative retention* with reference to isradipine (retention time = about 7 min): impurity A = about 0.8; impurity D = about 0.9; impurity B = about 1.8.

*System suitability*: reference solution (b):

– *resolution*: minimum 2.0 between the peaks due to isradipine and impurity D.

*Limits*:

– *correction factor*: for the calculation of content, multiply the peak area of impurity D by 1.4,

– *impurity A*: not more than twice the area of the principal peak in the chromatogram obtained with reference solution (a) (0.2 per cent),

– *impurity B*: not more than 8 times the area of the principal peak in the chromatogram obtained with reference solution (a) (0.8 per cent),

– *impurity D*: not more than the area of the principal peak in the chromatogram obtained with reference solution (a) (0.1 per cent),

– *any other impurity*: for each impurity, not more than the area of the principal peak in the chromatogram obtained with reference solution (a) (0.1 per cent),

– *total*: not more than 10 times the area of the principal peak in the chromatogram obtained with reference solution (a) (1.0 per cent),

– *disregard limit*: 0.5 times the area of the principal peak in the chromatogram obtained with reference solution (a) (0.05 per cent).

**Loss on drying (2.2.32)**: maximum 0.2 per cent, determined on 1.000 g by drying in an oven at 105 °C for 4 h.

**Sulfated ash (2.4.14)**: maximum 0.1 per cent, determined on 1.0 g.

## ASSAY

Liquid chromatography (2.2.29) as described in the test for related substances with the following modifications.

*Detection*: spectrophotometer at 326 nm.

*Injection*: test solution (b) and reference solution (c).

*Run time*: twice the retention time of isradipine.

Calculate the percentage content of isradipine from the areas of the peaks and the declared content of *isradipine CRS*.

## STORAGE

Protected from light.

## IMPURITIES

*Specified impurities*: A, B, D.

01/2011:1335

*Other detectable impurities* (the following substances would, if present at a sufficient level, be detected by one or other of the tests in the monograph. They are limited by the general acceptance criterion for other/unspecified impurities and/or by the general monograph *Substances for pharmaceutical use* (2034). It is therefore not necessary to identify these impurities for demonstration of compliance. See also 5.10. *Control of impurities in substances for pharmaceutical use*): C, E.

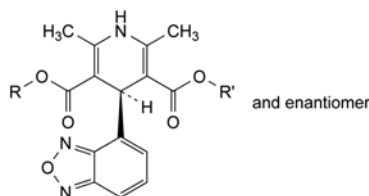

A. R = C<sub>2</sub>H<sub>5</sub>, R' = CH<sub>3</sub>: ethyl methyl (4*RS*)-4-(2,1,3-benzoxadiazol-4-yl)-2,6-dimethyl-1,4-dihydropyridine-3,5-dicarboxylate,

B. R = R' = CH(CH<sub>3</sub>)<sub>2</sub>: bis(1-methylethyl) (4*RS*)-4-(2,1,3-benzoxadiazol-4-yl)-2,6-dimethyl-1,4-dihydropyridine-3,5-dicarboxylate,

C. R = R' = CH<sub>3</sub>: dimethyl (4*RS*)-4-(2,1,3-benzoxadiazol-4-yl)-2,6-dimethyl-1,4-dihydropyridine-3,5-dicarboxylate,

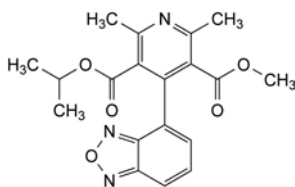

D. methyl 1-methylethyl 4-(2,1,3-benzoxadiazol-4-yl)-2,6-dimethylpyridine-3,5-dicarboxylate,

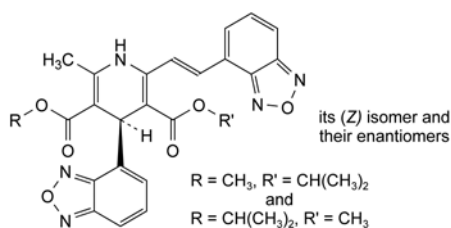

E. methyl 1-methylethyl (4*RS*)-4-(2,1,3-benzoxadiazol-4-yl)-2-[(*EZ*)-2-(2,1,3-benzoxadiazol-4-yl)ethenyl]-6-methyl-1,4-dihydropyridine-3,5-dicarboxylate.

## ITRACONAZOLE

### Itraconazolium

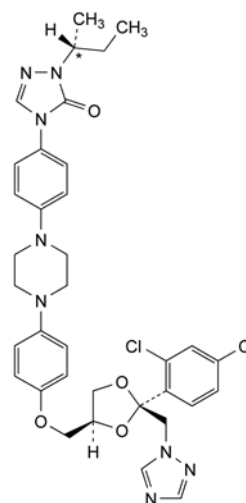

its epimer at C\*  
and their enantiomers

C<sub>35</sub>H<sub>38</sub>Cl<sub>2</sub>N<sub>6</sub>O<sub>4</sub>  
[84625-61-6]

M<sub>r</sub> 706

#### DEFINITION

4-[4-[4-[[*cis*-2-(2,4-Dichlorophenyl)-2-(1*H*-1,2,4-triazol-1-ylmethyl)-1,3-dioxolan-4-yl]methoxy]phenyl]piperazin-1-yl]phenyl]-2-[(1*RS*)-1-methylpropyl]-2,4-dihydro-3*H*-1,2,4-triazol-3-one.

*Content*: 99.0 per cent to 101.0 per cent (dried substance).

#### CHARACTERS

*Appearance*: white or almost white powder.

*Solubility*: practically insoluble in water, freely soluble in methylene chloride, very slightly soluble in ethanol (96 per cent).

#### IDENTIFICATION

Infrared absorption spectrophotometry (2.2.24).

*Comparison*: itraconazole CRS.

#### TESTS

**Solution S.** Dissolve 2.0 g in *methylene chloride R* and dilute to 20.0 mL with the same solvent.

**Appearance of solution.** Solution S is clear (2.2.1) and not more intensely coloured than reference solution R<sub>6</sub> or B<sub>6</sub> (2.2.2, *Method II*).

**Related substances.** Liquid chromatography (2.2.29). *Prepare the solutions immediately before use.*

**Test solution.** Dissolve 0.100 g of the substance to be examined in *methanolic hydrochloric acid R* and dilute to 10.0 mL with the same solvent.

**Reference solution (a).** Dilute 1.0 mL of the test solution to 100.0 mL with *methanolic hydrochloric acid R*. Dilute 1.0 mL of this solution to 10.0 mL with *methanolic hydrochloric acid R*.

**Reference solution (b).** Dissolve 10 mg of *itraconazole for system suitability CRS* (containing impurities B, C, D, E, F and G) in 1.0 mL of *methanolic hydrochloric acid R*.

**Column:**

– *size*: *l* = 0.10 m, Ø = 4.6 mm;

– *stationary phase*: *base-deactivated end-capped octadecylsilyl silica gel for chromatography R* (3 µm or 3.5 µm);

– *temperature*: 30 °C.

**Mobile phase:**

- mobile phase A: 27.2 g/L solution of *tetrabutylammonium hydrogen sulfate R1*;
- mobile phase B: *acetonitrile R1*;

Time (min)	Mobile phase A (per cent V/V)	Mobile phase B (per cent V/V)
0 - 2	80	20
2 - 22	80 → 50	20 → 50
22 - 27	50	50

**Flow rate:** 1.5 mL/min.

**Detection:** spectrophotometer at 225 nm.

**Injection:** 10 µL.

**Identification of impurities:** use the chromatogram supplied with *itraconazole for system suitability CRS* and the chromatogram obtained with reference solution (b) to identify the peaks due to impurities B, C, D, E, F and G.

**Relative retention** with reference to itraconazole (retention time = about 14 min): impurity B = about 0.7; impurities C and D = about 0.8; impurity E = about 0.9; impurity F = about 1.05; impurity G = about 1.3.

**System suitability:** reference solution (b):

- **peak-to-valley ratio:** minimum 1.5, where  $H_p$  = height above the baseline of the peak due to impurity F and  $H_v$  = height above the baseline of the lowest point of the curve separating this peak from the peak due to itraconazole.

**Limits:**

- **impurities B, G:** for each impurity, not more than 3 times the area of the principal peak in the chromatogram obtained with reference solution (a) (0.3 per cent);
- **impurity E:** not more than twice the area of the principal peak in the chromatogram obtained with reference solution (a) (0.2 per cent);
- **sum of impurities C and D:** not more than 3 times the area of the principal peak in the chromatogram obtained with reference solution (a) (0.3 per cent);
- **unspecified impurities:** for each impurity, not more than the area of the principal peak in the chromatogram obtained with reference solution (a) (0.10 per cent);
- **total:** not more than 8 times the area of the principal peak in the chromatogram obtained with reference solution (a) (0.8 per cent);
- **disregard limit:** 0.5 times the area of the principal peak in the chromatogram obtained with reference solution (a) (0.05 per cent).

**Loss on drying (2.2.32):** maximum 0.5 per cent, determined on 1.000 g by drying in an oven at 105 °C for 4 h.

**Sulfated ash (2.4.14):** maximum 0.1 per cent, determined on 1.0 g.

**ASSAY**

Dissolve 0.300 g in 70 mL of a mixture of 1 volume of *anhydrous acetic acid R* and 7 volumes of *methyl ethyl ketone R* by vigorous stirring for at least 10 min. Titrate with 0.1 M *perchloric acid*, determining the end-point potentiometrically at the second point of inflexion (2.2.20).

1 mL of 0.1 M *perchloric acid* is equivalent to 35.3 mg of  $C_{35}H_{38}Cl_2N_8O_4$ .

**STORAGE**

Protected from light.

**IMPURITIES**

**Specified impurities:** B, C, D, E, G.

**Other detectable impurities** (the following substances would, if present at a sufficient level, be detected by one or other of the tests in the monograph. They are limited by the general

acceptance criterion for other/unspecified impurities and/or by the general monograph *Substances for pharmaceutical use (2034)*. It is therefore not necessary to identify these impurities for demonstration of compliance. See also 5.10. *Control of impurities in substances for pharmaceutical use*): A, F.

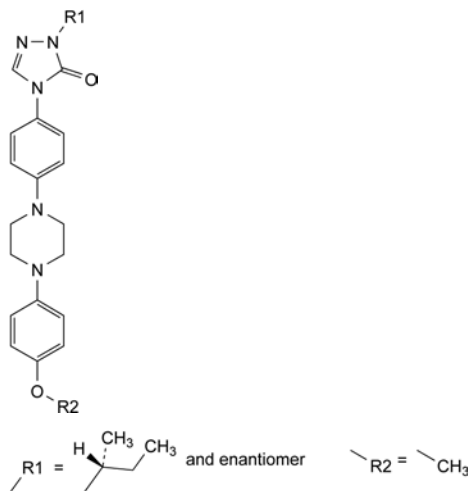

- A. 4-[4-[4-(4-methoxyphenyl)piperazin-1-yl]phenyl]-2-[(1*RS*)-1-methylpropyl]-2,4-dihydro-3*H*-1,2,4-triazol-3-one,

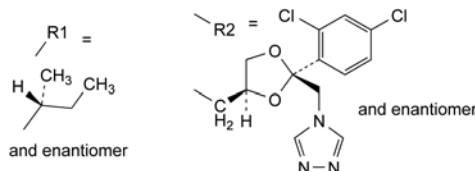

- B. 4-[4-[4-[4-[[*cis*-2-(2,4-dichlorophenyl)-2-(4*H*-1,2,4-triazol-4-ylmethyl)-1,3-dioxolan-4-yl]methoxy]phenyl]piperazin-1-yl]phenyl]-2-[(1*RS*)-1-methylpropyl]-2,4-dihydro-3*H*-1,2,4-triazol-3-one,

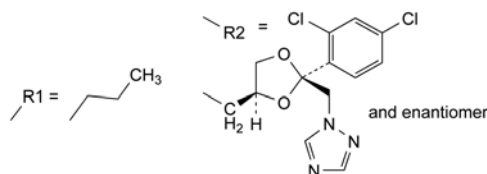

- C. 4-[4-[4-[4-[[*cis*-2-(2,4-dichlorophenyl)-2-(1*H*-1,2,4-triazol-1-ylmethyl)-1,3-dioxolan-4-yl]methoxy]phenyl]piperazin-1-yl]phenyl]-2-propyl-2,4-dihydro-3*H*-1,2,4-triazol-3-one,

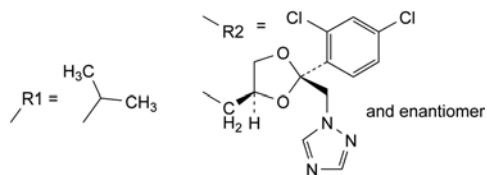

- D. 4-[4-[4-[4-[[*cis*-2-(2,4-dichlorophenyl)-2-(1*H*-1,2,4-triazol-1-ylmethyl)-1,3-dioxolan-4-yl]methoxy]phenyl]piperazin-1-yl]phenyl]-2-(1-methylethyl)-2,4-dihydro-3*H*-1,2,4-triazol-3-one,

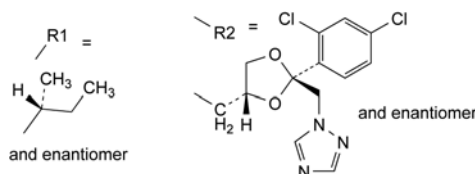

- E. 4-[4-[4-[4-[[*trans*-2-(2,4-dichlorophenyl)-2-(1*H*-1,2,4-triazol-1-ylmethyl)-1,3-dioxolan-4-yl]methoxy]phenyl]piperazin-1-yl]phenyl]-2-[(1*RS*)-1-methylpropyl]-2,4-dihydro-3*H*-1,2,4-triazol-3-one,



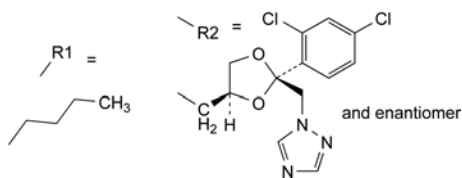

- F. 2-butyl-4-[4-[4-[4-[*cis*-2-(2,4-dichlorophenyl)-2-(1*H*-1,2,4-triazol-1-ylmethyl)-1,3-dioxolan-4-yl]methoxy]phenyl]piperazin-1-yl]phenyl]-2,4-dihydro-3*H*-1,2,4-triazol-3-one,

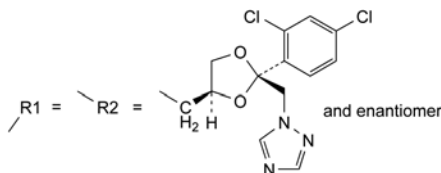

- G. 4-[4-[4-[4-[*cis*-2-(2,4-dichlorophenyl)-2-(1*H*-1,2,4-triazol-1-ylmethyl)-1,3-dioxolan-4-yl]methoxy]phenyl]piperazin-1-yl]phenyl]-2-[[*cis*-2-(2,4-dichlorophenyl)-2-(1*H*-1,2,4-triazol-1-ylmethyl)-1,3-dioxolan-4-yl]methyl]-2,4-dihydro-3*H*-1,2,4-triazol-3-one.

01/2008:1336  
corrected 6.0

## IVERMECTIN

### Ivermectinum

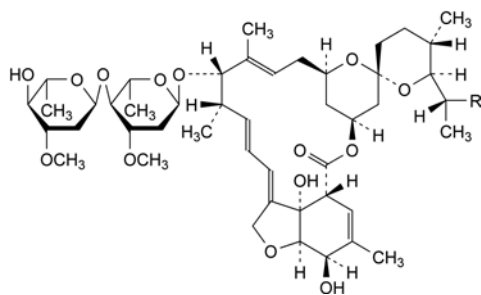

Component	R	Molecular formula	$M_r$
H <sub>2</sub> B <sub>1a</sub>	CH <sub>2</sub> -CH <sub>3</sub>	C <sub>48</sub> H <sub>74</sub> O <sub>14</sub>	875
H <sub>2</sub> B <sub>1b</sub>	CH <sub>3</sub>	C <sub>47</sub> H <sub>72</sub> O <sub>14</sub>	861

Ivermectin B1a: [70161-11-4]

Ivermectin B1b: [70288-86-7]

#### DEFINITION

Mixture of (2*aE*,4*E*,5'*S*,6*S*,6'*R*,7*S*,8*E*,11*R*,13*R*,15*S*,17*aR*,20*R*,20*aR*,20*bS*)-7-[[2,6-dideoxy-4-*O*-(2,6-dideoxy-3-*O*-methyl- $\alpha$ -*L*-arabino-hexopyranosyl)-3-*O*-methyl- $\alpha$ -*L*-arabino-hexopyranosyl]oxy]-20,20*b*-dihydroxy-5',6,8,19-tetramethyl-6'-[(1*S*)-1-methylpropyl]-3',4',5',6,6',7,10,11,14,15,17*a*,20,20*a*,20*b*-tetradecahydrospiro[11,15-methano-2*H*,13*H*,17*H*-furo[4,3,2-*pp*][2,6]benzodioxacyclooctadecene-13,2'-[2*H*]pyran]-17-one (or 5-*O*-demethyl-22,23-dihydroaivermectin A<sub>1a</sub>) (component H<sub>2</sub>B<sub>1a</sub>) and (2*aE*,4*E*,5'*S*,6*S*,6'*R*,7*S*,8*E*,11*R*,13*R*,15*S*,17*aR*,20*R*,20*aR*,20*bS*)-7-[[2,6-dideoxy-4-*O*-(2,6-dideoxy-3-*O*-methyl- $\alpha$ -*L*-arabino-hexopyranosyl)-3-*O*-methyl- $\alpha$ -*L*-arabino-hexopyranosyl]oxy]-20,20*b*-dihydroxy-5',6,8,19-tetramethyl-6'-[(1-methylethyl)-3',4',5',6,6',7,10,11,14,15,17*a*,20,20*a*,20*b*-tetradecahydrospiro[11,15-methano-2*H*,13*H*,17*H*-furo[4,3,2-*pp*][2,6]benzodioxacyclooctadecene-13,2'-[2*H*]pyran]-17-one (or 5-*O*-demethyl-25-de(1-methylpropyl)-25-(1-methylethyl)-22,23-dihydroaivermectin A<sub>1a</sub>) (component H<sub>2</sub>B<sub>1b</sub>).

Semi-synthetic product derived from a fermentation product.

#### Content:

- ivermectin (H<sub>2</sub>B<sub>1a</sub> + H<sub>2</sub>B<sub>1b</sub>): 95.0 per cent to 102.0 per cent (anhydrous substance),

- ratio H<sub>2</sub>B<sub>1a</sub>/(H<sub>2</sub>B<sub>1a</sub> + H<sub>2</sub>B<sub>1b</sub>) (areas by liquid chromatography): minimum 90.0 per cent.

#### CHARACTERS

**Appearance:** white or yellowish-white, crystalline powder, slightly hygroscopic.

**Solubility:** practically insoluble in water, freely soluble in methylene chloride, soluble in alcohol.

#### IDENTIFICATION

- A. Infrared absorption spectrophotometry (2.2.24).

**Comparison:** ivermectin CRS.

- B. Examine the chromatograms obtained in the assay.

**Results:** the retention times and sizes of the 2 principal peaks in the chromatogram obtained with the test solution are similar to those of the 2 principal peaks in the chromatogram obtained with reference solution (a).

#### TESTS

**Appearance of solution.** The solution is clear (2.2.1) and not more intensely coloured than reference solution BY<sub>7</sub> (2.2.2, Method II).

Dissolve 1.0 g in 50 mL of *toluene R*.

**Specific optical rotation (2.2.7):** – 17 to – 20 (anhydrous substance).

Dissolve 0.250 g in *methanol R* and dilute to 10.0 mL with the same solvent.

**Related substances.** Liquid chromatography (2.2.29).

**Test solution.** Dissolve 40.0 mg of the substance to be examined in *methanol R* and dilute to 50.0 mL with the same solvent.

**Reference solution (a).** Dissolve 40.0 mg of ivermectin CRS in *methanol R* and dilute to 50.0 mL with the same solvent.

**Reference solution (b).** Dilute 1.0 mL of reference solution (a) to 100.0 mL with *methanol R*.

**Reference solution (c).** Dilute 5.0 mL of reference solution (b) to 100.0 mL with *methanol R*.

#### Column:

- size:  $l = 0.25$  m,  $\varnothing = 4.6$  mm,
- stationary phase: octadecylsilyl silica gel for chromatography R (5  $\mu$ m).

**Mobile phase:** *water R*, *methanol R*, *acetonitrile R* (15:34:51 V/V/V).

**Flow rate:** 1 mL/min.

**Detection:** spectrophotometer at 254 nm.

**Injection:** 20  $\mu$ L.

#### System suitability:

- **resolution:** minimum of 3.0 between the first peak (component H<sub>2</sub>B<sub>1b</sub>) and the second peak (component H<sub>2</sub>B<sub>1a</sub>) in the chromatogram obtained with reference solution (a),
- **signal-to-noise ratio:** minimum of 10 for the principal peak in the chromatogram obtained with reference solution (c),
- **symmetry factor:** maximum of 2.5 for the principal peak in the chromatogram obtained with reference solution (a).

#### Limits:

- **impurity with a relative retention of 1.3 to 1.5** with reference to the principal peak: not more than 2.5 times the area of the principal peak in the chromatogram obtained with reference solution (b) (2.5 per cent),
- **any other impurity** (apart from the 2 principal peaks): not more than the area of the principal peak in the chromatogram obtained with reference solution (b) (1 per cent),
- **total:** not more than 5 times the area of the principal peak in the chromatogram obtained with reference solution (b) (5 per cent),
- **disregard limit:** area of the principal peak in the chromatogram obtained with reference solution (c) (0.05 per cent).

**Ethanol and formamide.** Gas chromatography (2.2.28).

**Internal standard solution.** Dilute 0.5 mL of *propanol R* to 100 mL with *water R*.

**Test solution.** In a centrifuge tube, dissolve 0.120 g of the substance to be examined in 2.0 mL of *m-xylene R* (if necessary heat in a water-bath at 40-50 °C). Add 2.0 mL of *water R*, mix thoroughly and centrifuge. Remove the upper layer and extract it with 2.0 mL of *water R*. Discard the upper layer and combine the aqueous layers. Add 1.0 mL of the internal standard solution. Centrifuge and discard any remaining *m-xylene*.

**Reference solution (a).** Dilute 3.0 g of *ethanol R* to 100.0 mL with *water R*.

**Reference solution (b).** Dilute 1.0 g of *formamide R* to 100.0 mL with *water R*.

**Reference solution (c).** Dilute 5.0 mL of reference solution (a) and 5.0 mL of reference solution (b) to 50.0 mL with *water R*. Introduce 2.0 mL of this solution into a centrifuge tube, add 2.0 mL of *m-xylene R*, mix thoroughly and centrifuge. Remove the upper layer and extract it with 2.0 mL of *water R*. Discard the upper layer and combine the aqueous layers. Add 1.0 mL of the internal standard solution. Centrifuge and discard any remaining *m-xylene*.

**Reference solution (d).** Dilute 10.0 mL of reference solution (a) and 10.0 mL of reference solution (b) to 50.0 mL with *water R*. Treat as prescribed for reference solution (c) (from "Introduce 2.0 mL of this solution...").

**Column:**

- *material:* fused silica,
- *size:*  $l = 30$  m,  $\varnothing = 0.53$  mm,
- *stationary phase:* *macrogol 20 000 R* (film thickness 1  $\mu$ m).

**Carrier gas:** *helium for chromatography R*.

**Flow rate:** 7.5 mL/min.

**Split ratio:** 1:10.

**Temperature:**

	Time (min)	Temperature (°C)
Column	0 - 2	50 → 80
	2 - 8	80 → 240
Injection port		220
Detector		280

**Detection:** flame ionisation.

**Injection:** 1  $\mu$ L; inject the test solution and reference solutions (c) and (d).

**Limits:**

- *ethanol:* maximum 5.0 per cent,
- *formamide:* maximum 3.0 per cent.

**Heavy metals (2.4.8):** maximum 20 ppm.

1.0 g complies with limit test C. Prepare the standard using 2 mL of *lead standard solution (10 ppm Pb) R*.

**Water (2.5.12):** maximum 1.0 per cent, determined on 0.50 g.

**Sulfated ash (2.4.14):** maximum 0.1 per cent, determined on 1.0 g.

**ASSAY**

Liquid chromatography (2.2.29) as described in the test for related substances.

**Injection:** 20  $\mu$ L; inject the test solution and reference solution (a).

Calculate the percentage contents of ivermectin ( $H_2B_{1a} + H_2B_{1b}$ ) and the ratio  $H_2B_{1a}/(H_2B_{1a} + H_2B_{1b})$  using the declared contents of *ivermectin CRS*.

**STORAGE**

In an airtight container.

**IMPURITIES**

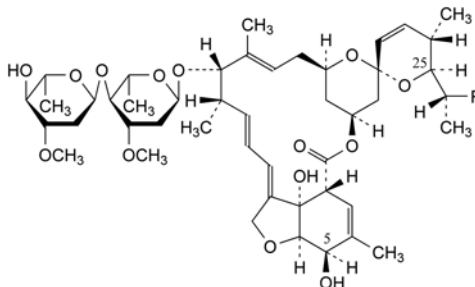

A. R = C<sub>2</sub>H<sub>5</sub>: 5-*O*-demethylavermectin A<sub>1a</sub> (avermectin B<sub>1a</sub>),

B. R = CH<sub>3</sub>: 5-*O*-demethyl-25-de(1-methylpropyl)-25-(1-methylethyl)avermectin A<sub>1a</sub> (avermectin B<sub>1b</sub>),

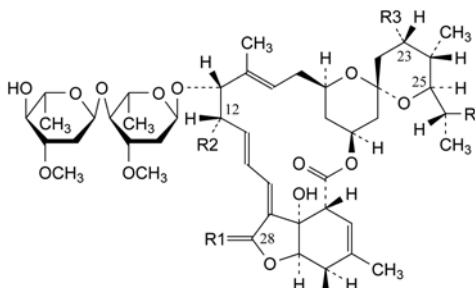

C. R1 = H<sub>2</sub>, R2 = CH<sub>3</sub>, R3 = OH, R4 = C<sub>2</sub>H<sub>5</sub>: (23*S*)-5-*O*-demethyl-23-hydroxy-22,23-dihydroavermectin A<sub>1a</sub> (avermectin B<sub>2a</sub>),

D. R1 = O, R2 = CH<sub>3</sub>, R3 = H, R4 = C<sub>2</sub>H<sub>5</sub>: 5-*O*-demethyl-28-oxo-22,23-dihydroavermectin A<sub>1a</sub> (28-oxo-H<sub>2</sub>B<sub>1a</sub>),

E. R1 = H<sub>2</sub>, R2 = C<sub>2</sub>H<sub>5</sub>, R3 = H, R4 = C<sub>2</sub>H<sub>5</sub>: 5-*O*,12-didemethyl-12-ethyl-22,23-dihydroavermectin A<sub>1a</sub> (12-demethyl-12-ethyl-H<sub>2</sub>B<sub>1a</sub>),

F. R1 = H<sub>2</sub>, R2 = C<sub>2</sub>H<sub>5</sub>, R3 = H, R4 = CH<sub>3</sub>: 5-*O*,12-didemethyl-25-de(1-methylpropyl)-12-ethyl-25-(1-methylethyl)-22,23-dihydroavermectin A<sub>1a</sub> (12-demethyl-12-ethyl-H<sub>2</sub>B<sub>1b</sub>),

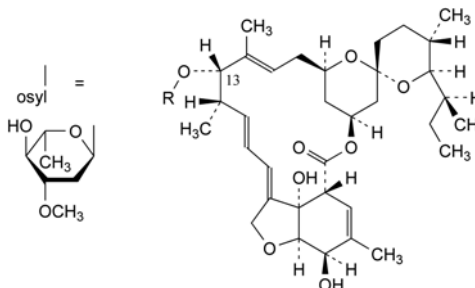

G. R = H: (6*R*,13*S*,25*R*)-5-*O*-demethyl-28-deoxy-6,28-epoxy-13-hydroxy-25-[(1*S*)-1-methylpropyl]milbemycin B (H<sub>2</sub>B<sub>1a</sub> aglycone),

H. R = osyl: 4'-*O*-de(2,6-dideoxy-3-*O*-methyl- $\alpha$ -*L*-arabino-hexopyranosyl)-5-*O*-demethyl-22,23-dihydroavermectin A<sub>1a</sub>,

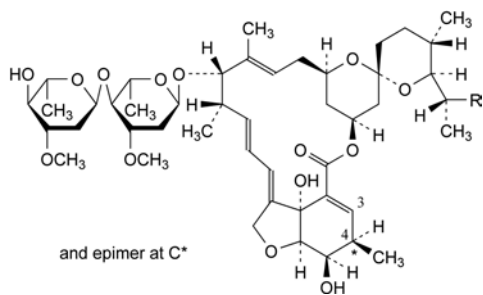

- I. R = C<sub>2</sub>H<sub>5</sub>: 2,3-didehydro-5-*O*-demethyl-3,4,22,23-tetrahydroavermectin A<sub>1a</sub> (Δ<sup>2,3</sup> H<sub>2</sub>B<sub>1a</sub>),  
 J. R = CH<sub>3</sub>: 2,3-didehydro-5-*O*-demethyl-25-de(1-methylpropyl)-25-(1-methylethyl)-3,4,22,23-tetrahydroavermectin A<sub>1a</sub> (Δ<sup>2,3</sup> H<sub>2</sub>B<sub>1b</sub>),

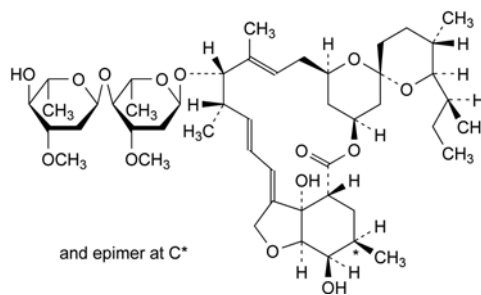

- K. (4*R*) and (4*S*)-5-*O*-demethyl-3,4,22,23-tetrahydroavermectin A<sub>1a</sub> (H<sub>4</sub>B<sub>1a</sub> isomers).

07/2010:1983

## JOSAMYCIN

## Josamycinum

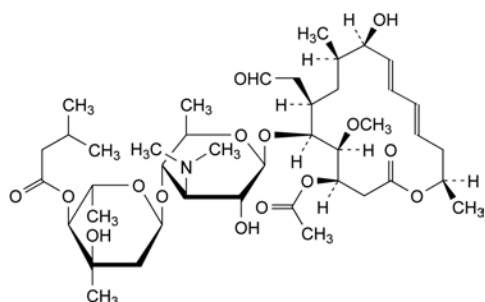

$C_{42}H_{69}NO_{15}$   
[16846-24-5]

 $M_r$  828

## DEFINITION

Josamycin is a macrolide antibiotic obtained by fermentation using, for example, certain strains of *Streptomyces narbonensis* var. *josamyceticus* var. *nova*. The main component is (4*R*,5*S*,6*S*,7*R*,9*R*,10*R*,11*E*,13*E*,16*R*)-4-(acetyloxy)-6-[[3,6-dideoxy-4-*O*-[2,6-dideoxy-3-*C*-methyl-4-*O*-(3-methylbutanoyl)- $\alpha$ -*L*-ribo-hexopyranosyl]-3-(dimethylamino)- $\beta$ -*D*-glucopyranosyl]oxy]-10-hydroxy-5-methoxy-9,16-dimethyl-7-(2-oxoethyl)oxacyclohexadeca-11,13-dien-2-one.

*Content*: minimum 900 Ph. Eur. U./mg (dried substance).

## CHARACTERS

*Appearance*: white or slightly yellowish powder, slightly hygroscopic.

*Solubility*: very slightly soluble in water, freely soluble in methanol and in methylene chloride, soluble in acetone.

## IDENTIFICATION

*First identification*: A, C.

*Second identification*: A, B.

A. Ultraviolet and visible absorption spectrophotometry (2.2.25).

*Test solution*. Dissolve 0.10 g in *methanol R* and dilute to 100.0 mL with the same solvent. Dilute 1.0 mL of this solution to 50.0 mL with *methanol R*.

*Spectral range*: 220-350 nm.

*Absorption maximum*: at 232 nm.

*Specific absorbance at the absorption maximum*: 330 to 370.

B. Thin-layer chromatography (2.2.27).

*Test solution*. Dissolve 10 mg of the substance to be examined in 2.5 mL of *methanol R*.

*Reference solution (a)*. Dissolve 10 mg of *josamycin CRS* in 2.5 mL of *methanol R*.

*Reference solution (b)*. Dissolve 10 mg of *josamycin propionate CRS* in 2.5 mL of *methanol R*.

*Plate*: TLC silica gel GF<sub>254</sub> plate *R*.

*Mobile phase*: *methanol R*, *acetone R*, *ethyl acetate R*, *toluene R*, *hexane R* (8:10:20:25:30 V/V/V/V/V).

*Application*: 5  $\mu$ L.

*Development*: over 2/3 of the plate.

*Drying*: at 100 °C for 10 min.

*Detection*: examine in ultraviolet light at 254 nm.

*Results*: the principal spot in the chromatogram obtained with the test solution is similar in position, colour and size to the principal spot in the chromatogram obtained with

reference solution (a) and different in position from the principal spot in the chromatogram obtained with reference solution (b).

C. Examine the chromatograms obtained in the test for related substances.

*Results*: the principal peak in the chromatogram obtained with the test solution is similar in position and size to the principal peak in the chromatogram obtained with reference solution (a).

## TESTS

**Appearance of solution**. The solution is clear (2.2.1) and not more intensely coloured than reference solution BY<sub>4</sub> (2.2.2, *Method II*).

Dissolve 2.0 g in *methanol R* and dilute to 20 mL with the same solvent.

**Specific optical rotation** (2.2.7): –65 to –75 (dried substance).

Dissolve 1.000 g in *methanol R* and dilute to 100.0 mL with the same solvent. Allow to stand for 30 min before measuring the angle of rotation.

**Related substances**. Liquid chromatography (2.2.29).

*Solvent mixture*: *acetonitrile R*, *water R* (30:70 V/V).

*Test solution*. Dissolve 50.0 mg of the substance to be examined in the solvent mixture and dilute to 20.0 mL with the solvent mixture.

*Reference solution (a)*. Dissolve 25.0 mg of *josamycin CRS* in the solvent mixture and dilute to 10.0 mL with the solvent mixture.

*Reference solution (b)*. Dilute 1.0 mL of reference solution (a) to 20.0 mL with the solvent mixture.

*Reference solution (c)*. Dilute 1.0 mL of reference solution (b) to 50.0 mL with the solvent mixture.

*Reference solution (d)*. To 10 mL of the test solution add 0.1 mL of *strong hydrogen peroxide solution R* and heat in a water-bath for 10 min. Mix 1.0 mL of this solution and 1.0 mL of the test solution.

*Reference solution (e)*. Dissolve 12.5 mg of *josamycin for peak identification CRS* (containing impurities A, B, C, D and E) in 5 mL of the solvent mixture.

*Column*:

– *size*:  $l = 0.25$  m,  $\varnothing = 4.6$  mm;

– *stationary phase*: *end-capped octadecylsilyl silica gel for chromatography R* (5  $\mu$ m);

– *temperature*: 45 °C.

*Mobile phase*:

– *mobile phase A*: mix 3 volumes of a 67.9 g/L solution of *tetrabutylammonium hydrogen sulfate R*, 5 volumes of a 27.6 g/L solution of *sodium dihydrogen phosphate monohydrate R* adjusted to pH 3.0 with *dilute phosphoric acid R*, and 21 volumes of *acetonitrile R*, and dilute to 100 volumes with *water R*;

– *mobile phase B*: mix 5 volumes of a 27.6 g/L solution of *sodium dihydrogen phosphate monohydrate R* adjusted to pH 3.0 with *dilute phosphoric acid R*, and 50 volumes of *acetonitrile R*, and dilute to 100 volumes with *water R*;

Time (min)	Mobile phase A (per cent V/V)	Mobile phase B (per cent V/V)
0 - 38	100	0
38 - 55	100 → 0	0 → 100

*Flow rate*: 2.0 mL/min.

*Detection*: spectrophotometer at 232 nm.

*Injection*: 10  $\mu$ L of the test solution and reference solutions (b), (c), (d) and (e).

**Identification of impurities:** use the chromatogram supplied with *josamycin* for peak identification CRS and the chromatogram obtained with reference solution (e) to identify the peaks due to impurities A, B, C, D and E.

**Relative retention** with reference to josamycin (retention time = about 35 min): impurity A = about 0.5; impurity B = about 0.8; impurity C = about 0.9; impurity D = about 1.2; impurity E = about 1.4.

**System suitability:** reference solution (d):

– **resolution:** minimum 1.7 between the 2 peaks due to josamycin and the peak eluted with a relative retention with reference to josamycin of about 1.1;

– **retention time of josamycin:** between 32 min and 38 min.

If necessary, adjust the concentration of acetonitrile in the mobile phases.

**Limits:**

– **impurities A, B, C, D, E** (any shoulder observed on the peak due to impurity A and/or the peak due to impurity B is not to be integrated separately): for each impurity, not more than the area of the principal peak in the chromatogram obtained with reference solution (b) (5.0 per cent);

– **any other impurity:** not more than 0.6 times the area of the principal peak in the chromatogram obtained with reference solution (b) (3.0 per cent);

– **total:** not more than 4 times the area of the principal peak in the chromatogram obtained with reference solution (b) (20.0 per cent);

– **disregard limit:** the area of the principal peak in the chromatogram obtained with reference solution (c) (0.1 per cent).

**Heavy metals (2.4.8):** maximum 30 ppm.

1.0 g complies with test C. Prepare the reference solution using 3 mL of lead standard solution (10 ppm Pb) R.

**Loss on drying (2.2.32):** maximum 1.0 per cent, determined on 1.000 g by drying *in vacuo* at 60 °C for 3 h.

**Sulfated ash (2.4.14):** maximum 0.2 per cent, determined on 1.0 g.

## ASSAY

Dissolve 30.0 mg in 5 mL of *methanol* R and dilute to 100.0 mL with *water* R.

Carry out the microbiological assay of antibiotics (2.7.2).

## STORAGE

In an airtight container.

## IMPURITIES

**Specified impurities:** A, B, C, D, E.

**Other detectable impurities** (the following substances would, if present at a sufficient level, be detected by one or other of the tests in the monograph. They are limited by the general acceptance criterion for other/unspecified impurities and/or by the general monograph *Substances for pharmaceutical use* (2034). It is therefore not necessary to identify these impurities for demonstration of compliance. See also 5.10. *Control of impurities in substances for pharmaceutical use*): F, G, H, I, J, K.

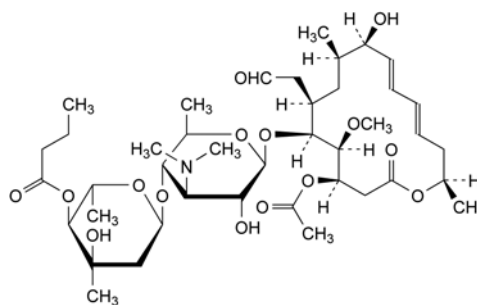

A. (4*R*,5*S*,6*S*,7*R*,9*R*,10*R*,11*E*,13*E*,16*R*)-4-(acetyloxy)-6-[[3,6-dideoxy-4-*O*-(2,6-dideoxy-4-*O*-butanoyl-3-*C*-methyl-α-*L*-ribo-hexopyranosyl)-3-(dimethylamino)-β-*D*-glucopyranosyl]oxy]-10-hydroxy-5-methoxy-9,16-dimethyl-7-(2-oxoethyl)oxacyclohexadeca-11,13-dien-2-one,

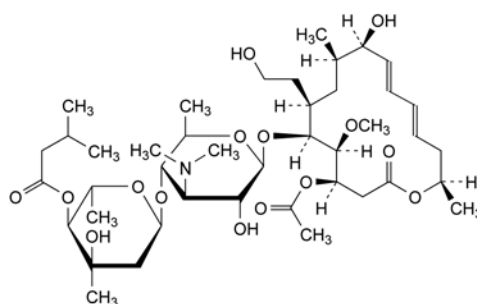

B. (4*R*,5*S*,6*S*,7*R*,9*R*,10*R*,11*E*,13*E*,16*R*)-4-(acetyloxy)-6-[[3,6-dideoxy-4-*O*-[2,6-dideoxy-3-*C*-methyl-4-*O*-(3-methylbutanoyl)-α-*L*-ribo-hexopyranosyl]-3-(dimethylamino)-β-*D*-glucopyranosyl]oxy]-10-hydroxy-7-(2-hydroxyethyl)-5-methoxy-9,16-dimethyloxacyclohexadeca-11,13-dien-2-one,

C. unidentified impurity,

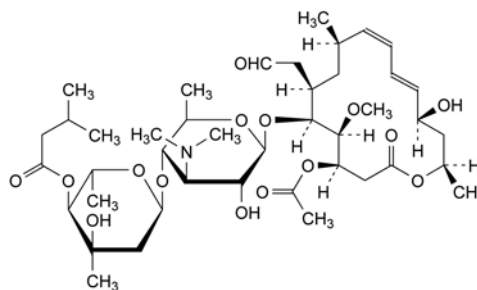

D. (4*R*,5*S*,6*S*,7*R*,9*R*,10*Z*,12*E*,14*R*,16*R*)-4-(acetyloxy)-6-[[3,6-dideoxy-4-*O*-[2,6-dideoxy-3-*C*-methyl-4-*O*-(3-methylbutanoyl)-α-*L*-ribo-hexopyranosyl]-3-(dimethylamino)-β-*D*-glucopyranosyl]oxy]-14-hydroxy-5-methoxy-9,16-dimethyl-7-(2-oxoethyl)oxacyclohexadeca-10,12-dien-2-one (isojosamycin),

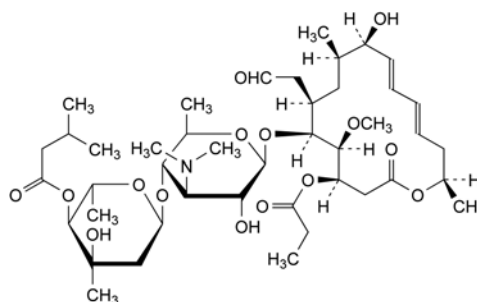

E. (4*R*,5*S*,6*S*,7*R*,9*R*,10*R*,11*E*,13*E*,16*R*)-6-[[3,6-dideoxy-4-*O*-[2,6-dideoxy-3-*C*-methyl-4-*O*-(3-methylbutanoyl)-α-*L*-ribo-hexopyranosyl]-3-(dimethylamino)-β-*D*-glucopyranosyl]oxy]-10-hydroxy-5-methoxy-9,16-dimethyl-7-(2-oxoethyl)-4-(propanoyloxy)oxacyclohexadeca-11,13-dien-2-one,

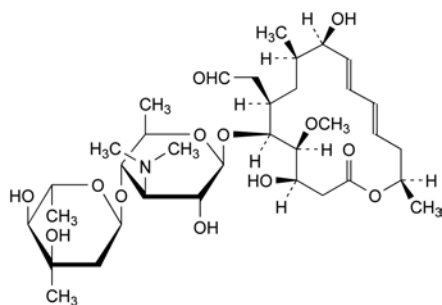

F. (4*R*,5*S*,6*S*,7*R*,9*R*,10*R*,11*E*,13*E*,16*R*)-6-[[3,6-dideoxy-4-*O*-(2,6-dideoxy-3-*C*-methyl- $\alpha$ -*L*-ribo-hexopyranosyl)-3-(dimethylamino)- $\beta$ -*D*-glucopyranosyl]oxy]-4,10-dihydroxy-5-methoxy-9,16-dimethyl-7-(2-oxoethyl)oxacyclohexadeca-11,13-dien-2-one,

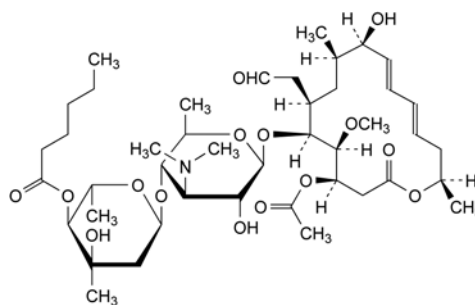

J. (4*R*,5*S*,6*S*,7*R*,9*R*,10*R*,11*E*,13*E*,16*R*)-4-(acetyloxy)-6-[[3,6-dideoxy-4-*O*-(2,6-dideoxy-4-*O*-hexanoyl-3-*C*-methyl- $\alpha$ -*L*-ribo-hexopyranosyl)-3-(dimethylamino)- $\beta$ -*D*-glucopyranosyl]oxy]-10-hydroxy-5-methoxy-9,16-dimethyl-7-(2-oxoethyl)oxacyclohexadeca-11,13-dien-2-one,

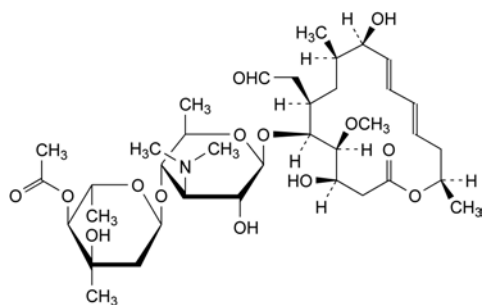

G. (4*R*,5*S*,6*S*,7*R*,9*R*,10*R*,11*E*,13*E*,16*R*)-6-[[4-*O*-(4-*O*-acetyl-2,6-dideoxy-3-*C*-methyl- $\alpha$ -*L*-ribo-hexopyranosyl)-3,6-dideoxy-3-(dimethylamino)- $\beta$ -*D*-glucopyranosyl]oxy]-4,10-dihydroxy-5-methoxy-9,16-dimethyl-7-(2-oxoethyl)oxacyclohexadeca-11,13-dien-2-one,

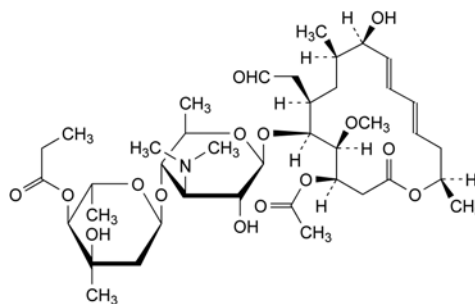

K. (4*R*,5*S*,6*S*,7*R*,9*R*,10*R*,11*E*,13*E*,16*R*)-4-(acetyloxy)-6-[[3,6-dideoxy-4-*O*-(2,6-dideoxy-3-*C*-methyl-4-*O*-propanoyl- $\alpha$ -*L*-ribo-hexopyranosyl)-3-(dimethylamino)- $\beta$ -*D*-glucopyranosyl]oxy]-10-hydroxy-5-methoxy-9,16-dimethyl-7-(2-oxoethyl)oxacyclohexadeca-11,13-dien-2-one.

01/2008:1982  
corrected 6.0

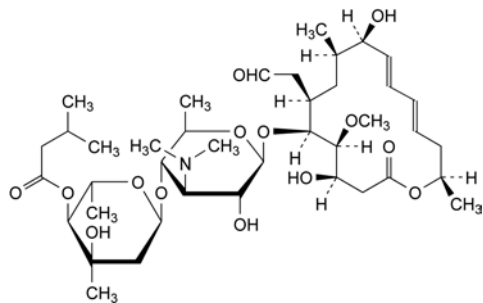

H. (4*R*,5*S*,6*S*,7*R*,9*R*,10*R*,11*E*,13*E*,16*R*)-6-[[3,6-dideoxy-4-*O*-[2,6-dideoxy-3-*C*-methyl-4-*O*-(3-methylbutanoyl)- $\alpha$ -*L*-ribo-hexopyranosyl]-3-(dimethylamino)- $\beta$ -*D*-glucopyranosyl]oxy]-4,10-dihydroxy-5-methoxy-9,16-dimethyl-7-(2-oxoethyl)oxacyclohexadeca-11,13-dien-2-one,

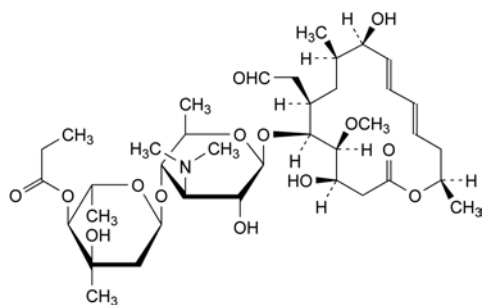

I. (4*R*,5*S*,6*S*,7*R*,9*R*,10*R*,11*E*,13*E*,16*R*)-6-[[3,6-dideoxy-4-*O*-(2,6-dideoxy-3-*C*-methyl-4-*O*-propanoyl- $\alpha$ -*L*-ribo-hexopyranosyl)-3-(dimethylamino)- $\beta$ -*D*-glucopyranosyl]oxy]-4,10-dihydroxy-5-methoxy-9,16-dimethyl-7-(2-oxoethyl)oxacyclohexadeca-11,13-dien-2-one,

## JOSAMYCIN PROPIONATE

### Josamycini propionas

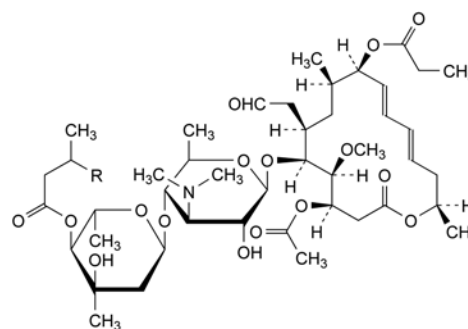

Leucomycin propionate	R	Mol. Formula	Mr
A3	CH <sub>3</sub>	C <sub>45</sub> H <sub>73</sub> NO <sub>16</sub>	884
A4	H	C <sub>44</sub> H <sub>71</sub> NO <sub>16</sub>	870

#### DEFINITION

Propionyl ester of a macrolide antibiotic produced by certain strains of *Streptomyces narbonensis* var. *josamyceticus* var. *nova*, or obtained by any other means. The main component is (4*R*,5*S*,6*S*,7*R*,9*R*,10*R*,11*E*,13*E*,16*R*)-4-(acetyloxy)-6-[[3,6-dideoxy-4-*O*-[2,6-dideoxy-3-*C*-methyl-4-*O*-(3-methylbutanoyl)- $\alpha$ -*L*-ribo-hexopyranosyl]-3-(dimethylamino)- $\beta$ -*D*-glucopyranosyl]oxy]-5-methoxy-9,16-dimethyl-7-(2-oxoethyl)-10-(propanoyloxy)oxacyclohexadeca-11,13-dien-2-one propionate (leucomycin A3 propionate).

Semi-synthetic product derived from a fermentation product.

**Content:**

- minimum 843 Ph. Eur. U./mg (dried substance).

**CHARACTERS**

**Appearance:** white or slightly yellowish, crystalline, slightly hygroscopic powder.

**Solubility:** practically insoluble in water, freely soluble in methanol and in methylene chloride, soluble in acetone.

**IDENTIFICATION**

**First identification:** A, B.

**Second identification:** B, C.

*Prepare solutions in methanol immediately before use.*

- A. Dissolve 0.10 g in *methanol R* and dilute to 100.0 mL with the same solvent. Dilute 1.0 mL of the solution to 50.0 mL with *methanol R*. Examined between 220 nm and 350 nm (2.2.25), the solution shows an absorption maximum at 231 nm. The specific absorbance at the absorption maximum is 310 to 350.

- B. Thin-layer chromatography (2.2.27).

**Test solution.** Dissolve 10 mg of the substance to be examined in *methanol R* and dilute to 1 mL with the same solvent.

**Reference solution (a).** Dissolve 10 mg of *josamycin propionate CRS* in *methanol R* and dilute to 1 mL with the same solvent.

**Reference solution (b).** Dissolve 10 mg of *josamycin CRS* in *methanol R* and dilute to 1 mL with the same solvent.

**Reference solution (c).** Dissolve 10 mg of *spiramycin CRS* in *methylene chloride R* and dilute to 1 mL with the same solvent.

**Reference solution (d).** Mix 0.5 mL of reference solution (a) with 0.5 mL of reference solution (b).

**Plate:** TLC silica gel G plate R.

**Mobile phase:** *methanol R*, *acetone R*, *ethyl acetate R*, *toluene R*, *hexane R* (8:10:20:25:30 V/V/V/V/V).

**Application:** 10 µL.

**Development:** over 2/3 of the plate.

**Drying:** at 100 °C for 10 min.

**Detection:** spray with *dilute sulfuric acid R* and heat at 100 °C for 10 min.

**System suitability:** the chromatogram obtained with reference solution (d) shows 2 clearly separated principal spots.

**Results:** the principal spot in the chromatogram obtained with the test solution is similar in position, colour and size to the principal spot in the chromatogram obtained with reference solution (a) and its position is different from that of the principal spot in the chromatograms obtained with reference solutions (b) and (c).

- C. Dissolve about 10 mg in 5 mL of *hydrochloric acid RI* and allow to stand for 10-20 min. A pink colour develops, turning brown.

**TESTS**

**Appearance of solution.** The solution is clear (2.2.1) and not more intensely coloured than reference solution BY<sub>4</sub> (2.2.2, Method II).

Dissolve 1 g in *methanol R* and dilute to 10 mL with the same solvent.

**Specific optical rotation** (2.2.7): – 65 to – 75 (dried substance).

Dissolve 1.000 g in *methanol R* and dilute to 100.0 mL with the same solvent. Allow to stand for 30 min before measuring the angle of rotation.

**Related substances.** Liquid chromatography (2.2.29).

**Test solution.** Dissolve 50.0 mg of the substance to be examined in *acetonitrile for chromatography R* and dilute to 100.0 mL with the same solvent.

**Reference solution (a).** Dissolve 50.0 mg of *josamycin propionate CRS* in *acetonitrile for chromatography R* and dilute to 100.0 mL with the same solvent.

**Reference solution (b).** Dissolve 5 mg of the substance to be examined in 10 mL of *methanol R* and add 40 µL of *dilute phosphoric acid R*. Mix, allow to stand for 5 min and inject.

**Reference solution (c).** Dilute 2.0 mL of reference solution (a) to 100.0 mL with *acetonitrile for chromatography R*.

**Column:**

- size:  $l = 0.15$  m,  $\varnothing = 3.9$  mm,

- stationary phase: end-capped octadecylsilyl silica gel for chromatography R (5 µm),

- temperature: 30 °C.

**Mobile phase:** *acetonitrile R*, a 15.4 g/L solution of *ammonium acetate R* previously adjusted to pH 6.0 with *dilute phosphoric acid R* (60:40 V/V).

**Flow rate:** 1.0 mL/min.

**Detection:** spectrophotometer at 232 nm.

**Injection:** 20 µL of the test solution and reference solutions (b) and (c).

**Run time:** 3 times the retention time of leucomycin A3 propionate.

**Relative retention** with reference to leucomycin A3 propionate (retention time = about 18 min): impurity E = about 0.2; impurity A = about 0.3; impurity B = about 0.5; leucomycin A4 propionate = about 0.7; impurity C = about 1.4; impurity D = about 2.0.

**System suitability:** reference solution (b):

- resolution: minimum 2.0 between the 2 peaks eluting with a relative retention with reference to leucomycin A3 propionate of about 0.5 and 0.7 respectively.

**Limits:**

- impurity D: not more than 1.5 times the area of the principal peak in the chromatogram obtained with reference solution (c),
- impurities A, B, C, E: for each impurity, not more than the area of the principal peak in the chromatogram obtained with reference solution (c),
- any other impurity: for each impurity, not more than the area of the principal peak in the chromatogram obtained with reference solution (c),
- total: not more than 7 times the area of the principal peak in the chromatogram obtained with reference solution (c),
- disregard limit: 0.1 times the area of the principal peak in the chromatogram obtained with reference solution (c).

**Loss on drying** (2.2.32): maximum 1.0 per cent, determined on 1.000 g by drying in an oven *in vacuo* at 60 °C for 3 h.

**Sulfated ash** (2.4.14): maximum 0.2 per cent, determined on 1.0 g.

**ASSAY**

Dissolve 40.0 mg in 20 mL of *methanol R* and dilute to 100.0 mL with *phosphate buffer solution pH 5.6 R*.

Carry out the microbiological assay of antibiotics (2.7.2).

**STORAGE**

In an airtight container.

## IMPURITIES

Specified impurities: A, B, C, D, E.

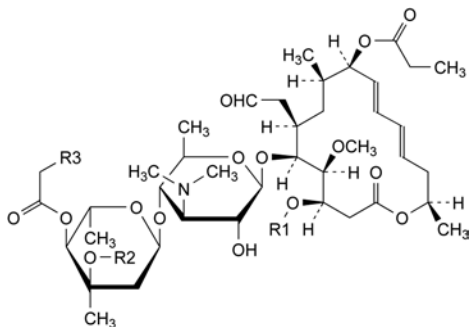

- A. R1 = CO-CH<sub>3</sub>, R2 = R3 = H: leucomycin A8 9-propionate,  
 B. R1 = R2 = H, R3 = C<sub>2</sub>H<sub>5</sub>: leucomycin A5 9-propionate,  
 C. R1 = CO-C<sub>2</sub>H<sub>5</sub>, R2 = H, R3 = CH(CH<sub>3</sub>)<sub>2</sub>: platenomycin A1 9-propionate,

- D. R1 = CO-CH<sub>3</sub>, R2 = CO-C<sub>2</sub>H<sub>5</sub>, R3 = CH(CH<sub>3</sub>)<sub>2</sub>: leucomycin A3 3',9-dipropionate,

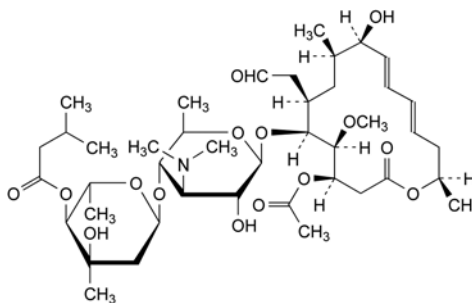

- E. (4*R*,5*S*,6*S*,7*R*,9*R*,10*R*,11*E*,13*E*,16*R*)-4-(acetyloxy)-6-[[3,6-dideoxy-4-*O*-[2,6-dideoxy-3-*C*-methyl-4-*O*-(3-methylbutanoyl)- $\alpha$ -*L*-ribo-hexopyranosyl]-3-(dimethylamino)- $\beta$ -*D*-glucopyranosyl]oxy]-10-hydroxy-5-methoxy-9,16-dimethyl-7-(2-oxoethyl)oxacyclohexadeca-11,13-dien-2-one (josamycin).



01/2008:0033  
corrected 6.0

## KANAMYCIN ACID SULFATE

### Kanamycini sulfas acidus

#### DEFINITION

Kanamycin acid sulfate is a form of kanamycin sulfate prepared by adding sulfuric acid to a solution of kanamycin monosulfate and drying by a suitable method. The potency is not less than 670 IU/mg, calculated with reference to the dried substance.

Fermentation product.

#### PRODUCTION

It is produced by methods of manufacture designed to eliminate or minimise substances lowering blood pressure.

The method of manufacture is validated to demonstrate that the product if tested would comply with the following test.

**Abnormal toxicity** (2.6.9). Inject into each mouse 0.5 mL of a solution containing 2 mg per millilitre of the substance to be examined.

#### CHARACTERS

A white or almost white powder, hygroscopic, soluble in about 1 part of water, practically insoluble in acetone and in alcohol.

#### IDENTIFICATION

A. Examine by thin-layer chromatography (2.2.27), using a plate coated with a 0.75 mm layer of the following mixture: mix 0.3 g of *carbomer R* with 240 mL of *water R* and allow to stand, with moderate shaking, for 1 h; adjust to pH 7 by the gradual addition, with continuous shaking, of *dilute sodium hydroxide solution R* and add 30 g of *silica gel H R*.

Heat the plate at 110 °C for 1 h, allow to cool and use immediately.

*Test solution.* Dissolve 10 mg of the substance to be examined in *water R* and dilute to 10 mL with the same solvent.

*Reference solution (a).* Dissolve 10 mg of *kanamycin monosulfate CRS* in *water R* and dilute to 10 mL with the same solvent.

*Reference solution (b).* Dissolve 10 mg of *kanamycin monosulfate CRS*, 10 mg of *neomycin sulfate CRS* and 10 mg of *streptomycin sulfate CRS* in *water R* and dilute to 10 mL with the same solvent.

Apply separately to the plate 10 µL of each solution. Develop over a path of 12 cm using a 70 g/L solution of *potassium dihydrogen phosphate R*. Dry the plate in a current of warm air and spray with a mixture of equal volumes of a 2 g/L solution of *dihydroxynaphthalene R* in *alcohol R* and a 460 g/L solution of *sulfuric acid R*. Heat at 150 °C for 5 min to 10 min. The principal spot in the chromatogram obtained with the test solution is similar in position, colour and size to the principal spot in the chromatogram obtained with reference solution (a). The test is not valid unless the chromatogram obtained with reference solution (b) shows 3 clearly separated spots.

B. Dissolve 0.5 g in 10 mL of *water R*. Add 10 mL of *picric acid solution R*. Initiate crystallisation if necessary by scratching the wall of the tube with a glass rod and allow to stand. Collect the crystals, wash with 20 mL of *water R* and filter. Dry at 100 °C. The crystals melt (2.2.14) at about 235 °C, with decomposition.

C. Dissolve about 50 mg in 2 mL of *water R*. Add 1 mL of a 10 g/L solution of *ninhydrin R* and heat for a few minutes on a water-bath. A violet colour develops.

D. It gives the reactions of sulfates (2.3.1).

#### TESTS

**Solution S.** Dissolve 0.20 g in *carbon dioxide-free water R* and dilute to 20.0 mL with the same solvent.

**pH** (2.2.3). The pH of solution S is 5.5 to 7.5.

**Specific optical rotation** (2.2.7). +103 to +115, determined on solution S and calculated with reference to the dried substance.

**Kanamycin B.** Examine by thin-layer chromatography (2.2.27), using a plate prepared as prescribed under identification test A. Heat the plate at 110 °C for 1 h, allow to cool and use immediately.

*Test solution.* Dissolve 0.11 g of the substance to be examined in *water R* and dilute to 20 mL with the same solvent.

*Reference solution.* Dissolve 4 mg of *kanamycin B sulfate CRS* in *water R* and dilute to 20 mL with the same solvent.

Apply separately to the plate 4 µL of each solution. Develop over a path of 12 cm using a 70 g/L solution of *potassium dihydrogen phosphate R*. Dry the plate in a current of warm air and spray with *ninhydrin and stannous chloride reagent R*. Heat the plate at 110 °C for 15 min. Any spot corresponding to kanamycin B in the chromatogram obtained with the test solution is not more intense than the spot in the chromatogram obtained with the reference solution (4.0 per cent).

**Loss on drying** (2.3.32). Not more than 5.0 per cent, determined on 1.00 g by drying at 60 °C at a pressure not exceeding 670 Pa for 3 h.

**Sulfated ash** (2.4.14). Not more than 0.5 per cent, determined on 1.0 g.

**Sulfate.** 23.0 per cent to 26.0 per cent of sulfate (SO<sub>4</sub>), calculated with reference to the dried substance. Dissolve 0.175 g in 100 mL of *water R* and adjust the solution to pH 11 using *concentrated ammonia R*. Add 10.0 mL of *0.1 M barium chloride* and about 0.5 mg of *phthalein purple R*. Titrate with *0.1 M sodium edetate* adding 50 mL of *alcohol R* when the colour of the solution begins to change and continue the titration until the violet-blue colour disappears.

1 mL of *0.1 M barium chloride* is equivalent to 9.606 mg of sulfate (SO<sub>4</sub>).

**Pyrogens** (2.6.8). If intended for use in the manufacture of parenteral preparations without a further appropriate procedure for the removal of pyrogens, it complies with the test for pyrogens. Inject per kilogram of the rabbit's mass 1 mL of a solution in *water for injections R* containing 10 mg per millilitre of the substance to be examined.

#### ASSAY

Carry out the microbiological assay of antibiotics (2.7.2). Use *kanamycin monosulfate CRS* as the reference substance.

#### STORAGE

If the substance is sterile, store in a sterile, tamper-proof container.

01/2008:0032

## KANAMYCIN MONOSULFATE

### Kanamycini monosulfas

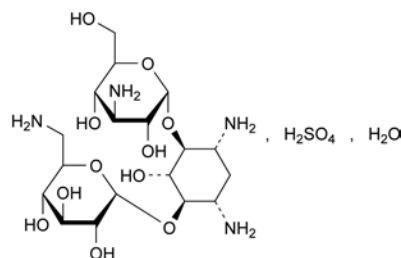

C<sub>18</sub>H<sub>38</sub>N<sub>4</sub>O<sub>15</sub>S<sub>2</sub>H<sub>2</sub>O

M<sub>r</sub> 601

## DEFINITION

Kanamycin monosulfate is 6-*O*-(3-amino-3-deoxy- $\alpha$ -D-glucopyranosyl)-4-*O*-(6-amino-6-deoxy- $\alpha$ -D-glucopyranosyl)-2-deoxy-D-streptomine sulfate, an antimicrobial substance produced by the growth of certain strains of *Streptomyces kanamyceticus*. The potency is not less than 750 IU/mg, calculated with reference to the dried substance.

## PRODUCTION

It is produced by methods of manufacture designed to eliminate or minimise substances lowering blood pressure.

The method of manufacture is validated to demonstrate that the product if tested would comply with the following test:

**Abnormal toxicity** (2.6.9). Inject into each mouse 0.5 mL of a solution containing 2 mg per millilitre of the substance to be examined.

## CHARACTERS

A white or almost white, crystalline powder, soluble in about 8 parts of water, practically insoluble in acetone and in alcohol.

## IDENTIFICATION

A. Examine by thin-layer chromatography (2.2.27), using a plate coated with a 0.75 mm layer of the following mixture: mix 0.3 g of *carbomer R* with 240 mL of *water R* and allow to stand, with moderate shaking, for 1 h; adjust to pH 7 by the gradual addition, with continuous shaking, of *dilute sodium hydroxide solution R* and add 30 g of *silica gel H R*.

Heat the plate at 110 °C for 1 h, allow to cool and use immediately.

**Test solution.** Dissolve 10 mg of the substance to be examined in *water R* and dilute to 10 mL with the same solvent.

**Reference solution (a).** Dissolve 10 mg of *kanamycin monosulfate CRS* in *water R* and dilute to 10 mL with the same solvent.

**Reference solution (b).** Dissolve 10 mg of *kanamycin monosulfate CRS*, 10 mg of *neomycin sulfate CRS* and 10 mg of *streptomycin sulfate CRS* in *water R* and dilute to 10 mL with the same solvent.

Apply separately to the plate 10  $\mu$ L of each solution. Develop over a path of 12 cm using a 70 g/L solution of *potassium dihydrogen phosphate R*. Dry the plate in a current of warm air and spray with a mixture of equal volumes of a 2 g/L solution of *dihydroxynaphthalene R* in *alcohol R* and a 460 g/L solution of *sulfuric acid R*. Heat at 150 °C for 5 min to 10 min. The principal spot in the chromatogram obtained with the test solution is similar in position, colour and size to the principal spot in the chromatogram obtained with reference solution (a). The test is not valid unless the chromatogram obtained with reference solution (b) shows three clearly separated spots.

B. Dissolve 0.5 g in 10 mL of *water R*. Add 10 mL of *picric acid solution R*. Initiate crystallisation if necessary by scratching the wall of the tube with a glass rod and allow to stand. Collect the crystals, wash with 20 mL of *water R* and filter. Dry at 100 °C. The crystals melt (2.2.14) at about 235 °C, with decomposition.

C. Dissolve about 50 mg in 2 mL of *water R*. Add 1 mL of a 10 g/L solution of *ninhydrin R* and heat for a few minutes on a water-bath. A violet colour develops.

D. It gives the reactions of sulfates (2.3.1).

## TESTS

**Solution S.** Dissolve 0.20 g in *carbon dioxide-free water R* and dilute to 20.0 mL with the same solvent.

**pH** (2.2.3). The pH of solution S is 6.5 to 8.5.

**Specific optical rotation** (2.2.7). +112 to +123, determined on solution S and calculated with reference to the dried substance.

**Kanamycin B.** Examine by thin-layer chromatography (2.2.27), using a plate prepared as prescribed under identification test A. Heat the plate at 110 °C for 1 h, allow to cool and use immediately.

**Test solution.** Dissolve 0.1 g of the substance to be examined in *water R* and dilute to 20 mL with the same solvent.

**Reference solution.** Dissolve 4 mg of *kanamycin B sulfate CRS* in *water R* and dilute to 20 mL with the same solvent.

Apply separately to the plate 4  $\mu$ L of each solution. Develop over a path of 12 cm using a 70 g/L solution of *potassium dihydrogen phosphate R*. Dry the plate in a current of warm air and spray with *ninhydrin and stannous chloride reagent R*. Heat the plate at 110 °C for 15 min. Any spot corresponding to kanamycin B in the chromatogram obtained with the test solution is not more intense than the spot in the chromatogram obtained with the reference solution.

**Loss on drying** (2.2.32). Not more than 1.5 per cent, determined on 1.00 g by drying at 60 °C at a pressure not exceeding 670 Pa for 3 h.

**Sulfated ash** (2.4.14). Not more than 0.5 per cent, determined on 1.0 g.

**Sulfate.** 15.0 per cent to 17.0 per cent of sulfate (SO<sub>4</sub>), calculated with reference to the dried substance. Dissolve 0.250 g in 100 mL of *water R* and adjust the solution to pH 11 using *concentrated ammonia R*. Add 10.0 mL of 0.1 M *barium chloride* and about 0.5 mg of *phthalein purple R*. Titrate with 0.1 M *sodium edetate* adding 50 mL of *alcohol R* when the colour of the solution begins to change and continue the titration until the violet-blue colour disappears.

1 mL of 0.1 M *barium chloride* is equivalent to 9.606 mg of sulfate (SO<sub>4</sub>).

**Pyrogens** (2.6.8). If intended for use in the manufacture of parenteral preparations without a further appropriate procedure for the removal of pyrogens, it complies with the test for pyrogens. Inject per kilogram of the rabbit's mass 1 mL of a solution in *water for injections R* containing 10 mg per millilitre of the substance to be examined.

## ASSAY

Carry out the microbiological assay of antibiotics (2.7.2).

## STORAGE

If the substance is sterile, store in a sterile, tamper-proof container.

07/2010:0503

## KAOLIN, HEAVY

## Kaolinum ponderosum

## DEFINITION

Purified, natural, hydrated aluminium silicate of variable composition.

## CHARACTERS

**Appearance:** fine, white or greyish-white, unctuous powder.

**Solubility:** practically insoluble in water and in organic solvents.

## IDENTIFICATION

A. To 0.5 g in a metal crucible add 1 g of *potassium nitrate R* and 3 g of *sodium carbonate R* and heat until the mixture melts. Allow to cool. To the residue add 20 mL of boiling *water R*, mix and filter. Wash the residue with 50 mL of *water R*. To the residue add 1 mL of *hydrochloric acid R* and 5 mL of *water R*. Filter. To the filtrate add 1 mL of *strong sodium hydroxide solution R* and filter. To the filtrate add 3 mL of *ammonium chloride solution R*. A gelatinous white precipitate is formed.

01/2008:1020

- B. Add 2.0 g in 20 portions to 100 mL of a 10 g/L solution of *sodium laurilsulfate R* in a 100 mL graduated cylinder about 30 mm in diameter. Allow 2 min between additions for each portion to settle. Allow to stand for 2 h. The apparent volume of the sediment is not greater than 5 mL.
- C. 0.25 g gives the reaction of silicates (2.3.1).

## TESTS

**Solution S.** To 4 g add a mixture of 6 mL of *acetic acid R* and 34 mL of *distilled water R*, shake for 1 min and filter.

**Acidity or alkalinity.** To 1.0 g add 20 mL of *carbon dioxide-free water R*, shake for 2 min and filter. To 10 mL of the filtrate add 0.1 mL of *phenolphthalein solution R*. The solution is colourless. Not more than 0.25 mL of 0.01 M *sodium hydroxide* is required to change the colour of the indicator to pink.

**Organic impurities.** Heat 0.3 g to redness in a calcination tube. The residue is only slightly more coloured than the original substance.

**Adsorption power.** To 1.0 g in a ground-glass-stoppered test-tube add 10.0 mL of a 3.7 g/L solution of *methylene blue R* and shake for 2 min. Allow to settle. Centrifuge and dilute the solution 1 to 100 with *water R*. The solution is not more intensely coloured than a 0.03 g/L solution of *methylene blue R*.

**Swelling power.** Triturate 2 g with 2 mL of *water R*. The mixture does not flow.

**Substances soluble in dilute hydrochloric acid:** maximum 1 per cent.

To 5.0 g add 7.5 mL of *dilute hydrochloric acid R* and 27.5 mL of *water R* and boil for 5 min. Filter, wash the residue on the filter with *water R* and dilute the combined filtrate and washings to 50.0 mL with *water R*. To 10.0 mL of the solution add 1.5 mL of *dilute sulfuric acid R*, evaporate to dryness on a water-bath and ignite. The residue weighs a maximum of 10 mg.

**Chlorides (2.4.4):** maximum 250 ppm.

Dilute 2 mL of solution S to 15 mL with *water R*.

**Sulfates (2.4.13):** maximum 0.1 per cent.

Dilute 1.5 mL of solution S to 15 mL with *distilled water R*.

**Calcium (2.4.3):** maximum 250 ppm.

Dilute 4 mL of solution S to 15 mL with *distilled water R*.

**Extractable heavy metals (2.4.8):** maximum 50 ppm.

To 5 mL of the solution prepared for the test for substances soluble in dilute hydrochloric acid add 5 mL of *water R*, 10 mL of *hydrochloric acid R* and 25 mL of *methyl isobutyl ketone R*. Shake for 2 min. Separate the layers. Evaporate the aqueous layer to dryness on a water-bath. Dissolve the residue in 1 mL of *acetic acid R* and dilute to 25 mL with *water R*. Filter. 12 mL of the solution complies with test A. Prepare the reference solution using *lead standard solution (1 ppm Pb) R*.

If intended for internal use, the above test is replaced by the following test for heavy metals (2.4.8): maximum 25 ppm.

To 10 mL of the solution prepared for the test for substances soluble in dilute hydrochloric acid add 10 mL of *water R*, 20 mL of *hydrochloric acid R* and 25 mL of *methyl isobutyl ketone R*. Shake for 2 min. Separate the layers. Evaporate the aqueous layer to dryness on a water-bath. Dissolve the residue in 1 mL of *acetic acid R* and dilute to 25 mL with *water R*. Filter. 12 mL of the solution complies with test A. Prepare the reference solution using *lead standard solution (1 ppm Pb) R*.

## Microbial contamination

TAMC: acceptance criterion 10<sup>3</sup> CFU/g (2.6.12).

TYMC: acceptance criterion 10<sup>2</sup> CFU/g (2.6.12).

## LABELLING

The label states, where applicable, that the substance is suitable for internal use.

## KETAMINE HYDROCHLORIDE

## Ketamini hydrochloridum

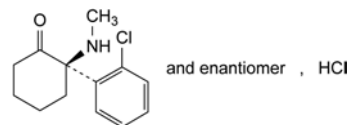

C<sub>13</sub>H<sub>17</sub>Cl<sub>2</sub>NO  
[1867-66-9]

M<sub>r</sub> 274.2

## DEFINITION

(*RS*)-2-(2-Chlorophenyl)-2-(methylamino)cyclohexanone hydrochloride.

**Content:** 99.0 per cent to 101.0 per cent.

## CHARACTERS

**Appearance:** white or almost white, crystalline powder.

**Solubility:** freely soluble in water and in methanol, soluble in ethanol (96 per cent).

mp: about 260 °C, with decomposition.

## IDENTIFICATION

A. Optical rotation (see Tests).

B. Infrared absorption spectrophotometry (2.2.24).

*Comparison:* ketamine hydrochloride CRS.

C. It gives reaction (a) of chlorides (2.3.1).

## TESTS

**Solution S.** Dissolve 5.0 g in *carbon dioxide-free water R* and dilute to 25.0 mL with the same solvent.

**Appearance of solution.** Solution S is clear (2.2.1) and colourless (2.2.2, *Method II*).

**pH (2.2.3):** 3.5 to 4.1

Dilute 10 mL of solution S to 20 mL with *carbon dioxide-free water R*.

**Optical rotation (2.2.7):** -0.2° to +0.2°.

Dilute 2.5 mL of solution S to 25.0 mL with *water R*.

**Related substances.** Liquid chromatography (2.2.29).

**Test solution.** Dissolve 50.0 mg of the substance to be examined in the mobile phase and dilute to 50.0 mL with the mobile phase.

**Reference solution (a).** Dissolve 25.0 mg of *ketamine impurity A CRS* in the mobile phase and dilute to 50.0 mL with the mobile phase (using ultrasound if necessary). To 1.0 mL of the solution, add 0.5 mL of the test solution and dilute to 100.0 mL with the mobile phase. Prepare immediately before use.

**Reference solution (b).** Dilute 1.0 mL of the test solution to 10.0 mL with the mobile phase. Dilute 1.0 mL of the solution to 20.0 mL with the mobile phase.

## Precolumn:

– size: *l* = 4 mm, Ø = 4.0 mm,

– stationary phase: spherical octadecylsilyl silica gel for chromatography R (5 µm).

## Column:

– size: *l* = 0.125 m, Ø = 4.0 mm,

– stationary phase: spherical octadecylsilyl silica gel for chromatography R (5 µm).

**Mobile phase:** dissolve 0.95 g of *sodium hexanesulfonate R* in 1 litre of a mixture of 25 volumes of *acetonitrile R* and 75 volumes of *water R* and add 4 mL of *acetic acid R*.

**Flow rate:** 1.0 mL/min.

**Detection:** spectrophotometer at 215 nm.

**Injection:** 20 µL.

**Run time:** 10 times the retention time of ketamine.

**System suitability:** reference solution (a):

- **retention time:** ketamine = 3 min to 4.5 min,
- **resolution:** minimum 1.5 between the peaks due to impurity A and ketamine.

**Limits:**

- **total:** not more than the area of the principal peak in the chromatogram obtained with reference solution (b) (0.5 per cent),
- **disregard limit:** 0.2 times the area of the principal peak in the chromatogram obtained with reference solution (b) (0.1 per cent).

**Heavy metals (2.4.8):** maximum 20 ppm.

Dilute 10 mL of solution S to 20 mL with *water R*. 12 mL of the solution complies with test A. Prepare the reference solution using *lead standard solution (2 ppm Pb) R*.

**Sulfated ash (2.4.14):** maximum 0.1 per cent, determined on 1.0 g.

#### ASSAY

Dissolve 0.200 g in 50 mL of *methanol R* and add 1.0 mL of 0.1 M *hydrochloric acid*. Carry out a potentiometric titration (2.2.20), using 0.1 M *sodium hydroxide*. Read the volume added between the 2 points of inflexion.

1 mL of 0.1 M *sodium hydroxide* is equivalent to 27.42 mg of  $C_{13}H_{17}Cl_2NO$ .

#### STORAGE

Protected from light.

#### IMPURITIES

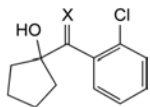

A. X = N-CH<sub>3</sub>: 1-[(2-chlorophenyl)(methylimino)methyl]cyclopentanol,

C. X = O: (2-chlorophenyl)(1-hydroxycyclopentyl)methanone,

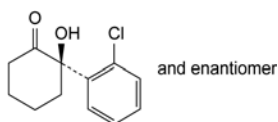

B. (2*RS*)-2-(2-chlorophenyl)-2-hydroxycyclohexanone.

01/2008:1746  
corrected 7.0

## KETOBEMIDONE HYDROCHLORIDE

### Cetobemidoni hydrochloridum

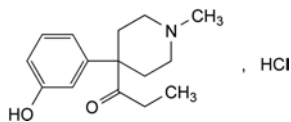

$C_{15}H_{22}ClNO_2$   
[5965-49-1]

$M_r$  283.8

#### DEFINITION

1-[4-(3-Hydroxyphenyl)-1-methylpiperidin-4-yl]propan-1-one hydrochloride.

**Content:** 99.0 per cent to 101.0 per cent (anhydrous substance).

#### CHARACTERS

**Appearance:** white or almost white, crystalline powder.

**Solubility:** freely soluble in water, soluble in ethanol (96 per cent), very slightly soluble in methylene chloride.

#### IDENTIFICATION

A. Infrared absorption spectrophotometry (2.2.24).

**Comparison:** *Ph. Eur. reference spectrum of ketobemidone hydrochloride*.

B. Solution S (see Tests) gives reaction (a) of chlorides (2.3.1).

#### TESTS

**Solution S.** Dissolve 0.250 g in *carbon dioxide-free water R* and dilute to 25.0 mL with the same solvent.

**Appearance of solution.** Solution S is clear (2.2.1) and not more intensely coloured than reference solution B<sub>5</sub> (2.2.2, *Method II*).

**pH (2.2.3):** 4.5 to 5.5 for solution S.

**Related substances.** Liquid chromatography (2.2.29).

**Solution A:** 1.54 g/L solution of *ammonium acetate R* adjusted to pH 8.0 with *dilute ammonia R1*.

**Test solution.** Dissolve 50.0 mg of the substance to be examined in solution A and dilute to 25.0 mL with the same solution.

**Reference solution (a).** Dissolve 1 mg of *ketobemidone impurity B CRS* and 1 mg of *ketobemidone impurity C CRS* in solution A and dilute to 25 mL with the same solution.

**Reference solution (b).** Dilute 1.0 mL of the test solution to 100.0 mL with solution A. Dilute 20.0 mL of this solution to 100.0 mL with solution A.

**Column:**

- **size:**  $l = 0.25$  m,  $\varnothing = 4.6$  mm;
- **stationary phase:** *phenylhexylsilyl silica gel for chromatography R (5  $\mu$ m)*;
- **temperature:** 40 °C.

**Mobile phase:** *acetonitrile R*, solution A (20:80 V/V).

**Flow rate:** 1.5 mL/min.

**Detection:** spectrophotometer at 278 nm.

**Injection:** 20  $\mu$ L.

**Run time:** 4.5 times the retention time of ketobemidone.

**Relative retention** with reference to ketobemidone (retention time = about 10 min): impurity A = about 0.4; impurity B = about 0.6; impurity C = about 0.7; impurity D = about 3.5.

**System suitability:** reference solution (a):

- **resolution:** minimum 4.0 between the peaks due to impurity B and impurity C.

**Limits:**

- **impurities A, B, C, D:** for each impurity, not more than the area of the principal peak in the chromatogram obtained with reference solution (b) (0.2 per cent);
- **unspecified impurities:** for each impurity, not more than 0.5 times the area of the principal peak in the chromatogram obtained with reference solution (b) (0.10 per cent);
- **total:** not more than 3.5 times the area of the principal peak in the chromatogram obtained with reference solution (b) (0.7 per cent);
- **disregard limit:** 0.25 times the area of the principal peak in the chromatogram obtained with reference solution (b) (0.05 per cent).

**Water (2.5.12):** maximum 1.0 per cent, determined on 0.50 g.

**Sulfated ash (2.4.14):** maximum 0.1 per cent, determined on 1.0 g.

#### ASSAY

Dissolve 0.200 g in a mixture of 5.0 mL of 0.01 M *hydrochloric acid* and 50 mL of *ethanol (96 per cent) R*. Carry out a potentiometric titration (2.2.20) using 0.1 M *sodium hydroxide*. Read the volume added between the 2 points of inflexion.

1 mL of 0.1 M *sodium hydroxide* is equivalent to 28.38 mg of  $C_{15}H_{22}ClNO_2$ .

## IMPURITIES

Specified impurities: A, B, C, D.

Other detectable impurities (the following substances would, if present at a sufficient level, be detected by one or other of the tests in the monograph. They are limited by the general acceptance criterion for other/unspecified impurities and/or by the general monograph *Substances for pharmaceutical use (2034)*. It is therefore not necessary to identify these impurities for demonstration of compliance. See also 5.10. *Control of impurities in substances for pharmaceutical use*): E.

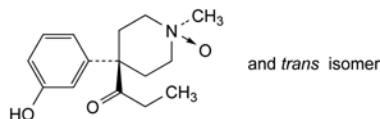

- A. 1-[4-(3-hydroxyphenyl)-1-methyl-1-oxidopiperidin-4-yl]propan-1-one (*cis* and *trans* isomers),

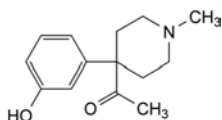

- B. 1-[4-(3-hydroxyphenyl)-1-methylpiperidin-4-yl]ethanone,

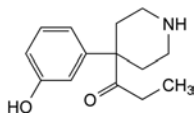

- C. 1-[4-(3-hydroxyphenyl)piperidin-4-yl]propan-1-one,

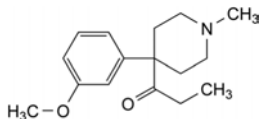

- D. 1-[4-(3-methoxyphenyl)-1-methylpiperidin-4-yl]propan-1-one,

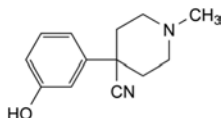

- E. 4-(3-hydroxyphenyl)-1-methylpiperidin-4-carbonitrile.

## CHARACTERS

*Appearance*: white or almost white powder.

*Solubility*: practically insoluble in water, freely soluble in methylene chloride, soluble in methanol, sparingly soluble in ethanol (96 per cent).

## IDENTIFICATION

*First identification*: B.

*Second identification*: A, C, D.

A. Melting point (2.2.14): 148 °C to 152 °C.

B. Infrared absorption spectrophotometry (2.2.24).

*Preparation*: discs.

*Comparison*: ketoconazole CRS.

C. Thin-layer chromatography (2.2.27).

*Test solution*. Dissolve 30 mg of the substance to be examined in the mobile phase and dilute to 5 mL with the mobile phase.

*Reference solution (a)*. Dissolve 30 mg of ketoconazole CRS in the mobile phase and dilute to 5 mL with the mobile phase.

*Reference solution (b)*. Dissolve 30 mg of ketoconazole CRS and 30 mg of econazole nitrate CRS in the mobile phase, then dilute to 5 mL with the mobile phase.

*Plate*: TLC octadecylsilyl silica gel plate R.

*Mobile phase*: ammonium acetate solution R, dioxan R, methanol R (20:40:40 V/V/V).

*Application*: 5 µL.

*Development*: over a path of 15 cm.

*Drying*: in a current of warm air for 15 min.

*Detection*: expose to iodine vapour until the spots appear and examine in daylight.

*System suitability*: reference solution (b):

– the chromatogram shows 2 clearly separated spots.

*Results*: the principal spot in the chromatogram obtained with the test solution is similar in position, colour and size to the principal spot in the chromatogram obtained with reference solution (a).

- D. To about 30 mg in a porcelain crucible add 0.3 g of anhydrous sodium carbonate R. Heat over an open flame for 10 min. Allow to cool. Take up the residue with 5 mL of dilute nitric acid R and filter. To 1 mL of the filtrate add 1 mL of water R. The solution gives reaction (a) of chlorides (2.3.1).

## TESTS

01/2008:0921  
corrected 6.0

**Solution S**. Dissolve 1.0 g in methylene chloride R and dilute to 10 mL with the same solvent.

**Appearance of solution**. Solution S is clear (2.2.1) and not more intensely coloured than reference solution BY<sub>4</sub> (2.2.2, Method II).

**Optical rotation** (2.2.7): –0.10° to +0.10°, determined on solution S.

**Related substances**. Liquid chromatography (2.2.29).

*Test solution*. Dissolve 0.100 g of the substance to be examined in methanol R and dilute to 10.0 mL with the same solvent.

*Reference solution (a)*. Dissolve 2.5 mg of ketoconazole CRS and 2.5 mg of loperamide hydrochloride CRS in methanol R, then dilute to 50.0 mL with the same solvent.

*Reference solution (b)*. Dilute 5.0 mL of the test solution to 100.0 mL with methanol R. Dilute 1.0 mL of this solution to 10.0 mL with methanol R.

*Column*:

– *size*: *l* = 0.10 m, Ø = 4.6 mm;

– *stationary phase*: octadecylsilyl silica gel for chromatography R (3 µm).

## KETOCONAZOLE

## Ketoconazolium

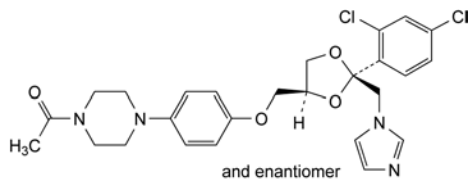

C<sub>26</sub>H<sub>26</sub>Cl<sub>2</sub>N<sub>4</sub>O<sub>4</sub>  
[65277-42-1]

M<sub>r</sub> 531.4

## DEFINITION

1-Acetyl-4-[4-[(2*RS*,4*SR*)-2-(2,4-dichlorophenyl)-2-(1*H*-imidazol-1-ylmethyl)-1,3-dioxolan-4-yl]methoxy]phenyl]piperazine.

*Content*: 99.0 per cent to 101.0 per cent (dried substance).

## Mobile phase:

- mobile phase A: acetonitrile R1, 3.4 g/L solution of tetrabutylammonium hydrogen sulfate R (5:95 V/V);
- mobile phase B: acetonitrile R1, 3.4 g/L solution of tetrabutylammonium hydrogen sulfate R (50:50 V/V);

Time (min)	Mobile phase A (per cent V/V)	Mobile phase B (per cent V/V)
0 - 10	100 → 0	0 → 100
10 - 15	0	100

Flow rate: 2 mL/min.

Detection: spectrophotometer at 220 nm.

Equilibration: with acetonitrile R for at least 30 min and then with mobile phase A for at least 5 min.

Injection: 10 µL; inject methanol R as a blank.

Retention time: ketoconazole = about 6 min; loperamide = about 8 min.

System suitability: reference solution (a):

- resolution: minimum 15 between the peaks due to ketoconazole and loperamide; if necessary, adjust the final concentration of acetonitrile in the mobile phase or adjust the time programme for the linear gradient elution.

## Limits:

- total: not more than the area of the principal peak in the chromatogram obtained with reference solution (b) (0.5 per cent);
- disregard limit: 0.1 times the area of the principal peak in the chromatogram obtained with reference solution (b) (0.05 per cent).

Heavy metals (2.4.8): maximum 20 ppm.

1.0 g complies with test D. Prepare the reference solution using 2 mL of lead standard solution (10 ppm Pb) R.

Loss on drying (2.2.32): maximum 0.5 per cent, determined on 1.000 g by drying in an oven at 105 °C.

Sulfated ash (2.4.14): maximum 0.1 per cent, determined on 1.0 g.

## ASSAY

Dissolve 0.200 g in 70 mL of a mixture of 1 volume of anhydrous acetic acid R and 7 volumes of methyl ethyl ketone R. Titrate with 0.1 M perchloric acid, determining the end-point potentiometrically (2.2.20).

1 mL of 0.1 M perchloric acid is equivalent to 26.57 mg of C<sub>26</sub>H<sub>28</sub>Cl<sub>2</sub>N<sub>4</sub>O<sub>4</sub>.

## STORAGE

Protected from light.

## IMPURITIES

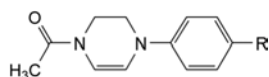
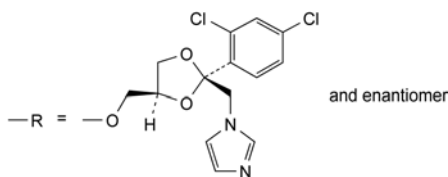

- A. 1-acetyl-4-[4-[(2RS,4SR)-2-(2,4-dichlorophenyl)-2-(1H-imidazol-1-ylmethyl)-1,3-dioxolan-4-yl]methoxy]phenyl]-1,2,3,4-tetrahydropyrazine,

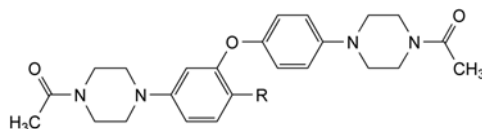

- B. 1-acetyl-4-[4-[(2RS,4SR)-2-(2,4-dichlorophenyl)-2-(1H-imidazol-1-ylmethyl)-1,3-dioxolan-4-yl]methoxy]-3-[4-(4-acetylpiperazin-1-yl)phenoxy]phenyl]piperazine,

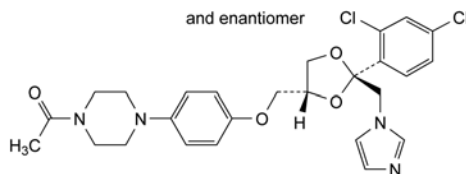

- C. 1-acetyl-4-[4-[(2RS,4RS)-2-(2,4-dichlorophenyl)-2-(1H-imidazol-1-ylmethyl)-1,3-dioxolan-4-yl]methoxy]phenyl]piperazine,

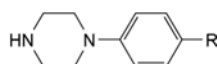

- D. 1-[4-[(2RS,4SR)-2-(2,4-dichlorophenyl)-2-(1H-imidazol-1-ylmethyl)-1,3-dioxolan-4-yl]methoxy]phenyl]piperazine,

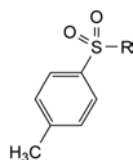

- E. [(2RS,4SR)-2-(2,4-dichlorophenyl)-2-(1H-imidazol-1-ylmethyl)-1,3-dioxolan-4-yl]methyl 4-methylbenzenesulfonate.

07/2010:0922

## KETOPROFEN

## Ketoprofenum

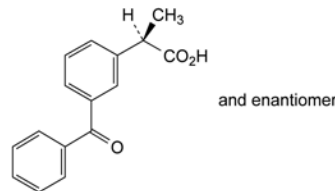

C<sub>16</sub>H<sub>14</sub>O<sub>3</sub>  
[22071-15-4]

M<sub>r</sub> 254.3

## DEFINITION

(2RS)-2-(3-Benzoylphenyl)propanoic acid.

Content: 99.0 per cent to 100.5 per cent (dried substance).

## CHARACTERS

Appearance: white or almost white, crystalline powder.

Solubility: practically insoluble in water, freely soluble in acetone, in ethanol (96 per cent) and in methylene chloride.

## IDENTIFICATION

First identification: C.

Second identification: A, B, D.

A. Melting point (2.2.14): 94 °C to 97 °C.

B. Ultraviolet and visible absorption spectrophotometry (2.2.25).

Test solution. Dissolve 50.0 mg in ethanol (96 per cent) R and dilute to 100.0 mL with the same solvent. Dilute 1.0 mL of this solution to 50.0 mL with ethanol (96 per cent) R.

Spectral range: 230-350 nm.

Absorption maximum: at 255 nm.

*Specific absorbance at the absorption maximum:* 615 to 680.

C. Infrared absorption spectrophotometry (2.2.24).

*Comparison:* ketoprofen CRS.

D. Thin-layer chromatography (2.2.27).

*Test solution.* Dissolve 10 mg of the substance to be examined in acetone R and dilute to 10 mL with the same solvent.

*Reference solution (a).* Dissolve 10 mg of ketoprofen CRS in acetone R and dilute to 10 mL with the same solvent.

*Reference solution (b).* Dissolve 10 mg of indometacin CRS in acetone R and dilute to 10 mL with the same solvent. To 1 mL of this solution add 1 mL of reference solution (a).

*Plate:* TLC silica gel GF<sub>254</sub> plate R.

*Mobile phase:* glacial acetic acid R, methylene chloride R, acetone R (1:49:50 V/V/V).

*Application:* 10 µL.

*Development:* over 3/4 of the plate.

*Drying:* in air.

*Detection:* examine in ultraviolet light at 254 nm.

*System suitability:* reference solution (b):

- the chromatogram shows 2 clearly separated principal spots.

*Results:* the principal spot in the chromatogram obtained with the test solution is similar in position and size to the principal spot in the chromatogram obtained with reference solution (a).

## TESTS

**Appearance of solution.** The solution is clear (2.2.1) and not more intensely coloured than reference solution Y<sub>6</sub> (2.2.2, Method II).

Dissolve 1.0 g in acetone R and dilute to 10 mL with the same solvent.

**Related substances.** Liquid chromatography (2.2.29). Prepare the solutions immediately before use.

*Test solution.* Dissolve 20.0 mg of the substance to be examined in the mobile phase and dilute to 20.0 mL with the mobile phase.

*Reference solution (a).* Dilute 1.0 mL of the test solution to 50.0 mL with the mobile phase. Dilute 1.0 mL of this solution to 10.0 mL with the mobile phase.

*Reference solution (b).* Dissolve 5.0 mg of ketoprofen impurity A CRS in the mobile phase and dilute to 50.0 mL with the mobile phase. Dilute 1.0 mL of this solution to 50.0 mL with the mobile phase.

*Reference solution (c).* Dissolve 5.0 mg of ketoprofen impurity C CRS in the mobile phase and dilute to 50.0 mL with the mobile phase. Dilute 1.0 mL of this solution to 50.0 mL with the mobile phase.

*Reference solution (d).* Dilute 1.0 mL of the test solution to 100.0 mL with the mobile phase. To 1.0 mL of this solution add 1.0 mL of reference solution (b).

*Column:*

- size:  $l = 0.15$  m,  $\varnothing = 4.6$  mm;
- stationary phase: spherical octadecylsilyl silica gel for chromatography R (5 µm) with a specific surface area of 350 m<sup>2</sup>/g and a pore size of 10 nm.

*Mobile phase:* mix 2 volumes of freshly prepared phosphate buffer solution pH 3.5 R, 43 volumes of acetonitrile R and 55 volumes of water R.

*Flow rate:* 1 mL/min.

*Detection:* spectrophotometer at 233 nm.

*Injection:* 20 µL.

*Identification of impurities:* use the chromatogram obtained with reference solution (b) to identify the peak due to impurity A; use the chromatogram obtained with reference solution (c) to identify the peak due to impurity C.

*Run time:* 7 times the retention time of ketoprofen.

*Relative retention* with reference to ketoprofen (retention time = about 7 min): impurity C = about 0.3; impurity E = about 0.69; impurity B = about 0.73; impurity D = about 1.35; impurity A = about 1.5; impurity F = about 2.0.

*System suitability:* reference solution (d):

- resolution: minimum 7.0 between the peaks due to ketoprofen and impurity A.

*Limits:*

- impurity A: not more than the area of the principal peak in the chromatogram obtained with reference solution (b) (0.2 per cent);
- impurity C: not more than the area of the principal peak in the chromatogram obtained with reference solution (c) (0.2 per cent);
- impurities B, D, E, F: for each impurity, not more than the area of the principal peak in the chromatogram obtained with reference solution (a) (0.2 per cent);
- unspecified impurities: for each impurity, not more than 0.5 times the area of the principal peak in the chromatogram obtained with reference solution (a) (0.10 per cent);
- sum of impurities other than A and C: not more than twice the area of the principal peak in the chromatogram obtained with reference solution (a) (0.4 per cent);
- disregard limit: 0.25 times the area of the principal peak in the chromatogram obtained with reference solution (a) (0.05 per cent).

**Heavy metals** (2.4.8): maximum 10 ppm.

2.0 g complies with test C. Prepare the reference solution using 2 mL of lead standard solution (10 ppm Pb) R.

**Loss on drying** (2.2.32): maximum 0.5 per cent, determined on 1.000 g by drying at 60 °C at a pressure not exceeding 0.67 kPa.

**Sulfated ash** (2.4.14): maximum 0.1 per cent, determined on 1.0 g.

## ASSAY

Dissolve 0.200 g in 25 mL of ethanol (96 per cent) R. Add 25 mL of water R. Titrate with 0.1 M sodium hydroxide, determining the end-point potentiometrically (2.2.20).

1 mL of 0.1 M sodium hydroxide is equivalent to 25.43 mg of C<sub>16</sub>H<sub>14</sub>O<sub>3</sub>.

## IMPURITIES

*Specified impurities:* A, B, C, D, E, F.

*Other detectable impurities* (the following substances would, if present at a sufficient level, be detected by one or other of the tests in the monograph. They are limited by the general acceptance criterion for other/unspecified impurities and/or by the general monograph *Substances for pharmaceutical use* (2034). It is therefore not necessary to identify these impurities for demonstration of compliance. See also 5.10. *Control of impurities in substances for pharmaceutical use*): G, H, I, J, K, L.

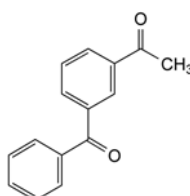

A. 1-(3-benzoylphenyl)ethanone,

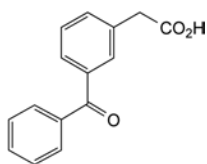

B. (3-benzoylphenyl)acetic acid,

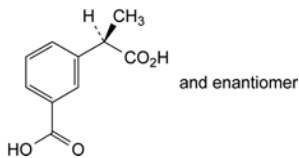
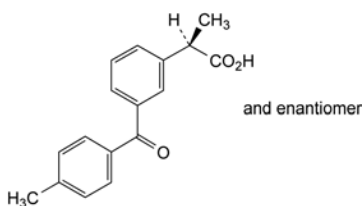
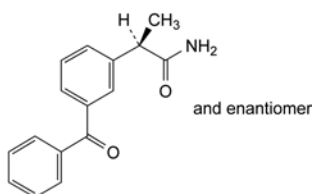
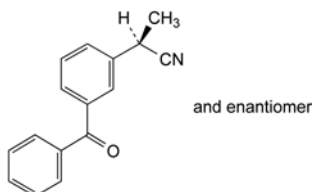
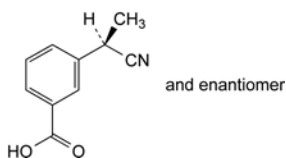
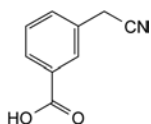
C. 3-[(1*S*)-1-carboxyethyl]benzoic acid,D. (2*R*)-2-[3-(4-methylbenzoyl)phenyl]propanoic acid,E. (2*R*)-2-(3-benzoylphenyl)propanamide,F. (2*R*)-2-(3-benzoylphenyl)propanenitrile,G. 3-[(1*S*)-1-cyanoethyl]benzoic acid,

H. 3-(cyanomethyl)benzoic acid,

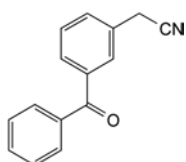

I. (3-benzoylphenyl)ethanenitrile,

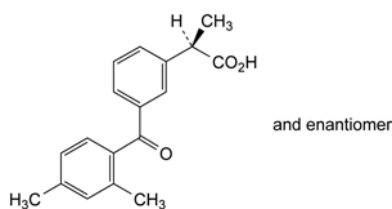
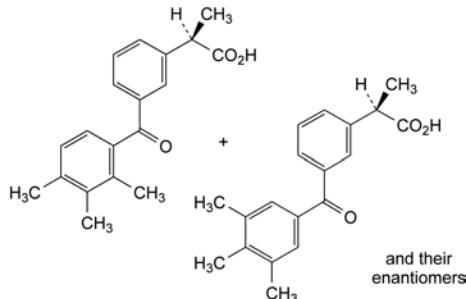
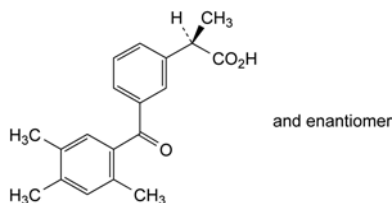
J. (2*R*)-2-[3-(2,4-dimethylbenzoyl)phenyl]propanoic acid,K. mixture of (2*R*)-2-[3-(2,3,4-trimethylbenzoyl)phenyl]propanoic acid and (2*R*)-2-[3-(3,4,5-trimethylbenzoyl)phenyl]propanoic acid,L. (2*R*)-2-[3-(2,4,5-trimethylbenzoyl)phenyl]propanoic acid.

01/2008:1755

**KETOROLAC TROMETAMOL**

## Ketorolacum trometamolum

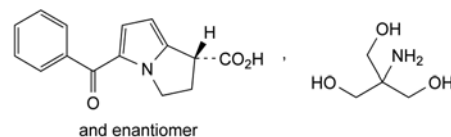
C<sub>19</sub>H<sub>24</sub>N<sub>2</sub>O<sub>6</sub>  
[74103-07-4]M<sub>r</sub> 376.4

## DEFINITION

2-Amino-2-(hydroxymethyl)propane-1,3-diol (1*S*)-5-benzoyl-2,3-dihydro-1*H*-pyrrolizine-1-carboxylate.*Content*: 98.5 per cent to 101.5 per cent (dried substance).

## CHARACTERS

*Appearance*: white or almost white, crystalline powder.*Solubility*: freely soluble in water and in methanol, slightly soluble in ethanol (96 per cent), practically insoluble in methylene chloride.

## IDENTIFICATION

Infrared absorption spectrophotometry (2.2.24).

*Comparison*: ketorolac trometamol CRS.

## TESTS

**Solution S.** Dissolve 0.75 g in carbon dioxide-free water R and dilute to 25.0 mL with the same solvent.**Appearance of solution.** Solution S is clear (2.2.1).**pH** (2.2.3): 5.7 to 6.7.

Dilute 5 mL of solution S to 15 mL with carbon dioxide-free water R.



**Absorbance** (2.2.25): maximum 0.10, determined at 430 nm for solution S.

**Related substances.** Liquid chromatography (2.2.29). *Protect the solutions from bright light.*

**Solvent mixture:** tetrahydrofuran R, water R (30:70 V/V).

**Test solution.** Dissolve 20 mg of the substance to be examined in the solvent mixture and dilute to 50 mL with the solvent mixture.

**Reference solution (a).** Dilute 1.0 mL of the test solution to 10.0 mL with the solvent mixture. Dilute 1.0 mL of this solution to 100.0 mL with the solvent mixture.

**Reference solution (b).** Dissolve 2 mg of ketorolac trometamol for peak identification CRS (containing impurities A, B, C and D) in 5 mL of the solvent mixture.

**Column:**

- size:  $l = 0.25$  m,  $\varnothing = 4.6$  mm;
- stationary phase: octylsilyl silica gel for chromatography R (5  $\mu$ m);
- temperature: 40 °C.

**Mobile phase:** mix 30 volumes of tetrahydrofuran R with 70 volumes of a solution prepared as follows: dissolve 5.75 g of ammonium dihydrogen phosphate R in 900 mL of water R, adjust to pH 3.0 with phosphoric acid R and dilute to 1000 mL with water R.

**Flow rate:** 1.5 mL/min.

**Detection:** spectrophotometer at 313 nm.

**Injection:** 10  $\mu$ L.

**Run time:** 3 times the retention time of ketorolac.

**Identification of impurities:** use the chromatogram supplied with ketorolac trometamol for peak identification CRS and the chromatogram obtained with reference solution (b) to identify the peaks due to impurities A, B, C and D.

**Relative retention** with reference to ketorolac (retention time = about 10 min): impurity C = about 0.5; impurity A = about 0.6; impurity D = about 0.7; impurity B = about 0.9.

**System suitability:** reference solution (b):

- resolution: minimum 1.5 between the peaks due to impurity B and ketorolac.

**Limits:**

- correction factors: for the calculation of content, multiply the peak areas of the following impurities by the corresponding correction factor: impurity A = 0.67; impurity B = 0.52; impurity C = 2.2;
- impurities A, B, C, D: for each impurity, not more than the area of the principal peak in the chromatogram obtained with reference solution (a) (0.1 per cent);
- unspecified impurities: for each impurity, not more than the area of the principal peak in the chromatogram obtained with reference solution (a) (0.10 per cent);
- total: not more than 10 times the area of the principal peak in the chromatogram obtained with reference solution (a) (1.0 per cent);
- disregard limit: 0.5 times the area of the principal peak in the chromatogram obtained with reference solution (a) (0.05 per cent).

**Heavy metals** (2.4.8): maximum 20 ppm.

1.0 g complies with test F. Prepare the reference solution using 2 mL of lead standard solution (10 ppm Pb) R.

**Loss on drying** (2.2.32): maximum 0.5 per cent, determined on 1.000 g by drying *in vacuo* at 60 °C for 3 h.

**Sulfated ash** (2.4.14): maximum 0.1 per cent, determined on 1.0 g.

**ASSAY**

Dissolve 0.300 g in 60 mL of anhydrous acetic acid R. Titrate with 0.1 M perchloric acid, determining the end-point potentiometrically (2.2.20).

1 mL of 0.1 M perchloric acid is equivalent to 37.64 mg of C<sub>19</sub>H<sub>24</sub>N<sub>2</sub>O<sub>6</sub>.

**STORAGE**

Protected from light.

**IMPURITIES**

**Specified impurities:** A, B, C, D.

**Other detectable impurities** (the following substances would, if present at a sufficient level, be detected by one or other of the tests in the monograph. They are limited by the general acceptance criterion for other/unspecified impurities and/or by the general monograph *Substances for pharmaceutical use* (2034). It is therefore not necessary to identify these impurities for demonstration of compliance. See also 5.10. *Control of impurities in substances for pharmaceutical use*): E, F, G, H, I, J.

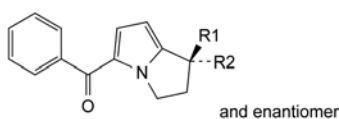

- A. R1 = H, R2 = OH: (1*R*S)-5-benzoyl-2,3-dihydro-1*H*-pyrrolizin-1-ol,
- B. R1 + R2 = O: 5-benzoyl-2,3-dihydro-1*H*-pyrrolizin-1-one,
- D. R1 = CO<sub>2</sub>H, R2 = OCH<sub>3</sub>: (1*R*S)-5-benzoyl-1-methoxy-2,3-dihydro-1*H*-pyrrolizine-1-carboxylic acid,
- E. R1 = H, R2 = CO-NH-C(CH<sub>2</sub>OH)<sub>2</sub>: (1*R*S)-5-benzoyl-*N*-[2-hydroxy-1,1-bis(hydroxymethyl)ethyl]-2,3-dihydro-1*H*-pyrrolizine-1-carboxamide,
- G. R1 = CO<sub>2</sub>CH<sub>3</sub>, R2 = OH: methyl (1*R*S)-5-benzoyl-1-hydroxy-2,3-dihydro-1*H*-pyrrolizine-1-carboxylate,
- H. R1 = H, R2 = CO<sub>2</sub>CH<sub>3</sub>: methyl (1*R*S)-5-benzoyl-2,3-dihydro-1*H*-pyrrolizine-1-carboxylate,
- I. R1 = R2 = H: phenyl(2,3-dihydro-1*H*-pyrrolizin-5-yl)methanone,
- J. R1 = H, R2 = CO<sub>2</sub>C<sub>2</sub>H<sub>5</sub>: ethyl (1*R*S)-5-benzoyl-2,3-dihydro-1*H*-pyrrolizine-1-carboxylate,

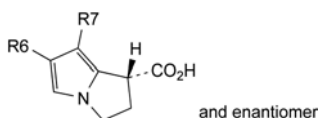

- C. R6 = CO-C<sub>6</sub>H<sub>5</sub>, R7 = H: (1*R*S)-6-benzoyl-2,3-dihydro-1*H*-pyrrolizine-1-carboxylic acid,
- F. R6 = H, R7 = CO-C<sub>6</sub>H<sub>5</sub>: (1*R*S)-7-benzoyl-2,3-dihydro-1*H*-pyrrolizine-1-carboxylic acid.

07/2010:1592

## KETOTIFEN HYDROGEN FUMARATE

Ketotifeni hydrogenofumaras

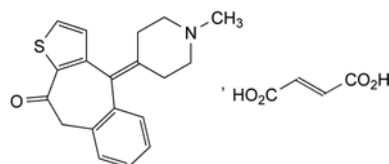

C<sub>23</sub>H<sub>23</sub>NO<sub>5</sub>S  
[34580-14-8]

*M*<sub>r</sub> 425.5

## DEFINITION

4-(1-Methylpiperidin-4-ylidene)-4,9-dihydro-10H-benzo[4,5]-cyclohepta[1,2-b]thiophen-10-one hydrogen (*E*)-butenedioate.

*Content*: 98.5 per cent to 101.0 per cent (dried substance).

## CHARACTERS

*Appearance*: white or brownish-yellow, fine, crystalline powder.

*Solubility*: sparingly soluble in water, slightly soluble in methanol, very slightly soluble in acetonitrile.

## IDENTIFICATION

## A. Infrared absorption spectrophotometry (2.2.24).

*Comparison*: Ph. Eur. reference spectrum of ketotifen hydrogen fumarate.

## B. Thin-layer chromatography (2.2.27).

*Test solution*. Dissolve 40 mg of the substance to be examined in methanol *R* and dilute to 10 mL with the same solvent.

*Reference solution*. Dissolve 11 mg of fumaric acid CRS in methanol *R* and dilute to 10 mL with the same solvent.

*Plate*: cellulose for chromatography *F*<sub>254</sub> *R* as the coating substance.

*Mobile phase*: water *R*, anhydrous formic acid *R*, di-isopropyl ether *R* (3:7:90 *V/V/V*).

*Application*: 5 µL.

*Development*: over 4/5 of the plate.

*Drying*: in a current of warm air.

*Detection*: examine in ultraviolet light at 254 nm. Spray lightly with a 5 g/L solution of potassium permanganate *R* in a 1.4 per cent *V/V* solution of sulfuric acid *R*. Examine in daylight by transparency.

*Results*: the spot due to fumaric acid in the chromatogram obtained with the test solution is similar in position, colour and intensity to the principal spot in the chromatogram obtained with the reference solution.

## TESTS

**Appearance of solution.** The solution is clear (2.2.1) and not more intensely coloured than reference solution *Y*<sub>4</sub>, *BY*<sub>4</sub> or *B*<sub>4</sub> (2.2.2, Method II).

Dissolve 0.2 g in methanol *R* and dilute to 10 mL with the same solvent.

**Related substances.** Liquid chromatography (2.2.29).

*Test solution*. Dissolve 30.0 mg of the substance to be examined in a mixture of equal volumes of methanol *R* and water *R* and dilute to 100.0 mL with the same mixture of solvents.

*Reference solution (a)*. Dilute 1.0 mL of the test solution to 50.0 mL with a mixture of equal volumes of methanol *R* and water *R*. Dilute 1.0 mL to 10.0 mL with a mixture of equal volumes of methanol *R* and water *R*.

*Reference solution (b)*. Dissolve the contents of a vial of ketotifen impurity *G* CRS in 1.0 mL of a solution prepared as follows: mix 1.0 mL of the test solution with 9.0 mL of a mixture of equal volumes of methanol *R* and water *R*. Protect the solution from light.

*Reference solution (c)*. To 1.0 mL of reference solution (b), add 14.0 mL with a mixture of equal volumes of methanol *R* and water *R*. Protect the solution from light.

*Column*:

- size: *l* = 0.15 m, Ø = 4.0 mm,
- stationary phase: octadecylsilyl silica gel for chromatography *R* (3 µm),
- temperature: 40 °C.

*Mobile phase*:

- mobile phase *A*: mix 175 µL of triethylamine *R* and 500 mL of water *R*,
- mobile phase *B*: mix 175 µL of triethylamine *R* and 500 mL of methanol *R*,

Time (min)	Mobile phase A (per cent <i>V/V</i> )	Mobile phase B (per cent <i>V/V</i> )
0 - 12	40	60
12 - 20	40 → 10	60 → 90
20 - 25	10	90

*Flow rate*: 1.0 mL/min.

*Detection*: spectrophotometer at 297 nm.

*Injection*: 20 µL.

*Relative retentions* with reference to ketotifen (retention time = about 10 min): impurity *D* = about 0.3; impurity *C* = about 0.6; impurity *G* = about 0.9; impurity *E* = about 1.2; impurity *F* = about 1.4; impurity *B* = about 1.7; impurity *A* = about 2.1.

*System suitability*:

- resolution: minimum of 1.5 between the peaks due to impurity *G* and ketotifen in the chromatogram obtained with reference solution (b);
- signal-to-noise ratio: minimum 70 for the peak due to impurity *G* in the chromatogram obtained with reference solution (c).

*Limits*:

- correction factor: for the calculation of contents, multiply the area of the corresponding peak by the following correction factor: impurity *G* = 1.4;
- impurities *A*, *B*, *C*, *D*, *E*, *F*, *G*: for each impurity, not more than the area of the principal peak in the chromatogram obtained with reference solution (a) (0.2 per cent);
- unspecified impurities: for each impurity, not more than 0.5 times the area of the principal peak in the chromatogram obtained with reference solution (a) (0.10 per cent);
- total: not more than 2.5 times the area of the principal peak in the chromatogram obtained with reference solution (a) (0.5 per cent);
- disregard limit: 0.25 times the area of the principal peak in the chromatogram obtained with reference solution (a) (0.05 per cent).

**Loss on drying** (2.2.32): maximum 0.5 per cent, determined on 1.000 g by drying in an oven at 105 °C for 4 h.

**Sulfated ash** (2.4.14): maximum 0.1 per cent, determined on 1.0 g.

## ASSAY

Dissolve 0.350 g in a mixture of 30 mL of anhydrous acetic acid *R* and 30 mL of acetic anhydride *R*. Titrate with 0.1 *M* perchloric acid, determining the end-point potentiometrically (2.2.20).

1 mL of 0.1 *M* perchloric acid is equivalent to 42.55 mg of C<sub>23</sub>H<sub>23</sub>NO<sub>3</sub>S.

## IMPURITIES

*Specified impurities*: *A*, *B*, *C*, *D*, *E*, *F*, *G*.

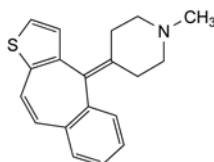

A. 4-(4*H*-benzo[4,5]cyclohepta[1,2-*b*]thiophen-4-ylidene)-1-methylpiperidine,

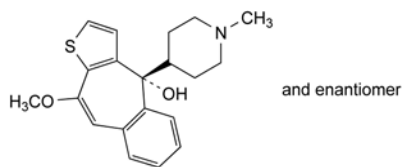

- B. (4*RS*)-10-methoxy-4-(1-methylpiperidin-4-yl)-4*H*-benzo[4,5]cyclohepta[1,2-*b*]thiophen-4-ol,

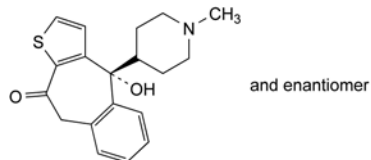

- C. (4*RS*)-4-hydroxy-4-(1-methylpiperidin-4-yl)-4,9-dihydro-10*H*-benzo[4,5]cyclohepta[1,2-*b*]thiophen-10-one,

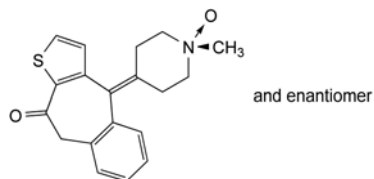

- D. 4-[(*aRaS*)-1-methylpiperidin-4-ylidene]-4,9-dihydro-10*H*-benzo[4,5]cyclohepta[1,2-*b*]thiophen-10-one *N*-oxide (ketotifen *N*-oxide),

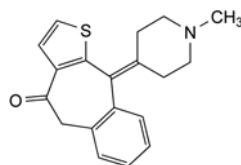

- E. 10-(1-methylpiperidin-4-ylidene)-5,10-dihydro-4*H*-benzo[5,6]cyclohepta[1,2-*b*]thiophen-4-one,

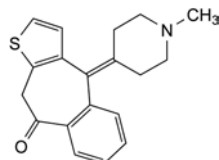

- F. 4-(1-methylpiperidin-4-ylidene)-4,10-dihydro-9*H*-benzo[4,5]cyclohepta[1,2-*b*]thiophen-9-one,

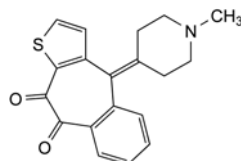

- G. 4-(1-methylpiperidin-4-ylidene)-4*H*-benzo[4,5]cyclohepta[1,2-*b*]thiophen-9,10-dione.

01/2008:0923 E. It gives reaction (a) of chlorides (2.3.1).  
corrected 6.0

## LABETALOL HYDROCHLORIDE

### Labetaloli hydrochloridum

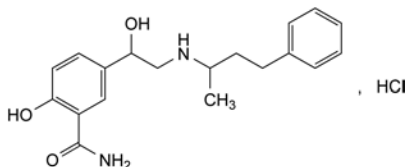

$C_{19}H_{25}ClN_2O_3$   
[32780-64-6]

$M_r$  364.9

#### DEFINITION

2-Hydroxy-5-[1-hydroxy-2-[(1-methyl-3-phenylpropyl)amino]ethyl]benzamide hydrochloride.

*Content*: 98.5 per cent to 101.0 per cent (dried substance).

#### CHARACTERS

*Appearance*: white or almost white powder.

*Solubility*: sparingly soluble in water and in ethanol (96 per cent), practically insoluble in methylene chloride.

#### IDENTIFICATION

*First identification*: A, C, E.

*Second identification*: A, B, D, E.

A. Optical rotation (2.2.7):  $-0.05^\circ$  to  $+0.05^\circ$ , determined on solution S (see Tests).

B. Ultraviolet and visible absorption spectrophotometry (2.2.25).

*Test solution*. Dissolve 25.0 mg in 0.1 M hydrochloric acid and dilute to 250.0 mL with the same acid.

*Spectral range*: 230-350 nm.

*Absorption maximum*: at 302 nm.

*Specific absorbance at the absorption maximum*: 83 to 88.

C. Infrared absorption spectrophotometry (2.2.24).

*Comparison*: labetalol hydrochloride CRS.

D. Thin-layer chromatography (2.2.27).

*Test solution*. Dissolve 10 mg of the substance to be examined in 1 mL of ethanol (96 per cent) R.

*Reference solution (a)*. Dissolve 10 mg of labetalol hydrochloride CRS in 1 mL of ethanol (96 per cent) R.

*Reference solution (b)*. Dissolve 10 mg of labetalol hydrochloride CRS and 10 mg of propranolol hydrochloride CRS in ethanol (96 per cent) R and dilute to 5 mL with the same solvent.

*Plate*: TLC octadecylsilyl silica gel  $F_{254}$  plate R.

*Mobile phase*: perchloric acid R, water R, methanol R (0.5:50:80 V/V/V).

*Application*: 2  $\mu$ L.

*Development*: place the plate in a chromatographic tank immediately after the addition of the mobile phase, close the tank and develop over a path of 15 cm.

*Drying*: in air.

*Detection*: examine in ultraviolet light at 254 nm.

*System suitability*: reference solution (b):

– the chromatogram shows 2 clearly separated spots.

*Results*: the principal spot in the chromatogram obtained with the test solution is similar in position and size to the principal spot in the chromatogram obtained with reference solution (a).

#### TESTS

**Solution S**. Dissolve 0.50 g in carbon dioxide-free water R and dilute to 50 mL with the same solvent. *Solution S must be freshly prepared.*

**Appearance of solution**. Solution S is clear (2.2.1) and not more intensely coloured than intensity 6 of the range of reference solutions of the most appropriate colour (2.2.2, *Method II*).

**pH** (2.2.3): 4.0 to 5.0 for solution S.

**Diastereoisomer ratio**. Gas chromatography (2.2.28).

*Test solution*. Dissolve 2.0 mg of the substance to be examined in 1.0 mL of a 12.0 g/L solution of butylboronic acid R in anhydrous pyridine R and allow to stand for 20 min.

*Column*:

– *material*: glass;

– *size*:  $l = 1.5$  m,  $\varnothing = 4$  mm;

– *stationary phase*: silanised diatomaceous earth for gas chromatography R (125-150  $\mu$ m) impregnated with 3 per cent *m/m* of polymethylphenylsiloxane R.

*Carrier gas*: nitrogen for chromatography R.

*Flow rate*: 40 mL/min.

*Temperature*:

– *column, injection port and detector*: 300  $^\circ$ C.

*Detection*: flame ionisation.

*Injection*: 2  $\mu$ L.

*System suitability*:

– the height of the trough separating the 2 peaks due to the pairs of diastereoisomers is less than 5 per cent of the full scale of the recorder.

*Limit*:

– *each pair of diastereoisomers*: for the area of each peak, 45 per cent to 55 per cent of the total area of the 2 peaks.

**Related substances**. Liquid chromatography (2.2.29).

*Test solution*. Dissolve 50.0 mg of the substance to be examined in the mobile phase and dilute to 10.0 mL with the mobile phase.

*Reference solution*. Dilute 0.5 mL of the test solution to 100.0 mL with the mobile phase.

*Column*:

– *size*:  $l = 0.15$  m,  $\varnothing = 4.6$  mm;

– *stationary phase*: octadecylsilyl silica gel for chromatography R (5  $\mu$ m).

*Mobile phase*: mix 150 mL of tetrahydrofuran R, 300 mL of methanol R, 550 mL of water R, 0.82 g of tetrabutylammonium hydrogen sulfate R, 1 g of sodium octyl sulfate R and 10 mL of a 10 per cent V/V solution of sulfuric acid R.

*Flow rate*: 1 mL/min.

*Detection*: spectrophotometer at 229 nm.

*Equilibration*: with the mobile phase for about 30 min.

*Injection*: 20  $\mu$ L.

*Run time*: 3 times the retention time of labetalol.

*Retention time*: labetalol = 10 min to 15 min; if necessary, adjust the water content of the mobile phase ensuring that the 2:1 ratio of methanol to tetrahydrofuran is maintained.

*Limits*:

– *impurities A, B*: for each impurity, not more than 0.6 times the area of the principal peak in the chromatogram obtained with the reference solution (0.3 per cent);

– *total*: not more than the area of the principal peak in the chromatogram obtained with the reference solution (0.5 per cent);

– *disregard limit*: 0.1 times the area of the principal peak in the chromatogram obtained with the reference solution (0.05 per cent).

**Heavy metals** (2.4.8): maximum 20 ppm.

1.0 g complies with test C. Prepare the reference solution using 2 mL of *lead standard solution (10 ppm Pb) R*.

**Loss on drying** (2.2.32): maximum 1.0 per cent, determined on 1.000 g by drying in an oven at 105 °C at a pressure not exceeding 0.7 kPa.

**Sulfated ash** (2.4.14): maximum 0.1 per cent, determined on 1.0 g.

#### ASSAY

*In order to avoid overheating in the reaction medium, mix thoroughly throughout and stop the titration immediately after the end-point has been reached.*

Dissolve 0.200 g in a mixture of 10 mL of *anhydrous formic acid R* and 40 mL of *acetic anhydride R*. Titrate with 0.1 M *perchloric acid*, determining the end-point potentiometrically (2.2.20).

1 mL of 0.1 M *perchloric acid* is equivalent to 36.49 mg of C<sub>19</sub>H<sub>25</sub>ClN<sub>2</sub>O<sub>3</sub>.

#### IMPURITIES

*Specified impurities: A, B.*

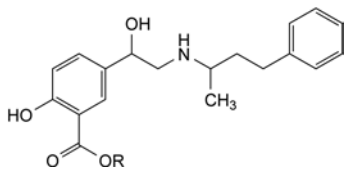

A. R = H: 2-hydroxy-5-[1-hydroxy-2-[(1-methyl-3-phenylpropyl)amino]ethyl]benzoic acid,

B. R = CH<sub>3</sub>: methyl 2-hydroxy-5-[1-hydroxy-2-[(1-methyl-3-phenylpropyl)amino]ethyl]benzoate.

01/2008:0458

## LACTIC ACID

### Acidum lacticum

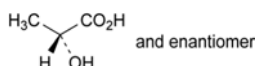

C<sub>3</sub>H<sub>6</sub>O<sub>3</sub>

M<sub>r</sub> 90.1

#### DEFINITION

Mixture of 2-hydroxypropanoic acid, its condensation products, such as lactoyl-lactic acid and polylactic acids, and water. The equilibrium between lactic acid and polylactic acids depends on the concentration and temperature. It is usually the racemate ((*RS*)-lactic acid).

*Content*: 88.0 per cent *m/m* to 92.0 per cent *m/m* of C<sub>3</sub>H<sub>6</sub>O<sub>3</sub>.

#### CHARACTERS

*Appearance*: colourless or slightly yellow, syrupy liquid.

*Solubility*: miscible with water and with ethanol (96 per cent).

#### IDENTIFICATION

A. Dissolve 1 g in 10 mL of *water R*. The solution is strongly acidic (2.2.4).

B. Relative density (2.2.5): 1.20 to 1.21.

C. It gives the reaction of lactates (2.3.1).

#### TESTS

**Solution S.** Dissolve 5.0 g in 42 mL of 1 M *sodium hydroxide* and dilute to 50 mL with *distilled water R*.

**Appearance.** The substance to be examined is not more intensely coloured than reference solution Y<sub>6</sub> (2.2.2, *Method II*).

**Ether-insoluble substances.** Dissolve 1.0 g in 25 mL of *ether R*. The solution is not more opalescent than the solvent used for the test.

**Sugars and other reducing substances.** To 1 mL of solution S add 1 mL of 1 M *hydrochloric acid*, heat to boiling, allow to cool and add 1.5 mL of 1 M *sodium hydroxide* and 2 mL of *cupri-tartaric solution R*. Heat to boiling. No red or greenish precipitate is formed.

**Methanol** (2.4.24): maximum 50 ppm, if intended for use in the manufacture of parenteral preparations.

**Citric, oxalic and phosphoric acids.** To 5 mL of solution S add *dilute ammonia R1* until slightly alkaline (2.2.4). Add 1 mL of *calcium chloride solution R*. Heat on a water-bath for 5 min. Both before and after heating, any opalescence in the solution is not more intense than that in a mixture of 1 mL of *water R* and 5 mL of solution S.

**Sulfates** (2.4.13): maximum 200 ppm.

Dilute 7.5 mL of solution S to 15 mL with *distilled water R*.

**Calcium** (2.4.3): maximum 200 ppm.

Dilute 5 mL of solution S to 15 mL with *distilled water R*.

**Heavy metals** (2.4.8): maximum 10 ppm.

12 mL of solution S complies with limit test A. Prepare the reference solution using *lead standard solution (1 ppm Pb) R*.

**Sulfated ash** (2.4.14): maximum 0.1 per cent, determined on 1.0 g.

**Bacterial endotoxins** (2.6.14): less than 5 IU/g, if intended for use in the manufacture of parenteral preparations without a further appropriate procedure for the removal of bacterial endotoxins. Before use, neutralise the test solution to pH 7.0-7.5 with *strong sodium hydroxide solution R* and shake vigorously.

#### ASSAY

Place 1.000 g in a ground-glass-stoppered flask and add 10 mL of *water R* and 20.0 mL of 1 M *sodium hydroxide*. Close the flask and allow to stand for 30 min. Using 0.5 mL of *phenolphthalein solution R* as indicator, titrate with 1 M *hydrochloric acid* until the pink colour is discharged.

1 mL of 1 M *sodium hydroxide* is equivalent to 90.1 mg of C<sub>3</sub>H<sub>6</sub>O<sub>3</sub>.

#### LABELLING

The label states, where applicable, that the substance is suitable for use in the manufacture of parenteral preparations.

01/2008:1771

## (S)-LACTIC ACID

### Acidum (S)-lacticum

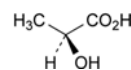

C<sub>3</sub>H<sub>6</sub>O<sub>3</sub>

M<sub>r</sub> 90.1

#### DEFINITION

Mixture of (*S*)-2-hydroxypropanoic acid, its condensation products, such as lactoyl-lactic acid and polylactic acids, and water. The equilibrium between lactic acid and polylactic acids depends on the concentration and temperature.

*Content*: 88.0 per cent *m/m* to 92.0 per cent *m/m* of C<sub>3</sub>H<sub>6</sub>O<sub>3</sub>, not less than 95.0 per cent of which is the (*S*)-enantiomer.

#### CHARACTERS

*Appearance*: colourless or slightly yellow, syrupy liquid.

*Solubility*: miscible with water and with ethanol (96 per cent).

## IDENTIFICATION

- A. Dissolve 1 g in 10 mL of *water R*. The solution is strongly acidic (2.2.4).
- B. Relative density (2.2.5): 1.20 to 1.21.
- C. It gives the reaction of lactates (2.3.1).
- D. It complies with the limits of the assay.

## TESTS

**Solution S.** Dissolve 5.0 g in 42 mL of 1 M sodium hydroxide and dilute to 50 mL with *distilled water R*.

**Appearance.** The substance to be examined is not more intensely coloured than reference solution Y<sub>6</sub> (2.2.2, Method II).

**Ether-insoluble substances.** Dissolve 1.0 g in 25 mL of *ether R*. The solution is not more opalescent than the solvent used for the test.

**Sugars and other reducing substances.** To 1 mL of solution S add 1 mL of 1 M hydrochloric acid, heat to boiling, allow to cool and add 1.5 mL of 1 M sodium hydroxide and 2 mL of *cupri-tartaric solution R*. Heat to boiling. No red or greenish precipitate is formed.

**Methanol (2.4.24):** maximum 50 ppm, if intended for use in the manufacture of parenteral preparations.

**Citric, oxalic and phosphoric acids.** To 5 mL of solution S add *dilute ammonia R1* until slightly alkaline (2.2.4). Add 1 mL of *calcium chloride solution R*. Heat on a water-bath for 5 min. Both before and after heating, any opalescence in the solution is not more intense than that in a mixture of 1 mL of *water R* and 5 mL of solution S.

**Sulfates (2.4.13):** maximum 200 ppm.

Dilute 7.5 mL of solution S to 15 mL with *distilled water R*.

**Calcium (2.4.3):** maximum 200 ppm.

Dilute 5 mL of solution S to 15 mL with *distilled water R*.

**Heavy metals (2.4.8):** maximum 10 ppm.

12 mL of solution S complies with limit test A. Prepare the reference solution using *lead standard solution (1 ppm Pb) R*.

**Sulfated ash (2.4.14):** maximum 0.1 per cent, determined on 1.0 g.

**Bacterial endotoxins (2.6.14):** less than 5 IU/g if intended for use in the manufacture of parenteral preparations without a further appropriate procedure for the removal of bacterial endotoxins. Before use, neutralise the test solution to pH 7.0-7.5 with *strong sodium hydroxide solution R* and shake vigorously.

## ASSAY

Place 1.000 g in a ground-glass-stoppered flask and add 10 mL of *water R* and 20.0 mL of 1 M sodium hydroxide. Close the flask and allow to stand for 30 min. Using 0.5 mL of *phenolphthalein solution R* as indicator, titrate with 1 M hydrochloric acid until the pink colour is discharged.

1 mL of 1 M sodium hydroxide is equivalent to 90.1 mg of C<sub>3</sub>H<sub>6</sub>O<sub>3</sub>.

**(S)-enantiomer**

Transfer an amount of the substance to be examined equivalent to 2.00 g of lactic acid into a round-bottomed flask, add 25 mL of 1 M sodium hydroxide and boil gently for 15 min. Cool down and adjust to pH 7.0 using 1 M hydrochloric acid. Add 5.0 g of *ammonium molybdate R*, dissolve and dilute to 50.0 mL with *water R*. Filter and measure the angle of optical rotation (2.2.7). Calculate the percentage content of (S)-enantiomer using the expression:

$$50 + \left( 24.18 \times \alpha \times \frac{2.222}{m} \times \frac{90}{c} \right)$$

- $\alpha$  = angle of optical rotation (absolute value),
- $m$  = mass of the substance to be examined, in grams,
- $c$  = percentage content of C<sub>3</sub>H<sub>6</sub>O<sub>3</sub> in the substance to be examined.

The complex of (S)-lactic acid formed under these test conditions is laevorotatory.

## LABELLING

The label states, where applicable, that the substance is suitable for use in the manufacture of parenteral preparations.

01/2009:1337  
corrected 6.5

## LACTITOL MONOHYDRATE

## Lactitolum monohydricum

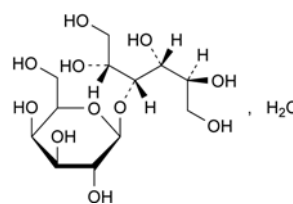

C<sub>12</sub>H<sub>24</sub>O<sub>11</sub>·H<sub>2</sub>O  
[81025-04-9]

M<sub>r</sub> 362.3

## DEFINITION

4-O-(β-D-Galactopyranosyl)-D-glucitol monohydrate.

*Content:* 96.5 per cent to 102.0 per cent (anhydrous substance).

## CHARACTERS

*Appearance:* white or almost white, crystalline powder.

*Solubility:* very soluble in water, slightly soluble in ethanol (96 per cent), practically insoluble in methylene chloride

## IDENTIFICATION

*First identification:* B.

*Second identification:* A, C.

A. Specific optical rotation (see Tests).

B. Infrared absorption spectrophotometry (2.2.24).

*Comparison:* lactitol monohydrate CRS.

C. Thin-layer chromatography (2.2.27).

*Test solution.* Dissolve 50 mg of the substance to be examined in *methanol R* and dilute to 20 mL with the same solvent.

*Reference solution (a).* Dissolve 5 mg of *lactitol monohydrate CRS* in *methanol R* and dilute to 2 mL with the same solvent.

*Reference solution (b).* Dissolve 2.5 mg of *sorbitol CRS* (impurity E) in 1 mL of reference solution (a) and dilute to 10 mL with *methanol R*.

*Plate:* TLC silica gel G plate R.

*Mobile phase:* *water R*, *acetonitrile R* (25:75 V/V).

*Application:* 2 µL.

*Development:* over 2/3 of the plate.

*Drying:* in air.

*Detection:* spray with 4-aminobenzoic acid solution R and dry in a current of cold air until the solvent is removed; heat at 100 °C for 15 min and allow to cool; spray with a 2 g/L solution of *sodium periodate R* and dry in a current of cold air; heat at 100 °C for 15 min.

*System suitability:* the chromatogram obtained with reference solution (b) shows 2 clearly separated spots.

**Results:** the principal spot in the chromatogram obtained with the test solution is similar in position, colour and size to the principal spot in the chromatogram obtained with reference solution (a).

#### TESTS

**Solution S.** Dissolve 5.000 g in *carbon dioxide-free water R* and dilute to 50.0 mL with the same solvent.

**Appearance of solution.** Solution S is clear (2.2.1) and not more intensely coloured than reference solution BY<sub>7</sub> (2.2.2, Method II).

**Acidity or alkalinity.** To 10 mL of solution S add 10 mL of *carbon dioxide-free water R*. To 10 mL of this solution add 0.05 mL of *phenolphthalein solution R*. Not more than 0.2 mL of 0.01 M *sodium hydroxide* is required to change the colour of the indicator to pink. To a further 10 mL of the solution add 0.05 mL of *methyl red solution R*. Not more than 0.3 mL of 0.01 M *hydrochloric acid* is required to change the colour of the indicator to red.

**Specific optical rotation**(2.2.7): + 13.5 to + 15.5 (anhydrous substance), determined on solution S.

**Related substances.** Liquid chromatography (2.2.29).

**Test solution (a).** Dissolve 50.0 mg of the substance to be examined in *water R* and dilute to 10.0 mL with the same solvent.

**Test solution (b).** Dilute 2.0 mL of test solution (a) to 50.0 mL with *water R*.

**Reference solution (a).** Dissolve 5.0 mg of *lactitol monohydrate CRS* and 5 mg of *glycerol R* in *water R* and dilute to 25.0 mL with the same solvent.

**Reference solution (b).** Dilute 1.0 mL of test solution (a) to 100.0 mL with *water R*. Dilute 5.0 mL of this solution to 100.0 mL with *water R*.

**Reference solution (c).** Dilute 2.5 mL of reference solution (a) to 10.0 mL with *water R*.

**Column:**

- size:  $l = 0.30$  m,  $\varnothing = 7.8$  mm;
- stationary phase: strong cation exchange resin (calcium form) *R*;
- temperature: 60 °C.

**Mobile phase:** *water R*.

**Flow rate:** 0.6 mL/min.

**Detection:** refractive index detector maintained at a constant temperature.

**Injection:** 100 µL; inject test solution (a) and reference solutions (b) and (c).

**Run time:** 2.5 times the retention time of lactitol.

**Relative retention** with reference to lactitol (retention time = about 13 min): impurity A = about 0.7; impurity B = about 0.8; glycerol = about 1.3; impurity C = about 1.5; impurity D = about 1.8; impurity E = about 1.9.

**System suitability:** reference solution (c):

- resolution: minimum 5 between the peaks due to lactitol and glycerol.

**Limits:**

- impurity B: not more than the area of the peak due to lactitol in the chromatogram obtained with reference solution (c) (1.0 per cent);
- total of other impurities: not more than the area of the peak due to lactitol in the chromatogram obtained with reference solution (c) (1.0 per cent);
- disregard limit: the area of the principal peak in the chromatogram obtained with reference solution (b) (0.05 per cent); disregard any peak due to the solvent.

**Reducing sugars:** maximum 0.2 per cent.

Dissolve 5.0 g in 3 mL of *water R* with gentle heating. Cool and add 20 mL of *cupri-citric solution R* and a few glass beads. Heat so that boiling begins after 4 min and maintain boiling for 3 min. Cool rapidly and add 100 mL of a 2.4 per cent V/V solution of *glacial acetic acid R* and 20.0 mL of 0.025 M *iodine*. With continuous shaking, add 25 mL of a mixture of 6 volumes of *hydrochloric acid R* and 94 volumes of *water R*. When the precipitate has dissolved, titrate the excess of iodine with 0.05 M *sodium thiosulfate* using 1 mL of *starch solution R* added towards the end of the titration, as indicator. Not less than 12.8 mL of 0.05 M *sodium thiosulfate* is required.

**Lead** (2.4.10): maximum 0.5 ppm.

**Nickel** (2.4.15): maximum 1 ppm.

**Water** (2.5.12): 4.5 per cent to 5.5 per cent, determined on 0.30 g.

**Sulfated ash** (2.4.14): maximum 0.1 per cent, determined on 1.0 g.

#### Microbial contamination

TAMC: acceptance criterion 10<sup>3</sup> CFU/g (2.6.12).

TYMC: acceptance criterion 10<sup>2</sup> CFU/g (2.6.12).

Absence of *Escherichia coli* (2.6.13).

Absence of *Salmonella* (2.6.13).

Absence of *Pseudomonas aeruginosa* (2.6.13).

#### ASSAY

Liquid chromatography (2.2.29) as described in the test for related substances with the following modification.

**Injection:** test solution (b) and reference solution (a).

Calculate the percentage content of C<sub>12</sub>H<sub>24</sub>O<sub>11</sub> using the chromatograms obtained with test solution (b) and reference solution (a) and the declared content of *lactitol monohydrate CRS*.

#### IMPURITIES

**Specified impurities:** A, B, C, D, E.

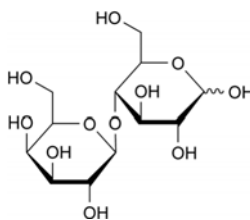

A. *O*-β-D-galactopyranosyl-(1→4)-β-D-glucopyranose or mixture of *O*-β-D-galactopyranosyl-(1→4)-α-D-glucopyranose and *O*-β-D-galactopyranosyl-(1→4)-β-D-glucopyranose (lactose),

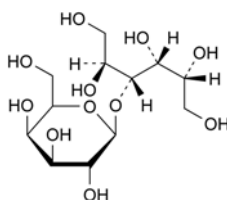

B. 3-*O*-(β-D-galactopyranosyl)-D-glucitol (lactulitol),

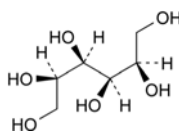

C. D-mannitol,

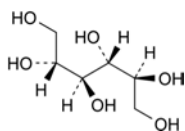

D. galactitol (dulcitol),

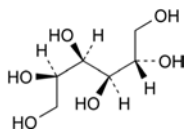

E. D-glucitol (D-sorbitol).

01/2008:1647

**LACTOBIONIC ACID**

## Acidum lactobionicum

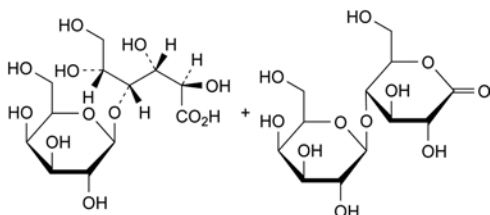

$C_{12}H_{22}O_{12}$  (acid form)  
[96-82-2]

 $M_r$  358.3

$C_{12}H_{20}O_{11}$  ( $\delta$ -lactone)  
[5965-65-1]

 $M_r$  340.3**DEFINITION**

Mixture in variable proportions of 4-*O*- $\beta$ -D-galactopyranosyl-D-gluconic acid and 4-*O*- $\beta$ -D-galactopyranosyl-D-glucono-1,5-lactone.

*Content*: 98.0 per cent to 102.0 per cent (anhydrous substance).

**CHARACTERS**

*Appearance*: white or almost white powder.

*Solubility*: freely soluble in water, slightly soluble in glacial acetic acid, in anhydrous ethanol and in methanol.

mp: about 125 °C with decomposition.

**IDENTIFICATION**

A. Infrared absorption spectrophotometry (2.2.24).

*Comparison*: lactobionic acid CRS.

If the spectra obtained show differences, dissolve the substance to be examined and the reference substance separately in *water R*, dry at 105 °C and record new spectra using the residues.

B. Thin-layer chromatography (2.2.27).

*Test solution*. Dissolve 10 mg of the substance to be examined in *water R* and dilute to 1 mL with the same solvent.

*Reference solution*. Dissolve 10 mg of lactobionic acid CRS in *water R* and dilute to 1 mL with the same solvent.

*Plate*: TLC silica gel plate R.

*Mobile phase*: concentrated ammonia R1, ethyl acetate R, water R, methanol R (2:2:2:4 V/V/V/V).

*Application*: 5  $\mu$ L.

*Development*: over 3/4 of the plate.

*Detection*: spray 3 times with ammonium molybdate solution R6 and heat in an oven at 110 °C for 15 min.

*Results*: the principal spot in the chromatogram obtained with the test solution is similar in position and colour to the principal spot in the chromatogram obtained with the reference solution.

**TESTS**

**Appearance of solution**. The solution is clear (2.2.1) and not more intensely coloured than reference solution Y<sub>5</sub> (2.2.2, Method II).

Dissolve 3.0 g in 25 mL of *water R*.

**Specific optical rotation** (2.2.7): +23.0 to +29.0 (anhydrous substance).

Dissolve 1.0 g in 80 mL of *water R* and dilute to 100.0 mL with the same solvent. Allow to stand for 24 h.

**Reducing sugars**: maximum 0.2 per cent, calculated as glucose.

Dissolve 5.0 g in 25 mL of *water R* with the aid of gentle heat. Cool and add 20 mL of *cupri-citric solution R* and a few glass beads. Heat so that boiling begins after 4 min and maintain boiling for 3 min. Cool rapidly and add 100 mL of a 2.4 per cent V/V solution of *glacial acetic acid R* and 20.0 mL of 0.025 M iodine. With continuous shaking, add 25 mL of a mixture of 6 volumes of *hydrochloric acid R* and 94 volumes of *water R* and, when the precipitate has dissolved, titrate the excess of iodine with 0.05 M sodium thiosulfate using 1 mL of *starch solution R*, added towards the end of the titration, as indicator. Not less than 12.8 mL of 0.05 M sodium thiosulfate is required.

**Heavy metals** (2.4.8): maximum 20 ppm.

1.0 g complies with limit test E. Prepare the reference solution using 2 mL of *lead standard solution (10 ppm Pb) R*.

**Water** (2.5.12): maximum 5.0 per cent, determined on 0.50 g. Use a mixture of 1 volume of *formamide R* and 2 volumes of *methanol R* as solvent.

**Total ash** (2.4.16): maximum 0.2 per cent.

**ASSAY**

Dissolve 0.350 g in 50 mL of *carbon dioxide-free water R*, previously heated to 30 °C. Immediately titrate with 0.1 M sodium hydroxide and determine the 2 equivalence points potentiometrically (2.2.20).

The first equivalence point ( $V_1$ ) corresponds to the acid form of lactobionic acid and the second equivalence point ( $V_2 - V_1$ ) corresponds to the  $\delta$ -lactone form.

1 mL of 0.1 M sodium hydroxide is equivalent to 35.83 mg of  $C_{12}H_{22}O_{12}$ .

1 mL of 0.1 M sodium hydroxide is equivalent to 34.03 mg of  $C_{12}H_{20}O_{11}$ .

The sum of the 2 results is expressed as a percentage content of lactobionic acid.

07/2009:1061

**LACTOSE, ANHYDROUS**

## Lactosum anhydricum

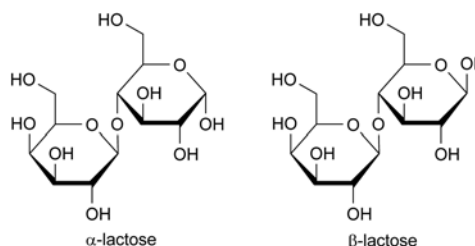
 $C_{12}H_{22}O_{11}$  $M_r$  342.3**DEFINITION**

*O*- $\beta$ -D-Galactopyranosyl-(1 $\rightarrow$ 4)- $\beta$ -D-glucopyranose or mixture of *O*- $\beta$ -D-galactopyranosyl-(1 $\rightarrow$ 4)- $\alpha$ -D-glucopyranose and *O*- $\beta$ -D-galactopyranosyl-(1 $\rightarrow$ 4)- $\beta$ -D-glucopyranose.



## CHARACTERS

*Appearance*: white or almost white, crystalline powder.

*Solubility*: freely but slowly soluble in water, practically insoluble in ethanol (96 per cent).

## IDENTIFICATION

*First identification*: A, D.

*Second identification*: B, C, D.

A. Infrared absorption spectrophotometry (2.2.24).

*Comparison*: anhydrous lactose CRS.

B. Thin-layer chromatography (2.2.27).

*Solvent mixture*: water R, methanol R (2:3 V/V).

*Test solution*. Dissolve 10 mg of the substance to be examined in the solvent mixture and dilute to 20 mL with the solvent mixture.

*Reference solution (a)*. Dissolve 10 mg of anhydrous lactose CRS in the solvent mixture and dilute to 20 mL with the solvent mixture.

*Reference solution (b)*. Dissolve 10 mg of anhydrous lactose CRS, 10 mg of fructose CRS, 10 mg of glucose CRS and 10 mg of sucrose CRS in the solvent mixture and dilute to 20 mL with the solvent mixture.

*Plate*: TLC silica gel G plate R.

*Mobile phase*: water R, methanol R, glacial acetic acid R, ethylene chloride R (10:15:25:50 V/V/V/V); measure the volumes accurately, as a slight excess of water produces cloudiness.

*Application*: 2 µL; thoroughly dry the points of application.

*Development A*: over a path of 15 cm.

*Drying A*: in a current of warm air.

*Development B*: immediately, over a path of 15 cm, after renewing the mobile phase.

*Drying B*: in a current of warm air.

*Detection*: spray with a solution of 0.5 g of thymol R in a mixture of 5 mL of sulfuric acid R and 95 mL of ethanol (96 per cent) R; heat at 130 °C for 10 min.

*System suitability*: reference solution (b):

– the chromatogram shows 4 clearly separated spots.

*Results*: the principal spot in the chromatogram obtained with the test solution is similar in position, colour and size to the principal spot in the chromatogram obtained with reference solution (a).

C. Dissolve 0.25 g in 5 mL of water R. Add 5 mL of ammonia R and heat in a water-bath at 80 °C for 10 min. A red colour develops.

D. Water (see Tests).

## TESTS

**Appearance of solution**. The solution is clear (2.2.1) and not more intensely coloured than reference solution BY<sub>7</sub> (2.2.2, Method II).

Dissolve 1.0 g in boiling water R and dilute to 10 mL with the same solvent.

**Acidity or alkalinity**. Dissolve 6.0 g by heating in 25 mL of carbon dioxide-free water R, cool and add 0.3 mL of phenolphthalein solution R1. The solution is colourless. Not more than 0.4 mL of 0.1 M sodium hydroxide is required to change the colour of the indicator to pink or red.

**Specific optical rotation** (2.2.7): + 54.4 to + 55.9 (anhydrous substance).

Dissolve 10.0 g in 80 mL of water R, heating to 50 °C. Allow to cool and add 0.2 mL of dilute ammonia R1. Allow to stand for 30 min and dilute to 100.0 mL with water R.

**Absorbance** (2.2.25).

*Test solution (a)*. Dissolve 1.0 g in boiling water R and dilute to 10.0 mL with the same solvent.

*Test solution (b)*. Dilute 1.0 mL of test solution (a) to 10.0 mL with water R.

*Spectral range*: 400 nm for test solution (a) and 210-300 nm for test solution (b).

*Results*:

- at 400 nm: maximum 0.04 for test solution (a);
- from 210 nm to 220 nm: maximum 0.25 for test solution (b);
- from 270 nm to 300 nm: maximum 0.07 for test solution (b).

**Heavy metals** (2.4.8): maximum 5 ppm.

2.0 g complies with test C. Prepare the reference solution using 1.0 mL of lead standard solution (10 ppm Pb) R.

**Water** (2.5.12): maximum 1.0 per cent, determined on 0.50 g, using a mixture of 1 volume of formamide R and 2 volumes of methanol R as the solvent.

**Sulfated ash** (2.4.14): maximum 0.1 per cent, determined on 1.0 g.

**Microbial contamination**

TAMC: acceptance criterion 10<sup>2</sup> CFU/g (2.6.12).

Absence of *Escherichia coli* (2.6.13).

## FUNCTIONALITY-RELATED CHARACTERISTICS

*This section provides information on characteristics that are recognised as being relevant control parameters for one or more functions of the substance when used as an excipient (see chapter 5.15). This section is a non-mandatory part of the monograph and it is not necessary to verify the characteristics to demonstrate compliance. Control of these characteristics can however contribute to the quality of a medicinal product by improving the consistency of the manufacturing process and the performance of the medicinal product during use. Where control methods are cited, they are recognised as being suitable for the purpose, but other methods can also be used. Wherever results for a particular characteristic are reported, the control method must be indicated.*

*The following characteristics may be relevant for anhydrous lactose used as a filler/diluent in solid dosage forms (compressed and powder).*

**Particle size distribution** (2.9.31 or 2.9.38).

**Bulk and tapped density** (2.9.34). Determine the bulk density and the tapped density. Calculate the Hausner index using the following expression:

$$\frac{V_0}{V_f}$$

$V_0$  = volume of bulk substance;

$V_f$  = volume of tapped substance.

**α-Lactose and β-lactose**. Gas chromatography (2.2.28).

*Silylation reagent*. Mix 28 volumes of *N*-trimethylsilylimidazole R and 72 volumes of pyridine R.

*Test solution*. Dissolve about 1 mg of the substance to be examined in 0.45 mL of dimethyl sulfoxide R. Add 1.8 mL of the silylation reagent. Mix gently and allow to stand for 20 min.

*Reference solution*. Prepare a mixture of α-lactose monohydrate R and β-lactose R having an anomeric ratio of about 1:1 based on the labelled anomeric contents of the α-lactose monohydrate and β-lactose. Dissolve about 1 mg of this mixture in 0.45 mL of dimethyl sulfoxide R. Add 1.8 mL of the silylation reagent. Mix gently and allow to stand for 20 min.

*Column*:

- *material*: glass;
  - *size*:  $l = 0.9$  m,  $\varnothing = 4$  mm;
  - *stationary phase*: silanised diatomaceous earth for gas chromatography R impregnated with 3 per cent *m/m* of poly[(cyanopropyl)(methyl)][(phenyl)(methyl)] siloxane R.
- Carrier gas*: helium for chromatography R.

Flow rate: 40 mL/min.

Temperature:

– column: 215 °C;

– injection port and detector: 275 °C.

Detection: flame ionisation.

Injection: 2 µL.

System suitability: reference solution:

– relative retention with reference to β-lactose:

α-lactose = about 0.7;

– resolution: minimum 3.0 between the peaks due to α-lactose and β-lactose.

Calculate the percentage content of α-lactose from the following expression:

$$\frac{100S_a}{S_a + S_b}$$

Calculate the percentage content of β-lactose from the following expression:

$$\frac{100S_b}{S_a + S_b}$$

$S_a$  = area of the peak due to α-lactose;

$S_b$  = area of the peak due to β-lactose.

**Loss on drying (2.2.32).** Determine on 1.000 g by drying in an oven at 80 °C for 2 h.

07/2009:0187

## LACTOSE MONOHYDRATE

### Lactosum monohydricum

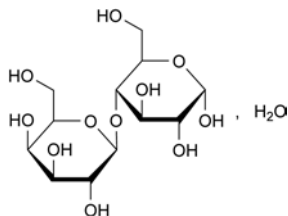

$C_{12}H_{22}O_{11} \cdot H_2O$

$M_r$  360.3

#### DEFINITION

O-β-D-Galactopyranosyl-(1→4)-α-D-glucopyranose monohydrate.

#### CHARACTERS

**Appearance:** white or almost white, crystalline powder.

**Solubility:** freely but slowly soluble in water, practically insoluble in ethanol (96 per cent).

#### IDENTIFICATION

**First identification:** A, D.

**Second identification:** B, C, D.

A. Infrared absorption spectrophotometry (2.2.24).

**Comparison:** lactose CRS.

B. Thin-layer chromatography (2.2.27).

**Solvent mixture:** water R, methanol R (2:3 V/V).

**Test solution.** Dissolve 10 mg of the substance to be examined in the solvent mixture and dilute to 20 mL with the solvent mixture.

**Reference solution (a).** Dissolve 10 mg of lactose CRS in the solvent mixture and dilute to 20 mL with the solvent mixture.

**Reference solution (b).** Dissolve 10 mg of fructose CRS, 10 mg of glucose CRS, 10 mg of lactose CRS and 10 mg of sucrose CRS in the solvent mixture and dilute to 20 mL with the solvent mixture.

**Plate:** TLC silica gel G plate R.

**Mobile phase:** water R, methanol R, glacial acetic acid R, ethylene chloride R (10:15:25:50 V/V/V/V); measure the volumes accurately, as a slight excess of water produces cloudiness.

**Application:** 2 µL; thoroughly dry the points of application.

**Development A:** over a path of 15 cm.

**Drying A:** in a current of warm air.

**Development B:** immediately, over a path of 15 cm, after renewing the mobile phase.

**Drying B:** in a current of warm air.

**Detection:** spray with a solution of 0.5 g of thymol R in a mixture of 5 mL of sulfuric acid R and 95 mL of ethanol (96 per cent) R; heat at 130 °C for 10 min.

**System suitability:** reference solution (b):

– the chromatogram shows 4 clearly separated spots.

**Results:** the principal spot in the chromatogram obtained with the test solution is similar in position, colour and size to the principal spot in the chromatogram obtained with reference solution (a).

C. Dissolve 0.25 g in 5 mL of water R. Add 5 mL of ammonia R and heat in a water-bath at 80 °C for 10 min. A red colour develops.

D. Water (see Tests).

#### TESTS

**Appearance of solution.** The solution is clear (2.2.1) and not more intensely coloured than reference solution BY<sub>7</sub> (2.2.2, Method II).

Dissolve 1.0 g in boiling water R and dilute to 10 mL with the same solvent.

**Acidity or alkalinity.** Dissolve 6.0 g by heating in 25 mL of carbon dioxide-free water R, cool and add 0.3 mL of phenolphthalein solution R1. The solution is colourless. Not more than 0.4 mL of 0.1 M sodium hydroxide is required to change the colour of the indicator to pink or red.

**Specific optical rotation (2.2.7):** + 54.4 to + 55.9 (anhydrous substance).

Dissolve 10.0 g in 80 mL of water R, heating to 50 °C. Allow to cool and add 0.2 mL of dilute ammonia R1. Allow to stand for 30 min and dilute to 100.0 mL with water R.

**Absorbance (2.2.25).**

**Test solution (a).** Dissolve 1.0 g in boiling water R and dilute to 10.0 mL with the same solvent.

**Test solution (b).** Dilute 1.0 mL of test solution (a) to 10.0 mL with water R.

**Spectral range:** 400 nm for test solution (a) and 210-300 nm for test solution (b).

**Results:**

- at 400 nm: maximum 0.04 for test solution (a);
- from 210 nm to 220 nm: maximum 0.25 for test solution (b);
- from 270 nm to 300 nm: maximum 0.07 for test solution (b).

**Heavy metals (2.4.8):** maximum 5 ppm.

Dissolve 4.0 g in water R with warming, add 1 mL of 0.1 M hydrochloric acid and dilute to 20 mL with water R. 12 mL of the solution complies with test A. Prepare the reference solution using lead standard solution (1 ppm Pb) R.

**Water (2.5.12):** 4.5 per cent to 5.5 per cent, determined on 0.50 g, using a mixture of 1 volume of formamide R and 2 volumes of methanol R as the solvent.

**Sulfated ash (2.4.14):** maximum 0.1 per cent, determined on 1.0 g.

#### Microbial contamination

TAMC: acceptance criterion 10<sup>2</sup> CFU/g (2.6.12).

Absence of *Escherichia coli* (2.6.13).

## STORAGE

In an airtight container.

## FUNCTIONALITY-RELATED CHARACTERISTICS

This section provides information on characteristics that are recognised as being relevant control parameters for one or more functions of the substance when used as an excipient (see chapter 5.15). This section is a non-mandatory part of the monograph and it is not necessary to verify the characteristics to demonstrate compliance. Control of these characteristics can however contribute to the quality of a medicinal product by improving the consistency of the manufacturing process and the performance of the medicinal product during use. Where control methods are cited, they are recognised as being suitable for the purpose, but other methods can also be used. Wherever results for a particular characteristic are reported, the control method must be indicated.

The following characteristics may be relevant for lactose monohydrate used as a filler/diluent in solid dosage forms (compressed and powder).

**Particle size distribution** (2.9.31 or 2.9.38).

**Bulk and tapped density** (2.9.34). Determine the bulk density and the tapped density. Calculate the Hausner Index using the following expression:

$$\frac{V_0}{V_f}$$

$V_0$  = volume of bulk substance;

$V_f$  = volume of tapped substance.

01/2009:1230

## LACTULOSE

Lactulosum

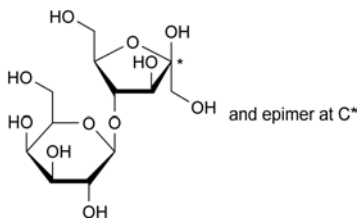

$C_{12}H_{22}O_{11}$   
[4618-18-2]

$M_r$  342.3

## DEFINITION

4-O-(β-D-Galactopyranosyl)-D-arabino-hex-2-ulofuranose.

**Content:** 95.0 per cent to 102.0 per cent (anhydrous substance).

## CHARACTERS

**Appearance:** white or almost white, crystalline powder.

**Solubility:** freely soluble in water, sparingly soluble in methanol, practically insoluble in toluene.

**mp:** about 168 °C.

## IDENTIFICATION

**First identification:** B, C, D, E.

**Second identification:** A, C, D, E.

**A.** Thin-layer chromatography (2.2.27).

**Test solution.** Dissolve 50.0 mg of the substance to be examined in *water R* and dilute to 10.0 mL with the same solvent.

**Reference solution.** Dissolve 50.0 mg of *lactulose CRS* in *water R* and dilute to 10.0 mL with the same solvent.

**Plate:** TLC silica gel G plate R.

**Mobile phase:** glacial acetic acid R, 50 g/L solution of boric acid R, methanol R, ethyl acetate R (10:15:20:55 V/V/V/V).

**Application:** 2 µL.

**Development:** over a path of 15 cm.

**Drying:** at 100-105 °C for 5 min and allow to cool.

**Detection:** spray with a 1.0 g/L solution of 1,3-dihydroxynaphthalene R in a mixture of 10 volumes of sulfuric acid R and 90 volumes of methanol R; heat at 110 °C for 5 min.

**Results:** the principal spot in the chromatogram obtained with the test solution is similar in position, colour and size to the principal spot in the chromatogram obtained with the reference solution.

**B.** Examine the chromatograms obtained in the assay.

**Results:** the principal peak in the chromatogram obtained with the test solution is similar in retention time and size to the principal peak in the chromatogram obtained with reference solution (b).

**C.** Dissolve 50 mg in 10 mL of *water R*. Add 3 mL of cupri-tartaric solution R and heat. A red precipitate is formed.

**D.** Dissolve 0.125 g in 5 mL of *water R*. Add 5 mL of ammonia R. Heat on a water-bath at 80 °C for 10 min. A red colour develops.

**E.** Specific optical rotation (see Tests).

## TESTS

**Solution S.** Dissolve 3.0 g in carbon dioxide-free water R and dilute to 50 mL with the same solvent.

**Appearance of solution.** Solution S is clear (2.2.1) and not more intensely coloured than reference solution BY<sub>5</sub> (2.2.2, Method II).

**pH** (2.2.3): 3.0 to 7.0.

To 10 mL of solution S add 0.1 mL of a saturated solution of potassium chloride R.

**Specific optical rotation** (2.2.7): –46.0 to –50.0 (anhydrous substance).

Dissolve 1.25 g in *water R*, add 0.2 mL of concentrated ammonia R and dilute to 25.0 mL with *water R*.

**Related substances.** Liquid chromatography (2.2.29).

**Test solution.** Dissolve 1.00 g of the substance to be examined in 10 mL of *water R*. Add 12.5 mL of acetonitrile R with gentle heating and dilute to 25.0 mL with *water R*.

**Reference solution (a).** To 3 mL of the test solution add 47.5 mL of acetonitrile R with gentle heating and dilute to 100.0 mL with *water R*.

**Reference solution (b).** Dissolve 1.00 g of *lactulose CRS* in 10 mL of *water R*. Add 12.5 mL of acetonitrile R with gentle heating and dilute to 25.0 mL with *water R*.

**Reference solution (c).** Dissolve the contents of a vial of *lactulose for system suitability CRS* in 1 mL of a mixture of equal volumes of acetonitrile R and *water R*.

**Precolumn:**

– **size:**  $l = 0.05$  m,  $\varnothing = 4.6$  mm;

– **stationary phase:** aminopropylsilyl silica gel for chromatography R (3 µm);

– **temperature:**  $38 \pm 1$  °C.

**Column:**

– **size:**  $l = 0.15$  m,  $\varnothing = 4.6$  mm;

– **stationary phase:** aminopropylsilyl silica gel for chromatography R (3 µm);

– **temperature:**  $38 \pm 1$  °C.

**Mobile phase:** dissolve 0.253 g of sodium dihydrogen phosphate R in 220 mL of *water R* and add 780 mL of acetonitrile R.

**Flow rate:** 1.0 mL/min.

**Detection:** refractometer maintained at a constant temperature.

**Injection:** 20 µL of the test solution and reference solutions (a) and (c).

**Run time:** 2.5 times the retention time of lactulose.

**Relative retention** with reference to lactulose (retention time = about 18.3 min): impurity E = about 0.38; impurity D = about 0.42; impurity B = about 0.57; impurity A = about 0.90; impurity C = about 1.17.

**System suitability:** reference solution (c):

- **resolution:** minimum 1.3 between the peaks due to lactulose and impurity A; if necessary, adjust the concentration of acetonitrile in the mobile phase to between 75.0 per cent V/V and 82.0 per cent V/V;
- the chromatogram obtained is similar to the chromatogram supplied with *lactulose for system suitability CRS*.

**Limit:**

- **sum of impurities A, B, C, D and E:** not more than the area of the peak due to lactulose in the chromatogram obtained with reference solution (a) (3 per cent).

**Methanol.** Head-space gas chromatography (2.2.28).

**Internal standard solution.** Mix 0.5 mL of *propanol R* with 100.0 mL of *water R*. Dilute 1.0 mL of this solution to 100.0 mL with *water R*. Dilute 5.0 mL of the solution to 50.0 mL with *water R*.

**Test solution.** To 79 mg of the substance to be examined in a 20 mL vial add 1.0 mL of the internal standard solution and 5 µL of a 0.1 per cent V/V solution of *methanol R*.

**Reference solution.** To 1.0 mL of the internal standard solution in a 20 mL vial add 5 µL of a 0.1 per cent V/V solution of *methanol R*.

**Column:**

- **size:**  $l = 2$  m,  $\varnothing = 2$  mm;
- **stationary phase:** ethylvinylbenzene-divinylbenzene copolymer R (180 µm).

**Carrier gas:** helium for chromatography R.

**Flow rate:** 30 mL/min.

**Static head-space conditions which may be used:**

- **equilibration temperature:** 60 °C;
- **equilibration time:** 1 h;
- **pressurisation time:** 1 min.

**Temperature:**

- **column:** 140 °C;
- **injection port:** 200 °C;
- **detector:** 220 °C.

**Detection:** flame ionisation.

**Injection:** 1 mL of the gaseous phase.

Calculate the content of methanol, taking its density (2.2.5) at 20 °C to be 0.79 g/mL.

**Limit:**

- **methanol:** calculate the ratio (*R*) of the area of the peak due to methanol to the area of the peak due to the internal standard in the chromatogram obtained with the reference solution; calculate the ratio of the area of the peak due to methanol to the area of the peak due to the internal standard in the chromatogram obtained with the test solution: this ratio is not greater than 2*R* (50 ppm).

**Boron:** maximum 9 ppm.

**Avoid where possible the use of glassware.**

**Reference solution.** Dissolve 50.0 mg of *boric acid R* in *water R* and dilute to 100.0 mL with the same solvent. Dilute 5.0 mL of this solution to 100.0 mL with *water R*. Keep in a well-closed polyethylene container.

In 4 polyethylene 25 mL flasks, place separately:

- 0.50 g of the substance to be examined dissolved in 2.0 mL of *water R* (solution A);

- 0.50 g of the substance to be examined dissolved in 1.0 mL of the reference solution and 1.0 mL of *water R* (solution B);
- 1.0 mL of the reference solution and 1.0 mL of *water R* (solution C);
- 2.0 mL of *water R* (solution D).

To each flask, add 4.0 mL of *acetate-edetate buffer solution pH 5.5 R*. Mix and add 4.0 mL of freshly prepared *azomethine H solution R*. Mix and allow to stand for 1 h. Measure the absorbance (2.2.25) of solutions A, B and C at 420 nm, using solution D as the compensation liquid. The test is not valid unless the absorbance of solution C is at least 0.25. The absorbance of solution B is not less than twice that of solution A.

**Lead (2.4.10):** maximum 0.5 ppm.

**Water (2.5.12):** maximum 2.5 per cent, determined on 0.500 g.

**Sulfated ash (2.4.14):** maximum 0.1 per cent, determined on 1.0 g.

**Microbial contamination**

TAMC: acceptance criterion  $10^2$  CFU/g (2.6.12).

Absence of *Escherichia coli* (2.6.13).

**ASSAY**

Liquid chromatography (2.2.29) as described in the test for related substances with the following modification.

**Injection:** test solution and reference solution (b).

Calculate the percentage content of  $C_{12}H_{22}O_{11}$  from the declared content of *lactulose CRS*.

**IMPURITIES**

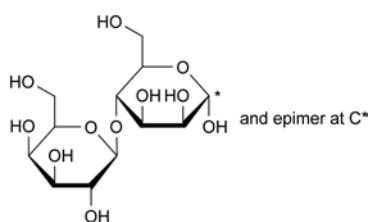

A. 4-*O*-(β-D-galactopyranosyl)-D-mannopyranose (epilactose),

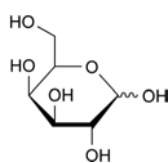

B. D-galactopyranose (galactose),

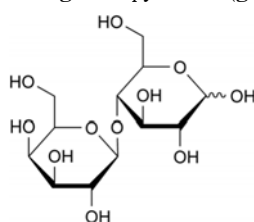

C. *O*-β-D-galactopyranosyl-(1→4)-β-D-glucopyranose or mixture of *O*-β-D-galactopyranosyl-(1→4)-α-D-glucopyranose and *O*-β-D-galactopyranosyl-(1→4)-β-D-glucopyranose (lactose),

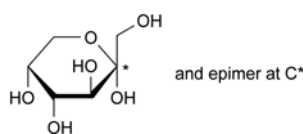

D. (-)-D-*arabino*-hex-2-ulopyranose (fructose),

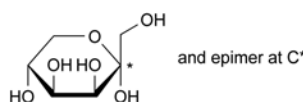

E. D-*lyxo*-hex-2-ulopyranose (tagatose).

01/2009:0924 *Reference solution (a).* To 5 mL of the test solution, add 47.5 mL of *acetonitrile R* with gentle heating and dilute to 100.0 mL with *water R*.

## LACTULOSE, LIQUID

### Lactulosum liquidum

#### DEFINITION

Aqueous solution of 4-*O*-(β-D-galactopyranosyl)-D-*arabino*-hex-2-ulofuranose normally prepared by alkaline isomerisation of lactose. It may contain lesser amounts of other sugars including lactose, epilactose, galactose, tagatose and fructose.

*Content:* minimum 620 g/L of lactulose (C<sub>12</sub>H<sub>22</sub>O<sub>11</sub>; *M<sub>r</sub>* 342.3) and 95.0 per cent to 105.0 per cent of the content of lactulose stated on the label.

It may contain a suitable antimicrobial preservative.

#### CHARACTERS

*Appearance:* clear, viscous liquid, colourless or pale brownish-yellow.

*Solubility:* miscible with water. It may be a supersaturated solution or may contain crystals that disappear on heating.

A 10 per cent *V/V* solution is laevorotatory.

#### IDENTIFICATION

*First identification:* B, C, D.

*Second identification:* A, C, D.

A. Thin-layer chromatography (2.2.27).

*Test solution.* Dilute 0.50 g of the substance to be examined to 50 mL with *water R*.

*Reference solution.* Dissolve 60 mg of *lactulose CRS* in *water R* and dilute to 10 mL with the same solvent.

*Plate:* TLC silica gel G plate R.

*Mobile phase:* glacial acetic acid R, 50 g/L solution of boric acid R, methanol R, ethyl acetate R (10:15:20:55 *V/V/V/V*).

*Application:* 2 µL.

*Development:* over a path of 15 cm.

*Drying:* at 100-105 °C for 5 min and allow to cool.

*Detection:* spray with a 1.0 g/L solution of 1,3-dihydroxynaphthalene R in a mixture of 10 volumes of sulfuric acid R and 90 volumes of methanol R; heat at 110 °C for 5 min.

*Results:* the principal spot in the chromatogram obtained with the test solution is similar in position, colour and size to the principal spot in the chromatogram obtained with the reference solution.

B. Examine the chromatograms obtained in the assay.

*Results:* the principal peak in the chromatogram obtained with the test solution is similar in retention time to the principal peak in the chromatogram obtained with reference solution (b).

C. To 0.1 g add 10 mL of *water R* and 3 mL of *cupri-tartaric solution R* and heat. A red precipitate is formed.

D. To 0.25 g add 5 mL of *water R* and 5 mL of *ammonia R*. Heat in a water-bath at 80 °C for 10 min. A red colour develops.

#### TESTS

**Solution S.** Mix 10 g with *carbon dioxide-free water R* and dilute to 100 mL with the same solvent.

**Appearance of solution.** Solution S is clear (2.2.1) and not more intensely coloured than reference solution BY<sub>5</sub> (2.2.2, Method II).

**pH** (2.2.3): 3.0 to 7.0.

To 10 mL of solution S, add 0.1 mL of a saturated solution of *potassium chloride R*.

**Related substances.** Liquid chromatography (2.2.29).

*Test solution.* Mix 4.00 g of the substance to be examined with 20 mL of *water R*. Add 25.0 mL of *acetonitrile R* with gentle heating and dilute to 50.0 mL with *water R*.

*Reference solution (b).* Dissolve 2.00 g of *lactulose CRS* in 20 mL of *water R*. Add 25.0 mL of *acetonitrile R* with gentle heating and dilute to 50.0 mL with *water R*.

*Reference solution (c).* Dissolve the contents of a vial of *lactulose for system suitability CRS* in 1 mL of a mixture of equal volumes of *acetonitrile R* and *water R*.

*Precolumn:*

– *size:* *l* = 0.05 m, Ø = 4.6 mm;

– *stationary phase:* aminopropylsilyl silica gel for chromatography R (3 µm);

– *temperature:* 38 ± 1 °C.

*Column:*

– *size:* *l* = 0.15 m, Ø = 4.6 mm;

– *stationary phase:* aminopropylsilyl silica gel for chromatography R (3 µm);

– *temperature:* 38 ± 1 °C.

*Mobile phase:* dissolve 0.253 g of *sodium dihydrogen phosphate R* in 220 mL of *water R* and add 780 mL of *acetonitrile R*.

*Flow rate:* 1.0 mL/min.

*Detection:* refractometer maintained at a constant temperature.

*Injection:* 20 µL of the test solution and reference solutions (a) and (c).

*Run time:* 2.5 times the retention time of lactulose.

*Relative retention* with reference to lactulose (retention time = about 18 min): impurity E = about 0.38; impurity D = about 0.42; impurity B = about 0.57; impurity A = about 0.90; impurity C = about 1.17.

*System suitability:* reference solution (c):

– *resolution:* minimum 1.3 between the peaks due to lactulose and impurity A; if necessary, adjust the concentration of acetonitrile in the mobile phase to between 75.0 per cent *V/V* and 82.0 per cent *V/V*;

– the chromatogram obtained is similar to the chromatogram supplied with *lactulose for system suitability CRS*.

*Limits:*

– *impurity B:* not more than 3 times the area of the peak due to lactulose in the chromatogram obtained with reference solution (a) (15 per cent);

– *impurities A, C:* for each impurity, not more than twice the area of the peak due to lactulose in the chromatogram obtained with reference solution (a) (10 per cent);

– *impurity E:* not more than 0.8 times the area of the peak due to lactulose in the chromatogram obtained with reference solution (a) (4 per cent);

– *impurity D:* not more than 0.2 times the area of the peak due to lactulose in the chromatogram obtained with reference solution (a) (1 per cent).

**Methanol.** Head-space gas chromatography (2.2.28).

*Internal standard solution.* Mix 0.5 mL of *propanol R* with 100.0 mL of *water R*. Dilute 1.0 mL of this solution to 100.0 mL with *water R*. Dilute 5.0 mL of the solution to 50.0 mL with *water R*.

*Test solution.* To 0.13 g of the substance to be examined in a 20 mL vial add 1.0 mL of the internal standard solution and 5 µL of a 0.1 per cent *V/V* solution of *methanol R*.

*Reference solution.* To 1.0 mL of the internal standard solution in a 20 mL vial add 5 µL of a 0.1 per cent *V/V* solution of *methanol R*.

*Column:*

– *size:* *l* = 2 m, Ø = 2 mm;

– *stationary phase:* ethylvinylbenzene-divinylbenzene copolymer R (180 µm).

Carrier gas: helium for chromatography R.

Flow rate: 30 mL/min.

Static head-space conditions which may be used:

- equilibration temperature: 60 °C;
- equilibration time: 1 h;
- pressurisation time: 1 min.

Temperature:

- column: 140 °C;
- injection port: 200 °C;
- detector: 220 °C.

Detection: flame ionisation.

Injection: 1 mL of the gaseous phase.

Calculate the content of methanol, taking its density (2.2.5) at 20 °C to be 0.79 g/mL.

Limit:

- **methanol**: calculate the ratio (*R*) of the area of the peak due to methanol to the area of the peak due to the internal standard in the chromatogram obtained with the reference solution; calculate the ratio of the area of the peak due to methanol to the area of the peak due to the internal standard in the chromatogram obtained with the test solution: this ratio is not greater than 2*R* (30 ppm).

**Sulfites**: maximum 30 ppm.

Mix 5.0 g with 40 mL of water R, add 2.0 mL of 0.1 M sodium hydroxide and dilute to 100 mL with water R. To 10.0 mL of this solution, add 1.0 mL of hydrochloric acid R1, 2.0 mL of decolorised fuchsin solution R1 and 2.0 mL of a 0.5 per cent V/V solution of formaldehyde R. Allow to stand for 30 min and measure the absorbance (2.2.25) at 583 nm using as the compensation liquid a solution prepared at the same time and in the same manner with 10.0 mL of water R instead of the solution of the substance to be examined. The absorbance is not greater than that of a reference solution prepared at the same time and in the same manner using 10.0 mL of sulfite standard solution (1.5 ppm SO<sub>2</sub>) R instead of the solution of the substance to be examined.

**Boron**: maximum 5 ppm.

Avoid where possible the use of glassware.

**Reference solution.** Dissolve 56.0 mg of boric acid R in water R and dilute to 100.0 mL with the same solvent. Dilute 5.0 mL of this solution to 100.0 mL with water R. Keep in a well-closed polyethylene container.

In 4 polyethylene 25 mL flasks, place separately:

- 1.00 g of the substance to be examined and 1 mL of water R (solution A);
- 1.00 g of the substance to be examined and 1 mL of the reference solution (solution B);
- 1 mL of the reference solution and 1 mL of water R (solution C);
- 2 mL of water R (solution D).

To each flask, add 4.0 mL of acetate-edetate buffer solution pH 5.5 R. Mix and add 4.0 mL of freshly prepared azomethine H solution R. Mix and allow to stand for 1 h. Measure the absorbance (2.2.25) of solutions A, B and C at 420 nm, using solution D as the compensation liquid. The test is not valid unless the absorbance of solution C is at least 0.25. The absorbance of solution B is not less than twice that of solution A.

**Lead (2.4.10)**: maximum 0.5 ppm, calculated with reference to the declared content of lactulose.

**Sulfated ash (2.4.14)**: maximum 0.2 per cent, determined on 1.5 g and calculated with reference to the declared content of lactulose.

**Microbial contamination**

TAMC: acceptance criterion 10<sup>2</sup> CFU/g (2.6.12).

TYMC: acceptance criterion 10<sup>1</sup> CFU/g (2.6.12).

Absence of *Escherichia coli* (2.6.13).

ASSAY

Liquid chromatography (2.2.29) as described in the test for related substances with the following modification.

**Injection**: test solution and reference solution (b).

Calculate the percentage content of C<sub>12</sub>H<sub>22</sub>O<sub>11</sub> from the declared content of lactulose CRS.

LABELLING

The label states the declared content of lactulose.

IMPURITIES

Specified impurities: A, B, C, D, E.

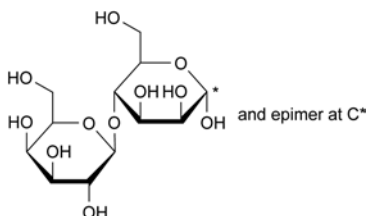

A. 4-O-(β-D-galactopyranosyl)-D-mannopyranose (epilactose),

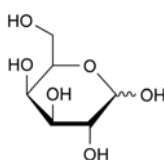

B. D-galactopyranose (galactose),

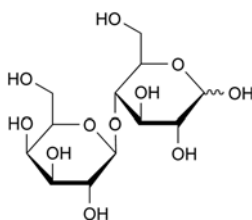

C. O-β-D-galactopyranosyl-(1→4)-β-D-glucopyranose or mixture of O-β-D-galactopyranosyl-(1→4)-α-D-glucopyranose and O-β-D-galactopyranosyl-(1→4)-β-D-glucopyranose (lactose),

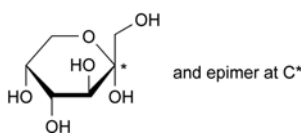

D. (-)-D-arabino-hex-2-ulopyranose (fructose),

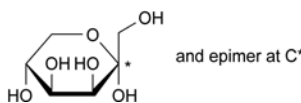

E. D-lyxo-hex-2-ulopyranose (tagatose).

01/2008:2217

## LAMIVUDINE

### Lamivudinum

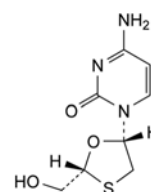

C<sub>8</sub>H<sub>11</sub>N<sub>3</sub>O<sub>3</sub>S  
[134678-17-4]

M<sub>r</sub> 229.3

## DEFINITION

4-Amino-1-[(2*R*,5*S*)-2-(hydroxymethyl)-1,3-oxathiolan-5-yl]pyrimidin-2(1*H*)-one.

*Content*: 97.5 per cent to 102.0 per cent (dried substance).

## CHARACTERS

*Appearance*: white or almost white powder.

*Solubility*: soluble in water, sparingly soluble in methanol, slightly soluble in ethanol (96 per cent).

It shows polymorphism (5.9).

## IDENTIFICATION

*First identification*: B, C.

*Second identification*: A, B.

A. Specific optical rotation (2.2.7):  $-97$  to  $-99$  (dried substance).

Dissolve 0.250 g in *water R* and dilute to 50.0 mL with the same solvent.

B. Infrared absorption spectrophotometry (2.2.24).

*Comparison*: lamivudine CRS.

If the spectra obtained in the solid state show differences, dissolve the substance to be examined and the reference substance separately in *methanol R*, evaporate to dryness and record new spectra using the residues.

C. Enantiomeric purity (see Tests).

## TESTS

**Absorbance** (2.2.25): maximum 0.3 at 440 nm, using a path length of 4 cm.

Dissolve 1.00 g in *water R*, using sonication if necessary, and dilute to 20.0 mL with the same solvent.

**Related substances**. Liquid chromatography (2.2.29).

*Test solution*. Dissolve 50.0 mg of the substance to be examined in the mobile phase and dilute to 100.0 mL with the mobile phase.

*Reference solution (a)*. Dilute 1.0 mL of the test solution to 100.0 mL with the mobile phase. Dilute 1.0 mL of this solution to 10.0 mL with the mobile phase.

*Reference solution (b)*. Dissolve 5 mg of *salicylic acid R* in the mobile phase and dilute to 100.0 mL with the mobile phase. Dilute 1.0 mL of the solution to 100.0 mL with the mobile phase.

*Reference solution (c)*. Dissolve 50.0 mg of lamivudine CRS in the mobile phase and dilute to 100.0 mL with the mobile phase.

*Reference solution (d)*. Dissolve 5 mg of *cytosine R* and 5 mg of *uracil R* in the mobile phase and dilute to 100.0 mL with the mobile phase. Dilute 2.0 mL of this solution to 10.0 mL with the mobile phase.

*Reference solution (e)*. Dissolve 5 mg of lamivudine for system suitability 1 CRS (containing impurities A and B) in 2 mL of mobile phase. Add 1.0 mL of reference solution (d) and dilute to 10.0 mL with the mobile phase.

*Column*:

- *size*:  $l = 0.25$  m,  $\varnothing = 4.6$  mm,
- *stationary phase*: base-deactivated octadecylsilyl silica gel for chromatography R (5  $\mu$ m),
- *temperature*: 35 °C.

*Mobile phase*: mix 5 volumes of *methanol R* and 95 volumes of a 1.9 g/L solution of *ammonium acetate R*, previously adjusted to pH 3.8 with *glacial acetic acid R*.

*Flow rate*: 1.0 mL/min.

*Detection*: spectrophotometer at 277 nm.

*Injection*: 10  $\mu$ L.

*Run time*: 3 times the retention time of lamivudine.

*Identification of impurities*: use the chromatograms obtained with reference solutions (e) and (b) to identify the peaks due to impurities A, B, E, F and C.

*Relative retention* with reference to lamivudine (retention time = about 9 min): impurity E = about 0.28; impurity F = about 0.32; impurity A = about 0.36; impurity B = about 0.91; impurity J = about 1.45; impurity C = about 2.32.

*System suitability*: reference solution (e):

- *resolution*: minimum 1.5 between the peaks due to impurity F and impurity A; minimum 1.5 between the peaks due to impurity B and lamivudine.

*Limits*:

- *correction factors*: for the calculation of content, multiply the peak areas of the following impurities by the corresponding correction factor: impurity E = 0.6; impurity F = 2.2; impurity J = 2.2;
- *impurity A*: not more than 3 times the area of the principal peak in the chromatogram obtained with reference solution (a) (0.3 per cent);
- *impurity B*: not more than twice the area of the principal peak in the chromatogram obtained with reference solution (a) (0.2 per cent);
- *impurity C*: not more than the area of the principal peak in the chromatogram obtained with reference solution (b) (0.1 per cent);
- *any other impurity*: for each impurity, not more than the area of the principal peak in the chromatogram obtained with reference solution (a) (0.1 per cent);
- *total*: not more than 6 times the area of the principal peak in the chromatogram obtained with reference solution (a) (0.6 per cent);
- *disregard limit*: 0.5 times the area of the principal peak in the chromatogram obtained with reference solution (a) (0.05 per cent).

**Enantiomeric purity**. Liquid chromatography (2.2.29): use the normalisation procedure.

*Test solution*. Dissolve 25.0 mg of the substance to be examined in *water R* and dilute to 100.0 mL with the same solvent.

*Reference solution*. Dissolve the contents of a vial of lamivudine for system suitability 2 CRS (containing impurity D) in 1.0 mL of *water R*.

*Column*:

- *size*:  $l = 0.25$  m,  $\varnothing = 4.6$  mm,
- *stationary phase*: silica gel BC for chiral chromatography R,
- *temperature*: maintain at constant temperature between 15 °C and 30 °C; the temperature may be adjusted to optimise the resolution between lamivudine and impurity D; a lower temperature favours improved resolution.

*Mobile phase*: mix 5 volumes of *methanol R* and 95 volumes of a 7.7 g/L solution of *ammonium acetate R*.

*Flow rate*: 1.0 mL/min.

*Detection*: spectrophotometer at 270 nm.

*Injection*: 10  $\mu$ L.

*Run time*: twice the retention time of lamivudine.

*Relative retention* with reference to lamivudine (retention time = about 8 min): impurity D = about 1.2; impurity B and enantiomer = about 1.3 and 1.5.

*System suitability*: reference solution:

- *peak-to-valley-ratio*: minimum 15, where  $H_p$  = height above the baseline of the peak due to impurity D and  $H_v$  = height above the baseline of the lowest point of the curve separating this peak from the peak due to lamivudine.

Calculate the sum of the percentage contents of all impurity peaks with a relative retention from 1.2 to 1.5. Subtract the percentage content of impurity B as obtained in the test for related substances.

*Limit*:

- *impurity D*: maximum 0.3 per cent.

**Heavy metals** (2.4.8): maximum 20 ppm.

1.0 g complies with test F. Prepare the reference solution using 2 mL of *lead standard solution* (10 ppm Pb) R.

**Loss on drying** (2.2.32): maximum 0.5 per cent, determined on 1.000 g by drying in an oven at 105 °C.

**Sulfated ash** (2.4.14): maximum 0.1 per cent, determined on 1.0 g.

#### ASSAY

Liquid chromatography (2.2.29) as described in the test for related substances with the following modification.

*Injection*: test solution and reference solution (c).

Calculate the percentage content of  $C_8H_{11}N_3O_3S$  using the chromatograms obtained with the test solution and reference solution (c) and the declared content of  $C_8H_{11}N_3O_3S$  in *lamivudine CRS*.

#### STORAGE

Protected from light.

#### IMPURITIES

*Specified impurities*: A, B, C, D.

*Other detectable impurities* (the following substances would, if present at a sufficient level, be detected by one or other of the tests in the monograph. They are limited by the general acceptance criterion for other/unspecified impurities and/or by the general monograph *Substances for pharmaceutical use* (2034). It is therefore not necessary to identify these impurities for demonstration of compliance. See also 5.10. *Control of impurities in substances for pharmaceutical use*): E, F, G, H, I, J.

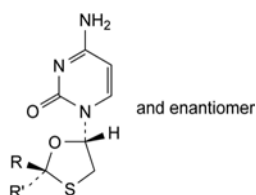

- A. R = H, R' = CO<sub>2</sub>H: (2*RS*,5*SR*)-5-(4-amino-2-oxopyrimidin-1(2*H*)-yl)-1,3-oxathiolane-2-carboxylic acid,
- B. R = CH<sub>2</sub>OH, R' = H: 4-amino-1-[(2*RS*,5*RS*)-2-(hydroxymethyl)-1,3-oxathiolan-5-yl]pyrimidin-2(1*H*)-one ((±)-*trans*-lamivudine),

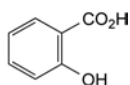

- C. 2-hydroxybenzenecarboxylic acid (salicylic acid),

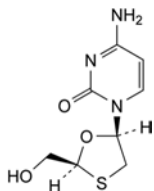

- D. 4-amino-1-[(2*S*,5*R*)-2-(hydroxymethyl)-1,3-oxathiolan-5-yl]pyrimidin-2(1*H*)-one,

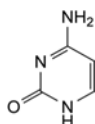

- E. 4-aminopyrimidin-2(1*H*)-one (cytosine),

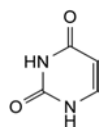

- F. pyrimidine-2,4(1*H*,3*H*)-dione (uracil),

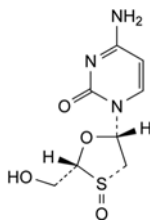

- G. 4-amino-1-[(2*R*,3*S*,5*S*)-2-(hydroxymethyl)-1,3-oxathiolan-5-yl]pyrimidin-2(1*H*)-one *S*-oxide,

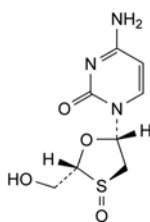

- H. 4-amino-1-[(2*R*,3*R*,5*S*)-2-(hydroxymethyl)-1,3-oxathiolan-5-yl]pyrimidin-2(1*H*)-one *S*-oxide,

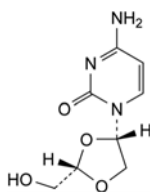

- I. 4-amino-1-[(2*S*,4*S*)-2-(hydroxymethyl)-1,3-dioxolan-4-yl]pyrimidin-2(1*H*)-one,

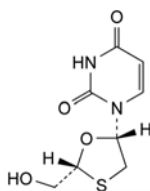

- J. 1-[(2*R*,5*S*)-2-(hydroxymethyl)-1,3-oxathiolan-5-yl]pyrimidine-2,4(1*H*,3*H*)-dione.

01/2009:1756  
corrected 6.6

## LAMOTRIGINE

### Lamotriginum

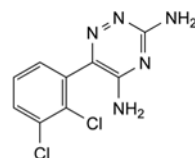

$C_9H_7Cl_2N_5$   
[84057-84-1]

$M_r$  256.1

#### DEFINITION

6-(2,3-Dichlorophenyl)-1,2,4-triazine-3,5-diamine.

*Content*: 99.0 per cent to 101.0 per cent (dried substance).

#### CHARACTERS

*Appearance*: white or almost white powder.



**Solubility:** very slightly soluble in water, slightly soluble in anhydrous ethanol.

#### IDENTIFICATION

Infrared absorption spectrophotometry (2.2.24).

**Comparison:** lamotrigine CRS.

#### TESTS

**Related substances.** Liquid chromatography (2.2.29).

**Test solution.** Dissolve 20 mg of the substance to be examined in 5 mL of methanol R and dilute to 100.0 mL with a 10.3 g/L solution of hydrochloric acid R.

**Reference solution (a).** Dissolve 5 mg of lamotrigine for system suitability CRS (containing impurity G) in 2.5 mL of methanol R and dilute to 50.0 mL with a 10.3 g/L solution of hydrochloric acid R. Dilute 1.0 mL of this solution to 10.0 mL with a 10.3 g/L solution of hydrochloric acid R.

**Reference solution (b).** Dilute 1.0 mL of the test solution to 100.0 mL with a 10.3 g/L solution of hydrochloric acid R. Dilute 2.0 mL of this solution to 10.0 mL with a 10.3 g/L solution of hydrochloric acid R.

**Reference solution (c).** Dissolve 5.0 mg of lamotrigine impurity E CRS in a mixture of 0.25 mL of hydrochloric acid R and 45 mL of methanol R and dilute to 50.0 mL with methanol R. Dilute 5.0 mL of the solution to 100.0 mL with a 10.3 g/L solution of hydrochloric acid R. To 4.0 mL of this solution add 5 mL of methanol R and dilute to 100.0 mL with a 10.3 g/L solution of hydrochloric acid R.

**Reference solution (d).** Dissolve 10 mg of lamotrigine for peak identification CRS (containing impurities A, E and F) in 2.5 mL of methanol R and dilute to 50.0 mL with a 10.3 g/L solution of hydrochloric acid R.

**Blank solution.** Mix 5 volumes of methanol R and 95 volumes of a 10.3 g/L solution of hydrochloric acid R.

**Column:**

- size:  $l = 0.15$  m,  $\varnothing = 4.6$  mm;
- stationary phase: base-deactivated end-capped octadecylsilyl silica gel for chromatography R (5  $\mu$ m);
- temperature: 35 °C.

**Mobile phase:**

- mobile phase A: mix 1 volume of triethylamine R and 150 volumes of a 2.7 g/L solution of potassium dihydrogen phosphate R; adjust to pH 2.0 with phosphoric acid R;
- mobile phase B: acetonitrile R;

Time (min)	Mobile phase A (per cent V/V)	Mobile phase B (per cent V/V)
0 - 4	85	15
4 - 14	85 → 20	15 → 80

**Flow rate:** 1.0 mL/min.

**Detection:** spectrophotometer at 270 nm.

**Injection:** 10  $\mu$ L of the test solution, reference solutions (a), (b) and (d) and the blank solution.

**Identification of impurities:** use the chromatogram supplied with lamotrigine for peak identification CRS and the chromatogram obtained with reference solution (d) to identify the peaks due to impurities A, E and F; use the chromatogram supplied with lamotrigine for system suitability CRS and the chromatogram obtained with reference solution (a) to identify the peak due to impurity G.

**Relative retention** with reference to lamotrigine (retention time = about 7 min): impurity G = about 1.1; impurity A = about 1.3; impurity E = about 1.7; impurity F = about 1.8.

**System suitability:** reference solution (a):

- peak-to-valley ratio: minimum 1.2, where  $H_p$  = height above the baseline due to impurity G and  $H_v$  = height above the baseline of the lowest point of the curve separating this peak from the peak due to lamotrigine.

**Limits:**

- correction factor: for the calculation of content, multiply the peak area of impurity F by 1.3;
- impurity F: not more than the area of the principal peak in the chromatogram obtained with reference solution (b) (0.2 per cent);
- impurities A, G: for each impurity, not more than 0.5 times the area of the principal peak in the chromatogram obtained with reference solution (b) (0.1 per cent);
- unspecified impurities: for each impurity, not more than 0.5 times the area of the principal peak in the chromatogram obtained with reference solution (b) (0.10 per cent);
- total: not more than the area of the principal peak in the chromatogram obtained with reference solution (b) (0.2 per cent);
- disregard limit: 0.25 times the area of the principal peak in the chromatogram obtained with reference solution (b) (0.05 per cent); disregard any peak due to the blank and any peak due to impurity E.

**Impurity E.** Liquid chromatography (2.2.29) as described in the test for related substances with the following modifications.

**Mobile phase:** acetonitrile for chromatography R, mobile phase A (35:65 V/V).

**Detection:** spectrophotometer at 210 nm.

**Injection:** test solution and reference solutions (d) and (c).

**Run time:** 10 min.

**Retention time:** impurity E = about 5.5 min; impurity F = about 8.5 min.

**System suitability:** reference solution (d):

- the chromatogram obtained is similar to the chromatogram supplied with lamotrigine for peak identification CRS.

**Limit:**

- impurity E: not more than the area of the corresponding peak in the chromatogram obtained with reference solution (c) (0.1 per cent).

**Heavy metals (2.4.8):** maximum 10 ppm.

To the residue obtained in the test for sulfated ash add 2 mL of hydrochloric acid R and evaporate slowly to dryness on a water-bath. Moisten the residue with 0.05 mL of hydrochloric acid R, add 10 mL of boiling water R and heat the mixture for 10 min on a water-bath. Allow to cool to room temperature, filter if necessary and adjust the volume of the filtrate and washings to 20 mL with water R. 12 mL of the solution complies with test A. Prepare the reference solution using 10 mL of lead standard solution (1 ppm Pb) R.

**Loss on drying (2.2.32):** maximum 0.5 per cent, determined on 2.000 g by drying in an oven at 105 °C at a pressure not exceeding 0.7 kPa for 3 h.

**Sulfated ash (2.4.14):** maximum 0.1 per cent, determined on 2.0 g.

#### ASSAY

Dissolve 0.200 g in 60 mL of anhydrous acetic acid R. Titrate with 0.1 M perchloric acid, determining the end-point potentiometrically (2.2.20). Carry out a blank titration.

1 mL of 0.1 M perchloric acid is equivalent to 25.61 mg of C<sub>9</sub>H<sub>7</sub>Cl<sub>2</sub>N<sub>5</sub>.

#### IMPURITIES

**Specified impurities:** A, E, F, G.

**Other detectable impurities** (the following substances would, if present at a sufficient level, be detected by one or other of the tests in the monograph. They are limited by the general

01/2010:2219

acceptance criterion for other/unspecified impurities and/or by the general monograph *Substances for pharmaceutical use (2034)*. It is therefore not necessary to identify these impurities for demonstration of compliance. See also 5.10. *Control of impurities in substances for pharmaceutical use*): B, C, D.

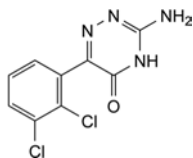

A. 3-amino-6-(2,3-dichlorophenyl)-1,2,4-triazin-5(4H)-one,

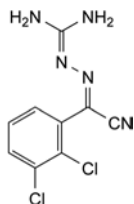

B. (2E)-[2-(diaminomethylidene)diazanylidene](2,3-dichlorophenyl)acetonitrile,

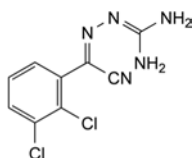

C. (2Z)-[2-(diaminomethylidene)diazanylidene](2,3-dichlorophenyl)acetonitrile,

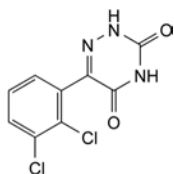

D. 6-(2,3-dichlorophenyl)-1,2,4-triazine-3,5(2H,4H)-dione,

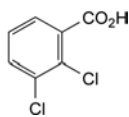

E. 2,3-dichlorobenzoic acid,

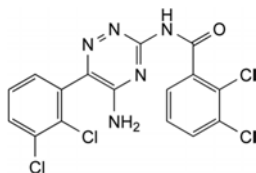

F. N-[5-amino-6-(2,3-dichlorophenyl)-1,2,4-triazin-3-yl]-2,3-dichlorobenzamide,

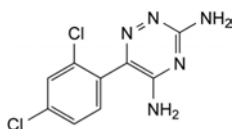

G. 6-(2,4-dichlorophenyl)-1,2,4-triazine-3,5-diamine.

## LANSOPRAZOLE

### Lansoprazolum

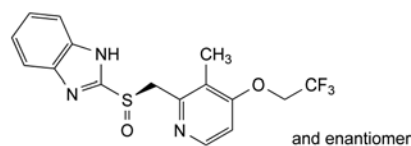

$C_{16}H_{14}F_3N_3O_2S$   
[103577-45-3]

$M_r$  369.4

#### DEFINITION

2-[(*RS*)-[[3-Methyl-4-(2,2,2-trifluoroethoxy)pyridin-2-yl]methyl]sulfinyl]-1*H*-benzimidazole.

*Content*: 99.0 per cent to 101.0 per cent (anhydrous substance).

#### CHARACTERS

*Appearance*: white or brownish powder.

*Solubility*: practically insoluble in water, soluble in anhydrous ethanol, very slightly soluble in acetonitrile.

It shows polymorphism (5.9).

#### IDENTIFICATION

Infrared absorption spectrophotometry (2.2.24).

*Comparison*: lansoprazole CRS.

If the spectra obtained in the solid state show differences, dissolve the substance to be examined and the reference substance separately in *anhydrous ethanol R*, evaporate to dryness and record new spectra using the residues.

#### TESTS

**Appearance of solution.** The solution is clear (2.2.1) and not more intensely coloured than reference solution B<sub>2</sub> or BY<sub>2</sub> (2.2.2, Method II).

Dissolve 1.0 g in *dimethylformamide R* and dilute to 20 mL with the same solvent.

**Related substances.** Liquid chromatography (2.2.29). Prepare the solutions immediately before use and protect them from light.

*Solvent mixture*: mix 1 volume of *triethylamine R* and 60 volumes of *water R* and adjust to pH 10.5 with *phosphoric acid R*; mix this solution with 40 volumes of *acetonitrile R1*.

*Test solution*. Dissolve 10 mg of the substance to be examined in the solvent mixture and dilute to 10 mL with the solvent mixture.

*Reference solution (a)*. Dissolve the contents of a vial of *lansoprazole for peak identification CRS* (containing impurities A and B) in 1.0 mL of the solvent mixture.

*Reference solution (b)*. Dilute 2.0 mL of the test solution to 100.0 mL with the solvent mixture. Dilute 1.0 mL of this solution to 10.0 mL with the solvent mixture.

*Reference solution (c)*. Dissolve 5 mg of *2-hydroxybenzimidazole R* (impurity D) and 5 mg of *2-mercaptobenzimidazole R* (impurity E) in the solvent mixture and dilute to 100 mL with the solvent mixture. Dilute 1 mL of this solution to 10 mL with the solvent mixture.

*Column*:

– size:  $l = 0.25$  m,  $\varnothing = 4.6$  mm;

– stationary phase: amidohexadecylsilyl silica gel for chromatography R (5  $\mu$ m).

*Mobile phase*: mix 1 volume of *triethylamine R* and 60 volumes of *water R* and adjust to pH 6.2 with *phosphoric acid R*; mix this solution with 40 volumes of *acetonitrile R1*.

*Flow rate*: 1.2 mL/min.

*Detection*: spectrophotometer at 285 nm.

**Injection:** 10 µL.

**Run time:** 3 times the retention time of lansoprazole.

**Identification of impurities:** use the chromatogram supplied with *lansoprazole for peak identification CRS* and the chromatogram obtained with reference solution (a) to identify the peaks due to impurities A and B; use the chromatogram obtained with reference solution (c) to identify the peaks due to impurities D and E.

**Relative retention** with reference to lansoprazole (retention time = about 7 min): impurity D = about 0.4; impurity A = about 0.5; impurity E = about 0.6; impurity B = about 1.2.

**System suitability:** reference solution (a):

- **resolution:** minimum 3.0 between the peaks due to lansoprazole and impurity B.

**Limits:**

- **correction factor:** for the calculation of content, multiply the peak area of impurity E by 0.4;
- **impurity B:** not more than twice the area of the principal peak in the chromatogram obtained with reference solution (b) (0.4 per cent);
- **impurities A, D, E:** for each impurity, not more than 0.5 times the area of the principal peak in the chromatogram obtained with reference solution (b) (0.1 per cent);
- **unspecified impurities:** for each impurity, not more than 0.5 times the area of the principal peak in the chromatogram obtained with reference solution (b) (0.10 per cent);
- **total:** not more than 3 times the area of the principal peak in the chromatogram obtained with reference solution (b) (0.6 per cent);
- **disregard limit:** 0.25 times the area of the principal peak in the chromatogram obtained with reference solution (b) (0.05 per cent).

**Water (2.5.32):** maximum 0.1 per cent, determined on 0.150-0.200 g using the evaporation technique:

- **temperature:** 50-70 °C;
- **heating time:** 15 min;
- **flow rate:** 150 mL/min.

**Sulfated ash (2.4.14):** maximum 0.1 per cent, determined on 1.0 g.

**ASSAY**

Dissolve 0.300 g in 40 mL of *ethanol (96 per cent) R* and dilute to 50 mL with *water R*. Titrate with 0.1 M sodium hydroxide, determining the end-point potentiometrically (2.2.20).

1 mL of 0.1 M sodium hydroxide is equivalent to 36.94 mg of C<sub>16</sub>H<sub>14</sub>F<sub>3</sub>N<sub>3</sub>O<sub>2</sub>S.

**STORAGE**

In an airtight container, protected from light.

**IMPURITIES**

**Specified impurities:** A, B, D, E.

**Other detectable impurities** (the following substances would, if present at a sufficient level, be detected by one or other of the tests in the monograph. They are limited by the general acceptance criterion for other/unspecified impurities and/or by the general monograph *Substances for pharmaceutical use (2034)*. It is therefore not necessary to identify these impurities for demonstration of compliance. See also 5.10. *Control of impurities in substances for pharmaceutical use*): C, F.

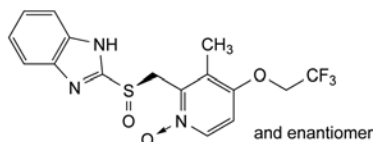

A. 2-[(RS)-[3-methyl-1-oxido-4-(2,2,2-trifluoroethoxy)pyridin-2-yl]methyl]sulfinyl]-1H-benzimidazole,

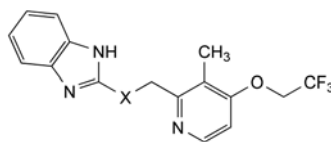

B. X = SO<sub>2</sub>: 2-[[[3-methyl-4-(2,2,2-trifluoroethoxy)pyridin-2-yl]methyl]sulfonyl]-1H-benzimidazole,

C. X = S: 2-[[[3-methyl-4-(2,2,2-trifluoroethoxy)pyridin-2-yl]methyl]sulfanyl]-1H-benzimidazole,

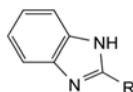

D. R = OH: 1H-benzimidazol-2-ol,

E. R = SH: 1H-benzimidazole-2-thiol,

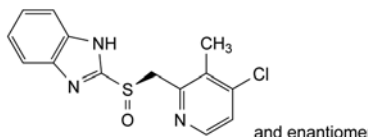

F. 2-[(RS)-[(4-chloro-3-methylpyridin-2-yl)methyl]sulfinyl]-1H-benzimidazole.

01/2009:2046  
corrected 7.0

**LAUROMACROGOL 400**

**Lauromacrogolum 400**

**DEFINITION**

Mixture of lauryl alcohol (dodecanol) monoethers of mixed macrogols. It may contain some free macrogols and it contains various amounts of free lauryl alcohol. The number of moles of ethylene oxide reacted per mole of lauryl alcohol is 9. The name of the substance is followed by a number (400) corresponding approximately to the average molecular mass of the macrogol portion.

This monograph applies to lauromacrogol 400 used as active substance.

**CHARACTERS**

**Appearance:** white or almost white, unctuous and hygroscopic mass, melting at 24 °C into a colourless or yellowish, viscous liquid.

**Solubility:** freely soluble in water, very soluble in acetone and in ethanol (96 per cent).

**IDENTIFICATION**

- A. Hydroxyl value (see Tests).
- B. Saponification value (see Tests).
- C. Warm the substance to be examined in an incubator at 50 °C for 1 h until fully molten and clear. Transfer 50 mL to a warmed cloud-point tube (flat-bottomed glass tube 30-33.5 mm in internal diameter and 115-125 mm high). Insert the tube into a cooling bath that allows the outer surface of the tube to be in contact with chilled air, contained within a cylindrical metal container (internal diameter 9.5-12.5 mm greater than the external diameter of the sample tube, 115 mm high) that is surrounded by iced water. The base of the glass tube rests on a 6 mm thick cork disc, which prevents direct thermal contact with the cooled metal cylinder. Stir the substance to be examined continuously with a thermometer so that the temperature is constant throughout the substance. Periodically lift the tube out of the cooling bath to check for signs of cloudiness at the bottom of the tube. Examine the tube against a bright light source. When cloudiness is first observed, check more frequently until the substance becomes completely

cloudy and the thermometer, suspended in the centre of the substance, is only just visible when viewed horizontally. Record the temperature. It is 20 °C to 25 °C.

## TESTS

**Appearance.** The molten substance to be examined is clear (2.2.1) and not more intensely coloured than reference solution GY<sub>6</sub> (2.2.2, Method I).

**Alkalinity.** Dissolve 2.0 g in a hot mixture of 10 mL of *carbon dioxide-free water R* and 10 mL of *ethanol (96 per cent) R*. Add 0.1 mL of *bromothymol blue solution RI*. Not more than 0.5 mL of 0.1 M *hydrochloric acid* is required to change the colour of the indicator to yellow.

**Acid value (2.5.1):** maximum 1.0, determined on 5.0 g.

**Hydroxyl value (2.5.3, Method A):** 90 to 105, determined on 0.35 g.

**Iodine value (2.5.4, Method A):** maximum 2.0.

**Peroxide value:** maximum 5.0.

Introduce 10.0 g into a 100 mL beaker, dissolve with *glacial acetic acid R* and dilute to 20 mL with the same solvent.

Add 1 mL of *saturated potassium iodide solution R*, mix and allow to stand for 1 min. Add 50 mL of *carbon dioxide-free water R*. Titrate with 0.01 M *sodium thiosulfate*, determining the end-point potentiometrically (2.2.20). Carry out a blank titration.

Determine the peroxide value using the following expression:

$$\frac{(n_1 - n_2) \times M \times 1000}{m}$$

$n_1$  = volume of 0.01 M *sodium thiosulfate* required for the substance to be examined, in millilitres;

$n_2$  = volume of 0.01 M *sodium thiosulfate* required for the blank titration, in millilitres;

$M$  = molarity of the sodium thiosulfate solution, in moles per litre;

$m$  = mass of the substance to be examined, in grams.

**Saponification value (2.5.6):** maximum 3.0.

**Free lauryl alcohol (dodecanol).** Gas chromatography (2.2.28).

**Test solution.** Dissolve 0.200 g of the substance to be examined in *acetone R* and dilute to 10.0 mL with the same solvent.

**Reference solution.** Dissolve 2.00 g of *lauryl alcohol R* in *acetone R* and dilute to 100.0 mL with the same solvent. Dilute 1.0 mL of this solution to 50.0 mL with *acetone R*.

**Column:**

- *material:* fused silica;
- *size:*  $l = 30$  m,  $\emptyset = 0.25$  mm;
- *stationary phase:* *poly(dimethyl)(diphenyl)siloxane R* (film thickness 0.1 µm).

**Carrier gas:** *helium for chromatography R*.

**Flow rate:** 1 mL/min.

**Split ratio:** 50:1.

**Temperature:**

	Time (min)	Temperature (°C)
Column	0 - 1	120
	1 - 23	120 → 350
	23 - 33	350
Injection port		300
Detector		350

**Detection:** flame ionisation.

**Injection:** 1.0 µL.

**Retention time:** lauryl alcohol = about 5 min.

**Limit:**

- *free lauryl alcohol:* not more than the area of the corresponding peak in the chromatogram obtained with the reference solution (2.0 per cent).

**Free macrogols.** Size-exclusion chromatography (2.2.30).

**Test solution.** Dissolve 5.0 g of the substance to be examined in the mobile phase and dilute to 250.0 mL with the mobile phase.

**Reference solution (a).** Dissolve about 0.4 g of *macrogol 1000 R* in the mobile phase and dilute to 250.0 mL with the mobile phase.

**Reference solution (b).** Dilute 50.0 mL of reference solution (a) to 100.0 mL with the mobile phase.

**Precolumns (2):**

- *size:*  $l = 0.125$  m,  $\emptyset = 4$  mm;
- *stationary phase:* spherical *octadecylsilyl silica gel for chromatography R* (5 µm) with a pore size of 10 nm.

**Column:**

- *size:*  $l = 0.30$  m,  $\emptyset = 7.8$  mm;
- *stationary phase:* *hydroxylated polymethacrylate gel R* (6 µm) with a pore size of 12 nm.

Connect both precolumns to the column using a 3-way valve and switch the mobile phase flow according to the following programme:

- 0-114 s: precolumn 1 and column;
- 115 s to the end: precolumn 2 and column;
- 115 s to 8 min: flow back of precolumn 1.

**Mobile phase:** *water R*, *methanol R* (2:8 V/V).

**Flow rate:** 1.1 mL/min.

**Detection:** refractometer.

**Injection:** 20 µL.

Calculate the percentage content of free macrogols using the following expression:

$$\frac{A_1 \times m_2 \times 200}{m_1 \times (A_2 + 2A_3)}$$

$m_1$  = mass of the substance to be examined in the test solution, in grams;

$m_2$  = mass of *macrogol 1000 R* in reference solution (a), in grams;

$A_1$  = area of the peak due to free macrogols in the chromatogram obtained with the test solution;

$A_2$  = area of the peak due to *macrogol 1000 R* in the chromatogram obtained with reference solution (a);

$A_3$  = area of the peak due to *macrogol 1000 R* in the chromatogram obtained with reference solution (b).

**Limit:**

- *free macrogols:* maximum 3.0 per cent.

**Average chain length of the fatty alcohol and average number of moles of ethylene oxide.** Nuclear magnetic resonance spectrometry (2.2.33).

**Test solution.** If the substance is in the solid state at room temperature, heat gently before sampling. Dissolve 0.4 mL of the substance to be examined in 0.3 mL of a mixture of 1 volume of *deuterated methanol R* and 2 volumes of *deuterated chloroform R*, containing 0.1 mol/L of *chromium(III) acetylacetonate R* as a relaxation aid.

**Apparatus:** high resolution FT-NMR spectrometer operating at minimum 300 MHz.

**Acquisition of <sup>13</sup>C NMR spectra.** The following parameters may be used:

- *sweep width:* 250 ppm (– 15 ppm to 235 ppm);
- *irradiation frequency offset:* 110 ppm;
- *time domain:* 64 K;
- *pulse delay:* 3 s;

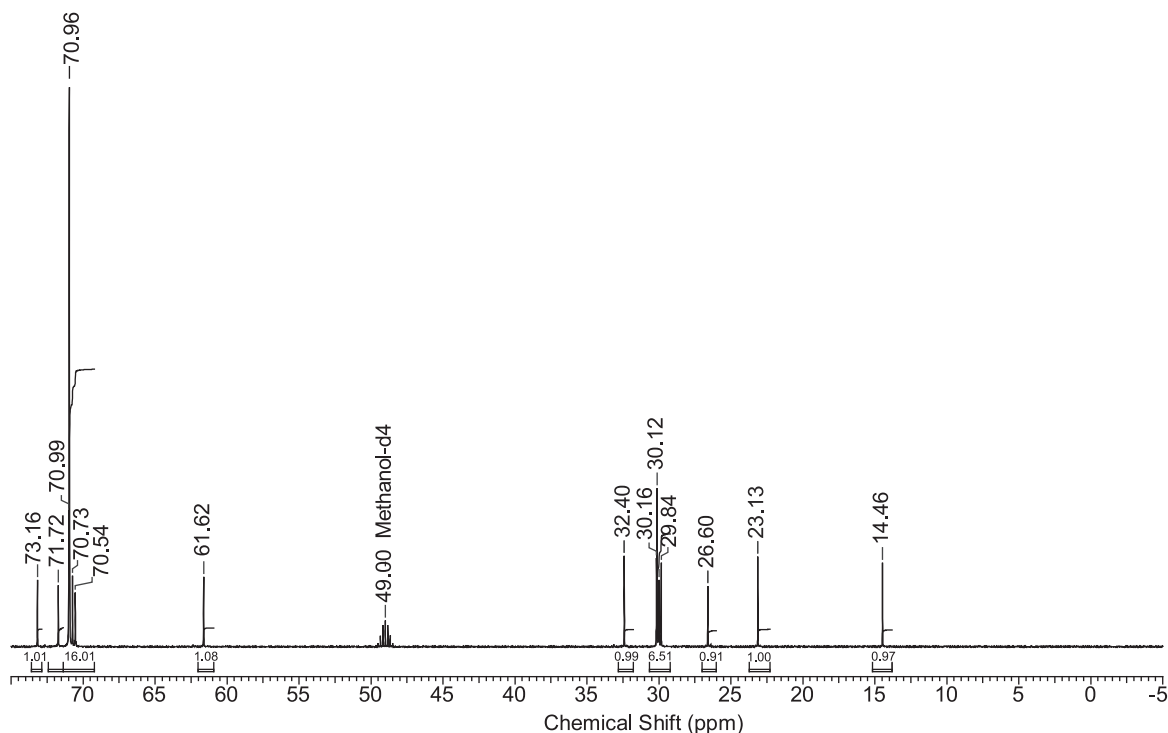

Figure 2046.-1. - <sup>13</sup>C NMR spectrum of lauromacrogol 400

- pulse program: zgig 30 (inverse gated, 30° excitation pulse);
- dummy scans: 4;
- number of scans: 2048.

Processing and plotting. The following parameters may be used:

- size: 64 K (zero-filling);
- window multiplication: exponential;
- Lorentzian broadening factor: 1 Hz.

Use the CD<sub>3</sub>OD signal for shift referencing. The shift of the central peak of the multiplet is set to 49.0 ppm.

Plot the spectral region δ 0.0-80.0 ppm. Compare the spectrum with the spectrum in Figure 2046.-1. The shift values lie near the values given in Table 2046.-1.

Table 2046.-1. - Shift values

Signal	Shift (ppm)	Normalised integrals
CH <sub>3</sub>	14.4	0.989
CH <sub>2</sub> (alkyl chain)	23.2	1.000
CH <sub>2</sub> (alkyl chain)	25.5	1.001
CH <sub>2</sub> 's (alkyl chain)	30	7.410
CH <sub>2</sub> (alkyl chain)	32.5	0.963
CH <sub>2</sub> (-CH <sub>2</sub> -OH) (end CH <sub>2</sub> -group of macrogol)	61.6	1.001
CH <sub>2</sub> 's (macrogol)	70.7	16.25
CH <sub>2</sub> (R-CH-O-macrogol) (CH <sub>2</sub> in alpha position)	72.6	0.998
CH <sub>2</sub> (macrogol)	73.1	0.929

System suitability:

- signal-to-noise ratio: minimum 150, for the smallest relevant peak (CH<sub>2</sub> at 73.1 ppm);
- peak width at half-height: maximum 0.05 ppm, for the central CDCl<sub>3</sub> signal (at δ 78.6 ppm).

Calculation of the average chain length of the fatty alcohol and the average number of moles of ethylene oxide: define the signal at 23.2 ppm as 1.000 and normalise the integrals of the other signals listed in Table 2046.-1.

The average chain length of the fatty alcohol is calculated using the following expression:

$$\frac{\sum_{14-33} I_{n,i} + I_{n,72.6}}{I_{n,72.6}}$$

$\sum_{14-33} I_{n,i}$  = sum of the normalised integrals of the signals from 14 ppm to 33 ppm;

$I_{n,72.6}$  = normalised integral of the signal at 72.6 ppm.

The average number of moles of ethylene oxide is calculated using the following expression:

$$0.5 \times (I_{n,62} + I_{n,71} + I_{n,73})$$

$I_{n,62}, I_{n,71}, I_{n,73}$  = normalised integral of the signals at 62 ppm, 71 ppm and 73 ppm respectively.

The sum of the normalised integrals of the signals at 62 ppm, 71 ppm and 73 ppm corresponds to the average number of methylene groups in the macrogol part of lauromacrogol 400.

Limits:

- average chain length of the fatty alcohol: 10.0 to 14.0;
- average number of moles of ethylene oxide: 7.0 to 11.0.

**Ethylene oxide and dioxan (2.4.25, Method A):** maximum 1 ppm of ethylene oxide and maximum 10 ppm of dioxan.

**Water (2.5.12):** maximum 2.0 per cent, determined on 0.500 g.

**Total ash (2.4.16):** maximum 0.2 per cent, determined on 2.0 g.

01/2008:1231

## LAUROYL MACROGOLGLYCERIDES

### Macrogolglyceridorum laurates

#### DEFINITION

Mixtures of monoesters, diesters and triesters of glycerol and monoesters and diesters of macrogols with a mean relative molecular mass between 300 and 1500.

They are obtained by partial alcoholysis of saturated oils mainly containing triglycerides of lauric (dodecanoic) acid, using macrogol, or by esterification of glycerol and macrogol

with saturated fatty acids, or by mixing glycerol esters and condensates of ethylene oxide with the fatty acids of these hydrogenated oils.

#### CHARACTERS

**Appearance:** pale yellow waxy solid.

**Solubility:** dispersible in hot water, freely soluble in methylene chloride.

#### IDENTIFICATION

##### A. Thin-layer chromatography (2.2.27).

**Test solution.** Dissolve 1.0 g of the substance to be examined in *methylene chloride R* and dilute to 20 mL with the same solvent.

**Plate:** *TLC silica gel plate R*.

**Mobile phase:** *hexane R, ether R* (30:70 V/V).

**Application:** 10 µL.

**Development:** over a path of 15 cm.

**Drying:** in air.

**Detection:** spray with a 0.1 g/L solution of *rhodamine B R* in *ethanol (96 per cent) R* and examine in ultraviolet light at 365 nm.

**Results:** the chromatogram shows a spot due to triglycerides with an  $R_f$  value of about 0.9 ( $R_{st}$  1) and spots due to 1,3-diglycerides ( $R_{st}$  0.7), to 1,2-diglycerides ( $R_{st}$  0.6), to monoglycerides ( $R_{st}$  0.1) and to esters of macrogol ( $R_{st}$  0).

##### B. Hydroxyl value (see Tests).

##### C. Saponification value (see Tests).

##### D. Fatty acid composition (see Tests).

#### TESTS

**Drop point (2.2.17).** Introduce into the cup the substance to be examined, which has been melted by heating for 1 h in an oven at  $100 \pm 2$  °C, and allow to stand for 5 h at about 5 °C.

Ethylene oxide units per molecule (nominal value)	Type of macrogol	Drop point
6	300	33 - 38
8	400	36 - 41
12	600	38 - 43
32	1500	42.5 - 47.5

**Acid value (2.5.1):** maximum 2.0, determined on 2.0 g.

**Hydroxyl value (2.5.3, Method A).** Use 1.0 g.

Ethylene oxide units per molecule (nominal value)	Type of macrogol	Hydroxyl value
6	300	65 - 85
8	400	60 - 80
12	600	50 - 70
32	1500	36 - 56

**Peroxide value (2.5.5, Method A):** maximum 6.0, determined on 2.0 g.

**Saponification value (2.5.6).** Use 2.0 g.

Ethylene oxide units per molecule (nominal value)	Type of macrogol	Saponification value
6	300	190 - 204
8	400	170 - 190
12	600	150 - 170
32	1500	79 - 93

**Alkaline impurities.** Introduce 5.0 g into a test tube and carefully add a mixture, neutralised if necessary with 0.01 M *hydrochloric acid* or with 0.01 M *sodium hydroxide*, of 0.05 mL of a 0.4 g/L solution of *bromophenol blue R* in *ethanol (96 per cent) R*, 0.3 mL of *water R* and 10 mL of *ethanol (96 per cent) R*. Shake and allow to stand. Not more than 1.0 mL of 0.01 M *hydrochloric acid* is required to change the colour of the upper layer to yellow.

**Free glycerol:** maximum 3.0 per cent.

Dissolve 1.20 g in 25.0 mL of *methylene chloride R*. Heat if necessary. After cooling, add 100 mL of *water R*. Shake and add 25.0 mL of *periodic acetic acid solution R*. Shake and allow to stand for 30 min. Add 40 mL of a 75 g/L solution of *potassium iodide R*. Allow to stand for 1 min. Add 1 mL of *starch solution R*. Titrate the iodine with 0.1 M *sodium thiosulfate*. Carry out a blank titration.

1 mL of 0.1 M *sodium thiosulfate* is equivalent to 2.3 mg of glycerol.

**Composition of fatty acids (2.4.22, Method A).**

**Composition of the fatty-acid fraction of the substance:**

- *caprylic acid*: maximum 15.0 per cent;
- *capric acid*: maximum 12.0 per cent;
- *lauric acid*: 30.0 per cent to 50.0 per cent;
- *myristic acid*: 5.0 per cent to 25.0 per cent;
- *palmitic acid*: 4.0 per cent to 25.0 per cent;
- *stearic acid*: 5.0 per cent to 35.0 per cent.

**Ethylene oxide and dioxan (2.4.25):** maximum 1 ppm of ethylene oxide and maximum 10 ppm of dioxan.

**Heavy metals (2.4.8):** maximum 10 ppm.

2.0 g complies with test C. Prepare the reference solution using 2 mL of *lead standard solution (10 ppm Pb) R*.

**Water (2.5.12):** maximum 1.0 per cent, determined on 1.0 g. Use a mixture of 30 volumes of *anhydrous methanol R* and 70 volumes of *methylene chloride R* as solvent.

**Total ash (2.4.16):** maximum 0.1 per cent.

#### LABELLING

The label states the type of macrogol used (mean relative molecular mass) or the number of units of ethylene oxide per molecule (nominal value).

01/2008:2330

## LEFLUNOMIDE

### Leflunomidum

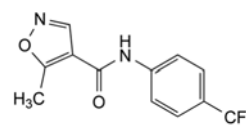

$C_{12}H_9F_3N_2O_2$

$M_r$  270.2

#### DEFINITION

5-Methyl-N-[4-(trifluoromethyl)phenyl]isoxazole-4-carboxamide.

**Content:** 98.0 per cent to 102.0 per cent (dried substance).

#### CHARACTERS

**Appearance:** white or almost white powder.

**Solubility:** practically insoluble in water, freely soluble in methanol, sparingly soluble in methylene chloride.

It shows polymorphism (5.9).

## IDENTIFICATION

Infrared absorption spectrophotometry (2.2.24).

*Preparation*: heat the substance to be examined and the reference substance at 130 °C for 10 min.

*Comparison*: leflunomide CRS.

## TESTS

**Related substances.** Liquid chromatography (2.2.29). Store all solutions protected from light.

*Test solution (a)*. Dissolve 25.0 mg of the substance to be examined in 5 mL of acetonitrile for chromatography R and dilute to 50.0 mL with the mobile phase.

*Test solution (b)*. Dissolve 0.125 g of the substance to be examined in 5 mL of acetonitrile for chromatography R and dilute to 50.0 mL with the mobile phase.

*Reference solution (a)*. Dilute 5.0 mL of test solution (a) to 50.0 mL with the mobile phase. Dilute 1.0 mL of this solution to 100.0 mL with the mobile phase.

*Reference solution (b)*. Dissolve 12.5 mg of leflunomide impurity A CRS in 5 mL of acetonitrile for chromatography R and dilute to 100.0 mL with the mobile phase. Dilute 10.0 mL of the solution to 100.0 mL with the mobile phase. Dilute 2.0 mL of this solution to 100.0 mL with the mobile phase.

*Reference solution (c)*. Dissolve 25.0 mg of leflunomide CRS in 5 mL of acetonitrile for chromatography R and dilute to 50.0 mL with the mobile phase.

*Reference solution (d)*. Dissolve the contents of 1 vial of leflunomide for peak identification CRS (containing impurities B and C) in 2.0 mL of the mobile phase and sonicate for 10 min.

*Column*:

- size:  $l = 0.125$  m,  $\varnothing = 4.0$  mm;
- stationary phase: end-capped octadecylsilyl silica gel for chromatography R (5  $\mu$ m).

*Mobile phase*: mix 5 volumes of triethylamine R with 650 volumes of water for chromatography R, adjust to pH  $3.4 \pm 0.1$  with phosphoric acid R and add 350 volumes of acetonitrile for chromatography R.

*Flow rate*: 1.0 mL/min.

*Detection*: spectrophotometer at 210 nm.

*Injection*: 20  $\mu$ L of test solutions (a) and (b) and reference solutions (a), (b) and (d).

*Run time*: twice the retention time of leflunomide.

*Identification of impurities*: use the chromatogram supplied with leflunomide for peak identification CRS and the chromatogram obtained with reference solution (d) to identify the peaks due to impurities B and C.

*Relative retention* with reference to leflunomide (retention time = about 25 min): impurity B = about 0.2; impurity A = about 0.4; impurity C = about 0.9.

*System suitability*: reference solution (d):

- *peak-to-valley ratio*: minimum 3, where  $H_p$  = height above the baseline of the peak due to impurity C and  $H_v$  = height above the baseline of the lowest point of the curve separating this peak from the peak due to leflunomide.

*Limits*: test solution (a):

- *impurity B*: not more than 3 times the area of the principal peak in the chromatogram obtained with reference solution (a) (0.3 per cent);
- *sum of impurities C and E*: not more than the area of the principal peak in the chromatogram obtained with reference solution (a) (0.1 per cent);
- *unspecified impurities*: for each impurity, not more than the area of the principal peak in the chromatogram obtained with reference solution (a) (0.10 per cent);
- *sum of impurities other than B*: not more twice the area of the principal peak in the chromatogram obtained with reference solution (a) (0.2 per cent);

- *disregard limit*: 0.5 times the area of the principal peak in the chromatogram obtained with reference solution (a) (0.05 per cent).

*Limit*: test solution (b):

- *impurity A*: not more than the area of the principal peak in the chromatogram obtained with reference solution (b) (0.01 per cent).

**Heavy metals** (2.4.8): maximum 20 ppm.

1.0 g complies with test F. Prepare the reference solution using 2 mL of lead standard solution (10 ppm Pb) R.

**Loss on drying** (2.2.32): maximum 0.3 per cent, determined on 1.000 g by drying *in vacuo* at 60 °C for 4 h.

**Sulfated ash** (2.4.14): maximum 0.1 per cent, determined on 1.0 g in a platinum crucible.

## ASSAY

Liquid chromatography (2.2.29) as described in the test for related substances with the following modification.

*Injection*: test solution (a) and reference solution (c).

Calculate the percentage content of  $C_{12}H_9F_3N_2O_2$  from the declared content of leflunomide CRS.

## STORAGE

Protected from light.

## IMPURITIES

*Specified impurities*: A, B.

*Other detectable impurities* (the following substances would, if present at a sufficient level, be detected by one or other of the tests in the monograph. They are limited by the general acceptance criterion for other/unspecified impurities and/or by the general monograph *Substances for pharmaceutical use* (2034). It is therefore not necessary to identify these impurities for demonstration of compliance. See also 5.10. *Control of impurities in substances for pharmaceutical use*): C, D, E, F, G, H.

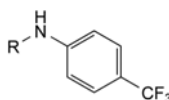

A. R = H: 4-(trifluoromethyl)aniline,

H. R = CO-CH<sub>2</sub>-CN: 2-cyano-*N*-[4-(trifluoromethyl)phenyl]acetamide,

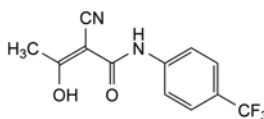

B. (2*Z*)-2-cyano-3-hydroxy-*N*-[4-(trifluoromethyl)phenyl]but-2-enamide (teriflunomide),

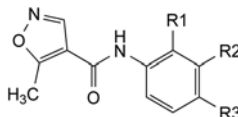

C. R1 = R3 = H, R2 = CF<sub>3</sub>: 5-methyl-*N*-[3-(trifluoromethyl)phenyl]isoxazole-4-carboxamide,

F. R1 = CF<sub>3</sub>, R2 = R3 = H: 5-methyl-*N*-[2-(trifluoromethyl)phenyl]isoxazole-4-carboxamide,

G. R1 = R2 = H, R3 = CH<sub>3</sub>: 5-methyl-*N*-(4-methylphenyl)isoxazole-4-carboxamide,

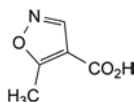

D. 5-methylisoxazole-4-carboxylic acid,

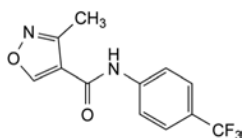

E. 3-methyl-N-[4-(trifluoromethyl)phenyl]isoxazole-4-carboxamide.

01/2008:2334

## LETROZOLE

### Letrozolum

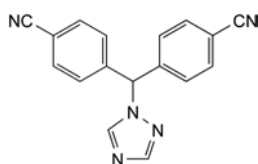

C<sub>17</sub>H<sub>11</sub>N<sub>5</sub>  
[112809-51-5]

M<sub>r</sub> 285.3

#### DEFINITION

4,4'-(1*H*-1,2,4-Triazol-1-ylmethylene)dibenzonitrile.

*Content*: 97.5 per cent to 102.0 per cent (anhydrous substance).

#### CHARACTERS

*Appearance*: white or yellowish, crystalline powder.

*Solubility*: practically insoluble in water, freely soluble in methylene chloride, sparingly soluble in methanol.

#### IDENTIFICATION

Infrared absorption spectrophotometry (2.2.24).

*Comparison*: letrozole CRS.

#### TESTS

**Related substances.** Liquid chromatography (2.2.29).

*Test solution (a)*. Dissolve 25.0 mg of the substance to be examined in 15 mL of acetonitrile R1 and dilute to 50.0 mL with water R.

*Test solution (b)*. To 2.0 mL of test solution (a) add 30 mL of acetonitrile R1 and dilute to 100.0 mL with water R.

*Reference solution (a)*. Dissolve 5.0 mg of letrozole CRS (containing impurities A and B) in 3 mL of acetonitrile R1 and dilute to 10.0 mL with water R.

*Reference solution (b)*. To 2.0 mL of test solution (a) add 30 mL of acetonitrile R1 and dilute to 100.0 mL with water R. To 1.0 mL of this solution add 6 mL of acetonitrile R1 and dilute to 20.0 mL with water R.

*Reference solution (c)*. Dissolve 25.0 mg of letrozole CRS in 15 mL of acetonitrile R1 and dilute to 50.0 mL with water R. To 2.0 mL of this solution add 30 mL of acetonitrile R1 and dilute to 100.0 mL with water R.

*Column*:

- size:  $l = 0.125$  m,  $\varnothing = 4.6$  mm;
- stationary phase: octadecylsilyl silica gel for chromatography R (5  $\mu$ m).

*Mobile phase*:

- mobile phase A: water R;

- mobile phase B: acetonitrile R1;

Time (min)	Mobile phase A (per cent V/V)	Mobile phase B (per cent V/V)
0 - 4	70	30
4 - 29	70 → 30	30 → 70
29 - 30	30 → 70	70 → 30

*Flow rate*: 1.0 mL/min.

*Detection*: spectrophotometer at 230 nm.

*Injection*: 20  $\mu$ L of test solution (a) and reference solutions (a) and (b).

*Relative retention* with reference to letrozole (retention time = about 13 min): impurity A = about 0.6; impurity B = about 1.9.

*System suitability*: reference solution (a):

- resolution: minimum 5 between the peaks due to impurity A and letrozole;
- the chromatogram obtained is similar to the chromatogram supplied with letrozole CRS.

*Limits*:

- impurity A: not more than 3 times the area of the principal peak in the chromatogram obtained with reference solution (b) (0.3 per cent);
- impurity B: not more than twice the area of the principal peak in the chromatogram obtained with reference solution (b) (0.2 per cent);
- unspecified impurities: for each impurity, not more than the area of the principal peak in the chromatogram obtained with reference solution (b) (0.10 per cent);
- total: not more than 5 times the area of the principal peak in the chromatogram obtained with reference solution (b) (0.5 per cent);
- disregard limit: 0.5 times the area of the principal peak in the chromatogram obtained with reference solution (b) (0.05 per cent).

**Water** (2.5.12): maximum 0.3 per cent, determined on 1.000 g. Use a validated pyridine-free iodosulfurous reagent.

#### ASSAY

Liquid chromatography (2.2.29) as described in the test for related substances with the following modifications.

*Injection*: test solution (b) and reference solution (c).

*System suitability*: reference solution (c):

- symmetry factor: maximum 1.7 for the peak due to letrozole. Calculate the percentage content of C<sub>17</sub>H<sub>11</sub>N<sub>5</sub> from the declared content of letrozole CRS.

#### IMPURITIES

*Specified impurities*: A, B.

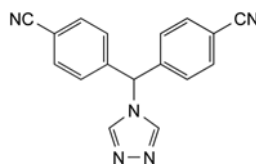

A. 4,4'-(4*H*-1,2,4-triazol-4-ylmethylene)dibenzonitrile,

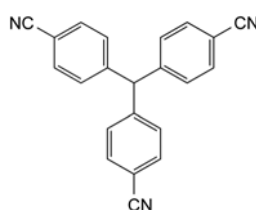

B. 4,4',4''-methanetriyltribenzonitrile.



01/2008:0771  
corrected 6.0

## LEUCINE

## Leucinum

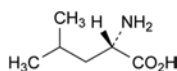
C<sub>6</sub>H<sub>13</sub>NO<sub>2</sub>  
[61-90-5]M<sub>r</sub> 131.2

## DEFINITION

Leucine contains not less than 98.5 per cent and not more than the equivalent of 101.0 per cent of (S)-2-amino-4-methylpentanoic acid, calculated with reference to the dried substance.

## CHARACTERS

White or almost white crystalline powder or shiny flakes, sparingly soluble in water, practically insoluble in alcohol. It dissolves in dilute mineral acids and in dilute solutions of alkali hydroxides.

## IDENTIFICATION

First identification: A, C.

Second identification: A, B, D.

- A. Specific optical rotation (see Tests).  
 B. Dissolve 0.50 g in *water R* and dilute to 25 mL with the same solvent. The solution is laevorotatory.  
 C. Examine by infrared absorption spectrophotometry (2.2.24), comparing with the spectrum obtained with *leucine CRS*. Examine the substances prepared as discs.  
 D. Examine the chromatograms obtained in the test for ninhydrin-positive substances. The principal spot in the chromatogram obtained with test solution (b) is similar in position, colour and size to the principal spot in the chromatogram obtained with reference solution (a).

## TESTS

**Appearance of solution.** Dissolve 0.5 g in 1 M *hydrochloric acid* and dilute to 10 mL with the same acid. The solution is clear (2.2.1) and not more intensely coloured than reference solution BY<sub>6</sub> (2.2.2, Method II).

**Specific optical rotation** (2.2.7). Dissolve 1.00 g in *hydrochloric acid R1* and dilute to 25.0 mL with the same acid. The specific optical rotation is + 14.5 to + 16.5, calculated with reference to the dried substance.

**Ninhydrin-positive substances.** Examine by thin-layer chromatography (2.2.27), using a *TLC silica gel plate R*.

**Test solution (a).** Dissolve 0.10 g of the substance to be examined in 0.1 M *hydrochloric acid* and dilute to 10 mL with the same acid.

**Test solution (b).** Dilute 1 mL of test solution (a) to 50 mL with *water R*.

**Reference solution (a).** Dissolve 10 mg of *leucine CRS* in 0.1 M *hydrochloric acid* and dilute to 50 mL with the same acid.

**Reference solution (b).** Dilute 5 mL of test solution (b) to 20 mL with *water R*.

**Reference solution (c).** Dissolve 10 mg of *leucine CRS* and 10 mg of *valine CRS* in 0.1 M *hydrochloric acid* and dilute to 25 mL with the same acid.

Apply separately to the plate 5 µL of each solution. Allow the plate to dry in air. Develop over a path of 15 cm using a mixture of 20 volumes of *glacial acetic acid R*, 20 volumes of *water R* and 60 volumes of *butanol R*. Allow the plate to dry in air, spray with *ninhydrin solution R* and heat at 100 °C to 105 °C for 15 min. Any spot in the chromatogram obtained with test solution (a), apart from the principal spot, is not more intense than the spot in the chromatogram obtained with reference

solution (b) (0.5 per cent). The test is not valid unless the chromatogram obtained with reference solution (c) shows two clearly separated spots.

**Chlorides** (2.4.4). Dissolve 0.25 g in *water R* and dilute to 15 mL with the same solvent. The solution complies with the limit test for chlorides (200 ppm).

**Sulfates** (2.4.13). Dissolve 0.5 g in 3 mL of *dilute hydrochloric acid R* and dilute to 15 mL with *distilled water R*. The solution complies with the limit test for sulfates (300 ppm).

**Ammonium** (2.4.1). 50 mg complies with limit test B for ammonium (200 ppm). Prepare the standard using 0.1 mL of *ammonium standard solution (100 ppm NH<sub>4</sub>) R*.

**Iron** (2.4.9). In a separating funnel, dissolve 1.0 g in 10 mL of *dilute hydrochloric acid R*. Shake with three quantities, each of 10 mL, of *methyl isobutyl ketone R1*, shaking for 3 min each time. To the combined organic layers add 10 mL of *water R* and shake for 3 min. The aqueous layer complies with the limit test for iron (10 ppm).

**Heavy metals** (2.4.8). 2.0 g complies with limit test D for heavy metals (10 ppm). Prepare the standard using 2 mL of *lead standard solution (10 ppm Pb) R*.

**Loss on drying** (2.2.32). Not more than 0.5 per cent, determined on 1.000 g by drying in an oven at 105 °C.

**Sulfated ash** (2.4.14). Not more than 0.1 per cent, determined on 1.0 g.

## ASSAY

Dissolve 0.100 g in 3 mL of *anhydrous formic acid R*. Add 30 mL of *anhydrous acetic acid R*. Titrate with 0.1 M *perchloric acid* using 0.1 mL of *naphtholbenzein solution R* as indicator, until the colour changes from brownish-yellow to green.

1 mL of 0.1 M *perchloric acid* is equivalent to 13.12 mg of C<sub>6</sub>H<sub>13</sub>NO<sub>2</sub>.

## STORAGE

Store protected from light.

01/2008:1442

## LEUPRORELIN

## Leuprorelinum

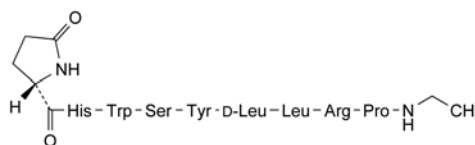
C<sub>59</sub>H<sub>84</sub>N<sub>16</sub>O<sub>12</sub>  
[53714-56-0]M<sub>r</sub> 1209

## DEFINITION

5-Oxo-L-prolyl-L-histidyl-L-tryptophyl-L-seryl-L-tyrosyl-D-leucyl-L-leucyl-L-arginyl-N-ethyl-L-prolinamide.

Synthetic nonapeptide analogue of the hypothalamic peptide, gonadorelin. It is obtained by chemical synthesis and is available as an acetate.

**Content:** 97.0 per cent to 103.0 per cent (anhydrous and acetic acid-free substance).

## CHARACTERS

**Appearance:** hygroscopic, white or almost white powder.

## IDENTIFICATION

A. Infrared absorption spectrophotometry (2.2.24).

**Preparation:** discs of *potassium bromide R*.

**Comparison:** *Ph. Eur. reference spectrum of leuprorelin*.

B. Examine the chromatograms obtained in the assay.

**Results:** the principal peak in the chromatogram obtained with test solution (b) is similar in retention time and size to the principal peak in the chromatogram obtained with reference solution (b).

C. Amino acid analysis (2.2.56). For hydrolysis use Method 1 and for analysis use Method 1.

Express the content of each amino acid in moles. Calculate the relative proportions of the amino acids taking one seventh of the sum of the number of moles of histidine, glutamic acid, leucine, proline, tyrosine and arginine as equal to 1. The values fall within the following limits: serine present; glutamic acid = 0.85 to 1.1; proline = 0.85 to 1.1; leucine = 1.8 to 2.2; tyrosine = 0.85 to 1.1; histidine = 0.85 to 1.1 and arginine = 0.85 to 1.1. Not more than traces of other amino acids are present, with the exception of tryptophan.

## TESTS

**Specific optical rotation** (2.2.7): –38.0 to –42.0 (anhydrous and acetic acid-free substance).

Dissolve the substance to be examined in a 1 per cent V/V solution of *glacial acetic acid R* to obtain a concentration of 10.0 mg/mL.

**Related substances.** Liquid chromatography (2.2.29): use the normalisation procedure.

**Test solution (a).** Dissolve the substance to be examined in the mobile phase to obtain a concentration of 1.0 mg/mL.

**Test solution (b).** Dilute 0.5 mL of test solution (a) to 10.0 mL with the mobile phase.

**Reference solution (a).** Dissolve *leuprorelin CRS* in the mobile phase to obtain a concentration of 1.0 mg/mL.

**Reference solution (b).** Dilute 0.5 mL of reference solution (a) to 10.0 mL with the mobile phase.

**Resolution solution.** Dilute 5.0 mL of reference solution (a) to 50.0 mL with *water R*. To 5 mL of the solution add 100 µL of 1 M *sodium hydroxide* and shake vigorously. Heat in an oven at 100 °C for 60 min, cool immediately and add 50 µL of *dilute phosphoric acid R*. Shake vigorously.

**Column:**

- size:  $l = 0.10$  m,  $\varnothing = 4.6$  mm;
- stationary phase: *octadecylsilyl silica gel for chromatography R* (3 µm).

**Mobile phase:** dissolve about 15.2 g of *triethylamine R* in 800 mL of *water R*, adjust to pH 3.0 with *phosphoric acid R* and dilute to 1000 mL with *water R*. Add 850 mL of this solution to 150 mL of a mixture of 2 volumes of *propanol R* and 3 volumes of *acetonitrile R*.

**Flow rate:** 1.0–1.5 mL/min.

**Detection:** spectrophotometer at 220 nm.

**Injection:** 20 µL of test solution (a) and the resolution solution.

**Run time:** 90 min.

**Relative retention** with reference to leuprorelin (retention time = 41–49 min): impurity E = about 0.7; impurity F = about 0.7; impurity H = about 0.78; impurity A = about 0.8; impurity B = about 0.9; impurity I = about 0.94; impurity J = about 1.09; impurity C = about 1.2; impurity G = about 1.3; impurity K = about 1.31; impurity D = about 1.5.

**System suitability:** resolution solution:

- resolution: minimum 1.5 between the peaks due to impurity B and leuprorelin.

**Limits:**

- impurity D: maximum 1.0 per cent;
- impurities A, B, C: for each impurity, maximum 0.5 per cent;
- unspecified impurities: for each impurity, maximum 0.5 per cent;

– total: maximum 2.5 per cent;

– disregard limit: 0.1 per cent.

**Acetic acid** (2.5.34): 4.7 per cent to 9.0 per cent.

**Test solution.** Dissolve 10.0 mg of the substance to be examined in a mixture of 5 volumes of mobile phase B and 95 volumes of mobile phase A and dilute to 10.0 mL with the same mixture of mobile phases.

**Water** (2.5.32): maximum 5.0 per cent.

**Sulfated ash** (2.4.14): maximum 0.3 per cent.

**Bacterial endotoxins** (2.6.14, *Method D*): less than 16.7 IU/mg, if intended for use in the manufacture of parenteral preparations without a further appropriate procedure for removal of bacterial endotoxins.

## ASSAY

Liquid chromatography (2.2.29) as described in the test for related substances with the following modifications.

**Run time:** 60 min.

**Injection:** 20 µL of test solution (b) and reference solution (b).

Calculate the content of leuprorelin ( $C_{59}H_{84}N_{16}O_{12}$ ) using the areas of the peaks and the declared content of  $C_{59}H_{84}N_{16}O_{12}$  in *leuprorelin CRS*.

## STORAGE

In an airtight container, protected from light, at a temperature not exceeding 30 °C.

If the substance is sterile, store in a sterile, airtight, tamper-proof container.

## LABELLING

The label states the mass of peptide in the container.

## IMPURITIES

**Specified impurities:** A, B, C, D.

**Other detectable impurities** (the following substances would, if present at a sufficient level, be detected by one or other of the tests in the monograph. They are limited by the general acceptance criterion for other/unspecified impurities and/or by the general monograph *Substances for pharmaceutical use* (2034). It is therefore not necessary to identify these impurities for demonstration of compliance. See also 5.10. *Control of impurities in substances for pharmaceutical use*): E, F, G, H, I, J, K.

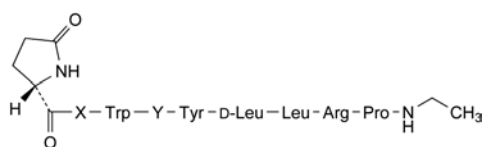

A. X = L-His, Y = D-Ser: [4-D-serine]leuprorelin,

B. X = D-His, Y = L-Ser: [2-D-histidine]leuprorelin,

F. X = D-His, Y = D-Ser: [2-D-histidine,4-D-serine]leuprorelin,

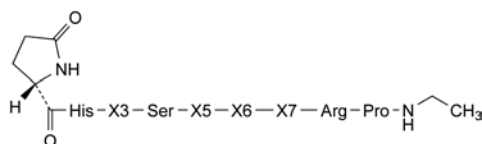

C. X<sub>3</sub> = L-Trp, X<sub>5</sub> = L-Tyr, X<sub>6</sub> = X<sub>7</sub> = L-Leu: [6-L-leucine]leuprorelin,

E. X<sub>3</sub> = D-Trp, X<sub>5</sub> = L-Tyr, X<sub>6</sub> = D-Leu, X<sub>7</sub> = L-Leu: [3-D-tryptophane]leuprorelin,

G. X<sub>3</sub> = L-Trp, X<sub>5</sub> = D-Tyr, X<sub>6</sub> = D-Leu, X<sub>7</sub> = L-Leu: [5-D-tyrosine]leuprorelin,

H. X<sub>3</sub> = L-Trp, X<sub>5</sub> = L-Tyr, X<sub>6</sub> = X<sub>7</sub> = D-Leu: [7-D-leucine]leuprorelin,

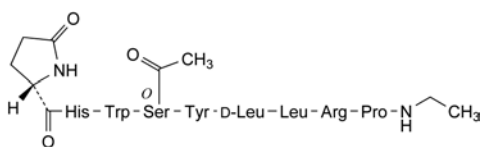

D. [4-(*O*-acetyl-L-serine)]leuprorelin,

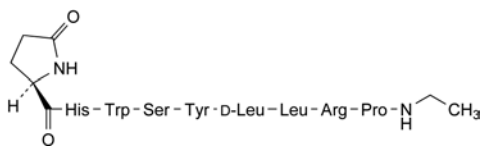

I. [1-(5-oxo-D-proline)]leuprorelin,

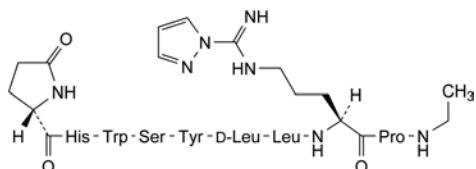

J. [8-[5-*N*-[imino(1*H*-pyrazol-1-yl)methyl]-L-ornithine]]leuprorelin,

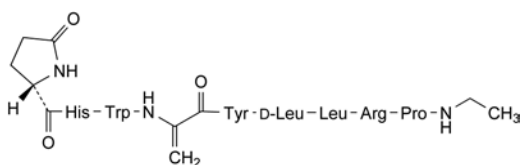

K. [4-dehydroalanine]leuprorelin.

**Appearance of solution.** Solution S is clear (2.2.1) and not more intensely coloured than reference solution BY<sub>6</sub> (2.2.2, Method II).

**Specific optical rotation** (2.2.7): –85 to –89 (anhydrous substance), determined on solution S.

**Related substances.** Liquid chromatography (2.2.29). Prepare the solutions immediately before use, protect from light and keep below 25 °C.

**Test solution.** Dissolve 0.100 g of the substance to be examined in methanol R and dilute to 10.0 mL with the same solvent.

**Reference solution (a).** Dissolve 50 mg of levamisole hydrochloride for system suitability CRS in methanol R, add 0.5 mL of concentrated ammonia R and dilute to 5.0 mL with methanol R.

**Reference solution (b).** Dilute 1.0 mL of the test solution to 100.0 mL with methanol R. Dilute 5.0 mL of the solution to 25.0 mL with methanol R.

**Column:**

– size:  $l = 0.10$  m,  $\varnothing = 4.6$  mm,

– stationary phase: base-deactivated octadecylsilyl silica gel for chromatography R (3  $\mu$ m).

**Mobile phase:**

– mobile phase A: dissolve 0.5 g of ammonium dihydrogen phosphate R in 90 mL of water R; adjust to pH 6.5 with a 40 g/L solution of sodium hydroxide R and dilute to 100 mL with water R,

– mobile phase B: acetonitrile R.

Time (min)	Mobile phase A (per cent V/V)	Mobile phase B (per cent V/V)
0 - 8	90 → 30	10 → 70
8 - 10	30	70

**Flow rate:** 1.5 mL/min.

**Detection:** spectrophotometer at 215 nm.

**Injection:** 10  $\mu$ L.

**Relative retention** with reference to levamisole (retention time = about 3 min): impurity A = about 0.9; impurity B = about 1.4; impurity C = about 1.5; impurity D = about 1.6; impurity E = about 2.0.

**System suitability:** reference solution (a):

– the chromatogram obtained is similar to the chromatogram supplied with levamisole hydrochloride for system suitability CRS.

**Limits:**

– **correction factors:** for the calculation of content, multiply the peak areas of the following impurities by the corresponding correction factor: impurity A = 2.0; impurity B = 1.7; impurity C = 2.9; impurity D = 1.3; impurity E = 2.7;

– **impurities A, B, C, D, E:** for each impurity, not more than the area of the principal peak in the chromatogram obtained with reference solution (b) (0.2 per cent);

– **any other impurity:** not more than half the area of the principal peak in the chromatogram obtained with reference solution (b) (0.1 per cent);

– **total:** not more than 1.5 times the area of the principal peak in the chromatogram obtained with reference solution (b) (0.3 per cent);

– **disregard limit:** 0.25 times the area of the principal peak in the chromatogram obtained with reference solution (b) (0.05 per cent).

**Water** (2.5.12): maximum 0.5 per cent, determined on 1.00 g.

**Sulfated ash** (2.4.14): maximum 0.1 per cent, determined on 1.0 g.

01/2008:1728  
corrected 7.0

## LEVAMISOLE FOR VETERINARY USE

### Levamisolum ad usum veterinarium

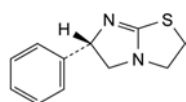

C<sub>11</sub>H<sub>12</sub>N<sub>2</sub>S  
[14769-73-4]

$M_r$  204.3

#### DEFINITION

(6*S*)-6-Phenyl-2,3,5,6-tetrahydroimidazo[2,1-*b*]thiazole.

**Content:** 98.5 per cent to 101.5 per cent (anhydrous substance).

#### CHARACTERS

**Appearance:** white or almost white powder.

**Solubility:** slightly soluble in water, freely soluble in alcohol and in methanol.

It shows polymorphism (5.9).

#### IDENTIFICATION

A. Specific optical rotation (see Tests).

B. Infrared absorption spectrophotometry (2.2.24).

**Comparison:** Ph. Eur. reference spectrum of levamisole.

If the spectra show differences, dissolve the substance to be examined in methylene chloride R, evaporate to dryness and record a new spectrum using the residue.

#### TESTS

**Solution S.** Dissolve 2.50 g in ethanol R and dilute to 50.0 mL with the same solvent.

## ASSAY

Dissolve 0.150 g in 50 mL of a mixture of 1 volume of *anhydrous acetic acid R* and 7 volumes of *methyl ethyl ketone R*. Titrate with 0.1 M perchloric acid, using 0.2 mL of *naphtholbenzein solution R* as indicator.

1 mL of 0.1 M perchloric acid is equivalent to 20.43 mg of  $C_{11}H_{12}N_2S$ .

## STORAGE

In an airtight container, protected from light.

## IMPURITIES

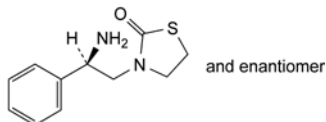

A. 3-[(2RS)-2-amino-2-phenylethyl]thiazolidin-2-one,

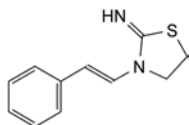

B. 3-[(E)-2-phenylethenyl]thiazolidin-2-imine,

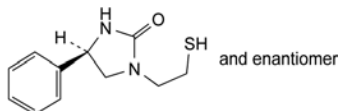

C. (4RS)-4-phenyl-1-(2-sulfanylethyl)imidazolidin-2-one,

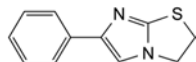

D. 6-phenyl-2,3-dihydroimidazo[2,1-b]thiazole,

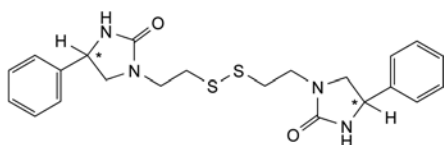

E. 1,1'-[(disulfane-1,2-diyl)bis(ethylene)]bis[(4RS)-4-phenylimidazolidin-2-one].

## IDENTIFICATION

- A. Specific optical rotation (see Tests).  
 B. Infrared absorption spectrophotometry (2.2.24).  
*Comparison: levamisole hydrochloride CRS.*  
 C. It gives reaction (a) of chlorides (2.3.1).

## TESTS

**Solution S.** Dissolve 2.50 g in *carbon dioxide-free water R* and dilute to 50.0 mL with the same solvent.

**Appearance of solution.** Solution S is clear (2.2.1) and not more intensely coloured than reference solution Y; (2.2.2, *Method II*).

**pH (2.2.3):** 3.0 to 4.5 for solution S.

**Specific optical rotation (2.2.7):** – 121 to – 128 (dried substance), determined on solution S.

**Related substances.** Liquid chromatography (2.2.29). *Prepare the solutions immediately before use, protect from light and keep below 25 °C.*

**Test solution.** Dissolve 0.100 g of the substance to be examined in *methanol R*, add 1.0 mL of *concentrated ammonia R* and dilute to 10.0 mL with *methanol R*.

**Reference solution (a).** Dissolve 50 mg of *levamisole hydrochloride for system suitability CRS* (containing impurities A, B, C, D and E) in *methanol R*, add 0.5 mL of *concentrated ammonia R* and dilute to 5.0 mL with *methanol R*.

**Reference solution (b).** Dilute 1.0 mL of the test solution to 100.0 mL with *methanol R*. Dilute 5.0 mL of this solution to 25.0 mL with *methanol R*.

**Column:**

- size:  $l = 0.10$  m,  $\varnothing = 4.6$  mm;
- stationary phase: *base-deactivated octadecylsilyl silica gel for chromatography R* (3  $\mu$ m).

**Mobile phase:**

- mobile phase A: dissolve 0.5 g of *ammonium dihydrogen phosphate R* in 90 mL of *water R*, adjust to pH 6.5 with a 40 g/L solution of *sodium hydroxide R* and dilute to 100 mL with *water R*;
- mobile phase B: *acetonitrile R*;

Time (min)	Mobile phase A (per cent V/V)	Mobile phase B (per cent V/V)
0 - 8	90 → 30	10 → 70
8 - 10	30	70

**Flow rate:** 1.5 mL/min.

**Detection:** spectrophotometer at 215 nm.

**Equilibration:** at least 4 min with the mobile phase at the initial composition.

**Injection:** 10  $\mu$ L.

**Identification of impurities:** use the chromatogram supplied with *levamisole hydrochloride for system suitability CRS* and the chromatogram obtained with reference solution (a) to identify the peaks due to impurities A, B, C, D and E.

**Relative retention** with reference to levamisole (retention time = about 3 min): impurity A = about 0.9; impurity B = about 1.4; impurity C = about 1.5; impurity D = about 1.6; impurity E = about 2.0.

**System suitability:**

- the chromatogram obtained with reference solution (a) is similar to the chromatogram supplied with *levamisole hydrochloride for system suitability CRS*;
- **symmetry factor:** maximum 3.5 for the principal peak in the chromatogram obtained with reference solution (b).

**Limits:**

- **correction factors:** for the calculation of content, multiply the peak areas of the following impurities by the corresponding correction factor: impurity A = 2.0; impurity B = 1.7; impurity C = 2.9; impurity D = 1.3; impurity E = 2.7;

04/2009:0726

## LEVAMISOLE HYDROCHLORIDE

## Levamisoli hydrochloridum

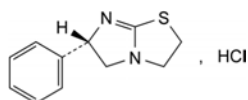

$C_{11}H_{13}ClN_2S$   
[16595-80-5]

$M_r$  240.8

## DEFINITION

(6S)-6-Phenyl-2,3,5,6-tetrahydroimidazo[2,1-b]thiazole hydrochloride.

**Content:** 98.5 per cent to 101.0 per cent (dried substance).

## CHARACTERS

**Appearance:** white or almost white, crystalline powder.

**Solubility:** freely soluble in water, soluble in ethanol (96 per cent), slightly soluble in methylene chloride.

01/2011:2535

## LEVETIRACETAM

## Levetiracetamum

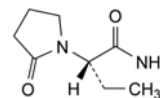

$C_8H_{14}N_2O_2$   
[102767-28-2]

$M_r$  170.2

## DEFINITION

(2S)-2-(2-Oxopyrrolidin-1-yl)butanamide.

*Content*: 98.0 per cent to 102.0 per cent (anhydrous substance).

## CHARACTERS

*Appearance*: white or almost white powder.

*Solubility*: very soluble in water, soluble in acetonitrile, practically insoluble in hexane.

## IDENTIFICATION

Carry out either tests A, B or tests B, C.

A. Specific optical rotation (2.2.7):  $-76$  to  $-82$ .

Dissolve 0.500 g in *water R* and dilute to 25.0 mL with the same solvent.

B. Infrared absorption spectrophotometry (2.2.24).

*Comparison*: levetiracetam CRS.

C. Enantiomeric purity (see Tests).

## TESTS

**Appearance of solution.** The solution is clear (2.2.1) and not more intensely coloured than reference solution BY<sub>6</sub> (2.2.2, Method II).

Dissolve 2.0 g in *water R* and dilute to 10.0 mL with the same solvent.

**Enantiomeric purity.** Liquid chromatography (2.2.29): use the normalisation procedure.

*Test solution.* Dissolve 0.200 g of the substance to be examined in *2-propanol R* and dilute to 10.0 mL with the same solvent. Dilute 1.0 mL of the solution to 20.0 mL with the mobile phase.

*Reference solution.* Dissolve 5 mg of the substance to be examined and 5 mg of *levetiracetam impurity D CRS* in the mobile phase and dilute to 5.0 mL with the mobile phase.

*Column*:

– *size*:  $l = 0.25$  m,  $\varnothing = 4.6$  mm;

– *stationary phase*: silica gel OD for chiral separations R.

*Mobile phase*: *2-propanol R*, *hexane R* (18:82 V/V).

*Flow rate*: 0.8 mL/min.

*Detection*: spectrophotometer at 205 nm.

*Injection*: 20  $\mu$ L.

*Run time*: 1.4 times the retention time of levetiracetam.

*Relative retention* with reference to levetiracetam (retention time = about 12 min): impurity D = about 0.8.

*System suitability*: reference solution:

– *resolution*: minimum 1.5 between the peaks due to impurity D and levetiracetam;

– *symmetry factor*: maximum 2.0 for the peak due to levetiracetam.

*Limit*:

– *impurity D*: maximum 0.8 per cent.

**Impurity C.** Liquid chromatography (2.2.29).

*Solvent mixture*: *water R*, *acetonitrile R1* (7:93 V/V).

*Test solution.* Dissolve 50 mg of the substance to be examined in the solvent mixture and dilute to 50.0 mL with the solvent mixture.

- *impurities A, B, C, D, E*: for each impurity, not more than the area of the principal peak in the chromatogram obtained with reference solution (b) (0.2 per cent);
- *unspecified impurities*: for each impurity, not more than 0.5 times the area of the principal peak in the chromatogram obtained with reference solution (b) (0.10 per cent);
- *total*: not more than 1.5 times the area of the principal peak in the chromatogram obtained with reference solution (b) (0.3 per cent);
- *disregard limit*: 0.25 times the area of the principal peak in the chromatogram obtained with reference solution (b) (0.05 per cent).

**Heavy metals** (2.4.8): maximum 20 ppm.

12 mL of solution S complies with test A. Prepare the reference solution using *lead standard solution (1 ppm Pb) R*.

**Loss on drying** (2.2.32): maximum 0.5 per cent, determined on 1.000 g by drying in an oven at 105 °C for 4 h.

**Sulfated ash** (2.4.14): maximum 0.1 per cent, determined on 1.0 g.

## ASSAY

Dissolve 0.200 g in 30 mL of *ethanol (96 per cent) R* and add 5.0 mL of 0.01 M *hydrochloric acid*. Carry out a potentiometric titration (2.2.20), using 0.1 M *sodium hydroxide*. Read the volume added between the 2 points of inflexion.

1 mL of 0.1 M *sodium hydroxide* is equivalent to 24.08 mg of  $C_{11}H_{13}ClN_2S$ .

## STORAGE

Protected from light.

## IMPURITIES

*Specified impurities*: A, B, C, D, E.

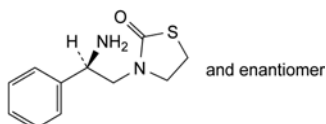

A. 3-[(2RS)-2-amino-2-phenylethyl]thiazolidin-2-one,

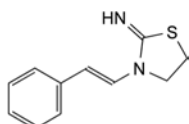

B. 3-[(E)-2-phenylethenyl]thiazolidin-2-imine,

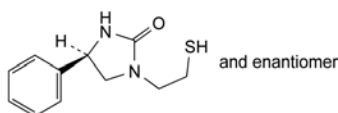

C. (4RS)-4-phenyl-1-(2-sulfanylethyl)imidazolidin-2-one,

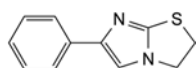

D. 6-phenyl-2,3-dihydroimidazo[2,1-b]thiazole,

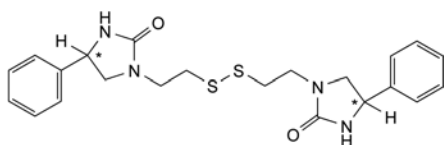

E. 1,1'-[(disulfane-1,2-diyl)bis(ethylene)]bis[(4RS)-4-phenylimidazolidin-2-one].

**Reference solution (a).** Dissolve 1 mg of the substance to be examined and 1 mg of *levetiracetam impurity C CRS* in the solvent mixture and dilute to 5.0 mL with the solvent mixture.

**Reference solution (b).** Dissolve 5.0 mg of *levetiracetam impurity C CRS* in the solvent mixture and dilute to 100.0 mL with the solvent mixture. Dilute 1.0 mL of the solution to 50.0 mL with the solvent mixture.

**Column:**

- size:  $l = 0.25$  m,  $\varnothing = 4.6$  mm;
- stationary phase: silica gel for chromatography R (5  $\mu$ m).

**Mobile phase:** 1.96 g/L solution of sulfuric acid R, acetonitrile R1 (7:93 V/V).

**Flow rate:** 0.5 mL/min.

**Detection:** spectrophotometer at 205 nm.

**Injection:** 20  $\mu$ L.

**Run time:** twice the retention time of levetiracetam.

**Relative retention** with reference to levetiracetam (retention time = about 14 min): impurity C = about 1.2.

**System suitability:** reference solution (a):

- resolution: minimum 4.0 between the peaks due to levetiracetam and impurity C.

**Limits:**

- impurity C: not more than 0.25 times the area of the corresponding peak in the chromatogram obtained with reference solution (b) (250 ppm).

**Related substances.** Liquid chromatography (2.2.29).

**Solvent mixture:** water R, acetonitrile R1 (4:96 V/V).

**Test solution.** Dissolve 50.0 mg of the substance to be examined in the solvent mixture and dilute to 25.0 mL with the solvent mixture. Dilute 5.0 mL of the solution to 50.0 mL with the solvent mixture.

**Reference solution (a).** Dissolve 5 mg of the substance to be examined and 5 mg of *2-pyrrolidone R* in the solvent mixture and dilute to 25.0 mL with the solvent mixture.

**Reference solution (b).** Dissolve 50.0 mg of *levetiracetam CRS* in the solvent mixture and dilute to 25.0 mL with the solvent mixture. Dilute 5.0 mL of the solution to 50.0 mL with the solvent mixture.

**Reference solution (c).** Dilute 1.0 mL of the test solution to 20.0 mL with the solvent mixture. Dilute 1.0 mL of this solution to 100.0 mL with the solvent mixture.

**Reference solution (d).** Dissolve 5 mg of *levetiracetam impurity A CRS* and 5 mg of *levetiracetam impurity B CRS* in the solvent mixture and dilute to 50.0 mL with the solvent mixture. Dilute 1.0 mL of the solution to 50.0 mL with the solvent mixture. Dilute 5.0 mL of this solution to 100.0 mL with the solvent mixture.

**Column:**

- size:  $l = 0.25$  m,  $\varnothing = 4.6$  mm;
- stationary phase: silica gel for chromatography R (5  $\mu$ m).

**Mobile phase:** 1.96 g/L solution of sulfuric acid R, acetonitrile R1 (4:96 V/V).

**Flow rate:** 1 mL/min.

**Detection:** spectrophotometer at 205 nm.

**Injection:** 10  $\mu$ L of the test solution and reference solutions (a), (c) and (d).

**Run time:** twice the retention time of levetiracetam.

**Identification of impurities:** use the chromatogram obtained with reference solution (d) to identify the peaks due to impurities A and B.

**Relative retention** with reference to levetiracetam (retention time = about 10 min): impurity A = about 0.5; 2-pyrrolidone = about 1.1; impurity B = about 1.2.

**System suitability:** reference solution (a):

- resolution: minimum 1.5 between the peaks due to levetiracetam and 2-pyrrolidone.

**Limits:**

- correction factor: for the calculation of content, multiply the peak area of impurity B by 0.5;
- impurity A: not more than 6 times the area of the principal peak in the chromatogram obtained with reference solution (c) (0.3 per cent);
- impurity B: not more than the area of the principal peak in the chromatogram obtained with reference solution (c) (0.05 per cent);
- unspecified impurities: for each impurity, not more than the area of the principal peak in the chromatogram obtained with reference solution (c) (0.05 per cent);
- sum of unspecified impurities: not more than twice the area of the principal peak in the chromatogram obtained with reference solution (c) (0.1 per cent);
- total: not more than 8 times the area of the principal peak in the chromatogram obtained with reference solution (c) (0.4 per cent);
- disregard limit: 0.6 times the area of the principal peak in the chromatogram obtained with reference solution (c) (0.03 per cent).

**Heavy metals (2.4.8):** maximum 10 ppm.

Dissolve 2.0 g in 20 mL of water R. 12 mL of the solution complies with test A. Prepare the reference solution using lead standard solution (1 ppm Pb) R.

**Water (2.5.32):** maximum 0.5 per cent, determined on 0.500 g.

**Sulfated ash (2.4.14):** maximum 0.1 per cent, determined on 1.0 g.

**ASSAY**

Liquid chromatography (2.2.29) as described in the test for related substances with the following modification.

**Injection:** test solution and reference solution (b).

Calculate the percentage content of  $C_8H_{14}N_2O_2$  from the declared content of *levetiracetam CRS*.

**IMPURITIES**

**Specified impurities:** A, B, C, D.

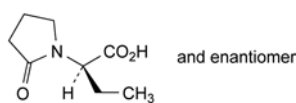

A. (2RS)-2-(2-oxopyrrolidin-1-yl)butanoic acid,

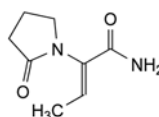

B. (2Z)-2-(2-oxopyrrolidin-1-yl)but-2-enamide,

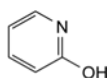

C. pyridin-2-ol,

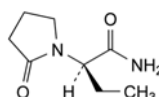

D. (2R)-2-(2-oxopyrrolidin-1-yl)butanamide ((R)-etiracetam).

01/2008:1484 *Temperature: 50 °C.*  
corrected 6.0

## LEVOCABASTINE HYDROCHLORIDE

### Levocabastini hydrochloridum

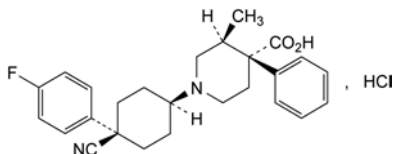

$C_{26}H_{30}ClFN_2O_2$   
[79547-78-7]

$M_r$  457.0

#### DEFINITION

(3*S*,4*R*)-1-[*cis*-4-Cyano-4-(4-fluorophenyl)cyclohexyl]-3-methyl-4-phenylpiperidine-4-carboxylic acid monohydrochloride.

*Content:* 98.5 per cent to 101.5 per cent (dried substance).

#### CHARACTERS

*Appearance:* white or almost white powder.

*Solubility:* practically insoluble in water, sparingly soluble in methanol, slightly soluble in ethanol (96 per cent) and in a 2 g/L solution of sodium hydroxide.

#### IDENTIFICATION

A. Infrared absorption spectrophotometry (2.2.24).

*Preparation:* discs.

*Comparison:* levocabastine hydrochloride CRS.

B. Dissolve 50 mg in a mixture of 0.4 mL of *ammonia R* and 2 mL of *water R*. Mix, allow to stand for 5 min and filter. Acidify the filtrate with *dilute nitric acid R*. It gives reaction (a) of chlorides (2.3.1).

C. Specific optical rotation (see Tests).

#### TESTS

**Solution S.** Dissolve 0.250 g in *methanol R* and dilute to 25.0 mL with the same solvent.

**Appearance of solution.** Solution S is clear (2.2.1) and not more intensely coloured than reference solution Y<sub>7</sub> (2.2.2, *Method II*).

**Specific optical rotation** (2.2.7): – 102 to – 106 (dried substance), determined on solution S.

**Related substances.** Capillary electrophoresis (2.2.47). *Prepare the solutions immediately before use.*

**Test solution.** Dissolve 25.0 mg of the substance to be examined in a 2 g/L solution of *sodium hydroxide R* and dilute to 10.0 mL with the same solution.

**Reference solution (a).** Dissolve 2.5 mg of *levocabastine hydrochloride CRS* and 2.5 mg of *levocabastine impurity D CRS* in a 2 g/L solution of *sodium hydroxide R* and dilute to 200.0 mL with the same solution.

**Reference solution (b).** Dilute 5.0 mL of this test solution to 100.0 mL with a 2 g/L solution of *sodium hydroxide R*. Dilute 1.0 mL of this solution to 10.0 mL with a 2 g/L solution of *sodium hydroxide R*.

**Blank solution.** A 2 g/L solution of *sodium hydroxide R*.

**Capillary:**

- *material:* uncoated fused silica;
- *size:* effective length = 0.5 m, Ø = 75 µm.

**Electrolyte solution:** dissolve 1.08 g of *sodium dodecyl sulfate R* and 0.650 g of *hydroxypropyl-β-cyclodextrin R* in 5 mL of *2-propanol R* and dilute to 50.0 mL with buffer solution pH 9.0 prepared as follows: dissolve 1.39 g of *boric acid R* in *water R* and adjust to pH 9.0 with 1 M *sodium hydroxide* (about 9 mL). Dilute to 100.0 mL with *water R*.

**Detection:** spectrophotometer at 214 nm.

**Preconditioning of the capillary:** rinse the capillary for 2 min with a 2 g/L solution of *sodium hydroxide R* and for at least 5 min with the electrolyte solution.

**Injection:** under pressure (3,45 kPa) for 5 s.

**Migration:**

Time (min)	Current (µA)
0 - 0.17	0 → 75
0.17 - 15	75 → 130
15 - 40	130
40 - 60	130 → 200

**Migration times:** levocabastine = about 28 min; impurity D = about 30 min.

**System suitability:** reference solution (a):

- *resolution:* minimum 4 between the peaks due to levocabastine and impurity D; if necessary adjust the current gradient.

**Limits:**

- *impurities A, B, C, D, E:* for each impurity, not more than the area of the principal peak in the electropherogram obtained with reference solution (b) (0.5 per cent);
- *total:* not more than twice the area of the principal peak in the electropherogram obtained with reference solution (b) (1.0 per cent);
- *disregard limit:* 0.1 times the area of the principal peak in the electropherogram obtained with reference solution (b) (0.05 per cent); disregard any peak due to the blank.

**Loss on drying** (2.2.32): maximum 0.5 per cent, determined on 1.000 g by drying in an oven at 105 °C.

**Sulfated ash** (2.4.14): maximum 0.1 per cent, determined on 1.0 g in a platinum crucible.

#### ASSAY

Dissolve 0.175 g in 50 mL of *ethanol (96 per cent) R* and add 5.0 mL of 0.01 M *hydrochloric acid*. Carry out a potentiometric titration (2.2.20), using 0.1 M *sodium hydroxide*. Read the volume added between the 1<sup>st</sup> and 3<sup>rd</sup> point of inflexion.

1 mL of 0.1 M *sodium hydroxide* is equivalent to 22.85 mg of  $C_{26}H_{30}ClFN_2O_2$ .

#### STORAGE

Protected from light.

#### IMPURITIES

**Specified impurities:** A, B, C, D, E.

**Other detectable impurities** (the following substances would, if present at a sufficient level, be detected by one or other of the tests in the monograph. They are limited by the general acceptance criterion for other/unspecified impurities and/or by the general monograph *Substances for pharmaceutical use* (2034). It is therefore not necessary to identify these impurities for demonstration of compliance. See also 5.10. *Control of impurities in substances for pharmaceutical use*): F, G, H, I.

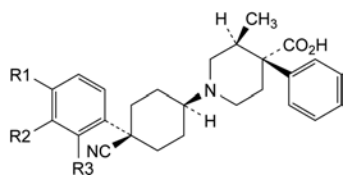
01/2008:1339  
corrected 6.0

- A. R1 = R2 = R3 = H: (3*S*,4*R*)-1-[(*cis*-4-cyano-4-phenylcyclohexyl)-3-methyl-4-phenylpiperidine-4-carboxylic acid,
- B. R1 = R2 = H, R3 = F: (3*S*,4*R*)-1-[(*cis*-4-cyano-4-(2-fluorophenyl)cyclohexyl)-3-methyl-4-phenylpiperidine-4-carboxylic acid,
- C. R1 = H, R2 = F, R3 = H: (3*S*,4*R*)-1-[(*cis*-4-cyano-4-(3-fluorophenyl)cyclohexyl)-3-methyl-4-phenylpiperidine-4-carboxylic acid,

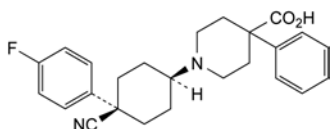

- D. 1-[(*cis*-4-cyano-4-(4-fluorophenyl)cyclohexyl)-4-phenylpiperidine-4-carboxylic acid,

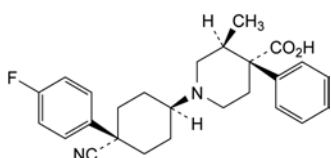

- E. (3*S*,4*R*)-1-[(*trans*-4-cyano-4-(4-fluorophenyl)cyclohexyl)-3-methyl-4-phenylpiperidine-4-carboxylic acid,

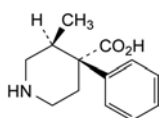

- F. (3*S*,4*R*)-3-methyl-4-phenylpiperidine-4-carboxylic acid,

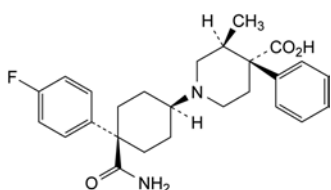

- G. (3*S*,4*R*)-1-[(*cis*-4-carbamoyl-4-(4-fluorophenyl)cyclohexyl)-3-methyl-4-phenylpiperidine-4-carboxylic acid,

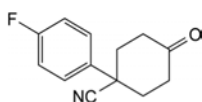

- H. 1-(4-fluorophenyl)-4-oxocyclohexanecarbonitrile,

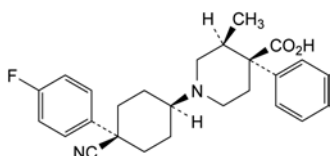

- I. (3*S*,4*S*)-1-[(*cis*-4-cyano-4-(4-fluorophenyl)cyclohexyl)-3-methyl-4-phenylpiperidine-4-carboxylic acid.

## LEVOCARNITINE

### Levocarnitinum

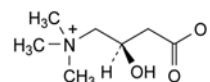

$C_7H_{15}NO_3$   
[541-15-1]

$M_r$  161.2

#### DEFINITION

(3*R*)-3-Hydroxy-4-(trimethylammonio)butanoate.

*Content*: 98.0 per cent to 102.0 per cent (anhydrous substance).

#### CHARACTERS

*Appearance*: white or almost white, crystalline powder or colourless crystals, hygroscopic.

*Solubility*: freely soluble in water, soluble in warm ethanol (96 per cent), practically insoluble in acetone.

#### IDENTIFICATION

*First identification*: A, B.

*Second identification*: A, C.

A. Specific optical rotation (see Tests).

B. Infrared absorption spectrophotometry (2.2.24).

*Preparation*: discs, prepared using substance previously dried *in vacuo* at 50 °C for 5 h.

*Comparison*: levocarnitine CRS.

C. To 1 mL of solution S (see Tests) add 9 mL of *water R*, 10 mL of *dilute sulfuric acid R* and 30 mL of *ammonium reineckate solution R*. A pink precipitate is formed. Allow to stand for 30 min. Filter and wash with *water R*, with *ethanol (96 per cent) R* and then with *acetone R* and dry at 80 °C. The precipitate melts (2.2.14) at 147 °C to 150 °C.

#### TESTS

**Solution S.** Dissolve 5.00 g in *carbon dioxide-free water R* prepared from *distilled water R* and dilute to 50.0 mL with the same solvent.

**Appearance of solution.** Solution S is clear (2.2.1) and colourless (2.2.2, *Method II*).

**pH (2.2.3)**: 6.5 to 8.5.

Dilute 10 mL of solution S to 20 mL with *carbon dioxide-free water R*.

**Specific optical rotation (2.2.7)**: –29.0 to –32.0 (anhydrous substance), determined on solution S at 25 °C.

**Related substances.** Liquid chromatography (2.2.29).

*Test solution.* Dissolve 0.10 g of the substance to be examined in the mobile phase and dilute to 20.0 mL with the mobile phase.

*Reference solution (a).* Dilute 1.0 mL of the test solution to 100.0 mL with the mobile phase. Dilute 1.0 mL of this solution to 10.0 mL with the mobile phase.

*Reference solution (b).* Dissolve 12.5 mg of *levocarnitine impurity A CRS* in *water R* and dilute to 50.0 mL with the same solvent. Dilute 2.0 mL of this solution to 20.0 mL with the mobile phase.

*Reference solution (c).* Dissolve 10.0 mg of *levocarnitine impurity A CRS* in *water R* and dilute to 10.0 mL with the same solvent. Dilute 2.0 mL of this solution to 20.0 mL with the mobile phase.

*Reference solution (d).* Dissolve 0.100 g of *levocarnitine CRS* in reference solution (c) and dilute to 10.0 mL with the same solution.



## Column:

- size:  $l = 0.30$  m,  $\varnothing = 3.9$  mm;
- stationary phase: aminopropylmethylsilyl silica gel for chromatography R (10  $\mu$ m);
- temperature: 30 °C.

Mobile phase: mix 35 volumes of a 6.81 g/L solution of potassium dihydrogen phosphate R adjusted to pH 4.7 with dilute sodium hydroxide solution R, and 65 volumes of acetonitrile R.

Flow rate: 1 mL/min.

Detection: spectrophotometer at 205 nm.

Injection: 25  $\mu$ L of the test solution and reference solutions (a), (b) and (d).

Retention time: levocarnitine = about 9.6 min; impurity A = about 10.6 min.

System suitability: reference solution (d):

- resolution: minimum 0.9 between the peaks due to levocarnitine and impurity A when the chromatogram is recorded over 15 min.

## Limits:

- impurity A: not more than the area of the principal peak in the chromatogram obtained with reference solution (b) (0.5 per cent);
- unspecified impurities: for each impurity, not more than the area of the principal peak in the chromatogram obtained with reference solution (a) (0.10 per cent).

**Chlorides** (2.4.4): maximum 200 ppm.

Dilute 2.5 mL of solution S to 15 mL with water R.

**Sulfates** (2.4.13): maximum 300 ppm.

Dilute 5 mL of solution S to 15 mL with distilled water R.

**Heavy metals** (2.4.8): maximum 10 ppm.

12 mL of solution S complies with test A. Prepare the reference solution using lead standard solution (1 ppm Pb) R.

**Water** (2.5.12): maximum 1.0 per cent, determined on 2.00 g.

**Sulfated ash** (2.4.14): maximum 0.1 per cent, determined on 1.0 g.

## ASSAY

Dissolve 0.125 g in a mixture of 3 volumes of anhydrous formic acid R and 50 volumes of anhydrous acetic acid R. Add 0.2 mL of crystal violet solution R. Titrate with 0.1 M perchloric acid until the colour changes from violet to green.

1 mL of 0.1 M perchloric acid is equivalent to 16.12 mg of  $C_7H_{15}NO_3$ .

## STORAGE

In an airtight container.

## IMPURITIES

Specified impurities: A.

Other detectable impurities (the following substances would, if present at a sufficient level, be detected by one or other of the tests in the monograph. They are limited by the general acceptance criterion for other/unspecified impurities and/or by the general monograph *Substances for pharmaceutical use* (2034). It is therefore not necessary to identify these impurities for demonstration of compliance. See also 5.10. *Control of impurities in substances for pharmaceutical use*): B, C, D.

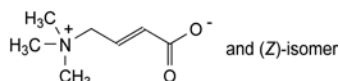

A. (*E*)- or (*Z*)-4-(trimethylammonio)but-2-enoate,

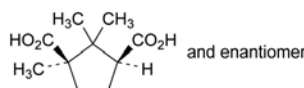

B. (*1R,3S*)-1,2,2-trimethylcyclopentane-1,3-dicarboxylic acid (camphoric acid),

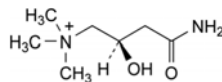

C. (*2R*)-4-amino-2-hydroxy-*N,N,N*-trimethyl-4-oxobutan-1-aminium (carnitinamide),

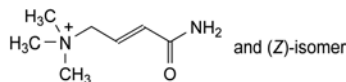

D. (*E*)- or (*Z*)-4-amino-*N,N,N*-trimethyl-4-oxobut-2-en-1-aminium.

01/2008:0038  
corrected 7.0

## LEVODOPA

## Levodopum

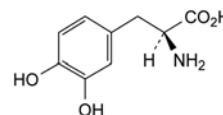

$C_9H_{11}NO_4$   
[59-92-7]

$M_r$  197.2

## DEFINITION

(2*S*)-2-Amino-3-(3,4-dihydroxyphenyl)propanoic acid.

Content: 99.0 per cent to 101.0 per cent (dried substance).

## CHARACTERS

Appearance: white or almost white, crystalline powder.

Solubility: slightly soluble in water, practically insoluble in ethanol (96 per cent). It is freely soluble in 1 M hydrochloric acid and sparingly soluble in 0.1 M hydrochloric acid.

## IDENTIFICATION

Infrared absorption spectrophotometry (2.2.24).

Comparison: levodopa CRS.

## TESTS

Appearance of solution. The solution is not more intensely coloured than reference solution BY<sub>6</sub> (2.2.2, Method II).

Dissolve 1.0 g in a 103 g/L solution of hydrochloric acid R and dilute to 25 mL with the same solution.

pH (2.2.3): 4.5 to 7.0.

Shake 0.10 g with 10 mL of carbon dioxide-free water R for 15 min.

## Related substances

Liquid chromatography (2.2.29). Use freshly prepared solutions.

Solution A. 10.3 g/L solution of hydrochloric acid R.

Test solution. Dissolve 0.100 g of the substance to be examined in solution A and dilute to 25 mL with solution A.

Reference solution (a). Dilute 1.0 mL of the test solution to 50.0 mL with solution A. Dilute 5.0 mL of this solution to 100.0 mL with solution A.

Reference solution (b). Dissolve 8 mg of tyrosine R (impurity B) and 4 mg of 3-methoxy-*L*-tyrosine R (*L*-isomer of impurity C) in 2 mL of the test solution and dilute to 50 mL with solution A. Dilute 5 mL of this solution to 100 mL with solution A.

**Column:**

- size:  $l = 0.25$  m,  $\varnothing = 4.6$  mm;
- stationary phase: spherical *di-isobutyloctadecylsilyl silica gel for chromatography R* (5  $\mu$ m) with a pore size of 8 nm.

**Mobile phase:**

- mobile phase A: 0.1 M phosphate buffer solution pH 3.0;
- mobile phase B: methanol R, 0.1 M phosphate buffer solution pH 3.0 (18:85 V/V);

Time (min)	Mobile phase A (per cent V/V)	Mobile phase B (per cent V/V)
0 - 18	90	10
18 - 22	90 $\rightarrow$ 0	10 $\rightarrow$ 100
22 - 35	0	100

Flow rate: 1 mL/min.

Detection: spectrophotometer at 280 nm.

Injection: 20  $\mu$ L.

Relative retention with reference to levodopa (retention time = about 6 min): impurity A = about 0.7; impurity B = about 2; impurity C = about 3.5.

System suitability: reference solution (b):

- resolution: minimum 10 between the peaks due to levodopa and impurity B.

**Limits:**

- correction factor: for the calculation of content, multiply the peak area of impurity B by 2.2;
- impurity A: not more than the area of the principal peak in the chromatogram obtained with reference solution (a) (0.1 per cent);
- impurity B: not more than 5 times the area of the principal peak in the chromatogram obtained with reference solution (a) (0.5 per cent);
- impurity C: not more than twice the area of the principal peak in the chromatogram obtained with reference solution (a) (0.2 per cent);
- unspecified impurities: for each impurity, not more than 0.5 times the area of the principal peak in the chromatogram obtained with reference solution (a) (0.05 per cent);
- total: not more than 10 times the area of the principal peak in the chromatogram obtained with reference solution (a) (1.0 per cent);
- disregard limit: 0.3 times the area of the principal peak in the chromatogram obtained with reference solution (a) (0.03 per cent).

**Enantiomeric purity.** Liquid chromatography (2.2.29). Use freshly prepared solutions.

**Test solution.** Dissolve 25 mg of the substance to be examined in the mobile phase and dilute to 25 mL with the mobile phase.

**Reference solution (a).** Dilute 5.0 mL of the test solution to 20.0 mL with the mobile phase. Dilute 1.0 mL of this solution to 50.0 mL with the mobile phase.

**Reference solution (b).** Dissolve 10 mg of *D-dopa R* (impurity D) in 10 mL of the test solution. Dilute 1 mL of this solution to 100 mL with the mobile phase.

**Column:**

- size:  $l = 0.15$  m,  $\varnothing = 3.9$  mm;
- stationary phase: spherical *end-capped octadecylsilyl silica gel for chromatography R* (5  $\mu$ m) with a specific surface area of 350 m<sup>2</sup>/g and a pore size of 10 nm.

**Mobile phase:** dissolve separately 200 mg of *copper acetate R* and 387 mg of *N,N-dimethyl-L-phenylalanine R* in water R; mix the 2 solutions and adjust immediately to pH 4.0 with *acetic acid R*; add 50 mL of *methanol R* and dilute to 1000 mL with water R; mix and filter.

Flow rate: 1 mL/min.

Detection: spectrophotometer at 280 nm.

Injection: 20  $\mu$ L.

Run time: twice the retention time of levodopa.

Relative retention with reference to levodopa (retention time = about 7 min): impurity D = about 0.4.

System suitability: reference solution (b):

- resolution: minimum 5 between the peaks due to impurity D and levodopa.

**Limit:**

- impurity D: not more than the area of the principal peak in the chromatogram obtained with reference solution (a) (0.5 per cent).

**Heavy metals (2.4.8):** maximum 10 ppm.

2.0 g complies with test C. Prepare the reference solution using 2 mL of *lead standard solution (10 ppm Pb) R*.

**Loss on drying (2.2.32):** maximum 1.0 per cent, determined on 0.500 g by drying in an oven at 105 °C.

**Sulfated ash (2.4.14):** maximum 0.1 per cent, determined on 1.0 g.

**ASSAY**

Dissolve 0.180 g, heating if necessary, in 5 mL of *anhydrous formic acid R*. Add 25 mL of *anhydrous acetic acid R*. Add 25 mL of *dioxan R* and 0.1 mL of *crystal violet solution R*. Titrate with 0.1 M *perchloric acid*, until a green colour is obtained.

1 mL of 0.1 M *perchloric acid* is equivalent to 19.72 mg of C<sub>9</sub>H<sub>11</sub>NO<sub>4</sub>.

**STORAGE**

Protected from light.

**IMPURITIES**

Specified impurities: A, B, C, D.

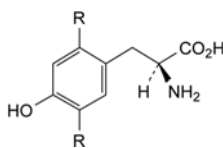

A. R = OH: (2*S*)-2-amino-3-(2,4,5-trihydroxyphenyl)propanoic acid,

B. R = H: (2*S*)-2-amino-3-(4-hydroxyphenyl)propanoic acid (tyrosine),

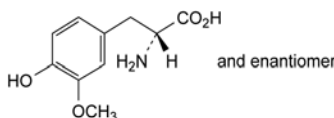

C. (2*RS*)-2-amino-3-(4-hydroxy-3-methoxyphenyl)propanoic acid (3-methoxy-DL-tyrosine),

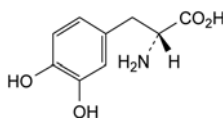

D. (2*R*)-2-amino-3-(3,4-dihydroxyphenyl)propanoic acid (D-dopa).

01/2011:1535 *Limits:***LEVODROPROPIZINE**

## Levodropropizinum

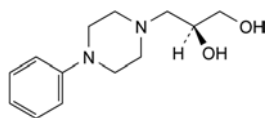

$C_{13}H_{20}N_2O_2$   
[99291-25-5]

 $M_r$  236.3**DEFINITION**(2*S*)-3-(4-Phenylpiperazin-1-yl)propane-1,2-diol.*Content:* 98.5 per cent to 101.0 per cent (dried substance).**CHARACTERS***Appearance:* white or almost white powder.*Solubility:* slightly soluble in water, freely soluble in dilute acetic acid and in methanol, slightly soluble in ethanol (96 per cent).**IDENTIFICATION**

Carry out either tests A, B or tests B, C.

A. Specific optical rotation (2.2.7): –30.0 to –33.5 (dried substance).

Dissolve 1.50 g in a 21 g/L solution of *hydrochloric acid R* and dilute to 50.0 mL with the same acid.

B. Infrared absorption spectrophotometry (2.2.24).

*Comparison:* *levodropropizine CRS*.

C. Enantiomeric purity (see Tests).

**TESTS****pH** (2.2.3): 9.2 to 10.2.Suspend 2.5 g in *carbon dioxide-free water R*, heat to dissolve, cool to room temperature and dilute to 100 mL with the same solvent.**Impurity B and related substances.** Liquid chromatography (2.2.29).*Test solution.* Dissolve 25.0 mg of the substance to be examined in the mobile phase and dilute to 50.0 mL with the mobile phase.*Reference solution (a).* Dissolve 25.0 mg of *levodropropizine impurity B CRS* in *methanol R* and dilute to 100.0 mL with the same solvent. Dilute 1.0 mL of this solution to 100.0 mL with the mobile phase.*Reference solution (b).* Mix 1.0 mL of the test solution with 1.0 mL of reference solution (a).*Column:*

- *size:*  $l = 0.15$  m,  $\varnothing = 4.6$  mm;
- *stationary phase:* *end-capped octadecylsilyl silica gel for chromatography R* (5  $\mu$ m).

*Mobile phase:* mix 12 volumes of *methanol R* and 88 volumes of a 6.81 g/L solution of *potassium dihydrogen phosphate R* adjusted to pH 3.0 with *phosphoric acid R*.*Flow rate:* 1.5 mL/min.*Detection:* spectrophotometer at 254 nm.*Injection:* 20  $\mu$ L.*Run time:* twice the retention time of levodropropizine.*Relative retention* with reference to levodropropizine (retention time = about 7 min): impurity B = about 1.2.*System suitability:* reference solution (b):

- *resolution:* minimum 2.0 between the peaks due to levodropropizine and impurity B.

- *impurity B:* not more than the area of the corresponding peak in the chromatogram obtained with reference solution (a) (0.5 per cent);

- *unspecified impurities:* for each impurity, not more than 0.2 times the area of the peak due to impurity B in the chromatogram obtained with reference solution (a) (0.10 per cent);

- *total:* not more than 1.2 times the area of the peak due to impurity B in the chromatogram obtained with reference solution (a) (0.6 per cent);

- *disregard limit:* 0.1 times the area of the peak due to impurity B in the chromatogram obtained with reference solution (a) (0.05 per cent).

**Impurity C.** Gas chromatography (2.2.28). *Prepare the solutions immediately before use.**Test solution.* Dissolve 0.50 g of the substance to be examined in *methylene chloride R* and dilute to 2.5 mL with the same solvent.*Reference solution (a).* Dissolve 0.20 g of *levodropropizine impurity C CRS* in *methylene chloride R* and dilute to 100.0 mL with the same solvent. Dilute 0.5 mL of this solution to 100.0 mL with *methylene chloride R*.*Reference solution (b).* Dissolve 0.50 g of the substance to be examined in *methylene chloride R*, add 250  $\mu$ L of reference solution (a) and dilute to 2.5 mL with *methylene chloride R*.*Column:*

- *material:* fused silica;
- *size:*  $l = 30$  m,  $\varnothing = 0.53$  mm;
- *stationary phase:* *poly[(cyanopropyl)(phenyl)][dimethyl]siloxane R* (film thickness 3  $\mu$ m).

*Carrier gas:* *helium for chromatography R*.*Flow rate:* 2.5 mL/min.*Split ratio:* 1:8.*Temperature:*

- *column:* 140 °C;
- *injection port:* 170 °C;
- *detector:* 250 °C.

*Detection:* flame ionisation.*Injection:* 1  $\mu$ L of the test solution and reference solution (b).

Use an appropriate split-liner, e.g. consisting of a column about 1 cm long packed with glass wool.

*Run time:* 2.5 times the retention time of impurity C.*System suitability:* reference solution (b):

- *signal-to-noise ratio:* minimum 10 for the peak due to impurity C.

At the end of a series of tests, heat the column at 250 °C for 4–6 h.

*Limit:*

- *impurity C:* not more than 0.5 times the area of the corresponding peak in the chromatogram obtained with reference solution (b) (5 ppm).

**Enantiomeric purity.** Liquid chromatography (2.2.29).*Solvent mixture:* *anhydrous ethanol R*, *hexane R* (40:60 V/V).*Test solution.* Dissolve 10.0 mg of the substance to be examined in 10.0 mL of the solvent mixture. Dilute 1.0 mL of this solution to 50.0 mL with the solvent mixture.*Reference solution (a).* Dissolve 10 mg of *levodropropizine CRS* in 10.0 mL of the solvent mixture. Dilute 1.0 mL of this solution to 50.0 mL with the solvent mixture.*Reference solution (b).* Dissolve 10.0 mg of *levodropropizine impurity A CRS* in 10.0 mL of the solvent mixture. Dilute 1.0 mL of this solution to 50.0 mL with the solvent mixture.*Reference solution (c).* Dilute 1.0 mL of reference solution (b) to 50.0 mL with the solvent mixture.

01/2008:0619

*Reference solution (d).* Dilute 0.5 mL of reference solution (b) to 25 mL with reference solution (a).

*Column:*

- *size:*  $l = 0.25$  m,  $\varnothing = 4.6$  mm;
- *stationary phase:* silica gel OD for chiral separations R.

*Mobile phase:* diethylamine R, anhydrous ethanol R, hexane R (0.2:5:95 V/V/V).

*Flow rate:* 0.8 mL/min.

*Detection:* spectrophotometer at 254 nm.

*Injection:* 20  $\mu$ L of the test solution and reference solutions (a), (c) and (d).

*Elution order:* impurity A, levodropropizine.

*System suitability:*

- *retention times:* the retention times of the principal peaks in the chromatograms obtained with the test solution and reference solution (a) are similar;
- *resolution:* minimum 1.3 between the peaks due to impurity A and levodropropizine in the chromatogram obtained with reference solution (d).

*Limit:*

- *impurity A:* not more than the area of the corresponding peak in the chromatogram obtained with reference solution (c) (2 per cent).

**Loss on drying (2.2.32):** maximum 1.0 per cent, determined on 0.500 g by drying *in vacuo* at 60 °C over diphosphorus pentoxide R at a pressure of 0.15–0.25 kPa for 4 h.

**Sulfated ash (2.4.14):** maximum 0.2 per cent, determined on 1.0 g.

#### ASSAY

Dissolve 0.100 g in 50 mL of anhydrous acetic acid R. Carry out a potentiometric titration (2.2.20), using 0.1 M perchloric acid. Read the volume added at the 2<sup>nd</sup> point of inflexion.

1 mL of 0.1 M perchloric acid is equivalent to 11.82 mg of  $C_{10}H_{20}O$ .

#### STORAGE

Protected from light.

#### IMPURITIES

*Specified impurities:* A, B, C.

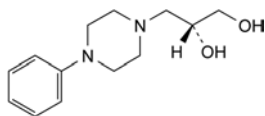

A. (2R)-3-(4-phenylpiperazin-1-yl)propane-1,2-diol (dextropropizine),

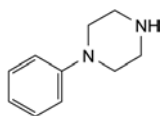

B. 1-phenylpiperazine,

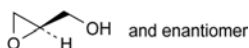

C. [(2R)-oxiran-2-yl]methanol (glycidol).

## LEVOMENTHOL

### Levomentholum

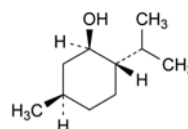

$C_{10}H_{20}O$   
[2216-51-5]

$M_r$  156.3

#### DEFINITION

(1R,2S,5R)-5-Methyl-2-(1-methylethyl)cyclohexanol.

#### CHARACTERS

*Appearance:* prismatic or acicular, colourless, shiny crystals.

*Solubility:* practically insoluble in water, very soluble in ethanol (96 per cent) and in light petroleum, freely soluble in fatty oils and in liquid paraffin, very slightly soluble in glycerol.

mp: about 43 °C.

#### IDENTIFICATION

*First identification:* A, C.

*Second identification:* B, D.

A. Specific optical rotation (see Tests).

B. Thin-layer chromatography (2.2.27).

*Test solution.* Dissolve 25 mg of the substance to be examined in methanol R and dilute to 5 mL with the same solvent.

*Reference solution.* Dissolve 25 mg of menthol CRS in methanol R and dilute to 5 mL with the same solvent.

*Plate:* TLC silica gel G plate R.

*Mobile phase:* ethyl acetate R, toluene R (5:95 V/V).

*Application:* 2  $\mu$ L.

*Development:* over a path of 15 cm.

*Drying:* in air, until the solvents have evaporated.

*Detection:* spray with anisaldehyde solution R and heat at 100–105 °C for 5–10 min.

*Results:* the principal spot in the chromatogram obtained with the test solution is similar in position, colour and size to the principal spot in the chromatogram obtained with the reference solution.

C. Examine the chromatograms obtained in the test for related substances.

*Results:* the principal peak in the chromatogram obtained with test solution (b) is similar in position and approximate dimensions to the principal peak in the chromatogram obtained with reference solution (c).

D. Dissolve 0.20 g in 0.5 mL of anhydrous pyridine R. Add 3 mL of a 150 g/L solution of dinitrobenzoyl chloride R in anhydrous pyridine R. Heat on a water-bath for 10 min. Add 7.0 mL of water R in small quantities with stirring and allow to stand in iced water for 30 min. A precipitate is formed. Allow to stand and decant the supernatant liquid. Wash the precipitate with 2 quantities, each of 5 mL, of iced water R, recrystallise from 10 mL of acetone R, wash with iced acetone R and dry at 75 °C at a pressure not exceeding 2.7 kPa for 30 min. The crystals melt (2.2.14) at 154 °C to 157 °C.

#### TESTS

**Solution S.** Dissolve 2.50 g in 10 mL of ethanol (96 per cent) R and dilute to 25.0 mL with the same solvent.

**Appearance of solution.** Solution S is clear (2.2.1) and colourless (2.2.2, Method II).

**Acidity or alkalinity.** Dissolve 1.0 g in *ethanol (96 per cent) R* and dilute to 10 mL with the same solvent. Add 0.1 mL of *phenolphthalein solution R*. The solution is colourless. Not more than 0.5 mL of 0.01 M *sodium hydroxide* is required to change the colour of the indicator to pink.

**Specific optical rotation (2.2.7):** – 48 to – 51, determined on solution S.

**Related substances.** Gas chromatography (2.2.28).

**Test solution (a).** Dissolve 0.20 g of the substance to be examined in *methylene chloride R* and dilute to 50.0 mL with the same solvent.

**Test solution (b).** Dilute 1.0 mL of test solution (a) to 10.0 mL with *methylene chloride R*.

**Reference solution (a).** Dissolve 40.0 mg of the substance to be examined and 40.0 mg of *isomenthol R* in *methylene chloride R* and dilute to 100.0 mL with the same solvent.

**Reference solution (b).** Dilute 0.10 mL of test solution (a) to 100.0 mL with *methylene chloride R*.

**Reference solution (c).** Dissolve 40.0 mg of *menthol CRS* in *methylene chloride R* and dilute to 100.0 mL with the same solvent.

**Column:**

- **material:** glass;
- **size:**  $l = 2.0$  m,  $\varnothing = 2$  mm;
- **stationary phase:** *diatomaceous earth for gas chromatography R* impregnated with 15 per cent *m/m* of *macrogol 1500 R*.

**Carrier gas:** *nitrogen for chromatography R*.

**Flow rate:** 30 mL/min.

**Temperature:**

- **column:** 120 °C;
- **injection port:** 150 °C;
- **detector:** 200 °C.

**Detection:** flame ionisation.

**Injection:** 1 µL.

**Run time:** twice the retention time of *menthol*.

**System suitability:**

- **resolution:** minimum 1.4 between the peaks due to *menthol* and *isomenthol* in the chromatogram obtained with reference solution (a);
- **signal-to-noise ratio:** minimum 5 for the principal peak in the chromatogram obtained with reference solution (b).

**Limits:** test solution (a):

- **total:** not more than 1 per cent of the area of the principal peak;
- **disregard limit:** 0.05 per cent of the area of the principal peak.

**Residue on evaporation:** maximum 0.05 per cent.

Evaporate 2.00 g on a water-bath and heat in an oven at 100–105 °C for 1 h. The residue weighs not more than 1.0 mg.

01/2008:0505  
corrected 6.0

## LEVOMEPRMAZINE HYDROCHLORIDE

### Levomepromazini hydrochloridum

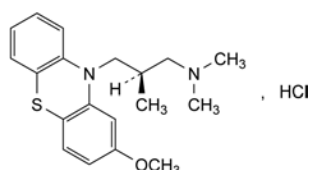

$C_{19}H_{25}ClN_2OS$   
[1236-99-3]

$M_r$  364.9

## DEFINITION

Levomepromazine hydrochloride contains not less than 98.5 per cent and not more than the equivalent of 101.0 per cent of (2*R*)-3-(2-methoxy-10*H*-phenothiazin-10-yl)-*N,N*,2-trimethylpropan-1-amine hydrochloride, calculated with reference to the dried substance.

## CHARACTERS

A white or very slightly yellow, crystalline powder, slightly hygroscopic, freely soluble in water and in alcohol. It deteriorates when exposed to air and light. It exists in two forms, one melting at about 142 °C and the other at about 162 °C.

## IDENTIFICATION

- A. **Prepare the solution protected from bright light and carry out the measurements immediately.** Dissolve 50.0 mg in *water R* and dilute to 500.0 mL with the same solvent. Dilute 10.0 mL of this solution to 100.0 mL with *water R*. Examined between 230 nm and 340 nm (2.2.25), the solution shows two absorption maxima, at 250 nm and 302 nm. The specific absorbance at the maximum at 250 nm is 640 to 700.
- B. It complies with the identification test for phenothiazines by thin-layer chromatography (2.3.3): use *levomepromazine hydrochloride CRS* to prepare the reference solution.
- C. Introduce 0.2 g into a 100 mL separating funnel. Add 5 mL of *water R* and 0.5 mL of *strong sodium hydroxide solution R*. Shake vigorously with two quantities, each of 10 mL, of *ether R*. Combine the ether layers, dry over *anhydrous sodium sulfate R* and evaporate to dryness. Keep the residue at 100 °C to 105 °C for 15 min and allow to crystallise in iced water. Initiate crystallisation if necessary by scratching the wall of the flask with a glass rod. Dry the crystals at 60 °C for 2 h. The crystals melt (2.2.14) at 122 °C to 128 °C.
- D. It gives reaction (b) of chlorides (2.3.1).

## TESTS

**Solution S.** Dissolve 2.50 g in *carbon dioxide-free water R* and dilute to 25.0 mL with the same solvent.

**Acidity or alkalinity.** To 10 mL of solution S add 0.1 mL of *bromocresol green solution R*. Not more than 0.5 mL of 0.01 M *sodium hydroxide* or 1.0 mL of 0.01 M *hydrochloric acid* is required to change the colour of the indicator.

**Specific optical rotation (2.2.7):** + 9.5 to + 11.5, determined on solution S and calculated with reference to the dried substance.

**Related substances.** Carry out the test protected from bright light. Examine by thin-layer chromatography (2.2.27), using *silica gel GF<sub>254</sub> R* as the coating substance.

**Test solution.** Dissolve 0.2 g of the substance to be examined in a mixture of 5 volumes of *diethylamine R* and 95 volumes of *methanol R* and dilute to 10 mL with the same mixture of solvents. Prepare immediately before use.

**Reference solution.** Dilute 0.5 mL of the test solution to 100 mL with a mixture of 5 volumes of *diethylamine R* and 95 volumes of *methanol R*.

Apply separately to the plate 10 µL of each solution. Develop over a path of 15 cm using a mixture of 10 volumes of *acetone R*, 10 volumes of *diethylamine R* and 80 volumes of *cyclohexane R*. Allow the plate to dry in air and examine in ultraviolet light at 254 nm. Any spot in the chromatogram obtained with the test solution, apart from the principal spot, is not more intense than the spot in the chromatogram obtained with the reference solution (0.5 per cent).

**Loss on drying (2.2.32).** Not more than 1.0 per cent, determined on 1.000 g by drying in an oven at 105 °C for 3 h.

**Sulfated ash (2.4.14).** Not more than 0.1 per cent, determined on 1.0 g.

## ASSAY

Dissolve 0.300 g in 5 mL of *water R* and add 50 mL of *2-propanol R*. Titrate with *0.1 M sodium hydroxide*, determining the end-point potentiometrically (2.2.20).

1 mL of *0.1 M sodium hydroxide* is equivalent to 36.49 mg of  $C_{19}H_{25}ClN_2OS$ .

## STORAGE

Store in an airtight container, protected from light.

01/2008:0925  
corrected 6.0

## LEVOMEPRMAZINE MALEATE

## Levomepromazini maleas

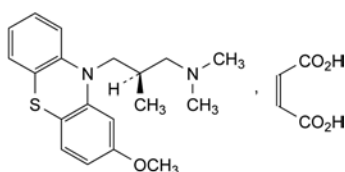

$C_{23}H_{28}N_2O_5S$   
[7104-38-3]

$M_r$  444.6

## DEFINITION

Levomepromazine maleate contains not less than 98.5 per cent and not more than the equivalent of 101.0 per cent of (2*R*)-3-(2-methoxy-10*H*-phenothiazin-10-yl)-*N,N*,2-trimethylpropan-1-amine (*Z*)-butenedioate, calculated with reference to the dried substance.

## CHARACTERS

A white or slightly yellowish, crystalline powder, slightly soluble in water, sparingly soluble in methylene chloride, slightly soluble in alcohol. It deteriorates when exposed to air and light.

It melts at about 186 °C, with decomposition.

## IDENTIFICATION

*First identification:* A, B.

*Second identification:* A, C, D.

- A. Specific optical rotation (see Tests).
- B. Examine by infrared absorption spectrophotometry (2.2.24), comparing with the spectrum obtained with *levomepromazine maleate CRS*. Examine the substances prepared as discs.
- C. Identification test for phenothiazines by thin-layer chromatography (2.3.3): use *levomepromazine maleate CRS* to prepare the reference solution.
- D. Examine by thin-layer chromatography (2.2.27), using *silica gel GF<sub>254</sub> R* as the coating substance.

*Test solution.* Dissolve 0.20 g of the substance to be examined in a mixture of 10 volumes of *water R* and 90 volumes of *acetone R* and dilute to 10 mL with the same mixture of solvents.

*Reference solution.* Dissolve 50 mg of *maleic acid CRS* in a mixture of 10 volumes of *water R* and 90 volumes of *acetone R* and dilute to 10 mL with the same mixture of solvents.

Apply separately to the plate as bands 10 mm by 2 mm 5 µL of each solution. Develop over a path of 12 cm using a mixture of 3 volumes of *water R*, 7 volumes of *anhydrous*

*formic acid R* and 90 volumes of *di-isopropyl ether R*. Dry the plate at 120 °C for 10 min and examine in ultraviolet light at 254 nm. The chromatogram obtained with the test solution shows a band at the point of application and another band similar in position and size to the principal band in the chromatogram obtained with the reference solution.

## TESTS

**pH** (2.2.3). Carry out the test protected from bright light. Introduce 0.50 g into a conical flask and add 25.0 mL of *carbon dioxide-free water R*. Shake and allow the solids to settle. The pH of the supernatant solution is 3.5 to 5.5.

**Specific optical rotation** (2.2.7). Dissolve 1.25 g in *dimethylformamide R* and dilute to 25.0 mL with the same solvent. The specific optical rotation is –7.0 to –8.5, calculated with reference to the dried substance.

**Related substances.** Carry out the test protected from bright light and prepare the solutions immediately before use. Examine by thin-layer chromatography (2.2.27), using *silica gel GF<sub>254</sub> R* as the coating substance.

*Test solution.* Dissolve 0.20 g of the substance to be examined in a mixture of 10 volumes of *water R* and 90 volumes of *acetone R* and dilute to 10 mL with the same mixture of solvents.

*Reference solution.* Dilute 0.5 mL of the test solution to 100 mL with a mixture of 10 volumes of *water R* and 90 volumes of *acetone R*.

Apply separately to the plate 10 µL of each solution. Develop over a path of 15 cm using a mixture of 10 volumes of *acetone R*, 10 volumes of *diethylamine R* and 80 volumes of *cyclohexane R*. Allow the plate to dry in air and examine in ultraviolet light at 254 nm. Any spot in the chromatogram obtained with the test solution, apart from the principal spot, is not more intense than the spot in the chromatogram obtained with the reference solution (0.5 per cent).

**Loss on drying** (2.2.32). Not more than 0.5 per cent, determined on 1.000 g by drying in an oven at 105 °C for 3 h.

**Sulfated ash** (2.4.14). Not more than 0.1 per cent, determined on 1.0 g.

## ASSAY

Dissolve 0.350 g in 50 mL of *anhydrous acetic acid R*. Titrate with *0.1 M perchloric acid*, determining the end-point potentiometrically (2.2.20).

1 mL of *0.1 M perchloric acid* is equivalent to 44.46 mg of  $C_{23}H_{28}N_2O_5S$ .

## STORAGE

Store protected from light.

## IMPURITIES

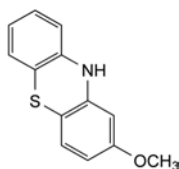

A. 2-methoxyphenothiazine,

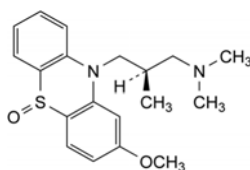

B. 10-[(2*R*)-3-(dimethylamino)-2-methylpropyl]-2-methoxy-10*H*-phenothiazine 5-oxide.

01/2008:1787  
corrected 6.5

## LEVOMETHADONE HYDROCHLORIDE

## Levomethadoni hydrochloridum

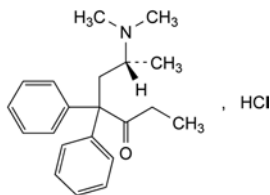
C<sub>21</sub>H<sub>28</sub>ClNO  
[5967-73-7]M<sub>r</sub> 345.9

## DEFINITION

(6*R*)-6-(Dimethylamino)-4,4-diphenylheptan-3-one hydrochloride.

Content: 99.0 per cent to 101.0 per cent (dried substance).

## CHARACTERS

Appearance: white or almost white, crystalline powder.

Solubility: soluble in water, freely soluble in ethanol (96 per cent).

## IDENTIFICATION

First identification: A, C, D.

Second identification: A, B, D.

A. Specific optical rotation (see Tests).

B. Melting point (2.2.14): 239 °C to 242 °C.

C. Infrared absorption spectrophotometry (2.2.24).

Comparison: Ph. Eur. reference spectrum of methadone hydrochloride.

D. Dilute 1 mL of solution S (see Tests) to 5 mL with water R and add 1 mL of dilute ammonia R1. Mix, allow to stand for 5 min and filter. The filtrate gives reaction (a) of chlorides (2.3.1).

## TESTS

**Solution S.** Dissolve 2.50 g in carbon dioxide-free water R and dilute to 50.0 mL with the same solvent.**Appearance of solution.** Solution S is clear (2.2.1) and colourless (2.2.2, Method II).**Acidity or alkalinity.** Dilute 10 mL of solution S to 25 mL with carbon dioxide-free water R. To 10 mL of the solution add 0.2 mL of methyl red solution R and 0.2 mL of 0.01 M sodium hydroxide. The solution is yellow. Add 0.4 mL of 0.01 M hydrochloric acid. The solution is red.**Specific optical rotation** (2.2.7): –125 to –135 (dried substance), determined on solution S.**Related substances.** Liquid chromatography (2.2.29).**Test solution.** Dissolve 25.0 mg of the substance to be examined in the mobile phase and dilute to 100.0 mL with the mobile phase.**Reference solution (a).** Dilute 1.0 mL of the test solution to 50.0 mL with the mobile phase. Dilute 1.0 mL of the solution to 10.0 mL with the mobile phase.**Reference solution (b).** Dissolve 12.0 mg of imipramine hydrochloride CRS in the mobile phase and dilute to 10 mL with the mobile phase. To 1 mL of the solution add 5 mL of the test solution and dilute to 10 mL with the mobile phase.**Column:**

- size:  $l = 0.125$  m,  $\varnothing = 4.6$  mm;
- stationary phase: octadecylsilyl silica gel for chromatography R (5  $\mu$ m);
- temperature: 25 °C.

**Mobile phase:** mix 35 volumes of acetonitrile R and 65 volumes of an 11.5 g/L solution of phosphoric acid R adjusted to pH 3.6 with tetraethylammonium hydroxide solution R.**Flow rate:** 1.0 mL/min.**Detection:** spectrophotometer at 210 nm.**Equilibration:** about 30 min.**Injection:** 10  $\mu$ L.**Run time:** 7 times the retention time of levomethadone.**Retention time:** levomethadone = about 5 min.**System suitability:** reference solution (b):

- resolution: minimum 2.5 between the peaks due to imipramine and levomethadone.

**Limits:**

- any impurity: not more than 0.5 times the area of the principal peak in the chromatogram obtained with reference solution (a) (0.1 per cent);
- total: not more than 2.5 times the area of the principal peak in the chromatogram obtained with reference solution (a) (0.5 per cent);
- disregard limit: 0.25 times the area of the principal peak in the chromatogram obtained with reference solution (a) (0.05 per cent).

**Dextromethadone.** Liquid chromatography (2.2.29).**Test solution.** Dissolve 40.0 mg of the substance to be examined in the mobile phase and dilute to 100.0 mL with the mobile phase.**Reference solution.** Dilute 1.0 mL of the test solution to 10.0 mL with the mobile phase. Dilute 1.0 mL of this solution to 20.0 mL with the mobile phase.**Column:**

- size:  $l = 0.25$  m,  $\varnothing = 4.6$  mm;
- stationary phase: 2-hydroxypropylbetadex for chromatography R (5  $\mu$ m);
- temperature: 10 °C.

**Mobile phase:** mix 1 volume of triethylamine R adjusted to pH 4.0 with phosphoric acid R, 15 volumes of acetonitrile R and 85 volumes of a 13.6 g/L solution of potassium dihydrogen phosphate R.**Flow rate:** 0.7 mL/min.**Detection:** spectrophotometer at 210 nm.**Equilibration:** about 30 min.**Injection:** 10  $\mu$ L.**Relative retention** with reference to levomethadone: dextromethadone = about 1.4.**System suitability:** test solution:

- number of theoretical plates: minimum 2000, calculated for the peak due to levomethadone;
- tailing factor: maximum 3 for the peak due to levomethadone.

**Limit:**

- dextromethadone: not more than the area of the principal peak in the chromatogram obtained with the reference solution (0.5 per cent).

**Loss on drying** (2.2.32): maximum 0.5 per cent, determined on 1.000 g by drying in an oven at 105 °C.**Sulfated ash** (2.4.14): maximum 0.1 per cent, determined on 1.0 g.

## ASSAY

Dissolve 0.300 g in a mixture of 40 mL of water R and 5 mL of acetic acid R. Titrate with 0.1 M silver nitrate. Determine the end-point potentiometrically (2.2.20), using a silver electrode.

1 mL of 0.1 M silver nitrate is equivalent to 34.59 mg of C<sub>21</sub>H<sub>28</sub>ClNO.

## STORAGE

Protected from light.

## IMPURITIES

Specified impurities: A, B, C, D, E, F.

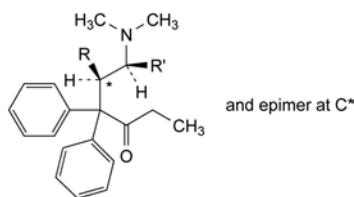

A. R = H, R' = CH<sub>3</sub>: (6*S*)-6-(dimethylamino)-4,4-diphenylheptan-3-one,

D. R = CH<sub>3</sub>, R' = H: (5*RS*)-6-(dimethylamino)-5-methyl-4,4-diphenylhexan-3-one,

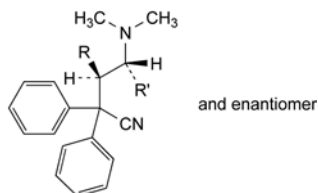

B. R = H, R' = CH<sub>3</sub>: (4*RS*)-4-(dimethylamino)-2,2-diphenylpentanenitrile,

C. R = CH<sub>3</sub>, R' = H: (3*RS*)-4-(dimethylamino)-3-methyl-2,2-diphenylbutanenitrile,

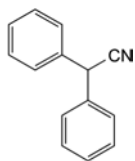

E. diphenylacetonitrile,

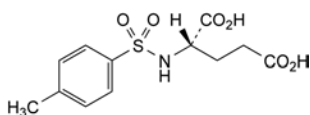

F. (2*S*)-2-[[[4-methylphenyl]sulfonyl]amino]pentanedioic acid (*N*-*p*-tosyl-*L*-glutamic acid).

01/2008:0926  
corrected 6.0

## LEVONORGESTREL

## Levonorgestrelum

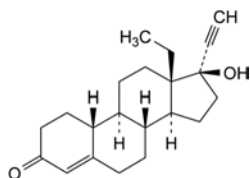

C<sub>21</sub>H<sub>28</sub>O<sub>2</sub>  
[797-63-7]

*M*<sub>r</sub> 312.5

## DEFINITION

Levonorgestrel contains not less than 98.0 per cent and not more than the equivalent of 102.0 per cent of 13-ethyl-17-hydroxy-18,19-dinor-17 $\alpha$ -pregn-4-en-20-yn-3-one, calculated with reference to the dried substance.

## CHARACTERS

A white or almost white, crystalline powder, practically insoluble in water, sparingly soluble in methylene chloride, slightly soluble in alcohol.

## IDENTIFICATION

A. Specific optical rotation (see Tests).

B. Examine by infrared absorption spectrophotometry (2.2.24), comparing with the spectrum obtained with *levonorgestrel CRS*.

## TESTS

**Specific optical rotation** (2.2.7). Dissolve 0.200 g in *chloroform R* and dilute to 10.0 mL with the same solvent. The specific optical rotation is -30 to -35.

**Related substances.** Examine by thin-layer chromatography (2.2.27), using *silica gel G R* as the coating substance.

**Test solution.** Dissolve 0.2 g of the substance to be examined in *chloroform R* and dilute to 10 mL with the same solvent.

**Reference solution (a).** Dilute 1 mL of the test solution to 10 mL with *methylene chloride R*. Dilute 1 mL of this solution to 20 mL with *methylene chloride R*.

**Reference solution (b).** Dilute 4 mL of reference solution (a) to 10 mL with *methylene chloride R*.

**Reference solution (c)** Dissolve 5 mg of *levonorgestrel CRS* and 5 mg of *ethinylestradiol CRS* in *methylene chloride R* and dilute to 50 mL with the same solvent.

Apply separately to the plate 10  $\mu$ L of each solution. Develop over a path of 15 cm using a mixture of 20 volumes of *ethyl acetate R* and 80 volumes of *methylene chloride R*. Allow the plate to dry in air, spray with a 100 g/L solution of *phosphomolybdic acid R* in *alcohol R*, heat at 100 °C to 105 °C for 15 min and examine immediately. Any spot in the chromatogram obtained with the test solution, apart from the principal spot, is not more intense than the principal spot in the chromatogram obtained with reference solution (a) (0.5 per cent) and at most two such spots are more intense than the spot in the chromatogram obtained with reference solution (b) (0.2 per cent). The test is not valid unless the chromatogram obtained with reference solution (c) shows two clearly separated spots.

**Loss on drying** (2.2.32). Not more than 0.5 per cent, determined on 1.000 g by drying in an oven at 105 °C.

**Sulfated ash** (2.4.14). Not more than 0.1 per cent, determined on 1.0 g.

## ASSAY

Dissolve 0.200 g in 45 mL of *tetrahydrofuran R*. Add 10 mL of a 100 g/L solution of *silver nitrate R*. After 1 min, titrate with 0.1 *M sodium hydroxide*, determining the end-point potentiometrically (2.2.20). Carry out a blank titration.

1 mL of 0.1 *M sodium hydroxide* is equivalent to 31.25 mg C<sub>21</sub>H<sub>28</sub>O<sub>2</sub>.

## STORAGE

Store protected from light.

## IMPURITIES

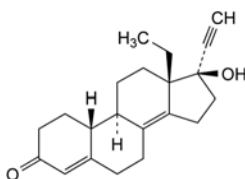

A. 13-ethyl-17-hydroxy-18,19-dinor-17 $\alpha$ -pregna-4,8(14)-dien-20-yn-3-one,



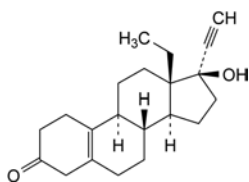

B. 13-ethyl-17-hydroxy-18,19-dinor-17 $\alpha$ -pregn-5(10)-en-20-yn-3-one,

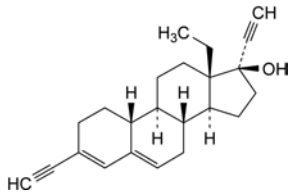

C. 13-ethyl-3-ethynyl-18,19-dinor-17 $\alpha$ -pregna-3,5-dien-20-yn-17-ol,

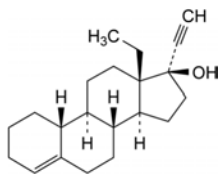

D. 13-ethyl-18,19-dinor-17 $\alpha$ -pregn-4-en-20-yn-17-ol,

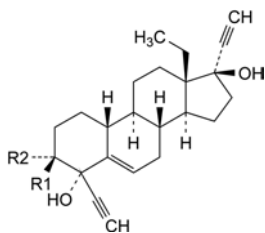

E. R1 = OH, R2 = C $\equiv$ CH: 13-ethyl-3,4-diethynyl-18,19-dinor-17 $\alpha$ -pregn-5-en-20-yn-3 $\beta$ ,4 $\alpha$ ,17-triol,

F. R1 = C $\equiv$ CH, R2 = OH: 13-ethyl-3,4-diethynyl-18,19-dinor-17 $\alpha$ -pregn-5-en-20-yn-3 $\alpha$ ,4 $\alpha$ ,17-triol.

#### IDENTIFICATION

*First identification:* A, B, E.

*Second identification:* A, C, D, E.

A. Specific optical rotation (see Tests).

B. Examine by infrared absorption spectrophotometry (2.2.24), comparing with the spectrum obtained with *levothyroxine sodium CRS*.

C. Examine by thin-layer chromatography (2.2.27), using *silica gel G R* as the coating substance.

*Test solution.* Dissolve 5 mg of the substance to be examined in a mixture of 5 volumes of *concentrated ammonia R* and 70 volumes of *methanol R* and dilute to 5 mL with the same mixture of solvents.

*Reference solution (a).* Dissolve 5 mg of *levothyroxine sodium CRS* in a mixture of 5 volumes of *concentrated ammonia R* and 70 volumes of *methanol R* and dilute to 5 mL with the same mixture of solvents.

*Reference solution (b).* Dissolve 5 mg of *liothyronine sodium CRS* in a mixture of 5 volumes of *concentrated ammonia R* and 70 volumes of *methanol R* and dilute to 5 mL with the same mixture of solvents. Mix 1 mL of this solution and 1 mL of the test solution.

Apply separately to the plate 5  $\mu$ L of each solution. Develop over a path of 15 cm using a mixture of 20 volumes of *concentrated ammonia R*, 35 volumes of *2-propanol R* and 55 volumes of *ethyl acetate R*. Allow the plate to dry in air and spray with *ninhydrin solution R*. Heat at 100-105  $^{\circ}$ C until the spots appear. Examine in daylight. The principal spot in the chromatogram obtained with the test solution is similar in position, colour and size to the principal spot in the chromatogram obtained with reference solution (a). The test is not valid unless the chromatogram obtained with reference solution (b) shows 2 clearly separated spots.

D. To about 50 mg in a porcelain dish add a few drops of *sulfuric acid R* and heat. Violet vapour is evolved.

E. To 200 mg add 2 mL of *dilute sulfuric acid R*. Heat on a water-bath and then carefully over a naked flame, increasing the temperature gradually up to about 600  $\pm$  50  $^{\circ}$ C. Continue the ignition until most of the black particles have disappeared. Dissolve the residue in 2 mL of *water R*. The solution gives reaction (a) of sodium (2.3.1).

01/2008:0401  
corrected 6.0

#### TESTS

**Solution S.** Dissolve 0.500 g in 23 mL of a gently boiling mixture of 1 volume of *1 M hydrochloric acid* and 4 volumes of *ethanol (96 per cent) R*. Cool and dilute to 25.0 mL with the same mixture of solvents.

**Appearance of solution.** Freshly prepared solution S is not more intensely coloured than reference solution BY<sub>3</sub> (2.2.2, *Method II*).

**Specific optical rotation** (2.2.7): + 16 to + 20, determined on solution S and calculated with reference to the dried substance.

**Liothyronine and other related substances.** Examine the chromatograms obtained in the assay. In the chromatogram obtained with test solution (a), the area of any peak due to liothyronine is not greater than that of the principal peak in the chromatogram obtained with reference solution (b) (1.0 per cent) and the sum of the areas of all the peaks apart from the principal peak and any peak due to liothyronine is not greater than the area of the principal peak in the chromatogram obtained with reference solution (a) (1.0 per cent). Disregard any peak with an area less than that of the peak in the chromatogram obtained with reference solution (d).

**Loss on drying** (2.2.32): 6.0 per cent to 12.0 per cent, determined on 0.100 g by drying in an oven at 105  $^{\circ}$ C.

#### ASSAY

Examine by liquid chromatography (2.2.29). *Protect the solutions from light throughout the assay.*

## LEVOTHYROXINE SODIUM

### Levothyroxinum natricum

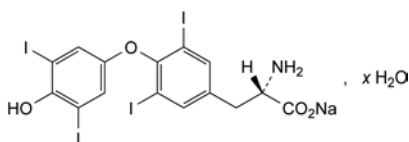

C<sub>15</sub>H<sub>10</sub>I<sub>4</sub>NNaO<sub>4</sub>·xH<sub>2</sub>O  
[55-03-8]

M<sub>r</sub> 799 (anhydrous substance)

#### DEFINITION

Levothyroxine sodium contains not less than 97.0 per cent and not more than the equivalent of 102.0 per cent of sodium (2S)-2-amino-3-[4-(4-hydroxy-3,5-diiodophenoxy)-3,5-diiodophenyl]propanoate, calculated with reference to the dried substance. It contains a variable amount of water.

#### CHARACTERS

An almost white or slightly brownish-yellow powder, or a fine, crystalline powder, very slightly soluble in water, slightly soluble in ethanol (96 per cent). It dissolves in dilute solutions of alkali hydroxides.

**Test solution (a).** Dissolve 20.0 mg of the substance to be examined in *methanolic sodium hydroxide solution R* and dilute to 100.0 mL with the same solvent.

**Test solution (b).** Dilute 2.0 mL of test solution (a) to 200 mL with *methanolic sodium hydroxide solution R*.

**Reference solution (a).** Dissolve 20.0 mg of *levothyroxine sodium CRS* in *methanolic sodium hydroxide solution R* and dilute to 100.0 mL with the same solvent. Dilute 2.0 mL of this solution to 200 mL with *methanolic sodium hydroxide solution R*.

**Reference solution (b).** Dissolve 5 mg of *liothyronine sodium CRS* in *methanolic sodium hydroxide solution R* and dilute to 50.0 mL with the same solvent. Dilute 10.0 mL of the solution to 50 mL with *methanolic sodium hydroxide solution R*. Dilute 10.0 mL of this solution to 100 mL with *methanolic sodium hydroxide solution R*.

**Reference solution (c).** Mix equal volumes of reference solution (a) and reference solution (b).

**Reference solution (d).** Dilute 1 mL of reference solution (a) to 10 mL with *methanolic sodium hydroxide solution R*.

The chromatographic procedure may be carried out using:

- a column 0.25 m long and 4 mm in internal diameter packed with *nitrile silica gel for chromatography R* (5-10 µm);
- as mobile phase at a flow rate of 1 mL/min a mixture of 1 volume of *phosphoric acid R*, 300 volumes of *acetonitrile R* and 700 volumes of *water R*;
- as detector a spectrophotometer set at 225 nm;
- a loop injector.

Inject separately 50 µL of each solution. Continue the chromatography for 3.5 times the retention time of the principal peak. The assay is not valid unless the resolution between the peaks due to levothyroxine and liothyronine in the chromatogram obtained with reference solution (c) is at least 4 and the principal peak in the chromatogram obtained with reference solution (d) has a signal-to-noise ratio of at least 5.

Calculate the percentage content of  $C_{15}H_{10}I_4NNaO_4$  from the declared content of *levothyroxine sodium CRS*.

#### STORAGE

In an airtight container, protected from light, at a temperature of 2 °C to 8 °C.

04/2008:0727

## LIDOCAINE

### Lidocainum

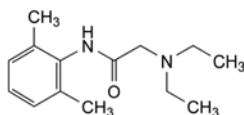

$C_{14}H_{22}N_2O$   
[137-58-6]

$M_r$  234.3

#### DEFINITION

2-(Diethylamino)-*N*-(2,6-dimethylphenyl)acetamide.

**Content:** 99.0 per cent to 101.0 per cent (anhydrous substance).

#### CHARACTERS

**Appearance:** white or almost white, crystalline powder.

**Solubility:** practically insoluble in water, very soluble in ethanol (96 per cent) and in methylene chloride.

#### IDENTIFICATION

**First identification:** A.

**Second identification:** B, C.

A. Infrared absorption spectrophotometry (2.2.24).

**Comparison:** *lidocaine CRS*.

B. Melting point (2.2.14): 66 °C to 70 °C, determined without previous drying.

C. To about 5 mg add 0.5 mL of *fuming nitric acid R*. Evaporate to dryness on a water-bath, cool, and dissolve the residue in 5 mL of *acetone R*. Add 0.2 mL of *alcoholic potassium hydroxide solution R*. A green colour develops.

#### TESTS

**Related substances.** Liquid chromatography (2.2.29).

**Test solution.** Dissolve 50.0 mg of the substance to be examined in the mobile phase and dilute to 10.0 mL with the mobile phase.

**Reference solution (a).** Dissolve 50.0 mg of 2,6-dimethylaniline *R* (impurity A) in the mobile phase and dilute to 100.0 mL with the mobile phase. Dilute 10.0 mL of this solution to 100.0 mL with the mobile phase.

**Reference solution (b).** Dissolve 5.0 mg of 2-chloro-*N*-(2,6-dimethylphenyl)acetamide *R* (impurity H) in the mobile phase and dilute to 10.0 mL with the mobile phase.

**Reference solution (c).** Dilute 1.0 mL of the test solution to 10.0 mL with the mobile phase.

**Reference solution (d).** Mix 1.0 mL of reference solution (a), 1.0 mL of reference solution (b) and 1.0 mL of reference solution (c), then dilute to 100.0 mL with the mobile phase.

**Column:**

- size:  $l = 0.15$  m,  $\varnothing = 3.9$  mm;
- stationary phase: end-capped polar-embedded octadecylsilyl amorphous organosilica polymer *R* (5 µm);
- temperature: 30 °C.

**Mobile phase:** mix 30 volumes of *acetonitrile for chromatography R* and 70 volumes of a 4.85 g/L solution of *potassium dihydrogen phosphate R* previously adjusted to pH 8.0 with *strong sodium hydroxide solution R*.

**Flow rate:** 1.0 mL/min.

**Detection:** spectrophotometer at 230 nm.

**Injection:** 20 µL.

**Run time:** 3.5 times the retention time of lidocaine.

**Relative retention** with reference to lidocaine (retention time = about 17 min): impurity H = about 0.37; impurity A = about 0.40.

**System suitability:** reference solution (d):

- resolution: minimum 1.5 between the peaks due to impurities H and A.

**Limits:**

- impurity A: not more than the area of the corresponding peak in the chromatogram obtained with reference solution (d) (0.01 per cent);
- unspecified impurities: for each impurity, not more than the area of the peak due to lidocaine in the chromatogram obtained with reference solution (d) (0.10 per cent);
- total: not more than 5 times the area of the peak due to lidocaine in the chromatogram obtained with reference solution (d) (0.5 per cent);
- disregard limit: 0.5 times the area of the peak due to lidocaine in the chromatogram obtained with reference solution (d) (0.05 per cent).

**Chlorides** (2.4.4): maximum 35 ppm.

Dissolve 1.4 g in a mixture of 3 mL of *dilute nitric acid R* and 12 mL of *water R*.

**Sulfates** (2.4.13): maximum 0.1 per cent.

Dissolve 0.2 g in 5 mL of *ethanol (96 per cent) R* and dilute to 20 mL with *distilled water R*.

**Water** (2.5.12): maximum 1.0 per cent, determined on 1.00 g.

**Sulfated ash** (2.4.14): maximum 0.1 per cent, determined on 1.0 g.

## ASSAY

To 0.200 g add 50 mL of *anhydrous acetic acid R* and stir until dissolution is complete. Titrate with 0.1 M *perchloric acid*, determining the end-point potentiometrically (2.2.20).

1 mL of 0.1 M *perchloric acid* is equivalent to 23.43 mg of  $C_{14}H_{22}N_2O$ .

## IMPURITIES

*Specified impurities: A.*

*Other detectable impurities* (the following substances would, if present at a sufficient level, be detected by one or other of the tests in the monograph. They are limited by the general acceptance criterion for other/unspecified impurities and/or by the general monograph *Substances for pharmaceutical use (2034)*. It is therefore not necessary to identify these impurities for demonstration of compliance. See also 5.10. *Control of impurities in substances for pharmaceutical use*): B, C, D, E, F, G, H, I, J.

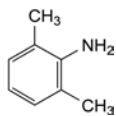

A. 2,6-dimethylaniline,

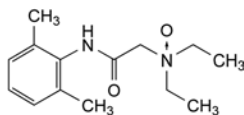

B. 2-(diethylazinoyl)-*N*-(2,6-dimethylphenyl)acetamide (lidocaine *N*-oxide),

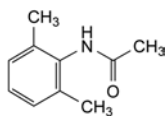

C. *N*-(2,6-dimethylphenyl)acetamide,

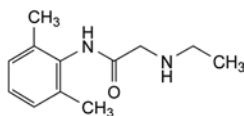

D. *N*-(2,6-dimethylphenyl)-2-(ethylamino)acetamide,

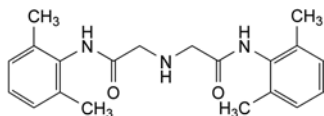

E. 2,2'-iminobis(*N*-(2,6-dimethylphenyl)acetamide),

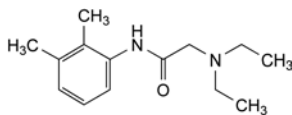

F. 2-(diethylamino)-*N*-(2,3-dimethylphenyl)acetamide,

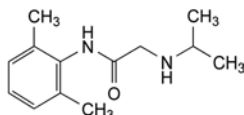

G. *N*-(2,6-dimethylphenyl)-2-((1-methylethyl)amino)acetamide,

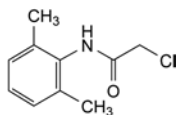

H. 2-chloro-*N*-(2,6-dimethylphenyl)acetamide,

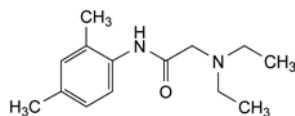

I. 2-(diethylamino)-*N*-(2,4-dimethylphenyl)acetamide,

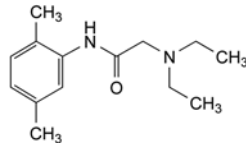

J. 2-(diethylamino)-*N*-(2,5-dimethylphenyl)acetamide.

01/2008:0227

## LIDOCAINE HYDROCHLORIDE

## Lidocaini hydrochloridum

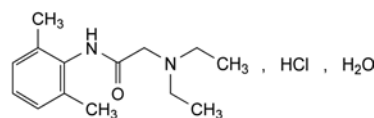

$C_{14}H_{23}ClN_2O \cdot H_2O$   
[6108-05-0]

$M_r$  288.8

## DEFINITION

2-(Diethylamino)-*N*-(2,6-dimethylphenyl)acetamide hydrochloride monohydrate.

*Content*: 99.0 per cent to 101.0 per cent (anhydrous substance).

## CHARACTERS

*Appearance*: white or almost white, crystalline powder.

*Solubility*: very soluble in water, freely soluble in ethanol (96 per cent).

## IDENTIFICATION

*First identification: B, D.*

*Second identification: A, C, D.*

A. Melting point (2.2.14): 74 °C to 79 °C, determined without previous drying.

B. Infrared absorption spectrophotometry (2.2.24).

*Comparison: lidocaine hydrochloride CRS.*

C. To about 5 mg add 0.5 mL of *fuming nitric acid R*. Evaporate to dryness on a water-bath, cool and dissolve the residue in 5 mL of *acetone R*. Add 0.2 mL of *alcoholic potassium hydroxide solution R*. A green colour is produced.

D. It gives reaction (a) of chlorides (2.3.1).

## TESTS

**Solution S.** Dissolve 1.0 g in *carbon dioxide-free water R* and dilute to 20 mL with the same solvent.

**Appearance of solution.** Solution S is clear (2.2.1) and colourless (2.2.2, *Method II*).

**pH** (2.2.3): 4.0 to 5.5.

Dilute 1 mL of solution S to 10 mL with *carbon dioxide-free water R*.

**Related substances.** Liquid chromatography (2.2.29).

*Test solution.* Dissolve 50.0 mg of the substance to be examined in the mobile phase and dilute to 10.0 mL with the mobile phase.

*Reference solution (a).* Dissolve 50.0 mg of 2,6-dimethylaniline *R* (impurity A) in the mobile phase and dilute to 100.0 mL with the mobile phase. Dilute 10.0 mL of this solution to 100.0 mL with the mobile phase.

*Reference solution (b).* Dissolve 5 mg of 2-chloro-*N*-(2,6-dimethylphenyl)acetamide *R* (impurity H) in the mobile phase and dilute to 10 mL with the mobile phase.

**Reference solution (c).** Dilute 1.0 mL of the test solution to 10.0 mL with the mobile phase.

**Reference solution (d).** Mix 1.0 mL of reference solution (a), 1.0 mL of reference solution (b) and 1.0 mL of reference solution (c) and dilute to 100.0 mL with the mobile phase.

**Column:**

- size:  $l = 0.15$  m,  $\varnothing = 3.9$  mm;
- stationary phase: end-capped polar-embedded octadecylsilyl amorphous organosilica polymer R (5  $\mu$ m);
- temperature: 30 °C.

**Mobile phase:** mix 30 volumes of acetonitrile for chromatography R and 70 volumes of a 4.85 g/L solution of potassium dihydrogen phosphate R adjusted to pH 8.0 with strong sodium hydroxide solution R.

**Flow rate:** 1.0 mL/min.

**Detection:** spectrophotometer at 230 nm.

**Injection:** 20  $\mu$ L.

**Run time:** 3.5 times the retention time of lidocaine.

**Relative retention** with reference to lidocaine (retention time = about 17 min): impurity H = about 0.37; impurity A = about 0.40.

**System suitability:** reference solution (d):

- resolution: minimum 1.5 between the peaks due to impurities H and A.

**Limits:**

- impurity A: not more than the area of the corresponding peak in the chromatogram obtained with reference solution (d) (0.01 per cent);
- unspecified impurities: for each impurity, not more than the area of the peak due to lidocaine in the chromatogram obtained with reference solution (d) (0.10 per cent);
- total: not more than 5 times the area of the peak due to lidocaine in the chromatogram obtained with reference solution (d) (0.5 per cent);
- disregard limit: 0.5 times the area of the peak due to lidocaine in the chromatogram obtained with reference solution (d) (0.05 per cent).

**Heavy metals (2.4.8):** maximum 5 ppm.

Dissolve 1.0 g in water R and dilute to 25 mL with the same solvent. Carry out the prefiltration. 10 mL of the prefiltrate complies with test E. Prepare the reference solution using 2 mL of lead standard solution (1 ppm Pb) R.

**Water (2.5.12):** 5.5 per cent to 7.0 per cent, determined on 0.25 g.

**Sulfated ash (2.4.14):** maximum 0.1 per cent, determined on 1.0 g.

**ASSAY**

Dissolve 0.220 g in 50 mL of ethanol (96 per cent) R and add 5.0 mL of 0.01 M hydrochloric acid. Carry out a potentiometric titration (2.2.20), using 0.1 M sodium hydroxide. Read the volume added between the 2 points of inflexion.

1 mL of 0.1 M sodium hydroxide is equivalent to 27.08 mg of  $C_{14}H_{23}ClN_2O_6$ .

**STORAGE**

Protected from light.

**IMPURITIES**

**Specified impurities: A.**

**Other detectable impurities** (the following substances would, if present at a sufficient level, be detected by one or other of the tests in the monograph. They are limited by the general acceptance criterion for other/unspecified impurities and/or by the general monograph *Substances for pharmaceutical use (2034)*. It is therefore not necessary to identify these impurities

for demonstration of compliance. See also 5.10. *Control of impurities in substances for pharmaceutical use*): B, C, D, E, F, G, H, I, J, K.

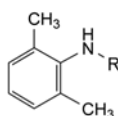

- A. R = H: 2,6-dimethylaniline,
- C. R = CO-CH<sub>3</sub>: *N*-(2,6-dimethylphenyl)acetamide,
- D. R = CO-CH<sub>2</sub>-NH-C<sub>2</sub>H<sub>5</sub>: *N*-(2,6-dimethylphenyl)-2-(ethylamino)acetamide,
- G. R = CO-CH<sub>2</sub>-NH-CH(CH<sub>3</sub>)<sub>2</sub>: *N*-(2,6-dimethylphenyl)-2-[(1-methylethyl)amino]acetamide,
- H. R = CO-CH<sub>2</sub>-Cl: 2-chloro-*N*-(2,6-dimethylphenyl)acetamide,
- K. R = CO-CH<sub>2</sub>-N(CH<sub>3</sub>)C<sub>2</sub>H<sub>5</sub>: *N*-(2,6-dimethylphenyl)-2-(ethylmethylamino)acetamide,

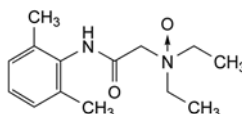

- B. 2-(diethylaziridinyl)-*N*-(2,6-dimethylphenyl)acetamide (lidocaine *N*<sup>2</sup>-oxide),

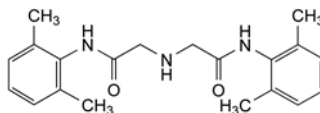

- E. 2-2'-(azanediyl)bis[*N*-(2,6-dimethylphenyl)acetamide],

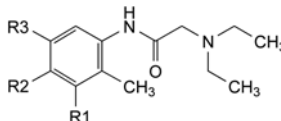

- F. R<sub>1</sub> = CH<sub>3</sub>, R<sub>2</sub> = R<sub>3</sub> = H: 2-(diethylamino)-*N*-(2,3-dimethylphenyl)acetamide,
- I. R<sub>1</sub> = R<sub>3</sub> = H, R<sub>2</sub> = CH<sub>3</sub>: 2-(diethylamino)-*N*-(2,4-dimethylphenyl)acetamide,
- J. R<sub>1</sub> = R<sub>2</sub> = H, R<sub>3</sub> = CH<sub>3</sub>: 2-(diethylamino)-*N*-(2,5-dimethylphenyl)acetamide.

01/2008:0583

## LINCOMYCIN HYDROCHLORIDE

Lincomycini hydrochloridum

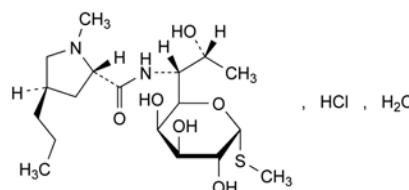

$C_{18}H_{35}ClN_2O_6 \cdot H_2O$   
[7179-49-9]

$M_r$  461.0

**DEFINITION**

Lincomycin hydrochloride consists mainly of the methyl 6,8-dideoxy-6-[[[(2*S*,4*R*)-1-methyl-4-propylpyrrolidin-2-yl]carbonyl]amino]-1-thio-*D*-erythro- $\alpha$ -*D*-galacto-octopyranoside hydrochloride, an antimicrobial substance produced by *Streptomyces lincolnensis* var. *lincolnensis* or by any other means. It contains not less than 89.5 per cent and not more than 102.0 per cent of lincomycin hydrochloride ( $C_{18}H_{35}ClN_2O_6$ S), calculated with reference to the anhydrous substance.

## CHARACTERS

A white or almost white, crystalline powder, very soluble in water, slightly soluble in ethanol (96 per cent), very slightly soluble in acetone.

## IDENTIFICATION

First identification: A, D.

Second identification: B, C, D.

A. Examine by infrared absorption spectrophotometry (2.2.24), comparing with the spectrum obtained with *lincomycin hydrochloride CRS*.

B. Examine by thin-layer chromatography (2.2.27), using *silica gel G R* as the coating substance.

*Test solution.* Dissolve 10 mg of the substance to be examined in *methanol R* and dilute to 10 mL with the same solvent.

*Reference solution (a).* Dissolve 10 mg of *lincomycin hydrochloride CRS* in *methanol R* and dilute to 10 mL with the same solvent.

*Reference solution (b).* Dissolve 10 mg of *lincomycin hydrochloride CRS* and 10 mg of *clindamycin hydrochloride CRS* in *methanol R* and dilute to 10 mL with the same solvent.

Apply separately to the plate 5 µL of each solution. Develop over a path of 15 cm using the upper layer from a mixture of 20 volumes of *2-propanol R*, 40 volumes of a 150 g/L solution of *ammonium acetate R* previously adjusted to pH 9.6 with *ammonia R* and 45 volumes of *ethyl acetate R*. Allow the plate to dry in air and spray with a 1 g/L solution of *potassium permanganate R*. The principal spot in the chromatogram obtained with the test solution is similar in position, colour and size to the principal spot in the chromatogram obtained with reference solution (a). The test is not valid unless the chromatogram obtained with reference solution (b) shows two clearly separated spots.

C. Dissolve about 10 mg in 2 mL of *dilute hydrochloric acid R* and heat in a water-bath for 3 min. Add 3 mL of *sodium carbonate solution R* and 1 mL of a 20 g/L solution of *sodium nitroprusside R*. A violet-red colour develops.

D. Dissolve 0.1 g in *water R* and dilute to 10 mL with the same solvent. The solution gives reaction (a) of chlorides (2.3.1).

## TESTS

**Solution S.** Dissolve 2.0 g in *carbon dioxide-free water R* and dilute to 20 mL with the same solvent.

**Appearance of solution.** Solution S is clear (2.2.1) and not more intensely coloured than reference solution Y<sub>6</sub> (2.2.2, Method II).

**pH (2.2.3).** The pH of solution S is 3.5 to 5.5.

**Specific optical rotation (2.2.7).** Dissolve 1.000 g in *water R* and dilute to 25.0 mL with the same solvent. The specific optical rotation is + 135 to + 150, calculated with reference to the anhydrous substance.

**Lincomycin B.** Examine the chromatogram obtained in the assay with test solution (a). The area of the peak due to lincomycin B, which is eluted just before lincomycin, is not more than 5 per cent of the area of the peak due to lincomycin.

**Heavy metals (2.4.8).** 2.0 g complies with test C for heavy metals (5 ppm). Prepare the reference solution using 1.0 mL of *lead standard solution (10 ppm Pb) R*.

**Water (2.5.12).** 3.1 per cent to 4.6 per cent, determined on 0.500 g by the semi-micro determination of water.

**Sulfated ash (2.4.14).** Not more than 0.5 per cent, determined on 1.0 g.

**Bacterial endotoxins (2.6.14):** less than 0.50 IU/mg, if intended for use in the manufacture of parenteral preparations without a further appropriate procedure for removal of bacterial endotoxins.

## ASSAY

Examine by gas chromatography (2.2.28), using *dotriacontane R* as the internal standard.

*Internal standard solution.* Dissolve 0.200 g of *dotriacontane R* in *chloroform R* and dilute to 25.0 mL with the same solvent.

*Test solution (a).* Dissolve 0.100 g of the substance to be examined in a 20 g/L solution of *imidazole R* in *chloroform R* and dilute to 100.0 mL with the same solution. Shake until dissolution is complete. Place 4.0 mL of the solution in a ground-glass-stoppered 15 mL centrifuge tube. Add 1.0 mL of a mixture of 1 volume of *chlorotrimethylsilane R* and 99 volumes of *N,O-bis(trimethylsilyl)acetamide R* and swirl gently. Position the glass stopper loosely in the tube and heat at 65 °C for 30 min.

*Test solution (b).* Prepare as described for test solution (a) but add 10.0 mL of the internal standard solution before dissolution of the substance to be examined.

*Reference solution.* Prepare as described for test solution (a) using 0.100 g of *lincomycin hydrochloride CRS* instead of the substance to be examined and adding 10.0 mL of the internal standard solution before dissolution of the reference substance.

The chromatographic procedure may be carried out using:

- a glass column 1.5 m long and 3 mm in internal diameter packed with *silanised diatomaceous earth for gas chromatography R* impregnated with 3 per cent *m/m* of *poly(methylphenylsiloxane) R*,
- *helium for chromatography R* as the carrier gas at a flow rate of about 45 mL/min,
- a flame-ionisation detector,

maintaining the temperature of the column at 260 °C and that of the injection port and of the detector between 260 °C and 290 °C. Inject the chosen volume of the test solutions and the reference solution.

## STORAGE

Store in an airtight container at a temperature not exceeding 30 °C. If the substance is sterile, store in a sterile, airtight, tamper-proof container.

01/2008:1232

## LINOLEOYL MACROGOLGLYCERIDES

## Macrogolglyceridorum linoleates

## DEFINITION

Mixtures of monoesters, diesters and triesters of glycerol and monoesters and diesters of macrogols.

They are obtained by partial alcoholysis of an unsaturated oil mainly containing triglycerides of linoleic (*cis,cis*-9,12-octadecadienoic) acid, using macrogol with a mean relative molecular mass between 300 and 400, or by esterification of glycerol and macrogol with unsaturated fatty acids, or by mixing glycerol esters and condensates of ethylene oxide with the fatty acids of this unsaturated oil.

## CHARACTERS

*Appearance:* amber, oily liquid which may give rise to a deposit after prolonged periods at 20 °C.

*Solubility:* practically insoluble but dispersible in water, freely soluble in methylene chloride.

*Viscosity:* about 35 mPas at 40 °C.

*Relative density:* about 0.95 at 20 °C.

*Refractive index:* about 1.47 at 20 °C.

## IDENTIFICATION

A. Thin-layer chromatography (2.2.27).

*Test solution.* Dissolve 1.0 g of the substance to be examined in *methylene chloride R* and dilute to 20 mL with the same solvent.

Plate: TLC silica gel plate R.

Mobile phase: hexane R, ether R (30:70 V/V).

Application: 10 µL.

Development: over a path of 15 cm.

Drying: in air.

Detection: spray with a 0.1 g/L solution of rhodamine B R in ethanol (96 per cent) R and examine in ultraviolet light at 365 nm.

Results: the chromatogram shows a spot due to triglycerides with an  $R_f$  value of about 0.9 ( $R_{st}$  1) and spots due to 1,3-diglycerides ( $R_{st}$  0.7), to 1,2-diglycerides ( $R_{st}$  0.6), to monoglycerides ( $R_{st}$  0.1) and to esters of macrogol ( $R_{st}$  0).

B. Hydroxyl value (see Tests).

C. Saponification value (see Tests).

D. Fatty acid composition (see Tests).

#### TESTS

**Acid value** (2.5.1): maximum 2.0, determined on 2.0 g.

**Hydroxyl value** (2.5.3, Method A): 45 to 65, determined on 1.0 g.

**Iodine value** (2.5.4, Method A): 90 to 110.

**Peroxide value** (2.5.5, Method A): maximum 12.0, determined on 2.0 g.

**Saponification value** (2.5.6): 150 to 170, determined on 2.0 g.

**Alkaline impurities.** Into a test tube introduce 5.0 g and carefully add a mixture, neutralised if necessary with 0.01 M hydrochloric acid or with 0.01 M sodium hydroxide, of 0.05 mL of a 0.4 g/L solution of bromophenol blue R in ethanol (96 per cent) R, 0.3 mL of water R and 10 mL of ethanol (96 per cent) R. Shake and allow to stand. Not more than 1.0 mL of 0.01 M hydrochloric acid is required to change the colour of the upper layer to yellow.

**Free glycerol:** maximum 3.0 per cent.

Dissolve 1.20 g in 25.0 mL of methylene chloride R. Heat if necessary. After cooling, add 100 mL of water R. Shake and add 25.0 mL of periodic acetic acid solution R. Shake and allow to stand for 30 min. Add 40 mL of a 75 g/L solution of potassium iodide R. Allow to stand for 1 min. Add 1 mL of starch solution R. Titrate the iodine with 0.1 M sodium thiosulfate. Carry out a blank titration.

1 mL of 0.1 M sodium thiosulfate is equivalent to 2.3 mg of glycerol.

**Composition of fatty acids** (2.4.22, Method A).

Composition of the fatty-acid fraction of the substance:

- palmitic acid: 4.0 per cent to 20.0 per cent;
- stearic acid: maximum 6.0 per cent;
- oleic acid: 20.0 per cent to 35.0 per cent;
- linoleic acid: 50.0 per cent to 65.0 per cent;
- linolenic acid: maximum 2.0 per cent;
- arachidic acid: maximum 1.0 per cent;
- eicosenoic acid: maximum 1.0 per cent.

**Ethylene oxide and dioxan** (2.4.25): maximum 1 ppm of ethylene oxide and maximum 10 ppm of dioxan.

**Heavy metals** (2.4.8): maximum 10 ppm.

2.0 g complies with test C. Prepare the reference solution using 2 mL of lead standard solution (10 ppm Pb) R.

**Water** (2.5.12): maximum 1.0 per cent, determined on 1.0 g. Use a mixture of 30 volumes of anhydrous methanol R and 70 volumes of methylene chloride R as solvent.

**Total ash** (2.4.16): maximum 0.1 per cent.

#### STORAGE

Protected from light.

#### LABELLING

The label states the type of macrogol used (mean relative molecular mass) or the number of units of ethylene oxide per molecule (nominal value).

01/2010:1908

## LINSEED OIL, VIRGIN

### Lini oleum virginale

#### DEFINITION

Fatty oil obtained by cold expression from ripe seeds of *Linum usitatissimum* L. A suitable antioxidant may be added.

#### CHARACTERS

**Appearance:** clear, yellow or brownish-yellow liquid, on exposure to air turning dark and gradually thickening. When cooled, it becomes a soft mass at about  $-20\text{ }^{\circ}\text{C}$ .

**Solubility:** very slightly soluble in ethanol (96 per cent), miscible with light petroleum.

**Relative density:** about 0.931.

**Refractive index:** about 1.480.

#### IDENTIFICATION

**First identification:** B, C.

**Second identification:** A, B.

A. Identification of fatty oils by thin-layer chromatography (2.3.2).

**Results:** the chromatogram obtained is similar to the corresponding chromatogram shown in Figure 2.3.2.-1.

B. Iodine value (see Tests).

C. Composition of fatty acids (see Tests).

#### TESTS

**Acid value** (2.5.1): maximum 4.5.

**Iodine value** (2.5.4): 160 to 200.

**Peroxide value** (2.5.5, Method A): maximum 15.0.

**Saponification value** (2.5.6): 188 to 195; carry out the saponification for 1 h.

**Unsaponifiable matter** (2.5.7): maximum 1.5 per cent, determined on 5.0 g.

**Composition of fatty acids.** Gas chromatography (2.4.22, Method C). Use the calibration mixture in Table 2.4.22.-3.

Composition of the fatty-acid fraction of the oil:

- fatty acids with a chain length less than  $C_{16}$ : maximum 1.0 per cent,
- palmitic acid: 3.0 per cent to 8.0 per cent,
- palmitoleic acid: maximum 1.0 per cent,
- stearic acid: 2.0 per cent to 8.0 per cent,
- oleic acid: 11.0 per cent to 35.0 per cent,
- linoleic acid: 11.0 per cent to 24.0 per cent,
- linolenic acid: 35.0 per cent to 65.0 per cent,
- arachidic acid: maximum 1.0 per cent.

**Cadmium** (2.4.27): maximum 0.5 ppm.

**Water** (2.5.32): maximum 0.1 per cent, determined on 1.00 g.

#### STORAGE

In an airtight container, protected from light.

04/2008:0728  
corrected 6.4

# LIOTHYRONINE SODIUM

Liothyroninum natricum

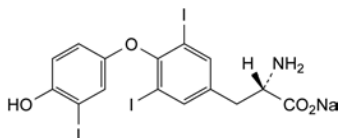

C<sub>15</sub>H<sub>11</sub>I<sub>3</sub>NNaO<sub>4</sub>  
[55-06-1]

M<sub>r</sub> 673

## DEFINITION

Sodium (2S)-2-amino-3-[4-(4-hydroxy-3-iodophenoxy)-3,5-diiodophenyl]propanoate.

Content: 95.0 per cent to 102.0 per cent (dried substance).

## CHARACTERS

Appearance: white or slightly coloured, hygroscopic powder.

Solubility: practically insoluble in water, slightly soluble in ethanol (96 per cent). It dissolves in dilute solutions of alkali hydroxides.

## IDENTIFICATION

First identification: A, C, E.

Second identification: A, B, D, E.

A. Specific optical rotation (see Tests).

B. Ultraviolet and visible absorption spectrophotometry (2.2.25).

Test solution. Dissolve 10.0 mg in 0.1 M sodium hydroxide and dilute to 100.0 mL with the same solvent.

Spectral range: 230-350 nm.

Absorption maximum: at 319 nm.

Specific absorbance at the absorption maximum: 63 to 69 (dried substance).

C. Infrared absorption spectrophotometry (2.2.24).

Comparison: liothyronine sodium CRS.

D. To about 50 mg in a porcelain dish add a few drops of sulfuric acid R and heat. Violet vapour is evolved.

E. To 200 mg add 2 mL of dilute sulfuric acid R. Heat on a water-bath and then carefully over a naked flame, increasing the temperature gradually up to about 600 °C. Continue the ignition until most of the particles have disappeared. Dissolve the residue in 2 mL of water R. The solution gives reaction (a) of sodium (2.3.1).

## TESTS

Specific optical rotation (2.2.7): + 18.0 to + 22.0 (dried substance).

Dissolve 0.200 g in a mixture of 1 volume of 1 M hydrochloric acid and 4 volumes of ethanol (96 per cent) R and dilute to 20.0 mL with the same mixture of solvents.

Related substances. Liquid chromatography (2.2.29). Protect the solutions from light throughout the test.

Solution A. Mix 10 volumes of mobile phase A with 90 volumes of methanol R.

Solution B. Mix 30 volumes of mobile phase B and 70 volumes of mobile phase A. Mix equal volumes of this solution with solution A.

Test solution. Dissolve 20.0 mg of the substance to be examined in 20 mL of solution A. Dilute 4.0 mL of this solution to 20.0 mL with solution B.

Reference solution (a). Dissolve 2.5 mg of levothyroxine sodium CRS (impurity A) and 2.5 mg of liothyronine sodium CRS in solution A and dilute to 25 mL with the same solution. Dilute 1.0 mL of this solution to 50.0 mL with solution B.

Reference solution (b). Dilute 1.0 mL of reference solution (a) to 10.0 mL with solution B.

Reference solution (c). Dissolve the contents of a vial of liothyronine for peak identification CRS (containing impurities A, B, C, D and E) in solution B and dilute to 1.0 mL with the same solution.

Reference solution (d). Dissolve 20.0 mg of liothyronine sodium CRS in 20 mL of solution A. Dilute 4.0 mL of this solution to 20.0 mL with solution B.

Blank solution: solution B.

Column:

– size: l = 0.15 m, Ø = 4.0 mm;

– stationary phase: end-capped octadecylsilyl silica gel for chromatography R (3 µm).

Mobile phase:

– mobile phase A: dissolve 9.7 g of sulfamic acid R in water R and dilute to 2000 mL with the same solvent; add 1.5 g of sodium hydroxide R and adjust to pH 2.0 with 2 M sodium hydroxide;

– mobile phase B: acetonitrile R1;

Time (min)	Mobile phase A (per cent V/V)	Mobile phase B (per cent V/V)
0 - 3	75	25
3 - 4	75 → 70	25 → 30
4 - 14	70	30
14 - 44	70 → 20	30 → 80
44 - 54	20	80

Flow rate: 1 mL/min.

Detection: spectrophotometer at 225 nm.

Injection: 25 µL of the test solution and reference solutions (a), (b) and (c).

Identification of impurities: use the chromatogram obtained with reference solution (c) to identify the peaks due to impurities A, B, C, D and E.

– relative retention with reference to liothyronine (retention time = about 14 min): impurity B = about 0.2; impurity E = about 0.5; impurity A = about 1.4; impurity C = about 2; impurity D = about 2.4.

System suitability:

– resolution: minimum 5.0 between the peaks due to impurity A and liothyronine in the chromatogram obtained with reference solution (a).

Limits:

– impurity A: not more than the area of the corresponding peak in the chromatogram obtained with reference solution (a) (1.0 per cent);

– impurity E: not more than 5 times the area of the peak due to liothyronine in the chromatogram obtained with reference solution (b) (0.5 per cent);

– impurities B, C: for each impurity, not more than 3 times the area of the peak due to liothyronine in the chromatogram obtained with reference solution (b) (0.3 per cent);

– impurity D: not more than twice the area of the peak due to liothyronine in the chromatogram obtained with reference solution (b) (0.2 per cent);

– unspecified impurities: for each impurity, not more than the area of the peak due to liothyronine in the chromatogram obtained with reference solution (b) (0.10 per cent);

- *total*: not more than twice the area of the peak due to liothyronine in the chromatogram obtained with reference solution (a) (2.0 per cent);
- *disregard limit*: 0.5 times the area of the peak due to liothyronine in the chromatogram obtained with reference solution (b) (0.05 per cent).

**Chlorides**: maximum 2.0 per cent, expressed as NaCl (dried substance).

Dissolve 0.500 g in a 2 g/L solution of *sodium hydroxide R* and dilute to 100 mL with the same solvent. Add 15 mL of *dilute nitric acid R* and titrate with *0.05 M silver nitrate*, determining the end-point potentiometrically (2.2.20).

1 mL of *0.05 M silver nitrate* is equivalent to 2.93 mg of NaCl.

**Loss on drying** (2.2.32): maximum 4.0 per cent, determined on 0.500 g by drying *in vacuo* at 60 °C.

#### ASSAY

Liquid chromatography (2.2.29) as described in the test for related substances with the following modifications.

*Injection*: test solution and reference solution (d).

Calculate the percentage content of  $C_{15}H_{11}I_3NNaO_4$  from the declared content of *liothyronine sodium CRS*.

#### STORAGE

In an airtight container, protected from light, at a temperature between 2 °C and 8 °C.

#### IMPURITIES

*Specified impurities: A, B, C, D, E.*

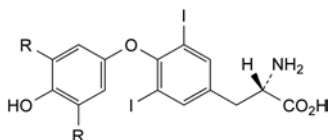

A. R = I: levothyroxine,

E. R = H: (2S)-2-amino-3-[4-(4-hydroxyphenoxy)-3,5-diiodophenyl]propanoic acid (diiodothyronine).

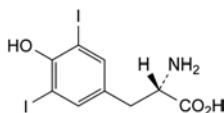

B. (2S)-2-amino-3-(4-hydroxy-3,5-diiodophenyl)propanoic acid (diiodotyrosine),

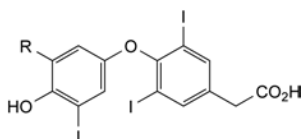

C. R = H: [4-(4-hydroxy-3-iodophenoxy)-3,5-diiodophenyl]acetic acid (triiodothyroacetic acid),

D. R = I: [4-(4-hydroxy-3,5-diiodophenoxy)-3,5-diiodophenyl]acetic acid (tetraiodothyroacetic acid),

01/2011:1120

## LISINOPRIL DIHYDRATE

### Lisinoprilum dihydricum

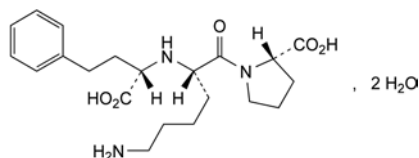

$C_{21}H_{31}N_3O_5 \cdot 2H_2O$   
[83915-83-7]

$M_r$  441.5

#### DEFINITION

(2S)-1-[(2S)-6-Amino-2-[[[(1S)-1-carboxy-3-phenylpropyl]-amino]hexanoyl]pyrrolidine-2-carboxylic acid dihydrate.

*Content*: 98.5 per cent to 101.5 per cent (anhydrous substance).

#### CHARACTERS

*Appearance*: white or almost white, crystalline powder.

*Solubility*: soluble in water, sparingly soluble in methanol, practically insoluble in acetone and in anhydrous ethanol.

#### IDENTIFICATION

Infrared absorption spectrophotometry (2.2.24).

*Comparison*: *lisinopril dihydrate CRS*.

#### TESTS

**Specific optical rotation** (2.2.7): –43 to –47 (anhydrous substance).

Dissolve 0.5 g in *zinc acetate solution R* and dilute to 50.0 mL with the same solvent.

**Related substances**. Liquid chromatography (2.2.29).

*Test solution*. Dissolve 20 mg of the substance to be examined in mobile phase A and dilute to 10.0 mL with mobile phase A.

*Reference solution (a)*. Dissolve the contents of a vial of *lisinopril for system suitability CRS* (containing impurities A, B, C, D and E) with 1.0 mL of mobile phase A.

*Reference solution (b)*. Dilute 0.5 mL of the test solution to 50.0 mL with mobile phase A.

*Reference solution (c)*. Dissolve the contents of a vial of *lisinopril impurity F CRS* in 1.0 mL of mobile phase A.

*Column*:

– *size*:  $l = 0.25$  m,  $\varnothing = 4.6$  mm;

– *stationary phase*: *octylsilyl silica gel for chromatography R* (5  $\mu$ m);

– *temperature*: 50 °C.

*Mobile phase*:

– *mobile phase A*: mix 3 volumes of *acetonitrile R1* and 97 volumes of a 3.12 g/L *sodium dihydrogen phosphate R* solution adjusted to pH 5.0 with a 50 g/L solution of *sodium hydroxide R*;

– *mobile phase B*: mix 20 volumes of *acetonitrile R1* and 80 volumes of a 3.12 g/L *sodium dihydrogen phosphate R* solution adjusted to pH 5.0 with a 50 g/L solution of *sodium hydroxide R*;

Time (min)	Mobile phase A (per cent V/V)	Mobile phase B (per cent V/V)
0 - 35	100 → 70	0 → 30
35 - 45	70	30
45 - 50	70 → 100	30 → 0

*Flow rate*: 1.8 mL/min.

*Detection*: spectrophotometer at 210 nm.

*Injection*: 20  $\mu$ L.

*Identification of impurities*: use the chromatogram supplied with *lisinopril for system suitability CRS* and the chromatogram obtained with reference solution (a) to identify the peaks due to impurities A, B, C, D and E; use the chromatogram obtained with reference solution (c) to identify the peak due to impurity F.

*Relative retention* with reference to lisinopril (retention time = about 6 min): impurity B = about 0.6; impurity A = about 0.7; impurity E = about 1.3; impurity F = about 2.7; impurity D = about 3.9; impurity C = about 4.3.

*System suitability*: reference solution (a):

– *resolution*: minimum 2.0 between the peaks due to impurities B and A;



– *peak-to-valley ratio*: minimum 7 where  $H_p$  = height above the baseline of the peak due to impurity E and  $H_v$  = height above the baseline of the lowest point of the curve separating this peak from the peak due to lisinopril; if necessary, adjust the pH of the mobile phase to 4.5 with *phosphoric acid R*; a further adjustment to pH 4.0 may be necessary with some columns before satisfactory separation of impurity A, lisinopril and impurity E is obtained; if, after adjustment, the retention time of the peaks due to impurities C and D becomes extended to the point where integration becomes difficult, increase the content of mobile phase B from 30 per cent to 40 per cent over the interval from 35-45 min from the start of the chromatogram; maintain this concentration for a further 10 min and return the concentration of mobile phase A to 100 per cent over the next 10 min prior to the next injection.

#### Limits:

- *impurities A, B, C, D, E, F*: for each impurity, not more than 0.3 times the area of the principal peak in the chromatogram obtained with reference solution (b) (0.3 per cent);
- *unspecified impurities*: for each impurity, not more than 0.1 times the area of the principal peak in the chromatogram obtained with reference solution (b) (0.10 per cent);
- *sum of impurities other than E*: not more than 0.5 times the area of the principal peak in the chromatogram obtained with reference solution (b) (0.5 per cent);
- *disregard limit*: 0.05 times the area of the principal peak in the chromatogram obtained with reference solution (b) (0.05 per cent); disregard any peak occurring in the first 3 min.

**Water (2.5.12)**: 8.0 per cent to 9.5 per cent, determined on 0.200 g.

**Sulfated ash (2.4.14)**: maximum 0.1 per cent, determined on 1.0 g.

#### ASSAY

Dissolve 0.350 g in 50 mL of *distilled water R*. Titrate with 0.1 M *sodium hydroxide*, determining the end-point potentiometrically (2.2.20).

1 mL of 0.1 M *sodium hydroxide* is equivalent to 40.55 mg of  $C_{21}H_{31}N_3O_5$ .

#### IMPURITIES

*Specified impurities: A, B, C, D, E, F.*

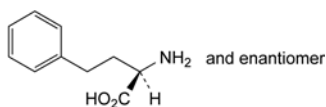

A. (2RS)-2-amino-4-phenylbutanoic acid,

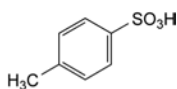

B. 4-methylbenzenesulfonic acid,

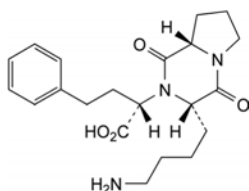

C. (2S)-2-[(3S,8aS)-3-(4-aminobutyl)-1,4-dioxohexahydro-pyrrolo[1,2-a]pyrazin-2(1H)-yl]-4-phenylbutanoic acid (S,S,S-diketopiperazine),

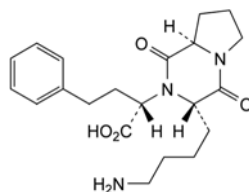

D. (2S)-2-[(3S,8aR)-3-(4-aminobutyl)-1,4-dioxohexahydro-pyrrolo[1,2-a]pyrazin-2(1H)-yl]-4-phenylbutanoic acid (R,S,S-diketopiperazine),

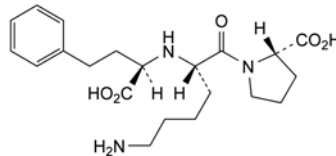

E. (2S)-1-[(2S)-6-amino-2-[(1R)-1-carboxy-3-phenyl-propyl]amino]hexanoyl]pyrrolidine-2-carboxylic acid (lisinopril R,S,S-isomer),

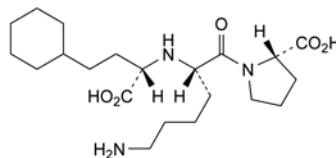

F. (2S)-1-[(2S)-6-amino-2-[(1S)-1-carboxy-3-cyclohexyl-propyl]amino]hexanoyl]pyrrolidine-2-carboxylic acid (cyclohexyl analogue).

01/2008:0228  
corrected 7.0

## LITHIUM CARBONATE

### Lithii carbonas

$Li_2CO_3$   
[554-13-2]

$M_r$  73.9

#### DEFINITION

*Content*: 98.5 per cent to 100.5 per cent.

#### CHARACTERS

*Appearance*: white or almost white powder.

*Solubility*: slightly soluble in water, practically insoluble in ethanol (96 per cent).

#### IDENTIFICATION

- A. When moistened with *hydrochloric acid R*, it gives a red colour to a non-luminous flame.
- B. Dissolve 0.2 g in 1 mL of *hydrochloric acid R*. Evaporate to dryness on a water-bath. The residue dissolves in 3 mL of *ethanol (96 per cent) R*.
- C. It gives the reaction of carbonates (2.3.1).

#### TESTS

**Solution S.** Suspend 10.0 g in 30 mL of *distilled water R* and dissolve by the addition of 22 mL of *nitric acid R*. Add *dilute sodium hydroxide solution R* until the solution is neutral and dilute to 100 mL with *distilled water R*.

**Appearance of solution.** Solution S is clear (2.2.1) and colourless (2.2.2, *Method II*).

**Chlorides (2.4.4)**: maximum 200 ppm.

Dilute 2.5 mL of solution S to 15 mL with *water R*.

**Sulfates (2.4.13)**: maximum 200 ppm.

Disperse 1.25 g in 5 mL of *distilled water R* and dissolve by adding 5 mL of *hydrochloric acid R1*. Boil for 2 min. Cool and add *dilute sodium hydroxide solution R* until neutral. Dilute to 25 mL with *distilled water R*.

**Arsenic** (2.4.2, Method A): maximum 2 ppm, determined on 0.5 g.

**Calcium** (2.4.3): maximum 200 ppm.

Dilute 5 mL of solution S to 15 mL with *distilled water R*.

**Iron** (2.4.9): maximum 20 ppm.

Dilute 5 mL of solution S to 10 mL with *water R*.

**Magnesium** (2.4.6): maximum 150 ppm.

Dilute 1 mL of solution S to 10 mL with *water R*. Dilute 6.7 mL of this solution to 10 mL with *water R*.

**Potassium**: maximum 300 ppm.

Atomic emission spectrometry (2.2.22, Method I).

**Test solution.** Dissolve 1.0 g in 10 mL of *hydrochloric acid R1* and dilute to 50.0 mL with *water R*.

**Reference solutions.** Prepare the reference solutions using a solution of *potassium chloride R* containing 500 µg of K per millilitre, diluted as necessary with *water R*.

**Wavelength:** 766.5 nm.

**Sodium**: maximum 300 ppm.

Atomic emission spectrometry (2.2.22, Method I).

**Test solution.** Dissolve 1.0 g in 10 mL of *hydrochloric acid R1* and dilute to 50.0 mL with *water R*.

**Reference solutions.** Prepare the reference solutions using a solution of *sodium chloride R* containing 500 µg of Na per millilitre, diluted as necessary with *water R*.

**Wavelength:** 589 nm.

**Heavy metals** (2.4.8): maximum 20 ppm.

12 mL of solution S complies with test A. Prepare the reference solution using *lead standard solution (2 ppm Pb) R*.

#### ASSAY

Dissolve 0.500 g in 25.0 mL of *1 M hydrochloric acid*. Titrate with *1 M sodium hydroxide*, using *methyl orange solution R* as indicator.

1 mL of *1 M hydrochloric acid* is equivalent to 36.95 mg of  $\text{Li}_2\text{CO}_3$ .

01/2008:0621

## LITHIUM CITRATE

### Lithii citras

$\text{C}_6\text{H}_5\text{Li}_3\text{O}_7 \cdot 4\text{H}_2\text{O}$

$M_r$  282.0

#### DEFINITION

Trilithium 2-hydroxypropane-1,2,3-tricarboxylate tetrahydrate.

**Content:** 98.0 per cent to 102.0 per cent (anhydrous substance).

#### CHARACTERS

**Appearance:** white or almost white, fine crystalline powder.

**Solubility:** freely soluble in water, slightly soluble in ethanol (96 per cent).

#### IDENTIFICATION

- When moistened with *hydrochloric acid R*, it gives a red colour to a non-luminous flame.
- Dilute 3 mL of solution S (see Tests) to 10 mL with *water R*. Add 3 mL of *potassium ferriperiodate solution R*. A white or yellowish-white precipitate is formed.
- To 1 mL of solution S add 4 mL of *water R*. The solution gives the reaction of citrates (2.3.1).

#### TESTS

**Solution S.** Dissolve 10.0 g in *carbon dioxide-free water R* prepared from *distilled water R* and dilute to 100 mL with the same solvent.

**Appearance of solution.** Solution S is clear (2.2.1) and colourless (2.2.2, Method II).

**Acidity or alkalinity.** To 10 mL of solution S add 0.1 mL of *phenolphthalein solution R*. Not more than 0.2 mL of *0.1 M hydrochloric acid* or *0.1 M sodium hydroxide* is required to change the colour of the indicator.

**Readily carbonisable substances.** To 0.20 g of the powdered substance to be examined add 10 mL of *sulfuric acid R* and heat in a water-bath at  $90 \pm 1$  °C for 60 min. Cool rapidly. The solution is not more intensely coloured than reference solution  $Y_2$  or  $GY_2$  (2.2.2, Method II).

**Chlorides** (2.4.4): maximum 100 ppm.

Dilute 5 mL of solution S to 15 mL with *water R*.

**Oxalates:** maximum 300 ppm, calculated as anhydrous oxalate ion.

Dissolve 0.50 g in 4 mL of *water R*, add 3 mL of *hydrochloric acid R* and 1 g of *zinc R* in granules and heat on a water-bath for 1 min. Allow to stand for 2 min, decant the liquid into a test-tube containing 0.25 mL of a 10 g/L solution of *phenylhydrazine hydrochloride R* and heat to boiling. Cool rapidly, transfer to a graduated cylinder and add an equal volume of *hydrochloric acid R* and 0.25 mL of *potassium ferricyanide solution R*. Shake and allow to stand for 30 min. Any pink colour in the solution is not more intense than that in a standard prepared at the same time and in the same manner using 4 mL of a 0.05 g/L solution of *oxalic acid R*.

**Sulfates** (2.4.13): maximum 500 ppm.

To 3 mL of solution S add 2 mL of *hydrochloric acid R1* and dilute to 17 mL with *distilled water R*. Prepare the reference solution using 15 mL of a mixture of 2 mL of *hydrochloric acid R1* and 15 mL of *sulfate standard solution (10 ppm  $\text{SO}_4$ ) R* and compare the opalescence after 15 min.

**Heavy metals** (2.4.8): maximum 10 ppm.

12 mL of solution S complies with test A. Prepare the reference solution using *lead standard solution (1 ppm Pb) R*.

**Water** (2.5.12): 24.0 per cent to 27.0 per cent, determined on 0.100 g. After adding the substance to be examined, stir for 15 min before titrating. Carry out a blank titration.

#### ASSAY

Dissolve 80.0 mg in 50 mL of *anhydrous acetic acid R*, heating to about 50 °C. Allow to cool. Titrate with *0.1 M perchloric acid*, using 0.25 mL of *naphtholbenzein solution R* as indicator, until the colour changes from yellow to green.

1 mL of *0.1 M perchloric acid* is equivalent to 7.00 mg of  $\text{C}_6\text{H}_5\text{Li}_3\text{O}_7$ .

#### STORAGE

In an airtight container.

01/2008:1988

## LOBELINE HYDROCHLORIDE

### Lobelini hydrochloridum

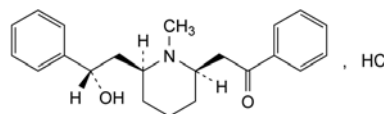

$\text{C}_{22}\text{H}_{28}\text{ClNO}_2$   
[134-63-4]

$M_r$  373.9

#### DEFINITION

2-[(2R,6S)-6-[(2S)-2-Hydroxy-2-phenylethyl]-1-methylpiperidin-2-yl]-1-phenylethanone hydrochloride.

**Content:** 99.0 per cent to 101.0 per cent (dried substance).

## CHARACTERS

**Appearance:** white or almost white, microcrystalline powder.

**Solubility:** sparingly soluble in water, freely soluble in ethanol (96 per cent), soluble in methylene chloride.

## IDENTIFICATION

**First identification:** A, B.

**Second identification:** B, C.

A. Infrared absorption spectrophotometry (2.2.24).

**Comparison:** lobeline hydrochloride CRS.

B. Solution S (see Tests) gives reaction (a) of chlorides (2.3.1).

C. Examine the chromatograms obtained in the test for foreign alkaloids.

**Results:** the principal spot in the chromatogram obtained with test solution (b) is similar in position and size to the principal spot in the chromatogram obtained with reference solution (b).

## TESTS

**Solution S.** Dissolve 0.250 g in carbon dioxide-free water R prepared from distilled water R and dilute to 25.0 mL with the same solvent.

**Appearance of solution.** Solution S is clear (2.2.1) and colourless (2.2.2, Method II).

**pH** (2.2.3): 4.6 to 6.4 for solution S.

**Specific optical rotation** (2.2.7):  $-55$  to  $-59$  (dried substance), determined on solution S.

**Foreign alkaloids.** Thin-layer chromatography (2.2.27).

**Test solution (a).** Dissolve 0.10 g of the substance to be examined in methanol R and dilute to 5.0 mL with the same solvent.

**Test solution (b).** Dilute 1 mL of test solution (a) to 10 mL with methanol R.

**Reference solution (a).** Dilute 0.1 mL of test solution (a) to 10 mL with methanol R.

**Reference solution (b).** Dissolve 10 mg of lobeline hydrochloride CRS in methanol R and dilute to 5 mL with the same solvent.

**Plate:** TLC silica gel GF<sub>254</sub> plate R.

**Mobile phase:** diethylamine R, cyclohexane R (10:90 V/V).

**Application:** 10 µL.

**Development:** over 2/3 of the plate.

**Drying:** at 120 °C.

**Detection:** examine in ultraviolet light at 254 nm.

**Limits:** in the chromatogram obtained with test solution (a):

- any impurity: any spot, apart from the principal spot, is not more intense than the spot in the chromatogram obtained with reference solution (a) (1 per cent).

**Related substances.** Liquid chromatography (2.2.29).

**Test solution.** Dissolve 10.0 mg of the substance to be examined in the mobile phase and dilute to 10.0 mL with the mobile phase.

**Reference solution (a).** Dilute 1.0 mL of the test solution to 100.0 mL with the mobile phase. Dilute 1.0 mL of this solution to 10.0 mL with the mobile phase.

**Reference solution (b).** Dissolve 5 mg of phenytoin CRS in the mobile phase and dilute to 100.0 mL with the mobile phase. To 1 mL of the solution add 0.1 mL of the test solution and dilute to 25 mL with the mobile phase.

**Column:**

– size:  $l = 0.25$  m,  $\varnothing = 4$  mm,

– stationary phase: spherical end-capped octylsilyl silica gel for chromatography R (5 µm).

**Mobile phase:** dissolve 1.0 g of sodium methanesulfonate R and 2.50 g of disodium hydrogen phosphate dihydrate R in a mixture of 3 volumes of a 6.7 per cent V/V solution of

phosphoric acid R, 29 volumes of acetonitrile R and 70 volumes of water R and dilute to 1000 mL with the same mixture of solvents.

**Flow rate:** 1.5 mL/min.

**Detection:** spectrophotometer at 210 nm.

**Injection:** 10 µL.

**Run time:** 2 times the retention time of lobeline which is about 17 min.

**System suitability:** reference solution (b):

- resolution: minimum 4.0 between the peaks due to phenytoin and to lobeline.

**Limits:**

- any impurity: not more than the area of the principal peak in the chromatogram obtained with reference solution (a) (0.1 per cent),
- total: maximum of 2 times the area of the principal peak in the chromatogram obtained with reference solution (a) (0.2 per cent),
- disregard level: 0.5 times the area of the principal peak in the chromatogram obtained with reference solution (a) (0.05 per cent).

**Sulfates** (2.4.13): maximum 0.1 per cent, determined on solution S.

**Loss on drying** (2.2.32): maximum 1.0 per cent, determined on 1.000 g in vacuo.

**Sulfated ash** (2.4.14): maximum 0.1 per cent, determined on the residue obtained in the test for loss on drying.

## ASSAY

Dissolve 0.300 g in 50 mL of ethanol (96 per cent) R. Add 5 mL of 0.01 M hydrochloric acid. Carry out a potentiometric titration (2.2.20), using 0.1 M sodium hydroxide. Read the volume added between the 2 points of inflexion.

1 mL of 0.1 M sodium hydroxide is equivalent to 37.39 mg of C<sub>22</sub>H<sub>28</sub>ClNO<sub>2</sub>.

## STORAGE

Protected from light.

## IMPURITIES

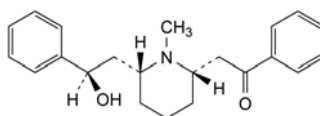

A. 2-[(2S,6R)-6-[(2R)-2-hydroxy-2-phenylethyl]-1-methylpiperidin-2-yl]-1-phenylethanone ((+)-lobeline),

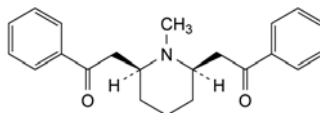

B. 2,2'-[(2R,6S)-1-methylpiperidine-2,6-diyl]bis(1-phenylethanone) (lobelanine),

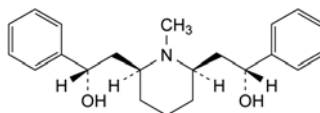

C. meso-(1R,1'S)-2,2'-[(2R,6S)-1-methylpiperidine-2,6-diyl]bis(1-phenylethanol) (lobelanidine),

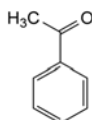

D. acetophenone.

07/2010:0928

**LOMUSTINE**

## Lomustinum

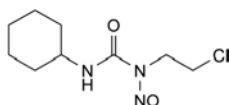

C<sub>9</sub>H<sub>16</sub>ClN<sub>3</sub>O<sub>2</sub>  
[13010-47-4]

M<sub>r</sub> 233.7**DEFINITION**

1-(2-Chloroethyl)-3-cyclohexyl-1-nitrosourea.

*Content*: 98.5 per cent to 100.5 per cent (dried substance).**CHARACTERS***Appearance*: yellow, crystalline powder.*Solubility*: practically insoluble in water, freely soluble in acetone and in methylene chloride, soluble in ethanol (96 per cent).

Carry out the tests protected from light and prepare all the solutions immediately before use.

**IDENTIFICATION***First identification*: C.*Second identification*: A, B, D, E.

A. Melting point (2.2.14): 89 °C to 91 °C.

B. Ultraviolet and visible absorption spectrophotometry (2.2.25).

*Test solution*. Dissolve 50.0 mg in ethanol (96 per cent) R and dilute to 50.0 mL with the same solvent. Dilute 2.0 mL of this solution to 100.0 mL with ethanol (96 per cent) R.*Spectral range*: 220-350 nm.*Absorption maximum*: at 230 nm.*Specific absorbance at the absorption maximum*: 250 to 270.

C. Infrared absorption spectrophotometry (2.2.24).

*Preparation*: discs.*Comparison*: lomustine CRS.

D. Examine the chromatograms obtained in the test for related substances.

*Results*: the principal spot in the chromatogram obtained with test solution (b) is similar in position, colour and size to the principal spot in the chromatogram obtained with reference solution (a).

E. Dissolve about 25 mg in 1 mL of methanol R, add 0.1 mL of dilute sodium hydroxide solution R and 2 mL of water R. Acidify by adding dropwise dilute nitric acid R. Filter. The filtrate gives reaction (a) of chlorides (2.3.1).

**TESTS****Related substances**

A. Thin-layer chromatography (2.2.27).

*Test solution (a)*. Dissolve 0.25 g of the substance to be examined in methanol R and dilute to 10 mL with the same solvent.*Test solution (b)*. Dilute 1 mL of test solution (a) to 25 mL with methanol R.*Reference solution (a)*. Dissolve 10 mg of lomustine CRS in methanol R and dilute to 10 mL with the same solvent.*Reference solution (b)*. Dilute 1 mL of test solution (b) to 10 mL with methanol R.*Reference solution (c)*. Dilute 1 mL of test solution (b) to 20 mL with methanol R.*Reference solution (d)*. Dissolve 10 mg of lomustine CRS and 10 mg of dicyclohexylurea R (impurity C) in methanol R and dilute to 10 mL with the same solvent.*Plate*: TLC silica gel G plate R.*Mobile phase*: glacial acetic acid R, toluene R (20:80 V/V).*Application*: 5 µL.*Development*: over 3/4 of the plate.*Drying*: at 110 °C for 1 h.*Chlorine treatment*: place at the bottom of a chromatographic tank an evaporating dish containing a mixture of 1 volume of hydrochloric acid R1, 1 volume of water R and 2 volumes of a 15 g/L solution of potassium permanganate R; close the tank and allow to stand for 15 min; place the dried plate in the tank and close the tank; leave the plate in contact with the chlorine vapour for 5 min; withdraw the plate and place it in a current of cold air until the excess of chlorine is removed and an area of coating below the points of application does not give a blue colour with a drop of potassium iodide and starch solution R.*Detection*: spray with potassium iodide and starch solution R.*System suitability*: reference solution (d):

– the chromatogram shows 2 clearly separated principal spots.

*Limit*: test solution (a):– *impurities A, B, C*: any spot, apart from the principal spot, is not more intense than the principal spot in the chromatogram obtained with reference solution (b) (0.4 per cent) and at most one such spot is more intense than the principal spot in the chromatogram obtained with reference solution (c) (0.2 per cent).

B. Liquid chromatography (2.2.29).

*Test solution*. Dissolve 0.25 g of the substance to be examined in methanol R and dilute to 10.0 mL with the same solvent.*Reference solution*. Dilute 1.0 mL of the test solution to 100.0 mL with methanol R.*Column*:– *size*: *l* = 0.25 m, Ø = 4 mm;– *stationary phase*: octadecylsilyl silica gel for chromatography R (5-10 µm).*Mobile phase*: methanol R, water R (50:50 V/V).*Flow rate*: 2 mL/min.*Detection*: spectrophotometer at 230 nm.*Injection*: 20 µL.*Limits*:– *unspecified impurities*: for each impurity, not more than 0.1 times the area of the principal peak in the chromatogram obtained with the reference solution (0.10 per cent);  
– *total*: not more than the area of the principal peak in the chromatogram obtained with the reference solution (1 per cent);  
– *disregard limit*: 0.05 times the area of the principal peak in the chromatogram obtained with the reference solution (0.05 per cent).**Chlorides (2.4.4)**: maximum 500 ppm.

Dissolve 0.24 g in 4 mL of methanol R and add 20 mL of water R. Allow to stand for 20 min and filter. To 10 mL of the filtrate, add 5 mL of methanol R. When preparing the standard, replace the 5 mL of water R with 5 mL of methanol R.

**Loss on drying (2.2.32)**: maximum 1.0 per cent, determined on 1.000 g by drying in a desiccator over diphosphorus pentoxide R at a pressure not exceeding 0.7 kPa for 24 h.

## ASSAY

Dissolve 0.200 g in about 3 mL of *ethanol (96 per cent) R* and add 20 mL of a 200 g/L solution of *potassium hydroxide R* and boil under a reflux condenser for 2 h. Add 75 mL of *water R* and 4 mL of *nitric acid R*. Cool and titrate with 0.1 M *silver nitrate*, determining the end-point potentiometrically (2.2.20). Carry out a blank titration.

1 mL of 0.1 M *silver nitrate* is equivalent to 23.37 mg of  $C_9H_{16}ClN_3O_2$ .

## STORAGE

Protected from light.

## IMPURITIES

Specified impurities: A, B, C.

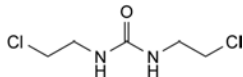

A. 1,3-bis(2-chloroethyl)urea,

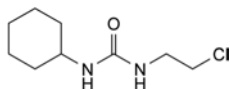

B. 1-(2-chloroethyl)-3-cyclohexylurea,

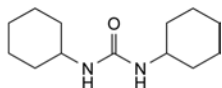

C. 1,3-dicyclohexylurea.

If the spectra obtained show differences, dissolve the substance to be examined and the reference substance separately in the minimum volume of *methylene chloride R*, evaporate to dryness and record new spectra using the residues.

## TESTS

**Related substances.** Liquid chromatography (2.2.29).

**Test solution.** Dissolve 0.100 g of the substance to be examined in *methanol R* and dilute to 10.0 mL with the same solvent.

**Reference solution (a).** Dissolve 10.0 mg of *loperamide hydrochloride for system suitability CRS* in *methanol R* and dilute to 1.0 mL with the same solvent.

**Reference solution (b).** Dilute 1.0 mL of the test solution to 20.0 mL with *methanol R*. Dilute 1.0 mL of this solution to 25.0 mL with *methanol R*.

**Column:**

- size:  $l = 0.10$  m,  $\varnothing = 4.6$  mm,
- stationary phase: base-deactivated octadecylsilyl silica gel for chromatography R (3  $\mu$ m),
- temperature: 35 °C.

**Mobile phase:**

- mobile phase A: 17.0 g/L solution of *tetrabutylammonium hydrogen sulfate R1*,
- mobile phase B: *acetonitrile R*,

Time (min)	Mobile phase A (per cent V/V)	Mobile phase B (per cent V/V)
0 - 15	90 → 30	10 → 70
15 - 17	30	70

**Flow rate:** 1.5 mL/min.

**Detection:** spectrophotometer at 220 nm.

**Injection:** 10  $\mu$ L.

**System suitability:** reference solution (a):

- *peak-to-valley ratio*: minimum 1.5, where  $H_p$  = height above the baseline of the peak due to impurity G and  $H_v$  = height above the baseline of the lowest point of the curve separating this peak from the peak due to impurity H;
- *peak-to-valley ratio*: minimum 1.5, where  $H_p$  = height above the baseline of the peak due to impurity E and  $H_v$  = height above the baseline of the lowest point of the curve separating this peak from the peak due to impurity A;
- the chromatogram obtained is concordant with the chromatogram supplied with *loperamide hydrochloride for system suitability CRS*.

**Limits:**

- *correction factors*: for the calculation of contents, multiply the peak areas of the following impurities by the corresponding correction factor: impurity A = 1.3; impurity D = 1.7;
- *impurities A, B, C, D, E, F, G, H*: for each impurity, not more than the area of the principal peak in the chromatogram obtained with reference solution (b) (0.2 per cent);
- *unspecified impurities*: for each impurity, not more than 0.5 times the area of the principal peak in the chromatogram obtained with reference solution (b) (0.10 per cent);
- *total*: not more than 1.5 times the area of the principal peak in the chromatogram obtained with reference solution (b) (0.3 per cent);
- *disregard limit*: 0.25 times the area of the principal peak in the chromatogram obtained with reference solution (b) (0.05 per cent).

**Loss on drying** (2.2.32): maximum 0.5 per cent, determined on 1.000 g by drying in an oven at 105 °C for 4 h.

**Sulfated ash** (2.4.14): maximum 0.1 per cent, determined on 1.0 g.

01/2008:0929  
corrected 7.0

## LOPERAMIDE HYDROCHLORIDE

## Loperamidi hydrochloridum

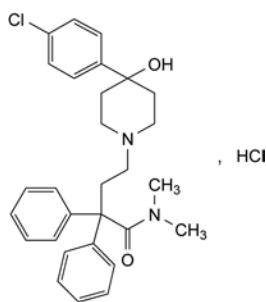

$C_{29}H_{34}Cl_2N_2O_2$   
[34552-83-5]

$M_r$  513.5

## DEFINITION

4-[4-(4-Chlorophenyl)-4-hydroxypiperidin-1-yl]-*N,N*-dimethyl-2,2-diphenylbutanamide hydrochloride.

**Content:** 99.0 per cent to 101.0 per cent (dried substance).

## CHARACTERS

**Appearance:** white or almost white powder.

**Solubility:** slightly soluble in water, freely soluble in ethanol (96 per cent) and in methanol.

It shows polymorphism (5.9).

## IDENTIFICATION

Infrared absorption spectrophotometry (2.2.24).

**Comparison:** *loperamide hydrochloride CRS*.

## ASSAY

Dissolve 0.400 g in 50 mL of *ethanol (96 per cent) R* and add 5.0 mL of 0.01 M *hydrochloric acid*. Carry out a potentiometric titration (2.2.20), using 0.1 M *sodium hydroxide*. Read the volume added between the 2 points of inflexion.

1 mL of 0.1 M *sodium hydroxide* is equivalent to 51.35 mg of  $C_{29}H_{34}Cl_2N_2O_2$ .

## STORAGE

Protected from light.

## IMPURITIES

*Specified impurities: A, B, C, D, E, F, G, H.*

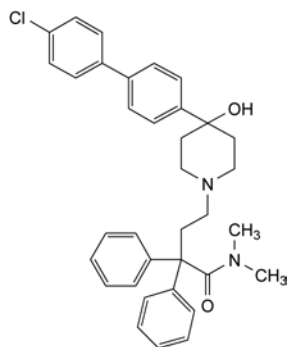

A. 4-[4-(4'-chlorobiphenyl-4-yl)-4-hydroxypiperidin-1-yl]-*N,N*-dimethyl-2,2-diphenylbutanamide,

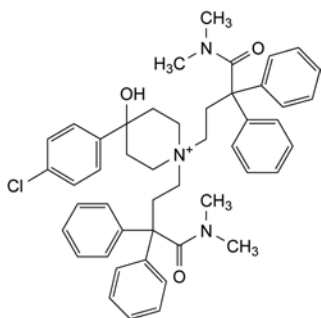

B. 4-(4-chlorophenyl)-1,1-bis[4-(dimethylamino)-4-oxo-3,3-diphenylbutyl]-4-hydroxypiperidinium,

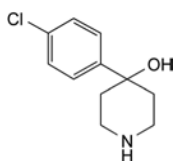

C. 4-(4-chlorophenyl)piperidin-4-ol,

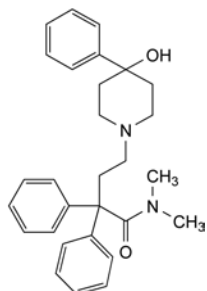

D. 4-(4-hydroxy-4-phenylpiperidin-1-yl)-*N,N*-dimethyl-2,2-diphenylbutanamide,

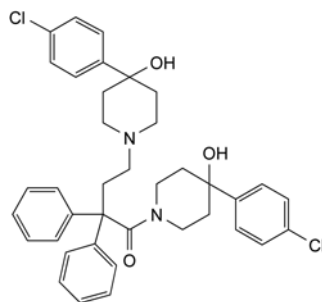

E. 4-(4-chlorophenyl)-1-[4-[4-(4-chlorophenyl)-4-hydroxypiperidin-1-yl]-2,2-diphenylbutanoyl]piperidin-4-ol,

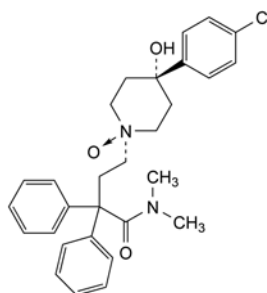

F. 4-[*trans*-4-(4-chlorophenyl)-4-hydroxy-1-oxidopiperidin-1-yl]-*N,N*-dimethyl-2,2-diphenylbutanamide (loperamide oxide),

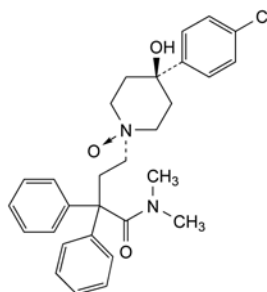

G. 4-[*cis*-4-(4-chlorophenyl)-4-hydroxy-1-oxidopiperidin-1-yl]-*N,N*-dimethyl-2,2-diphenylbutanamide,

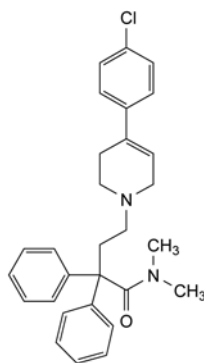

H. 4-[4-(4-chlorophenyl)-3,6-dihydropyridin-1(2*H*)-yl]-*N,N*-dimethyl-2,2-diphenylbutanamide.

01/2008:1729  
corrected 7.0

## LOPERAMIDE OXIDE MONOHYDRATE

### Loperamidi oxidum monohydricum

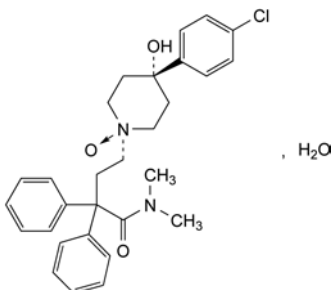

$C_{29}H_{33}ClN_2O_3 \cdot H_2O$

$M_r$  511.1

#### DEFINITION

4-[*trans*-4-(4-Chlorophenyl)-4-hydroxy-1-oxidopiperidin-1-yl]-*N,N*-dimethyl-2,2-diphenylbutanamide monohydrate.

*Content*: 99.0 per cent to 101.0 per cent (anhydrous substance).

#### CHARACTERS

*Appearance*: white or almost white powder, slightly hygroscopic.

*Solubility*: practically insoluble in water, freely soluble in alcohol and in methylene chloride.

mp: about 152 °C, with decomposition.

#### IDENTIFICATION

Infrared absorption spectrophotometry (2.2.24).

*Comparison*: loperamide oxide monohydrate CRS.

#### TESTS

**Related substances.** Liquid chromatography (2.2.29).

*Test solution.* Dissolve 0.100 g of the substance to be examined in *methanol R* and dilute to 10.0 mL with the same solvent.

*Reference solution (a).* Dissolve 5.0 mg of *loperamide hydrochloride CRS* in *methanol R*, add 0.5 mL of the test solution and dilute to 100.0 mL with *methanol R*.

*Reference solution (b).* Dilute 1.0 mL of the test solution to 20.0 mL with *methanol R*. Dilute 1.0 mL of this solution to 25.0 mL with *methanol R*.

*Column*:

- *size*:  $l = 0.10$  m,  $\varnothing = 4.6$  mm,
- *stationary phase*: base-deactivated octadecylsilyl silica gel for chromatography *R* (3  $\mu$ m),
- *temperature*: 35 °C.

*Mobile phase*:

- *mobile phase A*: 17.0 g/L solution of *tetrabutylammonium hydrogen sulfate RI*,
- *mobile phase B*: *acetonitrile R*,

Time (min)	Mobile phase A (per cent V/V)	Mobile phase B (per cent V/V)
0 - 15	90 → 30	10 → 70
15 - 17	30	70

*Flow rate*: 1.5 mL/min.

*Detection*: spectrophotometer at 220 nm.

*Injection*: 10  $\mu$ L.

*Relative retention* with reference to loperamide oxide (retention time = about 7 min): impurity A = about 0.9; impurity B = about 1.11; impurity C = about 1.13.

*System suitability*: reference solution (a):

- *resolution*: minimum 3.8 between the peaks due to loperamide oxide and impurity A.

*Limits*:

- *impurities A, B, C*: for each impurity, not more than the area of the principal peak in the chromatogram obtained with reference solution (b) (0.2 per cent),
- *unspecified impurities*: for each impurity, not more than 0.5 times the area of the principal peak in the chromatogram obtained with reference solution (b) (0.10 per cent),
- *total*: not more than 1.5 times the area of the principal peak in the chromatogram obtained with reference solution (b) (0.3 per cent),
- *disregard limit*: 0.25 times the area of the principal peak in the chromatogram obtained with reference solution (b) (0.05 per cent).

**Water** (2.5.12): 3.4 per cent to 4.2 per cent, determined on 0.500 g.

**Sulfated ash** (2.4.14): maximum 0.1 per cent, determined on 1.0 g.

#### ASSAY

Dissolve 0.350 g in 50 mL of a mixture of 1 volume of *anhydrous acetic acid R* and 7 volumes of *methyl ethyl ketone R*. Titrate with 0.1 M *perchloric acid* using 0.2 mL of *naphtholbenzein solution R* as indicator.

1 mL of 0.1 M *perchloric acid* is equivalent to 49.30 mg of  $C_{29}H_{33}ClN_2O_3$ .

#### STORAGE

In an airtight container, protected from light.

#### IMPURITIES

*Specified impurities*: A, B, C.

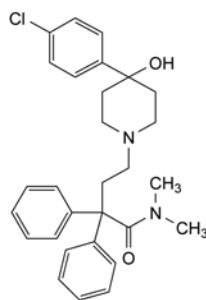

A. 4-[4-(4-chlorophenyl)-4-hydroxypiperidin-1-yl]-*N,N*-dimethyl-2,2-diphenylbutanamide (loperamide),

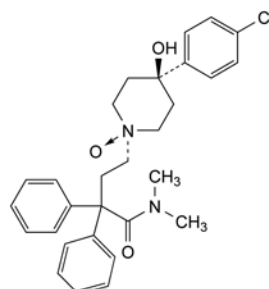

B. 4-[*cis*-4-(4-chlorophenyl)-4-hydroxy-1-oxidopiperidin-1-yl]-*N,N*-dimethyl-2,2-diphenylbutanamide,

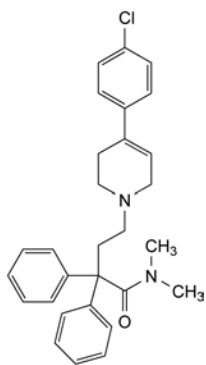

C. 4-[4-(4-chlorophenyl)-3,6-dihydropyridin-1(2H)-yl]-N,N-dimethyl-2,2-diphenylbutanamide.

01/2010:2124  
corrected 6.8

## LORATADINE

### Loratadinum

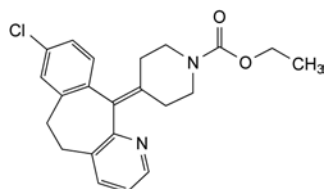

C<sub>22</sub>H<sub>23</sub>ClN<sub>2</sub>O<sub>2</sub>  
[79794-75-5]

M<sub>r</sub> 382.9

#### DEFINITION

Ethyl 4-(8-chloro-5,6-dihydro-11H-benzo[5,6]cyclohepta[1,2-b]pyridin-11-ylidene)piperidine-1-carboxylate.

Content: 98.5 per cent to 101.5 per cent (dried substance).

#### CHARACTERS

**Appearance:** white or almost white, crystalline powder.

**Solubility:** practically insoluble in water, freely soluble in acetone and in methanol.

It shows polymorphism (5.9).

#### IDENTIFICATION

Infrared absorption spectrophotometry (2.2.24).

**Comparison:** loratadine CRS.

If the spectra obtained in the solid state show differences, dissolve the substance to be examined and the reference substance separately in acetone R, evaporate to dryness and record new spectra using the residues.

#### TESTS

**Appearance of solution.** The solution is clear (2.2.1) and not more intensely coloured than reference solution BY<sub>5</sub> (2.2.2, Method II).

Dissolve 1.0 g in methanol R and dilute to 20.0 mL with the same solvent.

**Impurity H.** Gas chromatography (2.2.28).

**Internal standard solution.** Dissolve 25 mg of isoamyl benzoate R in methylene chloride R and dilute to 100 mL with the same solvent. Dilute 5.0 mL of this solution to 50 mL with methylene chloride R.

**Test solution.** Dissolve 25.0 mg of the substance to be examined in methylene chloride R, add 1.0 mL of reference solution (a) and 1.0 mL of the internal standard solution and dilute to 5.0 mL with methylene chloride R.

**Reference solution (a).** Dissolve 25.0 mg of loratadine impurity H CRS in methylene chloride R and dilute to 100.0 mL with the same solvent. Dilute 5.0 mL of this solution to 50.0 mL with methylene chloride R.

**Reference solution (b).** To 1.0 mL of reference solution (a) add 1.0 mL of the internal standard solution and dilute to 5.0 mL with methylene chloride R.

#### Column:

- material: fused silica;
- size:  $l = 25$  m,  $\varnothing = 0.32$  mm;
- stationary phase: poly(dimethyl)siloxane R (film thickness 0.52  $\mu$ m).

**Carrier gas:** helium for chromatography R.

**Flow rate:** 1.0 mL/min.

**Split ratio:** 1:30.

**Temperature:**

	Time (min)	Temperature (°C)
Column	0 - 1	80
	1 - 23	80 → 300
	23 - 33	300
Injection port		260
Detector		300

**Detection:** flame ionisation.

**Injection:** 1  $\mu$ L of the test solution and reference solution (b).

**Relative retention** with reference to loratadine (retention time = about 32 min): impurity H = about 0.33; isoamyl benzoate = about 0.37.

**System suitability:** reference solution (b):

- resolution: minimum 2.0 between the peaks due to impurity H and isoamyl benzoate;
- signal-to-noise ratio: minimum 10 for the peak due to impurity H.

**Limit:**

- impurity H: calculate the ratio ( $R$ ) of the area of the peak due to impurity H to the area of the peak due to isoamyl benzoate from the chromatogram obtained with reference solution (b); from the chromatogram obtained with the test solution, calculate the ratio of the area of the peak due to impurity H to the area of the peak due to isoamyl benzoate: this ratio is not greater than twice  $R$  (0.1 per cent).

**Related substances.** Liquid chromatography (2.2.29).

**Test solution.** Dissolve 25.0 mg of the substance to be examined in the mobile phase and dilute to 25.0 mL with the mobile phase.

**Reference solution (a).** Dissolve 5 mg of loratadine impurity F CRS in the mobile phase and dilute to 25 mL with the mobile phase. Dilute 1 mL of this solution to 10 mL with the mobile phase.

**Reference solution (b).** Dissolve 5 mg of loratadine for system suitability CRS (containing impurities A and E) in the mobile phase, add 0.5 mL of reference solution (a) and dilute to 5 mL with the mobile phase.

**Reference solution (c).** Dilute 1.0 mL of the test solution to 100.0 mL with the mobile phase. Dilute 1.0 mL of this solution to 10.0 mL with the mobile phase.

**Column:**

- size:  $l = 0.25$  m,  $\varnothing = 4.6$  mm;
- stationary phase: spherical end-capped octadecylsilyl silica gel for chromatography R (5  $\mu$ m) with very low silanol activity;
- temperature: 40 °C.



**Mobile phase:** mix 30 volumes of *methanol R*, 35 volumes of a 6.8 g/L solution of *potassium dihydrogen phosphate R* previously adjusted to pH  $2.80 \pm 0.05$  with *phosphoric acid R* and 40 volumes of *acetonitrile R*.

**Flow rate:** 1.5 mL/min.

**Detection:** spectrophotometer at 220 nm.

**Injection:** 20 µL of the test solution and reference solutions (b) and (c).

**Run time:** 5 times the retention time of loratadine.

**Identification of impurities:** use the chromatogram supplied with *loratadine for system suitability CRS* and the chromatogram obtained with reference solution (b) to identify the peaks due to impurities A and E.

**Relative retention** with reference to loratadine (retention time = about 12 min): impurity D = about 0.2; impurity B = about 0.4; impurity F = about 0.9; impurity E = about 1.1; impurity A = about 2.4; impurity C = about 2.7.

**System suitability:** reference solution (b):

- **peak-to-valley ratio:** minimum 2.5, where  $H_p$  = height above the baseline of the peak due to impurity E and  $H_v$  = height above the baseline of the lowest point of the curve separating this peak from the peak due to loratadine.

**Limits:**

- **correction factors:** for the calculation of content, multiply the peak areas of the following impurities by the corresponding correction factor: impurity A = 1.7; impurity F = 1.6; impurity E = 1.9;
- **impurity F:** not more than twice the area of the principal peak in the chromatogram obtained with reference solution (c) (0.2 per cent);
- **impurities A, B, C, D, E:** for each impurity, not more than the area of the principal peak in the chromatogram obtained with reference solution (c) (0.1 per cent);
- **unspecified impurities:** for each impurity, not more than the area of the principal peak in the chromatogram obtained with reference solution (c) (0.10 per cent);
- **total:** not more than 5 times the area of the principal peak in the chromatogram obtained with reference solution (c) (0.5 per cent);
- **disregard limit:** 0.5 times the area of the principal peak in the chromatogram obtained with reference solution (c) (0.05 per cent).

**Sulfates (2.4.13):** maximum 150 ppm.

Ignite 1.33 g at  $800 \pm 25$  °C and take up the residue with 20 mL of *distilled water R*. Filter, if necessary, through paper free from sulfates. Repeat the filtration with new paper filters until the filtrate is no longer turbid.

**Loss on drying (2.2.32):** maximum 0.5 per cent, determined on 1.000 g by drying in an oven at 105 °C.

**Sulfated ash (2.4.14):** maximum 0.1 per cent, determined on 1.0 g.

**ASSAY**

Dissolve 0.300 g in 50 mL of *glacial acetic acid R*. Titrate with 0.1 M *perchloric acid*, determining the end-point potentiometrically (2.2.20).

1 mL of 0.1 M *perchloric acid* is equivalent to 38.29 mg of  $C_{22}H_{23}ClN_2O_2$ .

**IMPURITIES**

**Specified impurities:** A, B, C, D, E, F, H.

**Other detectable impurities** (the following substances would, if present at a sufficient level, be detected by one or other of the tests in the monograph. They are limited by the general acceptance criterion for other/unspecified impurities and/or by the general monograph *Substances for pharmaceutical use (2034)*. It is therefore not necessary to identify these impurities for demonstration of compliance. See also 5.10. *Control of impurities in substances for pharmaceutical use*): G.

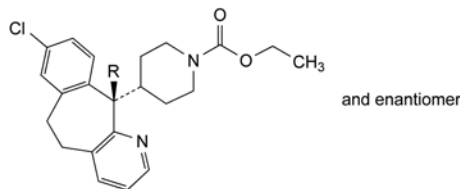

A. R = OH: ethyl 4-[(11RS)-8-chloro-11-hydroxy-6,11-dihydro-5H-benzo[5,6]cyclohepta[1,2-b]pyridin-11-yl]piperidine-1-carboxylate,

F. R = F: ethyl 4-[(11RS)-8-chloro-11-fluoro-6,11-dihydro-5H-benzo[5,6]cyclohepta[1,2-b]pyridin-11-yl]piperidine-1-carboxylate,

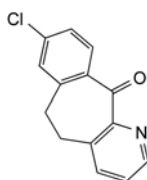

B. 8-chloro-5,6-dihydro-11H-benzo[5,6]cyclohepta[1,2-b]pyridin-11-one,

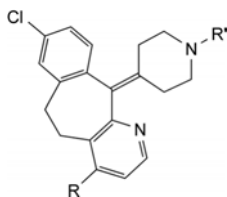

C. R = Cl, R' = CO-OC<sub>2</sub>H<sub>5</sub>: ethyl 4-(4,8-dichloro-5,6-dihydro-11H-benzo[5,6]cyclohepta[1,2-b]pyridin-11-ylidene)piperidine-1-carboxylate,

D. R = R' = H: 8-chloro-11-(piperidin-4-ylidene)-6,11-dihydro-5H-benzo[5,6]cyclohepta[1,2-b]pyridine,

G. R = H, R' = CH<sub>3</sub>: 8-chloro-11-(1-methylpiperidin-4-ylidene)-6,11-dihydro-5H-benzo[5,6]cyclohepta[1,2-b]pyridine,

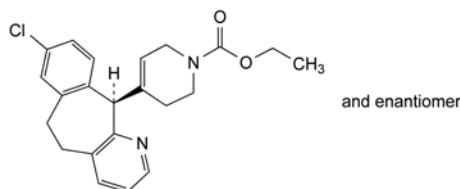

E. ethyl 4-[(11RS)-8-chloro-6,11-dihydro-5H-benzo[5,6]cyclohepta[1,2-b]pyridin-11-yl]-3,6-dihydropyridine-1(2H)-carboxylate,

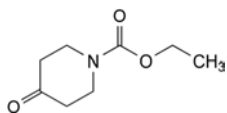

H. ethyl 4-oxopiperidine-1-carboxylate.

01/2008:1121 – mobile phase B: acetonitrile R1;  
corrected 6.0

## LORAZEPAM

### Lorazepamum

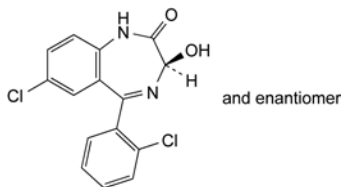

$C_{15}H_{10}Cl_2N_2O_2$   
[846-49-1]

$M_r$  321.2

#### DEFINITION

(3*RS*)-7-Chloro-5-(2-chlorophenyl)-3-hydroxy-1,3-dihydro-2*H*-1,4-benzodiazepin-2-one.

*Content*: 98.5 per cent to 102.0 per cent (dried substance).

#### CHARACTERS

*Appearance*: white or almost white, crystalline powder.

*Solubility*: practically insoluble in water, sparingly soluble in ethanol (96 per cent), sparingly soluble or slightly soluble in methylene chloride.

It shows polymorphism (5.9).

#### IDENTIFICATION

Infrared absorption spectrophotometry (2.2.24).

*Spectral range*: 600-2000  $cm^{-1}$ .

*Comparison*: lorazepam CRS.

#### TESTS

**Related substances.** Liquid chromatography (2.2.29). Prepare the solutions immediately before use.

*Test solution.* Dissolve 40.0 mg of the substance to be examined in 25 mL of acetonitrile R1 and dilute to 50.0 mL with water R.

*Reference solution (a).* Dilute 1.0 mL of the test solution to 100.0 mL with a mixture of equal volumes of acetonitrile R1 and water R. Dilute 1.0 mL of this solution to 10.0 mL with a mixture of equal volumes of acetonitrile R1 and water R.

*Reference solution (b).* Dissolve the contents of a vial of lorazepam for system suitability CRS (containing impurities B and D) in 1.0 mL of a mixture of equal volumes of acetonitrile R1 and water R.

*Reference solution (c).* Dissolve 4.0 mg of lorazepam impurity D CRS in 25 mL of acetonitrile R1 and dilute to 50.0 mL with water R. Dilute 1.0 mL of this solution to 100.0 mL with a mixture of equal volumes of acetonitrile R1 and water R.

*Column*:

- size:  $l = 0.25$  m,  $\varnothing = 4.6$  mm;
- stationary phase: spherical end-capped octadecylsilyl silica gel for chromatography R (5  $\mu m$ ) resistant to bases up to pH 11.5.

*Mobile phase*:

- mobile phase A: dissolve 3.48 g of dipotassium hydrogen phosphate R in a mixture of 50 mL of acetonitrile R1 and 850 mL of water R; adjust the apparent pH to 10.5 with a 40 g/L solution of sodium hydroxide R and dilute to 1000 mL with water R;

Time (min)	Mobile phase A (per cent V/V)	Mobile phase B (per cent V/V)
0 - 5	80	20
5 - 35	80 → 30	20 → 70
35 - 50	30	70
50 - 60	30 → 80	70 → 20

*Flow rate*: 1.0 mL/min.

*Detection*: spectrophotometer at 235 nm.

*Injection*: 20  $\mu L$ .

*Relative retention* with reference to lorazepam (retention time = about 17 min): impurity D = about 0.9; impurity B = about 1.1.

*System suitability*: reference solution (b):

- resolution: minimum 4.5 between the peaks due to impurity D and lorazepam;
- peak-to-valley ratio: minimum 5.0, where  $H_p$  = height above the baseline of the peak due to impurity B and  $H_v$  = height above the baseline of the lowest point of the curve separating this peak from the peak due to lorazepam.

*Limits*:

- impurity B: not more than the area of the principal peak in the chromatogram obtained with reference solution (a) (0.1 per cent);
- impurity D: not more than the area of the principal peak in the chromatogram obtained with reference solution (c) (0.1 per cent);
- unspecified impurities: for each impurity, not more than the area of the principal peak in the chromatogram obtained with reference solution (a) (0.10 per cent);
- total: not more than twice the area of the principal peak in the chromatogram obtained with reference solution (a) (0.2 per cent);
- disregard limit: 0.5 times the area of the principal peak in the chromatogram obtained with reference solution (a) (0.05 per cent).

**Loss on drying** (2.2.32): maximum 0.5 per cent, determined on 1.000 g under high vacuum at 105 °C.

**Sulfated ash** (2.4.14): maximum 0.1 per cent, determined on 1.0 g.

#### ASSAY

Dissolve 0.250 g in 30 mL of dimethylformamide R. Titrate with 0.1 M tetrabutylammonium hydroxide, determining the end-point potentiometrically (2.2.20). Protect the solution from atmospheric carbon dioxide throughout the titration.

1 mL of 0.1 M tetrabutylammonium hydroxide is equivalent to 32.12 mg of  $C_{15}H_{10}Cl_2N_2O_2$ .

#### IMPURITIES

*Specified impurities*: B, D.

*Other detectable impurities* (the following substances would, if present at a sufficient level, be detected by one or other of the tests in the monograph. They are limited by the general acceptance criterion for other/unspecified impurities and/or by the general monograph *Substances for pharmaceutical use* (2034). It is therefore not necessary to identify these impurities for demonstration of compliance. See also 5.10. *Control of impurities in substances for pharmaceutical use*): A, C, E.

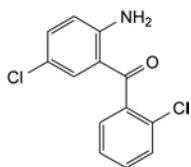

A. (2-amino-5-chlorophenyl)(2-chlorophenyl)methanone,

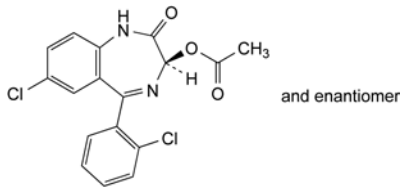
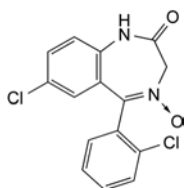
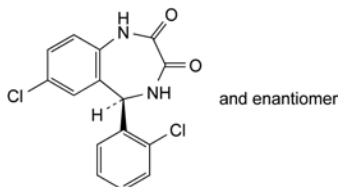
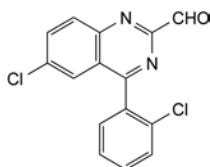
B. (3*RS*)-7-chloro-5-(2-chlorophenyl)-2-oxo-2,3-dihydro-1*H*-1,4-benzodiazepin-3-yl acetate,C. 7-chloro-5-(2-chlorophenyl)-1,3-dihydro-2*H*-1,4-benzodiazepin-2-one 4-oxide,D. (5*RS*)-7-chloro-5-(2-chlorophenyl)-4,5-dihydro-1*H*-1,4-benzodiazepine-2,3-dione,

E. 6-chloro-4-(2-chlorophenyl)quinazoline-2-carbaldehyde.

**Solubility:** freely soluble in water and in methanol, slightly soluble in acetonitrile.

It shows polymorphism (5.9).

#### IDENTIFICATION

##### A. Infrared absorption spectrophotometry (2.2.24).

**Comparison:** *losartan potassium CRS*.

If the spectra obtained in the solid state show differences, dissolve the substance to be examined and the reference substance separately in *methanol R*, evaporate to dryness and record new spectra using the residues.

##### B. Dissolve 25 mg in 3 mL of *water R*. The solution gives reaction (a) of potassium (2.3.1).

#### TESTS

**Related substances.** Liquid chromatography (2.2.29). *Prepare the solutions immediately before use.*

**Test solution.** Dissolve 30.0 mg of the substance to be examined in *methanol R* and dilute to 100.0 mL with the same solvent.

**Reference solution (a).** Dilute 1.0 mL of the test solution to 100.0 mL with *methanol R*. Dilute 1.0 mL of this solution to 10.0 mL with *methanol R*.

**Reference solution (b).** Dissolve 6 mg of *triphenylmethanol R* (impurity G) in 100.0 mL of *methanol R*. Dilute 1.0 mL of the solution to 100.0 mL with *methanol R*. Use 1.0 mL of this solution to dissolve the contents of a vial of *losartan for system suitability CRS* (containing impurities J, K, L and M) and sonicate for 5 min.

**Reference solution (c).** Dissolve 3.0 mg of *losartan impurity D CRS* in *methanol R* and dilute to 100.0 mL with the same solvent. Dilute 1.5 mL of this solution to 100.0 mL with *methanol R*.

**Column:**

- size:  $l = 0.25$  m,  $\varnothing = 4.6$  mm;
- stationary phase: end-capped octadecylsilyl silica gel for chromatography *R* (5  $\mu$ m);
- temperature: 35 °C.

**Mobile phase:**

- mobile phase A: dilute 1.0 mL of *phosphoric acid R* to 1000 mL with *water R*;
- mobile phase B: *acetonitrile R1*;

Time (min)	Mobile phase A (per cent V/V)	Mobile phase B (per cent V/V)
0 - 5	75	25
5 - 30	75 → 10	25 → 90
30 - 40	10	90

**Flow rate:** 1.3 mL/min.

**Detection:** spectrophotometer at 220 nm.

**Injection:** 10  $\mu$ L.

**Identification of impurities:** use the chromatogram supplied with *losartan for system suitability CRS* and the chromatogram obtained with reference solution (b) to identify the peaks due to impurities G, J, K, L and M; use the chromatogram obtained with reference solution (c) to identify the peak due to impurity D.

**Relative retention** with reference to losartan (retention time = about 14 min): impurity D = about 0.9; impurity J = about 1.4; impurity K = about 1.5; impurity L = about 1.6; impurity M = about 1.75; impurity G = about 1.8.

**System suitability:** reference solution (b):

- peak-to-valley ratio: minimum 2.0, where  $H_p$  = height above the baseline of the peak due to impurity M and  $H_v$  = height above the baseline of the lowest point of the curve separating this peak from the peak due to impurity G.

04/2009:2232

## LOSARTAN POTASSIUM

### Losartanum kalicum

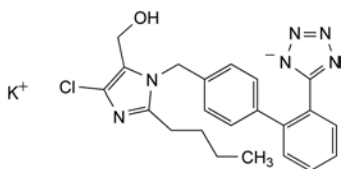

$C_{22}H_{22}ClKN_6O$   
[124750-99-8]

$M_r$  461.0

#### DEFINITION

Potassium 5-[4'-[[2-butyl-4-chloro-5-(hydroxymethyl)-1*H*-imidazol-1-yl]methyl]biphenyl-2-yl]tetrazol-1-ide.

**Content:** 98.5 per cent to 101.5 per cent (dried substance).

#### CHARACTERS

**Appearance:** white or almost white, crystalline powder, hygroscopic.

**Limits:**

- *impurity D*: not more than the area of the corresponding peak in the chromatogram obtained with reference solution (c) (0.15 per cent);
- *impurities J, K, L, M*: for each impurity, not more than 1.5 times the area of the principal peak in the chromatogram obtained with reference solution (a) (0.15 per cent);
- *unspecified impurities*: for each impurity, not more than the area of the principal peak in the chromatogram obtained with reference solution (a) (0.10 per cent);
- *total*: not more than 3 times the area of the principal peak in the chromatogram obtained with reference solution (a) (0.3 per cent);
- *disregard limit*: 0.5 times the area of the principal peak in the chromatogram obtained with reference solution (a) (0.05 per cent).

**Heavy metals:** maximum 20 ppm.

**Prescribed solution.** Dissolve 1.0 g in 20 mL of a mixture of equal volumes of *ethanol (96 per cent) R* and *water R*.

**Test solution.** 12 mL of the prescribed solution.

**Reference solution.** Mix 1.0 mL of *lead standard solution (10 ppm Pb) R*, 2.0 mL of the prescribed solution and 9 mL of *water R*.

**Blank solution.** Mix 2.0 mL of the prescribed solution and 10 mL of *water R*.

To each solution, add 2 mL of *buffer solution pH 3.5 R*. Mix. The substance will precipitate. Dilute each solution to 40 mL with *ethanol (96 per cent) R*. The substance dissolves completely. Mix and add to 1.2 mL of *thioacetamide reagent R*. Mix immediately.

Filter the solutions through a membrane filter (nominal pore size 0.45 µm) (2.4.8). Compare the spots on the filters obtained with the different solutions. The test is invalid if the reference solution does not show a slight brownish-black colour compared to the blank solution. The substance to be examined complies with the test if the brownish-black colour of the spot resulting from the test solution is not more intense than that of the spot resulting from the reference solution.

**Loss on drying (2.2.32):** maximum 0.5 per cent, determined on 1.000 g by drying in an oven at 105 °C.

**ASSAY**

Dissolve 0.200 g in 75 mL of *anhydrous acetic acid R* and sonicate for 10 min. Carry out a potentiometric titration (2.2.20) using 0.1 M *perchloric acid*.

1 mL of 0.1 M *perchloric acid* is equivalent to 23.05 mg of C<sub>22</sub>H<sub>22</sub>ClKN<sub>6</sub>O.

**STORAGE**

In an airtight container.

**IMPURITIES**

*Specified impurities: D, J, K, L, M.*

*Other detectable impurities* (the following substances would, if present at a sufficient level, be detected by one or other of the tests in the monograph. They are limited by the general acceptance criterion for other/unspecified impurities and/or by the general monograph *Substances for pharmaceutical use (2034)*. It is therefore not necessary to identify these impurities for demonstration of compliance. See also 5.10. *Control of impurities in substances for pharmaceutical use*): B, C, E, F, G, H, I.

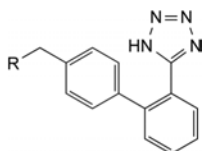

B. R = OH: [2'-(1*H*-tetrazol-5-yl)biphenyl-4-yl]methanol,

E. R = H: 5-(4'-methylbiphenyl-2-yl)-1*H*-tetrazole,

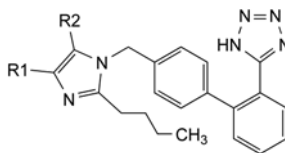

C. R1 = CH<sub>2</sub>-OH, R2 = Cl: [2-butyl-5-chloro-1-[[2'-(1*H*-tetrazol-5-yl)biphenyl-4-yl]methyl]-1*H*-imidazol-4-yl]methanol,

F. R1 = Cl, R2 = CH<sub>2</sub>-O-CH(CH<sub>3</sub>)<sub>2</sub>: 5-[4'-[[2-butyl-4-chloro-5-[[[(1-methylethyl)oxy]methyl]-1*H*-imidazol-1-yl]methyl]biphenyl-2-yl]-1*H*-tetrazole,

I. R1 = Cl, R2 = CH<sub>2</sub>-O-CPh<sub>3</sub>: 5-[4'-[[2-butyl-4-chloro-5-[[[(triphenylmethyl)oxy]methyl]-1*H*-imidazol-1-yl]methyl]biphenyl-2-yl]-1*H*-tetrazole,

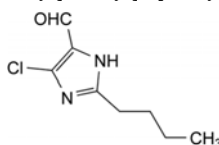

D. 2-butyl-4-chloro-1*H*-imidazole-5-carbaldehyde,

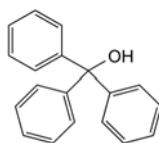

G. triphenylmethanol,

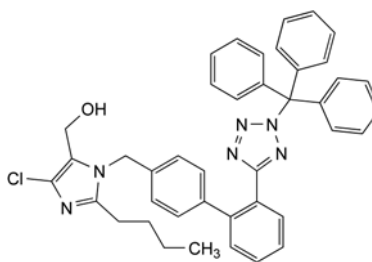

H. [2-butyl-4-chloro-1-[[2'-[2-(triphenylmethyl)-2*H*-tetrazol-5-yl]biphenyl-4-yl]methyl]-1*H*-imidazol-5-yl]methanol,

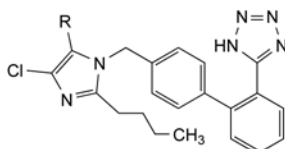

J. R = CH<sub>2</sub>-O-CO-CH<sub>3</sub>: [2-butyl-4-chloro-1-[[2'-(1*H*-tetrazol-5-yl)biphenyl-4-yl]methyl]-1*H*-imidazol-5-yl]methyl acetate,

K. R = CHO: 2-butyl-4-chloro-1-[[2'-(1*H*-tetrazol-5-yl)biphenyl-4-yl]methyl]-1*H*-imidazol-5-carbaldehyde,

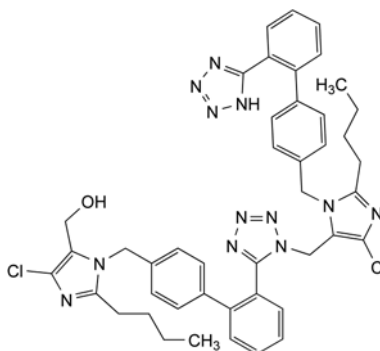

L. [2-butyl-1-[[2'-[1-[[2-butyl-4-chloro-1-[[2'-(1*H*-tetrazol-5-yl)biphenyl-4-yl]methyl]-1*H*-imidazol-5-yl]methyl]-1*H*-tetrazol-5-yl]biphenyl-4-yl]methyl]-4-chloro-1*H*-imidazol-5-yl]methanol,

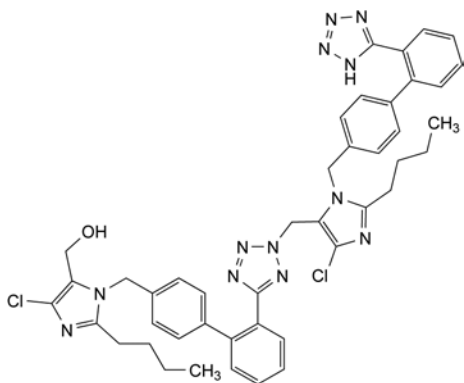

M. [2-butyl-1-[[2'-[2-[[2-butyl-4-chloro-1-[[2'-(1*H*-tetrazol-5-yl)biphenyl-4-yl]methyl]-1*H*-imidazol-5-yl]methyl]-2*H*-tetrazol-5-yl]biphenyl-4-yl]methyl]-4-chloro-1*H*-imidazol-5-yl]methanol.

07/2010:1538

## LOVASTATIN

### Lovastatinum

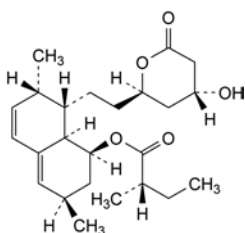

$C_{24}H_{36}O_5$   
[75330-75-5]

$M_r$  404.5

#### DEFINITION

(1*S*,3*R*,7*S*,8*S*,8*aR*)-8-[2-[(2*R*,4*R*)-4-Hydroxy-6-oxo-tetrahydro-2*H*-pyran-2-yl]ethyl]-3,7-dimethyl-1,2,3,7,8,8*a*-hexahydronaphthalen-1-yl (2*S*)-2-methylbutanoate.

*Content*: 97.0 per cent to 102.0 per cent (dried substance).

#### CHARACTERS

*Appearance*: white or almost white, crystalline powder.

*Solubility*: practically insoluble in water, soluble in acetone, sparingly soluble in anhydrous ethanol.

#### IDENTIFICATION

A. Specific optical rotation (see Tests).

B. Infrared absorption spectrophotometry (2.2.24).

*Comparison*: lovastatin CRS.

#### TESTS

**Specific optical rotation** (2.2.7): + 325 to + 340 (dried substance).

Dissolve 0.125 g in *acetonitrile R* and dilute to 25.0 mL with the same solvent.

**Impurity E**. Liquid chromatography (2.2.29).

*Test solution*. Dissolve 25 mg of the substance to be examined in *acetonitrile R1* and dilute to 25.0 mL with the same solvent.

*Reference solution (a)*. Dilute 5.0 mL of the test solution to 100.0 mL with *acetonitrile R1*. Dilute 5.0 mL of this solution to 50.0 mL with *acetonitrile R1*.

*Reference solution (b)*. Dissolve 4 mg of lovastatin for peak identification CRS (containing impurities A, B, C, D and E) in *acetonitrile R1* and dilute to 10.0 mL with the same solvent.

#### Column:

– *size*:  $l = 0.25$  m,  $\emptyset = 4.6$  mm;

– *stationary phase*: octylsilyl silica gel for chromatography R (5  $\mu$ m);

– *temperature*: 40 °C.

*Mobile phase*: mix 7 volumes of a 1.1 g/L solution of phosphoric acid R and 13 volumes of acetonitrile R1.

*Flow rate*: 1.5 mL/min.

*Detection*: spectrophotometer at 200 nm.

*Injection*: 10  $\mu$ L.

*Run time*: 3 times the retention time of lovastatin.

*Identification of impurities*: use the chromatogram supplied with lovastatin for peak identification CRS and the chromatogram obtained with reference solution (b) to identify the peak due to impurity E.

*Relative retention* with reference to lovastatin (retention time = about 5 min): impurity E = about 1.3.

*System suitability*: reference solution (b):

– *resolution*: minimum 5.0 between the peaks due to lovastatin and impurity E.

#### Limits:

– *correction factor*: for the calculation of content, multiply the peak area of impurity E by 1.6;

– *impurity E*: not more than the area of the principal peak in the chromatogram obtained with reference solution (a) (0.5 per cent).

**Related substances**. Liquid chromatography (2.2.29).

*Test solution*. Dissolve 20.0 mg of the substance to be examined in *acetonitrile R* and dilute to 50.0 mL with the same solvent.

*Reference solution (a)*. Dissolve 20.0 mg of lovastatin CRS in *acetonitrile R* and dilute to 50.0 mL with the same solvent.

*Reference solution (b)*. Dilute 5.0 mL of the test solution to 100.0 mL with *acetonitrile R*. Dilute 5.0 mL of this solution to 50.0 mL with *acetonitrile R*.

*Reference solution (c)*. To 2.5 mL of reference solution (a) add 1 mg of simvastatin CRS and dilute to 50.0 mL with *acetonitrile R*.

*Reference solution (d)*. Dissolve 4 mg of lovastatin for peak identification CRS (containing impurities A, B, C, D and E) in *acetonitrile R* and dilute to 10.0 mL with the same solvent.

#### Column:

– *size*:  $l = 0.25$  m,  $\emptyset = 4.6$  mm;

– *stationary phase*: octylsilyl silica gel for chromatography R (5  $\mu$ m).

#### Mobile phase:

– *mobile phase A*: 0.1 per cent V/V solution of phosphoric acid R;

– *mobile phase B*: *acetonitrile R*;

Time (min)	Mobile phase A (per cent V/V)	Mobile phase B (per cent V/V)
0 - 7	40	60
7 - 9	40 → 35	60 → 65
9 - 15	35 → 10	65 → 90
15 - 20	10	90

*Flow rate*: 1.5 mL/min.

*Detection*: spectrophotometer at 238 nm.

*Injection*: 10  $\mu$ L of the test solution and reference solutions (b), (c) and (d).

*Identification of impurities*: use the chromatogram supplied with lovastatin for peak identification CRS and the chromatogram obtained with reference solution (d) to identify the peaks due to impurities A, B, C and D.

*Relative retention* with reference to lovastatin (retention time = about 7 min): impurity B = about 0.6; impurity A = about 0.8; simvastatin = about 1.1; impurity C = about 1.6; impurity D = about 2.3.

*System suitability*: reference solution (c):

– *resolution*: minimum 5.0 between the peaks due to lovastatin and simvastatin.

*Limits*:

- *impurities A, B, C, D*: for each impurity, not more than 0.6 times the area of the principal peak in the chromatogram obtained with reference solution (b) (0.3 per cent);
- *unspecified impurities*: for each impurity, not more than 0.2 times the area of the principal peak in the chromatogram obtained with reference solution (b) (0.10 per cent);
- *total*: not more than twice the area of the principal peak in the chromatogram obtained with reference solution (b) (1.0 per cent);
- *disregard limit*: 0.1 times the area of the principal peak in the chromatogram obtained with reference solution (b) (0.05 per cent).

**Heavy metals** (2.4.8): maximum 20 ppm.

1.0 g complies with test F. Prepare the reference solution using 2 mL of lead standard solution (10 ppm Pb) R.

**Loss on drying** (2.2.32): maximum 0.5 per cent, determined on 1.000 g by drying in a desiccator under high vacuum at 60 °C for 3 h.

**Sulfated ash** (2.4.14): maximum 0.2 per cent, determined on 1.0 g.

#### ASSAY

Liquid chromatography (2.2.29) as described in the test for related substances with the following modification.

*Injection*: test solution and reference solution (a).

Calculate the content of C<sub>24</sub>H<sub>36</sub>O<sub>5</sub> from the declared content of lovastatin CRS.

#### STORAGE

Under nitrogen, at a temperature of 2 °C to 8 °C.

#### IMPURITIES

*Specified impurities*: A, B, C, D, E.

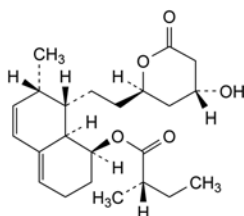
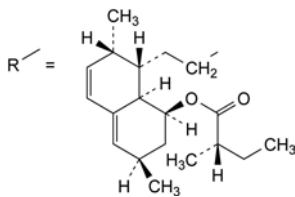

A. (1*S*,7*S*,8*S*,8*aR*)-8-[2-[(2*R*,4*R*)-4-hydroxy-6-oxotetrahydro-2*H*-pyran-2-yl]ethyl]-7-methyl-1,2,3,7,8,8*a*-hexahydronaphthalen-1-yl (2*S*)-2-methylbutanoate (mevastatin),

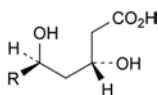

B. (3*R*,5*R*)-7-[(1*S*,2*S*,6*R*,8*S*,8*aR*)-2,6-dimethyl-8-[(2*S*)-2-methylbutanoyl]oxy]-1,2,6,7,8,8*a*-hexahydronaphthalen-1-yl]-3,5-dihydroxyheptanoic acid (hydroxyacid lovastatin),

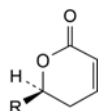

C. (1*S*,3*R*,7*S*,8*S*,8*aR*)-3,7-dimethyl-8-[2-[(2*R*)-6-oxo-3,6-dihydro-2*H*-pyran-2-yl]ethyl]-1,2,3,7,8,8*a*-hexahydronaphthalen-1-yl (2*S*)-2-methylbutanoate (dehydrolovastatin),

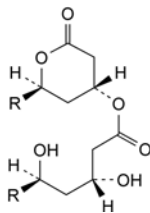

D. (2*R*,4*R*)-2-[2-[(1*S*,2*S*,6*R*,8*S*,8*aR*)-2,6-dimethyl-8-[(2*S*)-2-methylbutanoyl]oxy]-1,2,6,7,8,8*a*-hexahydronaphthalen-1-yl]ethyl]-6-oxotetrahydro-2*H*-pyran-4-yl (3*R*,5*R*)-7-[(1*S*,2*S*,6*R*,8*S*,8*aR*)-2,6-dimethyl-8-[(2*S*)-2-methylbutanoyl]oxy]-1,2,6,7,8,8*a*-hexahydronaphthalen-1-yl]-3,5-dihydroxyheptanoate (lovastatin dimer),

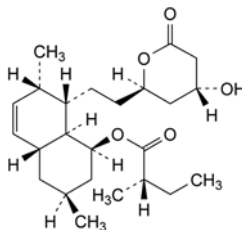

E. (1*S*,3*S*,4*aR*,7*S*,8*S*,8*aS*)-8-[2-[(2*R*,4*R*)-4-hydroxy-6-oxotetrahydro-2*H*-pyran-2-yl]ethyl]-3,7-dimethyl-1,2,3,4,4*a*,7,8,8*a*-octahydronaphthalen-1-yl (2*S*)-2-methylbutanoate (4,4*a*-dihydrolovastatin).

01/2011:2177

## LUFENURON (ANHYDROUS) FOR VETERINARY USE

Lufenuronum anhydricum ad usum veterinarium

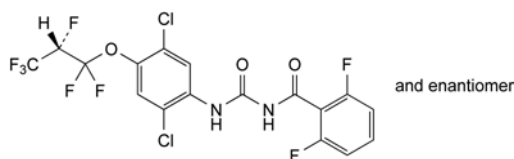

C<sub>17</sub>H<sub>8</sub>Cl<sub>2</sub>F<sub>8</sub>N<sub>2</sub>O<sub>3</sub>  
[103055-07-8]

M<sub>r</sub> 511.2

#### DEFINITION

1-[2,5-Dichloro-4-[(2*RS*)-1,1,2,3,3,3-hexafluoropropoxy]phenyl]-3-(2,6-difluorobenzoyl)urea.

*Content*: 98.0 per cent to 102.0 per cent (dried substance).

#### CHARACTERS

*Appearance*: white or pale yellow powder.

*Solubility*: practically insoluble in water, freely soluble in acetonitrile, soluble in anhydrous ethanol.

It shows polymorphism (5.9).

mp: about 172 °C.

#### IDENTIFICATION

Infrared absorption spectrophotometry (2.2.24).

*Comparison*: lufenuron CRS.

If the spectra obtained in the solid state show differences, dissolve the substance to be examined and the reference substance separately in *2-propanol R*, evaporate to dryness and record new spectra using the residues.

## TESTS

**Related substances.** Liquid chromatography (2.2.29).

*Solvent mixture: water R, acetonitrile R (30:70 V/V).*

*Test solution (a).* Dissolve 40.0 mg of the substance to be examined in the solvent mixture by sonicating for about 10 min and dilute to 100.0 mL with the solvent mixture.

*Test solution (b).* Dilute 1.0 mL of test solution (a) to 10.0 mL with the solvent mixture.

*Reference solution (a).* Dilute 1.0 mL of test solution (b) to 100.0 mL with the solvent mixture.

*Reference solution (b).* Dissolve 7 mg of *lufenuron impurity G CRS* in test solution (a) and dilute to 50.0 mL with test solution (a).

*Reference solution (c).* Dissolve the contents of a vial of *lufenuron for peak identification CRS* (containing impurities B and C) in 1.0 mL of the solvent mixture.

*Reference solution (d).* Dissolve 40.0 mg of *lufenuron CRS* in the solvent mixture by sonicating for about 10 min and dilute to 100.0 mL with the solvent mixture. Dilute 1.0 mL of the solution to 10.0 mL with the solvent mixture.

*Column:*

- *size:*  $l = 0.25$  m,  $\varnothing = 4.0$  mm;
- *stationary phase:* end-capped octadecylsilyl silica gel for chromatography R (5  $\mu$ m).

*Mobile phase:*

- *mobile phase A:* 0.01 per cent V/V of phosphoric acid R;
- *mobile phase B:* acetonitrile R;

Time (min)	Mobile phase A (per cent V/V)	Mobile phase B (per cent V/V)
0 - 5	30	70
5 - 15	30 → 10	70 → 90
15 - 17	10	90

*Flow rate:* 1.0 mL/min.

*Detection:* spectrophotometer at 255 nm.

*Injection:* 20  $\mu$ L of test solution (a) and reference solutions (a), (b) and (c).

*Identification of impurities:* use the chromatogram supplied with *lufenuron for peak identification CRS* and the chromatogram obtained with reference solution (c) to identify the peaks due to impurities B and C.

*Relative retention* with reference to lufenuron (retention time = about 9 min): impurity B = about 0.3; impurity C = about 0.7; impurity G = about 0.9.

*System suitability:* reference solution (b):

- *resolution:* minimum 3.0 between the peaks due to impurity G and lufenuron.

*Limits:*

- *correction factors:* for the calculation of content, multiply the peak areas of the following impurities by the corresponding correction factor: impurity B = 1.3; impurity C = 1.3;
- *impurity C:* not more than 4 times the area of the principal peak in the chromatogram obtained with reference solution (a) (0.4 per cent);
- *impurity B:* not more than 3 times the area of the principal peak in the chromatogram obtained with reference solution (a) (0.3 per cent);
- *unspecified impurities:* for each impurity, not more than twice the area of the principal peak in the chromatogram obtained with reference solution (a) (0.20 per cent);

- *total:* not more than 10 times the area of the principal peak in the chromatogram obtained with reference solution (a) (1.0 per cent);
- *disregard limit:* the area of the principal peak in the chromatogram obtained with reference solution (a) (0.1 per cent).

**Heavy metals (2.4.8):** maximum 20 ppm.

Dissolve 1.0 g in 20 mL of a mixture of 15 volumes of *water R* and 85 volumes of *dioxan R*. 12 mL of the solution complies with test B. Prepare the reference solution using lead standard solution (1 ppm Pb) obtained by diluting *lead standard solution (100 ppm Pb) R* with a mixture of 15 volumes of *water R* and 85 volumes of *dioxan R*.

**Loss on drying (2.2.32):** maximum 0.5 per cent, determined on 1.000 g by drying in an oven at 105 °C.

**Sulfated ash (2.4.14):** maximum 0.1 per cent, determined on 1.0 g in a porcelain crucible.

## ASSAY

Liquid chromatography (2.2.29) as described in the test for related substances with the following modification.

*Injection:* test solution (b) and reference solution (d).

Calculate the percentage content of  $C_{17}H_8Cl_2F_8N_2O_3$  from the declared content of *lufenuron CRS*.

## IMPURITIES

*Specified impurities: B, C.*

*Other detectable impurities* (the following substances would, if present at a sufficient level, be detected by one or other of the tests in the monograph. They are limited by the general acceptance criterion for other/unspecified impurities and/or by the general monograph *Substances for pharmaceutical use (2034)*. It is therefore not necessary to identify these impurities for demonstration of compliance. See also 5.10. *Control of impurities in substances for pharmaceutical use*): A, D, E, F, G, H.

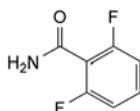

A. 2,6-difluorobenzamide,

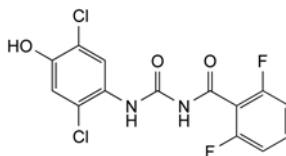

B. 1-(2,5-dichloro-4-hydroxyphenyl)-3-(2,6-difluorobenzoyl)urea,

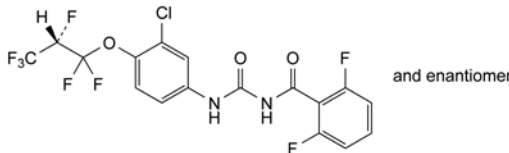

C. 1-[3-chloro-4-[(2RS)-1,1,2,3,3,3-hexafluoropropoxy]phenyl]-3-(2,6-difluorobenzoyl)urea,

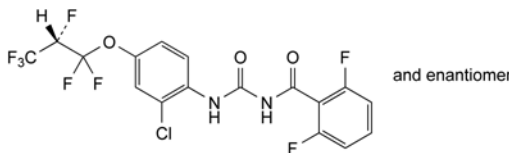

D. 1-[2-chloro-4-[(2RS)-1,1,2,3,3,3-hexafluoropropoxy]phenyl]-3-(2,6-difluorobenzoyl)urea,

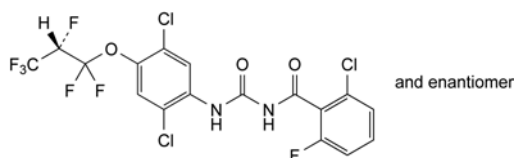

E. 1-(2-chloro-6-fluorobenzoyl)-3-[2,5-dichloro-4-((2R)-1,1,2,3,3,3-hexafluoropropoxy)phenyl]urea, and enantiomer

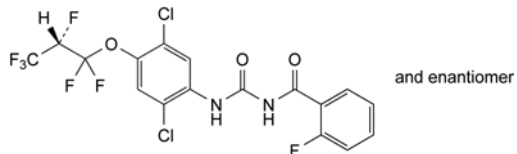

F. 1-[2,5-dichloro-4-((2R)-1,1,2,3,3,3-hexafluoropropoxy)phenyl]-3-(2-fluorobenzoyl)urea, and enantiomer

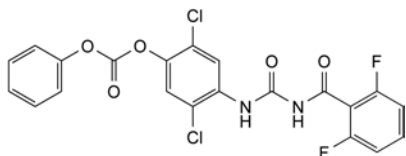

G. 2,5-dichloro-4-[[[(2,6-difluorophenyl)carbonyl]carbamoyl]-amino]phenyl phenyl carbonate, and enantiomer

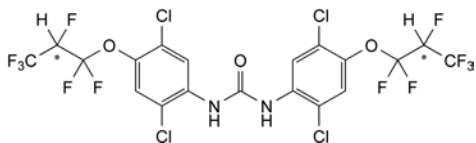

H. 1,3-bis[2,5-dichloro-4-(1,1,2,3,3,3-hexafluoropropoxy)phenyl]urea, and enantiomer

04/2008:1654

## LYMECYCLINE

### Lymecyclinum

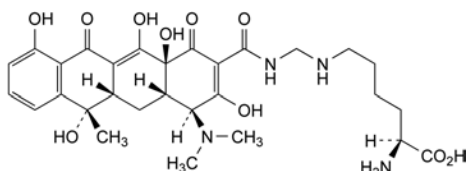

$C_{26}H_{38}N_4O_{10}$   
[992-21-2]

$M_r$  603

#### DEFINITION

(2S)-2-Amino-6-[[[(4S,4aS,5aS,6S,12aS)-4-(dimethylamino)-3,6,10,12,12a-pentahydroxy-6-methyl-1,11-dioxo-1,4,4a,5,5a,6,11,12a-octahydrotetracen-2-yl]carbonyl]-amino]methyl]amino]hexanoic acid (reaction product of formaldehyde, lysine and tetracycline).

Semi-synthetic product derived from a fermentation product.

**Content:** 81.0 per cent to 102.0 per cent (equivalent to 60.0 per cent to 75.0 per cent of tetracycline) (anhydrous substance).

#### CHARACTERS

**Appearance:** yellow, hygroscopic powder.

**Solubility:** very soluble in water, slightly soluble in ethanol (96 per cent), practically insoluble in methylene chloride.

#### IDENTIFICATION

A. Thin-layer chromatography (2.2.27).

**Test solution.** Dissolve 5 mg of the substance to be examined in methanol R and dilute to 10 mL with the same solvent.

**Reference solution (a).** Dissolve 5 mg of tetracycline hydrochloride CRS in methanol R and dilute to 10 mL with the same solvent.

**Reference solution (b).** Dissolve 5 mg of tetracycline hydrochloride CRS, 5 mg of demeclocycline hydrochloride R and 5 mg of oxytetracycline hydrochloride R in methanol R and dilute to 10 mL with the same solvent.

**Plate:** TLC octadecylsilyl silica gel  $F_{254}$  plate R (2-10  $\mu$ m).

**Mobile phase:** mix 20 volumes of acetonitrile R, 20 volumes of methanol R and 60 volumes of a 63 g/L solution of oxalic acid R previously adjusted to pH 2.0 with concentrated ammonia R.

**Application:** 2  $\mu$ L.

**Development:** over half of the plate.

**Drying:** in air.

**Detection:** examine in ultraviolet light at 254 nm.

**System suitability:** reference solution (b):

– the chromatogram shows 3 clearly separated spots.

**Results:** the principal spot in the chromatogram obtained with the test solution is similar in position and size to the principal spot in the chromatogram obtained with reference solution (a).

B. Thin-layer chromatography (2.2.27).

**Test solution.** Dissolve 50 mg of the substance to be examined in 50 mL of water R.

**Reference solution (a).** Dissolve 10 mg of lysine hydrochloride CRS in water R and dilute to 50 mL with the same solvent.

**Reference solution (b).** Dissolve 10 mg of arginine CRS and 10 mg of lysine hydrochloride CRS in water R and dilute to 25 mL with the same solvent.

**Plate:** TLC silica gel plate R.

**Mobile phase:** concentrated ammonia R, 2-propanol R (30:70 V/V).

**Application:** 5  $\mu$ L.

**Development:** over 3/4 of the plate.

**Drying:** at 100-105 °C until the ammonia disappears completely.

**Detection:** spray with ninhydrin solution R and heat at 100-105 °C for 15 min.

**System suitability:** reference solution (b):

– the chromatogram shows 2 clearly separated principal spots.

**Results:** the principal spot in the chromatogram obtained with the test solution is similar in position, colour and size to the principal spot in the chromatogram obtained with reference solution (a).

C. Dissolve 0.2 g in 5 mL of water R, add 0.3 mL of phosphoric acid R and distil. To 1 mL of the distillate add 10 mL of chromotropic acid-sulfuric acid solution R. A violet colour is produced.

D. Specific optical rotation (see Tests).

#### TESTS

**pH (2.2.3):** 7.8 to 8.2.

Dissolve 0.1 g in 10 mL of carbon dioxide-free water R.

**Specific optical rotation (2.2.7):** – 180 to – 210 (anhydrous substance).

Dissolve 0.250 g in water R and dilute to 50.0 mL with the same solvent.

**Free tetracycline (impurity H):** maximum 2.5 per cent (anhydrous and methanol-free substance).

To 0.5 g add 50 mL of butyl acetate R and allow to stand at 25 °C for 1 h. Filter and extract the filtrate with 2 quantities, each of 25 mL, of 0.1 M hydrochloric acid. Combine the extracts and dilute to 50.0 mL with 0.1 M hydrochloric acid. Dilute 10.0 mL of this solution to 100.0 mL with 0.1 M hydrochloric acid. The



absorbance (2.2.25) measured at 355 nm is not greater than 0.64.

**Light-absorbing impurities:** the absorbance (2.2.25) is not greater than 0.50 at 430 nm (anhydrous and methanol-free substance).

Dissolve 25.0 mg in 0.01 M hydrochloric acid and dilute to 10.0 mL with the same acid.

**Related substances.** Liquid chromatography (2.2.29). Prepare the solutions immediately before use.

**Test solution.** Dissolve 0.125 g of the substance to be examined in 5.0 mL of water R. Add 1.0 mL of a 40 g/L solution of sodium metabisulfite R and allow to stand in the dark at 20–25 °C for 16–24 h, without stirring. Add 50 mL of 0.05 M hydrochloric acid, shake to dissolve the precipitate and dilute to 100.0 mL with water R.

**Reference solution (a).** Dissolve 25.0 mg of tetracycline hydrochloride CRS in 0.01 M hydrochloric acid and dilute to 25.0 mL with the same acid.

**Reference solution (b).** Dissolve 12.5 mg of 4-epitetracycline hydrochloride CRS (impurity A) in 0.01 M hydrochloric acid and dilute to 50.0 mL with the same acid.

**Reference solution (c).** Dissolve 10.0 mg of anhydrotetracycline hydrochloride CRS (impurity C) in 0.01 M hydrochloric acid and dilute to 100.0 mL with the same acid.

**Reference solution (d).** Dissolve 10.0 mg of 4-epianhydrotetracycline hydrochloride CRS (impurity D) in 0.01 M hydrochloric acid and dilute to 50.0 mL with the same acid.

**Reference solution (e).** Mix 1 mL of reference solution (a), 2 mL of reference solution (b) and 5 mL of reference solution (d) and dilute to 25 mL with 0.01 M hydrochloric acid.

**Reference solution (f).** Mix 40.0 mL of reference solution (b), 20.0 mL of reference solution (c) and 5.0 mL of reference solution (d) and dilute to 200.0 mL with 0.01 M hydrochloric acid.

**Column:**

- size:  $l = 0.25$  m,  $\varnothing = 4.6$  mm;
- stationary phase: styrene-divinylbenzene copolymer R (8  $\mu$ m) with a pore size of 10 nm;
- temperature: 60 °C.

**Mobile phase:** weigh 80.0 g of 2-methyl-2-propanol R and transfer to a 1000 mL volumetric flask with the aid of 200 mL of water R; add 100 mL of a 35 g/L solution of dipotassium hydrogen phosphate R adjusted to pH 8.0 with dilute phosphoric acid R, 200 mL of a 10 g/L solution of tetrabutylammonium hydrogen sulfate R adjusted to pH 8.0 with dilute sodium hydroxide solution R, and 10 mL of a 40 g/L solution of sodium edetate R adjusted to pH 8.0 with dilute sodium hydroxide solution R; dilute to 1000.0 mL with water R.

**Flow rate:** 1.0 mL/min.

**Detection:** spectrophotometer at 254 nm.

**Injection:** 20  $\mu$ L of the test solution and reference solutions (e) and (f).

**Run time:** 5 times the retention time of the principal peak in the chromatogram obtained with the test solution.

**Relative retention** with reference to tetracycline (retention time = about 8 min): impurity E = about 0.50; impurity A = about 0.6; impurity F = about 0.68; impurity B (eluting on the tail of the principal peak) = about 1.2; impurity D = about 1.45; impurity G = about 1.45; impurity C = about 2.95.

**System suitability:** reference solution (e):

- resolution: minimum 3.0 between the 1<sup>st</sup> peak (impurity A) and the 2<sup>nd</sup> peak (tetracycline) and minimum 5.0 between the 2<sup>nd</sup> peak and the 3<sup>rd</sup> peak (impurity D); adjust the concentration of 2-methyl-2-propanol in the mobile phase if necessary;
- symmetry factor: maximum 1.25 for the peak due to tetracycline.

**Limits:**

- impurity A: not more than the area of the corresponding peak in the chromatogram obtained with reference solution (f) (5.0 per cent),
- impurity C: not more than the area of the corresponding peak in the chromatogram obtained with reference solution (f) (1.0 per cent),
- impurities B, E, F: for each impurity, not more than 0.1 times the area of the peak due to impurity A in the chromatogram obtained with reference solution (f) (0.5 per cent),
- sum of impurities D and G: not more than the area of the corresponding peak in the chromatogram obtained with reference solution (f) (0.5 per cent),
- any other impurity: for each impurity, not more than 0.04 times the area of the peak due to impurity A in the chromatogram obtained with reference solution (f) (0.2 per cent),
- total: not more than 1.6 times the area of the peak due to impurity A in the chromatogram obtained with reference solution (f) (8.0 per cent),
- disregard limit: 0.02 times the area of the peak due to impurity A in the chromatogram obtained with reference solution (f) (0.1 per cent).

**Methanol (2.4.24, System A):** maximum 1.5 per cent.

**Water (2.5.12):** maximum 5.0 per cent, determined on 0.20 g.

**Sulfated ash (2.4.14):** maximum 0.5 per cent, determined on 1.0 g.

#### ASSAY

Liquid chromatography (2.2.29) as described in the test for related substances with the following modifications.

**Injection:** test solution and reference solution (a).

**System suitability:**

- repeatability: maximum relative standard deviation of 1.0 per cent after 6 injections of reference solution (a).

Calculate the percentage content of tetracycline and multiply it by 1.356 to obtain the percentage content of lymecycline.

#### STORAGE

In an airtight container, protected from light.

#### IMPURITIES

**Specified impurities:** A, B, C, D, E, F, G, H.

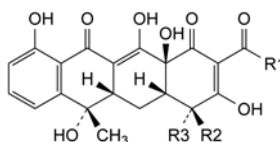

- A. R1 = NH<sub>2</sub>, R2 = H, R3 = N(CH<sub>3</sub>)<sub>2</sub>: (4R,4aS,5aS,6S,12aS)-4-(dimethylamino)-3,6,10,12,12a-pentahydroxy-6-methyl-1,11-dioxo-1,4,4a,5,5a,6,11,12a-octahydrotetracene-2-carboxamide (4-epitetracycline),
- B. R1 = CH<sub>3</sub>, R2 = N(CH<sub>3</sub>)<sub>2</sub>, R3 = H: (4S,4aS,5aS,6S,12aS)-2-acetyl-4-(dimethylamino)-3,6,10,12,12a-pentahydroxy-6-methyl-4a,5a,6,12a-tetrahydrotetracene-1,11(4H,5H)-dione (2-acetyl-2-decarbonyltetracycline),

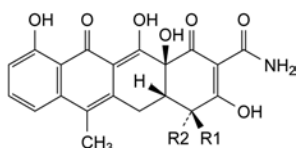

C. R1 = N(CH<sub>3</sub>)<sub>2</sub>, R2 = H: (4*S*,4*aS*,12*aS*)-4-(dimethylamino)-3,10,11,12*a*-tetrahydroxy-6-methyl-1,12-dioxo-1,4,4*a*,5,12,12*a*-hexahydrotetracene-2-carboxamide (anhydrotetracycline),

D. R1 = H, R2 = N(CH<sub>3</sub>)<sub>2</sub>: (4*R*,4*aS*,12*aS*)-4-(dimethylamino)-3,10,11,12*a*-tetrahydroxy-6-methyl-1,12-dioxo-1,4,4*a*,5,12,12*a*-hexahydrotetracene-2-carboxamide (4-epianhydrotetracycline),

E. unknown structure,

F. unknown structure,

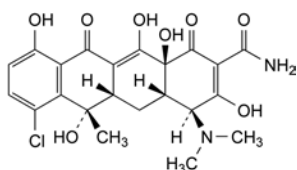

G. (4*S*,4*aS*,5*aS*,6*S*,12*aS*)-7-chloro-4-(dimethylamino)-3,6,10,12,12*a*-penta-hydroxy-6-methyl-1,11-dioxo-1,4,4*a*,5,5*a*,6,11,12*a*-octahydrotetracene-2-carboxamide (chlortetracycline),

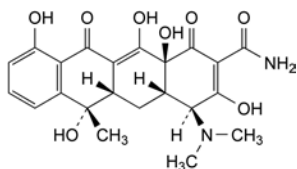

H. (4*S*,4*aS*,5*aS*,6*S*,12*aS*)-4-(dimethylamino)-3,6,10,12,12*a*-penta-hydroxy-6-methyl-1,11-dioxo-1,4,4*a*,5,5*a*,6,11,12*a*-octahydrotetracene-2-carboxamide (tetracycline).

01/2009:0558

## LYNESTRENOL

### Lynestrenolum

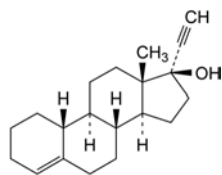

C<sub>20</sub>H<sub>28</sub>O  
[52-76-6]

*M<sub>r</sub>* 284.4

#### DEFINITION

19-Nor-17*α*-pregn-4-en-20-yn-17-ol.

*Content*: 98.0 per cent to 102.0 per cent (dried substance).

#### CHARACTERS

*Appearance*: white or almost white, crystalline powder.

*Solubility*: practically insoluble in water, soluble in acetone and in ethanol (96 per cent).

#### IDENTIFICATION

Infrared absorption spectrophotometry (2.2.24).

*Comparison*: lynestrenol CRS.

#### TESTS

**Appearance of solution.** The solution is clear (2.2.1) and colourless (2.2.2, Method II).

Dissolve 0.2 g in ethanol (96 per cent) R and dilute to 10 mL with the same solvent.

**Specific optical rotation** (2.2.7): –9.5 to –11 (dried substance).

Dissolve 0.900 g in ethanol (96 per cent) R and dilute to 25.0 mL with the same solvent.

**Related substances.** Gas chromatography (2.2.28).

*Test solution.* Dissolve 0.250 g of the substance to be examined in ethyl acetate R and dilute to 25.0 mL with the same solvent.

*Reference solution (a).* Dilute 1.0 mL of the test solution to 100.0 mL with ethyl acetate R. Dilute 1.0 mL of this solution to 10.0 mL with ethyl acetate R.

*Reference solution (b).* Dissolve 10 mg of lynestrenol for peak identification CRS (containing impurities A, B and C) in 1.0 mL of ethyl acetate R.

*Column*:

– *material*: fused silica;

– *size*: *l* = 50 m, Ø = 0.32 mm;

– *stationary phase*: poly(dimethyl)(diphenyl)siloxane R (film thickness 1.0 µm).

*Carrier gas*: helium for chromatography R.

*Flow rate*: 3.0 mL/min.

*Split ratio*: 1:34.

*Temperature*:

	Time (min)	Temperature (°C)
Column	0 - 30	80 → 230
	30 - 32	230 → 310
	32 - 42	310
Injection port		150
Detector		300

*Detection*: flame ionisation.

*Injection*: 1.0 µL.

*Identification of impurities*: use the chromatogram supplied with lynestrenol for peak identification CRS and the chromatogram obtained with reference solution (b) to identify the peaks due to impurities A, B and C.

*Relative retention* with reference to lynestrenol (retention time = about 38 min): artefact degradation peak = about 0.97; impurity A = about 0.99; impurity B = about 1.005; impurity C = about 1.01.

*System suitability*: reference solution (b):

– *peak-to-valley ratio*: minimum 2.5, where *H<sub>p</sub>* = height above the baseline of the peak due to impurity B and *H<sub>v</sub>* = height above the baseline of the lowest point of the curve separating this peak from the peak due to lynestrenol.

*Limits*:

– *impurity A*: not more than 3 times the area of the principal peak in the chromatogram obtained with reference solution (a) (0.3 per cent);

– *impurity C*: not more than twice the area of the principal peak in the chromatogram obtained with reference solution (a) (0.2 per cent);

– *unspecified impurities*: for each impurity, not more than the area of the principal peak in the chromatogram obtained with reference solution (a) (0.10 per cent);

– *total*: not more than 10 times the area of the principal peak in the chromatogram obtained with reference solution (a) (1.0 per cent);

– *disregard limit*: 0.5 times the area of the principal peak in the chromatogram obtained with reference solution (a) (0.05 per cent). Disregard the artefact peak, which may be generated in the injection system.

**Loss on drying** (2.2.32): maximum 0.5 per cent, determined on 0.500 g by drying in an oven at 105 °C.

## ASSAY

Dissolve 0.150 g in 40 mL of *tetrahydrofuran R* and add 5.0 mL of a 100 g/L solution of *silver nitrate R*. Titrate with 0.1 M *sodium hydroxide*. Determine the end-point potentiometrically (2.2.20), using a glass indicator electrode and as comparison electrode a silver-silver chloride double-junction electrode with a saturated solution of *potassium nitrate R* as junction liquid. Carry out a blank titration.

1 mL of 0.1 M *sodium hydroxide* is equivalent to 28.44 mg of  $C_{20}H_{28}O$ .

## STORAGE

Protected from light.

## IMPURITIES

*Specified impurities: A, C.*

*Other detectable impurities* (the following substances would, if present at a sufficient level, be detected by one or other of the tests in the monograph. They are limited by the general acceptance criterion for other/unspecified impurities and/or by the general monograph *Substances for pharmaceutical use (2034)*. It is therefore not necessary to identify these impurities for demonstration of compliance. See also 5.10. *Control of impurities in substances for pharmaceutical use*): B.

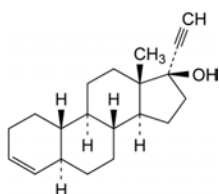

A. 19-nor-5 $\alpha$ ,17 $\alpha$ -pregn-3-en-20-yn-17-ol,

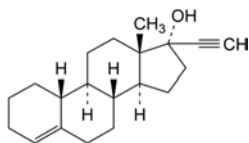

B. 19-norpregn-4-en-20-yn-17-ol,

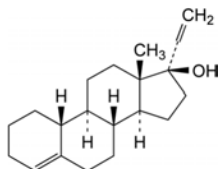

C. 19-nor-17 $\alpha$ -pregna-4,20-dien-17-ol.

01/2008:2114

## LYSINE ACETATE

## Lysini acetat

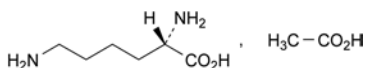

$C_8H_{18}N_2O_4$   
[57282-49-2]

$M_r$  206.2

## DEFINITION

(2S)-2,6-Diaminohexanoic acid acetate.

*Content*: 98.5 per cent to 101.0 per cent (dried substance).

## CHARACTERS

*Appearance*: white or almost white, crystalline powder or colourless crystals.

*Solubility*: freely soluble in water, very slightly soluble in ethanol (96 per cent).

## IDENTIFICATION

*First identification: A, B, E.*

*Second identification: A, C, D, E.*

A. Specific optical rotation (see Tests).

B. Infrared absorption spectrophotometry (2.2.24).

*Comparison: lysine acetate CRS.*

If the spectra obtained in the solid state show differences, dissolve the substance to be examined and the reference substance separately in the minimum volume of *water R*, evaporate to dryness at 60 °C and record new spectra using the residues.

C. Examine the chromatograms obtained in the test for ninhydrin-positive substances.

*Results*: the principal spot in the chromatogram obtained with test solution (b) is similar in position, colour and size to the principal spot in the chromatogram obtained with reference solution (a).

D. To 0.1 mL of solution S (see Tests) add 2 mL of *water R* and 1 mL of a 50 g/L solution of *phosphomolybdic acid R*. A yellowish-white precipitate is formed.

E. It gives reaction (a) of acetates (2.3.1).

## TESTS

**Solution S.** Dissolve 5.0 g in *distilled water R* and dilute to 50 mL with the same solvent.

**Appearance of solution.** Solution S is clear (2.2.1) and colourless (2.2.2, *Method II*).

**Specific optical rotation (2.2.7):** + 8.5 to + 10.0 (dried substance), determined on solution S.

**Ninhydrin-positive substances.** Thin-layer chromatography (2.2.27).

*Test solution (a).* Dissolve 0.10 g of the substance to be examined in *water R* and dilute to 10 mL with the same solvent.

*Test solution (b).* Dilute 1.0 mL of test solution (a) to 50 mL with *water R*.

*Reference solution (a).* Dissolve 10 mg of *lysine acetate CRS* in *water R* and dilute to 50 mL with the same solvent.

*Reference solution (b).* Dilute 5 mL of test solution (b) to 20 mL with *water R*.

*Reference solution (c).* Dissolve 10 mg of *lysine acetate CRS* and 10 mg of *arginine CRS* in *water R* and dilute to 25 mL with the same solvent.

*Plate: TLC silica gel plate R.*

*Mobile phase: concentrated ammonia R, 2-propanol R (30:70 V/V).*

*Application:* 5  $\mu$ L.

*Development:* over 2/3 of the plate.

*Drying:* at 100-105 °C until the ammonia has evaporated.

*Detection:* spray with *ninhydrin solution R* and heat at 100-105 °C for 15 min.

*System suitability:* reference solution (c):

– the chromatogram shows 2 clearly separated spots.

*Limits:* test solution (a):

– *any impurity:* any spot, apart from the principal spot, is not more intense than the principal spot in the chromatogram obtained with reference solution (b) (0.5 per cent).

**Chlorides (2.4.4):** maximum 200 ppm.

Dilute 2.5 mL of solution S to 15 mL with *water R*.

**Sulfates (2.4.13):** maximum 300 ppm.

Dilute 5 mL of solution S to 15 mL with *distilled water R*.

**Ammonium (2.4.1, Method B):** maximum 200 ppm, determined on 50 mg.

Prepare the standard using 0.1 mL of *ammonium standard solution (100 ppm NH<sub>4</sub>) R*.

**Iron (2.4.9):** maximum 30 ppm.

In a separating funnel, dissolve 0.33 g in 10 mL of *dilute hydrochloric acid R*. Shake with 3 quantities, each of 10 mL, of *methyl isobutyl ketone R1*, shaking for 3 min each time. To the combined organic layers add 10 mL of *water R* and shake for 3 min. The aqueous layer complies with the test.

**Heavy metals (2.4.8):** maximum 10 ppm.

12 mL of solution S complies with test A. Prepare the reference solution using *lead standard solution (1 ppm Pb) R*.

**Loss on drying (2.2.32):** maximum 0.5 per cent, determined on 1.000 g by drying in an oven at 60 °C for 3 h.

**Sulfated ash (2.4.14):** maximum 0.1 per cent, determined on 1.0 g.

#### ASSAY

Dissolve 80.0 mg in 3 mL of *anhydrous formic acid R*. Add 50 mL of *anhydrous acetic acid R*. Titrate with 0.1 M *perchloric acid*, determining the end-point potentiometrically (2.2.20). Carry out a blank titration.

1 mL of 0.1 M *perchloric acid* is equivalent to 10.31 mg of  $C_8H_{18}N_2O_4$ .

#### STORAGE

Protected from light.

#### IMPURITIES

*Specified impurities: A, B, C, D, E, F.*

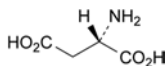

A. (2S)-2-aminobutanedioic acid (aspartic acid),

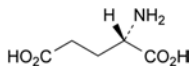

B. (2S)-2-aminopentanedioic acid (glutamic acid),

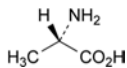

C. (S)-2-aminopropanoic acid (alanine),

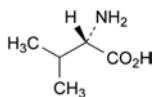

D. (S)-2-amino-3-methylbutanoic acid (valine),

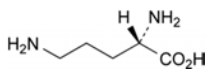

E. (2S)-2,5-diaminopentanoic acid (ornithine),

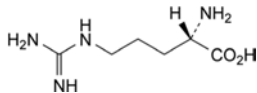

F. (S)-2-amino-5-guanidinopentanoic acid (arginine).

01/2008:0930  
corrected 6.0

## LYSINE HYDROCHLORIDE

Lysini hydrochloridum

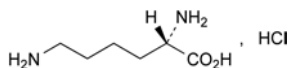

$C_6H_{15}ClN_2O_2$   
[657-27-2]

$M_r$  182.7

#### DEFINITION

Lysine hydrochloride contains not less than 98.5 per cent and not more than the equivalent of 101.0 per cent of (S)-2,6-diaminohexanoic acid hydrochloride, calculated with reference to the dried substance.

#### CHARACTERS

A white or almost white, crystalline powder or colourless crystals, freely soluble in water, slightly soluble in alcohol.

#### IDENTIFICATION

*First identification: A, B, E.*

*Second identification: A, C, D, E.*

A. Specific optical rotation (see Tests).

B. Examine by infrared absorption spectrophotometry (2.2.24), comparing with the spectrum obtained with *lysine hydrochloride CRS*. Examine the substances prepared as discs. If the spectra obtained show differences, dissolve the substance to be examined and the reference substance separately in the minimum volume of *water R*, evaporate to dryness at 60 °C, and record new spectra using the residues.

C. Examine the chromatograms obtained in the test for ninhydrin-positive substances. The principal spot in the chromatogram obtained with test solution (b) is similar in position, colour and size to the principal spot in the chromatogram obtained with reference solution (a).

D. To 0.1 mL of solution S (see Tests) add 2 mL of *water R* and 1 mL of a 50 g/L solution of *phosphomolybdic acid R*. A yellowish-white precipitate is formed.

E. To 0.1 mL of solution S add 2 mL of *water R*. The solution gives reaction (a) of chlorides (2.3.1).

#### TESTS

**Solution S.** Dissolve 5.0 g in *carbon dioxide-free water R* prepared from *distilled water R* and dilute to 50 mL with the same solvent.

**Appearance of solution.** Solution S is clear (2.2.1) and not more intensely coloured than reference solution B<sub>7</sub> or GY<sub>7</sub> (2.2.2, *Method II*).

**Specific optical rotation (2.2.7).** Dissolve 2.00 g in *hydrochloric acid R1* and dilute to 25.0 mL with the same acid. The specific optical rotation is + 21.0 to + 22.5, calculated with reference to the dried substance.

**Ninhydrin-positive substances.** Examine by thin-layer chromatography (2.2.27), using a *TLC silica gel plate R*.

*Test solution (a).* Dissolve 0.10 g of the substance to be examined in *water R* and dilute to 10 mL with the same solvent.

*Test solution (b).* Dilute 1 mL of test solution (a) to 50 mL with *water R*.

*Reference solution (a).* Dissolve 10 mg of *lysine hydrochloride CRS* in *water R* and dilute to 50 mL with the same solvent.

*Reference solution (b).* Dilute 5 mL of test solution (b) to 20 mL with *water R*.

*Reference solution (c).* Dissolve 10 mg of *lysine hydrochloride CRS* and 10 mg of *arginine CRS* in *water R* and dilute to 25 mL with the same solvent.

Apply separately to the plate 5 µL of each solution. Develop over a path of 15 cm using a mixture of 30 volumes of *concentrated ammonia R* and 70 volumes of *2-propanol R*. Dry the plate at 100 °C to 105 °C until the ammonia disappears completely. Spray with *ninhydrin solution R* and heat at 100 °C to 105 °C for 15 min. Any spot in the chromatogram obtained with test solution (a), apart from the principal spot, is not more intense than the spot in the chromatogram obtained with reference solution (b) (0.5 per cent). The test is not valid unless the chromatogram obtained with reference solution (c) shows two clearly separated principal spots.

**Sulfates** (2.4.13). Dilute 5 mL of solution S to 15 mL with *distilled water R*. The solution complies with the limit test for sulfates (300 ppm).

**Ammonium** (2.4.1). 50 mg complies with limit test B for ammonium (200 ppm). Prepare the standard using 0.1 mL of *ammonium standard solution (100 ppm NH<sub>4</sub>) R*.

**Iron** (2.4.9). In a separating funnel, dissolve 0.33 g in 10 mL of *dilute hydrochloric acid R*. Shake with three quantities, each of 10 mL, of *methyl isobutyl ketone RI*, shaking for 3 min each time. To the combined organic layers add 10 mL of *water R* and shake for 3 min. The aqueous layer complies with the limit test for iron (30 ppm).

**Heavy metals** (2.4.8). 12 mL of solution S complies with limit test A for heavy metals (10 ppm). Prepare the standard using *lead standard solution (1 ppm Pb) R*.

**Loss on drying** (2.2.32). Not more than 0.5 per cent, determined on 1.000 g by drying in an oven at 105 °C.

**Sulfated ash** (2.4.14). Not more than 0.1 per cent, determined on 1.0 g.

#### ASSAY

Dissolve 0.150 g in 5 mL of *anhydrous formic acid R*. Add 50 mL of *anhydrous acetic acid R*. Titrate with 0.1 M *perchloric acid*, determining the end-point potentiometrically (2.2.20).

1 mL of 0.1 M *perchloric acid* is equivalent to 18.27 mg of C<sub>6</sub>H<sub>15</sub>ClN<sub>2</sub>O<sub>2</sub>.

#### STORAGE

Store protected from light.

01/2008:1123

**MACROGOL CETOSTEARYL ETHER****Macrogoli aether cetostearylicus****DEFINITION**

Mixture of ethers of mixed macrogols with linear fatty alcohols, mainly cetostearyl alcohol. It may contain some free macrogols and it contains various amounts of free cetostearyl alcohol. The number of moles of ethylene oxide reacted per mole of cetostearyl alcohol is 2 to 33 (nominal value).

**CHARACTERS**

**Appearance:** white or yellowish-white, waxy, unctuous mass, pellets, microbeads or flakes.

**Solubility:**

- macrogol cetostearyl ether with low numbers of moles of ethylene oxide reacted per mole: practically insoluble in water, soluble in ethanol (96 per cent) and in methylene chloride;
- macrogol cetostearyl ether with higher numbers of moles of ethylene oxide reacted per mole: dispersible or soluble in water, soluble in ethanol (96 per cent) and in methylene chloride.

It solidifies at 32 °C to 52 °C.

**IDENTIFICATION**

- A. Hydroxyl value (see Tests).
- B. Iodine value (see Tests).
- C. Saponification value (see Tests).
- D. Thin-layer chromatography (2.2.27).

**Test solution.** Dissolve the prescribed amount of substance to be examined (see table below) in a mixture of 1 volume of water R and 9 volumes of methanol R and dilute to 75 mL with the same mixture of solvents.

Number of moles of ethylene oxide reacted per mole	Amount to be dissolved (g)
2 - 6	5.0
10 - 22	10.0
25 - 33	15.0

Add 60 mL of hexane R and shake for 3 min. The formation of foam can be reduced by the addition of some drops of ethanol (96 per cent) R. Filter the upper layer through anhydrous sodium sulfate R, wash the filter with 3 quantities, each of 10 mL, of hexane R and evaporate the combined filtrates to dryness. Dissolve 0.05 g of the residue in 10 mL of methanol R (the solution may be opalescent).

**Reference solution.** Dissolve 25 mg of stearyl alcohol CRS in methanol R and dilute to 25 mL with the same solvent.

**Plate:** TLC silica gel plate R.

**Mobile phase:** ethyl acetate R.

**Application:** 20 µL.

**Development:** over a path of 15 cm.

**Drying:** in air.

**Detection:** spray with vanillin-sulfuric acid reagent prepared as follows: dissolve 0.5 g of vanillin R in 50 mL of ethanol (96 per cent) R and dilute to 100 mL with sulfuric acid R; allow to dry in air; heat at about 130 °C for 15 min and allow to cool in air.

**Results:** the chromatogram obtained with the test solution shows several spots; one of these spots corresponds to the principal spot in the chromatogram obtained with the reference solution.

E. Dissolve or disperse 0.1 g in 5 mL of ethanol (96 per cent) R, add 2 mL of water R, 10 mL of dilute hydrochloric acid R, 10 mL of barium chloride solution R1 and 10 mL of a 100 g/L solution of phosphomolybdic acid R. A precipitate is formed.

**TESTS**

**Appearance of solution.** The solution is not more intensely coloured than reference solution BY<sub>5</sub> (2.2.2, Method II).

Dissolve 5.0 g in ethanol (96 per cent) R and dilute to 50 mL with the same solvent.

**Alkalinity.** Dissolve 2.0 g in a hot mixture of 10 mL of ethanol (96 per cent) R and 10 mL of water R. Add 0.1 mL of bromothymol blue solution R1. Not more than 0.5 mL of 0.1 M hydrochloric acid is required to change the colour of the indicator to yellow.

**Acid value (2.5.1):** maximum 1.0, determined on 5.0 g.

**Hydroxyl value (2.5.3, Method A).**

Number of moles of ethylene oxide reacted per mole (nominal value)	Hydroxyl value
2	150 - 180
3	135 - 155
5 - 6	100 - 134
10	75 - 90
12	67 - 77
15	58 - 67
20 - 22	40 - 55
25	36 - 46
30 - 33	32 - 40

**Iodine value (2.5.4, Method A):** maximum 2.0.

**Saponification value (2.5.6):** maximum 3.0, determined on 10.0 g.

**Ethylene oxide and dioxan (2.4.25):** maximum 1 ppm of ethylene oxide and maximum 10 ppm of dioxan.

**Water (2.5.12):** maximum 3.0 per cent, determined on 2.00 g.

**Total ash (2.4.16):** maximum 0.2 per cent, determined on 2.0 g.

**STORAGE**

In an airtight container.

**LABELLING**

The label states the number of moles of ethylene oxide reacted per mole of cetostearyl alcohol (nominal value).

01/2008:1443  
corrected 6.0

**MACROGOL 6 GLYCEROL CAPRYLOCAPRATE****Macrogol 6 glyceroli caprylocapras****DEFINITION**

Mixture of mainly mono- and diesters of polyoxyethylene glycerol ethers mainly with caprylic (octanoic) and capric (decanoic) acids. The average number of moles of ethylene oxide reacted per mole of substance is 6.

Macrogol 6 glycerol caprylocaprate may be obtained by ethoxylation of glycerol and esterification with distilled coconut or palm kernel fatty acids, or by ethoxylation of mono- and diglycerides of caprylic and capric acids.

**CHARACTERS**

**Appearance:** pale yellow liquid.

**Solubility:** partly soluble in water, freely soluble in castor oil, in glycerol, in isopropanol and in propylene glycol.

**Viscosity:** about 145 mPas.

#### IDENTIFICATION

A. Dissolve 1.0 g in 99 g of a mixture of 10 volumes of 2-propanol R and 90 volumes of water R. Heat the solution obtained to about 40 °C. A turbidity is produced. Allow to cool until the turbidity disappears. The cloud point is between 15 °C and 35 °C.

B. Saponification value (see Tests).

C. Composition of fatty acids (see Tests).

#### TESTS

**Appearance.** The substance to be examined is clear (2.2.1) and not more intensely coloured than reference solution Y<sub>2</sub> (2.2.2, Method I).

**Alkalinity.** Dissolve 2.0 g in a hot mixture of 10 mL of ethanol (96 per cent) R and 10 mL of water R. Add 0.1 mL of bromothymol blue solution R1. Not more than 0.5 mL of 0.1 M hydrochloric acid is required to change the colour of the indicator to yellow.

**Acid value (2.5.1):** maximum 5.0, determined on 5.0 g.

**Hydroxyl value (2.5.3, Method A):** 165 to 225.

**Saponification value (2.5.6):** 85 to 105, determined on 2.0 g.

**Composition of fatty acids.** Gas chromatography (2.4.22, Method A).

*Composition of the fatty-acid fraction of the substance:*

- caproic acid: maximum 2.0 per cent;
- caprylic acid: 50.0 per cent to 80.0 per cent;
- capric acid: 20.0 per cent to 50.0 per cent;
- lauric acid: maximum 3.0 per cent;
- myristic acid: maximum 1.0 per cent.

**Ethylene oxide and dioxan (2.4.25):** maximum 1 ppm of ethylene oxide and maximum 10 ppm of dioxan.

**Water (2.5.12):** maximum 1.0 per cent, determined on 1.00 g.

**Total ash (2.4.16):** maximum 0.3 per cent.

**Solubility:** soluble in water and in ethanol (96 per cent) and practically insoluble in light petroleum (bp: 50-70 °C) for macrogol 7 glycerol cocoate and macrogol 23 glycerol cocoate.

**Relative density:** about 1.05 for macrogol 7 glycerol cocoate; about 1.09 for macrogol 23 glycerol cocoate.

#### IDENTIFICATION

A. Dissolve 1.0 g of macrogol 7 glycerol cocoate in 99 g of a mixture of 10 volumes of 2-propanol R and 90 volumes of water R. Heat the solution to about 65 °C. A turbidity is produced. Allow to cool until the turbidity disappears. The cloud point is between 35 °C and 54 °C.

Heat a 10 g/L solution of macrogol 23 glycerol cocoate in a 100 g/L solution of sodium chloride R to about 90 °C. A turbidity is produced. Allow to cool until the turbidity disappears. The cloud point is between 65 °C and 85 °C.

B. Iodine value (see Tests).

C. Saponification value (see Tests).

#### TESTS

**Appearance.** The substance to be examined is clear (2.2.1) and not more intensely coloured than reference solution Y<sub>2</sub> (2.2.2, Method I).

**Alkalinity.** Dissolve 2.0 g in a hot mixture of 10 mL of ethanol (96 per cent) R and 10 mL of water R. Add 0.1 mL of bromothymol blue solution R1. Not more than 0.5 mL of 0.1 M hydrochloric acid is required to change the colour of the indicator to yellow.

**Acid value (2.5.1):** maximum 5.0, determined on 5.0 g.

**Hydroxyl value (2.5.3, Method A):** see Table 1122.-1.

**Saponification value (2.5.6):** see Table 1122.-1.

Table 1122.-1

Number of moles of ethylene oxide reacted per mole (nominal value)	Hydroxyl value	Saponification value (determined on 2.0 g)
7	170 - 210	85 - 105
23	80 - 100	40 - 50

**Iodine value (2.5.4, Method A):** maximum 5.0.

**Composition of fatty acids.** Gas chromatography (2.4.22, Method A).

*Composition of the fatty-acid fraction of the substance:*

- caproic acid: maximum 1.0 per cent;
- caprylic acid: 5.0 per cent to 10.0 per cent;
- capric acid: 4.0 per cent to 10.0 per cent;
- lauric acid: 40.0 per cent to 55.0 per cent;
- myristic acid: 14.0 per cent to 23.0 per cent;
- palmitic acid: 8.0 per cent to 12.0 per cent;
- stearic acid: 1.0 per cent to 5.0 per cent;
- oleic acid: 5.0 per cent to 10.0 per cent;
- linoleic acid: maximum 3.0 per cent.

**Ethylene oxide and dioxan (2.4.25):** maximum 1 ppm of ethylene oxide and maximum 10 ppm of dioxan.

**Water (2.5.12):** maximum 1.0 per cent, determined on 1.0 g.

**Total ash (2.4.16):** maximum 0.3 per cent.

#### LABELLING

The label states the number of moles of ethylene oxide reacted per mole of substance (nominal value).

01/2008:1122  
corrected 6.0

## MACROGOLGLYCEROL COCOATES

### Macroglyceroli cocoates

#### DEFINITION

Mixtures of mono-, di- and triesters of ethoxylated glycerol with fatty acids of vegetable origin having a composition corresponding to the fatty acid composition of the oil extracted from the hard, dried fraction of the endosperm of *Cocos nucifera* L. The average number of moles of ethylene oxide reacted per mole of substance (nominal value) is either 7 (macrogol 7 glycerol cocoate) or 23 (macrogol 23 glycerol cocoate).

#### CHARACTERS

**Appearance:** clear, yellowish, oily liquid.

01/2008:1083 TESTS

## MACROGOLGLYCEROL HYDROXYSTEARATE

### Macrogolglyceroli hydroxystearas

#### DEFINITION

Contains mainly trihydroxystearyl glycerol ethoxylated with 7 to 60 molecules of ethylene oxide (nominal value), with small amounts of macrogol hydroxystearate and of the corresponding free glycols. It results from the reaction of hydrogenated castor oil with ethylene oxide.

#### CHARACTERS

##### Appearance:

- if less than 10 units of ethylene oxide per molecule: yellowish, turbid, viscous liquid;
- if more than 20 units of ethylene oxide per molecule: white or yellowish semi-liquid or pasty mass.

##### Solubility:

- if less than 10 units of ethylene oxide per molecule: practically insoluble in water, soluble in acetone, dispersible in ethanol (96 per cent);
- if more than 20 units of ethylene oxide per molecule: freely soluble in water, in acetone and in ethanol (96 per cent), practically insoluble in light petroleum.

#### IDENTIFICATION

- Iodine value (see Tests).
- Saponification value (see Tests).
- Thin-layer chromatography (2.2.27).

**Test solution.** To 1 g of the substance to be examined, add 100 mL of a 100 g/L solution of *potassium hydroxide R* and boil under a reflux condenser for 30 min. Allow to cool. Acidify the solution with 20 mL of *hydrochloric acid R*. Shake the mixture with 50 mL of *ether R* and allow to stand until separation of the layers is obtained. Transfer the clear upper layer to a suitable tube, add 5 g of *anhydrous sodium sulfate R*, close the tube and allow to stand for 30 min. Filter and evaporate the filtrate to dryness on a water-bath. Dissolve 50 mg of the residue in 25 mL of *ether R*.

**Reference solution.** Dissolve 50 mg of *12-hydroxystearic acid R* in *methylene chloride R* and dilute to 25 mL with the same solvent.

**Plate:** *TLC octadecylsilyl silica gel plate R*.

**Mobile phase:** *methylene chloride R*, *glacial acetic acid R*, *acetone R* (10:40:50 V/V/V).

**Application:** 2 µL.

**Development:** over a path of 8 cm.

**Drying:** in a current of cold air.

**Detection:** spray with a 80 g/L solution of *phosphomolybdic acid R* in *2-propanol R* and heat at 120 °C for about 1-2 min.

**Results:** the principal spot in the chromatogram obtained with the test solution is similar in position and colour to the principal spot in the chromatogram obtained with the reference solution.

- Place about 2 g in a test-tube and add 0.2 mL of *sulfuric acid R*. Close the tube using a stopper fitted with a glass tube bent twice at right angles. Heat the tube until white fumes appear. Collect the fumes in 1 mL of *mercuric chloride solution R*. A white precipitate is formed and the fumes turn a filter paper impregnated with *alkaline potassium tetraiodomercurate solution R* black.

#### TESTS

**Solution S.** Dissolve 5.0 g of macrogolglycerol hydroxystearate with less than 40 units of ethylene oxide per molecule in a mixture of 50 volumes of *acetone R* and 50 volumes of *anhydrous ethanol R* and dilute to 50 mL with the same mixture of solvents.

Dissolve 5.0 g of macrogolglycerol hydroxystearate with 40 units or more of ethylene oxide per molecule in *carbon dioxide-free water R* and dilute to 50 mL with the same solvent.

**Appearance of solution.** Solution S is not more opalescent than reference suspension III (2.2.1) and not more intensely coloured than reference solution BY<sub>6</sub> (2.2.2, Method II).

**Alkalinity.** To 2 mL of solution S add 0.5 mL of *bromothymol blue solution R1*. The solution is not blue.

**Acid value (2.5.1):** maximum 2.0, determined on 5.0 g.

**Hydroxyl value (2.5.3, Method A).** See Table 1083-1.

**Iodine value (2.5.4):** maximum 5.0.

**Saponification value (2.5.6).** See Table 1083-1.

Table 1083-1

Ethylene oxide units per molecule (nominal value)	Hydroxyl value	Saponification value
7	115 - 135	125 - 140
25	70 - 90	70 - 90
40	60 - 80	45 - 69
60	45 - 67	40 - 51

**Residual ethylene oxide and dioxan (2.4.25):** maximum 1 ppm of residual ethylene oxide and 10 ppm of residual dioxan.

**Heavy metals (2.4.8).**

**Substances soluble in acetone/anhydrous ethanol:** maximum 10 ppm.

12 mL of solution S complies with test B. Prepare the reference solution using lead standard solution (1 ppm Pb) obtained by diluting *lead standard solution (100 ppm Pb) R* with a mixture of equal volumes of *acetone R* and *anhydrous ethanol R*.

**Substances soluble in water:** maximum 10 ppm.

12 mL of solution S complies with limit test A. Prepare the reference solution using *lead standard solution (1 ppm Pb) R*.

**Water (2.5.12):** maximum 3.0 per cent, determined on 2.000 g.

**Total ash (2.4.16):** maximum 0.3 per cent, determined on 2.0 g.

#### LABELLING

The label states the number of ethylene oxide units per molecule (nominal value).

01/2008:2044

## MACROGOL 20 GLYCEROL MONOSTEARATE

### Macrogol 20 glyceroli monostearas

#### DEFINITION

Macrogol 20 glycerol monostearate is obtained by ethoxylation with ethylene oxide of different types of glycerol stearates, mainly *Glycerol monostearate 40-55 (0495)*. The number of moles of ethylene oxide reacted per mole of glycerol stearate is 20 (nominal value).

#### CHARACTERS

**Appearance:** pale yellow, oily liquid or gel.

**Solubility:** soluble in water at 40 °C and above and in ethanol (96 per cent), practically insoluble in light liquid paraffin and in fatty oils.

**Relative density:** about 1.07.



## IDENTIFICATION

- A. Hydroxyl value (see Tests).  
 B. Saponification value (see Tests).  
 C. Composition of fatty acids (see Tests).  
 D. Place 1 g in a test tube and add 0.1 mL of *sulfuric acid R*. Heat the tube until white fumes appear. The fumes turn filter paper impregnated with *alkaline potassium tetraiodomercurate solution R* black.

## TESTS

**Acid value (2.5.1):** maximum 2.0, determined on 5.0 g.

**Hydroxyl value (2.5.3, Method A):** 65 to 85, determined on 0.350 g.

**Iodine value (2.5.4, Method A):** maximum 2.0.

**Peroxide value (2.5.5, Method A):** maximum 6.0.

**Saponification value (2.5.6):** 40 to 60.

**Composition of fatty acids.** Gas chromatography (2.4.22, Method C).

*Composition of the fatty-acid fraction of the substance:*

Type of macrogol 20 glycerol monostearate	Type of glycerol stearate used	Composition of fatty acids
Type I	Type I (obtained using stearic acid 50)	<i>Stearic acid:</i> 40.0 per cent to 60.0 per cent, <i>Sum of the contents of palmitic and stearic acids:</i> minimum 90.0 per cent.
Type II	Type II (obtained using stearic acid 70)	<i>Stearic acid:</i> 60.0 per cent to 80.0 per cent, <i>Sum of the contents of palmitic and stearic acids:</i> minimum 90.0 per cent.
Type III	Type III (obtained using stearic acid 95)	<i>Stearic acid:</i> 90.0 per cent to 99.0 per cent, <i>Sum of the contents of palmitic and stearic acids:</i> minimum 96.0 per cent.

**Ethylene oxide and dioxan (2.4.25, Method A):** maximum 1 ppm of ethylene oxide and maximum 10 ppm of dioxan.

**Heavy metals (2.4.8):** maximum 10 ppm.

2.0 g complies with test C. Prepare the reference solution using 2 mL of *lead standard solution (10 ppm Pb) R*.

**Water (2.5.12):** maximum 3.0 per cent, determined on 1.00 g.

**Total ash (2.4.16):** maximum 0.2 per cent.

## STORAGE

Protected from light.

## LABELLING

The label states the type of macrogol 20 glycerol monostearate.

01/2008:1082

## MACROGOLGLYCEROL RICINOLEATE

## Macrogolglyceroli ricinoleas

## DEFINITION

Contains mainly ricinoleyl glycerol ethoxylated with 30-50 molecules of ethylene oxide (nominal value), with small amounts of macrogol ricinoleate and of the corresponding free glycols. It results from the reaction of castor oil with ethylene oxide.

## CHARACTERS

*Appearance:* clear, yellow viscous liquid or semi-solid.

*Solubility:* freely soluble in water, very soluble in methylene chloride, freely soluble in ethanol (96 per cent).

*Relative density:* about 1.05.

*Viscosity:* 500 mPa·s to 800 mPa·s at 25 °C.

## IDENTIFICATION

- A. Iodine value (see Tests).  
 B. Saponification value (see Tests).  
 C. Thin-layer chromatography (2.2.27).

*Test solution.* To 1 g of the substance to be examined add 100 mL of a 100 g/L solution of *potassium hydroxide R* and boil under a reflux condenser for 30 min. Allow to cool. Acidify the solution with 20 mL of *hydrochloric acid R*. Shake the mixture with 50 mL of *ether R* and allow to stand until separation of the layers is obtained. Transfer the clear upper layer to a suitable tube, add 5 g of *anhydrous sodium sulfate R*, close the tube and allow to stand for 30 min. Filter and evaporate the filtrate to dryness on a water-bath. Dissolve 50 mg of the residue in 25 mL of *ether R*.

*Reference solution.* Dissolve 50 mg of *ricinoleic acid R* in *methylene chloride R* and dilute to 25 mL with the same solvent.

*Plate:* TLC octadecylsilyl silica gel plate R.

*Mobile phase:* *methylene chloride R*, *glacial acetic acid R*, *acetone R* (10:40:50 V/V/V).

*Application:* 2 µL.

*Development:* over a path of 8 cm.

*Drying:* in a current of cold air.

*Detection:* spray with an 80 g/L solution of *phosphomolybdic acid R* in *2-propanol R* and heat at 120 °C for 1-2 min.

*Results:* the principal spot in the chromatogram obtained with the test solution is similar in position and colour to the principal spot in the chromatogram obtained with the reference solution.

- D. Place about 2 g of the substance to be examined in a test-tube and add 0.2 mL of *sulfuric acid R*. Close the tube using a stopper fitted with a glass tube bent twice at right angles. Heat the tube until white fumes appear. Collect the fumes in 1 mL of *mercuric chloride solution R*. A white precipitate is formed and the fumes turn a filter paper impregnated with *alkaline potassium tetraiodomercurate solution R* black.

## TESTS

**Solution S.** Dissolve 5.0 g in *carbon dioxide-free water R* and dilute to 50 mL with the same solvent.

**Appearance of solution.** Solution S is not more opalescent than reference suspension III (2.2.1) and not more intensely coloured than reference solution BY<sub>5</sub> (2.2.2, Method II). If intended for use in the manufacture of parenteral preparations, solution S is not more intensely coloured than reference solution BY<sub>6</sub> (2.2.2, Method II).

**Alkalinity.** Dissolve 2.0 g in a hot mixture of 10 mL of *water R* and 10 mL of *ethanol (96 per cent) R*. Add 0.1 mL of *bromothymol blue solution R1*. Not more than 0.5 mL of 0.1 M *hydrochloric acid* is required to change the colour of the indicator to yellow.

**Acid value (2.5.1):** maximum 2.0, determined on 5.0 g.

**Hydroxyl value (2.5.3, Method A).** See Table 1082.-1.

**Iodine value (2.5.4):** 25 to 35.

**Saponification value (2.5.6).** See Table 1082.-1.

Table 1082.-1

Ethylene oxide units per molecule (nominal value)	Hydroxyl value	Saponification value
30 - 35	65 - 82	60 - 75
50	48 - 68	38 - 52

**Residual ethylene oxide and dioxan (2.4.25):** maximum 1 ppm of residual ethylene oxide and 10 ppm of residual dioxan.

**Heavy metals** (2.4.8): maximum 10 ppm.

12 mL of solution S, filtered if necessary, complies with test A. Prepare the reference solution using *lead standard solution* (1 ppm Pb) R.

**Water** (2.5.12): maximum 3.0 per cent, determined on 2.000 g.

**Total ash** (2.4.16): maximum 0.3 per cent, determined on 2.0 g.

#### STORAGE

Protected from light.

#### LABELLING

The label states:

- the amount of ethylene oxide reacted with castor oil (nominal value),
- where applicable, that the substance is suitable for use in the manufacture of parenteral preparations.

01/2008:2052

## MACROGOL 15 HYDROXYSTEARATE

### Macrogoli 15 hydroxystearas

#### DEFINITION

Mixture of mainly monoesters and diesters of 12-hydroxystearic (12-hydroxyoctadecanoic) acid and macrogols obtained by ethoxylation of 12-hydroxystearic acid. The number of moles of ethylene oxide reacted per mole of 12-hydroxystearic acid is 15 (nominal value). It contains free macrogols.

#### CHARACTERS

*Appearance*: yellowish, waxy mass.

*Solubility*: very soluble in water, soluble in ethanol (96 per cent), insoluble in liquid paraffin.

It solidifies at about 25 °C.

#### IDENTIFICATION

A. Thin-layer chromatography (2.2.27).

*Test solution*. To 1.0 g add 100 mL of a 100 g/L solution of *potassium hydroxide* R and boil under a reflux condenser for 30 min. Acidify the warm solution with 20 mL of *hydrochloric acid* R and cool to room temperature. Shake the mixture with 50 mL of *ether* R and allow to stand until a separation of the layers is visible. Separate the clear upper layer, add 5 g of *anhydrous sodium sulfate* R, wait for 30 min, filter and evaporate to dryness on a water-bath. Dissolve 50 mg of the residue in 25 mL of *ether* R.

*Reference solution*. Dissolve 50 mg of *12-hydroxystearic acid* R in 25 mL of *methylene chloride* R.

*Plate*: TLC octadecylsilyl silica gel plate R.

*Mobile phase*: *methylene chloride* R, *glacial acetic acid* R, *acetone* R (10:40:50 V/V/V).

*Application*: 2 µL.

*Development*: over 2/3 of the plate.

*Drying*: in a current of cold air.

*Detection*: spray with a 80 g/L solution of *phosphomolybdic acid* R in *2-propanol* R and heat at 120 °C for 1-2 min.

*Results*: the principal spot in the chromatogram obtained with the test solution is similar in position and colour to the principal spot in the chromatogram obtained with the reference solution.

B. Dissolve 15.0 g in 50 mL of *water* R. The viscosity (2.2.9) has a maximum of 20 mPas.

C. Free macrogols (see Tests).

#### TESTS

**Appearance of solution**. The solution is not more opalescent than reference suspension III (2.2.1) and not more intensely coloured than reference solution B<sub>6</sub> or BY<sub>6</sub> (2.2.2, Method II). Dissolve 2.0 g in *water* R and dilute to 20 mL with the same solvent.

**Acid value** (2.5.1): maximum 1.0, determined on 2.0 g.

**Hydroxyl value** (2.5.3, Method A): 90 to 110.

**Iodine value** (2.5.4, Method A): maximum 2.0.

**Peroxide value** (2.5.5, Method A): maximum 5.0.

**Saponification value** (2.5.6): 53 to 63.

**Free macrogols**. Size-exclusion chromatography (2.2.30).

*Test solution*. Dissolve 1.20 g of the substance to be examined in the mobile phase and dilute to 250.0 mL with the mobile phase.

*Reference solution (a)*. Dissolve about 0.4 g of *macrogol 1000* R in the mobile phase and dilute to 250.0 mL with the mobile phase.

*Reference solution (b)*. Dilute 50.0 mL of reference solution (a) to 100.0 mL with the mobile phase.

*Precolumns* (2):

– *size*:  $l = 0.125$  m,  $\emptyset = 4$  mm;

– *stationary phase*: spherical octadecylsilyl silica gel for chromatography R (5 µm) with a pore size of 10 nm.

*Column*:

– *size*:  $l = 0.30$  m,  $\emptyset = 7.8$  mm;

– *stationary phase*: hydroxylated polymethacrylate gel R (6 µm) with a pore size of 12 nm.

Connect both precolumns to the column using a 3-way valve and switch the mobile phase flow according to the following programme:

– 0-114 s: precolumn 1 and column;

– 115 s to the end: precolumn 2 and column;

– 115 s to 7 min: flow back of precolumn 1.

*Mobile phase*: *water* R, *methanol* R (2:8 V/V).

*Flow rate*: 1.1 mL/min.

*Detection*: refractometer.

*Injection*: 50 µL.

Calculate the percentage content of free macrogols using the following expression:

$$\frac{A_1 \times m_2 \times 200}{m_1 \times (A_2 + 2A_3)}$$

$m_1$  = mass of the substance to be examined in the test solution, in grams;

$m_2$  = mass of *macrogol 1000* R in reference solution (a), in grams;

$A_1$  = area of the peak due to free macrogols in the substance to be examined in the chromatogram obtained with the test solution;

$A_2$  = area of the peak due to *macrogol 1000* in the chromatogram obtained with reference solution (a);

$A_3$  = area of the peak due to *macrogol 1000* in the chromatogram obtained with reference solution (b).

*Limit*:

– *free macrogols*: 27.0 per cent to 39.0 per cent.

**Ethylene oxide and dioxan** (2.4.25): maximum 1 ppm of ethylene oxide and maximum 50 ppm of dioxan.

**Nickel** (2.4.31): maximum 1 ppm.

**Water** (2.5.12): maximum 1.0 per cent, determined on 2.00 g.

**Total ash** (2.4.16): maximum 0.3 per cent, determined on 1.0 g.

#### STORAGE

In an airtight container.

01/2008:1124 STORAGE  
corrected 6.0 In an airtight container.

## MACROGOL LAURYL ETHER

### Macrogoli aether laurilicus

#### DEFINITION

Mixture of ethers of mixed macrogols with fatty alcohols, mainly  $C_{12}H_{26}O$ . It contains a variable amount of free  $C_{12}H_{26}O$  and it may contain free macrogols. The number of moles of ethylene oxide reacted per mole of  $C_{12}H_{26}O$  is 3 to 23 (nominal value).

#### CHARACTERS

- Macrogol lauryl ether with 3 to 5 units of ethylene oxide per molecule.

*Appearance*: colourless liquid.

*Solubility*: practically insoluble in water, soluble or dispersible in alcohol, practically insoluble in light petroleum.

- Macrogol lauryl ether with 9 to 23 units of ethylene oxide per molecule.

*Appearance*: white or almost white, waxy mass.

*Solubility*: soluble or dispersible in water, soluble in alcohol, practically insoluble in light petroleum.

#### IDENTIFICATION

- Hydroxyl value (see Tests).
- Iodine value (see Tests).
- Saponification value (see Tests).
- Dissolve or disperse 0.1 g in 5 mL of *alcohol R*, add 10 mL of *dilute hydrochloric acid R*, 10 mL of *barium chloride solution RI* and 10 mL of a 100 g/L solution of *phosphomolybdic acid R*. A precipitate is formed.

#### TESTS

**Appearance of solution.** The solution is not more intensely coloured than reference solution BY<sub>5</sub> (2.2.2, *Method II*).

Dissolve 5.0 g in *alcohol R* and dilute to 50 mL with the same solvent.

**Alkalinity.** Dissolve 2.0 g in a hot mixture of 10 mL of *water R* and 10 mL of *alcohol R*. Add 0.1 mL of *bromothymol blue solution RI*. Not more than 0.5 mL of 0.1 M *hydrochloric acid* is required to change the colour of the indicator to yellow.

**Acid value (2.5.1):** maximum 1.0, determined on 5.0 g.

**Hydroxyl value (2.5.3, Method A).**

Ethylene oxide units per molecule (nominal value)	Hydroxyl value
3	165 - 180
4	145 - 165
5	130 - 140
9	90 - 100
10	85 - 95
12	73 - 83
15	64 - 74
20 - 23	40 - 60

**Iodine value (2.5.4):** maximum 2.0.

**Saponification value (2.5.6):** maximum 3.0, determined on 10.0 g.

**Ethylene oxide and dioxan (2.4.25):** maximum 1 ppm of ethylene oxide and maximum 10 ppm of dioxan.

**Water (2.5.12):** maximum 3.0 per cent, determined on 2.00 g.

**Total ash (2.4.16):** maximum 0.2 per cent, determined on 2.0 g.

#### LABELLING

The label states the number of moles of ethylene oxide reacted per mole of  $C_{12}H_{26}O$  (nominal value).

01/2008:1618

## MACROGOL OLEATE

### Macrogoli oleas

#### DEFINITION

A mixture of monoesters and diesters of mainly oleic (*cis*-9-octadecenoic) acid and macrogols. It may be obtained by ethoxylation of *Oleic acid (0799)* or by esterification of macrogols with oleic acid of animal or vegetable origin. It may contain free macrogols. The average polymer length is equivalent to 5-6 or 10 moles of ethylene oxide per mole (nominal value). A suitable antioxidant may be added.

#### CHARACTERS

*Appearance*: slightly yellowish, viscous liquid.

*Solubility*: dispersible in water, soluble in ethanol (96 per cent) and in 2-propanol, dispersible in oils, miscible with fatty oils and with waxes.

*Refractive index*: about 1.466.

#### IDENTIFICATION

*First identification*: A, C.

*Second identification*: A, B.

A. Saponification value (see Tests).

B. Thin-layer chromatography (2.2.27).

*Test solution.* To 20 mg add 10 mL of *methylene chloride R* and mix.

*Plate:* TLC silica gel F<sub>254</sub> plate R.

*Mobile phase:* 25 per cent V/V solution of *concentrated ammonia R*, 2-propanol R (20:80 V/V).

*Application:* 10 µL.

*Development:* over a path of 15 cm.

*Drying:* in air.

*Detection:* spray with *potassium iodobismuthate solution R4*; examine the plate about 10 min later.

*Results:* the chromatogram obtained shows 3 principal spots, corresponding, in order of increasing  $R_f$  value, to free macrogol, macrogol mono-oleate and macrogol dioleate.

C. Composition of fatty acids (see Tests).

#### TESTS

**Alkalinity.** Dissolve 2.0 g in *ethanol (96 per cent) R* and dilute to 20 mL with the same solvent. To 2 mL of this solution add 0.05 mL of *phenol red solution R*. The solution is not red.

**Acid value (2.5.1):** maximum 2.0.

**Hydroxyl value (2.5.3, Method A):** see Table 1618-1.

**Iodine value (2.5.4, Method A):** see Table 1618-1.

**Peroxide value (2.5.5, Method A):** maximum 12.0.

**Saponification value (2.5.6):** see Table 1618-1.

Table 1618-1

	5-6 moles of ethylene oxide	10 moles of ethylene oxide
Hydroxyl value	50 - 70	65 - 90
Iodine value	50 - 60	27 - 34
Saponification value	105 - 120	68 - 85

**Composition of fatty acids.** Gas chromatography (2.4.22, Method A).

Composition of the fatty-acid fraction of the substance:

- *myristic acid*: maximum 5.0 per cent;
- *stearic acid*: maximum 6.0 per cent;
- *palmitic acid*: maximum 16.0 per cent;
- *palmitoleic acid*: maximum 8.0 per cent;
- *oleic acid*: 65.0 per cent to 88.0 per cent;
- *linoleic acid*: maximum 18.0 per cent;
- *linolenic acid*: maximum 4.0 per cent;
- *fatty acids with a chain length greater than C<sub>18</sub>*: maximum 4.0 per cent.

**Residual ethylene oxide and dioxan (2.4.25):** maximum 1 ppm of residual ethylene oxide and 10 ppm of residual dioxan.

**Water (2.5.12):** maximum 2.0 per cent, determined on 1.00 g using *anhydrous methanol R* as the solvent.

**Total ash (2.4.16):** maximum 0.3 per cent, determined on 1.0 g.

#### STORAGE

In an airtight container.

#### LABELLING

The label states the number of moles of ethylene oxide per mole (nominal value).

01/2008:1125

## MACROGOL OLEYL ETHER

### Macrogoli aether oleicus

#### DEFINITION

Mixture of ethers of mixed macrogols with linear fatty alcohols, mainly oleyl alcohol. It contains a variable amount of free oleyl alcohol and it may contain free macrogols. The number of moles of ethylene oxide reacted per mole of oleyl alcohol is 2 to 20 (nominal value). A suitable antioxidant may be added.

#### CHARACTERS

- Macroglol oleyl ether with 2 to 5 units of ethylene oxide per molecule.

*Appearance:* yellow liquid.

*Solubility:* practically insoluble in water, soluble in alcohol, practically insoluble in light petroleum.

- Macroglol oleyl ether with 10 to 20 units of ethylene oxide per molecule.

*Appearance:* yellowish-white waxy mass.

*Solubility:* dispersible or soluble in water, soluble in alcohol, practically insoluble in light petroleum.

#### IDENTIFICATION

- A. Hydroxyl value (see Tests).
- B. Iodine value (see Tests).
- C. Saponification value (see Tests).
- D. Dissolve or disperse 0.1 g in 5 mL of *alcohol R*, add 2 mL of *water R*, 10 mL of *dilute hydrochloric acid R*, 10 mL of *barium chloride solution R1* and 10 mL of a 100 g/L solution of *phosphomolybdic acid R*. A precipitate is formed.

#### TESTS

**Appearance of solution.** The solution is not more intensely coloured than reference solution BY<sub>5</sub> (2.2.2, Method II).

Dissolve 5.0 g in *alcohol R* and dilute to 50 mL with the same solvent.

**Alkalinity.** Dissolve 2.0 g in a hot mixture of 10 mL of *water R* and 10 mL of *alcohol R*. Add 0.1 mL of *bromothymol blue solution R1*. Not more than 0.5 mL of 0.1 M *hydrochloric acid* is required to change the colour of the indicator to yellow.

**Acid value (2.5.1):** maximum 1.0, determined on 5.0 g.

**Hydroxyl value (2.5.3, Method A).** See Table 1125-1.

**Iodine value (2.5.4).** See Table 1125-1.

Table 1125-1

Ethylene oxide units per molecule (nominal value)	Hydroxyl value	Iodine value
2	158 - 178	48 - 74*
5	110 - 125	48 - 56
10	75 - 95	24 - 38
20	40 - 65	14 - 24

\* This broad range is needed since 2 different grades of oleyl alcohol may be used for the synthesis. The iodine value does not differ by more than 5 units from the nominal iodine value and is within the limits stated in the table.

**Peroxide value (2.5.5):** maximum 10.0.

**Saponification value (2.5.6):** maximum 3.0.

**Ethylene oxide and dioxan (2.4.25):** maximum 1 ppm of ethylene oxide and 10 ppm of dioxan.

**Water (2.5.12):** maximum 3.0 per cent, determined on 2.00 g.

**Total ash (2.4.16):** maximum 0.2 per cent, determined on 2.0 g.

#### STORAGE

In an airtight container, protected from light.

#### LABELLING

The label states:

- the number of moles of ethylene oxide reacted per mole of oleyl alcohol (nominal value),
- the nominal iodine value for the type with 2 units of ethylene oxide per molecule.

04/2010:2523

## MACROGOL POLY(VINYL ALCOHOL) GRAFTED COPOLYMER

### Copolymerum macrogolo et alcoholi poly(vinyllico) constatum

#### DEFINITION

Grafted copolymer of macroglol and poly(vinyl alcohol), having a mean relative molecular mass of about 45 000.

It consists of about 75 per cent of poly(vinyl alcohol) units and 25 per cent of macroglol units. It may contain *Anhydrous colloidal silica (0434)* to improve flowability. The presence of anhydrous colloidal silica will result in an opalescent solution.

#### CHARACTERS

*Appearance:* white or slightly yellowish powder.

*Solubility:* very soluble in water, practically insoluble in anhydrous ethanol and in acetone. It dissolves in dilute acids and dilute solutions of alkali hydroxides.

#### IDENTIFICATION

- A. Infrared absorption spectrophotometry (2.2.24).

*Comparison:* macroglol poly(vinyl alcohol) grafted copolymer CRS.

*Preparation:* dissolve 0.2 g in *water R*. Spread 1.0 mL of this solution on a thallium bromoiodide plate. Evaporate the solvent at 110 °C for 30 min.

- B. Dissolve 0.4 g in 2 mL of *water R*. Place 1 mL on a glass plate and allow to dry. A clear film is formed.

## TESTS

**pH** (2.2.3): 5.0 to 8.0.

Dissolve 5.0 g with *carbon dioxide-free water R* and dilute to 25.0 mL with the same solvent.

**Ester value** (2.5.2): 10 to 75.

**Ethylene oxide and dioxan** (2.4.25): maximum 1 ppm of ethylene oxide and 10 ppm of dioxan.

**Impurity A.** Liquid chromatography (2.2.29).

*Test solution.* Introduce 0.250 g of the substance to be examined into a 10 mL volumetric flask and add about 1 mL of *methanol R2*. Sonicate. Add about 8 mL of *water for chromatography R* and dilute to 10.0 mL with the same solvent. Filter.

*Reference solution (a).* Dissolve 5.0 mg of *vinyl acetate CRS* (impurity A) in *methanol R2* and dilute to 10.0 mL with the same solvent. Dilute 1.0 mL of this solution to 20.0 mL with *water for chromatography R*. Dilute 1.0 mL of this solution to 10.0 mL with *water for chromatography R*.

*Reference solution (b).* Dissolve 5 mg of *vinyl acetate R* (impurity A) and 5 mg of *1-vinylpyrrolidin-2-one R* in 10 mL of *methanol R2* and dilute to 50 mL with *water for chromatography R*. Dilute 1 mL of this solution to 20 mL with *water for chromatography R*.

A precolumn containing *octadecylsilyl silica gel for chromatography R* (5 µm) may be used if a matrix effect is observed.

*Column:*

- size:  $l = 0.25$  m,  $\varnothing = 4.0$  mm;
- stationary phase: *octadecylsilyl silica gel for chromatography R* (5 µm);
- temperature: 30 °C.

*Mobile phase:*

- mobile phase A: *acetonitrile R1*, *methanol R2*, *water for chromatography R* (5:5:90 V/V/V);
- mobile phase B: *methanol R2*, *acetonitrile R1*, *water for chromatography R* (5:45:50 V/V/V);

Time (min)	Mobile phase A (per cent V/V)	Mobile phase B (per cent V/V)
0 - 2	100	0
2 - 40	100 → 85	0 → 15
40 - 42	85 → 0	15 → 100

*Flow rate:* 1.0 mL/min.

*Detection:* spectrophotometer at 205 nm.

*Injection:* 10 µL.

*Retention time:* impurity A = about 19 min; 1-vinylpyrrolidin-2-one = about 25 min.

*System suitability:* reference solution (b):

- resolution: minimum 5.0 between the peaks due to impurity A and 1-vinylpyrrolidin-2-one.

*Limit:*

- impurity A: not more than the area of the principal peak in the chromatogram obtained with reference solution (a) (100 ppm).

**Impurity B.** Liquid chromatography (2.2.29).

*Test solution.* Mix 0.200 g of the substance to be examined with *water for chromatography R* and dilute to 10.0 mL with the same solvent.

*Reference solution.* Dissolve 30 mg of *acetic acid R* (impurity B) and 30 mg of *citric acid R* in the mobile phase. Shake gently to dissolve and dilute to 100.0 mL with the mobile phase.

*Column:*

- size:  $l = 0.25$  m,  $\varnothing = 4.6$  mm;

- stationary phase: *octadecylsilyl silica gel for chromatography R* (5 µm).

*Mobile phase:* 0.005 M *sulfuric acid*.

*Flow rate:* 1.0 mL/min.

*Detection:* spectrophotometer at 205 nm.

*Injection:* 20 µL. After each injection, rinse the column with a mixture of equal volumes of *acetonitrile for chromatography R* and 0.005 M *sulfuric acid*.

*Retention time:* impurity B = about 5 min; citric acid = about 7 min.

*System suitability:* reference solution:

- resolution: minimum 2.0 between the peaks due to citric acid and impurity B.

*Limit:*

- impurity B: not more than the area of the corresponding peak in the chromatogram obtained with the reference solution (1.5 per cent).

**Sulfated ash** (2.4.14): maximum 3.0 per cent, determined on 5.0 g.

**Loss on drying** (2.2.32): maximum 5.0 per cent, determined on 1.000 g by drying *in vacuo* at 105 °C.

## IMPURITIES

*Specified impurities:* A, B.

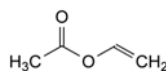

A. vinyl acetate,

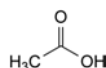

B. acetic acid.

## FUNCTIONALITY-RELATED CHARACTERISTICS

*This section provides information on characteristics that are recognised as being relevant control parameters for one or more functions of the substance when used as an excipient (see chapter 5.15). This section is a non-mandatory part of the monograph and it is not necessary to verify the characteristics to demonstrate compliance. Control of these characteristics can however contribute to the quality of a medicinal product by improving the consistency of the manufacturing process and the performance of the medicinal product during use. Where control methods are cited, they are recognised as being suitable for the purpose, but other methods can also be used. Wherever results for a particular characteristic are reported, the control method must be indicated.*

*The following characteristics may be relevant for macrogol poly(vinyl alcohol) grafted copolymer used as film former in film-coated tablets.*

**Apparent viscosity** (2.2.10): typically less than 250 mPa·s, determined on a 20 per cent (*m/m*) solution, using a rotating viscometer at 25 °C and rotation speed of 100 r/min.

01/2008:1444

## MACROGOLS

## Macrogola

## DEFINITION

Mixtures of polymers with the general formula  $H-(OCH_2-CH_2)_n-OH$  where  $n$  represents the average number of oxyethylene groups. The type of macrogol is defined by a number that indicates the average relative molecular mass. A suitable stabiliser may be added.

## CHARACTERS

Type of macrogol	Appearance	Solubility
300	clear, viscous, colourless or almost colourless hygroscopic liquid	miscible with water, very soluble in acetone, in alcohol, and in methylene chloride, practically insoluble in fatty oils and in mineral oils
400		
600		
1000	white or almost white, hygroscopic solid with a waxy or paraffin-like appearance	very soluble in water, freely soluble in alcohol and in methylene chloride, practically insoluble in fatty oils and in mineral oils
1500	white or almost white solid with a waxy or paraffin-like appearance	very soluble in water and in methylene chloride, freely soluble in alcohol, practically insoluble in fatty oils and in mineral oils
3000	white or almost white solid with a waxy or paraffin-like appearance	very soluble in water and in methylene chloride, very slightly soluble in alcohol, practically insoluble in fatty oils and in mineral oils
3350		
4000	white or almost white solid with a waxy or paraffin-like appearance	very soluble in water and in methylene chloride, practically insoluble in alcohol and in fatty oils and in mineral oils
6000		
8000		
20 000	white or almost white solid with a waxy or paraffin-like appearance	very soluble in water, soluble in methylene chloride, practically insoluble in alcohol and in fatty oils and in mineral oils
35 000		

## IDENTIFICATION

- A. It complies with the test for viscosity (see Tests).
- B. To 1 g in a test-tube add 0.5 mL of *sulfuric acid R*, close the test-tube with a stopper fitted with a bent delivery tube and heat until white fumes are evolved. Collect the fumes via the delivery tube into 1 mL of *mercuric chloride solution R*. An abundant white, crystalline precipitate is formed.
- C. To 0.1 g add 0.1 g of *potassium thiocyanate R* and 0.1 g of *cobalt nitrate R* and mix thoroughly with a glass rod. Add 5 mL of *methylene chloride R* and shake. The liquid phase becomes blue.

## TESTS

**Appearance of solution.** The solution is clear (2.2.1) and not more intensely coloured than reference solution BY<sub>6</sub> (2.2.2, Method II).

Dissolve 12.5 g in *water R* and dilute to 50 mL with the same solvent.

Table 1444-1

Type of macrogol	Kinematic viscosity (mm <sup>2</sup> ·s <sup>-1</sup> )	Dynamic viscosity (mPa·s)	Density* (g/mL)
300	71 - 94	80 - 105	1.120
400	94 - 116	105 - 130	1.120
600	13.9 - 18.5	15 - 20	1.080
1000	20.4 - 27.7	22 - 30	1.080
1500	31 - 46	34 - 50	1.080
3000	69 - 93	75 - 100	1.080
3350	76 - 110	83 - 120	1.080
4000	102 - 158	110 - 170	1.080
6000	185 - 250	200 - 270	1.080
8000	240 - 472	260 - 510	1.080
20 000	2500 - 3200	2700 - 3500	1.080
35 000	10 000 - 13 000	11 000 - 14 000	1.080

\*Density of the substance for macrogols 300 and 400. Density of the 50 per cent *m/m* solution for the other macrogols.

**Acidity or alkalinity.** Dissolve 5.0 g in 50 mL of *carbon dioxide-free water R* and add 0.15 mL of *bromothymol blue solution R1*. The solution is yellow or green. Not more than 0.1 mL of 0.1 M *sodium hydroxide* is required to change the colour of the indicator to blue.

**Viscosity (2.2.9).** The viscosity is calculated using a density given in Table 1444-1.

For macrogols having a relative molecular mass greater than 400, determine the viscosity on a 50 per cent *m/m* solution of the substance to be examined.

**Freezing point (2.2.18).** See Table 1444-2.

Table 1444-2

Type of macrogol	Freezing point (°C)
600	15 - 25
1000	35 - 40
1500	42 - 48
3000	50 - 56
3350	53 - 57
4000	53 - 59
6000	55 - 61
8000	55 - 62
20 000	minimum 57
35 000	minimum 57

**Hydroxyl value.** Introduce *m* g (see Table 1444-3) into a dry conical flask fitted with a reflux condenser. Add 25.0 mL of *phthalic anhydride solution R*, swirl to dissolve and boil under a reflux condenser on a hot plate for 60 min. Allow to cool. Rinse the condenser first with 25 mL of *pyridine R* and then with 25 mL of *water R*, add 1.5 mL of *phenolphthalein solution R* and titrate with 1 M *sodium hydroxide* until a faint pink colour is obtained (*n*<sub>1</sub> mL). Carry out a blank test (*n*<sub>2</sub> mL). Calculate the hydroxyl value using the expression:

$$\frac{56.1 \times (n_2 - n_1)}{m}$$

Table 1444-3

Type of macrogol	Hydroxyl value	<i>m</i> (g)
300	340 - 394	1.5
400	264 - 300	1.9
600	178 - 197	3.5
1000	107 - 118	5.0
1500	70 - 80	7.0
3000	34 - 42	12.0
3350	30 - 38	12.0
4000	25 - 32	14.0
6000	16 - 22	18.0
8000	12 - 16	24.0
20 000	-	-
35 000	-	-

For macrogols having a relative molecular mass greater than 1000, if the water content is more than 0.5 per cent, dry a sample of suitable mass at 100-105 °C for 2 h and carry out the determination of the hydroxyl value on the dried sample.

**Reducing substances.** Dissolve 1 g in 1 mL of a 10 g/L solution of *resorcinol R* and warm gently if necessary. Add 2 mL of *hydrochloric acid R*. After 5 min the solution is not more intensely coloured than reference solution R<sub>3</sub> (2.2.2, Method I).

**Formaldehyde:** maximum 30 ppm.

**Test solution.** To 1.00 g add 0.25 mL of *chromotropic acid, sodium salt solution R*, cool in iced water and add 5.0 mL of *sulfuric acid R*. Allow to stand for 15 min and complete slowly to 10 mL with *water R*.

**Reference solution.** Dilute 0.860 g of *formaldehyde solution R* to 100 mL with *water R*. Dilute 1.0 mL of this solution to 100 mL with *water R*. In a 10 mL flask, mix 1.00 mL of this solution with 0.25 mL of *chromotropic acid, sodium salt solution R*, cool in iced water and add 5.0 mL of *sulfuric acid R*. Allow to stand for 15 min and complete slowly to 10 mL with *water R*.

**Blank solution.** In a 10 mL flask mix 1.00 mL of *water R* with 0.25 mL of *chromotropic acid, sodium salt solution R*, cool in iced water and add 5.0 mL of *sulfuric acid R*. Complete slowly to 10 mL with *water R*.

Determine the absorbance (2.2.25) of the test solution at 567 nm, against the blank solution. It is not higher than that of the reference solution.

If the use of macrogols with a higher content of formaldehyde may have adverse effects, the competent authority may impose a limit of not more than 15 ppm.

**Ethylene glycol and diethylene glycol:** carry out this test only if the macrogol has a relative molecular mass below 1000.

Gas chromatography (2.2.28).

**Test solution.** Dissolve 5.00 g of the substance to be examined in *acetone R* and dilute to 100.0 mL with the same solvent.

**Reference solution.** Dissolve 0.10 g of *ethylene glycol R* and 0.50 g of *diethylene glycol R* in *acetone R* and dilute to 100.0 mL with the same solvent. Dilute 1.0 mL of this solution to 10.0 mL with *acetone R*.

**Column:**

- *material:* glass,
- *size:*  $l = 1.8$  m,  $\varnothing = 2$  mm,
- *stationary phase:* silanised diatomaceous earth for gas chromatography R, impregnated with 5 per cent *m/m* of *macrogol 20 000 R*,

**Carrier gas:** nitrogen for chromatography R.

**Flow rate:** 30 mL/min.

**Temperature:**

- *column:* if necessary, precondition the column by heating at 200 °C for about 15 h; adjust the initial temperature of the column to obtain a retention time of 14-16 min for diethylene glycol; raise the temperature of the column by about 30 °C at a rate of 2 °C/min but without exceeding 170 °C;
- *injection port and detector:* 250 °C.

**Detection:** flame ionisation.

**Injection:** 2 µL.

Carry out 5 replicate injections to check the repeatability of the response.

**Limit:** maximum 0.4 per cent, calculated as the sum of the contents of ethylene glycol and diethylene glycol.

**Ethylene oxide and dioxan (2.4.25):** maximum 1 ppm of ethylene oxide and 10 ppm of dioxan.

**Heavy metals (2.4.8):** maximum 20 ppm.

Dissolve 2.0 g in *water R* and dilute to 20 mL with the same solvent. 12 mL of the solution complies with limit test A. Prepare the standard using *lead standard solution (2 ppm Pb) R*.

**Water (2.5.12):** maximum 2.0 per cent for macrogol with a relative molecular mass not greater than 1000 and maximum 1.0 per cent for macrogol with a relative molecular mass greater than 1000, determined on 2.00 g.

**Sulfated ash (2.4.14):** maximum 0.2 per cent, determined on 1.0 g.

**STORAGE**

In an airtight container.

**LABELLING**

The label states:

- the type of macrogol,
- the content of formaldehyde.

01/2008:2396  
corrected 7.0

## MACROGOL 40 SORBITOL HEPTAOLEATE

### Macrogol 40 sorbitoli heptaoleas

**DEFINITION**

Mixture of esters of fatty acids, mainly *Oleic acid (0799)*, and sorbitol ethoxylated with approximately 40 moles of ethylene oxide for each mole of sorbitol. 7 moles of oleic acid are used for each mole of sorbitol. It also contains macrogol fatty acid esters.

**CHARACTERS**

**Appearance:** clear or slightly opalescent, yellowish, viscous, hygroscopic liquid.

**Solubility:** dispersible in water, soluble in isopropyl myristate, in isopropyl palmitate, in mineral oils and in vegetable fatty oils.

**Relative density:** about 1.0.

**Viscosity (2.2.9):** about 175 mPa·s at 25 °C.

**IDENTIFICATION**

**First identification:** A, D.

**Second identification:** B, C, D.

- A. Infrared absorption spectrophotometry (2.2.24).  
*Comparison:* *macrogol 40 sorbitol heptaoleate CRS*.
- B. Hydroxyl value (see Tests).
- C. Saponification value (see Tests).
- D. Composition of fatty acids (see Tests).

**TESTS**

**Acid value (2.5.1):** maximum 12.0, determined on 3.0 g.

**Hydroxyl value (2.5.3, Method A):** 22 to 55.

**Peroxide value:** maximum 10.0.

Introduce 10.0 g into a 100 mL beaker and dissolve with 20 mL of *glacial acetic acid R*. Add 1 mL of *saturated potassium iodide solution R*, mix and allow to stand for 1 min. Add 50 mL of *carbon dioxide-free water R* and a magnetic stirring bar. Titrate with 0.01 M *sodium thiosulfate*, determining the end-point potentiometrically (2.2.20). Carry out a blank titration.

Determine the peroxide value using the following expression:

$$\frac{(n_1 - n_2) \times M \times 1000}{m}$$

$n_1$  = volume of 0.01 M *sodium thiosulfate* required for the titration of the substance to be examined, in millilitres;

$n_2$  = volume of 0.01 M *sodium thiosulfate* required for the blank titration, in millilitres;

$M$  = molarity of the sodium thiosulfate solution;

$m$  = mass of the substance to be examined, in grams.

**Saponification value (2.5.6):** 90 to 110, determined on 4.0 g.

Use 30.0 mL of 0.5 M *alcoholic potassium hydroxide*, heat under reflux for 60 min and add 50 mL of *anhydrous ethanol R* before carrying out the titration.

**Composition of fatty acids** (2.4.22, Method C). Use the mixture of calibrating substances in Table 2.4.22.-3.

*Composition of the fatty-acid fraction of the substance:*

- *myristic acid*: maximum 5.0 per cent;
- *palmitic acid*: maximum 16.0 per cent;
- *palmitoleic acid*: maximum 8.0 per cent;
- *stearic acid*: maximum 6.0 per cent;
- *oleic acid*: minimum 58.0 per cent;
- *linoleic acid*: maximum 18.0 per cent;
- *linolenic acid*: maximum 4.0 per cent.

**Ethylene oxide and dioxan** (2.4.25, Method A): maximum 1 ppm of ethylene oxide and maximum 10 ppm of dioxan.

**Water** (2.5.12): maximum 0.5 per cent, determined on 0.50 g.

**Sulfated ash**: maximum 0.25 per cent.

Heat a silica crucible to redness for 30 min, allow to cool in a desiccator and weigh. Evenly distribute 1.0 g of the substance to be examined in the crucible and weigh. Dry at 100-105 °C for 1 h and ignite in a muffle furnace at 600 ± 25 °C, until the substance is thoroughly charred. Carry out the test for sulfated ash (2.4.14) on the residue obtained, starting from “Moisten the substance to be examined...”.

#### STORAGE

In an airtight container, protected from light.

01/2008:1234

## MACROGOL STEARATE

### Macrogoli stearas

#### DEFINITION

Mixture of monoesters and diesters of mainly stearic (octadecanoic) acid and/or palmitic (hexadecanoic) acid and macrogols. It may be obtained by ethoxylation or by esterification of macrogols with stearic acid 50 (type I) or stearic acid 95 (type II) (see *Stearic acid* (1474)). It may contain free macrogols. The average polymer length is equivalent to 6 to 100 ethylene oxide units per molecule (nominal value).

#### CHARACTERS

*Appearance*: white or slightly yellowish waxy mass.

*Solubility*: soluble in alcohol and in 2-propanol. Macrogol stearate corresponding to a product with 6 to 9 units of ethylene oxide per molecule is practically insoluble, but freely dispersible in water and miscible with fatty oils and with waxes. Macrogol stearate corresponding to a product with 20 to 100 units of ethylene oxide per molecule is soluble in water and practically insoluble in fatty oils and in waxes.

#### IDENTIFICATION

A. Saponification value (see Tests).

B. Composition of fatty acids (see Tests).

#### TESTS

**Alkalinity**. Dissolve 2.0 g in *alcohol R* and dilute to 20 mL with the same solvent. To 2 mL of this solution add 0.05 mL of *phenol red solution R*. The solution is not red.

**Melting point** (2.2.15). See Table 1234.-1.

Melt about 10 g at 80-90 °C. Introduce into the tube by capillary action, a sufficient amount of the substance, to form in the tube a column of the prescribed height. Allow to stand at 0 °C for 2 h.

**Acid value** (2.5.1): maximum 2.0, determined on 2.0 g.

**Hydroxyl value** (2.5.3, Method A). See Table 1234.-1.

**Iodine value** (2.5.4): maximum 2.0.

**Saponification value** (2.5.6). See Table 1234.-1.

Table 1234.-1

Ethylene oxide units per molecule (nominal value)	Melting point (°C)	Hydroxyl value	Saponification value
6		90 - 110	85 - 105
8 - 9	26 - 35	80 - 105	88 - 100
20	33 - 40	50 - 62	46 - 56
40 - 50	38 - 52	23 - 40	20 - 35
100	48 - 60	15 - 30	5 - 20

**Reducing substances**. Dissolve or disperse 2.0 g in *water R* and dilute to 20 mL with the same solvent. Mix 1.0 mL of the solution with 9 mL of 0.1 M *sodium hydroxide* and 0.5 mL of *triphenyltetrazolium chloride solution R*. Heat in a water-bath at 70 °C. After 5 min, the solution is not more intensely coloured than a mixture of 0.15 mL of yellow primary solution, 0.9 mL of red primary solution and 8.95 mL of a 10 g/L solution of *hydrochloric acid R* (2.2.2, Method II).

**Composition of fatty acids**. Gas chromatography (2.4.22, Method C).

*Composition of the fatty acid fraction of the substance:*

	Type of fatty acid used	Composition of fatty acids
Macrogol stearate type I	Stearic acid 50	<i>Stearic acid</i> : 40.0 per cent to 60.0 per cent, <i>Sum of the contents of palmitic and stearic acids</i> : not less than 90.0 per cent.
Macrogol stearate type II	Stearic acid 95	<i>Stearic acid</i> : 90.0 per cent to 99.0 per cent, <i>Sum of the contents of palmitic and stearic acids</i> : not less than 96.0 per cent.

**Ethylene oxide and dioxan** (2.4.25): maximum 1 ppm of ethylene oxide and 10 ppm of dioxan.

**Heavy metals** (2.4.8): maximum 10 ppm.

2.0 g complies with limit test C. Prepare the standard using 2 mL of *lead standard solution (10 ppm Pb) R*.

**Water** (2.5.12): maximum 3.0 per cent, determined on 0.50 g. Use as the solvent a mixture of equal volumes of *anhydrous methanol R* and *methylene chloride R*.

**Total ash** (2.4.16): maximum 0.3 per cent, determined on 1.0 g.

#### STORAGE

In an airtight container.

#### LABELLING

The label states:

- the number of ethylene oxide units per molecule (nominal value),
- the type of macrogol stearate.

01/2008:1340

## MACROGOL STEARYL ETHER

### Macrogoli aether stearylicus

#### DEFINITION

Mixture of ethers obtained by ethoxylation of stearyl alcohol. It may contain some free macrogols and various amounts of free stearyl alcohol. The number of moles of ethylene oxide reacted per mole of stearyl alcohol is 2 to 20 (nominal value).

#### CHARACTERS

*Appearance*: white or yellowish-white, waxy, unctuous mass, pellets, microbeads or flakes.



**Solubility:**

- macrogol stearyl ether with 2 moles of ethylene oxide reacted per mole: practically insoluble in water, soluble in ethanol (96 per cent) with heating and in methylene chloride;
- macrogol stearyl ether with 10 moles of ethylene oxide reacted per mole: soluble in water and in ethanol (96 per cent);
- macrogol stearyl ether with 20 moles of ethylene oxide reacted per mole: soluble in water, in ethanol (96 per cent) and in methylene chloride.

After melting, it solidifies at about 45 °C.

**IDENTIFICATION**

- Hydroxyl value (see Tests).
- Iodine value (see Tests).
- Saponification value (see Tests).
- Thin-layer chromatography (2.2.27).

**Test solution.** Dissolve 10.0 g in a mixture of 1 volume of *water R* and 9 volumes of *methanol R* and dilute to 75 mL with the same mixture of solvents. Add 60 mL of *heptane R* and shake for 3 min. The formation of foam can be reduced by the addition of a few drops of *ethanol (96 per cent) R*. Filter the upper layer through *anhydrous sodium sulfate R*, wash the filter with 3 quantities, each of 10 mL, of *heptane R* and evaporate the combined filtrates to dryness. Dissolve 50 mg of the residue in 10 mL of *methanol R* (the solution may be opalescent).

**Reference solution.** Dissolve 25 mg of *stearyl alcohol CRS* in *methanol R* and dilute to 25 mL with the same solvent.

**Plate:** TLC silica gel plate R.

**Mobile phase:** ethyl acetate R.

**Application:** 20 µL.

**Development:** over a path of 15 cm.

**Drying:** in air.

**Detection:** spray with vanillin-sulfuric acid reagent prepared as follows: dissolve 0.5 g of *vanillin R* in 50 mL of *ethanol (96 per cent) R* and dilute to 100 mL with *sulfuric acid R*; allow to dry in air; heat at about 130 °C for 15 min and allow to cool in air.

**Results:** the chromatogram obtained with the test solution shows several spots; one of these spots corresponds to the principal spot in the chromatogram obtained with the reference solution.

- Dissolve or disperse 0.1 g in 5 mL of *ethanol 96 per cent R*, add 2 mL of *water R*, 10 mL of *dilute hydrochloric acid R*, 10 mL of *barium chloride solution RI* and 10 mL of a 100 g/L solution of *phosphomolybdic acid R*. A precipitate is formed.

**TESTS**

**Appearance of solution.** The solution is not more intensely coloured than reference solution BY<sub>5</sub> (2.2.2, Method II).

Dissolve 5.0 g in *ethanol (96 per cent) R* and dilute to 50 mL with the same solvent.

**Alkalinity.** Dissolve 2.0 g in a hot mixture of 10 mL of *ethanol (96 per cent) R* and 10 mL of *water R*. Add 0.1 mL of *bromothymol blue solution RI*. Not more than 0.5 mL of 0.1 M *hydrochloric acid* is required to change the colour of the indicator to yellow.

**Acid value (2.5.1):** maximum 1.0, determined on 5.0 g.

**Hydroxyl value (2.5.3, Method A).**

Number of moles of ethylene oxide reacted per mole (nominal value)	Hydroxyl value
2	150 - 180
10	75 - 90
20	40 - 60

**Iodine value (2.5.4, Method A):** maximum 2.0.

**Saponification value (2.5.6):** maximum 3.0, determined on 10.0 g.

**Ethylene oxide and dioxan (2.4.25):** maximum 1 ppm of ethylene oxide and maximum 10 ppm of dioxan.

**Water (2.5.12):** maximum 3.0 per cent, determined on 1.00 g.

**STORAGE**

In an airtight container.

**LABELLING**

The label states the number of moles of ethylene oxide reacted per mole of stearyl alcohol (nominal value).

01/2008:1539  
corrected 6.3

**MAGALDRATE**

## Magaldratum

$\text{Al}_5\text{Mg}_{10}(\text{OH})_{31}(\text{SO}_4)_2 \cdot x\text{H}_2\text{O}$   $M_r$  1097 (anhydrous substance)

**DEFINITION**

Magaldrate is composed of aluminium and magnesium hydroxides and sulfates. Its composition corresponds approximately to the formula  $\text{Al}_5\text{Mg}_{10}(\text{OH})_{31}(\text{SO}_4)_2 \cdot x\text{H}_2\text{O}$ .

**Content:** 90.0 per cent to 105.0 per cent (dried substance).

**CHARACTERS**

**Appearance:** white or almost white, crystalline powder.

**Solubility:** practically insoluble in water and in ethanol (96 per cent). It is soluble in dilute mineral acids.

**IDENTIFICATION**

- Dissolve 0.6 g in 20 mL of 3 M *hydrochloric acid R*, add about 30 mL of *water R* and heat to boiling. Adjust to pH 6.2 with *dilute ammonia RI*, continue boiling for a further 2 min, filter and retain the precipitate and the filtrate. To 2 mL of the filtrate add 2 mL of *ammonium chloride solution R* and neutralise with a solution prepared by dissolving 2 g of *ammonium carbonate R* and 2 mL of *dilute ammonia RI* in 20 mL of *water R*; no precipitate is produced. Add *disodium hydrogen phosphate solution R*; a white, crystalline precipitate is produced which does not dissolve in *dilute ammonia RI*.
- The precipitate retained in identification test A gives the reaction of aluminium (2.3.1).
- The filtrate retained in identification test A gives reaction (a) of sulfates (2.3.1).

**TESTS**

**Soluble chlorides:** maximum 3.5 per cent.

Disperse 1 g in 50 mL of *water R*, boil for 5 min, cool, dilute again to 50.0 mL, mix and filter. To 25.0 mL of the filtrate add 0.2 mL of *potassium chromate solution R* and titrate with 0.1 M *silver nitrate* until a persistent violet-red colour is obtained. Not more than 5.0 mL of 0.1 M *silver nitrate* is required.

**Soluble sulfates:** maximum 1.9 per cent.

To 2.5 mL of the filtrate obtained in the test for soluble chlorides, add 30 mL of *water R*, neutralise to *blue litmus paper R* with *hydrochloric acid R*, add 3 mL of 1 M *hydrochloric acid*, 3 mL of a 120 g/L solution of *barium chloride R* and dilute to 50 mL with *water R*. Mix and allow to stand for 10 min. Any opalescence in the test solution is not more intense than that of a standard prepared at the same time in the same manner using 1 mL of 0.01 M *sulfuric acid* instead of 2.5 mL of filtrate.

**Sulfates:** 16.0 per cent to 21.0 per cent (dried substance).

Dissolve 0.875 g in a mixture of 5 mL of *glacial acetic acid R* and 10 mL of *water R* and dilute to 25.0 mL with *water R*.

01/2008:2035  
corrected 7.0

Prepare a chromatographic column of 1 cm in internal diameter containing 15 mL of *cation exchange resin R* (150-300 µm), previously washed with 30 mL of *water R*. Transfer 5.0 mL of the solution to be examined to the column and elute with 15 mL of *water R*. To the eluate add 5 mL of a 53.6 g/L solution of *magnesium acetate R*, 32 mL of *methanol R* and 0.2 mL of *alizarin S solution R*. Add from a burette about 4.0 mL of 0.05 M *barium chloride*, add a further 0.2 mL of *alizarin S solution R* and slowly complete the titration until the yellow colour disappears and a violet-red tinge is visible.

1 mL of 0.05 M *barium chloride* is equivalent to 4.803 mg of  $\text{SO}_4$ .

**Aluminium hydroxide:** 32.1 per cent to 45.9 per cent (dried substance).

Dissolve 0.800 g in 10 mL of *dilute hydrochloric acid R*, heating on a water-bath. Cool and dilute to 50.0 mL with *water R*. To 10.0 mL of this solution, add *dilute ammonia RI* until a precipitate begins to appear. Add the smallest quantity of *dilute hydrochloric acid R* needed to dissolve the precipitate and dilute to 20 mL with *water R*. Carry out the complexometric titration of aluminium (2.5.11).

1 mL of 0.1 M *sodium edetate* is equivalent to 7.80 mg of  $\text{Al}(\text{OH})_3$ .

**Magnesium hydroxide:** 49.2 per cent to 66.6 per cent (dried substance).

Dissolve 0.100 g in 2 mL of *dilute hydrochloric acid R* and carry out the complexometric titration of magnesium (2.5.11).

1 mL of 0.1 M *sodium edetate* is equivalent to 5.832 mg of  $\text{Mg}(\text{OH})_2$ .

**Sodium:** maximum 0.10 per cent.

Atomic absorption spectrometry (2.2.23, *Method I*).

**Test solution.** Weigh 2.00 g into a 100 mL volumetric flask, place in an ice-bath, add 5 mL of *nitric acid R* and swirl to mix. Allow to warm to room temperature and dilute to 100 mL with *water R*. Filter, if necessary, to obtain a clear solution. Dilute 10.0 mL of the filtrate to 100.0 mL with *water R*.

**Reference solutions.** Prepare the reference solutions using *sodium standard solution (200 ppm Na) R*, diluted as necessary with *dilute nitric acid R*.

**Source:** sodium hollow-cathode lamp.

**Wavelength:** 589 nm.

**Atomisation device:** air-acetylene flame.

**Heavy metals (2.4.8):** maximum 30 ppm.

Dissolve 2.0 g in 30 mL of *hydrochloric acid RI* and shake with 50 mL of *methyl isobutyl ketone R* for 2 min. Allow to stand, then separate and evaporate the aqueous layer to dryness. Dissolve the residue in 30 mL of *water R*. 12 mL of the solution complies with test A. Prepare the reference solution using *lead standard solution (2 ppm Pb) R*.

**Loss on drying (2.2.32):** 10.0 per cent to 20.0 per cent, determined on 1.000 g by drying in an oven at 200 °C for 4 h.

## ASSAY

To 1.500 g add 50.0 mL of 1 M *hydrochloric acid*. Titrate the excess hydrochloric acid with 1 M *sodium hydroxide* to pH 3.0, determining the end-point potentiometrically (2.2.20). Carry out a blank titration.

1 mL of 1 M *hydrochloric acid* is equivalent to 35.40 mg of  $\text{Al}_5\text{Mg}_{10}(\text{OH})_{31}(\text{SO}_4)_2$ .

## MAGNESIUM ACETATE TETRAHYDRATE

### Magnesii acetat tetrahydricus

$\text{Mg}(\text{CH}_3\text{COO})_2 \cdot 4\text{H}_2\text{O}$   
[16674-78-5]

$M_r$  214.5

#### DEFINITION

**Content:** 98.0 per cent to 101.0 per cent of magnesium acetate (anhydrous substance).

#### CHARACTERS

**Appearance:** colourless crystals or white or almost white, crystalline powder.

**Solubility:** freely soluble in water and in alcohol.

#### IDENTIFICATION

A. Dissolve about 100 mg in 2 mL of *water R*. Add 1 mL of *dilute ammonia RI* and heat. A white precipitate is formed that dissolves slowly on addition of 5 mL of *ammonium chloride solution R*. Add 1 mL of *disodium hydrogen phosphate solution R*. A white crystalline precipitate is formed.

B. It gives reaction (b) of acetates (2.3.1).

#### TESTS

**pH (2.2.3):** 7.5 to 8.5.

Dissolve 2.5 g in *carbon dioxide-free water R* and dilute to 50 mL with the same solvent.

**Chlorides (2.4.4):** maximum 330 ppm.

Dissolve 1.0 g in *water R* and dilute to 100 mL with the same solvent. 15 mL of the solution complies with the limit test for chlorides.

**Nitrates:** maximum 3 ppm.

Dissolve 1.0 g in *distilled water R* and dilute to 10 mL with the same solvent, add 5 mg of *sodium chloride R*, 0.05 mL of *indigo carmine solution R* and while stirring, 10 mL of *nitrogen-free sulfuric acid R*. A blue colour is produced which persists for at least 10 min.

**Sulfates (2.4.13):** maximum 600 ppm.

Dissolve 0.25 g in *distilled water R* and dilute to 15 mL with the same solvent.

**Aluminium (2.4.17):** maximum 1 ppm.

**Prescribed solution.** Dissolve 4.0 g in *water R* and dilute to 100 mL with the same solvent. Add 10 mL of *acetate buffer solution pH 6.0 R*.

**Reference solution.** Mix 2 mL of *aluminium standard solution (2 ppm Al) R*, 10 mL of *acetate buffer solution pH 6.0 R* and 98 mL of *water R*.

**Blank solution.** Mix 10 mL of *acetate buffer solution pH 6.0 R* and 100 mL of *water R*.

**Calcium (2.4.3):** maximum 100 ppm.

Dissolve 1.0 g in *distilled water R* and dilute to 15 mL with the same solvent.

**Potassium:** maximum 0.1 per cent.

Atomic emission spectrometry (2.2.22, *Method II*).

**Test solution.** Dissolve 0.5 g in *water R* and dilute to 100 mL with the same solvent.

**Reference solutions.** Prepare the reference solutions using *potassium standard solution (600 ppm K) R*, diluted as necessary with *water R*.

**Wavelength:** 766.5 nm.

**Sodium:** maximum 0.5 per cent.

Atomic emission spectrometry (2.2.22, Method II).

**Test solution.** Dissolve 1.0 g in *water R* and dilute to 100 mL with the same solvent.

**Reference solutions.** Prepare the reference solutions using *sodium standard solution (200 ppm Na) R*, diluted as necessary with *water R*.

**Wavelength:** 589.0 nm.

**Heavy metals (2.4.8):** maximum 40 ppm.

Dissolve 1.0 g in *water R* and dilute to 20 mL with the same solvent. 12 mL of the solution complies with limit test A. Prepare the standard using *lead standard solution (2 ppm Pb) R*.

**Readily oxidisable substances.** Dissolve 2.0 g in 100 mL of boiling *water R*, add 6 mL of a 150 g/L solution of *sulfuric acid R* and 0.3 mL of 0.02 M *potassium permanganate*. Mix and boil gently for 5 min. The pink colour is not completely discharged.

**Water (2.5.12):** 33.0 per cent to 35.0 per cent, determined on 0.100 g.

#### ASSAY

Dissolve 0.150 g in 300 mL of *water R*. Carry out the complexometric titration of magnesium (2.5.11).

1 mL of 0.1 M *sodium edetate* is equivalent to 14.24 mg of  $C_4H_6MgO_4$ .

01/2008:1445  
corrected 6.0

## MAGNESIUM ASPARTATE DIHYDRATE

### Magnesii aspartas dihydricus

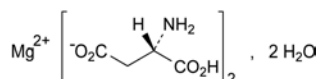

$C_8H_{12}MgN_2O_8 \cdot 2H_2O$

$M_r$  324.5

#### DEFINITION

Magnesium aspartate dihydrate contains not less than 98.0 per cent and not more than the equivalent of 102.0 per cent of magnesium di[(S)-2-aminohydrogenobutane-1,4-dioate], calculated with reference to the anhydrous substance.

#### CHARACTERS

A white or almost white, crystalline powder or colourless crystals, freely soluble in water.

#### IDENTIFICATION

- Specific optical rotation (see Tests).
- Examine the chromatograms obtained in the test for ninhydrin-positive substances. The principal spot in the chromatogram obtained with test solution (b) is similar in position, colour and size to the principal spot in the chromatogram obtained with reference solution (a).
- Ignite about 15 mg until a white residue is obtained. Dissolve the residue in 1 mL of *dilute hydrochloric acid R*, neutralise to *red litmus paper R* by the addition of *dilute sodium hydroxide solution R* and filter if necessary. The solution gives the reaction of magnesium (2.3.1).

#### TESTS

**Solution S.** Dissolve 2.5 g in *carbon dioxide-free water R* prepared from *distilled water R* and dilute to 100 mL with the same solvent.

**Appearance of solution.** Solution S is clear (2.2.1) and colourless (2.2.2, Method II).

**pH (2.2.3).** The pH of solution S is 6.0 to 8.0.

**Specific optical rotation (2.2.7).** Dissolve 0.50 g in a 515 g/L solution of *hydrochloric acid R* and dilute to 25.0 mL with the same acid. The specific optical rotation is + 20.5 to + 23.0, calculated with reference to the anhydrous substance.

**Ninhydrin-positive substances.** Examine by thin-layer chromatography (2.2.27), using a *TLC silica gel plate R*.

**Test solution (a).** Dissolve 0.10 g of the substance to be examined in *water R* and dilute to 10 mL with the same solvent.

**Test solution (b).** Dilute 1 mL of test solution (a) to 50 mL with *water R*.

**Reference solution (a).** Dissolve 10 mg of *magnesium aspartate dihydrate CRS* in *water R* and dilute to 50 mL with the same solvent.

**Reference solution (b).** Dilute 5 mL of test solution (b) to 20 mL with *water R*.

**Reference solution (c).** Dissolve 10 mg of *magnesium aspartate dihydrate CRS* and 10 mg of *glutamic acid CRS* in 2 mL of *water R* and dilute to 25 mL with the same solvent.

Apply to the plate 5 µL of each solution. Allow the plate to dry in air. Develop over a path of 15 cm using a mixture of 20 volumes of *glacial acetic acid R*, 20 volumes of *water R* and 60 volumes of *butanol R*. Allow the plate to dry in air and spray with *ninhydrin solution R*. Heat at 100 °C to 105 °C for 15 min. Any spot in the chromatogram obtained with test solution (a), apart from the principal spot, is not more intense than the spot in the chromatogram obtained with reference solution (b) (0.5 per cent). The test is not valid unless the chromatogram obtained with reference solution (c) shows two clearly separated principal spots.

**Chlorides (2.4.4).** Dilute 10 mL of solution S to 15 mL with *water R*. The solution complies with the limit test for chlorides (200 ppm).

**Sulfates (2.4.13).** Dilute 12 mL of solution S to 15 mL with *distilled water R*. The solution complies with the limit test for sulfates (500 ppm). Carry out the evaluation of the test after 30 min.

**Ammonium (2.4.1).** 50 mg complies with limit test B for ammonium (200 ppm). Prepare the standard using 0.1 mL of *ammonium standard solution (100 ppm NH<sub>4</sub>) R*.

**Iron (2.4.9).** In a separating funnel, dissolve 0.20 g in 10 mL of *dilute hydrochloric acid R*. Shake with three quantities, each of 10 mL, of *methyl isobutyl ketone R1*, shaking for 3 min each time. To the combined organic layers add 10 mL of *water R* and shake for 3 min. The aqueous layer complies with the limit test for iron (50 ppm).

**Heavy metals (2.4.8).** Dissolve 2.0 g with gentle heating in 20 mL of *water R*. 12 mL of the solution complies with limit test A for heavy metals (10 ppm). Prepare the standard using *lead standard solution (1 ppm Pb) R*.

**Water (2.5.12).** 10.0 per cent to 14.0 per cent, determined on 0.100 g by the semi-micro determination of water. Dissolve the substance in 10 mL of *formamide R1* at 50 °C protected from moisture, add 10 mL of *anhydrous methanol R* and allow to cool. Carry out a blank determination.

#### ASSAY

Dissolve 0.260 g in 10 mL of *water R* and carry out the complexometric titration of magnesium (2.5.11).

1 mL of 0.1 M *sodium edetate* is equivalent to 28.85 mg of  $C_8H_{12}MgN_2O_8$ .

#### IMPURITIES

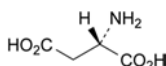

- (2S)-2-aminobutanedioic acid (aspartic acid).

**07/2008:0043** 1 mL of 0.1 M sodium edetate is equivalent to 4.030 mg of MgO.  
corrected 6.5

## MAGNESIUM CARBONATE, HEAVY

### Magnesii subcarbonas ponderosus

#### DEFINITION

Hydrated basic magnesium carbonate.

**Content:** 40.0 per cent to 45.0 per cent, calculated as MgO ( $M_r$  40.30).

#### CHARACTERS

**Appearance:** white or almost white powder.

**Solubility:** practically insoluble in water. It dissolves in dilute acids with effervescence.

#### IDENTIFICATION

- Bulk density (2.9.34): minimum 0.25 g/mL.
- It gives the reaction of carbonates (2.3.1).
- Dissolve about 15 mg in 2 mL of *dilute nitric acid R* and neutralise with *dilute sodium hydroxide solution R*. The solution gives the reaction of magnesium (2.3.1).

#### TESTS

**Solution S.** Dissolve 5.0 g in 100 mL of *dilute acetic acid R*. When the effervescence has ceased, boil for 2 min, allow to cool and dilute to 100 mL with *dilute acetic acid R*. Filter, if necessary, through a previously ignited and tared porcelain or silica filter crucible of suitable porosity to give a clear filtrate.

**Appearance of solution.** Solution S is not more intensely coloured than reference solution B<sub>4</sub> (2.2.2, Method II).

**Soluble substances:** maximum 1.0 per cent.

Mix 2.00 g with 100 mL of *water R* and boil for 5 min. Filter whilst hot through a sintered-glass filter (40) (2.1.2), allow to cool and dilute to 100 mL with *water R*. Evaporate 50 mL of the filtrate to dryness and dry at 100-105 °C. The residue weighs not more than 10 mg.

**Substances insoluble in acetic acid:** maximum 0.05 per cent.

Any residue obtained during the preparation of solution S, washed, dried, and ignited at 600 ± 50 °C, weighs not more than 2.5 mg.

**Chlorides** (2.4.4): maximum 700 ppm.

Dilute 1.5 mL of solution S to 15 mL with *water R*.

**Sulfates** (2.4.13): maximum 0.6 per cent.

Dilute 0.5 mL of solution S to 15 mL with *distilled water R*.

**Arsenic** (2.4.2, Method A): maximum 2 ppm, determined on 10 mL of solution S.

**Calcium** (2.4.3): maximum 0.75 per cent.

Dilute 2.6 mL of solution S to 150 mL with *distilled water R*. 15 mL of the solution complies with the test.

**Iron** (2.4.9): maximum 400 ppm.

Dissolve 0.1 g in 3 mL of *dilute hydrochloric acid R* and dilute to 10 mL with *water R*. Dilute 2.5 mL of the solution to 10 mL with *water R*.

**Heavy metals** (2.4.8): maximum 20 ppm.

To 20 mL of solution S add 15 mL of *hydrochloric acid R1* and shake with 25 mL of *methyl isobutyl ketone R* for 2 min. Allow to stand, separate the aqueous lower layer and evaporate to dryness. Dissolve the residue in 1 mL of *acetic acid R* and dilute to 20 mL with *water R*. 12 mL of the solution complies with test A. Prepare the reference solution using *lead standard solution (1 ppm Pb) R*.

#### ASSAY

Dissolve 0.150 g in a mixture of 2 mL of *dilute hydrochloric acid R* and 20 mL of *water R*. Carry out the complexometric titration of magnesium (2.5.11).

#### FUNCTIONALITY-RELATED CHARACTERISTICS

*This section provides information on characteristics that are recognised as being relevant control parameters for one or more functions of the substance when used as an excipient (see chapter 5.15). This section is a non-mandatory part of the monograph and it is not necessary to verify the characteristics to demonstrate compliance. Control of these characteristics can however contribute to the quality of a medicinal product by improving the consistency of the manufacturing process and the performance of the medicinal product during use. Where control methods are cited, they are recognised as being suitable for the purpose, but other methods can also be used. Wherever results for a particular characteristic are reported, the control method must be indicated.*

*The following characteristics may be relevant for heavy magnesium carbonate used as filler in tablets.*

**Particle-size distribution** (2.9.31 or 2.9.38).

**Bulk and tapped density** (2.9.34).

**04/2009:0042**

## MAGNESIUM CARBONATE, LIGHT

### Magnesii subcarbonas levis

[546-93-0]

#### DEFINITION

Hydrated basic magnesium carbonate.

**Content:** 40.0 per cent to 45.0 per cent, calculated as MgO ( $M_r$  40.30).

#### CHARACTERS

**Appearance:** white or almost white powder.

**Solubility:** practically insoluble in water. It dissolves in dilute acids with effervescence.

#### IDENTIFICATION

- Bulk density (2.9.34): maximum 0.15 g/mL.
- It gives the reaction of carbonates (2.3.1).
- Dissolve about 15 mg in 2 mL of *dilute nitric acid R* and neutralise with *dilute sodium hydroxide solution R*. The solution gives the reaction of magnesium (2.3.1).

#### TESTS

**Solution S.** Dissolve 5.0 g in 100 mL of *dilute acetic acid R*. When the effervescence has ceased, boil for 2 min, allow to cool and dilute to 100 mL with *dilute acetic acid R*. Filter, if necessary, through a previously ignited and tared porcelain or silica filter crucible of suitable porosity to give a clear filtrate.

**Appearance of solution.** Solution S is not more intensely coloured than reference solution B<sub>4</sub> (2.2.2, Method II).

**Soluble substances:** maximum 1.0 per cent.

Mix 2.00 g with 100 mL of *water R* and boil for 5 min. Filter whilst hot through a sintered-glass filter (40) (2.1.2), allow to cool and dilute to 100 mL with *water R*. Evaporate 50 mL of the filtrate to dryness and dry at 100-105 °C. The residue weighs a maximum of 10 mg.

**Substances insoluble in acetic acid:** maximum 0.05 per cent.

Any residue obtained during the preparation of solution S, washed, dried and ignited at 600 ± 50 °C, weighs a maximum of 2.5 mg.

**Chlorides** (2.4.4): maximum 700 ppm.

Dilute 1.5 mL of solution S to 15 mL with *water R*.

**Sulfates** (2.4.13): maximum 0.3 per cent.

Dilute 1 mL of solution S to 15 mL with *distilled water R*.

**Arsenic** (2.4.2, Method A): maximum 2 ppm, determined on 10 mL of solution S.

**Calcium** (2.4.3): maximum 0.75 per cent.

Dilute 2.6 mL of solution S to 150 mL with *distilled water R*. 15 mL of the solution complies with the test.

**Iron** (2.4.9): maximum 400 ppm.

Dissolve 0.1 g in 3 mL of *dilute hydrochloric acid R* and dilute to 10 mL with *water R*. Dilute 2.5 mL of this solution to 10 mL with *water R*.

**Heavy metals** (2.4.8): maximum 20 ppm.

To 20 mL of solution S add 15 mL of *hydrochloric acid R1* and shake with 25 mL of *methyl isobutyl ketone R* for 2 min. Allow to stand, separate the aqueous lower layer and evaporate to dryness. Dissolve the residue in 1 mL of *acetic acid R* and dilute to 20 mL with *water R*. 12 mL of the solution complies with test A. Prepare the reference solution using *lead standard solution (1 ppm Pb) R*.

#### ASSAY

Dissolve 0.150 g in a mixture of 2 mL of *dilute hydrochloric acid R* and 20 mL of *water R*. Carry out the complexometric titration of magnesium (2.5.11).

1 mL of 0.1 M sodium edetate is equivalent to 4.030 mg of MgO.

#### FUNCTIONALITY-RELATED CHARACTERISTICS

*This section provides information on characteristics that are recognised as being relevant control parameters for one or more functions of the substance when used as an excipient (see chapter 5.15). This section is a non-mandatory part of the monograph and it is not necessary to verify the characteristics to demonstrate compliance. Control of these characteristics can however contribute to the quality of a medicinal product by improving the consistency of the manufacturing process and the performance of the medicinal product during use. Where control methods are cited, they are recognised as being suitable for the purpose, but other methods can also be used. Wherever results for a particular characteristic are reported, the control method must be indicated.*

*The following characteristic may be relevant for light magnesium carbonate used as filler in oral solid dosage forms.*

**Particle-size distribution** (2.9.31 or 2.9.38).

**Bulk and tapped density** (2.9.34).

01/2008:1341  
corrected 7.0

## MAGNESIUM CHLORIDE 4.5-HYDRATE

### Magnesii chloridum 4.5-hydricum

$\text{MgCl}_2 \cdot x\text{H}_2\text{O}$  with  $x \approx 4.5$   $M_r$  95.21 (anhydrous substance)

#### DEFINITION

*Content*: 98.5 per cent to 101.0 per cent (anhydrous substance).

#### CHARACTERS

*Appearance*: white or almost white, granular powder, hygroscopic.

*Solubility*: very soluble in water, freely soluble in ethanol (96 per cent).

#### IDENTIFICATION

- Water (see Tests).
- It gives reaction (a) of chlorides (2.3.1).
- It gives the reaction of magnesium (2.3.1).

#### TESTS

**Solution S.** Dissolve 10.0 g in *carbon dioxide-free water R* prepared from *distilled water R* and dilute to 100.0 mL with the same solvent.

**Appearance of solution.** Solution S is clear (2.2.1) and colourless (2.2.2, Method II).

**Acidity or alkalinity.** To 5 mL of solution S add 0.05 mL of *phenol red solution R*. Not more than 0.3 mL of 0.01 M *hydrochloric acid* or 0.01 M *sodium hydroxide* is required to change the colour of the indicator.

**Bromides**: maximum 500 ppm.

Dilute 2.0 mL of solution S to 10.0 mL with *water R*. To 1.0 mL of the solution add 4.0 mL of *water R*, 2.0 mL of *phenol red solution R3* and 1.0 mL of *chloramine solution R2* and mix immediately. After exactly 2 min, add 0.30 mL of 0.1 M *sodium thiosulfate*, mix and dilute to 10.0 mL with *water R*. The absorbance (2.2.25) of the solution measured at 590 nm, using *water R* as the compensation liquid, is not greater than that of a standard prepared at the same time and in the same manner using 5.0 mL of a 3 mg/L solution of *potassium bromide R*.

**Sulfates** (2.4.13): maximum 100 ppm, determined on solution S.

**Aluminium** (2.4.17): maximum 1 ppm, if intended for use in the manufacture of peritoneal dialysis solutions, haemodialysis solutions, or haemofiltration solutions.

*Prescribed solution.* Dissolve 4 g in 100 mL of *water R* and add 10 mL of *acetate buffer solution pH 6.0 R*.

*Reference solution.* Mix 2 mL of *aluminium standard solution (2 ppm Al) R*, 10 mL of *acetate buffer solution pH 6.0 R* and 98 mL of *water R*.

*Blank solution.* Mix 10 mL of *acetate buffer solution pH 6.0 R* and 100 mL of *water R*.

**Arsenic** (2.4.2, Method A): maximum 2 ppm, determined on 0.5 g.

**Calcium** (2.4.3): maximum 0.1 per cent.

Dilute 1 mL of solution S to 15 mL with *distilled water R*.

**Iron** (2.4.9): maximum 10 ppm, determined on solution S.

**Potassium**: maximum 500 ppm, if intended for use in the manufacture of parenteral preparations.

Atomic emission spectrometry (2.2.22, Method I).

*Test solution.* Dissolve 1.00 g in *water R* and dilute to 100.0 mL with the same solvent.

*Reference solutions.* Prepare the reference solutions using the following solution, diluted as necessary with *water R*: dissolve 1.144 g of *potassium chloride R*, previously dried at 100-105 °C for 3 h, in *water R* and dilute to 1000.0 mL with the same solvent (600 µg of K per millilitre).

*Wavelength*: 766.5 nm.

**Heavy metals** (2.4.8): maximum 10 ppm.

12 mL of solution S complies with test A. Prepare the reference solution using *lead standard solution (1 ppm Pb) R*.

**Water** (2.5.12): 44.0 per cent to 48.0 per cent, determined on 50.0 mg.

#### ASSAY

Dissolve 0.250 g in 50 mL of *water R*. Carry out the complexometric titration of magnesium (2.5.11).

1 mL of 0.1 M *sodium edetate* is equivalent to 9.521 mg of  $\text{MgCl}_2$ .

#### STORAGE

In an airtight container.

#### LABELLING

The label states:

- where applicable, that the substance is suitable for use in the manufacture of peritoneal dialysis solutions, haemodialysis solutions or haemofiltration solutions,
- where applicable, that the substance is suitable for use in the manufacture of parenteral preparations.

01/2008:0402  
corrected 7.0**MAGNESIUM CHLORIDE  
HEXAHYDRATE**

Magnesii chloridum hexahydricum

MgCl<sub>2</sub>·6H<sub>2</sub>O  
[7791-18-6]M<sub>r</sub> 203.3

## DEFINITION

*Content:* 98.0 per cent to 101.0 per cent of MgCl<sub>2</sub>·6H<sub>2</sub>O.

## CHARACTERS

*Appearance:* colourless crystals, hygroscopic.*Solubility:* very soluble in water, freely soluble in ethanol (96 per cent).

## IDENTIFICATION

- A. Water (see Tests).  
 B. It gives reaction (a) of chlorides (2.3.1).  
 C. It gives the reaction of magnesium (2.3.1).

## TESTS

**Solution S.** Dissolve 10.0 g in *carbon dioxide-free water R* prepared from *distilled water R* and dilute to 100.0 mL with the same solvent.**Appearance of solution.** Solution S is clear (2.2.1) and colourless (2.2.2, *Method II*).**Acidity or alkalinity.** To 5 mL of solution S add 0.05 mL of *phenol red solution R*. Not more than 0.3 mL of 0.01 M *hydrochloric acid* or 0.01 M *sodium hydroxide* is required to change the colour of the indicator.**Bromides:** maximum 500 ppm.Dilute 2.0 mL of solution S to 10.0 mL with *water R*. To 1.0 mL of this solution add 4.0 mL of *water R*, 2.0 mL of *phenol red solution R3* and 1.0 mL of *chloramine solution R2* and mix immediately. After exactly 2 min, add 0.30 mL of 0.1 M *sodium thiosulfate*, mix and dilute to 10.0 mL with *water R*. The absorbance (2.2.25) of the solution measured at 590 nm, using *water R* as the compensation liquid, is not greater than that of a standard prepared at the same time and in the same manner using 5.0 mL of a 3 mg/L solution of *potassium bromide R*.**Sulfates** (2.4.13): maximum 100 ppm, determined on solution S.**Aluminium** (2.4.17): maximum 1 ppm, if intended for use in the manufacture of peritoneal dialysis solutions, haemodialysis solutions, or haemofiltration solutions.**Prescribed solution.** Dissolve 4 g in 100 mL of *water R* and add 10 mL of *acetate buffer solution pH 6.0 R*.**Reference solution.** Mix 2 mL of *aluminium standard solution (2 ppm Al) R*, 10 mL of *acetate buffer solution pH 6.0 R* and 98 mL of *water R*.**Blank solution.** Mix 10 mL of *acetate buffer solution pH 6.0 R* and 100 mL of *water R*.**Arsenic** (2.4.2, *Method A*): maximum 2 ppm, determined on 0.5 g.**Calcium** (2.4.3): maximum 0.1 per cent.Dilute 1 mL of solution S to 15 mL with *distilled water R*.**Iron** (2.4.9): maximum 10 ppm, determined on solution S.**Potassium:** maximum 500 ppm, if intended for use in the manufacture of parenteral preparations.Atomic emission spectrometry (2.2.22, *Method I*).**Test solution.** Dissolve 1.00 g in *water R* and dilute to 100.0 mL with the same solvent.**Reference solutions.** Prepare the reference solutions using the following solution, diluted as necessary with *water R*: dissolve 1.144 g of *potassium chloride R*, previously dried at 100-105 °C for 3 h in *water R* and dilute to 1000.0 mL with the same solvent (600 µg of K per millilitre).*Wavelength:* 766.5 nm.**Heavy metals** (2.4.8): maximum 10 ppm.12 mL of solution S complies with test A. Prepare the reference solution using *lead standard solution (1 ppm Pb) R*.**Water** (2.5.12): 51.0 per cent to 55.0 per cent, determined on 50.0 mg.

## ASSAY

Dissolve 0.300 g in 50 mL of *water R*. Carry out the complexometric titration of magnesium (2.5.11).1 mL of 0.1 M *sodium edetate* is equivalent to 20.33 mg of MgCl<sub>2</sub>·6H<sub>2</sub>O.

## STORAGE

In an airtight container.

## LABELLING

The label states:

- where applicable, that the substance is suitable for use in the manufacture of peritoneal dialysis solutions, haemodialysis solutions or haemofiltration solutions,
- where applicable, that the substance is suitable for use in the manufacture of parenteral preparations.

04/2009:2339

**MAGNESIUM CITRATE, ANHYDROUS**

Magnesii citras anhydricus

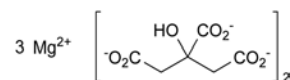
Mg<sub>3</sub>(C<sub>6</sub>H<sub>5</sub>O<sub>7</sub>)<sub>2</sub>  
[3344-18-1]M<sub>r</sub> 451.1

## DEFINITION

Trimagnesium bis(2-hydroxypropane-1,2,3-tricarboxylate).

*Content:* 15.0 per cent to 16.5 per cent of Mg (dried substance).

## CHARACTERS

*Appearance:* white or almost white, fine, slightly hygroscopic powder.*Solubility:* soluble in water, practically insoluble in ethanol (96 per cent). It dissolves in dilute hydrochloric acid.

## IDENTIFICATION

- A. It gives the reaction of citrates (2.3.1).  
 B. It gives the reaction of magnesium (2.3.1).  
 C. pH (see Tests).  
 D. Loss on drying (see Tests).

## TESTS

**Solution S.** Dissolve 5.0 g in *carbon dioxide-free water R*, heating at 60 °C, cool and dilute to 100 mL with the same solvent.**Appearance of solution.** Solution S is not more opalescent than reference suspension III (2.2.1) and not more intensely coloured than reference solutions Y<sub>7</sub> or BY<sub>6</sub> (2.2.2, *Method II*).**pH** (2.2.3): 6.0 to 8.5 for solution S.**Oxalates:** maximum 280 ppm.Dissolve 0.50 g in 4 mL of *water R*. Add 3 mL of *hydrochloric acid R* and 1 g of *activated zinc R*. Allow to stand for 5 min. Transfer the liquid to a tube containing 0.25 mL of a 10 g/L

solution of *phenylhydrazine hydrochloride R*. Heat to boiling. Cool rapidly, transfer to a graduated cylinder and add an equal volume of *hydrochloric acid R* and 0.25 mL of *potassium ferricyanide solution R*. Shake and allow to stand for 30 min. Any pink colour in the solution is not more intense than that in a standard prepared at the same time and in the same manner using 4 mL of a 50 mg/L solution of *oxalic acid R*.

**Sulfates** (2.4.13): maximum 0.2 per cent.

Dilute 1.5 mL of solution S to 15 mL with *distilled water R*.

**Calcium** (2.4.3): maximum 0.2 per cent.

Dilute 1.0 mL of solution S to 15 mL with *distilled water R*.

**Iron** (2.4.9): maximum 100 ppm.

Dilute 2.0 mL of solution S to 10 mL with *distilled water R*.

**Heavy metals** (2.4.8): maximum 10 ppm.

Dissolve 5.0 g in 15 mL of *dilute hydrochloric acid R* with heating. Adjust to pH 3.5 with *ammonia R* and dilute to 50 mL with *distilled water R*. 12 mL of this solution complies with test A. Prepare the reference solution using *lead standard solution (1 ppm Pb) R*.

**Loss on drying** (2.2.32): maximum 3.5 per cent, determined on 1.000 g by drying in an oven at  $180 \pm 10$  °C for 5 h.

#### ASSAY

Dissolve 0.150 g in 50 mL of *water R*. Carry out the complexometric titration of magnesium (2.5.11).

1 mL of 0.1 M *sodium edetate* is equivalent to 2.431 mg of Mg.

#### STORAGE

In a non-metallic, airtight container.

01/2010:2401  
corrected 6.8

## MAGNESIUM CITRATE DODECAHYDRATE

### Magnesii citras dodecahydricus

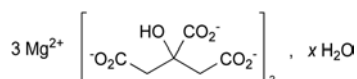

$\text{Mg}_3(\text{C}_6\text{H}_5\text{O}_7)_2 \cdot x\text{H}_2\text{O}$        $M_r$  451.1 (anhydrous substance)  
with  $x \approx 12$

#### DEFINITION

Trimagnesium bis(2-hydroxypropane-1,2,3-tricarboxylate) dodecahydrate.

**Content:** 15.0 per cent to 16.5 per cent of Mg (dried substance).

#### CHARACTERS

**Appearance:** white or almost white, fine powder.

**Solubility:** sparingly soluble in water, practically insoluble in ethanol (96 per cent). It dissolves in dilute hydrochloric acid.

#### IDENTIFICATION

- It gives the reaction of citrates (2.3.1).
- It gives the reaction of magnesium (2.3.1).
- Loss on drying (see Tests).

#### TESTS

**Solution S.** Dissolve 2.5 g in 15 mL of *dilute hydrochloric acid R* with heating. Cool and dilute to 100 mL with *distilled water R*.

**Appearance of solution.** Solution S is clear (2.2.1) and not more intensely coloured than reference solution BY<sub>6</sub> (2.2.2, *Method II*).

**pH** (2.2.3): 6.0 to 8.5.

Disperse 5.0 g in *carbon dioxide-free water R* and dilute to 100 mL with the same solvent. Centrifuge and measure the pH of the clear supernatant.

**Oxalates:** maximum 280 ppm.

Dissolve 0.50 g in a mixture of 3 mL of *hydrochloric acid R* and 4 mL of *water R* and add 1 g of *activated zinc R*. Allow to stand for 5 min. Transfer the liquid to a tube containing 0.25 mL of a 10 g/L solution of *phenylhydrazine hydrochloride R*. Heat to boiling. Cool rapidly, transfer to a graduated cylinder and add an equal volume of *hydrochloric acid R* and 0.25 mL of *potassium ferricyanide solution R*. Shake and allow to stand for 30 min. Any pink colour in the solution is not more intense than that of a standard prepared at the same time and in the same manner using 4 mL of a 50 mg/L solution of *oxalic acid R*.

**Sulfates** (2.4.13): maximum 0.2 per cent.

Dilute 3.0 mL of solution S to 15 mL with *distilled water R*.

**Calcium** (2.4.3): maximum 0.2 per cent.

To a mixture of 2 mL of solution S and 8 mL of *distilled water R*, add about 0.2 mL of *ammonia R* and dilute to 15 mL with *distilled water R*.

**Iron** (2.4.9): maximum 100 ppm.

Dilute 4.0 mL of solution S to 10 mL with *distilled water R*.

**Heavy metals** (2.4.8): maximum 10 ppm.

Dissolve 5.0 g in 15 mL of *dilute hydrochloric acid R* with heating. Adjust to pH 3.5 with *ammonia R* and dilute to 50 mL with *distilled water R*. 12 mL of the solution complies with test A. Prepare the reference solution using *lead standard solution (1 ppm Pb) R*.

**Loss on drying** (2.2.32): 29.0 per cent to 36.0 per cent, determined on 1.000 g by drying in an oven at  $180 \pm 10$  °C for 5 h.

#### ASSAY

Dissolve 0.200 g in 5 mL of *dilute hydrochloric acid R* with heating. Cool and add 50 mL of *water R*. Adjust to pH 7.0 with *ammonia R*. Carry out the complexometric titration of magnesium (2.5.11).

1 mL of 0.1 M *sodium edetate* is equivalent to 2.431 mg of Mg.

01/2010:2402

## MAGNESIUM CITRATE NONAHYDRATE

### Magnesii citras nonahydricus

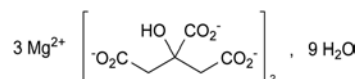

$\text{Mg}_3(\text{C}_6\text{H}_5\text{O}_7)_2 \cdot 9\text{H}_2\text{O}$        $M_r$  613  
[153531-96-5]

#### DEFINITION

Trimagnesium bis(2-hydroxypropane-1,2,3-tricarboxylate) nonahydrate.

**Content:** 15.0 per cent to 16.5 per cent of Mg (dried substance).

#### CHARACTERS

**Appearance:** white or almost white, fine powder.

**Solubility:** sparingly soluble in water, practically insoluble in ethanol (96 per cent). It dissolves in dilute hydrochloric acid.

#### IDENTIFICATION

- It gives the reaction of citrates (2.3.1).
- It gives the reaction of magnesium (2.3.1).
- Loss on drying (see Tests).

## TESTS

**Solution S.** Dissolve 2.5 g in 15 mL of *dilute hydrochloric acid R* with heating. Cool and dilute to 100 mL with *distilled water R*.

**Appearance of solution.** Solution S is clear (2.2.1) and not more intensely coloured than reference solution BY<sub>6</sub> (2.2.2, Method II).

**pH** (2.2.3): 6.0 to 8.5.

Disperse 5.0 g in *carbon dioxide-free water R* and dilute to 100 mL with the same solvent. Centrifuge and measure the pH of the clear supernatant.

**Oxalates:** maximum 280 ppm.

Dissolve 0.50 g in a mixture of 3 mL of *hydrochloric acid R* and 4 mL of *water R* and add 1 g of *activated zinc R*. Allow to stand for 5 min. Transfer the liquid to a tube containing 0.25 mL of a 10 g/L solution of *phenylhydrazine hydrochloride R*. Heat to boiling. Cool rapidly, transfer to a graduated cylinder and add an equal volume of *hydrochloric acid R* and 0.25 mL of *potassium ferricyanide solution R*. Shake and allow to stand for 30 min. Any pink colour in the solution is not more intense than that of a standard prepared at the same time and in the same manner using 4 mL of a 50 mg/L solution of *oxalic acid R*.

**Sulfates** (2.4.13): maximum 0.2 per cent.

Dilute 3.0 mL of solution S to 15 mL with *distilled water R*.

**Calcium** (2.4.3): maximum 0.2 per cent.

To a mixture of 2 mL of solution S and 8 mL of *distilled water R*, add about 0.2 mL of *ammonia R* and dilute to 15 mL with *distilled water R*.

**Iron** (2.4.9): maximum 100 ppm.

Dilute 4.0 mL of solution S to 10 mL with *distilled water R*.

**Heavy metals** (2.4.8): maximum 10 ppm.

Dissolve 5.0 g in 15 mL of *dilute hydrochloric acid R* with heating. Adjust to pH 3.5 with *ammonia R* and dilute to 50 mL with *distilled water R*. 12 mL of the solution complies with test A. Prepare the reference solution using *lead standard solution* (1 ppm Pb) R.

**Loss on drying** (2.2.32): 24.0 to 28.0 per cent, determined on 1.000 g by drying in an oven at 180 ± 10 °C for 5 h.

## ASSAY

Dissolve 0.200 g in 5 mL of *dilute hydrochloric acid R* with heating. Cool and add 50 mL of *water R*. Adjust to pH 7.0 with *ammonia R*. Carry out the complexometric titration of magnesium (2.5.11).

1 mL of 0.1 M *sodium edetate* is equivalent to 2.431 mg of Mg.

04/2008:2161

## MAGNESIUM GLUCONATE

## Magnesii gluconas

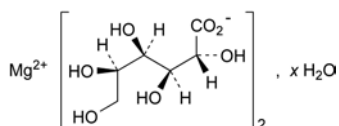

$$C_{12}H_{22}MgO_{14} \cdot xH_2O$$

$$M_r 414.6 \text{ (anhydrous substance)}$$

## DEFINITION

Anhydrous or hydrated magnesium D-gluconate.

**Content:** 98.0 per cent to 102.0 per cent (anhydrous substance).

## CHARACTERS

**Appearance:** white or almost white, amorphous, hygroscopic, crystalline or granular powder.

**Solubility:** freely soluble in water, slightly soluble in ethanol (96 per cent), very slightly soluble in methylene chloride.

## IDENTIFICATION

A. Thin-layer chromatography (2.2.27).

**Test solution.** Dissolve 20 mg of the substance to be examined in 1 mL of *water R*.

**Reference solution.** Dissolve 20 mg of *calcium gluconate CRS* in 1 mL of *water R*, heating if necessary in a water-bath at 60 °C.

**Plate:** TLC silica gel plate R (5-40 µm) [or TLC silica gel plate R (2-10 µm)].

**Mobile phase:** concentrated ammonia R, ethyl acetate R, water R, ethanol (96 per cent) R (10:10:30:50 V/V/V/V).

**Application:** 1 µL.

**Development:** over 3/4 of the plate.

**Drying:** at 100-105 °C for 20 min, then allow to cool to room temperature.

**Detection:** spray with a solution containing 25 g/L of *ammonium molybdate R* and 10 g/L of *cerium sulfate R* in *dilute sulfuric acid R*, then heat at 100-105 °C for about 10 min.

**Results:** the principal spot in the chromatogram obtained with the test solution is similar in position, colour and size to the principal spot in the chromatogram obtained with the reference solution.

B. To 10 mL of solution S (see Tests) add 3 mL of *ammonium chloride solution R*. A slight opalescence may be observed. Add 10 mL of *disodium hydrogen phosphate solution R*. A white precipitate is formed that does not dissolve upon the addition of 2 mL of *dilute ammonia R1*.

## TESTS

**Solution S.** Dissolve 1.0 g in *water R* and dilute to 50 mL with the same solvent.

**Appearance of solution.** Solution S is clear (2.2.1) and not more intensely coloured than reference solution Y<sub>7</sub> (2.2.2, Method II).

**Sucrose and reducing sugars.** Dissolve 0.5 g in a mixture of 2 mL of *hydrochloric acid R1* and 10 mL of *water R*. Boil for 5 min, allow to cool, add 10 mL of *sodium carbonate solution R* and allow to stand for 10 min. Dilute to 25 mL with *water R* and filter. To 5 mL of the filtrate add 2 mL of *cupri-tartaric solution R* and boil for 1 min. Allow to stand for 2 min. No red precipitate is formed.

**Chlorides** (2.4.4): maximum 500 ppm.

Dilute 5 mL of solution S to 15 mL with *water R*.

**Sulfates** (2.4.13): maximum 500 ppm.

Dissolve 2.0 g in a mixture of 10 mL of *acetic acid R* and 90 mL of *distilled water R*.

**Heavy metals** (2.4.8): maximum 10 ppm.

Dissolve 2.0 g in 20 mL of *water R*. 12 mL of the solution complies with test A. Prepare the reference solution using *lead standard solution* (1 ppm Pb) R.

**Water** (2.5.32): maximum 12.0 per cent, determined on 80 mg.

**Microbial contamination.** Total viable aerobic count (2.6.12) not more than 10<sup>3</sup> micro-organisms per gram, determined by plate count.

## ASSAY

Dissolve 0.350 g in 100 mL of *water R* and carry out the complexometric titration of magnesium (2.5.11).

1 mL of 0.1 M *sodium edetate* is equivalent to 41.46 mg of C<sub>12</sub>H<sub>22</sub>MgO<sub>14</sub>.

## STORAGE

In an airtight container.



01/2008:1446  
corrected 6.0

## MAGNESIUM GLYCEROPHOSPHATE

## Magnesii glycerophosphas

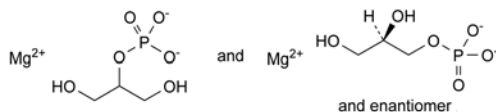
 $C_3H_7MgO_6P$  $M_r$  194.4

## DEFINITION

Mixture, in variable proportions, of magnesium salts of (*RS*)-2,3-dihydroxypropyl phosphate and 2-hydroxy-1-(hydroxymethyl)ethyl phosphate, which may be hydrated.

*Content*: 11.0 per cent to 12.5 per cent of Mg (dried substance).

## CHARACTERS

*Appearance*: white or almost white powder, hygroscopic.

*Solubility*: practically insoluble in ethanol (96 per cent). It dissolves in dilute solutions of acids.

## IDENTIFICATION

- A. Mix 1 g with 1 g of *potassium hydrogen sulfate R* in a test tube fitted with a glass tube. Heat strongly and direct the white vapour towards a piece of filter paper impregnated with a freshly prepared 10 g/L solution of *sodium nitroprusside R*. The filter paper develops a blue colour in contact with *piperidine R*.
- B. Ignite 0.1 g in a crucible. Take up the residue with 5 mL of *nitric acid R* and heat on a water-bath for 1 min. Filter. The filtrate gives reaction (b) of phosphates (2.3.1).
- C. It gives the reaction of magnesium (2.3.1).

## TESTS

**Solution S.** Dissolve 2.5 g in *carbon dioxide-free water R* prepared from *distilled water R* and dilute to 50 mL with the same solvent.

**Appearance of solution.** Solution S is not more opalescent than reference suspension III (2.2.1).

**Acidity.** Dissolve 1.0 g in 100 mL of *carbon dioxide-free water R*. Add 0.1 mL of *phenolphthalein solution R*. Not more than 1.5 mL of 0.1 M *sodium hydroxide* is required to change the colour of the indicator.

**Glycerol and ethanol (96 per cent)-soluble substances:** maximum 1.5 per cent.

Shake 1.0 g with 25 mL of *ethanol (96 per cent) R* for 2 min. Filter and wash the residue with 5 mL of *ethanol (96 per cent) R*. Combine the filtrate and the washings, evaporate to dryness on a water-bath and dry the residue at 70 °C for 1 h. The residue weighs a maximum of 15 mg.

**Chlorides (2.4.4):** maximum 0.15 per cent.

Dissolve 1.0 g in *water R* and dilute to 100 mL with the same solvent. Dilute 3.5 mL of this solution to 15 mL with *water R*.

**Phosphates (2.4.11):** maximum 0.5 per cent.

Dilute 4 mL of solution S to 100 mL with *water R*. Dilute 1 mL of this solution to 100 mL with *water R*.

**Sulfates (2.4.13):** maximum 0.1 per cent.

Dilute 3 mL of solution S to 15 mL with *distilled water R*.

**Iron (2.4.9):** maximum 150 ppm.

Dissolve 67 mg in *water R* and dilute to 10 mL with the same solvent.

**Heavy metals (2.4.8):** maximum 20 ppm.

To 20 mL of solution S add 15 mL of *hydrochloric acid R* and shake with 25 mL of *methyl isobutyl ketone R* for 2 min. Allow

to stand, then separate and evaporate the aqueous layer to dryness. Dissolve the residue in 2.5 mL of *acetic acid R* and dilute to 20 mL with *water R*. 12 mL of the solution complies with test A. Prepare the reference solution using *lead standard solution (1 ppm Pb) R*.

**Loss on drying (2.2.32):** maximum 12.0 per cent, determined on 1.000 g by drying in an oven at 150 °C for 4 h.

## ASSAY

Dissolve 0.200 g in 40 mL of *water R*. Carry out the complexometric titration of magnesium (2.5.11).

1 mL of 0.1 M *sodium edetate* is equivalent to 2.431 mg of Mg.

## STORAGE

In an airtight container.

01/2008:0039  
corrected 6.0

## MAGNESIUM HYDROXIDE

## Magnesii hydroxidum

 $Mg(OH)_2$   
[1309-42-8] $M_r$  58.32

## DEFINITION

*Content*: 95.0 per cent to 100.5 per cent of  $Mg(OH)_2$ .

## CHARACTERS

*Appearance*: white or almost white, fine, amorphous powder.

*Solubility*: practically insoluble in water. It dissolves in dilute acids.

## IDENTIFICATION

- A. Dissolve about 15 mg in 2 mL of *dilute nitric acid R* and neutralise with *dilute sodium hydroxide solution R*. The solution gives the reaction of magnesium (2.3.1).
- B. Loss on ignition (see Tests).

## TESTS

**Solution S.** Dissolve 5.0 g in a mixture of 50 mL of *acetic acid R* and 50 mL of *distilled water R*. Not more than slight effervescence is produced. Boil for 2 min, cool and dilute to 100 mL with *dilute acetic acid R*. Filter, if necessary, through a previously ignited and tared porcelain or silica filter crucible of suitable porosity to give a clear filtrate.

**Appearance of solution.** Solution S is not more intensely coloured than reference solution B<sub>3</sub> (2.2.2, *Method II*).

**Soluble substances:** maximum 2.0 per cent.

Mix 2.00 g with 100 mL of *water R* and boil for 5 min. Filter whilst hot through a sintered-glass filter (40) (2.1.2), allow to cool and dilute to 100 mL with *water R*. Evaporate 50 mL of the filtrate to dryness and dry at 100-105 °C. The residue weighs not more than 20 mg.

**Substances insoluble in acetic acid:** maximum 0.1 per cent.

Any residue obtained during the preparation of solution S, washed, dried, and ignited at 600 ± 50 °C, weighs not more than 5 mg.

**Chlorides (2.4.4):** maximum 0.1 per cent.

1 mL of solution S diluted to 15 mL with *water R* complies with the limit test for chlorides.

**Sulfates (2.4.13):** maximum 0.5 per cent.

0.6 mL of solution S diluted to 15 mL with *distilled water R* complies with the limit test for sulfates.

**Arsenic (2.4.2):** maximum 4 ppm.

5 mL of solution S complies with limit test A.

**Calcium** (2.4.3): maximum 1.5 per cent.

Dilute 1.3 mL of solution S to 150 mL with *distilled water R*. 15 mL of the solution complies with the limit test for calcium.

**Iron** (2.4.9): maximum 0.07 per cent.

Dissolve 0.15 g in 5 mL of *dilute hydrochloric acid R* and dilute to 10 mL with *water R*. 1 mL of this solution diluted to 10 mL with *water R* complies with the limit test for iron.

**Heavy metals** (2.4.8): maximum 30 ppm.

Dissolve 2.0 g in 20 mL of *hydrochloric acid R1* and shake with 25 mL of *methyl isobutyl ketone R* for 2 min. Allow to stand, separate the aqueous layer and evaporate to dryness. Dissolve the residue in 30 mL of *water R*. 12 mL of the solution complies with test A. Prepare the reference solution using *lead standard solution (2 ppm Pb) R*.

**Loss on ignition**: 29.0 per cent to 32.5 per cent.

Heat 0.5 g gradually to 900 ± 50 °C and ignite to constant mass.

#### ASSAY

Dissolve 0.100 g in a mixture of 20 mL of *water R* and 2 mL of *dilute hydrochloric acid R* and carry out the complexometric titration of magnesium (2.5.11).

1 mL of 0.1 M sodium edetate is equivalent to 5.832 mg of Mg(OH)<sub>2</sub>.

01/2008:2160

## MAGNESIUM LACTATE DIHYDRATE

### Magnesii lactas dihydricus

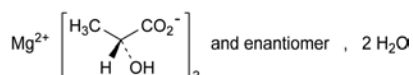

C<sub>6</sub>H<sub>10</sub>MgO<sub>6</sub>·2H<sub>2</sub>O

M<sub>r</sub> 238.5

#### DEFINITION

Magnesium bis(2-hydroxypropanoate) or mixture of magnesium (2*R*)-, (2*S*)- and (2*RS*)-2-hydroxypropanoate dihydrate.

**Content**: 98.0 per cent to 102.0 per cent (dried substance).

#### CHARACTERS

**Appearance**: white or almost white, crystalline or granular powder.

**Solubility**: slightly soluble in water, soluble in boiling water, practically insoluble in ethanol (96 per cent).

#### IDENTIFICATION

- It gives the reaction of lactates (2.3.1).
- It gives the reaction of magnesium (2.3.1).

#### TESTS

**Solution S**. Dissolve 5.0 g with heating in *carbon dioxide-free water R* prepared from *distilled water R*, allow to cool and dilute to 100 mL with the same solvent.

**Appearance of solution**. Solution S is not more opalescent than reference suspension II (2.2.1) and not more intensely coloured than reference solution BY<sub>6</sub> (2.2.2, *Method II*).

**pH** (2.2.3): 6.5 to 8.5 for solution S.

**Chlorides** (2.4.4): maximum 200 ppm.

Dilute 5 mL of solution S to 15 mL with *water R*.

**Sulfates** (2.4.13): maximum 400 ppm.

Dilute 7.5 mL of solution S to 15 mL with *distilled water R*.

**Iron** (2.4.9): maximum 50 ppm.

Dilute 4 mL of solution S to 10 mL with *water R*.

**Heavy metals** (2.4.8): maximum 20 ppm.

12 mL of solution S complies with test A. Prepare the reference solution using *lead standard solution (1 ppm Pb) R*.

**Loss on drying** (2.2.32): 14.0 per cent to 17.0 per cent, determined on 0.500 g by drying in an oven at 125 °C.

#### ASSAY

Dissolve 0.180 g in *water R* and dilute to 300 mL with the same solvent. Carry out the complexometric titration of magnesium (2.5.11).

1 mL of 0.1 M sodium edetate is equivalent to 20.25 mg of C<sub>6</sub>H<sub>10</sub>MgO<sub>6</sub>.

04/2009:0041

## MAGNESIUM OXIDE, HEAVY

### Magnesii oxidum ponderosum

MgO

M<sub>r</sub> 40.30

[1309-48-4]

#### DEFINITION

**Content**: 98.0 per cent to 100.5 per cent of MgO (ignited substance).

#### CHARACTERS

**Appearance**: fine, white or almost white powder.

**Solubility**: practically insoluble in water. It dissolves in dilute acids with at most slight effervescence.

#### IDENTIFICATION

A. Bulk density (2.9.34): minimum 0.25 g/mL.

B. Dissolve about 15 mg in 2 mL of *dilute nitric acid R* and neutralise with *dilute sodium hydroxide solution R*. The solution gives the reaction of magnesium (2.3.1).

C. Loss on ignition (see Tests).

#### TESTS

**Solution S**. Dissolve 5.0 g in a mixture of 30 mL of *distilled water R* and 70 mL of *acetic acid R*, boil for 2 min, cool and dilute to 100 mL with *dilute acetic acid R*. Filter, if necessary, through a previously ignited and tared porcelain or silica filter crucible of suitable porosity to give a clear filtrate.

**Appearance of solution**. Solution S is not more intensely coloured than reference solution B<sub>3</sub> (2.2.2, *Method II*).

**Soluble substances**: maximum 2.0 per cent.

To 2.00 g add 100 mL of *water R* and boil for 5 min. Filter whilst hot through a sintered-glass filter (40) (2.1.2), allow to cool and dilute to 100 mL with *water R*. Evaporate 50 mL of the filtrate to dryness and dry at 100-105 °C. The residue weighs a maximum of 20 mg.

**Substances insoluble in acetic acid**: maximum 0.1 per cent.

Any residue obtained during the preparation of solution S, washed, dried and ignited at 600 ± 50 °C, weighs a maximum of 5 mg.

**Chlorides** (2.4.4): maximum 0.1 per cent.

Dilute 1 mL of solution S to 15 mL with *water R*.

**Sulfates** (2.4.13): maximum 1.0 per cent.

Dilute 0.3 mL of solution S to 15 mL with *distilled water R*.

**Arsenic** (2.4.2, *Method A*): maximum 4 ppm, determined on 5 mL of solution S.

**Calcium** (2.4.3): maximum 1.5 per cent.

Dilute 1.3 mL of solution S to 150 mL with *distilled water R*. 15 mL of the solution complies with the test.

**Iron** (2.4.9): maximum 0.07 per cent.

Dissolve 0.15 g in 5 mL of *dilute hydrochloric acid R* and dilute to 10 mL with *water R*. Dilute 1 mL of the solution to 10 mL with *water R*.

**Heavy metals** (2.4.8): maximum 30 ppm.

To 20 mL of solution S add 15 mL of *hydrochloric acid R1* and shake with 25 mL of *methyl isobutyl ketone R* for 2 min. Allow to stand, then separate and evaporate the aqueous layer to dryness. Dissolve the residue in 1 mL of *acetic acid R* and dilute to 30 mL with *water R*. 12 mL of the solution complies with test A. Prepare the reference solution using *lead standard solution (1 ppm Pb) R*.

**Loss on ignition:** maximum 8.0 per cent, determined on 1.00 g at  $900 \pm 25$  °C.

#### ASSAY

Dissolve 0.320 g in 20 mL of *dilute hydrochloric acid R* and dilute to 100.0 mL with *water R*. Using 20.0 mL of the solution, carry out the complexometric titration of magnesium (2.5.11).

1 mL of 0.1 M *sodium edetate* is equivalent to 4.030 mg of MgO.

#### FUNCTIONALITY-RELATED CHARACTERISTICS

*This section provides information on characteristics that are recognised as being relevant control parameters for one or more functions of the substance when used as an excipient (see chapter 5.15). This section is a non-mandatory part of the monograph and it is not necessary to verify the characteristics to demonstrate compliance. Control of these characteristics can however contribute to the quality of a medicinal product by improving the consistency of the manufacturing process and the performance of the medicinal product during use. Where control methods are cited, they are recognised as being suitable for the purpose, but other methods can also be used. Wherever results for a particular characteristic are reported, the control method must be indicated.*

*The following characteristics may be relevant for heavy magnesium oxide used as filler in oral solid dosage forms.*

**Particle-size distribution** (2.9.31 or 2.9.38).

**Bulk and tapped density** (2.9.34).

#### TESTS

**Solution S.** Dissolve 5.0 g in a mixture of 30 mL of *distilled water R* and 70 mL of *acetic acid R*, boil for 2 min, allow to cool and dilute to 100 mL with *dilute acetic acid R*. Filter, if necessary, through a previously ignited and tared porcelain or silica filter crucible of a suitable porosity to give a clear filtrate.

**Appearance of solution.** Solution S is not more intensely coloured than reference solution B<sub>2</sub> (2.2.2, *Method II*).

**Soluble substances:** maximum 2.0 per cent.

To 2.00 g add 100 mL of *water R* and boil for 5 min. Filter whilst hot through a sintered-glass filter (40) (2.1.2), allow to cool and dilute to 100 mL with *water R*. Evaporate 50 mL of the filtrate to dryness and dry at 100-105 °C. The residue weighs a maximum of 20 mg.

**Substances insoluble in acetic acid:** maximum 0.1 per cent.

Any residue obtained during the preparation of solution S, washed, dried, and ignited at  $600 \pm 50$  °C, weighs a maximum of 5 mg.

**Chlorides** (2.4.4): maximum 0.15 per cent.

Dilute 0.7 mL of solution S to 15 mL with *water R*.

**Sulfates** (2.4.13): maximum 1.0 per cent.

Dilute 0.3 mL of solution S to 15 mL with *distilled water R*.

**Arsenic** (2.4.2, *Method A*): maximum 4 ppm, determined on 5 mL of solution S.

**Calcium** (2.4.3): maximum 1.5 per cent.

Dilute 1.3 mL of solution S to 150 mL with *distilled water R*. 15 mL of this solution complies with the test.

**Iron** (2.4.9): maximum 0.1 per cent.

Dissolve 50 mg in 5 mL of *dilute hydrochloric acid R* and dilute to 10 mL with *water R*. Dilute 2 mL of this solution to 10 mL with *water R*.

**Heavy metals** (2.4.8): maximum 30 ppm.

To 20 mL of solution S add 15 mL of *hydrochloric acid R1* and shake with 25 mL of *methyl isobutyl ketone R* for 2 min. Allow to stand, then separate and evaporate the aqueous layer to dryness. Dissolve the residue in 1.5 mL of *acetic acid R* and dilute to 30 mL with *water R*. 12 mL of the solution complies with test A. Prepare the reference solution using *lead standard solution (1 ppm Pb) R*.

**Loss on ignition:** maximum 8.0 per cent, determined on 1.00 g at  $900 \pm 25$  °C.

#### ASSAY

Dissolve 0.320 g in 20 mL of *dilute hydrochloric acid R* and dilute to 100.0 mL with *water R*. Using 20.0 mL of this solution, carry out the complexometric titration of magnesium (2.5.11).

1 mL of 0.1 M *sodium edetate* is equivalent to 4.030 mg of MgO.

#### FUNCTIONALITY-RELATED CHARACTERISTICS

*This section provides information on characteristics that are recognised as being relevant control parameters for one or more functions of the substance when used as an excipient (see chapter 5.15). This section is a non-mandatory part of the monograph and it is not necessary to verify the characteristics to demonstrate compliance. Control of these characteristics can however contribute to the quality of a medicinal product by improving the consistency of the manufacturing process and the performance of the medicinal product during use. Where control methods are cited, they are recognised as being suitable for the purpose, but other methods can also be used. Wherever results for a particular characteristic are reported, the control method must be indicated.*

*The following characteristics may be relevant for light magnesium oxide used as filler in oral solid dosage forms.*

**Particle-size distribution** (2.9.31 or 2.9.38).

**Bulk and tapped density** (2.9.34).

04/2009:0040

## MAGNESIUM OXIDE, LIGHT

### Magnesii oxidum leve

MgO  
[1309-48-4]

*M<sub>r</sub>* 40.30

#### DEFINITION

**Content:** 98.0 per cent to 100.5 per cent of MgO (ignited substance).

#### CHARACTERS

**Appearance:** fine, white or almost white, amorphous powder.

**Solubility:** practically insoluble in water. It dissolves in dilute acids with at most slight effervescence.

#### IDENTIFICATION

A. Bulk density (2.9.34): maximum 0.15 g/mL.

B. Dissolve about 15 mg in 2 mL of *dilute nitric acid R* and neutralise with *dilute sodium hydroxide solution R*. The solution gives the reaction of magnesium (2.3.1).

C. Loss on ignition (see Tests).

01/2008:1540  
corrected 6.0**MAGNESIUM PEROXIDE**

## Magnesii peroxidum

## DEFINITION

Mixture of magnesium peroxide and magnesium oxide.

*Content:* 22.0 per cent to 28.0 per cent of MgO<sub>2</sub> (*M<sub>r</sub>* 56.30).

## CHARACTERS

*Appearance:* white or slightly yellow, amorphous, light powder.*Solubility:* practically insoluble in water and in ethanol (96 per cent). It dissolves in dilute mineral acids.

## IDENTIFICATION

- A. Dissolve about 15 mg in 2 mL of *dilute nitric acid R* and neutralise with *dilute sodium hydroxide solution R*. The solution gives the reaction of magnesium (2.3.1).
- B. Dissolve 0.1 g in 2 mL of *dilute sulfuric acid R* and dilute to 10 mL with *water R*. Shake 1 mL of this solution with 5 mL of *ether R* and 0.5 mL of *potassium dichromate solution R1*. The ether layer is blue.

## TESTS

**Solution S1.** Dissolve cautiously 5.0 g in 40 mL of *hydrochloric acid R1*. Cautiously evaporate the solution to 10 mL and dilute to 100 mL with a mixture of equal volumes of *acetic acid R* and *distilled water R*. Filter, if necessary, through a previously ignited and tared porcelain or silica filter crucible of suitable porosity to give a clear filtrate. Keep the residue for the test for acid insoluble substances.

**Solution S2.** Dilute 5 mL of solution S1 to 25 mL with *distilled water R*.

**Appearance of solution.** Solution S1 is not more intensely coloured than reference solution B<sub>4</sub> (2.2.2, *Method II*).

**Acidity or alkalinity.** To 2.0 g add 100 mL of *carbon dioxide-free water R* and heat to boiling for 5 min. Filter whilst hot through a sintered-glass filter (40) (2.1.2), allow to cool and dilute to 100 mL with *carbon dioxide-free water R*. To 15 mL of the filtrate, add 0.1 mL of *phenolphthalein solution R*. The solution is red. Not more than 0.2 mL of 0.1 M *hydrochloric acid* is necessary to change the colour of the indicator. Keep the filtrate for the test for soluble substances.

**Acid insoluble substances:** maximum 0.1 per cent.

Any residue obtained during the preparation of solution S1, washed, dried and ignited at 600 ± 50 °C, weighs a maximum of 5 mg.

**Soluble substances:** maximum 1.5 per cent.

Take 50 mL of the filtrate obtained in the test for acidity or alkalinity, evaporate to dryness and dry at 100-105 °C. The residue weighs a maximum of 15 mg.

**Chlorides** (2.4.4): maximum 0.1 per cent.

Dissolve 50 mg in 5 mL of *dilute nitric acid R* and dilute to 15 mL with *water R*.

**Sulfates** (2.4.13): maximum 0.5 per cent.

Dilute 3 mL of solution S2 to 15 mL with *distilled water R*.

**Arsenic** (2.4.2, *Method A*): maximum 4 ppm, determined on 5 mL of solution S1.

**Calcium** (2.4.3): maximum 1.0 per cent.

Dilute 1 mL of solution S2 to 15 mL with *distilled water R*.

**Iron** (2.4.9): maximum 500 ppm.

Dilute 2 mL of solution S2 to 10 mL with *water R*.

**Heavy metals** (2.4.8): maximum 30 ppm.

To 20 mL of solution S1 add 15 mL of *hydrochloric acid R1* and shake with 25 mL of *methyl isobutyl ketone R* for 2 min.

Allow to stand, then separate and evaporate the aqueous layer to dryness. Dissolve the residue in 1.5 mL of *acetic acid R* and dilute to 30 mL with *water R*. 12 mL of the solution complies with test A. Prepare the reference solution using *lead standard solution* (1 ppm Pb) *R*.

## ASSAY

Dissolve 80.0 mg, shaking cautiously, in a mixture, previously cooled to 20 °C, of 10 mL of *sulfuric acid R* and 90 mL of *water R*. Titrate with 0.02 M *potassium permanganate* until a pink colour is obtained.

1 mL of 0.02 M *potassium permanganate* is equivalent to 2.815 mg of MgO<sub>2</sub>.

## STORAGE

Protected from light.

07/2010:1619

**MAGNESIUM PIDOLATE**

## Magnesii pidolas

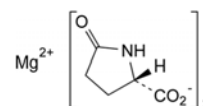
C<sub>10</sub>H<sub>12</sub>N<sub>2</sub>O<sub>6</sub>Mg  
[62003-27-4]*M<sub>r</sub>* 280.5

## DEFINITION

Magnesium bis[(2S)-5-oxopyrrolidine-2-carboxylate].

*Content:* 8.49 per cent to 8.84 per cent of Mg (*A<sub>r</sub>* = 24.31) (anhydrous substance).

## CHARACTERS

*Appearance:* amorphous, white or almost white powder, hygroscopic.

*Solubility:* very soluble in water, soluble in methanol, practically insoluble in methylene chloride.

## IDENTIFICATION

A. Thin-layer chromatography (2.2.27).

*Test solution.* Dissolve 60 mg of the substance to be examined in 2 mL of *water R* and dilute to 10 mL with *methanol R*.

*Reference solution.* Dissolve 55 mg of *pidolic acid CRS* in 2 mL of *water R* and dilute to 10 mL with *methanol R*.

*Plate:* TLC silica gel plate *R*.

*Mobile phase:* *methanol R*, *glacial acetic acid R*, *methylene chloride R* (15:20:65 V/V/V).

*Application:* 1 µL.

*Development:* over 2/3 of the plate.

*Drying:* at 100-105 °C for 15 min.

*Detection:* spray with *strong sodium hypochlorite solution R*. Allow to stand for 10 min and spray abundantly with *glacial acetic acid R*. Allow to stand again for 10 min and dry at 100-105 °C for 2 min. Spray with *potassium iodide and starch solution R* until spots appear.

*Results:* the principal spot in the chromatogram obtained with the test solution is similar in position, colour and size to the principal spot in the chromatogram obtained with the reference solution. The chromatogram obtained with the test solution may show 2 faint secondary spots.

B. To 0.15 mL of solution S (see Tests) add 1.8 mL of *water R*. The solution gives the reaction of magnesium (2.3.1).

## TESTS

**Solution S.** Dissolve 5.00 g in *carbon dioxide-free water R* prepared from *distilled water R* and dilute to 50.0 mL with the same solvent.

**Appearance of solution.** Solution S is clear (2.2.1) and not more intensely coloured than reference solution B<sub>8</sub> (2.2.2, *Method I*).

**pH** (2.2.3): 5.5 to 7.0 for solution S.

**Specific optical rotation** (2.2.7): –23.3 to –26.5 (anhydrous substance), determined on solution S.

**Related substances.** Liquid chromatography (2.2.29).

**Test solution.** Dissolve 0.500 g of the substance to be examined in the mobile phase and dilute to 100.0 mL with the mobile phase.

**Reference solution (a).** Dilute 1.0 mL of the test solution to 100.0 mL with the mobile phase.

**Reference solution (b).** Dissolve 50.0 mg of *pidolate impurity B CRS* in the mobile phase and dilute to 100.0 mL with the mobile phase. Dilute 5.0 mL of the solution to 50.0 mL with the mobile phase.

**Reference solution (c).** Dilute 10.0 mL of reference solution (b) to 100.0 mL with the mobile phase.

**Reference solution (d).** Dilute 1.0 mL of *nitrate standard solution (100 ppm NO<sub>3</sub>) R* to 100.0 mL with the mobile phase.

**Reference solution (e).** Dilute 6.0 mL of reference solution (a) to 10.0 mL with reference solution (b).

**Column:**

- size:  $l = 0.25$  m,  $\varnothing = 4.6$  mm,
- stationary phase: *octadecylsilyl silica gel for chromatography R* (5  $\mu$ m).

**Mobile phase:** dissolve 1.56 g of *sodium dihydrogen phosphate R* in 1000 mL of *water R* and adjust to pH 2.5 with a 10 per cent *V/V* solution of *phosphoric acid R*.

**Flow rate:** 1.5 mL/min.

**Detection:** spectrophotometer at 210 nm.

**Injection:** 10  $\mu$ L of the test solution and reference solutions (b), (c), (d) and (e).

**Run time:** 4 times the retention time of *pidolic acid*.

**Retention times:** *pidolic acid* = about 4.5 min; *impurity B* = about 7.5 min.

**System suitability:** reference solution (e):

- resolution: minimum 10 between the peaks due to *pidolic acid* and *impurity B*.

**Limits:**

- *impurity B*: not more than the area of the principal peak in the chromatogram obtained with reference solution (b) (1.0 per cent),
- *unspecified impurities*: for each impurity, not more than the area of the principal peak in the chromatogram obtained with reference solution (c) (0.10 per cent),
- *total of other impurities*: not more than 0.5 times the area of the principal peak in the chromatogram obtained with reference solution (b) (0.5 per cent),
- *disregard limit*: 0.5 times the area of the principal peak in the chromatogram obtained with reference solution (c) (0.05 per cent); disregard any peak corresponding to the nitrate ion (NO<sub>3</sub><sup>–</sup>).

**Impurity A.** Thin-layer chromatography (2.2.27).

**Test solution.** Dissolve 0.250 g of the substance to be examined in 4 mL of *water R* and dilute to 50.0 mL with *methanol R*.

**Reference solution (a).** Dissolve 60.0 mg of *glutamic acid R* in 50 mL of *water R* and dilute to 100.0 mL with *methanol R*. Dilute 1.0 mL of this solution to 20.0 mL with *methanol R*.

**Reference solution (b).** Dissolve 10 mg of *aspartic acid R* and 10 mg of *glutamic acid R* in *water R* and dilute to 25 mL with the same solvent. Dilute 1 mL of the solution to 10 mL with *water R*.

**Plate:** *TLC silica gel plate R*.

**Mobile phase:** *glacial acetic acid R*, *water R*, *butanol R* (20:20:60 *V/V/V*).

**Application:** 5  $\mu$ L.

**Development:** over 2/3 of the plate.

**Drying:** in air.

**Detection:** spray with *ninhydrin solution R* and heat at 100–105 °C for 15 min.

**System suitability:** reference solution (b):

- the chromatogram shows 2 clearly separated spots.

**Limit:**

- *impurity A*: any spot due to *impurity A* is not more intense than the spot in the chromatogram obtained with reference solution (a) (0.6 per cent).

**Chlorides** (2.4.4): maximum 500 ppm.

Dilute 1.0 mL of solution S to 15.0 mL with *water R*.

**Nitrates.** Examine the chromatogram obtained with the test solution in the test for related substances.

**Limit:**

- *nitrates*: not more than the area of the principal peak in the chromatogram obtained with reference solution (d) (200 ppm).

**Sulfates** (2.4.13): maximum 0.1 per cent.

Dilute 1.5 mL of solution S to 15.0 mL with *distilled water R*.

**Arsenic** (2.4.2, *Method A*): maximum 2 ppm, determined on 5.0 mL of solution S.

**Iron** (2.4.9): maximum 200 ppm.

Dilute 0.5 mL of solution S to 10 mL with *water R*.

**Heavy metals** (2.4.8): maximum 20 ppm.

12 mL of solution S complies with test A. Prepare the reference solution using *lead standard solution (2 ppm Pb) R*.

**Water** (2.5.12): maximum 8.0 per cent, determined on 0.200 g.

## ASSAY

Dissolve 0.300 g in 50 mL of *water R*. Carry out the complexometric titration of magnesium (2.5.11).

1 mL of 0.1 M *sodium edetate* is equivalent to 2.431 mg of Mg.

## STORAGE

In an airtight container.

## IMPURITIES

*Specified impurities:* A, B.

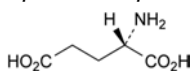

A. (2S)-2-aminopentanedioic acid (*glutamic acid*),

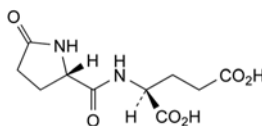

B. (2S)-2-[[[(2S)-5-oxopyrrolidin-2-yl]carbonyl]amino]pentanedioic acid.

07/2010:0229

## MAGNESIUM STEARATE

## Magnesii stearas

## DEFINITION

Compound of magnesium with a mixture of solid organic acids and consisting mainly of variable proportions of magnesium stearate and magnesium palmitate obtained from sources of vegetable or animal origin.

**Content:**

- magnesium (Mg;  $A_r$  24.305): 4.0 per cent to 5.0 per cent (dried substance);
- stearic acid in the fatty acid fraction: minimum 40.0 per cent;
- sum of stearic acid and palmitic acid in the fatty acid fraction: minimum 90.0 per cent.

**CHARACTERS**

**Appearance:** a white, very fine, light powder, greasy to the touch.

**Solubility:** practically insoluble in water and in anhydrous ethanol.

**IDENTIFICATION**

**First identification:** C, D.

**Second identification:** A, B, D.

A. Freezing point (2.2.18): minimum 53 °C, determined on the residue obtained in the preparation of solution S (see Tests).

B. Acid value (2.5.1): 195 to 210.

Dissolve 0.200 g of the residue obtained in the preparation of solution S in 25 mL of the prescribed mixture of solvents.

C. Examine the chromatograms obtained in the assay of stearic acid and palmitic acid.

**Results:** the 2 principal peaks in the chromatogram obtained with the test solution are similar in retention time to the 2 principal peaks in the chromatogram obtained with the reference solution.

D. To 1 mL of solution S add 1 mL of dilute ammonia R1; a white precipitate is formed that dissolves on addition of 1 mL of ammonium chloride solution R. Add 1 mL of a 120 g/L solution of disodium hydrogen phosphate R; a white crystalline precipitate is formed.

**TESTS**

**Solution S.** To 5.0 g add 50 mL of peroxide-free ether R, 20 mL of dilute nitric acid R and 20 mL of water R and heat under a reflux condenser until dissolution is complete. Allow to cool. In a separating funnel, separate the aqueous layer and shake the ether layer with 2 quantities, each of 4 mL, of water R. Combine the aqueous layers, wash with 15 mL of peroxide-free ether R and dilute to 50.0 mL with water R (solution S). Evaporate the organic layer to dryness and dry the residue at 100–105 °C. Keep the residue for identification tests A and B.

**Acidity or alkalinity.** To 1.0 g add 20 mL of carbon dioxide-free water R and boil for 1 min with continuous shaking. Cool and filter. To 10 mL of the filtrate add 0.05 mL of bromothymol blue solution R4. Not more than 0.05 mL of 0.1 M hydrochloric acid or 0.1 M sodium hydroxide is required to change the colour of the indicator.

**Chlorides:** maximum 0.1 per cent.

Dilute 10.0 mL of solution S to 40 mL with water R. Neutralise if necessary with nitric acid R using litmus R as indicator. Add 1 mL of nitric acid R and 1 mL of 0.1 M silver nitrate and dilute to 50 mL with water R. Mix and allow to stand for 5 min protected from light. The turbidity, if any, is not greater than that produced in a solution containing 1.4 mL of 0.02 M hydrochloric acid.

**Sulfates:** maximum 1.0 per cent.

Dilute 6.0 mL of solution S to 40 mL with water R. Neutralise if necessary with hydrochloric acid R using litmus R as indicator. Add 1 mL of 3 M hydrochloric acid and 3 mL of a 120 g/L solution of barium chloride R and dilute to 50 mL with water R. Mix and allow to stand for 10 min. The turbidity, if any, is not greater than that produced in a solution containing 3.0 mL of 0.02 M sulfuric acid.

**Cadmium:** maximum 3 ppm.

Atomic absorption spectrometry (2.2.23, Method II).

For the preparation of all aqueous solutions and for the rinsing of glassware before use, employ water that has been passed through a strong-acid, strong-base, mixed-bed ion-exchange resin before use. Select all reagents to have as low a content of cadmium, lead and nickel as practicable and store all reagent solutions in containers of borosilicate glass. Clean glassware before use by soaking in warm 8 M nitric acid for 30 min and by rinsing with deionised water.

**Blank solution.** Dilute 25 mL of cadmium- and lead-free nitric acid R to 100.0 mL with water R.

**Modifier solution.** Dissolve 20 g of ammonium dihydrogen phosphate R and 1 g of magnesium nitrate R in water R and dilute to 100 mL with the same solvent. Alternatively, use an appropriate matrix modifier as recommended by the graphite furnace atomic absorption (GFAA) spectrometer manufacturer.

**Test solution.** Place 0.100 g of the substance to be examined in a polytetrafluoroethylene digestion bomb and add 2.5 mL of cadmium- and lead-free nitric acid R. Close and seal the bomb according to the manufacturer's operating instructions (when using a digestion bomb, be thoroughly familiar with the safety and operating instructions. Carefully follow the bomb manufacturer's instructions regarding care and maintenance of these digestion bombs. Do not use metal jacketed bombs or liners which have been used with hydrochloric acid due to contamination from corrosion of the metal jacket by hydrochloric acid). Heat the bomb in an oven at 170 °C for 3 h. Cool the bomb slowly in air to room temperature according to the bomb manufacturer's instructions. Place the bomb in a hood and open carefully as corrosive gases may be expelled. Dissolve the residue in water R and dilute to 10.0 mL with the same solvent.

**Reference solution.** Prepare a solution of 0.0030 µg/mL of Cd by suitable dilutions of a 0.00825 µg/mL solution of cadmium nitrate tetrahydrate R in the blank solution.

Dilute 1.0 mL of the test solution to 10.0 mL with the blank solution. Prepare mixtures of this solution, the reference solution and the blank solution in the following proportions: (1.0:0:1.0 V/V/V), (1.0:0.5:0.5 V/V/V), (1.0:1.0:0 V/V/V). To each mixture add 50 µL of modifier solution and mix. These solutions contain respectively 0 µg, 0.00075 µg and 0.0015 µg of cadmium per millilitre from the reference solution (keep the remaining test solution for use in the test for lead and nickel).

**Source:** cadmium hollow-cathode lamp.

**Wavelength:** 228.8 nm.

**Atomisation device:** furnace.

**Platform:** pyrolytically coated with integrated tube.

**Operating conditions:** use the temperature programme recommended for cadmium by the GFAA manufacturer. An example of temperature parameters for GFAA analysis of cadmium is shown below.

Stage	Final temperature (°C)	Ramp time (s)	Hold time (s)
Drying	110	10	20
Ashing	600	10	30
Atomisation	1800	0	5

**Lead:** maximum 10 ppm.

Atomic absorption spectrometry (2.2.23, Method II).

For the preparation of all aqueous solutions and for the rinsing of glassware before use, employ water that has been passed through a strong-acid, strong-base, mixed-bed ion-exchange resin before use. Select all reagents to have as low a content of cadmium, lead and nickel as practicable and store all reagent solutions in containers of borosilicate glass. Clean glassware before use by soaking in warm 8 M nitric acid for 30 min and by rinsing with deionised water.

**Blank solution.** Use the solution described in the test for cadmium.

**Modifier solution.** Use the solution described in the test for cadmium.

**Test solution.** Use the solution described in the test for cadmium.

**Reference solution.** Prepare a solution of 0.100 µg/mL of Pb by suitable dilutions of *lead standard solution (100 ppm Pb) R* with the blank solution.

Prepare mixtures of the test solution, the reference solution and the blank solution in the following proportions: (1.0:0:1.0 V/V/V), (1.0:0.5:0.5 V/V/V), (1.0:1.0:0 V/V/V). To each mixture add 50 µL of modifier solution and mix. These solutions contain respectively 0 µg, 0.025 µg and 0.05 µg of lead per millilitre from the reference solution.

**Source:** lead hollow-cathode lamp.

**Wavelength:** 283.3 nm.

**Atomisation device:** furnace.

**Platform:** pyrolytically coated with integrated tube.

**Operating conditions:** use the temperature programme recommended for lead by the GFAA manufacturer. An example of temperature parameters for GFAA analysis of lead is shown below.

Stage	Final temperature (°C)	Ramp time (s)	Hold time (s)
Drying	110	10	20
Ashing	450	10	30
Atomisation	2000	0	5

**Nickel:** maximum 5 ppm.

Atomic absorption spectrometry (2.2.23, Method II).

*For the preparation of all aqueous solutions and for the rinsing of glassware before use, employ water that has been passed through a strong-acid, strong-base, mixed-bed ion-exchange resin before use. Select all reagents to have as low a content of cadmium, lead and nickel as practicable and store all reagent solutions in containers of borosilicate glass. Clean glassware before use by soaking in warm 8 M nitric acid for 30 min and by rinsing with deionised water.*

**Blank solution.** Use the solution described in the test for cadmium.

**Modifier solution.** Dissolve 20 g of *ammonium dihydrogen phosphate R* in *water R* and dilute to 100 mL with the same solvent. Alternatively, use an appropriate matrix modifier as recommended by the GFAA spectrometer manufacturer.

**Test solution.** Use the solution described in the test for cadmium.

**Reference solution.** Prepare a solution of 0.050 µg/mL of Ni by suitable dilutions of a 0.2477 µg/mL solution of *nickel nitrate hexahydrate R* in the blank solution.

Prepare mixtures of the test solution, the reference solution and the blank solution in the following proportions: (1.0:0:1.0 V/V/V), (1.0:0.5:0.5 V/V/V), (1.0:1.0:0 V/V/V). To each mixture add 50 µL of matrix modifier solution and mix. These reference solutions contain respectively 0 µg, 0.0125 µg and 0.025 µg of nickel per millilitre from the reference solution.

**Source:** nickel hollow-cathode lamp.

**Wavelength:** 232.0 nm.

**Atomisation device:** furnace.

**Platform:** pyrolytically coated with integrated tube.

**Operating conditions:** use the temperature programme recommended for nickel by the GFAA manufacturer. An example of temperature parameters for GFAA analysis of nickel is shown below.

Stage	Final temperature (°C)	Ramp time (s)	Hold time (s)
Drying	110	10	20
Ashing	1000	20	30
Atomisation	2300	0	5

**Loss on drying (2.2.32):** maximum 6.0 per cent, determined on 1.000 g by drying in an oven at 105 °C.

**Microbial contamination.**

TAMC: acceptance criterion 10<sup>3</sup> CFU/g (2.6.12).

TYMC: acceptance criterion 10<sup>2</sup> CFU/g (2.6.12).

Absence of *Escherichia coli* (2.6.13).

Absence of *Salmonella* (2.6.13).

ASSAY

**Magnesium.** To 0.500 g in a 250 mL conical flask add 50 mL of a mixture of equal volumes of *butanol R* and *anhydrous ethanol R*, 5 mL of *concentrated ammonia R*, 3 mL of *ammonium chloride buffer solution pH 10.0 R*, 30.0 mL of 0.1 M *sodium edetate* and 15 mg of *mordant black 11 triturate R*. Heat at 45-50 °C until the solution is clear and titrate with 0.1 M *zinc sulfate* until the colour changes from blue to violet. Carry out a blank titration.

1 mL of 0.1 M *sodium edetate* is equivalent to 2.431 mg of Mg.

**Stearic acid and palmitic acid.** Gas chromatography (2.2.28): use the normalisation procedure.

**Test solution.** In a conical flask fitted with a reflux condenser, dissolve 0.10 g of the substance to be examined in 5 mL of *boron trifluoride-methanol solution R*. Boil under a reflux condenser for 10 min. Add 4 mL of *heptane R* through the condenser and boil again under a reflux condenser for 10 min. Allow to cool. Add 20 mL of *saturated sodium chloride solution R*. Shake and allow the layers to separate. Dry the organic layer over 0.1 g of *anhydrous sodium sulfate R* (previously washed with *heptane R*). Dilute 1.0 mL of the solution to 10.0 mL with *heptane R*.

**Reference solution.** Prepare the reference solution in the same manner as the test solution using 50.0 mg of *palmitic acid CRS* and 50.0 mg of *stearic acid CRS* instead of the substance to be examined.

**Column:**

- *material:* fused silica;
- *size:* *l* = 30 m, Ø = 0.32 mm;
- *stationary phase:* *macrogol 20 000 R* (film thickness 0.5 µm).

**Carrier gas:** *helium for chromatography R*.

**Flow rate:** 2.4 mL/min.

**Temperature:**

	Time (min)	Temperature (°C)
Column	0 - 2	70
	2 - 36	70 → 240
	36 - 41	240
Injection port		220
Detector		260

**Detection:** flame ionisation.

**Injection:** 1 µL.

**Relative retention** with reference to methyl stearate: methyl palmitate = about 0.9.

**System suitability:** reference solution:

- *resolution:* minimum 5.0 between the peaks due to methyl palmitate and methyl stearate;

- *relative standard deviation*: maximum 3.0 per cent for the areas of the peaks due to methyl palmitate and methyl stearate, determined on 6 injections; maximum 1.0 per cent for the ratio of the areas of the peaks due to methyl palmitate to the areas of the peaks due to methyl stearate, determined on 6 injections.

## FUNCTIONALITY-RELATED CHARACTERISTICS

*This section provides information on characteristics that are recognised as being relevant control parameters for one or more functions of the substance when used as an excipient (see chapter 5.15). This section is a non-mandatory part of the monograph and it is not necessary to verify the characteristics to demonstrate compliance. Control of these characteristics can however contribute to the quality of a medicinal product by improving the consistency of the manufacturing process and the performance of the medicinal product during use. Where control methods are cited, they are recognised as being suitable for the purpose, but other methods can also be used. Wherever results for a particular characteristic are reported, the control method must be indicated.*

*The following characteristics may be relevant for magnesium stearate used as a lubricant in tablets and capsules.*

**Particle-size distribution** (2.9.31).

**Specific surface area** (2.9.26, *Method I*). Determine the specific surface area in the  $P/P_0$  range of 0.05 to 0.15.

*Sample outgassing*: 2 h at 40 °C.

**Thermogravimetry** (2.2.34).

01/2008:0044  
corrected 6.0

## MAGNESIUM SULFATE HEPTAHYDRATE

## Magnesii sulfas heptahydricus

$\text{MgSO}_4 \cdot 7\text{H}_2\text{O}$   $M_r$  246.5  
[10034-99-8]

## DEFINITION

*Content*: 99.0 per cent to 100.5 per cent (dried substance).

## CHARACTERS

*Appearance*: white or almost white, crystalline powder or brilliant, colourless crystals.

*Solubility*: freely soluble in water, very soluble in boiling water, practically insoluble in ethanol (96 per cent).

## IDENTIFICATION

- It gives the reactions of sulfates (2.3.1).
- It gives the reaction of magnesium (2.3.1).

## TESTS

**Solution S**. Dissolve 5.0 g in *water R* and dilute to 50 mL with the same solvent.

**Appearance of solution**. Solution S is clear (2.2.1) and colourless (2.2.2, *Method II*).

**Acidity or alkalinity**. To 10 mL of solution S add 0.05 mL of *phenol red solution R*. Not more than 0.2 mL of 0.01 M *hydrochloric acid* or 0.01 M *sodium hydroxide* is required to change the colour of the indicator.

**Chlorides** (2.4.4): maximum 300 ppm.

Dilute 1.7 mL of solution S to 15 mL with *water R*.

**Arsenic** (2.4.2, *Method A*): maximum 2 ppm, determined on 0.5 g.

**Iron** (2.4.9): maximum 20 ppm.

Dilute 5 mL of solution S to 10 mL with *water R*.

**Heavy metals** (2.4.8): maximum 10 ppm.

12 mL of solution S complies with test A. Prepare the reference solution using *lead standard solution (1 ppm Pb) R*.

**Loss on drying** (2.2.32): 48.0 per cent to 52.0 per cent, determined on 0.500 g by drying in an oven at 110-120 °C for 1 h and then at 400 °C to constant mass.

## ASSAY

Dissolve 0.450 g in 100 mL of *water R* and carry out the complexometric titration of magnesium (2.5.11).

1 mL of 0.1 M *sodium edetate* is equivalent to 12.04 mg of  $\text{MgSO}_4$ .

07/2010:0403

## MAGNESIUM TRISILICATE

## Magnesii trisilicas

## DEFINITION

It has a variable composition corresponding approximately to  $\text{Mg}_2\text{Si}_3\text{O}_8 \cdot x\text{H}_2\text{O}$ .

*Content*:

- *magnesium oxide* ( $\text{MgO}$ ;  $M_r$  40.30): minimum 29.0 per cent (ignited substance),
- *silicon dioxide* ( $\text{SiO}_2$ ;  $M_r$  60.1): minimum 65.0 per cent (ignited substance).

## CHARACTERS

*Appearance*: white or almost white powder.

*Solubility*: practically insoluble in water and in ethanol (96 per cent).

## IDENTIFICATION

- 0.25 g gives the reaction of silicates (2.3.1).
- 1 mL of solution S (see Tests) neutralised with *dilute sodium hydroxide solution R* gives the reaction of magnesium (2.3.1).

## TESTS

**Solution S**. To 2.0 g add a mixture of 4 mL of *nitric acid R* and 4 mL of *distilled water R*. Heat to boiling with frequent shaking. Add 12 mL of *distilled water R* and allow to cool. Filter or centrifuge to obtain a clear solution and dilute to 20 mL with *distilled water R*.

**Alkalinity**. To 10.0 g in a 200 mL conical flask, add 100.0 g of *water R* and heat on a water-bath for 30 min. Allow to cool and make up to the initial mass with *water R*. Allow to stand and filter or centrifuge until a clear liquid is obtained. To 10 mL of this liquid add 0.1 mL of *phenolphthalein solution R*. Not more than 1.0 mL of 0.1 M *hydrochloric acid* is required to change the colour of the indicator.

**Water-soluble salts**: maximum 1.5 per cent.

In a platinum dish, evaporate to dryness on a water-bath 20.0 mL of the liquid obtained in the test for alkalinity. The residue, ignited to constant mass at  $900 \pm 50$  °C, weighs a maximum of 30 mg.

**Chlorides** (2.4.4): maximum 500 ppm.

Dilute 0.5 mL of solution S to 15 mL with *water R*. Prepare the standard using a mixture of 5 mL of *chloride standard solution (5 ppm Cl) R* and 10 mL of *water R*.

**Sulfates** (2.4.13): maximum 0.5 per cent.

Dilute 0.3 mL of solution S to 15 mL with *distilled water R*.

**Arsenic** (2.4.2, *method A*): maximum 4 ppm, determined on 2.5 mL of solution S.

**Heavy metals** (2.4.8): maximum 40 ppm.

Neutralise 10 mL of solution S with *dilute ammonia RI*, using *metanil yellow solution R* as an external indicator. Dilute



to 20 mL with *water R* and filter if necessary. 12 mL of this solution complies with test A. Prepare the reference solution using *lead standard solution (2 ppm Pb) R*.

**Loss on ignition:** 17 per cent to 34 per cent, determined on 0.5 g by ignition to constant mass at  $900 \pm 50$  °C in a platinum crucible.

**Acid-absorbing capacity.** Suspend 0.25 g in 0.1 M hydrochloric acid, dilute to 100.0 mL with the same acid and allow to stand for 2 h in a water-bath at  $37 \pm 0.5$  °C, with frequent shaking. Allow to cool. To 20.0 mL of the supernatant solution add 0.1 mL of *bromophenol blue solution R* and titrate with 0.1 M sodium hydroxide until a blue colour is obtained. The acid-absorbing capacity is not less than 100.0 mL of 0.1 M hydrochloric acid per gram.

#### ASSAY

**Magnesium oxide.** To 1.000 g in a 200 mL conical flask, add 35 mL of *hydrochloric acid R* and 60 mL of *water R* and heat in a water-bath for 15 min. Allow to cool, filter, wash the conical flask and the residue with *water R* and dilute the combined filtrate and washings to 250.0 mL with *water R*. Neutralise 50.0 mL of the solution with *strong sodium hydroxide solution R* (about 8 mL). Carry out the complexometric titration of magnesium (2.5.11).

1 mL of 0.1 M sodium edetate is equivalent to 4.030 mg of MgO.

**Silicon dioxide.** To 0.700 g add 10 mL of *dilute sulfuric acid R* and 10 mL of *water R*. Heat for 90 min on a water-bath with frequent shaking, replacing the evaporated water. Allow to cool and decant onto an ashless filter paper (diameter 7 cm). Wash the precipitate by decantation with 3 quantities, each of 5 mL, of hot *water R*, transfer it to the filter and wash it with hot *water R* until 1 mL of the filtrate remains clear after the addition of 0.05 mL of *dilute hydrochloric acid R* and 2 mL of *barium chloride solution R1*. Incinerate the filter and its contents in a platinum crucible, then ignite the residue ( $\text{SiO}_2$ ) at  $900 \pm 50$  °C to constant mass.

#### FUNCTIONALITY-RELATED CHARACTERISTICS

*This section provides information on characteristics that are recognised as being relevant control parameters for one or more functions of the substance when used as an excipient (see chapter 5.15). This section is a non-mandatory part of the monograph and it is not necessary to verify the characteristics to demonstrate compliance. Control of these characteristics can however contribute to the quality of a medicinal product by improving the consistency of the manufacturing process and the performance of the medicinal product during use. Where control methods are cited, they are recognised as being suitable for the purpose, but other methods can also be used. Wherever results for a particular characteristic are reported, the control method must be indicated.*

*The following characteristics may be relevant for magnesium trisilicate used as a lubricant in tablets and capsules.*

**Particle-size distribution (2.9.31).**

**Specific surface area (2.9.26, Method I).**

**Solubility:** practically insoluble in water and in ethanol (96 per cent), miscible with light petroleum (bp: 40-60 °C) and with methylene chloride.

**Relative density:** about 0.920.

**Refractive index:** about 1.474.

#### IDENTIFICATION

A. Identification of fatty oils by thin-layer chromatography (2.3.2).

**Results:** the chromatogram obtained with the test solution is similar to the chromatogram obtained with the reference solution.

B. Composition of fatty acids (see Tests).

#### TESTS

**Acid value (2.5.1):** maximum 0.5, or maximum 0.3 if intended for use in the manufacture of parenteral preparations, determined on 10.0 g.

**Peroxide value (2.5.5, Method A):** maximum 10.0, or maximum 5.0 if intended for use in the manufacture of parenteral preparations.

**Unsaponifiable matter (2.5.7):** maximum 2.8 per cent, determined on 5.0 g.

**Alkaline impurities (2.4.19).** It complies with the test.

**Composition of fatty acids (2.4.22, Method A).** Use the mixture of calibrating substances in Table 2.4.22.-3.

**Composition of the fatty-acid fraction of the oil:**

- *fatty acids of chain length less than C<sub>16</sub>:* maximum 0.6 per cent;
- *palmitic acid:* 8.6 per cent to 16.5 per cent;
- *stearic acid:* maximum 3.3 per cent;
- *oleic acid:* 20.0 per cent to 42.2 per cent;
- *linoleic acid:* 39.4 per cent to 65.6 per cent;
- *linolenic acid:* 0.5 per cent to 1.5 per cent;
- *arachidic acid:* maximum 0.8 per cent;
- *eicosenoic acid:* maximum 0.5 per cent;
- *behenic acid:* maximum 0.5 per cent;
- *other fatty acids:* maximum 0.5 per cent.

**Sterols (2.4.23):** maximum 0.3 per cent of brassicasterol in the sterol fraction of the oil.

**Water (2.5.32):** maximum 0.1 per cent, determined on 1.00 g.

#### STORAGE

Protected from light, at a temperature not exceeding 25 °C.

#### LABELLING

The label states:

- where applicable, that the substance is suitable for use in the manufacture of parenteral preparations;
- whether the oil is obtained by mechanical expression or by extraction.

01/2009:0344

01/2010:1342  
corrected 6.8

## MAIZE OIL, REFINED

### Maydis oleum raffinatum

#### DEFINITION

Fatty oil obtained from the seeds of *Zea mays* L. by expression or by extraction. It is then refined.

#### CHARACTERS

**Appearance:** clear, light yellow or yellow oil.

## MAIZE STARCH

### Maydis amyllum

#### DEFINITION

Maize starch is obtained from the caryopsis of *Zea mays* L.

#### CHARACTERS

**Appearance:** matt, white to slightly yellowish, very fine powder that creaks when pressed between the fingers.

**Solubility:** practically insoluble in cold water and in ethanol (96 per cent).

The presence of granules with cracks or irregularities on the edge is exceptional.

#### IDENTIFICATION

- A. Examined under a microscope, using not less than 20 × magnification and using equal volumes of *glycerol R* and *water R*, it appears as either angular polyhedral granules of irregular sizes with diameters ranging from about 2 µm to about 23 µm or as rounded or spheroidal granules of irregular sizes with diameters ranging from about 25 µm to about 35 µm. The central hilum consists of a distinct cavity or 2- to 5-rayed cleft and there are no concentric striations. Between orthogonally orientated polarising plates or prisms, the starch granules show a distinct black cross intersecting at the hilum.
- B. Suspend 1 g in 50 mL of *water R*, boil for 1 min and cool. A thin, cloudy mucilage is formed.
- C. To 1 mL of the mucilage obtained in identification test B add 0.05 mL of *iodine solution RI*. An orange-red to dark blue colour is produced, which disappears on heating.

#### TESTS

**pH** (2.2.3): 4.0 to 7.0.

Shake 5.0 g with 25.0 mL of *carbon dioxide-free water R* for 60 s. Allow to stand for 15 min.

**Foreign matter.** Examined under a microscope using a mixture of equal volumes of *glycerol R* and *water R*, not more than traces of matter other than starch granules are present. No starch grains of any other origin are present.

**Oxidising substances** (2.5.30): maximum 20 ppm, calculated as H<sub>2</sub>O<sub>2</sub>.

**Sulfur dioxide** (2.5.29): maximum 50 ppm.

**Iron** (2.4.9): maximum 10 ppm.

Shake 1.5 g with 15 mL of *dilute hydrochloric acid R*. Filter. The filtrate complies with the test.

**Loss on drying** (2.2.32): maximum 15.0 per cent, determined on 1.000 g by drying in an oven at 130 °C for 90 min.

**Sulfated ash** (2.4.14): maximum 0.6 per cent, determined on 1.0 g.

#### Microbial contamination

TAMC: acceptance criterion 10<sup>3</sup> CFU/g (2.6.12).

TYMC: acceptance criterion 10<sup>2</sup> CFU/g (2.6.12).

Absence of *Escherichia coli* (2.6.13).

Absence of *Salmonella* (2.6.13).

01/2008:1343

## MALATHION

### Malathionum

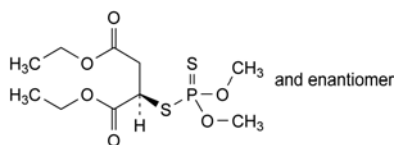

C<sub>10</sub>H<sub>16</sub>O<sub>6</sub>PS<sub>2</sub>  
[121-75-5]

M<sub>r</sub> 330.4

#### DEFINITION

Diethyl (2*RS*)-2-(dimethoxyphosphinodithioyl)butanedioate.

**Content:** 98.0 per cent to 102.0 per cent (anhydrous substance).

#### CHARACTERS

**Appearance:** clear, colourless or slightly yellowish liquid.

**Solubility:** slightly soluble in water, miscible with acetone, with cyclohexane, with ethanol (96 per cent) and with vegetable oils. It solidifies at about 3 °C.

#### IDENTIFICATION

Infrared absorption spectrophotometry (2.2.24).

**Comparison:** *malathion CRS*.

#### TESTS

**Relative density** (2.2.5): 1.220 to 1.240.

**Optical rotation** (2.2.7): −0.1° to +0.1°.

Dissolve 2.50 g in *ethanol (96 per cent) R* and dilute to 25.0 mL with the same solvent.

**Related substances.** Liquid chromatography (2.2.29).

**Solvent mixture:** *water R*, *acetonitrile R* (1:3 V/V).

**Test solution (a).** Dissolve 0.10 g of the substance to be examined in the solvent mixture and dilute to 5.0 mL with the solvent mixture.

**Test solution (b).** Dilute 1.0 mL of test solution (a) to 10.0 mL with the solvent mixture.

**Reference solution (a).** Dissolve 0.100 g of *malathion CRS* in the solvent mixture and dilute to 50.0 mL with the solvent mixture.

**Reference solution (b).** Dilute 0.5 mL of test solution (a) to 100.0 mL with the solvent mixture.

**Reference solution (c).** Dissolve 5.0 mg of *malathion impurity A CRS* and 5.0 mg of *malathion impurity B CRS* in the solvent mixture, then dilute 50.0 mL with the solvent mixture.

**Reference solution (d).** Dilute 2.0 mL of reference solution (c) to 10.0 mL with the solvent mixture.

#### Column:

– **size:** *l* = 0.15 m, Ø = 4.6 mm;

– **stationary phase:** *octadecylsilyl silica gel for chromatography R* (10 µm);

– **temperature:** 35 °C.

**Mobile phase:** *acetonitrile R*, *water R* (45:55 V/V).

**Flow rate:** 1 mL/min.

**Detection:** spectrophotometer at 210 nm.

**Injection:** 20 µL of test solution (a) and reference solutions (b), (c) and (d).

**Retention time:** impurity B = about 3.5 min; impurity A = about 5 min; malathion = about 16 min.

**System suitability:** reference solution (c):

– **resolution:** minimum 2.0 between the peaks due to impurities B and A.

#### Limits:

– **impurity A:** not more than 3 times the area of the corresponding peak in the chromatogram obtained with reference solution (d) (0.3 per cent);

– **impurity B:** not more than the area of the corresponding peak in the chromatogram obtained with reference solution (d) (0.1 per cent);

– **sum of impurities other than A and B:** not more than twice the area of the principal peak in the chromatogram obtained with reference solution (b) (1 per cent);

– **disregard limit:** 0.1 times the area of the principal peak in the chromatogram obtained with reference solution (b) (0.05 per cent).

**Water** (2.5.12): maximum 0.1 per cent, determined on 2.000 g.

#### ASSAY

Liquid chromatography (2.2.29) as described in the test for related substances with the following modifications.

**Injection:** test solution (b) and reference solution (a).

**System suitability:** reference solution (a):

– **repeatability:** maximum relative standard deviation of 1.0 per cent after 6 injections.

Calculate the percentage content of C<sub>10</sub>H<sub>16</sub>O<sub>6</sub>PS<sub>2</sub> from the declared content of *malathion CRS*.

## STORAGE

In an airtight container, protected from light.

## IMPURITIES

Specified impurities: A, B.

Other detectable impurities (the following substances would, if present at a sufficient level, be detected by one or other of the tests in the monograph. They are limited by the general acceptance criterion for other/unspecified impurities and/or by the general monograph *Substances for pharmaceutical use (2034)*. It is therefore not necessary to identify these impurities for demonstration of compliance. See also 5.10. *Control of impurities in substances for pharmaceutical use*): C.

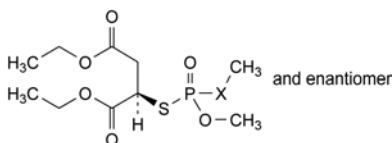

- A. X = S: diethyl (2RS)-2-[(methoxy)(methylsulfanyl)-S-phosphinothiyl]butanedioate (isomalathion),  
 B. X = O: diethyl (2RS)-2-(dimethoxy-S-phosphinothiyl)butanedioate (maloxon),

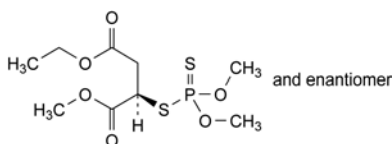

- C. ethyl and methyl (2RS)-2-(dimethoxyphosphino-dithiyl)butanedioate (methyl analogue).

01/2008:0365  
corrected 6.0

## MALEIC ACID

## Acidum maleicum



$C_4H_4O_4$   
[110-16-7]

$M_r$  116.1

## DEFINITION

Maleic acid contains not less than 99.0 per cent and not more than the equivalent of 101.0 per cent of (*Z*)-butenedioic acid, calculated with reference to the anhydrous substance.

## CHARACTERS

A white or almost white, crystalline powder, freely soluble in water and in alcohol.

## IDENTIFICATION

- A. Dilute 5 mL of solution S (see Tests) to 10 mL with *water R*. The pH of the dilution is less than 2.  
 B. Examine the chromatograms obtained in the test for fumaric acid. The principal spot in the chromatogram obtained with test solution (b) is similar in position and size to the principal spot in the chromatogram obtained with reference solution (a).  
 C. Dissolve 0.1 g in 10 mL of *water R* (solution a). To 0.3 mL of solution (a) add a solution of 10 mg of *resorcinol R* in 3 mL of *sulfuric acid R*. Heat on a water-bath for 15 min; no colour develops. To 3 mL of solution (a) add 1 mL of *bromine water R*. Heat on a water-bath to remove the bromine (15 min), heat to boiling and cool. To 0.2 mL of this solution add a solution of 10 mg of *resorcinol R* in 3 mL of *sulfuric acid R*. Heat on a water-bath for 15 min. A violet-pink colour develops.

## TESTS

**Solution S.** Dissolve 5.0 g in *water R* and dilute to 50 mL with the same solvent.

**Appearance of solution.** Solution S is clear (2.2.1) and not more intensely coloured than reference solution  $Y_7$  (2.2.2, *Method II*).

**Fumaric acid.** Examine by thin-layer chromatography (2.2.27), using *silica gel GF<sub>254</sub> R* as the coating substance.

**Test solution (a).** Dissolve 0.5 g of the substance to be examined in *acetone R* and dilute to 5 mL with the same solvent.

**Test solution (b).** Dilute 1 mL of test solution (a) to 50 mL with *acetone R*.

**Reference solution (a).** Dissolve 20 mg of *maleic acid CRS* in *acetone R* and dilute to 10 mL with the same solvent.

**Reference solution (b).** Dissolve 15 mg of *fumaric acid CRS* in *acetone R* and dilute to 10 mL with the same solvent.

**Reference solution (c).** Mix 5 mL of reference solution (a) and 5 mL of reference solution (b).

Apply separately to the plate 5  $\mu$ L of test solutions (a) and (b), 5  $\mu$ L of reference solutions (a) and (b) and 10  $\mu$ L of reference solution (c). Develop in an unsaturated tank over a path of 10 cm using a mixture of 12 volumes of *anhydrous formic acid R*, 16 volumes of *chloroform R*, 32 volumes of *butanol R* and 44 volumes of *heptane R*. Dry the plate at 100 °C for 15 min and examine in ultraviolet light at 254 nm. Any spot corresponding to fumaric acid in the chromatogram obtained with test solution (a) is not more intense than the spot in the chromatogram obtained with reference solution (b) (1.5 per cent). The test is not valid unless the chromatogram obtained with reference solution (c) shows two clearly separated spots.

**Iron.** To 10 mL of solution S add 2 mL of *dilute hydrochloric acid R* and 0.05 mL of *bromine water R*. After 5 min, remove the excess of bromine by passing a current of air and add 3 mL of *potassium thiocyanate solution R*. Shake. Prepare a standard at the same time and in the same manner, using a mixture of 5 mL of *iron standard solution (1 ppm Fe) R*, 1 mL of *dilute hydrochloric acid R*, 6 mL of *water R* and 0.05 mL of *bromine water R*. Allow both solutions to stand for 5 min. Any red colour in the test solution is not more intense than that in the standard (5 ppm).

**Heavy metals (2.4.8).** 1.0 g complies with limit test D for heavy metals (10 ppm). Prepare the standard using 1 mL of *lead standard solution (10 ppm Pb) R*.

**Water (2.5.12).** Not more than 2.0 per cent, determined on 1.00 g by the semi-micro determination of water.

**Sulfated ash (2.4.14).** Not more than 0.1 per cent, determined on 1.0 g.

## ASSAY

Dissolve 0.500 g in 50 mL of *water R*. Titrate with 1 M *sodium hydroxide* using 0.5 mL of *phenolphthalein solution R* as indicator.

1 mL of 1 M *sodium hydroxide* is equivalent to 58.04 mg of  $C_4H_4O_4$ .

## STORAGE

Store in a glass container, protected from light.

01/2008:2080  
corrected 6.0

## MALIC ACID

## Acidum malicum

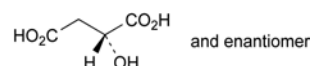

$C_4H_6O_5$   
[6915-15-7]

$M_r$  134.1

## DEFINITION

(2*RS*)-2-Hydroxybutanedioic acid.

*Content*: 99.0 per cent to 101.0 per cent (anhydrous substance).

## CHARACTERS

*Appearance*: white or almost white, crystalline powder.

*Solubility*: freely soluble in water and in alcohol, sparingly soluble in acetone.

## IDENTIFICATION

A. Melting point (2.2.14): 128 °C to 132 °C.

B. Infrared absorption spectrophotometry (2.2.24).

*Comparison*: Ph. Eur. reference spectrum of malic acid.

## TESTS

**Solution S.** Dissolve 5.00 g in *water R* and dilute to 25 mL with the same solvent.

**Appearance of solution.** Solution S is clear (2.2.1) and colourless (2.2.2, Method II).

**Optical rotation** (2.2.7):  $-0.10^\circ$  to  $+0.10^\circ$ , determined on solution S.

**Water-insoluble substances:** maximum 0.1 per cent.

Dissolve 25.0 g in 100 mL of *water R*, filter the solution through a tared sintered-glass filter (16) (2.1.2), wash the filter with hot *water R* and dry at 100-105 °C to constant weight. The residue weighs a maximum of 25 mg.

**Related substances.** Liquid chromatography (2.2.29).

*Test solution.* Dissolve 100.0 mg of the substance to be examined in the mobile phase and dilute to 100.0 mL with the mobile phase.

*Reference solution (a).* Dissolve 10.0 mg of *fumaric acid R* and 4.0 mg of *maleic acid R* in 25 mL of the mobile phase and dilute to 50.0 mL with the mobile phase.

*Reference solution (b).* Dilute 2.5 mL of reference solution (a) to 100.0 mL with the mobile phase.

*Reference solution (c).* Dissolve 20.0 mg of the substance to be examined in the mobile phase, add 1.0 mL of reference solution (a) and dilute to 20.0 mL with the mobile phase.

*Column*:

– *size*:  $l = 0.30$  m,  $\varnothing = 7.8$  mm,

– *stationary phase*: ion-exclusion resin for chromatography R (9  $\mu$ m),

– *temperature*: 37 °C.

*Mobile phase*: 0.005 M sulfuric acid.

*Flow rate*: 0.6 mL/min.

*Detection*: spectrophotometer at 210 nm.

*Injection*: 20  $\mu$ L.

*Run time*: twice the retention time of the principal peak in the chromatogram obtained with the test solution.

*Relative retention* with reference to malic acid (retention time = about 10 min): impurity B = about 0.8; impurity A = about 1.5.

*System suitability*: reference solution (c):

– *resolution*: minimum 2.5 between the peaks due to impurity B and malic acid.

*Limits*:

– *impurity A*: not more than twice the area of the corresponding peak in the chromatogram obtained with reference solution (b) (1.0 per cent),

– *impurity B*: not more than 0.25 times the area of the corresponding peak in the chromatogram obtained with reference solution (b) (0.05 per cent),

– *any other impurity*: for each impurity, not more than 0.5 times the area of the peak due to impurity B in the chromatogram obtained with reference solution (b) (0.1 per cent),

– *total of other impurities*: not more than 2.5 times the area of the peak due to impurity B in the chromatogram obtained with reference solution (b) (0.5 per cent),

– *disregard limit*: 0.1 times the area of the peak due to impurity B in the chromatogram obtained with reference solution (b) (0.02 per cent).

**Heavy metals** (2.4.8): maximum 20 ppm.

1.0 g complies with limit test F. Prepare the standard using 2 mL of *lead standard solution (10 ppm Pb) R*.

**Water** (2.5.12): maximum 2.0 per cent, determined on 1.00 g.

**Sulfated ash** (2.4.14): maximum 0.1 per cent, determined on 1.0 g.

## ASSAY

Dissolve 0.500 g in 50 mL of *carbon dioxide-free water R*. Titrate with 1 M *sodium hydroxide* determining the end-point potentiometrically (2.2.20).

1 mL of 1 M *sodium hydroxide* is equivalent to 67.05 mg of  $C_4H_6O_5$ .

## IMPURITIES

*Specified impurities*: A, B.

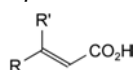

A. R =  $CO_2H$ , R' = H: (*E*)-butenedioic acid (fumaric acid),

B. R = H, R' =  $CO_2H$ : (*Z*)-butenedioic acid (maleic acid).

01/2009:1235

## MALTITOL

## Maltitolum

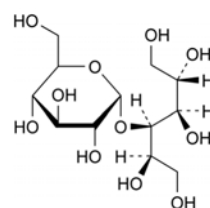

$C_{12}H_{24}O_{11}$   
[585-88-6]

$M_r$  344.3

## DEFINITION

4-*O*- $\alpha$ -D-Glucopyranosyl-D-glucitol (D-maltitol).

*Content*: 98.0 per cent to 102.0 per cent (anhydrous substance).

## CHARACTERS

*Appearance*: white or almost white, crystalline powder.

*Solubility*: very soluble in water, practically insoluble in anhydrous ethanol.

## IDENTIFICATION

*First identification*: A.

*Second identification*: B, C, D.

A. Infrared absorption spectrophotometry (2.2.24).

*Preparation*: discs.

*Comparison*: *maltitol CRS*.

B. Melting point (2.2.14): 148 °C to 151 °C.

C. Specific optical rotation (2.2.7):  $+105.5$  to  $+108.5$  (anhydrous substance).

Dissolve 5.00 g in *water R* and dilute to 100.0 mL with the same solvent.

D. Thin-layer chromatography (2.2.27).

*Test solution.* Dissolve 25 mg of the substance to be examined in *water R* and dilute to 10 mL with the same solvent.

**Reference solution (a).** Dissolve 25 mg of maltitol CRS in water R and dilute to 10 mL with the same solvent.

**Reference solution (b).** Dissolve 25 mg of maltitol CRS and 25 mg of sorbitol CRS in water R and dilute to 10 mL with the same solvent.

**Plate:** TLC silica gel G plate R.

**Mobile phase:** water R, ethyl acetate R, propanol R (10:20:70 V/V/V).

**Application:** 2 µL.

**Development:** over a path of 17 cm.

**Drying:** in air.

**Detection:** spray with 4-aminobenzoic acid solution R. Dry in a current of cold air until the acetone is removed. Heat at 100-105 °C for 15 min. Allow to cool and spray with a 2 g/L solution of sodium periodate R. Dry in a current of cold air. Heat at 100 °C for 15 min.

**System suitability:** test solution (b):

- the chromatogram shows 2 clearly separated spots.

**Results:** the principal spot in the chromatogram obtained with the test solution is similar in position, colour and size to the principal spot in the chromatogram obtained with reference solution (a).

## TESTS

**Appearance of solution.** The solution is clear (2.2.1) and colourless (2.2.2, Method II).

Dissolve 5.0 g in water R and dilute to 50 mL with the same solvent.

**Conductivity (2.2.38):** maximum 20 µS·cm<sup>-1</sup>.

Dissolve 20.0 g in carbon dioxide-free water R prepared from distilled water R and dilute to 100.0 mL with the same solvent. Measure the conductivity of the solution, while gently stirring with a magnetic stirrer.

**Reducing sugars:** maximum 0.2 per cent, expressed as glucose equivalent.

Dissolve 5.0 g in 6 mL of water R with the aid of gentle heat. Cool and add 20 mL of cupri-citric solution R and a few glass beads. Heat so that boiling begins after 4 min and maintain boiling for 3 min. Cool rapidly and add 100 mL of a 2.4 per cent V/V solution of glacial acetic acid R and 20.0 mL of 0.025 M iodine. With continuous shaking, add 25 mL of a mixture of 6 volumes of hydrochloric acid R and 94 volumes of water R and, when the precipitate has dissolved, titrate the excess of iodine with 0.05 M sodium thiosulfate using 1 mL of starch solution R, added towards the end of the titration as indicator. Not less than 12.8 mL of 0.05 M sodium thiosulfate is required.

**Related substances.** Liquid chromatography (2.2.29).

**Test solution.** Dissolve 5.0 g of the substance to be examined in 20 mL of water R and dilute to 100.0 mL with the same solvent.

**Reference solution (a).** Dissolve 0.50 g of maltitol CRS in 2.0 mL of water R and dilute to 10.0 mL with the same solvent.

**Reference solution (b).** Dilute 1.0 mL of the test solution to 100.0 mL with water R.

**Reference solution (c).** Dilute 10.0 mL of reference solution (b) to 100.0 mL with water R.

**Reference solution (d).** Dissolve 0.5 g of maltitol R and 0.5 g of sorbitol R in 5 mL of water R and dilute to 10.0 mL with the same solvent.

**Column:**

- size:  $l = 0.3$  m,  $\varnothing = 7.8$  mm;
- stationary phase: strong cation exchange resin (calcium form) R (9 µm);
- temperature:  $85 \pm 1$  °C.

**Mobile phase:** degassed water R.

**Flow rate:** 0.5 mL/min.

**Detection:** refractometer maintained at a constant temperature.

**Injection:** 20 µL of the test solution and reference solutions (b), (c) and (d).

**Run time:** 3 times the retention time of maltitol.

**Relative retention** with reference to maltitol (retention time = about 16 min): impurity B = about 0.8; impurity A = about 1.8.

**System suitability:** reference solution (d):

- resolution: minimum 2 between the peaks due to maltitol and impurity A.

**Limits:**

- any impurity: for each impurity, not more than the area of the principal peak in the chromatogram obtained with reference solution (b) (1.0 per cent);
- total: not more than twice the area of the principal peak in the chromatogram obtained with reference solution (b) (2.0 per cent);
- disregard limit: the area of the principal peak in the chromatogram obtained with reference solution (c) (0.1 per cent).

**Lead (2.4.10):** maximum 0.5 ppm.

**Nickel (2.4.15):** maximum 1 ppm.

**Water (2.5.12):** maximum 1.0 per cent, determined on 1.00 g.

## Microbial contamination

If intended for use in the manufacture of parenteral preparations:

- TAMC: acceptance criterion: 10<sup>2</sup> CFU/g (2.6.12).

If not intended for use in the manufacture of parenteral preparations:

- TAMC: acceptance criterion 10<sup>3</sup> CFU/g (2.6.12);
- TYMC: acceptance criterion 10<sup>2</sup> CFU/g (2.6.12);
- absence of *Escherichia coli* (2.6.13);
- absence of *Salmonella* (2.6.13).

**Bacterial endotoxins (2.6.14).** If intended for use in the manufacture of parenteral preparations without a further appropriate procedure for the removal of bacterial endotoxins:

- less than 4 IU/g for parenteral preparations having a concentration of less than 100 g/L of maltitol;
- less than 2.5 IU/g for parenteral preparations having a concentration of 100 g/L or more of maltitol.

## ASSAY

Liquid chromatography (2.2.29) as described in the test for related substances with the following modification.

**Injection:** test solution and reference solution (a).

Calculate the percentage content of D-maltitol from the declared content of maltitol CRS.

## LABELLING

The label states:

- where applicable, the maximum concentration of bacterial endotoxins,
- where applicable, that the substance is suitable for use in the manufacture of parenteral preparations.

## IMPURITIES

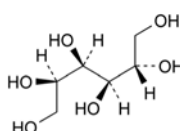

A. D-glucitol (D-sorbitol),

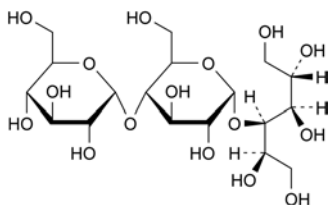

- B. *O*- $\alpha$ -D-glucopyranosyl-(1 $\rightarrow$ 4)-*O*- $\alpha$ -D-glucopyranosyl-(1 $\rightarrow$ 4)-D-glucitol (maltotriitol).

01/2008:1236

## MALTITOL, LIQUID

### Maltitolum liquidum

#### DEFINITION

Aqueous solution of a hydrogenated, partly hydrolysed starch, composed of a mixture of mainly 4-*O*- $\alpha$ -D-glucopyranosyl-D-glucitol (D-maltitol) with D-glucitol (D-sorbitol) and hydrogenated oligo- and polysaccharides.

#### Content:

- *D*-maltitol (C<sub>12</sub>H<sub>24</sub>O<sub>11</sub>): minimum 50.0 per cent *m/m* (anhydrous substance) and 95.0 per cent to 105.0 per cent of the content stated on the label;
- *D*-sorbitol (C<sub>6</sub>H<sub>14</sub>O<sub>6</sub>): maximum 8.0 per cent *m/m* (anhydrous substance);
- *anhydrous substance*: 68.0 per cent *m/m* to 85.0 per cent *m/m*.

#### CHARACTERS

*Appearance*: clear, colourless, syrupy liquid.

*Solubility*: miscible with water and with glycerol.

#### IDENTIFICATION

*First identification*: A.

*Second identification*: B, C.

- A. Examine the chromatograms obtained in the assay.

*Results*: the principal peak in the chromatogram obtained with the test solution is similar in retention time to the principal peak in the chromatogram obtained with reference solution (a).

- B. Thin-layer chromatography (2.2.27).

*Test solution*. Dilute 0.35 g of the substance to be examined to 100 mL with *water R*.

*Reference solution (a)*. Dissolve 20 mg of *maltitol CRS* in *water R* and dilute to 10 mL with the same solvent.

*Reference solution (b)*. Dissolve 20 mg of *maltitol CRS* and 20 mg of *sorbitol CRS* in *water R* and dilute to 10 mL with the same solvent.

*Plate*: TLC silica gel G plate *R*.

*Mobile phase*: *water R*, *ethyl acetate R*, *propanol R* (10:20:70 V/V/V)

*Application*: 2  $\mu$ L.

*Development*: over a path of 17 cm.

*Drying*: in air.

*Detection*: spray with 4-aminobenzoic acid solution *R*. Dry in a current of cold air until the acetone is removed. Heat at 100–105 °C for 15 min. Allow to cool and spray with a 2 g/L solution of sodium periodate *R*. Dry in a current of cold air. Heat at 100 °C for 15 min.

*System suitability*: reference solution (b):

- the chromatogram shows 2 clearly separated spots.

*Results*: the principal spot in the chromatogram obtained with the test solution is similar in position and colour to the principal spot in the chromatogram obtained with reference solution (a).

- C. To 3 mL of a freshly prepared 100 g/L solution of *pyrocatechol R*, add 6 mL of *sulfuric acid R* while cooling in iced water. To 3 mL of the cooled mixture, add 0.3 mL of solution S (see Tests). Heat gently over a naked-flame for about 30 s. A pink colour develops.

#### TESTS

**Solution S**. Dilute 7.0 g to 50 mL with *water R*.

**Appearance of solution**. Solution S is clear (2.2.1) and colourless (2.2.2, Method II).

**Conductivity** (2.2.38): maximum 10  $\mu$ S $\cdot$ cm<sup>-1</sup>, measured on undiluted liquid maltitol while gently stirring with a magnetic stirrer.

**Reducing sugars**: maximum 0.2 per cent, calculated as glucose equivalent.

To 5.0 g add 6 mL of *water R*, 20 mL of *cupri-citric solution R* and a few glass beads. Heat so that boiling begins after 4 min and maintain boiling for 3 min. Cool rapidly and add 100 mL of a 2.4 per cent V/V solution of *glacial acetic acid R* and 20.0 mL of 0.025 M *iodine*. With continuous shaking, add 25 mL of a mixture of 6 volumes of *hydrochloric acid R* and 94 volumes of *water R* and, when the precipitate has dissolved, titrate the excess of iodine with 0.05 M *sodium thiosulfate* using 1 mL of *starch solution R*, added towards the end of the titration, as indicator. Not less than 12.8 mL of 0.05 M *sodium thiosulfate* is required.

**Lead** (2.4.10): maximum 0.5 ppm.

**Nickel** (2.4.15): maximum 1 ppm.

**Water** (2.5.12): 15.0 per cent *m/m* to 32.0 per cent *m/m*, determined on 0.100 g. Use as solvent a mixture of equal volumes of *anhydrous methanol R* and *formamide R*. Carry out the titration at about 50 °C.

#### ASSAY

Liquid chromatography (2.2.29).

*Test solution*. Mix 1.00 g of the solution to be examined with 20 mL of *water R* and dilute to 50.0 mL with the same solvent.

*Reference solution (a)*. Dissolve 50.0 mg of *maltitol CRS* in 2 mL of *water R* and dilute to 5.0 mL with the same solvent.

*Reference solution (b)*. Dissolve 8.0 mg of *sorbitol CRS* in 2 mL of *water R* and dilute to 5.0 mL with the same solvent.

*Reference solution (c)*. Dissolve 50 mg of *maltitol R* and 50 mg of *sorbitol R* in 2 mL of *water R* and dilute to 5.0 mL with the same solvent.

*Column*:

- *size*: *l* = 0.3 m,  $\varnothing$  = 7.8 mm;
- *stationary phase*: strong cation exchange resin (calcium form) *R* (9  $\mu$ m);
- *temperature*: 85  $\pm$  2 °C.

*Mobile phase*: degassed *water R*.

*Flow rate*: 0.5 mL/min.

*Detection*: refractometer maintained at a constant temperature.

*Injection*: 20  $\mu$ L.

*Run time*: 3 times the retention time of maltitol.

*Relative retention* with reference to maltitol (retention time = about 16 min): sorbitol = about 1.8.

*System suitability*: reference solution (c):

- *resolution*: minimum 2 between the peaks due to sorbitol and maltitol.

Calculate the percentage contents of D-maltitol and D-sorbitol from the declared contents of *maltitol CRS* and *sorbitol CRS*.

#### LABELLING

The label states the content of D-maltitol.

- 07/2009:1542**  $V_0$  = total volume of glucose standard solution, in millilitres;  
 $V_1$  = total volume of test solution, in millilitres;  
 $M$  = sample mass, in grams;  
 $D$  = percentage content of dry matter in the substance.

## MALTODEXTRIN

### Maltodextrinum

#### DEFINITION

Mixture of glucose, disaccharides and polysaccharides, obtained by the partial hydrolysis of starch.

The degree of hydrolysis, expressed as dextrose equivalent (DE), is less than 20 (nominal value).

#### CHARACTERS

**Appearance:** white or almost white, slightly hygroscopic powder or granules.

**Solubility:** freely soluble in water.

#### IDENTIFICATION

- A. Dissolve 0.1 g in 2.5 mL of *water R* and heat with 2.5 mL of *cupri-tartaric solution R*. A red precipitate is formed.
- B. Dip, for 1 s, a suitable stick with a reactive pad containing glucose-oxidase, peroxidase and a hydrogen-donating substance, such as tetramethylbenzidine, in a 100 g/L solution of the substance to be examined. Observe the colour of the reactive pad; within 60 s the colour changes from yellow to green or blue.
- C. It is a powder or granules.
- D. Dextrose equivalent (see Tests).

#### TESTS

**Solution S.** Dissolve 12.5 g in *carbon dioxide-free water R* and dilute to 50.0 mL with the same solvent.

**pH (2.2.3):** 4.0 to 7.0.

Mix 1 mL of a 223.6 g/L solution of *potassium chloride R* and 30 mL of solution S.

**Sulfur dioxide (2.5.29):** maximum 20 ppm.

**Heavy metals (2.4.8):** maximum 10 ppm.

Dilute 4 mL of solution S to 30 mL with *water R*. The solution complies with test E. Prepare the reference solution using 10 mL of *lead standard solution (1 ppm Pb) R*.

**Loss on drying (2.2.32):** maximum 6.0 per cent, determined on 10.00 g by drying in an oven at 105 °C.

**Sulfated ash (2.4.14):** maximum 0.5 per cent, determined on 1.0 g.

**Dextrose equivalent (DE):** within 2 DE units of the nominal value.

Weigh an amount of the substance to be examined equivalent to 2.85-3.15 g of reducing carbohydrates, calculated as dextrose equivalent, into a 500 mL volumetric flask. Dissolve in *water R* and dilute to 500.0 mL with the same solvent. Transfer the solution to a 50 mL burette.

Pipette 25.0 mL of *cupri-tartaric solution R* into a 250 mL flask and add 18.5 mL of the test solution from the burette, mix and add a few glass beads. Place the flask on a hot plate, previously adjusted so that the solution begins to boil within 2 min ± 15 s. Allow to boil for exactly 120 s, add 1 mL of a 1 g/L solution of *methylene blue R* and titrate with the test solution ( $V_1$ ) until the blue colour disappears. Maintain the solution at boiling throughout the titration.

Standardise the cupri-tartaric solution using a 6.00 g/L solution of *glucose R* ( $V_0$ ).

Calculate the dextrose equivalent using the following expression:

$$\frac{300 \times V_0 \times 100}{V_1 \times M \times D}$$

#### Microbial contamination

TAMC: acceptance criterion  $10^3$  CFU/g (2.6.12).

TYMC: acceptance criterion  $10^2$  CFU/g (2.6.12).

Absence of *Escherichia coli* (2.6.13).

Absence of *Salmonella* (2.6.13).

#### LABELLING

The label states the dextrose equivalent (DE) (= nominal value).

#### FUNCTIONALITY-RELATED CHARACTERISTICS

*This section provides information on characteristics that are recognised as being relevant control parameters for one or more functions of the substance when used as an excipient (see chapter 5.15). This section is a non-mandatory part of the monograph and it is not necessary to verify the characteristics to demonstrate compliance. Control of these characteristics can however contribute to the quality of a medicinal product by improving the consistency of the manufacturing process and the performance of the medicinal product during use. Where control methods are cited, they are recognised as being suitable for the purpose, but other methods can also be used. Wherever results for a particular characteristic are reported, the control method must be indicated.*

*The following characteristics may be relevant for maltodextrin used as filler and binder in tablets and capsules.*

**Dextrose equivalent** (see Tests).

**Particle-size distribution (2.9.31 or 2.9.38).**

**Powder flow (2.9.36).**

**04/2008:2162**

## MANGANESE GLUCONATE

### Mangani gluconas

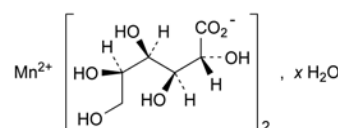

$C_{12}H_{22}MnO_{14} \cdot xH_2O$

$M_r$  445.2 (anhydrous substance)

#### DEFINITION

Anhydrous or hydrated manganese(II) D-gluconate.

**Content:** 98.0 per cent to 102.0 per cent (anhydrous substance).

#### CHARACTERS

**Appearance:** white or pale pink, slightly hygroscopic, crystalline powder.

**Solubility:** soluble in water, practically insoluble in anhydrous ethanol, insoluble in methylene chloride.

#### IDENTIFICATION

- A. Thin-layer chromatography (2.2.27).

**Test solution.** Dissolve 20 mg of the substance to be examined in 1 mL of *water R*.

**Reference solution.** Dissolve 20 mg of *calcium gluconate CRS* in 1 mL of *water R*, heating if necessary in a water-bath at 60 °C.

**Plate:** *TLC silica gel plate R* (5-40 µm) [or *TLC silica gel plate R* (2-10 µm)].

Mobile phase: concentrated ammonia R, ethyl acetate R, water R, ethanol (96 per cent) R (10:10:30:50 V/V/V/V).

Application: 1 µL.

Development: over 3/4 of the plate.

Drying: at 100-105 °C for 20 min, then allow to cool to room temperature.

Detection: spray with a solution containing 25 g/L of ammonium molybdate R and 10 g/L of cerium sulfate R in dilute sulfuric acid R, and heat at 100-105 °C for about 10 min.

Results: the principal spot in the chromatogram obtained with the test solution is similar in position, colour and size to the principal spot in the chromatogram obtained with the reference solution.

- B. Dissolve 50 mg in 5 mL of water R. Add 0.5 mL of ammonium sulfide solution R. A pale pink precipitate is formed that dissolves upon the addition of 1 mL of glacial acetic acid R.

## TESTS

**Solution S.** Dissolve 1.0 g in water R and dilute to 50 mL with the same solvent.

**Appearance of solution.** Solution S is not more opalescent than reference suspension II (2.2.1) and not more intensely coloured than intensity 6 of the range of reference solutions of the most appropriate colour (2.2.2, Method II).

**Sucrose and reducing sugars.** Dissolve 0.5 g in a mixture of 2 mL of hydrochloric acid R1 and 10 mL of water R. Boil for 5 min, allow to cool, add 10 mL of sodium carbonate solution R and allow to stand for 10 min. Dilute to 25 mL with water R and filter. To 5 mL of the filtrate add 2 mL of cupri-tartaric solution R and boil for 1 min. Allow to stand for 2 min. No red precipitate is formed.

**Chlorides (2.4.4):** maximum 500 ppm.

Dilute 5 mL of solution S to 15 mL with water R.

**Sulfates (2.4.13):** maximum 500 ppm.

Dissolve 2.0 g in a mixture of 10 mL of acetic acid R and 90 mL of distilled water R.

**Zinc:** maximum 50 ppm.

To 10 mL of solution S add 1 mL of sulfuric acid R and 0.1 mL of potassium ferrocyanide solution R. After 30 s, any opalescence in the solution is not more intense than that in a mixture of 1.0 mL of zinc standard solution (10 ppm Zn) R, 9 mL of water R, 1 mL of sulfuric acid R and 0.1 mL of potassium ferrocyanide solution R.

**Heavy metals (2.4.8):** maximum 10 ppm.

Dissolve 2.0 g in 20 mL of water R, heating in a water-bath at 60 °C. 12 mL of the solution complies with test A. Prepare the reference solution using lead standard solution (1 ppm Pb) R.

**Water (2.5.32):** maximum 9.0 per cent, determined on 80 mg.

**Microbial contamination.** Total viable aerobic count (2.6.12) not more than 10<sup>3</sup> micro-organisms per gram, determined by plate count.

## ASSAY

Dissolve 0.400 g in 50 mL of water R. Add 10 mg of ascorbic acid R, 20 mL of ammonium chloride buffer solution pH 10.0 R and 0.2 mL of a 2 g/L solution of mordant black 11 R in triethanolamine R. Titrate with 0.1 M sodium edetate until the colour changes from violet to pure blue.

1 mL of 0.1 M sodium edetate is equivalent to 44.52 mg of C<sub>12</sub>H<sub>22</sub>MnO<sub>14</sub>.

## STORAGE

In a non-metallic, airtight container.

01/2008:2163  
corrected 6.4

## MANGANESE GLYCEROPHOSPHATE, HYDRATED

Mangani glycerophosphas hydricus

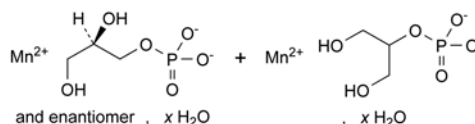

C<sub>3</sub>H<sub>7</sub>MnO<sub>6</sub>P<sub>1</sub>·xH<sub>2</sub>O

M<sub>r</sub> 225.0 (anhydrous substance)

## DEFINITION

Mixture of variable proportions of hydrated manganese(II) (2*RS*)-2,3-dihydroxypropyl phosphate and hydrated manganese(II) 2-hydroxy-1-(hydroxymethyl)ethyl phosphate.

**Content:** 97.0 per cent to 102.0 per cent (dried substance).

## CHARACTERS

**Appearance:** white or pale pink, hygroscopic powder.

**Solubility:** practically insoluble in water and in ethanol (96 per cent). It is freely soluble in dilute mineral acids.

## IDENTIFICATION

- Mix 1 g with 1 g of potassium hydrogen sulfate R in a test tube fitted with a delivery tube. Heat strongly and direct the white vapour towards a piece of filter paper impregnated with a freshly prepared 10 g/L solution of sodium nitroprusside R. The filter paper develops a blue colour in contact with piperidine R.
- Disperse 50 mg in 5 mL of water R. Add 0.5 mL of ammonium sulfide solution R. A pale pink precipitate is formed that dissolves on the addition of 1 mL of acetic acid R.
- Ignite 0.1 g in a crucible. Take up the residue with 5 mL of nitric acid R and heat on a water-bath for 1 min. Filter. The filtrate gives reaction (b) of phosphates (2.3.1).

## TESTS

**Solution S.** Dissolve 5.0 g in 20 mL of dilute hydrochloric acid R. Filter if necessary. Add dilute ammonia R1 until a precipitate is formed. Dissolve the precipitate by adding the minimum quantity needed of dilute hydrochloric acid R and dilute to 100 mL with distilled water R.

**Glycerol and ethanol (96 per cent)-soluble substances:** maximum 1.0 per cent.

Shake 1.00 g with 25 mL of ethanol (96 per cent) R for 1 min. Filter. Evaporate the filtrate to dryness on a water-bath and dry the residue at 70 °C for 1 h. The residue weighs a maximum of 10 mg.

**Chlorides (2.4.4):** maximum 0.15 per cent.

Dissolve 0.22 g in a mixture of 1 mL of nitric acid R and 10 mL of water R and dilute to 100 mL with water R.

**Phosphates (2.4.11):** maximum 0.3 per cent.

Dilute 1.0 mL of solution S to 100.0 mL with water R. To 10 mL of this solution add 140 mL of water R.

**Sulfates (2.4.13):** maximum 0.2 per cent.

Dilute 5 mL of solution S to 50 mL with distilled water R.

**Iron (2.4.9):** maximum 50 ppm.

Dilute 4 mL of solution S to 10 mL with water R.

**Heavy metals (2.4.8):** maximum 20 ppm.

12 mL of solution S complies with test A. Prepare the reference solution using lead standard solution (1 ppm Pb) R.

**Loss on drying (2.2.32):** maximum 12.0 per cent, determined on 1.000 g by drying in an oven at 105 °C for 4 h.



## ASSAY

To 0.200 g add 1.5 mL of 1 M hydrochloric acid, 50 mL of water R, 10 mg of ascorbic acid R and 20 mL of ammonium chloride buffer solution pH 10.0 R. Stir until dissolution. Immediately add 0.3 mL of a 2 g/L solution of mordant black 11 R in triethanolamine R and titrate with 0.1 M sodium edetate until the colour changes from violet to pure blue.

1 mL of 0.1 M sodium edetate is equivalent to 22.50 mg of  $C_3H_7MnO_6P$ .

## STORAGE

In an airtight container.

01/2008:1543  
corrected 6.0

## MANGANESE SULFATE MONOHYDRATE

## Mangani sulfas monohydricus

$MnSO_4 \cdot H_2O$   
[10034-96-5]

$M_r$  169.0

## DEFINITION

Content: 99.0 per cent to 101.0 per cent (ignited substance).

## CHARACTERS

Appearance: pale pink crystalline powder, slightly hygroscopic.

Solubility: freely soluble in water, practically insoluble in ethanol (96 per cent).

## IDENTIFICATION

- Solution S (see Tests) gives reaction (a) of sulfates (2.3.1).
- Dissolve 50 mg in 5 mL of water R. Add 0.5 mL of ammonium sulfide solution R. A pale pink precipitate is formed which dissolves on the addition of 1 mL of anhydrous acetic acid R.
- Loss on ignition (see Tests).

## TESTS

**Solution S.** Dissolve 10.0 g in distilled water R and dilute to 100 mL with the same solvent.

**Appearance of solution.** Solution S is not more opalescent than reference suspension II (2.2.1).

**Chlorides** (2.4.4): maximum 100 ppm.

Dilute 5 mL of solution S to 15 mL with water R.

**Iron** (2.4.9): maximum 10 ppm, determined on solution S.

**Zinc:** maximum 50 ppm.

To 10 mL of solution S add 1 mL of sulfuric acid R and 0.1 mL of potassium ferrocyanide solution R. After 30 s, any opalescence in the solution is not more intense than that in a mixture of 5 mL of zinc standard solution (10 ppm Zn) R, 5 mL of water R, 1 mL of sulfuric acid R and 0.1 mL of potassium ferrocyanide solution R.

**Heavy metals** (2.4.8): maximum 20 ppm.

12 mL of solution S complies with test A. Prepare the reference solution using lead standard solution (2 ppm Pb) R.

**Loss on ignition:** 10.0 per cent to 12.0 per cent, determined on 1.00 g at  $500 \pm 50$  °C.

## ASSAY

Dissolve 0.150 g in 50 mL of water R. Add 10 mg of ascorbic acid R, 20 mL of ammonium chloride buffer solution pH 10.0 R and 0.2 mL of a 2 g/L solution of mordant black 11 R in triethanolamine R. Titrate with 0.1 M sodium edetate until the colour changes from violet to pure blue.

1 mL of 0.1 M sodium edetate is equivalent to 15.10 mg of  $MnSO_4$ .

04/2009:0559

## MANNITOL

## Mannitolum

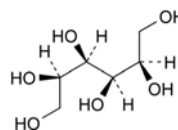

$C_6H_{14}O_6$   
[69-65-8]

$M_r$  182.2

## DEFINITION

D-Mannitol.

Content: 98.0 per cent to 102.0 per cent (anhydrous substance).

## CHARACTERS

Appearance: white or almost white, crystalline powder or free-flowing granules.

Solubility: freely soluble in water, very slightly soluble in ethanol (96 per cent).

It shows polymorphism (5.9).

## IDENTIFICATION

First identification: C.

Second identification: A, B, D.

- Specific optical rotation (2.2.7): + 23 to + 25 (anhydrous substance).

Dissolve 2.00 g of the substance to be examined and 2.6 g of disodium tetraborate R in about 20 mL of water R at 30 °C; shake continuously for 15-30 min without further heating. Dilute the resulting clear solution to 25.0 mL with water R.

- Melting point (2.2.14): 165 °C to 170 °C.

- Infrared absorption spectrophotometry (2.2.24).

Preparation: discs.

Comparison: mannitol CRS.

If the spectra obtained in the solid state show differences, dissolve separately in 2 glass vials 25 mg of the substance to be examined and 25 mg of the reference substance in 0.25 mL of distilled water R without heating. The solutions obtained are clear. Evaporate to dryness by heating in a microwave oven with a power range of 1000-1300 W for 15-30 min or by heating in an oven *in vacuo* at 100 °C. Non-sticky, white or slightly yellowish powders are obtained. Record new spectra using the residues.

- Thin-layer chromatography (2.2.27).

Test solution. Dissolve 25 mg of the substance to be examined in water R and dilute to 10 mL with the same solvent.

Reference solution (a). Dissolve 25 mg of mannitol CRS in water R and dilute to 10 mL with the same solvent.

Reference solution (b). Dissolve 25 mg of mannitol R and 25 mg of sorbitol R in water R and dilute to 10 mL with the same solvent.

Plate: TLC silica gel G plate R.

Mobile phase: water R, ethyl acetate R, propanol R (10:20:70 V/V/V).

Application: 2 µL.

Development: over 2/3 of the plate.

Drying: in air.

Detection: spray with 4-aminobenzoic acid solution R. Dry in a current of cold air until the acetone is removed. Heat at 100 °C for 15 min. Allow to cool and spray with a 2 g/L solution of sodium periodate R. Dry in a current of cold air. Heat at 100 °C for 15 min.

**System suitability:** reference solution (b):

- the chromatogram shows 2 clearly separated spots.

**Results:** the principal spot in the chromatogram obtained with the test solution is similar in position, colour and size to the principal spot in the chromatogram obtained with reference solution (a).

## TESTS

**Appearance of solution.** The solution is clear (2.2.1) and colourless (2.2.2, Method II).

Dissolve 5.0 g in *water R* and dilute to 50 mL with the same solvent.

**Conductivity** (2.2.38): maximum 20  $\mu\text{S}\cdot\text{cm}^{-1}$ .

Dissolve 20.0 g in *carbon dioxide-free water R* prepared from *distilled water R* by heating at 40–50 °C and dilute to 100.0 mL with the same solvent. After cooling, measure the conductivity of the solution while gently stirring with a magnetic stirrer.

**Reducing sugars:** maximum 0.2 per cent (calculated as glucose equivalent).

Dissolve 5.0 g in 25 mL of *water R* with the aid of gentle heating. Cool and add 20 mL of *cupri-citric solution R* and a few glass beads. Heat so that boiling begins after 4 min and maintain boiling for 3 min. Cool rapidly and add 100 mL of a 2.4 per cent *V/V* solution of *glacial acetic acid R* and 20.0 mL of 0.025 *M iodine*. With continuous shaking, add 25 mL of a mixture of 6 volumes of *hydrochloric acid R* and 94 volumes of *water R* and, when the precipitate has dissolved, titrate the excess of iodine with 0.05 *M sodium thiosulfate* using 1 mL of *starch solution R*, added towards the end of the titration, as indicator. Not less than 12.8 mL of 0.05 *M sodium thiosulfate* is required.

**Related substances.** Liquid chromatography (2.2.29).

**Test solution.** Dissolve 5.0 g of the substance to be examined in 25 mL of *water R* and dilute to 100.0 mL with the same solvent.

**Reference solution (a).** Dissolve 0.50 g of *mannitol CRS* in 2.5 mL of *water R* and dilute to 10.0 mL with the same solvent.

**Reference solution (b).** Dilute 2.0 mL of the test solution to 100.0 mL with *water R*.

**Reference solution (c).** Dilute 0.5 mL of reference solution (b) to 20.0 mL with *water R*.

**Reference solution (d).** Dissolve 0.5 g of *mannitol R* and 0.5 g of *sorbitol R* (impurity A) in 5 mL of *water R* and dilute to 10.0 mL with the same solvent.

**Reference solution (e).** Dissolve 0.1 g of *maltitol R* (impurity B) and 0.1 g of *isomalt R* (impurity C) in 5 mL of *water R* and dilute to 100 mL with the same solvent.

**Column:**

- size:  $l = 0.3$  m,  $\varnothing = 7.8$  mm;
- stationary phase: strong cation-exchange resin (calcium form) *R* (9  $\mu\text{m}$ );
- temperature:  $85 \pm 1$  °C.

**Mobile phase:** degassed *water R*.

**Flow rate:** 0.5 mL/min.

**Detection:** refractometer maintained at a constant temperature.

**Injection:** 20  $\mu\text{L}$  of the test solution and reference solutions (b), (c), (d) and (e).

**Run time:** twice the retention time of mannitol.

**Relative retention** with reference to mannitol (retention time = about 22 min): impurity C (eluted in 2 peaks) = about 0.7; impurity B = about 0.8; impurity A = about 1.2.

**System suitability:** reference solution (d):

- resolution: minimum 2 between the peaks due to mannitol and impurity A.

**Limits:**

- *impurities A, B:* for each impurity, not more than the area of the principal peak in the chromatogram obtained with reference solution (b) (2.0 per cent);
- *impurity C:* for the sum of the areas of the 2 peaks, not more than the area of the principal peak in the chromatogram obtained with reference solution (b) (2.0 per cent);
- *unspecified impurities:* for each impurity, not more than twice the area of the principal peak in the chromatogram obtained with reference solution (c) (0.10 per cent);
- *total:* not more than the area of the principal peak in the chromatogram obtained with reference solution (b) (2.0 per cent);
- *disregard limit:* the area of the principal peak in the chromatogram obtained with reference solution (c) (0.05 per cent).

**Lead** (2.4.10): maximum 0.5 ppm.

Dissolve the substance to be examined in 150.0 mL of the prescribed mixture of solvents.

**Nickel** (2.4.15): maximum 1 ppm.

Dissolve the substance to be examined in 150.0 mL of the prescribed mixture of solvents.

**Water** (2.5.12): maximum 0.5 per cent, determined on 1.00 g. Use as solvent 40 mL of a mixture of equal volumes of *anhydrous methanol R* and *formamide R* at about 50 °C.

## Microbial contamination

If intended for use in the manufacture of parenteral preparations:

- TAMC: acceptance criterion  $10^2$  CFU/g (2.6.12).

If not intended for use in the manufacture of parenteral preparations:

- TAMC: acceptance criterion  $10^3$  CFU/g (2.6.12);
- TYMC: acceptance criterion  $10^2$  CFU/g (2.6.12);
- absence of *Escherichia coli* (2.6.13);
- absence of *Salmonella* (2.6.13).

**Bacterial endotoxins** (2.6.14). If intended for use in the manufacture of parenteral preparations without a further appropriate procedure for the removal of bacterial endotoxins:

- less than 4 IU/g for parenteral preparations having a concentration of 100 g/L or less of mannitol;
- less than 2.5 IU/g for parenteral preparations having a concentration of more than 100 g/L of mannitol.

## ASSAY

Liquid chromatography (2.2.29) as described in the test for related substances with the following modification.

**Injection:** test solution and reference solution (a).

Calculate the percentage content of D-mannitol from the areas of the peaks and the declared content of *mannitol CRS*.

## LABELLING

The label states:

- where applicable, the maximum concentration of bacterial endotoxins;
- where applicable, that the substance is suitable for use in the manufacture of parenteral preparations.

## IMPURITIES

**Specified impurities:** A, B, C.

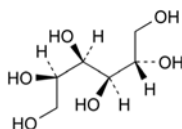

A. D-glucitol (D-sorbitol),

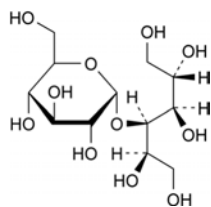

B. 4-O- $\alpha$ -D-glucopyranosyl-D-glucitol (D-maltitol),

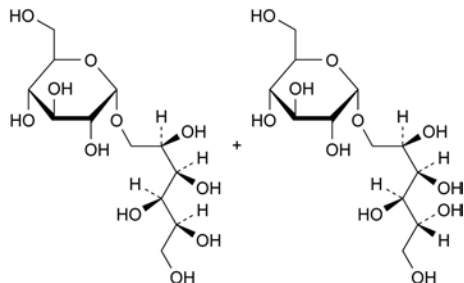

C. mixture of 6-O- $\alpha$ -D-glucopyranosyl-D-glucitol and 1-O- $\alpha$ -D-glucopyranosyl-D-mannitol (isomalt).

FUNCTIONALITY-RELATED CHARACTERISTICS

This section provides information on characteristics that are recognised as being relevant control parameters for one or more functions of the substance when used as an excipient (see chapter 5.15). This section is a non-mandatory part of the monograph and it is not necessary to verify the characteristics to demonstrate compliance. Control of these characteristics can however contribute to the quality of a medicinal product by improving the consistency of the manufacturing process and the performance of the medicinal product during use. Where control methods are cited, they are recognised as being suitable for the purpose, but other methods can also be used. Wherever results for a particular characteristic are reported, the control method must be indicated.

The following characteristics may be relevant for mannitol used as filler in tablets and capsules.

**Particle-size distribution** (2.9.31 or 2.9.38).

**Powder flow** (2.9.36).

07/2010:1237

MAPROTILINE HYDROCHLORIDE

Maprotilini hydrochloridum

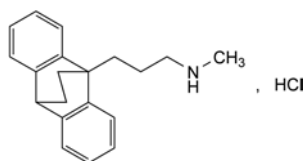

C<sub>20</sub>H<sub>24</sub>ClN  
[10347-81-6]

M<sub>r</sub> 313.9

DEFINITION

3-(9,10-Ethanoanthracen-9(10H)-yl)-N-methylpropan-1-amine hydrochloride.

Content: 99.0 per cent to 101.0 per cent (dried substance).

CHARACTERS

**Appearance:** white or almost white, crystalline powder.

**Solubility:** slightly soluble in water, freely soluble in methanol, soluble in ethanol (96 per cent), sparingly soluble in methylene chloride, very slightly soluble in acetone.

It shows polymorphism (5.9).

IDENTIFICATION

**First identification:** B, D.

**Second identification:** A, C, D.

A. Ultraviolet and visible absorption spectrophotometry (2.2.25).

**Test solution.** Dissolve 10 mg in 1 M hydrochloric acid and dilute to 100 mL with the same acid.

**Spectral range:** 250-300 nm.

**Absorption maxima:** at 265 nm and 272 nm.

**Absorption minimum:** at 268 nm.

**Absorbance ratio:** A<sub>272</sub>/A<sub>265</sub> = 1.1 to 1.3.

B. Infrared absorption spectrophotometry (2.2.24).

**Comparison:** maprotiline hydrochloride CRS.

If the spectra obtained show differences, dissolve the substance to be examined and the reference substance separately in methanol R, evaporate to dryness and record new spectra using the residues.

C. Thin-layer chromatography (2.2.27).

**Test solution.** Dissolve 25 mg of the substance to be examined in methanol R and dilute to 5 mL with the same solvent.

**Reference solution (a).** Dissolve 25 mg of maprotiline hydrochloride CRS in methanol R and dilute to 5 mL with the same solvent.

**Reference solution (b).** Dissolve 10 mg of maprotiline impurity D CRS in reference solution (a) and dilute to 2 mL with reference solution (a).

**Plate:** TLC silica gel F<sub>254</sub> plate R.

**Mobile phase:** ethyl acetate R, dilute ammonia R1, 2-butanol R (4:5:14 V/V/V).

**Application:** 5  $\mu$ L.

**Development:** over half of the plate.

**Drying:** in a current of warm air.

**Detection:** examine in ultraviolet light at 254 nm.

**System suitability:** reference solution (b):

- the chromatogram shows 2 clearly separated principal spots.

**Results:** the principal spot in the chromatogram obtained with the test solution is similar in position and size to the principal spot in the chromatogram obtained with reference solution (a).

D. Dilute 0.5 mL of solution S (see Tests) to 2 mL with methanol R. The solution gives reaction (a) of chlorides (2.3.1).

TESTS

**Solution S.** Dissolve 1.0 g in methanol R and dilute to 20 mL with the same solvent.

**Appearance of solution.** Solution S is clear (2.2.1) and not more intensely coloured than reference solution BY<sub>6</sub> (2.2.2, Method II).

**Related substances.** Liquid chromatography (2.2.29).

**Test solution.** Dissolve 0.10 g of the substance to be examined in the mobile phase and dilute to 100.0 mL with the mobile phase.

**Reference solution (a).** Dilute 1.0 mL of the test solution to 10.0 mL with the mobile phase. Dilute 2.0 mL of this solution to 100.0 mL with the mobile phase.

**Reference solution (b).** Dissolve 1.0 mg of maprotiline impurity D CRS in the test solution and dilute to 10.0 mL with the test solution.

**Column:**

- size: l = 0.25 m,  $\varnothing$  = 4.6 mm;
- stationary phase: silica gel for chromatography R (5  $\mu$ m).

**Mobile phase:** dissolve about 0.580 g of ammonium acetate R in 200 mL of water R and add 2 mL of a 70 g/L solution of concentrated ammonia R; add 150 mL of 2-propanol R and 650 mL of methanol R; the resulting apparent pH value is between 8.2 and 8.4.

Flow rate: 1 mL/min.

Detection: spectrophotometer at 272 nm.

Injection: 20 µL.

Run time: 1.5 times the retention time of maprotiline.

Identification of impurities: use the chromatogram obtained with reference solution (b) to identify the peak due to impurity D.

Relative retention with reference to maprotiline (retention time = about 10 min): impurity A = about 0.3; impurity B = about 0.5; impurity C = about 0.7; impurity D = about 0.8; impurity E = about 1.3.

System suitability: reference solution (b):

- resolution: 1.8 to 3.2 between the peaks due to impurity D and maprotiline; if necessary, adjust the pH of the mobile phase, in steps of 0.1 pH unit, by adding a 50 per cent V/V solution of acetic acid R if the resolution is less than 1.8, or by adding a 70 g/L solution of concentrated ammonia R if the resolution is greater than 3.2.

Limits:

- impurities A, B, C, D, E: for each impurity, not more than the area of the principal peak in the chromatogram obtained with reference solution (a) (0.2 per cent);
- unspecified impurities: for each impurity, not more than 0.5 times the area of the principal peak in the chromatogram obtained with reference solution (a) (0.10 per cent);
- total: not more than 5 times the area of the principal peak in the chromatogram obtained with reference solution (a) (1.0 per cent);
- disregard limit: 0.25 times the area of the principal peak in the chromatogram obtained with reference solution (a) (0.05 per cent).

Loss on drying (2.2.32): maximum 1.0 per cent, determined on 1.000 g by drying in an oven at 80 °C at a pressure not exceeding 2.5 kPa for 6 h.

Sulfated ash (2.4.14): maximum 0.1 per cent, determined on 1.0 g.

#### ASSAY

Dissolve 0.250 g in a mixture of 5 mL of 0.1 M hydrochloric acid and 50 mL of ethanol (96 per cent) R. Carry out a potentiometric titration (2.2.20), using 0.1 M sodium hydroxide. Read the volume added between the 2 points of inflexion.

1 mL of 0.1 M sodium hydroxide is equivalent to 31.39 mg of C<sub>20</sub>H<sub>24</sub>CIN.

#### IMPURITIES

Specified impurities: A, B, C, D, E.

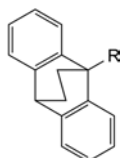

- A. R = CH=CH-CH=O: 3-(9,10-ethanoanthracen-9(10H)-yl)prop-2-enal,
- C. R = CH<sub>2</sub>-CH<sub>2</sub>-CH<sub>2</sub>-NH<sub>2</sub>: 3-(9,10-ethanoanthracen-9(10H)-yl)propan-1-amine,
- D. R = CH=CH-CH<sub>2</sub>-NH-CH<sub>3</sub>: 3-(9,10-ethanoanthracen-9(10H)-yl)-N-methylprop-2-en-1-amine (dehydromaprotiline),
- E. R = CH<sub>2</sub>-CH<sub>2</sub>-CH<sub>2</sub>-N(CH<sub>3</sub>)<sub>2</sub>: 3-(9,10-ethanoanthracen-9(10H)-yl)-N,N-dimethylpropan-1-amine,

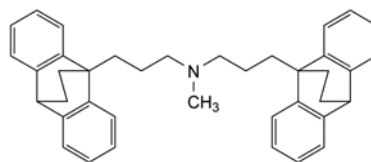

- B. 3-(9,10-ethanoanthracen-9(10H)-yl)-N-[3-(9,10-ethanoanthracen-9(10H)-yl)propyl]-N-methylpropan-1-amine.

04/2008:2233  
corrected 7.0

## MARBOFLOXACIN FOR VETERINARY USE

### Marbofloxacinum ad usum veterinarium

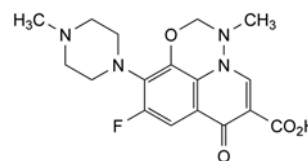

C<sub>17</sub>H<sub>19</sub>FN<sub>4</sub>O<sub>4</sub>  
[115550-35-1]

M<sub>r</sub> 362.4

#### DEFINITION

9-Fluoro-3-methyl-10-(4-methylpiperazin-1-yl)-7-oxo-2,3-dihydro-7H-pyrido[3,2,1-ij][4,1,2]benzoxadiazine-6-carboxylic acid.

Content: 99.0 per cent to 101.0 per cent (dried substance).

#### CHARACTERS

Appearance: light yellow, crystalline powder.

Solubility: slightly soluble in water, sparingly soluble or slightly soluble in methylene chloride, very slightly soluble in ethanol (96 per cent).

#### IDENTIFICATION

Infrared absorption spectrophotometry (2.2.24).

Comparison: marbofloxacin CRS.

#### TESTS

**Absorbance** (2.2.25): maximum 0.20, determined at 450 nm.

Dissolve 0.400 g in borate buffer solution pH 10.4 R and dilute to 10.0 mL with the same buffer solution.

**Related substances.** Liquid chromatography (2.2.29). Carry out the test protected from light.

Solvent mixture: methanol R, water R (23:77 V/V).

Test solution. To 0.100 g of the substance to be examined add 80 mL of the solvent mixture, sonicate until dissolution and dilute to 100.0 mL with the solvent mixture.

Reference solution (a). Dilute 5.0 mL of the test solution to 100.0 mL with the solvent mixture. Dilute 1.0 mL of this solution to 50.0 mL with the solvent mixture.

Reference solution (b). Dissolve 10 mg of marbofloxacin for peak identification CRS (containing impurities A, B, C, D and E) in the solvent mixture and dilute to 10 mL with the solvent mixture.

Column:

- size:  $l = 0.15$  m,  $\varnothing = 4.6$  mm;
- stationary phase: end-capped polar-embedded octadecylsilyl amorphous organosilica polymer R (3.5 µm);
- temperature: 40 °C.

Mobile phase: mix 230 volumes of methanol R and 5 volumes of glacial acetic acid R with 770 volumes of a 2.70 g/L solution of sodium dihydrogen phosphate R containing 3.50 g/L of sodium octanesulfonate R and previously adjusted to pH 2.5 with phosphoric acid R.

Flow rate: 1.2 mL/min.

**Detection:** spectrophotometer at 315 nm.

**Injection:** 10 µL.

**Run time:** 2.5 times the retention time of marbofloxacin.

**Identification of impurities:** use the chromatogram supplied with *marbofloxacin* for peak identification CRS and the chromatogram obtained with reference solution (b) to identify the peaks due to impurities A, B, C, D and E.

**Relative retention** with reference to marbofloxacin (retention time = about 33 min): impurity B = about 0.5; impurity A = about 0.7; impurity C = about 0.9; impurity D = about 1.3; impurity E = about 1.5.

**System suitability:** reference solution (b):

- **resolution:** minimum 1.5 between the peaks due to impurity C and marbofloxacin, and minimum 4.0 between the peaks due to marbofloxacin and impurity D.

**Limits:**

- **correction factor:** for the calculation of content, multiply the peak area of impurity E by 1.5;
- **impurities C, D, E:** for each impurity, not more than twice the area of the principal peak in the chromatogram obtained with reference solution (a) (0.2 per cent);
- **impurities A, B:** for each impurity, not more than the area of the principal peak in the chromatogram obtained with reference solution (a) (0.1 per cent);
- **unspecified impurities:** for each impurity, not more than twice the area of the principal peak in the chromatogram obtained with reference solution (a) (0.2 per cent);
- **total:** not more than 5 times the area of the principal peak in the chromatogram obtained with reference solution (a) (0.5 per cent);
- **disregard limit:** the area of the principal peak in the chromatogram obtained with reference solution (a) (0.1 per cent).

**Heavy metals** (2.4.8): maximum 20 ppm.

Dissolve 0.5 g in *dilute acetic acid R* and dilute to 30 mL with the same solvent. Adding 2 mL of *water R* instead of 2 mL of *buffer solution pH 3.5 R*, the filtrate complies with test E. Prepare the reference solution using 5 mL of *lead standard solution (2 ppm Pb) R*.

**Loss on drying** (2.2.32): maximum 0.5 per cent, determined on 1.000 g by drying at 105 °C for 4 h.

**Sulfated ash** (2.4.14): maximum 0.1 per cent, determined on 1.0 g in a platinum crucible.

**ASSAY**

Dissolve 0.300 g in 80 mL of *glacial acetic acid R*. Titrate with 0.1 M *perchloric acid*, determining the end-point potentiometrically (2.2.20).

1 mL of 0.1 M *perchloric acid* is equivalent to 36.24 mg of C<sub>17</sub>H<sub>19</sub>FN<sub>4</sub>O<sub>4</sub>.

**STORAGE**

Protected from light.

**IMPURITIES**

**Specified impurities:** A, B, C, D, E.

**Other detectable impurities** (the following substances would, if present at a sufficient level, be detected by one or other of the tests in the monograph. They are limited by the general acceptance criterion for other/unspecified impurities and/or by the general monograph *Substances for pharmaceutical use* (2034). It is therefore not necessary to identify these impurities for demonstration of compliance. See also 5.10. *Control of impurities in substances for pharmaceutical use*): F.

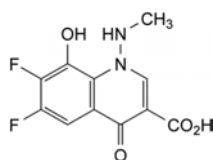

A. 6,7-difluoro-8-hydroxy-1-(methylamino)-4-oxo-1,4-dihydroquinoline-3-carboxylic acid,

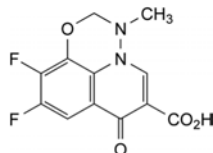

B. 9,10-difluoro-3-methyl-7-oxo-2,3-dihydro-7H-pyrido[3,2,1-ij][4,1,2]benzoxadiazine-6-carboxylic acid,

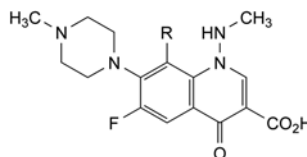

C. R = F: 6,8-difluoro-1-(methylamino)-7-(4-methylpiperazin-1-yl)-4-oxo-1,4-dihydroquinoline-3-carboxylic acid,

D. R = OH: 6-fluoro-8-hydroxy-1-(methylamino)-7-(4-methylpiperazin-1-yl)-4-oxo-1,4-dihydroquinoline-3-carboxylic acid,

E. R = O-C<sub>2</sub>H<sub>5</sub>: 8-ethoxy-6-fluoro-1-(methylamino)-7-(4-methylpiperazin-1-yl)-4-oxo-1,4-dihydroquinoline-3-carboxylic acid,

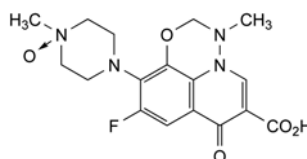

F. 4-[6-carboxy-9-fluoro-3-methyl-7-oxo-2,3-dihydro-7H-pyrido[3,2,1-ij][4,1,2]benzoxadiazin-10-yl]-1-methylpiperazine 1-oxide.

01/2008:0845  
corrected 7.0

## MEBENDAZOLE

### Mebendazolium

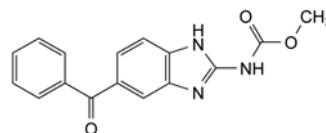

C<sub>16</sub>H<sub>13</sub>N<sub>3</sub>O<sub>3</sub>  
[31431-39-7]

M<sub>r</sub> 295.3

**DEFINITION**

Methyl (5-benzoyl-1H-benzimidazol-2-yl)carbamate.

**Content:** 99.0 per cent to 101.0 per cent (dried substance).

**CHARACTERS**

**Appearance:** white or almost white powder.

**Solubility:** practically insoluble in water, in alcohol and in methylene chloride.

It shows polymorphism (5.9).

**IDENTIFICATION**

Infrared absorption spectrophotometry (2.2.24).

**Comparison:** Ph. Eur. reference spectrum of mebendazole.

## TESTS

**Related substances.** Liquid chromatography (2.2.29).

**Test solution.** Dissolve 25.0 mg of the substance to be examined in *dimethylformamide R* and dilute to 25.0 mL with the same solvent.

**Reference solution (a).** Dissolve 5.0 mg of *mebendazole for system suitability CRS* in *dimethylformamide R* and dilute to 5.0 mL with the same solvent.

**Reference solution (b).** Dilute 1.0 mL of the test solution to 100.0 mL with *dimethylformamide R*. Dilute 5.0 mL of this solution to 20.0 mL with *dimethylformamide R*.

**Column:**

- size:  $l = 0.10$  m,  $\varnothing = 4.6$  mm,
- stationary phase: base-deactivated octadecylsilyl silica gel for chromatography R (3  $\mu$ m),
- temperature: 40 °C.

**Mobile phase:**

- mobile phase A: 7.5 g/L solution of *ammonium acetate R*,
- mobile phase B: *acetonitrile R*,

Time (min)	Mobile phase A (per cent V/V)	Mobile phase B (per cent V/V)
0 - 15	80 → 70	20 → 30
15 - 20	70 → 10	30 → 90
20 - 25	10	90

**Flow rate:** 1.2 mL/min.

**Detection:** spectrophotometer at 250 nm.

**Injection:** 10  $\mu$ L.

**System suitability:** reference solution (a):

- the chromatogram obtained is similar to the chromatogram supplied with *mebendazole for system suitability CRS*.

**Limits:**

- **correction factor:** for the calculation of content, multiply the peak area of impurity G by 1.4,
- **impurity G:** not more than twice the area of the principal peak in the chromatogram obtained with reference solution (b) (0.5 per cent),
- **any other impurity:** not more than the area of the principal peak in the chromatogram obtained with reference solution (b) (0.25 per cent),
- **total:** not more than 4 times the area of the principal peak in the chromatogram obtained with reference solution (b) (1.0 per cent),
- **disregard limit:** 0.2 times the area of the principal peak in the chromatogram obtained with reference solution (b) (0.05 per cent).

**Loss on drying** (2.2.32): maximum 0.5 per cent, determined on 1.000 g by drying in an oven at 105 °C for 4 h.

**Sulfated ash** (2.4.14): maximum 0.1 per cent, determined on 1.0 g.

## ASSAY

Dissolve 0.250 g in 3 mL of *anhydrous formic acid R* and add 50 mL of a mixture of 1 volume of *anhydrous acetic acid R* and 7 volumes of *methyl ethyl ketone R*. Titrate with 0.1 M *perchloric acid*, determining the end-point potentiometrically (2.2.20).

1 mL of 0.1 M *perchloric acid* is equivalent to 29.53 mg of  $C_{16}H_{13}N_3O_3$ .

## STORAGE

Protected from light.

## IMPURITIES

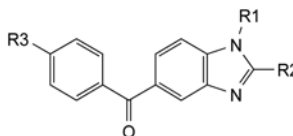

- A. R1 = R3 = H, R2 = NH<sub>2</sub>: (2-amino-1*H*-benzimidazol-5-yl)phenylmethanone,  
 B. R1 = R3 = H, R2 = OH: (2-hydroxy-1*H*-benzimidazol-5-yl)phenylmethanone,  
 C. R1 = CH<sub>3</sub>, R2 = NH<sub>2</sub>, R3 = H: (2-amino-1-methyl-1*H*-benzimidazol-5-yl)phenylmethanone,  
 D. R1 = CH<sub>3</sub>, R2 = NH-CO-OCH<sub>3</sub>, R3 = H: methyl (5-benzoyl-1-methyl-1*H*-benzimidazol-2-yl)carbamate,  
 E. R1 = R3 = H, R2 = NH-CO-OC<sub>2</sub>H<sub>5</sub>: ethyl (5-benzoyl-1*H*-benzimidazol-2-yl)carbamate,  
 F. R1 = H, R2 = NH-CO-OCH<sub>3</sub>, R3 = CH<sub>3</sub>: methyl [5-(4-methylbenzoyl)-1*H*-benzimidazol-2-yl]carbamate,

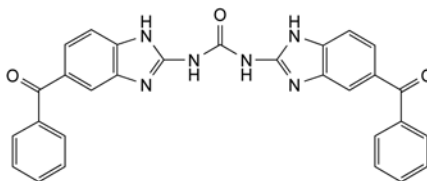

- G. *N,N'*-bis(5-benzoyl-1*H*-benzimidazol-2-yl)urea.

01/2011:0622

## MECLOZINE DIHYDROCHLORIDE

## Meclozini dihydrochloridum

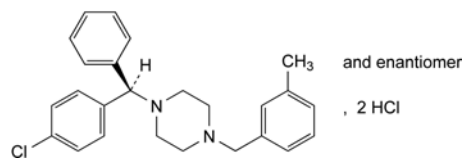

$C_{25}H_{29}Cl_3N_2$   
[1104-22-9]

$M_r$  463.9

## DEFINITION

1-[(*RS*)-(4-Chlorophenyl)phenylmethyl]-4-[(3-methylphenyl)methyl]piperazine dihydrochloride.

**Content:** 98.0 per cent to 102.0 per cent (anhydrous substance).

## CHARACTERS

**Appearance:** white or yellowish-white, slightly hygroscopic, crystalline powder.

**Solubility:** slightly soluble in water, soluble in ethanol (96 per cent) and in methylene chloride.

## IDENTIFICATION

**First identification:** B, D.

**Second identification:** A, C, D.

A. Ultraviolet and visible absorption spectrophotometry (2.2.25).

**Test solution.** Dissolve 15.0 mg in 0.1 M *hydrochloric acid* and dilute to 100.0 mL with the same acid. Dilute 10.0 mL of this solution to 100.0 mL with 0.1 M *hydrochloric acid*.

**Spectral range:** 220-350 nm.

**Absorption maximum:** at 232 nm.

**Specific absorbance at the absorption maximum:** 345 to 380 (anhydrous substance).

The solution also shows a weak absorbance without a defined maximum between 260 nm and 300 nm.

## B. Infrared absorption spectrophotometry (2.2.24).

*Comparison: meclozine dihydrochloride CRS.*

## C. Thin-layer chromatography (2.2.27).

*Test solution.* Dissolve 50 mg of the substance to be examined in *methanol R* and dilute to 10 mL with the same solvent.

*Reference solution.* Dissolve 50 mg of *meclozine dihydrochloride CRS* in *methanol R* and dilute to 10 mL with the same solvent.

*Plate: TLC silica gel GF<sub>254</sub> plate R.*

*Mobile phase: diethylamine R, toluene R, cyclohexane R (10:15:75 V/V/V).*

*Application: 10 µL.*

*Development: over 2/3 of the plate.*

*Drying: in a current of warm air for 5 min.*

*Detection: examine in ultraviolet light at 254 nm.*

*Results:* the principal spot in the chromatogram obtained with the test solution is similar in position and size to the principal spot in the chromatogram obtained with the reference solution.

D. Dissolve about 15 mg in 2 mL of *ethanol (96 per cent) R*. The solution gives reaction (a) of chlorides (2.3.1).

## TESTS

**Acidity or alkalinity.** Calculate the acidity or alkalinity from the titration volumes obtained in the assay using the following equation:

$$A = V_2 - 2V_1$$

$V_1$  = volume of 0.1 M sodium hydroxide added at the 1<sup>st</sup> point of inflexion;

$V_2$  = volume of 0.1 M sodium hydroxide added at the 2<sup>nd</sup> point of inflexion.

A is not less than -0.3 mL and not more than 0.3 mL for 0.350 g of the substance to be examined.

**Related substances.** Liquid chromatography (2.2.29).

*Solvent mixture: acetonitrile R, water R (50:50 V/V).*

*Test solution.* Dissolve 50 mg of the substance to be examined in the solvent mixture and dilute to 100.0 mL with the solvent mixture.

*Reference solution (a).* Dilute 1.0 mL of the test solution to 100.0 mL with the solvent mixture. Dilute 1.0 mL of this solution to 10.0 mL with the solvent mixture.

*Reference solution (b).* Dissolve 7.5 mg of *meclozine impurity B CRS* and 7.5 mg of *meclozine impurity H CRS* in the solvent mixture and dilute to 100.0 mL with the solvent mixture. Dilute 1.0 mL of this solution to 100.0 mL with the solvent mixture.

*Column:*

- size:  $l = 0.15$  m,  $\varnothing = 4.6$  mm;
- stationary phase: end-capped octadecylsilyl amorphous organosilica polymer R (3.5 µm);
- temperature: 35 °C.

*Mobile phase:*

- mobile phase A: 0.1 per cent V/V solution of concentrated ammonia R;
- mobile phase B: acetonitrile R1;

Time (min)	Mobile phase A (per cent V/V)	Mobile phase B (per cent V/V)
0 - 3	60	40
3 - 13	60 → 15	40 → 85
13 - 23	15 → 5	85 → 95
23 - 33	5	95

*Flow rate: 1.0 mL/min.*

*Detection: spectrophotometer at 225 nm.*

*Injection: 10 µL.*

*Identification of impurities:* use the chromatogram obtained with reference solution (b) to identify the peaks due to impurities B and H.

*Relative retention* with reference to meclozine (retention time = about 18 min): impurity B = about 0.45; impurity H = about 0.49.

*System suitability: reference solution (b):*

- resolution: minimum 1.5 between the peaks due to impurities B and H.

*Limits:*

- impurity B: not more than 1.5 times the area of the corresponding peak in the chromatogram obtained with reference solution (b) (0.15 per cent);
- unspecified impurities: for each impurity, not more than the area of the principal peak in the chromatogram obtained with reference solution (a) (0.10 per cent);
- total: not more than 3 times the area of the principal peak in the chromatogram obtained with reference solution (a) (0.3 per cent);
- disregard limit: 0.5 times the area of the principal peak in the chromatogram obtained with reference solution (a) (0.05 per cent).

**Water (2.5.12):** maximum 5.0 per cent, determined on 0.200 g.

**Sulfated ash (2.4.14):** maximum 0.1 per cent, determined on 1.0 g.

## ASSAY

Dissolve 0.350 g in 50 mL of *ethanol (96 per cent) R*. Carry out a potentiometric titration (2.2.20), using 0.1 M sodium hydroxide. Read the volume added between the 2 points of inflexion.

1 mL of 0.1 M sodium hydroxide is equivalent to 46.39 mg of  $C_{25}H_{29}Cl_3N_2$ .

## STORAGE

In an airtight container.

## IMPURITIES

*Specified impurities: B.*

*Other detectable impurities* (the following substances would, if present at a sufficient level, be detected by one or other of the tests in the monograph. They are limited by the general acceptance criterion for other/unspecified impurities and/or by the general monograph *Substances for pharmaceutical use (2034)*. It is therefore not necessary to identify these impurities for demonstration of compliance. See also 5.10. *Control of impurities in substances for pharmaceutical use*): C, D, E, F, H.

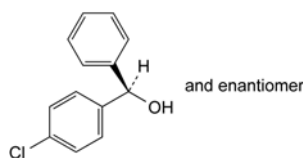

B. (RS)-(4-chlorophenyl)phenylmethanol,

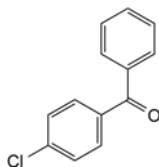

C. (4-chlorophenyl)phenylmethanone (4-chlorobenzophenone),

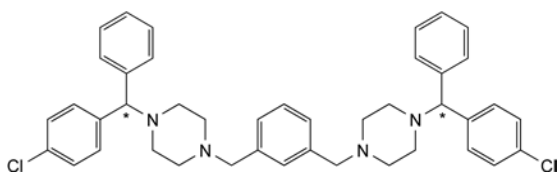

D. 1,1'-(1,3-phenylenebismethylene)bis[4-[(4-chlorophenyl)phenylmethyl]piperazine],

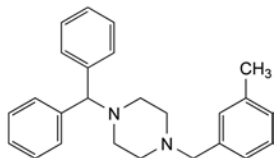

E. 1-(diphenylmethyl)-4-[(3-methylphenyl)methyl]piperazine,

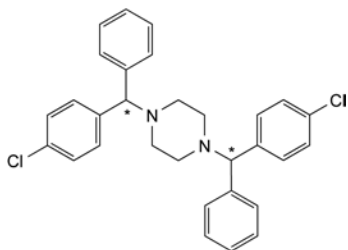

F. 1,4-bis[(4-chlorophenyl)phenylmethyl]piperazine,

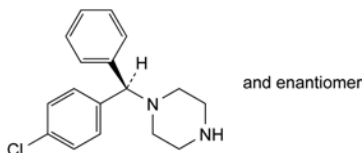

H. 1-[(RS)-(4-chlorophenyl)phenylmethyl]piperazine.

01/2008:0673

## MEDROXYPROGESTERONE ACETATE

### Medroxyprogesteroni acetas

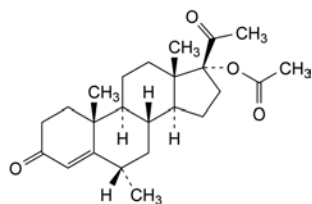

$C_{24}H_{34}O_4$   
[71-58-9]

$M_r$  386.5

#### DEFINITION

6-Methyl-3,20-dioxopregn-4-en-17-yl acetate.

Content: 97.0 per cent to 103.0 per cent (dried substance).

#### CHARACTERS

Appearance: white or almost white, crystalline powder.

Solubility: practically insoluble in water, freely soluble in methylene chloride, soluble in acetone, sparingly soluble in ethanol (96 per cent).

#### IDENTIFICATION

Infrared absorption spectrophotometry (2.2.24).

Comparison: medroxyprogesterone acetate CRS.

#### TESTS

Specific optical rotation (2.2.7): + 47 to + 53 (dried substance).

Dissolve 0.250 g in acetone R and dilute to 25.0 mL with the same solvent.

Impurity F. Thin-layer chromatography (2.2.27).

Test solution. Dissolve 0.200 g of the substance to be examined in methylene chloride R and dilute to 10.0 mL with the same solvent.

Reference solution. To 20.0 mg of medroxyprogesterone acetate for performance test CRS (containing 0.5 per cent of impurity F) add 1.0 mL of methylene chloride R and dissolve.

Plate: TLC silica gel plate R.

Mobile phase: tetrahydrofuran R, 1,1-dimethylethyl methyl ether R, heptane R (10:45:45 V/V/V).

Application: 10  $\mu$ L.

Development 1: over a path of 10 cm.

Drying 1: in air.

Development 2: over a path of 10 cm in the same direction with the same mobile phase.

Drying 2: at 120 °C for 10 min.

Detection: spray with a 200 g/L solution of toluenesulfonic acid R in ethanol (96 per cent) R. Heat at 120 °C for 10 min. Allow to cool. Examine the chromatograms in ultraviolet light at 365 nm.

System suitability: reference solution:

– the chromatogram obtained shows 2 clearly separated spots.

Limit:

– impurity F: in the chromatogram obtained with the test solution the blue fluorescent spot with an  $R_f$  value higher than the principal spot due to medroxyprogesterone acetate is not more intense than the corresponding blue fluorescent spot due to impurity F in the chromatogram obtained with the reference solution (0.5 per cent).

Related substances. Liquid chromatography (2.2.29).

Test solution. Dissolve 20.0 mg of the substance to be examined in a mixture of equal volumes of acetonitrile R and water R and dilute to 10.0 mL with the same mixture of solvents.

Reference solution (a). Dissolve 4 mg of medroxyprogesterone acetate for system suitability CRS (containing impurities A, B, C, D, E, G and I) in a mixture of equal volumes of acetonitrile R and water R and dilute to 2 mL with the same mixture of solvents.

Reference solution (b). Dilute 1.0 mL of the test solution to 100.0 mL with a mixture of equal volumes of acetonitrile R and water R.

Reference solution (c). Dilute 1.0 mL of reference solution (b) to 10.0 mL with a mixture of equal volumes of acetonitrile R and water R.

Column:

– size:  $l = 0.25$  m,  $\varnothing = 3.0$  mm;

– stationary phase: end-capped octadecylsilyl silica gel for chromatography R (5  $\mu$ m);

– temperature: 60 °C.

Mobile phase: tetrahydrofuran R, acetonitrile R, water R (12:23:65 V/V/V).

Flow rate: 0.9 mL/min.

Detection: spectrophotometer at 254 nm.

Injection: 10  $\mu$ L.

Run time: twice the retention time of medroxyprogesterone acetate.

Identification of impurities: use the chromatogram supplied with medroxyprogesterone acetate for system suitability CRS and the chromatogram obtained with reference solution (a) to identify the peaks due to impurities A, B, C, D, E, G and I.

Relative retention with reference to medroxyprogesterone acetate (retention time = about 20 min): impurity A = about 0.3; impurity I = about 0.5; impurity H = about 0.65; impurity B = about 0.7; impurity C = about 0.8; impurity G = about 0.85; impurity D = about 0.9; impurity E = about 0.95.



*System suitability*: reference solution (a):

- *peak-to-valley ratio*: minimum 2.5, where  $H_p$  = height above the baseline of the peak due to impurity E and  $H_v$  = height above the baseline of the lowest point of the curve separating this peak from the peak due to medroxyprogesterone acetate.

*Limits*:

- *correction factor*: for the calculation of content, multiply the peak areas of the following impurities by the corresponding correction factor: impurity A = 1.5; impurity G = 2.6;
- *impurity D*: not more than the area of the principal peak in the chromatogram obtained with reference solution (b) (1.0 per cent);
- *impurity B*: not more than 0.7 times the area of the principal peak in the chromatogram obtained with reference solution (b) (0.7 per cent);
- *impurity A*: not more than 3 times the area of the principal peak in the chromatogram obtained with reference solution (c) (0.3 per cent);
- *impurities C, E, G, I*: for each impurity, not more than twice the area of the principal peak in the chromatogram obtained with reference solution (c) (0.2 per cent);
- *unspecified impurities*: for each impurity, not more than the area of the principal peak in the chromatogram obtained with reference solution (c) (0.10 per cent);
- *total*: not more than 1.5 times the area of the principal peak in the chromatogram obtained with reference solution (b) (1.5 per cent);
- *disregard limit*: 0.5 times the area of the principal peak in the chromatogram obtained with reference solution (c) (0.05 per cent).

**Loss on drying** (2.2.32): maximum 1.0 per cent, determined on 0.500 g by drying in an oven at 105 °C for 3 h.

#### ASSAY

Dissolve 50.0 mg in *ethanol (96 per cent) R* and dilute to 50.0 mL with the same solvent. Dilute 2.0 mL of this solution to 100.0 mL with *ethanol (96 per cent) R*. Measure the absorbance (2.2.25) at the absorption maximum at 241 nm.

Calculate the content of  $C_{24}H_{34}O_4$  taking the specific absorbance to be 420.

#### STORAGE

Protected from light.

#### IMPURITIES

*Specified impurities*: A, B, C, D, E, F, G, I.

*Other detectable impurities* (the following substances would, if present at a sufficient level, be detected by one or other of the tests in the monograph. They are limited by the general acceptance criterion for other/unspecified impurities and/or by the general monograph *Substances for pharmaceutical use (2034)*. It is therefore not necessary to identify these impurities for demonstration of compliance. See also 5.10. *Control of impurities in substances for pharmaceutical use*): H.

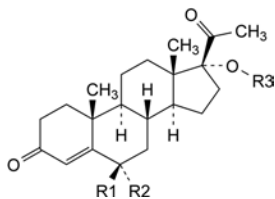

- A. R1 = OH, R2 = CH<sub>3</sub>, R3 = CO-CH<sub>3</sub>: 6-hydroxy-6-methyl-3,20-dioxopregn-4-en-17-yl acetate (6-hydroxymedroxyprogesterone acetate),
- B. R1 = R3 = H, R2 = CH<sub>3</sub>: 17-hydroxy-6-methylpregn-4-ene-3,20-dione (medroxyprogesterone),
- D. R1 = CH<sub>3</sub>, R2 = H, R3 = CO-CH<sub>3</sub>: 6-methyl-3,20-dioxopregn-4-en-17-yl acetate (6-epimedroxyprogesterone acetate),

- E. R1 + R2 = CH<sub>2</sub>, R3 = CO-CH<sub>3</sub>: 6-methylidene-3,20-dioxopregn-4-en-17-yl acetate (6-methylenehydroxyprogesterone acetate),
- H. R1 = R2 = H, R3 = CO-CH<sub>3</sub>: 3,20-dioxopregn-4-en-17-yl acetate (hydroxyprogesterone acetate),

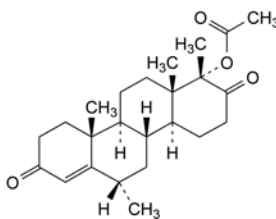

- C. 6,17a-dimethyl-3,17-dioxo-D-homoandrost-4-en-17a-yl acetate,

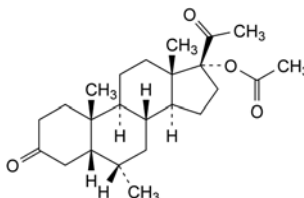

- F. 6-methyl-3,20-dioxo-5-pregnan-17-yl acetate (4,5-dihydromedroxyprogesterone acetate),

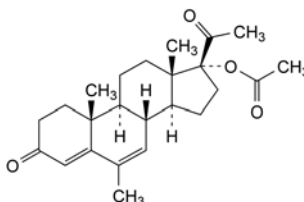

- G. 6-methyl-3,20-dioxopregna-4,6-dien-17-yl acetate (megestrol acetate),

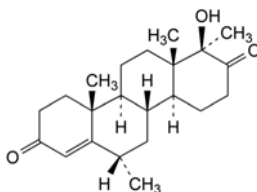

- I. (17aβ)-17a-hydroxy-6,17a-dimethyl-D-homoandrost-4-ene-3,17-dione.

01/2010:1240  
corrected 7.0

## MEFENAMIC ACID

### Acidum mefenamicum

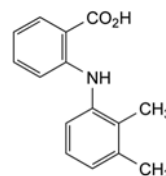

$C_{15}H_{15}NO_2$   
[61-68-7]

$M_r$  241.3

#### DEFINITION

2-[(2,3-Dimethylphenyl)amino]benzoic acid.

*Content*: 99.0 per cent to 101.0 per cent (dried substance).

#### CHARACTERS

*Appearance*: white or almost white, microcrystalline powder.

*Solubility*: practically insoluble in water, slightly soluble in ethanol (96 per cent) and in methylene chloride. It dissolves in dilute solutions of alkali hydroxides.

It shows polymorphism (5.9).

#### IDENTIFICATION

Infrared absorption spectrophotometry (2.2.24).

*Comparison: mefenamic acid CRS.*

If the spectra obtained in the solid state show differences, dissolve the substance to be examined and the reference substance separately in *ethanol (96 per cent) R*, evaporate to dryness and record new spectra using the residues.

#### TESTS

**Related substances.** Liquid chromatography (2.2.29).

*Test solution.* Dissolve 25.0 mg of the substance to be examined in the mobile phase and dilute to 25.0 mL with the mobile phase.

*Reference solution (a).* Dilute 1.0 mL of the test solution to 100.0 mL with the mobile phase. Dilute 1.0 mL of this solution to 10.0 mL with the mobile phase.

*Reference solution (b).* Dissolve 50 mg of *2-chlorobenzoic acid R* (impurity C) and 50 mg of *benzoic acid R* (impurity D) in the mobile phase and dilute to 100.0 mL with the mobile phase. Dilute 1.0 mL of this solution to 100.0 mL with the mobile phase.

*Reference solution (c).* Dissolve 10.0 mg of *mefenamic acid impurity A CRS* in the mobile phase and dilute to 10.0 mL with the mobile phase. Dilute 1.0 mL of the solution to 100.0 mL with the mobile phase. Dilute 1.0 mL of this solution to 100.0 mL with the mobile phase.

*Reference solution (d).* Dissolve 20.0 mg of *benzoic acid R* in the mobile phase and dilute to 1000.0 mL with the mobile phase. Dilute 1.0 mL of this solution to 100.0 mL with the mobile phase.

*Column:*

- *size:*  $l = 0.25$  m,  $\varnothing = 4.6$  mm;
- *stationary phase:* spherical octadecylsilyl silica gel for chromatography R (5  $\mu$ m).

*Mobile phase:* mix 14 volumes of *tetrahydrofuran R*, 40 volumes of a 5.75 g/L solution of *ammonium dihydrogen phosphate R* adjusted to pH 5.0 with *dilute ammonia R2*, and 46 volumes of *acetonitrile R1*.

*Flow rate:* 1.0 mL/min.

*Detection:* spectrophotometer at 254 nm.

*Injection:* 10  $\mu$ L.

*Run time:* 4 times the retention time of mefenamic acid.

*Identification of impurities:* use the chromatogram obtained with reference solution (b) to identify the peaks due to impurities C and D.

*Relative retention* with reference to mefenamic acid (retention time = about 8 min): impurity C = about 0.3; impurity D = about 0.35; impurity A = about 0.5.

*System suitability:*

- *resolution:* minimum 3.0 between the peaks due to impurities C and D in the chromatogram obtained with reference solution (b);
- *signal-to-noise ratio:* minimum 10 for the principal peak in the chromatogram obtained with reference solution (d).

*Limits:*

- *correction factors:* for the calculation of content, multiply the peak areas of the following impurities by the corresponding correction factor: impurity C = 5.9; impurity D = 4.0;
- *impurities C, D:* for each impurity, not more than the area of the principal peak in the chromatogram obtained with reference solution (a) (0.1 per cent);
- *impurity A:* not more than the area of the corresponding peak in the chromatogram obtained with reference solution (c) (100 ppm);
- *unspecified impurities:* for each impurity, not more than the area of the principal peak in the chromatogram obtained with reference solution (a) (0.10 per cent);

- *total:* not more than twice the area of the principal peak in the chromatogram obtained with reference solution (a) (0.2 per cent);
- *disregard limit:* 0.5 times the area of the principal peak in the chromatogram obtained with reference solution (a) (0.05 per cent); disregard the peak due to impurity A.

**Copper:** maximum 10 ppm.

Atomic absorption spectrometry (2.2.23, *Method I*).

*Test solution.* Place 1.00 g in a silica crucible, moisten with *sulfuric acid R*, heat cautiously on a flame for 30 min and then progressively to 650 °C. Continue ignition until all black particles have disappeared. Allow to cool, dissolve the residue in 0.1 M *hydrochloric acid* and dilute to 25.0 mL with the same acid.

*Reference solutions.* Prepare the reference solutions using *copper standard solution (0.1 per cent Cu) R*, diluting with 0.1 M *nitric acid*.

*Source:* copper hollow-cathode lamp.

*Wavelength:* 324.8 nm.

*Atomisation device:* air-acetylene flame.

**Loss on drying** (2.2.32): maximum 0.5 per cent, determined on 1.000 g by drying in an oven at 105 °C.

**Sulfated ash** (2.4.14): maximum 0.1 per cent, determined on 1.0 g.

#### ASSAY

Dissolve with the aid of ultrasound 0.200 g in 100 mL of warm *anhydrous ethanol R*, previously neutralised to *phenol red solution R*. Add 0.1 mL of *phenol red solution R* and titrate with 0.1 M *sodium hydroxide*.

1 mL of 0.1 M *sodium hydroxide* is equivalent to 24.13 mg of  $C_{15}H_{15}NO_2$ .

#### IMPURITIES

*Specified impurities:* A, C, D.

*Other detectable impurities* (the following substances would, if present at a sufficient level, be detected by one or other of the tests in the monograph. They are limited by the general acceptance criterion for other/unspecified impurities and/or by the general monograph *Substances for pharmaceutical use (2034)*. It is therefore not necessary to identify these impurities for demonstration of compliance. See also 5.10. *Control of impurities in substances for pharmaceutical use*): B, E.

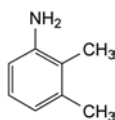

A. 2,3-dimethylaniline,

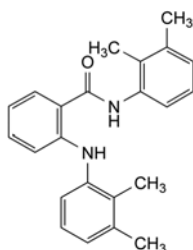

B. *N*-(2,3-dimethylphenyl)-2-[(2,3-dimethylphenyl)amino]benzamide,

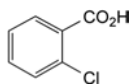

C. 2-chlorobenzoic acid,

D. benzoic acid,

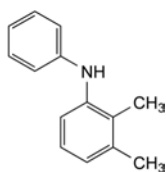
E. 2,3-dimethyl-*N*-phenylaniline.

01/2008:1241

## MEFLOQUINE HYDROCHLORIDE

## Mefloquini hydrochloridum

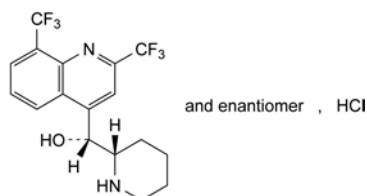

$C_{17}H_{17}ClF_6N_2O$   
[51773-92-3]

 $M_r$  414.8

## DEFINITION

(*RS*)-[2,8-Bis(trifluoromethyl)quinolin-4-yl][(2*SR*)-piperidin-2-yl]methanol hydrochloride.

*Content*: 99.0 per cent to 101.0 per cent (anhydrous substance).

## CHARACTERS

*Appearance*: white or slightly yellow, crystalline powder.

*Solubility*: very slightly soluble in water, freely soluble in methanol, soluble in ethanol (96 per cent).

It shows polymorphism (5.9).

mp: about 260 °C, with decomposition.

## IDENTIFICATION

*First identification*: A, E.

*Second identification*: B, C, D, E.

A. Infrared absorption spectrophotometry (2.2.24).

*Comparison*: mefloquine hydrochloride CRS.

If the spectra obtained show differences, dissolve the substance to be examined and the reference substance separately in *methanol R*, evaporate to dryness and record new spectra using the residues.

B. Thin-layer chromatography (2.2.27).

*Test solution*. Dissolve 8 mg of the substance to be examined in *methanol R* and dilute to 5 mL with the same solvent.

*Reference solution (a)*. Dissolve 8 mg of *mefloquine hydrochloride CRS* in *methanol R* and dilute to 5 mL with the same solvent.

*Reference solution (b)*. Dilute 2.5 mL of the test solution to 100 mL with *methanol R*.

*Reference solution (c)*. To 1 mL of reference solution (b) add 1 mL of a 0.016 g/L solution of *quinidine sulfate R* in *methanol R*.

*Plate*: TLC silica gel  $F_{254}$  plate *R*.

*Pretreatment*: develop the plate with a mixture of 20 volumes of *methanol R* and 80 volumes of *methylene chloride R*, and dry at 100-105 °C for 15 min before use.

*Mobile phase*: *anhydrous acetic acid R*, *methanol R*, *methylene chloride R* (10:10:80 V/V/V).

*Application*: 20 µL.

*Development*: over a path of 10 cm.

*Drying*: in a current of warm air for 15 min.

*Detection*: examine in ultraviolet light at 254 nm; lightly spray with a mixture prepared immediately before use of 1 volume of *sulfuric acid R* and 40 volumes of *iodoplatinate reagent R*; spray with *strong hydrogen peroxide solution R*.

*System suitability*: reference solution (c):

– the chromatogram shows 2 clearly separated spots.

*Results*: the principal spot in the chromatogram obtained with the test solution is similar in position, colour and size to the principal spot in the chromatogram obtained with reference solution (a).

C. Mix about 10 mg with 45 mg of *heavy magnesium oxide R* and ignite in a crucible until a practically white residue is obtained. Allow to cool, then add 2 mL of *water R*, 0.05 mL of *phenolphthalein solution R1* and about 1 mL of *dilute hydrochloric acid R* to make the solution colourless. Filter. To the filtrate add a freshly prepared mixture of 0.1 mL of *alizarin S solution R* and 0.1 mL of *zirconyl nitrate solution R*. Mix, allow to stand for 5 min and compare the colour of the solution with a blank prepared in the same manner. The test solution is yellow and the blank is red.

D. To about 20 mg add 0.2 mL of *sulfuric acid R*. Blue fluorescence appears in ultraviolet light at 365 nm.

E. It gives reaction (b) of chlorides (2.3.1).

## TESTS

**Solution S**. Dissolve 2.50 g in *methanol R* and dilute to 50.0 mL with the same solvent.

**Appearance of solution**. Solution S is clear (2.2.1) and not more intensely coloured than reference solution BY<sub>7</sub> (2.2.2, *Method I*).

**Optical rotation** (2.2.7):  $-0.2^\circ$  to  $+0.2^\circ$ , determined on solution S.

**Related substances**. Liquid chromatography (2.2.29).

*Test solution*. Dissolve 0.10 g of the substance to be examined in the mobile phase and dilute to 25.0 mL with the mobile phase.

*Reference solution (a)*. Dilute 1.0 mL of the test solution to 50.0 mL with the mobile phase. Dilute 1.0 mL of this solution to 20.0 mL with the mobile phase.

*Reference solution (b)*. Dissolve 8 mg of *mefloquine hydrochloride CRS* and 8 mg of *quinidine sulfate R* in the mobile phase, then dilute to 50.0 mL with the mobile phase. Dilute 5.0 mL of this solution to 100.0 mL with the mobile phase.

*Precolumn*:

– *size*:  $l = 0.025$  m,  $\varnothing = 4$  mm;

– *stationary phase*: end-capped octadecylsilyl silica gel for chromatography *R* (5 µm).

*Column*:

– *size*:  $l = 0.25$  m,  $\varnothing = 4$  mm;

– *stationary phase*: end-capped octadecylsilyl silica gel for chromatography *R* (5 µm).

*Mobile phase*: dissolve 1 g of *tetraheptylammonium bromide R* in a mixture of 200 volumes of *methanol R*, 400 volumes of a 1.5 g/L solution of *sodium hydrogen sulfate R* and 400 volumes of *acetonitrile R*.

*Flow rate*: 0.8 mL/min.

*Detection*: spectrophotometer at 280 nm.

*Equilibration*: with the mobile phase at a flow rate of 2 mL/min for about 30 min.

*Injection*: 20 µL.

*Run time*: 10 times the retention time of mefloquine.

*Retention time*: quinidine = about 2 min; mefloquine = about 4 min; impurity B = about 15 min; impurity A = about 36 min.

*System suitability*: reference solution (b):

– *resolution*: minimum 8.5 between the peaks due to quinidine and mefloquine.

01/2008:1593  
corrected 6.0**Limits:**

- *impurity with a relative retention with reference to mefloquine of about 0.7*: not more than twice the area of the principal peak in the chromatogram obtained with reference solution (a) (0.2 per cent);
- *any other impurity*: for each impurity, not more than the area of the principal peak in the chromatogram obtained with reference solution (a) (0.1 per cent);
- *sum of impurities other than the impurity with a relative retention with reference to mefloquine of about 0.7*: not more than 5 times the area of the principal peak in the chromatogram obtained with reference solution (a) (0.5 per cent);
- *disregard limit*: 0.2 times the area of the principal peak in the chromatogram obtained with reference solution (a) (0.02 per cent).

**Heavy metals** (2.4.8): maximum 20 ppm.1.0 g complies with test C. Prepare the reference solution using 2 mL of *lead standard solution* (10 ppm Pb) R.**Water** (2.5.12): maximum 3.0 per cent, determined on 1.000 g.**Sulfated ash** (2.4.14): maximum 0.1 per cent, determined on 1.0 g.**ASSAY**Dissolve 0.350 g in 15 mL of *anhydrous formic acid* R and add 40 mL of *acetic anhydride* R. Titrate with 0.1 M *perchloric acid*, determining the end-point potentiometrically (2.2.20).1 mL of 0.1 M *perchloric acid* is equivalent to 41.48 mg of C<sub>17</sub>H<sub>17</sub>ClF<sub>6</sub>N<sub>2</sub>O.**STORAGE**

Protected from light.

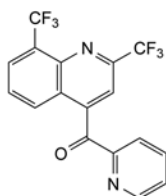
**IMPURITIES**

- A. [2,8-bis(trifluoromethyl)quinolin-4-yl](pyridin-2-yl)methanone,

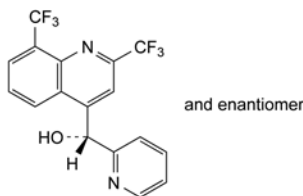

- B. (RS)-[2,8-bis(trifluoromethyl)quinolin-4-yl](pyridin-2-yl)methanol,

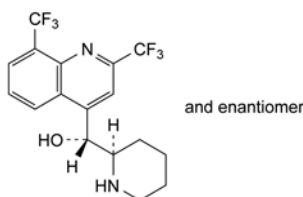

- C. (RS)-[2,8-bis(trifluoromethyl)quinolin-4-yl][(2RS)-piperidin-2-yl]methanol.

**MEGESTROL ACETATE**

## Megestrol acetate

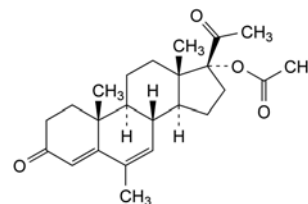
C<sub>24</sub>H<sub>32</sub>O<sub>4</sub>  
[595-33-5]M<sub>r</sub> 384.5**DEFINITION**

6-Methyl-3,20-dioxopregna-4,6-dien-17-yl acetate.

*Content*: 97.0 per cent to 103.0 per cent (dried substance).**CHARACTERS***Appearance*: a white or almost white, crystalline powder.*Solubility*: practically insoluble in water, soluble in acetone, sparingly soluble in alcohol.

mp: about 217 °C.

**IDENTIFICATION**

Infrared absorption spectrophotometry (2.2.24).

*Comparison*: Ph. Eur. reference spectrum of megestrol acetate.**TESTS****Specific optical rotation** (2.2.7): + 14.0 to + 17.0 (dried substance).Dissolve 2.50 g in *methylene chloride* R and dilute to 25.0 mL with the same solvent.**Related substances**. Liquid chromatography (2.2.29).*Test solution*. Dissolve 25.0 mg of the substance to be examined in a mixture of 145 volumes of *tetrahydrofuran* R and 255 volumes of *acetonitrile* R, dilute to 20 mL with the same mixture of solvents and then dilute to 50.0 mL with *water* R.*Reference solution (a)*. Dissolve 25.0 mg of *medroxyprogesterone acetate* CRS in a mixture of 145 volumes of *tetrahydrofuran* R and 255 volumes of *acetonitrile* R, dilute to 20 mL with the same mixture of solvents and then dilute to 50.0 mL with *water* R.*Reference solution (b)*. Dilute 1.0 mL of reference solution (a) to 200.0 mL with the mobile phase.*Reference solution (c)*. To 3 mL of the test solution, add 1 mL of reference solution (a) and dilute to 50 mL with the mobile phase.*Column*:– *size*: l = 0.25 m, Ø = 4.6 mm,– *stationary phase*: octadecylsilyl silica gel for chromatography R (5 µm).*Mobile phase*: *tetrahydrofuran* R, *acetonitrile* R, *water* R (145:255:600 V/V/V).*Flow rate*: 1.5 mL/min.*Detection*: spectrophotometer at 254 nm.*Injection*: 20 µL.*Sensitivity*: reference solution (b).*Run time*: 1.5 times the retention time of megestrol acetate.*System suitability*: reference solution (c):– *resolution*: minimum 4.0 between the peaks corresponding to impurity A and megestrol acetate.

**Limits:**

- *impurity A*: not more than the area of the principal peak in the chromatogram obtained with reference solution (b) (0.5 per cent),
- *total of other impurities*: not more than twice the area of the principal peak in the chromatogram obtained with reference solution (b) (1.0 per cent),
- *disregard limit*: 0.1 times the area of the principal peak in the chromatogram obtained with reference solution (b) (0.05 per cent).

**Loss on drying** (2.2.32): maximum 0.5 per cent, determined on 1.000 g by drying in an oven at 105 °C.

**ASSAY**

Dissolve 15.0 mg in *ethanol R* and dilute to 100.0 mL with the same solvent. Dilute 5.0 mL of the solution to 100.0 mL with *ethanol R*. Measure the absorbance (2.2.25) at the maximum at 287 nm.

Calculate the content of  $C_{24}H_{32}O_4$  taking the specific absorbance to be 640.

**STORAGE**

Protected from light.

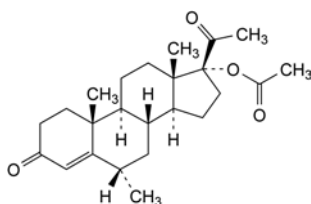
**IMPURITIES**

- A. 6 $\alpha$ -methyl-3,20-dioxopregna-4-en-17-yl acetate (medroxyprogesterone acetate),

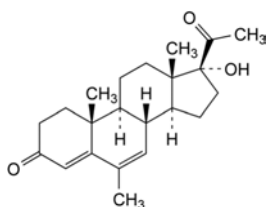

- B. 6-methyl-17-hydroxypregna-4,6-diene-3,20-dione (megestrol),

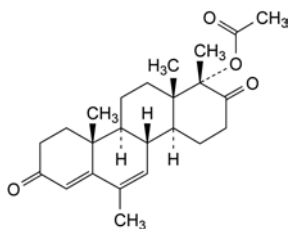

- C. 6,17a-dimethyl-3,17-dioxo-*D*-homoandrosta-4,6-dien-17 $\alpha$ -yl acetate (*D*-homo megestrol acetate),

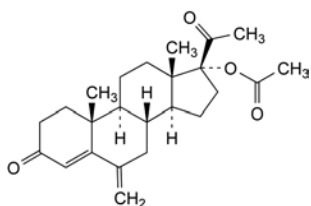

- D. 6-methylene-3,20-dioxopregna-4-en-17-yl acetate (6-methylene hydroxyprogesterone acetate),

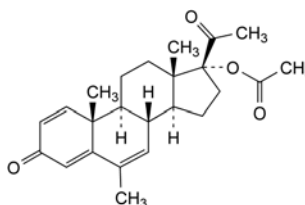

- E. 6-methyl-3,20-dioxopregna-1,4,6-trien-17-yl acetate.

07/2010:2055

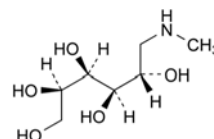
**MEGLUMINE****Megluminum**

$C_7H_{17}NO_5$   
[6284-40-8]

$M_r$  195.2

**DEFINITION**

1-Deoxy-1-(methylamino)-*D*-glucitol.

*Content*: 99.0 per cent to 101.0 per cent (dried substance).

**CHARACTERS**

*Appearance*: white or almost white, crystalline powder.

*Solubility*: freely soluble in water, sparingly soluble in ethanol (96 per cent), practically insoluble in methylene chloride.

*mp*: about 128 °C.

**IDENTIFICATION**

Infrared absorption spectrophotometry (2.2.24).

*Comparison*: meglumine CRS.

**TESTS**

**Solution S**. Dissolve 20.0 g in *distilled water R* and dilute to 100.0 mL with the same solvent.

**Appearance of solution**. The solution is clear (2.2.1) and its absorbance (2.2.25) at 420 nm is not greater than 0.03.

Dissolve the residue obtained in the test for loss on drying in *water R* and dilute to 10 mL with the same solvent.

**Specific optical rotation** (2.2.7): – 16.0 to – 17.0 (dried substance).

Dilute 12.5 mL of solution S to 25.0 mL with *water R*.

**Reducing substances**: maximum 0.2 per cent, expressed as glucose.

Dilute 1.25 mL of solution S to 2.5 mL with *water R*, add 2 mL of *cupri-tartaric solution R* and heat on a water-bath for 10 min. Cool under running water for 1 min, then sonicate for 20 s. Immediately filter through a filter 25 mm in diameter and 0.5  $\mu$ m in pore size. Rinse with 10 mL of *water R*. Prepare a standard in the same manner using 2.5 mL of a solution obtained by dissolving 20 mg of *glucose R* in *water R* and diluting to 100 mL with the same solvent. Any precipitate on the membrane filter obtained with the test solution is not more intensely coloured than the precipitate obtained with the standard.

**Chlorides** (2.4.4): maximum 100 ppm.

To 2.5 mL of solution S add 12.5 mL of *water R*.

**Sulfates** (2.4.13): maximum 150 ppm.

To 5 mL of solution S add 10 mL of *distilled water R*.

**Aluminium**: maximum 5 ppm.

Inductively coupled plasma-atomic emission spectrometry (ICP-AES) (2.2.57).

**Test solution.** Dissolve 5.00 g in 30 mL of *water R*, add 10.0 mL of *lead-free hydrochloric acid R* and dilute to 50.0 mL with *water R*.

**Reference solutions.** Prepare the reference solutions using *aluminium standard solution (10 ppm Al) R*, diluted as necessary with *water R*.

**Wavelength:** 396.153 nm.

**Iron:** maximum 10 ppm.

To 10 mL of solution S add about 0.8 mL of *hydrochloric acid R* and 0.05 mL of *bromine water R*. Allow to stand for 5 min, evaporate the excess of bromine in a current of air and add 3 mL of *potassium thiocyanate solution R*. Prepare a reference solution at the same time and in the same manner using 10 mL of *iron standard solution (2 ppm Fe) R*, to which 2 mL of *hydrochloric acid R* has been added. After 5 min, any red colour in the test solution is not more intense than that in the reference solution.

**Nickel:** maximum 5 ppm.

Inductively coupled plasma-atomic emission spectrometry (ICP-AES) (2.2.57).

**Test solution.** Dissolve 5.00 g in 30 mL of *water R*, add 10.0 mL of *lead-free hydrochloric acid R* and dilute to 50.0 mL with *water R*.

**Reference solutions.** Prepare the reference solutions using *nickel standard solution (10 ppm Ni) R*, diluted as necessary with *water R*.

**Wavelength:** 231.604 nm.

**Heavy metals (2.4.8):** maximum 10 ppm.

Adjust 10 mL of solution S to pH 3-4 with *dilute acetic acid R*. Dilute to 20 mL with *water R*. 12 mL of the solution complies with test A. Prepare the reference solution using *lead standard solution (1 ppm Pb) R*.

**Loss on drying (2.2.32):** maximum 0.5 per cent, determined on 1.000 g by drying in an oven at 105 °C for 3 h.

**Sulfated ash (2.4.14):** maximum 0.1 per cent, determined on 1.0 g.

**Bacterial endotoxins (2.6.14):** less than 1.5 IU/g, if intended for use in the manufacture of parenteral preparations without a further appropriate procedure for the removal of bacterial endotoxins.

#### ASSAY

Dissolve 0.180 g in 30 mL of *water R*. Titrate with *0.05 M sulfuric acid*, determining the end-point potentiometrically (2.2.20).

1 mL of *0.05 M sulfuric acid* is equivalent to 19.52 mg of  $C_7H_{17}NO_5$ .

**Content:** 99.0 per cent to 101.0 per cent (dried substance).

#### CHARACTERS

**Appearance:** pale yellow powder.

**Solubility:** practically insoluble in water, soluble in dimethylformamide, very slightly soluble in ethanol (96 per cent).

It shows polymorphism (5.9).

#### IDENTIFICATION

Infrared absorption spectrophotometry (2.2.24).

**Comparison:** *meloxicam CRS*.

If the spectra obtained in the solid state show differences, dissolve the substance to be examined and the reference substance separately in *acetone R*, evaporate to dryness and record new spectra using the residues.

#### TESTS

**Related substances.** Liquid chromatography (2.2.29).

**Test solution.** Dissolve 40 mg of the substance to be examined in a mixture of 5 mL of *methanol R* and 0.3 mL of *1 M sodium hydroxide* and dilute to 20.0 mL with *methanol R*.

**Reference solution (a).** Dilute 2.0 mL of the test solution to 100.0 mL with *methanol R*. Dilute 5.0 mL of this solution to 100.0 mL with *methanol R*.

**Reference solution (b).** Dissolve 2 mg of the substance to be examined, 2 mg of *meloxicam impurity A CRS*, 2 mg of *meloxicam impurity B CRS*, 2 mg of *meloxicam impurity C CRS* and 2 mg of *meloxicam impurity D CRS* in a mixture of 5 mL of *methanol R* and 0.3 mL of *1 M sodium hydroxide* and dilute to 25 mL with *methanol R*.

**Column:**

- size:  $l = 0.15$  m,  $\varnothing = 4.6$  mm;
- stationary phase: *end-capped octadecylsilyl silica gel for chromatography R (5  $\mu$ m)*;
- temperature: 45 °C.

**Mobile phase:**

- mobile phase A: 1 g/L solution of *potassium dihydrogen phosphate R* adjusted to pH 6.0 with *1 M sodium hydroxide*;
- mobile phase B: *methanol R*;

Time (min)	Mobile phase A (per cent V/V)	Mobile phase B (per cent V/V)
0 - 2	60	40
2 - 10	60 → 30	40 → 70
10 - 15	30	70

**Flow rate:** 1.0 mL/min.

**Detection:** spectrophotometer at 260 nm and 350 nm.

**Injection:** 10  $\mu$ L.

**Relative retention** with reference to meloxicam (retention time = about 7 min): impurity B = about 0.5; impurity A = about 1.4; impurity C = about 1.7; impurity D = about 1.9.

**System suitability:** reference solution (b):

- resolution: minimum 3.0 between the peaks due to meloxicam and impurity A at 350 nm; minimum 3.0 between the peaks due to impurity B and meloxicam at 260 nm.

**Limits:**

- correction factor: for the calculation of content, multiply the peak area of impurity A by 2.0;
- impurity A at 350 nm: not more than the area of the principal peak in the chromatogram obtained with reference solution (a) at 350 nm (0.1 per cent);
- impurity B at 260 nm: not more than the area of the principal peak in the chromatogram obtained with reference solution (a) at 350 nm (0.1 per cent);

01/2009:2373

## MELOXICAM

### Meloxicamum

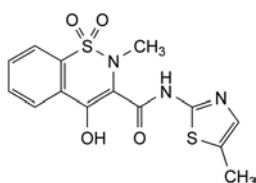

$C_{14}H_{13}N_3O_5S_2$   
[71125-38-7]

$M_r$  351.4

#### DEFINITION

4-Hydroxy-2-methyl-N-(5-methylthiazol-2-yl)-2H-1,2-benzothiazine-3-carboxamide 1,1-dioxide.

- *impurities C, D at 350 nm*: for each impurity, not more than 0.5 times the area of the principal peak in the chromatogram obtained with reference solution (a) at 350 nm (0.05 per cent);
- *unspecified impurities*: for each impurity, at the wavelength giving the higher value for the impurity, not more than the area of the principal peak in the chromatogram obtained with reference solution (a) at the same wavelength (0.10 per cent);
- *total*: not more than 0.3 per cent;
- *disregard limit*: 0.3 times the area of the principal peak in the chromatogram obtained with reference solution (a) at the same wavelength (0.03 per cent).

**Heavy metals** (2.4.8): maximum 20 ppm.

1.0 g complies with test F. Prepare the reference solution using 2 mL of *lead standard solution* (10 ppm Pb) R.

**Loss on drying** (2.2.32): maximum 0.5 per cent, determined on 1.000 g by drying in an oven at 105 °C for 4 h.

**Sulfated ash** (2.4.14): maximum 0.1 per cent, determined on 1.0 g.

#### ASSAY

*In order to avoid overheating during the titration, mix thoroughly throughout and stop the titration immediately after the end-point has been reached.*

Dissolve 0.250 g in a mixture of 5 mL of *anhydrous formic acid* R and 50 mL of *anhydrous acetic acid* R. Titrate with 0.1 M *perchloric acid*, determining the end-point potentiometrically (2.2.20).

1 mL of 0.1 M *perchloric acid* is equivalent to 35.14 mg of  $C_{14}H_{13}N_3O_4S_2$ .

#### STORAGE

Protected from light.

#### IMPURITIES

*Specified impurities: A, B, C, D.*

*Other detectable impurities* (the following substances would, if present at a sufficient level, be detected by one or other of the tests in the monograph. They are limited by the general acceptance criterion for other/unspecified impurities and/or by the general monograph *Substances for pharmaceutical use* (2034). It is therefore not necessary to identify these impurities for demonstration of compliance. See also 5.10. *Control of impurities in substances for pharmaceutical use*): E, F.

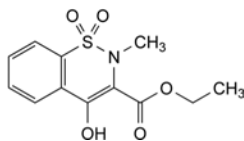

- A. ethyl 4-hydroxy-2-methyl-2H-1,2-benzothiazine-3-carboxylate 1,1-dioxide,

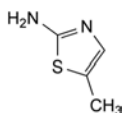

- B. 5-methylthiazol-2-amine,

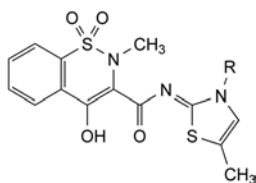

- C. R = CH<sub>3</sub>: *N*-[(2*Z*)-3,5-dimethylthiazol-2(3*H*)-ylidene]-4-hydroxy-2-methyl-2*H*-1,2-benzothiazine-3-carboxamide 1,1-dioxide,

- D. R = C<sub>2</sub>H<sub>5</sub>: *N*-[(2*Z*)-3-ethyl-5-methylthiazol-2(3*H*)-ylidene]-4-hydroxy-2-methyl-2*H*-1,2-benzothiazine-3-carboxamide 1,1-dioxide,

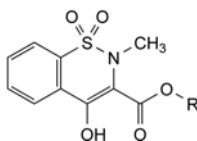

- E. R = CH<sub>3</sub>: methyl 4-hydroxy-2-methyl-2*H*-1,2-benzothiazine-3-carboxylate 1,1-dioxide,

- F. R = CH(CH<sub>3</sub>)<sub>2</sub>: isopropyl 4-hydroxy-2-methyl-2*H*-1,2-benzothiazine-3-carboxylate 1,1-dioxide.

01/2008:0507

## MENADIONE

### Menadionum

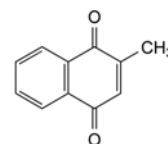

$C_{11}H_8O_2$   
[58-27-5]

$M_r$  172.2

#### DEFINITION

Menadione contains not less than 98.5 per cent and not more than the equivalent of 101.0 per cent of 2-methylnaphthalene-1,4-dione, calculated with reference to the dried substance.

#### CHARACTERS

A pale-yellow, crystalline powder, practically insoluble in water, freely soluble in toluene, sparingly soluble in alcohol and in methanol. It is unstable in light.

#### IDENTIFICATION

*First identification: A, B.*

*Second identification: A, C, D.*

- A. Melting point (2.2.14): 105 °C to 108 °C.
- B. Examine by infrared absorption spectrophotometry (2.2.24), comparing with the spectrum obtained with *menadione CRS*.
- C. Dissolve about 1 mg in 5 mL of *alcohol R*, add 2 mL of *ammonia R* and 0.2 mL of *ethyl cyanoacetate R*. An intense bluish-violet colour develops. Add 2 mL of *hydrochloric acid R*. The colour disappears.
- D. Dissolve about 10 mg in 1 mL of *alcohol R*, add 1 mL of *hydrochloric acid R* and heat in a water-bath. A red colour develops.

#### TESTS

**Related substances.** Carry out the test protected from bright light. Examine by thin-layer chromatography (2.2.27), using *silica gel GF<sub>254</sub> R* as the coating substance.

*Test solution.* Dissolve 0.2 g of the substance to be examined in *acetone R* and dilute to 10 mL with the same solvent.

*Reference solution.* Dilute 0.5 mL of the test solution to 100 mL with *acetone R*.

Apply separately to the plate 5 µL of each solution. Develop over a path of 15 cm using a mixture of 1 volume of *nitromethane R*, 2 volumes of *acetone R*, 5 volumes of *ethylene chloride R* and 90 volumes of *cyclohexane R*. Dry the plate in a current of hot air. Repeat the development and drying a further two times. Examine in ultraviolet light at 254 nm. Any spot in the chromatogram obtained with the test solution, apart from

the principal spot, is not more intense than the spot in the chromatogram obtained with the reference solution (0.5 per cent).

**Loss on drying** (2.2.32). Not more than 0.5 per cent, determined on 1.000 g by drying over *diphosphorus pentoxide R* at a pressure of 2 kPa to 3 kPa for 4 h.

**Sulfated ash** (2.4.14). Not more than 0.1 per cent, determined on 1.0 g.

#### ASSAY

Dissolve 0.150 g in 15 mL of *glacial acetic acid R* in a flask with a stopper fitted with a valve. Add 15 mL of *dilute hydrochloric acid R* and 1 g of *zinc powder R*. Close the flask. Allow the mixture to stand for 60 min, protected from light, with occasional shaking. Filter the solution over a cotton wad, wash with three quantities, each of 10 mL, of *carbon dioxide-free water R*. Add 0.1 mL of *ferroin R* and immediately titrate the combined filtrate and washings with *0.1 M ammonium and cerium nitrate*.

1 mL of *0.1 M ammonium and cerium nitrate* is equivalent to 8.61 mg of  $C_{11}H_{18}O_2$ .

#### STORAGE

Store protected from light.

01/2008:0623  
corrected 7.0

## MENTHOL, RACEMIC

### Mentholum racemicum

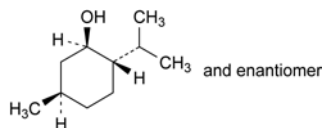

$C_{10}H_{20}O$   
[89-78-1]

$M_r$  156.3

#### DEFINITION

Mixture of equal parts of (1*RS*,2*SR*,5*RS*)-5-methyl-2-(1-methylethyl)cyclohexanol.

#### CHARACTERS

**Appearance:** free-flowing or agglomerated, crystalline powder or prismatic or acicular, colourless, shiny crystals.

**Solubility:** practically insoluble in water, very soluble in ethanol (96 per cent) and in light petroleum, freely soluble in fatty oils and in liquid paraffin, very slightly soluble in glycerol.

mp: about 34 °C.

#### IDENTIFICATION

**First identification:** A, C.

**Second identification:** B, D.

A. Optical rotation (see Tests).

B. Thin-layer chromatography (2.2.27).

**Test solution.** Dissolve 25 mg of the substance to be examined in *methanol R* and dilute to 5 mL with the same solvent.

**Reference solution.** Dissolve 25 mg of *menthol CRS* in *methanol R* and dilute to 5 mL with the same solvent.

**Plate:** *TLC silica gel G plate R*.

**Mobile phase:** *ethyl acetate R, toluene R* (5:95 V/V).

**Application:** 2 µL.

**Development:** over a path of 15 cm.

**Drying:** in air, until the solvents have evaporated.

**Detection:** spray with *anisaldehyde solution R* and heat at 100-105 °C for 5-10 min.

**Results:** the principal spot in the chromatogram obtained with the test solution is similar in position, colour and size to the principal spot in the chromatogram obtained with the reference solution.

C. Examine the chromatograms obtained in the test for related substances.

**Results:** the principal peak in the chromatogram obtained with test solution (b) is similar in position and approximate dimensions to the principal peak in the chromatogram obtained with reference solution (c).

D. Dissolve 0.20 g in 0.5 mL of *anhydrous pyridine R*. Add 3 mL of a 150 g/L solution of *dinitrobenzoyl chloride R* in *anhydrous pyridine R*. Heat on a water-bath for 10 min. Add 7.0 mL of *water R* in small quantities with stirring and allow to stand in iced water for 30 min. A precipitate is formed. Allow to stand and decant the supernatant liquid. Wash the precipitate with 2 quantities, each of 5 mL, of iced *water R*, recrystallise from 10 mL of *acetone R*, wash with iced *acetone R* and dry at 75 °C at a pressure not exceeding 2.7 kPa for 30 min. The crystals melt (2.2.14) at 130 °C to 131 °C.

#### TESTS

**Solution S.** Dissolve 2.50 g in 10 mL of *ethanol (96 per cent) R* and dilute to 25.0 mL with the same solvent.

**Appearance of solution.** Solution S is clear (2.2.1) and colourless (2.2.2, *Method II*).

**Acidity or alkalinity.** Dissolve 1.0 g in *ethanol (96 per cent) R* and dilute to 10 mL with the same solvent. Add 0.1 mL of *phenolphthalein solution R*. The solution is colourless. Not more than 0.5 mL of *0.01 M sodium hydroxide* is required to change the colour of the indicator to pink.

**Optical rotation** (2.2.7):  $-0.2^\circ$  to  $+0.2^\circ$ , determined on solution S.

**Related substances.** Gas chromatography (2.2.28).

**Test solution (a).** Dissolve 0.20 g of the substance to be examined in *methylene chloride R* and dilute to 50.0 mL with the same solvent.

**Test solution (b).** Dilute 1.0 mL of test solution (a) to 10.0 mL with *methylene chloride R*.

**Reference solution (a).** Dissolve 40.0 mg of the substance to be examined and 40.0 mg of *isomenthol R* in *methylene chloride R* and dilute to 100.0 mL with the same solvent.

**Reference solution (b).** Dilute 0.10 mL of test solution (a) to 100.0 mL with *methylene chloride R*.

**Reference solution (c).** Dissolve 40.0 mg of *menthol CRS* in *methylene chloride R* and dilute to 100.0 mL with the same solvent.

**Column:**

- **material:** glass;
- **size:**  $l = 2.0$  m,  $\varnothing = 2$  mm;
- **stationary phase:** *diatomaceous earth for gas chromatography R* impregnated with 15 per cent *m/m* of *macrogol 1500 R*.

**Carrier gas:** *nitrogen for chromatography R*.

**Flow rate:** 30 mL/min.

**Temperature:**

- **column:** 120 °C;
- **injection port:** 150 °C;
- **detector:** 200 °C.

**Detection:** flame ionisation.

**Injection:** 1 µL.

**Run time:** twice the retention time of menthol.

**System suitability:**

- **resolution:** minimum 1.4 between the peaks due to menthol and isomenthol in the chromatogram obtained with reference solution (a);



– *signal-to-noise ratio*: minimum 5 for the principal peak in the chromatogram obtained with reference solution (b).

*Limits*: test solution (a):

– *total*: not more than 1 per cent of the area of the principal peak;

– *disregard limit*: 0.05 per cent of the area of the principal peak.

**Residue on evaporation**: maximum 0.05 per cent.

Evaporate 2.00 g on a water-bath and heat in an oven at 100-105 °C for 1 h. The residue weighs not more than 1.0 mg.

01/2008:1242  
corrected 6.0

## MEPIVACAINE HYDROCHLORIDE

### Mepivacaini hydrochloridum

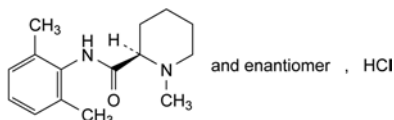

C<sub>15</sub>H<sub>23</sub>ClN<sub>2</sub>O  
[1722-62-9]

M<sub>r</sub> 282.8

#### DEFINITION

(*RS*)-*N*-(2,6-Dimethylphenyl)-1-methylpiperidine-2-carboxamide hydrochloride.

*Content*: 98.5 per cent to 101.0 per cent (dried substance).

#### CHARACTERS

*Appearance*: white or almost white, crystalline powder.

*Solubility*: freely soluble in water and in ethanol (96 per cent), very slightly soluble in methylene chloride.

mp: about 260 °C, with decomposition.

#### IDENTIFICATION

*First identification*: A, B, D.

*Second identification*: B, C, D.

A. Infrared absorption spectrophotometry (2.2.24).

*Preparation*: discs.

*Comparison*: mepivacaine hydrochloride CRS.

B. Thin-layer chromatography (2.2.27).

*Test solution*. Dissolve 20 mg of the substance to be examined in ethanol (96 per cent) R and dilute to 5 mL with the same solvent.

*Reference solution (a)*. Dissolve 20 mg of mepivacaine hydrochloride CRS in ethanol (96 per cent) R and dilute to 5 mL with the same solvent.

*Reference solution (b)*. Dissolve 20 mg of mepivacaine hydrochloride CRS and 20 mg of lidocaine hydrochloride CRS in ethanol (96 per cent) R and dilute to 5 mL with the same solvent.

*Plate*: TLC silica gel F<sub>254</sub> plate R.

*Mobile phase*: concentrated ammonia R, methanol R, ether R (1:5:100 V/V/V).

*Application*: 10 µL.

*Development*: over a path of 12 cm.

*Drying*: in air.

*Detection*: examine in ultraviolet light at 254 nm.

*System suitability*: reference solution (b):

– the chromatogram shows 2 clearly separated principal spots.

*Results*: the principal spot in the chromatogram obtained with the test solution is similar in position and size to the principal spot in the chromatogram obtained with reference solution (a).

C. To 5 mL of solution S (see Tests) add 1 mL of dilute sodium hydroxide solution R and shake with 2 quantities, each of 10 mL, of ether R. Dry the combined upper layers over anhydrous sodium sulfate R. Filter and evaporate the ether on a water-bath. Dry the residue at 100-105 °C for 2 h. The melting point (2.2.14) is 151 °C to 155 °C.

D. It gives reaction (a) of chlorides (2.3.1).

#### TESTS

**Solution S**. Dissolve 1.5 g in carbon dioxide-free water R and dilute to 30 mL with the same solvent.

**Appearance of solution**. Solution S is clear (2.2.1) and not more intensely coloured than reference solution B<sub>r</sub> (2.2.2, Method II).

**pH** (2.2.3): 4.0 to 5.0.

Dilute 2 mL of solution S to 5 mL with carbon dioxide-free water R.

**Optical rotation** (2.2.7): –0.10° to +0.10°, determined on solution S.

**Related substances**. Liquid chromatography (2.2.29).

*Test solution*. Dissolve 20.0 mg of the substance to be examined in the mobile phase and dilute to 10.0 mL with the mobile phase.

*Reference solution (a)*. Dissolve 20.0 mg of the substance to be examined and 30.0 mg of mepivacaine impurity B CRS in the mobile phase and dilute to 100.0 mL with the mobile phase. Dilute 1.0 mL of this solution to 100.0 mL with the mobile phase.

*Reference solution (b)*. Dilute 1.0 mL of the test solution to 100.0 mL with the mobile phase. Dilute 1.0 mL of this solution to 10.0 mL with the mobile phase.

*Column*:

– *size*: *l* = 0.125 m, Ø = 4.6 mm;

– *stationary phase*: base-deactivated octadecylsilyl silica gel for chromatography R (5 µm).

*Mobile phase*: mix 35 volumes of acetonitrile R1 and 65 volumes of a 2.25 g/L solution of phosphoric acid R adjusted to pH 7.6 with strong sodium hydroxide solution R.

*Flow rate*: 1 mL/min.

*Detection*: spectrophotometer at 220 nm.

*Injection*: 20 µL.

*Run time*: 3 times the retention time of mepivacaine.

*System suitability*: reference solution (a):

– *resolution*: minimum 2.5 between the peaks due to impurity B and mepivacaine.

*Limits*:

– *impurities B, C, D, E*: for each impurity, not more than twice the area of the principal peak in the chromatogram obtained with reference solution (b) (0.2 per cent), and not more than one of the peaks has an area greater than the area of the principal peak in the chromatogram obtained with reference solution (b) (0.1 per cent);

– *total*: not more than 5 times the area of the principal peak in the chromatogram obtained with reference solution (b) (0.5 per cent);

– *disregard limit*: 0.2 times the area of the principal peak in the chromatogram obtained with reference solution (b) (0.02 per cent).

**Impurity A**: maximum 100 ppm.

Dissolve 0.50 g in methanol R and dilute to 10 mL with the same solvent. To 2 mL of this solution add 1 mL of a freshly prepared 10 g/L solution of dimethylaminobenzaldehyde R in methanol R and 2 mL of glacial acetic acid R and allow to stand for 10 min. Any yellow colour in the solution is not more intense than that in a standard prepared at the same time and in the same manner using 2 mL of a 5 mg/L solution of 2,6-dimethylaniline R in methanol R.

**Heavy metals** (2.4.8): maximum 5 ppm.

Dissolve 1.0 g in *water R* and dilute to 25 mL with the same solvent. Carry out the prefiltration. 10 mL of the filtrate complies with test E. Prepare the reference solution using 2 mL of *lead standard solution (1 ppm Pb) R*.

**Loss on drying** (2.2.32): maximum 1.0 per cent, determined on 1.000 g by drying in an oven at 105 °C.

**Sulfated ash** (2.4.14): maximum 0.1 per cent, determined on 1.0 g.

#### ASSAY

Dissolve 0.250 g in a mixture of 5.0 mL of 0.01 M *hydrochloric acid* and 50 mL of *ethanol (96 per cent) R*. Carry out a potentiometric titration (2.2.20), using 0.1 M *sodium hydroxide*. Read the volume added between the 2 points of inflexion.

1 mL of 0.1 M *sodium hydroxide* is equivalent to 28.28 mg of  $C_{15}H_{23}ClN_2O$ .

#### IMPURITIES

*Specified impurities: A, B, C, D, E.*

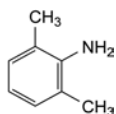

A. 2,6-dimethylaniline,

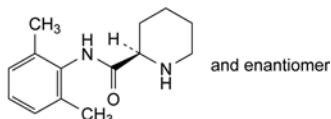

B. (RS)-N-(2,6-dimethylphenyl)piperidine-2-carboxamide,

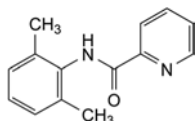

C. N-(2,6-dimethylphenyl)pyridine-2-carboxamide,

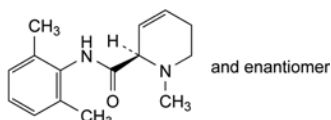

D. (RS)-N-(2,6-dimethylphenyl)-1-methyl-1,2,5,6-tetrahydropyridine-2-carboxamide,

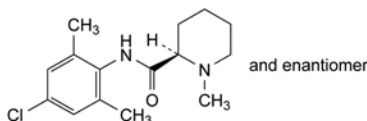

E. (RS)-N-(4-chloro-2,6-dimethylphenyl)-1-methylpiperidine-2-carboxamide.

01/2008:0407

## MEPROBAMATE

### Meprobamatum

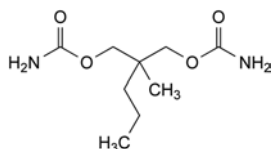

$C_9H_{18}N_2O_4$   
[57-53-4]

$M_r$  218.3

#### DEFINITION

Meprobamate contains not less than 97.0 per cent and not more than the equivalent of 101.0 per cent of 2-methyl-2-propylpropane-1,3-diyl dicarbamate, calculated with reference to the dried substance.

#### CHARACTERS

A white or almost white, amorphous or crystalline powder, slightly soluble in water, freely soluble in alcohol.

#### IDENTIFICATION

*First identification: A, B.*

*Second identification: A, C, D.*

A. Melting point (2.2.14): 104 °C to 108 °C.

B. Examine by infrared absorption spectrophotometry (2.2.24), comparing with the spectrum obtained with *meprobamate CRS*.

C. To 0.5 g add 1 mL of *acetic anhydride R* and 0.05 mL of *sulfuric acid R*, mix and allow to stand for 30 min, shaking frequently. Pour the solution dropwise into 50 mL of *water R*, mix and allow to stand. Initiate crystallisation by scratching the wall of the tube with a glass rod. Collect the precipitate by filtration, wash and dry at 60 °C. The precipitate melts (2.2.14) at 124 °C to 128 °C.

D. Dissolve 0.2 g in 15 mL of 0.5 M *alcoholic potassium hydroxide* and boil under a reflux condenser for 15 min. Add 0.5 mL of *glacial acetic acid R* and 1 mL of a 50 g/L solution of *cobalt nitrate R* in *ethanol R*. A deep-blue colour develops.

#### TESTS

**Appearance of solution.** Dissolve 1.0 g in 20 mL of *ethanol R*. The solution is clear (2.2.1) and colourless (2.2.2, *Method II*).

**Related substances.** Examine by thin-layer chromatography (2.2.27), using *silica gel G R* as the coating substance.

**Test solution.** Dissolve 0.20 g of the substance to be examined in *alcohol R* and dilute to 10 mL with the same solvent.

**Reference solution.** Dilute 0.1 mL of the test solution to 10 mL with *alcohol R*.

Apply separately to the plate 5 µL of each solution. Develop over a path of 15 cm using a mixture of 10 volumes of *pyridine R*, 30 volumes of *acetone R* and 70 volumes of *hexane R*. Dry the plate at 120 °C for 30 min, allow to cool and spray with a solution of 0.25 g of *vanillin R* in a cooled mixture of 10 mL of *alcohol R* and 40 mL of *sulfuric acid R* and heat at 100 °C to 105 °C for 30 min. Any spot in the chromatogram obtained with the test solution, apart from the principal spot, is not more intense than the spot in the chromatogram obtained with the reference solution (1.0 per cent).

**Heavy metals** (2.4.8). Dissolve 2.0 g in a mixture of 15 volumes of *water R* and 85 volumes of *acetone R* and dilute to 20 mL with the same mixture of solvents. 12 mL of the solution complies with limit test B for heavy metals (10 ppm). Prepare the standard using lead standard solution (1 ppm Pb) obtained by diluting *lead standard solution (100 ppm Pb) R* with the mixture of *water R* and *acetone R*.

**Loss on drying** (2.2.32). Not more than 0.5 per cent, determined on 1.000 g by drying *in vacuo* at 60 °C.

**Sulfated ash** (2.4.14). Not more than 0.1 per cent, determined on 1.0 g.

#### ASSAY

Dissolve 0.1000 g in 15 mL of a 25 per cent V/V solution of *sulfuric acid R* and boil under a reflux condenser for 3 h. Cool, dissolve by cautiously adding 30 mL of *water R*, cool again and place in a steam-distillation apparatus. Add 40 mL of *strong sodium hydroxide solution R* and distil immediately by passing steam through the mixture. Collect the distillate into 40 mL of a 40 g/L solution of *boric acid R* until the total volume in

the receiver reaches about 200 mL. Add 0.25 mL of *methyl red mixed solution R*. Titrate with 0.1 M *hydrochloric acid* until the colour changes from green to violet. Carry out a blank titration. 1 mL of 0.1 M *hydrochloric acid* is equivalent to 10.91 mg of  $C_9H_{18}N_2O_4$ .

01/2008:0278  
corrected 6.0

## MEPYRAMINE MALEATE

### Mepyramini maleas

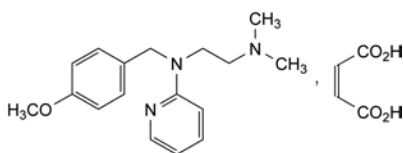

$C_{21}H_{27}N_3O_5$   
[59-33-6]

$M_r$  401.5

#### DEFINITION

*N*-(4-Methoxybenzyl)-*N,N'*-dimethyl-*N*-(pyridin-2-yl)ethane-1,2-diamine (*Z*)-butenedioate.

*Content*: 99.0 per cent to 101.0 per cent (dried substance).

#### CHARACTERS

*Appearance*: white or slightly yellowish, crystalline powder.

*Solubility*: very soluble in water, freely soluble in ethanol (96 per cent).

#### IDENTIFICATION

*First identification*: B.

*Second identification*: A, C, D, E.

A. Melting point (2.2.14): 99 °C to 103 °C.

B. Infrared absorption spectrophotometry (2.2.24).

*Preparation*: 50 g/L solutions in *methylene chloride R* using a 0.1 mm cell.

*Comparison*: *mepyramine maleate CRS*.

C. Dissolve 0.100 g in 0.01 M *hydrochloric acid* and dilute to 100.0 mL with the same acid. Dilute 1.0 mL of this solution to 100.0 mL with 0.01 M *hydrochloric acid*. Examined between 220 nm and 350 nm (2.2.25), the solution shows 2 absorption maxima, at 239 nm and 316 nm. The specific absorbances at the absorption maxima are 431 to 477 and 196 to 220, respectively.

D. Thin-layer chromatography (2.2.27).

*Test solution*. Dissolve 40 mg of the substance to be examined in *methylene chloride R* and dilute to 10 mL with the same solvent.

*Reference solution*. Dissolve 40 mg of *mepyramine maleate CRS* in *methylene chloride R* and dilute to 10 mL with the same solvent.

*Plate*: TLC silica gel GF<sub>254</sub> plate R.

*Mobile phase*: *diethylamine R*, *ethyl acetate R* (2:100 V/V).

*Application*: 5 µL.

*Development*: over 2/3 of the plate.

*Drying*: in air.

*Detection*: examine in ultraviolet light at 254 nm.

*Results*: the principal spot in the chromatogram obtained with the test solution is similar in position and size to the principal spot in the chromatogram obtained with the reference solution.

E. Triturate 0.1 g with 3 mL of *water R* and 1 mL of *strong sodium hydroxide solution R*. Shake with 3 quantities, each of 5 mL, of *ether R*. To 0.1 mL of the aqueous layer add a

solution of 10 mg of *resorcinol R* in 3 mL of *sulfuric acid R*. Heat on a water-bath for 15 min; no colour develops. To the rest of the aqueous layer add 1 mL of *bromine water R*. Heat on a water-bath for 15 min and then heat to boiling and cool. To 0.2 mL of this solution add a solution of 10 mg of *resorcinol R* in 3 mL of *sulfuric acid R*. Heat on a water-bath for 15 min; a violet-pink colour develops.

#### TESTS

**Solution S**. Dissolve 5.0 g in *carbon dioxide-free water R* and dilute to 25 mL with the same solvent.

**Appearance of solution**. The solution is clear (2.2.1) and not more intensely coloured than reference solution Y<sub>6</sub> (2.2.2, *Method II*).

Dilute 5 mL of solution S to 25 mL with *carbon dioxide-free water R*.

**pH** (2.2.3): 4.9 to 5.2.

Dilute 1.0 mL of solution S to 10 mL with *carbon dioxide-free water R*.

**Related substances**. Liquid chromatography (2.2.29).

*Test solution*. Dissolve 25.0 mg of the substance to be examined in the mobile phase and dilute to 50.0 mL with the mobile phase.

*Reference solution (a)*. Dissolve 5 mg of *anisaldehyde R* (impurity B), 5.0 mg of *mepyramine impurity A CRS* and 5.0 mg of *mepyramine impurity C CRS* in the mobile phase and dilute to 100.0 mL with the mobile phase. Dilute 2.0 mL of this solution to 100.0 mL with the mobile phase.

*Reference solution (b)*. Dilute 1.0 mL of the test solution to 100.0 mL with the mobile phase. Dilute 1.0 mL of this solution to 10.0 mL with the mobile phase.

*Column*:

– *size*:  $l = 0.25$  m,  $\varnothing = 4.6$  mm;

– *stationary phase*: *phenylsilyl silica gel for chromatography R1* (5 µm).

*Mobile phase*: mix 0.1 volume of *triethylamine R*, 40 volumes of a 0.771 g/L solution of *ammonium acetate R* and 60 volumes of *methanol R*.

*Flow rate*: 1.0 mL/min.

*Detection*: spectrophotometer at 230 nm.

*Injection*: 20 µL.

*Run time*: 3 times the retention time of mepyramine.

*Relative retention* with reference to mepyramine (retention time = about 13 min): maleic acid = about 0.2; impurity C = about 0.3; impurity B = about 0.4; impurity A = about 0.5.

*System suitability*: reference solution (a):

– *resolution*: minimum 3.0 between the peaks due to impurities C and B.

*Limits*:

– *impurities A, C*: for each impurity, not more than the area of the corresponding peak in the chromatogram obtained with reference solution (a) (0.2 per cent);

– *impurity B*: not more than twice the area of the principal peak in the chromatogram obtained with reference solution (b) (0.2 per cent);

– *unspecified impurities*: for each impurity, not more than the area of the principal peak in the chromatogram obtained with reference solution (b) (0.10 per cent);

– *total*: not more than 5 times the area of the principal peak in the chromatogram obtained with reference solution (b) (0.5 per cent);

– *disregard limit*: 0.5 times the area of the principal peak in the chromatogram obtained with reference solution (b) (0.05 per cent); disregard the peak due to maleic acid.

**Chlorides** (2.4.4): maximum 100 ppm.

Dilute 2.5 mL of solution S to 15 mL with *water R*.

**Heavy metals** (2.4.8): maximum 20 ppm.

1.0 g complies with test D. Prepare the reference solution using 2 mL of *lead standard solution* (10 ppm Pb) R.

**Loss on drying** (2.2.32): maximum 0.25 per cent, determined on 1.000 g by drying in an oven at 80 °C.

**Sulfated ash** (2.4.14): maximum 0.1 per cent, determined on the residue obtained in the test for loss on drying.

#### ASSAY

Dissolve 0.150 g in 40 mL of *anhydrous acetic acid* R. Titrate with 0.1 M *perchloric acid*, determining the end-point potentiometrically (2.2.20).

1 mL of 0.1 M *perchloric acid* is equivalent to 20.07 mg of  $C_{21}H_{27}N_3O_5$ .

#### STORAGE

Protected from light.

#### IMPURITIES

*Specified impurities*: A, B, C.

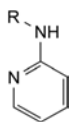

A. R =  $CH_2-C_6H_4-p-OCH_3$ : *N*-(4-methoxybenzyl)pyridin-2-amine,

C. R = H: pyridin-2-amine,

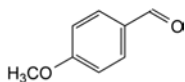

B. 4-methoxybenzaldehyde (anisaldehyde).

#### TESTS

**Hypoxanthine**. Examine by thin-layer chromatography (2.2.27), using *silica gel GF<sub>254</sub>* R as the coating substance.

*Test solution*. Dissolve 50 mg of the substance to be examined in 1 mL of *dimethyl sulfoxide* R and dilute to 10 mL with *methanol* R.

*Reference solution*. Dissolve 10 mg of *hypoxanthine* R in 10 mL of *dimethyl sulfoxide* R and dilute to 100 mL with *methanol* R. Apply separately to the plate 5 µL of each solution. Develop over a path of 10 cm using a mixture of 3 volumes of *concentrated ammonia* R, 7 volumes of *water* R and 90 volumes of *acetone* R. Allow the plate to dry in air and examine in ultraviolet light at 254 nm. Any spot corresponding to hypoxanthine in the chromatogram obtained with the test solution is not more intense than the spot in the chromatogram obtained with the reference solution (2.0 per cent).

**Water** (2.5.12). 10.0 per cent to 12.0 per cent, determined on 0.250 g by the semi-micro determination of water.

**Sulfated ash** (2.4.14). Not more than 0.1 per cent, determined on 1.0 g.

#### ASSAY

Dissolve 0.100 g in 50 mL of *dimethylformamide* R. Titrate with 0.1 M *tetrabutylammonium hydroxide*, determining the end-point potentiometrically (2.2.20).

1 mL of 0.1 M *tetrabutylammonium hydroxide* is equivalent to 15.22 mg of  $C_5H_4N_4S$ .

#### STORAGE

Store protected from light.

01/2008:0120  
corrected 6.0

01/2008:0096

## MERCAPTOPURINE

### Mercaptopurinum

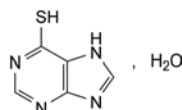

$C_5H_4N_4S, H_2O$   
[6112-76-1]

$M_r$  170.2

#### DEFINITION

Mercaptopurine contains not less than 98.5 per cent and not more than the equivalent of 101.0 per cent of 7*H*-purine-6-thiol, calculated with reference to the anhydrous substance.

#### CHARACTERS

A yellow, crystalline powder, practically insoluble in water, slightly soluble in alcohol. It dissolves in solutions of alkali hydroxides.

#### IDENTIFICATION

- Dissolve 20 mg in 5 mL of *dimethyl sulfoxide* R and dilute to 100 mL with 0.1 M *hydrochloric acid*. Dilute 5 mL of the solution to 200 mL with 0.1 M *hydrochloric acid*. Examined between 230 nm and 350 nm (2.2.25), the solution shows only one absorption maximum, at 325 nm.
- Dissolve about 20 mg in 20 mL of *alcohol* R heated to 60 °C and add 1 mL of a saturated solution of *mercuric acetate* R in *alcohol* R. A white precipitate is formed.
- Dissolve about 20 mg in 20 mL of *alcohol* R heated to 60 °C and add 1 mL of a 10 g/L solution of *lead acetate* R in *alcohol* R. A yellow precipitate is formed.

## MERCURIC CHLORIDE

### Hydrargyri dichloridum

$HgCl_2$   
[7487-94-7]

$M_r$  271.5

#### DEFINITION

*Content*: 99.5 per cent to 100.5 per cent (dried substance).

#### CHARACTERS

*Appearance*: white or almost white, crystalline powder or colourless or white or almost white crystals or heavy crystalline masses.

*Solubility*: soluble in water and in glycerol, freely soluble in ethanol (96 per cent).

#### IDENTIFICATION

- It gives the reactions of chlorides (2.3.1).
- Solution S (see Tests) gives the reactions of mercury (2.3.1).

#### TESTS

**Solution S**. Dissolve 1.0 g in *carbon dioxide-free water* R and dilute to 20 mL with the same solvent.

**Appearance of solution**. Solution S is not more opalescent than reference suspension II (2.2.1) and is colourless (2.2.2, *Method II*).

**Acidity or alkalinity**. To 10 mL of solution S add 0.1 mL of *methyl red solution* R. The solution is red. Add 0.5 g of *sodium chloride* R. The solution becomes yellow. Not more than 0.5 mL of 0.01 M *hydrochloric acid* is required to change the colour to red.

**Mercurous chloride**. Dissolve 1.0 g in 30 mL of *ether* R. The solution shows no opalescence.

**Loss on drying** (2.2.32): maximum 1.0 per cent, determined on 2.00 g by drying *in vacuo* for 24 h.

#### ASSAY

Dissolve 0.500 g in 100 mL of *water R*. Add 20.0 mL of 0.1 M *sodium edetate* and 5 mL of *buffer solution pH 10.9 R*. Allow to stand for 15 min. Add 0.1 g of *mordant black 11 triturate R* and titrate with 0.1 M *zinc sulfate* until the colour changes to purple. Add 3 g of *potassium iodide R*, allow to stand for 2 min, add a further 0.1 g of *mordant black 11 triturate R* and titrate with 0.1 M *zinc sulfate*.

1 mL of 0.1 M *zinc sulfate* used in the second titration is equivalent to 27.15 mg of  $\text{HgCl}_2$ .

#### STORAGE

Protected from light.

01/2011:2234

## MEROPENEM TRIHYDRATE

### Meropenemum trihydricum

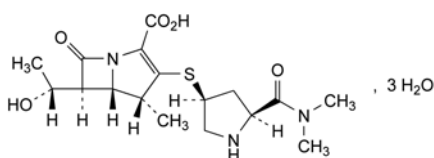

$\text{C}_{17}\text{H}_{25}\text{N}_3\text{O}_5\text{S}\cdot 3\text{H}_2\text{O}$   
[119478-56-7]

$M_r$  437.5

#### DEFINITION

(4*R*,5*S*,6*S*)-3-[[[(3*S*,5*S*)-5-[(Dimethylamino)carbonyl]pyrrolidin-3-yl]sulfonyl]-6-[(1*R*)-1-hydroxyethyl]-4-methyl-7-oxo-1-azabicyclo[3.2.0]hept-2-ene-2-carboxylic acid trihydrate.

Semi-synthetic product derived from a fermentation product.

**Content:** 97.5 per cent to 102.0 per cent (anhydrous substance).

#### CHARACTERS

**Appearance:** white or light yellow, crystalline powder.

**Solubility:** sparingly soluble in water, practically insoluble in ethanol (96 per cent) and in methylene chloride.

#### IDENTIFICATION

Infrared absorption spectrophotometry (2.2.24).

**Comparison:** *meropenem trihydrate CRS*.

#### TESTS

**Appearance of solution.** The solution is clear (2.2.1) and not more intensely coloured than reference solution  $Y_5$  (2.2.2, *Method II*).

Dissolve 1.0 g in 20 mL of a 50 g/L solution of *sodium hydrogen carbonate R*.

**pH** (2.2.3): 4.0 to 6.0.

Dissolve 0.20 g in *carbon dioxide-free water R* and dilute to 20 mL with the same solvent.

**Specific optical rotation** (2.2.7): – 17 to – 21 (anhydrous substance).

Dissolve 0.125 g in *water R* and dilute to 25.0 mL with the same solvent.

**Related substances.** Liquid chromatography (2.2.29). Prepare test solutions (a) and (b) and reference solution (c) immediately before use. Prepare and store reference solution (a) at 4 °C and use within 6 h.

**Solvent mixture.** To 1.0 mL of *triethylamine R* add 900 mL of *water for chromatography R*. Adjust to pH 5.0 with *dilute phosphoric acid R* and dilute to 1000.0 mL with *water for chromatography R*.

**Test solution (a).** Dissolve 0.100 g of the substance to be examined in the solvent mixture and dilute to 25.0 mL with the solvent mixture.

**Test solution (b).** Dissolve 50.0 mg of the substance to be examined in the mobile phase and dilute to 100.0 mL with the mobile phase.

**Reference solution (a).** Dilute 1.0 mL of test solution (a) to 100.0 mL with the solvent mixture. Dilute 1.0 mL of this solution to 10.0 mL with the solvent mixture.

**Reference solution (b).** In order to prepare impurities A and B *in-situ*, heat 10 mL of test solution (a) to 60 °C for about 20 min or, alternatively, allow 10 mL of test solution (a) to stand at ambient temperature for about 8 h.

**Reference solution (c).** Dissolve 50.0 mg of *meropenem trihydrate CRS* in the mobile phase and dilute to 100.0 mL with the mobile phase.

#### Column:

– **size:**  $l = 0.25$  m,  $\varnothing = 4.6$  mm;

– **stationary phase:** base-deactivated end-capped octadecylsilyl silica gel for chromatography *R* (5  $\mu\text{m}$ );

– **temperature:** 40 °C.

**Mobile phase:** *acetonitrile R1*, solvent mixture (7:100 *V/V*).

**Flow rate:** 1.6 mL/min.

**Detection:** spectrophotometer at 220 nm.

**Injection:** 10  $\mu\text{L}$  of test solution (a) and reference solutions (a) and (b).

**Run time:** 4 times the retention time of meropenem.

**Relative retention** with reference to meropenem (retention time = about 6 min): impurity A = about 0.5; impurity B = about 2.2.

**System suitability:** reference solution (b):

– **resolution:** minimum 5.0 between the peaks due to impurity A and meropenem.

#### Limits:

– **correction factor:** for the calculation of content, multiply the peak area of impurity A by 1.6;

– **impurity A:** not more than 5 times the area of the principal peak in the chromatogram obtained with reference solution (a) (0.5 per cent);

– **impurity B:** not more than 3 times the area of the principal peak in the chromatogram obtained with reference solution (a) (0.3 per cent);

– **unspecified impurities:** for each impurity, not more than the area of the principal peak in the chromatogram obtained with reference solution (a) (0.10 per cent);

– **sum of impurities other than A and B:** not more than 3 times the area of the principal peak in the chromatogram obtained with reference solution (a) (0.3 per cent);

– **disregard limit:** 0.5 times the area of the principal peak in the chromatogram obtained with reference solution (a) (0.05 per cent).

**Heavy metals** (2.4.8): maximum 10 ppm.

0.50 g complies with test G. Prepare the reference solution using 0.5 mL of *lead standard solution (10 ppm Pb) R*.

**Water** (2.5.12): 11.4 per cent to 13.4 per cent, determined on 0.100 g.

**Sulfated ash** (2.4.14): maximum 0.1 per cent, determined on 1.0 g.

**Bacterial endotoxins** (2.6.14): less than 0.125 IU/mg, if intended for use in the manufacture of parenteral preparations without a further appropriate procedure for the removal of bacterial endotoxins.

#### ASSAY

Liquid chromatography (2.2.29) as described in the test for related substances with the following modification.

**Injection:** test solution (b) and reference solution (c).

Calculate the percentage content of  $C_{17}H_{25}N_3O_5S$  from the declared content of *meropenem trihydrate CRS*.

#### STORAGE

If the substance is sterile, store in a sterile, airtight, tamper-proof container.

#### LABELLING

The label states, where applicable, that the substance is suitable for use in the manufacture of parenteral preparations.

#### IMPURITIES

Specified impurities: A, B.

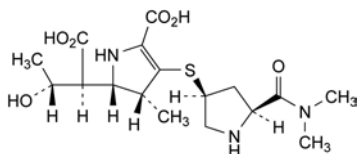

- A. (4*R*,5*S*)-5-[(1*S*,2*R*)-1-carboxy-2-hydroxypropyl]-3-[(3*S*,5*S*)-5-[(dimethylamino)carbonyl]pyrrolidin-3-yl]sulfanyl]-4-methyl-4,5-dihydro-1*H*-pyrrole-2-carboxylic acid,

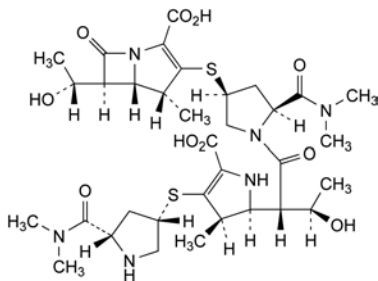

- B. (4*R*,5*S*,6*S*)-3-[(3*S*,5*S*)-1-[(2*S*,3*R*)-2-[(2*S*,3*R*)-5-carboxy-4-[(3*S*,5*S*)-5-[(dimethylamino)carbonyl]pyrrolidin-3-yl]sulfanyl]-3-methyl-2,3-dihydro-1*H*-pyrrol-2-yl]-3-hydroxybutanoyl]-5-[(dimethylamino)carbonyl]pyrrolidin-3-yl]sulfanyl]-6-[(1*R*)-1-hydroxyethyl]-4-methyl-7-oxo-1-azabicyclo[3.2.0]hept-2-ene-2-carboxylic acid.

01/2008:1699  
corrected 6.0

## MESALAZINE

### Mesalazinum

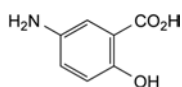

$C_7H_7NO_3$   
[89-57-6]

$M_r$  153.1

#### DEFINITION

5-Amino-2-hydroxybenzoic acid.

Content: 98.5 per cent to 101.0 per cent (dried substance).

#### CHARACTERS

Appearance: almost white or light grey or light pink powder or crystals.

Solubility: very slightly soluble in water, practically insoluble in alcohol. It dissolves in dilute solutions of alkali hydroxides and in dilute hydrochloric acid.

#### IDENTIFICATION

First identification: B.

Second identification: A, C.

- A. Dissolve 50.0 mg in 10 mL of a 10.3 g/L solution of hydrochloric acid *R* and dilute to 100.0 mL with the same acid. Dilute 5.0 mL to 200.0 mL with a 10.3 g/L solution of hydrochloric acid *R*. Examined between 210 nm and

250 nm (2.2.25), the solution shows an absorption maximum at about 230 nm. The specific absorbance at the maximum is 430 to 450.

- B. Infrared absorption spectrophotometry (2.2.24).

Preparation: discs.

Comparison: mesalazine *CRS*.

- C. Thin-layer chromatography (2.2.27).

Test solution. Dissolve 50 mg of the substance to be examined in 10 mL of a mixture of equal volumes of glacial acetic acid *R* and water *R* and dilute to 20.0 mL with methanol *R*.

Reference solution. Dissolve 50 mg of mesalazine *CRS* in 10 mL of a mixture of equal volumes of glacial acetic acid *R* and water *R* and dilute to 20.0 mL with methanol *R*.

Plate: a suitable silica gel as the coating substance.

Mobile phase: glacial acetic acid *R*, methanol *R*, methyl isobutyl ketone *R* (10:40:50 V/V/V).

Application: 5  $\mu$ L.

Development: over a path of 10 cm.

Drying: in air.

Detection: examine in ultraviolet light at 365 nm.

Results: the principal spot in the chromatogram obtained with the test solution is similar in position, colour and size to the principal spot in the chromatogram obtained with the reference solution.

#### TESTS

Appearance of solution. Maintain the solutions at 40 °C during preparation and measurements. Dissolve 0.5 g in 1 *M* hydrochloric acid and dilute to 20 mL with the same acid. The solution is clear (2.2.1). Immediately measure the absorbance (2.2.25) of the solution at 440 nm and 650 nm. The absorbance is not greater than 0.15 at 440 nm and 0.10 at 650 nm.

Reducing substances. Dissolve 0.10 g in dilute hydrochloric acid *R* and dilute to 25 mL with the same acid. Add 0.2 mL of starch solution *R* and 0.25 mL of 0.01 *M* iodine. Allow to stand for 2 min. The solution is blue or violet-brown.

Related substances. Liquid chromatography (2.2.29). Use freshly prepared solutions and mobile phases.

Test solution. Dissolve 50.0 mg of the substance to be examined in mobile phase A and dilute to 50.0 mL with mobile phase A.

Reference solution (a). Dilute 1.0 mL of the test solution to 100.0 mL with mobile phase A.

Reference solution (b). Dissolve 5.0 mg of 3-aminobenzoic acid *R* in mobile phase A and dilute to 100.0 mL with mobile phase A. Dilute 1.0 mL to 25.0 mL with the test solution.

Reference solution (c). Dissolve 5.0 mg of 3-aminobenzoic acid *R* in mobile phase A and dilute to 100.0 mL with mobile phase A. Dilute 1.0 mL to 50.0 mL with mobile phase A.

Reference solution (d). Dissolve 10.0 mg of 3-aminophenol *R* in mobile phase A and dilute to 100.0 mL with mobile phase A. Dilute 1.0 mL to 50.0 mL with mobile phase A.

Reference solution (e). Dissolve 5.0 mg of 2,5-dihydroxybenzoic acid *R* in mobile phase A and dilute to 100.0 mL with mobile phase A. Dilute 1.0 mL to 50.0 mL with mobile phase A.

Reference solution (f). Dissolve 15.0 mg of salicylic acid *R* in mobile phase A and dilute to 100.0 mL with mobile phase A. Dilute 1.0 mL to 50.0 mL with mobile phase A.

Blank solution. Mobile phase A.

Column:

– size:  $l = 0.25$  m,  $\varnothing = 4.6$  mm,

– stationary phase: spherical base-deactivated octylsilyl silica gel for chromatography *R* (5  $\mu$ m).

Mobile phase:

– mobile phase A: dissolve 2.2 g of perchloric acid *R* and 1.0 g of phosphoric acid *R* in water *R* and dilute to 1000.0 mL with the same solvent,

- *mobile phase B*: dissolve 1.7 g of *perchloric acid R* and 1.0 g of *phosphoric acid R* in *acetonitrile R* and dilute to 1000.0 mL with the same solvent,

Time (min)	Mobile phase A (per cent V/V)	Mobile phase B (per cent V/V)
0 - 7	100	0
7 - 25	100 → 40	0 → 60
25 - 30	40 → 100	60 → 0
30 - 40	100	0

*Flow rate*: 1.25 mL/min.

*Detection*: spectrophotometer at 220 nm.

*Injection*: 10 µL.

*Relative retention* with reference to mesalazine (retention time = about 5 min): impurity B = about 0.8; impurity D = about 1.2; impurity G = about 3.1; impurity H = about 3.9.

*System suitability*: reference solution (b):

- *peak-to-valley ratio*: minimum 1.5, where  $H_p$  = height above the baseline of the peak due to impurity D and  $H_v$  = height above the baseline of the lowest point of the curve separating this peak from the peak due to mesalazine.

*Limits*:

- *impurity B*: not more than the area of the principal peak in the chromatogram obtained with reference solution (d) (0.2 per cent),
- *impurity D*: not more than the area of the principal peak in the chromatogram obtained with reference solution (c) (0.1 per cent),
- *impurity G*: not more than the area of the principal peak in the chromatogram obtained with reference solution (e) (0.1 per cent),
- *impurity H*: not more than the area of the principal peak in the chromatogram obtained with reference solution (f) (0.3 per cent),
- *any other impurity*: not more than 0.1 times the area of the principal peak in the chromatogram obtained with reference solution (a) (0.1 per cent),
- *total*: not more than the area of the principal peak in the chromatogram obtained with reference solution (a) (1.0 per cent),
- *disregard limit*: 0.05 times the area of the principal peak in the chromatogram obtained with reference solution (a) (0.05 per cent). Disregard any peaks obtained with the blank solution.

**Impurity A and impurity C.** Liquid chromatography (2.2.29).

Use freshly prepared mobile phases.

*Test solution.* Dissolve 50.0 mg of the substance to be examined in mobile phase A and dilute to 50.0 mL with mobile phase A.

*Reference solution (a).* Dissolve 5.0 mg of *2-aminophenol R* in mobile phase A and dilute to 100.0 mL with mobile phase A. Dilute 10.0 mL to 100.0 mL with mobile phase A.

*Reference solution (b).* Dissolve 5.0 mg of *4-aminophenol R* in mobile phase A and dilute to 250.0 mL with mobile phase A. To 1.0 mL of this solution, add 1.0 mL of reference solution (a) and dilute to 100.0 mL with mobile phase A.

*Reference solution (c).* Dilute 1.0 mL of the test solution to 200.0 mL with mobile phase A. To 5.0 mL of this solution add 5.0 mL of reference solution (a).

*Column*:

- *size*:  $l = 0.25$  m,  $\emptyset = 4.6$  mm,
- *stationary phase*: spherical *end-capped octadecylsilyl silica gel for chromatography R* (3 µm).

*Mobile phase*:

- *mobile phase A*: dissolve 2.2 g of *perchloric acid R* and 1.0 g of *phosphoric acid R* in *water R* and dilute to 1000.0 mL with the same solvent,
- *mobile phase B*: dissolve 1.7 g of *perchloric acid R* and 1.0 g of *phosphoric acid R* in *acetonitrile R* and dilute to 1000.0 mL with the same solvent,

Time (min)	Mobile phase A (per cent V/V)	Mobile phase B (per cent V/V)
0 - 8	100	0
8 - 25	100 → 40	0 → 60
25 - 30	40 → 100	60 → 0
30 - 40	100	0

*Flow rate*: 1.0 mL/min.

*Detection*: spectrophotometer at 220 nm.

*Injection*: 20 µL; inject the test solution and reference solutions (b) and (c).

*Relative retention* with reference to mesalazine (retention time = about 9 min): impurity A = about 0.5; impurity C = about 0.9.

*System suitability*: reference solution (c):

- *resolution*: minimum 3 between the peaks due to impurity C and mesalazine.

*Limits*:

- *impurity A*: not more than the area of the corresponding peak in the chromatogram obtained with reference solution (b) (200 ppm),
- *impurity C*: not more than 4 times the area of the corresponding peak in the chromatogram obtained with reference solution (b) (200 ppm).

**Impurity K.** Liquid chromatography (2.2.29).

*Test solution.* Dissolve 40.0 mg of the substance to be examined in the mobile phase and dilute to 20.0 mL with the mobile phase.

*Reference solution.* Dissolve 27.8 mg of *aniline hydrochloride R* in the mobile phase and dilute to 100.0 mL with the mobile phase. Dilute 0.20 mL of this solution to 20.0 mL with the mobile phase. Dilute 0.20 mL of this solution to 20.0 mL with the mobile phase.

*Column*:

- *size*:  $l = 0.25$  m,  $\emptyset = 4$  mm,
- *stationary phase*: spherical *octadecylsilyl silica gel for chromatography R* (5 µm),
- *temperature*: 40 °C.

*Mobile phase*: mix 15 volumes of *methanol R* and 85 volumes of a solution containing 1.41 g/L of *potassium dihydrogen phosphate R* and 0.47 g/L of *disodium hydrogen phosphate dihydrate R* previously adjusted to pH 8.0 with a 42 g/L solution of *sodium hydroxide R*.

*Flow rate*: 1.0 mL/min.

*Detection*: spectrophotometer at 205 nm.

*Injection*: 50 µL.

*Retention time*: impurity K = about 15 min.

*System suitability*: reference solution:

- *signal-to-noise ratio*: minimum 10 for the principal peak.

*Limit*:

- *impurity K*: not more than the area of the corresponding peak in the chromatogram obtained with the reference solution (10 ppm).

**Chlorides**: maximum 0.1 per cent.

Dissolve 1.50 g in 50 mL of *anhydrous formic acid R*. Add 100 mL of *water R* and 5 mL of 2 M *nitric acid*. Titrate with 0.005 M *silver nitrate* determining the end-point potentiometrically (2.2.20).

1 mL of 0.005 M *silver nitrate* is equivalent to 0.1773 mg of Cl.

**Sulfates** (2.4.13): maximum 200 ppm.

Shake 1.0 g with 20 mL of *distilled water R* for 1 min and filter. 15 mL of the filtrate complies with the limit test for sulfates.

**Heavy metals** (2.4.8): maximum 20 ppm.

1.0 g complies with limit test F. Prepare the standard using 2 mL of *lead standard solution (10 ppm Pb) R*.

**Loss on drying** (2.2.32): maximum 0.5 per cent, determined on 1.000 g by drying in an oven at 105 °C.

**Sulfated ash** (2.4.14): maximum 0.2 per cent, determined on 1.0 g.

#### ASSAY

Dissolve 50.0 mg in 100 mL of boiling *water R*. Cool rapidly to room temperature and titrate with 0.1 M *sodium hydroxide*, determining the end-point potentiometrically (2.2.20).

1 mL of 0.1 M *sodium hydroxide* is equivalent to 15.31 mg of C<sub>7</sub>H<sub>7</sub>NO<sub>3</sub>.

#### STORAGE

In an airtight container, protected from light.

#### IMPURITIES

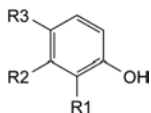

A. R1 = R2 = H, R3 = NH<sub>2</sub>: 4-aminophenol,

B. R1 = R3 = H, R2 = NH<sub>2</sub>: 3-aminophenol,

C. R1 = NH<sub>2</sub>, R2 = R3 = H: 2-aminophenol,

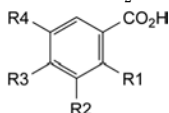

D. R1 = R3 = R4 = H, R2 = NH<sub>2</sub>: 3-aminobenzoic acid,

E. R1 = OH, R2 = R4 = H, R3 = NH<sub>2</sub>: 4-amino-2-hydroxybenzoic acid (4-aminosalicylic acid),

F. R1 = OH, R2 = NH<sub>2</sub>, R3 = R4 = H: 3-amino-2-hydroxybenzoic acid (3-aminosalicylic acid),

G. R1 = R4 = OH, R2 = R3 = H: 2,5-dihydroxybenzoic acid,

H. R1 = OH, R2 = R3 = R4 = H: 2-hydroxybenzoic acid (salicylic acid),

I. R1 = OH, R2 = R3 = H, R4 = N=N-C<sub>6</sub>H<sub>5</sub>: 2-hydroxy-5-(phenyldiazenyl)benzoic acid (phenylazosalicic acid),

J. R1 = OH, R2 = R4 = NH<sub>2</sub>, R3 = H: 3,5-diamino-2-hydroxybenzoic acid (diaminosalicic acid),

L. R1 = Cl, R2 = R3 = R4 = H: 2-chlorobenzoic acid,

M. R1 = Cl, R2 = R3 = H, R4 = NO<sub>2</sub>: 2-chloro-5-nitrobenzoic acid,

N. R1 = OH, R2 = R3 = H, R4 = NO<sub>2</sub>: 2-hydroxy-5-nitrobenzoic acid (5-nitrosalicic acid),

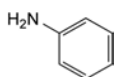

K. aniline.

01/2008:1674

## MESNA

### Mesnum



C<sub>2</sub>H<sub>5</sub>NaO<sub>3</sub>S<sub>2</sub>  
[19767-45-4]

M<sub>r</sub> 164.2

#### DEFINITION

Sodium 2-sulfanylethanesulfonate.

*Content*: 96.0 per cent to 102.0 per cent (dried substance).

#### CHARACTERS

*Appearance*: white or slightly yellow, crystalline powder, hygroscopic.

*Solubility*: freely soluble in water, slightly soluble in ethanol (96 per cent), practically insoluble in cyclohexane.

#### IDENTIFICATION

A. Infrared absorption spectrophotometry (2.2.24).

*Comparison*: Ph. Eur. reference spectrum of mesna.

B. It gives reaction (a) of sodium (2.3.1).

#### TESTS

**Solution S.** Dissolve 10.0 g in *carbon dioxide-free water R* prepared from *distilled water R* and dilute to 50 mL with the same solvent.

**Appearance of solution.** Solution S is not more opalescent than reference suspension II (2.2.1) and not more intensely coloured than reference solution Y<sub>7</sub> (2.2.2, *Method II*).

**pH** (2.2.3): 4.5 to 6.0.

Dilute 10 mL of solution S to 20 mL with *carbon dioxide-free water R*.

**Related substances.** Liquid chromatography (2.2.29).

*Test solution.* Dissolve 0.10 g of the substance to be examined in the mobile phase and dilute to 25.0 mL with the mobile phase.

*Reference solution (a).* Dissolve 4.0 mg of *mesna impurity C CRS* in the mobile phase and dilute to 50.0 mL with the mobile phase. Dilute 2.0 mL of the solution to 20.0 mL with the mobile phase.

*Reference solution (b).* Dissolve 6.0 mg of *mesna impurity D CRS* in the mobile phase and dilute to 50.0 mL with the mobile phase.

*Reference solution (c).* Dilute 3.0 mL of the test solution to 10.0 mL with the mobile phase.

*Reference solution (d).* Dilute 1.0 mL of reference solution (c) to 100.0 mL with the mobile phase.

*Reference solution (e).* Dilute 6.0 mL of reference solution (c) to 20.0 mL with the mobile phase. To 10 mL of the solution add 10 mL of reference solution (a).

#### Column:

– *size*: *l* = 0.25 m, Ø = 4.6 mm,

– *stationary phase*: octadecylsilyl silica gel for chromatography R (10 µm).

*Mobile phase*: dissolve 2.94 g of *potassium dihydrogen phosphate R*, 2.94 g of *dipotassium hydrogen phosphate R* and 2.6 g of *tetrabutylammonium hydrogen sulfate R* in about 600 mL of *water R*. Adjust to pH 2.3 with *phosphoric acid R*, add 335 mL of *methanol R* and dilute to 1000 mL with *water R*.

*Flow rate*: 1 mL/min.

*Detection*: spectrophotometer at 235 nm.

*Injection*: 20 µL.

*Run time*: 4 times the retention time of mesna.

*Relative retention* with reference to mesna (retention time = about 4.8 min): impurities A and B = about 0.6; impurity E = about 0.8; impurity C = about 1.4; impurity D = about 2.3.

*System suitability*: reference solution (e):

– *resolution*: minimum 3.0 between the peaks due to mesna and impurity C.

#### Limits:

– *correction factors*: for the calculation of content, multiply the peak areas of impurities A, B and E by 0.01,



- *impurity C*: not more than the area of the corresponding peak in the chromatogram obtained with reference solution (a) (0.2 per cent),
- *impurity D*: not more than the area of the corresponding peak in the chromatogram obtained with reference solution (b) (3.0 per cent),
- *impurities A, B, E*: for each impurity, not more than the area of the principal peak in the chromatogram obtained with reference solution (d) (0.3 per cent),
- *any other impurity*: for each impurity, not more than one third of the area of the principal peak in the chromatogram obtained with reference solution (d) (0.1 per cent),
- *sum of other impurities*: not more than the area of the principal peak in the chromatogram obtained with reference solution (d) (0.3 per cent),
- *disregard limit*: 0.15 times the area of the principal peak in the chromatogram obtained with reference solution (d) (0.045 per cent).

**Chlorides** (2.4.4): maximum 250 ppm.

Dilute 1 mL of solution S to 15 mL with *water R*.

**Sulfates** (2.4.13): maximum 300 ppm.

Dilute 5 mL of solution S to 30 mL with *distilled water R*. 15 mL of the solution complies with the test.

**Disodium edetate**: maximum 500 ppm.

Dissolve 4.000 g in 90 mL of *water R* and adjust to pH 4.5 using 0.1 M *hydrochloric acid*. Add 10 mL of *acetate buffer solution pH 4.5 R* and 50 mL of *2-propanol R*. Add 2 mL of a 0.25 g/L solution of *dithizone R* in *2-propanol R*. Titrate with 0.01 M *zinc sulfate* until the colour changes from bluish-grey to pink.

1 mL of 0.01 M *zinc sulfate* is equivalent to 3.72 mg of  $C_{10}H_{14}N_2Na_2O_8 \cdot 2H_2O$ .

**Heavy metals** (2.4.8): maximum 10 ppm.

Dilute 10 mL of solution S to 20 mL with *water R*. 12 mL of the solution complies with limit test A. Prepare the reference solution using *lead standard solution (1 ppm Pb) R*.

**Loss on drying** (2.2.32): maximum 1.0 per cent, determined on 1.000 g under high vacuum at 60 °C for 2 h.

#### ASSAY

Dissolve 0.120 g in 10 mL of *water R*. Add 10 mL of 1 M *sulfuric acid* and 10.0 mL of 0.1 M *iodine*. Titrate with 0.1 M *sodium thiosulfate* adding 1 mL of *starch solution R* near the endpoint. Carry out a blank titration.

1 mL of 0.1 M *sodium thiosulfate* is equivalent to 16.42 mg of  $C_2H_5NaO_3S_2$ .

#### STORAGE

In an airtight container.

#### IMPURITIES

*Specified impurities: A, B, C, D, E.*

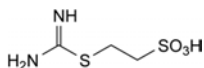

A. 2-(carbamimidoylsulfanyl)ethanesulfonic acid,

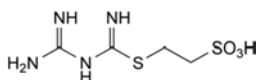

B. 2-[[[(guanidino)(imino)methyl]sulfanyl]ethanesulfonic acid,

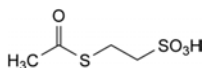

C. 2-(acetylsulfanyl)ethanesulfonic acid,

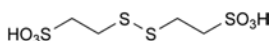

D. 2,2'-(disulfanediy)bis(ethanesulfonic acid),

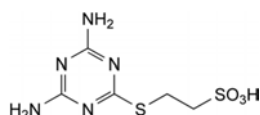

E. 2-(4,6-diamino-1,3,5-triazin-2-yl)sulfanylethanesulfonic acid.

01/2008:1730  
corrected 6.0

## MESTEROLONE

### Mesterololum

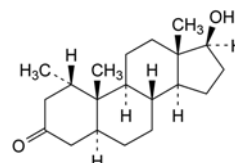

$C_{20}H_{32}O_2$   
[1424-00-6]

$M_r$  304.5

#### DEFINITION

17β-Hydroxy-1α-methyl-5α-androstan-3-one.

*Content*: 98.0 per cent to 102.0 per cent (dried substance).

#### CHARACTERS

*Appearance*: white or yellowish crystalline powder.

*Solubility*: practically insoluble in water, sparingly soluble in acetone, in ethyl acetate and in methanol.

#### IDENTIFICATION

A. Melting point (2.2.14): 206 °C to 211 °C.

B. Infrared absorption spectrophotometry (2.2.24).

*Preparation*: discs.

*Comparison*: *mesterolone CRS*.

#### TESTS

**Specific optical rotation** (2.2.7): + 20 to + 24 (dried substance).

Dissolve 0.200 g in *methylene chloride R* and dilute to 10.0 mL with the same solvent.

**Impurity B**: maximum 0.5 per cent.

Thin-layer chromatography (2.2.27).

*Test solution*. Dissolve 100.0 mg of the substance to be examined in a mixture of equal volumes of *methanol R* and *methylene chloride R* and dilute to 10.0 mL with the same mixture of solvents.

*Reference solution (a)*. Dilute 1.0 mL of the test solution to 200.0 mL with a mixture of equal volumes of *methanol R* and *methylene chloride R*.

*Reference solution (b)*. Dissolve 5.0 mg of *mesterolone impurity A CRS* in reference solution (a) and dilute to 100.0 mL with the same solution.

*Plate*: *TLC silica gel plate R*.

*Mobile phase*: *methanol R*, *acetone R*, *toluene R* (2:15:85 V/V/V).

*Application*: 10 μL.

*Development*: over 2/3 of the plate.

*Drying*: in air.

*Detection*: examine in ultraviolet light at 366 nm; spray with a 200 g/L solution of *toluenesulfonic acid R* in *alcohol R* and heat the plate for 10 min at 120 °C.

*System suitability*: the chromatogram obtained with reference solution (b) shows 2 clearly separated spots (blue spot due to mesterolone and yellow spot due to impurity A).

**Limit:**

- *impurity B*: any blue spot, apart from the main spot, is not more intense than the spot in the chromatogram obtained with reference solution (a) (0.5 per cent).

**Related substances.** Liquid chromatography (2.2.29).

**Test solution.** Dissolve 50.0 mg of the substance to be examined in a mixture of 20 volumes of *water R* and 80 volumes of *acetonitrile R* and dilute to 25.0 mL with the same mixture of solvents.

**Reference solution (a).** Dissolve 50.0 mg of *mesterolone CRS* in a mixture of 20 volumes of *water R* and 80 volumes of *acetonitrile R* and dilute to 25.0 mL with the same mixture of solvents.

**Reference solution (b).** Dissolve 10.0 mg of *mesterolone impurity A CRS* in a mixture of 20 volumes of *water R* and 80 volumes of *acetonitrile R* and dilute to 5.0 mL with the same mixture of solvents.

**Reference solution (c).** Dilute 0.5 mL of reference solution (a) and 0.5 mL of reference solution (b) to 100.0 mL with a mixture of 20 volumes of *water R* and 80 volumes of *acetonitrile R*.

**Column:**

- *size*:  $l = 0.25$  m,  $\varnothing = 4.6$  mm,
- *stationary phase*: octadecylsilyl silica gel for chromatography *R* (3  $\mu$ m).

**Mobile phase:** *acetonitrile R*, *water R*, *methanol R* (20:40:60 V/V/V).

**Flow rate:** 0.9 mL/min.

**Detection:** spectrophotometer at 200 nm.

**Injection:** 50  $\mu$ L; inject the test solution and reference solution (c).

**Run time:** 3 times the retention time of mesterolone.

**Relative retention** with reference to mesterolone (retention time = about 22 min): *impurity A* = about 0.7.

**System suitability:** reference solution (c):

- *resolution*: minimum 6.0 between the peaks due to *impurity A* and to mesterolone.

**Limits:**

- *impurity A*: not more than the area of the peak due to *impurity A* in the chromatogram obtained with reference solution (c) (0.5 per cent),
- *any other impurity*: not more than half the area of the peak due to mesterolone in the chromatogram obtained with reference solution (c) (0.25 per cent),
- *total*: not more than 1.5 times the area of the peak due to mesterolone in the chromatogram obtained with reference solution (c) (0.75 per cent),
- *disregard limit*: 0.1 times the area of the peak due to mesterolone in the chromatogram obtained with reference solution (c) (0.05 per cent).

**Loss on drying** (2.2.32): maximum 0.5 per cent, determined on 1.000 g by drying in an oven at 105 °C.

**Sulfated ash** (2.4.14): maximum 0.1 per cent, determined on 1.0 g.

**ASSAY**

Liquid chromatography (2.2.29) as described in the test for related substances.

**Injection:** 10  $\mu$ L; inject the test solution and reference solution (a).

Calculate the percentage content of  $C_{20}H_{32}O_2$ .

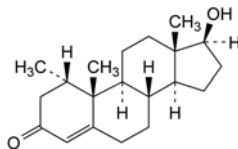
**IMPURITIES**

A. 17 $\beta$ -hydroxy-1 $\alpha$ -methylandrosta-4-en-3-one,

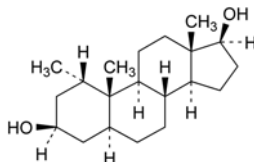

B. 1 $\alpha$ -methyl-5 $\alpha$ -androstane-3 $\beta$ ,17 $\beta$ -diol.

01/2008:0509  
corrected 6.0

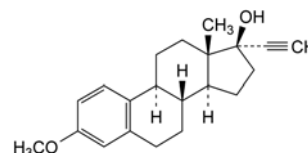
**MESTRANOL****Mestranolum**

$C_{21}H_{26}O_2$   
[72-33-3]

$M_r$  310.4

**DEFINITION**

Mestranol contains not less than 98.0 per cent and not more than the equivalent of 102.0 per cent of 3-methoxy-19-nor-17 $\alpha$ -pregna-1,3,5(10)-trien-20-yn-17-ol, calculated with reference to the dried substance.

**CHARACTERS**

A white or almost white, crystalline powder, practically insoluble in water, sparingly soluble in alcohol.

**IDENTIFICATION**

**First identification:** *B*.

**Second identification:** *A, C, D*.

- Melting point (2.2.14): 150 °C to 154 °C.
- Examine by infrared absorption spectrophotometry (2.2.24), comparing with the spectrum obtained with *mestranol CRS*.
- Examine the chromatograms obtained in the test for related substances in daylight and in ultraviolet light at 365 nm. The principal spot in the chromatogram obtained with test solution (b) is similar in position, colour, fluorescence and size to the principal spot in the chromatogram obtained with reference solution (a).
- Dissolve about 5 mg in 1 mL of *sulfuric acid R*. A red colour develops with a greenish-yellow fluorescence in ultraviolet light at 365 nm. Add the solution to 10 mL of *water R* and mix. The solution becomes pink and a pink to violet precipitate is formed on standing.

**TESTS**

**Specific optical rotation** (2.2.7). Dissolve 0.100 g in *anhydrous pyridine R* and dilute to 10.0 mL with the same solvent. The specific optical rotation is  $-20$  to  $-24$ , calculated with reference to the dried substance.

**Absorbance** (2.2.25). Dissolve 25.0 mg in *alcohol R* and dilute to 25.0 mL with the same solvent. Dilute 10.0 mL of this solution to 100.0 mL with *alcohol R*. Examined between 260 nm and 310 nm, the solution shows two absorption

maxima, at 279 nm and 288 nm, and a minimum at 286 nm. The specific absorbances at the maxima are 62 to 68 and 59 to 64, respectively.

**Related substances.** Examine by thin-layer chromatography (2.2.27), using *silica gel G R* as the coating substance.

**Test solution (a).** Dissolve 0.10 g of the substance to be examined in *chloroform R* and dilute to 10 mL with the same solvent.

**Test solution (b).** Dilute 1 mL of test solution (a) to 10 mL with *chloroform R*.

**Reference solution (a).** Dissolve 10 mg of *mestranol CRS* in *chloroform R* and dilute to 10 mL with the same solvent.

**Reference solution (b).** Dilute 1 mL of test solution (b) to 10 mL with *chloroform R*.

**Reference solution (c).** Dilute 5 mL of reference solution (b) to 10 mL with *chloroform R*.

Apply separately to the plate 5 µL of each solution. Develop over a path of 15 cm using a mixture of 10 volumes of *alcohol R* and 90 volumes of *toluene R*. Allow the plate to dry in air until the solvent has evaporated. Heat at 110 °C for 10 min. Spray the hot plate with *alcoholic solution of sulfuric acid R*. Heat again at 110 °C for 10 min. Examine in daylight and in ultraviolet light at 365 nm. Any spot in the chromatogram obtained with test solution (a), apart from the principal spot, is not more intense than the spot in the chromatogram obtained with reference solution (b) (1.0 per cent) and at most one such spot is more intense than the spot in the chromatogram obtained with reference solution (c) (0.5 per cent).

**Loss on drying (2.2.32).** Not more than 1.0 per cent, determined on 0.500 g by drying in an oven at 105 °C for 3 h.

#### ASSAY

Dissolve 0.200 g in 40 mL of *tetrahydrofuran R* and add 5 mL of a 100 g/L solution of *silver nitrate R*. Titrate with 0.1 M *sodium hydroxide*, determining the end-point potentiometrically (2.2.20). Carry out a blank titration.

1 mL of 0.1 M *sodium hydroxide* is equivalent to 31.04 mg of  $C_{21}H_{26}O_2$ .

#### STORAGE

Store protected from light.

#### TESTS

**Solution S.** Dissolve 1.5 g in *carbon dioxide-free water R* and dilute to 100 mL with the same solvent.

**Appearance of solution.** Freshly prepared solution S is not more opalescent than reference suspension III (2.2.1) and not more intensely coloured than reference solution BY<sub>7</sub> (2.2.2, Method II).

**Acidity.** To 25 mL of solution S add 0.15 mL of *methyl red solution R*. The solution is red. Not more than 0.5 mL of 0.01 M *sodium hydroxide* is required to change the colour of the indicator to yellow.

**Related substances.** Gas chromatography (2.2.28): use the normalisation procedure.

**Test solution.** Dissolve 1.00 g of the substance to be examined in *methanol R* and dilute to 100.0 mL with the same solvent.

**Reference solution (a).** Dissolve 0.10 g of *cresol R*, 0.10 g of *p-cresol R* and 0.10 g of the substance to be examined in *methanol R* and dilute to 20.0 mL with the same solvent.

**Reference solution (b).** Dilute 1.0 mL of the test solution to 100.0 mL with *methanol R*. Dilute 1.0 mL of this solution to 20.0 mL with *methanol R*.

**Column:**

- *material:* fused silica,
- *size:*  $l = 25$  m,  $\varnothing = 0.25$  mm,
- *stationary phase:* *poly[(cyanopropyl)(methyl)][(phenyl)(methyl)]siloxane R* (0.2 µm).

*Carrier gas:* helium for chromatography R.

*Flow rate:* 1.8 mL/min.

*Split ratio:* 1:30.

*Temperature:*

	Time (min)	Temperature (°C)
Column	0 - 35	100
	35 - 40	100 → 150
	40 - 50	150
Injection port		200
Detector		200

*Detection:* flame ionisation.

*Injection:* 1.0 µL.

*Relative retention* with reference to metacresol (retention time = about 28 min): impurity B = about 0.75; impurity C = about 0.98.

*System suitability:* reference solution (a):

- *resolution:* minimum 1.4 between the peaks due to impurity C and metacresol.

*Limits:*

- *impurities B, C:* for each impurity, not more than 0.5 per cent,
- *any other impurity:* for each impurity, not more than 0.1 per cent,
- *total:* not more than 1.0 per cent.
- *disregard limit:* the area of the peak due to metacresol in the chromatogram obtained with reference solution (b) (0.05 per cent).

**Residue on evaporation:** maximum 0.1 per cent.

Evaporate 2.0 g to dryness on a water-bath under a fume hood and dry at 100-105 °C for 1 h. The residue weighs a maximum of 2 mg.

#### STORAGE

In an airtight container, protected from light.

#### IMPURITIES

*Specified impurities:* B, C.

01/2008:2077

## METACRESOL

### Metacresolum

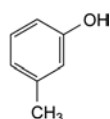

$C_7H_8O$   
[108-39-4]

$M_r$  108.1

#### DEFINITION

3-Methylphenol.

#### CHARACTERS

*Appearance:* colourless or yellowish liquid.

*Solubility:* sparingly soluble in water, miscible with ethanol (96 per cent) and with methylene chloride.

*Relative density:* about 1.03.

mp: about 11 °C.

bp: about 202 °C.

#### IDENTIFICATION

Infrared absorption spectrophotometry (2.2.24).

*Comparison:* Ph. Eur. reference spectrum of metacresol.

*Other detectable impurities* (the following substances would, if present at a sufficient level, be detected by one or other of the tests in the monograph. They are limited by the general acceptance criterion for other/unspecified impurities and/or by the general monograph *Substances for pharmaceutical use (2034)*. It is therefore not necessary to identify these impurities for demonstration of compliance. See also 5.10. *Control of impurities in substances for pharmaceutical use*): A, D, E, F, G, H, I, J, K, L, M.

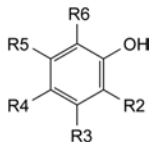

- A. R2 = R3 = R4 = R5 = R6 = H: phenol,  
 B. R2 = CH<sub>3</sub>, R3 = R4 = R5 = R6 = H: 2-methylphenol (*o*-cresol, cresol),  
 C. R2 = R3 = R5 = R6 = H, R4 = CH<sub>3</sub>: 4-methylphenol (*p*-cresol),  
 D. R2 = R6 = CH<sub>3</sub>, R3 = R4 = R5 = H: 2,6-dimethylphenol (2,6-xyleneol),  
 E. R2 = C<sub>2</sub>H<sub>5</sub>, R3 = R4 = R5 = R6 = H: 2-ethylphenol (*o*-ethylphenol),  
 F. R2 = R4 = CH<sub>3</sub>, R3 = R5 = R6 = H: 2,4-dimethylphenol (2,4-xyleneol),  
 G. R2 = R5 = CH<sub>3</sub>, R3 = R4 = R6 = H: 2,5-dimethylphenol (2,5-xyleneol),  
 H. R2 = CH(CH<sub>3</sub>)<sub>2</sub>, R3 = R4 = R5 = R6 = H: 2-(1-methylethyl)phenol,  
 I. R2 = R3 = CH<sub>3</sub>, R4 = R5 = R6 = H: 2,3-dimethylphenol (2,3-xyleneol),  
 J. R2 = R4 = R6 = H, R3 = R5 = CH<sub>3</sub>: 3,5-dimethylphenol (3,5-xyleneol),  
 K. R2 = R3 = R5 = R6 = H, R4 = C<sub>2</sub>H<sub>5</sub>: 4-ethylphenol (*p*-ethylphenol),  
 L. R2 = R5 = R6 = H, R3 = R4 = CH<sub>3</sub>: 3,4-dimethylphenol (3,4-xyleneol),  
 M. R2 = R3 = R5 = CH<sub>3</sub>, R4 = R6 = H: 2,3,5-trimethylphenol.

*Second identification: B, C, D.*

- A. Infrared absorption spectrophotometry (2.2.24).  
*Comparison: metamizole sodium CRS.*  
 B. Dissolve 50 mg in 1 mL of *strong hydrogen peroxide solution R*. A blue colour is produced which fades rapidly and turns to intense red in a few minutes.  
 C. Place 0.10 g in a test tube, add some glass beads and dissolve the substance in 1.5 mL of *water R*. Add 1.5 mL of *dilute hydrochloric acid R* and place a filter paper wetted with a solution of 20 mg of *potassium iodate R* in 2 mL of *starch solution R* at the open end of the test tube. Heat gently, the evolving vapour of sulfur dioxide colours the filter paper blue. After heating gently for 1 min take a glass rod with a drop of a 10 g/L solution of *chromotropic acid, sodium salt R* in *sulfuric acid R* and place in the opening of the tube. Within 10 min, a blue-violet colour develops in the drop of the reagent.  
 D. 0.5 mL of solution S (see Tests) gives reaction (a) of sodium (2.3.1).

#### TESTS

**Solution S.** Dissolve 2.0 g in *carbon dioxide-free water R* and dilute to 40 mL with the same solvent.

**Appearance of solution.** Solution S is clear (2.2.1) and immediately after preparation, not more intensely coloured than reference solution BY<sub>6</sub> (2.2.2, *Method I*).

**Acidity or alkalinity.** To 5 mL of solution S, add 0.1 mL of *phenolphthalein solution RI*. The solution is colourless. Not more than 0.1 mL of 0.02 M *sodium hydroxide* is required to change the colour of the indicator to pink.

**Related substances.** Liquid chromatography (2.2.29). *Prepare the solutions immediately before use.*

*Test solution.* Dissolve 50.0 mg of the substance to be examined in *methanol R* and dilute to 10.0 mL with the same solvent.

*Reference solution (a).* Dissolve 10.0 mg of *metamizole impurity A CRS* in *methanol R* and dilute to 20.0 mL with the same solvent.

*Reference solution (b).* Dilute 1.0 mL of reference solution (a) to 20.0 mL with *methanol R*.

*Reference solution (c).* Dissolve 40 mg of *metamizole sodium CRS* in *methanol R* and dilute to 20.0 mL with the same solvent.

*Reference solution (d).* In order to prepare impurity C *in situ*, boil 10 mL of reference solution (c) under reflux for 10 min. Allow to cool to room temperature and dilute to 20.0 mL with *methanol R*.

*Reference solution (e).* To 6 mL of reference solution (a) add 1 mL of reference solution (c).

*Column:*

- size:  $l = 0.25$  m,  $\varnothing = 4.6$  mm;
- stationary phase: base-deactivated octadecylsilyl silica gel for chromatography R (5  $\mu$ m).

*Mobile phase:* mix 28 volumes of *methanol R* and 72 volumes of a buffer solution prepared as follows: mix 1000 volumes of a 6.0 g/L solution of *sodium dihydrogen phosphate R* and 1 volume of *triethylamine R*, then adjust to pH 7.0 with *strong sodium hydroxide solution R*.

*Flow rate:* 1.0 mL/min.

*Detection:* spectrophotometer at 254 nm.

*Injection:* 10  $\mu$ L of the test solution and reference solutions (b), (d) and (e).

*Run time:* 3.5 times the retention time of metamizole.

*Elution order:* impurity A, metamizole, impurity B, impurity C, impurity D.

*System suitability:* reference solution (e):

- resolution: minimum 2.5 between the peaks due to impurity A and metamizole.

01/2008:1346

## METAMIZOLE SODIUM

### Metamizolum natricum

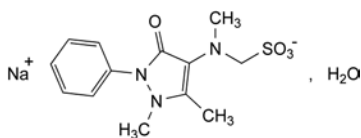

C<sub>13</sub>H<sub>16</sub>N<sub>3</sub>NaO<sub>4</sub>S·H<sub>2</sub>O  
 [5907-38-0]

$M_r$  351.4

#### DEFINITION

Sodium [(1,5-dimethyl-3-oxo-2-phenyl-2,3-dihydro-1H-pyrazol-4-yl)-N-methylamino]methanesulfonate monohydrate.

*Content:* 99.0 per cent to 101.0 per cent (dried substance).

#### CHARACTERS

*Appearance:* white or almost white, crystalline powder.

*Solubility:* very soluble in water, soluble in ethanol (96 per cent).

#### IDENTIFICATION

*First identification:* A, D.

**Limits:**

- *impurity C*: not more than the area of the principal peak in the chromatogram obtained with reference solution (b) (0.5 per cent);
- *impurities A, B, D*: for each impurity, not more 0.4 times the area of the principal peak in the chromatogram obtained with reference solution (b) (0.2 per cent);
- *total*: not more than the area of the principal peak in the chromatogram obtained with reference solution (b) (0.5 per cent);
- *disregard limit*: 0.05 times the area of the principal peak in the chromatogram obtained with the reference solution (b) (0.025 per cent).

**Sulfates** (2.4.13): maximum 0.1 per cent.

Dissolve 0.150 g in *distilled water R* and dilute to 15 mL with the same solvent.

**Heavy metals** (2.4.8): maximum 20 ppm.

Dissolve 2.0 g in *water R* and dilute to 20 mL with the same solvent. 12 mL of the freshly prepared solution complies with test A. Prepare the reference solution using *lead standard solution (2 ppm Pb) R*.

**Loss on drying** (2.2.32): 4.9 per cent to 5.3 per cent, determined on 1.000 g by drying in an oven at 105 °C.

**ASSAY**

Dissolve 0.200 g in 10 mL of 0.01 M *hydrochloric acid* previously cooled in iced water and titrate immediately, dropwise, with 0.05 M *iodine*. Before each addition of 0.05 M *iodine* dissolve the precipitate by swirling. At the end of the titration add 2 mL of *starch solution R* and titrate until the blue colour of the solution persists for at least 2 min. The temperature of the solution during the titration must not exceed 10 °C.

1 mL of 0.05 M *iodine* is equivalent to 16.67 mg of C<sub>13</sub>H<sub>16</sub>N<sub>3</sub>NaO<sub>4</sub>S.

**STORAGE**

Protected from light.

**IMPURITIES**

*Specified impurities: A, B, C, D.*

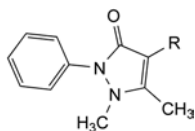

- A. R = NHCHO: 4-formylamino-1,5-dimethyl-2-phenyl-1,2-dihydro-3H-pyrazol-3-one,
- B. R = NH<sub>2</sub>: 4-amino-1,5-dimethyl-2-phenyl-1,2-dihydro-3H-pyrazol-3-one,
- C. R = NHCH<sub>3</sub>: 4-methylamino-1,5-dimethyl-2-phenyl-1,2-dihydro-3H-pyrazol-3-one,
- D. R = N(CH<sub>3</sub>)<sub>2</sub>: 4-dimethylamino-1,5-dimethyl-2-phenyl-1,2-dihydro-3H-pyrazol-3-one.

01/2008:0931  
corrected 6.0

**METFORMIN HYDROCHLORIDE**

Metformini hydrochloridum

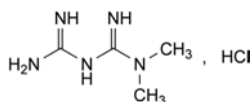

C<sub>4</sub>H<sub>12</sub>ClN<sub>5</sub>  
[1115-70-4]

M<sub>r</sub> 165.6

**DEFINITION**

1,1-Dimethylbiguanide hydrochloride.

*Content*: 98.5 per cent to 101.0 per cent (dried substance).

**CHARACTERS**

*Appearance*: white or almost white crystals.

*Solubility*: freely soluble in water, slightly soluble in alcohol, practically insoluble in acetone and in methylene chloride.

**IDENTIFICATION**

*First identification: B, E.*

*Second identification: A, C, D, E.*

A. Melting point (2.2.14): 222 °C to 226 °C.

B. Infrared absorption spectrophotometry (2.2.24).

*Preparation*: discs of *potassium chloride R*.

*Comparison*: *metformin hydrochloride CRS*.

C. Thin-layer chromatography (2.2.27).

*Test solution*. Dissolve 20 mg of the substance to be examined in *water R* and dilute to 5 mL with the same solvent.

*Reference solution*. Dissolve 20 mg of *metformin hydrochloride CRS* in *water R* and dilute to 5 mL with the same solvent.

*Plate*: *TLC silica gel G plate R*.

*Mobile phase*: upper layer of a mixture of 10 volumes of *glacial acetic acid R*, 40 volumes of *butanol R* and 50 volumes of *water R*.

*Application*: 5 µL.

*Development*: over a path of 15 cm.

*Drying*: at 100-105 °C for 15 min.

*Detection*: spray with a mixture of equal volumes of a 100 g/L solution of *sodium nitroprusside R*, a 100 g/L solution of *potassium ferricyanide R* and a 100 g/L solution of *sodium hydroxide R*, prepared 20 min before use.

*Results*: the principal spot in the chromatogram obtained with the test solution is similar in position, colour and size to the principal spot in the chromatogram obtained with the reference solution.

D. Dissolve about 5 mg in *water R* and dilute to 100 mL with the same solvent. To 2 mL of the solution add 0.25 mL of *strong sodium hydroxide solution R* and 0.10 mL of *α-naphthol solution R*. Mix and allow to stand in iced water for 15 min. Add 0.5 mL of *sodium hypobromite solution R* and mix. A pink colour develops.

E. It gives reaction (a) of chlorides (2.3.1).

**TESTS**

**Solution S**. Dissolve 2.0 g in *water R* and dilute to 20 mL with the same solvent.

**Appearance of solution**. Solution S is clear (2.2.1) and colourless (2.2.2, *Method II*).

**Related substances**. Liquid chromatography (2.2.29).

*Test solution*. Dissolve 0.50 g of the substance to be examined in the mobile phase and dilute to 100.0 mL with the mobile phase.

*Reference solution (a)*. Dissolve 20.0 mg of *cyanoguanidine R* in *water R* and dilute to 100.0 mL with the same solvent. Dilute 1.0 mL to 200.0 mL with the mobile phase.

*Reference solution (b)*. Dilute 1.0 mL of the test solution to 50.0 mL with the mobile phase. Dilute 1.0 mL of this solution to 20.0 mL with the mobile phase.

*Reference solution (c)*. Dissolve 10.0 mg of *melamine R* in about 90 mL of *water R*. Add 5.0 mL of the test solution and dilute to 100.0 mL with *water R*. Dilute 1.0 mL of this solution to 50.0 mL with the mobile phase.

*Column*:

– *size*: *l* = 0.25 m, *Ø* = 4.6 mm,

– *stationary phase*: irregular, porous silica gel to which benzenesulfonic acid groups have been chemically bonded (10 µm),

or

– *size*:  $l = 0.11$  m,  $\emptyset = 4.7$  mm,

– *stationary phase*: regular, porous silica gel to which benzenesulfonic acid groups have been chemically bonded (5 µm).

*Mobile phase*: 17 g/L solution of *ammonium dihydrogen phosphate R* adjusted to pH 3.0 with *phosphoric acid R*.

*Flow rate*: 1 mL/min.

*Detection*: spectrophotometer at 218 nm.

*Injection*: 20 µL.

*Run time*: twice the retention time of metformin hydrochloride.

*System suitability*: reference solution (c):

– *resolution*: minimum of 10 between the peaks due to melamine and to metformin hydrochloride.

*Limits*:

– *impurity A*: not more than the area of the corresponding peak in the chromatogram obtained with reference solution (a) (0.02 per cent),

– *any other impurity*: not more than the area of the principal peak in the chromatogram obtained with reference solution (b) (0.1 per cent).

**Heavy metals** (2.4.8): maximum 10 ppm.

12 mL of solution S complies with limit test A. Prepare the standard using *lead standard solution (1 ppm Pb) R*.

**Loss on drying** (2.2.32): maximum 0.5 per cent, determined on 1.000 g by drying in an oven at 105 °C for 5 h.

**Sulfated ash** (2.4.14): maximum 0.1 per cent, determined on 1.0 g.

#### ASSAY

Dissolve 0.100 g in 4 mL of *anhydrous formic acid R*. Add 80 mL of *acetoneitrile R*. Carry out the titration immediately. Titrate with 0.1 M *perchloric acid*, determining the end-point potentiometrically (2.2.20).

1 mL of 0.1 M *perchloric acid* is equivalent to 16.56 mg of  $C_4H_{12}ClN_5$ .

#### IMPURITIES

*Specified impurities*: A.

*Other detectable impurities* (the following substances would, if present at a sufficient level, be detected by one or other of the tests in the monograph. They are limited by the general acceptance criterion for other/unspecified impurities and/or by the general monograph *Substances for pharmaceutical use (2034)*. It is therefore not necessary to identify these impurities for demonstration of compliance. See also 5.10. *Control of impurities in substances for pharmaceutical use*): B, C, D, E, F.

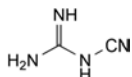

A. cyanoguanidine,

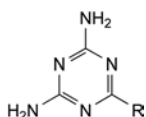

B. R = NH-C(=NH)-NH<sub>2</sub>: (4,6-diamino-1,3,5-triazin-2-yl)guanidine,

C. R = N(CH<sub>3</sub>)<sub>2</sub>: *N,N*-dimethyl-1,3,5-triazine-2,4,6-triamine,

D. R = NH<sub>2</sub>: 1,3,5-triazine-2,4,6-triamine (melamine),

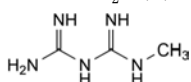

E. 1-methylbiguanide,

F. CH<sub>3</sub>-NH-CH<sub>3</sub>: *N*-methylmethanamine.

01/2008:1128  
corrected 7.0

## METHACRYLIC ACID - ETHYL ACRYLATE COPOLYMER (1:1)

### Acidi methacrylici et ethylis acrylatis polymerisatum 1:1

#### DEFINITION

Copolymer of methacrylic acid and ethyl acrylate having a mean relative molecular mass of about 250 000. The ratio of carboxylic groups to ester groups is about 1:1. The substance is in the acid form (type A) or partially neutralised using sodium hydroxide (type B). It may contain suitable surface-active agents such as sodium dodecyl sulfate and polysorbate 80.

*Content*:

– type A: 46.0 per cent to 50.6 per cent of methacrylic acid units (dried substance);

– type B: 43.0 per cent to 48.0 per cent of methacrylic acid units (dried substance).

#### CHARACTERS

*Appearance*: white or almost white, free-flowing powder.

*Solubility*: practically insoluble in water (type A) or dispersible in water (type B), freely soluble in anhydrous ethanol, practically insoluble in ethyl acetate. It is freely soluble in a 40 g/L solution of sodium hydroxide.

#### IDENTIFICATION

A. Infrared absorption spectrophotometry (2.2.24).

*Preparation*: dissolve 0.1 g of the substance to be examined in 1 mL of *ethanol (90 per cent V/V) R*, and place 2 drops of the solution on a sodium chloride plate; dry to allow the formation of a film and cover with another sodium chloride plate.

*Comparison*: *Methacrylic acid - ethyl acrylate copolymer (1:1) (type A or type B) CRS*.

B. It complies with the limits of the assay.

C. Sulfated ash (see Tests).

#### TESTS

**Ethyl acrylate and methacrylic acid**. Liquid chromatography (2.2.29).

*Blank solution*. To 50.0 mL of *methanol R* add 25.0 mL of the mobile phase.

*Test solution*. Dissolve 40 mg of the substance to be examined in 50.0 mL of *methanol R* and add 25.0 mL of the mobile phase.

*Reference solution*. Dissolve 10 mg of *ethyl acrylate R* and 10 mg of *methacrylic acid R* in *methanol R* and dilute to 50.0 mL with the same solvent. Dilute 0.1 mL of this solution to 50.0 mL with *methanol R* and add 25.0 mL of the mobile phase.

*Column*:

– *size*:  $l = 0.10$  m,  $\emptyset = 4$  mm;

– *stationary phase*: *octadecylsilyl silica gel for chromatography R* (5 µm).

*Mobile phase*: *methanol R*, *phosphate buffer solution pH 2.0 R* (30:70 V/V).

*Flow rate*: 2.5 mL/min.

*Detection*: spectrophotometer at 202 nm.

*Injection*: 50 µL.

*System suitability*:

– *resolution*: minimum 2.0 between the peaks due to ethyl acrylate and methacrylic acid in the chromatogram obtained with the reference solution;

01/2009:1129

- the chromatogram obtained with the blank solution does not show peaks with the same retention time as the peaks due to ethyl acrylate or methacrylic acid.

**Limit:**

- *sum of the contents of ethyl acrylate and methacrylic acid:* maximum 0.1 per cent.

**Loss on drying** (2.2.32): maximum 5.0 per cent, determined on 1.000 g by drying in an oven at 105 °C for 6 h.

**Sulfated ash** (2.4.14): maximum 0.4 per cent (type A) or 0.5 per cent to 3.0 per cent (type B), determined on 1.0 g.

**ASSAY**

Dissolve 1.000 g in a mixture of 40 mL of *water R* and 60 mL of *2-propanol R*. Titrate slowly while stirring with 0.5 M sodium hydroxide, using *phenolphthalein solution R* as indicator.

1 mL of 0.5 M sodium hydroxide is equivalent to 43.05 mg of C<sub>4</sub>H<sub>6</sub>O<sub>2</sub> (methacrylic acid units).

**LABELLING**

The label states the type (type A or type B).

**FUNCTIONALITY-RELATED CHARACTERISTICS**

*This section provides information on characteristics that are recognised as being relevant control parameters for one or more functions of the substance when used as an excipient (see chapter 5.15). This section is a non-mandatory part of the monograph and it is not necessary to verify the characteristics to demonstrate compliance. Control of these characteristics can however contribute to the quality of a medicinal product by improving the consistency of the manufacturing process and the performance of the medicinal product during use. Where control methods are cited, they are recognised as being suitable for the purpose, but other methods can also be used. Wherever results for a particular characteristic are reported, the control method must be indicated.*

*The following characteristics may be relevant for methacrylic acid - ethyl acrylate copolymer (1:1) used as gastro-resistant coating agent.*

**Apparent viscosity:**

- *Type A:* 100 mPa·s to 200 mPa·s.

Dissolve a quantity of the substance to be examined corresponding to 37.5 g of the dried substance in a mixture of 7.9 g of *water R* and 254.6 g of *2-propanol R*. Determine the viscosity (2.2.10) at 20 °C using a rotating viscometer at a shear rate of 10 s<sup>-1</sup>.

- *Type B:* not more than 100 mPa·s.

Disperse a quantity of the substance to be examined corresponding to 80.0 g of the dried substance in *water R* and make up to 320 g with the same solvent. Stir for 3 h and determine the viscosity (2.2.10) at 23 °C using a rotating viscometer and a spindle rotating at 100 r/min (rotor 2).

**Solubility of a film.** Place 1 mL of the solution (type A) or dispersion (type B) prepared for the test on apparent viscosity on a glass plate and allow to dry. A clear brittle film is formed. Take a piece of the film and place it in a flask containing phosphate buffer solution pH 6.8. It dissolves.

**METHACRYLIC ACID - ETHYL ACRYLATE COPOLYMER (1:1) DISPERSION 30 PER CENT****Acidi methacrylici et ethylis acrylatis polymerisati 1:1 dispersio 30 per centum****DEFINITION**

Dispersion in water of a copolymer of methacrylic acid and ethyl acrylate having a mean relative molecular mass of about 250 000. The ratio of carboxylic groups to ester groups is about 1:1.

*Content:* 46.0 per cent to 50.6 per cent of methacrylic acid units (residue on evaporation).

It may contain suitable surface-active agents such as sodium dodecyl sulfate and polysorbate 80.

**CHARACTERS**

*Appearance:* opaque, white or almost white, slightly viscous liquid.

*Solubility:* miscible with water. On addition of solvents such as acetone, anhydrous ethanol or 2-propanol, a precipitate is formed which dissolves on addition of excess solvent. It is miscible with a 40 g/L solution of sodium hydroxide.

It is sensitive to spoilage by microbial contaminants.

**IDENTIFICATION**

A. Infrared absorption spectrophotometry (2.2.24).

*Comparison:* Ph. Eur. reference spectrum of methacrylic acid - ethyl acrylate copolymer (1:1) dispersion 30 per cent.

B. It complies with the limits of the assay.

**TESTS**

**Apparent viscosity** (2.2.10): maximum 15 mPa·s, determined using a rotating viscometer at 20 °C and at a shear rate of 50 s<sup>-1</sup>.

**Appearance of a film.** Place 1 mL on a glass plate and allow to dry. A clear, brittle film is formed.

**Particulate matter.** Filter 100.0 g through a tared stainless steel sieve (90). Rinse with *water R* until a clear filtrate is obtained and dry at 100-105 °C. The residue weighs not more than 1.00 g.

**Ethyl acrylate and methacrylic acid.** Liquid chromatography (2.2.29).

*Blank solution.* To 50.0 mL of *methanol R* add 25.0 mL of the mobile phase.

*Test solution.* Dissolve 40 mg of the dispersion to be examined in 50.0 mL of *methanol R* and add 25.0 mL of the mobile phase.

*Reference solution.* Dissolve 10 mg of *ethyl acrylate R* and 10 mg of *methacrylic acid R* in *methanol R*, then dilute to 50.0 mL with the same solvent. Dilute 0.1 mL of this solution to 50.0 mL with *methanol R* and add 25.0 mL of the mobile phase.

**Column:**

- *size:*  $l = 0.10$  m,  $\varnothing = 4$  mm;
- *stationary phase:* octadecylsilyl silica gel for chromatography R (5 µm).

*Mobile phase:* *methanol R*, phosphate buffer solution pH 2.0 R (30:70 V/V).

*Flow rate:* 2.5 mL/min.

*Detection:* spectrophotometer at 202 nm.

*Injection:* 50 µL.

**System suitability:**

- *resolution:* minimum 2.0 between the peaks due to ethyl acrylate and methacrylic acid in the chromatogram obtained with the reference solution;

- the chromatogram obtained with the blank solution does not show peaks with the same retention times as ethyl acrylate or methacrylic acid.

**Limit:**

- *sum of the contents of ethyl acrylate and methacrylic acid*: maximum 0.1 per cent.

**Residue on evaporation**: 28.5 per cent to 31.5 per cent.

Dry 1.000 g at 110 °C for 5 h. The residue weighs not less than 0.285 g and not more than 0.315 g.

**Sulfated ash (2.4.14)**: maximum 0.2 per cent, determined on 1.0 g.

**Microbial contamination**

TAMC: acceptance criterion 10<sup>3</sup> CFU/g (2.6.12).

TYMC: acceptance criterion 10<sup>2</sup> CFU/g (2.6.12).

**ASSAY**

Dissolve 1.500 g in a mixture of 40 mL of *water R* and 60 mL of *2-propanol R*. Titrate slowly while stirring with 0.5 M sodium hydroxide, using *phenolphthalein solution R* as indicator.

1 mL of 0.5 M sodium hydroxide is equivalent to 43.05 mg of C<sub>4</sub>H<sub>6</sub>O<sub>2</sub> (methacrylic acid units).

**STORAGE**

Protected from freezing. Handle the substance so as to minimise microbial contamination.

**LABELLING**

The label states, where applicable, the name and concentration of any surface-active agents.

01/2008:1127  
corrected 6.0

## METHACRYLIC ACID - METHYL METHACRYLATE COPOLYMER (1:1)

### Acidi methacrylici et methylis methacrylatis polymerisatum 1:1

**DEFINITION**

Copolymer of methacrylic acid and methyl methacrylate having a mean relative molecular mass of about 135 000. The ratio of carboxylic groups to ester groups is about 1:1.

*Content*: 46.0 per cent to 50.6 per cent of methacrylic acid units (dried substance).

**CHARACTERS**

*Appearance*: white or almost white, free-flowing powder.

*Solubility*: practically insoluble in water, freely soluble in anhydrous ethanol and in 2-propanol, practically insoluble in ethyl acetate. It is freely soluble in a 40 g/L solution of sodium hydroxide.

**IDENTIFICATION**

A. Infrared absorption spectrophotometry (2.2.24).

*Comparison*: Ph. Eur. reference spectrum of *methacrylic acid - methyl methacrylate copolymer (1:1)*.

B. It complies with the limits of the assay.

**TESTS**

**Apparent viscosity (2.2.10)**: 50 mPas to 200 mPas.

Dissolve a quantity of the substance to be examined corresponding to 37.5 g of the dried substance in a mixture of 7.9 g of *water R* and 254.6 g of *2-propanol R*. Determine the viscosity using a rotating viscometer at 20 °C and at a shear rate of 10 s<sup>-1</sup>.

**Appearance of a film**. Place 1 mL of the solution prepared in the test for apparent viscosity on a glass plate and allow to dry. A clear brittle film is formed.

**Methyl methacrylate and methacrylic acid**. Liquid chromatography (2.2.29).

*Blank solution*. To 50.0 mL of *methanol R* add 25.0 mL of the mobile phase.

*Test solution*. Dissolve 40 mg of the substance to be examined in 50.0 mL of *methanol R* and add 25.0 mL of the mobile phase.

*Reference solution*. Dissolve 10 mg of *methyl methacrylate R* and 10 mg of *methacrylic acid R* in *methanol R*, then dilute to 50.0 mL with the same solvent. Dilute 0.1 mL of this solution to 50.0 mL with *methanol R* and add 25.0 mL of the mobile phase.

**Column:**

- *size*:  $l = 0.10$  m,  $\varnothing = 4$  mm;
- *stationary phase*: *octadecylsilyl silica gel for chromatography R* (5 µm).

*Mobile phase*: *methanol R*, *phosphate buffer solution pH 2.0 R* (30:70 V/V).

*Flow rate*: 2.5 mL/min.

*Detection*: spectrophotometer at 202 nm.

*Injection*: 50 µL.

**System suitability:**

- *resolution*: minimum 2.0 between the peaks due to methyl methacrylate and methacrylic acid in the chromatogram obtained with the reference solution;
- the chromatogram obtained with the blank solution does not show peaks with the same retention times as methyl methacrylate or methacrylic acid.

**Limit:**

- *sum of the contents of methyl methacrylate and methacrylic acid*: maximum 0.1 per cent.

**Loss on drying (2.2.32)**: maximum 5.0 per cent, determined on 1.000 g by drying in an oven at 105 °C for 6 h.

**Sulfated ash (2.4.14)**: maximum 0.1 per cent, determined on 1.0 g.

**ASSAY**

Dissolve 1.000 g in a mixture of 40 mL of *water R* and 60 mL of *2-propanol R*. Titrate slowly while stirring with 0.5 M sodium hydroxide, using *phenolphthalein solution R* as indicator.

1 mL of 0.5 M sodium hydroxide is equivalent to 43.05 mg of C<sub>4</sub>H<sub>6</sub>O<sub>2</sub> (methacrylic acid units).

01/2008:1130  
corrected 6.0

## METHACRYLIC ACID - METHYL METHACRYLATE COPOLYMER (1:2)

### Acidi methacrylici et methylis methacrylatis polymerisatum 1:2

**DEFINITION**

Copolymer of methacrylic acid and methyl methacrylate having a mean relative molecular mass of about 135 000. The ratio of carboxylic groups to ester groups is about 1:2.

*Content*: 27.6 per cent to 30.7 per cent of methacrylic acid units (dried substance).

**CHARACTERS**

*Appearance*: white or almost white, free-flowing powder.

*Solubility*: practically insoluble in water, freely soluble in anhydrous ethanol and in 2-propanol, practically insoluble in ethyl acetate. It is freely soluble in a 40 g/L solution of sodium hydroxide.

**IDENTIFICATION**

A. Infrared absorption spectrophotometry (2.2.24).

*Comparison*: Ph. Eur. reference spectrum of *methacrylic acid - methyl methacrylate copolymer (1:2)*.



B. It complies with the limits of the assay.

01/2008:0408  
corrected 6.0

## TESTS

**Apparent viscosity** (2.2.10): 50 mPa·s to 200 mPa·s.

Dissolve a quantity of the substance to be examined corresponding to 37.5 g of the dried substance in a mixture of 7.9 g of *water R* and 254.6 g of *2-propanol R*. Determine the viscosity using a rotating viscometer at 20 °C and at a shear rate of 10 s<sup>-1</sup>.

**Appearance of a film.** Place 1 mL of the solution prepared for the viscosity test on a glass plate and allow to dry. A clear brittle film is formed.

**Methyl methacrylate and methacrylic acid.** Liquid chromatography (2.2.29).

**Blank solution.** To 50.0 mL of *methanol R* add 25.0 mL of the mobile phase.

**Test solution.** Dissolve 40 mg of the substance to be examined in 50.0 mL of *methanol R* and add 25.0 mL of the mobile phase.

**Reference solution.** Dissolve 10 mg of *methyl methacrylate R* and 10 mg of *methacrylic acid R* in *methanol R*, then dilute to 50.0 mL with the same solvent. Dilute 0.1 mL of this solution to 50.0 mL with *methanol R* and add 25.0 mL of the mobile phase.

**Column:**

- size:  $l = 0.10$  m,  $\varnothing = 4$  mm;
- stationary phase: octadecylsilyl silica gel for chromatography *R* (5  $\mu$ m).

**Mobile phase:** *methanol R*, phosphate buffer solution pH 2.0 *R* (30:70 V/V).

**Flow rate:** 2.5 mL/min.

**Detection:** spectrophotometer at 202 nm.

**Injection:** 50  $\mu$ L.

**System suitability:**

- resolution: minimum 2.0 between the peaks due to methyl methacrylate and methacrylic acid in the chromatogram obtained with the reference solution;
- the chromatogram obtained with the blank solution does not show peaks with the same retention times as methyl methacrylate or methacrylic acid.

**Limit:**

- sum of the contents of methyl methacrylate and methacrylic acid: maximum 0.1 per cent.

**Loss on drying** (2.2.32): maximum 5.0 per cent, determined on 1.000 g by drying in an oven at 105 °C for 6 h.

**Sulfated ash** (2.4.14): maximum 0.1 per cent, determined on 1.0 g.

## ASSAY

Dissolve 1.000 g in a mixture of 40 mL of *water R* and 60 mL of *2-propanol R*. Titrate slowly while stirring with 0.5 M sodium hydroxide, using phenolphthalein solution *R* as indicator.

1 mL of 0.5 M sodium hydroxide is equivalent to 43.05 mg of C<sub>21</sub>H<sub>28</sub>ClNO (methacrylic acid units).

## METHADONE HYDROCHLORIDE

### Methadoni hydrochloridum

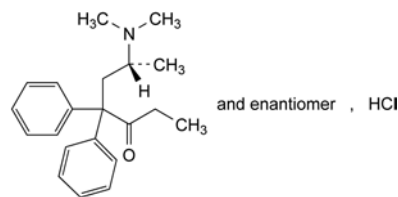

C<sub>21</sub>H<sub>28</sub>ClNO  
[1095-90-5]

*M<sub>r</sub>* 345.9

## DEFINITION

(6*RS*)-6-(Dimethylamino)-4,4-diphenylheptan-3-one hydrochloride.

**Content:** 99.0 per cent to 101.0 per cent (dried substance).

## CHARACTERS

**Appearance:** white or almost white, crystalline powder.

**Solubility:** soluble in water, freely soluble in ethanol (96 per cent).

## IDENTIFICATION

**First identification:** A, C, D.

**Second identification:** A, B, D.

- A. Optical rotation (see Tests).
- B. Melting point (2.2.14): 233 °C to 236 °C.
- C. Infrared absorption spectrophotometry (2.2.24).  
*Comparison:* Ph. Eur. reference spectrum of methadone hydrochloride.
- D. Dilute 1 mL of solution S (see Tests) to 5 mL with *water R* and add 1 mL of dilute ammonia *R1*. Mix, allow to stand for 5 min and filter. The filtrate gives reaction (a) of chlorides (2.3.1).

## TESTS

**Solution S.** Dissolve 2.50 g in carbon dioxide-free water *R* and dilute to 50.0 mL with the same solvent.

**Appearance of solution.** Solution S is clear (2.2.1) and colourless (2.2.2, Method II).

**Acidity or alkalinity.** Dilute 10 mL of solution S to 25 mL with carbon dioxide-free water *R*. To 10 mL of the solution add 0.2 mL of methyl red solution *R* and 0.2 mL of 0.01 M sodium hydroxide. The solution is yellow. Add 0.4 mL of 0.01 M hydrochloric acid. The solution is red.

**Optical rotation** (2.2.7):  $-0.05^\circ$  to  $+0.05^\circ$ , determined on solution S in a 2 dm tube.

**Related substances.** Gas chromatography (2.2.28).

**Test solution.** Dissolve 0.100 g of the substance to be examined in *methanol R* and dilute to 10.0 mL with the same solvent.

**Reference solution (a).** Dilute 1.0 mL of the test solution to 10.0 mL with *methanol R*. Dilute 1.0 mL of this solution to 100.0 mL with *methanol R*.

**Reference solution (b).** Dissolve 5 mg of imipramine hydrochloride CRS and 5 mg of cyclobenzaprine hydrochloride CRS in 100.0 mL of *methanol R*.

**Column:**

- material: fused silica;
- size:  $l = 50$  m,  $\varnothing = 0.32$  mm;
- stationary phase: poly(dimethyl)(diphenyl)siloxane *R* (film thickness 1.05  $\mu$ m).

**Carrier gas:** helium for chromatography *R*.

Flow rate: 1.2 mL/min.

Injection liner: packed with deactivated glass wool to wipe the needle.

Split ratio: 1:100.

Temperature:

	Time (min)	Temperature (°C)
Column	0 - 4	150 → 250
	4 - 35	250
Injection port		200
Detector		250

Detection: flame ionisation.

Injection: 2 µL.

Run time: 1.5 times the retention time of methadone.

Relative retention with reference to methadone (retention time = about 25 min): impurity E = about 0.44; impurity C = about 0.81; impurity B = about 0.89; impurity D = about 0.98; impurity A = about 1.14; imipramine = about 1.19; cyclobenzaprine = about 1.24.

System suitability: reference solution (b):

- resolution: minimum 3.0 between the peaks due to imipramine and cyclobenzaprine.

Limits:

- impurities A, B, C, D, E: for each impurity, not more than the area of the principal peak in the chromatogram obtained with reference solution (a) (0.1 per cent);
- unspecified impurities: for each impurity, not more than the area of the principal peak in the chromatogram obtained with reference solution (a) (0.10 per cent);
- total: not more than 3 times the area of the principal peak in the chromatogram obtained with reference solution (a) (0.3 per cent);
- disregard limit: 0.5 times the area of the principal peak in the chromatogram obtained with reference solution (a) (0.05 per cent).

Loss on drying (2.2.32): maximum 0.5 per cent, determined on 1.000 g by drying in an oven at 105 °C.

Sulfated ash (2.4.14): maximum 0.1 per cent, determined on 1.0 g.

#### ASSAY

Dissolve 0.300 g in a mixture of 5 mL of 0.01 M hydrochloric acid and 50 mL of anhydrous ethanol R. Carry out a potentiometric titration (2.2.20), using 0.1 M sodium hydroxide. Read the volume added between the 2 points of inflexion. Carry out a blank titration.

1 mL of 0.1 M sodium hydroxide is equivalent to 34.59 mg of C<sub>21</sub>H<sub>28</sub>ClNO.

#### STORAGE

Protected from light.

#### IMPURITIES

Specified impurities: A, B, C, D, E.

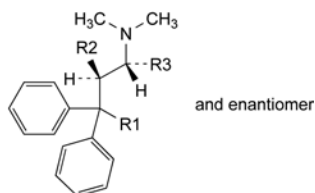

A. R1 = CNH-C<sub>2</sub>H<sub>5</sub>, R2 = CH<sub>3</sub>, R3 = H: (2*RS*)-4-imino-*N,N*,2-trimethyl-3,3-diphenylhexan-1-amine (isomethadone ketimine),

B. R1 = CN, R2 = H, R3 = CH<sub>3</sub>: (4*RS*)-4-(dimethylamino)-2,2-diphenylpentanenitrile (didiavallo),

C. R1 = CN, R2 = CH<sub>3</sub>, R3 = H: (3*RS*)-4-(dimethylamino)-3-methyl-2,2-diphenylbutanenitrile (isodidiavallo),

D. R1 = CO-C<sub>2</sub>H<sub>5</sub>, R2 = CH<sub>3</sub>, R3 = H: (5*RS*)-6-(dimethylamino)-5-methyl-4,4-diphenylhexan-3-one (isomethadone),

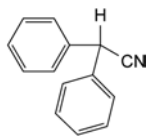

E. diphenylacetone nitrile.

01/2008:1989

## METHANOL

### Methanolum



CH<sub>4</sub>O  
[67-56-1]

*M*<sub>r</sub> 32.04

#### DEFINITION

Methyl alcohol.

#### CHARACTERS

Appearance: clear, colourless, volatile, hygroscopic liquid.

Solubility: miscible with water and with methylene chloride.

bp: about 64 °C.

It is flammable.

#### IDENTIFICATION

A. Refractive index (2.2.6): 1.328 to 1.330.

B. Infrared absorption spectrophotometry (2.2.24).

Comparison: Ph. Eur. reference spectrum of methanol.

#### TESTS

Appearance. It is clear (2.2.1) and colourless (2.2.2, Method II).

Acidity or alkalinity. To 25 mL add 25 mL of water R and 0.25 mL of phenolphthalein solution R1. The solution is colourless. Not more than 0.9 mL of 0.01 M sodium hydroxide is required to change the colour of the indicator to pink.

Relative density (2.2.5): 0.791 to 0.793.

Absorbance (2.2.25): maximum 0.15 at 230 nm, maximum 0.05 at 250 nm, maximum 0.02 at 270 nm and maximum 0.01 at 290 nm.

Examine between 230 nm and 290 nm using water R as the compensation liquid. The absorption curve is smooth.

Impurity A. Gas chromatography (2.2.28).

Test solution (a). The substance to be examined.

Test solution (b). Dilute 1.0 mL of 4-methylpentan-2-ol R to 50.0 mL with test solution (a). Dilute 5.0 mL of this solution to 100.0 mL with test solution (a).

Reference solution (a). To 50 µL of anhydrous ethanol R add 50 µL of acetone R and dilute to 50.0 mL with test solution (a). Dilute 100 µL of this solution to 10.0 mL with test solution (a).

Reference solution (b). Dilute 100 µL of benzene R to 100.0 mL with test solution (a). Dilute 0.20 mL to 100.0 mL with test solution (a).

Column:

– material: fused silica,

– size: *l* = 30 m, Ø = 0.32 mm,

– stationary phase: poly[(cyanopropyl)(phenyl)][dimethylsiloxane R (film thickness 1.8 µm).

Carrier gas: helium for chromatography R.

Linear velocity: 35 cm/s.

Split ratio: 1:20.

Temperature:

	Time (min)	Temperature (°C)
Column	0 - 12	40
	12 - 32	40 → 240
	32 - 42	240
Injection port		200
Detector		280

Detection: flame ionisation.

Injection: 1 µL.

System suitability: reference solution (a):

- resolution: minimum 4.0 between the peaks due to impurity B (1<sup>st</sup> peak) and impurity C (2<sup>nd</sup> peak).

Limit:

- impurity A: maximum 2 ppm V/V.

Calculate the content of impurity A in parts per million (V/V) using the following expression:

$$\frac{2 \times A_1}{A_2 - A_1}$$

- $A_1$  = area of the peak due to impurity A in the chromatogram obtained with test solution (a),
- $A_2$  = area of the peak due to impurity A in the chromatogram obtained with reference solution (b).

If necessary, the identity of impurity A can be confirmed using another suitable chromatographic system (stationary phase with a different polarity).

**Related substances.** Gas chromatography (2.2.28) as described in the test for impurity A.

Limits:

- any impurity: for each impurity, not more than the area of the peak due to 4-methylpentan-2-ol in the chromatogram obtained with test solution (b) (0.1 per cent),
- total: not more than 3 times the area of the peak due to 4-methylpentan-2-ol in the chromatogram obtained with test solution (b) (0.3 per cent),
- disregard limit: 0.05 times the area of the peak due to 4-methylpentan-2-ol in the chromatogram obtained with test solution (b) (50 ppm).

**Reducing substances.** To 20 mL add 0.1 mL of 0.02 M potassium permanganate. The pink colour is not completely discharged within 5 min.

**Residue on evaporation:** maximum 10 ppm.

Evaporate 100 g to dryness on a water bath and dry in an oven at 100-105 °C. The residue weighs a maximum of 1 mg.

**Water** (2.5.12): maximum 0.10 per cent, determined on 10.0 g.

#### STORAGE

In an airtight container.

#### IMPURITIES

Specified impurities: A.

Other detectable impurities (the following substances would, if present at a sufficient level, be detected by one or other of the tests in the monograph. They are limited by the general acceptance criterion for other/unspecified impurities and/or by the general monograph *Substances for pharmaceutical use* (2034). It is therefore not necessary to identify these impurities for demonstration of compliance. See also 5.10. *Control of impurities in substances for pharmaceutical use*): B, C.



A. benzene,



B. ethanol,

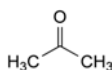

C. propanone (acetone).

01/2008:0510  
corrected 6.0

## METHAQUALONE

### Methaqualonum

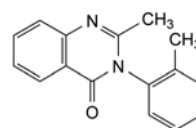

$C_{16}H_{14}N_2O$   
[72-44-6]

$M_r$  250.3

#### DEFINITION

2-Methyl-3-(2-methylphenyl)quinazolin-4(3H)-one.

**Content:** 99.0 per cent to 101.0 per cent (dried substance).

#### CHARACTERS

**Appearance:** white or almost white, crystalline powder.

**Solubility:** very slightly soluble in water, soluble in ethanol (96 per cent). It dissolves in dilute sulfuric acid.

#### IDENTIFICATION

**First identification:** A, C.

**Second identification:** A, B, D.

A. Melting point (2.2.14): 114 °C to 117 °C.

B. Ultraviolet and visible absorption spectrophotometry (2.2.25).

**Test solution.** Dissolve 50.0 mg in 0.1 M hydrochloric acid, warming if necessary, and dilute to 100.0 mL with the same acid. Dilute 1.0 mL of this solution to 100.0 mL with 0.1 M hydrochloric acid.

**Spectral range:** 220-300 nm.

**Absorption maxima:** at 235 nm and 270 nm.

**Specific absorbances at the absorption maxima:**

– at 235 nm: 1270 to 1390,

– at 270 nm: 315 to 345.

C. Infrared absorption spectrophotometry (2.2.24).

**Comparison:** Ph. Eur. reference spectrum of methaqualone.

D. Dissolve about 10 mg in 2 mL of ethanol (96 per cent) R. Add 1 mL of dimethylaminobenzaldehyde solution R1 and heat on a water-bath for 5 min. A reddish-orange colour develops.

#### TESTS

**Appearance of solution.** The solution is clear (2.2.1) and not more intensely coloured than reference solution BY<sub>7</sub> (2.2.2, Method II).

Dissolve 1.0 g in methanol R and dilute to 25 mL with the same solvent.

**Acidity.** Shake 0.6 g with 30 mL of carbon dioxide-free water R for 5 min and filter. To 10 mL of the filtrate add 0.1 mL of phenolphthalein solution R. Not more than 0.2 mL of 0.01 M sodium hydroxide is required to change the colour of the indicator.

**2-Aminobenzoic acid:** maximum 20 ppm.

*Test solution.* Dissolve 1.00 g in a mixture of 1 volume of *water R* and 3 volumes of *ethanol (96 per cent) R* and dilute to 50.0 mL with the same mixture of solvents.

*Reference solution.* Dissolve 40 mg of *2-aminobenzoic acid R* in a mixture of 1 volume of *water R* and 3 volumes of *ethanol (96 per cent) R* and dilute to 100.0 mL with the same mixture of solvents; dilute 10.0 mL of this solution to 100.0 mL with a mixture of 1 volume of *water R* and 3 volumes of *ethanol (96 per cent) R*; dilute 0.5 mL of this solution to 50.0 mL with a mixture of 1 volume of *water R* and 3 volumes of *ethanol (96 per cent) R*.

To the test solution and to the reference solution add 5 mL of *dilute hydrochloric acid R* and cool in iced water for 5 min. Add 0.1 mL of *sodium nitrite solution R* and cool again in iced water for 5 min. Add 1.5 mL of a freshly prepared 10 g/L solution of *sulfamic acid R* and shake until the colour of the solution is discharged. Add 2.5 mL of a freshly prepared 2 g/L solution of *naphthylethylenediamine dihydrochloride R* and allow to stand for 2 h 30 min. The test solution is not more intensely coloured (2.2.2, *Method II*) than the reference solution.

**o-Toluidine:** maximum 10 ppm.

*Test solution.* Dissolve 0.50 g in *acetone R* and dilute to 10.0 mL with the same solvent.

*Reference solution.* Dissolve 50 mg of freshly distilled *o-toluidine R* in 5 mL of *acetone R* and dilute to 100.0 mL with *dilute hydrochloric acid R*; dilute 10.0 mL of the solution to 100.0 mL with *dilute hydrochloric acid R*; dilute 0.1 mL of this solution to 10.0 mL with *acetone R*.

To the test solution and to the reference solution add 5 mL of *water R* and cool in iced water for 5 min. Add 0.1 mL of *sodium nitrite solution R* and cool again in iced water for 5 min. Add 10 mL of a freshly prepared 2 g/L solution of *β-naphthol R* in *dilute sodium hydroxide solution R*. The test solution is not more intensely coloured (2.2.2, *Method II*) than the reference solution.

**Heavy metals (2.4.8):** maximum 20 ppm.

1.0 g complies with test C. Prepare the reference solution using 2 mL of *lead standard solution (10 ppm Pb) R*.

**Loss on drying (2.2.32):** maximum 1.0 per cent, determined on 1.000 g by drying in an oven at 105 °C.

**Sulfated ash (2.4.14):** maximum 0.1 per cent, determined on 1.0 g.

#### ASSAY

Dissolve 0.200 g in 30 mL of *anhydrous acetic acid R*. Titrate with *0.1 M perchloric acid*, determining the end-point potentiometrically (2.2.20).

1 mL of *0.1 M perchloric acid* is equivalent to 25.03 mg of  $C_{16}H_{14}N_2O$ .

#### STORAGE

Protected from light.

#### DEFINITION

1,3,5,7-Tetraazotricyclo[3.3.1.1<sup>3,7</sup>]decane.

*Content:* 99.0 per cent to 100.5 per cent (dried substance).

#### CHARACTERS

*Appearance:* white or almost white, crystalline powder or colourless crystals.

*Solubility:* freely soluble in water, soluble in ethanol (96 per cent) and in methylene chloride.

#### IDENTIFICATION

*First identification: A.*

*Second identification: B, C, D.*

A. Infrared absorption spectrophotometry (2.2.24).

*Comparison: methenamine CRS.*

B. To 1 mL of solution S (see Tests) add 1 mL of *sulfuric acid R* and immediately heat to boiling. Allow to cool. To 1 mL of the solution add 4 mL of *water R* and 5 mL of *acetylacetone reagent R1*. Heat on a water-bath for 5 min. An intense yellow colour develops.

C. To 1 mL of solution S add 1 mL of *dilute sulfuric acid R* and immediately heat to boiling. The solution gives the reaction of ammonium salts and salts of volatile bases (2.3.1).

D. Dissolve 10 mg in 5 mL of *water R* and acidify with *dilute hydrochloric acid R*. Add 1 mL of *potassium iodobismuthate solution R*. An orange precipitate is formed immediately.

#### TESTS

**Solution S.** Dissolve 10.0 g in *carbon dioxide-free water R* prepared from *distilled water R* and dilute to 100 mL with the same solvent.

**Appearance of solution.** Solution S is clear (2.2.1) and colourless (2.2.2, *Method II*).

**Acidity or alkalinity.** To 5 mL of solution S add 0.1 mL of *phenolphthalein solution R*. Not more than 0.2 mL of *0.1 M hydrochloric acid* or *0.1 M sodium hydroxide* is required to change the colour of the indicator.

**Free formaldehyde:** maximum 50 ppm.

Dissolve 0.8 g in *water R* and dilute to 8 mL with the same solvent. Add 2 mL of *ammoniacal silver nitrate solution R*. After 5 min, any grey colour in the solution is not more intense than that in a standard prepared at the same time and in the same manner with a mixture of 8 mL of freshly prepared *formaldehyde standard solution (5 ppm CH<sub>2</sub>O) R* and 2 mL of *ammoniacal silver nitrate solution R*.

**Chlorides (2.4.4):** maximum 100 ppm.

Dilute 5 mL of solution S to 15 mL with *water R*.

**Sulfates (2.4.13):** maximum 100 ppm, determined on solution S.

**Ammonium (2.4.1):** maximum 50 ppm.

Dilute 2 mL of freshly prepared solution S to 13 mL with *water R*. Add 2 mL of *dilute sodium hydroxide solution R*.

**Heavy metals (2.4.8):** maximum 20 ppm.

12 mL of solution S complies with test A. Prepare the reference solution using *lead standard solution (2 ppm Pb) R*.

**Loss on drying (2.2.32):** maximum 2.0 per cent, determined on 1.000 g by drying in a desiccator.

#### ASSAY

Dissolve 0.100 g in 30 mL of *methanol R*. Titrate with *0.1 M perchloric acid*, determining the end-point potentiometrically (2.2.20).

1 mL of *0.1 M perchloric acid* is equivalent to 14.02 mg of  $C_6H_{12}N_4$ .

#### STORAGE

Protected from light.

01/2008:1545

## METHENAMINE

### Methenaminum

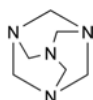

$C_6H_{12}N_4$   
[100-97-0]

$M_r$  140.2

01/2008:1027  
corrected 6.0

## METHIONINE

## Methioninum

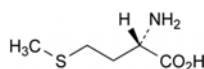
C<sub>5</sub>H<sub>11</sub>NO<sub>2</sub>S  
[63-68-3]M<sub>r</sub> 149.2

## DEFINITION

Methionine contains not less than 99.0 per cent and not more than the equivalent of 101.0 per cent of (2S)-2-amino-4-(methylsulfanyl)butanoic acid, calculated with reference to the dried substance.

## CHARACTERS

A white or almost white, crystalline powder or colourless crystals, soluble in water, very slightly soluble in alcohol.

## IDENTIFICATION

First identification: A, B.

Second identification: A, C, D.

- A. Specific optical rotation (see Tests).
- B. Examine by infrared absorption spectrophotometry (2.2.24), comparing with the spectrum obtained with *methionine CRS*. Examine the substances prepared as discs.
- C. Examine the chromatograms obtained in the test for ninhydrin-positive substances. The principal spot in the chromatogram obtained with test solution (b) is similar in position, colour and size to the principal spot in the chromatogram obtained with reference solution (a).
- D. Dissolve 0.1 g of the substance to be examined and 0.1 g of *glycine R* in 4.5 mL of *dilute sodium hydroxide solution R*. Add 1 mL of a 25 g/L solution of *sodium nitroprusside R*. Heat to 40 °C for 10 min. Allow to cool and add 2 mL of a mixture of 1 volume of *phosphoric acid R* and 9 volumes of *hydrochloric acid R*. A dark red colour develops.

## TESTS

**Solution S.** Dissolve 2.5 g in *carbon dioxide-free water R* and dilute to 100 mL with the same solvent.

**Appearance of solution.** Solution S is clear (2.2.1) and colourless (2.2.2, *Method II*).

**pH (2.2.3).** The pH of solution S is 5.5 to 6.5.

**Specific optical rotation (2.2.7).** Dissolve 1.00 g in *hydrochloric acid R1* and dilute to 50.0 mL with the same acid. The specific optical rotation is + 22.5 to + 24.0, calculated with reference to the dried substance.

**Ninhydrin-positive substances.** Examine by thin-layer chromatography (2.2.27), using a *TLC silica gel plate R*.

**Test solution (a).** Dissolve 0.10 g of the substance to be examined in *dilute hydrochloric acid R* and dilute to 10 mL with the same acid.

**Test solution (b).** Dilute 1 mL of test solution (a) to 50 mL with *water R*.

**Reference solution (a).** Dissolve 10 mg of *methionine CRS* in a 10 g/L solution of *hydrochloric acid R* and dilute to 50 mL with the same acid solution.

**Reference solution (b).** Dilute 5 mL of test solution (b) to 20 mL with *water R*.

**Reference solution (c).** Dissolve 10 mg of *methionine CRS* and 10 mg of *serine CRS* in a 10 g/L solution of *hydrochloric acid R* and dilute to 25 mL with the same acid solution.

Apply separately to the plate 5 µL of each solution. Develop over a path of 15 cm using a mixture of 20 volumes of *glacial acetic acid R*, 20 volumes of *water R* and 60 volumes of

*butanol R*. Allow the plate to dry in air, spray with *ninhydrin solution R* and heat at 100 °C to 105 °C for 15 min. Any spot in the chromatogram obtained with test solution (a), apart from the principal spot, is not more intense than the spot in the chromatogram obtained with reference solution (b) (0.5 per cent). The test is not valid unless the chromatogram obtained with reference solution (c) shows two clearly separated spots.

**Chlorides.** To 10 mL of solution S add 25 mL of *water R*, 5 mL of *dilute nitric acid R* and 10 mL of *silver nitrate solution R2*. Allow to stand protected from light for 5 min. Any opalescence in the solution is not more intense than that in a standard prepared at the same time and in the same manner using 10 mL of *chloride standard solution (5 ppm Cl) R* (200 ppm). Examine the tubes laterally against a black background.

**Sulfates (2.4.13).** Dissolve 0.5 g in 3 mL of *dilute hydrochloric acid R* and dilute to 15 mL with *distilled water R*. The solution complies with the limit test for sulfates (300 ppm).

**Ammonium (2.4.1).** 0.10 g complies with limit test B for ammonium (200 ppm). Prepare the standard using 0.2 mL of *ammonium standard solution (100 ppm NH<sub>4</sub>) R*.

**Iron (2.4.9).** In a separating funnel, dissolve 1.0 g in 10 mL of *dilute hydrochloric acid R*. Shake with three quantities, each of 10 mL, of *methyl isobutyl ketone R1*, shaking for 3 min each time. To the combined upper layers add 10 mL of *water R* and shake for 3 min. The lower layer complies with the limit test for iron (10 ppm).

**Heavy metals (2.4.8).** 2.0 g complies with limit test C for heavy metals (10 ppm). Prepare the standard using 2 mL of *lead standard solution (10 ppm Pb) R*.

**Loss on drying (2.2.32).** Not more than 0.5 per cent, determined on 1.000 g by drying in an oven at 105 °C.

**Sulfated ash (2.4.14).** Not more than 0.1 per cent, determined on 1.0 g.

## ASSAY

Dissolve 0.125 g in 5 mL of *anhydrous formic acid R*. Add 30 mL of *anhydrous acetic acid R*. Titrate with 0.1 M *perchloric acid*, determining the end-point potentiometrically (2.2.20). 1 mL of 0.1 M *perchloric acid* is equivalent to 14.92 mg of C<sub>5</sub>H<sub>11</sub>NO<sub>2</sub>S.

## STORAGE

Store protected from light.

01/2008:0624  
corrected 6.0

## DL-METHIONINE

## DL-Methioninum

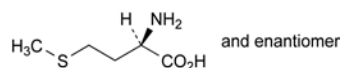
C<sub>5</sub>H<sub>11</sub>NO<sub>2</sub>S  
[59-51-8]M<sub>r</sub> 149.2

## DEFINITION

DL-Methionine contains not less than 99.0 per cent and not more than the equivalent of 101.0 per cent of (2RS)-2-amino-4-(methylsulfanyl)butanoic acid, calculated with reference to the dried substance.

## CHARACTERS

Almost white, crystalline powder or small flakes, sparingly soluble in water, very slightly soluble in alcohol. It dissolves in dilute acids and in dilute solutions of the alkali hydroxides. It melts at about 270 °C (instantaneous method).

## IDENTIFICATION

First identification: A, C.

Second identification: B, C, D.

- A. Examine by infrared absorption spectrophotometry (2.2.24), comparing with the spectrum obtained with *DL-methionine CRS*. Dry the substances at 105 °C.
- B. Examine the chromatograms obtained in the test for related substances. The principal spot in the chromatogram obtained with test solution (b) is similar in position, colour and size to the principal spot in the chromatogram obtained with reference solution (a).
- C. Dissolve 2.50 g in 1 M hydrochloric acid and dilute to 50.0 mL with the same acid. The angle of optical rotation (2.2.7) is  $-0.05^\circ$  to  $+0.05^\circ$ .
- D. Dissolve 0.1 g of the substance to be examined and 0.1 g of *glycine R* in 4.5 mL of dilute sodium hydroxide solution R. Add 1 mL of a 25 g/L solution of sodium nitroprusside R. Heat to 40 °C for 10 min. Allow to cool and add 2 mL of a mixture of 1 volume of phosphoric acid R and 9 volumes of hydrochloric acid R. A deep-red colour develops.

#### TESTS

**Solution S.** Dissolve 1.0 g in carbon dioxide-free water R and dilute to 50 mL with the same solvent.

**Appearance of solution.** Solution S is clear (2.2.1) and colourless (2.2.2, Method II).

**pH (2.2.3).** The pH of solution S is 5.4 to 6.1.

**Related substances.** Examine by thin-layer chromatography (2.2.27), using silica gel G R as the coating substance.

**Test solution (a).** Dissolve 0.2 g in water R and dilute to 10 mL with the same solvent.

**Test solution (b).** Dilute 1 mL of test solution (a) to 50 mL with water R.

**Reference solution (a).** Dissolve 20 mg of *DL-methionine CRS* in water R and dilute to 50 mL with the same solvent.

**Reference solution (b).** Dilute 1 mL of reference solution (a) to 10 mL with water R.

Apply separately to the plate 5 µL of each solution. Develop over a path of 10 cm using a mixture of 20 volumes of glacial acetic acid R, 20 volumes of water R and 60 volumes of butanol R. Allow the plate to dry in air and spray with ninhydrin solution R. Heat the plate at 100 °C to 105 °C for 15 min. Any spot in the chromatogram obtained with test solution (a), apart from the principal spot, is not more intense than the spot in the chromatogram obtained with reference solution (b) (0.2 per cent).

**Chlorides.** Dissolve 0.25 g in 35 mL of water R. Add 5 mL of dilute nitric acid R and 10 mL of silver nitrate solution R2. Allow to stand protected from light for 5 min. Any opalescence in the solution is not more intense than that in a standard prepared at the same time in the same manner using a mixture of 10 mL of chloride standard solution (5 ppm Cl) R and 25 mL of water R (200 ppm). Examine the tubes laterally against a black background.

**Sulfates (2.4.13).** Dissolve 1.0 g in 20 mL of distilled water R, heating to 60 °C. Cool to 10 °C and filter. 15 mL of the solution complies with the limit test for sulfates (200 ppm).

**Heavy metals (2.4.8).** 1.0 g complies with limit test D for heavy metals (20 ppm). Prepare the standard using 2 mL of lead standard solution (10 ppm Pb) R.

**Loss on drying (2.2.32).** Not more than 0.5 per cent, determined on 1.000 g by drying in an oven at 105 °C.

**Sulfated ash (2.4.14).** Not more than 0.1 per cent, determined on 1.0 g.

#### ASSAY

Dissolve 0.140 g in 3 mL of anhydrous formic acid R. Add 30 mL of anhydrous acetic acid R. Immediately after dissolution, titrate with 0.1 M perchloric acid, determining the end-point potentiometrically (2.2.20).

1 mL of 0.1 M perchloric acid is equivalent to 14.92 mg of  $C_5H_{11}NO_2S$ .

#### STORAGE

Store protected from light.

01/2009:0560  
corrected 7.0

## METHOTREXATE

### Methotrexatum

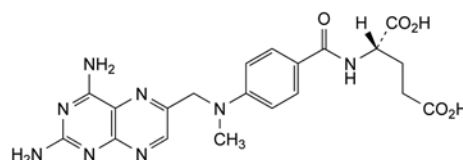

$C_{20}H_{22}N_8O_5$   
[59-05-2]

$M_r$  454.4

#### DEFINITION

(2S)-2-[4-[[[(2,4-Diaminopteridin-6-yl)methyl]methylamino]benzoyl]amino]pentanedioic acid.

**Content:** 97.0 per cent to 102.0 per cent (anhydrous substance).

#### CHARACTERS

**Appearance:** yellow or orange, crystalline, hygroscopic powder.

**Solubility:** practically insoluble in water, in ethanol (96 per cent) and in methylene chloride. It dissolves in dilute mineral acids and in dilute solutions of alkali hydroxides and carbonates.

#### IDENTIFICATION

Infrared absorption spectrophotometry (2.2.24).

**Comparison:** methotrexate CRS.

#### TESTS

**Related substances.** Liquid chromatography (2.2.29).

**Test solution (a).** Dissolve 40.0 mg of the substance to be examined in a mixture of 0.5 mL of dilute ammonia R1 and 5 mL of mobile phase A and dilute to 100.0 mL with mobile phase A.

**Test solution (b).** Dissolve 25.0 mg of the substance to be examined in a mixture of 0.5 mL of dilute ammonia R1 and 5 mL of mobile phase A and dilute to 50.0 mL with mobile phase A. Dilute 5.0 mL of this solution to 50.0 mL with mobile phase A.

**Reference solution (a).** Dissolve 25.0 mg of methotrexate CRS in a mixture of 0.5 mL of dilute ammonia R1 and 5 mL of mobile phase A and dilute to 50.0 mL with mobile phase A. Dilute 5.0 mL of this solution to 50.0 mL with mobile phase A.

**Reference solution (b).** Dilute 5.0 mL of test solution (a) to 100.0 mL with mobile phase A. Dilute 5.0 mL of this solution to 50.0 mL with mobile phase A.

**Reference solution (c).** Dilute 5.0 mL of reference solution (b) to 25.0 mL with mobile phase A.

**Reference solution (d).** Dissolve 5 mg of the substance to be examined, 5 mg of 4-aminofolic acid R (impurity B), 5 mg of methotrexate impurity C CRS, 5 mg of methotrexate impurity D CRS and 5 mg of methotrexate impurity E CRS in a mixture of 0.5 mL of dilute ammonia R1 and 5 mL of mobile phase A and dilute to 100 mL with mobile phase A.

**Reference solution (e).** Dissolve 8 mg of methotrexate for peak identification CRS (containing impurities H and I) in a mixture of 0.1 mL of dilute ammonia R1 and 1 mL of mobile phase A and dilute to 20 mL with mobile phase A.

**Column:**

– size:  $l = 0.25$  m,  $\varnothing = 4.0$  mm;

- *stationary phase*: spherical *end-capped octadecylsilyl silica gel for chromatography R* (5 µm).

**Mobile phase:**

- *mobile phase A*: mix 5 volumes of *acetonitrile for chromatography R* and 95 volumes of a 3.4 g/L solution of *anhydrous sodium dihydrogen phosphate R* previously adjusted to pH 6.0 with a 42 g/L solution of *sodium hydroxide R*;
- *mobile phase B*: mix 50 volumes of *acetonitrile for chromatography R* and 50 volumes of a 3.4 g/L solution of *anhydrous sodium dihydrogen phosphate R* previously adjusted to pH 6.0 with a 42 g/L solution of *sodium hydroxide R*;

Time (min)	Mobile phase A (per cent V/V)	Mobile phase B (per cent V/V)
0 - 10	100	0
10 - 20	100 → 95	0 → 5
20 - 28	95 → 50	5 → 50
28 - 37	50	50

*Flow rate*: 1.5 mL/min.

*Detection*: spectrophotometer at 280 nm.

*Injection*: 20 µL of test solution (a) and reference solutions (b), (c), (d) and (e).

*Identification of impurities*: use the chromatogram supplied with *methotrexate for peak identification CRS* and the chromatogram obtained with reference solution (e) to identify the peaks due to impurities H and I.

*Relative retention* with reference to methotrexate (retention time = about 18 min): impurity B = about 0.3; impurity C = about 0.4; impurity E = about 1.4; impurity I = about 1.5; impurity H = about 1.6.

**System suitability:**

- *resolution*: minimum 2.0 between the peaks due to impurities B and C and minimum 1.5 between the peaks due to impurity D and methotrexate, in the chromatogram obtained with reference solution (d); minimum 1.5 between the peaks due to impurities I and H in the chromatogram obtained with reference solution (e); if the resolution between impurity D and methotrexate does not comply, increase the flow rate to meet the requirement.

**Limits:**

- *correction factors*: for the calculation of content, multiply the peak areas of the following impurities by the corresponding correction factor: impurity E = 0.8; impurity I = 1.4;
- *impurity C*: not more than the area of the principal peak in the chromatogram obtained with reference solution (b) (0.5 per cent);
- *impurities B, E*: for each impurity, not more than 0.6 times the area of the principal peak in the chromatogram obtained with reference solution (b) (0.3 per cent);
- *impurities H, I*: for each impurity, not more than twice the area of the principal peak in the chromatogram obtained with reference solution (c) (0.2 per cent);
- *unspecified impurities*: for each impurity, not more than 0.5 times the area of the principal peak in the chromatogram obtained with reference solution (c) (0.05 per cent);
- *sum of impurities other than B, C and E*: not more than the area of the principal peak in the chromatogram obtained with reference solution (b) (0.5 per cent);
- *disregard limit*: 0.3 times the area of the principal peak in the chromatogram obtained with reference solution (c) (0.03 per cent).

**Enantiomeric purity.** Liquid chromatography (2.2.29).

*Test solution.* Dissolve 20.0 mg of the substance to be examined in the mobile phase and dilute to 100.0 mL with the mobile phase.

*Reference solution (a).* Dilute 1.0 mL of the test solution to 100.0 mL with the mobile phase.

*Reference solution (b).* Dissolve 4.0 mg of (*RS*)-methotrexate *R* in the mobile phase and dilute to 100.0 mL with the mobile phase.

**Column:**

- *size*:  $l = 0.15$  m,  $\varnothing = 4.0$  mm;
- *stationary phase*: *bovine albumin R* bound to *silica gel for chromatography R* (7 µm) with a pore size of 30 nm.

*Mobile phase*: add 500 mL of a 7.1 g/L solution of *anhydrous disodium hydrogen phosphate R* to 600 mL of a 6.9 g/L solution of *sodium dihydrogen phosphate monohydrate R*, mix, and adjust to pH 6.9 with *dilute sodium hydroxide solution R*; to 920 mL of this mixture add 80 mL of *propanol R*.

*Flow rate*: 1.5 mL/min.

*Detection*: spectrophotometer at 302 nm.

*Injection*: 20 µL.

*System suitability*: reference solution (b):

- *resolution*: minimum 2.0 between the peaks due to methotrexate and impurity F.

**Limit:**

- *impurity F*: not more than 3 times the area of the principal peak in the chromatogram obtained with reference solution (a) (3.0 per cent).

**Heavy metals** (2.4.8): maximum 50 ppm.

1.0 g complies with test C. Prepare the reference solution using 5 mL of *lead standard solution (10 ppm Pb) R*.

**Water** (2.5.12): maximum 13.0 per cent, determined on 0.10 g.

**Sulfated ash** (2.4.14): maximum 0.1 per cent, determined on 1.0 g.

**ASSAY**

Liquid chromatography (2.2.29) as described in the test for related substances with the following modification.

*Injection*: test solution (b) and reference solution (a).

Calculate the percentage content of  $C_{20}H_{22}N_8O_5$  from the declared content of *methotrexate CRS*.

**STORAGE**

In an airtight container, protected from light.

**IMPURITIES**

*Specified impurities*: B, C, E, F, H, I.

*Other detectable impurities* (the following substances would, if present at a sufficient level, be detected by one or other of the tests in the monograph. They are limited by the general acceptance criterion for other/unspecified impurities and/or by the general monograph *Substances for pharmaceutical use (2034)*. It is therefore not necessary to identify these impurities for demonstration of compliance. See also 5.10. *Control of impurities in substances for pharmaceutical use*): A, D, G, J, K, L.

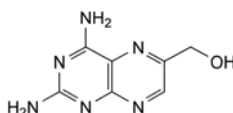

A. (2,4-diaminopteridin-6-yl)methanol,

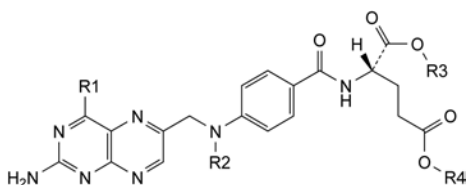

- B. R1 = NH<sub>2</sub>, R2 = R3 = R4 = H: (2*S*)-2-[[4-[[[(2,4-diaminopteridin-6-yl)methyl]amino]benzoyl]amino]pentanedioic acid (4-aminofolic acid, aminopterin),
- H. R1 = NH<sub>2</sub>, R2 = R4 = CH<sub>3</sub>, R3 = H: (2*S*)-2-[[4-[[[(2,4-diaminopteridin-6-yl)methyl]methylamino]benzoyl]amino]-5-methoxy-5-oxopentanoic acid (methotrexate 5-methyl ester),
- I. R1 = NH<sub>2</sub>, R2 = R3 = CH<sub>3</sub>, R4 = H: (4*S*)-4-[[4-[[[(2,4-diaminopteridin-6-yl)methyl]methylamino]benzoyl]amino]-5-methoxy-5-oxopentanoic acid (methotrexate 1-methyl ester),
- J. R1 = NH<sub>2</sub>, R2 = R3 = R4 = CH<sub>3</sub>: dimethyl (2*S*)-2-[[4-[[[(2,4-diaminopteridin-6-yl)methyl]methylamino]benzoyl]amino]pentanedioate (methotrexate dimethyl ester),

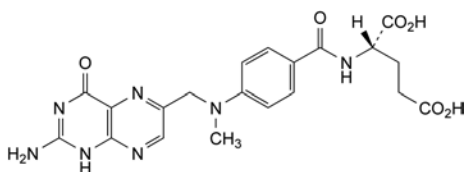

- C. (2*S*)-2-[[4-[[[(2-amino-4-oxo-1,4-dihydropteridin-6-yl)methyl]methylamino]benzoyl]amino]pentanedioic acid (*N*-methylfolic acid, methopterin),

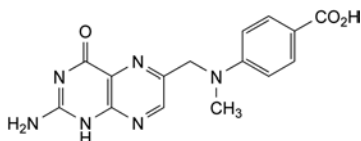

- D. 4-[[[(2-amino-4-oxo-1,4-dihydropteridin-6-yl)methyl]methylamino]benzoic acid (*N*<sup>70</sup>-methylpteroic acid),

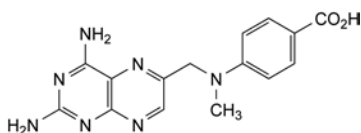

- E. 4-[[[(2,4-diaminopteridin-6-yl)methyl]methylamino]benzoic acid (4-amino-*N*<sup>70</sup>-methylpteroic acid, APA),

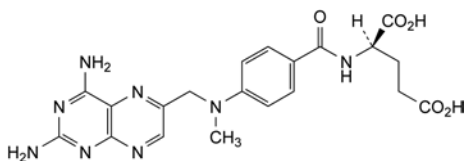

- F. (2*R*)-2-[[4-[[[(2,4-diaminopteridin-6-yl)methyl]methylamino]benzoyl]amino]pentanedioic acid ((*R*)-methotrexate),

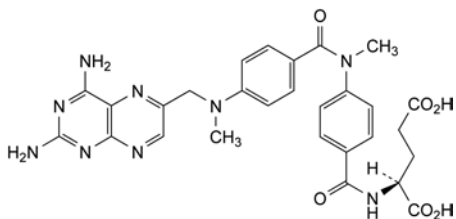

- G. (2*S*)-2-[[4-[[[(2,4-diaminopteridin-6-yl)methyl]methylamino]benzoyl]amino]pentanedioic acid,

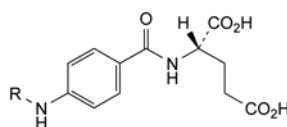

K. R = H: (2*S*)-2-[[4-aminobenzoyl]amino]pentanedioic acid,

L. R = CH<sub>3</sub>: (2*S*)-2-[[4-(methylamino)benzoyl]amino]pentanedioic acid.

01/2008:0511

corrected 6.0

## METHYLATROPINE BROMIDE

### Methylatropini bromidum

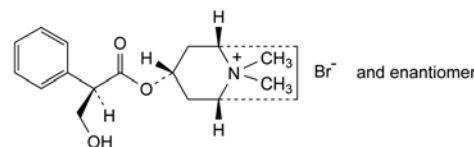

C<sub>18</sub>H<sub>26</sub>BrNO<sub>3</sub>  
[2870-71-5]

M<sub>r</sub> 384.3

#### DEFINITION

Methylatropine bromide contains not less than 99.0 per cent and not more than the equivalent of 101.0 per cent of (1*R*,3*r*,5*S*)-3-[[[(2*RS*)-3-hydroxy-2-phenylpropanoyl]oxy]-8,8-dimethyl-8-azoniabicyclo[3.2.1]octane bromide, calculated with reference to the dried substance.

#### CHARACTERS

A white or almost white, crystalline powder or colourless crystals, freely soluble in water, sparingly soluble in alcohol. It melts at about 219 °C, with decomposition.

#### IDENTIFICATION

*First identification:* B, E.

*Second identification:* A, C, D, E.

- A. Optical rotation (see Tests).
- B. Examine by infrared absorption spectrophotometry (2.2.24), comparing with the spectrum obtained with *methylatropine bromide CRS*.
- C. To 5 mL of solution S (see Tests) add 2 mL of *dilute sodium hydroxide solution R*. No precipitate is formed.
- D. To about 1 mg add 0.2 mL of *fuming nitric acid R* and evaporate to dryness on a water-bath. Dissolve the residue in 2 mL of *acetone R* and add 0.1 mL of a 30 g/L solution of *potassium hydroxide R* in *methanol R*. A violet colour develops.
- E. It gives reaction (a) of bromides (2.3.1).

#### TESTS

**Solution S.** Dissolve 1.25 g in *carbon dioxide-free water R* and dilute to 25 mL with the same solvent.

**Appearance of solution.** Solution S is clear (2.2.1) and not more intensely coloured than reference solution B<sub>9</sub> (2.2.2, *Method II*).

**Acidity or alkalinity.** To 10 mL of solution S add 0.1 mL of *phenolphthalein solution R*; the solution is colourless. Add 0.5 mL of 0.01 M *sodium hydroxide*; the solution is red.

**Optical rotation** (2.2.7). Dissolve 2.50 g in *water R* and dilute to 25.0 mL with the same solvent. The angle of optical rotation, measured in a 2 dm tube, is −0.25° to +0.05°.

**Related substances.** Examine by thin-layer chromatography (2.2.27), using a *TLC silica gel G plate R*.

**Test solution.** Dissolve 0.2 g of the substance to be examined in a mixture of 1 volume of *water R* and 9 volumes of *methanol R* and dilute to 5 mL with the same mixture of solvents.



**Sulfated ash** (2.4.14): maximum 1.0 per cent, determined on 1.000 g.

#### LABELLING

The label states the apparent viscosity in millipascal seconds for a 2 per cent *m/m* solution.

01/2008:2129

## METHYL NICOTINATE

### Methylis nicotinas

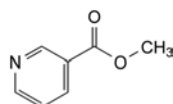

$C_7H_7NO_2$   
[93-60-7]

$M_r$  137.1

#### DEFINITION

Methyl pyridine-3-carboxylate.

**Content:** 99.0 per cent to 101.0 per cent (anhydrous substance).

#### CHARACTERS

**Appearance:** white or almost white powder.

**Solubility:** very soluble in water, in ethanol (96 per cent) and in methylene chloride.

#### IDENTIFICATION

**First identification:** B.

**Second identification:** A, C, D.

A. Melting point (2.2.14): 40 °C to 42 °C.

B. Infrared absorption spectrophotometry (2.2.24).

**Comparison:** methyl nicotinate CRS.

C. Thin-layer chromatography (2.2.27).

**Test solution.** Dissolve 10 mg of the substance to be examined in methanol *R* and dilute to 2 mL with the same solvent.

**Reference solution.** Dissolve 10 mg of methyl nicotinate CRS in methanol *R* and dilute to 2 mL with the same solvent.

**Plate:** TLC silica gel  $F_{254}$  plate *R*.

**Mobile phase:** methanol *R*, toluene *R* (10:90 *V/V*).

**Application:** 2 µL.

**Development:** over 2/3 of the plate.

**Drying:** in air.

**Detection:** examine in ultraviolet light at 254 nm.

**Results:** the principal spot in the chromatogram obtained with the test solution is similar in position and size to the principal spot in the chromatogram obtained with the reference solution.

D. To 0.5 g add 0.1 g of citric acid *R* and 0.2 mL of acetic anhydride *R*. Heat cautiously for 1 min. A yellow colour is produced which turns first to orange, then to red and then to violet.

#### TESTS

**Related substances.** Liquid chromatography (2.2.29).

**Test solution.** Dissolve 25 mg of the substance to be examined in the mobile phase and dilute to 25.0 mL with the mobile phase.

**Reference solution (a).** Dissolve 25 mg of nicotinic acid *R* in the mobile phase and dilute to 25.0 mL with the mobile phase. To 0.5 mL of this solution add 0.5 mL of the test solution and dilute to 100 mL with the mobile phase.

**Reference solution (b).** Dilute 1.0 mL of the test solution to 100.0 mL with the mobile phase. Dilute 1.0 mL of this solution to 10.0 mL with the mobile phase.

#### Column:

- **size:**  $l = 0.25$  m,  $\varnothing = 4$  mm,
- **stationary phase:** octadecylsilyl silica gel for chromatography *R* (5 µm).

**Mobile phase:** acetic acid *R*, water *R*, acetonitrile *R* (1:29:70 *V/V/V*).

**Flow rate:** 1 mL/min.

**Detection:** spectrophotometer at 261 nm.

**Injection:** 20 µL.

**Run time:** 3 times the retention time of methyl nicotinate.

**Retention time:** methyl nicotinate = about 3.3 min.

**System suitability:** reference solution (a):

- **resolution:** minimum 2 between the peaks due to impurity A and methyl nicotinate.

#### Limits:

- **impurity A:** not more than the area of the principal peak in the chromatogram obtained with reference solution (b) (0.1 per cent),
- **any other impurity:** for each impurity, not more than the area of the principal peak in the chromatogram obtained with reference solution (b) (0.1 per cent),
- **total:** not more than 5 times the area of the principal peak in the chromatogram obtained with reference solution (b) (0.5 per cent),
- **disregard limit:** 0.5 times the area of the principal peak in the chromatogram obtained with reference solution (b) (0.05 per cent).

**Chlorides** (2.4.4): maximum 200 ppm.

Dissolve 0.25 g in water *R* and dilute to 15 mL with the same solvent.

**Water** (2.5.12): maximum 0.5 per cent, determined on 2.000 g.

**Sulfated ash** (2.4.14): maximum 0.1 per cent, determined on 1.0 g.

#### ASSAY

Dissolve 0.120 g in 50 mL of glacial acetic acid *R*. Titrate with 0.1 *M* perchloric acid, determining the end-point potentiometrically (2.2.20).

1 mL of 0.1 *M* perchloric acid is equivalent to 13.71 mg of  $C_7H_7NO_2$ .

#### STORAGE

Protected from light.

#### IMPURITIES

**Specified impurities:** A.

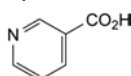

A. pyridine-3-carboxylic acid (nicotinic acid).

07/2010:0409

## METHYL PARAHYDROXYBENZOATE

### Methylis parahydroxybenzoas

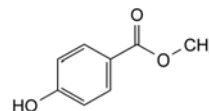

$C_8H_8O_3$   
[99-76-3]

$M_r$  152.1

#### DEFINITION

Methyl 4-hydroxybenzoate.

**Content:** 98.0 per cent to 102.0 per cent.

## CHARACTERS

**Appearance:** white or almost white, crystalline powder or colourless crystals.

**Solubility:** very slightly soluble in water, freely soluble in ethanol (96 per cent) and in methanol.

## IDENTIFICATION

**First identification:** A, B.

**Second identification:** A, C.

A. Melting point (2.2.14): 125 °C to 128 °C.

B. Infrared absorption spectrophotometry (2.2.24).

**Comparison:** methyl parahydroxybenzoate CRS.

C. Thin-layer chromatography (2.2.27).

**Test solution (a).** Dissolve 0.10 g of the substance to be examined in acetone R and dilute to 10 mL with the same solvent.

**Test solution (b).** Dilute 1 mL of test solution (a) to 10 mL with acetone R.

**Reference solution (a).** Dissolve 10 mg of methyl parahydroxybenzoate CRS in acetone R and dilute to 10 mL with the same solvent.

**Reference solution (b).** Dissolve 10 mg of ethyl parahydroxybenzoate CRS in 1 mL of test solution (a) and dilute to 10 mL with acetone R.

**Plate:** TLC octadecylsilyl silica gel  $F_{254}$  plate R.

**Mobile phase:** glacial acetic acid R, water R, methanol R (1:30:70 V/V/V).

**Application:** 2 µL of test solution (b) and reference solutions (a) and (b).

**Development:** over 2/3 of the plate.

**Drying:** in air.

**Detection:** examine in ultraviolet light at 254 nm.

**System suitability:** reference solution (b):

- the chromatogram shows 2 clearly separated principal spots.

**Results:** the principal spot in the chromatogram obtained with test solution (b) is similar in position and size to the principal spot in the chromatogram obtained with reference solution (a).

## TESTS

**Solution S.** Dissolve 1.0 g in ethanol (96 per cent) R and dilute to 10 mL with the same solvent.

**Appearance of solution.** Solution S is clear (2.2.1) and not more intensely coloured than reference solution BY<sub>6</sub> (2.2.2, Method II).

**Acidity.** To 2 mL of solution S add 3 mL of ethanol (96 per cent) R, 5 mL of carbon dioxide-free water R and 0.1 mL of bromocresol green solution R. Not more than 0.1 mL of 0.1 M sodium hydroxide is required to change the colour of the indicator to blue.

**Related substances.** Liquid chromatography (2.2.29).

**Test solution.** Dissolve 50.0 mg of the substance to be examined in 2.5 mL of methanol R and dilute to 50.0 mL with the mobile phase. Dilute 10.0 mL of this solution to 100.0 mL with the mobile phase.

**Reference solution (a).** Dissolve 5 mg of 4-hydroxybenzoic acid R (impurity A) and 5 mg of the substance to be examined in the mobile phase and dilute to 100.0 mL with the mobile phase. Dilute 1.0 mL of this solution to 10.0 mL with the mobile phase.

**Reference solution (b).** Dissolve 50.0 mg of methyl parahydroxybenzoate CRS in 2.5 mL of methanol R and dilute to 50.0 mL with the mobile phase. Dilute 10.0 mL of this solution to 100.0 mL with the mobile phase.

**Reference solution (c).** Dilute 1.0 mL of the test solution to 20.0 mL with the mobile phase. Dilute 1.0 mL of this solution to 10.0 mL with the mobile phase.

**Column:**

– **size:**  $l = 0.15$  m,  $\emptyset = 4.6$  mm;

– **stationary phase:** end-capped octadecylsilyl silica gel for chromatography R (5 µm).

**Mobile phase:** 6.8 g/L solution of potassium dihydrogen phosphate R, methanol R (35:65 V/V).

**Flow rate:** 1.3 mL/min.

**Detection:** spectrophotometer at 272 nm.

**Injection:** 10 µL of the test solution and reference solutions (a) and (c).

**Run time:** 5 times the retention time of methyl parahydroxybenzoate.

**Relative retention** with reference to methyl parahydroxybenzoate (retention time = about 2.3 min): impurity A = about 0.6.

**System suitability:** reference solution (a):

- **resolution:** minimum 2.0 between the peaks due to impurity A and methyl parahydroxybenzoate.

**Limits:**

- **correction factor:** for the calculation of content, multiply the peak area of impurity A by 1.4;
- **impurity A:** not more than the area of the principal peak in the chromatogram obtained with reference solution (c) (0.5 per cent);
- **unspecified impurities:** for each impurity, not more than the area of the principal peak in the chromatogram obtained with reference solution (c) (0.5 per cent);
- **total:** not more than twice the area of the principal peak in the chromatogram obtained with reference solution (c) (1.0 per cent);
- **disregard limit:** 0.2 times the area of the principal peak in the chromatogram obtained with reference solution (c) (0.1 per cent).

**Sulfated ash (2.4.14):** maximum 0.1 per cent, determined on 1.0 g.

## ASSAY

Liquid chromatography (2.2.29) as described in the test for related substances with the following modification.

**Injection:** test solution and reference solution (b).

Calculate the percentage content of C<sub>8</sub>H<sub>8</sub>O<sub>3</sub> from the declared content of methyl parahydroxybenzoate CRS.

## IMPURITIES

**Specified impurities:** A.

**Other detectable impurities** (the following substances would, if present at a sufficient level, be detected by one or other of the tests in the monograph. They are limited by the general acceptance criterion for other/unspecified impurities and/or by the general monograph *Substances for pharmaceutical use (2034)*. It is therefore not necessary to identify these impurities for demonstration of compliance. See also 5.10. *Control of impurities in substances for pharmaceutical use*): B, C, D.

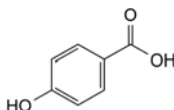

A. 4-hydroxybenzoic acid,

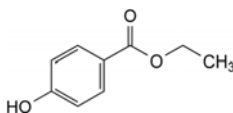

B. ethyl 4-hydroxybenzoate (ethyl parahydroxybenzoate),

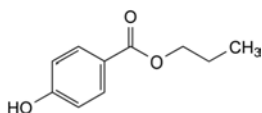

C. propyl 4-hydroxybenzoate (propyl parahydroxybenzoate),

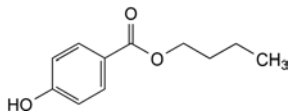

D. butyl 4-hydroxybenzoate (butyl parahydroxybenzoate).

01/2009:2235  
corrected 6.6**METHYLPHENIDATE HYDROCHLORIDE**

## Methylphenidati hydrochloridum

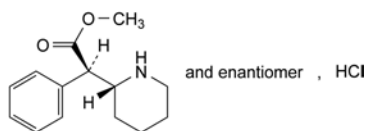
C<sub>14</sub>H<sub>20</sub>ClNO<sub>2</sub>  
[298-59-9]M<sub>r</sub> 269.8

## DEFINITION

Methyl (2*RS*)-phenyl[(2*RS*)-piperidin-2-yl]acetate hydrochloride.

Content: 99.0 per cent to 101.0 per cent (dried substance).

## CHARACTERS

Appearance: white or almost white, fine crystalline powder.

Solubility: freely soluble in water, soluble in ethanol (96 per cent), slightly soluble in methylene chloride.

## IDENTIFICATION

First identification: A, C.

Second identification: B, C.

A. Infrared absorption spectrophotometry (2.2.24).

Comparison: methylphenidate hydrochloride CRS.

B. Thin-layer chromatography (2.2.27).

Test solution. Dissolve 5 mg of the substance to be examined in 1.0 mL of methanol R.

Reference solution. Dissolve 5 mg of methylphenidate hydrochloride CRS in 1.0 mL of methanol R.

Plate: TLC silica gel plate R.

Mobile phase: concentrated ammonia R, methanol R, methylene chloride R (1:4:95 V/V/V).

Application: 5 µL.

Development: over 2/3 of the plate.

Drying: at 60 °C for 5 min.

Detection: spray with a freshly prepared 5 g/L solution of fast blue B salt R; heat to 60 °C for 1 min.

Results: the principal spot in the chromatogram obtained with the test solution is similar in position, colour and size to the principal spot obtained with the reference solution.

C. It gives reaction (a) of chlorides (2.3.1).

## TESTS

**Related substances.** Liquid chromatography (2.2.29). Prepare the solutions immediately before use.

Test solution. Dissolve 25 mg of the substance to be examined in the mobile phase and dilute to 50.0 mL with the mobile phase.

Reference solution (a). Dissolve the contents of a vial of methylphenidate impurity mixture CRS (containing impurities A and B) in 1.0 mL of the test solution.

Reference solution (b). Dilute 1.0 mL of the test solution to 100.0 mL with the mobile phase. Dilute 1.0 mL of this solution to 10.0 mL with the mobile phase.

## Column:

– size:  $l = 0.25$  m,  $\varnothing = 4.6$  mm;

– stationary phase: end-capped octadecylsilyl silica gel for chromatography R (5 µm);

– temperature: 40 °C.

Mobile phase: mix 7 volumes of methanol R2 and 18 volumes of a 1.82 g/L solution of potassium dihydrogen phosphate R.

Flow rate: 1.0 mL/min.

Detection: spectrophotometer at 209 nm.

Injection: 10 µL.

Run time: 1.5 times the retention time of methylphenidate.

Identification of impurities: use the chromatogram supplied with methylphenidate impurity mixture CRS and the chromatogram obtained with reference solution (a) to identify the peaks due to impurities A and B.

Relative retention with reference to methylphenidate (retention time = about 11 min): impurity B = about 0.6; impurity A = about 0.9.

System suitability: reference solution (a):

– peak-to-valley ratio: minimum 2.5, where  $H_p$  = height above the baseline of the peak due to impurity A and  $H_v$  = height above the baseline of the lowest point of the curve separating this peak from the peak due to methylphenidate.

## Limits:

– impurities A, B: for each impurity, not more than 5 times the area of the principal peak in the chromatogram obtained with reference solution (b) (0.5 per cent);

– unspecified impurities: for each impurity, not more than the area of the principal peak in the chromatogram obtained with reference solution (b) (0.10 per cent);

– total: not more than 10 times the area of the principal peak in the chromatogram obtained with reference solution (b) (1.0 per cent);

– disregard limit: 0.5 times the area of the principal peak in the chromatogram obtained with reference solution (b) (0.05 per cent).

**Heavy metals** (2.4.8): maximum 20 ppm.

Dissolve 1.0 g in water R and dilute to 20.0 mL with the same solvent. 12 mL of the solution complies with test A. Prepare the reference solution using lead standard solution (1 ppm Pb) R.

**Loss on drying** (2.2.32): maximum 0.5 per cent, determined on 1.000 g by drying *in vacuo* at 60 °C for 4 h.**Sulfated ash** (2.4.14): maximum 0.1 per cent, determined on 1.0 g.

## ASSAY

Dissolve 0.250 g in 50 mL of ethanol (96 per cent) R and add 5.0 mL of 0.01 M hydrochloric acid. Carry out a potentiometric titration (2.2.20) using 0.1 M sodium hydroxide and an electrode for non-aqueous acid-base titrations. Read the volume added between the 2 points of inflexion.

1 mL of 0.1 M sodium hydroxide is equivalent to 26.98 mg of C<sub>14</sub>H<sub>20</sub>ClNO<sub>2</sub>.

## STORAGE

Protected from light.

## IMPURITIES

Specified impurities: A, B.

Filter. To 3 mL of the filtrate add 0.5 mL of *silver nitrate solution R1*. A white turbidity is produced which slowly forms a dark, coagulating precipitate.

## TESTS

***N,N*-Dimethylaniline** (2.4.26, *Method A*): maximum 100 ppm.

**Test solution.** Dissolve in a ground-glass-stoppered tube 0.50 g of the substance to be examined in 30.0 mL of *water R*. Add 1.0 mL of the internal standard solution. Adjust the solution to 26-28 °C. Add 1.0 mL of *strong sodium hydroxide solution R* and mix for 2 min. Add 2.0 mL of *trimethylpentane R*. Shake for 2 min and centrifuge. Use the upper layer.

**Reference solution.** Dissolve 50.0 mg of *N,N*-dimethylaniline *R* in 4.0 mL of 0.1 M *hydrochloric acid* and dilute to 50.0 mL with *water R*. Dilute 1.0 mL of this solution to 100.0 mL with *water R*. To 0.50 g of the substance to be examined add 5.0 mL of this solution and dilute to 30.0 mL with *water R*. Add 1.0 mL of the internal standard solution and 1.0 mL of *strong sodium hydroxide solution R*. Add 2.0 mL of *trimethylpentane R*. Shake for 2 min and centrifuge. Use the upper layer.

## Limit:

- calculate the ratio (*R*) of the area of the peak due to *N,N*-dimethylaniline to the area of the peak due to the internal standard from the chromatogram obtained with the reference solution; from the chromatogram obtained with the test solution, calculate the ratio of the area of the peak due to *N,N*-dimethylaniline to the area of the peak due to the internal standard: this ratio is not greater than 0.5 *R*.

**Pentamethyl-*p*-rosanilinium.** Liquid chromatography (2.2.29): use the normalisation procedure.

**Test solution.** Dissolve 30.0 mg of the substance to be examined in *ethanol (96 per cent) R* and dilute to 100.0 mL with the same solvent.

**Reference solution (a).** Dissolve 3.0 mg of *methylrosanilinium for system suitability CRS* in *ethanol (96 per cent) R* and dilute to 10.0 mL with the same solvent.

**Reference solution (b).** Dilute 1.0 mL of the test solution to 20.0 mL with *ethanol (96 per cent) R*. Dilute 1.0 mL of this solution to 100.0 mL with *ethanol (96 per cent) R*.

## Column:

- size: *l* = 0.25 m, Ø = 4.6 mm,
- stationary phase: spherical *octylsilyl silica gel for chromatography R* (5 µm).

**Mobile phase:** *glacial acetic acid R*, *water R*, *methanol R* (10:190:800 *V/V/V*).

**Flow rate:** 1 mL/min.

**Detection:** spectrophotometer at 589 nm.

**Injection:** 20 µL.

**Run time:** 2.5 times the retention time of the principal peak.

**System suitability:** reference solution (a):

- resolution: peak due to pentamethyl-*p*-rosanilinium is baseline separated from the peak due to methylrosanilinium.

Locate the peak due to pentamethyl-*p*-rosanilinium using the chromatogram provided with *methylrosanilinium for system suitability CRS*.

## Limits:

- *pentamethyl-*p*-rosanilinium*: maximum 10 per cent.

**Related substances.** Liquid chromatography (2.2.29) as described in the test for pentamethyl-*p*-rosanilinium.

## Limits:

- impurity *A*: maximum 1.0 per cent;
- any other impurity: for each impurity, maximum 0.1 per cent;
- sum of impurities other than *A*: maximum 1.0 per cent;
- disregard limit: the area of the principal peak in the chromatogram obtained with reference solution (b) (0.05 per cent); disregard the peak due to pentamethyl-*p*-rosanilinium.

**Substances insoluble in ethanol (90 per cent *V/V*):** maximum 0.5 per cent.

In a conical flask introduce 1.0 g and add 50 mL of *ethanol (90 per cent *V/V*) R*. Boil under a reflux sintered glass filter (16) (2.1.2) previously dried at 100-105 °C. Wash with hot *ethanol (90 per cent *V/V*) R* until a colourless filtrate is obtained. Dry at 100-105 °C until constant weight.

**Water** (2.5.12): maximum 10.0 per cent, determined on 0.100 g.

**Sulfated ash** (2.4.14): maximum 1.5 per cent, determined on 1.0 g.

## ASSAY

Dissolve 50.0 mg in *ethanol (96 per cent) R* and dilute to 100.0 mL with the same solvent. Dilute 2.0 mL of the solution to 250.0 mL with *ethanol (96 per cent) R*. Measure the absorbance (2.2.25) at the maximum at 589 nm.

Calculate the content of  $C_{25}H_{30}ClN_3$  taking the specific absorbance to be 2605.

## STORAGE

In an airtight container.

## IMPURITIES

**Specified impurities:** *A*.

- A*. impurity of unknown structure with a relative retention of about 0.7.

01/2008:0230  
corrected 7.0

## METHYL SALICYLATE

## Methylis salicylas

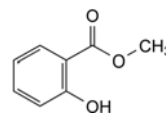

$C_8H_8O_3$   
[119-36-8]

$M_r$  152.1

## DEFINITION

Methyl 2-hydroxybenzoate.

**Content:** 99.0 per cent *m/m* to 100.5 per cent *m/m*.

## CHARACTERS

**Appearance:** colourless or slightly yellow liquid.

**Solubility:** very slightly soluble in water, miscible with ethanol (96 per cent) and with fatty and essential oils.

## IDENTIFICATION

**A.** Heat 0.25 mL with 2 mL of *dilute sodium hydroxide solution R* on a water-bath for 5 min. Add 3 mL of *dilute sulfuric acid R*. A crystalline precipitate is formed. Filter. The precipitate washed with *water R* and dried at 100-105 °C, melts (2.2.14) at 156 °C to 161 °C.

**B.** To 10 mL of a saturated solution add 0.05 mL of *ferric chloride solution R1*. A violet colour develops.

## TESTS

**Appearance of solution.** The solution is clear (2.2.1) and not more intensely coloured than reference solution  $Y_7$  (2.2.2, *Method II*).

To 2 mL add 10 mL of *ethanol (96 per cent) R*.

**Acidity.** Dissolve 5.0 g in a mixture of 0.2 mL of *bromocresol green solution R* and 50 mL of *ethanol (96 per cent) R* previously neutralised to a blue colour by addition of 0.1 M *sodium hydroxide*. Not more than 0.4 mL of 0.1 M *sodium hydroxide* is required to restore the blue colour.

**Relative density** (2.2.5): 1.180 to 1.186.

**Refractive index** (2.2.6): 1.535 to 1.538.

#### ASSAY

Dissolve 0.500 g in 25 mL of *ethanol (96 per cent) R*. Add 0.05 mL of *phenol red solution R* and neutralise with 0.1 M *sodium hydroxide*. To the neutralised solution add 50.0 mL of 0.1 M *sodium hydroxide* and heat under a reflux condenser on a water-bath for 30 min. Cool and titrate with 0.1 M *hydrochloric acid*. Calculate the volume of 0.1 M *sodium hydroxide* used in the saponification. Carry out a blank titration.

1 mL of 0.1 M *sodium hydroxide* is equivalent to 15.21 mg of  $C_{20}H_{30}O_2$ .

#### STORAGE

Protected from light.

07/2008:0410  
corrected 6.3

## METHYLTESTOSTERONE

### Methyltestosteronum

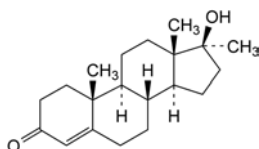

$C_{20}H_{30}O_2$   
[58-18-4]

$M_r$  302.5

#### DEFINITION

17 $\beta$ -Hydroxy-17-methylandrosta-4-en-3-one.

**Content:** 97.0 per cent to 103.0 per cent (dried substance).

#### CHARACTERS

**Appearance:** white or slightly yellowish-white, crystalline powder.

**Solubility:** practically insoluble in water, freely soluble in ethanol (96 per cent).

#### IDENTIFICATION

**First identification:** B.

**Second identification:** A, C.

A. Melting point (2.2.14): 162 °C to 168 °C.

B. Infrared absorption spectrophotometry (2.2.24).

*Comparison:* methyltestosterone CRS.

C. Thin-layer chromatography (2.2.27).

**Test solution.** Dissolve 0.2 g of the substance to be examined in a mixture of 1 volume of *methanol R* and 9 volumes of *chloroform R* and dilute to 10 mL with the same mixture of solvents.

**Reference solution.** Dissolve 20 mg of *methyltestosterone CRS* in 1 mL of a mixture of 1 volume of *methanol R* and 9 volumes of *chloroform R*.

**Plate:** TLC silica gel  $F_{254}$  plate R.

**Mobile phase:** anhydrous acetic acid R, light petroleum R, butyl acetate R (1:30:70 V/V/V).

**Application:** 5  $\mu$ L.

**Development:** over 2/3 of the plate.

**Drying:** in air.

**Detection:** examine in ultraviolet light at 254 nm and spray with a saturated solution of *potassium dichromate R* in a mixture of 30 volumes of *water R* and 70 volumes of *sulfuric acid R*. Examine immediately in daylight.

**Results:** the principal spot in the chromatogram obtained with the test solution is similar in position, colour and size to the principal spot in the chromatogram obtained with the reference solution.

#### TESTS

**Specific optical rotation** (2.2.7): + 79 to + 85 (dried substance).

Dissolve 0.250 g in *ethanol (96 per cent) R* and dilute to 25.0 mL with the same solvent.

**Related substances.** Liquid chromatography (2.2.29).

**Test solution.** Dissolve 50 mg of the substance to be examined in *methanol R* and dilute to 100.0 mL with the same solvent.

**Reference solution (a).** Dilute 0.5 mL of the test solution to 100.0 mL with *methanol R*.

**Reference solution (b).** Dissolve 5 mg of *methyltestosterone for system suitability CRS* (containing impurity A) in *methanol R* and dilute to 10 mL with the same solvent.

**Column:**

– size:  $l = 0.25$  m,  $\varnothing = 4.6$  mm;

– stationary phase: end-capped octadecylsilyl silica gel for chromatography R (5  $\mu$ m).

**Mobile phase:**

– mobile phase A: water R;

– mobile phase B: *methanol R*;

Time (min)	Mobile phase A (per cent V/V)	Mobile phase B (per cent V/V)
0 - 15	30	70
15 - 45	30 $\rightarrow$ 0	70 $\rightarrow$ 100
45 - 50	0	100

**Flow rate:** 1.5 mL/min.

**Detection:** spectrophotometer at 254 nm.

**Injection:** 20  $\mu$ L.

**Identification of impurities:** use the chromatogram supplied with *methyltestosterone for system suitability CRS* and the chromatogram obtained with reference solution (b) to identify the peak due to impurity A.

**Relative retention** with reference to methyltestosterone (retention time = about 8 min): impurity A = about 1.5.

**System suitability:** reference solution (b):

– resolution: minimum 5 between the peaks due to methyltestosterone and impurity A.

**Limits:**

– impurity A: not more than the area of the principal peak in the chromatogram obtained with reference solution (a) (0.5 per cent);

– unspecified impurities: for each impurity, not more than 0.2 times the area of the principal peak in the chromatogram obtained with reference solution (a) (0.10 per cent);

– total: not more than twice the area of the principal peak in the chromatogram obtained with reference solution (a) (1.0 per cent);

– disregard limit: 0.1 times the area of the principal peak in the chromatogram obtained with reference solution (a) (0.05 per cent).

**Loss on drying** (2.2.32): maximum 2.0 per cent, determined on 0.500 g by drying in an oven at 105 °C for 2 h.

#### ASSAY

Dissolve 50.0 mg in *ethanol (96 per cent) R* and dilute to 50.0 mL with the same solvent. Dilute 10.0 mL of the solution to 100.0 mL with *ethanol (96 per cent) R*. Dilute 10.0 mL of this solution to 100.0 mL with *ethanol (96 per cent) R*. Measure the absorbance (2.2.25) at the absorption maximum at 241 nm.

Calculate the content of  $C_{20}H_{30}O_2$ , taking the specific absorbance to be 540.

**Reference solution.** Dilute 0.5 mL of the test solution to 100 mL with a mixture of 1 volume of *water R* and 9 volumes of *methanol R*.

Apply to the plate 5 µL of each solution. Develop over a path of 15 cm using a mixture of 10 volumes of *methanol R*, 15 volumes of *anhydrous formic acid R*, 15 volumes of *water R* and 60 volumes of *ethyl acetate R*. Dry the plate at 100 °C to 105 °C until the solvent has evaporated, allow to cool and spray with *dilute potassium iodobismuthate solution R* until the spots appear. Any spot in the chromatogram obtained with the test solution, apart from the principal spot, is not more intense than the spot in the chromatogram obtained with the reference solution (0.5 per cent).

**Apomethylatropine.** Dissolve 0.10 g in 0.01 M *hydrochloric acid* and dilute to 100.0 mL with the same acid. Measure the absorbances (2.2.25) at the maxima at 252 nm and 257 nm. The ratio of the absorbance at 257 nm to that at 252 nm is at least 1.19.

**Loss on drying** (2.2.32). Not more than 0.5 per cent, determined on 0.500 g by drying in an oven at 105 °C.

**Sulfated ash** (2.4.14). Not more than 0.1 per cent, determined on the residue obtained in the test for loss on drying.

#### ASSAY

Dissolve 0.300 g in 50 mL of *anhydrous acetic acid R*, warming slightly if necessary. Titrate with 0.1 M *perchloric acid*, determining the end-point potentiometrically (2.2.20).

1 mL of 0.1 M *perchloric acid* is equivalent to 38.43 mg of  $C_{18}H_{26}BrNO_3$ .

#### STORAGE

Store protected from light.

C. To a mixture of 2.5 mL of solution S (see Tests) and 2.5 mL of *water R* add 2 mL of *dilute sodium hydroxide solution R*. No precipitate is formed.

D. To about 1 mg add 0.2 mL of *fuming nitric acid R* and evaporate to dryness on a water-bath. Dissolve the residue in 2 mL of *acetone R* and add 0.25 mL of a 30 g/L solution of *potassium hydroxide R* in *methanol R*. A violet colour develops.

E. To 0.05 mL of *diphenylamine solution R* add 0.05 mL of a 1 in 10 dilution of solution S. An intense blue colour is produced.

#### TESTS

**Solution S.** Dissolve 1.25 g in *carbon dioxide-free water R* and dilute to 25 mL with the same solvent.

**Appearance of solution.** Solution S is clear (2.2.1) and not more intensely coloured than reference solution B<sub>9</sub> (2.2.2, *Method II*).

**Acidity or alkalinity.** To 10 mL of solution S add 0.1 mL of *phenolphthalein solution R*; the solution is colourless. Add 0.5 mL of 0.01 M *sodium hydroxide*; the solution is red.

**Optical rotation** (2.2.7). Dissolve 2.50 g in *water R* and dilute to 25.0 mL with the same solvent. The angle of optical rotation, measured in a 2 dm tube, is  $-0.25^\circ$  to  $+0.05^\circ$ .

**Related substances.** Examine by thin-layer chromatography (2.2.27), using *silica gel G R* as the coating substance.

**Test solution.** Dissolve 0.2 g of the substance to be examined in a mixture of 1 volume of *water R* and 9 volumes of *methanol R* and dilute to 5 mL with the same mixture of solvents.

**Reference solution.** Dilute 0.5 mL of the test solution to 100 mL with a mixture of 1 volume of *water R* and 9 volumes of *methanol R*.

Apply to the plate 5 µL of each solution. Develop over a path of 15 cm using a mixture of 10 volumes of *methanol R*, 15 volumes of *anhydrous formic acid R*, 15 volumes of *water R* and 60 volumes of *ethyl acetate R*. Dry the plate at 100 °C to 105 °C until the solvent has evaporated, allow to cool and spray with *dilute potassium iodobismuthate solution R* until the spots appear. Any spot in the chromatogram obtained with the test solution, apart from the principal spot, is not more intense than the spot in the chromatogram obtained with the reference solution (0.5 per cent).

**Apomethylatropine.** Dissolve 0.10 g in 0.01 M *hydrochloric acid* and dilute to 100.0 mL with the same acid. Measure the absorbances (2.2.25) at the maxima at 252 nm and 257 nm. The ratio of the absorbance at 257 nm to that at 252 nm is not less than 1.17.

**Halides.** 15 mL of solution S complies with the limit test for chlorides (2.4.4). Prepare the standard using 1.5 mL of *chloride standard solution (5 ppm Cl) R* (10 ppm).

**Silver.** Dissolve 1.0 g in 10 mL of *water R* and add 0.1 mL of *sodium sulfide solution R*. Allow to stand for 2 min. The solution is not more intensely coloured than reference solution B<sub>8</sub> (2.2.2, *Method II*) (10 ppm).

**Loss on drying** (2.2.32). Not more than 0.5 per cent, determined on 0.500 g by drying in an oven at 105 °C.

**Sulfated ash** (2.4.14). Not more than 0.1 per cent, determined on the residue obtained in the test for loss on drying.

#### ASSAY

Dissolve 0.300 g in 50 mL of *anhydrous acetic acid R*. Titrate with 0.1 M *perchloric acid* determining the end-point potentiometrically (2.2.20).

1 mL of 0.1 M *perchloric acid* is equivalent to 36.64 mg of  $C_{18}H_{26}N_2O_6$ .

#### STORAGE

Store protected from light.

01/2008:0512  
corrected 6.0

## METHYLATROPINE NITRATE

### Methylatropini nitras

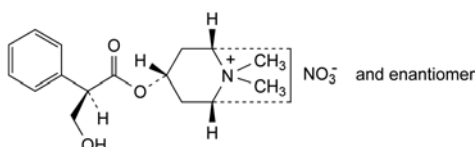

$C_{18}H_{26}N_2O_6$   
[52-88-0]

$M_r$  366.4

#### DEFINITION

Methylatropine nitrate contains not less than 99.0 per cent and not more than the equivalent of 101.0 per cent of (1*R*,3*r*,5*S*)-3-[[[(2*RS*)-3-hydroxy-2-phenylpropanoyl]oxy]-8,8-dimethyl-8-azoniabicyclo[3.2.1]octane nitrate, calculated with reference to the dried substance.

#### CHARACTERS

A white or almost white, crystalline powder or colourless crystals, freely soluble in water, soluble in alcohol.

It melts at about 167 °C.

#### IDENTIFICATION

**First identification:** B, E.

**Second identification:** A, C, D, E.

A. Optical rotation (see Tests).

B. Examine by infrared absorption spectrophotometry (2.2.24), comparing with the spectrum obtained with *methylatropine nitrate CRS*.

**01/2008:0345** **Heavy metals (2.4.8):** maximum 20 ppm.  
**corrected 6.3**

## METHYLCELLULOSE

### Methylcellulosum

[9004-67-5]

#### DEFINITION

Partly *O*-methylated cellulose.

#### CHARACTERS

**Appearance:** white, yellowish-white or greyish-white powder or granules, hygroscopic after drying.

**Solubility:** practically insoluble in hot water, in acetone, in anhydrous ethanol and in toluene. It dissolves in cold water giving a colloidal solution.

#### IDENTIFICATION

- Evenly distribute 1.0 g onto the surface of 100 mL of *water R* in a beaker, tapping the top of the beaker gently if necessary to ensure a uniform layer on the surface. Allow to stand for 1-2 min: the powdered material aggregates on the surface.
- Evenly distribute 1.0 g into 100 mL of boiling *water R*, and stir the mixture using a magnetic stirrer with a bar 25 mm long: a slurry is formed and the particles do not dissolve. Allow the slurry to cool to 5 °C and stir using a magnetic stirrer: a clear or slightly turbid solution occurs with its thickness dependent on the viscosity grade.
- To 0.1 mL of the solution obtained in identification B add 9 mL of a 90 per cent *V/V* solution of *sulfuric acid R*, shake, heat on a water-bath for exactly 3 min, immediately cool in an ice-bath, carefully add 0.6 mL of a 20 g/L solution of *ninhydrin R*, shake and allow to stand at 25 °C: a red colour develops and does not change to purple within 100 min.
- Place 2-3 mL of the solution obtained in identification B on a glass slide as a thin film and allow the water to evaporate: a coherent, clear film forms on the glass slide.
- Add exactly 50 mL of the solution obtained in identification B to exactly 50 mL of *water R* in a beaker. Insert a thermometer into the solution. Stir the solution on a magnetic stirrer/hot plate and begin heating, increasing the temperature at a rate of 2-5 °C per minute. Determine the temperature at which a turbidity increase begins to occur and designate the temperature as the flocculation temperature: the flocculation temperature is higher than 50 °C.

#### TESTS

**Solution S.** While stirring, introduce a quantity of the substance to be examined equivalent to 1.0 g of the dried substance into 50 g of *carbon dioxide-free water R* heated to 90 °C. Allow to cool, adjust the mass of the solution to 100 g with *carbon dioxide-free water R* and stir until dissolution is complete. Allow to stand at 2-8 °C for 1 h before carrying out the test for appearance of solution.

**Appearance of solution.** Solution S is not more opalescent than reference suspension III (2.2.1) and not more intensely coloured than reference solution  $Y_6$  (2.2.2, *Method II*).

**pH (2.2.3):** 5.0 to 8.0 for the solution prepared as described under Apparent viscosity.

Read the pH after the probe has been immersed for  $5 \pm 0.5$  min.

1.0 g complies with test F. Prepare the reference solution using 2 mL of *lead standard solution (10 ppm Pb) R*.

**Loss on drying (2.2.32):** maximum 5.0 per cent, determined on 1.000 g by drying in an oven at 105 °C for 1 h.

**Sulfated ash (2.4.14):** maximum 1.5 per cent, determined on 1.0 g.

#### FUNCTIONALITY-RELATED CHARACTERISTICS

*This section provides information on characteristics that are recognised as being relevant control parameters for one or more functions of the substance when used as an excipient (see chapter 5.15). This section is a non-mandatory part of the monograph and it is not necessary to verify the characteristics to demonstrate compliance. Control of these characteristics can however contribute to the quality of a medicinal product by improving the consistency of the manufacturing process and the performance of the medicinal product during use. Where control methods are cited, they are recognised as being suitable for the purpose, but other methods can also be used. Wherever results for a particular characteristic are reported, the control method must be indicated.*

*The following characteristics may be relevant for methylcellulose used as binder, viscosity-enhancing agent or film former.*

**Apparent viscosity:** minimum 80 per cent and maximum 120 per cent of the nominal value for samples with a viscosity of less than 600 mPas (Method 1); minimum 75 per cent and maximum 140 per cent of the nominal value for samples with a viscosity of 600 mPas or higher (Method 2).

*Method 1, to be applied to samples with a viscosity of less than 600 mPas.* Weigh accurately a quantity of the substance to be examined equivalent to 4.000 g of the dried substance. Transfer into a wide-mouthed bottle, and adjust the mass to 200.0 g with *water R*. Capping the bottle, stir by mechanical means at  $400 \pm 50$  r/min for 10-20 min until the particles are thoroughly dispersed and wetted. Scrape down the insides of the bottle with a spatula if necessary, to ensure that there is no undissolved material on the sides of the bottle, and continue the stirring in a cooling water-bath maintained at a temperature below 5 °C for another 20-40 min. Adjust the solution mass if necessary to 200.0 g using cold *water R*. Centrifuge the solution if necessary to expel any entrapped air bubbles. Using a spatula remove any foam, if present. Determine the viscosity of this solution using the capillary viscometer method (2.2.9) to obtain the kinematic viscosity ( $\nu$ ). Separately, determine the density ( $\rho$ ) (2.2.5) of the solution and calculate the dynamic viscosity ( $\eta$ ), as  $\eta = \rho\nu$ .

*Method 2, to be applied to samples with a viscosity of 600 mPas or higher.* Weigh accurately a quantity of the substance to be examined equivalent to 10.00 g of the dried substance. Transfer into a wide-mouthed bottle, and adjust the mass to 500.0 g with *water R*. Capping the bottle, stir by mechanical means at  $400 \pm 50$  r/min for 10-20 min until the particles are thoroughly dispersed and wetted. Scrape down the insides of the bottle with a spatula if necessary, to ensure that there is no undissolved material on the sides of the bottle, and continue the stirring in a cooling water-bath maintained at a temperature below 5 °C for another 20-40 min. Adjust the solution mass if necessary to 500.0 g using cold *water R*. Centrifuge the solution if necessary to expel any entrapped air bubbles. Using a spatula, remove any foam, if present. Determine the viscosity (2.2.10) of this solution at  $20 \pm 0.1$  °C using a rotating viscometer.

**Apparatus:** single-cylinder type spindle viscometer.

**Rotor number, revolution and calculation multiplier:** apply the conditions specified in Table 0345.-1.

Table 0345-1.

Nominal viscosity* (mPa·s)	Rotor number	Revolution (r/min)	Calculation multiplier
600 to less than 1400	3	60	20
1400 to less than 3500	3	12	100
3500 to less than 9500	4	60	100
9500 to less than 99 500	4	6	1000
99 500 or more	4	3	2000

\*the nominal viscosity is based on the manufacturer's specifications.

Allow the spindle to rotate for 2 min before taking the measurement. Allow a rest period of 2 min between subsequent measurements. Repeat the measurement twice and determine the mean of the 3 readings.

**Degree of substitution:** 26.0 per cent to 33.0 per cent of methoxy groups (dried substance).

Gas chromatography (2.2.28).

**Apparatus:**

- **reaction vial:** a 5 mL pressure-tight vial, 50 mm in height, 20 mm in external diameter and 13 mm in internal diameter at the mouth, equipped with a pressure-tight butyl rubber membrane stopper coated with polytetrafluoroethylene and secured with an aluminium crimped cap or another sealing system providing a sufficient air-tightness;
- **heater:** a heating module with a square aluminium block having holes 20 mm in diameter and 32 mm in depth, so that the reaction vials fit; mixing of the contents of the vial is effected using a magnetic stirrer equipped in the heating module or using a reciprocal shaker that performs approximately 100 cycles/min.

**Internal standard solution:** 30 g/L solution of *octane R* in *xylene R*.

**Test solution.** Weigh 65.0 mg of the substance to be examined, place in a reaction vial, add 0.06-0.10 g of *adipic acid R*, 2.0 mL of the internal standard solution and 2.0 mL of *hydriodic acid R*, immediately cap and seal the vial, and weigh accurately. Using a magnetic stirrer, mix the contents of the vial continuously for 60 min while heating the block so that the temperature of the contents is maintained at  $130 \pm 2$  °C. If a reciprocal shaker or magnetic stirrer cannot be used, shake the vial well by hand at 5-minute intervals during the initial 30 min of the heating time. Allow the vial to cool, and again weigh accurately. If the loss of mass is less than 0.50 per cent of the contents and there is no evidence of a leak, use the upper layer of the mixture as the test solution.

**Reference solution.** Place 0.06-0.10 g of *adipic acid R*, 2.0 mL of the internal standard solution and 2.0 mL of *hydriodic acid R* in another reaction vial, cap and seal the vial, and weigh accurately. Add 45 µL of *methyl iodide R* through the septum with a syringe, and weigh accurately. Shake the reaction vial well, and use the upper layer as the reference solution.

**Column:**

- **size:**  $l = 1.8-3$  m,  $\varnothing = 3-4$  mm;
- **stationary phase:** *diatomaceous earth for gas chromatography R* impregnated with 10-20 per cent of *poly(dimethyl)(75)(diphenyl)(25)siloxane R* (film thickness 125-150 µm);
- **temperature:** 100 °C.

**Carrier gas:** *helium for chromatography R* (thermal conductivity); *helium for chromatography R* or *nitrogen for chromatography R* (flame ionisation).

**Flow rate:** adjusted so that the retention time of the internal standard is about 10 min.

**Detection:** flame ionisation or thermal conductivity.

**Injection:** 1-2 µL.

**System suitability:** reference solution:

- **resolution:** well-resolved peaks of methyl iodide (1<sup>st</sup> peak) and internal standard (2<sup>nd</sup> peak).

**Calculation:**

- **methoxy groups:** calculate the ratio ( $Q$ ) of the area of the peak due to methyl iodide to the area of the peak due to the internal standard in the chromatogram obtained with the test solution, and the ratio ( $Q_1$ ) of the area of the peak due to methyl iodide to the area of the peak due to the internal standard in the chromatogram obtained with the reference solution.

Calculate the percentage content of methoxy groups using the following expression:

$$\frac{Q \times m_1}{Q_1 \times m} \times 21.864$$

- $m_1$  = mass of methyl iodide in the reference solution, in milligrams;
- $m$  = mass of the sample (dried substance), in milligrams.

07/2009:0045

## METHYLDOPA

### Methyldopum

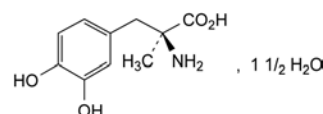

$C_{10}H_{13}NO_4 \cdot 1\frac{1}{2}H_2O$   
[41372-08-1]

$M_r$  238.2

#### DEFINITION

(2S)-2-Amino-3-(3,4-dihydroxyphenyl)-2-methylpropanoic acid.

**Content:** 98.5 per cent to 101.0 per cent (anhydrous substance).

#### CHARACTERS

**Appearance:** white or yellowish white, crystalline powder or colourless or almost colourless crystals.

**Solubility:** slightly soluble in water, very slightly soluble in ethanol (96 per cent). It is freely soluble in dilute mineral acids.

#### IDENTIFICATION

Carry out either Tests A, B or Tests A, C

A. Infrared absorption spectrophotometry (2.2.24).

**Comparison:** *methyldopa CRS*.

B. Enantiomeric purity (see Tests).

C. Specific optical rotation (2.2.7):  $-25.0$  to  $-28.0$ .

Dissolve a quantity equivalent to 2.20 g of the anhydrous substance in *aluminium chloride solution R* and dilute to 50.0 mL with the same solution.

#### TESTS

**Appearance of solution.** Dissolve 1.0 g in 1 M *hydrochloric acid* and dilute to 25 mL with the same solvent. The solution is not more intensely coloured than reference solution BY<sub>6</sub> or B<sub>6</sub> (2.2.2, *Method II*).

**Acidity.** Dissolve 1.0 g with heating in 100 mL of *carbon dioxide-free water R*. Add 0.1 mL of *methyl red solution R*. Not more than 0.5 mL of 0.1 M *sodium hydroxide* is required to produce the pure yellow colour of the indicator.



**Absorbance** (2.2.25).

**Test solution.** Dissolve 40.0 mg in 0.1 M hydrochloric acid and dilute to 100.0 mL with the same acid. Dilute 10.0 mL of this solution to 100.0 mL with 0.1 M hydrochloric acid.

**Spectral range:** 230-350 nm.

**Absorption maximum:** at 280 nm.

**Specific absorbance at the absorption maximum:** 122 to 137 (anhydrous substance).

**Related substances.** Liquid chromatography (2.2.29). Prepare the solutions immediately before use.

**Test solution.** Dissolve 0.100 g of the substance to be examined in 0.1 M hydrochloric acid and dilute to 25.0 mL with the same acid.

**Reference solution (a).** Dilute 1.0 mL of the test solution to 50.0 mL with 0.1 M hydrochloric acid. Dilute 5.0 mL of this solution to 100.0 mL with 0.1 M hydrochloric acid.

**Reference solution (b).** Dissolve the contents of a vial of methyldopa for system suitability CRS (containing impurities A, B and C) in 1.0 mL of 0.1 M hydrochloric acid.

**Column:**

- size:  $l = 0.25$  m,  $\emptyset = 4.6$  mm;
- stationary phase: spherical di-isobutyloctadecylsilyl silica gel for chromatography R (5  $\mu$ m) with a pore size of 8 nm.

**Mobile phase:** methanol R, 0.1 M phosphate buffer solution pH 3.0 R (15:85 V/V).

**Flow rate:** 1 mL/min.

**Detection:** spectrophotometer at 280 nm.

**Injection:** 20  $\mu$ L.

**Run time:** 6 times the retention time of methyldopa.

**Identification of impurities:** use the chromatogram supplied with methyldopa for system suitability CRS and the chromatogram obtained with reference solution (b) to identify the peaks due to impurities A, B and C.

**Relative retention** with reference to methyldopa (retention time = about 5 min): impurity A = about 1.9; impurity B = about 4.3; impurity C = about 4.9.

**System suitability:** reference solution (b):

- resolution: minimum 2.0 between the peaks due to impurities B and C.

**Limits:**

- correction factors: for the calculation of content, multiply the peak areas of the following impurities by the corresponding correction factor: impurity B = 2.6; impurity C = 1.3;
- impurities A, B, C: for each impurity, not more than 1.5 times the area of the principal peak in the chromatogram obtained with reference solution (a) (0.15 per cent);
- unspecified impurities: for each impurity, not more than 0.5 times the area of the principal peak in the chromatogram obtained with reference solution (a) (0.05 per cent);
- total: not more than 5 times the area of the principal peak in the chromatogram obtained with reference solution (a) (0.5 per cent);
- disregard limit: 0.3 times the area of the principal peak in the chromatogram obtained with reference solution (a) (0.03 per cent).

**Enantiomeric purity.** Liquid chromatography (2.2.29).

**Test solution.** Dissolve 25 mg of the substance to be examined in the mobile phase and dilute to 25.0 mL with the mobile phase.

**Reference solution (a).** Dilute 5.0 mL of the test solution to 20.0 mL with the mobile phase. Dilute 1.0 mL of this solution to 50.0 mL with the mobile phase.

**Reference solution (b).** Dissolve 2 mg of racemic methyldopa R in the mobile phase and dilute to 10.0 mL with the mobile phase.

**Column:**

- size:  $l = 0.15$  m,  $\emptyset = 3.9$  mm;
- stationary phase: spherical end-capped octadecylsilyl silica gel for chromatography R (5  $\mu$ m).

**Mobile phase:** dissolve separately 0.200 g of copper acetate R and 0.387 g of *N,N*-dimethyl-L-phenylalanine R in water R; mix the 2 solutions and adjust immediately to pH 4.3 with acetic acid R; add 50 mL of methanol R and dilute to 1000 mL with water R; mix and filter.

Equilibrate the column with the mobile phase for about 2 h.

If necessary, decrease the concentration of methanol R so the peak corresponding to D-methyldopa is clearly separated from the negative system peak that appears at about 6 min.

**Flow rate:** 1 mL/min.

**Detection:** spectrophotometer at 280 nm.

**Injection:** 20  $\mu$ L.

**Run time:** twice the retention time of L-methyldopa.

**Relative retention** with reference to L-methyldopa (retention time = about 14 min): D-methyldopa = about 0.7.

**System suitability:** reference solution (b):

- resolution: minimum 5.0 between the peaks due to D-methyldopa and L-methyldopa.

**Limits:**

- D-methyldopa: not more than the area of the principal peak in the chromatogram obtained with reference solution (a) (0.5 per cent).

**Heavy metals** (2.4.8): maximum 20 ppm.

1.0 g complies with test C. Prepare the reference solution using 2 mL of lead standard solution (10 ppm Pb) R.

**Water** (2.5.12): 10.0 per cent to 13.0 per cent, determined on 0.20 g.

**Sulfated ash** (2.4.14): maximum 0.1 per cent, determined on 1.0 g.

**ASSAY**

Dissolve 0.180 g, heating if necessary, in 50 mL of glacial acetic acid R. Titrate with 0.1 M perchloric acid, determining the end-point potentiometrically (2.2.20).

1 mL of 0.1 M perchloric acid is equivalent to 21.12 mg of  $C_{10}H_{13}NO_4$ .

**STORAGE**

Protected from light.

**IMPURITIES**

**Specified impurities:** A, B, C, D.

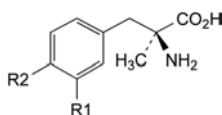

A. R1 = OCH<sub>3</sub>, R2 = OH: (2*S*)-2-amino-3-(4-hydroxy-3-methoxyphenyl)-2-methylpropanoic acid (3-methoxymethyldopa),

B. R1 = H, R2 = OCH<sub>3</sub>: (2*S*)-2-amino-3-(4-methoxyphenyl)-2-methylpropanoic acid,

C. R1 = R2 = OCH<sub>3</sub>: (2*S*)-2-amino-3-(3,4-dimethoxyphenyl)-2-methylpropanoic acid,

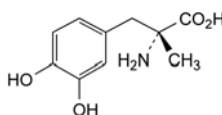

D. (2*R*)-2-amino-3-(3,4-dihydroxyphenyl)-2-methylpropanoic acid (D-methyldopa).

07/2010:0932 *Temperature:***METHYLENE CHLORIDE**

## Methyleni chloridum

CH<sub>2</sub>Cl<sub>2</sub>  
[75-09-2]*M<sub>r</sub>* 84.9

## DEFINITION

Dichloromethane.

It may contain maximum 2.0 per cent *V/V* of anhydrous ethanol and/or maximum 0.03 per cent *V/V* of 2-methylbut-2-ene as stabiliser.

## CHARACTERS

*Appearance:* clear, colourless, volatile liquid.

*Solubility:* sparingly soluble in water, miscible with ethanol (96 per cent).

## IDENTIFICATION

*First identification:* B, C.

*Second identification:* A, D, E.

A. Relative density (see Tests).

B. Refractive index (see Tests).

C. Infrared absorption spectrophotometry (2.2.24).

*Preparation:* films.

*Comparison:* methylene chloride CRS.

D. Heat 2 mL with 2 g of *potassium hydroxide R* and 20 mL of *ethanol (96 per cent) R* under a reflux condenser for 30 min. Allow to cool. Add 15 mL of *dilute sulfuric acid R* and filter. To 1 mL of the filtrate add 1 mL of a 15 g/L solution of *chromotropic acid, sodium salt R*, 2 mL of *water R* and 8 mL of *sulfuric acid R*. A violet colour is produced.

E. 2 mL of the filtrate obtained in identification test D gives reaction (a) of chlorides (2.3.1).

## TESTS

**Appearance.** It is clear (2.2.1) and colourless (2.2.2, *Method II*).

**Acidity.** To 50 mL of *methanol R* previously neutralised to 0.1 mL of *bromothymol blue solution RI*, add 50 g of the substance to be examined. Not more than 0.15 mL of 0.1 M *sodium hydroxide* is required to change the colour of the indicator to blue.

**Relative density** (2.2.5): 1.320 to 1.332.

**Refractive index** (2.2.6): 1.423 to 1.425.

**Ethanol, 2-methylbut-2-ene and volatile impurities.** Gas chromatography (2.2.28).

*Test solution.* The substance to be examined.

*Reference solution (a).* Dilute 100 µL of *carbon tetrachloride R* (impurity A), 500 µL of *chloroform R* (impurity B), 3.0 mL of *2-methylbut-2-ene R* and 5.0 mL of *methanol R* (impurity D) to 100.0 mL with the test solution.

*Reference solution (b).* Dilute 2.0 mL of *anhydrous ethanol R* and 1.0 mL of reference solution (a) to 100.0 mL with the test solution.

*Column:*

- *material:* fused silica;
- *size:* *l* = 30 m,  $\varnothing$  = 0.32 mm;
- *stationary phase:* poly[(cyanopropyl)(phenyl)]-[dimethyl]siloxane *R* (film thickness 1.8 µm).

*Carrier gas:* nitrogen for chromatography *R*.

*Flow rate:* 1.0 mL/min, constant flow.

*Split ratio:* 1:40.

	Time (min)	Temperature (°C)
Column	0 - 5	40
	5 - 12.5	40 → 55
	12.5 - 18	55 → 100
	18 - 20	100
Injection port		260
Detector		300

*Detection:* flame ionisation; make-up gas flow rate: 25 mL/min.

*Injection:* 2 µL.

*Relative retention* with reference to methylene chloride (retention time = about 7 min): impurity D = about 0.6; ethanol = about 0.8; 2-methylbut-2-ene = about 0.9; impurity B = about 1.7; impurity A = about 1.8.

*System suitability:* reference solution (b):

- *resolution:* minimum 3.0 between the peaks due to ethanol and 2-methylbut-2-ene;
- *signal-to-noise ratio:* minimum 5 for the peak due to impurity A.

*Limits:*

- *ethanol:* not more than the difference between the areas of the corresponding peaks in the chromatograms obtained with the test solution and with reference solution (b) (2.0 per cent *V/V*);
- *2-methylbut-2-ene:* not more than the difference between the areas of the corresponding peaks in the chromatograms obtained with the test solution and with reference solution (b) (300 ppm *V/V*);
- *impurity A:* not more than 0.5 times the area of the corresponding peak in the chromatogram obtained with reference solution (b) (10 ppm *V/V*);
- *impurity B:* not more than 0.5 times the area of the corresponding peak in the chromatogram obtained with reference solution (b) (50 ppm *V/V*);
- *total of impurities other than ethanol and 2-methylbut-2-ene:* not more than twice the difference between the areas of the peaks due to impurity D in the chromatograms obtained with the test solution and with reference solution (b) (0.1 per cent *V/V*);
- *disregard limit:* 0.2 times the difference between the areas of the peaks due to impurity B in the chromatograms obtained with the test solution and with reference solution (b) (10 ppm *V/V*). The disregard limit does not apply to impurity A.

**Free chlorine.** Place 5 mL in a ground-glass-stoppered tube. Add 5 mL of a 100 g/L solution of *potassium iodide R* and 0.2 g of *soluble starch R*. Shake for 30 s and allow to stand for 5 min. No blue colour develops.

**Heavy metals** (2.4.8): maximum 1 ppm.

To the residue obtained in the test for residue on evaporation add 1 mL of *hydrochloric acid R* and evaporate again. Dissolve the residue in 2 mL of *acetic acid R* and dilute to 50 mL with *water R*. 12 mL of the solution complies with test A. Prepare the reference solution using 10 mL of *lead standard solution (1 ppm Pb) R*.

**Residue on evaporation:** maximum 20 ppm.

Evaporate 50.0 g to dryness on a water-bath and dry at 100-105 °C for 30 min. The residue weighs a maximum of 1 mg.

**Water** (2.5.32): maximum 0.02 per cent *m/m*, determined on 10.00 g.

## STORAGE

In an airtight container, protected from light.

## LABELLING

The label states the name and concentration of any stabilisers.

## IMPURITIES

Specified impurities: A, B.

Other detectable impurities (the following substances would, if present at a sufficient level, be detected by one or other of the tests in the monograph. They are limited by the general acceptance criterion for other/unspecified impurities and/or by the general monograph *Substances for pharmaceutical use (2034)*. It is therefore not necessary to identify these impurities for demonstration of compliance. See also 5.10. *Control of impurities in substances for pharmaceutical use*): D.



A. carbon tetrachloride,



B. trichloromethane (chloroform),



D. methanol.

07/2009:1788

## METHYLERGOMETRINE MALEATE

## Methylethergometrini maleas

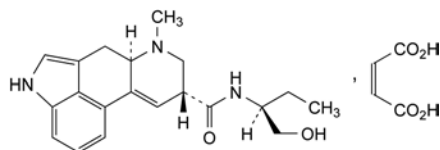

$C_{24}H_{26}N_3O_6$   
[57432-61-8]

$M_r$  455.5

## DEFINITION

(6a*R*,9*R*)-*N*-[(1*S*)-1-(Hydroxymethyl)propyl]-7-methyl-4,6,6a,7,8,9-hexahydroindolo[4,3-*fg*]quinoline-9-carboxamide (*Z*)-butenedioate.

Content: 99.0 per cent to 101.0 per cent (dried substance).

## CHARACTERS

Appearance: white or almost white, hygroscopic, crystalline powder.

Solubility: soluble in water, slightly soluble in anhydrous ethanol.

## IDENTIFICATION

A. Specific optical rotation (see Tests).

B. Infrared absorption spectrophotometry (2.2.24).

Comparison: methylethergometrine maleate CRS.

## TESTS

**Solution S.** Dissolve 0.100 g in carbon dioxide-free water R and dilute to 20.0 mL with the same solvent.

pH (2.2.3): 4.4 to 5.2.

Dilute 2.0 mL of solution S to 50.0 mL with carbon dioxide-free water R.

**Specific optical rotation (2.2.7):** + 44.0 to + 50.0 (dried substance), determined on solution S.

**Related substances.** Liquid chromatography (2.2.29). Carry out the test protected from light.

**Test solution.** Dissolve 25 mg of the substance to be examined in 15 mL of mobile phase B and dilute to 50.0 mL with water R.

**Reference solution (a).** Dilute 1.0 mL of the test solution to 100.0 mL with water R. Dilute 1.0 mL of this solution to 10.0 mL with water R.

**Reference solution (b).** Dissolve the contents of a vial of methylethergometrine for system suitability CRS (containing impurities A, B, C, D, E, F, G, H and I) in 1.0 mL of a mixture of 30 volumes of mobile phase B and 70 volumes of water R.

Column:

- size:  $l = 0.10$  m,  $\varnothing = 4.6$  mm;
- stationary phase: end-capped octadecylsilyl silica gel for chromatography R (3.5  $\mu$ m).

Mobile phase:

- mobile phase A: 2 g/L solution of ammonium carbamate R;
- mobile phase B: acetonitrile R, water R (50:50 V/V);

Time (min)	Mobile phase A (per cent V/V)	Mobile phase B (per cent V/V)
0 - 2	85	15
2 - 7	85 → 65	15 → 35
7 - 12	65	35
12 - 17	65 → 20	35 → 80
17 - 19	20	80

Flow rate: 2.0 mL/min.

Detection: spectrophotometer at 310 nm.

Injection: 20  $\mu$ L.

Identification of impurities: use the chromatogram supplied with methylethergometrine for system suitability CRS and the chromatogram obtained with reference solution (b) to identify the peaks due to impurities A, B, C, D, E, F, G, H and I.

Relative retention with reference to methylethergometrine (retention time = about 12 min): impurity A = about 0.2; impurity B = about 0.5; impurity C = about 0.6; impurity D = about 0.7; impurity I = about 1.10; impurity E = about 1.14; impurity F = about 1.2; impurity G = about 1.3; impurity H = about 1.4.

System suitability: reference solution (b):

- resolution: minimum 3.0 between the peaks due to methylethergometrine and impurity I; minimum 1.5 between the peaks due to impurities I and E.

Limits:

- impurity I: not more than 3 times the area of the principal peak in the chromatogram obtained with reference solution (a) (0.3 per cent);
- impurity C: not more than twice the area of the principal peak in the chromatogram obtained with reference solution (a) (0.2 per cent);
- impurities A, B, D, E, F, G, H: for each impurity, not more than 1.5 times the area of the principal peak in the chromatogram obtained with reference solution (a) (0.15 per cent);
- unspecified impurities: for each impurity, not more than the area of the principal peak in the chromatogram obtained with reference solution (a) (0.10 per cent);
- total: not more than 6 times the area of the principal peak in the chromatogram obtained with reference solution (a) (0.6 per cent);
- disregard limit: 0.5 times the area of the principal peak in the chromatogram obtained with reference solution (a) (0.05 per cent).

**Loss on drying (2.2.32):** maximum 2.0 per cent, determined on 1.000 g by drying in an oven at 105 °C.

**Sulfated ash (2.4.14):** maximum 0.1 per cent, determined on 1.0 g.

## ASSAY

Dissolve 0.300 g in 60 mL of *anhydrous acetic acid R*. Titrate with 0.1 M *perchloric acid*, determining the end-point potentiometrically (2.2.20).

1 mL of 0.1 M *perchloric acid* is equivalent to 45.55 mg of  $C_{24}H_{29}N_3O_6$ .

## STORAGE

In an airtight container, protected from light.

## IMPURITIES

Specified impurities: A, B, C, D, E, F, G, H, I.

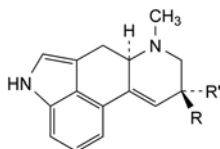

- A. R = H, R' = CO<sub>2</sub>H: (6a*R*,9*R*)-7-methyl-4,6,6a,7,8,9-hexahydroindolo[4,3-*fg*]quinoline-9-carboxylic acid,  
 B. R = CO<sub>2</sub>H, R' = H: (6a*R*,9*S*)-7-methyl-4,6,6a,7,8,9-hexahydroindolo[4,3-*fg*]quinoline-9-carboxylic acid,  
 C. R = H, R' = CONH<sub>2</sub>: (6a*R*,9*R*)-7-methyl-4,6,6a,7,8,9-hexahydroindolo[4,3-*fg*]quinoline-9-carboxamide,  
 E. R = CONH<sub>2</sub>, R' = H: (6a*R*,9*S*)-7-methyl-4,6,6a,7,8,9-hexahydroindolo[4,3-*fg*]quinoline-9-carboxamide,

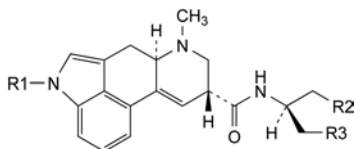

- D. R<sub>1</sub> = R<sub>2</sub> = H, R<sub>3</sub> = OH: (6a*R*,9*R*)-*N*-[(1*S*)-2-hydroxy-1-methylethyl]-7-methyl-4,6,6a,7,8,9-hexahydroindolo[4,3-*fg*]quinoline-9-carboxamide (ergometrine),  
 G. R<sub>1</sub> = R<sub>2</sub> = CH<sub>3</sub>, R<sub>3</sub> = OH: (6a*R*,9*R*)-*N*-[(1*S*)-1-(hydroxymethyl)propyl]-4,7-dimethyl-4,6,6a,7,8,9-hexahydroindolo[4,3-*fg*]quinoline-9-carboxamide (methysergide),  
 I. R<sub>1</sub> = H, R<sub>2</sub> = OH, R<sub>3</sub> = CH<sub>3</sub>: (6a*R*,9*R*)-*N*-[(1*R*)-1-(hydroxymethyl)propyl]-7-methyl-4,6,6a,7,8,9-hexahydroindolo[4,3-*fg*]quinoline-9-carboxamide (1'-*epi*-methylergometrine),

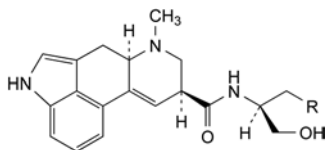

- F. R = H: (6a*R*,9*S*)-*N*-[(1*S*)-2-hydroxy-1-methylethyl]-7-methyl-4,6,6a,7,8,9-hexahydroindolo[4,3-*fg*]quinoline-9-carboxamide (ergometrinine),  
 H. R = CH<sub>3</sub>: (6a*R*,9*S*)-*N*-[(1*S*)-1-(hydroxymethyl)propyl]-7-methyl-4,6,6a,7,8,9-hexahydroindolo[4,3-*fg*]quinoline-9-carboxamide (methylergometrinine).

01/2008:0346  
corrected 6.0

## METHYLHYDROXYETHYLCELLULOSE

## Methylhydroxyethylcellulosum

## DEFINITION

Partly *O*-methylated and *O*-(2-hydroxyethylated) cellulose.

## CHARACTERS

*Appearance*: white, yellowish-white or greyish-white powder or granules, hygroscopic after drying.

*Solubility*: practically insoluble in hot water, in acetone, in anhydrous ethanol and in toluene. It dissolves in cold water giving a colloidal solution.

## IDENTIFICATION

- A. Heat 10 mL of solution S (see Tests) in a water-bath while stirring. At a temperature above 50 °C, the solution becomes cloudy or a flocculent precipitate is formed. The solution becomes clear again on cooling.  
 B. To 10 mL of solution S add 0.3 mL of *dilute acetic acid R* and 2.5 mL of a 100 g/L solution of *tannic acid R*. A yellowish-white flocculent precipitate is formed which dissolves in *dilute ammonia R1*.  
 C. In a test-tube about 160 mm long, thoroughly mix 1 g with 2 g of finely powdered *manganese sulfate R*. Introduce to a depth of 2 cm into the upper part of the tube a strip of filter paper impregnated with a freshly prepared mixture of 1 volume of a 20 per cent V/V solution of *diethanolamine R* and 11 volumes of a 50 g/L solution of *sodium nitroprusside R*, adjusted to about pH 9.8 with 1 M *hydrochloric acid*. Insert the tube 8 cm into a silicone-oil bath at 190-200 °C. The filter paper becomes blue within 10 min. Carry out a blank test.  
 D. Dissolve completely 0.2 g without heating in 15 mL of a 70 per cent *m/m* solution of *sulfuric acid R*. Pour the solution with stirring into 100 mL of iced *water R* and dilute to 250 mL with iced *water R*. In a test-tube, mix thoroughly while cooling in iced water 1 mL of this solution with 8 mL of *sulfuric acid R* added dropwise. Heat in a water-bath for exactly 3 min and immediately cool in iced water. While the mixture is cold, carefully add 0.6 mL of *ninhydrin solution R2* and mix well. Allow to stand at 25 °C. A pink colour is produced immediately and does not become violet within 100 min.  
 E. Place 1 mL of solution S on a glass plate. After evaporation of the water a thin film is formed.

## TESTS

**Solution S.** While stirring, introduce a quantity of the substance to be examined equivalent to 1.0 g of the dried substance into 50 g of *carbon dioxide-free water R* heated to 90 °C. Allow to cool, adjust the mass of the solution to 100 g with *carbon dioxide-free water R* and stir until dissolution is complete.

**Appearance of solution.** Solution S is not more opalescent than reference suspension III (2.2.1) and not more intensely coloured than reference solution Y<sub>6</sub> (2.2.2, *Method II*).

**pH (2.2.3):** 5.5 to 8.0 for solution S.

**Apparent viscosity (2.2.10):** 75 per cent to 140 per cent of the value stated on the label.

While stirring, introduce a quantity of the substance to be examined equivalent to 6.00 g of the dried substance into 150 g of *water R* heated to 90 °C. Stir with a propeller-type stirrer for 10 min, place the flask in a bath of iced water, continue the stirring and allow to remain in the bath of iced water for 40 min to ensure that dissolution is complete. Adjust the mass of the solution to 300 g and centrifuge the solution to expel any entrapped air. Adjust the temperature of the solution to 20 ± 0.1 °C. Determine the viscosity with a rotating viscometer at 20 °C and a shear rate of 10 s<sup>-1</sup>.

**Chlorides (2.4.4):** maximum 0.5 per cent.

Dilute 1 mL of solution S to 15 mL with *water R*.

**Heavy metals (2.4.8):** maximum 20 ppm.

1.0 g complies with test C. Prepare the reference solution using 2 mL of *lead standard solution (10 ppm Pb) R*.

**Loss on drying (2.2.32):** maximum 10.0 per cent, determined on 1.000 g by drying in an oven at 105 °C.

**Sulfated ash** (2.4.14): maximum 1.0 per cent, determined on 1.000 g.

#### LABELLING

The label states the apparent viscosity in millipascal seconds for a 2 per cent *m/m* solution.

01/2008:2129

## METHYL NICOTINATE

### Methylis nicotinas

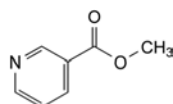

$C_7H_7NO_2$   
[93-60-7]

$M_r$  137.1

#### DEFINITION

Methyl pyridine-3-carboxylate.

**Content:** 99.0 per cent to 101.0 per cent (anhydrous substance).

#### CHARACTERS

**Appearance:** white or almost white powder.

**Solubility:** very soluble in water, in ethanol (96 per cent) and in methylene chloride.

#### IDENTIFICATION

**First identification:** B.

**Second identification:** A, C, D.

A. Melting point (2.2.14): 40 °C to 42 °C.

B. Infrared absorption spectrophotometry (2.2.24).

**Comparison:** methyl nicotinate CRS.

C. Thin-layer chromatography (2.2.27).

**Test solution.** Dissolve 10 mg of the substance to be examined in methanol *R* and dilute to 2 mL with the same solvent.

**Reference solution.** Dissolve 10 mg of methyl nicotinate CRS in methanol *R* and dilute to 2 mL with the same solvent.

**Plate:** TLC silica gel  $F_{254}$  plate *R*.

**Mobile phase:** methanol *R*, toluene *R* (10:90 *V/V*).

**Application:** 2 µL.

**Development:** over 2/3 of the plate.

**Drying:** in air.

**Detection:** examine in ultraviolet light at 254 nm.

**Results:** the principal spot in the chromatogram obtained with the test solution is similar in position and size to the principal spot in the chromatogram obtained with the reference solution.

D. To 0.5 g add 0.1 g of citric acid *R* and 0.2 mL of acetic anhydride *R*. Heat cautiously for 1 min. A yellow colour is produced which turns first to orange, then to red and then to violet.

#### TESTS

**Related substances.** Liquid chromatography (2.2.29).

**Test solution.** Dissolve 25 mg of the substance to be examined in the mobile phase and dilute to 25.0 mL with the mobile phase.

**Reference solution (a).** Dissolve 25 mg of nicotinic acid *R* in the mobile phase and dilute to 25.0 mL with the mobile phase. To 0.5 mL of this solution add 0.5 mL of the test solution and dilute to 100 mL with the mobile phase.

**Reference solution (b).** Dilute 1.0 mL of the test solution to 100.0 mL with the mobile phase. Dilute 1.0 mL of this solution to 10.0 mL with the mobile phase.

#### Column:

– **size:**  $l = 0.25$  m,  $\varnothing = 4$  mm,

– **stationary phase:** octadecylsilyl silica gel for chromatography *R* (5 µm).

**Mobile phase:** acetic acid *R*, water *R*, acetonitrile *R* (1:29:70 *V/V/V*).

**Flow rate:** 1 mL/min.

**Detection:** spectrophotometer at 261 nm.

**Injection:** 20 µL.

**Run time:** 3 times the retention time of methyl nicotinate.

**Retention time:** methyl nicotinate = about 3.3 min.

**System suitability:** reference solution (a):

– **resolution:** minimum 2 between the peaks due to impurity A and methyl nicotinate.

#### Limits:

– **impurity A:** not more than the area of the principal peak in the chromatogram obtained with reference solution (b) (0.1 per cent),

– **any other impurity:** for each impurity, not more than the area of the principal peak in the chromatogram obtained with reference solution (b) (0.1 per cent),

– **total:** not more than 5 times the area of the principal peak in the chromatogram obtained with reference solution (b) (0.5 per cent),

– **disregard limit:** 0.5 times the area of the principal peak in the chromatogram obtained with reference solution (b) (0.05 per cent).

**Chlorides** (2.4.4): maximum 200 ppm.

Dissolve 0.25 g in water *R* and dilute to 15 mL with the same solvent.

**Water** (2.5.12): maximum 0.5 per cent, determined on 2.000 g.

**Sulfated ash** (2.4.14): maximum 0.1 per cent, determined on 1.0 g.

#### ASSAY

Dissolve 0.120 g in 50 mL of glacial acetic acid *R*. Titrate with 0.1 *M* perchloric acid, determining the end-point potentiometrically (2.2.20).

1 mL of 0.1 *M* perchloric acid is equivalent to 13.71 mg of  $C_7H_7NO_2$ .

#### STORAGE

Protected from light.

#### IMPURITIES

**Specified impurities:** A.

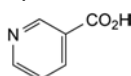

A. pyridine-3-carboxylic acid (nicotinic acid).

07/2010:0409

## METHYL PARAHYDROXYBENZOATE

### Methylis parahydroxybenzoas

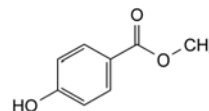

$C_8H_8O_3$   
[99-76-3]

$M_r$  152.1

#### DEFINITION

Methyl 4-hydroxybenzoate.

**Content:** 98.0 per cent to 102.0 per cent.

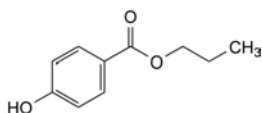

C. propyl 4-hydroxybenzoate (propyl parahydroxybenzoate),

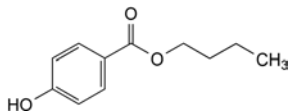

D. butyl 4-hydroxybenzoate (butyl parahydroxybenzoate).

01/2009:2235  
corrected 6.6

## METHYLPHENIDATE HYDROCHLORIDE

### Methylphenidati hydrochloridum

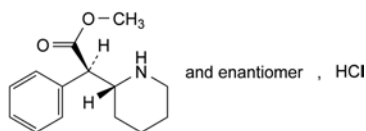

$C_{14}H_{20}ClNO_2$   
[298-59-9]

$M_r$  269.8

#### DEFINITION

Methyl (2*RS*)-phenyl[(2*RS*)-piperidin-2-yl]acetate hydrochloride.

*Content*: 99.0 per cent to 101.0 per cent (dried substance).

#### CHARACTERS

*Appearance*: white or almost white, fine crystalline powder.

*Solubility*: freely soluble in water, soluble in ethanol (96 per cent), slightly soluble in methylene chloride.

#### IDENTIFICATION

*First identification*: A, C.

*Second identification*: B, C.

A. Infrared absorption spectrophotometry (2.2.24).

*Comparison*: methylphenidate hydrochloride CRS.

B. Thin-layer chromatography (2.2.27).

*Test solution*. Dissolve 5 mg of the substance to be examined in 1.0 mL of methanol R.

*Reference solution*. Dissolve 5 mg of methylphenidate hydrochloride CRS in 1.0 mL of methanol R.

*Plate*: TLC silica gel plate R.

*Mobile phase*: concentrated ammonia R, methanol R, methylene chloride R (1:4:95 V/V/V).

*Application*: 5 µL.

*Development*: over 2/3 of the plate.

*Drying*: at 60 °C for 5 min.

*Detection*: spray with a freshly prepared 5 g/L solution of fast blue B salt R; heat to 60 °C for 1 min.

*Results*: the principal spot in the chromatogram obtained with the test solution is similar in position, colour and size to the principal spot obtained with the reference solution.

C. It gives reaction (a) of chlorides (2.3.1).

#### TESTS

**Related substances.** Liquid chromatography (2.2.29). Prepare the solutions immediately before use.

*Test solution*. Dissolve 25 mg of the substance to be examined in the mobile phase and dilute to 50.0 mL with the mobile phase.

*Reference solution (a)*. Dissolve the contents of a vial of methylphenidate impurity mixture CRS (containing impurities A and B) in 1.0 mL of the test solution.

*Reference solution (b)*. Dilute 1.0 mL of the test solution to 100.0 mL with the mobile phase. Dilute 1.0 mL of this solution to 10.0 mL with the mobile phase.

*Column*:

– *size*:  $l = 0.25$  m,  $\varnothing = 4.6$  mm;

– *stationary phase*: end-capped octadecylsilyl silica gel for chromatography R (5 µm);

– *temperature*: 40 °C.

*Mobile phase*: mix 7 volumes of methanol R2 and 18 volumes of a 1.82 g/L solution of potassium dihydrogen phosphate R.

*Flow rate*: 1.0 mL/min.

*Detection*: spectrophotometer at 209 nm.

*Injection*: 10 µL.

*Run time*: 1.5 times the retention time of methylphenidate.

*Identification of impurities*: use the chromatogram supplied with methylphenidate impurity mixture CRS and the chromatogram obtained with reference solution (a) to identify the peaks due to impurities A and B.

*Relative retention* with reference to methylphenidate (retention time = about 11 min): impurity B = about 0.6; impurity A = about 0.9.

*System suitability*: reference solution (a):

– *peak-to-valley ratio*: minimum 2.5, where  $H_p$  = height above the baseline of the peak due to impurity A and  $H_v$  = height above the baseline of the lowest point of the curve separating this peak from the peak due to methylphenidate.

*Limits*:

– *impurities A, B*: for each impurity, not more than 5 times the area of the principal peak in the chromatogram obtained with reference solution (b) (0.5 per cent);

– *unspecified impurities*: for each impurity, not more than the area of the principal peak in the chromatogram obtained with reference solution (b) (0.10 per cent);

– *total*: not more than 10 times the area of the principal peak in the chromatogram obtained with reference solution (b) (1.0 per cent);

– *disregard limit*: 0.5 times the area of the principal peak in the chromatogram obtained with reference solution (b) (0.05 per cent).

**Heavy metals** (2.4.8): maximum 20 ppm.

Dissolve 1.0 g in water R and dilute to 20.0 mL with the same solvent. 12 mL of the solution complies with test A. Prepare the reference solution using lead standard solution (1 ppm Pb) R.

**Loss on drying** (2.2.32): maximum 0.5 per cent, determined on 1.000 g by drying *in vacuo* at 60 °C for 4 h.

**Sulfated ash** (2.4.14): maximum 0.1 per cent, determined on 1.0 g.

#### ASSAY

Dissolve 0.250 g in 50 mL of ethanol (96 per cent) R and add 5.0 mL of 0.01 M hydrochloric acid. Carry out a potentiometric titration (2.2.20) using 0.1 M sodium hydroxide and an electrode for non-aqueous acid-base titrations. Read the volume added between the 2 points of inflexion.

1 mL of 0.1 M sodium hydroxide is equivalent to 26.98 mg of  $C_{14}H_{20}ClNO_2$ .

#### STORAGE

Protected from light.

#### IMPURITIES

*Specified impurities*: A, B.

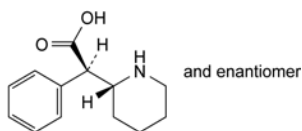

A. (2*RS*)-phenyl[(2*RS*)-piperidin-2-yl]acetic acid,

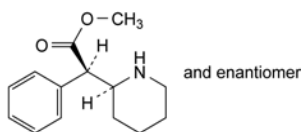

B. methyl (2*RS*)-phenyl[(2*SR*)-piperidin-2-yl]acetate.

01/2011:0189

## METHYLPHENOBARBITAL

### Methylphenobarbitalum

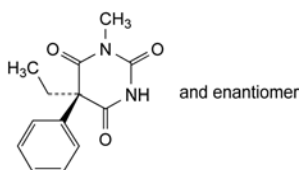

$C_{13}H_{14}N_2O_3$   
[115-38-8]

$M_r$  246.3

#### DEFINITION

(5*RS*)-5-Ethyl-1-methyl-5-phenylpyrimidine-2,4,6-(1*H*,3*H*,5*H*)-trione.

*Content*: 98.0 per cent to 102.0 per cent (dried substance).

#### CHARACTERS

*Appearance*: white or almost white, crystalline powder or colourless crystals.

*Solubility*: practically insoluble in water, very slightly soluble in ethanol (96 per cent).

It forms water-soluble compounds with alkali hydroxides and carbonates and with ammonia.

#### IDENTIFICATION

*First identification*: A, B.

*Second identification*: A, C, D.

A. Determine the melting point (2.2.14) of the substance to be examined. Mix equal parts of the substance to be examined and *methylphenobarbital CRS* and determine the melting point of the mixture. The difference between the melting points (which are about 178 °C) is not greater than 2 °C.

B. Infrared absorption spectrophotometry (2.2.24).

*Comparison*: *methylphenobarbital CRS*.

C. Thin-layer chromatography (2.2.27).

*Test solution*. Dissolve 10 mg of the substance to be examined in *methylene chloride R* and dilute to 10 mL with the same solvent.

*Reference solution*. Dissolve 10 mg of *methylphenobarbital CRS* in *methylene chloride R* and dilute to 10 mL with the same solvent.

*Plate*: TLC silica gel GF<sub>254</sub> plate R.

*Mobile phase*: concentrated ammonia R, ethanol (96 per cent) R, *methylene chloride R* (5:15:80 V/V/V); use the lower layer.

*Application*: 10 µL.

*Development*: over 2/3 of the plate.

*Detection*: examine immediately in ultraviolet light at 254 nm.

*Results*: the principal spot in the chromatogram obtained with the test solution is similar in position and size to the principal spot in the chromatogram obtained with the reference solution.

D. To about 10 mg add 0.2 mL of *sulfuric acid R* and 0.1 mL of *nitric acid R*. Heat on a water-bath for 10 min. Cool in iced water and add 5 mL of *water R* and 5 mL of *strong sodium hydroxide solution R*. Add 5 mL of *acetone R*, shake and allow to stand. A dark-red colour develops in the upper layer.

#### TESTS

**Appearance of solution.** The solution is clear (2.2.1) and not more intensely coloured than reference solution Y<sub>6</sub> (2.2.2, *Method II*).

Dissolve 1.0 g, with gentle heating, in a mixture of 4 mL of *dilute sodium hydroxide solution R* and 6 mL of *water R*.

**Acidity.** Boil 1.0 g with 50 mL of *water R* for 2 min, allow to cool and filter. To 10 mL of the filtrate add 0.15 mL of *methyl red solution R*. The solution is orange-yellow. Not more than 0.1 mL of 0.1 M *sodium hydroxide* is required to produce a pure yellow colour.

**Related substances.** Liquid chromatography (2.2.29).

*Test solution.* Dissolve 50 mg of the substance to be examined in 10.0 mL of *methanol R* and dilute to 50.0 mL with the mobile phase.

*Reference solution (a).* Dilute 1.0 mL of the test solution to 100.0 mL with the mobile phase. Dilute 5.0 mL of this solution to 10.0 mL with the mobile phase.

*Reference solution (b).* Dissolve 2 mg of *phenobarbital CRS* (impurity A) in 1.0 mL of *methanol R* and dilute to 100.0 mL with the mobile phase. Dilute 1.0 mL of this solution to 10.0 mL with the test solution.

#### Column:

– *size*:  $l = 0.25$  m,  $\varnothing = 4.6$  mm;

– *stationary phase*: end-capped octadecylsilyl silica gel for chromatography R (5 µm).

*Mobile phase.* Dissolve 6.60 g of *sodium acetate R* in 900 mL of *water R*, add 3 mL of *glacial acetic acid R*, adjust to pH 4.5 with *glacial acetic acid R* and dilute to 1000 mL with *water R*. Mix 40 volumes of this solution with 60 volumes of *methanol R*.

*Flow rate*: 1.0 mL/min.

*Detection*: spectrophotometer at 254 nm.

*Injection*: 20 µL.

*Run time*: 3.5 times the retention time of methylphenobarbital.

*Identification of impurities*: use the chromatogram obtained with reference solution (b) to identify the peak due to impurity A.

*Relative retention* with reference to methylphenobarbital (retention time = about 7 min): impurity A = about 0.7.

*System suitability*: reference solution (b):

– *resolution*: minimum 5.0 between the peaks due to impurity A and methylphenobarbital.

#### Limits:

– *impurity A*: not more than the area of the principal peak in the chromatogram obtained with reference solution (a) (0.5 per cent);

– *unspecified impurities*: for each impurity, not more than 0.2 times the area of the principal peak in the chromatogram obtained with reference solution (a) (0.10 per cent);

– *total*: not more than 1.4 times the area of the principal peak in the chromatogram obtained with reference solution (a) (0.7 per cent);

– *disregard limit*: 0.1 times the area of the principal peak in the chromatogram obtained with reference solution (a) (0.05 per cent).

**Loss on drying** (2.2.32): maximum 0.5 per cent, determined on 1.000 g by drying in an oven at 105 °C.

**Sulfated ash (2.4.14):** maximum 0.1 per cent, determined on 1.0 g.

#### ASSAY

Dissolve 0.100 g in 70 mL of *ethanol (96 per cent) R* and add 20 mL of *water R*. Stir with a mechanical stirrer for about 30 min and sonicate to achieve complete dissolution. Titrate with 0.1 M *sodium hydroxide*, determining the end-point potentiometrically (2.2.20).

1 mL of 0.1 M *sodium hydroxide* is equivalent to 24.63 mg of  $C_{13}H_{14}N_2O_3$ .

#### IMPURITIES

*Specified impurities: A.*

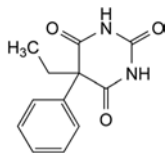

A. 5-ethyl-5-phenylpyrimidine-2,4,6(1H,3H,5H)-trione (phenobarbital).

01/2008:0561  
corrected 7.0

## METHYLPREDNISOLONE

### Methylprednisolonum

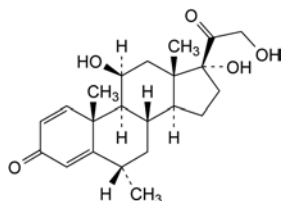

$C_{22}H_{30}O_5$   
[83-43-2]

$M_r$  374.5

#### DEFINITION

11 $\beta$ ,17,21-Trihydroxy-6 $\alpha$ -methylpregna-1,4-diene-3,20-dione.

*Content:* 97.0 per cent to 103.0 per cent (dried substance).

#### CHARACTERS

*Appearance:* white or almost white, crystalline powder.

*Solubility:* practically insoluble in water, sparingly soluble in ethanol (96 per cent), slightly soluble in acetone and in methylene chloride.

It shows polymorphism (5.9).

#### IDENTIFICATION

*First identification: A, B.*

*Second identification: C, D.*

A. Infrared absorption spectrophotometry (2.2.24).

*Comparison: methylprednisolone CRS.*

If the spectra obtained in the solid state show differences, dissolve the substance to be examined and the reference substance separately in the minimum volume of *acetone R*, evaporate to dryness on a water-bath and record new spectra using the residues.

B. Thin-layer chromatography (2.2.27).

*Solvent mixture: methanol R, methylene chloride R (1:9 V/V).*

*Test solution.* Dissolve 10 mg of the substance to be examined in the solvent mixture and dilute to 10 mL with the solvent mixture.

*Reference solution (a).* Dissolve 20 mg of *methylprednisolone CRS* in the solvent mixture and dilute to 20 mL with the solvent mixture.

*Reference solution (b).* Dissolve 10 mg of *hydrocortisone CRS* in reference solution (a) and dilute to 10 mL with reference solution (a).

*Plate: TLC silica gel F<sub>254</sub> plate R.*

*Mobile phase A:* add a mixture of 1.2 volumes of *water R* and 8 volumes of *methanol R* to a mixture of 15 volumes of *ether R* and 77 volumes of *methylene chloride R*.

*Mobile phase B:* *butanol R* saturated with *water R*, *toluene R*, *ether R* (5:15:80 V/V/V).

*Application:* 5  $\mu$ L.

*1<sup>st</sup> development:* over a path of 15 cm with mobile phase A.

*2<sup>nd</sup> development:* over a path of 15 cm with mobile phase B.

*Drying:* in air.

*Detection A:* examine in ultraviolet light at 254 nm.

*Results A:* the principal spot in the chromatogram obtained with the test solution is similar in position and size to the principal spot in the chromatogram obtained with reference solution (a).

*Detection B:* spray with *alcoholic solution of sulfuric acid R*. Heat at 120 °C for 10 min or until the spots appear. Allow to cool. Examine in daylight and in ultraviolet light at 365 nm.

*Results B:* the principal spot in the chromatogram obtained with the test solution is similar in position, colour in daylight, fluorescence in ultraviolet light at 365 nm and size to the principal spot in the chromatogram obtained with reference solution (a).

*System suitability:* reference solution (b):

– the chromatogram shows 2 clearly separated spots.

C. Thin-layer chromatography (2.2.27).

*Test solution (a).* Dissolve 25 mg of the substance to be examined in *methanol R* and dilute to 5 mL with the same solvent (solution A). Dilute 2 mL of solution A to 10 mL with *methylene chloride R*.

*Test solution (b).* Transfer 0.4 mL of solution A to a glass tube 100 mm long and 20 mm in diameter and fitted with a ground-glass stopper or a polytetrafluoroethylene cap and evaporate the solvent with gentle heating under a stream of *nitrogen R*. Add 2 mL of a 15 per cent V/V solution of *glacial acetic acid R* and 50 mg of *sodium bismuthate R*. Stopper the tube and shake the suspension in a mechanical shaker protected from light for 1 h. Add 2 mL of a 15 per cent V/V solution of *glacial acetic acid R* and filter into a 50 mL separating funnel, washing the filter with 2 quantities, each of 5 mL, of *water R*. Shake the clear filtrate with 10 mL of *methylene chloride R*. Wash the organic layer with 5 mL of 1 M *sodium hydroxide* and 2 quantities, each of 5 mL, of *water R*. Dry over *anhydrous sodium sulfate R*.

*Reference solution (a).* Dissolve 25 mg of *methylprednisolone CRS* in *methanol R* and dilute to 5 mL with the same solvent (solution B). Dilute 2 mL of solution B to 10 mL with *methylene chloride R*.

*Reference solution (b).* Transfer 0.4 mL of solution B to a glass tube 100 mm long and 20 mm in diameter and fitted with a ground-glass stopper or a polytetrafluoroethylene cap and evaporate the solvent with gentle heating under a stream of *nitrogen R*. Add 2 mL of a 15 per cent V/V solution of *glacial acetic acid R* and 50 mg of *sodium bismuthate R*. Stopper the tube and shake the suspension in a mechanical shaker protected from light for 1 h. Add 2 mL of a 15 per cent V/V solution of *glacial acetic acid R* and filter into a 50 mL separating funnel, washing the filter with 2 quantities, each of 5 mL, of *water R*. Shake the clear filtrate with 10 mL of *methylene chloride R*. Wash the organic layer with 5 mL of 1 M *sodium hydroxide* and 2 quantities, each of 5 mL, of *water R*. Dry over *anhydrous sodium sulfate R*.

*Plate: TLC silica gel F<sub>254</sub> plate R.*



**Mobile phase:** butanol R saturated with water R, toluene R, ether R (5:10:85 V/V/V).

**Application:** 5 µL of test solution (a) and reference solution (a), 10 µL of test solution (b) and reference solution (b), applying the latter 2 in small quantities in order to obtain small spots.

**Development:** over a path of 15 cm.

**Drying:** in air.

**Detection A:** examine in ultraviolet light at 254 nm.

**Results A:** the principal spot in each of the chromatograms obtained with the test solutions is similar in position, and size to the principal spot in the chromatogram obtained with the corresponding reference solution.

**Detection B:** spray with alcoholic solution of sulfuric acid R and heat at 120 °C for 15 min. Allow to cool. Examine in daylight and in ultraviolet light at 365 nm.

**Results B:** the principal spot in each of the chromatograms obtained with the test solutions is similar in position, colour in daylight, fluorescence in ultraviolet light at 365 nm and size to the principal spot in the chromatogram obtained with the corresponding reference solution. The principal spot in each of the chromatograms obtained with test solution (b) and reference solution (b) have an  $R_f$  value distinctly higher than that of the principal spot in each of the chromatograms obtained with test solution (a) and reference solution (a).

- D. Add about 2 mg to 2 mL of sulfuric acid R and shake to dissolve. Within 5 min, an intense red colour develops. When examined in ultraviolet light at 365 nm, brownish-red fluorescence is seen. Add this solution to 10 mL of water R and mix. The colour fades and there is a yellowish-green fluorescence in ultraviolet light at 365 nm.

## TESTS

**Specific optical rotation (2.2.7):** + 79.0 to + 86.0 (dried substance).

Dissolve 0.250 g in dioxan R and dilute to 25.0 mL with the same solvent.

**Related substances.** Liquid chromatography (2.2.29).

**Test solution.** Dissolve 25.0 mg of the substance to be examined in a mixture of equal volumes of acetonitrile R and methanol R and dilute to 10.0 mL with the same mixture of solvents.

**Reference solution (a).** Dissolve 2 mg of methylprednisolone CRS and 2 mg of betamethasone CRS in mobile phase A and dilute to 100.0 mL with mobile phase A.

**Reference solution (b).** Dilute 1.0 mL of the test solution to 100.0 mL with mobile phase A.

**Column:**

- size:  $l = 0.25$  m,  $\varnothing = 4.6$  mm;
- stationary phase: octadecylsilyl silica gel for chromatography R (5 µm);
- temperature: 45 °C.

**Mobile phase:**

- mobile phase A: in a 1000 mL volumetric flask mix 250 mL of acetonitrile R with 700 mL of water R and allow to equilibrate; dilute to 1000 mL with water R and mix again;
- mobile phase B: acetonitrile R;

Time (min)	Mobile phase A (per cent V/V)	Mobile phase B (per cent V/V)
0 - 15	100	0
15 - 40	100 → 0	0 → 100

**Flow rate:** 2.5 mL/min.

**Detection:** spectrophotometer at 254 nm.

**Equilibration:** with mobile phase B for at least 30 min, then with mobile phase A for 5 min. For subsequent chromatograms, use the conditions described from 40 min to 46 min.

**Injection:** 20 µL; inject a mixture of equal volumes of acetonitrile R and methanol R as a blank.

**Retention time:** methylprednisolone = about 11.5 min; betamethasone = about 12.5 min.

**System suitability:** reference solution (a):

- resolution: minimum 1.5 between the peaks due to methylprednisolone and betamethasone; if necessary, adjust the concentration of acetonitrile in mobile phase A.

**Limits:**

- impurities A, B, C, D: for each impurity, not more than 0.5 times the area of the principal peak in the chromatogram obtained with reference solution (b) (0.5 per cent);
- total: not more than twice the area of the principal peak in the chromatogram obtained with reference solution (b) (2 per cent);
- disregard limit: 0.05 times the area of the principal peak in the chromatogram obtained with reference solution (b) (0.05 per cent).

**Loss on drying (2.2.32):** maximum 1.0 per cent, determined on 0.500 g by drying in an oven at 105 °C.

## ASSAY

Dissolve 0.100 g in ethanol (96 per cent) R and dilute to 100.0 mL with the same solvent. Dilute 2.0 mL of this solution to 100.0 mL with ethanol (96 per cent) R. Measure the absorbance (2.2.25) at the absorption maximum at 243 nm.

Calculate the content of  $C_{22}H_{30}O_5$  taking the specific absorbance to be 395.

## STORAGE

Protected from light.

## IMPURITIES

**Specified impurities:** A, B, C, D.

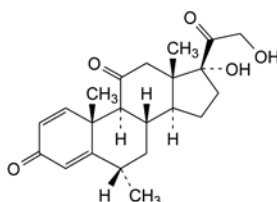

A. 17,21-dihydroxy-6 $\alpha$ -methylpregna-1,4-diene-3,11,20-trione,

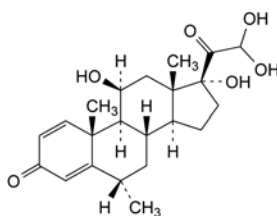

B. 11 $\beta$ ,17,21,21-tetrahydroxy-6 $\alpha$ -methylpregna-1,4-diene-3,20-dione,

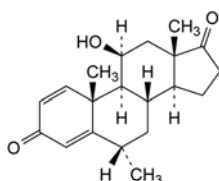

C. 11 $\beta$ -hydroxy-6 $\alpha$ -methylandrosta-1,4-diene-3,17-dione,

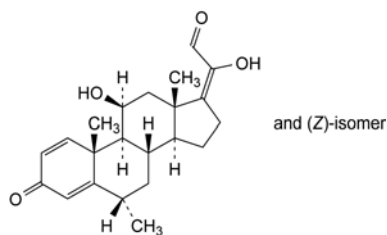

D. (*E*)- and (*Z*)-11β,20-dihydroxy-6α-methylpregna-1,4,17(20)-triene-3,21-dione.

01/2008:0933  
corrected 6.0

## METHYLPREDNISOLONE ACETATE

### Methylprednisoloni acetat

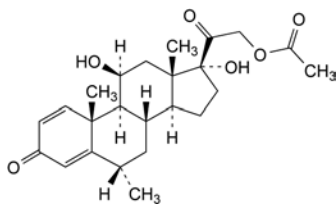

$C_{24}H_{32}O_6$   
[53-36-1]

$M_r$  416.5

#### DEFINITION

11β,17-Dihydroxy-6α-methyl-3,20-dioxopregna-1,4-dien-21-yl acetate.

*Content*: 97.0 per cent to 103.0 per cent (dried substance).

#### CHARACTERS

*Appearance*: white or almost white, crystalline powder.

*Solubility*: practically insoluble in water, sparingly soluble in acetone and in ethanol (96 per cent).

#### IDENTIFICATION

*First identification*: A, B.

*Second identification*: C, D, E.

A. Infrared absorption spectrophotometry (2.2.24).

*Comparison*: methylprednisolone acetate CRS.

If the spectra obtained in the solid state show differences, dissolve the substance to be examined and the reference substance separately in the minimum volume of acetone R, evaporate to dryness and record new spectra using the residues.

B. Thin-layer chromatography (2.2.27).

*Solvent mixture*: methanol R, methylene chloride R (1:9 V/V).

*Test solution*. Dissolve 10 mg of the substance to be examined in the solvent mixture and dilute to 10 mL with the solvent mixture.

*Reference solution (a)*. Dissolve 10 mg of methylprednisolone acetate CRS in the solvent mixture and dilute to 10 mL with the solvent mixture.

*Reference solution (b)*. Dissolve 10 mg of prednisolone acetate CRS and 10 mg of methylprednisolone acetate CRS in the solvent mixture, then dilute to 10 mL with the solvent mixture.

*Plate*: TLC silica gel GF<sub>254</sub> plate R.

*Mobile phase*: butanol R, toluene R, ether R (5:10:85 V/V/V).

*Application*: 5 μL.

*Development*: over a path of 15 cm.

*Drying*: in air.

*Detection A*: examine in ultraviolet light at 254 nm.

*Results A*: the principal spot in the chromatogram obtained with the test solution is similar in position and size to the principal spot in the chromatogram obtained with reference solution (a).

*Detection B*: spray with alcoholic solution of sulfuric acid R. Heat at 120 °C for 10 min or until the spots appear. Allow to cool. Examine in daylight and in ultraviolet light at 365 nm.

*Results B*: the principal spot in the chromatogram obtained with the test solution is similar in position, colour in daylight, fluorescence in ultraviolet light at 365 nm and size to the principal spot in the chromatogram obtained with reference solution (a).

*System suitability*: reference solution (b):

– the chromatogram shows 2 spots which, when examined in ultraviolet light at 365 nm, may not be completely separated.

C. Thin-layer chromatography (2.2.27).

*Test solution (a)*. Dissolve 25 mg of the substance to be examined in methanol R and dilute to 5 mL with the same solvent (solution A). Dilute 2 mL of this solution to 10 mL with methylene chloride R.

*Test solution (b)*. Transfer 2 mL of solution A to a 15 mL glass tube with a ground-glass stopper or a polytetrafluoroethylene cap. Add 10 mL of saturated methanolic potassium hydrogen carbonate solution R and immediately pass a current of nitrogen R through the solution for 5 min. Stopper the tube. Heat in a water-bath at 45 °C protected from light for 1 h. Allow to cool.

*Reference solution (a)*. Dissolve 25 mg of methylprednisolone acetate CRS in methanol R and dilute to 5 mL with the same solvent (solution B). Dilute 2 mL of this solution to 10 mL with methylene chloride R.

*Reference solution (b)*. Transfer 2 mL of solution B to a 15 mL glass tube with a ground-glass stopper or a polytetrafluoroethylene cap. Add 10 mL of saturated methanolic potassium hydrogen carbonate solution R and immediately pass a current of nitrogen R through the solution for 5 min. Stopper the tube. Heat in a water-bath at 45 °C protected from light for 1 h. Allow to cool.

*Plate*: TLC silica gel GF<sub>254</sub> plate R.

*Mobile phase*: add a mixture of 1.2 volumes of water R and 8 volumes of methanol R to a mixture of 15 volumes of ether R and 77 volumes of methylene chloride R.

*Application*: 5 μL.

*Development*: over a path of 15 cm.

*Drying*: in air.

*Detection A*: examine in ultraviolet light at 254 nm.

*Results A*: the principal spot in each of the chromatograms obtained with the test solutions is similar in position and size to the principal spot in the chromatogram obtained with the corresponding reference solution.

*Detection B*: spray with alcoholic solution of sulfuric acid R. Heat at 120 °C for 10 min or until the spots appear. Allow to cool. Examine in daylight and in ultraviolet light at 365 nm.

*Results B*: the principal spot in each of the chromatograms obtained with the test solutions is similar in position, colour in daylight, fluorescence in ultraviolet light at 365 nm and size to the principal spot in the chromatogram obtained with the corresponding reference solution. The principal spot in each of the chromatograms obtained with test solution (b) and reference solution (b) has an  $R_f$  value distinctly lower than that of the principal spot in each of the chromatograms obtained with test solution (a) and reference solution (a).

D. Add about 2 mg to 2 mL of sulfuric acid R and shake to dissolve. Within 5 min, an intense red colour develops. When examined in ultraviolet light at 365 nm, a reddish-brown fluorescence is seen. Add this solution to 10 mL of water R and mix. The colour fades and there is a greenish-yellow fluorescence in ultraviolet light at 365 nm.

E. About 10 mg gives the reaction of acetyl (2.3.1).

#### TESTS

**Specific optical rotation** (2.2.7): + 97 to + 105 (dried substance).

Dissolve 0.250 g in *dioxan R* and dilute to 25.0 mL with the same solvent.

**Related substances.** Liquid chromatography (2.2.29).

**Test solution.** Dissolve 20.0 mg of the substance to be examined in 5 mL of *tetrahydrofuran R* and dilute to 10.0 mL with *water R*.

**Reference solution (a).** Dissolve 4 mg of *methylprednisolone acetate CRS* and 4 mg of *dexamethasone acetate CRS* in the mobile phase, then dilute to 20.0 mL with the mobile phase. Dilute 2.0 mL of this solution to 10.0 mL with the mobile phase.

**Reference solution (b).** Dilute 1.0 mL of the test solution to 50.0 mL with the mobile phase.

**Column:**

- size:  $l = 0.25$  m,  $\varnothing = 4.6$  mm;
- stationary phase: *octadecylsilyl silica gel for chromatography R* (5  $\mu$ m).

**Mobile phase:** in a 1000 mL volumetric flask mix 260 mL *tetrahydrofuran R* and 700 mL of *water R*, then allow to equilibrate; dilute to 1000 mL with *water R* and mix again.

**Flow rate:** 1 mL/min.

**Detection:** spectrophotometer at 254 nm.

**Equilibration:** with the mobile phase for about 45 min.

**Injection:** 20  $\mu$ L.

**Run time:** 1.5 times the retention time of methylprednisolone acetate.

**Retention time:** methylprednisolone acetate = about 43 min; dexamethasone acetate = about 57 min.

**System suitability:** reference solution (a):

- **resolution:** minimum 6.5 between the peaks due to methylprednisolone acetate and dexamethasone acetate; if necessary, adjust the concentration of *water R* in the mobile phase.

**Limits:**

- **total:** not more than 0.5 times the area of the principal peak in the chromatogram obtained with reference solution (b) (1.0 per cent);
- **disregard limit:** 0.025 times the area of the principal peak in the chromatogram obtained with reference solution (b) (0.05 per cent).

**Loss on drying** (2.2.32): maximum 0.5 per cent, determined on 1.000 g by drying in an oven at 105 °C.

#### ASSAY

Dissolve 0.100 g in *ethanol (96 per cent) R* and dilute to 100.0 mL with the same solvent. Dilute 1.0 mL of this solution to 100.0 mL with *ethanol (96 per cent) R*. Measure the absorbance (2.2.25) at the absorption maximum at 243 nm.

Calculate the content of  $C_{24}H_{32}O_6$  taking the specific absorbance to be 355.

#### STORAGE

Protected from light.

#### IMPURITIES

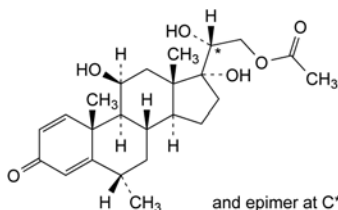

A. (20*R*)-11 $\beta$ ,17,20-trihydroxy-6 $\alpha$ -methyl-3-oxopregna-1,4-dien-21-yl acetate,

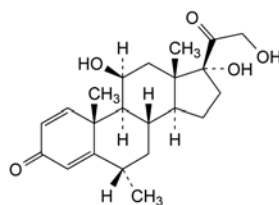

B. 11 $\beta$ ,17,21-trihydroxy-6 $\alpha$ -methylpregna-1,4-diene-3,20-dione (methylprednisolone),

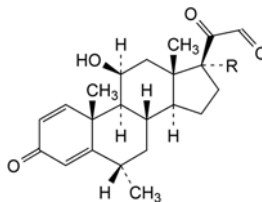

C. R = OH: 11 $\beta$ ,17-dihydroxy-6 $\alpha$ -methylpregna-1,4-diene-3,20,21-trione,

D. R = H: 11 $\beta$ -hydroxy-6 $\alpha$ -methylpregna-1,4-diene-3,20,21-trione,

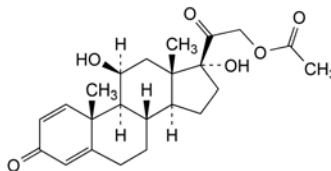

E. 11 $\beta$ ,17-dihydroxy-3,20-dioxopregna-1,4-dien-21-yl acetate (prednisolone acetate),

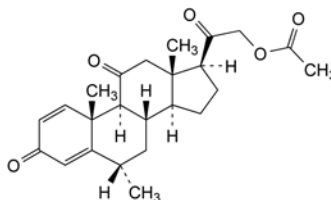

F. 6 $\alpha$ -methyl-3,11,20-trioxopregna-1,4-dien-21-yl acetate,

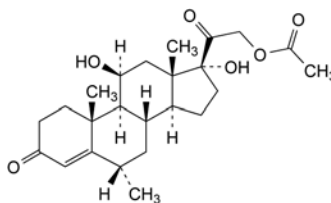

G. 11 $\beta$ ,17-dihydroxy-6 $\alpha$ -methyl-3,20-dioxopregna-4-en-21-yl acetate,

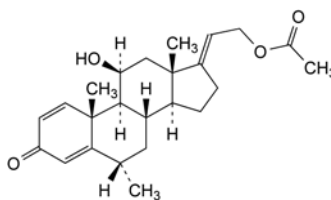

H. 11 $\beta$ -hydroxy-6 $\alpha$ -methyl-3-oxopregna-1,4,17(20)-trien-21-yl acetate.

01/2008:1131  
corrected 6.0**METHYLPREDNISOLONE HYDROGEN  
SUCCINATE**

Methylprednisoloni hydrogenosuccinas

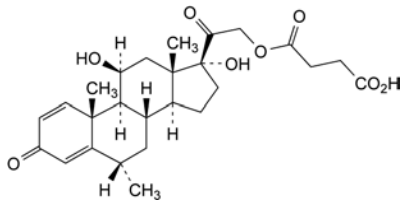
C<sub>26</sub>H<sub>34</sub>O<sub>8</sub>  
[2921-57-5]M<sub>r</sub> 474.6**DEFINITION**

4-[(11β,17-Dihydroxy-6α-methyl-3,20-dioxopregna-1,4-dien-21-yl)oxy]-4-oxobutanoic acid.

*Content*: 97.0 per cent to 103.0 per cent (dried substance).**CHARACTERS***Appearance*: white or almost white, hygroscopic powder.*Solubility*: practically insoluble in water, slightly soluble in acetone and in anhydrous ethanol. It dissolves in dilute solutions of alkali hydroxides.**IDENTIFICATION***First identification*: A, B.*Second identification*: C, D.

A. Infrared absorption spectrophotometry (2.2.24).

*Comparison*: methylprednisolone hydrogen succinate CRS.

B. Thin layer chromatography (2.2.27).

*Solvent mixture*: methanol R, methylene chloride R (1:9 V/V).*Test solution*. Dissolve 10 mg of the substance to be examined in the solvent mixture and dilute to 10 mL with the solvent mixture.*Reference solution (a)*. Dissolve 20 mg of methylprednisolone hydrogen succinate CRS in the solvent mixture and dilute to 20 mL with the solvent mixture.*Reference solution (b)*. Dissolve 10 mg of hydrocortisone hydrogen succinate CRS in reference solution (a) and dilute to 10 mL with reference solution (a).*Plate*: TLC silica gel F<sub>254</sub> plate R.*Mobile phase*: anhydrous formic acid R, anhydrous ethanol R, methylene chloride R (0.1:1:15 V/V/V).*Application*: 10 μL.*Development*: over a path of 15 cm.*Drying*: in air.*Detection A*: examine in ultraviolet light at 254 nm.*Results A*: the principal spot in the chromatogram obtained with the test solution is similar in position and size to the principal spot in the chromatogram obtained with reference solution (a).*Detection B*: spray with alcoholic solution of sulfuric acid R; heat at 120 °C for 10 min or until the spots appear and allow to cool; examine in daylight and in ultraviolet light at 365 nm.*Results B*: the principal spot in the chromatogram obtained with the test solution is similar in position, colour in daylight, fluorescence in ultraviolet light at 365 nm and size to the principal spot in the chromatogram obtained with reference solution (a).*System suitability*: reference solution (b):

- the chromatogram shows 2 spots which may, however, not be completely separated.

C. Thin layer chromatography (2.2.27).

*Test solution (a)*. Dissolve 25 mg of the substance to be examined in methanol R with gentle heating and dilute to 5 mL with the same solvent (solution A). Dilute 2 mL of this solution to 10 mL with methylene chloride R.*Test solution (b)*. Transfer 2 mL of solution A to a 15 mL glass tube with a ground-glass stopper or a polytetrafluoroethylene cap. Add 10 mL of a 0.8 g/L solution of sodium hydroxide R in methanol R and immediately pass a stream of nitrogen R through the solution for 5 min. Stopper the tube. Heat in a water-bath at 45 °C, protected from light, for 30 min. Allow to cool.*Reference solution (a)*. Dissolve 25 mg of methylprednisolone hydrogen succinate CRS in methanol R with gentle heating and dilute to 5 mL with the same solvent (solution B). Dilute 2 mL of this solution to 10 mL with methylene chloride R.*Reference solution (b)*. Transfer 2 mL of solution B to a 15 mL glass tube with a ground-glass stopper or a polytetrafluoroethylene cap. Add 10 mL of a 0.8 g/L solution of sodium hydroxide R in methanol R and immediately pass a stream of nitrogen R through the solution for 5 min. Stopper the tube. Heat in a water-bath at 45 °C, protected from light, for 30 min. Allow to cool.*Plate*: TLC silica gel F<sub>254</sub> plate R.*Mobile phase*: add a mixture of 1.2 volumes of water R and 8 volumes of methanol R to a mixture of 15 volumes of ether R and 77 volumes of methylene chloride R.*Application*: 5 μL.*Development*: over a path of 15 cm.*Drying*: in air.*Detection A*: examine in ultraviolet light at 254 nm.*Results A*: the principal spot in each of the chromatograms obtained with the test solutions is similar in position and size to the principal spot in the chromatogram obtained with the corresponding reference solution.*Detection B*: spray with alcoholic solution of sulfuric acid R. Heat at 120 °C for 10 min or until the spots appear. Allow to cool. Examine in daylight and in ultraviolet light at 365 nm.*Results B*: the principal spot in each of the chromatograms obtained with the test solutions is similar in position, colour in daylight, fluorescence in ultraviolet light at 365 nm and size to the principal spot in the chromatogram obtained with the corresponding reference solution. The principal spot in each of the chromatograms obtained with test solution (b) and reference solution (b) has an R<sub>F</sub> value distinctly higher than that of the principal spot in each of the chromatograms obtained with test solution (a) and reference solution (a).

D. Add about 2 mg to 2 mL of sulfuric acid R and shake to dissolve. Within 5 min a reddish-brown colour develops. Add this solution to 10 mL of water R and mix. The colour fades and a precipitate is formed.

**TESTS****Appearance of solution**. The solution is clear (2.2.1).

Dissolve 0.100 g in 5 mL of sodium hydrogen carbonate solution R.

**Specific optical rotation** (2.2.7): + 87 to + 95 (dried substance).

Dissolve 0.250 g in dioxan R and dilute to 25.0 mL with the same solvent.

**Related substances**. Liquid chromatography (2.2.29).*Test solution*. Dissolve 25.0 mg of the substance to be examined in the mobile phase and dilute to 10.0 mL with the mobile phase.

**Reference solution (a).** Dissolve 25 mg of *methylprednisolone hydrogen succinate* for performance test CRS in the mobile phase and dilute to 10.0 mL with the mobile phase.

**Reference solution (b).** Dilute 1.0 mL of the test solution to 100.0 mL with the mobile phase.

**Column:**

- size:  $l = 0.25$  m,  $\varnothing = 4.0$  mm;
- stationary phase: octadecylsilyl silica gel for chromatography R (5  $\mu$ m).

**Mobile phase:** acetonitrile R, 3 per cent V/V solution of glacial acetic acid R (33:67 V/V).

**Flow rate:** 1 mL/min.

**Detection:** spectrophotometer at 254 nm.

**Equilibration:** with the mobile phase for about 30 min.

**Injection:** 20  $\mu$ L.

**Run time:** twice the retention time of methylprednisolone hydrogen succinate.

**Retention time:** methylprednisolone hydrogen succinate = about 22 min; impurity D (eluting immediately after the main peak and appearing as a shoulder) = about 24 min.

**System suitability:** reference solution (a):

- **peak-to-valley ratio:** minimum 4, where  $H_p$  = height above the base line of the peak due to impurity D and  $H_v$  = height above the base line of the lowest point of the curve separating this peak from the peak due to methylprednisolone hydrogen succinate; if necessary, adjust the concentration of acetonitrile in the mobile phase.

**Limits:**

- **impurities A, B, C, D:** for each impurity, not more than 0.5 times the area of the principal peak in the chromatogram obtained with reference solution (b) (0.5 per cent);
- **total:** not more than the area of the principal peak in the chromatogram obtained with reference solution (b) (1 per cent);
- **disregard limit:** 0.05 times the area of the principal peak in the chromatogram obtained with reference solution (b) (0.05 per cent).

**Loss on drying (2.2.32):** maximum 1.0 per cent, determined on 1.000 g by drying in an oven at 105 °C.

**Sulfated ash (2.4.14):** maximum 0.1 per cent, determined on 1.0 g.

**ASSAY**

Dissolve 50.0 mg in *ethanol (96 per cent) R* and dilute to 100.0 mL with the same solvent. Dilute 2.0 mL of this solution to 50.0 mL with *ethanol (96 per cent) R*. Measure the absorbance (2.2.25) at the absorption maximum at 243 nm.

Calculate the content of  $C_{26}H_{34}O_8$  taking the specific absorbance to be 316.

**STORAGE**

In an airtight container, protected from light.

**IMPURITIES**

**Specified impurities:** A, B, C, D.

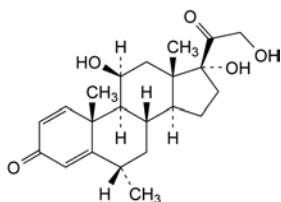

- A. 11 $\beta$ ,17,21-trihydroxy-6 $\alpha$ -methylpregna-1,4-diene-3,20-dione (methylprednisolone),

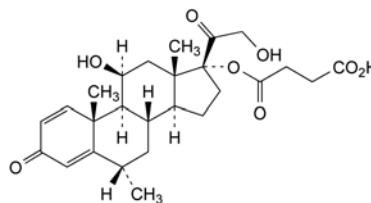

- B. 4-[(11 $\beta$ ,21-dihydroxy-6 $\alpha$ -methyl-3,20-dioxopregna-1,4-dien-17-yl)oxy]-4-oxobutanoic acid (methylprednisolone 17-(hydrogen succinate)),

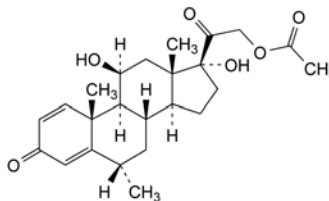

- C. 11 $\beta$ ,17-dihydroxy-6 $\alpha$ -methyl-3,20-dioxopregna-1,4-dien-21-yl acetate (methylprednisolone acetate),

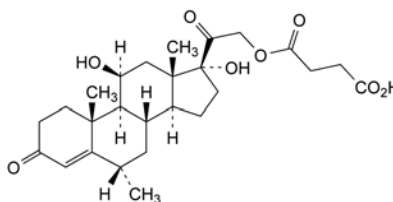

- D. 4-[(11 $\beta$ ,17-dihydroxy-6 $\alpha$ -methyl-3,20-dioxopregn-4-en-21-yl)oxy]-4-oxobutanoic acid (methylhydrocortisone 21-(hydrogen succinate)).

01/2008:1675

## N-METHYLPYRROLIDONE

### N-Methylpyrrolidonum



$C_5H_9NO$   
[872-50-4]

$M_r$  99.1

**DEFINITION**

1-Methylpyrrolidin-2-one.

**CHARACTERS**

**Appearance:** clear, colourless liquid.

**Solubility:** miscible with water and with alcohol.  
bp: about 204 °C.

**Relative density:** about 1.034.

**Refractive index:** about 1.469.

**IDENTIFICATION**

Infrared absorption spectrophotometry (2.2.24).

**Preparation:** films.

**Comparison:** Ph. Eur. reference spectrum of *N-methylpyrrolidone*.

**TESTS**

**Appearance.** The substance to be examined is clear (2.2.1) and colourless (2.2.2, *Method II*).

**Alkalinity.** Dissolve 50 mL of the substance to be examined in 50 mL of *water R* previously adjusted with 0.02 M *potassium hydroxide* or 0.02 M *hydrochloric acid* until a yellow colour is obtained using 0.5 mL of *bromothymol blue solution RI* as

indicator. Titrate with 0.02 M hydrochloric acid to the initial coloration. Not more than 8.0 mL of 0.02 M hydrochloric acid is required.

**Related substances.** Gas chromatography (2.2.28): use the normalisation procedure.

**Test solution.** The substance to be examined.

**Reference solution.** To 1 mL of the substance to be examined, add 1 mL of 2-pyrrolidone R and dilute to 20 mL with methylene chloride R.

**Column:**

- material: fused silica,
- size:  $l = 30$  m,  $\varnothing = 0.32$  mm,
- stationary phase: poly(dimethyl)siloxane R (5  $\mu$ m).

**Carrier gas:** nitrogen for chromatography R.

**Linear velocity:** 20 cm/s.

**Split ratio:** 1:100.

**Temperature:**

	Time (min)	Temperature (°C)
Column	0	100
	0 - 23.3	100 → 170
	23.3 - 53	170
Injection port		280
Detector		280

**Detection:** flame ionisation.

**Injection:** 1  $\mu$ L.

**System suitability:** reference solution:

- resolution: minimum 2.0 between the peaks due to *N*-methylpyrrolidone and impurity G.

**Limits:**

- any impurity: maximum 0.1 per cent,
- total: maximum 0.3 per cent,
- disregard limit: 0.02 per cent.

**Heavy metals** (2.4.8): maximum 10 ppm.

Dissolve 4.0 g in water R and dilute to 20.0 mL with the same solvent. 12 mL of the solution complies with limit test A. Prepare the standard using lead standard solution (2 ppm Pb) R.

**Water** (2.5.32): maximum 0.1 per cent, determined on 1.000 g.

#### STORAGE

Protected from light.

#### IMPURITIES

$\text{H}_3\text{C}-\text{NH}_2$

A. methanamine (methylamine),



B. dihydrofuran-2(3H)-one ( $\gamma$ -butyrolactone),

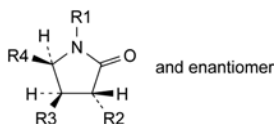

C.  $\text{R}_1 = \text{R}_2 = \text{CH}_3$ ,  $\text{R}_3 = \text{R}_4 = \text{H}$ : (3*RS*)-1,3-dimethylpyrrolidin-2-one,

D.  $\text{R}_1 = \text{R}_3 = \text{CH}_3$ ,  $\text{R}_2 = \text{R}_4 = \text{H}$ : (4*RS*)-1,4-dimethylpyrrolidin-2-one,

E.  $\text{R}_1 = \text{R}_4 = \text{CH}_3$ ,  $\text{R}_2 = \text{R}_3 = \text{H}$ : (5*RS*)-1,5-dimethylpyrrolidin-2-one,

G.  $\text{R}_1 = \text{R}_2 = \text{R}_3 = \text{R}_4 = \text{H}$ : pyrrolidin-2-one (2-pyrrolidone),

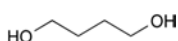

F. butane-1,4-diol,

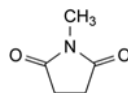

H. 1-methylpyrrolidine-2,5-dione (*N*-methylsuccinimide),

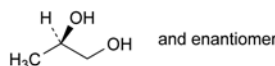

I. (*RS*)-propane-1,2-diol (propylene glycol).

01/2008:1990

## METHYLOSANILINIUM CHLORIDE

### Methylrosanilini chloridum

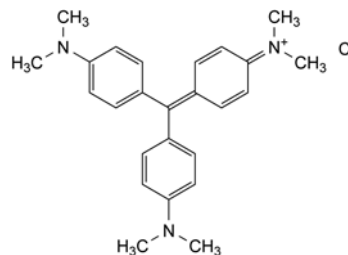

$\text{C}_{25}\text{H}_{30}\text{ClN}_3$   
[548-62-9]

$M_r$  408.0

#### DEFINITION

*N*-[4-[Bis[4(dimethylamino)phenyl]methylene]cyclohexa-2,5-dienylidene]-*N*-methylmethanaminium chloride (hexamethyl-*p*-rosanilinium chloride). It contains not more than 10 per cent of pentamethyl-*p*-rosanilinium chloride and is also known as crystal violet and gentian violet.

**Content:** 95.0 per cent to 103.0 per cent (anhydrous substance).

#### CHARACTERS

**Appearance:** dark green, shiny powder, hygroscopic.

**Solubility:** sparingly soluble in water, freely soluble in ethanol (96 per cent) and in methylene chloride.

#### IDENTIFICATION

**First identification:** A.

**Second identification:** B, C.

A. Infrared absorption spectrophotometry (2.2.24).

**Comparison:** methylrosanilinium chloride CRS.

B. Thin-layer chromatography (2.2.27).

**Test solution.** Dissolve 10 mg of the substance to be examined in methanol R and dilute to 10 mL with the same solvent.

**Reference solution.** Dissolve 10 mg of methylrosanilinium chloride CRS in methanol R and dilute to 10 mL with the same solvent.

**Plate:** TLC silica gel G plate R.

**Mobile phase:** glacial acetic acid R, water R, butanol R (17:17:66 V/V/V).

**Application:** 2  $\mu$ L.

**Development:** over 2/3 of the plate.

**Drying:** in air.

**Detection:** examine in daylight.

**Results:** the principal spot in the chromatogram obtained with the test solution is similar in position, colour and size to the principal spot in the chromatogram obtained with the reference solution. In the chromatogram obtained with the test solution, a secondary spot may be observed.

C. Dissolve 50 mg in water R and dilute to 5 mL with the same solvent; add 3 mL of dilute sulfuric acid R, 1 g of zinc powder R and heat gently. The mixture decolourises.

Filter. To 3 mL of the filtrate add 0.5 mL of *silver nitrate solution R1*. A white turbidity is produced which slowly forms a dark, coagulating precipitate.

## TESTS

***N,N*-Dimethylaniline** (2.4.26, *Method A*): maximum 100 ppm.

**Test solution.** Dissolve in a ground-glass-stoppered tube 0.50 g of the substance to be examined in 30.0 mL of *water R*. Add 1.0 mL of the internal standard solution. Adjust the solution to 26–28 °C. Add 1.0 mL of *strong sodium hydroxide solution R* and mix for 2 min. Add 2.0 mL of *trimethylpentane R*. Shake for 2 min and centrifuge. Use the upper layer.

**Reference solution.** Dissolve 50.0 mg of *N,N*-dimethylaniline *R* in 4.0 mL of 0.1 M *hydrochloric acid* and dilute to 50.0 mL with *water R*. Dilute 1.0 mL of this solution to 100.0 mL with *water R*. To 0.50 g of the substance to be examined add 5.0 mL of this solution and dilute to 30.0 mL with *water R*. Add 1.0 mL of the internal standard solution and 1.0 mL of *strong sodium hydroxide solution R*. Add 2.0 mL of *trimethylpentane R*. Shake for 2 min and centrifuge. Use the upper layer.

## Limit:

- calculate the ratio (*R*) of the area of the peak due to *N,N*-dimethylaniline to the area of the peak due to the internal standard from the chromatogram obtained with the reference solution; from the chromatogram obtained with the test solution, calculate the ratio of the area of the peak due to *N,N*-dimethylaniline to the area of the peak due to the internal standard: this ratio is not greater than 0.5 *R*.

**Pentamethyl-*p*-rosanilinium.** Liquid chromatography (2.2.29): use the normalisation procedure.

**Test solution.** Dissolve 30.0 mg of the substance to be examined in *ethanol (96 per cent) R* and dilute to 100.0 mL with the same solvent.

**Reference solution (a).** Dissolve 3.0 mg of *methylrosanilinium for system suitability CRS* in *ethanol (96 per cent) R* and dilute to 10.0 mL with the same solvent.

**Reference solution (b).** Dilute 1.0 mL of the test solution to 20.0 mL with *ethanol (96 per cent) R*. Dilute 1.0 mL of this solution to 100.0 mL with *ethanol (96 per cent) R*.

## Column:

- size: *l* = 0.25 m, Ø = 4.6 mm,
- stationary phase: spherical *octylsilyl silica gel for chromatography R* (5 µm).

**Mobile phase:** *glacial acetic acid R*, *water R*, *methanol R* (10:190:800 *V/V/V*).

**Flow rate:** 1 mL/min.

**Detection:** spectrophotometer at 589 nm.

**Injection:** 20 µL.

**Run time:** 2.5 times the retention time of the principal peak.

**System suitability:** reference solution (a):

- resolution: peak due to pentamethyl-*p*-rosanilinium is baseline separated from the peak due to methylrosanilinium.

Locate the peak due to pentamethyl-*p*-rosanilinium using the chromatogram provided with *methylrosanilinium for system suitability CRS*.

## Limits:

- pentamethyl-*p*-rosanilinium: maximum 10 per cent.

**Related substances.** Liquid chromatography (2.2.29) as described in the test for pentamethyl-*p*-rosanilinium.

## Limits:

- impurity *A*: maximum 1.0 per cent;
- any other impurity: for each impurity, maximum 0.1 per cent;
- sum of impurities other than *A*: maximum 1.0 per cent;
- disregard limit: the area of the principal peak in the chromatogram obtained with reference solution (b) (0.05 per cent); disregard the peak due to pentamethyl-*p*-rosanilinium.

**Substances insoluble in ethanol (90 per cent *V/V*):** maximum 0.5 per cent.

In a conical flask introduce 1.0 g and add 50 mL of *ethanol (90 per cent *V/V*) R*. Boil under a reflux sintered glass filter (16) (2.1.2) previously dried at 100–105 °C. Wash with hot *ethanol (90 per cent *V/V*) R* until a colourless filtrate is obtained. Dry at 100–105 °C until constant weight.

**Water** (2.5.12): maximum 10.0 per cent, determined on 0.100 g.

**Sulfated ash** (2.4.14): maximum 1.5 per cent, determined on 1.0 g.

## ASSAY

Dissolve 50.0 mg in *ethanol (96 per cent) R* and dilute to 100.0 mL with the same solvent. Dilute 2.0 mL of the solution to 250.0 mL with *ethanol (96 per cent) R*. Measure the absorbance (2.2.25) at the maximum at 589 nm.

Calculate the content of  $C_{25}H_{30}ClN_3$  taking the specific absorbance to be 2605.

## STORAGE

In an airtight container.

## IMPURITIES

**Specified impurities:** *A*.

- A*. impurity of unknown structure with a relative retention of about 0.7.

01/2008:0230  
corrected 7.0

## METHYL SALICYLATE

## Methylis salicylas

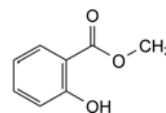

$C_8H_8O_3$   
[119-36-8]

$M_r$  152.1

## DEFINITION

Methyl 2-hydroxybenzoate.

**Content:** 99.0 per cent *m/m* to 100.5 per cent *m/m*.

## CHARACTERS

**Appearance:** colourless or slightly yellow liquid.

**Solubility:** very slightly soluble in water, miscible with ethanol (96 per cent) and with fatty and essential oils.

## IDENTIFICATION

**A.** Heat 0.25 mL with 2 mL of *dilute sodium hydroxide solution R* on a water-bath for 5 min. Add 3 mL of *dilute sulfuric acid R*. A crystalline precipitate is formed. Filter. The precipitate washed with *water R* and dried at 100–105 °C, melts (2.2.14) at 156 °C to 161 °C.

**B.** To 10 mL of a saturated solution add 0.05 mL of *ferric chloride solution R1*. A violet colour develops.

## TESTS

**Appearance of solution.** The solution is clear (2.2.1) and not more intensely coloured than reference solution  $Y_7$  (2.2.2, *Method II*).

To 2 mL add 10 mL of *ethanol (96 per cent) R*.

**Acidity.** Dissolve 5.0 g in a mixture of 0.2 mL of *bromocresol green solution R* and 50 mL of *ethanol (96 per cent) R* previously neutralised to a blue colour by addition of 0.1 M *sodium hydroxide*. Not more than 0.4 mL of 0.1 M *sodium hydroxide* is required to restore the blue colour.

**Relative density** (2.2.5): 1.180 to 1.186.

**Refractive index** (2.2.6): 1.535 to 1.538.

#### ASSAY

Dissolve 0.500 g in 25 mL of *ethanol (96 per cent) R*. Add 0.05 mL of *phenol red solution R* and neutralise with 0.1 M *sodium hydroxide*. To the neutralised solution add 50.0 mL of 0.1 M *sodium hydroxide* and heat under a reflux condenser on a water-bath for 30 min. Cool and titrate with 0.1 M *hydrochloric acid*. Calculate the volume of 0.1 M *sodium hydroxide* used in the saponification. Carry out a blank titration.

1 mL of 0.1 M *sodium hydroxide* is equivalent to 15.21 mg of  $C_{20}H_{30}O_2$ .

#### STORAGE

Protected from light.

07/2008:0410  
corrected 6.3

## METHYLTESTOSTERONE

### Methyltestosteronum

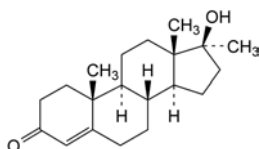

$C_{20}H_{30}O_2$   
[58-18-4]

$M_r$  302.5

#### DEFINITION

17 $\beta$ -Hydroxy-17-methylandrosta-4-en-3-one.

**Content:** 97.0 per cent to 103.0 per cent (dried substance).

#### CHARACTERS

**Appearance:** white or slightly yellowish-white, crystalline powder.

**Solubility:** practically insoluble in water, freely soluble in ethanol (96 per cent).

#### IDENTIFICATION

**First identification:** B.

**Second identification:** A, C.

A. Melting point (2.2.14): 162 °C to 168 °C.

B. Infrared absorption spectrophotometry (2.2.24).

*Comparison:* methyltestosterone CRS.

C. Thin-layer chromatography (2.2.27).

**Test solution.** Dissolve 0.2 g of the substance to be examined in a mixture of 1 volume of *methanol R* and 9 volumes of *chloroform R* and dilute to 10 mL with the same mixture of solvents.

**Reference solution.** Dissolve 20 mg of *methyltestosterone CRS* in 1 mL of a mixture of 1 volume of *methanol R* and 9 volumes of *chloroform R*.

**Plate:** TLC silica gel  $F_{254}$  plate R.

**Mobile phase:** anhydrous acetic acid R, light petroleum R, butyl acetate R (1:30:70 V/V/V).

**Application:** 5  $\mu$ L.

**Development:** over 2/3 of the plate.

**Drying:** in air.

**Detection:** examine in ultraviolet light at 254 nm and spray with a saturated solution of *potassium dichromate R* in a mixture of 30 volumes of *water R* and 70 volumes of *sulfuric acid R*. Examine immediately in daylight.

**Results:** the principal spot in the chromatogram obtained with the test solution is similar in position, colour and size to the principal spot in the chromatogram obtained with the reference solution.

#### TESTS

**Specific optical rotation** (2.2.7): + 79 to + 85 (dried substance).

Dissolve 0.250 g in *ethanol (96 per cent) R* and dilute to 25.0 mL with the same solvent.

**Related substances.** Liquid chromatography (2.2.29).

**Test solution.** Dissolve 50 mg of the substance to be examined in *methanol R* and dilute to 100.0 mL with the same solvent.

**Reference solution (a).** Dilute 0.5 mL of the test solution to 100.0 mL with *methanol R*.

**Reference solution (b).** Dissolve 5 mg of *methyltestosterone for system suitability CRS* (containing impurity A) in *methanol R* and dilute to 10 mL with the same solvent.

**Column:**

– size:  $l = 0.25$  m,  $\varnothing = 4.6$  mm;

– stationary phase: end-capped octadecylsilyl silica gel for chromatography R (5  $\mu$ m).

**Mobile phase:**

– mobile phase A: water R;

– mobile phase B: methanol R;

Time (min)	Mobile phase A (per cent V/V)	Mobile phase B (per cent V/V)
0 - 15	30	70
15 - 45	30 $\rightarrow$ 0	70 $\rightarrow$ 100
45 - 50	0	100

**Flow rate:** 1.5 mL/min.

**Detection:** spectrophotometer at 254 nm.

**Injection:** 20  $\mu$ L.

**Identification of impurities:** use the chromatogram supplied with *methyltestosterone for system suitability CRS* and the chromatogram obtained with reference solution (b) to identify the peak due to impurity A.

**Relative retention** with reference to methyltestosterone (retention time = about 8 min): impurity A = about 1.5.

**System suitability:** reference solution (b):

– resolution: minimum 5 between the peaks due to methyltestosterone and impurity A.

**Limits:**

– impurity A: not more than the area of the principal peak in the chromatogram obtained with reference solution (a) (0.5 per cent);

– unspecified impurities: for each impurity, not more than 0.2 times the area of the principal peak in the chromatogram obtained with reference solution (a) (0.10 per cent);

– total: not more than twice the area of the principal peak in the chromatogram obtained with reference solution (a) (1.0 per cent);

– disregard limit: 0.1 times the area of the principal peak in the chromatogram obtained with reference solution (a) (0.05 per cent).

**Loss on drying** (2.2.32): maximum 2.0 per cent, determined on 0.500 g by drying in an oven at 105 °C for 2 h.

#### ASSAY

Dissolve 50.0 mg in *ethanol (96 per cent) R* and dilute to 50.0 mL with the same solvent. Dilute 10.0 mL of the solution to 100.0 mL with *ethanol (96 per cent) R*. Dilute 10.0 mL of this solution to 100.0 mL with *ethanol (96 per cent) R*. Measure the absorbance (2.2.25) at the absorption maximum at 241 nm.

Calculate the content of  $C_{20}H_{30}O_2$ , taking the specific absorbance to be 540.



## STORAGE

Protected from light.

## IMPURITIES

Specified impurities: A.

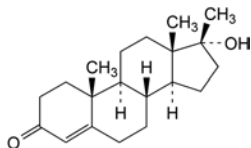

A. 17 $\alpha$ -hydroxy-17-methylandrosta-4-en-3-one.

01/2008:1132  
corrected 7.0

## METHYLTHIONINIUM CHLORIDE

## Methylthioninii chloridum

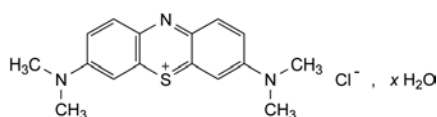

$C_{16}H_{18}ClN_3 \cdot xH_2O$

$M_r$  319.9 (anhydrous substance)

## DEFINITION

3,7-Bis(dimethylamino)phenothiazin-5-ylum chloride (methylene blue).

Content: 95.0 per cent to 101.0 per cent (dried substance).

## CHARACTERS

Appearance: dark blue, crystalline powder with a copper-coloured sheen, or green crystals with a bronze-coloured sheen.

Solubility: soluble in water, slightly soluble in ethanol (96 per cent).

## IDENTIFICATION

A. Ultraviolet and visible absorption spectrophotometry (2.2.25).

Test solution. Dissolve 10 mg in dilute hydrochloric acid R and dilute to 100 mL with the same acid. Dilute 5 mL of the solution to 100 mL with dilute hydrochloric acid R.

Spectral range: 240-800 nm.

Absorption maxima: at 255-260 nm, 285-290 nm, 675-685 nm and 740-750 nm.

B. Thin-layer chromatography (2.2.27).

Test solution. Dissolve 10 mg of the substance to be examined in methanol R and dilute to 10 mL with the same solvent. Dilute 1 mL of the solution to 10 mL with methanol R.

Reference solution. Dissolve 10 mg of methylthioninium chloride CRS in methanol R and dilute to 10 mL with the same solvent. Dilute 1 mL of the solution to 10 mL with methanol R.

Plate: TLC silica gel plate R.

Mobile phase: anhydrous formic acid R, propanol R (20:80 V/V).

Application: 2  $\mu$ L.

Development: over a path of 8 cm.

Drying: in air, protected from light.

Detection: examine in daylight.

Results: the principal spot in the chromatogram obtained with the test solution is similar in position and size to the principal spot in the chromatogram obtained with the reference solution. A secondary spot may appear above the principal spot in both chromatograms.

- C. Dissolve about 1 mg in 10 mL of water R. Add 1 mL of glacial acetic acid R and 0.1 g of zinc powder R. Heat to boiling. The solution becomes colourless. Filter and shake the filtrate. It becomes blue on contact with air.
- D. Ignite 50 mg with 0.5 g of anhydrous sodium carbonate R. Cool and dissolve the residue in 10 mL of dilute nitric acid R. Filter. The filtrate, without further addition of dilute nitric acid R, gives reaction (a) of chlorides (2.3.1).

## TESTS

**Methanol-insoluble substances:** maximum 10.0 mg (1.0 per cent).

To 1.0 g add 20 mL of methanol R and boil under a reflux condenser for 5 min. Filter through a tared sintered-glass filter (40) (2.1.2) and wash the filter with methanol R until a colourless filtrate is obtained. Dry the filter at 100 °C and weigh.

**Related substances.** Liquid chromatography (2.2.29).

Test solution. Dissolve 15.0 mg of the substance to be examined in the mobile phase and dilute to 100.0 mL with the mobile phase.

Reference solution (a). Dissolve 7.5 mg of methylthioninium impurity A CRS in the mobile phase and dilute to 50.0 mL with the mobile phase. To 1.0 mL of this solution add 1.0 mL of the test solution and dilute to 10.0 mL with the mobile phase.

Reference solution (b). Dilute 1.0 mL of the test solution to 100.0 mL with the mobile phase.

## Column:

- size:  $l = 0.25$  m,  $\varnothing = 4$  mm,
- stationary phase: octadecylsilyl silica gel for chromatography R (7  $\mu$ m).

Mobile phase: mix 27 volumes of acetonitrile R and 73 volumes of a mixture of 3.4 mL of phosphoric acid R and 1000 mL of water R.

Flow rate: 1 mL/min.

Detection: spectrophotometer at 246 nm.

Injection: 20  $\mu$ L.

Run time: twice the retention time of methylthioninium.

Relative retention with reference to methylthioninium (retention time = about 11 min): impurity A = about 0.7.

System suitability: reference solution (a):

- resolution: minimum 1.5 between the peaks due to impurity A and methylthioninium. If necessary, adjust the concentration of acetonitrile in the mobile phase.

## Limits:

- impurity A: not more than 5 times the area of the principal peak in the chromatogram obtained with reference solution (b) (5.0 per cent),
- any other impurity: for each impurity, not more than 0.5 times the area of the principal peak in the chromatogram obtained with reference solution (b) (0.5 per cent),
- sum of impurities other than A: not more than the area of the principal peak in the chromatogram obtained with reference solution (b) (1.0 per cent),
- disregard limit: 0.1 times the area of the principal peak in the chromatogram obtained with reference solution (b) (0.1 per cent).

**Metals.** Atomic emission spectrometry (2.2.22) in argon plasma, using as detector a conventional optical system or a mass spectrometer; in the case of a mass spectrometer, use indium as internal standard.

Test solution. In a 10 mL volumetric flask, dissolve with stirring 100 mg of the substance to be examined in 9 mL of water R, add 100.0  $\mu$ L of a 10  $\mu$ g/mL solution of indium prepared from indium elementary standard solution for atomic spectrometry (1.000 g/L) R in nitric acid R which has been diluted fifty-fold with water R. Dilute to 10.0 mL with water R.

**Reference solutions.** Into a 100 mL volumetric flask, introduce 10.0 mL of a standard solution containing 1.00 µg/mL of each of the metals to be determined and prepared by dilution, with *water R*, of each *elementary standard solution for atomic spectrometry (1.000 g/L) R* for the corresponding elements. Add 1.00 mL of a 10 µg/mL solution of indium prepared from indium *elementary standard solution for atomic spectrometry (1.000 g/L) R* in *nitric acid R* which has been diluted fifty-fold with *water R*. Dilute to 100.0 mL with *water R*.

**Blank solution.** Dilute one hundred-fold with *water R* the 10 µg/mL solution of indium used for the test and reference solutions.

Element	Optical detection			Mass detection
	Signal (nm)	Background 1 (nm)	Background 2 (nm)	Isotope
Aluminium	396.15	396.05	396.25	27
Cadmium	214.44	214.37	214.51	114
Chromium	283.56	283.49	283.64	*
Copper	327.40	327.31	327.48	65
Tin	190.00**	189.90	190.10	118
Iron	238.20	238.27	238.14	*
Manganese	260.57	260.50	260.64	55
Mercury	253.70***	253.60	253.80	200
Molybdenum	202.03	202.02	202.04	95
Nickel	231.60	231.54	231.66	60
Lead	217.00**	216.90	217.10	208
Zinc	213.86	213.80	213.91	66
Indium				115

\*Element difficult, if not impossible, to be determined with a mass spectrometer as detector.

\*\*Borderline sensitivity with conventional optical spectrometry.

\*\*\*Mercury is often impossible to determine using conventional optical spectrometry; it may be quantified using a device for the determination of hydrides.

Element	Maximum content in ppm
Aluminium	100 ppm
Cadmium	1 ppm
Chromium	100 ppm
Copper	300 ppm
Tin	10 ppm
Iron	200 ppm
Manganese	10 ppm
Mercury	1 ppm
Molybdenum	10 ppm
Nickel	10 ppm
Lead	10 ppm
Zinc	100 ppm

**Loss on drying (2.2.32):** 8.0 per cent to 22.0 per cent, determined on 1.000 g by drying in an oven at 105 °C.

**Sulfated ash (2.4.14):** maximum 0.25 per cent, determined on 1.0 g.

#### ASSAY

Dissolve 0.300 g in 30 mL of *water R* with heating. Cool, add 50.0 mL of *potassium dichromate solution RI* and dilute to 100.0 mL with *water R*. Allow to stand for 10 min. Filter and discard the first 20 mL of filtrate. Introduce 50.0 mL of the filtrate into a flask with a ground-glass neck, add 50 mL of *dilute*

*sulfuric acid R* and 8.0 mL of *potassium iodide solution R*. Allow to stand protected from light for 5 min, then add 80 mL of *water R*. Titrate with 0.1 M *sodium thiosulfate* using 2 mL of *starch solution R*, added towards the end of the titration, as indicator. Carry out a blank titration.

1 mL of 0.1 M *sodium thiosulfate* is equivalent to 10.66 mg of C<sub>16</sub>H<sub>18</sub>ClN<sub>3</sub>S.

#### STORAGE

In an airtight container, protected from light.

#### IMPURITIES

*Specified impurities: A.*

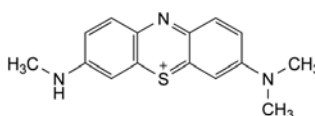

A. 3-(dimethylamino)-7-(methylamino)phenothiazin-5-ylum.

01/2008:1347

## METIXENE HYDROCHLORIDE

### Metixeni hydrochloridum

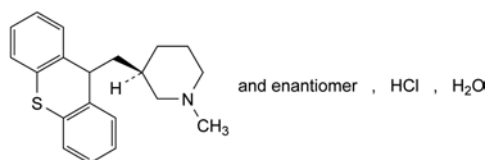

C<sub>20</sub>H<sub>24</sub>ClNS, H<sub>2</sub>O  
[7081-40-5]

M<sub>r</sub> 363.9

#### DEFINITION

Metixene hydrochloride contains not less than 98.0 per cent and not more than the equivalent of 102.0 per cent of (*RS*)-1-methyl-3-[(9*H*-thioxanthen-9-yl)methyl]piperidine hydrochloride, calculated with reference to the dried substance.

#### CHARACTERS

A white or almost white, crystalline or fine crystalline powder, soluble in water, soluble in alcohol and in methylene chloride.

#### IDENTIFICATION

- A. Examine by infrared absorption spectrophotometry (2.2.24), comparing with the spectrum obtained with *metixene hydrochloride CRS*.
- B. It gives reaction (a) of chlorides (2.3.1).

#### TESTS

**Appearance of solution.** Dissolve 0.40 g in *methanol R* and dilute to 20.0 mL with the same solvent. The solution is clear (2.2.1) and not more intensely coloured than reference solution Y<sub>6</sub> (2.2.2, *Method I*).

**pH (2.2.3).** Dissolve 0.18 g in *carbon dioxide-free water R* heating if necessary at about 50 °C, cool and dilute to 10.0 mL with the same solvent. The pH of the solution, measured immediately, is 4.4 to 5.8.

**Related substances.** Examine by thin-layer chromatography (2.2.27), using a *TLC silica gel plate R*. Carry out the test rapidly and protected from light.

**Test solution.** Dissolve 50 mg of the substance to be examined in *methylene chloride R* and dilute to 5.0 mL with the same solvent.

**Reference solution (a).** Dissolve 5 mg of *metixene hydrochloride CRS* in *methylene chloride R* and dilute to 100.0 mL with the same solvent.

07/2008:1348

*Reference solution (b).* Dissolve 20 mg of *thioxanthene CRS* in 50 mL of *methylene chloride R*. Dilute 1.0 mL of the solution to 20.0 mL with *methylene chloride R*.

*Reference solution (c).* Dissolve 5 mg of *thioxanthone CRS* in 50 mL of *methylene chloride R*. Dilute 1.0 mL of the solution to 20.0 mL with *methylene chloride R*.

*Reference solution (d).* Dilute 4 mL of reference solution (a) to 10.0 mL with *methylene chloride R*.

Apply to the plate as narrow bands 5 µL of each solution. Develop over a path of 10 cm using a mixture of 10 volumes of *glacial acetic acid R*, 10 volumes of *methanol R* and 80 volumes of *methylene chloride R*. Dry the plate in a stream of cold air. Spray with a mixture of 1 volume of *sulfuric acid R* and 9 volumes of *alcohol R* and heat at 100 °C for 10 min. Allow the plate to cool and examine in ultraviolet light at 365 nm. Thioxanthene shows orange fluorescence and thioxanthone shows greenish-blue fluorescence. Any band corresponding to thioxanthene in the chromatogram obtained with the test solution is not more intense than the band in the chromatogram obtained with reference solution (b) (0.2 per cent); any band corresponding to thioxanthone in the chromatogram obtained with the test solution is not more intense than the band in the chromatogram obtained with reference solution (c) (0.05 per cent); any band, apart from the principal band and the bands corresponding to thioxanthene and thioxanthone, is not more intense than the band in the chromatogram obtained with reference solution (a) (0.5 per cent) and at most one such band is more intense than the band in the chromatogram obtained with reference solution (d) (0.2 per cent). The test is not valid unless the bands in the chromatograms obtained with reference solutions (b) and (c) are clearly visible and differentiated.

**Loss on drying (2.2.32).** Not less than 4.0 per cent and not more than 6.0 per cent, determined on 0.500 g by drying in an oven at 138-142 °C.

**Sulfated ash (2.4.14).** Not more than 0.1 per cent, determined on 1.0 g.

#### ASSAY

Dissolve 0.250 g in a mixture of 5.0 mL of 0.01 M *hydrochloric acid* and 50 mL of *alcohol R*. Carry out a potentiometric titration (2.2.20), using 0.1 M *sodium hydroxide*. Read the volume added between the 2 points of inflexion.

1 mL of 0.1 M *sodium hydroxide* is equivalent to 34.59 mg of C<sub>20</sub>H<sub>24</sub>ClN<sub>3</sub>O<sub>2</sub>.

#### STORAGE

Store protected from light.

#### IMPURITIES

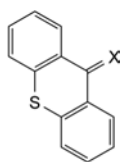

A. X = H<sub>2</sub>: 9*H*-thioxanthene,

B. X = O: 9*H*-thioxanthone (thioxanthone).

## METOCLOPRAMIDE

### Metoclopramidum

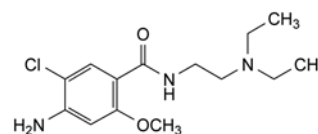

C<sub>14</sub>H<sub>22</sub>ClN<sub>3</sub>O<sub>2</sub>  
[364-62-5]

M<sub>r</sub> 299.8

#### DEFINITION

4-Amino-5-chloro-*N*-[2-(diethylamino)ethyl]-2-methoxybenzamide.

*Content:* 99.0 per cent to 101.0 per cent (dried substance).

#### CHARACTERS

*Appearance:* white or almost white, fine powder.

*Solubility:* practically insoluble in water, sparingly soluble or slightly soluble in ethanol (96 per cent), slightly soluble in methylene chloride.

It shows polymorphism (5.9).

#### IDENTIFICATION

*First identification:* A, B.

*Second identification:* A, C.

A. Melting point (2.2.14): 145 °C to 149 °C.

B. Infrared absorption spectrophotometry (2.2.24).

*Comparison:* metoclopramide CRS.

C. Examine the chromatograms obtained in test A for related substances.

*Detection:* examine in ultraviolet light at 254 nm before spraying with *dimethylaminobenzaldehyde solution RI*.

*Results:* the principal spot in the chromatogram obtained with test solution (a) is similar in position and size to the principal spot in the chromatogram obtained with reference solution (a).

#### TESTS

**Appearance of solution.** The freshly prepared solution is clear (2.2.1) and not more intensely coloured than reference solution Y<sub>6</sub> (2.2.2, *Method II*).

Dissolve 2.5 g in 25 mL of 1 M *hydrochloric acid*.

#### Related substances

A. Thin-layer chromatography (2.2.27).

*Test solution (a).* Dissolve 40 mg of the substance to be examined in *methanol R* and dilute to 10 mL with the same solvent.

*Test solution (b).* Dissolve 0.160 g of the substance to be examined in *methanol R* and dilute to 10 mL with the same solvent.

*Reference solution (a).* Dissolve 20 mg of *metoclopramide CRS* and 10 mg of *sulpiride CRS* in *methanol R* and dilute to 5 mL with the same solvent.

*Reference solution (b).* Dissolve 20 mg of *N,N*-diethylethane-1,2-diamine *R* (impurity E) in *methanol R* and dilute to 50 mL with the same solvent. Dilute 2 mL of this solution to 25 mL with *methanol R*.

*Plate:* TLC silica gel F<sub>254</sub> plate *R*.

*Mobile phase:* concentrated ammonia *R*, dioxan *R*, methanol *R*, methylene chloride *R* (2:10:14:90 V/V/V/V).

*Application:* 10 µL.

*Development:* over 2/3 of the plate.

*Drying:* in air.

**Detection:** examine in ultraviolet light at 254 nm (identification C), then spray with *dimethylaminobenzaldehyde solution R1* and allow to dry in air.

**System suitability:** reference solution (a):

- the chromatogram shows 2 clearly separated spots.

**Limit:** test solution (b):

- *impurity E*: any spot due to impurity E (not visualised in ultraviolet light at 254 nm) is not more intense than the corresponding spot in the chromatogram obtained with reference solution (b) (0.2 per cent).

#### B. Liquid chromatography (2.2.29).

**Test solution.** Dissolve 10.0 mg of the substance to be examined in the mobile phase and dilute to 10.0 mL with the mobile phase.

**Reference solution (a).** Dilute 0.2 mL of the test solution to 100.0 mL with the mobile phase.

**Reference solution (b).** Dissolve 10 mg of *metoclopramide impurity A CRS* in the mobile phase and dilute to 100 mL with the mobile phase. Mix 1 mL of this solution with 0.1 mL of the test solution and dilute to 10 mL with the mobile phase.

**Column:**

- *size*:  $l = 0.25$  m,  $\varnothing = 4.6$  mm;
- *stationary phase*: *octylsilyl silica gel for chromatography R* (5  $\mu$ m).

**Mobile phase:** dissolve 6.8 g of *potassium dihydrogen phosphate R* in 700 mL of *water R*; add 0.2 mL of *N,N-dimethyloctylamine R* and adjust to pH 4.0 with *dilute phosphoric acid R*; dilute to 1000 mL with *water R*, add 250 mL of *acetonitrile R* and mix.

**Flow rate:** 1.5 mL/min.

**Detection:** spectrophotometer at 240 nm.

**Injection:** 10  $\mu$ L.

**Run time:** 8 times the retention time of metoclopramide.

**Relative retention** with reference to metoclopramide (retention time = about 3.6 min): *impurity A* = about 0.82; *impurity F* = about 0.89; *impurity H* = about 0.91; *impurity G* = about 1.7; *impurity C* = about 2.7; *impurity D* = about 2.8; *impurity B* = about 6.4.

**System suitability:** reference solution (b):

- *resolution*: minimum 2.0 between the peaks due to *impurity A* and metoclopramide.

**Limits:**

- *impurities A, B, C, D, F, G, H*: for each impurity, not more than the area of the principal peak in the chromatogram obtained with reference solution (a) (0.2 per cent);
- *total*: not more than 3 times the area of the principal peak in the chromatogram obtained with reference solution (a) (0.6 per cent);
- *disregard limit*: 0.1 times the area of the principal peak in the chromatogram obtained with reference solution (a) (0.02 per cent).

**Heavy metals** (2.4.8): maximum 20 ppm.

1.0 g complies with test C. Prepare the reference solution using 2 mL of *lead standard solution (10 ppm Pb) R*.

**Loss on drying** (2.2.32): maximum 1.0 per cent, determined on 1.000 g by drying in an oven at 105 °C.

**Sulfated ash** (2.4.14): maximum 0.1 per cent, determined on 1.0 g.

#### ASSAY

Dissolve 0.250 g in 50 mL of *anhydrous acetic acid R* and add 5 mL of *acetic anhydride R*. Titrate with 0.1 M *perchloric acid*, determining the end-point potentiometrically (2.2.20).

1 mL of 0.1 M *perchloric acid* is equivalent to 29.98 mg of  $C_{14}H_{22}ClN_3O_2$ .

#### IMPURITIES

**Specified impurities:** A, B, C, D, E, F, G, H.

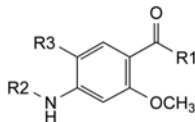

A. R<sub>1</sub> = NH-CH<sub>2</sub>-CH<sub>2</sub>-N(C<sub>2</sub>H<sub>5</sub>)<sub>2</sub>, R<sub>2</sub> = CO-CH<sub>3</sub>, R<sub>3</sub> = Cl: 4-(acetylamino)-5-chloro-N-[2-(diethylamino)ethyl]-2-methoxybenzamide,

B. R<sub>1</sub> = OCH<sub>3</sub>, R<sub>2</sub> = CO-CH<sub>3</sub>, R<sub>3</sub> = Cl: methyl 4-(acetylamino)-5-chloro-2-methoxybenzoate,

C. R<sub>1</sub> = OH, R<sub>2</sub> = H, R<sub>3</sub> = Cl: 4-amino-5-chloro-2-methoxybenzoic acid,

D. R<sub>1</sub> = OCH<sub>3</sub>, R<sub>2</sub> = CO-CH<sub>3</sub>, R<sub>3</sub> = H: methyl 4-(acetylamino)-2-methoxybenzoate,

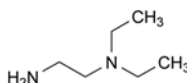

E. *N,N*-diethylethane-1,2-diamine,

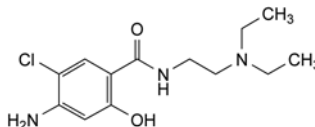

F. 4-amino-5-chloro-N-[2-(diethylamino)ethyl]-2-hydroxybenzamide,

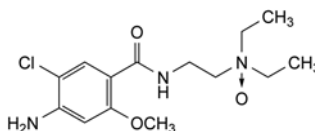

G. *N'*-(4-amino-5-chloro-2-methoxybenzoyl)-*N,N*-diethylethane-1,2-diamine *N*-oxide,

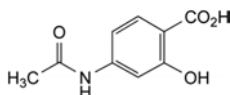

H. 4-(acetylamino)-2-hydroxybenzoic acid.

01/2008:0674

## METOCLOPRAMIDE HYDROCHLORIDE

### Metoclopramidi hydrochloridum

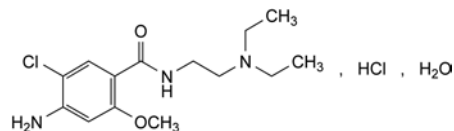

$C_{14}H_{23}Cl_2N_3O_2 \cdot H_2O$   
[54143-57-6]

$M_r$  354.3

#### DEFINITION

Metoclopramide hydrochloride contains not less than 99.0 per cent and not more than the equivalent of 101.0 per cent of 4-amino-5-chloro-N-[2-(diethylamino)ethyl]-2-methoxybenzamide hydrochloride, calculated with reference to the anhydrous substance.

## CHARACTERS

White or almost white, crystalline powder or crystals, very soluble in water, freely soluble in alcohol, sparingly soluble in methylene chloride.

It melts at about 183 °C with decomposition.

## IDENTIFICATION

*First identification:* A, B, D.

*Second identification:* A, C, D, E.

- A. The pH (2.2.3) of solution S (see Tests) is 4.5 to 6.0.
- B. Examine by infrared absorption spectrophotometry (2.2.24), comparing with the spectrum obtained with *metoclopramide hydrochloride* CRS. Examine the substances as discs prepared using *potassium chloride* R.
- C. Examine the chromatograms obtained in the test for related substances in ultraviolet light before spraying with *dimethylaminobenzaldehyde solution* R1. The principal spot in the chromatogram obtained with test solution (b) is similar in position and size to the principal spot in the chromatogram obtained with reference solution (a).
- D. Dilute 1 mL of solution S to 2 mL with *water* R. The solution gives reaction (a) of chlorides (2.3.1).
- E. Dissolve about 2 mg in 2 mL of *water* R. The solution gives the reaction of primary aromatic amines (2.3.1).

## TESTS

**Solution S.** Dissolve 2.5 g in *carbon dioxide-free water* R and dilute to 25 mL with the same solvent.

**Appearance of solution.** Solution S is clear (2.2.1) and colourless (2.2.2, *Method II*).

**Related substances.** Examine by thin-layer chromatography (2.2.27), using *silica gel* HF<sub>254</sub> R as the coating substance.

*Test solution (a).* Dissolve 0.40 g of the substance to be examined in *methanol* R and dilute to 10 mL with the same solvent.

*Test solution (b).* Dilute 1 mL of test solution (a) to 10 mL with *methanol* R.

*Reference solution (a).* Dissolve 20 mg of *metoclopramide hydrochloride* CRS in *methanol* R and dilute to 5 mL with the same solvent.

*Reference solution (b).* Dilute 5 mL of test solution (a) to 100 mL with *methanol* R. Dilute 1 mL of this solution to 10 mL with *methanol* R.

*Reference solution (c).* Dissolve 10 mg of *N,N-diethylethylenediamine* R in *methanol* R and dilute to 50 mL with the same solvent.

Apply separately to the plate 5 µL of each solution. Develop over a path of 12 cm using a mixture of 2 volumes of *concentrated ammonia* R, 10 volumes of *dioxan* R, 14 volumes of *methanol* R and 90 volumes of *methylene chloride* R. Allow the plate to dry in air. Examine in ultraviolet light at 254 nm. Any spot in the chromatogram obtained with test solution (a), apart from the principal spot, is not more intense than the spot in the chromatogram obtained with reference solution (b) (0.5 per cent). Spray with *dimethylaminobenzaldehyde solution* R1. Allow the plate to dry in air. Any spot in the chromatogram obtained with test solution (a) that has not been visualised in ultraviolet light at 254 nm is not more intense than the spot in the chromatogram obtained with reference solution (c) (0.5 per cent).

**Heavy metals** (2.4.8). 12 mL of solution S complies with limit test A for heavy metals (20 ppm). Prepare the standard using *lead standard solution* (2 ppm Pb) R.

**Water** (2.5.12): 4.5 per cent to 5.5 per cent, determined on 0.500 g by the semi-micro determination of water.

**Sulfated ash** (2.4.14). Not more than 0.1 per cent, determined on 1.0 g.

## ASSAY

Dissolve 0.2500 g in a mixture of 5.0 mL of 0.01 M *hydrochloric acid* and 50 mL of *alcohol* R. Carry out a potentiometric titration (2.2.20), using 0.1 M *sodium hydroxide*. Read the volume of 0.1 M *sodium hydroxide* added between the two points of inflexion.

1 mL of 0.1 M *sodium hydroxide* is equivalent to 33.63 mg of C<sub>14</sub>H<sub>23</sub>Cl<sub>2</sub>N<sub>3</sub>O<sub>2</sub>.

## STORAGE

Store protected from light.

01/2008:1757  
corrected 6.0

## METOLAZONE

## Metolazonum

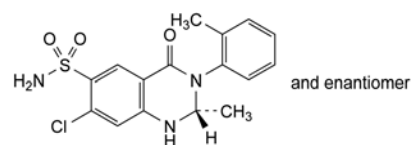

C<sub>16</sub>H<sub>16</sub>ClN<sub>3</sub>O<sub>3</sub>S

M<sub>r</sub> 365.8

## DEFINITION

(2*RS*)-7-Chloro-2-methyl-3-(2-methylphenyl)-4-oxo-1,2,3,4-tetrahydroquinazolin-6-sulfonamide.

*Content:* 97.0 per cent to 102.0 per cent (dried substance).

## CHARACTERS

*Appearance:* white or slightly yellowish, crystalline powder.

*Solubility:* very slightly soluble in water, sparingly soluble in methanol, slightly soluble in ethyl acetate, very slightly soluble in methylene chloride.

It shows polymorphism (5.9).

## IDENTIFICATION

Infrared absorption spectrophotometry (2.2.24).

*Comparison:* *metolazone* CRS.

If the spectra obtained in the solid state show differences, dissolve the substance to be examined and the reference substance separately in *anhydrous ethanol* R, evaporate to dryness and record new spectra using the residues.

## TESTS

**Related substances.** Liquid chromatography (2.2.29).

*Test solution (a).* Dissolve 30.0 mg of the substance to be examined in *methanol* R and dilute to 10.0 mL with the same solvent.

*Test solution (b).* Dilute 2.0 mL of test solution (a) to 100.0 mL with *methanol* R.

*Reference solution (a).* Dissolve 3.0 mg of *metolazone* for *system suitability* CRS (containing impurities A, B, C, D and E) in 1 mL of *methanol* R.

*Reference solution (b).* Dilute 1.0 mL of test solution (a) to 100.0 mL with *methanol* R. Dilute 5.0 mL of this solution to 10.0 mL with *methanol* R.

*Reference solution (c).* Dissolve 30.0 mg of *metolazone* CRS in *methanol* R and dilute to 10.0 mL with the same solvent. Dilute 2.0 mL of this solution to 100.0 mL with *methanol* R.

*Column:*

- *size:* *l* = 0.25 m, Ø = 4.6 mm;
- *stationary phase:* *octadecylsilyl silica gel* for *chromatography* R (5 µm);
- *temperature:* 30 °C.

**Mobile phase:**

- mobile phase A: 5.44 g/L solution of potassium dihydrogen phosphate R;
- mobile phase B: methanol R;

Time (min)	Mobile phase A (per cent V/V)	Mobile phase B (per cent V/V)
0 - 5	70	30
5 - 25	70 → 50	30 → 50
25 - 35	50	50
35 - 38	50 → 70	50 → 30
38 - 48	70	30

**Flow rate:** 1.5 mL/min.

**Detection:** spectrophotometer at 230 nm.

**Injection:** 10 µL of test solution (a) and reference solutions (a) and (b).

**Identification of impurities:** use the chromatogram supplied with metolazone for system suitability CRS and the chromatogram obtained with reference solution (a) to identify the peaks due to impurities A, B, C, D and E.

**System suitability:** reference solution (a):

- resolution: minimum 1.6 between the peaks due to impurities E and C and minimum 1.5 between the peaks due to impurities A and B.

**Limits:**

- impurities A, B, C, D, E: for each impurity, not more than the area of the principal peak in the chromatogram obtained with reference solution (b) (0.5 per cent);
- unspecified impurities: for each impurity, not more than 0.2 times the area of the principal peak in the chromatogram obtained with reference solution (b) (0.10 per cent);
- total: not more than twice the area of the principal peak in the chromatogram obtained with reference solution (b) (1.0 per cent);
- disregard limit: 0.1 times the area of the principal peak in the chromatogram obtained with reference solution (b) (0.05 per cent).

**Heavy metals (2.4.8):** maximum 20 ppm.

1.0 g complies with test F. Prepare the reference solution using 2 mL of lead standard solution (10 ppm Pb) R.

**Loss on drying (2.2.32):** maximum 1.0 per cent, determined on 1.000 g by drying in an oven at 105 °C for 4 h.

**Sulfated ash (2.4.14):** maximum 0.1 per cent, determined on 1.0 g.

**ASSAY**

Liquid chromatography (2.2.29) as described in the test for related substances with the following modification.

**Injection:** test solution (b) and reference solution (c).

Calculate the percentage content of C<sub>16</sub>H<sub>16</sub>ClN<sub>3</sub>O<sub>3</sub>S from the declared content of metolazone CRS.

**STORAGE**

Protected from light.

**IMPURITIES**

**Specified impurities:** A, B, C, D, E.

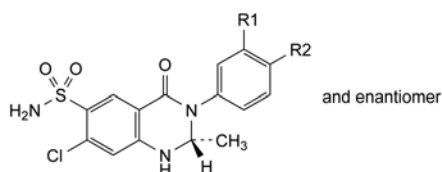

A. R<sub>1</sub> = CH<sub>3</sub>, R<sub>2</sub> = H: (2*RS*)-7-chloro-2-methyl-3-(3-methylphenyl)-4-oxo-1,2,3,4-tetrahydroquinazoline-6-sulfonamide,

B. R<sub>1</sub> = H, R<sub>2</sub> = CH<sub>3</sub>: (2*RS*)-7-chloro-2-methyl-3-(4-methylphenyl)-4-oxo-1,2,3,4-tetrahydroquinazoline-6-sulfonamide,

C. R<sub>1</sub> = R<sub>2</sub> = H: (2*RS*)-7-chloro-2-methyl-4-oxo-3-phenyl-1,2,3,4-tetrahydroquinazoline-6-sulfonamide,

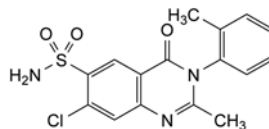

D. 7-chloro-2-methyl-3-(2-methylphenyl)-4-oxo-3,4-dihydroquinazoline-6-sulfonamide,

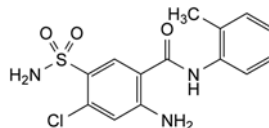

E. 2-amino-4-chloro-*N*-(2-methylphenyl)-5-sulfamoylbenzamide.

01/2008:1448  
corrected 6.0

**METOPROLOL SUCCINATE**

## Metoprololi succinas

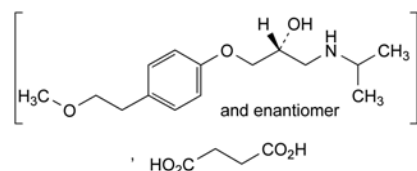

C<sub>34</sub>H<sub>56</sub>N<sub>2</sub>O<sub>10</sub>  
[98418-47-4]

M<sub>r</sub> 653

**DEFINITION**

Bis[(2*RS*)-1-[4-(2-methoxyethyl)phenoxy]-3-[(1-methylethyl)amino]propan-2-ol] butanedioate.

**Content:** 99.0 per cent to 101.0 per cent (dried substance).

**CHARACTERS**

**Appearance:** white or almost white, crystalline powder.

**Solubility:** freely soluble in water, soluble in methanol, slightly soluble in alcohol, very slightly soluble in ethyl acetate.

**IDENTIFICATION**

Infrared absorption spectrophotometry (2.2.24).

**Comparison:** Ph. Eur. reference spectrum of metoprolol succinate.

**TESTS**

**Solution S.** Dissolve 0.500 g in carbon dioxide-free water R and dilute to 25.0 mL with the same solvent.

**Appearance of solution.** Solution S is not more opalescent than reference suspension II (2.2.1) and it is colourless (2.2.2, Method II).

**pH (2.2.3):** 7.0 to 7.6 for solution S.

**Related substances**

A. Thin-layer chromatography (2.2.27).

**Test solution.** Dissolve 0.50 g of the substance to be examined in methanol R and dilute to 10 mL with the same solvent.

**Reference solution.** Dilute 1 mL of the test solution to 50 mL with methanol R. Dilute 5 mL of this solution to 50 mL with methanol R.

**Plate:** TLC silica gel plate R.

**Mobile phase:** place 2 beakers each containing 30 volumes of concentrated ammonia R at the bottom of a chromatographic tank containing a mixture of 20 volumes of methanol R and 80 volumes of ethyl acetate R.

**Application:** 10 µL.

**Development:** over a path of 12 cm in a tank saturated for at least 1 h.

**Drying:** in air for at least 3 h.

**Detection:** expose the plate to iodine vapour for at least 15 h.

**Limits:**

- any impurity: any spot, apart from the principal spot, is not more intense than the spot in the chromatogram obtained with the reference solution (0.2 per cent),
- disregard any spot on the line of application.

#### B. Liquid chromatography (2.2.29).

**Test solution.** Dissolve 20.0 mg of the substance to be examined in the mobile phase and dilute to 10.0 mL with the mobile phase.

**Reference solution (a).** Dissolve 5.0 mg of the substance to be examined and 3.0 mg of metoprolol impurity A CRS in the mobile phase and dilute to 100.0 mL with the mobile phase.

**Reference solution (b).** Dilute 1.0 mL of the test solution to 100.0 mL with the mobile phase. Dilute 1.0 mL of the solution to 10.0 mL with the mobile phase.

**Reference solution (c).** If this solution is required (see below), it is to be prepared in a fume cupboard. This solution is used only to identify the peak due to impurity C. Dissolve 10 mg of the substance to be examined in 10 mL of 0.1 M hydrochloric acid. Transfer this solution to an evaporating dish 10 cm in diameter. Place the dish so that the surface of the solution is 5 cm from a lamp emitting ultraviolet light (2.1.3) at 254 nm for 6 h. Dilute 0.5 mL of this solution to 25 mL with the mobile phase.

**Column:**

- size:  $l = 0.15$  m,  $\emptyset = 3.9$  mm,
- stationary phase: octadecylsilyl silica gel for chromatography R1 (5 µm) with a pore size of 10 nm and a carbon loading of 19 per cent.

**Mobile phase:** dissolve 3.9 g of ammonium acetate R in 810 mL of water R, add 2.0 mL of triethylamine R, 10.0 mL of glacial acetic acid R, 3.0 mL of phosphoric acid R and 146 mL of acetonitrile R and mix.

**Flow rate:** 1 mL/min.

**Detection:** spectrophotometer at 280 nm.

**Injection:** 20 µL; inject the test solution and reference solutions (a) and (b).

**Run time:** 3 times the retention time of metoprolol.

**Relative retention** with reference to metoprolol (retention time = about 7 min): impurity C = about 0.3; impurity A = about 0.7.

**System suitability:** reference solution (a):

- resolution: minimum of 6.0 between the peaks due to impurity A and to metoprolol.

**Limits:**

- any impurity: not more than the area of the principal peak in the chromatogram obtained with reference solution (b) (0.1 per cent),
- total: not more than 5 times the area of the principal peak in the chromatogram obtained with reference solution (b) (0.5 per cent),
- disregard limit: 0.5 times the area of the principal peak in the chromatogram obtained with reference solution (b) (0.05 per cent); disregard any peak due to succinic acid.

If a peak occurs with a retention time of about 2.3 min (impurity C) which has an area greater than the area of the principal peak in the chromatogram obtained with reference

solution (b), prepare and inject reference solution (c). For the chromatogram obtained with the test solution, multiply the peak area of impurity C by a correction factor of 0.1.

**Heavy metals (2.4.8):** maximum 10 ppm.

Dissolve 2.0 g in 20 mL of water R. 12 mL of the solution complies with limit test A. Prepare the standard using lead standard solution (1 ppm Pb) R.

**Loss on drying (2.2.32):** maximum 0.5 per cent, determined on 1.000 g by drying in an oven at 105 °C.

**Sulfated ash (2.4.14):** maximum 0.1 per cent, determined on 1.0 g.

**ASSAY**

Dissolve 0.250 g in 40 mL of anhydrous acetic acid R. Titrate with 0.1 M perchloric acid, determining the end-point potentiometrically (2.2.20).

1 mL of 0.1 M perchloric acid is equivalent to 32.64 mg of  $C_{34}H_{56}N_2O_{10}$ .

**STORAGE**

Protected from light.

**IMPURITIES**

By liquid chromatography: A, B, C, D, E, F, G, H, J.

By thin-layer chromatography: M, N, O.

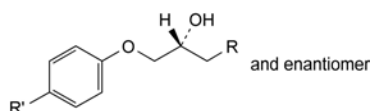

A. R = NH-CH<sub>2</sub>-CH<sub>3</sub>, R' = CH<sub>2</sub>-CH<sub>2</sub>-OCH<sub>3</sub>: (2*RS*)-1-(ethylamino)-3-[4-(2-methoxyethyl)phenoxy]propan-2-ol,

C. R = NH-CH(CH<sub>3</sub>)<sub>2</sub>, R' = CHO: 4-[(2*RS*)-2-hydroxy-3-[(1-methylethyl)amino]propoxy]benzaldehyde,

D. R = OH, R' = CH<sub>2</sub>-CH<sub>2</sub>-OCH<sub>3</sub>: (2*RS*)-3-[4-(2-methoxyethyl)phenoxy]propane-1,2-diol,

H. R = NH-CH(CH<sub>3</sub>)<sub>2</sub>, R' = CH<sub>2</sub>-CH<sub>2</sub>-OH: (2*RS*)-1-[4-(2-hydroxyethyl)phenoxy]-3-[(1-methylethyl)amino]propan-2-ol,

J. R = O-CH<sub>2</sub>-CHOH-CH<sub>2</sub>-NH-CH(CH<sub>3</sub>)<sub>2</sub>, R' = CH<sub>2</sub>-CH<sub>2</sub>-OCH<sub>3</sub>: 1-[2-hydroxy-3-[(1-methylethyl)amino]propoxy]-3-[4-(2-methoxyethyl)phenoxy]propan-2-ol,

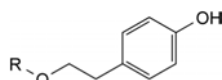

B. R = CH<sub>3</sub>: 4-(2-methoxyethyl)phenol,

G. R = H: 2-(4-hydroxyphenyl)ethanol,

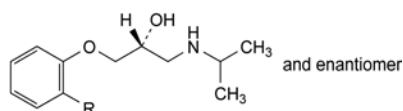

E. R = CH<sub>2</sub>-CH<sub>2</sub>-OCH<sub>3</sub>: (2*RS*)-1-[2-(2-methoxyethyl)phenoxy]-3-[(1-methylethyl)amino]propan-2-ol,

F. R = H: (2*RS*)-1-[(1-methylethyl)amino]-3-phenoxypropan-2-ol,

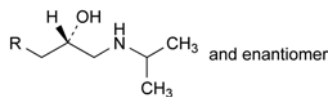

M. R = NH-CH(CH<sub>3</sub>)<sub>2</sub>: 1,3-bis[(1-methylethyl)amino]propan-2-ol,

N. R = OH: (2*RS*)-3-[(1-methylethyl)amino]propane-1,2-diol,

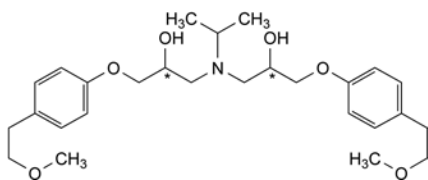

O. 1,1'-(1-methylethyl)imino]bis[3-[4-(2-methoxyethyl)phenoxy]propan-2-ol].

01/2008:1028  
corrected 6.0

## METOPROLOL TARTRATE

### Metoprololi tartras

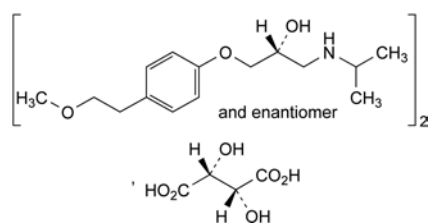

$C_{34}H_{56}N_2O_{12}$   
[56392-17-7]

$M_r$  685

#### DEFINITION

Bis[(2*RS*)-1-[4-(2-methoxyethyl)phenoxy]-3-[(1-methylethyl)amino]propan-2-ol] (2*R*,3*R*)-2,3-dihydroxybutanedioate.

*Content*: 99.0 per cent to 101.0 per cent (dried substance).

#### CHARACTERS

*Appearance*: white or almost white, crystalline powder or colourless crystals.

*Solubility*: very soluble in water, freely soluble in alcohol.

It shows polymorphism (5.9).

#### IDENTIFICATION

A. Specific optical rotation (see Tests).

B. Infrared absorption spectrophotometry (2.2.24).

*Comparison*: metoprolol tartrate CRS.

If the spectra obtained in the solid state show differences, record further spectra using discs prepared by placing 25  $\mu$ L of a 100 g/L solution in methylene chloride R on a disc of potassium bromide R and evaporating the solvent. Examine immediately.

#### TESTS

**Solution S.** Dissolve 0.500 g in carbon dioxide-free water R and dilute to 25.0 mL with the same solvent.

**Appearance of solution.** Solution S is clear (2.2.1) and not more intensely coloured than reference solution B<sub>8</sub> (2.2.2, Method II).

**pH** (2.2.3): 6.0 to 7.0 for solution S.

**Specific optical rotation** (2.2.7): + 7.0 to + 10.0 (dried substance), determined on solution S.

#### Related substances

A. Thin-layer chromatography (2.2.27).

*Test solution.* Dissolve 0.50 g of the substance to be examined in methanol R and dilute to 10 mL with the same solvent.

*Reference solution (a).* Dilute 1 mL of the test solution to 20 mL with methanol R. Dilute 5 mL of this solution to 50 mL with methanol R.

*Reference solution (b).* Dilute 4 mL of reference solution (a) to 10 mL with methanol R.

*Plate*: TLC silica gel plate R.

*Mobile phase*: place 2 beakers each containing 30 volumes of concentrated ammonia R at the bottom of a chromatographic tank containing a mixture of 20 volumes of methanol R and 80 volumes of ethyl acetate R.

*Application*: 5  $\mu$ L.

*Development*: over a path of 12 cm in a tank saturated for at least 1 h.

*Drying*: in air for at least 3 h.

*Detection*: expose the plate to iodine vapour for at least 15 h.

#### Limits:

– *any impurity*: any spot, apart from the principal spot, is not more intense than the spot in the chromatogram obtained with reference solution (a) (0.5 per cent) and at most 1 such spot is more intense than the spot in the chromatogram obtained with reference solution (b) (0.2 per cent),

– *disregard* any spot on the line of application.

B. Liquid chromatography (2.2.29).

*Test solution.* Dissolve 20.0 mg of the substance to be examined in the mobile phase and dilute to 10.0 mL with the mobile phase.

*Reference solution (a).* Dissolve 5.0 mg of metoprolol tartrate CRS and 3.0 mg of metoprolol impurity A CRS in the mobile phase and dilute to 100.0 mL with the mobile phase.

*Reference solution (b).* Dilute 1.0 mL of the test solution to 20.0 mL with the mobile phase. Dilute 3.0 mL of the solution to 50.0 mL with the mobile phase.

*Reference solution (c).* If this solution is required (see below), it is to be prepared in a fume cupboard. This solution is used only to identify the peak due to impurity C. Dissolve 10 mg of metoprolol tartrate CRS in 10 mL of 0.1 M hydrochloric acid. Transfer this solution to an evaporating dish 10 cm in diameter. Place the dish so that the surface of the solution is 5 cm from a lamp emitting ultraviolet light (2.1.3) at 254 nm for 6 h. Dilute 0.5 mL of this solution to 25 mL with the mobile phase.

#### Column:

– *size*:  $l = 0.15$  m,  $\emptyset = 3.9$  mm,

– *stationary phase*: octadecylsilyl silica gel for chromatography R1 (5  $\mu$ m) with a pore size of 10 nm and a carbon loading of 19 per cent.

*Mobile phase*: dissolve 3.9 g of ammonium acetate R in 810 mL of water R, add 2.0 mL of triethylamine R, 10.0 mL of glacial acetic acid R, 3.0 mL of phosphoric acid R and 146 mL of acetonitrile R and mix.

*Flow rate*: 1 mL/min.

*Detection*: spectrophotometer at 280 nm.

*Injection*: 20  $\mu$ L; inject the test solution and reference solutions (a) and (b).

*Run time*: 3 times the retention time of metoprolol.

*Relative retention* with reference to metoprolol (retention time = about 7 min): impurity C = about 0.3; impurity A = about 0.7.

*System suitability*: reference solution (a):

– *resolution*: minimum of 6.0 between the peaks due to impurity A and to metoprolol.

#### Limits:

– *any impurity (A to J)*: not more than the area of the principal peak in the chromatogram obtained with reference solution (b) (0.3 per cent),

– *total*: not more than 1.7 times the area of the principal peak in the chromatogram obtained with reference solution (b) (0.5 per cent),

– *disregard limit*: 0.17 times the area of the principal peak in the chromatogram obtained with reference solution (b) (0.05 per cent); disregard any peak due to tartaric acid.



If a peak occurs with a retention time of about 2.3 min (impurity C) which has an area greater than the area of the principal peak in the chromatogram obtained with reference solution (b), prepare and inject reference solution (c). For the chromatogram obtained with the test solution, multiply the peak area of impurity C by a correction factor of 0.1.

**Heavy metals** (2.4.8): maximum 10 ppm.

Dissolve 2.0 g in 20 mL of *water R*. 12 mL of the solution complies with limit test A. Prepare the standard using *lead standard solution (1 ppm Pb) R*.

**Loss on drying** (2.2.32): maximum 0.5 per cent, determined on 1.000 g by drying *in vacuo* over *anhydrous calcium chloride R* for 4 h.

**Sulfated ash** (2.4.14): maximum 0.1 per cent, determined on 1.0 g.

#### ASSAY

Dissolve 0.250 g in 30 mL of *anhydrous acetic acid R*. Titrate with 0.1 M *perchloric acid*, determining the end-point potentiometrically (2.2.20).

1 mL of 0.1 M *perchloric acid* is equivalent to 34.24 mg of  $C_{34}H_{56}N_2O_{12}$ .

#### STORAGE

Protected from light.

#### IMPURITIES

By liquid chromatography: A, B, C, D, E, F, G, H, J.

By thin-layer chromatography: M, N, O.

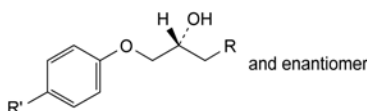

A. R = NH-CH<sub>2</sub>-CH<sub>3</sub>, R' = CH<sub>2</sub>-CH<sub>2</sub>-OCH<sub>3</sub>: (2*RS*)-1-(ethylamino)-3-[4-(2-methoxyethyl)phenoxy]propan-2-ol,

C. R = NH-CH(CH<sub>3</sub>)<sub>2</sub>, R' = CHO: 4-[(2*RS*)-2-hydroxy-3-[(1-methylethyl)amino]propoxy]benzaldehyde,

D. R = OH, R' = CH<sub>2</sub>-CH<sub>2</sub>-OCH<sub>3</sub>: (2*RS*)-3-[4-(2-methoxyethyl)phenoxy]propane-1,2-diol,

H. R = NH-CH(CH<sub>3</sub>)<sub>2</sub>, R' = CH<sub>2</sub>-CH<sub>2</sub>-OH: (2*RS*)-1-[4-(2-hydroxyethyl)phenoxy]-3-[(1-methylethyl)amino]propan-2-ol,

J. R = O-CH<sub>2</sub>-CHOH-CH<sub>2</sub>-NH-CH(CH<sub>3</sub>)<sub>2</sub>, R' = CH<sub>2</sub>-CH<sub>2</sub>-OCH<sub>3</sub>: 1-[2-hydroxy-3-[(1-methylethyl)amino]propoxy]-3-[4-(2-methoxyethyl)phenoxy]propan-2-ol,

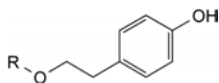

B. R = CH<sub>3</sub>: 4-(2-methoxyethyl)phenol,

G. R = H: 2-(4-hydroxyphenyl)ethanol,

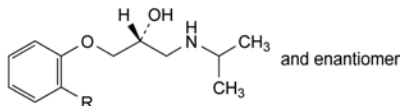

E. R = CH<sub>2</sub>-CH<sub>2</sub>-OCH<sub>3</sub>: (2*RS*)-1-[2-(2-methoxyethyl)phenoxy]-3-[(1-methylethyl)amino]propan-2-ol,

F. R = H: (2*RS*)-1-[(1-methylethyl)amino]-3-phenoxypropan-2-ol,

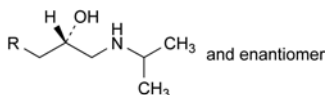

M. R = NH-CH(CH<sub>3</sub>)<sub>2</sub>: 1,3-bis[(1-methylethyl)amino]propan-2-ol,

N. R = OH: (2*RS*)-3-[(1-methylethyl)amino]propane-1,2-diol,

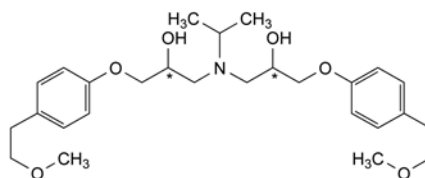

O. 1,1'-[(1-methylethyl)imino]bis[3-[4-(2-methoxyethyl)phenoxy]propan-2-ol].

01/2008:1133  
corrected 6.0

## METRIFONATE

### Metrifonatum

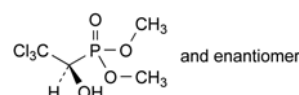

$C_4H_8Cl_3O_4P$   
[52-68-6]

$M_r$  257.4

#### DEFINITION

Dimethyl (*RS*)-(2,2,2-trichloro-1-hydroxyethyl)phosphonate.

*Content*: 98.0 per cent to 100.5 per cent (anhydrous substance).

#### CHARACTERS

*Appearance*: white or almost white, crystalline powder.

*Solubility*: freely soluble in water, very soluble in methylene chloride, freely soluble in acetone and in ethanol (96 per cent).

*mp*: 76 °C to 81 °C.

#### IDENTIFICATION

*First identification*: A, B.

*Second identification*: B, C, D.

A. Infrared absorption spectrophotometry (2.2.24).

*Preparation*: discs.

*Comparison*: *metrifonate CRS*.

B. Thin-layer chromatography (2.2.27).

*Test solution*. Dissolve 10 mg of the substance to be examined in *methanol R* and dilute to 10 mL with the same solvent.

*Reference solution*. Dissolve 10 mg of *metrifonate CRS* in *methanol R* and dilute to 10 mL with the same solvent.

*Plate*: TLC silica gel plate *R*.

*Mobile phase*: glacial acetic acid *R*, dioxan *R*, toluene *R* (5:25:70 V/V/V).

*Application*: 10 µL.

*Development*: in an unsaturated tank over a path of 15 cm.

*Drying*: in air.

*Detection*: spray with a 50 g/L solution of 4-(4-nitrobenzyl)pyridine *R* in acetone *R* and heat at 120 °C for 15 min; spray the still-warm plate with a 100 g/L solution of tetraethylene pentamine *R* in acetone *R* and examine immediately.

*Results*: the principal spot in the chromatogram obtained with the test solution is similar in position, colour and size to the principal spot in the chromatogram obtained with the reference solution.

C. Dissolve about 20 mg in 1 mL of dilute sodium hydroxide solution *R*. Add 1 mL of pyridine *R*. Shake and heat on a water-bath for 2 min. A red colour develops in the upper layer.

D. To 0.1 g add 0.5 mL of nitric acid *R*, 0.5 mL of a 500 g/L solution of ammonium nitrate *RI* and 0.1 mL of strong hydrogen peroxide solution *R*. Heat on a water-bath for

10 min. Heat to boiling and add 1 mL of *ammonium molybdate solution R*. A yellow colour is produced or a yellow precipitate is formed.

## TESTS

**Appearance of solution.** The solution is clear (2.2.1) and not more intensely coloured than reference solution Y<sub>7</sub> (2.2.2, Method II).

Dissolve 5.0 g in 20 mL of *methanol R*.

**Acidity.** Dissolve 2.5 g in *carbon dioxide-free water R* and dilute to 50 mL with the same solvent. Add 0.1 mL of *methyl red solution R*. Not more than 1.0 mL of 0.1 M *sodium hydroxide* is required to change the colour of the indicator to yellow.

**Optical rotation** (2.2.7):  $-0.10^\circ$  to  $+0.10^\circ$ .

Dissolve 0.1 g in *ethanol (96 per cent) R* and dilute to 10.0 mL with the same solvent.

**Related substances.** Liquid chromatography (2.2.29).

**Solvent mixture:** mobile phase B, mobile phase A (10:90 V/V).

**Test solution.** Dissolve 0.20 g of the substance to be examined in the solvent mixture and dilute to 10.0 mL with the solvent mixture.

**Reference solution (a).** Use a freshly prepared solution.

Dissolve 10.0 mg of *desmethylmetrifonate CRS* (impurity A) in the solvent mixture and dilute to 20.0 mL with the solvent mixture. Dilute 1.0 mL of this solution to 5.0 mL with the solvent mixture.

**Reference solution (b).** Dissolve 0.10 g of *dichlorvos R* (impurity B) in the solvent mixture and dilute to 50.0 mL with the solvent mixture. Dilute 1.0 mL of this solution to 50.0 mL with the solvent mixture.

**Reference solution (c).** Dilute 1.0 mL of the test solution to 10.0 mL with the solvent mixture. Dilute 5.0 mL of this solution to 100.0 mL with the solvent mixture.

**Reference solution (d).** Use a freshly prepared solution. Mix 1.0 mL of reference solution (a), 1.0 mL of reference solution (b) and 0.025 mL of the test solution.

**Reference solution (e).** Dilute 4.0 mL of the test solution to 100.0 mL with the solvent mixture. Dilute 1.0 mL of this solution to 10.0 mL with the solvent mixture.

**Column:**

- size:  $l = 0.25$  m,  $\varnothing = 4.6$  mm;
- stationary phase: *octadecylsilyl silica gel for chromatography R* (10  $\mu$ m);
- temperature: 40 °C.

**Mobile phase:**

- mobile phase A: 1.36 g/L solution of *potassium dihydrogen phosphate R*, previously adjusted to pH 2.9 with *phosphoric acid R*;
- mobile phase B: *acetonitrile R*;

Time (min)	Mobile phase A (per cent V/V)	Mobile phase B (per cent V/V)
0 - 5	90	10
5 - 25	90 → 85	10 → 15
25 - end	85 → 45	15 → 55

**Flow rate:** 1 mL/min.

**Detection:** spectrophotometer at 210 nm.

**Injection:** 50  $\mu$ L.

**Run time:** 3 times the retention time of metrifonate.

**Elution order:** impurity A, metrifonate, impurity B.

**System suitability:** reference solution (d):

- resolution: minimum 3.0 between the peaks due to impurity A and metrifonate and minimum 4.5 between the peaks due to metrifonate and impurity B.

**Limits:**

- *impurity A*: not more than the area of the principal peak in the chromatogram obtained with reference solution (a) (0.5 per cent);
- *impurity B*: not more than the area of the principal peak in the chromatogram obtained with reference solution (b) (0.2 per cent);
- *any other impurity*: for each impurity, not more than the area of the principal peak in the chromatogram obtained with reference solution (c) (0.5 per cent);
- *sum of impurities other than A and B*: not more than twice the area of the principal peak in the chromatogram obtained with reference solution (c) (1 per cent);
- *disregard limit*: 0.1 times the area of the principal peak in the chromatogram obtained with reference solution (e) (0.04 per cent).

**Chlorides:** maximum 500 ppm.

Dissolve 5.00 g in 30 mL of *ethanol (96 per cent) R* and add a mixture of 15 mL of *nitric acid R* and 100 mL of *water R*. Titrate with 0.01 M *silver nitrate* determining the end-point potentiometrically (2.2.20), using a silver electrode.

1 mL of 0.01 M *silver nitrate* is equivalent to 0.3546 mg of Cl.

**Heavy metals** (2.4.8): maximum 10 ppm.

Dissolve 2.0 g in 20 mL of *water R*. 12 mL of the solution complies with test A. Prepare the reference solution using *lead standard solution (1 ppm Pb) R*.

**Water** (2.5.12): maximum 0.3 per cent, determined on 3.000 g.

## ASSAY

Dissolve 0.300 g in 30 mL of *ethanol (96 per cent) R*. Add 10 mL of *ethanolamine R* and allow to stand for 1 h at 20–22 °C. Add a chilled mixture of 15 mL of *nitric acid R* and 100 mL of *water R* maintaining the temperature of the mixture at 20–22 °C. Maintain at that temperature and titrate with 0.1 M *silver nitrate*, determining the end-point potentiometrically (2.2.20), using a silver electrode.

Calculate the percentage content of C<sub>4</sub>H<sub>8</sub>Cl<sub>3</sub>O<sub>4</sub>P, taking into account the content of chloride and using the following expression:

$$\left[ \frac{V_P}{M_P} - \frac{V_{Cl} \times 0.1}{M_{Cl}} \right] \times 25.74 \times 0.1$$

$V_P$  = volume of silver nitrate used in the assay, in millilitres;

$M_P$  = mass of substance used in the assay, in grams;

$V_{Cl}$  = volume of silver nitrate used in the test for chlorides, in millilitres;

$M_{Cl}$  = mass of substance used in the test for chlorides, in grams.

## STORAGE

Protected from light.

## IMPURITIES

**Specified impurities:** A, B.

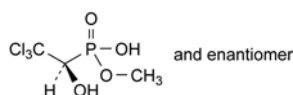

A. methyl (*RS*)-(2,2,2-trichloro-1-hydroxyethyl)phosphonate acid (desmethylmetrifonate),

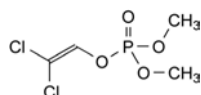

B. 2,2-dichloroethenyl dimethyl phosphate (dichlorvos).

01/2008:0675  
corrected 6.0

## METRONIDAZOLE

## Metronidazolium

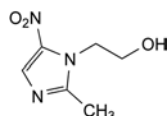
C<sub>6</sub>H<sub>9</sub>N<sub>3</sub>O<sub>3</sub>  
[443-48-1]M<sub>r</sub> 171.2

## DEFINITION

2-(2-Methyl-5-nitro-1*H*-imidazol-1-yl)ethanol.

Content: 99.0 per cent to 101.0 per cent (dried substance).

## CHARACTERS

Appearance: white or yellowish, crystalline powder.

Solubility: slightly soluble in water, in acetone, in alcohol and in methylene chloride.

## IDENTIFICATION

First identification: C.

Second identification: A, B, D.

A. Melting point (2.2.14): 159 °C to 163 °C.

B. Dissolve 40.0 mg in 0.1 M hydrochloric acid and dilute to 100.0 mL with the same acid. Dilute 5.0 mL of the solution to 100.0 mL with 0.1 M hydrochloric acid. Examined between 230 nm and 350 nm (2.2.25), the solution shows an absorption maximum at 277 nm and a minimum at 240 nm. The specific absorbance at the maximum is 365 to 395.

C. Infrared absorption spectrophotometry (2.2.24).

Preparation: discs.

Comparison: metronidazole CRS.

D. To about 10 mg add about 10 mg of zinc powder R, 1 mL of water R and 0.25 mL of dilute hydrochloric acid R. Heat on a water-bath for 5 min. Cool. The solution gives the reaction of primary aromatic amines (2.3.1).

## TESTS

**Appearance of solution.** The solution is not more opalescent than reference suspension II (2.2.1) and not more intensely coloured than reference solution GY<sub>6</sub> (2.2.2, Method II).

Dissolve 1.0 g in 1 M hydrochloric acid and dilute to 20 mL with the same acid.

**Related substances.** Liquid chromatography (2.2.29). Prepare the solutions protected from light.**Test solution.** Dissolve 0.05 g of the substance to be examined in the mobile phase and dilute to 100.0 mL with the mobile phase.**Reference solution (a).** Dilute 1.0 mL of the test solution to 100.0 mL with the mobile phase and dilute 1.0 mL of this solution to 10.0 mL with the mobile phase.**Reference solution (b).** Dissolve 5.0 mg of metronidazole impurity A CRS in the mobile phase, add 10.0 mL of the test solution and dilute to 100.0 mL with the mobile phase. Dilute 1.0 mL to 100.0 mL with the mobile phase.

Column:

- size:  $l = 0.25$  m,  $\varnothing = 4.6$  mm,
- stationary phase: octadecylsilyl silica gel for chromatography R (5  $\mu$ m).

Mobile phase: mix 30 volumes of methanol R and 70 volumes of a 1.36 g/L solution of potassium dihydrogen phosphate R,

Flow rate: 1 mL/min.

Detection: spectrophotometer at 315 nm.

Injection: 10  $\mu$ L.

Run time: 3 times the retention time of metronidazole.

Relative retention with reference to metronidazole (retention time = about 7 min): impurity A = about 0.7.

System suitability: reference solution (b):

- resolution: minimum of 2.0 between the peaks due to metronidazole and to impurity A.

Limits:

- any impurity: not more than the area of the principal peak in the chromatogram obtained with reference solution (a) (0.1 per cent),
- total: not more than twice the area of the principal peak in the chromatogram obtained with reference solution (a) (0.2 per cent),
- disregard limit: 0.1 times the area of the principal peak in the chromatogram obtained with reference solution (a) (0.01 per cent).

**Heavy metals (2.4.8):** maximum 20 ppm.

1.0 g complies with limit test C. Prepare the standard using 2 mL of lead standard solution (10 ppm Pb) R.

**Loss on drying (2.2.32):** maximum 0.5 per cent, determined on 1.000 g by drying in an oven at 105 °C for 3 h.**Sulfated ash (2.4.14):** maximum 0.1 per cent, determined on 1.0 g.

## ASSAY

Dissolve 0.150 g in 50 mL of anhydrous acetic acid R.

Titrate with 0.1 M perchloric acid, determining the end-point potentiometrically (2.2.20).

1 mL of 0.1 M perchloric acid is equivalent to 17.12 mg of C<sub>6</sub>H<sub>9</sub>N<sub>3</sub>O<sub>3</sub>.

## STORAGE

Protected from light.

## IMPURITIES

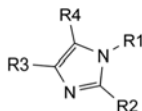

- A. R<sub>1</sub> = R<sub>4</sub> = H, R<sub>2</sub> = CH<sub>3</sub>, R<sub>3</sub> = NO<sub>2</sub>: 2-methyl-4-nitroimidazole,
- B. R<sub>1</sub> = R<sub>2</sub> = R<sub>4</sub> = H, R<sub>3</sub> = NO<sub>2</sub>: 4-nitroimidazole,
- C. R<sub>1</sub> = CH<sub>2</sub>-CH<sub>2</sub>-OH, R<sub>2</sub> = R<sub>4</sub> = H, R<sub>3</sub> = NO<sub>2</sub>: 2-(4-nitro-1*H*-imidazol-1-yl)ethanol,
- D. R<sub>1</sub> = CH<sub>2</sub>-CH<sub>2</sub>-OH, R<sub>2</sub> = R<sub>3</sub> = H, R<sub>4</sub> = NO<sub>2</sub>: 2-(5-nitro-1*H*-imidazol-1-yl)ethanol,
- E. R<sub>1</sub> = CH<sub>2</sub>-CH<sub>2</sub>-OH, R<sub>2</sub> = CH<sub>3</sub>, R<sub>3</sub> = NO<sub>2</sub>, R<sub>4</sub> = H: 2-(2-methyl-4-nitro-1*H*-imidazol-1-yl)ethanol,
- F. R<sub>1</sub> = CH<sub>2</sub>-CH<sub>2</sub>-O-CH<sub>2</sub>-CH<sub>2</sub>-OH, R<sub>2</sub> = CH<sub>3</sub>, R<sub>3</sub> = H, R<sub>4</sub> = NO<sub>2</sub>: 2-[2-(2-methyl-5-nitro-1*H*-imidazol-1-yl)ethoxy]ethanol,
- G. R<sub>1</sub> = CH<sub>2</sub>-CO<sub>2</sub>H, R<sub>2</sub> = CH<sub>3</sub>, R<sub>3</sub> = H, R<sub>4</sub> = NO<sub>2</sub>: 2-(2-methyl-5-nitro-1*H*-imidazol-1-yl)acetic acid.

01/2008:0934  
corrected 7.0

## METRONIDAZOLE BENZOATE

## Metronidazoli benzoas

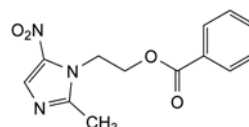
C<sub>13</sub>H<sub>13</sub>N<sub>3</sub>O<sub>4</sub>  
[13182-89-3]M<sub>r</sub> 275.3

## DEFINITION

2-(2-Methyl-5-nitro-1*H*-imidazol-1-yl)ethyl benzoate.

*Content*: 98.5 per cent to 101.0 per cent (dried substance).

## CHARACTERS

*Appearance*: white or slightly yellowish, crystalline powder or flakes.

*Solubility*: practically insoluble in water, freely soluble in methylene chloride, soluble in acetone, slightly soluble in alcohol.

## IDENTIFICATION

*First identification*: C.

*Second identification*: A, B, D.

A. Melting point (2.2.14): 99 °C to 102 °C.

B. Dissolve 0.100 g in a 103 g/L solution of *hydrochloric acid R* and dilute to 100.0 mL with the same acid. Dilute 1.0 mL of the solution to 100.0 mL with a 103 g/L solution of *hydrochloric acid R*. Examined between 220 nm and 350 nm (2.2.25), the solution shows 2 absorption maxima, at 232 nm and 275 nm. The specific absorbance at the absorption maximum at 232 nm is 525 to 575.

C. Infrared absorption spectrophotometry (2.2.24).

*Comparison*: Ph. Eur. reference spectrum of *metronidazole benzoate*.

D. To about 10 mg add about 10 mg of *zinc powder R*, 1 mL of *water R* and 0.3 mL of *hydrochloric acid R*. Heat on a water-bath for 5 min and cool. The solution gives the reaction of primary aromatic amines (2.3.1).

## TESTS

**Appearance of solution.** The solution is not more opalescent than reference suspension II (2.2.1) and not more intensely coloured than reference solution GY<sub>3</sub> (2.2.2, Method II).

Dissolve 1.0 g in *dimethylformamide R* and dilute to 10 mL with the same solvent.

**Acidity.** Dissolve 2.0 g in a mixture of 20 mL of *dimethylformamide R* and 20 mL of *water R*, previously neutralised with 0.02 M *hydrochloric acid* or 0.02 M *sodium hydroxide* using 0.2 mL of *methyl red solution R*. Not more than 0.25 mL of 0.02 M *sodium hydroxide* is required to change the colour of the indicator.

**Related substances.** Liquid chromatography (2.2.29).

*Solvent mixture.* Mix 45 volumes of mobile phase B and 55 volumes of mobile phase A.

*Test solution.* Dissolve 0.100 g of the substance to be examined in the solvent mixture and dilute to 10.0 mL with the solvent mixture.

*Reference solution (a).* Dilute 1.0 mL of the test solution to 100.0 mL with the solvent mixture. Dilute 1.0 mL of the solution to 10.0 mL with the solvent mixture.

*Reference solution (b).* Dissolve 5.0 mg of *metronidazole CRS*, 5.0 mg of *2-methyl-5-nitroimidazole R* and 5.0 mg of *benzoic acid R* in the solvent mixture and dilute to 50.0 mL with the solvent mixture. Dilute 1.0 mL of the solution to 10.0 mL with the solvent mixture.

*Column*:

- size:  $l = 0.25$  m,  $\varnothing = 4.6$  mm,
- stationary phase: spherical *di-isobutyloctadecylsilyl silica gel for chromatography R* (5 µm) with a specific surface area of 180 m<sup>2</sup>/g, a pore size of 8 nm and a carbon loading of 10 per cent.

*Mobile phase*:

- mobile phase A: 1.5 g/L solution of *potassium dihydrogen phosphate R* adjusted to pH 3.2 with *phosphoric acid R*,
- mobile phase B: *acetonitrile R*,

Time (min)	Mobile phase A (per cent V/V)	Mobile phase B (per cent V/V)
0 - 5	80	20
5 - 15	80 → 55	20 → 45
15 - 40	55	45

*Flow rate*: 1 mL/min.

*Detection*: spectrophotometer at 235 nm.

*Injection*: 10 µL.

*Relative retention* with reference to metronidazole benzoate (retention time = about 20 min): impurity B = about 0.17; impurity A = about 0.20; impurity C = about 0.7.

*System suitability*: reference solution (b):

- resolution: minimum 2.0 between the peaks due to impurity A and impurity B.

*Limits*:

- impurities A, B, C: for each impurity, not more than the area of the corresponding peak in the chromatogram obtained with reference solution (b) (0.1 per cent),
- any other impurity: for each impurity, not more than the area of the principal peak in the chromatogram obtained with reference solution (a) (0.1 per cent),
- total: not more than twice the area of the principal peak in the chromatogram obtained with reference solution (a) (0.2 per cent),
- disregard limit: 0.1 times the area of the principal peak in the chromatogram obtained with reference solution (a) (0.01 per cent).

**Heavy metals** (2.4.8): maximum 20 ppm.

1.0 g complies with limit test C. Prepare the standard using 2 mL of *lead standard solution (10 ppm Pb) R*.

**Loss on drying** (2.2.32): maximum 0.5 per cent, determined on 1.000 g by drying in an oven at 80 °C for 3 h.

**Sulfated ash** (2.4.14): maximum 0.1 per cent, determined on 1.0 g.

## ASSAY

Dissolve 0.250 g in 50 mL of *anhydrous acetic acid R*. Titrate with 0.1 M *perchloric acid*, determining the end-point potentiometrically (2.2.20).

1 mL of 0.1 M *perchloric acid* is equivalent to 27.53 mg of C<sub>13</sub>H<sub>13</sub>N<sub>3</sub>O<sub>4</sub>.

## STORAGE

Protected from light.

## IMPURITIES

*Specified impurities*: A, B, C.

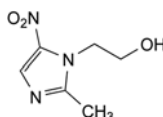

A. 2-(2-methyl-5-nitro-1*H*-imidazol-1-yl)ethanol (metronidazole),

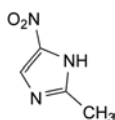

B. 2-methyl-5-nitroimidazole,

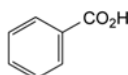

C. benzenecarboxylic acid (benzoic acid).

01/2008:1029 **Related substances.** Liquid chromatography (2.2.29).**MEXILETINE HYDROCHLORIDE**

## Mexiletini hydrochloridum

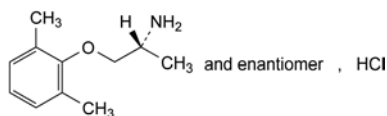
C<sub>11</sub>H<sub>18</sub>ClNO  
[5370-01-4]M<sub>r</sub> 215.7**DEFINITION**

(2*RS*)-1-(2,6-Dimethylphenoxy)propan-2-amine hydrochloride.  
Content: 99.0 per cent to 101.0 per cent (anhydrous substance).

**CHARACTERS**

*Appearance*: white or almost white, crystalline powder.  
*Solubility*: freely soluble in water and in methanol, sparingly soluble in methylene chloride.  
It shows polymorphism (5.9).

**IDENTIFICATION****A. Infrared absorption spectrophotometry (2.2.24).**

*Comparison*: mexiletine hydrochloride CRS.

If the spectra obtained in the solid state show differences, dissolve the substance to be examined and the reference substance separately in *methanol R*, evaporate to dryness and record new spectra using the residues.

**B. Dilute 1.5 mL of solution S (see Tests) to 15 mL with water R. The solution gives reaction (a) of chlorides (2.3.1).****TESTS**

**Solution S.** Dissolve 2.0 g in *carbon dioxide-free water R* and dilute to 20 mL with the same solvent.

**Appearance of solution.** The solution is clear (2.2.1) and colourless (2.2.2, *Method II*).

Dilute 5 mL of solution S to 10 mL with *water R*.

**pH (2.2.3)**: 4.0 to 5.5 for solution S.

**Impurity D.** Thin-layer chromatography (2.2.27).

*Test solution.* Dissolve 0.500 g of the substance to be examined in *methanol R* and dilute to 5.0 mL with the same solvent.

*Reference solution (a).* Dissolve the contents of a vial of *mexiletine impurity D CRS* in 4.0 mL of *methanol R*.

*Reference solution (b).* Dilute 1.0 mL of the test solution to 20.0 mL with *methanol R*.

*Reference solution (c).* Dilute 1.0 mL of reference solution (a) to 5.0 mL with *methanol R*.

*Reference solution (d).* Dilute 1.0 mL of reference solution (a) to 5.0 mL with reference solution (b).

*Plate*: TLC silica gel plate R.

*Mobile phase*: concentrated ammonia R, ethanol (96 per cent) R, acetone R, toluene R (3:7:45:45 V/V/V/V).

*Application*: 5 µL of the test solution and reference solutions (c) and (d).

*Development*: over a path of 10 cm.

*Drying*: in air.

*Detection*: spray with *ninhydrin solution R3* and heat at 100-105 °C for 15 min or until the spots appear.

*System suitability*: the chromatogram obtained with reference solution (b) shows 2 clearly separated spots.

**Limit:**

- *impurity D*: any spot corresponding to impurity D in the chromatogram obtained with the test solution is not more intense than the spot in the chromatogram obtained with reference solution (c) (0.1 per cent).

*Test solution.* Dissolve 0.200 g of the substance to be examined in the mobile phase and dilute to 10.0 mL with the mobile phase.

*Reference solution (a).* Dilute 1.0 mL of the test solution to 10.0 mL with the mobile phase.

*Reference solution (b).* Dissolve the contents of a vial of *mexiletine impurity C CRS* in the mobile phase and transfer the solution quantitatively to a volumetric flask containing 16.0 mg of *2,6-dimethylphenol R*. Dilute to 20.0 mL with the mobile phase. Mix 1.0 mL of this solution with 2.0 mL of reference solution (a) and dilute the mixture to 100.0 mL with the mobile phase.

**Column:**

- *size*:  $l = 0.25$  m,  $\varnothing = 4.6$  mm;
- *stationary phase*: end-capped octadecylsilyl silica gel for chromatography R (5 µm).

*Mobile phase*: mix 65 volumes of *methanol R2* and 35 volumes of a solution prepared as follows: dissolve 11.5 g of *anhydrous sodium acetate R* in 500 mL of *water R*, add 3.2 mL of *glacial acetic acid R*, mix and allow to cool; adjust to pH 4.8 with *glacial acetic acid R* and dilute to 1000 mL with *water R*.

*Flow rate*: 1.0 mL/min.

*Detection*: spectrophotometer at 262 nm.

*Injection*: 20 µL.

*Run time*: 5.5 times the retention time of mexiletine.

*Relative retention* with reference to mexiletine (retention time = about 4 min): *impurity C* = about 0.7; *impurity A* = about 1.8.

*System suitability*: reference solution (b):

- *resolution*: minimum 5.0 between the peaks due to *impurity C* and mexiletine.

**Limits:**

- *impurity A*: not more than 2.5 times the area of the corresponding peak in the chromatogram obtained with reference solution (b) (0.1 per cent);
- *impurity C*: not more than 20 times the area of the corresponding peak in the chromatogram obtained with reference solution (b) (0.1 per cent);
- *any other impurity*: for each impurity, not more than 0.5 times the area of the peak due to mexiletine in the chromatogram obtained with reference solution (b) (0.1 per cent);
- *total*: not more than 2.5 times the area of the peak due to mexiletine in the chromatogram obtained with reference solution (b) (0.5 per cent);
- *disregard limit*: 0.25 times the area of the peak due to mexiletine in the chromatogram obtained with reference solution (b) (0.05 per cent).

**Heavy metals (2.4.8)**: maximum 10 ppm.

2.0 g complies with test C. Prepare the reference solution using 2 mL of *lead standard solution (10 ppm Pb) R*.

**Water (2.5.12)**: maximum 0.5 per cent, determined on 1.00 g.

**Sulfated ash (2.4.14)**: maximum 0.1 per cent, determined on 1.0 g.

**ASSAY**

Dissolve 0.150 g in 50 mL of a mixture of equal volumes of *acetic anhydride R* and *anhydrous acetic acid R*. Titrate immediately with 0.1 M *perchloric acid*, determining the end-point potentiometrically (2.2.20) and completing the titration within 2 min.

1 mL of 0.1 M *perchloric acid* is equivalent to 21.57 mg of C<sub>11</sub>H<sub>18</sub>ClNO.

**IMPURITIES**

*Specified impurities*: A, C, D.

*Other detectable impurities* (the following substances would, if present at a sufficient level, be detected by one or other of the tests in the monograph. They are limited by the general acceptance criterion for other/unspecified impurities and/or by the general monograph *Substances for pharmaceutical use* (2034). It is therefore not necessary to identify these impurities for demonstration of compliance. See also 5.10. *Control of impurities in substances for pharmaceutical use*): B.

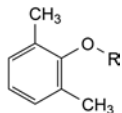

A. R = H: 2,6-dimethylphenol,

B. R = CH<sub>2</sub>-CO-CH<sub>3</sub>: 1-(2,6-dimethylphenoxy)propan-2-one,

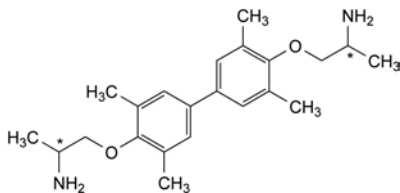

C. 1,1'-[(3,3',5,5'-tetramethylbiphenyl-4,4'-diyl)bisoxy]dipropyl-2-amine,

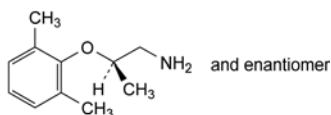

D. (2*RS*)-2-(2,6-dimethylphenoxy)propan-1-amine.

01/2009:0846

## MIANSERIN HYDROCHLORIDE

### Mianserini hydrochloridum

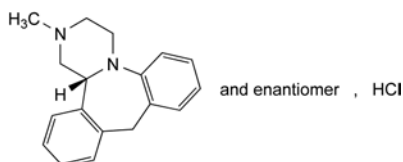

C<sub>18</sub>H<sub>21</sub>ClN<sub>2</sub>  
[21535-47-7]

M<sub>r</sub> 300.8

#### DEFINITION

(14*bRS*)-2-Methyl-1,2,3,4,10,14*b*-hexahydrodibenzo-*c*,*l*]pyrazino[1,2-*a*]azepine hydrochloride.

*Content*: 98.5 per cent to 101.0 per cent (dried substance).

#### CHARACTERS

*Appearance*: white or almost white, crystalline powder or crystals.

*Solubility*: sparingly soluble in water, soluble in methylene chloride, slightly soluble in ethanol (96 per cent).

#### IDENTIFICATION

*First identification*: B, D.

*Second identification*: A, C, D.

A. Ultraviolet and visible absorption spectrophotometry (2.2.25).

*Test solution*. Dissolve 50.0 mg in *water R* and dilute to 50.0 mL with the same solvent. Dilute 5.0 mL of the solution to 50.0 mL with *water R*.

*Spectral range*: 230-350 nm.

*Absorption maximum*: at 279 nm.

*Specific absorbance at the absorption maximum*: 64 to 72.

B. Infrared absorption spectrophotometry (2.2.24).

*Comparison*: mianserin hydrochloride CRS.

If the spectra obtained in the solid state show differences, dissolve the substance to be examined and the reference substance separately in *methanol R*, evaporate to dryness and record new spectra using the residues.

C. Thin-layer chromatography (2.2.27).

*Test solution*. Dissolve 10 mg of the substance to be examined in *methylene chloride R* and dilute to 5 mL with the same solvent.

*Reference solution (a)*. Dissolve 10 mg of *mianserin hydrochloride CRS* in *methylene chloride R* and dilute to 5 mL with the same solvent.

*Reference solution (b)*. Dissolve 10 mg of *mianserin hydrochloride CRS* and 10 mg of *cyproheptadine hydrochloride CRS* in *methylene chloride R* and dilute to 5 mL with the same solvent.

*Plate*: TLC silica gel GF<sub>254</sub> plate R.

*Mobile phase*: diethylamine R, ether R, cyclohexane R (5:20:75 V/V/V).

*Application*: 2 µL.

*Development*: over 2/3 of the plate.

*Detection*: examine in ultraviolet light at 254 nm.

*System suitability*: reference solution (b):

– the chromatogram shows 2 clearly separated principal spots.

*Results*: the principal spot in the chromatogram obtained with the test solution is similar in position and size to the principal spot in the chromatogram obtained with reference solution (a).

D. It gives reaction (a) of chlorides (2.3.1).

#### TESTS

**pH** (2.2.3): 4.0 to 5.5.

Dissolve 0.10 g in *carbon dioxide-free water R* and dilute to 10 mL with the same solvent.

**Related substances**. Liquid chromatography (2.2.29).

*Buffer solution pH 3.0*. Dissolve 5.0 g of *sodium octanesulfonate R* in *water R* and dilute to 350 mL with the same solvent. Stir until complete dissolution. Adjust to pH 3.0 with a mixture of 1 volume of *phosphoric acid R* and 3 volumes of *water R*. Dilute to 400 mL with *water R*.

*Test solution*. Dissolve 25 mg of the substance to be examined in the mobile phase and dilute to 25.0 mL with the mobile phase.

*Reference solution (a)*. Dilute 1.0 mL of the test solution to 100.0 mL with the mobile phase. Dilute 1.0 mL of this solution to 10.0 mL with the mobile phase.

*Reference solution (b)*. Dissolve the contents of a vial of *mianserin for system suitability CRS* (containing impurities A, D and E) in 1.0 mL of the mobile phase.

*Reference solution (c)*. Dissolve 5.0 mg of *mianserin impurity B CRS* in the mobile phase and dilute to 50.0 mL with the mobile phase. Dilute 1.0 mL of this solution to 100.0 mL with the mobile phase.

*Column*:

– *size*: *l* = 0.15 m, Ø = 3.9 mm;

– *stationary phase*: end-capped octylsilyl silica gel for chromatography R (5 µm).

*Mobile phase*: buffer solution pH 3.0, *methanol R* (37:63 V/V).

*Flow rate*: 0.5 mL/min.

*Detection*: spectrophotometer at 250 nm.

*Injection*: 10 µL.

*Run time*: twice the retention time of mianserin.

*Identification of impurities*: use the chromatogram supplied with *mianserin for system suitability CRS* and the chromatogram obtained with reference solution (b) to identify the peaks due to impurities A, D and E.

*Relative retention* with reference to mianserin (retention time = about 18 min): impurity B = about 0.2; impurity A = about 0.5; impurity D = about 0.7; impurity E = about 1.1.

*System suitability*: reference solution (b):

- *peak-to-valley ratio*: minimum 4.0, where  $H_p$  = height above the baseline of the peak due to impurity E and  $H_v$  = height above the baseline of the lowest point of the curve separating this peak from the peak due to mianserin.

*Limits*:

- *correction factor*: for the calculation of content, multiply the peak areas of the following impurities by the corresponding correction factor: impurity A = 2.4; impurity D = 2.1;
- *impurity B*: not more than 3 times the area of the principal peak in the chromatogram obtained with reference solution (c) (0.3 per cent);
- *impurities A, D, E*: for each impurity, not more than 1.5 times the area of the principal peak in the chromatogram obtained with reference solution (a) (0.15 per cent);
- *unspecified impurities*: for each impurity, not more than the area of the principal peak in the chromatogram obtained with reference solution (a) (0.10 per cent);
- *total*: not more than 5 times the area of the principal peak in the chromatogram obtained with reference solution (a) (0.5 per cent);
- *disregard limit*: 0.5 times the area of the principal peak in the chromatogram obtained with reference solution (a) (0.05 per cent).

**Loss on drying** (2.2.32): maximum 0.5 per cent, determined on 1.000 g by drying over *diphosphorus pentoxide R* at 65 °C at a pressure not exceeding 0.7 kPa for 3 h.

**Sulfated ash** (2.4.14): maximum 0.1 per cent, determined on 1.0 g.

#### ASSAY

Dissolve 0.200 g in a mixture of 5.0 mL of 0.01 M hydrochloric acid and 50 mL of ethanol (96 per cent) R. Carry out a potentiometric titration (2.2.20), using 0.1 M sodium hydroxide. Read the volume added between the 2 points of inflexion.

1 mL of 0.1 M sodium hydroxide is equivalent to 30.08 mg of  $C_{18}H_{21}ClN_2$ .

#### STORAGE

Protected from light.

#### IMPURITIES

*Specified impurities*: A, B, D, E.

*Other detectable impurities* (the following substances would, if present at a sufficient level, be detected by one or other of the tests in the monograph. They are limited by the general acceptance criterion for other/unspecified impurities and/or by the general monograph *Substances for pharmaceutical use* (2034). It is therefore not necessary to identify these impurities for demonstration of compliance. See also 5.10. *Control of impurities in substances for pharmaceutical use*): C, F.

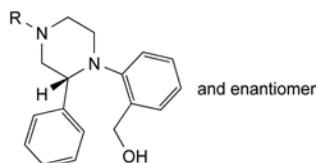

- A. R = CH<sub>3</sub>: [2-[(2*RS*)-4-methyl-2-phenylpiperazin-1-yl]phenyl]methanol,
- D. R = CH<sub>2</sub>-C<sub>6</sub>H<sub>5</sub>: [2-[(2*RS*)-4-benzyl-2-phenylpiperazin-1-yl]phenyl]methanol,

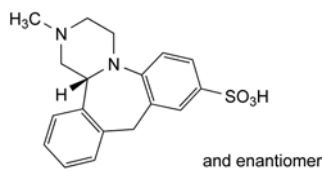

- B. (14*bRS*)-2-methyl-1,2,3,4,10,14*b*-hexahydrodibenzo[*c,f*]pyrazino[1,2-*a*]azepine-8-sulfonic acid,

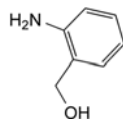

- C. (2-aminophenyl)methanol,

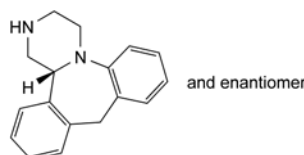

- E. (14*bRS*)-1,2,3,4,10,14*b*-hexahydrodibenzo[*c,f*]pyrazino[1,2-*a*]azepine,

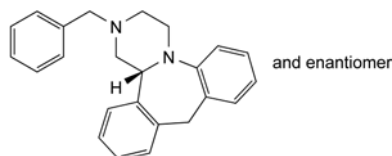

- F. (14*bRS*)-2-benzyl-1,2,3,4,10,14*b*-hexahydrodibenzo[*c,f*]pyrazino[1,2-*a*]azepine.

01/2008:0935

## MICONAZOLE

### Miconazolium

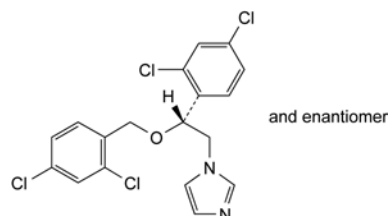

$C_{18}H_{14}Cl_4N_2O$   
[22916-47-8]

$M_r$  416.1

#### DEFINITION

1-[(2*RS*)-2-[(2,4-Dichlorobenzyl)oxy]-2-(2,4-dichlorophenyl)ethyl]-1*H*-imidazole.

*Content*: 99.0 per cent to 101.0 per cent (dried substance).

#### CHARACTERS

*Appearance*: white or almost white powder.

*Solubility*: very slightly soluble in water, freely soluble in methanol, soluble in ethanol (96 per cent).

It shows polymorphism (5.9).

#### IDENTIFICATION

*First identification*: A, B.

*Second identification*: A, C, D.

A. Melting point (2.2.14): 83 °C to 87 °C.

B. Infrared absorption spectrophotometry (2.2.24).

*Preparation*: discs of potassium bromide R.

*Comparison*: miconazole CRS.

C. Thin-layer chromatography (2.2.27).

**Test solution.** Dissolve 30 mg of the substance to be examined in the mobile phase and dilute to 5 mL with the mobile phase.

**Reference solution (a).** Dissolve 30 mg of *miconazole CRS* in the mobile phase and dilute to 5 mL with the mobile phase.

**Reference solution (b).** Dissolve 30 mg of *miconazole CRS* and 30 mg of *econazole nitrate CRS* in the mobile phase and dilute to 5 mL with the mobile phase.

**Plate:** *TLC octadecylsilyl silica gel plate R.*

**Mobile phase:** *ammonium acetate solution R, dioxan R, methanol R (20:40:40 V/V/V).*

**Application:** 5 µL.

**Development:** over a path of 15 cm.

**Drying:** in a current of warm air for 15 min.

**Detection:** expose to iodine vapour until the spots appear and examine in daylight.

**System suitability:** reference solution (b):

- the chromatogram shows 2 clearly separated spots.

**Results:** the principal spot in the chromatogram obtained with the test solution is similar in position, colour and size to the principal spot in the chromatogram obtained with reference solution (a).

- D. To 30 mg in a porcelain crucible add 0.3 g of *anhydrous sodium carbonate R*. Heat over an open flame for 10 min. Allow to cool. Take up the residue with 5 mL of *dilute nitric acid R* and filter. To 1 mL of the filtrate add 1 mL of *water R*. The solution gives reaction (a) of chlorides (2.3.1).

## TESTS

**Solution S.** Dissolve 0.1 g in *methanol R* and dilute to 10 mL with the same solvent.

**Appearance of solution.** Solution S is clear (2.2.1) and not more intensely coloured than reference solution Y<sub>6</sub> (2.2.2, Method II).

**Optical rotation (2.2.7):** –0.10° to +0.10°, determined on solution S.

**Related substances.** Liquid chromatography (2.2.29).

**Test solution.** Dissolve 0.100 g of the substance to be examined in the mobile phase and dilute to 10.0 mL with the mobile phase.

**Reference solution (a).** Dissolve 2.5 mg of *miconazole CRS* and 2.5 mg of *econazole nitrate CRS* in the mobile phase and dilute to 100.0 mL with the mobile phase.

**Reference solution (b).** Dilute 1.0 mL of the test solution to 100.0 mL with the mobile phase. Dilute 5.0 mL of this solution to 20.0 mL with the mobile phase.

**Column:**

- size:  $l = 0.10$  m,  $\varnothing = 4.6$  mm;
- stationary phase: *octadecylsilyl silica gel for chromatography R (3 µm).*

**Mobile phase:** dissolve 6.0 g of *ammonium acetate R* in a mixture of 300 mL of *acetonitrile R*, 320 mL of *methanol R* and 380 mL of *water R*.

**Flow rate:** 2 mL/min.

**Detection:** spectrophotometer at 235 nm.

**Equilibration:** with the mobile phase for about 30 min.

**Injection:** 10 µL.

**Run time:** 1.2 times the retention time of miconazole.

**Retention time:** *econazole* = about 10 min; *miconazole* = about 20 min.

**System suitability:** reference solution (a):

- resolution: minimum 10 between the peaks due to *econazole* and *miconazole*; if necessary, adjust the composition of the mobile phase.

**Limits:**

- impurities A, B, C, D, E, F, G: for each impurity, not more than the area of the principal peak in the chromatogram obtained with reference solution (b) (0.25 per cent);

- total: not more than twice the area of the principal peak in the chromatogram obtained with reference solution (b) (0.5 per cent);
- disregard limit: 0.2 times the area of the principal peak in the chromatogram obtained with reference solution (b) (0.05 per cent).

**Loss on drying (2.2.32):** maximum 0.5 per cent, determined on 1.000 g by drying *in vacuo* at 60 °C for 4 h.

**Sulfated ash (2.4.14):** maximum 0.1 per cent, determined on 1.0 g.

## ASSAY

Dissolve 0.300 g in 50 mL of a mixture of 1 volume of *anhydrous acetic acid R* and 7 volumes of *methyl ethyl ketone R*. Using 0.2 mL of *naphtholbenzein solution R* as indicator, titrate with 0.1 M *perchloric acid* until the colour changes from orange-yellow to green.

1 mL of 0.1 M *perchloric acid* is equivalent to 41.61 mg of C<sub>18</sub>H<sub>14</sub>Cl<sub>4</sub>N<sub>2</sub>O.

## STORAGE

Protected from light.

## IMPURITIES

**Specified impurities:** A, B, C, D, E, F, G.

**Other detectable impurities** (the following substances would, if present at a sufficient level, be detected by one or other of the tests in the monograph. They are limited by the general acceptance criterion for other/unspecified impurities and/or by the general monograph *Substances for pharmaceutical use (2034)*. It is therefore not necessary to identify these impurities for demonstration of compliance. See also 5.10. *Control of impurities in substances for pharmaceutical use*): H, I.

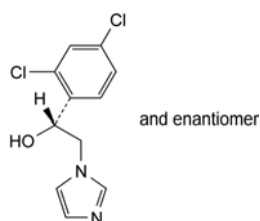

A. (1*R*)-1-(2,4-dichlorophenyl)-2-(1*H*-imidazol-1-yl)ethanol,

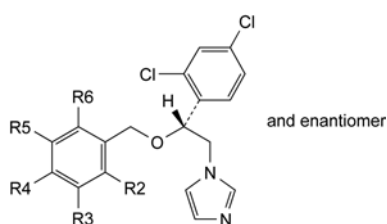

B. R<sub>2</sub> = R<sub>3</sub> = R<sub>5</sub> = R<sub>6</sub> = H, R<sub>4</sub> = Cl: 1-[(2*RS*)-2-[(4-chlorobenzyl)oxy]-2-(2,4-dichlorophenyl)ethyl]-1*H*-imidazole,

D. R<sub>2</sub> = R<sub>6</sub> = Cl, R<sub>3</sub> = R<sub>4</sub> = R<sub>5</sub> = H: 1-[(2*RS*)-2-[(2,6-dichlorobenzyl)oxy]-2-(2,4-dichlorophenyl)ethyl]-1*H*-imidazole,

F. R<sub>2</sub> = R<sub>5</sub> = R<sub>6</sub> = H, R<sub>3</sub> = R<sub>4</sub> = Cl: 1-[(2*RS*)-2-[(3,4-dichlorobenzyl)oxy]-2-(2,4-dichlorophenyl)ethyl]-1*H*-imidazole,

G. R<sub>2</sub> = R<sub>5</sub> = Cl, R<sub>3</sub> = R<sub>4</sub> = R<sub>6</sub> = H: 1-[(2*RS*)-2-[(2,5-dichlorobenzyl)oxy]-2-(2,4-dichlorophenyl)ethyl]-1*H*-imidazole,

H. R<sub>2</sub> = R<sub>3</sub> = R<sub>4</sub> = R<sub>5</sub> = R<sub>6</sub> = H: 1-[(2*RS*)-2-benzoyloxy-2-(2,4-dichlorophenyl)ethyl]-1*H*-imidazole,

I. R<sub>2</sub> = Cl, R<sub>3</sub> = R<sub>4</sub> = R<sub>5</sub> = R<sub>6</sub> = H: 1-[(2*RS*)-2-[(2-chlorobenzyl)oxy]-2-(2,4-dichlorophenyl)ethyl]-1*H*-imidazole,



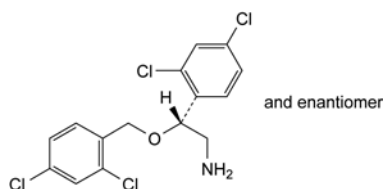

C. (2*RS*)-2-[(2,4-dichlorobenzyl)oxy]-2-(2,4-dichlorophenyl)ethanamine,

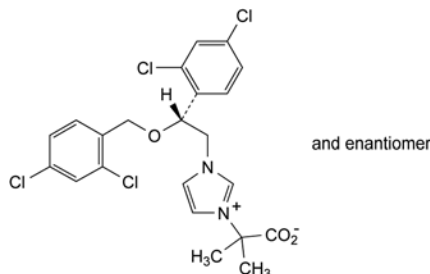

E. 2-[1-[(2*RS*)-2-[(2,4-dichlorobenzyl)oxy]-2-(2,4-dichlorophenyl)ethyl]-1*H*-imidazol-3-yl]-2-methylpropanoate.

01/2008:0513  
corrected 6.0

## MICONAZOLE NITRATE

### Miconazoli nitras

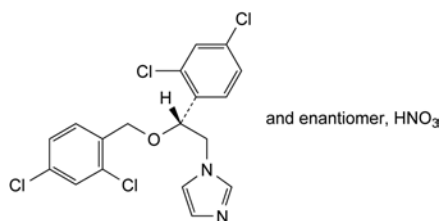

$C_{18}H_{15}Cl_4N_3O_4$   
[22832-87-7]

$M_r$  479.1

#### DEFINITION

1-[(2*RS*)-2-[(2,4-Dichlorobenzyl)oxy]-2-(2,4-dichlorophenyl)ethyl]-1*H*-imidazole nitrate.

*Content*: 99.0 per cent to 101.0 per cent (dried substance).

#### CHARACTERS

*Appearance*: white or almost white powder.

*Solubility*: very slightly soluble in water, sparingly soluble in methanol, slightly soluble in ethanol (96 per cent).

#### IDENTIFICATION

*First identification*: A, B.

*Second identification*: A, C, D.

A. Melting point (2.2.14): 178 °C to 184 °C.

B. Infrared absorption spectrophotometry (2.2.24).

*Preparation*: discs of potassium bromide *R*.

*Comparison*: miconazole nitrate CRS.

C. Thin-layer chromatography (2.2.27).

*Test solution*. Dissolve 30 mg of the substance to be examined in the mobile phase and dilute to 5 mL with the mobile phase.

*Reference solution (a)*. Dissolve 30 mg of miconazole nitrate CRS in the mobile phase and dilute to 5 mL with the mobile phase.

*Reference solution (b)*. Dissolve 30 mg of miconazole nitrate CRS and 30 mg of econazole nitrate CRS in the mobile phase, then dilute to 5 mL with the mobile phase.

*Plate*: TLC octadecylsilyl silica gel plate *R*.

*Mobile phase*: ammonium acetate solution *R*, dioxan *R*, methanol *R* (20:40:40 V/V/V).

*Application*: 5 µL.

*Development*: over a path of 15 cm.

*Drying*: in a current of warm air for 15 min.

*Detection*: expose to iodine vapour until the spots appear and examine in daylight.

*System suitability*: reference solution (b):

– the chromatogram shows 2 clearly separated spots.

*Results*: the principal spot in the chromatogram obtained with the test solution is similar in position, colour and size to the principal spot in the chromatogram obtained with reference solution (a).

D. It gives the reaction of nitrates (2.3.1).

#### TESTS

**Solution S**. Dissolve 0.1 g in methanol *R* and dilute to 10 mL with the same solvent.

**Appearance of solution**. Solution S is clear (2.2.1) and not more intensely coloured than reference solution Y<sub>7</sub> (2.2.2, Method II).

**Optical rotation** (2.2.7): –0.10° to +0.10°, determined on solution S.

**Related substances**. Liquid chromatography (2.2.29).

*Test solution*. Dissolve 0.100 g of the substance to be examined in the mobile phase and dilute to 10.0 mL with the mobile phase.

*Reference solution (a)*. Dissolve 2.5 mg of miconazole nitrate CRS and 2.5 mg of econazole nitrate CRS in the mobile phase, then dilute to 100.0 mL with the mobile phase.

*Reference solution (b)*. Dilute 1.0 mL of the test solution to 100.0 mL with the mobile phase. Dilute 5.0 mL of this solution to 20.0 mL with the mobile phase.

*Column*:

– size:  $l = 0.10$  m,  $\varnothing = 4.6$  mm;

– stationary phase: octadecylsilyl silica gel for chromatography *R* (3 µm).

*Mobile phase*: dissolve 6.0 g of ammonium acetate *R* in a mixture of 300 mL of acetonitrile *R*, 320 mL of methanol *R* and 380 mL of water *R*.

*Flow rate*: 2 mL/min.

*Detection*: spectrophotometer at 235 nm.

*Equilibration*: with the mobile phase for about 30 min.

*Injection*: 10 µL.

*Run time*: 1.2 times the retention time of miconazole.

*Retention time*: econazole = about 10 min; miconazole = about 20 min.

*System suitability*: reference solution (a):

– *resolution*: minimum 10 between the peaks due to econazole and miconazole; if necessary, adjust the composition of the mobile phase.

*Limits*:

– *impurities A, B, C, D, E, F, G*: for each impurity, not more than the area of the principal peak in the chromatogram obtained with reference solution (b) (0.25 per cent);

– *total*: not more than twice the area of the principal peak in the chromatogram obtained with reference solution (b) (0.5 per cent);

– *disregard limit*: 0.2 times the area of the principal peak in the chromatogram obtained with reference solution (b) (0.05 per cent); disregard any peak due to the nitrate ion.

**Loss on drying** (2.2.32): maximum 0.5 per cent, determined on 1.000 g by drying in an oven at 105 °C for 2 h.

**Sulfated ash** (2.4.14): maximum 0.1 per cent, determined on 1.0 g.

## ASSAY

Dissolve 0.350 g in 75 mL of *anhydrous acetic acid R*, with slight heating if necessary. Titrate with 0.1 M perchloric acid, determining the end-point potentiometrically (2.2.20). Carry out a blank titration.

1 mL of 0.1 M perchloric acid is equivalent to 47.91 mg of  $C_{18}H_{15}Cl_4N_3O_4$ .

## STORAGE

Protected from light.

## IMPURITIES

Specified impurities: A, B, C, D, E, F, G.

Other detectable impurities (the following substances would, if present at a sufficient level, be detected by one or other of the tests in the monograph. They are limited by the general acceptance criterion for other/unspecified impurities and/or by the general monograph *Substances for pharmaceutical use (2034)*. It is therefore not necessary to identify these impurities for demonstration of compliance. See also 5.10. *Control of impurities in substances for pharmaceutical use*): H, I.

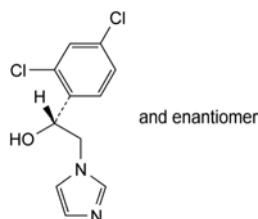

A. (1RS)-1-(2,4-dichlorophenyl)-2-(1H-imidazol-1-yl)ethanol,

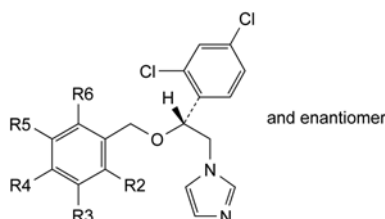

B. R2 = R3 = R5 = R6 = H, R4 = Cl: 1-[(2RS)-2-[(4-chlorobenzyl)oxy]-2-(2,4-dichlorophenyl)ethyl]-1H-imidazole,

D. R2 = R6 = Cl, R3 = R4 = R5 = H: 1-[(2RS)-2-[(2,6-dichlorobenzyl)oxy]-2-(2,4-dichlorophenyl)ethyl]-1H-imidazole,

F. R2 = R5 = R6 = H, R3 = R4 = Cl: 1-[(2RS)-2-[(3,4-dichlorobenzyl)oxy]-2-(2,4-dichlorophenyl)ethyl]-1H-imidazole,

G. R2 = R5 = Cl, R3 = R4 = R6 = H: 1-[(2RS)-2-[(2,5-dichlorobenzyl)oxy]-2-(2,4-dichlorophenyl)ethyl]-1H-imidazole,

H. R2 = R3 = R4 = R5 = R6 = H: 1-[(2RS)-2-benzyloxy-2-(2,4-dichlorophenyl)ethyl]-1H-imidazole,

I. R2 = Cl, R3 = R4 = R5 = R6 = H: 1-[(2RS)-2-[(2-chlorobenzyl)oxy]-2-(2,4-dichlorophenyl)ethyl]-1H-imidazole,

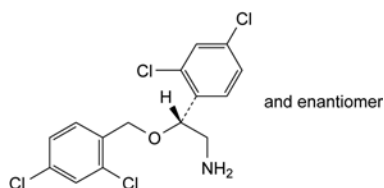

C. (2RS)-2-[(2,4-dichlorobenzyl)oxy]-2-(2,4-dichlorophenyl)ethanamine,

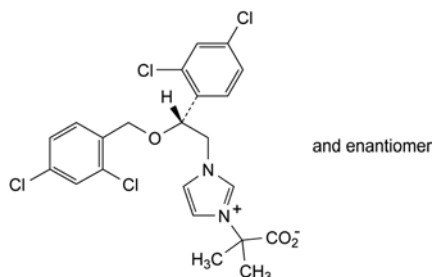

E. 2-[1-[(2RS)-2-[(2,4-dichlorobenzyl)oxy]-2-(2,4-dichlorophenyl)ethyl]-1H-imidazol-3-yl]-2-methylpropanoate.

01/2008:2050  
corrected 7.0

## MICROCRYSTALLINE CELLULOSE AND CARMELLOSE SODIUM

### Cellulosum microcristallinum et carmellosum natricum

## DEFINITION

Colloid-forming, powdered mixture of *Microcrystalline Cellulose (0316)* with 5 per cent to 22 per cent of *Carmellose sodium (0472)*.

*Content*: 75.0 per cent to 125.0 per cent of the nominal amount of carmellose sodium (dried substance).

## CHARACTERS

*Appearance*: white or off-white, coarse or fine powder.

*Solubility*: dispersible in water producing a white, opaque colloidal dispersion; practically insoluble in organic solvents and in dilute acids.

## IDENTIFICATION

A. Mix 6 g with 300 mL of *water R* and stir at 18 000 r/min for 5 min. A white opaque dispersion is obtained which does not produce a supernatant liquid.

B. Add several drops of the dispersion obtained in identification A to a 10 per cent V/V solution of *aluminium chloride R*. Each drop forms a white, opaque globule which does not disperse on standing.

C. Add 2 mL of *iodinated potassium iodide solution R* to the dispersion obtained in test A. No blue or purplish colour is produced.

D. It complies with the limits of the assay.

## TESTS

**Solubility.** Add 50 mg to 10 mL of *ammoniacal solution of copper tetrammine R* and shake. It dissolves completely leaving no residue.

**pH (2.2.3):** 6.0 to 8.0 for the dispersion obtained in identification A.

**Loss on drying (2.2.32):** maximum 8.0 per cent, determined on 1.000 g by drying in an oven at 105 °C.

**Sulfated ash (2.4.14):** maximum 7.4 per cent, determined on 2.0 g.

## ASSAY

Heat 2.00 g with 75 mL of *anhydrous acetic acid R* under a reflux condenser for 2 h, cool and titrate with 0.1 M perchloric acid, determining the end point potentiometrically (2.2.20).

1 mL of 0.1 M perchloric acid is equivalent to 29.6 mg of carmellose sodium.

## LABELLING

The label states the nominal percentage *m/m* of carmellose sodium.

## FUNCTIONALITY-RELATED CHARACTERISTICS

This section provides information on characteristics that are recognised as being relevant control parameters for one or more functions of the substance when used as an excipient (see chapter 5.15). This section is a non-mandatory part of the monograph and it is not necessary to verify the characteristics to demonstrate compliance. Control of these characteristics can however contribute to the quality of a medicinal product by improving the consistency of the manufacturing process and the performance of the medicinal product during use. Where control methods are cited, they are recognised as being suitable for the purpose, but other methods can also be used. Wherever results for a particular characteristic are reported, the control method must be indicated.

The following characteristics may be relevant for microcrystalline cellulose and carmellose sodium used as a suspending agent.

**Apparent viscosity (2.2.10)** : 60 per cent to 140 per cent of the nominal value.

Calculate the quantity ( $x$  g) needed to prepare exactly 600 g of a dispersion of the stated percentage  $m/m$  (dried substance). To  $(600 - x)$  g of water R at 23-25 °C contained in a 1000 mL high-speed blender bowl add  $x$  g of the substance to be examined and stir at reduced speed, taking care to avoid contacting the sides of the bowl with the powder. Continue stirring at low speed for 15 s after the addition of the powder and then stir at 18 000 r/min for exactly 2 min.

Determine the viscosity with a suitable relative rotational viscometer under the following conditions:

- spindle: as appropriate;
- speed: 20 r/min.

Immerse the spindle into the suspension immediately after preparation, switch on the rotation spindle after 30 s, after a further 30 s take scale readings and calculate the viscosity according to the viscometer manual.

C. Examine the chromatograms obtained in the test for impurity C.

**Results:** the principal spot in the chromatogram obtained with test solution (b) is similar in position and size to the principal spot in the chromatogram obtained with reference solution (b).

D. Mix 90 mg with 0.30 g of anhydrous sodium carbonate R and ignite in a crucible until an almost white residue is obtained (normally in less than 5 min). Allow to cool and dissolve the residue in 5 mL of dilute nitric acid R. Filter (the filtrate is also used in identification test E). Add 1.0 mL of the filtrate to a freshly prepared mixture of 0.1 mL of alizarin S solution R and 0.1 mL of zirconyl nitrate solution R. Mix, allow to stand for 5 min and compare the colour of the solution with that of a blank prepared in the same manner. The test solution is yellow and the blank solution is red.

E. To 1 mL of the filtrate obtained in identification test D add 1 mL of water R. The solution gives reaction (a) of chlorides (2.3.1).

## TESTS

**Appearance of solution.** The solution is clear (2.2.1) and not more intensely coloured than reference solution Y<sub>6</sub> (2.2.2, Method II).

Dissolve 0.1 g in 0.1 M hydrochloric acid and dilute to 10 mL with the same acid.

**Related substances.** Liquid chromatography (2.2.29).

**Test solution.** Dissolve 50.0 mg of the substance to be examined in methanol R and dilute to 50.0 mL with the same solvent.

**Reference solution (a).** Dilute 1.0 mL of the test solution to 100.0 mL with methanol R. Dilute 1.0 mL of this solution to 10.0 mL with methanol R.

**Reference solution (b).** Dissolve the contents of a vial of midazolam for system suitability CRS (containing impurities A, B, E, G and H) in 1.0 mL of methanol R.

**Column:**

- size:  $l = 0.25$  m,  $\varnothing = 4.0$  mm,
- stationary phase: octylsilyl silica gel for chromatography R (5  $\mu$ m).

**Mobile phase:** prepare a solution containing 7.7 g/L of ammonium acetate R and 10 mL/l of tetrabutylammonium hydroxide solution (400 g/L) R and adjust to pH 5.3 with glacial acetic acid R. Mix 44 volumes of this solution with 56 volumes of methanol R.

**Flow rate:** 1.0 mL/min.

**Detection:** spectrophotometer at 254 nm.

**Injection:** 10  $\mu$ L.

**Run time:** 2.5 times the retention time of midazolam.

**Relative retention** with reference to midazolam (retention time = about 17 min): impurity I = about 0.25; impurity J (2 peaks) = about 0.3; impurity D = about 0.4; impurity E = about 0.5; impurity F = about 0.7; impurity A = about 0.9; impurity G = about 1.2; impurity H = about 1.9; impurity B = about 2.2.

**System suitability:** reference solution (b):

- **peak-to-valley ratio:** minimum 3.0 where  $H_p$  = height above the baseline of the peak due to impurity A and  $H_v$  = height above the baseline of the lowest point of the curve separating this peak from the peak due to midazolam.

**Limits:**

- **correction factors:** for the calculation of content, multiply the peak areas of the following impurities by the corresponding correction factor: impurity A = 2; impurity E = 2; impurity H = 1.7;
- **impurity B:** not more than twice the area of the principal peak in the chromatogram obtained with reference solution (a) (0.2 per cent),

01/2008:0936  
corrected 6.0

## MIDAZOLAM

## Midazolamum

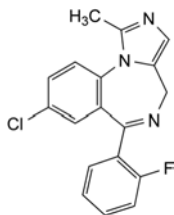

C<sub>18</sub>H<sub>13</sub>ClFN<sub>3</sub>  
[59467-70-8]

$M_r$  325.8

## DEFINITION

8-Chloro-6-(2-fluorophenyl)-1-methyl-4H-imidazo[1,5-a][1,4]-benzodiazepine.

**Content:** 98.5 per cent to 101.5 per cent (dried substance).

## CHARACTERS

**Appearance:** white or yellowish, crystalline powder.

**Solubility:** practically insoluble in water, freely soluble in acetone and in ethanol (96 per cent), soluble in methanol.

## IDENTIFICATION

**First identification:** B.

**Second identification:** A, C, D, E.

A. Melting point (2.2.14): 161 °C to 164 °C.

B. Infrared absorption spectrophotometry (2.2.24).

**Comparison:** midazolam CRS.

- *impurities A, G*: for each impurity, not more than the area of the principal peak in the chromatogram obtained with reference solution (a) (0.1 per cent);
- *unspecified impurities*: for each impurity, not more than the area of the principal peak in the chromatogram obtained with reference solution (a) (0.1 per cent);
- *total*: not more than 3 times the area of the principal peak in the chromatogram obtained with reference solution (a) (0.3 per cent);
- *disregard limit*: 0.5 times the area of the principal peak in the chromatogram obtained with reference solution (a) (0.05 per cent).

**Impurity C.** Thin-layer chromatography (2.2.27).

*Test solution (a).* Dissolve 0.20 g of the substance to be examined in *ethanol (96 per cent) R* and dilute to 5 mL with the same solvent.

*Test solution (b).* Dilute 1 mL of test solution (a) to 50 mL with *ethanol (96 per cent) R*.

*Reference solution (a).* Dissolve the contents of a vial of *midazolam impurity C CRS* in 2.0 mL of *methanol R*.

*Reference solution (b).* Dissolve 8 mg of *midazolam CRS* in *ethanol (96 per cent) R* and dilute to 10 mL with the same solvent.

*Reference solution (c).* Dissolve 40 mg of the substance to be examined in 1 mL of reference solution (a).

*Plate:* TLC silica gel  $F_{254}$  plate *R*.

*Mobile phase:* glacial acetic acid *R*, water *R*, methanol *R*, ethyl acetate *R* (2:15:20:80 V/V/V/V).

*Application:* 5  $\mu$ L.

*Development:* over 2/3 of the plate.

*Drying:* in air.

*Detection:* examine in ultraviolet light at 254 nm.

*System suitability:* reference solution (c):

- the chromatogram shows 2 clearly separated spots.

*Limit:*

- *impurity C*: any spot due to impurity C in the chromatogram obtained with test solution (a) is not more intense than the spot in the chromatogram obtained with reference solution (a) (0.1 per cent).

**Loss on drying** (2.2.32): maximum 0.5 per cent, determined on 1.000 g by drying in an oven at 105 °C for 2 h.

**Sulfated ash** (2.4.14): maximum 0.1 per cent, determined on 1.0 g in a platinum crucible.

**ASSAY**

Dissolve 0.120 g in 30 mL of *anhydrous acetic acid R* and add 20 mL of *acetic anhydride R*. Titrate with 0.1 M *perchloric acid* to the 2<sup>nd</sup> point of inflexion, determining the end-point potentiometrically (2.2.20).

1 mL of 0.1 M *perchloric acid* is equivalent to 16.29 mg of  $C_{18}H_{13}ClFN_3$ .

**IMPURITIES**

*Specified impurities:* A, B, C, G.

*Other detectable impurities* (the following substances would, if present at a sufficient level, be detected by one or other of the tests in the monograph. They are limited by the general acceptance criterion for other/unspecified impurities and/or by the general monograph *Substances for pharmaceutical use* (2034). It is therefore not necessary to identify these impurities for demonstration of compliance. See also 5.10. *Control of impurities in substances for pharmaceutical use*): D, E, F, H, I, J.

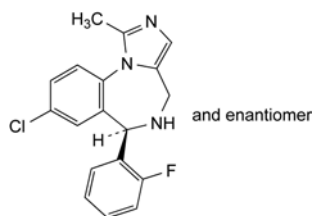

A. (6*RS*)-8-chloro-6-(2-fluorophenyl)-1-methyl-5,6-dihydro-4*H*-imidazo[1,5-*a*][1,4]benzodiazepine,

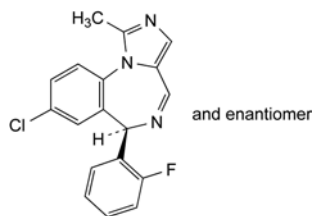

B. (6*RS*)-8-chloro-6-(2-fluorophenyl)-1-methyl-6*H*-imidazo[1,5-*a*][1,4]benzodiazepine,

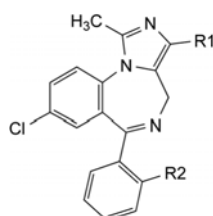

C. R1 = CO<sub>2</sub>H, R2 = F: 8-chloro-6-(2-fluorophenyl)-1-methyl-4*H*-imidazo[1,5-*a*][1,4]benzodiazepine-3-carboxylic acid,

G. R1 = R2 = H: 8-chloro-1-methyl-6-phenyl-4*H*-imidazo[1,5-*a*][1,4]benzodiazepine (desfluoromidazolam),

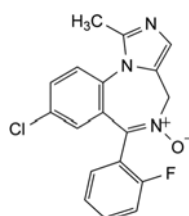

D. 8-chloro-6-(2-fluorophenyl)-1-methyl-4*H*-imidazo[1,5-*a*][1,4]benzodiazepine 5-oxide,

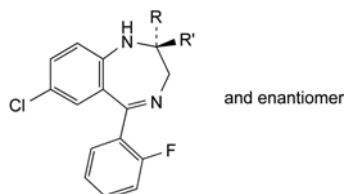

E. R = CH<sub>2</sub>-NH<sub>2</sub>, R' = H: [(2*RS*)-7-chloro-5-(2-fluorophenyl)-2,3-dihydro-1*H*-1,4-benzodiazepine-2-yl]methanamine,

F. R + R' = O: 7-chloro-5-(2-fluorophenyl)-1,3-dihydro-2*H*-1,4-benzodiazepin-2-one (1-des[(diethylamino)ethyl]flurazepam),

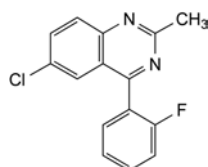

H. 6-chloro-4-(2-fluorophenyl)-2-methylquinazoline,

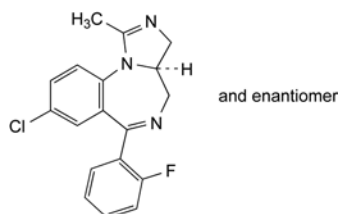

- I. (3aRS)-8-chloro-6-(2-fluorophenyl)-1-methyl-3a,4-dihydro-3H-imidazo[1,5-a][1,4]benzodiazepine,

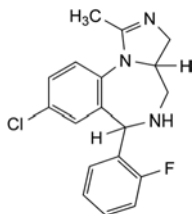

- J. 8-chloro-6-(2-fluorophenyl)-1-methyl-3a,4,5,6-tetrahydro-3H-imidazo[1,5-a][1,4]benzodiazepine.

01/2008:1030  
corrected 7.0

## MINOCYCLINE HYDROCHLORIDE DIHYDRATE

### Minocyclini hydrochloridum dihydricum

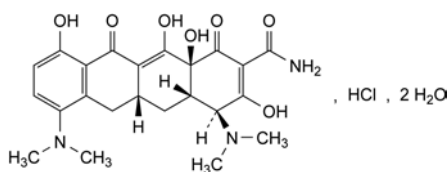

C<sub>23</sub>H<sub>28</sub>ClN<sub>3</sub>O<sub>7</sub>·2H<sub>2</sub>O  
[13614-98-7]

M<sub>r</sub> 530.0

#### DEFINITION

(4S,4aS,5aR,12aS)-4,7-Bis(dimethylamino)-3,10,12,12a-tetrahydroxy-1,11-dioxo-1,4,4a,5,5a,6,11,12a-octahydrotetracene-2-carboxamide hydrochloride dihydrate. Semi-synthetic product derived from a fermentation product. *Content*: 96.0 per cent to 102.5 per cent (anhydrous substance).

#### CHARACTERS

*Appearance*: yellow, hygroscopic, crystalline powder.

*Solubility*: sparingly soluble in water, slightly soluble in ethanol (96 per cent). It dissolves in solutions of alkali hydroxides and carbonates.

#### IDENTIFICATION

- A. Thin-layer chromatography (2.2.27).

*Test solution*. Dissolve 5 mg of the substance to be examined in *methanol R* and dilute to 10 mL with the same solvent.

*Reference solution (a)*. Dissolve 5 mg of *minocycline hydrochloride CRS* in *methanol R* and dilute to 10 mL with the same solvent.

*Reference solution (b)*. Dissolve 5 mg of *minocycline hydrochloride CRS* and 5 mg of *oxytetracycline hydrochloride CRS* in *methanol R* and dilute to 10 mL with the same solvent.

*Plate*: TLC octadecylsilyl silica gel F<sub>254</sub> plate R.

*Mobile phase*: mix 20 volumes of *acetonitrile R*, 20 volumes of *methanol R* and 60 volumes of a 63 g/L solution of *oxalic acid R* previously adjusted to pH 2 with *concentrated ammonia R*.

*Application*: 1 µL

*Development*: over 3/4 of the plate.

*Drying*: in air.

*Detection*: examine in ultraviolet light at 254 nm.

*System suitability*: reference solution (b):

- the chromatogram shows 2 clearly separated spots.

*Results*: the principal spot in the chromatogram obtained with the test solution is similar in position and size to the principal spot in the chromatogram obtained with reference solution (a).

- B. To about 2 mg add 5 mL of *sulfuric acid R*. A bright yellow colour develops. Add 2.5 mL of *water R* to the solution. The solution becomes pale yellow.
- C. It gives reaction (a) of chlorides (2.3.1).

#### TESTS

**Solution S**. Dissolve 0.200 g in *carbon dioxide-free water R* and dilute to 20.0 mL with the same solvent.

**Appearance of solution**. The solution is clear (2.2.1) and its absorbance (2.2.25) at 450 nm using a 1 cm cell is not greater than 0.23.

Dilute 1.0 mL of solution S to 10.0 mL with *water R*.

**pH** (2.2.3): 3.5 to 4.5 for solution S.

**Light-absorbing impurities**. Carry out the measurement within 1 h of preparing solution S.

The absorbance (2.2.25) of solution S measured at 560 nm is not greater than 0.06.

**Related substances**. Liquid chromatography (2.2.29).

Carry out the test protected from bright light. Store the solutions at a temperature of 2–8 °C and use them within 3 h of preparation.

*Test solution (a)*. Dissolve 25.0 mg of the substance to be examined in the mobile phase and dilute to 100.0 mL with the mobile phase.

*Test solution (b)*. Dilute 10.0 mL of test solution (a) to 20.0 mL with the mobile phase.

*Reference solution (a)*. Dissolve 12.5 mg of *minocycline hydrochloride CRS* in the mobile phase and dilute to 100.0 mL with the mobile phase.

*Reference solution (b)*. Dilute 2.0 mL of test solution (a) to 100.0 mL with the mobile phase.

*Reference solution (c)*. Dilute 1.2 mL of test solution (a) to 100.0 mL with the mobile phase.

*Reference solution (d)*. Dissolve 10 mg of *minocycline hydrochloride CRS* in 1 mL of *water R*. Boil the solution on a water-bath for 20 min. Dilute to 25 mL with the mobile phase.

*Column*:

- size:  $l = 0.20$  m,  $\varnothing = 4.6$  mm;
- stationary phase: octylsilyl silica gel for chromatography R (5 µm).

*Mobile phase*: mix 25 volumes of a 4 g/L solution of *sodium edetate R*, 27 volumes of *dimethylformamide R* and 50 volumes of a 28 g/L solution of *ammonium oxalate R*, and adjust to pH 7.0 with *tetrabutylammonium hydroxide solution* (104 g/L) R.

*Flow rate*: 1 mL/min.

*Detection*: spectrophotometer at 280 nm.

*Injection*: 20 µL of test solution (a) and reference solutions (a), (b), (c) and (d).

*Run time*: 1.5 times the retention time of minocycline.

*System suitability*:

- resolution: minimum 2.0 between the peaks due to impurity A and minocycline in the chromatogram obtained with reference solution (d);
- number of theoretical plates: minimum 3000, calculated for the peak due to minocycline in the chromatogram obtained with reference solution (a).

01/2008:0937  
corrected 6.7**Limits:**

- *impurity A*: not more than the area of the principal peak in the chromatogram obtained with reference solution (c) (1.2 per cent);
- *any other impurity*: for each impurity, not more than the area of the principal peak in the chromatogram obtained with reference solution (c) (1.2 per cent);
- *total of impurities other than A*: not more than the area of the principal peak in the chromatogram obtained with reference solution (b) (2.0 per cent).

**Heavy metals** (2.4.8): maximum 50 ppm.0.5 g complies with test C. Prepare the reference solution using 2.5 mL of *lead standard solution* (10 ppm Pb) R.**Water** (2.5.12): 5.0 per cent to 8.0 per cent, determined on 0.500 g.**Sulfated ash** (2.4.14): maximum 0.5 per cent, determined on 1.0 g.**Bacterial endotoxins** (2.6.14): less than 1.25 IU/mg, if intended for use in the manufacture of parenteral preparations without a further appropriate procedure for the removal of bacterial endotoxins.**ASSAY**

Liquid chromatography (2.2.29) as described in the test for related substances with the following modifications.

*Injection*: test solution (b) and reference solution (a).*System suitability*:

- *repeatability*: maximum relative standard deviation of the peak area for minocycline of 1.5 per cent after 6 injections of reference solution (a).

Calculate the percentage content of  $C_{23}H_{28}ClN_3O_7$  from the declared content of *minocycline hydrochloride CRS*.**STORAGE**

In an airtight container, protected from light. If the substance is sterile, store in a sterile, airtight, tamper-proof container.

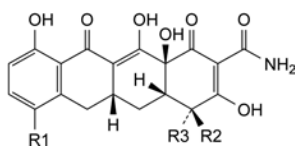
**IMPURITIES***Specified impurities: A, B, C, D.*

- A. R1 = R3 =  $N(CH_3)_2$ , R2 = H: (4*R*,4*aS*,5*aR*,12*aS*)-4,7-bis(dimethylamino)-3,10,12,12*a*-tetrahydroxy-1,11-dioxo-1,4,4*a*,5,5*a*,6,11,12*a*-octahydrodrotetracene-2-carboxamide (4-epiminocycline),
- B. R1 = R3 = H, R2 =  $N(CH_3)_2$ : (4*S*,4*aS*,5*aR*,12*aS*)-4-(dimethylamino)-3,10,12,12*a*-tetrahydroxy-1,11-dioxo-1,4,4*a*,5,5*a*,6,11,12*a*-octahydrodrotetracene-2-carboxamide (sancycline),
- C. R1 =  $NH-CH_3$ , R2 =  $N(CH_3)_2$ , R3 = H: (4*S*,4*aS*,5*aR*,12*aS*)-4-(dimethylamino)-3,10,12,12*a*-tetrahydroxy-7-(methylamino)-1,11-dioxo-1,4,4*a*,5,5*a*,6,11,12*a*-octahydrodrotetracene-2-carboxamide (7-monodemethylminocycline),
- D. R1 =  $NH_2$ , R2 =  $N(CH_3)_2$ , R3 = H: (4*S*,4*aS*,5*aR*,12*aS*)-7-amino-4-(dimethylamino)-3,10,12,12*a*-tetrahydroxy-1,11-dioxo-1,4,4*a*,5,5*a*,6,11,12*a*-octahydrodrotetracene-2-carboxamide (7-aminosancycline).

**MINOXIDIL**

## Minoxidilum

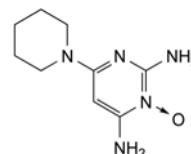
 $C_9H_{15}N_5O$   
[38304-91-5] $M_r$  209.3**DEFINITION**

6-(Piperidin-1-yl)pyrimidine-2,4-diamine 3-oxide.

*Content*: 98.5 per cent to 101.0 per cent (dried substance).**CHARACTERS***Appearance*: white or almost white, crystalline powder.*Solubility*: slightly soluble in water, soluble in methanol and in propylene glycol.**IDENTIFICATION***First identification: A, B.**Second identification: A, C, D.*

A. Ultraviolet and visible absorption spectrophotometry (2.2.25).

*Test solution (a)*. Dissolve 20.0 mg in 0.1 M hydrochloric acid and dilute to 100.0 mL with the same acid (solution A). Dilute 2.0 mL of this solution to 100.0 mL with 0.1 M hydrochloric acid.*Test solution (b)*. Dilute 2.0 mL of solution A to 100.0 mL with 0.1 M sodium hydroxide.*Spectral range*: 200-350 nm.*Absorption maxima*: at 230 nm and 281 nm for test solution (a); at 230 nm, 262 nm and 288 nm for test solution (b);*Specific absorbances at the absorption maxima*:

- at 230 nm: 1015 to 1120 for test solution (a); 1525 to 1685 for test solution (b);
- at 262 nm: 485 to 535 for test solution (b);
- at 281 nm: 1060 to 1170 for test solution (a);
- at 288 nm: 555 to 605 for test solution (b).

B. Infrared absorption spectrophotometry (2.2.24).

*Comparison: minoxidil CRS.*

C. Thin-layer chromatography (2.2.27).

*Test solution*. Dissolve 10 mg of the substance to be examined in methanol R and dilute to 10 mL with the same solvent.*Reference solution*. Dissolve 10 mg of minoxidil CRS in methanol R and dilute to 10 mL with the same solvent.*Plate: TLC silica gel GF<sub>254</sub> plate R.**Mobile phase: concentrated ammonia R, methanol R* (1.5:100 V/V).*Application*: 2  $\mu$ L.*Development*: over a path of 10 cm.*Drying*: in air.*Detection*: examine in ultraviolet light at 254 nm.*Results*: the principal spot in the chromatogram obtained with the test solution is similar in position and size to the principal spot in the chromatogram obtained with the reference solution.

D. Dissolve about 10 mg in 1 mL of *methanol R*. Add 0.1 mL of *copper sulfate solution R*. A green colour develops. The solution becomes greenish-yellow on the addition of 0.1 mL of *dilute hydrochloric acid R*.

## TESTS

**Appearance of solution.** The solution is clear (2.2.1) and not more intensely coloured than reference solution Y<sub>6</sub> (2.2.2, Method II).

Dissolve 0.5 g in 12.5 mL of *methanol R* and dilute to 25 mL with *water R*.

**Related substances.** Liquid chromatography (2.2.29).

**Test solution.** Dissolve 25.0 mg of the substance to be examined in the mobile phase and dilute to 100.0 mL with the mobile phase.

**Reference solution (a).** Dilute 1.0 mL of the test solution to 100.0 mL with the mobile phase.

**Reference solution (b).** Dissolve the contents of a vial of *desoxyminoxidil CRS* (impurity E) with 1 mL of the mobile phase, add 1 mL of the test solution and dilute to 5 mL with the mobile phase.

**Column:**

- size:  $l = 0.10$  m,  $\emptyset = 3$  mm;
- stationary phase: *octadecylsilyl silica gel for chromatography R* (5  $\mu$ m).

**Mobile phase:** dissolve 3.0 g of *docosate sodium R* in a mixture of 10 mL of *glacial acetic acid R*, 300 mL of *water R* and 700 mL of *methanol R*, and adjust to pH 3.0 with *perchloric acid R*.

**Flow rate:** 1 mL/min.

**Detection:** spectrophotometer at 240 nm.

**Injection:** 10  $\mu$ L.

**Run time:** twice the retention time of the principal peak.

**System suitability:** reference solution (b):

- resolution: minimum 2.0 between the peaks due to minoxidil and impurity E.

**Limits:**

- total: not more than 1.5 times the area of the principal peak in the chromatogram obtained with reference solution (a) (1.5 per cent);
- disregard limit: 0.1 times the area of the principal peak in the chromatogram obtained with reference solution (a) (0.1 per cent).

**Heavy metals** (2.4.8): maximum 20 ppm.

1.0 g complies with test C. Prepare the reference solution using 2 mL of *lead standard solution (10 ppm Pb) R*.

**Loss on drying** (2.2.32): maximum 0.5 per cent, determined on 1.000 g by drying in an oven at 105 °C.

**Sulfated ash** (2.4.14): maximum 0.1 per cent, determined on 1.0 g.

## ASSAY

Dissolve 0.150 g in 50 mL of *anhydrous acetic acid R*. Titrate with 0.1 M *perchloric acid*, determining the end-point potentiometrically (2.2.20). Carry out a blank titration.

1 mL of 0.1 M *perchloric acid* is equivalent to 20.93 mg of C<sub>9</sub>H<sub>15</sub>N<sub>5</sub>O.

## STORAGE

Protected from light.

## IMPURITIES

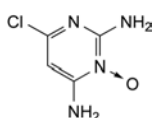

A. 6-chloropyrimidine-2,4-diamine 3-oxide,

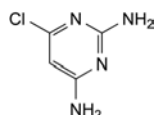

B. 6-chloropyrimidine-2,4-diamine,

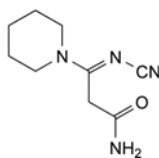

C. 3-(cyanoimino)-3-(piperidin-1-yl)propanamide,

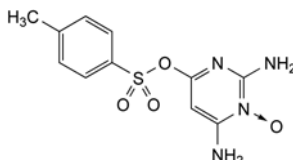

D. 6-[[[4-methylphenyl)sulfonyl]oxy]pyrimidine-2,4-diamine 3-oxide,

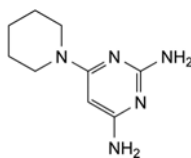

E. 6-(piperidin-1-yl)pyrimidine-2,4-diamine (desoxyminoxidil).

07/2009:2338

## MIRTAZAPINE

## Mirtazapinum

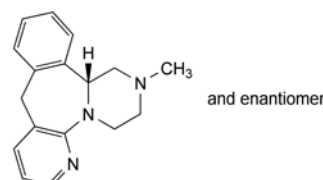

C<sub>17</sub>H<sub>19</sub>N<sub>3</sub>  
[61337-67-5]

M<sub>r</sub> 265.4

## DEFINITION

(14b*RS*)-2-Methyl-1,2,3,4,10,14b-hexahydropyrazino[2,1-*a*]pyrido[2,3-*c*][2]benzazepine.

**Content:** 99.0 per cent to 101.0 per cent (anhydrous substance).

## CHARACTERS

**Appearance:** white or almost white powder, slightly hygroscopic to hygroscopic.

**Solubility:** practically insoluble in water, freely soluble in anhydrous ethanol.

It shows polymorphism (5.9).

## IDENTIFICATION

Infrared absorption spectrophotometry (2.2.24).

**Comparison:** *mirtazapine CRS*.

If the spectra obtained in the solid state show differences, dissolve the substance to be examined and the reference substance separately in *anhydrous ethanol R*, evaporate to dryness and record new spectra using the residues.

## TESTS

**Optical rotation** (2.2.7):  $-0.10^\circ$  to  $+0.10^\circ$  (anhydrous substance).

Dissolve 0.250 g in *anhydrous ethanol R* and dilute to 25.0 mL with the same solvent.

**Related substances.** Liquid chromatography (2.2.29).

*Solvent mixture: acetonitrile R, water R (50:50 V/V).*

*Buffer solution.* Dissolve 18.0 g of *tetramethylammonium hydroxide R* in 950 mL of *water R*. While stirring, adjust to pH 7.4 with *phosphoric acid R*, then dilute to 1000 mL with *water R* and mix.

*Test solution.* Dissolve 30 mg of the substance to be examined in the solvent mixture and dilute to 20 mL with the solvent mixture.

*Reference solution (a).* Dissolve 3 mg of *mirtazapine for system suitability CRS* (containing impurities A, B, C, D, E and F) in 2 mL of the solvent mixture.

*Reference solution (b).* Dilute 1.0 mL of the test solution to 100.0 mL with the solvent mixture. Dilute 1.0 mL of this solution to 10.0 mL with the solvent mixture.

*Column:*

- size:  $l = 0.25$  m,  $\varnothing = 4.6$  mm;
- stationary phase: *end-capped octadecylsilyl silica gel for chromatography R* (5  $\mu$ m);
- temperature: 40 °C.

*Mobile phase: tetrahydrofuran for chromatography R, methanol R, acetonitrile R, buffer solution (7.5:12.5:15:65 V/V/V/V).*

*Flow rate:* 1.5 mL/min.

*Detection:* spectrophotometer at 240 nm.

*Injection:* 10  $\mu$ L.

*Run time:* twice the retention time of mirtazapine.

*Identification of impurities:* use the chromatogram supplied with *mirtazapine for system suitability CRS* and the chromatogram obtained with reference solution (a) to identify the peaks due to impurities A, B, C, D, E and F.

*Relative retention* with reference to mirtazapine (retention time = about 25 min): impurity A = about 0.2; impurity B = about 0.3; impurity C = about 0.35; impurity D = about 0.4; impurity E = about 1.3; impurity F = about 1.35.

*System suitability:*

- *resolution:* minimum 1.5 between the peaks due to impurities E and F in the chromatogram obtained with reference solution (a);
- *symmetry factor:* 0.8 to 2.0 for the principal peak in the chromatogram obtained with reference solution (b).

*Limits:*

- *correction factors:* for the calculation of content, multiply the peak areas of the following impurities by the corresponding correction factor: impurity A = 1.3; impurity B = 1.3; impurity F = 0.2;
- *impurities A, B, C, D, E, F:* for each impurity, not more than the area of the principal peak in the chromatogram obtained with reference solution (b) (0.1 per cent);
- *unspecified impurities:* for each impurity, not more than the area of the principal peak in the chromatogram obtained with reference solution (b) (0.10 per cent);
- *total:* not more than twice the area of the principal peak in the chromatogram obtained with reference solution (b) (0.2 per cent);
- *disregard limit:* 0.5 times the area of the principal peak in the chromatogram obtained with reference solution (b) (0.05 per cent).

**Water** (2.5.12): maximum 3.5 per cent, determined on 1.00 g.

**Sulfated ash** (2.4.14): maximum 0.1 per cent, determined on 1.0 g.

## ASSAY

Dissolve 0.100 g in 35 mL of *glacial acetic acid R*. Titrate with 0.1 M *perchloric acid*, determining the end-point potentiometrically (2.2.20).

1 mL of 0.1 M *perchloric acid* is equivalent to 13.27 mg of  $C_{17}H_{19}N_3$ .

## STORAGE

In an airtight container.

## IMPURITIES

*Specified impurities: A, B, C, D, E, F.*

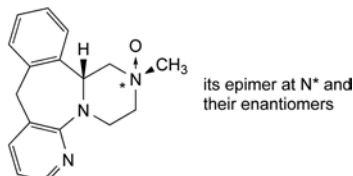

A. (14bRS)-2-methyl-1,2,3,4,10,14b-hexahydropyrazino[2,1-a]pyrido[2,3-c][2]benzazepine 2-oxide,

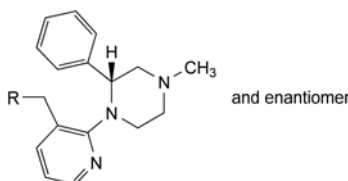

B. R = OH: [2-[(2RS)-4-methyl-2-phenylpiperazin-1-yl]pyridin-3-yl]methanol,

E. R = H: (2RS)-4-methyl-1-(3-methylpyridin-2-yl)-2-phenylpiperazine,

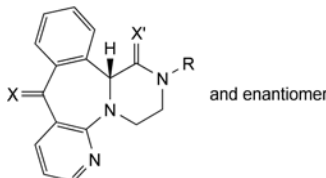

C. R =  $CH_3$ , X =  $H_2$ , X' = O: (14bRS)-2-methyl-3,4,10,14b-tetrahydropyrazino[2,1-a]pyrido[2,3-c][2]benzazepin-1(2H)-one,

D. R = H, X = X' =  $H_2$ : (14bRS)-1,2,3,4,10,14b-hexahydropyrazino[2,1-a]pyrido[2,3-c][2]benzazepine,

F. R =  $CH_3$ , X = O, X' =  $H_2$ : (14bRS)-2-methyl-1,3,4,14b-tetrahydropyrazino[2,1-a]pyrido[2,3-c][2]benzazepin-10(2H)-one.

04/2010:1731

## MISOPROSTOL

## Misoprostolum

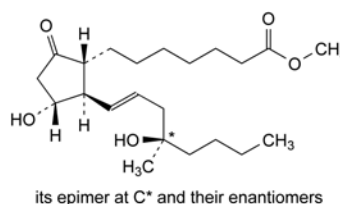

$C_{22}H_{38}O_5$   
[59122-46-2]

$M_r$  382.5



## DEFINITION

Mixture of methyl 7-[(1*RS*,2*RS*,3*RS*)-3-hydroxy-2-[(1*E*,4*RS*)-4-hydroxy-4-methyloct-1-enyl]-5-oxocyclopentyl]heptanoate and methyl 7-[(1*RS*,2*RS*,3*RS*)-3-hydroxy-2-[(1*E*,4*SR*)-4-hydroxy-4-methyloct-1-enyl]-5-oxocyclopentyl]heptanoate.

The 4 stereoisomers are present in approximately equal proportions.

*Content*: 96.5 per cent to 102.0 per cent (anhydrous substance).

## CHARACTERS

*Appearance*: clear, colourless or yellowish, oily liquid, hygroscopic.

*Solubility*: practically insoluble in water, soluble in ethanol (96 per cent), sparingly soluble in acetonitrile.

## IDENTIFICATION

Infrared absorption spectrophotometry (2.2.24).

*Comparison*: misoprostol CRS.

## TESTS

**Related substances.** Liquid chromatography (2.2.29). Use freshly prepared solutions.

*Test solution.* Dissolve 25.0 mg of the substance to be examined in the mobile phase and dilute to 5.0 mL with the mobile phase.

*Reference solution (a).* Dissolve 25.0 mg of misoprostol CRS in the mobile phase and dilute to 5.0 mL with the mobile phase.

*Reference solution (b).* Dilute 1.0 mL of reference solution (a) to 100.0 mL with the mobile phase. Dilute 1.0 mL of this solution to 10.0 mL with the mobile phase.

*Reference solution (c).* Dissolve 5 mg of misoprostol for system suitability CRS (containing impurities A, B and C) in 1 mL of the mobile phase.

*Column*:

- size:  $l = 0.25$  m,  $\varnothing = 4.6$  mm;
- stationary phase: silica gel for chromatography R (5  $\mu$ m).

*Mobile phase*: mix 5 volumes of acetonitrile R1, 215 volumes of dioxan R, 780 volumes of heptane R and sonicate for 10 min.

*Flow rate*: 2.0 mL/min.

*Detection*: spectrophotometer at 210 nm.

*Injection*: 20  $\mu$ L of the test solution and reference solutions (b) and (c).

*Run time*: 1.5 times the retention time of misoprostol.

*Identification of impurities*: use the chromatogram supplied with misoprostol for system suitability CRS and the chromatogram obtained with reference solution (c) to identify the peaks due to impurities A, B and C.

*Relative retention* with reference to misoprostol (retention time = about 18 min): impurity C = about 0.2; impurity A = about 0.7; impurity B (1<sup>st</sup> peak) = about 0.85; impurity B (2<sup>nd</sup> peak) = about 0.91.

*System suitability*: reference solution (c):

- resolution: minimum 1.2 between the peaks due to impurity B (2<sup>nd</sup> peak) and misoprostol.

*Limits*:

- correction factor: for the calculation of content, multiply the peak area of impurity C by 0.13;
- impurity B (sum of 1<sup>st</sup> and 2<sup>nd</sup> peaks): not more than 10 times the area of the principal peak in the chromatogram obtained with reference solution (b) (1.0 per cent);
- impurity A: not more than 3 times the area of the principal peak in the chromatogram obtained with reference solution (b) (0.3 per cent);

- impurity C: not more than 1.5 times the area of the principal peak in the chromatogram obtained with reference solution (b) (0.15 per cent);
- unspecified impurities: for each impurity, not more than the area of the principal peak in the chromatogram obtained with reference solution (b) (0.10 per cent);
- total: not more than 15 times the area of the principal peak in the chromatogram obtained with reference solution (b) (1.5 per cent);
- disregard limit: 0.5 times the area of the principal peak in the chromatogram obtained with reference solution (b) (0.05 per cent).

**Diastereoisomers.** Liquid chromatography (2.2.29). Use freshly prepared solutions.

*Test solution.* Dissolve 10.0 mg of the substance to be examined in the mobile phase and dilute to 10.0 mL with the mobile phase.

*Column*:

- size:  $l = 0.25$  m,  $\varnothing = 4.6$  mm;
- stationary phase: silica gel for chromatography R (5  $\mu$ m);
- temperature: 40 °C.

*Mobile phase*: mix 20 volumes of 2-propanol R, 40 volumes of anhydrous ethanol R, 940 volumes of heptane R and sonicate for 10 min.

*Flow rate*: 1.0 mL/min.

*Detection*: spectrophotometer at 205 nm.

*Injection*: 20  $\mu$ L.

*Run time*: 1.5 times the retention time of the 1<sup>st</sup> peak of misoprostol.

*Retention time*: misoprostol 1<sup>st</sup> peak = about 19 min; misoprostol 2<sup>nd</sup> peak = about 21 min.

*System suitability*: test solution:

- resolution: minimum 2.0 between the 1<sup>st</sup> and 2<sup>nd</sup> peaks of misoprostol.

*Limit*:

- 1<sup>st</sup> peak of misoprostol: 45 per cent to 55 per cent of the sum of the areas of the 2 peaks due to misoprostol.

**Water** (2.5.32): maximum 1.0 per cent.

Use 1.0 mL of a 10 mg/mL solution of the substance to be examined in methanol R.

## ASSAY

Liquid chromatography (2.2.29) as described in the test for related substances with the following modifications.

*Injection*: 20  $\mu$ L of the test solution and reference solution (a).

*System suitability*: reference solution (a):

- symmetry factor: maximum 3.7 for the peak due to misoprostol.

Calculate the percentage content of C<sub>22</sub>H<sub>38</sub>O<sub>5</sub> using the declared content of misoprostol CRS.

## STORAGE

In an airtight container, at –20 °C.

## IMPURITIES

*Specified impurities*: A, B, C.

*Other detectable impurities* (the following substances would, if present at a sufficient level, be detected by one or other of the tests in the monograph. They are limited by the general acceptance criterion for other/unspecified impurities and/or by the general monograph *Substances for pharmaceutical use* (2034). It is therefore not necessary to identify these impurities for demonstration of compliance. See also 5.10. *Control of impurities in substances for pharmaceutical use*): D, E, F.

01/2008:1655

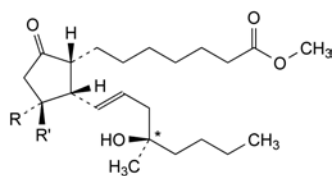

its epimer at C\* and their enantiomers

A. R = H, R' = OH: mixture of methyl 7-[(1RS,2SR,3SR)-3-hydroxy-2-[(1E,4RS)-4-hydroxy-4-methyloct-1-enyl]-5-oxocyclopentyl]heptanoate and methyl 7-[(1RS,2SR,3SR)-3-hydroxy-2-[(1E,4SR)-4-hydroxy-4-methyloct-1-enyl]-5-oxocyclopentyl]heptanoate (8-epimisoprostol),

B. R = OH, R' = H: mixture of methyl 7-[(1RS,2SR,3RS)-3-hydroxy-2-[(1E,4RS)-4-hydroxy-4-methyloct-1-enyl]-5-oxocyclopentyl]heptanoate and methyl 7-[(1RS,2SR,3RS)-3-hydroxy-2-[(1E,4SR)-4-hydroxy-4-methyloct-1-enyl]-5-oxocyclopentyl]heptanoate (12-epimisoprostol),

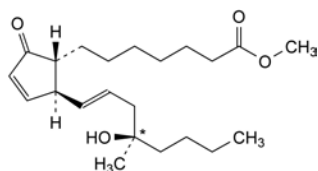

its epimer at C\* and their enantiomers

C. mixture of methyl 7-[(1RS,2SR)-2-[(1E,4RS)-4-hydroxy-4-methyloct-1-enyl]-5-oxocyclopent-3-enyl]heptanoate and methyl 7-[(1RS,2SR)-2-[(1E,4SR)-4-hydroxy-4-methyloct-1-enyl]-5-oxocyclopent-3-enyl]heptanoate (misoprostol A),

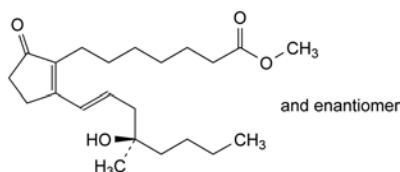

and enantiomer

D. methyl 7-[2-[(1E,4RS)-4-hydroxy-4-methyloct-1-enyl]-5-oxocyclopent-1-enyl]heptanoate (misoprostol B),

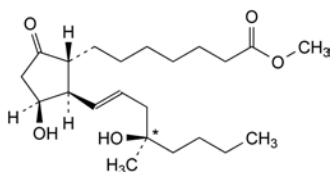

its epimer at C\* and their enantiomers

E. mixture of methyl 7-[(1RS,2RS,3SR)-3-hydroxy-2-[(1E,4RS)-4-hydroxy-4-methyloct-1-enyl]-5-oxocyclopentyl]heptanoate and methyl 7-[(1RS,2RS,3SR)-3-hydroxy-2-[(1E,4SR)-4-hydroxy-4-methyloct-1-enyl]-5-oxocyclopentyl]heptanoate (11-epi misoprostol),

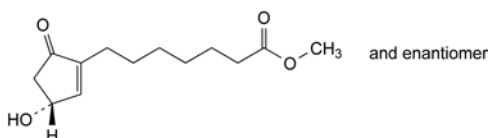

and enantiomer

F. methyl 7-[(3RS)-3-hydroxy-5-oxocyclopent-1-enyl]heptanoate.

## MITOMYCIN

## Mitomycinum

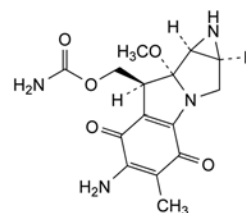

C<sub>15</sub>H<sub>18</sub>N<sub>4</sub>O<sub>5</sub>  
[50-07-7]

M<sub>r</sub> 334.3

## DEFINITION

[(1aS,8S,8aR,8bS)-6-Amino-8a-methoxy-5-methyl-4,7-dioxo-1,1a,2,4,7,8,8a,8b-octahydroazirino[2',3':3,4]pyrrolo[1,2-a]-indol-8-yl]methyl carbamate (mitomycin C).

Substance produced by a strain of *Streptomyces caespitosus*.

Content: 97.0 per cent to 102.0 per cent (anhydrous substance).

## CHARACTERS

Appearance: blue-violet crystals or crystalline powder.

Solubility: slightly soluble in water, freely soluble in dimethylacetamide, sparingly soluble in methanol, slightly soluble in acetone.

## IDENTIFICATION

A. Infrared absorption spectrophotometry (2.2.24).

Comparison: mitomycin CRS.

B. Examine the chromatograms obtained in the assay.

Results: the principal peak in the chromatogram obtained with the test solution is similar in retention time and size to the principal peak in the chromatogram obtained with reference solution (a).

## TESTS

pH (2.2.3): 5.5 to 7.5.

Dissolve 10 mg in 10 mL of carbon dioxide-free water R.

Related substances. Liquid chromatography (2.2.29). Prepare the solutions immediately before use.

Test solution. Dissolve 50.0 mg of the substance to be examined in methanol R and dilute to 10.0 mL with the same solvent.

Reference solution (a). Dilute 1.0 mL of the test solution to 100.0 mL with methanol R. Dilute 5.0 mL of this solution to 10.0 mL with methanol R.

Reference solution (b). Dissolve 10 mg of cinnamamide R in methanol R and dilute to 10 mL with the same solvent. Mix 2 mL of this solution and 1 mL of the test solution and dilute to 10 mL with methanol R.

Column:

- size:  $l = 0.25$  m,  $\varnothing = 4.6$  mm,
- stationary phase: spherical base-deactivated end-capped octadecylsilyl silica gel for chromatography R (5  $\mu$ m),
- temperature: 30 °C.

Mobile phase:

- mobile phase A: methanol R, 0.77 g/L solution of ammonium acetate R (20:80 V/V);

- *mobile phase B*: methanol R, 0.77 g/L solution of ammonium acetate R (50:50 V/V);

Time (min)	Mobile phase A (per cent V/V)	Mobile phase B (per cent V/V)
0 - 10	100	0
10 - 30	100 → 0	0 → 100
30 - 45	0	100
45 - 50	0 → 100	100 → 0

*Flow rate*: 1.0 mL/min.

*Detection*: spectrophotometer at 254 nm.

*Injection*: 10 µL.

*Relative retention* with reference to mitomycin (retention time = about 21 min): impurity D = about 0.6; impurity C = about 1.2; impurity A = about 1.3; impurity B = about 1.6.

*System suitability*: reference solution (b):

- *resolution*: minimum 15.0 between the peaks due to mitomycin and impurity A.

*Limits*:

- *correction factor*: for the calculation of content, multiply the peak area of impurity A by 0.35,
- *impurities A, B, C, D*: for each impurity, not more than the area of the principal peak in the chromatogram obtained with reference solution (a) (0.5 per cent),
- *any other impurity*: for each impurity, not more than the area of the principal peak in the chromatogram obtained with reference solution (a) (0.5 per cent),
- *total*: not more than 4 times the area of the principal peak in the chromatogram obtained with reference solution (a) (2.0 per cent),
- *disregard limit*: 0.1 times the area of the principal peak in the chromatogram obtained with reference solution (a) (0.05 per cent).

**Water** (2.5.12): maximum 2.5 per cent, determined on 0.30 g.

**Bacterial endotoxins** (2.6.14, Method B): less than 10 IU/mg, if intended for use in the manufacture of parenteral preparations without a further appropriate procedure for the removal of bacterial endotoxins.

## ASSAY

Liquid chromatography (2.2.29).

*Test solution*. Dissolve 50.0 mg of the substance to be examined in dimethylacetamide R and dilute to 100.0 mL with the same solvent.

*Reference solution (a)*. Dissolve 50.0 mg of mitomycin CRS in dimethylacetamide R and dilute to 100.0 mL with the same solvent.

*Reference solution (b)*. Dissolve 10 mg of cinnamamide R in methanol R and dilute to 20 mL with the same solvent. Mix 2 mL of this solution with 2 mL of reference solution (a).

*Column*:

- *size*:  $l = 0.30$  m,  $\varnothing = 3.9$  mm,
- *stationary phase*: end-capped phenylsilyl silica gel for chromatography R (10 µm) with a specific surface area of 330 m<sup>2</sup>/g, a carbon loading of 8 per cent and a pore size of 12.5 nm.

*Mobile phase*: mix 23 volumes of methanol R, 77 volumes of a solution containing 2.05 g/L of ammonium acetate R and 2.8 mL/L of dilute acetic acid R.

*Flow rate*: 2.0 mL/min.

*Detection*: variable wavelength spectrophotometer capable of operating at 365 nm and 254 nm.

*Injection*: 20 µL.

*Run time*: twice the retention time of mitomycin.

*Relative retention* with reference to mitomycin (retention time = about 8 min): impurity A = about 1.2.

*System suitability*:

- *resolution*: minimum 1.8 between the peaks due to mitomycin and impurity A in the chromatogram obtained with reference solution (b) at 254 nm,
- *symmetry factor*: maximum 1.3 for the principal peak in the chromatogram obtained with reference solution (a) at 365 nm.

Calculate the percentage content of C<sub>15</sub>H<sub>18</sub>N<sub>4</sub>O<sub>5</sub>, from the chromatograms obtained at 365 nm and the declared content of mitomycin CRS.

## STORAGE

Protected from light.

## IMPURITIES

*Specified impurities*: A, B, C, D.

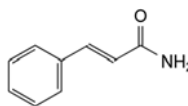

A. (E)-3-phenylprop-2-enamide (cinnamamide),

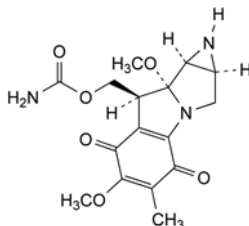

B. [(1aS,8S,8aR,8bS)-6,8a-dimethoxy-5-methyl-4,7-dioxo-1,1a,2,4,7,8,8a,8b-octahydroazirino[2',3':3,4]pyrrolo[1,2-a]indol-8-yl]methyl carbamate (mitomycin A),

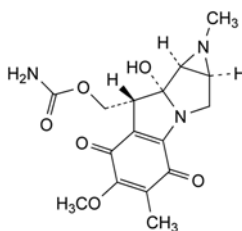

C. [(1aS,8R,8aR,8bS)-8a-hydroxy-6-methoxy-1,5-dimethyl-4,7-dioxo-1,1a,2,4,7,8,8a,8b-octahydroazirino[2',3':3,4]pyrrolo[1,2-a]indol-8-yl]methyl carbamate (mitomycin B),

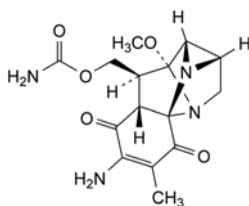

D. [(1S,2S,4S,5R,6S,6aR,10aS,11S)-8-amino-5-methoxy-9-methyl-7,10-dioxo-2,3,6,6a,7,10-hexahydro-1,2,5-metheno-1H,5H-imidazo[2,1-i]indol-6-yl]methyl carbamate (albomitomycin C).

01/2008:1243 *Detection*: spectrophotometer at 254 nm.**MITOXANTRONE HYDROCHLORIDE**

## Mitoxantroni hydrochloridum

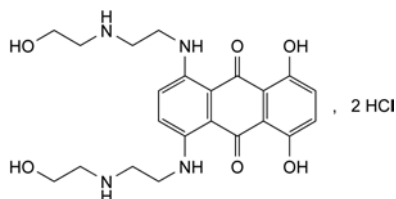

$C_{22}H_{30}Cl_2N_4O_6$   
[70476-82-3]

 $M_r$  517.4**DEFINITION**

1,4-Dihydroxy-5,8-bis[[2-[(2-hydroxyethyl)amino]ethyl]-amino]anthracene-9,10-dione dihydrochloride.

*Content*: 97.0 per cent to 102.0 per cent (anhydrous substance).

**CHARACTERS**

*Appearance*: dark blue, electrostatic, hygroscopic powder.

*Solubility*: sparingly soluble in water, slightly soluble in methanol, practically insoluble in acetone.

**CAUTION**: mitoxantrone hydrochloride and impurity A are electrostatic; the use of an antistatic gun or other suitable method to discharge the solids before weighing or transfer is recommended.

**IDENTIFICATION**

A. Infrared absorption spectrophotometry (2.2.24).

*Preparation*: dissolve 2-3 mg in 1 mL of methanol R by warming in a water-bath at 40-50 °C. Evaporate to dryness under a stream of dry nitrogen, warming gently if necessary. Examine the residue.

*Comparison*: mitoxantrone hydrochloride CRS.

B. It gives reaction (b) of chlorides (2.3.1).

**TESTS**

**Related substances.** Liquid chromatography (2.2.29).

*Test solution.* Dissolve 20.0 mg of the substance to be examined in about 40 mL of the mobile phase, sonicating if necessary, and dilute to 50.0 mL with the mobile phase.

*Reference solution (a).* Dissolve 20.0 mg of mitoxantrone hydrochloride CRS in about 40 mL of the mobile phase, sonicating if necessary, and dilute to 50.0 mL with the mobile phase.

*Reference solution (b).* Dilute 1 mL of the test solution to 100 mL with the mobile phase.

*Reference solution (c).* Dissolve 2.0 mg of mitoxantrone impurity A CRS in 1.0 mL of reference solution (a).

*Reference solution (d).* Dilute 1 mL of reference solution (b) to 10 mL with the mobile phase.

*Column*:

- size:  $l = 0.30$  m,  $\emptyset = 3.0$  mm;
- stationary phase: phenylsilyl silica gel for chromatography R (10  $\mu$ m).

*Mobile phase*: mix 750 volumes of water R, 250 volumes of acetonitrile R and 25 volumes of a solution prepared as follows: dissolve 22.0 g of sodium heptanesulfonate R in about 150 mL of water R and filter through a 0.45  $\mu$ m filter; wash the filter with water R and combine the filtrate and washings; add 32.0 mL of glacial acetic acid R and dilute to 250 mL with water R.

*Flow rate*: 3 mL/min.

*Injection*: 50  $\mu$ L of the test solution and reference solutions (b), (c) and (d).

*Run time*: 3 times the retention time of mitoxantrone.

*System suitability*: reference solution (c):

- resolution: minimum 3.0 between the peaks due to mitoxantrone and impurity A.

*Limits*:

- impurities A, B, C, D: for each impurity, not more than the area of the principal peak in the chromatogram obtained with reference solution (b) (1 per cent);
- total: not more than twice the area of the principal peak in the chromatogram obtained with reference solution (b) (2 per cent);
- disregard limit: the area of the principal peak in the chromatogram obtained with reference solution (d) (0.1 per cent).

**Ethanol.** Gas chromatography (2.2.28).

*Internal standard solution.* Dilute 2.0 mL of propanol R to 100 mL with water R. Dilute 5.0 mL of this solution to 100 mL with water R.

*Test solution.* Mix 0.100 g of the substance to be examined with 2.0 mL of the internal standard solution and dilute to 5.0 mL with water R. Place the flask in an ultrasonic bath for 2 min, then shake the flask for 2 min. If necessary, repeat the sonication and shaking until dissolution is complete.

*Reference solution.* Dilute 2.0 mL of anhydrous ethanol R to 100.0 mL with water R. Dilute 5.0 mL of the solution to 100.0 mL with water R. Dilute 10.0 mL of this solution and 10.0 mL of the internal standard solution to 25.0 mL with water R.

*Column*:

- size:  $l = 2$  m,  $\emptyset = 3$  mm;
- stationary phase: ethylvinylbenzene-divinylbenzene copolymer R.

*Carrier gas*: helium for chromatography R.

*Flow rate*: 19 mL/min.

*Temperature*:

- column: 120 °C;
- injection port: 175 °C;
- detector: 210 °C.

*Detection*: flame ionisation.

*Injection*: 1  $\mu$ L.

*Retention time*: ethanol = about 1 min; propanol = about 2 min.

*System suitability*: reference solution:

- resolution: minimum 6 between the peaks due to ethanol and propanol.

Calculate the content of ethanol, taking its density (2.2.5) to be 0.790 g/mL at 20 °C.

*Limit*:

- ethanol: maximum 1.6 per cent *m/m*.

**Water** (2.5.12): maximum 6.0 per cent, determined on 0.300 g.

**ASSAY**

Liquid chromatography (2.2.29) as described in the test for related substances with the following modification.

*Injection*: test solution and reference solution (a).

Calculate the percentage content of  $C_{22}H_{30}Cl_2N_4O_6$  from the declared content of mitoxantrone hydrochloride CRS.

**STORAGE**

In an airtight container.

**IMPURITIES**

*Specified impurities*: A, B, C, D.

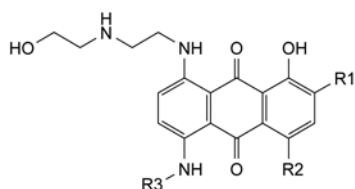

- A. R1 = R3 = H, R2 = OH: 1-amino-5,8-dihydroxy-4-[[2-[(2-hydroxyethyl)amino]ethyl]amino]anthracene-9,10-dione,
- B. R1 = R2 = H, R3 = CH<sub>2</sub>-CH<sub>2</sub>-NH-CH<sub>2</sub>-CH<sub>2</sub>OH: 5-hydroxy-1,4-bis[[2-[(2-hydroxyethyl)amino]ethyl]amino]anthracene-9,10-dione,
- C. R1 = Cl, R2 = OH, R3 = CH<sub>2</sub>-CH<sub>2</sub>-NH-CH<sub>2</sub>-CH<sub>2</sub>OH: 2-chloro-1,4-dihydroxy-5,8-bis[[2-[(2-hydroxyethyl)amino]ethyl]amino]anthracene-9,10-dione,

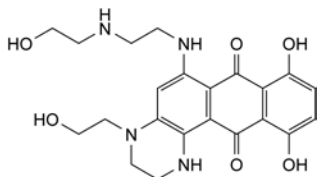

- D. 8,11-dihydroxy-4-(2-hydroxyethyl)-6-[[2-[(2-hydroxyethyl)amino]ethyl]amino]-1,2,3,4-tetrahydronaphtho[2,3-f]quinoxaline-7,12-dione.

01/2008:2307  
corrected 6.0

## MODAFINIL

### Modafinilum

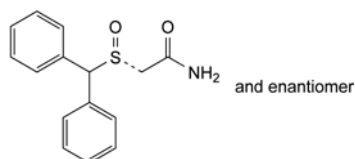

C<sub>15</sub>H<sub>15</sub>NO<sub>2</sub>S  
[68693-11-8]

M<sub>r</sub> 273.4

#### DEFINITION

2-[(*RS*)-(Diphenylmethyl)sulfinyl]acetamide.

*Content*: 98.0 per cent to 102.0 per cent (dried substance).

#### CHARACTERS

*Appearance*: white or almost white, crystalline powder.

*Solubility*: very slightly soluble or practically insoluble in water, sparingly soluble in methanol, slightly soluble in ethanol (96 per cent).

It shows polymorphism (5.9).

#### IDENTIFICATION

Infrared absorption spectrophotometry (2.2.24).

*Comparison*: modafinil CRS.

If the spectra obtained in the solid state show differences, dissolve the substance to be examined and the reference substance separately in *methanol R*, evaporate to dryness and record new spectra using the residues.

#### TESTS

**Related substances.** Liquid chromatography (2.2.29).

*Solvent mixture*: acetonitrile R1, water R (35:65 V/V).

*Test solution.* Dissolve 50.0 mg of the substance to be examined in 35 mL of *acetonitrile R1* and dilute to 50.0 mL with *water R*. Dilute 1.0 mL of this solution to 10.0 mL with the solvent mixture.

*Reference solution (a).* Dissolve 50.0 mg of *modafinil CRS* in 35 mL of *acetonitrile R1* and dilute to 50.0 mL with *water R*. Dilute 1.0 mL of this solution to 10.0 mL with the solvent mixture.

*Reference solution (b).* Dilute 1.0 mL of the test solution to 100.0 mL with the solvent mixture. Dilute 2.0 mL of this solution to 20.0 mL with the solvent mixture.

*Reference solution (c).* Add 2.0 mL of the solvent mixture to a vial of *modafinil for system suitability CRS* (containing impurities A, B and C) and sonicate for 10 min.

#### Column:

- *size*: *l* = 0.15 m, Ø = 4.6 mm;
- *stationary phase*: end-capped octadecylsilyl silica gel for chromatography R (5 µm);
- *temperature*: 40 °C.

*Mobile phase*: mix 35 volumes of *acetonitrile R1* and 65 volumes of a 6.8 g/L solution of *potassium dihydrogen phosphate R* previously adjusted to pH 2.3 with *phosphoric acid R*.

*Flow rate*: 1.0 mL/min.

*Detection*: spectrophotometer at 220 nm.

*Injection*: 20 µL of the test solution and reference solutions (b) and (c).

*Run time*: 4 times the retention time of modafinil.

*Identification of impurities*: use the chromatogram supplied with *modafinil for system suitability CRS* and the chromatogram obtained with reference solution (c) to identify the peaks due to impurities A, B and C.

*Relative retention* with reference to modafinil (retention time = about 4 min): impurity A = about 1.3; impurity B = about 1.8; impurity C = about 3.0.

*System suitability*: reference solution (c):

- *peak-to-valley ratio*: minimum 2.5, where *H<sub>p</sub>* = height above the baseline of the peak due to impurity A and *H<sub>v</sub>* = height above the baseline of the lowest point of the curve separating this peak from the peak due to modafinil.

#### Limits:

- *impurity A*: not more than twice the area of the principal peak in the chromatogram obtained with reference solution (b) (0.2 per cent);
- *impurities B, C*: for each impurity, not more than 5 times the area of the principal peak in the chromatogram obtained with reference solution (b) (0.5 per cent);
- *unspecified impurities*: for each impurity, not more than the area of the principal peak in the chromatogram obtained with reference solution (b) (0.10 per cent);
- *total*: not more than 10 times the area of the principal peak in the chromatogram obtained with reference solution (b) (1.0 per cent);
- *disregard limit*: 0.5 times the area of the principal peak in the chromatogram obtained with reference solution (b) (0.05 per cent).

**Heavy metals (2.4.8)**: maximum 20 ppm.

Dissolve 1.0 g in 40 mL of *methanol R*, warming slightly. Add 7.5 mL of *water R*. Allow to cool, then dilute to 50.0 mL with *methanol R*. 12 mL of the solution complies with test B. Prepare the reference solution using 2 mL of *lead standard solution (2 ppm Pb) R*, 8 mL of *methanol R* and 2 mL of the test solution.

**Loss on drying (2.2.32)**: maximum 0.5 per cent, determined on 1.000 g by drying in an oven at 105 °C.

**Sulfated ash (2.4.14)**: maximum 0.1 per cent, determined on 1.0 g.

#### ASSAY

Liquid chromatography (2.2.29) as described in the test for related substances with the following modification.

*Injection*: test solution and reference solution (a).

Calculate the percentage content of modafinil from the declared content of  $C_{15}H_{15}NO_2S$  in *modafinil CRS*.

#### IMPURITIES

Specified impurities: A, B, C.

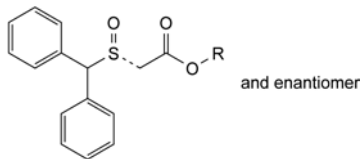

A. R = H: [(*RS*)-(diphenylmethyl)sulfinyl]acetic acid,

C. R =  $CH_3$ : methyl [(*RS*)-(diphenylmethyl)sulfinyl]acetate,

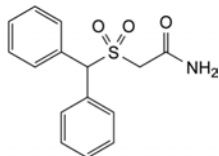

B. 2-[(diphenylmethyl)sulfonyl]acetamide.

01/2008:1641

## MOLGRAMOSTIM CONCENTRATED SOLUTION

### Molgramostimi solutio concentrata

APARSPSPST	QPWEHVNAIQ	EARRLLNLSR
DTAAEMNETV	EVISEMFDLQ	EPTCLQTRLE
LYKQGLRGSL	TKLKGPLTMM	ASHYKQHCPP
TPETSCATQI	ITFESFKENL	KDFLLVIPFD
CWEPVQE		

$C_{639}H_{1007}N_{171}O_{196}S_8$

$M_r$  14 477

#### DEFINITION

Solution of a protein having the structure of the granulocyte macrophage colony stimulating factor which is produced and secreted by various human blood cell types. The protein stimulates the differentiation and proliferation of leucocyte stem cells into mature granulocytes and macrophages.

*Content*: minimum 2.0 mg of protein per millilitre.

*Potency*: minimum  $0.7 \times 10^7$  IU per milligram of protein.

#### PRODUCTION

Molgramostim concentrated solution is produced by a method based on recombinant DNA (rDNA) technology, using bacteria as host cells. It is produced under conditions designed to minimise microbial contamination of the product.

Prior to release, the following tests are carried out on each batch of the final bulk product, unless exemption has been granted by the competent authority.

**Host-cell derived proteins**: the limit is approved by the competent authority.

**Host-cell or vector derived DNA**: the limit is approved by the competent authority.

#### CHARACTERS

*Appearance*: clear, colourless liquid.

#### IDENTIFICATION

A. It shows the expected biological activity (see Assay).

B. Isoelectric focusing (2.2.54).

*Test solution*. Dilute the preparation to be examined with *water R* to obtain a concentration of 0.25 mg/mL.

*Reference solution (a)*. Dilute *molgramostim CRS* with *water R* to obtain a concentration of 0.25 mg/mL.

*Reference solution (b)*. Use an isoelectric point (pI) calibration solution, in the pI range of 2.5-6.5, prepared according to the manufacturer's instructions.

*Focusing*:

– *pH gradient*: 4.0-6.5,

– *catholyte*: 8.91 g/L (0.1 M) solution of *β-alanine R*,

– *anolyte*: 14.7 g/L (0.1 M) solution of *glutamic acid R* in a 50 per cent V/V solution of *dilute phosphoric acid R* (0.5 M),

– *application*: 20 μL.

*Detection*: immerse the gel in a suitable volume of a solution containing 115 g/L of *trichloroacetic acid R* and 34.5 g/L of *sulfosalicylic acid R* and shake the container gently for 30 min. Transfer the gel to a mixture of 32 volumes of *glacial acetic acid R*, 100 volumes of *ethanol R* and 268 volumes of *water R* (mixture A) and rinse for 5 min. Immerse the gel for 10 min in a staining solution prewarmed to 60 °C and prepared by adding *brilliant blue R* at a concentration of 1.2 g/L to mixture A. Wash the gel in several containers with mixture A and keep the gel in this mixture until the background is clear (12-24 h). After adequate destaining, soak the gel for 1 h in a 10 per cent V/V solution of *glycerol R* in mixture A.

*System suitability*:

– in the electropherogram obtained with reference solution (b), the relevant isoelectric point markers are distributed along the entire length of the gel,

– in the electropherogram obtained with reference solution (a), the pI of the principal band is 4.9 to 5.4.

*Results*: the principal band in the electropherogram obtained with the test solution corresponds in position to the principal band in the electropherogram obtained with reference solution (a). Plot the migration distances of the relevant pI markers versus their pI and determine the isoelectric points of the principal component of each of the test solution and reference solution (a). They do not differ by more than 0.2 pI units.

C. Examine the electropherograms obtained under reducing conditions in the test for impurities with molecular masses differing from that of molgramostim. The principal band in the electropherogram obtained with test solution (a) is similar in position to the principal band in the electropherogram obtained with reference solution (a).

D. Peptide mapping (2.2.55).

*Test solution*. Introduce 50 μL of *tris-hydrochloride buffer solution pH 8.0 R* and 50 μL of the preparation to be examined at a concentration of 2 mg/mL into a polypropylene tube of 0.5 mL capacity. Add 4 μL of a 1 mg/mL solution of *trypsin for peptide mapping R* in a 0.01 per cent V/V solution of *trifluoroacetic acid R*, cap tightly and mix well. Incubate at about 37 °C for 18 h. Add 125 μL of a 764 g/L (8 M) solution of *guanidine hydrochloride R* and mix well. Add 10 μL of a 154.2 g/L (1 M) solution of *dithiothreitol R* and mix well. Place the capped tube in boiling water for 1 min. Cool to room temperature.

*Reference solution*. Prepare at the same time and in the same manner as for the test solution but use *molgramostim CRS* instead of the preparation to be examined.

Examine the 2 tryptic digests by liquid chromatography (2.2.29).

*Column*:

– *size*:  $l = 0.10$  m,  $\varnothing = 4.6$  mm,

– *stationary phase*: *octadecylsilyl silica gel for chromatography R* (5 μm) with a pore size of 30 nm.

*Mobile phase:*

- *mobile phase A:* dilute 1 mL of *trifluoroacetic acid R* in 1000 mL of *water R*;
- *mobile phase B:* dilute 1 mL of *trifluoroacetic acid R* in 100 mL of *water R*; add 900 mL of *acetonitrile for chromatography R* and mix;

Time (min)	Mobile Phase A (per cent V/V)	Mobile Phase B (per cent V/V)
0 - 35.0	100 → 65	0 → 35
35.0 - 105.0	65 → 35	35 → 65
105.0 - 107.5	35 → 100	65 → 0
107.5 - 120.0	100	0

*Flow rate:* 1.0 mL/min.

*Detection:* spectrophotometer at 214 nm.

*Equilibration:* at initial conditions for at least 12 min.

*Injection:* 200 µL.

*System suitability:* the chromatograms obtained with the reference solution and the test solution are qualitatively similar to the *Ph. Eur. reference chromatogram of molgramostim digest*.

*Results:* the profile of the chromatogram obtained with the test solution corresponds to that of the chromatogram obtained with the reference solution.

E. *N*-Terminal sequence analysis.

Perform the Edman degradation using an automated solid-phase sequencer, operated in accordance with the manufacturer's instructions.

Load about 1 nmol of the test preparation to a sequencing cartridge using the protocol provided by the manufacturer. Run 16 sequencing cycles, noting, if appropriate, the presence of proline at positions 2, 6, 8 and 12.

Identify the phenylthiohydantoin (PTH)-amino acids released at each sequencing cycle by reverse-phase liquid chromatography. The procedure may be carried out using the column and reagents recommended by the manufacturer of the sequencing equipment for the separation of PTH-amino acids.

The separation procedure is calibrated using:

- the mixture of PTH-amino acids provided by the manufacturer of the sequencer, with the gradient conditions adjusted as indicated to achieve optimum resolution of all amino acids,
- a sample obtained from a blank sequencing cycle obtained as recommended by the equipment manufacturer.

*Results:* the first 16 amino acids are: Ala-Pro-Ala-Arg-Ser-Pro-Ser-Pro-Ser-Thr-Gln-Pro-Trp-Glu-His-Val.

## TESTS

**Impurities with molecular masses differing from that of molgramostim.** Polyacrylamide gel electrophoresis (2.2.31) under both reducing and non-reducing conditions.

*Gel dimensions:* 0.75 mm thick.

*Resolving gel:* 14 per cent acrylamide.

*Sample buffer A.* Mix equal volumes of *water R* and *concentrated SDS-PAGE sample buffer R*.

*Sample buffer B (reducing conditions).* Mix equal volumes of *water R* and *concentrated SDS-PAGE sample buffer for reducing conditions R*.

*Test solution (a).* Dilute the preparation to be examined in *water R* to obtain a concentration of 1.0 mg/mL. To 1 volume of this solution add 1 volume of *concentrated SDS-PAGE sample buffer R*.

*Test solution (b)* (2 per cent control). Dilute 0.020 mL of test solution (a) to 1.0 mL with sample buffer A.

*Test solution (c)* (1 per cent control). To 0.20 mL of test solution (b) add 0.20 mL of sample buffer A.

*Test solution (d)* (0.5 per cent control). To 0.20 mL of test solution (c) add 0.20 mL of sample buffer A.

*Test solution (e)* (0.25 per cent control). To 0.20 mL of test solution (d) add 0.20 mL of sample buffer A.

*Test solution (f)* (0.1 per cent control). To 0.20 mL of test solution (e) add 0.30 mL of sample buffer A.

*Test solution (g)* (0.05 per cent control). To 0.20 mL of test solution (f) add 0.20 mL of sample buffer A.

*Test solution (h)* (0.025 per cent control). To 0.20 mL of test solution (g) add 0.20 mL of sample buffer A.

*Test solution (i).* Prepare as for test solution (a), but using *concentrated SDS-PAGE sample buffer for reducing conditions R*.

*Test solutions (j)-(p).* Prepare as for test solutions (b)-(h), but using sample buffer B.

*Reference solution (a).* Dilute *molgramostim CRS* in *water R* to obtain a concentration of 0.02 mg/mL. Mix 1 volume of this solution with 1 volume of *concentrated SDS-PAGE sample buffer R*.

*Reference solution (b).* Prepare as for reference solution (a), but using *concentrated SDS-PAGE sample buffer for reducing conditions R*.

*Reference solution (c).* Use a solution of molecular mass markers suitable for calibrating SDS-PAGE gels in the range of 14 400-94 000. Dissolve in sample buffer or sample buffer (reducing conditions), as appropriate.

*Sample treatment:* boil for 3 min.

*Application:* 50 µL; apply reduced and non-reduced solutions to separate gels.

*Detection:* silver staining as described below.

Immerse the gel overnight in a mixture of 10 volumes of *acetic acid R*, 40 volumes of *water R* and 50 volumes of *methanol R*. Transfer the gel to a 100 g/L solution of *glutaraldehyde R* and shake for about 30 min. Replace the glutaraldehyde solution with *water R*, and keep the gel in *water R* for 20 min. Repeat this washing-step twice. Transfer the gel to a mixture containing 0.75 g/L of *sodium hydroxide R*, 14 g/L of *concentrated ammonia R* and 8 g/L of *silver nitrate R*. This solution is prepared immediately before use. Place the gel on a shaker in the dark for 5 min. Wash the gel for 30 s in each of 3 containers with *water R* and shake the gel in a mixture consisting of 0.05 g/L of *citric acid R*, 0.05 per cent V/V of *formaldehyde R* and 0.005 per cent V/V of *methanol R* in *water R*. Protein bands become visible during this step. Keep the gel in the solution until sufficiently stained and then rinse the gel repeatedly with *water R* in a shaking water bath. Soak gels in a solution consisting of 10 per cent V/V of *acetic acid R* and 1 per cent V/V of *glycerol R*.

*System suitability:*

- the validation criteria are met (2.2.31),
- a band is seen in the electropherogram obtained with test solution (h),
- a gradation of intensity of staining is seen in the electropherograms obtained with test solutions (a)-(h) and (i)-(p),
- the molecular mass of the principal band in the electropherogram obtained with reference solution (a) or (b) is within the range of 15 100 to 17 100.

*Limits:* compare the staining intensity of each non-molgramostim band observed in the electropherogram obtained with test solution (a) to the staining intensity of the principal band in the electropherograms obtained with test solutions (b)-(h). Proceed similarly with the electropherograms obtained with test solutions (i)-(p). The impurity level is estimated as the dilution, in percentage, of the solution giving the electropherogram with the closest intensity of staining.

Reducing conditions:

- *impurity with an apparent molecular mass of 20 000:* maximum 1 per cent,

- impurity with an apparent molecular mass of 25 000: maximum 0.1 per cent,
- impurity with an apparent molecular mass of 30 000: maximum 0.3 per cent,
- total: maximum 2 per cent.

Non-reducing conditions:

- total of all impurities of molecular masses higher than 30 000: maximum 1 per cent.

**Related proteins.** Liquid chromatography (2.2.29): use the normalisation procedure.

**Test solution (a).** Dilute the preparation to be examined with 0.05 M phosphate buffer solution pH 7.0 R to obtain a concentration of 0.5 mg/mL.

**Test solution (b).** Mix 1 volume of test solution (a) with 4 volumes of a 0.125 mg/mL solution of human albumin R or bovine albumin R in 0.05 M phosphate buffer solution pH 7.0 R.

**Reference solution (a).** Dilute molgramostim CRS with 0.05 M phosphate buffer solution pH 7.0 R to obtain a concentration of 0.5 mg/mL.

**Reference solution (b).** Mix 1 volume of reference solution (a) with 4 volumes of a 0.125 mg/mL solution of human albumin R or bovine albumin R in 0.05 M phosphate buffer solution pH 7.0 R.

**Column:**

- size:  $l = 0.15$  m,  $\varnothing = 4.6$  mm,
- stationary phase: butylsilyl silica gel for chromatography R (5  $\mu$ m) with a pore size of 30 nm.

**Mobile phase:**

- mobile phase A: to about 800 mL of water R add 1.0 mL of trifluoroacetic acid R and dilute to 1000 mL with water R;
- mobile phase B: to 100 mL of water R add 1.0 mL of trifluoroacetic acid R and 900 mL of acetonitrile for chromatography R;

Time (min)	Mobile Phase A (per cent V/V)	Mobile Phase B (per cent V/V)
0 - 30	64 → 44	36 → 56
30 - 35	44 → 0	56 → 100
35 - 45	0	100
45 - 50	0 → 64	100 → 36
50 - 60	64	36

**Flow rate:** 1.2 mL/min.

**Detection:** spectrophotometer at 214 nm.

**Injection:** 100  $\mu$ L of test solution (a), reference solutions (a) and (b).

**System suitability:** reference solution (b):

- retention time: molgramostin = about 22 min,
- repeatability: maximum relative standard deviation of 5.0 per cent after 4 injections,
- resolution: minimum 2 between the peaks due to albumin and molgramostim.

**Limits:**

- any impurity: for each impurity, maximum 1.5 per cent,
- total of impurities eluting between 5 min and 30 min: maximum 4 per cent.

**Bacterial endotoxins (2.6.14):** less than 5 IU in the volume that contains 1.0 mg of protein.

**ASSAY**

**Protein.** Liquid chromatography (2.2.29) as described in the test for related proteins.

**Injection:** 150  $\mu$ L of test solution (b) and reference solution (b). Calculate the content of molgramostim using the declared content of molgramostim in molgramostim CRS.

**Potency.** Determination of the biological activity of molgramostim concentrated solution based on the stimulation of proliferation of TF-1 cells by molgramostim.

The following method uses the conversion of tetrazolium bromide (MTT) as a staining method. Validated alternative stains such as Almar blue have also been found suitable.

TF-1 cells are incubated with varying dilutions of test and reference preparations of molgramostim. They are then incubated with a solution of MTT. This cytochemical stain is converted by cellular dehydrogenases to a purple formazan product. The formazan is then measured spectrophotometrically. The potency of the preparation to be examined is determined by comparison of the dilutions of the test preparation with the dilutions of the appropriate International Standard of molgramostim or with a reference preparation calibrated in International Units, which yield the same response (50 per cent maximal stimulation).

The International Unit is the activity contained in a stated amount of the appropriate International Standard. The equivalence in International Units of the International Standard is stated by the World Health Organisation.

Add 50  $\mu$ L of dilution medium to all wells of a 96-well microtitre plate. Add an additional 50  $\mu$ L of this solution to the wells designed for the blanks. Add 50  $\mu$ L of each solution to be tested in triplicate (test preparation and reference preparation at a concentration of about 65 IU/mL, plus a series of 10 twofold dilutions to obtain a standard curve). Then add to each well 50  $\mu$ L of a TF-1 cell suspension containing  $3 \times 10^5$  cells per millilitre, maintaining the cells in a uniform suspension during addition.

Incubate the plate at 36.0-38.0 °C for a minimum of 24 h in a humidified incubator using  $6 \pm 1$  per cent CO<sub>2</sub>. Add 25  $\mu$ L of a 5.0 g/L sterile solution of tetrazolium bromide R to each well. Reincubate for 5 h. Remove the plates from the incubator and add to each well 100  $\mu$ L of a 240 g/L solution of sodium dodecyl sulfate R previously adjusted to pH 2.7 with hydrochloric acid. Reincubate overnight.

Determine the relative quantity of purple formazan product formed in each well by measuring the absorbance (2.2.25) using a 96-well microtitre plate reader. Read each plate at 570 nm and at 690 nm. Subtract the reading at 690 nm from the reading at 570 nm. Analyse the data by fitting a sigmoidal dose-response curve to the data obtained and by using a suitable statistical method, for example the 4-parameter model (see 5.3).

The estimated potency is not less than 80 per cent and not more than 125 per cent of the stated potency. The confidence limits ( $P = 0.95$ ) of the estimated potency are not less than 74 per cent and not more than 136 per cent of the stated potency.

**STORAGE**

In an airtight container, protected from light, at a temperature below -65 °C.

**LABELLING**

The label states:

- the content, in milligrams of protein per millilitre,
- the potency, in International Units per milligram of protein.

04/2008:1701  
corrected 6.5

## MOLSIDOMINE

### Molsidominum

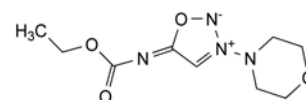

C<sub>9</sub>H<sub>14</sub>N<sub>4</sub>O<sub>4</sub>  
[25717-80-0]

$M_r$  242.2



## DEFINITION

*N*-(Ethoxycarbonyl)-3-(morpholin-4-yl)sydnonimine.

*Content*: 99.0 per cent to 101.0 per cent (dried substance).

## CHARACTERS

*Appearance*: white or almost white, crystalline powder.

*Solubility*: sparingly soluble in water, soluble in anhydrous ethanol and in methylene chloride.

mp: about 142 °C.

## IDENTIFICATION

Infrared absorption spectrophotometry (2.2.24).

*Comparison*: molsidomine CRS.

## TESTS

**Appearance of solution.** The solution is clear (2.2.1) and not more intensely coloured than reference solution B<sub>7</sub> (2.2.2, Method II).

Dissolve 1.0 g in *anhydrous ethanol R* and dilute to 20.0 mL with the same solvent.

**pH** (2.2.3): 5.5 to 7.5.

Dissolve 0.50 g in *carbon dioxide-free water R* and dilute to 50.0 mL with the same solvent.

**Impurity B.** Liquid chromatography (2.2.29) as described in the test for related substances with the following modifications.

*Detection*: spectrophotometer at 240 nm.

*Injection*: 20 µL of test solution (a) and reference solution (b).

*Relative retention* with reference to molsidomine (retention time = about 9 min): impurity B = about 0.43.

*System suitability*: reference solution (b):

– *signal-to-noise ratio*: minimum 20 for the principal peak.

*Limit*:

– *impurity B*: not more than the area of the corresponding peak in the chromatogram obtained with reference solution (b) (3 ppm).

**Impurity E.** Liquid chromatography (2.2.29).

*Test solution.* Dissolve 0.200 g of the substance to be examined in the mobile phase and dilute to 100.0 mL with the mobile phase.

*Reference solution (a).* Dissolve 50.0 mg of *morpholine for chromatography R* in 500.0 mL of *water for chromatography R*. Dilute 20.0 mL of the solution to 500.0 mL with *water for chromatography R*. Dilute 5.0 mL of this solution to 100.0 mL with *water for chromatography R*.

*Reference solution (b).* Mix 10.0 mL of the test solution with 10.0 mL of reference solution (a).

*Column*:

– *size*:  $l = 0.25$  m,  $\emptyset = 4.0$  mm;

– *stationary phase*: resin for reversed-phase ion chromatography R;

– *temperature*: 25 °C.

*Mobile phase*: mix 3.0 mL of *methanesulfonic acid R* and 75 mL of *acetonitrile R* in *water for chromatography R* and dilute to 5000 mL with *water for chromatography R*.

*Suppressor regenerant*: *water for chromatography R*.

*Flow rate*: 1.0 mL/min.

*Expected background conductivity*: less than 0.5 µS.

*Detection*: conductivity detector at 10 µS.

*Injection*: 50 µL.

*Run time*: 20 min.

*Relative retention* with reference to molsidomine (retention time = about 3 min): impurity E = about 2.4.

*System suitability*: reference solution (b):

– *signal-to-noise ratio*: minimum 6 for the peak due to impurity E.

*Limit*:

– *impurity E*: not more than the area of the principal peak in the chromatogram obtained with reference solution (a) (0.01 per cent).

**Related substances.** Liquid chromatography (2.2.29). *Protect the solutions from light.*

*Solvent mixture*: *methanol R*, mobile phase A (10:90 V/V).

*Test solution (a).* Dissolve 0.200 g of the substance to be examined in 2.5 mL of *methanol R* and dilute to 5.0 mL with mobile phase A.

*Test solution (b).* Dilute 1.0 mL of test solution (a) to 20.0 mL with the solvent mixture.

*Reference solution (a).* Dilute 1.0 mL of test solution (b) to 100.0 mL with the solvent mixture. Dilute 1.0 mL of this solution to 10.0 mL with the solvent mixture.

*Reference solution (b).* Dissolve 2.4 mg of *molsidomine impurity B CRS* in 80 mL of *methanol R* and dilute to 100.0 mL with *methanol R*. Dilute 2.0 mL of the solution to 100.0 mL with the solvent mixture. Dilute 5.0 mL of this solution to 20.0 mL with the solvent mixture.

*Reference solution (c).* Dissolve 10 mg of *linsidomine hydrochloride R* (impurity A) and 5 mg of *molsidomine impurity D CRS* in 10 mL of *methanol R* and dilute to 50.0 mL with the solvent mixture. Dilute 5.0 mL of this solution to 50.0 mL with the solvent mixture.

*Column*:

– *size*:  $l = 0.15$  m,  $\emptyset = 4.6$  mm;

– *stationary phase*: end-capped octadecylsilyl silica gel for chromatography R (5 µm);

– *temperature*: 30 °C.

*Mobile phase*:

– *mobile phase A*: dissolve 4.0 g of *potassium dihydrogen phosphate R* in *water for chromatography R* and dilute to 1000 mL with the same solvent;

– *mobile phase B*: *methanol R1*;

Time (min)	Mobile phase A (per cent V/V)	Mobile phase B (per cent V/V)
0 - 3	90	10
3 - 10	90 → 20	10 → 80
10 - 13	20	80

*Flow rate*: 1.3 mL/min.

*Detection*: spectrophotometer at 210 nm.

*Injection*: 20 µL of test solution (b) and reference solutions (a) and (c).

*Relative retention* with reference to molsidomine (retention time = about 9 min): impurity A = about 0.2; impurity D = about 0.3.

*System suitability*: reference solution (c):

– *resolution*: minimum 3.5 between the peaks due to impurities A and D.

*Limits*:

– *unspecified impurities*: for each impurity, not more than the area of the peak due to molsidomine in the chromatogram obtained with reference solution (a) (0.10 per cent);

– *total*: not more than 3 times the area of the peak due to molsidomine in the chromatogram obtained with reference solution (a) (0.3 per cent);

– *disregard limit*: 0.5 times the area of the peak due to molsidomine in the chromatogram obtained with reference solution (a) (0.05 per cent).

**Heavy metals**: maximum 20 ppm.

*Prescribed solution.* Dissolve 0.5 g in 20 mL of *ethanol (96 per cent) R*.

*Test solution.* 12 mL of the prescribed solution.

01/2008:1449  
corrected 6.0

**Reference solution.** Mix 6 mL of lead standard solution (1 ppm Pb) (obtained by diluting *lead standard solution (100 ppm Pb) R* with *ethanol (96 per cent) R*) with 2 mL of the prescribed solution and 4 mL of *water R*.

**Blank solution.** Mix 10 mL of *ethanol (96 per cent) R* and 2 mL of the prescribed solution.

To each solution, add 2 mL of *buffer solution pH 3.5 R*. Mix and add to 1.2 mL of *thioacetamide reagent R*. Mix immediately. Filter the solutions through a membrane filter (nominal pore size 0.45 µm) (2.4.8). Carry out the filtration slowly and uniformly, applying moderate and constant pressure to the piston. Compare the spots on the filters obtained with the different solutions. The test is invalid if the reference solution does not show a slight brown colour compared to the blank solution. The substance to be examined complies with the test if the brown colour of the spot resulting from the test solution is not more intense than that of the spot resulting from the reference solution.

**Loss on drying (2.2.32):** maximum 0.5 per cent, determined on 1.000 g by drying in an oven at 105 °C.

**Sulfated ash (2.4.14):** maximum 0.1 per cent, determined on 1.0 g.

#### ASSAY

Dissolve 0.200 g in a mixture of 5 mL of *acetic anhydride R* and 50 mL of *anhydrous acetic acid R*. Titrate with 0.1 M *perchloric acid*, determining the end-point potentiometrically (2.2.20).

1 mL of 0.1 M *perchloric acid* is equivalent to 24.22 mg of C<sub>27</sub>H<sub>30</sub>Cl<sub>2</sub>O<sub>6</sub>.

#### STORAGE

Protected from light.

#### IMPURITIES

**Specified impurities:** B, E.

**Other detectable impurities** (the following substances would, if present at a sufficient level, be detected by one or other of the tests in the monograph. They are limited by the general acceptance criterion for other/unspecified impurities and/or by the general monograph *Substances for pharmaceutical use (2034)*. It is therefore not necessary to identify these impurities for demonstration of compliance. See also 5.10. *Control of impurities in substances for pharmaceutical use*): A, C, D.

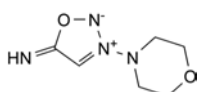

A. 3-(morpholin-4-yl)sydnimine (linsidomine),



B. R = NO: 4-nitrosomorpholine,

D. R = CHO: morpholine-4-carbaldehyde,

E. R = H: morpholine,

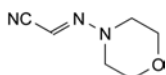

C. (2E)-(morpholin-4-ylimino)acetonitrile.

## MOMETASONE FUROATE

### Mometasoni furoas

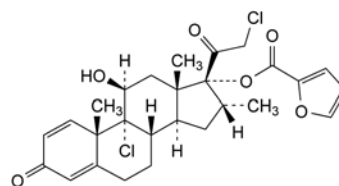

C<sub>27</sub>H<sub>30</sub>Cl<sub>2</sub>O<sub>6</sub>  
[83919-23-7]

M<sub>r</sub> 521.4

#### DEFINITION

9,21-Dichloro-11β-hydroxy-16α-methyl-3,20-dioxopregna-1,4-dien-17-yl furan-2-carboxylate.

**Content:** 97.0 per cent to 103.0 per cent (dried substance).

#### CHARACTERS

**Appearance:** white or almost white powder.

**Solubility:** practically insoluble in water, soluble in acetone and in methylene chloride, slightly soluble in ethanol (96 per cent). mp: about 220 °C, with decomposition.

#### IDENTIFICATION

**First identification:** A, B.

**Second identification:** B, C, D.

A. Infrared absorption spectrophotometry (2.2.24).

**Preparation:** discs.

**Comparison:** mometasone furoate CRS.

B. Thin-layer chromatography (2.2.27).

**Test solution.** Dissolve 10 mg of the substance to be examined in *methylene chloride R* and dilute to 10 mL with the same solvent.

**Reference solution (a).** Dissolve 20 mg of *mometasone furoate CRS* in *methylene chloride R* and dilute to 20 mL with the same solvent.

**Reference solution (b).** Dissolve 10 mg of *anhydrous beclometasone dipropionate CRS* in reference solution (a) and dilute to 10 mL with reference solution (a).

**Plate:** TLC silica gel F<sub>254</sub> plate R.

**Mobile phase:** add a mixture of 1.2 volumes of *water R* and 8 volumes of *methanol R* to a mixture of 15 volumes of *ether R* and 77 volumes of *methylene chloride R*.

**Application:** 5 µL.

**Development:** over a path of 15 cm.

**Drying:** in air.

**Detection A:** examine in ultraviolet light at 254 nm.

**Results A:** the principal spot in the chromatogram obtained with the test solution is similar in position and size to the principal spot in the chromatogram obtained with reference solution (a).

**Detection B:** spray with *alcoholic solution of sulfuric acid R*. Heat at 120 °C for 10 min or until the spots appear. Allow to cool; examine in daylight and in ultraviolet light at 365 nm.

**Results B:** the principal spot in the chromatogram obtained with the test solution is similar in position, colour in daylight, fluorescence in ultraviolet light at 365 nm and size to the principal spot in the chromatogram obtained with reference solution (a).

**System suitability:** reference solution (b):

– the chromatogram shows 2 spots which, when examined in ultraviolet light at 365 nm, may not be completely separated.

- C. Add about 2 mg to 2 mL of *sulfuric acid R* and shake to dissolve. Within 15 min a light yellow colour develops. When examined in ultraviolet light at 365 nm, no fluorescence is seen. Add this solution to 10 mL of *water R* and mix. The colour fades and there is no fluorescence.
- D. Mix 80 mg with 0.30 g of *anhydrous sodium carbonate R* and ignite in a crucible until an almost white residue is obtained. Allow to cool and dissolve the residue in 5 mL of *dilute nitric acid R*; filter. To 1 mL of the filtrate add 1 mL of *water R*. The solution gives reaction (a) of chlorides (2.3.1).

## TESTS

**Specific optical rotation** (2.2.7): + 50 to + 55 (dried substance).

Dissolve 50.0 mg in *ethanol (96 per cent) R* and dilute to 10.0 mL with the same solvent.

**Related substances.** Liquid chromatography (2.2.29). Prepare the solutions immediately before use.

**Solvent mixture.** Mix 50 mL of *acetonitrile R* and 50 mL of *water R*, then add 0.1 mL of *acetic acid R*.

**Test solution.** Dissolve 20.0 mg of the substance to be examined in 4.0 mL of *acetonitrile R* and dilute to 20.0 mL with the solvent mixture.

**Reference solution (a).** Dissolve 2 mg of *mometasone furoate CRS* and 6 mg of *anhydrous beclometasone dipropionate CRS* in the solvent mixture, then dilute to 10.0 mL with the solvent mixture. Dilute 0.25 mL of this solution to 10.0 mL with the solvent mixture.

**Reference solution (b).** Dilute 1.0 mL of the test solution to 20.0 mL with the solvent mixture. Dilute 1.0 mL of this solution to 10.0 mL with the solvent mixture.

## Column:

- size:  $l = 0.25$  m,  $\varnothing = 4.6$  mm;
- stationary phase: octadecylsilyl silica gel for chromatography *R* (5  $\mu$ m).

**Mobile phase:** *acetonitrile R*, *water R* (50:50 V/V).

**Flow rate:** 1 mL/min.

**Detection:** spectrophotometer at 254 nm.

**Injection:** 20  $\mu$ L.

**Run time:** twice the retention time of mometasone furoate.

**Retention time:** mometasone furoate = about 17 min;  
beclometasone dipropionate = about 22 min.

**System suitability:** reference solution (a):

- resolution: minimum 6 between the peaks due to mometasone furoate and beclometasone dipropionate; if necessary, adjust the concentration of acetonitrile in the mobile phase.

## Limits:

- impurities A, B, C, D, E, F, G, H, I: for each impurity, not more than 0.6 times the area of the principal peak in the chromatogram obtained with reference solution (b) (0.3 per cent);
- total: not more than 1.2 times the area of the principal peak in the chromatogram obtained with reference solution (b) (0.6 per cent);
- disregard limit: 0.1 times the area of the principal peak in the chromatogram obtained with reference solution (b) (0.05 per cent).

**Loss on drying** (2.2.32): maximum 0.5 per cent, determined on 1.000 g by drying in an oven at 105 °C.

## ASSAY

Dissolve 50.0 mg in *ethanol (96 per cent) R* and dilute to 100.0 mL with the same solvent. Dilute 2.0 mL of this solution to 100.0 mL with *ethanol (96 per cent) R*. Measure the absorbance (2.2.25) at the absorption maximum at 249 nm.

Calculate the content of  $C_{27}H_{30}Cl_2O_6$  taking the specific absorbance to be 481.

## IMPURITIES

Specified impurities: A, B, C, D, E, F, G, H, I.

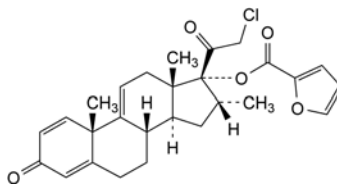

- A. 21-chloro-16 $\alpha$ -methyl-3,20-dioxopregna-1,4,9(11)-trien-17-yl furan-2-carboxylate,

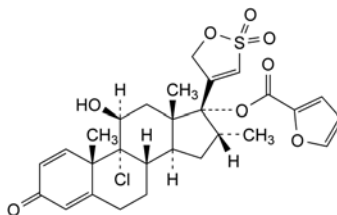

- B. 4-[9-chloro-17-[(furan-2-ylcarbonyl)oxy]-11 $\beta$ -hydroxy-16 $\alpha$ -methyl-3-oxoandrosta-1,4-dien-17-yl]-5H-1,2-oxathiole 2,2-dioxide,

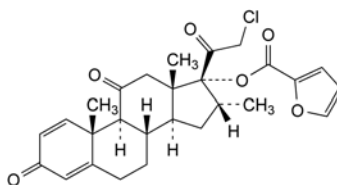

- C. 21-chloro-16 $\alpha$ -methyl-3,11,20-trioxopregna-1,4-dien-17-yl furan-2-carboxylate,

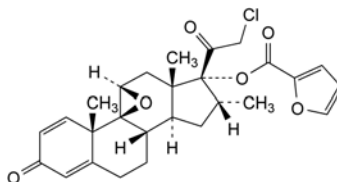

- D. 21-chloro-9,11 $\beta$ -epoxy-16 $\alpha$ -methyl-3,20-dioxo-9 $\beta$ -pregna-1,4-dien-17-yl furan-2-carboxylate,

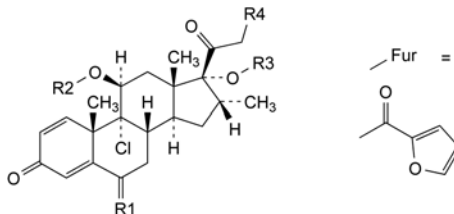

- E. R1 = H<sub>2</sub>, R2 = R3 = Fur, R4 = Cl: 9,21-dichloro-16 $\alpha$ -methyl-3,20-dioxopregna-1,4-diene-11 $\beta$ ,17-diyl bis(furan-2-carboxylate),

- F. R1 = O, R2 = H, R3 = Fur, R4 = Cl: 9,21-dichloro-11 $\beta$ -hydroxy-16 $\alpha$ -methyl-3,6,20-trioxopregna-1,4-dien-17-yl furan-2-carboxylate,

- G. R1 = H<sub>2</sub>, R2 = R3 = H, R4 = Cl: 9,21-dichloro-11 $\beta$ ,17-dihydroxy-16 $\alpha$ -methylpregna-1,4-diene-3,20-dione (mometasone),

- H. R1 = H<sub>2</sub>, R2 = H, R3 = Fur, R4 = OH: 9-chloro-11 $\beta$ ,21-dihydroxy-16 $\alpha$ -methyl-3,20-dioxopregna-1,4-dien-17-yl furan-2-carboxylate,

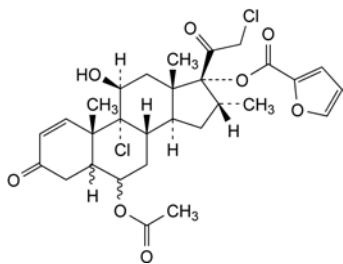

- I. 9,21-dichloro-11β-hydroxy-16α-methyl-3,20-dioxo-5ξ-pregn-1-ene-6ξ,17-diyl 6-acetate 17-(furan-2-carboxylate).

01/2008:1546  
corrected 6.0

## MORANTEL HYDROGEN TARTRATE FOR VETERINARY USE

### Moranteli hydrogenotartras ad usum veterinarium

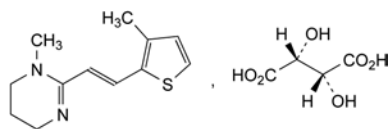

$C_{16}H_{22}N_2O_6S$   
[26155-31-7]

$M_r$  370.4

#### DEFINITION

1-Methyl-2-[(*E*)-2-(3-methylthiophen-2-yl)ethenyl]-1,4,5,6-tetrahydropyrimidine hydrogen tartrate.

*Content*: 98.5 per cent to 101.5 per cent (dried substance).

#### CHARACTERS

*Appearance*: white or pale yellow, crystalline powder.

*Solubility*: very soluble in water and in ethanol (96 per cent), practically insoluble in ethyl acetate.

#### IDENTIFICATION

*First identification*: B.

*Second identification*: A, C, D.

A. Melting point (2.2.14): 167 °C to 172 °C.

B. Infrared absorption spectrophotometry (2.2.24).

*Comparison*: morantel hydrogen tartrate CRS.

C. Dissolve about 10 mg in 1 mL of a 5 g/L solution of ammonium vanadate R. Evaporate to dryness. Add 0.1 mL of sulfuric acid R. A purple colour is produced.

D. Dissolve about 10 mg in 1 mL of 0.1 M sodium hydroxide. Transfer to a separating funnel and shake with 5 mL of methylene chloride R. Discard the organic layer. Neutralise the aqueous layer with a few drops of dilute hydrochloric acid R. The solution gives reaction (b) of tartrates (2.3.1).

#### TESTS

**Solution S.** Dissolve 0.25 g in carbon dioxide-free water R and dilute to 25.0 mL with the same solvent.

**Appearance of solution.** Solution S is clear (2.2.1) and not more intensely coloured than reference solution GY<sub>6</sub> or Y<sub>6</sub> (2.2.2, Method II).

**pH** (2.2.3): 3.3 to 3.9 for solution S.

**Related substances.** Liquid chromatography (2.2.29). Carry out the test protected from light.

**Test solution.** Dissolve 50.0 mg of the substance to be examined in the mobile phase and dilute to 100.0 mL with the mobile phase.

**Reference solution (a).** Dilute 1.0 mL of the test solution to 100.0 mL with the mobile phase.

**Reference solution (b).** Dilute 2.0 mL of reference solution (a) to 100.0 mL with the mobile phase.

**Reference solution (c).** Expose 10 mL of reference solution (a) to daylight for 15 min before injection.

**Reference solution (d).** Dissolve 15.0 mg of tartaric acid R in the mobile phase and dilute to 100.0 mL with the mobile phase.

#### Column:

– size:  $l = 0.25$  m,  $\varnothing = 4.6$  mm;

– stationary phase: base-deactivated end-capped octadecylsilyl silica gel for chromatography R (5 µm).

**Mobile phase:** to a mixture of 0.35 volumes of triethylamine R and 85 volumes of water R adjusted to pH 2.5 with phosphoric acid R, add 5 volumes of tetrahydrofuran R and 10 volumes of methanol R.

**Flow rate:** 0.75 mL/min.

**Detection:** spectrophotometer at 226 nm.

**Injection:** 20 µL.

**Run time:** twice the retention time of morantel.

**System suitability:** reference solution (c):

– resolution: minimum of 2 between the principal peak and the preceding peak ((*Z*)-isomer).

#### Limits:

– any impurity apart from the peak due to tartaric acid: not more than 0.5 times the area of the principal peak in the chromatogram obtained with reference solution (a) (0.5 per cent);

– total: not more than the area of the principal peak in the chromatogram obtained with reference solution (a) (1 per cent);

– disregard limit: the area of the principal peak in the chromatogram obtained with reference solution (b) (0.02 per cent).

**Heavy metals** (2.4.8): maximum 20 ppm.

1.0 g complies with test C. Prepare the reference solution using 2 mL of lead standard solution (10 ppm Pb) R.

**Loss on drying** (2.2.32): maximum 1.5 per cent, determined on 1.000 g by drying in an oven at 105 °C.

**Sulfated ash** (2.4.14): maximum 0.1 per cent, determined on 1.0 g.

#### ASSAY

Dissolve 0.280 g in 40 mL of anhydrous acetic acid R. Titrate with 0.1 M perchloric acid, determining the end-point potentiometrically (2.2.20).

1 mL of 0.1 M perchloric acid is equivalent to 37.04 mg of  $C_{16}H_{22}N_2O_6S$ .

#### STORAGE

Protected from light.

#### IMPURITIES

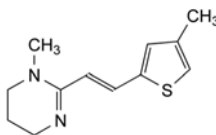

- A. 1-methyl-2-[(*E*)-2-(4-methylthiophen-2-yl)ethenyl]-1,4,5,6-tetrahydropyrimidine,

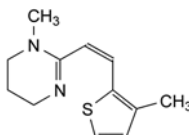

- B. 1-methyl-2-[(*Z*)-2-(3-methylthiophen-2-yl)ethenyl]-1,4,5,6-tetrahydropyrimidine,

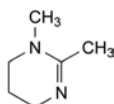

C. 1,2-dimethyl-1,4,5,6-tetrahydropyrimidine,

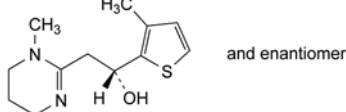

D. (1*RS*)-2-(1-methyl-1,4,5,6-tetrahydropyrimidin-2-yl)-1-(3-methylthiophen-2-yl)ethanol,

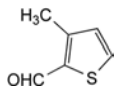

E. 3-methylthiophene-2-carbaldehyde.

04/2008:0097  
corrected 6.7

## MORPHINE HYDROCHLORIDE

### Morphini hydrochloridum

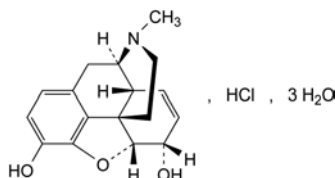

$C_{17}H_{20}ClNO_3 \cdot 3H_2O$   
[6055-06-7]

$M_r$  375.8

#### DEFINITION

7,8-Didehydro-4,5 $\alpha$ -epoxy-17-methylmorphinan-3,6 $\alpha$ -diol hydrochloride trihydrate.

*Content*: 98.0 per cent to 102.0 per cent (anhydrous substance).

#### CHARACTERS

*Appearance*: white or almost white, crystalline powder or colourless, silky needles or cubical masses, efflorescent in a dry atmosphere.

*Solubility*: soluble in water, slightly soluble in ethanol (96 per cent), practically insoluble in toluene.

#### IDENTIFICATION

*First identification*: A, E.

*Second identification*: B, C, D, E.

A. Infrared absorption spectrophotometry (2.2.24).

*Comparison*: morphine hydrochloride CRS.

B. Ultraviolet and visible absorption spectrophotometry (2.2.25).

*Solution A*. Dissolve 25.0 mg in water R and dilute to 25.0 mL with the same solvent.

*Test solution (a)*. Dilute 10.0 mL of solution A to 100.0 mL with water R.

*Test solution (b)*. Dilute 10.0 mL of solution A to 100.0 mL with 0.1 M sodium hydroxide.

*Spectral range*: 250-350 nm for test solutions (a) and (b).

*Absorption maximum*: at 285 nm for test solution (a); at 298 nm for test solution (b).

*Specific absorbance at the absorption maximum*: 37 to 43 for test solution (a); 64 to 72 for test solution (b).

C. To about 1 mg of powdered substance in a porcelain dish add 0.5 mL of sulfuric acid-formaldehyde reagent R. A purple colour develops and becomes violet.

D. It gives the reaction of alkaloids (2.3.1).

E. It gives reaction (a) of chlorides (2.3.1).

#### TESTS

**Solution S**. Dissolve 0.500 g in carbon dioxide-free water R and dilute to 25.0 mL with the same solvent.

**Appearance of solution**. Solution S is clear (2.2.1) and not more intensely coloured than reference solution Y<sub>6</sub> or BY<sub>6</sub> (2.2.2, Method II).

**Acidity or alkalinity**. To 10 mL of solution S add 0.05 mL of methyl red solution R. Not more than 0.2 mL of 0.02 M sodium hydroxide or 0.02 M hydrochloric acid is required to change the colour of the indicator.

**Specific optical rotation (2.2.7)**: –110 to –115 (anhydrous substance), determined on solution S.

**Related substances**. Liquid chromatography (2.2.29).

*Test solution*. Dissolve 0.125 g of the substance to be examined in a 1 per cent V/V solution of acetic acid R and dilute to 50 mL with the same solution.

*Reference solution (a)*. Dilute 1.0 mL of the test solution to 100.0 mL with a 1 per cent V/V solution of acetic acid R. Dilute 2.0 mL of this solution to 10.0 mL with a 1 per cent V/V solution of acetic acid R.

*Reference solution (b)*. Dissolve 5 mg of morphine for system suitability CRS (containing impurities B, C, E and F) in a 1 per cent V/V solution of acetic acid R and dilute to 2 mL with the same solution.

*Column*:

– size:  $l = 0.15$  m,  $\varnothing = 4.6$  mm;

– stationary phase: end-capped octadecylsilyl silica gel for chromatography R (5  $\mu$ m);

– temperature: 35 °C.

*Mobile phase*:

– mobile phase A: 1.01 g/L solution of sodium heptanesulfonate R adjusted to pH 2.6 with a 50 per cent V/V solution of phosphoric acid R;

– mobile phase B: methanol R;

Time (min)	Mobile phase A (per cent V/V)	Mobile phase B (per cent V/V)
0 - 2	85	15
2 - 35	85 → 50	15 → 50
35 - 40	50	50

*Flow rate*: 1.5 mL/min.

*Detection*: spectrophotometer at 230 nm.

*Injection*: 10  $\mu$ L.

*Identification of impurities*: use the chromatogram supplied with morphine for system suitability CRS and the chromatogram obtained with reference solution (b) to identify the peaks due to impurities B, C, E and F.

*Relative retention* with reference to morphine (retention time = about 12.5 min): impurity F = about 0.95; impurity E = about 1.1; impurity C = about 1.6; impurity B = about 1.9.

*System suitability*: reference solution (b):

– peak-to-valley ratio: minimum 2, where  $H_p$  = height above the baseline of the peak due to impurity F and  $H_v$  = height above the baseline of the lowest point of the curve separating this peak from the peak due to morphine.

*Limits*:

– correction factors: for the calculation of content, multiply the peak areas of the following impurities by the corresponding correction factor: impurity B = 0.25; impurity C = 0.4; impurity E = 0.5;

– impurity B: not more than twice the area of the principal peak in the chromatogram obtained with reference solution (a) (0.4 per cent);

- *impurities C, E*: for each impurity, not more than the area of the principal peak in the chromatogram obtained with reference solution (a) (0.2 per cent);
- *any other impurity*: for each impurity, not more than the area of the principal peak in the chromatogram obtained with reference solution (a) (0.2 per cent);
- *total*: not more than 5 times the area of the principal peak in the chromatogram obtained with reference solution (a) (1.0 per cent);
- *disregard limit*: 0.25 times the area of the principal peak in the chromatogram obtained with reference solution (a) (0.05 per cent).

The thresholds indicated under Related substances (Table 2034.-1) in the general monograph *Substances for pharmaceutical use (2034)* do not apply.

**Water (2.5.12)**: 12.5 per cent to 15.5 per cent, determined on 0.10 g.

**Sulfated ash (2.4.14)**: maximum 0.1 per cent, determined on 1.0 g.

#### ASSAY

Dissolve 0.300 g in a mixture of 5 mL of 0.01 M hydrochloric acid and 30 mL of ethanol (96 per cent) R. Carry out a potentiometric titration (2.2.20), using 0.1 M sodium hydroxide. Read the volume added between the 2 points of inflexion.

1 mL of 0.1 M sodium hydroxide is equivalent to 32.18 mg of  $C_{17}H_{20}ClNO_3$ .

#### STORAGE

Protected from light.

#### IMPURITIES

*Specified impurities: B, C, E.*

*Other detectable impurities* (the following substances would, if present at a sufficient level, be detected by one or other of the tests in the monograph. They are limited by the general acceptance criterion for other/unspecified impurities. It is therefore not necessary to identify these impurities for demonstration of compliance. See also 5.10. *Control of impurities in substances for pharmaceutical use*): A, D, F.

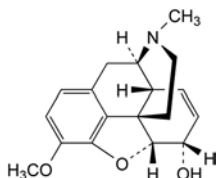

- A. 7,8-didehydro-4,5 $\alpha$ -epoxy-3-methoxy-17-methylmorphinan-6 $\alpha$ -ol (codeine),

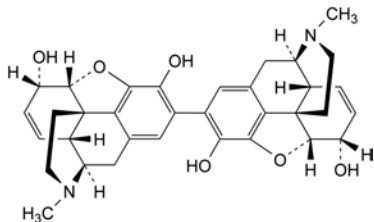

- B. 7,7',8,8'-tetrahydro-4,5 $\alpha$ :4',5' $\alpha$ -diepoxy-17,17'-dimethyl-2,2'-bimorphinanyl-3,3',6 $\alpha$ ,6' $\alpha$ -tetrol (2,2'-bimorphine),

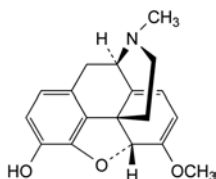

- C. 6,7,8,14-tetrahydro-4,5 $\alpha$ -epoxy-6-methoxy-17-methylmorphinan-3-ol (oripavine),

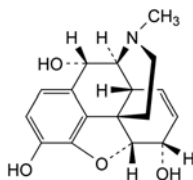

- D. 7,8-didehydro-4,5 $\alpha$ -epoxy-17-methylmorphinan-3,6 $\alpha$ ,10 $\alpha$ -triol (10S-hydroxymorphine),

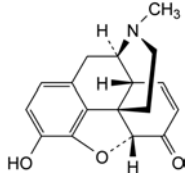

- E. 7,8-didehydro-4,5 $\alpha$ -epoxy-3-hydroxy-17-methylmorphinan-6-one (morphinone),

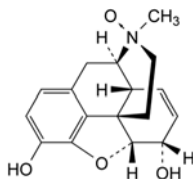

- F. (17S)-7,8-didehydro-4,5 $\alpha$ -epoxy-17-methylmorphinan-3,6 $\alpha$ -diol 17-oxide (morphine N-oxide).

04/2008:1244  
corrected 6.7

## MORPHINE SULFATE

### Morphini sulfas

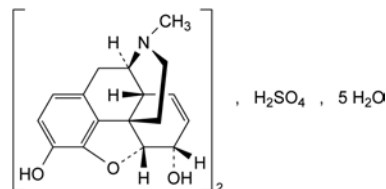

$C_{34}H_{40}N_2O_{10}S_5 \cdot 5H_2O$   
[6211-15-0]

$M_r$  759

#### DEFINITION

Di(7,8-didehydro-4,5 $\alpha$ -epoxy-17-methylmorphinan-3,6 $\alpha$ -diol) sulfate pentahydrate.

*Content*: 98.0 per cent to 102.0 per cent (anhydrous substance).

#### CHARACTERS

*Appearance*: white or almost white, crystalline powder.

*Solubility*: soluble in water, very slightly soluble in ethanol (96 per cent), practically insoluble in toluene.

#### IDENTIFICATION

*First identification: A, E.*

*Second identification: B, C, D, E.*

A. Infrared absorption spectrophotometry (2.2.24).

*Preparation*: dissolve 20 mg in 1 mL of water R, add 0.05 mL of 1 M sodium hydroxide and shake. A precipitate is formed. Filter, wash with 2 quantities, each of 0.5 mL, of water R and dry the precipitate at 145 °C for 1 h. Prepare discs using the dried precipitate.

*Comparison*: repeat the operations using 20 mg of morphine sulfate CRS.

B. Ultraviolet and visible absorption spectrophotometry (2.2.25).

*Solution A*. Dissolve 25.0 mg in water R and dilute to 25.0 mL with the same solvent.

**Test solution (a).** Dilute 10.0 mL of solution A to 100.0 mL with *water R*.

**Test solution (b).** Dilute 10.0 mL of solution A to 100.0 mL with 0.1 M *sodium hydroxide*.

**Spectral range:** 250-350 nm for test solutions (a) and (b).

**Absorption maximum:** at 285 nm for test solution (a); at 298 nm for test solution (b).

**Specific absorbance at the absorption maximum:** 37 to 43 for test solution (a); 64 to 72 for test solution (b).

C. To about 1 mg of powdered substance in a porcelain dish add 0.5 mL of *sulfuric acid-formaldehyde reagent R*. A purple colour develops and becomes violet.

D. It gives the reaction of alkaloids (2.3.1).

E. It gives the reactions of sulfates (2.3.1).

## TESTS

**Solution S.** Dissolve 0.500 g in *carbon dioxide-free water R* and dilute to 25.0 mL with the same solvent.

**Appearance of solution.** Solution S is clear (2.2.1) and not more intensely coloured than reference solution Y<sub>6</sub> or BY<sub>6</sub> (2.2.2, *Method II*).

**Acidity or alkalinity.** To 10 mL of solution S add 0.05 mL of *methyl red solution R*. Not more than 0.2 mL of 0.02 M *sodium hydroxide* or 0.02 M *hydrochloric acid* is required to change the colour of the indicator.

**Specific optical rotation (2.2.7):** – 107 to – 110 (anhydrous substance), determined on solution S.

**Related substances.** Liquid chromatography (2.2.29).

**Test solution.** Dissolve 0.125 g of the substance to be examined in a 1 per cent V/V solution of *acetic acid R* and dilute to 50 mL with the same solution.

**Reference solution (a).** Dilute 1.0 mL of the test solution to 100.0 mL with a 1 per cent V/V solution of *acetic acid R*. Dilute 2.0 mL of this solution to 10.0 mL with a 1 per cent V/V solution of *acetic acid R*.

**Reference solution (b).** Dissolve 5 mg of *morphine for system suitability CRS* (containing impurities B, C, E and F) in a 1 per cent V/V solution of *acetic acid R* and dilute to 2 mL with the same solution.

**Column:**

- **size:**  $l = 0.15$  m,  $\varnothing = 4.6$  mm;
- **stationary phase:** *end-capped octadecylsilyl silica gel for chromatography R* (5  $\mu$ m);
- **temperature:** 35 °C.

**Mobile phase:**

- **mobile phase A:** 1.01 g/L solution of *sodium heptanesulfonate R* adjusted to pH 2.6 with a 50 per cent V/V solution of *phosphoric acid R*;
- **mobile phase B:** *methanol R*;

Time (min)	Mobile phase A (per cent V/V)	Mobile phase B (per cent V/V)
0 - 2	85	15
2 - 35	85 → 50	15 → 50
35 - 40	50	50

**Flow rate:** 1.5 mL/min.

**Detection:** spectrophotometer at 230 nm.

**Injection:** 10  $\mu$ L.

**Identification of impurities:** use the chromatogram supplied with *morphine for system suitability CRS* and the chromatogram obtained with reference solution (b) to identify the peaks due to impurities B, C, E and F.

**Relative retention** with reference to morphine (retention time = about 12.5 min): impurity F = about 0.95; impurity E = about 1.1; impurity C = about 1.6; impurity B = about 1.9.

**System suitability:** reference solution (b):

- **peak-to-valley ratio:** minimum 2, where  $H_p$  = height above the baseline of the peak due to impurity F and  $H_v$  = height above the baseline of the lowest point of the curve separating this peak from the peak due to morphine.

**Limits:**

- **correction factors:** for the calculation of content, multiply the peak areas of the following impurities by the corresponding correction factor: impurity B = 0.25; impurity C = 0.4; impurity E = 0.5;
- **impurity B:** not more than twice the area of the principal peak in the chromatogram obtained with reference solution (a) (0.4 per cent);
- **impurities C, E:** for each impurity, not more than the area of the principal peak in the chromatogram obtained with reference solution (a) (0.2 per cent);
- **any other impurity:** for each impurity, not more than the area of the principal peak in the chromatogram obtained with reference solution (a) (0.2 per cent);
- **total:** not more than 5 times the area of the principal peak in the chromatogram obtained with reference solution (a) (1.0 per cent);
- **disregard limit:** 0.25 times the area of the principal peak in the chromatogram obtained with reference solution (a) (0.05 per cent).

The thresholds indicated under Related substances (Table 2034-1) in the general monograph *Substances for pharmaceutical use (2034)* do not apply.

**Iron (2.4.9):** maximum 5 ppm.

Dissolve the residue from the test for sulfated ash in *water R* and dilute to 10.0 mL with the same solvent.

**Water (2.5.12):** 10.4 per cent to 13.4 per cent, determined on 0.10 g.

**Sulfated ash (2.4.14):** maximum 0.1 per cent, determined on 2.0 g.

## ASSAY

Dissolve 0.500 g in 120 mL of *anhydrous acetic acid R*. Titrate with 0.1 M *perchloric acid*, determining the end-point potentiometrically (2.2.20).

1 mL of 0.1 M *perchloric acid* is equivalent to 66.88 mg of C<sub>34</sub>H<sub>40</sub>N<sub>2</sub>O<sub>10</sub>S.

## STORAGE

Protected from light.

## IMPURITIES

**Specified impurities:** B, C, E.

**Other detectable impurities** (the following substances would, if present at a sufficient level, be detected by one or other of the tests in the monograph. They are limited by the general acceptance criterion for other/unspecified impurities. It is therefore not necessary to identify these impurities for demonstration of compliance. See also 5.10. *Control of impurities in substances for pharmaceutical use*): A, D, F.

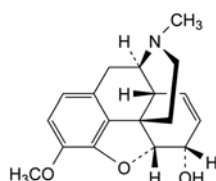

A. 7,8-dihydro-4,5 $\alpha$ -epoxy-3-methoxy-17-methylmorphinan-6 $\alpha$ -ol (codeine),

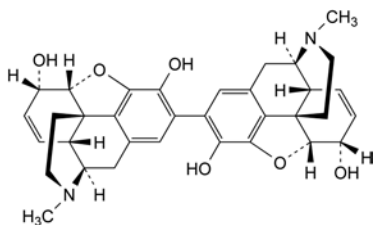

- B. 7,7',8,8'-tetrahydro-4,5α:4',5'α-diepoxy-17,17'-dimethyl-2,2'-bimorphinan-3,3',6α,6'α-tetrol (2,2'-bimorphine),

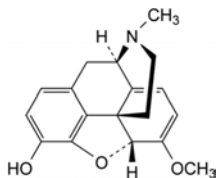

- C. 6,7,8,14-tetrahydro-4,5α-epoxy-6-methoxy-17-methylmorphinan-3-ol (oripavine),

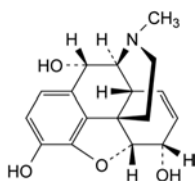

- D. 7,8-didehydro-4,5α-epoxy-17-methylmorphinan-3,6α,10α-triol (10S-hydroxymorphine),

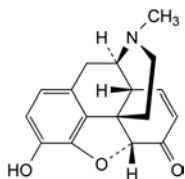

- E. 7,8-didehydro-4,5α-epoxy-3-hydroxy-17-methylmorphinan-6-one (morphinone),

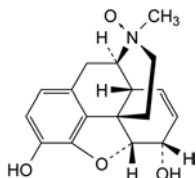

- F. (17S)-7,8-didehydro-4,5α-epoxy-17-methylmorphinan-3,6α-diol 17-oxide (morphine N-oxide).

01/2008:1656  
corrected 6.5

## MOXIDECTIN FOR VETERINARY USE

### Moxidectinum ad usum veterinarium

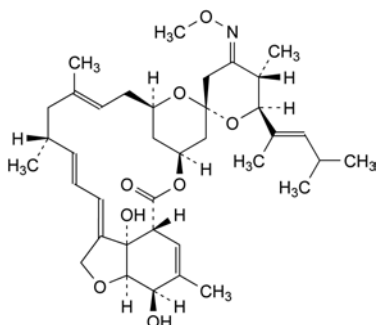

C<sub>37</sub>H<sub>53</sub>NO<sub>8</sub>  
[113507-06-5]

M<sub>r</sub> 640

#### DEFINITION

(2*aE*,2'*R*,4*E*,4'*E*,5'*S*,6*R*,6'*S*,8*E*,11*R*,15*S*,17*aR*,20*R*,20*aR*,20*bS*)-6'-[(1*E*)-1,3-Dimethylbut-1-enyl]-20,20*b*-dihydroxy-4'-(methoxyimino)-5',6,8,19-tetramethyl-3',4',5',6,6',7,10-,11,14,15,17*a*,20,20*a*,20*b*-tetradecahydrospiro[2*H*,17*H*-11-,15-methanofuro[4,3,2-*pq*][2,6]benzodioxacyclooctadecine-13,2'-pyran]-17-one ((6*R*,23*E*,25*S*)-5*O*-demethyl-28-deoxy-25-[(1*E*)-1,3-dimethylbut-1-enyl]-6,28-epoxy-23-(methoxyimino)milbemycin B).

Semi-synthetic product derived from a fermentation product.

It may contain suitable stabilisers such as antioxidants.

*Content*: 92.0 per cent to 102.0 per cent (anhydrous substance).

#### CHARACTERS

*Appearance*: white or pale yellow, amorphous powder.

*Solubility*: practically insoluble in water, very soluble in ethanol (96 per cent), slightly soluble in hexane.

#### IDENTIFICATION

Infrared absorption spectrophotometry (2.2.24).

*Comparison*: moxidectin CRS.

#### TESTS

**Appearance of solution.** The solution is clear (2.2.1) and not more intensely coloured than reference solution GY<sub>5</sub> (2.2.2, Method II).

Dissolve 0.40 g in *benzyl alcohol R* and dilute to 20 mL with the same solvent.

**Related substances.** Liquid chromatography (2.2.29).

**A. Test solution.** Dissolve 25.0 mg of the substance to be examined in *acetonitrile R* and dilute to 25.0 mL with the same solvent.

*Reference solution (a).* Dilute 1.0 mL of the test solution to 100.0 mL *acetonitrile R*.

*Reference solution (b).* Dissolve 5 mg of *moxidectin for system suitability CRS* (containing impurities A, B, C, D, E, F, G, H, I, J and K) in 5 mL of *acetonitrile R*.

*Reference solution (c).* Dissolve 25.0 mg of *moxidectin CRS* in *acetonitrile R* and dilute to 25.0 mL with the same solvent.

*Column*:

– *size*: *l* = 0.15 m, Ø = 3.9 mm;

– *stationary phase*: end-capped octadecylsilyl silica gel for chromatography R (4 µm);

– *temperature*: 50 °C.

*Mobile phase*: dissolve 7.7 g of *ammonium acetate R* in 400 mL of *water R*, adjust to pH 4.8 with *glacial acetic acid R* and add 600 mL of *acetonitrile R*.

*Flow rate*: 2.5 mL/min.

*Detection*: spectrophotometer at 242 nm.

*Injection*: 10 µL of the test solution and reference solutions (a) and (b).

*Run time*: 2 times the retention time of moxidectin.

*Identification of impurities*: use the chromatogram supplied with *moxidectin for system suitability CRS* and the chromatogram obtained with reference solution (b) to identify the peaks due to impurities A, B, C, D, E + F and G.

*Relative retention* with reference to moxidectin (retention time = about 12 min): impurity A = about 0.5; impurity B = about 0.7; impurity C = about 0.75; impurity D = about 0.94; impurities E and F = about 1.3-1.5; impurity G = about 1.6.

*System suitability*: reference solution (b):

– *peak-to-valley ratio*: minimum 3.0, where *H<sub>p</sub>* = height above the baseline of the peak due to impurity D and *H<sub>v</sub>* = height above the baseline of the lowest point of the curve separating this peak from the peak due to moxidectin.



**Limits:**

- *impurity D*: not more than 2.5 times the area of the principal peak in the chromatogram obtained with reference solution (a) (2.5 per cent);
- *sum of impurities E and F*: not more than 1.7 times the area of the principal peak in the chromatogram obtained with reference solution (a) (1.7 per cent);
- *impurities A, C, G*: for each impurity, not more than 1.5 times the area of the principal peak in the chromatogram obtained with reference solution (a) (1.5 per cent);
- *impurity B*: not more than 0.5 times the area of the principal peak in the chromatogram obtained with reference solution (a) (0.5 per cent);
- *any other impurity eluting before impurity G*: for each impurity, not more than 0.5 times the area of the principal peak in the chromatogram obtained with reference solution (a) (0.5 per cent);
- *disregard limit*: 0.1 times the area of the principal peak in the chromatogram obtained with reference solution (a) (0.1 per cent); disregard the peak due to the stabiliser (identify this peak, where applicable, by injecting a suitable reference solution).

B. *Test solution*. Dissolve 75.0 mg of the substance to be examined in *acetonitrile R* and dilute to 25.0 mL with the same solvent.

*Reference solution (a)*. Dilute 1.0 mL of the test solution to 100.0 mL with *acetonitrile R*.

*Reference solution (b)*. Dissolve 5 mg of *moxidectin for system suitability CRS* (containing impurities A, B, C, D, E, F, G, H, I, J and K) in 5 mL of *acetonitrile R*.

**Column:**

- *size*:  $l = 0.15$  m,  $\varnothing = 3.9$  mm;
- *stationary phase*: end-capped octadecylsilyl silica gel for chromatography R (4  $\mu$ m);
- *temperature*: 35 °C.

*Mobile phase*: dissolve 3.8 g of *ammonium acetate R* in 250 mL of *water R*, adjust to pH 4.2 with *acetic acid R* and add 750 mL of *acetonitrile R*.

*Flow rate*: 2.0 mL/min.

*Detection*: spectrophotometer at 242 nm.

*Injection*: 10  $\mu$ L.

*Run time*: 10 times the retention time of moxidectin.

*Identification of impurities*: use the chromatogram supplied with *moxidectin for system suitability CRS* and the chromatogram obtained with reference solution (b) to identify the peaks due to impurities H + I, J and K.

*Relative retention* with reference to moxidectin (retention time = about 4 min): impurity G = about 1.4; impurities H and I = about 2.0; impurity J = about 2.2; impurity K = about 3.4.

*System suitability*: reference solution (b):

- *resolution*: baseline separation between the peaks due to impurities H + I and J.

**Limits:**

- *sum of impurities H and I*: not more than the area of the principal peak in the chromatogram obtained with reference solution (a) (1.0 per cent);
- *impurities J, K*: for each impurity, not more than 0.5 times the area of the principal peak in the chromatogram obtained with reference solution (a) (0.5 per cent);
- *any other impurity eluting after impurity G*: for each impurity, not more than 0.5 times the area of the principal peak in the chromatogram obtained with reference solution (a) (0.5 per cent);

- *disregard limit*: 0.1 times the area of the principal peak in the chromatogram obtained with reference solution (a) (0.1 per cent); disregard the peak due to the stabiliser (identify this peak, where applicable, by injecting a suitable reference solution).

*Total of all impurities*. Calculate the sum of the impurities eluting from the start of the run to impurity G in test A, and from impurities H + I to the end of the run in test B. The total of all impurities is not more than 7.0 per cent.

**Heavy metals (2.4.8)**: maximum 20 ppm.

It complies with test A with the following modifications.

*Prescribed solution*. Dissolve 0.50 g in 20 mL of *ethanol (96 per cent) R*.

*Test solution*. 12 mL of the prescribed solution.

*Reference solution*. A mixture of 2 mL of the prescribed solution, 4 mL of *water R* and 6 mL of *lead standard solution (1 ppm Pb) R*.

*Blank solution*. A mixture of 2 mL of the prescribed solution and 10 mL of *ethanol (96 per cent) R*.

Use a membrane filter (nominal pore size 0.45  $\mu$ m).

**Water (2.5.12)**: maximum 1.3 per cent, determined on 0.50 g.

**Sulfated ash (2.4.14)**: maximum 0.2 per cent, determined on 1.0 g.

**ASSAY**

Liquid chromatography (2.2.29) as described in test A for related substances with the following modification.

*Injection*: test solution and reference solution (c).

Calculate the percentage content of  $C_{37}H_{53}NO_8$  using the declared content of *moxidectin CRS*.

**IMPURITIES**

*Specified impurities*: A, B, C, D, E, F, G, H, I, J, K.

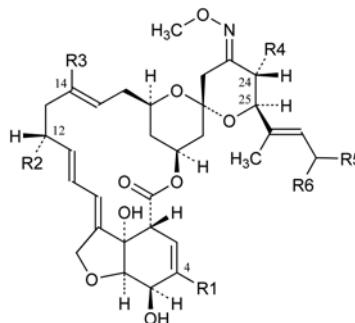

- A. R1 = R2 = R3 = R4 = CH<sub>3</sub>, R5 = R6 = H: 25-des[(1E)-1,3-dimethylbut-1-enyl]-25-[(1E)-1-methylprop-1-enyl]moxidectin,
- B. R1 = R2 = R3 = R5 = R6 = CH<sub>3</sub>, R4 = H: 24-desmethylmoxidectin,
- C. R1 = R2 = R3 = R4 = R5 = CH<sub>3</sub>, R6 = H: 25-des[(1E)-1,3-dimethylbut-1-enyl]-25-[(1E)-1-methylbut-1-enyl]moxidectin,
- F. one of groups R1 to R6 is C<sub>2</sub>H<sub>5</sub>, the others are CH<sub>3</sub>: x-desmethyl-x-ethylmoxidectin,

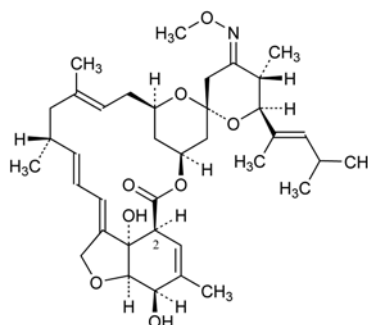

D. 2-*epi*-moxidectin,

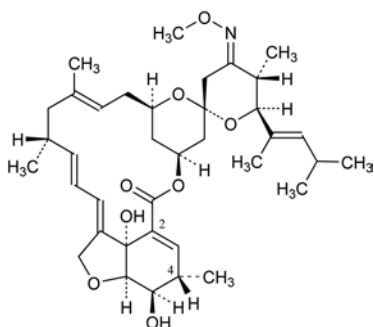
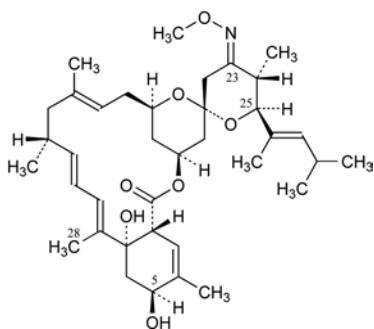
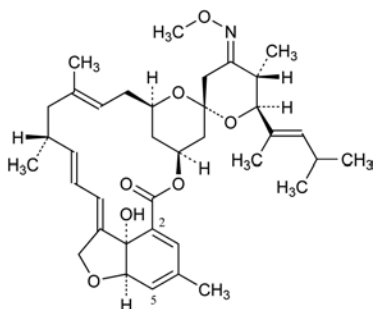
E. (4*S*)-2-dehydro-4-hydromoxidectin,G. (23*E*,25*S*)-5-*O*-desmethyl-28-deoxy-25-[(1*E*)-1,3-dimethylbut-1-enyl]-23-(methoxyimino)milbemycin B,

H. 2,5-didehydro-5-deoxymoxidectin,

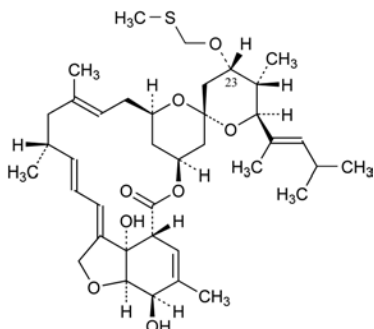
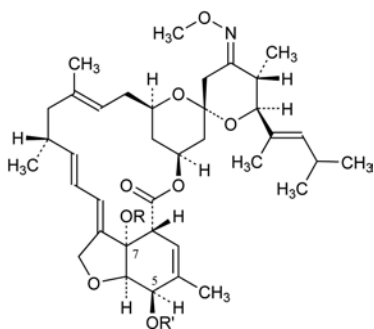
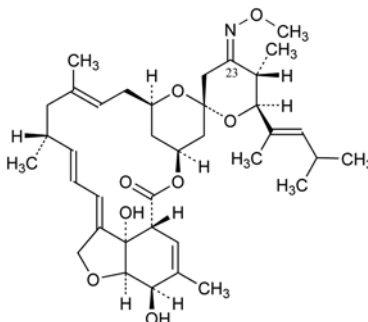
I. (23*S*)-23-des(methoxyimino)-23-[(methylsulfonyl)methoxy]moxidectin,J. R = CH<sub>2</sub>-S-CH<sub>3</sub>, R' = H: 7-*O*-[(methylsulfonyl)methyl]-moxidectin,K. R = H, R' = CO-C<sub>6</sub>H<sub>4</sub>-*p*-NO<sub>2</sub>: 5-*O*-(4-nitrobenzoyl)moxidectin,L. (23*Z*)-moxidectin.01/2008:2254  
corrected 6.2**MOXIFLOXACIN HYDROCHLORIDE**

## Moxifloxacinum hydrochloridum

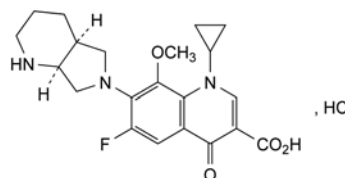
C<sub>21</sub>H<sub>25</sub>ClFN<sub>3</sub>O<sub>4</sub>M<sub>r</sub> 437.9**DEFINITION**1-Cyclopropyl-6-fluoro-8-methoxy-7-[(4*aS*,7*aS*)-octahydro-6*H*-pyrrolo[3,4-*b*]pyridin-6-yl]-4-oxo-1,4-dihydroquinoline-3-carboxylic acid hydrochloride.*Content*: 98.0 per cent to 102.0 per cent (anhydrous substance).**PRODUCTION**

The production method is validated to demonstrate the satisfactory enantiomeric purity of the final product.

**CHARACTERS***Appearance*: light yellow or yellow powder or crystals, slightly hygroscopic.*Solubility*: sparingly soluble in water, slightly soluble in ethanol (96 per cent), practically insoluble in acetone.**IDENTIFICATION**

A. Specific optical rotation (see Tests).

B. Infrared absorption spectrophotometry (2.2.24).

*Comparison*: moxifloxacin hydrochloride CRS.C. Dissolve 50 mg in 5 mL of *water R*, add 1 mL of *dilute nitric acid R*, mix, allow to stand for 5 min and filter. The filtrate gives reaction (a) of chlorides (2.3.1).**TESTS****Appearance of solution.** The solution is not more opalescent than reference suspension II (2.2.1) and not more intensely coloured than reference solution GY<sub>2</sub> (2.2.2, *Method II*). If intended for use in the manufacture of parenteral preparations, the solution is clear (2.2.1) and not more intensely coloured than reference solution GY<sub>2</sub> (2.2.2, *Method II*).Dissolve 1.0 g in 20 mL of *dilute sodium hydroxide solution R*.**pH** (2.2.3): 3.9 to 4.6.Dissolve 0.10 g in 50 mL of *carbon dioxide-free water R*.**Specific optical rotation** (2.2.7): –125 to –138 (anhydrous substance).Dissolve 0.200 g in 20.0 mL of a mixture of equal volumes of *acetonitrile R* and *water R*.

**Related substances.** Liquid chromatography (2.2.29). Carry out the test protected from light.

**Solution A.** Dissolve 0.50 g of tetrabutylammonium hydrogen sulfate R and 1.0 g of potassium dihydrogen phosphate R in about 500 mL of water R. Add 2 mL of phosphoric acid R and 0.050 g of anhydrous sodium sulfite R, then dilute to 1000.0 mL with water R.

**Test solution (a).** Dissolve 50.0 mg of the substance to be examined in solution A and dilute to 50.0 mL with the same solution.

**Test solution (b).** Dilute 2.0 mL of test solution (a) to 20.0 mL with solution A.

**Reference solution (a).** Dissolve 50.0 mg of moxifloxacin hydrochloride CRS in solution A and dilute to 50.0 mL with the same solution. Dilute 2.0 mL of this solution to 20.0 mL with solution A.

**Reference solution (b).** Dissolve 5 mg of moxifloxacin for peak identification CRS (containing impurities A, B, C, D and E) in solution A and dilute to 5.0 mL with the same solution.

**Reference solution (c).** Dilute 1.0 mL of test solution (a) to 100.0 mL with solution A. Dilute 1.0 mL of this solution to 10.0 mL with solution A.

**Column:**

- size:  $l = 0.25$  m,  $\emptyset = 4.6$  mm;
- stationary phase: end-capped phenylsilyl silica gel for chromatography R (5  $\mu$ m);
- temperature: 45 °C.

**Mobile phase:** mix 28 volumes of methanol R and 72 volumes of a solution containing 0.5 g/L of tetrabutylammonium hydrogen sulfate R, 1.0 g/L of potassium dihydrogen phosphate R and 3.4 g/L of phosphoric acid R.

**Flow rate:** 1.3 mL/min.

**Detection:** spectrophotometer at 293 nm.

**Injection:** 10  $\mu$ L of test solution (a) and reference solutions (b) and (c).

**Run time:** 2.5 times the retention time of moxifloxacin.

**Identification of impurities:** use the chromatogram supplied with moxifloxacin for peak identification CRS and the chromatogram obtained with reference solution (b) to identify the peaks due to impurities A, B, C, D and E.

**Relative retention** with reference to moxifloxacin (retention time = about 14 min): impurity A = about 1.1; impurity B = about 1.3; impurity C = about 1.4; impurity D = about 1.6; impurity E = about 1.7.

**System suitability:** reference solution (b):

- resolution: minimum 1.5 between the peaks due to moxifloxacin and impurity A;
- the chromatogram obtained is similar to the chromatogram supplied with moxifloxacin for peak identification CRS.

**Limits:**

- correction factors: for the calculation of content, multiply the peak areas of the following impurities by the corresponding correction factor: impurity B = 1.4; impurity E = 3.5;
- impurities A, B, C, D, E: for each impurity, not more than the area of the principal peak in the chromatogram obtained with reference solution (c) (0.1 per cent);
- unspecified impurities: for each impurity, not more than the area of the principal peak in the chromatogram obtained with reference solution (c) (0.10 per cent);
- total: not more than 3 times the area of the principal peak in the chromatogram obtained with reference solution (c) (0.3 per cent);
- disregard limit: 0.5 times the area of the principal peak in the chromatogram obtained with reference solution (c) (0.05 per cent).

**Water** (2.5.12): maximum 4.5 per cent, determined on 0.200 g.

**Sulfated ash** (2.4.14): maximum 0.1 per cent, determined on 1.0 g in a platinum crucible.

**ASSAY**

Liquid chromatography (2.2.29) as described in the test for related substances with the following modification.

**Injection:** test solution (b) and reference solution (a).

Calculate the percentage content of  $C_{21}H_{25}ClFN_3O_4$  from the declared content of moxifloxacin hydrochloride CRS.

**STORAGE**

In an airtight container, protected from light.

**LABELLING**

The label states, where applicable, that the substance is suitable for use in the manufacture of parenteral preparations.

**IMPURITIES**

**Specified impurities:** A, B, C, D, E.

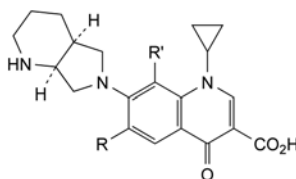

- R = R' = F: 1-cyclopropyl-6,8-difluoro-7-[(4a*S*,7a*S*)-octahydro-6*H*-pyrrolo[3,4-*b*]pyridin-6-yl]-4-oxo-1,4-dihydroquinoline-3-carboxylic acid,
- R = R' = OCH<sub>3</sub>: 1-cyclopropyl-6,8-dimethoxy-7-[(4a*S*,7a*S*)-octahydro-6*H*-pyrrolo[3,4-*b*]pyridin-6-yl]-4-oxo-1,4-dihydroquinoline-3-carboxylic acid,
- R = F, R' = OC<sub>2</sub>H<sub>5</sub>: 1-cyclopropyl-8-ethoxy-6-fluoro-7-[(4a*S*,7a*S*)-octahydro-6*H*-pyrrolo[3,4-*b*]pyridin-6-yl]-4-oxo-1,4-dihydroquinoline-3-carboxylic acid,
- R = OCH<sub>3</sub>, R' = F: 1-cyclopropyl-8-fluoro-6-methoxy-7-[(4a*S*,7a*S*)-octahydro-6*H*-pyrrolo[3,4-*b*]pyridin-6-yl]-4-oxo-1,4-dihydroquinoline-3-carboxylic acid,
- R = F, R' = OH: 1-cyclopropyl-6-fluoro-8-hydroxy-7-[(4a*S*,7a*S*)-octahydro-6*H*-pyrrolo[3,4-*b*]pyridin-6-yl]-4-oxo-1,4-dihydroquinoline-3-carboxylic acid.

01/2008:1758  
corrected 6.0

## MOXONIDINE

### Moxonidinum

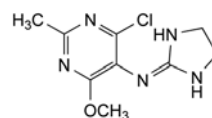

$C_6H_{12}ClN_5O$   
[75438-57-2]

$M_r$  241.7

**DEFINITION**

4-Chloro-*N*-(imidazolidin-2-ylidene)-6-methoxy-2-methylpyrimidin-5-amine.

**Content:** 97.5 per cent to 102.0 per cent (dried substance).

**CHARACTERS**

**Appearance:** white or almost white powder.

**Solubility:** very slightly soluble in water, sparingly soluble in methanol, slightly soluble in methylene chloride, very slightly soluble in acetonitrile.

**IDENTIFICATION**

Infrared absorption spectrophotometry (2.2.24).

*Preparation*: discs.

*Comparison*: moxonidine CRS.

## TESTS

**Related substances.** Liquid chromatography (2.2.29).

*Test solution.* Dissolve 0.100 g of the substance to be examined in a mixture of equal volumes of *methanol R* and *water R* and dilute to 100.0 mL with the same mixture of solvents.

*Reference solution (a).* Dissolve 10.0 mg of moxonidine CRS in a mixture of equal volumes of *methanol R* and *water R* and dilute to 10.0 mL with the same mixture of solvents.

*Reference solution (b).* Dilute 1.0 mL of reference solution (a) to 100.0 mL with a mixture of equal volumes of *methanol R* and *water R*. Dilute 2.0 mL of this solution to 20.0 mL with a mixture of equal volumes of *methanol R* and *water R*.

*Reference solution (c).* Dissolve 5.0 mg of moxonidine impurity A CRS in a mixture of equal volumes of *methanol R* and *water R* and dilute to 100.0 mL with the same mixture of solvents.

*Reference solution (d).* Dilute 6.0 mL of reference solution (c) to 100.0 mL with a mixture of equal volumes of *methanol R* and *water R*.

*Reference solution (e).* Dilute 2.5 mL of reference solution (a) to 50.0 mL with reference solution (c).

*Column*:

- size:  $l = 0.25$  m,  $\varnothing = 4$  mm;
- stationary phase: base-deactivated octylsilyl silica gel for chromatography R (5  $\mu$ m);
- temperature: 40 °C.

*Mobile phase*: mix 136 volumes of acetonitrile R with 1000 volumes of a 3.48 g/L solution of sodium pentanesulfonate R previously adjusted to pH 3.5 with dilute sulfuric acid R.

*Flow rate*: 1.2 mL/min.

*Detection*: spectrophotometer at 230 nm.

*Injection*: 20  $\mu$ L; inject a blank, the test solution and reference solutions (b), (d) and (e).

*Run time*: twice the retention time of moxonidine.

*Relative retentions* with reference to moxonidine (retention time = about 11.6 min): impurity A = about 0.9; impurity B = about 1.7.

*System suitability*: reference solution (e):

- resolution: minimum of 2 between the peaks due to impurity A and moxonidine.

*Limits*:

- impurity A: not more than the area of the corresponding peak in the chromatogram obtained with reference solution (d) (0.3 per cent);
- impurity B: not more than 3 times the area of the principal peak in the chromatogram obtained with reference solution (b) (0.3 per cent);
- unspecified impurities: for each impurity, not more than the area of the principal peak in the chromatogram obtained with reference solution (b) (0.10 per cent);
- total: not more than 5 times the area of the principal peak in the chromatogram obtained with reference solution (b) (0.5 per cent);
- disregard limit: 0.5 times the area of the principal peak in the chromatogram obtained with reference solution (b) (0.05 per cent); disregard any peak observed with the blank run.

**Loss on drying** (2.2.32): maximum 0.5 per cent, determined on 1.000 g by drying in an oven at 105 °C for 3 h.

**Sulfated ash** (2.4.14): maximum 0.1 per cent, determined on 1.0 g.

## ASSAY

Liquid chromatography (2.2.29) as described in the test for related substances with the following modification.

*Injection*: test solution and reference solution (a).

Calculate the percentage content of  $C_9H_{12}ClN_5O$  from the areas of the peaks and the declared content of moxonidine CRS.

## IMPURITIES

*Specified impurities*: A, B.

*Other detectable impurities* (the following substances would, if present at a sufficient level, be detected by one or other of the tests in the monograph. They are limited by the general acceptance criterion for other/unspecified impurities and/or by the general monograph *Substances for pharmaceutical use* (2034). It is therefore not necessary to identify these impurities for demonstration of compliance. See also 5.10. *Control of impurities in substances for pharmaceutical use*): C, D.

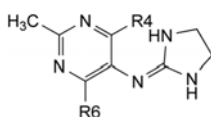

- A. R4 = R6 = Cl: 4,6-dichloro-*N*-(imidazolidin-2-ylidene)-2-methylpyrimidin-5-amine (6-chloromoxonidine),
- B. R4 = R6 = OCH<sub>3</sub>: *N*-(imidazolidin-2-ylidene)-4,6-dimethoxy-2-methylpyrimidin-5-amine (4-methoxymoxonidine),
- C. R4 = OH, R6 = OCH<sub>3</sub>: 5-[(imidazolidin-2-ylidene)amino]-6-methoxy-2-methylpyrimidin-4-ol (4-hydroxymoxonidine),
- D. R4 = OH, R6 = Cl: 6-chloro-5-[(imidazolidin-2-ylidene)amino]-2-methylpyrimidin-4-ol (6-desmethylmoxonidine).

01/2008:1450  
corrected 6.0

## MUPIROCIN

### Mupirocinum

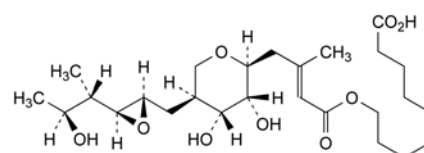

$C_{26}H_{44}O_9$   
[12650-69-0]

$M_r$  500.6

## DEFINITION

9-[[[(2*E*)-4-[(2*S*,3*R*,4*R*,5*S*)-3,4-Dihydroxy-5-[[[(2*S*,3*S*)-3-[(1*S*,2*S*)-2-hydroxy-1-methylpropyl]oxiranyl]methyl]tetrahydro-2*H*-pyran-2-yl]-3-methylbut-2-enoyl]oxy]nonanoic acid.

Substance produced by the growth of certain strains of *Pseudomonas fluorescens* or obtained by any other means.

*Content*: 93.0 per cent to 102.0 per cent (anhydrous substance).

## CHARACTERS

*Appearance*: white or almost white powder.

*Solubility*: slightly soluble in water, freely soluble in acetone, in anhydrous ethanol and in methylene chloride.

It shows polymorphism (5.9).

## IDENTIFICATION

Infrared absorption spectrophotometry (2.2.24).

*Comparison*: Ph. Eur. reference spectrum of mupirocin.

## TESTS

**pH** (2.2.3): 3.5 to 4.0 for a freshly prepared saturated solution (about 10 g/L) in carbon dioxide-free water R.

**Specific optical rotation** (2.2.7): –17 to –21 (anhydrous substance).

Dissolve 0.50 g in *methanol R* and dilute to 10.0 mL with the same solvent.

**Related substances.** Liquid chromatography (2.2.29).

**Solvent mixture.** Mix 50 volumes of *methanol R* and 50 volumes of a 13.6 g/L solution of *sodium acetate R* adjusted to pH 4.0 with *acetic acid R*.

**Test solution.** Dissolve 50.0 mg of the substance to be examined in the solvent mixture and dilute to 10.0 mL with the solvent mixture.

**Reference solution (a).** Dilute 1.0 mL of the test solution to 50.0 mL with the solvent mixture.

**Reference solution (b).** Adjust 10 mL of reference solution (a) to pH 2.0 with *hydrochloric acid R* and allow to stand for 20 h.

**Reference solution (c).** Dissolve 25 mg of *mupirocin lithium CRS* in the solvent mixture and dilute to 200.0 mL with the solvent mixture.

**Column:**

- size:  $l = 0.25$  m,  $\varnothing = 4.6$  mm;
- stationary phase: *octylsilyl silica gel for chromatography R* (5  $\mu$ m).

**Mobile phase:** mix 20 volumes of *water R*, 30 volumes of *tetrahydrofuran R* and 50 volumes of a 10.5 g/L solution of *ammonium acetate R* adjusted to pH 5.7 with *acetic acid R*.

**Flow rate:** 1 mL/min.

**Detection:** spectrophotometer at 240 nm.

**Injection:** 20  $\mu$ L.

**Run time:** 3.5 times the retention time of mupirocin.

**Relative retention** with reference to mupirocin: impurity C = about 0.75.

**System suitability:** reference solution (b):

- resolution: minimum 7.0 between the 2<sup>nd</sup> of the 2 peaks due to hydrolysis products and the peak due to mupirocin.

**Limits:**

- **impurity C:** not more than twice the area of the principal peak in the chromatogram obtained with reference solution (a) (4 per cent);
- **any other impurity:** for each impurity, not more than 0.5 times the area of the principal peak in the chromatogram obtained with reference solution (a) (1 per cent);
- **total:** not more than 3 times the area of the principal peak in the chromatogram obtained with reference solution (a) (6 per cent);
- **disregard limit:** 0.05 times the area of the principal peak in the chromatogram obtained with reference solution (a) (0.1 per cent).

**Water** (2.5.12): maximum 1.0 per cent, determined on 0.500 g.

#### ASSAY

Liquid chromatography (2.2.29).

**Test solution.** Dissolve 25.0 mg of the substance to be examined in 5 mL of *methanol R* and dilute to 200.0 mL with a 7.5 g/L solution of *ammonium acetate R* adjusted to pH 5.7 with *acetic acid R*.

**Reference solution (a).** Dissolve 25.0 mg of *mupirocin lithium CRS* in 5 mL of *methanol R* and dilute to 200.0 mL with a 7.5 g/L solution of *ammonium acetate R* adjusted to pH 5.7 with *acetic acid R*.

**Reference solution (b).** Adjust 10 mL of the test solution to pH 2.0 with *hydrochloric acid R* and allow to stand for 20 h.

**Column:**

- size:  $l = 0.25$  m,  $\varnothing = 4.6$  mm;
- stationary phase: *octylsilyl silica gel for chromatography R* (5  $\mu$ m).

**Mobile phase:** mix 19 volumes of *water R*, 32 volumes of *tetrahydrofuran R* and 49 volumes of a 10.5 g/L solution of *ammonium acetate R* adjusted to pH 5.7 with *acetic acid R*.

**Flow rate:** 1 mL/min.

**Detection:** spectrophotometer at 230 nm.

**Injection:** 20  $\mu$ L.

**System suitability:**

- resolution: minimum 7.0 between the 2<sup>nd</sup> of the 2 peaks due to hydrolysis products and the peak due to mupirocin in the chromatogram obtained with reference solution (b);
- repeatability: maximum relative standard deviation of 1.0 per cent after 6 injections of reference solution (a).

#### STORAGE

Protected from light.

#### IMPURITIES

**Specified impurities:** C.

**Other detectable impurities** (the following substances would, if present at a sufficient level, be detected by one or other of the tests in the monograph. They are limited by the general acceptance criterion for other/unspecified impurities and/or by the general monograph *Substances for pharmaceutical use* (2034). It is therefore not necessary to identify these impurities for demonstration of compliance. See also 5.10. *Control of impurities in substances for pharmaceutical use*): A, B, D, E, F.

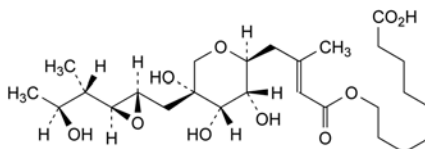

- A. 9-[[[(2E)-4-[(2S,3R,4R,5R)-3,4,5-trihydroxy-5-[[[(2S,3S)-3-[(1S,2S)-2-hydroxy-1-methylpropyl]oxiranyl]methyl]-tetrahydro-2H-pyran-2-yl]-3-methylbut-2-enyl]oxy]nonanoic acid (pseudomonic acid B),

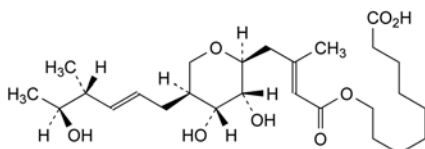

- B. 9-[[[(2E)-4-[(2S,3R,4R,5S)-3,4-dihydroxy-5-[(2E,4R,5S)-5-hydroxy-4-methylhex-2-enyl]tetrahydro-2H-pyran-2-yl]-3-methylbut-2-enyl]oxy]nonanoic acid (pseudomonic acid C),

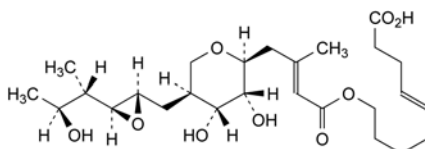

- C. (4E)-9-[[[(2E)-4-[(2S,3R,4R,5S)-3,4-dihydroxy-5-[[[(2S,3S)-3-[(1S,2S)-2-hydroxy-1-methylpropyl]oxiranyl]methyl]-tetrahydro-2H-pyran-2-yl]-3-methylbut-2-enyl]oxy]-non-4-enoic acid (pseudomonic acid D),

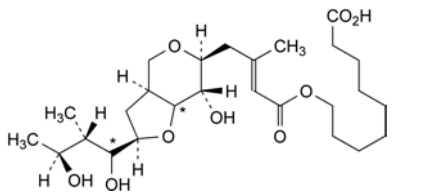

- D. 9-[[[(2E)-4-[(2R,3aS,6S,7S)-2-[(2S,3S)-1,3-dihydroxy-2-methylbutyl]-7-hydroxyhexahydro-4H-furo[3,2-c]pyran-6-yl]-3-methylbut-2-enyl]oxy]nonanoic acid,

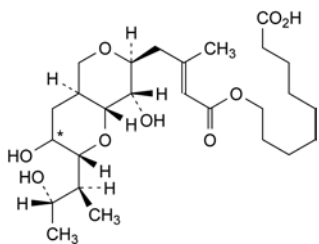

- E. 9-[[2E]-4-[(2R,3RS,4aS,7S,8S,8aR)-3,8-dihydroxy-2-[(1S,2S)-2-hydroxy-1-methylpropyl]hexahydro-2H,5H-pyran[4,3-b]pyran-7-yl]-3-methylbut-2-enoyl]oxy]nonanoic acid,

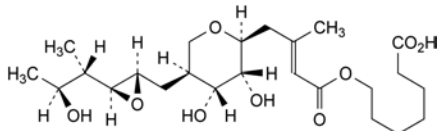

- F. 7-[[2E]-4-[(2S,3R,4R,5S)-3,4-dihydroxy-5-[[2S,3S)-3-[(1S,2S)-2-hydroxy-1-methylpropyl]oxiranyl]methyl]tetrahydro-2H-pyran-2-yl]-3-methylbut-2-enoyl]oxy]heptanoic acid.

07/2010:1451

## MUPIROCIN CALCIUM

### Mupirocinum calcium

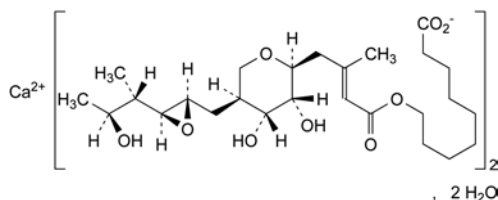

$C_{52}H_{86}CaO_{18} \cdot 2H_2O$   
[115074-43-6]

$M_r$  1075

#### DEFINITION

Calcium bis[9-[[2E]-4-[(2S,3R,4R,5S)-3,4-dihydroxy-5-[[2S,3S)-3-[(1S,2S)-2-hydroxy-1-methylpropyl]oxiranyl]methyl]tetrahydro-2H-pyran-2-yl]-3-methylbut-2-enoyl]oxy]nonanoate] dihydrate.

Substance produced by the growth of certain strains of *Pseudomonas fluorescens* or obtained by any other means.

*Content*: 93.0 per cent to 102.0 per cent (anhydrous substance).

#### CHARACTERS

*Appearance*: white or almost white powder.

*Solubility*: very slightly soluble in water, sparingly soluble in anhydrous ethanol and in methylene chloride.

#### IDENTIFICATION

A. Infrared absorption spectrophotometry (2.2.24).

*Comparison*: Ph. Eur. reference spectrum of mupirocin calcium.

B. It gives reaction (a) of calcium (2.3.1).

#### TESTS

**Specific optical rotation** (2.2.7): – 16 to – 20 (anhydrous substance).

Dissolve 0.50 g in *methanol R* and dilute to 10.0 mL with the same solvent.

**Related substances**. Liquid chromatography (2.2.29).

*Solvent mixture*. Mix 50 volumes of *methanol R* and 50 volumes of a 13.6 g/L solution of *sodium acetate R* adjusted to pH 4.0 with *acetic acid R*.

*Test solution*. Dissolve 50.0 mg of the substance to be examined in the solvent mixture and dilute to 10.0 mL with the solvent mixture.

*Reference solution (a)*. Dilute 1.0 mL of the test solution to 50.0 mL with the solvent mixture.

*Reference solution (b)*. Adjust 10 mL of reference solution (a) to pH 2.0 with *hydrochloric acid R* and allow to stand for 20 h.

*Reference solution (c)*. Dissolve 25 mg of *mupirocin lithium CRS* in the solvent mixture and dilute to 200.0 mL with the solvent mixture.

#### Column:

– *size*:  $l = 0.25$  m,  $\varnothing = 4.6$  mm;

– *stationary phase*: *octylsilyl silica gel for chromatography R* (5  $\mu$ m).

*Mobile phase*: mix 20 volumes of *water R*, 30 volumes of *tetrahydrofuran R* and 50 volumes of a 10.5 g/L solution of *ammonium acetate R* adjusted to pH 5.7 with *acetic acid R*.

*Flow rate*: 1 mL/min.

*Detection*: spectrophotometer at 240 nm.

*Injection*: 20  $\mu$ L.

*Run time*: 3.5 times the retention time of mupirocin.

*Relative retention* with reference to mupirocin: impurity C = about 0.75.

*System suitability*: reference solution (b):

– *resolution*: minimum 7.0 between the 2<sup>nd</sup> of the 2 peaks due to hydrolysis products and the peak due to mupirocin.

#### Limits:

– *impurity C*: not more than 1.25 times the area of the principal peak in the chromatogram obtained with reference solution (a) (2.5 per cent);

– *any other impurity*: for each impurity, not more than 0.5 times the area of the principal peak in the chromatogram obtained with reference solution (a) (1 per cent);

– *total*: not more than 2.25 times the area of the principal peak in the chromatogram obtained with reference solution (a) (4.5 per cent);

– *disregard limit*: 0.05 times the area of the principal peak in the chromatogram obtained with reference solution (a) (0.1 per cent).

**Chlorides** (2.4.4): maximum 0.5 per cent.

Dissolve 10.0 mg in a mixture of 1 mL of *dilute nitric acid R* and 15 mL of *methanol R*.

**Water** (2.5.12): 3.0 per cent to 4.5 per cent, determined on 0.500 g.

#### ASSAY

Liquid chromatography (2.2.29).

*Test solution*. Dissolve 25.0 mg of the substance to be examined in 5 mL of *methanol R* and dilute to 200.0 mL with a 7.5 g/L solution of *ammonium acetate R* adjusted to pH 5.7 with *acetic acid R*.

*Reference solution (a)*. Dissolve 25.0 mg of *mupirocin lithium CRS* in 5 mL of *methanol R* and dilute to 200.0 mL with a 7.5 g/L solution of *ammonium acetate R* adjusted to pH 5.7 with *acetic acid R*.

*Reference solution (b)*. Adjust 10 mL of the test solution to pH 2.0 with *hydrochloric acid R* and allow to stand for 20 h.

#### Column:

– *size*:  $l = 0.25$  m,  $\varnothing = 4.6$  mm;

– *stationary phase*: *octylsilyl silica gel for chromatography R* (5  $\mu$ m).

*Mobile phase*: mix 19 volumes of *water R*, 32 volumes of *tetrahydrofuran R* and 49 volumes of a 10.5 g/L solution of *ammonium acetate R* adjusted to pH 5.7 with *acetic acid R*.

*Flow rate*: 1 mL/min.

*Detection*: spectrophotometer at 230 nm.

*Injection*: 20  $\mu$ L.

*System suitability:*

- *resolution*: minimum 7.0 between the 2<sup>nd</sup> of the 2 peaks due to hydrolysis products and the peak due to mupirocin in the chromatogram obtained with reference solution (b);
- *repeatability*: maximum relative standard deviation of 1.0 per cent after 6 injections of reference solution (a).

Calculate the percentage content of mupirocin calcium by multiplying the percentage content of mupirocin in mupirocin lithium by 1.038.

## IMPURITIES

*Specified impurities: C.*

*Other detectable impurities* (the following substances would, if present at a sufficient level, be detected by one or other of the tests in the monograph. They are limited by the general acceptance criterion for other/unspecified impurities and/or by the general monograph *Substances for pharmaceutical use (2034)*. It is therefore not necessary to identify these impurities for demonstration of compliance. See also 5.10. *Control of impurities in substances for pharmaceutical use*): A, B, D, E, F, G, H, I.

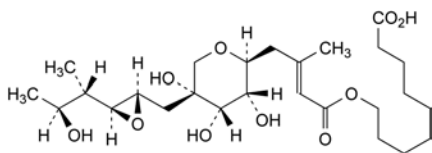

- A. 9-[[*(2E)*-4-[(*2S,3R,4R,5R*)-3,4,5-trihydroxy-5-[(*2S,3S*)-3-[(*1S,2S*)-2-hydroxy-1-methylpropyl]oxiranyl]methyl]-tetrahydro-2*H*-pyran-2-yl]-3-methylbut-2-enoyl]oxy]nonanoic acid (pseudomonic acid B),

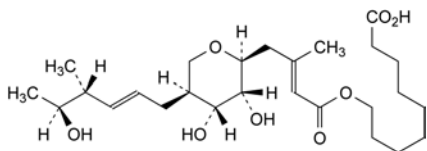

- B. 9-[[*(2E)*-4-[(*2S,3R,4R,5S*)-3,4-dihydroxy-5-(*2E,4R,5S*)-5-hydroxy-4-methylhex-2-enyl]tetrahydro-2*H*-pyran-2-yl]-3-methylbut-2-enoyl]oxy]nonanoic acid (pseudomonic acid C),

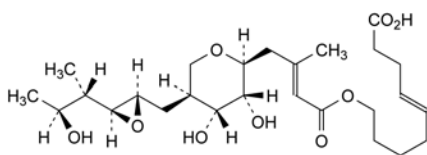

- C. (*4E*)-9-[[*(2E)*-4-[(*2S,3R,4R,5S*)-3,4-dihydroxy-5-[(*2S,3S*)-3-[(*1S,2S*)-2-hydroxy-1-methylpropyl]oxiranyl]methyl]-tetrahydro-2*H*-pyran-2-yl]-3-methylbut-2-enoyl]oxy]-non-4-enoic acid (pseudomonic acid D),

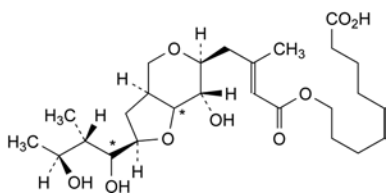

- D. 9-[[*(2E)*-4-[(*2R,3aS,6S,7S*)-2-[(*2S,3S*)-1,3-dihydroxy-2-methylbutyl]-7-hydroxyhexahydro-4*H*-furo[3,2-*c*]pyran-6-yl]-3-methylbut-2-enoyl]oxy]nonanoic acid,

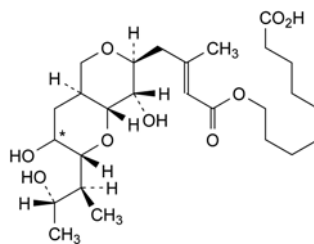

- E. 9-[[*(2E)*-4-[(*2R,3RS,4aS,7S,8S,8aR*)-3,8-dihydroxy-2-[(*1S,2S*)-2-hydroxy-1-methylpropyl]hexahydro-2*H,5H*-pyran[4,3-*b*]pyran-7-yl]-3-methylbut-2-enoyl]oxy]nonanoic acid,

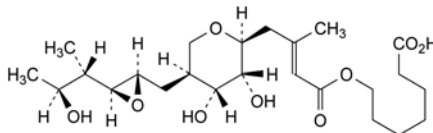

- F. 7-[[*(2E)*-4-[(*2S,3R,4R,5S*)-3,4-dihydroxy-5-[(*2S,3S*)-3-[(*1S,2S*)-2-hydroxy-1-methylpropyl]oxiranyl]methyl]tetrahydro-2*H*-pyran-2-yl]-3-methylbut-2-enoyl]oxy]heptanoic acid,

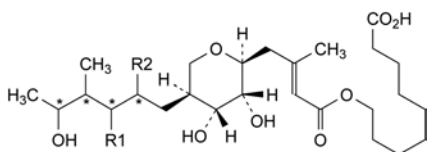

- G. R1 = OH, R2 = Cl: 9-[[*(2E)*-4-[(*2S,3R,4R,5S*)-5-(2-chloro-3,5-dihydroxy-4-methylhexyl)-3,4-dihydroxytetrahydro-2*H*-pyran-2-yl]-3-methylbut-2-enoyl]oxy]nonanoic acid,

- H. R1 = Cl, R2 = OH: 9-[[*(2E)*-4-[(*2S,3R,4R,5S*)-5-(3-chloro-2,5-dihydroxy-4-methylhexyl)-3,4-dihydroxytetrahydro-2*H*-pyran-2-yl]-3-methylbut-2-enoyl]oxy]nonanoic acid,

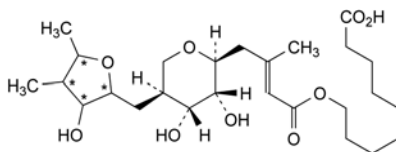

- I. 9-[[*(2E)*-4-[(*2S,3R,4R,5S*)-3,4-dihydroxy-5-[(3-hydroxy-4,5-dimethyltetrahydrofuran-2-yl)methyl]tetrahydro-2*H*-pyran-2-yl]-3-methylbut-2-enoyl]oxy]nonanoic acid.

01/2008:1700

## MYCOPHENOLATE MOFETIL

## Mycophenolas mofetil

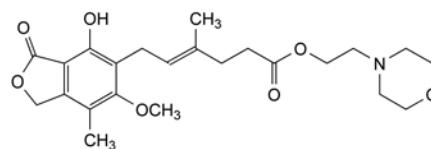

$C_{23}H_{31}NO_7$   
[128794-94-5]

$M_r$  433.5

## DEFINITION

2-(Morpholin-4-yl)ethyl (*4E*)-6-(4-hydroxy-6-methoxy-7-methyl-3-oxo-1,3-dihydroisobenzofuran-5-yl)-4-methylhex-4-enoate.

*Content*: 98.0 per cent to 102.0 per cent (dried substance).

## CHARACTERS

*Appearance*: white or almost white, crystalline powder.

*Solubility*: practically insoluble in water, freely soluble in acetone, sparingly soluble in anhydrous ethanol.

mp: about 96 °C.

## IDENTIFICATION

Infrared absorption spectrophotometry (2.2.24).

Comparison: *mycophenolate mofetil CRS*.

## TESTS

**Appearance of solution.** The solution is clear (2.2.1) and colourless (2.2.2, Method II).

Dissolve 0.10 g in *ethanol (96 per cent) R* and dilute to 10 mL with the same solvent.

**Related substances.** Liquid chromatography (2.2.29). *Protect the solutions from light. Prepare the solutions immediately before use, or store them at 4–8 °C. Keep the temperature of the autosampler at 10 °C, allow the temperature of the solutions to equilibrate in the vials for 15 min before injection.*

**Test solution.** Dissolve 20 mg of the substance to be examined in *acetonitrile R* and dilute to 10 mL with the same solvent.

**Reference solution (a).** Dilute 1.0 mL of the test solution to 100.0 mL with *acetonitrile R*. Dilute 1.0 mL of this solution to 10.0 mL with *acetonitrile R*.

**Reference solution (b).** Dissolve 5 mg of *mycophenolate mofetil for peak identification CRS* (mycophenolate mofetil with impurities A, B, D, E, F, G and H) in *acetonitrile R* and dilute to 2.5 mL with the same solvent.

**Column:**

- size:  $l = 0.25$  m,  $\varnothing = 4.6$  mm,
- stationary phase: *octylsilyl silica gel for chromatography R* (5  $\mu$ m),
- temperature: 45 °C.

**Mobile phase:** mix 350 mL of *acetonitrile R* with a mixture of 650 mL of *water R* and 2.0 mL of *triethylamine R* previously adjusted to pH 5.3 with *dilute phosphoric acid R*.

**Flow rate:** 1.5 mL/min.

**Detection:** spectrophotometer at 250 nm.

**Injection:** 10  $\mu$ L.

**Run time:** 3 times the retention time of *mycophenolate mofetil*.

**Relative retention** with reference to *mycophenolate mofetil* (retention time = about 22 min): impurity F = about 0.3; impurity A = about 0.4; impurity H = about 0.5; impurity G = about 0.6; impurity B = about 0.8; impurity D = about 1.2; impurity E = about 1.6.

**System suitability:** reference solution (b):

- resolution: minimum 2.0 between the peaks due to impurity A and impurity H,
- the chromatogram obtained is similar to the chromatogram supplied with *mycophenolate mofetil for peak identification CRS*.

**Limits:**

- correction factor: for the calculation of content, multiply the peak area of impurity B by 2.1,
- impurity F: not more than 5 times the area of the principal peak in the chromatogram obtained with reference solution (a) (0.5 per cent),
- impurity B: not more than twice the area of the principal peak in the chromatogram obtained with reference solution (a) (0.2 per cent),
- impurities A, D, E, G, H: for each impurity, not more than the area of the principal peak in the chromatogram obtained with reference solution (a) (0.1 per cent),
- any other impurity: for each impurity, not more than the area of the principal peak in the chromatogram obtained with reference solution (a) (0.1 per cent),
- total: not more than 7 times the area of the principal peak in the chromatogram obtained with reference solution (a) (0.7 per cent),

- disregard limit: 0.5 times the area of the principal peak in the chromatogram obtained with reference solution (a) (0.05 per cent).

**Heavy metals (2.4.8):** maximum 20 ppm.

1.0 g complies with limit test F. Prepare the reference solution using 2 mL of *lead standard solution (10 ppm Pb) R*.

**Loss on drying (2.2.32):** maximum 0.5 per cent, determined on 1.000 g by drying *in vacuo* at 60 °C for 3 h.

**Sulfated ash (2.4.14):** maximum 0.1 per cent, determined on 1.0 g.

## ASSAY

Dissolve 0.400 g in 50 mL of *anhydrous acetic acid R*. Titrate with 0.1 M *perchloric acid* determining the end-point potentiometrically (2.2.20).

1 mL of 0.1 M *perchloric acid* is equivalent to 43.35 mg of  $C_{23}H_{31}NO_7$ .

## STORAGE

Protected from light.

## IMPURITIES

**Specified impurities:** A, B, D, E, F, G, H.

**Other detectable impurities** (the following substances would, if present at a sufficient level, be detected by one or other of the tests in the monograph. They are limited by the general acceptance criterion for other/unspecified impurities and/or by the general monograph *Substances for pharmaceutical use (2034)*. It is therefore not necessary to identify these impurities for demonstration of compliance. See also 5.10. *Control of impurities in substances for pharmaceutical use*): C.

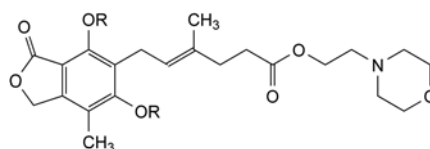

A. R = H: 2-(morpholin-4-yl)ethyl (4E)-6-(4,6-dihydroxy-7-methyl-3-oxo-1,3-dihydroisobenzofuran-5-yl)-4-methylhex-4-enoate,

D. R =  $CH_3$ : 2-(morpholin-4-yl)ethyl (4E)-6-(4,6-dimethoxy-7-methyl-3-oxo-1,3-dihydroisobenzofuran-5-yl)-4-methylhex-4-enoate,

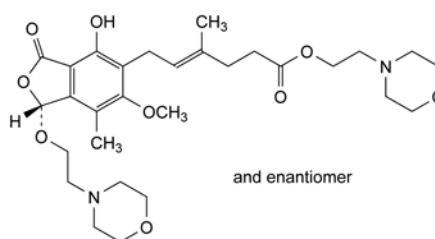

B. 2-(morpholin-4-yl)ethyl (4E)-6-[(1R)-4-hydroxy-6-methoxy-7-methyl-1-[2-(morpholin-4-yl)ethoxy]-3-oxo-1,3-dihydroisobenzofuran-5-yl]-4-methylhex-4-enoate,

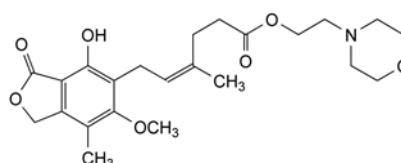

C. 2-(morpholin-4-yl)ethyl (4Z)-6-(4-hydroxy-6-methoxy-7-methyl-3-oxo-1,3-dihydroisobenzofuran-5-yl)-4-methylhex-4-enoate,



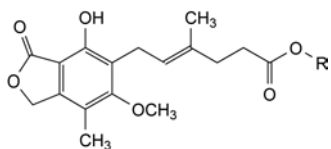

E. R = CH<sub>3</sub>: methyl (4*E*)-6-(4-hydroxy-6-methoxy-7-methyl-3-oxo-1,3-dihydroisobenzofuran-5-yl)-4-methylhex-4-enoate,

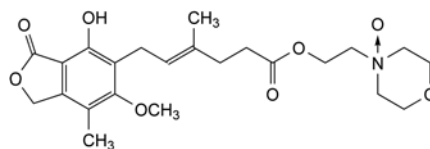

G. 2-(morpholin-4-yl)ethyl (4*E*)-6-(4-hydroxy-6-methoxy-7-methyl-3-oxo-1,3-dihydroisobenzofuran-5-yl)-4-methylhex-4-enoate *N*-oxide,

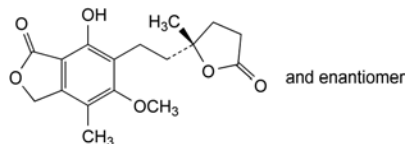

F. R = H: (4*E*)-6-(4-hydroxy-6-methoxy-7-methyl-3-oxo-1,3-dihydroisobenzofuran-5-yl)-4-methylhex-4-enoic acid (mycophenolic acid),

H. 7-hydroxy-5-methoxy-4-methyl-6-[2-[(2*RS*)-2-methyl-5-oxotetrahydrofuran-2-yl]ethyl]isobenzofuran-1(3*H*)-one.

## NABUMETONE

## Nabumetonum

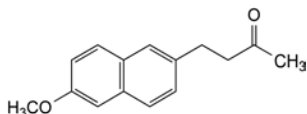

$C_{15}H_{16}O_2$   
[42924-53-8]

$M_r$  228.3

## DEFINITION

4-(6-Methoxynaphthalen-2-yl)butan-2-one.

*Content*: 97.0 per cent to 102.0 per cent (anhydrous substance).

## CHARACTERS

*Appearance*: white or almost white, crystalline powder.

*Solubility*: practically insoluble in water, freely soluble in acetone, slightly soluble in methanol.

## IDENTIFICATION

Infrared absorption spectrophotometry (2.2.24).

*Comparison*: nabumetone CRS.

## TESTS

**Related substances.** Liquid chromatography (2.2.29).

*Test solution (a).* Dissolve 50.0 mg of the substance to be examined in *acetonitrile R* and dilute to 10.0 mL with the same solvent.

*Test solution (b).* Dilute 1.0 mL of test solution (a) to 25.0 mL with *acetonitrile R*. Dilute 1.0 mL of this solution to 5.0 mL with *acetonitrile R*.

*Reference solution (a).* Dissolve 20.0 mg of *nabumetone CRS* in *acetonitrile R* and dilute to 10.0 mL with the same solvent. Dilute 1.0 mL of this solution to 50.0 mL with *acetonitrile R*.

*Reference solution (b).* Dilute 0.5 mL of test solution (a) to 100.0 mL with *acetonitrile R*.

*Reference solution (c).* Dissolve 1.5 mg of *nabumetone impurity F CRS* in *acetonitrile R* and dilute to 100.0 mL with the same solvent.

*Reference solution (d).* Dissolve 4 mg of *nabumetone impurity D CRS* in *acetonitrile R* and dilute to 100 mL with the same solvent. To 5 mL of this solution, add 5 mL of test solution (b).

*Column*:

- *size*:  $l = 0.15$  m,  $\varnothing = 4.6$  mm;
- *stationary phase*: base-deactivated octadecylsilyl silica gel for chromatography R (4  $\mu$ m);
- *temperature*: 40 °C.

*Mobile phase*:

- *mobile phase A*: mix 12 volumes of *tetrahydrofuran R*, 28 volumes of *acetonitrile for chromatography R* and 60 volumes of a 0.1 per cent V/V solution of *glacial acetic acid R* in *carbon dioxide-free water R* prepared from *distilled water R*;
- *mobile phase B*: mix 24 volumes of *tetrahydrofuran R*, 56 volumes of *acetonitrile for chromatography R* and 20 volumes of a 0.1 per cent V/V solution of *glacial acetic acid R* in *carbon dioxide-free water R* prepared from *distilled water R*;

Time (min)	Mobile phase A (per cent V/V)	Mobile phase B (per cent V/V)
0 - 12	100	0
12 - 28	100 → 0	0 → 100
28 - 33	0	100

07/2010:1350 *Flow rate*: 1 mL/min.

*Detection*: spectrophotometer at 254 nm.

*Injection*: 20  $\mu$ L of test solution (a) and reference solutions (b), (c) and (d).

*Retention time*: nabumetone = about 11 min.

*System suitability*: reference solution (d):

- *resolution*: minimum 1.5 between the peaks due to nabumetone and impurity D.

*Limits*:

- *impurity F*: not more than the area of the principal peak in the chromatogram obtained with reference solution (c) (0.3 per cent);
- *unspecified impurities*: for each impurity, not more than 0.2 times the area of the principal peak in the chromatogram obtained with reference solution (b) (0.10 per cent);
- *sum of impurities other than F*: not more than the area of the principal peak in the chromatogram obtained with reference solution (b) (0.5 per cent);
- *disregard limit*: 0.1 times the area of the principal peak in the chromatogram obtained with reference solution (b) (0.05 per cent).

**Heavy metals** (2.4.8): maximum 10 ppm.

2.0 g complies with test C. Prepare the reference solution using 2 mL of *lead standard solution (10 ppm Pb) R*.

**Water** (2.5.12): maximum 0.2 per cent, determined on 1.000 g.

**Sulfated ash** (2.4.14): maximum 0.1 per cent, determined on 1.0 g.

## ASSAY

Liquid chromatography (2.2.29) as described in the test for related substances with the following modifications.

*Injection*: test solution (b) and reference solution (a).

*System suitability*: reference solution (a):

- *repeatability*: maximum relative standard deviation of 1.0 per cent after 6 injections.

Calculate the percentage content of  $C_{15}H_{16}O_2$  from the declared content of *nabumetone CRS*.

## STORAGE

Protected from light.

## IMPURITIES

*Specified impurities*: F.

*Other detectable impurities* (the following substances would, if present at a sufficient level, be detected by one or other of the tests in the monograph. They are limited by the general acceptance criterion for other/unspecified impurities and/or by the general monograph *Substances for pharmaceutical use (2034)*. It is therefore not necessary to identify these impurities for demonstration of compliance. See also 5.10. *Control of impurities in substances for pharmaceutical use*): A, B, C, D, E.

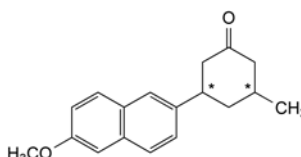

A. 3-(6-methoxynaphthalen-2-yl)-5-methylcyclohexanone,

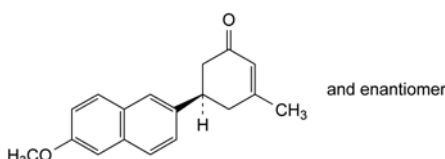

B. (5*RS*)-5-(6-methoxynaphthalen-2-yl)-3-methylcyclohex-2-enone,

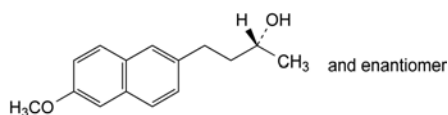
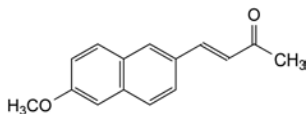
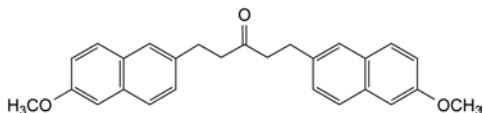
C. (2*RS*)-4-(6-methoxynaphthalen-2-yl)butan-2-ol,D. (*E*)-4-(6-methoxynaphthalen-2-yl)but-3-en-2-one,

E. 1,5-bis(6-methoxynaphthalen-2-yl)pentan-3-one,

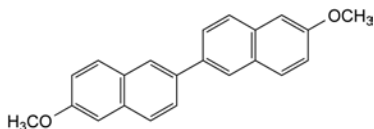

F. 6,6'-dimethoxy-2,2'-binaphthalenyl.

01/2008:1789

**NADOLOL**

## Nadololum

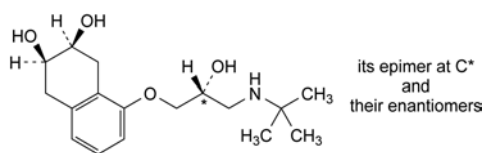
C<sub>17</sub>H<sub>27</sub>NO<sub>4</sub>  
[42200-33-9]M<sub>r</sub> 309.4**DEFINITION**

*cis*-5-[3-[(1,1-Dimethylethyl)amino]-2-hydroxypropoxy]-1,2,3,4-tetrahydronaphthalene-2,3-diol.

It consists of 2 pairs of enantiomers which are present as 2 racemic compounds: racemate A and racemate B.

*Content*: 98.5 per cent to 101.0 per cent (dried substance).

**CHARACTERS**

*Appearance*: white or almost white, crystalline powder.

*Solubility*: slightly soluble in water, freely soluble in alcohol, practically insoluble in acetone.

**IDENTIFICATION**

Infrared absorption spectrophotometry (2.2.24).

*Comparison*: nadolol CRS.

**TESTS**

**Racemate content.** Infrared absorption spectrophotometry (2.2.24).

Prepare a mull in *liquid paraffin R* of the substance to be examined (dried substance), adjusting the thickness of the mull to give an absorbance reading of  $0.6 \pm 0.1$  at  $1587 \text{ cm}^{-1}$ . Record the spectrum from  $1667$  to  $1111 \text{ cm}^{-1}$ , using *liquid paraffin R* as reference. Measure the absorbance  $A_a$ , corresponding to racemate A, at the maximum at  $1266 \text{ cm}^{-1}$  and the absorbance  $A_b$ , corresponding to racemate B, at the maximum at  $1250 \text{ cm}^{-1}$ . The ratio  $A_a/A_b$  is 0.72 to 1.08 (corresponding to racemate A content of between 40 per cent and 60 per cent).

**Related substances.** Liquid chromatography (2.2.29).

*Test solution.* Dissolve 0.100 g of the substance to be examined in 4.0 mL of *methanol R* and dilute to 100.0 mL with a mixture of 20 volumes of *acetonitrile R* and 80 volumes of *water R*.

*Reference solution (a).* Dilute 1.0 mL of the test solution to 50.0 mL with a mixture of 20 volumes of *acetonitrile R* and 80 volumes of *water R*. Dilute 5.0 mL of the solution to 50.0 mL with a mixture of 20 volumes of *acetonitrile R* and 80 volumes of *water R*.

*Reference solution (b).* Dissolve 20 mg of *pindolol CRS* and 20 mg of the substance to be examined in 20 mL of *methanol R* and dilute to 100.0 mL with a mixture of 20 volumes of *acetonitrile R* and 80 volumes of *water R*. Dilute 1.0 mL of the solution to 100.0 mL with a mixture of 20 volumes of *acetonitrile R* and 80 volumes of *water R*.

*Reference solution (c).* Dilute 5.0 mL of reference solution (a) to 20.0 mL with a mixture of 20 volumes of *acetonitrile R* and 80 volumes of *water R*.

*Column*:

- *size*:  $l = 0.30 \text{ m}$ ,  $\varnothing = 3.9 \text{ mm}$ ,
- *stationary phase*: spherical *end-capped octadecylsilyl silica gel for chromatography R* ( $5 \mu\text{m}$ ), with a specific surface area of  $700 \text{ m}^2/\text{g}$ , a pore size of 0.9 nm and a carbon loading of 12 per cent.
- *temperature*:  $40 \text{ }^\circ\text{C}$ .

*Mobile phase*:

- *mobile phase A*: 5.6 g/L solution of *sodium octanesulfonate R* adjusted to pH 3.5 with a 300 g/L solution of *phosphoric acid R*,
- *mobile phase B*: *acetonitrile R*,

Time (min)	Mobile phase A (per cent V/V)	Mobile phase B (per cent V/V)
0 - 7	77	23
7 - 30	77 → 65	23 → 35
30 - 45	65	35
45 - 50	65 → 77	35 → 23
50 - 60	77	23

*Flow rate*: 1 mL/min.

*Detection*: spectrophotometer at 206 nm.

*Injection*: 20  $\mu\text{L}$ .

*Relative retention* with reference to nadolol (retention time = about 18 min): impurity A = 0.25; impurity B = 0.4; impurity C (doublet) = 0.6 and 0.7; impurity D = 1.4; impurity E = 1.6; impurity F = 2.2; impurity G = 2.6.

*System suitability*: reference solution (b):

- *resolution*: minimum of 8.0 between the peaks due to nadolol and to pindolol.

*Limits*:

- *correction factors*: for the calculation of contents, multiply the peak areas of the following impurities by the corresponding correction factor: impurity A = 1.7; impurity B = 1.7; impurity C = 1.7 (multiply the sum of the areas of the 2 peaks);
- *impurity A, B, C, D, E, F, G*: for each impurity, not more than the area of the principal peak in the chromatogram obtained with reference solution (a) (0.2 per cent);
- *any other impurity*: not more than half the area of the principal peak in the chromatogram obtained with reference solution (a) (0.1 per cent);
- *total*: not more than 2.5 times the area of the principal peak in the chromatogram obtained with reference solution (a) (0.5 per cent);
- *disregard limit*: area of the principal peak in the chromatogram obtained with reference solution (c) (0.05 per cent).

01/2008:1134

**Heavy metals** (2.4.8): maximum 30 ppm.1.0 g complies with limit test D. Prepare the standard using 3 mL of *lead standard solution* (10 ppm Pb) R.**Loss on drying** (2.2.32): maximum 2.0 per cent, determined on 1.000 g by drying *in vacuo* at 60 °C for 3 h.**Sulfated ash** (2.4.14): maximum 0.1 per cent, determined on 1.0 g.

## ASSAY

Dissolve 0.250 g in 100 mL of *anhydrous acetic acid* R. Titrate with 0.1 M *perchloric acid*, determining the end-point potentiometrically (2.2.20).1 mL of 0.1 M *perchloric acid* is equivalent to 30.94 mg of C<sub>17</sub>H<sub>27</sub>NO<sub>4</sub>.

## IMPURITIES

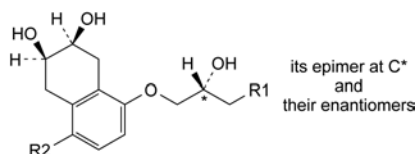
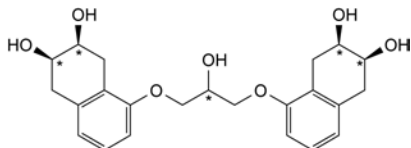
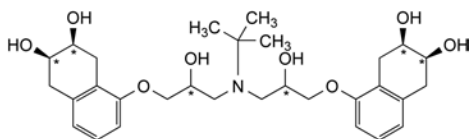
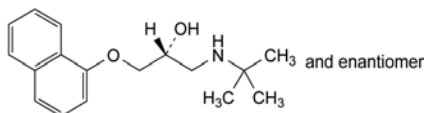
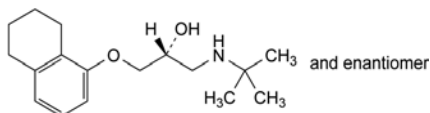
A. R1 = OH, R2 = H: *cis*-5-[(2*RS*)-2,3-dihydroxypropoxy]-1,2,3,4-tetrahydronaphthalene-2,3-diol (tetraol),B. R1 = OCH<sub>3</sub>, R2 = H: *cis*-5-[(2*RS*)-2-hydroxy-3-methoxypropoxy]-1,2,3,4-tetrahydronaphthalene-2,3-diol,E. R1 = NH-C(CH<sub>3</sub>)<sub>3</sub>, R2 = I: *cis*-5-[(2*RS*)-3-[(1,1-dimethylethyl)amino]-2-hydroxypropoxy]-8-iodo-1,2,3,4-tetrahydronaphthalene-2,3-diol,C. 5,5'-[(2-hydroxypropane-1,3-diyl)bis(oxy)]bis(*cis*-1,2,3,4-tetrahydronaphthalene-2,3-diol),D. 5,5'-[[[(1,1-dimethylethyl)imino]bis[(2-hydroxypropane-1,3-diyl)oxy]]bis(*cis*-1,2,3,4-tetrahydronaphthalene-2,3-diol),F. (2*RS*)-1-[(1,1-dimethylethyl)amino]-3-(naphthalen-1-yloxy)propan-2-ol,G. (2*RS*)-1-[(1,1-dimethylethyl)amino]-3-[(5,6,7,8-tetrahydronaphthalen-1-yl)oxy]propan-2-ol.

## NADROPARIN CALCIUM

## Nadroparinum calcicum

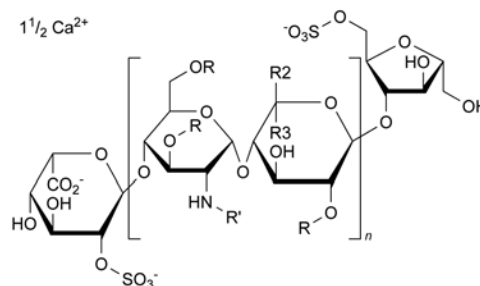

R = H or SO<sub>3</sub>(<sup>1</sup>/<sub>2</sub> Ca) , R' = H or SO<sub>3</sub>(<sup>1</sup>/<sub>2</sub> Ca) or CO-CH<sub>3</sub>  
 R2 = H and R3 = CO<sub>2</sub>(<sup>1</sup>/<sub>2</sub> Ca) or R2 = CO<sub>2</sub>(<sup>1</sup>/<sub>2</sub> Ca) and R3 = H

## DEFINITION

Calcium salt of low-molecular-mass heparin obtained by nitrous acid depolymerisation of heparin from pork intestinal mucosa, followed by fractionation to eliminate selectively most of the chains with a molecular mass lower than 2000. The majority of the components have a 2-*O*-sulfo-α-*L*-idopyranosuronic acid structure at the non-reducing end and a 6-*O*-sulfo-2,5-anhydro-*D*-mannitol structure at the reducing end of their chain.

*Nadroparin calcium complies with the monograph Low-molecular-mass heparins (0828) with the modifications and additional requirements below.*

The mass-average relative molecular mass ranges between 3600 and 5000 with a characteristic value of about 4300.

The degree of sulfatation is about 2 per disaccharide unit.

The potency is not less than 95 IU and not more than 130 IU of anti-factor Xa activity per milligram, calculated with reference to the dried substance. The ratio of anti-factor Xa activity to anti-factor IIa activity is between 2.5 and 4.0.

## IDENTIFICATION

Carry out identification test A as described in the monograph *Low-molecular-mass heparins (0828)* using *nadroparin calcium CRS*.

Carry out identification test C as described in the monograph *Low-molecular-mass heparins (0828)*. The following requirements apply.

The mass-average relative molecular mass ranges between 3600 and 5000. The mass percentage of chains lower than 2000 is not more than 15 per cent. The mass percentage of chains between 2000 and 8000 ranges between 75 per cent and 95 per cent. The mass percentage of chains between 2000 and 4000 ranges between 35 per cent and 55 per cent.

## TESTS

**Appearance of solution.** The solution is not more opalescent than reference suspension II (2.2.1) and not more intensely coloured than reference solution Y<sub>5</sub> (2.2.2, *Method II*).

Dissolve 0.5 g in *water R* and dilute to 10 mL with the same solvent.

**Ethanol.** Head-space gas chromatography (2.2.28).

**Internal standard solution.** Dilute 1.0 mL of 2-propanol R to 100.0 mL with *water R*. Dilute 1.0 mL of the solution to 50.0 mL with *water R*.

**Blank solution.** 1.0 mL of *water R*.

**Test solution (a).** To 10.0 mg of the substance to be examined, add 1.0 mL of *water R*.

**Test solution (b).** To 10.0 mg of the substance to be examined, add 0.50 mL of *water R* and 0.50 mL of the internal standard solution.

**Reference solution (a).** Dilute 1.0 mL of *anhydrous ethanol R* to 100.0 mL with *water R*. Dilute 0.5 mL of the solution to 20.0 mL with *water R*.

**Reference solution (b).** To 0.50 mL of reference solution (a), add 0.50 mL of the internal standard solution.

**Column:**

- *material:* nickel;
- *size:*  $l = 1.5$  m,  $\varnothing = 2$  mm;
- *stationary phase:* ethylvinylbenzene divinylbenzene copolymer R (150-180  $\mu\text{m}$ ).

**Carrier gas:** helium for chromatography R or nitrogen for chromatography R.

**Flow rate:** 30 mL/min.

**Static head-space conditions that may be used:**

- *equilibration temperature:* 90 °C;
- *equilibration time:* 15 min;
- *pressurisation time:* 1 min.

**Temperature:**

- *column:* 150 °C;
- *injection port and detector:* 250 °C.

**Detection:** flame ionisation.

**Identification of peaks:** use the chromatogram obtained with reference solution (b) to identify the peaks due to ethanol and 2-propanol.

**Retention time:** ethanol = about 2.5 min; 2-propanol = about 4 min.

Calculate the content of ethanol (*m/m*) taking its density at 20 °C to be 0.792 g/mL.

**Limit:**

- *ethanol:* maximum 1.0 per cent *m/m*.

**N-NO groups:** maximum 0.25 ppm.

The content of N-NO-groups is determined by cleavage of the N-NO bond with hydrobromic acid in ethyl acetate under a reflux condenser and detection of the released NO by chemiluminescence.

**Description of the apparatus** (Figure 1134.-1). Use a 500 mL borosilicate glass round-bottomed flask, above which is attached a condenser which is equipped with:

- on one side, a torion joint through which a stream of *argon R* can be introduced via a cannula;
- on the other side, a screw joint with a piston equipped with a septum through which the reference solution and test solution will be injected.

The round-bottomed flask is connected in series to 3 bubble traps which are themselves connected to 2 cold traps, which are in turn connected to a chemiluminescence detector. Suitable tubing ensures the junctions are leak-free.

**Preparation of the chemiluminescence detector.** Switch on the chemiluminescence detector 48 h before use and start the vacuum pump. The vacuum must be less than 0.5 mm Hg. 1 h before use, open the oxygen valve at a pressure of 0.2 MPa and a flow rate of 9.4 mL/min.

**Preparation of the bubble trap.** In each bubble trap, place 30 mL of a 300 g/L solution of *sodium hydroxide R* in *water R*.

**Preparation of the cold traps.**

- Trap at –120 °C: Slowly add liquid nitrogen to an isothermic flask containing 250 mL of *anhydrous ethanol R* whilst stirring with a wooden spatula until a paste is obtained. Place the cold trap in the isothermic flask prepared as described.
- Trap at –160 °C: Slowly add liquid nitrogen to an isothermic flask containing 250 mL of *2-methylbutane R* whilst stirring with a wooden spatula until a paste is obtained. Place the cold trap in the isothermic flask prepared as described.

**Drying of the 500 mL borosilicate-glass round-bottomed flask and condenser.** Boil 50 mL of *ethyl acetate R* under reflux for 1 h under *argon R* without connecting the system to the chemiluminescence detector.

**Test solution.** Dry the substance to be examined for 12 h over *diphosphorus pentoxide R* at 60 °C under vacuum. Dissolve 0.10 g of the treated substance to be examined in 1.0 mL of *treated formamide R*. Shake the solution obtained for 30 min.

**Reference solution.** Dilute 0.1 mL of *nitrosodipropylamine solution R* in 6.0 mL of *anhydrous ethanol R*. Dilute 0.1 mL of the solution obtained in 1.0 mL of *treated formamide R*. (This solution is equivalent to 0.05 ppm of N-NO groups).

Place 50 mL of *treated ethyl acetate R* in the dry 500 mL borosilicate glass round-bottomed flask equipped with a septum. Connect the round-bottomed flask to the condenser which has been previously cooled to –15 °C for 2 h.

Connect the *argon R* cannula and adjust the flow rate to 0.1 L/min. Check that the system is leak-free. Only the connector to the chemiluminescence detector remains open in order to avoid excess pressure.

Heat the *treated ethyl acetate R* to boiling.

Evacuate the system by slowly turning the valve of the chemiluminescence detector. At the same time tighten the inlet on the chemiluminescence detector.

When the system is equilibrated, the vacuum reaches 4 mm Hg. The signal of the zero adjuster on the chemiluminescence detector is set to 10 per cent of the full scale of the recorder.

Through the septum of the 500 mL borosilicate glass round-bottomed flask, sequentially inject 0.5 mL of *water R*, 2.0 mL of *dilute hydrobromic acid R* and then another 2.0 mL of *dilute hydrobromic acid R*, making sure that the recorder pen has returned to the baseline between each injection.

Inject 50.0  $\mu\text{L}$  of the reference solution, then 50.0  $\mu\text{L}$  of the test solution after the recorder pen has returned to the baseline.

Calculate the content of N-NO groups of the substance to be examined.

**Free sulfates.** Liquid chromatography (2.2.29).

**Test solution.** Dissolve 30.0 mg of the substance to be examined in *water R* and dilute to 10.0 mL with the same solvent.

**Reference solution.** Dissolve 1.4787 g of *anhydrous sodium sulfate R* in *water R* and dilute to 1000.0 mL with the same solvent. Dilute 1.0 mL of the solution to 200.0 mL with *distilled water R* (5 ppm of sulfate ions).

**Column:**

- *size:*  $l = 50$  mm,  $\varnothing = 4.6$  mm;
- *stationary phase:* anion-exchange resin.

**Chemical neutralisation system:** neutralisation micromembrane in line with the mobile phase for anion detection; continuously pump in counter-flow with a 2.45 g/L solution of *sulfuric acid R*, at a flow rate of 4 mL/min.

**Mobile phase:**

- *mobile phase A:* 1.91 g/L solution of *disodium tetraborate R*;
- *mobile phase B:* 0.1 M *sodium hydroxide*;

Time (min)	Mobile phase A (per cent V/V)	Mobile phase B (per cent V/V)
0 - 15	100	0
15 - 15.5	100 → 0	0 → 100
15.5 - 25.5	0	100

**Flow rate:** 1.0 mL/min.

**Detection:** conductivity detector with a sensitivity of 30  $\mu\text{S}$ .

**Injection:** 50  $\mu\text{L}$ .

**Identification of peaks:** use the chromatogram obtained with the reference solution to identify the principal peak due to the sulfate ion.

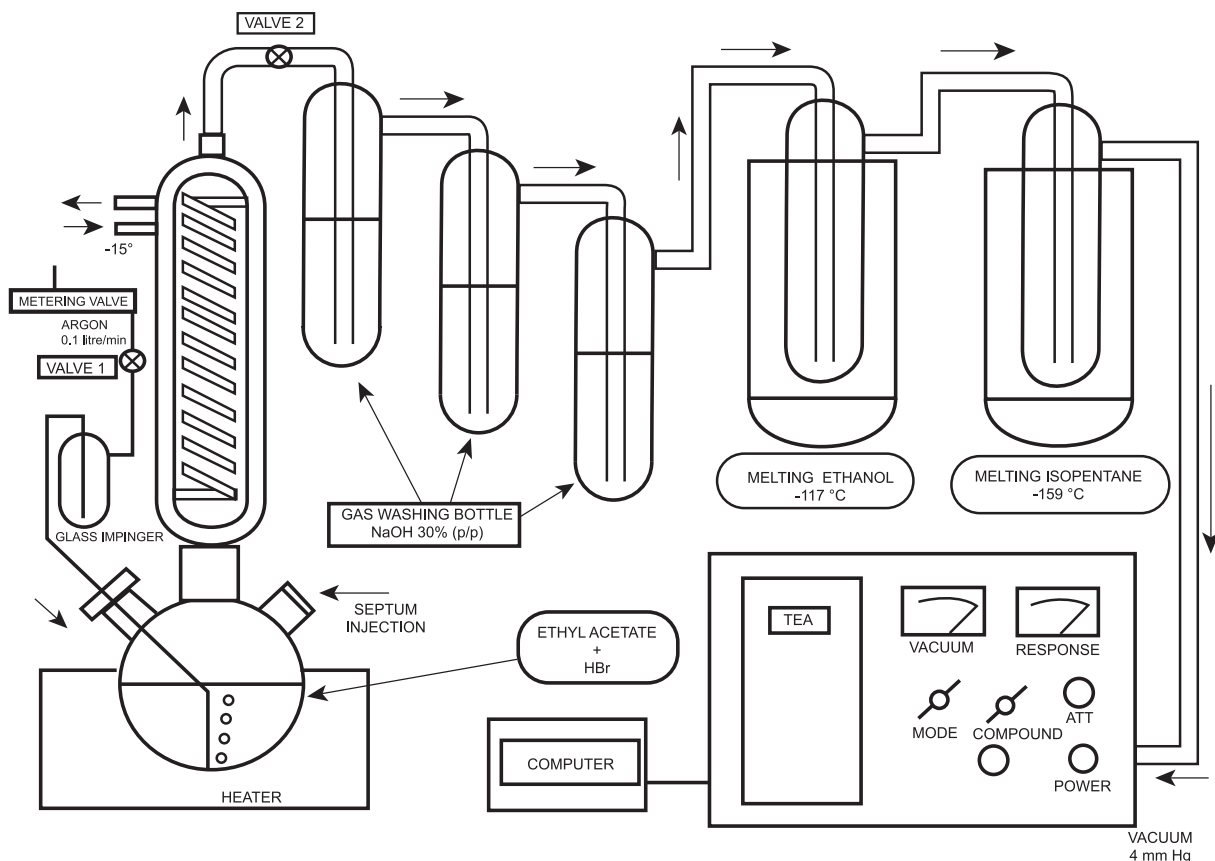

*Bubble traps.* Height: 24 cm, internal diameter: 2.5 cm, internal tubing 23 cm in length by 0.5 cm internal diameter. Centrally positioned Rotulex mounting. Equipped with torion joints on the inlet and outlet.

*Chemiluminescence detector.*

*Cold trap.* Height: 16.5 cm, internal diameter: 4 cm, internal tubing 14 cm in length and internal diameter 1.3 cm. Equipped with torion joints on the inlet and outlet.

*Condenser.* Height: 21 cm, internal diameter: 3 cm. Lower rodavis joint and upper torion joint.

*Flask.* Round-bottomed borosilicate glass flask equipped with a central rodavis joint, a torion joint on the left neck and a 15 cm screw joint on the right neck.

*Isothermic flask.* Internal depth: 22 cm, internal diameter: 8 cm.

*Septum.* Silicone material, diameter: 14 mm, thickness: 3.5 mm.

*Torion joint.*

*Tubing.* Polytetrafluoroethylene FEP material, internal diameter: 3.2 mm, thickness: 0.8 mm.

Figure 1134.-1. – Apparatus used for the assay of N-NO groups

*Retention time:* sulfate ion = about 7.5 min. Change the composition of the mobile phase, if necessary, to obtain the prescribed retention time.

*Limit:*

– *free sulfates:* maximum 0.5 per cent.

**DEFINITION**

Mixture of 4 stereoisomers of 2-(diethylamino)ethyl 2-[(naphthalen-1-yl)methyl]-3-(tetrahydrofuran-2-yl)propanoate hydrogen oxalate.

*Content:* 99.0 per cent to 101.0 per cent (dried substance).

**CHARACTERS**

*Appearance:* white or almost white powder.

*Solubility:* freely soluble in water, freely soluble or soluble in ethanol (96 per cent), slightly or sparingly soluble in acetone.

**IDENTIFICATION**

A. Infrared absorption spectrophotometry (2.2.24).

*Preparation:* dissolve 1.0 g in *water R* and dilute to 50 mL with the same solvent. Add 2 mL of *concentrated ammonia R* and shake with 3 quantities, each of 10 mL, of *methylene chloride R*. To the combined lower layers, add *anhydrous sodium sulfate R*, shake, filter and evaporate the filtrate at a temperature not exceeding 30 °C, using a rotary evaporator. Use the residue obtained.

*Comparison:* Ph. Eur. reference spectrum of naftidrofuryl.

01/2008:1594 corrected 6.0

**NAFTIDROFURYL HYDROGEN OXALATE**

Naftidrofuryli hydrogenoxalas

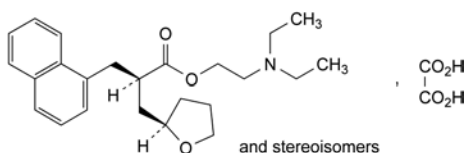

C<sub>26</sub>H<sub>35</sub>NO<sub>7</sub>  
[3200-06-4]

M<sub>r</sub> 473.6

Monographs N-O

B. Dissolve 0.5 g in *water R* and dilute to 10 mL with the same solvent. Add 2.0 mL of *calcium chloride solution R*. A white precipitate is formed. The precipitate dissolves after the addition of 3.0 mL of *hydrochloric acid R*.

#### TESTS

**Absorbance** (2.2.25): maximum 0.1 at 430 nm.

Dissolve 1.5 g in *water R* and dilute to 10 mL with the same solvent. If necessary use an ultrasonic bath.

#### Related substances

A. Liquid chromatography (2.2.29).

**Test solution.** Dissolve 80.0 mg of the substance to be examined in the mobile phase and dilute to 20.0 mL with the mobile phase. Treat in an ultrasonic bath for 10 s. A precipitate is formed. Filter through a membrane filter (nominal pore size 0.45 µm), discarding the first 5 mL. Use a freshly prepared solution.

**Reference solution (a).** Dissolve 5.0 mg of *naftidrofuryl impurity A CRS* in *acetonitrile R* and dilute to 25.0 mL with the same solvent. Dilute 1.0 mL of this solution to 50.0 mL with the mobile phase.

**Reference solution (b).** Dissolve 5 mg of *naftidrofuryl impurity B CRS* and 5 mg of the substance to be examined in *acetonitrile R* and dilute to 50 mL with the same solvent. Dilute 1 mL of this solution to 50 mL with the mobile phase.

**Column:**

- *size:*  $l = 0.25$  m,  $\emptyset = 4.6$  mm;
- *stationary phase:* spherical *end-capped octadecylsilyl silica gel for chromatography R* (5 µm) with a specific surface area of 350 m<sup>2</sup>/g, a pore size of 10 nm and a carbon loading of 14 per cent.

**Mobile phase:** mix 60 mL of *methanol R* with 150 mL of *tetrabutylammonium buffer solution pH 7.0 R* and dilute to 1000 mL with *acetonitrile R*.

**Flow rate:** 1 mL/min.

**Detection:** spectrophotometer at 283 nm.

**Injection:** 20 µL.

**Run time:** 2.3 times the retention time of *naftidrofuryl*.

**Relative retention** with reference to *naftidrofuryl* (retention time = about 7 min): *impurity A* = about 0.5; *impurity B* = about 0.8; *impurity C* = about 1.8.

**System suitability:** reference solution (b):

- *resolution:* minimum 3.0 between the peaks due to *impurity B* and *naftidrofuryl*.

**Limits:**

- *impurities A, B, C:* for each impurity, not more than the area of the principal peak in the chromatogram obtained with reference solution (a) (0.1 per cent);
- *any other impurity:* for each impurity, not more than the area of the principal peak in the chromatogram obtained with reference solution (a) (0.1 per cent);
- *total:* not more than 3 times the area of the principal peak in the chromatogram obtained with reference solution (a) (0.3 per cent);
- *disregard limit:* 0.2 times the area of the principal peak in the chromatogram obtained with reference solution (a) (0.02 per cent).

B. Gas chromatography (2.2.28).

**Test solution (a).** Dissolve 1.0 g of the substance to be examined in *water R* and dilute to 50 mL with the same solvent. Add 2 mL of *concentrated ammonia R* and shake with 3 quantities, each of 10 mL, of *methylene chloride R*. To the combined lower layers, add *anhydrous sodium sulfate R*, shake, filter and evaporate the filtrate at a temperature not exceeding 30 °C, using a rotary evaporator. Take up the residue with *methylene chloride R* and dilute to 20.0 mL with the same solvent.

**Test solution (b).** Dilute 1.0 mL of test solution (a) to 10.0 mL with *methylene chloride R*.

**Reference solution.** Dissolve 5 mg of *naftidrofuryl impurity F CRS* in *methylene chloride R* and dilute to 50 mL with the same solvent.

**Column:**

- *material:* fused silica;
- *size:*  $l = 25$  m,  $\emptyset = 0.32$  mm;
- *stationary phase:* *poly(dimethyl)(diphenyl)siloxane R* (film thickness 0.45 µm).

**Carrier gas:** *helium for chromatography R*.

**Splitter flow rate:** 25 mL/min.

**Flow rate:** 2.9 mL/min.

**Temperature:**

	Time (min)	Temperature (°C)
Column	0 - 4	210
	4 - 8	210 → 230
	8 - 18	230 → 260
	18 - 30	260
Injection port		290
Detector		290

**Detection:** flame ionisation.

**Injection:** 1 µL.

**Relative retention** with reference to the second eluting peak of *naftidrofuryl*: *impurity D* = about 0.14; *impurity B* = about 0.55 (for the second eluting peak); *impurity E* = about 0.86; *impurity F* = about 1.04 (for the second eluting peak).

**System suitability:** test solution (b):

- *resolution:* minimum 1.0 between the 2 peaks due to the diastereoisomers of *naftidrofuryl*.

**Limits:** test solution (a):

- *impurity F:* for the sum of the areas of the 2 peaks, maximum 0.20 per cent of the sum of the areas of the 2 peaks due to *naftidrofuryl* (0.20 per cent);
- *impurity E:* maximum 0.20 per cent of the sum of the areas of the 2 peaks due to *naftidrofuryl* (0.20 per cent);
- *impurity D:* maximum 0.10 per cent of the sum of the areas of the 2 peaks due to *naftidrofuryl* (0.10 per cent);
- *any other impurity:* for each impurity, maximum 0.10 per cent of the sum of the areas of the 2 peaks due to *naftidrofuryl* (0.10 per cent);
- *total:* maximum 0.50 per cent of the sum of the areas of the 2 peaks due to *naftidrofuryl* (0.50 per cent);
- *disregard limit:* 0.02 per cent of the sum of the areas of the 2 peaks due to *naftidrofuryl* (0.02 per cent); disregard any peaks due to *impurity B*.

**Diastereoisomer ratio.** Gas chromatography (2.2.28) as described in test B for related substances.

**Limits:** test solution (b):

- *first eluting naftidrofuryl diastereoisomer:* minimum 30 per cent of the sum of the areas of the 2 peaks due to *naftidrofuryl*.

**Heavy metals** (2.4.8): maximum 10 ppm.

In a silica crucible, mix thoroughly 1.0 g of the substance to be examined with 0.5 g of *magnesium oxide RI*. Ignite to dull redness until a homogeneous white or greyish-white mass is obtained. If after 30 min of ignition the mixture remains coloured, allow to cool, mix using a fine glass rod and repeat the ignition. If necessary repeat the operation. Heat at 800 ± 50 °C for about 1 h. Take up the residue with 2 quantities, each of 5 mL, of a mixture of equal volumes of *hydrochloric acid RI* and *water R*. Add 0.1 mL of *phenolphthalein solution R* and

01/2008:0701  
corrected 6.0

then *concentrated ammonia R* until a pink colour is obtained. Cool, add *glacial acetic acid R* until the solution is decolourised and add 0.5 mL in excess. Filter if necessary and wash the filter. Dilute to 20 mL with *water R*. The solution complies with test E. Prepare the reference solution using 10 mL of *lead standard solution (1 ppm Pb) R*.

**Loss on drying (2.2.32):** maximum 0.5 per cent, determined on 1.000 g by drying in an oven at 105 °C.

**Sulfated ash (2.4.14):** maximum 0.1 per cent, determined on 1.0 g.

## ASSAY

Dissolve 0.350 g in 50 mL of *anhydrous acetic acid R*. Titrate with 0.1 M *perchloric acid*, determining the end-point potentiometrically (2.2.20).

1 mL of 0.1 M *perchloric acid* is equivalent to 47.36 mg of  $C_{26}H_{35}NO_7$ .

## IMPURITIES

*Specified impurities: A, B, C, D, E, F.*

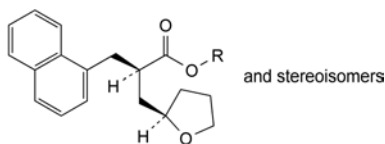

A. R = H: 2-[(naphthalen-1-yl)methyl]-3-(tetrahydrofuran-2-yl)propanoic acid,

B. R =  $C_2H_5$ : ethyl 2-[(naphthalen-1-yl)methyl]-3-(tetrahydrofuran-2-yl)propanoate,

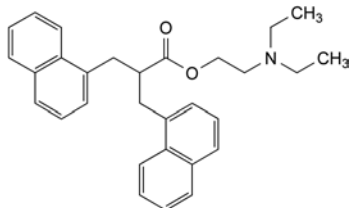

C. 2-(diethylamino)ethyl 3-(naphthalen-1-yl)-2-[(naphthalen-1-yl)methyl]propanoate,

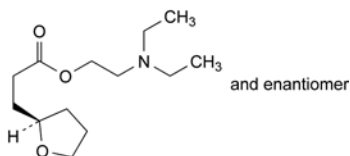

D. 2-(diethylamino)ethyl 3-[(2*RS*)-tetrahydrofuran-2-yl]propanoate,

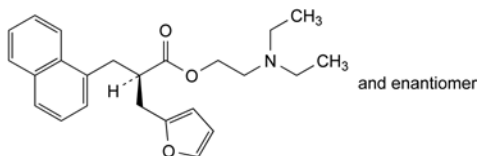

E. 2-(diethylamino)ethyl (2*RS*)-2-[(furan-2-yl)methyl]-3-(naphthalen-1-yl)propanoate,

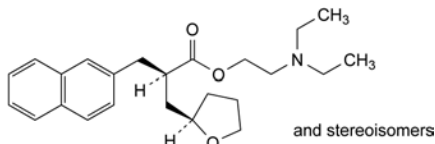

F. 2-(diethylamino)ethyl 2-[(naphthalen-2-yl)methyl]-3-(tetrahydrofuran-2-yl)propanoate.

## NALIDIXIC ACID

## Acidum nalidixicum

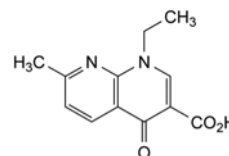

$C_{12}H_{12}N_2O_3$   
[389-08-2]

$M_r$  232.2

## DEFINITION

Nalidixic acid contains not less than 99.0 per cent and not more than the equivalent of 101.0 per cent of 1-ethyl-7-methyl-4-oxo-1,4-dihydro-1,8-naphthyridine-3-carboxylic acid, calculated with reference to the dried substance.

## CHARACTERS

An almost white or pale yellow, crystalline powder, practically insoluble in water, soluble in methylene chloride, slightly soluble in acetone and in alcohol. It dissolves in dilute solutions of alkali hydroxides.

It melts at about 230 °C.

## IDENTIFICATION

*First identification: B.*

*Second identification: A, C, D.*

A. Dissolve 12.5 mg in 0.1 M *sodium hydroxide* and dilute to 50.0 mL with the same solvent. Dilute 2.0 mL of this solution to 100.0 mL with 0.1 M *sodium hydroxide*. Examined between 230 nm and 350 nm (2.2.25), the solution shows two absorption maxima, at 258 nm and 334 nm. The ratio of the absorbance measured at 258 nm to that measured at 334 nm is 2.2 to 2.4.

B. Examine by infrared absorption spectrophotometry (2.2.24), comparing with the spectrum obtained with *nalidixic acid CRS*. Examine the substances prepared as discs.

C. Examine the chromatograms obtained in the test for related substances. The principal spot in the chromatogram obtained with the test solution (b) is similar in position and size to the principal spot in the chromatogram obtained with reference solution (a).

D. Dissolve 0.1 g in 2 mL of *hydrochloric acid R*. Add 0.5 mL of a 100 g/L solution of *β-naphthol R* in *alcohol R*. An orange-red colour develops.

## TESTS

**Absorbance.** Dissolve 1.50 g in *methylene chloride R* and dilute to 50.0 mL with the same solvent. The absorbance (2.2.25) measured at 420 nm is not greater than 0.10.

**Related substances.** Examine by thin-layer chromatography (2.2.27), using a *TLC silica gel F<sub>254</sub> plate R*.

*Test solution (a).* Dissolve 0.20 g of the substance to be examined in *methylene chloride R* and dilute to 10 mL with the same solvent.

*Test solution (b).* Dilute 1 mL of test solution (a) to 20 mL with *methylene chloride R*.

*Reference solution (a).* Dissolve 20 mg of *nalidixic acid CRS* in *methylene chloride R* and dilute to 20 mL with the same solvent.

*Reference solution (b).* Dilute 2 mL of test solution (b) to 10 mL with *methylene chloride R*.

*Reference solution (c).* Dilute 1 mL of reference solution (b) to 10 mL with *methylene chloride R*.



**Reference solution (d).** Dilute 1 mL of reference solution (b) to 25 mL with *methylene chloride R*.

Apply to the plate 10 µL of each solution. Develop over a path of 15 cm using a mixture of 10 volumes of *dilute ammonia R1*, 20 volumes of *methylene chloride R* and 70 volumes of *alcohol R*. Allow the plate to dry in air and examine in ultraviolet light at 254 nm. Any spot in the chromatogram obtained with the test solution (a), apart from the principal spot, is not more intense than the spot in the chromatogram obtained with reference solution (c) (0.1 per cent) and not more than one such spot is more intense than the spot in the chromatogram obtained with reference solution (d).

**Heavy metals (2.4.8).** 1.0 g complies with limit test D for heavy metals (20 ppm). Prepare the standard using 2 mL of *lead standard solution (10 ppm Pb) R*.

**Loss on drying (2.2.32).** Not more than 0.5 per cent, determined on 1.000 g by drying in an oven at 105 °C.

**Sulfated ash (2.4.14).** Not more than 0.1 per cent, determined on 1.0 g.

#### ASSAY

Dissolve 0.150 g in 10 mL of *methylene chloride R* and add 30 mL of *2-propanol R* and 10 mL of *carbon dioxide-free water R*. Keep the titration vessel covered and pass *nitrogen R* through the solution throughout the titration. Keep the temperature of the solution between 15 °C and 20 °C. Titrate with 0.1 M *ethanolic sodium hydroxide*, determining the end-point potentiometrically (2.2.20) using a silver-silver chloride comparison electrode with a sleeve diaphragm or a capillary tip, filled with a saturated solution of *lithium chloride R* in *ethanol R*, and a glass electrode as indicator electrode.

1 mL of 0.1 M *ethanolic sodium hydroxide* is equivalent to 23.22 mg of C<sub>19</sub>H<sub>22</sub>N<sub>2</sub>O<sub>3</sub>.

#### STORAGE

Store in an airtight container, protected from light.

01/2008:0729

## NALOXONE HYDROCHLORIDE DIHYDRATE

Naloxoni hydrochloridum dihydricum

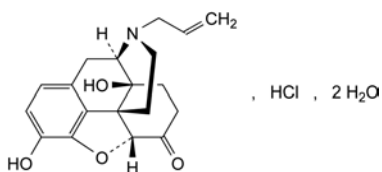

C<sub>19</sub>H<sub>22</sub>ClNO<sub>4</sub>·2H<sub>2</sub>O  
[51481-60-8]

M<sub>r</sub> 399.9

#### DEFINITION

4,5α-Epoxy-3,14-dihydroxy-17-(prop-2-enyl)morphinan-6-one hydrochloride dihydrate.

**Content:** 98.0 per cent to 102.0 per cent (anhydrous substance).

#### CHARACTERS

**Appearance:** white or almost white, hygroscopic, crystalline powder.

**Solubility:** freely soluble in water, soluble in ethanol (96 per cent), practically insoluble in toluene.

#### IDENTIFICATION

**First identification:** A, C.

**Second identification:** B, C.

A. Infrared absorption spectrophotometry (2.2.24).

**Comparison:** *naloxone hydrochloride dihydrate CRS*.

B. Thin-layer chromatography (2.2.27).

**Test solution.** Dissolve 8 mg of the substance to be examined in 0.5 mL of *water R* and dilute to 1 mL with *methanol R*.

**Reference solution.** Dissolve 8 mg of *naloxone hydrochloride dihydrate CRS* in 0.5 mL of *water R* and dilute to 1 mL with *methanol R*.

**Plate:** *TLC silica gel G plate R*.

**Mobile phase:** mix 5 volumes of *methanol R* and 95 volumes of the upper layer from a mixture of 60 mL of *dilute ammonia R2* and 100 mL of *butanol R*.

**Application:** 5 µL.

**Development:** over 2/3 of the plate.

**Drying:** in air.

**Detection:** spray with a freshly prepared 5 g/L solution of *potassium ferricyanide R* in *ferric chloride solution R1*; examine in daylight.

**Results:** the principal spot in the chromatogram obtained with the test solution is similar in position, colour and size to the principal spot in the chromatogram obtained with the reference solution.

C. It gives reaction (a) of chlorides (2.3.1).

#### TESTS

**Solution S.** Dissolve 0.50 g in *carbon dioxide-free water R* and dilute to 25.0 mL with the same solvent.

**Appearance of solution.** Solution S is clear (2.2.1) and colourless (2.2.2, *Method II*).

**Acidity or alkalinity.** To 10.0 mL of solution S add 0.05 mL of *methyl red solution R*. Not more than 0.2 mL of 0.02 M *sodium hydroxide* or 0.02 M *hydrochloric acid* is required to change the colour of the indicator.

**Specific optical rotation (2.2.7):** –170 to –181 (anhydrous substance), determined on solution S.

**Related substances.** Liquid chromatography (2.2.29).

**Test solution.** Dissolve 0.125 g of the substance to be examined in 0.1 M *hydrochloric acid* and dilute to 25.0 mL with the same acid.

**Reference solution (a).** Dissolve 5 mg of *naloxone for peak identification CRS* (containing impurities A, B, C, D, E and F) in 1 mL of 0.1 M *hydrochloric acid*.

**Reference solution (b).** Dilute 1.0 mL of the test solution to 20.0 mL with 0.1 M *hydrochloric acid*. Dilute 1.0 mL of this solution to 25.0 mL with 0.1 M *hydrochloric acid*.

**Solution A.** Dissolve 1.10 g of *sodium octanesulfonate R* in 1000 mL of *water R*, adjust to pH 2.0 with a 50 per cent V/V solution of *phosphoric acid R* and filter.

**Column:**

– size: *l* = 0.125 m, Ø = 4.0 mm;

– stationary phase: end-capped octylsilyl silica gel for chromatography R (5 µm);

– temperature: 40 °C.

**Mobile phase:**

– mobile phase A: *acetonitrile R*, *tetrahydrofuran R*, solution A (20:40:940 V/V/V);

– mobile phase B: *tetrahydrofuran R*, *acetonitrile R*, solution A (40:170:790 V/V/V);

Time (min)	Mobile phase A (per cent V/V)	Mobile phase B (per cent V/V)
0 - 40	100 → 0	0 → 100
40 - 50	0	100

**Flow rate:** 1.5 mL/min.

**Detection:** spectrophotometer at 230 nm.

**Injection:** 20 µL.

*Relative retention* with reference to naloxone (retention time = about 11 min): impurity C = about 0.6; impurity A = about 0.8; impurity F = about 0.9; impurity D = about 1.1; impurity E = about 3.0; impurity B = about 3.2.

*Identification of impurities:* use the chromatogram supplied with *naloxone* for peak identification CRS and the chromatogram obtained with reference solution (a) to identify the peaks due to impurities A, B, C, D, E and F.

*System suitability:* reference solution (a):

- *peak-to-valley ratio:* minimum 2.0, where  $H_p$  = height above the baseline of the peak due to impurity D and  $H_v$  = height above the baseline of the lowest point of the curve separating this peak from the peak due to naloxone.

*Limits:*

- *correction factor:* for the calculation of content, multiply the peak area of impurity E by 0.5;
- *impurities A, B, C, E, F:* for each impurity, not more than the area of the principal peak in the chromatogram obtained with reference solution (b) (0.2 per cent);
- *impurity D:* not more than 1.5 times the area of the principal peak in the chromatogram obtained with reference solution (b) (0.3 per cent);
- *unspecified impurities:* for each impurity, not more than 0.5 times the area of the principal peak in the chromatogram obtained with reference solution (b) (0.10 per cent);
- *total:* not more than 4 times the area of the principal peak in the chromatogram obtained with reference solution (b) (0.8 per cent);
- *disregard limit:* 0.25 times the area of the principal peak in the chromatogram obtained with reference solution (b) (0.05 per cent).

**Water** (2.5.12): 7.5 per cent to 11.0 per cent, determined on 0.200 g.

**Sulfated ash** (2.4.14): maximum 0.2 per cent, determined on 0.50 g.

#### ASSAY

Dissolve 0.300 g in 50 mL of *ethanol (96 per cent) R* and add 5.0 mL of 0.01 M *hydrochloric acid*. Carry out a potentiometric titration (2.2.20), using 0.1 M *ethanolic sodium hydroxide*. Read the volume added between the 2 points of inflexion.

1 mL of 0.1 M *ethanolic sodium hydroxide* is equivalent to 36.38 mg of  $C_{19}H_{22}ClNO_4$ .

#### STORAGE

In an airtight container, protected from light.

#### IMPURITIES

*Specified impurities:* A, B, C, D, E, F.

*Other detectable impurities* (the following substances would, if present at a sufficient level, be detected by one or other of the tests in the monograph. They are limited by the general acceptance criterion for other/unspecified impurities and/or by the general monograph *Substances for pharmaceutical use (2034)*. It is therefore not necessary to identify these impurities for demonstration of compliance. See also 5.10. *Control of impurities in substances for pharmaceutical use*): G.

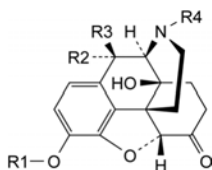

A.  $R_1 = R_2 = R_3 = R_4 = H$ : 4,5 $\alpha$ -epoxy-3,14-dihydroxymorphinan-6-one (noroxymorphone),

B.  $R_1 = R_4 = CH_2-CH=CH_2$ ,  $R_2 = R_3 = H$ : 4,5 $\alpha$ -epoxy-14-hydroxy-17-(prop-2-enyl)-3-(prop-2-enyloxy)morphinan-6-one (3-*O*-allylnaloxone),

C.  $R_1 = R_3 = H$ ,  $R_2 = OH$ ,  $R_4 = CH_2-CH=CH_2$ : 4,5 $\alpha$ -epoxy-3,10 $\alpha$ ,14-trihydroxy-17-(prop-2-enyl)morphinan-6-one (10 $\alpha$ -hydroxynaloxone),

F.  $R_1 = R_2 = H$ ,  $R_3 = OH$ ,  $R_4 = CH_2-CH=CH_2$ : 4,5 $\alpha$ -epoxy-3,10 $\beta$ ,14-trihydroxy-17-(prop-2-enyl)morphinan-6-one (10 $\beta$ -hydroxynaloxone),

G.  $R_1 = CH_3$ ,  $R_2 = R_3 = H$ ,  $R_4 = CH_2-CH=CH_2$ : 4,5 $\alpha$ -epoxy-14-hydroxy-3-methoxy-17-(prop-2-enyl)morphinan-6-one (3-*O*-methylnaloxone),

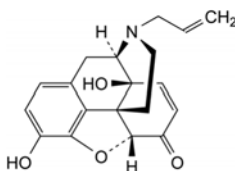

D. 7,8-didehydro-4,5 $\alpha$ -epoxy-3,14-dihydroxy-17-(prop-2-enyl)morphinan-6-one (7,8-didehydronaloxone),

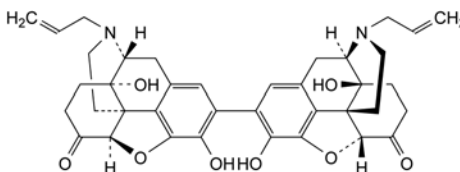

E. 4,5 $\alpha$ :4',5' $\alpha$ -diepoxy-3,3',14,14'-tetrahydroxy-17,17'-bis(prop-2-enyl)-2,2'-bimorphinan-6,6'-dione (2,2'-binaloxone).

01/2008:1790

## NALTREXONE HYDROCHLORIDE

### Naltrexoni hydrochloridum

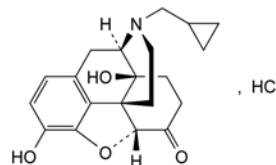

$C_{20}H_{24}ClNO_4$

$M_r$  377.9

#### DEFINITION

17-(Cyclopropylmethyl)-4,5 $\alpha$ -epoxy-3,14-dihydroxymorphinan-6-one hydrochloride. It may be anhydrous, a monohydrate or a dihydrate, a mixture or a solvate.

*Content:* 98.0 per cent to 102.0 per cent (anhydrous substance).

#### CHARACTERS

*Appearance:* white or almost white powder, very hygroscopic.

*Solubility:* freely soluble in water, slightly soluble in ethanol (96 per cent), practically insoluble in methylene chloride.

#### IDENTIFICATION

A. Infrared absorption spectrophotometry (2.2.24).

Dissolve 20 mg in *water R* and dilute to 5 mL with the same solvent. Make alkaline with *dilute ammonia R1*. Shake with 10 mL of *methylene chloride R*, separate the organic layer and evaporate the solvent. Dry the residue obtained *in vacuo*.

*Comparison:* *naltrexone hydrochloride CRS*.

B. It gives reaction (a) of chlorides (2.3.1).

#### TESTS

**Solution S.** Dissolve 0.40 g in *carbon dioxide-free water R* and dilute to 20.0 mL with the same solvent.

**Appearance of solution.** Solution S is clear (2.2.1) and not more intensely coloured than reference solution Y<sub>6</sub> or B<sub>6</sub> (2.2.2, Method II).

**Acidity and alkalinity.** To 10 mL of solution S, add 0.05 mL of methyl red solution R. Not more than 0.2 mL of 0.02 M sodium hydroxide or 0.02 M hydrochloric acid is required to change the colour of the indicator.

**Specific optical rotation** (2.2.7): –187 to –195 (anhydrous substance).

Dissolve 0.40 g in water R and dilute to 20.0 mL with the same solvent.

**Related substances.** Liquid chromatography (2.2.29).

**Test solution.** Dissolve 20.0 mg of the substance to be examined in 0.1 M hydrochloric acid and dilute to 10.0 mL with the same solvent.

**Reference solution (a).** Dissolve 5.0 mg of naltrexone impurity C CRS in 0.1 M hydrochloric acid and dilute to 2.5 mL with the same solvent.

**Reference solution (b).** Dilute 1.0 mL of the test solution and 1.0 mL of reference solution (a) to 100.0 mL with 0.1 M hydrochloric acid. Dilute 1.0 mL of this solution to 10.0 mL with 0.1 M hydrochloric acid.

**Column:**

- size:  $l = 0.15$  m,  $\varnothing = 4.6$  mm;
- stationary phase: octadecylsilyl silica gel for chromatography R1 (5  $\mu$ m);
- temperature: 40 °C.

**Mobile phase:**

- mobile phase A: 1.1 g/L solution of sodium octanesulfonate R adjusted to pH 2.3 with phosphoric acid R;
- mobile phase B: acetonitrile R;

Time (min)	Mobile phase A (per cent V/V)	Mobile phase B (per cent V/V)
0 - 45	90 → 55	10 → 45
45 - 47	55 → 90	45 → 10
47 - 55	90	10

**Flow rate:** 1.2 mL/min.

**Detection:** spectrophotometer at 230 nm.

**Equilibration:** 8 min.

**Injection:** 10  $\mu$ L.

**Relative retention** with reference to naltrexone (retention time = about 16 min): impurity A = about 0.4; impurity B = about 0.7; impurity F = about 0.8; impurity G = about 0.9; impurity C = about 1.05; impurity H = about 1.1; impurity I = about 1.2; impurity J = about 1.3; impurity D = about 1.4; impurity E = 1.7.

**System suitability:** reference solution (b):

- resolution: minimum 2.0 between the peaks due to naltrexone and impurity C.

**Limits:**

- correction factor: for the calculation of content, multiply the peak area of impurity D by 0.4;
- impurities C, D, E, F, G: for each impurity, not more than twice the area of the peak due to naltrexone in the chromatogram obtained with reference solution (b) (0.2 per cent);
- impurities A, B, H, I, J: for each impurity, not more than the area of the peak due to naltrexone in the chromatogram obtained with reference solution (b) (0.1 per cent);
- any other impurity: for each impurity, not more than the area of the peak due to naltrexone in the chromatogram obtained with reference solution (b) (0.1 per cent);

- total: not more than 10 times the area of the peak due to naltrexone in the chromatogram obtained with reference solution (b) (1.0 per cent);
- disregard limit: 0.5 times the area of the peak due to naltrexone in the chromatogram obtained with reference solution (b) (0.05 per cent).

**Ethanol** (2.4.24, System A): maximum 3.0 per cent.

**Test solution.** Dissolve 0.25 g of the substance to be examined in water R and dilute to 10.0 mL with the same solvent.

**Reference solution.** Dilute 0.750 g of anhydrous ethanol R to 1000.0 mL with water R.

**Water** (2.5.12): maximum 10.0 per cent, determined on 0.200 g.

**Sulfated ash** (2.4.14): maximum 0.1 per cent, determined on 1.0 g.

#### ASSAY

Dissolve 0.200 g in 60 mL of ethanol (96 per cent) R, add 1.0 mL of 0.1 M hydrochloric acid. Carry out a potentiometric titration (2.2.20), using 0.1 M sodium hydroxide. The curve shows 3 points of inflexion. Read the volume added between the first 2 points of inflexion.

1 mL of 0.1 M sodium hydroxide is equivalent to 37.79 mg of C<sub>20</sub>H<sub>24</sub>ClNO<sub>4</sub>.

#### STORAGE

In an airtight container. Protected from light.

#### IMPURITIES

**Specified impurities:** A, B, C, D, E, F, G, H, I, J.

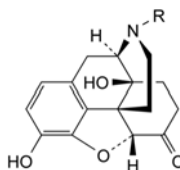

A. R = CHO: 17-formyl-4,5 $\alpha$ -epoxy-3,14-dihydroxymorphinan-6-one,

B. R = H: 4,5 $\alpha$ -epoxy-3,14-dihydroxymorphinan-6-one (noroxymorphone),

C. R = CH<sub>2</sub>-CH<sub>2</sub>-CH=CH<sub>2</sub>: 17-but-3-enyl-4,5 $\alpha$ -epoxy-3,14-dihydroxymorphinan-6-one,

H. R = CH<sub>2</sub>-CH<sub>2</sub>-CH<sub>2</sub>-CH<sub>3</sub>: 17-butyl-4,5 $\alpha$ -epoxy-3,14-dihydroxymorphinan-6-one,

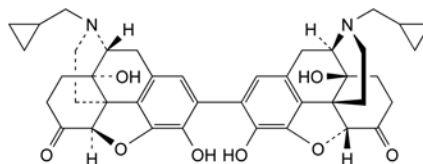

D. 17,17'-bis(cyclopropylmethyl)-4,5 $\alpha$ :4',5' $\alpha$ -diepoxy-3,3',14,14'-tetrahydroxy-2,2'-bimorphinan-6,6'-dione (pseudonaltrexone),

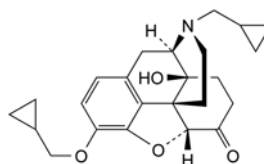

E. 3-(cyclopropylmethoxy)-17-(cyclopropylmethyl)-4,5 $\alpha$ -epoxy-14-hydroxymorphinan-6-one,

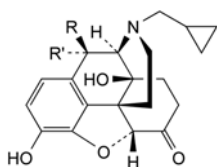

- F. R = H, R' = OH: 17-(cyclopropylmethyl)-4,5 $\alpha$ -epoxy-3,10 $\alpha$ ,14-trihydroxymorphinan-6-one,  
 G. R = OH, R' = H: 17-(cyclopropylmethyl)-4,5 $\alpha$ -epoxy-3,10 $\beta$ ,14-trihydroxymorphinan-6-one,  
 I. R + R' = O: 17-(cyclopropylmethyl)-4,5 $\alpha$ -epoxy-3,14-dihydroxymorphinan-6,10-dione,

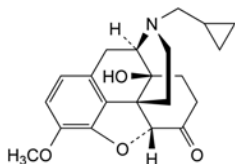

- J. 17-(cyclopropylmethyl)-4,5 $\alpha$ -epoxy-14-hydroxy-3-methoxymorphinan-6-one.

01/2008:1992

## NANDROLONE DECANOATE

### Nandroloni decanoas

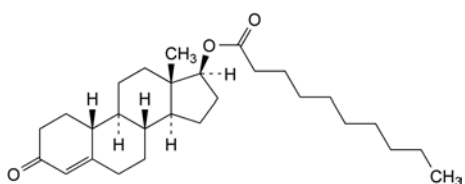

C<sub>28</sub>H<sub>44</sub>O<sub>3</sub>  
 [360-70-3]

M<sub>r</sub> 428.7

#### DEFINITION

3-Oxoestr-4-en-17 $\beta$ -yl decanoate.

Content: 97.0 per cent to 103.0 per cent (dried substance).

#### CHARACTERS

Appearance: white or almost white, crystalline powder.

Solubility: practically insoluble in water, very soluble in ethanol (96 per cent) and in methylene chloride.

#### IDENTIFICATION

- A. Melting point (2.2.14): 34 °C to 38 °C.  
 B. Infrared absorption spectrophotometry (2.2.24).

Comparison: nandrolone decanoate CRS.

#### TESTS

**Appearance of solution.** The solution is clear (2.2.1) and not more intensely coloured than reference solution Y<sub>6</sub> (2.2.2, Method II).

Dissolve 0.20 g in 10 mL of methanol R.

**Specific optical rotation** (2.2.7): + 35.0 to + 40.0 (dried substance).

Dissolve 0.200 g in anhydrous ethanol R and dilute to 20.0 mL with the same solvent.

**Impurities A, B, C.** Thin-layer chromatography (2.2.27).

**Test solution.** Dissolve 50 mg of the substance to be examined in methylene chloride R and dilute to 5.0 mL with the same solvent.

**Reference solution (a).** Dilute 1.0 mL of the test solution to 10.0 mL with methylene chloride R.

**Reference solution (b).** Dilute 1.0 mL of reference solution (a) to 10.0 mL with methylene chloride R.

**Reference solution (c).** Dilute 1.0 mL of reference solution (a) to 20.0 mL with methylene chloride R.

**Reference solution (d).** Dissolve 5 mg of nandrolone decanoate for system suitability CRS (containing impurities A, B, C) in 0.5 mL of methylene chloride R.

Plate: TLC silica gel plate R.

Mobile phase: acetone R, heptane R (30:70 V/V).

Application: 10  $\mu$ L of the test solution and reference solutions (b), (c) and (d).

Development: over 2/3 of the plate.

Drying: in air.

Detection: treat with alcoholic solution of sulfuric acid R and heat at 130 °C until the spots appear. Examine in ultraviolet light at 366 nm.

Retardation factors: nandrolone decanoate = about 0.37; impurity A = about 0.45; impurity B = about 0.55; impurity C = about 0.58.

System suitability: reference solution (d):

– the chromatogram shows 4 clearly separated spots.

Limits:

– impurity A: any spot due to impurity A is not more intense than the principal spot in the chromatogram obtained with reference solution (b) (1.0 per cent);

– impurities B, C: any spot due to impurity B or C is not more intense than the principal spot in the chromatogram obtained with reference solution (c) (0.5 per cent).

**Related substances.** Liquid chromatography (2.2.29).

**Test solution.** Dissolve 25 mg of the substance to be examined in methanol R and dilute to 10.0 mL with the same solvent.

**Reference solution (a).** Dilute 1.0 mL of the test solution to 100.0 mL with methanol R. Dilute 1.0 mL of this solution to 10.0 mL with methanol R.

**Reference solution (b).** Dissolve 5 mg of nandrolone decanoate for peak identification CRS (containing impurities D, F, G, H, I, K, L) in methanol R and dilute to 2.0 mL with the same solvent.

Column:

– size:  $l = 0.15$  m,  $\varnothing = 3.9$  mm,

– stationary phase: octadecylsilyl silica gel for chromatography R (5  $\mu$ m).

Mobile phase:

– mobile phase A: water R,

– mobile phase B: acetonitrile R,

Time (min)	Mobile phase A (per cent V/V)	Mobile phase B (per cent V/V)
0 - 5	35	65
5 - 40	35 $\rightarrow$ 0	65 $\rightarrow$ 100
40 - 75	0	100
75 - 80	0 $\rightarrow$ 35	100 $\rightarrow$ 65

Flow rate: 1.0 mL/min.

Detection: spectrophotometer at 254 nm.

Injection: 20  $\mu$ L.

Relative retention with reference to nandrolone decanoate (retention time = about 30 min): impurity D = about 0.05; impurity F = about 0.6; impurity K = about 0.7; impurity L = about 0.9; impurity G = about 0.97; impurity H = about 1.1; impurity I = about 1.2.

System suitability: reference solution (b):

– peak-to-valley ratio: minimum 1.5, where  $H_p$  = height above the baseline of the peak due to impurity G and  $H_v$  = height above the baseline of the lowest point of the curve separating this peak from the peak due to nandrolone decanoate.

**Limits:**

- **correction factors:** for the calculation of contents, multiply the peak areas of the following impurities by the corresponding correction factor: impurity D = 0.5; impurity F = 0.6; impurity H = 1.1; impurity I = 1.3; impurity K = 0.8;
- **impurities D, F, G, H, I, K, L:** for each impurity, not more than 5 times the area of the principal peak in the chromatogram obtained with reference solution (a) (0.5 per cent);
- **unspecified impurities:** for each impurity, not more than the area of the principal peak in the chromatogram obtained with reference solution (a) (0.10 per cent);
- **total:** not more than 15 times the area of the principal peak in the chromatogram obtained with reference solution (a) (1.5 per cent);
- **disregard limit:** 0.5 times the area of the principal peak in the chromatogram obtained with reference solution (a) (0.05 per cent).

**Loss on drying** (2.2.32): maximum 0.5 per cent, determined on 1.000 g by drying over *diphosphorus pentoxide R*, at a pressure not exceeding 0.7 kPa for 4 h at room temperature.

**Sulfated ash** (2.4.14): maximum 0.1 per cent, determined on 1.0 g.

**ASSAY**

Dissolve 10.0 mg in *anhydrous ethanol R* and dilute to 100.0 mL with the same solvent. Dilute 5.0 mL of this solution to 50.0 mL with *anhydrous ethanol R*. Measure the absorbance (2.2.25) at the absorption maximum at 240 nm. Calculate the content of  $C_{28}H_{44}O_3$  taking the specific absorbance to be 407.

**STORAGE**

Under nitrogen, protected from light and at a temperature of 2 °C to 8 °C.

**IMPURITIES**

**Specified impurities:** A, B, C, D, F, G, H, I, K, L.

**Other detectable impurities** (the following substances would, if present at a sufficient level, be detected by one or other of the tests in the monograph. They are limited by the general acceptance criterion for other/unspecified impurities and/or by the general monograph *Substances for pharmaceutical use (2034)*. It is therefore not necessary to identify these impurities for demonstration of compliance. See also 5.10. *Control of impurities in substances for pharmaceutical use*): E, J.

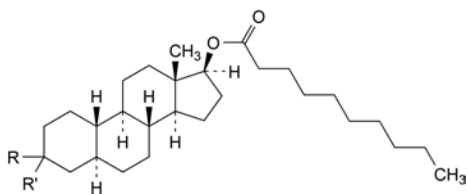

- A.  $R + R' = O$ : 3-oxo-5 $\alpha$ -estran-17 $\beta$ -yl decanoate,  
 C.  $R = R' = OCH_3$ : 3,3-dimethoxy-5 $\alpha$ -estran-17 $\beta$ -yl decanoate,

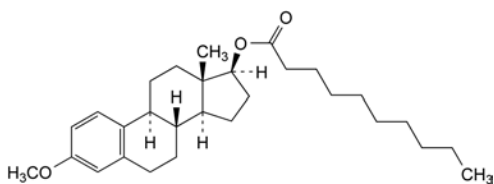

- B. 3-methoxyestra-1,3,5(10)-trien-17 $\beta$ -yl decanoate,

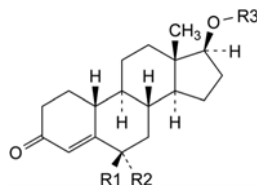

- D.  $R_1 = R_2 = R_3 = H$ : 17 $\beta$ -hydroxyestr-4-en-3-one,  
 E.  $R_1 = H, R_2 = OH, R_3 = CO-[CH_2]_8-CH_3$ : 6 $\alpha$ -hydroxy-3-oxoestr-4-en-17 $\beta$ -yl decanoate,  
 F.  $R_1 + R_2 = O, R_3 = CO-[CH_2]_8-CH_3$ : 3,6-dioxoestr-4-en-17 $\beta$ -yl decanoate,  
 H.  $R_1 = R_2 = H, R_3 = CO-[CH_2]_9-CH_3$ : 3-oxoestr-4-en-17 $\beta$ -yl undecanoate,  
 I.  $R_1 = R_2 = H, R_3 = CO-[CH_2]_{10}-CH_3$ : 3-oxoestr-4-en-17 $\beta$ -yl dodecanoate,  
 K.  $R_1 = R_2 = H, R_3 = CO-[CH_2]_6-CH_3$ : 3-oxoestr-4-en-17 $\beta$ -yl octanoate,  
 L.  $R_1 = R_2 = H, R_3 = CO-[CH_2]_7-CH_3$ : 3-oxoestr-4-en-17 $\beta$ -yl nonanoate,

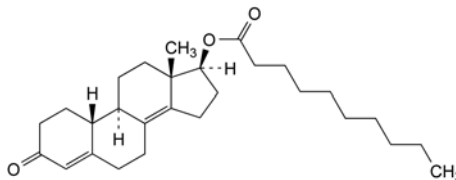

- G. 3-oxoestra-4,8(14)-dien-17 $\beta$ -yl decanoate,

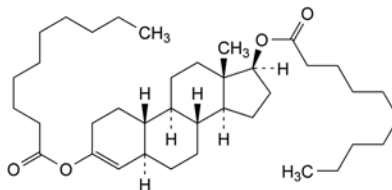

- J. 5 $\alpha$ -estr-3-ene-3,17 $\beta$ -diyl didecanoate.

01/2009:0730

**NAPHAZOLINE HYDROCHLORIDE**

## Naphazolini hydrochloridum

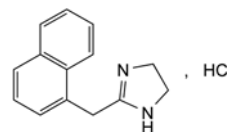

$C_{14}H_{15}ClN_2$   
 [550-99-2]

$M_r$  246.7

**DEFINITION**

2-(Naphthalen-1-ylmethyl)-4,5-dihydro-1H-imidazole hydrochloride.

**Content:** 99.0 per cent to 101.0 per cent (dried substance).

**CHARACTERS**

**Appearance:** white or almost white, crystalline powder.

**Solubility:** freely soluble in water, soluble in ethanol (96 per cent).

**mp:** about 259 °C, with decomposition.

**IDENTIFICATION**

**First identification:** B.

**Second identification:** A, C.

- A. Dissolve 50.0 mg in 0.01 M hydrochloric acid and dilute to 250.0 mL with the same acid. Dilute 25.0 mL of the solution to 100.0 mL with 0.01 M hydrochloric acid. Examined between 230 nm and 350 nm (2.2.25), the solution shows 4 absorption maxima, at 270 nm, 280 nm, 287 nm and 291 nm. The ratios of the absorbances measured at the maxima at 270 nm, 287 nm and 291 nm to that measured at the maximum at 280 nm are 0.82 to 0.86, 0.67 to 0.70 and 0.65 to 0.69, respectively.
- B. Infrared absorption spectrophotometry (2.2.24).  
*Comparison: naphazoline hydrochloride CRS.*
- C. It gives reaction (a) of chlorides (2.3.1).

## TESTS

**Solution S.** Dissolve 0.5 g in carbon dioxide-free water R and dilute to 50 mL with the same solvent.

**Appearance of solution.** Solution S is clear (2.2.1) and colourless (2.2.2, Method II).

**Acidity or alkalinity.** To 20 mL of solution S add 0.2 mL of 0.01 M sodium hydroxide and 0.1 mL of methyl red solution R. The solution is yellow. Not more than 0.6 mL of 0.01 M hydrochloric acid is required to change the colour of the solution to red.

**Related substances.** Liquid chromatography (2.2.29).

**Test solution.** Dissolve 50.0 mg of the substance to be examined in the mobile phase and dilute to 100.0 mL with the mobile phase.

**Reference solution (a).** Dissolve 5 mg of 1-naphthylacetic acid R in the mobile phase, add 5 mL of the test solution and dilute to 100 mL with the mobile phase.

**Reference solution (b).** Dissolve 5.0 mg of naphazoline impurity A CRS in the mobile phase and dilute to 100.0 mL with the mobile phase. Dilute 1.0 mL of this solution to 100.0 mL with the mobile phase.

**Reference solution (c).** Dilute 1.0 mL of the test solution to 10.0 mL with the mobile phase. Dilute 1.0 mL of this solution to 100.0 mL with the mobile phase.

## Column:

- size:  $l = 0.25$  m,  $\varnothing = 4.0$  mm;
- stationary phase: base-deactivated end-capped octylsilyl silica gel for chromatography R (4  $\mu$ m) with a pore size of 6 nm.

**Mobile phase:** dissolve 1.1 g of sodium octanesulfonate R in a mixture of 5 mL of glacial acetic acid R, 300 mL of acetonitrile R and 700 mL of water R.

**Flow rate:** 1 mL/min.

**Detection:** spectrophotometer at 280 nm.

**Injection:** 20  $\mu$ L.

**Run time:** 3 times the retention time of naphazoline.

**Retention time:** naphazoline = about 14 min.

**System suitability:** reference solution (a):

- resolution: minimum 5.0 between the peaks due to naphazoline and impurity B.

## Limits:

- impurity A: not more than the area of the principal peak in the chromatogram obtained with reference solution (b) (0.1 per cent);
- unspecified impurities: not more than the area of the principal peak in the chromatogram obtained with reference solution (c) (0.10 per cent);
- total: not more than 5 times the area of the principal peak in the chromatogram obtained with reference solution (c) (0.5 per cent);
- disregard limit: 0.5 times the area of the principal peak in the chromatogram obtained with reference solution (c) (0.05 per cent).

**Loss on drying (2.2.32):** maximum 0.5 per cent, determined on 1.000 g by drying in an oven at 105 °C.

**Sulfated ash (2.4.14):** maximum 0.1 per cent, determined on 1.0 g.

## ASSAY

Dissolve 0.200 g in a mixture of 5.0 mL of 0.01 M hydrochloric acid and 50 mL of ethanol (96 per cent) R. Carry out a potentiometric titration (2.2.20), using 0.1 M sodium hydroxide. Read the volume added between the 2 points of inflexion.

1 mL of 0.1 M sodium hydroxide is equivalent to 24.67 mg of  $C_{14}H_{15}ClN_2$ .

## STORAGE

Protected from light.

## IMPURITIES

*Specified impurities: A.*

*Other detectable impurities: B, C, D.*

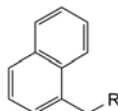

- A. R = CO-NH-[CH<sub>2</sub>]<sub>2</sub>-NH<sub>2</sub>: N-(2-aminoethyl)-2-(naphthalen-1-yl)acetamide (naphthylacetylenediamine),
- B. R = CO<sub>2</sub>H: (naphthalen-1-yl)acetic acid (1-naphthylacetic acid),
- C. R = CN: (naphthalen-1-yl)acetonitrile (1-naphthylacetonitrile),

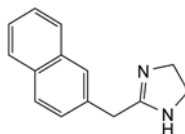

- D. 2-(naphthalen-2-ylmethyl)-4,5-dihydro-1H-imidazole ( $\beta$ -naphazoline).

01/2008:0147  
corrected 6.0

## NAPHAZOLINE NITRATE

## Naphazolini nitras

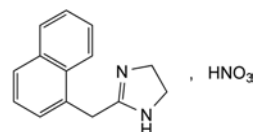

$C_{14}H_{15}N_3O_3$   
[5144-52-5]

$M_r$  273.3

## DEFINITION

2-(Naphthalen-1-ylmethyl)-4,5-dihydro-1H-imidazole nitrate.

**Content:** 99.0 per cent to 101.0 per cent (dried substance).

## CHARACTERS

**Appearance:** white or almost white, crystalline powder.

**Solubility:** sparingly soluble in water, soluble in ethanol (96 per cent).

## IDENTIFICATION

**First identification: C.**

**Second identification: A, B, D.**

A. Melting point (2.2.14): 167 °C to 170 °C.

B. Ultraviolet and visible absorption spectrophotometry (2.2.25).

**Test solution.** Dissolve 50.0 mg in 0.01 M hydrochloric acid and dilute to 250.0 mL with the same acid. Dilute 25.0 mL of the solution to 100.0 mL with 0.01 M hydrochloric acid.

**Spectral range:** 230-350 nm.

**Absorption maximum:** at 270 nm, 280 nm, 287 nm and 291 nm.

**Absorbance ratio:**

$$- A_{270}/A_{280} = 0.82 \text{ to } 0.86,$$

$$- A_{291}/A_{280} = 0.65 \text{ to } 0.69.$$

C. Infrared absorption spectrophotometry (2.2.24).

**Comparison:** naphazoline nitrate CRS.

D. Dissolve 45 mg of the substance to be examined in 2 mL of water R. Add 1 mL of sulfuric acid R. Shake carefully and allow to cool. Add 1 mL of ferrous sulfate solution R2 dropwise along the walls of the container. At the junction of the 2 liquids, a brown colour develops.

## TESTS

**Solution S.** Dissolve 0.5 g in carbon dioxide-free water R, warming gently, and dilute to 50 mL with the same solvent.

**Appearance of solution.** Solution S is clear (2.2.1) and colourless (2.2.2, Method II).

**pH (2.2.3):** 5.0 to 6.5 for solution S.

**Related substances.** Liquid chromatography (2.2.29).

**Test solution.** Dissolve 50.0 mg of the substance to be examined in the mobile phase and dilute to 100.0 mL with the mobile phase.

**Reference solution (a).** Dissolve 5 mg of 1-naphthylacetic acid R in the mobile phase, add 5 mL of the test solution and dilute to 100 mL with the mobile phase.

**Reference solution (b).** Dissolve 5.0 mg of naphazoline impurity A CRS in the mobile phase and dilute to 100.0 mL with the same solvent. Dilute 5.0 mL of this solution to 100.0 mL with the mobile phase.

**Reference solution (c).** Dilute 2.0 mL of the test solution to 10.0 mL with the mobile phase. Dilute 1.0 mL of this solution to 100.0 mL with the mobile phase.

**Column:**

– size:  $l = 0.25$  m,  $\varnothing = 4.0$  mm,

– stationary phase: end-capped base-deactivated octylsilyl silica gel for chromatography R (4  $\mu$ m) with a pore size of 6 nm.

**Mobile phase:** dissolve 1.1 g of sodium octanesulfonate R in a mixture of 5 mL of glacial acetic acid R, 300 mL of acetonitrile R and 700 mL of water R.

**Flow rate:** 1 mL/min.

**Detection:** spectrophotometer at 280 nm.

**Injection:** 20  $\mu$ L.

**Run time:** 3 times the retention time of naphazoline.

**Relative retention** with reference to naphazoline (retention time = about 14 min): impurity A = about 0.76; impurity D = about 1.24; impurity B = about 1.27; impurity C = about 2.8.

**System suitability:** reference solution (a):

– resolution: minimum 5.0 between the peaks due to naphazoline and impurity B.

**Limits:**

- impurity A: not more than the area of the principal peak in the chromatogram obtained with reference solution (b) (0.5 per cent),
- unspecified impurities: for each impurity, not more than 0.5 times the area of the principal peak in the chromatogram obtained with reference solution (c) (0.10 per cent),
- total: not more than 5 times the area of the principal peak in the chromatogram obtained with reference solution (c) (1.0 per cent),

– disregard limit: 0.25 times the area of the principal peak in the chromatogram obtained with reference solution (c) (0.05 per cent); disregard the peak due to the nitrate ion.

**Chlorides (2.4.4):** maximum 330 ppm, determined on solution S.

**Loss on drying (2.2.32):** maximum 0.5 per cent, determined on 1.000 g by drying in an oven at 105 °C.

**Sulfated ash (2.4.14):** maximum 0.1 per cent, determined on 1.0 g.

## ASSAY

Dissolve 0.200 g in 30 mL of anhydrous acetic acid R. Titrate with 0.1 M perchloric acid, determining the end-point potentiometrically (2.2.20).

1 mL of 0.1 M perchloric acid is equivalent to 27.33 mg of C<sub>14</sub>H<sub>15</sub>N<sub>3</sub>O<sub>3</sub>.

## STORAGE

Protected from light.

## IMPURITIES

**Specified impurities:** A.

**Other detectable impurities** (the following substances would, if present at a sufficient level, be detected by one or other of the tests in the monograph. They are limited by the general acceptance criterion for other/unspecified impurities and/or by the general monograph *Substances for pharmaceutical use (2034)*. It is therefore not necessary to identify these impurities for demonstration of compliance. See also 5.10. *Control of impurities in substances for pharmaceutical use*): B, C, D.

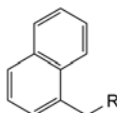

A. R = CO-NH-[CH<sub>2</sub>]<sub>2</sub>-NH<sub>2</sub>: N-(2-aminoethyl)-2-(naphthalen-1-yl)acetamide (naphthylacetylthylenediamine),

B. R = CO<sub>2</sub>H: (naphthalen-1-yl)acetic acid (1-naphthylacetic acid),

C. R = CN: (naphthalen-1-yl)acetonitrile (1-naphthylacetonitrile),

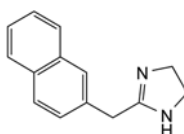

D. 2-(naphthalen-2-ylmethyl)-4,5-dihydro-1H-imidazole ( $\beta$ -naphazoline).

07/2008:0731

## NAPROXEN

### Naproxenum

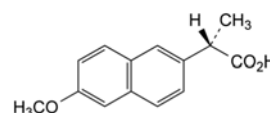

C<sub>14</sub>H<sub>14</sub>O<sub>3</sub>  
[22204-53-1]

$M_r$  230.3

## DEFINITION

(2S)-2-(6-Methoxynaphthalen-2-yl)propanoic acid.

**Content:** 99.0 per cent to 101.0 per cent (dried substance).

## CHARACTERS

**Appearance:** white or almost white, crystalline powder.

**Solubility:** practically insoluble in water, soluble in ethanol (96 per cent) and in methanol.

## IDENTIFICATION

*First identification:* A, D.

*Second identification:* A, B, C.

- A. Specific optical rotation (2.2.7): + 59 to + 62 (dried substance).  
Dissolve 0.50 g in *ethanol (96 per cent) R* and dilute to 25.0 mL with the same solvent.
- B. Melting point (2.2.14): 154 °C to 158 °C.
- C. Dissolve 40.0 mg in *methanol R* and dilute to 100.0 mL with the same solvent. Dilute 10.0 mL of this solution to 100.0 mL with *methanol R*. Examined between 230 nm and 350 nm (2.2.25), the solution shows 4 absorption maxima, at 262 nm, 271 nm, 316 nm and 331 nm. The specific absorbances at the absorption maxima are 216 to 238, 219 to 241, 61 to 69 and 79 to 87, respectively.
- D. Infrared absorption spectrophotometry (2.2.24).

*Comparison:* naproxen CRS.

## TESTS

**Appearance of solution.** The solution is clear (2.2.1) and not more intensely coloured than reference solution BY<sub>7</sub> (2.2.2, Method II).

Dissolve 1.25 g in *methanol R* and dilute to 25 mL with the same solvent.

**Enantiomeric purity.** Liquid chromatography (2.2.29). *Protect the solutions from light.*

*Test solution.* Dissolve 25.0 mg of the substance to be examined in *tetrahydrofuran R* and dilute to 50.0 mL with the same solvent. Dilute 2.0 mL of this solution to 20.0 mL with the mobile phase.

*Reference solution (a).* Dilute 2.5 mL of the test solution to 100.0 mL with the mobile phase.

*Reference solution (b).* Dissolve 5 mg of *racemic naproxen CRS* in 10 mL of *tetrahydrofuran R* and dilute to 100 mL with the mobile phase.

*Column:*

- size:  $l = 0.25$  m,  $\emptyset = 4.6$  mm;
- stationary phase: *silica gel*  $\pi$ -acceptor/ $\pi$ -donor for chiral separations R (5  $\mu$ m) (S,S);
- temperature: 25 °C.

*Mobile phase:* *glacial acetic acid R*, *acetonitrile R*, *2-propanol R*, *hexane R* (5:50:100:845 V/V/V/V).

*Flow rate:* 2 mL/min.

*Detection:* spectrophotometer at 263 nm.

*Injection:* 20  $\mu$ L.

*Run time:* 1.5 times the retention time of naproxen (retention time = about 5 min).

*System suitability:* reference solution (b):

- resolution: minimum 3 between the peaks due to impurity G and naproxen.

*Limit:*

- impurity G: not more than the area of the principal peak in the chromatogram obtained with reference solution (a) (2.5 per cent).

**Related substances.** Liquid chromatography (2.2.29). *Protect the solutions from light.*

*Test solution.* Dissolve 12 mg of the substance to be examined in the mobile phase and dilute to 20 mL with the mobile phase.

*Reference solution (a).* Dilute 1.0 mL of the test solution to 50.0 mL with the mobile phase. Dilute 1.0 mL of this solution to 20.0 mL with the mobile phase.

*Reference solution (b).* Dissolve 6 mg of *bromomethoxy-naphthalene R* (impurity N), 6 mg of *1-(6-methoxy-naphthalen-2-yl)ethanone R* (impurity L) and 6 mg of

*(1RS)-1-(6-methoxynaphthalen-2-yl)ethanol R* (impurity K) in *acetonitrile R* and dilute to 10 mL with the same solvent. To 1 mL of this solution add 1 mL of the test solution and dilute to 50 mL with the mobile phase. Dilute 1 mL of this solution to 20 mL with the mobile phase.

*Column:*

- size:  $l = 0.10$  m,  $\emptyset = 4.0$  mm;
- stationary phase: *octadecylsilyl silica gel for chromatography R* (3  $\mu$ m);
- temperature: 50 °C.

*Mobile phase:* mix 42 volumes of *acetonitrile R* and 58 volumes of a 1.36 g/L solution of *potassium dihydrogen phosphate R* previously adjusted to pH 2.0 with *phosphoric acid R*.

*Flow rate:* 1.5 mL/min.

*Detection:* spectrophotometer at 230 nm.

*Injection:* 20  $\mu$ L.

*Run time:* 1.5 times the retention time of impurity N.

*Relative retention* with reference to naproxen (retention time = about 2.5 min): impurity K = about 0.9; impurity L = about 1.4; impurity N = about 5.3.

*System suitability:* reference solution (b):

- resolution: minimum 2.2 between the peaks due to impurity K and naproxen.

*Limits:*

- impurity L: not more than the area of the corresponding peak in the chromatogram obtained with reference solution (b) (0.1 per cent);
- unspecified impurities: for each impurity, not more than the area of the principal peak in the chromatogram obtained with reference solution (a) (0.10 per cent);
- total: not more than 3 times the area of the principal peak in the chromatogram obtained with reference solution (a) (0.3 per cent);
- disregard limit: 0.5 times the area of the principal peak in the chromatogram obtained with reference solution (a) (0.05 per cent).

**Heavy metals** (2.4.8): maximum 20 ppm.

1.0 g complies with limit test C. Prepare the reference solution using 2 mL of *lead standard solution (10 ppm Pb) R*.

**Loss on drying** (2.2.32): maximum 0.5 per cent, determined on 1.000 g by drying in an oven at 105 °C for 3 h.

**Sulfated ash** (2.4.14): maximum 0.1 per cent, determined on 1.0 g.

## ASSAY

Dissolve 0.200 g in a mixture of 25 mL of *water R* and 75 mL of *methanol R*. Titrate with 0.1 M *sodium hydroxide*, using 1 mL of *phenolphthalein solution R* as indicator.

1 mL of 0.1 M *sodium hydroxide* is equivalent to 23.03 mg of C<sub>14</sub>H<sub>14</sub>O<sub>3</sub>.

## STORAGE

Protected from light.

## IMPURITIES

*Specified impurities:* G, L.

*Other detectable impurities* (the following substances would, if present at a sufficient level, be detected by one or other of the tests in the monograph. They are limited by the general acceptance criterion for other/unspecified impurities and/or by the general monograph *Substances for pharmaceutical use* (2034). It is therefore not necessary to identify these impurities for demonstration of compliance. See also 5.10. *Control of impurities in substances for pharmaceutical use*): A, B, C, D, E, F, H, I, J, K, M, N.



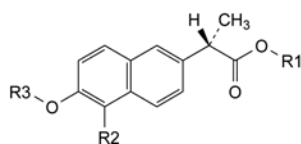

- A. R1 = R2 = R3 = H: (2*S*)-2-(6-hydroxynaphthalen-2-yl)propanoic acid,  
 B. R1 = H, R2 = Cl, R3 = CH<sub>3</sub>: (2*S*)-2-(5-chloro-6-methoxynaphthalen-2-yl)propanoic acid,  
 C. R1 = H, R2 = Br, R3 = CH<sub>3</sub>: (2*S*)-2-(5-bromo-6-methoxynaphthalen-2-yl)propanoic acid,  
 D. R1 = H, R2 = I, R3 = CH<sub>3</sub>: (2*S*)-2-(5-iodo-6-methoxynaphthalen-2-yl)propanoic acid,  
 E. R1 = R3 = CH<sub>3</sub>, R2 = H: methyl (2*S*)-2-(6-methoxynaphthalen-2-yl)propanoate,  
 F. R1 = C<sub>2</sub>H<sub>5</sub>, R2 = H, R3 = CH<sub>3</sub>: ethyl (2*S*)-2-(6-methoxynaphthalen-2-yl)propanoate,

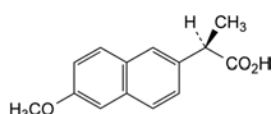

- G. (2*R*)-2-(6-methoxynaphthalen-2-yl)propanoic acid ((*R*)-enantiomer),

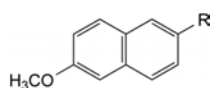

- H. R = OH: 6-methoxynaphthalen-2-ol,  
 I. R = CH<sub>2</sub>-CO<sub>2</sub>H: (6-methoxynaphthalen-2-yl)acetic acid,  
 J. R = C<sub>2</sub>H<sub>5</sub>: 2-ethyl-6-methoxynaphthalene,  
 K. R = CHOH-CH<sub>3</sub>: (1*R*)-1-(6-methoxynaphthalen-2-yl)ethanol,  
 M. R = H: 2-methoxynaphthalene (nerolin),  
 N. R = Br: 2-bromo-6-methoxynaphthalene,

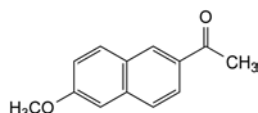

- L. 1-(6-methoxynaphthalen-2-yl)ethanone.

01/2008:1702  
corrected 7.0

## NAPROXEN SODIUM

### Naproxenum natrium

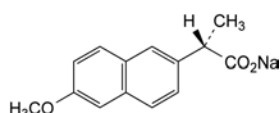

C<sub>14</sub>H<sub>13</sub>O<sub>3</sub>Na  
[26159-34-2]

*M<sub>r</sub>* 252.2

#### DEFINITION

Sodium (2*S*)-2-(6-methoxynaphthalen-2-yl)propanoate.  
*Content*: 98.0 per cent to 101.0 per cent (dried substance).

#### CHARACTERS

*Appearance*: white or almost white, hygroscopic, crystalline powder.

*Solubility*: freely soluble in water, freely soluble or soluble in methanol, sparingly soluble in ethanol (96 per cent).

#### IDENTIFICATION

*First identification*: A, C, D.

*Second identification*: A, B, D.

- A. Specific optical rotation (2.2.7): – 14.7 to – 17.0 (dried substance).

Dissolve 0.50 g in a 4.2 g/L solution of *sodium hydroxide R* and dilute to 25.0 mL with the same solution.

- B. Ultraviolet and visible absorption spectrophotometry (2.2.25).

*Test solution*. Dissolve 40.0 mg in *methanol R* and dilute to 100.0 mL with the same solvent. Dilute 10.0 mL of this solution to 100.0 mL with *methanol R*.

*Spectral range*: 230-350 nm.

*Absorption maxima*: at 262 nm, 271 nm, 316 nm and 331 nm.

*Specific absorbance at the absorption maxima*:

- at 262 nm: 207 to 227;
- at 271 nm: 200 to 220;
- at 316 nm: 56 to 68;
- at 331 nm: 72 to 84.

- C. Infrared absorption spectrophotometry (2.2.24).

*Preparation*. Dissolve 50 mg in 5 mL of *water R*. Add 1 mL of *dilute sulfuric acid R* and 5 mL of *ethyl acetate R*. Shake vigorously. Allow the 2 layers to separate. Evaporate the upper layer to dryness and subsequently dry at 60 °C for 15 min. Record the spectrum using the residue.

*Comparison*: *naproxen CRS*.

- D. It gives reaction (a) of sodium (2.3.1).

#### TESTS

**Appearance of solution.** The solution is clear (2.2.1) and not more intensely coloured than reference solution BY<sub>7</sub> (2.2.2, *Method II*).

Dissolve 1.25 g in *water R* and dilute to 25 mL with the same solvent.

**pH** (2.2.3): 7.0 to 9.8.

Dissolve 0.5 g in *carbon dioxide-free water R* and dilute to 25 mL with the same solvent.

**Enantiomeric purity.** Liquid chromatography (2.2.29). *Protect the solutions from light.*

*Test solution*. Dissolve 25.0 mg of the substance to be examined in 15 mL of *water R* and add 1 mL of *hydrochloric acid R*. Shake with 2 quantities, each of 10 mL, of *ethyl acetate R*, combine the upper layers and evaporate to dryness under reduced pressure. Dissolve the residue in 50.0 mL of *tetrahydrofuran R*. Dilute 2.0 mL of this solution to 20.0 mL with the mobile phase.

*Reference solution (a)*. Dilute 2.5 mL of the test solution to 100.0 mL with the mobile phase.

*Reference solution (b)*. Dissolve 5 mg of *racemic naproxen CRS* in 10 mL of *tetrahydrofuran R* and dilute to 100 mL with the mobile phase.

*Column*:

- *size*: *l* = 0.25 m, Ø = 4.6 mm;
- *stationary phase*: *silica gel π-acceptor/π-donor for chiral separations R* (5 µm) (S,S);
- *temperature*: 25 °C.

*Mobile phase*: *glacial acetic acid R*, *acetonitrile R*, *2-propanol R*, *hexane R* (5:50:100:845 V/V/V/V).

*Flow rate*: 2 mL/min.

*Detection*: spectrophotometer at 263 nm.

*Injection*: 20 µL.

*Run time*: 1.5 times the retention time of naproxen (retention time = about 5 min).

*System suitability*: reference solution (b):

- *resolution*: minimum 3 between the peaks due to impurity G and naproxen.

**Limit:**

- **impurity G:** not more than the area of the principal peak in the chromatogram obtained with reference solution (a) (2.5 per cent).

**Related substances.** Liquid chromatography (2.2.29). *Protect the solutions from light.*

**Test solution.** Dissolve 12 mg of the substance to be examined in the mobile phase and dilute to 20 mL with the mobile phase.

**Reference solution (a).** Dilute 1.0 mL of the test solution to 50.0 mL with the mobile phase. Dilute 1.0 mL of this solution to 20.0 mL with the mobile phase.

**Reference solution (b).** Dissolve 6 mg of *bromomethoxynaphthalene R* (impurity N), 6.0 mg of *naproxen impurity L CRS* and 6 mg of *(1RS)-1-(6-methoxynaphthalen-2-yl)ethanol R* (impurity K) in *acetonitrile R* and dilute to 10 mL with the same solvent. To 1 mL of the solution add 1 mL of the test solution and dilute to 50 mL with the mobile phase. Dilute 1 mL of this solution to 20 mL with the mobile phase.

**Column:**

- **size:**  $l = 0.10$  m,  $\varnothing = 4.0$  mm;
- **stationary phase:** *octadecylsilyl silica gel for chromatography R* (3  $\mu$ m);
- **temperature:** 50 °C.

**Mobile phase:** mix 42 volumes of *acetonitrile R* and 58 volumes of a 1.36 g/L solution of *potassium dihydrogen phosphate R* previously adjusted to pH 2.0 with *phosphoric acid R*.

**Flow rate:** 1.5 mL/min.

**Detection:** spectrophotometer at 230 nm.

**Injection:** 20  $\mu$ L.

**Run time:** 1.5 times the retention time of impurity N.

**Relative retention** with reference to naproxen (retention time = about 2.5 min): impurity K = about 0.9; impurity L = about 1.4; impurity N = about 5.3.

**System suitability:** reference solution (b):

- **resolution:** minimum 2.2 between the peaks due to impurity K and naproxen.

**Limits:**

- **impurity L:** not more than the area of the corresponding peak in the chromatogram obtained with reference solution (b) (0.1 per cent);
- **unspecified impurities:** for each impurity, not more than the area of the principal peak in the chromatogram obtained with reference solution (a) (0.10 per cent);
- **total:** not more than 3 times the area of the principal peak in the chromatogram obtained with reference solution (a) (0.3 per cent);
- **disregard limit:** 0.5 times the area of the principal peak in the chromatogram obtained with reference solution (a) (0.05 per cent).

**Heavy metals** (2.4.8): maximum 20 ppm.

Dissolve 2.0 g in 20.0 mL of *water R*. 12 mL of the solution complies with test A. Prepare the reference solution using 2 mL of *lead standard solution (10 ppm Pb) R*.

After the addition of *buffer solution pH 3.5 R*, the substance precipitates. Dilute each solution to 40 mL with *anhydrous ethanol R*: the substance dissolves completely. Proceed as described in the test, filtering the solutions to evaluate the result.

**Loss on drying** (2.2.32): maximum 1.0 per cent, determined on 1.000 g by drying in an oven at 105 °C for 3 h.

**ASSAY**

Dissolve 0.200 g in 50 mL of *anhydrous acetic acid R*. Titrate with 0.1 M *perchloric acid*, determining the end-point potentiometrically (2.2.20).

1 mL of 0.1 M *perchloric acid* is equivalent to 25.22 mg of  $C_{14}H_{13}O_3Na$ .

**STORAGE**

In an airtight container, protected from light.

**IMPURITIES**

**Specified impurities:** G, L.

**Other detectable impurities** (the following substances would, if present at a sufficient level, be detected by one or other of the tests in the monograph. They are limited by the general acceptance criterion for other/unspecified impurities and/or by the general monograph *Substances for pharmaceutical use (2034)*. It is therefore not necessary to identify these impurities for demonstration of compliance. See also 5.10. *Control of impurities in substances for pharmaceutical use*): A, B, C, D, E, F, H, I, J, K, M, N.

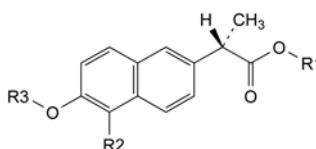

- A.  $R_1 = R_2 = R_3 = H$ : (2S)-2-(6-hydroxynaphthalen-2-yl)propanoic acid,
- B.  $R_1 = H$ ,  $R_2 = Cl$ ,  $R_3 = CH_3$ : (2S)-2-(5-chloro-6-methoxynaphthalen-2-yl)propanoic acid,
- C.  $R_1 = H$ ,  $R_2 = Br$ ,  $R_3 = CH_3$ : (2S)-2-(5-bromo-6-methoxynaphthalen-2-yl)propanoic acid,
- D.  $R_1 = H$ ,  $R_2 = I$ ,  $R_3 = CH_3$ : (2S)-2-(5-iodo-6-methoxynaphthalen-2-yl)propanoic acid,
- E.  $R_1 = R_3 = CH_3$ ,  $R_2 = H$ : methyl (2S)-2-(6-methoxynaphthalen-2-yl)propanoate,
- F.  $R_1 = C_2H_5$ ,  $R_2 = H$ ,  $R_3 = CH_3$ : ethyl (2S)-2-(6-methoxynaphthalen-2-yl)propanoate,

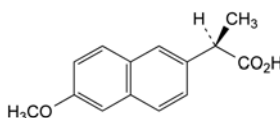

- G. (2R)-2-(6-methoxynaphthalen-2-yl)propanoic acid,

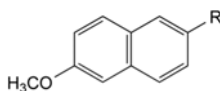

- H.  $R = OH$ : 6-methoxynaphthalen-2-ol,
- I.  $R = CH_2-CO_2H$ : (6-methoxynaphthalen-2-yl)acetic acid,
- J.  $R = C_2H_5$ : 2-ethyl-6-methoxynaphthalene,
- K.  $R = CHOH-CH_3$ : (1RS)-1-(6-methoxynaphthalen-2-yl)ethanol,
- L.  $R = CO-CH_3$ : 1-(6-methoxynaphthalen-2-yl)ethanone,
- M.  $R = H$ : 2-methoxynaphthalene (nerolin),
- N.  $R = Br$ : 2-bromo-6-methoxynaphthalene.

01/2008:1547 – *stationary phase*: spherical octadecylsilyl silica gel for chromatography R (4 µm) with a carbon loading of 7 per cent,

– *temperature*: 30 °C.

*Mobile phase*: mix 20 volumes of acetonitrile R and 80 volumes of a solution prepared by adding 5.0 mL of glacial acetic acid R to 1000.0 mL of water R.

*Flow rate*: 1.0 mL/min.

*Detection*: spectrophotometer at 282 nm.

*Injection*: 10 µL; inject test solution (a) and reference solutions (a), (b), (c) and (d).

*Run time*: 5 times the retention time of neohesperidin-dihydrochalcone which is about 10 min.

*Relative retention* with reference to neohesperidin-dihydrochalcone: impurity B = about 0.4; impurity D = about 0.7; impurity F = about 1.2; impurity G = about 3.7.

*System suitability*:

– *resolution*: minimum of 2.5 between the first peak (neohesperidin-dihydrochalcone) and the second peak (impurity F) in the chromatogram obtained with reference solution (d),

– chromatogram obtained with reference solution (a) is similar to the chromatogram provided with *neohesperidin-dihydrochalcone CRS*.

*Limits*:

– *impurity B*: not more than the area of the principal peak in the chromatogram obtained with reference solution (b) (2 per cent),

– *impurity D*: not more than twice the area of the principal peak in the chromatogram obtained with reference solution (c) (2 per cent),

– *any other impurity*: not more than 0.5 times the area of the principal peak in the chromatogram obtained with reference solution (c) (0.5 per cent),

– *total of all impurities apart from impurity B*: not more than 2.5 times the area of the principal peak in the chromatogram obtained with reference solution (c) (2.5 per cent),

– *disregard limit*: 0.05 times the area of the principal peak in the chromatogram obtained with reference solution (c) (0.05 per cent).

**Heavy metals** (2.4.8): maximum 10 ppm.

2.0 g complies with limit test D. Prepare the standard using 2 mL of lead standard solution (10 ppm Pb) R.

**Water** (2.5.12): maximum 12.0 per cent, determined on 0.200 g.

**Sulfated ash** (2.4.14): maximum 0.2 per cent, determined on 1.0 g.

ASSAY

Liquid chromatography (2.2.29) as described in the test for related substances.

*Injection*: 10 µL; inject test solution (b) and reference solutions (a) and (d).

*System suitability*:

– *resolution*: minimum of 2.5 between the first peak (neohesperidin-dihydrochalcone) and the second peak (impurity F) in the chromatogram obtained with reference solution (d),

– *repeatability*: reference solution (a).

Calculate the percentage content of C<sub>28</sub>H<sub>36</sub>O<sub>15</sub> using the chromatogram obtained with reference solution (a) and the stated content of C<sub>28</sub>H<sub>36</sub>O<sub>15</sub> in *neohesperidin-dihydrochalcone CRS*, correcting for the water content of the substance to be examined.

STORAGE

Protected from light.

## NEOHESPERIDIN-DIHYDROCHALCONE

### Neohesperidin-dihydrochalconum

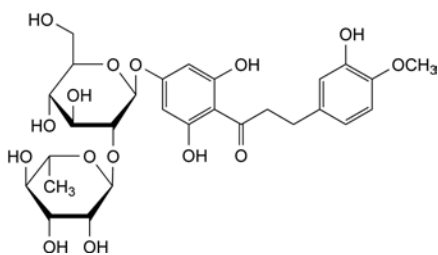

C<sub>28</sub>H<sub>36</sub>O<sub>15</sub>  
[20702-77-6]

M<sub>r</sub> 613

#### DEFINITION

1-[4-[[2-O-(6-Deoxy-α-L-mannopyranosyl)-β-D-glucopyranosyl]-oxy]-2,6-dihydroxyphenyl]-3-(3-hydroxy-4-methoxyphenyl)-propan-1-one.

*Content*: 96.0 per cent to 101.0 per cent (anhydrous substance).

#### CHARACTERS

*Appearance*: white or yellowish-white powder.

*Solubility*: practically insoluble in water, freely soluble in dimethyl sulfoxide, soluble in methanol, practically insoluble in methylene chloride.

#### IDENTIFICATION

A. Infrared absorption spectrophotometry (2.2.24).

*Comparison*: *neohesperidin-dihydrochalcone CRS*.

B. Examine the chromatograms obtained in the assay.

*Results*: the principal peak in the chromatogram obtained with test solution (b) is similar in retention time and size to the principal peak in the chromatogram obtained with reference solution (a).

#### TESTS

**Appearance of solution.** The solution is clear (2.2.1) and not more intensely coloured than reference solution Y<sub>4</sub> (2.2.2, Method II).

Dissolve 0.25 g in *methanol R* and dilute to 25 mL with the same solvent.

**Related substances.** Liquid chromatography (2.2.29).

*Test solution (a).* Dissolve 0.10 g of the substance to be examined in *dimethyl sulfoxide R* and dilute to 50.0 mL with the same solvent.

*Test solution (b).* Dilute 10.0 mL of test solution (a) to 20.0 mL with *dimethyl sulfoxide R*.

*Reference solution (a).* Dissolve 50.0 mg of *neohesperidin-dihydrochalcone CRS* in *dimethyl sulfoxide R* and dilute to 50.0 mL with the same solvent.

*Reference solution (b).* Dissolve 4.0 mg of *neohesperidin-dihydrochalcone impurity B CRS* in *dimethyl sulfoxide R* and dilute to 100.0 mL with the same solvent.

*Reference solution (c).* Dilute 1.0 mL of test solution (a) to 100.0 mL with *dimethyl sulfoxide R*.

*Reference solution (d).* In order to prepare *in situ* impurity F and impurity G, suspend 0.10 g of the substance to be examined in 10.0 mL of a 100 g/L solution of *sulfuric acid R*. Heat the sample for 5 min on a water-bath. Dilute immediately 1.0 mL of the resulting solution to 50.0 mL with *dimethyl sulfoxide R*.

*Column*:

– *size*: *l* = 0.15 m, *Ø* = 3.9 mm,

## IMPURITIES

01/2008:0197

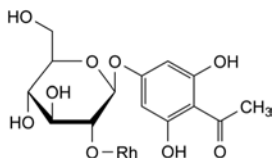
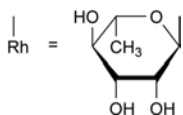

- A. 1-[4-[[2-O-(6-deoxy- $\alpha$ -L-mannopyranosyl)- $\beta$ -D-glucopyranosyl]oxy]-2,6-dihydroxyphenyl]ethanone (phloracetophenone neohesperidoside),

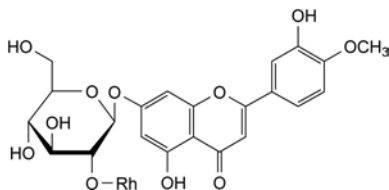

- B. 7-[[2-O-(6-deoxy- $\alpha$ -L-mannopyranosyl)- $\beta$ -D-glucopyranosyl]oxy]-5-hydroxy-2-(3-hydroxy-4-methoxyphenyl)-4H-1-benzopyran-4-one (neodiosmin),

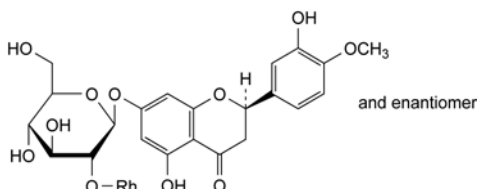

- C. (2*RS*)-7-[[2-O-(6-deoxy- $\alpha$ -L-mannopyranosyl)- $\beta$ -D-glucopyranosyl]oxy]-5-hydroxy-2-(3-hydroxy-4-methoxyphenyl)-2,3-dihydro-4H-1-benzopyran-4-one (neohesperidin),

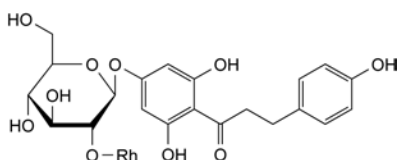

- D. 1-[4-[[2-O-(6-deoxy- $\alpha$ -L-mannopyranosyl)- $\beta$ -D-glucopyranosyl]oxy]-2,6-dihydroxyphenyl]-3-(4-hydroxyphenyl)propan-1-one (naringin-dihydrochalcone),

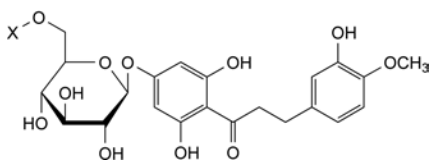

- E. X = Rh: 1-[4-[[6-O-(6-deoxy- $\alpha$ -L-mannopyranosyl)- $\beta$ -D-glucopyranosyl]oxy]-2,6-dihydroxyphenyl]-3-(3-hydroxy-4-methoxyphenyl)propan-1-one (hesperidin-dihydrochalcone),

- F. X = H: 1-[4-( $\beta$ -D-glucopyranosyloxy)-2,6-dihydroxyphenyl]-3-(3-hydroxy-4-methoxyphenyl)propan-1-one (hesperetin-dihydrochalcone 7'-glucoside),

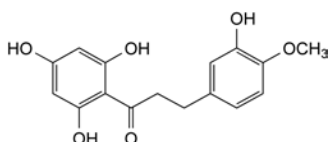

- G. 3-(3-hydroxy-4-methoxyphenyl)-1-(2,4,6-trihydroxyphenyl)propan-1-one (hesperetin-dihydrochalcone).

## NEOMYCIN SULFATE

## Neomycini sulfas

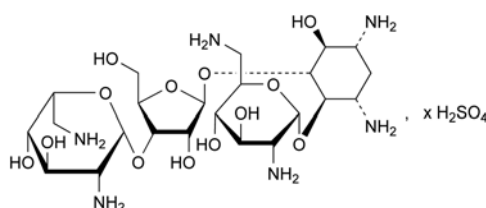
 $C_{23}H_{46}N_6O_{13} \cdot xH_2SO_4$  $M_r$  615 (base)

## DEFINITION

Mixture of sulfates of substances produced by the growth of certain selected strains of *Streptomyces fradiae*, the main component being the sulfate of 2-deoxy-4-O-(2,6-diamino-2,6-dideoxy- $\alpha$ -D-glucopyranosyl)-5-O-[3-O-(2,6-diamino-2,6-dideoxy- $\beta$ -L-idopyranosyl)- $\beta$ -D-ribofuranosyl]-D-streptamine (neomycin B).

*Content*: minimum of 680 IU/mg (dried substance).

## CHARACTERS

*Appearance*: white or yellowish-white powder, hygroscopic.

*Solubility*: very soluble in water, very slightly soluble in alcohol, practically insoluble in acetone.

## IDENTIFICATION

- A. Examine the chromatograms obtained in the test for related substances.

*Results*:

- the retention time of the principal peak in the chromatogram obtained with the test solution is approximately the same as that of the principal peak in the chromatogram obtained with reference solution (e),
- it complies with the limits given for impurity C.

- B. It gives reaction (a) of sulfates (2.3.1).

## TESTS

**pH** (2.2.3): 5.0 to 7.5.

Dissolve 0.1 g in *carbon dioxide-free water R* and dilute to 10 mL with the same solvent.

**Specific optical rotation** (2.2.7): + 53.5 to + 59.0 (dried substance).

Dissolve 1.00 g in *water R* and dilute to 10.0 mL with the same solvent.

**Related substances**. Liquid chromatography (2.2.29).

*Test solution*. Dissolve 25.0 mg of the substance to be examined in the mobile phase and dilute to 50.0 mL with the mobile phase.

*Reference solution (a)*. Dissolve 25.0 mg of *framycetin sulfate CRS* in the mobile phase and dilute to 50.0 mL with the mobile phase.

*Reference solution (b)*. Dilute 5.0 mL of reference solution (a) to 100.0 mL with the mobile phase.

*Reference solution (c)*. Dilute 1.0 mL of reference solution (a) to 100.0 mL with the mobile phase.

*Reference solution (d)*. Dissolve the contents of a vial of *neamine CRS* (corresponding to 0.5 mg) in the mobile phase and dilute to 50.0 mL with the mobile phase.

*Reference solution (e)*. Dissolve 10 mg of *neomycin sulfate CRS* in the mobile phase and dilute to 100.0 mL with the mobile phase.

*Column*:

- *size*:  $l = 0.25$  m,  $\varnothing = 4.6$  mm,
- *stationary phase*: base-deactivated octadecylsilyl silica gel for chromatography R (5  $\mu$ m),

– *temperature*: 25 °C.

*Mobile phase*: mix 20.0 mL of *trifluoroacetic acid R*, 6.0 mL of *carbonate-free sodium hydroxide solution R* and 500 mL of *water R*, allow to equilibrate, dilute to 1000 mL with *water R* and degas.

*Flow rate*: 0.7 mL/min.

*Post-column solution*: *carbonate-free sodium hydroxide solution R* diluted 1 in 25 previously degassed, which is added pulse-less to the column effluent using a 375 µL polymeric mixing coil.

*Flow rate*: 0.5 mL/min.

*Detection*: pulsed amperometric detector with a gold indicator electrode, a silver-silver chloride reference electrode and a stainless steel auxiliary electrode which is the cell body, held at respectively 0.00 V detection, + 0.80 V oxidation and – 0.60 V reduction potentials, with pulse durations according to the instrument used.

*Injection*: 10 µL; inject the test solution and the reference solutions (b), (c), (d) and (e).

*Run time*: 1.5 times the retention time of neomycin B.

*Relative retention* with reference to neomycin B (retention time = about 10 min): impurity A = about 0.65; impurity C = about 0.9; impurity G = about 1.1.

*System suitability*:

- *resolution*: minimum of 2.0 between the peaks due to impurity C and to neomycin B in the chromatogram obtained with reference solution (e); if necessary, adjust the volume of the carbonate-free sodium hydroxide solution in the mobile phase,
- *signal-to-noise ratio*: minimum 10 for the principal peak in the chromatogram obtained with reference solution (c).

*Limits*:

- *impurity A*: not more than the area of the principal peak in the chromatogram obtained with reference solution (d) (2.0 per cent),
- *impurity C*: not more than 3 times the area of the principal peak in the chromatogram obtained with reference solution (b) (15.0 per cent) and not less than 0.6 times the area of the principal peak in the chromatogram obtained with reference solution (b) (3.0 per cent),
- *any other impurity*: not more than the area of the principal peak in the chromatogram obtained with reference solution (b) (5.0 per cent),
- *total of other impurities*: not more than 3 times the area of the principal peak in the chromatogram obtained with reference solution (b) (15.0 per cent),
- *disregard limit*: area of the principal peak in the chromatogram obtained with reference solution (c) (1.0 per cent).

**Sulfate**: 27.0 per cent to 31.0 per cent (dried substance).

Dissolve 0.250 g in 100 mL of *water R* and adjust the solution to pH 11 using *concentrated ammonia R*. Add 10.0 mL of 0.1 M *barium chloride* and about 0.5 mg of *phthalein purple R*. Titrate with 0.1 M *sodium edetate* adding 50 mL of *alcohol R* when the colour of the solution begins to change, continuing the titration until the violet-blue colour disappears.

1 mL of 0.1 M *barium chloride* is equivalent to 9.606 mg of SO<sub>4</sub>.

**Loss on drying** (2.2.32): maximum 8.0 per cent, determined on 1.000 g by drying at 60 °C over *diphosphorus pentoxide R* at a pressure not exceeding 0.7 kPa for 3 h.

**Sulfated ash** (2.4.14): maximum 1.0 per cent, determined on 1.0 g.

**ASSAY**

Carry out the microbiological assay of antibiotics (2.7.2).

**STORAGE**

In an airtight container, protected from light.

#### IMPURITIES

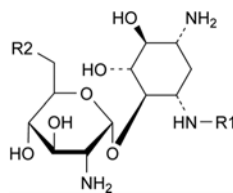

- A. R1 = H, R2 = NH<sub>2</sub>: 2-deoxy-4-O-(2,6-diamino-2,6-dideoxy-α-D-glucopyranosyl)-D-streptamine (neamine or neomycin A-LP),
- B. R1 = CO-CH<sub>3</sub>, R2 = NH<sub>2</sub>: 3-*N*-acetyl-2-deoxy-4-O-(2,6-diamino-2,6-dideoxy-α-D-glucopyranosyl)-D-streptamine (3-acetylneamine),
- D. R1 = H, R2 = OH: 4-O-(2-amino-2-deoxy-α-D-glucopyranosyl)-2-deoxy-D-streptamine (paromamine or neomycin D),

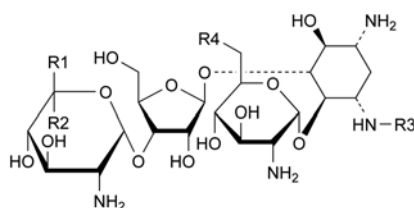

- C. R1 = CH<sub>2</sub>-NH<sub>2</sub>, R2 = R3 = H, R4 = NH<sub>2</sub>: 2-deoxy-4-O-(2,6-diamino-2,6-dideoxy-α-D-glucopyranosyl)-5-O-[3-O-(2,6-diamino-2,6-dideoxy-α-D-glucopyranosyl)]-β-D-ribofuranosyl]-D-streptamine (neomycin C),
- E. R1 = R3 = H, R2 = CH<sub>2</sub>-NH<sub>2</sub>, R4 = OH: 4-O-(2-amino-2-deoxy-α-D-glucopyranosyl)-2-deoxy-5-O-[3-O-(2,6-diamino-2,6-dideoxy-β-L-idopyranosyl)]-β-D-ribofuranosyl]-D-streptamine (paromomycin I or neomycin E),
- F. R1 = CH<sub>2</sub>-NH<sub>2</sub>, R2 = R3 = H, R4 = OH: 4-O-(2-amino-2-deoxy-α-D-glucopyranosyl)-2-deoxy-5-O-[3-O-(2,6-diamino-2,6-dideoxy-α-D-glucopyranosyl)]-β-D-ribofuranosyl]-D-streptamine (paromomycin II or neomycin F),
- G. R1 = H, R2 = CH<sub>2</sub>-NH<sub>2</sub>, R3 = CO-CH<sub>3</sub>, R4 = NH<sub>2</sub>: 3-*N*-acetyl-2-deoxy-4-O-(2,6-diamino-2,6-dideoxy-α-D-glucopyranosyl)-5-O-[3-O-(2,6-diamino-2,6-dideoxy-β-L-idopyranosyl)]-β-D-ribofuranosyl]-D-streptamine (neomycin B-LP).

01/2008:0046  
corrected 6.0

## NEOSTIGMINE BROMIDE

### Neostigmini bromidum

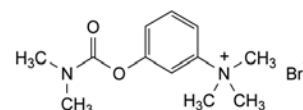

C<sub>12</sub>H<sub>19</sub>BrN<sub>2</sub>O<sub>2</sub>  
[114-80-7]

M<sub>r</sub> 303.2

#### DEFINITION

3-[(Dimethylcarbamoyl)oxy]-*N,N,N*-trimethylanilinium bromide.

*Content*: 98.5 per cent to 101.0 per cent (dried substance).

#### CHARACTERS

*Appearance*: white or almost white, crystalline powder or colourless crystals, hygroscopic.

*Solubility*: very soluble in water, freely soluble in ethanol (96 per cent).

#### IDENTIFICATION

*First identification*: B, D.

*Second identification*: A, C, D.

- A. Ultraviolet and visible absorption spectrophotometry (2.2.25).  
*Test solution.* Dissolve 20 mg in 0.5 M sulfuric acid and dilute to 100 mL with the same acid.  
*Spectral range:* 230-350 nm.  
*Absorption maxima:* at 260 nm and 266 nm.  
*Specific absorbances at the absorption maxima:*  
 – at 260 nm: about 16;  
 – at 266 nm: about 14.
- B. Infrared absorption spectrophotometry (2.2.24).  
*Comparison:* neostigmine bromide CRS.
- C. Heat about 50 mg with a mixture of 0.4 g of potassium hydroxide R and 2 mL of ethanol (96 per cent) R on a water-bath for 3 min, replacing the evaporated ethanol (96 per cent). Cool and add 2 mL of water R and 2 mL of diazobenzenesulfonic acid solution R1. An orange-red colour develops.
- D. It gives the reactions of bromides (2.3.1).

## TESTS

**Solution S.** Dissolve 2.5 g in distilled water R and dilute to 50 mL with the same solvent.

**Appearance of solution.** Solution S is clear (2.2.1) and colourless (2.2.2, Method II).

**Impurity A:** maximum 0.33 per cent.

Dissolve 50 mg in a mixture of 1 mL of sodium carbonate solution R and 9 mL of water R. The absorbance (2.2.25) measured immediately at 294 nm is not greater than 0.25.

**Sulfates (2.4.13):** maximum 200 ppm, determined on solution S.

**Loss on drying (2.2.32):** maximum 1.0 per cent, determined on 1.00 g by drying in an oven at 105 °C.

**Sulfated ash (2.4.14):** maximum 0.1 per cent, determined on 1.0 g.

## ASSAY

Dissolve 0.225 g in 2 mL of anhydrous formic acid R. Add 50 mL of acetic anhydride R. Titrate with 0.1 M perchloric acid, determining the end-point potentiometrically (2.2.20).

1 mL of 0.1 M perchloric acid is equivalent to 30.32 mg of C<sub>12</sub>H<sub>19</sub>BrN<sub>2</sub>O<sub>2</sub>.

## STORAGE

Protected from light.

## IMPURITIES

*Specified impurities:* A.

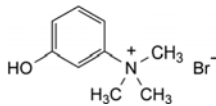

- A. 3-hydroxy-*N,N,N*-trimethylanilinium bromide.

01/2008:0626  
corrected 6.0

## NEOSTIGMINE METILSULFATE

## Neostigmini metilsulfas

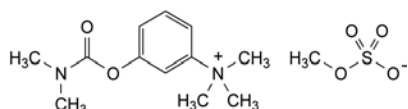

C<sub>13</sub>H<sub>22</sub>N<sub>2</sub>O<sub>6</sub>S  
[51-60-5]

*M<sub>r</sub>* 334.4

## DEFINITION

3-[(Dimethylcarbamoyl)oxy]-*N,N,N*-trimethylanilinium methyl sulfate.

*Content:* 98.5 per cent to 101.0 per cent (dried substance).

## CHARACTERS

*Appearance:* white or almost white, crystalline powder or colourless crystals, hygroscopic.

*Solubility:* very soluble in water, freely soluble in ethanol (96 per cent).

## IDENTIFICATION

*First identification:* A, C.

*Second identification:* A, B, D, E.

A. Melting point (2.2.14): 144 °C to 149 °C.

B. Ultraviolet and visible absorption spectrophotometry (2.2.25).

*Test solution.* Dissolve 50 mg in 0.5 M sulfuric acid and dilute to 100.0 mL with the same acid.

*Spectral range:* 230-350 nm.

*Absorption maxima:* at 261 nm and 267 nm.

*Resolution (2.2.25):* minimum 1.9 for the absorbance ratio.

*Absorbance ratio:*  $A_{267} / A_{261} = 0.84$  to 0.87.

C. Infrared absorption spectrophotometry (2.2.24).

*Preparation:* discs.

*Comparison:* neostigmine metilsulfate CRS.

D. To 50 mg add 0.4 g of potassium hydroxide R and 2 mL of ethanol (96 per cent) R and heat on a water-bath for 3 min, replacing the evaporated ethanol (96 per cent). Cool and add 2 mL of water R and 2 mL of diazobenzenesulfonic acid solution R1. An orange-red colour develops.

E. Dissolve 0.1 g in 5 mL of distilled water R and add 1 mL of barium chloride solution R1. No precipitate is formed. Add 2 mL of hydrochloric acid R and heat in a water-bath for 10 min. A fine, white precipitate is formed.

## TESTS

**Solution S.** Dissolve 2.5 g in distilled water R and dilute to 50 mL with the same solvent.

**Appearance of solution.** Solution S is clear (2.2.1) and colourless (2.2.2, Method II).

**Acidity or alkalinity.** To 4.0 mL of solution S add 6.0 mL of water R and 0.1 mL of phenolphthalein solution R1. The solution is colourless. Add 0.3 mL of 0.01 M sodium hydroxide; the solution becomes red. Add 0.4 mL of 0.01 M hydrochloric acid; the solution becomes colourless. Add 0.1 mL of methyl red solution R; the solution becomes red or yellowish-red.

**(3-Hydroxyphenyl)trimethylammonium methyl sulfate.**

Dissolve 50 mg in a mixture of 1 mL of sodium carbonate solution R and 9 mL of water R. The absorbance (2.2.25) measured immediately at 294 nm is not greater than 0.20.

**Sulfates (2.4.13):** maximum 200 ppm, determined on solution S.

**Loss on drying (2.2.32):** maximum 0.5 per cent, determined on 1.000 g by drying in an oven at 105 °C.

**Sulfated ash (2.4.14):** maximum 0.1 per cent, determined on 1.0 g.

## ASSAY

Dissolve 0.300 g in 150 mL of water R and add 100 mL of dilute sodium hydroxide solution R. Distil collecting the distillate in 40 mL of a 40 g/L solution of boric acid R until the total volume in the collecting vessel is about 250 mL. Titrate the solution in the collecting vessel with 0.1 M hydrochloric acid, using 0.25 mL of methyl red mixed solution R as indicator. Carry out a blank test.

1 mL of 0.1 M hydrochloric acid is equivalent to 33.44 mg of C<sub>13</sub>H<sub>22</sub>N<sub>2</sub>O<sub>6</sub>S.

## STORAGE

In a airtight container, protected from light.

01/2008:1351  
corrected 6.0

## NETILMICIN SULFATE

## Netilmicini sulfas

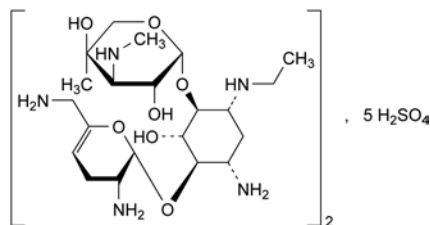

$C_{42}H_{92}N_{10}O_{34}S_5$   
[56391-57-2]

$M_r$  1442

## DEFINITION

2-Deoxy-6-*O*-[3-deoxy-4-*C*-methyl-3-(methylamino)- $\beta$ -L-arabinopyranosyl]-4-*O*-(2,6-diamino-2,3,4,6-tetra-deoxy- $\alpha$ -D-glycero-hex-4-enopyranosyl)-1-*N*-ethyl-D-streptamine sulfate.

Substance obtained by synthesis from sisomicin.

Semi-synthetic product derived from a fermentation product.

Content: minimum 650 IU/mg (dried substance).

## CHARACTERS

**Appearance:** white or yellowish-white powder, very hygroscopic.

**Solubility:** very soluble in water, practically insoluble in acetone and in alcohol.

## IDENTIFICATION

A. Examine the chromatograms obtained in the test for related substances.

**Results:** the retention time and size of the principal peak in the chromatogram obtained with test solution (a) are approximately the same as those of the principal peak in the chromatogram obtained with reference solution (a).

B. It gives reaction (a) of sulfates (2.3.1).

## TESTS

**Solution S.** Dissolve 0.80 g in carbon dioxide-free water *R* and dilute to 20.0 mL with the same solvent.

**Appearance of solution.** Solution S is clear (2.2.1) and its absorbance at 400 nm (2.2.25) has a maximum of 0.08.

**pH (2.2.3):** 3.5 to 5.5 for solution S.

**Specific optical rotation (2.2.7):** + 88.0 to + 96.0 (dried substance).

Dissolve 0.50 g in water *R* and dilute to 10.0 mL with the same solvent.

**Related substances.** Liquid chromatography (2.2.29).

**Test solution (a).** Dissolve 25.0 mg of the substance to be examined in the mobile phase and dilute to 25.0 mL with the mobile phase.

**Test solution (b).** Dilute 1.0 mL of test solution (a) to 100.0 mL with the mobile phase. Dilute 1.0 mL of this solution to 10.0 mL with the mobile phase.

**Reference solution (a).** Dissolve 25.0 mg of netilmicin sulfate CRS in the mobile phase and dilute to 25.0 mL with the mobile phase.

**Reference solution (b).** Dissolve 25.0 mg of sisomicin sulfate CRS in the mobile phase and dilute to 25.0 mL with the mobile phase.

**Reference solution (c).** Dissolve 20.5 mg of 1-*N*-ethylgaramine sulfate CRS in the mobile phase and dilute to 25.0 mL with the mobile phase.

**Reference solution (d).** Dilute 1.0 mL of reference solution (a), 1.0 mL of reference solution (b) and 1.0 mL of reference solution (c) to 100.0 mL with the mobile phase.

**Column:**

– size:  $l = 0.25$  m,  $\varnothing = 4.6$  mm,

– stationary phase: styrene-divinylbenzene copolymer *R* (8  $\mu$ m) with a pore size of 100 nm,

– temperature: 50 °C.

**Mobile phase:** prepare a solution in carbon dioxide-free water *R* containing 35 g/L of anhydrous sodium sulfate *R*, 0.5 g/L of sodium octanesulfonate *R*, 10 mL/L of tetrahydrofuran *R*, 50 mL/L of 0.2 M potassium dihydrogenphosphate *R* previously adjusted to pH 3.0 with a 22.5 g/L solution of phosphoric acid *R* and degassed.

**Flow rate:** 1.0 mL/min.

**Post-column solution:** 20 g/L carbonate-free solution of sodium hydroxide *R* previously degassed, which is added pulse-less to the column effluent using a 375  $\mu$ L polymeric mixing coil.

**Flow rate:** 0.3 mL/min.

**Detection:** pulsed amperometric detector with a gold indicator electrode, a silver-silver chloride reference electrode and a stainless steel auxiliary electrode which is the cell body, held at respectively + 0.05 V detection, + 0.75 V oxidation and – 0.15 V reduction potentials, with pulse durations according to the instrument used.

**Injection:** 20  $\mu$ L; inject test solutions (a) and (b) and reference solution (d).

**Run time:** 3 times the retention time of netilmicin.

**Retention time:** netilmicin = about 12 min.

**System suitability:**

– resolution: minimum of 2.0 between the peaks due to impurity B (first peak) and to impurity A (second peak); minimum of 3.0 between the peaks due to impurity A (second peak) and to netilmicin (third peak) in the chromatogram obtained with reference solution (d). If necessary, adjust the concentration of sodium octanesulfonate in the mobile phase.

– signal-to-noise ratio: minimum of 10 for the principal peak in the chromatogram obtained with test solution (b).

**Limits:**

– impurity A: not more than the area of the second peak in the chromatogram obtained with reference solution (d) and taking into account the declared content of sisomicin sulfate CRS (1 per cent),

– impurity B: not more than the area of the first peak in the chromatogram obtained with reference solution (d) and taking into account the declared content of 1-*N*-ethylgaramine sulfate CRS (1 per cent),

– any other impurity: not more than the area of the third peak in the chromatogram obtained with reference solution (d) (1 per cent),

– total of other impurities: not more than twice the area of the third peak in the chromatogram obtained with reference solution (d) (2 per cent),

– disregard limit: any peak with an area less than that of the principal peak in the chromatogram obtained with test solution (b) (0.1 per cent).

**Sulfate:** 31.5 per cent to 35.0 per cent (dried substance).

Dissolve 0.12 g in 100 mL of water *R* and adjust the solution to pH 11 using concentrated ammonia *R*. Add 30.0 mL of 0.1 M barium chloride and about 0.5 mg of phthalein purple *R*. Titrate with 0.1 M sodium edetate adding 50 mL of alcohol *R* when the colour of the solution begins to change and continue the titration until the violet-blue colour disappears.

1 mL of 0.1 M barium chloride is equivalent to 9.606 mg of SO<sub>4</sub>.

**Loss on drying** (2.2.32): maximum 15.0 per cent, determined on 0.500 g by drying at 110 °C under high vacuum for 3 h.

**Sulfated ash** (2.4.14): maximum 1.0 per cent, determined on 0.5 g.

**Bacterial endotoxins** (2.6.14): less than 1.25 IU/mg, if intended for use in the manufacture of parenteral preparations without a further appropriate procedure for the removal of bacterial endotoxins.

#### ASSAY

Carry out the microbiological assay of antibiotics (2.7.2), using the diffusion method.

#### STORAGE

In an airtight container, protected from light. If the substance is sterile, store in a sterile, airtight, tamper-proof container.

#### IMPURITIES

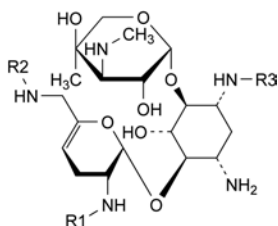

- A. R<sub>1</sub> = R<sub>2</sub> = R<sub>3</sub> = H: 2-deoxy-4-*O*-[3-deoxy-4-*C*-methyl-3-(methylamino)-β-*L*-arabinopyranosyl]-6-*O*-(2,6-diamino-2,3,4,6-tetra-deoxy-α-*D*-glycero-hex-4-enopyranosyl)-*L*-streptamine (sisomicin),
- C. R<sub>1</sub> = R<sub>3</sub> = C<sub>2</sub>H<sub>5</sub>, R<sub>2</sub> = H: 4-*O*-[6-amino-2,3,4,6-tetra-deoxy-2-(ethylamino)-α-*D*-glycero-hex-4-enopyranosyl]-2-deoxy-6-*O*-[3-deoxy-4-*C*-methyl-3-(methylamino)-β-*L*-arabinopyranosyl]-1-*N*-ethyl-*D*-streptamine (2'-*N*-ethylnetilmicin),
- D. R<sub>1</sub> = H, R<sub>2</sub> = R<sub>3</sub> = C<sub>2</sub>H<sub>5</sub>: 4-*O*-[2-amino-2,3,4,6-tetra-deoxy-6-(ethylamino)-α-*D*-glycero-hex-4-enopyranosyl]-2-deoxy-6-*O*-[3-deoxy-4-*C*-methyl-3-(methylamino)-β-*L*-arabinopyranosyl]-1-*N*-ethyl-*D*-streptamine (6'-*N*-ethylnetilmicin),

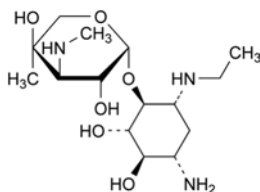

- B. 2-deoxy-6-*O*-[3-deoxy-4-*C*-methyl-3-(methylamino)-β-*L*-arabinopyranosyl]-1-*N*-ethyl-*D*-streptamine (1-*N*-ethylgaramine).

01/2008:2255  
corrected 6.0

## NEVIRAPINE, ANHYDROUS

### Nevirapinum anhydricum

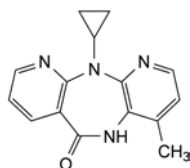

C<sub>15</sub>H<sub>14</sub>N<sub>4</sub>O  
[129618-40-2]

*M*<sub>r</sub> 266.3

#### DEFINITION

11-Cyclopropyl-4-methyl-5,11-dihydro-6*H*-dipyrido [3,2-*b*:2',3'-*e*][1,4]diazepin-6-one.

**Content:** 97.5 per cent to 102.0 per cent (dried substance).

#### CHARACTERS

**Appearance:** white or almost white powder.

**Solubility:** practically insoluble in water, sparingly soluble or slightly soluble in methylene chloride, slightly soluble in methanol.

#### IDENTIFICATION

A. Infrared absorption spectrophotometry (2.2.24).

*Comparison:* anhydrous nevirapine CRS.

B. Loss on drying (see Tests).

#### TESTS

**Related substances.** Liquid chromatography (2.2.29).

**Test solution (a).** Dissolve 24.0 mg of the substance to be examined in a mixture of 4 mL of acetonitrile *R* and 80 mL of the mobile phase and sonicate until dissolution is complete. Dilute to 100.0 mL with the mobile phase.

**Test solution (b).** Dilute 3.0 mL of test solution (a) to 25.0 mL with the mobile phase.

**Reference solution (a).** Dilute 1.0 mL of test solution (a) to 100.0 mL with the mobile phase. Dilute 5.0 mL of this solution to 50.0 mL with the mobile phase.

**Reference solution (b).** Add 2.0 mL of the mobile phase to a vial of nevirapine for peak identification CRS (containing impurities A, B and C), mix and sonicate for 1 min.

**Reference solution (c).** Dissolve 24.0 mg of anhydrous nevirapine CRS in a mixture of 4 mL of acetonitrile *R* and 80 mL of the mobile phase and sonicate until complete dissolution. Dilute to 100.0 mL with the mobile phase. Dilute 3.0 mL of this solution to 25.0 mL with the mobile phase.

**Column:**

- size: *l* = 0.15 m,  $\varnothing$  = 4.6 mm,
- stationary phase: hexadecylamidylsilyl silica gel for chromatography *R* (5  $\mu$ m),
- temperature: 35 °C.

**Mobile phase:** mix 20 volumes of acetonitrile *R* and 80 volumes of a 2.88 g/L solution of ammonium dihydrogen phosphate *R*, previously adjusted to pH 5.0 using dilute sodium hydroxide solution *R*.

**Flow rate:** 1.0 mL/min.

**Detection:** spectrophotometer at 220 nm.

**Injection:** 50  $\mu$ L of test solution (a) and reference solutions (a) and (b).

**Run time:** 10 times the retention time of nevirapine.

**Identification of impurities:** use the chromatogram supplied with nevirapine for peak identification CRS and the chromatogram obtained with reference solution (b) to identify the peaks due to impurities A, B and C.

**Relative retention** with reference to nevirapine (retention time = about 8 min): impurity B = 0.7; impurity A = 1.5; impurity C = 2.8.

**System suitability:** reference solution (b):

- resolution: minimum 5 between the peaks due to impurity B and nevirapine.

**Limits:**

- impurities A, B, C: for each impurity, not more than twice the area of the principal peak in the chromatogram obtained with reference solution (a) (0.2 per cent),
- unspecified impurities: for each impurity, not more than the area of the principal peak in the chromatogram obtained with reference solution (a) (0.1 per cent),
- total: not more than 6 times the area of the principal peak in the chromatogram obtained with reference solution (a) (0.6 per cent),



– *disregard limit*: 0.5 times the area of the principal peak in the chromatogram obtained with reference solution (a) (0.05 per cent).

**Heavy metals** (2.4.8): maximum 20 ppm.

0.50 g complies with test G. Prepare the reference solution using 1 mL of *lead standard solution* (10 ppm Pb) R.

**Loss on drying** (2.2.32): maximum 0.5 per cent, determined on 1.000 g by drying in an oven at 105 °C.

**Sulfated ash** (2.4.14): maximum 0.1 per cent, determined on 1.0 g.

#### ASSAY

Liquid chromatography (2.2.29) as described in the test for related substances with the following modification.

*Injection*: 25 µL of test solution (b) and reference solution (c).

Calculate the percentage content of C<sub>15</sub>H<sub>14</sub>N<sub>4</sub>O from the declared content of *anhydrous nevirapine CRS*.

#### IMPURITIES

*Specified impurities*: A, B, C.

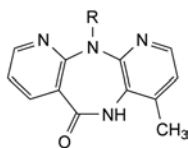

- A. R = C<sub>2</sub>H<sub>5</sub>: 11-ethyl-4-methyl-5,11-dihydro-6*H*-dipyrido[3,2-*b*:2',3'-*e*][1,4]diazepin-6-one,  
 B. R = H: 4-methyl-5,11-dihydro-6*H*-dipyrido[3,2-*b*:2',3'-*e*][1,4]diazepin-6-one,  
 C. R = CH<sub>2</sub>-CH<sub>2</sub>-CH<sub>3</sub>: 4-methyl-11-propyl-5,11-dihydro-6*H*-dipyrido[3,2-*b*:2',3'-*e*][1,4]diazepin-6-one.

01/2008:1998

## NICERGOLINE

### Nicergolinum

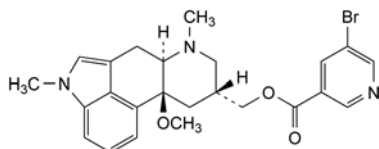

C<sub>24</sub>H<sub>26</sub>BrN<sub>3</sub>O<sub>3</sub>  
[27848-84-6]

*M<sub>r</sub>* 484.4

#### DEFINITION

[(6*aR*,9*R*,10*aS*)-10*a*-Methoxy-4,7-dimethyl-4,6,6*a*,7,8,9,10,10*a*-octahydroindolo[4,3-*fg*]quinolin-9-yl]methyl 5-bromopyridine-3-carboxylate.

*Content*: 99.0 per cent to 101.0 per cent (anhydrous substance).

#### CHARACTERS

*Appearance*: fine to granular, white or yellowish powder.

*Solubility*: practically insoluble in water, freely soluble in methylene chloride, soluble in alcohol.

It shows polymorphism (5.9).

#### IDENTIFICATION

*First identification*: A, C.

*Second identification*: A, B, D.

- A. Specific optical rotation (2.2.7): + 4.8 to + 5.8 (anhydrous substance).  
 Dissolve 0.50 g in *alcohol R* and dilute to 10.0 mL with the same solvent.

B. Dissolve 50.0 mg in *alcohol R* and dilute to 100.0 mL with the same solvent. Dilute 5.0 mL to 50.0 mL with *alcohol R*. Examined between 220 nm and 350 nm (2.2.25), the solution shows an absorption maximum at 288 nm and an absorption minimum at 251 nm. The specific absorbance at the maximum at 288 nm is 175 to 185 (anhydrous substance).

C. Infrared absorption spectrophotometry (2.2.24).

*Preparation*: discs.

*Comparison*: *Ph. Eur. reference spectrum of nicergoline*.

If the spectra obtained show differences, dissolve the substance to be examined in *alcohol R*, evaporate to dryness and record a further spectrum using the residue.

D. Dissolve 2 mg in 2 mL of *sulfuric acid R*. A blue colour develops.

#### TESTS

**Appearance of solution.** The solution is not more opalescent than reference suspension II (2.2.1) and not more intensely coloured than intensity 5 of the range of reference solutions of the most appropriate colour (2.2.2, *Method II*).

Dissolve 0.5 g in *alcohol R* and dilute to 10 mL with the same solvent.

**Related substances.** Liquid chromatography (2.2.29).

*Test solution.* Dissolve 25.0 mg in *acetonitrile R* and dilute to 25.0 mL with the same solvent.

*Reference solution (a).* Dilute 1.0 mL of the test solution to 100.0 mL with *acetonitrile R*. Dilute 10.0 mL of this solution to 50.0 mL with *acetonitrile R*.

*Reference solution (b).* Dissolve 25.0 mg of the substance to be examined and 10.0 mg of *nicergoline impurity A CRS* in *acetonitrile R* and dilute to 25.0 mL with the same solvent. Dilute 1.0 mL to 100.0 mL with *acetonitrile R*.

*Column*:

- *size*: *l* = 0.25 m, Ø = 4.6 mm,
- *stationary phase*: octadecylsilyl silica gel for chromatography R (5 µm).

*Mobile phase*: mix 30 volumes of *acetonitrile R*, 35 volumes of *methanol R* and 35 volumes of a freshly prepared solution of 6.8 g/L *potassium dihydrogen phosphate R* previously adjusted to pH 7.0 with *triethylamine R*.

*Flow rate*: 1.0 mL/min.

*Detection*: spectrophotometer at 288 nm.

*Injection*: 20 µL.

*Run time*: twice the retention time of nicergoline.

*Relative retention* with reference to nicergoline (retention time = about 25 min): impurity B = 0.5.

*System suitability*: reference solution (b):

- *resolution*: minimum 1.5 between the peaks due to nicergoline and impurity A.

*Limits*:

- *impurity B*: not more than 4 times the area of the principal peak in the chromatogram obtained with reference solution (a) (0.8 per cent),
- *any other impurity*: not more than 2.5 times the area of the principal peak in the chromatogram obtained with reference solution (a) (0.5 per cent) and not more than 2 such peaks have an area greater than the area of the principal peak in the chromatogram obtained with reference solution (a) (0.2 per cent),
- *total*: not more than 7.5 times the area of the principal peak in the chromatogram obtained with reference solution (a) (1.5 per cent),
- *disregard limit*: 0.25 times the area of the principal peak in the chromatogram obtained with reference solution (a) (0.05 per cent).

**Water** (2.5.32): maximum 0.5 per cent, determined on 0.100 g.

**Sulfated ash** (2.4.14): maximum 0.1 per cent, determined on 1.0 g.

#### ASSAY

Dissolve 0.400 g in 50 mL of *acetone R*. Titrate with 0.1 M *perchloric acid*, determining the end-point potentiometrically (2.2.20). Titrate to the 1<sup>st</sup> point of inflexion.

1 mL of 0.1 M *perchloric acid* is equivalent to 48.44 mg of C<sub>24</sub>H<sub>26</sub>BrN<sub>3</sub>O<sub>3</sub>.

#### IMPURITIES

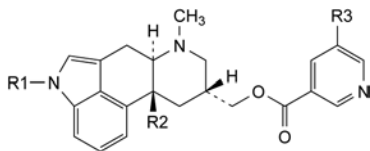

- A. R1 = CH<sub>3</sub>, R2 = OCH<sub>3</sub>, R3 = Cl: [(6*aR*,9*R*,10*aS*)-10*a*-methoxy-4,7-dimethyl-4,6,6*a*,7,8,9,10,10*a*-octahydroindolo[4,3-*fg*]quinolin-9-yl]methyl 5-chloropyridine-3-carboxylate,
- B. R1 = H, R2 = OCH<sub>3</sub>, R3 = Br: [(6*aR*,9*R*,10*aS*)-10*a*-methoxy-7-methyl-4,6,6*a*,7,8,9,10,10*a*-octahydroindolo[4,3-*fg*]quinolin-9-yl]methyl 5-bromopyridine-3-carboxylate,
- E. R1 = CH<sub>3</sub>, R2 = OH, R3 = Br: [(6*aR*,9*R*,10*aS*)-10*a*-hydroxy-4,7-dimethyl-4,6,6*a*,7,8,9,10,10*a*-octahydroindolo[4,3-*fg*]quinolin-9-yl]methyl 5-bromopyridine-3-carboxylate,
- G. R1 = CH<sub>3</sub>, R2 = H, R3 = Br: [(6*aR*,9*R*,10*aR*)-4,7-dimethyl-4,6,6*a*,7,8,9,10,10*a*-octahydroindolo[4,3-*fg*]quinolin-9-yl]methyl 5-bromopyridine-3-carboxylate

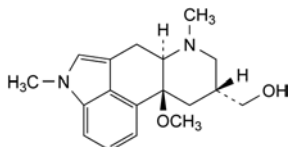

- C. [(6*aR*,9*R*,10*aS*)-10*a*-methoxy-4,7-dimethyl-4,6,6*a*,7,8,9,10,10*a*-octahydroindolo[4,3-*fg*]quinolin-9-yl]methanol,

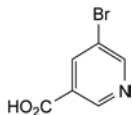

- D. 5-bromopyridine-3-carboxylic acid,

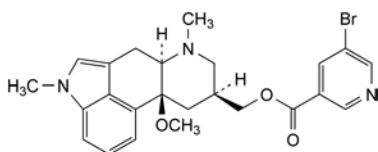

- F. [(6*aR*,9*S*,10*aS*)-10*a*-methoxy-4,7-dimethyl-4,6,6*a*,7,8,9,10,10*a*-octahydroindolo[4,3-*fg*]quinolin-9-yl]methyl 5-bromopyridine-3-carboxylate.

01/2008:0679  
corrected 6.0

## NICLOSAMIDE, ANHYDROUS

### Niclosamidum anhydricum

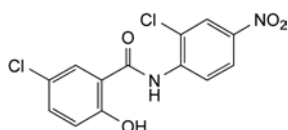

C<sub>13</sub>H<sub>8</sub>Cl<sub>2</sub>N<sub>2</sub>O<sub>4</sub>  
[50-65-7]

M<sub>r</sub> 327.1

#### DEFINITION

5-Chloro-*N*-(2-chloro-4-nitrophenyl)-2-hydroxybenzamide.

*Content*: 98.0 per cent to 101.0 per cent (dried substance).

#### CHARACTERS

*Appearance*: yellowish-white or yellowish, fine crystals.

*Solubility*: practically insoluble in water, sparingly soluble in acetone, slightly soluble in anhydrous ethanol.

#### IDENTIFICATION

*First identification*: B, E.

*Second identification*: A, C, D, E.

A. Melting point (2.2.14): 227 °C to 232 °C.

B. Infrared absorption spectrophotometry (2.2.24).

*Preparation*: discs prepared using about 0.5 mg of substance and 0.3 g of *potassium bromide R*.

*Comparison*: *anhydrous niclosamide CRS*.

C. To 50 mg add 5 mL of 1 M *hydrochloric acid* and 0.1 g of *zinc powder R*, heat in a water-bath for 10 min, cool and filter. To the filtrate add 1 mL of a 5 g/L solution of *sodium nitrite R* and allow to stand for 3 min; add 2 mL of a 20 g/L solution of *ammonium sulfamate R*, shake, allow to stand for 3 min and add 2 mL of a 5 g/L solution of *naphthylethylenediamine dihydrochloride R*. A violet colour is produced.

D. Heat the substance on a copper wire in a non-luminous flame. The flame becomes green.

E. Loss on drying (see Tests).

#### TESTS

**Related substances.** Liquid chromatography (2.2.29).

*Test solution.* Dissolve 50 mg of the substance to be examined in *methanol R*, heating gently, cool and dilute to 50.0 mL with the same solvent.

*Reference solution.* Dilute 1.0 mL of the test solution to 100.0 mL with *acetonitrile R*. Dilute 1.0 mL of this solution to 20.0 mL with *acetonitrile R*.

*Column*:

– *size*: *l* = 0.125 m, Ø = 4 mm;

– *stationary phase*: octadecylsilyl silica gel for chromatography R (5 µm).

*Mobile phase*: mixture of equal volumes of *acetonitrile R* and a solution containing 2 g/L of *potassium dihydrogen phosphate R*, 1 g/L of *disodium hydrogen phosphate R* and 2 g/L of *tetrabutylammonium hydrogen sulfate R*.

*Flow rate*: 1.0 mL/min.

*Detection*: spectrophotometer at 230 nm.

*Injection*: 20 µL.

*Run time*: twice the retention time of niclosamide.

*Limits*:

– *total*: not more than 4 times the area of the principal peak in the chromatogram obtained with the reference solution (0.2 per cent);

– *disregard limit*: 0.1 times the area of the principal peak in the chromatogram obtained with the reference solution (0.005 per cent).

**5-Chlorosalicylic acid**: maximum 60 ppm.

*Test solution.* To 1.0 g add 15 mL of *water R*, boil for 2 min, cool, filter through a membrane filter (nominal pore size 0.45 µm), wash the filter and dilute the combined filtrate and washings to 20.0 mL with *water R*.

*Reference solution.* Dissolve 30 mg of *5-chlorosalicylic acid R* in 20 mL of *methanol R* and dilute to 100.0 mL with *water R*. Dilute 1.0 mL of this solution to 100.0 mL with *water R*.

To 10.0 mL of the test solution and to 10.0 mL of the reference solution add separately 0.1 mL of *ferric chloride solution R2*. Any violet colour in the test solution is not more intense than that in the reference solution.

**2-Chloro-4-nitroaniline:** maximum 100 ppm.

**Test solution.** To 0.250 g add 5 mL of *methanol R*, heat to boiling, cool, add 45 mL of *1 M hydrochloric acid*, heat again to boiling, cool, filter and dilute the filtrate to 50.0 mL with *1 M hydrochloric acid*.

**Reference solution.** Dissolve 50 mg of *2-chloro-4-nitroaniline R* in *methanol R* and dilute to 100.0 mL with the same solvent. Dilute 1.0 mL of the solution to 100.0 mL with *methanol R*. Dilute 2.0 mL of this solution to 20.0 mL with *1 M hydrochloric acid*.

To 10.0 mL of the test solution and to 10.0 mL of the reference solution add separately 0.5 mL of a 5 g/L solution of *sodium nitrite R* and allow to stand for 3 min. Add 1 mL of a 20 g/L solution of *ammonium sulfamate R*, shake, allow to stand for 3 min and add 1 mL of a 5 g/L solution of *naphthylethylenediamine dihydrochloride R*. Any pinkish-violet colour in the test solution is not more intense than that in the reference solution.

**Chlorides (2.4.4):** maximum 500 ppm.

To 2 g add a mixture of 1.2 mL of *acetic acid R* and 40 mL of *water R*, boil for 2 min, cool and filter. Dilute 2 mL of the filtrate to 15 mL with *water R*.

**Loss on drying (2.2.32):** maximum 0.5 per cent, determined on 1.000 g by drying in an oven at 105 °C for 4 h.

**Sulfated ash (2.4.14):** maximum 0.1 per cent, determined on 1.0 g.

#### ASSAY

Dissolve 0.3000 g in 80 mL of a mixture of equal volumes of *acetone R* and *methanol R*. Titrate with *0.1 M tetrabutylammonium hydroxide*, determining the end-point potentiometrically (2.2.20).

1 mL of *0.1 M tetrabutylammonium hydroxide* is equivalent to 32.71 mg of  $C_{13}H_8Cl_2N_2O_4$ .

#### STORAGE

In an airtight container, protected from light.

01/2008:0680  
corrected 6.0

## NICLOSAMIDE MONOHYDRATE

### Niclosamidum monohydricum

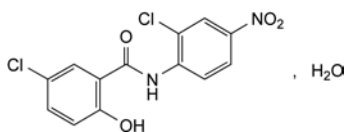

$C_{13}H_8Cl_2N_2O_4 \cdot H_2O$

$M_r$  345.1

#### DEFINITION

5-Chloro-*N*-(2-chloro-4-nitrophenyl)-2-hydroxybenzamide monohydrate.

**Content:** 98.0 per cent to 101.0 per cent (dried substance).

#### CHARACTERS

**Appearance:** yellowish, fine crystals.

**Solubility:** practically insoluble in water, sparingly soluble in acetone, slightly soluble in anhydrous ethanol.

#### IDENTIFICATION

**First identification:** B, E.

**Second identification:** A, C, D, E.

A. Melting point (2.2.14): 227 °C to 232 °C, determined after drying at 100-105 °C for 4 h.

B. Infrared absorption spectrophotometry (2.2.24).

**Preparation:** dry the substance to be examined at 100-105 °C for 4 h and examine as discs prepared using about 0.5 mg of substance and 0.3 g of *potassium bromide R*.

**Comparison:** *anhydrous niclosamide CRS*.

C. To 50 mg add 5 mL of *1 M hydrochloric acid* and 0.1 g of *zinc powder R*, heat in a water-bath for 10 min, cool and filter. To the filtrate add 1 mL of a 5 g/L solution of *sodium nitrite R* and allow to stand for 3 min; add 2 mL of a 20 g/L solution of *ammonium sulfamate R*, shake, allow to stand for 3 min and add 2 mL of a 5 g/L solution of *naphthylethylenediamine dihydrochloride R*. A violet colour is produced.

D. Heat the substance on a copper wire in a non-luminous flame. The flame becomes green.

E. Loss on drying (see Tests).

#### TESTS

**Related substances.** Liquid chromatography (2.2.29).

**Test solution.** Dissolve 50 mg of the substance to be examined in *methanol R*, heating gently, cool and dilute to 50.0 mL with the same solvent.

**Reference solution.** Dilute 1.0 mL of the test solution to 100.0 mL with *acetonitrile R*. Dilute 1.0 mL of this solution to 20.0 mL with *acetonitrile R*.

**Column:**

– size:  $l = 0.125$  m,  $\varnothing = 4$  mm;

– stationary phase: *octadecylsilyl silica gel for chromatography R* (5  $\mu$ m).

**Mobile phase:** mixture of equal volumes of *acetonitrile R* and a solution containing 2 g/L of *potassium dihydrogen phosphate R*, 1 g/L of *disodium hydrogen phosphate R* and 2 g/L of *tetrabutylammonium hydrogen sulfate R*.

**Flow rate:** 1.0 mL/min.

**Detection:** spectrophotometer at 230 nm.

**Injection:** 20  $\mu$ L.

**Run time:** twice the retention time of niclosamide.

**Limits:**

– total: not more than 4 times the area of the principal peak in the chromatogram obtained with the reference solution (0.2 per cent);

– disregard limit: 0.1 times the area of the principal peak in the chromatogram obtained with the reference solution (0.005 per cent).

**5-Chlorosalicylic acid:** maximum 60 ppm.

**Test solution.** To 1.0 g add 15 mL of *water R*, boil for 2 min, cool, filter through a membrane filter (nominal pore size 0.45  $\mu$ m), wash the filter and dilute the combined filtrate and washings to 20.0 mL with *water R*.

**Reference solution.** Dissolve 30 mg of *5-chlorosalicylic acid R* in 20 mL of *methanol R* and dilute to 100.0 mL with *water R*. Dilute 1.0 mL of this solution to 100.0 mL with *water R*.

To 10.0 mL of the test solution and to 10.0 mL of the reference solution add separately 0.1 mL of *ferric chloride solution R2*. Any violet colour produced in the test solution is not more intense than that in the reference solution.

**2-Chloro-4-nitroaniline:** maximum 100 ppm.

**Test solution.** To 0.250 g add 5 mL of *methanol R*, heat to boiling, cool, add 45 mL of *1 M hydrochloric acid*, heat again to boiling, cool, filter and dilute the filtrate to 50.0 mL with *1 M hydrochloric acid*.

**Reference solution.** Dissolve 50 mg of *2-chloro-4-nitroaniline R* in *methanol R* and dilute to 100.0 mL with the same solvent. Dilute 1.0 mL of the solution to 100.0 mL with *methanol R*. Dilute 2.0 mL of this solution to 20.0 mL with *1 M hydrochloric acid*.

To 10.0 mL of the test solution and to 10.0 mL of the reference solution add separately 0.5 mL of a 5 g/L solution of *sodium nitrite R* and allow to stand for 3 min. Add 1 mL

of a 20 g/L solution of *ammonium sulfamate R*, shake, allow to stand for 3 min and add 1 mL of a 5 g/L solution of *naphthylethylenediamine dihydrochloride R*. Any pinkish-violet colour produced in the test solution is not more intense than that in the reference solution.

**Chlorides (2.4.4):** maximum 500 ppm.

To 2 g add a mixture of 1.2 mL of *acetic acid R* and 40 mL of *water R*, boil for 2 min, cool and filter. Dilute 2 mL of the filtrate to 15 mL with *water R*.

**Loss on drying (2.2.32):** 4.5 per cent to 6.0 per cent, determined on 1.000 g by drying in an oven at 105 °C for 4 h.

**Sulfated ash (2.4.14):** maximum 0.1 per cent, determined on 1.0 g.

#### ASSAY

Dissolve 0.3000 g in 80 mL of a mixture of equal volumes of *acetone R* and *methanol R*. Titrate with 0.1 M *tetrabutylammonium hydroxide*, determining the end-point potentiometrically (2.2.20).

1 mL of 0.1 M *tetrabutylammonium hydroxide* is equivalent to 32.71 mg of C<sub>13</sub>H<sub>8</sub>Cl<sub>2</sub>N<sub>2</sub>O<sub>4</sub>.

#### STORAGE

Protected from light.

01/2008:0047  
corrected 6.0

## NICOTINAMIDE

### Nicotinamidum

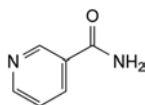

C<sub>6</sub>H<sub>6</sub>N<sub>2</sub>O  
[98-92-0]

*M*<sub>r</sub> 122.1

#### DEFINITION

Nicotinamide contains not less than 99.0 per cent and not more than the equivalent of 101.0 per cent of pyridine-3-carboxamide, calculated with reference to the dried substance.

#### CHARACTERS

A white or almost white, crystalline powder or colourless crystals, freely soluble in water and in ethanol.

#### IDENTIFICATION

*First identification: A, B.*

*Second identification: A, C, D.*

- Melting point (2.2.14): 128 °C to 131 °C.
- Examine by infrared absorption spectrophotometry (2.2.24), comparing with the spectrum obtained with *nicotinamide CRS*.
- Boil 0.1 g with 1 mL of *dilute sodium hydroxide solution R*. Ammonia is evolved which is recognisable by its odour.
- Dilute 2 mL of solution S (see Tests) to 100 mL with *water R*. To 2 mL of the solution, add 2 mL of *cyanogen bromide solution R* and 3 mL of a 25 g/L solution of *aniline R* and shake. A yellow colour develops.

#### TESTS

**Solution S.** Dissolve 2.5 g in *carbon dioxide-free water R* and dilute to 50 mL with the same solvent.

**Appearance of solution.** Solution S is clear (2.2.1) and not more intensely coloured than reference solution BY<sub>7</sub> (2.2.2, *Method II*).

**pH (2.2.3).** The pH of solution S is 6.0 to 7.5.

**Related substances.** Examine by thin-layer chromatography (2.2.27), using a *TLC silica gel GF<sub>254</sub> plate R*.

**Test solution.** Dissolve 0.4 g of the substance to be examined in a mixture of equal volumes of *alcohol R* and *water R* and dilute to 5.0 mL with the same mixture of solvents.

**Reference solution.** Dilute 0.5 mL of the test solution to 200 mL with a mixture of equal volumes of *alcohol R* and *water R*.

Apply to the plate 5 µL of each solution. Develop over a path of 10 cm using a mixture of 4 volumes of *water R*, 45 volumes of *ethanol R* and 48 volumes of *chloroform R*. Allow the plate to dry and examine in ultraviolet light at 254 nm. Any spot in the chromatogram obtained with the test solution, apart from the principal spot, is not more intense than the spot in the chromatogram obtained with the reference solution (0.25 per cent).

**Heavy metals (2.4.8).** Dilute 12 mL of solution S to 18 mL with *water R*. 12 mL of the solution complies with limit test A for heavy metals (30 ppm). Prepare the standard using *lead standard solution (1 ppm Pb) R*.

**Loss on drying (2.2.32).** Not more than 0.5 per cent, determined on 1.00 g by drying *in vacuo* for 18 h.

**Sulfated ash (2.4.14).** Not more than 0.1 per cent, determined on 1.0 g.

#### ASSAY

Dissolve 0.250 g in 20 mL of *anhydrous acetic acid R*, heating slightly if necessary, and add 5 mL of *acetic anhydride R*. Titrate with 0.1 M *perchloric acid*, using *crystal violet solution R* as indicator until the colour changes to greenish-blue.

1 mL of 0.1 M *perchloric acid* is equivalent to 12.21 mg of C<sub>6</sub>H<sub>6</sub>N<sub>2</sub>O.

01/2009:1452  
corrected 6.6

## NICOTINE

### Nicotinum

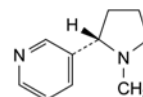

C<sub>10</sub>H<sub>14</sub>N<sub>2</sub>  
[54-11-5]

*M*<sub>r</sub> 162.2

#### DEFINITION

3-[(2*S*)-1-Methylpyrrolidin-2-yl]pyridine.

**Content:** 99.0 per cent to 101.0 per cent (anhydrous substance).

#### CHARACTERS

**Appearance:** colourless or brownish viscous liquid, volatile, hygroscopic.

**Solubility:** soluble in water, miscible with anhydrous ethanol.

#### IDENTIFICATION

- Specific optical rotation (see Tests).
- Infrared absorption spectrophotometry (2.2.24).  
*Comparison: Ph. Eur. reference spectrum of nicotine.*

#### TESTS

**Appearance of solution.** Dissolve 1.0 g in *water R* and dilute to 10 mL with the same solvent. The solution is clear (2.2.1) and not more intensely coloured than reference solution Y<sub>5</sub>, BY<sub>5</sub> or R<sub>5</sub> (2.2.2, *Method II*).

**Specific optical rotation (2.2.7):** –140 to –152.

Dissolve 1.00 g in *anhydrous ethanol R* and dilute to 50.0 mL with the same solvent.

**Related substances.** Liquid chromatography (2.2.29). Prepare the solutions immediately before use.

**Test solution.** Dissolve 20.0 mg of the substance to be examined in water R and dilute to 25.0 mL with the same solvent.

**Reference solution (a).** Dissolve the contents of a vial of nicotine for system suitability CRS (containing impurities A, B, C, D, E, F and G) in 1.0 mL of water R.

**Reference solution (b).** Dilute 1.0 mL of the test solution to 10.0 mL with water R. Dilute 1.0 mL of this solution to 100.0 mL with water R.

**Column:**

- size:  $l = 0.15$  m,  $\varnothing = 4.6$  mm;
- stationary phase: end-capped polar-embedded octadecylsilyl amorphous organosilica polymer R (5  $\mu$ m).

**Mobile phase:**

- mobile phase A: to 900 mL of water R, add 25 mL of a 60 g/L solution of acetic acid R, then add 6 mL of concentrated ammonia R1. Adjust to pH 10.0 with dilute ammonia R2 or dilute acetic acid R and dilute to 1000 mL with water R;
- mobile phase B: acetonitrile R;

Time (min)	Mobile phase A (per cent V/V)	Mobile phase B (per cent V/V)
0 - 3	100	0
3 - 3.01	100 → 95	0 → 5
3.01 - 28	95 → 74	5 → 26
28 - 32	74 → 60	26 → 40

**Flow rate:** 1.0 mL/min.

**Detection:** spectrophotometer at 254 nm.

**Injection:** 20  $\mu$ L.

**Identification of impurities:** use the chromatogram supplied with nicotine for system suitability CRS and the chromatogram obtained with reference solution (a) to identify the peaks due to impurities A, B, C, D, E, F and G.

**Relative retention** with reference to nicotine (retention time = about 17.8 min): impurity E = about 0.3; impurity C = about 0.55; impurity F = about 0.7; impurity A = about 0.8; impurity D = about 0.86; impurity G = about 0.9; impurity B = about 1.6.

**System suitability:** reference solution (a):

- resolution: minimum 2.5 between the peaks due to impurity G and nicotine.

**Limits:**

- impurities A, B, C, D, E, F, G: for each impurity, not more than 3 times the area of the principal peak in the chromatogram obtained with reference solution (b) (0.3 per cent);
- unspecified impurities: for each impurity, not more than the area of the principal peak in the chromatogram obtained with reference solution (b) (0.10 per cent);
- total: not more than 8 times the area of the principal peak in the chromatogram obtained with reference solution (b) (0.8 per cent);
- disregard limit: 0.5 times the area of the principal peak in the chromatogram obtained with reference solution (b) (0.05 per cent).

**Water (2.5.12):** maximum 0.5 per cent, determined on 1.00 g.

**ASSAY**

Dissolve 60.0 mg in 30 mL of anhydrous acetic acid R. Titrate with 0.1 M perchloric acid determining the end-point potentiometrically (2.2.20).

1 mL of 0.1 M perchloric acid is equivalent to 8.11 mg of  $C_{10}H_{14}N_2$ .

**STORAGE**

Under nitrogen, in an airtight container, protected from light.

**IMPURITIES**

**Specified impurities:** A, B, C, D, E, F, G.

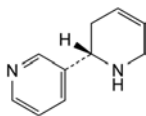

A. (2S)-1,2,3,6-tetrahydro-2,3'-bipyridyl (anatabine),

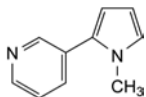

B. 3-(1-methyl-1H-pyrrol-2-yl)pyridine ( $\beta$ -nicotyrine),

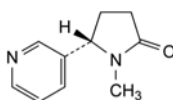

C. (5S)-1-methyl-5-(pyridin-3-yl)pyrrolidin-2-one (cotinine),

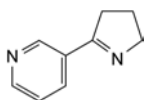

D. 3-(4,5-dihydro-3H-pyrrol-2-yl)pyridine (myosmine),

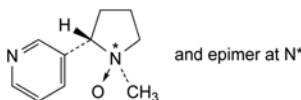

E. (1RS,2S)-1-methyl-2-(pyridin-3-yl)pyrrolidine 1-oxide (nicotine  $N'$ -oxide),

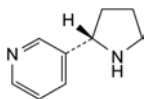

F. 3-[(2S)-pyrrolidin-2-yl]pyridine (nornicotine),

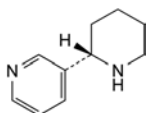

G. 3-[(2S)-piperidin-2-yl]pyridine (anabasine).

01/2009:1792  
corrected 6.6

## NICOTINE RESINATE

### Nicotini resinas

**DEFINITION**

Complex of nicotine (3-[(2S)-1-methylpyrrolidin-2-yl]pyridine) with a weak cationic exchange resin.

**Content:** 95.0 per cent to 115.0 per cent of the declared content of nicotine ( $C_{10}H_{14}N_2$ ) stated on the label (anhydrous substance).

It may contain glycerol.

**CHARACTERS**

**Appearance:** white or slightly yellowish powder.

**Solubility:** practically insoluble in water.

## IDENTIFICATION

## A. Infrared absorption spectrophotometry (2.2.24).

*Preparation:* shake a quantity of the substance to be examined equivalent to 100 mg of nicotine with a mixture of 10 mL of *dilute ammonia R2*, 10 mL of *water R*, 5 mL of *strong sodium hydroxide solution R* and 20 mL of *hexane R* for 5 min. Transfer the upper layer to a beaker and evaporate to produce an oily residue. Record the spectrum of the oily residue as a thin film between *sodium chloride R* plates.

*Comparison:* Ph. Eur. reference spectrum of nicotine.

## B. Nicotine release (see Tests).

## TESTS

**Nicotine release:** minimum 70 per cent of the content determined under Assay in 10 min.

Transfer an accurately weighed quantity of the substance to be examined equivalent to about 4 mg of nicotine, to a glass-stoppered test-tube, add 10.0 mL of a 9 g/L solution of *sodium chloride R* previously heated to 37 °C and shake vigorously for 10 min. Immediately filter the liquid through a dry filter paper discarding the 1<sup>st</sup> millilitre of filtrate. Transfer 1.0 mL of the filtrate to a 20 mL volumetric flask, dilute to 20 mL with 0.1 M *hydrochloric acid* and mix. Determine the absorbance (2.2.25) at the minima at about 236 nm and 282 nm and at the maximum at 259 nm using 1.0 mL of a 9 g/L solution of *sodium chloride R* diluted to 20 mL with 0.1 M *hydrochloric acid* as compensation liquid.

Calculate the percentage of nicotine release using the following expression:

$$\frac{20 \times 10^6 \times (A_{259} - 0.5A_{236} - 0.5A_{282})}{323 \times C \times m}$$

323	=	specific absorbance of nicotine at 259 nm;
C	=	percentage of nicotine in the substance to be examined determined in the assay;
m	=	mass of the substance to be examined, in milligrams;
$A_{236}, A_{259}, A_{282}$	=	absorbances of the solution at the wavelength indicated by the subscript.

**Related substances.** Liquid chromatography (2.2.29). Prepare the solutions immediately before use.

*Test solution.* Weigh a quantity of the substance to be examined equivalent to 30.0 mg of nicotine into a glass-stoppered test-tube, add 10.0 mL of *dilute ammonia R2* solution and shake vigorously for 10 min. Centrifuge for 20 min at about 3000 r/min. To 5.0 mL of the clear solution, add 5 mL of a 60 g/L solution of *acetic acid R* and dilute to 25.0 mL with *water R*.

*Reference solution (a).* Dissolve the contents of a vial of *nicotine for system suitability CRS* (containing impurities A, B, C, D, E, F and G) in 1.0 mL of *water R*.

*Reference solution (b).* Dilute 1.0 mL of the test solution to 10.0 mL with *water R*. Dilute 1.0 mL of this solution to 100.0 mL with *water R*.

*Reference solution (c).* Dissolve 46.0 mg of *nicotine ditartrate CRS* in *water R* and dilute to 25.0 mL with the same solvent.

*Column:*

- size:  $l = 0.15$  m,  $\varnothing = 4.6$  mm;
- stationary phase: end-capped polar-embedded octadecylsilyl amorphous organosilica polymer R (5 µm).

*Mobile phase:*

- *mobile phase A:* to 900 mL of *water R*, add 25 mL of a 60 g/L solution of *acetic acid R*, then add 6 mL of *concentrated ammonia R1*; adjust to pH 10.0 with *dilute ammonia R2* or *dilute acetic acid R* and dilute to 1000 mL with *water R*;
- *mobile phase B:* *acetonitrile R*;

Time (min)	Mobile phase A (per cent V/V)	Mobile phase B (per cent V/V)
0 - 3	100	0
3 - 3.01	100 → 95	0 → 5
3.01 - 28	95 → 74	5 → 26
28 - 32	74 → 60	26 → 40

*Flow rate:* 1.0 mL/min.

*Detection:* spectrophotometer at 254 nm.

*Injection:* 20 µL.

*Identification of impurities:* use the chromatogram supplied with *nicotine for system suitability CRS* and the chromatogram obtained with reference solution (a) to identify the peaks due to impurities A, B, C, D, E, F and G.

*Relative retention* with reference to nicotine (retention time = about 17.8 min): impurity E = about 0.3; impurity C = about 0.55; impurity F = about 0.7; impurity A = about 0.8; impurity D = about 0.86; impurity G = about 0.9; impurity B = about 1.6.

*System suitability:* reference solution (a):

- *resolution:* minimum 2.5 between the peaks due to impurity G and nicotine.

*Limits:*

- *impurities A, B, C, D, E, F, G:* for each impurity, not more than 3 times the area of the principal peak in the chromatogram obtained with reference solution (b) (0.3 per cent);
- *unspecified impurities:* for each impurity, not more than the area of the principal peak in the chromatogram obtained with reference solution (b) (0.10 per cent);
- *total:* not more than 8 times the area of the principal peak in the chromatogram obtained with reference solution (b) (0.8 per cent);
- *disregard limit:* 0.5 times the area of the principal peak in the chromatogram obtained with reference solution (b) (0.05 per cent).

**Water (2.5.12):** maximum 5.0 per cent.

Suspend 1.0 g in 20.0 mL of *methanol R*, shake for 30 min and allow to stand for 30 min. Use 10 mL of the methanol layer for the titration. Carry out a blank titration.

## ASSAY

Liquid chromatography (2.2.29) as described in the test for related substances with the following modification.

*Injection:* test solution and reference solution (c).

Calculate the percentage content of nicotine ( $C_{10}H_{14}N_2$ ) (anhydrous substance) from the declared content of  $C_{10}H_{14}N_2$  in *nicotine ditartrate CRS*.

## STORAGE

In an airtight container, protected from light.

## LABELLING

The label states the content of nicotine.

## IMPURITIES

Specified impurities: A, B, C, D, E, F, G.

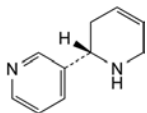

A. (2S)-1,2,3,6-tetrahydro-2,3'-bipyridyl (anatabine),

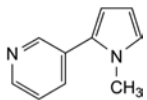
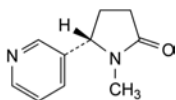
B. 3-(1-methyl-1H-pyrrol-2-yl)pyridine ( $\beta$ -nicotyrine),

C. (5S)-1-methyl-5-(pyridin-3-yl)pyrrolidin-2-one (cotinine),

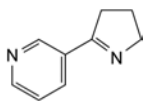

D. 3-(4,5-dihydro-3H-pyrrol-2-yl)pyridine (myosmine),

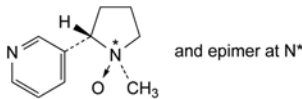
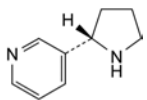
E. (1RS,2S)-1-methyl-2-(pyridin-3-yl)pyrrolidine 1-oxide (nicotine  $N^{\circ}$ -oxide),

F. 3-[(2S)-pyrrolidin-2-yl]pyridine (nornicotine),

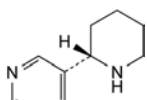

G. 3-[(2S)-piperidin-2-yl]pyridine (anabasine).

01/2011:0459

## NICOTINIC ACID

## Acidum nicotinicum

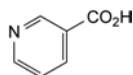
C<sub>6</sub>H<sub>5</sub>NO<sub>2</sub>  
[59-67-6] $M_r$  123.1

## DEFINITION

Pyridine-3-carboxylic acid.

Content: 99.5 per cent to 100.5 per cent (dried substance).

## CHARACTERS

Appearance: white or almost white, crystalline powder.

Solubility: sparingly soluble in water, soluble in boiling water and in boiling ethanol (96 per cent). It dissolves in dilute solutions of alkali hydroxides and carbonates.

## IDENTIFICATION

First identification: A, B.

Second identification: A, C.

A. Melting point (2.2.14): 234 °C to 240 °C.

B. Infrared absorption spectrophotometry (2.2.24).

Comparison: nicotinic acid CRS.

C. Ultraviolet and visible absorption spectrophotometry (2.2.25).

Solvent mixture. Dissolve 6.8 g of potassium dihydrogen phosphate R in 900 mL of water R, adjust to pH 7.0 with dilute sodium hydroxide solution R and dilute to 1000 mL with water R.

Test solution. Dissolve 50 mg in the solvent mixture and dilute to 100.0 mL with the solvent mixture. Dilute 1.0 mL of the solution to 25.0 mL with the solvent mixture.

Spectral range: 237-262 nm.

Absorption maximum: at 262 nm.

Absorption minimum: at 237 nm.

Absorbance ratio:  $A_{237}/A_{262} = 0.46$  to  $0.50$ .

## TESTS

Related substances. Liquid chromatography (2.2.29).

Test solution. Dissolve 0.120 g of the substance to be examined in 200  $\mu$ L of dilute ammonia R1 and dilute to 10.0 mL with mobile phase A.

Reference solution (a). Dilute 1.0 mL of the test solution to 100.0 mL with mobile phase A. Dilute 1.0 mL of this solution to 10.0 mL with mobile phase A.

Reference solution (b). Dissolve the contents of a vial of nicotinic acid impurity mixture CRS (impurities A and B) in 1.0 mL of mobile phase A.

Column:

- size:  $l = 0.25$  m,  $\varnothing = 4.6$  mm;
- stationary phase: end-capped silica gel for chromatography, alkyl-bonded for use with highly aqueous mobile phase R (4  $\mu$ m);
- temperature: 15 °C.

Mobile phase:

- mobile phase A: dilute 2 mL of acetic acid R in 950 mL of water R, adjust to pH 5.6 with dilute ammonia R1 and dilute to 1000 mL with water R;
- mobile phase B: acetonitrile R, methanol R (50:50 V/V);

Time (min)	Mobile phase A (per cent V/V)	Mobile phase B (per cent V/V)
0 - 10	100	0
10 - 30	100→20	0→80
30 - 35	20	80

Flow rate: 1.0 mL/min.

Detection: spectrophotometer at 250 nm.

Injection: 10  $\mu$ L.

Identification of impurities: use the chromatogram supplied with nicotinic acid impurity mixture CRS and the chromatogram obtained with reference solution (b) to identify the peaks due to impurities A and B.

Relative retention with reference to nicotinic acid (retention time = about 6 min): impurity A = about 2.7; impurity B = about 2.8.

System suitability: reference solution (b):

- resolution: minimum 1.5 between the peaks due to impurities A and B.

Limits:

- unspecified impurities: for each impurity, not more than 0.5 times the area of the principal peak in the chromatogram obtained with reference solution (a) (0.05 per cent);
- total: not more than 0.5 times the area of the principal peak in the chromatogram obtained with reference solution (a) (0.05 per cent);
- disregard limit: 0.3 times the area of the principal peak in the chromatogram obtained with reference solution (a) (0.03 per cent).

**Chlorides** (2.4.4): maximum 200 ppm.

Dissolve 0.25 g in *water R*, heating on a water-bath, and dilute to 15 mL with the same solvent.

**Heavy metals** (2.4.8): maximum 20 ppm.

1.0 g complies with test C. Prepare the reference solution using 2 mL of *lead standard solution (10 ppm Pb) R*.

**Loss on drying** (2.2.32): maximum 1.0 per cent, determined on 1.000 g by drying in an oven at 105 °C for 1 h.

**Sulfated ash** (2.4.14): maximum 0.1 per cent, determined on 1.0 g.

#### ASSAY

Dissolve 0.250 g in 50 mL of *water R*. Add 0.25 mL of *phenolphthalein solution R*. Titrate with 0.1 M *sodium hydroxide* until a pink colour is obtained. Carry out a blank titration.

1 mL of 0.1 M *sodium hydroxide* is equivalent to 12.31 mg of  $C_{17}H_{18}N_2O_6$ .

#### STORAGE

Protected from light.

#### IMPURITIES

*Other detectable impurities* (the following substances would, if present at a sufficient level, be detected by one or other of the tests in the monograph. They are limited by the general acceptance criterion for other/unspecified impurities and/or by the general monograph *Substances for pharmaceutical use (2034)*. It is therefore not necessary to identify these impurities for demonstration of compliance. See also 5.10. *Control of impurities in substances for pharmaceutical use*): A, B, C, D, E, F, G, H, I.

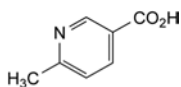

A. 6-methylpyridine-3-carboxylic acid (6-methylnicotinic acid),

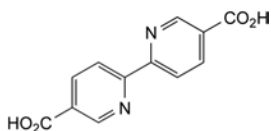

B. 2,2'-bipyridine-5,5'-dicarboxylic acid (6,6'-dinicotinic acid),

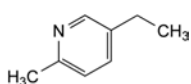

C. 5-ethyl-2-methylpyridine,

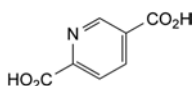

D. pyridine-2,5-dicarboxylic acid,

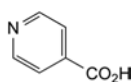

E. pyridine-4-carboxylic acid (isonicotinic acid),

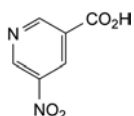

F. 5-nitropyridine-3-carboxylic acid (5-nitronicotinic acid),



G. pyridine,

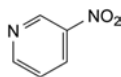

H. 3-nitropyridine,

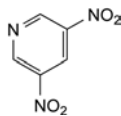

I. 3,5-dinitropyridine.

01/2008:0627  
corrected 6.0

## NIFEDIPINE

### Nifedipinum

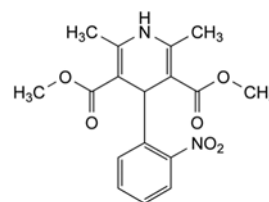

$C_{17}H_{18}N_2O_6$   
[21829-25-4]

$M_r$  346.3

#### DEFINITION

Dimethyl 2,6-dimethyl-4-(2-nitrophenyl)-1,4-dihydropyridine-3,5-dicarboxylate.

*Content*: 98.0 per cent to 102.0 per cent (dried substance).

#### CHARACTERS

*Appearance*: yellow, crystalline powder.

*Solubility*: practically insoluble in water, freely soluble in acetone, sparingly soluble in ethanol.

When exposed to daylight and to artificial light of certain wavelengths, it readily converts to a nitrosophenylpyridine derivative. Exposure to ultraviolet light leads to the formation of a nitrophenylpyridine derivative.

*Prepare solutions immediately before use in the dark or under long-wavelength light (> 420 nm) and protect them from light.*

#### IDENTIFICATION

*First identification*: B.

*Second identification*: A, C, D.

A. Melting point (2.2.14): 171 °C to 175 °C.

B. Infrared absorption spectrophotometry (2.2.24).

*Comparison*: *nifedipine CRS*.

C. Thin-layer chromatography (2.2.27).

*Test solution*. Dissolve 10 mg of the substance to be examined in *methanol R* and dilute to 10 mL with the same solvent.

*Reference solution*. Dissolve 10 mg of *nifedipine CRS* in *methanol R* and dilute to 10 mL with the same solvent.

*Plate*: TLC silica gel  $F_{254}$  plate R.

*Mobile phase*: *ethyl acetate R*, *cyclohexane R* (40:60 V/V).

*Application*: 5 µL.

*Development*: over 3/4 of the plate.

*Drying*: in air.

*Detection*: examine in ultraviolet light at 254 nm.

*Results*: the principal spot in the chromatogram obtained with the test solution is similar in position, appearance at 254 nm and size to the principal spot in the chromatogram obtained with the reference solution.



D. To 25 mg in a test tube, add 10 mL of a mixture of 1.5 volumes of *hydrochloric acid R*, 3.5 volumes of *water R* and 5 volumes of *alcohol R* and dissolve with gentle heating. Add 0.5 g of *zinc R* in granules and allow to stand for 5 min with occasional swirling. Filter into a second test tube, add 5 mL of a 10 g/L solution of *sodium nitrite R* to the filtrate and allow to stand for 2 min. Add 2 mL of a 50 g/L solution of *ammonium sulfamate R*, shake vigorously with care and add 2 mL of a 5 g/L solution of *naphthylethylenediamine dihydrochloride R*. An intense red colour develops which persists for not less than 5 min.

## TESTS

**Impurity D and other basic impurities.** Transfer 4 g to a 250 mL conical flask and dissolve in 160 mL of *glacial acetic acid R* using an ultrasonic bath. Titrate with 0.1 M *perchloric acid* using 0.25 mL of *naphtholbenzein solution R* as indicator until the colour changes from brownish-yellow to green. Not more than 0.48 mL of 0.1 M *perchloric acid* is required (0.14 per cent).

**Related substances.** Liquid chromatography (2.2.29).

**Test solution.** Dissolve 0.200 g of the substance to be examined in 20 mL of *methanol R* and dilute to 50.0 mL with the mobile phase.

**Reference solution (a).** Dissolve 10 mg of *nifedipine impurity A CRS* in *methanol R* and dilute to 25.0 mL with the same solvent.

**Reference solution (b).** Dissolve 10 mg of *nifedipine impurity B CRS* in *methanol R* and dilute to 25.0 mL with the same solvent.

**Reference solution (c).** Mix 1.0 mL of reference solution (a), 1.0 mL of reference solution (b) and 0.1 mL of the test solution and dilute to 20.0 mL with the mobile phase. Dilute 2.0 mL of this solution to 10.0 mL with the mobile phase.

## Column:

- size:  $l = 0.15$  m,  $\varnothing = 4.6$  mm,
- stationary phase: octadecylsilyl silica gel for chromatography R (5  $\mu$ m).

**Mobile phase:** acetonitrile R, *methanol R*, *water R* (9:36:55 V/V/V).

**Flow rate:** 1.0 mL/min.

**Detection:** spectrophotometer at 235 nm.

**Injection:** 20  $\mu$ L; inject the test solution and reference solution (c).

**Run time:** twice the retention time of nifedipine.

**Elution order:** impurity A, impurity B, nifedipine.

**Retention time:** nifedipine = about 15.5 min.

**System suitability:** reference solution (c):

- resolution: minimum 1.5 between the peaks due to impurity A and impurity B and minimum 1.5 between the peaks due to impurity B and nifedipine.

## Limits:

- **impurity A:** not more than the area of the corresponding peak in the chromatogram obtained with reference solution (c) (0.1 per cent),
- **impurity B:** not more than the area of the corresponding peak in the chromatogram obtained with reference solution (c) (0.1 per cent),
- **any other impurity:** not more than the area of the peak due to nifedipine in the chromatogram obtained with reference solution (c) (0.1 per cent),
- **total:** not more than 0.3 per cent,
- **disregard limit:** 0.1 times the area of the peak due to nifedipine in the chromatogram obtained with reference solution (c) (0.01 per cent).

**Loss on drying (2.2.32):** maximum 0.5 per cent, determined on 1.000 g by drying in an oven at 105 °C for 2 h.

**Sulfated ash (2.4.14):** maximum 0.1 per cent, determined on 1.0 g.

## ASSAY

Dissolve 0.1300 g in a mixture of 25 mL of *2-methyl-2-propanol R* and 25 mL of *perchloric acid solution R*. Titrate with 0.1 M *cerium sulfate* using 0.1 mL of *ferroin R* as indicator, until the pink colour disappears. Titrate slowly towards the end of the titration. Carry out a blank titration.

1 mL of 0.1 M *cerium sulfate* is equivalent to 17.32 mg of  $C_{17}H_{18}N_2O_6$ .

## STORAGE

Protected from light.

## IMPURITIES

**Specified impurities:** A, B, C, D.

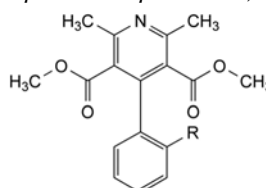

A. R = NO<sub>2</sub>: dimethyl 2,6-dimethyl-4-(2-nitrophenyl)pyridine-3,5-dicarboxylate (nitrophenylpyridine analogue),

B. R = NO: dimethyl 2,6-dimethyl-4-(2-nitrosophenyl)pyridine-3,5-dicarboxylate (nitrosophenylpyridine analogue),

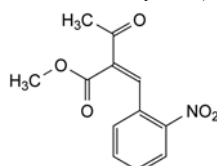

C. methyl 2-(2-nitrobenzylidene)-3-oxobutanoate,

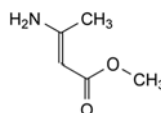

D. methyl 3-aminobut-2-enoate.

04/2008:2115

## NIFLUMIC ACID

## Acidum niflumicum

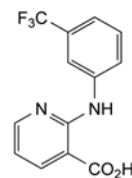

$C_{13}H_9F_3N_2O_2$   
[4394-00-7]

$M_r$  282.2

## DEFINITION

2-[[3-(Trifluoromethyl)phenyl]amino]pyridine-3-carboxylic acid.

**Content:** 98.5 per cent to 101.5 per cent (dried substance).

## CHARACTERS

**Appearance:** pale yellow, crystalline powder.

**Solubility:** practically insoluble in water, freely soluble in acetone, soluble in ethanol (96 per cent) and in methanol. mp: about 204 °C.

## IDENTIFICATION

Infrared absorption spectrophotometry (2.2.24).

Comparison: niflumic acid CRS.

## TESTS

**Impurity C.** Thin-layer chromatography (2.2.27).

**Test solution.** Dissolve 0.50 g of the substance to be examined in 5 mL of *methanol R* and dilute to 10.0 mL with the same solvent.

**Reference solution.** Dissolve 25 mg of *3-trifluoromethyl-aniline R* (impurity C) in 20 mL of *methanol R* and dilute to 100 mL with the same solvent. Dilute 1.0 mL of this solution to 100 mL with *methanol R*.

**Plate:** TLC silica gel  $F_{254}$  plate *R*.

**Mobile phase:** *acetic acid R*, *ethyl acetate R*, *toluene R* (5:25:90 V/V/V).

**Application:** 10  $\mu$ L.

**Development:** over 3/4 of the plate.

**Drying:** in air, until the solvents have evaporated.

**Detection:** spray with *4-dimethylaminocinnamaldehyde solution R* and heat at 60 °C for 10 min.

**Limit:**

- **impurity C:** any spot due to impurity C is not more intense than the principal spot in the chromatogram obtained with the reference solution (50 ppm).

**Related substances.** Liquid chromatography (2.2.29).

**Test solution.** Dissolve 20.0 mg of the substance to be examined in 10 mL of *acetonitrile R* and dilute to 20.0 mL with *water R*.

**Reference solution.** Dissolve 5.0 mg of *niflumic acid impurity A CRS*, 5.0 mg of *niflumic acid impurity B CRS* and 6.0 mg of *niflumic acid impurity E CRS* in 20 mL of *acetonitrile R*, add 5.0 mL of the test solution and dilute to 50.0 mL with *water R*. Dilute 1.0 mL of this solution to 100.0 mL with a mixture of equal volumes of *acetonitrile R* and *water R*.

**Column:**

- **size:**  $l = 0.125$  m,  $\varnothing = 4.0$  mm;
- **stationary phase:** *octylsilyl silica gel for chromatography R* (5  $\mu$ m);
- **temperature:** 25 °C.

**Mobile phase:** *phosphoric acid R*, *acetonitrile R*, *water R* (2.5:500:500 V/V/V).

**Flow rate:** 1.0 mL/min.

**Detection:** spectrophotometer at 267 nm.

**Injection:** 10  $\mu$ L.

**Run time:** 4 times the retention time of niflumic acid.

**Relative retention** with reference to niflumic acid (retention time = about 5.5 min): impurity A = about 0.25; impurity B = about 0.57; impurity E = about 0.64.

**System suitability:** reference solution:

- **resolution:** minimum 1.5 between the peaks due to impurities B and E.

**Limits:**

- **impurity B:** not more than 4 times the area of the corresponding peak in the chromatogram obtained with the reference solution (0.4 per cent);
- **impurity A:** not more than the area of the corresponding peak in the chromatogram obtained with the reference solution (0.1 per cent);
- **unspecified impurities:** for each impurity, not more than the area of the peak due to niflumic acid in the chromatogram obtained with the reference solution (0.10 per cent);
- **sum of impurities other than B:** not more than twice the area of the peak due to niflumic acid in the chromatogram obtained with the reference solution (0.2 per cent);
- **disregard limit:** 0.5 times the area of the peak due to niflumic acid in the chromatogram obtained with the reference solution (0.05 per cent).

**Chlorides** (2.4.4): maximum 200 ppm.

Dissolve 0.5 g in a mixture of 1 mL of *nitric acid R* and 10 mL of *methanol R*, and dilute to 20 mL with *water R*. To 10 mL of this solution add 5 mL of *water R*.

**Phosphates** (2.4.11): maximum 100 ppm.

Dilute 1.0 mL of the solution prepared in the test for heavy metals to 100 mL with *water R*.

**Heavy metals** (2.4.8): maximum 10 ppm.

2.0 g complies with test C. Prepare the reference solution using 2 mL of *lead standard solution (10 ppm Pb) R*.

**Loss on drying** (2.2.32): maximum 0.3 per cent, determined on 2.000 g by drying in an oven at 105 °C.

**Sulfated ash** (2.4.14): maximum 0.1 per cent, determined on 1.0 g in a platinum crucible.

## ASSAY

Dissolve 0.200 g in a mixture of 10 mL of *water R* and 40 mL of *ethanol (96 per cent) R*. Titrate with 0.1 M *sodium hydroxide*, determining the end-point potentiometrically (2.2.20).

1 mL of 0.1 M *sodium hydroxide* is equivalent to 28.22 mg of  $C_{13}H_9F_3N_2O_2$ .

## IMPURITIES

**Specified impurities:** A, B, C.

**Other detectable impurities** (the following substances would, if present at a sufficient level, be detected by one or other of the tests in the monograph. They are limited by the general acceptance criterion for other/unspecified impurities and/or by the general monograph *Substances for pharmaceutical use (2034)*. It is therefore not necessary to identify these impurities for demonstration of compliance. See also 5.10. *Control of impurities in substances for pharmaceutical use*): E, F.

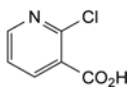

A. 2-chloropyridine-3-carboxylic acid,

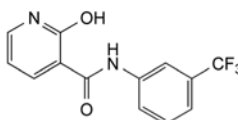

B. 2-hydroxy-*N*-[3-(trifluoromethyl)phenyl]pyridine-3-carboxamide,

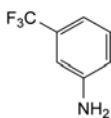

C. 3-(trifluoromethyl)aniline,

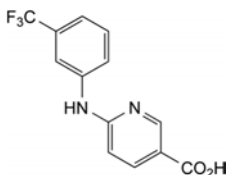

E. 6-[[3-(trifluoromethyl)phenyl]amino]pyridine-3-carboxylic acid,

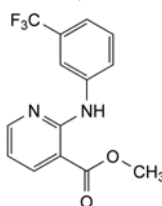

F. methyl 2-[[3-(trifluoromethyl)phenyl]amino]pyridine-3-carboxylate.

**04/2008:1999** *Reference solution (c).* Dissolve 5.0 mg of *methyl parahydroxybenzoate CRS* (impurity B) in the solvent mixture and dilute to 100.0 mL with the solvent mixture. Dilute 1.0 mL of this solution to 100.0 mL with the solvent mixture.

## NIFUROXAZIDE

### Nifuroxazidum

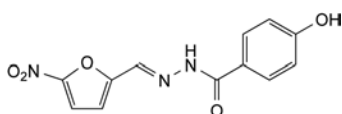

$C_{12}H_9N_3O_5$   
[965-52-6]

$M_r$  275.2

#### DEFINITION

(*E*)-4-Hydroxy-*N'*-[(5-nitrofuran-2-yl)methylidene]-benzohydrazide.

*Content*: 98.5 per cent to 101.5 per cent (dried substance).

#### CHARACTERS

*Appearance*: bright yellow, crystalline powder.

*Solubility*: practically insoluble in water, slightly soluble in ethanol (96 per cent), practically insoluble in methylene chloride.

#### IDENTIFICATION

Infrared absorption spectrophotometry (2.2.24).

*Comparison*: nifuroxazide CRS.

#### TESTS

**Specific absorbance** (2.2.25): 940 to 1000 at the absorption maximum at 367 nm.

Protected from light, dissolve 10.0 mg in 10 mL of *ethylene glycol monomethyl ether R* and dilute to 100.0 mL with *methanol R*. Dilute 5.0 mL of this solution to 100.0 mL with *methanol R*.

**Impurity A**: maximum 0.05 per cent.

*Test solution (a).* Dissolve 1.0 g of the substance to be examined in *dimethyl sulfoxide R* and dilute to 10.0 mL with the same solvent.

*Test solution (b).* To 5.5 mL of test solution (a) add 50.0 mL of *water R* while stirring. Allow to stand for 15 min and filter.

*Reference solution.* To 0.5 mL of test solution (a) add 5.0 mL of a 50 mg/L solution of *4-hydroxybenzohydrazide R* (impurity A) in *dimethyl sulfoxide R*. Add 50.0 mL of *water R* while stirring. Allow to stand for 15 min and filter.

Add 0.5 mL of *phosphomolybdotungstic reagent R* and 10.0 mL of *sodium carbonate solution R* separately to 10.0 mL of test solution (b) and to 10.0 mL of the reference solution. Allow to stand for 1 h. Examine the 2 solutions at 750 nm. The absorbance (2.2.25) of the solution obtained with test solution (b) is not greater than that obtained with the reference solution.

**Related substances.** Liquid chromatography (2.2.29). Use *amber volumetric flasks*, unless otherwise specified.

*Solvent mixture*: acetonitrile R, water R (40:60 V/V).

*Test solution.* Dissolve 10.0 mg of the substance to be examined in the solvent mixture, using sonication for not more than 5 min, and dilute to 100.0 mL with the solvent mixture.

*Reference solution (a).* Dilute 1.0 mL of the test solution to 100.0 mL with the solvent mixture. Dilute 1.0 mL of this solution to 10.0 mL with the solvent mixture.

*Reference solution (b).* In order to prepare impurity E *in situ*, dissolve 5 mg of the substance to be examined in the solvent mixture in a colourless volumetric flask, using sonication for 5 min, and dilute to 50 mL with the solvent mixture. Allow to stand in ambient light for 1 h.

#### Column:

- *size*:  $l = 0.25$  m,  $\varnothing = 4.6$  mm;
- *stationary phase*: spherical octadecylsilyl silica gel for chromatography R (5  $\mu$ m);
- *temperature*: 10 °C.

#### Mobile phase:

- *mobile phase A*: tetrahydrofuran R, water R (5:95 V/V);
- *mobile phase B*: acetonitrile R;

Time (min)	Mobile phase A (per cent V/V)	Mobile phase B (per cent V/V)
0 - 10	67	33
10 - 30	67 → 43	33 → 57

*Flow rate*: 1.0 mL/min.

*Detection*: spectrophotometer at 280 nm.

*Injection*: 50  $\mu$ L.

*Relative retention* with reference to nifuroxazide (retention time = about 8 min): impurity A (keto-enol tautomers) = about 0.36 and 0.39; impurity E = about 0.9; impurity B = about 1.2; impurity C = about 2.6; impurity D = about 3.4.

*System suitability*: reference solution (b):

- *resolution*: minimum 2.0 between the peaks due to impurity E and nifuroxazide.

#### Limits:

- *impurity E*: not more than 3 times the area of the principal peak in the chromatogram obtained with reference solution (a) (0.3 per cent);
- *impurities B, C, D*: for each impurity, not more than 0.6 times the area of the principal peak in the chromatogram obtained with reference solution (c) (0.3 per cent), and not more than 1 such peak has an area greater than 0.2 times the area of the principal peak in the chromatogram obtained with reference solution (c) (0.1 per cent);
- *unspecified impurities*: for each impurity, not more than the area of the principal peak in the chromatogram obtained with reference solution (a) (0.10 per cent);
- *sum of impurities other than E*: not more than the area of the principal peak in the chromatogram obtained with reference solution (c) (0.5 per cent);
- *disregard limit*: 0.1 times the area of the principal peak in the chromatogram obtained with reference solution (c) (0.05 per cent); disregard the peaks due to impurity A.

**Heavy metals** (2.4.8): maximum 20 ppm.

1.0 g complies with test D. Prepare the reference solution using 2 mL of *lead standard solution (10 ppm Pb) R*.

**Loss on drying** (2.2.32): maximum 0.5 per cent, determined on 1.000 g by drying in an oven at 105 °C for 3 h.

**Sulfated ash** (2.4.14): maximum 0.1 per cent, determined on 1.0 g.

#### ASSAY

Dissolve 0.200 g, with heating if necessary, in 30 mL of *dimethylformamide R* and add 20 mL of *water R*. Titrate with 0.1 M *sodium hydroxide*, determining the end-point potentiometrically (2.2.20).

1 mL of 0.1 M *sodium hydroxide* is equivalent to 27.52 mg of  $C_{12}H_9N_3O_5$ .

#### STORAGE

Protected from light.

## IMPURITIES

Specified impurities: A, B, C, D, E.

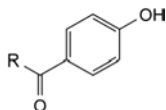

- A. R = NH-NH<sub>2</sub>: 4-hydroxybenzohydrazide (*p*-hydroxybenzohydrazide),  
 B. R = OCH<sub>3</sub>: methyl 4-hydroxybenzoate (methyl parahydroxybenzoate),

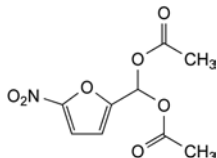

- C. (5-nitrofuran-2-yl)methylidene diacetate,

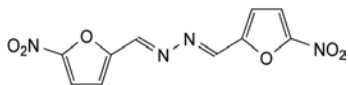

- D. (*E,E*)-*N,N'*-bis[(5-nitrofuran-2-yl)methylidene]hydrazine (5-nitrofurfural azine),

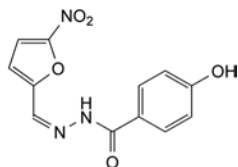

- E. (*Z*)-4-hydroxy-*N'*-[(5-nitrofuran-2-yl)methylidene]benzohydrazide.

- C. Heat 0.1 g with 1 mL of *dilute sodium hydroxide solution R*. Diethylamine is evolved progressively and is recognisable by its characteristic odour and by its turning *red litmus paper R* blue.  
 D. Dilute 1 mL of solution S (see Tests) to 250 mL with *water R*. To 2 mL of this solution add 2 mL of *cyanogen bromide solution R*. Add 3 mL of a 25 g/L solution of *aniline R* and shake. A yellow colour develops.

## TESTS

**Solution S.** Dissolve 2.5 g in *carbon dioxide-free water R* and dilute to 10 mL with the same solvent.

**Appearance.** The substance to be examined, in liquid form or liquefied by slight heating, is clear (2.2.1) and not more intensely coloured than reference solution Y<sub>5</sub> (2.2.2, *Method II*).

**pH (2.2.3).** The pH of solution S is 6.0 to 7.8.

**Refractive index (2.2.6).** 1.524 to 1.526.

**Related substances.** Examine by thin-layer chromatography (2.2.27), using *silica gel GF<sub>254</sub> R* as the coating substance.

**Test solution.** Dissolve 0.4 g of the substance to be examined in *methanol R* and dilute to 10 mL with the same solvent.

**Reference solution (a).** Dissolve 40 mg of *ethylnicotinamide CRS* in *methanol R* and dilute to 100 mL with the same solvent.

**Reference solution (b).** Dilute 1 mL of reference solution (a) to 10 mL with *methanol R*.

Apply separately to the plate 10 µL of each solution. Develop over a path of 15 cm using a mixture of 25 volumes of *propanol R* and 75 volumes of *chloroform R*. Allow the plate to dry in air and examine in ultraviolet light at 254 nm. In the chromatogram obtained with the test solution, any spot corresponding to ethylnicotinamide is not more intense than the spot in the chromatogram obtained with reference solution (a) (1.0 per cent) and any spot, apart from the principal spot and the spot corresponding to ethylnicotinamide, is not more intense than the spot in the chromatogram obtained with reference solution (b) (0.1 per cent).

**Heavy metals (2.4.8).** Dilute 10 mL of solution S to 25 mL with *water R*. 12 mL of this solution complies with limit test A for heavy metals (10 ppm). Prepare the standard using *lead standard solution (1 ppm Pb) R*.

**Water (2.5.12).** Not more than 0.3 per cent, determined on 2.00 g by the semi-micro determination of water.

**Sulfated ash (2.4.14).** Not more than 0.1 per cent, determined on 1.0 g.

## ASSAY

Dissolve 0.150 g in a mixture of 5 mL of *acetic anhydride R* and 20 mL of *anhydrous acetic acid R*. Titrate with 0.1 M *perchloric acid*, determining the end-point potentiometrically (2.2.20).

1 mL of 0.1 M *perchloric acid* is equivalent to 17.82 mg of C<sub>10</sub>H<sub>14</sub>N<sub>2</sub>O.

01/2008:0233

## NIKETHAMIDE

## Nicethamidum

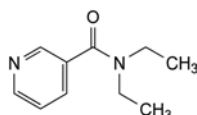

C<sub>10</sub>H<sub>14</sub>N<sub>2</sub>O  
[59-26-7]

M<sub>r</sub> 178.2

## DEFINITION

Nikethamide contains not less than 99.0 per cent and not more than the equivalent of 101.0 per cent of *N,N*-diethylpyridine-3-carboxamide, calculated with reference to the anhydrous substance.

## CHARACTERS

An oily liquid or a crystalline mass, colourless or slightly yellowish, miscible with water and with alcohol.

## IDENTIFICATION

*First identification:* A, B.

*Second identification:* A, C, D.

- A. Dissolve 0.15 g in 0.01 M *hydrochloric acid* and dilute to 100.0 mL with the same acid. Dilute 1.0 mL of this solution to 100.0 mL with 0.01 M *hydrochloric acid*. Examined between 230 nm and 350 nm (2.2.25) in a 2 cm cell, the solution shows a single absorption maximum, at 263 nm. The specific absorbance at the maximum is about 285.  
 B. Examine by infrared absorption spectrophotometry (2.2.24), comparing with the spectrum obtained with *nikethamide CRS*.

07/2008:2256  
corrected 7.0

## NILUTAMIDE

## Nilutamidum

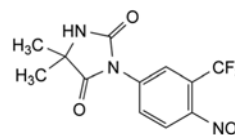

C<sub>12</sub>H<sub>10</sub>F<sub>3</sub>N<sub>3</sub>O<sub>4</sub>  
[63612-50-0]

M<sub>r</sub> 317.2

## DEFINITION

5,5-Dimethyl-3-[4-nitro-3-(trifluoromethyl)phenyl]-imidazolidine-2,4-dione.

*Content*: 98.0 per cent to 102.0 per cent (anhydrous substance).

## CHARACTERS

*Appearance*: white or almost white powder.

*Solubility*: very slightly soluble in water, freely soluble in acetone, soluble in anhydrous ethanol.

## IDENTIFICATION

Infrared absorption spectrophotometry (2.2.24).

*Comparison*: nilutamide CRS.

## TESTS

**Related substances.** Liquid chromatography (2.2.29). Prepare the solutions immediately before use.

*Solvent mixture*: acetonitrile for chromatography R, water R (35:65 V/V).

*Test solution.* Dissolve 0.10 g of the substance to be examined in the solvent mixture and dilute to 100 mL with the solvent mixture.

*Reference solution (a).* Dilute 20.0 mL of the test solution to 100.0 mL with the solvent mixture. Dilute 1.0 mL of this solution to 100.0 mL with the solvent mixture.

*Reference solution (b).* Dissolve 2 mg of the substance to be examined and 2 mg of nilutamide impurity B CRS in the solvent mixture and dilute to 50 mL with the solvent mixture.

*Column*:

- size:  $l = 0.15$  m,  $\varnothing = 4.6$  mm;
- stationary phase: spherical octadecylsilyl silica gel for chromatography R (5  $\mu$ m).

*Mobile phase*:

- mobile phase A: 2.0 g/L solution of potassium dihydrogen phosphate R adjusted to pH 7.5 with 1 M sodium hydroxide;
- mobile phase B: acetonitrile for chromatography R;

Time (min)	Mobile phase A (per cent V/V)	Mobile phase B (per cent V/V)
0 - 8	55	45
8 - 30	55 → 30	45 → 70

*Flow rate*: 1.5 mL/min.

*Detection*: spectrophotometer at 230 nm.

*Injection*: 20  $\mu$ L.

*Relative retention* with reference to nilutamide (retention time = about 5.3 min): impurity B = about 0.9.

*System suitability*: reference solution (b):

- resolution: minimum 3.0 between the peaks due to impurity B and nilutamide.

*Limits*:

- unspecified impurities: for each impurity, not more than 0.5 times the area of the principal peak in the chromatogram obtained with reference solution (a) (0.10 per cent);
- total: not more than 1.5 times the area of the principal peak in the chromatogram obtained with reference solution (a) (0.3 per cent);
- disregard limit: 0.25 times the area of the principal peak in the chromatogram obtained with reference solution (a) (0.05 per cent).

**Heavy metals** (2.4.8): maximum 20 ppm.

It complies with test B with the following modifications.

*Prescribed solution.* Dissolve 0.5 g in a mixture of 10 volumes of water R and 90 volumes of acetone R and dilute to 20 mL with the same mixture of solvents.

*Test solution.* 12 mL of the prescribed solution.

*Reference solution.* Dilute 0.5 mL of lead standard solution (10 ppm Pb) R to 10 mL with a mixture of 10 volumes of water R and 90 volumes of acetone R and add 2 mL of the prescribed solution.

Filter the solutions through a membrane filter (nominal pore size 0.45  $\mu$ m). Compare the spots on the filters obtained with the different solutions. The substance to be examined complies with the test if the brown colour of the spot obtained with the test solution is not more intense than that of the spot obtained with the reference solution.

**Water** (2.5.12): maximum 0.5 per cent, determined on 0.500 g.

**Sulfated ash** (2.4.14): maximum 0.1 per cent, determined on 1.0 g in a platinum crucible.

## ASSAY

Liquid chromatography (2.2.29). The solutions are stable for 24 h at room temperature and in daylight.

*Solvent mixture*: acetonitrile for chromatography R, water R (35:65 V/V).

*Test solution.* Dissolve 50.0 mg of the substance to be examined in the solvent mixture and dilute to 100.0 mL with the solvent mixture.

*Reference solution.* Dissolve 50.0 mg of nilutamide CRS in the solvent mixture and dilute to 100.0 mL with the solvent mixture.

*Column*:

- size:  $l = 0.15$  m,  $\varnothing = 4.6$  mm;
- stationary phase: spherical octadecylsilyl silica gel for chromatography R (5  $\mu$ m).

*Mobile phase*: mix 40 volumes of acetonitrile R and 60 volumes of a 2.0 g/L solution of potassium dihydrogen phosphate R adjusted to pH 7.5 with 1 M sodium hydroxide.

*Flow rate*: 1.5 mL/min.

*Detection*: spectrophotometer at 267 nm.

*Injection*: 20  $\mu$ L.

*Retention time*: about 9 min.

Calculate the percentage content of  $C_{12}H_{10}F_3N_3O_4$  from the declared content of nilutamide CRS.

## STORAGE

Protected from light.

## IMPURITIES

*Other detectable impurities* (the following substances would, if present at a sufficient level, be detected by one or other of the tests in the monograph. They are limited by the general acceptance criterion for other/unspecified impurities and/or by the general monograph *Substances for pharmaceutical use* (2034). It is therefore not necessary to identify these impurities for demonstration of compliance. See also 5.10. *Control of impurities in substances for pharmaceutical use*): A, B, C, D.

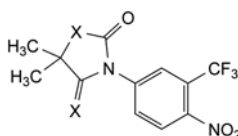

A. X = NH: 5-imino-4,4-dimethyl-1-[4-nitro-3-(trifluoromethyl)phenyl]imidazolidin-2-one,

C. X = O: 5,5-dimethyl-3-[4-nitro-3-(trifluoromethyl)phenyl]-oxazolidine-2,4-dione,

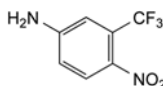

B. 4-nitro-3-(trifluoromethyl)aniline (nifeline),

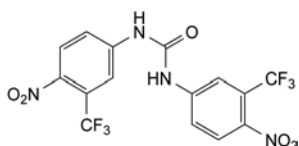

D. 1,3-bis[4-nitro-3-(trifluoromethyl)phenyl]urea.

01/2011:1548 *Detection*: spectrophotometer at 230 nm.

## NIMESULIDE

### Nimesulidum

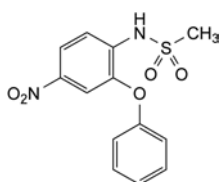

$C_{13}H_{12}N_2O_5S$   
[51803-78-2]

$M_r$  308.3

#### DEFINITION

*N*-(4-Nitro-2-phenoxyphenyl)methanesulfonamide.

*Content*: 98.5 per cent to 101.5 per cent (dried substance).

#### CHARACTERS

*Appearance*: yellowish, crystalline powder.

*Solubility*: practically insoluble in water, freely soluble in acetone, slightly soluble in anhydrous ethanol.

mp: about 149 °C.

It shows polymorphism (5.9).

#### IDENTIFICATION

Infrared absorption spectrophotometry (2.2.24).

*Comparison*: nimesulide CRS.

If the spectra obtained show differences, dissolve the substance to be examined and the reference substance separately in acetone *R*, evaporate to dryness and record new spectra using the residues.

#### TESTS

**Absorbance** (2.2.25): maximum 0.50 at 450 nm.

Dissolve 1.0 g in acetone *R* and dilute to 10.0 mL with the same solvent.

**Related substances**. Liquid chromatography (2.2.29).

*Test solution*. Dissolve 20 mg of the substance to be examined in 8 mL of acetonitrile *R* and dilute to 20.0 mL with water *R*.

*Reference solution (a)*. Dissolve 5 mg of 2-phenoxyaniline *R* (impurity C) in 10 mL of acetonitrile *R* and dilute to 25.0 mL with water *R*. Dilute 1.0 mL of the solution to 50.0 mL with the mobile phase. Mix 1.0 mL of this solution with the contents of a vial of nimesulide impurity D CRS previously dissolved in 1.0 mL of acetonitrile *R*.

*Reference solution (b)*. Dilute 1.0 mL of the test solution to 10.0 mL with the mobile phase. Dilute 1.0 mL of this solution to 100.0 mL with the mobile phase.

*Reference solution (c)*. Dissolve 4 mg of nimesulide for peak identification CRS (containing impurities A, B, E and F) in 4.0 mL of acetonitrile *R* and dilute to 10.0 mL with the mobile phase.

#### Column:

- size:  $l = 0.125$  m,  $\emptyset = 4.0$  mm;
- stationary phase: octadecylsilyl silica gel for chromatography *R* (5  $\mu$ m).

*Mobile phase*: a mixture of 35 volumes of acetonitrile *R* and 65 volumes of a 1.15 g/L solution of ammonium dihydrogen phosphate *R* adjusted to pH 7.0 with ammonia *R*.

*Flow rate*: 1.3 mL/min.

*Injection*: 20  $\mu$ L.

*Run time*: 7 times the retention time of nimesulide.

*Identification of impurities*: use the chromatogram supplied with nimesulide for peak identification CRS and the chromatogram obtained with reference solution (c) to identify the peaks due to impurities A, B, E and F; use the chromatogram obtained with reference solution (a) to identify the peaks due to impurities C and D.

*Relative retention* with reference to nimesulide (retention time = about 5 min): impurity A = about 0.3; impurity B = about 2.4; impurity C = about 3.2; impurity D = about 3.7; impurity E = about 4.2; impurity F = about 6.1.

*System suitability*: reference solution (a):

- resolution: minimum 2.0 between the peaks due to impurities C and D.

#### Limits:

- impurities A, B, C, D, E, F: for each impurity, not more than 1.5 times the area of the principal peak in the chromatogram obtained with reference solution (b) (0.15 per cent);
- unspecified impurities: for each impurity, not more than the area of the principal peak in the chromatogram obtained with reference solution (b) (0.10 per cent);
- total: not more than 5 times the area of the principal peak in the chromatogram obtained with reference solution (b) (0.5 per cent);
- disregard limit: 0.5 times the area of the principal peak in the chromatogram obtained with reference solution (b) (0.05 per cent).

**Heavy metals** (2.4.8): maximum 20 ppm.

1.0 g complies with test D. Prepare the reference solution using 2 mL of lead standard solution (10 ppm Pb) *R*.

**Loss on drying** (2.2.32): maximum 0.5 per cent, determined on 1.000 g by drying in an oven at 105 °C for 4 h.

**Sulfated ash** (2.4.14): maximum 0.1 per cent, determined on 1.0 g.

#### ASSAY

Dissolve 0.240 g in 30 mL of previously neutralised acetone *R* and add 20 mL of water *R*. Titrate with 0.1 M sodium hydroxide, determining the end-point potentiometrically (2.2.20).

1 mL of 0.1 M sodium hydroxide is equivalent to 30.83 mg of  $C_{13}H_{12}N_2O_5S$ .

#### IMPURITIES

*Specified impurities*: A, B, C, D, E, F.

*Other detectable impurities* (the following substances would, if present at a sufficient level, be detected by one or other of the tests in the monograph. They are limited by the general acceptance criterion for other/unspecified impurities and/or by the general monograph *Substances for pharmaceutical use* (2034). It is therefore not necessary to identify these impurities for demonstration of compliance. See also 5.10. *Control of impurities in substances for pharmaceutical use*): G.

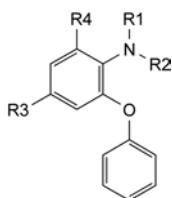

- A. R1 = SO<sub>2</sub>-CH<sub>3</sub>, R2 = H, R3 = R4 = NO<sub>2</sub>: *N*-(2,4-dinitro-6-phenoxyphenyl)methanesulfonamide,
- B. R1 = SO<sub>2</sub>-CH<sub>3</sub>, R2 = R3 = R4 = H: *N*-(2-phenoxyphenyl)methanesulfonamide,
- C. R1 = R2 = R3 = R4 = H: 2-phenoxyaniline,
- D. R1 = R2 = R4 = H, R3 = NO<sub>2</sub>: 4-nitro-2-phenoxyaniline,
- E. R1 = R2 = SO<sub>2</sub>-CH<sub>3</sub>, R3 = R4 = H: *N,N*-bis(methylsulfonyl)-2-phenoxyaniline,
- F. R1 = R2 = SO<sub>2</sub>-CH<sub>3</sub>, R3 = NO<sub>2</sub>, R4 = H: *N,N*-bis(methylsulfonyl)-4-nitro-2-phenoxyaniline,

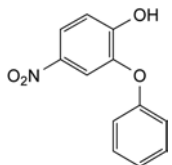

- G. 4-nitro-2-phenoxyphenol.

01/2008:1245  
corrected 6.0

## NIMODIPINE

### Nimodipinum

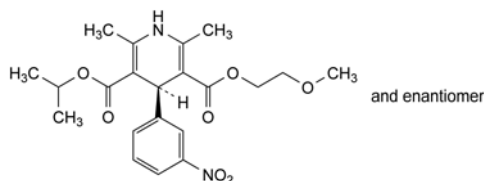

C<sub>21</sub>H<sub>26</sub>N<sub>2</sub>O<sub>7</sub>  
[66085-59-4]

M<sub>r</sub> 418.4

#### DEFINITION

2-Methoxyethyl 1-methylethyl (4*RS*)-2,6-dimethyl-4-(3-nitrophenyl)-1,4-dihydropyridine-3,5-dicarboxylate.

*Content*: 98.5 per cent to 101.5 per cent (dried substance).

#### CHARACTERS

*Appearance*: light yellow or yellow, crystalline powder.

*Solubility*: practically insoluble in water, freely soluble in ethyl acetate, sparingly soluble in anhydrous ethanol.

It shows polymorphism (5.9).

Exposure to ultraviolet light leads to the formation of a nitrophenylpyridine derivative.

*Prepare solutions immediately before use either protected from light or under long-wavelength light (> 420 nm).*

#### IDENTIFICATION

Infrared absorption spectrophotometry (2.2.24).

*Comparison*: nimodipine CRS.

If the spectra obtained in the solid state show differences, record new spectra using 20 g/L solutions in *methylene chloride R* and a 0.2 mm cell.

#### TESTS

**Solution S.** Dissolve 1.0 g in *acetone R* and dilute to 20.0 mL with the same solvent.

**Appearance of solution.** Solution S is clear (2.2.1).

**Optical rotation** (2.2.7): -0.10° to +0.10°, determined on solution S.

**Related substances.** Liquid chromatography (2.2.29).

*Test solution.* Dissolve 40.0 mg of the substance to be examined in 2.5 mL of *tetrahydrofuran R* and dilute to 25.0 mL with the mobile phase.

*Reference solution (a).* Dilute 1.0 mL of the test solution to 100.0 mL with the mobile phase. Dilute 2.0 mL of this solution to 10.0 mL with the mobile phase.

*Reference solution (b).* *Nimodipine impurity A CRS.*

*Reference solution (c).* Dilute the test solution as described in the leaflet accompanying *nimodipine impurity A CRS.*

*Reference solution (d).* Mix reference solution (b) and reference solution (c) as described in the leaflet accompanying *nimodipine impurity A CRS.*

*Column*:

- size: *l* = 0.125 m, Ø = 4.6 mm;
- stationary phase: octadecylsilyl silica gel for chromatography R (5 µm);
- temperature: 40 °C.

*Mobile phase*: *methanol R, tetrahydrofuran R, water R* (20:20:60 V/V/V).

*Flow rate*: 2.0 mL/min.

*Detection*: spectrophotometer at 235 nm.

*Injection*: 20 µL of the test solution and reference solutions (a) and (d).

*Run time*: 4 times the retention time of nimodipine.

*Retention time*: impurity A = about 7 min; nimodipine = about 8 min.

*System suitability*: reference solution (d):

- resolution: minimum 1.5 between the peaks due to impurity A and nimodipine.

*Limits*:

- *impurity A*: not more than the area of the corresponding peak in the chromatogram obtained with reference solution (d) (0.1 per cent);
- *impurities B, C*: for each impurity, not more than the area of the principal peak in the chromatogram obtained with reference solution (a) (0.2 per cent);
- *total*: not more than 2.5 times the area of the principal peak in the chromatogram obtained with reference solution (a) (0.5 per cent);
- *disregard limit*: 0.5 times the area of the peak due to nimodipine in the chromatogram obtained with reference solution (d) (0.05 per cent).

**Loss on drying** (2.2.32): maximum 0.5 per cent, determined on 1.000 g by drying in an oven at 105 °C.

**Sulfated ash** (2.4.14): maximum 0.1 per cent, determined on 1.0 g.

#### ASSAY

Dissolve with gentle heating 0.180 g in a mixture of 25 mL of *2-methyl-2-propanol R* and 25 mL of *perchloric acid solution R*. Add 0.1 mL of *ferroin R*. Titrate with 0.1 M *cerium sulfate*. Titrate slowly towards the end of the titration. Carry out a blank titration.

1 mL of 0.1 M *cerium sulfate* is equivalent to 20.92 mg of C<sub>21</sub>H<sub>26</sub>N<sub>2</sub>O<sub>7</sub>.

#### STORAGE

Protected from light.

#### IMPURITIES

*Specified impurities*: A, B, C.

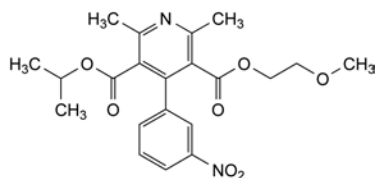

A. 2-methoxyethyl 1-methylethyl 2,6-dimethyl-4-(3-nitrophenyl)pyridine-3,5-dicarboxylate,

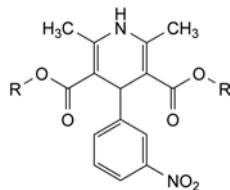

B. R = CH(CH<sub>3</sub>)<sub>2</sub>: bis(1-methylethyl) 2,6-dimethyl-4-(3-nitrophenyl)-1,4-dihydropyridine-3,5-dicarboxylate,

C. R = CH<sub>2</sub>-CH<sub>2</sub>-OCH<sub>3</sub>: bis(2-methoxyethyl) 2,6-dimethyl-4-(3-nitrophenyl)-1,4-dihydropyridine-3,5-dicarboxylate.

04/2010:0415

## NITRAZEPAM

### Nitrazepamum

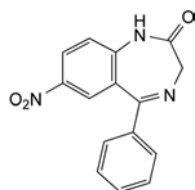

C<sub>15</sub>H<sub>11</sub>N<sub>3</sub>O<sub>3</sub>  
[146-22-5]

M<sub>r</sub> 281.3

#### DEFINITION

7-Nitro-5-phenyl-1,3-dihydro-2H-1,4-benzodiazepin-2-one.

Content: 99.0 per cent to 101.0 per cent (dried substance).

#### CHARACTERS

Appearance: white or yellow, crystalline powder.

Solubility: practically insoluble in water, slightly soluble in ethanol (96 per cent).

#### IDENTIFICATION

Infrared absorption spectrophotometry (2.2.24).

Comparison: nitrazepam CRS.

#### TESTS

**Related substances.** Liquid chromatography (2.2.29). Carry out the test protected from light.

**Test solution.** Dissolve 50 mg of the substance to be examined in acetonitrile R and dilute to 20.0 mL with the same solvent.

**Reference solution (a).** Dilute 1.0 mL of the test solution to 100.0 mL with acetonitrile R. Dilute 1.0 mL of this solution to 10.0 mL with acetonitrile R.

**Reference solution (b).** Dissolve 2 mg of clonazepam CRS in acetonitrile R and dilute to 100.0 mL with the same solvent. Dilute 1.0 mL of this solution to 10.0 mL with the test solution.

Column:

- size:  $l = 0.25$  m,  $\varnothing = 4.0$  mm;
- stationary phase: octylsilyl silica gel for chromatography R (5  $\mu$ m);
- temperature: 40 °C.

Mobile phase:

- mobile phase A: 7.8 g/L solution of sodium dihydrogen phosphate R adjusted to pH 3.0 with phosphoric acid R;

– mobile phase B: acetonitrile R;

Time (min)	Mobile phase A (per cent V/V)	Mobile phase B (per cent V/V)
0 - 3	65	35
3 - 10	65 → 50	35 → 50
10 - 20	50	50

Flow rate: 1 mL/min.

Detection: spectrophotometer at 270 nm.

Injection: 10  $\mu$ L.

Relative retention with reference to nitrazepam (retention time = about 9 min): clonazepam = about 1.1.

System suitability: reference solution (b):

- peak-to-valley ratio: minimum 4.0, where  $H_p$  = height above the baseline of the peak due to clonazepam and  $H_v$  = height above the baseline of the lowest point of the curve separating this peak from the peak due to nitrazepam.

Limits:

- unspecified impurities: for each impurity, not more than the area of the principal peak in the chromatogram obtained with reference solution (a) (0.10 per cent);
- total: not more than twice the area of the principal peak in the chromatogram obtained with reference solution (a) (0.2 per cent);
- disregard limit: 0.5 times the area of the principal peak in the chromatogram obtained with reference solution (a) (0.05 per cent).

**Loss on drying** (2.2.32): maximum 0.5 per cent, determined on 1.000 g by drying in an oven at 105 °C for 4 h.

**Sulfated ash** (2.4.14): maximum 0.1 per cent, determined on 1.0 g.

#### ASSAY

Dissolve 0.250 g in 25 mL of acetic anhydride R. Titrate with 0.1 M perchloric acid, determining the end-point potentiometrically (2.2.20).

1 mL of 0.1 M perchloric acid is equivalent to 28.13 mg of C<sub>15</sub>H<sub>11</sub>N<sub>3</sub>O<sub>3</sub>.

#### STORAGE

Protected from light.

#### IMPURITIES

Other detectable impurities (the following substances would, if present at a sufficient level, be detected by one or other of the tests in the monograph. They are limited by the general acceptance criterion for other/unspecified impurities and/or by the general monograph Substances for pharmaceutical use (2034). It is therefore not necessary to identify these impurities for demonstration of compliance. See also 5.10. Control of impurities in substances for pharmaceutical use): A, B, C, D.

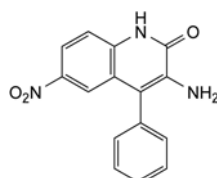

A. 3-amino-6-nitro-4-phenylquinolin-2(1H)-one,

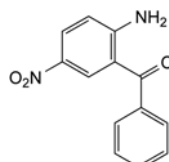

B. (2-amino-5-nitrophenyl)phenylmethanone,

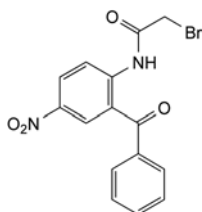
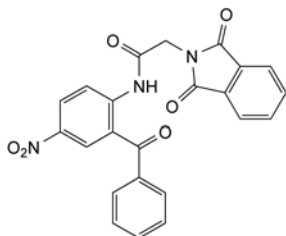

C. 2-bromo-*N*-[4-nitro-2-(phenylcarbonyl)phenyl]acetamide,D. 2-(1,3-dioxo-1,3-dihydro-2*H*-isoindol-2-yl)-*N*-[4-nitro-2-(phenylcarbonyl)phenyl]acetamide.01/2008:1246  
corrected 6.0

## NITRENDIPINE

## Nitrendipinum

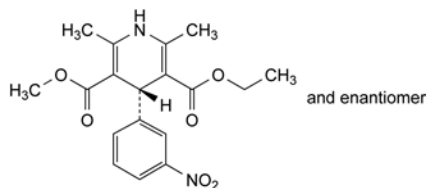
C<sub>18</sub>H<sub>20</sub>N<sub>2</sub>O<sub>6</sub>  
[39562-70-4]*M*<sub>r</sub> 360.4

## DEFINITION

Ethyl methyl (4*RS*)-2,6-dimethyl-4-(3-nitrophenyl)-1,4-dihydropyridine-3,5-dicarboxylate.*Content*: 98.5 per cent to 101.5 per cent (dried substance).

## CHARACTERS

*Appearance*: yellow, crystalline powder.*Solubility*: practically insoluble in water, freely soluble in ethyl acetate, sparingly soluble in anhydrous ethanol and in methanol.

It shows polymorphism (5.9).

Exposure to ultraviolet light leads to the formation of a nitrophenylpyridine derivative

*Prepare solutions immediately before use either protected from light or under long-wavelength light (> 420 nm).*

## IDENTIFICATION

Infrared absorption spectrophotometry (2.2.24).

*Comparison*: nitrendipine CRS.If the spectra obtained in the solid state show differences, record new spectra using 20 g/L solutions in methylene chloride *R* and a 0.2 mm cell.

## TESTS

**Optical rotation** (2.2.7): –0.10° to +0.10°.Dissolve 0.2 g in acetone *R* and dilute to 10.0 mL with the same solvent.**Related substances.** Liquid chromatography (2.2.29).*Test solution.* Dissolve 40.0 mg of the substance to be examined in 2.5 mL of tetrahydrofuran *R* and dilute to 25.0 mL with the mobile phase.*Reference solution (a).* Dilute 2.0 mL of the test solution to 10.0 mL with the mobile phase. Dilute 1.0 mL of this solution to 25.0 mL with the mobile phase.*Reference solution (b).* Dissolve 20.0 mg of nitrendipine impurity A CRS in 2.5 mL of tetrahydrofuran *R* and dilute to 25.0 mL with the mobile phase. Dilute 1.0 mL of this solution to 20.0 mL with the mobile phase.*Reference solution (c).* Dilute 0.5 mL of the test solution to 20.0 mL with the mobile phase.*Reference solution (d).* Mix 1.0 mL of reference solution (b) and 1.0 mL of reference solution (c), then dilute to 25.0 mL with the mobile phase.*Column*:

- *size*: *l* = 0.125 m, Ø = 4 mm;
- *stationary phase*: octadecylsilyl silica gel for chromatography *R* (5 µm);
- *temperature*: 40 °C.

*Mobile phase*: acetonitrile *R*, tetrahydrofuran *R*, water *R* (14:22:64 V/V/V).*Flow rate*: 1 mL/min.*Detection*: spectrophotometer at 235 nm.*Injection*: 20 µL of the test solution and reference solutions (a) and (d).*Run time*: 5 times the retention time of nitrendipine.*Retention time*: impurity A = about 6 min; nitrendipine = about 8 min.*System suitability*: reference solution (d):

- *resolution*: minimum 2.0 between the peaks due to impurity A and nitrendipine.

*Limits*:

- *impurities B, C*: for each impurity, not more than the area of the peak due to nitrendipine in the chromatogram obtained with reference solution (a) (0.8 per cent);
- *impurity A*: not more than the area of the corresponding peak in the chromatogram obtained with reference solution (d) (0.1 per cent);
- *total*: not more than 1.5 times the area of the principal peak in the chromatogram obtained with reference solution (a) (1.2 per cent);
- *disregard limit*: 0.5 times the area of the peak due to nitrendipine in the chromatogram obtained with reference solution (d) (0.05 per cent).

**Loss on drying** (2.2.32): maximum 0.5 per cent, determined on 1.000 g by drying in an oven at 105 °C.**Sulfated ash** (2.4.14): maximum 0.1 per cent, determined on 1.0 g.

## ASSAY

Dissolve 0.160 g with gentle heating if necessary in a mixture of 25 mL of 2-methyl-2-propanol *R* and 25 mL of perchloric acid solution *R*. Titrate with 0.1 M cerium sulfate, using 0.1 mL of ferroin *R* as indicator. Titrate slowly towards the end of the titration. Carry out a blank titration.1 mL of 0.1 M cerium sulfate is equivalent to 18.02 mg of C<sub>18</sub>H<sub>20</sub>N<sub>2</sub>O<sub>6</sub>.

## STORAGE

Protected from light.

## IMPURITIES

*Specified impurities*: A, B, C.

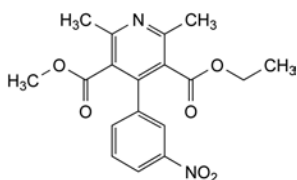

A. ethyl methyl 2,6-dimethyl-4-(3-nitrophenyl)pyridine-3,5-dicarboxylate,

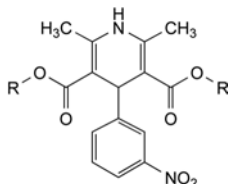

B. R = CH<sub>3</sub>: dimethyl 2,6-dimethyl-4-(3-nitrophenyl)-1,4-dihydroimidopyridine-3,5-dicarboxylate,

C. R = CH<sub>2</sub>-CH<sub>3</sub>: diethyl 2,6-dimethyl-4-(3-nitrophenyl)-1,4-dihydroimidopyridine-3,5-dicarboxylate.

01/2008:1549

## NITRIC ACID

### Acidum nitricum

HNO<sub>3</sub>  
[7697-37-2]

M<sub>r</sub> 63.0

#### DEFINITION

*Content*: 68.0 per cent *m/m* to 70.0 per cent *m/m*.

#### CHARACTERS

*Appearance*: clear, colourless or almost colourless liquid.

*Solubility*: miscible with water.

*Relative density*: about 1.41.

#### IDENTIFICATION

A. Dilute 1 mL to 100 mL with *water R*. The solution is strongly acid (2.2.4).

B. 0.2 mL of the solution obtained in identification test A gives the reaction of nitrates (2.3.1).

#### TESTS

**Appearance of solution.** The solution is clear (2.2.1) and not more intensely coloured than reference solution Y<sub>6</sub> (2.2.2, Method II).

Dilute 2 mL to 10 mL with *water R*.

**Chlorides** (2.4.4): maximum 0.5 ppm.

To 5 g add 10 mL of *water R* and 0.3 mL of *silver nitrate solution R2* and allow to stand for 2 min protected from light. Any opalescence is not more intense than that of a standard prepared at the same time in the same manner using 13 mL of *water R*, 0.5 mL of *nitric acid R*, 0.5 mL of *chloride standard solution (5 ppm Cl) R* and 0.3 mL of *silver nitrate solution R2*.

**Sulfates** (2.4.13): maximum 10 ppm.

To 15 g add 0.2 g of *sodium carbonate R*. After carbon dioxide has evolved, evaporate to dryness. Dissolve the residue in 15 mL of *distilled water R*.

**Iron** (2.4.9): maximum 10 ppm.

Dissolve the residue obtained in the test for sulfated ash in 1 mL of *dilute hydrochloric acid R* and dilute to 20 mL with *water R*. Dilute 1 mL of this solution to 10 mL with *water R*.

**Heavy metals** (2.4.8): maximum 2 ppm.

Carefully evaporate 10.0 g to dryness on a water-bath. Moisten the residue with a few drops of *dilute hydrochloric acid R* and dilute to 20 mL with *water R*. 12 mL of the solution complies

with test A. Prepare the reference solution using *lead standard solution (2 ppm Pb) R*.

**Sulfated ash**: maximum 0.01 per cent.

Carefully evaporate 20.00 g to dryness. Moisten the residue with a few drops of *sulfuric acid R* and ignite to dull red.

#### ASSAY

To 0.750 g add 50 mL of *water R* and titrate with 1 M *sodium hydroxide*, determining the end-point potentiometrically (2.2.20).

1 mL of 1 M *sodium hydroxide* is equivalent to 63.0 mg of HNO<sub>3</sub>.

#### STORAGE

Protected from light.

01/2008:1550

## NITRIC OXIDE

### Nitrogenii oxidum

NO  
[10102-43-9]

M<sub>r</sub> 30.01

#### DEFINITION

*Content*: minimum 99.0 per cent V/V of NO.

This monograph applies to nitric oxide for medicinal use.

#### CHARACTERS

*Appearance*: colourless gas which turns brown when exposed to air.

*Solubility*: at 20 °C and at a pressure of 101 kPa, 1 volume dissolves in about 21 volumes of water.

#### PRODUCTION

**Carbon dioxide.** Gas chromatography (2.2.28).

*Gas to be examined.* The substance to be examined.

*Reference gas:* mixture containing 3000 ppm V/V of *carbon dioxide R1* in *nitrogen R*.

*Column:*

- *material*: stainless steel;
- *size*: *l* = 3.5 m, Ø = 2 mm;
- *stationary phase*: *ethylvinylbenzene-divinylbenzene copolymer R*;
- *temperature*: 50 °C.

*Carrier gas:* *helium for chromatography R*.

*Flow rate*: 15 mL/min.

*Detection*: thermal conductivity.

*Injection*: loop injector.

*System suitability:*

- the chromatograms obtained show a clear separation of carbon dioxide from nitric oxide.

*Limit:*

- *carbon dioxide*: not more than the area of the corresponding peak in the chromatogram obtained with the reference gas (3000 ppm V/V).

**Nitrogen.** Gas chromatography (2.2.28).

*Gas to be examined.* The substance to be examined.

*Reference gas:* mixture containing 3000 ppm V/V of *nitrogen R* in *helium for chromatography R*.

*Column:*

- *material*: stainless steel;
- *size*: *l* = 3.5 m, Ø = 2 mm;
- *stationary phase*: *molecular sieve for chromatography R* (0.5 nm);
- *temperature*: 50 °C.

*Carrier gas:* *helium for chromatography R*.

*Flow rate:* 15 mL/min.

*Detection:* thermal conductivity.

*Injection:* loop injector.

*System suitability:*

- the chromatograms obtained show a clear separation of nitrogen from nitric oxide.

*Limit:*

- *nitrogen:* not more than the area of the corresponding peak in the chromatogram obtained with the reference gas (3000 ppm V/V).

**Nitrogen dioxide:** maximum 400 ppm V/V.

Ultraviolet absorption spectrophotometry analyser.

*Gas to be examined.* The substance to be examined.

*Reference gas (a): nitrogen R1.*

*Reference gas (b):* mixture containing 400 ppm V/V of *nitrogen dioxide R* in *nitrogen R*.

*Apparatus:*

- an ultraviolet-visible light source (analytical wavelength about 400 nm);
- a sample gas cell through which the feed gas flows;
- a closed reference gas cell containing *nitrogen R1* in parallel with the sample gas cell;
- a rotating chopper which feeds light alternately through the reference gas cell and the sample gas cell;
- a semiconductor detector which generates a frequency modulated output whose amplitude is a measure of the difference of absorption of the sample gas and the reference gas.

*Analysis:*

- set the zero of the instrument using reference gas (a) through the sample gas cell at a flow rate of 1 L/min;
- adjust the span while feeding reference gas (b) through the sample gas cell at a flow rate of 1 L/min;
- feed the gas to be examined through the sample gas cell at a flow rate of 1 L/min, read the value from the instrument output and calculate, if necessary, the concentration of nitrogen dioxide.

**Nitrous oxide.** Gas chromatography (2.2.28).

*Gas to be examined.* The substance to be examined.

*Reference gas:* mixture containing 3000 ppm V/V of *nitrous oxide R* in *nitrogen R*.

*Column:*

- *material:* stainless steel;
- *size:*  $l = 3.5$  m,  $\varnothing = 2$  mm;
- *stationary phase:* ethylvinylbenzene-divinylbenzene copolymer R;
- *temperature:* 50 °C.

*Carrier gas:* helium for chromatography R.

*Flow rate:* 15 mL/min.

*Detection:* thermal conductivity.

*Injection:* loop injector.

*System suitability:*

- the chromatograms obtained show a clear separation of nitrous oxide from nitric oxide.

*Limit:*

- *nitrous oxide:* not more than the area of the corresponding peak in the chromatogram obtained with the reference gas (3000 ppm V/V).

**Water (2.5.28):** maximum 100 ppm V/V.

**Assay.** Determine the content of nitric oxide by difference using the mass balance equation after determining the sum of the impurities described under Production.

#### IDENTIFICATION

Infrared absorption spectrophotometry (2.2.24).

*Comparison:* Ph. Eur. reference spectrum of nitric oxide.

#### STORAGE

Compressed at a pressure not exceeding 2.5 MPa (25 bars) measured at 15 °C, in suitable containers complying with the legal regulations.

#### IMPURITIES

*Specified impurities:* A, B, C, D, E.

A. CO<sub>2</sub>: carbon dioxide,

B. N<sub>2</sub>: nitrogen,

C. NO<sub>2</sub>: nitrogen dioxide,

D. N<sub>2</sub>O: nitrous oxide,

E. H<sub>2</sub>O: water.

01/2008:1135

corrected 6.0

## NITROFURAL

### Nitrofuralem

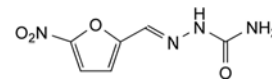

C<sub>6</sub>H<sub>6</sub>N<sub>4</sub>O<sub>4</sub>  
[59-87-0]

*M<sub>r</sub>* 198.1

#### DEFINITION

2-[(5-Nitrofuranyl)methylene]diazanecarboxamide.

*Content:* 97.0 per cent to 103.0 per cent (dried substance).

#### CHARACTERS

*Appearance:* yellow or brownish-yellow, crystalline powder.

*Solubility:* very slightly soluble in water, slightly soluble in ethanol (96 per cent).

#### IDENTIFICATION

*First identification:* B.

*Second identification:* A, C, D.

A. Ultraviolet and visible absorption spectrophotometry (2.2.25). Carry out the test protected from bright light.

*Test solution.* Use the solution prepared for the assay.

*Spectral range:* 220-400 nm.

*Absorption maxima:* at 260 nm and 375 nm.

*Absorbance ratio:*  $A_{375}/A_{260} = 1.15$  to 1.30.

B. Infrared absorption spectrophotometry (2.2.24).

*Preparation:* discs.

*Comparison:* nitrofurantoin CRS.

C. Thin-layer chromatography (2.2.27).

*Test solution.* Dissolve 10 mg of the substance to be examined in *methanol R* and dilute to 10 mL with the same solvent.

*Reference solution.* Dissolve 10 mg of *nitrofurantoin CRS* in *methanol R* and dilute to 10 mL with the same solvent.

*Plate:* TLC silica gel G plate R.

*Mobile phase:* *methanol R*, *nitromethane R* (10:90 V/V).

*Application:* 5 µL.

*Development:* over a path of 15 cm.

*Drying:* in air.

*Detection:* spray with *phenylhydrazine hydrochloride solution R*.

*Results:* the principal spot in the chromatogram obtained with the test solution is similar in position, colour and size to the principal spot in the chromatogram obtained with the reference solution.

D. Dissolve about 1 mg in 1 mL of *dimethylformamide R* and add 0.1 mL of *alcoholic potassium hydroxide solution R*. A violet-red colour is produced.

## TESTS

**pH** (2.2.3): 5.0 to 7.0.

To 1.0 g add 100 mL of *carbon dioxide-free water R*. Shake and filter.

**Related substances.** Liquid chromatography (2.2.29).

**Test solution.** Dissolve 0.10 g of the substance to be examined in the mobile phase and dilute to 100.0 mL with the mobile phase.

**Reference solution (a).** Dissolve 10.0 mg of *(5-nitro-2-furyl)methylene diacetate R* (impurity B) in the mobile phase and dilute to 20.0 mL with the mobile phase. Dilute 1.0 mL of this solution to 100.0 mL with the mobile phase.

**Reference solution (b).** Dissolve 10 mg of *nitrofurantoin R* and 10 mg of *nitrofurantoin R* in the mobile phase and dilute to 100 mL with the mobile phase. Dilute 5 mL of this solution to 100 mL with the mobile phase.

**Column:**

- size:  $l = 0.25$  m,  $\varnothing = 4.6$  mm;
- stationary phase: *octadecylsilyl silica gel for chromatography R* (5  $\mu$ m).

**Mobile phase:** *acetonitrile R*, *water R* (40:60 V/V).

**Flow rate:** 1 mL/min.

**Detection:** spectrophotometer at 310 nm.

**Injection:** 20  $\mu$ L.

**Run time:** 10 times the retention time of nitrofurantoin.

**Retention time:** nitrofurantoin = about 3 min.

**System suitability:** reference solution (b):

- resolution: minimum 2.0 between the peaks due to nitrofurantoin and nitrofurantoin.

**Limits:**

- impurities A, B: for each impurity, not more than the area of the principal peak in the chromatogram obtained with reference solution (a) (0.5 per cent);
- total: not more than twice the area of the principal peak in the chromatogram obtained with reference solution (a) (1.0 per cent);
- disregard limit: 0.05 times the area of the principal peak in the chromatogram obtained with reference solution (a) (0.025 per cent).

**Loss on drying** (2.2.32): maximum 0.5 per cent, determined on 1.000 g by drying in an oven at 105 °C.

**Sulfated ash** (2.4.14): maximum 0.1 per cent, determined on 1.0 g.

## ASSAY

**Carry out the assay protected from bright light.** Dissolve 60.0 mg in 20 mL of *dimethylformamide R* and dilute to 500.0 mL with *water R*. Dilute 5.0 mL of this solution to 100.0 mL with *water R*. Prepare a reference solution in the same manner using 60.0 mg of *nitrofurantoin CRS*. Measure the absorbances (2.2.25) of the 2 solutions at the absorption maximum at 375 nm.

Calculate the content of  $C_8H_6N_4O_5$  from the absorbances measured and the concentrations of the solutions.

## STORAGE

Protected from light.

## IMPURITIES

**Specified impurities:** A, B.

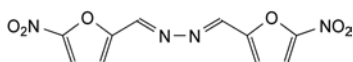

A. bis[(5-nitrofurantoin-2-yl)methylene]diazane,

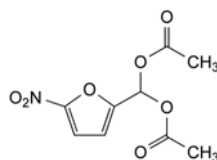

B. (5-nitrofurantoin-2-yl)methylene diacetate.

01/2008:0101  
corrected 7.0

## NITROFURANTOIN

## Nitrofurantoinum

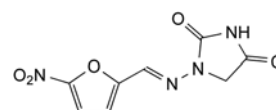

$C_8H_6N_4O_5$   
[67-20-9]

$M_r$  238.2

## DEFINITION

Nitrofurantoin contains not less than 98.0 per cent and not more than the equivalent of 102.0 per cent of 1-[[[(5-nitrofurantoin-2-yl)methylene]amino]imidazolidine-2,4-dione], calculated with reference to the dried substance.

## CHARACTERS

A yellow, crystalline powder or yellow crystals, very slightly soluble in water and in ethanol (96 per cent), soluble in dimethylformamide.

## IDENTIFICATION

- A. **Carry out the test protected from bright light.** Use the solution prepared for the assay. Examined between 220 nm and 400 nm (2.2.25), the solution shows two absorption maxima, at 266 nm and 367 nm. The ratio of the absorbance at the maximum at 367 nm to that at the maximum at 266 nm is 1.36 to 1.42.
- B. Dissolve about 10 mg in 10 mL of *dimethylformamide R*. To 1 mL of the solution add 0.1 mL of 0.5 M *alcoholic potassium hydroxide*. A brown colour develops.

## TESTS

**Related substances.** Examine by thin-layer chromatography (2.2.27), using *silica gel HF<sub>254</sub> R* as the coating substance.

**Test solution.** Dissolve 0.25 g of the substance to be examined in a minimum of *dimethylformamide R* and dilute to 10 mL with *acetone R*.

**Reference solution.** Dilute 1 mL of the test solution to 100 mL with *acetone R*.

Apply separately to the plate 10  $\mu$ L of each solution. Develop over a path of 15 cm using a mixture of 10 volumes of *methanol R* and 90 volumes of *nitromethane R*. Allow the plate to dry in air and heat at 100 °C to 105 °C for 5 min. Examine in ultraviolet light at 254 nm. Spray with *phenylhydrazine hydrochloride solution R*. Heat the plate at 100 °C to 105 °C for a further 10 min. When examined in ultraviolet light and after spraying, any spot in the chromatogram obtained with the test solution, apart from the principal spot, is not more intense than the spot in the chromatogram obtained with the reference solution (1.0 per cent).

**Loss on drying** (2.2.32). Not more than 1.0 per cent, determined on 1.00 g by drying in an oven at 105 °C.

**Sulfated ash** (2.4.14). Not more than 0.1 per cent, determined on 1.0 g.

## ASSAY

Carry out the assay protected from bright light. Dissolve 0.120 g in 50 mL of *dimethylformamide R* and dilute to 1000.0 mL with *water R*. Dilute 5.0 mL of the solution to 100.0 mL with a solution containing 18 g/L of *sodium acetate R* and 0.14 per cent V/V of *glacial acetic acid R*. Measure the absorbance (2.2.25) at the absorption maximum at 367 nm, using the sodium acetate solution described above as compensation liquid.

Calculate the content of  $C_8H_6N_4O_5$ , taking the specific absorbance to be 765.

## STORAGE

Store protected from light, at a temperature below 25 °C.

01/2008:1247

## NITROGEN

## Nitrogenium

$N_2$   
[7727-37-9]

 $M_r$  28.01

## DEFINITION

*Content*: minimum 99.5 per cent V/V of  $N_2$ .

This monograph applies to nitrogen for medicinal use.

## CHARACTERS

*Appearance*: colourless, odourless gas.

*Solubility*: at 20 °C and at a pressure of 101 kPa, 1 volume dissolves in about 62 volumes of water and about 10 volumes of ethanol (96 per cent).

## PRODUCTION

**Carbon dioxide**: maximum 300 ppm V/V, determined using an infrared analyser (2.5.24).

*Gas to be examined*. The substance to be examined. It must be filtered to avoid stray light phenomena.

*Reference gas (a)*. Nitrogen R1.

*Reference gas (b)*. Mixture containing 300 ppm V/V of carbon dioxide R1 in nitrogen R1.

Calibrate the apparatus and set the sensitivity using reference gases (a) and (b). Measure the content of carbon dioxide in the gas to be examined.

**Carbon monoxide**: maximum 5 ppm V/V, determined using an infrared analyser (2.5.25).

*Gas to be examined*. The substance to be examined. It must be filtered to avoid stray light phenomena.

*Reference gas (a)*. Nitrogen R1.

*Reference gas (b)*. Mixture containing 5 ppm V/V of carbon monoxide R in nitrogen R1.

Calibrate the apparatus and set the sensitivity using reference gases (a) and (b). Measure the content of carbon monoxide in the gas to be examined.

**Oxygen**: maximum 50 ppm V/V, determined using an oxygen analyser with a detector scale ranging from 0-100 ppm V/V and equipped with an electrochemical cell.

The gas to be examined passes through a detection cell containing an aqueous solution of an electrolyte, generally potassium hydroxide. The presence of oxygen in the gas to be examined produces variation in the electric signal recorded at the outlet of the cell that is proportional to the oxygen content. Calibrate the analyser according to the instructions of the manufacturer. Pass the gas to be examined through the analyser using a suitable pressure regulator and airtight metal tubes and operating at the prescribed flow-rates until constant readings are obtained.

**Water** (2.5.28): maximum 67 ppm V/V.

**Assay**. Gas chromatography (2.2.28).

*Gas to be examined*. The substance to be examined.

*Reference gas (a)*. Ambient air.

*Reference gas (b)*. Nitrogen R1.

*Column*:

- *material*: stainless steel;
- *size*:  $l = 2$  m,  $\varnothing = 2$  mm;
- *stationary phase*: molecular sieve for chromatography R (0.5 nm).

*Carrier gas*: helium for chromatography R.

*Flow rate*: 40 mL/min.

*Temperature*:

- *column*: 50 °C;
- *detection*: 130 °C.

*Detection*: thermal conductivity.

*Injection*: loop injector.

Inject reference gas (a). Adjust the injected volumes and operating conditions so that the height of the peak due to nitrogen in the chromatogram obtained with the reference gas is at least 35 per cent of the full scale of the recorder.

*System suitability*:

- the chromatograms obtained show a clear separation of oxygen and nitrogen.

Calculate the content of  $N_2$  in the gas to be examined.

## IDENTIFICATION

*First identification*: A.

*Second identification*: B, C.

A. Examine the chromatograms obtained in the assay (see Production).

*Results*: the principal peak in the chromatogram obtained with the substance to be examined is similar in retention time to the principal peak in the chromatogram obtained with reference gas (b).

B. In a 250 mL conical flask replace the air by the substance to be examined. Place a burning or glowing splinter of wood in the flask. The splinter is extinguished.

C. In a suitable test tube, place 0.1 g of *magnesium R* in turnings. Close the tube with a two-hole stopper fitted with a glass tube reaching about 1 cm above the turnings. Pass the substance to be examined through the glass tube for 1 min without heating, then for 15 min while heating the test tube to a red glow. After cooling, add 5 mL of *dilute sodium hydroxide solution R*. The evolving vapours change the colour of moistened *red litmus paper R* blue.

## TESTS

**Carbon dioxide** (2.1.6): maximum 300 ppm V/V, determined using a carbon dioxide detector tube.

**Carbon monoxide** (2.1.6): maximum 5 ppm V/V, determined using a carbon monoxide detector tube.

**Water vapour** (2.1.6): maximum 67 ppm V/V, determined using a water vapour detector tube.

## STORAGE

As a compressed gas or a liquid in appropriate containers complying with the legal regulations.

## IMPURITIES

*Specified impurities*: A, B, C, D.

- A.  $CO_2$ : carbon dioxide,
- B. CO: carbon monoxide,
- C.  $O_2$ : oxygen,
- D.  $H_2O$ : water.

01/2008:1685

**NITROGEN, LOW-OXYGEN****Nitrogenium oxygenio depletum**N<sub>2</sub>M<sub>r</sub> 28.01**DEFINITION**

This monograph applies to nitrogen which is used for inerting finished medicinal products which are particularly sensitive to degradation by oxygen. It does not necessarily apply to nitrogen used in earlier production steps.

**Content:** minimum 99.5 per cent V/V of N<sub>2</sub>, calculated by deduction of the sum of impurities found when performing the test for impurities.

**CHARACTERS**

Colourless and odourless gas.

**Solubility:** at 20 °C and at a pressure of 101 kPa, 1 volume dissolves in about 62 volumes of water and about 10 volumes of alcohol.

**PRODUCTION**

**Oxygen:** maximum 5 ppm V/V, determined using an oxygen analyser with a detector scale ranging from 0 ppm V/V to 100 ppm V/V and equipped with an electrochemical cell.

The gas to be examined passes through a detection cell containing an aqueous solution of an electrolyte, generally potassium hydroxide. The presence of oxygen in the gas to be examined produces variation in the electric signal recorded at the outlet of the cell that is proportional to the oxygen content.

Calibrate the analyser according to the manufacturer's instructions. Pass the gas to be examined through the analyser using a suitable pressure regulator and airtight metal tubes and operating at the prescribed flow rates until constant readings are obtained.

**Impurities.** Gas chromatography (2.2.28).

*Gas to be examined.* The substance to be examined.

*Reference gas (a).* Use ambient air.

*Reference gas (b).* Use nitrogen R1.

**Column:**

- *material:* stainless steel,
- *size:*  $l = 2$  m,  $\varnothing = 2$  mm,
- *stationary phase:* appropriate molecular sieve for chromatography (0.5 nm).

*Carrier gas:* helium for chromatography R.

*Flow rate:* 40 mL/min.

**Temperature:**

- *column:* 50 °C,
- *detector:* 130 °C.

**Detection:** thermal conductivity.

**System suitability:** reference gas (a): adjust the injected volumes and operating conditions so that the height of the peak due to nitrogen in the chromatogram obtained is at least 35 per cent of the full scale of the recorder:

- the chromatogram obtained shows a clear separation of oxygen and nitrogen.

**Limit:**

- *total:* not more than 0.5 per cent of the sum of the areas of all the peaks (0.5 per cent V/V).

**IDENTIFICATION**

**First identification:** A.

**Second identification:** B, C.

A. Examine the chromatograms obtained in the test for impurities (see Production).

**Results:** the principal peak in the chromatogram obtained with the gas to be examined is similar in retention time to the principal peak in the chromatogram obtained with reference gas (b).

- B. In a 250 mL conical flask replace the air by the gas to be examined. Place a burning or glowing splinter of wood in the flask. The splinter is extinguished.
- C. In a suitable test tube, place 0.1 g of *magnesium R* in turnings. Close the tube with a two-hole stopper fitted with a glass tube reaching about 1 cm above the turnings. Pass the gas to be examined through the glass tube for 1 min without heating, then for 15 min while heating the test tube to a red glow. After cooling, add 5 mL of *dilute sodium hydroxide solution R*. The evolving vapours turn the colour of moistened *red litmus paper R* blue.

**STORAGE**

Where the gas has to be stored, store as a compressed gas or a liquid in appropriate containers complying with the legal regulations.

**IMPURITIES**

- A. O<sub>2</sub>: oxygen,
- B. Ar: argon.

01/2008:0416

**NITROUS OXIDE****Dinitrogenii oxidum**N<sub>2</sub>OM<sub>r</sub> 44.01

[10024-97-2]

**DEFINITION**

**Content:** minimum 98.0 per cent V/V of N<sub>2</sub>O in the gaseous phase, when sampled at 15 °C.

This monograph applies to nitrous oxide for medicinal use.

**CHARACTERS**

**Appearance:** colourless gas.

**Solubility:** at 20 °C and at a pressure of 101 kPa, 1 volume dissolves in about 1.5 volumes of water.

**PRODUCTION**

Nitrous oxide is produced from ammonium nitrate by thermic decomposition.

*Examine the gaseous phase.*

*If the test is performed on a cylinder, keep the cylinder at room temperature for at least 6 h before carrying out the tests. Keep the cylinder in the vertical position with the outlet valve uppermost.*

**Carbon dioxide.** Gas chromatography (2.2.28).

*Gas to be examined.* The substance to be examined.

**Reference gas.** A mixture containing 300 ppm V/V of *carbon dioxide R1* in *nitrous oxide R*.

**Column:**

- *material:* stainless steel;
- *size:*  $l = 3.5$  m,  $\varnothing = 2$  mm;
- *stationary phase:* *ethylvinylbenzene-divinylbenzene copolymer R*.

*Carrier gas:* helium for chromatography R.

*Flow rate:* 15 mL/min.

**Temperature:**

- *column:* 40 °C;
- *detector:* 90 °C.

**Detection:** thermal conductivity.

**Injection:** loop injector.

Adjust the injected volumes and operating conditions so that the height of the peak due to carbon dioxide in the chromatogram obtained with the reference gas is at least 35 per cent of the full scale of the recorder. The test is not valid unless the chromatograms obtained show a clear separation of carbon dioxide from nitrous oxide.

**Limit:**

- *carbon dioxide*: not more than the area of the corresponding peak in the chromatogram obtained with the reference gas (300 ppm V/V).

**Carbon monoxide.** Gas chromatography (2.2.28). When the test is carried out on a cylinder, use the first portion of gas to be withdrawn.

*Gas to be examined.* The substance to be examined.

*Reference gas.* A mixture containing 5 ppm V/V of carbon monoxide R in nitrous oxide R.

**Column:**

- *material*: stainless steel;
- *size*:  $l = 2$  m,  $\varnothing = 4$  mm;
- *stationary phase*: suitable molecular sieve for chromatography (0.5 nm).

*Carrier gas: helium for chromatography R.*

*Flow rate:* 60 mL/min.

**Temperature:**

- *column*: 50 °C;
- *injection port and detector*: 130 °C.

*Detection:* flame ionisation with methaniser.

*Injection:* loop injector.

Adjust the injected volumes and the operating conditions so that the height of the peak due to carbon monoxide in the chromatogram obtained with the reference gas is at least 35 per cent of the full scale of the recorder.

**Limit:**

- *carbon monoxide*: not more than the area of the corresponding peak in the chromatogram obtained with the reference gas (5 ppm V/V).

**Nitrogen monoxide and nitrogen dioxide:** maximum 2 ppm V/V in total in the gaseous and liquid phases, determined using a chemiluminescence analyser (2.5.26).

*Gas to be examined.* The substance to be examined.

*Reference gas (a). Nitrous oxide R.*

*Reference gas (b).* A mixture containing 2 ppm V/V of nitrogen monoxide R in nitrogen R1.

Calibrate the apparatus and set the sensitivity using reference gases (a) and (b). Measure the content of nitrogen monoxide and nitrogen dioxide, separately examining the samples collected from the gaseous phase and the liquid phase of the gas to be examined.

Multiply the result obtained by the quenching correction factor in order to correct the quenching effect on the analyser response caused by the nitrous oxide matrix effect.

The quenching correction factor is determined by applying a known reference mixture of nitrogen monoxide in nitrous oxide and comparing the actual content with the content indicated by the analyser which has been calibrated with an NO/N<sub>2</sub> reference mixture.

$$\text{Quenching correction factor} = \frac{\text{actual nitrogen monoxide content}}{\text{indicated nitrogen monoxide content}}$$

**Water:** maximum 67 ppm V/V, determined using an electrolytic hygrometer (2.5.28).

**Assay.** Infrared analyser (2.5.35).

*Gas to be examined.* The substance to be examined. It must be filtered to avoid stray light phenomena.

*Reference gas (a). Nitrous oxide R.*

*Reference gas (b).* A mixture containing 5.0 per cent V/V of nitrogen R1 and 95.0 per cent V/V of nitrous oxide R.

Calibrate the apparatus and set the sensitivity using reference gases (a) and (b). Measure the content of nitrous oxide in the gas to be examined.

**IDENTIFICATION**

*First identification: A.*

*Second identification: B, C.*

- It complies with the limits of the assay.
- Place a glowing splinter of wood in the substance to be examined. The splinter bursts into flame.
- Introduce the substance to be examined into *alkaline pyrogallol solution R*. A brown colour does not develop.

**TESTS**

*Examine the gaseous phase.*

*If the test is performed on a cylinder, keep the cylinder of the substance to be examined at room temperature for at least 6 h before carrying out the tests. Keep the cylinder in the vertical position with the outlet valve uppermost.*

**Carbon dioxide:** maximum 300 ppm V/V, determined using a carbon dioxide detector tube (2.1.6).

**Carbon monoxide:** maximum 5 ppm V/V, determined using a carbon monoxide detector tube (2.1.6). When the test is carried out on a cylinder, use the first portion of the gas to be withdrawn.

**Nitrogen monoxide and nitrogen dioxide:** maximum 2 ppm V/V, determined using a nitrogen monoxide and nitrogen dioxide detector tube (2.1.6).

**Water vapour:** maximum 67 ppm V/V, determined using a water vapour detector tube (2.1.6).

**STORAGE**

Store liquefied under pressure in suitable containers complying with the legal regulations. The taps and valves are not greased or oiled.

**IMPURITIES**

*Specified impurities: A, B, C, D, E.*

- CO<sub>2</sub>: carbon dioxide,
- CO: carbon monoxide,
- NO: nitrogen monoxide,
- NO<sub>2</sub>: nitrogen dioxide,
- H<sub>2</sub>O: water.

01/2008:1453  
corrected 6.0

**NIZATIDINE**

Nizatidinum

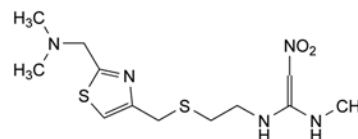

C<sub>12</sub>H<sub>21</sub>N<sub>5</sub>O<sub>2</sub>S<sub>2</sub>  
[76963-41-2]

M<sub>r</sub> 331.5

**DEFINITION**

(*EZ*)-*N*-[2-[[[2-[(Dimethylamino)methyl]thiazol-4-yl]methyl]sulfanyl]ethyl]-*N'*-methyl-2-nitroethane-1,1-diamine.

*Content:* 97.0 per cent to 101.0 per cent (dried substance).

## CHARACTERS

**Appearance:** almost white or slightly brownish, crystalline powder.

**Solubility:** sparingly soluble in water, soluble in methanol.

## IDENTIFICATION

**First identification:** C.

**Second identification:** A, B, D.

A. Melting point (2.2.14): 131 °C to 134 °C.

B. Ultraviolet and visible absorption spectrophotometry (2.2.25).

**Test solution.** Dissolve 0.10 g in *methanol R* and dilute to 100.0 mL with the same solvent. Dilute 2.0 mL of this solution to 100.0 mL with *methanol R*.

**Spectral range:** 220-350 nm.

**Absorption maxima:** at 242 nm and 325 nm.

**Absorbance ratio:**  $A_{325}/A_{242} = 2.2$  to 2.5.

C. Infrared absorption spectrophotometry (2.2.24).

**Preparation:** discs.

**Comparison:** *nizatidine CRS*.

D. Thin-layer chromatography (2.2.27).

**Test solution.** Dissolve 50 mg of the substance to be examined in *methanol R* and dilute to 10 mL with the same solvent.

**Reference solution (a).** Dissolve 50 mg of *nizatidine CRS* in *methanol R* and dilute to 10 mL with the same solvent.

**Reference solution (b).** Dissolve 50 mg of *nizatidine CRS* and 50 mg of *ranitidine hydrochloride CRS* in *methanol R* and dilute to 10 mL with the same solvent.

**Plate:** *TLC silica gel plate R*.

**Mobile phase:** *water R, concentrated ammonia R1, 2-propanol R, ethyl acetate R* (2:4:15:25 V/V/V/V).

**Application:** 5 µL.

**Development:** over 2/3 of the plate.

**Drying:** in air.

**Detection:** expose to iodine vapour until the spots are clearly visible. Examine in daylight.

**System suitability:** reference solution (b):

– the chromatogram shows 2 clearly separated spots.

**Results:** the principal spot in the chromatogram obtained with the test solution is similar in position and size to the principal spot in the chromatogram obtained with reference solution (a).

## TESTS

**Appearance of solution.** The solution is clear (2.2.1) and not more intensely coloured than reference solution  $Y_5$  (2.2.2, *Method II*).

Dissolve 0.2 g in a 10 g/L solution of *hydrochloric acid R* and dilute to 20 mL with the same acid solution.

**pH** (2.2.3): 8.5 to 10.0.

Dissolve 0.2 g in *carbon dioxide-free water R* and dilute to 20 mL with the same solvent.

**Related substances.** Liquid chromatography (2.2.29).

**Test solution (a).** Dissolve 50.0 mg of the substance to be examined in a mixture of 24 volumes of mobile phase B and 76 volumes of mobile phase A and dilute to 10.0 mL with the same mixture of mobile phases.

**Test solution (b).** Dissolve 15.0 mg of the substance to be examined in a mixture of 24 volumes of mobile phase B and 76 volumes of mobile phase A and dilute to 50.0 mL with the same mixture of mobile phases.

**Reference solution (a).** Dilute 1.0 mL of test solution (a) to 100.0 mL with a mixture of 24 volumes of mobile phase B and 76 volumes of mobile phase A.

**Reference solution (b).** Dissolve 15.0 mg of *nizatidine CRS* in a mixture of 24 volumes of mobile phase B and 76 volumes of mobile phase A and dilute to 50.0 mL with the same mixture of mobile phases.

**Reference solution (c).** Dissolve 5 mg of *nizatidine CRS* and 0.5 mg of *nizatidine impurity F CRS* in a mixture of 24 volumes of mobile phase B and 76 volumes of mobile phase A and dilute to 100.0 mL with the same mixture of mobile phases.

**Column:**

– **size:**  $l = 0.25$  m,  $\varnothing = 4.6$  mm;

– **stationary phase:** *octadecylsilyl silica gel for chromatography R* (5 µm).

**Mobile phase:**

– **mobile phase A:** dissolve 5.9 g of *ammonium acetate R* in 760 mL of *water R*, add 1 mL of *diethylamine R*, and adjust to pH 7.5 with *acetic acid R*;

– **mobile phase B:** *methanol R*;

Time (min)	Mobile phase A (per cent V/V)	Mobile phase B (per cent V/V)
0 - 3	76	24
3 - 20	76 → 50	24 → 50
20 - 45	50	50
45 - 50	50 → 76	50 → 24
50 - 60	76	24

**Flow rate:** 1.0 mL/min.

**Detection:** spectrophotometer at 254 nm.

**Injection:** 20 µL of test solution (a) and reference solutions (a) and (c).

**System suitability:**

– **retention time:** *nizatidine* = 10 min to 20 min in the chromatogram obtained with reference solution (a);

– **symmetry factor:** maximum 2.0 for the peak due to *nizatidine* in the chromatogram obtained with reference solution (a);

– **resolution:** minimum 2.0 between the peaks due to *nizatidine* (1<sup>st</sup> peak) and *impurity F* (2<sup>nd</sup> peak) in the chromatogram obtained with reference solution (c).

**Limits:**

– **impurities A, B, C, D, E, F, G, H, I, J, K:** for each impurity, not more than 0.3 times the area of the principal peak in the chromatogram obtained with reference solution (a) (0.3 per cent);

– **total:** not more than 1.5 times the area of the principal peak in the chromatogram obtained with reference solution (a) (1.5 per cent);

– **disregard limit:** 0.03 times the area of the principal peak in the chromatogram obtained with reference solution (a) (0.03 per cent).

**Heavy metals** (2.4.8): maximum 20 ppm.

1.0 g complies with test C. Prepare the reference solution using 2 mL of *lead standard solution (10 ppm Pb) R*.

**Loss on drying** (2.2.32): maximum 0.5 per cent, determined on 1.000 g by drying in an oven at 105 °C.

**Sulfated ash** (2.4.14): maximum 0.1 per cent, determined on 1.0 g.

## ASSAY

Liquid chromatography (2.2.29) as described in the test for related substances with the following modifications.

**Mobile phase:** mobile phase B, mobile phase A (35:65 V/V).

**Injection:** test solution (b) and reference solution (b).

**System suitability:** reference solution (b):

– **retention time:** *nizatidine* = 8 min to 10 min;

– **symmetry factor:** maximum 2.0 for the peak due to *nizatidine*;



– *repeatability*: maximum relative standard deviation of 2.0 per cent after 6 injections.

01/2008:1551  
corrected 6.0

Calculate the percentage content of nizatidine from the declared content of *nizatidine CRS*.

IMPURITIES

Specified impurities: A, B, C, D, E, F, G, H, I, J, K.

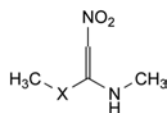

A. X = NH: *N,N'*-dimethyl-2-nitroethene-1,1-diamine,

B. X = S: (*EZ*)-*N*-methyl-1-(methylsulfonyl)-2-nitroethen-1-amine,

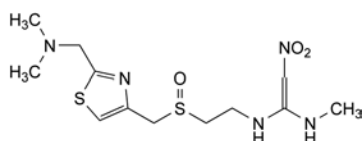

C. (*EZ*)-*N*-[2-[[[2-[(dimethylamino)methyl]thiazol-4-yl]methyl]sulfonyl]ethyl]-*N'*-methyl-2-nitroethene-1,1-diamine,

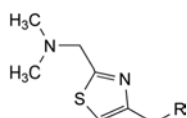

D. R = S-CH<sub>2</sub>-CH<sub>2</sub>-NH<sub>2</sub>: 2-[[[2-[(dimethylamino)methyl]thiazol-4-yl]methyl]sulfonyl]ethanamine,

E. R = S-CH<sub>2</sub>-CH<sub>2</sub>-NH-CO-CH<sub>2</sub>-NO<sub>2</sub>: *N*-[2-[[[2-[(dimethylamino)methyl]thiazol-4-yl]methyl]sulfonyl]ethyl]-2-nitroacetamide,

I. R = S-CH<sub>2</sub>-CH<sub>2</sub>-NH-CO-NH-CH<sub>3</sub>: *N*-[2-[[[2-[(dimethylamino)methyl]thiazol-4-yl]methyl]sulfonyl]ethyl]-*N'*-methylurea,

J. R = OH: [2-[(dimethylamino)methyl]thiazol-4-yl]methanol,

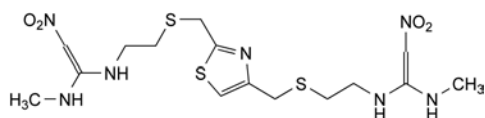

F. (*EZ*)-*N',N''*-[thiazole-2,4-diylbis(methylenesulfaneyl)ethylene]bis(*N'*-methyl-2-nitroethene-1,1-diamine),

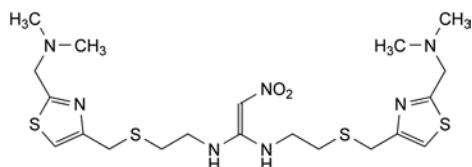

G. *N,N'*-bis[2-[[[2-[(dimethylamino)methyl]thiazol-4-yl]methyl]sulfonyl]ethyl]-2-nitroethene-1,1-diamine,

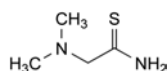

H. 2-(dimethylamino)thioacetamide,

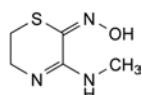

K. 3-(methylamino)-5,6-dihydro-2*H*-1,4-thiazin-2-one oxime.

NOMEGESTROL ACETATE

Nomegestroli acetas

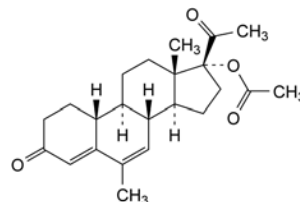

C<sub>23</sub>H<sub>30</sub>O<sub>4</sub>  
[58652-20-3]

M<sub>r</sub> 370.5

DEFINITION

6-Methyl-3,20-dioxo-19-norpregna-4,6-dien-17-yl acetate.

*Content*: 97.0 per cent to 103.0 per cent (dried substance).

CHARACTERS

*Appearance*: white or almost white, crystalline powder.

*Solubility*: practically insoluble in water, freely soluble in acetone, soluble in ethanol (96 per cent).

IDENTIFICATION

Infrared absorption spectrophotometry (2.2.24).

*Comparison*: nomegestrol acetate CRS.

TESTS

**Appearance of solution.** The solution is clear (2.2.1) and not more intensely coloured than reference solution Y<sub>5</sub> (2.2.2, Method II).

Dissolve 1.0 g in *methylene chloride R* and dilute to 10 mL with the same solvent.

**Specific optical rotation** (2.2.7): –60.0 to –64.0 (dried substance).

Dissolve 0.500 g in *anhydrous ethanol R* and dilute to 25.0 mL with the same solvent.

**Related substances.** Liquid chromatography (2.2.29).

*Test solution.* Dissolve 25.0 mg of the substance to be examined in *methanol R* and dilute to 50.0 mL with the same solvent.

*Reference solution (a).* Dilute 1.0 mL of the test solution to 200.0 mL with the mobile phase.

*Reference solution (b).* Dissolve 25.0 mg of *nomegestrol acetate impurity A CRS* in *methanol R* and dilute to 50.0 mL with the same solvent.

*Reference solution (c).* Dissolve 25.0 mg of *nomegestrol acetate CRS* in 20 mL of *methanol R*, add 0.25 mL of reference solution (b) and dilute to 50.0 mL with the mobile phase.

*Column*:

– *size*: *l* = 0.25 m, Ø = 4.6 mm;

– *stationary phase*: octadecylsilyl silica gel for chromatography R (5 µm).

*Mobile phase*: acetonitrile R, methanol R, water R (24:38:38 V/V/V).

*Flow rate*: 1.3 mL/min.

*Detection*: spectrophotometer at 245 nm and at 290 nm.

*Injection*: 10 µL.

*Run time*: 1.5 times the retention time of nomegestrol acetate.

*Retention time* at 245 nm: nomegestrol acetate = about 17 min; impurity A = about 18.5 min.

– *repeatability*: maximum relative standard deviation of 2.0 per cent after 6 injections.

01/2008:1551  
corrected 6.0

Calculate the percentage content of nizatidine from the declared content of *nizatidine CRS*.

IMPURITIES

Specified impurities: A, B, C, D, E, F, G, H, I, J, K.

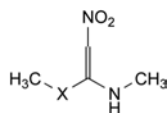

A. X = NH: *N,N'*-dimethyl-2-nitroethene-1,1-diamine,

B. X = S: (*EZ*)-*N*-methyl-1-(methylsulfonyl)-2-nitroethen-1-amine,

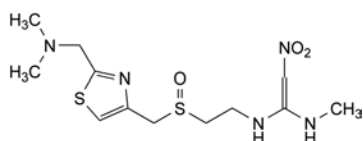

C. (*EZ*)-*N*-[2-[[[2-[(dimethylamino)methyl]thiazol-4-yl]methyl]sulfonyl]ethyl]-*N'*-methyl-2-nitroethene-1,1-diamine,

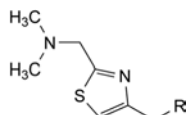

D. R = S-CH<sub>2</sub>-CH<sub>2</sub>-NH<sub>2</sub>: 2-[[[2-[(dimethylamino)methyl]thiazol-4-yl]methyl]sulfonyl]ethanamine,

E. R = S-CH<sub>2</sub>-CH<sub>2</sub>-NH-CO-CH<sub>2</sub>-NO<sub>2</sub>: *N*-[2-[[[2-[(dimethylamino)methyl]thiazol-4-yl]methyl]sulfonyl]ethyl]-2-nitroacetamide,

I. R = S-CH<sub>2</sub>-CH<sub>2</sub>-NH-CO-NH-CH<sub>3</sub>: *N*-[2-[[[2-[(dimethylamino)methyl]thiazol-4-yl]methyl]sulfonyl]ethyl]-*N'*-methylurea,

J. R = OH: [2-[(dimethylamino)methyl]thiazol-4-yl]methanol,

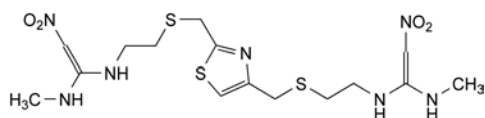

F. (*EZ*)-*N*<sup>1</sup>,*N*<sup>1'</sup>-[thiazole-2,4-diylbis(methylenesulfaneyl)ethylene]bis(*N'*-methyl-2-nitroethene-1,1-diamine),

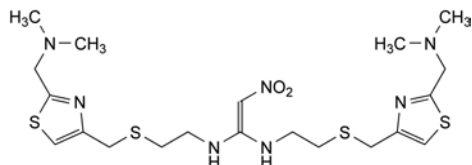

G. *N,N'*-bis[2-[[[2-[(dimethylamino)methyl]thiazol-4-yl]methyl]sulfonyl]ethyl]-2-nitroethene-1,1-diamine,

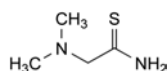

H. 2-(dimethylamino)thioacetamide,

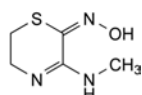

K. 3-(methylamino)-5,6-dihydro-2*H*-1,4-thiazin-2-one oxime.

NOMEGESTROL ACETATE

Nomegestroli acetas

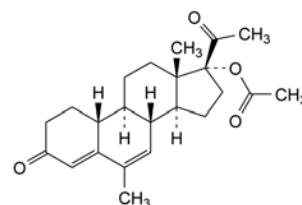

C<sub>23</sub>H<sub>30</sub>O<sub>4</sub>  
[58652-20-3]

M<sub>r</sub> 370.5

DEFINITION

6-Methyl-3,20-dioxo-19-norpregna-4,6-dien-17-yl acetate.

*Content*: 97.0 per cent to 103.0 per cent (dried substance).

CHARACTERS

*Appearance*: white or almost white, crystalline powder.

*Solubility*: practically insoluble in water, freely soluble in acetone, soluble in ethanol (96 per cent).

IDENTIFICATION

Infrared absorption spectrophotometry (2.2.24).

*Comparison*: nomegestrol acetate CRS.

TESTS

**Appearance of solution.** The solution is clear (2.2.1) and not more intensely coloured than reference solution Y<sub>5</sub> (2.2.2, Method II).

Dissolve 1.0 g in *methylene chloride R* and dilute to 10 mL with the same solvent.

**Specific optical rotation** (2.2.7): –60.0 to –64.0 (dried substance).

Dissolve 0.500 g in *anhydrous ethanol R* and dilute to 25.0 mL with the same solvent.

**Related substances.** Liquid chromatography (2.2.29).

*Test solution.* Dissolve 25.0 mg of the substance to be examined in *methanol R* and dilute to 50.0 mL with the same solvent.

*Reference solution (a).* Dilute 1.0 mL of the test solution to 200.0 mL with the mobile phase.

*Reference solution (b).* Dissolve 25.0 mg of *nomegestrol acetate impurity A CRS* in *methanol R* and dilute to 50.0 mL with the same solvent.

*Reference solution (c).* Dissolve 25.0 mg of *nomegestrol acetate CRS* in 20 mL of *methanol R*, add 0.25 mL of reference solution (b) and dilute to 50.0 mL with the mobile phase.

*Column*:

– *size*: *l* = 0.25 m, Ø = 4.6 mm;

– *stationary phase*: octadecylsilyl silica gel for chromatography R (5 µm).

*Mobile phase*: acetonitrile R, *methanol R*, *water R* (24:38:38 V/V/V).

*Flow rate*: 1.3 mL/min.

*Detection*: spectrophotometer at 245 nm and at 290 nm.

*Injection*: 10 µL.

*Run time*: 1.5 times the retention time of nomegestrol acetate.

*Retention time* at 245 nm: nomegestrol acetate = about 17 min; impurity A = about 18.5 min.

*System suitability*: reference solution (c) at 245 nm:

- *peak-to-valley ratio*: minimum 5, where  $H_p$  = height above the baseline of the peak due to impurity A and  $H_v$  = height above the baseline of the lowest point of the curve separating this peak from the peak due to nomegestrol acetate.

*Limits*:

- *impurity A at 245 nm*: not more than 0.4 times the area of the corresponding peak in the chromatogram obtained with reference solution (c) (0.2 per cent);
- *unspecified impurities at 245 nm*: for each impurity, not more than 0.2 times the area of the peak due to impurity A in the chromatogram obtained with reference solution (c) (0.10 per cent);
- *unspecified impurities at 290 nm*: for each impurity, not more than 0.2 times the area of the principal peak in the chromatogram obtained with reference solution (a) (0.10 per cent);
- *sum of impurities other than A at 290 nm and 245 nm*: maximum 0.3 per cent;
- *disregard limit at 245 nm*: 0.1 times the area of the peak due to impurity A in the chromatogram obtained with reference solution (c) (0.05 per cent);
- *disregard limit at 290 nm*: 0.04 times the area of the principal peak in the chromatogram obtained with reference solution (a) (0.02 per cent).

**Loss on drying** (2.2.32): maximum 0.5 per cent, determined on 1.000 g by drying in an oven at 105 °C.

#### ASSAY

Dissolve 50.0 mg in *anhydrous ethanol R* and dilute to 100.0 mL with the same solvent. Dilute 2.0 mL of this solution to 100.0 mL with *anhydrous ethanol R*. Measure the absorbance (2.2.25) at the absorption maximum at 287 nm.

Calculate the content of  $C_{23}H_{30}O_4$  taking the specific absorbance to be 685.

#### STORAGE

Protected from light.

#### IMPURITIES

*Specified impurities*: A.

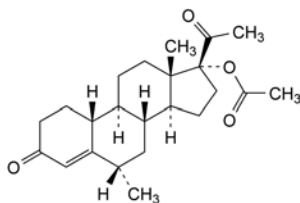

- A. 6 $\alpha$ -methyl-3,20-dioxo-19-norpregn-4-en-17-yl acetate.

01/2008:1454

## NONOXINOL 9

### Nonoxinolum 9

#### DEFINITION

$\alpha$ -(4-Nonylphenyl)- $\omega$ -hydroxynona(oxyethylene).

Mixture consisting mainly of monononylphenyl ethers of macrogols corresponding to the formula:  $C_9H_{19}C_6H_4[OCH_2CH_2]_nOH$  where the average value of  $n$  is 9. It may contain free macrogols.

#### CHARACTERS

*Appearance*: clear, colourless or light yellow, viscous liquid.

*Solubility*: miscible with water, with ethanol (96 per cent) and with vegetable oils.

#### IDENTIFICATION

A. Infrared absorption spectrophotometry (2.2.24).

*Comparison*: nonoxinol 9 CRS.

*Preparation*: film between *sodium chloride R* plates.

B. Cloud point (see Tests).

#### TESTS

**Acidity or alkalinity**. Boil 1.0 g with 20 mL of *carbon dioxide-free water R* for 1 min, with constant stirring. Cool and filter. To 10 mL of the filtrate, add 0.05 mL of *bromothymol blue solution RI*. Not more than 0.5 mL of 0.01 M *hydrochloric acid* or 0.01 M *sodium hydroxide* is required to change the colour of the indicator.

**Hydroxyl value** (2.5.3, *Method A*): 84 to 94.

**Cloud point**: 52 °C to 58 °C.

Dissolve 1.0 g in 99 g of *water R*. Transfer about 30 mL of this solution into a test-tube, heat on a water-bath and stir continuously until the solution becomes cloudy. Remove the test-tube from the water-bath (ensuring that the temperature does not increase to more than 2 °C) and continue to stir. The cloud point is the temperature at which the solution becomes sufficiently clear that the entire thermometer bulb is plainly seen.

**Ethylene oxide and dioxan** (2.4.25): maximum 1 ppm of ethylene oxide and maximum 10 ppm of dioxan.

**Heavy metals** (2.4.8): maximum 10 ppm.

Dissolve 2.0 g in *distilled water R* and dilute to 20.0 mL with the same solvent. 12 mL of this solution complies with test A. Prepare the reference solution using *lead standard solution (1 ppm Pb) R*.

**Water** (2.5.12): maximum 0.5 per cent, determined on 2.00 g.

**Total ash** (2.4.16): maximum 0.4 per cent, determined on 1.0 g.

#### STORAGE

In an airtight container.

01/2008:0732

## NORADRENALINE HYDROCHLORIDE

### Noradrenalini hydrochloridum

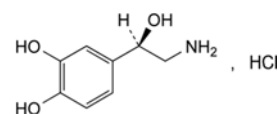

$C_8H_{12}ClNO_3$   
[329-56-6]

$M_r$ , 205.6

#### DEFINITION

(1R)-2-Amino-1-(3,4-dihydroxyphenyl)ethanol hydrochloride.

*Content*: 98.5 per cent to 101.0 per cent (anhydrous substance).

#### CHARACTERS

*Appearance*: white or brownish-white, crystalline powder.

*Solubility*: very soluble in water, slightly soluble in ethanol (96 per cent).

It becomes coloured on exposure to air and light.

#### IDENTIFICATION

A. Specific optical rotation (see Tests).

B. Infrared absorption spectrophotometry (2.2.24).

*Preparation*: discs of noradrenaline base prepared as follows. Dissolve 2 g in 20 mL of a 5 g/L solution of *sodium metabisulfite R* and make alkaline by addition of *ammonia R*. Keep in iced water for 1 h and filter. Wash the

precipitate with 3 quantities, each of 2 mL, of *water R*, then with 5 mL of *ethanol 96 per cent R* and finally with 5 mL of *methylene chloride R* and dry *in vacuo* for 3 h.

*Comparison*: use noradrenaline base prepared as above from a suitable amount of *noradrenaline tartrate CRS*.

C. 0.2 mL of solution S (see Tests) gives reaction (a) of chlorides (2.3.1).

## TESTS

**Solution S.** Dissolve 0.500 g in *carbon dioxide-free water R* and dilute to 25.0 mL with the same solvent.

**Appearance of solution.** The solution is clear (2.2.1) and not more intensely coloured than a mixture of 0.2 mL of blue primary solution, 0.4 mL of yellow primary solution, 0.4 mL of red primary solution and 9 mL of a 13.7 per cent V/V solution of *dilute hydrochloric acid R* (2.2.2, Method II).

Dissolve 0.2 g in *carbon dioxide-free water R* and dilute to 10 mL with the same solvent. Examine the solution immediately.

**pH** (2.2.3): 3.5 to 4.5 for solution S.

**Specific optical rotation** (2.2.7): –37 to –41 (anhydrous substance), determined on solution S.

**Related substances.** Liquid chromatography (2.2.29). *Protect the solutions from air. Remove oxygen from the mobile phases with nitrogen R immediately before use. Fill up the flasks.*

*Test solution.* Dissolve 0.125 g of the substance to be examined in mobile phase A and dilute to 50 mL with mobile phase A.

*Reference solution (a).* Dilute 1.0 mL of the test solution to 100.0 mL with mobile phase A. Dilute 1.0 mL of this solution to 10.0 mL with mobile phase A.

*Reference solution (b).* Dissolve 10 mg of the substance to be examined in 5 mL of *0.1 M hydrochloric acid*. To 1 mL of this solution add 0.1 mL of *strong hydrogen peroxide solution R* and expose to UV light at 254 nm for 90 min. Dilute to 10 mL with mobile phase A. The degradation of noradrenaline produces 2 peaks, one with a relative retention of about 1.2 (unidentified compound) and the other with a relative retention of about 1.5 (impurity B). Use this solution to identify the peak due to impurity B.

*Reference solution (c).* Dissolve 7.5 mg of *noradrenaline impurity D CRS* and 5 mg of *noradrenaline impurity E CRS* in mobile phase A and dilute to 100 mL with mobile phase A.

*Reference solution (d).* Dissolve 5 mg of *noradrenaline impurity F CRS* in mobile phase A and dilute to 10 mL with mobile phase A. To 1 mL of this solution, add 1 mL of reference solution (c) and dilute to 20 mL with mobile phase A.

**Column:**

- size:  $l = 0.10$  m,  $\varnothing = 4.6$  mm;
- stationary phase: *monolithic octadecylsilyl silica gel for chromatography R*;
- temperature: 25 °C.

**Mobile phase:**

- mobile phase A: dissolve 0.50 g of *sodium heptasulfonate R* in *water for chromatography R* and dilute to 1000 mL with the same solvent; adjust to pH 2.2 with *phosphoric acid R*;
- mobile phase B: dissolve 0.25 g of *sodium heptasulfonate R* in *water for chromatography R* and dilute to 500 mL with the same solvent; add 500 mL of *acetonitrile for chromatography R* and adjust the apparent pH to 2.4 with *phosphoric acid R*;

Time (min)	Mobile phase A (per cent V/V)	Mobile phase B (per cent V/V)	Flow rate (mL/min)
0 - 2.0	98	2	1.5
2.0 - 17.0	98 → 70	2 → 30	1.5
17.0 - 24.0	70 → 50	30 → 50	1.5
24.0 - 24.1	50 → 0	50 → 100	1.5 → 4.0
24.1 - 28.0	0	100	4.0
28.0 - 28.1	0 → 98	100 → 2	4.0
28.1 - 30.0	98	2	4.0 → 1.5

*Detection*: spectrophotometer at 280 nm, except for impurity F: spectrophotometer at 254 nm.

*Injection*: 20 µL of the test solution and reference solutions (a), (b) and (d).

*Relative retention* with reference to noradrenaline (retention time = about 3 min): impurity B = about 1.5; impurity D = about 2.8; impurity E = about 3.0; impurity F = about 6.9.

*System suitability*: reference solution (d):

- *resolution*: minimum 1.5 between the peaks due to impurities D and E.

*Limits*:

- *correction factors*: for the calculation of content, multiply the peak areas of the following impurities by the corresponding correction factor: impurity B = 0.3; impurity E = 0.3; impurity F = 1.5;
- *impurity D at 280 nm*: not more than 5 times the area of the principal peak in the chromatogram obtained with reference solution (a) (0.5 per cent);
- *impurity F at 254 nm*: not more than the area of the principal peak in the chromatogram obtained with reference solution (a) (0.1 per cent);
- *impurities B, E at 280 nm*: for each impurity, not more than the area of the principal peak in the chromatogram obtained with reference solution (a) (0.1 per cent);
- *unspecified impurities at 280 nm*: for each impurity, not more than the area of the principal peak in the chromatogram obtained with reference solution (a) (0.10 per cent);
- *sum of impurities other than D at 280 nm*: not more than twice the area of the principal peak in the chromatogram obtained with reference solution (a) (0.2 per cent);
- *sum of the impurities at 280 nm and impurity F at 254 nm*: maximum 0.7 per cent;
- *disregard limit at 280 nm*: 0.5 times the area of the principal peak in the chromatogram obtained with reference solution (a) (0.05 per cent).

**Water** (2.5.12): maximum 0.5 per cent, determined on 1.000 g.

**Sulfated ash** (2.4.14): maximum 0.1 per cent, determined on 1.0 g.

## ASSAY

*In order to avoid overheating in the reaction medium, mix thoroughly throughout and stop the titration immediately after the end-point has been reached.*

Dissolve 0.180 g in 50 mL of *acetic anhydride R* and add 10 mL of *anhydrous formic acid R*. Titrate with *0.1 M perchloric acid*, determining the end-point potentiometrically (2.2.20).

1 mL of *0.1 M perchloric acid* is equivalent to 20.56 mg of  $C_8H_{12}ClNO_3$ .

## STORAGE

In an airtight container, or preferably in a sealed tube under vacuum or under an inert gas, protected from light.

## IMPURITIES

*Specified impurities*: B, D, E, F.

**Other detectable impurities** (the following substances would, if present at a sufficient level, be detected by one or other of the tests in the monograph. They are limited by the general acceptance criterion for other/unspecified impurities and/or by the general monograph *Substances for pharmaceutical use (2034)*. It is therefore not necessary to identify these impurities for demonstration of compliance. See also 5.10. *Control of impurities in substances for pharmaceutical use*): A, C, G.

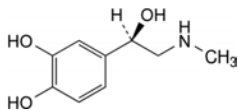

A. 4-[(1*R*)-1-hydroxy-2-(methylamino)ethyl]benzene-1,2-diol (adrenaline),

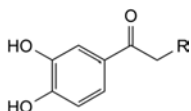

B. R = NH<sub>2</sub>: 2-amino-1-(3,4-dihydroxyphenyl)ethanone (noradrenalone),

E. R = Cl: 2-chloro-1-(3,4-dihydroxyphenyl)ethanone,

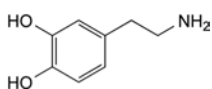

C. 4-(2-aminoethyl)benzene-1,2-diol (dopamine),

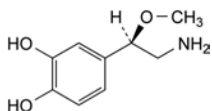

D. 4-[(1*R*)-2-amino-1-methoxyethyl]benzene-1,2-diol (noradrenaline methyl ether),

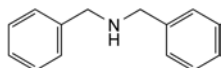

F. *N*-benzyl-1-phenylmethanamine,

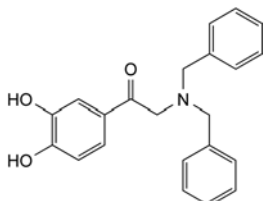

G. 2-(dibenzylamino)-1-(3,4-dihydroxyphenyl)ethanone.

**Solubility**: freely soluble in water, slightly soluble in ethanol (96 per cent).

#### IDENTIFICATION

A. Dissolve 2 g in 20 mL of a 5 g/L solution of *sodium metabisulfite R* and make alkaline by addition of *ammonia R*. Keep in iced water for 1 h and filter. Reserve the filtrate for identification test C. Wash the precipitate with 3 quantities, each of 2 mL, of *water R*, then with 5 mL of *ethanol (96 per cent) R* and finally with 5 mL of *methylene chloride R* and dry *in vacuo* for 3 h. The specific optical rotation (2.2.7) of the precipitate (noradrenaline base) is –44 to –48, determined using a 20.0 g/L solution in 0.5 *M* *hydrochloric acid*.

B. Infrared absorption spectrophotometry (2.2.24).

**Preparation**: discs of noradrenaline base prepared as described in identification test A.

**Comparison**: use noradrenaline base prepared as described in identification test A from a suitable amount of *noradrenaline tartrate CRS*.

C. 0.2 mL of the filtrate obtained in identification test A gives reaction (b) of tartrates (2.3.1).

#### TESTS

**Appearance of solution**. The solution is clear (2.2.1) and not more intensely coloured than reference solution BY<sub>5</sub> (2.2.2, *Method II*).

Dissolve 0.2 g in *water R* and dilute to 10 mL with the same solvent. Examine the solution immediately.

**Related substances**. Liquid chromatography (2.2.29). *Protect the solutions from air. Remove oxygen from the mobile phases with nitrogen R immediately before use. Fill up the flasks.*

**Test solution**. Dissolve 0.20 g of the substance to be examined in mobile phase A and dilute to 50 mL with mobile phase A.

**Reference solution (a)**. Dilute 1.0 mL of the test solution to 100.0 mL with mobile phase A. Dilute 1.0 mL of this solution to 10.0 mL with mobile phase A.

**Reference solution (b)**. Dissolve 10 mg of the substance to be examined in 5 mL of 0.1 *M* *hydrochloric acid*. To 1 mL of this solution add 0.1 mL of *strong hydrogen peroxide solution R* and expose to UV light at 254 nm for 90 min. Dilute to 10 mL with mobile phase A. The degradation of noradrenaline produces 2 peaks, one with a relative retention of about 1.2 (unidentified compound) and the other with a relative retention of about 1.5 (impurity B). Use this solution to identify the peak due to impurity B.

**Reference solution (c)**. Dissolve 7.5 mg of *noradrenaline impurity D CRS* and 5 mg of *noradrenaline impurity E CRS* in mobile phase A and dilute to 100 mL with mobile phase A.

**Reference solution (d)**. Dissolve 5 mg of *noradrenaline impurity F CRS* in mobile phase A and dilute to 10 mL with mobile phase A. To 1 mL of this solution, add 1 mL of reference solution (c) and dilute to 20 mL with mobile phase A.

**Column**:

– size: *l* = 0.10 m, Ø = 4.6 mm;

– stationary phase: monolithic octadecylsilyl silica gel for chromatography *R*;

– temperature: 25 °C.

**Mobile phase**:

– mobile phase A: dissolve 0.50 g of *sodium heptanesulfonate R* in *water for chromatography R* and dilute to 1000 mL with the same solvent; adjust to pH 2.2 with *phosphoric acid R*;

– mobile phase B: dissolve 0.25 g of *sodium heptanesulfonate R* in *water for chromatography R* and dilute to 500 mL with the same solvent; add 500 mL of *acetonitrile for chromatography R* and adjust the apparent pH to 2.4 with *phosphoric acid R*;

01/2008:0285

## NORADRENALINE TARTRATE

Noradrenalini tartras

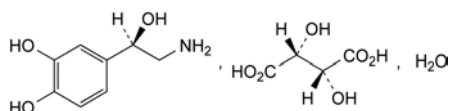

C<sub>12</sub>H<sub>17</sub>NO<sub>9</sub>·H<sub>2</sub>O  
[108341-18-0]

*M*<sub>r</sub> 337.3

#### DEFINITION

(1*R*)-2-Amino-1-(3,4-dihydroxyphenyl)ethanol hydrogen (2*R*,3*R*)-2,3-dihydroxybutanedioate monohydrate.

**Content**: 98.5 per cent to 101.0 per cent (anhydrous substance).

#### CHARACTERS

**Appearance**: white or almost white, crystalline powder.

Time (min)	Mobile phase A (per cent V/V)	Mobile phase B (per cent V/V)	Flow rate (mL/min)
0 - 2.0	98	2	1.5
2.0 - 17.0	98 → 70	2 → 30	1.5
17.0 - 24.0	70 → 50	30 → 50	1.5
24.0 - 24.1	50 → 0	50 → 100	1.5 → 4.0
24.1 - 28.0	0	100	4.0
28.0 - 28.1	0 → 98	100 → 2	4.0
28.1 - 30.0	98	2	4.0 → 1.5

**Detection:** spectrophotometer at 280 nm, except for impurity F: spectrophotometer at 254 nm.

**Injection:** 20 µL of the test solution and reference solutions (a), (b) and (d).

**Relative retention** with reference to noradrenaline (retention time = about 3 min): impurity B = about 1.5; impurity D = about 2.8; impurity E = about 3.0; impurity F = about 6.9.

**System suitability:** reference solution (d):

– **resolution:** minimum 1.5 between the peaks due to impurities D and E.

**Limits:**

- **correction factors:** for the calculation of content, multiply the peak areas of the following impurities by the corresponding correction factor: impurity B = 0.3; impurity E = 0.3; impurity F = 1.5;
- **impurity F at 254 nm:** not more than the area of the principal peak in the chromatogram obtained with reference solution (a) (0.1 per cent);
- **impurities B, D, E at 280 nm:** for each impurity, not more than the area of the principal peak in the chromatogram obtained with reference solution (a) (0.1 per cent);
- **unspecified impurities at 280 nm:** for each impurity, not more than the area of the principal peak in the chromatogram obtained with reference solution (a) (0.10 per cent);
- **sum of the impurities at 280 nm and impurity F at 254 nm:** maximum 0.3 per cent;
- **disregard limit at 280 nm:** 0.5 times the area of the principal peak in the chromatogram obtained with reference solution (a) (0.05 per cent).

**Water (2.5.12):** 4.5 per cent to 5.8 per cent, determined on 0.500 g.

**Sulfated ash (2.4.14):** maximum 0.1 per cent, determined on 1.0 g.

#### ASSAY

Dissolve 0.300 g in 50 mL of *anhydrous acetic acid R*, heating gently if necessary. Titrate with 0.1 M *perchloric acid* using 0.1 mL of *crystal violet solution R* as indicator, until a bluish-green colour is obtained.

1 mL of 0.1 M *perchloric acid* is equivalent to 31.93 mg of C<sub>12</sub>H<sub>17</sub>NO<sub>9</sub>.

#### STORAGE

In an airtight container or preferably in a sealed tube under vacuum or under an inert gas, protected from light.

#### IMPURITIES

**Specified impurities:** B, D, E, F.

**Other detectable impurities** (the following substances would, if present at a sufficient level, be detected by one or other of the tests in the monograph. They are limited by the general acceptance criterion for other/unspecified impurities and/or by the general monograph *Substances for pharmaceutical use (2034)*. It is therefore not necessary to identify these impurities for demonstration of compliance. See also 5.10. *Control of impurities in substances for pharmaceutical use*): A, C, G.

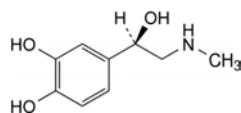

A. 4-[(1R)-1-hydroxy-2-(methylamino)ethyl]benzene-1,2-diol (adrenaline),

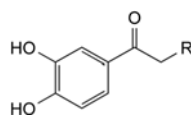

B. R = NH<sub>2</sub>: 2-amino-1-(3,4-dihydroxyphenyl)ethanone (noradrenalone),

E. R = Cl: 2-chloro-1-(3,4-dihydroxyphenyl)ethanone,

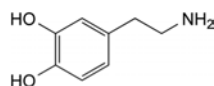

C. 4-(2-aminoethyl)benzene-1,2-diol (dopamine),

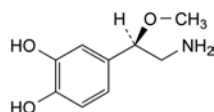

D. 4-[(1R)-2-amino-1-methoxyethyl]benzene-1,2-diol (noradrenaline methyl ether),

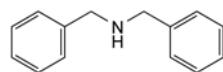

F. *N*-benzyl-1-phenylmethanamine,

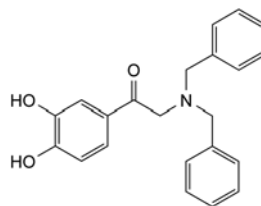

G. 2-(dibenzylamino)-1-(3,4-dihydroxyphenyl)ethanone.

01/2008:0234  
corrected 7.0

## NORETHISTERONE

### Norethisteronum

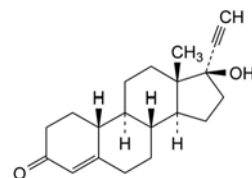

C<sub>20</sub>H<sub>26</sub>O<sub>2</sub>  
[68-22-4]

M<sub>r</sub> 298.4

#### DEFINITION

17-Hydroxy-19-nor-17α-pregn-4-en-20-yn-3-one.

**Content:** 98.0 per cent to 101.0 per cent (dried substance).

#### CHARACTERS

**Appearance:** white or yellowish-white, crystalline powder.

**Solubility:** practically insoluble in water, soluble in methylene chloride, sparingly soluble in acetone and in anhydrous ethanol.

#### IDENTIFICATION

Infrared absorption spectrophotometry (2.2.24).

**Comparison:** norethisterone CRS.

## TESTS

**Specific optical rotation** (2.2.7):  $-32.0$  to  $-37.0$  (dried substance).

Dissolve  $0.250$  g in *acetone R* and dilute to  $25.0$  mL with the same solvent.

**Related substances.** Liquid chromatography (2.2.29).

**Test solution.** Dissolve  $25.0$  mg of the substance to be examined in a mixture of  $40$  volumes of *water R* and  $60$  volumes of *acetonitrile R1* and dilute to  $10.0$  mL with the same mixture of solvents.

**Reference solution (a).** Dissolve  $5$  mg of *norethisterone for system suitability CRS* (containing impurities A, B, C, D, E, F, G and H) in a mixture of  $40$  volumes of *water R* and  $60$  volumes of *acetonitrile R1* and dilute to  $2.0$  mL with the same mixture of solvents.

**Reference solution (b).** Dilute  $1.0$  mL of the test solution to  $100.0$  mL with a mixture of  $40$  volumes of *water R* and  $60$  volumes of *acetonitrile R1*. Dilute  $1.0$  mL of this solution to  $10.0$  mL with a mixture of  $40$  volumes of *water R* and  $60$  volumes of *acetonitrile R1*.

**Column:**

- size:  $l = 0.15$  m,  $\varnothing = 4.6$  mm,
- stationary phase: spherical *end-capped octylsilyl silica gel for chromatography R* ( $5$   $\mu$ m).

**Mobile phase:**

- mobile phase A: *water R*;
- mobile phase B: *acetonitrile R1*;

Time (min)	Mobile phase A (per cent V/V)	Mobile phase B (per cent V/V)
0 - 20	63	37
20 - 25	63 $\rightarrow$ 20	37 $\rightarrow$ 80
25 - 35	20	80

**Flow rate:**  $1.0$  mL/min.

**Detection:** variable wavelength spectrophotometer capable of operating at  $254$  nm and at  $210$  nm.

**Injection:**  $20$   $\mu$ L.

**Identification of impurities:** use the chromatogram obtained with reference solution (a) and the chromatogram supplied with *norethisterone for system suitability CRS* to identify the peaks due to the impurities A, B, C, D, E, F, G and H.

**Relative retention at 254 nm** with reference to *norethisterone* (retention time = about  $10$  min): impurity H = about  $0.3$ ; impurity A = about  $0.8$ ; impurity B = about  $0.9$ ; impurity G = about  $1.5$ ; impurity C (at  $210$  nm) = about  $1.6$ ; impurity D (at  $210$  nm) = about  $1.7$ ; impurity E = about  $2.3$ ; impurity F = about  $2.4$ .

**System suitability:** reference solution (a) at  $254$  nm:

- resolution: baseline separation between the peaks due to impurity B and *norethisterone*;
- peak-to-valley ratio: minimum  $1.2$ , where  $H_p$  = height above the baseline of the peak due to impurity A and  $H_v$  = height above the baseline of the lowest point of the curve separating this peak from the peak due to impurity B.

**Limits:** spectrophotometer at  $254$  nm:

- correction factors: for the calculation of content, multiply the peak areas of the following impurities by the corresponding correction factor: impurity A =  $2.5$ ; impurity E =  $0.7$ ; impurity F =  $1.4$ ; impurity H =  $1.7$ ;
- impurities E, G, H: for each impurity, not more than twice the area of the principal peak in the chromatogram obtained with reference solution (b) ( $0.2$  per cent);
- impurities A, B, F: for each impurity, not more than the area of the principal peak in the chromatogram obtained with reference solution (b) ( $0.1$  per cent);

- unspecified impurities: for each impurity, not more than the area of the principal peak in the chromatogram obtained with reference solution (b) ( $0.10$  per cent);
- total: not more than  $3$  times the area of the principal peak in the chromatogram obtained with reference solution (b) ( $0.3$  per cent);
- disregard limit:  $0.5$  times the area of the principal peak in the chromatogram obtained with reference solution (b) ( $0.05$  per cent).

**Limits:** spectrophotometer at  $210$  nm:

- impurities C, D: for each impurity, not more than twice the area of the principal peak in the chromatogram obtained with reference solution (b) ( $0.2$  per cent).

**Loss on drying** (2.2.32): maximum  $0.5$  per cent, determined on  $1.000$  g by drying in an oven at  $105$  °C for  $3$  h.

## ASSAY

Dissolve  $0.200$  g in  $40$  mL of *tetrahydrofuran R*. Add  $10$  mL of a  $100$  g/L solution of *silver nitrate R* and titrate with  $0.1$  M *sodium hydroxide*, determining the end-point potentiometrically (2.2.20). Rinse the electrode with *acetone R* after each titration.

$1$  mL of  $0.1$  M *sodium hydroxide* is equivalent to  $29.84$  mg of  $C_{20}H_{26}O_2$ .

## IMPURITIES

**Specified impurities:** A, B, C, D, E, F, G, H.

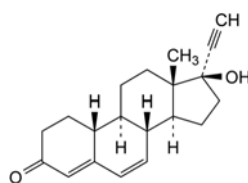

A. 17-hydroxy-19-nor-17 $\alpha$ -pregna-4,6-dien-20-yn-3-one,

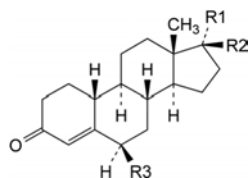

B.  $R_1 + R_2 = O$ ,  $R_3 = H$ : estr-4-ene-3,17-dione (norandrostenedione),

G.  $R_1 = OH$ ,  $R_2 = C\equiv CH$ ,  $R_3 = H$ : 17-hydroxy-19-norpregn-4-en-20-yn-3-one (17-*epi*-norethisterone),

H.  $R_1 = C\equiv CH$ ,  $R_2 = R_3 = OH$ : 6 $\beta$ ,17-dihydroxy-19-nor-17 $\alpha$ -pregn-4-en-20-yn-3-one (6 $\beta$ -hydroxynorethisterone),

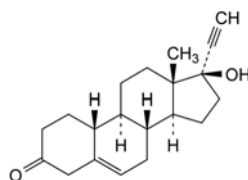

C. 17-hydroxy-19-nor-17 $\alpha$ -pregn-5-en-20-yn-3-one,

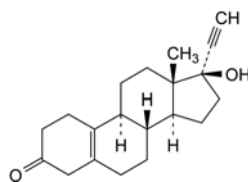

D. 17-hydroxy-19-nor-17 $\alpha$ -pregn-5(10)-en-20-yn-3-one,

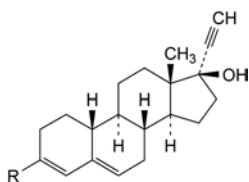

- E. R = C≡CH: 3-ethynyl-19-nor-17 $\alpha$ -pregna-3,5-dien-20-yn-17-ol,  
 F. R = O-C<sub>2</sub>H<sub>5</sub>: 3-ethoxy-19-nor-17 $\alpha$ -pregna-3,5-dien-20-yn-17-ol.

01/2008:0850  
 corrected 6.0

## NORETHISTERONE ACETATE

### Norethisteroni acetat

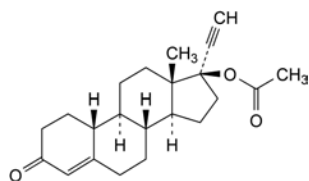

C<sub>22</sub>H<sub>28</sub>O<sub>3</sub>  
 [51-98-9]

M<sub>r</sub> 340.5

#### DEFINITION

3-Oxo-19-nor-17 $\alpha$ -pregn-4-en-20-yn-17-yl acetate.

Content: 98.0 per cent to 101.0 per cent (dried substance).

#### CHARACTERS

Appearance: white or yellowish-white, crystalline powder.

Solubility: practically insoluble in water, freely soluble in methylene chloride, soluble in alcohol.

It shows polymorphism (5.9).

#### IDENTIFICATION

Infrared absorption spectrophotometry (2.2.24).

Preparation: discs.

Comparison: norethisterone acetate CRS.

If the spectra show differences, dissolve the substance to be examined and the reference substance separately in methylene chloride R, evaporate to dryness on a water-bath and record new spectra using the residues.

#### TESTS

Specific optical rotation (2.2.7) – 30 to – 35 (dried substance).

Dissolve 0.500 g in ethanol R and dilute to 25.0 mL with the same solvent.

Related substances. Liquid chromatography (2.2.29).

Test solution. Dissolve 25.0 mg of the substance to be examined in the mobile phase and dilute to 10.0 mL with the mobile phase.

Reference solution (a). Dissolve 2 mg of desoxycortone acetate CRS and 2 mg of norethisterone acetate CRS in the mobile phase and dilute to 50.0 mL with the mobile phase.

Reference solution (b). Dilute 1.0 mL of the test solution to 100.0 mL with the mobile phase.

Column:

- size:  $l = 0.25$  m,  $\varnothing = 4.6$  mm,
- stationary phase: octadecylsilyl silica gel for chromatography R (5  $\mu$ m).

Mobile phase: acetonitrile R, water R (60:40 V/V).

Flow rate: 1.0 mL/min.

Detection: variable wavelength spectrophotometer capable of operating at 254 nm and at 210 nm.

Injection: 20  $\mu$ L.

Run time: 3 times the retention time of norethisterone acetate.

Relative retention with reference to norethisterone acetate (retention time = about 10 min): impurity A = about 0.48; impurity D = about 0.65; impurity E = about 0.83; impurity C = about 1.35; impurity B = about 1.40.

System suitability: reference solution (a) at 254 nm:

- resolution: minimum of 3.5 between the peaks due to norethisterone acetate and to desoxycortone acetate.

Limits: spectrophotometer at 254 nm:

- any impurity: not more than 0.5 times the area of the principal peak in the chromatogram obtained with reference solution (b) (0.5 per cent),
- total: not more than 0.75 times the area of the principal peak in the chromatogram obtained with reference solution (b) (0.75 per cent),
- disregard limit: 0.05 times the area of the principal peak in the chromatogram obtained with reference solution (b) (0.05 per cent).

Limits: spectrophotometer at 210 nm:

- any impurity with a relative retention between 1.0 and 1.6, with reference to norethisterone acetate (retention time = about 10 min): not more than 0.3 times the area of the principal peak in the chromatogram obtained with reference solution (b) (0.3 per cent),
- total of these impurities: not more than 0.5 times the area of the principal peak in the chromatogram obtained with reference solution (b) (0.5 per cent),
- disregard limit: 0.05 times the area of the principal peak in the chromatogram obtained with reference solution (b) (0.05 per cent).

Loss on drying (2.2.32): maximum 0.5 per cent, determined on 1.000 g by drying in an oven at 105 °C.

#### ASSAY

Dissolve 0.200 g in 40 mL of tetrahydrofuran R. Add 10 mL of a 100 g/L solution of silver nitrate R and titrate with 0.1 M sodium hydroxide, determining the end-point potentiometrically (2.2.20). Carry out a blank titration.

1 mL of 0.1 M sodium hydroxide is equivalent to 34.05 mg of C<sub>22</sub>H<sub>28</sub>O<sub>3</sub>.

#### IMPURITIES

Specified impurities: A, B, C, D, E.

Other detectable impurities (the following substances would, if present at a sufficient level, be detected by one or other of the tests in the monograph. They are limited by the general acceptance criterion for other/unspecified impurities and/or by the general monograph Substances for pharmaceutical use (2034). It is therefore not necessary to identify these impurities for demonstration of compliance. See also 5.10. Control of impurities in substances for pharmaceutical use): F, G.

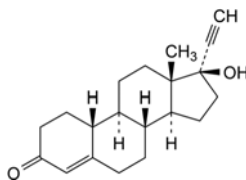

- A. 17-hydroxy-19-nor-17 $\alpha$ -pregn-4-en-20-yn-3-one (norethisterone),

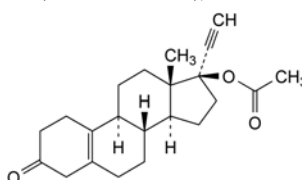

- B. 3-oxo-19-nor-17 $\alpha$ -pregn-5(10)-en-20-yn-17-yl acetate,

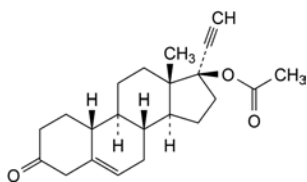
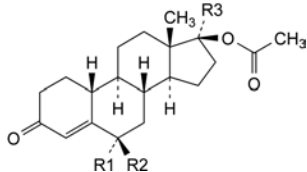

C. 3-oxo-19-nor-17 $\alpha$ -pregn-5-en-20-yn-17-yl acetate,D. R1 = H, R2 = CO-CH<sub>3</sub>, R3 = C $\equiv$ CH: 6 $\beta$ -acetyl-3-oxo-19-nor-17 $\alpha$ -pregn-4-en-20-yn-17-yl acetate,E. R1 = R2 = H, R3 = CO-CH<sub>3</sub>: 3,20-dioxo-19-nor-17 $\alpha$ -pregn-4-en-17-yl acetate,F. R1 = H, R2 = OH, R3 = C $\equiv$ CH: 6 $\beta$ -hydroxy-3-oxo-19-nor-17 $\alpha$ -pregn-4-en-20-yn-17-yl acetate,G. R1 + R2 = O, R3 = C $\equiv$ CH: 3,6-dioxo-19-nor-17 $\alpha$ -pregn-4-en-20-yn-17-yl acetate.

07/2008:1248

## NORFLOXACIN

### Norfloxacinum

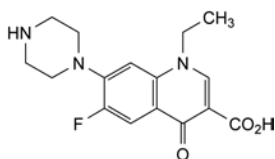
C<sub>16</sub>H<sub>18</sub>FN<sub>3</sub>O<sub>3</sub>  
[70458-96-7]M<sub>r</sub> 319.3

#### DEFINITION

1-Ethyl-6-fluoro-4-oxo-7-(piperazin-1-yl)-1,4-dihydroquinoline-3-carboxylic acid.

*Content*: 99.0 per cent to 101.0 per cent (dried substance).

#### CHARACTERS

*Appearance*: white or pale yellow, hygroscopic, photosensitive, crystalline powder.*Solubility*: very slightly soluble in water, slightly soluble in acetone and in ethanol (96 per cent).

#### IDENTIFICATION

Infrared absorption spectrophotometry (2.2.24).

*Comparison*: norfloxacin CRS.

#### TESTS

**Appearance of solution.** Dissolve 0.5 g in a previously filtered 4 g/L solution of sodium hydroxide R in methanol R and dilute to 50 mL with the same solution. The solution is not more opalescent than reference suspension II (2.2.1) and not more intensely coloured than reference solution B<sub>7</sub> (2.2.2, Method II).

**Related substances.** Liquid chromatography (2.2.29).

*Solution A.* Mix 5 volumes of acetonitrile R and 95 volumes of water R previously adjusted to pH 2.0 with phosphoric acid R.

*Test solution.* Dissolve 20 mg of the substance to be examined in 25 mL of solution A. Sonicate for 5 min and dilute to 50.0 mL with solution A.

*Reference solution (a).* Dilute 1.0 mL of the test solution to 100.0 mL with solution A. Dilute 1.0 mL of this solution to 10.0 mL with solution A.

*Reference solution (b).* Dissolve 4 mg of norfloxacin for system suitability CRS (containing impurities A, E and H) in 5 mL of solution A. Sonicate for 5 min and dilute to 10 mL with solution A.

#### Column:

- size:  $l = 0.25$  m,  $\varnothing = 4.6$  mm;
- stationary phase: end-capped hexadecylamidylysilyl silica gel for chromatography R (5  $\mu$ m);
- temperature: 60 °C.

#### Mobile phase:

- mobile phase A: water R adjusted to pH 2.0 with phosphoric acid R;
- mobile phase B: acetonitrile R;

Time (min)	Mobile phase A (per cent V/V)	Mobile phase B (per cent V/V)
0 - 5	95	5
5 - 7	95 $\rightarrow$ 93	5 $\rightarrow$ 7
7 - 10	93 $\rightarrow$ 87	7 $\rightarrow$ 13
10 - 15	87 $\rightarrow$ 47	13 $\rightarrow$ 53
15 - 20	47 $\rightarrow$ 10	53 $\rightarrow$ 90

*Flow rate*: 1.4 mL/min.*Detection*: spectrophotometer at 265 nm.*Injection*: 20  $\mu$ L.

*Identification of impurities:* use the chromatogram supplied with norfloxacin for system suitability CRS and the chromatogram obtained with reference solution (b) to identify the peaks due to impurities A, E and H.

*Relative retention* with reference to norfloxacin (retention time = about 11 min): impurity E = about 0.97; impurity A = about 1.5; impurity H = about 1.6.

*System suitability:* reference solution (b):

- resolution: minimum 3.0 between the peaks due to impurities A and H;
- peak-to-valley ratio: minimum 5, where  $H_p$  = height above the baseline of the peak due to impurity E and  $H_v$  = height above the baseline of the lowest point of the curve separating this peak from the peak due to norfloxacin.

#### Limits:

- impurity E: not more than the area of the principal peak in the chromatogram obtained with reference solution (a) (0.1 per cent);
- unspecified impurities: for each impurity, not more than the area of the principal peak in the chromatogram obtained with reference solution (a) (0.10 per cent);
- total: not more than 5 times the area of the principal peak in the chromatogram obtained with reference solution (a) (0.5 per cent);
- disregard limit: 0.5 times the area of the principal peak in the chromatogram obtained with reference solution (a) (0.05 per cent).

**Heavy metals** (2.4.8): maximum 15 ppm.

2.0 g complies with test D. Prepare the reference solution using 3 mL of lead standard solution (10 ppm Pb) R.

**Loss on drying** (2.2.32): maximum 1.0 per cent, determined on 1.000 g by drying under high vacuum at 105 °C for 2 h.

**Sulfated ash** (2.4.14): maximum 0.1 per cent, determined on 1.0 g in a platinum crucible.

#### ASSAY

Dissolve 0.240 g in 80 mL of anhydrous acetic acid R. Titrate with 0.1 M perchloric acid, determining the end-point potentiometrically (2.2.20).

1 mL of 0.1 M perchloric acid is equivalent to 31.93 mg of C<sub>16</sub>H<sub>18</sub>FN<sub>3</sub>O<sub>3</sub>.

## STORAGE

In an airtight container, protected from light.

## IMPURITIES

Specified impurities: E.

Other detectable impurities (the following substances would, if present at a sufficient level, be detected by one or other of the tests in the monograph. They are limited by the general acceptance criterion for other/unspecified impurities and/or by the general monograph *Substances for pharmaceutical use* (2034). It is therefore not necessary to identify these impurities for demonstration of compliance. See also 5.10. *Control of impurities in substances for pharmaceutical use*): A, B, C, D, F, G, H, I, J.

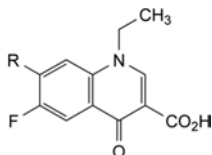

A. R = Cl: 7-chloro-1-ethyl-6-fluoro-4-oxo-1,4-dihydroquinoline-3-carboxylic acid,

B. R = NH-CH<sub>2</sub>-CH<sub>2</sub>-NH<sub>2</sub>: 7-[(2-aminoethyl)amino]-1-ethyl-6-fluoro-4-oxo-1,4-dihydroquinoline-3-carboxylic acid,

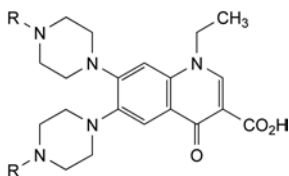

C. R = H: 1-ethyl-4-oxo-6,7-bis(piperazin-1-yl)-1,4-dihydroquinoline-3-carboxylic acid,

J. R = CO-O-C<sub>2</sub>H<sub>5</sub>: 6,7-bis[4-(ethoxycarbonyl)piperazin-1-yl]-1-ethyl-4-oxo-1,4-dihydroquinoline-3-carboxylic acid,

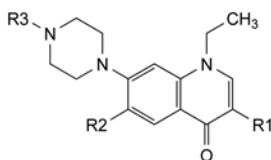

D. R<sub>1</sub> = R<sub>3</sub> = H, R<sub>2</sub> = F: 1-ethyl-6-fluoro-7-(piperazin-1-yl)quinolin-4(1*H*)-one,

F. R<sub>1</sub> = CO<sub>2</sub>H, R<sub>2</sub> = Cl, R<sub>3</sub> = H: 6-chloro-1-ethyl-4-oxo-7-(piperazin-1-yl)-1,4-dihydroquinoline-3-carboxylic acid,

G. R<sub>1</sub> = CO<sub>2</sub>H, R<sub>2</sub> = F, R<sub>3</sub> = CHO: 1-ethyl-6-fluoro-7-(4-formylpiperazin-1-yl)-4-oxo-1,4-dihydroquinoline-3-carboxylic acid,

H. R<sub>1</sub> = CO<sub>2</sub>H, R<sub>2</sub> = F, R<sub>3</sub> = CO-O-C<sub>2</sub>H<sub>5</sub>: 7-[4-(ethoxycarbonyl)piperazin-1-yl]-1-ethyl-6-fluoro-4-oxo-1,4-dihydroquinoline-3-carboxylic acid,

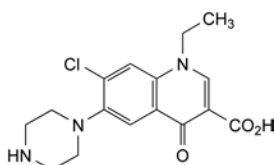

E. 7-chloro-1-ethyl-4-oxo-6-(piperazin-1-yl)-1,4-dihydroquinoline-3-carboxylic acid,

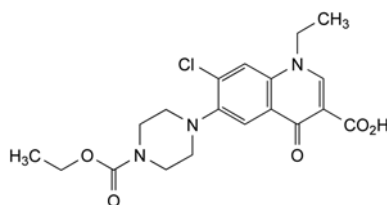

I. 7-chloro-6-[4-(ethoxycarbonyl)piperazin-1-yl]-1-ethyl-4-oxo-1,4-dihydroquinoline-3-carboxylic acid.

01/2008:1732

## NORGESTIMATE

## Norgestimum

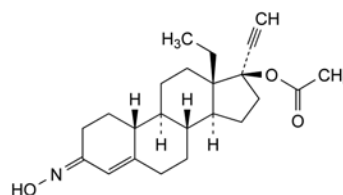

C<sub>23</sub>H<sub>31</sub>NO<sub>3</sub>  
[35189-28-7]

*M*<sub>r</sub> 369.5

## DEFINITION

(3*EZ*)-13β-Ethyl-3-(hydroxyimino)-18,19-dinor-17α-pregn-4-en-20-yn-17-yl acetate.

*Content*: 98.5 per cent to 101.5 per cent (dried substance).

## CHARACTERS

*Appearance*: white or almost white powder.

*Solubility*: practically insoluble in water, freely soluble in methylene chloride, soluble in acetone.

## IDENTIFICATION

Infrared absorption spectrophotometry (2.2.24).

*Comparison*: norgestimate CRS.

## TESTS

**Specific optical rotation** (2.2.7): + 42.0 to + 50.0 (dried substance).

Dissolve 0.200 g in *methylene chloride R* and dilute to 20.0 mL with the same solvent.

**Related substances.** Liquid chromatography (2.2.29).

*Solvent mixture*: water R, methanol R (1:4 V/V).

*Test solution.* Dissolve 25.0 mg of the substance to be examined in the solvent mixture and dilute to 50.0 mL with the solvent mixture.

*Reference solution (a).* Dilute 2.0 mL of the test solution to 100.0 mL with the solvent mixture. Dilute 1.0 mL of this solution to 20.0 mL with the solvent mixture.

*Reference solution (b).* Dissolve 2 mg of norgestimate for system suitability CRS (containing impurity A) in 4 mL of the solvent mixture.

## Column:

– size: *l* = 0.10 m, Ø = 4.6 mm;

– stationary phase: spherical end-capped octadecylsilyl silica gel for chromatography R (5 µm);

– temperature: 40 °C.

*Mobile phase*: acetonitrile R, tetrahydrofuran for chromatography R, water R (18:22:60 V/V/V).

*Flow rate*: 1.0 mL/min.

*Detection*: spectrophotometer at 244 nm.

*Injection*: 25 µL.

*Run time*: twice the retention time of the (*E*)-isomer of norgestimate.

**Identification of impurities:** use the chromatogram supplied with *norgestimate for system suitability CRS* and the chromatogram obtained with reference solution (b) to identify the peak due to impurity A.

**Relative retention** with reference to the (*E*)-isomer of norgestimate (retention time = about 14 min): impurity A = about 0.7; (*Z*)-isomer of norgestimate = about 0.9.

**System suitability:** reference solution (b):

- **resolution:** minimum 1.5 between the peaks due to the (*E*)- and (*Z*)-isomers of norgestimate.

**Limits:**

- **correction factor:** for the calculation of content, multiply the peak area of the (*Z*)-isomer of norgestimate by 1.33;
- **impurity A:** not more than twice the sum of the areas of the peaks due to the (*E*)- and (*Z*)-isomers of norgestimate in the chromatogram obtained with reference solution (a) (0.2 per cent);
- **unspecified impurities:** for each impurity, not more than the sum of the areas of the peaks due to the (*E*)- and (*Z*)-isomers of norgestimate in the chromatogram obtained with reference solution (a) (0.10 per cent);
- **total:** not more than 3 times the sum of the areas of the peaks due to the (*E*)- and (*Z*)-isomers of norgestimate in the chromatogram obtained with reference solution (a) (0.3 per cent);
- **disregard limit:** 0.5 times the sum of the areas of the peaks due to the (*E*)- and (*Z*)-isomers of norgestimate in the chromatogram obtained with reference solution (a) (0.05 per cent).

**Ratio of (*E*)- to (*Z*)-isomers.** Liquid chromatography (2.2.29) as described in the test for related substances with the following modification.

**Injection:** test solution.

Calculate the (*E*)- to (*Z*)-isomer ratio by dividing the area of the peak due to the (*E*)-isomer by 1.33 times the area of the peak due to the (*Z*)-isomer. The ratio is 1.27 to 1.78.

**Loss on drying** (2.2.32): maximum 0.5 per cent, determined on 0.500 g by drying in an oven at 105 °C for 3 h.

#### ASSAY

Dissolve 0.300 g in 40 mL of *tetrahydrofuran R*. Add 10 mL of a 100 g/L solution of *silver nitrate R* and titrate with 0.1 M *sodium hydroxide*, determining the end-point potentiometrically (2.2.20). Rinse the electrode with *acetone R* after each titration. If necessary, after several titrations re-equilibrate the electrode in *water R* for 15 min to obtain sharper titration curves.

1 mL of 0.1 M *sodium hydroxide* is equivalent to 36.95 mg of  $C_{23}H_{31}NO_3$ .

#### IMPURITIES

**Specified impurities:** A.

**Other detectable impurities** (the following substances would, if present at a sufficient level, be detected by one or other of the tests in the monograph. They are limited by the general acceptance criterion for other/unspecified impurities and/or by the general monograph *Substances for pharmaceutical use* (2034). It is therefore not necessary to identify these impurities for demonstration of compliance. See also 5.10. **Control of impurities in substances for pharmaceutical use):** B, C, D.

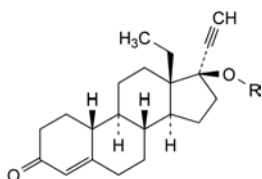

A. R = CO-CH<sub>3</sub>; 13β-ethyl-3-oxo-18,19-dinor-17α-pregn-4-en-20-yn-17-yl acetate (levonorgestrel acetate),

B. R = H; 13β-ethyl-17β-hydroxy-18,19-dinor-17α-pregn-4-en-20-yn-3-one (levonorgestrel),

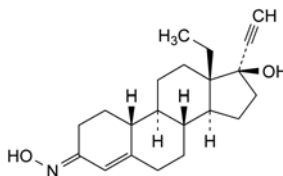

C. (3*E*)-13β-ethyl-3-(hydroxyimino)-18,19-dinor-17α-pregn-4-en-20-yn-17-ol ((*E*)-norelgestromin),

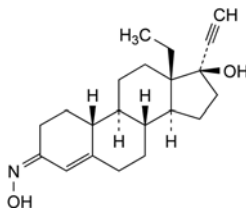

D. (3*Z*)-13β-ethyl-3-(hydroxyimino)-18,19-dinor-17α-pregn-4-en-20-yn-17-ol ((*Z*)-norelgestromin).

01/2008:0940  
corrected 6.0

## NORGESTREL

### Norgestrelum

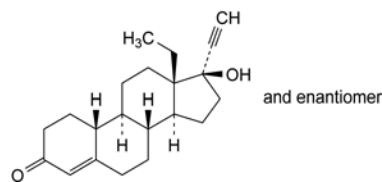

$C_{21}H_{28}O_2$   
[6533-00-2]

$M_r$  312.5

#### DEFINITION

Norgestrel contains not less than 98.0 per cent and not more than the equivalent of 102.0 per cent of *rac*-13-ethyl-17-hydroxy-18,19-dinor-17α-pregn-4-en-20-yn-3-one, calculated with reference to the dried substance.

#### CHARACTERS

A white or almost white, crystalline powder, practically insoluble in water, sparingly soluble in methylene chloride, slightly soluble in alcohol.

#### IDENTIFICATION

- Dissolve 0.5 g in *methylene chloride R* and dilute to 10.0 mL with the same solvent. The angle of optical rotation (2.2.7) is + 0.05° to – 0.05°.
- Examine by infrared absorption spectrophotometry (2.2.24), comparing with the spectrum obtained with *norgestrel CRS*.

#### TESTS

**Related substances.** Examine by thin-layer chromatography (2.2.27), using *silica gel G R* as the coating substance.

**Test solution.** Dissolve 0.2 g of the substance to be examined in *methylene chloride R* and dilute to 10 mL with the same solvent.

**Reference solution (a).** Dilute 1 mL of the test solution to 10 mL with *methylene chloride R*. Dilute 1 mL of this solution to 20 mL with *methylene chloride R*.

**Reference solution (b).** Dilute 4 mL of reference solution (a) to 10 mL with *methylene chloride R*.

**Reference solution (c).** Dissolve 5 mg of *norgestrel CRS* and 5 mg of *ethinylestradiol CRS* in *methylene chloride R* and dilute to 50 mL with the same solvent.

Apply to the plate 10 µL of each solution. Develop over a path of 15 cm using a mixture of 20 volumes of *ethyl acetate R* and 80 volumes of *methylene chloride R*. Allow the plate to dry in air, spray with a 100 g/L solution of *phosphomolybdic acid R* in *alcohol R*, heat at 100-105 °C for 15 min and examine immediately. Any spot in the chromatogram obtained with the test solution, apart from the principal spot, is not more intense than the principal spot in the chromatogram obtained with reference solution (a) (0.5 per cent) and at most two such spots are more intense than the spot in the chromatogram obtained with reference solution (b) (0.2 per cent). The test is not valid unless the chromatogram obtained with reference solution (c) shows two clearly separated spots.

**Loss on drying** (2.2.32). Not more than 0.5 per cent, determined on 1.000 g by drying in an oven at 105 °C.

**Sulfated ash** (2.4.14). Not more than 0.1 per cent, determined on 1.0 g.

#### ASSAY

Dissolve 0.200 g in 45 mL of *tetrahydrofuran R*. Add 10 mL of a 100 g/L solution of *silver nitrate R*. After 1 min, titrate with 0.1 M *sodium hydroxide* determining the end-point potentiometrically (2.2.20). Carry out a blank titration.

1 mL of 0.1 M *sodium hydroxide* is equivalent to 31.25 mg of C<sub>21</sub>H<sub>28</sub>O<sub>2</sub>.

#### STORAGE

Store protected from light.

01/2010:0941

## NORTRIPTYLINE HYDROCHLORIDE

### Nortriptylini hydrochloridum

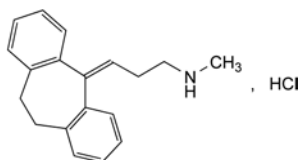

C<sub>19</sub>H<sub>22</sub>ClN  
[894-71-3]

M<sub>r</sub> 299.8

#### DEFINITION

3-(10,11-Dihydro-5H-dibenzo[*a,d*][7]annulen-5-ylidene)-*N*-methylpropan-1-amine hydrochloride.

**Content:** 98.0 per cent to 101.0 per cent (dried substance).

#### CHARACTERS

**Appearance:** white or almost white powder.

**Solubility:** sparingly soluble in water, soluble in ethanol (96 per cent) and in methylene chloride.

#### IDENTIFICATION

**First identification:** C, E.

**Second identification:** A, B, D, E.

A. Melting point (2.2.14): 216 °C to 220 °C.

B. Ultraviolet and visible absorption spectrophotometry (2.2.25).

**Test solution.** Dissolve 20.0 mg in *methanol R* and dilute to 100.0 mL with the same solvent. Dilute 5.0 mL of this solution to 100.0 mL with *methanol R*.

**Spectral range:** 230-350 nm.

**Absorption maximum:** at 239 nm.

**Specific absorbance at the absorption maximum:** 465 to 495.

C. Infrared absorption spectrophotometry (2.2.24).

**Comparison:** *nortriptyline hydrochloride CRS*.

D. Dissolve 50 mg in 3 mL of warm *water R*, cool and add 0.05 mL of a 25 g/L solution of *quinhydrone R* in *methanol R*. A red colour develops slowly.

E. 50 mg gives reaction (b) of chlorides (2.3.1).

#### TESTS

**Appearance of solution.** The solution is clear (2.2.1) and not more intensely coloured than reference solution B<sub>7</sub> (2.2.2, *Method II*).

Dissolve 0.5 g in *water R* with gentle heating and dilute to 25 mL with the same solvent.

**Acidity or alkalinity.** Dissolve 0.2 g with gentle heating in *carbon dioxide-free water R* and dilute to 10 mL with the same solvent. Add 0.1 mL of *methyl red solution R* and 0.2 mL of 0.01 M *sodium hydroxide*. The solution is yellow. Add 0.4 mL of 0.01 M *hydrochloric acid*. The solution is red.

**Related substances.** Liquid chromatography (2.2.29). *Protect the solutions from light.*

**Test solution.** Dissolve 50.0 mg of the substance to be examined in the mobile phase and dilute to 25.0 mL with the mobile phase.

**Reference solution (a).** Dilute 1.0 mL of the test solution to 100.0 mL with the mobile phase. Dilute 1.0 mL of this solution to 10.0 mL with the mobile phase.

**Reference solution (b).** Dissolve 10.0 mg of *dibenzo-suberone CRS* (impurity A) and 20 mg of *norcyclobenzaprine CRS* (impurity B) in the mobile phase and dilute to 100.0 mL with the mobile phase. Dilute 1.0 mL of this solution to 10.0 mL with the mobile phase.

**Reference solution (c).** Dissolve 10 mg of *nortriptyline for system suitability CRS* (containing impurity D) in the mobile phase, add 1.0 mL of reference solution (b) and dilute to 10.0 mL with the mobile phase.

#### Column:

– **size:** *l* = 0.15 m, Ø = 4.6 mm;

– **stationary phase:** spherical *end-capped octylsilyl silica gel for chromatography R* (5 µm);

– **temperature:** 45 °C.

**Mobile phase:** mix 70 volumes of *methanol R2* and 30 volumes of a solution prepared as follows: dissolve 3.25 mL of *tetrabutylammonium hydroxide solution (400 g/L) R* and 0.68 g of *potassium dihydrogen phosphate R* in 900 mL of *water R*, adjust to pH 7.5 with *dilute phosphoric acid R* and dilute to 1000 mL with *water R*.

**Flow rate:** 1.0 mL/min.

**Detection:** spectrophotometer at 220 nm.

**Injection:** 10 µL of the test solution and reference solutions (a) and (c).

**Run time:** 3 times the retention time of nortriptyline.

**Identification of impurities:** use the chromatogram obtained with reference solution (c) to identify the peaks due to impurities A, B and D.

**Relative retention** with reference to nortriptyline (retention time = about 13 min): impurity A = about 0.5; impurity D = about 0.8; impurity B = about 0.9.

**System suitability:** reference solution (c):

– **resolution:** minimum 1.4 between the peaks due to impurities D and B, and minimum 2.0 between the peaks due to impurity B and nortriptyline.

#### Limits:

– **correction factor:** for the calculation of content, multiply the peak area of impurity D by 1.7;

– **impurity D:** not more than 1.5 times the area of the principal peak in the chromatogram obtained with reference solution (a) (0.15 per cent);

– **impurity A:** not more than the area of the corresponding peak in the chromatogram obtained with reference solution (c) (0.05 per cent);

- *unspecified impurities*: for each impurity, not more than the area of the principal peak in the chromatogram obtained with reference solution (a) (0.10 per cent);
- *total*: not more than twice the area of the principal peak in the chromatogram obtained with reference solution (a) (0.2 per cent);
- *disregard limit*: 0.5 times the area of the principal peak in the chromatogram obtained with reference solution (a) (0.05 per cent).

**Heavy metals** (2.4.8): maximum 20 ppm.

1.0 g complies with test C. Prepare the reference solution using 2 mL of *lead standard solution* (10 ppm Pb) R.

**Loss on drying** (2.2.32): maximum 0.5 per cent, determined on 1.000 g by drying in an oven at 105 °C for 2 h.

**Sulfated ash** (2.4.14): maximum 0.1 per cent, determined on 1.0 g.

#### ASSAY

Dissolve 0.250 g in 30 mL of *ethanol* (96 per cent) R. Add 1.0 mL of 0.1 M *hydrochloric acid*. Carry out a potentiometric titration (2.2.20), using 0.1 M *sodium hydroxide*. Read the volume added between the 2 points of inflexion.

1 mL of 0.1 M *sodium hydroxide* is equivalent to 29.98 mg of C<sub>19</sub>H<sub>22</sub>ClN.

#### STORAGE

Protected from light.

#### IMPURITIES

*Specified impurities*: A, D.

*Other detectable impurities* (the following substances would, if present at a sufficient level, be detected by one or other of the tests in the monograph. They are limited by the general acceptance criterion for other/unspecified impurities and/or by the general monograph *Substances for pharmaceutical use* (2034). It is therefore not necessary to identify these impurities for demonstration of compliance. See also 5.10. *Control of impurities in substances for pharmaceutical use*): B, E, F, G, H, I, J.

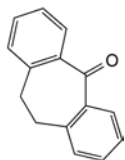

- A. 10,11-dihydro-5H-dibenzo[*a,d*][7]annulen-5-one (dibenzosuberone),

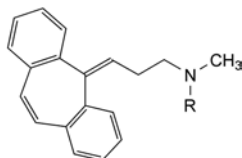

- B. R = H: 3-(5H-dibenzo[*a,d*][7]annulen-5-ylidene)-*N*-methylpropan-1-amine (norcyclobenzaprine),  
E. R = CH<sub>3</sub>: 3-(5H-dibenzo[*a,d*][7]annulen-5-ylidene)-*N,N*-dimethylpropan-1-amine (cyclobenzaprine),

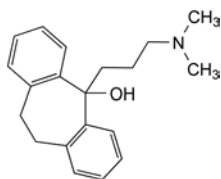

- D. 5-[3-(dimethylamino)propyl]-10,11-dihydro-5H-dibenzo[*a,d*][7]annulen-5-ol,  
F. amitriptyline,

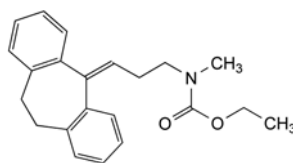

- G. ethyl [3-(10,11-dihydro-5H-dibenzo[*a,d*][7]annulen-5-ylidene)propyl]methylcarbamate,

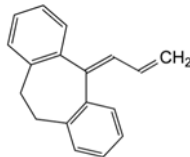

- H. 5-prop-2-en-1-ylidene-10,11-dihydro-5H-dibenzo[*a,d*][7]annulene,

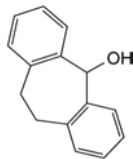

- I. 10,11-dihydro-5H-dibenzo[*a,d*][7]annulen-5-ol (dibenzosuberol),

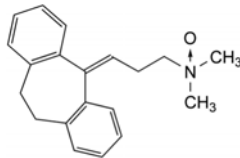

- J. [3-(10,11-dihydro-5H-dibenzo[*a,d*][7]annulen-5-ylidene)propyl]dimethylamine oxide (amitriptyline-*N*-oxide).

01/2008:0516  
corrected 6.0

## NOSCAPINE

### Noscapinum

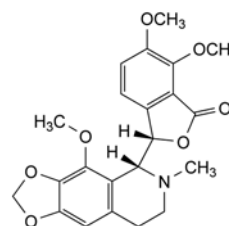

C<sub>22</sub>H<sub>23</sub>NO<sub>7</sub>  
[128-62-1]

*M*<sub>r</sub> 413.4

#### DEFINITION

(3*S*)-6,7-Dimethoxy-3-[(5*R*)-4-methoxy-6-methyl-5,6,7,8-tetrahydro-1,3-dioxolo[4,5-*g*]isoquinolin-5-yl]isobenzofuran-1(3*H*)-one.

*Content*: 99.0 per cent to 101.0 per cent (dried substance).

#### CHARACTERS

*Appearance*: white or almost white, crystalline powder or colourless crystals.

*Solubility*: practically insoluble in water, soluble in acetone, slightly soluble in ethanol (96 per cent). It dissolves in strong acids; on dilution of the solution with water, the base may be precipitated.

#### IDENTIFICATION

*First identification*: C, E.

*Second identification*: A, B, D, E.

- A. Specific optical rotation (see Tests).  
 B. Melting point (2.2.14): 174 °C to 177 °C.  
 C. Infrared absorption spectrophotometry (2.2.24).

*Comparison: noscapine CRS.*

- D. Thin-layer chromatography (2.2.27).

*Test solution.* Dissolve 25 mg of the substance to be examined in *acetone R* and dilute to 100 mL with the same solvent.

*Reference solution.* Dissolve 25 mg of *noscapine CRS* in *acetone R* and dilute to 100 mL with the same solvent.

*Plate: TLC silica gel plate R.*

*Mobile phase: concentrated ammonia R, ethanol (96 per cent) R, acetone R, toluene R (1:3:20:20 V/V/V/V).*

*Application: 10 µL.*

*Development: over 2/3 of the plate.*

*Drying: in air.*

*Detection: spray with dilute potassium iodobismuthate solution R.*

*Results:* the principal spot in the chromatogram obtained with the test solution is similar in position, colour and size to the principal spot in the chromatogram obtained with the reference solution.

- E. To 20 mg add 10 mL of *water R* and shake. It does not dissolve.

#### TESTS

**Appearance of solution.** The solution is clear (2.2.1) and not more intensely coloured than reference solution Y<sub>6</sub> (2.2.2, Method II).

Dissolve 0.2 g in *acetone R* and dilute to 10 mL with the same solvent. Examine immediately after preparation.

**Specific optical rotation (2.2.7):** + 42 to + 48 (dried substance).

Dissolve 0.500 g in 0.1 M *hydrochloric acid* and dilute to 25.0 mL with the same acid.

**Related substances.** Liquid chromatography (2.2.29).

*Test solution.* Dissolve 20.0 mg of the substance to be examined with gentle heating in 14 mL of *methanol R*, cool the solution and dilute to 20.0 mL with *phosphate buffer solution pH 6.0 R1*.

*Reference solution (a).* Dilute 1.0 mL of the test solution to 20.0 mL with the mobile phase. Dilute 1.0 mL of the solution to 10.0 mL with the mobile phase.

*Reference solution (b).* Dissolve 5 mg of *papaverine hydrochloride R* in the mobile phase and dilute to 50.0 mL with the mobile phase. Dilute 1.0 mL of the solution to 20.0 mL with the mobile phase.

*Reference solution (c).* Dissolve 1.5 mg of *papaverine hydrochloride R* in 10 mL of the test solution and dilute to 50 mL with the mobile phase.

*Column:*

- size:  $l = 0.125$  m,  $\varnothing = 4.6$  mm;
- stationary phase: nitrile silica gel for chromatography R (5 µm).

*Mobile phase: methanol R, phosphate buffer solution pH 6.0 R1 (350:650 V/V).*

*Flow rate: 1 mL/min.*

*Detection: spectrophotometer at 240 nm.*

*Injection: 20 µL.*

*Run time: 2.5 times the retention time of noscapine.*

*Relative retention* with reference to noscapine (retention time = about 10 min): impurity A = about 1.3.

*System suitability: reference solution (c):*

- resolution: minimum 2 between the peaks due to noscapine and to impurity A.

#### Limits:

- *impurity A:* not more than the area of the principal peak in the chromatogram obtained with reference solution (b) (0.5 per cent);
- *any other impurity:* not more than 0.4 times the area of the principal peak in the chromatogram obtained with reference solution (a) (0.2 per cent);
- *total of other impurities:* not more than the area of the principal peak in the chromatogram obtained with reference solution (a) (0.5 per cent);
- *disregard limit:* 0.1 times the area of the principal peak in the chromatogram obtained with reference solution (a) (0.05 per cent).

**Loss on drying (2.2.32):** maximum 1.0 per cent, determined on 0.500 g by drying in an oven at 105 °C.

**Sulfated ash (2.4.14):** maximum 0.1 per cent, determined on 1.0 g.

#### ASSAY

Dissolve 0.350 g in 40 mL of *anhydrous acetic acid R*, warming gently. Titrate with 0.1 M *perchloric acid*, determining the end-point potentiometrically (2.2.20).

1 mL of 0.1 M *perchloric acid* is equivalent to 41.34 mg of C<sub>22</sub>H<sub>23</sub>NO<sub>7</sub>.

#### STORAGE

Protected from light.

#### IMPURITIES

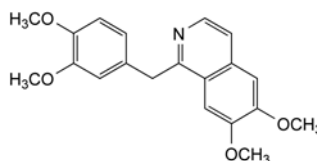

- A. 1-(3,4-dimethoxybenzyl)-6,7-dimethoxyisoquinoline (papaverine).

01/2008:0515  
corrected 6.0

## NOSCAPINE HYDROCHLORIDE

### Noscapini hydrochloridum

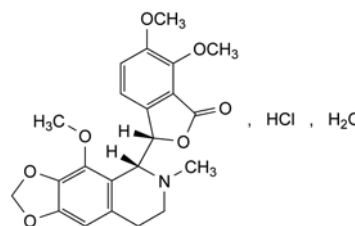

C<sub>22</sub>H<sub>24</sub>ClNO<sub>7</sub>·H<sub>2</sub>O

*M*, 467.9

#### DEFINITION

(3*S*)-6,7-Dimethoxy-3-[(5*R*)-4-methoxy-6-methyl-5,6,7,8-tetrahydro-1,3-dioxolo[4,5-*g*]isoquinolin-5-yl]isobenzofuran-1(3*H*)-one hydrochloride monohydrate.

**Content:** 99.0 per cent to 101.0 per cent (dried substance).

#### CHARACTERS

**Appearance:** white or almost white, crystalline powder or colourless crystals, hygroscopic.

**Solubility:** freely soluble in water and in ethanol (96 per cent). Aqueous solutions are slightly acid; the base may be precipitated when the solutions are allowed to stand.

**mp:** about 200 °C, with decomposition.

## IDENTIFICATION

First identification: C, E.

Second identification: A, B, D, E.

A. Specific optical rotation (see Tests).

B. Melting point (2.2.14) of the precipitate obtained in identification test E: 174 °C to 177 °C.

C. Infrared absorption spectrophotometry (2.2.24).

Preparation: examine the precipitate obtained in identification test E.

Comparison: noscapine CRS.

D. Thin-layer chromatography (2.2.27).

Test solution. Dissolve 25 mg of the substance to be examined in ethanol (96 per cent) R and dilute to 100 mL with the same solvent.

Reference solution. Dissolve 22 mg of noscapine CRS in acetone R and dilute to 100 mL with the same solvent.

Plate: TLC silica gel plate R.

Mobile phase: concentrated ammonia R, ethanol (96 per cent) R, acetone R, toluene R (1:3:20:20 V/V/V/V).

Application: 10 µL.

Development: over 2/3 of the plate.

Drying: in air.

Detection: spray with dilute potassium iodobismuthate solution R.

Results: the principal spot in the chromatogram obtained with the test solution is similar in position, colour and size to the principal spot in the chromatogram obtained with the reference solution.

E. Dissolve about 40 mg in a mixture of 2 mL of water R and 3 mL of ethanol (96 per cent) R and add 1 mL of dilute ammonia R2. Heat until dissolution is complete. Allow to cool, scratching the wall of the tube with a glass rod. Filter. The filtrate gives reaction (a) of chlorides (2.3.1). Wash the precipitate with water R, dry at 100-105 °C and reserve for identification tests B and C.

## TESTS

**Appearance of solution.** The solution is clear (2.2.1) and not more intensely coloured than reference solution Y<sub>6</sub> or BY<sub>6</sub> (2.2.2, Method II).

Dissolve 0.5 g in water R, add 0.3 mL of 0.1 M hydrochloric acid and dilute to 25 mL with water R.

**pH** (2.2.3): minimum 3.0.

Dissolve 0.2 g in 10 mL of carbon dioxide-free water R.

**Specific optical rotation** (2.2.7): + 38.5 to + 44.0 (dried substance).

Dissolve 0.500 g in 0.01 M hydrochloric acid and dilute to 25.0 mL with the same acid.

**Related substances.** Liquid chromatography (2.2.29).

Test solution. Dissolve 20.0 mg of the substance to be examined with gentle heating in 14 mL of methanol R, cool the solution and dilute to 20.0 mL with phosphate buffer solution pH 6.0 R1.

Reference solution (a). Dilute 1.0 mL of the test solution to 20.0 mL with the mobile phase. Dilute 1.0 mL of the solution to 10.0 mL with the mobile phase.

Reference solution (b). Dissolve 5 mg of papaverine hydrochloride R in the mobile phase and dilute to 50.0 mL with the mobile phase. Dilute 1.0 mL of the solution to 20.0 mL with the mobile phase.

Reference solution (c). Dissolve 1.5 mg of papaverine hydrochloride R in 10 mL of the test solution and dilute to 50 mL with the mobile phase.

Column:

– size:  $l = 0.125$  m,  $\emptyset = 4.6$  mm;

– stationary phase: nitrile silica gel for chromatography R (5 µm).

Mobile phase: methanol R, phosphate buffer solution pH 6.0 R1 (350:650 V/V).

Flow rate: 1 mL/min.

Detection: spectrophotometer at 240 nm.

Injection: 20 µL.

Run time: 2.5 times the retention time of noscapine.

Relative retention with reference to noscapine (retention time = about 10 min): impurity A = about 1.3.

System suitability: reference solution (c):

– resolution: minimum 2 between the peaks due to noscapine and to impurity A.

Limits:

– impurity A: not more than the area of the principal peak in the chromatogram obtained with reference solution (b) (0.5 per cent);

– any other impurity: not more than 0.4 times the area of the principal peak in the chromatogram obtained with reference solution (a) (0.2 per cent);

– total of other impurities: not more than the area of the principal peak in the chromatogram obtained with reference solution (a) (0.5 per cent);

– disregard limit: 0.1 times the area of the principal peak in the chromatogram obtained with reference solution (a) (0.05 per cent).

**Loss on drying** (2.2.32): 2.5 per cent to 6.5 per cent, determined on 0.200 g by drying in an oven at 105 °C.

**Sulfated ash** (2.4.14): maximum 0.1 per cent, determined on 1.0 g.

## ASSAY

Dissolve 0.400 g in a mixture of 5.0 mL of 0.01 M hydrochloric acid and 50 mL of ethanol (96 per cent) R. Carry out a potentiometric titration (2.2.20), using 0.1 M sodium hydroxide. Read the volume added between the 2 points of inflexion.

1 mL of 0.1 M sodium hydroxide is equivalent to 44.99 mg of C<sub>22</sub>H<sub>24</sub>ClNO<sub>7</sub>.

## STORAGE

In an airtight container, protected from light.

## IMPURITIES

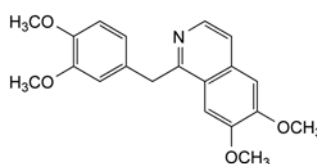

A. 1-(3,4-dimethoxybenzyl)-6,7-dimethoxyisoquinoline (papaverine).

01/2008:0517

## NYSTATIN

## Nystatinum

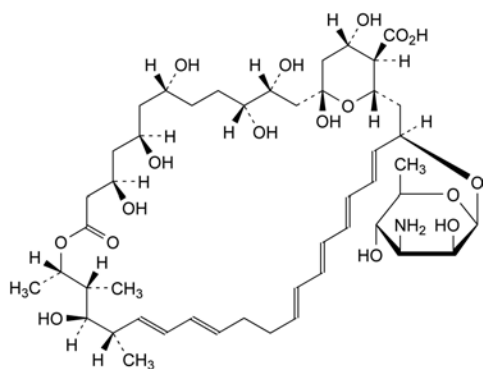
C<sub>47</sub>H<sub>75</sub>NO<sub>17</sub>M<sub>r</sub> 926

## DEFINITION

Antifungal substance obtained by fermentation using certain strains of *Streptomyces noursei* as the production micro-organism. It contains mainly tetraenes, the principal component being (1*S*,3*R*,4*R*,7*R*,9*R*,11*R*,15*S*,16*R*,17*R*,18*S*,19*E*,21*E*,25*E*,27*E*,29*E*,31*E*,33*R*,35*S*,36*R*,37*S*)-33-[(3-amino-3,6-dideoxy-β-D-mannopyranosyl)oxy]-1,3,4,7,9,11,17,37-octahydroxy-15,16,18-trimethyl-13-oxo-14,39-dioxabicyclo[33.3.1]nonatriaconta-19,21,25,27,29,31-hexaene-36-carboxylic acid (nystatin A1).

*Content*: minimum 4400 IU/mg (dried substance) and minimum 5000 IU/mg (dried substance) if intended for oral administration.

## PRODUCTION

If nystatin is not intended for cutaneous administration, the method of manufacture is validated to demonstrate that the product, if tested, would comply with the following test.

**Abnormal toxicity** (2.6.9). Inject intraperitoneally into each mouse a quantity equivalent to not less than 600 IU suspended in 0.5 mL of a 5 g/L solution of *acacia R*.

## CHARACTERS

*Appearance*: yellow or slightly brownish powder, hygroscopic.

*Solubility*: practically insoluble in water, freely soluble in dimethylformamide and in dimethyl sulfoxide, slightly soluble in methanol, practically insoluble in alcohol.

## IDENTIFICATION

*First identification*: B, E.

*Second identification*: A, C, D.

A. Examine the solution prepared in the test for absorbance between 220 nm and 350 nm (2.2.25). The solution shows 4 absorption maxima at 230 nm, 291 nm, 305 nm and 319 nm, and a shoulder at 280 nm. The ratios of the absorbances at the absorption maxima at 291 nm and 319 nm to the absorbance at the absorption maximum at 305 nm are 0.61 to 0.73 and 0.83 to 0.96, respectively. The ratio of the absorbance measured at the absorption maximum at 230 nm to that measured at the shoulder at 280 nm is 0.83 to 1.25.

B. Infrared absorption spectrophotometry (2.2.24).

*Comparison*: *nystatin CRS*.

C. To about 2 mg add 0.1 mL of *hydrochloric acid R*. A brown colour develops.

D. To about 2 mg add 0.1 mL of *sulfuric acid R*. A brown colour develops that becomes violet on standing.

E. Examine the chromatograms obtained in the test for composition.

*Results*: the principal peak in the chromatogram obtained with the test solution is similar in retention time to the principal peak in the chromatogram obtained with reference solution (a).

## TESTS

**Absorbance** (2.2.25). Dissolve 0.10 g in a mixture of 5.0 mL of *glacial acetic acid R* and 50 mL of *methanol R* and dilute to 100.0 mL with *methanol R*. Dilute 1.0 mL of the solution to 100.0 mL with *methanol R*. Determined at the maximum at 305 nm within 30 min of preparation of the solution, the absorbance is not less than 0.60.

**Composition**. Liquid chromatography (2.2.29): use the normalisation procedure. Carry out the test protected from light.

*Test solution*. Dissolve 20 mg of the substance to be examined in *dimethyl sulfoxide R* and dilute to 50 mL with the same solvent.

*Reference solution (a)*. Dissolve 20 mg of *nystatin CRS* in *dimethyl sulfoxide R* and dilute to 50 mL with the same solvent.

*Reference solution (b)*. Dissolve 20 mg of the substance to be examined in 25 mL of *methanol R* and dilute to 50 mL with *water R*. To 10.0 mL of the solution add 2.0 mL of *dilute hydrochloric acid R*. Allow to stand at room temperature for 1 h.

*Reference solution (c)*. Dilute 1.0 mL of reference solution (a) to 100.0 mL with *dimethyl sulfoxide R*. Dilute 1.0 mL of this solution to 10.0 mL with *dimethyl sulfoxide R*.

*Column*:

- *size*:  $l = 0.15$  m,  $\varnothing = 4.6$  mm,
- *stationary phase*: base-deactivated end-capped octadecylsilyl silica gel for chromatography R (5 μm),
- *temperature*: 30 °C.

*Mobile phase*:

- *mobile phase A*: *acetonitrile R*, 3.85 g/L solution of *ammonium acetate R* (29:71 V/V),
- *mobile phase B*: 3.85 g/L solution of *ammonium acetate R*, *acetonitrile R* (40:60 V/V),

Time (min)	Mobile phase A (per cent V/V)	Mobile phase B (per cent V/V)
0 - 25	100	0
25 - 35	100 → 0	0 → 100
35 - 45	0	100
45 - 50	0 → 100	100 → 0
50 - 55	100	0

*Flow rate*: 1.0 mL/min.

*Detection*: spectrophotometer at 305 nm.

*Injection*: 20 μL

*Retention time*: *nystatin A1* = about 14 min.

*System suitability*: reference solution (b):

- *resolution*: minimum 3.5 between the 2 principal peaks (retention time = about 13 min and 19 min).

*Composition*:

- *nystatin A1*: minimum 85.0 per cent,
- *any other compound*: maximum 4.0 per cent,
- *disregard limit*: the area of the principal peak in the chromatogram obtained with reference solution (c); disregard any peak with a retention time of less than 2 min.

**Heavy metals** (2.4.8): maximum 20 ppm.

1.0 g complies with test C. Prepare the reference solution using 2 mL of *lead standard solution (10 ppm Pb) R*.

**Loss on drying** (2.2.32): maximum 5.0 per cent, determined on 1.000 g by drying at 60 °C over *diphosphorus pentoxide R* at a pressure not exceeding 0.1 kPa for 3 h.



**Sulfated ash** (2.4.14): maximum 3.5 per cent, determined on 1.0 g.

#### ASSAY

Carry out the microbiological assay of antibiotics (2.7.2).  
*Protect the solutions from light throughout the assay.*

Dissolve the substance to be examined and *nystatin CRS* separately in *dimethylformamide R* and dilute with a mixture of 5 volumes of *dimethylformamide R* and 95 volumes of buffer solution pH 6.0.

#### STORAGE

In an airtight container, protected from light.

#### LABELLING

The label states where applicable, that the substance is only for cutaneous use.

## OCTOXINOL 10

## Octoxinolum 10

## DEFINITION

$\alpha$ -[4-(1,1,3,3-Tetramethylbutyl)phenyl]- $\omega$ -hydroxydeca(oxyethylene).

Mixture consisting mainly of mono-octylphenyl ethers of macrogols corresponding to the formula  $C_8H_{17}C_6H_4[OCH_2CH_2]_nOH$  where the average value of  $n$  is 10. It may contain free macrogols.

## CHARACTERS

*Appearance*: clear, colourless or light yellow, viscous liquid.

*Solubility*: miscible with water, with ethanol (96 per cent) and with vegetable oils.

## IDENTIFICATION

A. Infrared absorption spectrophotometry (2.2.24).

*Comparison*: octoxinol 10 CRS.

*Preparation*: film between sodium chloride R plates.

B. Cloud point (see Tests).

## TESTS

**Acidity or alkalinity**. Boil 1.0 g with 20 mL of carbon dioxide-free water R for 1 min, with constant stirring. Cool and filter. To 10 mL of the filtrate, add 0.05 mL of bromothymol blue solution R1. Not more than 0.5 mL of 0.01 M hydrochloric acid or 0.01 M sodium hydroxide is required to change the colour of the indicator.

**Hydroxyl value** (2.5.3, Method A): 85 to 101.

**Cloud point**: 63 °C to 70 °C.

Dissolve 1.0 g in 99 g of water R. Transfer about 30 mL of this solution to a test-tube, heat on a water-bath and stir continuously until the solution becomes cloudy. Remove the test-tube from the water-bath (ensuring that the temperature does not increase more than 2 °C), and continue to stir. The cloud point is the temperature at which the solution becomes sufficiently clear that the entire thermometer bulb is plainly seen.

**Ethylene oxide and dioxan** (2.4.25): maximum 1 ppm of ethylene oxide and maximum 10 ppm of dioxan.

**Heavy metals** (2.4.8): maximum 10 ppm.

Dissolve 2.0 g in distilled water R and dilute to 20.0 mL with the same solvent. 12 mL of this solution complies with test A. Prepare the reference solution using lead standard solution (1 ppm Pb) R.

**Water** (2.5.12): maximum 0.5 per cent, determined on 2.00 g.

**Total ash** (2.4.16): maximum 0.4 per cent, determined on 1.0 g.

## STORAGE

In an airtight container.

## 01/2008:1553 DEFINITION

Octyl 3,4,5-trihydroxybenzoate.

*Content*: 97.0 per cent to 103.0 per cent (dried substance).

## CHARACTERS

*Appearance*: white or almost white, crystalline powder.

*Solubility*: practically insoluble in water, freely soluble in ethanol (96 per cent), practically insoluble in methylene chloride.

## IDENTIFICATION

A. Melting point (2.2.14).

Determine the melting point of the substance to be examined. Mix equal parts of the substance to be examined and *octyl gallate CRS* and determine the melting point of the mixture. The difference between the melting points (which are about 101 °C) is not greater than 2 °C.

B. Examine the chromatograms obtained in the test for impurity A.

*Results*: the principal spot in the chromatogram obtained with test solution (b) is similar in position, colour and size to the principal spot in the chromatogram obtained with reference solution (a).

## TESTS

**Impurity A**. Thin-layer chromatography (2.2.27).

*Test solution (a)*. Dissolve 0.20 g of the substance to be examined in acetone R and dilute to 10 mL with the same solvent.

*Test solution (b)*. Dilute 1.0 mL of test solution (a) to 20 mL with acetone R.

*Reference solution (a)*. Dissolve 10 mg of *octyl gallate CRS* in acetone R and dilute to 10 mL with the same solvent.

*Reference solution (b)*. Dissolve 20 mg of *gallic acid R* in acetone R and dilute to 20 mL with the same solvent.

*Reference solution (c)*. Dilute 1.0 mL of reference solution (b) to 10 mL with acetone R.

*Reference solution (d)*. Dilute 1.0 mL of reference solution (b) to 5 mL with test solution (a).

*Plate*: TLC silica gel plate R.

*Mobile phase*: anhydrous formic acid R, ethyl formate R, toluene R (10:40:50 V/V/V).

*Application*: 5  $\mu$ L of test solutions (a) and (b) and reference solutions (a), (c) and (d).

*Development*: over 2/3 of the plate.

*Drying*: in air for 10 min.

*Detection*: spray with a mixture of 1 volume of *ferric chloride solution R1* and 9 volumes of *ethanol (96 per cent) R*.

*System suitability*: reference solution (d):

– the chromatogram shows 2 clearly separated principal spots.

*Limit*: test solution (a):

– *impurity A*: any spot due to impurity A is not more intense than the spot in the chromatogram obtained with reference solution (c) (0.5 per cent).

**Chlorides** (2.4.4): maximum 100 ppm.

To 1.65 g add 50 mL of water R. Shake for 5 min. Filter. 15 mL of the filtrate complies with the test.

**Heavy metals** (2.4.8): maximum 10 ppm.

2.0 g complies with test C. Prepare the reference solution using 2 mL of lead standard solution (10 ppm Pb) R.

**Loss on drying** (2.2.32): maximum 0.5 per cent, determined on 1.000 g by drying in an oven at 70 °C.

**Sulfated ash** (2.4.14): maximum 0.1 per cent, determined on 1.0 g.

## 01/2008:2057

## OCTYL GALLATE

## Octylis gallas

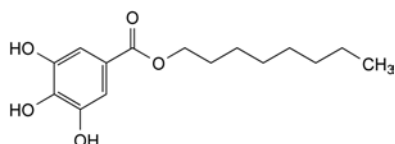

$C_{15}H_{22}O_5$   
[1034-01-1]

$M_r$  282.3

## ASSAY

Dissolve 0.100 g in *methanol R* and dilute to 250.0 mL with the same solvent. Dilute 5.0 mL of the solution to 200.0 mL with *methanol R*. Measure the absorbance (2.2.25) at the absorption maximum at 275 nm.

Calculate the content of  $C_{15}H_{22}O_5$  taking the specific absorbance to be 387.

## STORAGE

In a non-metallic container, protected from light.

## IMPURITIES

Specified impurities: A.

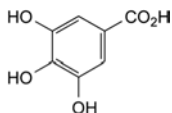

A. 3,4,5-trihydroxybenzoic acid (gallic acid).

01/2008:1136

## OCTYLDODECANOL

## Octyldodecanolum

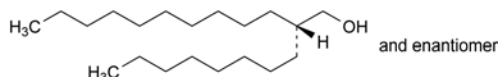

[5333-42-6]

## DEFINITION

Condensation product of saturated liquid fatty alcohols.

*Content*: minimum 90 per cent of (2*RS*)-2-octyldodecan-1-ol ( $C_{20}H_{42}O$ ;  $M_r$  298.6), the remainder consisting mainly of related alcohols.

## CHARACTERS

*Appearance*: clear, colourless or yellowish, oily liquid.

*Solubility*: practically insoluble in water, miscible with ethanol (96 per cent).

*Relative density*: about 0.840.

*Refractive index*: about 1.455.

## IDENTIFICATION

A. Hydroxyl value (see Tests).

B. Thin-layer chromatography (2.2.27).

*Test solution*. Dissolve 0.20 g of the substance to be examined in *toluene R* and dilute to 20 mL with the same solvent.

*Reference solution*. Dissolve 0.20 g of *octyldodecanol CRS* in *toluene R* and dilute to 20 mL with the same solvent.

*Plate*: suitable silica gel plate.

*Mobile phase*: *ethyl acetate R*, *toluene R* (5:95 V/V).

*Application*: 2  $\mu$ L.

*Development*: over a path of 12 cm.

*Drying*: in air.

*Detection*: spray with about 7 mL of a mixture of 1 volume of a 25 g/L solution of *vanillin R* in *ethanol (96 per cent) R* and 4 volumes of *sulfuric acid R* and heat at 130 °C for 5-10 min.

*Results*: the principal spot in the chromatogram obtained with the test solution is similar in position, colour and size to the principal spot in the chromatogram obtained with the reference solution.

## TESTS

**Acidity or alkalinity**. Mix 5.0 g thoroughly for 1 min with a mixture of 0.1 mL of *bromothymol blue solution R1*, 2 mL of *heptane R* and 10 mL of *water R*. If the aqueous layer is blue, not more than 0.15 mL of 0.01 M *hydrochloric acid* is required to change the colour of the indicator to yellow. If the aqueous layer is yellow, add 0.45 mL of 0.01 M *sodium hydroxide* and shake vigorously. After standing to ensure complete separation, the aqueous layer is blue.

**Optical rotation** (2.2.7):  $-0.10^\circ$  to  $+0.10^\circ$ .

Dissolve 2.50 g in *ethanol (96 per cent) R* and dilute to 25 mL with the same solvent.

**Hydroxyl value** (2.5.3, *Method A*): 175 to 190.

**Iodine value** (2.5.4, *Method A*): maximum 8.0.

**Peroxide value** (2.5.5, *Method A*): maximum 5.0.

**Saponification value** (2.5.6): maximum 5.0.

**Heavy metals** (2.4.8): maximum 10 ppm.

2.0 g complies with test C. Prepare the reference solution using 2 mL of *lead standard solution (10 ppm Pb) R*.

**Water** (2.5.12): maximum 0.5 per cent, determined on 2.00 g.

**Sulfated ash** (2.4.14): maximum 0.1 per cent, determined on 1.0 g.

## ASSAY

Gas chromatography (2.2.28).

*Internal standard solution*. Dissolve 0.4 g of *tetradecane R* in *hexane R* and dilute to 100.0 mL with the same solvent.

*Test solution*. Dissolve 0.100 g of the substance to be examined in the internal standard solution and dilute to 10.0 mL with the same solution.

*Reference solution*. Dissolve 0.100 g of *octyldodecanol CRS* in the internal standard solution and dilute to 10.0 mL with the same solution.

*Column*:

- *material*: stainless steel,
- *size*:  $l = 60$  m,  $\varnothing = 0.25$  mm,
- *stationary phase*: *poly(dimethyl)(diphenyl)(divinyl)siloxane R* (film thickness 0.25  $\mu$ m).

*Carrier gas*: *helium for chromatography R*.

*Flow rate*: 0.68 mL/min.

*Split ratio*: 1:50.

*Temperature*:

	Time (min)	Temperature (°C)
	0 - 2	180
Column	2 - 22	180 → 280
	22 - 52	280
Injection port		290
Detector		300

*Detection*: flame ionisation.

*Injection*: 1  $\mu$ L.

Calculate the content of  $C_{20}H_{42}O$  in the substance to be examined.

## STORAGE

Protected from light.

## OFLOXACIN

## Ofloxacinum

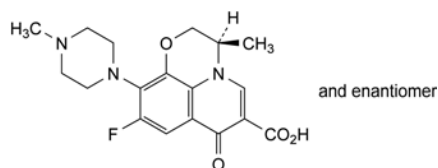

$C_{18}H_{20}FN_3O_4$   
[82419-36-1]

$M_r$  361.4

## DEFINITION

(3*RS*)-9-Fluoro-3-methyl-10-(4-methylpiperazin-1-yl)-7-oxo-2,3-dihydro-7*H*-pyrido[1,2,3-*de*]-1,4-benzoxazine-6-carboxylic acid.

*Content*: 99.0 per cent to 101.0 per cent (dried substance).

## CHARACTERS

*Appearance*: pale yellow or bright yellow, crystalline powder.

*Solubility*: slightly soluble in water, soluble in glacial acetic acid, slightly soluble or soluble in methylene chloride, slightly soluble in methanol.

## IDENTIFICATION

Infrared absorption spectrophotometry (2.2.24).

*Comparison*: ofloxacin CRS.

## TESTS

**Optical rotation** (2.2.7):  $-0.10^\circ$  to  $+0.10^\circ$ .

Dissolve 0.300 g in a mixture of 10 volumes of *methanol R* and 40 volumes of *methylene chloride R* and dilute to 10.0 mL with the same mixture of solvents.

**Absorbance** (2.2.25): maximum 0.25 at 440 nm.

Dissolve 0.5 g in 0.1 M *hydrochloric acid* and dilute to 100.0 mL with the same acid.

**Impurity A**. Thin-layer chromatography (2.2.27).

*Solvent mixture*: *methanol R*, *methylene chloride R* (10:40 V/V).

*Test solution*. Dissolve 0.250 g of the substance to be examined in the solvent mixture and dilute to 5.0 mL with the solvent mixture.

*Reference solution*. Dissolve 10.0 mg of *ofloxacin impurity A CRS* in the solvent mixture and dilute to 100.0 mL with the solvent mixture.

*Plate*: TLC silica gel GF<sub>254</sub> plate R (2-10  $\mu$ m).

*Mobile phase*: *glacial acetic acid R*, *water R*, *ethyl acetate R* (10:10:20 V/V/V).

*Application*: 10  $\mu$ L.

*Development*: over 2/3 of the plate.

*Drying*: in air.

*Detection*: examine in ultraviolet light at 254 nm.

*Limit*:

- *impurity A*: any spot due to impurity A is not more intense than the corresponding spot in the chromatogram obtained with the reference solution (0.2 per cent).

**Related substances**. Liquid chromatography (2.2.29). Prepare the solutions immediately before use.

*Solvent mixture*: *acetonitrile R*, *water R* (10:60 V/V).

*Test solution*. Dissolve 10 mg of the substance to be examined in the solvent mixture and dilute to 50.0 mL with the solvent mixture.

01/2011:1455 *Reference solution (a)*. Dilute 1.0 mL of the test solution to 50.0 mL with the solvent mixture. Dilute 1.0 mL of this solution to 10.0 mL with the solvent mixture.

*Reference solution (b)*. Dissolve 10 mg of *ofloxacin impurity E CRS* in the solvent mixture and dilute to 100.0 mL with the solvent mixture. Mix 10 mL of the solution and 5 mL of the test solution and dilute to 50.0 mL with the solvent mixture. Dilute 1.0 mL of this solution to 50.0 mL with the solvent mixture.

*Column*:

- *size*:  $l = 0.15$  m,  $\emptyset = 4.6$  mm;
- *stationary phase*: octadecylsilyl silica gel for chromatography R (5  $\mu$ m);
- *temperature*: 45 °C.

*Mobile phase*: dissolve 4.0 g of *ammonium acetate R* and 7.0 g of *sodium perchlorate R* in 1300 mL of *water R*; adjust to pH 2.2 with *phosphoric acid R* and add 240 mL of *acetonitrile R*.

*Flow rate*: adjust so that a retention time of about 20 min is obtained for ofloxacin.

*Detection*: spectrophotometer at 294 nm.

*Injection*: 10  $\mu$ L.

*Run time*: 2.5 times the retention time of ofloxacin.

*Identification of impurities*: use the chromatogram obtained with reference solution (b) to identify the peak due to impurity E.

*Relative retention* with reference to ofloxacin (retention time = about 20 min): impurity B = about 0.3; impurity C = about 0.5; impurity D = about 0.7; impurity E = about 0.9; impurity F = about 1.6.

*System suitability*: reference solution (b):

- *resolution*: minimum 2.0 between the peaks due to impurity E and ofloxacin.

*Limits*:

- *impurities B, C, D, E, F*: for each impurity, not more than the area of the principal peak in the chromatogram obtained with reference solution (a) (0.2 per cent);
- *unspecified impurities*: for each impurity, not more than 0.5 times the area of the principal peak in the chromatogram obtained with reference solution (a) (0.10 per cent);
- *total*: not more than 2.5 times the area of the principal peak in the chromatogram obtained with reference solution (a) (0.5 per cent);
- *disregard limit*: 0.25 times the area of the principal peak in the chromatogram obtained with reference solution (a) (0.05 per cent).

**Heavy metals** (2.4.8): maximum 10 ppm.

2.0 g complies with test C. Prepare the reference solution using 2 mL of *lead standard solution (10 ppm Pb) R*.

**Loss on drying** (2.2.32): maximum 0.2 per cent, determined on 1.000 g by drying at 105 °C for 4 h.

**Sulfated ash** (2.4.14): maximum 0.1 per cent, determined on 1.0 g.

## ASSAY

Dissolve 0.300 g in 100 mL of *anhydrous acetic acid R*. Titrate with 0.1 M *perchloric acid*, determining the end-point potentiometrically (2.2.20).

1 mL of 0.1 M *perchloric acid* is equivalent to 36.14 mg of  $C_{18}H_{20}FN_3O_4$ .

## STORAGE

In an airtight container, protected from light.

## IMPURITIES

*Specified impurities*: A, B, C, D, E, F.

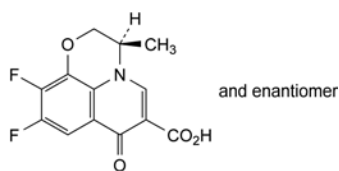

- A. (3RS)-9,10-difluoro-3-methyl-7-oxo-2,3-dihydro-7H-pyrido[1,2,3-de]-1,4-benzoxazine-6-carboxylic acid (FPA),

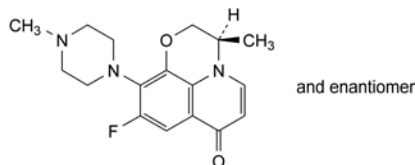

- B. (3RS)-9-fluoro-3-methyl-10-(4-methylpiperazin-1-yl)-2,3-dihydro-7H-pyrido[1,2,3-de]-1,4-benzoxazin-7-one,

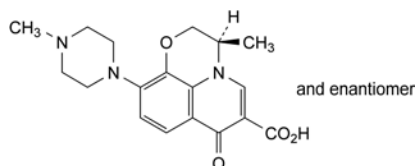

- C. (3RS)-3-methyl-10-(4-methylpiperazin-1-yl)-7-oxo-2,3-dihydro-7H-pyrido[1,2,3-de]-1,4-benzoxazine-6-carboxylic acid,

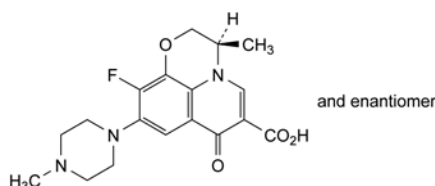

- D. (3RS)-10-fluoro-3-methyl-9-(4-methylpiperazin-1-yl)-7-oxo-2,3-dihydro-7H-pyrido[1,2,3-de]-1,4-benzoxazine-6-carboxylic acid,

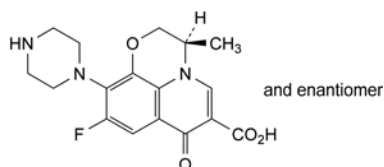

- E. (3RS)-9-fluoro-3-methyl-7-oxo-10-(piperazin-1-yl)-2,3-dihydro-7H-pyrido[1,2,3-de]-1,4-benzoxazine-6-carboxylic acid,

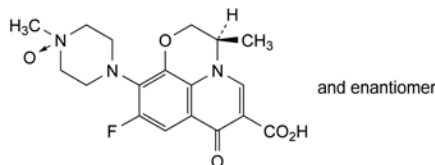

- F. 4-[(3RS)-6-carboxy-9-fluoro-3-methyl-7-oxo-2,3-dihydro-7H-pyrido[1,2,3-de]-1,4-benzoxazin-10-yl]-1-methylpiperazine 1-oxide.

01/2008:0799

## OLEIC ACID

### Acidum oleicum

[112-80-1]

#### DEFINITION

(Z)-Octadec-9-enoic acid (C<sub>18</sub>H<sub>34</sub>O<sub>2</sub>; M<sub>r</sub> 282.5), together with varying amounts of saturated and other unsaturated fatty acids. A suitable antioxidant may be added.

Content: 65.0 per cent to 88.0 per cent of C<sub>18</sub>H<sub>34</sub>O<sub>2</sub>.

#### CHARACTERS

*Appearance*: clear, yellowish or brownish, oily liquid.

*Solubility*: practically insoluble in water, miscible with alcohol and with methylene chloride.

*Relative density*: about 0.892.

#### IDENTIFICATION

A. Acid value (see Tests).

B. Iodine value (see Tests).

C. Composition of fatty acids (see Tests).

*Margaric acid*: maximum 0.2 per cent for oleic acid of vegetable origin and maximum 4.0 per cent for oleic acid of animal origin.

#### TESTS

**Appearance.** The substance to be examined is not more intensely coloured than reference solution Y<sub>1</sub> or BY<sub>1</sub> (2.2.2, Method I).

**Acid value (2.5.1)**: 195 to 204, determined on 0.5 g.

**Iodine value (2.5.4)**: 89 to 105.

**Peroxide value (2.5.5)**: maximum 10.0.

**Composition of fatty acids.** Gas chromatography (2.4.22, Method C).

*Test solution.* Prepare as described in the method but omitting the initial hydrolysis.

*Composition of the fatty acid fraction of the substance:*

- *myristic acid*: maximum 5.0 per cent,
- *palmitic acid*: maximum 16.0 per cent,
- *palmitoleic acid*: maximum 8.0 per cent,
- *stearic acid*: maximum 6.0 per cent,
- *oleic acid*: 65.0 per cent to 88.0 per cent,
- *linoleic acid*: maximum 18.0 per cent,
- *linolenic acid*: maximum 4.0 per cent,
- *fatty acids of chain length greater than C<sub>18</sub>*: maximum 4.0 per cent.

**Total ash (2.4.16)**: maximum 0.1 per cent, determined on 2.00 g.

#### STORAGE

In an airtight, well-filled container, protected from light.

#### LABELLING

The label states the origin of oleic acid (animal or vegetable).

01/2008:1249

## OLEOYL MACROGOLGLYCERIDES

### Macrogolglyceridorum oleates

#### DEFINITION

Mixtures of monoesters, diesters and triesters of glycerol and monoesters and diesters of macrogols.

They are obtained by partial alcoholysis of an unsaturated oil mainly containing triglycerides of oleic (*cis*-9-octadecenoic) acid, using macrogol with a mean relative molecular mass between 300 and 400, or by esterification of glycerol and macrogol with unsaturated fatty acids, or by mixing glycerol esters and condensates of ethylene oxide with the fatty acids of this unsaturated oil.

#### CHARACTERS

*Appearance*: amber oily liquid, which may give rise to a deposit after prolonged periods at 20 °C.

*Solubility*: practically insoluble but dispersible in water, freely soluble in methylene chloride.

*Viscosity*: about 35 mPa·s at 40 °C.

*Relative density*: about 0.95 at 20 °C.

*Refractive index*: about 1.47 at 20 °C.

## IDENTIFICATION

A. Thin-layer chromatography (2.2.27).

*Test solution*. Dissolve 1.0 g of the substance to be examined in *methylene chloride R* and dilute to 20 mL with the same solvent.

*Plate*: TLC silica gel plate R.

*Mobile phase*: hexane R, ether R (30:70 V/V).

*Application*: 10 µL.

*Development*: over a path of 15 cm.

*Drying*: in air.

*Detection*: spray with a 0.1 g/L solution of *rhodamine B R* in *ethanol (96 per cent) R* and examine in ultraviolet light at 365 nm.

*Results*: the chromatogram shows a spot due to triglycerides with an  $R_f$  value of about 0.9 ( $R_{st}$  1) and spots due to 1,3-diglycerides ( $R_{st}$  0.7), to 1,2-diglycerides ( $R_{st}$  0.6), to monoglycerides ( $R_{st}$  0.1) and to esters of macrogol ( $R_{st}$  0).

B. Hydroxyl value (see Tests).

C. Saponification value (see Tests).

D. Fatty acid composition (see Tests).

## TESTS

**Acid value** (2.5.1): maximum 2.0, determined on 2.0 g.

**Hydroxyl value** (2.5.3, *Method A*): 45 to 65, determined on 1.0 g.

**Iodine value** (2.5.4, *Method A*): 75 to 95.

**Peroxide value** (2.5.5, *Method A*): maximum 12.0, determined on 2.0 g.

**Saponification value** (2.5.6): 150 to 170, determined on 2.0 g.

**Alkaline impurities**. Introduce 5.0 g into a test tube and carefully add a mixture, neutralised if necessary with 0.01 M *hydrochloric acid* or with 0.01 M *sodium hydroxide*, of 0.05 mL of a 0.4 g/L solution of *bromophenol blue R* in *ethanol (96 per cent) R*, 0.3 mL of *water R* and 10 mL of *ethanol (96 per cent) R*. Shake and allow to stand. Not more than 1.0 mL of 0.01 M *hydrochloric acid* is required to change the colour of the upper layer to yellow.

**Free glycerol**: maximum 3.0 per cent.

Dissolve 1.20 g in 25.0 mL of *methylene chloride R*. Heat if necessary. After cooling, add 100 mL of *water R*. Shake and add 25.0 mL of *periodic acetic acid solution R*. Shake and allow to stand for 30 min. Add 40 mL of a 75 g/L solution of *potassium iodide R*. Allow to stand for 1 min. Add 1 mL of *starch solution R*. Titrate the iodine with 0.1 M *sodium thiosulfate*. Carry out a blank titration.

1 mL of 0.1 M *sodium thiosulfate* is equivalent to 2.3 mg of glycerol.

**Composition of fatty acids** (2.4.22, *Method A*).

*Composition of the fatty-acid fraction of the substance*:

- *palmitic acid*: 4.0 per cent to 9.0 per cent;
- *stearic acid*: maximum 6.0 per cent;
- *oleic acid*: 58.0 per cent to 80.0 per cent;
- *linoleic acid*: 15.0 per cent to 35.0 per cent;
- *linolenic acid*: maximum 2.0 per cent;
- *arachidic acid*: maximum 2.0 per cent;
- *eicosenoic acid*: maximum 2.0 per cent.

**Ethylene oxide and dioxan** (2.4.25): maximum 1 ppm of ethylene oxide and maximum 10 ppm of dioxan.

**Heavy metals** (2.4.8): maximum 10 ppm.

2.0 g complies with test C. Prepare the reference solution using 2 mL of *lead standard solution (10 ppm Pb) R*.

**Water** (2.5.12): maximum 1.0 per cent, determined on 1.0 g. Use a mixture of 30 volumes of *anhydrous methanol R* and 70 volumes of *methylene chloride R* as solvent.

**Total ash** (2.4.16): maximum 0.1 per cent.

## STORAGE

Protected from light.

## LABELLING

The label states the type of macrogol used (mean relative molecular mass) or the number of units of ethylene oxide per molecule (nominal value).

01/2008:2073

## OLEYL ALCOHOL

## Alcohol oleicus

## DEFINITION

Mixture of unsaturated and saturated long-chain fatty alcohols consisting mainly of octadec-9-enol (oleyl alcohol and elaidyl alcohol;  $C_{18}H_{36}O$ ;  $M_r$  268.5). It may be of vegetable or animal origin.

## CHARACTERS

*Appearance*: colourless or light yellow liquid.

## IDENTIFICATION

A. Hydroxyl value (see Tests).

B. Composition of fatty alcohols (see Tests).

## TESTS

**Appearance**. The substance to be examined is clear (2.2.1) and not more intensely coloured than reference solution B<sub>6</sub> (2.2.2, *Method II*).

**Refractive index** (2.2.6): 1.458 to 1.460, determined at 25 °C.

**Cloud point**: maximum 10 °C.

Introduce about 60 g into a cylindrical flat-bottomed container, 30-33.5 mm internal diameter and 115-125 mm high. Heat to 30 °C, cool, and immerse the container in iced water with the surfaces of the water and the sample at the same level. Insert a thermometer and, using it as a stirring rod begin stirring rapidly and steadily when the temperature falls below 20 °C. Keep the thermometer immersed throughout the test, remove and examine the container at regular intervals. The cloud point is the temperature at which the immersed portion of the thermometer, positioned vertically in the centre of the container, is no longer visible when viewed horizontally through the container and sample.

**Acid value** (2.5.1): maximum 1.0, determined on 5.0 g.

**Hydroxyl value** (2.5.3, *Method A*): 205 to 215.

**Saponification value** (2.5.6): maximum 2.0.

**Composition of fatty alcohols**. Gas chromatography (2.2.28): use the normalisation procedure.

*Test solution*. Mix 25 mg of the substance to be examined with 1.0 mL of *methylene chloride R*.

*Reference solution (a)*. Dissolve 25 mg of each of *arachidyl alcohol R*, *linolenyl alcohol R*, *linoleyl alcohol R*, *oleyl alcohol R*, *palmityl alcohol R* and *stearyl alcohol R* in *methylene chloride R* and dilute to 5 mL with the same solvent. Dilute 1 mL of this solution to 5 mL with *methylene chloride R*.

*Reference solution (b)*. Dissolve 10 mg of *linoleyl alcohol R* and 1 g of *oleyl alcohol R* in *methylene chloride R* and dilute to 40 mL with the same solvent.

*Column*:

- *size*:  $l = 30$  m,  $\varnothing = 0.32$  mm,
- *stationary phase*: *poly(dimethyl)siloxane R* (film thickness 1 µm).

Carrier gas: helium for chromatography R.

Flow rate: 1 mL/min.

Split ratio: 1:11.

Temperature:

	Time (min)	Temperature (°C)
Column	0 - 1	170
	1 - 9	170 → 210
	9 - 65	210
Injection port		270
Detector		280

Detection: flame ionisation.

Injection: 1 µL.

Identify the peaks using the chromatogram obtained with reference solution (a).

Relative retention with reference to oleyl alcohol (retention time = about 30 min): palmityl alcohol = about 0.6; linolenyl alcohol = about 0.8; linoleyl alcohol = about 0.9; stearyl alcohol = about 1.1; arachidyl alcohol = about 1.9 (elaidyl alcohol co-elutes with oleyl alcohol).

System suitability: reference solution (b):

– peak-to-valley ratio: minimum 1.2 between the peaks due to linoleyl alcohol and oleyl alcohol.

Limits:

- palmityl alcohol: maximum 8.0 per cent,
- stearyl alcohol: maximum 5.0 per cent,
- oleyl alcohol (sum of oleyl and elaidyl alcohols): minimum 80.0 per cent,
- linoleyl alcohol: maximum 3.0 per cent,
- linolenyl alcohol: maximum 0.5 per cent,
- arachidyl alcohol: maximum 0.3 per cent.

01/2010:1456

## OLIVE OIL, REFINED

### Olivae oleum raffinatum

#### DEFINITION

Fatty oil obtained by refining of crude olive oil, obtained by cold expression or other suitable mechanical means from the ripe drupes of *Olea europaea* L. A suitable antioxidant may be added.

#### CHARACTERS

Appearance: clear, colourless or greenish-yellow transparent liquid.

Solubility: practically insoluble in ethanol (96 per cent), miscible with light petroleum (bp: 50-70 °C).

When cooled, it begins to become cloudy at 10 °C and becomes a butter-like mass at about 0 °C.

Relative density: about 0.913.

#### IDENTIFICATION

A. Acid value (see Tests).

B. Identification of fatty oils by thin-layer chromatography (2.3.2).

Results: the chromatogram obtained is similar to the corresponding chromatogram shown in Figure 2.3.2.-1. For certain types of olive oil, the difference in the size of spots E and F is less pronounced than in the corresponding chromatogram shown in Figure 2.3.2.-1.

#### TESTS

Acid value (2.5.1): maximum 0.3, determined on 10.0 g.

Peroxide value (2.5.5, Method A): maximum 10.0, or maximum 5.0 if intended for use in the manufacture of parenteral preparations.

Unsaponifiable matter: maximum 1.5 per cent.

Place 5.0 g (*m* g) in a 150 mL flask fitted with a reflux condenser. Add 50 mL of 2 M alcoholic potassium hydroxide R and heat on a water-bath for 1 h, shaking frequently. Add 50 mL of water R through the top of the condenser, shake, allow to cool and transfer the contents of the flask to a separating funnel. Rinse the flask with several portions totalling 50 mL of light petroleum R1 and add the rinsings to the separating funnel. Shake vigorously for 1 min. Allow to separate and transfer the aqueous layer to a 2<sup>nd</sup> separating funnel. If an emulsion forms, add small quantities of ethanol (96 per cent) R or a concentrated solution of potassium hydroxide R. Shake the aqueous layer with 2 quantities, each of 50 mL, of light petroleum R1. Combine the light petroleum layers in a 3<sup>rd</sup> separating funnel and wash with 3 quantities, each of 50 mL, of ethanol (50 per cent V/V) R. Transfer the light petroleum layer to a tared 250 mL flask. Rinse the separating funnel with small quantities of light petroleum R1 and add to the flask. Evaporate the light petroleum on a water-bath and dry the residue at 100-105 °C for 15 min, keeping the flask horizontal. Allow to cool in a desiccator and weigh (*a* g). Repeat the drying for successive periods of 15 min until the loss of mass between 2 successive weighings does not exceed 0.1 per cent. Dissolve the residue in 20 mL of ethanol (96 per cent) R, previously neutralised to 0.1 mL of bromophenol blue solution R. If necessary, titrate with 0.1 M hydrochloric acid (*b* mL).

Calculate the percentage content of unsaponifiable matter using the following expression:

$$\frac{100(a - 0.032b)}{m}$$

If 0.032*b* is greater than 5 per cent of *a*, the test is not valid and must be repeated.

Alkaline impurities (2.4.19). It complies with the test.

Specific absorbance (2.2.25): maximum 1.20, determined at the absorption maximum at 270 nm.

To 1.00 g add cyclohexane R and dilute to 100.0 mL with the same solvent.

Composition of fatty acids (2.4.22, Method A). Use the mixture of calibrating substances in Table 2.4.22.-3.

Composition of the fatty-acid fraction of the oil:

- saturated fatty acids of chain length less than C<sub>16</sub>: maximum 0.1 per cent;
- palmitic acid: 7.5 per cent to 20.0 per cent;
- palmitoleic acid maximum 3.5 per cent;
- stearic acid: 0.5 per cent to 5.0 per cent;
- oleic acid 56.0 per cent to 85.0 per cent;
- linoleic acid 3.5 per cent to 20.0 per cent;
- linolenic acid maximum 1.2 per cent;
- arachidic acid: maximum 0.7 per cent;
- eicosenoic acid maximum 0.4 per cent;
- behenic acid: maximum 0.2 per cent;
- lignoceric acid: maximum 0.2 per cent.

Sterols (2.4.23).

Composition of the sterol fraction of the oil:

- cholesterol: maximum 0.5 per cent;
- campesterol: maximum 4.0 per cent;
- Δ<sup>7</sup>-stigmaterol: maximum 0.5 per cent;
- sum of contents of Δ<sup>5</sup>,23-stigmastadienol, clerosterol, β-sitosterol, sitostanol, Δ<sup>5</sup>-avenasterol and Δ<sup>5</sup>,24-stigmastadienol: minimum 93.0 per cent.

The content of stigmaterol is not greater than that of campesterol.

**Sesame oil.** In a ground-glass-stoppered cylinder shake 10 mL for about 1 min with a mixture of 0.5 mL of a 0.35 per cent *V/V* solution of *furfural R* in *acetic anhydride R* and 4.5 mL of *acetic anhydride R*. Filter through a filter paper impregnated with *acetic anhydride R*. To the filtrate add 0.2 mL of *sulfuric acid R*. No bluish-green colour develops.

**Water (2.5.32):** maximum 0.1 per cent, determined on 1.00 g.

#### STORAGE

In a well-filled container, protected from light, at a temperature not exceeding 25 °C. If intended for use in the manufacture of parenteral preparations, store under an inert gas.

#### LABELLING

The label states:

- where applicable, that the substance is suitable for use in the manufacture of parenteral preparations;
- the name of the inert gas.

01/2010:0518

## OLIVE OIL, VIRGIN

### Olivae oleum virginale

#### DEFINITION

Fatty oil obtained by cold expression or other suitable mechanical means from the ripe drupes of *Olea europaea L.*

#### CHARACTERS

**Appearance:** clear, transparent, yellow or greenish-yellow liquid.

**Solubility:** practically insoluble in ethanol (96 per cent), miscible with light petroleum (bp: 50-70 °C).

When cooled, it begins to become cloudy at 10 °C and becomes a butter-like mass at about 0 °C.

**Relative density:** about 0.913.

#### IDENTIFICATION

Identification of fatty oils by thin-layer chromatography (2.3.2).

**Results:** the chromatogram obtained is similar to the corresponding chromatogram shown in Figure 2.3.2-1. For certain types of olive oil, the difference in the size of spots E and F is less pronounced than in the corresponding chromatogram shown in Figure 2.3.2-1.

#### TESTS

**Acid value (2.5.1):** maximum 2.0, determined on 5.0 g.

**Peroxide value (2.5.5, Method A):** maximum 20.0.

**Unsaponifiable matter:** maximum 1.5 per cent.

Place 5.0 g (*m g*) in a 150 mL flask fitted with a reflux condenser. Add 50 mL of 2 *M alcoholic potassium hydroxide R* and heat on a water-bath for 1 h, shaking frequently. Add 50 mL of *water R* through the top of the condenser, shake, allow to cool and transfer the contents of the flask to a separating funnel. Rinse the flask with several portions totalling 50 mL of *light petroleum R1* and add the rinsings to the separating funnel. Shake vigorously for 1 min. Allow to separate and transfer the aqueous layer to a 2<sup>nd</sup> separating funnel. If an emulsion forms, add small quantities of *ethanol (96 per cent) R* or a concentrated solution of *potassium hydroxide R*. Shake the aqueous layer with 2 quantities, each of 50 mL, of *light petroleum R1*. Combine the light petroleum layers in a 3<sup>rd</sup> separating funnel and wash with 3 quantities, each of 50 mL, of *ethanol (50 per cent V/V) R*. Transfer the light petroleum layer to a tared 250 mL flask. Rinse the separating funnel with small quantities of *light petroleum R1* and add to the tared flask. Evaporate the light petroleum on a water-bath and dry the residue at 100-105 °C for 15 min, keeping the flask horizontal. Allow to cool in a desiccator and weigh (*a g*). Repeat the drying for successive periods of 15 min until the loss of mass between

2 successive weighings does not exceed 0.1 per cent. Dissolve the residue in 20 mL of *ethanol (96 per cent) R*, previously neutralised to 0.1 mL of *bromophenol blue solution R*. If necessary, titrate with 0.1 *M hydrochloric acid (b mL)*. Calculate the percentage content of unsaponifiable matter using the following expression:

$$\frac{100(a - 0.032b)}{m}$$

If 0.032*b* is greater than 5 per cent of *a*, the test is not valid and must be repeated.

**Absorbance (2.2.25):** maximum 0.20 at 270 nm. The ratio of the absorbance at 232 nm to that at 270 nm is greater than 8. To 1.00 g add *cyclohexane R* and dilute to 100.0 mL with the same solvent.

**Composition of fatty acids (2.4.22, Method A).** Use the mixture of calibrating substances in Table 2.4.22-3.

**Composition of the fatty-acid fraction of the oil:**

- *saturated fatty acids of chain length less than C<sub>16</sub>*: maximum 0.1 per cent,
- *palmitic acid*: 7.5 per cent to 20.0 per cent,
- *palmitoleic acid* maximum 3.5 per cent,
- *stearic acid*: 0.5 per cent to 5.0 per cent,
- *oleic acid* 56.0 per cent to 85.0 per cent,
- *linoleic acid* 3.5 per cent to 20.0 per cent,
- *linolenic acid* maximum 1.2 per cent,
- *arachidic acid*: maximum 0.7 per cent,
- *eicosenoic acid* maximum 0.4 per cent,
- *behenic acid*: maximum 0.2 per cent,
- *lignoceric acid*: maximum 0.2 per cent.

**Sterols (2.4.23).**

**Composition of the sterol fraction of the oil:**

- *cholesterol*: maximum 0.5 per cent,
- *campesterol*: maximum 4.0 per cent,
- $\Delta^7$ -*stigmasterol*: maximum 0.5 per cent,
- *sum of contents of  $\Delta^5,23$ -stigmasteradienol, clerosterol,  $\beta$ -sitosterol, sitostanol,  $\Delta^5$ -avenasterol and  $\Delta^5,24$ -stigmasteradienol*: minimum 93.0 per cent.

The content of stigmasterol is not greater than that of campesterol.

**Sesame oil.** In a ground-glass-stoppered cylinder shake 10 mL for about 1 min with a mixture of 0.5 mL of a 0.35 per cent *V/V* solution of *furfural R* in *acetic anhydride R* and 4.5 mL of *acetic anhydride R*. Filter through a filter paper impregnated with *acetic anhydride R*. To the filtrate add 0.2 mL of *sulfuric acid R*. No bluish-green colour develops.

**Water (2.5.32):** maximum 0.1 per cent, determined on 1.00 g.

#### STORAGE

In a well-filled container, protected from light, at a temperature not exceeding 25 °C.

01/2008:1457  
corrected 6.0

## OLSALAZINE SODIUM

### Olsalazinum natricum

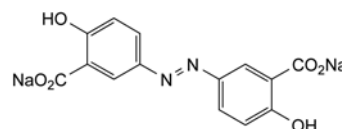

C<sub>14</sub>H<sub>8</sub>N<sub>2</sub>Na<sub>2</sub>O<sub>6</sub>  
[6054-98-4]

*M<sub>r</sub>* 346.2



## DEFINITION

Disodium 3,3'-diazenediylbis(6-hydroxybenzoate).

*Content*: 98.0 per cent to 102.0 per cent (dried substance).

## CHARACTERS

*Appearance*: yellow, fine, crystalline powder.

*Solubility*: sparingly soluble in water, soluble in dimethyl sulfoxide, very slightly soluble in methanol.

It shows polymorphism (5.9).

## IDENTIFICATION

*First identification*: B, D.

*Second identification*: A, C, D.

## A. Ultraviolet and visible absorption spectrophotometry (2.2.25).

*Test solution*. Dissolve 40.0 mg in 5 mL of 0.1 M sodium hydroxide and dilute to 100.0 mL with a 7.8 g/L solution of sodium dihydrogen phosphate R adjusted to pH 7.2 with strong sodium hydroxide solution R (buffer solution). Dilute 2.0 mL of the solution to 100.0 mL with the buffer solution.

*Spectral range*: 240 nm to 400 nm.

*Absorption maxima*: at 255 nm and 362 nm.

*Absorbance ratio*:  $A_{255}/A_{362} = 0.53$  to 0.56.

## B. Infrared absorption spectrophotometry (2.2.24).

*Comparison*: olsalazine sodium CRS.

If the spectra obtained in the solid state show differences, dissolve the substance to be examined and the reference substance separately in methanol R, evaporate to dryness and record new spectra using the residues.

## C. Thin-layer chromatography (2.2.27).

*Test solution*. Dissolve 10 mg of the substance to be examined in a mixture of 1 volume of dilute ammonia R2 and 4 volumes of ethanol (96 per cent) R and dilute to 10 mL with the same mixture of solvents.

*Reference solution (a)*. Dissolve 10 mg of olsalazine sodium CRS in a mixture of 1 volume of dilute ammonia R2 and 4 volumes of ethanol (96 per cent) R and dilute to 10 mL with the same mixture of solvents.

*Reference solution (b)*. Dissolve 5 mg of sulfasalazine CRS in reference solution (a) and dilute to 5 mL with reference solution (a).

*Plate*: TLC silica gel F<sub>254</sub> plate R.

*Mobile phase*: anhydrous formic acid R, acetone R, methylene chloride R (5:50:60 V/V/V).

*Application*: 10 µL.

*Development*: over a path of 15 cm.

*Drying*: in air.

*Detection*: examine in ultraviolet light at 254 nm.

*System suitability*: reference solution (b):

- the chromatogram shows 2 separated spots.

*Results*: the principal spot in the chromatogram obtained with the test solution is similar in position and size to the principal spot in the chromatogram obtained with reference solution (a).

## D. To 0.5 g add 2 mL of sulfuric acid R. Progressively heat to ignition and continue heating until an almost white or at most greyish residue is obtained. Carry out the ignition at a temperature up to 800 ± 50 °C. Dissolve the residue in 10 mL of boiling water R and filter. 2 mL of the filtrate gives reaction (a) of sodium (2.3.1).

## TESTS

**Acetate**. Liquid chromatography (2.2.29).

*Test solution*. Dissolve 0.125 g of the substance to be examined in 25.0 mL of water R and add 1.0 mL of dilute hydrochloric acid R. Centrifuge and then filter the solution through a

0.45 µm filter and also through an appropriate filter for removal of chlorides.

*Reference solution (a)*. Dissolve 0.140 g of sodium acetate R, 0.150 g of sodium formate R and 0.180 g of potassium sulfate R in 100.0 mL of water R. Dilute 1.0 mL of this solution to 100.0 mL with water R.

*Reference solution (b)*. Use suitable amounts of sodium acetate R to prepare not fewer than 5 reference solutions containing 10-50 µg/mL of acetate.

*Column*:

- *size*:  $l = 0.25$  m,  $\emptyset = 9$  mm;
- *stationary phase*: ion-exclusion resin for chromatography R with a capacity of about 27 meq/column.

*Suppressor column*.

*Mobile phase*: 0.0001 M hydrochloric acid.

*Flow rate*: 0.9 mL/min.

*Detection*: conductivity detector at 10 µscm<sup>-1</sup>.

*Injection*: 0.1 mL.

*System suitability*: reference solution (a):

- the chromatogram shows 3 separated peaks.

Determine the concentration of acetate in the test solution using the calibration curve generated by the average of the readings obtained with the reference solutions. Measure the peak area for acetate. Calculate the percentage content of acetate using the following expression:

$$\frac{2.6 c}{m}$$

*c* = concentration of acetate in the test solution, in micrograms per millilitre, determined by linear interpolation of the standard curve for reference solution (b);

*m* = mass of sample, in milligrams.

*Limit*:

- *acetate*: maximum 1.0 per cent.

**Methanesulfonic acid**. Liquid chromatography (2.2.29).

*Test solution*. Dissolve 0.25 g of the substance to be examined in 20 mL of water R, add 1.0 mL of dilute hydrochloric acid R and dilute to 25.0 mL with water R. Centrifuge and then filter the solution through a 0.45 µm filter and also through an appropriate filter for removal of chlorides.

*Reference solution (a)*. Dissolve 0.25 g of methanesulfonic acid R in 50 mL of water R. Add 0.58 g of sodium acetate R and 0.08 g of sodium chloride R and dilute to 100.0 mL with water R. Dilute 1.0 mL of this solution to 100.0 mL with water R.

*Reference solution (b)*. Dissolve 0.10 g of methanesulfonic acid R in water R and dilute to 100.0 mL with water R. Dilute 3.0 mL of this solution to 100.0 mL with water R.

*Precolumn*:

- *size*:  $l = 0.035$  m,  $\emptyset = 4$  mm;
- *stationary phase*: resin for reversed-phase ion chromatography R (10 µm).

*Column*:

- *size*:  $l = 0.25$  m,  $\emptyset = 4$  mm;
- *stationary phase*: resin for reversed-phase ion chromatography R (10 µm).

*Mobile phase*: mix 10 volumes of acetonitrile for chromatography R and 990 volumes of a solution containing 1.6 g/L of tetrabutylammonium hydroxide R and 0.053 g/L of anhydrous sodium carbonate R.

*Flow rate*: 1.0 mL/min.

*Detection*: conductivity detector at 50 µscm<sup>-1</sup>.

*Injection*: 100 µL.

*System suitability*: reference solution (a):

- the chromatogram shows 3 separated peaks.

**Limit:**

- *methanesulfonic acid*: not more than the area of the corresponding peak in the chromatogram obtained with reference solution (b) (0.3 per cent).

**Related substances.** Liquid chromatography (2.2.29).

**Test solution.** Dissolve 20.0 mg of the substance to be examined in mobile phase A and dilute to 25.0 mL with mobile phase A.

**Reference solution (a).** Dilute 0.5 mL of the test solution to 100.0 mL with mobile phase A.

**Reference solution (b).** Dissolve 20.0 mg of *olsalazine sodium for performance test CRS* in mobile phase A and dilute to 25.0 mL with mobile phase A.

**Column:**

- *size*:  $l = 0.125$  m,  $\varnothing = 4.0$  mm;
- *stationary phase*: octadecylsilyl silica gel for chromatography R (5  $\mu$ m);
- *temperature*: 30 °C.

**Mobile phase:**

- *mobile phase A*: dissolve 2.38 g of *tetrabutylammonium hydrogen sulfate R* and 3.6 g of *disodium hydrogen phosphate dihydrate R* in 900 mL of *water R*, adjust to pH 7.6 with *dilute sodium hydroxide solution R* and dilute to 1000.0 mL with *water R*; mix 700 mL of this buffer solution with 300 mL of *methanol R*;
- *mobile phase B*: dissolve 4.75 g of *tetrabutylammonium hydrogen sulfate R* and 3.6 g of *disodium hydrogen phosphate dihydrate R* in 900 mL of *water R*, adjust to pH 7.6 with *dilute sodium hydroxide solution R* and dilute to 1000.0 mL with *water R*; mix 350 mL of this buffer solution with 650 mL of *methanol R*;

Time (min)	Mobile phase A (per cent V/V)	Mobile phase B (per cent V/V)
0 - 15	55	45
15 - 45	55 → 0	45 → 100
45 - 50	0 → 55	100 → 45
50 - 65	55	45

**Flow rate:** 1 mL/min.

**Detection:** spectrophotometer at 360 nm.

**Injection:** 20  $\mu$ L.

**System suitability:** reference solution (b):

- the chromatogram is similar to the chromatogram obtained with *olsalazine sodium for performance test CRS*.

**Limits:**

- *impurities A, B, C, D, E, F, G, H, I*: for each impurity, not more than twice the area of the principal peak in the chromatogram obtained with reference solution (a) (1.0 per cent), and not more than one of the peaks has an area greater than the area of the principal peak in the chromatogram obtained with reference solution (a) (0.5 per cent);
- *total*: not more than 4 times the area of the principal peak in the chromatogram obtained with reference solution (a) (2.0 per cent);
- *disregard limit*: 0.05 times the area of the principal peak in the chromatogram obtained with reference solution (a) (0.025 per cent).

**Heavy metals (2.4.8):** maximum 20 ppm.

1.0 g complies with test D. Prepare the reference solution using 2 mL of *lead standard solution (10 ppm Pb) R*.

**Loss on drying (2.2.32):** maximum 2.0 per cent, determined on 1.000 g by drying in an oven at 150 °C.

**ASSAY**

Dissolve 0.100 g in 15 mL of *ethylene glycol R*. Add 40 mL of *dioxan R* and 0.2 mL of a 224 g/L solution of *potassium chloride R*. Titrate with 0.1 M *hydrochloric acid*, determining the end-point potentiometrically (2.2.20). Carry out a blank titration.

Correct the volume consumed for the content of acetate, taking the molecular mass of acetate to be 59.0.

1 mL of 0.1 M *hydrochloric acid* is equivalent to 17.31 mg of  $C_{14}H_8N_2Na_2O_6$ .

**IMPURITIES**

**Specified impurities:** A, B, C, D, E, F, G, H, I.

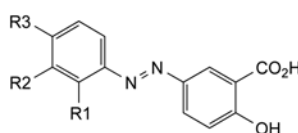

- A. R1 = H, R2 = CO<sub>2</sub>H, R3 = OCH<sub>3</sub>: 6-hydroxy-6'-methoxy-3,3'-diazenediylidibenzoic acid,
- B. R1 = OH, R2 = CO<sub>2</sub>H, R3 = H: 2,6'-dihydroxy-3,3'-diazenediylidibenzoic acid,
- C. R1 = R2 = H, R3 = OH: 2-hydroxy-5-[(4-hydroxyphenyl)diazanyl]benzoic acid,
- D. R1 = H, R2 = CO<sub>2</sub>H, R3 = Cl: 6-chloro-6'-hydroxy-3,3'-diazenediylidibenzoic acid,
- E. R1 = H, R2 = CO-CH<sub>2</sub>-SO<sub>3</sub>H, R3 = OH: 2-hydroxy-5-[[4-hydroxy-3-(sulfoacetyl)phenyl]diazanyl]benzoic acid,

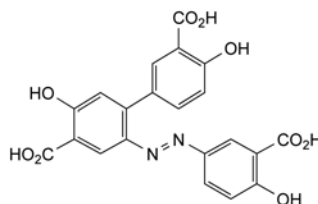

- F. 2'-[(3-carboxy-4-hydroxyphenyl)diazanyl]-4,5'-dihydroxybiphenyl-3,4'-dicarboxylic acid,

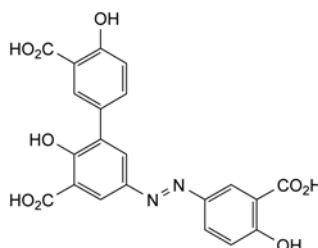

- G. 5-[(3-carboxy-4-hydroxyphenyl)diazanyl]-2,4'-dihydroxybiphenyl-3,3'-dicarboxylic acid,

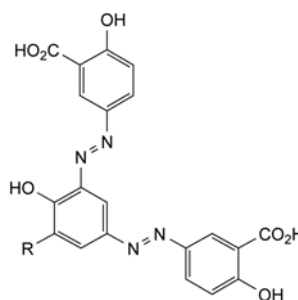

- H. R = CO<sub>2</sub>H: 3,3'-[5-carboxy-4-hydroxy-1,3-phenylenebis(diazenediyl)]bis(6-hydroxybenzoic acid),

- I. R = H: 3,3'-[4-hydroxy-1,3-phenylenebis(diazenediyl)]bis(6-hydroxybenzoic acid).

01/2009:2063 TESTS

## OMEGA-3-ACID ETHYL ESTERS 60

## Omega-3 acidorum esteri ethylici 60

## DEFINITION

Ethyl esters of *alpha*-linolenic acid (C18:3 n-3), moroctic acid (C18:4 n-3), eicosatetraenoic acid (C20:4 n-3), timnodonic (eicosapentaenoic) acid (C20:5 n-3; EPA), heneicosapentaenoic acid (C21:5 n-3), clupanodonic acid (C22:5 n-3) and cervonic (docosahexaenoic) acid (C22:6 n-3; DHA). Omega-3-acid ethyl esters 60 are obtained by transesterification of the body oil obtained from fish of families such as *Engraulidae*, *Carangidae*, *Clupeidae*, *Osmeridae*, *Salmonidae* and *Scombridae* and subsequent physico-chemical purification processes, including molecular distillation. The minimum content of total omega-3-acid ethyl esters and the minimum content of the omega-3-acids EPA and DHA ethyl esters are indicated in Table 2063-1.

Table 2063-1

Total omega-3-acid ethyl esters	EPA and DHA ethyl esters	EPA ethyl esters	DHA ethyl esters
	Minimum content (per cent)		
65	50	25	20
60	50	-	40
55	50	40	-

Authorised antioxidants in concentrations not exceeding the levels specified by the competent authority may be added.

## CHARACTERS

*Appearance*: light yellow liquid.

Slight fish-like odour.

*Solubility*: practically insoluble in water, very soluble in acetone, in ethanol (96 per cent), in heptane and in methanol.

## IDENTIFICATION

A. Examine the chromatograms obtained in the assay for EPA and DHA ethyl esters.

*Results*: the peaks due to eicosapentaenoic acid ethyl ester and docosahexaenoic acid ethyl ester in the chromatogram obtained with the test solution are similar in retention time to the corresponding peaks in the chromatogram obtained with the reference solution.

B. It complies with the limits of the assay for total omega-3-acid ethyl esters.

**Absorbance** (2.2.25): maximum 0.60 at 233 nm.

Dilute 0.300 g to 50.0 mL with *trimethylpentane R*. Dilute 2.0 mL of this solution to 50.0 mL with *trimethylpentane R*.

**Acid value** (2.5.1): maximum 2.0, determined on 10 g in 50 mL of the prescribed mixture of solvents.

**Anisidine value** (2.5.36): maximum 20.0.

**Peroxide value** (2.5.5, *Method A*): maximum 10.0.

**Oligomers and partial glycerides**. Size-exclusion chromatography (2.2.30).

*Test solution*. Dilute 50.0 mg of the substance to be examined to 10.0 mL with *tetrahydrofuran R*.

*Reference solution*. Dissolve 50 mg of *monodocosahexaenoic R*, 30 mg of *didocosahexaenoic R* and 20 mg of *tridocosahexaenoic R* in *tetrahydrofuran R* and dilute to 100.0 mL with the same solvent.

*Column 1*:

– *dimensions*:  $l = 0.3$  m,  $\varnothing = 7.8$  mm;

– *stationary phase*: *styrene-divinylbenzene copolymer R* (7  $\mu$ m), with a pore size of 10 nm.

*Columns 2 and 3* placed closest to the injector:

– *dimensions*:  $l = 0.3$  m,  $\varnothing = 7.8$  mm;

– *stationary phase*: *styrene-divinylbenzene copolymer R* (7  $\mu$ m), with a pore size of 50 nm.

*Mobile phase*: *tetrahydrofuran R*.

*Flow rate*: 0.8 mL/min.

*Detection*: differential refractometer.

*Injection*: 40  $\mu$ L.

*System suitability*: reference solution:

– *elution order*: tridocosahexaenoic, didocosahexaenoic, monodocosahexaenoic;

– *resolution*: minimum 2.0 between the peaks due to monodocosahexaenoic and didocosahexaenoic; minimum 1.0 between the peaks due to didocosahexaenoic and tridocosahexaenoic.

Calculate the percentage content of oligomers plus partial glycerides using the following expression:

$$\frac{B}{A} \times 100$$

A = sum of the areas of all the peaks in the chromatogram;

B = sum of the areas of the peaks with a retention time less than the retention time of the peaks due to ethyl esters.

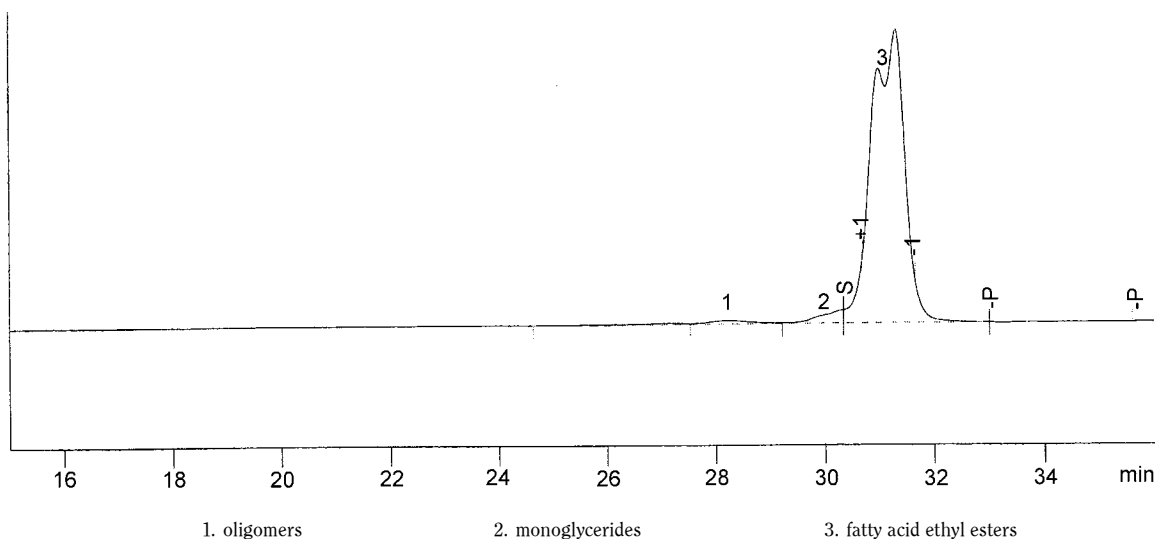

Figure 2063-1. – Chromatogram for the test for oligomers and partial glycerides

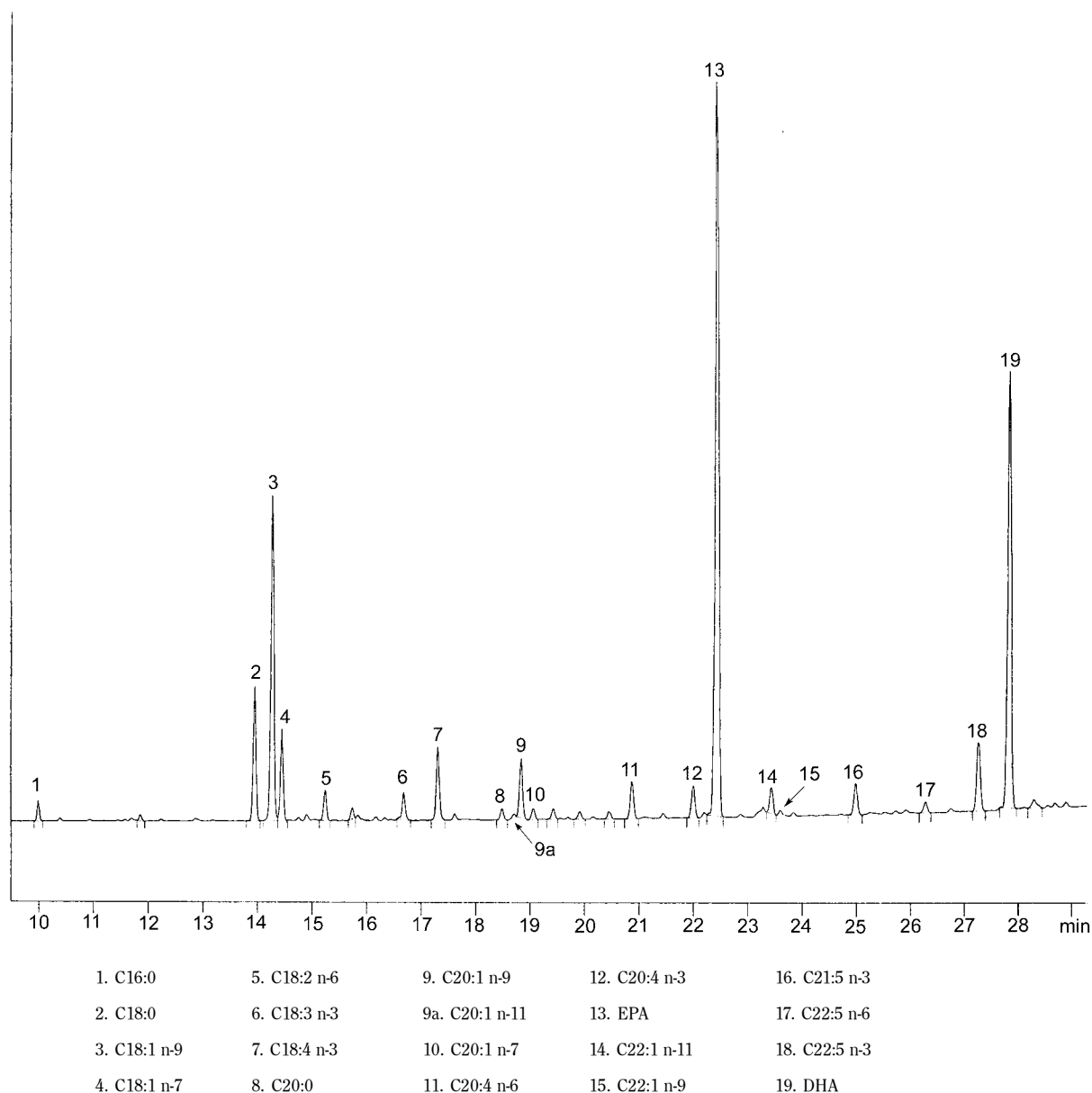

Figure 2063.-2. – Chromatogram for the assays

The ethyl ester peaks, which may be present in the form of an unresolved double peak, are identified as the major peaks in the chromatogram (see Figure 2063.-1).

01/2009:1250

**Limit:**

– *sum of oligomers and partial glycerides*: maximum 7.0 per cent.

**ASSAY**

**EPA and DHA ethyl esters** (2.4.29). For identification of the peaks, see Figure 2063.-2.

**Total omega-3-acids ethyl esters** (2.4.29). See Figure 2063.-2.

**STORAGE**

Under an inert gas, in an airtight container, protected from light.

**LABELLING**

The label states:

- the content of total omega-3-acid ethyl esters;
- the content of EPA ethyl ester and DHA ethyl ester.

**OMEGA-3-ACID ETHYL ESTERS 90**

## Omega-3 acidorum esteri ethylici 90

**DEFINITION**

Ethyl esters of *alpha*-linolenic acid (C18:3 n-3), moroctic acid (C18:4 n-3), eicosatetraenoic acid (C20:4 n-3), timnodonic (eicosapentaenoic) acid (C20:5 n-3; EPA), heneicosapentaenoic acid (C21:5 n-3), clupanodonic acid (C22:5 n-3) and cervonic (docosahexaenoic) acid (C22:6 n-3; DHA). Omega-3-acid ethyl esters are obtained by transesterification of the body oil obtained from fish of families such as *Engraulidae*, *Carangidae*, *Clupeidae*, *Osmeridae*, *Salmonidae* and *Scorpaenidae* and subsequent physico-chemical purification processes, including urea fractionation followed by molecular distillation.

**Content:**

- *EPA and DHA ethyl esters*: minimum 80 per cent, with minimum 40 per cent of EPA ethyl esters and minimum 34 per cent of DHA ethyl esters;
  - *total omega-3-acid ethyl esters*: minimum 90 per cent.
- Tocopherol may be added as an antioxidant.

## CHARACTERS

**Appearance:** light yellow liquid.

**Solubility:** practically insoluble in water, very soluble in acetone, in ethanol (96 per cent), in heptane and in methanol.

## IDENTIFICATION

A. Examine the chromatograms obtained in the assay for EPA and DHA ethyl esters.

**Results:** the peaks due to eicosapentaenoic acid ethyl ester and docosahexaenoic acid ethyl ester in the chromatogram obtained with the test solution are similar in retention time to the corresponding peaks in the chromatogram obtained with the reference solution.

B. It complies with the limits of the assay for total omega-3-acid ethyl esters.

## TESTS

**Absorbance (2.2.25):** maximum 0.55 at 233 nm.

Dilute 0.300 g to 50.0 mL with *trimethylpentane R*. Dilute 2.0 mL of this solution to 50.0 mL with *trimethylpentane R*.

**Acid value (2.5.1):** maximum 2.0, determined on 10 g in 50 mL of the prescribed mixture of solvents.

**Anisidine value (2.5.36):** maximum 20.0.

**Peroxide value (2.5.5, Method A):** maximum 10.0.

**Oligomers.** Size-exclusion chromatography (2.2.30).

**Test solution.** Dilute 50.0 mg of the substance to be examined to 10.0 mL with *tetrahydrofuran R*.

**Reference solution.** Dissolve 50 mg of *monodocosahexaenoic acid R*, 30 mg of *didocosahexaenoic acid R* and 20 mg of *tridocosahexaenoic acid R* in *tetrahydrofuran R* and dilute to 100.0 mL with the same solvent.

**Column 1:**

- size:  $l = 0.3$  m,  $\varnothing = 7.8$  mm;
- stationary phase: *styrene-divinylbenzene copolymer R* (7  $\mu$ m) with a pore size of 10 nm.

**Columns 2 and 3** placed closest to the injector:

- size:  $l = 0.3$  m,  $\varnothing = 7.8$  mm;
- stationary phase: *styrene-divinylbenzene copolymer R* (7  $\mu$ m) with a pore size of 50 nm.

**Mobile phase:** *tetrahydrofuran R*.

**Flow rate:** 0.8 mL/min.

**Detection:** differential refractometer.

**Injection:** 40  $\mu$ L.

**System suitability:** reference solution:

- **elution order:** tridocosahexaenoic acid, didocosahexaenoic acid, monodocosahexaenoic acid;
- **resolution:** minimum 2.0 between the peaks due to monodocosahexaenoic acid and didocosahexaenoic acid and minimum 1.0 between the peaks due to didocosahexaenoic acid and tridocosahexaenoic acid.

Calculate the percentage content of oligomers using the following expression:

$$\frac{B}{A} \times 100$$

A = sum of the areas of all the peaks in the chromatogram;

B = sum of the areas of the peaks with a retention time less than the retention time of the peaks due to ethyl esters.

The ethyl ester peaks, which may be present in the form of an unresolved double peak, are identified as the major peaks in the chromatogram (see Figure 1250.-1).

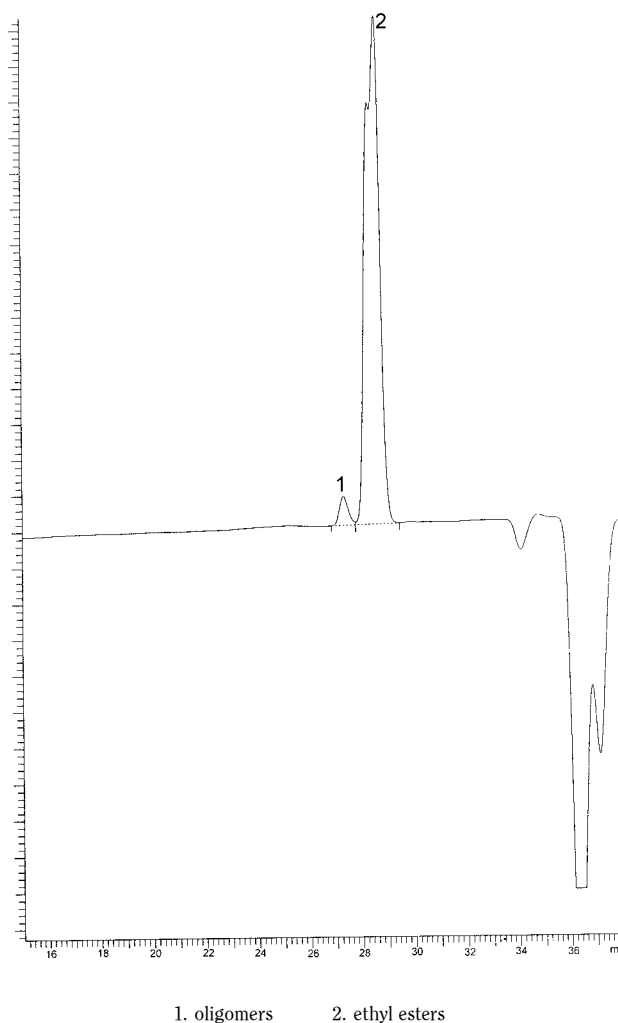

Figure 1250.-1. – Chromatogram for the test for oligomers: spiked sample

Where the result obtained exceeds the limit due to the presence of monoglycerides, the following procedure is carried out.

**Test solution.** Weigh 10.0 mg of the substance to be examined into a quartz tube. Add 1.5 mL of a 20 g/L solution of *sodium hydroxide R* in *methanol R*, cover with *nitrogen R*, cap tightly with a polytetrafluoroethylene-lined cap, mix and heat on a water-bath for 7 min. Allow to cool. Add 2 mL of *boron trichloride-methanol solution R*, cover with *nitrogen R*, cap tightly, mix and heat on a water-bath for 30 min. Cool to 40-50 °C, add 1 mL of *trimethylpentane R*, cap and shake vigorously for at least 30 s. Immediately add 5 mL of *saturated sodium chloride solution R*, cover with *nitrogen R*, cap and shake thoroughly for at least 15 s. Transfer the upper layer to a separate tube. Shake the methanol layer once more with 1 mL of *trimethylpentane R*. Carefully evaporate the solvent under a current of *nitrogen R* then add 10.0 mL of *tetrahydrofuran R* to the residue. Add a small amount of *anhydrous sodium sulfate R* and filter.

Calculate the percentage content of oligomers using the following expression:

$$\frac{B'}{A} \times 100$$

B' = sum of the areas of the peaks with a retention time less than the retention time of the peaks due to methyl esters.

**Limit:**

- **oligomers:** maximum 1.0 per cent.

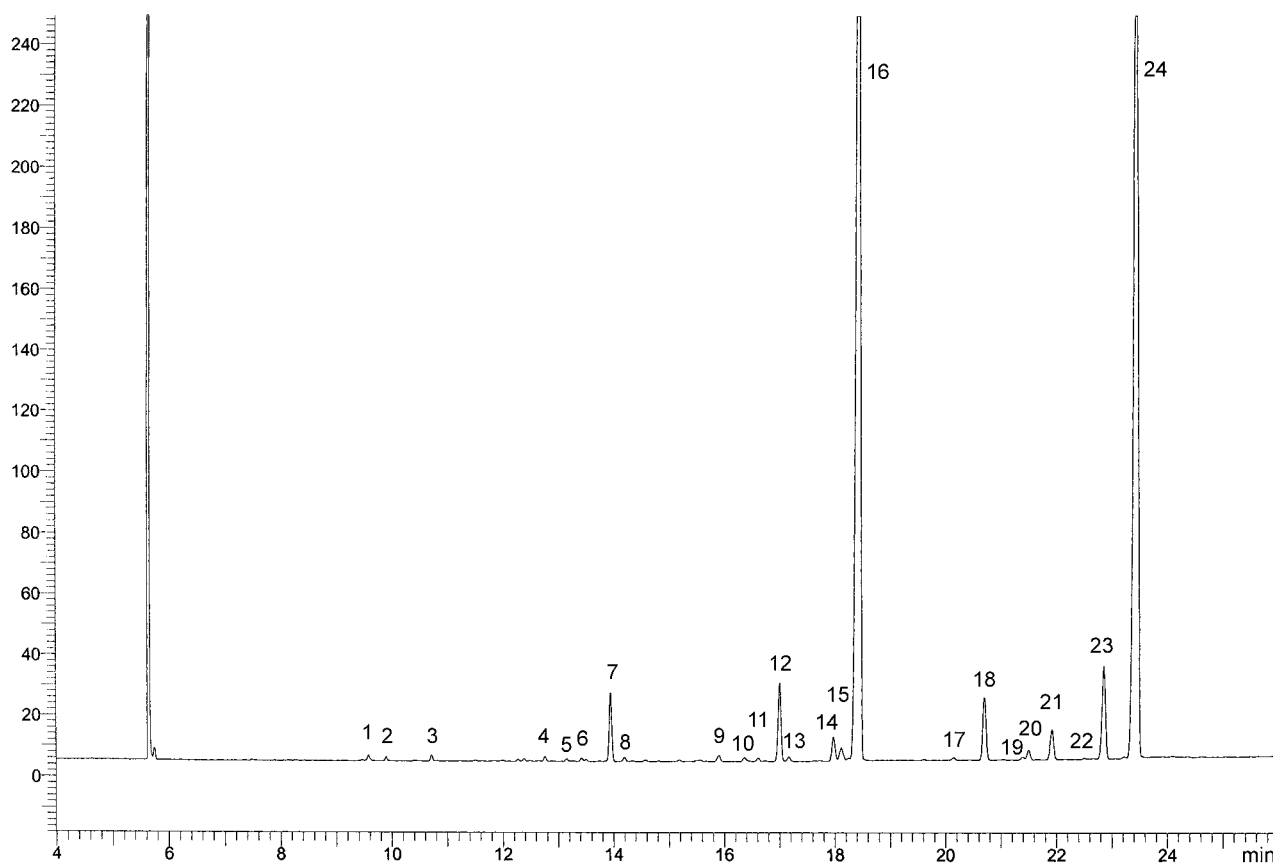

1. phytanic acid	7. C18:4 n-3	13. furan acid 7	19. C22:4
2. C16:3 n-4	8. C18:4 n-1	14. C20:4 n-3	20. furan acid 10
3. C16:4 n-1	9. furan acid 5	15. furan acid 8	21. C22:5 n-6
4. C18:3 n-6	10. C19:5	16. EPA	22. furan acid 11
5. C18:3 n-4	11. C20:3 n-6	17. furan acid 9	23. C22:5 n-3
6. C18:3 n-3	12. C20:4 n-6	18. C21:5 n-3	24. DHA

Figure 1250.-2. – Chromatogram for the assays

**ASSAY**

**EPA and DHA ethyl esters (2.4.29).** For identification of the peaks, see Figure 1250.-2.

**Total omega-3-acid ethyl esters (2.4.29).** See Figure 1250.-2.

**STORAGE**

Under an inert gas, in an airtight container, protected from light.

**Content:**

- sum of the contents of the omega-3 acids EPA and DHA, expressed as triglycerides: minimum 45 per cent;
- total omega-3 acids, expressed as triglycerides: minimum 60 per cent.

Authorised antioxidants in concentrations not exceeding the levels specified by the competent authority may be added.

**CHARACTERS**

**Appearance:** pale yellow liquid.

**Solubility:** practically insoluble in water, very soluble in acetone and in heptane, slightly soluble in anhydrous ethanol.

**IDENTIFICATION**

Examine the chromatograms obtained in the assay for EPA and DHA.

**Results:** the peaks due to eicosapentaenoic acid methyl ester and docosahexaenoic acid methyl ester in the chromatogram obtained with test solution (b) are similar in retention time to the corresponding peaks in the chromatogram obtained with reference solution (a).

**TESTS**

**Absorbance (2.2.25):** maximum 0.73 at 233 nm.

Dilute 0.300 g to 50.0 mL with *trimethylpentane R*. Dilute 2.0 mL of this solution to 50.0 mL with *trimethylpentane R*.

01/2009:1352

**OMEGA-3-ACID TRIGLYCERIDES**

## Omega-3 acidorum triglycerida

**DEFINITION**

Mixture of mono-, di- and triesters of omega-3 acids with glycerol containing mainly triesters and obtained either by esterification of concentrated and purified omega-3 acids with glycerol or by transesterification of the omega-3 acid ethyl esters with glycerol. The origin of the omega-3 acids is the body oil obtained from fish of families such as *Engraulidae*, *Carangidae*, *Clupeidae*, *Osmeridae*, *Salmonidae* and *Scombridae*. The omega-3 acids are identified as the following acids: *alpha*-linolenic acid (C18:3 n-3), moroctic acid (C18:4 n-3), eicosatetraenoic acid (C20:4 n-3), timnodonic (eicosapentaenoic) acid (C20:5 n-3; EPA), heneicosapentaenoic acid (C21:5 n-3), clupanodonic acid (C22:5 n-3) and cervonic (docosahexaenoic) acid (C22:6 n-3; DHA).

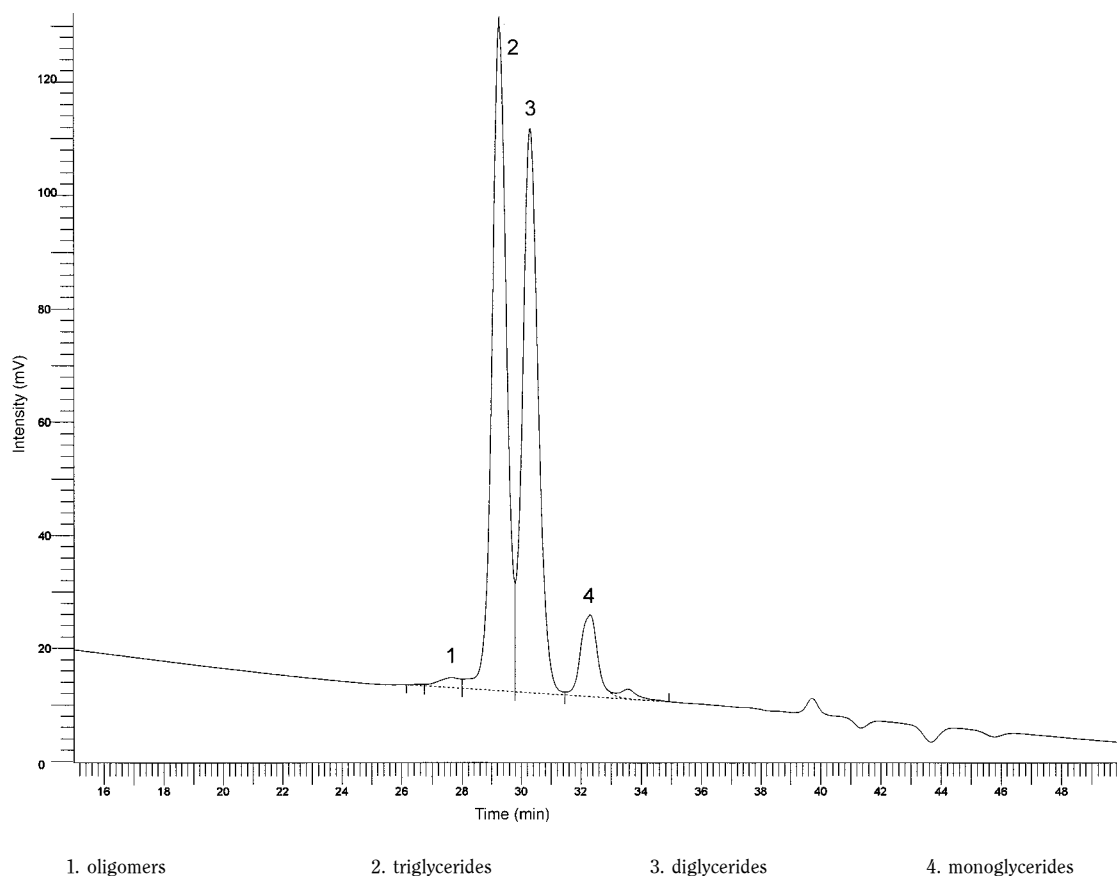

Figure 1352.-1. – Chromatogram for the test for oligomers and partial glycerides

**Acid value (2.5.1):** maximum 3.0, determined on 10.0 g in 50 mL of the prescribed mixture of solvents.

**Anisidine value (2.5.36):** maximum 30.0.

**Peroxide value (2.5.5, Method A):** maximum 10.0.

**Oligomers and partial glycerides.** Size-exclusion chromatography (2.2.30).

**Test solution.** Dilute 50.0 mg of the substance to be examined to 10.0 mL with *tetrahydrofuran R*.

**Reference solution.** Dissolve 50 mg of *monodocosahexaenoin R*, 30 mg of *didocosahexaenoin R* and 20 mg of *tridocosahexaenoin R* in *tetrahydrofuran R* and dilute to 100.0 mL with the same solvent.

**Column 1:**

- *dimensions:*  $l = 0.3$  m,  $\varnothing = 7.8$  mm;
- *stationary phase:* *styrene-divinylbenzene copolymer R* (7  $\mu$ m) with a pore size of 10 nm.

**Columns 2 and 3** placed closest to the injector:

- *dimensions:*  $l = 0.3$  m,  $\varnothing = 7.8$  mm;
- *stationary phase:* *styrene-divinylbenzene copolymer R* (7  $\mu$ m) with a pore size of 50 nm.

**Mobile phase:** *tetrahydrofuran R*.

**Flow rate:** 0.8 mL/min.

**Detection:** differential refractometer.

**Injection:** 40  $\mu$ L.

**System suitability:** reference solution:

- *elution order:* tridocosahexaenoin, didocosahexaenoin, monodocosahexaenoin;
- *resolution:* minimum 2.0 between the peaks due to monodocosahexaenoin and didocosahexaenoin; minimum 1.0 between the peaks due to didocosahexaenoin and tridocosahexaenoin.

Identify the peaks using the chromatogram shown in figure 1352.-1. Calculate the percentage content of oligomers using the following expression:

$$\frac{B}{A} \times 100$$

$A$  = sum of the areas of all the peaks in the chromatogram;

$B$  = area of the peak with a retention time less than the retention time of the peak due to the triglyceride.

Calculate the percentage content of partial glycerides using the following expression:

$$\frac{C}{A} \times 100$$

$C$  = (sum of the) area(s) of the peak(s) due to the mono- and diglycerides.

**Limits:**

- *oligomers:* maximum 3.0 per cent;
- *partial glycerides:* maximum 50.0 per cent.

**ASSAY**

**EPA and DHA (2.4.29).** For identification of the peaks, see Figure 1352.-2.

**Total omega-3-acids (2.4.29).** See Figure 1352.-2.

**STORAGE**

In an airtight, well-filled container, protected from light, under an inert gas.

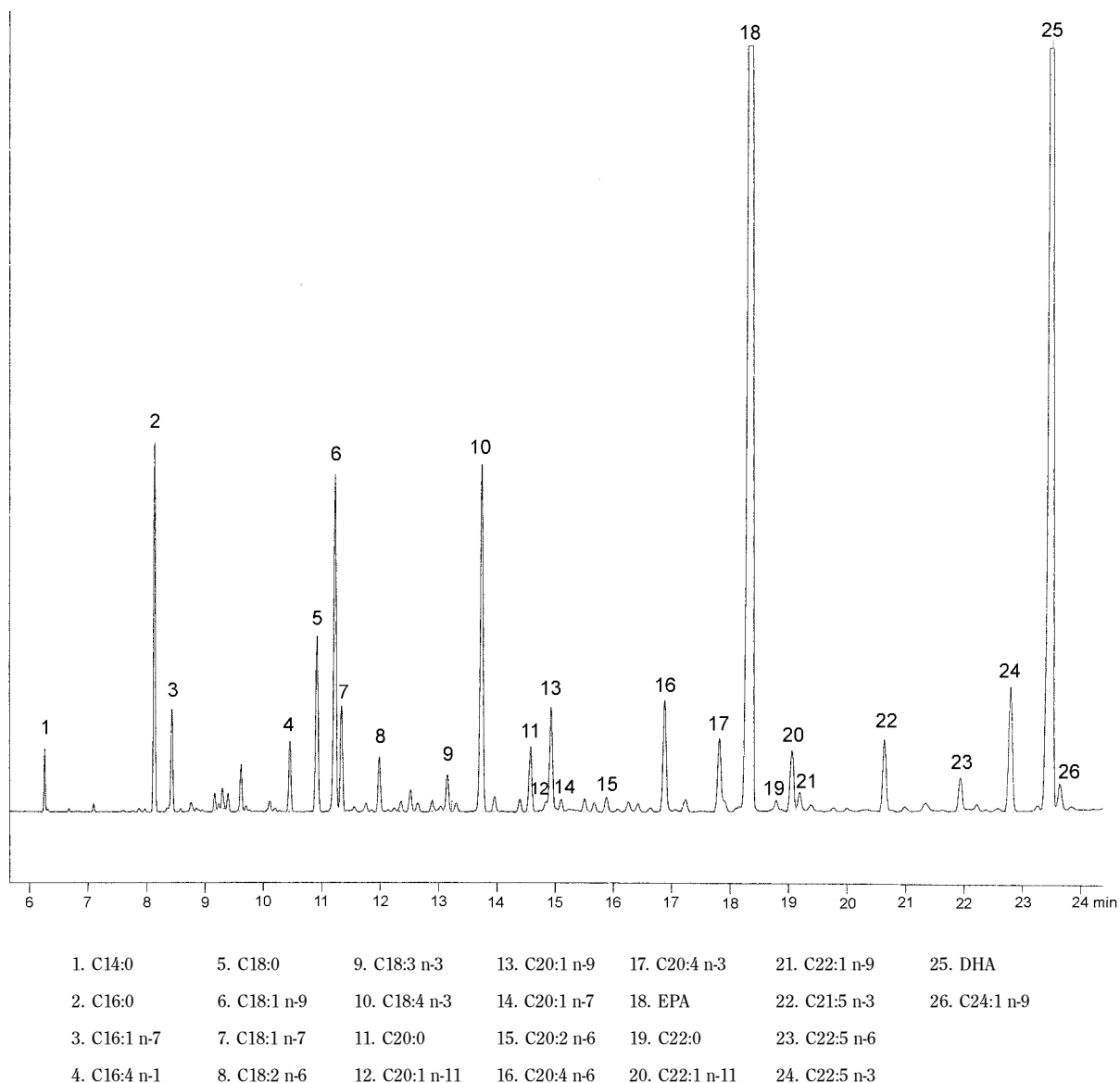

Figure 1352.-2. – Chromatogram for the assays

**07/2010:0942 IDENTIFICATION**

Infrared absorption spectrophotometry (2.2.24).

*Comparison: omeprazole CRS.*

If the spectra obtained in the solid state show differences, dissolve the substance to be examined and the reference substance separately in *methanol R*, evaporate to dryness and record new spectra using the residues.

**TESTS**

**Solution S.** Dissolve 0.50 g in *methylene chloride R* and dilute to 25 mL with the same solvent.

**Appearance of solution.** Solution S is clear (2.2.1).

**Impurities F and G:** maximum 350 ppm for the sum of the contents.

The absorbance (2.2.25) of solution S determined at 440 nm is not greater than 0.10.

**Related substances.** Liquid chromatography (2.2.29). *Prepare the solutions immediately before use.*

**Test solution.** Dissolve 3 mg of the substance to be examined in the mobile phase and dilute to 25.0 mL with the mobile phase.

**Reference solution (a).** Dissolve 1 mg of *omeprazole CRS* and 1 mg of *omeprazole impurity D CRS* in the mobile phase and dilute to 10.0 mL with the mobile phase.

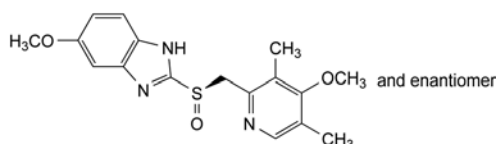
**OMEPRAZOLE****Omeprazolium**

$C_{17}H_{19}N_3O_3S$   
[73590-58-6]

$M_r$  345.4

**DEFINITION**

5-Methoxy-2-[(*RS*)-(4-methoxy-3,5-dimethylpyridin-2-yl)methyl]sulfinyl]-1*H*-benzimidazole.

**Content:** 99.0 per cent to 101.0 per cent (dried substance).

**CHARACTERS**

**Appearance:** white or almost white powder.

**Solubility:** very slightly soluble in water, soluble in methylene chloride, sparingly soluble in ethanol (96 per cent) and in methanol. It dissolves in dilute solutions of alkali hydroxides. It shows polymorphism (5.9).



**Reference solution (b).** Dilute 1.0 mL of the test solution to 100.0 mL with the mobile phase. Dilute 1.0 mL of this solution to 10.0 mL with the mobile phase.

**Reference solution (c).** Dissolve 3 mg of omeprazole for peak identification CRS (containing impurity E) in the mobile phase and dilute to 20.0 mL with the mobile phase.

**Column:**

- size:  $l = 0.125$  m,  $\varnothing = 4.6$  mm;
- stationary phase: octylsilyl silica gel for chromatography R (5  $\mu$ m).

**Mobile phase:** mix 27 volumes of acetonitrile R and 73 volumes of a 1.4 g/L solution of disodium hydrogen phosphate R previously adjusted to pH 7.6 with phosphoric acid R.

**Flow rate:** 1 mL/min.

**Detection:** spectrophotometer at 280 nm.

**Injection:** 40  $\mu$ L.

**Run time:** 5 times the retention time of omeprazole.

**Identification of impurities:** use the chromatogram obtained with reference solution (a) to identify the peak due to impurity D; use the chromatogram supplied with omeprazole for peak identification CRS and the chromatogram obtained with reference solution (c) to identify the peak due to impurity E.

**Relative retention** with reference to omeprazole (retention time = about 9 min): impurity E = about 0.6; impurity D = about 0.8.

**System suitability:** reference solution (a):

- resolution: minimum 3.0 between the peaks due to impurity D and omeprazole; if necessary, adjust the pH of the aqueous part of the mobile phase or the concentration of acetonitrile R; an increase in the pH will improve the resolution.

**Limits:**

- impurities D, E: for each impurity, not more than 1.5 times the area of the principal peak in the chromatogram obtained with reference solution (b) (0.15 per cent);
- unspecified impurities: for each impurity, not more than the area of the principal peak in the chromatogram obtained with reference solution (b) (0.10 per cent);
- total: not more than 5 times the area of the principal peak in the chromatogram obtained with reference solution (b) (0.5 per cent);
- disregard limit: 0.5 times the area of the principal peak in the chromatogram obtained with reference solution (b) (0.05 per cent).

**Chloroform and methylene chloride.** Head-space gas chromatography (2.2.28): use the standard additions method.

**Test solution.** Place 0.50 g of the substance to be examined in a 10 mL vial. Add 4.0 mL of dimethylacetamide R and stopper the vial.

**Column:**

- material: fused silica;
- size:  $l = 30$  m,  $\varnothing = 0.32$  mm;
- stationary phase: cross-linked poly[(cyanopropyl)(phenyl)]dimethylsiloxane R (film thickness 1.8  $\mu$ m).

**Carrier gas:** nitrogen for chromatography R.

**Static head-space conditions that may be used:**

- equilibration temperature: 80 °C;
- equilibration time: 1 h.

**Detection:** flame ionisation.

**Limits:**

- methylene chloride: maximum 100 ppm;
- chloroform: maximum 50 ppm.

**Loss on drying** (2.2.32): maximum 0.2 per cent, determined on 1.000 g by drying under high vacuum at 60 °C for 4 h.

**Sulfated ash** (2.4.14): maximum 0.1 per cent, determined on 1.0 g.

**ASSAY**

Dissolve 1.100 g in a mixture of 10 mL of water R and 40 mL of ethanol (96 per cent) R. Titrate with 0.5 M sodium hydroxide, determining the end-point potentiometrically (2.2.20).

1 mL of 0.5 M sodium hydroxide is equivalent to 0.1727 g of  $C_{17}H_{19}N_3O_3S$ .

**STORAGE**

In an airtight container, protected from light, at a temperature of 2 °C to 8 °C.

**IMPURITIES**

**Specified impurities:** D, E, F, G.

**Other detectable impurities** (the following substances would, if present at a sufficient level, be detected by one or other of the tests in the monograph. They are limited by the general acceptance criterion for other/unspecified impurities and/or by the general monograph *Substances for pharmaceutical use* (2034). It is therefore not necessary to identify these impurities for demonstration of compliance. See also 5.10. *Control of impurities in substances for pharmaceutical use*): A, B, C, H, I.

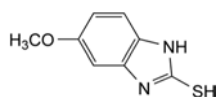

A. 5-methoxy-1H-benzimidazole-2-thiol,

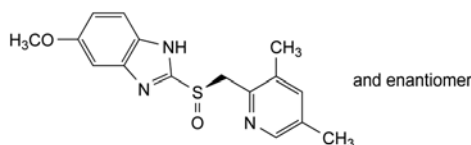

B. 2-[(RS)-[(3,5-dimethylpyridin-2-yl)methyl]sulfinyl]-5-methoxy-1H-benzimidazole,

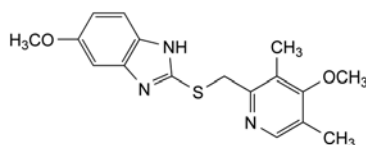

C. 5-methoxy-2-[[4-methoxy-3,5-dimethylpyridin-2-yl)methyl]sulfonyl]-1H-benzimidazole (ufiprazole),

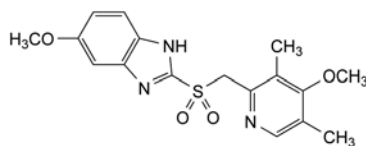

D. 5-methoxy-2-[[4-methoxy-3,5-dimethylpyridin-2-yl)methyl]sulfonyl]-1H-benzimidazole (omeprazole sulfone),

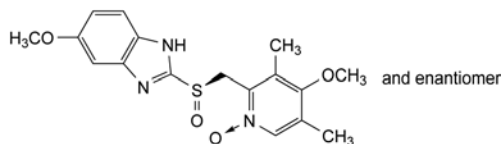

E. 4-methoxy-2-[[4-methoxy-3,5-dimethylpyridin-2-yl)methyl]sulfonyl]-1H-benzimidazole (omeprazole sulfone),

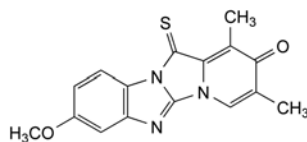

F. 8-methoxy-1,3-dimethyl-12-thioxopyrido[1',2':3,4]imidazo[1,2-a]benzimidazol-2(12H)-one,

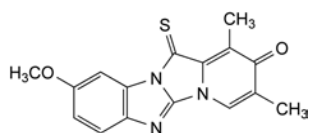

G. 9-methoxy-1,3-dimethyl-12-thioxopyrido[1',2':3,4]imidazo[1,2-a]benzimidazol-2(12H)-one,

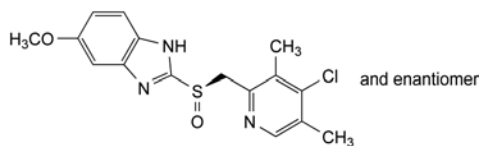

H. 2-[(RS)-(4-chloro-3,5-dimethylpyridin-2-yl)methyl]sulfinyl]-5-methoxy-1H-benzimidazole,

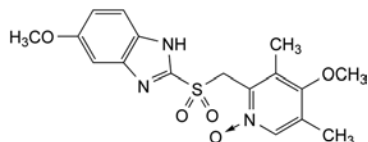

I. 4-methoxy-2-[[5-methoxy-1H-benzimidazol-2-yl)sulfonyl]methyl]-3,5-dimethylpyridine 1-oxide.

01/2009:2374  
corrected 6.7

## OMEPRAZOLE MAGNESIUM

### Omeprazolium magnesicum

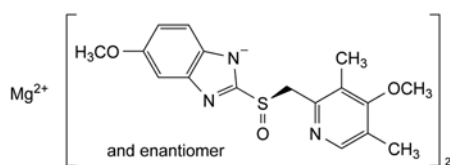

$C_{34}H_{36}MgN_6O_6S_2$   
[95382-33-5]

$M_r$  713

#### DEFINITION

Magnesium bis[5-methoxy-2-[(RS)-(4-methoxy-3,5-dimethylpyridin-2-yl)methyl]sulfinyl]-1H-benzimidazol-1-ide]. It contains a variable quantity of water.

*Content*: 97.5 per cent to 102.0 per cent (anhydrous substance).

#### CHARACTERS

*Appearance*: white or almost white, hygroscopic powder.

*Solubility*: very slightly soluble in water, sparingly soluble in methanol, practically insoluble in heptane.

#### IDENTIFICATION

Carry out either tests A, B, C or tests A, B, D.

A. Optical rotation (2.2.7):  $-0.10^\circ$  to  $+0.10^\circ$ .

Dissolve 0.250 g in *methanol R* and dilute to 25.0 mL with the same solvent.

B. Infrared absorption spectrophotometry (2.2.24).

*Comparison*: *omeprazole magnesium CRS*.

C. Atomic absorption spectrometry (2.2.23) as described in the test for magnesium.

The test solution shows the absorption maximum at 285.2 nm.

D. Ignite about 0.5 g of the substance to be examined according to the procedure for the sulfated ash test (2.4.14). Dissolve the residue in 10 mL of *water R*. 2 mL of this solution gives the reaction of magnesium (2.3.1).

#### TESTS

**Absorbance** (2.2.25): maximum 0.10 at 440 nm.

Dissolve 0.500 g in *methanol R* and dilute to 25.0 mL with the same solvent. Filter the solution through a membrane filter (nominal pore size 0.45  $\mu$ m).

**Related substances**. Liquid chromatography (2.2.29): use the normalisation procedure. *Prepare the solutions immediately before use*.

*Test solution*. Dissolve 3.5 mg of the substance to be examined in the mobile phase and dilute to 25.0 mL with the mobile phase.

*Reference solution (a)*. Dissolve 1 mg of *omeprazole CRS* and 1 mg of *omeprazole impurity D CRS* in the mobile phase and dilute to 10.0 mL with the mobile phase.

*Reference solution (b)*. Dissolve 3 mg of *omeprazole for peak identification CRS* (containing impurity E) in the mobile phase and dilute to 20.0 mL with the mobile phase.

*Reference solution (c)*. Dilute 1.0 mL of the test solution to 100.0 mL with the mobile phase. Dilute 1.0 mL of this solution to 10.0 mL with the mobile phase.

*Column*:

– *size*:  $l = 0.125$  m,  $\varnothing = 4.6$  mm;

– *stationary phase*: *octylsilyl silica gel for chromatography R* (5  $\mu$ m).

*Mobile phase*: mix 27 volumes of *acetonitrile R* and 73 volumes of a 1.4 g/L solution of *disodium hydrogen phosphate R* previously adjusted to pH 7.6 with *phosphoric acid R*.

*Flow rate*: 1 mL/min.

*Detection*: spectrophotometer at 280 nm.

*Injection*: 40  $\mu$ L.

*Run time*: 5 times the retention time of omeprazole.

*Identification of impurities*:

- use the chromatogram supplied with *omeprazole for peak identification CRS* and the chromatogram obtained with reference solution (b) to identify the peak due to impurity E;
- use the chromatogram obtained with reference solution (a) to identify the peak due to impurity D.

*Relative retention* with reference to omeprazole (retention time = about 9 min): impurity E = about 0.6, impurity D = about 0.8.

*System suitability*: reference solution (a):

- *resolution*: minimum 3.0 between the peaks due to impurity D and omeprazole; if necessary, adjust the pH of the aqueous part of the mobile phase or its proportion of acetonitrile; an increase in the pH will improve the resolution.

*Limits*:

- *impurities D, E*: for each impurity, maximum 0.1 per cent;
- *unspecified impurities*: for each impurity, maximum 0.10 per cent;
- *total*: maximum 0.5 per cent;
- *disregard limit*: half the area of the principal peak in the chromatogram obtained with reference solution (c) (0.05 per cent).

**Magnesium**: 3.30 per cent to 3.55 per cent (anhydrous substance).

Atomic absorption spectrometry (2.2.23, *Method I*).

*Test solution*. Dissolve 0.250 g in 20.0 mL of a 103 g/L solution of *hydrochloric acid R* by slow addition of the acid and dilute to 100.0 mL with *water R*. Dilute 10.0 mL of the solution to 200.0 mL with *water R*. To 10.0 mL of this solution add 4 mL of *lanthanum chloride solution R* and dilute to 100.0 mL with *water R*.

*Reference solutions*. Prepare the reference solutions using *magnesium standard solution (1000 ppm Mg) R*, diluting with a mixture of 1 mL of a 103 g/L solution of *hydrochloric acid R* and 1000.0 mL of *water R*.

Wavelength: 285.2 nm.

**Water** (2.5.12): 7.0 per cent to 10.0 per cent, determined on 0.200 g.

#### ASSAY

Liquid chromatography (2.2.29).

**Buffer pH 11.0.** Mix 11 mL of a 95.0 g/L solution of *trisodium phosphate dodecahydrate R* and 22 mL of a 179.1 g/L solution of *disodium hydrogen phosphate R*. Dilute to 100.0 mL with *water R*.

**Test solution.** Dissolve 10.0 mg of the substance to be examined in about 10 mL of *methanol R*. Add 10 mL of buffer pH 11.0 and dilute to 200.0 mL with *water R*.

**Reference solution.** Dissolve 10.0 mg of *omeprazole CRS* in about 10 mL of *methanol R*. Add 10 mL of buffer pH 11.0 and dilute to 200.0 mL with *water R*.

**Column:**

- size:  $l = 0.125$  m,  $\varnothing = 4$  mm;
- stationary phase: *octylsilyl silica gel for chromatography R* (5  $\mu$ m).

**Mobile phase:** mix 35 volumes of *acetonitrile R* and 65 volumes of a 1.4 g/L solution of *disodium hydrogen phosphate R* previously adjusted to pH 7.6 with *phosphoric acid R*.

**Flow rate:** 1 mL/min.

**Detection:** spectrophotometer at 280 nm.

**Injection:** 20  $\mu$ L.

**Run time:** 1.5 times the retention time of omeprazole.

**Retention time:** omeprazole = about 4 min.

Calculate the percentage content of  $C_{34}H_{36}MgN_6O_6S_2$  from the declared content of *omeprazole CRS*.

1 g of omeprazole is equivalent to 1.032 g of omeprazole magnesium.

#### STORAGE

In an airtight container, protected from light.

#### IMPURITIES

**Specified impurities:** D, E.

**Other detectable impurities** (the following substances would, if present at a sufficient level, be detected by one or other of the tests in the monograph. They are limited by the general acceptance criterion for other/unspecified impurities and/or by the general monograph *Substances for pharmaceutical use* (2034). It is therefore not necessary to identify these impurities for demonstration of compliance. See also 5.10. *Control of impurities in substances for pharmaceutical use*): A, B, C.

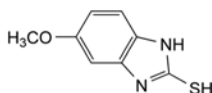

A. 5-methoxy-1*H*-benzimidazole-2-thiol,

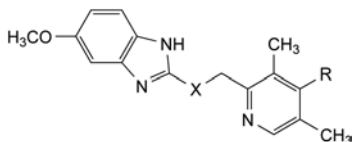

B. R = H, X = SO: 2-[(*RS*)-[(3,5-dimethylpyridin-2-yl)methyl]sulfanyl]-5-methoxy-1*H*-benzimidazole,

C. R = OCH<sub>3</sub>, X = S: 5-methoxy-2-[[4-methoxy-3,5-dimethylpyridin-2-yl)methyl]sulfanyl]-1*H*-benzimidazole,

D. R = OCH<sub>3</sub>, X = SO<sub>2</sub>: 5-methoxy-2-[[4-methoxy-3,5-dimethylpyridin-2-yl)methyl]sulfonyl]-1*H*-benzimidazole,

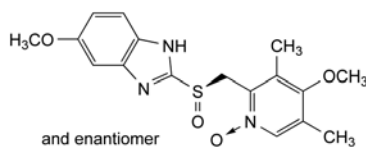

E. 4-methoxy-2-[[*(RS)*-(5-methoxy-1*H*-benzimidazol-2-yl)sulfinyl]methyl]-3,5-dimethylpyridine 1-oxide.

01/2011:1032

## OMEPRAZOLE SODIUM

### Omeprazolium natricum

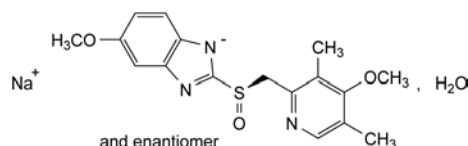

$C_{17}H_{18}N_3NaO_3S \cdot H_2O$   
[95510-70-6]

$M_r$  385.4

#### DEFINITION

Sodium 5-methoxy-2-[(*RS*)-[(4-methoxy-3,5-dimethylpyridin-2-yl)methyl]sulfinyl]-1*H*-benzimidazole monohydrate.

**Content:** 98.0 per cent to 101.0 per cent (anhydrous substance).

#### CHARACTERS

**Appearance:** white or almost white, hygroscopic powder.

**Solubility:** freely soluble in water and in ethanol (96 per cent), soluble in propylene glycol, very slightly soluble in methylene chloride.

#### IDENTIFICATION

A. Optical rotation (2.2.7):  $-0.10^\circ$  to  $+0.10^\circ$ , determined on solution S.

B. Infrared absorption spectrophotometry (2.2.24).

**Preparation:** dissolve 0.50 g of the substance to be examined in 1.50 mL of *water R*, add 3.0 mL of *methanol R* and stir; while stirring, adjust to pH 8-9 by adding, dropwise, *dilute acetic acid R* (about 0.4 mL); continue stirring until crystallisation and isolate the crystalline precipitate by filtration; wash with 5 mL of *water R*, then 2 mL of *methanol R*, and dry *in vacuo* at 40 °C for 30 min.

**Comparison:** *omeprazole CRS*.

If the spectra obtained in the solid state show differences, dissolve the crystalline precipitate and the reference substance separately in *methanol R*, evaporate to dryness and record new spectra using the residues.

C. Ignite 1 g and cool. Add 1 mL of *water R* to the residue and neutralise with *hydrochloric acid R*. Filter and dilute the filtrate to 4 mL with *water R*. 0.1 mL of the solution gives reaction (b) of sodium (2.3.1).

#### TESTS

**Solution S.** Dissolve 0.50 g in *carbon dioxide-free water R* and dilute to 25 mL with the same solvent.

**Appearance of solution.** Solution S is clear (2.2.1) and not more intensely coloured than reference solution B<sub>6</sub> (2.2.2, *Method II*).

**pH** (2.2.3): 10.3 to 11.3 for solution S.

**Related substances.** Liquid chromatography (2.2.29). *Prepare solutions immediately before use.*

**Test solution.** Dissolve 3 mg of the substance to be examined in the mobile phase and dilute to 25.0 mL with the mobile phase.

**Reference solution (a).** Dissolve 1 mg of *omeprazole CRS* and 1 mg of *omeprazole impurity D CRS* in the mobile phase and dilute to 10.0 mL with the mobile phase.

**Reference solution (b).** Dilute 1.0 mL of the test solution to 100.0 mL with the mobile phase. Dilute 1.0 mL of this solution to 10.0 mL with the mobile phase.

**Reference solution (c).** Dissolve 3 mg of omeprazole for peak identification CRS (containing impurity E) in the mobile phase and dilute to 25.0 mL with the mobile phase.

**Column:**

- size:  $l = 0.125$  m,  $\varnothing = 4.6$  mm;
- stationary phase: octylsilyl silica gel for chromatography R (5  $\mu$ m).

**Mobile phase:** mix 27 volumes of acetonitrile R and 73 volumes of a 1.4 g/L solution of disodium hydrogen phosphate R, previously adjusted to pH 7.6 with phosphoric acid R.

**Flow rate:** 1 mL/min.

**Detection:** spectrophotometer at 280 nm.

**Injection:** 40  $\mu$ L.

**Run time:** 5 times the retention time of omeprazole.

**Identification of impurities:** use the chromatogram supplied with omeprazole for peak identification CRS and the chromatogram obtained with reference solution (c) to identify the peak due to impurity E; use the chromatogram obtained with reference solution (a) to identify the peak due to impurity D.

**Relative retention** with reference to omeprazole (retention time = about 9 min): impurity E = about 0.6; impurity D = about 0.8.

**System suitability:** reference solution (a):

- resolution: minimum 3.0 between the peaks due to impurity D and omeprazole; if necessary adjust the pH of the aqueous part of the mobile phase or the concentration of acetonitrile R; an increase in the pH will improve the resolution.

**Limits:**

- impurities D, E: for each impurity, not more than 1.5 times the area of the principal peak in the chromatogram obtained with reference solution (b) (0.15 per cent);
- unspecified impurities: for each impurity, not more than the area of the principal peak in the chromatogram obtained with reference solution (b) (0.10 per cent);
- total: not more than 5 times the area of the principal peak in the chromatogram obtained with reference solution (b) (0.5 per cent);
- disregard limit: 0.5 times the area of the principal peak in the chromatogram obtained with reference solution (b) (0.05 per cent).

**Heavy metals (2.4.8):** maximum 20 ppm.

1.0 g complies with test C. Prepare the reference solution using 2 mL of lead standard solution (10 ppm Pb) R.

**Water (2.5.12):** 4.5 per cent to 10.0 per cent, determined on 0.300 g.

**ASSAY**

Dissolve 0.300 g in 50 mL of water R. Titrate with 0.1 M hydrochloric acid, determining the end-point potentiometrically (2.2.20).

1 mL of 0.1 M hydrochloric acid corresponds to 36.74 mg of  $C_{17}H_{18}N_3NaO_3S$ .

**STORAGE**

In an airtight container, protected from light.

**IMPURITIES**

**Specified impurities:** D, E.

**Other detectable impurities** (the following substances would, if present at a sufficient level, be detected by one or other of the tests in the monograph. They are limited by the general acceptance criterion for other/unspecified impurities and/or by the general monograph *Substances for pharmaceutical use*

(2034). It is therefore not necessary to identify these impurities for demonstration of compliance. See also 5.10. *Control of impurities in substances for pharmaceutical use*): A, B, C.

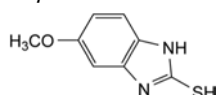

A. 5-methoxy-1H-benzimidazole-2-thiol,

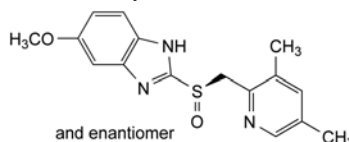

B. 2-[(RS)-[(3,5-dimethylpyridin-2-yl)methyl]sulfinyl]-5-methoxy-1H-benzimidazole,

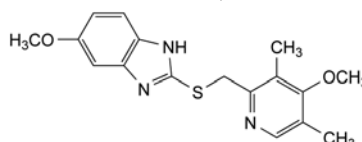

C. 5-methoxy-2-[[4-methoxy-3,5-dimethylpyridin-2-yl)methyl]sulfonyl]-1H-benzimidazole (ufiprazole),

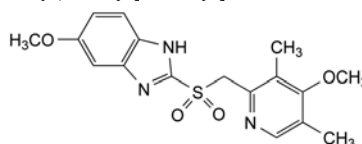

D. 5-methoxy-2-[[4-methoxy-3,5-dimethylpyridin-2-yl)methyl]sulfonyl]-1H-benzimidazole (omeprazole-sulfone),

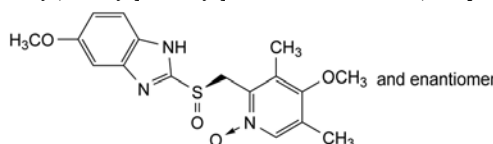

E. 4-methoxy-2-[(RS)-(5-methoxy-1H-benzimidazol-2-yl)sulfinyl]methyl]-3,5-dimethylpyridine 1-oxide.

01/2008:2016

## ONDANSETRON HYDROCHLORIDE DIHYDRATE

Ondansetroni hydrochloridum dihydricum

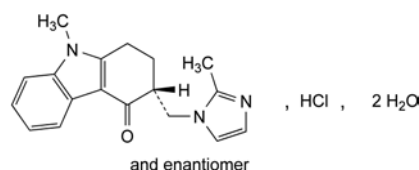

$C_{18}H_{20}ClN_3O \cdot 2H_2O$

$M_r$  365.9

**DEFINITION**

(3RS)-9-Methyl-3-[(2-methyl-1H-imidazol-1-yl)methyl]-1,2,3,9-tetrahydro-4H-carbazol-4-one hydrochloride dihydrate.

**Content:** 97.5 per cent to 102.0 per cent (anhydrous substance).

**CHARACTERS**

**Appearance:** white or almost white powder.

**Solubility:** sparingly soluble in water and in alcohol, soluble in methanol, slightly soluble in methylene chloride.

**IDENTIFICATION**

A. Infrared absorption spectrophotometry (2.2.24).

*Comparison:* ondansetron hydrochloride dihydrate CRS.

B. It gives reaction (a) of chlorides (2.3.1).

## TESTS

**Impurity B.** Thin-layer chromatography (2.2.27).

**Test solution.** Dissolve 0.125 g of the substance to be examined in a mixture of 0.5 volumes of *concentrated ammonia R*, 100 volumes of *alcohol R* and 100 volumes of *methanol R*, and dilute to 10.0 mL with the same mixture of solvents.

**Reference solution (a).** Dissolve 12.5 mg of *ondansetron for TLC system suitability CRS* in a mixture of 0.5 volumes of *concentrated ammonia R*, 100 volumes of *alcohol R* and 100 volumes of *methanol R*, and dilute to 1.0 mL with the same mixture of solvents.

**Reference solution (b).** Dilute 1 mL of the test solution to 100 mL with a mixture of 0.5 volumes of *concentrated ammonia R*, 100 volumes of *alcohol R* and 100 volumes of *methanol R*. Dilute 4.0 mL to 10.0 mL with a mixture of 0.5 volumes of *concentrated ammonia R*, 100 volumes of *alcohol R* and 100 volumes of *methanol R*.

**Plate:** *TLC silica gel F<sub>254</sub> plate R*.

**Mobile phase:** *concentrated ammonia R*, *methanol R*, *ethyl acetate R*, *methylene chloride R* (2:40:50:90 V/V/V/V).

**Application:** 20 µL.

**Development:** over 3/4 of the plate.

**Drying:** in air.

**Detection:** examine in ultraviolet light at 254 nm.

**Order of elution:** ondansetron, impurity B, impurity A.

**System suitability:** the chromatogram obtained with reference solution (a) shows 3 clearly separated spots.

**Limit:**

- **impurity B:** any spot corresponding to impurity B in the chromatogram obtained with the test solution is not more intense than the principal spot in the chromatogram obtained with reference solution (b) (0.4 per cent).

**Related substances.** Liquid chromatography (2.2.29).

**Test solution (a).** Dissolve 50.0 mg of the substance to be examined in the mobile phase and dilute to 100.0 mL with the mobile phase.

**Test solution (b).** Dissolve 90.0 mg of the substance to be examined in the mobile phase and dilute to 100.0 mL with the mobile phase. Dilute 10.0 mL to 100.0 mL with the mobile phase.

**Reference solution (a).** Dilute 2.0 mL of test solution (a) to 100.0 mL with the mobile phase. Dilute 10.0 mL to 100.0 mL with the mobile phase.

**Reference solution (b).** Dissolve 10.0 mg of *imidazole R* and 10.0 mg of *2-methylimidazole R* in the mobile phase and dilute to 100.0 mL with the mobile phase. Dilute 1.0 mL to 100.0 mL with the mobile phase.

**Reference solution (c).** Dissolve 5.0 mg of *ondansetron for LC system suitability CRS* in the mobile phase and dilute to 10.0 mL with the mobile phase.

**Reference solution (d).** Dissolve 5.0 mg of *ondansetron impurity D CRS* in the mobile phase and dilute to 100.0 mL with the mobile phase. Dilute 1.0 mL to 100.0 mL with the mobile phase.

**Reference solution (e).** Dissolve 90.0 mg of *ondansetron hydrochloride dihydrate CRS* in the mobile phase and dilute to 100.0 mL with the mobile phase. Dilute 10.0 mL to 100.0 mL with the mobile phase.

**Column:**

- **size:**  $l = 0.25$  m,  $\varnothing = 4.6$  mm,
- **stationary phase:** spherical *nitrile silica gel for chromatography R* (5 µm) with a specific surface area of 220 m<sup>2</sup>/g and a pore size of 8 nm.

**Mobile phase:** mix 20 volumes of *acetonitrile R* and 80 volumes of a 2.8 g/L solution of *sodium dihydrogen phosphate monohydrate R* previously adjusted to pH 5.4 with a 40 g/L solution of *sodium hydroxide R*.

**Flow rate:** 1.5 mL/min.

**Detection:** spectrophotometer at 216 nm.

**Injection:** 20 µL; inject test solution (a) and reference solutions (a), (b), (c) and (d).

**Run time:** 1.5 times the retention time of ondansetron.

**Relative retentions** with reference to ondansetron (retention time = about 18 min): impurity E = about 0.1; impurity F = about 0.2; impurity C = about 0.4; impurity D = about 0.5; impurity H = about 0.7; impurity A = about 0.8; impurity G = about 0.9.

**System suitability:**

- **resolution:** minimum of 1.3 between the peak due to impurity E (first peak) and the peak due to impurity F (second peak) in the chromatogram obtained with reference solution (b) and minimum of 2.5 between the peak due to impurity C (first peak) and the peak due to impurity D (second peak) in the chromatogram obtained with reference solution (c).

**Limits:**

- **correction factor:** for the calculation of contents, multiply the peak area of impurity C by 0.6,
- **impurity C:** not more than the area of the principal peak in the chromatogram obtained with reference solution (a) (0.2 per cent),
- **impurity D:** not more than the area of the principal peak in the chromatogram obtained with reference solution (d) (0.1 per cent),
- **impurity E:** not more than the area of the corresponding peak in the chromatogram obtained with reference solution (b) (0.2 per cent),
- **impurity F:** not more than the area of the corresponding peak in the chromatogram obtained with reference solution (b) (0.2 per cent),
- **any other impurity:** not more than the area of the principal peak in the chromatogram obtained with reference solution (a) (0.2 per cent),
- **total:** not more than twice the area of the principal peak in the chromatogram obtained with reference solution (a) (0.4 per cent),
- **disregard limit:** 0.2 times the area of the principal peak in the chromatogram obtained with reference solution (a) (0.04 per cent).

**Water (2.5.12):** 9.0 per cent to 10.5 per cent, determined on 0.200 g.

**Sulfated ash (2.4.14):** maximum 0.1 per cent, determined on 1.0 g.

## ASSAY

Liquid chromatography (2.2.29) as described in the test for related substances with the following modification.

**Injection:** test solution (b) and reference solution (e).

Calculate the percentage content of C<sub>18</sub>H<sub>20</sub>ClN<sub>3</sub>O.

## STORAGE

Protected from light.

## IMPURITIES

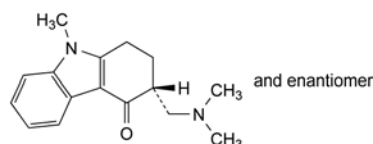

A. (3RS)-3-[(dimethylamino)methyl]-9-methyl-1,2,3,9-tetrahydro-4H-carbazol-4-one,

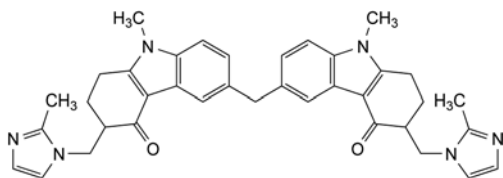

B. 6,6'-methylenebis[(3*RS*)-9-methyl-3-[(2-methyl-1*H*-imidazol-1-yl)methyl]-1,2,3,9-tetrahydro-4*H*-carbazol-4-one],

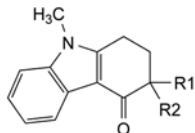

C. R1 = R2 = H: 9-methyl-1,2,3,9-tetrahydro-4*H*-carbazol-4-one,

D. R1 + R2 = CH<sub>2</sub>: 9-methyl-3-methylene-1,2,3,9-tetrahydro-4*H*-carbazol-4-one,



E. R = H: 1*H*-imidazole,

F. R = CH<sub>3</sub>: 2-methyl-1*H*-imidazole,

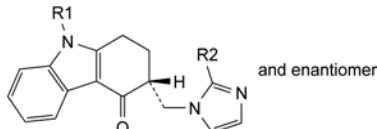

G. R1 = CH<sub>3</sub>, R2 = H: (3*RS*)-3-[(1*H*-imidazol-1-yl)methyl]-9-methyl-1,2,3,9-tetrahydro-4*H*-carbazol-4-one (C-demethylondansetron),

H. R1 = H, R2 = CH<sub>3</sub>: (3*RS*)-3-[(2-methyl-1*H*-imidazol-1-yl)methyl]-1,2,3,9-tetrahydro-4*H*-carbazol-4-one (N-demethylondansetron).

01/2010:2259  
corrected 7.0

## ORBIFLOXACIN FOR VETERINARY USE

### Orbifloxacinum ad usum veterinarium

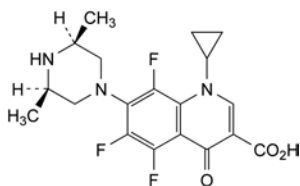

C<sub>19</sub>H<sub>20</sub>F<sub>3</sub>N<sub>3</sub>O<sub>3</sub>  
[113617-63-3]

M<sub>r</sub> 395.4

#### DEFINITION

1-Cyclopropyl-7-[(3*R*,5*S*)-3,5-dimethylpiperazin-1-yl]-5,6,8-trifluoro-4-oxo-1,4-dihydroquinoline-3-carboxylic acid.

Content: 99.0 per cent to 101.0 per cent (anhydrous substance).

#### CHARACTERS

Appearance: white or pale yellow, crystals or crystalline powder.

Solubility: very slightly soluble in water, soluble in glacial acetic acid, practically insoluble in anhydrous ethanol.

It shows polymorphism (5.9).

#### IDENTIFICATION

Infrared absorption spectrophotometry (2.2.24).

Comparison: orbifloxacin CRS.

If the spectra obtained in the solid state show differences, dissolve 0.1 g of the substance to be examined and 0.1 g of the reference substance separately in 12 mL of *methanol R*. Heat to boiling while shaking. Filter the solutions and let them cool slowly to room temperature. Filter under vacuum and wash the residues with cooled *methanol R*. Dry the residues under vacuum and record new spectra using the residues.

#### TESTS

**Appearance of solution.** The solution is clear (2.2.1) and not more intensely coloured than reference solution GY<sub>4</sub> (2.2.2, Method II).

Dissolve 0.4 g in a 4 g/L solution of *sodium hydroxide R* and dilute to 20 mL with the same solution.

**Related substances.** Liquid chromatography (2.2.29).

**Buffer solution.** Dissolve 5.9 g of *sodium citrate R* in 800 mL of *water R*, add 90 mL of *glacial acetic acid R* and mix. Adjust to pH 3.5 with a 240 g/L solution of *sodium hydroxide R* in *water R* and dilute to 1000 mL with *water R*.

**Test solution.** Dissolve 10 mg of the substance to be examined in the buffer solution and dilute to 50.0 mL with the buffer solution.

**Reference solution (a).** Dilute 1.0 mL of the test solution to 50.0 mL with the buffer solution. Dilute 1.0 mL of this solution to 10.0 mL with the buffer solution.

**Reference solution (b).** Dissolve 10.0 mg of *methyl 4-aminobenzoate R* in the buffer solution and dilute to 100.0 mL with the buffer solution. Mix 10.0 mL of the solution with 5.0 mL of the test solution and dilute to 50.0 mL with the buffer solution. Dilute 1.0 mL of this solution to 50.0 mL with the buffer solution.

**Reference solution (c).** Dissolve the contents of a vial of *orbifloxacin impurity mixture CRS* (impurities A and D) in 1.0 mL of the buffer solution.

**Reference solution (d).** Dilute 0.25 mL of reference solution (c) to 1.0 mL of the buffer solution.

#### Column:

– size: *l* = 33 mm, Ø = 4.6 mm;

– stationary phase: base-deactivated octadecylsilyl silica gel for chromatography R (3 µm).

Mobile phase: *dioxane R*, *methanol R*, buffer solution (4:11:86 V/V/V).

Flow rate: 1 mL/min.

Detection: spectrophotometer at 290 nm.

Injection: 10 µL.

Run time: 9 times the retention time of orbifloxacin.

Identification of the impurities: use the chromatogram supplied with *orbifloxacin impurity mixture CRS* and the chromatogram obtained with reference solution (c) to identify the peaks due to impurities A and D.

Relative retention with reference to orbifloxacin (retention time = about 2 min): impurity A = about 0.5; methyl 4-aminobenzoate = about 1.2; impurity D = about 2.5.

#### System suitability:

– resolution: minimum 2.0 between the peaks due to orbifloxacin and methyl 4-aminobenzoate in the chromatogram obtained with reference solution (b);

– signal-to-noise ratio: minimum 10 for the peak due to impurity A in the chromatogram obtained with reference solution (d).

#### Limits:

– correction factors: for the calculation of contents, multiply the peak areas of the following impurities by the corresponding correction factor: impurity A = 2.8; impurity D = 1.4;

– impurities A, D: for each impurity, not more than the area of the principal peak in the chromatogram obtained with reference solution (a) (0.2 per cent);

- *unspecified impurities*: for each impurity, not more than the area of the principal peak in the chromatogram obtained with reference solution (a) (0.20 per cent);
- *total*: not more than twice the area of the principal peak in the chromatogram obtained with reference solution (a) (0.4 per cent);
- *disregard limit*: 0.5 times the area of the principal peak in the chromatogram obtained with reference solution (a) (0.10 per cent).

**Water** (2.5.12): 1.5 per cent to 2.9 per cent, determined on 0.250 g.

**Sulfated ash** (2.4.14): maximum 0.1 per cent, determined on 1.0 g.

#### ASSAY

Dissolve 0.300 g in 100 mL of *anhydrous acetic acid R*. Titrate with 0.1 M *perchloric acid* determining the end-point potentiometrically (2.2.20).

1 mL of 0.1 M *perchloric acid* is equivalent to 39.54 mg of  $C_{19}H_{20}F_3N_3O_3$ .

#### IMPURITIES

*Specified impurities*: A, D.

*Other detectable impurities* (the following substances would, if present at a sufficient level, be detected by one or other of the tests in the monograph. They are limited by the general acceptance criterion for other/unspecified impurities and/or by the general monograph *Substances for pharmaceutical use* (2034). It is therefore not necessary to identify these impurities for demonstration of compliance. See also 5.10. *Control of impurities in substances for pharmaceutical use*): B, C, E, F, G.

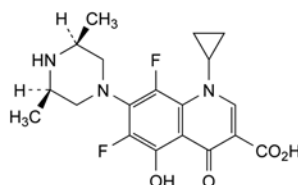

D. 1-cyclopropyl-7-[(3*R*,5*S*)-3,5-dimethylpiperazin-1-yl]-6,8-difluoro-5-hydroxy-4-oxo-1,4-dihydroquinoline-3-carboxylic acid,

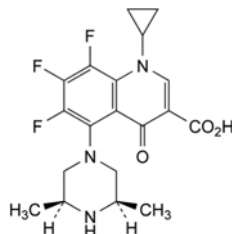

E. 1-cyclopropyl-5-[(3*R*,5*S*)-3,5-dimethylpiperazin-1-yl]-6,7,8-trifluoro-4-oxo-1,4-dihydroquinoline-3-carboxylic acid,

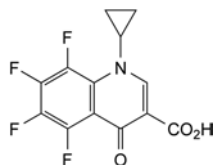

F. 1-cyclopropyl-5,6,7,8-tetrafluoro-4-oxo-1,4-dihydroquinoline-3-carboxylic acid.

07/2008:1033  
corrected 7.0

## ORCIPRENALINE SULFATE

### Orciprenalini sulfas

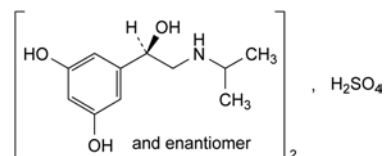

$C_{22}H_{36}N_2O_{10}S$   
[5874-97-5]

$M_r$  520.6

#### DEFINITION

Bis[5-[(1*RS*)-1-hydroxy-2-[(1-methylethyl)amino]ethyl]-benzene-1,3-diol] sulfate.

*Content*: 98.0 per cent to 102.0 per cent (anhydrous substance).

#### CHARACTERS

*Appearance*: white or almost white, slightly hygroscopic, crystalline powder.

*Solubility*: freely soluble in water, slightly soluble in ethanol (96 per cent), practically insoluble in methylene chloride.

#### IDENTIFICATION

*First identification*: B, E.

*Second identification*: A, C, D, E.

A. Ultraviolet and visible absorption spectrophotometry (2.2.25).

*Test solution*. Dissolve 50.0 mg in a 0.04 per cent *V/V* solution of *hydrochloric acid R* and dilute to 50.0 mL with the same solution. Dilute 5.0 mL of this solution to 50.0 mL with a 0.04 per cent *V/V* solution of *hydrochloric acid R*.

*Spectral range*: 240-350 nm.

*Absorption maximum*: at 278 nm.

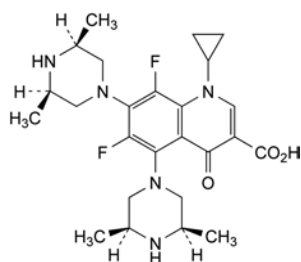

A. 1-cyclopropyl-5,7-bis[(3*R*,5*S*)-3,5-dimethylpiperazin-1-yl]-6,8-difluoro-4-oxo-1,4-dihydroquinoline-3-carboxylic acid,

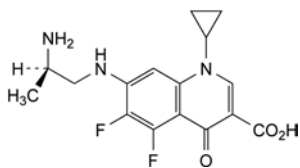

B. 7-[(2*R*)-2-aminopropyl]amino]-1-cyclopropyl-5,6-difluoro-4-oxo-1,4-dihydroquinoline-3-carboxylic acid,

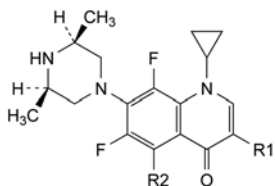

C. R1 = CO<sub>2</sub>H, R2 = H : 1-cyclopropyl-7-[(3*R*,5*S*)-3,5-dimethylpiperazin-1-yl]-6,8-difluoro-4-oxo-1,4-dihydroquinoline-3-carboxylic acid,

G. R1 = H, R2 = F : 1-cyclopropyl-7-[(3*R*,5*S*)-3,5-dimethylpiperazin-1-yl]-5,6,8-trifluoroquinolin-4(1*H*)-one,

*Specific absorbance at the absorption maximum:* 68.5 to 76.0 (anhydrous substance).

**B. Infrared absorption spectrophotometry (2.2.24).**

*Comparison:* orciprenaline sulfate CRS.

If the spectra obtained show differences, dissolve separately, with heating, 50 mg of the substance to be examined and 50 mg of the reference substance, in the minimum volume of water R. Add 10 mL of acetone R and centrifuge. Dry the precipitates at 40 °C under reduced pressure for 3 h and record new spectra using the residues.

**C. Thin-layer chromatography (2.2.27).**

*Test solution.* Dissolve 10 mg of the substance to be examined in ethanol (96 per cent) R and dilute to 10 mL with the same solvent.

*Reference solution (a).* Dissolve 10 mg of orciprenaline sulfate CRS in ethanol (96 per cent) R and dilute to 10 mL with the same solvent.

*Reference solution (b).* Dissolve 10 mg of orciprenaline sulfate CRS and 10 mg of salbutamol CRS in ethanol (96 per cent) R and dilute to 10 mL with the same solvent.

*Plate:* TLC silica gel G plate R.

*Mobile phase:* ammonia R, water R, aldehyde-free methanol R (1.5:10:90 V/V/V).

*Application:* 2 µL.

*Development:* over 2/3 of the plate.

*Drying:* in air.

*Detection:* spray with a 10 g/L solution of potassium permanganate R.

*System suitability:* reference solution (b):

- the chromatogram shows 2 clearly separated principal spots.

*Results:* the principal spot in the chromatogram obtained with the test solution is similar in position, colour and size to the principal spot in the chromatogram obtained with reference solution (a).

**D.** Dissolve about 20 mg in 2 mL of ethanol (96 per cent) R. Add 2 mL of a 1 g/L solution of dichloroquinonechlorimide R in ethanol (96 per cent) R and 1 mL of sodium carbonate solution R. A violet colour is produced, turning to brown.

**E.** It gives reaction (a) of sulfates (2.3.1).

**TESTS**

**Solution S.** Dissolve 2.0 g in carbon dioxide-free water R and dilute to 20 mL with the same solvent.

**Appearance of solution.** Solution S is clear (2.2.1) and colourless (2.2.2, Method II).

**pH (2.2.3):** 4.0 to 5.5 for solution S.

**Related substances.** Liquid chromatography (2.2.29).

*Test solution.* Dissolve 20 mg of the substance to be examined in the mobile phase and dilute to 20 mL with the mobile phase.

*Reference solution (a).* Dilute 1.0 mL of the test solution to 100.0 mL with the mobile phase. Dilute 1.0 mL of this solution to 10.0 mL with the mobile phase.

*Reference solution (b).* Dissolve 2 mg of orciprenaline for system suitability CRS (containing impurities A and B) in 2.0 mL of the mobile phase.

*Column:*

- size:  $l = 0.125$  m,  $\varnothing = 4.0$  mm;
- stationary phase: spherical end-capped octadecylsilyl silica gel for chromatography R (5 µm);
- temperature: 45 °C.

*Mobile phase.* Dissolve 9.1 g of potassium dihydrogen phosphate R and 4.6 g of sodium octanesulfonate R in water R, adjust to pH 4.0 with dilute phosphoric acid R and dilute to 1000 mL with water R. Add 140 mL of acetonitrile R.

*Flow rate:* 1.5 mL/min.

*Detection:* spectrophotometer at 280 nm.

*Injection:* 10 µL.

*Run time:* twice the retention time of orciprenaline.

*Identification of impurities:* use the chromatogram supplied with orciprenaline for system suitability CRS and the chromatogram obtained with reference solution (b) to identify the peaks due to impurities A and B.

*Relative retention* with reference to orciprenaline (retention time = about 7 min): impurity A = about 0.9; impurity B = about 1.3.

*System suitability:* reference solution (b):

- resolution: minimum 2.0 between the peaks due to impurity A and orciprenaline.

*Limits:*

- correction factor: for the calculation of content, multiply the peak area of impurity B by 0.3;
- impurities A, B: for each impurity, not more than the area of the principal peak in the chromatogram obtained with reference solution (a) (0.1 per cent);
- unspecified impurities: for each impurity, not more than the area of the principal peak in the chromatogram obtained with reference solution (a) (0.10 per cent);
- total: not more than twice the area of the principal peak in the chromatogram obtained with reference solution (a) (0.2 per cent);
- disregard limit: 0.5 times the area of the principal peak in the chromatogram obtained with reference solution (a) (0.05 per cent).

**Phenone:** maximum 0.1 per cent.

Dissolve 0.50 g in a 0.04 per cent V/V solution of hydrochloric acid R and dilute to 25.0 mL with the same solution. The absorbance (2.2.25) of the solution measured at 328 nm is not greater than 0.16.

**Iron (2.4.9):** maximum 20 ppm.

The residue obtained in the test for sulfated ash complies with the test. Prepare the reference solution using iron standard solution (2 ppm Fe) R.

**Heavy metals (2.4.8):** maximum 20 ppm.

1.0 g complies with test C. Prepare the reference solution using 2 mL of lead standard solution (10 ppm Pb) R.

**Water (2.5.12):** maximum 2.0 per cent, determined on 1.000 g.

**Sulfated ash (2.4.14):** maximum 0.1 per cent, determined on 1.0 g.

**ASSAY**

Dissolve 0.400 g in 5 mL of anhydrous formic acid R and add 30 mL of anhydrous acetic acid R. Titrate with 0.1 M perchloric acid using 0.1 mL of crystal violet solution R as indicator.

1 mL of 0.1 M perchloric acid is equivalent to 52.06 mg of C<sub>22</sub>H<sub>36</sub>N<sub>2</sub>O<sub>10</sub>S.

**STORAGE**

In an airtight container, protected from light.

**IMPURITIES**

*Specified impurities:* A, B.

*Other detectable impurities* (the following substances would, if present at a sufficient level, be detected by one or other of the tests in the monograph. They are limited by the general acceptance criterion for other/unspecified impurities and/or by the general monograph Substances for pharmaceutical use (2034). It is therefore not necessary to identify these impurities for demonstration of compliance. See also 5.10. Control of impurities in substances for pharmaceutical use): C.



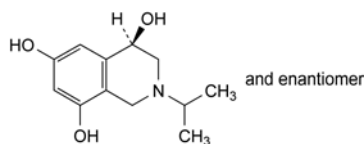

A. (4*RS*)-2-(1-methylethyl)-1,2,3,4-tetrahydroisoquinoline-4,6,8-triol,

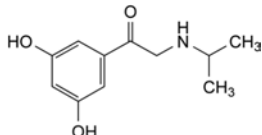

B. 1-(3,5-dihydroxyphenyl)-2-[(1-methylethyl)amino]ethanone,

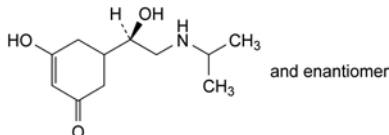

C. 3-hydroxy-5-[(1*RS*)-1-hydroxy-2-[(1-methylethyl)amino]ethyl]cyclohex-2-enone.

07/2010:1759

## ORPHENADRINE CITRATE

### Orphenadrini citras

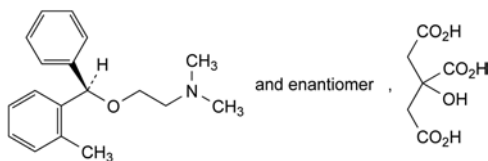

$C_{24}H_{31}NO_8$   
[4682-36-4]

$M_r$  461.5

#### DEFINITION

(*RS*)-*N,N*-Dimethyl-2-[(2-methylphenyl)phenylmethoxy]ethanamine dihydrogen 2-hydroxypropane-1,2,3-tricarboxylate.

*Content*: 98.5 per cent to 101.0 per cent (dried substance).

#### CHARACTERS

*Appearance*: white or almost white, crystalline powder.

*Solubility*: sparingly soluble in water, slightly soluble in ethanol (96 per cent).

mp: about 137 °C.

#### IDENTIFICATION

Infrared absorption spectrophotometry (2.2.24).

*Comparison*: orphenadrine citrate CRS.

#### TESTS

**Appearance of solution.** The solution is clear (2.2.1) and its absorbance (2.2.25) at 436 nm has a maximum of 0.050.

Dissolve 1.0 g in a 3.6 per cent *V/V* solution of *hydrochloric acid R* in *ethanol (96 per cent) R* and dilute to 10.0 mL with the same acid solution.

**Related substances.** Gas chromatography (2.2.28): use the normalisation procedure.

**Test solution.** Dissolve 0.500 g of the substance to be examined in *water R* and dilute to 50 mL with the same solvent. Add 2 mL of *concentrated ammonia R* and shake with 3 quantities, each of 10 mL, of *toluene R*. To the combined upper layers add *anhydrous sodium sulfate R*, shake, filter and evaporate the filtrate, at a temperature not exceeding 50 °C, using a rotary

evaporator. Take up the residue with *toluene R* and dilute to 20.0 mL with the same solvent.

**Reference solution (a).** Dissolve 30 mg of *orphenadrine citrate CRS* and 30 mg of *orphenadrine impurity E CRS* in 20 mL of *water R*. Add 1 mL of *concentrated ammonia R* and shake with 3 quantities, each of 5 mL, of *toluene R*. To the combined upper layers add *anhydrous sodium sulfate R*, shake, filter and evaporate the filtrate, at a temperature not exceeding 50 °C, using a rotary evaporator. Take up the residue with *toluene R* and dilute to 20.0 mL with the same solvent.

**Reference solution (b).** Dissolve the contents of a vial of *orphenadrine for peak identification CRS* (containing impurities A, B, C, D and F) in 1.0 mL of *toluene R*.

#### Column:

- size:  $l = 60$  m,  $\varnothing = 0.32$  mm;
- stationary phase: *poly(dimethyl)(diphenyl)siloxane R* (film thickness 1.0  $\mu$ m).

*Carrier gas*: helium for chromatography *R*.

*Flow rate*: 1 mL/min.

*Split ratio*: 1:25.

#### Temperature:

- column: 240 °C;
- injection port and detector: 290 °C.

*Detection*: flame ionisation.

*Injection*: 2  $\mu$ L.

*Run time*: 1.3 times the retention time of orphenadrine.

*Identification of impurities*: use the chromatogram supplied with *orphenadrine for peak identification CRS* and the chromatogram obtained with reference solution (b) to identify the peaks due to impurities A, B, C, D and F. Use the chromatogram obtained with reference solution (a) to identify the peak due to impurity E.

*Relative retention* with reference to orphenadrine (retention time = about 13 min): impurity B = about 0.5; impurity A = about 0.6; impurity D = about 0.8; impurity C = about 0.9; impurity E = about 0.98; impurity F = about 1.1.

*System suitability*: reference solution (a):

- resolution: minimum of 1.5 between the peaks due to impurity E and orphenadrine.

#### Limits:

- impurities A, B, C, D, E, F: for each impurity, not more than 0.3 per cent;
- unspecified impurities: for each impurity, not more than 0.10 per cent;
- total: maximum 1.0 per cent;
- disregard limit: 0.05 per cent.

**Heavy metals** (2.4.8): maximum 10 ppm.

2.0 g complies with test C. Prepare the reference solution using 2 mL of *lead standard solution (10 ppm Pb) R*.

**Loss on drying** (2.2.32): maximum 0.5 per cent, determined on 1.000 g by drying in an oven at 105 °C for 3 h.

**Sulfated ash** (2.4.14): maximum 0.1 per cent, determined on 1.0 g.

#### ASSAY

Dissolve 0.350 g in 50 mL of *anhydrous acetic acid R*. Titrate with 0.1 *M perchloric acid*, determining the end-point potentiometrically (2.2.20).

1 mL of 0.1 *M perchloric acid* is equivalent to 46.15 mg of  $C_{24}H_{31}NO_8$ .

#### STORAGE

Protected from light. If the substance is sterile, store in a sterile, airtight, tamper-proof container, protected from light.

#### IMPURITIES

*Specified impurities*: A, B, C, D, E, F.

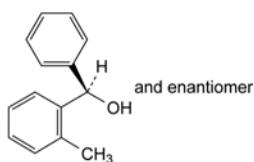

A. (RS)-2-(2-methylphenyl)phenylmethanol (2-methylbenzhydrol),

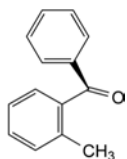

B. (2-methylphenyl)phenylmethanone (2-methylbenzophenone),

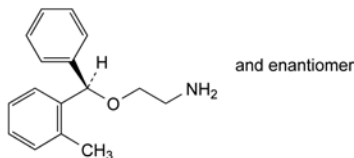

C. (RS)-2-[(2-methylphenyl)phenylmethoxy]ethanamine,

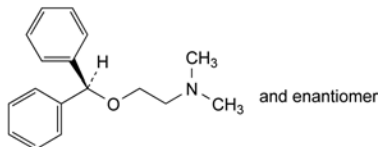

D. 2-[(diphenylmethoxy)-N,N-dimethylethanamine] (diphenhydramine),

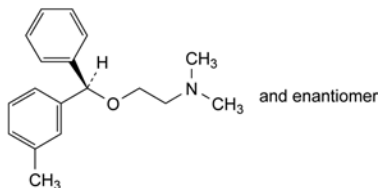

E. (RS)-N,N-dimethyl-2-[(3-methylphenyl)phenylmethoxy]ethanamine (meta-methylbenzyl isomer),

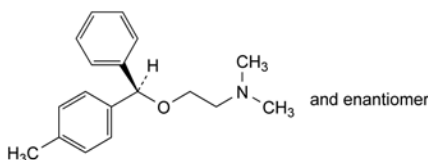

F. (RS)-N,N-dimethyl-2-[(4-methylphenyl)phenylmethoxy]ethanamine (para-methylbenzyl isomer).

07/2010:1760

## ORPHENADRINE HYDROCHLORIDE

### Orphenadrini hydrochloridum

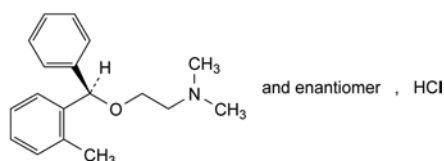

$C_{18}H_{24}ClNO$   
[341-69-5]

$M_r$  305.9

#### DEFINITION

(RS)-N,N-Dimethyl-2-[(2-methylphenyl)phenylmethoxy]ethanamine hydrochloride.

Content: 98.5 per cent to 101.0 per cent (dried substance).

#### CHARACTERS

**Appearance:** white or almost white, crystalline powder.

**Solubility:** freely soluble in water and in ethanol (96 per cent).

mp: about 160 °C.

#### IDENTIFICATION

A. Infrared absorption spectrophotometry (2.2.24).

Comparison: orphenadrine hydrochloride CRS.

B. It gives reaction (a) of chlorides (2.3.1).

#### TESTS

**Appearance of solution.** The solution is clear (2.2.1) and its absorbance (2.2.25) at 436 nm has a maximum of 0.050.

Dissolve 0.70 g in ethanol (96 per cent) R and dilute to 10.0 mL with the same solvent.

**Related substances.** Gas chromatography (2.2.28): use the normalisation procedure.

**Test solution.** Dissolve 0.300 g of the substance to be examined in water R and dilute to 50 mL with the same solvent. Add 2 mL of concentrated ammonia R and shake with 3 quantities, each of 10 mL, of toluene R. To the combined upper layers add anhydrous sodium sulfate R, shake, filter and evaporate the filtrate, at a temperature not exceeding 50 °C, using a rotary evaporator. Take up the residue with toluene R and dilute to 20.0 mL with the same solvent.

**Reference solution (a).** Dissolve 20 mg of orphenadrine hydrochloride CRS and 20 mg of orphenadrine impurity E CRS in 20 mL of water R. Add 1 mL of concentrated ammonia R and shake with 3 quantities, each of 5 mL, of toluene R. To the combined upper layers add anhydrous sodium sulfate R, shake, filter and evaporate the filtrate, at a temperature not exceeding 50 °C, using a rotary evaporator. Take up the residue with toluene R and dilute to 20.0 mL with the same solvent.

**Reference solution (b).** Dissolve the contents of a vial of orphenadrine for peak identification CRS (containing impurities A, B, C, D and F) in 1.0 mL of toluene R.

#### Column:

– size:  $l = 60$  m,  $\varnothing = 0.32$  mm;

– stationary phase: poly(dimethyl)(diphenyl)siloxane R (film thickness 1.0  $\mu$ m).

Carrier gas: helium for chromatography R.

Flow rate: 1 mL/min.

Split ratio: 1:25.

#### Temperature:

– column: 240 °C;

– injection port and detector: 290 °C.

Detection: flame ionisation.

Injection: 2  $\mu$ L.

Run time: 1.3 times the retention time of orphenadrine.

Identification of impurities: use the chromatogram supplied with orphenadrine for peak identification CRS and the chromatogram obtained with reference solution (b) to identify the peaks due to impurities A, B, C, D and F. Use the chromatogram obtained with reference solution (a) to identify the peak due to impurity E.

Relative retention with reference to orphenadrine (retention time = about 13 min): impurity B = about 0.5; impurity A = about 0.6; impurity D = about 0.8; impurity C = about 0.9; impurity E = about 0.98; impurity F = about 1.1.

System suitability: reference solution (a):

– resolution: minimum 1.5 between the peaks due to impurity E and orphenadrine.

#### Limits:

– impurities A, B, C, D, E, F: for each impurity, not more than 0.3 per cent;

– unspecified impurities: for each impurity, not more than 0.10 per cent;

- *total*: not more than 1.0 per cent;
- *disregard limit*: 0.05 per cent.

**Heavy metals** (2.4.8): maximum 10 ppm.

2.0 g complies with test C. Prepare the reference solution using 2 mL of *lead standard solution* (10 ppm Pb) R.

**Loss on drying** (2.2.32): maximum 0.5 per cent, determined on 1.000 g by drying in an oven at 105 °C for 3 h.

**Sulfated ash** (2.4.14): maximum 0.1 per cent, determined on 1.0 g.

#### ASSAY

Dissolve 0.250 g in 50 mL of *acetic anhydride* R. Titrate with 0.1 M *perchloric acid*, determining the end-point potentiometrically (2.2.20).

1 mL of 0.1 M *perchloric acid* is equivalent to 30.59 mg of C<sub>18</sub>H<sub>24</sub>ClNO.

#### STORAGE

Protected from light. If the substance is sterile, store in a sterile, airtight, tamper-proof container, protected from light.

#### IMPURITIES

*Specified impurities*: A, B, C, D, E, F.

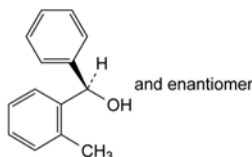

A. (RS)-(2-methylphenyl)phenylmethanol (2-methylbenzhydrol),

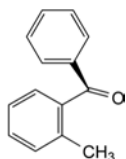

B. (2-methylphenyl)phenylmethanone (2-methylbenzophenone),

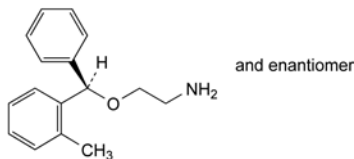

C. (RS)-2-[(2-methylphenyl)phenylmethoxy]ethanamine,

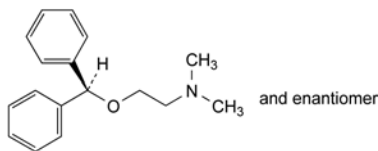

D. 2-(diphenylmethoxy)-N,N-dimethylethanamine (diphenhydramine),

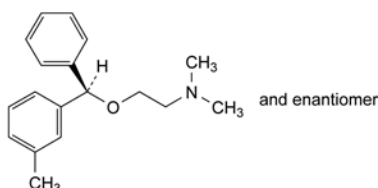

E. (RS)-N,N-dimethyl-2-[(3-methylphenyl)phenylmethoxy]ethanamine (*meta*-methylbenzyl isomer),

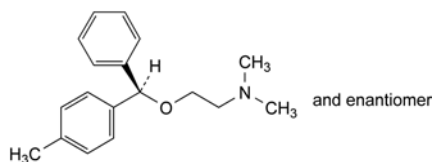

F. (RS)-N,N-dimethyl-2-[(4-methylphenyl)phenylmethoxy]ethanamine (*para*-methylbenzyl isomer).

01/2008:0048  
corrected 6.0

## OUABAIN

### Ouabainum

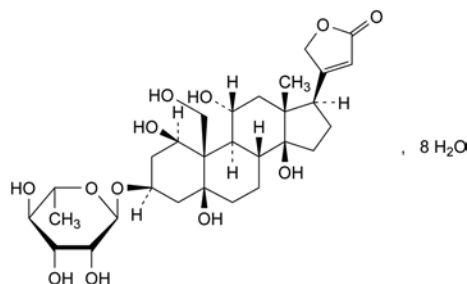

C<sub>29</sub>H<sub>44</sub>O<sub>12</sub>·8H<sub>2</sub>O  
[11018-89-6]

M<sub>r</sub> 729

#### DEFINITION

Ouabain contains not less than 96.0 per cent and not more than the equivalent of 104.0 per cent of 3β-[(6-deoxy-α-L-mannopyranosyl)oxy]-1β,5,11α,14,19-pentahydroxy-5β,14β-card-20(22)-enolide, calculated with reference to the anhydrous substance.

#### CHARACTERS

A white or almost white, crystalline powder or colourless crystals, sparingly soluble in water and in ethanol, practically insoluble in ethyl acetate.

#### IDENTIFICATION

- Examine the chromatograms obtained in the test for related substances. The principal spot in the chromatogram obtained with the test solution is similar in position, colour and size to the spot in the chromatogram obtained with reference solution (a).
- Dissolve 2 mg to 3 mg in 2 mL of *sulfuric acid* R; a pink colour develops which quickly changes to red. The solution shows green fluorescence in ultraviolet light.
- Dissolve about 1 mg in 1 mL of *dinitrobenzene solution* R and add 0.2 mL of *dilute sodium hydroxide solution* R. An intense blue colour develops.
- Dissolve 0.1 g in 5 mL of a 150 g/L solution of *sulfuric acid* R and boil for a few minutes. The solution becomes yellow and turbid. Filter and add to the filtrate 5 mL of a 120 g/L solution of *sodium hydroxide* R and 3 mL of *cupri-tartaric solution* R. Heat. A red precipitate is formed.

#### TESTS

**Solution S.** Dissolve 0.20 g in 15 mL of *water* R, heating on a water-bath. Allow to cool and dilute to 20.0 mL with the same solvent.

**Appearance of solution.** Solution S is clear (2.2.1) and colourless (2.2.2, *Method II*).

**Specific optical rotation** (2.2.7). –30 to –33, determined on solution S and calculated with reference to the anhydrous substance.

07/2008:2260

**Related substances.** Examine by thin-layer chromatography (2.2.27), using *silica gel G R* as the coating substance.

**Test solution.** Dissolve a quantity of the substance to be examined corresponding to 20 mg of the anhydrous substance in 1.0 mL of a mixture of 32 volumes of *water R*, 100 volumes of *chloroform R* and 100 volumes of *methanol R*.

**Reference solution (a).** Dissolve a quantity of *ouabain CRS* corresponding to 20 mg of the anhydrous substance in 1.0 mL of a mixture of 32 volumes of *water R*, 100 volumes of *chloroform R* and 100 volumes of *methanol R*.

**Reference solution (b).** Dissolve a quantity of *ouabain CRS* corresponding to 10 mg of the anhydrous substance in a mixture of 32 volumes of *water R*, 100 volumes of *chloroform R*, 100 volumes of *methanol R* and dilute to 25 mL with the same mixture of solvents.

**Reference solution (c).** Dilute 2.5 mL of reference solution (b) to 10 mL with a mixture of 32 volumes of *water R*, 100 volumes of *chloroform R* and 100 volumes of *methanol R*.

Apply separately to the plate 5 µL of each solution. Develop over a path of 13 cm using a homogeneous mixture of 4 volumes of *water R*, 15 volumes of *methanol R*, 15 volumes of *dimethyl sulfoxide R* and 70 volumes of *chloroform R*. Dry the plate immediately at 140 °C for 30 min in a ventilated drying oven. Allow to cool, spray with *alcoholic sulfuric acid solution R* and heat at 140 °C for 15 min. Any spot in the chromatogram obtained with the test solution, apart from the principal spot, is not more intense than the spot in the chromatogram obtained with reference solution (b) (2.0 per cent). The test is not valid unless the principal spot in the chromatogram obtained with reference solution (a) and the principal spot in the chromatogram obtained with the test solution migrate over a distance sufficient to give unequivocal separation of the secondary spots and the spot in the chromatogram obtained with reference solution (c) is clearly visible.

**Alkaloids and strophanthin-K.** To 5.0 mL of solution S add 0.5 mL of a 100 g/L solution of *tannic acid R*. No precipitate is formed.

**Water (2.5.12).** 18.0 per cent to 22.0 per cent, determined on 0.100 g by the semi-micro determination of water.

**Sulfated ash (2.4.14).** Not more than 0.1 per cent, determined on 1.0 g.

## ASSAY

Dissolve 40.0 mg in *alcohol R* and dilute to 50.0 mL with the same solvent. Dilute 5.0 mL of the solution to 100.0 mL with *alcohol R*. Prepare a reference solution in the same manner using 40.0 mg of *ouabain CRS*. To 5.0 mL of each solution add 3.0 mL of *alkaline sodium picrate solution R*, allow to stand protected from bright light for 30 min and measure the absorbance (2.2.25) of each solution at the maximum at 495 nm using as the compensation liquid a mixture of 5.0 mL of *alcohol R* and 3.0 mL of *alkaline sodium picrate solution R* prepared at the same time.

Calculate the content of  $C_{19}H_{18}N_3NaO_5S \cdot H_2O$  from the absorbances measured and the concentrations of the solutions.

## STORAGE

Store protected from light.

# OXACILLIN SODIUM MONOHYDRATE

## Oxacillinum natricum monohydricum

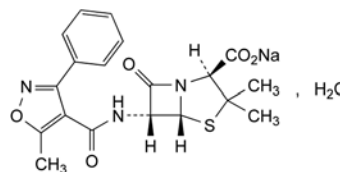

$C_{19}H_{18}N_3NaO_5S \cdot H_2O$   
[7240-38-2]

$M_r$  441.4

## DEFINITION

Sodium (2*S*,5*R*,6*R*)-3,3-dimethyl-6-[[5-methyl-3-phenylisoxazol-4-yl]carbonyl]amino]-7-oxo-4-thia-1-azabicyclo[3.2.0]heptane-2-carboxylate monohydrate.

Semi-synthetic product derived from a fermentation product.

**Content:** 95.0 per cent to 102.0 per cent (anhydrous substance).

## CHARACTERS

**Appearance:** white or almost white powder.

**Solubility:** freely soluble in water, soluble in methanol, practically insoluble in methylene chloride.

## IDENTIFICATION

A. Infrared absorption spectrophotometry (2.2.24).

*Comparison:* *oxacillin sodium monohydrate CRS*.

B. It gives reaction (a) of sodium (2.3.1).

## TESTS

**Appearance of solution.** The solution is clear (2.2.1) and its absorbance (2.2.25) at 430 nm is not greater than 0.10.

Dissolve 2.50 g in *water R* and dilute to 25.0 mL with the same solvent.

**pH (2.2.3):** 4.5 to 7.5.

Dissolve 0.30 g in *carbon dioxide-free water R* and dilute to 10 mL with the same solvent.

**Specific optical rotation (2.2.7):** + 196 to + 212 (anhydrous substance).

Dissolve 0.250 g in *water R* and dilute to 25.0 mL with the same solvent.

**Related substances.** Liquid chromatography (2.2.29).

**Test solution (a).** Dissolve 50.0 mg of the substance to be examined in the mobile phase and dilute to 50.0 mL with the mobile phase.

**Test solution (b).** Dilute 5.0 mL of test solution (a) to 50.0 mL with the mobile phase.

**Reference solution (a).** Dissolve 50.0 mg of *oxacillin sodium monohydrate CRS* in the mobile phase and dilute to 50.0 mL with the mobile phase. Dilute 5.0 mL of this solution to 50.0 mL with the mobile phase.

**Reference solution (b).** Dilute 5.0 mL of test solution (b) to 50.0 mL with the mobile phase.

**Reference solution (c).** Dissolve 5 mg of *cloxacillin sodium CRS* (impurity E) and 5 mg of *oxacillin sodium monohydrate CRS* in the mobile phase and dilute to 50.0 mL with the mobile phase.

**Reference solution (d).** In order to prepare impurities B and D *in situ*, dissolve 25 mg of the substance to be examined in 1 mL of 0.05 M sodium hydroxide, allow to stand for 3 min, then dilute to 100 mL with the mobile phase. Inject immediately.

**Reference solution (e).** Dissolve 5 mg of *oxacillin for peak identification CRS* (containing impurities E, F, G, I and J) in 5 mL of the mobile phase.

**Column:**

– size:  $l = 0.25$  m,  $\varnothing = 4.0$  mm;

– *stationary phase*: octadecylsilyl silica gel for chromatography R (5 µm).

*Mobile phase*: mix 25 volumes of acetonitrile R and 75 volumes of a 2.7 g/L solution of potassium dihydrogen phosphate R previously adjusted to pH 5.0 with dilute sodium hydroxide solution R.

*Flow rate*: 1.0 mL/min.

*Detection*: spectrophotometer at 225 nm.

*Injection*: 20 µL of test solution (a) and reference solutions (b), (c), (d) and (e).

*Run time*: 7 times the retention time of oxacillin.

*Identification of impurities*:

- in the chromatogram obtained with reference solution (d), the 2 principal peaks eluting before the main peak are due to impurities B and D respectively;
- use the chromatogram supplied with *oxacillin for peak identification CRS* and the chromatogram obtained with reference solution (e) to identify the peaks due to impurities E, F, G, I and J.

*Relative retention* with reference to oxacillin (retention time = about 5 min): impurity A = about 0.3; impurity B (isomer 1) = about 0.4; impurity B (isomer 2) = about 0.5; impurity C = about 0.65; impurity D (2 isomers) = about 0.9; impurity E = about 1.5; impurity F = about 1.9; impurity G = about 2.1; impurity H = about 3.5; impurity I = about 3.8; impurity J = about 5.8.

*System suitability*:

- *resolution*: minimum 2.5 between the peaks due to oxacillin and impurity E in the chromatogram obtained with reference solution (c);
- the chromatogram obtained with reference solution (e) is similar to the chromatogram supplied with *oxacillin for peak identification CRS*.

*Limits*:

- *impurity B*: for the sum of the areas of the 2 isomer peaks, not more than 1.5 times the area of the principal peak in the chromatogram obtained with reference solution (b) (1.5 per cent);
- *impurity E*: not more than the area of the principal peak in the chromatogram obtained with reference solution (b) (1.0 per cent);
- *impurities D (sum of the 2 isomers), F, G, I, J*: for each impurity, not more than 0.5 times the area of the principal peak in the chromatogram obtained with reference solution (b) (0.5 per cent);
- *any other impurity*: for each impurity, not more than 0.5 times the area of the principal peak in the chromatogram obtained with reference solution (b) (0.5 per cent);
- *total*: not more than 3 times the area of the principal peak in the chromatogram obtained with reference solution (b) (3.0 per cent);
- *disregard limit*: 0.05 times the area of the principal peak in the chromatogram obtained with reference solution (b) (0.05 per cent).

**Ethyl acetate and butyl acetate.** Head-space gas chromatography (2.2.28).

*Test solution.* Dissolve 0.200 g of the substance to be examined in 6.0 mL of water R.

*Reference solution.* Dissolve 83 mg of ethyl acetate R and 83 mg of butyl acetate R in water R and dilute to 250.0 mL with the same solvent. Use 6.0 mL of this solution.

Close the vials immediately with a rubber membrane stopper coated with polytetrafluoroethylene and secured with an aluminium crimped cap. Mix to obtain a homogeneous solution.

*Column*:

- *material*: fused silica;
- *size*:  $l = 50$  m,  $\varnothing = 0.32$  mm;
- *stationary phase*: poly(dimethyl)siloxane R (film thickness 5 µm).

*Carrier gas*: helium for chromatography R.

*Flow rate*: 2 mL/min.

*Static head-space conditions that may be used*:

- *equilibration temperature*: 80 °C;
- *equilibration time*: 60 min;
- *transfer-line temperature*: 140 °C;
- *pressurisation time*: 30 s.

*Temperature*:

	Time (min)	Temperature (°C)
Column	0 - 6	70
	6 - 16	70 → 220
	16 - 18	220
Injection port		140
Detector		250

*Detection*: flame ionisation.

*Retention time*: ethyl acetate = about 10 min; butyl acetate = about 15.5 min.

*Limits*:

- *ethyl acetate*: maximum 1.0 per cent,
- *butyl acetate*: maximum 1.0 per cent.

**N,N-Dimethylaniline** (2.4.26, Method B): maximum 20 ppm.

**2-Ethylhexanoic acid** (2.4.28): maximum 0.8 per cent.

**Water** (2.5.12): 3.5 per cent to 5.0 per cent, determined on 0.300 g.

**Bacterial endotoxins** (2.6.14): less than 0.20 IU/mg, if intended for use in the manufacture of parenteral preparations without a further appropriate procedure for the removal of bacterial endotoxins.

**ASSAY**

Liquid chromatography (2.2.29) as described in the test for related substances with the following modification.

*Injection*: test solution (b) and reference solution (a).

Calculate the percentage content of  $C_{19}H_{18}N_3NaO_5S$  from the declared content of *oxacillin sodium monohydrate CRS*.

**IMPURITIES**

*Specified impurities*: B, D, E, F, G, I, J.

*Other detectable impurities* (the following substances would, if present at a sufficient level, be detected by one or other of the tests in the monograph. They are limited by the general acceptance criterion for other/unspecified impurities and/or by the general monograph *Substances for pharmaceutical use* (2034). It is therefore not necessary to identify these impurities for demonstration of compliance. See also 5.10. *Control of impurities in substances for pharmaceutical use*): A, C, H.

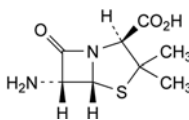

A. (2S,5R,6R)-6-amino-3,3-dimethyl-7-oxo-4-thia-1-azabicyclo[3.2.0]heptane-2-carboxylic acid (6-aminopenicillanic acid),

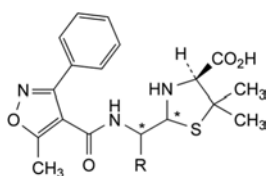

B. R = CO<sub>2</sub>H: (4*S*)-2-[carboxyl[[[(5-methyl-3-phenylisoxazol-4-yl)carbonyl]amino]methyl]-5,5-dimethylthiazolidine-4-carboxylic acid (penicilloic acids of oxacillin),

D. R = H: (2*R,S*,4*S*)-5,5-dimethyl-2-[[[(5-methyl-3-phenylisoxazol-4-yl)carbonyl]amino]methyl]thiazolidine-4-carboxylic acid (penicilloic acids of oxacillin),

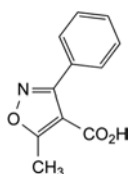

C. 5-methyl-3-phenylisoxazole-4-carboxylic acid,

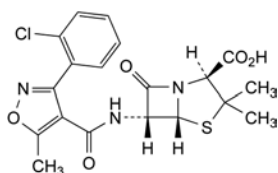

E. (2*S*,5*R*,6*R*)-6-[[[3-(2-chlorophenyl)-5-methylisoxazol-4-yl]carbonyl]amino]-3,3-dimethyl-7-oxo-4-thia-1-azabicyclo[3.2.0]heptane-2-carboxylic acid (cloxacillin),

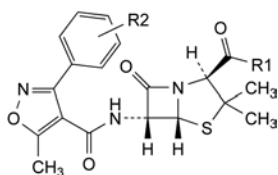

F. R<sub>1</sub> = SH, R<sub>2</sub> = H: (2*R*,5*R*,6*R*)-3,3-dimethyl-6-[[[(5-methyl-3-phenylisoxazol-4-yl)carbonyl]amino]-7-oxo-4-thia-1-azabicyclo[3.2.0]heptane-2-carbothioic acid (thiooxacillin),

G. R<sub>1</sub> = OH, R<sub>2</sub> = Cl: (2*S*,5*R*,6*R*)-6-[[[3-(chlorophenyl)-5-methylisoxazol-4-yl]carbonyl]amino]-3,3-dimethyl-7-oxo-4-thia-1-azabicyclo[3.2.0]heptane-2-carboxylic acid (cloxacillin isomer),

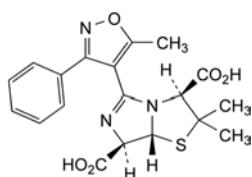

H. (3*S*,7*R*,7*aR*)-2,2-dimethyl-5-(5-methyl-3-phenylisoxazol-4-yl)-2,3,7,7*a*-tetrahydroimidazo[5,1-*b*]thiazole-3,7-dicarboxylic acid (penicilloic acid of oxacillin),

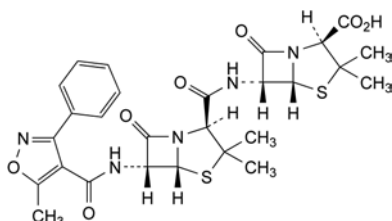

I. (2*S*,5*R*,6*R*)-6-[[[(2*S*,5*R*,6*R*)-3,3-dimethyl-6-[[[(5-methyl-3-phenylisoxazol-4-yl)carbonyl]amino]-7-oxo-4-thia-1-azabicyclo[3.2.0]heptane-2-carboxyl]amino]-3,3-dimethyl-7-oxo-4-thia-1-azabicyclo[3.2.0]heptane-2-carboxylic acid (6-APA oxacillin amide),

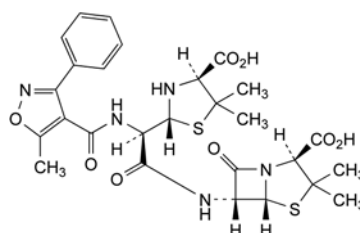

J. (2*S*,5*R*,6*R*)-6-[[[(2*R*)-(2*R*,4*S*)-4-carboxy-5,5-dimethylthiazolidin-2-yl]]-[[[(5-methyl-3-phenylisoxazol-4-yl)carbonyl]amino]acetyl]amino]-3,3-dimethyl-7-oxo-4-thia-1-azabicyclo[3.2.0]heptane-2-carboxylic acid (ozolamide of 6-APA dimer).

01/2009:2017  
corrected 7.0

## OXALIPLATIN

### Oxaliplatinum

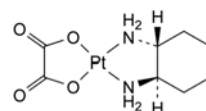

C<sub>8</sub>H<sub>14</sub>N<sub>2</sub>O<sub>4</sub>Pt  
[61825-94-3]

*M*<sub>r</sub> 397.3

#### DEFINITION

(*SP*-4-2)-[(1*R*,2*R*)-Cyclohexane-1,2-diamine-κ*N*,κ*N'*]-[ethanedioato(2-)-κ*O*<sup>1</sup>,κ*O*<sup>2</sup>]platinum.

*Content*: 98.0 per cent to 102.0 per cent (dried substance).

#### CHARACTERS

*Appearance*: white or almost white, crystalline powder.

*Solubility*: slightly soluble in water, very slightly soluble in methanol, practically insoluble in anhydrous ethanol.

#### IDENTIFICATION

A. Infrared absorption spectrophotometry (2.2.24).

*Comparison*: oxaliplatin CRS.

B. Specific optical rotation (see Tests).

#### TESTS

**Appearance of solution.** The solution is clear (2.2.1) and colourless (2.2.2, *Method II*).

Dissolve 0.10 g in *water R* and dilute to 50 mL with the same solvent.

**Acidity.** Dissolve 0.10 g in *carbon dioxide-free water R*, dilute to 50 mL with the same solvent and add 0.5 mL of *phenolphthalein solution RI*. The solution is colourless. Not more than 0.60 mL of 0.01 *M* sodium hydroxide is required to change the colour of the indicator to pink.

**Specific optical rotation** (2.2.7): + 74.5 to + 78.0 (dried substance).

Dissolve 0.250 g in *water R* and dilute to 50.0 mL with the same solvent.

#### Related substances

A. Impurity A. Liquid chromatography (2.2.29). Use vigorous shaking and very brief sonication to dissolve the substance to be examined. Inject the test solution within 20 min of preparation.

*Test solution.* Dissolve 0.100 g of the substance to be examined in *water R* and dilute to 50.0 mL with the same solvent.

*Reference solution (a).* Dissolve 14.0 mg of *oxalic acid R* (impurity A) in *water R* and dilute to 250.0 mL with the same solvent.

*Reference solution (b).* Dilute 5.0 mL of reference solution (a) to 200.0 mL with *water R*.

*Reference solution (c).* Dissolve 12.5 mg of *sodium nitrate R* in *water R* and dilute to 250.0 mL with the same solvent. Dilute a mixture of 2.0 mL of this solution and 25.0 mL of reference solution (a) to 100.0 mL with *water R*.

*Column:*

- *size:*  $l = 0.25$  m,  $\emptyset = 4.6$  mm;
- *stationary phase:* base-deactivated octadecylsilyl silica gel for chromatography *R* (5  $\mu$ m);
- *temperature:* 40 °C.

*Mobile phase:* mix 20 volumes of *acetonitrile R* with 80 volumes of a solution prepared as follows: to 10 mL of a 320 g/L solution of *tetrabutylammonium hydroxide R* add 1.36 g of *potassium dihydrogen phosphate R*, dilute to 1000 mL with *water R* and adjust to pH 6.0 with *phosphoric acid R*.

*Flow rate:* 2 mL/min.

*Detection:* spectrophotometer at 205 nm.

*Injection:* 20  $\mu$ L of the test solution and reference solutions (b) and (c).

*Run time:* twice the retention time of impurity A.

*Retention times:* nitrate = about 2.7 min; impurity A = about 4.7 min.

*System suitability:*

- *resolution:* minimum 9 between the peaks due to nitrate and impurity A in the chromatogram obtained with reference solution (c);
- *signal-to-noise ratio:* minimum 10 for the peak due to impurity A in the chromatogram obtained with reference solution (b).

*Limit:*

- *impurity A:* not more than twice the area of the principal peak in the chromatogram obtained with reference solution (b) (0.1 per cent).

B. Impurity B. Liquid chromatography (2.2.29). Use vigorous shaking and very brief sonication to dissolve the substance to be examined. Inject the test solution within 20 min of preparation. Use suitable polypropylene containers for the preparation and injection of all solutions. Glass pipettes may be used for diluting solutions.

*Test solution.* Dissolve 0.100 g of the substance to be examined in *water R* and dilute to 50.0 mL with the same solvent.

*Reference solution (a).* Add 12.5 mg of *oxaliplatin impurity B CRS* to 63 mL of *methanol R* and dilute to 250.0 mL with *water R*. Sonicate for about 1.5 h until dissolved. Dilute 3.0 mL of this solution to 200.0 mL with *water R*.

*Reference solution (b).* In order to prepare impurity E *in situ*, add 12.5 mg of *oxaliplatin impurity B CRS* to 63 mL of *methanol R* and dilute to 250 mL with *water R*. Sonicate for about 1.5 h until dissolved. Adjust to pH 6.0 with a 0.2 g/L solution of *sodium hydroxide R*. Heat at 70 °C for 4 h and allow to cool.

*Column:*

- *size:*  $l = 0.25$  m,  $\emptyset = 4.6$  mm;
- *stationary phase:* base-deactivated octadecylsilyl silica gel for chromatography *R* (5  $\mu$ m);
- *temperature:* 40 °C.

*Mobile phase:* mix 20 volumes of *acetonitrile R* with 80 volumes of a solution prepared as follows: dissolve 1.36 g of *potassium dihydrogen phosphate R* and 1 g of *sodium heptanesulfonate R* in 1000 mL of *water R* and adjust to pH  $3.0 \pm 0.05$  with *phosphoric acid R*.

*Flow rate:* 2.0 mL/min.

*Detection:* spectrophotometer at 215 nm.

*Injection:* 20  $\mu$ L.

*Run time:* 2.5 times the retention time of impurity B.

*Retention time:* impurity B = about 4.3 min; impurity E = about 6.4 min.

*System suitability:*

- *resolution:* minimum 7 between the peaks due to impurities B and E in the chromatogram obtained with reference solution (b);
- *signal-to-noise ratio:* minimum 10 for the peak due to impurity B in the chromatogram obtained with reference solution (a).

*Limit:*

- *impurity B:* not more than 3.3 times the area of the principal peak in the chromatogram obtained with reference solution (a) (0.1 per cent).

C. Impurity C and other related substances. Liquid chromatography (2.2.29). Use vigorous shaking and very brief sonication to dissolve the substance to be examined. Inject the test solution within 20 min of preparation.

*Test solution (a).* Dissolve 0.100 g of the substance to be examined in *water R* and dilute to 50.0 mL with the same solvent.

*Test solution (b).* Dissolve 50.0 mg of the substance to be examined in *water R* and dilute to 500.0 mL with the same solvent.

*Reference solution (a).* Dissolve 10 mg of *oxaliplatin impurity C CRS* and 10 mg of *oxaliplatin CRS* in *water R* and dilute to 100.0 mL with the same solvent.

*Reference solution (b).* Dilute 1.0 mL of reference solution (a) to 100.0 mL with *water R*.

*Reference solution (c).* Dissolve 5 mg of *dichlorodiaminocyclohexaneplatinum CRS* in *methanol R* and dilute to 50.0 mL with the same solvent. To 10.0 mL of this solution add 10.0 mL of reference solution (a) and dilute to 100.0 mL with *water R*.

*Reference solution (d).* Dissolve 50.0 mg of *oxaliplatin CRS* in *water R* and dilute to 500.0 mL with the same solvent.

*Reference solution (e).* Dissolve 5.0 mg of *dichlorodiaminocyclohexaneplatinum CRS* in reference solution (d) and dilute to 50.0 mL with reference solution (d).

*Reference solution (f).* To 0.100 g of the substance to be examined add 1.0 mL of reference solution (a) and dilute to 50.0 mL with *water R*.

*Column:*

- *size:*  $l = 0.25$  m,  $\emptyset = 4.6$  mm;
- *stationary phase:* octadecylsilyl silica gel for chromatography *R* (5  $\mu$ m);
- *temperature:* 40 °C.

*Mobile phase:* mix 1 volume of *acetonitrile R* with 99 volumes of a solution prepared as follows: dilute 0.6 mL of *dilute phosphoric acid R* in 1000 mL of *water R* and adjust to pH 3.0 with either *sodium hydroxide solution R* or *phosphoric acid R*.

*Flow rate:* 1.2 mL/min.

*Detection:* spectrophotometer at 210 nm.

*Injection:* 10  $\mu$ L of test solution (a) and reference solutions (b), (c) and (f).

*Run time:* 3 times the retention time of oxaliplatin.

*Retention time:* impurity C = about 4.4 min; dichlorodiaminocyclohexaneplatinum = about 6.9 min; oxaliplatin = about 8.0 min.

**System suitability:**

- **resolution:** minimum 2.0 between the peaks due to dichlorodiaminocyclohexaneplatinum and oxaliplatin in the chromatogram obtained with reference solution (c);
- **signal-to-noise ratio:** minimum 50 for the peak due to impurity C and minimum 10 for the peak due to oxaliplatin in the chromatogram obtained with reference solution (b).

**Limits:**

- **impurity C:** not more than 0.5 times the area of the peak due to impurity C in the chromatogram obtained with reference solution (f) (0.1 per cent);
- **any other impurity:** not more than twice the area of the peak due to oxaliplatin in the chromatogram obtained with reference solution (b) (0.1 per cent);
- **total of other impurities:** not more than twice the area of the peak due to oxaliplatin in the chromatogram obtained with reference solution (b) (0.1 per cent);
- **disregard limit:** the area of the peak due to oxaliplatin in the chromatogram obtained with reference solution (b) (0.05 per cent); disregard any peak with a retention time less than 2 min.

D. Total of impurities: the sum of impurities A, B, C and other related impurities is not greater than 0.30 per cent.

**Impurity D.** Liquid chromatography (2.2.29).

**Test solution.** Dissolve 30 mg of the substance to be examined in *methanol R* and dilute to 50.0 mL with the same solvent.

**Reference solution (a).** Dissolve 5 mg of *oxaliplatin impurity D CRS* in *methanol R* and dilute to 100.0 mL with the same solvent.

**Reference solution (b).** Dilute 15.0 mL of reference solution (a) to 50.0 mL with *methanol R*.

**Reference solution (c).** Dissolve 150.0 mg of *oxaliplatin CRS* in *methanol R* and dilute to 200.0 mL with the same solvent.

**Reference solution (d).** Dilute 5.0 mL of reference solution (c) to 100.0 mL with *methanol R*.

**Reference solution (e).** To 40 mL of reference solution (c) add 1.0 mL of reference solution (b) and dilute to 50.0 mL with *methanol R*.

**Reference solution (f).** To 4.0 mL of reference solution (a) add 5.0 mL of reference solution (d) and dilute to 50.0 mL with *methanol R*.

**Column:**

- **size:**  $l = 0.25$  m,  $\varnothing = 4.6$  mm;
- **stationary phase:** *silica gel OC for chiral separations R*;
- **temperature:** 40 °C.

**Mobile phase:** *anhydrous ethanol R, methanol R* (30:70 V/V).

**Flow rate:** 0.3 mL/min.

**Detection:** spectrophotometer at 254 nm.

**Injection:** 20  $\mu$ L of the test solution and reference solutions (e) and (f).

**Run time:** twice the retention time of oxaliplatin.

**Retention time:** oxaliplatin = about 14 min; impurity D = about 16 min.

**System suitability:**

- **resolution:** minimum 1.5 between the peaks due to oxaliplatin and impurity D in the chromatogram obtained with reference solution (f);
- **signal-to-noise ratio:** minimum 10 for the peak due to impurity D in the chromatogram obtained with reference solution (e).

**Limit:**

- **impurity D:** not more than twice the peak height of the corresponding peak in the chromatogram obtained with reference solution (e) (0.1 per cent).

**Silver:** maximum 5 ppm.

Atomic absorption spectrometry (2.2.23, *Method II*).

**Test solution.** Dissolve 0.1000 g of the substance to be examined in *water R* and dilute to 50.0 mL with the same solvent. Dilute 20  $\mu$ L of this solution to 40  $\mu$ L with 0.5 M *nitric acid*.

**Reference solution (a).** Dilute a solution of *silver nitrate R* containing 1000 ppm of silver in 0.5 M *nitric acid* with 0.5 M *nitric acid* to obtain a solution which contains 10 ppb of silver.

**Reference solution (b).** Mix 20  $\mu$ L of the test solution and 8  $\mu$ L of reference solution (a) and dilute to 40  $\mu$ L with 0.5 M *nitric acid*.

**Reference solution (c).** Mix 20  $\mu$ L of the test solution and 16  $\mu$ L of reference solution (a) and dilute to 40  $\mu$ L with 0.5 M *nitric acid*.

**Source:** silver hollow-cathode lamp.

**Wavelength:** 328.1 nm.

**Atomisation device:** furnace.

Measure the absorbance of the test solution and reference solutions (b) and (c).

**Loss on drying (2.2.32):** maximum 0.5 per cent, determined on 1.000 g by drying in an oven at 105 °C for 2 h.

**Bacterial endotoxins (2.6.14):** less than 1.0 IU/mg, if intended for use in the manufacture of parenteral preparations without a further appropriate procedure for the removal of bacterial endotoxins.

**ASSAY**

Liquid chromatography (2.2.29) as described in the test for impurity C and other related substances with the following modifications.

**Injection:** 20  $\mu$ L of test solution (b) and reference solutions (d) and (e).

**System suitability:**

- **resolution:** minimum 2.0 between the peaks due to dichlorodiaminocyclohexaneplatinum and oxaliplatin in the chromatogram obtained with reference solution (e),
- **repeatability:** reference solution (d).

Calculate the percentage content of oxaliplatin using the chromatogram obtained with reference solution (d).

**IMPURITIES**

**Specified impurities:** A, B, C, D.

**Other detectable impurities** (the following substances would, if present at a sufficient level, be detected by one or other of the tests in the monograph. They are limited by the general acceptance criterion for other/unspecified impurities and/or by the general monograph *Substances for pharmaceutical use (2034)*. It is therefore not necessary to identify these impurities for demonstration of compliance. See also 5.10. *Control of impurities in substances for pharmaceutical use*): E.



A. ethanedioic acid (oxalic acid),

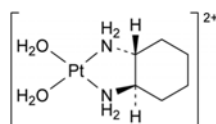

B. (SP-4-2)-diaqua[(1R,2R)-cyclohexane-1,2-diamine- $\kappa$ N, $\kappa$ N']platinum (diaquodiaminocyclohexaneplatinum),

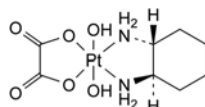

C. (OC-6-33)-[(1R,2R)-cyclohexane-1,2-diamine- $\kappa$ N, $\kappa$ N']ethanedioato(2-)- $\kappa$ O', $\kappa$ O''dihydroxyplatinum,



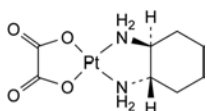

D. (SP-4-2)-[(1S,2S)-cyclohexane-1,2-diamine- $\kappa N$ , $\kappa N'$ ][ethanedioato(2-)- $\kappa O'$ , $\kappa O''$ ]platinum (S,S-enantiomer of oxaliplatin),

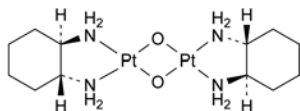

E. (SP-4-2)-di- $\mu$ -oxobis[(1R,2R)-cyclohexane-1,2-diamine- $\kappa N$ , $\kappa N'$ ]diplatinum (diaquodiaminocyclohexaneplatinum dimer).

01/2008:0778  
corrected 6.0

## OXAZEPAM

### Oxazepamum

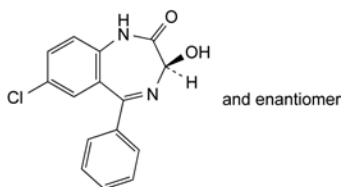

$C_{15}H_{11}ClN_2O_2$   
[604-75-1]

$M_r$  286.7

#### DEFINITION

(3RS)-7-Chloro-3-hydroxy-5-phenyl-1,3-dihydro-2H-1,4-benzodiazepin-2-one.

Content: 99.0 per cent to 101.0 per cent (dried substance).

#### CHARACTERS

Appearance: white or almost white, crystalline powder.

Solubility: practically insoluble in water, slightly soluble in ethanol (96 per cent).

#### IDENTIFICATION

Infrared absorption spectrophotometry (2.2.24).

Comparison: oxazepam CRS.

#### TESTS

**Related substances.** Liquid chromatography (2.2.29). Prepare the solutions immediately before use.

**Test solution.** Dissolve 40.0 mg of the substance to be examined in 25 mL of a mixture of equal volumes of acetonitrile R and water R and dilute to 50.0 mL with the same mixture of solvents.

**Reference solution (a).** Dilute 1.0 mL of the test solution to 100.0 mL with a mixture of equal volumes of acetonitrile R and water R. Dilute 2.0 mL of this solution to 10.0 mL with a mixture of equal volumes of acetonitrile R and water R.

**Reference solution (b).** Dissolve the contents of a vial of oxazepam for peak identification CRS (containing impurities A, B, C, D and E) in 1.0 mL of the test solution.

Column:

- size:  $l = 0.25$  m,  $\varnothing = 4.6$  mm;
- stationary phase: end-capped octadecylsilyl silica gel for chromatography R (5  $\mu$ m) resistant to bases up to pH 11.

Mobile phase:

- mobile phase A: dissolve 3.48 g of dipotassium hydrogen phosphate R in 900 mL of water R, adjust to pH 10.5 with a 40 g/L solution of sodium hydroxide R and dilute to 1000 mL with water R;

– mobile phase B: acetonitrile R;

Time (min)	Mobile phase A (per cent V/V)	Mobile phase B (per cent V/V)
0 - 4	75	25
4 - 34	75 $\rightarrow$ 25	25 $\rightarrow$ 75
34 - 45	25	75
45 - 50	25 $\rightarrow$ 75	75 $\rightarrow$ 25
50 - 60	75	25

Flow rate: 1.0 mL/min.

Detection: spectrophotometer at 235 nm.

Injection: 10  $\mu$ L.

Identification of impurities: use the chromatogram obtained with reference solution (b) and the chromatogram supplied with oxazepam for peak identification CRS to identify the peaks due to impurities A, B, C, D and E.

Relative retention with reference to oxazepam (retention time = about 15 min): impurity E = about 0.7; impurity A = about 0.8; impurity B = about 1.2; impurity C = about 1.4; impurity D = about 2.0.

System suitability: reference solution (b):

- resolution: minimum 1.5 between the peaks due to impurities E and A.

Limits:

- correction factors: for the calculation of content, multiply the peak areas of the following impurities by the corresponding correction factor: impurity A = 4.0; impurity B = 1.1;
- impurities A, B, C, D, E: for each impurity, not more than the area of the principal peak in the chromatogram obtained with reference solution (a) (0.2 per cent);
- unspecified impurities: for each impurity, not more than 0.5 times the area of the principal peak in the chromatogram obtained with reference solution (a) (0.10 per cent);
- total: not more than 5 times the area of the principal peak in the chromatogram obtained with reference solution (a) (1.0 per cent);
- disregard limit: 0.25 times the area of the principal peak in the chromatogram obtained with reference solution (a) (0.05 per cent).

Loss on drying (2.2.32): maximum 0.5 per cent, determined on 1.000 g by drying in an oven at 105 °C at a pressure not exceeding 0.7 kPa.

Sulfated ash (2.4.14): maximum 0.1 per cent, determined on 1.0 g.

#### ASSAY

Dissolve 0.250 g in a mixture of 10 mL of anhydrous acetic acid R and 90 mL of acetic anhydride R. Titrate with 0.1 M perchloric acid, determining the end-point potentiometrically (2.2.20).

1 mL of 0.1 M perchloric acid is equivalent to 28.67 mg of  $C_{15}H_{11}ClN_2O_2$ .

#### STORAGE

Protected from light.

#### IMPURITIES

Specified impurities: A, B, C, D, E.

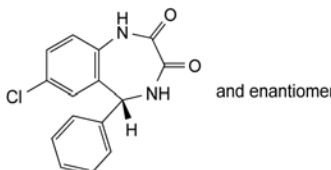

A. (5RS)-7-chloro-5-phenyl-4,5-dihydro-1H-1,4-benzodiazepine-2,3-dione,

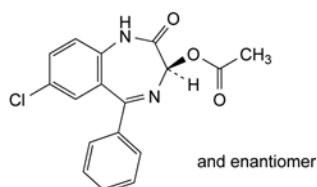

B. (3*RS*)-7-chloro-2-oxo-5-phenyl-2,3-dihydro-1*H*-1,4-benzodiazepin-3-yl acetate,

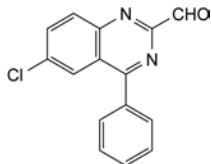

C. 6-chloro-4-phenylquinazoline-2-carbaldehyde,

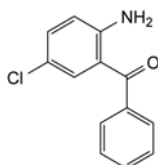

D. (2-amino-5-chlorophenyl)phenylmethanone,

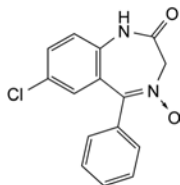

E. 7-chloro-5-phenyl-1,3-dihydro-2*H*-1,4-benzodiazepin-2-one 4-oxide.

01/2008:1761

## OXELADIN HYDROGEN CITRATE

### Oxeladini hydrogenocitras

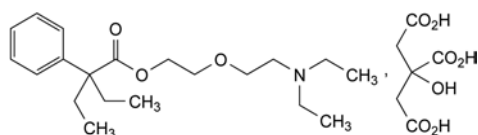

$C_{26}H_{41}NO_{10}$   
[52432-72-1]

$M_r$  527.6

#### DEFINITION

2-[2-(Diethylamino)ethoxy]ethyl 2-ethyl-2-phenylbutanoate dihydrogen 2-hydroxypropane-1,2,3-tricarboxylate.

*Content*: 99.0 per cent to 101.0 per cent (dried substance).

#### CHARACTERS

*Appearance*: white or almost white, crystalline powder.

*Solubility*: freely soluble in water, slightly to very slightly soluble in ethyl acetate.

It shows polymorphism (5.9).

#### IDENTIFICATION

Infrared absorption spectrophotometry (2.2.24).

*Comparison*: oxeladin hydrogen citrate CRS.

If the spectra obtained in the solid state show differences, dissolve the substance to be examined and the reference substance separately in *anhydrous ethanol R*, evaporate to dryness and record new spectra using the residues.

#### TESTS

**Appearance of solution.** The solution is clear (2.2.1) and not more intensely coloured than reference solution  $Y_6$  (2.2.2, *Method II*).

Dissolve 2.0 g in *water R* and dilute to 10.0 mL with the same solvent.

**Related substances.** Gas chromatography (2.2.28): use the normalisation procedure. *Prepare the solutions immediately before use.*

*Test solution.* Dissolve 0.500 g of the substance to be examined in *water R* and dilute to 50 mL with the same solvent. Add 1 mL of a 10.3 g/L solution of *hydrochloric acid R* and shake with 3 quantities, each of 10 mL, of *methylene chloride R*. Combine the lower layers. Add 5 mL of *concentrated ammonia R* to the aqueous layer and shake with 3 quantities, each of 10 mL, of *methylene chloride R*. Combine the lower layers obtained to the lower layers obtained previously, add *anhydrous sodium sulfate R*, shake, filter and evaporate the filtrate, at a temperature not exceeding 30 °C, using a rotary evaporator. Take up the residue with *methylene chloride R* and dilute to 20.0 mL with the same solvent.

*Reference solution (a).* Dissolve 5 mg of *oxeladin impurity D CRS* in 10 mL of *water R*, add 0.5 mL of *concentrated ammonia R* and shake with 3 quantities, each of 2 mL, of *methylene chloride R*. To the combined lower layers, add 0.2 mL of the test solution and dilute to 10.0 mL with *methylene chloride R*.

*Reference solution (b).* Dilute 1.0 mL of the test solution to 100.0 mL with *methylene chloride R*. Dilute 1.0 mL of this solution to 20.0 mL with *methylene chloride R*.

*Reference solution (c).* Dissolve 5 mg of *oxeladin impurity C CRS* in 10 mL of *water R*, add 0.5 mL of *concentrated ammonia R* and shake with 3 quantities, each of 2 mL, of *methylene chloride R*. Combine the lower layers and dilute to 10 mL with *methylene chloride R*.

#### Column:

- *material*: fused silica,
- *size*:  $l = 25$  m,  $\varnothing = 0.32$  mm,
- *stationary phase*: *poly(dimethyl)(diphenyl)siloxane R* (film thickness 0.4  $\mu$ m).

*Carrier gas*: helium for chromatography *R*.

*Flow rate*: 1.0 mL/min. Adjust the flow rate if necessary to obtain a retention time of about 13 min for oxeladin.

*Split ratio*: 1:15.

*Temperature*:

	Time (min)	Temperature (°C)
Column	0 - 4	160
	4 - 12	160 → 240
	12 - 21	240
	21 - 30	240 → 160
Injection port		280
Detector		280

*Detection*: flame ionisation.

*Injection*: 1  $\mu$ L.

*Relative retention* with reference to oxeladin (retention time = about 13 min): impurity A = about 0.2; impurity B = about 0.4; impurity C = about 0.8; impurity D = about 0.9.

*System suitability*: reference solution (a):

- *resolution*: minimum 10 between the peaks due to impurity D and oxeladin.

*Limits*:

- *impurity C*: maximum 0.2 per cent,

- *impurity D*: maximum 0.3 per cent,
- *any other impurity*: for each impurity, maximum 0.1 per cent,
- *total*: maximum 1.0 per cent,
- *disregard limit*: the area of the principal peak in the chromatogram obtained with reference solution (b) (0.05 per cent).

**Loss on drying** (2.2.32): maximum 0.5 per cent, determined on 1.000 g by drying *in vacuo* at 60 °C for 3 h.

**Sulfated ash** (2.4.14): maximum 0.1 per cent, determined on 1.0 g.

#### ASSAY

Dissolve 0.400 g in 50 mL of *anhydrous acetic acid R*. Titrate with 0.1 M *perchloric acid*, determining the end-point potentiometrically (2.2.20).

1 mL of 0.1 M *perchloric acid* is equivalent to 52.76 mg of  $C_{26}H_{41}NO_{10}$ .

#### IMPURITIES

*Specified impurities: C, D.*

*Other detectable impurities* (the following substances would, if present at a sufficient level, be detected by one or other of the tests in the monograph. They are limited by the general acceptance criterion for other/unspecified impurities and/or by the general monograph *Substances for pharmaceutical use* (2034). It is therefore not necessary to identify these impurities for demonstration of compliance. See also 5.10. *Control of impurities in substances for pharmaceutical use*): A, B.

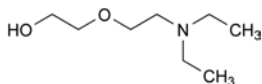

A. 2-[2-(diethylamino)ethoxy]ethanol,

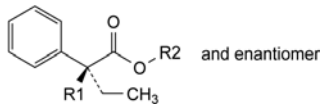

B. R1 =  $C_2H_5$ , R2 = H: 2-ethyl-2-phenylbutanoic acid,

C. R1 =  $C_2H_5$ , R2 =  $[CH_2]_2-N(C_2H_5)_2$ : 2-(diethylamino)ethyl 2-ethyl-2-phenylbutanoate,

D. R1 = H, R2 =  $[CH_2]_2-O-[CH_2]_2-N(C_2H_5)_2$ : 2-[2-(diethylamino)ethoxy]ethyl (2*RS*)-2-phenylbutanoate.

07/2008:1458

## OXFENDAZOLE FOR VETERINARY USE

### Oxfendazolium ad usum veterinarium

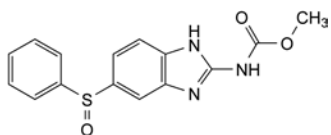

$C_{15}H_{13}N_3O_3S$   
[53716-50-0]

$M_r$  315.4

#### DEFINITION

Methyl [5-(phenylsulfanyl)-1*H*-benzimidazol-2-yl]carbamate.  
*Content*: 97.5 per cent to 100.5 per cent (dried substance).

#### CHARACTERS

*Appearance*: white or almost white powder.

*Solubility*: practically insoluble in water, slightly soluble in ethanol (96 per cent) and in methylene chloride.

It shows polymorphism (5.9).

#### IDENTIFICATION

Infrared absorption spectrophotometry (2.2.24).

*Comparison*: oxfendazole CRS.

If the spectra obtained in the solid state show differences, dissolve the substance to be examined and the reference substance separately in *ethanol (96 per cent) R*, evaporate to dryness and record new spectra using the residues.

#### TESTS

**Related substances.** Liquid chromatography (2.2.29).

*Test solution.* Dissolve 25.0 mg of the substance to be examined in the mobile phase and dilute to 100.0 mL with the mobile phase.

*Reference solution (a).* Dilute 1.0 mL of the test solution to 100.0 mL with the mobile phase.

*Reference solution (b).* To 10 mL of the test solution, add 0.25 mL of *strong hydrogen peroxide solution R* and dilute to 25 mL with the mobile phase.

*Reference solution (c).* Dissolve 5.0 mg of *fenbendazole CRS* (impurity A) and 10.0 mg of *oxfendazole impurity B CRS* in the mobile phase and dilute to 100.0 mL with the mobile phase. Dilute 1.0 mL of this solution to 20.0 mL with the mobile phase.

*Reference solution (d).* Dissolve 5 mg of *oxfendazole with impurity D CRS* in the mobile phase and dilute to 20 mL with the mobile phase (for identification of impurity D).

*Column*:

– *size*:  $l = 0.25$  m,  $\emptyset = 4.6$  mm;

– *stationary phase*: spherical *end-capped octadecylsilyl silica gel for chromatography R* (5  $\mu$ m) with a specific surface area of 350 m<sup>2</sup>/g, a pore size of 10 nm and a carbon loading of 14 per cent.

*Mobile phase*: mix 36 volumes of *acetonitrile R* and 64 volumes of a 2 g/L solution of *sodium pentanesulfonate R* previously adjusted to pH 2.7 with a 2.8 per cent *V/V* solution of *sulfuric acid R*.

*Flow rate*: 1 mL/min.

*Detection*: spectrophotometer at 254 nm.

*Injection*: 20  $\mu$ L.

*Run time*: 4 times the retention time of oxfendazole.

*Relative retention* with reference to oxfendazole (retention time = about 6.5 min): impurity C = about 0.7; impurity B = about 1.5; impurity D = about 1.9; impurity A = about 3.4.

*System suitability*: reference solution (b):

– *resolution*: minimum 4.0 between the peaks due to impurity C and oxfendazole.

*Limits*:

– *impurity B*: not more than the area of the corresponding peak in the chromatogram obtained with reference solution (c) (2.0 per cent);

– *impurity A*: not more than the area of the corresponding peak in the chromatogram obtained with reference solution (c) (1.0 per cent);

– *impurities C, D*: for each impurity, not more than the area of the principal peak in the chromatogram obtained with reference solution (a) (1.0 per cent);

– *unspecified impurities*: not more than 0.1 times the area of the principal peak in the chromatogram obtained with reference solution (a) (0.10 per cent);

– *total*: not more than 3 times the area of the principal peak in the chromatogram obtained with reference solution (a) (3.0 per cent);

– *disregard limit*: 0.05 times the area of the principal peak in the chromatogram obtained with reference solution (a) (0.05 per cent).

**Loss on drying** (2.2.32): maximum 0.5 per cent, determined on 1.000 g by drying in an oven at 105 °C at a pressure not exceeding 0.7 kPa for 2 h.

**Sulfated ash** (2.4.14): maximum 0.2 per cent, determined on 1.0 g.

#### ASSAY

Dissolve 0.250 g in 3 mL of *anhydrous formic acid R*. Add 40 mL of *anhydrous acetic acid R*. Titrate with 0.1 M *perchloric acid*, determining the end-point potentiometrically (2.2.20).

1 mL of 0.1 M *perchloric acid* is equivalent to 31.54 mg of C<sub>15</sub>H<sub>13</sub>N<sub>3</sub>O<sub>3</sub>S.

#### STORAGE

Protected from light.

#### IMPURITIES

*Specified impurities: A, B, C, D.*

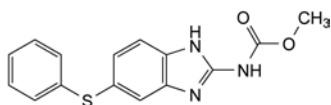

A. methyl [5-(phenylsulfanyl)-1H-benzimidazol-2-yl]carbamate (fenbendazole),

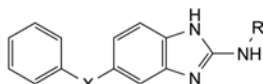

B. X = SO<sub>2</sub>, R = CO<sub>2</sub>-CH<sub>3</sub>: methyl [5-(phenylsulfonyl)-1H-benzimidazol-2-yl]carbamate,

C. X = SO, R = H: 5-(phenylsulfinyl)-1H-benzimidazol-2-amine,

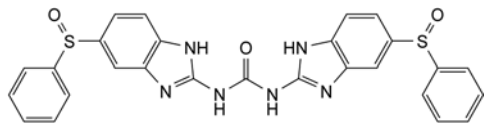

D. *N,N'*-bis[5-(phenylsulfinyl)-1H-benzimidazol-2-yl]urea.

01/2008:2170  
corrected 6.0

## OXITROPIUM BROMIDE

### Oxitropii bromidum

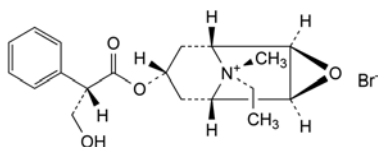

C<sub>19</sub>H<sub>26</sub>BrNO<sub>4</sub>  
[30286-75-0]

*M<sub>r</sub>* 412.3

#### DEFINITION

(1*R*,2*R*,4*S*,5*S*,7*s*,9*r*)-9-Ethyl-7-[[[(2*S*)-3-hydroxy-2-phenylpropanoyl]oxy]-9-methyl-3-oxa-9-azoniatricyclo[3.3.1.0<sup>2,4</sup>]nonane bromide (ethylhyoscine).

*Content*: 99.0 per cent to 101.0 per cent (dried substance).

#### CHARACTERS

*Appearance*: white or almost white, crystalline powder.

*Solubility*: very soluble in water, freely soluble in methanol, sparingly soluble in ethanol (96 per cent), practically insoluble in methylene chloride.

It shows polymorphism (5.9).

#### IDENTIFICATION

A. Infrared absorption spectrophotometry (2.2.24).

*Comparison: oxitropium bromide CRS.*

If the spectra obtained in the solid state show differences at about 1700 cm<sup>-1</sup> and about 3300 cm<sup>-1</sup>, dissolve the substance to be examined and the reference substance separately in *methanol R*, evaporate to dryness and record new spectra using the residues.

B. It gives reaction (a) of bromides (2.3.1).

#### TESTS

**Specific optical rotation** (2.2.7): -24 to -26 (dried substance).

Dissolve 1.0 g in *water R* and dilute to 20.0 mL with the same solvent.

**Related substances.** Liquid chromatography (2.2.29).

*Test solution.* Dissolve 75.0 mg of the substance to be examined in the mobile phase and dilute to 50.0 mL with the mobile phase. Dilute 5.0 mL of this solution to 50.0 mL with the mobile phase.

*Reference solution (a).* Dissolve 7.5 mg of *oxitropium bromide impurity B CRS* in the mobile phase and dilute to 50.0 mL with the mobile phase.

*Reference solution (b).* Dilute 5.0 mL of reference solution (a) to 50.0 mL with the mobile phase. Dilute 5.0 mL of the solution to 50.0 mL with the mobile phase. Dilute 5.0 mL of this solution to 50.0 mL with the mobile phase.

*Reference solution (c).* Mix 5.0 mL of the test solution and 5.0 mL of reference solution (a).

*Reference solution (d).* Dilute 15.0 mL of the test solution to 100.0 mL with the mobile phase. Dilute 5.0 mL of this solution to 50.0 mL with the mobile phase.

*Reference solution (e).* Dilute 5.0 mL of the test solution to 50.0 mL with the mobile phase. Dilute 5.0 mL of the solution to 50.0 mL with the mobile phase. Dilute 5.0 mL of this solution to 50.0 mL with the mobile phase.

*Column:*

– *size*: *l* = 0.125 m, Ø = 4.0 mm;

– *stationary phase*: base-deactivated octylsilyl silica gel for chromatography R (5 µm) with a specific surface area of 350 m<sup>2</sup>/g and a pore size of 6 nm.

*Mobile phase*: mix 1 volume of *acetonitrile for chromatography R* with 10 volumes of a 7.8 g/L solution of *sodium dihydrogen phosphate R*.

*Flow rate*: 2.0 mL/min.

*Detection*: spectrophotometer at 210 nm.

*Injection*: 50 µL of the test solution and reference solutions (b), (c), (d) and (e).

*Relative retention* with reference to oxitropium (retention time = about 6 min): impurity A = about 0.8; impurity B = about 0.9; impurity C = about 1.3.

*System suitability*: reference solution (c):

– *resolution*: minimum 1.6 between the peaks due to impurity B and oxitropium.

*Limits*:

– *impurity A*: not more than the area of the principal peak in the chromatogram obtained with reference solution (e) (0.1 per cent);

– *impurity B*: not more than the area of the corresponding peak in the chromatogram obtained with reference solution (b) (0.1 per cent);

– *impurity C*: not more than the area of the principal peak in the chromatogram obtained with reference solution (d) (1.5 per cent);

– *unspecified impurities*: for each impurity, not more than the area of the principal peak in the chromatogram obtained with reference solution (e) (0.10 per cent);

– *sum of unspecified impurities*: not more than twice the area of the principal peak in the chromatogram obtained with reference solution (e) (0.2 per cent);

- *disregard limit*: 0.5 times the area of the principal peak in the chromatogram obtained with reference solution (e) (0.05 per cent).

**Impurity D.** Liquid chromatography (2.2.29).

*Test solution.* Dissolve 75.0 mg of the substance to be examined in the mobile phase and dilute to 50.0 mL with the mobile phase. Dilute 5.0 mL of this solution to 50.0 mL with the mobile phase.

*Reference solution (a).* Dissolve 6.0 mg of *oxitropium bromide impurity D CRS* in the mobile phase and dilute to 50.0 mL with the mobile phase.

*Reference solution (b).* Dilute 5.0 mL of reference solution (a) to 200.0 mL with the mobile phase. Dilute 5.0 mL of this solution to 50.0 mL with the mobile phase.

*Reference solution (c).* To 5.0 mL of the test solution add 5.0 mL of reference solution (a).

**Column:**

- *size*:  $l = 0.125$  m,  $\varnothing = 4.0$  mm;
- *stationary phase*: *base-deactivated octylsilyl silica gel for chromatography R* (5  $\mu$ m).

*Mobile phase*: mix 185 volumes of *acetonitrile for chromatography R* with 1000 volumes of a 7.8 g/L solution of *sodium dihydrogen phosphate R*.

*Flow rate*: 2.0 mL/min.

*Detection*: spectrophotometer at 210 nm.

*Injection*: 50  $\mu$ L of the test solution and reference solutions (b) and (c).

*System suitability*: reference solution (c):

- *resolution*: minimum 3.0 between the peaks due to impurity D and oxitropium.

**Limit:**

- *impurity D*: not more than the area of the corresponding peak in the chromatogram obtained with reference solution (b) (0.2 per cent).

**Loss on drying** (2.2.32): maximum 0.5 per cent, determined on 1.000 g by drying in an oven at 105 °C.

**ASSAY**

Dissolve 0.350 g in 100 mL of *water R* and add 5.0 mL of *dilute nitric acid R*. Titrate with 0.1 M *silver nitrate*. Determine the end-point potentiometrically (2.2.20) using a silver indicator electrode and a silver-silver chloride reference electrode.

1 mL of 0.1 M *silver nitrate* is equivalent to 41.23 mg of  $C_{19}H_{26}BrNO_4$ .

**IMPURITIES**

*Specified impurities: A, B, C, D.*

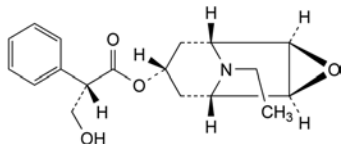

- A. (1*R*,2*R*,4*S*,5*S*,7*s*)-9-ethyl-3-oxa-9-azatricyclo[3.3.1.0<sup>2,4</sup>]nonan-7yl [(2*S*)-3-hydroxy-2-phenylpropanoate] (*N*-ethylnorhyosine),

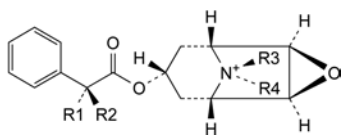

- B.  $R_1 = CH_2OH$ ,  $R_2 = H$ ,  $R_3 = R_4 = CH_3$ : (1*R*,2*R*,4*S*,5*S*,7*s*)-7-[[[(2*S*)-3-hydroxy-2-phenylpropanoyl]oxy]-9,9-dimethyl-3-oxa-9-azoniatricyclo[3.3.1.0<sup>2,4</sup>]nonane (methylhyosine),
- C.  $R_1 = CH_2OH$ ,  $R_2 = H$ ,  $R_3 = C_2H_5$ ,  $R_4 = CH_3$ : (1*R*,2*R*,4*S*,5*S*,7*s*,9*s*)-9-ethyl-7-[[[(2*S*)-3-hydroxy-2-phenylpropanoyl]oxy]-9-methyl-3-oxa-9-azoniatricyclo[3.3.1.0<sup>2,4</sup>]nonane (pseudo-isomer),

- D.  $R_1 + R_2 = CH_2$ ,  $R_3 = CH_3$ ,  $R_4 = C_2H_5$ : (1*R*,2*R*,4*S*,5*S*,7*s*,9*r*)-9-ethyl-9-methyl-7-[[[(2-phenylprop-2-enoyl)oxy]-3-oxa-9-azoniatricyclo[3.3.1.0<sup>2,4</sup>]nonane (apo-*N*-ethylhyosine).

07/2009:1353

**OXOLINIC ACID**

**Acidum oxolinicum**

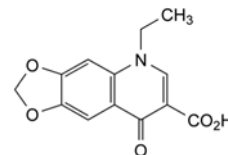

$C_{13}H_{11}NO_5$   
[14698-29-4]

$M_r$  261.2

**DEFINITION**

5-Ethyl-8-oxo-5,8-dihydro-1,3-dioxolo[4,5-*g*]quinoline-7-carboxylic acid.

*Content*: 98.0 per cent to 102.0 per cent (dried substance).

**CHARACTERS**

*Appearance*: almost white or pale yellow, crystalline powder.

*Solubility*: practically insoluble in water, very slightly soluble in methylene chloride, practically insoluble in ethanol (96 per cent). It dissolves in dilute solutions of alkali hydroxides.

**IDENTIFICATION**

*First identification: B.*

*Second identification: A, C.*

- A. Ultraviolet and visible absorption spectrophotometry (2.2.25).

*Test solution.* Dissolve 25.0 mg in 5 mL of 0.1 M *sodium hydroxide*, heating on a water-bath. Allow to cool and dilute to 100.0 mL with *methanol R*. Dilute 2.0 mL of this solution to 100.0 mL with 0.1 M *hydrochloric acid*.

*Spectral range*: 220-350 nm.

*Absorption maxima*: at 260 nm, 322 nm and 336 nm.

*Absorbance ratio*:  $A_{260}/A_{336} = 4.9$  to 5.2.

- B. Infrared absorption spectrophotometry (2.2.24).

*Preparation*: discs.

*Comparison*: *oxolinic acid CRS*.

- C. Thin-layer chromatography (2.2.27).

*Test solution.* Dissolve 10 mg of the substance to be examined in 3 mL of *dilute sodium hydroxide solution R* and dilute to 20 mL with *ethanol (96 per cent) R*.

*Reference solution (a).* Dissolve 10 mg of *oxolinic acid CRS* in 3 mL of *dilute sodium hydroxide solution R* and dilute to 20 mL with *ethanol (96 per cent) R*.

*Reference solution (b).* Dissolve 5 mg of *ciprofloxacin hydrochloride CRS* in *methanol R* and dilute to 10 mL with the same solvent. Dilute 1 mL of this solution to 2 mL with reference solution (a).

*Plate*: *TLC silica gel plate R*.

*Mobile phase*: *acetonitrile R*, *concentrated ammonia R*, *methanol R*, *methylene chloride R* (10:20:40:40 V/V/V/V).

*Application*: 10  $\mu$ L.

*Development*: at the bottom of a chromatographic tank, place an evaporating disk containing 50 mL of *concentrated ammonia R* and expose the plate to the ammonia vapour for 15 min in the closed tank; withdraw the plate, transfer to a second chromatographic tank and proceed with development over a path of 15 cm.

*Drying*: in air.

*Detection*: examine in ultraviolet light at 254 nm.

*System suitability*: reference solution (b):

- the chromatogram shows 2 clearly separated principal spots.

*Results*: the principal spot in the chromatogram obtained with the test solution is similar in position, colour and size to the principal spot in the chromatogram obtained with reference solution (a).

#### TESTS

**Solution S.** Dissolve 0.6 g in 20 mL of a 40 g/L solution of sodium hydroxide R.

**Appearance of solution.** Solution S is clear (2.2.1) and not more intensely coloured than reference solution B<sub>7</sub> (2.2.2, Method II).

**Related substances.** Thin-layer chromatography (2.2.27).

*Test solution.* Dissolve 0.10 g of the substance to be examined in 3 mL of dilute sodium hydroxide solution R and dilute to 10 mL with ethanol (96 per cent) R.

*Reference solution (a).* Dilute 1 mL of the test solution to 50.0 mL with ethanol (96 per cent) R. Dilute 1.0 mL of this solution to 5.0 mL with ethanol (96 per cent) R.

*Reference solution (b).* Dissolve 2 mg of oxolinic acid impurity B CRS in ethanol (96 per cent) R and dilute to 10 mL with the same solvent. Dilute 1.0 mL of this solution to 10 mL with ethanol (96 per cent) R.

*Reference solution (c).* Dissolve 5 mg of the substance to be examined and 5 mg of oxolinic acid impurity A CRS in 2 mL of dilute sodium hydroxide solution R and dilute to 40 mL with ethanol (96 per cent) R.

*Plate:* cellulose for chromatography R as the coating substance.

*Mobile phase:* ammonia R, water R, propanol R (15:30:55 V/V/V).

*Application:* 5 µL, in sufficiently small portions to obtain small spots.

*Development:* over 2/3 of the plate.

*Drying:* in air.

*Detection:* examine in ultraviolet light at 254 nm.

*System suitability*: reference solution (c):

- the chromatogram shows 2 clearly separated principal spots.

*Limits*:

- *impurity B*: any spot due to impurity B is not more intense than the corresponding spot in the chromatogram obtained with reference solution (b) (0.2 per cent);
- *impurities A, C*: any spot due to impurities A or C is not more intense than the principal spot in the chromatogram obtained with reference solution (a) (0.4 per cent).

**Heavy metals** (2.4.8): maximum 10 ppm.

2.0 g complies with test D. Prepare the reference solution using 2 mL of lead standard solution (10 ppm Pb) R.

**Loss on drying** (2.2.32): maximum 0.5 per cent, determined on 1.000 g by heating in an oven at 105 °C.

**Sulfated ash** (2.4.14): maximum 0.1 per cent, determined on 1.0 g.

#### ASSAY

Dissolve 0.200 g in 150 mL of dimethylformamide R. Titrate with 0.1 M tetrabutylammonium hydroxide, determining the end-point potentiometrically (2.2.20). Use a glass indicator electrode and a calomel reference electrode containing, as the electrolyte, a saturated solution of potassium chloride R in methanol R. Carry out a blank titration.

1 mL of 0.1 M tetrabutylammonium hydroxide is equivalent to 26.12 mg of C<sub>13</sub>H<sub>11</sub>NO<sub>5</sub>.

#### STORAGE

Protected from light.

#### IMPURITIES

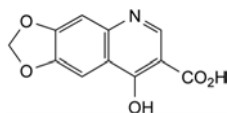

A. 8-hydroxy-1,3-dioxolo[4,5-g]quinoline-7-carboxylic acid,

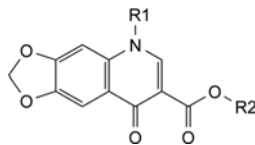

B. R<sub>1</sub> = R<sub>2</sub> = C<sub>2</sub>H<sub>5</sub>: ethyl 5-ethyl-8-oxo-5,8-dihydro-1,3-dioxolo[4,5-g]quinoline-7-carboxylate,

C. R<sub>1</sub> = CH<sub>3</sub>, R<sub>2</sub> = H: 5-methyl-8-oxo-5,8-dihydro-1,3-dioxolo[4,5-g]quinoline-7-carboxylic acid.

01/2008:0628  
corrected 7.0

## OXPRENOLOL HYDROCHLORIDE

### Oxprenololi hydrochloridum

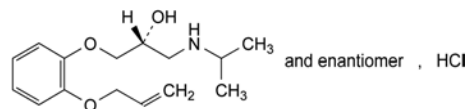

C<sub>15</sub>H<sub>24</sub>ClNO<sub>3</sub>  
[6452-73-9]

M<sub>r</sub> 301.8

#### DEFINITION

(2*RS*)-1-[(1-methylethyl)amino]-3-[2-(prop-2-enyloxy)phenoxy]propan-2-ol hydrochloride.

*Content*: 98.5 per cent to 101.5 per cent (dried substance).

#### CHARACTERS

*Appearance*: white or almost white, crystalline powder.

*Solubility*: very soluble in water, freely soluble in alcohol.

#### IDENTIFICATION

*First identification*: B, D.

*Second identification*: A, C, D.

A. Melting point (2.2.14): 107 °C to 110 °C.

B. Infrared absorption spectrophotometry (2.2.24).

*Comparison*: oxprenolol hydrochloride CRS.

If the spectra obtained in the solid state show differences, dissolve the substance to be examined and the reference substance separately in ethyl acetate R, evaporate to dryness and record new spectra using the residues.

C. Examine the chromatograms obtained in the test for related substances.

*Results*: the principal spot in the chromatogram obtained with test solution (b) is similar in position, colour and size to the principal spot in the chromatogram obtained with reference solution (a).

D. It gives reaction (a) of chlorides (2.3.1).

#### TESTS

**Solution S.** Dissolve 2.0 g in carbon dioxide-free water R and dilute to 20 mL with the same solvent.

01/2008:1251  
corrected 6.0

**Appearance of solution.** Solution S is clear (2.2.1) and not more intensely coloured than reference solution GY<sub>6</sub> (2.2.2, Method II).

**pH** (2.2.3): 4.5 to 6.0 for freshly prepared solution S.

**Related substances.** Thin-layer chromatography (2.2.27).

**Test solution (a).** Dissolve 0.10 g of the substance to be examined in 2 mL of a mixture of 1 volume of *methanol R* and 9 volumes of *methylene chloride R*.

**Test solution (b).** Dilute 1 mL of test solution (a) to 10 mL with a mixture of 1 volume of *methanol R* and 9 volumes of *methylene chloride R*.

**Reference solution (a).** Dissolve 10 mg of *oxprenolol hydrochloride CRS* in 2 mL of a mixture of 1 volume of *methanol R* and 9 volumes of *methylene chloride R*.

**Reference solution (b).** Dilute 0.4 mL of test solution (a) to 100 mL with a mixture of 1 volume of *methanol R* and 9 volumes of *methylene chloride R*.

**Reference solution (c).** Dilute 5 mL of reference solution (b) to 10 mL with a mixture of 1 volume of *methanol R* and 9 volumes of *methylene chloride R*.

**Reference solution (d).** Dissolve 5 mg of *alprenolol hydrochloride CRS* in 1 mL of reference solution (a).

**Plate:** TLC silica gel G plate R.

**Mobile phase:** concentrated ammonia R, *methanol R*, *methylene chloride R* (2:12:88 V/V/V).

**Application:** 2 µL; allow the spots to dry in air for 15 min.

**Development:** over a path of 13 cm.

**Drying:** in a current of warm air for 10 min.

**Detection:** allow to cool and spray with *anisaldehyde solution R*. Heat at 100-105 °C for 5-10 min. Examine in daylight.

**System suitability:** the test is not valid unless the chromatogram obtained with reference solution (d) shows 2 clearly separated spots.

**Limits:** in the chromatogram obtained with test solution (a):

- **any impurity:** any spot, apart from the principal spot, is not more intense than the spot in the chromatogram obtained with reference solution (b) (0.4 per cent); not more than 1 such spot is more intense than the spot in the chromatogram obtained with reference solution (c) (0.2 per cent).

**Lead:** maximum 5 ppm.

Atomic absorption spectrometry (2.2.23, Method II).

**Test solution.** Dissolve 1.00 g of the substance to be examined in *water R* and dilute to 25.0 mL with the same solvent.

**Reference solutions.** Prepare the reference solutions using 0.5 mL and 1.0 mL respectively of *lead standard solution (10 ppm Pb) R* diluted to 25.0 mL with *water R*.

**Source:** lead hollow-cathode lamp.

**Wavelength:** 217.0 nm.

**Loss on drying** (2.2.32): maximum 0.5 per cent, determined on 1.000 g by drying *in vacuo* at 60 °C for 6 h.

**Sulfated ash** (2.4.14): maximum 0.1 per cent, determined on 1.0 g.

#### ASSAY

Dissolve 0.250 g in a mixture of 5.0 mL of 0.01 M *hydrochloric acid* and 50 mL of *alcohol R*. Carry out a potentiometric titration (2.2.20), using 0.1 M *sodium hydroxide*. Read the volume added between the 2 points of inflexion.

1 mL of 0.1 M *sodium hydroxide* is equivalent to 30.18 mg of C<sub>17</sub>H<sub>29</sub>ClN<sub>2</sub>O<sub>3</sub>.

#### STORAGE

Protected from light.

## OXYBUPROCAINE HYDROCHLORIDE

### Oxybuprocaini hydrochloridum

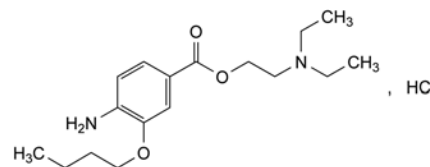

C<sub>17</sub>H<sub>29</sub>ClN<sub>2</sub>O<sub>3</sub>  
[5987-82-6]

M<sub>r</sub> 344.9

#### DEFINITION

2-(Diethylamino)ethyl 4-amino-3-butoxybenzoate hydrochloride.

**Content:** 98.5 per cent to 101.5 per cent (dried substance).

#### CHARACTERS

**Appearance:** white or almost white, crystalline powder or colourless crystals.

**Solubility:** very soluble in water, freely soluble in ethanol (96 per cent).

It shows polymorphism (5.9).

#### IDENTIFICATION

**First identification:** B, D.

**Second identification:** A, C, D.

A. Melting point (2.2.14): 158 °C to 162 °C.

B. Infrared absorption spectrophotometry (2.2.24).

**Preparation:** discs.

**Comparison:** *oxybuprocaine hydrochloride CRS*.

If the spectra obtained show differences, dissolve the substance to be examined and the reference substance separately in *methanol R*, evaporate to dryness and record new spectra using the residues.

C. Thin-layer chromatography (2.2.27).

**Test solution.** Dissolve 40 mg of the substance to be examined in *methanol R* and dilute to 10 mL with the same solvent.

**Reference solution (a).** Dissolve 40 mg of *oxybuprocaine hydrochloride CRS* in *methanol R* and dilute to 10 mL with the same solvent.

**Reference solution (b).** Dissolve 20 mg of *procaine hydrochloride R* in reference solution (a) and dilute to 5 mL with reference solution (a).

**Plate:** TLC silica gel F<sub>254</sub> plate R.

**Mobile phase:** *anhydrous formic acid R*, *methanol R*, *water R*, *ethyl acetate R* (10:15:15:60 V/V/V/V).

**Application:** 5 µL.

**Development:** over a path of 10 cm.

**Drying:** in a current of warm air for 10 min.

**Detection:** spray with *dimethylaminobenzaldehyde solution R7* and examine in ultraviolet light at 254 nm.

**System suitability:** reference solution (b):

- the chromatogram shows 2 clearly separated spots.

**Results:** the principal spot in the chromatogram obtained with the test solution is similar in position, colour and size to the principal spot in the chromatogram obtained with reference solution (a).

D. Dilute 0.2 mL of solution S (see Tests) to 2 mL with *water R*. The solution gives reaction (a) of chlorides (2.3.1).

#### TESTS

**Solution S.** Dissolve 5.0 g in *carbon dioxide-free water R* and dilute to 50 mL with the same solvent.

**Appearance of solution.** Solution S is clear (2.2.1) and not more intensely coloured than reference solution Y<sub>5</sub> (2.2.2, Method II).

**pH** (2.2.3): 4.5 to 6.0 for solution S.

**Related substances.** Liquid chromatography (2.2.29).

**Buffer solution pH 2.5.** Add 6 mL of perchloric acid solution R and 12 mL of dilute phosphoric acid R to 950 mL of water R. Adjust to pH 2.5 with a 40 g/L solution of sodium hydroxide R and dilute to 1000.0 mL with water R.

**Test solution.** Dissolve 10.0 mg of the substance to be examined in the mobile phase and dilute to 25.0 mL with the mobile phase.

**Reference solution (a).** Dilute 1.0 mL of the test solution to 20.0 mL with the mobile phase. Dilute 5.0 mL of this solution to 100.0 mL with the mobile phase.

**Reference solution (b).** Mix 1.0 mL of the test solution with 1 mL of a 40 g/L solution of sodium hydroxide R and allow to stand for 20 min. Add 1 mL of dilute phosphoric acid R and dilute to 100.0 mL with the mobile phase. Dilute 25 mL of this solution to 100.0 mL with the mobile phase.

**Column:**

- size:  $l = 0.15$  m,  $\varnothing = 3.9$  mm;
- stationary phase: octadecylsilyl silica gel for chromatography R1 (5  $\mu$ m) with a pore size of 10 nm and a carbon loading of 19 per cent;
- temperature: 35 °C.

**Mobile phase:** acetonitrile R, buffer solution pH 2.5 (25:75 V/V).

**Flow rate:** 1 mL/min.

**Detection:** spectrophotometer at 309 nm.

**Injection:** 20  $\mu$ L.

**Run time:** 4 times the retention time of oxybuprocaine.

**Retention time:** oxybuprocaine = about 9 min.

**System suitability:** reference solution (b):

- resolution: minimum 12 between the peaks due to oxybuprocaine and impurity B (hydrolysis product).

**Limits:**

- any impurity: for each impurity, not more than 0.4 times the area of the principal peak in the chromatogram obtained with reference solution (a) (0.1 per cent);
- total: not more than the area of the principal peak in the chromatogram obtained with reference solution (a) (0.25 per cent);
- disregard limit: 0.05 times the area of the principal peak in the chromatogram obtained with reference solution (a) (0.0125 per cent).

**Heavy metals** (2.4.8): maximum 10 ppm.

12 mL of solution S complies with test A. Prepare the reference solution using lead standard solution (1 ppm Pb) R.

**Loss on drying** (2.2.32): maximum 0.5 per cent determined on 1.000 g by drying in an oven at 105 °C.

**Sulfated ash** (2.4.14): maximum 0.1 per cent, determined on 1.0 g.

**ASSAY**

Dissolve 0.300 g in a mixture of 20 mL of anhydrous acetic acid R and 20 mL of acetic anhydride R. Titrate with 0.1 M perchloric acid, determining the end-point potentiometrically (2.2.20).

1 mL of 0.1 M perchloric acid is equivalent to 34.49 mg of C<sub>17</sub>H<sub>29</sub>ClN<sub>2</sub>O<sub>3</sub>.

**STORAGE**

Protected from light.

**IMPURITIES**

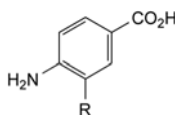

A. R = H: 4-aminobenzoic acid,

B. R = O-CH<sub>2</sub>-CH<sub>2</sub>-CH<sub>2</sub>-CH<sub>3</sub>: 4-amino-3-butoxybenzoic acid,

C. R = OH: 4-amino-3-hydroxybenzoic acid.

07/2010:1354

## OXYBUTYNIN HYDROCHLORIDE

Oxybutynini hydrochloridum

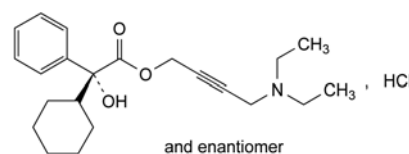

C<sub>22</sub>H<sub>32</sub>ClNO<sub>3</sub>  
[1508-65-2]

*M*<sub>r</sub> 394.0

**DEFINITION**

4-(Diethylamino)but-2-ynyl (*RS*)-2-cyclohexyl-2-hydroxy-2-phenylacetate hydrochloride.

**Content:** 99.0 per cent to 102.0 per cent (dried substance).

**CHARACTERS**

**Appearance:** white or almost white, crystalline powder.

**Solubility:** freely soluble in water and in ethanol (96 per cent), soluble in acetone, practically insoluble in cyclohexane.

**IDENTIFICATION**

**First identification:** B, D.

**Second identification:** A, C, D.

A. Melting point (2.2.14): 124 °C to 129 °C.

B. Infrared absorption spectrophotometry (2.2.24).

*Comparison:* oxybutynin hydrochloride CRS.

C. Thin-layer chromatography (2.2.27).

**Test solution.** Dissolve 50 mg of the substance to be examined in ethanol (96 per cent) R and dilute to 10 mL with the same solvent.

**Reference solution.** Dissolve 10 mg of oxybutynin hydrochloride CRS in ethanol (96 per cent) R and dilute to 2 mL with the same solvent.

**Plate:** TLC silica gel plate R.

**Mobile phase:** methanol R.

**Application:** 5  $\mu$ L.

**Development:** over 2/3 of the plate.

**Drying:** in air.

**Detection:** expose to iodine vapour for 30 min.

**Results:** the principal spot in the chromatogram obtained with the test solution is similar in position, colour and size to the principal spot in the chromatogram obtained with the reference solution.

D. It gives reaction (a) of chlorides (2.3.1).

**TESTS**

**Solution S.** Dissolve 2.00 g in water R and dilute to 20.0 mL with the same solvent.

**Appearance of solution.** Solution S is clear (2.2.1) and not more intensely coloured than reference solution BY<sub>5</sub> (2.2.2, Method II).

**Optical rotation** (2.2.7):  $-0.10^\circ$  to  $+0.10^\circ$ , determined on solution S.



**Related substances.** Liquid chromatography (2.2.29).

**Test solution.** Dissolve 50.0 mg of the substance to be examined in the mobile phase and dilute to 10.0 mL with the mobile phase.

**Reference solution (a).** Dissolve 5.0 mg of *oxybutynin hydrochloride CRS* and 5.0 mg of *oxybutynin impurity A CRS* in the mobile phase and dilute to 10.0 mL with the mobile phase. Dilute 5.0 mL of this solution to 50.0 mL with the mobile phase.

**Reference solution (b).** Dilute 1.0 mL of the test solution to 200.0 mL with the mobile phase.

**Column:**

- size:  $l = 0.15$  m,  $\varnothing = 3.9$  mm;
- stationary phase: *octylsilyl silica gel for chromatography R2* (5  $\mu$ m).

**Mobile phase:** mix 49 volumes of a solution containing 3.4 g/L of *potassium dihydrogen phosphate R* and 4.36 g/L of *dipotassium hydrogen phosphate R* and 51 volumes of *acetonitrile R1*.

**Flow rate:** 1 mL/min.

**Detection:** spectrophotometer at 210 nm.

**Injection:** 10  $\mu$ L.

**Run time:** twice the retention time of oxybutynin.

**Retention time:** oxybutynin = about 15 min; impurity A = about 24 min.

**System suitability:** reference solution (a):

- resolution: minimum 11.0 between the peaks due to oxybutynin and impurity A.

**Limits:**

- *impurity A*: not more than 1.5 times the area of the corresponding peak in the chromatogram obtained with reference solution (a) (1.5 per cent);
- *unspecified impurities*: for each impurity, not more than 0.2 times the area of the principal peak in the chromatogram obtained with reference solution (b) (0.10 per cent);
- *sum of impurities other than A*: not more than the area of the principal peak in the chromatogram obtained with reference solution (b) (0.5 per cent);
- *disregard limit*: 0.1 times the area of the principal peak in the chromatogram obtained with reference solution (b) (0.05 per cent).

**Heavy metals (2.4.8):** maximum 20 ppm.

12 mL of solution S complies with test A. Prepare the reference solution using 2 mL of *lead standard solution (10 ppm Pb) R*.

**Loss on drying (2.2.32):** maximum 3.0 per cent, determined on 1.000 g by drying in an oven at 105 °C.

**Sulfated ash (2.4.14):** maximum 0.1 per cent, determined on 1.0 g.

**ASSAY**

Dissolve 0.300 g in a mixture of 5.0 mL of 0.01 M *hydrochloric acid* and 50 mL of *ethanol (96 per cent) R*. Carry out a potentiometric titration (2.2.20), using 0.1 M *sodium hydroxide*. Read the volume added between the 2 points of inflexion.

1 mL of 0.1 M *sodium hydroxide* is equivalent to 39.4 mg of  $C_{22}H_{32}ClNO_3$ .

**STORAGE**

Protected from light.

**IMPURITIES**

**Specified impurities: A.**

**Other detectable impurities** (the following substances would, if present at a sufficient level, be detected by one or other of the tests in the monograph. They are limited by the general acceptance criterion for other/unspecified impurities and/or by the general monograph *Substances for pharmaceutical use (2034)*. It is therefore not necessary to identify these impurities for demonstration of compliance. See also 5.10. *Control of impurities in substances for pharmaceutical use*): B, C, D, E.

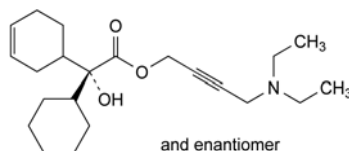

A. 4-(diethylamino)but-2-ynyl (*RS*)-2-(cyclohex-3-enyl)-cyclohexyl-2-hydroxyacetate,

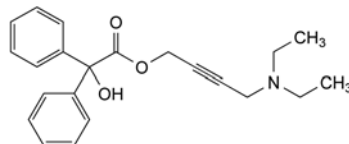

B. 4-(diethylamino)but-2-ynyl 2-hydroxy-2,2-diphenylacetate (diphenyl analogue of oxybutynin),

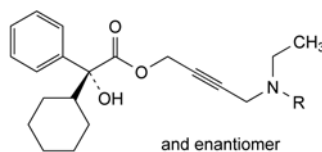

C. R = CH<sub>3</sub>: 4-(ethylmethylamino)but-2-ynyl (*RS*)-2-cyclohexyl-2-hydroxy-2-phenylacetate (methylethyl analogue of oxybutynin),

E. R = CH<sub>2</sub>-CH<sub>2</sub>-CH<sub>3</sub>: 4-(ethylpropylamino)but-2-ynyl (*RS*)-2-cyclohexyl-2-hydroxy-2-phenylacetate (ethylpropyl analogue of oxybutynin),

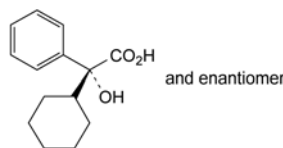

D. (*RS*)-2-cyclohexyl-2-hydroxy-2-phenylacetic acid (phenylcyclohexylglycolic acid).

01/2008:1793  
corrected 7.0

## OXYCODONE HYDROCHLORIDE

### Oxycodoni hydrochloridum

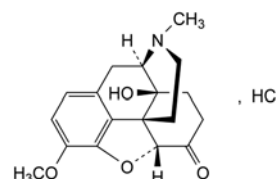

$C_{18}H_{22}ClNO_4$   
[124-90-3]

$M_r$  351.9

**DEFINITION**

4,5 $\alpha$ -Epoxy-14-hydroxy-3-methoxy-17-methylmorphinan-6-one hydrochloride.

**Content:** 98.5 per cent to 101.5 per cent (anhydrous substance).

**CHARACTERS**

**Appearance:** white or almost white powder, hygroscopic.

**Solubility:** freely soluble in water, sparingly soluble in anhydrous ethanol, practically insoluble in toluene.

**IDENTIFICATION**

A. Infrared absorption spectrophotometry (2.2.24).

**Preparation:** discs.

Dissolve 50 mg in *water R* and dilute to 5 mL with the same solvent. Render the solution alkaline with *dilute ammonia R1*. Allow the mixture to stand until a precipitate is formed. Filter, wash the precipitate with 10 mL of cold *water R*, and dry for 1 h at 105 °C. Examine the precipitate.

**Comparison:** repeat the operations using 50 mg of *oxycodone hydrochloride CRS*.

B. It gives reaction (a) of chlorides (2.3.1).

#### TESTS

**Solution S.** Dissolve 1.00 g in *carbon dioxide-free water R* and dilute to 50.0 mL with the same solvent.

**Acidity or alkalinity.** To 10 mL of solution S add 0.05 mL of *methyl red solution R*. Not more than 0.2 mL of 0.02 M *sodium hydroxide* or 0.02 M *hydrochloric acid* is required to change the colour of the indicator.

**Specific optical rotation (2.2.7):** – 140 to – 148 (anhydrous substance), determined on solution S.

**Related substances.** Liquid chromatography (2.2.29). Prepare the solutions protected from light.

**Test solution.** Dissolve 0.100 g of the substance to be examined in a 1 per cent V/V solution of *dilute acetic acid R* and dilute to 50.0 mL with the same solvent.

**Reference solution (a).** Dissolve 20.0 mg of *oxycodone impurity D CRS* in a 1 per cent V/V solution of *dilute acetic acid R* and dilute to 10.0 mL with the same solution.

**Reference solution (b).** To 1.0 mL of the test solution, add 1.0 mL of reference solution (a) and dilute to 100.0 mL with a 1 per cent V/V solution of *dilute acetic acid R*. Dilute 1.0 mL of the solution to 10.0 mL with a 1 per cent V/V solution of *dilute acetic acid R*.

**Column:**

- size:  $l = 0.15$  m,  $\varnothing = 4.6$  mm;
- stationary phase: octadecylsilyl silica gel for chromatography R (5  $\mu$ m);
- temperature: 40 °C.

**Mobile phase:**

- mobile phase A: mix 830 mL of a 1.1 g/L solution of *sodium heptanesulfonate monohydrate R* previously adjusted to pH 2.0 with a mixture of equal volumes of *phosphoric acid R* and *water R*, with 70 mL of *acetonitrile R* and 100 mL of *methanol R*;
- mobile phase B: mix 600 mL of a 1.1 g/L solution of *sodium heptanesulfonate monohydrate R* previously adjusted to pH 2.0 with a mixture of equal volumes of *phosphoric acid R* and *water R*, with 150 mL of *acetonitrile R* and 250 mL of *methanol R*;

Time (min)	Mobile phase A (per cent V/V)	Mobile phase B (per cent V/V)
0 - 60	100 → 50	0 → 50

**Flow rate:** 1.5 mL/min.

**Detection:** spectrophotometer at 230 nm.

**Injection:** 20  $\mu$ L.

**Relative retention** with reference to oxycodone (retention time = about 24 min): impurity A = about 0.4; impurity B = about 0.7; impurity C = about 1.14; impurity D = about 1.18; impurity E = about 1.18; impurity F = about 2.4.

**System suitability:** reference solution (b):

- resolution: minimum 3 between the peaks due to oxycodone and impurity D.

**Limits:**

- correction factor: for the calculation of content, multiply the peak area of impurity F by 0.5;

- sum of impurities D and E: not more than 10 times the area of the peak due to oxycodone in the chromatogram obtained with reference solution (b) (1.0 per cent);
- impurities A, B, C, F: for each impurity, not more than the area of the peak due to oxycodone in the chromatogram obtained with reference solution (b) (0.1 per cent);
- any other impurity: for each impurity, not more than the area of the peak due to oxycodone in the chromatogram obtained with reference solution (b) (0.1 per cent);
- total: not more than 15 times the area of the peak due to oxycodone in the chromatogram obtained with reference solution (b) (1.5 per cent);
- disregard limit: 0.5 times the area of the peak due to oxycodone in the chromatogram obtained with reference solution (b) (0.05 per cent).

**Ethanol (2.4.24, System A):** maximum 1.0 per cent.

**Water (2.5.12):** maximum 7.0 per cent, determined on 0.250 g.

**Sulfated ash (2.4.14):** maximum 0.1 per cent, determined on 1.0 g.

#### ASSAY

Dissolve 0.250 g in a mixture of 5.0 mL of 0.01 M *hydrochloric acid* and 60 mL of *ethanol (96 per cent) R*. Titrate with 0.1 M *ethanolic sodium hydroxide*, determining the end-point potentiometrically (2.2.20). Measure the volume used between the 2 inflexion points.

1 mL of 0.1 M *ethanolic sodium hydroxide* is equivalent to 35.19 mg of  $C_{18}H_{22}ClNO_4$ .

#### STORAGE

In an airtight container, protected from light.

#### IMPURITIES

**Specified impurities:** A, B, C, D, E, F.

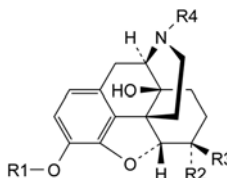

- A. R1 = H, R2 = R3 = O, R4 = CH<sub>3</sub>: 4,5 $\alpha$ -epoxy-3,14-dihydroxy-17-methylmorphinan-6-one (oxymorphone),
- B. R1 = R4 = CH<sub>3</sub>, R2 = OH, R3 = H: 4,5 $\alpha$ -epoxy-3-methoxy-17-methylmorphinan-6 $\alpha$ ,14-diol (7,8-dihydro-14-hydroxycodone),
- C. R1 = CH<sub>3</sub>, R2 + R3 = O, R4 = H: 4,5 $\alpha$ -epoxy-14-hydroxy-3-methoxymorphinan-6-one (noroxycodone),

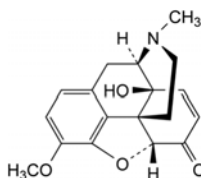

- D. 7,8-dihydro-4,5 $\alpha$ -epoxy-14-hydroxy-3-methoxy-17-methylmorphinan-6-one (14-hydroxycodone),

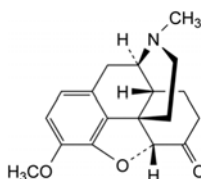

- E. 4,5 $\alpha$ -epoxy-3-methoxy-17-methylmorphinan-6-one (hydrocodone),

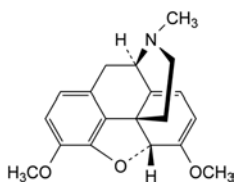

F. 6,7,8,14-tetrahydro-4,5 $\alpha$ -epoxy-3,6-dimethoxy-17-methylmorphinan (thebain).

01/2010:0417

## OXYGEN

### Oxygenium

O<sub>2</sub>  
[7782-44-7]

*M*<sub>r</sub> 32.00

#### DEFINITION

*Content*: minimum 99.5 per cent *V/V* of O<sub>2</sub>.

This monograph applies to oxygen for medicinal use.

#### CHARACTERS

*Appearance*: colourless gas.

*Solubility*: at 20 °C and at a pressure of 101 kPa, 1 volume dissolves in about 32 volumes of water.

#### PRODUCTION

Oxygen is produced by a purification process followed by cryodistillation of the ambient air.

**Carbon dioxide**: maximum 300 ppm *V/V*, determined using an infrared analyser (2.5.24).

*Gas to be examined*. Filter the substance to be examined to avoid stray light phenomena.

*Reference gas (a)*. Oxygen R.

*Reference gas (b)*. Mixture containing 300 ppm *V/V* of carbon dioxide R1 in nitrogen R1.

Calibrate the apparatus and set the sensitivity using reference gases (a) and (b). Measure the content of carbon dioxide in the gas to be examined.

**Carbon monoxide**: maximum 5 ppm *V/V*, determined using an infrared analyser (2.5.25).

*Gas to be examined*. Filter the substance to be examined to avoid stray light phenomena.

*Reference gas (a)*. Oxygen R.

*Reference gas (b)*. Mixture containing 5 ppm *V/V* of carbon monoxide R in nitrogen R1.

Calibrate the apparatus and set the sensitivity using reference gases (a) and (b). Measure the content of carbon monoxide in the gas to be examined.

**Water**: maximum 67 ppm *V/V*, determined using an electrolytic hygrometer (2.5.28).

**Assay**. Determine the concentration of oxygen using a paramagnetic analyser (2.5.27).

#### IDENTIFICATION

It complies with the limits of the assay.

#### TESTS

**Carbon dioxide**: maximum 300 ppm *V/V*, determined using a carbon dioxide detector tube (2.1.6).

**Carbon monoxide**: maximum 5 ppm *V/V*, determined using a carbon monoxide detector tube (2.1.6).

**Water vapour**: maximum 67 ppm *V/V*, determined using a water vapour detector tube (2.1.6).

#### STORAGE

As a compressed gas or liquid in appropriate containers, complying with the legal regulations. Oils and grease are not to be used unless they are oxygen-compatible.

#### IMPURITIES

*Specified impurities*: A, B, C.

A. CO<sub>2</sub>: carbon dioxide,

B. CO: carbon monoxide,

C. H<sub>2</sub>O: water.

01/2009:0943

## OXYMETAZOLINE HYDROCHLORIDE

### Oxymetazolini hydrochloridum

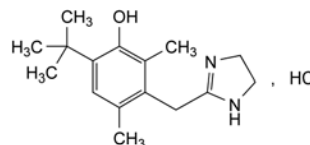

C<sub>16</sub>H<sub>25</sub>ClN<sub>2</sub>O  
[2315-02-8]

*M*<sub>r</sub> 296.8

#### DEFINITION

3-[(4,5-Dihydro-1*H*-imidazol-2-yl)methyl]-6-(1,1-dimethylethyl)-2,4-dimethylphenol hydrochloride.

*Content*: 99.0 per cent to 101.0 per cent (dried substance).

#### CHARACTERS

*Appearance*: white or almost white, crystalline powder.

*Solubility*: freely soluble in water and in ethanol (96 per cent).

#### IDENTIFICATION

*First identification*: A, D.

*Second identification*: B, C, D.

A. Infrared absorption spectrophotometry (2.2.24).

*Comparison*: oxymetazoline hydrochloride CRS.

B. Thin layer chromatography (2.2.27).

*Test solution*. Dissolve 20 mg of the substance to be examined in a mixture of equal volumes of ethyl acetate R and methanol R and dilute to 5 mL with the same mixture of solvents.

*Reference solution*. Dissolve 20 mg of oxymetazoline hydrochloride CRS in a mixture of equal volumes of ethyl acetate R and methanol R and dilute to 5 mL with the same mixture of solvents.

*Plate*: TLC silica gel G plate R.

*Mobile phase*: diethylamine R, cyclohexane R, anhydrous ethanol R (6:15:79 *V/V/V*).

*Application*: 5  $\mu$ L.

*Development*: over 2/3 of the plate.

*Drying*: in a current of warm air for 5 min, then allow to cool.

*Detection*: spray with a freshly prepared 5.0 g/L solution of potassium ferricyanide R in ferric chloride solution R2; examine in daylight.

*Results*: the principal spot in the chromatogram obtained with the test solution is similar in position, colour and size to the principal spot in the chromatogram obtained with the reference solution.

C. Dissolve about 2 mg in 1 mL of water R, then add 0.2 mL of a 50 g/L solution of sodium nitroprusside R and 0.2 mL of dilute sodium hydroxide solution R. Allow to stand for 10 min. Add 2 mL of sodium hydrogen carbonate solution R. A violet colour develops.

D. It gives reaction (a) of chlorides (2.3.1).

## TESTS

**Appearance of solution.** The solution is clear (2.2.1) and not more intensely coloured than reference solution BY<sub>7</sub> (2.2.2, Method II).

Dissolve 2.5 g in *water R* and dilute to 50 mL with the same solvent.

**Acidity or alkalinity.** Dissolve 0.25 g in *carbon dioxide-free water R* and dilute to 25 mL with the same solvent. Add 0.1 mL of *methyl red solution R* and 0.2 mL of 0.01 M *hydrochloric acid*. The solution is red. Not more than 0.4 mL of 0.01 M *sodium hydroxide* is required to change the colour of the indicator to yellow.

**Related substances.** Liquid chromatography (2.2.29). Prepare the solutions immediately before use.

**Test solution.** Dissolve 50.0 mg of the substance to be examined in *water R* and dilute to 50.0 mL with the same solvent.

**Reference solution (a).** Dilute 5.0 mL of the test solution to 100.0 mL with *water R*. Dilute 2.0 mL of this solution to 100.0 mL with *water R*.

**Reference solution (b).** Dissolve 5.0 mg of *oxymetazoline impurity A CRS* and 5 mg of the substance to be examined in *water R* and dilute to 50.0 mL with the same solvent. Dilute 10.0 mL of this solution to 50.0 mL with *water R*.

**Reference solution (c).** Dilute 1.0 mL of reference solution (b) to 20.0 mL with *water R*.

**Column:**

- size:  $l = 0.25$  m,  $\varnothing = 4.6$  mm;
- stationary phase: end-capped octadecylsilyl silica gel for chromatography with polar incorporated groups R (5  $\mu$ m).

**Mobile phase:**

- mobile phase A: 1.36 g/L solution of *potassium dihydrogen phosphate R* adjusted to pH 3.0 with *phosphoric acid R*;
- mobile phase B: *acetonitrile R1*;

Time (min)	Mobile phase A (per cent V/V)	Mobile phase B (per cent V/V)
0 - 5	70	30
5 - 20	70 → 15	30 → 85
20 - 35	15	85

**Flow rate:** 1.0 mL/min.

**Detection:** spectrophotometer at 220 nm.

**Injection:** 10  $\mu$ L.

**Relative retention** with reference to *oxymetazoline* (retention time = about 5.0 min): impurity A = about 0.9.

**System suitability:** reference solution (b):

- resolution: minimum 4.0 between the peaks due to impurity A and *oxymetazoline*.

**Limits:**

- **impurity A:** not more than the area of the corresponding peak in the chromatogram obtained with reference solution (c) (0.1 per cent);
- **unspecified impurities:** for each impurity, not more than the area of the principal peak in the chromatogram obtained with reference solution (a) (0.10 per cent);
- **total:** not more than 5 times the area of the principal peak in the chromatogram obtained with reference solution (a) (0.5 per cent);
- **disregard limit:** 0.5 times the area of the principal peak in the chromatogram obtained with reference solution (a) (0.05 per cent).

**Loss on drying** (2.2.32): maximum 1.0 per cent, determined on 1.000 g by drying in an oven at 105 °C.

**Sulfated ash** (2.4.14): maximum 0.1 per cent, determined on 1.0 g.

## ASSAY

Dissolve 0.200 g in a mixture of 20 mL of *anhydrous acetic acid R* and 20 mL of *acetic anhydride R*. Titrate with 0.1 M *perchloric acid*, determining the end-point potentiometrically (2.2.20).

1 mL of 0.1 M *perchloric acid* is equivalent to 29.68 mg of C<sub>16</sub>H<sub>25</sub>ClN<sub>2</sub>O.

## IMPURITIES

**Specified impurities:** A.

**Other detectable impurities** (the following substances would, if present at a sufficient level, be detected by one or other of the tests in the monograph. They are limited by the general acceptance criterion for other/unspecified impurities and/or by the general monograph *Substances for pharmaceutical use* (2034). It is therefore not necessary to identify these impurities for demonstration of compliance. See also 5.10. *Control of impurities in substances for pharmaceutical use*): B, C, D, E.

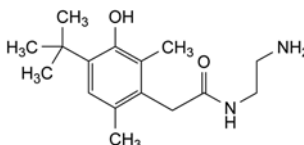

A. *N*-(2-aminoethyl)-2-[4-(1,1-dimethylethyl)-3-hydroxy-2,6-dimethylphenyl]acetamide,

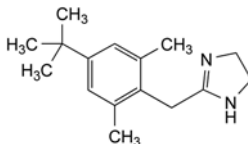

B. 2-[4-(1,1-dimethylethyl)-2,6-dimethylbenzyl]-4,5-dihydro-1H-imidazole (xylometazoline),

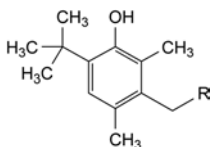

C. R=CO-NH<sub>2</sub>: 2-[4-(1,1-dimethylethyl)-3-hydroxy-2,6-dimethylphenyl]acetamide,

D. R=CO<sub>2</sub>H: [4-(1,1-dimethylethyl)-3-hydroxy-2,6-dimethylphenyl]acetic acid,

E. R=CN: [4-(1,1-dimethylethyl)-3-hydroxy-2,6-dimethylphenyl]acetonitrile.

01/2008:0199

## OXYTETRACYCLINE DIHYDRATE

## Oxytetracyclinum dihydricum

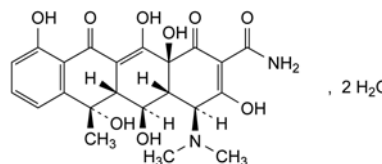
C<sub>22</sub>H<sub>24</sub>N<sub>2</sub>O<sub>9</sub>·2 H<sub>2</sub>OM<sub>r</sub> 496.4

## DEFINITION

(4S,4aR,5S,5aR,6S,12aS)-4-(Dimethylamino)-3,5,6,10,12,12a-hexahydroxy-6-methyl-1,11-dioxo-1,4,4a,5,5a,6,11,12a-octahydrotetracycline-2-carboxamide dihydrate.

Substance produced by the growth of certain strains of *Streptomyces rimosus* or obtained by any other means.

**Content:** 95.0 per cent to 102.0 per cent (anhydrous substance).

## CHARACTERS

**Appearance:** yellow, crystalline powder.

**Solubility:** very slightly soluble in water. It dissolves in dilute acid and alkaline solutions.

## IDENTIFICATION

A. Thin-layer chromatography (2.2.27).

**Test solution.** Dissolve 5 mg of the substance to be examined in *methanol R* and dilute to 10 mL with the same solvent.

**Reference solution (a).** Dissolve 5 mg of *oxytetracycline CRS* in *methanol R* and dilute to 10 mL with the same solvent.

**Reference solution (b).** Dissolve 5 mg of *oxytetracycline CRS*, 5 mg of *tetracycline hydrochloride R* and 5 mg of *minocycline hydrochloride R* in *methanol R* and dilute to 10 mL with the same solvent.

**Plate:** TLC octadecylsilyl silica gel  $F_{254}$  plate *R*.

**Mobile phase:** mix 20 volumes of *acetonitrile R*, 20 volumes of *methanol R* and 60 volumes of a 63 g/L solution of *oxalic acid R* previously adjusted to pH 2 with *concentrated ammonia R*.

**Application:** 1  $\mu$ L.

**Development:** over 3/4 of the plate.

**Drying:** in air.

**Detection:** examine in ultraviolet light at 254 nm.

**System suitability:** the chromatogram obtained with reference solution (b) shows 3 clearly separated spots.

**Results:** the principal spot in the chromatogram obtained with the test solution is similar in position and size to the principal spot in the chromatogram obtained with reference solution (a).

B. To about 2 mg add 5 mL of *sulfuric acid R*. A deep red colour develops. Add the solution to 2.5 mL of *water R*. The colour becomes yellow.

C. Dissolve about 10 mg in a mixture of 1 mL of *dilute nitric acid R* and 5 mL of *water R*. Shake and add 1 mL of *silver nitrate solution R2*. Any opalescence in the solution is not more intense than that in a mixture of 1 mL of *dilute nitric acid R*, 5 mL of a 0.021 g/L solution of *potassium chloride R* and 1 mL of *silver nitrate solution R2*.

## TESTS

**pH (2.2.3):** 4.5 to 7.5.

Suspend 0.1 g in 10 mL of *carbon dioxide-free water R*.

**Specific optical rotation (2.2.7):** –203 to –216 (anhydrous substance).

Dissolve 0.250 g in 0.1 M *hydrochloric acid* and dilute to 25.0 mL with the same acid.

**Specific absorbance (2.2.25):** 290 to 310 determined at 353 nm (anhydrous substance).

Dissolve 20.0 mg in *buffer solution pH 2.0 R* and dilute to 100.0 mL with the same buffer solution. Dilute 10.0 mL of this solution to 100.0 mL with *buffer solution pH 2.0 R*.

**Light-absorbing impurities.** Carry out the measurements within 1 h of preparing the solutions.

Dissolve 20.0 mg in a mixture of 1 volume of 1 M *hydrochloric acid* and 99 volumes of *methanol R* and dilute to 10.0 mL with the same mixture of solvents. The absorbance (2.2.25), determined at 430 nm has a maximum of 0.25 (anhydrous substance).

Dissolve 0.100 g in a mixture of 1 volume of 1 M *hydrochloric acid* and 99 volumes of *methanol R* and dilute to 10.0 mL with the same mixture of solvents. The absorbance (2.2.25) determined at 490 nm has a maximum of 0.20 (anhydrous substance).

**Related substances.** Liquid chromatography (2.2.29). Prepare the solutions immediately before use.

**Test solution.** Dissolve 20.0 mg of the substance to be examined in 0.01 M *hydrochloric acid* and dilute to 25.0 mL with the same acid.

**Reference solution (a).** Dissolve 20.0 mg of *oxytetracycline CRS* in 0.01 M *hydrochloric acid* and dilute to 25.0 mL with the same acid.

**Reference solution (b).** Dissolve 20.0 mg of 4-epioxytetracycline *CRS* in 0.01 M *hydrochloric acid* and dilute to 25.0 mL with the same acid.

**Reference solution (c).** Dissolve 20.0 mg of *tetracycline hydrochloride CRS* in 0.01 M *hydrochloric acid* and dilute to 25.0 mL with the same acid.

**Reference solution (d).** Mix 1.5 mL of reference solution (a), 1.0 mL of reference solution (b) and 3.0 mL of reference solution (c) and dilute to 25.0 mL with 0.01 M *hydrochloric acid*.

**Reference solution (e).** Mix 1.0 mL of reference solution (b) and 4.0 mL of reference solution (c) and dilute to 200.0 mL with 0.01 M *hydrochloric acid*.

**Column:**

– size:  $l = 0.25$  m,  $\varnothing = 4.6$  mm;

– stationary phase: *styrene-divinylbenzene copolymer R* (8  $\mu$ m);

– temperature: 60 °C.

**Mobile phase:** weigh 60.0 g of 2-methyl-2-propanol *R* and transfer to a 1000 mL volumetric flask with the aid of 200 mL of *water R*; add 60 mL of 0.33 M *phosphate buffer solution pH 7.5 R*, 50 mL of a 10 g/L solution of *tetrabutylammonium hydrogen sulfate R* adjusted to pH 7.5 with *dilute sodium hydroxide solution R* and 10 mL of a 0.4 g/L solution of *sodium edetate R* adjusted to pH 7.5 with *dilute sodium hydroxide solution R*; dilute to 1000 mL with *water R*.

**Flow rate:** 1.0 mL/min.

**Detection:** spectrophotometer at 254 nm.

**Injection:** 20  $\mu$ L of the test solution and reference solutions (d) and (e).

**System suitability:** reference solution (d):

– resolution: minimum 4.0 between the peaks due to impurity A (1<sup>st</sup> peak) and oxytetracycline (2<sup>nd</sup> peak) and minimum 5.0 between the peaks and due to oxytetracycline and impurity B (3<sup>rd</sup> peak); adjust the 2-methyl-2-propanol content in the mobile phase if necessary;

– symmetry factor: maximum 1.25 for the peak due to oxytetracycline.

**Limits:**

– impurity A: not more than the area of the corresponding peak in the chromatogram obtained with reference solution (e) (0.5 per cent);

– impurity B: not more than the area of the corresponding peak in the chromatogram obtained with reference solution (e) (2.0 per cent);

– impurity C (eluting on the tail of the principal peak): not more than 4 times the area of the peak due to impurity A in the chromatogram obtained with reference solution (e) (2.0 per cent);

– disregard limit: 0.02 times the area of the peak due to oxytetracycline in the chromatogram obtained with reference solution (d) (0.1 per cent).

**Heavy metals (2.4.8):** maximum 50 ppm.

0.5 g complies with test F. Prepare the reference solution using 2.5 mL of *lead standard solution (10 ppm Pb) R*.

**Water (2.5.12):** 6.0 per cent to 9.0 per cent, determined on 0.250 g.

**Sulfated ash (2.4.14):** maximum 0.5 per cent, determined on 1.0 g.

## ASSAY

Liquid chromatography (2.2.29) as described in the test for related substances with the following modification.

*Injection*: test solution and reference solution (a).

Calculate the percentage content of  $C_{22}H_{24}N_2O_9$ .

## STORAGE

In an airtight container, protected from light.

## IMPURITIES

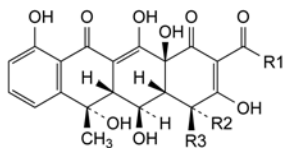

A.  $R_1 = NH_2$ ,  $R_2 = N(CH_3)_2$ ,  $R_3 = H$ : (4*R*,4*aR*,5*S*,5*aR*,6*S*,12*aS*)-4-(dimethylamino)-3,5,6,10,12,12*a*-hexahydroxy-6-methyl-1,11-dioxo-1,4,4*a*,5,5*a*,6,11,12*a*-octahydro-tetracycline-2-carboxamide (4-epioxytetracycline),

C.  $R_1 = CH_3$ ,  $R_2 = H$ ,  $R_3 = N(CH_3)_2$ : (4*S*,4*aR*,5*S*,5*aR*,6*S*,12*aS*)-2-acetyl-4-(dimethylamino)-3,5,6,10,12,12*a*-hexahydroxy-6-methyl-4*a*,5*a*,6,12*a*-tetrahydro-tetracycline-1,11(4*H*,5*H*)-dione (2-acetyl-2-decarbamoxytetracycline),

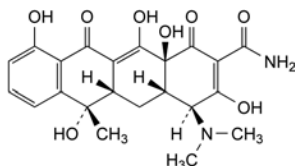

B. (4*S*,4*aS*,5*aS*,6*S*,12*aS*)-4-(dimethylamino)-3,6,10,12,12*a*-pentahydroxy-6-methyl-1,11-dioxo-1,4,4*a*,5,5*a*,6,11,12*a*-octahydro-tetracycline-2-carboxamide (tetracycline).

01/2008:0198

## OXYTETRACYCLINE HYDROCHLORIDE

## Oxytetracyclini hydrochloridum

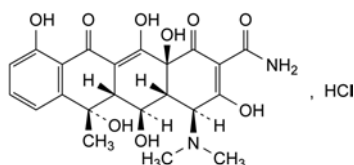

$C_{22}H_{25}ClN_2O_9$   
[2058-46-0]

$M_r$  496.9

## DEFINITION

(4*S*,4*aR*,5*S*,5*aR*,6*S*,12*aS*)-4-(Dimethylamino)-3,5,6,10,12,12*a*-hexahydroxy-6-methyl-1,11-dioxo-1,4,4*a*,5,5*a*,6,11,12*a*-octahydro-tetracycline-2-carboxamide hydrochloride.

Substance produced by the growth of certain strains of *Streptomyces rimosus* or obtained by any other means.

*Content*: 95.0 per cent to 102.0 per cent (anhydrous substance).

## CHARACTERS

*Appearance*: yellow, crystalline powder, hygroscopic.

*Solubility*: freely soluble in water, sparingly soluble in ethanol (96 per cent). Solutions in water become turbid on standing, owing to the precipitation of oxytetracycline.

## IDENTIFICATION

A. Thin-layer chromatography (2.2.27).

*Test solution*. Dissolve 5 mg of the substance to be examined in *methanol R* and dilute to 10 mL with the same solvent.

*Reference solution (a)*. Dissolve 5 mg of *oxytetracycline hydrochloride CRS* in *methanol R* and dilute to 10 mL with the same solvent.

*Reference solution (b)*. Dissolve 5 mg of *oxytetracycline hydrochloride CRS*, 5 mg of *tetracycline hydrochloride R* and 5 mg of *minocycline hydrochloride R* in *methanol R* and dilute to 10 mL with the same solvent.

*Plate*: TLC octadecylsilyl silica gel  $F_{254}$  plate *R*.

*Mobile phase*: mix 20 volumes of *acetonitrile R*, 20 volumes of *methanol R* and 60 volumes of a 63 g/L solution of *oxalic acid R* previously adjusted to pH 2 with *concentrated ammonia R*.

*Application*: 1  $\mu$ L.

*Development*: over 3/4 of the plate.

*Drying*: in air.

*Detection*: examine in ultraviolet light at 254 nm.

*System suitability*: the chromatogram obtained with reference solution (b) shows 3 clearly separated spots.

*Results*: the principal spot in the chromatogram obtained with the test solution is similar in position and size to the principal spot in the chromatogram obtained with reference solution (a).

B. To about 2 mg add 5 mL of *sulfuric acid R*. A deep red colour develops. Add the solution to 2.5 mL of *water R*. The colour becomes yellow.

C. It gives reaction (a) of chlorides (2.3.1).

## TESTS

**pH** (2.2.3): 2.3 to 2.9.

Dissolve 0.1 g in 10 mL of *carbon dioxide-free water R*.

**Specific optical rotation** (2.2.7): –188 to –200 (anhydrous substance).

Dissolve 0.250 g in 0.1 *M hydrochloric acid* and dilute to 25.0 mL with the same acid.

**Specific absorbance** (2.2.25): 270 to 290 determined at 353 nm (anhydrous substance).

Dissolve 20.0 mg in *buffer solution pH 2.0 R* and dilute to 100.0 mL with the same buffer solution. Dilute 10.0 mL of the solution to 100.0 mL with *buffer solution pH 2.0 R*.

**Light-absorbing impurities**. Carry out the measurements within 1 h of preparing the solutions.

Dissolve 20.0 mg in a mixture of 1 volume of 1 *M hydrochloric acid* and 99 volumes of *methanol R* and dilute to 10.0 mL with the same mixture of solvents. The absorbance (2.2.25) determined at 430 nm has a maximum of 0.50 (anhydrous substance).

Dissolve 0.100 g in a mixture of 1 volume of 1 *M hydrochloric acid* and 99 volumes of *methanol R* and dilute to 10.0 mL with the same mixture of solvents. The absorbance (2.2.25) determined at 490 nm has a maximum of 0.20 (anhydrous substance).

**Related substances**. Liquid chromatography (2.2.29). Prepare the solutions immediately before use.

*Test solution*. Dissolve 20.0 mg of the substance to be examined in 0.01 *M hydrochloric acid* and dilute to 25.0 mL with the same acid.

*Reference solution (a)*. Dissolve 20.0 mg of *oxytetracycline CRS* in 0.01 *M hydrochloric acid* and dilute to 25.0 mL with the same acid.

*Reference solution (b)*. Dissolve 20.0 mg of 4-epioxytetracycline *CRS* in 0.01 *M hydrochloric acid* and dilute to 25.0 mL with the same acid.

*Reference solution (c)*. Dissolve 20.0 mg of *tetracycline hydrochloride CRS* in 0.01 *M hydrochloric acid* and dilute to 25.0 mL with the same acid.

**Reference solution (d).** Dissolve 8.0 mg of  $\alpha$ -apo-oxytetracycline CRS in 5 mL of 0.01 M sodium hydroxide and dilute to 100.0 mL with 0.01 M hydrochloric acid.

**Reference solution (e).** Dissolve 8.0 mg of  $\beta$ -apo-oxytetracycline CRS in 5 mL of 0.01 M sodium hydroxide and dilute to 100.0 mL with 0.01 M hydrochloric acid.

**Reference solution (f).** Mix 1.5 mL of reference solution (a), 1.0 mL of reference solution (b), 3.0 mL of reference solution (c), 3.0 mL of reference solution (d) and 3.0 mL of reference solution (e) and dilute to 25.0 mL with 0.01 M hydrochloric acid.

**Reference solution (g).** Mix 1.0 mL of reference solution (b), 4.0 mL of reference solution (c) and 40.0 mL of reference solution (e) and dilute to 200.0 mL with 0.01 M hydrochloric acid.

**Column:**

- size:  $l = 0.25$  m,  $\varnothing = 4.6$  mm;
- stationary phase: styrene-divinylbenzene copolymer R (8  $\mu$ m);
- temperature: 60 °C.

**Mobile phase:** weigh 30.0 g (for mobile phase A) and 100.0 g (for mobile phase B) of 2-methyl-2-propanol R and transfer separately to 1000 mL volumetric flasks with the aid of 200 mL of water R; to each flask add 60 mL of 0.33 M phosphate buffer solution pH 7.5 R, 50 mL of a 10 g/L solution of tetrabutylammonium hydrogen sulfate R adjusted to pH 7.5 with dilute sodium hydroxide solution R and 10 mL of a 0.4 g/L solution of sodium edetate R adjusted to pH 7.5 with dilute sodium hydroxide solution R; dilute each solution to 1000 mL with water R;

Time (min)	Mobile phase A (per cent V/V)	Mobile phase B (per cent V/V)
0 - 15	70	30
15 - 30	30	70
30 - 45	70	30

**Flow rate:** 1 mL/min.

**Detection:** spectrophotometer at 254 nm.

**Injection:** 20  $\mu$ L of the test solution and reference solutions (f) and (g).

**System suitability:** reference solution (f):

- resolution: minimum 4.0 between the peaks due to impurity A (1<sup>st</sup> peak) and oxytetracycline (2<sup>nd</sup> peak), minimum 5.0 between the peaks due to oxytetracycline and impurity B (3<sup>rd</sup> peak) and minimum 3.5 between the peaks due to impurity D (4<sup>th</sup> peak) and impurity E (5<sup>th</sup> peak); if necessary, adapt the ratio mobile phase A: mobile phase B and/or adjust the time programme used to produce the 1-step gradient elution;
- symmetry factor: maximum 1.25 for the peak due to oxytetracycline.

**Limits:**

- impurity A: not more than the area of the corresponding peak in the chromatogram obtained with reference solution (g) (0.5 per cent);
- impurity B: not more than the area of the corresponding peak in the chromatogram obtained with reference solution (g) (2.0 per cent);
- impurity C (eluting on the tail of the main peak): not more than 4 times the area of the peak due to impurity A in the chromatogram obtained with reference solution (g) (2.0 per cent);
- total of impurities D, E and F (eluting between the latter two): not more than the area of the peak due to impurity E in the chromatogram obtained with reference solution (g) (2.0 per cent);

- disregard limit: 0.02 times the area of the peak due to oxytetracycline in the chromatogram obtained with reference solution (f) (0.1 per cent).

**Heavy metals (2.4.8):** maximum 50 ppm.

0.5 g complies with test F. Prepare the reference solution using 2.5 mL of lead standard solution (10 ppm Pb) R.

**Water (2.5.12):** maximum 2.0 per cent, determined on 0.500 g.

**Sulfated ash (2.4.14):** maximum 0.5 per cent, determined on 1.0 g.

**Bacterial endotoxins (2.6.14):** less than 0.4 IU/mg, if intended for use in the manufacture of parenteral preparations without a further appropriate procedure for the removal of bacterial endotoxins.

#### ASSAY

Liquid chromatography (2.2.29) as described in the test for related substances with the following modification.

**Injection:** test solution and reference solution (a).

Calculate the percentage content of  $C_{22}H_{25}ClN_2O_9$  taking 1 mg of oxytetracycline as equivalent to 1.079 mg of oxytetracycline hydrochloride.

#### STORAGE

In an airtight container, protected from light. If the substance is sterile, store in a sterile, airtight, tamper-proof container.

#### IMPURITIES

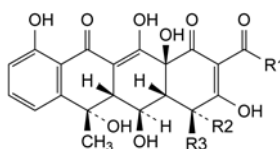

A.  $R_1 = NH_2$ ,  $R_2 = N(CH_3)_2$ ,  $R_3 = H$ : (4*R*,4*aR*,5*S*,5*aR*,6*S*,12*aS*)-4-(dimethylamino)-3,5,6,10,12,12*a*-hexahydroxy-6-methyl-1,11-dioxo-1,4,4*a*,5,5*a*,6,11,12*a*-octahydrotetracene-2-carboxamide (4-epioxytetracycline),

C.  $R_1 = CH_3$ ,  $R_2 = H$ ,  $R_3 = N(CH_3)_2$ : (4*S*,4*aS*,5*S*,5*aR*,6*S*,12*aS*)-2-acetyl-4-(dimethylamino)-3,5,6,10,12,12*a*-hexahydroxy-6-methyl-4*a*,5*a*,6,12*a*-tetrahydrotetracene-1,11(4*H*,5*H*)-dione (2-acetyl-2-decarbamoxytetracycline),

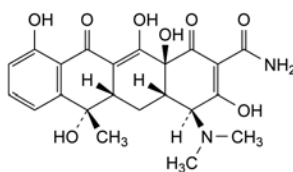

B. (4*S*,4*aS*,5*aS*,6*S*,12*aS*)-4-(dimethylamino)-3,6,10,12,12*a*-pentahydroxy-6-methyl-1,11-dioxo-1,4,4*a*,5,5*a*,6,11,12*a*-octahydrotetracene-2-carboxamide (tetracycline),

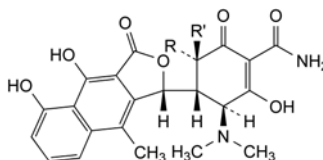

D.  $R = OH$ ,  $R' = H$ : (3*S*,4*S*,5*S*)-4-[(1*R*)-4,5-dihydroxy-9-methyl-3-oxo-1,3-dihydronaphtho[2,3-*c*]furan-1-yl]-3-(dimethylamino)-2,5-dihydroxy-6-oxocyclohex-1-enecarboxamide ( $\alpha$ -apo-oxytetracycline),

E.  $R = H$ ,  $R' = OH$ : (3*S*,4*S*,5*R*)-4-[(1*R*)-4,5-dihydroxy-9-methyl-3-oxo-1,3-dihydronaphtho[2,3-*c*]furan-1-yl]-3-(dimethylamino)-2,5-dihydroxy-6-oxocyclohex-1-enecarboxamide ( $\beta$ -apo-oxytetracycline),

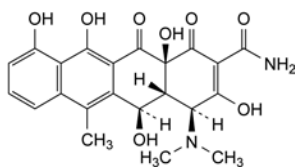

- F. (4*S*,4*aR*,5*R*,12*aS*)-4-(dimethylamino)-3,5,10,11,12*a*-penta-hydroxy-6-methyl-1,12-dioxo-1,4,4*a*,5,12,12*a*-hexahydrotetracene-2-carboxamide (anhydro-oxytetracycline).

01/2008:0780  
corrected 6.0

## OXYTOCIN

### Oxytocinum

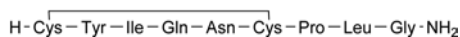

$\text{C}_{43}\text{H}_{66}\text{N}_{12}\text{O}_{12}\text{S}_2$   
[50-56-6]

$M_r$  1007

#### DEFINITION

L-Cysteinyl-L-tyrosyl-L-isoleucyl-L-glutamyl-L-asparaginyl-L-cysteinyl-L-prolyl-L-leucylglycinamide cyclic (1→6)-disulfide.

Synthetic cyclic nonapeptide having the structure of the hormone produced by the posterior lobe of the pituitary gland that stimulates contraction of the uterus and milk ejection in receptive mammals. It is available in the freeze-dried form as an acetate.

**Content:** 93.0 per cent to 102.0 per cent (anhydrous and acetic acid-free substance).

By convention, for the purpose of labelling oxytocin preparations, 1 mg of oxytocin peptide ( $\text{C}_{43}\text{H}_{66}\text{N}_{12}\text{O}_{12}\text{S}_2$ ) is equivalent to 600 IU of biological activity.

#### CHARACTERS

**Appearance:** white or almost white, hygroscopic powder.

**Solubility:** very soluble in water. It dissolves in dilute solutions of acetic acid and of ethanol (96 per cent).

#### IDENTIFICATION

- A. Examine the chromatograms obtained in the assay.

**Results:** the principal peak in the chromatogram obtained with the test solution is similar in retention time to the principal peak in the chromatogram obtained with the reference solution.

- B. Amino acid analysis (2.2.56). For hydrolysis use Method 1 and for analysis use Method 1.

Express the content of each amino acid in moles. Calculate the relative proportions of the amino acids, taking 1/6 of the sum of the number of moles of aspartic acid, glutamic acid, proline, glycine, isoleucine and leucine as equal to 1. The values fall within the following limits: aspartic acid: 0.90 to 1.10; glutamic acid: 0.90 to 1.10; proline: 0.90 to 1.10; glycine: 0.90 to 1.10; leucine: 0.90 to 1.10; isoleucine: 0.90 to 1.10; tyrosine: 0.7 to 1.05; half-cystine: 1.4 to 2.1. Not more than traces of other amino acids are present.

#### TESTS

**pH** (2.2.3): 3.0 to 6.0.

Dissolve 0.200 g in carbon dioxide-free water R and dilute to 10.0 mL with the same solvent.

**Related substances.** Liquid chromatography (2.2.29): use the normalisation procedure.

**Test solution.** Prepare a 0.25 mg/mL solution of the substance to be examined in a 15.6 g/L solution of sodium dihydrogen phosphate R.

**Resolution solution.** Dissolve the contents of a vial of oxytocin/desmopressin validation mixture CRS in 1 mL of a 15.6 g/L solution of sodium dihydrogen phosphate R.

**Column:**

- size:  $l = 0.125$  m,  $\varnothing = 4.6$  mm;
- stationary phase: octadecylsilyl silica gel for chromatography R (5  $\mu\text{m}$ ).

**Mobile phase:**

- mobile phase A: 15.6 g/L solution of sodium dihydrogen phosphate R;
- mobile phase B: acetonitrile for chromatography R, water R (50:50 V/V);

Time (min)	Mobile phase A (per cent V/V)	Mobile phase B (per cent V/V)
0 - 30	70 → 40	30 → 60
30 - 30.1	40 → 70	60 → 30
30.1 - 45	70	30

**Flow rate:** 1 mL/min.

**Detection:** spectrophotometer at 220 nm.

**Injection:** 50  $\mu\text{L}$ .

**Retention time:** oxytocin = about 7.5 min; desmopressin = about 10 min.

**System suitability:** resolution solution:

- resolution: minimum 5.0 between the peaks due to desmopressin and oxytocin.

**Limits:**

- any impurity: maximum 1.5 per cent;
- total: maximum 5 per cent;
- disregard limit: 0.1 per cent.

**Acetic acid** (2.5.34): 6.0 per cent to 10.0 per cent.

**Test solution.** Dissolve 15.0 mg of the substance to be examined in a mixture of 5 volumes of mobile phase B and 95 volumes of mobile phase A and dilute to 10.0 mL with the same mixture of mobile phases.

**Water** (2.5.12): maximum 5.0 per cent, determined on at least 50 mg.

**Bacterial endotoxins** (2.6.14): less than 300 IU/mg, if intended for use in the manufacture of parenteral preparations without a further appropriate procedure for removal of bacterial endotoxins.

#### ASSAY

Liquid chromatography (2.2.29) as described in the test for related substances with the following modifications.

**Reference solution.** Dissolve the contents of a vial of oxytocin CRS in a 15.6 g/L solution of sodium dihydrogen phosphate R to obtain a concentration of 0.25 mg/mL.

**Injection:** 25  $\mu\text{L}$ .

Calculate the content of oxytocin ( $\text{C}_{43}\text{H}_{66}\text{N}_{12}\text{O}_{12}\text{S}_2$ ) from the declared content of  $\text{C}_{43}\text{H}_{66}\text{N}_{12}\text{O}_{12}\text{S}_2$  in oxytocin CRS.

#### STORAGE

In an airtight container, protected from light, at a temperature of 2 °C to 8 °C. If the substance is sterile, store in a sterile, airtight, tamper-proof container.

#### LABELLING

The label states the oxytocin peptide content ( $\text{C}_{43}\text{H}_{66}\text{N}_{12}\text{O}_{12}\text{S}_2$ ).



01/2008:0779 Column:

**OXYTOCIN CONCENTRATED SOLUTION**

## Oxytocini solutio concentrata

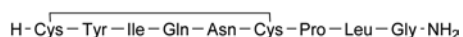
C<sub>43</sub>H<sub>66</sub>N<sub>12</sub>O<sub>12</sub>S<sub>2</sub>M<sub>r</sub> 1007

## DEFINITION

L-Cysteinyl-L-tyrosyl-L-isoleucyl-L-glutamyl-L-asparaginyl-L-cysteinyl-L-prolyl-L-leucylglycinamide cyclic (1→6)-disulfide.

Solution of oxytocin, a synthetic cyclic nonapeptide having the structure of the hormone produced by the posterior lobe of the pituitary gland that stimulates contraction of the uterus and milk ejection in receptive mammals. It is available as a solution with a stated concentration of not less than 0.25 mg of oxytocin per millilitre, in a solvent that may contain an appropriate antimicrobial preservative.

**Content:** 95.0 per cent to 105.0 per cent of the amount of the peptide stated per millilitre.

By convention, for the purpose of labelling oxytocin preparations, 1 mg of oxytocin peptide (C<sub>43</sub>H<sub>66</sub>N<sub>12</sub>O<sub>12</sub>S<sub>2</sub>) is equivalent to 600 IU of biological activity.

## CHARACTERS

**Appearance:** clear, colourless liquid.

## IDENTIFICATION

A. Examine the chromatograms obtained in the assay.

**Results:** the principal peak in the chromatogram obtained with the test solution is similar in retention time to the principal peak in the chromatogram obtained with the reference solution.

B. Amino acid analysis (2.2.56). For hydrolysis use Method 1 and for analysis use Method 1.

Express the content of each amino acid in moles. Calculate the relative proportions of the amino acids taking 1/6 of the sum of the number of moles of aspartic acid, glutamic acid, proline, glycine, isoleucine and leucine as equal to 1. The values fall within the following limits: aspartic acid: 0.90 to 1.10; glutamic acid: 0.90 to 1.10; proline: 0.90 to 1.10; glycine: 0.90 to 1.10; leucine: 0.90 to 1.10; isoleucine: 0.90 to 1.10; tyrosine: 0.7 to 1.05; half cystine: 1.4 to 2.1. Not more than traces of other amino acids are present.

## TESTS

**pH** (2.2.3): 3.0 to 5.0.

**Related substances.** Liquid chromatography (2.2.29): use the normalisation procedure.

**Test solution.** The preparation to be examined.

**Resolution solution.** Dissolve the contents of a vial of oxytocin/desmopressin validation mixture CRS in 1 mL of a 15.6 g/L solution of sodium dihydrogen phosphate R.

- size:  $l = 0.125$  m,  $\emptyset = 4.6$  mm;
- stationary phase: octadecylsilyl silica gel for chromatography R (5  $\mu$ m).

**Mobile phase:**

- mobile phase A: 15.6 g/L solution of sodium dihydrogen phosphate R;
- mobile phase B: acetonitrile for chromatography R, water R (50:50 V/V);

Time (min)	Mobile phase A (per cent V/V)	Mobile phase B (per cent V/V)
0 - 30	70 → 40	30 → 60
30 - 30.1	40 → 70	60 → 30
30.1 - 45	70	30

**Flow rate:** 1 mL/min.

**Detection:** spectrophotometer at 220 nm.

**Injection:** 50  $\mu$ L.

**Retention time:** oxytocin = about 7.5 min; desmopressin = about 10 min.

**System suitability:** resolution solution:

- resolution: minimum 5.0 between the peaks due to desmopressin and oxytocin.

**Limits:**

- any impurity: maximum 1.5 per cent;
- total: maximum 5 per cent;
- disregard limit: 0.1 per cent.

**Bacterial endotoxins** (2.6.14): less than 300 IU in the volume that contains 1 mg of oxytocin, if intended for use in the manufacture of parenteral preparations without a further appropriate procedure for the removal of bacterial endotoxins.

## ASSAY

Liquid chromatography (2.2.29) as described in the test for related substances with the following modifications.

**Reference solution.** Dissolve the contents of a vial of oxytocin CRS in a 15.6 g/L solution of sodium dihydrogen phosphate R to obtain a concentration of 0.25 mg/mL.

**Injection:** 25  $\mu$ L.

Calculate the content of oxytocin (C<sub>43</sub>H<sub>66</sub>N<sub>12</sub>O<sub>12</sub>S<sub>2</sub>) from the declared content of C<sub>43</sub>H<sub>66</sub>N<sub>12</sub>O<sub>12</sub>S<sub>2</sub> in oxytocin CRS.

## STORAGE

At a temperature of 2 °C to 8 °C, protected from light. If the substance is sterile, store in a sterile, airtight, tamper-proof container.

## LABELLING

The label states the oxytocin peptide content in milligrams of C<sub>43</sub>H<sub>66</sub>N<sub>12</sub>O<sub>12</sub>S<sub>2</sub> per millilitre.

01/2009:1794

**PACLITAXEL**

## Paclitaxelum

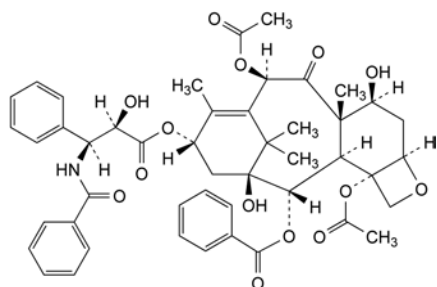

$C_{47}H_{51}NO_{14}$   
[33069-62-4]

$M_r$  854

**DEFINITION**

5 $\beta$ ,20-Epoxy-1,7 $\beta$ -dihydroxy-9-oxotax-11-ene-2 $\alpha$ ,4,10 $\beta$ ,13 $\alpha$ -tetrayl 4,10-diacetate 2-benzoate 13-[(2*R*,3*S*)-3-(benzoylamino)-2-hydroxy-3-phenylpropanoate].

It is isolated from natural sources or produced by fermentation or by a semi-synthetic process.

*Content*: 97.0 per cent to 102.0 per cent (anhydrous substance).

**CHARACTERS**

*Appearance*: white or almost white, crystalline powder.

*Solubility*: practically insoluble in water, soluble in methanol and freely soluble in methylene chloride.

**IDENTIFICATION**

A. Specific optical rotation (see Tests).

B. Infrared absorption spectrophotometry (2.2.24).

*Comparison*: paclitaxel CRS.

If the spectra obtained in the solid state show differences, dissolve 10 mg of the substance to be examined and the reference substance separately in 0.4 mL of *methylene chloride R*, evaporate to dryness and record new spectra using the residues.

**TESTS**

**Appearance of solution.** The solution is clear (2.2.1) and colourless (2.2.2, Method II).

Dissolve 0.1 g in 10 mL of *methanol R*.

**Specific optical rotation** (2.2.7): –49.0 to –55.0 (anhydrous substance).

Dissolve 0.250 g in *methanol R* and dilute to 25.0 mL with the same solvent.

**Related substances.** Liquid chromatography (2.2.29).

A. Paclitaxel isolated from natural sources or produced by fermentation.

*Test solution (a).* Dissolve 20.0 mg of the substance to be examined in *acetonitrile R1* and dilute to 10.0 mL with the same solvent.

*Test solution (b).* Dilute 1.0 mL of test solution (a) to 20.0 mL with *acetonitrile R1*.

*Reference solution (a).* Dilute 1.0 mL of test solution (a) to 10.0 mL with *acetonitrile R1*. Dilute 1.0 mL of this solution to 100.0 mL with *acetonitrile R1*.

*Reference solution (b).* Dissolve 5.0 mg of *paclitaxel CRS* in *acetonitrile R1* and dilute to 5.0 mL with the same solvent. Dilute 2.0 mL of this solution to 20.0 mL with *acetonitrile R1*.

*Reference solution (c).* Dissolve 2.0 mg of *paclitaxel impurity C CRS* in *acetonitrile R1* and dilute to 20.0 mL with the same solvent.

*Reference solution (d).* Dilute 1.0 mL of reference solution (c) to 50.0 mL with *acetonitrile R1*.

*Reference solution (e).* To 1 mL of reference solution (b) add 1 mL of reference solution (c).

*Reference solution (f).* Dissolve 5 mg of *paclitaxel natural for peak identification CRS* (containing impurities A, B, C, D, E, F, H, O, P, Q and R) in *acetonitrile R1* and dilute to 5 mL with the same solvent.

**Column:**

- *size*:  $l = 0.25$  m,  $\varnothing = 4.6$  mm;
- *stationary phase*: diisopropylcyanopropylsilyl silica gel for chromatography R (5  $\mu$ m) with a specific surface area of 180 m<sup>2</sup>/g and a pore size of 8 nm;
- *temperature*: 20  $\pm$  1  $^{\circ}$ C.

**Mobile phase:**

- *mobile phase A*: *methanol R*, *water R* (200:800 V/V);
- *mobile phase B*: *methanol R*, *acetonitrile for chromatography R* (200:800 V/V);

Time (min)	Mobile phase A (per cent V/V)	Mobile phase B (per cent V/V)
0 - 60	85 $\rightarrow$ 56	15 $\rightarrow$ 44
60 - 61	56 $\rightarrow$ 85	44 $\rightarrow$ 15
61 - 75	85	15

*Flow rate*: 1.0 mL/min.

*Detection*: spectrophotometer at 227 nm.

*Injection*: 10  $\mu$ L of test solution (a) and reference solutions (a), (d), (e) and (f).

*Identification of impurities*: use the chromatogram supplied with *paclitaxel natural for peak identification CRS* and the chromatogram obtained with reference solution (f) to identify the peaks due to impurities A, B, C, D, E, F, H, O, P, Q and R.

*Relative retention* with reference to paclitaxel (retention time = about 50 min): impurities A and B = about 0.90; impurity R = about 0.93; impurity H = about 0.96; impurities Q and P = about 1.02; impurity C = about 1.05; impurity D = about 1.07; impurities O and E = about 1.15; impurity F = about 1.20.

*System suitability*: reference solution (e):

- *resolution*: minimum 3.5 between the peaks due to paclitaxel and impurity C.

**Limits:**

- *sum of impurities E and O*: not more than 5 times the area of the principal peak in the chromatogram obtained with reference solution (a) (0.5 per cent);
- *impurity R*: not more than 5 times the area of the principal peak in the chromatogram obtained with reference solution (a) (0.5 per cent);
- *sum of impurities A and B*: not more than 4 times the area of the principal peak in the chromatogram obtained with reference solution (a) (0.4 per cent);
- *impurity C*: not more than 3 times the area of the corresponding peak in the chromatogram obtained with reference solution (d) (0.3 per cent);
- *impurity D*: not more than twice the area of the principal peak in the chromatogram obtained with reference solution (a) (0.2 per cent);
- *sum of impurities P and Q*: not more than twice the area of the principal peak in the chromatogram obtained with reference solution (a) (0.2 per cent);
- *impurity F*: not more than the area of the principal peak in the chromatogram obtained with reference solution (d) (0.1 per cent);
- *unspecified impurities*: for each impurity, not more than the area of the principal peak in the chromatogram obtained with reference solution (a) (0.10 per cent);
- *total*: not more than 15 times the area of the principal peak in the chromatogram obtained with reference solution (a) (1.5 per cent);
- *disregard limit*: 0.5 times the area of the principal peak in the chromatogram obtained with reference solution (a) (0.05 per cent).

**B. Paclitaxel produced by a semi-synthetic process.**

**Test solution.** Dissolve 10.0 mg of the substance to be examined in *acetonitrile R1* and dilute to 10.0 mL with the same solvent.

**Reference solution (a).** Dilute 1.0 mL of the test solution to 10.0 mL with *acetonitrile R1*. Dilute 1.0 mL of this solution to 100.0 mL with *acetonitrile R1*.

**Reference solution (b).** Dissolve 5.0 mg of *paclitaxel CRS* in *acetonitrile R1* and dilute to 5.0 mL with the same solvent.

**Reference solution (c).** Dissolve 5 mg of *paclitaxel semi-synthetic for peak identification CRS* (containing impurities A, G, I and L) in *acetonitrile R1* and dilute to 5 mL with the same solvent.

**Reference solution (d).** Dissolve the contents of a vial of *paclitaxel semi-synthetic for system suitability CRS* (containing impurities E, H and N) in 1 mL of *acetonitrile R1*.

**Column:**

- *size*:  $l = 0.15$  m,  $\varnothing = 4.6$  mm;
- *stationary phase*: *end-capped octadecylsilyl silica gel for chromatography R* (3  $\mu$ m) with a specific surface area of 300 m<sup>2</sup>/g and a pore size of 12 nm;
- *temperature*: 35 °C.

**Mobile phase:**

- *mobile phase A*: *acetonitrile for chromatography R*, *water R* (400:600 V/V);
- *mobile phase B*: *acetonitrile for chromatography R*;

Time (min)	Mobile phase A (per cent V/V)	Mobile phase B (per cent V/V)
0 - 20	100	0
20 - 60	100 → 10	0 → 90
60 - 62	10 → 100	90 → 0
62 - 70	100	0

**Flow rate:** 1.2 mL/min.

**Detection:** spectrophotometer at 227 nm.

**Injection:** 15  $\mu$ L of the test solution and reference solutions (a), (c) and (d).

**Identification of impurities:** use the chromatogram supplied with *paclitaxel semi-synthetic for peak identification CRS* and the chromatogram obtained with reference solution (c) to identify the peaks due to impurities A, G, I and L; use the chromatogram supplied with *paclitaxel semi-synthetic for system suitability CRS* and the chromatogram obtained with reference solution (d) to identify the peaks due to impurities E, H and N.

**Relative retention** with reference to paclitaxel (retention time = about 23 min): impurity N = about 0.2; impurity G = about 0.5; impurity A = about 0.8; impurities M, J and H = about 0.9; impurity E = about 1.3; impurity I = about 1.4; impurity L = about 1.5; impurity K = about 2.2.

**System suitability:** reference solution (d):

- *resolution*: minimum 1.5 between the peaks due to impurity H and paclitaxel.

**Limits:**

- *correction factor*: for the calculation of content, multiply the peak area of impurity N by 1.29;
- *impurity A*: not more than 7 times the area of the principal peak in the chromatogram obtained with reference solution (a) (0.7 per cent);
- *impurity L*: not more than 5 times the area of the principal peak in the chromatogram obtained with reference solution (a) (0.5 per cent);
- *impurities E, I*: for each impurity, not more than 4 times the area of the principal peak in the chromatogram obtained with reference solution (a) (0.4 per cent);
- *sum of impurities H, J and M*: not more than 4 times the area of the principal peak in the chromatogram obtained with reference solution (a) (0.4 per cent);
- *impurities G, K, N*: for each impurity, not more than twice the area of the principal peak in the chromatogram obtained with reference solution (a) (0.2 per cent);
- *unspecified impurities*: for each impurity, not more than the area of the principal peak in the chromatogram obtained with reference solution (a) (0.10 per cent);
- *total*: not more than 12 times the area of the principal peak in the chromatogram obtained with reference solution (a) (1.2 per cent);
- *disregard limit*: 0.5 times the area of the principal peak in the chromatogram obtained with reference solution (a) (0.05 per cent).

**Heavy metals (2.4.8):** maximum 20 ppm.

Dissolve 1.0 g in *methanol R* and dilute to 20 mL with the same solvent. 12 mL of the solution complies with test B. Prepare the reference solution using 10 mL of lead standard solution (1 ppm Pb), obtained by diluting *lead standard solution (100 ppm Pb) R* with *methanol R* and 2 mL of the test solution. To 12 mL of each solution, add 2 mL of *buffer solution pH 3.5 R*. Mix. Add 1.2 mL of *thioacetamide reagent R*. The substance will precipitate. Dilute to 40 mL with *methanol R*; the substance re-dissolves completely. Filter the solution through a membrane filter (nominal pore size 0.45  $\mu$ m). Compare the spots on the filters obtained with the different solutions. The substance to be examined complies with the test if any brownish-black colour in the spot obtained with the test solution is not more intense than that of the spot obtained with the reference solution.

**Water (2.5.32):** maximum 3.0 per cent, determined on 0.050 g.

**Microbial contamination**

TAMC: acceptance criterion 10<sup>2</sup> CFU/g (2.6.12).

**Bacterial endotoxins (2.6.14):** less than 0.4 IU/mg.

## ASSAY

- A. Paclitaxel isolated from natural sources or produced by fermentation.

Liquid chromatography (2.2.29) as described in test A for related substances with the following modification.

*Injection*: test solution (b) and reference solution (b).

Calculate the percentage content of  $C_{47}H_{51}NO_{14}$  from the declared content of *paclitaxel CRS*.

- B. Paclitaxel produced by a semi-synthetic process.

Liquid chromatography (2.2.29) as described in test B for related substances with the following modification.

*Injection*: 10  $\mu$ L of the test solution and reference solution (b).

Calculate the percentage content of  $C_{47}H_{51}NO_{14}$  from the declared content of *paclitaxel CRS*.

## STORAGE

In an airtight container, protected from light.

## LABELLING

The label states the origin of the substance:

- isolated from natural sources;
- produced by fermentation;
- produced by a semi-synthetic process.

## IMPURITIES

## Test A

*Specified impurities*: A, B, C, D, E, F, O, P, Q, R.

*Other detectable impurities* (the following substances would, if present at a sufficient level, be detected by one or other of the tests in the monograph. They are limited by the general acceptance criterion for other/unspecified impurities and/or by the general monograph *Substances for pharmaceutical use (2034)*. It is therefore not necessary to identify these impurities for demonstration of compliance. See also 5.10. *Control of impurities in substances for pharmaceutical use*): H.

## Test B

*Specified impurities*: A, E, G, H, I, J, K, L, M, N.

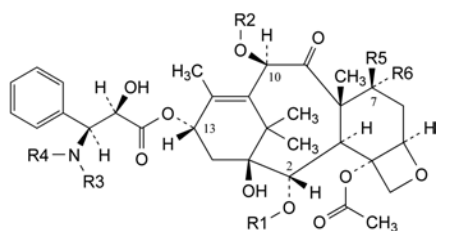

## Abbreviations used

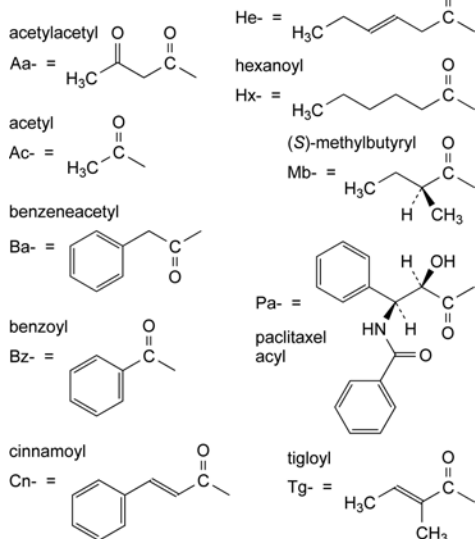

- A. R1 = Tg, R2 = Ac, R3 = Bz, R4 = R6 = H, R5 = OH: 2-*O*-debenzoyl-2-*O*-tigloylpaclitaxel,
- B. R1 = Bz, R2 = Ac, R3 = Tg, R4 = R6 = H, R5 = OH: *N*-debenzoyl-*N*-tigloylpaclitaxel (cephalomannine),
- C. R1 = Bz, R2 = Ac, R3 = Hx, R4 = R6 = H, R5 = OH: *N*-debenzoyl-*N*-hexanoylpaclitaxel (paclitaxel C),
- D. R1 = Bz, R2 = Ac, R3 = Tg, R4 = R5 = H, R6 = OH: *N*-debenzoyl-*N*-tigloyl-7-*epi*-paclitaxel (7-*epi*-cephalomannine),
- E. R1 = R3 = Bz, R2 = Ac, R4 = R5 = H, R6 = OH: 7-*epi*-paclitaxel,
- F. R1 = Bz, R2 = Ac, R3 = Hx, R4 = CH<sub>3</sub>, R5 = OH, R6 = H: *N*-debenzoyl-*N*-hexanoyl-*N*-methylpaclitaxel (*N*-methylpaclitaxel C),
- G. R1 = R3 = Bz, R2 = R4 = R6 = H, R5 = OH: 10-*O*-deacetylpaclitaxel,
- H. R1 = R3 = Bz, R2 = R4 = R5 = H, R6 = OH: 10-*O*-deacetyl-7-*epi*-paclitaxel,
- I. R1 = R3 = Bz, R2 = Pa, R4 = R6 = H, R5 = OH: 10-*O*-[(2*R*,3*S*)-3-(benzoylamino)-2-hydroxy-3-phenylpropanoyl]-10-*O*-deacetylpaclitaxel,
- J. R1 = R3 = Bz, R2 = Aa, R4 = R6 = H, R5 = OH: 10-*O*-deacetyl-10-*O*-(3-oxobutanoyl)paclitaxel,
- K. R1 = R3 = Bz, R2 = Ac, R4 = R6 = H, R5 = O-Si(C<sub>2</sub>H<sub>5</sub>)<sub>3</sub>: 7-*O*-(triethylsilyl)paclitaxel,
- L. R1 = R3 = Bz, R2 = Ac, R4 = R6 = H, R5 = O-CO-CH<sub>3</sub>: 7-*O*-acetylpaclitaxel,
- O. R1 = Bz, R2 = Ac, R3 = Cn, R4 = R6 = H, R5 = OH: *N*-cinnamoyl-*N*-debenzoylpaclitaxel,
- P. R1 = Bz, R2 = Ac, R3 = Ba, R4 = R6 = H, R5 = OH: *N*-debenzoyl-*N*-(phenylacetyl)paclitaxel,
- Q. R1 = Bz, R2 = Ac, R3 = He, R4 = R6 = H, R5 = OH: *N*-debenzoyl-*N*-[(3*E*)-hex-3-enoyl]paclitaxel,
- R. R1 = Bz, R2 = Ac, R3 = Mb, R4 = R6 = H, R5 = OH: *N*-debenzoyl-*N*-[(2*S*)-2-methylbutanoyl]paclitaxel,

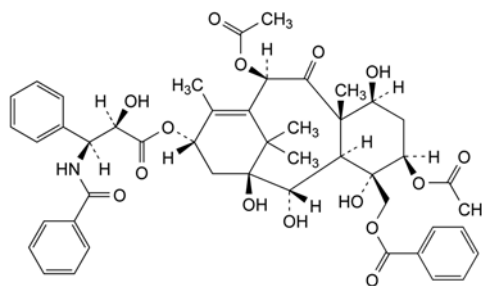

- M. 1,2 $\alpha$ ,4,7 $\beta$ -dihydroxy-9-oxotax-11-ene-5 $\beta$ ,10 $\beta$ ,13 $\alpha$ ,20-tetraol 5,10-diacetate 20-benzoate 13-[(2*R*,3*S*)-3-(benzoylamino)-2-hydroxy-3-phenylpropanoate],

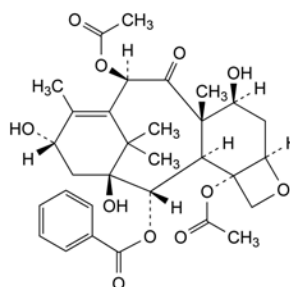

- N. 13-*O*-de[(2*R*,3*S*)-3-(benzoylamino)-2-hydroxy-3-phenylpropanoyl]paclitaxel (baccatin III).

## PALMITIC ACID

### Acidum palmiticum

[57-10-3]

## DEFINITION

Hexadecanoic acid (C<sub>16</sub>H<sub>32</sub>O<sub>2</sub>; M<sub>r</sub> 256.4), obtained from fats or oils of vegetable or animal origin.

*Content*: minimum 92.0 per cent.

## CHARACTERS

*Appearance*: white or almost white, waxy solid.

*Solubility*: practically insoluble in water, soluble in ethanol (96 per cent).

## IDENTIFICATION

- A. Freezing point (see Tests).  
 B. Acid value (2.5.1): 216 to 220, determined on 0.1 g.  
 C. Examine the chromatograms obtained in the assay.

*Results*: the principal peak in the chromatogram obtained with the test solution is similar in retention time to the principal peak in the chromatogram obtained with the reference solution.

## TESTS

**Appearance.** Heat the substance to be examined to about 75 °C. The resulting liquid is not more intensely coloured than reference solution Y<sub>7</sub> or BY<sub>7</sub> (2.2.2, Method I).

**Acidity.** Melt 5.0 g, stir for 2 min in 10 mL of hot *carbon dioxide-free water R*, cool slowly and filter. To the filtrate add 0.05 mL of *methyl orange solution R*. No red colour develops.

**Freezing point** (2.2.18): 60 °C to 66 °C.

**Iodine value** (2.5.4): maximum 1.

**Stearic acid**: maximum 6.0 per cent, determined as prescribed in the assay.

**Nickel** (2.4.31): maximum 1 ppm.

## ASSAY

Gas chromatography (2.4.22, Method C). Prepare the solutions as described in the method but omitting the initial hydrolysis.

*Reference solution.* Prepare the reference solution in the same manner as the test solution using a mixture of 50 mg of *palmitic acid R* and 50 mg of *stearic acid R* instead of the substance to be examined.

*Relative retention* with reference to methyl stearate: methyl palmitate = about 0.9.

*System suitability*:

- *resolution*: minimum 5.0 between the peaks due to methyl stearate and methyl palmitate.

## 01/2008:1904 DEFINITION

Disodium dihydrogen (3-amino-1-hydroxypropylidene)-bisphosphonate pentahydrate.

*Content*: 98.0 per cent to 101.0 per cent (anhydrous substance).

## CHARACTERS

*Appearance*: white or almost white, crystalline powder.

*Solubility*: soluble in water, practically insoluble in methylene chloride. It is sparingly soluble in dilute mineral acids and dissolves in dilute alkaline solutions.

## IDENTIFICATION

- A. Infrared absorption spectrophotometry (2.2.24).

*Comparison*: *pamidronate disodium pentahydrate CRS*.

- B. Dissolve 0.5 g in 10 mL of *water R*. The solution gives reaction (a) of sodium (2.3.1).

## TESTS

**Appearance of solution.** The solution is clear (2.2.1) and not more intensely coloured than reference solution Y<sub>6</sub> (2.2.2, Method II).

Dissolve 0.20 g in *carbon dioxide-free water R* and dilute to 10 mL with the same solvent.

**pH** (2.2.3): 7.8 to 8.8.

Dissolve 0.100 g in *carbon dioxide-free water R* and dilute to 10 mL with the same solvent.

**Impurity A.** Thin-layer chromatography (2.2.27).

*Test solution.* Dissolve 30 mg of the substance to be examined in *water R* and dilute to 10.0 mL with the same solvent.

*Reference solution.* Dissolve 15 mg of *β-alanine R* in *water R* and dilute to 100.0 mL with the same solvent. Dilute 1.0 mL of this solution to 10.0 mL with *water R*.

*Plate*: TLC silica gel plate R.

*Mobile phase*: concentrated ammonia R, di-isopropyl ether R, methanol R (4:8:9 V/V/V).

*Application*: 10 µL.

*Development*: over 2/3 of the plate.

*Drying*: in a current of warm air.

*Detection*: spray with a *ninhydrin solution R*. Heat at 100-105 °C for 15 min.

*Limit*:

- *impurity A*: any spot due to impurity A is not more intense than the spot in the chromatogram obtained with the reference solution (0.5 per cent).

**Impurities B and C.** Liquid chromatography (2.2.29).

*Test solution.* Dissolve 20.0 mg of the substance to be examined in *water R* and dilute to 10.0 mL with the same solvent.

*Reference solution.* To 2.0 mL of a 0.3 g/L solution of *phosphoric acid R* add 2.0 mL of a 0.25 g/L solution of *phosphorous acid R* and dilute to 50.0 mL with *water R*.

*Column*:

- *size*: l = 0.10 m, Ø = 4.6 mm,
- *stationary phase*: anion exchange resin R (5 µm),
- *temperature*: 35 °C.

*Mobile phase*: to 0.5 mL of *anhydrous formic acid R* add 2500 mL of *water R*; adjust to pH 3.5 with an 80 g/L solution of *sodium hydroxide R*.

*Flow rate*: 1.0 mL/min.

*Detection*: refractometer.

*Injection*: 100 µL.

*Relative retention* with reference to *pamidronate* (retention time = about 13 min): impurity B = about 1.3; impurity C = about 1.6.

*System suitability*: reference solution:

- *resolution*: minimum 2.5 between the peaks due to impurities B and C.

## 01/2008:1779

## PAMIDRONATE DISODIUM PENTAHYDRATE

### Dinatrii pamidronas pentahydricus

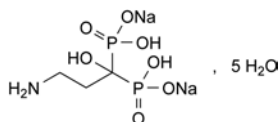

C<sub>3</sub>H<sub>9</sub>NNa<sub>2</sub>O<sub>7</sub>P<sub>2</sub>·5H<sub>2</sub>O  
 [109552-15-0]

M<sub>r</sub> 369.1

**Limits:**

- *impurities B, C*: for each impurity, not more than the area of the corresponding peaks in the chromatogram obtained with the reference solution (0.5 per cent).

**Heavy metals (2.4.8)**: maximum 20 ppm.

2.0 g complies with test C. Prepare the reference solution using *lead standard solution (2 ppm Pb) R*.

**Water (2.5.12)**: 23.0 per cent to 27.0 per cent, determined on 0.100 g.

**ASSAY**

Dissolve 0.250 g in 70 mL of *water R*. Titrate with 0.1 M *hydrochloric acid* determining the end-point potentiometrically (2.2.20).

1 mL of 0.1 M *hydrochloric acid* is equivalent to 27.91 mg of  $C_3H_9NNa_2O_7P_2$ .

**IMPURITIES**

*Specified impurities: A, B, C.*

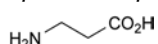

- A. 3-aminopropanoic acid ( $\beta$ -alanine),  
 B.  $H_3PO_4$ : phosphoric acid,  
 C.  $H_3PO_3$ : phosphorous acid.

01/2011:0350

**PANCREAS POWDER**

## Pancreatis pulvis

**DEFINITION**

Pancreas powder is prepared from the fresh or frozen pancreases of mammals. It contains various enzymes having proteolytic, lipolytic and amylolytic activities.

1 mg of pancreas powder contains not less than 1.0 Ph. Eur. U. of total proteolytic activity, 15 Ph. Eur. U. of lipolytic activity and 12 Ph. Eur. U. of amylolytic activity.

**PRODUCTION**

The animals from which pancreas powder is derived must fulfil the requirements for the health of animals suitable for human consumption.

**CHARACTERS**

*Appearance*: slightly brown, amorphous powder.

*Solubility*: partly soluble in water, practically insoluble in ethanol (96 per cent).

**IDENTIFICATION**

- A. Triturate 0.5 g with 10 mL of *water R* and adjust to pH 8 with 0.1 M *sodium hydroxide*, using 0.1 mL of *cresol red solution R* as indicator. Divide the suspension into 2 equal parts (suspension (a) and suspension (b)). Boil suspension (a). To each suspension add 10 mg of *fibrin congo red R*, heat to 38-40 °C and maintain at this temperature for 1 h. Suspension (a) is colourless or slightly pink and suspension (b) is distinctly more red.
- B. Triturate 0.25 g with 10 mL of *water R* and adjust to pH 8 with 0.1 M *sodium hydroxide*, using 0.1 mL of *cresol red solution R* as indicator. Divide the suspension into 2 equal parts (suspension (a) and suspension (b)). Boil suspension (a). Dissolve 0.1 g of *soluble starch R* in 100 mL of boiling *water R*, boil for 2 min, cool and dilute to 150 mL with *water R*. To 75 mL of the starch solution add suspension (a) and to the remaining 75 mL add suspension (b). Heat each mixture to 38-40 °C and maintain at this temperature for 5 min.

To 1 mL of each mixture add 10 mL of *iodine solution R2*. The mixture obtained with suspension (a) has an intense blue-violet colour; the mixture obtained with suspension (b) has the colour of the iodine solution.

**TESTS**

**Fat content**: maximum 5.0 per cent.

In an extraction apparatus, treat 1.0 g with *light petroleum R1* for 3 h. Evaporate the solvent and dry the residue at 100-105 °C for 2 h. The residue weighs a maximum of 50 mg.

**Loss on drying (2.2.32)**: maximum 5.0 per cent, determined on 0.50 g by drying at 60 °C at a pressure not exceeding 670 Pa for 4 h.

**Microbial contamination**

TAMC: acceptance criterion  $10^4$  CFU/g (2.6.12).

TYMC: acceptance criterion  $10^2$  CFU/g (2.6.12).

Absence of *Escherichia coli* (2.6.13).

Absence of *Salmonella* (2.6.13).

**ASSAY**

**Total proteolytic activity.** The total proteolytic activity of pancreas powder is determined by comparing the quantity of peptides non-precipitable by a 50 g/L solution of *trichloroacetic acid R* released per minute from a substrate of casein solution with the quantity of such peptides released by *pancreas powder (protease) BRP* from the same substrate in the same conditions. *Casein solution.* Suspend a quantity of *casein BRP* equivalent to 1.25 g of dried substance in 5 mL of *water R*, add 10 mL of 0.1 M *sodium hydroxide* and stir for 1 min. (Determine the water content of *casein BRP* prior to the test by heating at 60 °C *in vacuo* for 4 h.) Add 60 mL of *water R* and stir with a magnetic stirrer until the solution is practically clear. Adjust to pH 8.0 with 0.1 M *sodium hydroxide* or 0.1 M *hydrochloric acid*. Dilute to 100.0 mL with *water R*. Use the solution on the day of preparation.

*Enterokinase solution.* Dissolve 50 mg of *enterokinase BRP* in 0.02 M *calcium chloride solution R* and dilute to 50.0 mL with the same solvent. Use the solution on the day of preparation.

*For the test suspension and the reference suspension, prepare the suspension and carry out the dilution at 0-4 °C.*

*Test suspension.* Triturate 0.100 g of the substance to be examined for 5 min adding gradually 25 mL of 0.02 M *calcium chloride solution R*. Transfer completely to a volumetric flask and dilute to 100.0 mL with 0.02 M *calcium chloride solution R*. To 10.0 mL of this suspension add 10.0 mL of the enterokinase solution and heat on a water-bath at  $35 \pm 0.5$  °C for 15 min. Cool and dilute with *borate buffer solution pH 7.5 R* at  $5 \pm 3$  °C to a final concentration of about 0.065 Ph. Eur. U. of total proteolytic activity per millilitre calculated on the basis of the stated activity.

*Reference suspension.* Prepare a suspension of *pancreas powder (protease) BRP* as described for the test suspension but without the addition of enterokinase so as to obtain a known final concentration of about 0.065 Ph. Eur. U. per millilitre calculated on the basis of the stated activity.

Designate tubes in duplicate T, T<sub>b</sub>, S<sub>1</sub>, S<sub>1b</sub>, S<sub>2</sub>, S<sub>2b</sub>, S<sub>3</sub>, S<sub>3b</sub>; designate a tube B.

Add *borate buffer solution pH 7.5 R* to the tubes as follows:

B: 3.0 mL,

S<sub>1</sub> and S<sub>1b</sub>: 2.0 mL,

S<sub>2</sub>, S<sub>2b</sub>, T and T<sub>b</sub>: 1.0 mL.

Add the reference suspension to the tubes as follows:

S<sub>1</sub> and S<sub>1b</sub>: 1.0 mL,

S<sub>2</sub> and S<sub>2b</sub>: 2.0 mL,

S<sub>3</sub> and S<sub>3b</sub>: 3.0 mL.

Add 2.0 mL of the test suspension to tubes T and T<sub>b</sub>.

Add 5.0 mL of a 50 g/L solution of *trichloroacetic acid R* to tubes B, S<sub>1b</sub>, S<sub>2b</sub>, S<sub>3b</sub> and T<sub>b</sub>. Mix by shaking.

Place the tubes and the casein solution in a water-bath at  $35 \pm 0.5$  °C. Place a glass rod in each tube. When temperature equilibrium is reached, add 2.0 mL of the casein solution to tubes B, S<sub>1b</sub>, S<sub>2b</sub>, S<sub>3b</sub> and T<sub>b</sub>. Mix. At time zero, add 2.0 mL of casein solution successively and at intervals of 30 s to tubes S<sub>1</sub>, S<sub>2</sub>, S<sub>3</sub> and T. Mix immediately after each addition. Exactly 30 min after addition of the casein solution, taking into account the regular interval adopted, add 5.0 mL of a 50 g/L solution of *trichloroacetic acid R* to tubes S<sub>1</sub>, S<sub>2</sub>, S<sub>3</sub> and T. Mix. Withdraw the tubes from the water-bath and allow to stand at room temperature for 20 min.

Filter the contents of each tube twice through the same suitable filter paper previously washed with a 50 g/L solution of *trichloroacetic acid R*, then with *water R* and dried.

A suitable filter paper complies with the following test: filter 5 mL of a 50 g/L solution of *trichloroacetic acid R* on a 7 cm disc of white filter paper; the absorbance (2.2.25) of the filtrate, measured at 275 nm using unfiltered trichloroacetic acid solution as the compensation liquid, is less than 0.04.

A schematic presentation of the above operations is shown in Table 0350-1.

Table 0350-1

	Tubes									
	S <sub>1</sub>	S <sub>1b</sub>	S <sub>2</sub>	S <sub>2b</sub>	S <sub>3</sub>	S <sub>3b</sub>	T	T <sub>b</sub>	B	
Buffer solution	2	2	1	1			1	1	3	
Reference suspension	1	1	2	2	3	3				
Test suspension							2	2		
Trichloroacetic acid solution		5		5		5		5	5	
Mix		+		+		+		+	+	
Water-bath 35 °C	+	+	+	+	+	+	+	+	+	
Casein solution		2		2		2		2	2	
Mix		+		+		+		+	+	
Casein solution	2		2		2		2			
Mix	+		+		+		+			
Water-bath 35 °C 30 min	+	+	+	+	+	+	+	+	+	
Trichloroacetic acid solution	5		5		5		5			
Mix	+		+		+		+			
Room temperature 20 min	+	+	+	+	+	+	+	+	+	
Filter	+	+	+	+	+	+	+	+	+	

Measure the absorbance (2.2.25) of the filtrates at 275 nm using the filtrate obtained from tube B as the compensation liquid.

Correct the average absorbance values for the filtrates obtained from tubes S<sub>1</sub>, S<sub>2</sub> and S<sub>3</sub> by subtracting the average values obtained for the filtrates from tubes S<sub>1b</sub>, S<sub>2b</sub> and S<sub>3b</sub> respectively. Draw a calibration curve of the corrected values against the volume of reference suspension used.

Determine the activity of the substance to be examined using the corrected absorbance for the test suspension (T – T<sub>b</sub>) and the calibration curve and taking into account the dilution factors.

The test is not valid unless the corrected absorbance values are between 0.15 and 0.60.

**Lipolytic activity.** The lipolytic activity is determined by comparing the rate at which a suspension of pancreas powder hydrolyses a substrate of olive oil emulsion with the rate at which a suspension of *pancreas powder (amylase and lipase) BRP* hydrolyses the same substrate under the same conditions. *The test is carried out under nitrogen.*

**Olive oil stock emulsion.** In an 800 mL beaker 9 cm in diameter, place 40 mL of *olive oil R*, 330 mL of *acacia solution R* and 30 mL of *water R*. Place an electric mixer at the bottom of the beaker. Place the beaker in a vessel containing *ethanol*

(96 per cent) *R* and a sufficient quantity of ice as a cooling mixture. Emulsify using the mixer at an average speed of 1000-2000 r/min. Cool to 5-10 °C. Increase the mixing speed to 8000 r/min. Mix for 30 min keeping the temperature below 25 °C by the continuous addition of crushed ice into the cooling mixture. (A mixture of calcium chloride and crushed ice is also suitable). Store the stock emulsion in a refrigerator and use within 14 days. The emulsion must not separate into 2 distinct layers. Check the diameter of the globules of the emulsion under a microscope. At least 90 per cent have a diameter below 3 µm and none has a diameter greater than 10 µm. Shake the emulsion thoroughly before preparing the emulsion substrate.

**Olive oil emulsion.** For 10 determinations, mix the following solutions in the order indicated: 100 mL of the stock emulsion, 80 mL of *tris(hydroxymethyl)aminomethane solution R1*, 20 mL of a freshly prepared 80 g/L of *sodium taurocholate BRP* and 95 mL of *water R*. Use on the day of preparation.

**Apparatus.** Use a reaction vessel of about 50 mL capacity provided with:

- a device that will maintain a temperature of  $37 \pm 0.5$  °C;
- a magnetic stirrer;
- a lid with holes for the insertion of electrodes, the tip of a burette, a tube for the admission of nitrogen and the introduction of reagents.

An automatic or manual titration apparatus may be used. In the latter case, the burette is graduated in 0.005 mL and the pH-meter is provided with a wide reading scale and glass-calomel or glass-silver-silver chloride electrodes. After each test the reaction vessel is evacuated by suction and washed several times with *water R*, the washings being removed each time by suction.

**Test suspension.** In a small mortar cooled to 0-4 °C, triturate carefully a quantity of the substance to be examined equivalent to about 2500 Ph. Eur. U. of lipolytic activity with 1 mL of cooled *maleate buffer solution pH 7.0 R* (lipase solvent) until a very fine suspension is obtained. Dilute the suspension with cold *maleate buffer solution pH 7.0 R*, transfer quantitatively to a volumetric flask and dilute to 100.0 mL with the cold buffer solution. Keep the flask containing the test suspension in iced water during the titration.

**Reference suspension.** To avoid absorption of water formed by condensation, allow the reference preparation to reach room temperature before opening the container. Prepare a suspension of *pancreas powder (amylase and lipase) BRP* as described for the test suspension using a quantity equivalent to about 2500 Ph. Eur. U.

Carry out the titrations immediately after preparation of the test suspension and the reference suspension. Place 29.5 mL of olive oil emulsion in the reaction vessel equilibrated at  $37 \pm 0.5$  °C. Fit the vessel with the electrodes, a stirrer and the burette (the tip being immersed in the olive oil emulsion).

Put the lid in place and switch on the apparatus. Carefully add 0.1 M *sodium hydroxide* with stirring to adjust to pH 9.2. Using a rapid-flow graduated pipette transfer about 0.5 mL of the previously homogenised reference suspension, start the chronometer and add continuously 0.1 M *sodium hydroxide* to maintain the pH at 9.0. After exactly 1 min, note the volume of 0.1 M *sodium hydroxide* used. Carry out the measurement a further 4 times. Discard the first reading and determine the average of the 4 others (S<sub>1</sub>). Make 2 further determinations (S<sub>2</sub> and S<sub>3</sub>). Calculate the average of the values S<sub>1</sub>, S<sub>2</sub> and S<sub>3</sub>. The average volume of 0.1 M *sodium hydroxide* used should be about 0.12 mL per minute with limits of 0.08 mL to 0.16 mL.

Carry out 3 determinations in the same manner for the test suspension (T<sub>1</sub>, T<sub>2</sub> and T<sub>3</sub>). If the quantity of 0.1 M *sodium hydroxide* used is outside the limits of 0.08 mL to 0.16 mL per minute, the assay is repeated with a quantity of test suspension that is more suitable but situated between 0.4 mL and 0.6 mL. Otherwise the quantity of the substance to be examined is adjusted to comply with the conditions of the test. Calculate the average of the values T<sub>1</sub>, T<sub>2</sub> and T<sub>3</sub>.

Calculate the activity in European Pharmacopoeia Units per milligram using the following expression:

$$\frac{n \times m_1}{n_1 \times m} \times A$$

- $n$  = average volume of 0.1 M sodium hydroxide used per minute during the titration of the test suspension, in millilitres;
- $n_1$  = average volume of 0.1 M sodium hydroxide used per minute during the titration of the reference suspension, in millilitres;
- $m$  = mass of the substance to be examined, in milligrams;
- $m_1$  = mass of the reference preparation, in milligrams;
- $A$  = activity of pancreas powder (amylase and lipase) BRP, in European Pharmacopoeia Units per milligram.

**Amylolytic activity.** The amylolytic activity is determined by comparing the rate at which a suspension of pancreas powder hydrolyses a substrate of starch solution with the rate at which a suspension of pancreas powder (amylase and lipase) BRP hydrolyses the same substrate under the same conditions.

**Starch solution.** To a quantity of starch BRP equivalent to 2.0 g of the dried substance add 10 mL of water R and mix. (Determine the water content of starch BRP prior to the test by heating at 120 °C for 4 h). Add this suspension, whilst stirring continuously, to 160 mL of boiling water R. Wash the container several times with successive quantities, each of 10 mL, of water R and add the washings to the hot starch solution. Heat to boiling, stirring continuously. Cool to room temperature and dilute to 200 mL with water R. Use the solution on the day of preparation.

For the test suspension and the reference suspension, prepare the suspension and carry out the dilution at 0-4 °C.

**Test suspension.** Triturate a quantity of the substance to be examined equivalent to about 1500 Ph. Eur. U. of amylolytic activity with 60 mL of phosphate buffer solution pH 6.8 R1 for 15 min. Transfer quantitatively to a volumetric flask and dilute to 100.0 mL with phosphate buffer solution pH 6.8 R1.

**Reference suspension.** Prepare a suspension of pancreas powder (amylase and lipase) BRP as described for the test suspension, using a quantity equivalent to about 1500 Ph. Eur. U.

In a test-tube 200 mm long and 22 mm in diameter, fitted with a ground-glass stopper, place 25.0 mL of starch solution, 10.0 mL of phosphate buffer solution pH 6.8 R1 and 1.0 mL of an 11.7 g/L solution of sodium chloride R. Close the tube, shake and place in a water-bath at 25.0 ± 0.1 °C. When the temperature equilibrium has been reached, add 1.0 mL of the test suspension and start the chronometer. Mix and place the tube in the water-bath. After exactly 10 min, add 2 mL of 1 M hydrochloric acid. Transfer the mixture quantitatively to a 300 mL conical flask fitted with a ground-glass stopper. Whilst shaking continuously, add 10.0 mL of 0.05 M iodine immediately followed by 45 mL of 0.1 M sodium hydroxide. Allow to stand in the dark at a temperature between 15 °C and 25 °C for 15 min. Add 4 mL of a mixture of 1 volume of sulfuric acid R and 4 volumes of water R. Titrate the excess of iodine with 0.1 M sodium thiosulfate using a microburette. Carry out a blank titration adding the 2 mL of 1 M hydrochloric acid before introducing the test suspension. Carry out the titration of the reference suspension in the same manner.

Calculate the amylolytic activity in European Pharmacopoeia Units per milligram using the following expression:

$$\frac{(n' - n) m_1}{(n'_1 - n_1) m} \times A$$

- $n$  = volume of 0.1 M sodium thiosulfate used in the titration of the test suspension, in millilitres;
- $n_1$  = volume of 0.1 M sodium thiosulfate used in the titration of the reference suspension, in millilitres;
- $n'$  = volume of 0.1 M sodium thiosulfate used in the blank titration of the test suspension, in millilitres;
- $n'_1$  = volume of 0.1 M sodium thiosulfate used in the blank titration of the reference suspension, in millilitres;
- $m$  = mass of the substance to be examined, in milligrams;
- $m_1$  = mass of the reference preparation, in milligrams;
- $A$  = activity of pancreas powder (amylase and lipase) BRP, in European Pharmacopoeia Units per milligram.

#### STORAGE

In an airtight container.

01/2008:0681

## PANCURONIUM BROMIDE

### Pancuronii bromidum

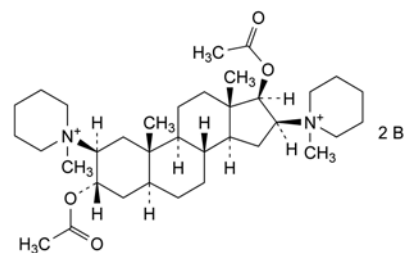

C<sub>35</sub>H<sub>60</sub>Br<sub>2</sub>N<sub>2</sub>O<sub>4</sub>  
[15500-66-0]

$M_r$  733

#### DEFINITION

1,1'-[3 $\alpha$ ,17 $\beta$ -Bis(acetyloxy)-5 $\alpha$ -androstane-2 $\beta$ ,16 $\beta$ -diyl]bis(1-methylpiperidinium) dibromide.

**Content:** 98.0 per cent to 102.0 per cent (anhydrous substance).

#### CHARACTERS

**Appearance:** white, yellowish-white or slightly pink, crystalline powder, hygroscopic.

**Solubility:** very soluble or freely soluble in water, very soluble in methylene chloride, freely soluble in ethanol (96 per cent).

#### IDENTIFICATION

A. Infrared absorption spectrophotometry (2.2.24).

*Comparison:* pancuronium bromide CRS.

B. It gives reaction (a) of bromides (2.3.1).

#### TESTS

**Appearance of solution.** The solution is clear (2.2.1) and colourless (2.2.2, Method II).

Dissolve 50 mg in water R and dilute to 25 mL with the same solvent.

**Specific optical rotation** (2.2.7): + 38.0 to + 42.0 (anhydrous substance).

Dissolve 0.75 g in water R and dilute to 25.0 mL with the same solvent.

**Related substances.** Thin-layer chromatography (2.2.27).

*Prepare the solutions immediately before use.*

**Test solution.** Dissolve 50.0 mg of the substance to be examined in methylene chloride R and dilute to 5.0 mL with the same solvent.



**Reference solution (a).** Dilute 1.0 mL of the test solution to 50.0 mL with *methylene chloride R*. Dilute 1.0 mL of this solution to 20.0 mL with *methylene chloride R*.

**Reference solution (b).** Dissolve 10.0 mg of *pancuronium bromide for system suitability CRS* (containing 1.0 per cent of impurity D) in 1.0 mL of *methylene chloride R*.

**Plate:** TLC silica gel plate R (2-10 µm).

**Mobile phase:** 400 g/L solution of *sodium iodide R*, *acetonitrile R*, *2-propanol R* (5:10:85 V/V/V).

**Application:** 5 µL.

**Development:** in an unlined and unsaturated tank over a path of 8 cm.

**Drying:** in a current of air at room temperature.

**Detection:** spray with a 20 g/L solution of *sodium nitrite R* and allow to dry for 5 min. Then spray with *potassium iodobismuthate solution R5*. Cover the plate with a transparent glass cover.

**System suitability:**

- the chromatogram obtained with reference solution (b) shows 2 clearly separated spots due to pancuronium bromide ( $R_F$  = about 0.5) and impurity D ( $R_F$  = about 0.6);
- the chromatogram obtained with reference solution (a) shows a clearly visible spot.

**Note:** impurity A if present will co-migrate with impurity D.

**Limits:**

- *impurities A, D:* any spot due to impurities A and/or D is not more intense than the spot due to impurity D in the chromatogram obtained with reference solution (b) (1.0 per cent),
- *unspecified impurities:* any other spot is not more intense than the spot in the chromatogram obtained with reference solution (a) (0.10 per cent).

**Water (2.5.12):** maximum 8.0 per cent, determined on 0.300 g.

**Sulfated ash (2.4.14):** maximum 0.1 per cent, determined on 1.0 g.

**ASSAY**

Dissolve 0.200 g in 50 mL of *acetic anhydride R*, heating if necessary. Titrate with 0.1 M *perchloric acid*, determining the end-point potentiometrically (2.2.20).

1 mL of 0.1 M *perchloric acid* is equivalent to 36.63 mg of  $C_{35}H_{60}Br_2N_2O_4$ .

**STORAGE**

In an airtight container, protected from light.

**IMPURITIES**

**Specified impurities:** A, D.

**Other detectable impurities** (the following substances would, if present at a sufficient level, be detected by one or other of the tests in the monograph. They are limited by the general acceptance criterion for other/unspecified impurities and/or by the general monograph *Substances for pharmaceutical use* (2034). It is therefore not necessary to identify these impurities for demonstration of compliance. See also 5.10. *Control of impurities in substances for pharmaceutical use*): B, C, E.

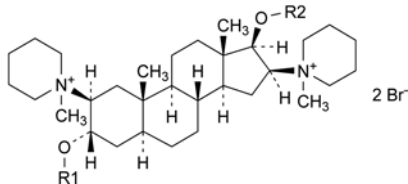

A.  $R_1 = CO-CH_3$ ,  $R_2 = H$ : 1,1'-[3α-(acetyloxy)-17β-hydroxy-5α-androstane-2β,16β-diyl]bis(1-methylpiperidinium) dibromide (dacuronium bromide),

B.  $R_1 = H$ ,  $R_2 = CO-CH_3$ : 1,1'-[17β-(acetyloxy)-3α-hydroxy-5α-androstane-2β,16β-diyl]bis(1-methylpiperidinium) dibromide,

C.  $R_1 = R_2 = H$ : 1,1'-[3α,17β-dihydroxy-5α-androstane-2β,16β-diyl]bis(1-methylpiperidinium) dibromide,

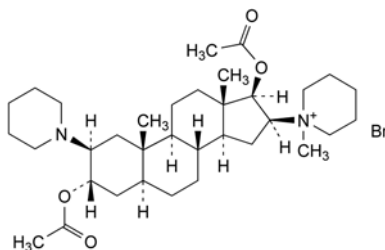

D. 1-[3α,17β-bis(acetyloxy)-2β-(piperidin-1-yl)-5α-androstan-16β-yl]-1-methylpiperidinium bromide (vecuronium bromide),

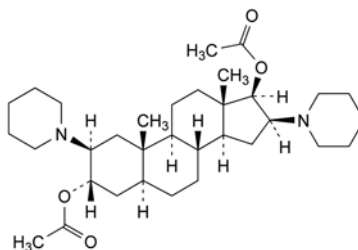

E. 2β,16β-bis(piperidin-1-yl)-5α-androstane-3α,17β-diyl diacetate.

04/2008:2296

## PANTOPRAZOLE SODIUM SESQUIHYDRATE

Pantoprazolum natricum sesquihydricum

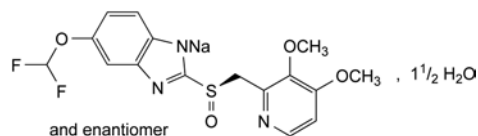

$C_{16}H_{14}F_2N_3NaO_4S \cdot 1\frac{1}{2}H_2O$   
[164579-32-2]

$M_r$  432.4

**DEFINITION**

Sodium 5-(difluoromethoxy)-2-[(*RS*)-[(3,4-dimethoxy)pyridin-2-yl)methyl]sulfinyl]benzimidazol-1-ide sesquihydrate.

**Content:** 99.0 per cent to 101.0 per cent (anhydrous substance).

**PRODUCTION**

It is produced by methods of manufacture designed to guarantee the proper hydrate form and it complies, if tested, with a suitable test that demonstrates its sesquihydrate nature (for example near-infrared spectrophotometry (2.2.40) or X-ray powder diffraction (2.9.33)).

**CHARACTERS**

**Appearance:** white or almost white powder.

**Solubility:** freely soluble in water and in ethanol (96 per cent), practically insoluble in hexane.

**IDENTIFICATION**

A. Infrared absorption spectrophotometry (2.2.24).

*Comparison:* pantoprazole sodium sesquihydrate CRS.

B. It gives reaction (a) of sodium (2.3.1).

**TESTS**

**Appearance of solution.** The solution is clear (2.2.1) and not more intensely coloured than reference solution B<sub>6</sub> (2.2.2, *Method II*).

Dissolve 0.20 g in *water R* and dilute to 20.0 mL with the same solvent.

**Optical rotation** (2.2.7):  $-0.4^{\circ}$  to  $+0.4^{\circ}$ .

Dissolve 0.2 g in 10 mL of *water R*. Adjust to pH 11.5-12.0 with an 8 g/L solution of *sodium hydroxide R*. Dilute to 20.0 mL with *water R*.

**Related substances.** Liquid chromatography (2.2.29).

**Solvent mixture:** acetonitrile for chromatography R, 40 mg/L solution of *sodium hydroxide R* (50:50 V/V).

**Test solution.** Dissolve 23 mg of the substance to be examined in the solvent mixture and dilute to 50.0 mL with the solvent mixture.

**Reference solution (a).** Dilute 1.0 mL of the test solution to 100.0 mL with the solvent mixture. Dilute 1.0 mL of this solution to 10.0 mL with the solvent mixture.

**Reference solution (b).** Dissolve the contents of a vial of *pantoprazole for system suitability CRS* (containing impurities A, B, C, D and E) in 1.0 mL of the solvent mixture.

**Column:**

- size:  $l = 0.125$  m,  $\varnothing = 4$  mm;
- stationary phase: octadecylsilyl silica gel for chromatography R (5  $\mu$ m);
- temperature: 40  $^{\circ}$ C.

**Mobile phase:**

- mobile phase A: 1.74 g/L solution of *dipotassium hydrogen phosphate R* adjusted to pH 7.00  $\pm$  0.05 with a 330 g/L solution of *phosphoric acid R*;
- mobile phase B: acetonitrile for chromatography R;

Time (min)	Mobile phase A (per cent V/V)	Mobile phase B (per cent V/V)
0 - 40	80 $\rightarrow$ 20	20 $\rightarrow$ 80
40 - 45	20 $\rightarrow$ 80	80 $\rightarrow$ 20

**Flow rate:** 1.0 mL/min.

**Detection:** spectrophotometer at 290 nm and, for impurity C, at 305 nm.

**Injection:** 20  $\mu$ L.

**Identification of impurities:** use the chromatogram supplied with *pantoprazole for system suitability CRS* and the chromatogram obtained with reference solution (b) to identify the peaks due to impurities A, B, C, D + F and E.

**Relative retention** with reference to pantoprazole (retention time = about 11 min): impurity C = about 0.6; impurity A = about 0.9; impurities D and F = about 1.2; impurity E = about 1.3; impurity B = about 1.5.

**System suitability:** reference solution (b):

- resolution: minimum 1.5 between the peaks due to impurities E and D + F;
- the chromatogram obtained is similar to the chromatogram supplied with *pantoprazole for system suitability CRS*.

**Limits:**

- correction factor: for the calculation of content, multiply the peak area of impurity C by 0.3;
- impurity A: not more than twice the area of the principal peak in the chromatogram obtained with reference solution (a) (0.2 per cent);
- sum of impurities D and F: not more than twice the area of the principal peak in the chromatogram obtained with reference solution (a) (0.2 per cent);
- impurities B, C, E: for each impurity, not more than the area of the principal peak in the chromatogram obtained with reference solution (a) (0.1 per cent);
- unspecified impurities: for each impurity, not more than the area of the principal peak in the chromatogram obtained with reference solution (a) (0.10 per cent);
- total: not more than 5 times the area of the principal peak in the chromatogram obtained with reference solution (a) (0.5 per cent);

- disregard limit: 0.5 times the area of the principal peak in the chromatogram obtained with reference solution (a) (0.05 per cent).

**Heavy metals** (2.4.8): maximum 20 ppm.

1.0 g complies with test C. Prepare the reference solution using 2 mL of *lead standard solution (10 ppm Pb) R*.

**Water** (2.5.12): 5.9 per cent to 6.9 per cent, determined on 0.150 g.

**ASSAY**

Dissolve 0.200 g in 80 mL of *anhydrous acetic acid R*, add 5 mL of *acetic anhydride R* and mix for at least 10 min. Titrate with 0.1 M *perchloric acid*, determining the end-point potentiometrically (2.2.20).

1 mL of 0.1 M *perchloric acid* is equivalent to 20.27 mg of  $C_{16}H_{14}F_2N_3NaO_4S$ .

**STORAGE**

Protected from light.

**IMPURITIES**

**Specified impurities:** A, B, C, D, E, F.

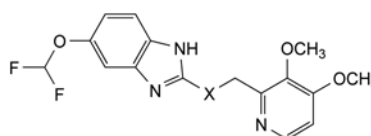

- A. X = SO<sub>2</sub>: 5-(difluoromethoxy)-2-[(3,4-dimethoxy-5-pyridin-2-yl)methyl]sulfonyl]-1H-benzimidazole,
- B. X = S: 5-(difluoromethoxy)-2-[(3,4-dimethoxy-5-pyridin-2-yl)methyl]sulfanyl]-1H-benzimidazole,

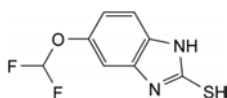

- C. 5-(difluoromethoxy)-1H-benzimidazole-2-thiol,

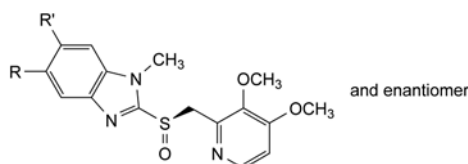

- D. R = OCHF<sub>2</sub>, R' = H: 5-(difluoromethoxy)-2-[(RS)-[(3,4-dimethoxy-5-pyridin-2-yl)methyl]sulfinyl]-1-methyl-1H-benzimidazole,
- F. R = H, R' = OCHF<sub>2</sub>: 6-(difluoromethoxy)-2-[(RS)-[(3,4-dimethoxy-5-pyridin-2-yl)methyl]sulfinyl]-1-methyl-1H-benzimidazole,

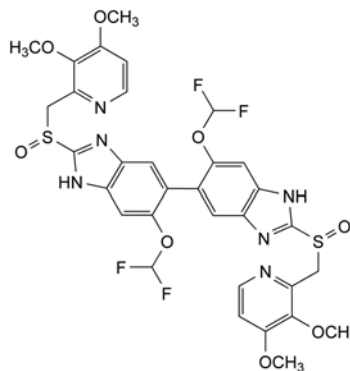

- E. mixture of the stereoisomers of 6,6'-bis(difluoromethoxy)-2,2'-bis[[[(3,4-dimethoxy-5-pyridin-2-yl)methyl]sulfinyl]-1H,1'H-5,5'-bibenzimidazolyl].

01/2008:0102  
corrected 7.0

## PAPAVERINE HYDROCHLORIDE

## Papaverini hydrochloridum

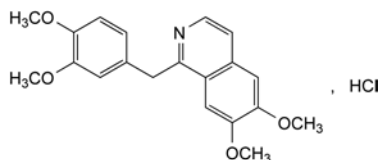
C<sub>20</sub>H<sub>22</sub>ClNO<sub>4</sub>  
[61-25-6]M<sub>r</sub> 375.9

## DEFINITION

1-(3,4-Dimethoxybenzyl)-6,7-dimethoxyisoquinoline hydrochloride.

Content: 99.0 per cent to 101.0 per cent (dried substance).

## CHARACTERS

*Appearance*: white or almost white crystalline powder or white or almost white crystals.*Solubility*: sparingly soluble in water, slightly soluble in alcohol.

## IDENTIFICATION

*First identification*: A, D.*Second identification*: B, C, D.

A. Infrared absorption spectrophotometry (2.2.24).

*Comparison*: papaverine hydrochloride CRS.

B. Thin-layer chromatography (2.2.27).

*Test solution*. Dissolve 5 mg of the substance to be examined in methanol R and dilute to 10 mL with the same solvent.*Reference solution*. Dissolve 5 mg of papaverine hydrochloride CRS in methanol R and dilute to 10 mL with the same solvent.*Plate*: TLC silica gel GF<sub>254</sub> plate R.*Mobile phase*: diethylamine R, ethyl acetate R, toluene R (10:20:70 V/V/V).*Application*: 10 µL.*Development*: over 2/3 of the plate.*Drying*: at 100-105 °C for 2 h.*Detection*: examine in ultraviolet light at 254 nm.*Results*: the principal spot in the chromatogram obtained with the test solution is similar in position and size to the principal spot in the chromatogram obtained with the reference solution.

C. To 10 mL of solution S (see Tests) add 5 mL of ammonia R dropwise and allow to stand for 10 min. The precipitate, washed and dried, melts (2.2.14) at 146 °C to 149 °C.

D. It gives reaction (a) of chlorides (2.3.1).

## TESTS

**Solution S**. Dissolve 0.4 g in carbon dioxide-free water R, heating gently if necessary, and dilute to 20 mL with the same solvent.**Appearance of solution**. Solution S is clear (2.2.1) and not more intensely coloured than reference solution BY<sub>6</sub> (2.2.2, Method II).**pH** (2.2.3): 3.0 to 4.0 for solution S.**Related substances**. Liquid chromatography (2.2.29).*Solvent mixture*: acetonitrile R, mobile phase A (20:80 V/V).*Test solution*. Dissolve 20.0 mg of the substance to be examined in the solvent mixture and dilute to 10.0 mL with the solvent mixture.*Reference solution (a)*. Dilute 1.0 mL of the test solution to 100.0 mL with the solvent mixture. Dilute 1.0 mL of this solution to 10.0 mL with the solvent mixture.*Reference solution (b)*. Dissolve 12 mg of noscapine CRS in 1.0 mL of the test solution and dilute to 100.0 mL with the solvent mixture.*Column*:– size: *l* = 0.25 m, Ø = 4.0 mm,

– stationary phase: base-deactivated octylsilyl silica gel for chromatography R (5 µm).

*Mobile phase*:

– mobile phase A: 3.4 g/L solution of potassium dihydrogen phosphate R adjusted to pH 3.0 with dilute phosphoric acid R,

– mobile phase B: acetonitrile R,

– mobile phase C: methanol R,

Time (min)	Mobile phase A (per cent V/V/V)	Mobile phase B (per cent V/V/V)	Mobile phase C (per cent V/V/V)
0 - 5	85	5	10
5 - 12	85 → 60	5	10 → 35
12 - 20	60	5	35
20 - 24	60 → 40	5 → 20	35 → 40
24 - 27	40	20	40

*Flow rate*: 1 mL/min.*Detection*: spectrophotometer at 238 nm.*Injection*: 10 µL.*Relative retention* with reference to papaverine (retention time = about 23.4 min): impurity E = about 0.7; impurity C = about 0.75; impurity B = about 0.8; impurity A = about 0.9; impurity F = about 1.1; impurity D = about 1.2.*System suitability*: reference solution (b):

– resolution: minimum 1.5 between the peaks due to impurity A and papaverine.

*Limits*:

– correction factors: for the calculation of contents, multiply the peak areas of the following impurities by the corresponding correction factor: impurity C = 2.7; impurity D = 0.5; impurity A = 6.2;

– any impurity: not more than the area of the principal peak in the chromatogram obtained with reference solution (a) (0.1 per cent);

– total: not more than 5 times the area of the principal peak in the chromatogram obtained with reference solution (a) (0.5 per cent);

– disregard limit: 0.5 times the area of the principal peak in the chromatogram obtained with reference solution (a) (0.05 per cent).

**Loss on drying** (2.2.32): maximum 0.5 per cent, determined on 1.000 g by drying in an oven at 105 °C.**Sulfated ash** (2.4.14): maximum 0.1 per cent, determined on the residue from the test for loss on drying.

## ASSAY

Dissolve 0.300 g in a mixture of 5.0 mL of 0.01 M hydrochloric acid and 50 mL of alcohol R. Carry out a potentiometric titration (2.2.20), using 0.1 M sodium hydroxide. Read the volume added between the 2 points of inflexion.

1 mL of 0.1 M sodium hydroxide is equivalent to 37.59 mg of C<sub>20</sub>H<sub>22</sub>ClNO<sub>4</sub>.

## IMPURITIES

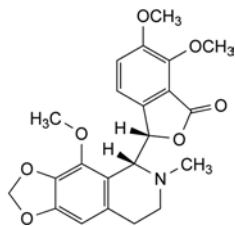

- A. (3*S*)-6,7-dimethoxy-3-[(5*R*)-4-methoxy-6-methyl-5,6,7,8-tetrahydro-1,3-dioxolo[4,5-*g*]isoquinolin-5-yl]isobenzofuran-1(3*H*)-one (noscapine),

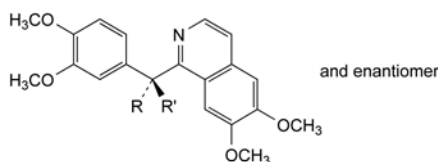

- B. R = OH, R' = H: (RS)-(3,4-dimethoxyphenyl)(6,7-dimethoxyisoquinolin-1-yl)methanol (papaverinol),  
D. R + R' = O: (3,4-dimethoxyphenyl)(6,7-dimethoxyisoquinolin-1-yl)methanone (papaveraldine),

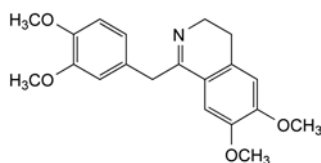

- C. 1-(3,4-dimethoxybenzyl)-6,7-dimethoxy-3,4-dihydroisoquinoline (dihydropapaverine),

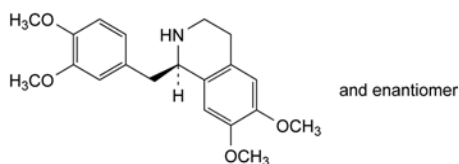

- E. (1*RS*)-1-(3,4-dimethoxybenzyl)-6,7-dimethoxy-1,2,3,4-tetrahydroisoquinoline (tetrahydropapaverine),

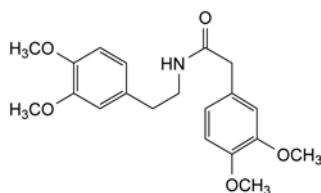

- F. 2-(3,4-dimethoxyphenyl)-*N*-[2-(3,4-dimethoxyphenyl)ethyl]acetamide.

## CHARACTERS

*Appearance*: white or almost white, crystalline powder.

*Solubility*: sparingly soluble in water, freely soluble in alcohol, very slightly soluble in methylene chloride.

## IDENTIFICATION

*First identification*: A, C.

*Second identification*: A, B, D, E.

A. Melting point (2.2.14): 168 °C to 172 °C.

B. Dissolve 0.1 g in *methanol R* and dilute to 100.0 mL with the same solvent. To 1.0 mL of the solution add 0.5 mL of a 10.3 g/L solution of *hydrochloric acid R* and dilute to 100.0 mL with *methanol R*. Protect the solution from bright light and immediately measure the absorbance (2.2.25) at the absorption maximum at 249 nm. The specific absorbance at the maximum is 860 to 980.

C. Infrared absorption spectrophotometry (2.2.24).

*Preparation*: discs.

*Comparison*: *paracetamol CRS*.

D. To 0.1 g add 1 mL of *hydrochloric acid R*, heat to boiling for 3 min, add 1 mL of *water R* and cool in an ice bath. No precipitate is formed. Add 0.05 mL of a 4.9 g/L solution of *potassium dichromate R*. A violet colour develops which does not change to red.

E. It gives the reaction of acetyl (2.3.1). Heat over a naked flame.

## TESTS

**Related substances.** Liquid chromatography (2.2.29). *Prepare the solutions immediately before use.*

*Test solution.* Dissolve 0.200 g of the substance to be examined in 2.5 mL of *methanol R* containing 4.6 g/L of a 400 g/L solution of *tetrabutylammonium hydroxide R* and dilute to 10.0 mL with a mixture of equal volumes of a 17.9 g/L solution of *disodium hydrogen phosphate R* and of a 7.8 g/L solution of *sodium dihydrogen phosphate R*.

*Reference solution (a).* Dilute 1.0 mL of the test solution to 50.0 mL with the mobile phase. Dilute 5.0 mL of this solution to 100.0 mL with the mobile phase.

*Reference solution (b).* Dilute 1.0 mL of reference solution (a) to 10.0 mL with the mobile phase.

*Reference solution (c).* Dissolve 5.0 mg of *4-aminophenol R*, 5 mg of *paracetamol CRS* and 5.0 mg of *chloroacetanilide R* in *methanol R* and dilute to 20.0 mL with the same solvent. Dilute 1.0 mL to 250.0 mL with the mobile phase.

*Reference solution (d).* Dissolve 20.0 mg of *4-nitrophenol R* in *methanol R* and dilute to 50.0 mL with the same solvent. Dilute 1.0 mL to 20.0 mL with the mobile phase.

*Column*:

– *size*:  $l = 0.25$  m,  $\varnothing = 4.6$  mm,

– *stationary phase*: *octylsilyl silica gel for chromatography R* (5  $\mu$ m),

– *temperature*: 35 °C.

*Mobile phase*: mix 375 volumes of a 17.9 g/L solution of *disodium hydrogen phosphate R*, 375 volumes of a 7.8 g/L solution of *sodium dihydrogen phosphate R* and 250 volumes of *methanol R* containing 4.6 g/L of a 400 g/L solution of *tetrabutylammonium hydroxide R*.

*Flow rate*: 1.5 mL/min.

*Detection*: spectrophotometer at 245 nm.

*Injection*: 20  $\mu$ L.

*Run time*: 12 times the retention time of paracetamol.

*Relative retentions* with reference to paracetamol (retention time = about 4 min): impurity K = about 0.8; impurity F = about 3; impurity J = about 7.

*System suitability*: reference solution (c):

– *resolution*: minimum 4.0 between the peaks due to impurity K and to paracetamol,

01/2008:0049  
corrected 6.0

## PARACETAMOL

## Paracetamolum

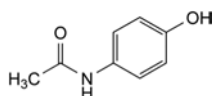

C<sub>8</sub>H<sub>9</sub>NO<sub>2</sub>  
[103-90-2]

*M<sub>r</sub>* 151.2

## DEFINITION

*N*-(4-Hydroxyphenyl)acetamide.

*Content*: 99.0 per cent to 101.0 per cent (dried substance).

- *signal-to-noise ratio*: minimum 50 for the peak due to impurity J.

**Limits:**

- *impurity J*: not more than 0.2 times the area of the corresponding peak in the chromatogram obtained with reference solution (c) (10 ppm),
- *impurity K*: not more than the area of the corresponding peak in the chromatogram obtained with reference solution (c) (50 ppm),
- *impurity F*: not more than half the area of the corresponding peak in the chromatogram obtained with reference solution (d) (0.05 per cent),
- *any other impurity*: not more than half the area of the principal peak in the chromatogram obtained with reference solution (a) (0.05 per cent),
- *total of other impurities*: not more than the area of the principal peak in the chromatogram obtained with reference solution (a) (0.1 per cent),
- *disregard limit* for the calculation of the total of other impurities: the area of the principal peak in the chromatogram obtained with reference solution (b) (0.01 per cent).

**Heavy metals (2.4.8)**: maximum 20 ppm.

Dissolve 1.0 g in a mixture of 15 volumes of *water R* and 85 volumes of *acetone R* and dilute to 20 mL with the same mixture of solvents. 12 mL of the solution complies with limit test B. Prepare the standard using lead standard solution (1 ppm Pb) obtained by diluting *lead standard solution (100 ppm Pb) R* with a mixture of 15 volumes of *water R* and 85 volumes of *acetone R*.

**Loss on drying (2.2.32)**: maximum 0.5 per cent, determined on 1.000 g by drying in an oven at 105 °C.

**Sulfated ash (2.4.14)**: maximum 0.1 per cent, determined on 1.0 g.

**ASSAY**

Dissolve 0.300 g in a mixture of 10 mL of *water R* and 30 mL of *dilute sulfuric acid R*. Boil under a reflux condenser for 1 h, cool and dilute to 100.0 mL with *water R*. To 20.0 mL of the solution add 40 mL of *water R*, 40 g of ice, 15 mL of *dilute hydrochloric acid R* and 0.1 mL of *ferroin R*. Titrate with 0.1 M *cerium sulfate* until a greenish-yellow colour is obtained. Carry out a blank titration.

1 mL of 0.1 M *cerium sulfate* is equivalent to 7.56 mg of C<sub>8</sub>H<sub>9</sub>NO<sub>2</sub>.

**STORAGE**

Protected from light.

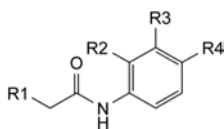
**IMPURITIES**

- A. R<sub>1</sub> = R<sub>3</sub> = R<sub>4</sub> = H, R<sub>2</sub> = OH: *N*-(2-hydroxyphenyl)acetamide,
- B. R<sub>1</sub> = CH<sub>3</sub>, R<sub>2</sub> = R<sub>3</sub> = H, R<sub>4</sub> = OH: *N*-(4-hydroxyphenyl)prop-*anamide*,
- C. R<sub>1</sub> = R<sub>2</sub> = H, R<sub>3</sub> = Cl, R<sub>4</sub> = OH: *N*-(3-chloro-4-hydroxyphenyl)acetamide,
- D. R<sub>1</sub> = R<sub>2</sub> = R<sub>3</sub> = R<sub>4</sub> = H: *N*-phenylacetamide,
- H. R<sub>1</sub> = R<sub>2</sub> = R<sub>3</sub> = H, R<sub>4</sub> = O-CO-CH<sub>3</sub>: 4-(acetylamino)phenyl acetate,
- J. R<sub>1</sub> = R<sub>2</sub> = R<sub>3</sub> = H, R<sub>4</sub> = Cl: *N*-(4-chlorophenyl)acetamide (chloroacetanilide),

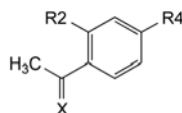

- E. X = O, R<sub>2</sub> = H, R<sub>4</sub> = OH: 1-(4-hydroxyphenyl)ethanone,
- G. X = N-OH, R<sub>2</sub> = H, R<sub>4</sub> = OH: 1-(4-hydroxyphenyl)ethanone oxime,
- I. X = O, R<sub>2</sub> = OH, R<sub>4</sub> = H: 1-(2-hydroxyphenyl)ethanone,

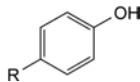

- F. R = NO<sub>2</sub>: 4-nitrophenol,
- K. R = NH<sub>2</sub>: 4-aminophenol.

01/2008:1034

**PARAFFIN, HARD****Paraffinum solidum****DEFINITION**

A purified mixture of solid saturated hydrocarbons generally obtained from petroleum. It may contain a suitable antioxidant.

**CHARACTERS**

*Appearance*: colourless or white or almost white mass; the melted substance is free from fluorescence in daylight.

*Solubility*: practically insoluble in water, freely soluble in methylene chloride, practically insoluble in ethanol (96 per cent).

**IDENTIFICATION**

*First identification*: A, C.

*Second identification*: B, C.

A. Infrared absorption spectrophotometry (2.2.24).

*Comparison*: *hard paraffin CRS*.

*Preparation*: place about 2 mg on a sodium chloride plate, heat in an oven at 100 °C for 10 min, spread the melted substance with another sodium chloride plate and remove one of the plates.

B. Acidity or alkalinity (see Tests).

C. Melting point (2.2.16): 50 °C to 61 °C.

**TESTS**

**Acidity or alkalinity.** To 15 g add 30 mL of boiling *water R* and shake vigorously for 1 min. Allow to cool and to separate. To 10 mL of the aqueous layer add 0.1 mL of *phenolphthalein solution R*. The solution is colourless. Not more than 1.0 mL of 0.01 M *sodium hydroxide* is required to change the colour of the indicator to red. To a further 10 mL of the aqueous layer add 0.1 mL of *methyl red solution R*. The solution is yellow. Not more than 0.5 mL of 0.01 M *hydrochloric acid* is required to change the colour of the indicator to red.

**Polycyclic aromatic hydrocarbons.** *Use reagents for ultraviolet absorption spectrophotometry.* Dissolve 0.50 g in 25 mL of *heptane R* and place in a 125 mL separating funnel with unlubricated ground-glass parts (stopper, stopcock). Add 5.0 mL of *dimethyl sulfoxide R*. Shake vigorously for 1 min and allow to stand until 2 clear layers are formed. Transfer the lower layer to a 2<sup>nd</sup> separating funnel, add 2 mL of *heptane R* and shake the mixture vigorously. Allow to stand until 2 clear layers are formed. Separate the lower layer and measure its absorbance (2.2.25) between 265 nm and 420 nm using as the compensation liquid the clear lower layer obtained by vigorously shaking 5.0 mL of *dimethyl sulfoxide R* with 25 mL of *heptane R* for 1 min. Prepare a 7.0 mg/L reference solution of *naphthalene R* in *dimethyl sulfoxide R* and measure the absorbance of this solution at the absorption maximum at 278 nm using *dimethyl*

*sulfoxide R* as the compensation liquid. At wavelengths from 265 nm to 420 nm, the absorbance of the test solution is not greater than one-third that of the reference solution at 278 nm.

**Sulfates** (2.4.13): maximum 150 ppm.

Introduce 2.0 g of the melted substance to be examined into a 50 mL ground-glass-stoppered separating funnel. Add 30 mL of boiling *distilled water R*, shake vigorously for 1 min and filter.

#### STORAGE

Protected from light.

01/2008:0240

## PARAFFIN, LIGHT LIQUID

### Paraffinum perliquidum

#### DEFINITION

Purified mixture of liquid saturated hydrocarbons obtained from petroleum.

#### CHARACTERS

**Appearance:** colourless, transparent, oily liquid, free from fluorescence in daylight.

**Solubility:** practically insoluble in water, slightly soluble in ethanol (96 per cent), miscible with hydrocarbons.

#### IDENTIFICATION

*First identification:* A, C.

*Second identification:* B, C.

A. Infrared absorption spectrophotometry (2.2.24).

*Comparison:* Ph. Eur. reference spectrum of liquid paraffin.

B. In a test tube cautiously boil 1 mL with 1 mL of 0.1 M sodium hydroxide, with continuous shaking, for about 30 s. On cooling to room temperature, 2 phases separate. To the aqueous phase add 0.1 mL of *phenolphthalein solution R*. The solution becomes red.

C. Viscosity (see Tests).

#### TESTS

**Acidity or alkalinity.** To 10 mL add 20 mL of boiling *water R* and shake vigorously for 1 min. Separate the aqueous layer and filter. To 10 mL of the filtrate, add 0.1 mL of *phenolphthalein solution R*. The solution is colourless. Not more than 0.1 mL of 0.1 M sodium hydroxide is required to change the colour of the indicator to pink.

**Relative density** (2.2.5): 0.810 to 0.875.

**Viscosity** (2.2.9): 25 mPa·s to 80 mPa·s.

**Polycyclic aromatic hydrocarbons.** Use reagents for ultraviolet spectrophotometry.

Introduce 25.0 mL into a 125 mL separating funnel with unlubricated ground-glass parts (stopper, stopcock). Add 25 mL of *hexane R* which has been previously shaken twice with one-fifth its volume of *dimethyl sulfoxide R*. Mix and add 5.0 mL of *dimethyl sulfoxide R*. Shake vigorously for 1 min and allow to stand until 2 clear layers are formed. Transfer the lower layer to a 2<sup>nd</sup> separating funnel, add 2 mL of *hexane R* and shake the mixture vigorously. Allow to stand until 2 clear layers are formed. Separate the lower layer and measure its absorbance (2.2.25) between 260 nm and 420 nm, using as the compensation liquid the clear lower layer obtained by vigorously shaking 5.0 mL of *dimethyl sulfoxide R* with 25 mL of *hexane R* for 1 min. Prepare a 7.0 mg/L reference solution of *naphthalene R* in *trimethylpentane R* and measure the absorbance of the solution at the absorption maximum at 275 nm, using *trimethylpentane R* as the compensation liquid. At no wavelength between 260 nm and 420 nm does

the absorbance of the test solution exceed one-third that of the reference solution at 275 nm.

**Readily carbonisable substances.** Use a ground-glass-stoppered tube about 125 mm long and 18 mm in internal diameter, graduated at 5 mL and 10 mL; wash with hot *water R* (temperature at least 60 °C), *acetone R*, *heptane R* and finally with *acetone R*, dry at 100–110 °C. Cool in a desiccator.

Introduce 5 mL of the substance to be examined and add 5 mL of *nitrogen-free sulfuric acid R1*. Insert the stopper and shake as vigorously as possible, in the longitudinal direction of the tube, for 5 s. Loosen the stopper, immediately place the tube in a water-bath, avoiding contact of the tube with the bottom or side of the bath, and heat for 10 min. After 2 min, 4 min, 6 min and 8 min, remove the tube from the bath and shake as vigorously as possible, in the longitudinal direction of the tube for 5 s. At the end of 10 min of heating, remove the tube from the water-bath and allow to stand for 10 min. Centrifuge at 2000 *g* for 5 min. The lower layer is not more intensely coloured (2.2.2, *Method 1*) than a mixture of 0.5 mL of blue primary solution, 1.5 mL of red primary solution, 3.0 mL of yellow primary solution and 2 mL of a 10 g/L solution of *hydrochloric acid R*.

**Solid paraffins.** Dry a suitable quantity of the substance to be examined by heating at 100 °C for 2 h and cool in a desiccator over *sulfuric acid R*. Place in a glass tube with an internal diameter of about 25 mm, close the tube and immerse in a bath of iced water. After 4 h, the liquid is sufficiently clear for a black line, 0.5 mm wide, to be easily seen against a white background held vertically behind the tube.

#### STORAGE

Protected from light.

01/2008:0239

## PARAFFIN, LIQUID

### Paraffinum liquidum

#### DEFINITION

Purified mixture of liquid saturated hydrocarbons obtained from petroleum.

#### CHARACTERS

**Appearance:** colourless, transparent, oily liquid, free from fluorescence in daylight.

**Solubility:** practically insoluble in water, slightly soluble in ethanol (96 per cent), miscible with hydrocarbons.

#### IDENTIFICATION

*First identification:* A, C.

*Second identification:* B, C.

A. Infrared absorption spectrophotometry (2.2.24).

*Comparison:* Ph. Eur. reference spectrum of liquid paraffin.

B. In a test tube cautiously boil 1 mL with 1 mL of 0.1 M sodium hydroxide, with continuous shaking, for about 30 s. On cooling to room temperature, 2 phases separate. To the aqueous phase add 0.1 mL of *phenolphthalein solution R*. The solution becomes red.

C. Viscosity (see Tests).

#### TESTS

**Acidity or alkalinity.** To 10 mL add 20 mL of boiling *water R* and shake vigorously for 1 min. Separate the aqueous layer and filter. To 10 mL of the filtrate, add 0.1 mL of *phenolphthalein solution R*. The solution is colourless. Not more than 0.1 mL of 0.1 M sodium hydroxide is required to change the colour of the indicator to pink.

**Relative density** (2.2.5): 0.827 to 0.890.

**Viscosity** (2.2.9): 110 mPa·s to 230 mPa·s.

**Polycyclic aromatic hydrocarbons.** Use reagents for ultraviolet spectrophotometry.

Introduce 25.0 mL into a 125 mL separating funnel with unlubricated ground-glass parts (stopper, stopcock). Add 25 mL of *hexane R* which has been previously shaken twice with one-fifth its volume of *dimethyl sulfoxide R*. Mix and add 5.0 mL of *dimethyl sulfoxide R*. Shake vigorously for 1 min and allow to stand until 2 clear layers are formed. Transfer the lower layer to a 2<sup>d</sup> separating funnel, add 2 mL of *hexane R* and shake the mixture vigorously. Allow to stand until 2 clear layers are formed. Separate the lower layer and measure its absorbance (2.2.25) between 260 nm and 420 nm, using as the compensation liquid the clear lower layer obtained by vigorously shaking 5.0 mL of *dimethyl sulfoxide R* with 25 mL of *hexane R* for 1 min. Prepare a 7.0 mg/L reference solution of *naphthalene R* in *trimethylpentane R* and measure the absorbance of the solution at the absorption maximum at 275 nm, using *trimethylpentane R* as the compensation liquid. At no wavelength between 260 nm and 420 nm does the absorbance of the test solution exceed one-third that of the reference solution at 275 nm.

**Readily carbonisable substances.** Use a ground-glass-stoppered tube about 125 mm long and 18 mm in internal diameter, graduated at 5 mL and 10 mL; wash with hot *water R* (temperature at least 60 °C), *acetone R*, *heptane R* and finally with *acetone R*, dry at 100-110 °C. Cool in a desiccator. Introduce 5 mL of the substance to be examined and add 5 mL of *nitrogen-free sulfuric acid R1*. Insert the stopper and shake as vigorously as possible, in the longitudinal direction of the tube, for 5 s. Loosen the stopper, immediately place the tube in a water-bath, avoiding contact of the tube with the bottom or side of the bath, and heat for 10 min. After 2 min, 4 min, 6 min and 8 min, remove the tube from the bath and shake as vigorously as possible, in the longitudinal direction of the tube for 5 s. At the end of 10 min of heating, remove the tube from the water-bath and allow to stand for 10 min. Centrifuge at 2000 *g* for 5 min. The lower layer is not more intensely coloured (2.2.2, Method I) than a mixture of 0.5 mL of blue primary solution, 1.5 mL of red primary solution, 3.0 mL of yellow primary solution and 2 mL of a 10 g/L solution of *hydrochloric acid R*.

**Solid paraffins.** Dry a suitable quantity of the substance to be examined by heating at 100 °C for 2 h and cool in a desiccator over *sulfuric acid R*. Place in a glass tube with an internal diameter of about 25 mm, close the tube and immerse in a bath of iced water. After 4 h, the liquid is sufficiently clear for a black line, 0.5 mm wide, to be easily seen against a white background held vertically behind the tube.

#### STORAGE

Protected from light.

07/2009:1799

## PARAFFIN, WHITE SOFT

### Vaselinum album

#### DEFINITION

Purified and wholly or nearly decolorised mixture of semi-solid hydrocarbons, obtained from petroleum. It may contain a suitable antioxidant. White soft paraffin described in this monograph is not suitable for oral use.

#### CHARACTERS

**Appearance:** white or almost white, translucent, soft unctuous mass, slightly fluorescent in daylight when melted.

**Solubility:** practically insoluble in water, slightly soluble in methylene chloride, practically insoluble in ethanol (96 per cent) and in glycerol.

#### IDENTIFICATION

**First identification:** A, B, D.

**Second identification:** A, C, D.

A. The drop point is between 35 °C and 70 °C and does not differ by more than 5 °C from the value stated on the label, according to method (2.2.17) with the following modification to fill the cup: heat the substance to be examined at a temperature not exceeding 80 °C, with stirring to ensure uniformity. Warm the metal cup at a temperature not exceeding 80 °C in an oven, remove it from the oven, place on a clean plate or ceramic tile and pour a sufficient quantity of the melted sample into the cup to fill it completely. Allow the filled cup to cool for 30 min on the plate or the ceramic tile and place it in a water bath at 24-26 °C for 30-40 min. Level the surface of the sample with a single stroke of a knife or razor blade, avoiding compression of the sample.

B. Infrared absorption spectrophotometry (2.2.24).

**Preparation:** place about 2 mg on a *sodium chloride R* plate, spread the substance with another *sodium chloride R* plate and remove 1 of the plates.

**Comparison:** repeat the operations using *white soft paraffin CRS*.

C. Melt 2 g and when a homogeneous phase is obtained, add 2 mL of *water R* and 0.2 mL of 0.05 M *iodine*. Shake. Allow to cool. The solid upper layer is violet-pink or brown.

D. Appearance (see Tests).

#### TESTS

**Appearance.** The substance is white. Melt 12 g on a water-bath. The melted mass is not more intensely coloured than a mixture of 1 volume of yellow primary solution and 9 volumes of a 10 g/L solution of *hydrochloric acid R* (2.2.2, Method II).

**Acidity or alkalinity.** To 10 g add 20 mL of boiling *water R* and shake vigorously for 1 min. Allow to cool and decant. To 10 mL of the aqueous layer add 0.1 mL of *phenolphthalein solution R*. The solution is colourless. Not more than 0.5 mL of 0.01 M *sodium hydroxide* is required to change the colour of the indicator to red.

**Consistency** (2.9.9): 60 to 300.

**Polycyclic aromatic hydrocarbons.** Use reagents for ultraviolet spectrophotometry. Dissolve 1.0 g in 50 mL of *hexane R* which has been previously shaken twice with 10 mL of *dimethyl sulfoxide R*. Transfer the solution to a 125 mL separating funnel with unlubricated ground-glass parts (stopper, stopcock). Add 20 mL of *dimethyl sulfoxide R*. Shake vigorously for 1 min and allow to stand until 2 clear layers are formed. Transfer the lower layer to a second separating funnel. Repeat the extraction with a further 20 mL of *dimethyl sulfoxide R*. Shake vigorously the combined lower layers with 20 mL of *hexane R* for 1 min. Allow to stand until 2 clear layers are formed. Separate the lower layer and dilute to 50.0 mL with *dimethyl sulfoxide R*. Measure the absorbance (2.2.25) over the range 260 nm to 420 nm using a path length of 4 cm and as compensation liquid the clear lower layer obtained by vigorously shaking 10 mL of *dimethyl sulfoxide R* with 25 mL of *hexane R* for 1 min. Prepare a reference solution in *dimethyl sulfoxide R* containing 6.0 mg of *naphthalene R* per litre and measure the absorbance of the solution at the maximum at 278 nm using a path length of 4 cm and *dimethyl sulfoxide R* as compensation liquid. At no wavelength in the range 260 nm to 420 nm does the absorbance of the test solution exceed that of the reference solution at 278 nm.

**Sulfated ash** (2.4.14): maximum 0.05 per cent, determined on 2.0 g.

#### STORAGE

Protected from light.

#### LABELLING

The label states the nominal drop point.

07/2008:1554  
corrected 6.8

## PARAFFIN, YELLOW SOFT

## Vaselinum flavum

## DEFINITION

Purified mixture of semi-solid hydrocarbons, obtained from petroleum. It may contain a suitable antioxidant.

## CHARACTERS

*Appearance*: yellow, translucent, unctuous mass, slightly fluorescent in daylight when melted.

*Solubility*: practically insoluble in water, slightly soluble in methylene chloride, practically insoluble in ethanol (96 per cent) and in glycerol.

## IDENTIFICATION

*First identification*: A, B, D.

*Second identification*: A, C, D.

A. The drop point (2.2.17) is 40 °C to 60 °C and does not differ by more than 5 °C from the value stated on the label, with the following modification to fill the cup: heat the substance to be examined at 118-122 °C, with stirring to ensure uniformity, then cool to 100-107 °C. Warm the metal cup at 103-107 °C in an oven, remove it from the oven, place on a clean plate or ceramic tile and pour a sufficient quantity of the melted sample into the cup to fill it completely. Allow the filled cup to cool for 30 min on the ceramic tile and place it in a water-bath at 24-26 °C for a further 30-40 min. Level the surface of the sample with a single stroke of a knife or razor blade, avoiding compression of the sample.

B. Examine by infrared absorption spectrophotometry (2.2.24).

*Preparation*: place about 2 mg on a *sodium chloride R* plate, spread the substance with another *sodium chloride R* plate and remove 1 of the plates.

*Comparison*: repeat the operations using *yellow soft paraffin CRS*.

C. Melt 2 g and when a homogeneous phase is obtained, add 2 mL of *water R* and 0.2 mL of 0.05 M *iodine*. Shake. Allow to cool. The solid upper layer is violet-pink or brown.

D. Appearance (see Tests).

## TESTS

**Appearance.** The substance is yellow. Melt 12 g on a water-bath. The melted mass is not more intensely coloured than a mixture of 7.6 volumes of yellow primary solution and 2.4 volumes of red primary solution (2.2.2, *Method II*).

**Acidity or alkalinity.** To 10 g add 20 mL of boiling *water R* and shake vigorously for 1 min. Allow to cool and decant. To 10 mL of the aqueous layer add 0.1 mL of *phenolphthalein solution R*. The solution is colourless. Not more than 0.5 mL of 0.01 M *sodium hydroxide* is required to change the colour of the indicator to red.

**Consistency** (2.9.9): 100 to 300.

**Polycyclic aromatic hydrocarbons.** Use reagents for ultraviolet absorption spectrophotometry. Dissolve 1.0 g in 50 mL of *hexane R* which has been previously shaken twice with one-fifth its volume of *dimethyl sulfoxide R*. Transfer the solution to a 125 mL separating funnel with unlubricated ground-glass parts (stopper, stopcock). Add 20 mL of *dimethyl sulfoxide R*. Shake vigorously for 1 min and allow to stand until two clear layers are formed. Transfer the lower layer to a 2<sup>nd</sup> separating funnel. Repeat the extraction with a further 20 mL of *dimethyl sulfoxide R*. Shake vigorously the combined lower layers with 20 mL of *hexane R* for 1 min. Allow to stand until 2 clear layers are formed. Separate the lower layer and dilute to 50.0 mL with *dimethyl sulfoxide R*. Measure the absorbance (2.2.25) between 260 nm and 420 nm using a path length of 4 cm and using

as the compensation liquid the clear lower layer obtained by vigorously shaking 10 mL of *dimethyl sulfoxide R* with 25 mL of *hexane R* for 1 min. Prepare a 9.0 mg/L reference solution of *naphthalene R* in *dimethyl sulfoxide R* and measure the absorbance of this solution at the maximum at 278 nm using a path length of 4 cm and using *dimethyl sulfoxide R* as the compensation liquid. At no wavelength in the range of 260 nm to 420 nm does the absorbance of the test solution exceed that of the reference solution at 278 nm.

**Sulfated ash** (2.4.14): not more than 0.05 per cent, determined on 2.0 g.

## STORAGE

Store protected from light.

## LABELLING

The label states the nominal drop point.

01/2008:0351

## PARALDEHYDE

## Paraldehydum

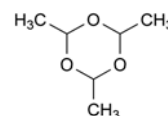

$C_6H_{12}O_3$   
[123-63-7]

$M_r$  132.2

## DEFINITION

2,4,6-Trimethyl-1,3,5-trioxane (cyclic trimer of acetaldehyde).

It may contain a suitable quantity of an antioxidant.

## CHARACTERS

*Appearance*: colourless or slightly yellow, transparent liquid. It solidifies on cooling to form a crystalline mass.

*Solubility*: soluble in water, but less soluble in boiling water, miscible with ethanol (96 per cent) and with essential oils.

## IDENTIFICATION

A. Solution S (see Tests) is clear (2.2.1) but becomes turbid on warming.

B. To 5 mL add 0.1 mL of *dilute sulfuric acid R* and heat. Acetaldehyde, recognisable by its odour, is evolved.

C. To 5 mL of solution S in a test-tube add 5 mL of *ammoniacal silver nitrate solution R* and heat in a water-bath. Silver is deposited as a mirror on the wall of the tube.

## TESTS

**Solution S.** Dissolve 20.0 mL in *carbon dioxide-free water R* and dilute to 200.0 mL with the same solvent.

**Acidity.** To 50.0 mL of solution S add 0.05 mL of *phenolphthalein solution R*. Not more than 1.5 mL of 0.1 M *sodium hydroxide* is required to change the colour of the indicator.

**Refractive index** (2.2.6): 1.403 to 1.406.

**Relative density** (2.2.5): 0.991 to 0.996.

**Distillation range** (2.2.11): a maximum of 10 per cent distils below 123 °C and a minimum of 95 per cent distils below 126 °C.

**Freezing point** (2.2.18): 10 °C to 13 °C.

**Acetaldehyde.** To 5.0 mL add a mixture of 0.2 mL of *methyl orange solution R*, 5 mL of *ethanol (60 per cent V/V) R* and 5 mL of *alcoholic hydroxylamine solution R* and shake. Not more than 0.8 mL of 0.5 M *sodium hydroxide* is required to change the colour of the indicator to pure yellow.



**Peroxides.** Place 50.0 mL of solution S in a ground-glass-stoppered flask, add 5 mL of *dilute sulfuric acid R* and 10 mL of *potassium iodide solution R*, close the flask and allow to stand protected from light for 15 min. Titrate with 0.1 M *sodium thiosulfate* using 1 mL of *starch solution R* as indicator. Allow to stand for 5 min and, if necessary complete the titration. Not more than 2.0 mL of 0.1 M *sodium thiosulfate* is required.

**Non-volatile residue:** maximum 0.6 g/L.

Heat 5.0 mL in a tared evaporating dish on a water-bath and dry at 105 °C for 1 h. The residue weighs a maximum of 3 mg.

#### STORAGE

In a small, well-filled, airtight container, protected from light. If the substance has solidified the whole contents of the container must be liquefied before use.

01/2008:1252  
corrected 7.0

## PARNAPARIN SODIUM

### Parnaparinum natricum

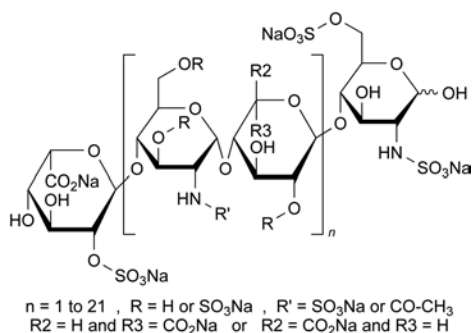

#### DEFINITION

Sodium salt of a low-molecular-mass heparin that is obtained by radical-catalysed depolymerisation, with hydrogen peroxide and with a cupric salt, of heparin from bovine or porcine intestinal mucosa. The majority of the components have a 2-*O*-sulfo- $\alpha$ -L-idopyranosuronic acid structure at the non-reducing end and a 2-*N*,6-*O*-disulfo-D-glucosamine structure at the reducing end of their chain.

*Parnaparin sodium complies with the monograph Low-molecular-mass heparins (0828), with the modifications and additional requirements below.*

The mass-average relative molecular mass ranges between 4000 and 6000 with a characteristic value of about 5000.

The degree of sulfatation is 2.0 to 2.6 per disaccharide unit.

The potency is not less than 75 IU and not more than 110 IU of anti-factor Xa activity per milligram calculated with reference to the dried substance. The ratio of anti-factor Xa activity to anti-factor IIa activity is between 1.5 and 3.0.

#### IDENTIFICATION

Carry out identification test A as described in the monograph *Low-molecular-mass heparins (0828)* using *parnaparin sodium CRS*.

Carry out identification test C as described in the monograph *Low-molecular-mass heparins (0828)*. In order to verify the suitability of the system in the lower molecular mass ranges (for example  $M_r$  2000), a suitable reference preparation is used. The following requirements apply.

The mass-average relative molecular mass ranges between 4000 and 6000. The mass percentage of chains lower than 3000 is not more than 30 per cent. The mass percentage of chains between 3000 and 8000 ranges between 50 per cent and 60 per cent.

#### TESTS

**Appearance of solution.** The solution is clear (2.2.1) and not more intensely coloured than reference solution Y<sub>5</sub> (2.2.2, Method II).

Dissolve 1.5 g in 10 mL of *water R*.

**Copper:** maximum 10 ppm, determined by atomic absorption spectrometry (2.2.23, Method I) and calculated with reference to the dried substance.

01/2008:2283

## PAROXETINE HYDROCHLORIDE, ANHYDROUS

### Paroxetini hydrochloridum anhydricum

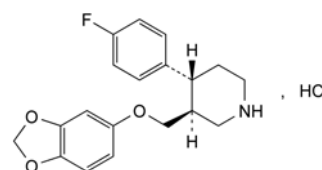

$\text{C}_{19}\text{H}_{21}\text{ClFNO}_3$   
[78246-49-8]

$M_r$  365.8

#### DEFINITION

(3*S*,4*R*)-3-[(1,3-Benzodioxol-5-yloxy)methyl]-4-(4-fluorophenyl)piperidine hydrochloride anhydrous.

*Content:* 97.5 per cent to 102.0 per cent (anhydrous substance).

#### PRODUCTION

**Impurity G:** maximum 1 ppm, determined by a suitable, validated method.

#### CHARACTERS

*Appearance:* white or almost white, hygroscopic, crystalline powder.

*Solubility:* slightly soluble in water, freely soluble in methanol, sparingly soluble in anhydrous ethanol and in methylene chloride.

It shows polymorphism (5.9).

#### IDENTIFICATION

A. Infrared absorption spectrophotometry (2.2.24).

*Comparison:* *anhydrous paroxetine hydrochloride CRS*.

If the spectra obtained in the solid state show differences, mix 1 part of the substance to be examined and 1 part of the reference substance separately with 30 parts of anhydrous *acetone R* and heat to boiling to dissolve. Recrystallise and record new spectra using the residues.

B. Water (see Tests).

C. It gives reaction (b) of chlorides (2.3.1).

#### TESTS

**Impurity D.** Liquid chromatography (2.2.29).

*Test solution.* Dissolve 50.0 mg of the substance to be examined in 5 mL of *methanol R* and dilute to 50.0 mL with the mobile phase.

*Reference solution (a).* Dissolve 5 mg of *paroxetine impurity D CRS* in 2 mL of *methanol R* and dilute to 50.0 mL with the mobile phase.

*Reference solution (b).* Dilute 1.0 mL of reference solution (a) to 10.0 mL with the test solution.

*Reference solution (c).* Dilute 1.0 mL of reference solution (a) to 100.0 mL with the mobile phase.

*Column:*

— *size:*  $l = 0.10 \text{ m}$ ,  $\varnothing = 4.0 \text{ mm}$ ;

- *stationary phase*: silica gel AGP for chiral chromatography R (5 µm);
- *temperature*: 30 °C.

*Mobile phase*: dissolve 8.7 g of dipotassium hydrogen phosphate R in 1000 mL of water for chromatography R and adjust to pH 6.5 with phosphoric acid R; mix 930 mL of this solution and 70 mL of acetonitrile R.

*Flow rate*: 0.9 mL/min.

*Detection*: spectrophotometer at 295 nm.

*Injection*: 20 µL of the test solution and reference solutions (b) and (c).

*Run time*: 2.5 times the retention time of paroxetine which is about 12 min.

*System suitability*:

- *peak-to-valley ratio*: minimum 2.0, where  $H_p$  = height above the baseline of the peak due to impurity D and  $H_v$  = height above the baseline of the lowest point of the curve separating this peak from the peak due to paroxetine in the chromatogram obtained with reference solution (b);
- *signal-to-noise ratio*: minimum 3 for the principal peak in the chromatogram obtained with reference solution (c);
- *symmetry factor*: the requirements stated in chapter 2.2.46 are not applicable.

*Limit*:

- *impurity D*: not more than twice the area of the principal peak in the chromatogram obtained with reference solution (c) (0.2 per cent).

**Related substances.** Liquid chromatography (2.2.29).

*Solvent mixture*: tetrahydrofuran R, water R (10:90 V/V).

*Test solution*. Dissolve 50.0 mg of the substance to be examined in the solvent mixture and dilute to 50.0 mL with the solvent mixture.

*Reference solution (a)*. Dilute 5.0 mL of the test solution to 50.0 mL with the solvent mixture.

*Reference solution (b)*. Dissolve 5.0 mg of anhydrous paroxetine hydrochloride impurity H CRS in 25 mL of tetrahydrofuran R and dilute to 50.0 mL with water R.

*Reference solution (c)*. Dissolve 5 mg of anhydrous paroxetine hydrochloride impurity C CRS in 25 mL of tetrahydrofuran R and dilute to 50.0 mL with water R.

*Reference solution (d)*. To 5.0 mL of reference solution (a) add 1.0 mL of reference solution (b) and dilute to 100.0 mL with the solvent mixture.

*Reference solution (e)*. To 5.0 mL of reference solution (a) add 5.0 mL of reference solution (b) and 5.0 mL of reference solution (c). Dilute to 100.0 mL with the solvent mixture. Dilute 1.0 mL of this solution to 10.0 mL with the solvent mixture.

*Reference solution (f)*. Dissolve 2.5 mg of paroxetine impurity E CRS in the solvent mixture, add 2.5 mL of the test solution and dilute to 100.0 mL with the solvent mixture.

*Reference solution (g)*. Dissolve 5 mg of paroxetine impurity A CRS in the solvent mixture and dilute to 50 mL with the solvent mixture. Use this solution to identify the peak due to impurity A.

*Column*:

- *size*:  $l = 0.25$  m,  $\emptyset = 4.6$  mm;
- *stationary phase*: end-capped octylsilyl silica gel for chromatography R (5 µm);
- *temperature*: 40 °C.

*Mobile phase*:

- *mobile phase A*: trifluoroacetic acid R, tetrahydrofuran R, water R (5:100:900 V/V/V);
- *mobile phase B*: trifluoroacetic acid R, tetrahydrofuran R, acetonitrile R (5:100:900 V/V/V);

Time (min)	Mobile phase A (per cent V/V)	Mobile phase B (per cent V/V)
0 - 30	80	20
30 - 50	80 → 20	20 → 80
50 - 55	20	80
55 - 60	20 → 80	80 → 20
60 - 65	80	20

*Flow rate*: 1.0 mL/min.

*Detection*: spectrophotometer at 295 nm.

*Injection*: 20 µL of the test solution and reference solutions (d), (e), (f) and (g).

*Relative retention* with reference to paroxetine (retention time = about 28 min): impurity A = about 0.8; impurity E = about 0.9; impurity C = about 1.5.

*Relative retention* with reference to impurity C: impurity F = about 0.97; impurity J = about 1.02.

*System suitability*:

- *resolution*: minimum 3.5 between the peaks due to impurity E and paroxetine in the chromatogram obtained with reference solution (f);
- *signal-to-noise ratio*: minimum 3 for the peak due to paroxetine in the chromatogram obtained with reference solution (e).

*Limits*:

- *correction factors*: for the calculation of content, multiply the peak areas of the following impurities by the corresponding correction factor: impurity C = 1.6; impurity F = 1.7; impurity J = 1.3;
- *impurity A*: not more than 0.6 times the area of the peak due to paroxetine in the chromatogram obtained with reference solution (d) (0.3 per cent);
- *impurities C, F, J*: for each impurity, not more than 0.2 times the area of the peak due to paroxetine in the chromatogram obtained with reference solution (d) (0.1 per cent);
- *unspecified impurities*: for each impurity, not more than 0.2 times the area of the peak due to paroxetine in the chromatogram obtained with reference solution (d) (0.10 per cent);
- *total*: not more than the area of the peak due to paroxetine in the chromatogram obtained with reference solution (d) (0.5 per cent);
- *disregard limit*: the area of the peak due to paroxetine in the chromatogram obtained with reference solution (e) (0.05 per cent).

**Impurities H and I.** Liquid chromatography (2.2.29) as described in the test for related substances with the following modifications.

*Detection*: spectrophotometer at 263 nm.

*Injection*: test solution and reference solutions (d) and (e).

*Relative retention* with reference to paroxetine (retention time = about 28 min): impurity I = about 0.2; impurity H = about 0.4.

*System suitability*: reference solution (e):

- *signal-to-noise ratio*: minimum 3 for the peak due to impurity H.

*Limits*:

- *impurities H, I*: for each impurity, not more than the area of the peak due to impurity H in the chromatogram obtained with reference solution (d) (0.1 per cent).

**Acetone** (2.4.24, *System B*): maximum 3.5 per cent.

**2-Propanol** (2.4.24, *System B*): maximum 4.3 per cent.

**Heavy metals** (2.4.8): maximum 20 ppm.

1.0 g complies with test C. Use a platinum crucible. Prepare the reference solution using 2 mL of *lead standard solution* (10 ppm Pb) R.

**Water** (2.5.12): maximum 1.5 per cent, determined on 0.500 g.

**Sulfated ash** (2.4.14): maximum 0.1 per cent, determined on 1.0 g in a platinum crucible.

#### ASSAY

Liquid chromatography (2.2.29).

**Test solution.** Dissolve 50.0 mg of the substance to be examined in *water R* and dilute to 100.0 mL with the same solvent.

**Reference solution (a).** Dissolve 51.2 mg of *paroxetine hydrochloride hemihydrate CRS* in *water R* and dilute to 100.0 mL with the same solvent.

**Reference solution (b).** Dissolve 5.0 mg of *paroxetine hydrochloride hemihydrate CRS* and 5 mg of *paroxetine impurity A CRS* in *water R* and dilute to 10.0 mL with the same solvent.

**Column:**

- size:  $l = 0.25$  m,  $\varnothing = 4.6$  mm;
- stationary phase: trimethylsilyl silica gel for chromatography R (5  $\mu$ m).

**Mobile phase:** dissolve 3.85 g of *ammonium acetate R* in *water R*, adjust to pH 5.5 with *anhydrous acetic acid R* and dilute to 600 mL with *water R*; add 400 mL of *acetonitrile R*; slowly add, with stirring, 10 mL of *triethylamine R* and adjust to pH 5.5 with *anhydrous acetic acid R*.

**Flow rate:** 1 mL/min.

**Detection:** spectrophotometer at 295 nm.

**Injection:** 10  $\mu$ L.

**Run time:** twice the retention time of paroxetine.

**System suitability:** reference solution (b):

- resolution: minimum 2 between the peaks due to paroxetine and impurity A.

Calculate the percentage content of  $C_{19}H_{21}ClFNO_3$  using the chromatogram obtained with reference solution (a) and the declared content of *paroxetine hydrochloride hemihydrate CRS*.

#### STORAGE

In an airtight container, at a temperature not exceeding 25 °C.

#### IMPURITIES

**Specified impurities:** A, C, D, F, G, H, I, J.

**Other detectable impurities** (the following substances would, if present at a sufficient level, be detected by one or other of the tests in the monograph. They are limited by the general acceptance criterion for other/unspecified impurities and/or by the general monograph *Substances for pharmaceutical use* (2034). It is therefore not necessary to identify these impurities for demonstration of compliance. See also 5.10. *Control of impurities in substances for pharmaceutical use*): B, E.

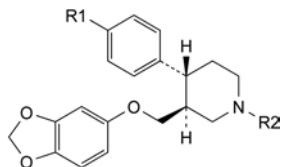

- A.  $R_1 = R_2 = H$ : (3*S*,4*R*)-3-[(1,3-benzodioxol-5-yloxy)methyl]-4-phenylpiperidine (desfluoroparoxetine),
- C.  $R_1 = F$ ,  $R_2 = CH_2-C_6H_5$ : (3*S*,4*R*)-3-[(1,3-benzodioxol-5-yloxy)methyl]-1-benzyl-4-(4-fluorophenyl)piperidine (*N*-benzylparoxetine),
- F.  $R_1 = H$ ,  $R_2 = CH_2-C_6H_5$ : (3*S*,4*R*)-3-[(1,3-benzodioxol-5-yloxy)methyl]-1-benzyl-4-phenylpiperidine (*N*-benzyl-desfluoroparoxetine),

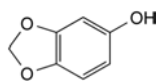

- B. 1,3-benzodioxol-5-ol (sesamol),

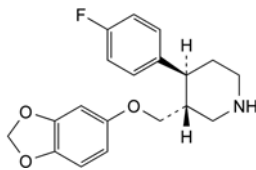

- D. (3*R*,4*S*)-3-[(1,3-benzodioxol-5-yloxy)methyl]-4-(4-fluorophenyl)piperidine ((+)-*trans*-paroxetine),

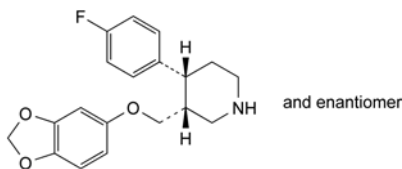

- E. (3*RS*,4*RS*)-3-[(1,3-benzodioxol-5-yloxy)methyl]-4-(4-fluorophenyl)piperidine (*cis*-paroxetine),

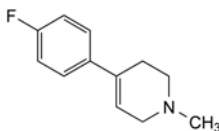

- G. 4-(4-fluorophenyl)-1-methyl-1,2,3,6-tetrahydropyridine,

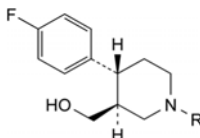

- H.  $R = CH_2-C_6H_5$ : [(3*S*,4*R*)-1-benzyl-4-(4-fluorophenyl)piperidin-3-yl]methanol,

- I.  $R = H$ : [(3*S*,4*R*)-4-(4-fluorophenyl)piperidin-3-yl]methanol,

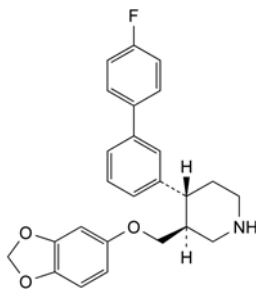

- J. (3*S*,4*R*)-3-[(1,3-benzodioxol-5-yloxy)methyl]-4-(4'-fluorobiphenyl-3-yl)piperidine.

01/2008:2018

## PAROXETINE HYDROCHLORIDE HEMIHYDRATE

Paroxetini hydrochloridum hemihydricum

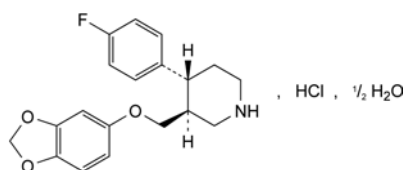

$C_{19}H_{21}ClFNO_3 \cdot \frac{1}{2}H_2O$   
[110429-35-1]

$M_r$  374.8

## DEFINITION

(3*S*,4*R*)-3-[(1,3-Benzodioxol-5-yloxy)methyl]-4-(4-fluorophenyl)piperidine hydrochloride hemihydrate.

*Content*: 97.5 per cent to 102.0 per cent (anhydrous substance).

## PRODUCTION

**Impurity G**: maximum 1 ppm, determined by a suitable, validated method.

## CHARACTERS

*Appearance*: white or almost white, crystalline powder.

*Solubility*: slightly soluble in water, freely soluble in methanol, sparingly soluble in ethanol (96 per cent) and in methylene chloride.

It shows pseudopolymorphism (5.9).

## IDENTIFICATION

## A. Infrared absorption spectrophotometry (2.2.24).

*Comparison*: paroxetine hydrochloride hemihydrate CRS.

If the spectra obtained show differences, dissolve 1 part of the substance to be examined and 1 part of the reference substance separately in 10 parts of a mixture of 1 volume of water R and 9 volumes of 2-propanol R and heat to 70 °C to dissolve. Recrystallise and record new spectra using the residues.

## B. Examine the chromatograms obtained in the test for impurity D.

*Injection*: test solution and reference solution (c).

*Results*: the principal peak in the chromatogram obtained with the test solution is similar in retention time and size to the principal peak in the chromatogram obtained with reference solution (c).

## C. Water (see Tests).

## D. It gives reaction (b) of chlorides (2.3.1).

## TESTS

**Impurity D**. Liquid chromatography (2.2.29).

*Test solution*. Dissolve 0.1000 g of the substance to be examined in 20 mL of methanol R and dilute to 100.0 mL with the mobile phase.

*Reference solution (a)*. Dilute 1.0 mL of the test solution to 100.0 mL with the mobile phase. Dilute 1.0 mL of this solution to 10.0 mL with the mobile phase.

*Reference solution (b)*. Dissolve 5 mg of paroxetine impurity D CRS and 5 mg of paroxetine hydrochloride hemihydrate CRS in 2 mL of methanol R and dilute to 100.0 mL with the mobile phase.

*Reference solution (c)*. Dissolve 10 mg of paroxetine hydrochloride hemihydrate CRS in 2 mL of methanol R and dilute to 10.0 mL with the mobile phase.

*Column*:

- size:  $l = 0.10$  m,  $\emptyset = 4.0$  mm;
- stationary phase: silica gel AGP for chiral chromatography R (5  $\mu$ m).

*Mobile phase*: mix 2 volumes of methanol R and 8 volumes of a 5.8 g/L solution of sodium chloride R.

*Flow rate*: 0.5 mL/min.

*Detection*: spectrophotometer at 295 nm.

*Injection*: 10  $\mu$ L of the test solution and reference solutions (a) and (b).

*Run time*: 2.5 times the retention time of paroxetine.

*Retention time*: paroxetine = about 30 min.

*System suitability*: reference solution (b):

- resolution: minimum 2.2 between the peaks due to impurity D and paroxetine.

*Limit*:

- impurity D: not more than twice the area of the principal peak in the chromatogram obtained with reference solution (a) (0.2 per cent).

**Related substances**. Liquid chromatography (2.2.29).

*Solvent mixture*: tetrahydrofuran R, water R (1:9 V/V).

*Test solution*. Dissolve 50.0 mg of the substance to be examined in the solvent mixture and dilute to 50.0 mL with the same solvent mixture.

*Reference solution (a)*. Dilute 5.0 mL of the test solution to 50.0 mL with the solvent mixture. Dilute 2.0 mL of this solution to 200.0 mL with the solvent mixture.

*Reference solution (b)*. Dissolve 2 mg of paroxetine for system suitability CRS (containing impurity C) in the solvent mixture and dilute to 10 mL with the solvent mixture. Dilute 1 mL of this solution to 10 mL with the solvent mixture.

*Reference solution (c)*. Dissolve 2 mg of paroxetine impurity A CRS in the solvent mixture and dilute to 20 mL with the same solvent mixture.

*Column*:

- size:  $l = 0.25$  m,  $\emptyset = 4.6$  mm;
- stationary phase: end-capped octylsilyl silica gel for chromatography R (5  $\mu$ m);
- temperature: 40 °C.

*Mobile phase*:

- mobile phase A: trifluoroacetic acid R, tetrahydrofuran R, water R (5:100:900 V/V/V);
- mobile phase B: trifluoroacetic acid R, tetrahydrofuran R, acetonitrile R (5:100:900 V/V/V);

Time (min)	Mobile phase A (per cent V/V)	Mobile phase B (per cent V/V)
0 - 30	80	20
30 - 50	80 → 20	20 → 80
50 - 60	20	80
60 - 65	20 → 80	80 → 20
65 - 70	80	20

*Flow rate*: 1 mL/min.

*Detection*: spectrophotometer at 295 nm.

*Injection*: 20  $\mu$ L.

*Relative retention* with reference to paroxetine: impurity A = about 0.8.

*System suitability*: reference solution (b):

- resolution: minimum 3.5 between the peaks due to impurity C and paroxetine.

*Limits*:

- impurity A: not more than 3 times the area of the principal peak in the chromatogram obtained with reference solution (a) (0.3 per cent);
- unspecified impurities: for each impurity, not more than the area of the principal peak in the chromatogram obtained with reference solution (a) (0.10 per cent);
- total: not more than 5 times the area of the principal peak in the chromatogram obtained with reference solution (a) (0.5 per cent);
- disregard limit: 0.5 times the area of the principal peak in the chromatogram obtained with reference solution (a) (0.05 per cent).

**Heavy metals** (2.4.8): maximum 20 ppm.

1.0 g complies with test C. Use a platinum crucible. Prepare the reference solution using 2 mL of lead standard solution (10 ppm Pb) R.

**Water** (2.5.12): 2.2 per cent to 2.7 per cent, determined on 0.300 g.

**Sulfated ash (2.4.14):** maximum 0.1 per cent, determined on 1.0 g in a platinum crucible.

#### ASSAY

Liquid chromatography (2.2.29).

**Test solution.** Dissolve 50.0 mg of the substance to be examined in *water R* and dilute to 100.0 mL with the same solvent.

**Reference solution (a).** Dissolve 50.0 mg of *paroxetine hydrochloride hemihydrate CRS* in *water R* and dilute to 100.0 mL with the same solvent.

**Reference solution (b).** Dissolve 5.0 mg of *paroxetine hydrochloride hemihydrate CRS* and 5 mg of *paroxetine impurity A CRS* in *water R* and dilute to 10.0 mL with the same solvent.

**Column:**

- size:  $l = 0.25$  m,  $\varnothing = 4.6$  mm;
- stationary phase: trimethylsilyl silica gel for chromatography *R* (5  $\mu$ m).

**Mobile phase:** dissolve 3.85 g of *ammonium acetate R* in *water R*, adjust to pH 5.5 with *anhydrous acetic acid R* and dilute to 600 mL with the same solvent; add 400 mL of *acetonitrile R*; slowly add, with stirring, 10 mL of *triethylamine R* and readjust to pH 5.5 with *anhydrous acetic acid R*.

**Flow rate:** 1 mL/min.

**Detection:** spectrophotometer at 295 nm.

**Injection:** 10  $\mu$ L.

**Run time:** twice the retention time of paroxetine.

**System suitability:** reference solution (b):

- resolution: minimum 2 between the peaks due to paroxetine and impurity A.

Calculate the percentage content of paroxetine hydrochloride using the chromatogram obtained with reference solution (a).

#### STORAGE

Protected from light.

#### IMPURITIES

**Specified impurities:** A, D, G.

**Other detectable impurities** (the following substances would, if present at a sufficient level, be detected by one or other of the tests in the monograph. They are limited by the general acceptance criterion for other/unspecified impurities and/or by the general monograph *Substances for pharmaceutical use (2034)*. It is therefore not necessary to identify these impurities for demonstration of compliance. See also 5.10. *Control of impurities in substances for pharmaceutical use*): B, C, E, F.

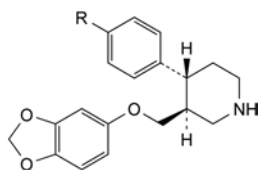

- A. R = H: (3*S*,4*R*)-3-[(1,3-benzodioxol-5-yloxy)methyl]-4-phenylpiperidine (desfluoroparoxetine),
- B. R = OCH<sub>3</sub>: (3*S*,4*R*)-3-[(1,3-benzodioxol-5-yloxy)methyl]-4-(4-methoxyphenyl)piperidine,
- C. R = OC<sub>2</sub>H<sub>5</sub>: (3*S*,4*R*)-3-[(1,3-benzodioxol-5-yloxy)methyl]-4-(4-ethoxyphenyl)piperidine,

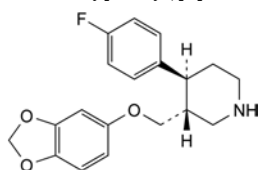

- D. (3*R*,4*S*)-3-[(1,3-benzodioxol-5-yloxy)methyl]-4-(4-fluorophenyl)piperidine ((+)-*trans*-paroxetine),

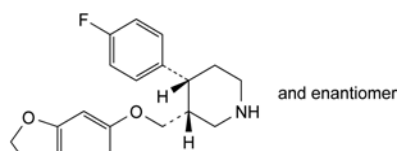

- E. (3*RS*,4*RS*)-3-[(1,3-benzodioxol-5-yloxy)methyl]-4-(4-fluorophenyl)piperidine (*cis*-paroxetine),

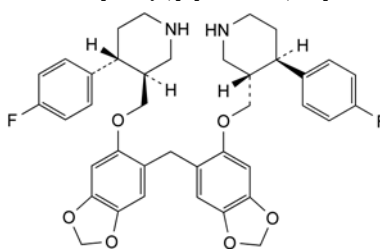

- F. 3,3'-[methylenebis(1,3-benzodioxole-6,5-diyloxymethylene)]bis[3*S*,4*R*]-4-(4-fluorophenyl)piperidine],

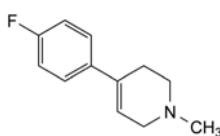

- G. 4-(4-fluorophenyl)-1-methyl-1,2,3,6-tetrahydropyridine.

01/2009:2403

## PEA STARCH

### Pisi amyllum

#### DEFINITION

Pea starch is obtained from the seeds of *Pisum sativum* L.

#### CHARACTERS

**Appearance:** white or almost white, very fine powder.

**Solubility:** practically insoluble in cold water and in ethanol (96 per cent).

#### IDENTIFICATION

- A. Examined under a microscope using equal volumes of *glycerol R* and *water R*, it presents a majority of large elliptical granules, 25-45  $\mu$ m in size, sometimes irregular, or reniform. It also presents a minority of small rounded granules, 5-8  $\mu$ m in size. Granules can present cracks or irregularities. Sometimes, granules show barely visible concentric striations. Exceptionally, granules show a slit along the main axis. Between orthogonally oriented polarising plates or prisms, the granules show a distinct black cross.
- B. Suspend 1 g in 50 mL of *water R*, boil for 1 min and cool. A thin, cloudy mucilage is formed.
- C. To 1 mL of the mucilage obtained in identification test B, add 0.05 mL of *iodine solution R1*. A dark blue colour is produced, which disappears on heating.

#### TESTS

**pH (2.2.3):** 5.0 to 8.0.

Shake 5.0 g with 25.0 mL of *carbon dioxide-free water R* for 60 s. Allow to stand for 15 min and shake again.

**Foreign matter.** Examined under a microscope using a mixture of equal volumes of *glycerol R* and *water R*, not more than traces of matter other than starch granules are present. No starch granules of any other origin are present.

**Oxidising substances (2.5.30):** maximum 20 ppm, calculated as H<sub>2</sub>O<sub>2</sub>.

**Sulfur dioxide (2.5.29):** maximum 50 ppm.

**Iron (2.4.9):** maximum 50 ppm.

Shake 1.0 g with 50 mL of *dilute hydrochloric acid R*. Filter. The filtrate complies with the test for iron.

**Loss on drying (2.2.32):** maximum 16.0 per cent, determined on 1.000 g by drying in an oven at 130 °C for 90 min.

**Sulfated ash (2.4.14):** maximum 0.6 per cent, determined on 1.0 g.

#### Microbial contamination

TAMC: acceptance criterion 10<sup>3</sup> CFU/g (2.6.12).

TYMC: acceptance criterion 10<sup>2</sup> CFU/g (2.6.12).

Absence of *Escherichia coli* (2.6.13).

Absence of *Salmonella* (2.6.13).

01/2008:1460

## PEFLOXACIN MESILATE DIHYDRATE

Pefloxacin mesilas dihydricus

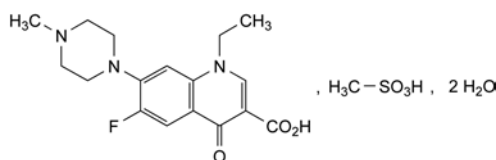

C<sub>18</sub>H<sub>24</sub>FN<sub>3</sub>O<sub>6</sub>S<sub>2</sub>H<sub>2</sub>O  
[70458-95-6]

M<sub>r</sub> 465.5

#### DEFINITION

1-Ethyl-6-fluoro-7-(4-methylpiperazin-1-yl)-4-oxo-1,4-dihydroquinoline-3-carboxylic acid methanesulfonate dihydrate.

**Content:** 98.5 per cent to 101.5 per cent (anhydrous substance).

#### PRODUCTION

The production method must be evaluated to determine the potential for formation of alkyl mesilates, which is particularly likely to occur if the reaction medium contains lower alcohols. Where necessary, the production method is validated to demonstrate that alkyl mesilates are not detectable in the final product.

#### CHARACTERS

**Appearance:** fine, white or almost white powder.

**Solubility:** freely soluble in water, slightly soluble in ethanol (96 per cent), very slightly soluble in methylene chloride.

#### IDENTIFICATION

##### A. Infrared absorption spectrophotometry (2.2.24).

**Preparation:** dissolve 0.1 g in 10 mL of *water R*. Add 5 mL of 1 M *sodium hydroxide*. Adjust to pH 7.4 ± 0.1 with *phosphoric acid R* and shake with 2 quantities, each of 30 mL, of *methylene chloride R*. Combine the organic layers and dry over *anhydrous sodium sulfate R*. Evaporate to dryness. Examine the residue as a disc of *potassium bromide R*.

**Comparison:** repeat the operations using 0.1 g of *pefloxacin mesilate dihydrate CRS*.

##### B. Thin-layer chromatography (2.2.27).

**Test solution.** Dissolve 40 mg in *water R* and dilute to 1 mL with the same solvent.

**Reference solution.** Dissolve 60 mg of *methanesulfonic acid R* in *water R* and dilute to 10 mL with the same solvent.

**Plate:** TLC silica gel plate R.

**Mobile phase:** *water R*, *ammonia R*, *butanol R*, *acetone R* (5:10:20:65 V/V/V/V).

**Application:** 10 µL.

**Development:** over a path of 15 cm.

**Drying:** in air.

**Detection:** spray with a 0.4 g/L solution of *bromocresol purple R* in *ethanol (50 per cent V/V) R*, adjusted to pH 10 using 1 M *sodium hydroxide*.

**Results:** the principal spot in the chromatogram obtained with the test solution is similar in position, colour and size to the principal spot in the chromatogram obtained with the reference solution.

#### TESTS

**Solution S.** Dissolve 1.0 g in *carbon dioxide-free water R* and dilute to 10.0 mL with the same solvent.

**Appearance of solution.** Examined within 1 h after its preparation, solution S is not more opalescent than reference suspension II (2.2.1) and not more intensely coloured than intensity 3 of the range of reference solutions of the most appropriate colour (2.2.2, *Method II*).

**pH (2.2.3):** 3.5 to 4.5.

Dilute 1 mL of solution S to 10 mL with *carbon dioxide-free water R*.

**Related substances.** Liquid chromatography (2.2.29).

**Test solution.** Dissolve 20.0 mg of the substance to be examined in the mobile phase and dilute to 100.0 mL with the mobile phase.

**Reference solution (a).** Dissolve 5.0 mg of *pefloxacin impurity B CRS* in the mobile phase and dilute to 50.0 mL with the mobile phase. Dilute 1.0 mL of the solution to 100.0 mL with the mobile phase. In 2.0 mL of this solution, dissolve the contents of a vial of *pefloxacin impurity C CRS*.

**Reference solution (b).** Dissolve 10.0 mg of *norfloxacin impurity A CRS* (impurity F) in the mobile phase and dilute to 100.0 mL with the mobile phase. Dilute 1.0 mL of this solution to 100.0 mL with the mobile phase.

**Column:**

- **size:** *l* = 0.15 m, Ø = 6 mm;
- **stationary phase:** octadecylsilyl vinyl polymer for chromatography R (5 µm).

**Mobile phase:** mix 30 volumes of *acetonitrile R*, 70 volumes of a solution containing 2.70 g/L of *cetyltrimethylammonium bromide R* and 6.18 g/L of *boric acid R* (exactly adjusted to pH 8.30 with 1 M *sodium hydroxide*), and 0.2 volumes of *thiodiethylene glycol R*.

**Flow rate:** 1 mL/min.

**Detection:** spectrophotometer at 258 nm and at 273 nm.

**Injection:** 20 µL.

**Run time:** 4 times the retention time of pefloxacin (about 60 min).

**Relative retentions and correction factors:**

	Approximate relative retention	Correction factor
Impurity E	0.2	–
Impurity D	0.3	–
Impurity A	0.5	–
Impurity G	0.8	1.4
Pefloxacin	1	–
Impurity C	1.7	2.4
Impurity B	1.8	–
Impurity H	2.4	1.8
Impurity F	3.5	–

**System suitability:** reference solution (a) at 273 nm:

- **resolution:** minimum 1.5 between the peaks due to impurities C and B.

From the chromatogram obtained at 258 nm with the test solution, calculate the percentage content of impurities C, F, G and H using the area of the principal peak in the chromatogram obtained at 258 nm with reference solution (b) (external standardisation) taking into account the correction factors indicated in the table.

From the chromatogram obtained at 273 nm with the test solution, calculate the percentage content of impurities A, B, D and E and of any other impurity from the areas of the peaks in the chromatogram obtained with the test solution by the normalisation procedure.

#### Limits:

- impurities A, B, D, E and any other impurity at 273 nm and impurities C, F, G, H at 258 nm: for each impurity, maximum 0.5 per cent and not more than 3 impurities have a content between 0.2 per cent and 0.5 per cent;
- total: maximum 1.0 per cent;
- disregard limit at 273 nm: 0.0005 times the area of the principal peak in the chromatogram obtained with the test solution (0.05 per cent).

**Heavy metals** (2.4.8): maximum 10 ppm.

1.0 g complies with test E. Prepare the reference solution using 10.0 mL of lead standard solution (1 ppm Pb) R.

**Water** (2.5.12): 7.0 per cent to 8.5 per cent, determined on 50.0 mg using a mixture of 10 volumes of methanol R and 50 volumes of methylene chloride R.

**Sulfated ash** (2.4.14): maximum 0.1 per cent, determined on 1.0 g.

#### ASSAY

Dissolve 0.200 g in 15.0 mL of anhydrous acetic acid R and add 75.0 mL of acetic anhydride R. Titrate with 0.1 M perchloric acid, determining the end-point potentiometrically (2.2.20).

1 mL of 0.1 M perchloric acid is equivalent to 21.48 mg of C<sub>18</sub>H<sub>24</sub>FN<sub>3</sub>O<sub>6</sub>S.

#### STORAGE

In an airtight container, protected from light.

#### IMPURITIES

Specified impurities: A, B, C, D, E, F, G, H.

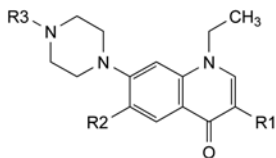

- A. R<sub>1</sub> = CO<sub>2</sub>H, R<sub>2</sub> = F, R<sub>3</sub> = H: 1-ethyl-6-fluoro-4-oxo-7-(piperazin-1-yl)-1,4-dihydroquinoline-3-carboxylic acid (demethylated pefloxacin or norfloxacin),
- B. R<sub>1</sub> = CO<sub>2</sub>H, R<sub>2</sub> = Cl, R<sub>3</sub> = CH<sub>3</sub>: 6-chloro-1-ethyl-7-(4-methylpiperazin-1-yl)-4-oxo-1,4-dihydroquinoline-3-carboxylic acid (chlorinated homologue of pefloxacin),
- E. R<sub>1</sub> = H, R<sub>2</sub> = F, R<sub>3</sub> = CH<sub>3</sub>: 1-ethyl-6-fluoro-7-(4-methylpiperazin-1-yl)quinoline-4(1H)-one (decarboxylated pefloxacin),

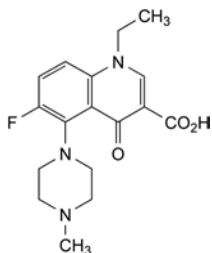

- C. 1-ethyl-6-fluoro-5-(4-methylpiperazin-1-yl)-4-oxo-1,4-dihydroquinoline-3-carboxylic acid (isopefloxacin),

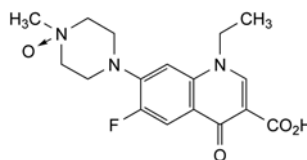

- D. 4-(3-carboxy-1-ethyl-6-fluoro-4-oxo-1,4-dihydroquinolin-7-yl)-1-methylpiperazine 1-oxide (N-oxide of pefloxacin),

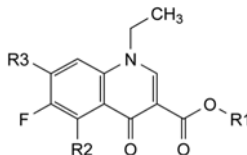

- F. R<sub>1</sub> = R<sub>2</sub> = H, R<sub>3</sub> = Cl: 7-chloro-1-ethyl-6-fluoro-4-oxo-1,4-dihydroquinoline-3-carboxylic acid (N-ethyl acid) (norfloxacin impurity A),
- G. R<sub>1</sub> = C<sub>2</sub>H<sub>5</sub>, R<sub>2</sub> = H, R<sub>3</sub> = Cl: ethyl 7-chloro-1-ethyl-6-fluoro-4-oxo-1,4-dihydroquinoline-3-carboxylate (N-ethyl ester),
- H. R<sub>1</sub> = R<sub>3</sub> = H, R<sub>2</sub> = Cl: 5-chloro-1-ethyl-6-fluoro-4-oxo-1,4-dihydroquinoline-3-carboxylic acid (iso-N-ethyl acid).

01/2008:1461  
corrected 6.0

## PENBUTOLOL SULFATE

### Penbutololi sulfas

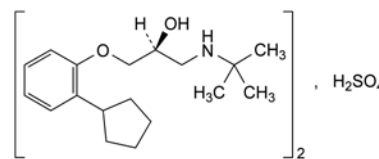

C<sub>36</sub>H<sub>60</sub>N<sub>2</sub>O<sub>8</sub>S  
[38363-32-5]

M<sub>r</sub> 681

#### DEFINITION

Di[(2S)-1-(2-cyclopentylphenoxy)-3-[(1,1-dimethylethyl)-amino]propan-2-ol] sulfate.

Content: 99.0 per cent to 101.0 per cent (dried substance).

#### CHARACTERS

Appearance: white or almost white, crystalline powder.

Solubility: slightly soluble in water, soluble in methanol, practically insoluble in cyclohexane.

#### IDENTIFICATION

First identification: A, C, D.

Second identification: B, C, D.

A. Infrared absorption spectrophotometry (2.2.24).

Comparison: penbutolol sulfate CRS.

B. Thin-layer chromatography (2.2.27).

Test solution. Dissolve 40 mg of the substance to be examined in 1 mL of methanol R.

Reference solution. Dissolve 40 mg of penbutolol sulfate CRS in 1 mL of methanol R.

Plate: TLC silica gel F<sub>254</sub> plate R.

Mobile phase: glacial acetic acid R, water R, butanol R, ethyl acetate R (10:20:35:35 V/V/V/V).

Application: 5 µL.

Development: over a path of 15 cm.

Drying: in air.

Detection: examine in ultraviolet light at 254 nm.

**Results:** the principal spot in the chromatogram obtained with the test solution is similar in position and size to the principal spot in the chromatogram obtained with the reference solution.

C. Dissolve 50 mg in a mixture of 5 mL of *water R* and 1 mL of 0.1 M *hydrochloric acid*. The solution gives reaction (a) of sulfates (2.3.1).

D. Specific optical rotation (see Tests).

#### TESTS

**Solution S.** Dissolve 1.00 g in *methanol R* and dilute to 20.0 mL with the same solvent.

**Acidity or alkalinity.** To 4 mL of solution S add 4 mL of *carbon dioxide-free water R*. Add 0.1 mL of *methyl red solution R* and 0.2 mL of 0.01 M *sodium hydroxide*; the solution is yellow. Add 0.4 mL of 0.01 M *hydrochloric acid*; the solution is red.

**Specific optical rotation (2.2.7):** – 23 to – 25 (dried substance), determined on solution S.

**Related substances.** Liquid chromatography (2.2.29).

**Solvent mixture:** mobile phase B, mobile phase A (40:60 V/V).

**Test solution.** Dissolve 40.0 mg of the substance to be examined in the solvent mixture and dilute to 10.0 mL with the solvent mixture.

**Reference solution (a).** Dissolve 4.0 mg of the substance to be examined and 1.0 mg of *penbutolol impurity A CRS* in 5.0 mL of the solvent mixture.

**Reference solution (b).** Dilute 1.0 mL of the test solution to 200.0 mL with the solvent mixture.

**Reference solution (c).** Dilute 1.0 mL of reference solution (b) to 10.0 mL with the solvent mixture.

**Reference solution (d).** Dissolve 5.0 mg of *penbutolol impurity A CRS* in the solvent mixture and dilute to 50.0 mL with the solvent mixture. Dilute 2.0 mL of this solution to 10.0 mL with the solvent mixture.

**Column:**

- size:  $l = 0.25$  m,  $\varnothing = 4.6$  mm;
- stationary phase: *octadecylsilyl silica gel for chromatography R* (5  $\mu$ m).

**Mobile phase:**

- mobile phase A: *acetonitrile for chromatography R*, *methanol R* (39:61 V/V);
- mobile phase B: dissolve 11 g of *sodium heptanesulfonate R* in 1000 mL of *water R*, add 5.0 mL of *triethylamine R* and adjust to pH 2.7 with *phosphoric acid R*;

Time (min)	Mobile phase A (per cent V/V)	Mobile phase B (per cent V/V)
0 - 15	60	40
15 - 35	60 → 80	40 → 20

**Flow rate:** 1.0 mL/min.

**Detection:** spectrophotometer at 270 nm.

**Injection:** 10  $\mu$ L.

**System suitability:** reference solution (a):

- resolution: minimum 3.0 between the 2 principal peaks.

**Limits:**

- *impurity A*: not more than the area of the principal peak in the chromatogram obtained with reference solution (d) (0.5 per cent);
- *any other impurity*: for each impurity, not more than the area of the principal peak in the chromatogram obtained with reference solution (b) (0.5 per cent);
- *sum of impurities other than A*: not more than twice the area of the principal peak in the chromatogram obtained with reference solution (b) (1 per cent);

- *disregard limit*: the area of the principal peak in the chromatogram obtained with reference solution (c) (0.05 per cent).

**Heavy metals (2.4.8):** maximum 10 ppm.

1.0 g complies with test F. Prepare the reference solution using 1 mL of *lead standard solution (10 ppm Pb) R*.

**Loss on drying (2.2.32):** maximum 0.5 per cent, determined on 1.000 g by drying in an oven at 105 °C.

**Sulfated ash (2.4.14):** maximum 0.1 per cent, determined on 1.0 g.

#### ASSAY

Dissolve 0.500 g in 40 mL of *anhydrous acetic acid R*. Titrate with 0.1 M *perchloric acid*, determining the end-point potentiometrically (2.2.20).

1 mL of 0.1 M *perchloric acid* is equivalent to 68.10 mg of  $C_{36}H_{60}N_2O_8S$ .

#### STORAGE

Protected from light.

#### IMPURITIES

**Specified impurities: A.**

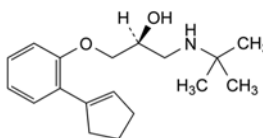

A. (2S)-1-[2-(cyclopent-1-enyl)phenoxy]-3-[(1,1-dimethylethyl)amino]propan-2-ol.

07/2009:0566  
corrected 7.0

## PENICILLAMINE

### Penicillaminum

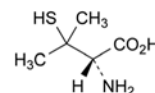

$C_5H_{11}NO_2S$   
[52-67-5]

$M_r$  149.2

#### DEFINITION

(2S)-2-Amino-3-methyl-3-sulfanylbutanoic acid.

**Content:** 98.0 per cent to 101.0 per cent (dried substance).

#### CHARACTERS

**Appearance:** white or almost white, crystalline powder.

**Solubility:** freely soluble in water, slightly soluble in ethanol (96 per cent).

#### IDENTIFICATION

**First identification:** A, B, D.

**Second identification:** A, C, D.

- A. Dissolve 0.5 g in a mixture of 0.5 mL of *hydrochloric acid R* and 4 mL of warm *acetone R*, cool in iced water and initiate crystallisation by scratching the wall of the tube with a glass rod. A white precipitate is formed. Filter with the aid of vacuum, wash with *acetone R* and dry with suction. A 10 g/L solution of the precipitate is dextrorotatory.
- B. Examine the chromatograms obtained in the test for impurity A.

**Results:** the principal peak in the chromatogram obtained with the test solution is similar in retention time and approximate size to the principal peak in the chromatogram obtained with reference solution (a).



## C. Thin-layer chromatography (2.2.27).

**Test solution.** Dissolve 10 mg of the substance to be examined in 4 mL of *water R*.

**Reference solution.** Dissolve 10 mg of *penicillamine CRS* in 4 mL of *water R*.

**Plate:** *TLC silica gel G plate R*.

**Mobile phase:** *glacial acetic acid R, water R, butanol R* (18:18:72 V/V/V).

**Application:** 2 µL.

**Development:** over a path of 10 cm.

**Drying:** at 100-105 °C for 5-10 min.

**Detection:** expose to iodine vapour for 5-10 min.

**Results:** the principal spot in the chromatogram obtained with the test solution is similar in position, colour and size to the principal spot in the chromatogram obtained with the reference solution.

D. Dissolve 40 mg in 4 mL of *water R* and add 2 mL of *phosphotungstic acid solution R*. Allow to stand for 5 min. A blue colour develops.

## TESTS

**Solution S.** Dissolve 2.5 g in *carbon dioxide-free water R* and dilute to 25 mL with the same solvent.

**Appearance of solution.** Solution S is clear (2.2.1) and not more intensely coloured than intensity 6 of the range of reference solutions of the most appropriate colour (2.2.2, *Method II*).

**pH** (2.2.3): 4.5 to 5.5.

Dilute 1 mL of solution S to 10 mL with *carbon dioxide-free water R*.

**Specific optical rotation** (2.2.7): –61.0 to –65.0 (dried substance).

Dissolve 0.500 g in 1 M *sodium hydroxide* and dilute to 10.0 mL with the same solvent.

**Ultraviolet-absorbing substances:** maximum 0.5 per cent of penilloic acid.

Dissolve 0.100 g in *water R* and dilute to 50.0 mL with the same solvent. The absorbance (2.2.25) of the solution at 268 nm is not greater than 0.07.

**Impurity A.** Liquid chromatography (2.2.29). Prepare the solutions immediately before use.

**Test solution.** Dissolve 40.0 mg of the substance to be examined in the mobile phase and dilute to 10.0 mL with the mobile phase.

**Reference solution (a).** Dissolve 40 mg of *penicillamine CRS* in the mobile phase and dilute to 10.0 mL with the mobile phase.

**Reference solution (b).** Dissolve 20.0 mg of *penicillamine disulfide CRS* (impurity A) in the mobile phase and dilute to 50.0 mL with the mobile phase. Dilute 1.0 mL of this solution to 10.0 mL with the mobile phase.

**Column:**

– size:  $l = 0.25$  m,  $\varnothing = 4.6$  mm;

– stationary phase: *octylsilyl silica gel for chromatography R* (10 µm).

**Mobile phase:** solution containing 0.1 g/L of *sodium edetate R* and 2 g/L of *methanesulfonic acid R*.

**Flow rate:** 1.7 mL/min.

**Detection:** spectrophotometer at 220 nm.

**Injection:** 20 µL.

**Relative retention** with reference to penicillamine (retention time = about 6 min): impurity A = about 1.8.

**System suitability:** reference solution (a):

– resolution: minimum 4.0 between the peaks due to penicillamine and impurity A.

**Limit:**

– impurity A: not more than the area of the corresponding peak in the chromatogram obtained with reference solution (b) (1 per cent).

**Impurity B:** maximum 0.1 ppm.

Carry out all the operations in a penicillin-free atmosphere and with equipment reserved for this test. Sterilise the equipment at 180 °C for 3 h and the buffer solutions at 121 °C for 20 min before use.

**Test solution (a).** Dissolve 1.000 g in 8 mL of *buffer solution pH 2.5 R* and add 8 mL of *ether R*. Shake vigorously for 1 min. Repeat the extraction and combine the ether layers. Add 8 mL of *buffer solution pH 2.5 R*. Shake for 1 min, allow to settle and quantitatively separate the upper layer, taking care to eliminate the aqueous phase completely (*penicillin is unstable at pH 2.5; carry out operations at this pH within 6-7 min*). Add 8 mL of *phosphate buffer solution pH 6.0 R2* to the ether phase, shake for 5 min, allow to settle, then separate the aqueous layer and check that the pH is 6.0.

**Test solution (b).** To 2 mL of test solution (a) add 20 µL of *penicillinase solution R* and incubate at 37 °C for 1 h.

**Reference solution (a).** Dissolve 5 mg of *benzylpenicillin sodium R* in 500 mL of *phosphate buffer solution pH 6.0 R2*. Dilute 0.25 mL of the solution to 200.0 mL with *buffer solution pH 2.5 R*. Carry out the extraction using 8 mL of this solution as described for test solution (a).

**Reference solution (b).** To 2 mL of reference solution (a) add 20 µL of *penicillinase solution R* and incubate at 37 °C for 1 h.

**Blank solution.** Prepare the solution as described for test solution (a) but omitting the substance to be examined.

Liquefy a suitable nutrient medium such as that described below and inoculate it at a suitable temperature with a culture of *Kocuria rhizophila* (ATCC 9341), to give  $5 \times 10^4$  micro-organisms per millilitre or a different quantity if necessary to obtain the required sensitivity and formation of clearly defined inhibition zones of suitable diameter. Immediately pour the inoculated medium into 5 Petri dishes 10 cm in diameter to give uniform layers 2-5 mm deep. The medium may alternatively consist of 2 layers, only the upper layer being inoculated. Store the dishes so that no appreciable growth or death of the micro-organisms occurs before use and so that the surface of the agar is dry at the time of use. In each dish, place 5 stainless steel hollow cylinders 6 mm in diameter on the surface of the agar evenly spaced on a circle with a radius of about 25 mm and concentric with the dish. For each dish, place in separate cylinders 0.15 mL of test solutions (a) and (b), reference solutions (a) and (b) and the blank solution. Maintain at 30 °C for at least 24 h. Measure the diameters of the inhibition zones with a precision of at least 0.1 mm. The test is valid if reference solution (a) gives a clear inhibition zone and if reference solution (b) and the blank solution give no inhibition zone. If test solution (a) gives an inhibition zone, this is caused by penicillin if test solution (b) gives no inhibition zone. If this is so, the average diameter of the inhibition zones given by test solution (a) for the 5 Petri dishes is less than the average diameter of the inhibition zones given by reference solution (a) measured in the same conditions.

**Nutrient medium (pH 6.0)**

Peptone	5 g
Yeast extract	1.5 g
Meat extract	1.5 g
Sodium chloride	3.5 g
Agar	15 g
Distilled water R	1000 mL

**Mercury:** maximum 10 ppm.

Atomic absorption spectrometry (2.2.23, *Method I*).

**Test solution.** To 1.00 g add 10 mL of *water R* and 0.15 mL of *perchloric acid R* and swirl until dissolution is complete. Add 1.0 mL of a 10 g/L solution of *ammonium pyrrolidinedithiocarbamate R* which has been washed immediately before use 3 times, each time with an equal volume

of *methyl isobutyl ketone R*. Mix and add 2.0 mL of *methyl isobutyl ketone R* and shake for 1 min. Dilute to 25.0 mL with *water R* and allow the 2 layers to separate; use the methyl isobutyl ketone layer.

**Reference solutions.** Dissolve a quantity of *mercuric oxide R* equivalent to 0.108 g of HgO in the smallest necessary volume of *dilute hydrochloric acid R* and dilute to 1000.0 mL with *water R* (100 ppm Hg). Prepare the reference solutions in the same manner as the test solution but using instead of the substance to be examined suitable volumes of the solution containing 100 ppm of Hg.

**Source:** mercury hollow-cathode lamp.

**Wavelength:** 254 nm.

**Atomisation device:** air-acetylene flame.

Set the zero of the instrument using a methyl isobutyl ketone layer obtained as described for the test solution but omitting the substance to be examined.

**Heavy metals (2.4.8):** maximum 20 ppm.

12 mL of solution S complies with test A. Prepare the reference solution using *lead standard solution (2 ppm Pb) R*.

**Loss on drying (2.2.32):** maximum 0.5 per cent, determined on 1.000 g by drying over *diphosphorus pentoxide R* at 60 °C at a pressure not exceeding 0.67 kPa.

**Sulfated ash (2.4.14):** maximum 0.1 per cent, determined on 1.0 g.

#### ASSAY

Dissolve 0.1000 g in 30 mL of *anhydrous acetic acid R*. Titrate with 0.1 M *perchloric acid*, determining the end-point potentiometrically (2.2.20).

1 mL of 0.1 M *perchloric acid* is equivalent to 14.92 mg of C<sub>5</sub>H<sub>11</sub>NO<sub>2</sub>S.

#### IMPURITIES

**Specified impurities:** A, B.

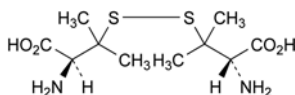

A. 3,3'-(disulfanediy)bis[(2S)-2-amino-3-methylbutanoic] acid (penicillamine disulfide),

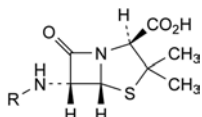

B. penicillin.

07/2009:1355

## PENTAERYTHRITYL TETRANITRATE, DILUTED

Pentaerythrityli tetranitras dilutus

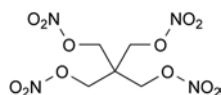

C<sub>5</sub>H<sub>8</sub>N<sub>4</sub>O<sub>12</sub>

M<sub>r</sub> 316.1

#### DEFINITION

Dry mixture of 2,2-bis(hydroxymethyl)propane-1,3-diol tetranitrate (pentaerythrityl tetranitrate) and *Lactose monohydrate (0187)* or *Mannitol (0559)*.

**Content:** 95.0 per cent *m/m* to 105.0 per cent *m/m* of the declared content of pentaerythrityl tetranitrate.

**CAUTION:** undiluted pentaerythrityl tetranitrate may explode if subjected to percussion or excessive heat. Appropriate precautions must be taken and only very small quantities handled.

#### CHARACTERS

**Appearance of pentaerythrityl tetranitrate:** white or slightly yellowish powder.

**Solubility of pentaerythrityl tetranitrate:** practically insoluble in water, soluble in acetone, slightly soluble in ethanol (96 per cent).

The solubility of diluted pentaerythrityl tetranitrate depends on the diluent and its concentration.

#### IDENTIFICATION

**First identification:** A, C.

**Second identification:** B, C.

A. Infrared absorption spectrophotometry (2.2.24).

**Preparation:** separately shake a quantity of the substance to be examined and a quantity of the reference substance, each corresponding to 25 mg of pentaerythrityl tetranitrate, with 10 mL of *acetone R* for 5 min; filter, evaporate to dryness at a temperature below 40 °C, and dry the residue over *diphosphorus pentoxide R* at a pressure of 0.7 kPa for 16 h. Examine the residues prepared as discs.

**Comparison:** *diluted pentaerythrityl tetranitrate CRS*.

B. Thin-layer chromatography (2.2.27).

**Test solution.** Shake a quantity of the substance to be examined corresponding to 10 mg of pentaerythrityl tetranitrate with 10 mL of *ethanol (96 per cent) R* for 5 min and filter.

**Reference solution.** Shake a quantity of *diluted pentaerythrityl tetranitrate CRS* corresponding to 10 mg of pentaerythrityl tetranitrate with 10 mL of *ethanol (96 per cent) R* for 5 min and filter.

**Plate:** *TLC silica gel plate R*.

**Mobile phase:** *ethyl acetate R, toluene R* (20:80 V/V).

**Application:** 10 µL.

**Development:** over 2/3 of the plate.

**Drying:** in air.

**Detection:** spray with freshly prepared *potassium iodide and starch solution R*, expose to ultraviolet light at 254 nm for 15 min and examine in daylight.

**Results:** the principal spot in the chromatogram obtained with the test solution is similar in position, colour and size to the principal spot in the chromatogram obtained with the reference solution.

C. Thin-layer chromatography (2.2.27).

**Test solution.** Shake a quantity of the substance to be examined corresponding to 0.10 g of lactose or mannitol with 10 mL of *water R*. Filter if necessary.

**Reference solution (a)** Dissolve 0.10 g of *lactose R* in *water R* and dilute to 10 mL with the same solvent.

**Reference solution (b).** Dissolve 0.10 g of *mannitol R* in *water R* and dilute to 10 mL with the same solvent.

**Reference solution (c).** Mix equal volumes of reference solutions (a) and (b).

**Plate:** *TLC silica gel G plate R*.

**Mobile phase:** *water R, methanol R, anhydrous acetic acid R, ethylene chloride R* (10:15:25:50 V/V/V/V). Measure the volumes accurately since a slight excess of water produces cloudiness.

**Application:** 1 µL; thoroughly dry the points of application.

**Development A:** over 2/3 of the plate.

**Drying A:** in a current of warm air.

**Development B:** immediately, over 2/3 of the plate, after renewing the mobile phase.

**Drying B:** in a current of warm air.

**Detection:** spray with 4-aminobenzoic acid solution R, dry in a current of cold air until the acetone is removed, then heat at 100 °C for 15 min; allow to cool, spray with a 2 g/L solution of sodium periodate R, dry in a current of cold air and heat at 100 °C for 15 min.

**System suitability:** reference solution (c):

- the chromatogram shows 2 clearly separated spots.

**Results:** the principal spot in the chromatogram obtained with the test solution is similar in position, colour and size to the principal spot in the chromatogram obtained with reference solution (a) for lactose or to the principal spot in the chromatogram obtained with reference solution (b) for mannitol.

## TESTS

**Impurity A.** Thin-layer chromatography (2.2.27).

**Test solution.** Shake a quantity of the substance to be examined corresponding to 0.10 g of pentaerythrityl tetranitrate with 5 mL of ethanol (96 per cent) R and filter.

**Reference solution.** Dissolve 10 mg of potassium nitrate R in 1 mL of water R and dilute to 100 mL with ethanol (96 per cent) R.

**Plate:** TLC silica gel plate R.

**Mobile phase:** glacial acetic acid R, acetone R, toluene R (15:30:60 V/V/V).

**Application:** 10 µL.

**Development:** over 2/3 of the plate.

**Drying:** in a current of air until the acetic acid is completely removed.

**Detection:** spray copiously with freshly prepared potassium iodide and starch solution R, expose the plate to ultraviolet light at 254 nm for 15 min and examine in daylight.

**Limit:**

- nitrate: any spot due to nitrate is not more intense than the spot in the chromatogram obtained with the reference solution (0.5 per cent, calculated as potassium nitrate).

**Related substances.** Liquid chromatography (2.2.29).

**Test solution (a).** Sonicate for 15 min a quantity of the substance to be examined corresponding to 25.0 mg of pentaerythrityl tetranitrate in 20 mL of the mobile phase and dilute to 25.0 mL with the mobile phase. Filter.

**Test solution (b).** Dilute 1.0 mL of test solution (a) to 10.0 mL with the mobile phase.

**Reference solution (a).** Sonicate for 15 min a quantity of diluted pentaerythrityl tetranitrate CRS corresponding to 25.0 mg of pentaerythrityl tetranitrate in 20 mL of the mobile phase and dilute to 25.0 mL with the mobile phase. Filter.

**Reference solution (b).** Dilute 1.0 mL of reference solution (a) to 10.0 mL with the mobile phase.

**Reference solution (c).** Dilute 0.3 mL of reference solution (b) to 10.0 mL with the mobile phase.

**Reference solution (d).** Dilute 200 µL of glyceryl trinitrate solution CRS to 25.0 mL with the mobile phase.

**Reference solution (e).** To 1 mL of reference solution (b) add 1 mL of reference solution (d) and dilute to 10 mL with the mobile phase.

**Reference solution (f).** Dilute 1.0 mL of reference solution (a) to 20.0 mL with the mobile phase. Dilute 0.5 mL of this solution to 50.0 mL with the mobile phase.

**Column:**

- size:  $l = 0.15$  m,  $\varnothing = 3.9$  mm;
- stationary phase: octylsilyl silica gel for chromatography R (5 µm).

**Mobile phase:** water R, acetonitrile R (35:65 V/V).

**Flow rate:** 1.4 mL/min.

**Detection:** spectrophotometer at 220 nm.

**Injection:** 20 µL of test solution (a) and reference solutions (c), (e) and (f).

**Run time:** 5 times the retention time of pentaerythrityl tetranitrate.

**Relative retention** with reference to pentaerythrityl tetranitrate (retention time = about 2.4 min): impurity B = about 0.7; impurity C = about 3.0.

**System suitability:** reference solution (e):

- resolution: minimum 3.0 between the peaks due to glyceryl trinitrate and pentaerythrityl tetranitrate.

**Limits:**

- impurities C, D: for each impurity, not more than the area of the principal peak in the chromatogram obtained with reference solution (c) (0.3 per cent);
- unspecified impurities: for each impurity, not more than twice the area of the principal peak in the chromatogram obtained with reference solution (f) (0.10 per cent);
- total: not more than twice the area of the principal peak in the chromatogram obtained with reference solution (c) (0.6 per cent);
- disregard limit: the area of the principal peak in the chromatogram obtained with reference solution (f) (0.05 per cent).

## ASSAY

Liquid chromatography (2.2.29) as described in the test for related substances with the following modification.

**Injection:** test solution (b) and reference solution (b).

Calculate the percentage content of C<sub>5</sub>H<sub>8</sub>N<sub>4</sub>O<sub>12</sub> from the declared content of diluted pentaerythrityl tetranitrate CRS.

## STORAGE

Protected from light and heat.

## LABELLING

The label states:

- the percentage content of pentaerythrityl tetranitrate;
- the diluent used.

## IMPURITIES

**Specified impurities:** A, C, D.

**Other detectable impurities** (the following substances would, if present at a sufficient level, be detected by one or other of the tests in the monograph. They are limited by the general acceptance criterion for other/unspecified impurities and/or by the general monograph *Substances for pharmaceutical use (2034)*. It is therefore not necessary to identify these impurities for demonstration of compliance. See also 5.10. *Control of impurities in substances for pharmaceutical use*): B.



A. NO<sub>3</sub><sup>-</sup>: inorganic nitrates,

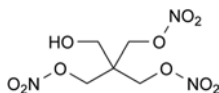

B. 2,2-bis(hydroxymethyl)propane-1,3-diol trinitrate (pentaerythritol trinitrate),

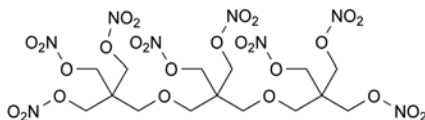

C. 2,2-bis[[3-hydroxy-2,2-bis(hydroxymethyl)propyl]methyl]propane-1,3-diol octanitrate (tripentaerythritol octanitrate),

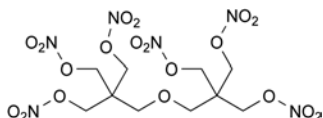

D. 2,2'-(oxybismethylene)bis[2-(hydroxymethyl)propane-1,3-diol] hexanitrate (dipentaerythrityl hexanitrate).

01/2008:1137  
corrected 6.0

## PENTAMIDINE DISETIONATE

### Pentamidini diisetionas

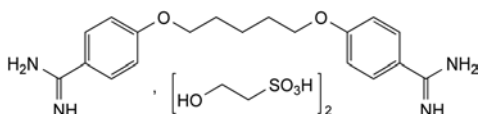

$C_{23}H_{36}N_4O_{10}S_2$   
[140-64-7]

$M_r$  592.7

#### DEFINITION

4,4'-[Pentane-1,5-diylobis(oxy)]dibenzamidine di(2-hydroxyethanesulfonate).

*Content*: 98.5 per cent to 101.5 per cent (dried substance).

#### PRODUCTION

The production method must be evaluated to determine the potential for formation of alkyl 2-hydroxyethanesulfonates, which is particularly likely to occur if the reaction medium contains lower alcohols. Where necessary, the production method is validated to demonstrate that alkyl 2-hydroxyethanesulfonates are not detectable in the final product.

#### CHARACTERS

*Appearance*: white or almost white powder or colourless crystals, hygroscopic.

*Solubility*: freely soluble in water, sparingly soluble in ethanol (96 per cent), practically insoluble in methylene chloride.

#### IDENTIFICATION

A. Infrared absorption spectrophotometry (2.2.24).

*Preparation*: discs.

*Comparison*: pentamidine diisetionate CRS.

B. Dissolve about 40 mg in 5 mL of *water R* and add dropwise with shaking 1 mL of a 10 g/L solution of *sodium chloride R*. Allow to stand for 5 min. The mixture remains clear.

C. Treat 0.15 g by the oxygen-flask method (2.5.10). Use 10 mL of *dilute hydrogen peroxide solution R* to absorb the combustion products. The solution gives reaction (a) of sulfates (2.3.1).

#### TESTS

**Appearance of solution.** The solution is not more opalescent than reference suspension II (2.2.1) and not more intensely coloured than intensity 6 of the range of reference solutions of the most appropriate colour (2.2.2, *Method II*).

Dissolve 2.0 g in *water R* and dilute to 20 mL with the same solvent.

**pH** (2.2.3): 4.5 to 6.5.

Dissolve 0.5 g in *carbon dioxide-free water R* and dilute to 10 mL with the same solvent.

**Related substances.** Liquid chromatography (2.2.29).

*Test solution.* Dissolve 0.100 g of the substance to be examined in the mobile phase and dilute to 100.0 mL with the mobile phase.

*Reference solution (a).* Dilute 2.0 mL of the test solution to 100.0 mL with the mobile phase. Dilute 1.0 mL of this solution to 10.0 mL with the mobile phase.

*Reference solution (b).* To 0.1 g in a conical flask, add 40 mL of *water R* and glass beads. Adjust to pH 10.5 with *dilute sodium hydroxide solution R* and boil under reflux for 20 min. Cool and dilute to 50 mL with *water R*. Dilute 1 mL of the solution to 50 mL with the mobile phase.

*Column*:

- *size*:  $l = 0.25$  m,  $\varnothing = 4.6$  mm,
- *stationary phase*: octadecylsilyl silica gel for chromatography R (5  $\mu$ m).

*Mobile phase*: mix 65 volumes of *methanol R* and 35 volumes of a 30 g/L solution of *ammonium acetate R* previously adjusted to pH 7.5 using *triethylamine R*.

*Flow rate*: 1 mL/min.

*Detection*: spectrophotometer at 265 nm.

*Injection*: 10  $\mu$ L.

*Run time*: 3.5 times the retention time of pentamidine.

*System suitability*: reference solution (b):

- the chromatogram obtained shows 2 principal peaks,
- *resolution*: minimum 2.0 between the 2 principal peaks.

*Limits*:

- *any impurity*: for each impurity, not more than the area of the principal peak in the chromatogram obtained with reference solution (a) (0.2 per cent),
- *total*: not more than twice the area of the principal peak in the chromatogram obtained with reference solution (a) (0.4 per cent),
- *disregard limit*: 0.1 times the area of the principal peak in the chromatogram obtained with reference solution (a) (0.02 per cent).

**Heavy metals** (2.4.8): maximum 20 ppm.

1.0 g complies with test C. Prepare the reference solution using 2 mL of *lead standard solution (10 ppm Pb) R*.

**Loss on drying** (2.2.32): maximum 4.0 per cent, determined on 1.000 g by drying in an oven at 105 °C.

**Sulfated ash** (2.4.14): maximum 0.1 per cent, determined on 1.0 g.

#### ASSAY

Dissolve 0.250 g in 50 mL of *dimethylformamide R*. Add 0.25 mL of *thymol blue solution R*. Titrate with 0.1 M *tetrabutylammonium hydroxide*, under a current of *nitrogen R*, until the colour of the indicator changes to blue. Carry out a blank titration.

1 mL of 0.1 M *tetrabutylammonium hydroxide* is equivalent to 29.63 mg of  $C_{23}H_{36}N_4O_{10}S_2$ .

#### STORAGE

In an airtight container.

#### IMPURITIES

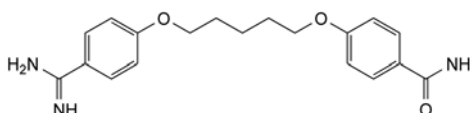

A. 4-[[5-(4-amidinophenoxy)pentyl]oxy]benzenecarboxamide.

01/2008:1462 ASSAY

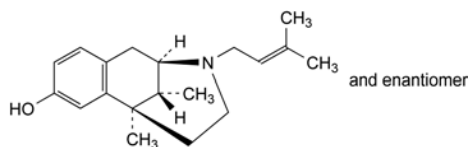
**PENTAZOCINE****Pentazocinum**C<sub>19</sub>H<sub>27</sub>NO  
[359-83-1]M<sub>r</sub> 285.4**DEFINITION**

Pentazocine contains not less than 99.0 per cent and not more than the equivalent of 101.0 per cent of (2*RS*,6*RS*,11*RS*)-6,11-dimethyl-3-(3-methylbut-2-enyl)-1,2,3,4,5,6-hexahydro-2,6-methano-3-benzazocin-8-ol, calculated with reference to the dried substance.

**CHARACTERS**

A white or almost white powder, practically insoluble in water, freely soluble in methylene chloride and soluble in ethanol (96 per cent).

It shows polymorphism (5.9).

**IDENTIFICATION**

Examine by infrared absorption spectrophotometry (2.2.24), comparing with the *Ph. Eur. reference spectrum for pentazocine (form A)*.

**TESTS**

**Absorbance** (2.2.25). Dissolve 0.100 g in a mixture of 20 mL of *water R* and 1 mL of 1 M *hydrochloric acid*, and dilute to 100.0 mL with *water R*. To 10.0 mL add 1 mL of 1 M *hydrochloric acid* and dilute to 100.0 mL with *water R*. The absorbance at the absorption maximum at 278 nm is 0.67 to 0.71, calculated with reference to the dried substance.

**Related substances.** Examine by thin-layer chromatography (2.2.27), using a *TLC silica gel F<sub>254</sub> plate R*.

**Test solution.** Dissolve 0.20 g of the substance to be examined in *methylene chloride R* and dilute to 10 mL with the same solvent.

**Reference solution (a).** Dilute 1 mL of the test solution to 100 mL with *methylene chloride R*.

**Reference solution (b).** Dilute 5 mL of reference solution (a) to 10 mL with *methylene chloride R*.

**Reference solution (c).** Dilute 5 mL of reference solution (a) to 20 mL with *methylene chloride R*.

Apply to the plate 10 µL of each solution. Develop over a path corresponding to two thirds of the plate height using a mixture of 3 volumes of *isopropylamine R*, 3 volumes of *methanol R* and 94 volumes of *methylene chloride R*. Allow the plate to dry in air and examine in ultraviolet light at 254 nm. Heat the plate at 100-105 °C for 15 min, allow to cool, expose to iodine vapour and re-examine under ultraviolet light at 254 nm. By each method of visualisation: any spot in the chromatogram obtained with the test solution, apart from the principal spot, is not more intense than the spot obtained with reference solution (a) (1 per cent); not more than one such spot is more intense than the spot in the chromatogram obtained with reference solution (b) (0.5 per cent) and not more than 4 such spots are more intense than the spot in the chromatogram obtained with reference solution (c) (0.25 per cent).

**Loss on drying** (2.2.32). Not more than 0.5 per cent, determined on 1.000 g by drying at 60 °C at a pressure not exceeding 0.7 kPa for 4 h.

**Sulfated ash** (2.4.14). Not more than 0.1 per cent, determined on 1.0 g.

Dissolve 0.200 g in 50 mL of *anhydrous acetic acid R*. Titrate with 0.1 M *perchloric acid*, determining the end-point potentiometrically (2.2.20).

1 mL of 0.1 M *perchloric acid* is equivalent to 28.54 mg of C<sub>19</sub>H<sub>27</sub>NO.

**STORAGE**

Store protected from light.

01/2008:1463

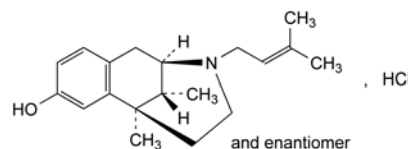
**PENTAZOCINE HYDROCHLORIDE****Pentazocini hydrochloridum**C<sub>19</sub>H<sub>28</sub>ClNO  
[64024-15-3]M<sub>r</sub> 321.9**DEFINITION**

Pentazocine hydrochloride contains not less than 99.0 per cent and not more than the equivalent of 101.0 per cent of (2*RS*,6*RS*,11*RS*)-6,11-dimethyl-3-(3-methylbut-2-enyl)-1,2,3,4,5,6-hexahydro-2,6-methano-3-benzazocin-8-ol hydrochloride, calculated with reference to the dried substance.

**CHARACTERS**

A white or almost white powder, sparingly soluble in water, soluble in ethanol (96 per cent) and sparingly soluble in methylene chloride.

It shows polymorphism (5.9).

**IDENTIFICATION**

A. Examine by infrared absorption spectrophotometry (2.2.24), comparing with the *Ph. Eur. reference spectrum of pentazocine hydrochloride*.

B. It gives reaction (a) of chlorides (2.3.1).

**TESTS**

**pH** (2.2.3). Dissolve 0.1 g in 10 mL of *carbon dioxide-free water R*. The pH of the solution is 4.0 to 6.0.

**Absorbance** (2.2.25). Dissolve 0.100 g in a mixture of 20 mL of *water R* and 1 mL of 1 M *hydrochloric acid*, and dilute to 100.0 mL with *water R*. To 10.0 mL add 1 mL of 1 M *hydrochloric acid* and dilute to 100.0 mL with *water R*. The absorbance at the absorption maximum at 278 nm is 0.59 to 0.63, calculated with reference to the dried substance.

**Related substances.** Examine by thin-layer chromatography (2.2.27), using a *TLC silica gel F<sub>254</sub> plate R*.

**Test solution.** Dissolve 0.20 g in 3 mL of *methanol R* and dilute to 10 mL with *methylene chloride R*.

**Reference solution (a).** Dilute 1 mL of the test solution to 100 mL with *methylene chloride R*.

**Reference solution (b).** Dilute 5 mL of reference solution (a) to 10 mL with *methylene chloride R*.

**Reference solution (c).** Dilute 5 mL of reference solution (a) to 20 mL with *methylene chloride R*.

Apply to the plate 10 µL of each solution. Develop over a path corresponding to two-thirds of the plate height using a mixture of 3 volumes of *isopropylamine R*, 3 volumes of *methanol R* and 94 volumes of *methylene chloride R*. Allow the plate to dry in air and examine in ultraviolet light at 254 nm. Heat the plate at 100-105 °C for 15 min, allow to cool, expose to iodine vapour and re-examine under ultraviolet light at 254 nm. By each method of visualisation: any spot in the chromatogram obtained

with the test solution, apart from the principal spot, is not more intense than the spot obtained with reference solution (a) (1 per cent); not more than 1 such spot is more intense than the spot in the chromatogram obtained with reference solution (b) (0.5 per cent); and not more than 4 such spots are more intense than the spot in the chromatogram obtained with reference solution (c) (0.25 per cent).

**Loss on drying** (2.2.32). Not more than 0.5 per cent, determined on 1.000 g by drying at 60 °C at a pressure not exceeding 0.7 kPa for 4 h.

**Sulfated ash** (2.4.14). Not more than 0.1 per cent, determined on 1.0 g.

#### ASSAY

Dissolve 0.250 g in 50 mL of *ethanol (96 per cent) R*. Add 5 mL of 0.01 M *hydrochloric acid*. Carry out a potentiometric titration (2.2.20), using 0.1 M *sodium hydroxide*. Read the volume added between the 2 points of inflection.

1 mL of 0.1 M *sodium hydroxide* is equivalent to 32.19 mg of C<sub>19</sub>H<sub>28</sub>CINO.

#### STORAGE

Store protected from light.

01/2008:2000  
corrected 6.0

## PENTAZOCINE LACTATE

### Pentazocini lactas

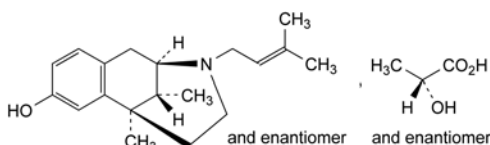

C<sub>22</sub>H<sub>33</sub>NO<sub>4</sub>  
[17146-95-1]

M<sub>r</sub> 375.5

#### DEFINITION

(2*RS*,6*RS*,11*RS*)-6,11-Dimethyl-3-(3-methylbut-2-enyl)-1,2,3,4,5,6-hexahydro-2,6-methano-3-benzazocin-8-ol (2*RS*)-2-hydroxypropanoate.

*Content*: 99.0 per cent to 101.0 per cent (dried substance).

#### CHARACTERS

*Appearance*: white or almost white powder.

*Solubility*: sparingly soluble in water, freely soluble in methanol, slightly soluble in methylene chloride.

#### IDENTIFICATION

Infrared absorption spectrophotometry (2.2.24).

*Comparison*: Ph. Eur. reference spectrum of pentazocine lactate.

#### TESTS

**pH** (2.2.3): 5.5 to 6.5.

Dissolve 0.1 g in 10 mL of *carbon dioxide-free water R*.

**Absorbance** (2.2.25): 0.50 to 0.54, determined at the absorption maximum at 278 nm.

Dissolve 0.10 g in 10.0 mL of 1 M *hydrochloric acid* and dilute to 100.0 mL with *water R*. Dilute 10.0 mL of the solution to 100.0 mL with *water R*.

**Related substances**. Thin-layer chromatography (2.2.27).

*Test solution*. Dissolve 0.20 g of the substance to be examined in *methylene chloride R* and dilute to 10 mL with the same solvent.

*Reference solution (a)*. Dissolve 100 mg of the substance to be examined in *acetic anhydride R* and dilute to 5 mL with the same solvent. Heat at 80 °C for 10 min. Dilute 1 mL of the solution to 10 mL with *methanol R*. Mix 1 mL of this solution with 1 mL of the test solution.

*Reference solution (b)*. Dilute 1 mL of the test solution to 100 mL with *methylene chloride R*. Dilute 2 mL of this solution to 10 mL with *methylene chloride R*.

*Plate*: TLC silica gel F<sub>254</sub> plate R.

*Mobile phase*: *isopropylamine R*, *methanol R*, *methylene chloride R* (3:3:94 V/V/V).

*Application*: 10 µL.

*Development*: over 2/3 of the plate.

*Drying*: in air.

*Detection*: examine in ultraviolet light at 254 nm. Heat at 100-105 °C for 15 min. Allow to cool. Expose to iodine vapour and re-examine in ultraviolet light at 254 nm.

*System suitability*: reference solution (a):

– the chromatogram shows 2 clearly separated spots.

*Limits*: by each method of detection:

– *any impurity*: any spots, apart from the principal spot, are not more intense than the spot in the chromatogram obtained with reference solution (b) (0.2 per cent).

**Loss on drying** (2.2.32): maximum 0.5 per cent, determined on 1.000 g by drying in an oven at 105 °C.

**Sulfated ash** (2.4.14): maximum 0.1 per cent, determined on 1.0 g.

#### ASSAY

Dissolve 0.300 g in 30 mL of *anhydrous acetic acid R* and add 30 mL of *dioxan R*. Titrate with 0.1 M *perchloric acid*, determining the end-point potentiometrically (2.2.20).

1 mL of 0.1 M *perchloric acid* is equivalent to 37.55 mg of C<sub>22</sub>H<sub>33</sub>NO<sub>4</sub>.

#### STORAGE

Protected from light.

01/2008:0200  
corrected 6.0

## PENTOBARBITAL

### Pentobarbitalum

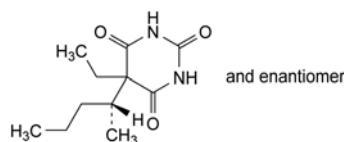

C<sub>11</sub>H<sub>18</sub>N<sub>2</sub>O<sub>3</sub>  
[76-74-4]

M<sub>r</sub> 226.3

#### DEFINITION

Pentobarbital contains not less than 99.0 per cent and not more than the equivalent of 101.0 per cent of 5-ethyl-5-[(1*RS*)-1-methylbutyl]pyrimidine-2,4,6-(1*H*,3*H*,5*H*)-trione, calculated with reference to the dried substance.

#### CHARACTERS

A white or almost white, crystalline powder or colourless crystals, very slightly soluble in water, freely soluble in ethanol. It forms water-soluble compounds with alkali hydroxides and carbonates and with ammonia.

## IDENTIFICATION

- A. Determine the melting point (2.2.14) of the substance to be examined. Mix equal parts of the substance to be examined and *pentobarbital CRS* and determine the melting point of the mixture. The difference between the melting points (which are about 133 °C) is not greater than 2 °C.
- B. Examine by thin-layer chromatography (2.2.27), using *silica gel GF<sub>254</sub> R* as the coating substance.  
*Test solution.* Dissolve 0.1 g of the substance to be examined in *alcohol R* and dilute to 100 mL with the same solvent.  
*Reference solution.* Dissolve 0.1 g of *pentobarbital CRS* in *alcohol R* and dilute to 100 mL with the same solvent.  
 Apply to the plate 10 µL of each solution. Develop over a path of 18 cm using the lower layer of a mixture of 5 volumes of *concentrated ammonia R*, 15 volumes of *alcohol R* and 80 volumes of *chloroform R*. Examine immediately in ultraviolet light at 254 nm. The principal spot in the chromatogram obtained with the test solution is similar in position and size to the principal spot in the chromatogram obtained with the reference solution.
- C. To about 10 mg add about 10 mg of *vanillin R* and 2 mL of *sulfuric acid R*. Mix and heat on a water-bath for 2 min. A reddish-brown colour develops. Cool and add cautiously 5 mL of *ethanol R*. The colour becomes violet and then blue.

## TESTS

**Appearance of solution.** Dissolve 1.0 g in a mixture of 4 mL of *dilute sodium hydroxide solution R* and 6 mL of *water R*. The solution is clear (2.2.1) and not more intensely coloured than reference solution Y<sub>6</sub> (2.2.2, *Method II*).

**Acidity.** Boil 1.0 g with 50 mL of *water R* for 2 min, allow to cool and filter. To 10 mL of the filtrate add 0.15 mL of *methyl red solution R*. The solution is orange-yellow. Not more than 0.1 mL of 0.1 M *sodium hydroxide* is required to produce a pure yellow colour.

**Related substances.** Examine by thin-layer chromatography (2.2.27), using *silica gel GF<sub>254</sub> R* as the coating substance.

*Test solution.* Dissolve 1.0 g of the substance to be examined in *alcohol R* and dilute to 100 mL with the same solvent.

*Reference solution.* Dilute 0.5 mL of the test solution to 100 mL with *alcohol R*.

Apply to the plate 20 µL of each solution. Develop over a path of 15 cm using the lower layer of a mixture of 5 volumes of *concentrated ammonia R*, 15 volumes of *alcohol R* and 80 volumes of *chloroform R*. Examine immediately in ultraviolet light at 254 nm. Spray with *diphenylcarbazone mercuric reagent R*. Allow the plate to dry in air and spray with freshly prepared *alcoholic potassium hydroxide solution R* diluted 1 in 5 with *aldehyde-free alcohol R*. Heat at 100 °C to 105 °C for 5 min and examine immediately. When examined in ultraviolet light and after spraying, any spot in the chromatogram obtained with the test solution, apart from the principal spot, is not more intense than the spot in the chromatogram obtained with the reference solution (0.5 per cent).

**Isomer.** Dissolve 0.3 g in 5 mL of a 50 g/L solution of *anhydrous sodium carbonate R*, heating slightly if necessary. Add a solution of 0.3 g of *nitrobenzyl chloride R* in 10 mL of *alcohol R* and heat under a reflux condenser for 30 min. Cool to 25 °C, filter and wash the precipitate with five quantities, each of 5 mL, of *water R*. In a small flask, heat the precipitate with 25 mL of *alcohol R* under a reflux condenser until dissolved (about 10 min). Cool to 25 °C, if necessary scratching the wall of the flask with a glass rod to induce crystallisation, and filter. The precipitate, washed with two quantities, each of 5 mL, of *water R* and dried at 100 °C to 105 °C for 30 min, melts (2.2.14) at 136 °C to 148 °C.

**Loss on drying** (2.2.32). Not more than 0.5 per cent, determined on 1.000 g by drying in an oven at 105 °C.

**Sulfated ash** (2.4.14). Not more than 0.1 per cent, determined on 1.0 g.

## ASSAY

Dissolve 0.100 g in 5 mL of *pyridine R*. Add 0.5 mL of *thymolphthalein solution R* and 10 mL of *silver nitrate solution in pyridine R*. Titrate with 0.1 M *ethanolic sodium hydroxide* until a pure blue colour is obtained. Carry out a blank titration. 1 mL of 0.1 M *ethanolic sodium hydroxide* is equivalent to 11.31 mg of C<sub>11</sub>H<sub>18</sub>N<sub>2</sub>O<sub>3</sub>.

01/2008:0419  
corrected 6.0

## PENTOBARBITAL SODIUM

## Pentobarbitalum natricum

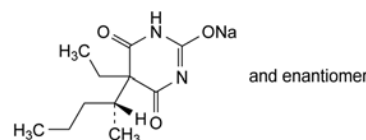

C<sub>11</sub>H<sub>17</sub>N<sub>2</sub>NaO<sub>3</sub>  
[57-33-0]

M<sub>r</sub> 248.3

## DEFINITION

Pentobarbital sodium contains not less than 99.0 per cent and not more than the equivalent of 101.5 per cent of the sodium derivative of 5-ethyl-5-[(1*RS*)-1-methylbutyl]pyrimidine-2,4,6-(1*H*, 3*H*,5*H*)-trione, calculated with reference to the dried substance.

## CHARACTERS

A white or almost white, crystalline powder, hygroscopic, very soluble in water.

## IDENTIFICATION

- A. Dissolve 1 g in 10 mL of *water R* and add 5 mL of *dilute acetic acid R*. A white, crystalline precipitate is formed. Filter, wash the precipitate with *water R* and dry at 100 °C to 105 °C. Determine the melting point (2.2.14) of the precipitate. Mix equal parts of the precipitate and *pentobarbital CRS* and determine the melting point of the mixture. The difference between the melting points (which are about 131 °C) is not greater than 2 °C.
- B. Examine by thin-layer chromatography (2.2.27), using a *TLC silica gel GF<sub>254</sub> plate R*.  
*Test solution.* Dissolve 25 mg of the precipitate obtained in identification test A in *alcohol R* and dilute to 25 mL with the same solvent.  
*Reference solution.* Dissolve 25 mg of *pentobarbital CRS* in *alcohol R* and dilute to 25 mL with the same solvent.  
 Apply to the plate 10 µL of each solution. Develop over a path of 18 cm using the lower layer from a mixture of 5 volumes of *concentrated ammonia R*, 15 volumes of *alcohol R* and 80 volumes of *chloroform R*. Examine immediately in ultraviolet light at 254 nm. The principal spot in the chromatogram obtained with the test solution is similar in position and size to the principal spot in the chromatogram obtained with the reference solution.
- C. To about 10 mg add about 10 mg of *vanillin R* and 2 mL of *sulfuric acid R*. Mix and heat on a water-bath for 2 min. A reddish-brown colour develops. Cool and add cautiously 5 mL of *ethanol R*. The colour becomes violet and then blue.
- D. Ignite 1 g. The residue gives reaction (a) of sodium (2.3.1).

## TESTS

**pH** (2.2.3). Dissolve 1.0 g in *carbon dioxide-free water R* and dilute to 10 mL with the same solvent. The pH measured immediately after preparation of the solution is 9.6 to 11.0.

01/2008:0851

**Related substances.** Examine by thin-layer chromatography (2.2.27), using a *TLC silica gel GF<sub>254</sub>* plate R.

**Test solution.** Dissolve 0.2 g of the substance to be examined in *alcohol R* and dilute to 10 mL with the same solvent.

**Reference solution.** Dilute 0.5 mL of the test solution to 100 mL with *alcohol R*.

Apply to the plate 10 µL of each solution. Develop over a path of 15 cm using the lower layer from a mixture of 5 volumes of *concentrated ammonia R*, 15 volumes of *alcohol R* and 80 volumes of *chloroform R*. Examine immediately in ultraviolet light at 254 nm. Any spot in the chromatogram obtained with the test solution, apart from the principal spot, is not more intense than the spot in the chromatogram obtained with the reference solution (0.5 per cent). Spray with *diphenylcarbazone mercuric reagent R*. Allow the plate to dry in air and spray with freshly prepared *alcoholic potassium hydroxide solution R* diluted 1 in 5 with *aldehyde-free alcohol R*. Heat at 100 °C to 105 °C for 5 min and examine immediately in daylight. Any spot in the chromatogram obtained with the test solution, apart from the principal spot, is not more intense than the spot in the chromatogram obtained with the reference solution (0.5 per cent).

**Free pentobarbital.** Not more than 3.5 per cent. Dissolve 2.00 g in 75 mL of *dimethylformamide R*, heating gently if necessary. Titrate with 0.1 M *sodium methoxide* until the colour changes from olive-green to blue, using 0.25 mL of a 10 g/L solution of *thymol blue R* in *dimethylformamide R* as indicator. Carry out a blank titration.

1 mL of 0.1 M *sodium methoxide* is equivalent to 22.63 mg of pentobarbital.

**Isomer.** Dissolve 0.3 g in 5 mL of a 50 g/L solution of *anhydrous sodium carbonate R*. Add a solution of 0.3 g of *nitrobenzyl chloride R* in 10 mL of *alcohol R* and heat under a reflux condenser for 30 min. Cool to 25 °C, if necessary scratching the wall of the container with a glass rod to induce crystallisation. Filter and wash the precipitate with five quantities, each of 5 mL, of *water R*. In a small flask, heat the precipitate with 25 mL of *alcohol R* under a reflux condenser until dissolved (about 10 min). Cool to 25 °C, if necessary scratching the wall of the flask with a glass rod to induce crystallisation, and filter. The precipitate, washed with two quantities, each of 5 mL, of *water R* and dried at 100 °C to 105 °C for 30 min, melts (2.2.14) at 136 °C to 148 °C.

**Heavy metals** (2.4.8). Dissolve 1.0 g in *water R* and dilute to 10.0 mL with the same solvent. To 9 mL of the solution, add 3 mL of *dilute acetic acid R* and 3 mL of *buffer solution pH 3.5 R* and filter. Dilute the filtrate to 18 mL with *water R*. 12 mL of the solution complies with limit test A for heavy metals (20 ppm). In preparing the test solution, replace the buffer solution with *water R*. Prepare the standard using *lead standard solution (1 ppm Pb) R*.

**Loss on drying** (2.2.32). Not more than 3.0 per cent, determined on 1.00 g by drying in an oven at 105 °C.

#### ASSAY

Dissolve 0.200 g in 15 mL of a 127.5 g/L solution of *silver nitrate R* in *pyridine R*. Titrate with 0.1 M *ethanolic sodium hydroxide* until a pure blue colour is obtained, using 0.5 mL of *thymolphthalein solution R* as indicator. Carry out a blank titration.

1 mL of 0.1 M *ethanolic sodium hydroxide* is equivalent to 24.83 mg of C<sub>11</sub>H<sub>17</sub>N<sub>2</sub>NaO<sub>3</sub>.

#### STORAGE

Store in an airtight container.

## PENTOXIFYLLINE

### Pentoxifyllinum

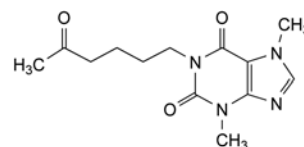

C<sub>13</sub>H<sub>18</sub>N<sub>4</sub>O<sub>3</sub>  
[6493-05-6]

M<sub>r</sub> 278.3

#### DEFINITION

3,7-Dimethyl-1-(5-oxohexyl)-3,7-dihydro-1H-purine-2,6-dione.

**Content:** 99.0 per cent to 101.0 per cent (dried substance).

#### CHARACTERS

**Appearance:** white or almost white, crystalline powder.

**Solubility:** soluble in water, freely soluble in methylene chloride, sparingly soluble in ethanol (96 per cent).

#### IDENTIFICATION

**First identification:** A, B.

**Second identification:** A, C, D.

A. Melting point (2.2.14): 103 °C to 107 °C.

B. Infrared absorption spectrophotometry (2.2.24).

**Comparison:** *pentoxifylline CRS*.

C. Thin-layer chromatography (2.2.27).

**Test solution.** Dissolve 20 mg of the substance to be examined in *methanol R* and dilute to 10 mL with the same solvent.

**Reference solution.** Dissolve 20 mg of *pentoxifylline CRS* in *methanol R* and dilute to 10 mL with the same solvent.

**Plate:** *TLC silica gel F<sub>254</sub>* plate R.

**Mobile phase:** *methanol R*, *ethyl acetate R* (15:85 V/V).

**Application:** 5 µL.

**Development:** over 2/3 of the plate.

**Drying:** in air.

**Detection:** examine in ultraviolet light at 254 nm.

**Results:** the principal spot in the chromatogram obtained with the test solution is similar in position and size to the principal spot in the chromatogram obtained with the reference solution.

D. It gives the reaction of xanthines (2.3.1).

#### TESTS

**Solution S.** Dissolve 2.5 g in *carbon dioxide-free water R* prepared from *distilled water R* and dilute to 50 mL with the same solvent.

**Appearance of solution.** A 40 per cent (V/V) solution of solution S is clear (2.2.1) and not more intensely coloured than reference solution Y<sub>7</sub> (2.2.2, *Method II*).

**Acidity.** To 8 mL of solution S add 12 mL of *carbon dioxide-free water R* and 0.05 mL of *bromothymol blue solution R1*. The solution is green or yellow. Not more than 0.2 mL of 0.01 M *sodium hydroxide* is required to change the colour of the indicator to blue.

**Related substances.** Liquid chromatography (2.2.29).

**Solvent mixture.** A mixture of equal volumes of a 5.44 g/L solution of *potassium dihydrogen phosphate R* and *methanol R*.

**Test solution.** Dissolve 50.0 mg of the substance to be examined in the solvent mixture and dilute to 25.0 mL with the solvent mixture.



**Reference solution (a).** Dilute 2.0 mL of the test solution to 100.0 mL with the solvent mixture. Dilute 5.0 mL of this solution to 100.0 mL with the solvent mixture.

**Reference solution (b).** Dilute 10.0 mL of reference solution (a) to 50.0 mL with the solvent mixture.

**Reference solution (c).** Dissolve 2 mg of *caffeine R* (impurity F) and 2 mg of *theophylline R* (impurity C) in the solvent mixture, add 1 mL of the test solution and dilute to 10 mL with the solvent mixture.

**Reference solution (d).** Dissolve 5.0 mg of *caffeine R* (impurity F), 5.0 mg of *theobromine R* (impurity A) and 5.0 mg of *theophylline R* (impurity C) in the solvent mixture and dilute to 100.0 mL with the solvent mixture. Dilute 1.0 mL to 25.0 mL with the solvent mixture.

**Column:**

- size:  $l = 0.25$  m,  $\varnothing = 4.0$  mm,
- stationary phase: base-deactivated octylsilyl silica gel for chromatography R (5  $\mu$ m),
- temperature: 30 °C.

**Mobile phase:**

- mobile phase A: mix 30 volumes of *methanol R* and 70 volumes of a 5.44 g/L solution of *potassium dihydrogen phosphate R*;
- mobile phase B: mix 30 volumes of a 5.44 g/L solution of *potassium dihydrogen phosphate R* and 70 volumes of *methanol R*;

Time (min)	Mobile phase A (per cent V/V)	Mobile phase B (per cent V/V)
0 - 6	85	15
6 - 13	85 → 10	15 → 90
13 - 30	10	90
30 - 35	10 → 85	90 → 15
35 - 45	85	15

**Flow rate:** 1 mL/min.

**Detection:** spectrophotometer at 272 nm.

**Injection:** 10  $\mu$ L.

**Relative retention** with reference to pentoxifylline (retention time = about 12 min): impurity A = about 0.3; impurity C = about 0.4; impurity F = about 0.5; impurity J = about 1.6.

**System suitability:** reference solution (c):

- retention time: impurity F = 4 min to 7 min; pentoxifylline = 9 min to 13 min; if necessary adapt the mixing ratio of the mobile phases;
- resolution: minimum 4 between the peaks due to impurity C and impurity F.

**Limits:**

- impurities A, C, F: for each impurity, not more than the area of the corresponding peak in the chromatogram obtained with reference solution (d) (0.1 per cent),
- impurity J: not more than the area of the principal peak in the chromatogram obtained with reference solution (a) (0.1 per cent),
- any other impurity: for each impurity, not more than the area of the principal peak in the chromatogram obtained with reference solution (a) (0.1 per cent),
- total: not more than 5 times the area of the principal peak in the chromatogram obtained with reference solution (a) (0.5 per cent),
- disregard limit: the area of the principal peak in the chromatogram obtained with reference solution (b) (0.02 per cent).

**Chlorides (2.4.4):** maximum 100 ppm.

Place 20 mL of solution S in a separating funnel and shake with 2 quantities, each of 20 mL, of *2-methylpropan-1-ol R*. Dilute 10 mL of the aqueous layer to 15 mL with *water R*.

**Sulfates (2.4.13):** maximum 200 ppm, determined on 15 mL of solution S.

**Heavy metals (2.4.8):** maximum 10 ppm.

2.0 g complies with limit test C. Prepare the reference solution using 2 mL of *lead standard solution (10 ppm Pb) R*.

**Loss on drying (2.2.32):** maximum 0.5 per cent, determined on 1.000 g by drying over *diphosphorus pentoxide R* at 60 °C at a pressure not exceeding 700 Pa.

**Sulfated ash (2.4.14):** maximum 0.1 per cent, determined on 1.0 g.

**ASSAY**

Dissolve 0.200 g in 5 mL of *anhydrous acetic acid R*. Add 20 mL of *acetic anhydride R*. Titrate with 0.1 M *perchloric acid* determining the end-point potentiometrically (2.2.20).

1 mL of 0.1 M *perchloric acid* is equivalent to 27.83 mg of  $C_{13}H_{18}N_4O_3$ .

**STORAGE**

Protected from light.

**IMPURITIES**

**Specified impurities:** A, C, F, J.

**Other detectable impurities** (the following substances would, if present at a sufficient level, be detected by one or other of the tests in the monograph. They are limited by the general acceptance criterion for other/unspecified impurities and/or by the general monograph *Substances for pharmaceutical use (2034)*. It is therefore not necessary to identify these impurities for demonstration of compliance. See also 5.10. *Control of impurities in substances for pharmaceutical use*): B, D, E, G, H, I, K.

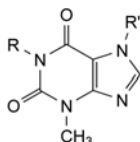

A. R = H, R' = CH<sub>3</sub>: theobromine,

B. R = R' = H: 3-methyl-3,7-dihydro-1H-purine-2,6-dione,

C. R = CH<sub>3</sub>, R' = H: theophylline,

D. R = CH<sub>2</sub>-CH<sub>2</sub>-CH<sub>2</sub>-OH, R' = CH<sub>3</sub>: 1-(3-hydroxypropyl)-3,7-dimethyl-3,7-dihydro-1H-purine-2,6-dione,

F. R = R' = CH<sub>3</sub>: caffeine,

H. R = R' = CH<sub>2</sub>-(CH<sub>2</sub>)<sub>3</sub>-CO-CH<sub>3</sub>: 3-methyl-1,7-bis(5-oxohexyl)-3,7-dihydro-1H-purine-2,6-dione,

I. R = CH<sub>2</sub>-C<sub>6</sub>H<sub>5</sub>, R' = CH<sub>3</sub>: 1-benzyl-3,7-dimethyl-3,7-dihydro-1H-purine-2,6-dione,

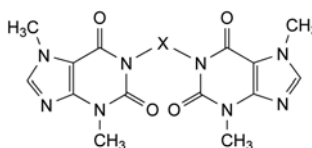

E. X = CH<sub>2</sub>: 1,1'-methylenebis(3,7-dimethyl-3,7-dihydro-1H-purine-2,6-dione),

K. X = CH<sub>2</sub>-CH<sub>2</sub>-CH<sub>2</sub>: 1,1'-(propane-1,3-diyl)bis(3,7-dimethyl-3,7-dihydro-1H-purine-2,6-dione),

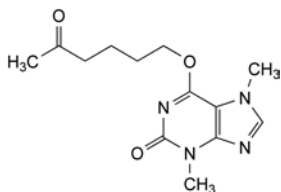

G. 3,7-dimethyl-6-(5-oxohexyloxy)-3,7-dihydro-2H-purin-2-one,

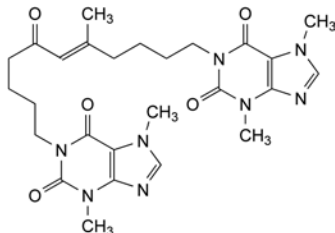

J. 1-[(5E)-11-(3,7-dimethyl-2,6-dioxo-2,3,6,7-tetrahydro-1H-purin-1-yl)-5-methyl-7-oxoundec-5-enyl]-3,7-dimethyl-3,7-dihydro-1H-purine-2,6-dione.

01/2008:1621

## PENTOXIFYVERINE HYDROGEN CITRATE

### Pentoxifyverini hydrogenocitras

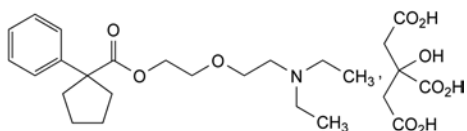

$C_{26}H_{39}NO_{10}$   
[23142-01-0]

$M_r$  525.6

#### DEFINITION

2-[2-(Diethylamino)ethoxy]ethyl 1-phenylcyclopentanecarboxylate dihydrogen 2-hydroxypropane-1,2,3-tricarboxylate.

*Content*: 98.5 per cent to 101.0 per cent (dried substance).

#### CHARACTERS

*Appearance*: white or almost white, crystalline powder.

*Solubility*: freely soluble in water, very soluble in glacial acetic acid, freely soluble in methanol, soluble in alcohol and in methylene chloride.

mp: about 93 °C.

#### IDENTIFICATION

A. Infrared absorption spectrophotometry (2.2.24).

*Comparison*: Ph. Eur. reference spectrum of pentoxifyverine hydrogen citrate.

B. Dissolve 0.25 g in 5 mL of *water R*. The solution gives the reaction of citrates (2.3.1).

#### TESTS

**Solution S**. Dissolve 5.0 g in *carbon dioxide-free water R* and dilute to 50 mL with the same solvent.

**Appearance of solution**. Solution S is clear (2.2.1) and not more intensely coloured than reference solution  $Y_6$  (2.2.2, *Method II*).

**pH** (2.2.3): 3.3 to 3.7 for solution S.

**Related substances**. Liquid chromatography (2.2.29).

*Test solution*. Dissolve 25.0 mg of the substance to be examined in the mobile phase and dilute to 25.0 mL with the mobile phase.

*Reference solution*. Introduce 5.0 mg of *pentoxifyverine impurity A CRS* and 5.0 mg of *pentoxifyverine impurity B CRS* in a conical flask, add 5.0 mL of the test solution and dilute to 100.0 mL with the mobile phase. Dilute 3.0 mL of the solution to 50.0 mL with the mobile phase.

#### Column:

- *size*:  $l = 0.15$  m,  $\emptyset = 3.9$  mm,
- *stationary phase*: end-capped octylsilyl silica gel for chromatography *R* (5  $\mu$ m) with a pore size of 10 nm and a carbon loading of 12 per cent,
- *temperature*: 50 °C.

*Mobile phase*: mix 35 volumes of *acetonitrile R* and 65 volumes of a 1.5 g/L solution of *sodium heptanesulfonate R* adjusted to pH 3.0 with *dilute sulfuric acid R*.

*Flow rate*: 1.0 mL/min.

*Detection*: spectrophotometer at 205 nm.

*Injection*: 20  $\mu$ L.

*Run time*: 3 times the retention time of pentoxifyverine.

*Relative retention* with reference to pentoxifyverine (retention time = about 6 min): impurity B = about 0.8; impurity A = about 1.5.

*System suitability*: reference solution:

- *resolution*: minimum of 5.0 between the peaks due to pentoxifyverine and to impurity A,
- *signal-to-noise ratio*: minimum of 100 for the peak due to pentoxifyverine,
- *symmetry factor*: maximum of 2.0 for the peak due to pentoxifyverine.

#### Limits:

- *impurity A*: not more than the area of the corresponding peak in the chromatogram obtained with the reference solution (0.3 per cent),
- *impurity B*: not more than the area of the corresponding peak in the chromatogram obtained with the reference solution (0.3 per cent),
- *any other impurity*: not more than one-third of the area of the peak due to pentoxifyverine in the chromatogram obtained with the reference solution (0.1 per cent),
- *total of any other impurity*: not more than the area of the peak due to pentoxifyverine in the chromatogram obtained with the reference solution (0.3 per cent),
- *disregard limit*: 0.1 times the area of the peak due to pentoxifyverine in the chromatogram obtained with the reference solution (0.03 per cent); disregard any peak with a retention time less than or equal to 2.5 min.

**Loss on drying** (2.2.32): maximum 0.5 per cent, determined on 1.000 g by drying *in vacuo* at 60 °C for 4 h.

**Sulfated ash** (2.4.14): maximum 0.1 per cent, determined on 1.0 g.

#### ASSAY

Dissolve 0.400 g in 70 mL of *anhydrous acetic acid R*. Titrate with 0.1 M *perchloric acid*, determining the end-point potentiometrically (2.2.20).

1 mL of 0.1 M *perchloric acid* is equivalent to 52.56 mg of  $C_{26}H_{39}NO_{10}$ .

#### STORAGE

Protected from light.

#### IMPURITIES

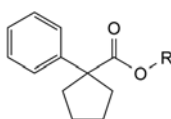

- A. R = H: 1-phenylcyclopentanecarboxylic acid,
- B. R =  $CH_2-CH_2-N(CH_2-CH_3)_2$ : 2-(diethylamino)ethyl 1-phenylcyclopentanecarboxylate (caramiphen).

## 01/2009:0682 TESTS

## PEPSIN POWDER

## Pepsini pulvis

[9001-75-6]

## DEFINITION

Powder prepared from the gastric mucosa of pigs, cattle or sheep. It contains gastric proteinases, active in acid medium (pH 1 to 5).

*Activity*: not less than 0.5 Ph. Eur. U./mg (dried substance).

## PRODUCTION

The animals from which pepsin powder is derived must fulfil the requirements for the health of animals suitable for human consumption.

## CHARACTERS

*Appearance*: white or slightly yellow, crystalline or amorphous powder, hygroscopic.

*Solubility*: soluble in water, practically insoluble in ethanol (96 per cent).

The solution in water may be slightly opalescent with a weak acidic reaction.

## IDENTIFICATION

In a mortar, pound 30 mg of *fibrin blue R*. Suspend in 20 mL of *dilute hydrochloric acid R2*. Filter the suspension on a filter paper and wash with *dilute hydrochloric acid R2* until a colourless filtrate is obtained. Perforate the filter paper and wash the *fibrin blue R* through it into a conical flask using 20 mL of *dilute hydrochloric acid R2*. Shake before use. Dissolve a quantity of the substance to be examined, equivalent to not less than 20 Ph. Eur. U., in 2 mL of *dilute hydrochloric acid R2* and adjust to pH 1.6 ± 0.1. Add 1 mL of this solution to a test-tube containing 4 mL of the fibrin blue suspension, mix and place in a water-bath at 25 °C with gentle shaking. Prepare a blank solution at the same time and in the same manner using 1 mL of *water R*. After 15 min of incubation the blank solution is colourless and the test solution is blue.

**Loss on drying** (2.2.32): maximum 5.0 per cent, determined on 0.500 g by drying at 60 °C over *diphosphorus pentoxide R* at a pressure not exceeding 670 Pa for 4 h.

**Microbial contamination**

TAMC: acceptance criterion 10<sup>4</sup> CFU/g (2.6.12).

TYMC: acceptance criterion 10<sup>2</sup> CFU/g (2.6.12).

Absence of *Escherichia coli* (2.6.13).

Absence of *Salmonella* (2.6.13).

## ASSAY

The activity of pepsin powder is determined by comparing the quantity of peptides, non-precipitable by *trichloroacetic acid solution R* and assayed using the *phosphomolybdotungstic reagent R*, which are released per minute from a substrate of *haemoglobin solution R*, with the quantity of such peptides released by *pepsin powder BRP* from the same substrate in the same conditions.

*For the test solution and the reference solution, prepare the solution and carry out the dilution at 0 °C to 4 °C.*

*Avoid shaking and foaming during preparation of the test and reference solutions.*

*Test solution.* Immediately before use, prepare a solution of the substance to be examined expected to contain 0.5 Ph. Eur. U./mL in *dilute hydrochloric acid R2*; before dilution to volume, adjust to pH 1.6 ± 0.1, if necessary, using *1 M hydrochloric acid*.

*Reference solution.* Less than 15 min before use, prepare a solution of *pepsin powder BRP* containing 0.5 Ph. Eur. U./mL in *dilute hydrochloric acid R2*; before dilution to volume, adjust to pH 1.6 ± 0.1, if necessary, using *1 M hydrochloric acid*.

Designate tubes in duplicate T, T<sub>b</sub>, S<sub>1</sub>, S<sub>1b</sub>, S<sub>2</sub>, S<sub>2b</sub>, S<sub>3</sub>, S<sub>3b</sub>; designate a tube B.

Add *dilute hydrochloric acid R2* to the tubes as follows:

B: 1.0 mL

S<sub>1</sub> and S<sub>1b</sub>: 0.5 mL

S<sub>2</sub>, S<sub>2b</sub> and T and T<sub>b</sub>: 0.25 mL

Add the reference solution to the tubes as follows:

S<sub>1</sub> and S<sub>1b</sub>: 0.5 mL

S<sub>2</sub> and S<sub>2b</sub>: 0.75 mL

S<sub>3</sub> and S<sub>3b</sub>: 1.0 mL

Add 0.75 mL of the test solution to tubes T and T<sub>b</sub>.

Table 0682-1

	Tubes								
	S <sub>1</sub>	S <sub>1b</sub>	S <sub>2</sub>	S <sub>2b</sub>	S <sub>3</sub>	S <sub>3b</sub>	T	T <sub>b</sub>	B
<i>Dilute hydrochloric acid R2</i> (mL)	0.5	0.5	0.25	0.25			0.25	0.25	1.0
Reference solution (mL)	0.5	0.5	0.75	0.75	1.0	1.0			
Test solution (mL)							0.75	0.75	
<i>Trichloroacetic acid solution R</i> (mL)		10.0		10.0		10.0		10.0	10.0
Mix		+		+		+		+	+
Water bath at 25 °C	+	+	+	+	+	+	+	+	+
<i>Haemoglobin solution R</i> (mL)		5.0		5.0		5.0		5.0	5.0
Mix		+		+		+		+	+
<i>Haemoglobin solution R</i> (mL)	5.0		5.0		5.0		5.0		
Mix	+		+		+		+		
Water bath at 25 °C, 10 min	+	+	+	+	+	+	+	+	+
<i>Trichloroacetic acid solution R</i> (mL)	10.0		10.0		10.0		10.0		
Mix	+		+		+		+		
Filter	+	+	+	+	+	+	+	+	+

Add 10.0 mL of *trichloroacetic acid solution R* to tubes S<sub>1b</sub>, S<sub>2b</sub>, S<sub>3b</sub>, T<sub>b</sub> and B. Mix by shaking.

Place the tubes and *haemoglobin solution R* in a water bath at 25 ± 0.1 °C. When temperature equilibrium is reached, add 5.0 mL of *haemoglobin solution R* to tubes B, S<sub>1b</sub>, S<sub>2b</sub>, S<sub>3b</sub> and T<sub>b</sub>. Mix.

At time zero add 5.0 mL of *haemoglobin solution R* successively and at intervals of 30 s to tubes S<sub>1</sub>, S<sub>2</sub>, S<sub>3</sub> and T.

Mix immediately after each addition.

Exactly 10 min after adding the *haemoglobin solution R*, stop the reaction by adding, at intervals of 30 s, 10.0 mL of *trichloroacetic acid solution R* to tubes S<sub>1</sub>, S<sub>2</sub>, S<sub>3</sub> and T (the use of a fast-flowing or blow-out pipette is recommended) and mix.

Filter the contents of each tube (samples and blanks) twice through the same suitable filter paper previously washed with a 50 g/L solution of *trichloroacetic acid R*, then with *water R* and dried. Discard the first 5 mL of filtrate. Place 3.0 mL of each filtrate separately in a tube containing 20 mL of *water R*. Mix.

A suitable filter paper complies with the following test: filter 5 mL of a 50 g/L solution of *trichloroacetic acid R* through a 7 cm disc of white filter paper: the absorbance (2.2.25) of the filtrate, measured at 275 nm using unfiltered *trichloroacetic acid R* solution as the compensation liquid, is less than 0.04.

Add to each tube 1.0 mL of *sodium hydroxide solution R* and 1.0 mL of *phosphomolybdotungstic reagent R*, beginning with the blanks and then the samples of each set, in a known order.

A schematic presentation of the above operations is shown in Table 0682-1.

After 15 min measure the absorbance (2.2.25) of solutions S<sub>1</sub>, S<sub>2</sub>, S<sub>3</sub>, S<sub>1b</sub>, S<sub>2b</sub>, S<sub>3b</sub> and T at 540 nm using the filtrate obtained from tube B as the compensation liquid. Correct the average absorbance values for the filtrates obtained from tubes S<sub>1</sub>, S<sub>2</sub> and S<sub>3</sub> by subtracting the average values obtained for the filtrates from tubes S<sub>1b</sub>, S<sub>2b</sub>, S<sub>3b</sub> respectively.

Draw a calibration curve of the corrected values against volume of reference solution used. Determine the activity of the substance to be examined using the corrected absorbance for the test solution (T – T<sub>b</sub>) together with the calibration curve and taking into account the dilution factors.

#### STORAGE

Store in an airtight container, protected from light, at a temperature of 2 °C to 8 °C.

#### LABELLING

The label states the activity in European Pharmacopoeia Units per milligram.

01/2008:1555  
corrected 6.0

## PERGOLIDE MESILATE

### Pergolidi mesilas

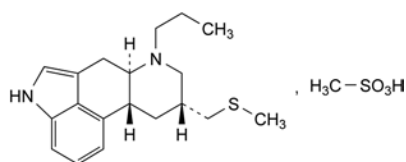

C<sub>26</sub>H<sub>30</sub>N<sub>2</sub>O<sub>2</sub>S<sub>2</sub>  
[66104-23-2]

M<sub>r</sub> 410.6

#### DEFINITION

(6a*R*,9*R*,10a*R*)-9-[(Methylsulfanyl)methyl]-7-propyl-4,6,6a,7,8,9,10,10a-octahydroindolo[4,3-*fg*]quinoline monomethanesulfonate.

*Content*: 97.5 per cent to 102.0 per cent (dried substance).

#### PRODUCTION

The production method must be evaluated to determine the potential for formation of alkyl mesilates, which is particularly likely to occur if the reaction medium contains lower alcohols. Where necessary, the production method is validated to demonstrate that alkyl mesilates are not detectable in the final product.

#### CHARACTERS

*Appearance*: white or almost white, crystalline powder.

*Solubility*: slightly soluble in water, sparingly soluble in methanol, slightly soluble in ethanol (96 per cent) and in methylene chloride, very slightly soluble in acetone.

#### IDENTIFICATION

A. Specific optical rotation (2.2.7): – 17 to – 23 (dried substance).

Dissolve 0.25 g in *dimethylformamide R* and dilute to 25.0 mL with the same solvent.

B. Infrared absorption spectrophotometry (2.2.24).

*Preparation*: discs.

*Comparison*: *pergolide mesilate CRS*.

#### TESTS

**Related substances.** Liquid chromatography (2.2.29).

*Test solution.* Dissolve 30.0 mg of the substance to be examined in *methanol R* and dilute to 10.0 mL with the same solvent.

*Reference solution (a).* Dilute 1.0 mL of the test solution to 100.0 mL with *methanol R*. Dilute 1.0 mL of this solution to 10.0 mL with *methanol R*.

*Reference solution (b).* Dissolve 10 mg of 4,4'-*dimethoxybenzophenone R* in *methanol R* and dilute to 10 mL with the same solvent. To 1 mL of the solution add 2 mL of the test solution and dilute to 100 mL with *methanol R*. Dilute 1 mL of this solution to 10 mL with *methanol R*.

*Column*:

- *size*:  $l = 0.25$  m,  $\varnothing = 4.6$  mm;
- *stationary phase*: *base-deactivated octadecylsilyl silica gel for chromatography R* (5 µm);
- *temperature*: 40 °C.

*Mobile phase*:

- *mobile phase A*: mix 5.0 mL of *morpholine for chromatography R* with 995 mL of *water R* and adjust to pH 7.0 with *phosphoric acid R*; use within 24 h;
- *mobile phase B*: *acetonitrile R*, *methanol R*, *tetrahydrofuran R* (1:1:1 V/V/V);

Time (min)	Mobile phase A (per cent V/V)	Mobile phase B (per cent V/V)
0 - 35	70 → 0	30 → 100
35 - 40	0 → 70	100 → 30
40 - 50	70	30

*Flow rate*: 1 mL/min.

*Detection*: spectrophotometer at 280 nm.

*Injection*: 20 µL.

*System suitability*: reference solution (b):

- *resolution*: minimum 2.0 between the peaks due to 4,4'-dimethoxybenzophenone (1<sup>st</sup> peak) and pergolide (2<sup>nd</sup> peak).

*Limits*:

- *impurity A*: not more than the area of the principal peak in the chromatogram obtained with reference solution (a) (0.1 per cent);
- *total*: not more than 5 times the area of the principal peak in the chromatogram obtained with reference solution (a) (0.5 per cent);

01/2008:2019

- *disregard limit*: 0.2 times the area of the principal peak in the chromatogram obtained with reference solution (a) (0.02 per cent).

**Loss on drying** (2.2.32): maximum 0.5 per cent, determined on 1.000 g by drying *in vacuo* at 105 °C for 1 h.

**Sulfated ash** (2.4.14): maximum 0.1 per cent, determined on 1.0 g.

#### ASSAY

Liquid chromatography (2.2.29).

**Solution A.** Dissolve 5.0 mg of *DL*-methionine *R* in 500 mL of 0.01 *M* hydrochloric acid. Add 500 mL of methanol *R* and mix.

**Test solution.** Dissolve 65.0 mg of the substance to be examined in solution A and dilute to 100.0 mL with solution A. Dilute 10.0 mL of this solution to 100.0 mL with solution A.

**Reference solution.** Dissolve 65.0 mg of *pergolide mesilate CRS* in solution A and dilute to 100.0 mL with solution A. Dilute 10.0 mL of this solution to 100.0 mL with solution A.

**Column:**

- *size*:  $l = 0.25$  m,  $\varnothing = 4.6$  mm;
- *stationary phase*: base-deactivated octylsilyl silica gel for chromatography *R* (5  $\mu$ m);
- *temperature*: 40 °C.

**Mobile phase:** mix 1 volume of acetonitrile *R*, 1 volume of methanol *R* and 2 volumes of a mixture prepared as follows: dissolve 2.0 g of sodium octanesulfonate *R* in water *R*, add 1.0 mL of anhydrous acetic acid *R* and dilute to 1000 mL with water *R*.

**Flow rate:** 1 mL/min.

**Detection:** spectrophotometer at 280 nm.

**Injection:** 20  $\mu$ L.

**Retention time:** pergolide = about 9 min.

**System suitability:** reference solution:

- *symmetry factor*: maximum 1.5 for the peak due to pergolide.

Calculate the percentage content of  $C_{20}H_{30}N_2O_3S_2$  from the declared content of *pergolide mesilate CRS*.

#### STORAGE

Protected from light.

#### IMPURITIES

**Specified impurities:** A.

**Other detectable impurities** (the following substances would, if present at a sufficient level, be detected by one or other of the tests in the monograph. They are limited by the general acceptance criterion for other/unspecified impurities and/or by the general monograph *Substances for pharmaceutical use* (2034). It is therefore not necessary to identify these impurities for demonstration of compliance. See also 5.10. *Control of impurities in substances for pharmaceutical use*): B.

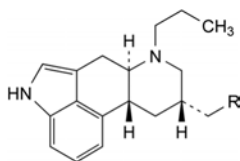

- A.  $R = SO-CH_3$ : (6*aR*,9*R*,10*aR*)-9-[(methylsulfinyl)methyl]-7-propyl-4,6,6*a*,7,8,9,10,10*a*-octahydroindolo[4,3-*fg*]quinoline (pergolide sulfoxide),
- B.  $R = SO_2-CH_3$ : (6*aR*,9*R*,10*aR*)-9-[(methylsulfonyl)methyl]-7-propyl-4,6,6*a*,7,8,9,10,10*a*-octahydroindolo[4,3-*fg*]quinoline (pergolide sulfone).

## PERINDOPRIL *tert*-BUTYLAMINE

### *tert*-Butylamini perindoprilum

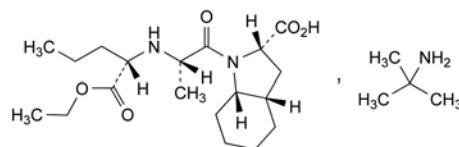

$C_{23}H_{43}N_3O_5$   
[107133-36-8]

$M_r$  441.6

#### DEFINITION

2-Methylpropan-2-amine (2*S*,3*aS*,7*aS*)-1-[(2*S*)-2-[(1*S*)-1-(ethoxycarbonyl)butyl]amino]propanoyl]octahydro-1*H*-indole-2-carboxylate.

**Content:** 99.0 per cent to 101.0 per cent (anhydrous substance).

#### CHARACTERS

**Appearance:** white or almost white, slightly hygroscopic, crystalline powder.

**Solubility:** freely soluble in water and in ethanol (96 per cent), soluble or sparingly soluble in methylene chloride.

It shows polymorphism (5.9).

#### IDENTIFICATION

- A. Specific optical rotation (2.2.7): –66 to –69 (anhydrous substance).

Dissolve 0.250 g in ethanol (96 per cent) *R* and dilute to 25.0 mL with the same solvent.

- B. Infrared absorption spectrophotometry (2.2.24).

**Comparison:** *perindopril tert-butylamine CRS*.

If the spectra obtained show differences, dissolve the substance to be examined and the reference substance separately in methylene chloride *R*, evaporate to dryness and record new spectra using the residues.

- C. Examine the chromatograms obtained in the test for impurity A.

**Results:** in the chromatogram obtained with the test solution a spot is observed with the same  $R_f$  as the spot with the higher  $R_f$  in the chromatogram obtained with reference solution (c) (*tert*-butylamine).

#### TESTS

**Impurity A.** Thin-layer chromatography (2.2.27).

**Test solution.** Dissolve 0.20 g of the substance to be examined in methanol *R* and dilute to 10.0 mL with the same solvent.

**Reference solution (a).** Dissolve 5 mg of *perindopril impurity A CRS* in methanol *R* and dilute to 25.0 mL with the same solvent.

**Reference solution (b).** Dilute 5.0 mL of reference solution (a) to 20.0 mL with methanol *R*.

**Reference solution (c).** To 5 mL of reference solution (a) add 5 mL of a 20 g/L solution of 1,1-dimethylethylamine *R* in methanol *R*.

**Plate:** TLC silica gel plate *R*.

**Mobile phase:** glacial acetic acid *R*, toluene *R*, methanol *R* (1:40:60 V/V/V).

**Application:** 10  $\mu$ L of the test solution and reference solutions (b) and (c).

**Development:** over 2/3 of the plate.

**Drying:** in a current of warm air.

**Detection:** expose to iodine vapour for at least 20 h.

**System suitability:** reference solution (c):

- the chromatogram shows 2 clearly separated spots.

**Limit:**

- *impurity A*: any spot due to impurity A is not more intense than the spot in the chromatogram obtained with reference solution (b) (0.25 per cent).

**Stereochemical purity.** Liquid chromatography (2.2.29).

**Test solution.** Dissolve 20 mg of the substance to be examined in ethanol (96 per cent) R and dilute to 10.0 mL with the same solvent.

**Reference solution (a).** Dilute 1.0 mL of the test solution to 100.0 mL with ethanol (96 per cent) R. Dilute 1.0 mL of this solution to 10.0 mL with the same solvent.

**Reference solution (b).** Dissolve 10 mg of perindopril for stereochemical purity CRS (containing impurity I) in ethanol (96 per cent) R and dilute to 5.0 mL with the same solvent.

**Column:**

- *size*:  $l = 0.25$  m,  $\emptyset = 4.6$  mm;
- *stationary phase*: spherical octadecylsilyl silica gel for chromatography R (5  $\mu$ m);
- *temperature*: 50 °C for the column and the tubing preceding the column (the method has been developed with a temperature of 50 °C for at least 30 cm of the tubing preceding the column).

**Mobile phase:** mix, in the following order, 21.7 volumes of acetonitrile R, 0.3 volumes of pentanol R, and 78 volumes of a 1.50 g/L solution of sodium heptanesulfonate R previously adjusted to pH 2.0 with a mixture of equal volumes of perchloric acid R and water R.

**Flow rate:** 0.8 mL/min.

**Detection:** spectrophotometer at 215 nm.

**Equilibration:** minimum 4 h.

**Injection:** 10  $\mu$ L.

**Identification of impurities:** use the chromatogram supplied with perindopril for stereochemical purity CRS and the chromatogram obtained with reference solution (b) to identify the peak due to impurity I.

**Run time:** 1.5 times the retention time of perindopril.

**Relative retention** with reference to perindopril (retention time = about 100 min): impurity I = about 0.9.

**System suitability:**

- the chromatogram obtained with reference solution (b) is similar to the chromatogram supplied with perindopril for stereochemical purity CRS;
- *signal-to-noise ratio*: minimum 3 for the principal peak in the chromatogram obtained with reference solution (a);
- *peak-to-valley ratio*: minimum 3, where  $H_p$  = height above the baseline of the peak due to impurity I and  $H_v$  = height above the baseline of the lowest point of the curve separating this peak from the peak due to perindopril in the chromatogram obtained with reference solution (b).

**Limits:**

- *impurity I*: not more than the area of the principal peak in the chromatogram obtained with reference solution (a) (0.1 per cent);
- *unspecified impurities*: for each impurity, not more than the area of the principal peak in the chromatogram obtained with reference solution (a) (0.10 per cent);
- *disregard limit*: disregard any peak with a relative retention with reference to perindopril of less than 0.6 or more than 1.4.

**Related substances.** Liquid chromatography (2.2.29). Prepare the solutions immediately before use or maintain them at a temperature below 10 °C.

**Test solution.** Dissolve 60 mg of the substance to be examined in mobile phase A and dilute to 20.0 mL with mobile phase A.

**Reference solution (a).** Dissolve 3 mg of perindopril for peak identification CRS (containing impurities B, E, F, H and K) in 1 mL of mobile phase A.

**Reference solution (b).** Dilute 1.0 mL of the test solution to 200.0 mL with mobile phase A.

**Reference solution (c).** Dilute 1.0 mL of reference solution (b) to 10.0 mL with mobile phase A.

**Column:**

- *size*:  $l = 0.15$  m,  $\emptyset = 4$  mm;
- *stationary phase*: spherical end-capped octylsilyl silica gel for chromatography R (5  $\mu$ m) with a pore size of 15 nm;
- *temperature*: 60 °C for the column and the tubing preceding the column.

**Mobile phase:**

- *mobile phase A*: water R adjusted to pH 2.5 with a mixture of equal volumes of perchloric acid R and water R;
- *mobile phase B*: 0.03 per cent V/V solution of perchloric acid R in acetonitrile R1;

Time (min)	Mobile phase A (per cent V/V)	Mobile phase B (per cent V/V)
0 - (5 - t)	95	5
(5 - t) - (60 - t)	95 → 40	5 → 60
(60 - t) - (65 - t)	40 → 95	60 → 5

The isocratic step is described for a chromatographic system with a dwell volume (*D*) of 2 mL. If *D* is different from 2 mL, correct the gradient times with the value *t*, calculated using the following expression:

$$\frac{D - 2}{\text{flow rate}}$$

**Flow rate:** 1.0 mL/min.

**Detection:** spectrophotometer at 215 nm.

**Injection:** 20  $\mu$ L.

**Identification of impurities:** use the chromatogram supplied with perindopril for peak identification CRS and the chromatogram obtained with reference solution (a) to identify the peaks due to impurities B, E, F, H and K.

**Relative retention** with reference to perindopril (retention time = about 25 min): impurity B = about 0.68; impurity K = about 0.72; impurity E = about 1.2; impurity F = about 1.6; impurity H = about 1.8 (impurity H may be eluted as 1 or 2 peaks).

**System suitability:** reference solution (a):

- *peak-to-valley ratio*: minimum 3, where  $H_p$  = height above the baseline of the peak due to impurity B and  $H_v$  = height above the baseline of the lowest point of the curve separating this peak from the peak due to impurity K.

**Limits:**

- *impurity E*: not more than 0.8 times the area of the principal peak in the chromatogram obtained with reference solution (b) (0.4 per cent);
- *impurity B*: not more than 0.6 times the area of the principal peak in the chromatogram obtained with reference solution (b) (0.3 per cent);
- *impurities F, H*: for each impurity, not more than 0.4 times the area of the principal peak in the chromatogram obtained with reference solution (b) (0.2 per cent);
- *unspecified impurities*: for each impurity, not more than 0.2 times the area of the principal peak in the chromatogram obtained with reference solution (b) (0.10 per cent);
- *total*: not more than twice the area of the principal peak in the chromatogram obtained with reference solution (b) (1.0 per cent);
- *disregard limit*: the area of the principal peak in the chromatogram obtained with reference solution (c) (0.05 per cent).

**Water (2.5.12):** maximum 1.0 per cent, determined on 0.50 g.

**Sulfated ash (2.4.14):** maximum 0.1 per cent, determined on 1.0 g.

## ASSAY

Dissolve 0.160 g in 50 mL of *anhydrous acetic acid R*. Titrate with 0.1 M *perchloric acid*, determining the end-point potentiometrically (2.2.20).

1 mL of 0.1 M *perchloric acid* is equivalent to 22.08 mg of  $C_{23}H_{43}N_3O_5$ .

## STORAGE

In an airtight container.

## IMPURITIES

*Specified impurities: A, B, E, F, H, I.*

*Other detectable impurities* (the following substances would, if present at a sufficient level, be detected by one or other of the tests in the monograph. They are limited by the general acceptance criterion for other/unspecified impurities and/or by the general monograph *Substances for pharmaceutical use* (2034). It is therefore not necessary to identify these impurities for demonstration of compliance. See also 5.10. *Control of impurities in substances for pharmaceutical use*): C, D, G, J, K, L, M, N, O, P, Q, R, S, T, U, V, W, X, Y, Z, AA, BB, CC.

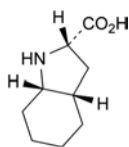

A. (2*S*,3*aS*,7*aS*)-octahydro-1*H*-indole-2-carboxylic acid,

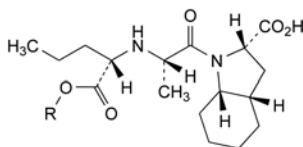

B. R = H: (2*S*,3*aS*,7*aS*)-1-[(2*S*)-2-[(1*S*)-1-carboxybutyl]amino]propanoyl]octahydro-1*H*-indole-2-carboxylic acid (perindoprilat),

E. R = CH(CH<sub>3</sub>)<sub>2</sub>: (2*S*,3*aS*,7*aS*)-1-[(2*S*)-2-[(1*S*)-1-(1-methylethoxy)carbonyl]butyl]amino]propanoyl]octahydro-1*H*-indole-2-carboxylic acid,

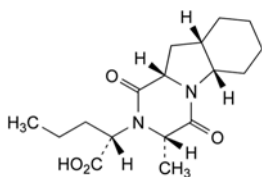

C. (2*S*)-2-[(3*S*,5*aS*,9*aS*,10*aS*)-3-methyl-1,4-dioxo-decahydropyrazino[1,2-*a*]indol-2(1*H*)-yl]pentanoic acid,

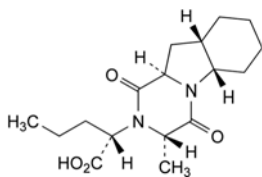

D. (2*S*)-2-[(3*S*,5*aS*,9*aS*,10*aR*)-3-methyl-1,4-dioxo-decahydropyrazino[1,2-*a*]indol-2(1*H*)-yl]pentanoic acid,

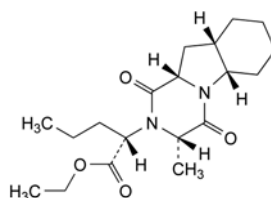

F. ethyl (2*S*)-2-[(3*S*,5*aS*,9*aS*,10*aS*)-3-methyl-1,4-dioxo-decahydropyrazino[1,2-*a*]indol-2(1*H*)-yl]pentanoate,

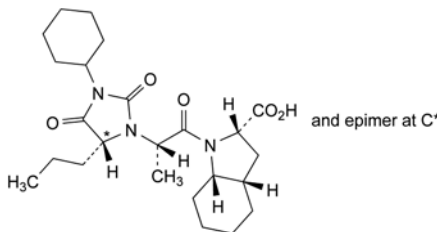

G. (2*S*,3*aS*,7*aS*)-1-[(2*S*)-2-[(5*R*)-3-cyclohexyl-2,4-dioxo-5-propylimidazolidin-1-yl]propanoyl]octahydro-1*H*-indole-2-carboxylic acid,

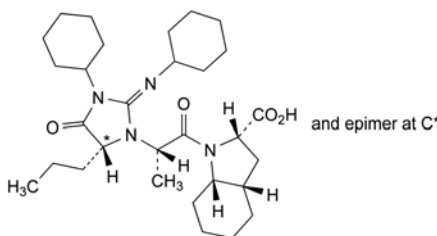

H. (2*S*,3*aS*,7*aS*)-1-[(2*S*)-2-[(5*R*)-3-cyclohexyl-2-(cyclohexylimino)-4-oxo-5-propylimidazolidin-1-yl]propanoyl]octahydro-1*H*-indole-2-carboxylic acid,

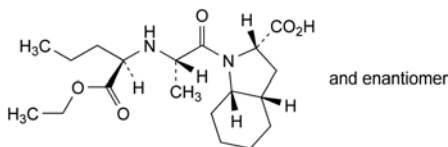

I. (2*RS*,3*aRS*,7*aRS*)-1-[(2*RS*)-2-[(1*SR*)-1-(ethoxycarbonyl)butyl]amino]propanoyl]octahydro-1*H*-indole-2-carboxylic acid ((±)-1''-*epi*-perindopril),

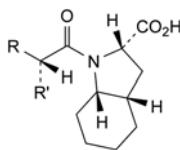

J. R = NH<sub>2</sub>, R' = CH<sub>3</sub>: (2*S*,3*aS*,7*aS*)-1-[(2*S*)-2-aminopropanoyl]octahydro-1*H*-indole-2-carboxylic acid,

L. R = R' = H: (2*S*,3*aS*,7*aS*)-1-acetyloctahydro-1*H*-indole-2-carboxylic acid,

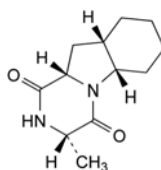

K. (3*S*,5*aS*,9*aS*,10*aS*)-3-methyldecahydropyrazino[1,2-*a*]indole-1,4-dione,

01/2011:0862

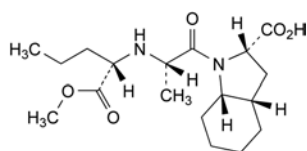

M. (2*S*,3*aS*,7*aS*)-1-[(2*S*)-2-[[[(1*S*)-1-(methoxycarbonyl)butyl]amino]propanoyl]octahydro-1*H*-indole-2-carboxylic acid,

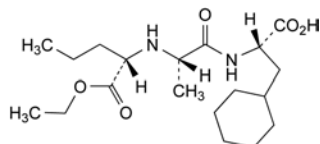

N. (2*S*)-3-cyclohexyl-2-[[[(2*S*)-2-[[[(1*S*)-1-(ethoxycarbonyl)butyl]amino]propanoyl]amino]propanoic acid,

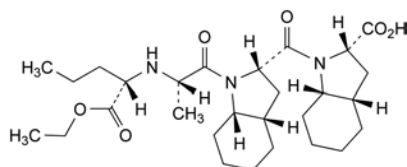

O. (2*S*,3*aS*,7*aS*)-1-[[[(2*S*,3*aS*,7*aS*)-1-[(2*S*)-2-[[[(1*S*)-1-(ethoxycarbonyl)butyl]amino]propanoyl]octahydro-1*H*-indol-2-yl]carbonyl]octahydro-1*H*-indole-2-carboxylic acid,

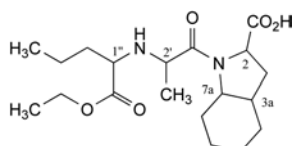

1-[2-[[1-(ethoxycarbonyl)butyl]amino]propanoyl]octahydro-1*H*-indole-2-carboxylic acid,

P. (2*RS*,3*aRS*,7*aRS*)-, (2'*SR*)-, (1''*RS*)-: (±)-2'-*epi*-perindopril,

Q. (2*RS*,3*aRS*,7*aSR*)-, (2'*RS*)-, (1''*RS*)-: (±)-7*a-epi*-perindopril,

R. (2*RS*,3*aSR*,7*aRS*)-, (2'*RS*)-, (1''*RS*)-: (±)-3*a-epi*-perindopril,

S. (2*SR*,3*aRS*,7*aRS*)-, (2'*RS*)-, (1''*RS*)-: (±)-2-*epi*-perindopril,

T. (2*RS*,3*aRS*,7*aRS*)-, (2'*SR*)-, (1''*SR*)-: (±)-1'',2'-*di-epi*-perindopril,

U. (2*RS*,3*aRS*,7*aSR*)-, (2'*RS*)-, (1''*SR*)-: (±)-1'',7*a-epi*-perindopril,

V. (2*SR*,3*aSR*,7*aRS*)-, (2'*RS*)-, (1''*RS*)-: (±)-2,3*a-di-epi*-perindopril,

W. (2*SR*,3*aRS*,7*aRS*)-, (2'*RS*)-, (1''*SR*)-: (±)-1'',2-*di-epi*-perindopril,

X. (2*SR*,3*aRS*,7*aSR*)-, (2'*RS*)-, (1''*RS*)-: (±)-2,7*a-di-epi*-perindopril,

Y. (2*SR*,3*aRS*,7*aRS*)-, (2'*SR*)-, (1''*RS*)-: (±)-2,2'-*di-epi*-perindopril,

Z. (2*RS*,3*aSR*,7*aRS*)-, (2'*RS*)-, (1''*SR*)-: (±)-1'',3*a-di-epi*-perindopril,

AA. (2*RS*,3*aSR*,7*aSR*)-, (2'*RS*)-, (1''*RS*)-: (±)-3*a*,7*a-di-epi*-perindopril,

BB. (2*RS*,3*aSR*,7*aRS*)-, (2'*SR*)-, (1''*RS*)-: (±)-2',3*a-di-epi*-perindopril,

CC. (2*RS*,3*aRS*,7*aRS*)-, (2'*SR*)-, (1''*RS*)-: (±)-2',7*a-di-epi*-perindopril.

## PERITONEAL DIALYSIS, SOLUTIONS FOR

### Soluciones ad peritonealem dialysim

#### DEFINITION

Preparations for intraperitoneal use containing electrolytes with a concentration close to the electrolytic composition of plasma. They contain glucose in varying concentrations or other suitable osmotic agents.

Solutions for peritoneal dialysis are supplied in:

- rigid or semi-rigid plastic containers;
- flexible plastic containers fitted with a special connecting device; these are generally filled to a volume below their nominal capacity and presented in closed protective envelopes;
- glass containers.

The containers and closures comply with the requirements for containers for preparations for parenteral administration (3.2).

Several formulations are used. The concentrations of the components per litre of solution are usually in the following range (see Table 862.-1):

Table 0862.-1.

	Concentration in mmol/L	Concentration in mEq/L
Sodium	125 - 150	125 - 150
Potassium	0 - 4.5	0 - 4.5
Calcium	0 - 2.5	0 - 5.0
Magnesium	0.25 - 1.5	0.50 - 3.0
Acetate and/or lactate and/or hydrogen carbonate	30 - 60	30 - 60
Chloride	90 - 120	90 - 120
Glucose	25 - 250	

When hydrogen carbonate is present, the solution of sodium hydrogen carbonate is supplied in a container or a separate compartment and is added to the electrolyte solution immediately before use.

Unless otherwise justified and authorised, antioxidants are not added to the solutions.

#### IDENTIFICATION

According to the stated composition, the solution to be examined gives the following identification reactions (2.3.1):

- potassium: reaction (b);
- calcium: reaction (a);
- sodium: reaction (b);
- chlorides: reaction (a);
- acetates: to 5 mL of the solution to be examined add 1 mL of *hydrochloric acid R* in a test-tube fitted with a stopper and a bent tube, heat and collect a few millilitres of distillate; carry out reaction (b) of acetates on the distillate;
- lactates, hydrogen carbonates: the identification is carried out together with the assay;
- magnesium: to 0.1 mL of *titan yellow solution R* add 10 mL of *water R*, 2 mL of the solution to be examined and 1 mL of 1 M *sodium hydroxide*; a pink colour is produced;
- glucose: to 5 mL of the solution to be examined, add 2 mL of *dilute sodium hydroxide solution R* and 0.05 mL of *copper sulfate solution R*; the solution is blue and clear; heat to boiling; an abundant red precipitate is formed.



## TESTS

**Appearance of solution.** The solution is clear (2.2.1) and not more intensely coloured than reference solution Y<sub>4</sub> (2.2.2, Method I).

**pH (2.2.3):** 5.0 to 6.5. If the solution contains hydrogen carbonate, the pH is 6.5 to 8.0.

**Hydroxymethylfurfural.** Carry out the test only if glucose is added to the preparation. To a volume of the solution to be examined containing the equivalent of 25 mg of glucose, add 5.0 mL of a 100 g/L solution of *p*-toluidine R in 2-propanol R containing 10 per cent V/V of *glacial acetic acid* R, then add 1.0 mL of a 5 g/L solution of *barbituric acid* R. The absorbance (2.2.25) determined at 550 nm after allowing the mixture to stand for 2-3 min is not greater than that of a standard prepared at the same time and in the same manner using a solution containing 10 µg of *hydroxymethylfurfural* R in the same volume as the solution to be examined (400 ppm expressed with reference to the glucose concentration). If the solution contains hydrogen carbonate, use as the standard a solution containing 20 µg of *hydroxymethylfurfural* R (800 ppm expressed with reference to the glucose concentration).

**Aluminium (2.4.17):** maximum 15 µg/L.

**Prescribed solution.** Take 400 mL of the solution to be examined, adjust to pH 6.0 using 0.1 M *hydrochloric acid* or 0.1 M *sodium hydroxide* and add 10 mL of *acetate buffer solution pH 6.0 R*.

**Reference solution.** Mix 3 mL of *aluminium standard solution (2 ppm Al) R*, 10 mL of *acetate buffer solution pH 6.0 R* and 9 mL of *water R*.

**Blank solution.** Mix 10 mL of *acetate buffer solution pH 6.0 R* and 10 mL of *water R*.

**Particulate contamination (2.9.19, Method I).** Use 50 mL of the solution to be examined.

**Extractable volume (2.9.17).** The solution complies with the test prescribed for parenteral infusions.

**Sterility (2.6.1).** The solution complies with the test for sterility.

**Bacterial endotoxins (2.6.14):** less than 0.25 IU/mL.

**Pyrogens (2.6.8).** Solutions for which a validated test for bacterial endotoxins cannot be carried out comply with the test for pyrogens. Inject per kilogram of the rabbit's mass 10 mL of the solution.

## ASSAY

**Sodium:** 97.5 per cent to 102.5 per cent of the content of sodium (Na) stated on the label.

Atomic emission spectrometry (2.2.22, Method I).

**Test solution.** If necessary, dilute the solution to be examined with *water R* to a concentration suitable for the instrument to be used.

**Reference solutions.** Prepare the reference solutions using *sodium standard solution (200 ppm Na) R*.

**Wavelength:** 589.0 nm or 589.6 nm (sodium emits as a doublet).

**Potassium:** 95.0 per cent to 105.0 per cent of the content of potassium (K) stated on the label.

Atomic absorption spectrometry (2.2.23, Method I).

**Test solution.** If necessary, dilute the solution to be examined with *water R* to a concentration suitable for the instrument to be used. To 100 mL of the solution add 10 mL of a 22 g/L solution of *sodium chloride R*.

**Reference solutions.** Prepare the reference solutions using *potassium standard solution (100 ppm K) R*. To 100 mL of each reference solution add 10 mL of a 22 g/L solution of *sodium chloride R*.

**Source:** potassium hollow-cathode lamp.

**Wavelength:** 766.5 nm.

**Atomisation device:** air-propane or air-acetylene flame.

**Calcium:** 95.0 per cent to 105.0 per cent of the content of calcium (Ca) stated on the label.

Atomic absorption spectrometry (2.2.23, Method I).

**Test solution.** If necessary, dilute the solution to be examined with *water R* to a concentration suitable for the instrument to be used.

**Reference solutions.** Prepare the reference solutions using *calcium standard solution (400 ppm Ca) R*.

**Source:** calcium hollow-cathode lamp.

**Wavelength:** 422.7 nm.

**Atomisation device:** air-propane or air-acetylene flame.

**Magnesium:** 95.0 per cent to 105.0 per cent of the content of magnesium (Mg) stated on the label.

Atomic absorption spectrometry (2.2.23, Method I).

**Test solution.** If necessary, dilute the solution to be examined with *water R* to a concentration suitable for the instrument to be used.

**Reference solutions.** Prepare the reference solutions using *magnesium standard solution (100 ppm Mg) R*.

**Source:** magnesium hollow-cathode lamp.

**Wavelength:** 285.2 nm.

**Atomisation device:** air-propane or air-acetylene flame.

**Total chloride:** 95.0 per cent to 105.0 per cent of the content of chloride (Cl) stated on the label.

Dilute to 50 mL with *water R* an accurately measured volume of the solution to be examined containing the equivalent of about 60 mg of chloride. Add 5 mL of *dilute nitric acid R*, 25.0 mL of 0.1 M *silver nitrate* and 2 mL of *dibutyl phthalate R*. Shake. Using 2 mL of *ferric ammonium sulfate solution R2* as indicator, titrate with 0.1 M *ammonium thiocyanate* until a reddish-yellow colour is obtained.

1 mL of 0.1 M *silver nitrate* is equivalent to 3.545 mg of Cl.

**Acetate:** 95.0 per cent to 105.0 per cent of the content of acetate stated on the label.

To a volume of the solution to be examined, corresponding to about 0.7 mmol of acetate, add 10.0 mL of 0.1 M *hydrochloric acid*. Carry out a potentiometric titration (2.2.20), using 0.1 M *sodium hydroxide*. Read the volume added between the 2 points of inflexion.

1 mL of 0.1 M *sodium hydroxide* is equivalent to 0.1 mmol of acetate.

**Lactate:** 95.0 per cent to 105.0 per cent of the content of lactate stated on the label.

To a volume of the solution to be examined, corresponding to about 0.7 mmol of lactate, add 10.0 mL of 0.1 M *hydrochloric acid*. Add 50 mL of *acetonitrile R*. Carry out a potentiometric titration (2.2.20), using 0.1 M *sodium hydroxide*. Read the volume added between the 2 points of inflexion.

1 mL of 0.1 M *sodium hydroxide* is equivalent to 0.1 mmol of lactate.

**Sodium hydrogen carbonate:** 95.0 per cent to 105.0 per cent of the content of sodium hydrogen carbonate stated on the label.

Titrate with 0.1 M *hydrochloric acid*, a volume of the solution to be examined corresponding to about 0.1 g of sodium hydrogen carbonate, determining the end-point potentiometrically (2.2.20).

1 mL of 0.1 M *hydrochloric acid* is equivalent to 8.40 mg of NaHCO<sub>3</sub>.

**Lactate and hydrogen carbonate:** 95.0 per cent to 105.0 per cent of the content of lactates and hydrogen carbonates stated on the label.

Liquid chromatography (2.2.29).

**Test solution.** The solution to be examined.

01/2009:0629

**Reference solution.** Dissolve in 100 mL of water for chromatography R quantities of lactates and hydrogen carbonates, accurately weighed, in order to obtain solutions having concentrations representing about 90 per cent, 100 per cent and 110 per cent of the concentrations stated on the label.

**Column:**

- size:  $l = 0.30$  m,  $\varnothing = 7.8$  mm;
- stationary phase: cation exchange resin R (9  $\mu$ m);
- temperature: 60 °C.

**Mobile phase:** 0.005 M sulfuric acid previously degassed with helium R.

**Flow rate:** 0.6 mL/min.

**Detection:** differential refractometer.

**Injection:** 20  $\mu$ L, twice.

**Order of elution:** lactates, hydrogen carbonates.

Determine the concentration of lactate and hydrogen carbonates in the test solution by interpolating the peak area for lactate and the peak height for hydrogen carbonate from the linear regression curve obtained with the reference solutions.

**Reducing sugars** (expressed as anhydrous glucose): 95.0 per cent to 105.0 per cent of the content of glucose stated on the label.

Transfer a volume of the solution to be examined containing the equivalent of 25 mg of glucose to a 250 mL conical flask with a ground-glass neck and add 25.0 mL of cupri-citric solution R. Add a few grains of pumice, fit a reflux condenser, heat so that boiling occurs within 2 min and boil for exactly 10 min. Cool and add 3 g of potassium iodide R dissolved in 3 mL of water R. Carefully add, in small amounts, 25 mL of a 25 per cent *m/m* solution of sulfuric acid R. Titrate with 0.1 M sodium thiosulfate using starch solution R, added towards the end of the titration, as indicator. Carry out a blank titration using 25.0 mL of water R.

Calculate the content of reducing sugars expressed as anhydrous glucose (C<sub>6</sub>H<sub>12</sub>O<sub>6</sub>), using Table 0862.-2.

Table 0862.-2.

Volume of 0.1 M sodium thiosulfate in mL	Anhydrous glucose in mg
8	19.8
9	22.4
10	25.0
11	27.6
12	30.3
13	33.0
14	35.7
15	38.5
16	41.3

#### STORAGE

At a temperature not below 4 °C.

#### LABELLING

The label states:

- the formula of the solution for peritoneal dialysis, expressed in grams per litre and in millimoles per litre;
- the calculated osmolarity, expressed in milliosmoles per litre;
- the nominal volume of the solution for peritoneal dialysis in the container;
- that the solution is free from bacterial endotoxins, or where applicable, that it is apyrogenic;
- the storage conditions;
- that the solution is not to be used for intravenous infusion;
- that any unused portion of solution is to be discarded.

## PERPHENAZINE

### Perphenazinum

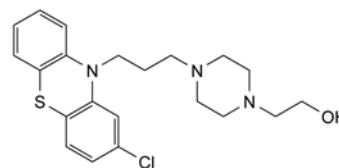

C<sub>21</sub>H<sub>26</sub>ClN<sub>3</sub>OS  
[58-39-9]

*M<sub>r</sub>* 404.0

#### DEFINITION

2-[4-[3-(2-Chloro-10H-phenothiazin-10-yl)propyl]piperazin-1-yl]ethanol.

**Content:** 99.0 per cent to 101.0 per cent (dried substance).

#### CHARACTERS

**Appearance:** white or yellowish-white, crystalline powder.

**Solubility:** practically insoluble in water, freely soluble in methylene chloride, soluble in ethanol (96 per cent). It dissolves in dilute solutions of hydrochloric acid.

#### IDENTIFICATION

A. Melting point (2.2.14): 96 °C to 100 °C.

B. Infrared absorption spectrophotometry (2.2.24).

**Comparison:** perphenazine CRS.

#### TESTS

**Appearance of solution.** The solution is clear (2.2.1).

Dissolve 0.20 g in 10 mL of methanol R.

**Related substances.** Liquid chromatography (2.2.29). Prepare the solutions immediately before use. Carry out the test protected from light.

**Test solution.** Dissolve 20 mg of the substance to be examined in mobile phase A and dilute to 10.0 mL with mobile phase A.

**Reference solution (a).** Dilute 1.0 mL of the test solution to 100.0 mL with mobile phase A. Dilute 1.0 mL of this solution to 10.0 mL with mobile phase A.

**Reference solution (b).** Dissolve 2 mg of perphenazine for system suitability CRS (containing impurities A and B) in 1.0 mL of mobile phase A.

**Column:**

- size:  $l = 0.25$  m,  $\varnothing = 4.6$  mm;
- stationary phase: spherical base-deactivated octylsilyl silica gel for chromatography R (4  $\mu$ m);
- temperature: 30 °C.

**Mobile phase:**

- mobile phase A: mix 35 volumes of acetonitrile R and 65 volumes of a 7 g/L solution of sodium dihydrogen phosphate R;
- mobile phase B: acetonitrile R;

Time (min)	Mobile phase A (per cent V/V)	Mobile phase B (per cent V/V)
0 - 5	100	0
5 - 10	100 → 80	0 → 20
10 - 33	80 → 30	20 → 70
33 - 48	30 → 100	70 → 0

**Flow rate:** 1.3 mL/min.

**Detection:** spectrophotometer at 245 nm.

**Injection:** 10  $\mu$ L.

01/2008:0420  
corrected 7.0

**Identification of impurities:** use the chromatogram supplied with *perphenazine for system suitability CRS* and the chromatogram obtained with reference solution (b) to identify the peaks due to impurities A and B.

**Relative retention** with reference to perphenazine (retention time = about 12 min): impurity A = about 0.3; impurity B = about 0.8.

**System suitability:** reference solution (b):

- **resolution:** minimum 4.0 between the peaks due to impurity B and perphenazine.

**Limits:**

- **correction factor:** for the calculation of content, multiply the peak area of impurity A by 0.6;
- **impurity A:** not more than twice the area of the principal peak in the chromatogram obtained with reference solution (a) (0.2 per cent);
- **impurity B:** not more than 5 times the area of the principal peak in the chromatogram obtained with reference solution (a) (0.5 per cent);
- **unspecified impurities:** for each impurity, not more than the area of the principal peak in the chromatogram obtained with reference solution (a) (0.10 per cent);
- **total:** not more than 10 times the area of the principal peak in the chromatogram obtained with reference solution (a) (1.0 per cent);
- **disregard limit:** 0.5 times the area of the principal peak in the chromatogram obtained with reference solution (a) (0.05 per cent).

**Loss on drying** (2.2.32): maximum 0.5 per cent, determined on 1.000 g by drying *in vacuo* at 65 °C for 4 h.

**Sulfated ash** (2.4.14): maximum 0.1 per cent, determined on 1.0 g.

#### ASSAY

Dissolve 0.150 g in 25 mL of *anhydrous acetic acid R*. Titrate with 0.1 M *perchloric acid* determining the end-point potentiometrically (2.2.20).

1 mL of 0.1 M *perchloric acid* is equivalent to 20.20 mg of  $C_{21}H_{26}ClN_3OS$ .

#### STORAGE

Protected from light.

#### IMPURITIES

**Specified impurities:** A, B.

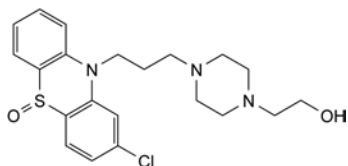

- A. 2-[4-[3-(2-chloro-5-oxido-10H-phenothiazin-10-yl)propyl]piperazin-1-yl]ethanol,

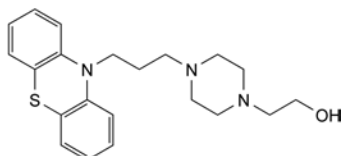

- B. 2-[4-[3-(10H-phenothiazin-10-yl)propyl]piperazin-1-yl]ethanol.

## PETHIDINE HYDROCHLORIDE

### Pethidini hydrochloridum

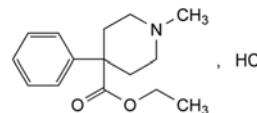

$C_{15}H_{22}ClNO_2$   
[50-13-5]

$M_r$  283.8

#### DEFINITION

Ethyl 1-methyl-4-phenylpiperidine-4-carboxylate hydrochloride.

**Content:** 99.0 per cent to 101.0 per cent (dried substance).

#### PRODUCTION

If intended for use in the manufacture of parenteral preparations, the manufacturing process is validated to show that the content of impurity B is not more than 0.1 ppm.

#### CHARACTERS

**Appearance:** white or almost white, crystalline powder.

**Solubility:** very soluble in water, freely soluble in alcohol.

#### IDENTIFICATION

**First identification:** B, D.

**Second identification:** A, C, D.

A. Melting point (2.2.14): 187 °C to 190 °C.

B. Infrared absorption spectrophotometry (2.2.24).

*Comparison:* Ph. Eur. reference spectrum of pethidine hydrochloride.

C. Dissolve 0.1 g in 10 mL of *ethanol R* and add 10 mL of *picric acid solution R*. A crystalline precipitate is formed which, when washed with *water R* and dried at 100-105 °C, melts (2.2.14) at 186 °C to 193 °C. Mix equal quantities of the precipitate and the substance to be examined and determine the melting point of the mixture. The melting point is at least 20 °C lower than that of the precipitate.

D. To 5 mL of solution S (see Tests) add 5 mL of *water R*. The solution gives reaction (a) of chlorides (2.3.1).

#### TESTS

**Solution S.** Dissolve 0.5 g in *carbon dioxide-free water R* and dilute to 25 mL with the same solvent.

**Appearance of solution.** Solution S is clear (2.2.1) and colourless (2.2.2, *Method II*).

**Acidity or alkalinity.** To 10 mL of solution S add 0.2 mL of *methyl red solution R* and 0.2 mL of 0.01 M *sodium hydroxide*. The solution is yellow. Add 0.3 mL of 0.01 M *hydrochloric acid*. The solution is red.

**Impurity B.** Liquid chromatography (2.2.29).

**Test solution (a).** Dissolve 0.100 g of the substance to be examined in a mixture of 20 volumes of *acetonitrile R* and 80 volumes of *water R* and dilute to 25.0 mL with the same mixture of solvents.

**Test solution (b).** Dissolve 0.125 g of the substance to be examined in a mixture of 20 volumes of *acetonitrile R* and 80 volumes of *water R* and dilute to 10.0 mL with the same mixture of solvents.

**Reference solution (a).** Dilute 0.5 mL of test solution (a) to 100.0 mL with a mixture of 20 volumes of *acetonitrile R* and 80 volumes of *water R*.

**Content:** 99.0 per cent to 101.0 per cent (dried substance).

#### CHARACTERS

**Appearance:** white or almost white, crystalline powder or colourless crystals.

**Solubility:** very soluble in water, in ethanol (96 per cent) and in methylene chloride.

#### IDENTIFICATION

**First identification:** A, B.

**Second identification:** A, C, D.

A. Melting point (2.2.14): 109 °C to 113 °C.

B. Infrared absorption spectrophotometry (2.2.24).

*Comparison:* phenazone CRS.

C. To 1 mL of solution S (see Tests) add 4 mL of water R and 0.25 mL of dilute sulfuric acid R. Add 1 mL of sodium nitrite solution R; a green colour develops.

D. To 1 mL of solution S add 4 mL of water R and 0.5 mL of ferric chloride solution R2. A red colour develops which is discharged on the addition of dilute sulfuric acid R.

#### TESTS

**Solution S.** Dissolve 2.5 g in carbon dioxide-free water R and dilute to 50 mL with the same solvent.

**Appearance of solution.** Solution S is clear (2.2.1) and colourless (2.2.2, Method II).

**Acidity or alkalinity.** To 10 mL of solution S add 0.1 mL of phenolphthalein solution R; the solution is colourless. Add 0.2 mL of 0.01 M sodium hydroxide; the solution is red. Add 0.25 mL of methyl red solution R and 0.4 mL of 0.01 M hydrochloric acid; the solution is red or yellowish-red.

**Related substances.** Liquid chromatography (2.2.29).

**Test solution.** Dissolve 50.0 mg of the substance to be examined in the mobile phase and dilute to 100.0 mL with the mobile phase.

**Reference solution (a).** Dilute 1.0 mL of the test solution to 100.0 mL with the mobile phase. Dilute 1.0 mL of this solution to 10.0 mL with the mobile phase.

**Reference solution (b).** Dissolve 5 mg of phenazone impurity A CRS in the mobile phase, add 10 mL of the test solution and dilute to 20.0 mL with the mobile phase. Dilute 1.0 mL of this solution to 50.0 mL with the mobile phase.

**Reference solution (c).** Dissolve 5.0 mg of phenazone impurity A CRS in the mobile phase and dilute to 20.0 mL with the mobile phase. Dilute 1.0 mL of this solution to 100.0 mL with the mobile phase. Dilute 1.0 mL of this solution to 10.0 mL with the mobile phase.

**Column:**

- size:  $l = 0.15$  m,  $\varnothing = 6.0$  mm;
- stationary phase: spherical octadecylsilyl silica gel for chromatography R (5  $\mu$ m).

**Mobile phase:** dissolve 6.8 g of potassium dihydrogen phosphate R in water R and dilute to 1000 mL with the same solvent. Add 2 mL of triethylamine R and adjust to pH 7.0 with sodium hydroxide solution R. Add 430 mL of methanol R.

**Flow rate:** 1.0 mL/min.

**Detection:** spectrophotometer at 254 nm.

**Injection:** 10  $\mu$ L.

**Run time:** 3 times the retention time of phenazone.

**Relative retention** with reference to phenazone (retention time = about 13 min): impurity A = about 0.8.

**System suitability:** reference solution (b):

- resolution: minimum 3.0 between the peaks due to impurity A and phenazone.

#### Limits:

- **impurity A:** not more than the area of the corresponding peak in the chromatogram obtained with reference solution (c) (0.05 per cent);
- **unspecified impurities:** for each impurity, not more than 0.5 times the area of the principal peak in the chromatogram obtained with reference solution (a) (0.05 per cent);
- **total:** not more than the area of the principal peak in the chromatogram obtained with reference solution (a) (0.1 per cent);
- **disregard limit:** 0.3 times the area of the principal peak in the chromatogram obtained with reference solution (a) (0.03 per cent).

**Chlorides** (2.4.4): maximum 100 ppm.

Dilute 10 mL of solution S to 15 mL with water R.

**Sulfates** (2.4.13): maximum 100 ppm.

Dissolve 1.5 g in distilled water R and dilute to 15 mL with the same solvent.

**Heavy metals** (2.4.8): maximum 20 ppm.

12 mL of solution S complies with test A. Prepare the reference solution using lead standard solution (1 ppm Pb) R.

**Loss on drying** (2.2.32): maximum 1.0 per cent, determined on 1.000 g by drying *in vacuo* at 60 °C for 6 h.

**Sulfated ash** (2.4.14): maximum 0.1 per cent, determined on 1.0 g.

#### ASSAY

Dissolve 0.150 g in 20 mL of water R. Add 2 g of sodium acetate R and 25.0 mL of 0.05 M iodine. Allow to stand protected from light for 30 min. Add 25 mL of methylene chloride R and shake until the precipitate dissolves. Titrate with 0.1 M sodium thiosulfate, using 1 mL of starch solution R, added towards the end of the titration, as indicator. Carry out a blank titration.

1 mL of 0.05 M iodine is equivalent to 9.41 mg of C<sub>11</sub>H<sub>12</sub>N<sub>2</sub>O.

#### STORAGE

Protected from light.

#### IMPURITIES

**Specified impurities:** A.

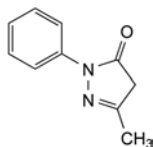

A. 5-methyl-2-phenyl-2,4-dihydro-3H-pyrazol-3-one.

01/2008:1357  
corrected 6.0

## PHENIRAMINE MALEATE

Pheniramini maleas

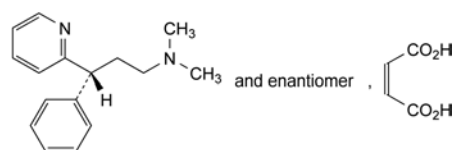

C<sub>20</sub>H<sub>24</sub>N<sub>2</sub>O<sub>4</sub>  
[132-20-7]

$M_r$  356.4

#### DEFINITION

(3*RS*)-*N,N*-Dimethyl-3-phenyl-3-(pyridin-2-yl)propan-1-amine (*Z*)-butenedioate.

**Content:** 98.0 per cent to 102.0 per cent (dried substance).

## CHARACTERS

**Appearance:** white or almost white, crystalline powder.

**Solubility:** very soluble in water, freely soluble in ethanol (96 per cent), in methanol and in methylene chloride.

## IDENTIFICATION

**First identification:** C, D.

**Second identification:** A, B, D.

A. Melting point (2.2.14): 106 °C to 109 °C.

B. Ultraviolet and visible absorption spectrophotometry (2.2.25).

**Test solution.** Dissolve 40.0 mg in 0.1 M hydrochloric acid and dilute to 100.0 mL with the same acid. Dilute 5.0 mL of this solution to 50.0 mL with 0.1 M hydrochloric acid.

**Spectral range:** 220-320 nm.

**Absorption maximum:** at 265 nm.

**Shoulder:** at 261 nm.

**Specific absorbance at the absorption maximum:** 200 to 220.

C. Infrared absorption spectrophotometry (2.2.24).

**Preparation:** discs.

**Comparison:** pheniramine maleate CRS.

D. Thin-layer chromatography (2.2.27).

**Test solution.** Dissolve 0.10 g of the substance to be examined in methanol R and dilute to 5.0 mL with the same solvent.

**Reference solution (a).** Dissolve 65 mg of maleic acid R in methanol R and dilute to 10 mL with the same solvent.

**Reference solution (b).** Dissolve 0.10 g of pheniramine maleate CRS in methanol R and dilute to 5.0 mL with the same solvent.

**Plate:** TLC silica gel  $F_{254}$  plate R.

**Mobile phase:** water R, anhydrous formic acid R, methanol R, di-isopropyl ether R (3:7:20:70 V/V/V/V).

**Application:** 5 µL.

**Development:** over a path of 12 cm.

**Detection:** examine in ultraviolet light at 254 nm.

**Results:** the chromatogram obtained with the test solution shows 2 clearly separated spots; the upper spot is similar in position and size to the spot in the chromatogram obtained with reference solution (a); the lower spot is similar in position and size to the spot in the chromatogram obtained with reference solution (b).

## TESTS

**Solution S.** Dissolve 2.0 g in water R and dilute to 20 mL with the same solvent.

**Appearance of solution.** Solution S is clear (2.2.1) and not more intensely coloured than reference solution BY<sub>6</sub> (2.2.2, Method II).

**pH** (2.2.3): 4.5 to 5.5.

Dissolve 0.20 g in 20.0 mL of carbon dioxide-free water R.

**Optical rotation** (2.2.7): -0.10° to +0.10°, determined on solution S.

**Related substances.** Liquid chromatography (2.2.29).

**Solvent mixture:** acetonitrile R, mobile phase A (1:9 V/V).

**Test solution.** Dissolve 20.0 mg of the substance to be examined in the solvent mixture and dilute to 20.0 mL with the solvent mixture.

**Reference solution (a).** Dissolve 10.0 mg of 2-benzylpyridine R (impurity A) in 10.0 mL of the test solution and dilute to 100.0 mL with the solvent mixture.

**Reference solution (b).** Dilute 2.0 mL of the test solution to 100.0 mL with the solvent mixture. Dilute 1.0 mL of this solution to 10.0 mL with the solvent mixture.

**Column:**

– size:  $l = 0.30$  m,  $\varnothing = 3.9$  mm;

– stationary phase: dimethyloctadecylsilyl silica gel for chromatography R (10 µm).

**Mobile phase:**

– mobile phase A: 5.056 g/L solution of sodium heptanesulfonate R adjusted to pH 2.5 with phosphoric acid R;

– mobile phase B: acetonitrile R;

Time (min)	Mobile phase A (per cent V/V)	Mobile phase B (per cent V/V)
0 - 35	90 → 62	10 → 38
35 - 37	62 → 90	38 → 10

**Flow rate:** 1 mL/min.

**Detection:** spectrophotometer at 264 nm.

**Injection:** 20 µL.

**System suitability:** reference solution (a):

- the chromatogram obtained shows 3 principal peaks: maleic acid, impurity A and pheniramine, in order of elution;
- resolution: minimum 8 between the peaks due to impurity A and pheniramine.

**Limits:**

- impurities A, B, C, D: for each impurity, not more than the area of the principal peak in the chromatogram obtained with reference solution (b) (0.2 per cent);
- total: not more than 5 times the area of the principal peak in the chromatogram obtained with reference solution (b) (1 per cent);
- disregard limit: 0.5 times the area of the principal peak in the chromatogram obtained with reference solution (b) (0.1 per cent); disregard the peak due to maleic acid.

**Heavy metals** (2.4.8): maximum 20 ppm.

1.0 g complies with test C. Prepare the reference solution using 2 mL of lead standard solution (10 ppm Pb) R.

**Loss on drying** (2.2.32): maximum 0.5 per cent, determined on 1.000 g by drying *in vacuo* in an oven at 60 °C for 3 h.

**Sulfated ash** (2.4.14): maximum 0.1 per cent, determined on 1.0 g.

## ASSAY

Dissolve 0.260 g in 50 mL of anhydrous acetic acid R. Titrate with 0.1 M perchloric acid, determining the end-point potentiometrically (2.2.20).

1 mL of 0.1 M perchloric acid is equivalent to 17.82 mg of C<sub>20</sub>H<sub>24</sub>N<sub>2</sub>O<sub>4</sub>.

## STORAGE

Protected from light.

## IMPURITIES

**Specified impurities:** A, B, C, D.

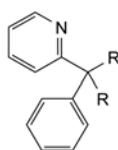

A. R = H: 2-benzylpyridine,

D. R = CH<sub>2</sub>-CH<sub>2</sub>-N(CH<sub>3</sub>)<sub>2</sub>: N,N,N',N'-tetramethyl-3-phenyl-3-(pyridin-2-yl)pentane-1,5-diamine,

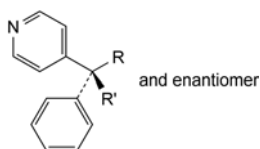

- B. R = R' = H: 4-benzylpyridine,  
 C. R = CH<sub>2</sub>-CH<sub>2</sub>-N(CH<sub>3</sub>)<sub>2</sub>, R' = H: (3*RS*)-*N,N*-dimethyl-3-phenyl-3-(pyridin-4-yl)propan-1-amine.

01/2008:0201  
corrected 6.0

## PHENOBARBITAL

### Phenobarbitalum

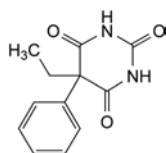

C<sub>12</sub>H<sub>12</sub>N<sub>2</sub>O<sub>3</sub>  
[50-06-6]

*M<sub>r</sub>* 232.2

#### DEFINITION

Phenobarbital contains not less than 99.0 per cent and not more than the equivalent of 101.0 per cent of 5-ethyl-5-phenylpyrimidine-2,4,6(1*H*,3*H*,5*H*)-trione, calculated with reference to the dried substance.

#### CHARACTERS

A white or almost white, crystalline powder or colourless crystals, very slightly soluble in water, freely soluble in alcohol. It forms water-soluble compounds with alkali hydroxides and carbonates and with ammonia.

#### IDENTIFICATION

*First identification:* A, B.

*Second identification:* A, C, D.

- A. Determine the melting point (2.2.14) of the substance to be examined. Mix equal parts of the substance to be examined and *phenobarbital CRS* and determine the melting point of the mixture. The difference between the melting points (which are about 176 °C) is not greater than 2 °C.
- B. Examine by infrared absorption spectrophotometry (2.2.24), comparing with the spectrum obtained with *phenobarbital CRS*.
- C. Examine by thin-layer chromatography (2.2.27), using *silica gel GF<sub>254</sub> R* as the coating substance.  
*Test solution.* Dissolve 0.1 g of the substance to be examined in *alcohol R* and dilute to 100 mL with the same solvent.  
*Reference solution.* Dissolve 0.1 g of *phenobarbital CRS* in *alcohol R* and dilute to 100 mL with the same solvent.  
 Apply separately to the plate 10 µL of each solution. Develop over a path of 18 cm using the lower layer of a mixture of 5 volumes of *concentrated ammonia R*, 15 volumes of *alcohol R* and 80 volumes of *chloroform R*. Examine immediately in ultraviolet light at 254 nm. The principal spot in the chromatogram obtained with the test solution is similar in position and size to the principal spot in the chromatogram obtained with the reference solution.
- D. It gives the reaction of non-nitrogen substituted barbiturates (2.3.1).

#### TESTS

**Appearance of solution.** Dissolve 1.0 g in a mixture of 4 mL of *dilute sodium hydroxide solution R* and 6 mL of *water R*. The solution is clear (2.2.1) and not more intensely coloured than reference solution Y<sub>6</sub> (2.2.2, *Method II*).

**Acidity.** Boil 1.0 g with 50 mL of *water R* for 2 min, allow to cool and filter. To 10 mL of the filtrate add 0.15 mL of *methyl red solution R*. The solution is orange-yellow. Not more than 0.1 mL of 0.1 *M sodium hydroxide* is required to produce a pure yellow colour.

**Related substances.** Examine by thin-layer chromatography (2.2.27), using *silica gel GF<sub>254</sub> R* as the coating substance.

*Test solution.* Dissolve 1.0 g of the substance to be examined in *alcohol R* and dilute to 100 mL with the same solvent.

*Reference solution.* Dilute 0.5 mL of the test solution to 100 mL with *alcohol R*.

Apply separately to the plate 20 µL of each solution. Develop over a path of 15 cm using the lower layer of a mixture of 5 volumes of *concentrated ammonia R*, 15 volumes of *alcohol R* and 80 volumes of *chloroform R*. Examine immediately in ultraviolet light at 254 nm. Spray with *diphenylcarbazone mercuric reagent R*. Allow the plate to dry in air and spray with freshly prepared *alcoholic potassium hydroxide solution R* diluted 1 in 5 with *aldehyde-free alcohol R*. Heat at 100 °C to 105 °C for 5 min and examine immediately. When examined in ultraviolet light and after spraying, any spot in the chromatogram obtained with the test solution, apart from the principal spot, is not more intense than the spot in the chromatogram obtained with the reference solution (0.5 per cent).

**Loss on drying** (2.2.32). Not more than 0.5 per cent, determined on 1.00 g by drying in an oven at 105 °C.

**Sulfated ash** (2.4.14). Not more than 0.1 per cent, determined on 1.0 g.

#### ASSAY

Dissolve 0.100 g in 5 mL of *pyridine R*. Add 0.5 mL of *thymolphthalein solution R* and 10 mL of *silver nitrate solution in pyridine R*. Titrate with 0.1 *M ethanolic sodium hydroxide* until a pure blue colour is obtained. Carry out a blank titration. 1 mL of 0.1 *M ethanolic sodium hydroxide* is equivalent to 11.61 mg of C<sub>12</sub>H<sub>12</sub>N<sub>2</sub>O<sub>3</sub>.

01/2008:0630  
corrected 6.0

## PHENOBARBITAL SODIUM

### Phenobarbitalum natriicum

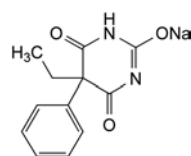

C<sub>12</sub>H<sub>11</sub>N<sub>2</sub>NaO<sub>3</sub>  
[57-30-7]

*M<sub>r</sub>* 254.2

#### DEFINITION

Phenobarbital sodium contains not less than 99.0 per cent and not more than the equivalent of 101.0 per cent of the sodium derivative of 5-ethyl-5-phenylpyrimidine-2,4,6(1*H*,3*H*,5*H*)-trione, calculated with reference to the dried substance.

#### CHARACTERS

A white or almost white, crystalline powder, hygroscopic, freely soluble in carbon dioxide-free water (a small fraction may be insoluble), soluble in alcohol, practically insoluble in methylene chloride.

#### IDENTIFICATION

*First identification:* A, B, E.

*Second identification:* A, C, D, E.

- A. Acidify 10 mL of solution S (see Tests) with *dilute hydrochloric acid R* and shake with 20 mL of *ether R*. Separate the ether layer, wash with 10 mL of *water R*, dry over *anhydrous sodium sulfate R* and filter. Evaporate the filtrate to dryness and dry the residue at 100 °C to 105 °C. Determine the melting point (2.2.14) of the test residue. Mix equal parts of the residue and of *phenobarbital CRS* and determine the melting point of the mixture. The difference between the two melting points (which are about 176 °C) is not greater than 2 °C.
- B. Examine by infrared absorption spectrophotometry (2.2.24), comparing the residue obtained during identification test A with the spectrum obtained with *phenobarbital CRS*. If the spectra obtained in the solid state show differences, dissolve the test residue and the reference substance separately in *ethanol R*, evaporate to dryness and record the spectra again.
- C. Examine by thin-layer chromatography (2.2.27), using *silica gel GF<sub>254</sub> R* as the coating substance.
- Test solution.* Dissolve 0.10 g of the substance to be examined in *alcohol (50 per cent V/V) R* and dilute to 100 mL with the same solvent.
- Reference solution.* Dissolve 90 mg of *phenobarbital CRS* in *alcohol (50 per cent V/V) R* and dilute to 100 mL with the same solvent.
- Apply separately to the plate 10 µL of each solution. Develop over a path of 18 cm using the lower layer from a mixture of 5 volumes of *concentrated ammonia R*, 15 volumes of *alcohol R* and 80 volumes of *chloroform R*. Examine immediately in ultraviolet light at 254 nm. The principal spot in the chromatogram obtained with the test solution is similar in position and size to the principal spot in the chromatogram obtained with the reference solution.
- D. It gives the reaction of non-nitrogen substituted barbiturates (2.3.1).
- E. It gives reaction (a) of sodium (2.3.1).

## TESTS

**Solution S.** Dissolve 5.0 g in *alcohol (50 per cent V/V) R* and dilute to 50 mL with the same solvent.

**Appearance of solution.** Solution S is clear (2.2.1) and not more intensely coloured than reference solution Y<sub>7</sub> (2.2.2, Method II).

**pH (2.2.3).** Dissolve 5.0 g as completely as possible in *carbon dioxide-free water R* and dilute to 50 mL with the same solvent. The pH of the solution is not greater than 10.2.

**Related substances.** Examine by thin-layer chromatography (2.2.27), using *silica gel GF<sub>254</sub> R* as the coating substance.

*Test solution.* Dissolve 1.0 g of the substance to be examined in *alcohol (50 per cent V/V) R* and dilute to 100 mL with the same solvent.

*Reference solution.* Dilute 0.5 mL of the test solution to 100 mL with *alcohol (50 per cent V/V) R*.

Apply separately to the plate 20 µL of each solution. Develop over a path of 15 cm using the lower layer from a mixture of 5 volumes of *concentrated ammonia R*, 15 volumes of *alcohol R* and 80 volumes of *chloroform R*. Examine immediately in ultraviolet light at 254 nm. Spray with *diphenylcarbazone mercuric reagent R*. Allow the plate to dry in air and spray with freshly prepared *alcoholic potassium hydroxide solution R* diluted 1 in 5 with *aldehyde-free alcohol R*. Heat at 100 °C to 105 °C for 5 min and examine immediately. When examined in ultraviolet light and after spraying, any spot in the chromatogram obtained with the test solution, apart from the principal spot, is not more intense than the spot in the chromatogram obtained with the reference solution (0.5 per cent). Disregard any spot at the point of application.

**Loss on drying (2.2.32).** Not more than 7.0 per cent, determined on 0.500 g by drying in an oven at 150 °C for 4 h.

## ASSAY

Dissolve 0.150 g in 2 mL of *water R* and add 8 mL of 0.05 M *sulfuric acid*. Heat to boiling and cool. Add 30 mL of *methanol R* and shake until dissolution is complete. Carry out a potentiometric titration (2.2.20), using 0.1 M *sodium hydroxide*. After the first point of inflexion, interrupt the addition of sodium hydroxide, add 10 mL of *pyridine R*, mix and continue the titration. Read the volume added between the two points of inflexion.

1 mL of 0.1 M *sodium hydroxide* is equivalent to 25.42 mg of C<sub>12</sub>H<sub>11</sub>N<sub>2</sub>NaO<sub>3</sub>.

## STORAGE

Store in an airtight container.

01/2008:0631  
corrected 6.3

## PHENOL

## Phenolium

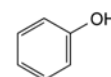

C<sub>6</sub>H<sub>6</sub>O  
[108-95-2]

M<sub>r</sub> 94.1

## DEFINITION

*Content:* 99.0 per cent to 100.5 per cent.

## CHARACTERS

*Appearance:* colourless or faintly pink or faintly yellowish, crystals or crystalline masses, deliquescent.

*Solubility:* soluble in water, very soluble in ethanol (96 per cent), in glycerol and in methylene chloride.

## IDENTIFICATION

A. Dissolve 0.5 g in 2 mL of *concentrated ammonia R*. The substance dissolves completely. Dilute to about 100 mL with *water R*. To 2 mL of this solution add 0.05 mL of *strong sodium hypochlorite solution R*. A blue colour develops and becomes progressively more intense.

B. To 1 mL of solution S (see Tests) add 10 mL of *water R* and 0.1 mL of *ferric chloride solution R1*. A violet colour is produced which disappears on addition of 5 mL of *2-propanol R*.

C. To 1 mL of solution S add 10 mL of *water R* and 1 mL of *bromine water R*. A white precipitate is formed.

## TESTS

**Solution S.** Dissolve 1.0 g in *water R* and dilute to 15 mL with the same solvent.

**Appearance of solution.** Solution S is clear (2.2.1) and not more intensely coloured than reference solution B<sub>6</sub> (2.2.2, Method II).

**Acidity.** To 2 mL of solution S add 0.05 mL of *methyl orange solution R*. The solution is yellow.

**Freezing point (2.2.18):** minimum 39.5 °C.

**Residue on evaporation:** maximum 0.05 per cent.

Evaporate 5.000 g to dryness on a water-bath and dry at 100-105 °C for 1 h. The residue weighs a maximum of 2.5 mg.

## ASSAY

Dissolve 2.000 g in *water R* and dilute to 1000.0 mL with the same solvent. Transfer 25.0 mL of the solution to a ground-glass-stoppered flask and add 50.0 mL of 0.0167 M *bromide-bromate* and 5 mL of *hydrochloric acid R*, close the flask, allow to stand with occasional swirling for 30 min. Then allow to stand for 15 min. Add 5 mL of a 200 g/L solution of *potassium iodide R*, shake and titrate with 0.1 M *sodium*

*thiosulfate* until a faint yellow colour remains. Add 0.5 mL of *starch solution R* and 10 mL of *chloroform R* and continue the titration with vigorous shaking. Carry out a blank titration.

1 mL of 0.0167 M *bromide-bromate* is equivalent to 1.569 mg of  $C_{20}H_{14}O_4$ .

#### STORAGE

In an airtight container, protected from light.

01/2008:1584  
corrected 6.0

## PHENOLPHTHALEIN

### Phenolphthaleinum

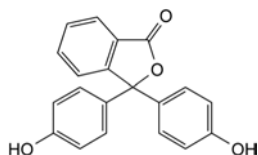

$C_{20}H_{14}O_4$   
[77-09-8]

$M_r$  318.3

#### DEFINITION

Phenolphthalein contains not less than 98.0 per cent and not more than the equivalent of 101.0 per cent of 3,3-bis(4-hydroxyphenyl)isobenzofuran-1(3H)-one, calculated with reference to the dried substance.

#### CHARACTERS

A white or almost white powder, practically insoluble in water, soluble in alcohol.

It melts at about 260 °C.

#### IDENTIFICATION

- A. Dissolve 25.0 mg in *alcohol R* and dilute to 100.0 mL with the same solvent (solution A). To 2.0 mL of solution A add 5.0 mL of 1 M *hydrochloric acid* and dilute to 50.0 mL with *alcohol R* (solution A<sub>1</sub>). To 10.0 mL of solution A add 5.0 mL of 1 M *hydrochloric acid* and dilute to 50.0 mL with *alcohol R* (solution A<sub>2</sub>). To 2.0 mL of solution A add 5.0 mL of 1 M *sodium hydroxide* and dilute to 50.0 mL with *alcohol R* (solution B). Examined between 220 nm and 250 nm (2.2.25), solution A<sub>1</sub> shows an absorption maximum at 229 nm. The specific absorbance at the maximum at 229 nm is 922 to 1018. Examined between 250 nm and 300 nm, solution A<sub>2</sub> shows an absorption maximum at 276 nm. The specific absorbance at the maximum at 276 nm is 142 to 158. Examined between 230 nm and 270 nm, solution B shows an absorption maximum at 249 nm. The specific absorbance at the maximum at 249 nm is 744 to 822.
- B. Dissolve about 10 mg in *alcohol R*. Add 1 mL of *dilute sodium hydroxide solution R*. The solution is red. Add 5 mL of *dilute sulfuric acid R*. The colour disappears.

#### TESTS

**Solution S.** To 2.0 g add 40 mL of *distilled water R* and heat to boiling. Cool and filter.

**Appearance of solution.** Dissolve 0.20 g in 5 mL of *alcohol R*. The solution is clear (2.2.1) and not more intensely coloured than reference solution Y<sub>7</sub> (2.2.2, *Method II*).

**Acidity or alkalinity.** To 10 mL of solution S add 0.15 mL of *bromothymol blue solution R1*. Add 0.05 mL of 0.01 M *hydrochloric acid*, the solution is yellow. Add 0.10 mL of 0.01 M *sodium hydroxide*, the solution is blue.

**Related substances.** Examine by thin-layer chromatography (2.2.27), using a *TLC silica gel F<sub>254</sub> plate R*.

**Test solution.** Dissolve 0.5 g of the substance to be examined in *alcohol R* and dilute to 10 mL with the same solvent.

**Reference solution (a).** Dilute 1 mL of the test solution to 10 mL with *alcohol R*. Dilute 5 mL of this solution to 100 mL with *alcohol R*.

**Reference solution (b).** Dissolve 25 mg of *fluorene R* in *alcohol R*, add 0.5 mL of the test solution and dilute to 10 mL with *alcohol R*.

Apply to the plate 5 µL of the test solution and 5 µL of each of the reference solutions. Develop over a path corresponding to two-thirds of the plate height using a mixture of 50 volumes of *acetone R* and 50 volumes of *methylene chloride R*. Allow the plate to dry in air. Examine in ultraviolet light at 254 nm and re-examine after exposure to ammonia vapour. Any spot in the chromatogram obtained with the test solution, apart from the principal spot, is not more intense than the spot in the chromatogram obtained with reference solution (a) (0.5 per cent). The test is not valid unless the chromatogram obtained with reference solution (b) shows 2 clearly separated spots.

**Chlorides** (2.4.4). Dilute 10 mL of solution S to 15 mL with *water R*. The solution complies with the limit test for chlorides (100 ppm).

**Sulfates** (2.4.13). 15 mL of solution S complies with the limit test for sulfates (200 ppm).

**Heavy metals** (2.4.8). Heat 3 g with 50 mL of *dilute hydrochloric acid R* on a water-bath for 5 min and filter. Evaporate the filtrate almost to dryness and dissolve the residue in 30 mL of *water R*. 12 mL of this solution complies with limit test A for heavy metals (10 ppm). Prepare the standard using 10 mL of *lead standard solution (1 ppm Pb) R*.

**Loss on drying** (2.2.32). Not more than 0.5 per cent, determined on 1.000 g by drying in an oven at 105 °C.

**Sulfated ash** (2.4.14). Not more than 0.1 per cent, determined on 1.0 g.

#### ASSAY

Dissolve 0.100 g in 5 mL of *dimethylformamide R*. Add 5 mL of *sodium carbonate solution R*, 10 mL of *sodium hydrogen carbonate solution R*, 35 mL of *water R* and 50.0 mL of 0.05 M *iodine*. Add 10 mL of *methylene chloride R* and 20 mL of *dilute sulfuric acid R*. Titrate the excess of iodine with 0.1 M *sodium thiosulfate*, using 0.3 mL of *starch solution R* added towards the end of the titration, as indicator. Carry out a blank titration. 1 mL of 0.05 M *iodine* is equivalent to 3.979 mg of  $C_{20}H_{14}O_4$ .

#### STORAGE

Store protected from light.

01/2008:0242  
corrected 6.0

## PHENOLSULFONPHTHALEIN

### Phenolsulfonphthaleinum

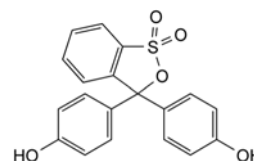

$C_{19}H_{14}O_5S$   
[143-74-8]

$M_r$  354.4

#### DEFINITION

Phenolsulfonphthalein (phenol red) contains not less than 98.0 per cent and not more than the equivalent of 102.0 per cent of 3,3-bis(4-hydroxyphenyl)-3H-2,1-benzoxathiole 1,1-dioxide, calculated with reference to the dried substance.



## CHARACTERS

A bright-red to dark-red, crystalline powder, very slightly soluble in water, slightly soluble in alcohol.

## IDENTIFICATION

- A. Dissolve 10 mg in a 10 g/L solution of *sodium carbonate R* and dilute to 200.0 mL with the sodium carbonate solution. Dilute 5.0 mL of the solution to 100.0 mL with a 10 g/L solution of *sodium carbonate R*. Examined between 400 nm and 630 nm (2.2.25), the solution shows an absorption maximum at 558 nm. The specific absorbance at the maximum is 1900 to 2100.
- B. Dissolve about 10 mg in 1 mL of *dilute sodium hydroxide solution R* and add 9 mL of *water R*. The solution is deep red. To 5 mL of the solution add a slight excess of *dilute sulfuric acid R*. The colour becomes orange.
- C. To 5 mL of the solution prepared for identification test B add 1 mL of 0.0167 M *bromide-bromate R* and 1 mL of *dilute hydrochloric acid R*, shake and allow to stand for 15 min. Make alkaline with *dilute sodium hydroxide solution R*. An intense violet-blue colour is produced.

## TESTS

**Related substances.** Examine by thin-layer chromatography (2.2.27), using *silica gel GF<sub>254</sub> R* as the coating substance.

**Test solution.** Dissolve 0.1 g of the substance to be examined in 0.1 M *sodium hydroxide* and dilute to 5 mL with the same solvent.

**Reference solution.** Dilute 0.5 mL of the test solution to 100 mL with 0.1 M *sodium hydroxide*.

Apply separately to the plate 10 µL of each solution. Develop over a path of 15 cm using a mixture of 25 volumes of *glacial acetic acid R*, 25 volumes of *water R* and 100 volumes of *tert-pentyl alcohol R*. Allow the plate to dry in air until the solvent has evaporated and expose the plate to the vapour from *concentrated ammonia R*. Examine in ultraviolet light at 254 nm. Not more than one spot, apart from the principal spot, appears in the chromatogram obtained with the test solution and this spot is not more intense than the spot in the chromatogram obtained with the reference solution (0.5 per cent).

**Insoluble matter.** To 1.0 g of the finely powdered substance to be examined add 12 mL of *sodium hydrogen carbonate solution R*. Allow to stand for 1 h, shaking frequently. Dilute to 100 mL with *water R* and allow to stand for 15 h. Centrifuge at 2000 g to 3000 g, for 30 min, decant the supernatant liquid and wash the residue with 25 mL of a 10 g/L solution of *sodium hydrogen carbonate R* and then 25 mL of *water R*. Dry at 100 °C to 105 °C. The residue weighs not more than 5 mg (0.5 per cent).

**Loss on drying** (2.2.32). Not more than 1.0 per cent, determined on 1.00 g of the powdered substance to be examined by drying in an oven at 105 °C.

**Sulfated ash** (2.4.14). Not more than 0.2 per cent, determined on 0.5 g.

## ASSAY

Dissolve 0.900 g in 15 mL of 1 M *sodium hydroxide* and dilute to 250.0 mL with *water R*. To 10.0 mL of the solution in a glass-stoppered flask add 25 mL of *glacial acetic acid R*, 20.0 mL of 0.0167 M *potassium bromate R*, 5 mL of a 100 g/L solution of *potassium bromide R* and 5 mL of *hydrochloric acid R*. Allow to stand protected from light for 15 min, add 10 mL of a 100 g/L solution of *potassium iodide R* and titrate immediately with 0.1 M *sodium thiosulfate*, using 0.1 mL of *starch solution R* as indicator.

1 mL of 0.0167 M *potassium bromate* is equivalent to 4.43 mg of C<sub>8</sub>H<sub>10</sub>O<sub>2</sub>S.

01/2008:0781

## PHENOXYETHANOL

## Phenoxyethanolum

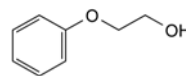

C<sub>8</sub>H<sub>10</sub>O<sub>2</sub>  
[122-99-6]

*M*<sub>r</sub> 138.2

## DEFINITION

2-Phenoxyethanol.

**Content:** 99.0 per cent *m/m* to 100.5 per cent *m/m*.

## CHARACTERS

**Appearance:** colourless, slightly viscous liquid.

**Solubility:** slightly soluble in water, miscible with acetone, with ethanol (96 per cent) and with glycerol, slightly soluble in arachis oil and in olive oil.

## IDENTIFICATION

**First identification:** C.

**Second identification:** A, B, D.

A. Refractive index (2.2.6): 1.537 to 1.539.

B. Ultraviolet and visible absorption spectrophotometry (2.2.25).

**Test solution.** Dissolve 80.0 mg in *water R* and dilute to 100.0 mL with the same solvent. Dilute 10.0 mL of this solution to 100.0 mL with *water R*.

**Spectral range:** 240-350 nm.

**Absorption maxima:** at 269 nm and 275 nm.

**Specific absorbances at the absorption maxima:**

- at 269 nm: 95 to 105;
- at 275 nm: 75 to 85.

C. Infrared absorption spectrophotometry (2.2.24).

**Comparison:** *phenoxyethanol CRS*.

D. Shake 2 mL with a mixture of 4 g of *potassium permanganate R*, 5.4 g of *sodium carbonate R* and 75 mL of *water R* for 30 min. Add 25 g of *sodium chloride R* and stir continuously for 60 min, filter and acidify with *hydrochloric acid R* to about pH 1.7. The melting point of the precipitate, after recrystallisation from *water R*, is 96 °C to 99 °C (2.2.14).

## TESTS

**Relative density** (2.2.5): 1.105 to 1.110.

**Related substances.** Gas chromatography (2.2.28).

**Internal standard solution.** Dissolve 1.25 g of *methyl laurate R* in *methylene chloride R* and dilute to 25 mL with the same solvent.

**Test solution (a).** Dissolve 5.0 g of the substance to be examined in *methylene chloride R* and dilute to 10.0 mL with the same solvent.

**Test solution (b).** Dissolve 5.0 g of the substance to be examined in *methylene chloride R*, add 1.0 mL of the internal standard solution and dilute to 10.0 mL with *methylene chloride R*.

**Reference solution.** To 1.0 mL of test solution (a) add 10.0 mL of the internal standard solution and dilute to 100.0 mL with *methylene chloride R*.

**Column:**

- **material:** glass;
- **size:** *l* = 1.5 m, Ø = 4 mm,
- **stationary phase:** *silanised diatomaceous earth for gas chromatography R* (150-180 µm) impregnated with 3 per cent *m/m* of *polymethylphenylsiloxane R*.

**Carrier gas:** *nitrogen for chromatography R*.

Flow rate: 30 mL/min.

Temperature:

– column: 130 °C;

– injection port and detector: 200 °C.

Detection: flame ionisation.

Injection: 1 µL.

Run time: 5 times the retention time of phenoxyethanol.

Elution order: phenoxyethanol, methyl laurate.

Retention time: phenoxyethanol = about 5 min.

System suitability:

- resolution: minimum 12 between the peaks due to phenoxyethanol and methyl laurate in the chromatogram obtained with the reference solution;
- in the chromatogram obtained with test solution (a) there is no peak with the same retention time as the internal standard.

Limit:

- total: calculate the ratio (*R*) of the area of the peak due to phenoxyethanol to the area of the peak due to the internal standard from the chromatogram obtained with the reference solution; from the chromatogram obtained with test solution (b), calculate the ratio of the sum of the areas of any peaks, apart from the principal peak and the peak due to the internal standard, to the area of the peak due to the internal standard: this ratio is not greater than *R* (1.0 per cent).

Phenol: maximum 0.1 per cent.

Dissolve 1.00 g in 50 mL of *methylene chloride R*, add 1 mL of *dilute sodium hydroxide solution R* and 10 mL of *water R*. Shake. Wash the upper layer with 2 quantities, each of 20 mL, of *methylene chloride R* and dilute to 100.0 mL with *water R*. The absorbance (2.2.25) of the solution measured at the absorption maximum at 287 nm is not greater than 0.27.

ASSAY

To 2.000 g in an acetylation flask fitted with an air condenser, add 10.0 mL of freshly prepared *acetic anhydride solution R1* and heat with frequent shaking in a water-bath for 45 min. Cool and carefully add 10 mL of *water R*. Heat for a further 2 min. Cool, add 10 mL of *butanol R*, shake vigorously and titrate the excess of acetic acid with 1 M *sodium hydroxide* using 0.2 mL of *phenolphthalein solution R* as indicator. Repeat the procedure without the substance to be examined. The difference between the volumes used in the titrations represents the amount of acetic anhydride required for the acetylation of the substance to be examined.

1 mL of 1 M *sodium hydroxide* is equivalent to 0.1382 g of C<sub>8</sub>H<sub>10</sub>O<sub>2</sub>.

01/2008:0148  
corrected 6.1

## PHENOXYMETHYLPENICILLIN

### Phenoxymethylpenicillinum

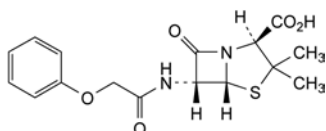

C<sub>16</sub>H<sub>18</sub>N<sub>2</sub>O<sub>5</sub>S  
[87-08-1]

*M*<sub>r</sub> 350.4

DEFINITION

(2*S*,5*R*,6*R*)-3,3-Dimethyl-7-oxo-6-[(phenoxyacetyl)amino]-4-thia-1-azabicyclo[3.2.0]heptane-2-carboxylic acid.

Substance produced by the growth of certain strains of *Penicillium notatum* or related organisms on a culture medium containing an appropriate precursor, or obtained by any other means.

Content: 95.0 per cent to 102.0 per cent for the sum of the percentage contents of phenoxymethylpenicillin and 4-hydroxyphenoxymethylpenicillin (anhydrous substance).

CHARACTERS

Appearance: white or almost white, slightly hygroscopic, crystalline powder.

Solubility: very slightly soluble in water, soluble in ethanol (96 per cent).

IDENTIFICATION

First identification: *B*.

Second identification: *A, C, D*.

*A*. pH (see Tests).

*B*. Infrared absorption spectrophotometry (2.2.24).

Comparison: *phenoxymethylpenicillin CRS*.

*C*. Thin-layer chromatography (2.2.27).

Test solution. Dissolve 25 mg of the substance to be examined in 5 mL of *acetone R*.

Reference solution (a). Dissolve 25 mg of *phenoxymethylpenicillin CRS* in 5 mL of *acetone R*.

Reference solution (b). Dissolve 25 mg of *benzylpenicillin potassium CRS* and 25 mg of *phenoxymethylpenicillin potassium CRS* in 5 mL of *water R*.

Plate: *TLC silanised silica gel plate R*.

Mobile phase: mix 30 volumes of *acetone R* and 70 volumes of a 154 g/L solution of *ammonium acetate R* adjusted to pH 5.0 with *glacial acetic acid R*.

Application: 1 µL.

Development: over a path of 15 cm.

Drying: in air.

Detection: expose to iodine vapour until the spots appear and examine in daylight.

System suitability: reference solution (b):

- the chromatogram shows 2 clearly separated spots.

Results: the principal spot in the chromatogram obtained with the test solution is similar in position, colour and size to the principal spot in the chromatogram obtained with reference solution (a).

*D*. Place about 2 mg in a test-tube about 150 mm long and 15 mm in diameter. Moisten with 0.05 mL of *water R* and add 2 mL of *sulfuric acid-formaldehyde reagent R*. Mix the contents of the tube by swirling; the solution is reddish-brown. Place the test-tube on a water-bath for 1 min; a dark reddish-brown colour develops.

TESTS

pH (2.2.3): 2.4 to 4.0.

Suspend 50 mg in 10 mL of *carbon dioxide-free water R*.

Specific optical rotation (2.2.7): + 186 to + 200 (anhydrous substance).

Dissolve 0.250 g in *butanol R* and dilute to 25.0 mL with the same solvent.

Related substances. Liquid chromatography (2.2.29).

Dissolution mixture. To 250 mL of 0.2 M *potassium dihydrogen phosphate R* add 500 mL of *water R*, adjust to pH 6.5 with an 8.4 g/L solution of *sodium hydroxide R* and dilute to 1000 mL with *water R*.

Test solution (a). Dissolve 50.0 mg of the substance to be examined in the dissolution mixture and dilute to 50.0 mL with the dissolution mixture.

**Test solution (b).** Prepare immediately before use. Dissolve 80.0 mg of the substance to be examined in the dissolution mixture and dilute to 20.0 mL with the dissolution mixture.

**Reference solution (a).** Dissolve 55.0 mg of *phenoxymethylpenicillin potassium CRS* in the dissolution mixture and dilute to 50.0 mL with the dissolution mixture.

**Reference solution (b).** Dissolve 4.0 mg of *4-hydroxyphenoxymethylpenicillin potassium CRS* in the dissolution mixture and dilute to 10.0 mL with the dissolution mixture. Dilute 5.0 mL of this solution to 100.0 mL with the dissolution mixture.

**Reference solution (c).** Dissolve 10 mg of *phenoxymethylpenicillin potassium CRS* and 10 mg of *benzylpenicillin sodium CRS* (impurity A) in the dissolution mixture and dilute to 50 mL with the dissolution mixture.

**Reference solution (d).** Dilute 1.0 mL of reference solution (a) to 20 mL with the dissolution mixture. Dilute 1.0 mL of this solution to 50 mL with the dissolution mixture.

**Reference solution (e).** Dilute 1.0 mL of reference solution (a) to 25.0 mL with the dissolution mixture.

**Column:**

- size:  $l = 0.25$  m,  $\varnothing = 4.6$  mm;
- stationary phase: octadecylsilyl silica gel for chromatography R (5  $\mu$ m).

**Mobile phase:**

- mobile phase A: phosphate buffer solution pH 3.5 R, methanol R, water R (10:30:60 V/V/V);
- mobile phase B: phosphate buffer solution pH 3.5 R, water R, methanol R (10:35:55 V/V/V);

Time (min)	Mobile phase A (per cent V/V)	Mobile phase B (per cent V/V)
0 - $t_R$	60	40
$t_R - (t_R + 20)$	60 $\rightarrow$ 0	40 $\rightarrow$ 100
$(t_R + 20) - (t_R + 35)$	0	100
$(t_R + 35) - (t_R + 50)$	0 $\rightarrow$ 60	100 $\rightarrow$ 40

$t_R$  = retention time of phenoxymethylpenicillin determined with reference solution (d)

If the mobile phase composition has been adjusted to achieve the required resolution, the adjusted composition will apply at time zero in the gradient and in the assay.

**Flow rate:** 1.0 mL/min.

**Detection:** spectrophotometer at 254 nm.

**Injection:** 20  $\mu$ L of reference solutions (c), (d) and (e) with isocratic elution at the initial mobile phase composition and 20  $\mu$ L of test solution (b) according to the elution gradient described under Mobile phase; inject the dissolution mixture as a blank according to the elution gradient described under Mobile phase.

**System suitability:**

- resolution: minimum 6.0 between the peaks due to impurity A and phenoxymethylpenicillin in the chromatogram obtained with reference solution (c); if necessary, adjust the ratio A:B of the mobile phase;
- signal-to-noise ratio: minimum 3 for the principal peak in the chromatogram obtained with reference solution (d);
- mass distribution ratio: 5.0 to 7.0 for the peak due to phenoxymethylpenicillin (2<sup>nd</sup> peak) in the chromatogram obtained with reference solution (c).

**Limits:**

- any impurity: for each impurity, not more than the area of the principal peak in the chromatogram obtained with reference solution (e) (1 per cent);

- disregard limit: disregard the peak due to 4-hydroxyphenoxymethylpenicillin.

**4-Hydroxyphenoxymethylpenicillin.** Liquid chromatography (2.2.29) as described in the test for related substances with the following modifications.

**Mobile phase:** initial composition of the mixture of mobile phases A and B, adjusted where applicable.

**Injection:** test solution (a) and reference solution (b).

**Limit:**

- 4-hydroxyphenoxymethylpenicillin: maximum 4.0 per cent (anhydrous substance).

Calculate the percentage content by multiplying, if necessary, by the correction factor supplied with the CRS.

**Water (2.5.12):** maximum 0.5 per cent, determined on 1.000 g.

**ASSAY**

Liquid chromatography (2.2.29) as described in the test for related substances with the following modifications.

**Mobile phase:** initial composition of the mixture of mobile phases A and B, adjusted where applicable.

**Injection:** test solution (a) and reference solutions (a) and (b).

**System suitability:** reference solution (a):

- repeatability: maximum relative standard deviation of 1.0 per cent after 6 injections.

Calculate the percentage content of phenoxymethylpenicillin by multiplying the percentage content of phenoxymethylpenicillin potassium by 0.902. Calculate the percentage content of 4-hydroxyphenoxymethylpenicillin by multiplying, if necessary, by the correction factor supplied with the CRS.

**STORAGE**

In an airtight container.

**IMPURITIES**

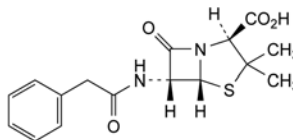

- A. (2*S*,5*R*,6*R*)-3,3-dimethyl-7-oxo-6-[(phenylacetyl)amino]-4-thia-1-azabicyclo[3.2.0]heptane-2-carboxylic acid (benzylpenicillin),

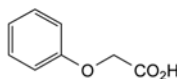

- B. phenoxyacetic acid,

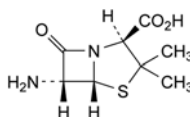

- C. (2*S*,5*R*,6*R*)-6-amino-3,3-dimethyl-7-oxo-4-thia-1-azabicyclo[3.2.0]heptane-2-carboxylic acid (6-aminopenicillanic acid),

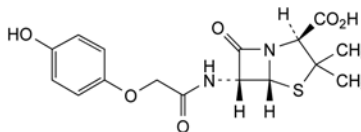

- D. (2*S*,5*R*,6*R*)-3,3-dimethyl-7-oxo-6-[[2-(4-hydroxyphenoxy)acetyl]amino]-4-thia-1-azabicyclo[3.2.0]heptane-2-carboxylic acid (4-hydroxyphenoxymethylpenicillin),

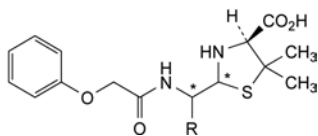

- E. R = CO<sub>2</sub>H: (4S)-2-[carboxy[(phenoxyacetyl)amino]methyl]-5,5-dimethylthiazolidine-4-carboxylic acid (penicilloic acids of phenoxymethylpenicillin),
- F. R = H: (2RS,4S)-5,5-dimethyl-2-[[[(phenoxyacetyl)amino]methyl]thiazolidine-4-carboxylic acid (penilloic acids of phenoxymethylpenicillin).

01/2008:0149  
corrected 6.1

## PHENOXYMETHYLPENICILLIN POTASSIUM

### Phenoxymethylpenicillinum kalicum

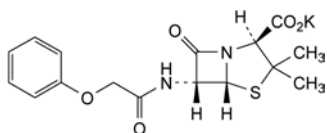

C<sub>16</sub>H<sub>17</sub>KN<sub>2</sub>O<sub>5</sub>S  
[132-98-9]

M<sub>r</sub> 388.5

#### DEFINITION

Potassium salt of (2S,5R,6R)-3,3-dimethyl-7-oxo-6-[(phenoxyacetyl)amino]-4-thia-1-azabicyclo[3.2.0]heptane-2-carboxylic acid.

Substance produced by the growth of certain strains of *Penicillium notatum* or related organisms on a culture medium containing an appropriate precursor, or obtained by any other means.

**Content:** 95.0 per cent to 102.0 per cent for the sum of the percentage contents of phenoxymethylpenicillin potassium and 4-hydroxyphenoxymethylpenicillin potassium (anhydrous substance).

#### CHARACTERS

**Appearance:** white or almost white, crystalline powder.

**Solubility:** freely soluble in water, practically insoluble in ethanol (96 per cent).

#### IDENTIFICATION

**First identification:** A, D.

**Second identification:** B, C, D.

A. Infrared absorption spectrophotometry (2.2.24).

**Comparison:** phenoxymethylpenicillin potassium CRS.

B. Thin-layer chromatography (2.2.27).

**Test solution.** Dissolve 25 mg of the substance to be examined in 5 mL of water R.

**Reference solution (a).** Dissolve 25 mg of phenoxymethylpenicillin potassium CRS in 5 mL of water R.

**Reference solution (b).** Dissolve 25 mg of benzylpenicillin potassium CRS and 25 mg of phenoxymethylpenicillin potassium CRS in 5 mL of water R.

**Plate:** TLC silanised silica gel plate R.

**Mobile phase:** mix 30 volumes of acetone R and 70 volumes of a 154 g/L solution of ammonium acetate R adjusted to pH 5.0 with glacial acetic acid R.

**Application:** 1 µL.

**Development:** over a path of 15 cm.

**Drying:** in air.

**Detection:** expose to iodine vapour until the spots appear and examine in daylight.

**System suitability:** reference solution (b):

– the chromatogram shows 2 clearly separated spots.

**Results:** the principal spot in the chromatogram obtained with the test solution is similar in position, colour and size to the principal spot in the chromatogram obtained with reference solution (a).

C. Place about 2 mg in a test-tube about 150 mm long and 15 mm in diameter. Moisten with 0.05 mL of water R and add 2 mL of sulfuric acid-formaldehyde reagent R. Mix the contents of the tube by swirling; the solution is reddish-brown. Place the test-tube in a water-bath for 1 min; a dark reddish-brown colour develops.

D. It gives reaction (a) of potassium (2.3.1).

#### TESTS

**pH (2.2.3):** 5.5 to 7.5.

Dissolve 50 mg in carbon dioxide-free water R and dilute to 10 mL with the same solvent.

**Specific optical rotation (2.2.7):** + 215 to + 230 (anhydrous substance).

Dissolve 0.250 g in carbon dioxide-free water R and dilute to 25.0 mL with the same solvent.

**Related substances.** Liquid chromatography (2.2.29).

**Dissolution mixture.** To 250 mL of 0.2 M potassium dihydrogen phosphate R add 500 mL of water R and adjust to pH 6.5 with an 8.4 g/L solution of sodium hydroxide R. Dilute to 1000 mL with water R.

**Test solution (a).** Dissolve 50.0 mg of the substance to be examined in the dissolution mixture and dilute to 50.0 mL with the dissolution mixture.

**Test solution (b).** Prepare immediately before use. Dissolve 80.0 mg of the substance to be examined in the dissolution mixture and dilute to 20.0 mL with the dissolution mixture.

**Reference solution (a).** Dissolve 50.0 mg of phenoxymethylpenicillin potassium CRS in the dissolution mixture and dilute to 50.0 mL with the dissolution mixture.

**Reference solution (b).** Dissolve 4.0 mg of 4-hydroxyphenoxy-methylpenicillin potassium CRS in the dissolution mixture and dilute to 10.0 mL with the dissolution mixture. Dilute 5.0 mL of this solution to 100.0 mL with the dissolution mixture.

**Reference solution (c).** Dissolve 10 mg of phenoxymethylpenicillin potassium CRS and 10 mg of benzylpenicillin sodium CRS (impurity A) in the dissolution mixture and dilute to 50 mL with the dissolution mixture.

**Reference solution (d).** Dilute 1.0 mL of reference solution (a) to 20 mL with the dissolution mixture. Dilute 1.0 mL of this solution to 50 mL with the dissolution mixture.

**Reference solution (e).** Dilute 1.0 mL of reference solution (a) to 25.0 mL with the dissolution mixture.

**Column:**

– size:  $l = 0.25$  m,  $\varnothing = 4.6$  mm;

– stationary phase: octadecylsilyl silica gel for chromatography R (5 µm).

**Mobile phase:**

– mobile phase A: phosphate buffer solution pH 3.5 R, methanol R, water R (10:30:60 V/V/V);

– mobile phase B: phosphate buffer solution pH 3.5 R, water R, methanol R (10:35:55 V/V/V);

Time (min)	Mobile phase A (per cent V/V)	Mobile phase B (per cent V/V)
0 - $t_R$	60	40
$t_R - (t_R + 20)$	60 → 0	40 → 100
$(t_R + 20) - (t_R + 35)$	0	100
$(t_R + 35) - (t_R + 50)$	0 → 60	100 → 40

$t_R$  = retention time of phenoxymethylpenicillin determined with reference solution (d)

If the mobile phase composition has been adjusted to achieve the required resolution, the adjusted composition will apply at time zero in the gradient and in the assay.

Flow rate: 1.0 mL/min.

Detection: spectrophotometer at 254 nm.

Injection: 20 µL of reference solutions (c), (d) and (e) with isocratic elution at the initial mobile phase composition and 20 µL of test solution (b) according to the elution gradient described under Mobile phase; inject the dissolution mixture as a blank according to the elution gradient described under Mobile phase.

System suitability:

- *resolution*: minimum 6.0 between the peaks due to impurity A and phenoxymethylpenicillin in the chromatogram obtained with reference solution (c); if necessary, adjust the ratio A:B of the mobile phase;
- *signal-to-noise ratio*: minimum 3 for the principal peak in the chromatogram obtained with reference solution (d);
- *mass distribution ratio*: 5.0 to 7.0 for the peak due to phenoxymethylpenicillin (2<sup>nd</sup> peak) in the chromatogram obtained with reference solution (c).

Limits:

- *any impurity*: for each impurity, not more than the area of the principal peak in the chromatogram obtained with reference solution (e) (1 per cent);
- *disregard limit*: disregard the peak due to 4-hydroxyphenoxymethylpenicillin.

**4-Hydroxyphenoxymethylpenicillin potassium.** Liquid chromatography (2.2.29) as described in the test for related substances with the following modifications.

*Mobile phase*: initial composition of the mixture of mobile phases A and B, adjusted where applicable.

*Injection*: test solution (a) and reference solution (b).

*Limit*:

- *4-hydroxyphenoxymethylpenicillin potassium*: maximum 4.0 per cent (anhydrous substance).

Calculate the percentage content by multiplying, if necessary, by the correction factor supplied with the CRS.

**Water** (2.5.12): maximum 1.0 per cent, determined on 1.000 g.

#### ASSAY

Liquid chromatography (2.2.29) as described in the test for related substances with the following modifications.

*Mobile phase*: initial composition of the mixture of mobile phases A and B, adjusted where applicable.

*Injection*: test solution (a) and reference solutions (a) and (b).

*System suitability*: reference solution (a):

- *repeatability*: maximum relative standard deviation of 1.0 per cent after 6 injections.

Calculate the percentage content of phenoxymethylpenicillin potassium and of 4-hydroxyphenoxymethylpenicillin potassium.

#### IMPURITIES

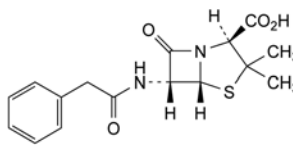

A. (2*S*,5*R*,6*R*)-3,3-dimethyl-7-oxo-6-[(phenylacetyl)amino]-4-thia-1-azabicyclo[3.2.0]heptane-2-carboxylic acid (benzylpenicillin),

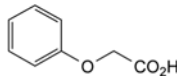

B. phenoxyacetic acid,

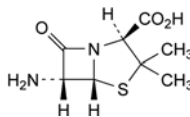

C. (2*S*,5*R*,6*R*)-6-amino-3,3-dimethyl-7-oxo-4-thia-1-azabicyclo[3.2.0]heptane-2-carboxylic acid (6-aminopenicillanic acid),

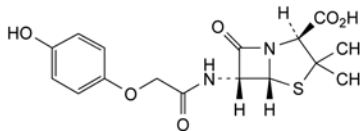

D. (2*S*,5*R*,6*R*)-3,3-dimethyl-7-oxo-6-[[2-(4-hydroxyphenoxy)acetyl]amino]-4-thia-1-azabicyclo[3.2.0]heptane-2-carboxylic acid (4-hydroxyphenoxymethylpenicillin),

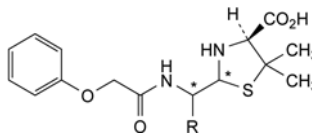

E. R = CO<sub>2</sub>H: (4*S*)-2-[carboxy[(phenoxyacetyl)amino]methyl]-5,5-dimethylthiazolidine-4-carboxylic acid (penicilloic acids of phenoxymethylpenicillin),

F. R = H: (2*R*S,4*S*)-5,5-dimethyl-2-[(phenoxyacetyl)amino]methyl]thiazolidine-4-carboxylic acid (penicilloic acids of phenoxymethylpenicillin).

01/2011:1138

## PHENTOLAMINE MESILATE

### Phentolamini mesilas

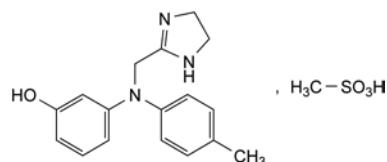

C<sub>18</sub>H<sub>23</sub>N<sub>3</sub>O<sub>4</sub>S  
[65-28-1]

$M_r$  377.5

#### DEFINITION

3-[[[(4,5-Dihydro-1*H*-imidazol-2-yl)methyl](4-methylphenyl)amino]phenol]methanesulfonate.

*Content*: 98.0 per cent to 101.0 per cent (dried substance).

#### PRODUCTION

The production method must be evaluated to determine the potential for formation of alkyl mesilates, which is particularly likely to occur if the reaction medium contains lower alcohols. Where necessary, the production method is validated to demonstrate that alkyl mesilates are not detectable in the final product.

## CHARACTERS

**Appearance:** white or almost white, slightly hygroscopic, crystalline powder.

**Solubility:** freely soluble in water and in ethanol (96 per cent), practically insoluble in methylene chloride.

## IDENTIFICATION

**First identification:** C, E

**Second identification:** A, B, D, E.

A. Melting point (2.2.14): 178 °C to 182 °C.

B. Ultraviolet and visible absorption spectrophotometry (2.2.25).

**Test solution.** Dissolve 60.0 mg in *water R* and dilute to 100.0 mL with the same solvent. Dilute 5.0 mL of the solution to 100.0 mL with *water R*.

**Spectral range:** 230-350 nm.

**Absorption maximum:** at 278 nm.

**Specific absorbance at the absorption maximum:** 220 to 245.

C. Infrared absorption spectrophotometry (2.2.24).

**Comparison:** *phentolamine mesilate CRS*.

D. Dissolve 0.5 g in a mixture of 5 mL of *ethanol (96 per cent) R* and 5 mL of a 10 g/L solution of *hydrochloric acid R* and add 0.5 mL of a 5 g/L solution of *ammonium vanadate R*. A light green precipitate is produced.

E. Mix 50 mg with 0.2 g of *sodium hydroxide R*, heat to fusion and continue heating for a few seconds. Allow to cool and add 0.5 mL of warm *water R*. Acidify with *dilute hydrochloric acid R* and heat. Sulfur dioxide is evolved, which turns moistened *starch iodate paper R* blue.

## TESTS

**Acidity.** Dissolve 0.1 g in *carbon dioxide-free water R* and dilute to 10 mL with the same solvent. Add 0.1 mL of *methyl red solution R*. If the solution is red, not more than 0.05 mL of 0.1 M *sodium hydroxide* is required to change the colour of the indicator to yellow.

**Related substances.** Liquid chromatography (2.2.29). Prepare the solutions immediately before use.

**Test solution.** Dissolve 25 mg of the substance to be examined in the mobile phase and dilute to 50.0 mL with the mobile phase.

**Reference solution (a).** Dilute 5.0 mL of the test solution to 100.0 mL with the mobile phase. Dilute 2.0 mL of this solution to 50.0 mL with the mobile phase.

**Reference solution (b).** Dissolve 5 mg of *phentolamine for system suitability CRS* (containing impurities A and C) in the mobile phase and dilute to 10.0 mL with the mobile phase.

**Column:**

- size:  $l = 0.25$  m,  $\varnothing = 4.6$  mm;
- stationary phase: *phenylsilyl silica gel for chromatography R1* (5  $\mu$ m);
- temperature: 30 °C.

**Mobile phase:** mix 33 volumes of *acetonitrile R1* and 67 volumes of a 0.5 g/L solution of *ammonium acetate R* previously adjusted to pH 5.9 with *dilute acetic acid R*.

**Flow rate:** 1.5 mL/min.

**Detection:** spectrophotometer at 230 nm.

**Injection:** 10  $\mu$ L.

**Run time:** 1.5 times the retention time of phentolamine.

**Identification of impurities:** use the chromatogram supplied with *phentolamine for system suitability CRS* and the chromatogram obtained with reference solution (b) to identify the peaks due to impurities A and C.

**Relative retention** with reference to phentolamine (retention time = about 15 min): impurity A = about 0.7; impurity C = about 1.2.

**System suitability:** reference solution (b):

- **resolution:** minimum 3.0 between the peaks due to phentolamine and impurity C.

**Limits:**

- **correction factor:** for the calculation of content, multiply the peak area of impurity A by 1.7;
- **impurity A:** not more than the area of the principal peak in the chromatogram obtained with reference solution (a) (0.2 per cent);
- **unspecified impurities:** for each impurity, not more than 0.5 times the area of the principal peak in the chromatogram obtained with reference solution (a) (0.10 per cent);
- **total:** not more than 2.5 times the area of the principal peak in the chromatogram obtained with reference solution (a) (0.5 per cent);
- **disregard limit:** 0.25 times the area of the principal peak in the chromatogram obtained with reference solution (a) (0.05 per cent).

**Loss on drying** (2.2.32): maximum 0.5 per cent, determined on 1.000 g by drying in an oven at 105 °C.

**Sulfated ash** (2.4.14): maximum 0.1 per cent, determined on 1.0 g.

## ASSAY

Dissolve 0.300 g in 100 mL of *2-propanol R1*. Titrate under a stream of nitrogen with 0.1 M *tetrabutylammonium hydroxide in 2-propanol*. Determine the end-point potentiometrically (2.2.20), using a glass indicator electrode and a calomel reference electrode containing a saturated solution of *tetramethylammonium chloride R* in *2-propanol R1*. Carry out a blank titration.

1 mL of 0.1 M *tetrabutylammonium hydroxide in 2-propanol* is equivalent to 37.75 mg of  $C_{18}H_{23}N_3O_4S$ .

## STORAGE

In an airtight container, protected from light.

## IMPURITIES

**Specified impurities:** A.

**Other detectable impurities** (the following substances would, if present at a sufficient level, be detected by one or other of the tests in the monograph. They are limited by the general acceptance criterion for other/unspecified impurities and/or by the general monograph *Substances for pharmaceutical use* (2034). It is therefore not necessary to identify these impurities for demonstration of compliance. See also 5.10. *Control of impurities in substances for pharmaceutical use*): B, C.

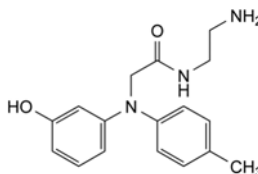

A. *N*-(2-aminoethyl)-2-[(3-hydroxyphenyl)(4-methylphenyl)amino]acetamide,

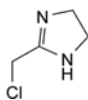

B. 2-(chloromethyl)-4,5-dihydro-1*H*-imidazole,

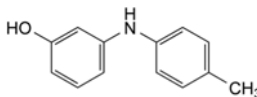

C. 3-[(4-methylphenyl)amino]phenol.

01/2008:0782  
corrected 6.0

## PHENYLALANINE

## Phenylalaninum

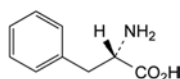
C<sub>9</sub>H<sub>11</sub>NO<sub>2</sub>  
[63-91-2]M<sub>r</sub> 165.2

## DEFINITION

Phenylalanine contains not less than 98.5 per cent and not more than the equivalent of 101.0 per cent of (S)-2-amino-3-phenylpropanoic acid, calculated with reference to the dried substance.

## CHARACTERS

A white or almost white, crystalline powder, or shiny, white flakes, sparingly soluble in water, very slightly soluble in alcohol. It dissolves in dilute mineral acids and in dilute solutions of alkali hydroxides.

## IDENTIFICATION

First identification: A, B.

Second identification: A, C, D.

- A. Specific optical rotation (see Tests).
- B. Examine by infrared absorption spectrophotometry (2.2.24), comparing with the spectrum obtained with *phenylalanine CRS*. Examine the substances prepared as discs.
- C. Examine the chromatograms obtained in the test for ninhydrin-positive substances. The principal spot in the chromatogram obtained with test solution (b) is similar in position, colour and size to the principal spot in the chromatogram obtained with reference solution (a).
- D. To about 10 mg add 0.5 g of *potassium nitrate R* and 2 mL of *sulfuric acid R*. Heat on a water-bath for 20 min. Allow to cool. Add 5 mL of a 50 g/L solution of *hydroxylamine hydrochloride R* and allow to stand in iced water for 10 min. Add 9 mL of *strong sodium hydroxide solution R*. A violet-red to violet-brown colour develops.

## TESTS

**Appearance of solution.** Dissolve 0.5 g in 1 M *hydrochloric acid* and dilute to 10 mL with the same acid. The solution is clear (2.2.1) and not more intensely coloured than reference solution BY<sub>6</sub> (2.2.2, *Method II*).

**Specific optical rotation** (2.2.7). Dissolve 0.50 g in *water R* and dilute to 25.0 mL with the same solvent. The specific optical rotation is –33.0 to –35.5, calculated with reference to the dried substance.

**Ninhydrin-positive substances.** Examine by thin-layer chromatography (2.2.27), using a *TLC silica gel plate R*.

**Test solution (a).** Dissolve 0.10 g of the substance to be examined in a mixture of equal volumes of *glacial acetic acid R* and *water R* and dilute to 10 mL with the same mixture of solvents.

**Test solution (b).** Dilute 1 mL of test solution (a) to 50 mL with a mixture of equal volumes of *glacial acetic acid R* and *water R*.

**Reference solution (a).** Dissolve 10 mg of *phenylalanine CRS* in a mixture of equal volumes of *glacial acetic acid R* and *water R* and dilute to 50 mL with the same mixture of solvents.

**Reference solution (b).** Dilute 5 mL of test solution (b) to 20 mL with a mixture of equal volumes of *glacial acetic acid R* and *water R*.

**Reference solution (c).** Dissolve 10 mg of *phenylalanine CRS* and 10 mg of *tyrosine CRS* in a mixture of equal volumes of *glacial acetic acid R* and *water R* and dilute to 25 mL with the same mixture of solvents.

Apply separately to the plate 5 µL of each solution. Develop over a path of 15 cm using a mixture of 20 volumes of *glacial acetic acid R*, 20 volumes of *water R* and 60 volumes of *butanol R*. Allow the plate to dry in air, spray with *ninhydrin solution R* and heat at 100 °C to 105 °C for 15 min. Any spot in the chromatogram obtained with test solution (a), apart from the principal spot, is not more intense than the spot in the chromatogram obtained with reference solution (b) (0.5 per cent). The test is not valid unless the chromatogram obtained with reference solution (c) shows two clearly separated spots.

**Chlorides** (2.4.4). Dissolve 0.25 g in 3 mL of *dilute nitric acid R* and dilute to 15 mL with *water R*. The solution complies with the limit test for chlorides, without any further addition of nitric acid (200 ppm).

**Sulfates** (2.4.13). Dissolve 0.5 g in a mixture of 5 volumes of *dilute hydrochloric acid R* and 25 volumes of *distilled water R* and dilute to 15 mL with the same mixture of solvents. The solution complies with the limit test for sulfates (300 ppm).

**Ammonium** (2.4.1). 50 mg complies with limit test B for ammonium (200 ppm). Prepare the standard using 0.1 mL of *ammonium standard solution (100 ppm NH<sub>4</sub>) R*.

**Iron** (2.4.9). In a separating funnel, dissolve 1.0 g in 10 mL of *dilute hydrochloric acid R*. Shake with three quantities, each of 10 mL, of *methyl isobutyl ketone R1*, shaking for 3 min each time. To the combined organic layers add 10 mL of *water R* and shake for 3 min. The aqueous layer complies with the limit test for iron (10 ppm).

**Heavy metals** (2.4.8). 2.0 g complies with limit test D for heavy metals (10 ppm). Prepare the standard using 2 mL of *lead standard solution (10 ppm Pb) R*.

**Loss on drying** (2.2.32). Not more than 0.5 per cent, determined on 1.000 g by drying in an oven at 105 °C.

**Sulfated ash** (2.4.14). Not more than 0.1 per cent, determined on 1.0 g.

## ASSAY

Dissolve 0.100 g in 3 mL of *anhydrous formic acid R*. Add 30 mL of *anhydrous acetic acid R*. Titrate with 0.1 M *perchloric acid* using 0.1 mL of *naphtholbenzein solution R* as indicator, until the colour changes from yellow to green.

1 mL of 0.1 M *perchloric acid* is equivalent to 16.52 mg of C<sub>9</sub>H<sub>11</sub>NO<sub>2</sub>.

## STORAGE

Store protected from light.

01/2008:0422

## PHENYLBUTAZONE

## Phenylbutazonum

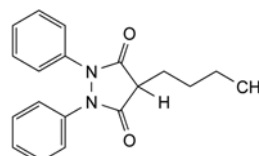
C<sub>19</sub>H<sub>20</sub>N<sub>2</sub>O<sub>2</sub>  
[50-33-9]M<sub>r</sub> 308.4

## DEFINITION

4-Butyl-1,2-diphenylpyrazolidine-3,5-dione.

**Content:** 99.0 per cent to 101.0 per cent (dried substance).

## CHARACTERS

**Appearance:** white or almost white, crystalline powder.

**Solubility:** practically insoluble in water, sparingly soluble in alcohol. It dissolves in alkaline solutions.

## IDENTIFICATION

**First identification:** A, C.

**Second identification:** A, B, D.

A. Melting point (2.2.14): 104 °C to 107 °C.

B. Thin-layer chromatography (2.2.27).

**Test solution.** Dissolve 25 mg of the substance to be examined in a mixture of equal volumes of *ethanol R* and *methylene chloride R* and dilute to 25 mL with the same mixture of solvents.

**Reference solution.** Dissolve 25 mg of *phenylbutazone CRS* in a mixture of equal volumes of *ethanol R* and *methylene chloride R* and dilute to 25 mL with the same mixture of solvents.

**Plate:** TLC silica gel GF<sub>254</sub> plate R.

**Mobile phase:** acetone R, methylene chloride R (20:80 V/V).

**Application:** 5 µL.

**Development:** over a path of 10 cm.

**Drying:** in air.

**Detection:** examine in ultraviolet light at 254 nm.

**Results:** the principal spot in the chromatogram obtained with the test solution is similar in position and size to the principal spot in the chromatogram obtained with the reference solution.

C. Infrared absorption spectrophotometry (2.2.24).

**Comparison:** *phenylbutazone CRS*.

D. To 0.1 g add 1 mL of *glacial acetic acid R* and 2 mL of *hydrochloric acid R* and heat the mixture under a reflux condenser for 30 min. Cool, add 10 mL of *water R* and filter. To the filtrate add 3 mL of a 7 g/L solution of *sodium nitrite R*. A yellow colour is produced. To 1 mL of the solution add a solution of 10 mg of *β-naphthol R* in 5 mL of *sodium carbonate solution R*. A brownish-red to violet-red precipitate is formed.

## TESTS

**Solution S.** Dissolve 1.0 g with shaking in 20 mL of *dilute sodium hydroxide solution R* and maintain the solution at 25 °C for 3 h.

**Appearance of solution.** Solution S is clear (2.2.1).

**Acidity or alkalinity.** Heat to boiling 1.0 g in 50 mL of *water R*, cool with shaking in a closed flask and filter. To 25 mL of the filtrate add 0.5 mL of *phenolphthalein solution R*. The solution is colourless. Not more than 0.5 mL of 0.01 M *sodium hydroxide* is required to change the colour of the indicator. Add 0.6 mL of 0.01 M *hydrochloric acid* and 0.1 mL of *methyl red solution R*; the solution is red or orange.

**Absorbance** (2.2.25): maximum 0.20 for solution S at 420 nm in a 4 cm cell.

**Related substances.** Liquid chromatography (2.2.29). Prepare the solutions immediately before use.

**Test solution.** Dissolve 100.0 mg of the substance to be examined in *acetonitrile R* and dilute to 10.0 mL with the same solvent.

**Reference solution (a).** Dilute 1.0 mL of the test solution to 100.0 mL with *acetonitrile R*. Dilute 1.0 mL to 10.0 mL with *acetonitrile R*.

**Reference solution (b).** Dissolve 5 mg of *phenylbutazone impurity B CRS* and 5 mg of *1,2-diphenylhydrazine R* in *acetonitrile R*, add 0.5 mL of the test solution and dilute to 50 mL with *acetonitrile R*. Dilute 2.5 mL to 10 mL with *acetonitrile R*.

**Reference solution (c).** Dissolve 1.0 mg of *benzidine R* in *acetonitrile R* and dilute to 100.0 mL with the same solvent. Dilute 1.0 mL to 100.0 mL with *acetonitrile R*. Dilute 5.0 mL to 10.0 mL with *acetonitrile R*.

**Column:**

- size:  $l = 0.125$  m,  $\varnothing = 4.0$  mm,
- stationary phase: octadecylsilyl silica gel for chromatography R (5 µm),
- temperature: 30 °C.

**Mobile phase:**

- mobile phase A: dissolve 1.36 g of *sodium acetate R* in *water R*, adjust to pH 5.2 with a 52.5 g/L solution of *citric acid R* and dilute to 1000 mL with *water R*,
- mobile phase B: *acetonitrile R*,

Time (min)	Mobile phase A (per cent V/V)	Mobile phase B (per cent V/V)
0 - 10	70	30
10 - 20	70 → 40	30 → 60
20 - 35	40	60
35 - 40	40 → 70	60 → 30

**Flow rate:** 1.5 mL/min.

**Detection:** spectrophotometer at 240 nm.

**Injection:** 20 µL; inject the test solution and reference solutions (a) and (b).

**Relative retentions** with reference to phenylbutazone (retention time = about 13 min): impurity E = about 0.2; impurity A = about 0.5; impurity B = about 1.2; impurity C = about 1.3; impurity D = about 1.7.

**System suitability:** reference solution (b):

- resolution: minimum 2.0 between the peaks due to phenylbutazone and to impurity B.

**Limits:**

- correction factor: for the calculation of content, multiply the peak area of impurity C by 0.55,
- impurities A, B: for each impurity, not more than 2.5 times the area of the principal peak in the chromatogram obtained with reference solution (a) (0.25 per cent),
- impurity C: not more than twice the area of the principal peak in the chromatogram obtained with reference solution (a) (0.20 per cent),
- any other impurity: not more than the area of the principal peak in the chromatogram obtained with reference solution (a) (0.1 per cent),
- total: not more than 5 times the area of the principal peak in the chromatogram obtained with reference solution (a) (0.5 per cent),
- disregard limit: 0.25 times the area of the principal peak in the chromatogram obtained with reference solution (a) (0.025 per cent); disregard any peak due to impurity E.

**Impurity E.** Liquid chromatography (2.2.29) as described in the test for related substances with the following modifications.

**Detection:** spectrophotometer at 280 nm.

**Injection:** test solution and reference solution (c).

**System suitability:** reference solution (c):

- signal-to-noise ratio: minimum 10 for the principal peak.

**Limit:**

- impurity E: not more than the area of the principal peak in the chromatogram obtained with reference solution (c) (5 ppm).

**Heavy metals** (2.4.8): maximum 20 ppm.

1.0 g complies with limit test C. Prepare the standard using 2 mL of *lead standard solution (10 ppm Pb) R*.

**Loss on drying** (2.2.32): maximum 0.2 per cent, determined on 1.000 g by drying *in vacuo* at 80 °C for 4 h.



**Sulfated ash** (2.4.14): maximum 0.1 per cent, determined on 1.0 g.

#### ASSAY

Dissolve 0.250 g in 25 mL of *acetone R* and add 0.5 mL of *bromothymol blue solution RI*. Titrate with 0.1 M *sodium hydroxide* until a blue colour is obtained which persists for 15 s. Carry out a blank titration.

1 mL of 0.1 M *sodium hydroxide* is equivalent to 30.84 mg of  $C_{19}H_{20}N_2O_2$ .

#### STORAGE

Protected from light.

#### IMPURITIES

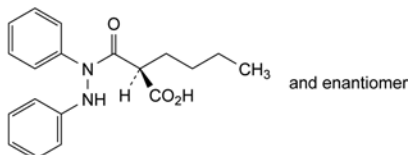

A. (2*RS*)-2-[(1,2-diphenyldiazanyl)carbonyl]hexanoic acid,

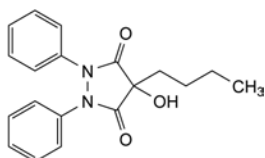

B. 4-butyl-4-hydroxy-1,2-diphenylpyrazolidine-3,5-dione,

C.  $C_6H_5-NH-NH-C_6H_5$ : 1,2-diphenylhydrazine, (1,2-diphenylhydrazine),

D.  $C_6H_5-N=N-C_6H_5$ : 1,2-diphenyldiazene,

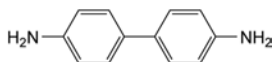

E. biphenyl-4,4'-diamine (benzidine).

*Second identification*: A, C, D.

A. Specific optical rotation (see Tests).

B. Infrared absorption spectrophotometry (2.2.24).

*Comparison*: *phenylephrine CRS*.

C. Thin-layer chromatography (2.2.27).

*Solvent mixture*. A mixture of equal volumes of *methylene chloride R* and methanolic hydrochloric acid (*hydrochloric acid R* diluted 10-fold with *methanol R*).

*Test solution*. Dissolve 0.1 g of the substance to be examined in the solvent mixture and dilute to 5 mL with the solvent mixture.

*Reference solution*. Dissolve 20 mg of *phenylephrine CRS* in the solvent mixture and dilute to 1 mL with the solvent mixture.

*Plate*: *TLC silica gel F<sub>254</sub> plate R*.

*Mobile phase*: concentrated ammonia *R*, *methanol R*, *methylene chloride R* (0.5:25:70 V/V/V).

*Application*: 10 µL.

*Development*: over a path of 15 cm.

*Drying*: in a current of cold air.

*Detection*: examine in ultraviolet light at 254 nm; spray with a 1 g/L solution of *fast red B salt R* in a 50 g/L solution of *sodium carbonate R* and examine in daylight.

*Results*: the principal spot in the chromatogram obtained with the test solution is similar in position, colour and size to the principal spot in the chromatogram obtained with the reference solution.

D. Dissolve about 10 mg in 1 mL of 1 M *hydrochloric acid*, add 0.05 mL of *copper sulfate solution R* and 1 mL of a 200 g/L solution of *sodium hydroxide R*. A violet colour develops. Add 1 mL of *ether R* and shake. The upper layer remains colourless.

#### TESTS

**Appearance of solution**. The solution is clear (2.2.1) and not more intensely coloured than reference solution  $Y_7$  (2.2.2, *Method II*).

Dissolve 1 g in 1 M *hydrochloric acid* and dilute to 10 mL with the same acid.

**Specific optical rotation** (2.2.7):  $-53$  to  $-57$  (dried substance).

Dissolve 1.250 g in 1 M *hydrochloric acid* and dilute to 25.0 mL with the same acid.

**Related substances**. Liquid chromatography (2.2.29).

*Solvent mixture*: dilute *hydrochloric acid R*, mobile phase B, mobile phase A (5:200:800 V/V/V).

*Buffer solution pH 2.8*. Dissolve 3.25 g of *sodium octanesulfonate monohydrate R* in 1000 mL of *water R* by stirring for 30 min and adjust to pH 2.8 with *dilute phosphoric acid R*.

*Test solution*. Dissolve 41.0 mg of the substance to be examined in the solvent mixture and dilute to 50.0 mL with the solvent mixture.

*Reference solution (a)*. Dilute 5.0 mL of the test solution to 100.0 mL with the solvent mixture. Dilute 2.0 mL of this solution to 100.0 mL with the solvent mixture.

*Reference solution (b)*. Dissolve the contents of a vial of *phenylephrine hydrochloride for peak identification CRS* (containing impurities C and E) in 2.0 mL of the solvent mixture.

*Column*:

– *size*:  $l = 0.055$  m,  $\varnothing = 4.0$  mm;

– *stationary phase*: end-capped octadecylsilyl silica gel for chromatography *R* (3 µm);

– *temperature*: 45 °C.

*Mobile phase*:

– *mobile phase A*: *acetonitrile RI*, buffer solution pH 2.8 (10:90 V/V);

01/2008:1035  
corrected 7.0

## PHENYLEPHRINE

### Phenylephrinum

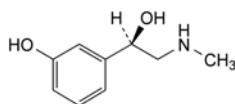

$C_9H_{13}NO_2$   
[59-42-7]

$M_r$  167.2

#### DEFINITION

(1*R*)-1-(3-Hydroxyphenyl)-2-(methylamino)ethanol.

*Content*: 99.0 per cent to 100.5 per cent (dried substance).

#### CHARACTERS

*Appearance*: white or almost white, crystalline powder.

*Solubility*: slightly soluble in water, sparingly soluble in methanol, slightly soluble in ethanol (96 per cent). It dissolves in dilute mineral acids and in dilute solutions of alkali hydroxides.

mp: about 174 °C.

#### IDENTIFICATION

*First identification*: A, B.

– *mobile phase B*: buffer solution pH 2.8, acetonitrile *R1* (10:90 *V/V*);

Time (min)	Mobile phase A (per cent <i>V/V</i> )	Mobile phase B (per cent <i>V/V</i> )
0 - 3	93	7
3 - 13	93 → 70	7 → 30
13 - 14	70 → 93	30 → 7

*Flow rate*: 1.5 mL/min.

*Detection*: spectrophotometer at 215 nm.

*Injection*: 10 µL.

*Relative retention* with reference to phenylephrine (retention time = about 2.8 min): impurity C = about 1.3; impurity E = about 3.6.

*System suitability*:

- *symmetry factor*: maximum 1.9 for the principal peak in the chromatogram obtained with the test solution;
- *peak-to-valley ratio*: minimum 5, where  $H_p$  = height above the baseline of the peak due to impurity C and  $H_v$  = height above the baseline of the lowest point of the curve separating this peak from the peak due to phenylephrine in the chromatogram obtained with reference solution (b).

*Limits*:

- *correction factors*: for the calculation of content, multiply the peak areas of the following impurities by the corresponding correction factor: impurity C = 0.5; impurity E = 0.5;
- *impurities C, E*: for each impurity, not more than the area of the principal peak in the chromatogram obtained with reference solution (a) (0.1 per cent);
- *unspecified impurities*: for each impurity, not more than the area of the principal peak in the chromatogram obtained with reference solution (a) (0.10 per cent);
- *total*: not more than twice the area of the principal peak in the chromatogram obtained with reference solution (a) (0.2 per cent);
- *disregard limit*: 0.5 times the area of the principal peak in the chromatogram obtained with reference solution (a) (0.05 per cent).

**Loss on drying** (2.2.32): maximum 0.5 per cent, determined on 1.000 g by drying in an oven at 105 °C.

**Sulfated ash** (2.4.14): maximum 0.1 per cent, determined on 1.0 g.

#### ASSAY

Dissolve 0.150 g in 60 mL of *anhydrous acetic acid R*. Titrate with 0.1 M *perchloric acid* determining the end-point potentiometrically (2.2.20).

1 mL of 0.1 M *perchloric acid* is equivalent to 16.72 mg of  $C_9H_{13}NO_2$ .

#### STORAGE

In an airtight container, protected from light.

#### IMPURITIES

*Specified impurities*: C, E.

*Other detectable impurities* (the following substances would, if present at a sufficient level, be detected by one or other of the tests in the monograph. They are limited by the general acceptance criterion for other/unspecified impurities and/or by the general monograph *Substances for pharmaceutical use* (2034). It is therefore not necessary to identify these impurities for demonstration of compliance. See also 5.10. *Control of impurities in substances for pharmaceutical use*): A, D.

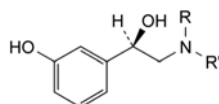

A. R = R' = H: (1*R*)-2-amino-1-(3-hydroxyphenyl)ethanol (norphenylephrine),

D. R =  $CH_2-C_6H_5$ , R' =  $CH_3$ : (1*R*)-2-(benzylmethylamino)-1-(3-hydroxyphenyl)ethanol (benzylphenylephrine),

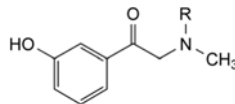

C. R = H: 1-(3-hydroxyphenyl)-2-(methylamino)ethanone (phenylephrone),

E. R =  $CH_2-C_6H_5$ : 2-(benzylmethylamino)-1-(3-hydroxyphenyl)ethanone (benzylphenylephrone).

01/2008:0632  
corrected 7.0

## PHENYLEPHRINE HYDROCHLORIDE

### Phenylephrini hydrochloridum

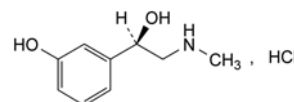

$C_9H_{13}ClNO_2$   
[61-76-7]

$M_r$  203.7

#### DEFINITION

(1*R*)-1-(3-Hydroxyphenyl)-2-(methylamino)ethanol hydrochloride.

*Content*: 98.5 per cent to 101.0 per cent (dried substance).

#### CHARACTERS

*Appearance*: white or almost white, crystalline powder.

*Solubility*: freely soluble in water and in ethanol (96 per cent).

mp: about 143 °C.

#### IDENTIFICATION

*First identification*: A, C, E.

*Second identification*: A, B, D, E.

A. Specific optical rotation (see Tests).

B. Melting point (2.2.14): 171 °C to 176 °C.

Dissolve 0.3 g in 3 mL of *water R*, add 1 mL of *dilute ammonia R1* and initiate crystallisation by scratching the wall of the tube with a glass rod. Wash the crystals with iced *water R* and dry at 105 °C for 2 h.

C. Infrared absorption spectrophotometry (2.2.24).

*Preparation*: discs.

*Comparison*: *phenylephrine hydrochloride CRS*.

D. Dissolve about 10 mg in 1 mL of *water R* and add 0.05 mL of a 125 g/L solution of *copper sulfate R* and 1 mL of a 200 g/L solution of *sodium hydroxide R*. A violet colour is produced. Add 1 mL of *ether R* and shake; the upper layer remains colourless.

E. It gives reaction (a) of chlorides (2.3.1).

#### TESTS

**Solution S**. Dissolve 2.00 g in *carbon dioxide-free water R* prepared from *distilled water R* and dilute to 100.0 mL with the same solvent.

**Appearance of solution**. Solution S is clear (2.2.1) and colourless (2.2.2, *Method II*).

**Acidity or alkalinity.** To 10 mL of solution S add 0.1 mL of methyl red solution R and 0.2 mL of 0.01 M sodium hydroxide. The solution is yellow. Not more than 0.4 mL of 0.01 M hydrochloric acid is required to change the colour of the indicator to red.

**Specific optical rotation (2.2.7):** –43 to –47 (dried substance), determined on solution S.

**Related substances.** Liquid chromatography (2.2.29).

**Solvent mixture:** mobile phase B, mobile phase A (20:80 V/V).

**Buffer solution pH 2.8.** Dissolve 3.25 g of sodium octanesulfonate monohydrate R in 1000 mL of water R by stirring for 30 min and adjust to pH 2.8 with dilute phosphoric acid R.

**Test solution.** Dissolve 50.0 mg of the substance to be examined in the solvent mixture and dilute to 50.0 mL with the solvent mixture.

**Reference solution (a).** Dilute 5.0 mL of the test solution to 100.0 mL with the solvent mixture. Dilute 2.0 mL of this solution to 100.0 mL with the solvent mixture.

**Reference solution (b).** Dissolve the contents of a vial of phenylephrine hydrochloride for peak identification CRS (containing impurities C and E) in 2.0 mL of the solvent mixture.

**Column:**

- size:  $l = 0.055$  m,  $\varnothing = 4.0$  mm;
- stationary phase: end-capped octadecylsilyl silica gel for chromatography R (3  $\mu$ m);
- temperature: 45 °C.

**Mobile phase:**

- mobile phase A: acetonitrile R1, buffer solution pH 2.8 (10:90 V/V);
- mobile phase B: buffer solution pH 2.8, acetonitrile R1 (10:90 V/V);

Time (min)	Mobile phase A (per cent V/V)	Mobile phase B (per cent V/V)
0 - 3	93	7
3 - 13	93 → 70	7 → 30
13 - 14	70 → 93	30 → 7

**Flow rate:** 1.5 mL/min.

**Detection:** spectrophotometer at 215 nm.

**Injection:** 10  $\mu$ L.

**Relative retention** with reference to phenylephrine (retention time = about 2.8 min): impurity C = about 1.3; impurity E = about 3.6.

**System suitability:**

- symmetry factor: maximum 1.9 for the principal peak in the chromatogram obtained with the test solution;
- peak-to-valley ratio: minimum 5, where  $H_p$  = height above the baseline of the peak due to impurity C and  $H_v$  = height above the baseline of the lowest point of the curve separating this peak from the peak due to phenylephrine in the chromatogram obtained with reference solution (b).

**Limits:**

- correction factors: for the calculation of content, multiply the peak areas of the following impurities by the corresponding correction factor: impurity C = 0.5; impurity E = 0.5;
- impurities C, E: for each impurity, not more than the area of the principal peak in the chromatogram obtained with reference solution (a) (0.1 per cent);
- unspecified impurities: for each impurity, not more than the area of the principal peak in the chromatogram obtained with reference solution (a) (0.10 per cent);
- total: not more than twice the area of the principal peak in the chromatogram obtained with reference solution (a) (0.2 per cent);

- disregard limit: 0.5 times the area of the principal peak in the chromatogram obtained with reference solution (a) (0.05 per cent).

**Sulfates (2.4.13):** maximum 500 ppm, determined on solution S.

**Loss on drying (2.2.32):** maximum 1.0 per cent, determined on 1.000 g by drying in an oven at 105 °C.

**Sulfated ash (2.4.14):** maximum 0.1 per cent, determined on 1.0 g.

**ASSAY**

Dissolve 0.150 g in a mixture of 0.5 mL of 0.1 M hydrochloric acid and 80 mL of ethanol (96 per cent) R. Carry out a potentiometric titration (2.2.20) using 0.1 M ethanolic sodium hydroxide. Read the volume added between the 2 points of inflexion.

1 mL of 0.1 M ethanolic sodium hydroxide is equivalent to 20.37 mg of  $C_9H_{14}ClNO_2$ .

**IMPURITIES**

**Specified impurities: C, E.**

**Other detectable impurities** (the following substances would, if present at a sufficient level, be detected by one or other of the tests in the monograph. They are limited by the general acceptance criterion for other/unspecified impurities and/or by the general monograph *Substances for pharmaceutical use (2034)*. It is therefore not necessary to identify these impurities for demonstration of compliance. See also 5.10. *Control of impurities in substances for pharmaceutical use*): A, D.

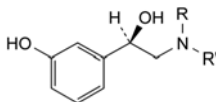

A. R = R' = H: (1R)-2-amino-1-(3-hydroxyphenyl)ethanol (norphenylephrine),

D. R =  $CH_2-C_6H_5$ , R' =  $CH_3$ : (1R)-2-(benzylmethylamino)-1-(3-hydroxyphenyl)ethanol (benzylphenylephrine),

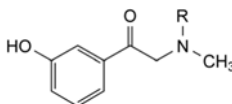

C. R = H: 1-(3-hydroxyphenyl)-2-(methylamino)ethanone (phenylephrone),

E. R =  $CH_2-C_6H_5$ : 2-(benzylmethylamino)-1-(3-hydroxyphenyl)ethanone (benzylphenylephrone).

01/2008:2042

## PHENYLMERCURIC ACETATE

### Phenylhydrargyri acetat

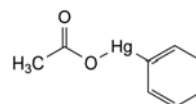

$C_8H_8HgO_2$   
[62-38-4]

$M_r$  336.7

**DEFINITION**

**Content:** 98.0 per cent to 100.5 per cent (dried substance).

**CHARACTERS**

**Appearance:** white or yellowish, crystalline powder or small, colourless crystals.

**Solubility:** slightly soluble in water, soluble in acetone and in alcohol.

**IDENTIFICATION**

**First identification: A.**

Second identification: B, C.

A. Infrared absorption spectrophotometry (2.2.24).

Comparison: Ph. Eur. reference spectrum of phenylmercuric acetate.

B. To 5 mL of solution S (see Tests) add 5 mL of water R and 0.1 mL of sodium sulfide solution R. A white precipitate is formed that darkens slowly on heating.

C. To 10 mL of solution S add 2 mL of potassium iodide solution R and shake vigorously. Filter. The filtrate gives reaction (b) of acetates (2.3.1).

#### TESTS

**Solution S.** Dissolve 0.250 g in 40 mL of water R by heating to boiling. Allow to cool and dilute to 50 mL with water R. Prepare the solution immediately before use.

**Appearance of solution.** Solution S is not more opalescent than reference suspension II (2.2.1) and is colourless (2.2.2, Method II).

**Ionised mercury:** maximum 0.2 per cent.

To 2 mL of solution S add 8 mL of water R, 2 mL of potassium iodide solution R and 3 mL of dilute hydrochloric acid R. Filter. The filtrate is not more coloured than the potassium iodide solution used. Wash the precipitate with 3 mL of water R. Combine the filtrate and the washings, add 2 mL of dilute sodium hydroxide solution R and dilute to 20 mL with water R. 12 mL of this solution complies with limit test A for heavy metals (2.4.8). Prepare the standard using lead standard solution (1 ppm Pb) R.

**Polymercuric benzene compounds:** maximum 1.5 per cent.

Shake 0.2 g with 10 mL of acetone R. Filter. Wash the residue twice with 5 mL of acetone R. Dry the residue at 105 °C for 1 h. The residue weighs a maximum of 3 mg.

**Loss on drying** (2.2.32): maximum 0.5 per cent, determined on 0.500 g by drying in an oven at 45 °C for 15 h.

#### ASSAY

Dissolve with heating 0.300 g in 100 mL of water R. Cool and add 3 mL of nitric acid R. Titrate with 0.1 M ammonium thiocyanate using 2 mL of ferric ammonium sulfate solution R2 as indicator, until a persistent reddish-yellow colour is obtained.

1 mL of 0.1 M ammonium thiocyanate is equivalent to 33.67 mg of phenylmercuric acetate.

#### STORAGE

Protected from light.

01/2008:0103

## PHENYLMERCURIC BORATE

### Phenylhydrargyri boras

#### DEFINITION

Compound consisting of equimolecular proportions of phenylmercuric orthoborate and phenylmercuric hydroxide ( $C_{12}H_{13}BHg_2O_4$ ;  $M_r$  633) or of the dehydrated form (metaborate,  $C_{12}H_{11}BHg_2O_3$ ;  $M_r$  615) or of a mixture of the 2 compounds.

Content:

- mercury (Hg;  $A_r$  200.6): 64.5 per cent to 66.0 per cent (dried substance),
- borates expressed as  $H_3BO_3$ : 9.8 per cent to 10.3 per cent (dried substance).

#### CHARACTERS

**Appearance:** white or slightly yellowish, crystalline powder or colourless, shiny crystals.

**Solubility:** slightly soluble in water and in ethanol (96 per cent).

#### IDENTIFICATION

A. Infrared absorption spectrophotometry (2.2.24).

Preparation: discs.

Comparison: Ph. Eur. reference spectrum of phenylmercuric borate.

B. To 2 mL of solution S (see Tests) add 8 mL of water R and 0.1 mL of sodium sulfide solution R. A white precipitate is formed that darkens slowly on heating.

C. Dissolve about 20 mg in 2 mL of methanol R. The solution is clear and colourless. Ignite; the solution burns with a green-edged flame.

#### TESTS

**Solution S.** Dissolve 0.25 g by sprinkling it on the surface of 25 mL of boiling water R, cool and dilute to 25 mL with water R.

**Appearance of solution.** Solution S is clear (2.2.1) and colourless (2.2.2, Method II).

**Ionised mercury:** maximum 0.01 per cent.

To 10 mL of solution S add 2 mL of potassium iodide solution R and 3 mL of dilute hydrochloric acid R. Filter. The filtrate is colourless. Wash the precipitate with 3 mL of water R. Combine the filtrate and the washings, add 2 mL of dilute sodium hydroxide solution R and dilute to 20 mL with water R. 12 mL of this solution complies with test A for heavy metals (2.4.8). Prepare the reference solution using a mixture of 2.5 mL of lead standard solution (2 ppm Pb) R and 7.5 mL of water R.

**Loss on drying** (2.2.32): maximum 3.5 per cent, determined on 0.50 g by drying in an oven at 45 °C for 15 h ± 30 min.

#### ASSAY

**Mercury.** Dissolve 0.300 g in 100 mL of water R and add 3 mL of nitric acid R. Titrate with 0.1 M ammonium thiocyanate, using 2 mL of ferric ammonium sulfate solution R2 as indicator, until a persistent reddish-yellow colour is obtained.

1 mL of 0.1 M ammonium thiocyanate is equivalent to 20.06 mg of Hg.

**Borates.** Dissolve 0.600 g with heating in 25 mL of water R. Dissolve 10 g of sorbitol R in the hot solution and cool. Titrate with 0.1 M sodium hydroxide, using 0.5 mL of phenolphthalein solution R as indicator, until a persistent pink colour is obtained. Carry out a blank titration.

1 mL of 0.1 M sodium hydroxide is equivalent to 6.18 mg of  $H_3BO_3$ .

#### STORAGE

Protected from light.

01/2008:0783

## PHENYLMERCURIC NITRATE

### Phenylhydrargyri nitras

#### DEFINITION

Mixture of phenylmercuric nitrate ( $C_6H_5HgNO_3$ ;  $M_r$  339.7) and phenylmercuric hydroxide ( $C_6H_5HgOH$ ;  $M_r$  294.7).

Content: 62.5 per cent to 64.0 per cent of Hg ( $A_r$  200.6) (dried substance).

#### CHARACTERS

**Appearance:** white or pale yellow powder.

**Solubility:** very slightly soluble in water and in ethanol (96 per cent), slightly soluble in hot water. It dissolves in glycerol and in fatty oils.

#### IDENTIFICATION

A. To 5 mL of solution S (see Tests) add 8 mL of water R and 0.1 mL of sodium sulfide solution R. A white precipitate is formed that darkens slowly on heating.

- B. To 1 mL of a saturated solution of the substance to be examined add 1 mL of *dilute hydrochloric acid R*. A white, flocculent precipitate is formed.
- C. To 5 mL of solution S add 1 mL of *dilute hydrochloric acid R*, 2 mL of *methylene chloride R* and 0.2 mL of *dithizone solution R*. Shake. The lower layer is orange-yellow.
- D. About 10 mg gives the reaction of nitrates (2.3.1).

## TESTS

**Solution S.** To 0.1 g add 45 mL of *water R* and heat to boiling with shaking. Cool, filter and dilute to 50 mL with *water R*.

**Appearance of solution.** Solution S is colourless (2.2.2, *Method II*).

**Inorganic mercuric compounds:** maximum 0.1 per cent.

To 10 mL of solution S add 2 mL of *potassium iodide solution R* and 3 mL of *dilute hydrochloric acid R*. Filter. The filtrate is colourless. Wash the precipitate with 2 mL of *water R*. Combine the filtrate and washings, add 2 mL of *dilute sodium hydroxide solution R* and dilute to 20 mL with *water R*. 12 mL of the solution complies with test A for heavy metals (2.4.8). Prepare the reference solution using *lead standard solution (1 ppm Pb) R*.

**Loss on drying** (2.2.32): maximum 1.0 per cent, determined on 1.000 g by drying *in vacuo* for 24 h.

## ASSAY

Dissolve 0.150 g in a mixture of 10 mL of *dilute nitric acid R* and 90 mL of *water R*, heating to boiling. Cool to 15–20 °C. Titrate with 0.1 M *ammonium thiocyanate* using 2 mL of *ferric ammonium sulfate solution R2* as indicator, until a persistent reddish-yellow colour is obtained. Carry out a blank titration.

1 mL of 0.1 M *ammonium thiocyanate* is equivalent to 20.06 mg of Hg.

## STORAGE

Protected from light.

01/2008:0683  
corrected 6.0

## PHENYLPROPANOLAMINE HYDROCHLORIDE

### Phenylpropanolamini hydrochloridum

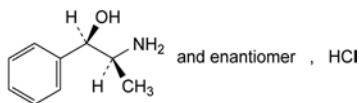

C<sub>9</sub>H<sub>14</sub>ClNO  
[154-41-6]

M<sub>r</sub> 187.7

## DEFINITION

Phenylpropanolamine hydrochloride contains not less than 99.0 per cent and not more than the equivalent of 101.5 per cent of (1*R*,2*S*)-2-amino-1-phenylpropan-1-ol hydrochloride, calculated with reference to the dried substance.

## CHARACTERS

A white or almost white, crystalline powder, freely soluble in water and in alcohol, practically insoluble in methylene chloride.

## IDENTIFICATION

*First identification:* B, E.

*Second identification:* A, C, D, E.

- A. Melting point (2.2.14): 194 °C to 197 °C.
- B. Examine by infrared absorption spectrophotometry (2.2.24), comparing with the spectrum obtained with *phenylpropanolamine hydrochloride CRS*. Examine the substances prepared as discs without recrystallisation.

- C. Examine the chromatograms obtained in the test for related substances. The principal spot in the chromatogram obtained with test solution (b) is similar in position, colour and size to the principal spot in the chromatogram obtained with reference solution (a).

- D. Dissolve 50 mg in 5 mL of *water R*, add 0.2 mL of *copper sulfate solution R* and 0.3 mL of *dilute sodium hydroxide solution R*. A violet colour develops. Add 2 mL of *ether R* and shake. A violet precipitate is formed between the two layers.

- E. It gives reaction (a) of chlorides (2.3.1).

## TESTS

**Solution S.** Dissolve 1.25 g in *water R* and dilute to 25 mL with the same solvent.

**Appearance of solution.** Solution S is clear (2.2.1) and colourless (2.2.2, *Method II*).

**Acidity or alkalinity.** To 10 mL of solution S add 0.1 mL of *methyl red solution R* and 0.2 mL of 0.01 M *sodium hydroxide*. The solution is yellow. Add 0.4 mL of 0.01 M *hydrochloric acid*. The solution is red.

**Related substances.** Examine by thin-layer chromatography (2.2.27), using *silica gel H R* as the coating substance.

*Test solution (a).* Dissolve 0.20 g of the substance to be examined in *alcohol R* and dilute to 10 mL with the same solvent.

*Test solution (b).* Dilute 1 mL of test solution (a) to 10 mL with *alcohol R*.

*Reference solution (a).* Dissolve 20 mg of *phenylpropanolamine hydrochloride CRS* in *alcohol R* and dilute to 10 mL with the same solvent.

*Reference solution (b).* Dilute 1 mL of reference solution (a) to 10 mL with *alcohol R*.

*Reference solution (c).* Dissolve 20 mg of *norpseudoephedrine hydrochloride CRS* in *alcohol R*, add 1 mL of test solution (a) and dilute to 10 mL with *alcohol R*.

*Reference solution (d).* Dissolve 60 mg of *ammonium chloride R* in *methanol R* and dilute to 10 mL with the same solvent.

Before applying the solutions, spray the plate with a 20 g/L solution of *disodium tetraborate R*, using 8 mL for a plate 100 mm by 200 mm and dry in a stream of cold air for 30 min. Apply separately to the plate as bands about 10 mm by 3 mm 10 µL of each solution. Develop over a path of 10 cm using a mixture of 6 volumes of *concentrated ammonia R*, 24 volumes of *alcohol R* and 70 volumes of *butanol R*. Dry the plate in a current of warm air until the solvents have evaporated, allow to cool, spray with a 2 g/L solution of *ninhydrin R* in *alcohol R* and heat at 110 °C for 15 min. Any spot in the chromatogram obtained with test solution (a) apart from the principal spot and the spot corresponding to ammonium chloride is not more intense than the spot in the chromatogram obtained with reference solution (b) (1.0 per cent). The test is not valid unless the chromatogram obtained with reference solution (c) shows two clearly separated spots.

**Phenylpropanolamine.** Dissolve 1.0 g in 0.01 M *hydrochloric acid* and dilute to 50.0 mL with the same acid. The absorbance (2.2.25) of the solution measured at 283 nm is not greater than 0.10.

**Heavy metals** (2.4.8). 12 mL of solution S complies with limit test A for heavy metals (20 ppm). Prepare the standard using *lead standard solution (1 ppm Pb) R*.

**Loss on drying** (2.2.32). Not more than 0.5 per cent, determined on 1.000 g by drying in an oven at 105 °C.

**Sulfated ash** (2.4.14). Not more than 0.1 per cent, determined on 1.0 g.

## ASSAY

Dissolve 0.1500 g in a mixture of 5 mL of 0.01 M hydrochloric acid and 50 mL of alcohol R. Carry out a potentiometric titration (2.2.20), using 0.1 M sodium hydroxide. Read the volume added between the two points of inflexion.

1 mL of 0.1 M sodium hydroxide is equivalent to 18.77 mg of C<sub>9</sub>H<sub>14</sub>N<sub>2</sub>O<sub>2</sub>.

04/2009:1253

## PHENYTOIN

## Phenytoinum

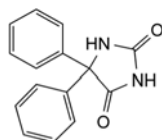

C<sub>15</sub>H<sub>12</sub>N<sub>2</sub>O<sub>2</sub>  
[57-41-0]

M<sub>r</sub> 252.3

## DEFINITION

5,5-Diphenylimidazolidine-2,4-dione.

Content: 99.0 per cent to 101.0 per cent (dried substance).

## CHARACTERS

Appearance: white or almost white, crystalline powder.

Solubility: practically insoluble in water, sparingly soluble in ethanol (96 per cent), very slightly soluble in methylene chloride. It dissolves in dilute solutions of alkali hydroxides.

## IDENTIFICATION

Infrared absorption spectrophotometry (2.2.24).

Comparison: phenytoin CRS.

## TESTS

**Appearance of solution.** The solution is clear (2.2.1) and not more intensely coloured than reference solution BY<sub>6</sub> (2.2.2, Method II).

Dissolve 1.0 g in a mixture of 5 mL of 1 M sodium hydroxide and 20 mL of water R.

**Acidity or alkalinity.** To 1.0 g add 45 mL of water R and boil for 2 min. Allow to cool and filter. Wash the filter with carbon dioxide-free water R and dilute the combined filtrate and washings to 50 mL with the same solvent. To 10 mL of the solution add 0.15 mL of methyl red solution R. Not more than 0.5 mL of 0.01 M hydrochloric acid is required to change the colour of the indicator to red. To 10 mL of the solution add 0.15 mL of bromothymol blue solution R1. Not more than 0.5 mL of 0.01 M sodium hydroxide is required to change the colour of the indicator to blue.

**Related substances.** Liquid chromatography (2.2.29).

**Test solution.** Dissolve 50 mg of the substance to be examined in the mobile phase and dilute to 50.0 mL with the mobile phase.

**Reference solution (a).** Dilute 1.0 mL of the test solution to 100.0 mL with the mobile phase. Dilute 1.0 mL of this solution to 10.0 mL with the mobile phase.

**Reference solution (b).** Dissolve 2 mg of 2,2-diphenylglycine R (impurity C) in 100.0 mL of the mobile phase.

**Reference solution (c).** Dissolve 10 mg of phenytoin for system suitability CRS (containing impurities D and E) in the mobile phase, add 1.0 mL of reference solution (b) and dilute to 10.0 mL with the mobile phase.

Column:

– size:  $l = 0.25$  m,  $\varnothing = 4.6$  mm;

– stationary phase: end-capped octadecylsilyl silica gel for chromatography R (5  $\mu$ m).

Mobile phase: mix 20 volumes of methanol R2, 35 volumes of acetonitrile R1 and 45 volumes of a 5.75 g/L solution of ammonium dihydrogen phosphate R adjusted to pH 2.5 with phosphoric acid R.

Flow rate: 1.5 mL/min.

Detection: spectrophotometer at 220 nm.

Injection: 20  $\mu$ L of the test solution and reference solutions (a) and (c).

Run time: 4 times the retention time of phenytoin.

Identification of impurities: use the chromatogram supplied with phenytoin for system suitability CRS and the chromatogram obtained with reference solution (c) to identify the peaks due to impurities C, D and E.

Relative retention with reference to phenytoin (retention time = about 4 min): impurity C = about 0.5; impurity D = about 0.6; impurity E = about 0.8.

System suitability: reference solution (c):

– resolution: minimum 3.5 between the peaks due to impurities D and E.

Limits:

– correction factors: for the calculation of content, multiply the peaks areas of the following impurities by the corresponding correction factor: impurity D = 1.7; impurity E = 1.4;

– impurity E: not more than 3 times the area of the principal peak in the chromatogram obtained with reference solution (a) (0.3 per cent);

– impurity C: not more than twice the area of the principal peak in the chromatogram obtained with reference solution (a) (0.2 per cent);

– impurity D: not more than the area of the principal peak in the chromatogram obtained with reference solution (a) (0.1 per cent);

– unspecified impurities: for each impurity, not more than the area of the principal peak in the chromatogram obtained with reference solution (a) (0.10 per cent);

– total: not more than 5 times the area of the principal peak in the chromatogram obtained with reference solution (a) (0.5 per cent);

– disregard limit: 0.5 times the area of the principal peak in the chromatogram obtained with reference solution (a) (0.05 per cent).

Heavy metals (2.4.8): maximum 10 ppm.

2.0 g complies with test C. Prepare the reference solution using 2 mL of lead standard solution (10 ppm Pb) R.

Loss on drying (2.2.32): maximum 0.5 per cent, determined on 1.000 g by drying in an oven at 105 °C.

Sulfated ash (2.4.14): maximum 0.1 per cent, determined on 1.0 g.

## ASSAY

Dissolve 0.200 g in 50 mL of dimethylformamide R. Titrate with 0.1 M sodium methoxide, determining the end-point potentiometrically (2.2.20).

1 mL of 0.1 M sodium methoxide is equivalent to 25.23 mg of C<sub>15</sub>H<sub>12</sub>N<sub>2</sub>O<sub>2</sub>.

## IMPURITIES

Specified impurities: C, D, E.

Other detectable impurities (the following substances would, if present at a sufficient level, be detected by one or other of the tests in the monograph. They are limited by the general acceptance criterion for other/unspecified impurities and/or by the general monograph Substances for pharmaceutical use (2034). It is therefore not necessary to identify these impurities for demonstration of compliance. See also 5.10. Control of impurities in substances for pharmaceutical use): A, B, F.

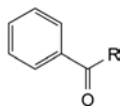

A. R = C<sub>6</sub>H<sub>5</sub>: diphenylmethanone (benzophenone),

B. R = CO-C<sub>6</sub>H<sub>5</sub>: diphenylethanedione (benzil),

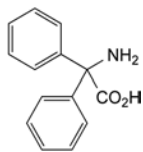

C. amino(diphenyl)acetic acid (2,2-diphenylglycine),

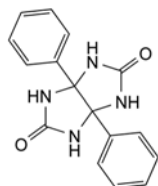

D. 3a,6a-diphenyltetrahydroimidazo[4,5-d]imidazole-2,5(1H,3H)-dione,

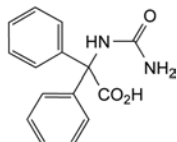

E. (carbamoylamino)(diphenyl)acetic acid,

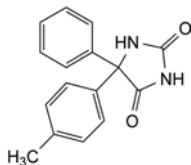

F. 5-(4-methylphenyl)-5-phenylimidazolidine-2,4-dione.

A. Infrared absorption spectrophotometry (2.2.24).

*Preparation*: suspend 0.1 g in 20 mL of *water R*. Acidify with *dilute hydrochloric acid R* and shake with 3 quantities, each of 30 mL, of *ethyl acetate R*. Wash the combined ethyl acetate layers with *water R*, evaporate to dryness and dry the residue at 100-105 °C (test residue). Repeat the operations using 0.1 g of *phenytoin sodium CRS* (reference residue). Examine as discs prepared using *potassium bromide R*.

*Comparison*: *phenytoin sodium CRS*.

B. To about 10 mg add 1 mL of *water R* and 0.05 mL of *ammonia R*. Heat until boiling begins. Add 0.05 mL of a 50 g/L solution of *copper sulfate R* in *dilute ammonia R2* and shake. A pink, crystalline precipitate is formed.

C. Ignite 1 g and cool. Add 2 mL of *water R* to the residue and neutralise the solution with *hydrochloric acid R*. Filter and dilute the filtrate to 4 mL with *water R*. 0.1 mL of the solution gives reaction (b) of sodium (2.3.1).

#### TESTS

**Appearance of solution.** Suspend 1.0 g in 5 mL of *water R* and dilute to 20 mL with 0.1 M *sodium hydroxide*. The solution is clear (2.2.1) and not more intensely coloured than reference solution BY<sub>6</sub> (2.2.2, *Method II*).

**Related substances.** Liquid chromatography (2.2.29).

*Test solution.* Dissolve 50 mg of the substance to be examined in the mobile phase and dilute to 50.0 mL with the mobile phase.

*Reference solution (a).* Dilute 1.0 mL of the test solution to 100.0 mL with the mobile phase. Dilute 1.0 mL of this solution to 10.0 mL with the mobile phase.

*Reference solution (b).* Dissolve 2 mg of 2,2-diphenylglycine *R* (impurity C) in 100.0 mL of the mobile phase.

*Reference solution (c).* Dissolve 10 mg of *phenytoin for system suitability CRS* (containing impurities D and E) in the mobile phase, add 1.0 mL of reference solution (b) and dilute to 10.0 mL with the mobile phase.

*Column*:

– *size*:  $l = 0.25$  m,  $\varnothing = 4.6$  mm;

– *stationary phase*: end-capped octadecylsilyl silica gel for chromatography *R* (5 µm).

*Mobile phase*: mix 20 volumes of *methanol R2*, 35 volumes of *acetonitrile R1* and 45 volumes of a 5.75 g/L solution of *ammonium dihydrogen phosphate R* adjusted to pH 2.5 with *phosphoric acid R*.

*Flow rate*: 1.5 mL/min.

*Detection*: spectrophotometer at 220 nm.

*Injection*: 20 µL of the test solution and reference solutions (a) and (c).

*Run time*: 4 times the retention time of phenytoin.

*Identification of impurities*: use the chromatogram supplied with *phenytoin for system suitability CRS* and the chromatogram obtained with reference solution (c) to identify the peaks due to impurities C, D and E.

*Relative retention* with reference to phenytoin (retention time = about 4 min): impurity C = about 0.5; impurity D = about 0.6; impurity E = about 0.8.

*System suitability*: reference solution (c):

– *resolution*: minimum 3.5 between the peaks due to impurities D and E.

*Limits*:

– *correction factors*: for the calculation of content, multiply the peak areas of the following impurities by the corresponding correction factor: impurity D = 1.7; impurity E = 1.4;

– *impurity E*: not more than 3 times the area of the principal peak in the chromatogram obtained with reference solution (a) (0.3 per cent);

– *impurity C*: not more than twice the area of the principal peak in the chromatogram obtained with reference solution (a) (0.2 per cent);

04/2009:0521

## PHENYTOIN SODIUM

### Phenytoinum natrium

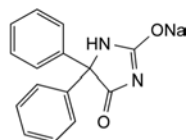

C<sub>15</sub>H<sub>11</sub>N<sub>2</sub>NaO<sub>2</sub>  
[630-93-3]

$M_r$  274.3

#### DEFINITION

Sodium 4-oxo-5,5-diphenyl-4,5-dihydro-1H-imidazol-2-olate.

*Content*: 98.5 per cent to 100.5 per cent (anhydrous substance).

#### CHARACTERS

*Appearance*: white or almost white, slightly hygroscopic, crystalline powder.

*Solubility*: soluble in water and in ethanol (96 per cent), practically insoluble in methylene chloride.

#### IDENTIFICATION

*First identification*: A, C.

*Second identification*: B, C.

- *impurity D*: not more than the area of the principal peak in the chromatogram obtained with reference solution (a) (0.1 per cent);
- *unspecified impurities*: for each impurity, not more than the area of the principal peak in the chromatogram obtained with reference solution (a) (0.10 per cent);
- *total*: not more than 5 times the area of the principal peak in the chromatogram obtained with reference solution (a) (0.5 per cent);
- *disregard limit*: 0.5 times the area of the principal peak in the chromatogram obtained with reference solution (a) (0.05 per cent).

**Free phenytoin.** Dissolve 0.30 g in 10 mL of a mixture of equal volumes of *pyridine R* and *water R*. Add 0.5 mL of *phenolphthalein solution R* and 3 mL of *silver nitrate solution in pyridine R*. Not more than 1.0 mL of 0.1 M *sodium hydroxide* is required to change the colour of the indicator to pink.

**Heavy metals (2.4.8):** maximum 10 ppm.

2.0 g complies with test C. Prepare the reference solution using 2 mL of *lead standard solution (10 ppm Pb) R*.

**Water (2.5.12):** maximum 3.0 per cent, determined on 1.000 g.

#### ASSAY

Suspend 0.180 g in 2 mL of *water R*. Add 8.0 mL of 0.05 M *sulfuric acid* and heat gently for 1 min. Add 30 mL of *methanol R* and cool. Carry out a potentiometric titration (2.2.20), using 0.1 M *sodium hydroxide*. After reaching the 1<sup>st</sup> point of inflexion, interrupt the addition of 0.1 M *sodium hydroxide*, add 5 mL of *silver nitrate solution in pyridine R*, mix and continue the titration. Read the volume of 0.1 M *sodium hydroxide* added between the 2 points of inflexion.

1 mL of 0.1 M *sodium hydroxide* is equivalent to 27.43 mg of  $C_{15}H_{11}N_2NaO_2$ .

#### STORAGE

In an airtight container.

#### IMPURITIES

*Specified impurities: C, D, E.*

*Other detectable impurities* (the following substances would, if present at a sufficient level, be detected by one or other of the tests in the monograph. They are limited by the general acceptance criterion for other/unspecified impurities and/or by the general monograph *Substances for pharmaceutical use (2034)*. It is therefore not necessary to identify these impurities for demonstration of compliance. See also 5.10. *Control of impurities in substances for pharmaceutical use*): A, B, F.

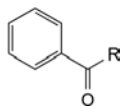

A. R =  $C_6H_5$ : diphenylmethanone (benzophenone),

B. R =  $CO-C_6H_5$ : diphenylethanedione (benzil),

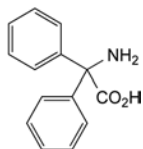

C. amino(diphenyl)acetic acid (2,2-diphenylglycine),

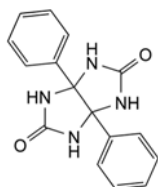

D. 3a,6a-diphenyltetrahydroimidazo[4,5-d]imidazole-2,5(1H,3H)-dione,

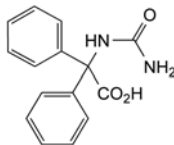

E. (carbamoylamino)(diphenyl)acetic acid,

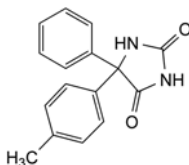

F. 5-(4-methylphenyl)-5-phenylimidazolidine-2,4-dione.

01/2011:2301

## PHLOROGLUCINOL, ANHYDROUS

### Phloroglucinolum anhydricum

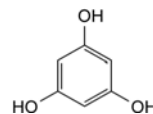

$C_6H_6O_3$   
[108-73-6]

$M_r$  126.1

#### DEFINITION

Benzene-1,3,5-triol.

*Content*: 99.0 per cent to 101.0 per cent (dried substance).

#### CHARACTERS

*Appearance*: white or almost white powder.

*Solubility*: sparingly soluble in water, freely soluble in ethanol (96 per cent), practically insoluble in methylene chloride.

#### IDENTIFICATION

A. Infrared absorption spectrophotometry (2.2.24).

*Comparison*: *anhydrous phloroglucinol CRS*.

B. Thin-layer chromatography (2.2.27).

*Test solution*. Dissolve 0.20 g of the substance to be examined in *methanol R* and dilute to 10 mL with the same solvent.

*Reference solution*. Dissolve 0.20 g of *anhydrous phloroglucinol CRS* in *methanol R* and dilute to 10 mL with the same solvent.

*Plate*: TLC silica gel  $F_{254}$  plate R.

*Mobile phase*: *anhydrous formic acid R*, *hexane R*, *ethyl acetate R* (2:37.5:62.5 V/V/V).

*Application*: 10  $\mu$ L.

*Development*: over 2/3 of the plate.

*Detection*: examine in ultraviolet light at 254 nm.

*Results*: the principal spot in the chromatogram obtained with the test solution is similar in position and size to the principal spot in the chromatogram obtained with the reference solution.

C. Loss on drying (see Tests).



## TESTS

**Solution S.** Dissolve 2.50 g in *ethanol (96 per cent) R* and dilute to 25 mL with the same solvent.

**Appearance of solution.** Solution S is clear (2.2.1) and not more intensely coloured than reference solution BY<sub>5</sub> (2.2.2, Method II).

**pH (2.2.3):** 4.0 to 6.0.

Dilute 10 mL of solution S to 100 mL with *carbon dioxide-free water R*.

**Related substances.** Liquid chromatography (2.2.29). Prepare the solutions immediately before use and protect from light.

**Solvent mixture:** mobile phase B, mobile phase A (10:90 V/V).

**Test solution.** Dissolve 50 mg of the substance to be examined in the solvent mixture and dilute to 10.0 mL with the solvent mixture.

**Reference solution (a).** Dilute 1.0 mL of the test solution to 100.0 mL with the solvent mixture. Dilute 1.0 mL of this solution to 10.0 mL with the solvent mixture.

**Reference solution (b).** Dissolve 6 mg each of *resorcinol R* (impurity B), *phloroglucide R* (impurity D) and *pyrogallol R* (impurity A) in 10 mL of the solvent mixture, add 2 mL of the test solution and dilute to 20.0 mL with the solvent mixture. Dilute 1.0 mL of this solution to 50.0 mL with the solvent mixture.

**Reference solution (c).** Dissolve 4 mg each of *pyrogallol R* (impurity A), *phloroglucide R* (impurity D), *benzene-1,2,4-triol R* (impurity E), *2,6-dichlorophenol R* (impurity I), *4-chlororesorcinol R* (impurity K) and *3,5-dichloroaniline R* (impurity L) in 10 mL of the solvent mixture and dilute to 20.0 mL with the solvent mixture.

**Reference solution (d).** Dissolve 10 mg of the substance to be examined in 10 mL of the solvent mixture, add 1.0 mL of reference solution (c) and dilute to 20.0 mL with the solvent mixture.

**Column:**

- size:  $l = 0.25$  m,  $\varnothing = 4.0$  mm;
- stationary phase: end-capped octadecylsilyl silica gel for chromatography with embedded polar groups R (5  $\mu$ m).

**Mobile phase:**

- mobile phase A: 1.36 g/L solution of *potassium dihydrogen phosphate R* previously adjusted to pH 3.0 with *phosphoric acid R*;
- mobile phase B: *acetonitrile R*;

Time (min)	Mobile phase A (per cent V/V)	Mobile phase B (per cent V/V)
0 - 9	100	0
9 - 15	100 → 50	0 → 50
15 - 25	50 → 20	50 → 80
25 - 30	20	80

**Flow rate:** 1.0 mL/min.

**Detection:** spectrophotometer at 265 nm.

**Injection:** 20  $\mu$ L of the test solution and reference solutions (a), (b) and (d).

**Identification of impurities:** use the chromatogram obtained with reference solution (d) to identify the peaks due to impurities A, D, E, I, K and L.

**Relative retention** with reference to phloroglucinol (retention time = about 12 min): impurity E = about 0.7; impurity A = about 0.9; impurity D = about 1.3; impurity B = about 1.35; impurity K = about 1.5; impurity I = about 1.8; impurity L = about 2.0.

**System suitability:** reference solution (b):

- resolution: minimum 2.5 between the peaks due to impurity A and phloroglucinol; minimum 4.0 between the peaks due to impurities D and B.

**Limits:**

- correction factors: for the calculation of content, multiply the peak areas of the following impurities by the corresponding correction factor: impurity A = 0.6; impurity D = 0.2; impurity E = 0.7; impurity I = 0.6; impurity K = 0.6; impurity L = 0.4;
- impurities A, D, E, I, K, L: for each impurity, not more than 1.5 times the area of the principal peak in the chromatogram obtained with reference solution (a) (0.15 per cent);
- unspecified impurities: for each impurity, not more than the area of the principal peak in the chromatogram obtained with reference solution (a) (0.10 per cent);
- total: not more than 3 times the area of the principal peak in the chromatogram obtained with reference solution (a) (0.3 per cent);
- disregard limit: 0.5 times the area of the principal peak in the chromatogram obtained with reference solution (a) (0.05 per cent).

**Chlorides (2.4.4):** maximum 200 ppm.

Dilute 2.5 mL of solution S to 15 mL with *water R*.

**Sulfates (2.4.13):** maximum 500 ppm.

Dilute 3 mL of solution S to 15 mL with *distilled water R*.

**Heavy metals (2.4.8):** maximum 20 ppm.

**Solvent mixture:** *water R*, *ethanol (96 per cent) R* (10:90 V/V).

0.500 g complies with test H. Prepare the reference solution using 1 mL of *lead standard solution (10 ppm Pb) R*.

**Loss on drying (2.2.32):** maximum 1.0 per cent, determined on 1.000 g by drying in an oven at 105 °C.

**Sulfated ash (2.4.14):** maximum 0.1 per cent, determined on 1.0 g.

## ASSAY

Dissolve 0.500 g in 50 mL of *water R*. Titrate with 1 M *sodium hydroxide*, determining the end-point potentiometrically (2.2.20).

1 mL of 1 M *sodium hydroxide* is equivalent to 63.05 mg of C<sub>6</sub>H<sub>6</sub>O<sub>3</sub>.

## STORAGE

Protected from light.

## IMPURITIES

**Specified impurities:** A, D, E, I, K, L.

**Other detectable impurities (the following substances would, if present at a sufficient level, be detected by one or other of the tests in the monograph. They are limited by the general acceptance criterion for other/unspecified impurities. It is therefore not necessary to identify these impurities for demonstration of compliance. See also 5.10. Control of impurities in substances for pharmaceutical use):** B, O.

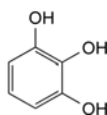

A. benzene-1,2,3-triol (pyrogallol),

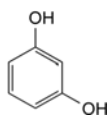

B. benzene-1,3-diol (resorcinol),

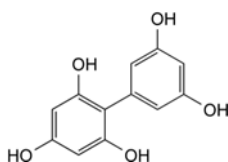

D. 2,3',4,5',6-biphenylpentol (phloroglucide),

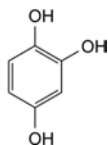

E. benzene-1,2,4-triol,

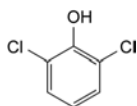

I. 2,6-dichlorophenol,

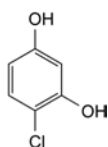

K. 4-chlorobenzene-1,3-diol (4-chlororesorcinol),

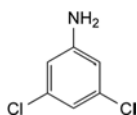

L. 3,5-dichloroaniline,

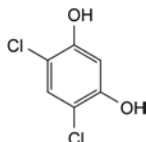

O. 4,6-dichlorobenzene-1,3-diol (4,6-dichlororesorcinol).

*Preparation:* previously dry the substance to be examined in an oven at 105 °C.

*Comparison:* anhydrous phloroglucinol CRS.

B. Thin-layer chromatography (2.2.27).

*Test solution.* Dissolve 0.20 g of the substance to be examined in *methanol R* and dilute to 10 mL with the same solvent.

*Reference solution.* Dissolve 0.20 g of *anhydrous phloroglucinol CRS* in *methanol R* and dilute to 10 mL with the same solvent.

*Plate:* TLC silica gel  $F_{254}$  plate *R*.

*Mobile phase:* anhydrous formic acid *R*, hexane *R*, ethyl acetate *R* (2:37.5:62.5 V/V/V).

*Application:* 10 µL.

*Development:* over 2/3 of the plate.

*Detection:* examine in ultraviolet light at 254 nm.

*Results:* the principal spot in the chromatogram obtained with the test solution is similar in position and size to the principal spot in the chromatogram obtained with the reference solution.

C. Loss on drying (see Tests).

#### TESTS

**Solution S.** Dissolve 2.50 g in *ethanol (96 per cent) R* and dilute to 25 mL with the same solvent.

**Appearance of solution.** Solution S is clear (2.2.1) and not more intensely coloured than reference solution BY<sub>5</sub> (2.2.2, Method II).

**pH (2.2.3):** 4.0 to 6.0.

Dilute 10 mL of solution S to 100 mL with *carbon dioxide-free water R*.

**Related substances.** Liquid chromatography (2.2.29). Prepare the solutions immediately before use and protect from light.

*Solvent mixture:* mobile phase B, mobile phase A (10:90 V/V).

*Test solution.* Dissolve 50 mg of the substance to be examined in the solvent mixture and dilute to 10.0 mL with the solvent mixture.

*Reference solution (a).* Dilute 1.0 mL of the test solution to 100.0 mL with the solvent mixture. Dilute 1.0 mL of this solution to 10.0 mL with the solvent mixture.

*Reference solution (b).* Dissolve 6 mg each of *resorcinol R* (impurity B), *phloroglucide R* (impurity D) and *pyrogallol R* (impurity A) in 10 mL of the solvent mixture, add 2 mL of the test solution and dilute to 20.0 mL with the solvent mixture. Dilute 1.0 mL of this solution to 50.0 mL with the solvent mixture.

*Reference solution (c).* Dissolve 4 mg each of *pyrogallol R* (impurity A), *phloroglucide R* (impurity D), *benzene-1,2,4-triol R* (impurity E), *2,6-dichlorophenol R* (impurity I), *4-chlororesorcinol R* (impurity K) and *3,5-dichloroaniline R* (impurity L) in 10 mL of the solvent mixture and dilute to 20.0 mL with the solvent mixture.

*Reference solution (d).* Dissolve 10 mg of the substance to be examined in 10 mL of the solvent mixture, add 1.0 mL of reference solution (c) and dilute to 20.0 mL with the solvent mixture.

*Column:*

– *size:*  $l = 0.25$  m,  $\varnothing = 4.0$  mm;

– *stationary phase:* end-capped octadecylsilyl silica gel for chromatography with embedded polar groups *R* (5 µm).

*Mobile phase:*

– *mobile phase A:* 1.36 g/L solution of *potassium dihydrogen phosphate R* previously adjusted to pH 3.0 with *phosphoric acid R*;

– *mobile phase B:* *acetonitrile R*;

01/2011:2302

## PHLOROGLUCINOL DIHYDRATE

### Phloroglucinolum dihydricum

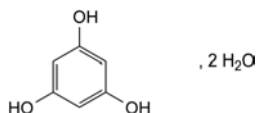

$C_6H_6O_3 \cdot 2H_2O$   
[6099-90-7]

$M_r$  162.1

#### DEFINITION

Benzene-1,3,5-triol dihydrate.

*Content:* 99.0 per cent to 101.0 per cent (dried substance).

#### CHARACTERS

*Appearance:* white or almost white powder.

*Solubility:* sparingly soluble in water, freely soluble in ethanol (96 per cent), practically insoluble in methylene chloride.

#### IDENTIFICATION

A. Infrared absorption spectrophotometry (2.2.24).

Time (min)	Mobile phase A (per cent V/V)	Mobile phase B (per cent V/V)
0 - 9	100	0
9 - 15	100 → 50	0 → 50
15 - 25	50 → 20	50 → 80
25 - 30	20	80

Flow rate: 1.0 mL/min.

Detection: spectrophotometer at 265 nm.

Injection: 20 µL of the test solution and reference solutions (a), (b) and (d).

Identification of impurities: use the chromatogram obtained with reference solution (d) to identify the peaks due to impurities A, D, E, I, K and L.

Relative retention with reference to phloroglucinol (retention time = about 12 min): impurity E = about 0.7; impurity A = about 0.9; impurity D = about 1.3; impurity B = about 1.35; impurity K = about 1.5; impurity I = about 1.8; impurity L = about 2.0.

System suitability: reference solution (b):

- resolution: minimum 2.5 between the peaks due to impurity A and phloroglucinol; minimum 4.0 between the peaks due to impurities D and B.

Limits:

- correction factors: for the calculation of content, multiply the peak areas of the following impurities by the corresponding correction factor: impurity A = 0.6; impurity D = 0.2; impurity E = 0.7; impurity I = 0.6; impurity K = 0.6; impurity L = 0.4;
- impurities A, D, E, I, K, L: for each impurity, not more than 1.5 times the area of the principal peak in the chromatogram obtained with reference solution (a) (0.15 per cent);
- unspecified impurities: for each impurity, not more than the area of the principal peak in the chromatogram obtained with reference solution (a) (0.10 per cent);
- total: not more than 3 times the area of the principal peak in the chromatogram obtained with reference solution (a) (0.3 per cent);
- disregard limit: 0.5 times the area of the principal peak in the chromatogram obtained with reference solution (a) (0.05 per cent).

**Chlorides** (2.4.4): maximum 200 ppm.

Dilute 2.5 mL of solution S to 15 mL with water R.

**Sulfates** (2.4.13): maximum 500 ppm.

Dilute 3 mL of solution S to 15 mL with distilled water R.

**Heavy metals** (2.4.8): maximum 20 ppm.

Solvent mixture: water R, ethanol (96 per cent) R (10:90 V/V).

0.500 g complies with test H. Prepare the reference solution using 1 mL of lead standard solution (10 ppm Pb) R.

**Loss on drying** (2.2.32): 20.0 per cent to 23.0 per cent, determined on 1.000 g by drying in an oven at 105 °C.

**Sulfated ash** (2.4.14): maximum 0.1 per cent, determined on 1.0 g.

ASSAY

Dissolve 0.600 g in 50 mL of water R. Titrate with 1 M sodium hydroxide, determining the end-point potentiometrically (2.2.20).

1 mL of 1 M sodium hydroxide is equivalent to 63.05 mg of C<sub>6</sub>H<sub>6</sub>O<sub>3</sub>.

STORAGE

Protected from light.

## IMPURITIES

Specified impurities: A, D, E, I, K, L.

Other detectable impurities (the following substances would, if present at a sufficient level, be detected by one or other of the tests in the monograph. They are limited by the general acceptance criterion for other/unspecified impurities and/or by the general monograph *Substances for pharmaceutical use* (2034). It is therefore not necessary to identify these impurities for demonstration of compliance. See also 5.10. *Control of impurities in substances for pharmaceutical use*): B, O.

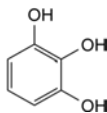

A. benzene-1,2,3-triol (pyrogallol),

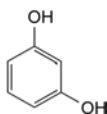

B. benzene-1,3-diol (resorcinol),

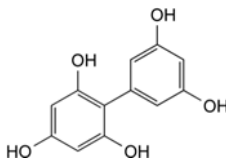

D. 2,3',4,5',6-biphenylpentol (phloroglucide),

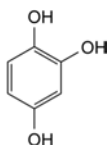

E. benzene-1,2,4-triol,

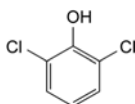

I. 2,6-dichlorophenol,

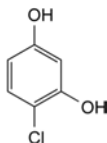

K. 4-chlorobenzene-1,3-diol (4-chlororesorcinol),

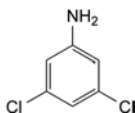

L. 3,5-dichloroaniline,

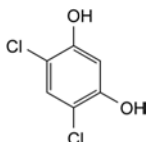

O. 4,6-dichlorobenzene-1,3-diol (4,6-dichlororesorcinol).

01/2008:0522 *Detection*: spectrophotometer at 238 nm.  
corrected 7.0 *Injection*: 20 µL.

## PHOLCODINE

### Pholcodinum

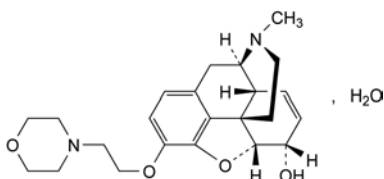

$C_{23}H_{30}N_2O_4 \cdot H_2O$

$M_r$  416.5

#### DEFINITION

7,8-Didehydro-4,5 $\alpha$ -epoxy-17-methyl-3-[2-(morpholin-4-yl)ethoxy]morphinan-6 $\alpha$ -ol monohydrate.

*Content*: 98.5 per cent to 101.5 per cent (dried substance).

#### CHARACTERS

*Appearance*: white or almost white, crystalline powder or colourless crystals.

*Solubility*: sparingly soluble in water, freely soluble in acetone and in ethanol (96 per cent). It dissolves in dilute mineral acids.

#### IDENTIFICATION

Infrared absorption spectrophotometry (2.2.24).

*Comparison*: pholcodine CRS.

#### TESTS

**Specific optical rotation** (2.2.7): –94 to –98 (dried substance).

Dissolve 1.000 g in ethanol (96 per cent) R and dilute to 50.0 mL with the same solvent.

**Related substances**. Liquid chromatography (2.2.29).

*0.02 M phosphate buffer solution*. To 80.0 mL of 0.2 M sodium hydroxide add 100.0 mL of 0.2 M potassium dihydrogen phosphate R and dilute to 1000.0 mL with water R.

*Solvent mixture*. Dilute 80 mL of acetonitrile R to 1000 mL with the 0.02 M phosphate buffer solution.

*Test solution*. Dissolve 50 mg of the substance to be examined in the solvent mixture and dilute to 50 mL with the solvent mixture.

*Reference solution (a)*. Dissolve 10 mg of codeine R (impurity B) in the solvent mixture and dilute to 10 mL with the solvent mixture. To 0.5 mL of this solution add 0.5 mL of the test solution and dilute to 50 mL with the solvent mixture.

*Reference solution (b)*. Dilute 1.0 mL of the test solution to 100.0 mL with the solvent mixture. Dilute 1.0 mL of this solution to 10.0 mL with the solvent mixture.

*Reference solution (c)*. Dissolve 5 mg of pholcodine for peak identification CRS (containing impurities A, B and D) in the solvent mixture and dilute to 5 mL with the solvent mixture.

#### Column:

- *size*:  $l = 0.075$  m,  $\varnothing = 4.6$  mm;
- *stationary phase*: spherical end-capped phenylhexylsilyl silica gel for chromatography R (3 µm) with a specific surface area of 400 m<sup>2</sup>/g and a pore size of 10 nm;
- *temperature*: 35 °C.

*Mobile phase*: to 50 mL of tetrahydrofuran for chromatography R add 75 mL of acetonitrile R and dilute to 1000 mL with the 0.02 M phosphate buffer solution; adjust to pH 7.9 ± 0.05 with 0.2 M sodium hydroxide; the pH must not exceed 8.0.

*Flow rate*: 1.0 mL/min.

*Relative retention* with reference to pholcodine (retention time = about 10 min): impurity A = about 0.4; impurity B = about 0.8; impurity D = about 2.3.

*System suitability*: reference solution (a):

- *resolution*: minimum 3 between the peaks due to impurity B and pholcodine.

#### Limits:

- *impurities A, B, D*: for each impurity, not more than twice the area of the principal peak in the chromatogram obtained with reference solution (b) (0.2 per cent);
- *unspecified impurities*: for each impurity, not more than the area of the principal peak in the chromatogram obtained with reference solution (b) (0.10 per cent);
- *total*: not more than 7 times the area of the principal peak in the chromatogram obtained with reference solution (b) (0.7 per cent);
- *disregard limit*: 0.5 times the area of the principal peak in the chromatogram obtained with reference solution (b) (0.05 per cent).

**Loss on drying** (2.2.32): 3.9 per cent to 4.5 per cent, determined on 0.500 g by drying in an oven at 105 °C.

**Sulfated ash** (2.4.14): maximum 0.1 per cent, determined on 1.0 g.

#### ASSAY

Dissolve 0.180 g in 50 mL of anhydrous acetic acid R, warming gently. Titrate with 0.1 M perchloric acid, determining the end-point potentiometrically (2.2.20).

1 mL of 0.1 M perchloric acid is equivalent to 19.93 mg of  $C_{23}H_{30}N_2O_4$ .

#### IMPURITIES

*Specified impurities*: A, B, D.

*Other detectable impurities* (the following substances would, if present at a sufficient level, be detected by one or other of the tests in the monograph. They are limited by the general acceptance criterion for other/unspecified impurities and/or by the general monograph *Substances for pharmaceutical use* (2034). It is therefore not necessary to identify these impurities for demonstration of compliance. See also 5.10. *Control of impurities in substances for pharmaceutical use*): C, E, F.

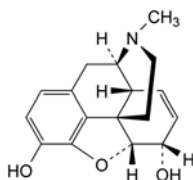

A. 7,8-didehydro-4,5 $\alpha$ -epoxy-17-methylmorphinan-3,6 $\alpha$ -diol (morphine),

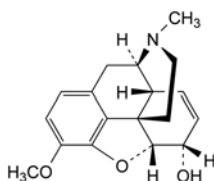

B. 7,8-didehydro-4,5 $\alpha$ -epoxy-3-methoxy-17-methylmorphinan-6 $\alpha$ -ol (codeine),

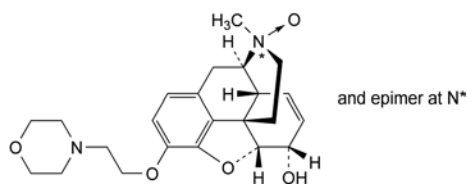

C. (17*RS*)-7,8-didehydro-4,5 $\alpha$ -epoxy-17-methyl-3-[2-(morpholin-4-yl)ethoxy]morphinan-6 $\alpha$ -ol 17-oxide (pholcodine *N*-oxide),

D. unknown structure,

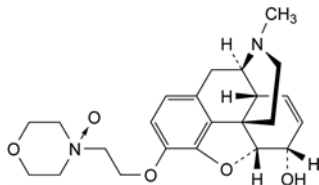

E. 7,8-didehydro-4,5 $\alpha$ -epoxy-17-methyl-3-[2-(4-oximorpholin-4-yl)ethoxy]morphinan-6 $\alpha$ -ol (pholcodine *N'*-oxide),

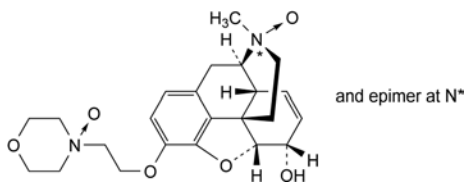

F. (17*RS*)-7,8-didehydro-4,5 $\alpha$ -epoxy-17-methyl-3-[2-(4-oximorpholin-4-yl)ethoxy]morphinan-6 $\alpha$ -ol 17-oxide (pholcodine *N,N'*-dioxide).

01/2008:0004

## PHOSPHORIC ACID, CONCENTRATED

### Acidum phosphoricum concentratum

H<sub>3</sub>PO<sub>4</sub>  
[7664-38-2]

*M*<sub>r</sub> 98.0

#### DEFINITION

*Content*: 84.0 per cent *m/m* to 90.0 per cent *m/m*.

#### CHARACTERS

*Appearance*: clear, colourless, syrupy liquid, corrosive.

*Solubility*: miscible with water and with ethanol (96 per cent).

When stored at a low temperature it may solidify into a mass of colourless crystals which do not melt at a temperature below 28 °C.

*Relative density*: about 1.7.

#### IDENTIFICATION

A. Dilute with *water R*. The solution is strongly acid (2.2.4).

B. Solution S (see Tests) neutralised with *dilute sodium hydroxide solution R* gives the reactions of phosphates (2.3.1).

#### TESTS

**Solution S.** Dilute 10.0 g to 150 mL with *water R*.

**Appearance of solution.** Solution S is clear (2.2.1) and colourless (2.2.2, *Method II*).

**Substances precipitated with ammonia.** To 10 mL of solution S add 8 mL of *dilute ammonia R1*. Any opalescence in the solution is not more intense than that in a mixture of 10 mL of solution S and 8 mL of *water R*.

**Hypophosphorous acid and phosphorous acid.** To 5 mL of solution S add 2 mL of *silver nitrate solution R2* and heat on a water-bath for 5 min. The solution shows no change in appearance.

**Chlorides** (2.4.4): maximum 50 ppm, determined on solution S.

**Sulfates** (2.4.13): maximum 100 ppm.

Dilute 1.5 g to 15 mL with *distilled water R*.

**Arsenic** (2.4.2, *Method A*): maximum 2 ppm, determined on 7.5 mL of solution S.

**Iron** (2.4.9): maximum 50 ppm.

Dilute 3 mL of solution S to 10 mL with *water R*.

**Heavy metals** (2.4.8): maximum 10 ppm.

To 2.5 g add 4 mL of *dilute ammonia R1* and dilute to 25 mL with *water R*. 12 mL of the solution complies with test A.

Prepare the reference solution using *lead standard solution (1 ppm Pb) R*.

#### ASSAY

To 1.000 g add a solution of 10 g of *sodium chloride R* in 30 mL of *water R*. Titrate with 1 M *sodium hydroxide*, using *phenolphthalein solution R* as indicator.

1 mL of 1 M *sodium hydroxide* is equivalent to 49.00 mg of H<sub>3</sub>PO<sub>4</sub>.

#### STORAGE

In a glass container.

01/2008:0005

## PHOSPHORIC ACID, DILUTE

### Acidum phosphoricum dilutum

#### DEFINITION

*Content*: 9.5 per cent *m/m* to 10.5 per cent *m/m* of H<sub>3</sub>PO<sub>4</sub> (*M*<sub>r</sub> 98.0).

#### PREPARATION

To 885 g of *water R* add 115 g of concentrated phosphoric acid and mix.

#### IDENTIFICATION

A. It is strongly acid (2.2.4).

B. Solution S (see Tests), neutralised with *dilute sodium hydroxide solution R*, gives the reactions of phosphates (2.3.1).

#### TESTS

**Solution S.** Dilute 86 g to 150 mL with *water R*.

**Appearance of solution.** Solution S is clear (2.2.1) and colourless (2.2.2, *Method II*).

**Substances precipitated with ammonia.** To 10 mL of solution S add 8 mL of *dilute ammonia R1*. Any opalescence in the solution is not more intense than that in a mixture of 10 mL of solution S and 8 mL of *water R*.

**Hypophosphorous acid and phosphorous acid.** To 5 mL of solution S add 2 mL of *silver nitrate solution R2* and heat on a water-bath for 5 min. The solution shows no change in appearance.

**Chlorides** (2.4.4): maximum 6 ppm, determined on solution S.

**Sulfates** (2.4.13): maximum 10 ppm, determined on the preparation to be examined.

**Arsenic** (2.4.2, *Method A*): maximum 0.2 ppm, determined on 7.5 mL of solution S.

**Iron** (2.4.9): maximum 6 ppm.

Dilute 3 mL of solution S to 10 mL with *water R*.

**Heavy metals** (2.4.8): maximum 1 ppm.

To 20 g add 4 mL of *dilute ammonia R1* and dilute to 25 mL with *water R*. 12 mL of the solution complies with test A.

Prepare the reference solution using a mixture of 2 mL of *water R* and 8 mL of *lead standard solution (1 ppm Pb) R*.

## ASSAY

To 8.60 g add a solution of 10 g of *sodium chloride R* in 30 mL of *water R*. Titrate with *1 M sodium hydroxide*, using *phenolphthalein solution R* as indicator.

1 mL of *1 M sodium hydroxide* is equivalent to 49.00 mg of  $\text{H}_3\text{PO}_4$ .

01/2008:0352  
corrected 6.0

## PHTHALYLSULFATHIAZOLE

## Phthalylsulfathiazolum

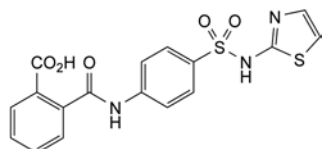

$\text{C}_{17}\text{H}_{13}\text{N}_3\text{O}_5\text{S}_2$   
[85-73-4]

$M_r$  403.4

## DEFINITION

2-[[4-(Thiazol-2-ylsulfamoyl)phenyl]carbamoyl]benzoic acid.

*Content*: 98.5 per cent to 101.5 per cent (dried substance).

## CHARACTERS

*Appearance*: white or yellowish-white, crystalline powder.

*Solubility*: practically insoluble in water, freely soluble in dimethylformamide, slightly soluble in acetone and in ethanol (96 per cent).

## IDENTIFICATION

*First identification*: A, B, E.

*Second identification*: B, C, D, E.

A. Infrared absorption spectrophotometry (2.2.24).

*Comparison*: phthalylsulfathiazole CRS.

B. To 1 g add 8.5 mL of *dilute sodium hydroxide solution R* and boil under a reflux condenser for 30 min. Cool and add 17.5 mL of *dilute hydrochloric acid R*. Shake vigorously and filter. Neutralise the filtrate with *dilute sodium hydroxide solution R*. Filter, wash the precipitate with *water R*, recrystallise from *water R* and dry the crystals at 100-105 °C. The crystals melt (2.2.14) at 200 °C to 203 °C.

C. To 0.1 g in a test-tube add 3 mL of *dilute sulfuric acid R* and 0.5 g of *zinc powder R*. Fumes are evolved which produce a black stain on *lead acetate paper R*.

D. To 0.1 g add 0.5 g of *resorcinol R* and 0.3 mL of *sulfuric acid R* and heat on a water-bath until a homogeneous mixture is obtained. Allow to cool. Add 5 mL of *dilute sodium hydroxide solution R*. Dilute 0.1 mL of this brownish-red mixture to 25 mL with *water R*. An intense green fluorescence appears which disappears on acidification.

E. Dissolve about 10 mg of the crystals obtained in identification test B in 200 mL of *0.1 M hydrochloric acid*. 2 mL of the solution gives the reaction of primary aromatic amines (2.3.1) with formation of an orange precipitate.

## TESTS

**Appearance of solution** The solution is clear (2.2.1) and not more intensely coloured than reference solution BY<sub>5</sub> (2.2.2, Method II).

Dissolve 1.0 g in *1 M sodium hydroxide* and dilute to 20 mL with the same solvent.

**Acidity**. To 2.0 g add 20 mL of *water R*, shake continuously for 30 min and filter. To 10 mL of the filtrate add 0.1 mL of *phenolphthalein solution R*. Not more than 0.2 mL of *0.1 M sodium hydroxide* is required to change the colour of the indicator.

**Sulfathiazole and other primary aromatic amines**: maximum 2.0 per cent.

Dissolve 5 mg in a mixture of 3.5 mL of *water R*, 6 mL of *dilute hydrochloric acid R* and 25 mL of *ethanol (96 per cent) R*, previously cooled to 15 °C. Place immediately in iced water and add 1 mL of a 2.5 g/L solution of *sodium nitrite R*. Allow to stand for 3 min, add 2.5 mL of a 40 g/L solution of *sulfamic acid R* and allow to stand for 5 min. Add 1 mL of a 4 g/L solution of *naphthylethylenediamine dihydrochloride R* and dilute to 50 mL with *water R*. Measured at 550 nm, the absorbance (2.2.25) is not greater than that of a standard prepared at the same time and in the same manner using a mixture of 1 mL of a 100 mL aqueous solution containing 10 mg of *sulfathiazole R* and 0.5 mL of *hydrochloric acid R*; 2.5 mL of *water R*; 6 mL of *dilute hydrochloric acid R*; and 25 mL of *ethanol (96 per cent) R*.

**Heavy metals** (2.4.8): maximum 20 ppm.

1.0 g complies with test C. Prepare the reference solution using 2 mL of *lead standard solution (10 ppm Pb) R*.

**Loss on drying** (2.2.32): maximum 2 per cent, determined on 1.00 g by drying in an oven at 105 °C.

**Sulfated ash** (2.4.14): maximum 0.1 per cent, determined on 1.0 g.

## ASSAY

Dissolve 0.300 g in 40 mL of *dimethylformamide R*. Titrate with *0.1 M sodium hydroxide* until the colour becomes blue, using 0.2 mL of *thymolphthalein solution R* as indicator. Carry out a blank titration.

1 mL of *0.1 M sodium hydroxide* is equivalent to 20.17 mg of  $\text{C}_{17}\text{H}_{13}\text{N}_3\text{O}_5\text{S}_2$ .

## STORAGE

Protected from light.

01/2008:0286  
corrected 6.0

## PHYSOSTIGMINE SALICYLATE

## Physostigmini salicylas

## Eserini salicylas

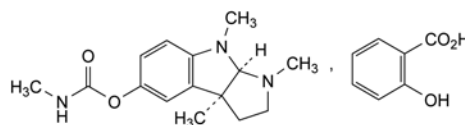

$\text{C}_{22}\text{H}_{27}\text{N}_3\text{O}_5$   
[57-64-7]

$M_r$  413.5

## DEFINITION

Physostigmine salicylate contains not less than 98.5 per cent and not more than the equivalent of 101.0 per cent of (3a*S*,8a*R*)-1,2,3,3a,8,8a-hexahydro-1,3a,8-trimethylpyrrolo[2,3-*b*]indol-5-yl methylcarbamate salicylate, calculated with reference to the dried substance.

## CHARACTERS

Colourless or almost colourless crystals, sparingly soluble in water, soluble in alcohol. The crystals gradually become red when exposed to air and light; the colour develops more quickly when the crystals are also exposed to moisture. Aqueous solutions are unstable.

It melts at about 182 °C, with decomposition.

## IDENTIFICATION

*First identification*: A, B.

*Second identification*: B, C, D.

- A. Examine by infrared absorption spectrophotometry (2.2.24), comparing with the spectrum obtained with *physostigmine salicylate CRS*.
- B. Examine the chromatograms obtained in the test for related substances. The principal spot in the chromatogram obtained with test solution (b) is similar in position, colour and size to the principal spot in the chromatogram obtained with reference solution (a).
- C. Heat about 10 mg in a porcelain dish with a few drops of *dilute ammonia RI*. An orange colour develops. Evaporate the solution to dryness. The residue dissolves in *alcohol R* giving a blue solution. Add 0.1 mL of *glacial acetic acid R*. The colour becomes violet. Dilute with *water R*. An intense red fluorescence appears.
- D. Solution S (see Tests) gives reaction (a) of salicylates (2.3.1).

## TESTS

**Solution S.** Dissolve 0.900 g, without heating, in 95 mL of *carbon dioxide-free water R* prepared from *distilled water R* and dilute to 100.0 mL with the same solvent. Prepare immediately before use.

**Appearance of solution.** Solution S is clear (2.2.1) and colourless (2.2.2, *Method II*).

**pH** (2.2.3). The pH of solution S is 5.1 to 5.9.

**Specific optical rotation** (2.2.7): –90 to –94, determined on solution S and calculated with reference to the dried substance.

**Related substances.** Examine by thin-layer chromatography (2.2.27), using *silica gel G R* as the coating substance.

**Test solution (a).** Dissolve 0.2 g of the substance to be examined in *alcohol R* and dilute to 10 mL with the same solvent.

**Test solution (b).** Dilute 2.5 mL of test solution (a) to 50 mL with *alcohol R*.

**Reference solution (a).** Dissolve 10 mg of *physostigmine salicylate CRS* in *alcohol R* and dilute to 10 mL with the same solvent.

**Reference solution (b).** Dilute 2 mL of reference solution (a) to 20 mL with *alcohol R*.

Apply to the plate 20 µL of each solution. Develop over a path of 15 cm using a mixture of 2 volumes of *concentrated ammonia R*, 23 volumes of *2-propanol R* and 100 volumes of *cyclohexane R*. Dry the plate in a current of cold air and carry out a second development in the same direction. Allow the plate to dry in air and spray with freshly prepared *potassium iodobismuthate solution R* and then with *dilute hydrogen peroxide solution R*. Examine the plate within 2 min. Any spot in the chromatogram obtained with test solution (a), apart from the principal spot, is not more intense than the spot in the chromatogram obtained with reference solution (b) (0.5 per cent).

**Eseridine.** To 5 mL of solution S add a few crystals of *potassium iodate R*, 0.05 mL of *dilute hydrochloric acid R* and 2 mL of *chloroform R*. Shake. No violet colour develops in the chloroform layer within 1 min.

**Sulfates** (2.4.13). 15 mL of solution S complies with the limit test for sulfates (0.1 per cent).

**Loss on drying** (2.2.32). Not more than 1.0 per cent, determined on 1.00 g by drying in an oven at 105 °C.

**Sulfated ash** (2.4.14). Not more than 0.1 per cent, determined on the residue obtained in the test for loss on drying.

## ASSAY

Dissolve 0.350 g in 50 mL of a mixture of equal volumes of *anhydrous acetic acid R* and *chloroform R*. Titrate with 0.1 M *perchloric acid* determining the end-point potentiometrically (2.2.20).

1 mL of 0.1 M *perchloric acid* is equivalent to 41.35 mg of  $C_{30}H_{44}N_6O_8S$ .

## STORAGE

Store in an airtight container, protected from light.

01/2008:0684  
corrected 6.0

## PHYSOSTIGMINE SULFATE

Physostigmini sulfas

Eserini sulfas

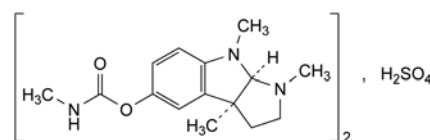

$C_{30}H_{44}N_6O_8S$   
[64-47-1]

$M_r$  649

## DEFINITION

Physostigmine sulfate contains not less than 97.0 per cent and not more than the equivalent of 101.0 per cent of di[(3a*S*,8a*R*)-1,2,3,3a,8,8a-hexahydro-1,3a,8-trimethylpyrrolo[2,3-*b*]indol-5-yl methylcarbamate] sulfate, calculated with reference to the dried substance.

## CHARACTERS

A white or almost white, crystalline powder, hygroscopic, very soluble in water, freely soluble in alcohol. It gradually becomes red when exposed to air and light; the colour develops more quickly when the substance is also exposed to moisture. Aqueous solutions are unstable.

It melts at about 145 °C, with decomposition.

## IDENTIFICATION

*First identification:* A, D.

*Second identification:* B, C, D.

- A. Examine by infrared absorption spectrophotometry (2.2.24), comparing with the spectrum obtained with *physostigmine sulfate CRS*. Examine the substances prepared as discs using *potassium bromide R*.
- B. Examine the chromatograms obtained in the test for related substances. The principal spot in the chromatogram obtained with test solution (b) is similar in position, colour and size to the principal spot in the chromatogram obtained with reference solution (a).
- C. Heat about 10 mg in a porcelain dish with 0.5 mL of *dilute ammonia RI*. An orange colour develops. Evaporate the solution to dryness. The residue dissolves in *alcohol R* giving a blue solution. Add 0.1 mL of *glacial acetic acid R*. The colour becomes violet. Dilute with water. An intense red fluorescence appears.
- D. It gives reaction (a) of sulfates (2.3.1).

## TESTS

**Solution S.** Dissolve 0.500 g without heating in *carbon dioxide-free water R* and dilute to 50.0 mL with the same solvent. Prepare immediately before use.

**Appearance of solution.** Solution S is clear (2.2.1) and colourless (2.2.2, *Method II*).

**pH** (2.2.3). The pH of solution S is 3.5 to 5.5.

**Specific optical rotation** (2.2.7): –116 to –120, determined on solution S and calculated with reference to the dried substance.

**Related substances.** Examine by thin-layer chromatography (2.2.27), using *silica gel G R* as the coating substance.

**Test solution (a).** Dissolve 0.15 g of the substance to be examined in *alcohol R* and dilute to 5 mL with the same solvent.

**Test solution (b).** Dilute 1 mL of test solution (a) to 10 mL with alcohol R.

**Reference solution (a).** Dissolve 30 mg of *physostigmine sulfate CRS* in alcohol R and dilute to 10 mL with the same solvent.

**Reference solution (b).** Dilute 5 mL of test solution (b) to 100 mL with alcohol R.

Apply separately to the plate 10 µL of each solution. Develop over a path of 15 cm using a mixture of 2 volumes of concentrated ammonia R, 23 volumes of 2-propanol R and 100 volumes of cyclohexane R. Dry the plate in a current of cold air and carry out a second development in the same direction. Allow the plate to dry in air and spray with freshly prepared potassium iodo-bismuthate solution R and then with dilute hydrogen peroxide solution R. Examine the plate within 2 min. Any spot in the chromatogram obtained with test solution (a), apart from the principal spot, is not more intense than the spot in the chromatogram obtained with reference solution (b) (0.5 per cent).

**Eseridine.** To 5 mL of solution S add a few crystals of potassium iodate R, 0.05 mL of dilute hydrochloric acid R and 2 mL of chloroform R and shake. After 1 min, the chloroform layer is not more intensely coloured than a reference solution prepared at the same time in the same manner using 5 mL of water R instead of solution S.

**Loss on drying (2.2.32).** Not more than 1.0 per cent, determined on 1.000 g by drying in an oven at 105 °C.

**Sulfated ash (2.4.14).** Not more than 0.1 per cent, determined on the residue obtained in the test for loss on drying.

#### ASSAY

Dissolve 0.5000 g in a mixture of 20 mL of anhydrous acetic acid R and 40 mL of acetic anhydride R. Titrate with 0.1 M perchloric acid determining the end-point potentiometrically (2.2.20) at the first inflexion point.

1 mL of 0.1 M perchloric acid is equivalent to 64.88 mg of C<sub>30</sub>H<sub>44</sub>N<sub>6</sub>O<sub>8</sub>S.

#### STORAGE

Store in a well-filled, airtight glass container, protected from light.

#### CHARACTERS

A clear, intense yellow, viscous, oily liquid, practically insoluble in water, sparingly soluble in ethanol (96 per cent), miscible with fatty oils.

It decomposes on exposure to actinic light.

The refractive index is about 1.526.

#### IDENTIFICATION

Carry out all operations as rapidly as possible avoiding exposure to actinic light.

- Dissolve 10.0 mg in trimethylpentane R and dilute to 100.0 mL with the same solvent. Examined between 275 nm and 340 nm (2.2.25), the solution shows an absorption maximum at 327 nm and an absorption minimum at 285 nm. The specific absorbance at the maximum is 67 to 73. Dilute 10.0 mL of the solution to 50.0 mL with trimethylpentane R. Examined between 230 nm and 280 nm, the solution shows four absorbance maxima, at 243 nm, 249 nm, 261 nm and 270 nm respectively.
- Examine the chromatograms obtained in the test for menadione and other related substances. The principal spot in the chromatogram obtained with test solution (b) is similar in position, colour and size to the principal spot in the chromatogram obtained with reference solution (a).
- Dissolve 50 mg in 10 mL of methanol R and add 1 mL of a 200 g/L solution of potassium hydroxide R in methanol R. A green colour is produced which becomes violet-red on heating in a water-bath at 40 °C and then reddish-brown on standing.

#### TESTS

**Appearance of solution.** Dissolve 2.5 g in trimethylpentane R and dilute to 25 mL with the same solvent. The solution is clear (2.2.1).

**Acid value (2.5.1).** Not more than 2.0, determined on 2.00 g.

**Menadione and other related substances.** Examine by thin-layer chromatography (2.2.27), using a TLC silica gel F<sub>254</sub> plate R.

**Test solution (a).** Dissolve 0.40 g of the substance to be examined in cyclohexane R and dilute to 10 mL with the same solvent.

**Test solution (b).** Dilute 1 mL of test solution (a) to 10 mL with cyclohexane R.

**Reference solution (a).** Dissolve 40 mg of phytomenadione CRS in cyclohexane R and dilute to 10 mL with the same solvent.

**Reference solution (b).** Dilute 1 mL of test solution (b) to 20 mL with cyclohexane R.

**Reference solution (c).** Dissolve 4.0 mg of menadione R in cyclohexane R and dilute to 50 mL with the same solvent.

Apply to the plate 10 µL of each solution. Develop over a path of 15 cm using a mixture of 20 volumes of cyclohexane R and 80 volumes of toluene R. Allow the plate to dry in air for 5 min. Examine in ultraviolet light at 254 nm and spray with a 100 g/L solution of phosphomolybdic acid R in ethanol R. Heat at 120 °C for 5 min. Examine in daylight. In the chromatogram obtained with test solution (a): any spot corresponding to menadione is not more intense than the spot in the chromatogram obtained with reference solution (c) (0.2 per cent); any spot, apart from the principal spot and any spot corresponding to menadione, is not more intense than the spot in the chromatogram obtained with reference solution (b) (0.5 per cent). Disregard any spot below the principal spot, which may not be completely separated from the principal spot.

The thresholds indicated under Related substances (Table 2034-1) in the general monograph *Substances for pharmaceutical use (2034)* do not apply.

**Sulfated ash (2.4.14).** Not more than 0.1 per cent, determined on 1.0 g.

01/2008:1036

## PHYTOMENADIONE

### Phytomenadionum

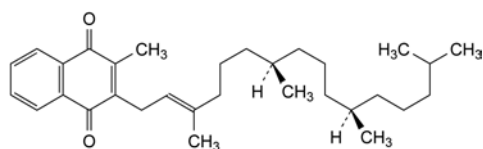

C<sub>31</sub>H<sub>46</sub>O<sub>2</sub>

M<sub>r</sub> 450.7

#### DEFINITION

Phytomenadione is a mixture of 2-methyl-3-[(2*E*)-(7*R*,11*R*)-3,7,11,15-tetramethylhexadec-2-enyl]naphthalene-1,4-dione (*trans*-phytomenadione), 2-methyl-3-[(2*Z*)-(7*R*,11*R*)-3,7,11,15-tetramethylhexadec-2-enyl]naphthalene-1,4-dione (*cis*-phytomenadione) and 2,3-epoxy-2-methyl-3-[(2*E*)-(7*R*,11*R*)-3,7,11,15-tetramethylhexadec-2-enyl]-2,3-dihydronaphthalene-1,4-dione (*trans*-epoxyphytomenadione). It contains not more than 4.0 per cent of *trans*-epoxyphytomenadione and not less than 75.0 per cent of *trans*-phytomenadione. The total of the three components is not less than 97.0 per cent and not more than the equivalent of 103.0 per cent.



## ASSAY

Examine by liquid chromatography (2.2.29).

**Test solution.** Dissolve 15.0 mg of the substance to be examined in the mobile phase and dilute to 10.0 mL with the mobile phase.

**Reference solution (a).** Dissolve 15.0 mg of *phytomenadione CRS* in the mobile phase and dilute to 10.0 mL with the mobile phase.

**Reference solution (b).** Dissolve 15.0 mg of *phytomenadione CRS* and 4.0 mg of *trans-epoxyphytomenadione CRS* in the mobile phase and dilute to 10.0 mL with the mobile phase.

The chromatographic procedure may be carried out using:

- a stainless steel column 0.25 m long and 4.6 mm in internal diameter packed with spherical *silica gel for chromatography R* (5 µm) with a porosity of 8 nm,
- as mobile phase at a flow rate of 0.4 mL/min a mixture of 0.67 volumes of *octanol R*, 3.3 volumes of *di-isopropyl ether R* and 1000 volumes of *heptane R*,
- as detector a spectrophotometer set at 254 nm,
- a 20 µL loop injector.

Inject reference solution (b). When using a recorder, adjust the sensitivity of the system so that the height of the principal peak is at least 50 per cent of the full scale of the recorder. The test is not valid unless the order of elution of the peaks is: *trans-epoxyphytomenadione*, *cis-phytomenadione* and *trans-phytomenadione*. Carry out six replicate injections of reference solution (a). The assay is not valid unless the relative standard deviation of the peak area of the *trans-isomer* is less than 1.0 per cent and the resolution between the peaks corresponding to *trans-phytomenadione* and *cis-phytomenadione* is at least 2.5. Inject the test solution and reference solution (a) and calculate the percentage contents of *trans-phytomenadione*, *cis-phytomenadione* and *trans-epoxyphytomenadione* using the following expressions:

$$\text{trans-phytomenadione} = \frac{m' \times A'_{trans} \times S_{trans}}{m \times S'_{trans}}$$

$$\text{cis-phytomenadione} = \frac{m' \times A'_{cis} \times S_{cis}}{m \times S'_{cis}}$$

$$\text{trans-epoxyphytomenadione} = \frac{m' \times A'_{epoxy} \times S_{epoxy}}{m \times S'_{epoxy}}$$

- $m'$  = mass of the reference substance in reference solution (a), in milligrams,
- $m$  = mass of the substance to be examined in the test solution, in milligrams,
- $A'_{trans}$  = percentage content of *trans-phytomenadione* in *phytomenadione CRS*,
- $A'_{cis}$  = percentage content of *cis-phytomenadione* in *phytomenadione CRS*,
- $A'_{epoxy}$  = percentage content of *trans-epoxyphytomenadione* in *phytomenadione CRS*,
- $S_{trans}$  = area of the peak corresponding to the *trans-isomer* in the chromatogram obtained with the test solution,
- $S_{cis}$  = area of the peak corresponding to the *cis-isomer* in the chromatogram obtained with the test solution,
- $S_{epoxy}$  = area of the peak corresponding to *trans-epoxyphytomenadione* in the chromatogram obtained with the test solution,

$S'_{trans}$  = area of the peak corresponding to the *trans-isomer* in the chromatogram obtained with reference solution (a),

$S'_{cis}$  = area of the peak corresponding to the *cis-isomer* in the chromatogram obtained with reference solution (a),

$S'_{epoxy}$  = area of the peak corresponding to *trans-epoxyphytomenadione* in the chromatogram obtained with reference solution (a).

## STORAGE

Store protected from light.

## IMPURITIES

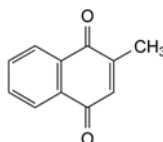

A. 2-methylnaphthalene-1,4-dione (menadione).

01/2008:1911  
corrected 6.0

## PHYTOSTEROL

## Phytosterolum

## DEFINITION

Natural mixture of sterols obtained from plants of the genera *Hypoxis*, *Pinus* and *Picea*.

**Content:** minimum 70.0 per cent of β-sitosterol (dried substance).

## CHARACTERS

**Appearance:** white or almost white powder.

**Solubility:** practically insoluble in water, soluble in tetrahydrofuran, sparingly soluble in ethyl acetate.

## IDENTIFICATION

A. Mix 1 mL of *acetic anhydride R* with 0.5 mL of solution S (see Tests). After the addition of 0.1 mL of *sulfuric acid R* a red colour is produced, which changes rapidly to violet, then to blue and finally to green.

B. Examine the chromatograms obtained in the assay.

**Results:** the principal peak in the chromatogram obtained with the test solution is similar in retention time to the peak in the chromatogram obtained with reference solution (b).

## TESTS

**Solution S.** Dissolve 1.0 g in *tetrahydrofuran R* and dilute to 20 mL with the same solvent.

**Appearance of solution.** Solution S is clear (2.2.1) and not more intensely coloured than reference solution Y<sub>6</sub> (2.2.2, Method II).

**Acidity or alkalinity.** Shake 0.20 g with a mixture of 4.0 mL of *ethyl acetate R* and 10.0 mL of *carbon dioxide-free water R* for 3 min. Allow the layers to separate. To the aqueous layer add 0.1 mL of *bromothymol blue solution R1*. If the solution is yellow, not more than 0.5 mL of 0.01 M *sodium hydroxide* is required to change the colour to blue. If the solution is blue, not more than 0.5 mL of 0.01 M *hydrochloric acid* is required to change the colour to yellow.

**Specific optical rotation (2.2.7):** – 15.0 to – 28.0 (dried substance).

Dissolve 0.500 g in *ethyl acetate R* and dilute to 10.0 mL with the same solvent.

**Acid value (2.5.1):** maximum 1.0, determined on 2.0 g.

**Peroxide value (2.5.5):** maximum 10.0.

**Saponification value** (2.5.6): maximum 1.0.

Carry out the test using 2.50 g of the substance to be examined, 0.1 M alcoholic potassium hydroxide, 0.1 M hydrochloric acid, and a factor of 5.61 (instead of 28.05).

**Other sterols.** Examine the chromatogram obtained with the test solution in the assay (Figure 1911-1).

**Composition of the other sterols:**

- cholesterol: maximum 0.5 per cent;
- brassicasterol: maximum 0.5 per cent;
- campesterol: maximum 15.0 per cent;
- campestanol: maximum 5.0 per cent;
- stigmasterol: maximum 5.0 per cent;
- sitostanol: maximum 15.0 per cent;
- $\Delta^7$ -stigmasterol: maximum 5.0 per cent.

**Loss on drying** (2.2.32): maximum 4.0 per cent, determined on 0.250 g by drying in an oven at 105 °C for 2 h.

**Total ash** (2.4.16): maximum 0.5 per cent, determined on 1.0 g.

**ASSAY**

Gas chromatography (2.2.28): use the normalisation procedure.

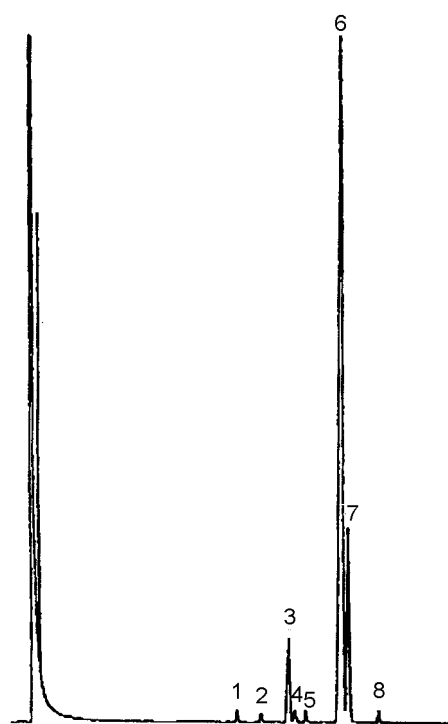

- |                   |                             |
|-------------------|-----------------------------|
| 1. cholesterol    | 5. stigmasterol             |
| 2. brassicasterol | 6. $\beta$ -sitosterol      |
| 3. campesterol    | 7. sitostanol               |
| 4. campestanol    | 8. $\Delta^7$ -stigmasterol |

Figure 1911-1. – Chromatogram for the assay of phytosterol (trimethylsilyl derivatives)

**Test solution.** Dissolve 0.100 g in tetrahydrofuran *R* and dilute to 10.0 mL with the same solvent. Introduce 100  $\mu$ L of this solution into a 3 mL flask and evaporate to dryness under nitrogen *R*. Add 100  $\mu$ L of a freshly prepared mixture of 50  $\mu$ L of 1-methylimidazole *R* and 1.0 mL of heptafluoro-*N*-methyl-*N*-(trimethylsilyl)butanamide *R*, close the flask tightly and heat to 100 °C for 15 min. Allow to cool.

**Reference solution (a).** Dissolve 25 mg of  $\beta$ -sitosterol *R* and 25 mg of sitostanol *R* in tetrahydrofuran *R* and dilute to 10.0 mL with the same solvent. Introduce 100  $\mu$ L of this solution into a 3 mL flask and evaporate to dryness under nitrogen *R*. Add 100  $\mu$ L of a freshly prepared

mixture of 50  $\mu$ L of 1-methylimidazole and 1.0 mL of heptafluoro-*N*-methyl-*N*-(trimethylsilyl)butanamide *R*. Close the flask tightly and heat to 100 °C for 15 min. Allow to cool.

**Reference solution (b).** Dissolve 0.100 g of  $\beta$ -sitosterol *R* in tetrahydrofuran *R* and dilute to 10.0 mL with the same solvent. Introduce 100  $\mu$ L of this solution into a 3 mL flask and evaporate to dryness under nitrogen *R*. Add 100  $\mu$ L of a freshly prepared mixture of 50  $\mu$ L of 1-methylimidazole *R* and 1.0 mL of heptafluoro-*N*-methyl-*N*-(trimethylsilyl)butanamide *R*. Close the flask tightly and heat to 100 °C for 15 min. Allow to cool.

**Column:**

- material: quartz;
- size:  $l = 25$  m,  $\varnothing = 0.3$  mm;
- stationary phase: poly(dimethyl)(diphenyl)(divinyl)siloxane *R* (1  $\mu$ m).

**Carrier gas:** hydrogen for chromatography *R*.

**Flow rate:** 2 mL/min.

**Split ratio:** 1:20.

**Temperature:**

- column: 280 °C;
- injection port and detector: 300 °C.

**Detection:** flame ionisation.

**Injection:** 1  $\mu$ L.

**Relative retentions** with reference to  $\beta$ -sitosterol (retention time = about 16 min): cholesterol = about 0.7; brassicasterol = about 0.77; campesterol = about 0.84; campestanol = about 0.86; stigmasterol = about 0.9; sitostanol = about 1.02;  $\Delta^7$ -stigmasterol = about 1.1.

**System suitability:** reference solution (a):

- resolution: minimum 1.0 between the peaks due to  $\beta$ -sitosterol and sitostanol.

**STORAGE**

In an airtight container, protected from light.

01/2008:1358

## PICOTAMIDE MONOHYDRATE

Picotamidum monohydricum

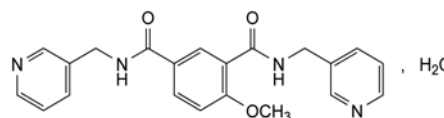

$C_{21}H_{20}N_4O_3 \cdot H_2O$

$M_r$  394.4

**DEFINITION**

Picotamide monohydrate contains not less than 98.0 per cent and not more than 101.0 per cent of 4-methoxy-*N,N'*-bis(pyridin-3-ylmethyl)benzene-1,3-dicarboxamide, calculated with reference to the anhydrous substance.

**CHARACTERS**

A white or almost white, crystalline powder, slightly soluble in water, soluble in ethanol and in methylene chloride. It dissolves in dilute mineral acids.

It shows polymorphism (5.9).

**IDENTIFICATION**

Examine by infrared spectrophotometry (2.2.24), comparing with the spectrum obtained with picotamide monohydrate CRS. If the spectra obtained in the solid state shows differences, dissolve the substance to be examined and the reference substance separately in acetone *R*, evaporate to dryness and record new spectra using the residues.

## TESTS

**Appearance of solution.** Dissolve 2.5 g in *methanol R* and dilute to 50 mL with the same solvent. The solution is clear (2.2.1) and not more intensely coloured than reference solution Y<sub>6</sub> (2.2.2, Method II).

**Related substances.** Examine by thin-layer chromatography (2.2.27), using a *TLC silica gel F<sub>254</sub> plate R*.

**Test solution.** Dissolve 0.5 g of the substance to be examined in *methanol R* and dilute to 10 mL with the same solvent.

**Reference solution (a).** Dilute 1 mL of the test solution to 10 mL with *methanol R*. Dilute 1 mL of the solution to 20 mL with *methanol R*.

**Reference solution (b).** Dilute 5 mL of reference solution (a) to 10 mL with *methanol R*.

**Reference solution (c).** Dissolve 0.5 g of the substance to be examined and 5 mg of *picotamide impurity A CRS* in *methanol R* and dilute to 10 mL with the same solvent.

Apply to the plate 5 µL of each solution. Develop over a path of 15 cm using a mixture 0.8 volumes of *glacial acetic acid R*, 1 volume of *water R*, 2.5 volumes of *methanol R* and 8 volumes of *butanol R*. Allow the plate to dry in air and examine in ultraviolet light at 254 nm. Any spot in the chromatogram obtained with the test solution, apart from the principal spot, is not more intense than the principal spot in the chromatogram obtained with reference solution (a) (0.5 per cent) and not more than one such spot is more intense than the spot in the chromatogram obtained with reference solution (b) (0.25 per cent). The test is not valid unless the chromatogram obtained with reference solution (c) shows two clearly separated principal spots.

**Chlorides (2.4.4).** Dissolve 0.25 g in a mixture of 2.5 mL of *dilute nitric acid R* and 12.5 mL of *water R*. The solution complies with the limit test for chlorides (200 ppm).

**Heavy metals (2.4.8).** Dissolve 1.0 g by gently heating in a mixture of 15 volumes of *water R* and 85 volumes of *methanol R* and dilute to 20 mL with the same mixture of solvents. 12 mL of the solution complies with limit test B for heavy metals (20 ppm). Prepare the standard, using lead standard solution (1 ppm Pb) obtained by diluting *lead standard solution (100 ppm Pb) R* with a mixture of 15 volumes of *water R* and 85 volumes of *methanol R*.

**Water (2.5.12):** 4.5 per cent to 5.0 per cent, determined on 0.300 g by the semi-micro determination of water.

**Sulfated ash (2.4.14).** Not more than 0.1 per cent, determined on 1.0 g.

## ASSAY

Dissolve 0.150 g in a mixture of 20 mL of *anhydrous acetic acid R* and 20 mL of *acetic anhydride R*. Titrate with 0.1 M *perchloric acid*, determining the end-point potentiometrically (2.2.20).

1 mL of 0.1 M *perchloric acid* is equivalent to 18.82 mg of C<sub>21</sub>H<sub>20</sub>N<sub>4</sub>O<sub>3</sub>.

## IMPURITIES

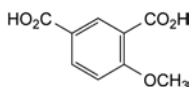

A. 4-methoxybenzene-1,3-dicarboxylic acid,

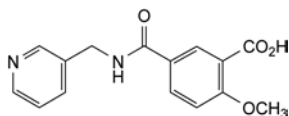

B. 2-methoxy-5-[(pyridin-3-ylmethyl)amino]benzoic acid,

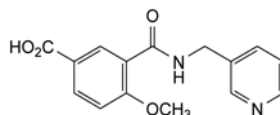

C. 4-methoxy-3-[(pyridin-3-ylmethyl)amino]benzoic acid,

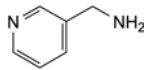

D. (pyridin-3-yl)methanamine.

01/2008:0633  
corrected 6.3

## PILOCARPINE HYDROCHLORIDE

## Pilocarpini hydrochloridum

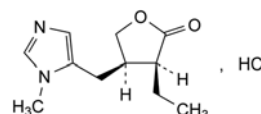

C<sub>11</sub>H<sub>17</sub>ClN<sub>2</sub>O<sub>2</sub>  
[54-71-7]

M<sub>r</sub> 244.7

## DEFINITION

(3*S*,4*R*)-3-Ethyl-4-[(1-methyl-1*H*-imidazol-5-yl)methyl]-dihydrofuran-2(3*H*)-one hydrochloride.

**Content:** 99.0 per cent to 101.0 per cent (dried substance).

## CHARACTERS

**Appearance:** white or almost white, crystalline powder or colourless crystals, hygroscopic.

**Solubility:** very soluble in water and in ethanol (96 per cent). mp: about 203 °C.

## IDENTIFICATION

**First identification:** A, B, E.

**Second identification:** A, C, D, E.

A. Specific optical rotation (see Tests).

B. Infrared absorption spectrophotometry (2.2.24).

**Comparison:** *pilocarpine hydrochloride CRS*.

If the substances are examined as discs, prepare them using *potassium chloride R*.

C. Thin-layer chromatography (2.2.27).

**Test solution.** Dissolve 10 mg in *methanol R* and dilute to 2 mL with the same solvent.

**Reference solution.** Dissolve 10 mg of *pilocarpine hydrochloride CRS* in *methanol R* and dilute to 2 mL with the same solvent.

**Plate:** *TLC silica gel G plate R*.

**Mobile phase:** *concentrated ammonia R*, *methanol R*, *methylene chloride R* (1:14:85 V/V/V).

**Application:** 2 µL.

**Development:** over a path of 15 cm.

**Drying:** at 100-105 °C for 10 min, then allow to cool.

**Detection:** spray with *dilute potassium iodobismuthate solution R*.

**Results:** the principal spot in the chromatogram obtained with the test solution is similar in position, colour and size to the principal spot in the chromatogram obtained with the reference solution.

D. Dilute 0.2 mL of solution S (see Tests) to 2 mL with *water R*. Add 0.05 mL of a 50 g/L solution of *potassium dichromate R*, 1 mL of *dilute hydrogen peroxide solution R* and 2 mL of *methylene chloride R* and shake. A violet colour develops in the organic layer.

E. It gives reaction (a) of chlorides (2.3.1).

#### TESTS

**Solution S.** Dissolve 2.50 g in carbon dioxide-free water R and dilute to 50.0 mL with the same solvent.

**Appearance of solution.** Solution S is clear (2.2.1) and not more intensely coloured than reference solution Y<sub>7</sub> (2.2.2, Method II).

**pH** (2.2.3): 3.5 to 4.5 for solution S.

**Specific optical rotation** (2.2.7): + 89 to + 93 (dried substance), determined on solution S.

**Related substances.** Liquid chromatography (2.2.29).

**Test solution.** Dissolve 0.100 g of the substance to be examined in water R and dilute to 100.0 mL with the same solvent.

**Reference solution (a).** Dilute 5.0 mL of the test solution to 100.0 mL with water R. Dilute 2.0 mL of this solution to 20.0 mL with water R.

**Reference solution (b).** Dissolve 5.0 mg of pilocarpine nitrate for system suitability CRS (containing impurity A) in water R and dilute to 50.0 mL with the same solvent.

**Reference solution (c).** To 5 mL of the test solution, add 0.1 mL of ammonia R and heat the solution on a water-bath for 30 min, cool and dilute to 25 mL with water R. Dilute 3 mL of this solution to 25 mL with water R. Mainly pilocarpic acid (impurity B) is formed.

**Column:**

- size:  $l = 0.15$  m,  $\varnothing = 4.6$  mm;
- stationary phase: octadecylsilyl silica gel for chromatography R1 (5  $\mu$ m) with a pore size of 10 nm and a carbon loading of 19 per cent.

**Mobile phase:** mix 55 volumes of methanol R, 60 volumes of acetonitrile R and 885 volumes of a 0.679 g/L solution of tetrabutylammonium dihydrogen phosphate R previously adjusted to pH 7.7 with dilute ammonia R2.

**Flow rate:** 1.2 mL/min.

**Detection:** spectrophotometer at 220 nm.

**Injection:** 20  $\mu$ L.

**Run time:** twice the retention time of pilocarpine.

**Elution order:** impurity B, impurity C, impurity A, pilocarpine.

**Retention time:** pilocarpine = about 20 min.

**System suitability:** reference solution (b):

- resolution: minimum 1.6 between the peaks due to impurity A and pilocarpine.

**Limits:**

- impurity A: not more than twice the area of the principal peak in the chromatogram obtained with reference solution (a) (1 per cent);
- sum of impurities A and B: not more than 3 times the area of the principal peak in the chromatogram obtained with reference solution (a) (1.5 per cent);
- sum of impurities other than A and B: not more than the area of the principal peak in the chromatogram obtained with reference solution (a) (0.5 per cent);
- disregard limit: 0.4 times the area of the principal peak in the chromatogram obtained with reference solution (a) (0.2 per cent).

**Iron** (2.4.9): maximum 10 ppm, determined on solution S. Prepare the standard using 5 mL of iron standard solution (1 ppm Fe) R and 5 mL of water R.

**Loss on drying** (2.2.32): maximum 0.5 per cent, determined on 1.000 g by drying in an oven at 105 °C.

**Sulfated ash** (2.4.14): maximum 0.1 per cent, determined on 1.0 g.

#### ASSAY

Dissolve 0.200 g in 50 mL of ethanol (96 per cent) R and add 5 mL of 0.01 M hydrochloric acid. Titrate with 0.1 M sodium hydroxide, determining the end-point potentiometrically (2.2.20). Read the volume added between the 2 points of inflexion.

1 mL of 0.1 M sodium hydroxide is equivalent to 24.47 mg of C<sub>11</sub>H<sub>17</sub>N<sub>3</sub>O<sub>5</sub>.

#### STORAGE

In an airtight container, protected from light.

#### IMPURITIES

**Specified impurities:** A, B.

**Other detectable impurities** (the following substances would, if present at a sufficient level, be detected by one or other of the tests in the monograph. They are limited by the general acceptance criterion for other/unspecified impurities and/or by the general monograph *Substances for pharmaceutical use* (2034). It is therefore not necessary to identify these impurities for demonstration of compliance. See also 5.10. *Control of impurities in substances for pharmaceutical use*): C.

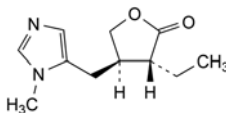

A. (3*R*,4*R*)-3-ethyl-4-[(1-methyl-1*H*-imidazol-5-yl)methyl]dihydrofuran-2(3*H*)-one (isopilocarpine),

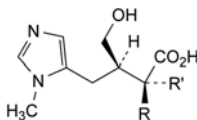

B. R = C<sub>2</sub>H<sub>5</sub>, R' = H: (2*S*,3*R*)-2-ethyl-3-(hydroxymethyl)-4-(1-methyl-1*H*-imidazol-5-yl)butanoic acid (pilocarpic acid),

C. R = H, R' = C<sub>2</sub>H<sub>5</sub>: (2*R*,3*R*)-2-ethyl-3-(hydroxymethyl)-4-(1-methyl-1*H*-imidazol-5-yl)butanoic acid (isopilocarpic acid).

01/2008:0104  
corrected 6.3

## PILOCARPINE NITRATE

### Pilocarpini nitras

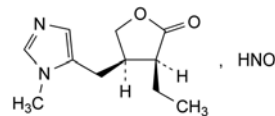

C<sub>11</sub>H<sub>17</sub>N<sub>3</sub>O<sub>5</sub>  
[148-72-1]

$M_r$  271.3

#### DEFINITION

(3*S*,4*R*)-3-Ethyl-4-[(1-methyl-1*H*-imidazol-5-yl)methyl]-dihydrofuran-2(3*H*)-one nitrate.

**Content:** 98.5 per cent to 101.0 per cent (dried substance).

#### CHARACTERS

**Appearance:** white or almost white, crystalline powder or colourless crystals, sensitive to light.

**Solubility:** freely soluble in water, sparingly soluble in ethanol (96 per cent).

mp: about 174 °C, with decomposition.

#### IDENTIFICATION

**First identification:** A, B, E.

**Second identification:** A, C, D, E.

A. Specific optical rotation (see Tests).

B. Infrared absorption spectrophotometry (2.2.24).

*Comparison: pilocarpine nitrate CRS.*

C. Thin-layer chromatography (2.2.27).

**Test solution.** Dissolve 10 mg of the substance to be examined in *water R* and dilute to 10 mL with the same solvent.

**Reference solution.** Dissolve 10 mg of *pilocarpine nitrate CRS* in *water R* and dilute to 10 mL with the same solvent.

**Plate:** *TLC silica gel G plate R.*

**Mobile phase:** concentrated ammonia *R*, methanol *R*, methylene chloride *R* (1:14:85 *V/V/V*).

**Application:** 10 µL.

**Development:** over a path of 15 cm.

**Drying:** at 100-105 °C for 10 min and allow to cool.

**Detection:** spray with *potassium iodobismuthate solution R.*

**Results:** the principal spot in the chromatogram obtained with the test solution is similar in position, colour and size to the principal spot in the chromatogram obtained with the reference solution.

D. Dilute 0.2 mL of solution S (see Tests) to 2 mL with *water R*. Add 0.05 mL of a 50 g/L solution of *potassium dichromate R*, 1 mL of *dilute hydrogen peroxide solution R* and 2 mL of *methylene chloride R* and shake. A violet colour develops in the organic layer.

E. It gives the reaction of nitrates (2.3.1).

## TESTS

**Solution S.** Dissolve 2.50 g in *carbon dioxide-free water R* and dilute to 50.0 mL with the same solvent. Prepare immediately before use.

**Appearance of solution.** Solution S is clear (2.2.1) and not more intensely coloured than reference solution Y<sub>6</sub> (2.2.2, *Method II*).

**pH** (2.2.3): 3.5 to 4.5 for solution S.

**Specific optical rotation** (2.2.7): + 80 to + 83 (dried substance), determined on solution S.

**Related substances.** Liquid chromatography (2.2.29).

**Test solution.** Dissolve 0.100 g of the substance to be examined in *water R* and dilute to 100.0 mL with the same solvent.

**Reference solution (a).** Dissolve 5.0 mL of the test solution to 100.0 mL with *water R*. Dilute 2.0 mL of this solution to 20.0 mL with *water R*.

**Reference solution (b).** Dissolve 5.0 mg of *pilocarpine nitrate for system suitability CRS* (containing impurity A) in *water R* and dilute to 50.0 mL with the same solvent.

**Reference solution (c).** To 5 mL of the test solution, add 0.1 mL of ammonia *R* and heat the solution on a water-bath for 30 min, cool and dilute to 25 mL with *water R*. Dilute 3 mL of this solution to 25 mL with *water R*. Mainly pilocarpic acid (impurity B) is formed.

**Column:**

- size:  $l = 0.15$  m,  $\varnothing = 4.6$  mm;
- stationary phase: octadecylsilyl silica gel for chromatography R1 (5 µm) with a pore size of 10 nm and a carbon loading of 19 per cent.

**Mobile phase:** mix 55 volumes of *methanol R*, 60 volumes of *acetonitrile R* and 885 volumes of a 0.679 g/L solution of *tetrabutylammonium dihydrogen phosphate R* previously adjusted to pH 7.7 with *diluted ammonia R2*.

**Flow rate:** 1.2 mL/min.

**Detection:** spectrophotometer at 220 nm.

**Injection:** 20 µL.

**Run time:** twice the retention time of pilocarpine.

**Elution order:** impurity B, impurity C, impurity A, pilocarpine.

**Retention time:** pilocarpine = about 20 min.

**System suitability:** reference solution (b):

- resolution: minimum 1.6 between the peaks due to impurity A and pilocarpine.

**Limits:**

- impurity A: not more than twice the area of the principal peak in the chromatogram obtained with reference solution (a) (1 per cent);
- sum of impurities A and B: not more than 3 times the area of the principal peak in the chromatogram obtained with reference solution (a) (1.5 per cent);
- sum of impurities other than A and B: not more than the area of the principal peak in the chromatogram obtained with reference solution (a) (0.5 per cent);
- disregard limit: 0.4 times the area of the principal peak in the chromatogram obtained with reference solution (a) (0.2 per cent); disregard any peak due to the nitrate ion with a relative retention time with reference to pilocarpine of about 0.3.

**Chlorides** (2.4.4): maximum 70 ppm, determined on solution S.

**Iron** (2.4.9): maximum 10 ppm, determined on solution S. Prepare the standard using 5 mL of *iron standard solution (1 ppm Fe) R* and 5 mL of *water R*.

**Loss on drying** (2.2.32): maximum 0.5 per cent, determined on 1.000 g by drying in an oven at 105 °C.

**Sulfated ash** (2.4.14): maximum 0.1 per cent, determined on 1.0 g.

## ASSAY

Dissolve 0.250 g in 30 mL of *anhydrous acetic acid R*. Titrate with 0.1 M *perchloric acid* determining the end-point potentiometrically (2.2.20).

1 mL of 0.1 M *perchloric acid* is equivalent to 27.13 mg of C<sub>11</sub>H<sub>17</sub>N<sub>3</sub>O<sub>5</sub>.

## STORAGE

Protected from light.

## IMPURITIES

**Specified impurities:** A, B.

**Other detectable impurities** (the following substances would, if present at a sufficient level, be detected by one or other of the tests in the monograph. They are limited by the general acceptance criterion for other/unspecified impurities and/or by the general monograph *Substances for pharmaceutical use (2034)*. It is therefore not necessary to identify these impurities for demonstration of compliance. See also 5.10. *Control of impurities in substances for pharmaceutical use*): C.

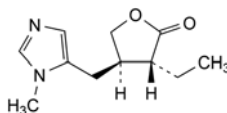

A. (3*R*,4*R*)-3-ethyl-4-[(1-methyl-1*H*-imidazol-5-yl)methyl]dihydrofuran-2(3*H*)-one (isopilocarpine),

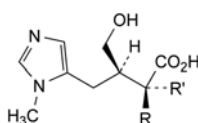

B. R = C<sub>2</sub>H<sub>5</sub>, R' = H: (2*S*,3*R*)-2-ethyl-3-(hydroxymethyl)-4-(1-methyl-1*H*-imidazol-5-yl)butanoic acid (pilocarpic acid),

C. R = H, R' = C<sub>2</sub>H<sub>5</sub>: (2*R*,3*R*)-2-ethyl-3-(hydroxymethyl)-4-(1-methyl-1*H*-imidazol-5-yl)butanoic acid (isopilocarpic acid).

## PIMOBENDAN

## Pimobendanum

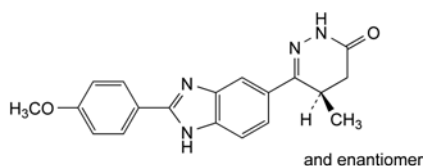

$C_{19}H_{18}N_4O_2$   
[74150-27-9]

$M_r$  334.4

## DEFINITION

(5*RS*)-6-[2-(4-Methoxyphenyl)-1*H*-benzimidazol-5-yl]-5-methyl-4,5-dihydropyridazin-3(2*H*)-one.

*Content*: 98.0 per cent to 101.0 per cent (anhydrous substance).

## CHARACTERS

*Appearance*: white or slightly yellowish powder, hygroscopic.

*Solubility*: practically insoluble in water, freely soluble in dimethylformamide, slightly soluble in acetone and in methanol. mp: about 242 °C.

## IDENTIFICATION

Infrared absorption spectrophotometry (2.2.24).

*Comparison*: pimobendan CRS.

## TESTS

**Related substances.** Liquid chromatography (2.2.29).

*Test solution.* Dissolve 50 mg of the substance to be examined in methanol *R* and dilute to 10.0 mL with the same solvent.

*Reference solution (a).* Dilute 1.0 mL of the test solution to 100.0 mL with methanol *R*.

*Reference solution (b).* Dissolve the contents of a vial of pimobendan for system suitability CRS (impurities A and B) in 1.0 mL of methanol *R*.

*Column*:

- *size*:  $l = 0.125$  m,  $\varnothing = 4.6$  mm,
- *stationary phase*: spherical end-capped octadecylsilyl silica gel for chromatography R1 (5  $\mu$ m),
- *temperature*: 45 °C.

*Mobile phase*:

- *mobile phase A*: dissolve 3.0 g of potassium dihydrogen phosphate *R* in 950 mL of water for chromatography *R*, adjust to pH 2.5 with dilute phosphoric acid *R* and dilute to 1000 mL with water for chromatography *R*,
- *mobile phase B*: acetonitrile for chromatography *R*,

Time (min)	Mobile phase A (per cent V/V)	Mobile phase B (per cent V/V)
0 - 6	85 → 80	15 → 20
6 - 20	80 → 20	20 → 80
20 - 20.1	20 → 85	80 → 15
20.1 - 30	85	15

*Flow rate*: 1 mL/min.

*Detection*: spectrophotometer at 290 nm.

*Injection*: 10  $\mu$ L.

*Relative retention* with reference to pimobendan (retention time = about 8.3 min): impurity A = about 1.3; impurity B = about 1.4.

*System suitability*: reference solution (b):

- *resolution*: minimum 2.0 between the peaks due to impurity A and impurity B.

## 01/2008:2179 Limits:

- *impurities A, B*: for each impurity, not more than 0.1 times the area of the principal peak in the chromatogram obtained with reference solution (a) (0.1 per cent),
- *any other impurity*: for each impurity, not more than 0.1 times the area of the principal peak in the chromatogram obtained with reference solution (a) (0.1 per cent),
- *total*: not more than 0.2 times the area of the principal peak in the chromatogram obtained with reference solution (a) (0.2 per cent),
- *disregard limit*: 0.05 times the area of the principal peak in the chromatogram obtained with reference solution (a) (0.05 per cent).

**Heavy metals** (2.4.8): maximum 10 ppm.

2.0 g complies with test F. Prepare the reference solution using 2 mL of lead standard solution (10 ppm Pb) *R*.

**Water** (2.5.12): maximum 1.0 per cent, determined on 0.500 g.

**Sulfated ash** (2.4.14): maximum 0.1 per cent, determined on 1.0 g.

## ASSAY

Dissolve 0.250 g in 5 mL of anhydrous formic acid *R*. Add 10 mL of acetic anhydride *R* and 70 mL of anhydrous acetic acid *R*. Titrate with 0.1 *M* perchloric acid, determining the end-point potentiometrically (2.2.20).

1 mL of 0.1 *M* perchloric acid is equivalent to 33.44 mg of  $C_{19}H_{18}N_4O_2$ .

## STORAGE

In an airtight container.

## IMPURITIES

*Specified impurities*: A, B.

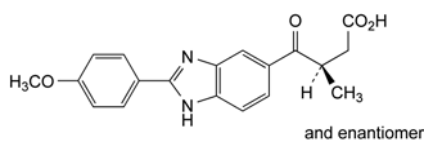

A. (3*RS*)-4-[2-(4-methoxyphenyl)-1*H*-benzimidazol-5-yl]-3-methyl-4-oxobutanoic acid,

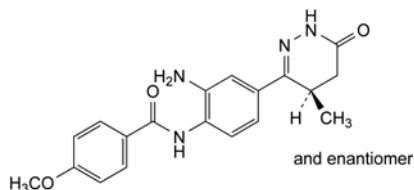

B. *N*-[2-amino-4-[(4*RS*)-4-methyl-6-oxo-1,4,5,6-tetrahydropyridazin-3-yl]phenyl]-4-methoxybenzamide.

01/2008:1254  
corrected 6.0

## PIMOZIDE

## Pimozidum

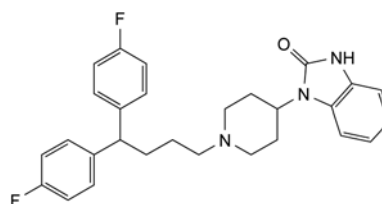

$C_{28}H_{29}F_2N_3O$   
[2062-78-4]

$M_r$  461.6

## DEFINITION

1-[1-[4,4-Bis(4-fluorophenyl)butyl]piperidin-4-yl]-1,3-dihydro-2H-benzimidazol-2-one.

Content: 99.0 per cent to 101.0 per cent (dried substance).

## CHARACTERS

Appearance: white or almost white powder.

Solubility: practically insoluble in water, soluble in methylene chloride, sparingly soluble in methanol, slightly soluble in ethanol (96 per cent).

## IDENTIFICATION

First identification: B.

Second identification: A, C, D.

A. Melting point (2.2.14): 216 °C to 220 °C.

B. Infrared absorption spectrophotometry (2.2.24).

Preparation: discs.

Comparison: pimozide CRS.

C. Thin-layer chromatography (2.2.27).

Test solution. Dissolve 30 mg of the substance to be examined in the mobile phase and dilute to 10 mL with the mobile phase.

Reference solution (a). Dissolve 30 mg of pimozide CRS in the mobile phase and dilute to 10 mL with the mobile phase.

Reference solution (b). Dissolve 30 mg of pimozide CRS and 30 mg of benperidol CRS in the mobile phase and dilute to 10 mL with the mobile phase.

Plate: TLC silica gel plate R.

Mobile phase: acetone R, methanol R (1:9 V/V).

Application: 10 µL.

Development: over a path of 15 cm.

Drying: in a current of warm air for 15 min.

Detection: expose to iodine vapour until the spots appear.

System suitability: reference solution (b):

– the chromatogram shows 2 clearly separated spots.

Results: the principal spot in the chromatogram obtained with the test solution is similar in position and size to the principal spot in the chromatogram obtained with reference solution (a).

D. Mix about 5 mg with 45 mg of heavy magnesium oxide R and ignite in a crucible until an almost white residue is obtained (usually less than 5 min). Allow to cool, then add 1 mL of water R, 0.05 mL of phenolphthalein solution R1 and about 1 mL of dilute hydrochloric acid R to render the solution colourless. Filter. To a freshly prepared mixture of 0.1 mL of alizarin S solution R and 0.1 mL of zirconyl nitrate solution R, add 1.0 mL of the filtrate. Mix, allow to stand for 5 min and compare the colour of the solution with that of a blank prepared in the same manner. The test solution is yellow and the blank is red.

## TESTS

Appearance of solution. The solution is clear (2.2.1) and not more intensely coloured than reference solution Y<sub>7</sub> (2.2.2, Method II).

Dissolve 0.2 g in methanol R and dilute to 20 mL with the same solvent.

Related substances. Liquid chromatography (2.2.29).

Test solution. Dissolve 0.10 g of the substance to be examined in methanol R and dilute to 10.0 mL with the same solvent.

Reference solution (a). Dissolve 5.0 mg of pimozide CRS and 2.0 mg of mebendazole CRS in methanol R and dilute to 100.0 mL with the same solvent.

Reference solution (b). Dilute 5.0 mL of the test solution to 100.0 mL with methanol R. Dilute 1.0 mL of this solution to 10.0 mL with methanol R.

## Column:

– size:  $l = 0.1$  m,  $\varnothing = 4.6$  mm,

– stationary phase: octadecylsilyl silica gel for chromatography R (3 µm).

## Mobile phase:

– mobile phase A: solution containing 2.5 g/L of ammonium acetate R and 8.5 g/L of tetrabutylammonium hydrogen sulfate R;

– mobile phase B: acetonitrile R;

Time (min)	Mobile phase A (per cent V/V)	Mobile phase B (per cent V/V)
0 - 10	80 → 70	20 → 30
10 - 15	70	30
15 - 20	80	20

Flow rate: 2.0 mL/min.

Detection: spectrophotometer at 280 nm.

Equilibration: with the mobile phase at the initial composition for at least 10 min.

Injection: 10 µL; inject methanol R as a blank.

Retention time: mebendazole = about 7 min; pimozide = about 8 min.

System suitability: reference solution (a):

– resolution: minimum 5.0 between the peaks due to mebendazole and pimozide; if necessary, adjust the concentration of acetonitrile in the mobile phase or adjust the time programme for the linear-gradient elution.

## Limits:

– impurities A, B, C, D, E: for each impurity, not more than the area of the principal peak in the chromatogram obtained with reference solution (b) (0.5 per cent);

– total: not more than 1.5 times the area of the principal peak in the chromatogram obtained with reference solution (b) (0.75 per cent);

– disregard limit: 0.1 times the area of the principal peak in the chromatogram obtained with reference solution (b) (0.05 per cent).

Loss on drying (2.2.32): maximum 0.5 per cent, determined on 1.000 g by drying in an oven at 105 °C.

Sulfated ash (2.4.14): maximum 0.1 per cent, determined on 1.0 g in a platinum crucible.

## ASSAY

Dissolve 0.300 g in 50 mL of a mixture of 1 volume of anhydrous acetic acid R and 7 volumes of methyl ethyl ketone R. Titrate with 0.1 M perchloric acid, using 0.2 mL of naphtholbenzein solution R as indicator.

1 mL 0.1 M perchloric acid is equivalent to 46.16 mg of C<sub>28</sub>H<sub>29</sub>F<sub>2</sub>N<sub>3</sub>O.

## STORAGE

Protected from light.

## IMPURITIES

Specified impurities: A, B, C, D, E.

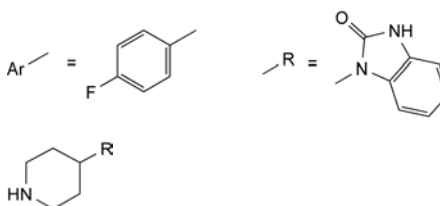

A. 1-(piperidin-4-yl)-1,3-dihydro-2H-benzimidazol-2-one,

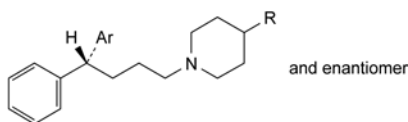

- B. 1-[1-[(4RS)-4-(4-fluorophenyl)-4-phenylbutyl]piperidin-4-yl]-1,3-dihydro-2H-benzimidazol-2-one,

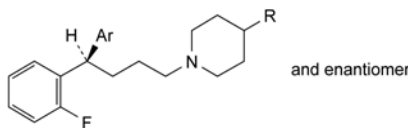

- C. 1-[1-[(4RS)-4-(2-fluorophenyl)-4-(4-fluorophenyl)butyl]piperidin-4-yl]-1,3-dihydro-2H-benzimidazol-2-one,

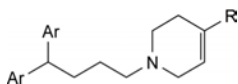

- D. 1-[1-[4,4-bis(4-fluorophenyl)butyl]-1,2,3,6-tetrahydropyridin-4-yl]-1,3-dihydro-2H-benzimidazol-2-one,

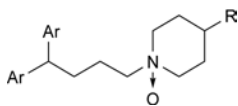

- E. 1-[1-[4,4-bis(4-fluorophenyl)butyl]piperidin-4-yl]-1,3-dihydro-2H-benzimidazol-2-one.

01/2008:0634  
corrected 6.0

## PINDOLOL

### Pindololum

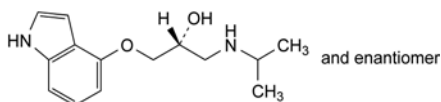

$C_{14}H_{20}N_2O_2$   
[13523-86-9]

$M_r$  248.3

#### DEFINITION

Pindolol contains not less than 99.0 per cent and not more than the equivalent of 101.0 per cent of (2RS)-1-(1H-indol-4-yloxy)-3-[(1-methylethyl)amino]propan-2-ol, calculated with reference to the dried substance.

#### CHARACTERS

A white or almost white, crystalline powder, practically insoluble in water, slightly soluble in methanol. It dissolves in dilute mineral acids.

#### IDENTIFICATION

First identification: A, C.

Second identification: A, B, D.

A. Melting point (2.2.14): 169 °C to 174 °C.

B. Dissolve 20.0 mg in a 0.085 per cent V/V solution of hydrochloric acid R in methanol R and dilute to 100.0 mL with the same solution. Dilute 10.0 mL of the solution to 100.0 mL with a 0.085 per cent V/V solution of hydrochloric acid R in methanol R. Examined between 230 nm and 320 nm (2.2.25), the solution shows two absorption maxima, at 264 nm and at 287 nm, and a shoulder at 275 nm. The specific absorbance at the maxima are 330 to 350 and 170 to 190, respectively.

C. Examine by infrared absorption spectrophotometry (2.2.24), comparing with the spectrum obtained with pindolol CRS.

D. Examine in daylight the chromatograms on plate A obtained in the test for related substances. The principal spot in the chromatogram obtained with test solution (b) is similar in position, colour and size to the principal spot in the chromatogram obtained with reference solution (a).

#### TESTS

**Appearance of solution.** Dissolve 0.5 g in dilute acetic acid R and dilute to 10 mL with the same acid. The solution is clear (2.2.1) and not more intensely coloured than reference solution BY<sub>5</sub> or B<sub>5</sub> (2.2.2, Method II).

**Related substances.** Examine by thin-layer chromatography (2.2.27), using silica gel GF<sub>254</sub> R as the coating substance. Carry out all operations as rapidly as possible, protected from light.

**Test solution (a).** Dissolve 0.10 g of the substance to be examined in a mixture of 1 volume of anhydrous acetic acid R and 99 volumes of methanol R and dilute to 5 mL with the same mixture of solvents. Prepare immediately before use and apply this solution to the plate last.

**Test solution (b).** Dilute 1 mL of test solution (a) to 10 mL with a mixture of 1 volume of anhydrous acetic acid R and 99 volumes of methanol R.

**Reference solution (a).** Dissolve 20 mg of pindolol CRS in a mixture of 1 volume of anhydrous acetic acid R and 99 volumes of methanol R and dilute to 10 mL with the same mixture of solvents.

**Reference solution (b).** Dilute 1.5 mL of reference solution (a) to 50 mL with a mixture of 1 volume of anhydrous acetic acid R and 99 volumes of methanol R.

A. Apply separately 5 µL of each solution. Develop the plate without delay over a path of 10 cm using a freshly prepared mixture of 4 volumes of concentrated ammonia R, 50 volumes of ethyl acetate R and 50 volumes of methanol R. Dry the plate briefly in a current of cold air. Spray the plate without delay with dimethylaminobenzaldehyde solution R7 and heat to 50 °C for 20 min. Any spot in the chromatogram obtained with test solution (a), apart from the principal spot, is not more intense than the spot in the chromatogram obtained with reference solution (b) (0.3 per cent).

B. Apply separately 10 µL of each solution. Develop the plate without delay over a path of 10 cm using a freshly prepared mixture of 4 volumes of concentrated ammonia R, 50 volumes of ethyl acetate R and 50 volumes of methanol R. Dry the plate briefly in a current of cold air. Examine the plate without delay in ultraviolet light at 254 nm. Any spot in the chromatogram obtained with test solution (a), apart from the principal spot and the spots detected on plate A, is not more intense than the spot in the chromatogram obtained with reference solution (b) (0.3 per cent).

**Heavy metals (2.4.8).** 1.0 g complies with limit test C for heavy metals (20 ppm). Prepare the standard using 2 mL of lead standard solution (10 ppm Pb) R.

**Loss on drying (2.2.32).** Not more than 0.5 per cent, determined on 1.000 g by drying in an oven at 105 °C.

**Sulfated ash (2.4.14).** Not more than 0.1 per cent, determined on 1.0 g.

#### ASSAY

Dissolve 0.200 g in 80 mL of methanol R. Titrate with 0.1 M hydrochloric acid, determining the end-point potentiometrically (2.2.20).

1 mL of 0.1 M hydrochloric acid is equivalent to 24.83 mg of  $C_{14}H_{20}N_2O_2$ .

#### STORAGE

Store protected from light.



## IMPURITIES

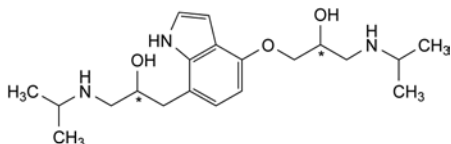

- A. 1-[[7-[2-hydroxy-3-[(1-methylethyl)amino]propyl]-1H-indol-4-yl]oxy]-3-[(1-methylethyl)amino]propan-2-ol,

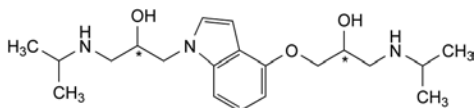

- B. 1-[4-[2-hydroxy-3-[(1-methylethyl)amino]propoxy]-1H-indol-1-yl]-3-[(1-methylethyl)amino]propan-2-ol,

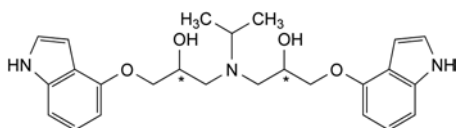

- C. 1,1'-[(1-methylethyl)imino]bis[3-(1H-indol-4-yloxy)propan-2-ol],

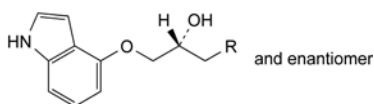

- D. R = OH: (2RS)-3-(1H-indol-4-yloxy)propane-1,2-diol,

- F. R = Cl: (2RS)-1-chloro-3-(1H-indol-4-yloxy)propan-2-ol,

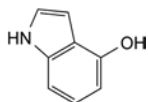

- E. 1H-indol-4-ol.

**Solubility:** very slightly soluble in water. It dissolves in dilute solutions of acids and of alkali hydroxides.

## IDENTIFICATION

Infrared absorption spectrophotometry (2.2.24).

**Comparison:** Ph. Eur. reference spectrum of pipemidic acid trihydrate.

## TESTS

**Related substances.** Liquid chromatography (2.2.29).

**Test solution.** Dissolve 20 mg of the substance to be examined in 10 mL of the mobile phase and dilute to 20.0 mL with the mobile phase. Dilute 1.0 mL of the solution to 10.0 mL with the mobile phase.

**Reference solution (a).** Dilute 2.0 mL of the test solution to 10.0 mL with the mobile phase. Dilute 1.0 mL of the solution to 100.0 mL with the mobile phase.

**Reference solution (b).** Dissolve 10.0 mg of *ethyl parahydroxybenzoate R* in 2.0 mL of the test solution and dilute to 20.0 mL with the mobile phase.

## Column:

- size:  $l = 0.15$  m,  $\varnothing = 4.6$  mm,
- stationary phase: octadecylsilyl silica gel for chromatography R1 (5  $\mu$ m) with a pore size of 18 nm and a carbon loading of 13 per cent.

**Mobile phase:** mix 20 volumes of acetonitrile R, 20 volumes of methanol R and 60 volumes of a solution containing 5.7 g/L of citric acid R and 1.7 g/L of sodium decanesulfonate R.

**Flow rate:** 0.8 mL/min.

**Detection:** spectrophotometer at 275 nm.

**Injection:** 20  $\mu$ L.

**Run time:** 2.5 times the retention time of pipemidic acid.

**System suitability:** reference solution (b):

- resolution: minimum 4.0 between the peaks due to pipemidic acid and to ethyl parahydroxybenzoate.

## Limits:

- any impurity: not more than the area of the principal peak in the chromatogram obtained with reference solution (a) (0.2 per cent),
- total: not more than 5 times the area of the principal peak in the chromatogram obtained with reference solution (a) (1.0 per cent),
- disregard limit: 0.25 times the area of the principal peak in the chromatogram obtained with reference solution (a) (0.05 per cent).

**Heavy metals (2.4.8):** maximum 20 ppm.

1.0 g complies with limit test C. Prepare the standard using 2.0 mL of lead standard solution (10 ppm Pb) R.

**Loss on drying (2.2.32):** 14.0 per cent to 16.0 per cent, determined on 1.000 g by drying in an oven at 105 °C.

**Sulfated ash (2.4.14):** maximum 0.1 per cent, determined on 1.0 g.

## ASSAY

Dissolve 0.240 g in 50 mL of anhydrous acetic acid R. Titrate with 0.1 M perchloric acid, determining the end-point potentiometrically (2.2.20).

1 mL of 0.1 M perchloric acid is equivalent to 30.33 mg of  $C_{14}H_{17}N_5O_3$ .

## STORAGE

Protected from light.

01/2008:1743  
corrected 6.0

## PIPEMIDIC ACID TRIHYDRATE

## Acidum pipemidicum trihydricum

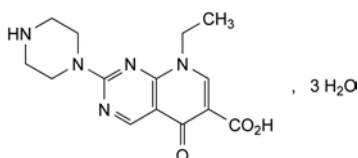

$C_{14}H_{17}N_5O_3 \cdot 3H_2O$   
[72571-82-5]

$M_r$  357.4

## DEFINITION

8-Ethyl-5-oxo-2-(piperazin-1-yl)-5,8-dihydropyrido[2,3-d]pyrimidine-6-carboxylic acid trihydrate.

**Content:** 98.5 per cent to 101.0 per cent (dried substance).

## CHARACTERS

**Appearance:** pale yellow or yellow, crystalline powder.

## IMPURITIES

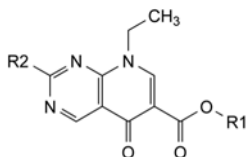

- A. R1 = H, R2 = OH: 8-ethyl-2-hydroxy-5-oxo-5,8-dihydropyrido[2,3-*d*]pyrimidine-6-carboxylic acid,  
 B. R1 = H, R2 = OCH<sub>3</sub>: 8-ethyl-2-methoxy-5-oxo-5,8-dihydropyrido[2,3-*d*]pyrimidine-6-carboxylic acid,  
 C. R1 = H, R2 = OC<sub>2</sub>H<sub>5</sub>: 2-ethoxy-8-ethyl-5-oxo-5,8-dihydropyrido[2,3-*d*]pyrimidine-6-carboxylic acid,  
 D. R1 = C<sub>2</sub>H<sub>5</sub>, R2 = Cl: ethyl 2-chloro-8-ethyl-5-oxo-5,8-dihydropyrido[2,3-*d*]pyrimidine-6-carboxylate,

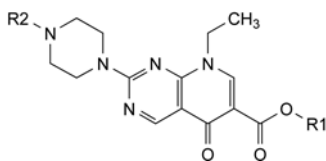

- E. R1 = C<sub>2</sub>H<sub>5</sub>, R2 = H: ethyl 8-ethyl-5-oxo-2-(piperazin-1-yl)-5,8-dihydropyrido[2,3-*d*]pyrimidine-6-carboxylate,  
 F. R1 = H, R2 = CO-CH<sub>3</sub>: 2-(4-acetyl-piperazin-1-yl)-8-ethyl-5-oxo-5,8-dihydropyrido[2,3-*d*]pyrimidine-6-carboxylic acid (acetyl-pipemidic acid).

01/2008:1169  
corrected 6.0

## PIPERACILLIN

## Piperacillinum

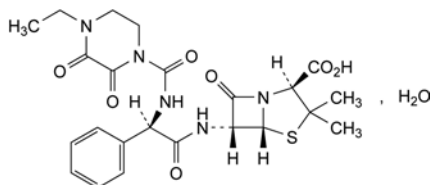

C<sub>23</sub>H<sub>27</sub>N<sub>5</sub>O<sub>7</sub>S<sub>2</sub>H<sub>2</sub>O  
[66258-76-2]

M<sub>r</sub> 535.6

## DEFINITION

(2*S*,5*R*,6*R*)-6-[[[(2*R*)-2-[(4-Ethyl-2,3-dioxopiperazin-1-yl)carbonyl]amino]-2-phenylacetyl]amino]-3,3-dimethyl-7-oxo-4-thia-1-azabicyclo[3.2.0]heptane-2-carboxylic acid monohydrate.

Semi-synthetic product derived from a fermentation product.

*Content*: 96.0 per cent to 102.0 per cent (anhydrous substance).

## CHARACTERS

*Appearance*: white or almost white powder.

*Solubility*: slightly soluble in water, freely soluble in methanol, slightly soluble in ethyl acetate.

## IDENTIFICATION

Infrared absorption spectrophotometry (2.2.24).

*Comparison*: piperacillin CRS.

## TESTS

**Solution S.** Dissolve 2.50 g in sodium carbonate solution R and dilute to 25 mL with the same solvent.

**Appearance of solution.** Solution S is not more opalescent than reference suspension II (2.2.1) and its absorbance (2.2.25) at 430 nm is not greater than 0.10.

**Specific optical rotation** (2.2.7): + 165 to + 175 (anhydrous substance).

Dissolve 0.250 g in methanol R and dilute to 25.0 mL with the same solvent.

**Related substances.** Liquid chromatography (2.2.29).

*Solvent mixture*: acetonitrile R, 31.2 g/L solution of sodium dihydrogen phosphate R (25:75 V/V).

*Test solution (a).* Dissolve 25.0 mg of the substance to be examined in the solvent mixture and dilute to 50.0 mL with the solvent mixture.

*Test solution (b).* Prepare the solution immediately before use. Dissolve 40.0 mg of the substance to be examined in the solvent mixture and dilute to 20.0 mL with the solvent mixture.

*Reference solution (a).* Dissolve 25.0 mg of piperacillin CRS in the solvent mixture and dilute to 50.0 mL with the solvent mixture.

*Reference solution (b).* Dilute 1.0 mL of reference solution (a) to 25.0 mL with the solvent mixture.

*Reference solution (c).* Dissolve 10.0 mg of piperacillin CRS and 10.0 mg of anhydrous ampicillin CRS (impurity A) in the solvent mixture and dilute to 50.0 mL with the solvent mixture.

*Reference solution (d).* Dilute 1.0 mL of reference solution (a) to 100.0 mL with the solvent mixture. Dilute 1.0 mL of this solution to 50.0 mL with the solvent mixture.

*Column*:

- size: *l* = 0.25 m, Ø = 4.6 mm;
- stationary phase: octadecylsilyl silica gel for chromatography R (5 µm).

*Mobile phase*:

- mobile phase A: mix 576 mL of water R, 200 mL of a 31.2 g/L solution of sodium dihydrogen phosphate R and 24 mL of an 80 g/L solution of tetrabutylammonium hydroxide R; if necessary, adjust to pH 5.5 with dilute phosphoric acid R or dilute sodium hydroxide solution R; add 200 mL of acetonitrile R;
- mobile phase B: mix 126 mL of water R, 200 mL of a 31.2 g/L solution of sodium dihydrogen phosphate R and 24 mL of an 80 g/L solution of tetrabutylammonium hydroxide R; if necessary, adjust to pH 5.5 with dilute phosphoric acid R or dilute sodium hydroxide solution R; add 650 mL of acetonitrile R;

Time (min)	Mobile phase A (per cent V/V)	Mobile phase B (per cent V/V)
0 - <i>t<sub>R</sub></i>	88	12
<i>t<sub>R</sub></i> - ( <i>t<sub>R</sub></i> + 30)	88 → 0	12 → 100
( <i>t<sub>R</sub></i> + 30) - ( <i>t<sub>R</sub></i> + 45)	0 → 88	100 → 12

*t<sub>R</sub>* = retention time of piperacillin determined with reference solution (b)

If the mobile phase composition has been adjusted to achieve the required resolution, the adjusted composition will apply at time zero in the gradient and in the assay.

*Flow rate*: 1.0 mL/min.

*Detection*: spectrophotometer at 220 nm.

*Injection*: 20 µL of reference solutions (b), (c) and (d) with isocratic elution at the initial mobile phase composition and 20 µL of test solution (b) according to the elution gradient described under Mobile phase.

*System suitability*:

- resolution: minimum 10 between the peaks due to impurity A and piperacillin in the chromatogram obtained with reference solution (c); if necessary, adjust the ratio A:B of the mobile phase;
- signal-to-noise ratio: minimum 3 for the principal peak in the chromatogram obtained with reference solution (d);

- *mass distribution ratio*: 2.0 to 3.0 for the peak due to piperacillin in the chromatogram obtained with reference solution (c).

**Limit:**

- *any impurity*: for each impurity, not more than twice the area of the principal peak in the chromatogram obtained with reference solution (b) (2 per cent).

***N,N*-Dimethylaniline** (2.4.26, *Method A*): maximum 20 ppm.

**Heavy metals** (2.4.8): maximum 20 ppm.

1.0 g complies with test C. Prepare the reference solution using 2 mL of *lead standard solution* (10 ppm Pb) R.

**Water** (2.5.12): 2.0 per cent to 4.0 per cent, determined on 0.500 g.

**ASSAY**

Liquid chromatography (2.2.29) as described in the test for related substances with the following modifications.

*Mobile phase*: initial composition of the mixture of mobile phases A and B, adjusted where applicable.

*Injection*: test solution (a) and reference solution (a).

*System suitability*: reference solution (a):

- *repeatability*: maximum relative standard deviation of 1.0 per cent after 6 injections.

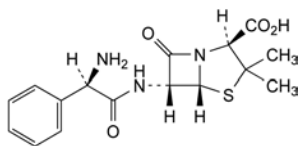
**IMPURITIES**

- A. (2*S*,5*R*,6*R*)-6-[[*(2R)*-2-amino-2-phenylacetyl]amino]-3,3-dimethyl-7-oxo-4-thia-1-azabicyclo[3.2.0]heptane-2-carboxylic acid (ampicillin),

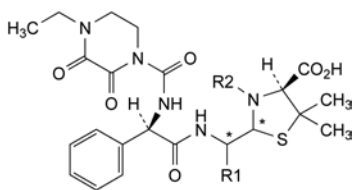

- B. R1 = CO<sub>2</sub>H, R2 = H: (4*S*)-2-[carboxy[[*(2R)*-2-[[*(4-ethyl-2,3-dioxopiperazin-1-yl)*carbonyl]amino]-2-phenylacetyl]amino]methyl]-5,5-dimethylthiazolidine-4-carboxylic acid (penicilloic acids of piperacillin),
- C. R1 = R2 = H: (2*R**S*,4*S*)-2-[[*(2R)*-2-[[*(4-ethyl-2,3-dioxopiperazin-1-yl)*carbonyl]amino]-2-phenylacetyl]amino]methyl]-5,5-dimethylthiazolidine-4-carboxylic acid (penicilloic acids of piperacillin),
- F. R1 = CO<sub>2</sub>H, R2 = CO-CH<sub>3</sub>: (4*S*)-3-acetyl-2-[carboxy[[*(2R)*-2-[[*(4-ethyl-2,3-dioxopiperazin-1-yl)*carbonyl]amino]-2-phenylacetyl]amino]methyl]-5,5-dimethylthiazolidine-4-carboxylic acid (acetylated penicilloic acids of piperacillin),

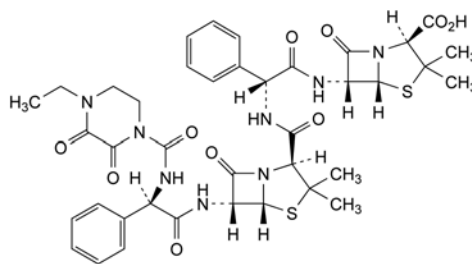

- D. (2*S*,5*R*,6*R*)-6-[[*(2R)*-2-[[*(2S*,5*R*,6*R*)-6-[[*(2R)*-2-[[*(4-ethyl-2,3-dioxopiperazin-1-yl)*carbonyl]amino]-2-phenylacetyl]amino]-3,3-dimethyl-7-oxo-4-thia-1-azabicyclo[3.2.0]heptane-2-carboxylic acid (piperacillinylampicillin),

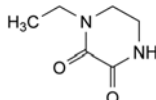

- E. 1-ethylpiperazine-2,3-dione.

01/2008:1168  
corrected 6.0

**PIPERACILLIN SODIUM**

## Piperacillinum natricum

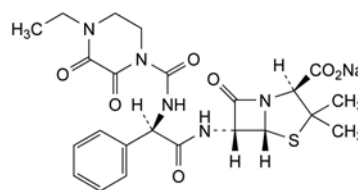

C<sub>23</sub>H<sub>26</sub>N<sub>5</sub>NaO<sub>7</sub>S  
[59703-84-3]

M<sub>r</sub> 539.5

**DEFINITION**

Sodium (2*S*,5*R*,6*R*)-6-[[*(2R)*-2-[[*(4-ethyl-2,3-dioxopiperazin-1-yl)*carbonyl]amino]-2-phenylacetyl]amino]-3,3-dimethyl-7-oxo-4-thia-1-azabicyclo[3.2.0]heptane-2-carboxylate.

Semi-synthetic product derived from a fermentation product.

*Content*: 95.0 per cent to 102.0 per cent (anhydrous substance).

**CHARACTERS**

*Appearance*: white or almost white, hygroscopic powder.

*Solubility*: freely soluble in water and in methanol, practically insoluble in ethyl acetate.

**IDENTIFICATION**

- A. Infrared absorption spectrophotometry (2.2.24).

*Preparation*: dissolve 0.250 g in *water R*, add 0.5 mL of *dilute hydrochloric acid R* and 5 mL of *ethyl acetate R*; stir and allow to stand for 10 min in iced water. Filter the crystals through a small sintered-glass filter (40), applying suction. Wash with 5 mL of *water R* and 5 mL of *ethyl acetate R*, then dry in an oven at 60 °C for 60 min.

*Comparison*: piperacillin CRS.

- B. It gives reaction (a) of sodium (2.3.1).

**TESTS**

**Solution S**. Dissolve 2.50 g in *carbon dioxide-free water R* and dilute to 25 mL with the same solvent.

**Appearance of solution**. Solution S is clear (2.2.1) and its absorbance (2.2.25) at 430 nm is not greater than 0.10.

**pH** (2.2.3): 5.0 to 7.0 for solution S.

**Specific optical rotation** (2.2.7): + 175 to + 190 (anhydrous substance).

Dissolve 0.250 g in *water R* and dilute to 25.0 mL with the same solvent.

**Related substances.** Liquid chromatography (2.2.29).

**Solvent mixture:** *acetonitrile R*, 31.2 g/L solution of *sodium dihydrogen phosphate R* (25:75 V/V).

**Test solution (a).** Dissolve 25.0 mg of the substance to be examined in the solvent mixture and dilute to 50.0 mL with the solvent mixture.

**Test solution (b).** Prepare the solution immediately before use. Dissolve 40.0 mg of the substance to be examined in the solvent mixture and dilute to 20.0 mL with the solvent mixture.

**Reference solution (a).** Dissolve 25.0 mg of *piperacillin CRS* in the solvent mixture and dilute to 50.0 mL with the solvent mixture.

**Reference solution (b).** Dilute 1.0 mL of reference solution (a) to 25.0 mL with the solvent mixture.

**Reference solution (c).** Dissolve 10.0 mg of *piperacillin CRS* and 10.0 mg of *anhydrous ampicillin CRS* (impurity A) in the solvent mixture and dilute to 50.0 mL with the solvent mixture.

**Reference solution (d).** Dilute 1.0 mL of reference solution (a) to 100.0 mL with the solvent mixture. Dilute 1.0 mL of this solution to 50.0 mL with the solvent mixture.

**Column:**

- size:  $l = 0.25$  m,  $\varnothing = 4.6$  mm;
- stationary phase: octadecylsilyl silica gel for chromatography *R* (5  $\mu$ m).

**Mobile phase:**

- mobile phase A: mix 576 mL of *water R*, 200 mL of a 31.2 g/L solution of *sodium dihydrogen phosphate R* and 24 mL of an 80 g/L solution of *tetrabutylammonium hydroxide R*; if necessary, adjust to pH 5.5 with *dilute phosphoric acid R* or *dilute sodium hydroxide solution R*; add 200 mL of *acetonitrile R*;
- mobile phase B: mix 126 mL of *water R*, 200 mL of a 31.2 g/L solution of *sodium dihydrogen phosphate R* and 24 mL of an 80 g/L solution of *tetrabutylammonium hydroxide R*; if necessary, adjust to pH 5.5 with *dilute phosphoric acid R* or *dilute sodium hydroxide solution R*; add 650 mL of *acetonitrile R*;

Time (min)	Mobile phase A (per cent V/V)	Mobile phase B (per cent V/V)
0 - $t_R$	88	12
$t_R - (t_R + 30)$	88 $\rightarrow$ 0	12 $\rightarrow$ 100
$(t_R + 30) - (t_R + 45)$	0 $\rightarrow$ 88	100 $\rightarrow$ 12

$t_R$  = retention time of piperacillin determined with reference solution (b)

If the mobile phase composition has been adjusted to achieve the required resolution, the adjusted composition will apply at time zero in the gradient and in the assay.

**Flow rate:** 1.0 mL/min.

**Detection:** spectrophotometer at 220 nm.

**Injection:** 20  $\mu$ L of reference solutions (b), (c) and (d) with isocratic elution at the initial mobile phase composition and 20  $\mu$ L of test solution (b) according to the elution gradient described under Mobile phase.

**System suitability:**

- resolution: minimum 10 between the peaks due to impurity A and piperacillin in the chromatogram obtained with reference solution (c); if necessary, adjust the ratio A:B of the mobile phase;
- signal-to-noise ratio: minimum 3 for the principal peak in the chromatogram obtained with reference solution (d);
- mass distribution ratio: 2.0 to 3.0 for the peak due to piperacillin in the chromatogram obtained with reference solution (c).

**Limit:**

- any impurity: for each impurity, not more than twice the area of the principal peak in the chromatogram obtained with reference solution (b) (2 per cent).

**N,N-Dimethylaniline** (2.4.26, Method A): maximum 20 ppm.

**Heavy metals** (2.4.8): maximum 20 ppm.

1.0 g complies with test C. Prepare the reference solution using 2 mL of *lead standard solution* (10 ppm Pb) *R*.

**Water** (2.5.12): maximum 2.0 per cent, determined on 0.500 g.

**Bacterial endotoxins** (2.6.14): less than 0.07 IU/mg, if intended for use in the manufacture of parenteral preparations without a further appropriate procedure for the removal of bacterial endotoxins.

**ASSAY**

Liquid chromatography (2.2.29) as described in the test for related substances with the following modifications.

**Mobile phase:** initial composition of the mixture of mobile phases A and B, adjusted where applicable.

**Injection:** test solution (a) and reference solution (a).

**System suitability:** reference solution (a):

- repeatability: maximum relative standard deviation of 1.0 per cent after 6 injections.

Calculate the percentage content of piperacillin sodium, multiplying the result by 1.042.

**STORAGE**

In an airtight container. If the substance is sterile, store in a sterile, airtight, tamper-proof container.

**IMPURITIES**

**Specified impurities:** A, B, C, D, E, F, G.

**Other detectable impurities** (the following substances would, if present at a sufficient level, be detected by one or other of the tests in the monograph. They are limited by the general acceptance criterion for other/unspecified impurities and/or by the general monograph *Substances for pharmaceutical use* (2034). It is therefore not necessary to identify these impurities for demonstration of compliance. See also 5.10. *Control of impurities in substances for pharmaceutical use*): H.

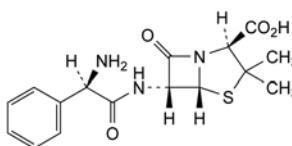

A. (2S,5R,6R)-6-[[[(2R)-2-amino-2-phenylacetyl]amino]-3,3-dimethyl-7-oxo-4-thia-1-azabicyclo[3.2.0]heptane-2-carboxylic acid (ampicillin),

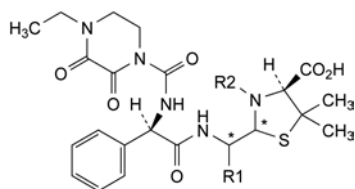
01/2008:0423  
corrected 6.0

B. R1 = CO<sub>2</sub>H, R2 = H: (4*S*)-2-[carboxy[[[(2*R*)-2-[[[4-ethyl-2,3-dioxopiperazin-1-yl]carbonyl]amino]-2-phenylacetyl]amino]methyl]-5,5-dimethylthiazolidine-4-carboxylic acid (penicilloic acids of piperacillin),

C. R1 = R2 = H: (2*R,S*,4*S*)-2-[[[(2*R*)-2-[[[4-ethyl-2,3-dioxopiperazin-1-yl]carbonyl]amino]-2-phenylacetyl]amino]methyl]-5,5-dimethylthiazolidine-4-carboxylic acid (penilloic acids of piperacillin),

F. R1 = CO<sub>2</sub>H, R2 = CO-CH<sub>3</sub>: (4*S*)-3-acetyl-2-[carboxy[[[(2*R*)-2-[[[4-ethyl-2,3-dioxopiperazin-1-yl]carbonyl]amino]-2-phenylacetyl]amino]methyl]-5,5-dimethylthiazolidine-4-carboxylic acid (acetylated penicilloic acids of piperacillin),

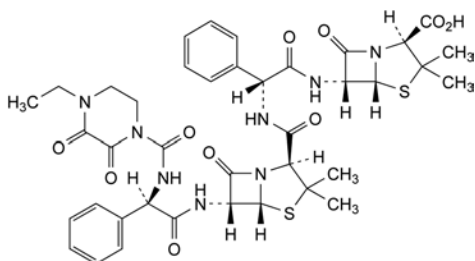

D. (2*S*,5*R*,6*R*)-6-[[[(2*R*)-2-[[[(2*S*,5*R*,6*R*)-6-[[[(2*R*)-2-[[[4-ethyl-2,3-dioxopiperazin-1-yl]carbonyl]amino]-2-phenylacetyl]amino]-3,3-dimethyl-7-oxo-4-thia-1-azabicyclo[3.2.0]hept-2-yl]carbonyl]amino]-2-phenylacetyl]amino]-3,3-dimethyl-7-oxo-4-thia-1-azabicyclo[3.2.0]heptane-2-carboxylic acid (piperacillinylampicillin),

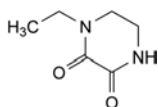

E. 1-ethylpiperazine-2,3-dione,

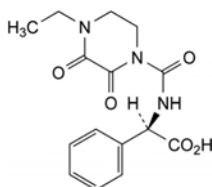

G. (2*R*)-2-[[[4-ethyl-2,3-dioxopiperazin-1-yl]carbonyl]amino]-2-phenylacetic acid,

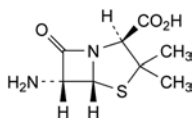

H. (2*S*,5*R*,6*R*)-6-amino-3,3-dimethyl-7-oxo-4-thia-1-azabicyclo[3.2.0]heptane-2-carboxylic acid (6-aminopenicillanic acid).

## PIPERAZINE ADIPATE

### Piperazini adipas

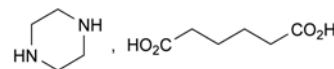

C<sub>10</sub>H<sub>20</sub>N<sub>2</sub>O<sub>4</sub>  
[142-88-1]

*M*<sub>r</sub> 232.3

#### DEFINITION

Piperazine adipate contains not less than 98.0 per cent and not more than the equivalent of 101.0 per cent of piperazine hexanedioate, calculated with reference to the anhydrous substance.

#### CHARACTERS

A white or almost white crystalline powder, soluble in water, practically insoluble in alcohol. It melts at about 250 °C, with decomposition.

#### IDENTIFICATION

*First identification:* A.

*Second identification:* B, C.

A. Examine by infrared absorption spectrophotometry (2.2.24), comparing with the spectrum obtained with *piperazine adipate CRS*. Examine the substances prepared as discs.

B. Examine the chromatograms obtained in the test for related substances after spraying with the ninhydrin solutions. The principal spot in the chromatogram obtained with test solution (b) is similar in position, colour and size to the principal spot in the chromatogram obtained with reference solution (a).

C. To 10 mL of solution S (see Tests) add 5 mL of *hydrochloric acid R* and shake with three quantities, each of 10 mL, of *ether R*. Evaporate the combined ether layers to dryness. The residue, washed with 5 mL of *water R* and dried at 100 °C to 105 °C, melts (2.2.14) at 150 °C to 154 °C.

#### TESTS

**Solution S.** Dissolve 2.5 g in *water R* and dilute to 50 mL with the same solvent.

**Appearance of solution.** Solution S is clear (2.2.1) and not more intensely coloured than reference solution B<sub>8</sub> (2.2.2, *Method II*).

**Related substances.** Examine by thin-layer chromatography (2.2.27), using a suitable silica gel as the coating substance.

*Test solution (a).* Dissolve 1.0 g of the substance to be examined in 6 mL of *concentrated ammonia R* and dilute to 10 mL with *ethanol R*.

*Test solution (b).* Dilute 1 mL of test solution (a) to 10 mL with a mixture of 2 volumes of *ethanol R* and 3 volumes of *concentrated ammonia R*.

*Reference solution (a).* Dissolve 0.1 g of *piperazine adipate CRS* in a mixture of 2 volumes of *ethanol R* and 3 volumes of *concentrated ammonia R* and dilute to 10 mL with the same mixture of solvents.

*Reference solution (b).* Dissolve 25 mg of *ethylenediamine R* in a mixture of 2 volumes of *ethanol R* and 3 volumes of *concentrated ammonia R* and dilute to 100 mL with the same mixture of solvents.

*Reference solution (c).* Dissolve 25 mg of *triethylenediamine R* in a mixture of 2 volumes of *ethanol R* and 3 volumes of *concentrated ammonia R* and dilute to 100 mL with the same mixture of solvents.

**Reference solution (d).** Dissolve 12.5 mg of *triethylenediamine R* in 5.0 mL of test solution (a) and dilute to 50 mL with a mixture of 2 volumes of *ethanol R* and 3 volumes of *concentrated ammonia R*.

Apply separately to the plate 5 µL of each solution. Develop over a path of 15 cm using a freshly prepared mixture of 20 volumes of *concentrated ammonia R* and 80 volumes of *acetone R*. Dry the plate at 105 °C and spray successively with a 3 g/L solution of *ninhydrin R* in a mixture of 3 volumes of *anhydrous acetic acid R* and 100 volumes of *butanol R* and a 1.5 g/L solution of *ninhydrin R* in *ethanol R*. Dry the plate at 105 °C for 10 min. Any spot in the chromatogram obtained with test solution (a), apart from the principal spot, is not more intense than the spot in the chromatogram obtained with reference solution (b) (0.25 per cent). Spray the plate with 0.05 M *iodine* and allow to stand for about 10 min. Any spot corresponding to triethylenediamine in the chromatogram obtained with test solution (a) is not more intense than the spot in the chromatogram obtained with reference solution (c) (0.25 per cent). The test is not valid unless the chromatogram obtained with reference solution (d) shows two clearly separated spots. Disregard any spots remaining on the line of application.

**Heavy metals (2.4.8).** 12 mL of solution S complies with limit test A for heavy metals (20 ppm). Prepare the standard using *lead standard solution (1 ppm Pb) R*.

**Water (2.5.12).** Not more than 0.5 per cent, determined on 1.00 g by the semi-micro determination of water.

**Sulfated ash (2.4.14).** Not more than 0.1 per cent, determined on 1.0 g.

#### ASSAY

Dissolve 0.100 g in 10 mL of *anhydrous acetic acid R* with gentle heating and dilute to 70 mL with the same acid. Titrate with 0.1 M *perchloric acid* using 0.25 mL of *naphtholbenzein solution R* as indicator until the colour changes from brownish-yellow to green.

1 mL of 0.1 M *perchloric acid* is equivalent to 11.61 mg of  $C_{10}H_{20}N_2O_4$ .

01/2008:0424  
corrected 6.5

## PIPERAZINE CITRATE

### Piperazini citras

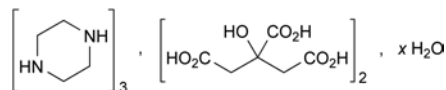

$C_{24}H_{46}N_6O_{14} \cdot xH_2O$

$M_r$  643 (anhydrous substance)

#### DEFINITION

Piperazine citrate contains not less than 98.0 per cent and not more than the equivalent of 101.0 per cent of tripiperazine bis(2-hydroxy-propane-1,2,3-tricarboxylate), calculated with reference to the anhydrous substance. It contains a variable quantity of water.

#### CHARACTERS

A white or almost white granular powder, freely soluble in water, practically insoluble in ethanol (96 per cent).

After drying at 100 °C to 105 °C, it melts at about 190 °C.

#### IDENTIFICATION

*First identification:* A.

*Second identification:* B, C.

A. Examine by infrared absorption spectrophotometry (2.2.24), comparing with the spectrum obtained with *piperazine citrate CRS*. Dry the substance to be examined and the reference substance at 120 °C for 5 h, powder the substances avoiding uptake of water, prepare discs and record the spectra without delay.

B. Examine the chromatograms obtained in the test for related substances after spraying with the ninhydrin solutions. The principal spot in the chromatogram obtained with test solution (b) is similar in position, colour and size to the principal spot in the chromatogram obtained with reference solution (a).

C. Dissolve 0.5 g in *water R* and dilute to 5 mL with the same solvent. The solution gives the reaction of citrates (2.3.1).

#### TESTS

**Solution S.** Dissolve 1.25 g in *water R* and dilute to 25 mL with the same solvent.

**Appearance of solution.** Solution S is clear (2.2.1) and not more intensely coloured than reference solution B<sub>8</sub> (2.2.2, *Method II*).

**Related substances.** Examine by thin-layer chromatography (2.2.27), using a suitable silica gel as the coating substance.

**Test solution (a).** Dissolve 1.0 g of the substance to be examined in 6 mL of *concentrated ammonia R* and dilute to 10 mL with *anhydrous ethanol R*.

**Test solution (b).** Dilute 1 mL of test solution (a) to 10 mL with a mixture of 2 volumes of *anhydrous ethanol R* and 3 volumes of *concentrated ammonia R*.

**Reference solution (a).** Dissolve 0.1 g of *piperazine citrate CRS* in a mixture of 2 volumes of *anhydrous ethanol R* and 3 volumes of *concentrated ammonia R* and dilute to 10 mL with the same mixture of solvents.

**Reference solution (b).** Dissolve 25 mg of *ethylenediamine R* in a mixture of 2 volumes of *anhydrous ethanol R* and 3 volumes of *concentrated ammonia R* and dilute to 100 mL with the same mixture of solvents.

**Reference solution (c).** Dissolve 25 mg of *triethylenediamine R* in a mixture of 2 volumes of *anhydrous ethanol R* and 3 volumes of *concentrated ammonia R* and dilute to 100 mL with the same mixture of solvents.

**Reference solution (d).** Dissolve 12.5 mg of *triethylenediamine R* in 5.0 mL of test solution (a) and dilute to 50 mL with a mixture of 2 volumes of *anhydrous ethanol R* and 3 volumes of *concentrated ammonia R*.

Apply separately to the plate 5 µL of each solution. Develop over a path of 15 cm using a freshly prepared mixture of 20 volumes of *concentrated ammonia R* and 80 volumes of *acetone R*. Dry the plate at 105 °C and spray successively with a 3 g/L solution of *ninhydrin R* in a mixture of 3 volumes of *anhydrous acetic acid R* and 100 volumes of *butanol R* and a 1.5 g/L solution of *ninhydrin R* in *anhydrous ethanol R*. Dry the plate at 105 °C for 10 min. Any spot in the chromatogram obtained with test solution (a), apart from the principal spot, is not more intense than the spot in the chromatogram obtained with reference solution (b) (0.25 per cent). Spray the plate with 0.05 M *iodine* and allow to stand for about 10 min. Any spot corresponding to triethylenediamine in the chromatogram obtained with test solution (a) is not more intense than the spot in the chromatogram obtained with reference solution (c) (0.25 per cent). The test is not valid unless the chromatogram obtained with reference solution (d) shows 2 clearly separated spots. Disregard any spots remaining on the line of application.

**Heavy metals (2.4.8).** 12 mL of solution S complies with limit test A for heavy metals (20 ppm). Prepare the reference solution using *lead standard solution (1 ppm Pb) R*.

**Water (2.5.12).** 10.0 per cent to 14.0 per cent, determined on 0.300 g by the semi-micro determination of water.

**Sulfated ash (2.4.14).** Not more than 0.1 per cent, determined on 1.0 g.

## ASSAY

Dissolve 0.100 g in 10 mL of *anhydrous acetic acid R* with gentle heating and dilute to 70 mL with the same acid. Titrate with 0.1 M *perchloric acid* using 0.25 mL of *naphtholbenzein solution R* as indicator until the colour changes from brownish-yellow to green.

1 mL of 0.1 M *perchloric acid* is equivalent to 10.71 mg of  $C_{24}H_{46}N_6O_{14}$ .

01/2008:0425

## PIPERAZINE HYDRATE

## Piperazinum hydicum

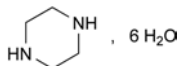

$C_4H_{10}N_2 \cdot 6H_2O$   
[142-63-2]

 $M_r$  194.2

## DEFINITION

Piperazine hydrate contains not less than 98.0 per cent and not more than the equivalent of 101.0 per cent of piperazine hexahydrate.

## CHARACTERS

Colourless, deliquescent crystals, freely soluble in water and in alcohol.

It melts at about 43 °C.

## IDENTIFICATION

*First identification: A.*

*Second identification: B, C.*

- A. Examine by infrared absorption spectrophotometry (2.2.24), comparing with the spectrum obtained with *piperazine hydrate CRS*. Dry the substance to be examined and the reference substance over *diphosphorus pentoxide R in vacuo* for 48 h, powder the substances avoiding uptake of water, prepare discs and record the spectra without delay.
- B. Examine the chromatograms obtained in the test for related substances after spraying with the ninhydrin solutions. The principal spot in the chromatogram obtained with test solution (b) is similar in position, colour and size to the principal spot in the chromatogram obtained with reference solution (a).
- C. Dissolve 0.5 g in 5 mL of *dilute sodium hydroxide solution R*. Add 0.2 mL of *benzoyl chloride R* and mix. Continue to add *benzoyl chloride R* in portions of 0.2 mL until no further precipitate is formed. Filter and wash the precipitate with a total of 10 mL of *water R* added in small portions. Dissolve the precipitate in 2 mL of hot *alcohol R* and pour the solution into 5 mL of *water R*. Allow to stand for 4 h, filter, wash the crystals with *water R* and dry at 100 °C to 105 °C. The crystals melt (2.2.14) at 191 °C to 196 °C.

## TESTS

**Solution S.** Dissolve 1.0 g in *carbon dioxide-free water R* and dilute to 20 mL with the same solvent.

**Appearance of solution.** Solution S is clear (2.2.1) and not more intensely coloured than reference solution B<sub>8</sub> (2.2.2, *Method II*).

**pH** (2.2.3). The pH of solution S is 10.5 to 12.0.

**Related substances.** Examine by thin-layer chromatography (2.2.27), using a suitable silica gel as the coating substance.

**Test solution (a).** Dissolve 1.0 g of the substance to be examined in 6 mL of *concentrated ammonia R* and dilute to 10 mL with *ethanol R*.

**Test solution (b).** Dilute 1 mL of test solution (a) to 10 mL with a mixture of 2 volumes of *ethanol R* and 3 volumes of *concentrated ammonia R*.

**Reference solution (a).** Dissolve 0.1 g of *piperazine hydrate CRS* in a mixture of 2 volumes of *ethanol R* and 3 volumes of *concentrated ammonia R* and dilute to 10 mL with the same mixture of solvents.

**Reference solution (b).** Dissolve 25 mg of *ethylenediamine R* in a mixture of 2 volumes of *ethanol R* and 3 volumes of *concentrated ammonia R* and dilute to 100 mL with the same mixture of solvents.

**Reference solution (c).** Dissolve 25 mg of *triethylenediamine R* in a mixture of 2 volumes of *ethanol R* and 3 volumes of *concentrated ammonia R* and dilute to 100 mL with the same mixture of solvents.

**Reference solution (d).** Dissolve 12.5 mg of *triethylenediamine R* in 5.0 mL of test solution (a) and dilute to 50 mL with a mixture of 2 volumes of *ethanol R* and 3 volumes of *concentrated ammonia R*.

Apply separately to the plate 5 µL of each solution. Develop over a path of 15 cm using a freshly prepared mixture of 20 volumes of *concentrated ammonia R* and 80 volumes of *acetone R*. Dry the plate at 105 °C and spray successively with a 3 g/L solution of *ninhydrin R* in a mixture of 3 volumes of *anhydrous acetic acid R* and 100 volumes of *butanol R* and a 1.5 g/L solution of *ninhydrin R* in *ethanol R*. Dry the plate at 105 °C for 10 min. Any spot in the chromatogram obtained with test solution (a), apart from the principal spot, is not more intense than the spot in the chromatogram obtained with reference solution (b) (0.25 per cent). Spray the plate with 0.05 M *iodine* and allow to stand for about 10 min. Any spot corresponding to triethylenediamine in the chromatogram obtained with test solution (a) is not more intense than the spot in the chromatogram obtained with reference solution (c) (0.25 per cent). The test is not valid unless the chromatogram obtained with reference solution (d) shows two clearly separated spots.

**Heavy metals** (2.4.8). 12 mL of solution S complies with limit test A for heavy metals (20 ppm). Prepare the standard using *lead standard solution (1 ppm Pb) R*.

**Sulfated ash** (2.4.14). Not more than 0.1 per cent, determined on 1.0 g.

## ASSAY

Dissolve 80.0 mg in 10 mL of *anhydrous acetic acid R* with gentle heating and dilute to 70 mL with the same acid. Titrate with 0.1 M *perchloric acid* using 0.25 mL of *naphtholbenzein solution R* as indicator until the colour changes from brownish-yellow to green.

1 mL of 0.1 M *perchloric acid* is equivalent to 9.705 mg of  $C_4H_{10}N_2 \cdot 6H_2O$ .

## STORAGE

Store in an airtight container, protected from light.

01/2008:1733  
corrected 6.0

## PIRACETAM

## Piracetamum

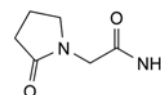

$C_6H_{10}N_2O_2$   
[7491-74-9]

 $M_r$  142.2

## DEFINITION

2-(2-Oxopyrrolidin-1-yl)acetamide.

**Content:** 98.0 per cent to 102.0 per cent (dried substance).

## CHARACTERS

**Appearance:** white or almost white, powder.

**Solubility:** freely soluble in water, soluble in ethanol (96 per cent).

It shows polymorphism (5.9).

#### IDENTIFICATION

Infrared absorption spectrophotometry (2.2.24).

**Comparison:** *piracetam CRS*.

If the spectra obtained in the solid state show differences, dissolve the substance to be examined and the reference substance separately in *ethanol (96 per cent) R*, evaporate to dryness on a water-bath and record new spectra using the residues.

#### TESTS

**Appearance of solution.** The solution is clear (2.2.1) and colourless (2.2.2, *Method II*).

Dissolve 2.0 g in *water R* and dilute to 10 mL with the same solvent.

**Related substances.** Liquid chromatography (2.2.29).

**Test solution (a).** Dissolve 50.0 mg of the substance to be examined in a mixture of 10 volumes of *acetonitrile R1* and 90 volumes of *water R* and dilute to 100.0 mL with the same mixture of solvents.

**Test solution (b).** Dilute 10.0 mL of test solution (a) to 50.0 mL with a mixture of 10 volumes of *acetonitrile R1* and 90 volumes of *water R*.

**Reference solution (a).** Dissolve 5 mg of the substance to be examined and 10 µL of *2-pyrrolidone R* in a mixture of 10 volumes of *acetonitrile R1* and 90 volumes of *water R* and dilute to 100.0 mL with the same mixture of solvents.

**Reference solution (b).** Dilute 1.0 mL of test solution (a) to 100.0 mL with a mixture of 10 volumes of *acetonitrile R1* and 90 volumes of *water R*. Dilute 5.0 mL of this solution to 50.0 mL with a mixture of 10 volumes of *acetonitrile R1* and 90 volumes of *water R*.

**Reference solution (c).** Dissolve 50.0 mg of *piracetam CRS* in a mixture of 10 volumes of *acetonitrile R1* and 90 volumes of *water R* and dilute to 100.0 mL with the same mixture of solvents. Dilute 10.0 mL of this solution to 50.0 mL with a mixture of 10 volumes of *acetonitrile R1* and 90 volumes of *water R*.

**Column:**

- size:  $l = 0.25$  m,  $\varnothing = 4.6$  mm,
- stationary phase: end-capped octadecylsilyl silica gel for chromatography R (5 µm).

**Mobile phase:** mix 10 volumes of *acetonitrile R1* and 90 volumes of a 1.0 g/L solution of *dipotassium hydrogen phosphate R*; adjust to pH 6.0 with *dilute phosphoric acid R*.

**Flow rate:** 1.0 mL/min.

**Detection:** spectrophotometer at 205 nm.

**Injection:** 20 µL of test solution (a) and reference solutions (a) and (b).

**Run time:** 8 times the retention time of *piracetam*.

**Relative retention** with reference to *piracetam* (retention time = about 4 min): impurity D = about 0.8; impurity A = about 1.15; impurity B = about 2.8; impurity C = about 6.3.

**System suitability:** reference solution (a):

- resolution: minimum 3.0 between the peaks due to *piracetam* and impurity A,
- symmetry factor: maximum 2.0 for the peak due to *piracetam*.

**Limits:**

- impurities A, B, C, D: for each impurity, not more than the area of the principal peak in the chromatogram obtained with reference solution (b) (0.1 per cent),
- unspecified impurities: for each impurity, not more than the area of the principal peak in the chromatogram obtained with reference solution (b) (0.1 per cent),

- total: not more than 3 times the area of the principal peak in the chromatogram obtained with reference solution (b) (0.3 per cent),
- disregard limit: 0.5 times the area of the principal peak in the chromatogram obtained with reference solution (b) (0.05 per cent).

**Heavy metals** (2.4.8): maximum 10 ppm.

Dissolve 2.0 g in 20 mL of *water R*. 12 mL of the solution complies with test A. Prepare the reference solution using *lead standard solution (1 ppm Pb) R*.

**Loss on drying** (2.2.32): maximum 1.0 per cent, determined on 1.000 g by drying in an oven at 105 °C.

**Sulfated ash** (2.4.14): maximum 0.1 per cent, determined on 1.0 g.

#### ASSAY

Liquid chromatography (2.2.29) as described in the test for related substances with the following modification.

**Injection:** test solution (b) and reference solution (c).

Calculate the percentage content of  $C_6H_{10}N_2O_2$  from the areas of the peaks and the declared content of *piracetam CRS*.

#### STORAGE

Protected from light.

#### IMPURITIES

**Specified impurities:** A, B, C, D.



- A. R = H: pyrrolidin-2-one (2-pyrrolidone),
- B. R =  $CH_2COOCH_3$ : methyl (2-oxopyrrolidin-1-yl)acetate,
- C. R =  $CH_2COOC_2H_5$ : ethyl (2-oxopyrrolidin-1-yl)acetate,
- D. R =  $CH_2CO_2H$ : (2-oxopyrrolidin-1-yl)acetic acid.

01/2008:2001  
corrected 7.0

## PIRENZEPINE DIHYDROCHLORIDE MONOHYDRATE

Pirenzepini dihydrochloridum monohydricum

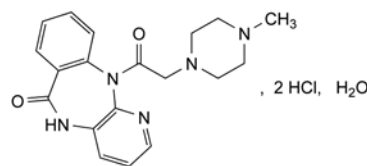

$C_{19}H_{23}Cl_2N_5O_2 \cdot H_2O$

$M_r$  442.3

#### DEFINITION

11-[(4-Methylpiperazin-1-yl)acetyl]-5,11-dihydro-6H-pyrido[2,3-b][1,4]benzodiazepin-6-one dihydrochloride monohydrate.

**Content:** 98.0 per cent to 102.0 per cent (anhydrous substance).

#### CHARACTERS

**Appearance:** white or yellowish, crystalline powder.

**Solubility:** freely soluble in water, slightly soluble in methanol, very slightly soluble in ethanol, practically insoluble in methylene chloride.

#### IDENTIFICATION

**First identification:** B, D.

**Second identification:** A, C, D.



- A. Dissolve 30.0 mg in *methanol R* and dilute to 100.0 mL with the same solvent. Dilute 10.0 mL of the solution to 100.0 mL with *methanol R*. Examined between 240 nm and 360 nm (2.2.25), the solution shows an absorption maximum at 283 nm. The specific absorbance at the maximum is 190 to 205 (anhydrous substance).
- B. Infrared absorption spectrophotometry (2.2.24).  
*Comparison: pirenzepine dihydrochloride monohydrate CRS.*
- C. Examine the chromatograms obtained in the test for impurity D.  
*Results:* the principal band obtained in the chromatogram obtained with test solution (b) is similar in position, colour and size to the principal band in the chromatogram obtained with reference solution (d).
- D. To 0.2 mL of solution S (see Tests) add 1.8 mL of *water R*. The solution gives reaction (a) of chlorides (2.3.1).

## TESTS

**Solution S.** Dissolve 2.5 g in *carbon dioxide-free water R* and dilute to 25 mL with the same solvent.

**Appearance of solution.** Solution S is clear (2.2.1) and not more intensely coloured than reference solution GY<sub>5</sub> (2.2.2, Method II).

**pH** (2.2.3): 1.0 to 2.0 for solution S.

**Impurity D.** Thin-layer chromatography (2.2.27).

*Test solution (a).* To 0.10 g add 0.1 mL of *concentrated ammonia R* and dilute to 10 mL with *methanol R*.

*Test solution (b).* Dilute 1 mL of test solution (a) to 10 mL with *methanol R*.

*Reference solution (a).* To 0.1 g of *pirenzepine dihydrochloride monohydrate CRS* add 0.1 mL of *concentrated ammonia R* and dilute to 10 mL with *methanol R*.

*Reference solution (b).* Dissolve 25 mg of *methylpiperazine R* in *methanol R* and dilute to 25 mL with the same solvent. Dilute 2.0 mL of the solution to 100 mL with *methanol R*.

*Reference solution (c).* Dilute 5 mL of test solution (a) to 100 mL with *methanol R*. Dilute 4 mL of this solution to 100 mL with *methanol R*. Mix 1 mL with 1 mL of reference solution (b).

*Reference solution (d).* Dilute 1 mL of reference solution (a) to 10 mL with *methanol R*.

*Plate:* TLC silica gel plate R.

*Mobile phase:* *concentrated ammonia R*, *methanol R*, *ethyl acetate R*, *toluene R* (7:25:28:40 V/V/V/V).

*Application:* 20 µL as bands of 20 mm by 2 mm.

*Development:* over 2/3 of the plate.

*Drying:* in air.

*Detection:* expose the plate to iodine vapour until the band in the chromatogram obtained with reference solution (b) is clearly visible (at most 60 min).

*System suitability:* the test is not valid unless the chromatogram obtained with reference solution (c) shows 2 clearly separated bands.

*Limit:*

- *impurity D:* any band corresponding to impurity D in the chromatogram obtained with test solution (a) is not more intense than the band in the chromatogram obtained with reference solution (b) (0.2 per cent).

**Related substances.** Liquid chromatography (2.2.29).

*Test solution.* Dissolve 0.30 g of the substance to be examined in *water R* and dilute to 10.0 mL with the same solvent. To 1.0 mL of the solution add 5 mL of *methanol R* and dilute to 10.0 mL with mobile phase A.

*Reference solution (a).* Dilute 2.0 mL of the test solution to 100.0 mL with mobile phase A. Dilute 1.0 mL of this solution to 10.0 mL with mobile phase A.

*Reference solution (b).* Dissolve 0.1 g of *1-phenylpiperazine R* in *methanol R* and dilute to 10 mL with the same solvent. Mix 1 mL of the solution with 1 mL of the test solution, add 5 mL of *methanol R* and dilute to 10 mL with mobile phase A.

*Column:*

- *size:*  $l = 0.125$  m,  $\emptyset = 4.6$  mm,
- *stationary phase:* *octadecylsilyl silica gel for chromatography R* (5 µm).

*Mobile phase:*

- *mobile phase A:* dissolve 2.0 g of *sodium dodecyl sulfate R* in *water R*, adjust to pH 3.2 with *acetic acid R* and dilute to 1000 mL with *water R*,
- *mobile phase B:* *methanol R*,
- *mobile phase C:* *acetonitrile R*,

Time (min)	Mobile phase A (per cent V/V)	Mobile phase B (per cent V/V)	Mobile phase C (per cent V/V)
0 - 15	55 → 25	30	15 → 45
15 - 18	25 → 20	30 → 0	45 → 80

*Flow rate:* 1 mL/min.

*Detection:* spectrophotometer at 283 nm.

*Injection:* 10 µL.

*System suitability:* reference solution (b):

- *resolution:* minimum of 5.0 between the peaks corresponding to pirenzepine and to 1-phenylpiperazine.

*Limits:*

- *any impurity:* not more than the peak area of the principal peak in the chromatogram obtained with reference solution (a) (0.2 per cent),
- *total:* not more than 2.5 times the area of the principal peak in the chromatogram obtained with reference solution (a) (0.5 per cent),
- *disregard limit:* 0.2 times the area of the principal peak in the chromatogram obtained with reference solution (a) (0.04 per cent).

**Water** (2.5.12): 3.5 per cent to 5.0 per cent, determined on 0.250 g.

**Sulfated ash** (2.4.14): maximum 0.1 per cent, determined on 1.0 g.

## ASSAY

Dissolve 0.300 g in 50 mL of *water R*. Carry out a potentiometric titration (2.2.20), using 0.1 M *sodium hydroxide*. Read the volume at the first point of inflection.

1 mL of 0.1 M *sodium hydroxide* is equivalent to 42.43 mg of C<sub>19</sub>H<sub>23</sub>Cl<sub>2</sub>N<sub>5</sub>O<sub>2</sub>.

## STORAGE

Protected from light.

## IMPURITIES

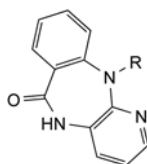

- A. R = CO-CH<sub>2</sub>-Cl: 11-(chloroacetyl)-5,11-dihydro-6H-pyrido[2,3-b][1,4]benzodiazepin-6-one,
- B. R = H: 5,11-dihydro-6H-pyrido[2,3-b][1,4]benzodiazepin-6-one,

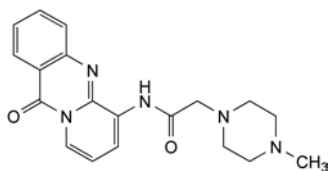

C. 6-[[[4-methylpiperazin-1-yl]acetyl]amino]-11H-pyrido[2,1-b]quinazolin-11-one,

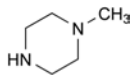

D. 1-methylpiperazine.

01/2008:1556  
corrected 6.0

## PIRETANIDE

### Piretanidum

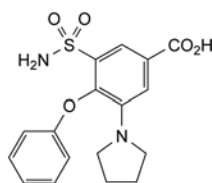

$C_{17}H_{18}N_2O_5S$   
[55837-27-9]

$M_r$  362.4

#### DEFINITION

4-Phenoxy-3-(pyrrolidin-1-yl)-5-sulfamoylbenzoic acid.

*Content*: 99.0 per cent to 101.0 per cent (dried substance).

#### CHARACTERS

*Appearance*: yellowish-white or yellowish powder.

*Solubility*: very slightly soluble in water, sparingly soluble in anhydrous ethanol.

It shows polymorphism (5.9).

#### IDENTIFICATION

Infrared absorption spectrophotometry (2.2.24).

*Preparation*: discs.

*Comparison*: piretanide CRS.

If the spectra obtained show differences, dissolve the substance to be examined and the reference substance separately in acetone R, evaporate to dryness and record new spectra using the residues.

#### TESTS

**Appearance of solution.** The solution is clear (2.2.1) and not more intensely coloured than reference solution GY<sub>4</sub> (2.2.2, Method II).

Dissolve 0.1 g in methanol R and dilute to 10 mL with the same solvent.

**Related substances.** Liquid chromatography (2.2.29).

*Solvent mixture*: anhydrous ethanol R, acetonitrile R, water R (10:45:45 V/V/V).

*Test solution.* Dissolve 20 mg of the substance to be examined in the solvent mixture and dilute to 20.0 mL with the solvent mixture.

*Reference solution (a).* Dissolve 10 mg of piretanide CRS and 3 mg of piretanide impurity A CRS in the solvent mixture and dilute to 10.0 mL with the solvent mixture.

*Reference solution (b).* Dilute 0.3 mL of the test solution to 100.0 mL with the solvent mixture.

#### Column:

– size:  $l = 0.125$  m,  $\emptyset = 4$  mm;

– stationary phase: octylsilyl silica gel for chromatography R (5  $\mu$ m).

*Mobile phase*: a mixture of 35 volumes of acetonitrile R1 and 65 volumes of a solution prepared as follows: add 1 mL of trifluoroacetic acid R to 500 mL of water for chromatography R, add 1 mL of triethylamine R and dilute to 1000 mL with water for chromatography R.

*Flow rate*: 1 mL/min.

*Detection*: spectrophotometer at 232 nm.

*Injection*: 10  $\mu$ L.

*Run time*: 5 times the retention time of piretanide.

*Relative retention* with reference to piretanide (retention time = about 10 min): impurity A = about 0.9.

*System suitability*: reference solution (a):

– resolution: minimum 2 between the peaks due to impurity A and piretanide.

#### Limits:

– impurities A, B, C: for each impurity, not more than the area of the principal peak in the chromatogram obtained with reference solution (b) (0.3 per cent);

– total: not more than 3.33 times the area of the principal peak in the chromatogram obtained with reference solution (b) (1.0 per cent);

– disregard limit: 0.1 times the area of the principal peak in the chromatogram obtained with reference solution (b) (0.03 per cent).

**Heavy metals** (2.4.8): maximum 10 ppm.

2.0 g complies with test C. Prepare the reference solution using 2 mL of lead standard solution (10 ppm Pb) R.

**Loss on drying** (2.2.32): maximum 0.5 per cent, determined on 1.000 g by drying in an oven at 105 °C for 4 h.

**Sulfated ash** (2.4.14): maximum 0.1 per cent, determined on 1.0 g.

#### ASSAY

Dissolve 0.300 g in 25 mL of anhydrous acetic acid R. Titrate with 0.1 M perchloric acid determining the end-point potentiometrically (2.2.20).

1 mL of 0.1 M perchloric acid is equivalent to 36.24 mg of  $C_{17}H_{18}N_2O_5S$ .

#### STORAGE

Protected from light.

#### IMPURITIES

*Specified impurities*: A, B, C.

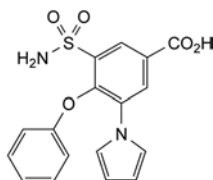

A. 4-phenoxy-3-(1H-pyrrol-1-yl)-5-sulfamoylbenzoic acid,

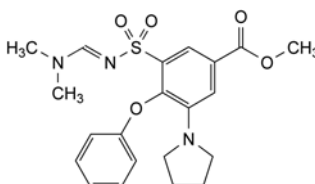

B. methyl-3-[[[dimethylamino]methylene]sulfamoyl]-4-phenoxy-5-(pyrrolidin-1-yl)benzoate,

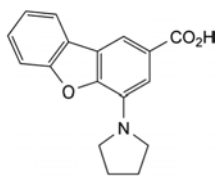
C. 4-(pyrrolidin-1-yl)dibenzo[*b,d*]furan-2-carboxylic acid.01/2008:0944  
corrected 6.0**PIROXICAM**

## Piroxicamum

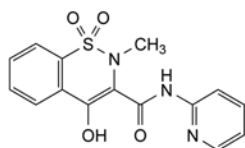
C<sub>15</sub>H<sub>13</sub>N<sub>3</sub>O<sub>4</sub>S  
[36322-90-4]M<sub>r</sub> 331.4

## DEFINITION

4-Hydroxy-2-methyl-*N*-(pyridin-2-yl)-2*H*-1,2-benzothiazine-3-carboxamide 1,1-dioxide.*Content*: 98.5 per cent to 101.0 per cent (dried substance).

## CHARACTERS

*Appearance*: white or slightly yellow, crystalline powder.*Solubility*: practically insoluble in water, soluble in methylene chloride, slightly soluble in anhydrous ethanol.

It shows polymorphism (5.9).

## IDENTIFICATION

Infrared absorption spectrophotometry (2.2.24).

*Preparation*: discs of *potassium bromide R*.*Comparison*: *piroxicam CRS*.If the spectra obtained in the solid state show differences, dissolve the substance to be examined and the reference substance separately in the minimum volume of *methylene chloride R*, evaporate to dryness on a water-bath and record new spectra using the residues.

## TESTS

**Related substances.** Liquid chromatography (2.2.29).*Test solution.* Dissolve 75 mg of the substance to be examined in *acetonitrile R*, warming slightly if necessary, and dilute to 50.0 mL with the same solvent.*Reference solution (a).* Dissolve 5 mg of *piroxicam for system suitability CRS* in *acetonitrile R* and dilute to 25.0 mL with the same solvent.*Reference solution (b).* Dilute 1.0 mL of the test solution to 10.0 mL with *acetonitrile R*. Dilute 1.0 mL of this solution to 50.0 mL with *acetonitrile R*.*Column*:

- *size*:  $l = 0.25$  m,  $\varnothing = 4.6$  mm;
- *stationary phase*: base-deactivated octadecylsilyl silica gel for chromatography *R* (5  $\mu$ m);
- *temperature*: 40 °C.

*Mobile phase*: mix 40 volumes of *acetonitrile R* and 60 volumes of a 6.81 g/L solution of *potassium dihydrogen phosphate R* adjusted to pH 3.0 with *phosphoric acid R*.*Flow rate*: 1 mL/min.*Detection*: spectrophotometer at 230 nm.*Injection*: 20  $\mu$ L.*Run time*: 5 times the retention time of piroxicam.*System suitability*: reference solution (a):

- *relative retention* with reference to piroxicam: impurity B = about 0.85;
- *symmetry factor*: maximum 1.5 for the peak due to impurity B;
- the chromatogram obtained is similar to the chromatogram supplied with *piroxicam for system suitability CRS*.

*Limits*:

- *impurities A, B, C, D, E, F, G, H, I, J, K, L*: for each impurity, not more than the area of the principal peak in the chromatogram obtained with reference solution (b) (0.2 per cent);
- *total*: not more than twice the area of the principal peak in the chromatogram obtained with reference solution (b) (0.4 per cent);
- *disregard limit*: 0.1 times the area of the principal peak in the chromatogram obtained with reference solution (b) (0.02 per cent).

**Heavy metals** (2.4.8): maximum 20 ppm.1.0 g complies with test C. Prepare the reference solution using 2 mL of *lead standard solution (10 ppm Pb) R*.**Loss on drying** (2.2.32): maximum 0.5 per cent, determined on 1.000 g by drying *in vacuo* at 105 °C for 4 h.**Sulfated ash** (2.4.14): maximum 0.1 per cent, determined on 1.0 g.

## ASSAY

Dissolve 0.250 g in 60 mL of a mixture of equal volumes of *acetic anhydride R* and *anhydrous acetic acid R*. Titrate with 0.1 M *perchloric acid*, determining the end-point potentiometrically (2.2.20).1 mL of 0.1 M *perchloric acid* is equivalent to 33.14 mg of C<sub>15</sub>H<sub>13</sub>N<sub>3</sub>O<sub>4</sub>S.

## STORAGE

In an airtight container, protected from light.

## IMPURITIES

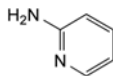
*Specified impurities*: A, B, C, D, E, F, G, H, I, J, K, L.

A. pyridin-2-amine,

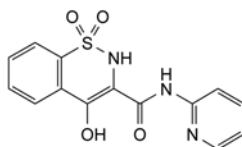
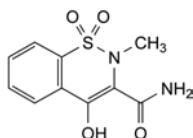
B. 4-hydroxy-*N*-(pyridin-2-yl)-2*H*-1,2-benzothiazine-3-carboxamide 1,1-dioxide,C. 4-hydroxy-2-methyl-2*H*-1,2-benzothiazine-3-carboxamide 1,1-dioxide,

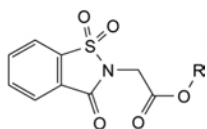

- D. R = CH<sub>3</sub>: methyl (1,1-dioxido-3-oxo-1,2-benzisothiazol-2(3H)-yl)acetate,  
 E. R = C<sub>2</sub>H<sub>5</sub>: ethyl (1,1-dioxido-3-oxo-1,2-benzisothiazol-2(3H)-yl)acetate,  
 F. R = CH(CH<sub>3</sub>)<sub>2</sub>: 1-methylethyl (1,1-dioxido-3-oxo-1,2-benzisothiazol-2(3H)-yl)acetate,

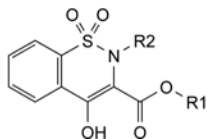

- G. R<sub>1</sub> = CH<sub>3</sub>, R<sub>2</sub> = H: methyl 4-hydroxy-2H-1,2-benzothiazine-3-carboxylate 1,1-dioxide,  
 H. R<sub>1</sub> = C<sub>2</sub>H<sub>5</sub>, R<sub>2</sub> = H: ethyl 4-hydroxy-2H-1,2-benzothiazine-3-carboxylate 1,1-dioxide,  
 I. R<sub>1</sub> = CH(CH<sub>3</sub>)<sub>2</sub>, R<sub>2</sub> = H: 1-methylethyl 4-hydroxy-2H-1,2-benzothiazine-3-carboxylate 1,1-dioxide,  
 J. R<sub>1</sub> = R<sub>2</sub> = CH<sub>3</sub>: methyl 4-hydroxy-2-methyl-2H-1,2-benzothiazine-3-carboxylate 1,1-dioxide,  
 K. R<sub>1</sub> = C<sub>2</sub>H<sub>5</sub>, R<sub>2</sub> = CH<sub>3</sub>: ethyl 4-hydroxy-2-methyl-2H-1,2-benzothiazine-3-carboxylate 1,1-dioxide,  
 L. R<sub>1</sub> = CH(CH<sub>3</sub>)<sub>2</sub>, R<sub>2</sub> = CH<sub>3</sub>: 1-methylethyl 4-hydroxy-2-methyl-2H-1,2-benzothiazine-3-carboxylate 1,1-dioxide.

01/2008:0852  
corrected 6.0

## PIVAMPICILLIN

### Pivampicillinum

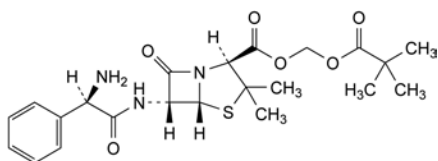

C<sub>22</sub>H<sub>29</sub>N<sub>3</sub>O<sub>6</sub>S  
[33817-20-8]

M<sub>r</sub> 463.6

#### DEFINITION

Methylene (2S,5R,6R)-6-[(2R)-2-amino-2-phenylacetyl]amino]-3,3-dimethyl-7-oxo-4-thia-1-azabicyclo[3.2.0]heptane-2-carboxylate 2,2-dimethylpropanoate.

Semi-synthetic product derived from a fermentation product.

Content: 95.0 per cent to 102.0 per cent (anhydrous substance).

#### CHARACTERS

Appearance: white or almost white, crystalline powder.

Solubility: practically insoluble in water, freely soluble in methanol, soluble in anhydrous ethanol. It dissolves in dilute acids.

#### IDENTIFICATION

First identification: A.

Second identification: B, C.

A. Infrared absorption spectrophotometry (2.2.24).

Comparison: pivampicillin CRS.

B. Thin-layer chromatography (2.2.27).

Test solution. Dissolve 10 mg of the substance to be examined in 2 mL of methanol R.

Reference solution (a). Dissolve 10 mg of pivampicillin CRS in 2 mL of methanol R.

Reference solution (b). Dissolve 10 mg of bacampicillin hydrochloride CRS, 10 mg of pivampicillin CRS and 10 mg of talampicillin hydrochloride CRS in 2 mL of methanol R.

Plate: TLC silanised silica gel plate R.

Mobile phase: mix 10 volumes of a 272 g/L solution of sodium acetate R adjusted to pH 5.0 with glacial acetic acid R, 40 volumes of water R and 50 volumes of ethanol (96 per cent) R.

Application: 1 µL.

Development: over a path of 15 cm.

Drying: in a current of warm air.

Detection: spray with ninhydrin solution R1 and heat at 60 °C for 10 min.

System suitability: reference solution (b):

– the chromatogram shows 3 clearly separated spots.

Results: the principal spot in the chromatogram obtained with the test solution is similar in position, colour and size to the principal spot in the chromatogram obtained with reference solution (a).

- C. Place about 2 mg in a test-tube about 150 mm long and 15 mm in diameter. Moisten with 0.05 mL of water R and add 2 mL of sulfuric acid-formaldehyde reagent R. Mix the contents of the tube by swirling; the solution is almost colourless. Place the test-tube in a water-bath for 1 min; a dark yellow colour develops.

#### TESTS

Appearance of solution. The solution is not more opalescent than reference suspension II (2.2.1) and not more intensely coloured than reference solution B<sub>7</sub> (2.2.2, Method I).

Dissolve 50 mg in 12 mL of 0.1 M hydrochloric acid.

Specific optical rotation (2.2.7): + 208 to + 222 (anhydrous substance).

Dissolve 0.100 g in 5.0 mL of ethanol (96 per cent) R and dilute to 10.0 mL with 0.1 M hydrochloric acid.

Triethanolamine. Thin-layer chromatography (2.2.27).

Test solution. Dissolve 0.100 g of the substance to be examined in 1.0 mL of a mixture of 1 volume of water R and 9 volumes of acetonitrile R.

Reference solution. Dissolve 5.0 mg of triethanolamine R in a mixture of 1 volume of water R and 9 volumes of acetonitrile R and dilute to 100 mL with the same mixture of solvents.

Plate: TLC silica gel plate R.

Mobile phase: methanol R, butanol R, phosphate buffer solution pH 5.8 R, glacial acetic acid R, butyl acetate R (5:15:24:40:80 V/V/V/V).

Application: 10 µL.

Development: over a path of 12 cm.

Drying: at 110 °C for 10 min and allow to cool.

Chlorine treatment: place at the bottom of a chromatographic tank an evaporating dish containing a mixture of 1 volume of hydrochloric acid R1, 1 volume of water R and 2 volumes of a 15 g/L solution of potassium permanganate R; close the tank and allow to stand for 15 min; place the dried plate in the tank and close the tank; leave the plate in contact with the chlorine vapour in the tank for 15-20 min; withdraw the plate and allow it to stand in air for 2-3 min.

Detection: spray with tetramethyldiaminodiphenylmethane reagent R.

Limit:

– triethanolamine: any spot due to triethanolamine is not more intense than the corresponding spot in the chromatogram obtained with the reference solution (0.05 per cent).

**Related substances.** Liquid chromatography (2.2.29). Prepare the solutions immediately before use.

**Test solution.** Dissolve 50.0 mg of the substance to be examined in 10.0 mL of acetonitrile R and dilute to 20 mL with a 1 g/L solution of phosphoric acid R.

**Reference solution.** Mix 2.0 mL of the test solution with 9.0 mL of acetonitrile R and 9.0 mL of a 1 g/L solution of phosphoric acid R.

**Column:**

- size:  $l = 0.125$  m,  $\varnothing = 4$  mm;
- stationary phase: end-capped octylsilyl silica gel for chromatography R.

**Mobile phase:**

- mobile phase A: mix 50 volumes of a 1.32 g/L solution of ammonium phosphate R, adjusted to pH 2.5 with a 100 g/L solution of phosphoric acid R, and 50 volumes of acetonitrile R;
- mobile phase B: mix 15 volumes of a 1.32 g/L solution of ammonium phosphate R, adjusted to pH 2.5 with a 100 g/L solution of phosphoric acid R, and 85 volumes of acetonitrile R;

Time (min)	Mobile phase A (per cent V/V)	Mobile phase B (per cent V/V)
0 - 10	100	0
10 - 12	0	100
12 - 17	100	0

**Flow rate:** 1.5 mL/min.

**Detection:** spectrophotometer at 220 nm.

**Injection:** 50  $\mu$ L.

**Retention time:** pivampicillin dimer = about 5 min.

**System suitability:** reference solution:

- ratio of the mass distribution ratio: minimum 12 for the peak due to pivampicillin dimer to that of the peak due to pivampicillin (principal peak).

**Limits:**

- total: not more than 0.3 times the area of the principal peak in the chromatogram obtained with the reference solution (3 per cent);
- disregard limit: 0.01 times the area of the principal peak in the chromatogram obtained with the reference solution (0.1 per cent).

***N,N*-Dimethylaniline (2.4.26, Method B):** maximum 20 ppm.

**Test solution.** To 1.00 g of the substance to be examined in a ground-glass-stoppered tube add 10 mL of 0.5 M sulfuric acid. Heat the tube for 10 min in a water-bath, cool and add 15 mL of 1 M sodium hydroxide and 1.0 mL of the internal standard solution. Stopper the tube and shake vigorously for 1 min. Centrifuge if necessary and use the upper layer.

**Water (2.5.12):** maximum 1.0 per cent, determined on 0.30 g.

**Sulfated ash (2.4.14):** maximum 0.5 per cent, determined on 1.0 g.

**ASSAY**

Liquid chromatography (2.2.29). Use the solutions within 2 h of preparation.

**Test solution.** Dissolve 50.0 mg of the substance to be examined in the mobile phase and dilute to 50.0 mL with the mobile phase. Dilute 10.0 mL of this solution to 50.0 mL with the mobile phase.

**Reference solution (a).** Dissolve 50.0 mg of pivampicillin CRS in the mobile phase and dilute to 50.0 mL with the mobile phase. Dilute 10.0 mL of this solution to 50.0 mL with the mobile phase.

**Reference solution (b).** Dissolve 25.0 mg of propyl parahydroxybenzoate CRS in the mobile phase and dilute to 50.0 mL with the mobile phase. Dilute 10.0 mL of the solution to 50.0 mL with the mobile phase. Mix 5.0 mL of this solution with 5.0 mL of reference solution (a).

**Column:**

- size:  $l = 0.125$  m,  $\varnothing = 4$  mm;
- stationary phase: octadecylsilyl silica gel for chromatography R (5  $\mu$ m).

**Mobile phase:** mix 40 volumes of acetonitrile R and 60 volumes of a 2.22 g/L solution of phosphoric acid R adjusted to pH 2.5 with triethylamine R.

**Flow rate:** 1.5 mL/min.

**Detection:** spectrophotometer at 220 nm.

**Injection:** 20  $\mu$ L.

**System suitability:**

- resolution: minimum 5.0 between the peaks due to pivampicillin (1<sup>st</sup> peak) and propyl parahydroxybenzoate (2<sup>nd</sup> peak) in the chromatogram obtained with reference solution (b);
- symmetry factor: maximum 2.0 for the peak due to pivampicillin in the chromatogram obtained with reference solution (b);
- repeatability: maximum relative standard deviation of 1.0 per cent after 6 injections of reference solution (a).

Calculate the percentage content of C<sub>22</sub>H<sub>29</sub>N<sub>3</sub>O<sub>6</sub>S from the declared content of pivampicillin CRS.

**STORAGE**

In an airtight container.

**IMPURITIES**

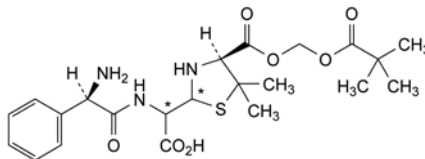

A. 2-[[[(2*R*)-2-amino-2-phenylacetyl]amino]-2-[[[(4*S*)-4-[[[(2,2-dimethylpropanoyl)oxy]methoxy]carbonyl]-5,5-dimethylthiazolidin-2-yl]acetic acid (penicilloic acids of pivampicillin),

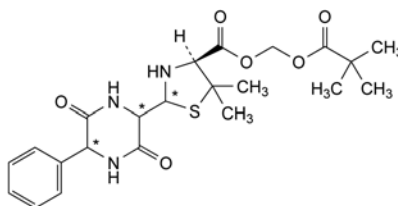

B. methylene (4*S*)-5,5-dimethyl-2-(3,6-dioxo-5-phenylpiperazin-2-yl)thiazolidine-4-carboxylate 2,2-dimethylpropanoate (diketopiperazines of pivampicillin),

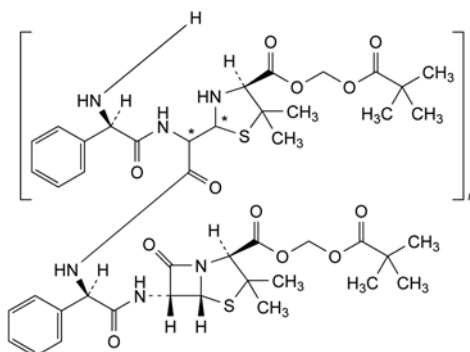

C. co-oligomers of pivampicillin and of penicilloic acids of pivampicillin.

01/2008:1359  
corrected 6.0

## PIVMECILLINAM HYDROCHLORIDE

### Pivmecillinami hydrochloridum

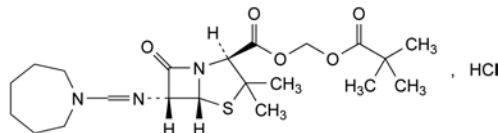

$C_{21}H_{34}ClN_3O_5S$   
[32887-03-9]

$M_r$  476.0

#### DEFINITION

Methylene 2,2-dimethylpropanoate (2*S*,5*R*,6*R*)-6-[[hexahydro-1*H*-azepin-1-yl)methylamino]-3,3-dimethyl-7-oxo-4-thia-1-azabicyclo[3.2.0]heptane-2-carboxylate hydrochloride. Semi-synthetic product derived from a fermentation product.

*Content*: 97.0 per cent to 102.0 per cent (anhydrous substance).

#### CHARACTERS

*Appearance*: white or almost white, crystalline powder.

*Solubility*: freely soluble in water, in anhydrous ethanol and in methanol, slightly soluble in acetone.

#### IDENTIFICATION

A. Infrared absorption spectrophotometry (2.2.24).

*Preparation*: discs.

*Comparison*: pivmecillinam hydrochloride CRS.

B. It gives reaction (a) of chlorides (2.3.1).

#### TESTS

**Appearance of solution.** The solution is not more opalescent than reference suspension II (2.2.1) and not more intensely coloured than reference solution B<sub>8</sub> (2.2.2, Method I).

Dissolve 0.5 g in *water R* and dilute to 10 mL with the same solvent.

**pH** (2.2.3): 2.8 to 3.8.

Dissolve 1.0 g in *carbon dioxide-free water R* and dilute to 10 mL with the same solvent.

**Related substances.** Liquid chromatography (2.2.29). Prepare the solutions immediately before use.

**Solvent mixture.** To 45 volumes of *acetonitrile R* add 55 volumes of a 13.5 g/L solution of *potassium dihydrogen phosphate R* previously adjusted to pH 3.0 with *dilute phosphoric acid R*.

**Test solution (a).** Dissolve 20.0 mg of the substance to be examined in the solvent mixture and dilute to 200.0 mL with the solvent mixture.

**Test solution (b).** Dissolve 25.0 mg of the substance to be examined in the solvent mixture and dilute to 25.0 mL with the solvent mixture.

**Reference solution (a).** Dissolve 20.0 mg of *pivmecillinam hydrochloride CRS* in the solvent mixture and dilute to 200.0 mL with the solvent mixture.

**Reference solution (b).** Dilute 5.0 mL of reference solution (a) to 50.0 mL with the solvent mixture.

**Reference solution (c).** Dissolve 5 mg of *pivmecillinam hydrochloride CRS* and 5 mg of *pivmecillinam impurity C CRS* in the solvent mixture, and dilute to 50 mL with the solvent mixture.

#### Column:

– *size*:  $l = 0.25$  m,  $\varnothing = 4.0$  mm;

– *stationary phase*: octadecylsilyl silica gel for chromatography R (5  $\mu$ m).

*Mobile phase*: dissolve 0.55 g of *tetraethylammonium hydrogen sulfate R* and 1.0 g of *tetramethylammonium hydrogen sulfate R* in the solvent mixture and dilute to 1000 mL with the solvent mixture.

*Flow rate*: 1.0 mL/min.

*Detection*: spectrophotometer at 220 nm.

*Injection*: 20  $\mu$ L of test solution (b) and reference solutions (b) and (c).

*Run time*: 3 times the retention time of pivmecillinam.

*System suitability*: reference solution (c):

– *resolution*: minimum 3.5 between the peaks due to pivmecillinam (1<sup>st</sup> peak) and impurity C (2<sup>nd</sup> peak).

#### Limits:

– *any impurity*: for each impurity, not more than 1.5 times the area of the principal peak in the chromatogram obtained with reference solution (b) (1.5 per cent);

– *total*: not more than 3 times the area of the principal peak in the chromatogram obtained with reference solution (b) (3 per cent);

– *disregard limit*: 0.1 times the area of the principal peak in the chromatogram obtained with reference solution (b) (0.1 per cent).

***N,N*-Dimethylaniline** (2.4.26, Method A): maximum 20 ppm.

**Test solution.** Prepare as described in the general method but heat at about 27 °C after the addition of *strong sodium hydroxide solution R*, to dissolve the precipitate formed, then add the *trimethylpentane R*.

**Heavy metals** (2.4.8): maximum 20 ppm.

Dissolve 1.0 g in *water R* and dilute to 20 mL with the same solvent. 12 mL of the solution complies with test A. Prepare the reference solution using *lead standard solution (1 ppm Pb) R*.

**Water** (2.5.12): maximum 0.5 per cent, determined on 1.00 g.

**Sulfated ash** (2.4.14): maximum 0.1 per cent, determined on 1.0 g.

#### ASSAY

Liquid chromatography (2.2.29) as described in the test for related substances with the following modifications.

*Injection*: test solution (a) and reference solution (a).

*System suitability*: reference solution (a):

– *repeatability*: maximum relative standard deviation of 1.0 per cent after 6 injections.

Calculate the percentage content of  $C_{21}H_{34}ClN_3O_5S$  from the declared content of *pivmecillinam hydrochloride CRS*.

#### STORAGE

Protected from light, at a temperature of 2 °C to 8 °C.

#### IMPURITIES

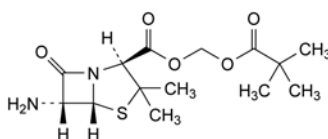

A. methylene (2*S*,5*R*,6*R*)-6-amino-3,3-dimethyl-7-oxo-4-thia-1-azabicyclo[3.2.0]heptane-2-carboxylate 2,2-dimethylpropanoate (pivaloyloxymethyl 6-aminopenicillanate),

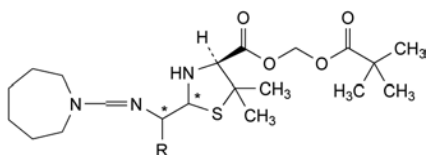

B. R = CO<sub>2</sub>H: 2-[[[(hexahydro-1H-azepin-1-yl)methylene]amino]-2-[(4S)-4-[[[(2,2-dimethylpropanoyl)oxy]methoxy]carbonyl]-5,5-dimethylthiazolidin-2-yl]acetic acid (penicilloic acids of pivmecillinam),

C. R = H: methylene 2,2-dimethylpropanoate (2RS,4S)-2-[[[(hexahydro-1H-azepin-1-yl)methylene]amino]methyl]-5,5-dimethylthiazolidin-4-carboxylate,

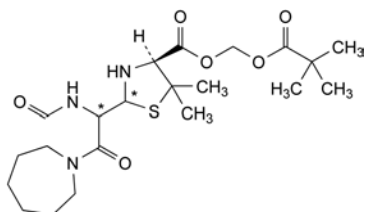

D. methylene 2,2-dimethylpropanoate (4S)-2-[1-(formylamino)-2-(hexahydro-1H-azepin-1-yl)-2-oxoethyl]-5,5-dimethylthiazolidin-4-carboxylate.

01/2008:1464

## POLOXAMERS

### Poloxamers

#### DEFINITION

Synthetic block copolymer of ethylene oxide and propylene oxide, represented by the following general formula:

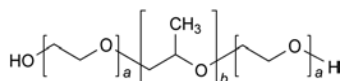

Poloxamer type	Ethylene oxide units (a)	Propylene oxide units (b)	Content of oxyethylene (per cent)	Average relative molecular mass
124	10 - 15	18 - 23	44.8 - 48.6	2090 - 2360
188	75 - 85	25 - 30	79.9 - 83.7	7680 - 9510
237	60 - 68	35 - 40	70.5 - 74.3	6840 - 8830
338	137 - 146	42 - 47	81.4 - 84.9	12 700 - 17 400
407	95 - 105	54 - 60	71.5 - 74.9	9840 - 14 600

A suitable antioxidant may be added.

#### CHARACTERS

##### Appearance:

- *poloxamer 124*: colourless or almost colourless liquid;
- *poloxamers 188, 237, 338, 407*: white or almost white, waxy powder, microbeads or flakes.

##### Solubility:

- *poloxamers 124, 237, 338, 407*: very soluble in water and in ethanol (96 per cent), practically insoluble in light petroleum (bp: 50-70 °C);
  - *poloxamer 188*: soluble in water and in ethanol (96 per cent).
- mp: about 50 °C for poloxamers 188, 237, 338 and 407.

#### IDENTIFICATION

*First identification*: A, B.

*Second identification*: B, C.

A. Infrared absorption spectrophotometry (2.2.24).

*Comparison*: chemical reference substance of the Ph. Eur. corresponding to the type of poloxamer to be examined.

B. Average relative molecular mass (see Tests).

C. Oxypropylene:oxyethylene ratio (see Tests).

#### TESTS

**Solution S.** Dissolve 10.0 g in *carbon dioxide-free water R* and dilute to 100 mL with the same solvent.

**Appearance of solution.** Solution S is not more intensely coloured than reference solution BY<sub>7</sub> (2.2.2, *Method II*).

**pH (2.2.3)**: 5.0 to 7.5 for solution S.

**Ethylene oxide, propylene oxide and dioxan.** Head-space gas chromatography (2.2.28).

**Ethylene oxide stock solution.** Introduce 0.5 g of *ethylene oxide solution R5* into a vial and dilute to 50.0 mL with *dimethyl sulfoxide R1*. Mix carefully.

**Ethylene oxide solution.** Dilute 1.0 mL of the ethylene oxide stock solution to 250 mL with *dimethyl sulfoxide R1*.

**Propylene oxide stock solution.** Introduce about 7 mL of *methylene chloride R* into a volumetric flask, add 0.500 g (*m*) of *propylene oxide R* and dilute to 10.0 mL with *methylene chloride R*. Dilute 0.5 mL of this solution to 50.0 mL with *dimethyl sulfoxide R1*. Mix carefully. Calculate the exact concentration of propylene oxide in mg/mL using the following expression:

$$\frac{m \times 1000 \times 0.5}{10 \times 50}$$

**Propylene oxide solution.** Dilute 1.0 mL of the propylene oxide stock solution to 50.0 mL with *dimethyl sulfoxide R1*.

Calculate the exact concentration of propylene oxide in µg/mL using the following expression:

$$\frac{C \times 1000 \times 1}{50}$$

*C* = concentration of the propylene oxide stock solution in mg/mL.

**Dioxan solution.** Introduce 0.100 g (*m*) of *dioxan R* into a flask and dilute to 50.0 mL with *dimethyl sulfoxide R1*. Dilute 2.50 mL of this solution to 100.0 mL with *dimethyl sulfoxide R1*. Calculate the exact concentration of dioxan in µg/mL using the following expression:

$$\frac{m \times 2.50 \times 1000 \times 1000}{50 \times 100}$$

**Mixture solution.** Dilute a mixture of 6.0 mL of the ethylene oxide solution, 6.0 mL of the propylene oxide solution and 2.5 mL of the dioxan solution to 25.0 mL with *dimethyl sulfoxide R1*.

**Test solution.** To 1.000 g of the substance to be examined in a head-space vial, add 4.0 mL of *dimethyl sulfoxide R1* and close the vial immediately.

**Reference solution.** To 1.000 g of the substance to be examined in a head-space vial, add 2.0 mL of *dimethyl sulfoxide R1* and 2.0 mL of the mixture solution. Close the vial immediately.

#### Column:

- *material*: fused silica;
- *size*: *l* = 50 m, Ø = 0.32 mm;
- *stationary phase*: *poly(dimethyl)(diphenyl)siloxane R* (film thickness 5 µm).

*Carrier gas*: helium for chromatography R.

*Flow rate*: 1.4 mL/min.

*Static head-space conditions*:

- *equilibrium temperature*: 110 °C;
- *equilibration time*: 30 min;
- *transfer-line temperature*: 140 °C;

- *pressurisation time*: 1 min;
- *injection time*: 0.05 min.

*Temperature*:

	Time (min)	Temperature (°C)
	0 - 10	70
Column	10 - 27	70 → 240
Injection port		250
Detector		250

*Detection*: flame ionisation.

*Injection*: inject a suitable volume of the gaseous phase, for example 1 mL.

*Relative retention* with reference to ethylene oxide (retention time = about 6 min): propylene oxide = about 1.3; methylene chloride = about 1.6; dioxan = about 3.0; dimethyl sulfoxide = about 3.7.

*Limits*:

- *ethylene oxide*: not more than 0.5 times the area of the corresponding peak in the chromatogram obtained with the reference solution (1 ppm);
- *propylene oxide*: not more than 0.5 times the area of the corresponding peak in the chromatogram obtained with the reference solution (5 ppm);
- *dioxan*: not more than 0.5 times the area of the corresponding peak in the chromatogram obtained with the reference solution (10 ppm).

**Average relative molecular mass.** Weigh 15 g (*m*) of the substance to be examined into a 250 mL ground-glass-stoppered flask, add 25.0 mL of *phthalic anhydride solution R* and a few glass beads and swirl to dissolve. Boil gently under a reflux condenser for 1 h, allow to cool and add 2 quantities, each of 10 mL, of *pyridine R*, through the condenser. Add 10 mL of *water R*, mix and allow to stand for 10 min. Add 40.0 mL of 0.5 M sodium hydroxide and 0.5 mL of a 10 g/L solution of *phenolphthalein R* in *pyridine R*. Titrate with 0.5 M sodium hydroxide to a light pink endpoint that persists for 15 s and record the volume of sodium hydroxide used (*S*). Prepare a blank. Record the volume of sodium hydroxide used (*B*).

Calculate the average relative molecular mass using the following expression:

$$\frac{4000m}{B - S}$$

**Oxypropylene:oxyethylene ratio.** Nuclear magnetic resonance spectrometry (2.2.33).

Use a 100 g/L solution of the substance to be examined in *deuterated chloroform R*. Record the average area of the doublet appearing at about 1.08 ppm due to the methyl groups of the oxypropylene units (*A*<sub>1</sub>) and the average area of the composite band from 3.2 ppm to 3.8 ppm due to CH<sub>2</sub>O groups of both the oxyethylene and oxypropylene units and the CHO groups of the oxypropylene units (*A*<sub>2</sub>) with reference to the internal standard.

Calculate the percentage of oxyethylene, by weight, in the sample being examined using the following expression:

$$\frac{3300\alpha}{33\alpha + 58}$$

where  $\alpha = \frac{A_2}{A_1} - 1$

**Water** (2.5.12): maximum 1.0 per cent, determined on 1.000 g.

**Total ash** (2.4.16): maximum 0.4 per cent, determined on 1.0 g.

**STORAGE**

In an airtight container.

**LABELLING**

The label states the type of poloxamer.

01/2009:0733

## POLYACRYLATE DISPERSION 30 PER CENT

Polyacrylatis dispersio 30 per centum

**DEFINITION**

Dispersion in water of a copolymer of ethyl acrylate and methyl methacrylate having a mean relative molecular mass of about 800 000.

*Content*: 28.5 per cent to 31.5 per cent (residue on evaporation). It may contain a suitable emulsifier.

**CHARACTERS**

*Appearance*: opaque, white or almost white, slightly viscous liquid.

*Solubility*: miscible with water, soluble in acetone, in anhydrous ethanol and in 2-propanol.

**IDENTIFICATION**

*First identification*: A.

*Second identification*: B, C, D, E.

A. Infrared absorption spectrophotometry (2.2.24).

*Comparison*: Ph. Eur. reference spectrum of polyacrylate.

B. To 1 g add 5 mL of *water R* and mix; the mixture remains opaque. Take 3 portions of 1 g and mix separately with 5 g of *anhydrous ethanol R*, 5 g of *acetone R* and 5 g of *2-propanol R*. Transparent solutions are obtained.

C. To 1 g add 10 mL of 0.1 M sodium hydroxide. The mixture remains opaque.

D. Appearance of a film (see Tests).

E. Dry 4 g in a Petri dish at 60 °C in an oven for 4 h and transfer the resulting clear film to a small test-tube (100 mm × 12 mm). Heat over a flame and collect the fumes that evolve in a 2<sup>nd</sup> test-tube held over the mouth of the 1<sup>st</sup> tube. The condensate gives the reaction of esters (2.3.1).

**TESTS**

**Relative density** (2.2.5): 1.037 to 1.047.

**Apparent viscosity** (2.2.10): maximum 50 mPa·s, determined using a rotating viscometer at 20 °C and a shear rate of 10 s<sup>-1</sup>.

**Appearance of a film.** Pour 1 mL on a glass plate and allow to dry. A clear elastic film is formed.

**Particulate matter.** Filter 100.0 g through a tared stainless steel sieve (90). Rinse with *water R* until a clear filtrate is obtained and dry at 80 °C to constant mass. The residue weighs not more than 0.500 g.

**Residual monomers.** Liquid chromatography (2.2.29).

*Test solution.* Dissolve 1.00 g of the substance to be examined in *tetrahydrofuran R* and dilute to 50.0 mL with the same solvent. To 5.0 mL of a 35 g/L solution of *sodium perchlorate R* add 10.0 mL of the solution dropwise whilst stirring continuously. Centrifuge and filter the clear supernatant liquid. Dilute 5.0 mL of this solution to 10.0 mL with *water R*.

*Reference solution.* Dissolve 10 mg of *ethyl acrylate R* and 10 mg of *methyl methacrylate R* in *tetrahydrofuran R* and dilute to 50.0 mL with the same solvent. Dilute 1.0 mL of this solution to 100.0 mL with *tetrahydrofuran R*. To 10.0 mL of the solution add 5.0 mL of a 35 g/L solution of *sodium perchlorate R* and mix. Dilute 5.0 mL of the mixture to 10.0 mL with *water R*.

*Column*:

- *size*: *l* = 0.12 m,  $\emptyset$  = 4.6 mm;
- *stationary phase*: octadecylsilyl silica gel for chromatography R (5-10  $\mu$ m).



*Mobile phase: acetonitrile R1, water for chromatography R* (15:85 V/V).

*Flow rate: 2 mL/min.*

*Detection: spectrophotometer at 205 nm.*

*Injection: about 50 µL.*

*Limit:*

– *residual monomers: maximum 100 ppm.*

**Heavy metals (2.4.8):** maximum 20 ppm.

1.0 g complies with test C. Prepare the reference solution using 2 mL of *lead standard solution (10 ppm Pb) R*.

**Sulfated ash (2.4.14):** maximum 0.4 per cent, determined on 1.0 g.

#### Microbial contamination

TAMC: acceptance criterion 10<sup>3</sup> CFU/g (2.6.12).

TYMC: acceptance criterion 10<sup>2</sup> CFU/g (2.6.12).

#### ASSAY

Dry 1.000 g at 110 °C for 3 h and weigh the residue.

#### STORAGE

At a temperature of 5 °C to 25 °C. Protect from freezing. Handle the substance so as to minimise microbial contamination.

#### LABELLING

The label states, where applicable, the name and concentration of any added emulsifier.

01/2008:0203

## POLYMYXIN B SULFATE

### Polymyxini B sulfas

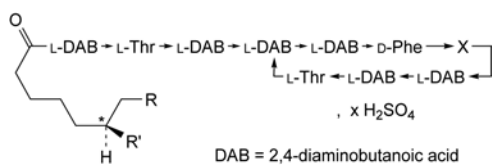

Polymyxin	R	R'	X	Molecular formula	<i>M<sub>r</sub></i>
B1	CH <sub>3</sub>	CH <sub>3</sub>	L-Leu	C <sub>56</sub> H <sub>98</sub> N <sub>16</sub> O <sub>13</sub>	1204
B2	H	CH <sub>3</sub>	L-Leu	C <sub>55</sub> H <sub>96</sub> N <sub>16</sub> O <sub>13</sub>	1190
B3	CH <sub>3</sub>	H	L-Leu	C <sub>55</sub> H <sub>96</sub> N <sub>16</sub> O <sub>13</sub>	1190
B1-I	CH <sub>3</sub>	CH <sub>3</sub>	L-Ile	C <sub>56</sub> H <sub>98</sub> N <sub>16</sub> O <sub>13</sub>	1204

#### DEFINITION

Mixture of the sulfates of polypeptides produced by the growth of certain strains of *Paenibacillus polymyxa*, or obtained by any other means, the main component being polymyxin B1.

*Content:*

- *sum of polymyxins B1, B2, B3 and B1-I: minimum 80.0 per cent (dried substance);*
- *polymyxin B3: maximum 6.0 per cent (dried substance);*
- *polymyxin B1-I: maximum 15.0 per cent (dried substance).*

#### CHARACTERS

*Appearance:* white or almost white, hygroscopic powder.

*Solubility:* soluble in water, slightly soluble in ethanol (96 per cent).

#### IDENTIFICATION

*First identification: B, D.*

*Second identification: A, C, D.*

A. Thin-layer chromatography (2.2.27).

*Test solution.* Dissolve 5 mg of the substance to be examined in 1 mL of a mixture of equal volumes of *hydrochloric acid R* and *water R*. Heat at 135 °C in a sealed tube for 5 h. Evaporate to dryness on a water-bath and continue the heating until the hydrochloric acid has evaporated. Dissolve the residue in 0.5 mL of *water R*.

*Reference solution (a).* Dissolve 20 mg of *leucine R* in *water R* and dilute to 10 mL with the same solvent.

*Reference solution (b).* Dissolve 20 mg of *threonine R* in *water R* and dilute to 10 mL with the same solvent.

*Reference solution (c).* Dissolve 20 mg of *phenylalanine R* in *water R* and dilute to 10 mL with the same solvent.

*Reference solution (d).* Dissolve 20 mg of *serine R* in *water R* and dilute to 10 mL with the same solvent.

*Plate: TLC silica gel G plate R.*

*Carry out the following procedures protected from light.*

*Mobile phase: water R, phenol R (25:75 V/V).*

*Application:* 5 µL as bands of 10 mm, then place the plate in the chromatographic tank so that it is not in contact with the mobile phase, and allow it to become impregnated with the vapour of the mobile phase for at least 12 h.

*Development:* over a path of 12 cm using the same mobile phase.

*Drying:* at 100-105 °C.

*Detection:* spray with *ninhydrin solution R1* and heat at 110 °C for 5 min.

*Results:* the chromatogram obtained with the test solution shows zones corresponding to those in the chromatograms obtained with reference solutions (a), (b) and (c), but shows no zone corresponding to that in the chromatogram obtained with reference solution (d); the chromatogram obtained with the test solution also shows a zone with a very low *R<sub>F</sub>* value (2,4-diaminobutyric acid).

B. Examine the chromatograms obtained in the assay.

*Results:* the peaks due to polymyxins B1, B2, B3 and B1-I in the chromatogram obtained with the test solution are similar in retention time to the corresponding peaks in the chromatogram obtained with reference solution (a).

C. Dissolve about 2 mg in 5 mL of *water R* and add 5 mL of a 100 g/L solution of *sodium hydroxide R*. Shake and add dropwise 0.25 mL of a 10 g/L solution of *copper sulfate R*, shaking after each addition. A reddish-violet colour develops.

D. It gives reaction (a) of sulfates (2.3.1).

#### TESTS

**pH (2.2.3):** 5.0 to 7.0.

Dissolve 0.2 g in *carbon dioxide-free water R* and dilute to 10 mL with the same solvent.

**Specific optical rotation (2.2.7):** –78 to –90 (dried substance).

Dissolve 0.50 g in *water R* and dilute to 25.0 mL with the same solvent.

**Related substances.** Liquid chromatography (2.2.29): use the normalisation procedure.

*Test solution.* Dissolve 50.0 mg of the substance to be examined in a mixture of 20 volumes of *acetonitrile R* and 80 volumes of *water R* and dilute to 100.0 mL with the same mixture of solvents.

*Reference solution (a).* Dissolve 50.0 mg of *polymyxin B sulfate CRS* in a mixture of 20 volumes of *acetonitrile R* and 80 volumes of *water R* and dilute to 100.0 mL with the same mixture of solvents.

*Reference solution (b).* Dilute 1.0 mL of reference solution (a) to 100.0 mL with a mixture of 20 volumes of *acetonitrile R* and 80 volumes of *water R*.

*Column:*

– *size: l = 0.25 m, Ø = 4.6 mm;*

- *stationary phase*: base-deactivated end-capped octadecylsilyl silica gel for chromatography R (5 µm);
- *temperature*: 30 °C.

*Mobile phase*: mix 20 volumes of acetonitrile R and 80 volumes of a solution prepared as follows: dissolve 4.46 g of anhydrous sodium sulfate R in 900 mL of water R, adjust to pH 2.3 with dilute phosphoric acid R and dilute to 1000 mL with water R.

*Flow rate*: 1.0 mL/min.

*Detection*: spectrophotometer at 215 nm.

*Injection*: 20 µL.

*Run time*: 1.4 times the retention time of polymyxin B1.

*Relative retention* with reference to polymyxin B1 (retention time = about 35 min): polymyxin B2 = about 0.5; polymyxin B3 = about 0.6; polymyxin B1-I = about 0.8.

*System suitability*: reference solution (a):

- *resolution*: minimum 3.0 between the peaks due to polymyxin B2 and polymyxin B3.

*Limits*:

- *any impurity*: for each impurity, maximum 3.0 per cent;
- *total*: maximum 17.0 per cent;
- *disregard limit*: 0.7 times the area of the principal peak in the chromatogram obtained with reference solution (b).

**Sulfate**: 15.5 per cent to 17.5 per cent (dried substance).

Dissolve 0.250 g in 100 mL of water R and adjust the solution to pH 11 with concentrated ammonia R. Add 10.0 mL of 0.1 M barium chloride and about 0.5 mg of phthalein purple R. Titrate with 0.1 M sodium edetate, adding 50 mL of ethanol (96 per cent) R when the colour of the solution begins to change and continuing the titration until the violet-blue colour disappears.

1 mL of 0.1 M barium chloride is equivalent to 9.606 mg of SO<sub>4</sub>.

**Loss on drying** (2.2.32): maximum 6.0 per cent, determined on 1.000 g by drying at 60 °C over diphosphorus pentoxide R at a pressure not exceeding 670 Pa for 3 h.

**Sulfated ash** (2.4.14): maximum 0.75 per cent, determined on 1.0 g.

**Pyrogens** (2.6.8). If intended for use in the manufacture of parenteral preparations without a further appropriate procedure for the removal of pyrogens, it complies with the test for pyrogens. Inject, per kilogram of the rabbit's mass, 1 mL of a solution in water for injections R containing 1.5 mg of the substance to be examined per millilitre.

#### ASSAY

Liquid chromatography (2.2.29) as described in the test for related substances with the following modification.

*Injection*: test solution and reference solution (a).

Calculate the percentage content of polymyxin B3, of polymyxin B1-I, and of the sum of polymyxins B1, B2, B3 and B1-I, using the following expression:

$$C_{Bi} = \frac{A_{Bi} \times m_2 \times D_{Bi}}{m_1 \times B_{Bi}}$$

- $C_{Bi}$  = percentage content of polymyxin  $B_i$ ;
- $A_{Bi}$  = area of the peak due to polymyxin  $B_i$  in the chromatogram obtained with the test solution;
- $m_1$  = mass of the substance to be examined (dried substance) in the test solution, in milligrams;
- $B_{Bi}$  = area of the peak due to polymyxin  $B_i$  in the chromatogram obtained with reference solution (a);
- $m_2$  = mass of polymyxin B sulfate CRS in reference solution (a), in milligrams;
- $D_{Bi}$  = declared percentage content for polymyxin  $B_i$  in polymyxin B sulfate CRS.

#### STORAGE

In an airtight container, protected from light. If the substance is sterile, store in a sterile, airtight, tamper-proof container.

01/2008:0426  
corrected 7.0

## POLYSORBATE 20

### Polysorbatum 20

#### DEFINITION

Mixture of partial esters of fatty acids, mainly lauric (dodecanoic) acid, with sorbitol and its anhydrides ethoxylated with approximately 20 moles of ethylene oxide for each mole of sorbitol and sorbitol anhydrides.

#### CHARACTERS

*Appearance*: oily, yellow or brownish-yellow, clear or slightly opalescent liquid.

*Solubility*: soluble in water, in anhydrous ethanol, in ethyl acetate and in methanol, practically insoluble in fatty oils and in liquid paraffin.

*Relative density*: about 1.10.

*Viscosity*: about 400 mPa·s at 25 °C.

#### IDENTIFICATION

*First identification*: A, D.

*Second identification*: B, C, D, E.

A. Infrared absorption spectrophotometry (2.2.24).

*Comparison*: Ph. Eur. reference spectrum of polysorbate 20.

B. Hydroxyl value (see Tests).

C. Saponification value (see Tests).

D. Composition of fatty acids (see Tests).

E. Dissolve 0.1 g in 5 mL of methylene chloride R. Add 0.1 g of potassium thiocyanate R and 0.1 g of cobalt nitrate R. Stir with a glass rod. The solution becomes blue.

#### TESTS

**Acid value** (2.5.1): maximum 2.0.

Dissolve 5.0 g in 50 mL of the prescribed solvent mixture.

**Hydroxyl value** (2.5.3, Method A): 96 to 108.

**Peroxide value**: maximum 10.0.

Introduce 10.0 g into a 100 mL beaker and dissolve with 20 mL of glacial acetic acid R. Add 1 mL of saturated potassium iodide solution R, mix and allow to stand for 1 min. Add 50 mL of carbon dioxide-free water R and a magnetic stirring bar. Titrate with 0.01 M sodium thiosulfate, determining the end-point potentiometrically (2.2.20). Carry out a blank titration.

Determine the peroxide value using the following expression:

$$\frac{(n_1 - n_2) \times M \times 1000}{m}$$

$n_1$  = volume of 0.01 M sodium thiosulfate required for the substance to be examined, in millilitres;

$n_2$  = volume of 0.01 M sodium thiosulfate required for the blank titration, in millilitres;

$M$  = molarity of the sodium thiosulfate solution, in moles per litre;

$m$  = mass of the substance to be examined, in grams.

**Saponification value** (2.5.6): 40 to 50, determined on 4.0 g.

Use 15.0 mL of 0.5 M alcoholic potassium hydroxide and dilute with 50 mL of ethanol (96 per cent) R before carrying out the titration. Heat under reflux for 60 min.

**Composition of fatty acids** (2.4.22, Method C). Prepare reference solution (a) as indicated in Table 2.4.22-2.

**Column:**

- *material*: fused silica;
  - *size*:  $l = 30$  m,  $\varnothing = 0.32$  mm;
  - *stationary phase*: *macrogol 20 000 R* (film thickness 0.5  $\mu$ m).
- Carrier gas*: helium for chromatography R.

*Linear velocity*: 50 cm/s.

*Temperature:*

	Time (min)	Temperature (°C)
Column	0 - 14	80 → 220
	14 - 54	220
Injection port		250
Detector		250

*Detection*: flame ionisation.

*Injection*: 1  $\mu$ L.

*Composition of the fatty-acid fraction of the substance:*

- *caproic acid*: maximum 1.0 per cent;
- *caprylic acid*: maximum 10.0 per cent;
- *capric acid*: maximum 10.0 per cent;
- *lauric acid*: 40.0 per cent to 60.0 per cent;
- *myristic acid*: 14.0 per cent to 25.0 per cent;
- *palmitic acid*: 7.0 per cent to 15.0 per cent;
- *stearic acid*: maximum 7.0 per cent;
- *oleic acid*: maximum 11.0 per cent;
- *linoleic acid*: maximum 3.0 per cent.

**Ethylene oxide and dioxan** (2.4.25, Method A): maximum 1 ppm of ethylene oxide and 10 ppm of dioxan.

**Heavy metals** (2.4.8): maximum 10 ppm.

2.0 g complies with test C. Prepare the reference solution using 2 mL of *lead standard solution (10 ppm Pb) R*.

**Water** (2.5.12): maximum 3.0 per cent, determined on 1.00 g.

**Total ash** (2.4.16): maximum 0.25 per cent, determined on 2.0 g.

**STORAGE**

In an airtight container, protected from light.

01/2008:1914  
corrected 7.0

## POLYSORBATE 40

### Polysorbatum 40

**DEFINITION**

Mixture of partial esters of fatty acids, mainly *Palmitic acid (1904)*, with sorbitol and its anhydrides ethoxylated with approximately 20 moles of ethylene oxide for each mole of sorbitol and sorbitol anhydrides.

**CHARACTERS**

*Appearance*: oily, viscous, yellowish or brownish-yellow liquid.

*Solubility*: miscible with water, with anhydrous ethanol, with ethyl acetate and with methanol, practically insoluble in fatty oils and in liquid paraffin.

*Relative density*: about 1.10.

*Viscosity*: about 400 mPa·s at 30 °C.

**IDENTIFICATION**

*First identification*: A, D.

*Second identification*: B, C, D, E.

A. Infrared absorption spectrophotometry (2.2.24).

*Comparison*: Ph. Eur. reference spectrum of polysorbate 40.

B. Hydroxyl value (see Tests).

C. Saponification value (see Tests).

D. Composition of fatty acids (see Tests).

E. Dissolve 0.1 g in 5 mL of *methylene chloride R*. Add 0.1 g of *potassium thiocyanate R* and 0.1 g of *cobalt nitrate R*. Stir with a glass rod. The solution becomes blue.

**TESTS**

**Acid value** (2.5.1): maximum 2.0.

Dissolve 5.0 g in 50 mL of the prescribed solvent mixture.

**Hydroxyl value** (2.5.3, Method A): 89 to 105.

**Peroxide value**: maximum 10.0.

Introduce 10.0 g into a 100 mL beaker and dissolve with 20 mL of *glacial acetic acid R*. Add 1 mL of *saturated potassium iodide solution R*, mix and allow to stand for 1 min. Add 50 mL of *carbon dioxide-free water R* and a magnetic stirring bar. Titrate with 0.01 M *sodium thiosulfate*, determining the end-point potentiometrically (2.2.20). Carry out a blank titration.

Determine the peroxide value using the following expression:

$$\frac{(n_1 - n_2) \times M \times 1000}{m}$$

$n_1$  = volume of 0.01 M *sodium thiosulfate* required for the substance to be examined, in millilitres;

$n_2$  = volume of 0.01 M *sodium thiosulfate* required for the blank titration, in millilitres;

$M$  = molarity of the sodium thiosulfate solution, in moles per litre;

$m$  = mass of the substance to be examined, in grams.

**Saponification value** (2.5.6): 41 to 52, determined on 4.0 g.

Use 15.0 mL of 0.5 M *alcoholic potassium hydroxide* and dilute with 50 mL of *ethanol (96 per cent) R* before carrying out the titration. Heat under reflux for 60 min.

**Composition of fatty acids** (2.4.22, Method C). Prepare reference solution (a) as indicated in Table 2.4.22-1.

**Column:**

- *material*: fused silica;
  - *size*:  $l = 30$  m,  $\varnothing = 0.32$  mm;
  - *stationary phase*: *macrogol 20 000 R* (film thickness 0.5  $\mu$ m).
- Carrier gas*: helium for chromatography R.

*Linear velocity*: 50 cm/s.

*Temperature:*

	Time (min)	Temperature (°C)
Column	0 - 14	80 → 220
	14 - 54	220
Injection port		250
Detector		250

*Detection*: flame ionisation.

*Injection*: 1  $\mu$ L.

*Composition of the fatty-acid fraction of the substance:*

- *palmitic acid*: minimum 92.0 per cent.

**Ethylene oxide and dioxan** (2.4.25, Method A): maximum 1 ppm of ethylene oxide and maximum 10 ppm of dioxan.

**Heavy metals** (2.4.8): maximum 10 ppm.

2.0 g complies with test C. Prepare the reference solution using 2 mL of *lead standard solution (10 ppm Pb) R*.

**Water** (2.5.12): maximum 3.0 per cent, determined on 1.00 g.

**Total ash** (2.4.16): maximum 0.25 per cent, determined on 2.0 g.

**STORAGE**

In an airtight container, protected from light.

01/2008:0427 – stationary phase: macrogol 20 000 R (film thickness  
corrected 7.0 0.5 µm).

## POLYSORBATE 60

### Polysorbatum 60

#### DEFINITION

Mixture of partial esters of fatty acids, mainly *Stearic acid 50 (1474)*, with sorbitol and its anhydrides ethoxylated with approximately 20 moles of ethylene oxide for each mole of sorbitol and sorbitol anhydrides.

#### CHARACTERS

**Appearance:** yellowish-brown gelatinous mass which becomes a clear liquid at temperatures above 25 °C.

**Solubility:** soluble in water, in anhydrous ethanol, in ethyl acetate and in methanol, practically insoluble in fatty oils and in liquid paraffin.

**Relative density:** about 1.10.

**Viscosity:** about 400 mPas at 30 °C.

#### IDENTIFICATION

**First identification:** A, D.

**Second identification:** B, C, D, E.

A. Infrared absorption spectrophotometry (2.2.24).

*Comparison:* Ph. Eur. reference spectrum of polysorbate 60.

B. Hydroxyl value (see Tests).

C. Saponification value (see Tests).

D. Composition of fatty acids (see Tests).

E. Dissolve 0.1 g in 5 mL of *methylene chloride R*. Add 0.1 g of *potassium thiocyanate R* and 0.1 g of *cobalt nitrate R*. Stir with a glass rod. The solution becomes blue.

#### TESTS

**Acid value (2.5.1):** maximum 2.0.

Dissolve 5.0 g in 50 mL of the prescribed solvent mixture.

**Hydroxyl value (2.5.3, Method A):** 81 to 96.

**Peroxide value:** maximum 10.0.

Introduce 10.0 g into a 100 mL beaker and dissolve with 20 mL of *glacial acetic acid R*. Add 1 mL of *saturated potassium iodide solution R*, mix and allow to stand for 1 min. Add 50 mL of *carbon dioxide-free water R* and a magnetic stirring bar. Titrate with 0.01 M *sodium thiosulfate*, determining the end-point potentiometrically (2.2.20). Carry out a blank titration.

Determine the peroxide value using the following expression:

$$\frac{(n_1 - n_2) \times M \times 1000}{m}$$

$n_1$  = volume of 0.01 M *sodium thiosulfate* required for the substance to be examined, in millilitres;

$n_2$  = volume of 0.01 M *sodium thiosulfate* required for the blank titration, in millilitres;

$M$  = molarity of the sodium thiosulfate solution, in moles per litre;

$m$  = mass of the substance to be examined, in grams.

**Saponification value (2.5.6):** 45 to 55, determined on 4.0 g.

Use 15.0 mL of 0.5 M *alcoholic potassium hydroxide* and dilute with 50 mL of *ethanol (96 per cent) R* before carrying out the titration. Heat under reflux for 60 min.

**Composition of fatty acids (2.4.22, Method C).** Prepare reference solution (a) as indicated in Table 2.4.22-1.

**Column:**

– *material:* fused silica;

– *size:*  $l = 30$  m,  $\varnothing = 0.32$  mm;

*Carrier gas:* helium for chromatography R.

*Linear velocity:* 50 cm/s.

*Temperature:*

	Time (min)	Temperature (°C)
Column	0 - 14	80 → 220
	14 - 54	220
Injection port		250
Detector		250

**Detection:** flame ionisation.

**Injection:** 1 µL.

**Composition of the fatty-acid fraction of the substance:**

– *stearic acid:* 40.0 per cent to 60.0 per cent;

– *sum of the contents of palmitic and stearic acids:* minimum 90.0 per cent.

**Ethylene oxide and dioxan (2.4.25, Method A):** maximum 1 ppm of ethylene oxide and maximum 10 ppm of dioxan.

**Heavy metals (2.4.8):** maximum 10 ppm.

2.0 g complies with test C. Prepare the reference solution using 2 mL of *lead standard solution (10 ppm Pb) R*.

**Water (2.5.12):** maximum 3.0 per cent, determined on 1.00 g.

**Total ash (2.4.16):** maximum 0.25 per cent, determined on 2.0 g.

#### STORAGE

In an airtight container, protected from light.

01/2011:0428

## POLYSORBATE 80

### Polysorbatum 80

#### DEFINITION

Mixture of partial esters of fatty acids, mainly *Oleic acid (0799)*, with sorbitol and its anhydrides ethoxylated with approximately 20 moles of ethylene oxide for each mole of sorbitol and sorbitol anhydrides.

#### CHARACTERS

**Appearance:** oily, colourless or brownish-yellow, clear or slightly opalescent liquid.

**Solubility:** dispersible in water, in anhydrous ethanol, in ethyl acetate and in methanol, practically insoluble in fatty oils and in liquid paraffin.

**Relative density:** about 1.10.

**Viscosity:** about 400 mPas at 25 °C.

#### IDENTIFICATION

**First identification:** A, D.

**Second identification:** B, C, D, E.

A. Infrared absorption spectrophotometry (2.2.24).

*Comparison:* Ph. Eur. reference spectrum of polysorbate 80.

B. Hydroxyl value (see Tests).

C. Saponification value (see Tests).

D. Composition of fatty acids (see Tests).

E. Dissolve 0.1 g in 5 mL of *methylene chloride R*. Add 0.1 g of *cobalt nitrate R* and 0.1 g of *potassium thiocyanate R*. Stir with a glass rod. The solution becomes blue.

#### TESTS

**Acid value (2.5.1):** maximum 2.0.

Dissolve 5.0 g in 50 mL of the prescribed mixture of solvents.

**Hydroxyl value (2.5.3, Method A):** 65 to 80.

01/2008:0427 – stationary phase: macrogol 20 000 R (film thickness  
corrected 7.0 0.5 µm).

## POLYSORBATE 60

### Polysorbatum 60

#### DEFINITION

Mixture of partial esters of fatty acids, mainly *Stearic acid 50 (1474)*, with sorbitol and its anhydrides ethoxylated with approximately 20 moles of ethylene oxide for each mole of sorbitol and sorbitol anhydrides.

#### CHARACTERS

**Appearance:** yellowish-brown gelatinous mass which becomes a clear liquid at temperatures above 25 °C.

**Solubility:** soluble in water, in anhydrous ethanol, in ethyl acetate and in methanol, practically insoluble in fatty oils and in liquid paraffin.

**Relative density:** about 1.10.

**Viscosity:** about 400 mPas at 30 °C.

#### IDENTIFICATION

**First identification:** A, D.

**Second identification:** B, C, D, E.

A. Infrared absorption spectrophotometry (2.2.24).

*Comparison:* Ph. Eur. reference spectrum of polysorbate 60.

B. Hydroxyl value (see Tests).

C. Saponification value (see Tests).

D. Composition of fatty acids (see Tests).

E. Dissolve 0.1 g in 5 mL of *methylene chloride R*. Add 0.1 g of *potassium thiocyanate R* and 0.1 g of *cobalt nitrate R*. Stir with a glass rod. The solution becomes blue.

#### TESTS

**Acid value (2.5.1):** maximum 2.0.

Dissolve 5.0 g in 50 mL of the prescribed solvent mixture.

**Hydroxyl value (2.5.3, Method A):** 81 to 96.

**Peroxide value:** maximum 10.0.

Introduce 10.0 g into a 100 mL beaker and dissolve with 20 mL of *glacial acetic acid R*. Add 1 mL of *saturated potassium iodide solution R*, mix and allow to stand for 1 min. Add 50 mL of *carbon dioxide-free water R* and a magnetic stirring bar. Titrate with 0.01 M *sodium thiosulfate*, determining the end-point potentiometrically (2.2.20). Carry out a blank titration.

Determine the peroxide value using the following expression:

$$\frac{(n_1 - n_2) \times M \times 1000}{m}$$

$n_1$  = volume of 0.01 M *sodium thiosulfate* required for the substance to be examined, in millilitres;

$n_2$  = volume of 0.01 M *sodium thiosulfate* required for the blank titration, in millilitres;

$M$  = molarity of the sodium thiosulfate solution, in moles per litre;

$m$  = mass of the substance to be examined, in grams.

**Saponification value (2.5.6):** 45 to 55, determined on 4.0 g.

Use 15.0 mL of 0.5 M *alcoholic potassium hydroxide* and dilute with 50 mL of *ethanol (96 per cent) R* before carrying out the titration. Heat under reflux for 60 min.

**Composition of fatty acids (2.4.22, Method C).** Prepare reference solution (a) as indicated in Table 2.4.22-1.

**Column:**

– *material:* fused silica;

– *size:*  $l = 30$  m,  $\varnothing = 0.32$  mm;

*Carrier gas:* helium for chromatography R.

*Linear velocity:* 50 cm/s.

*Temperature:*

	Time (min)	Temperature (°C)
Column	0 - 14	80 → 220
	14 - 54	220
Injection port		250
Detector		250

**Detection:** flame ionisation.

**Injection:** 1 µL.

**Composition of the fatty-acid fraction of the substance:**

– *stearic acid:* 40.0 per cent to 60.0 per cent;

– *sum of the contents of palmitic and stearic acids:* minimum 90.0 per cent.

**Ethylene oxide and dioxan (2.4.25, Method A):** maximum 1 ppm of ethylene oxide and maximum 10 ppm of dioxan.

**Heavy metals (2.4.8):** maximum 10 ppm.

2.0 g complies with test C. Prepare the reference solution using 2 mL of *lead standard solution (10 ppm Pb) R*.

**Water (2.5.12):** maximum 3.0 per cent, determined on 1.00 g.

**Total ash (2.4.16):** maximum 0.25 per cent, determined on 2.0 g.

#### STORAGE

In an airtight container, protected from light.

01/2011:0428

## POLYSORBATE 80

### Polysorbatum 80

#### DEFINITION

Mixture of partial esters of fatty acids, mainly *Oleic acid (0799)*, with sorbitol and its anhydrides ethoxylated with approximately 20 moles of ethylene oxide for each mole of sorbitol and sorbitol anhydrides.

#### CHARACTERS

**Appearance:** oily, colourless or brownish-yellow, clear or slightly opalescent liquid.

**Solubility:** dispersible in water, in anhydrous ethanol, in ethyl acetate and in methanol, practically insoluble in fatty oils and in liquid paraffin.

**Relative density:** about 1.10.

**Viscosity:** about 400 mPas at 25 °C.

#### IDENTIFICATION

**First identification:** A, D.

**Second identification:** B, C, D, E.

A. Infrared absorption spectrophotometry (2.2.24).

*Comparison:* Ph. Eur. reference spectrum of polysorbate 80.

B. Hydroxyl value (see Tests).

C. Saponification value (see Tests).

D. Composition of fatty acids (see Tests).

E. Dissolve 0.1 g in 5 mL of *methylene chloride R*. Add 0.1 g of *cobalt nitrate R* and 0.1 g of *potassium thiocyanate R*. Stir with a glass rod. The solution becomes blue.

#### TESTS

**Acid value (2.5.1):** maximum 2.0.

Dissolve 5.0 g in 50 mL of the prescribed mixture of solvents.

**Hydroxyl value (2.5.3, Method A):** 65 to 80.

**Peroxide value:** maximum 10.0.

Introduce 10.0 g into a 100 mL beaker and dissolve with 20 mL of *glacial acetic acid R*. Add 1 mL of *saturated potassium iodide solution R*, mix and allow to stand for 1 min. Add 50 mL of *carbon dioxide-free water R* and a magnetic stirring bar. Titrate with 0.01 M *sodium thiosulfate*, determining the end-point potentiometrically (2.2.20). Carry out a blank titration.

Determine the peroxide value using the following expression:

$$\frac{(n_1 - n_2) \times M \times 1000}{m}$$

- $n_1$  = volume of 0.01 M *sodium thiosulfate* required for the substance to be examined, in millilitres;  
 $n_2$  = volume of 0.01 M *sodium thiosulfate* required for the blank titration, in millilitres;  
 $M$  = molarity of the sodium thiosulfate solution, in moles per litre;  
 $m$  = mass of the substance to be examined, in grams.

**Saponification value (2.5.6):** 45 to 55, determined on 4.0 g.

Use 30.0 mL of 0.5 M *alcoholic potassium hydroxide*, heat under reflux for 60 min and add 50 mL of *anhydrous ethanol R* before carrying out the titration.

**Composition of fatty acids (2.4.22, Method C).** Use the mixture of calibrating substances in Table 2.4.22-3.

**Column:**

- *material:* fused silica;
- *size:*  $l = 30$  m,  $\varnothing = 0.32$  mm;
- *stationary phase:* *macrogol 20 000 R* (film thickness 0.5  $\mu$ m).

*Carrier gas:* helium for chromatography R.

*Linear velocity:* 50 cm/s.

*Temperature:*

	Time (min)	Temperature (°C)
Column	0 - 14	80 → 220
	14 - 54	220
Injection port		250
Detector		250

*Detection:* flame ionisation.

*Injection:* 1  $\mu$ L.

*Composition of the fatty-acid fraction of the substance:*

- *myristic acid:* maximum 5.0 per cent;
- *palmitic acid:* maximum 16.0 per cent;
- *palmitoleic acid:* maximum 8.0 per cent;
- *stearic acid:* maximum 6.0 per cent;
- *oleic acid:* minimum 58.0 per cent;
- *linoleic acid:* maximum 18.0 per cent;
- *linolenic acid:* maximum 4.0 per cent.

**Ethylene oxide and dioxan:** maximum 1 ppm of ethylene oxide and maximum 10 ppm of dioxan.

Head-space gas chromatography (2.2.28).

*Ethylene oxide stock solution.* Dilute 0.5 mL of a commercially available solution of ethylene oxide in methylene chloride (50 mg/mL) to 50.0 mL with *water R*. [NOTE: the solution is stable for 3 months, if stored in vials with polytetrafluoroethylene coated silicone membrane crimped caps at  $-20$  °C]. Allow to reach room temperature. Dilute 1.0 mL of this solution to 250.0 mL with *water R*.

*Dioxan stock solution.* Dilute 1.0 mL of *dioxan R* to 200.0 mL with *water R*. Dilute 1.0 mL of this solution to 100.0 mL with *water R*.

*Acetaldehyde stock solution.* Weigh about 0.100 g of *acetaldehyde R* into a 100 mL volumetric flask and dilute to 100.0 mL with *water R*. Dilute 1.0 mL of this solution to 100.0 mL with *water R*.

*Standard solution.* To 6.0 mL of ethylene oxide stock solution add 2.5 mL of dioxan stock solution and dilute to 25.0 mL with *water R*.

*Test solution (a).* Weigh 1.00 g of the substance to be examined into a 10 mL head-space vial. Add 2.0 mL of *water R*, seal the vial immediately with a polytetrafluoroethylene coated silicon membrane and an aluminum cap. Mix carefully.

*Test solution (b).* Weigh 1.00 g of the substance to be examined into a 10 mL head-space vial. Add 2.0 mL of standard solution, seal the vial immediately with a polytetrafluoroethylene coated silicon membrane and an aluminum cap. Mix carefully.

*Reference solution.* Introduce 2.0 mL of acetaldehyde stock solution and 2.0 mL of ethylene oxide stock solution into a 10 mL head-space vial and seal the vial immediately with a polytetrafluoroethylene coated silicon membrane and an aluminum cap. Mix carefully.

**Column:**

- *material:* fused silica;
- *size:*  $l = 50$  m,  $\varnothing = 0.53$  mm;
- *stationary phase:* *poly(dimethyl)(diphenyl)siloxane R* (5  $\mu$ m).

*Carrier gas:* helium for chromatography R.

*Flow rate:* 4.0 mL/min.

*Split ratio:* 1:3.5.

*Static head-space conditions that may be used:*

- *equilibration temperature:* 80 °C;
- *equilibration time:* 30 min.

*Temperature:*

	Time (min)	Temperature (°C)
Column	0 - 18	70 → 250
	18 - 23	250
Injection port		85
Detector		250

*Detection:* flame ionisation.

*Injection:* 1.0 mL of test solutions (a) and (b) and of the reference solution.

*Relative retention* with reference to ethylene oxide (retention time = about 6.5 min): acetaldehyde = about 0.9; dioxan = about 1.9.

*System suitability:* reference solution:

- *resolution:* minimum 2.0 between the peaks due to acetaldehyde and ethylene oxide.

Calculate the content of ethylene oxide using the following expression:

$$\frac{2 C_{EO} \times A_a}{A_b - A_a}$$

- $C_{EO}$  = concentration of added ethylene oxide in test solution (b), in micrograms per millilitre;  
 $A_a$  = peak area of ethylene oxide in the chromatogram obtained with test solution (a);  
 $A_b$  = peak area of ethylene oxide in the chromatogram obtained with test solution (b).

Calculate the content of dioxan using the following expression:

$$\frac{2 \times 1.03 \times C_D \times A_{a'}}{A_{b'} - A_{a'}}$$

$C_D$  = concentration of added dioxan in test solution (b), in microlitres per millilitre;

1.03 = density of dioxan, in grams per millilitre;

$A_{a'}$  = peak area of dioxan in the chromatogram obtained with test solution (a);

$A_{b'}$  = peak area of dioxan in the chromatogram obtained with test solution (b).

**Heavy metals** (2.4.8): maximum 10 ppm.

2.0 g complies with test C. Prepare the reference solution using 2 mL of *lead standard solution (10 ppm Pb) R*.

**Water** (2.5.12): maximum 3.0 per cent, determined on 1.00 g.

**Total ash** (2.4.16): maximum 0.25 per cent, determined on 2.0 g.

#### STORAGE

In an airtight container, protected from light.

01/2008:1962  
corrected 6.0

## POLY(VINYL ACETATE)

### Poly(vinylis acetat)

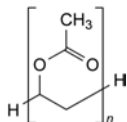

#### DEFINITION

Poly(vinyl acetate) is a thermoplastic polymer obtained by polymerisation of vinyl acetate using a suitable starter, without solvent or with water or 2-propanol. The vast majority of the acetate moieties are attached to non-neighbouring carbon atoms of the chain.

The index  $n$  is about 100 - 17 000. The relative molecular mass lies between 10 000 and 1500 000. The viscosity is 4 to 250 mPas. The ester value, which characterises the degree of hydrolysis, is 615 to 675.

#### CHARACTERS

**Appearance:** white or almost white powder or colourless granules or beads.

**Solubility:** practically insoluble in water, freely soluble in ethyl acetate, soluble in alcohol. It is hygroscopic and swells in water. It softens at temperatures above 40-50 °C.

#### IDENTIFICATION

A. Infrared absorption spectrophotometry (2.2.24).

**Preparation:** discs prepared as follows: dissolve about 200 mg in 5 mL of *acetone R*, place 2 drops on a *potassium bromide R* disc and dry to evaporate the solvent.

The spectrum obtained shows absorption maxima corresponding to poly(vinyl acetate) at 1750  $\text{cm}^{-1}$ , 1400  $\text{cm}^{-1}$  and 1020  $\text{cm}^{-1}$ .

B. Viscosity (see Tests).

C. Saponify 0.500 g in a mixture of 25.0 mL of 0.5 M *alcoholic potassium hydroxide R* and 25.0 mL of *water R* (2.5.6). The solution obtained gives the reaction of acetates (2.3.1).

#### TESTS

**Solution S.** Suspend 50.0 g in 100 mL of *ethyl acetate R* in a borosilicate glass flask with a ground-glass neck. Heat under a reflux condenser with constant stirring for 30 min. Allow to

cool. Filter through a tared sintered glass filter (16) (2.1.2) and wash the residue with 50.0 mL of *ethyl acetate R*, pour the filtrate into a 250 mL graduated flask. Dilute to 250 mL with *ethyl acetate R*.

**Appearance of solution.** Solution S is clear (2.2.1) and colourless (2.2.2, *Method I*).

**Viscosity** (2.2.49): 85 per cent to 115 per cent of the value stated on the label.

Determine the viscosity immediately after preparation of solution S at  $20 \pm 0.1$  °C by using a rolling ball viscosimeter.

**Acid value** (2.5.1): maximum 2.0, determined on 5.0 g dissolved in 50 mL of *alcohol R* by shaking for 3 h.

**Ester value** (2.5.2): 615 to 675.

Saponify 0.500 g in a mixture of 25.0 mL of 0.5 M *alcoholic potassium hydroxide* and 25.0 mL of *water R* (2.5.6).

**Residual peroxides:** maximum 100 ppm, calculated as hydrogen peroxide.

Place 0.85 g in a borosilicate glass flask with a ground-glass neck. Add 10 mL of *ethyl acetate R* and heat under a reflux condenser with constant agitation. Allow to cool. Replace the air in the container with *oxygen-free nitrogen R* and add a solution of 1 mL of *glacial acetic acid R* and 0.5 g of *sodium iodide R* in 40 mL of *water R*. Shake thoroughly and allow to stand protected from light for 20 min. Titrate with 0.005 M *sodium thiosulfate R* until the yellow colour is discharged. Carry out a blank titration. The difference between the titration volumes is not greater than 1.0 mL.

**Vinyl acetate.** Head-space gas chromatography (2.2.28).

**Reference solution.** Place 15 mL of *dimethylformamide R* in a 20 mL vial, add 45  $\mu\text{L}$  of *vinyl acetate R* and 50.0  $\mu\text{L}$  of *butanal R* and dilute to volume with *dimethylformamide R*. Dilute 1 mL of the solution to 10 mL with *dimethylformamide R*.

**Test solution (a).** Place 0.2000 g of the substance to be examined in a 20 mL vial and add 1.00 mL of *dimethylformamide R*. Close the vial and secure the stopper. Shake, avoiding contact between the stopper and the liquid.

**Test solution (b).** Place 0.2000 g of the substance to be examined in a 20 mL vial and add 1.00 mL of the reference solution. Close the vial and secure the stopper. Shake, avoiding contact between the stopper and the liquid.

#### Column:

- *material:* fused silica,
- *size:*  $l = 25$  m,  $\varnothing = 0.32$  mm,
- *stationary phase:* *poly(dimethyl)(diphenyl)(divinyl)siloxane R* (film thickness: 0.32  $\mu\text{m}$ ),

*Carrier gas:* *nitrogen for chromatography R*.

*Flow rate:* 20 mL/min.

*Static head-space conditions which may be used:*

- *equilibration temperature:* 60 °C,
- *equilibration time:* 20 min,
- *transfer-line temperature:* 120 °C,
- *carrier gas:* *nitrogen for chromatography R*.

#### Temperature:

- *column:* 155 °C,
- *injection port:* 120 °C,
- *detector:* 180 °C.

*Detection:* flame ionisation.

*Injection:* 1.6 mL of the gaseous phase of test solutions (a) and (b).

*System suitability:* test solution (b):

- *resolution:* minimum of 2.0 between the peaks due to vinyl acetate and butanal,
- *signal-to-noise ratio:* minimum of 5 for the vinyl acetate peak.

Calculate the percentage of vinyl acetate from the expression:

$$\frac{V \times S_1 \times 0.931}{(m_1 S_2 - m_2 S_1) \times 2000}$$

- $S_1$  = peak area or height for vinyl acetate in the chromatogram obtained with test solution (a),  
 $S_2$  = peak area or height for vinyl acetate in the chromatogram obtained with test solution (b),  
 $m_1$  = mass of the substance to be examined used to prepare test solution (a), in grams,  
 $m_2$  = mass of the substance to be examined used to prepare test solution (b), in grams,  
0.931 = density of vinyl acetate, in grams per millilitre,  
 $V$  = volume of vinyl acetate used to prepare the reference solution, in microlitres.

**Limit:**

– *vinyl acetate*: maximum 0.3 per cent.

**Heavy metals (2.4.8)**: maximum 10 ppm.

1.0 g complies with test D. Prepare the reference solution using 1 mL of *lead standard solution (10 ppm Pb) R*.

**Loss on drying (2.2.32)**: maximum 1.0 per cent, determined on 1.000 g by drying in an oven at 105 °C.

**Sulfated ash (2.4.14)**: maximum 0.1 per cent, determined on 1.0 g.

*The following test concerning the pharmacotechnological properties may be carried out depending on the intended formulation. It is not a mandatory requirement.*

**Infrared absorption spectrum (2.2.24)**. The determination of the spectrum and comparison with a suitable sample is useful for ensuring suitable functionality-related properties.

#### LABELLING

The label states:

- the nominal relative molecular mass,
- the viscosity.

01/2009:2152  
corrected 6.6

## POLY(VINYL ACETATE) DISPERSION 30 PER CENT

### Poly(vinylis acetatas) dispersio 30 per centum

#### DEFINITION

Dispersion in water of poly(vinyl acetate) having a mean relative molecular mass of about 450 000. It may contain *Povidone (0685)* and a suitable surface-active agent, such as *Sodium laurilsulfate (0098)*, as stabilisers.

**Content**: 25.0 per cent to 30.0 per cent of poly(vinyl acetate).

#### CHARACTERS

**Appearance**: opaque, white or almost white, slightly viscous liquid.

**Solubility**: miscible with water and with ethanol (96 per cent).

It is sensitive to spoilage by microbial contaminants.

#### IDENTIFICATION

A. Infrared absorption spectrophotometry (2.2.24).

**Preparation**: dry 1 mL *in vacuo*, dissolve the residue in *acetone R*, and spread 1 drop of the solution between 2 *sodium chloride R* plates; remove 1 plate and allow the solvent to evaporate.

**Comparison**: repeat the operation using *poly(vinyl acetate) dispersion 30 per cent CRS*.

B. Place 3 mL on a glass plate and allow to dry. A clear film is formed.

C. 50 mg gives the reaction of acetyl (2.3.1).

#### TESTS

**Agglomerates**. Filter 100.0 g through a tared stainless steel sieve (90). Rinse with *water R* until a clear filtrate is obtained and dry to constant mass at 100-105 °C. The mass of the residue is not greater than 0.5 g.

**Vinyl acetate**. Liquid chromatography (2.2.29).

**Test solution**. Introduce 0.250 g into a 10 mL volumetric flask and add about 1 mL of *methanol R2*. Sonicate. Add about 8 mL of *water for chromatography R*. Sonicate and dilute to 10.0 mL with *water for chromatography R*. Centrifuge for about 10 min and filter.

**Reference solution (a)**. Dissolve 5.0 mg of *vinyl acetate CRS* in *methanol R2* and dilute to 10.0 mL with the same solvent. Dilute 1.0 mL of the solution to 20.0 mL with mobile phase A. Dilute 1.0 mL of this solution to 10.0 mL with mobile phase A.

**Reference solution (b)**. To 5 mg of *vinyl acetate R* and 5 mg of *1-vinylpyrrolidin-2-one R*, add 10 mL of *methanol R2* and sonicate. Dilute to 50 mL with mobile phase A. Dilute 1 mL of this solution to 20 mL with mobile phase A.

A precolumn containing *octadecylsilyl silica gel for chromatography R* (5 µm) may be used if a matrix effect is observed.

**Column**:

- **size**:  $l = 0.25$  m,  $\emptyset = 4.0$  mm;
- **stationary phase**: *octadecylsilyl silica gel for chromatography R* (5 µm);
- **temperature**: 30 °C.

**Mobile phase**:

- **mobile phase A**: *acetonitrile for chromatography R*, *methanol R2*, *water for chromatography R* (5:5:90 V/V/V);
- **mobile phase B**: *methanol R2*, *acetonitrile for chromatography R*, *water for chromatography R* (5:45:50 V/V/V);

Time (min)	Mobile phase A (per cent V/V)	Mobile phase B (per cent V/V)
0 - 2	100	0
2 - 26	100 → 80	0 → 20
26 - 27	80 → 0	20 → 100
27 - 30	0 → 100	100 → 0

**Flow rate**: 1.0 mL/min.

**Detection**: spectrophotometer at 205 nm.

**Injection**: 10 µL.

**System suitability**: reference solution (b):

- **resolution**: minimum 5.0 between the peaks due to vinyl acetate and 1-vinylpyrrolidin-2-one.

**Limit**:

- **vinyl acetate**: not more than the area of the principal peak in the chromatogram obtained with reference solution (a) (100 ppm).

**Povidone**: maximum 4.0 per cent.

Carry out the determination of nitrogen by sulfuric acid digestion (2.5.9), using 0.25 g. Calculate the percentage content of povidone using the following expression:

$$\frac{N}{0.126}$$

$N$  = percentage content of nitrogen.



**Acetic acid.** Liquid chromatography (2.2.29).

**Test solution.** Mix 0.200 g with *water for chromatography R*. Sonicate for about 10 min and dilute to 10.0 mL with *water for chromatography R*.

**Reference solution.** Dissolve 30.0 mg of *acetic acid R* and 30 mg of *citric acid R* in the mobile phase. Shake gently to dissolve and dilute to 100.0 mL with the mobile phase.

**Column:**

- size:  $l = 0.25$  m,  $\varnothing = 4.6$  mm;
- stationary phase: octadecylsilyl silica gel for chromatography R (5  $\mu$ m).

**Mobile phase:** 0.005 M sulfuric acid.

**Flow rate:** 1.0 mL/min.

**Detection:** spectrophotometer at 205 nm.

**Injection:** 20  $\mu$ L; after each injection, rinse the column with a mixture of equal volumes of *acetonitrile for chromatography R* and 0.005 M sulfuric acid.

**Retention time:** acetic acid = about 6 min; citric acid = about 8 min.

**System suitability:** reference solution:

- resolution: minimum 2.0 between the peaks due to acetic acid and citric acid.

**Limit:**

- *acetic acid*: not more than the area of the corresponding peak in the chromatogram obtained with the reference solution (1.5 per cent).

**Residue on evaporation:** 28.5 per cent to 31.5 per cent, determined on 1.000 g at 110 °C for 5 h.

**Sulfated ash:** maximum 0.5 per cent, determined on 1.0 g.

Heat a silica crucible to redness for 30 min, allow to cool in a desiccator and weigh. Evenly distribute 1.00 g of the preparation to be examined in the crucible and weigh. Dry at 100-105 °C for 1 h and ignite in a muffle furnace at  $600 \pm 25$  °C, until the substance is thoroughly charred. Carry out the test for sulfated ash (2.4.14) on the residue obtained, starting with "Moisten the substance to be examined...".

#### Microbial contamination

TAMC: acceptance criterion  $10^3$  CFU/g (2.6.12).

TYMC: acceptance criterion  $10^2$  CFU/g (2.6.12).

#### ASSAY

Determine the saponification value (2.5.6) on 1.5 g and calculate the percentage content of poly(vinyl acetate) using the following expression:

$$I_s \times 0.1534$$

$I_s$  = saponification value.

#### STORAGE

At a temperature of 5 °C to 30 °C. Handle the substance so as to minimise microbial contamination.

#### FUNCTIONALITY-RELATED CHARACTERISTICS

*This section provides information on characteristics that are recognised as being relevant control parameters for one or more functions of the substance when used as an excipient (see chapter 5.15). This section is a non-mandatory part of the monograph and it is not necessary to verify the characteristics to demonstrate compliance. Control of these characteristics can however contribute to the quality of a medicinal product by improving the consistency of the manufacturing process and the performance of the medicinal product during use. Where control methods are cited, they are recognised as being suitable for the purpose, but other methods can also be used. Wherever results for a particular characteristic are reported, the control method must be indicated.*

*The following characteristics may be relevant for poly(vinyl acetate) dispersion 30 per cent used in the manufacture of modified-release dosage forms and to mask taste.*

**Solubility of a film.** Place the film obtained in identification test B in 50 mL of *phosphate buffer solution pH 6.8 R* whilst stirring continuously. The film does not dissolve within 30 min.

**Apparent viscosity (2.2.10):** maximum 100 mPas, determined using a rotating viscometer at 20 °C and a shear rate of 100 s<sup>-1</sup>.

01/2008:1961  
corrected 6.0

## POLY(VINYL ALCOHOL)

### Poly(alcohol vinylicus)

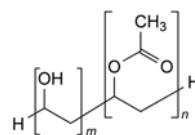

#### DEFINITION

Poly(vinyl alcohol) is obtained by polymerisation of vinyl acetate, followed by partial or almost complete hydrolysis of poly(vinyl acetate) in the presence of catalytic amounts of alkali or mineral acids.

Poly(vinyl alcohol) polymers comply with the following indices:

$$0 \leq \frac{n}{m} \leq 0.35$$

The mean relative molecular mass lies between 20 000 and 150 000. The viscosity is 3 to 70 mPas. The ester value which characterises the degree of hydrolysis is not greater than 280.

#### CHARACTERS

**Appearance:** yellowish-white powder or translucent granules.

**Solubility:** soluble in water, slightly soluble in ethanol, practically insoluble in acetone.

Various grades of poly(vinyl alcohol) are available. They differ in their degree of polymerisation and their degree of hydrolysis which determine the physical properties of the different grades. They are characterised by the viscosity and the ester value of the substance.

#### IDENTIFICATION

A. Infrared absorption spectrophotometry (2.2.24).

**Preparation:** discs; in some cases, the sample has to be milled, after cooling if necessary, before preparing the discs.

The spectrum obtained shows absorption maxima corresponding to poly(vinyl alcohol) at 2940 cm<sup>-1</sup> and 2920 cm<sup>-1</sup>.

B. Viscosity (see Tests).

#### TESTS

**Solution S.** Heat on a water-bath 250 mL of *water R* in a borosilicate round-bottomed flask attached to a reflux condenser with stirrer, add 10.0 g of the substance to be examined and continue heating for 30 min with continuous stirring. Remove the flask from the water-bath and continue stirring until room temperature is reached.

**Appearance of solution.** Solution S is clear (2.2.1) and not more intensely coloured than reference solution Y<sub>7</sub> (2.2.2, Method II).

**pH (2.2.3):** 4.5 to 6.5 for solution S.

**Viscosity (2.2.49):** 85 per cent to 115 per cent of the value stated on the label.

Determine the viscosity using a falling ball viscometer immediately after preparation of solution S at  $20 \pm 0.1$  °C.

**Acid value:** maximum 3.0.

Add 1 mL of *phenolphthalein solution R* to 50 mL of solution S and titrate with 0.05 M potassium hydroxide until the pink colour persists for 15 s. Calculate the acid value from the expression:

$$\frac{2.805V}{2}$$

V = number of millilitres of 0.05 M potassium hydroxide used.

**Ester value (2.5.2):** 90 per cent to 110 per cent of the value stated on the label.

Saponify 1.00 g in a mixture of 25.0 mL of 0.5 M alcoholic potassium hydroxide and 25.0 mL of water R (2.5.6).

**Heavy metals (2.4.8):** maximum 10 ppm.

1.0 g complies with test D. Prepare the reference solution using 1 mL of lead standard solution (10 ppm Pb) R.

**Loss on drying (2.2.32):** maximum 5.0 per cent, determined on 1.000 g by drying in an oven at 105 °C for 3 h.

**Sulfated ash (2.4.14):** maximum 1.0 per cent, determined on 1.0 g.

The following test concerning the pharmacotechnological properties may be carried out depending on the intended formulation. It is not a mandatory requirement.

**Infrared absorption spectrum (2.2.24).** The determination of the spectrum and comparison with a suitable sample is useful for ensuring suitable functionality-related properties. The intensities of the absorption maxima at 1720 cm<sup>-1</sup> and 1260 cm<sup>-1</sup> are inversely proportional to the degree of hydrolysis.

#### LABELLING

The label states:

- the viscosity for a 40 g/L solution,
- the ester value.

01/2008:1139  
corrected 7.0

## POTASSIUM ACETATE

### Kalii acetat

C<sub>2</sub>H<sub>3</sub>KO<sub>2</sub>  
[127-08-2]

M<sub>r</sub> 98.1

#### DEFINITION

**Content:** 99.0 per cent to 101.0 per cent (dried substance).

#### CHARACTERS

**Appearance:** white or almost white, crystalline powder or colourless crystals, deliquescent.

**Solubility:** very soluble in water, freely soluble in ethanol (96 per cent).

#### IDENTIFICATION

- It gives reaction (a) of acetates (2.3.1).
- It gives reaction (a) of potassium (2.3.1).

#### TESTS

**Solution S.** Dissolve 10.0 g in distilled water R and dilute to 100 mL with the same solvent.

**Appearance of solution.** Solution S is clear (2.2.1) and colourless (2.2.2, Method II).

**pH (2.2.3):** 7.5 to 9.0.

Dissolve 1.0 g in carbon dioxide-free water R and dilute to 20 mL with the same solvent.

**Reducing substances.** Dilute 10 mL of solution S to 100 mL with water R. Add 5 mL of dilute sulfuric acid R and 0.5 mL of a 0.32 g/L solution of potassium permanganate R. Mix and boil gently for 5 min. The solution remains pink.

**Chlorides (2.4.4):** maximum 200 ppm.

Dilute 2.5 mL of solution S to 15 mL with water R.

**Sulfates (2.4.13):** maximum 200 ppm.

Dilute 7.5 mL of solution S to 15 mL with distilled water R.

**Aluminium (2.4.17):** maximum 1 ppm, if intended for use in the manufacture of peritoneal dialysis solutions, haemofiltration solutions or haemodialysis solutions.

**Prescribed solution.** Dissolve 2.0 g in 50 mL of water R and add 5 mL of acetate buffer solution pH 6.0 R.

**Reference solution.** Mix 1 mL of aluminium standard solution (2 ppm Al) R, 5 mL of acetate buffer solution pH 6.0 R and 49 mL of water R.

**Blank solution.** Mix 5 mL of acetate buffer solution pH 6.0 R and 50 mL of water R.

**Iron (2.4.9):** maximum 20 ppm.

Dilute 5 mL of solution S to 10 mL with water R.

**Sodium:** maximum 0.5 per cent.

Atomic emission spectrometry (2.2.22, Method II).

**Test solution.** Dissolve 1.00 g in water R and dilute to 100.0 mL with the same solvent.

**Reference solutions.** Prepare the reference solutions using sodium standard solution (200 ppm Na) R, diluted as necessary with water R.

**Wavelength:** 589 nm.

**Heavy metals (2.4.8):** maximum 4 ppm.

Dissolve 5.0 g in water R and dilute to 20 mL with the same solvent. 12 mL of the solution complies with test A. Prepare the reference solution using lead standard solution (1 ppm Pb) R.

**Loss on drying (2.2.32):** maximum 3.0 per cent, determined on 1.000 g by drying in an oven at 105 °C.

#### ASSAY

Dissolve 80.0 mg in 20 mL of anhydrous acetic acid R. Add 0.2 mL of naphtholbenzein solution R. Titrate with 0.1 M perchloric acid. Carry out a blank titration.

1 mL of 0.1 M perchloric acid is equivalent to 9.81 mg of C<sub>2</sub>H<sub>3</sub>KO<sub>2</sub>.

#### STORAGE

In an airtight container.

01/2008:0184  
corrected 6.0

## POTASSIUM BROMIDE

### Kalii bromidum

KBr  
[7758-02-3]

M<sub>r</sub> 119.0

#### DEFINITION

**Content:** 98.0 per cent to 100.5 per cent (dried substance).

#### CHARACTERS

**Appearance:** white or almost white, crystalline powder or colourless crystals.

**Solubility:** freely soluble in water and in glycerol, slightly soluble in alcohol.

#### IDENTIFICATION

- It gives reaction (a) of bromides (2.3.1).
- Solution S (see Tests) gives the reactions of potassium (2.3.1).

## TESTS

01/2008:1557  
corrected 6.0

**Solution S.** Dissolve 10.0 g in *carbon dioxide-free water R* prepared from *distilled water R* and dilute to 100 mL with the same solvent.

**Appearance of solution.** Solution S is clear (2.2.1) and colourless (2.2.2, *Method II*).

**Acidity or alkalinity.** To 10 mL of solution S add 0.1 mL of *bromothymol blue solution R1*. Not more than 0.5 mL of 0.01 M *hydrochloric acid* or 0.01 M *sodium hydroxide* is required to change the colour of the indicator.

**Bromates.** To 10 mL of solution S add 1 mL of *starch solution R*, 0.1 mL of a 100 g/L solution of *potassium iodide R* and 0.25 mL of 0.5 M *sulfuric acid* and allow to stand protected from light for 5 min. No blue or violet colour develops.

**Chlorides:** maximum 0.6 per cent.

In a conical flask, dissolve 1.000 g in 20 mL of *dilute nitric acid R*. Add 5 mL of *strong hydrogen peroxide solution R* and heat on a water-bath until the solution is completely decolorised. Wash down the sides of the flask with a little *water R* and heat on a water-bath for 15 min. Allow to cool, dilute to 50 mL with *water R* and add 5.0 mL of 0.1 M *silver nitrate* and 1 mL of *dibutyl phthalate R*. Shake and titrate with 0.1 M *ammonium thiocyanate*, using 5 mL of *ferric ammonium sulfate solution R2* as indicator. Not more than 1.7 mL of 0.1 M *silver nitrate* is used. Note the volume of 0.1 M *silver nitrate* used (see Assay). Carry out a blank test.

**Iodides.** To 5 mL of solution S add 0.15 mL of *ferric chloride solution R1* and 2 mL of *methylene chloride R*. Shake and allow to separate. The lower layer is colourless (2.2.2, *Method I*).

**Sulfates** (2.4.13): maximum 100 ppm.

15 mL of solution S complies with the limit test for sulfates.

**Iron** (2.4.9): maximum 20 ppm.

5 mL of solution S diluted to 10 mL with *water R* complies with the limit test for iron.

**Magnesium and alkaline-earth metals** (2.4.7): maximum 200 ppm, calculated as Ca.

10.0 g complies with the limit test for magnesium and alkaline-earth metals. The volume of 0.01 M *sodium edetate* used does not exceed 5.0 mL.

**Heavy metals** (2.4.8): maximum 10 ppm.

12 mL of solution S complies with limit test A. Prepare the standard using *lead standard solution (1 ppm Pb) R*.

**Loss on drying** (2.2.32): maximum 1.0 per cent, determined on 1.000 g by drying in an oven at 105 °C for 3 h.

## ASSAY

Dissolve 2.000 g in *water R* and dilute to 100.0 mL with the same solvent. To 10.0 mL of the solution add 50 mL of *water R*, 5 mL of *dilute nitric acid R*, 25.0 mL of 0.1 M *silver nitrate* and 2 mL of *dibutyl phthalate R*. Shake. Titrate with 0.1 M *ammonium thiocyanate*, using 2 mL of *ferric ammonium sulfate solution R2* as indicator and shaking vigorously towards the end-point.

1 mL of 0.1 M *silver nitrate* is equivalent to 11.90 mg of KBr.

Calculate the percentage content of KBr from the expression:

$$a - 3.357 b$$

*a* = percentage content of KBr and KCl obtained in the assay and calculated as KBr,

*b* = percentage content of Cl in the test for chlorides.

## POTASSIUM CARBONATE

Kalii carbonas

K<sub>2</sub>CO<sub>3</sub>  
[584-08-7]*M*<sub>r</sub> 138.2

## DEFINITION

**Content:** 99.0 per cent to 101.0 per cent (dried substance).

## CHARACTERS

**Appearance:** white or almost white granular powder, hygroscopic.

**Solubility:** freely soluble in water, practically insoluble in ethanol (96 per cent).

## IDENTIFICATION

- Dissolve 1 g in 10 mL of *water R*. The solution is strongly alkaline (2.2.4).
- 2 mL of the solution prepared for identification test A gives the reaction of carbonates and bicarbonates (2.3.1).
- 1 mL of the solution prepared for identification test A gives reaction (b) of potassium (2.3.1).

## TESTS

**Solution S.** Dissolve 10.0 g in 25 mL of *distilled water R*. Slowly add 14 mL of *hydrochloric acid R*. When the effervescence has ceased, boil for a few minutes. Allow to cool and dilute to 50 mL with *distilled water R*.

**Appearance of solution.** Solution S is not more opalescent than reference suspension II (2.2.1) and not more intensely coloured than reference solution Y<sub>6</sub> (2.2.2, *Method II*).

**Chlorides** (2.4.4): maximum 100 ppm.

Dissolve 0.50 g in 10 mL of *water R*. Carefully add dropwise 1 mL of *nitric acid R*. Boil. Cool, add 5 mL of *dilute nitric acid R* and dilute to 15 mL with *water R*.

**Sulfates** (2.4.13): maximum 100 ppm.

Dilute 7.50 mL of solution S to 15 mL with *distilled water R*.

**Calcium** (2.4.3): maximum 100 ppm.

To 5 mL of solution S add 1 mL of *concentrated ammonia R*. Boil. Cool. Dilute to 15 mL with *distilled water R*.

**Iron** (2.4.9): maximum 10 ppm.

Dilute 5 mL of solution S to 10 mL with *water R*.

**Heavy metals** (2.4.8): maximum 20 ppm.

Dilute 10 mL of solution S to 20 mL with *water R*. 12 mL of the solution complies with test A. Prepare the reference solution using *lead standard solution (2 ppm Pb) R*.

**Loss on drying** (2.2.32): maximum 5.0 per cent, determined on 0.300 g by drying in an oven at 120-125 °C for 5 h.

## ASSAY

Dissolve 0.500 g in 50 mL of *carbon dioxide-free water R*. Carry out a potentiometric titration (2.2.20), using 1 M *hydrochloric acid*. Read the volume added at the 2<sup>nd</sup> point of inflexion.

1 mL of 1 M *hydrochloric acid* is equivalent to 69.1 mg of K<sub>2</sub>CO<sub>3</sub>.

## STORAGE

In an airtight container.

01/2008:0185  
corrected 7.0

## POTASSIUM CHLORIDE

## Kalii chloridum

KCl  
[7447-40-7] $M_r$  74.6

## DEFINITION

**Content:** 99.0 per cent to 100.5 per cent of KCl (dried substance).

## CHARACTERS

**Appearance:** white or almost white, crystalline powder or colourless crystals.

**Solubility:** freely soluble in water, practically insoluble in anhydrous ethanol.

## IDENTIFICATION

- A. It gives the reactions of chlorides (2.3.1).  
 B. Solution S (see Tests) gives the reactions of potassium (2.3.1).

## TESTS

**Solution S.** Dissolve 10.0 g in carbon dioxide-free water R prepared from distilled water R and dilute to 100 mL with the same solvent.

**Appearance of solution.** Solution S is clear (2.2.1) and colourless (2.2.2, Method II).

**Acidity or alkalinity.** To 50 mL of solution S add 0.1 mL of bromothymol blue solution R1. Not more than 0.5 mL of 0.01 M hydrochloric acid or 0.01 M sodium hydroxide is required to change the colour of the indicator.

**Bromides:** maximum 0.1 per cent.

Dilute 1.0 mL of solution S to 50 mL with water R. To 5.0 mL of the solution add 2.0 mL of phenol red solution R2 and 1.0 mL of chloramine solution R1 and mix immediately. After exactly 2 min add 0.15 mL of 0.1 M sodium thiosulfate, mix and dilute to 10.0 mL with water R. The absorbance (2.2.25) of the solution measured at 590 nm, using water R as the compensation liquid, is not greater than that of a standard prepared at the same time and in the same manner using 5 mL of a 3.0 mg/L solution of potassium bromide R.

**Iodides.** Moisten 5 g by the dropwise addition of a freshly prepared mixture of 0.15 mL of sodium nitrite solution R, 2 mL of 0.5 M sulfuric acid, 25 mL of iodide-free starch solution R and 25 mL of water R. After 5 min, examine in daylight. The substance shows no blue colour.

**Sulfates (2.4.13):** maximum 300 ppm.

Dilute 5 mL of solution S to 15 mL with distilled water R.

**Aluminium (2.4.17):** maximum 1.0 ppm, if intended for use in the manufacture of haemodialysis solutions.

**Prescribed solution.** Dissolve 4 g in 100 mL of water R and add 10 mL of acetate buffer solution pH 6.0 R.

**Reference solution.** Mix 2 mL of aluminium standard solution (2 ppm Al) R, 10 mL of acetate buffer solution pH 6.0 R and 98 mL of water R.

**Blank solution.** Mix 10 mL of acetate buffer solution pH 6.0 R and 100 mL of water R.

**Barium.** To 5 mL of solution S add 5 mL of distilled water R and 1 mL of dilute sulfuric acid R. After 15 min, any opalescence in the solution is not more intense than that in a mixture of 5 mL of solution S and 6 mL of distilled water R.

**Iron (2.4.9):** maximum 20 ppm.

Dilute 5 mL of solution S to 10 mL with water R.

**Magnesium and alkaline-earth metals (2.4.7):** maximum 200 ppm, calculated as Ca, determined on 10.0 g using 0.15 g of mordant black 11 triturate R. The volume of 0.01 M sodium edetate used does not exceed 5.0 mL.

**Sodium:** maximum 0.1 per cent, if intended for use in the manufacture of parenteral preparations or haemodialysis solutions.

Atomic emission spectrometry (2.2.22, Method I).

**Test solution.** Dissolve 1.00 g of the substance to be examined in water R and dilute to 100.0 mL with the same solvent.

**Reference solutions.** Prepare the reference solutions by diluting as required a solution containing 200 µg of Na per millilitre, prepared as follows: dissolve in water R 0.5084 g of sodium chloride R, previously dried at 100-105 °C for 3 h, and dilute to 1000.0 mL with the same solvent.

**Wavelength:** 589 nm.

**Heavy metals (2.4.8):** maximum 10 ppm.

12 mL of solution S complies with test A. Prepare the reference solution using lead standard solution (1 ppm Pb) R.

**Loss on drying (2.2.32):** maximum 1.0 per cent, determined on 1.000 g by drying in an oven at 105 °C for 3 h.

## ASSAY

Dissolve 1.300 g in water R and dilute to 100.0 mL with the same solvent. To 10.0 mL of the solution add 50 mL of water R, 5 mL of dilute nitric acid R, 25.0 mL of 0.1 M silver nitrate and 2 mL of dibutyl phthalate R. Shake. Titrate with 0.1 M ammonium thiocyanate, using 2 mL of ferric ammonium sulfate solution R2 as indicator and shaking vigorously towards the end-point.

1 mL of 0.1 M silver nitrate is equivalent to 7.46 mg of KCl.

## LABELLING

The label states:

- where applicable, that the substance is suitable for use in the manufacture of parenteral preparations;
- where applicable, that the substance is suitable for use in the manufacture of haemodialysis solutions.

01/2009:0400  
corrected 7.0

## POTASSIUM CITRATE

## Kalii citras

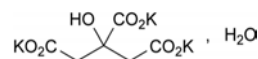
 $\text{C}_8\text{H}_5\text{K}_3\text{O}_7 \cdot \text{H}_2\text{O}$   
[6100-05-6] $M_r$  324.4

## DEFINITION

Tripotassium 2-hydroxypropane-1,2,3-tricarboxylate monohydrate.

**Content:** 99.0 per cent to 101.0 per cent (anhydrous substance).

## CHARACTERS

**Appearance:** white or almost white, granular powder or transparent crystals, hygroscopic.

**Solubility:** very soluble in water, practically insoluble in ethanol (96 per cent).

## IDENTIFICATION

- A. To 1 mL of solution S (see Tests) add 4 mL of water R. The solution gives the reaction of citrates (2.3.1).  
 B. 0.5 mL of solution S gives reaction (b) of potassium (2.3.1).

## TESTS

07/2010:1140

**Solution S.** Dissolve 10.0 g in *carbon dioxide-free water R* prepared from *distilled water R* and dilute to 100 mL with the same solvent.

**Appearance of solution.** Solution S is clear (2.2.1) and colourless (2.2.2, *Method II*).

**Acidity or alkalinity.** To 10 mL of solution S add 0.1 mL of *phenolphthalein solution R*. Not more than 0.2 mL of 0.1 M *hydrochloric acid* or 0.1 M *sodium hydroxide* is required to change the colour of the indicator.

**Readily carbonisable substances.** To 0.20 g of the powdered substance to be examined add 10 mL of *sulfuric acid R* and heat in a water-bath at  $90 \pm 1$  °C for 60 min. Cool rapidly. The solution is not more intensely coloured than reference solution Y<sub>2</sub> or GY<sub>2</sub> (2.2.2, *Method II*).

**Chlorides** (2.4.4): maximum 50 ppm.

Dilute 10 mL of solution S to 15 mL with *water R*.

**Oxalates:** maximum 300 ppm.

Dissolve 0.50 g in 4 mL of *water R*, add 3 mL of *hydrochloric acid R* and 1 g of *zinc R* in granules and heat on a water-bath for 1 min. Allow to stand for 2 min, decant the liquid into a test-tube containing 0.25 mL of a 10 g/L solution of *phenylhydrazine hydrochloride R* and heat to boiling. Cool rapidly, transfer to a graduated cylinder and add an equal volume of *hydrochloric acid R* and 0.25 mL of *potassium ferricyanide solution R*. Shake and allow to stand for 30 min. Any pink colour in the solution is not more intense than that in a standard prepared at the same time and in the same manner using 4 mL of a 0.05 g/L solution of *oxalic acid R*.

**Sulfates** (2.4.13): maximum 150 ppm.

To 10 mL of solution S add 2 mL of *hydrochloric acid R1* and dilute to 15 mL with *distilled water R*.

**Heavy metals** (2.4.8): maximum 10 ppm.

12 mL of solution S complies with test A. Prepare the reference solution using *lead standard solution (1 ppm Pb) R*.

**Sodium:** maximum 0.3 per cent.

Atomic emission spectrometry (2.2.22, *Method II*).

**Test solution.** To 10 mL of solution S add 1 mL of *dilute hydrochloric acid R* and dilute to 100 mL with *distilled water R*.

**Reference solutions.** Prepare the reference solutions using a solution of *sodium chloride R* containing 1 mg of Na per millilitre diluted as necessary with *distilled water R*.

**Wavelength:** 589 nm.

**Water** (2.5.12): 4.0 per cent to 7.0 per cent, determined on 0.250 g. Use a mixture of 1 volume of *formamide R* and 2 volumes of *methanol R* as solvent. After adding the substance to be examined, stir for 15 min before titrating.

## ASSAY

Dissolve 0.150 g in 20 mL of *anhydrous acetic acid R*, heating to about 50 °C. Allow to cool. Titrate with 0.1 M *perchloric acid* using 0.25 mL of *naphtholbenzein solution R* as indicator until a green colour is obtained.

1 mL of 0.1 M *perchloric acid* is equivalent to 10.21 mg of C<sub>8</sub>H<sub>8</sub>K<sub>3</sub>O<sub>7</sub>.

## STORAGE

In an airtight container.

## POTASSIUM CLAVULANATE

## Kalii clavulanate

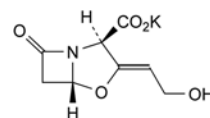

C<sub>8</sub>H<sub>8</sub>KNO<sub>5</sub>  
[61177-45-5]

M<sub>r</sub> 237.3

## DEFINITION

Potassium (2*R*,3*Z*,5*R*)-3-(2-hydroxyethylidene)-7-oxo-4-oxa-1-azabicyclo[3.2.0]heptane-2-carboxylate, the potassium salt of a substance produced by the growth of certain strains of *Streptomyces clavuligerus* or obtained by any other means.

**Content:** 96.5 per cent to 102.0 per cent (anhydrous substance).

## CHARACTERS

**Appearance:** white or almost white, crystalline powder, hygroscopic.

**Solubility:** freely soluble in water, slightly soluble in ethanol (96 per cent), very slightly soluble in acetone.

## PRODUCTION

The methods of production, extraction and purification are such that clavam-2-carboxylate is eliminated or present at a level not exceeding 0.01 per cent.

## IDENTIFICATION

A. Infrared absorption spectrophotometry (2.2.24).

*Comparison:* Ph. Eur. reference spectrum of potassium clavulanate.

B. It gives reaction (b) of potassium (2.3.1).

## TESTS

**Solution S.** Dissolve 0.400 g in *carbon dioxide-free water R* and dilute to 20.0 mL with the same solvent.

**pH** (2.2.3): 5.5 to 8.0.

Dilute 5 mL of solution S to 10 mL with *carbon dioxide-free water R*.

**Specific optical rotation** (2.2.7): + 53 to + 63 (anhydrous substance, determined on solution S).

**Polymeric impurities and other impurities absorbing at 278 nm**

Dissolve 50.0 mg in 0.1 M *phosphate buffer solution pH 7.0 R* and dilute to 50.0 mL with the same buffer solution. Measure the absorbance immediately.

The absorbance (2.2.25) of the solution determined at 278 nm is not greater than 0.40.

**Related substances.** Liquid chromatography (2.2.29). Prepare the solutions immediately before use.

**Test solution.** Dissolve 0.250 g of the substance to be examined in mobile phase A and dilute to 25.0 mL with mobile phase A.

**Reference solution (a).** Dilute 1.0 mL of the test solution to 100.0 mL with mobile phase A.

**Reference solution (b).** Dissolve 10 mg of *lithium clavulanate CRS* and 10 mg of *amoxicillin trihydrate CRS* in mobile phase A and dilute to 100 mL with mobile phase A.

**Reference solution (c).** Dissolve 2 mg of *potassium clavulanate impurity G CRS* in 20 mL of mobile phase A.

**Column:**

- size: *l* = 0.10 m, Ø = 4.6 mm;
- stationary phase: octadecylsilyl silica gel for chromatography R (5 µm);
- temperature: 40 °C.

**Mobile phase:**

- *mobile phase A*: a 7.8 g/L solution of *sodium dihydrogen phosphate R* adjusted to pH 4.0 with *phosphoric acid R*;
- *mobile phase B*: a mixture of equal volumes of *methanol R* and *mobile phase A*;

Time (min)	Mobile phase A (per cent V/V)	Mobile phase B (per cent V/V)
0 - 4	100	0
4 - 15	100 → 50	0 → 50
15 - 18	50	50

**Flow rate:** 1 mL/min.

**Detection:** spectrophotometer at 230 nm.

**Injection:** 20 µL.

**Relative retention** with reference to clavulanate (retention time = about 3 min): impurity E = about 2.3; impurity G = about 3.6.

**System suitability:** reference solution (b):

- **resolution:** minimum 13 between the peaks due to clavulanate (1<sup>st</sup> peak) and amoxicillin (2<sup>nd</sup> peak).

**Limits:**

- **impurities E, G:** for each impurity, not more than the area of the principal peak in the chromatogram obtained with reference solution (a) (1.0 per cent);
- **any other impurity:** for each impurity, not more than 0.2 times the area of the principal peak in the chromatogram obtained with reference solution (a) (0.2 per cent);
- **total:** not more than twice the area of the principal peak in the chromatogram obtained with reference solution (a) (2.0 per cent);
- **disregard limit:** 0.05 times the area of the principal peak in the chromatogram obtained with reference solution (a) (0.05 per cent).

**Aliphatic amines.** Gas chromatography (2.2.28).

The method shown below can be used to determine the following aliphatic amines: 1,1-dimethylethylamine; tetramethylethylenediamine; 1,1,3,3-tetramethylbutylamine; *N,N*-diisopropylethylenediamine; 2,2'-oxybis(*N,N*-dimethylethylamine).

**Internal standard solution:** dissolve 50 µL of 3-methylpentan-2-one *R* in water *R* and dilute to 100.0 mL with the same solvent.

**Test solution.** Weigh 1.00 g of the substance to be examined into a centrifuge tube. Add 5.0 mL of the internal standard solution, 5.0 mL of dilute sodium hydroxide solution *R*, 10.0 mL of water *R*, 5.0 mL of 2-methylpropanol *R* and 5 g of sodium chloride *R*. Shake vigorously for 1 min. Centrifuge to separate the layers.

**Reference solution.** Dissolve 80.0 mg of each of the following amines: 1,1-dimethylethylamine *R*; tetramethylethylenediamine *R*; 1,1,3,3-tetramethylbutylamine *R*; *N,N*-diisopropylethylenediamine *R* and 2,2'-oxybis(*N,N*-dimethylethylamine) *R* in dilute hydrochloric acid *R* and dilute to 200.0 mL with the same acid. Introduce 5.0 mL of this solution into a centrifuge tube. Add 5.0 mL of the internal standard solution, 10.0 mL of dilute sodium hydroxide solution *R*, 5.0 mL of 2-methylpropanol *R* and 5 g of sodium chloride *R*. Shake vigorously for 1 min. Centrifuge to separate the layers.

**Column:**

- **material:** fused silica;
- **size:**  $l = 50$  m,  $\emptyset = 0.53$  mm;
- **stationary phase:** poly(dimethyl)(diphenyl)siloxane *R* (film thickness 5 µm).

**Carrier gas:** helium for chromatography *R*.

**Flow rate:** 8 mL/min.

**Split ratio:** 1:10.

**Temperature:**

	Time (min)	Temperature (°C)
Column	0 - 7	35
	7 - 10.8	35 → 150
	10.8 - 25.8	150
Injection port		200
Detector		250

**Detection:** flame ionisation.

**Injection:** 1 µL of the upper layers obtained from the test solution and the reference solution.

**Relative retention** with reference to 3-methylpentan-2-one (retention time = about 11.4 min): impurity H = about 0.55; impurity J = about 1.07; impurity K = about 1.13; impurity L = about 1.33; impurity M = about 1.57.

**Limit:**

- **total of aliphatic amines:** maximum 0.2 per cent.

**2-Ethylhexanoic acid (2.4.28):** maximum 0.8 per cent.

**Water (2.5.12):** maximum 0.5 per cent, determined on 1.00 g.

**Bacterial endotoxins (2.6.14):** less than 0.03 IU/mg if intended for use in the manufacture of parenteral preparations without a further appropriate procedure for the removal of bacterial endotoxins.

**ASSAY**

Liquid chromatography (2.2.29). Prepare the solutions immediately before use.

**Test solution.** Dissolve 50.0 mg of the substance to be examined in a 4.1 g/L solution of sodium acetate *R* previously adjusted to pH 6.0 with glacial acetic acid *R*, and dilute to 50.0 mL with the same solution.

**Reference solution (a).** Dissolve 50.0 mg of lithium clavulanate CRS in a 4.1 g/L solution of sodium acetate *R* previously adjusted to pH 6.0 with glacial acetic acid *R* and dilute to 50.0 mL with the same solution.

**Reference solution (b).** Dissolve 10 mg of amoxicillin trihydrate CRS in 10 mL of reference solution (a).

**Column:**

- **size:**  $l = 0.3$  m,  $\emptyset = 4.6$  mm;
- **stationary phase:** octadecylsilyl silica gel for chromatography *R* (10 µm).

**Mobile phase:** mix 5 volumes of methanol *R1* and 95 volumes of a 15 g/L solution of sodium dihydrogen phosphate *R* previously adjusted to pH 4.0 with dilute phosphoric acid *R*.

**Flow rate:** 1 mL/min.

**Detection:** spectrophotometer at 230 nm.

**Injection:** 10 µL.

**System suitability:** reference solution (b):

- **resolution:** minimum 3.5 between the peaks due to clavulanate (1<sup>st</sup> peak) and amoxicillin (2<sup>nd</sup> peak).

1 mg of clavulanate ( $C_8H_9NO_5$ ) is equivalent to 1.191 mg of  $C_8H_8KNO_5$ .

**STORAGE**

In an airtight container, at a temperature of 2 °C to 8 °C. If the substance is sterile, store in a sterile, airtight, tamper-proof container.

**IMPURITIES**

**Specified impurities:** E, G, H, J, K, L, M.

**Other detectable impurities** (the following substances would, if present at a sufficient level, be detected by one or other of the tests in the monograph. They are limited by the general acceptance criterion for other/unspecified impurities and/or by the general monograph *Substances for pharmaceutical use*

(2034). It is therefore not necessary to identify these impurities for demonstration of compliance. See also 5.10. *Control of impurities in substances for pharmaceutical use*: A, B, C, D, F.

By liquid chromatography: A, B, C, D, E, F, G.

By gas chromatography: H, J, K, L, M.

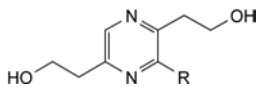

A. R = H: 2,2'-(pyrazine-2,5-diyl)diethanol,

B. R = CH<sub>2</sub>-CH<sub>2</sub>-CO<sub>2</sub>H: 3-[3,6-bis(2-hydroxyethyl)pyrazin-2-yl]propanoic acid,

C. R = CH<sub>2</sub>-CH<sub>3</sub>: 2,2'-(3-ethylpyrazine-2,5-diyl)diethanol,

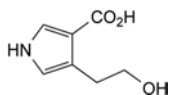

D. 4-(2-hydroxyethyl)-1*H*-pyrrole-3-carboxylic acid,

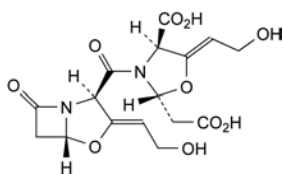

E. (2*R*,4*R*,5*Z*)-2-(carboxymethyl)-5-(2-hydroxyethylidene)-3-[[[(2*R*,3*Z*,5*R*)-3-(2-hydroxyethylidene)-7-oxo-4-oxa-1-azabicyclo[3.2.0]hept-2-yl]carbonyl]oxazolidine-4-carboxylic acid,

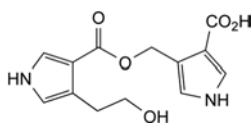

F. 4-[[[4-(2-hydroxyethyl)-1*H*-pyrrol-3-yl]carbonyl]oxy]methyl]-1*H*-pyrrole-3-carboxylic acid,

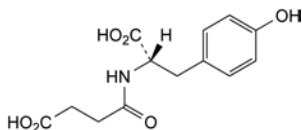

G. 4-[[[(1*S*)-1-carboxy-2-(4-hydroxyphenyl)ethyl]amino]-4-oxobutanoic acid (*N*-(hydrogensuccinyl)tyrosine),

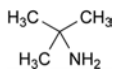

H. 2-methylpropan-2-amine (2-amino-2-methylpropane, *tert*-butylamine, ethyldimethylamine),

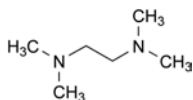

J. *N,N,N',N'*-tetramethylethane-1,2-diamine (1,2-bis(dimethylamino)ethane, *N,N,N',N'*-tetramethylethylenediamine),

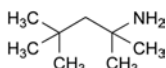

K. 2,4,4-trimethylpentan-2-amine (2-amino-2,4,4-trimethylpentane, 1,1,3,3-tetramethylbutylamine),

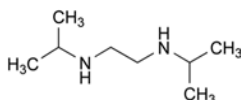

L. *N,N'*-diisopropylethane-1,2-diamine (*N,N'*-bis(1-methylethyl)ethane-1,2-diamine),

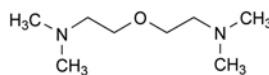

M. 2,2'-oxybis(*N,N*-dimethylethanamine) (bis[2-(dimethylamino)ethyl] ether, *N,N,N',N'*-tetramethyl(oxydiethylene)di-amine).

07/2010:1653

## POTASSIUM CLAVULANATE, DILUTED

### Kalii clavulanans dilutus

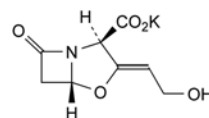

C<sub>8</sub>H<sub>8</sub>KNO<sub>5</sub>

*M*<sub>r</sub> 237.3

#### DEFINITION

Dry mixture of *Potassium clavulanate* (1140) and *Cellulose, microcrystalline* (0316) or *Silica, colloidal anhydrous* (0434) or *Silica, colloidal hydrated* (0738).

*Content*: 91.2 per cent to 107.1 per cent of the content of potassium clavulanate stated on the label.

#### CHARACTERS

*Appearance of diluted potassium clavulanate*: white or almost white powder, hygroscopic.

*Solubility of potassium clavulanate*: freely soluble in water, slightly soluble in ethanol (96 per cent), very slightly soluble in acetone.

The solubility of the diluted product depends on the diluent and its concentration.

#### IDENTIFICATION

A. Examine the chromatograms obtained in the assay.

*Results*: the principal peak in the chromatogram obtained with the test solution is similar in retention time to the principal peak in the chromatogram obtained with reference solution (a).

B. It gives reaction (b) of potassium (2.3.1).

C. Depending on the diluent used, carry out the corresponding identification test (a) or (b).

(a) A quantity of the substance to be examined, corresponding to 20 mg of cellulose, when placed on a watch-glass and dispersed in 4 mL of *iodinated zinc chloride solution R*, becomes violet-blue.

(b) It gives the reaction of silicates (2.3.1).

#### TESTS

**pH** (2.2.3): 4.8 to 8.0.

Suspend a quantity of the substance to be examined corresponding to 0.200 g of potassium clavulanate in 20 mL of *carbon dioxide-free water R*.

#### Polymeric impurities and other impurities absorbing at 278 nm

Disperse a quantity of the substance to be examined corresponding to 50.0 mg of potassium clavulanate in 10 mL of 0.1 M phosphate buffer solution pH 7.0 R, dilute to 50.0 mL with the same buffer solution and filter. Measure the absorbance immediately.

The absorbance (2.2.25) of the solution determined at 278 nm is not greater than 0.40.

**Related substances.** Liquid chromatography (2.2.29). Prepare the solutions immediately before use.

*Test solution.* Disperse a quantity of the substance to be examined corresponding to 0.250 g of potassium clavulanate in

5 mL of mobile phase A, dilute to 25.0 mL with mobile phase A and filter.

**Reference solution (a).** Dilute 1.0 mL of the test solution to 100.0 mL with mobile phase A.

**Reference solution (b).** Dissolve 10 mg of amoxicillin trihydrate CRS in 1 mL of the test solution and dilute to 100 mL with mobile phase A.

**Reference solution (c).** 2 mg of potassium clavulanate impurity G CRS in 20 mL of mobile phase A.

**Column:**

- size:  $l = 0.10$  m,  $\varnothing = 4.6$  mm;
- stationary phase: octadecylsilyl silica gel for chromatography R (5  $\mu$ m);
- temperature: 40 °C.

**Mobile phase:**

- mobile phase A: a 7.8 g/L solution of sodium dihydrogen phosphate R adjusted to pH 4.0 with dilute phosphoric acid R;
- mobile phase B: a mixture of equal volumes of mobile phase A and methanol R;

Time (min)	Mobile phase A (per cent V/V)	Mobile phase B (per cent V/V)
0 - 4	100	0
4 - 15	100 → 50	0 → 50
15 - 18	50	50

**Flow rate:** 1 mL/min.

**Detection:** spectrophotometer at 230 nm.

**Injection:** 20  $\mu$ L.

**Relative retention** with reference to clavulanate (retention time = about 3 min): impurity E = about 2.3; impurity G = about 3.6.

**System suitability:** reference solution (b):

- resolution: minimum 13 between the peaks due to clavulanate (1<sup>st</sup> peak) and amoxicillin (2<sup>nd</sup> peak).

**Limits:**

- impurities E, G: for each impurity, not more than the area of the principal peak in the chromatogram obtained with reference solution (a) (1.0 per cent);
- any other impurity: for each impurity, not more than 0.2 times the area of the principal peak in the chromatogram obtained with reference solution (a) (0.2 per cent);
- total: not more than twice the area of the principal peak in the chromatogram obtained with reference solution (a) (2.0 per cent);
- disregard limit: 0.05 times the area of the principal peak in the chromatogram obtained with reference solution (a) (0.05 per cent).

**Water (2.5.12):** maximum 2.5 per cent, determined on 1.000 g.

**ASSAY**

Liquid chromatography (2.2.29). Prepare the solutions immediately before use.

**Test solution.** Disperse a quantity of the substance to be examined corresponding to 50.0 mg of potassium clavulanate in a 4.1 g/L solution of sodium acetate R previously adjusted to pH 6.0 with glacial acetic acid R, dilute to 50.0 mL with the same solution and filter.

**Reference solution (a).** Dissolve 50.0 mg of lithium clavulanate CRS in a 4.1 g/L solution of sodium acetate R previously adjusted to pH 6.0 with glacial acetic acid R and dilute to 50.0 mL with the same solution.

**Reference solution (b).** Dissolve 10 mg of amoxicillin trihydrate CRS in 10 mL of reference solution (a).

**Column:**

- size:  $l = 0.3$  m,  $\varnothing = 4.6$  mm;
- stationary phase: octadecylsilyl silica gel for chromatography R (10  $\mu$ m).

**Mobile phase:** mix 5 volumes of methanol R1 and 95 volumes of a 15 g/L solution of sodium dihydrogen phosphate R previously adjusted to pH 4.0 with dilute phosphoric acid R.

**Flow rate:** 1 mL/min.

**Detection:** spectrophotometer at 230 nm.

**Injection:** 10  $\mu$ L.

**System suitability:** reference solution (b):

- resolution: minimum 3.5 between the peaks due to clavulanate (1<sup>st</sup> peak) and amoxicillin (2<sup>nd</sup> peak).

1 mg of C<sub>8</sub>H<sub>9</sub>NO<sub>5</sub> is equivalent to 1.191 mg of C<sub>8</sub>H<sub>8</sub>KNO<sub>5</sub>.

**STORAGE**

In an airtight container.

**LABELLING**

The label states the percentage content of potassium clavulanate and the diluent used to prepare the mixture.

**IMPURITIES**

**Specified impurities:** E, G.

**Other detectable impurities** (the following substances would, if present at a sufficient level, be detected by one or other of the tests in the monograph. They are limited by the general acceptance criterion for other/unspecified impurities and/or by the general monograph *Substances for pharmaceutical use (2034)*. It is therefore not necessary to identify these impurities for demonstration of compliance. See also 5.10. *Control of impurities in substances for pharmaceutical use*): A, B, C, D, F.

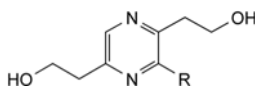

A. R = H: 2,2'-(pyrazine-2,5-diyl)diethanol,

B. R = CH<sub>2</sub>-CH<sub>2</sub>-CO<sub>2</sub>H: 3-[3,6-bis(2-hydroxyethyl)pyrazin-2-yl]propanoic acid,

C. R = CH<sub>2</sub>-CH<sub>3</sub>: 2,2'-(3-ethylpyrazine-2,5-diyl)diethanol,

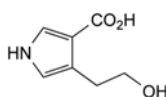

D. 4-(2-hydroxyethyl)-1H-pyrrole-3-carboxylic acid,

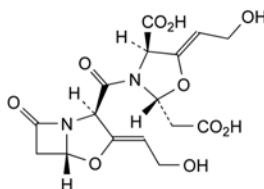

E. (2*R*,4*R*,5*Z*)-2-(carboxymethyl)-5-(2-hydroxyethylidene)-3-[[[(2*R*,3*Z*,5*R*)-3-(2-hydroxyethylidene)-7-oxo-4-oxa-1-azabicyclo[3.2.0]hept-2-yl]carbonyl]oxazolidine-4-carboxylic acid,

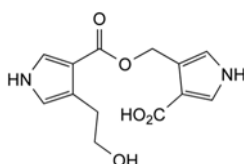

F. 4-[[[4-(2-hydroxyethyl)-1H-pyrrol-3-yl]carbonyl]oxy]-methyl]-1H-pyrrole-3-carboxylic acid,



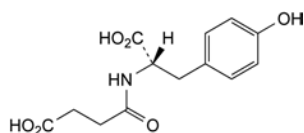

G. 4-[[[(1S)-1-carboxy-2-(4-hydroxyphenyl)ethyl]amino]-4-oxobutanoic acid (*N*-(hydrogensuccinyl)tyrosine).

01/2008:0920  
corrected 7.0

## POTASSIUM DIHYDROGEN PHOSPHATE

### Kalii dihydrogenophosphas

$\text{KH}_2\text{PO}_4$   
[7778-77-0]

$M_r$  136.1

#### DEFINITION

*Content*: 98.0 per cent to 100.5 per cent (dried substance).

#### CHARACTERS

*Appearance*: white or almost white, crystalline powder or colourless crystals.

*Solubility*: freely soluble in water, practically insoluble in ethanol (96 per cent).

#### IDENTIFICATION

- Solution S (see Tests) is faintly acid (2.2.4).
- Solution S gives reaction (b) of phosphates (2.3.1).
- 0.5 mL of solution S gives reaction (b) of potassium (2.3.1).

#### TESTS

**Solution S.** Dissolve 10.0 g in *carbon dioxide-free water R* prepared from *distilled water R* and dilute to 100 mL with the same solvent.

**Appearance of solution.** Solution S is clear (2.2.1) and colourless (2.2.2, *Method II*).

**pH** (2.2.3): 4.2 to 4.5.

To 5 mL of solution S add 5 mL of *carbon dioxide-free water R*.

**Reducing substances.** To 5 mL of solution S add 5 mL of *dilute sulfuric acid R* and 0.25 mL of 0.02 M *potassium permanganate*. Heat on a water-bath for 5 min. The colour of the permanganate is not completely discharged.

**Chlorides** (2.4.4): maximum 200 ppm.

Dilute 2.5 mL of solution S to 15 mL with *water R*.

**Sulfates** (2.4.13): maximum 300 ppm.

To 5 mL of solution S add 0.5 mL of *hydrochloric acid R* and dilute to 15 mL with *distilled water R*.

**Arsenic** (2.4.2, *Method A*): maximum 2 ppm, determined on 0.5 g.

**Iron** (2.4.9): maximum 10 ppm, determined on solution S.

**Sodium**: maximum 0.1 per cent, if intended for use in the manufacture of parenteral preparations.

Atomic emission spectrometry (2.2.22, *Method I*).

*Test solution.* Dissolve 1.00 g of the substance to be examined in *water R* and dilute to 100.0 mL with the same solvent.

*Reference solutions.* Prepare the reference solutions using the following solution, diluted as necessary with *water R*: dissolve 0.5084 g of *sodium chloride R*, previously dried at 100–105 °C for 3 h, in *water R* and dilute to 1000.0 mL with the same solvent (200 µg of Na per millilitre).

*Wavelength*: 589 nm.

**Heavy metals** (2.4.8): maximum 10 ppm.

12 mL of solution S complies with test A. Prepare the reference solution using *lead standard solution (1 ppm Pb) R*.

**Loss on drying** (2.2.32): maximum 2.0 per cent, determined on 1.000 g by drying in an oven at 125–130 °C.

#### ASSAY

Dissolve 1.000 g in 50 mL of *carbon dioxide-free water R*. Titrate with carbonate-free 1 M *sodium hydroxide*, determining the end-point potentiometrically (2.2.20).

1 mL of 1 M *sodium hydroxide* is equivalent to 0.1361 g of  $\text{KH}_2\text{PO}_4$ .

#### LABELLING

The label states, where applicable, that the substance is suitable for use in the manufacture of parenteral preparations.

01/2008:2076  
corrected 6.0

## POTASSIUM HYDROGEN ASPARTATE HEMIHYDRATE

### Kalii hydrogenoaspartas hemihydricus

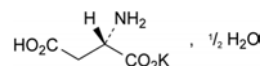

$\text{C}_4\text{H}_6\text{KNO}_4 \cdot \frac{1}{2}\text{H}_2\text{O}$

$M_r$  180.2

#### DEFINITION

Potassium hydrogen (2S)-2-aminobutanedioate hemihydrate.

*Content*: 99.0 per cent to 101.0 per cent (anhydrous substance).

#### CHARACTERS

*Appearance*: white or almost white, powder or crystalline powder, or colourless crystals.

*Solubility*: very soluble in water, practically insoluble in alcohol and in methylene chloride.

#### IDENTIFICATION

- Specific optical rotation (see Tests).
- Examine the chromatograms obtained in the test for ninhydrin-positive substances.

*Results*: the principal spot in the chromatogram obtained with test solution (b) is similar in position, colour and size to the principal spot in the chromatogram obtained with reference solution (a).

- It gives reaction (b) of potassium (2.3.1).

#### TESTS

**Solution S.** Dissolve 2.5 g in *carbon dioxide-free water R* prepared from *distilled water R* and dilute to 100 mL with the same solvent.

**Appearance of solution.** Solution S is clear (2.2.1) and colourless (2.2.2, *Method II*).

**pH** (2.2.3): 6.0 to 7.5 for solution S.

**Specific optical rotation** (2.2.7): + 18.0 to + 20.5 (anhydrous substance).

Dissolve 0.50 g in a mixture of equal volumes of *hydrochloric acid R* and *water R* and dilute to 25.0 mL with the same mixture of solvents.

**Ninhydrin-positive substances.** Thin-layer chromatography (2.2.27).

*Test solution (a).* Solution S.

*Test solution (b).* Dilute 1.0 mL of solution S to 10.0 mL with *water R*.

*Reference solution (a).* Dissolve 25 mg of *potassium hydrogen aspartate hemihydrate CRS* in *water R* and dilute to 10 mL with the same solvent.

*Reference solution (b).* Dilute 1.0 mL of test solution (b) to 20.0 mL with *water R*.

**Reference solution (c).** Dissolve 10 mg of *glutamic acid CRS* and 10 mg of the substance to be examined in *water R* and dilute to 25 mL with the same solvent.

**Plate:** *TLC silica gel plate R*.

**Mobile phase:** *glacial acetic acid R, water R, butanol R* (20:20:60 V/V/V).

**Application:** 5 µL.

**Development:** over 2/3 of the plate.

**Drying:** in air.

**Detection:** spray with *ninhydrin solution R* and heat at 100-105 °C for 15 min.

**System suitability:** reference solution (c):

– the chromatogram shows 2 clearly separated principal spots.

**Limits:** test solution (a):

– **any impurity:** any spot, apart from the principal spot, is not more intense than the spot in the chromatogram obtained with reference solution (b) (0.5 per cent).

**Chlorides (2.4.4):** maximum 200 ppm.

To 10 mL of solution S add 5 mL of *water R*.

**Sulfates (2.4.13):** maximum 500 ppm.

To 12 mL of solution S add 3 mL of *distilled water R*.

**Ammonium (2.4.1, Method B):** maximum 200 ppm, determined on 50 mg.

Prepare the standard using 0.1 mL of *ammonium standard solution (100 ppm NH<sub>4</sub>) R*.

**Iron (2.4.9):** maximum 30 ppm.

In a separating funnel, dissolve 0.33 g in 10 mL of *dilute hydrochloric acid R*. Shake with 3 quantities, each of 10 mL, of *methyl isobutyl ketone R1*, shaking for 3 min each time. To the combined organic layers add 10 mL of *water R* and shake for 3 min. The aqueous layer complies with the limit test for iron.

**Heavy metals (2.4.8):** maximum 10 ppm.

Dissolve 2.0 g in *water R* and dilute to 20 mL with the same solvent. 12 mL of the solution complies with limit test A. Prepare the standard using *lead standard solution (1 ppm Pb) R*.

**Water (2.5.12):** 4.0 per cent to 6.0 per cent, determined on 0.200 g.

Dissolve the substance to be examined in 10 mL of *formamide R1* and add 10 mL of *anhydrous methanol R*.

#### ASSAY

Dissolve 70.0 mg in 5 mL of *anhydrous formic acid R*, add 50 mL of *anhydrous acetic acid R*. Titrate with 0.1 M *perchloric acid*, determining the end-point potentiometrically (2.2.20).

1 mL of 0.1 M *perchloric acid* is equivalent to 8.56 mg of C<sub>4</sub>H<sub>6</sub>KNO<sub>4</sub>.

01/2008:1141  
corrected 7.0

## POTASSIUM HYDROGEN CARBONATE

### Kalii hydrogenocarbonas

KHCO<sub>3</sub>  
[298-14-6]

M<sub>r</sub> 100.1

#### DEFINITION

**Content:** 99.0 per cent to 101.0 per cent.

#### CHARACTERS

**Appearance:** white or almost white, crystalline powder or colourless crystals.

**Solubility:** freely soluble in water, practically insoluble in ethanol (96 per cent).

When heated in the dry state or in solution, it is gradually converted to potassium carbonate.

#### IDENTIFICATION

A. To 5 mL of solution S (see Tests) add 0.1 mL of *phenolphthalein solution R*. A pale pink colour is produced. Heat; gas is evolved and the colour becomes red.

B. It gives the reaction of carbonates and bicarbonates (2.3.1).

C. 1 mL of solution S gives reaction (b) of potassium (2.3.1).

#### TESTS

**Solution S.** Dissolve 5.0 g in 90 mL of *carbon dioxide-free water R* prepared from *distilled water R* and dilute to 100 mL with the same solvent.

**Appearance of solution.** Solution S is clear (2.2.1) and colourless (2.2.2, *Method II*).

**Carbonates.** The pH (2.2.3) of freshly prepared solution S is not greater than 8.6.

**Chlorides (2.4.4):** maximum 150 ppm.

Dilute 7 mL of solution S to 15 mL with *dilute nitric acid R*.

**Sulfates (2.4.13):** maximum 150 ppm.

Dilute 10 mL of solution S to 15 mL with *acetic acid R*. Prepare the standard using a mixture of 7.5 mL of *sulfate standard solution (10 ppm SO<sub>4</sub>) R* and 7.5 mL of *distilled water R*.

**Ammonium (2.4.1):** maximum 20 ppm.

Dilute 10 mL of solution S to 15 mL with *water R*.

**Calcium (2.4.3):** maximum 100 ppm.

Dilute 10 mL of solution S to 15 mL with *acetic acid R*. Prepare the standard using a mixture of 5 mL of *calcium standard solution (10 ppm Ca) R* and 10 mL of *distilled water R*.

**Iron (2.4.9):** maximum 20 ppm, determined on solution S.

**Sodium:** maximum 0.5 per cent.

Atomic emission spectrometry (2.2.22, *Method II*).

**Test solution.** Dissolve 1.00 g in *water R* and dilute to 100.0 mL with the same solvent.

**Reference solutions.** Prepare the reference solutions using *sodium standard solution (200 ppm Na) R*, diluted as necessary with *water R*.

**Wavelength:** 589 nm.

**Heavy metals (2.4.8):** maximum 10 ppm.

Dissolve 2.0 g in a mixture of 2 mL of *hydrochloric acid R* and 18 mL of *water R*. 12 mL of the solution complies with test A. Prepare the reference solution using *lead standard solution (1 ppm Pb) R*.

#### ASSAY

Dissolve 0.800 g in 50 mL of *carbon dioxide-free water R*. Add 0.1 mL of *methyl orange solution R*. Titrate with 1 M *hydrochloric acid* until the yellow colour begins to change to yellowish-pink. Heat cautiously and boil for at least 2 min. The solution becomes yellow. Cool and titrate until a yellowish-red colour is obtained.

1 mL of 1 M *hydrochloric acid* is equivalent to 0.1001 g of KHCO<sub>3</sub>.

01/2008:1984  
corrected 6.0

## POTASSIUM HYDROGEN TARTRATE

### Kalii hydrogenotartras

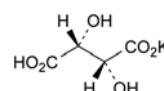

C<sub>4</sub>H<sub>5</sub>KO<sub>6</sub>  
[868-14-4]

M<sub>r</sub> 188.2

## DEFINITION

Potassium hydrogen (2*R*,3*R*)-2,3-dihydroxybutane-1,4-dioate.  
*Content*: 99.5 per cent to 100.5 per cent (dried substance).

## CHARACTERS

*Appearance*: white or almost white, crystalline powder or colourless crystals.

*Solubility*: slightly soluble in water, practically insoluble in alcohol. It dissolves in dilute solutions of mineral acids and alkali hydroxides.

## IDENTIFICATION

- Specific optical rotation (see Tests).
- Suspend 0.5 g in 50 mL of *water R* and boil until dissolution is complete. Allow to cool (solution A). To 5 mL of solution A, add 0.1 mL of *methyl red solution R*. The solution is red.
- Solution A gives reaction (a) of tartrates (2.3.1).
- Solution A gives reaction (b) of potassium (2.3.1).

## TESTS

**Specific optical rotation** (2.2.7): + 8.0 to + 9.2 (dried substance).

Dissolve 2.50 g in 20 mL of 1 *M hydrochloric acid* with heating. Allow to cool. Dilute to 25.0 mL with *water R*.

**Oxalic acid**: maximum 500 ppm.

Dissolve 0.43 g in 4 mL of *water R*. Add 3 mL of *hydrochloric acid R* and 1 g of *zinc R* in granules and boil for 1 min. Allow to stand for 2 min. Collect the liquid in a test-tube containing 0.25 mL of a 10 g/L solution of *phenylhydrazine hydrochloride R* and heat to boiling. Cool rapidly, transfer to a graduated cylinder and add an equal volume of *hydrochloric acid R* and 0.25 mL of a 50 g/L solution of *potassium ferricyanide R*. Shake and allow to stand for 30 min. Any pink colour in the solution is not more intense than that in a standard prepared at the same time in the same manner using a mixture of 1 mL of *water R* and 3 mL of a 0.1 g/L solution of *oxalic acid R*.

**Chlorides** (2.4.4): maximum 500 ppm.

Dissolve 1.0 g with heating in a mixture of 3 mL of *dilute nitric acid R* and 50 mL of *water R*. Dilute to 100 mL with *water R*. Dilute 10 mL of the solution to 15 mL with *water R*. The solution complies with the limit test for chlorides.

**Sulfates** (2.4.13): maximum 500 ppm.

Suspend 0.30 g in 3.0 mL of *dilute hydrochloric acid R* and dilute to 15 mL with *distilled water R*. Heat until dissolution is complete. The solution complies with the limit test for sulfates.

**Barium**. Suspend 0.50 g in a mixture of 1.5 mL of *dilute hydrochloric acid R* and 8.5 mL of *water R*. Heat until dissolution is complete. Allow to cool. Add 1 mL of *dilute sulfuric acid R*. The solution remains clear (2.2.1) on standing for 15 min.

**Heavy metals** (2.4.8): maximum 10 ppm.

2.0 g complies with limit test C. Prepare the standard using 2 mL of *lead standard solution (10 ppm Pb) R*.

**Loss on drying** (2.2.32): maximum 0.5 per cent, determined on 1.000 g by drying in an oven at 105 °C.

## ASSAY

Dissolve 0.170 g in 100 mL of *water R* at 100 °C. Titrate the hot solution with 0.1 *M sodium hydroxide*, using 0.3 mL of *phenolphthalein solution R* as indicator.

1 mL of 0.1 *M sodium hydroxide* is equivalent to 18.82 mg of C<sub>4</sub>H<sub>5</sub>KO<sub>6</sub>.

01/2008:0840  
corrected 6.0

## POTASSIUM HYDROXIDE

## Kalii hydroxidum

KOH  
[1310-58-3]

*M*, 56.11

## DEFINITION

*Content*: 85.0 per cent to 100.5 per cent of total alkali, calculated as KOH.

## CHARACTERS

*Appearance*: white or almost white, crystalline, hard masses, supplied as sticks, pellets or irregularly shaped pieces, deliquescent, hygroscopic, absorbing carbon dioxide.

*Solubility*: very soluble in water, freely soluble in ethanol (96 per cent).

## IDENTIFICATION

A. pH (2.2.3): minimum 10.5.

Dissolve 0.1 g in 10 mL of *water R* (solution A used for identification test B). Dilute 1 mL of this solution to 100 mL with *water R*.

B. 1 mL of solution A prepared in identification test A gives reaction (b) of potassium (2.3.1).

## TESTS

**Solution S1**. Dissolve 2.5 g in 10 mL of *water R*. Carefully add 2 mL of *nitric acid R* while cooling, and dilute to 25 mL with *dilute nitric acid R*.

**Solution S2**. Dissolve 10 g in 15 mL of *distilled water R*. Carefully add 12 mL of *hydrochloric acid R* while cooling, and dilute to 50 mL with *dilute hydrochloric acid R*.

**Appearance of solution**. The solution is clear (2.2.1) and colourless (2.2.2, *Method II*).

Dissolve 5 g in *carbon dioxide-free water R* and dilute to 50 mL with the same solvent.

**Carbonates**: maximum 2.0 per cent, calculated as K<sub>2</sub>CO<sub>3</sub> as determined in the assay.

**Chlorides** (2.4.4): maximum 50 ppm.

Dilute 10 mL of solution S1 to 15 mL with *water R*.

**Phosphates** (2.4.11): maximum 20 ppm.

Dilute 5 mL of solution S1 to 100 mL with *water R*.

**Sulfates** (2.4.13): maximum 50 ppm, determined on solution S2.

**Aluminium** (2.4.17): maximum 0.2 ppm, if intended for use in the manufacture of haemodialysis solutions.

*Prescribed solution*. Dissolve 20 g in 100 mL of *water R* and add 10 mL of *acetate buffer solution pH 6.0 R*.

*Reference solution*. Mix 2 mL of *aluminium standard solution (2 ppm Al) R*, 10 mL of *acetate buffer solution pH 6.0 R* and 98 mL of *water R*.

*Blank solution*. Mix 10 mL of *acetate buffer solution pH 6.0 R* and 100 mL of *water R*.

**Iron** (2.4.9): maximum 10 ppm.

Dilute 5 mL of solution S2 to 10 mL with *water R*.

**Sodium**: maximum 1.0 per cent.

Atomic absorption spectrometry (2.2.23, *Method II*)

*Test solution*. Dissolve 1.00 g in 50 mL of *water R*, add 5 mL of *sulfuric acid R* and dilute to 100.0 mL with *water R*. Dilute 1.0 mL of this solution to 10.0 mL with *water R*.

*Reference solutions*. Prepare the reference solutions using *sodium standard solution (200 ppm Na) R*, diluted as necessary with *water R*.

*Source*: sodium hollow-cathode lamp.

*Wavelength*: 589 nm.

*Atomisation device*: air-acetylene flame.

**Heavy metals** (2.4.8): maximum 10 ppm.

Dilute 10 mL of solution S2 to 20 mL with *water R*. 12 mL of the solution complies with test A. Prepare the reference solution using *lead standard solution (1 ppm Pb) R*.

#### ASSAY

Dissolve 2.000 g in 25 mL of *carbon-dioxide free water R*. Add 25 mL of freshly prepared *barium chloride solution R1* and 0.3 mL of *phenolphthalein solution R*. Add slowly while shaking 25.0 mL of *1 M hydrochloric acid* and continue the titration with *1 M hydrochloric acid* until the colour changes from pink to colourless. Add 0.3 mL of *bromophenol blue solution R* and continue the titration with *1 M hydrochloric acid* until the colour changes from violet-blue to yellow.

1 mL of *1 M hydrochloric acid* used in the 2<sup>nd</sup> part of the titration is equivalent to 69.11 mg of K<sub>2</sub>CO<sub>3</sub>.

1 mL of *1 M hydrochloric acid* used in the combined titrations is equivalent to 56.11 mg of total alkali, calculated as KOH.

#### STORAGE

In an airtight, non-metallic container.

#### LABELLING

The label states, where applicable, that the substance is suitable for use in the manufacture of haemodialysis solutions.

01/2008:0186  
corrected 6.0

## POTASSIUM IODIDE

### Kalii iodidum

KI 166.0  
[7681-11-0]

#### DEFINITION

*Content*: 99.0 per cent to 100.5 per cent (dried substance).

#### CHARACTERS

*Appearance*: white or almost white powder or colourless crystals.

*Solubility*: very soluble in water, freely soluble in glycerol, soluble in ethanol (96 per cent).

#### IDENTIFICATION

- A. Solution S (see Tests) gives the reactions of iodides (2.3.1).  
B. Solution S gives the reactions of potassium (2.3.1).

#### TESTS

**Solution S.** Dissolve 10.0 g in *carbon dioxide-free water R* prepared from *distilled water R* and dilute to 100 mL with the same solvent.

**Appearance of solution.** Solution S is clear (2.2.1) and colourless (2.2.2, *Method I*).

**Alkalinity.** To 12.5 mL of solution S add 0.1 mL of *bromothymol blue solution R1*. Not more than 0.5 mL of *0.01 M hydrochloric acid* is required to change the colour of the indicator.

**Iodates.** To 10 mL of solution S add 0.25 mL of *iodide-free starch solution R* and 0.2 mL of *dilute sulfuric acid R* and allow to stand protected from light for 2 min. No blue colour develops.

**Sulfates** (2.4.13): maximum 150 ppm.

Dilute 10 mL of solution S to 15 mL with *distilled water R*.

**Thiosulfates.** To 10 mL of solution S add 0.1 mL of *starch solution R* and 0.1 mL of *0.005 M iodine*. A blue colour is produced.

**Iron** (2.4.9): maximum 20 ppm.

Dilute 5 mL of solution S to 10 mL with *water R*.

**Heavy metals** (2.4.8): maximum 10 ppm.

12 mL of solution S complies with test A. Prepare the reference solution using *lead standard solution (1 ppm Pb) R*.

**Loss on drying** (2.2.32): maximum 1.0 per cent, determined on 1.00 g of previously powdered substance by drying in an oven at 105 °C for 3 h.

#### ASSAY

Dissolve 1.500 g in *water R* and dilute to 100.0 mL with the same solvent. To 20.0 mL of the solution add 40 mL of *hydrochloric acid R* and titrate with *0.05 M potassium iodate* until the colour changes from red to yellow. Add 5 mL of *chloroform R* and continue the titration, shaking vigorously, until the chloroform layer is decolourised.

1 mL of *0.05 M potassium iodate* is equivalent to 16.60 mg of KI.

#### STORAGE

Protected from light.

01/2008:2075  
corrected 7.0

## POTASSIUM METABISULFITE

### Kalii metabisulfis

K<sub>2</sub>S<sub>2</sub>O<sub>5</sub> M<sub>r</sub> 222.3  
[16731-55-8]

#### DEFINITION

Potassium metabisulfite (potassium disulfite).

*Content*: 95.0 per cent to 101.0 per cent.

#### CHARACTERS

*Appearance*: white or almost white powder, or colourless crystals.

*Solubility*: freely soluble in water, slightly soluble in ethanol (96 per cent).

#### IDENTIFICATION

- A. pH (see Tests).  
B. To 5 mL of solution S (see Tests), add 0.5 mL of *0.05 M iodine*. The mixture is colourless and gives reaction (a) of sulfates (2.3.1).  
C. Solution S gives reaction (a) of potassium (2.3.1).

#### TESTS

**Solution S.** Dissolve 5.0 g in *carbon dioxide-free water R* and dilute to 100 mL with the same solvent.

**Appearance of solution.** Solution S is clear (2.2.1) and colourless (2.2.2, *Method I*).

**pH** (2.2.3): 3.0 to 4.5 for solution S.

**Thiosulfates.** To 2.00 g add 25 mL of a 42.5 g/L solution of *sodium hydroxide R* and 75 mL of *water R*. Shake until dissolved and add 10 mL of *formaldehyde R* and 10 mL of *acetic acid R*. After 5 min, titrate with *0.05 M iodine* using 1 mL of *starch solution R*. Carry out a blank titration. The difference between the volumes consumed in the 2 titrations is not more than 0.15 mL.

**Iron**: maximum 10 ppm.

Atomic absorption spectrometry (2.2.23, *Method I*).

**Test solution.** Dilute 20 mL of solution S to 50 mL with *water R*.  
**Reference solutions.** Prepare the reference solutions using *iron standard solution (20 ppm Fe) R*, diluted as necessary with *water R*.

**Source**: iron hollow-cathode lamp.

*Wavelength*: 248.3 nm.

*Atomisation device*: air-acetylene flame.

**Selenium**: maximum 10 ppm.

To 3.0 g add 10 mL of *formaldehyde R*. Carefully add 2 mL of *hydrochloric acid R* in small portions. Heat on a water-bath for 20 min. Any pink colour in the solution is not more intense than that of a reference solution prepared at the same time in the same manner using 1.0 g of the substance to be examined to which 0.2 mL of *selenium standard solution (100 ppm Se) R* has been added.

**Zinc**: maximum 25 ppm.

Atomic absorption spectrometry (2.2.23, *Method I*).

*Test solution*. Dilute 20 mL of solution S to 50 mL with *water R*.

*Reference solutions*. Prepare the reference solutions using *zinc standard solution (100 ppm Zn) R*, diluted as necessary with *water R*.

*Source*: zinc hollow-cathode lamp.

*Wavelength*: 213.9 nm.

*Atomisation device*: air-acetylene flame.

**Heavy metals** (2.4.8): maximum 10 ppm.

Introduce 40 mL of solution S into a silica crucible, add 10 mL of *hydrochloric acid R* and evaporate to dryness. Dissolve the residue in 19 mL of *water R* and add 1 mL of a 40 g/L solution of *sodium fluoride R*. The solution complies with test E. Prepare the reference solution using 20 mL of *lead standard solution (1 ppm Pb) R*.

#### ASSAY

In a 500 mL conical flask containing 50.0 mL of 0.05 M *iodine* introduce 0.150 g and add 5 mL of *hydrochloric acid R*. Titrate the excess of iodine with 0.1 M *sodium thiosulfate* using 0.1 mL of *starch solution R*.

1 mL of 0.05 M *iodine* is equivalent to 5.558 mg of  $K_2S_2O_5$ .

#### STORAGE

In an airtight container, protected from light.

01/2008:1465  
corrected 7.0

## POTASSIUM NITRATE

### Kalii nitras

$KNO_3$   
[7757-79-1]

$M_r$  101.1

#### DEFINITION

*Content*: 99.0 per cent to 101.0 per cent (dried substance).

#### CHARACTERS

*Appearance*: white or almost white, crystalline powder or colourless crystals.

*Solubility*: freely soluble in water, very soluble in boiling water, practically insoluble in ethanol (96 per cent).

#### IDENTIFICATION

- It gives the reaction of nitrates (2.3.1).
- Solution S (see Tests) gives the reactions of potassium (2.3.1).

#### TESTS

**Solution S**. Dissolve 10.0 g in *carbon dioxide-free water R* prepared from *distilled water R* and dilute to 100 mL with the same solvent.

**Appearance of solution**. Solution S is clear (2.2.1) and colourless (2.2.2, *Method II*).

**Acidity or alkalinity**. To 10 mL of solution S add 0.05 mL of *bromothymol blue solution R1*. Not more than 0.5 mL of 0.01 M *hydrochloric acid* or 0.01 M *sodium hydroxide* is required to change the colour of the indicator.

**Reducible substances**. To 10 mL of solution S, add 0.5 mL of *dilute sulfuric acid R* and 2 mL of *zinc iodide and starch solution R*. The solution does not become blue within 2 min.

**Chlorides** (2.4.4): maximum 20 ppm, if intended for ophthalmic use.

Dissolve 2.5 g in *water R* and dilute to 15 mL with the same solvent.

**Sulfates** (2.4.13): maximum 150 ppm.

Dilute 10 mL of solution S to 15 mL with *distilled water R*.

**Ammonium** (2.4.1): maximum 100 ppm, determined in 1 mL of solution S; maximum 50 ppm if intended for ophthalmic use.

**Calcium** (2.4.3): maximum 100 ppm; maximum 50 ppm if intended for ophthalmic use.

Dilute 10 mL of solution S to 15 mL with *distilled water R*.

**Iron** (2.4.9): maximum 20 ppm; maximum 10 ppm if intended for ophthalmic use.

Dilute 5 mL of solution S to 10 mL with *water R*.

**Sodium**: maximum 0.1 per cent.

Atomic emission spectrometry (2.2.22, *Method II*).

*Test solution*. Dissolve 1.00 g in *water R* and dilute to 100.0 mL with the same solvent.

*Reference solutions*. Prepare the reference solutions using *sodium standard solution (200 ppm Na) R*, diluted as necessary with *water R*.

*Wavelength*: 589 nm.

**Heavy metals** (2.4.8): maximum 10 ppm.

12 mL of solution S complies with test A. Prepare the reference solution using *lead standard solution (1 ppm Pb) R*.

**Loss on drying** (2.2.32): maximum 0.5 per cent, determined on 1.000 g by drying in an oven at 105 °C.

#### ASSAY

Prepare a chromatography column 0.3 m long and 10 mm in internal diameter and filled with 10 g of *strongly acidic cation-exchange resin R* covered with *carbon dioxide-free water R*. Maintain a 1 cm layer of liquid above the resin at all times. Allow 100 mL of *dilute hydrochloric acid R* to run through the column at a flow rate of about 5 mL/min. Wash the column (with the tap completely open) with *carbon dioxide-free water R* until neutral to *blue litmus paper R*. Dissolve 0.200 g of the substance to be examined in 2 mL of *carbon dioxide-free water R* in a beaker and transfer it to the column reservoir, allow the solution to run through the column at a flow rate of about 3 mL/min and collect the eluate. Wash the beaker with 10 mL of *carbon dioxide-free water R* and transfer this solution at the same flow rate to the column before it runs dry. Finally wash the column with 200 mL of *carbon dioxide-free water R* (with the tap completely open) until neutral to *blue litmus paper R*. Titrate the combined eluate and washings with 0.1 M *sodium hydroxide*, using 1 mL of *phenolphthalein solution R* as indicator.

1 mL of 0.1 M *sodium hydroxide* is equivalent to 10.11 mg of  $KNO_3$ .

#### LABELLING

The label states, where applicable, that the substance is suitable for ophthalmic use.

01/2008:1987 ASSAY  
corrected 6.0

## POTASSIUM PERCHLORATE

### Kalii perchloras

KClO<sub>4</sub> *M<sub>r</sub>* 138.6  
[7778-74-7]

#### DEFINITION

*Content*: 99.0 per cent to 102.0 per cent.

#### CHARACTERS

*Appearance*: white or almost white, crystalline powder or colourless crystals.

*Solubility*: sparingly soluble in water, practically insoluble in alcohol.

#### IDENTIFICATION

- Dissolve 0.1 g in 5 mL of *water R*. Add 5 mL of *indigo carmine solution R* and heat to boiling. The colour of the solution does not disappear.
- Chlorates and chlorides (see Tests).
- Heat 10 mg over a flame for 2 min. Dissolve the residue in 2 mL of *water R*. The solution gives reaction (a) of chlorides (2.3.1).
- Dissolve 50 mg with heating in 5 mL of *water R*. Allow to cool to room temperature. The solution gives reaction (a) of potassium (2.3.1).

#### TESTS

**Solution S.** Suspend 5.0 g in 90 mL of *distilled water R* and heat to boiling. Allow to cool. Filter. Dilute the filtrate to 100 mL with *carbon dioxide-free water R*.

**Appearance of solution.** The solution is clear (2.2.1) and colourless (2.2.2, *Method II*).

Dissolve 0.20 g in *water R* and dilute to 20 mL with the same solvent.

**Acidity or alkalinity.** To 5 mL of solution S add 5 mL of *water R* and 0.1 mL of *phenolphthalein solution R*. Not more than 0.25 mL of 0.01 M *sodium hydroxide* is required to change the colour of the indicator. To 5 mL of solution S, add 5 mL of *water R* and 0.1 mL of *bromocresol green solution R*. Not more than 0.25 mL of 0.01 M *hydrochloric acid* is required to change the colour of the indicator.

**Chlorates and chlorides** (2.4.4): maximum 100 ppm (calculated as chlorides).

To 5 mL of solution S, add 5 mL of *water R* and heat to boiling. Add 1 mL of *nitric acid R* and 0.1 g of *sodium nitrite R*. Allow to cool to room temperature. Dilute to 15 mL with *water R*. The solution complies with the limit test for chlorides. Prepare the standard using 5 mL of *chloride standard solution (5 ppm Cl) R* and 10 mL of *water R*, and adding only 1 mL of *dilute nitric acid R*.

**Sulfates** (2.4.13): maximum 100 ppm.

15 mL of solution S complies with the limit test for sulfates. Prepare the standard using a mixture of 7.5 mL of *sulfate standard solution (10 ppm SO<sub>4</sub>) R* and 7.5 mL of *water R*.

**Calcium** (2.4.3): maximum 100 ppm.

15 mL of solution S complies with the limit test for calcium. Prepare the standard using a mixture of 7.5 mL of *calcium standard solution (10 ppm Ca) R*, 1 mL of *dilute acetic acid R* and 7.5 mL of *distilled water R*.

**Heavy metals** (2.4.8): maximum 20 ppm.

12 mL of solution S complies with test A. Prepare the reference solution using *lead standard solution (1 ppm Pb) R*.

Prepare a chromatography column 0.3 m long and 10 mm in internal diameter and filled with 10 g of *strongly acidic ion-exchange resin R* covered with *carbon dioxide-free water R*. Maintain a 1 cm layer of liquid above the resin throughout the determination. Allow 100 mL of *dilute hydrochloric acid R* to run through the column at a flow rate of about 5 mL/min. Wash the column (with the tap completely open) with *carbon dioxide-free water R* until the eluate is neutral to *blue litmus paper R*. Dissolve 0.100 g of the substance to be examined in 10 mL of *carbon dioxide-free water R* in a beaker and transfer it to the column reservoir, allow the solution to run through the column at a flow rate of about 3 mL/min and collect the eluate. Wash the beaker 3 times with 10 mL of *carbon dioxide-free water R* and transfer this solution at the same flow rate to the column before it runs dry. Finally, wash the column with 200 mL of *carbon dioxide-free water R* (with the tap completely open) until the eluate is neutral to *blue litmus paper R*. Titrate the combined eluate and washings with 0.1 M *sodium hydroxide*, using 1 mL of *phenolphthalein solution R* as indicator. 1 mL of 0.1 M *sodium hydroxide* is equivalent to 13.86 mg of KClO<sub>4</sub>.

01/2008:0121

## POTASSIUM PERMANGANATE

### Kalii permanganas

KMnO<sub>4</sub> *M<sub>r</sub>* 158.0  
[7722-64-7]

#### DEFINITION

*Content*: 99.0 per cent to 100.5 per cent.

#### CHARACTERS

*Appearance*: dark purple or brownish-black, granular powder or dark purple or almost black crystals, usually having a metallic lustre.

*Solubility*: soluble in cold water, freely soluble in boiling water. It decomposes on contact with certain organic substances.

#### IDENTIFICATION

- Dissolve about 50 mg in 5 mL of *water R* and add 1 mL of *ethanol (96 per cent) R* and 0.3 mL of *dilute sodium hydroxide solution R*. A green colour develops. Heat to boiling. A dark brown precipitate is formed.
- Filter the mixture obtained in identification test A. The filtrate gives reaction (b) of potassium (2.3.1).

#### TESTS

**Solution S.** Dissolve 0.75 g in 25 mL of *distilled water R*, add 3 mL of *ethanol (96 per cent) R* and boil for 2-3 min. Cool, dilute to 30 mL with *distilled water R* and filter.

**Appearance of solution.** Solution S is colourless (2.2.2, *Method II*).

**Substances insoluble in water:** maximum 1.0 per cent.

Dissolve 0.5 g in 50 mL of *water R* and heat to boiling. Filter through a tared sintered-glass filter (16) (2.1.2). Wash with *water R* until the filtrate is colourless and collect the residue on the filter. The residue, dried in an oven at 100-105 °C, weighs a maximum of 5 mg.

**Chlorides** (2.4.4): maximum 200 ppm.

Dilute 10 mL of solution S to 15 mL with *water R*.

**Sulfates** (2.4.13): maximum 500 ppm.

Dilute 12 mL of solution S to 15 mL with *distilled water R*.

## ASSAY

Dissolve 0.300 g in *water R* and dilute to 100.0 mL with the same solvent. To 20.0 mL of the solution add 20 mL of *water R*, 1 g of *potassium iodide R* and 10 mL of *dilute hydrochloric acid R*. Titrate the liberated iodine with 0.1 M *sodium thiosulfate*, using 1 mL of *starch solution R* as indicator.

1 mL of 0.1 M *sodium thiosulfate* is equivalent to 3.160 mg of  $\text{KMnO}_4$ .

01/2008:1986  
corrected 6.0

## POTASSIUM SODIUM TARTRATE TETRAHYDRATE

Kalii natrii tartras tetrahydricus

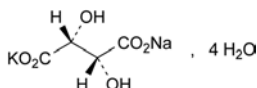

$\text{C}_4\text{H}_4\text{KNaO}_6 \cdot 4\text{H}_2\text{O}$   
[6381-59-5]

$M_r$  282.2

## DEFINITION

Potassium sodium (+)-(2*R*,3*R*)-2,3-dihydroxybutanedioate tetrahydrate.

*Content*: 98.0 per cent to 101.0 per cent (anhydrous substance).

## CHARACTERS

*Appearance*: white or almost white, crystalline powder or colourless, transparent crystals.

*Solubility*: very soluble in water, practically insoluble in alcohol.

## IDENTIFICATION

- Specific optical rotation (see Tests).
- It gives reaction (b) of tartrates (2.3.1).
- It gives reaction (b) of potassium (2.3.1).
- It gives reaction (a) of sodium (2.3.1).

## TESTS

**Solution S.** Dissolve 5.000 g in *carbon dioxide-free water R*, prepared from *distilled water R*, and dilute to 100.0 mL with the same solvent.

**Appearance of solution.** Solution S is clear (2.2.1) and colourless (2.2.2, *Method II*).

**Acidity or alkalinity.** To 5 mL of solution S, add 0.1 mL of *phenolphthalein solution R*. Not more than 0.5 mL of 0.01 M *hydrochloric acid* or 0.01 M *sodium hydroxide* is required to change the colour of the indicator.

**Specific optical rotation** (2.2.7): + 28.0 to + 30.0 (anhydrous substance), determined on solution S.

**Chlorides** (2.4.4): maximum 100 ppm.

Dilute 10 mL of solution S to 15 mL with *water R*. The solution complies with the limit test for chlorides.

**Sulfates** (2.4.13): maximum 50 ppm.

Dissolve 1.0 g in *distilled water R* and dilute to 15 mL with the same solvent. The solution complies with the limit test for sulfates. Prepare the reference solution with a mixture of 5 mL of *sulfate standard solution (10 ppm  $\text{SO}_4$ ) R* and 10 mL of *distilled water R*.

**Ammonium** (2.4.1): maximum 40 ppm.

5 mL of solution S complies with the limit test for ammonium.

**Barium and oxalates.** To 5 mL of solution S, add 3 mL of *calcium sulfate solution R*. Allow to stand for 5 min. Any opalescence in the solution is not more intense than that in a mixture of 3 mL of *calcium sulfate solution R* and 5 mL of *distilled water R*.

**Calcium** (2.4.3): maximum 200 ppm.

Dilute 10 mL of solution S to 15 mL with *distilled water R*. The solution complies with the limit test for calcium.

**Heavy metals** (2.4.8): maximum 10 ppm.

Dissolve 2.0 g in *water R* and dilute to 20 mL with the same solvent. 12 mL of the solution complies with limit test A. Prepare the standard using *lead standard solution (1 ppm Pb) R*

**Water** (2.5.12): 24.0 per cent to 26.5 per cent, determined on 50.0 mg. Use 50 mL of *anhydrous methanol R*. Titrate slowly.

## ASSAY

To 0.100 g of finely powdered substance add 40 mL of *anhydrous acetic acid R* and 20 mL of *acetic anhydride R*. Titrate slowly with 0.1 M *perchloric acid*, determining the end-point potentiometrically (2.2.20).

1 mL of 0.1 M *perchloric acid* is equivalent to 10.51 mg of  $\text{C}_4\text{H}_4\text{KNaO}_6$ .

01/2008:0618  
corrected 6.0

## POTASSIUM SORBATE

Kalii sorbas

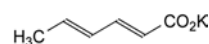

$\text{C}_6\text{H}_7\text{KO}_2$   
[590-00-1]

$M_r$  150.2

## DEFINITION

Potassium (*E,E*)-hexa-2,4-dienoate.

*Content*: 99.0 per cent to 101.0 per cent (dried substance).

## CHARACTERS

*Appearance*: white or almost white powder or granules.

*Solubility*: very soluble in water, slightly soluble in ethanol (96 per cent).

## IDENTIFICATION

*First identification*: B, D.

*Second identification*: A, C, D.

A. Ultraviolet and visible absorption spectrophotometry (2.2.25).

*Test solution.* Dissolve 50.0 mg in *water R* and dilute to 250.0 mL with the same solvent. Dilute 2.0 mL of this solution to 200.0 mL with 0.1 M *hydrochloric acid*.

*Spectral range*: 230-350 nm.

*Absorption maximum*: at 264 nm.

*Specific absorbance at the absorption maximum*: 1650 to 1900.

B. Infrared absorption spectrophotometry (2.2.24).

*Comparison*: *potassium sorbate CRS*.

C. Dissolve 1.0 g in 50 mL of *water R*, add 10 mL of *dilute hydrochloric acid R* and shake. Filter the crystalline precipitate, wash with *water R* and dry *in vacuo* over *sulfuric acid R* for 4 h. The residue obtained melts (2.2.14) at 132 °C to 136 °C.

D. Dissolve 0.2 g in 2 mL of *water R* and add 2 mL of *dilute acetic acid R*. Filter. The solution gives reaction (b) of potassium (2.3.1).

## TESTS

**Solution S.** Dissolve 2.5 g in *carbon dioxide-free water R* and dilute to 50 mL with the same solvent.

**Appearance of solution.** Solution S is clear (2.2.1) and not more intensely coloured than reference solution  $Y_5$  (2.2.2, *Method II*).

**Acidity or alkalinity.** To 20 mL of solution S add 0.1 mL of *phenolphthalein solution R*. Not more than 0.25 mL of 0.1 M *sodium hydroxide* or 0.1 M *hydrochloric acid* is required to change the colour of the indicator.

**Aldehydes:** maximum 0.15 per cent, expressed as C<sub>2</sub>H<sub>4</sub>O.

Dissolve 1.0 g in a mixture of 30 mL of *water R* and 50 mL of 2-propanol R, adjust to pH 4 with 1 M *hydrochloric acid* and dilute to 100 mL with *water R*. To 10 mL of the solution add 1 mL of *decolorised fuchsin solution R* and allow to stand for 30 min. Any colour in the solution is not more intense than that in a standard prepared at the same time by adding 1 mL of *decolorised fuchsin solution R* to a mixture of 1.5 mL of *acetaldehyde standard solution (100 ppm C<sub>2</sub>H<sub>4</sub>O) R*, 4 mL of 2-propanol R and 4.5 mL of *water R*.

**Heavy metals (2.4.8):** maximum 10 ppm.

2.0 g complies with test D. Prepare the reference solution using 2 mL of *lead standard solution (10 ppm Pb) R*.

**Loss on drying (2.2.32):** maximum 1.0 per cent, determined on 1.000 g by drying in an oven at 105 °C for 3 h.

#### ASSAY

Dissolve 0.120 g in 20 mL of *anhydrous acetic acid R*. Titrate with 0.1 M *perchloric acid* using 0.1 mL of *crystal violet solution R* as indicator until the colour changes from violet to bluish-green.

1 mL of 0.1 M *perchloric acid* is equivalent to 15.02 mg of C<sub>6</sub>H<sub>7</sub>KO<sub>2</sub>.

#### STORAGE

Protected from light.

01/2008:1622  
corrected 6.0

## POTASSIUM SULFATE

### Kalii sulfas

K<sub>2</sub>SO<sub>4</sub>  
[7778-80-5]

M<sub>r</sub> 174.3

#### DEFINITION

*Content:* 98.5 per cent to 101.0 per cent of K<sub>2</sub>SO<sub>4</sub> (dried substance).

#### CHARACTERS

*Appearance:* white or almost white, crystalline powder or colourless crystals.

*Solubility:* soluble in water, practically insoluble in ethanol.

#### IDENTIFICATION

- It gives the reactions of sulfates (2.3.1).
- It gives the reactions of potassium (2.3.1).

#### TESTS

**Solution S.** Dissolve 10.0 g in 90 mL of *carbon dioxide-free water R* prepared from *distilled water R*, heating gently. Allow to cool and dilute to 100 mL with *carbon dioxide-free water R* prepared from *distilled water R*.

**Appearance of solution.** Solution S is clear (2.2.1) and colourless (2.2.2, *Method II*).

**Acidity or alkalinity.** To 10 mL of solution S add 0.1 mL of *bromothymol blue solution R1*. Not more than 0.5 mL of 0.01 M *hydrochloric acid* or 0.01 M *sodium hydroxide* is required to change the colour of the indicator.

**Chlorides (2.4.4):** maximum 40 ppm.

Dilute 12.5 mL of solution S to 15 mL with *water R*.

**Calcium (2.4.3):** maximum 200 ppm.

Dilute 5 mL of solution S to 15 mL with *distilled water R*.

**Iron (2.4.9):** maximum 10 ppm, determined on 10 mL of solution S.

**Magnesium:** maximum 20 ppm.

To 5 mL of solution S add 5 mL of *water R*, 1 mL of *glycerol (85 per cent) R*, 0.15 mL of *titan yellow solution R*, 0.25 mL of *ammonium oxalate solution R* and 5 mL of *dilute sodium hydroxide solution R* and shake. Any pink colour in the test solution is not more intense than that in a standard prepared at the same time and in the same manner using a mixture of 1 mL of *magnesium standard solution (10 ppm Mg) R* and 9 mL of *water R*.

**Sodium:** maximum 0.10 per cent.

Atomic emission spectrometry (2.2.22, *Method I*).

*Test solution.* Dissolve 1.00 g of the substance to be examined in *water R* and dilute to 100.0 mL with the same solvent.

*Reference solutions.* Dissolve in *water R* 0.50 g of *sodium chloride R*, previously dried at 100-105 °C for 3 h, and dilute to 1000.0 mL with the same solvent (200 µg of Na per millilitre). Dilute as required.

*Wavelength:* 589 nm.

**Heavy metals (2.4.8):** maximum 20 ppm.

12 mL of solution S complies with limit test A. Prepare the standard using *lead standard solution (2 ppm Pb) R*.

**Loss on drying (2.2.32):** maximum 1.0 per cent, determined on 1.000 g by drying in an oven at 130 °C for 4 h.

#### ASSAY

Dissolve 0.150 g in 40 mL of *water R*. Add 0.2 mL of 0.1 M *hydrochloric acid* and 80 mL of *methanol R*. Carry out a potentiometric titration (2.2.20), using 0.1 M *lead nitrate* and as indicator electrode a lead-selective electrode and as reference electrode a silver-silver chloride electrode.

1 mL of 0.1 M *lead nitrate* is equivalent to 17.43 mg of K<sub>2</sub>SO<sub>4</sub>.

01/2009:0355

## POTATO STARCH

### Solani amyllum

#### DEFINITION

Potato starch is obtained from the tuber of *Solanum tuberosum* L.

#### CHARACTERS

*Appearance:* very fine, white or almost white powder which creaks when pressed between the fingers.

*Solubility:* practically insoluble in cold water and in ethanol (96 per cent).

Potato starch does not contain starch grains of any other origin. It may contain a minute quantity, if any, of tissue fragments of the original plant.

#### IDENTIFICATION

- Examined under a microscope using a mixture of equal volumes of *glycerol R* and *water R*, it presents granules, either irregularly shaped, ovoid or pear-shaped, usually 30-100 µm in size but occasionally exceeding 100 µm, or rounded, 10-35 µm in size. There are occasional compound granules having 2-4 components. The ovoid and pear-shaped granules have an eccentric hilum and the rounded granules acentric or slightly eccentric hilum. All granules show clearly visible concentric striations. Between orthogonally orientated polarising plates or prisms, the granules show a distinct black cross intersecting at the hilum.
- Suspend 1 g in 50 mL of *water R*, boil for 1 min and cool. A thick, opalescent mucilage is formed.



C. To 1 mL of the mucilage obtained in identification test B, add 0.05 mL of *iodine solution RI*. An orange-red to dark blue colour is produced which disappears on heating.

#### TESTS

**pH** (2.2.3): 5.0 to 8.0.

Shake 5.0 g with 25.0 mL of *carbon dioxide-free water R* for 60 s. Allow to stand for 15 min.

**Foreign matter.** Examined under a microscope using a mixture of equal volumes of *glycerol R* and *water R*, not more than traces of matter other than starch granules are present. No starch grains of any other origin are present.

**Oxidising substances** (2.5.30): maximum 20 ppm, calculated as H<sub>2</sub>O<sub>2</sub>.

**Sulfur dioxide** (2.5.29): maximum 50 ppm.

**Iron** (2.4.9): maximum 10 ppm.

Shake 1.5 g with 15 mL of *dilute hydrochloric acid R*. Filter. The filtrate complies with the limit test for iron.

**Loss on drying** (2.2.32): maximum 20.0 per cent, determined on 1.000 g by drying in an oven at 130 °C for 90 min.

**Sulfated ash** (2.4.14): maximum 0.6 per cent, determined on 1.0 g.

#### Microbial contamination

TAMC: acceptance criterion 10<sup>3</sup> CFU/g (2.6.12).

TYMC: acceptance criterion 10<sup>2</sup> CFU/g (2.6.12).

Absence of *Escherichia coli* (2.6.13).

Absence of *Salmonella* (2.6.13).

B. To 0.4 mL of solution S1 (see Tests) add 10 mL of *water R*, 5 mL of *dilute hydrochloric acid R* and 2 mL of *potassium dichromate solution R*. An orange-yellow precipitate is formed.

C. To 1 mL of solution S1 add 0.2 mL of *dimethylaminobenzaldehyde solution RI* and 0.1 mL of *sulfuric acid R*. A pink colour is produced.

D. To 0.1 mL of solution S1 add 5 mL of *water R* and 0.2 mL of 0.05 M *iodine*. A red colour is produced.

E. To 0.5 g add 10 mL of *water R* and shake. The substance dissolves.

#### TESTS

**Solution S.** Dissolve 1.0 g in *carbon dioxide-free water R* and dilute to 20 mL with the same solvent. Add the substance to be examined to the water in small portions, stirring using a magnetic stirrer.

**Solution S1.** Dissolve 2.5 g in *carbon dioxide-free water R* and dilute to 25 mL with the same solvent. Add the substance to be examined to the water in small portions, stirring using a magnetic stirrer.

**Appearance of solution.** Solution S is clear (2.2.1) and not more intensely coloured than reference solution B<sub>6</sub>, BY<sub>6</sub> or R<sub>6</sub> (2.2.2, Method II).

**pH** (2.2.3): 3.0 to 5.0 for solution S, for povidone having a stated *K*-value of not more than 30; 4.0 to 7.0 for solution S, for povidone having a stated *K*-value of more than 30.

**Viscosity, expressed as *K*-value.** For povidone having a stated value of 18 or less, use a 50 g/L solution. For povidone having a stated value of more than 18 and not more than 95, use a 10 g/L solution. For povidone having a stated value of more than 95, use a 1.0 g/L solution. Allow to stand for 1 h and determine the viscosity (2.2.9) of the solution at 25 °C, using viscometer No.1 with a minimum flow time of 100 s. Calculate the *K*-value using the following expression:

$$\frac{1.5 \log \eta - 1}{0.15 + 0.003c} + \frac{\sqrt{300c \log \eta + (c + 1.5c \log \eta)^2}}{0.15c + 0.003c^2}$$

*c* = concentration of the substance to be examined, calculated with reference to the anhydrous substance, in grams per 100 mL;

*η* = kinematic viscosity of the solution relative to that of *water R*.

The *K*-value of povidone having a stated *K*-value of 15 or less is 85.0 per cent to 115.0 per cent of the stated value.

The *K*-value of povidone having a stated *K*-value or a stated *K*-value range with an average of more than 15 is 90.0 per cent to 108.0 per cent of the stated value or of the average of the stated range.

**Aldehydes:** maximum 500 ppm, expressed as acetaldehyde.

**Test solution.** Dissolve 1.0 g of the substance to be examined in *phosphate buffer solution pH 9.0 R* and dilute to 100.0 mL with the same solvent. Stopper the flask tightly and heat at 60 °C for 1 h. Allow to cool to room temperature.

**Reference solution.** Dissolve 0.140 g of *acetaldehyde ammonia trimer trihydrate R* in *water R* and dilute to 200.0 mL with the same solvent. Dilute 1.0 mL of this solution to 100.0 mL with *phosphate buffer solution pH 9.0 R*.

Into 3 identical spectrophotometric cells with a path length of 1 cm, introduce separately 0.5 mL of the test solution, 0.5 mL of the reference solution and 0.5 mL of *water R* (blank). To each cell, add 2.5 mL of *phosphate buffer solution pH 9.0 R* and 0.2 mL of *nicotinamide-adenine dinucleotide solution R*. Mix and stopper tightly. Allow to stand at 22 ± 2 °C for 2-3 min and measure the absorbance (2.2.25) of each solution at 340 nm, using *water R* as the compensation liquid. To each cell, add 0.05 mL of *aldehyde dehydrogenase solution R*, mix and

07/2009:0685  
corrected 7.0

## POVIDONE

### Povidonum

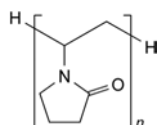

C<sub>6n</sub>H<sub>9n+2</sub>N<sub>n</sub>O<sub>n</sub>  
[9003-39-8]

#### DEFINITION

α-Hydro-α-hydropoly[1-(2-oxopyrrolidin-1-yl)ethylene]. It consists of linear polymers of 1-ethenylpyrrolidin-2-one.

**Content:** 11.5 per cent to 12.8 per cent of nitrogen (N; A<sub>r</sub> 14.01) (anhydrous substance).

The different types of povidone are characterised by their viscosity in solution expressed as a *K*-value.

#### CHARACTERS

**Appearance:** white or yellowish-white, hygroscopic powder or flakes.

**Solubility:** freely soluble in water, in ethanol (96 per cent) and in methanol, very slightly soluble in acetone.

#### IDENTIFICATION

**First identification:** A, E.

**Second identification:** B, C, D, E.

A. Infrared absorption spectrophotometry (2.2.24).

**Preparation:** dry the substances beforehand at 105 °C for 6 h. Record the spectra using 4 mg of substance.

**Comparison:** povidone CRS.

stopper tightly. Allow to stand at  $22 \pm 2$  °C for 5 min. Measure the absorbance of each solution at 340 nm using *water R* as the compensation liquid.

Calculate the content of aldehydes using the following expression:

$$\frac{(A_{t2} - A_{t1}) - (A_{b2} - A_{b1})}{(A_{s2} - A_{s1}) - (A_{b2} - A_{b1})} \times \frac{100\,000 \times C}{m}$$

- $A_{t1}$  = absorbance of the test solution before the addition of aldehyde dehydrogenase;  
 $A_{t2}$  = absorbance of the test solution after the addition of aldehyde dehydrogenase;  
 $A_{s1}$  = absorbance of the reference solution before the addition of aldehyde dehydrogenase;  
 $A_{s2}$  = absorbance of the reference solution after the addition of aldehyde dehydrogenase;  
 $A_{b1}$  = absorbance of the blank before the addition of aldehyde dehydrogenase;  
 $A_{b2}$  = absorbance of the blank after the addition of aldehyde dehydrogenase;  
 $m$  = mass of povidone calculated with reference to the anhydrous substance, in grams;  
 $C$  = concentration of acetaldehyde in the reference solution, calculated from the weight of the acetaldehyde ammonia trimer trihydrate with the factor 0.72, in milligrams per millilitre.

**Peroxides:** maximum 400 ppm, expressed as  $H_2O_2$ .

Dissolve a quantity of the substance to be examined equivalent to 4.0 g of the anhydrous substance in *water R* and dilute to 100.0 mL with the same solvent (stock solution). To 25.0 mL of this solution, add 2.0 mL of *titanium trichloride-sulfuric acid reagent R*. Allow to stand for 30 min. The absorbance (2.2.25) of the solution, measured at 405 nm using a mixture of 25.0 mL of stock solution and 2.0 mL of a 13 per cent *V/V* solution of *sulfuric acid R* as the compensation liquid, is not greater than 0.35.

**Formic acid.** Liquid chromatography (2.2.29).

**Test solution.** Dissolve a quantity of the substance to be examined equivalent to 2.0 g of the anhydrous substance in *water R* and dilute to 100.0 mL with the same solvent (test stock solution). Transfer a suspension of *strongly acidic ion exchange resin R* for column chromatography in *water R* to a column of about 0.8 cm in internal diameter to give a packing of about 20 mm in length and keep the strongly acidic ion exchange resin layer constantly immersed in *water R*. Pour 5 mL of *water R* and adjust the flow rate so that the water drops at a rate of about 20 drops per minute. When the level of the water comes down to near the top of the strongly acidic ion exchange resin layer, put the test stock solution into the column. After dropping 2 mL of the solution, collect 1.5 mL of the solution and use this solution as the test solution.

**Reference solution.** Dissolve 0.100 g of *anhydrous formic acid R* and dilute to 100.0 mL with *water R*. Dilute 1.0 mL of this solution to 100.0 mL with *water R*.

**Column:**

- size:  $l = 0.25\text{--}0.30$  m,  $\emptyset = 4\text{--}8$  mm;
- stationary phase: *strongly acidic ion-exchange resin R* for column chromatography (5–10  $\mu\text{m}$ );
- temperature: 30 °C.

**Mobile phase:** dilute 5 mL of *perchloric acid R* to 1000 mL with *water R*.

**Flow rate:** adjusted so that the retention time of formic acid is about 11 min.

**Detection:** spectrophotometer at 210 nm.

**Injection:** 50  $\mu\text{L}$  each of the test and reference solutions.

**System suitability:**

- **repeatability:** maximum relative standard deviation of 2.0 per cent after 6 injections of the reference solution.

**Limits:**

- **formic acid:** not more than 10 times the area of the principal peak in the chromatogram obtained with the reference solution (0.5 per cent).

**Hydrazine.** Thin-layer chromatography (2.2.27). Use freshly prepared solutions.

**Test solution.** Dissolve a quantity of the substance to be examined equivalent to 2.5 g of the anhydrous substance in 25 mL of *water R*. Add 0.5 mL of a 50 g/L solution of *salicylaldehyde R* in *methanol R*, mix and heat in a water-bath at 60 °C for 15 min. Allow to cool, add 2.0 mL of *toluene R*, shake for 2 min and centrifuge. Use the upper layer of the mixture.

**Reference solution.** Dissolve 90 mg of *salicylaldehyde azine R* in *toluene R* and dilute to 100 mL with the same solvent. Dilute 1 mL of this solution to 100 mL with *toluene R*.

**Plate:** TLC silanised silica gel plate  $F_{254}$  R.

**Mobile phase:** *water R*, *methanol R* (1:2 *V/V*).

**Application:** 10  $\mu\text{L}$ .

**Development:** over 2/3 of the plate.

**Drying:** in air.

**Detection:** examine in ultraviolet light at 365 nm.

**Retardation factor:** *salicylaldehyde azine* = about 0.3.

**Limit:**

- **hydrazine:** any spot due to *salicylaldehyde azine* is not more intense than the spot in the chromatogram obtained with the reference solution (1 ppm).

**Impurity A.** Liquid chromatography (2.2.29).

**Test solution.** Dissolve a quantity of the substance to be examined equivalent to 0.250 g of the anhydrous substance in the mobile phase and dilute to 10.0 mL with the mobile phase.

**Reference solution (a).** Dissolve 50.0 mg of *1-vinylpyrrolidin-2-one R* in *methanol R* and dilute to 100.0 mL with the same solvent. Dilute 1.0 mL of the solution to 100.0 mL with *methanol R*. Dilute 5.0 mL of this solution to 100.0 mL with the mobile phase.

**Reference solution (b).** Dissolve 10 mg of *1-vinylpyrrolidin-2-one R* and 0.5 g of *vinyl acetate R* in *methanol R* and dilute to 100.0 mL with the same solvent. Dilute 1.0 mL of the solution to 100.0 mL with the mobile phase.

**Precolumn:**

- size:  $l = 0.025$  m,  $\emptyset = 4$  mm;
- stationary phase: *octadecylsilyl silica gel for chromatography R* (5  $\mu\text{m}$ ).

**Column:**

- size:  $l = 0.25$  m,  $\emptyset = 4$  mm;
- stationary phase: *octadecylsilyl silica gel for chromatography R* (5  $\mu\text{m}$ );
- temperature: 40 °C.

**Mobile phase:** *acetonitrile R*, *water R* (10:90 *V/V*).

**Flow rate:** adjusted so that the retention time of the peak corresponding to impurity A is about 10 min.

**Detection:** spectrophotometer at 235 nm.

**Injection:** 50  $\mu\text{L}$ . After injection of the test solution, wait for about 2 min and wash the precolumn by passing the mobile phase through the column backwards for 30 min at the same flow rate as applied in the test.

**System suitability:**

- **resolution:** minimum 2.0 between the peaks due to impurity A and to vinyl acetate in the chromatogram obtained with reference solution (b);
- **repeatability:** maximum relative standard deviation of 2.0 per cent after 6 injections of reference solution (a).

**Limit:**

- **impurity A:** not more than the area of the principal peak in the chromatogram obtained with reference solution (a) (10 ppm).

**Impurity B.** Liquid chromatography (2.2.29).

**Test solution.** Dissolve a quantity of the substance to be examined equivalent to 0.100 g of the anhydrous substance in water R and dilute to 50.0 mL with the same solvent.

**Reference solution.** Dissolve 0.100 g of 2-pyrrolidone R in water R and dilute to 100.0 mL with the same solvent. Dilute 3.0 mL of this solution to 50.0 mL with water R.

**Precolumn:**

- **size:**  $l = 0.025$  m,  $\emptyset = 3$  mm;
- **stationary phase:** end-capped octadecylsilyl silica gel for chromatography R (5  $\mu$ m).

**Column:**

- **size:**  $l = 0.25$  m,  $\emptyset = 3$  mm;
- **stationary phase:** end-capped octadecylsilyl silica gel for chromatography R (5  $\mu$ m);
- **temperature:** 30 °C.

**Mobile phase:** water R, adjusted to pH 2.4 with phosphoric acid R.

**Flow rate:** adjusted so that the retention time of impurity B is about 11 min.

**Detection:** spectrophotometer at 205 nm.

**Injection:** 50  $\mu$ L. After each injection of the test solution, wash away the polymeric material of povidone from the precolumn by passing the mobile phase through the column backwards for about 30 min at the same flow rate as applied in the test.

**System suitability:**

- **repeatability:** maximum relative standard deviation of 2.0 per cent after 6 injections of the reference solution.

**Limit:**

- **impurity B:** not more than the area of the principal peak in the chromatogram obtained with the reference solution (3.0 per cent).

**Heavy metals (2.4.8):** maximum 10 ppm.

2.0 g complies with test D. Prepare the reference solution using 2.0 mL of lead standard solution (10 ppm Pb) R.

**Water (2.5.12):** maximum 5.0 per cent, determined on 0.500 g.

**Sulfated ash (2.4.14):** maximum 0.1 per cent, determined on 1.0 g.

**ASSAY**

Place 100.0 mg of the substance to be examined ( $m$  mg) in a combustion flask, add 5 g of a mixture of 1 g of copper sulfate R, 1 g of titanium dioxide R and 33 g of dipotassium sulfate R, and 3 glass beads. Wash any adhering particles from the neck into the flask with a small quantity of water R. Add 7 mL of sulfuric acid R, allowing it to run down the insides of the flask. Heat the flask gradually until the solution has a clear, yellowish-green colour, and the inside wall of the flask is free from a carbonised material, and then heat for a further 45 min. After cooling, add cautiously 20 mL of water R, and connect the flask to the distillation apparatus previously washed by passing steam through it. To the absorption flask add 30 mL of a 40 g/L solution of boric acid R, 3 drops of bromocresol green-methyl red solution R and sufficient water to immerse the lower end of the condenser tube. Add 30 mL of a solution of strong sodium hydroxide solution R through the funnel, rinse the funnel cautiously with 10 mL of water R, immediately close the clamp on the rubber tube, then start distillation with steam to obtain 80-100 mL of distillate. Remove the absorption flask from the lower end of the condenser tube, rinsing the end part with a small quantity of water R, and titrate the distillate with 0.025 M sulfuric acid until the colour of the solution changes from green through pale greyish blue to pale greyish reddish-purple. Carry out a blank determination.

1 mL of 0.025 M sulfuric acid is equivalent to 0.7004 mg of N.

**STORAGE**

In an airtight container.

**LABELLING**

The label indicates the nominal  $K$ -value.

**IMPURITIES**

A. R = CH=CH<sub>2</sub>: 1-ethenylpyrrolidin-2-one (1-vinylpyrrolidin-2-one),

B. R = H: pyrrolidin-2-one (2-pyrrolidone).

01/2008:1142  
corrected 6.0

**POVIDONE, IODINATED****Povidonum iodinatum****DEFINITION**

Complex of iodine and povidone.

**Content:** 9.0 per cent to 12.0 per cent of available iodine (dried substance).

**PRODUCTION**

It is produced using povidone that complies with the monograph on Povidone (0685), except that the povidone used may contain not more than 2.0 per cent of formic acid and not more than 8.0 per cent of water.

**CHARACTERS**

**Appearance:** yellowish-brown or reddish-brown, amorphous powder.

**Solubility:** soluble in water and in ethanol (96 per cent), practically insoluble in acetone.

**IDENTIFICATION**

A. Infrared absorption spectrophotometry (2.2.24).

*Comparison:* iodinated povidone CRS.

B. Dissolve 10 mg in 10 mL of water R and add 1 mL of starch solution R. An intense blue colour is produced.

C. Dissolve 0.1 g in 5 mL of water R and add a 10 g/L solution of sodium sulfite R dropwise, until the solution becomes colourless. Add 2 mL of potassium dichromate solution R and 1 mL of hydrochloric acid R. A light brown precipitate is formed.

**TESTS**

**pH (2.2.3):** 1.5 to 5.0.

Dissolve 1.0 g in 10 mL of carbon dioxide-free water R.

**Iodide:** maximum 6.0 per cent (dried substance).

Dissolve 0.500 g in 100 mL of water R. Add sodium metabisulfite R until the colour of the iodine has disappeared. Add 25.0 mL of 0.1 M silver nitrate, 10 mL of nitric acid R and 5 mL of ferric ammonium sulfate solution R2. Titrate with 0.1 M ammonium thiocyanate. Carry out a blank titration.

1 mL of 0.1 M silver nitrate is equivalent to 12.69 mg of total iodine. From the percentage of total iodine, calculated with reference to the dried substance, subtract the percentage of available iodine as determined in the assay to obtain the percentage of iodide.

**Loss on drying (2.2.32):** maximum 8.0 per cent, determined on 0.500 g by drying in an oven at 105 °C for 3 h.

**Sulfated ash (2.4.14):** maximum 0.1 per cent, determined on 1.0 g.

## ASSAY

Transfer 1.000 g into a ground-glass-stoppered flask containing 150 mL of *water R* and stir for 1 h. Add 0.1 mL of *dilute acetic acid R* and titrate with 0.1 M *sodium thiosulfate* using *starch solution R* as indicator.

1 mL of 0.1 M *sodium thiosulfate* is equivalent to 12.69 mg of available iodine.

## STORAGE

Protected from light.

07/2010:2416

PRAMIPEXOLE DIHYDROCHLORIDE  
MONOHYDRATE

Pramipexoli dihydrochloridum  
monohydricum

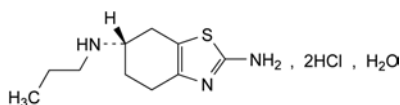

$C_{10}H_{19}Cl_2N_3S \cdot H_2O$   
[191217-81-9]

$M_r$  302.3

## DEFINITION

(6S)-6-N-Propyl-4,5,6,7-tetrahydro-1,3-benzothiazole-2,6-diamine dihydrochloride monohydrate.

*Content*: 99.0 per cent to 101.0 per cent (anhydrous substance).

## CHARACTERS

*Appearance*: white or almost white, crystalline powder.

*Solubility*: freely soluble in water, soluble in methanol, sparingly soluble to slightly soluble in ethanol (96 per cent) and practically insoluble in methylene chloride.

## IDENTIFICATION

Carry out either tests B, C, D or tests A, B, D.

A. Specific optical rotation (2.2.7):  $-67.0$  to  $-69.5$  (anhydrous substance).

Dissolve 0.250 g in *methanol R* and dilute to 25.0 mL with the same solvent.

B. Infrared absorption spectrophotometry (2.2.24).

*Comparison*: *pramipexole dihydrochloride monohydrate CRS*.

C. Enantiomeric purity (see Tests).

D. It gives reaction (a) of chlorides (2.3.1).

## TESTS

**Appearance of solution.** The solution is clear (2.2.1) and not more intensely coloured than reference solution  $Y_6$  (2.2.2, *Method II*).

Dissolve 0.1 g in *water R* and dilute to 10 mL with the same solvent.

**pH** (2.2.3): 2.8 to 3.4.

Dissolve 0.4 g in *carbon dioxide-free water R* and dilute to 20 mL with the same solvent.

**Related substances.** Liquid chromatography (2.2.29).

*Buffer solution.* Dissolve 5 g of *sodium octanesulfonate monohydrate R* and 9.1 g of *potassium dihydrogen phosphate R* in 900 mL of *water R*. Adjust to pH 3.0 with *phosphoric acid R* and dilute to 1000 mL with *water R*.

*Solvent mixture*: *acetonitrile R*, buffer solution (200:800 V/V).

*Test solution.* Dissolve 75 mg of the substance to be examined in the solvent mixture and dilute to 50.0 mL with the solvent mixture.

*Reference solution (a).* Dilute 1.0 mL of the test solution to 100.0 mL with the solvent mixture. Dilute 1.0 mL of this solution to 10.0 mL with the solvent mixture.

*Reference solution (b).* Dissolve 7.5 mg of *pramipexole for system suitability CRS* (containing impurities A, B and C) in 5.0 mL of the solvent mixture.

*Column*:

– *size*:  $l = 0.125$  m,  $\varnothing = 4.6$  mm;

– *stationary phase*: *end-capped octadecylsilyl silica gel for chromatography R* (5  $\mu$ m);

– *temperature*: 40 °C.

*Mobile phase*:

– *mobile phase A*: buffer solution;

– *mobile phase B*: *acetonitrile R*, buffer solution (500:500 V/V);

Time (min)	Mobile phase A (per cent V/V)	Mobile phase B (per cent V/V)
0 - 15	60 → 20	40 → 80

*Flow rate*: 1.5 mL/min.

*Detection*: spectrophotometer at 264 nm.

*Injection*: 5  $\mu$ L.

*Identification of impurities*: use the chromatogram supplied with *pramipexole for system suitability CRS* and the chromatogram obtained with reference solution (b) to identify the peaks due to impurities A, B and C.

*Relative retention* with reference to pramipexole (retention time = about 6 min): impurity A = about 0.7; impurity B = about 1.5; impurity C = about 1.7.

*System suitability*: reference solution (b):

– *resolution*: minimum 6.0 between the peaks due to impurity A and pramipexole.

*Limits*:

– *impurities A, B, C*: for each impurity, not more than 1.5 times the area of the principal peak in the chromatogram obtained with reference solution (a) (0.15 per cent);

– *unspecified impurities*: for each impurity, not more than the area of the principal peak in the chromatogram obtained with reference solution (a) (0.10 per cent);

– *total*: not more than 5 times the area of the principal peak in the chromatogram obtained with reference solution (a) (0.5 per cent);

– *disregard limit*: 0.5 times the area of the principal peak in the chromatogram obtained with reference solution (a) (0.05 per cent).

**Enantiomeric purity.** Liquid chromatography (2.2.29).

*Test solution.* Dissolve 6 mg of the substance to be examined in 5 mL of *anhydrous ethanol R* and dilute to 20.0 mL with the mobile phase.

*Reference solution (a).* Dissolve 2 mg of *pramipexole impurity D CRS* in the mobile phase and dilute to 10 mL with the mobile phase. To 1 mL of this solution add 1 mL of the test solution and dilute to 20 mL with the mobile phase.

*Reference solution (b).* Dilute 1.0 mL of the test solution to 20.0 mL with the mobile phase. Dilute 1.0 mL of this solution to 10.0 mL with the mobile phase.

*Column*:

– *size*:  $l = 0.25$  m,  $\varnothing = 4.6$  mm;

– *stationary phase*: *silica gel OD for chiral separations R*.

*Mobile phase*: *diethylamine R*, *anhydrous ethanol R*, *hexane R* (1:150:850 V/V/V).

*Flow rate*: 1.5 mL/min.

*Detection*: spectrophotometer at 254 nm.

*Injection*: 75  $\mu$ L.

*Run time*: 1.5 times the retention time of pramipexole.

*Relative retention* with reference to pramipexole (retention time = about 11 min): impurity D = about 0.5.

*System suitability*:

- *resolution*: minimum 5 between the peaks due to impurity D and pramipexole in the chromatogram obtained with reference solution (a);
- *symmetry factor*: maximum 2.4 for the peak due to pramipexole in the chromatogram obtained with reference solution (b).

*Limit*:

- *impurity D*: not more than the area of the principal peak in the chromatogram obtained with reference solution (b) (0.5 per cent).

**Heavy metals** (2.4.8): maximum 10 ppm.

*Solvent*: water R.

0.500 g complies with test H. Prepare the reference solution using 0.5 ml of *lead standard solution* (10 ppm Pb) R.

**Water** (2.5.12): 4.5 per cent to 6.5 per cent, determined on 0.500 g.

**Sulfated ash** (2.4.14): maximum 0.1 per cent, determined on 1.0 g.

ASSAY

Dissolve 0.120 g in 150 mL of *water R*. Add 10 mL of 3 M *nitric acid* and titrate with 0.1 M *silver nitrate*, determining the end-point potentiometrically (2.2.20).

1 mL of 0.1 M *silver nitrate* is equivalent to 14.213 mg of  $C_{10}H_{19}Cl_2N_3S$ .

IMPURITIES

*Specified impurities*: A, B, C, D.

*Other detectable impurities* (the following substances would, if present at a sufficient level, be detected by one or other of the tests in the monograph. They are limited by the general acceptance criterion for other/unspecified impurities and/or by the general monograph *Substances for pharmaceutical use* (2034). It is therefore not necessary to identify these impurities for demonstration of compliance. See also 5.10. *Control of impurities in substances for pharmaceutical use*): E.

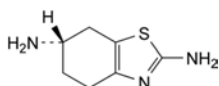

A. (6S)-4,5,6,7-tetrahydro-1,3-benzothiazole-2,6-diamine,

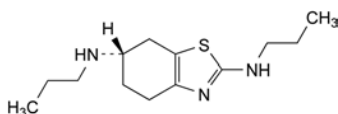

B. (6S)-N,N'-dipropyl-4,5,6,7-tetrahydro-1,3-benzothiazole-2,6-diamine,

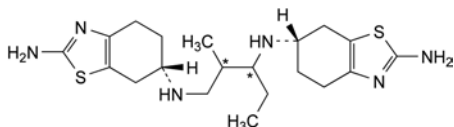

C. mixture of diastereoisomers of (6S)-6-N-[3-[(6S)-2-amino-4,5,6,7-tetrahydro-1,3-benzothiazol-6-yl]-1-ethyl-2-methylpropyl]-4,5,6,7-tetrahydro-1,3-benzothiazole-2,6-diamine,

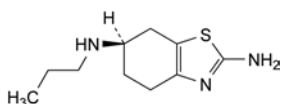

D. (6R)-6-N-propyl-4,5,6,7-tetrahydro-1,3-benzothiazole-2,6-diamine,

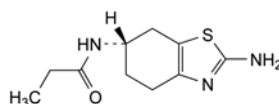

E. N-[(6S)-2-amino-4,5,6,7-tetrahydro-1,3-benzothiazol-6-yl]propanamide.

01/2010:2059

## PRAVASTATIN SODIUM

### Pravastatinum natricum

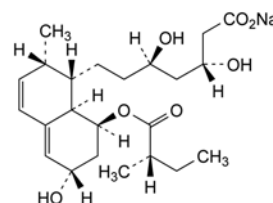

$C_{23}H_{35}NaO_7$   
[81131-70-6]

$M_r$  446.5

DEFINITION

Sodium (3R,5R)-3,5-dihydroxy-7-[(1S,2S,6S,8S,8aR)-6-hydroxy-2-methyl-8-[[[(2S)-2-methylbutanoyl]oxy]-1,2,6,7,8,8a-hexahydronaphthalen-1-yl]]heptanoate.

*Content*: 97.0 per cent to 102.0 per cent (anhydrous substance).

CHARACTERS

*Appearance*: white or yellowish-white powder or crystalline powder, hygroscopic.

*Solubility*: freely soluble in water and in methanol, soluble in anhydrous ethanol.

IDENTIFICATION

A. Specific optical rotation (see Tests).

B. Infrared absorption spectrophotometry (2.2.24).

*Comparison*: Ph. Eur. reference spectrum of pravastatin sodium.

C. 1 mL of solution S (see Tests) gives reaction (a) of sodium (2.3.1).

TESTS

**Solution S**. Dissolve 1.00 g in *carbon dioxide-free water R* and dilute to 20.0 mL with the same solvent.

**Appearance of solution**. The solution is clear (2.2.1) and not more intensely coloured than reference solution BY<sub>6</sub> (2.2.2, *Method II*).

Dilute 2.0 mL of solution S to 10.0 mL with *water R*.

**pH** (2.2.3): 7.2 to 9.0 for solution S.

**Specific optical rotation** (2.2.7): + 153 to + 159 (anhydrous substance).

Dilute 2.0 mL of solution S to 20.0 mL with *water R*.

**Related substances**. Liquid chromatography (2.2.29).

*Solvent mixture*: *methanol R*, *water R* (9:11 V/V).

*Test solution (a)*. Dissolve 0.1000 g of the substance to be examined in the solvent mixture and dilute to 100.0 mL with the solvent mixture.

*Test solution (b)*. Dilute 10.0 mL of test solution (a) to 100.0 mL with the solvent mixture.

*Reference solution (a)*. Dissolve the contents of a vial of *pravastatin impurity A CRS* in 1.0 mL of test solution (b).

*Reference solution (b)*. Dilute 2.0 mL of test solution (a) to 100.0 mL with the solvent mixture. Dilute 1.0 mL of this solution to 10.0 mL with the solvent mixture.

**Reference solution (c).** Dissolve 12.4 mg of pravastatin 1,1,3,3-tetramethylbutylamine CRS in the solvent mixture and dilute to 100.0 mL with the solvent mixture.

**Column:**

- size:  $l = 0.15$  m,  $\varnothing = 4.6$  mm;
- stationary phase: octadecylsilyl silica gel for chromatography R (5  $\mu$ m);
- temperature: 25 °C.

**Mobile phase:** glacial acetic acid R, triethylamine R, methanol R, water R (1:1:450:550 V/V/V/V).

**Flow rate:** 1.3 mL/min.

**Detection:** spectrophotometer at 238 nm.

**Injection:** 10  $\mu$ L of test solution (a) and reference solutions (a) and (b).

**Run time:** 2.5 times the retention time of pravastatin.

**Relative retention** with reference to pravastatin (retention time = about 21 min): impurity F = about 0.1; impurity B = about 0.2; impurity E = about 0.3; impurity G = about 0.4; impurity A = about 0.6; impurity D = about 1.9; impurity C = about 2.1.

**System suitability:** reference solution (a):

- resolution: minimum 7.0 between the peaks due to impurity A and pravastatin.

**Limits:**

- impurity A: not more than 1.5 times the area of the principal peak in the chromatogram obtained with reference solution (b) (0.3 per cent);
- impurities B, C, D, E: for each impurity, not more than the area of the principal peak in the chromatogram obtained with reference solution (b) (0.2 per cent);
- impurities F, G: for each impurity, not more than 0.75 times the area of the principal peak in the chromatogram obtained with reference solution (b) (0.15 per cent);
- unspecified impurities: for each impurity, not more than 0.5 times the area of the principal peak in the chromatogram obtained with reference solution (b) (0.10 per cent);
- total: not more than 3 times the area of the principal peak in the chromatogram obtained with reference solution (b) (0.6 per cent);
- disregard limit: 0.25 times the area of the principal peak in the chromatogram obtained with reference solution (b) (0.05 per cent).

**Ethanol (2.4.24, System A):** maximum 3.0 per cent *m/m*.

**Heavy metals (2.4.8):** maximum 20 ppm.

Dissolve 2.0 g in a mixture of 15 volumes of water R and 85 volumes of methanol R and dilute to 20 mL with the same mixture of solvents. 12 mL of the solution complies with test B. Prepare the reference solution using lead standard solution (2 ppm Pb) obtained by diluting lead standard solution (100 ppm Pb) R with a mixture of 15 volumes of water R and 85 volumes of methanol R.

**Water (2.5.12):** maximum 4.0 per cent, determined on 0.500 g.

#### ASSAY

Liquid chromatography (2.2.29) as described in the test for related substances with the following modification.

**Injection:** test solution (b) and reference solution (c).

Calculate the percentage content of  $C_{25}H_{35}NaO_7$  using the chromatogram obtained with reference solution (c) and the declared content of pravastatin in pravastatin 1,1,3,3-tetramethylbutylamine CRS.

1 mg of pravastatin is equivalent to 1.052 mg of pravastatin sodium.

#### STORAGE

In an airtight container.

#### IMPURITIES

**Specified impurities:** A, B, C, D, E, F, G.

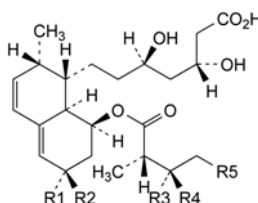

A. R1 = R3 = R4 = R5 = H, R2 = OH: (3*R*,5*R*)-3,5-dihydroxy-7-[(1*S*,2*S*,6*R*,8*S*,8*aR*)-6-hydroxy-2-methyl-8-[(2*S*)-2-methylbutanoyl]oxy]-1,2,6,7,8,8*a*-hexahydronaphthalen-1-yl]heptanoic acid (6'-epipravastatin),

B. R1 = R4 = OH, R2 = R3 = R5 = H: (3*R*,5*R*)-3,5-dihydroxy-7-[(1*S*,2*S*,6*S*,8*S*,8*aR*)-6-hydroxy-8-[(2*S*,3*R*)-3-hydroxy-2-methylbutanoyl]oxy]-2-methyl-1,2,6,7,8,8*a*-hexahydronaphthalen-1-yl]heptanoic acid (3''-(*R*)-hydroxypravastatin),

C. R1 = OH, R2 = R3 = R4 = H, R5 = CH<sub>3</sub>: (3*R*,5*R*)-3,5-dihydroxy-7-[(1*S*,2*S*,6*S*,8*S*,8*aR*)-6-hydroxy-2-methyl-8-[(2*S*)-2-methylpentanoyl]oxy]-1,2,6,7,8,8*a*-hexahydronaphthalen-1-yl]heptanoic acid,

E. R1 = R3 = OH, R2 = R4 = R5 = H: (3*R*,5*R*)-3,5-dihydroxy-7-[(1*S*,2*S*,6*S*,8*S*,8*aR*)-6-hydroxy-8-[(2*S*,3*S*)-3-hydroxy-2-methylbutanoyl]oxy]-2-methyl-1,2,6,7,8,8*a*-hexahydronaphthalen-1-yl]heptanoic acid (3''-(*S*)-hydroxypravastatin),

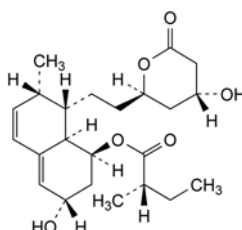

D. (1*S*,3*S*,7*S*,8*S*,8*aR*)-3-hydroxy-8-[2-[(2*R*,4*R*)-4-hydroxy-6-oxotetrahydro-2*H*-pyran-2-yl]ethyl]-7-methyl-1,2,3,7,8,8*a*-hexahydronaphthalen-1-yl (2*S*)-2-methylbutanoate (pravastatin lactone),

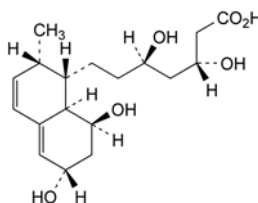

F. (3*R*,5*R*)-7-[(1*S*,2*S*,6*S*,8*S*,8*aR*)-6,8-dihydroxy-2-methyl-1,2,6,7,8,8*a*-hexahydronaphthalen-1-yl]-3,5-dihydroxyheptanoic acid,

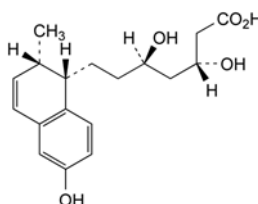

G. (3*R*,5*R*)-3,5-dihydroxy-7-[(1*S*,2*S*)-6-hydroxy-2-methyl-1,2-dihydronaphthalen-1-yl]heptanoic acid.

01/2008:1466  
corrected 6.0**PRAZEPAM**

## Prazepamum

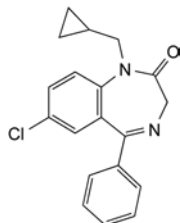
C<sub>19</sub>H<sub>17</sub>ClN<sub>2</sub>O  
[2955-38-6]M<sub>r</sub> 324.8

## DEFINITION

Prazepam contains not less than 98.5 per cent and not more than the equivalent of 101.0 per cent of 7-chloro-1-(cyclopropylmethyl)-5-phenyl-1,3-dihydro-2H-1,4-benzodiazepin-2-one, calculated with reference to the dried substance.

## CHARACTERS

A white or almost white, crystalline powder, practically insoluble in water, freely soluble in methylene chloride, sparingly soluble in ethanol.

It melts at about 145 °C.

## IDENTIFICATION

First identification: B.

Second identification: A, C.

- A. Dissolve 30.0 mg in *alcohol R* and dilute to 100.0 mL with the same solvent. Dilute 20.0 mL of the solution to 100.0 mL (solution A) and 2.0 mL of the solution to 100.0 mL (solution B) with the same solvent. Examined between 300 nm and 350 nm (2.2.25), solution A shows an absorption maximum at 312 nm. Examined between 210 nm and 300 nm, solution B shows an absorption maximum at 228 nm and a point of inflexion at about 252 nm. The specific absorbance at the maximum at 228 nm is 900 to 940. The specific absorbance at the maximum at 312 nm is 59 to 63.
- B. Examine by infrared absorption spectrophotometry (2.2.24), comparing with the spectrum obtained with *prazepam CRS*.
- C. Examine the chromatograms obtained in the test for related substances. The principal spot in the chromatogram obtained with test solution (b) is similar in position, fluorescence at 365 nm and size to the principal spot in the chromatogram obtained with reference solution (b).

## TESTS

**Appearance of solution.** Dissolve 0.25 g in *alcohol R* and dilute to 10 mL with the same solvent. The solution is clear (2.2.1) and colourless (2.2.2, *Method II*).

**Related substances.** Examine by thin-layer chromatography (2.2.27), using as the coating substance a suitable silica gel with a fluorescent indicator having an optimal intensity at 254 nm.

**Test solution (a).** Dissolve 0.50 g of the substance to be examined in *acetone R* and dilute to 5 mL with the same solvent.

**Test solution (b).** Dilute 1 mL of test solution (a) to 100 mL with *acetone R*.

**Reference solution (a).** Dilute 1 mL of test solution (b) to 10 mL with *acetone R*.

**Reference solution (b).** Dissolve 10 mg of *prazepam CRS* in *acetone R* and dilute to 10 mL with the same solvent.

**Reference solution (c).** Dissolve 15 mg of *nordazepam CRS* in *acetone R* and dilute to 50 mL with the same solvent.

**Reference solution (d).** To 1 mL of reference solution (a) add 1 mL of reference solution (c) and mix.

Apply to the plate 5 µL of each solution. Develop over a path of 10 cm using a freshly prepared mixture of 50 volumes of *ethyl acetate R* and 50 volumes of *heptane R*. Dry the plate in air and examine in ultraviolet light at 254 nm and 365 nm. In the chromatogram obtained with test solution (a): any spot corresponding to nordazepam is not more intense than the spot in the chromatogram obtained with reference solution (c) (0.3 per cent); not more than four additional spots are present, none of which are more intense than the spot in the chromatogram obtained with reference solution (a) (0.1 per cent). The test is not valid unless the chromatogram obtained with reference solution (d) shows two clearly separated spots.

**Heavy metals (2.4.8).** 1.0 g complies with limit test C for heavy metals (20 ppm). Prepare the standard using 2 mL of *lead standard solution (10 ppm Pb) R*.

**Loss on drying (2.2.32).** Not more than 0.5 per cent, determined on 1.000 g by drying in an oven at 105 °C.

**Sulfated ash (2.4.14).** Not more than 0.1 per cent, determined on 1.0 g.

## ASSAY

Dissolve 0.250 g in 25 mL of *anhydrous acetic acid R*. Titrate with 0.1 M *perchloric acid*, determining the end-point potentiometrically (2.2.20).

1 mL of 0.1 M *perchloric acid* is equivalent to 32.48 mg of C<sub>19</sub>H<sub>17</sub>ClN<sub>2</sub>O.

## STORAGE

Store protected from light.

## IMPURITIES

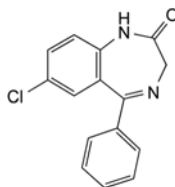

- A. 7-chloro-5-phenyl-1,3-dihydro-2H-1,4-benzodiazepin-2-one (nordazepam),

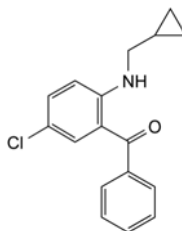

- B. [5-chloro-2-[(cyclopropylmethyl)amino]phenyl]phenylmethanone,

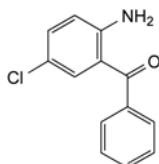

- C. (2-amino-5-chlorophenyl)phenylmethanone.

01/2008:0855  
corrected 7.0

## PRAZIQUANTEL

## Praziquantelum

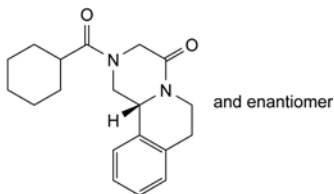
C<sub>19</sub>H<sub>24</sub>N<sub>2</sub>O<sub>2</sub>  
[55268-74-1]M<sub>r</sub> 312.4

## DEFINITION

(11bRS)-2-(Cyclohexylcarbonyl)-1,2,3,6,7,11b-hexahydro-4H-pyrazino[2,1-a]isoquinolin-4-one.

Content: 97.5 per cent to 102.0 per cent (dried substance).

## CHARACTERS

**Appearance:** white or almost white, crystalline powder.**Solubility:** very slightly soluble in water, freely soluble in ethanol (96 per cent) and in methylene chloride.

It shows polymorphism (5.9).

## IDENTIFICATION

Infrared absorption spectrophotometry (2.2.24).

**Comparison:** praziquantel CRS.If the spectra obtained show differences, dissolve 50 mg of the substance to be examined and 50 mg of the reference substance separately in 2 mL of *methanol R*. Evaporate and dry the residue at 60 °C at a pressure not exceeding 0.7 kPa. Record new spectra using the residues.

## TESTS

**Related substances.** Liquid chromatography (2.2.29).**Test solution (a).** Dissolve 40.0 mg of the substance to be examined in the mobile phase and dilute to 10.0 mL with the mobile phase.**Test solution (b).** Dilute 5.0 mL of test solution (a) to 100.0 mL with the mobile phase.**Reference solution (a).** Dissolve 40.0 mg of *praziquantel CRS* in the mobile phase and dilute to 10.0 mL with the mobile phase. Dilute 5.0 mL to 100.0 mL with the mobile phase.**Reference solution (b).** Dissolve 5 mg of *praziquantel impurity A CRS* in reference solution (a) and dilute to 25.0 mL with reference solution (a). Dilute 2.0 mL of this solution to 20.0 mL with the mobile phase.**Reference solution (c).** Dilute 1.0 mL of test solution (a) to 20.0 mL with the mobile phase. Dilute 5.0 mL of this solution to 50.0 mL with the mobile phase.**Column:**

- size:  $l = 0.25$  m,  $\emptyset = 4.0$  mm;
- stationary phase: octadecylsilyl silica gel for chromatography R (5  $\mu$ m).

**Mobile phase:** acetonitrile R, water R (45:55 V/V).**Flow rate:** 1 mL/min.**Detection:** spectrophotometer at 210 nm.**Injection:** 20  $\mu$ L of the test solution (a) and reference solutions (b) and (c).**Run time:** 5 times the retention time of praziquantel (retention time = about 9 min).**System suitability:** reference solution (b):

- **resolution:** minimum 3.0 between the peaks corresponding to impurity A and praziquantel.

**Limits:**

- **any impurity:** not more than the area of the principal peak in the chromatogram obtained with reference solution (c) (0.5 per cent), not more than 1 such peak having an area greater than 0.4 times the area of the principal peak in the chromatogram obtained with reference solution (c) (0.2 per cent),
- **total:** not more than the area of the principal peak in the chromatogram obtained with reference solution (c) (0.5 per cent),
- **disregard limit:** 0.1 times the area of the principal peak in the chromatogram obtained with reference solution (c) (0.05 per cent).

**Heavy metals (2.4.8):** maximum 20 ppm.1.0 g complies with test C. Prepare the reference solution using 2 mL of *lead standard solution (10 ppm Pb) R*.**Loss on drying (2.2.32):** maximum 0.5 per cent, determined on 1.000 g by drying in an oven at 50 °C over *diphosphorus pentoxide R* at a pressure not exceeding 0.7 kPa for 2 h.**Sulfated ash (2.4.14):** maximum 0.1 per cent, determined on 1.0 g.

## ASSAY

Liquid chromatography (2.2.29) as described in the test for related substances with the following modification.

**Injection:** test solution (b) and reference solution (a).Calculate the percentage content of C<sub>19</sub>H<sub>24</sub>N<sub>2</sub>O<sub>2</sub>.

## STORAGE

Protected from light.

## IMPURITIES

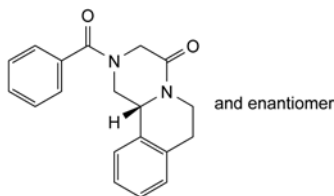

A. (11bRS)-2-benzoyl-1,2,3,6,7,11b-hexahydro-4H-pyrazino[2,1-a]isoquinolin-4-one,

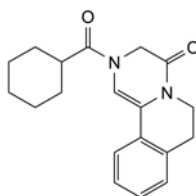

B. 2-(cyclohexylcarbonyl)-2,3,6,7-tetrahydro-4H-pyrazino[2,1-a]isoquinolin-4-one,

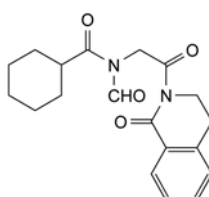
C. *N*-formyl-*N*-[2-oxo-2-(1-oxo-3,4-dihydroisoquinolin-2(1H)-yl)ethyl]cyclohexanecarboxamide.



01/2008:0856  
corrected 7.0

## PRAZOSIN HYDROCHLORIDE

## Prazosini hydrochloridum

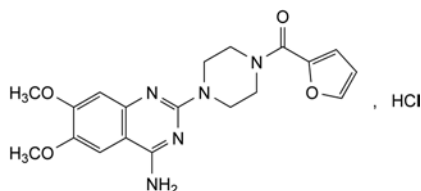
C<sub>19</sub>H<sub>22</sub>ClN<sub>5</sub>O<sub>4</sub>  
[19237-84-4]M<sub>r</sub> 419.9

## DEFINITION

1-(4-Amino-6,7-dimethoxyquinazolin-2-yl)-4-(furan-2-ylcarbonyl)piperazine hydrochloride.

*Content*: 98.5 per cent to 101.0 per cent (anhydrous substance).

## CHARACTERS

*Appearance*: white or almost white powder.*Solubility*: very slightly soluble in water, slightly soluble in alcohol and in methanol, practically insoluble in acetone.

## IDENTIFICATION

*First identification*: B, D.*Second identification*: A, C, D.

A. Dissolve 50.0 mg in a 0.1 per cent V/V solution of hydrochloric acid R in methanol R and dilute to 100.0 mL with the same acid solution. Dilute separately 1.0 mL and 5.0 mL of this solution to 100.0 mL with a 0.1 per cent V/V solution of hydrochloric acid R in methanol R (solution A and solution B, respectively). Examined between 220 nm and 280 nm (2.2.25), solution A shows an absorption maximum at 247 nm. The specific absorbance at the maximum is 1320 to 1400. Examined between 280 nm and 400 nm, solution B shows 2 absorption maxima, at 330 nm and 343 nm. The specific absorbances at the maxima are 260 to 280 and 240 to 265, respectively.

B. Infrared absorption spectrophotometry (2.2.24).

*Preparation*: discs of potassium chloride R.*Comparison*: prazosin hydrochloride CRS.

C. Thin-layer chromatography (2.2.27).

*Test solution*. Dissolve 10 mg of the substance to be examined in a mixture of 1 volume of diethylamine R, 10 volumes of methanol R and 10 volumes of methylene chloride R and dilute to 10 mL with the same mixture of solvents.*Reference solution*. Dissolve 10 mg of prazosin hydrochloride CRS in a mixture of 1 volume of diethylamine R, 10 volumes of methanol R and 10 volumes of methylene chloride R and dilute to 10 mL with the same mixture of solvents.*Plate*: TLC silica gel GF<sub>254</sub> plate R.*Mobile phase*: diethylamine R, ethyl acetate R (5:95 V/V).*Application*: 10 µL.*Development*: over 2/3 of the plate.*Drying*: in a current of warm air.*Detection*: examine in ultraviolet light at 254 nm.*Results*: the principal spot in the chromatogram obtained with the test solution is similar in position and size to the principal spot in the chromatogram obtained with the reference solution.

D. Dissolve about 2 mg in 2 mL of water R. The solution gives reaction (a) of chlorides (2.3.1).

## TESTS

**Related substances.** Liquid chromatography (2.2.29).*Test solution*. Dissolve 50.0 mg of the substance to be examined in the mobile phase and dilute to 50.0 mL with the mobile phase.*Reference solution (a)*. Dilute 1.0 mL of the test solution to 100.0 mL with the mobile phase. Dilute 1.0 mL of the solution to 10.0 mL with the mobile phase.*Reference solution (b)*. Dissolve 8 mg of metoclopramide hydrochloride CRS in 1 mL of the test solution and dilute to 25.0 mL with the mobile phase. Dilute 1.0 mL of the solution to 10.0 mL with the mobile phase.*Column*:– *size*:  $l = 0.25$  m,  $\varnothing = 4.6$  mm,– *stationary phase*: octadecylsilyl silica gel for chromatography R (5 µm),*Mobile phase*: mix 50 volumes of methanol R and 50 volumes of a solution containing 3.484 g/L of sodium pentanesulfonate R and 3.64 g/L of tetramethylammonium hydroxide R adjusted to pH 5.0 with glacial acetic acid R.*Flow rate*: 1 mL/min.*Detection*: spectrophotometer at 254 nm.*Injection*: 20 µL.*Run time*: 6 times the retention time of prazosin.*Retention times*: prazosin = about 9 min; metoclopramide = about 5 min.*System suitability*: reference solution (b):– *resolution*: minimum 8 between the peaks due to metoclopramide and to prazosin.*Limits*:– *any impurity*: not more than twice the area of the principal peak in the chromatogram obtained with reference solution (a) (0.2 per cent),– *total*: not more than 5 times the area of the principal peak in the chromatogram obtained with reference solution (a) (0.5 per cent),– *disregard limit*: 0.5 times the area of the principal peak in the chromatogram obtained with reference solution (a) (0.05 per cent).**Iron**: maximum 100 ppm.

Atomic absorption spectrometry (2.2.23, Method I).

*Test solution*. To 1.0 g add dropwise about 1.5 mL of nitric acid R. After fuming has subsided, evaporate on a water-bath and ignite by gradually raising the temperature from 150 °C to 1000 ± 50 °C, maintaining the final temperature for 1 h. Cool, dissolve the residue in 20 mL of dilute hydrochloric acid R, evaporate to about 5 mL and dilute to 25.0 mL with dilute hydrochloric acid R.*Reference solutions*. Prepare the reference solutions using iron standard solution (8 ppm Fe) R, diluted as necessary with water R.*Source*: iron hollow-cathode lamp.*Wavelength*: 248 nm.*Flame*: air-acetylene.**Nickel**: maximum 50 ppm.

Atomic absorption spectrometry (2.2.23, Method I).

*Test solution*. Use the test solution prepared in the test for iron.*Reference solutions*. Prepare the reference solutions using nickel standard solution (10 ppm Ni) R, diluted as necessary with water R.*Source*: nickel hollow-cathode lamp.*Wavelength*: 232 nm.*Flame*: air-acetylene.**Water** (2.5.12): maximum 0.5 per cent, determined on 1.000 g. Use a mixture of equal volumes of methanol R and methylene chloride R as the solvent.

**Sulfated ash** (2.4.14): maximum 0.1 per cent, determined on 1.0 g.

#### ASSAY

*In order to avoid overheating in the reaction medium, mix thoroughly throughout and stop the titration immediately after the end-point has been reached.*

Dissolve 0.350 g in a mixture of 20 mL of *anhydrous formic acid R* and 30 mL of *acetic anhydride R*. Titrate quickly with 0.1 M *perchloric acid*, determining the end-point potentiometrically (2.2.20).

1 mL of 0.1 M *perchloric acid* is equivalent to 41.99 mg of  $C_{19}H_{22}ClN_5O_4$ .

#### STORAGE

Protected from light.

#### IMPURITIES

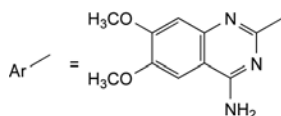

A. Ar-Cl: 2-chloro-6,7-dimethoxyquinazolin-4-amine,

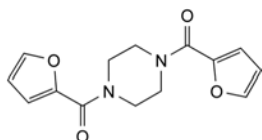

B. 1,4-bis(furan-2-ylcarbonyl)piperazine,

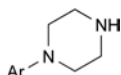

C. 6,7-dimethoxy-2-(piperazin-1-yl)quinazolin-4-amine,

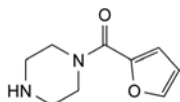

D. 1-(furan-2-ylcarbonyl)piperazine,

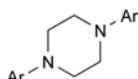

E. 2,2'-(piperazin-1,4-diyl)bis(6,7-dimethoxyquinazolin-4-amine).

01/2008:1467  
corrected 6.0

## PREDNICARBATE

### Prednicarbatum

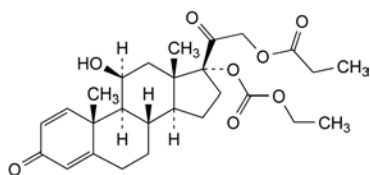

$C_{27}H_{36}O_8$   
[73771-04-7]

$M_r$  488.6

#### DEFINITION

11 $\beta$ -Hydroxy-3,20-dioxopregna-1,4-diene-17,21-diyl 17-ethylcarbonate 21-propanoate.

*Content*: 97.0 per cent to 102.0 per cent (dried substance).

#### CHARACTERS

*Appearance*: white or almost white, crystalline powder.

*Solubility*: practically insoluble in water, freely soluble in acetone and in ethanol (96 per cent), sparingly soluble in propylene glycol.

It shows polymorphism (5.9).

#### IDENTIFICATION

A. Infrared absorption spectrophotometry (2.2.24).

*Comparison*: *prednicarbate CRS*.

If the spectra obtained in the solid state show differences, dissolve the substance to be examined and the reference substance separately in the minimum volume of *ethanol (96 per cent) R*, evaporate to dryness on a water-bath and record new spectra using the residues.

B. Thin-layer chromatography (2.2.27).

*Solvent mixture*: *methanol R*, *methylene chloride R* (1:9 V/V).

*Test solution*. Dissolve 10 mg of the substance to be examined in the solvent mixture and dilute to 10 mL with the solvent mixture.

*Reference solution (a)*. Dissolve 10 mg of *prednicarbate CRS* in the solvent mixture and dilute to 10 mL with the solvent mixture.

*Reference solution (b)*. Dissolve 5 mg of *prednisolone acetate CRS* in 5 mL of reference solution (a).

*Plate*: TLC silica gel  $F_{254}$  plate *R*.

*Mobile phase*: add a mixture of 1.2 volumes of *water R* and 8 volumes of *methanol R* to a mixture of 15 volumes of *ether R* and 77 volumes of *methylene chloride R*.

*Application*: 5  $\mu$ L.

*Development*: over a path of 15 cm.

*Drying*: in air.

*Detection A*: examine in ultraviolet light at 254 nm.

*Results A*: the principal spot in the chromatogram obtained with the test solution is similar in position and size to the principal spot in the chromatogram obtained with reference solution (a).

*Detection B*: spray with *alcoholic solution of sulfuric acid R*; heat at 120 °C for 10 min or until the spots appear and allow to cool; examine in daylight and in ultraviolet light at 365 nm.

*Results B*: the principal spot in the chromatogram obtained with the test solution is similar in position, colour in daylight, fluorescence in ultraviolet light at 365 nm and size to the principal spot in the chromatogram obtained with reference solution (a).

*System suitability*: reference solution (b):

– the chromatogram shows 2 clearly separated spots.

#### TESTS

**Specific optical rotation** (2.2.7): + 60 to + 66 (dried substance).

Dissolve 0.250 g in *ethanol (96 per cent) R* and dilute to 25.0 mL with the same solvent.

**Related substances**. Liquid chromatography (2.2.29). *Prepare the solutions immediately before use.*

*Test solution*. Dissolve 30.0 mg of the substance to be examined in the mobile phase and dilute to 50.0 mL with the mobile phase.

*Reference solution (a)*. Dissolve 3 mg of *prednicarbate impurity F CRS* in the mobile phase, add 5.0 mL of the test solution and dilute to 100.0 mL with the mobile phase. Dilute 1.0 mL of this solution to 10.0 mL with the mobile phase.

*Reference solution (b)*. Dilute 1.0 mL of the test solution to 200.0 mL with the mobile phase.

*Reference solution (c)*. Dissolve 30.0 mg of *prednicarbate CRS* in the mobile phase and dilute to 50.0 mL with the mobile phase.

*Column*:

– *size*:  $l = 0.125$  m,  $\varnothing = 4$  mm;

– *stationary phase: octadecylsilyl silica gel for chromatography R* (5 µm).

*Mobile phase: acetonitrile R, water R* (5:6 V/V).

*Flow rate: 0.7 mL/min.*

*Detection: spectrophotometer at 243 nm.*

*Injection: 20 µL of the test solution and reference solutions (a) and (b).*

*Run time: twice the retention time of prednicarbate.*

*Retention time: prednicarbate = about 17 min; impurity F = about 19 min.*

*System suitability: reference solution (a):*

– *resolution: minimum 3.0 between the peaks due to prednicarbate and impurity F; if necessary, adjust the composition of the mobile phase.*

*Limits:*

- *impurity F: not more than twice the area of the principal peak in the chromatogram obtained with reference solution (b) (1 per cent);*
- *impurities A, B, C, D, E: for each impurity, not more than the area of the principal peak in the chromatogram obtained with reference solution (b) (0.5 per cent);*
- *total: not more than 4 times the area of the principal peak in the chromatogram obtained with reference solution (b) (2 per cent);*
- *disregard limit: 0.025 times the area of the principal peak in the chromatogram obtained with reference solution (b) (0.0125 per cent).*

**Loss on drying** (2.2.32): maximum 0.5 per cent, determined on 1.000 g by drying in an oven at 105 °C.

#### ASSAY

Liquid chromatography (2.2.29) as described in the test for related substances with the following modification.

*Injection: test solution and reference solution (c).*

Calculate the percentage content of C<sub>27</sub>H<sub>36</sub>O<sub>8</sub> from the declared content of *prednicarbate CRS*.

#### STORAGE

Protected from light.

#### IMPURITIES

*Specified impurities: A, B, C, D, E, F.*

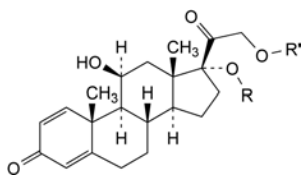

- A. R = R' = H: prednisolone,
- B. R = CO-O-C<sub>2</sub>H<sub>5</sub>, R' = H: prednisolone 17-ethylcarbonate,
- C. R = H, R' = CO-C<sub>2</sub>H<sub>5</sub>: prednisolone 21-propanoate,
- D. R = H, R' = CO-O-C<sub>2</sub>H<sub>5</sub>: prednisolone 21-ethylcarbonate,
- E. R = CO-O-C<sub>2</sub>H<sub>5</sub>, R' = CO-CH<sub>3</sub>: prednisolone 21-acetate 17-ethylcarbonate,

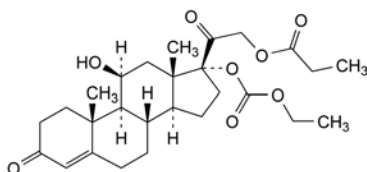

- F. 11β-hydroxy-3,20-dioxopregna-4-ene-17,21-diyl 17-ethylcarbonate 21-propanoate (1,2-dihydroprednicarbate).

01/2008:0353  
corrected 6.0

## PREDNISOLONE

### Prednisolonum

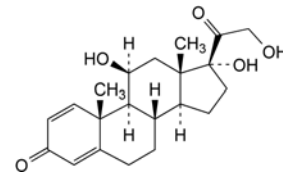

C<sub>21</sub>H<sub>28</sub>O<sub>5</sub>  
[50-24-8]

M<sub>r</sub> 360.4

#### DEFINITION

11β,17,21-Trihydroxypregna-1,4-diene-3,20-dione.

*Content: 97.0 per cent to 103.0 per cent (dried substance).*

#### CHARACTERS

*Appearance: white or almost white, crystalline, hygroscopic powder.*

*Solubility: very slightly soluble in water, soluble in ethanol (96 per cent) and in methanol, sparingly soluble in acetone, slightly soluble in methylene chloride.*

It shows polymorphism (5.9).

#### IDENTIFICATION

A. Infrared absorption spectrophotometry (2.2.24).

*Comparison: prednisolone CRS.*

If the spectra obtained in the solid state show differences, dissolve the substance to be examined and the reference substance separately in the minimum volume of *acetone R*, evaporate to dryness on a water-bath and record new spectra using the residues.

B. Thin-layer chromatography (2.2.27).

*Test solution.* Dissolve 10 mg of the substance to be examined in the mobile phase and dilute to 10 mL with the mobile phase.

*Reference solution (a).* Dissolve 20 mg of *prednisolone CRS* in the mobile phase and dilute to 20 mL with the mobile phase.

*Reference solution (b).* Dissolve 10 mg of *hydrocortisone CRS* in reference solution (a) and dilute to 10 mL with reference solution (a).

*Plate: TLC silica gel F<sub>254</sub> plate R.*

*Mobile phase: methanol R, methylene chloride R* (10:90 V/V).

*Application: 5 µL.*

*Development: over a path of 15 cm.*

*Drying: in air.*

*Detection A: examine in ultraviolet light at 254 nm.*

*Results A: the principal spot in the chromatogram obtained with the test solution is similar in position and size to the principal spot in the chromatogram obtained with reference solution (a).*

*Detection B: spray with alcoholic solution of sulfuric acid R; heat at 120 °C for 10 min or until the spots appear and allow to cool; examine in daylight and in ultraviolet light at 365 nm.*

*Results B: the principal spot in the chromatogram obtained with the test solution is similar in position, colour in daylight, fluorescence in ultraviolet light at 365 nm and size to the principal spot in the chromatogram obtained with reference solution (a).*

*System suitability: reference solution (b):*

– the chromatogram shows 2 clearly separated spots.

## TESTS

**Specific optical rotation** (2.2.7): + 96 to + 102 (dried substance).

Dissolve 0.250 g in *dioxan R* and dilute to 25.0 mL with the same solvent.

**Related substances.** Liquid chromatography (2.2.29).

**Test solution.** Dissolve 25.0 mg of the substance to be examined in 2 mL of *tetrahydrofuran R* and dilute to 10.0 mL with *water R*.

**Reference solution (a).** Dissolve 2 mg of *prednisolone CRS* and 2 mg of *hydrocortisone CRS* (impurity A) in the mobile phase and dilute to 100.0 mL with the mobile phase.

**Reference solution (b).** Dilute 1.0 mL of the test solution to 100.0 mL with the mobile phase.

**Column:**

- size:  $l = 0.25$  m,  $\varnothing = 4.6$  mm;
- stationary phase: base-deactivated end-capped octadecylsilyl silica gel for chromatography *R* (5  $\mu$ m);
- temperature: 45 °C.

**Mobile phase:** in a 1000 mL volumetric flask, mix 220 mL of *tetrahydrofuran R* with 700 mL of *water R* and allow to equilibrate; dilute to 1000 mL with *water R* and mix again.

**Flow rate:** 1 mL/min.

**Detection:** spectrophotometer at 254 nm.

**Equilibration:** with the mobile phase for about 30 min.

**Injection:** 20  $\mu$ L; inject the solvent mixture of the test solution as a blank.

**Run time:** 4.5 times the retention time of prednisolone.

**Retention time:** prednisolone = about 14 min; impurity A = about 15.5 min.

**System suitability:** reference solution (a):

- resolution: minimum 2.2 between the peaks due to prednisolone and impurity A; if necessary, adjust the concentration of *tetrahydrofuran R* in the mobile phase.

**Limits:**

- any impurity: for each impurity, not more than the area of the principal peak in the chromatogram obtained with reference solution (b) (1 per cent) and not more than one such peak has an area greater than 0.5 times the area of the principal peak in the chromatogram obtained with reference solution (b) (0.5 per cent);
- total: not more than twice the area of the principal peak in the chromatogram obtained with reference solution (b) (2 per cent);
- disregard limit: 0.05 times the area of the principal peak in the chromatogram obtained with reference solution (b) (0.05 per cent).

**Loss on drying** (2.2.32): maximum 1.0 per cent, determined on 0.500 g by drying in an oven at 105 °C.

## ASSAY

Dissolve 0.100 g in *ethanol (96 per cent) R* and dilute to 100.0 mL with the same solvent. Dilute 2.0 mL of this solution to 100.0 mL with *ethanol (96 per cent) R*. Measure the absorbance (2.2.25) at the absorption maximum at 243.5 nm.

Calculate the content of  $C_{21}H_{28}O_5$  taking the specific absorbance to be 415.

## STORAGE

In an airtight container, protected from light.

## IMPURITIES

**Specified impurities:** A.

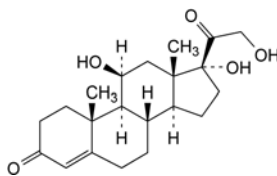

A. 11 $\beta$ ,17,21-trihydroxypregn-4-ene-3,20-dione (hydrocortisone).

01/2008:0734  
corrected 6.0

## PREDNISOLONE ACETATE

## Prednisoloni acetat

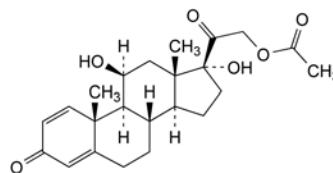

$C_{23}H_{30}O_6$   
[52-21-1]

$M_r$  402.5

## DEFINITION

11 $\beta$ ,17-Dihydroxy-3,20-dioxopregna-1,4-dien-21-yl acetate.

**Content:** 97.0 per cent to 103.0 per cent (dried substance).

## CHARACTERS

**Appearance:** white or almost white, crystalline powder.

**Solubility:** practically insoluble in water, slightly soluble in ethanol (96 per cent) and in methylene chloride.

## IDENTIFICATION

**First identification:** A, B.

**Second identification:** B, C, D.

A. Infrared absorption spectrophotometry (2.2.24).

**Comparison:** *prednisolone acetate CRS*.

B. Thin-layer chromatography (2.2.27).

**Test solution.** Dissolve 10 mg of the substance to be examined in a mixture of 1 volume of *methanol R* and 9 volumes of *methylene chloride R* and dilute to 10 mL with the same mixture of solvents.

**Reference solution (a).** Dissolve 20 mg of *prednisolone acetate CRS* in a mixture of 1 volume of *methanol R* and 9 volumes of *methylene chloride R* and dilute to 20 mL with the same mixture of solvents.

**Reference solution (b).** Dissolve 10 mg of *prednisolone pivalate CRS* in reference solution (a) and dilute to 10 mL with the same solution.

**Plate:** TLC silica gel plate  $F_{254}$  *R*.

**Mobile phase:** add a mixture of 1.2 volumes of *water R* and 8 volumes of *methanol R* to a mixture of 15 volumes of *ether R* and 77 volumes of *methylene chloride R*.

**Application:** 5  $\mu$ L.

**Development:** over a path of 15 cm.

**Drying:** in air.

**Detection A:** examine in ultraviolet light at 254 nm.

**Results A:** the principal spot in the chromatogram obtained with the test solution is similar in position and size to the principal spot in the chromatogram obtained with reference solution (a).

**Detection B:** spray with *alcoholic solution of sulfuric acid R*. Heat at 105 °C for 10 min or until the spots appear. Allow to cool. Examine in daylight and in ultraviolet light at 365 nm.

**System suitability:** reference solution (b):

- the chromatogram obtained shows 2 clearly separated spots.

**Results B:** the principal spot in the chromatogram obtained with the test solution is similar in position, colour in daylight, fluorescence in ultraviolet light at 365 nm and size to the principal spot in the chromatogram obtained with reference solution (a).

- C. Add about 2 mg to 2 mL of *sulfuric acid R* and shake to dissolve. Within 5 min, an intense red colour develops. When examined in ultraviolet light at 365 nm, a reddish-brown fluorescence is seen. Add the solution to 10 mL of *water R* and mix. The colour fades and there is greenish-yellow fluorescence in ultraviolet light at 365 nm.
- D. About 10 mg gives the reaction of acetyl (2.3.1).

#### TESTS

**Specific optical rotation** (2.2.7): + 128 to + 137 (dried substance).

Dissolve 70.0 mg in *methanol R2* and dilute to 20.0 mL with the same solvent.

**Related substances.** Liquid chromatography (2.2.29). Prepare the solutions immediately before use.

**Buffer solution pH 4.** Mix 1 volume of *dilute hydrochloric acid R*, 5 volumes of a 68.1 g/L solution of *sodium acetate R*, 15 volumes of a 37.3 g/L solution of *potassium chloride R* and 79 volumes of *water R*.

**Solvent mixture.** Mix equal volumes of *acetonitrile R* and buffer solution pH 4.

**Test solution.** Dissolve 25.0 mg of the substance to be examined in *methanol R* and dilute to 10.0 mL with the same solvent.

**Reference solution (a).** Dissolve 2 mg of *prednisolone acetate CRS* and 2 mg of *hydrocortisone acetate CRS* (impurity A) in the solvent mixture and dilute to 100.0 mL with the solvent mixture.

**Reference solution (b).** Dilute 1.0 mL of the test solution to 100.0 mL with the solvent mixture. Dilute 2.0 mL of this solution to 10.0 mL with the solvent mixture.

**Reference solution (c).** Dissolve 5 mg of *prednisolone acetate for peak identification CRS* (containing impurities A, B and C) in the solvent mixture and dilute to 50 mL with the solvent mixture.

**Column:**

- size:  $l = 0.25$  m,  $\varnothing = 4.6$  mm;
- stationary phase: end-capped octadecylsilyl silica gel for chromatography R (5  $\mu$ m);
- temperature: 40 °C.

**Mobile phase:** *acetonitrile R*, *water R* (350:650 V/V).

**Flow rate:** 1 mL/min.

**Detection:** spectrophotometer at 254 nm.

**Injection:** 20  $\mu$ L.

**Run time:** 2.5 times the retention time of prednisolone acetate.

**Identification of impurities:** use the chromatogram supplied with *prednisolone acetate for peak identification CRS* and the chromatogram obtained with reference solution (c) to identify the peaks due to impurities A, B and C.

**Relative retention** with reference to prednisolone acetate (retention time = about 17 min): impurity B = about 0.4; impurity A = about 1.1; impurity C = about 2.0.

**System suitability:** reference solution (a):

- resolution: minimum 2.0 between the peaks due to prednisolone acetate and impurity A.

**Limits:**

- impurities A, B: for each impurity, not more than 5 times the area of the principal peak in the chromatogram obtained with reference solution (b) (1.0 per cent);
- impurity C: not more than 2.5 times the area of the principal peak in the chromatogram obtained with reference solution (b) (0.5 per cent);

- unspecified impurities: for each impurity, not more than 0.5 times the area of the principal peak in the chromatogram obtained with reference solution (b) (0.10 per cent);
- total: not more than 10 times the area of the principal peak in the chromatogram obtained with reference solution (b) (2.0 per cent);
- disregard limit: 0.25 times the area of the principal peak in the chromatogram obtained with reference solution (b) (0.05 per cent).

**Loss on drying** (2.2.32): maximum 0.5 per cent, determined on 1.000 g by drying in an oven at 105 °C.

#### ASSAY

Dissolve 0.100 g in *ethanol (96 per cent) R* and dilute to 100.0 mL with the same solvent. Dilute 2.0 mL of this solution to 100.0 mL with *ethanol (96 per cent) R*. Measure the absorbance (2.2.25) at the absorption maximum at 243 nm.

Calculate the content of  $C_{23}H_{30}O_6$  taking the specific absorbance to be 370.

#### STORAGE

Protected from light.

#### IMPURITIES

**Specified impurities:** A, B, C.

**Other detectable impurities** (the following substances would, if present at a sufficient level, be detected by one or other of the tests in the monograph. They are limited by the general acceptance criterion for other/unspecified impurities and/or by the general monograph *Substances for pharmaceutical use (2034)*. It is therefore not necessary to identify these impurities for demonstration of compliance. See also 5.10. *Control of impurities in substances for pharmaceutical use*): D, E.

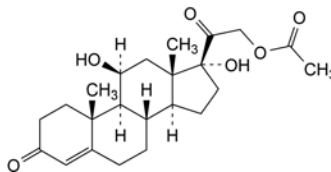

A. 11 $\beta$ ,17-dihydroxy-3,20-dioxopregna-4-en-21-yl acetate (hydrocortisone acetate),

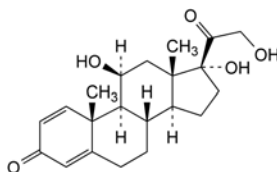

B. 11 $\beta$ ,17,21-trihydroxypregna-1,4-diene-3,20-dione (prednisolone),

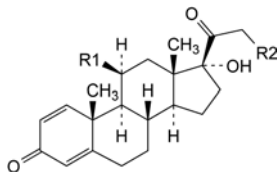

C. R1 = R2 = O-CO-CH<sub>3</sub>: 17-hydroxy-3,20-dioxopregna-1,4-diene-11 $\beta$ ,21-diyl diacetate (prednisolone 11,21-diacetate),

D. R1 = OH, R2 = H: 11 $\beta$ ,17-dihydroxypregna-1,4-diene-3,20-dione,

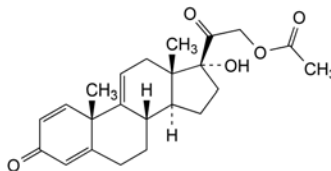

E. 17-hydroxy-3,20-dioxopregna-1,4,9(11)-trien-21-yl acetate.

01/2008:0736  
corrected 6.0

## PREDNISOLONE PIVALATE

## Prednisoloni pivalas

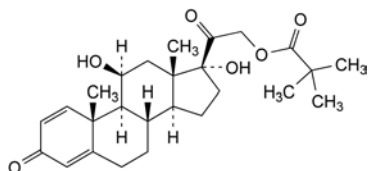
C<sub>26</sub>H<sub>36</sub>O<sub>6</sub>  
[1107-99-9]M<sub>r</sub> 444.6

## DEFINITION

11β,17-Dihydroxy-3,20-dioxopregna-1,4-dien-21-yl  
2,2-dimethylpropanoate.

Content: 97.0 per cent to 103.0 per cent (dried substance).

## CHARACTERS

Appearance: white or almost white, crystalline powder.

Solubility: practically insoluble in water, slightly soluble in ethanol (96 per cent), soluble in methylene chloride.

mp: about 229 °C, with decomposition.

## IDENTIFICATION

First identification: B, C.

Second identification: A, C, D.

A. Dissolve 10.0 mg in *anhydrous ethanol R* and dilute to 100.0 mL with the same solvent. Place 2.0 mL of this solution in a ground-glass-stoppered tube, add 10.0 mL of *phenylhydrazine-sulfuric acid solution R*, mix and heat in a water-bath at 60 °C for 20 min. Cool immediately. The absorbance (2.2.25) at the absorption maximum at 415 nm is 0.20 to 0.30.

B. Infrared absorption spectrophotometry (2.2.24).

Comparison: *prednisolone pivalate CRS*.

If the spectra obtained in the solid state show differences, dissolve the substance to be examined and the reference substance separately in the minimum volume of *ethanol (96 per cent) R*, evaporate to dryness on a water-bath and record new spectra using the residues.

C. Thin-layer chromatography (2.2.27).

Solvent mixture: *methanol R*, *methylene chloride R* (1:9 V/V).

Test solution. Dissolve 10 mg of the substance to be examined in the solvent mixture and dilute to 10 mL with the solvent mixture.

Reference solution (a). Dissolve 10 mg of *prednisolone pivalate CRS* in the solvent mixture and dilute to 10 mL with the solvent mixture.

Reference solution (b). Dissolve 10 mg of *prednisolone acetate CRS* in the solvent mixture and dilute to 10 mL with the solvent mixture. Dilute 5 mL of this solution to 10 mL with reference solution (a).

Plate: *TLC silica gel F<sub>254</sub> plate R*.

Mobile phase: add a mixture of 1.2 volumes of *water R* and 8 volumes of *methanol R* to a mixture of 15 volumes of *ether R* and 77 volumes of *methylene chloride R*.

Application: 5 µL.

Development: over a path of 15 cm.

Drying: in air.

Detection A: examine in ultraviolet light at 254 nm.

Results A: the principal spot in the chromatogram obtained with the test solution is similar in position and size to the principal spot in the chromatogram obtained with reference solution (a).

Detection B: spray with *alcoholic solution of sulfuric acid R*, heat at 120 °C for 10 min or until the spots appear, and allow to cool; examine in daylight and in ultraviolet light at 365 nm.

Results B: the principal spot in the chromatogram obtained with the test solution is similar in position, colour in daylight, fluorescence in ultraviolet light at 365 nm and size to the principal spot in the chromatogram obtained with reference solution (a).

System suitability: reference solution (b):

– the chromatogram shows 2 clearly separated spots.

D. To 2 mL of *sulfuric acid R*, add about 2 mg and shake to dissolve. Within 5 min, an intense red colour develops. When examined in ultraviolet light at 365 nm, a reddish-brown fluorescence is seen. Add this solution to 10 mL of *water R* and mix. The colour fades and there is greenish-yellow fluorescence in ultraviolet light at 365 nm.

## TESTS

Specific optical rotation (2.2.7): + 104 to + 112 (dried substance).

Dissolve 0.250 g in *dioxan R* and dilute to 25.0 mL with the same solvent.

Related substances. Liquid chromatography (2.2.29).

Test solution. Dissolve 62.5 mg of the substance to be examined in 2 mL of a mixture of 1 volume of *water R* and 4 volumes of *tetrahydrofuran R* and dilute to 25.0 mL with the mobile phase.

Reference solution (a). Dissolve 25 mg of *prednisolone acetate CRS*, 25 mg of *cortisone acetate CRS* and 25 mg of *prednisolone pivalate CRS* in 2 mL of a mixture of 1 volume of *water R* and 4 volumes of *tetrahydrofuran R* and dilute to 25.0 mL with the mobile phase. Dilute 1.0 mL of this solution to 25.0 mL with the mobile phase.

Reference solution (b). Dilute 1.0 mL of the test solution to 50.0 mL with the mobile phase.

Column:

– size:  $l = 0.15$  m,  $\varnothing = 4.6$  mm;– stationary phase: *octadecylsilyl silica gel for chromatography R* (5 µm).

Mobile phase: carefully mix 19 mL of *butyl acetate R1* with 37 mL of *tetrahydrofuran R* and 213 mL of *ethylene glycol monomethyl ether R*, then add with 231 mL of *water R*; mix, allow to equilibrate for 1 h and filter through a 0.45 µm filter.

Flow rate: 1 mL/min.

Detection: spectrophotometer at 254 nm.

Equilibration: with the mobile phase for about 30 min.

Injection: 20 µL.

Run time: 1.5 times the retention time of prednisolone pivalate.

Retention time: prednisolone acetate = about 3.5 min; cortisone acetate = about 4.5 min; prednisolone pivalate = about 13 min.

System suitability: reference solution (a):

– resolution: minimum 2.5 between the peaks due to prednisolone acetate and cortisone acetate; if necessary, adjust the concentration of water in the mobile phase.

Limits:

– any impurity: for each impurity, not more than the area of the principal peak in the chromatogram obtained with reference solution (b) (2.0 per cent), and not more than one such peak has an area greater than 0.5 times the area of the principal peak in the chromatogram obtained with reference solution (b) (1.0 per cent);

– total: not more than 1.25 times the area of the principal peak in the chromatogram obtained with reference solution (b) (2.5 per cent);

- *disregard limit*: 0.025 times the area of the principal peak in the chromatogram obtained with reference solution (b) (0.05 per cent).

**Loss on drying** (2.2.32): maximum 0.5 per cent, determined on 1.000 g by drying in an oven at 105 °C.

#### ASSAY

Dissolve 0.100 g in *ethanol (96 per cent) R* and dilute to 100.0 mL with the same solvent. Dilute 5.0 mL of this solution to 250.0 mL with *ethanol (96 per cent) R*. Measure the absorbance (2.2.25) at the absorption maximum at 243 nm. Calculate the content of C<sub>26</sub>H<sub>36</sub>O<sub>6</sub> taking the specific absorbance to be 337.

#### STORAGE

Protected from light.

01/2008:0735

## PREDNISOLONE SODIUM PHOSPHATE

### Prednisoloni natrii phosphas

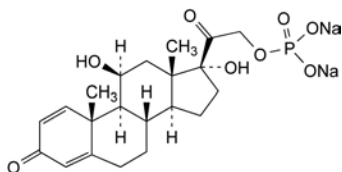

C<sub>21</sub>H<sub>27</sub>Na<sub>2</sub>O<sub>8</sub>P  
[125-02-0]

M<sub>r</sub> 484.4

#### DEFINITION

11β,17-Dihydroxy-3,20-dioxopregna-1,4-dien-21-yl disodium phosphate.

*Content*: 96.0 per cent to 103.0 per cent (anhydrous substance).

#### CHARACTERS

*Appearance*: white or almost white, hygroscopic, crystalline powder.

*Solubility*: freely soluble in water, very slightly soluble in ethanol (96 per cent).

#### IDENTIFICATION

*First identification*: B, C.

*Second identification*: A, C, D, E.

- A. Dissolve 10.0 mg in 5 mL of *water R* and dilute to 100.0 mL with *anhydrous ethanol R*. Place 2.0 mL of this solution in a ground-glass-stoppered tube, add 10.0 mL of *phenylhydrazine-sulfuric acid solution R*, mix and heat in a water-bath at 60 °C for 20 min. Cool immediately. The absorbance (2.2.25) at the absorption maximum at 415 nm is 0.10 to 0.20.

- B. Infrared absorption spectrophotometry (2.2.24).

*Comparison*: *prednisolone sodium phosphate CRS*.

If the spectra obtained in the solid state show differences, dissolve the substance to be examined and the reference substance separately in the minimum volume of *ethanol (96 per cent) R*, evaporate to dryness on a water-bath and record new spectra using the residues.

- C. Thin-layer chromatography (2.2.27).

*Test solution*. Dissolve 10 mg of the substance to be examined in *methanol R* and dilute to 10 mL with the same solvent.

*Reference solution (a)*. Dissolve 10 mg of *prednisolone sodium phosphate CRS* in *methanol R* and dilute to 10 mL with the same solvent.

*Reference solution (b)*. Dissolve 10 mg of *dexamethasone sodium phosphate CRS* in *methanol R* and dilute to 10 mL with the same solvent. Dilute 5 mL of this solution to 10 mL with reference solution (a).

*Plate*: TLC silica gel F<sub>254</sub> plate R.

*Mobile phase*: *glacial acetic acid R, water R, butanol R* (20:20:60 V/V/V).

*Application*: 5 µL.

*Development*: over a path of 15 cm.

*Drying*: in air.

*Detection A*: examine in ultraviolet light at 254 nm.

*Results A*: the principal spot in the chromatogram obtained with the test solution is similar in position and size to the principal spot in the chromatogram obtained with reference solution (a).

*Detection B*: spray with *alcoholic solution of sulfuric acid R*, heat at 120 °C for 10 min or until the spots appear, and allow to cool; examine in daylight and in ultraviolet light at 365 nm.

*Results B*: the principal spot in the chromatogram obtained with the test solution is similar in position, colour in daylight, fluorescence in ultraviolet light at 365 nm and size to the principal spot in the chromatogram obtained with reference solution (a).

*System suitability*: reference solution (b):

- the chromatogram shows 2 spots which may, however, not be completely separated.

- D. To 2 mL of *sulfuric acid R* add about 2 mg and shake to dissolve. Within 5 min, an intense red colour develops. When examined in ultraviolet light at 365 nm, a reddish-brown fluorescence is seen. Add this solution to 10 mL of *water R* and mix. The colour fades and there is a greenish-yellow fluorescence in ultraviolet light at 365 nm.
- E. To about 40 mg add 2 mL of *sulfuric acid R* and heat gently until white fumes are evolved. Add *nitric acid R* dropwise, continue the heating until the solution is almost colourless, and cool. Add 2 mL of *water R*, heat until white fumes are again evolved, cool, add 10 mL of *water R* and neutralise to *red litmus paper R* with *dilute ammonia R1*. The solution gives reaction (a) of sodium (2.3.1) and reaction (b) of phosphates (2.3.1).

#### TESTS

**Solution S**. Dissolve 1.0 g in *carbon dioxide-free water R* and dilute to 20 mL with the same solvent.

**Appearance of solution**. Solution S is clear (2.2.1) and not more intensely coloured than reference solution B<sub>7</sub> (2.2.2, *Method II*).

**pH** (2.2.3): 7.5 to 9.0 for solution S.

**Specific optical rotation** (2.2.7): + 94 to + 100 (anhydrous substance).

Dissolve 0.250 g in *water R* and dilute to 25.0 mL with the same solvent.

**Related substances**. Liquid chromatography (2.2.29).

*Test solution*. Dissolve 62.5 mg of the substance to be examined in the mobile phase and dilute to 25.0 mL with the mobile phase.

*Reference solution (a)*. Dissolve 25 mg of *prednisolone sodium phosphate CRS* and 25 mg of *prednisolone CRS* in the mobile phase and dilute to 25.0 mL with the mobile phase. Dilute 1.0 mL of this solution to 25.0 mL with the mobile phase.

*Reference solution (b)*. Dilute 1.0 mL of the test solution to 50.0 mL with the mobile phase.

*Column*:

- *size*: l = 0.15 m, Ø = 4.6 mm;
- *stationary phase*: *octadecylsilyl silica gel for chromatography R* (5 µm).

**Mobile phase:** into a 250 mL conical flask weigh 1.360 g of *potassium dihydrogen phosphate R* and 0.600 g of *hexylamine R*, mix, allow to stand for 10 min, then dissolve in 185 mL of *water R*; add 65 mL of *acetonitrile R*, mix, and filter through a 0.45 µm filter.

**Flow rate:** 1 mL/min.

**Detection:** spectrophotometer at 254 nm.

**Equilibration:** with the mobile phase for about 30 min.

**Injection:** 20 µL.

**Run time:** 3 times the retention time of prednisolone sodium phosphate.

**Retention time:** prednisolone sodium phosphate = about 6.5 min; prednisolone = about 8.5 min.

**System suitability:** reference solution (a):

- **resolution:** minimum 4.5 between the peaks due to prednisolone sodium phosphate and prednisolone; if necessary, increase the concentration of *acetonitrile R* or *water R* in the mobile phase.

**Limits:**

- **any impurity:** for each impurity, not more than the area of the principal peak in the chromatogram obtained with reference solution (b) (2 per cent), and not more than 1 such peak has an area greater than 0.5 times the area of the principal peak in the chromatogram obtained with reference solution (b) (1 per cent);
- **total:** not more than 1.5 times the area of the principal peak in the chromatogram obtained with reference solution (b) (3 per cent);
- **disregard limit:** 0.025 times the area of the principal peak in the chromatogram obtained with reference solution (b) (0.05 per cent).

**Inorganic phosphate:** maximum 1 per cent.

Dissolve 50 mg in *water R* and dilute to 100 mL with the same solvent. To 10 mL of this solution add 5 mL of *molybdovanadic reagent R*, mix, and allow to stand for 5 min. Any yellow colour in the solution is not more intense than that in a standard prepared at the same time and in the same manner using 10 mL of *phosphate standard solution (5 ppm PO<sub>4</sub>) R*.

**Water (2.5.12):** maximum 8.0 per cent, determined on 0.200 g.

#### ASSAY

Dissolve 0.100 g in *water R* and dilute to 100.0 mL with the same solvent. Dilute 5.0 mL of this solution to 250.0 mL with *water R*. Measure the absorbance (2.2.25) at the absorption maximum at 247 nm.

Calculate the content of C<sub>21</sub>H<sub>27</sub>Na<sub>2</sub>O<sub>8</sub>P taking the specific absorbance to be 312.

#### STORAGE

Protected from light.

**Content:** 97.0 per cent to 103.0 per cent (dried substance).

#### CHARACTERS

**Appearance:** white or almost white, crystalline powder.

**Solubility:** practically insoluble in water, slightly soluble in ethanol (96 per cent) and in methylene chloride.

It shows polymorphism (5.9).

#### IDENTIFICATION

**First identification:** A, B.

**Second identification:** C, D.

A. Infrared absorption spectrophotometry (2.2.24).

**Comparison:** *prednisone CRS*.

If the spectra obtained in the solid state show differences, dissolve the substance to be examined and the reference substance separately in the minimum volume of *acetone R*, evaporate to dryness on a water-bath and record new spectra using the residues.

B. Thin-layer chromatography (2.2.27).

**Solvent mixture:** *methanol R*, *methylene chloride R* (1:9 V/V).

**Test solution.** Dissolve 10 mg of the substance to be examined in the solvent mixture and dilute to 10 mL with the solvent mixture.

**Reference solution (a).** Dissolve 20 mg of *prednisone CRS* in the solvent mixture and dilute to 20 mL with the solvent mixture.

**Reference solution (b).** Dissolve 10 mg of *betamethasone CRS* in reference solution (a) and dilute to 10 mL with reference solution (a).

**Plate:** *TLC silica gel F<sub>254</sub> plate R*.

**Mobile phase:** add a mixture of 1.2 volumes of *water R* and 8 volumes of *methanol R* to a mixture of 15 volumes of *ether R* and 77 volumes of *methylene chloride R*.

**Application:** 5 µL.

**Development:** over a path of 15 cm.

**Drying:** in air.

**Detection A:** examine in ultraviolet light at 254 nm.

**Results A:** the principal spot in the chromatogram obtained with the test solution is similar in position and size to the principal spot in the chromatogram obtained with reference solution (a).

**Detection B:** spray with *alcoholic solution of sulfuric acid R*. Heat at 120 °C for 10 min or until the spots appear. Allow to cool. Examine in daylight and in ultraviolet light at 365 nm.

**Results B:** the principal spot in the chromatogram obtained with the test solution is similar in position, colour in daylight, fluorescence in ultraviolet light at 365 nm and size to the principal spot in the chromatogram obtained with reference solution (a).

**System suitability:** reference solution (b):

- the chromatogram shows 2 clearly separated spots.

C. Thin-layer chromatography (2.2.27).

**Test solution (a).** Dissolve 25 mg of the substance to be examined in *methanol R* and dilute to 5 mL with the same solvent (solution A). Dilute 2 mL of this solution to 10 mL with *methylene chloride R*.

**Test solution (b).** Transfer 0.4 mL of solution A to a glass tube 100 mm long and 20 mm in diameter and fitted with a ground-glass stopper or a polytetrafluoroethylene cap and evaporate the solvent with gentle heating under a stream of *nitrogen R*. Add 2 mL of a 15 per cent V/V solution of *glacial acetic acid R* and 50 mg of *sodium bismuthate R*. Stopper the tube and shake the suspension in a mechanical shaker, protected from light, for 1 h. Add 2 mL of a 15 per cent V/V solution of *glacial acetic acid R* and filter into a 50 mL separating funnel, washing the filter with 2 quantities, each of 5 mL, of *water R*. Shake the clear filtrate with 10 mL

01/2008:0354  
corrected 6.0

## PREDNISONE

### Prednisolum

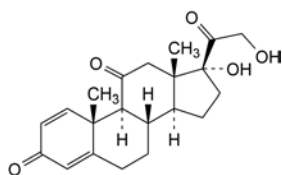

C<sub>21</sub>H<sub>26</sub>O<sub>5</sub>  
[53-03-2]

M<sub>r</sub> 358.4

#### DEFINITION

17,21-Dihydroxypregna-1,4-diene-3,11,20-trione.



of *methylene chloride R*. Wash the organic layer with 5 mL of 1 M sodium hydroxide and 2 quantities, each of 5 mL, of *water R*. Dry over *anhydrous sodium sulfate R*.

**Reference solution (a).** Dissolve 25 mg of *prednisone CRS* in *methanol R* and dilute to 5 mL with the same solvent (solution B). Dilute 2 mL of this solution to 10 mL with *methylene chloride R*.

**Reference solution (b).** Transfer 0.4 mL of solution B to a glass tube 100 mm long and 20 mm in diameter and fitted with a ground-glass stopper or a polytetrafluoroethylene cap and evaporate the solvent with gentle heating under a stream of *nitrogen R*. Add 2 mL of a 15 per cent V/V solution of *glacial acetic acid R* and 50 mg of *sodium bismuthate R*. Stopper the tube and shake the suspension in a mechanical shaker, protected from light, for 1 h. Add 2 mL of a 15 per cent V/V solution of *glacial acetic acid R* and filter into a 50 mL separating funnel, washing the filter with 2 quantities, each of 5 mL, of *water R*. Shake the clear filtrate with 10 mL of *methylene chloride R*. Wash the organic layer with 5 mL of 1 M sodium hydroxide and 2 quantities, each of 5 mL, of *water R*. Dry over *anhydrous sodium sulfate R*.

**Plate:** TLC silica gel  $F_{254}$  plate *R*.

**Mobile phase:** add a mixture of 1.2 volumes of *water R* and 8 volumes of *methanol R* to a mixture of 15 volumes of *ether R* and 77 volumes of *methylene chloride R*.

**Application:** 5  $\mu$ L of test solution (a) and reference solution (a) and 50  $\mu$ L of test solution (b) and reference solution (b), applying the latter 2 in small quantities in order to obtain small spots.

**Development:** over a path of 15 cm.

**Drying:** in air.

**Detection A:** examine in ultraviolet light at 254 nm.

**Results A:** the principal spot in each of the chromatograms obtained with the test solutions is similar in position and size to the principal spot in the chromatogram obtained with the corresponding reference solution.

**Detection B:** spray with *alcoholic solution of sulfuric acid R*. Heat at 120 °C for 10 min or until the spots appear. Allow to cool. Examine in daylight and in ultraviolet light at 365 nm.

**Results B:** the principal spot in each of the chromatograms obtained with the test solutions is similar in position, colour in daylight, fluorescence in ultraviolet light at 365 nm and size to the principal spot in the chromatogram obtained with the corresponding reference solution. The principal spots in the chromatograms obtained with test solution (b) and reference solution (b) have an  $R_f$  value distinctly higher than that of the principal spots in the chromatograms obtained with test solution (a) and reference solution (a).

- D. Add about 2 mg to 2 mL of *sulfuric acid R* and shake to dissolve. Within 5 min, a yellow colour develops with a blue fluorescence in ultraviolet light at 365 nm. Add this solution to 10 mL of *water R* and mix. The colour fades but the blue fluorescence in ultraviolet light does not disappear.

## TESTS

**Specific optical rotation (2.2.7):** + 167 to + 175 (dried substance).

Dissolve 0.125 g in *dioxan R* and dilute to 25.0 mL with the same solvent.

**Related substances.** Liquid chromatography (2.2.29).

**Test solution.** Dissolve 25.0 mg of the substance to be examined in *methanol R* and dilute to 10.0 mL with the same solvent.

**Reference solution (a).** Dissolve 2 mg of *prednisone CRS* and 2 mg of *prednisolone CRS* in *methanol R* and dilute to 100.0 mL with the same solvent.

**Reference solution (b).** Dilute 1.0 mL of the test solution to 100.0 mL with *methanol R*.

**Column:**

- size:  $l = 0.25$  m,  $\varnothing = 4.6$  mm;

- stationary phase: *octadecylsilyl silica gel for chromatography R* (5  $\mu$ m);

- temperature: 45 °C.

**Mobile phase:**

- mobile phase A: in a 1000 mL volumetric flask mix 100 mL of *acetonitrile R* with 200 mL of *methanol R* and 650 mL of *water R*; allow to equilibrate; adjust to 1000 mL with *water R* and mix again;

- mobile phase B: *acetonitrile R*;

Time (min)	Mobile phase A (per cent V/V)	Mobile phase B (per cent V/V)
0 - 25	100	0
25 - 40	100 → 40	0 → 60
40 - 41	40 → 0	60 → 100
41 - 46	0	100
46 - 47	0 → 100	100 → 0
47 - 52	100	0

**Flow rate:** 2.5 mL/min.

**Detection:** spectrophotometer at 254 nm.

**Equilibration:** with mobile phase B for at least 30 min, and then with mobile phase A for 5 min. For subsequent chromatograms, use the conditions described from 40.0 min to 52.0 min.

**Injection:** 20  $\mu$ L; inject *methanol R* as a blank.

**Retention time:** prednisone = about 19 min; prednisolone = about 23 min.

**System suitability:** reference solution (a):

- resolution: minimum 2.7 between the peaks due to prednisone and prednisolone; if necessary, adjust the concentration of acetonitrile in mobile phase A.

**Limits:**

- any impurity: for each impurity, not more than 0.25 times the area of the principal peak in the chromatogram obtained with reference solution (b) (0.25 per cent);
- total: not more than 0.75 times the area of the principal peak in the chromatogram obtained with reference solution (b) (0.75 per cent);
- disregard limit: 0.05 times the area of the principal peak in the chromatogram obtained with reference solution (b) (0.05 per cent).

**Loss on drying (2.2.32):** maximum 1.0 per cent, determined on 0.500 g by drying in an oven at 105 °C.

## ASSAY

Dissolve 0.100 g in *ethanol (96 per cent) R* and dilute to 100.0 mL with the same solvent. Dilute 2.0 mL of this solution to 100.0 mL with *ethanol (96 per cent) R*. Measure the absorbance (2.2.25) at the absorption maximum at 238 nm.

Calculate the content of  $C_{21}H_{26}O_5$  taking the specific absorbance to be 425.

## STORAGE

Protected from light.

01/2008:1362

## PRILOCAINE

### Prilocainum

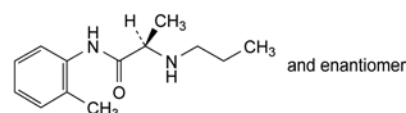

$C_{13}H_{20}N_2O$   
[721-50-6]

$M_r$  220.3

## DEFINITION

(*RS*)-*N*-(2-Methylphenyl)-2-(propylamino)propanamide.

*Content*: 99.0 per cent to 101.0 per cent (anhydrous substance).

## CHARACTERS

*Appearance*: white or almost white, crystalline powder.

*Solubility*: slightly soluble in water, very soluble in acetone and in ethanol (96 per cent).

## IDENTIFICATION

*First identification*: B.

*Second identification*: A, C.

A. Melting point (2.2.14): 36 °C to 39 °C, determined without previous drying.

B. Infrared absorption spectrophotometry (2.2.24).

*Preparation*: apply 50 µL of a 30 g/L solution of the substance to be examined or the reference substance in ether R to potassium bromide R discs and evaporate the solvent.

*Comparison*: prilocaine CRS.

C. Thin-layer chromatography (2.2.27).

*Test solution*. Dissolve 20.0 mg of the substance to be examined in ethanol (96 per cent) R and dilute to 5 mL with the same solvent.

*Reference solution (a)*. Dissolve 20.0 mg of prilocaine CRS in ethanol (96 per cent) R and dilute to 5 mL with the same solvent.

*Reference solution (b)*. Dissolve 20.0 mg of prilocaine CRS and 20.0 mg of lidocaine CRS in ethanol (96 per cent) R and dilute to 5 mL with the same solvent.

*Plate*: TLC silica gel GF<sub>254</sub> plate R.

*Mobile phase*: concentrated ammonia R, methanol R, ether R (1:5:100 V/V/V).

*Application*: 10 µL.

*Development*: over a path of 12 cm.

*Drying*: in air.

*Detection*: examine in ultraviolet light at 254 nm.

*System suitability*: reference solution (b):

– the chromatogram shows 2 clearly separated spots.

*Results*: the principal spot in the chromatogram obtained with the test solution is similar in position and size to the principal spot in the chromatogram obtained with reference solution (a).

## TESTS

**Solution S**. Dissolve 2.50 g in 15 mL of dilute hydrochloric acid R and dilute to 50.0 mL with water R.

**Appearance of solution**. Solution S is clear (2.2.1) and colourless (2.2.2, Method II).

**Optical rotation** (2.2.7): –0.10° to +0.10°, determined on solution S.

**Related substances**. Liquid chromatography (2.2.29).

*Test solution*. Dissolve 25.0 mg of the substance to be examined in the mobile phase and dilute to 10.0 mL with the mobile phase.

*Reference solution (a)*. Dissolve 2.5 mg of the substance to be examined and 3.0 mg of prilocaine impurity E CRS in the mobile phase and dilute to 100.0 mL with the mobile phase. Dilute 1.0 mL of this solution to 10.0 mL with the mobile phase.

*Reference solution (b)*. Dilute 1.0 mL of the test solution to 100.0 mL with the mobile phase. Dilute 1.0 mL of this solution to 10.0 mL with the mobile phase.

*Column*:

– size:  $l = 0.125$  m,  $\varnothing = 4.6$  mm;

– stationary phase: octadecylsilyl silica gel for chromatography R (5 µm).

*Mobile phase*: mix 40 volumes of acetonitrile R and 60 volumes of a solution prepared as follows: dissolve 0.180 g of sodium dihydrogen phosphate monohydrate R and 2.89 g of disodium hydrogen phosphate dihydrate R in 1000 mL of water R (pH 8.0).

*Flow rate*: 1 mL/min.

*Detection*: spectrophotometer at 240 nm.

*Injection*: 20 µL.

*Run time*: twice the retention time of prilocaine.

*Retention time*: prilocaine = about 7 min.

*System suitability*: reference solution (a):

– resolution: minimum 3.0 between the peaks due to impurity E and prilocaine.

*Limits*:

– impurities A, C, D, E, F: for each impurity, not more than twice the area of the principal peak in the chromatogram obtained with reference solution (b) (0.2 per cent) and not more than one such peak has an area greater than the area of the principal peak in the chromatogram obtained with reference solution (b) (0.1 per cent);

– total: not more than 5 times the area of the principal peak in the chromatogram obtained with reference solution (b) (0.5 per cent);

– disregard limit: 0.2 times the area of the principal peak in the chromatogram obtained with reference solution (b) (0.02 per cent).

**Impurity B**. Liquid chromatography (2.2.29) as described in the test for related substances with the following modifications.

*Use freshly prepared solutions*.

*Test solution*. Dissolve 0.100 g of the substance to be examined in the mobile phase and dilute to 10.0 mL with the mobile phase.

*Reference solution*. Dissolve 10.0 mg of *o*-toluidine hydrochloride R (impurity B) in the mobile phase and dilute to 100.0 mL with the mobile phase. Dilute 1.0 mL of this solution to 100.0 mL with the mobile phase.

*Limit*:

– impurity B: not more than the area of the corresponding peak in the chromatogram obtained with the reference solution (100 ppm).

**Heavy metals** (2.4.8): maximum 20 ppm.

1.0 g complies with test C. Prepare the reference solution using 2 mL of lead standard solution (10 ppm Pb) R.

**Water** (2.5.12): maximum 0.5 per cent, determined on 1.00 g.

**Sulfated ash** (2.4.14): maximum 0.1 per cent, determined on 1.0 g.

## ASSAY

Dissolve 0.400 g in 20 mL of anhydrous acetic acid R.

Titrate with 0.1 M perchloric acid, determining the end-point potentiometrically (2.2.20).

1 mL of 0.1 M perchloric acid is equivalent to 22.03 mg of C<sub>13</sub>H<sub>20</sub>N<sub>2</sub>O.

## IMPURITIES

*Specified impurities*: A, B, C, D, E, F.

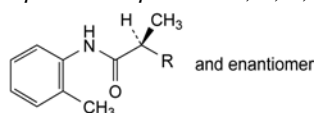

A. R = Cl: (*RS*)-2-chloro-*N*-(2-methylphenyl)propanamide,

C. R = NH-C<sub>2</sub>H<sub>5</sub>: (*RS*)-2-(ethylamino)-*N*-(2-methylphenyl)propanamide,

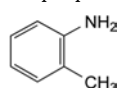

B. 2-methylbenzenamine (*o*-toluidine),

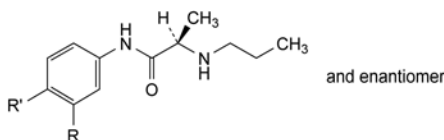

- D. R = CH<sub>3</sub>, R' = H: (*RS*)-*N*-(3-methylphenyl)-2-(propylamino)propanamide,  
 E. R = H, R' = CH<sub>3</sub>: (*RS*)-*N*-(4-methylphenyl)-2-(propylamino)propanamide,  
 F. R = R' = H: (*RS*)-*N*-phenyl-2-(propylamino)propanamide.

01/2008:1363  
corrected 6.0

## PRILOCAINE HYDROCHLORIDE

### Prilocaini hydrochloridum

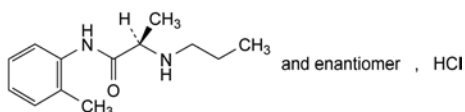

C<sub>13</sub>H<sub>21</sub>ClN<sub>2</sub>O  
[1786-81-8]

M<sub>r</sub> 256.8

#### DEFINITION

(*RS*)-*N*-(2-Methylphenyl)-2-(propylamino)propanamide hydrochloride.

*Content*: 99.0 per cent to 101.0 per cent (dried substance).

#### CHARACTERS

*Appearance*: white or almost white, crystalline powder or colourless crystals.

*Solubility*: freely soluble in water and in ethanol (96 per cent), very slightly soluble in acetone.

#### IDENTIFICATION

*First identification*: B, D.

*Second identification*: A, C, D.

- A. Melting point (2.2.14): 168 °C to 171 °C.  
 B. Infrared absorption spectrophotometry (2.2.24).

*Preparation*: discs.

*Comparison*: prilocaine hydrochloride CRS.

- C. Thin-layer chromatography (2.2.27).

*Test solution*. Dissolve 20.0 mg of the substance to be examined in ethanol (96 per cent) R and dilute to 5 mL with the same solvent.

*Reference solution (a)*. Dissolve 20.0 mg of prilocaine hydrochloride CRS in ethanol (96 per cent) R and dilute to 5 mL with the same solvent.

*Reference solution (b)*. Dissolve 20.0 mg of prilocaine hydrochloride CRS and 20.0 mg of lidocaine hydrochloride CRS in ethanol (96 per cent) R and dilute to 5 mL with the same solvent.

*Plate*: TLC silica gel GF<sub>254</sub> plate R.

*Mobile phase*: concentrated ammonia R, methanol R, ether R (1:5:100 V/V/V).

*Application*: 10 µL.

*Development*: over a path of 12 cm.

*Drying*: in air.

*Detection*: examine in ultraviolet light at 254 nm.

*System suitability*: reference solution (b):

- the chromatogram shows 2 clearly separated spots.

*Results*: the principal spot in the chromatogram obtained with the test solution is similar in position and size to the principal spot in the chromatogram obtained with reference solution (a).

D. It gives reaction (a) of chlorides (2.3.1).

#### TESTS

**Solution S**. Dissolve 2.50 g in carbon dioxide-free water R and dilute to 50.0 mL with the same solvent.

**Appearance of solution**. Solution S is clear (2.2.1) and colourless (2.2.2, Method II).

**Acidity or alkalinity**. Dilute 4 mL of solution S to 10 mL with carbon dioxide-free water R. Add 0.1 mL of bromocresol green solution R and 0.40 mL of 0.01 M sodium hydroxide; the solution is blue. Add 0.80 mL of 0.01 M hydrochloric acid; the solution is yellow.

**Optical rotation** (2.2.7): –0.10° to +0.10°, determined on solution S.

**Related substances**. Liquid chromatography (2.2.29).

*Test solution*. Dissolve 30.0 mg of the substance to be examined in the mobile phase and dilute to 10.0 mL with the mobile phase.

*Reference solution (a)*. Dissolve 3.0 mg of the substance to be examined and 3.0 mg of prilocaine impurity E CRS in the mobile phase and dilute to 100.0 mL with the mobile phase.

Dilute 1.0 mL of this solution to 10.0 mL with the mobile phase. *Reference solution (b)*. Dilute 1.0 mL of the test solution to 100.0 mL with the mobile phase. Dilute 1.0 mL of this solution to 10.0 mL with the mobile phase.

*Column*:

- size: *l* = 0.125 m, Ø = 4.6 mm;
- stationary phase: octadecylsilyl silica gel for chromatography R (5 µm).

*Mobile phase*: mix 40 volumes of acetonitrile R and 60 volumes of a solution prepared as follows: dissolve 0.180 g of sodium dihydrogen phosphate monohydrate R and 2.89 g of disodium hydrogen phosphate dihydrate R in 1000 mL of water R (pH 8.0).

*Flow rate*: 1 mL/min.

*Detection*: spectrophotometer at 240 nm.

*Injection*: 20 µL.

*Run time*: twice the retention time of prilocaine.

*Retention time*: prilocaine = about 7 min.

*System suitability*: reference solution (a):

- resolution: minimum 3.0 between the peaks due to impurity E and prilocaine.

*Limits*:

- impurities A, C, D, E, F: for each impurity, not more than twice the area of the principal peak in the chromatogram obtained with reference solution (b) (0.2 per cent) and not more than one such peak has an area greater than the area of the principal peak in the chromatogram obtained with reference solution (b) (0.1 per cent);
- total: not more than 5 times the area of the principal peak in the chromatogram obtained with reference solution (b) (0.5 per cent);
- disregard limit: 0.2 times the area of the principal peak in the chromatogram obtained with reference solution (b) (0.02 per cent).

**Impurity B**. Liquid chromatography (2.2.29) as described in the test for related substances with the following modifications.

*Use freshly prepared solutions*.

*Test solution*. Dissolve 0.100 g of the substance to be examined in the mobile phase and dilute to 10.0 mL with the mobile phase.

*Reference solution*. Dissolve 10.0 mg of *o*-toluidine hydrochloride R (impurity B) in the mobile phase and dilute to 100.0 mL with the mobile phase. Dilute 1.0 mL of this solution to 100.0 mL with the mobile phase.

*Limit*:

- impurity B: not more than the area of the corresponding peak in the chromatogram obtained with the reference solution (100 ppm).

**Heavy metals** (2.4.8): maximum 20 ppm.

1.0 g complies with test C. Prepare the reference solution using 2 mL of *lead standard solution* (10 ppm Pb) R.

**Loss on drying** (2.2.32): maximum 0.5 per cent, determined on 1.000 g by drying in an oven at 105 °C.

**Sulfated ash** (2.4.14): maximum 0.1 per cent, determined on 1.0 g.

#### ASSAY

Dissolve 0.400 g in a mixture of 5.0 mL of 0.01 M *hydrochloric acid* and 50 mL of *ethanol* (96 per cent) R. Carry out a potentiometric titration (2.2.20), using 0.1 M *sodium hydroxide*. Read the volume added between the 2 points of inflexion.

1 mL of 0.1 M *sodium hydroxide* is equivalent to 25.68 mg of C<sub>13</sub>H<sub>21</sub>ClN<sub>2</sub>O.

#### IMPURITIES

*Specified impurities: A, B, C, D, E, F.*

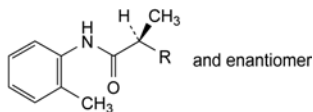

A. R = Cl: (*RS*)-2-chloro-*N*-(2-methylphenyl)propanamide,

C. R = NH-C<sub>2</sub>H<sub>5</sub>: (*RS*)-2-ethylamino-*N*-(2-methylphenyl)propanamide,

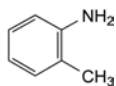

B. 2-methylbenzenamine (*o*-toluidine),

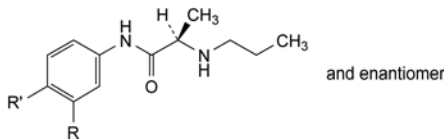

D. R = CH<sub>3</sub>, R' = H: (*RS*)-*N*-(3-methylphenyl)-2-(propylamino)propanamide,

E. R = H, R' = CH<sub>3</sub>: (*RS*)-*N*-(4-methylphenyl)-2-(propylamino)propanamide,

F. R = R' = H: (*RS*)-*N*-phenyl-2-(propylamino)propanamide.

01/2008:0635  
corrected 6.0

## PRIMAQUINE DIPHOSPHATE

### Primaquini diphosphas

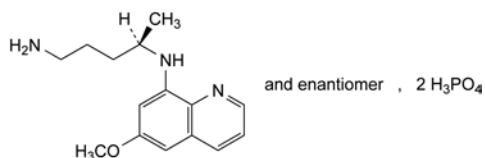

C<sub>15</sub>H<sub>27</sub>N<sub>3</sub>O<sub>9</sub>P<sub>2</sub>  
[63-45-6]

M<sub>r</sub> 455.3

#### DEFINITION

(4*RS*)-*N*<sup>4</sup>-(6-Methoxyquinolin-8-yl)pentane-1,4-diamine bisphosphate.

*Content*: 98.5 per cent to 101.5 per cent (dried substance).

#### CHARACTERS

*Appearance*: orange crystalline powder.

*Solubility*: soluble in water, practically insoluble in ethanol (96 per cent).

mp: about 200 °C, with decomposition.

#### IDENTIFICATION

*First identification: B, D.*

*Second identification: A, C, D.*

A. Ultraviolet and visible absorption spectrophotometry (2.2.25).

*Test solution (a)*. Dissolve 15 mg in 0.01 M *hydrochloric acid* and dilute to 100.0 mL with the same acid.

*Test solution (b)*. Dilute 5.0 mL of test solution (a) to 50.0 mL with 0.01 M *hydrochloric acid*.

*Spectral range*: 310-450 nm for test solution (a); 215-310 nm for test solution (b).

*Absorption maxima*: at 332 nm and 415 nm for test solution (a); at 225 nm, 265 nm and 282 nm for test solution (b).

*Specific absorbance at the absorption maxima*:

- at 332 nm: 45 to 52 for test solution (a);
- at 415 nm: 27 to 35 for test solution (a);
- at 225 nm: 495 to 515 for test solution (b);
- at 265 nm: 335 to 350 for test solution (b);
- at 282 nm: 330 to 345 for test solution (b).

B. Infrared absorption spectrophotometry (2.2.24).

*Preparation*: discs.

Dissolve separately 0.1 g of the substance to be examined and 0.1 g of the reference substance in 5 mL of *water R*, add 2 mL of *dilute ammonia R2* and 5 mL of *methylene chloride R*, then shake. Dry the methylene chloride layer over 0.5 g of *anhydrous sodium sulfate R*. Prepare a blank disc using about 0.3 g of *potassium bromide R*. Apply dropwise to the disc 0.1 mL of the methylene chloride layer, allowing the methylene chloride to evaporate between applications. Dry the disc at 50 °C for 2 min.

*Comparison: primaquine diphosphate CRS.*

C. Thin-layer chromatography (2.2.27). Carry out all operations as rapidly as possible, protected from light. Prepare the solutions immediately before use.

*Test solution*. Dissolve 0.20 g of the substance to be examined in 5 mL of *water R* and dilute to 10 mL with *methanol R*. Dilute 1 mL of this solution to 10 mL with a mixture of equal volumes of *methanol R* and *water R*.

*Reference solution*. Dissolve 20 mg of *primaquine diphosphate CRS* in 5 mL of *water R* and dilute to 10 mL with *methanol R*.

*Plate: TLC silica gel GF<sub>254</sub> plate R.*

*Pretreatment*: wash the plate with the mobile phase and allow to dry in air.

*Mobile phase: concentrated ammonia R, methanol R, methylene chloride R* (1:40:60 V/V/V).

*Application*: 5 µL.

*Development*: over a path of 15 cm.

*Drying*: in air.

*Detection*: examine in ultraviolet light at 254 nm.

*Results*: the principal spot in the chromatogram obtained with the test solution is similar in position and size to the principal spot in the chromatogram obtained with the reference solution.

D. Dissolve 50 mg in 5 mL of *water R*. Add 2 mL of *dilute sodium hydroxide solution R* and shake with 2 quantities, each of 5 mL, of *methylene chloride R*. The aqueous layer, acidified by addition of *nitric acid R*, gives reaction (b) of phosphates (2.3.1).

#### TESTS

**Related substances.** Liquid chromatography (2.2.29).

*Test solution*. Dissolve 50 mg of the substance to be examined in *water R* and dilute to 5.0 mL with the same solvent. To 1.0 mL of this solution add 0.2 mL of *concentrated ammonia R*

and shake with 10.0 mL of the mobile phase. Use the clear lower layer.

**Reference solution (a).** Dissolve 50 mg of *primaquine diphosphate CRS* in *water R* and dilute to 5.0 mL with the same solvent. To 1.0 mL of this solution add 0.2 mL of *concentrated ammonia R* and shake with 10.0 mL of the mobile phase. Use the clear lower layer.

**Reference solution (b).** Dilute 3.0 mL of the test solution to 100.0 mL with the mobile phase.

**Reference solution (c).** Dilute 1.0 mL of the test solution to 10.0 mL with the mobile phase. Dilute 1.0 mL of this solution to 50.0 mL with the mobile phase.

**Column:**

- size:  $l = 0.2$  m,  $\varnothing = 4.6$  mm;
  - stationary phase: *silica gel for chromatography R* (10  $\mu$ m).
- Mobile phase:** *concentrated ammonia R*, *methanol R*, *hexane R*, *methylene chloride R* (0.1:10:45:45 V/V/V/V).

**Flow rate:** 3.0 mL/min.

**Detection:** spectrophotometer at 261 nm.

**Injection:** 20  $\mu$ L.

**Run time:** at least twice the retention time of *primaquine*.

**System suitability:**

- the chromatogram obtained with reference solution (a) shows just before the principal peak a peak whose area is about 6 per cent of that of the principal peak;
- resolution: minimum 2.0 between the peak just before the principal peak and the principal peak in the chromatogram obtained with reference solution (a);
- signal-to-noise ratio: minimum 5 for the principal peak in the chromatogram obtained with reference solution (c).

**Limits:**

- total: not more than the area of the principal peak in the chromatogram obtained with reference solution (b) (3.0 per cent);
- disregard limit: the area of the principal peak in the chromatogram obtained with reference solution (c) (0.2 per cent).

**Loss on drying (2.2.32):** maximum 0.5 per cent, determined on 1.000 g by drying in an oven at 105 °C.

**ASSAY**

Dissolve 0.2000 g in 40 mL of *anhydrous acetic acid R*, heating gently. Allow to cool and titrate with 0.1 M *perchloric acid*, determining the end-point potentiometrically (2.2.20).

1 mL of 0.1 M *perchloric acid* is equivalent to 22.77 mg of  $C_{15}H_{27}N_3O_9P_2$ .

**STORAGE**

Protected from light.

01/2008:0584  
corrected 6.0

## PRIMIDONE

Primidonum

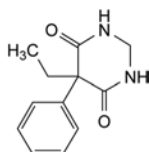

$C_{12}H_{14}N_2O_2$   
[125-33-7]

$M_r$  218.3

**DEFINITION**

5-Ethyl-5-phenyldihydropyrimidine-4,6(1*H*,5*H*)-dione.

**Content:** 98.0 per cent to 102.0 per cent (dried substance).

**CHARACTERS**

**Appearance:** white or almost white, crystalline powder.

**Solubility:** very slightly soluble in water, slightly soluble in ethanol (96 per cent). It dissolves in alkaline solutions.

**IDENTIFICATION**

**First identification:** B.

**Second identification:** A, C, D.

A. Use the solution prescribed for the assay. Examined between 240 nm and 300 nm (2.2.25), the solution shows 3 absorption maxima, at 252 nm, 257 nm and 264 nm, and 2 absorption minima, at 254 nm and 261 nm. The ratio of the absorbance measured at the absorption maximum at 257 nm to that measured at the absorption minimum at 261 nm is 2.00 to 2.20. The identification is valid if, in the test for resolution (2.2.25), the ratio of the absorbances is not less than 2.0.

B. Infrared absorption spectrophotometry (2.2.24).

**Preparation:** discs of *potassium bromide R*.

**Comparison:** *primidone CRS*.

C. Dissolve 0.1 g in 5 mL of a 5 g/L solution of *chromotropic acid, sodium salt R* in a mixture of 4 volumes of *water R* and 9 volumes of *sulfuric acid R*. A pinkish-blue colour develops on heating.

D. Mix 0.2 g and 0.2 g of *anhydrous sodium carbonate R*. Heat until the mixture melts. Ammonia is evolved which is detectable by its alkaline reaction (2.2.4).

**TESTS**

**Related substances.** Liquid chromatography (2.2.29).

**Test solution.** Dissolve 50.0 mg of the substance to be examined in *methanol R1* and dilute to 50.0 mL with the same solvent.

**Reference solution (a).** Dilute 1.0 mL of the test solution to 100.0 mL with *methanol R1*. Dilute 1.0 mL of this solution to 10.0 mL with *methanol R1*.

**Reference solution (b).** Dissolve 5 mg of *primidone for peak identification CRS* (containing impurities A, B, C, D, E and F) in *methanol R1* and dilute to 5 mL with the same solvent.

**Column:**

- size:  $l = 0.10$  m,  $\varnothing = 4.6$  mm,
- stationary phase: *monolithic octadecylsilyl silica gel for chromatography R*.

**Mobile phase:**

- mobile phase A: 1.36 g/L solution of *potassium dihydrogen phosphate R*,
- mobile phase B: *methanol R1*,

Time (min)	Mobile phase A (per cent V/V)	Mobile phase B (per cent V/V)
0 - 1	75	25
1 - 6	75 → 40	25 → 60
6 - 8	40	60
8 - 8.5	40 → 75	60 → 25
8.5 - 10	75	25

**Flow rate:** 3.2 mL/min.

**Detection:** spectrophotometer at 215 nm.

**Injection:** 10  $\mu$ L.

**Identification of impurities:** use the chromatogram supplied with *primidone for peak identification CRS* and the chromatogram obtained with reference solution (b) to identify the peaks.

**Relative retention** with reference to primidone (retention time = about 2.2 min): impurity A = about 0.5; impurity B = about 1.4; impurity C = about 1.6; impurity D = about 1.75; impurity E = about 2.0; impurity F = about 2.8.

*System suitability*: reference solution (b):

- *resolution*: minimum 2.5 between the peaks due to impurity B and impurity C.

*Limits*:

- *correction factors*: for the calculation of contents, multiply the peak areas of the following impurities by the corresponding correction factor: impurity A = 1.5; impurity C = 1.5; impurity D = 1.4; impurity E = 1.3;
- *impurity F*: not more than 3 times the area of the principal peak in the chromatogram obtained with reference solution (a) (0.3 per cent);
- *impurities A, B, C, D, E*: for each impurity, not more than the area of the principal peak in the chromatogram obtained with reference solution (a) (0.1 per cent);
- *any other impurity*: for each impurity, not more than the area of the principal peak in the chromatogram obtained with reference solution (a) (0.1 per cent);
- *total*: not more than 5 times the area of the principal peak in the chromatogram obtained with reference solution (a) (0.5 per cent);
- *disregard limit*: 0.5 times the area of the principal peak in the chromatogram obtained with reference solution (a) (0.05 per cent).

**Heavy metals** (2.4.8): maximum 10 ppm.

2.0 g complies with limit test D. Prepare the reference solution using 2 mL of *lead standard solution* (10 ppm Pb) R.

**Loss on drying** (2.2.32): maximum 0.5 per cent, determined on 1.000 g by drying in an oven at 105 °C for 2 h.

**Sulfated ash** (2.4.14): maximum 0.1 per cent, determined on 1.0 g.

#### ASSAY

Dissolve 60.0 mg with heating in 70 mL of *ethanol* (96 per cent) R, cool and dilute to 100.0 mL with the same solvent. Prepare a reference solution in the same manner using 60.0 mg of *primidone CRS*. Measure the absorbance (2.2.25) of the 2 solutions at the absorption maximum at 257 nm.

Calculate the content of C<sub>12</sub>H<sub>14</sub>N<sub>2</sub>O<sub>2</sub> from the absorbances measured and the concentrations of the solutions.

#### IMPURITIES

*Specified impurities*: A, B, C, D, E, F.

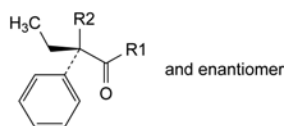

- A. R1 = NH<sub>2</sub>, R2 = CO-NH<sub>2</sub>: 2-ethyl-2-phenylpropanediamide (ethylphenylmalonamide),
- C. R1 = NH<sub>2</sub>, R2 = H: (2*RS*)-2-phenylbutanamide,
- D. R1 = NH<sub>2</sub>, R2 = CN: (2*RS*)-2-cyano-2-phenylbutanamide,
- E. R1 = OH, R2 = H: (2*RS*)-2-phenylbutanoic acid,

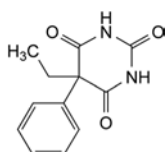

- B. 5-ethyl-5-phenylpyrimidine-2,4,6(1*H*,3*H*,5*H*)-trione (phenobarbital),

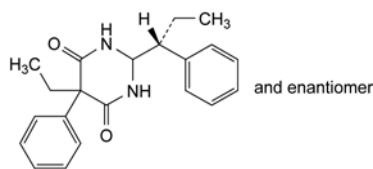

- F. 5-ethyl-5-phenyl-2-[(1*RS*)-1-phenylpropyl]dihydropyrimidine-4,6(1*H*,5*H*)-dione.

01/2008:0243  
corrected 6.0

## PROBENECID

### Probencidum

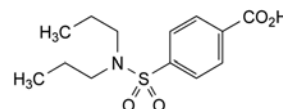

C<sub>13</sub>H<sub>19</sub>NO<sub>4</sub>S  
[57-66-9]

*M*<sub>r</sub> 285.4

#### DEFINITION

Probencid contains not less than 99.0 per cent and not more than the equivalent of 101.0 per cent of 4-(dipropylsulfamoyl)benzoic acid, calculated with reference to the dried substance.

#### CHARACTERS

A white or almost white, crystalline powder or small crystals, practically insoluble in water, soluble in acetone, sparingly soluble in ethanol.

#### IDENTIFICATION

*First identification*: A, C.

*Second identification*: A, B, D.

- A. Melting point (2.2.14): 197 °C to 202 °C.
- B. Dissolve 20 mg in a mixture of 1 volume of 0.1 *M* hydrochloric acid and 9 volumes of alcohol R and dilute to 100.0 mL with the same mixture of solvents. Dilute 5.0 mL of the solution to 100.0 mL with a mixture of 1 volume of 0.1 *M* hydrochloric acid and 9 volumes of alcohol R. Examined between 220 nm and 350 nm (2.2.25), the solution shows two absorption maxima, at 223 nm and 248 nm. The specific absorbance at the maximum at 248 nm is 310 to 350.
- C. Examine by infrared absorption spectrophotometry (2.2.24), comparing with the spectrum obtained with *probencid CRS*.
- D. Dissolve 0.2 g in the smallest necessary quantity of dilute ammonia R2 (about 0.6 mL). Add 3 mL of silver nitrate solution R2. A white precipitate is formed which dissolves in an excess of ammonia.

#### TESTS

**Appearance of solution.** Dissolve 1.0 g in 1 *M* sodium hydroxide and dilute to 10 mL with the same solvent. The solution is clear (2.2.1) and not more intensely coloured than reference solution Y<sub>6</sub> (2.2.2, Method II).

**Acidity.** To 2.0 g add 100 mL of water R and heat on a water-bath for 30 min. Make up to the original volume with water R, allow to cool to room temperature and filter. To 50 mL of the filtrate add 0.1 mL of phenolphthalein solution R. Not more than 0.5 mL of 0.1 *M* sodium hydroxide is required to change the colour of the indicator.

**Related substances.** Examine by thin-layer chromatography (2.2.27), using silica gel GF<sub>254</sub> R as the coating substance.

**Test solution.** Dissolve 0.1 g of the substance to be examined in acetone R and dilute to 10 mL with the same solvent.

**Reference solution.** Dilute 0.5 mL of the test solution to 100 mL with acetone R.

Apply separately to the plate 20 µL of each solution. Develop over a path of 15 cm using a mixture of 10 volumes of *glacial acetic acid R*, 15 volumes of *chloroform R*, 20 volumes of *di-isopropyl ether R* and 55 volumes of *toluene R*. Allow the plate to dry in air and examine in ultraviolet light at 254 nm. Any spot in the chromatogram obtained with the test solution, apart from the principal spot, is not more intense than the spot in the chromatogram obtained with the reference solution (0.5 per cent).

**Heavy metals (2.4.8).** 1.0 g complies with limit test C for heavy metals (20 ppm). Prepare the standard using 2 mL of *lead standard solution (10 ppm Pb) R*.

**Loss on drying (2.2.32).** Not more than 0.5 per cent, determined on 1.00 g by drying in an oven at 105 °C.

**Sulfated ash (2.4.14).** Not more than 0.1 per cent, determined on 1.0 g.

#### ASSAY

Dissolve 0.250 g in 50 mL of *alcohol R*, shaking and heating slightly if necessary. Titrate with 0.1 M *sodium hydroxide*, determining the end-point potentiometrically (2.2.20).

1 mL of 0.1 M *sodium hydroxide* is equivalent to 28.54 mg of C<sub>13</sub>H<sub>19</sub>NO<sub>4</sub>S.

01/2008:0567  
corrected 6.0

## PROCAINAMIDE HYDROCHLORIDE

### Procainamidi hydrochloridum

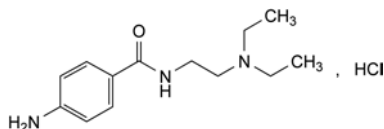

C<sub>13</sub>H<sub>22</sub>ClN<sub>3</sub>O  
[614-39-1]

*M<sub>r</sub>* 271.8

#### DEFINITION

Procainamide hydrochloride contains not less than 98.0 per cent and not more than the equivalent of 101.0 per cent of 4-amino-*N*-[2-(diethylamino)ethyl]benzamide hydrochloride, calculated with reference to the dried substance.

#### CHARACTERS

A white or very slightly yellow, crystalline powder, hygroscopic, very soluble in water, freely soluble in alcohol, slightly soluble in acetone.

#### IDENTIFICATION

*First identification:* C, D.

*Second identification:* A, B, D, E.

- Melting point (2.2.14): 166 °C to 170 °C.
- Dissolve 10.0 mg in 0.1 M *sodium hydroxide* and dilute to 100.0 mL with the same solvent. Dilute 10.0 mL of the solution to 100.0 mL with 0.1 M *sodium hydroxide*. Examined between 220 nm and 350 nm (2.2.25), the solution shows an absorption maximum at 273 nm. The specific absorbance at the maximum is 580 to 610.
- Examine by infrared absorption spectrophotometry (2.2.24), comparing with the spectrum obtained with *procainamide hydrochloride CRS*.
- Dilute 1 mL of solution S to 5 mL with *water R*. The solution gives reaction (a) of chlorides (2.3.1).
- Dilute 1 mL of solution S (see Tests) to 2 mL with *water R*. 1 mL of this solution gives the reaction of primary aromatic amines (2.3.1).

#### TESTS

**Solution S.** Dissolve 2.5 g in *carbon dioxide-free water R* and dilute to 25 mL with the same solvent.

**Appearance of solution.** Solution S is clear (2.2.1) and not more intensely coloured than reference solution B<sub>6</sub> (2.2.2, *Method II*), pH (2.2.3). The pH of solution S is 5.6 to 6.3.

**Related substances.** Examine by thin-layer chromatography (2.2.27), using *silica gel GF<sub>254</sub> R* as the coating substance.

**Test solution.** Dissolve 0.10 g of the substance to be examined in *alcohol R* and dilute to 10 mL with the same solvent.

**Reference solution.** Dilute 1 mL of the test solution to 200 mL with *alcohol R*.

Apply to the plate 5 µL of each solution. Develop over a path of 12 cm using a mixture of 15 volumes of *glacial acetic acid R*, 30 volumes of *water R* and 60 volumes of *butanol R*. Place the plate in a stream of cold air until the plate appears dry. Examine in ultraviolet light at 254 nm. Any spot in the chromatogram obtained with the test solution, apart from the principal spot, is not more intense than the spot in the chromatogram obtained with the reference solution (0.5 per cent).

**Heavy metals (2.4.8).** 1.0 g complies with limit test C for heavy metals (20 ppm). Prepare the standard using 2 mL of *lead standard solution (10 ppm Pb) R*.

**Loss on drying (2.2.32).** Not more than 0.5 per cent, determined on 1.000 g by drying in an oven at 105 °C.

**Sulfated ash (2.4.14).** Not more than 0.1 per cent, determined on 1.0 g.

#### ASSAY

Dissolve 0.2500 g in 50 mL of *dilute hydrochloric acid R*. Carry out the determination of primary aromatic amino-nitrogen (2.5.8).

1 mL of 0.1 M *sodium nitrite* is equivalent to 27.18 mg of C<sub>13</sub>H<sub>22</sub>ClN<sub>3</sub>O.

#### STORAGE

Store in an airtight container, protected from light.

01/2008:0050  
corrected 7.0

## PROCAINE HYDROCHLORIDE

### Procaini hydrochloridum

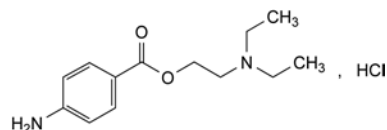

C<sub>13</sub>H<sub>21</sub>ClN<sub>2</sub>O<sub>2</sub>  
[51-05-8]

*M<sub>r</sub>* 272.8

#### DEFINITION

Procaine hydrochloride contains not less than 99.0 per cent and not more than the equivalent of 101.0 per cent of 2-(diethylamino)ethyl 4-aminobenzoate hydrochloride, calculated with reference to the dried substance.

#### CHARACTERS

A white or almost white, crystalline powder or colourless crystals, very soluble in water, soluble in ethanol (96 per cent).

#### IDENTIFICATION

*First identification:* A, B, E.

*Second identification:* A, C, D, E, F.

- Melting point (2.2.14): 154 °C to 158 °C.

Apply separately to the plate 20 µL of each solution. Develop over a path of 15 cm using a mixture of 10 volumes of *glacial acetic acid R*, 15 volumes of *chloroform R*, 20 volumes of *di-isopropyl ether R* and 55 volumes of *toluene R*. Allow the plate to dry in air and examine in ultraviolet light at 254 nm. Any spot in the chromatogram obtained with the test solution, apart from the principal spot, is not more intense than the spot in the chromatogram obtained with the reference solution (0.5 per cent).

**Heavy metals (2.4.8).** 1.0 g complies with limit test C for heavy metals (20 ppm). Prepare the standard using 2 mL of *lead standard solution (10 ppm Pb) R*.

**Loss on drying (2.2.32).** Not more than 0.5 per cent, determined on 1.00 g by drying in an oven at 105 °C.

**Sulfated ash (2.4.14).** Not more than 0.1 per cent, determined on 1.0 g.

#### ASSAY

Dissolve 0.250 g in 50 mL of *alcohol R*, shaking and heating slightly if necessary. Titrate with 0.1 M *sodium hydroxide*, determining the end-point potentiometrically (2.2.20).

1 mL of 0.1 M *sodium hydroxide* is equivalent to 28.54 mg of C<sub>13</sub>H<sub>19</sub>NO<sub>4</sub>S.

01/2008:0567  
corrected 6.0

## PROCAINAMIDE HYDROCHLORIDE

### Procainamidi hydrochloridum

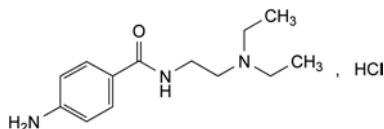

C<sub>13</sub>H<sub>22</sub>ClN<sub>3</sub>O  
[614-39-1]

M<sub>r</sub> 271.8

#### DEFINITION

Procainamide hydrochloride contains not less than 98.0 per cent and not more than the equivalent of 101.0 per cent of 4-amino-*N*-[2-(diethylamino)ethyl]benzamide hydrochloride, calculated with reference to the dried substance.

#### CHARACTERS

A white or very slightly yellow, crystalline powder, hygroscopic, very soluble in water, freely soluble in alcohol, slightly soluble in acetone.

#### IDENTIFICATION

*First identification:* C, D.

*Second identification:* A, B, D, E.

- Melting point (2.2.14): 166 °C to 170 °C.
- Dissolve 10.0 mg in 0.1 M *sodium hydroxide* and dilute to 100.0 mL with the same solvent. Dilute 10.0 mL of the solution to 100.0 mL with 0.1 M *sodium hydroxide*. Examined between 220 nm and 350 nm (2.2.25), the solution shows an absorption maximum at 273 nm. The specific absorbance at the maximum is 580 to 610.
- Examine by infrared absorption spectrophotometry (2.2.24), comparing with the spectrum obtained with *procainamide hydrochloride CRS*.
- Dilute 1 mL of solution S to 5 mL with *water R*. The solution gives reaction (a) of chlorides (2.3.1).
- Dilute 1 mL of solution S (see Tests) to 2 mL with *water R*. 1 mL of this solution gives the reaction of primary aromatic amines (2.3.1).

#### TESTS

**Solution S.** Dissolve 2.5 g in *carbon dioxide-free water R* and dilute to 25 mL with the same solvent.

**Appearance of solution.** Solution S is clear (2.2.1) and not more intensely coloured than reference solution B<sub>6</sub> (2.2.2, *Method II*), pH (2.2.3). The pH of solution S is 5.6 to 6.3.

**Related substances.** Examine by thin-layer chromatography (2.2.27), using *silica gel GF<sub>254</sub> R* as the coating substance.

**Test solution.** Dissolve 0.10 g of the substance to be examined in *alcohol R* and dilute to 10 mL with the same solvent.

**Reference solution.** Dilute 1 mL of the test solution to 200 mL with *alcohol R*.

Apply to the plate 5 µL of each solution. Develop over a path of 12 cm using a mixture of 15 volumes of *glacial acetic acid R*, 30 volumes of *water R* and 60 volumes of *butanol R*. Place the plate in a stream of cold air until the plate appears dry. Examine in ultraviolet light at 254 nm. Any spot in the chromatogram obtained with the test solution, apart from the principal spot, is not more intense than the spot in the chromatogram obtained with the reference solution (0.5 per cent).

**Heavy metals (2.4.8).** 1.0 g complies with limit test C for heavy metals (20 ppm). Prepare the standard using 2 mL of *lead standard solution (10 ppm Pb) R*.

**Loss on drying (2.2.32).** Not more than 0.5 per cent, determined on 1.000 g by drying in an oven at 105 °C.

**Sulfated ash (2.4.14).** Not more than 0.1 per cent, determined on 1.0 g.

#### ASSAY

Dissolve 0.2500 g in 50 mL of *dilute hydrochloric acid R*. Carry out the determination of primary aromatic amino-nitrogen (2.5.8).

1 mL of 0.1 M *sodium nitrite* is equivalent to 27.18 mg of C<sub>13</sub>H<sub>22</sub>ClN<sub>3</sub>O.

#### STORAGE

Store in an airtight container, protected from light.

01/2008:0050  
corrected 7.0

## PROCAINE HYDROCHLORIDE

### Procaini hydrochloridum

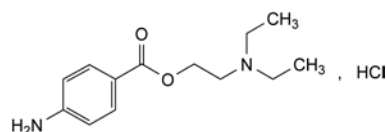

C<sub>13</sub>H<sub>21</sub>ClN<sub>2</sub>O<sub>2</sub>  
[51-05-8]

M<sub>r</sub> 272.8

#### DEFINITION

Procaine hydrochloride contains not less than 99.0 per cent and not more than the equivalent of 101.0 per cent of 2-(diethylamino)ethyl 4-aminobenzoate hydrochloride, calculated with reference to the dried substance.

#### CHARACTERS

A white or almost white, crystalline powder or colourless crystals, very soluble in water, soluble in ethanol (96 per cent).

#### IDENTIFICATION

*First identification:* A, B, E.

*Second identification:* A, C, D, E, F.

- Melting point (2.2.14): 154 °C to 158 °C.



07/2010:0244

- B. Examine by infrared absorption spectrophotometry (2.2.24), comparing with the spectrum obtained with *procaine hydrochloride* CRS.
- C. To about 5 mg add 0.5 mL of *fuming nitric acid* R. Evaporate to dryness on a water-bath, allow to cool and dissolve the residue in 5 mL of *acetone* R. Add 1 mL of 0.1 M *alcoholic potassium hydroxide*. Only a brownish-red colour develops.
- D. To 0.2 mL of solution S (see Tests) add 2 mL of *water* R and 0.5 mL of *dilute sulfuric acid* R and shake. Add 1 mL of a 1 g/L solution of *potassium permanganate* R. The colour is immediately discharged.
- E. It gives reaction (a) of chlorides (2.3.1).
- F. Dilute 1 mL of solution S to 100 mL with *water* R. 2 mL of this solution gives the reaction of primary aromatic amines (2.3.1).

## TESTS

**Solution S.** Dissolve 2.5 g in *carbon dioxide-free water* R and dilute to 50 mL with the same solvent.

**Appearance of solution.** Solution S is clear (2.2.1) and colourless (2.2.2, *Method II*).

**pH** (2.2.3). Dilute 4 mL of solution S to 10 mL with *carbon dioxide-free water* R. The pH of the solution is 5.0 to 6.5.

**Related substances.** Examine by thin-layer chromatography (2.2.27), using *silica gel GF<sub>254</sub>* R as the coating substance.

**Test solution.** Dissolve 1.0 g of the substance to be examined in *water* R and dilute to 10 mL with the same solvent.

**Reference solution.** Dissolve 50 mg of *4-aminobenzoic acid* R in *water* R and dilute to 100 mL with the same solvent. Dilute 1 mL of the solution to 10 mL with *water* R.

Apply separately to the plate 5 µL of each solution. Develop over a path of 10 cm using a mixture of 4 volumes of *glacial acetic acid* R, 16 volumes of *hexane* R and 80 volumes of *dibutyl ether* R. Dry the plate at 100 °C to 105 °C for 10 min and examine in ultraviolet light at 254 nm. Any spot in the chromatogram obtained with the test solution, apart from the principal spot, is not more intense than the spot in the chromatogram obtained with the reference solution (0.05 per cent). The principal spot in the chromatogram obtained with the test solution remains on the point of application.

**Heavy metals** (2.4.8). Dissolve 1.0 g in *water* R and dilute to 25.0 mL with the same solvent. Carry out the prefiltration. 10 mL of the prefiltrate complies with test E (5 ppm). Prepare the reference solution using 5 mL of *lead standard solution* (1 ppm Pb) R.

**Loss on drying** (2.2.32). Not more than 0.5 per cent, determined on 1.00 g by drying in an oven at 105 °C.

**Sulfated ash** (2.4.14). Not more than 0.1 per cent, determined on 1.0 g.

## ASSAY

Dissolve 0.400 g in 50 mL of *dilute hydrochloric acid* R. Carry out the determination of primary aromatic amino nitrogen (2.5.8).

1 mL of 0.1 M *sodium nitrite* is equivalent to 27.28 mg of C<sub>13</sub>H<sub>21</sub>ClN<sub>3</sub>O<sub>2</sub>.

## STORAGE

Store protected from light.

## PROCHLORPERAZINE MALEATE

## Prochlorperazini maleas

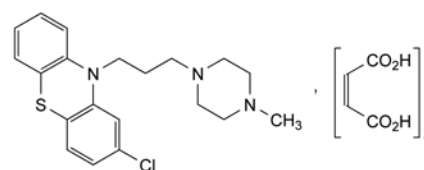

C<sub>28</sub>H<sub>32</sub>ClN<sub>3</sub>O<sub>8</sub>S  
[84-02-6]

M<sub>r</sub> 606

## DEFINITION

2-Chloro-10-[3-(4-methylpiperazin-1-yl)propyl]-10H-phenothiazine bis[hydrogen (*Z*)-butenedioate].

*Content*: 98.0 per cent to 101.0 per cent (dried substance).

## CHARACTERS

*Appearance*: white or pale-yellow, crystalline powder.

*Solubility*: very slightly soluble in water and in ethanol (96 per cent).

## IDENTIFICATION

*First identification*: B, C, D.

*Second identification*: A, C, D.

- A. Ultraviolet and visible absorption spectrophotometry (2.2.25). Carry out the identification test protected from light and measure the absorbances immediately.
- Test solution (a)*. Dissolve 50 mg in 0.1 M *hydrochloric acid* and dilute to 500.0 mL with the same acid.
- Test solution (b)*. Dilute 10.0 mL of test solution (a) to 100.0 mL with 0.1 M *hydrochloric acid*.
- Spectral range*: 280-350 nm for test solution (a); 230-280 nm for test solution (b).
- Absorption maximum*: at 305 nm for test solution (a); at 255 nm for test solution (b).
- Specific absorbance at the absorption maximum at 255 nm*: 525 to 575 for test solution (b).
- B. Infrared absorption spectrophotometry (2.2.24).
- Comparison*: *prochlorperazine maleate* CRS.
- C. Identification test for phenothiazines by thin-layer chromatography (2.3.3) with the following modifications.
- Test solution*. Dissolve 20 mg of the substance to be examined in a mixture of equal volumes of *methanol* R and *methylene chloride* R and dilute to 20 mL with the same mixture of solvents.
- Reference solution*. Dissolve 20 mg of *prochlorperazine maleate* CRS in a mixture of equal volumes of *methanol* R and *methylene chloride* R and dilute to 20 mL with the same mixture of solvents.
- Application*: 4 µL.
- D. Triturate 0.2 g with a mixture of 1 mL of *strong sodium hydroxide solution* R and 3 mL of *water* R. Shake with 3 quantities, each of 5 mL, of *ether* R. To 0.1 mL of the aqueous layer add a solution of 10 mg of *resorcinol* R in 3 mL of *sulfuric acid* R. Heat in a water-bath for 15 min. No colour develops. To the remainder of the aqueous layer add 2 mL of *bromine solution* R. Heat in a water-bath for 15 min and then heat to boiling. Cool. To 0.1 mL of the solution add a solution of 10 mg of *resorcinol* R in 3 mL of *sulfuric acid* R. Heat in a water-bath for 15 min. A blue colour develops.

## TESTS

**pH** (2.2.3): 3.0 to 4.0 for a freshly prepared saturated solution in *carbon dioxide-free water* R.

**Related substances.** Thin-layer chromatography (2.2.27). Carry out the test protected from light.

**Solvent mixture:** diethylamine R, methanol R (5:95 V/V).

**Test solution.** Dissolve 0.2 g of the substance to be examined in the solvent mixture and dilute to 10 mL with the solvent mixture. Prepare the solution immediately before use.

**Reference solution.** Dilute 1 mL of the test solution to 200 mL with the solvent mixture.

**Plate:** TLC silica gel GF<sub>254</sub> plate R.

**Mobile phase:** acetone R, diethylamine R, cyclohexane R (10:10:80 V/V/V).

**Application:** 10 µL.

**Development:** over 2/3 of the plate.

**Drying:** in air.

**Detection:** examine in ultraviolet light at 254 nm.

**Limit:** any spot, apart from the principal spot, is not more intense than the spot in the chromatogram obtained with the reference solution (0.5 per cent); disregard any spots remaining at the points of application.

**Loss on drying** (2.2.32): maximum 1.0 per cent, determined on 1.000 g by drying in an oven at 105 °C.

**Sulfated ash** (2.4.14): maximum 0.1 per cent, determined on 1.0 g.

#### ASSAY

Dissolve 0.200 g of the powdered substance to be examined in 50 mL of anhydrous acetic acid R, warming on a water-bath. Allow to cool to room temperature. Titrate with 0.1 M perchloric acid determining the end-point potentiometrically (2.2.20).

1 mL of 0.1 M perchloric acid is equivalent to 30.31 mg of C<sub>21</sub>H<sub>30</sub>ClN<sub>3</sub>O<sub>8</sub>S.

#### STORAGE

Protected from light.

01/2008:0429  
corrected 6.0

## PROGESTERONE

### Progesteronum

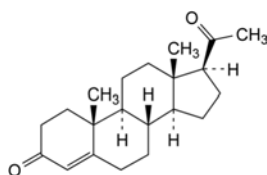

C<sub>21</sub>H<sub>30</sub>O<sub>2</sub>  
[57-83-0]

M<sub>r</sub> 314.5

#### DEFINITION

Pregn-4-ene-3,20-dione.

**Content:** 97.0 per cent to 103.0 per cent (dried substance).

#### CHARACTERS

**Appearance:** white or almost white, crystalline powder or colourless crystals.

**Solubility:** practically insoluble in water, freely soluble in ethanol, sparingly soluble in acetone and in fatty oils.

It shows polymorphism (5.9).

#### IDENTIFICATION

A. Infrared absorption spectrophotometry (2.2.24).

**Comparison:** progesterone CRS.

If the spectra obtained in the solid state show differences, dissolve the substance to be examined and the reference substance separately in ethanol R, evaporate to dryness and record new spectra using the residues.

B. Thin-layer chromatography (2.2.27)

**Test solution.** Dissolve 10 mg of the substance to be examined in a mixture of 1 volume of methanol R and 9 volumes of methylene chloride R and dilute to 10 mL with the same mixture of solvents.

**Reference solution.** Dissolve 10 mg of progesterone CRS in a mixture of 1 volume of methanol R and 9 volumes of methylene chloride R and dilute to 10 mL with the same mixture of solvents.

**Plate:** TLC silica gel F<sub>254</sub> plate R.

**Mobile phase:** ethyl acetate R, methylene chloride R (33:66 V/V).

**Application:** 5 µL.

**Development:** over 3/4 of the plate.

**Drying:** in air.

**Detection A:** examine in ultraviolet light at 254 nm.

**Detection B:** spray with alcoholic solution of sulfuric acid R, heat at 120 °C for 15 min and allow to cool. Examine in daylight and in ultraviolet light at 365 nm.

**Results A:** the principal spot in the chromatogram obtained with the test solution is similar in position, colour and size to the principal spot in the chromatogram obtained with the reference solution.

**Results B:** the principal spot in the chromatogram obtained with the test solution is similar in position, fluorescence in ultraviolet light at 365 nm and size to the principal spot in the chromatogram obtained with the reference solution.

#### TESTS

**Specific optical rotation** (2.2.7): + 186 to + 194 (dried substance).

Dissolve 0.250 g in ethanol R and dilute to 25.0 mL with the same solvent.

**Related substances.** Liquid chromatography (2.2.29).

**Test solution.** Dissolve 20.0 mg of the substance to be examined in methanol R and dilute to 50.0 mL with the same solvent.

**Reference solution (a).** Dissolve 2.0 mg of progesterone CRS and 2.0 mg of progesterone impurity C CRS in methanol R and dilute to 50.0 mL with the same solvent.

**Reference solution (b).** Dilute 1.0 mL of the test solution to 100.0 mL with methanol R.

**Column:**

– size: *l* = 0.15 m, Ø = 4.6 mm,

– stationary phase: spherical end-capped octadecylsilyl silica gel for chromatography R (5 µm).

**Mobile phase:**

– mobile phase A: water R,

– mobile phase B: acetonitrile R,

Time (min)	Mobile phase A (per cent V/V)	Mobile phase B (per cent V/V)
0 - 20	50	50
20 - 27	50 → 20	50 → 80
27 - 45	20	80
45 - 50	50	50

**Flow rate:** 0.8 mL/min.

**Detection:** spectrophotometer at 241 nm.

**Injection:** 10 µL.

**System suitability:** reference solution (a):

– resolution: minimum 1.5 between the peaks due to impurity C and to progesterone.

## Limits:

01/2008:2002  
corrected 6.0

- *any impurity*: not more than 0.5 times the area of the principal peak in the chromatogram obtained with reference solution (b) (0.5 per cent),
- *total*: not more than 0.8 times the area of the principal peak in the chromatogram obtained with reference solution (b) (0.8 per cent),
- *disregard limit*: 0.05 times the area of the principal peak in the chromatogram obtained with reference solution (b) (0.05 per cent).

**Loss on drying** (2.2.32): maximum 0.5 per cent, determined on 0.500 g by drying in an oven at 105 °C for 2 h.

## ASSAY

Dissolve 25.0 mg in *alcohol R* and dilute to 250.0 mL with the same solvent. Dilute 5.0 mL of the solution to 50.0 mL with *alcohol R*. Measure the absorbance (2.2.25) at the maximum at 241 nm.

Calculate the content of  $C_{21}H_{30}O_2$  taking the specific absorbance to be 535.

## STORAGE

Protected from light.

## IMPURITIES

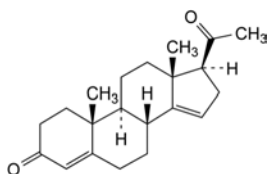

A. pregna-4,14-diene-3,20-dione,

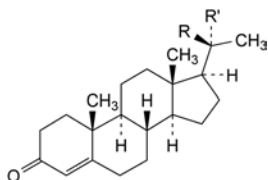

B. R = OH, R' = H: (20S)-20-hydroxypregn-4-en-3-one,

C. R = H, R' = OH: (20R)-20-hydroxypregn-4-en-3-one,

D. R = O-CO-CH<sub>3</sub>, R' = H: (20S)-3-oxopregn-4-en-20-yl acetate,

E. R = H, R' = O-CO-CH<sub>3</sub>: (20R)-3-oxopregn-4-en-20-yl acetate,

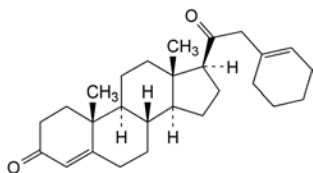

F. 21-(cyclohex-1-enyl)pregn-4-ene-3,20-dione,

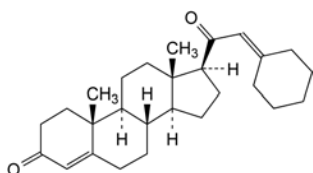

G. 21-(cyclohexylidene)pregn-4-ene-3,20-dione.

## PROGUANIL HYDROCHLORIDE

## Proguanili hydrochloridum

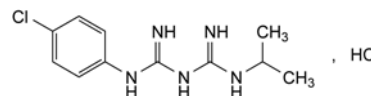

$C_{11}H_{17}Cl_2N_5$   
[637-32-1]

$M_r$  290.2

## DEFINITION

1-(4-Chlorophenyl)-5-(1-methylethyl)biguanide hydrochloride.

*Content*: 98.5 per cent to 101.0 per cent (dried substance).

## CHARACTERS

*Appearance*: white or almost white, crystalline powder.

*Solubility*: slightly soluble in water, sparingly soluble in ethanol, practically insoluble in methylene chloride.

## IDENTIFICATION

*First identification*: A, D.

*Second identification*: B, C, D.

A. Infrared absorption spectrophotometry (2.2.24).

*Comparison*: Ph. Eur. reference spectrum of proguanil hydrochloride.

B. Dissolve 0.4 g in 50 mL of *water R* (solution A). To 15 mL of solution A add 2 mL of *dilute sodium hydroxide solution R*. Extract with 20 mL of *ethyl acetate R*. Wash the organic layer with *water R*, evaporate to dryness and dry at 105 °C. The melting point (2.2.14) of the residue is 130 °C to 133 °C.

C. To 10 mL of solution A, add 1 drop of *copper sulfate solution R* and 2 mL of *dilute ammonia R1*. Add 5 mL of *toluene R* and stir. Allow to stand until separation of the layers is obtained. The upper layer is violet-red.

D. It gives reaction (a) of chlorides (2.3.1).

## TESTS

**Acidity or alkalinity.** To 35 mL of *water R* maintained at 60-65 °C, add 0.2 mL of *methyl red mixed solution R*. Neutralise to a grey colour with either 0.01 M *sodium hydroxide* or 0.01 M *hydrochloric acid*. Add 0.4 g of the substance to be examined and stir until completely dissolved. The solution is grey or green. Not more than 0.2 mL of 0.01 M *hydrochloric acid* is required to change the colour of the solution to reddish-violet.

**Chloroaniline:** maximum 250 ppm.

Dissolve 0.10 g in 1 mL of 2 M *hydrochloric acid R* and dilute to 20 mL with *water R*. Cool to 5 °C. Add 1 mL of a 3.45 g/L solution of *sodium nitrite R* and allow to stand at 5 °C for 5 min. Add 2 mL of a 50 g/L solution of *ammonium sulfamate R* and allow to stand for 10 min. Add 2 mL of *naphthylethylenediamine dihydrochloride solution R*, dilute to 50 mL with *water R* and allow to stand for 30 min. Any red colour produced is not more intense than that of a standard prepared at the same time and in the same manner, using 20 mL of a 1.25 mg/L solution of *chloroaniline R*.

**Related substances.** Liquid chromatography (2.2.29).

*Test solution.* Dissolve 10.0 mg of the substance to be examined in the mobile phase and dilute to 100.0 mL with the mobile phase.

*Reference solution (a).* Dilute 1.0 mL of the test solution to 50.0 mL with the mobile phase. Dilute 1.0 mL of this solution to 10.0 mL with the mobile phase.

*Reference solution (b).* Dissolve 5 mg of *proguanil impurity C CRS* in the mobile phase and dilute to 100 mL with the mobile phase. Dilute 0.1 mL to 10 mL with the mobile phase.

**Reference solution (c).** Dissolve 5 mg of *proguanil impurity D CRS* in the mobile phase and dilute to 100 mL with the mobile phase. Dilute 0.1 mL to 10 mL with the mobile phase.

**Reference solution (d).** Dilute 1 mL of the test solution to 200 mL with the mobile phase. To 1 mL add 1 mL of reference solution (c) and mix.

**Column:**

- **size:**  $l = 0.125$  m,  $\varnothing = 4.6$  mm,
- **stationary phase:** octadecylsilyl silica gel for chromatography R (5  $\mu$ m).

**Mobile phase:** dissolve 3.78 g of *sodium hexanesulfonate R* in a mixture of 10 volumes of *glacial acetic acid R*, 800 volumes of *water R* and 1200 volumes of *methanol R*.

**Flow rate:** 1 mL/min.

**Detection:** spectrophotometer at 230 nm and 254 nm.

**Injection:** 20  $\mu$ L.

**Run time:** 5 times the retention time of proguanil.

**Retention time:** proguanil = about 6 min.

**System suitability:** reference solution (d) at 230 nm:

- **resolution:** minimum 5 between the peaks due to impurity D and proguanil.

**Limits:**

- **impurity C:** not more than 3.5 times the area of the principal peak in the chromatogram obtained with reference solution (a) at 230 nm (0.7 per cent),
- **impurity D:** not more than the area of the principal peak in the chromatogram obtained with reference solution (a) at 230 nm (0.2 per cent),
- **any other impurity:** not more than 0.5 times the area of the principal peak in the chromatogram obtained with reference solution (a) at 230 nm and at 254 nm (0.1 per cent),
- **total:** the sum of the calculated percentage contents of known and unknown impurities is not greater than 1 per cent, considering each peak at the wavelength at which the peak shows the higher value,
- **disregard limit:** 0.25 times the area of the principal peak in the chromatogram obtained with reference solution (a) (0.05 per cent).

**Loss on drying (2.2.32):** maximum 0.5 per cent, determined on 1.000 g by drying in an oven at 105 °C.

**Sulfated ash (2.4.14):** maximum 0.1 per cent, determined on 1.0 g.

**ASSAY**

Suspend 0.100 g in 20 mL of *anhydrous acetic acid R*, shake and heat at 50 °C for 5 min. Cool to room temperature and add 40 mL of *acetic anhydride R*. Titrate with 0.1 M *perchloric acid*, determining the end-point potentiometrically (2.2.20).

1 mL of 0.1 M *perchloric acid* is equivalent to 14.51 mg of  $C_{11}H_{17}Cl_2N_5$ .

**STORAGE**

Protected from light.

**IMPURITIES**

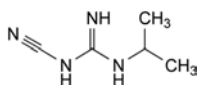

A. 1-cyano-3-(1-methylethyl)guanidine,

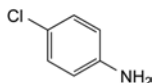

B. 4-chloroaniline,

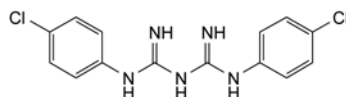

C. 1,5-bis(4-chlorophenyl)biguanide,

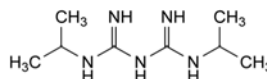

D. 1,5-bis(1-methylethyl)biguanide.

01/2008:0785  
corrected 6.0

## PROLINE

### Prolinum

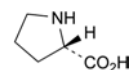

$C_5H_9NO_2$   
[147-85-3]

$M_r$  115.1

#### DEFINITION

Proline contains not less than 98.5 per cent and not more than the equivalent of 101.0 per cent of (S)-pyrrolidine-2-carboxylic acid, calculated with reference to the dried substance.

#### CHARACTERS

White or almost white, crystalline powder or colourless crystals, very soluble in water, freely soluble in alcohol.

#### IDENTIFICATION

**First identification:** A, B.

**Second identification:** A, C.

- Specific optical rotation (see Tests).
- Examine by infrared absorption spectrophotometry (2.2.24), comparing with the spectrum obtained with *proline CRS*. Examine the substances prepared as discs.
- Examine the chromatograms obtained in the test for ninhydrin-positive substances. The principal spot in the chromatogram obtained with test solution (b) is similar in position, colour and size to the principal spot in the chromatogram obtained with reference solution (a).

#### TESTS

**Solution S.** Dissolve 2.5 g in *distilled water R* and dilute to 50 mL with the same solvent.

**Appearance of solution.** Solution S is clear (2.2.1) and colourless (2.2.2, *Method II*).

**Specific optical rotation (2.2.7).** Dissolve 1.00 g in *water R* and dilute to 25.0 mL with the same solvent. The specific optical rotation is  $-84.0$  to  $-86.0$ , calculated with reference to the dried substance.

**Ninhydrin-positive substances.** Examine by thin-layer chromatography (2.2.27), using a *TLC silica gel plate R*.

**Test solution (a).** Dissolve 0.10 g of the substance to be examined in 0.1 M *hydrochloric acid* and dilute to 10 mL with the same acid.

**Test solution (b).** Dilute 1 mL of test solution (a) to 50 mL with *water R*.

**Reference solution (a).** Dissolve 10 mg of *proline CRS* in 0.1 M *hydrochloric acid* and dilute to 50 mL with the same acid.

**Reference solution (b).** Dilute 5 mL of test solution (b) to 20 mL with *water R*.

**Reference solution (c).** Dissolve 10 mg of *proline CRS* and 10 mg of *threonine CRS* in 0.1 M *hydrochloric acid* and dilute to 25 mL with the same acid.

Apply to the plate 5 µL of each solution. Allow the plate to dry in air. Develop over a path of 15 cm using a mixture of 20 volumes of *glacial acetic acid R*, 20 volumes of *water R* and 60 volumes of *butanol R*. Allow the plate to dry in air, spray with *ninhydrin solution R* and heat at 100 °C to 105 °C for 15 min. Any spot in the chromatogram obtained with test solution (a), apart from the principal spot, is not more intense than the spot in the chromatogram obtained with reference solution (b) (0.5 per cent). The test is not valid unless the chromatogram obtained with reference solution (c) shows two clearly separated spots.

**Chlorides** (2.4.4). Dilute 5 mL of solution S to 15 mL with *water R*. The solution complies with the limit test for chlorides (200 ppm).

**Sulfates** (2.4.13). Dilute 10 mL of solution S to 15 mL with *distilled water R*. The solution complies with the limit test for sulfates (300 ppm).

**Ammonium** (2.4.1). 50 mg complies with limit test B for ammonium (200 ppm). Prepare the standard using 0.1 mL of *ammonium standard solution (100 ppm NH<sub>4</sub>) R*.

**Iron** (2.4.9). In a separating funnel, dissolve 1.0 g in 10 mL of *dilute hydrochloric acid R*. Shake with three quantities, each of 10 mL, of *methyl isobutyl ketone R1*, shaking for 3 min each time. To the combined organic layers add 10 mL of *water R* and shake for 3 min. The aqueous layer complies with the limit test for iron (10 ppm).

**Heavy metals** (2.4.8). Dissolve 2.0 g in *water R* and dilute to 20 mL with the same solvent. 12 mL of the solution complies with limit test A for heavy metals (10 ppm). Prepare the standard using the *lead solution (1 ppm Pb) R*.

**Loss on drying** (2.2.32). Not more than 0.5 per cent, determined on 1.000 g by drying in an oven at 105 °C.

**Sulfated ash** (2.4.14). Not more than 0.1 per cent, determined on 1.0 g.

#### ASSAY

Dissolve 0.100 g in 3 mL of *anhydrous formic acid R*. Add 30 mL of *anhydrous acetic acid R*. Titrate with 0.1 M *perchloric acid* using 0.1 mL of *naphtholbenzein solution R* as indicator, until the colour changes from brownish-yellow to green.

1 mL of 0.1 M *perchloric acid* is equivalent to 11.51 mg of C<sub>17</sub>H<sub>21</sub>N<sub>2</sub>S.

#### STORAGE

Store protected from light.

01/2008:1365  
corrected 6.0

## PROMAZINE HYDROCHLORIDE

### Promazini hydrochloridum

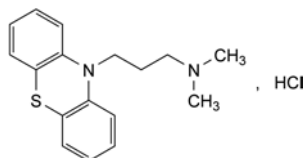

C<sub>17</sub>H<sub>21</sub>N<sub>2</sub>S  
[53-60-1]

*M<sub>r</sub>* 320.9

#### DEFINITION

Promazine hydrochloride contains not less than 99.0 per cent and not more than the equivalent of 101.0 per cent of 3-(10*H*-phenothiazin-10-yl)-*N,N*-dimethylpropan-1-amine hydrochloride, calculated with reference to the dried substance.

#### CHARACTERS

A white or almost white, crystalline powder, slightly hygroscopic, very soluble in water, in alcohol and in methylene chloride.

It melts at about 179 °C.

#### IDENTIFICATION

*First identification:* A, B, D.

*Second identification:* B, C, D.

A. Examine by infrared absorption spectrophotometry (2.2.24), comparing with the spectrum obtained with *promazine hydrochloride CRS*.

B. It complies with the identification test for phenothiazines by thin-layer chromatography (2.3.3). Use *promazine hydrochloride CRS* to prepare the reference solution.

C. Dissolve about 5 mg in 2 mL of *sulfuric acid R* and allow to stand for 5 min. An orange colour is produced.

D. It gives reaction (b) of chlorides (2.3.1).

#### TESTS

**pH** (2.2.3). Dissolve 0.5 g in *carbon dioxide-free water R* and dilute to 10 mL with the same solvent. The pH of the freshly prepared solution is 4.2 to 5.2.

**Related substances.** Carry out the test protected from bright light. Prepare the solutions immediately before use.

Examine by thin layer chromatography (2.2.27), using a *TLC silica gel F<sub>254</sub> plate R*.

*Test solution.* Dissolve 0.10 g of the substance to be examined in a mixture of 5 volumes of *diethylamine R* and 95 volumes of *methanol R* and dilute to 10 mL with the same mixture of solvents.

*Reference solution (a).* Dilute 1 mL of the test solution to 200 mL with a mixture of 5 volumes of *diethylamine R* and 95 volumes of *methanol R*.

*Reference solution (b).* Dissolve 10 mg of *chlorprothixene hydrochloride CRS* in a mixture of 5 volumes of *diethylamine R* and 95 volumes of *methanol R*, add 1 mL of the test solution and dilute to 10 mL with the same mixture of solvents.

Apply to the plate 10 µL of each solution. Develop over a path of 15 cm using a mixture of 10 volumes of *acetone R*, 10 volumes of *diethylamine R* and 80 volumes of *cyclohexane R*. Allow the plate to dry in air and examine in ultraviolet light at 254 nm. Any spot in the chromatogram obtained with the test solution, apart from the principal spot, is not more intense than the spot in the chromatogram obtained with the reference solution (a) (0.5 per cent). Disregard any spot at the point of application. The test is not valid unless the chromatogram obtained with reference solution (b) shows two clearly separated principal spots.

**Loss on drying** (2.2.32). Not more than 0.5 per cent, determined on 1.000 g by drying in an oven at 105 °C.

**Sulfated ash** (2.4.14). Not more than 0.1 per cent, determined on 1.0 g.

#### ASSAY

Dissolve 0.250 g in a mixture of 5.0 mL of 0.01 M *hydrochloric acid* and 50 mL of *alcohol R*. Carry out a potentiometric titration (2.2.20), using 0.1 M *sodium hydroxide*. Read the volume added between the two points of inflexion.

1 mL of 0.1 M *sodium hydroxide* is equivalent to 32.09 mg of C<sub>17</sub>H<sub>21</sub>N<sub>2</sub>S.

#### STORAGE

Store protected from light.

#### IMPURITIES

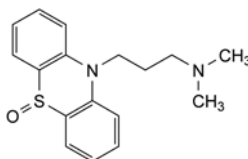

A. 3-(10*H*-phenothiazin-10-yl)-*N,N*-dimethylpropan-1-amine *S*-oxide (promazine sulfoxide).

01/2008:0524 *Mobile phase*: mix 20 volumes of *methanol R*, 30 volumes of *acetonitrile R* and 50 volumes of a 3.4 g/L solution of *potassium dihydrogen phosphate R* previously adjusted to pH 7.0 with *potassium hydroxide R*.

## PROMETHAZINE HYDROCHLORIDE

### Promethazini hydrochloridum

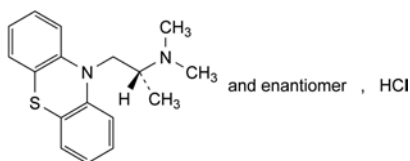

C<sub>17</sub>H<sub>21</sub>ClN<sub>2</sub>S  
[58-33-3]

M<sub>r</sub> 320.9

#### DEFINITION

(2*RS*)-*N,N*-Dimethyl-1-(10*H*-phenothiazin-10-yl)propan-2-amine hydrochloride.

*Content*: 99.0 per cent to 101.0 per cent (dried substance).

#### CHARACTERS

*Appearance*: white or faintly yellowish, crystalline powder.

*Solubility*: very soluble in water, freely soluble in ethanol (96 per cent) and in methylene chloride.

mp: about 222 °C, with decomposition.

#### IDENTIFICATION

*First identification*: A, B, D.

*Second identification*: B, C, D.

A. Infrared absorption spectrophotometry (2.2.24).

*Comparison*: *promethazine hydrochloride CRS*.

B. It complies with the identification test for phenothiazines by thin-layer chromatography (2.3.3): use *promethazine hydrochloride CRS* to prepare the reference solution.

C. Dissolve 0.1 g in 3 mL of *water R*. Add dropwise 1 mL of *nitric acid R*. A precipitate is formed which rapidly dissolves to give a red solution, becoming orange and then yellow. Heat to boiling. The solution becomes orange and an orange-red precipitate is formed.

D. It gives reaction (b) of chlorides (2.3.1).

#### TESTS

**pH** (2.2.3): 4.0 to 5.0, measured immediately after preparation.

Dissolve 1.0 g in *carbon dioxide-free water R* and dilute to 10 mL with the same solvent.

**Related substances**. Liquid chromatography (2.2.29). Carry out the test protected from light and use freshly prepared solutions.

*Solvent mixture*: *triethylamine R*, *methanol R* (1:1000 V/V).

*Test solution*. Dissolve 25.0 mg of the substance to be examined in the solvent mixture and dilute to 50.0 mL with the solvent mixture.

*Reference solution (a)*. Dissolve 2.5 mg of *promethazine for peak identification CRS* (containing impurities A, B and C) in the solvent mixture and dilute to 5 mL with the solvent mixture.

*Reference solution (b)*. Dilute 1.0 mL of the test solution to 100.0 mL with the solvent mixture. Dilute 1.0 mL of this solution to 10.0 mL with the solvent mixture.

*Reference solution (c)*. Dissolve 5.0 mg of *promethazine impurity D CRS* in the solvent mixture and dilute to 100.0 mL with the solvent mixture. Dilute 1 mL of this solution to 100 mL with the solvent mixture.

*Column*:

- *size*:  $l = 0.15$  m,  $\varnothing = 4.6$  mm;
- *stationary phase*: *end-capped octylsilyl silica gel for chromatography with polar incorporated groups R* (5  $\mu$ m).

*Flow rate*: 1.0 mL/min.

*Detection*: spectrophotometer at 254 nm.

*Injection*: 10  $\mu$ L.

*Run time*: 2.5 times the retention time of promethazine.

*Identification of impurities*: use the chromatogram supplied with *promethazine for peak identification CRS* and the chromatogram obtained with reference solution (a) to identify the peaks due to impurities A, B and C; use the chromatogram obtained with reference solution (c) to identify the peak due to impurity D.

*Relative retention* with reference to promethazine (retention time = about 18 min): impurity D = about 0.2; impurity C = about 0.5; impurity B = about 1.4; impurity A = about 1.8.

*System suitability*:

- *resolution*: minimum 2.0 between the peaks due to impurities B and A in the chromatogram obtained with reference solution (a);
- the chromatogram obtained with reference solution (a) is similar to the chromatogram supplied with *promethazine for peak identification CRS*.

*Limits*:

- *correction factor*: for the calculation of content, multiply the peak area of impurity A by 0.5;
- *impurity B*: not more than 8 times the area of the principal peak in the chromatogram obtained with reference solution (b) (0.8 per cent);
- *impurity C*: not more than twice the area of the principal peak in the chromatogram obtained with reference solution (b) (0.2 per cent);
- *impurity A*: not more than the area of the principal peak in the chromatogram obtained with reference solution (b) (0.1 per cent);
- *impurity D*: not more than the area of the corresponding peak in the chromatogram obtained with reference solution (c) (0.1 per cent);
- *unspecified impurities*: for each impurity, not more than the area of the principal peak in the chromatogram obtained with reference solution (b) (0.10 per cent);
- *total*: not more than 12 times the area of the principal peak in the chromatogram obtained with reference solution (b) (1.2 per cent);
- *disregard limit*: 0.5 times the area of the principal peak in the chromatogram obtained with reference solution (b) (0.05 per cent).

**Heavy metals** (2.4.8): maximum 10 ppm.

Dissolve 1.0 g in 5 mL of *water R*, then add 5 mL of *acetone R* and 5 mL of *buffer solution pH 3.5 R*. Carry out the prefiltration. The prefiltrate complies with test E. Prepare the reference solution using 5 mL of *lead standard solution (2 ppm Pb) R*.

**Loss on drying** (2.2.32): maximum 0.5 per cent, determined on 1.000 g by drying in an oven at 105 °C.

**Sulfated ash** (2.4.14): maximum 0.1 per cent, determined on 1.0 g.

#### ASSAY

Dissolve 0.250 g in a mixture of 5.0 mL of 0.01 M *hydrochloric acid* and 50 mL of *ethanol (96 per cent) R*. Carry out a potentiometric titration (2.2.20), using 0.1 M *sodium hydroxide*. Read the volume added between the 2 points of inflexion.

1 mL of 0.1 M *sodium hydroxide* is equivalent to 32.09 mg of C<sub>17</sub>H<sub>21</sub>ClN<sub>2</sub>S.

## STORAGE

Protected from light.

## IMPURITIES

Specified impurities: A, B, C, D.

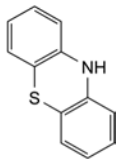

A. phenothiazine,

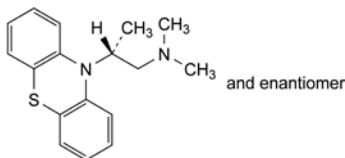

B. (2*RS*)-*N,N*-dimethyl-2-(10*H*-phenothiazin-10-yl)propan-1-amine (isopromethazine),

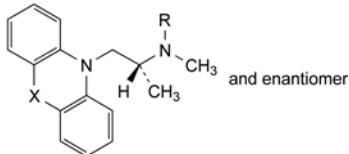

C. R = H, X = S: (2*RS*)-*N*-methyl-1-(10*H*-phenothiazin-10-yl)propan-2-amine,

D. R = CH<sub>3</sub>, X = SO: (2*RS*)-*N,N*-dimethyl-1-(10*H*-phenothiazin-10-yl)propan-2-amine *S*-oxide.

01/2008:1366  
corrected 6.0

## PROPACETAMOL HYDROCHLORIDE

## Propacetamoli hydrochloridum

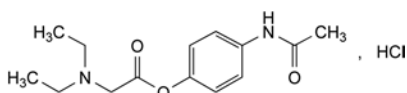

C<sub>14</sub>H<sub>21</sub>ClN<sub>2</sub>O<sub>3</sub>  
[66532-86-3]

*M<sub>r</sub>* 300.8

## DEFINITION

4-(Acetylamino)phenyl (diethylamino)acetate hydrochloride.

*Content*: 98.0 per cent to 102.0 per cent (dried substance).

## CHARACTERS

*Appearance*: white or almost white, crystalline powder.

*Solubility*: freely soluble in water, slightly soluble in anhydrous ethanol, practically insoluble in acetone.

## IDENTIFICATION

A. Infrared absorption spectrophotometry (2.2.24).

*Comparison*: Ph. Eur. reference spectrum of propacetamol hydrochloride.

B. It gives reaction (a) of chlorides (2.3.1).

## TESTS

**Solution S.** Prepare the solution immediately before use.

Dissolve 1.75 g in water *R* and dilute to 10.0 mL with the same solvent.

**Appearance of solution.** Solution S is clear (2.2.1) and not more intensely coloured than reference solution Y<sub>6</sub> or BY<sub>6</sub> (2.2.2, Method II).

**Absorbance** (2.2.25): maximum 0.05, determined at 390 nm on solution S.

**Impurity B.** Thin-layer chromatography (2.2.27).

*Test solution.* Suspend 4.00 g of the substance to be examined in 8 mL of acetonitrile *R*. Shake for 30 min and filter. Dilute to 10 mL with acetonitrile *R*.

*Reference solution (a).* Dissolve 25 mg of 4-aminophenol *R* (impurity B) in acetonitrile *R* and dilute to 50 mL with the same solvent. Dilute 10 mL of this solution to 50 mL with acetonitrile *R*.

*Reference solution (b).* Dilute 5 mL of reference solution (a) to 50 mL with acetonitrile *R*.

*Reference solution (c).* Dilute 0.2 mL of reference solution (a) to 5 mL with the test solution.

*Plate*: TLC silica gel F<sub>254</sub> plate *R*.

*Mobile phase*: anhydrous formic acid *R*, water *R*, methanol *R*, methylene chloride *R* (3:4:30:64 V/V/V/V).

*Application*: 50 µL of the test solution and of reference solutions (b) and (c).

*Development*: over a path of 15 cm.

*Drying*: in air.

*Detection*: examine in ultraviolet light at 254 nm. Spray with a 10 g/L solution of dimethylaminobenzaldehyde *R* in ethanol (96 per cent) *R*.

*Identification of spots*: reference solution (c) shows 2 spots, one visible in ultraviolet light due to propacetamol and the other one yellow, visible after spraying due to impurity B. An additional spot may appear in ultraviolet light and corresponds to impurity A.

*System suitability*: reference solution (c):

– the chromatogram shows 2 clearly separated spots.

*Limit*:

– *impurity B*: any yellow spot due to impurity B not visible in ultraviolet light is not more intense than the corresponding spot in the chromatogram obtained with reference solution (b) (25 ppm).

**Related substances.** Liquid chromatography (2.2.29).

*Solution A.* Dissolve 2.16 g of sodium octanesulfonate *R* in 900 mL of water *R* and dilute to 1000 mL with the same solvent. Adjust to pH 3.0 with acetic acid *R*.

*Test solution.* Suspend 1.00 g of the substance to be examined in 10.0 mL of acetonitrile *R*. Shake for 10 min. Allow to stand. Take 3.0 mL of the supernatant solution and dilute to 10.0 mL with solution A. Inject immediately.

*Reference solution (a).* Dissolve 50 mg of paracetamol *R* (impurity A) in acetonitrile *R* and dilute to 50.0 mL with the same solvent. Dilute 1.0 mL of the solution to 50.0 mL with acetonitrile *R*. Dilute 3.0 mL of this solution to 10.0 mL with solution A.

*Reference solution (b).* Dissolve 10 mg of paracetamol *R* (impurity A) and 0.100 g of 4-aminophenol *R* (impurity B) in acetonitrile *R* and dilute to 50.0 mL with the same solvent. Dilute 1.0 mL of the solution to 50.0 mL with acetonitrile *R*. Dilute 3.0 mL of this solution to 10.0 mL with solution A.

*Column*:

– *size*: *l* = 0.25 m, Ø = 4.6 mm;

– *stationary phase*: octadecylsilyl silica gel for chromatography *R* (5 µm).

*Mobile phase*: acetonitrile *R*, solution A (30:70 V/V).

*Flow rate*: 1 mL/min.

*Detection*: spectrophotometer at 246 nm.

*Injection*: 20 µL.

*Run time*: twice the retention time of propacetamol.

*Identification of impurities*: the chromatogram obtained with reference solution (b) shows a peak due to impurity A (1<sup>st</sup> peak) and a peak due to impurity B (2<sup>nd</sup> peak).

*Relative retention* with reference to impurity A: impurity B = about 1.6.

**Limits:**

- *impurity A*: not more than the area of the corresponding peak in the chromatogram obtained with reference solution (a) (200 ppm);
- *unspecified impurities*: for each impurity, not more than 3.2 times the area of the principal peak in the chromatogram obtained with reference solution (a) (0.10 per cent taking into account the response factor of paracetamol of 1.6);
- *total*: not more than 6.4 times the area of the principal peak in the chromatogram obtained with reference solution (a) (0.2 per cent taking into account the relative response factor of paracetamol of 1.6);
- *disregard limit*: 0.01 times the area of the principal peak in the chromatogram obtained with reference solution (a) (3 ppm taking into account the relative response factor of paracetamol of 1.6).

**Methanol.** Gas chromatography (2.2.28).

*Internal standard solution.* Dilute 2.0 mL of *propanol R* to 20.0 mL with *water R*. Dilute 1.0 mL of the solution to 25.0 mL with *water R*. Dilute 1.0 mL of this solution to 25.0 mL with *water R*.

*Test solution.* Dissolve 2.00 g of the substance to be examined in *water R*, add 2.0 mL of the internal standard solution and dilute to 10.0 mL with *water R*.

*Reference solution.* Dilute 0.8 mL of *methanol R* to 50.0 mL with *water R*. Dilute 1.0 mL of the solution to 25.0 mL with *water R*. To 2.0 mL of this solution, add 2.0 mL of the internal standard solution and dilute to 10.0 mL with *water R*.

**Column:**

- *material*: glass;
- *size*:  $l = 2$  m,  $\varnothing = 2$  mm;
- *stationary phase*: carbon molecular sieve impregnated with 0.2 per cent of macrogel 1500.

*Carrier gas*: nitrogen for chromatography R.

**Temperature:**

	Time (min)	Temperature (°C)
Column	0 - 1.5	60
	1.5 - 5.5	60 → 80
	5.5 - 15.5	80
Injection port		170
Detector		220

*Detection*: flame ionisation.

*Injection*: 2 µL.

**Limit:**

- *methanol*: calculate the ratio (*R*) of the area of the peak due to methanol to the area of the peak due to the internal standard from the chromatogram obtained with the reference solution; from the chromatogram obtained with the test solution, calculate the ratio of the area of any peak due to methanol to the area of the peak due to the internal standard: this ratio is not greater than *R* (500 ppm).

**Heavy metals** (2.4.8): maximum 10 ppm.

Dissolve 2.0 g in *water R* and dilute to 20 mL with the same solvent. 12 mL of the solution complies with test A. Prepare the reference solution using *lead standard solution 1 ppm (Pb) R*.

**Loss on drying** (2.2.32): maximum 0.5 per cent, determined on 1.000 g by drying in an oven at 105 °C for 3 h.

**Sulfated ash** (2.4.14): maximum 0.1 per cent, determined on 1.0 g.

**ASSAY**

Dissolve 0.250 g in a mixture of 25 mL of *anhydrous acetic acid R* and 25 mL of *acetic anhydride R*. Titrate with 0.1 M *perchloric acid*, determining the end-point potentiometrically (2.2.20).

1 mL of 0.1 M *perchloric acid* is equivalent to 30.08 mg of  $C_{14}H_{21}ClN_2O_3$ .

**STORAGE**

Protected from humidity.

**IMPURITIES**

*Specified impurities: A, B.*

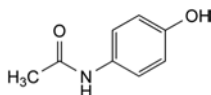

A. *N*-(4-hydroxyphenyl)acetamide (paracetamol),

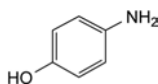

B. 4-aminophenol.

01/2008:2103  
corrected 7.0

## PROPAFENONE HYDROCHLORIDE

### Propafenoni hydrochloridum

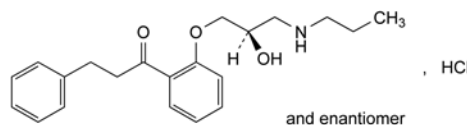

$C_{21}H_{28}ClNO_3$   
[34183-22-7]

$M_r$  377.9

**DEFINITION**

1-[2-[(2*RS*)-2-Hydroxy-3-(propylamino)propoxy]phenyl]-3-phenylpropan-1-one hydrochloride.

*Content*: 99.0 per cent to 101.0 per cent (dried substance).

**CHARACTERS**

*Appearance*: colourless crystals or white or almost white powder.

*Solubility*: slightly soluble in cold water, soluble in methanol and in hot water, practically insoluble in ethanol (96 per cent). mp: about 173 °C.

**IDENTIFICATION**

A. Infrared absorption spectrophotometry (2.2.24).

*Comparison*: *propafenone hydrochloride CRS*.

B. To 5.0 mL of solution S (see Tests) add 2 drops of *dilute nitric acid R*. A precipitate is formed. After 10 min, filter. 2.0 mL of the clear filtrate gives reaction (a) of chlorides (2.3.1).

**TESTS**

**Solution S.** To 0.500 g in a 100 mL volumetric flask add 50 mL of *water R*, and heat to boiling for 5 min. Allow to cool to room temperature and dilute to 100.0 mL with *carbon dioxide free water R*.

**Appearance of solution.** Solution S is not more opalescent than reference suspension II (2.2.1) and is colourless (2.2.2, *Method II*).

**pH** (2.2.3): 5.0 to 6.2 for solution S.

**Optical rotation** (2.2.7):  $-0.05^\circ$  to  $+0.05^\circ$ .

Dissolve 1.00 g in *methanol R* and dilute to 100.0 mL with the same solvent.



**Related substances.** Liquid chromatography (2.2.29).

**Solvent mixture:** mobile phase B, mobile phase A (35:65 V/V).

**Test solution.** Dissolve 50.0 mg of the substance to be examined in the solvent mixture and dilute to 50.0 mL with the solvent mixture.

**Reference solution (a).** Dilute 1.0 mL of the test solution to 100.0 mL with the solvent mixture. Dilute 1.0 mL of this solution to 10.0 mL with the solvent mixture.

**Reference solution (b).** Dilute 1.0 mL of reference solution (a) to 10.0 mL with the solvent mixture.

**Reference solution (c).** Dissolve 5.0 mg of the substance to be examined and 5.0 mg of *propafenone impurity B CRS* in the solvent mixture and dilute to 50.0 mL with the solvent mixture.

**Column:**

- size:  $l = 0.15$  m,  $\varnothing = 4.6$  mm,
- stationary phase: end-capped octylsilyl silica gel for chromatography R (5  $\mu$ m) with a specific surface area of 320-350 m<sup>2</sup>/g and a pore size of 12-13 nm,
- temperature: 30 °C.

**Mobile phase:**

- mobile phase A: 3.42 g/L solution of dipotassium hydrogen phosphate trihydrate R adjusted to pH 2.5 with phosphoric acid R,
- mobile phase B: acetonitrile for chromatography R,

Time (min)	Mobile phase A (per cent V/V)	Mobile phase B (per cent V/V)
0 - 8	65	35
8 - 20	65 → 30	35 → 70
20 - 30	30	70

**Flow rate:** 1.0 mL/min.

**Detection:** spectrophotometer at 220 nm.

**Equilibration:** 60 min with the mobile phase at the initial composition, before each series of injections.

**Injection:** 20  $\mu$ L of the test solution, reference solutions (a), (b) and (c) and of the solvent mixture as a blank.

**Relative retention** with reference to propafenone (retention time = about 5 min): impurity B = about 0.8; impurity D = about 2.3; impurity G = about 3.6; impurity C = about 4.1; impurity F = about 5.3.

**System suitability:** reference solution (c):

- resolution: minimum 3.0 between the peaks due to impurity B and propafenone.

**Limits:**

- impurities B, C, D, F, G: for each impurity, not more than the area of the principal peak in the chromatogram obtained with reference solution (a) (0.1 per cent),
- any other impurity: for each impurity, not more than the area of the principal peak in the chromatogram obtained with reference solution (a) (0.1 per cent),
- total: not more than 3 times the area of the principal peak in the chromatogram obtained with reference solution (a) (0.3 per cent),
- disregard limit: 3 times the area of the principal peak in the chromatogram obtained with reference solution (b) (0.03 per cent).

**Heavy metals** (2.4.8): maximum 10 ppm.

Dissolve 2.0 g in a mixture of 0.4 mL of *acetic acid R* and 15.0 mL of *water R*, heating on a water-bath. To the warm solution add 3 mL of *buffer solution pH 3.5 R*. After cooling to room temperature, filter through a sintered-glass filter (40) (2.1.2) and rinse with *water R* until 20.0 mL of filtrate is obtained. 12.0 mL of the filtrate complies with limit test A. Prepare the reference solution using *lead standard solution (1 ppm Pb) R*.

**Loss on drying** (2.2.32): maximum 0.5 per cent, determined on 1.000 g by drying in an oven at 105 °C.

**Sulfated ash** (2.4.14): maximum 0.1 per cent, determined on 1.0 g.

**ASSAY**

*In order to avoid overheating during the titration, mix thoroughly throughout and stop the titration immediately after the end-point has been reached.*

Dissolve 0.300 g in 2 mL of *anhydrous formic acid R*. Add 50 mL of *acetic anhydride R*. Titrate with 0.1 M *perchloric acid*, determining the end-point potentiometrically (2.2.20). Carry out a blank titration.

1 mL of 0.1 M *perchloric acid* is equivalent to 37.79 mg of C<sub>21</sub>H<sub>28</sub>ClNO<sub>3</sub>.

**IMPURITIES**

**Specified impurities:** B, C, D, F, G.

**Other detectable impurities** (the following substances would, if present at a sufficient level, be detected by one or other of the tests in the monograph. They are limited by the general acceptance criterion for other/unspecified impurities and/or by the general monograph *Substances for pharmaceutical use (2034)*. It is therefore not necessary to identify these impurities for demonstration of compliance. See also 5.10. *Control of impurities in substances for pharmaceutical use*): A, E, H.

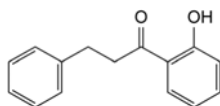

A. 1-(2-hydroxyphenyl)-3-phenylpropan-1-one,

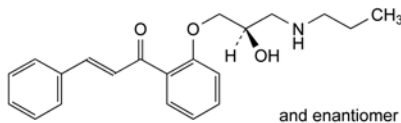

B. (2E)-1-[2-[(2RS)-2-hydroxy-3-(propylamino)propoxy]phenyl]-3-phenylprop-2-en-1-one,

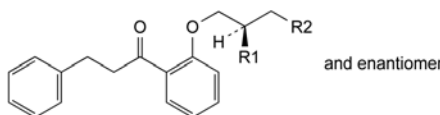

C. R1 + R2 = O: 1-[2-[(2RS)-oxiranyl]methoxy]phenyl]-3-phenylpropan-1-one,

D. R1 = R2 = OH: 1-[2-[(2RS)-2,3-dihydroxypropoxy]phenyl]-3-phenylpropan-1-one,

E. R1 = OH, R2 = Cl: 1-[2-[(2RS)-3-chloro-2-hydroxypropoxy]phenyl]-3-phenylpropan-1-one,

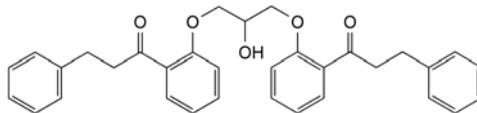

F. 1,1'-[2-hydroxypropane-1,3-diylbis(oxy-2,1-phenylene)]bis(3-phenylpropan-1-one),

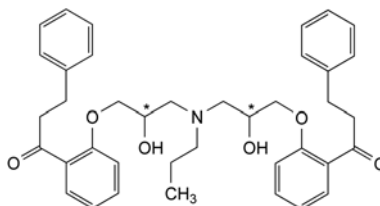

G. 1,1'-[propyliminobis[(2-hydroxypropane-3,1-diyl)oxy-2,1-phenylene]]bis(3-phenylpropan-1-one),

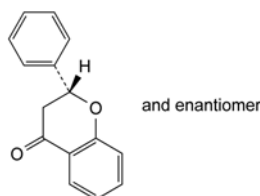

H. (2*RS*)-2-phenyl-2,3-dihydro-4*H*-1-benzopyran-4-one.

01/2008:2036

## PROPANOL

### Propanolum

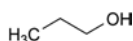

C<sub>3</sub>H<sub>8</sub>O  
[71-23-8]

*M*<sub>r</sub> 60.1

#### DEFINITION

Propan-1-ol.

#### CHARACTERS

*Appearance*: clear, colourless liquid.

*Solubility*: miscible with water and with ethanol.

#### IDENTIFICATION

*First identification*: C, B.

*Second identification*: A, B, D.

A. Refractive index (2.2.6): 1.384 to 1.387.

B. Boiling point (2.2.12): 96 °C to 98 °C.

C. Infrared absorption spectrophotometry (2.2.24).

*Comparison*: Ph. Eur. reference spectrum of propanol.

D. To 1.0 mL add 0.10 g of *dinitrobenzoyl chloride R* and 0.05 mL of *sulfuric acid R*. Boil under reflux for 30 min. Evaporate until the excess of propanol is removed, add 5 mL of *heptane R* to the residue and heat to boiling. Filter the hot solution. Wash the crystals formed on cooling with *heptane R* and dry in vacuum (2 kPa, at room temperature for 24 h). The small, colourless, shiny plates melt (2.2.14) between 71 °C and 74 °C.

#### TESTS

**Solution S.** Dissolve the residue obtained in the test for non-volatile matter in 1 mL of 1 *M* hydrochloric acid and dilute to 50.0 mL with *water R*.

**Appearance.** The substance to be examined is clear (2.2.1) and colourless (2.2.2, *Method II*). Dilute 2 mL to 10 mL with *water R*. After 5 min, the solution is clear (2.2.1).

**Acidity or alkalinity.** To 10.0 mL of *carbon dioxide-free water R* add 0.1 mL of *phenolphthalein solution R* and 0.01 *M* sodium hydroxide until the solution becomes pale pink. After addition of 5.0 mL of the substance to be examined the colour of the solution does not become more intense. If the colour fades, add 0.2 mL of 0.01 *M* sodium hydroxide. The solution is pink.

**Absorbance** (2.2.25). Measure the absorbance between 230 nm and 310 nm using *water R* as the compensation liquid. The absorbance *A* is not greater than the following values.

Wavelength (nm)	Absorbance <i>A</i>
230	0.300
250	0.100
270	0.030
290	0.020
310	0.010

The absorption curve does not show any peaks.

**Reducing substances.** Place 10.0 mL in a test tube of about 20 mm in diameter in a water bath at 20 °C. Keep protected from actinic light and add 1.0 mL of a freshly prepared 0.16 g/L solution of *potassium permanganate R*. The mixture, maintained at 20 °C, slowly changes its colour from violet to red. After 30 min, the test solution is not less intensely coloured (2.2.2, *Method II*) than 10.0 mL of a reference solution prepared as follows: to 5.5 mL of primary solution yellow, add 13.0 mL of primary solution red and dilute to 100.0 mL with *water R*.

**Related substances.** Gas chromatography (2.2.28).

*Test solution.* The substance to be examined.

*Reference solution (a).* Dilute 1.0 mL of the test solution to 100.0 mL with *heptane R*. Dilute 1.0 mL of the solution to 10.0 mL with *heptane R*.

*Reference solution (b).* Mix 0.1 mL of *acetone R* with 0.1 mL of 2-propanol *R* and dilute to 100 mL with the test solution.

*Column*:

- *material*: fused silica,
- *size*: *l* = 30 m, Ø = 0.25 mm,
- *stationary phase*: poly[(cyanopropyl)(phenyl)][dimethyl]siloxane *R* (film thickness 1.4 µm).

*Carrier gas*: helium for chromatography *R*.

*Linear velocity*: 25 cm/s.

*Split ratio*: 1:200.

*Temperature*:

	Time (min)	Temperature (°C)
Column	0 - 12	40
	12 - 28	40 → 200
	28 - 38	200
Injection port		240
Detector		240

*Detection*: flame ionisation.

*Injection*: 1 µL.

*System suitability*: reference solution (b):

- *resolution*: minimum 2.0 between the peaks due to impurity D and impurity E.

*Limits*:

- *any impurity*: not more than the area of the peak due to propanol in the chromatogram obtained with reference solution (a) (0.1 per cent),
- *total*: not more than 3 times the area of the peak due to propanol in the chromatogram obtained with reference solution (a) (0.3 per cent),
- *disregard limit*: 0.1 times the area of the peak due to propanol in the chromatogram obtained with reference solution (a) (0.01 per cent).

**Non-volatile matter**: maximum 0.004 per cent.

Evaporate 50 mL of the substance to be examined to dryness at 100 °C and dry the residue in an oven at 100-105 °C to constant mass. The residue weighs a maximum of 2 mg. The residue is used for the preparation of solution S.

**Water** (2.5.12): maximum 0.2 per cent, determined on 10 g.

#### STORAGE

Protected from light.

#### IMPURITIES

H<sub>3</sub>C–OH

A. methanol,

H<sub>3</sub>C–CH<sub>2</sub>–OH

B. ethanol,



C. propanal,

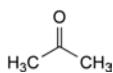

D. propanone (acetone),

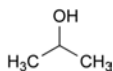

E. isopropyl alcohol (2-propanol),

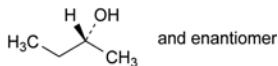
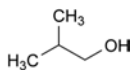
F. butan-2-ol (*sec*-butanol),

G. 2-methylpropan-1-ol (isobutanol),

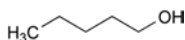
H. butan-1-ol (*n*-butanol),I. pentan-1-ol (*n*-pentanol),J. hexan-1-ol (*n*-hexanol).

- B. Dissolve 0.2 g in 15 mL of *water R* and add 1 mL of *strong sodium hydroxide solution R*. Boil for 2 min and cool slightly. Add 7.5 mL of *dilute hydrochloric acid R* and filter. Wash the residue with *water R* and recrystallise from *ethanol (50 per cent V/V) R*. Dry at 100-105 °C for 1 h. Dissolve about 10 mg of the residue in 5 mL of *sulfuric acid R*. The solution has an intense yellow colour and shows an intense yellowish-green fluorescence when examined in ultraviolet light at 365 nm.
- C. Dissolve 50 mg in 0.1 mL of *water R* in a 25 mL flask and add 1 mL of a saturated solution of *potassium permanganate R*. Attach a fractionating column and a condenser, with the end of the delivery tube immersed in 1 mL of *water R* in a test-tube placed in a bath of iced water. Distil fairly vigorously and continue heating for 1 min after a dry residue has been obtained in the flask. Prepare a blank by introducing into an identical test-tube a volume of *water R* equal to that of the distillate. Place the tubes in a bath of iced water. To each tube, add 0.5 mL of a 20 per cent V/V solution of *morpholine R* and 0.5 mL of a freshly prepared 50 g/L solution of *sodium nitroprusside R*. Mix and allow to stand at 0 °C for 5 min, and then at room temperature for 3 min. No blue colour develops in either tube. Add 1 g of *ammonium sulfate R*, mix and allow to stand for 15 min. A stable, intense pink colour develops in the test solution. A brownish-yellow colour develops in the blank.
- D. It gives reaction (a) of bromides (2.3.1).

## TESTS

**Appearance of solution.** The solution is clear (2.2.1).

Dissolve 0.6 g in *water R* and dilute to 20 mL with the same solvent.

**Related substances.** Liquid chromatography (2.2.29).

*Solvent mixture:* acetonitrile *R*, *water R* (40:60 V/V).

*Test solution (a).* Dissolve 6 mg of the substance to be examined in the solvent mixture and dilute to 50 mL with the solvent mixture.

*Test solution (b).* Dissolve 6 mg of the substance to be examined in 30 mL of the solvent mixture. Add 5 mL of reference solution (b) and dilute to 50 mL with the solvent mixture.

*Test solution (c).* Dissolve 6 mg of *xanthydrolyl R1* and 6 mg of the substance to be examined in the solvent mixture, then dilute to 50 mL with the solvent mixture.

*Reference solution (a).* Dissolve 6 mg of *xanthydrolyl R1* in the solvent mixture and dilute to 50 mL with the solvent mixture.

*Reference solution (b).* Dilute 5 mL of reference solution (a) to 50 mL with the solvent mixture.

*Column:*

- size:  $l = 0.25$  m,  $\varnothing = 4.6$  mm;
- stationary phase: octadecylsilyl silica gel for chromatography *R* (5  $\mu\text{m}$ ).

*Mobile phase:* mixture of equal volumes of acetonitrile *R* and of a solution containing 28 g/L of sodium perchlorate *R* and 11 g/L of phosphoric acid *R*, adjusted to pH 3.8 with strong sodium hydroxide solution *R* and then with 0.1 M sodium hydroxide.

*Flow rate:* 1 mL/min.

*Detection:* spectrophotometer at 206 nm.

*Injection:* 20  $\mu\text{L}$  of test solutions (a), (b), (c) and reference solution (a).

*Run time:* twice the retention time of proprantheline.

*System suitability:* test solution (c):

- in the chromatogram obtained with test solution (a), there is no peak corresponding to the principal peak in the chromatogram obtained with reference solution (a);
- resolution: minimum 8.0 between the peaks due to proprantheline and xanthydrolyl.

01/2008:0857  
corrected 6.0

## PROPRANTHELIN BROMIDE

### Propranthelini bromidum

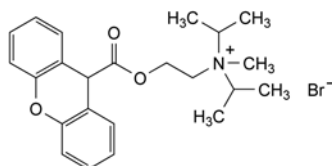

$\text{C}_{23}\text{H}_{30}\text{BrNO}_3$   
[50-34-0]

$M_r$  448.4

## DEFINITION

*N*-Methyl-*N,N*-bis(1-methylethyl)-2-[(9*H*-xanthen-9-ylcarbonyl)oxy]ethanaminium bromide.

*Content:* 98.5 per cent to 101.0 per cent (dried substance).

## CHARACTERS

*Appearance:* white or yellowish-white, slightly hygroscopic powder.

*Solubility:* very soluble in water, in ethanol (96 per cent) and in methylene chloride.

## IDENTIFICATION

A. Ultraviolet and visible absorption spectrophotometry (2.2.25).

*Test solution.* Dissolve 60 mg in *methanol R* and dilute to 100.0 mL with the same solvent. Dilute 10.0 mL of this solution to 100.0 mL with *methanol R*.

*Spectral range:* 230-350 nm.

*Absorption maxima:* at 246 nm and 282 nm.

*Specific absorbance at the absorption maxima:*

- at 246 nm: 115 to 125;
- at 282 nm: 57 to 63.

*Limits:* test solution (b):

- *any impurity:* for each impurity, not more than the area of the peak due to xanthidrol (1.0 per cent), and not more than one such peak has an area greater than or equal to 0.5 times the area of the peak due to xanthidrol (0.5 per cent);
- *disregard limit:* disregard any peak with a retention time relative to propantheline of less than 0.2 (bromide); disregard the peak due to xanthidrol.

**Loss on drying** (2.2.32): maximum 1.0 per cent, determined on 1.000 g by drying in an oven at 105 °C.

**Sulfated ash** (2.4.14): maximum 0.1 per cent, determined on 1.0 g.

#### ASSAY

Dissolve 0.400 g in 50 mL of *acetic anhydride R*. Titrate with 0.1 M *perchloric acid*, determining the end-point potentiometrically (2.2.20).

1 mL of 0.1 M *perchloric acid* corresponds to 44.84 mg of C<sub>23</sub>H<sub>30</sub>BrNO<sub>3</sub>.

#### STORAGE

In an airtight container.

01/2008:1558

## PROPOFOL

### Propofolum

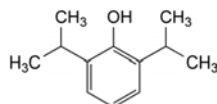

C<sub>12</sub>H<sub>18</sub>O  
[2078-54-8]

M<sub>r</sub> 178.3

#### DEFINITION

2,6-Bis(1-methylethyl)phenol.

*Content:* 98.0 per cent to 102.0 per cent.

This monograph applies to propofol prepared using distillation for purification.

#### CHARACTERS

*Appearance:* colourless or very light yellow, clear liquid.

*Solubility:* very slightly soluble in water, miscible with hexane and with methanol.

#### IDENTIFICATION

Infrared absorption spectrophotometry (2.2.24).

*Comparison:* propofol CRS.

#### TESTS

**Refractive index** (2.2.6): 1.5125 to 1.5145.

**Related substances.** Liquid chromatography (2.2.29).

*Test solution (a).* Dissolve 1.00 g of the substance to be examined in *hexane R* and dilute to 10.0 mL with the same solvent.

*Test solution (b).* Dissolve 0.240 g of the substance to be examined in *hexane R* and dilute to 100.0 mL with the same solvent.

*Reference solution (a).* Dissolve 5 µL of the substance to be examined and 15 µL of *propofol impurity J CRS* in *hexane R* and dilute to 50.0 mL with the same solvent.

*Reference solution (b).* Dilute 0.1 mL of *propofol for peak identification CRS* (containing impurities E and G) to 1.0 mL with *hexane R*.

*Reference solution (c).* Dilute 1.0 mL of test solution (a) to 100.0 mL with *hexane R*. Dilute 1.0 mL of this solution to 10.0 mL with *hexane R*.

*Reference solution (d).* Dissolve 0.240 g of *propofol CRS* in *hexane R* and dilute to 100.0 mL with the same solvent.

#### Column:

- *size:* l = 0.20 m, Ø = 4.6 mm;
- *stationary phase:* silica gel for chromatography R (5 µm).

*Mobile phase:* *anhydrous ethanol R*, *acetonitrile R*, *hexane R* (1.0:7.5:99.0 V/V/V).

*Flow rate:* 2.0 mL/min.

*Detection:* spectrophotometer at 275 nm.

*Injection:* 10 µL of test solution (a) and reference solutions (a), (b) and (c).

*Run time:* 7 times the retention time of propofol.

*Identification of impurities:* use the chromatogram obtained with reference solution (b) to identify the peaks due to impurities G and E.

*Relative retention* with reference to propofol (retention time = about 3 min): impurity G = about 0.5; impurity I = about 0.6; impurity B = about 0.7; impurity N = about 2.3; impurity D = about 2.5; impurity P = about 2.9; impurity A = about 3.0; impurity C = about 3.4; impurity E = about 4.0; impurity F = about 5.8; impurity H = about 6.4.

*System suitability:* reference solution (a):

- *resolution:* minimum 4.0 between the peaks due to impurity J and propofol.

#### Limits:

- *correction factors:* for the calculation of content, multiply the peak areas of the following impurities by the corresponding correction factor: impurity E = 0.25; impurity G = 5.0;
- *impurity G:* not more than twice the area of the peak due to propofol in the chromatogram obtained with reference solution (c) (0.2 per cent);
- *impurity E:* not more than 0.1 times the area of the peak due to propofol in the chromatogram obtained with reference solution (c) (0.01 per cent);
- *unspecified impurities:* for each impurity, not more than 0.5 times the area of the peak due to propofol in the chromatogram obtained with reference solution (c) (0.05 per cent);
- *total:* not more than 3 times the area of the peak due to propofol in the chromatogram obtained with reference solution (c) (0.3 per cent);
- *disregard limit:* 0.3 times the area of the peak due to propofol in the chromatogram obtained with reference solution (c) (0.03 per cent), except for impurity E.

**Impurities J, K, L and O.** Gas chromatography (2.2.28).

*Test solution.* Dissolve 40.0 mg of the substance to be examined in *methylene chloride R* and dilute to 10.0 mL with the same solvent.

*Reference solution (a).* Dilute 1.0 mL of the test solution to 100.0 mL with *methylene chloride R*. Dilute 1.0 mL of this solution to 10.0 mL with *methylene chloride R*.

*Reference solution (b).* Dissolve 5 µL of *propofol impurity J CRS* (corresponding to 5 mg) in *methylene chloride R* and dilute to 100 mL with the same solvent. Dilute 1.0 mL of this solution to 25 mL with *methylene chloride R*.

*Reference solution (c).* Dissolve 4 mg of *propofol CRS* in reference solution (b) and dilute to 1 mL with the same solution.

#### Column:

- *material:* fused silica;
- *size:* l = 30 m, Ø = 0.32 mm;
- *stationary phase:* polymethylphenylsiloxane R (film thickness 0.5 µm).

*Carrier gas:* helium for chromatography R.

*Flow rate:* 1.7 mL/min.

*Split ratio:* 1:5.

## Temperature:

	Time (min)	Temperature (°C)
Column	0 - 3	80
	3 - 25	80 → 210
	25 - 40	210
Injection port		100
Detector		270

Detection: flame ionisation.

Injection: 1 µL of the test solution and reference solutions (a) and (c).

Relative retention with reference to propofol (retention time = about 17 min): impurity K = about 0.76; impurity L = about 0.81; impurity J = about 1.01; impurity O = about 1.03.

System suitability: reference solution (c):

- peak-to-valley ratio: minimum 3.0, where  $H_p$  = height above the baseline of the peak due to impurity J, and  $H_v$  = height above the baseline of the lowest point of the curve separating this peak from the peak due to propofol.

Limits:

- impurities J, K, L, O: for each impurity, not more than 0.5 times the area of the principal peak in the chromatogram obtained with reference solution (a) (0.05 per cent).

## ASSAY

Liquid chromatography (2.2.29) as described in the test for related substances with the following modification.

Injection: test solution (b) and reference solution (d).

Calculate the percentage content of  $C_{12}H_{18}O$  using the declared content of propofol CRS.

## STORAGE

Protected from light under an inert gas.

## IMPURITIES

Specified impurities: E, G, J, K, L, O.

Other detectable impurities (the following substances would, if present at a sufficient level, be detected by one or other of the tests in the monograph. They are limited by the general acceptance criterion for other/unspecified impurities and/or by the general monograph *Substances for pharmaceutical use* (2034). It is therefore not necessary to identify these impurities for demonstration of compliance. See also 5.10. *Control of impurities in substances for pharmaceutical use*): A, B, C, D, F, H, I, N, P.

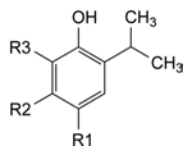

- A.  $R_1 = CH(CH_3)_2$ ,  $R_2 = R_3 = H$ : 2,4-bis(1-methylethyl)phenol,  
 B.  $R_1 = R_2 = H$ ,  $R_3 = C(CH_3)=CH_2$ : 2-(1-methylethenyl)-6-(1-methylethyl)phenol,  
 C.  $R_1 = R_2 = R_3 = H$ : 2-(1-methylethyl)phenol,  
 D.  $R_1 = R_3 = H$ ,  $R_2 = CH(CH_3)_2$ : 2,5-bis(1-methylethyl)phenol,  
 N.  $R_1 = CO_2H$ ,  $R_2 = H$ ,  $R_3 = CH(CH_3)_2$ : 4-hydroxy-3,5-bis(1-methylethyl)benzoic acid,  
 O.  $R_1 = R_2 = H$ ,  $R_3 = CH_2-CH_2-CH_3$ : 2-(1-methylethyl)-6-propylphenol,  
 P.  $R_1 = CO-O-CH(CH_3)_2$ ,  $R_2 = H$ ,  $R_3 = CH(CH_3)_2$ : 1-methylethyl 4-hydroxy-3,5-bis(1-methylethyl)benzoate,

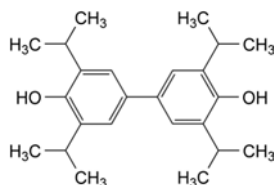

E. 3,3',5,5'-tetrakis(1-methylethyl)biphenyl-4,4'-diol,

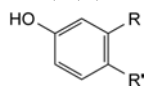

F.  $R = CH(CH_3)_2$ ,  $R' = H$ : 3-(1-methylethyl)phenol,

H.  $R = H$ ,  $R' = CH(CH_3)_2$ : 4-(1-methylethyl)phenol,

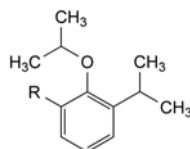

G.  $R = CH(CH_3)_2$ : 2-(1-methylethoxy)-1,3-bis(1-methylethyl)benzene,

K.  $R = H$ : 1-(1-methylethoxy)-2-(1-methylethyl)benzene,

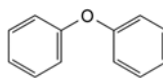

I. oxydibenzene,

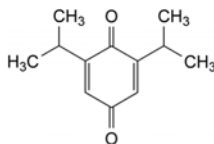

J. 2,6-bis(1-methylethyl)benzene-1,4-dione,

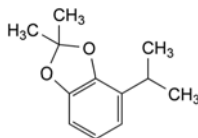

L. 2,2-dimethyl-4-(1-methylethyl)-1,3-benzodioxole.

01/2008:0568  
corrected 6.0

## PROPRANOLOL HYDROCHLORIDE

## Propranololi hydrochloridum

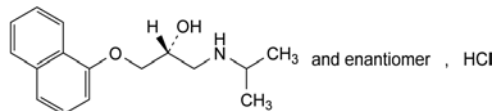

$C_{16}H_{22}ClNO_2$   
[318-98-9]

$M_r$  295.8

## DEFINITION

(2*RS*)-1-[(1-Methylethyl)amino]-3-(naphthalen-1-yloxy)propan-2-ol hydrochloride.

Content: 99.0 per cent to 101.0 per cent (dried substance).

## CHARACTERS

Appearance: white or almost white powder.

Solubility: soluble in water and in ethanol (96 per cent).

## IDENTIFICATION

First identification: B, D.

Second identification: A, C, D.

A. Melting point (2.2.14): 163 °C to 166 °C.

## B. Infrared absorption spectrophotometry (2.2.24).

*Comparison: propranolol hydrochloride CRS.*

## C. Thin-layer chromatography (2.2.27).

*Test solution.* Dissolve 10 mg of the substance to be examined in 1 mL of *methanol R*.

*Reference solution.* Dissolve 10 mg of *propranolol hydrochloride CRS* in 1 mL of *methanol R*.

*Plate: TLC silica gel G plate R.*

*Mobile phase: concentrated ammonia R1, methanol R (1:99 V/V).*

*Application: 10 µL.*

*Development: over a path of 15 cm.*

*Drying: at 100-105 °C.*

*Detection: spray with anisaldehyde solution R and heat at 100-105 °C until the colour of the spots reaches maximum intensity (10-15 min).*

*Results: the principal spot in the chromatogram obtained with the test solution is similar in position, colour and size to the principal spot in the chromatogram obtained with the reference solution.*

## D. It gives reaction (a) of chlorides (2.3.1).

## TESTS

**Appearance of solution.** The solution is clear (2.2.1) and not more intensely coloured than intensity 6 of the range of reference solutions of the most appropriate colour (2.2.2, *Method II*).

Dissolve 2.0 g in *methanol R* and dilute to 20 mL with the same solvent.

**Acidity or alkalinity.** Dissolve 0.20 g in *carbon dioxide-free water R* and dilute to 20 mL with the same solvent. Add 0.2 mL of *methyl red solution R* and 0.2 mL of 0.01 M *hydrochloric acid*; the solution is red. Add 0.4 mL of 0.01 M *sodium hydroxide*; the solution is yellow.

**Related substances.** Liquid chromatography (2.2.29).

*Test solution.* Dissolve 20.0 mg of the substance to be examined in the mobile phase and dilute to 10.0 mL with the mobile phase.

*Reference solution (a).* Dissolve 10.0 mg of *propranolol hydrochloride for performance test CRS* in the mobile phase and dilute to 10.0 mL with the mobile phase.

*Reference solution (b).* Dilute 2.0 mL of the test solution to 100.0 mL with the mobile phase. Dilute 1.0 mL of this solution to 10.0 mL with the mobile phase.

*Column:*

- size:  $l = 0.25$  m;  $\varnothing = 4.6$  mm;
- stationary phase: *octadecylsilyl silica gel for chromatography R (5 µm)*.

*Mobile phase:* mix 1.6 g of *sodium laurilsulfate R* and 0.31 g of *tetrabutylammonium dihydrogen phosphate R* in a mixture of 1 mL of *sulfuric acid R*, 450 mL of *water R* and 550 mL of *acetonitrile R*; adjust to pH 3.3 using *dilute sodium hydroxide solution R*.

*Flow rate: 1.8 mL/min.*

*Detection: spectrophotometer at 292 nm.*

*Equilibration: for at least 30 min.*

*Injection: 20 µL.*

*Run time: 7 times the retention time of propranolol.*

*Identification of impurities:* use the chromatogram supplied with *propranolol hydrochloride for performance test CRS* to identify the peak due to impurity A.

*System suitability:* reference solution (a):

- baseline separation is obtained between the peaks due to impurity A and propranolol.

*Limits:*

- *any impurity:* for each impurity, not more than 0.5 times the area of the principal peak in the chromatogram obtained with reference solution (b) (0.1 per cent);
- *total:* not more than twice the area of the principal peak in the chromatogram obtained with reference solution (b) (0.4 per cent).

**Heavy metals (2.4.8):** maximum 20 ppm.

Dissolve 1.0 g in a mixture of 15 volumes of *water R* and 85 volumes of *methanol R* and dilute to 20 mL with the same mixture of solvents. 12 mL of the solution complies with test B. Prepare the reference solution using lead standard solution (1 ppm Pb) prepared by diluting *lead standard solution (100 ppm Pb) R* with a mixture of 15 volumes of *water R* and 85 volumes of *methanol R*.

**Loss on drying (2.2.32):** maximum 0.5 per cent, determined on 1.000 g by drying in an oven at 105 °C.

**Sulfated ash (2.4.14):** maximum 0.1 per cent, determined on 1.0 g.

## ASSAY

Dissolve 0.250 g in 25 mL of *ethanol (96 per cent) R*. Titrate with 0.1 M *sodium hydroxide*, determining the end-point potentiometrically (2.2.20).

1 mL of 0.1 M *sodium hydroxide* is equivalent to 29.58 mg of  $C_{16}H_{22}ClNO_2$ .

## IMPURITIES

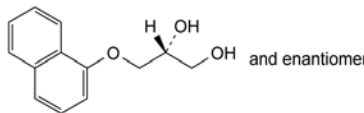

A. (2*RS*)-3-(naphthalen-1-yloxy)propane-1,2-diol (diol derivative),

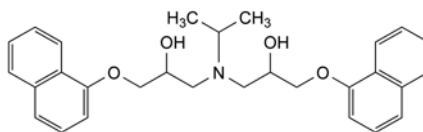

B. 1,1'-[(1-methylethyl)imino]bis[3-(naphthalen-1-yloxy)propan-2-ol] (tertiary amine derivative),

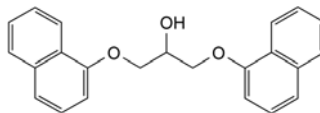

C. 1,3-bis(naphthalen-1-yloxy)propan-2-ol (bis-ether derivative).

01/2008:1039  
corrected 7.0

## PROPYL GALLATE

## Propylis gallas

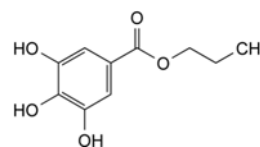

$C_{10}H_{12}O_5$   
[121-79-9]

$M_r$  212.2

## DEFINITION

Propyl gallate contains not less than 97.0 per cent and not more than the equivalent of 103.0 per cent of propyl 3,4,5-trihydroxybenzoate, calculated with reference to the dried substance.

## CHARACTERS

A white or almost white, crystalline powder, very slightly soluble in water, freely soluble in ethanol (96 per cent). It dissolves in dilute solutions of alkali hydroxides.

## IDENTIFICATION

*First identification:* B.

*Second identification:* A, C, D.

- A. Melting point (2.2.14): 148 °C to 151 °C.
- B. Examine by infrared absorption spectrophotometry (2.2.24), comparing with the spectrum obtained with *propyl gallate CRS*.
- C. Examine the chromatograms obtained in the test for gallic acid. The principal spot in the chromatogram obtained with test solution (b) is similar in position, colour and size to the principal spot in the chromatogram obtained with reference solution (a).
- D. Dissolve about 10 mg in 10 mL of *water R* by heating to about 70 °C. Cool and add 1 mL of *bismuth subnitrate solution R*. A bright yellow precipitate is formed.

## TESTS

**Appearance of solution.** Dissolve 1.0 g in *ethanol (96 per cent) R* and dilute to 20 mL with the same solvent. The solution is clear (2.2.1) and not more intensely coloured than reference solution BY<sub>5</sub> (2.2.2, *Method II*).

**Gallic acid.** Examine by thin-layer chromatography (2.2.27), using *silica gel G R* as the coating substance.

*Test solution (a).* Dissolve 0.20 g of the substance to be examined in *acetone R* and dilute to 10 mL with the same solvent.

*Test solution (b).* Dilute 1 mL of test solution (a) to 20 mL with *acetone R*.

*Reference solution (a).* Dissolve 10 mg of *propyl gallate CRS* in *acetone R* and dilute to 10 mL with the same solvent.

*Reference solution (b).* Dissolve 20 mg of *gallic acid R* in *acetone R* and dilute to 20 mL with the same solvent. Dilute 1 mL of the solution to 10 mL with *acetone R*.

*Reference solution (c).* Dilute 0.5 mL of test solution (b) to 5 mL with reference solution (b).

Apply separately to the plate 5 µL of each solution. Develop over a path of 8 cm using a mixture of 10 volumes of *anhydrous formic acid R*, 40 volumes of *ethyl formate R* and 50 volumes of *toluene R*. Allow the plate to dry in air for 10 min and spray with a mixture of 1 volume of *ferric chloride solution R1* and 9 volumes of *ethanol (96 per cent) R*. Any spot due to gallic acid in the chromatogram obtained with test solution (a) is not more intense than the spot in the chromatogram obtained with reference solution (b) (0.5 per cent). The test is not valid unless the chromatogram obtained with reference solution (c) shows 2 clearly separated principal spots.

**Total chlorine.** Mix 0.5 g with 2 g of *calcium carbonate R1*. Dry and ignite at 700 ± 50 °C. Take up the residue with 20 mL of *dilute nitric acid R* and dilute to 30 mL with *water R*. 15 mL of the solution, without further addition of *dilute nitric acid R*, complies with the limit test for chlorides (2.4.4) (200 ppm).

**Chlorides (2.4.4).** To 1.65 g add 50 mL of *water R*. Shake for 5 min. Filter. 15 mL of the filtrate complies with the limit test for chlorides (100 ppm).

**Zinc.** Not more than 25 ppm of Zn, determined by atomic absorption spectrometry (2.2.23, *Method II*).

*Test solution.* To 2.5 mL of the solution obtained in the test for heavy metals, add 2.5 mL of *water R*.

*Reference solutions.* Prepare the reference solutions using *zinc standard solution (10 ppm Zn) R*, diluted as necessary with *water R*.

Measure the absorbance at 213.9 nm using a zinc hollow-cathode lamp as the source of radiation and an air-acetylene flame.

**Heavy metals (2.4.8).** 2.0 g complies with limit test C for heavy metals (10 ppm). Prepare the reference solution using 2 mL of *lead standard solution (10 ppm Pb) R*.

**Loss on drying (2.2.32).** Not more than 0.5 per cent, determined on 1.000 g by drying in an oven at 105 °C.

**Sulfated ash (2.4.14).** Not more than 0.1 per cent, determined on 1.0 g.

## ASSAY

Dissolve 0.100 g in *methanol R* and dilute to 250.0 mL with the same solvent. Dilute 5.0 mL of the solution to 200.0 mL with *methanol R*. Measure the absorbance (2.2.25) at the absorption maximum at 275 nm.

Calculate the content of C<sub>10</sub>H<sub>12</sub>O<sub>3</sub> taking the specific absorbance to be 503.

## STORAGE

Protected from light.

## IMPURITIES

*Specified impurities:* A.

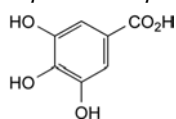

- A. 3,4,5-trihydroxybenzoic acid (gallic acid).

07/2010:0431

## PROPYL PARAHYDROXYBENZOATE

## Propylis parahydroxybenzoas

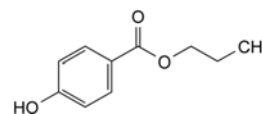

C<sub>10</sub>H<sub>12</sub>O<sub>3</sub>  
[94-13-3]

M<sub>r</sub> 180.2

## DEFINITION

Propyl 4-hydroxybenzoate.

*Content:* 98.0 per cent to 102.0 per cent.

## CHARACTERS

*Appearance:* white or almost white, crystalline powder.

*Solubility:* very slightly soluble in water, freely soluble in ethanol (96 per cent) and in methanol.

## IDENTIFICATION

*First identification:* A, B.

*Second identification:* A, C.

- A. Melting point (2.2.14): 96 °C to 99 °C.

- B. Infrared absorption spectrophotometry (2.2.24).

*Comparison:* *propyl parahydroxybenzoate CRS*.

- C. Thin-layer chromatography (2.2.27).

*Test solution (a).* Dissolve 0.10 g of the substance to be examined in *acetone R* and dilute to 10 mL with the same solvent.

*Test solution (b).* Dilute 1 mL of test solution (a) to 10 mL with *acetone R*.

*Reference solution (a).* Dissolve 10 mg of *propyl parahydroxybenzoate CRS* in *acetone R* and dilute to 10 mL with the same solvent.

*Reference solution (b).* Dissolve 10 mg of *ethyl parahydroxybenzoate CRS* in 1 mL of test solution (a) and dilute to 10 mL with *acetone R*.

*Plate:* *TLC octadecylsilyl silica gel F<sub>254</sub> plate R*.

**Mobile phase:** glacial acetic acid R, water R, methanol R (1:30:70 V/V/V).

**Application:** 2 µL of test solution (b) and reference solutions (a) and (b).

**Development:** over 2/3 of the plate.

**Drying:** in air.

**Detection:** examine in ultraviolet light at 254 nm.

**System suitability:** reference solution (b):

- the chromatogram shows 2 clearly separated principal spots.

**Results:** the principal spot in the chromatogram obtained with test solution (b) is similar in position and size to the principal spot in the chromatogram obtained with reference solution (a).

## TESTS

**Solution S.** Dissolve 1.0 g in ethanol (96 per cent) R and dilute to 10 mL with the same solvent.

**Appearance of solution.** Solution S is clear (2.2.1) and not more intensely coloured than reference solution BY<sub>6</sub> (2.2.2, Method II).

**Acidity.** To 2 mL of solution S add 3 mL of ethanol (96 per cent) R, 5 mL of carbon dioxide-free water R and 0.1 mL of bromocresol green solution R. Not more than 0.1 mL of 0.1 M sodium hydroxide is required to change the colour of the indicator to blue.

**Related substances.** Liquid chromatography (2.2.29).

**Test solution.** Dissolve 50.0 mg of the substance to be examined in 2.5 mL of methanol R and dilute to 50.0 mL with the mobile phase. Dilute 10.0 mL of this solution to 100.0 mL with the mobile phase.

**Reference solution (a).** Dissolve 5 mg of 4-hydroxybenzoic acid R (impurity A), 5 mg of ethyl parahydroxybenzoate R (impurity C) and 5 mg of the substance to be examined in the mobile phase and dilute to 100.0 mL with the mobile phase. Dilute 1.0 mL of this solution to 10.0 mL with the mobile phase.

**Reference solution (b).** Dissolve 50.0 mg of propyl parahydroxybenzoate CRS in 2.5 mL of methanol R and dilute to 50.0 mL with the mobile phase. Dilute 10.0 mL of this solution to 100.0 mL with the mobile phase.

**Reference solution (c).** Dilute 1.0 mL of the test solution to 20.0 mL with the mobile phase. Dilute 1.0 mL of this solution to 10.0 mL with the mobile phase.

**Column:**

- size:  $l = 0.15$  m,  $\varnothing = 4.6$  mm;
- stationary phase: end-capped octadecylsilyl silica gel for chromatography R (5 µm).

**Mobile phase:** 6.8 g/L solution of potassium dihydrogen phosphate R, methanol R (35:65 V/V).

**Flow rate:** 1.3 mL/min.

**Detection:** spectrophotometer at 272 nm.

**Injection:** 10 µL of the test solution and reference solutions (a) and (c).

**Run time:** 2.5 times the retention time of propyl parahydroxybenzoate.

**Relative retention** with reference to propyl parahydroxybenzoate (retention time = about 4.5 min): impurity A = about 0.3; impurity C = about 0.7.

**System suitability:** reference solution (a):

- resolution: minimum 3.0 between the peaks due to impurity C and propyl parahydroxybenzoate.

**Limits:**

- correction factor: for the calculation of content, multiply the peak area of impurity A by 1.4;
- impurity A: not more than the area of the principal peak in the chromatogram obtained with reference solution (c) (0.5 per cent);

- unspecified impurities: for each impurity, not more than the area of the principal peak in the chromatogram obtained with reference solution (c) (0.5 per cent);
- total: not more than twice the area of the principal peak in the chromatogram obtained with reference solution (c) (1.0 per cent);
- disregard limit: 0.2 times the area of the principal peak in the chromatogram obtained with reference solution (c) (0.1 per cent).

**Sulfated ash (2.4.14):** maximum 0.1 per cent, determined on 1.0 g.

## ASSAY

Liquid chromatography (2.2.29) as described in the test for related substances with the following modification.

**Injection:** test solution and reference solution (b).

Calculate the percentage content of C<sub>10</sub>H<sub>12</sub>O<sub>3</sub> from the declared content of propyl parahydroxybenzoate CRS.

## IMPURITIES

**Specified impurities:** A.

**Other detectable impurities** (the following substances would, if present at a sufficient level, be detected by one or other of the tests in the monograph. They are limited by the general acceptance criterion for other/unspecified impurities and/or by the general monograph *Substances for pharmaceutical use (2034)*. It is therefore not necessary to identify these impurities for demonstration of compliance. See also 5.10. *Control of impurities in substances for pharmaceutical use*): B, C, D.

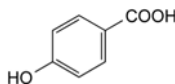

A. 4-hydroxybenzoic acid,

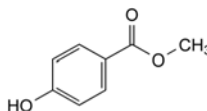

B. methyl 4-hydroxybenzoate (methyl parahydroxybenzoate),

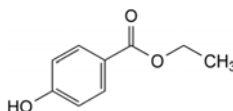

C. ethyl 4-hydroxybenzoate (ethyl parahydroxybenzoate),

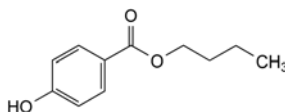

D. butyl 4-hydroxybenzoate (butyl parahydroxybenzoate).

01/2008:0430

## PROPYLENE GLYCOL

### Propylenglycolum

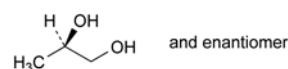

C<sub>3</sub>H<sub>8</sub>O<sub>2</sub>  
[57-55-6]

$M_r$  76.1

## DEFINITION

Propylene glycol is (RS)-propane-1,2-diol.

## CHARACTERS

A viscous, clear, colourless, hygroscopic liquid, miscible with water and with ethanol (96 per cent).



## CHARACTERS

**Appearance:** clear, oily liquid at 20 °C, colourless or slightly yellow.

**Solubility:** practically insoluble in water, very soluble in alcohol, in methanol and in methylene chloride.

## IDENTIFICATION

## A. Thin-layer chromatography (2.2.27).

**Test solution.** Dissolve 0.1 g of the substance to be examined in *methylene chloride R* and dilute to 2 mL with the same solvent.

**Reference solution.** Dissolve 0.1 g of *propylene glycol dilaurate CRS* in *methylene chloride R* and dilute to 2 mL with the same solvent.

**Plate:** TLC silica gel plate *R*.

**Mobile phase:** hexane *R*, ether *R* (30:70 V/V).

**Application:** 10 µL.

**Development:** over a path of 15 cm.

**Drying:** in air.

**Detection:** spray with a 0.1 g/L solution of *rhodamine 6 G R* in *alcohol R*. Examine in ultraviolet light at 365 nm.

**Results:** the spots in the chromatogram obtained with the test solution are similar in position to those in the chromatogram obtained with the reference solution.

## B. Composition of fatty acids (see Tests).

## C. It complies with the assay (content of diesters).

## TESTS

**Acid value (2.5.1):** maximum 4.0, determined on 5.00 g.

**Iodine value (2.5.4, Method A):** maximum 1.0.

**Saponification value (2.5.6):** 230 to 250.

**Composition of fatty acids.** Gas chromatography (2.4.22, Method C). Use the mixture of calibrating substances in Table 2.4.22-2.

**Composition of the fatty acid fraction of the substance:**

- *caprylic acid*: maximum 0.5 per cent,
- *capric acid*: maximum 2.0 per cent,
- *lauric acid*: minimum 95.0 per cent,
- *myristic acid*: maximum 3.0 per cent,
- *palmitic acid*: maximum 1.0 per cent.

**Free propylene glycol:** maximum 2.0 per cent, determined as prescribed under Assay.

**Water (2.5.12):** maximum 1.0 per cent, determined on 1.00 g.

**Total ash (2.4.16):** maximum 0.1 per cent, determined on 1.0 g.

## ASSAY

Size-exclusion chromatography (2.2.30).

**Stock solution.** Introduce 0.100 g of *propylene glycol R* into a flask and dilute to 25.0 mL with *tetrahydrofuran R*.

**Test solution.** In a 15 mL flask, weigh 0.200 g (*m*). Add 5.0 mL of *tetrahydrofuran R* and shake to dissolve. Reweigh the flask and calculate the total mass of solvent and substance (*M*).

**Reference solutions.** Into four 15 mL flasks, introduce respectively 0.25 mL, 0.5 mL, 1.0 mL and 2.5 mL of stock solution and add 5.0 mL of *tetrahydrofuran R*. Weigh each flask and calculate the concentration of propylene glycol in milligrams per gram for each reference solution.

**Column:**

- **size:**  $l = 0.6$  m,  $\emptyset = 7$  mm,
- **stationary phase:** styrene-divinylbenzene copolymer *R* (5 µm) with a pore size of 10 nm.

**Mobile phase:** *tetrahydrofuran R*.

**Flow rate:** 1 mL/min.

**Detection:** differential refractometer.

**Injection:** 40 µL.

**Relative retention** with reference to propylene glycol: diesters = about 0.85; monoesters = about 0.90.

**Calculations:**

- **free propylene glycol:** from the calibration curve obtained with the reference solutions, determine the concentration (*C*) in milligrams per gram in the test solution and calculate the percentage content in the substance to be examined using the following expression:

$$\frac{C \times M}{m \times 10}$$

- **monoesters:** calculate the percentage content of monoesters using the following expression:

$$\frac{A}{A + B} \times (100 - D)$$

*A* = area of the peak due to the monoesters,

*B* = area of the peak due to the diesters,

*D* = percentage content of free propylene glycol + percentage content of free fatty acids.

Calculate the percentage content of free fatty acids using the expression:

$$\frac{I_A \times 200}{561.1}$$

*I<sub>A</sub>* = acid value.

- **diesters:** calculate the percentage content of diesters using the following expression:

$$\frac{B}{A + B} \times (100 - D)$$

## STORAGE

Protected from moisture.

01/2008:1915

## PROPYLENE GLYCOL MONOLAURATE

## Propylenglycoli monolauras

## DEFINITION

Mixture of propylene glycol mono- and diesters of lauric (dodecanoic) acid.

**Content:**

- propylene glycol monolaurate (type I): 45.0 per cent to 70.0 per cent of monoesters and 30.0 per cent to 55.0 per cent of diesters,
- propylene glycol monolaurate (type II): minimum 90.0 per cent of monoesters and maximum 10.0 per cent of diesters.

## CHARACTERS

**Appearance:** clear, oily liquid at 20 °C, colourless or slightly yellow.

**Solubility:** practically insoluble in water, very soluble in alcohol, in methanol and in methylene chloride.

## IDENTIFICATION

## A. Thin-layer chromatography (2.2.27).

**Test solution.** Dissolve 0.1 g of the substance to be examined in *methylene chloride R* and dilute to 2 mL with the same solvent.

**Reference solution.** Dissolve 0.1 g of *propylene glycol monolaurate CRS* in *methylene chloride R* and dilute to 2 mL with the same solvent.

**Plate:** TLC silica gel plate *R*.

**Mobile phase:** hexane *R*, ether *R* (30:70 V/V).

*Application*: 10 µL.

*Development*: over a path of 15 cm.

*Drying*: in air.

*Detection*: spray with a 0.1 g/L solution of *rhodamine 6 G R* in *alcohol R*. Examine in ultraviolet light at 365 nm.

*Results*: the spots in the chromatogram obtained with the test solution are similar in position to those in the chromatogram obtained with the reference solution.

- B. It complies with the test for composition of fatty acids (see Tests).  
C. It complies with the assay (content of monoesters).

#### TESTS

**Acid value** (2.5.1): maximum 4.0, determined on 5.00 g.

**Iodine value** (2.5.4, *Method A*): maximum 1.0.

**Saponification value** (2.5.6): 210 to 245 for propylene glycol monolaurate (type I) and 200 to 230 for propylene glycol monolaurate (type II).

**Composition of fatty acids**. Gas chromatography (2.4.22, *Method C*). Use the mixture of calibrating substances in Table 2.4.22.-2.

*Composition of the fatty acid fraction of the substance*:

- *caprylic acid*: maximum 0.5 per cent,
- *capric acid*: maximum 2.0 per cent,
- *lauric acid*: minimum 95.0 per cent,
- *myristic acid*: maximum 3.0 per cent,
- *palmitic acid*: maximum 1.0 per cent.

**Free propylene glycol**: maximum 5.0 per cent for propylene glycol monolaurate (type I) and maximum 1.0 per cent for propylene glycol monolaurate (type II), determined as prescribed under Assay.

**Water** (2.5.12): maximum 1.0 per cent, determined on 1.00 g.

**Total ash** (2.4.16): maximum 0.1 per cent, determined on 1.0 g.

#### ASSAY

Size-exclusion chromatography (2.2.30).

*Stock solution*. Introduce 0.100 g of *propylene glycol R* into a vial and dilute to 25.0 mL with *tetrahydrofuran R*.

*Test solution*. In a 15 mL flask, weigh 0.200 g (*m*). Add 5.0 mL of *tetrahydrofuran R* and shake to dissolve. Reweigh the flask and calculate the total mass of solvent and substance (*M*).

*Reference solutions*. Into four 15 mL flasks, introduce respectively 0.25 mL, 0.5 mL, 1.0 mL and 2.5 mL of stock solution and add 5.0 mL of *tetrahydrofuran R*. In a fifth 15 mL flask, introduce 5.0 mL of stock solution. Weigh each flask and calculate the concentration of propylene glycol in milligrams per gram for each reference solution.

*Column*:

- *size*:  $l = 0.6$  m,  $\emptyset = 7$  mm,
- *stationary phase*: *styrene-divinylbenzene copolymer R* (5 µm) with a pore size of 10 nm.

*Mobile phase*: *tetrahydrofuran R*.

*Flow rate*: 1 mL/min.

*Detection*: differential refractometer.

*Injection*: 40 µL.

*Relative retention* with reference to propylene glycol: diesters = about 0.85; monoesters = about 0.90.

*Calculations*:

- *free propylene glycol*: from the calibration curve obtained with the reference solutions, determine the concentration (*C*) in milligrams per gram in the test solution and calculate the percentage content in the substance to be examined using the following expression:

$$\frac{C \times M}{m \times 10}$$

- *monoesters*: calculate the percentage content of monoesters using the following expression:

$$\frac{A}{A + B} \times (100 - D)$$

*A* = area of the peak due to the monoesters,

*B* = area of the peak due to the diesters,

*D* = percentage content of free propylene glycol + percentage content of free fatty acids.

Calculate the percentage content of free fatty acids using the expression:

$$\frac{I_A \times 200}{561.1}$$

*I<sub>A</sub>* = acid value.

- *diesters*: calculate the percentage content of diesters using the following expression:

$$\frac{B}{A + B} \times (100 - D)$$

#### STORAGE

Protected from moisture.

#### LABELLING

The label states the type of propylene glycol monolaurate (type I or type II).

01/2008:1469

## PROPYLENE GLYCOL MONOPALMITOSTEARATE

### Propylenglycoli monopalmitostearas

#### DEFINITION

Mixture of propylene glycol mono- and diesters and of stearic (octadecanoic) and palmitic (hexadecanoic) acids, produced by the condensation of propylene glycol and stearic acid 50 of vegetable or animal origin (see *Stearic acid (1474)*).

*Content*: minimum of 50.0 per cent of monoesters.

#### CHARACTERS

*Appearance*: white or almost white, waxy solid.

*Solubility*: practically insoluble in water, soluble in acetone and in hot alcohol.

#### IDENTIFICATION

- A. Melting point (see Tests).  
B. Composition of fatty acids (see Tests).  
C. It complies with the assay (monoesters content).

#### TESTS

**Melting point** (2.2.15): 33 °C to 40 °C.

**Acid value** (2.5.1): maximum 4.0, determined on 10.0 g.

**Iodine value** (2.5.4): maximum 3.0.

**Saponification value** (2.5.6): 170 to 185, determined on 2.0 g.

**Composition of fatty acids** (2.4.22, *Method A*). The fatty acid fraction has the following composition:

- *stearic acid*: 40.0 per cent to 60.0 per cent,
- *sum of contents of palmitic acid and stearic acid*: minimum 90.0 per cent.

**Free propylene glycol**: maximum 5.0 per cent, determined as prescribed under Assay.

**Total ash** (2.4.16): maximum 0.1 per cent, determined on 1.0 g.

## ASSAY

Size-exclusion chromatography (2.2.30).

**Test solution.** In a 15 mL flask, weigh about 0.2 g (*m*), to the nearest 0.1 mg. Add 5.0 mL of *tetrahydrofuran R* and shake to dissolve. Heat gently, if necessary. Reweigh the flask and calculate the total mass of solvent and substance (*M*).

**Reference solutions.** In four 15 mL flasks, weigh, to the nearest 0.1 mg, about 2.5 mg, 5.0 mg, 10.0 mg and 20.0 mg of *propylene glycol R*. Add 5.0 mL of *tetrahydrofuran R* and shake to dissolve. Weigh the flasks again and calculate the concentration of propylene glycol in milligrams per gram for each reference solution.

**Column:**

- size:  $l = 0.6$  m,  $\emptyset = 7$  mm,
- stationary phase: *styrene-divinylbenzene copolymer R* (particle diameter 5  $\mu$ m, pore size 10 nm).

**Mobile phase:** *tetrahydrofuran R*.

**Flow rate:** 1 mL/min.

**Detection:** differential refractometer.

**Injection:** 40  $\mu$ L.

**Relative retention** with reference to propylene glycol: diesters = about 0.78, monoesters = about 0.84.

**Limits:**

- *free propylene glycol:* from the calibration curve obtained with the reference solutions, determine the concentration (*C*) in milligrams per gram in the test solution and calculate the percentage content in the substance to be examined using the following expression:

$$\frac{C \times M}{m \times 10}$$

- *monoesters:* calculate the percentage content of monoesters using the following expression:

$$\frac{A}{A + B} \times (100 - D)$$

*A* = area of the peak due to the monoesters,

*B* = area of the peak due to the diesters,

*D* = percentage content of free propylene glycol + percentage content of free fatty acids which is determined using the following expression:

$$\frac{I_A \times 270}{561.1}$$

*I<sub>A</sub>* = acid value.

## STORAGE

Protected from light.

## DEFINITION

Propylthiouracil contains not less than 98.0 per cent and not more than the equivalent of 100.5 per cent of 2,3-dihydro-6-propyl-2-thioxopyrimidin-4(1*H*)-one, calculated with reference to the dried substance.

## CHARACTERS

White or almost white, crystalline powder or crystals, very slightly soluble in water, sparingly soluble in alcohol. It dissolves in solutions of alkali hydroxides.

## IDENTIFICATION

**First identification:** *A, B.*

**Second identification:** *A, C, D.*

- A.** Melting point (2.2.14): 217 °C to 221 °C.
- B.** Examine by infrared absorption spectrophotometry (2.2.24), comparing with the spectrum obtained with *propylthiouracil CRS*. Examine as discs prepared using 1 mg of substance and 0.3 g of *potassium bromide R*.
- C.** Examine the chromatograms obtained in the test for impurity *A* and related substances in ultraviolet light at 254 nm before exposure of the plate to iodine vapour. The principal spot in the chromatogram obtained with test solution (*b*) is similar in position and size to the principal spot in the chromatogram obtained with reference solution (*a*).
- D.** To about 20 mg add 8 mL of *bromine water R* and shake for a few minutes. Boil until the mixture is decolourised, allow to cool and filter. To the filtrate add 2 mL of *barium chloride solution R1*. A white precipitate is formed whose colour does not become violet on the addition of 5 mL of *dilute sodium hydroxide solution R*.

## TESTS

**Impurity A and related substances.** Examine by thin-layer chromatography (2.2.27), using a *TLC silica gel GF<sub>254</sub> plate R*.

**Test solution (a).** Dissolve 0.1 g of the substance to be examined in *methanol R* and dilute to 10 mL with the same solvent.

**Test solution (b).** Dilute 1 mL of test solution (*a*) to 10 mL with *methanol R*.

**Reference solution (a).** Dissolve 10 mg of *propylthiouracil CRS* in *methanol R* and dilute to 10 mL with the same solvent.

**Reference solution (b).** Dissolve 50 mg of *thiourea R* in *methanol R* and dilute to 100 mL with the same solvent. Dilute 1 mL of this solution to 100 mL with *methanol R*.

**Reference solution (c).** Dilute 1 mL of test solution (*a*) to 100 mL with *methanol R*.

Apply separately to the plate 10  $\mu$ L of each solution. Develop over a path of 15 cm using a mixture of 0.1 volumes of *glacial acetic acid R*, 6 volumes of *2-propanol R* and 50 volumes of *chloroform R*. Allow the plate to dry in air. Examine in ultraviolet light at 254 nm. Expose the plate to iodine vapour for 10 min. In the chromatogram obtained with test solution (*a*), any spot corresponding to impurity *A* is not more intense than the spot in the chromatogram obtained with reference solution (*b*) (0.05 per cent) and any spot apart from the principal spot and any spot corresponding to impurity *A* is not more intense than the spot in the chromatogram obtained with reference solution (*c*) (1.0 per cent).

**Heavy metals** (2.4.8). 1.0 g complies with limit test F for heavy metals (20 ppm). Prepare the standard using 2 mL of *lead standard solution (10 ppm Pb) R*.

**Loss on drying** (2.2.32). Not more than 0.5 per cent, determined on 1.000 g by drying in an oven at 105 °C.

**Sulfated ash** (2.4.14). Not more than 0.1 per cent, determined on 1.0 g.

## ASSAY

To 0.300 g add 30 mL of *water R* and 30.0 mL of 0.1 *M sodium hydroxide*. Boil and shake until dissolution is complete. Add 50 mL of 0.1 *M silver nitrate* while stirring, boil gently for 5 min

## PROPYLTHIOURACIL

## Propylthiouracilum

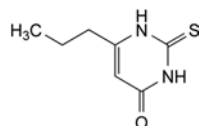

C<sub>7</sub>H<sub>10</sub>N<sub>2</sub>OS  
[51-52-5]

*M<sub>r</sub>* 170.2

and cool. Titrate with 0.1 M sodium hydroxide, determining the end-point potentiometrically (2.2.20). The volume of 0.1 M sodium hydroxide used is equal to the sum of the volume added initially and the volume used in the final titration.

1 mL of 0.1 M sodium hydroxide is equivalent to 8.511 mg of C<sub>7</sub>H<sub>10</sub>N<sub>2</sub>OS.

#### STORAGE

Store protected from light.

#### IMPURITIES

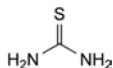

A. thiourea.

01/2008:0636

## PROPYPHENAZONE

### Propyphenazonum

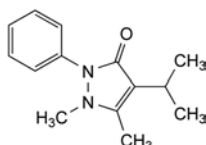

C<sub>14</sub>H<sub>18</sub>N<sub>2</sub>O  
[479-92-5]

M<sub>r</sub> 230.3

#### DEFINITION

Propyphenazone contains not less than 99.0 per cent and not more than the equivalent of 101.0 per cent of 1,5-dimethyl-4-(1-methylethyl)-2-phenyl-1,2-dihydro-3H-pyrazol-3-one, calculated with reference to the dried substance.

#### CHARACTERS

A white or slightly yellowish, crystalline powder, slightly soluble in water, freely soluble in alcohol and in methylene chloride.

#### IDENTIFICATION

First identification: A, B.

Second identification: A, C, D.

- Melting point (2.2.14): 102 °C to 106 °C.
- Examine by infrared absorption spectrophotometry (2.2.24), comparing with the spectrum obtained with propyphenazone CRS. Examine the substances prepared as discs.
- Examine the chromatograms obtained in the test for related substances. The principal spot in the chromatogram obtained with test solution (b) is similar in position, colour and size to the principal spot in the chromatogram obtained with reference solution (a).
- To 1 mL of solution S (see Tests) add 0.1 mL of ferric chloride solution R1. A brownish-red colour appears which becomes yellow on addition of 1 mL of dilute hydrochloric acid R.

#### TESTS

**Solution S.** Dissolve 2 g in a mixture of equal volumes of alcohol R and carbon dioxide-free water R and dilute to 50 mL with the same mixture of solvents.

**Appearance of solution.** Solution S is clear (2.2.1) and colourless (2.2.2, Method II).

**Acidity or alkalinity.** To 10 mL of solution S add 0.1 mL of phenolphthalein solution R. The solution is colourless. Add 0.2 mL of 0.01 M sodium hydroxide; the solution becomes

pink. Add 0.4 mL of 0.01 M hydrochloric acid; the solution becomes colourless. Add 0.2 mL of methyl red solution R. The solution becomes orange or red.

**Related substances.** Examine by thin-layer chromatography (2.2.27), using silica gel HF<sub>254</sub> R as the coating substance.

**Test solution (a).** Dissolve 0.40 g of the substance to be examined in methanol R and dilute to 5 mL with the same solvent.

**Test solution (b).** Dilute 1 mL of test solution (a) to 5 mL with methanol R.

**Reference solution (a).** Dissolve 80 mg of propyphenazone CRS in methanol R and dilute to 5 mL with the same solvent.

**Reference solution (b).** Dilute 1 mL of test solution (b) to 100 mL with methanol R.

Apply to the plate 5 µL of each solution. Develop over a path of 15 cm using a mixture of 10 volumes of butanol R, 45 volumes of cyclohexane R and 45 volumes of ethyl acetate R. Dry the plate in a current of hot air for 15 min and examine in ultraviolet light at 254 nm. Any spot in the chromatogram obtained with test solution (a), apart from the principal spot, is not more intense than the spot in the chromatogram obtained with reference solution (b) (0.2 per cent). Spray with a mixture of equal volumes of potassium ferricyanide solution R and ferric chloride solution R1. Any spot in the chromatogram obtained with test solution (a), apart from the principal spot, is not more intense than the spot in the chromatogram obtained with reference solution (b) (0.2 per cent).

**Heavy metals** (2.4.8). 1.0 g complies with limit test C (10 ppm). Prepare the standard using 1 mL of lead standard solution (10 ppm Pb) R.

**Loss on drying** (2.2.32). Not more than 0.5 per cent, determined on 1.000 g by drying *in vacuo* at 60 °C for 4 h.

**Sulfated ash** (2.4.14). Not more than 0.1 per cent, determined on 0.5 g.

#### ASSAY

Dissolve 0.2000 g in 10 mL of anhydrous acetic acid R and add 75 mL of ethylene chloride R. Titrate with 0.1 M perchloric acid, determining the end-point potentiometrically (2.2.20).

1 mL of 0.1 M perchloric acid is equivalent to 23.03 mg of C<sub>14</sub>H<sub>18</sub>N<sub>2</sub>O.

#### STORAGE

Store protected from light.

#### IMPURITIES

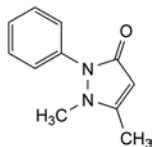

A. 1,5-dimethyl-2-phenyl-1,2-dihydro-3H-pyrazol-3-one (phenazone),

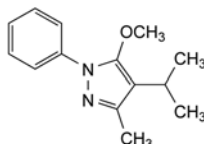

B. 5-methoxy-3-methyl-4-(1-methylethyl)-1-phenyl-1H-pyrazole,

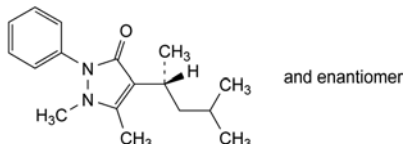

C. 4-[(1RS)-1,3-dimethylbutyl]-1,5-dimethyl-2-phenyl-1,2-dihydro-3H-pyrazol-3-one.

01/2011:0686

**PROTAMINE HYDROCHLORIDE**

## Protamini hydrochloridum

## DEFINITION

Protamine hydrochloride consists of the hydrochlorides of basic peptides extracted from the sperm or roe of fish, usually species of *Salmonidae* and *Clupeidae*. It binds with heparin in solution, inhibiting its anticoagulant activity; in the conditions of the assay this binding gives rise to a precipitate. Calculated with reference to the dried substance, 1 mg of protamine hydrochloride precipitates not less than 100 IU of heparin.

## PRODUCTION

The animals from which protamine hydrochloride is derived must fulfil the requirements for the health of animals suitable for human consumption.

The method of manufacture is validated to demonstrate that the product, if tested, would comply with the following test.

**Abnormal toxicity** (2.6.9). Inject into each mouse 0.5 mg dissolved in 0.5 mL of *water for injections R*.

## CHARACTERS

**Appearance:** white or almost white, hygroscopic powder.

**Solubility:** soluble in water, practically insoluble in ethanol (96 per cent).

## IDENTIFICATION

A. Specific optical rotation (2.2.7): –40 to –60 (dried substance).

Dissolve 1.000 g in 0.1 M *hydrochloric acid* and dilute to 100.0 mL with the same solvent.

B. In the conditions of the assay, protamine hydrochloride forms a precipitate.

C. To 0.5 mL of solution S (see Tests) add 4.5 mL of *water R*, 1.0 mL of a 100 g/L solution of *sodium hydroxide R* and 1.0 mL of a 0.2 g/L solution of  $\alpha$ -*naphthol R* and mix. Cool the mixture to 5 °C. Add 0.5 mL of *sodium hypobromite solution R*. An intense red colour is produced.

D. Heat 2 mL of solution S in a water-bath at 60 °C, add 0.1 mL of *mercuric sulfate solution R* and mix. No precipitate is formed. Cool the mixture in iced water. A precipitate is formed.

E. It gives reaction (a) of chlorides (2.3.1).

## TESTS

**Solution S.** Dissolve 0.50 g in *water R* and dilute to 25.0 mL with the same solvent.

**Appearance of solution.** The solution is not more opalescent than reference suspension II (2.2.1) and not more intensely coloured than reference solution BY<sub>6</sub> or Y<sub>6</sub> (2.2.2, *Method II*). To 2.5 mL of solution S add 7.5 mL of *water R*.

**Absorbance** (2.2.25): maximum 0.1 between wavelengths of 260 nm and 280 nm.

Dilute 2.5 mL of solution S to 5.0 mL with *water R*.

**Chloride:** 12.3 per cent to 19.0 per cent (dried substance).

Dissolve 0.400 g in 50 mL of *water R*. Add 5 mL of *dilute nitric acid R*, 25.0 mL of 0.1 M *silver nitrate* and 2 mL of *dibutyl phthalate R* and shake. Titrate with 0.1 M *ammonium thiocyanate* using 2 mL of *ferric ammonium sulfate solution R2* as indicator; shake vigorously when approaching the end-point.

1 mL of 0.1 M *silver nitrate* is equivalent to 3.545 mg of Cl.

**Sulfate:** maximum 4.0 per cent (dried substance).

Dissolve 0.500 g in 200 mL of *distilled water R*, add 5.0 mL of *dilute hydrochloric acid R* and heat to boiling. Add dropwise

10 mL of a hot 100 g/L solution of *barium chloride R* while stirring with a glass rod, cover the beaker with a watch glass and allow to stand on a water-bath for 2 h to obtain a coarse granular precipitate. Add 0.1 mL of a 100 g/L solution of *barium chloride R* to the clear supernatant. If a turbidity develops, repeat the precipitation procedure. Transfer the precipitate quantitatively to a previously ignited and tared porcelain crucible and wash with hot *distilled water R* until the addition of *silver nitrate solution R1* to the washings produces no opalescence. Ignite the precipitate at 600 ± 50 °C for 1 h. Allow to cool in a desiccator and weigh.

1 mg of residue is equivalent to 0.412 mg of SO<sub>4</sub>.

**Barium:** maximum 10 ppm.

Atomic absorption spectrometry (2.2.23, *Method I*).

**Test solution.** Dissolve 1.0 g of the substance to be examined in *distilled water R*, add 1 mL of a 250 g/L solution of *caesium chloride R* and 0.2 mL of *hydrochloric acid R* and dilute to 20.0 mL with *distilled water R*.

**Reference solution.** To 1.0 mL of *barium standard solution (50 ppm Ba) R* add 5 mL of a 250 g/L solution of *caesium chloride R* and 1 mL of *hydrochloric acid R* and dilute to 100.0 mL with *distilled water R*.

**Source:** hollow-cathode lamp.

**Wavelength:** 553.3 nm.

**Flame:** air-acetylene-nitrous oxide flame of suitable composition.

**Iron** (2.4.9): maximum 10 ppm.

Dissolve 1.0 g with heating in *water R* and dilute to 10 mL with the same solvent.

**Mercury:** maximum 10 ppm.

Introduce 2.0 g of the substance to be examined into a 250 mL ground-glass-stoppered conical flask and add 20 mL of a mixture of equal volumes of *nitric acid R* and *sulfuric acid R*. Boil under a reflux condenser for 1 h, cool and cautiously dilute with *water R*. Boil until nitrous fumes are no longer seen. Cool the solution, cautiously dilute to 200.0 mL with *water R*, mix and filter. Transfer 50.0 mL of the filtrate to a separating funnel. Shake with successive small portions of *chloroform R* until the chloroform layer remains colourless. Discard the chloroform layers. To the aqueous layer add 25 mL of *dilute sulfuric acid R*, 115 mL of *water R* and 10 mL of a 200 g/L solution of *hydroxylamine hydrochloride R*. Titrate with *dithizone solution R2*; after each addition, shake the mixture 20 times and towards the end of the titration allow to separate and discard the chloroform layer. Titrate until a bluish-green colour is obtained. Calculate the content of mercury using the equivalent in micrograms of mercury per millilitre of titrant, determined in the standardisation of the *dithizone solution R2*.

**Nitrogen:** 23.0 per cent to 27.0 per cent (dried substance).

Carry out the determination of nitrogen by sulfuric acid digestion (2.5.9), using 10.0 mg and heating for 3-4 h.

**Heavy metals** (2.4.8): maximum 20 ppm.

1.0 g complies with test D. Prepare the reference solution using 2 mL of *lead standard solution (10 ppm Pb) R*.

**Loss on drying** (2.2.32): maximum 5.0 per cent, determined on 1.000 g by drying in an oven at 105 °C for 3 h.

**Bacterial endotoxins** (2.6.14): less than 7.0 IU/mg, if intended for use in the manufacture of parenteral preparations without a further appropriate procedure for the removal of bacterial endotoxins.

## ASSAY

**Test solution (a).** Dissolve 15.0 mg of the substance to be examined in *water R* and dilute to 100.0 mL with the same solvent.

**Test solution (b).** Dilute 2.0 mL of test solution (a) to 3.0 mL with *water R*.

**Test solution (c).** Dilute 1.0 mL of test solution (a) to 3.0 mL with *water R*.

Use as titrant a 6-fold dilution of *heparin sodium BRP* in *water R* (for example, 1.7 mL diluted to 10.0 mL with *water R*). Titrate each test solution in duplicate as follows: introduce an accurately measured volume of the solution to be titrated, for example, 1.5 mL, into the cell of a suitable colorimeter, set the apparatus for measurement at a suitable wavelength (none is critical) in the visible range, add the titrant in small volumes until there is a sharp increase in the absorbance and note the volume of titrant added.

Carry out 3 independent assays. For each individual titration, calculate the number of International Units of heparin in the volume of titrant added at the end-point per milligram of the substance to be examined. Calculate the potency of the substance as the average of the 18 values. Test the linearity of the response by the usual statistical methods (for example, 5.3). Calculate the 3 standard deviations for the results obtained with each of the 3 test solutions. Calculate the 3 standard deviations for the results obtained with each of the 3 independent assays. The assay is not valid unless each of the 6 standard deviations is less than 5 per cent of the average result.

#### STORAGE

In an airtight, tamper-proof container. If the substance is sterile, store in a sterile, airtight, tamper-proof container.

01/2011:0569

## PROTAMINE SULFATE

### Protamini sulfas

[9009-65-8]

#### DEFINITION

Protamine sulfate consists of the sulfates of basic peptides extracted from the sperm or roe of fish, usually species of *Salmonidae* and *Clupeidae*. It binds with heparin in solution, inhibiting its anticoagulant activity; in the conditions of the assay this binding gives rise to a precipitate. Calculated with reference to the dried substance, 1 mg of protamine sulfate precipitates not less than 100 IU of heparin.

#### PRODUCTION

The animals from which protamine sulfate is derived must fulfil the requirements for the health of animals suitable for human consumption.

The method of manufacture is validated to demonstrate that the product, if tested, would comply with the following test.

**Abnormal toxicity** (2.6.9). Inject into each mouse 0.5 mg dissolved in 0.5 mL of *water for injections R*.

#### CHARACTERS

**Appearance:** white or almost white, hygroscopic powder.

**Solubility:** sparingly soluble in water, practically insoluble in ethanol (96 per cent).

#### IDENTIFICATION

A. Specific optical rotation (2.2.7): –65 to –85 (dried substance).

Dissolve 1.000 g in 0.1 M *hydrochloric acid* and dilute to 100.0 mL with the same solvent.

B. In the conditions of the assay, protamine sulfate forms a precipitate.

C. To 0.5 mL of solution S (see Tests) add 4.5 mL of *water R*, 1.0 mL of a 100 g/L solution of *sodium hydroxide R* and 1.0 mL of a 0.2 g/L solution of  $\alpha$ -*naphthol R* and mix. Cool the mixture to 5 °C. Add 0.5 mL of *sodium hypobromite solution R*. An intense red colour is produced.

D. Heat 2 mL of solution S in a water-bath at 60 °C, add 0.1 mL of *mercuric sulfate solution R* and mix. No precipitate is formed. Cool the mixture in iced water. A precipitate is formed.

E. It gives reaction (a) of sulfates (2.3.1).

#### TESTS

**Solution S.** Dissolve 0.20 g in *water R* and dilute to 10.0 mL with the same solvent.

**Appearance of solution.** The solution is not more opalescent than reference suspension II (2.2.1) and not more intensely coloured than reference solution BY<sub>6</sub> or Y<sub>6</sub> (2.2.2, Method II). To 2.5 mL of solution S add 7.5 mL of *water R*.

**Absorbance** (2.2.25): maximum 0.1 between wavelengths of 260 nm and 280 nm.

Dilute 2.5 mL of solution S to 5.0 mL with *water R*.

**Sulfate:** 16 per cent to 24 per cent (dried substance).

Dissolve 0.150 g in 15 mL of *distilled water R* in a beaker. Add 5 mL of *dilute hydrochloric acid R*. Heat to boiling and slowly add to the boiling solution 10 mL of a 100 g/L solution of *barium chloride R*. Cover the beaker and heat on a water-bath for 1 h. Filter. Wash the precipitate several times with small quantities of hot *water R*. Dry and ignite the residue at 600 ± 50 °C to constant mass.

1.0 g of residue is equivalent to 0.4117 g of SO<sub>4</sub>.

**Iron** (2.4.9): maximum 10 ppm.

Dissolve 1.0 g with heating in *water R* and dilute to 10 mL with the same solvent.

**Mercury:** maximum 10 ppm.

Introduce 2.0 g of the substance to be examined into a 250 mL ground-glass-stoppered conical flask and add 20 mL of a mixture of equal volumes of *nitric acid R* and *sulfuric acid R*. Boil under a reflux condenser for 1 h, cool and cautiously dilute with *water R*. Boil until nitrous fumes are no longer seen.

Cool the solution, cautiously dilute to 200.0 mL with *water R*, mix and filter. Transfer 50.0 mL of the filtrate to a separating funnel. Shake with successive small portions of *chloroform R* until the chloroform layer remains colourless. Discard the chloroform layers. To the aqueous layer add 25 mL of *dilute sulfuric acid R*, 115 mL of *water R* and 10 mL of a 200 g/L solution of *hydroxylamine hydrochloride R*. Titrate with *dithizone solution R2*; after each addition, shake the mixture 20 times and towards the end of the titration allow to separate and discard the chloroform layer. Titrate until a bluish-green colour is obtained. Calculate the content of mercury using the equivalent in micrograms of mercury per millilitre of titrant, determined in the standardisation of the *dithizone solution R2*.

**Nitrogen:** 21.0 per cent to 26.0 per cent (dried substance).

Carry out the determination of nitrogen by sulfuric acid digestion (2.5.9), using 10.0 mg and heating for 3-4 h.

**Heavy metals** (2.4.8): maximum 20 ppm.

1.0 g complies with test D. Prepare the reference solution using 2 mL of *lead standard solution (10 ppm Pb) R*.

**Loss on drying** (2.2.32): maximum 5.0 per cent, determined on 1.000 g by drying in an oven at 105 °C for 3 h.

**Bacterial endotoxins** (2.6.14): less than 7.0 IU/mg, if intended for use in the manufacture of parenteral preparations without a further appropriate procedure for the removal of bacterial endotoxins.

#### ASSAY

**Test solution (a).** Dissolve 15.0 mg of the substance to be examined in *water R* and dilute to 100.0 mL with the same solvent.

**Test solution (b).** Dilute 2.0 mL of test solution (a) to 3.0 mL with *water R*.

**Test solution (c).** Dilute 1.0 mL of test solution (a) to 3.0 mL with *water R*.

Use as titrant a 6-fold dilution of *heparin sodium BRP* in *water R* (for example, 1.7 mL diluted to 10.0 mL with *water R*). Titrate each test solution in duplicate as follows: introduce an accurately measured volume of the solution to be titrated, for example 1.5 mL, into the cell of a suitable colorimeter and set the apparatus for measurement at a suitable wavelength (none is critical) in the visible range. Add the titrant in small volumes until there is a sharp increase in the absorbance and note the volume of titrant added.

Carry out 3 independent assays. For each individual titration, calculate the number of International Units of heparin in the volume of titrant added at the end-point per milligram of the substance to be examined. Calculate the potency of the substance as the average of the 18 values. Test the linearity of the response by the usual statistical methods (for example, 5.3). Calculate the 3 standard deviations for the results obtained with each of the 3 test solutions. Calculate the 3 standard deviations for the results obtained with each of the 3 independent assays. The assay is not valid unless each of the 6 standard deviations is less than 5 per cent of the average result.

#### STORAGE

In an airtight, tamper-proof container. If the substance is sterile, store in a sterile, airtight, tamper-proof container.

01/2008:1144

## PROTIRELIN

### Protirelinum

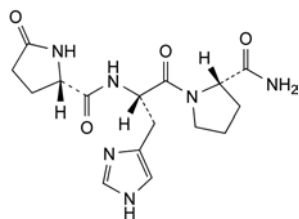

$C_{16}H_{22}N_6O_4$   
[24305-27-9]

$M_r$  362.4

#### DEFINITION

5-Oxo-L-prolyl-L-histidyl-L-prolinamide.

Synthetic tripeptide with the same sequence of amino acids as the natural hypothalamic neurohormone, which stimulates the release and synthesis of thyrotropin.

*Content*: 97.0 per cent to 102.0 per cent (anhydrous and acetic acid-free substance).

#### CHARACTERS

*Appearance*: white or yellowish-white powder, hygroscopic.

*Solubility*: very soluble in water, freely soluble in methanol.

#### IDENTIFICATION

A. Infrared absorption spectrophotometry (2.2.24).

*Comparison*: *protirelin CRS*.

B. Examine the chromatograms obtained in the assay.

*Results*: the principal peak in the chromatogram obtained with the test solution is similar in retention time and size to the principal peak in the chromatogram obtained with the reference solution.

#### TESTS

**Appearance of solution.** A 10 g/L solution is clear (2.2.1) and not more intensely coloured than reference solution  $Y_5$  (2.2.2, Method II).

**Specific optical rotation** (2.2.7): –62 to –70 (anhydrous and acetic acid-free substance).

Dissolve 10 mg in 1.0 mL of *water R*.

**Related substances.** Liquid chromatography (2.2.29).

*Test solution.* Dissolve 5.0 mg of the substance to be examined in mobile phase A and dilute to 5.0 mL with mobile phase A.

*Reference solution (a).* Dissolve the contents of a vial of *D-His-protirelin CRS* in an appropriate volume of mobile phase A to obtain a concentration of 1 mg/mL. Mix equal volumes of this solution and the test solution.

*Reference solution (b).* Dilute 0.2 mL of the test solution to 10.0 mL with mobile phase A.

*Column*:

- *size*:  $l = 0.25$  m,  $\varnothing = 4.0$  mm,
- *stationary phase*: spherical octadecylsilyl silica gel for chromatography R (5  $\mu$ m) with a pore size of 12 nm.

*Mobile phase*:

- *mobile phase A*: a mixture of 100 mL of *acetonitrile for chromatography R*, 1900 mL of *water R* and 2.0 g of *sodium octanesulfonate R*, containing 2.5 mL/L of *tetraethylammonium hydroxide solution R*; adjust to pH 3.5 with *phosphoric acid R*,
- *mobile phase B*: a mixture of 300 mL of *acetonitrile for chromatography R*, 1700 mL of *water R* and 2.0 g of *sodium octanesulfonate R*, containing 2.5 mL/L of *tetraethylammonium hydroxide solution R*; adjust to pH 3.5 with *phosphoric acid R*,

Time (min)	Mobile phase A (per cent V/V)	Mobile phase B (per cent V/V)
0 - 30	74 → 41	26 → 59
30 - 35	41 → 74	59 → 26
35 - 50	74	26

*Flow rate*: 1 mL/min.

*Detection*: spectrophotometer at 210 nm.

*Injection*: 10  $\mu$ L.

*Relative retention* with reference to protirelin (retention time = about 18 min): impurity C = about 0.2; impurity D = about 0.68; impurity A = about 0.91; impurity B = about 0.95; impurity E = about 1.08.

*System suitability*: reference solution (a):

- *resolution*: minimum 2.5 between the peaks due to impurity A and protirelin,
- *symmetry factor*: 0.9 to 1.2 for the peak due to protirelin.

*Limits*:

- *any impurity*: for each impurity, not more than the area of the principal peak in the chromatogram obtained with reference solution (b) (2 per cent),
- *total*: not more than 1.5 times the area of the principal peak in the chromatogram obtained with reference solution (b) (3 per cent),
- *disregard limit*: 0.05 times the area of the principal peak in the chromatogram obtained with reference solution (b) (0.1 per cent).

**Acetic acid** (2.5.34): maximum 2.0 per cent.

*Test solution.* Dissolve 40.0 mg of the substance to be examined in a mixture of 5 volumes of mobile phase B and 95 volumes of mobile phase A and dilute to 10.0 mL with the same mixture of solvents.

**Water** (2.5.12): maximum 7.0 per cent, determined on 0.200 g.

**Bacterial endotoxins** (2.6.14): less than 0.7 IU/mg, if intended for use in the manufacture of parenteral preparations without a further appropriate procedure for the removal of bacterial endotoxins.

#### ASSAY

Liquid chromatography (2.2.29) as described in the test for related substances with the following modification.

01/2008:0526  
corrected 6.0

**Reference solution.** Dissolve the contents of a vial of *protirelin CRS* in an appropriate volume of mobile phase A to obtain a concentration of 1.0 mg/mL.

Calculate the content of protirelin ( $C_{16}H_{22}N_6O_4$ ) using the peak areas of the chromatograms obtained with the test solution and the reference solution and the declared content of  $C_{16}H_{22}N_6O_4$  in *protirelin CRS*.

**STORAGE**

In an airtight container, protected from light at a temperature of 2 °C to 8 °C. If the substance is sterile, store in a sterile, airtight, tamper-proof container.

**LABELLING**

The label states the mass of peptide in the container.

**IMPURITIES**

*Specified impurities: A, B, C, D, E.*

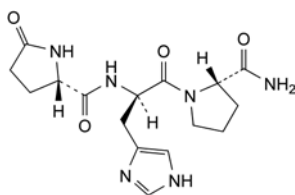

A. 5-oxo-L-prolyl-D-histidyl-L-prolinamide,

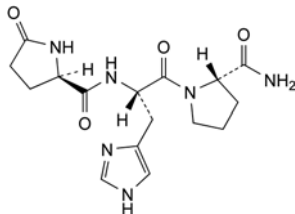

B. 5-oxo-D-prolyl-L-histidyl-L-prolinamide,

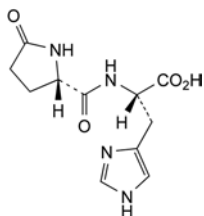

C. 5-oxo-L-prolyl-L-histidine,

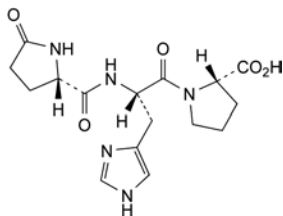

D. 5-oxo-L-prolyl-L-histidyl-L-proline,

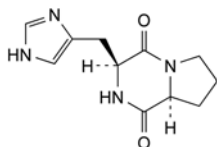

E. (3*S*,8*aS*)-3-(1*H*-imidazol-4-ylmethyl)hexahydropyrrolo[1,2-*a*]pyrazine-1,4-dione (cyclo-(L-histidyl-L-prolyl-)).

**PROXYPHYLLINE**

## Proxyphyllinum

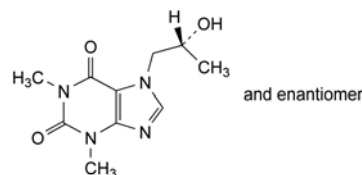

$C_{10}H_{14}N_4O_3$   
[603-00-9]

$M_r$  238.2

**DEFINITION**

Proxyphylline contains not less than 98.5 per cent and not more than the equivalent of 101.0 per cent of 7-[(2*RS*)-2-hydroxypropyl]-1,3-dimethyl-3,7-dihydro-1*H*-purine-2,6-dione, calculated with reference to the dried substance.

**CHARACTERS**

A white or almost white, crystalline powder, very soluble in water, soluble in alcohol.

**IDENTIFICATION**

*First identification: B, C.*

*Second identification: A, C, D.*

- A. Melting point (2.2.14): 134 °C to 136 °C.
- B. Examine by infrared absorption spectrophotometry (2.2.24), comparing with the spectrum obtained with *proxyphylline CRS*. Examine the substances as discs prepared using 0.5 mg to 1 mg of the substance to be examined in 0.3 g of *potassium bromide R*.
- C. Dissolve 1 g in 5 mL of *acetic anhydride R* and boil under a reflux condenser for 15 min. Allow to cool and add 100 mL of a mixture of 20 volumes of *ether R* and 80 volumes of *light petroleum R*. Cool in iced water for at least 20 min, shaking from time to time. Filter, wash the precipitate with a mixture of 20 volumes of *ether R* and 80 volumes of *light petroleum R*, recrystallise from *alcohol R* and dry *in vacuo*. The crystals melt (2.2.14) at 87 °C to 92 °C.
- D. It gives the reaction of xanthines (2.3.1).

**TESTS**

**Solution S.** Dissolve 2.5 g in *carbon dioxide-free water R* and dilute to 50 mL with the same solvent.

**Appearance of solution.** Solution S is clear (2.2.1) and colourless (2.2.2, *Method II*).

**Acidity or alkalinity.** To 10 mL of solution S add 0.25 mL of *bromothymol blue solution R1*. The solution is yellow or green. Not more than 0.4 mL of 0.01 *M sodium hydroxide* is required to change the colour of the indicator to blue.

**Related substances.** Examine by thin-layer chromatography (2.2.27), using *silica gel HF<sub>254</sub> R* as the coating substance.

**Test solution.** Dissolve 0.3 g of the substance to be examined in a mixture of 20 volumes of *water R* and 30 volumes of *methanol R* and dilute to 10 mL with the same mixture of solvents. Prepare immediately before use.

**Reference solution (a).** Dilute 1 mL of the test solution to 100 mL with *methanol R*.

**Reference solution (b).** Dilute 0.2 mL of the test solution to 100 mL with *methanol R*.

**Reference solution (c).** Dissolve 10 mg of *theophylline R* in *methanol R*, add 0.3 mL of the test solution and dilute to 10 mL with *methanol R*.



Apply separately to the plate 10 µL of each solution. Develop over a path of 15 cm using a mixture of 1 volume of *concentrated ammonia R*, 10 volumes of *ethanol R* and 90 volumes of *chloroform R*. Allow the plate to dry in air and examine in ultraviolet light at 254 nm. Any spot in the chromatogram obtained with the test solution, apart from the principal spot, is not more intense than the spot in the chromatogram obtained with reference solution (a) (1 per cent) and at most one such spot is more intense than the spot in the chromatogram obtained with reference solution (b) (0.2 per cent). The test is not valid unless the chromatogram obtained with reference solution (c) shows two clearly separated spots.

**Chlorides (2.4.4).** Dilute 2.5 mL of solution S to 15 mL with *water R*. The solution complies with the limit test for chlorides (400 ppm).

**Heavy metals (2.4.8).** 12 mL of solution S complies with limit test A for heavy metals (20 ppm). Prepare the standard using *lead standard solution (1 ppm Pb) R*.

**Loss on drying (2.2.32).** Not more than 0.5 per cent, determined on 1.000 g by drying in an oven at 105 °C.

**Sulfated ash (2.4.14).** Not more than 0.1 per cent, determined on 1.0 g.

#### ASSAY

*In order to avoid overheating in the reaction medium, mix thoroughly throughout and stop the titration immediately after the end-point has been reached.*

Dissolve 0.200 g in 3.0 mL of *anhydrous formic acid R* and add 50.0 mL of *acetic anhydride R*. Titrate with 0.1 M *perchloric acid* determining the end-point potentiometrically (2.2.20).

1 mL of 0.1 M *perchloric acid* is equivalent to 23.82 mg of  $C_{10}H_{14}N_4O_3$ .

#### STORAGE

Store protected from light.

*Comparison: pseudoephedrine hydrochloride CRS.*

C. Thin-layer chromatography (2.2.27).

*Test solution.* Dissolve 20 mg of the substance to be examined in *methanol R* and dilute to 10 mL with the same solvent.

*Reference solution (a).* Dissolve 20 mg of *pseudoephedrine hydrochloride CRS* in *methanol R* and dilute to 10 mL with the same solvent.

*Reference solution (b).* Dissolve 10 mg of *ephedrine hydrochloride CRS* in reference solution (a) and dilute to 5 mL with reference solution (a).

*Plate: TLC silica gel plate R.*

*Mobile phase: methylene chloride R, concentrated ammonia R, 2-propanol R (5:15:80 V/V/V).*

*Application: 10 µL.*

*Development: over 2/3 of the plate.*

*Drying: in air.*

*Detection: spray with ninhydrin solution R and heat at 110 °C for 5 min.*

*System suitability: reference solution (b):*

– the chromatogram shows 2 clearly separated spots.

*Results: the principal spot in the chromatogram obtained with the test solution is similar in position, colour and size to the principal spot in the chromatogram obtained with reference solution (a).*

D. Solution S (see Tests) gives reaction (a) of chlorides (2.3.1).

#### TESTS

**Solution S.** Dissolve 1.25 g in *carbon dioxide-free water R* and dilute to 25.0 mL with the same solvent.

**Appearance of solution.** Solution S is clear (2.2.1) and colourless (2.2.2, *Method II*).

**Acidity or alkalinity.** Dilute 2 mL of solution S to 10 mL with *carbon dioxide-free water R*. Add 0.1 mL of *methyl red solution R* and 0.1 mL of 0.01 M *sodium hydroxide*; the solution is yellow. Add 0.2 mL of 0.01 M *hydrochloric acid*; the solution is red.

**Specific optical rotation (2.2.7):** + 61.0 to + 62.5 (dried substance), determined on solution S.

**Related substances.** Liquid chromatography (2.2.29).

*Test solution.* Dissolve 50.0 mg of the substance to be examined in the mobile phase and dilute to 25.0 mL with the mobile phase.

*Reference solution (a).* Dissolve 20.0 mg of *ephedrine hydrochloride CRS* (impurity A) in the mobile phase and dilute to 20.0 mL with the mobile phase. Dilute 1.0 mL of this solution to 50.0 mL with the mobile phase.

*Reference solution (b).* Dilute 1.0 mL of the test solution to 200.0 mL with the mobile phase.

*Reference solution (c).* Dissolve 10 mg of *ephedrine hydrochloride CRS* (impurity A) in 5 mL of the test solution and dilute to 100 mL with the mobile phase.

**Column:**

– *size: l* = 0.25 m,  $\varnothing$  = 4.6 mm;

– *stationary phase: phenylsilyl silica gel for chromatography R* (5 µm).

*Mobile phase: mix 6 volumes of methanol R and 94 volumes of an 11.6 g/L solution of ammonium acetate R previously adjusted to pH 4.0 with glacial acetic acid R.*

*Flow rate: 1 mL/min.*

*Detection: spectrophotometer at 257 nm.*

*Injection: 20 µL.*

*Run time: 1.5 times the retention time of pseudoephedrine.*

*Relative retention with reference to pseudoephedrine (retention time = about 18 min): impurity A = about 0.9.*

07/2008:1367

## PSEUDOEPHEDRINE HYDROCHLORIDE

### Pseudoephedrini hydrochloridum

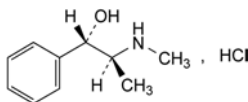

$C_{10}H_{16}ClNO$   
[345-78-8]

$M_r$  201.7

#### DEFINITION

(1S,2S)-2-(Methylamino)-1-phenylpropan-1-ol hydrochloride.

*Content:* 99.0 per cent to 101.0 per cent (dried substance).

#### CHARACTERS

*Appearance:* white or almost white, crystalline powder or colourless crystals.

*Solubility:* freely soluble in water and in ethanol (96 per cent), sparingly soluble in methylene chloride.

*mp:* about 184 °C.

#### IDENTIFICATION

*First identification: A, B, D.*

*Second identification: A, C, D.*

A. Specific optical rotation (see Tests).

B. Infrared absorption spectrophotometry (2.2.24).

**System suitability:** reference solution (c):

- **resolution:** minimum 2.0 between the peaks due to impurity A and pseudoephedrine; if necessary, reduce the content of methanol in the mobile phase.

**Limits:**

- **impurity A:** not more than the area of the principal peak in the chromatogram obtained with reference solution (a) (1.0 per cent);
- **any other impurity:** for each impurity, not more than the area of the principal peak in the chromatogram obtained with reference solution (b) (0.5 per cent);
- **sum of impurities other than A:** not more than twice the area of the principal peak in the chromatogram obtained with reference solution (b) (1.0 per cent);
- **disregard limit:** 0.1 times the area of the principal peak in the chromatogram obtained with reference solution (b) (0.05 per cent).

**Loss on drying (2.2.32):** maximum 0.5 per cent, determined on 1.000 g by drying in an oven at 105 °C.

**Sulfated ash (2.4.14):** maximum 0.1 per cent, determined on 1.0 g.

#### ASSAY

Dissolve 0.170 g in 30 mL of *ethanol (96 per cent) R*. Add 5.0 mL of 0.01 M *hydrochloric acid*. Carry out a potentiometric titration (2.2.20), using 0.1 M *sodium hydroxide*. Read the volume added between the 2 points of inflexion.

1 mL of 0.1 M *sodium hydroxide* is equivalent to 20.17 mg of C<sub>10</sub>H<sub>16</sub>ClNO.

#### STORAGE

Protected from light.

#### IMPURITIES

**Specified impurities:** A.

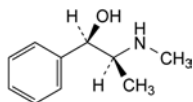

A. (1*R*,2*S*)-2-(methylamino)-1-phenylpropan-1-ol (ephedrine).

01/2008:1680  
corrected 6.0

## PYRANTEL EMBONATE

### Pyranteli embonas

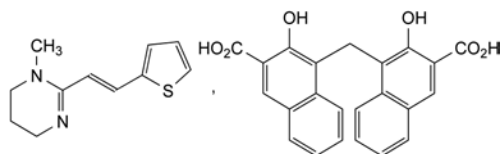

C<sub>34</sub>H<sub>30</sub>N<sub>2</sub>O<sub>6</sub>S  
[22204-24-6]

M<sub>r</sub> 594.7

#### DEFINITION

1-Methyl-2-[(*E*)-2-(thiophen-2-yl)ethenyl]-1,4,5,6-tetrahydropyrimidine hydrogen 4,4'-methylenebis(3-hydroxynaphthalene-2-carboxylate).

**Content:** 98.0 per cent to 102.0 per cent (dried substance).

#### CHARACTERS

**Appearance:** pale yellow or yellow powder.

**Solubility:** practically insoluble in water, soluble in dimethyl sulfoxide, practically insoluble in methanol.

#### IDENTIFICATION

Infrared absorption spectrophotometry (2.2.24).

**Comparison:** *pyrantel embonate CRS*.

#### TESTS

**Related substances.** Liquid chromatography (2.2.29). Prepare the solutions immediately before use and strictly protect from light at all stages.

**Solvent mixture.** Mix 5 volumes of *glacial acetic R* with 5 volumes of *water R* and add 2 volumes of *diethylamine R* with cooling.

**Test solution.** Dissolve 80 mg in 7 mL of the solvent mixture and dilute to 100.0 mL with *acetonitrile R*.

**Reference solution (a).** Dissolve 10.0 mg of *pyrantel impurity A CRS* in the solvent mixture, add 2.5 mL of the test solution and dilute to 50.0 mL with the solvent mixture. Dilute 2.0 mL of this solution to 100.0 mL with the solvent mixture.

**Reference solution (b).** Dilute 1.0 mL of the test solution to 200.0 mL with the mobile phase.

**Column:**

– **size:**  $l = 0.25$  m,  $\varnothing = 4.6$  mm;

– **stationary phase:** *silica gel for chromatography R* (5  $\mu$ m).

**Mobile phase:** solvent mixture, *acetonitrile for chromatography R* (72:928 V/V).

**Flow rate:** 1 mL/min.

**Detection:** spectrophotometer at 288 nm.

**Injection:** 20  $\mu$ L.

**Run time:** 4 times the retention time of pyrantel.

**Relative retention** with reference to pyrantel (retention time = about 11 min): embonic acid = about 0.5; impurity A = about 1.3; impurity B = about 1.8 (impurity A also gives rise to an embonate peak).

**System suitability:** reference solution (a):

- **resolution:** minimum 4.0 between the peaks due to pyrantel and impurity A.

**Limits:**

- **correction factor:** for the calculation of content, multiply the peak area of impurity B by 0.4;
- **impurity A:** not more than the area of the corresponding peak in the chromatogram obtained with reference solution (a) (0.5 per cent);
- **impurity B:** not more than 0.4 times the area of the principal peak in the chromatogram obtained with reference solution (b) (0.2 per cent);
- **unspecified impurities:** for each impurity, not more than 0.2 times the area of the principal peak in the chromatogram obtained with reference solution (b) (0.10 per cent);
- **sum of impurities other than A and B:** not more than 0.6 times the area of the principal peak in the chromatogram obtained with reference solution (b) (0.3 per cent);
- **disregard limit:** 0.1 times the area of the principal peak in the chromatogram obtained with reference solution (b) (0.05 per cent).

**Chlorides (2.4.4):** maximum 360 ppm.

To 0.46 g add 10 mL of *dilute nitric acid R* and 30 mL of *water R*. Heat on a water-bath for 5 min. Cool, dilute to 50 mL with *water R*, mix well and filter.

**Sulfates (2.4.13):** maximum 0.1 per cent.

To 0.50 g add 2.5 mL of *dilute nitric acid R* and dilute to 50 mL with *distilled water R*. Heat on a water-bath for 5 min, shake for 2 min, cool and filter.

**Iron (2.4.9):** maximum 75 ppm.

Ignite 0.66 g at 800  $\pm$  50 °C for 2 h. Dissolve the residue in 2.5 mL of *dilute hydrochloric acid R* with gentle heating for 10 min. Cool and dilute to 50 mL with *water R*.

**Heavy metals (2.4.8):** maximum 20 ppm.

1.0 g complies with test D. Prepare the reference solution using 2.0 mL of *lead standard solution (10 ppm Pb) R*.

**Loss on drying** (2.2.32): maximum 1.0 per cent, determined on 1.000 g by drying *in vacuo* at 60 °C for 3 h.

**Sulfated ash** (2.4.14): maximum 0.1 per cent, determined on 1.0 g.

#### ASSAY

To 0.450 g add 10 mL of *acetic anhydride R* and 50 mL *glacial acetic acid R*, heat at 50 °C and stir for 10 min. Allow to cool (a clear solution is not obtained). Titrate with 0.1 M *perchloric acid*, determining the end-point potentiometrically (2.2.20). Carry out a blank titration.

1 mL of 0.1 M *perchloric acid* is equivalent to 59.47 mg of C<sub>34</sub>H<sub>30</sub>N<sub>2</sub>O<sub>6</sub>S.

#### STORAGE

Protected from light.

#### IMPURITIES

*Specified impurities: A, B.*

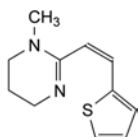

A. 1-methyl-2-[(Z)-2-(thiophen-2-yl)ethenyl]-1,4,5,6-tetrahydropyrimidine,

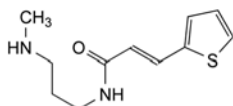

B. (*E*)-N-[3-(methylamino)propyl]-3-(thiophen-2-yl)prop-2-enamide.

01/2008:0859  
corrected 6.0

## PYRAZINAMIDE

### Pyrazinamidum

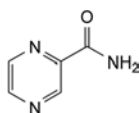

C<sub>5</sub>H<sub>5</sub>N<sub>3</sub>O  
[98-96-4]

M<sub>r</sub> 123.1

#### DEFINITION

Pyrazinamide contains not less than 99.0 per cent and not more than the equivalent of 100.5 per cent of pyrazine-2-carboxamide, calculated with reference to the anhydrous substance.

#### CHARACTERS

A white or almost white, crystalline powder, sparingly soluble in water, slightly soluble in alcohol and in methylene chloride.

#### IDENTIFICATION

*First identification: C.*

*Second identification: A, B, D.*

A. Melting point (2.2.14): 188 °C to 191 °C.

B. Dissolve 50.0 mg in *water R* and dilute to 100.0 mL with the same solvent (solution (a)). Dilute 1.0 mL of solution (a) to 10.0 mL with *water R*. Examined between 290 nm and 350 nm (2.2.25), the solution shows an absorption maximum at 310 nm. Dilute 2.0 mL of solution (a) to 100.0 mL with *water R*. Examined between 230 nm and 290 nm, the solution shows an absorption maximum at 268 nm. The specific absorbance at the maximum is 640 to 680.

C. Examine by infrared absorption spectrophotometry (2.2.24), comparing with the spectrum obtained with *pyrazinamide CRS*. Examine the substances prepared as discs. If the spectra obtained show differences, dissolve the substance to be examined and the reference substance separately in *alcohol R*, evaporate to dryness and record new spectra using the residues.

D. Dissolve 0.1 g in 5 mL of *water R*. Add 1 mL of *ferrous sulfate solution R2*. The solution becomes orange. Add 1 mL of *dilute sodium hydroxide solution R*. The solution becomes dark blue.

#### TESTS

**Solution S.** Dissolve 0.5 g in *carbon dioxide-free water R* and dilute to 50 mL with the same solvent.

**Appearance of solution.** Solution S is clear (2.2.1) and colourless (2.2.2, *Method II*).

**Acidity or alkalinity.** To 25 mL of solution S add 0.05 mL of *phenolphthalein solution R1* and 0.2 mL of 0.01 M *sodium hydroxide*. The solution is red. Add 1.0 mL of 0.01 M *hydrochloric acid*. The solution is colourless. Add 0.15 mL of *methyl red solution R*. The solution is red.

**Related substances.** Examine by thin-layer chromatography (2.2.27), using *silica gel GF<sub>254</sub> R* as the coating substance.

**Test solution.** Dissolve 0.1 g of the substance to be examined in a mixture of 1 volume of *methanol R* and 9 volumes of *methylene chloride R* and dilute to 10 mL with the same mixture of solvents.

**Reference solution (a).** Dilute 1 mL of the test solution to 50 mL with a mixture of 1 volume of *methanol R* and 9 volumes of *methylene chloride R*. Dilute 1 mL of the solution to 10 mL with a mixture of 1 volume of *methanol R* and 9 volumes of *methylene chloride R*.

**Reference solution (b).** Dissolve 10 mg of *nicotinic acid CRS* in a mixture of 1 volume of *methanol R* and 9 volumes of *methylene chloride R*, add 1 mL of the test solution and dilute to 10 mL with the same mixture of solvents.

Apply separately to the plate 20 µL of each solution. Develop over a path of 10 cm using a mixture of 20 volumes of *glacial acetic acid R*, 20 volumes of *water R* and 60 volumes of *butanol R*. Allow the plate to dry in air and examine immediately in ultraviolet light at 254 nm. Any spot in the chromatogram obtained with the test solution, apart from the principal spot, is not more intense than the spot in the chromatogram obtained with reference solution (a) (0.2 per cent). The test is not valid unless the chromatogram obtained with reference solution (b) shows two clearly separated principal spots.

**Heavy metals** (2.4.8). 1.0 g complies with limit test C for heavy metals (10 ppm). Prepare the standard using 1 mL of *lead standard solution (10 ppm Pb) R*.

**Water** (2.5.12). Not more than 0.5 per cent, determined on 2.00 g by the semi-micro determination of water.

**Sulfated ash** (2.4.14). Not more than 0.1 per cent, determined on 1.0 g.

#### ASSAY

Dissolve 0.100 g in 50 mL of *acetic anhydride R*. Titrate with 0.1 M *perchloric acid*, determining the end-point potentiometrically (2.2.20).

1 mL of 0.1 M *perchloric acid* is equivalent to 12.31 mg of C<sub>5</sub>H<sub>5</sub>N<sub>3</sub>O.

#### IMPURITIES

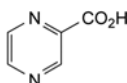

A. pyrazine-2-carboxylic acid.

01/2008:1255 *Limits:*

corrected 6.0

**PYRIDOSTIGMINE BROMIDE**

## Pyridostigmini bromidum

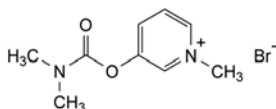
C<sub>9</sub>H<sub>13</sub>BrN<sub>2</sub>O<sub>2</sub>  
[101-26-8]M<sub>r</sub> 261.1

## DEFINITION

3-(Dimethylcarbamoyloxy)-1-methylpyridinium bromide.

*Content:* 98.5 per cent to 101.0 per cent (dried substance).

## CHARACTERS

*Appearance:* white or almost white, crystalline, deliquescent powder.*Solubility:* very soluble in water and in ethanol (96 per cent).

## IDENTIFICATION

A. Infrared absorption spectrophotometry (2.2.24).

*Comparison:* pyridostigmine bromide CRS.

B. It gives reaction (a) of bromides (2.3.1).

## TESTS

**Solution S.** Dissolve 1.0 g in carbon dioxide-free water R and dilute to 100 mL with the same solvent.**Appearance of solution.** Solution S is clear (2.2.1) and colourless (2.2.2, Method II).**Acidity or alkalinity.** To 40 mL of solution S add a few drops of methyl red solution R. To 20 mL of this solution add 0.2 mL of 0.02 M sodium hydroxide. The solution is yellow. To the other 20 mL add 0.2 mL of 0.02 M hydrochloric acid. The solution is red.**Related substances.** Liquid chromatography (2.2.29).*Test solution.* Dissolve 50 mg of the substance to be examined in the mobile phase at about 40 °C. Allow to cool and dilute to 50.0 mL with the mobile phase.*Reference solution (a).* Dissolve 4 mg of pyridostigmine impurity A CRS and 4 mg of pyridostigmine bromide CRS in the mobile phase and dilute to 100.0 mL with the mobile phase. Dilute 5.0 mL of this solution to 100.0 mL with the mobile phase.*Reference solution (b).* Dilute 1.0 mL of the test solution to 100.0 mL with the mobile phase. Dilute 10.0 mL of this solution to 50.0 mL with the mobile phase.*Reference solution (c).* Dilute 5.0 mL of reference solution (b) to 20.0 mL with the mobile phase.*Column:*

- size:  $l = 0.25$  m,  $\varnothing = 4.0$  mm;
- stationary phase: base-deactivated octadecylsilyl silica gel for chromatography R (5-10  $\mu$ m).

*Mobile phase:* mix 30 volumes of acetonitrile R and 70 volumes of a 4.33 g/L solution of sodium dodecyl sulfate R previously adjusted to pH 2.0 with phosphoric acid R.*Flow rate:* 1.1 mL/min.*Detection:* spectrophotometer at 220 nm.*Injection:* 20  $\mu$ L.*Run time:* twice the retention time of pyridostigmine.*System suitability:* reference solution (a):

- resolution: minimum 1.5 between the peaks due to pyridostigmine and impurity A.

- impurities A, B: for each impurity, not more than twice the area of the principal peak in the chromatogram obtained with reference solution (b) (0.4 per cent), at most one such peak has an area greater than the area of the principal peak in the chromatogram obtained with reference solution (b) (0.2 per cent) and at most one further peak has an area greater than 0.5 times the area of the principal peak in the chromatogram obtained with reference solution (b) (0.1 per cent);

- total: not more than 2.5 times the area of the principal peak in the chromatogram obtained with reference solution (b) (0.5 per cent);

- disregard limit: the area of the principal peak in the chromatogram obtained with reference solution (c) (0.05 per cent).

**Heavy metals** (2.4.8): maximum 20 ppm.

1.0 g complies with test C. Prepare the reference solution using 2 mL of lead standard solution (10 ppm Pb) R.

**Loss on drying** (2.2.32): maximum 0.5 per cent, determined on 1.000 g by drying in an oven at 105 °C.**Sulfated ash** (2.4.14): maximum 0.1 per cent, determined on 1.0 g.

## ASSAY

Dissolve 0.230 g in 10 mL of anhydrous acetic acid R. Add 40 mL of acetic anhydride R. Titrate with 0.1 M perchloric acid, determining the end-point potentiometrically (2.2.20).

1 mL of 0.1 M perchloric acid is equivalent to 26.11 mg of C<sub>9</sub>H<sub>13</sub>BrN<sub>2</sub>O<sub>2</sub>.

## STORAGE

In an airtight container, protected from light. If the substance is sterile, store in a sterile, airtight, tamper-proof container, protected from light.

## IMPURITIES

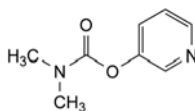
*Specified impurities:* A, B.

A. pyridin-3-yl dimethylcarbamate,

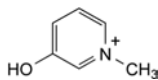

B. 3-hydroxy-1-methylpyridinium.

01/2010:0245

**PYRIDOXINE HYDROCHLORIDE**

## Pyridoxini hydrochloridum

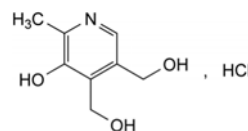
C<sub>8</sub>H<sub>12</sub>ClNO<sub>3</sub>  
[58-56-0]M<sub>r</sub> 205.6

## DEFINITION

(5-Hydroxy-6-methylpyridine-3,4-diol)dimethanol hydrochloride.

*Content:* 99.0 per cent to 101.0 per cent (dried substance).

## CHARACTERS

*Appearance:* white or almost white, crystalline powder.*Solubility:* freely soluble in water, slightly soluble in ethanol (96 per cent).

mp: about 205 °C, with decomposition.

#### IDENTIFICATION

*First identification:* B, D.

*Second identification:* A, C, D.

##### A. Ultraviolet and visible absorption spectrophotometry (2.2.25).

*Solution A.* Dilute 1.0 mL of solution S (see Tests) to 50.0 mL with 0.1 M hydrochloric acid.

*Solution B.* Dilute 1.0 mL of solution A to 100.0 mL with 0.1 M hydrochloric acid.

*Solution C.* Dilute 1.0 mL of solution A to 100.0 mL with the potassium dihydrogen phosphate 0.025 M + disodium hydrogen phosphate 0.025 M solution described in chapter 2.2.3.

*Spectral ranges:* 250-350 nm for solution B; 220-350 nm for solution C.

*Absorption maxima:* 288-296 nm for solution B; 248-256 nm and 320-327 nm for solution C.

*Specific absorbances at the absorption maxima:*

- 425-445 for solution B at 288-296 nm;
- 175-195 for solution C at 248-256 nm;
- 345-365 for solution C at 320-327 nm.

##### B. Infrared absorption spectrophotometry (2.2.24).

*Comparison:* pyridoxine hydrochloride CRS.

##### C. Thin-layer chromatography (2.2.27).

*Test solution.* Dissolve 1.0 g of the substance to be examined in water R and dilute to 10 mL with the same solvent. Dilute 1 mL of this solution to 10 mL with water R.

*Reference solution.* Dissolve 0.10 g of pyridoxine hydrochloride CRS in water R and dilute to 10 mL with the same solvent.

*Plate:* TLC silica gel G plate R.

*Mobile phase:* concentrated ammonia R, methylene chloride R, tetrahydrofuran R, acetone R (9:13:13:65 V/V/V/V).

*Application:* 2 µL.

*Development:* in an unsaturated tank, over a path of 15 cm.

*Drying:* in air.

*Detection:* spray with a 50 g/L solution of sodium carbonate R in a mixture of 30 volumes of ethanol (96 per cent) R and 70 volumes of water R; dry in a current of air, spray with a 1 g/L solution of dichloroquinonechlorimide R in ethanol (96 per cent) R and examine immediately.

*Results:* the principal spot in the chromatogram obtained with the test solution is similar in position, colour and size to the principal spot in the chromatogram obtained with the reference solution.

D. Solution S gives reaction (a) of chlorides (2.3.1).

#### TESTS

**Solution S.** Dissolve 2.50 g in carbon dioxide-free water R and dilute to 50.0 mL with the same solvent.

**Appearance of solution.** Solution S is clear (2.2.1) and not more intensely coloured than reference solution Y<sub>7</sub> (2.2.2, Method II).

**pH** (2.2.3): 2.4 to 3.0 for solution S.

**Related substances.** Liquid chromatography (2.2.29).

*Test solution.* Dissolve 25 mg of the substance to be examined in water R and dilute to 10.0 mL with the same solvent.

*Reference solution (a).* Dilute 1.0 mL of the test solution to 100.0 mL with water R. Dilute 1.0 mL of this solution to 10.0 mL with water R.

*Reference solution (b).* Dissolve 2.5 mg of pyridoxine impurity A CRS and 2.5 mg of 4-deoxypyridoxine hydrochloride R (impurity B) in water R and dilute to 10.0 mL with the same solvent. Dilute 2.0 mL of this solution to 10.0 mL with water R.

#### Column:

- *size:*  $l = 0.25$  m,  $\varnothing = 4.6$  mm;
- *stationary phase:* base-deactivated end-capped octadecylsilyl silica gel for chromatography R (5 µm).

*Mobile phase:* dissolve 2.72 g of potassium dihydrogen phosphate R in 900 mL of water R, adjust to pH 3.0 with dilute phosphoric acid R and dilute to 1000 mL with water R.

*Flow rate:* 1.0 mL/min.

*Detection:* spectrophotometer at 210 nm.

*Injection:* 5 µL.

*Run time:* 2.5 times the retention time of pyridoxine.

*Identification of impurities:* use the chromatogram obtained with reference solution (b) to identify the peaks due to impurities A and B.

*Relative retention* with reference to pyridoxine (retention time = about 12 min): impurity A = about 1.7; impurity B = about 1.9.

*System suitability:* reference solution (b):

- *resolution:* minimum 1.5 between the peaks due to impurities A and B.

#### Limits:

- *correction factor:* for the calculation of content, multiply the peak area of impurity B by 1.5;
- *impurity B:* not more than 1.5 times the area of the principal peak in the chromatogram obtained with reference solution (a) (0.15 per cent);
- *unspecified impurities:* for each impurity, not more than the area of the principal peak in the chromatogram obtained with reference solution (a) (0.10 per cent);
- *total:* not more than twice the area of the principal peak in the chromatogram obtained with reference solution (a) (0.2 per cent);
- *disregard limit:* 0.5 times the area of the principal peak in the chromatogram obtained with reference solution (a) (0.05 per cent).

**Heavy metals** (2.4.8): maximum 20 ppm.

12 mL of solution S complies with test A. Prepare the reference solution using lead standard solution (1 ppm Pb) R.

**Loss on drying** (2.2.32): maximum 0.5 per cent, determined on 1.000 g by drying in an oven at 105 °C.

**Sulfated ash** (2.4.14): maximum 0.1 per cent, determined on 1.0 g.

#### ASSAY

*In order to avoid overheating in the reaction medium, mix thoroughly throughout and stop the titration immediately after the end-point has been reached.*

Dissolve 0.150 g in 5 mL of anhydrous formic acid R. Add 50 mL of acetic anhydride R. Titrate with 0.1 M perchloric acid, determining the end-point potentiometrically (2.2.20). Carry out a blank titration.

1 mL of 0.1 M perchloric acid is equivalent to 20.56 mg of C<sub>8</sub>H<sub>12</sub>ClNO<sub>3</sub>.

#### STORAGE

Protected from light.

#### IMPURITIES

*Specified impurities:* B.

*Other detectable impurities* (the following substances would, if present at a sufficient level, be detected by one or other of the tests in the monograph. They are limited by the general acceptance criterion for other/unspecified impurities and/or by the general monograph *Substances for pharmaceutical use* (2034). It is therefore not necessary to identify these impurities for demonstration of compliance. See also 5.10. *Control of impurities in substances for pharmaceutical use*): A.

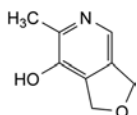

A. 6-methyl-1,3-dihydrofuro[3,4-c]pyridin-7-ol,

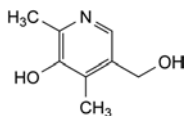

B. 5-(hydroxymethyl)-2,4-dimethylpyridin-3-ol.

01/2008:0288  
corrected 6.0

## PYRIMETHAMINE

### Pyrimethaminum

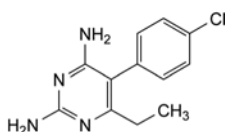
C<sub>12</sub>H<sub>13</sub>ClN<sub>4</sub>  
[58-14-0]M<sub>r</sub> 248.7

#### DEFINITION

Pyrimethamine contains not less than 99.0 per cent and not more than the equivalent of 101.0 per cent of 5-(4-chlorophenyl)-6-ethylpyrimidine-2,4-diamine, calculated with reference to the dried substance.

#### CHARACTERS

An almost white, crystalline powder or colourless crystals, practically insoluble in water, slightly soluble in alcohol.

#### IDENTIFICATION

*First identification:* C.

*Second identification:* A, B, D.

- A. Melting point (2.2.14): 239 °C to 243 °C.
- B. Dissolve 0.14 g in *ethanol R* and dilute to 100.0 mL with the same solvent. Dilute 10.0 mL of this solution to 100.0 mL with 0.1 M *hydrochloric acid*. Dilute 10.0 mL of this solution to 100.0 mL with 0.1 M *hydrochloric acid*. Examined between 250 nm and 300 nm (2.2.25), the solution shows an absorption maximum at 272 nm and an absorption minimum at 261 nm. The specific absorbance at the maximum is 310 to 330.
- C. Examine by infrared absorption spectrophotometry (2.2.24), comparing with the spectrum obtained with *pyrimethamine CRS*.
- D. Examine the chromatograms obtained in the test for related substances in ultraviolet light at 254 nm. The principal spot in the chromatogram obtained with test solution (b) is similar in position and size to the principal spot in the chromatogram obtained with reference solution (a).

#### TESTS

**Solution S.** Shake 1.0 g with 50 mL of *distilled water R* for 2 min and filter.

**Appearance of solution.** Prepare the solution immediately before use.

Dissolve 0.25 g in a mixture of 1 volume of *methanol R* and 3 volumes of *methylene chloride R* and dilute to 10 mL with the same mixture of solvents. The solution is clear (2.2.1) and not more intensely coloured than reference solution BY<sub>6</sub> (2.2.2, Method II).

**Acidity or alkalinity.** To 10 mL of solution S add 0.05 mL of *phenolphthalein solution R1*. The solution is colourless. Not more than 0.2 mL of 0.01 M *sodium hydroxide* is required to change the colour of the indicator to pink. Add 0.4 mL of 0.01 M *hydrochloric acid* and 0.05 mL of *methyl red solution R*. The solution is red or orange.

**Related substances.** Examine by thin-layer chromatography (2.2.27), using *silica gel GF<sub>254</sub> R* as the coating substance. Prepare the solutions immediately before use.

**Test solution (a).** Dissolve 0.25 g of the substance to be examined in a mixture of 1 volume of *methanol R* and 9 volumes of *chloroform R* and dilute to 25 mL with the same mixture of solvents.

**Test solution (b).** Dilute 1 mL of test solution (a) to 10 mL with a mixture of 1 volume of *methanol R* and 9 volumes of *chloroform R*.

**Reference solution (a).** Dissolve 0.1 g of *pyrimethamine CRS* in a mixture of 1 volume of *methanol R* and 9 volumes of *chloroform R* and dilute to 100 mL with the same mixture of solvents.

**Reference solution (b).** Dilute 2.5 mL of test solution (a) to 100 mL with a mixture of 1 volume of *methanol R* and 9 volumes of *chloroform R*. Dilute 1 mL of the solution to 10 mL with a mixture of 1 volume of *methanol R* and 9 volumes of *chloroform R*.

Apply to the plate 20 µL of each solution. Develop over a path of 10 cm using a mixture of 4 volumes of *chloroform R*, 8 volumes of *propanol R*, 12 volumes of *glacial acetic acid R* and 76 volumes of *toluene R*. Allow the plate to dry in air. Examine in ultraviolet light at 254 nm. Any spot in the chromatogram obtained with test solution (a), apart from the principal spot, is not more intense than the spot in the chromatogram obtained with reference solution (b) (0.25 per cent).

**Sulfates (2.4.13).** 15 mL of solution S complies with the limit test for sulfates (80 ppm). Prepare the standard using a mixture of 2.5 mL of *sulfate standard solution (10 ppm SO<sub>4</sub>) R* and 12.5 mL of *distilled water R*.

**Loss on drying (2.2.32).** Not more than 0.5 per cent, determined on 0.50 g by drying in an oven at 105 °C for 4 h.

**Sulfated ash (2.4.14).** Not more than 0.1 per cent, determined on 1.0 g.

#### ASSAY

Dissolve 0.200 g in 25 mL of *anhydrous acetic acid R*, heating gently. Cool. Titrate with 0.1 M *perchloric acid* determining the end-point potentiometrically (2.2.20).

1 mL of 0.1 M *perchloric acid* is equivalent to 24.87 mg of C<sub>12</sub>H<sub>13</sub>ClN<sub>4</sub>.

#### STORAGE

Store protected from light.

07/2009:2180

## PYRROLIDONE

### Pyrrolidonum

C<sub>4</sub>H<sub>7</sub>NO  
[616-45-5]M<sub>r</sub> 85.1

#### DEFINITION

Pyrrolidin-2-one.

#### CHARACTERS

**Appearance:** clear, colourless or slightly greyish liquid, or white or almost white crystals, or colourless crystal needles.

**Solubility:** miscible with water, with ethanol (96 per cent) and with most common organic solvents.

mp: about 25 °C; the molten substance remains liquid at temperatures below the melting point.

bp: about 245 °C.

#### IDENTIFICATION

*First identification:* A.

*Second identification:* B, C.

A. Infrared absorption spectrophotometry (2.2.24).

*Comparison:* pyrrolidone CRS.

B. Relative density (2.2.5): 1.112 to 1.115.

C. Refractive index (2.2.6): 1.487 to 1.490.

#### TESTS

*Use the molten substance for all tests.*

**Appearance.** The substance to be examined is clear (2.2.1) and not more intensely coloured than intensity 7 of the range of reference solutions of the most appropriate colour (2.2.2, Method II).

**Alkalinity.** To 100 mL of water R add 1.0 mL of bromothymol blue solution R1 and adjust to a green colour with 0.02 M potassium hydroxide or 0.02 M hydrochloric acid. To 50 mL of this solution add 20 mL of the substance to be examined and titrate with 0.02 M hydrochloric acid to the initial colour. Not more than 8.0 mL of 0.02 M hydrochloric acid is required.

**Related substances.** Gas chromatography (2.2.28): use the normalisation procedure.

*Test solution.* The substance to be examined.

*Reference solution (a).* Dissolve 1 mL of the substance to be examined and 1 mL of *N*-methylpyrrolidone R (impurity C) in methylene chloride R and dilute to 20 mL with the same solvent.

*Reference solution (b).* Dissolve 1.1 g of the substance to be examined in methylene chloride R and dilute to 100.0 mL with the same solvent. Dilute 1.0 mL of this solution to 20.0 mL with methylene chloride R.

*Reference solution (c).* Dissolve 1 mL of butyrolactone R (impurity B) and 1 mL of butane-1,4-diol R (impurity A) in methylene chloride R and dilute to 20 mL with the same solvent.

*Column:*

- *material:* fused silica;
- *size:*  $l = 30$  m,  $\varnothing = 0.32$  mm;
- *stationary phase:* poly(dimethyl)siloxane R (film thickness 5  $\mu$ m).

*Carrier gas:* nitrogen for chromatography R.

*Flow rate:* 1.3 mL/min.

*Split ratio:* 1:80.

*Temperature:*

	Time (min)	Temperature (°C)
Column	0 - 18.75	100 → 250
	18.75 - 30	250
Injection port		250
Detector		250

*Detection:* flame ionisation.

*Injection:* 0.1  $\mu$ L.

*Relative retention* with reference to pyrrolidone (retention time = about 13 min): impurity B = about 0.73; impurity A = about 0.76; impurity C = about 0.97.

Use the chromatogram obtained with reference solution (c) to identify the peaks due to impurities A and B; use the chromatogram obtained with reference solution (a) to identify the peak due to impurity C.

*System suitability:* reference solution (a):

- *resolution:* minimum 2.0 between the peaks due to impurity C and pyrrolidone.

*Limits:*

- *impurity B:* maximum 0.5 per cent;
- *impurities A, C:* for each impurity, maximum 0.15 per cent;
- *unspecified impurities:* for each impurity, maximum 0.10 per cent;
- *total:* maximum 0.7 per cent;
- *disregard limit:* the area of the principal peak in the chromatogram obtained with reference solution (b) (0.05 per cent).

**Heavy metals** (2.4.8): maximum 10 ppm.

Dissolve 4.0 g in water R and dilute to 20.0 mL with the same solvent. 12 mL of the solution complies with test A. Prepare the reference solution using lead standard solution (2 ppm Pb) R.

**Water** (2.5.32): maximum 0.1 per cent, determined on 1.00 g.

**Sulfated ash** (2.4.14): maximum 0.1 per cent, determined on 1.0 g.

#### STORAGE

Protected from light.

#### IMPURITIES

*Specified impurities:* A, B, C.

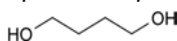

A. butane-1,4-diol,



B. dihydrofuran-2(3H)-one ( $\gamma$ -butyrolactone),



C. 1-methylpyrrolidin-2-one (*N*-methylpyrrolidone).

01/2008:0017 pH (2.2.3): 6.0 to 6.8.

## QUINIDINE SULFATE

## Chinidini sulfas

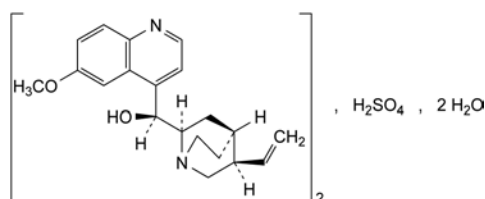

$C_{40}H_{50}N_4O_8S \cdot 2H_2O$   
[6591-63-5]

$M_r$  783

## DEFINITION

**Content:** 99.0 per cent to 101.0 per cent of alkaloid monosulfates, expressed as bis[(S)-[(2R,4S,5R)-5-ethenyl-1-azabicyclo[2.2.2]oct-2-yl][(6-methoxyquinolin-4-yl)methanol] sulfate (dried substance).

## CHARACTERS

**Appearance:** white or almost white, crystalline powder or silky, colourless needles.

**Solubility:** slightly soluble in water, soluble in boiling water and in ethanol (96 per cent), practically insoluble in acetone.

## IDENTIFICATION

## A. Thin-layer chromatography (2.2.27).

**Test solution.** Dissolve 0.10 g of the substance to be examined in *methanol R* and dilute to 10 mL with the same solvent.

**Reference solution.** Dissolve 0.10 g of *quinidine sulfate CRS* in *methanol R* and dilute to 10 mL with the same solvent.

**Plate:** TLC silica gel G plate R.

**Mobile phase:** diethylamine R, ether R, toluene R (10:24:40 V/V/V).

**Application:** 5  $\mu$ L.

**Development:** twice over a path of 15 cm; dry in a current of air for 15 min between the 2 developments.

**Drying:** at 105 °C for 30 min and allow to cool.

**Detection:** spray with iodoplatinate reagent R.

**Results:** the principal spot in the chromatogram obtained with the test solution is similar in position, colour and size to the principal spot in the chromatogram obtained with the reference solution.

B. Dissolve about 5 mg in 5 mL of *water R*. Add 0.2 mL of *bromine water R* and 1 mL of *dilute ammonia R2*. A green colour develops.C. Dissolve 0.1 g in 3 mL of *dilute sulfuric acid R* and dilute to 100 mL with *water R*. When examined in ultraviolet light at 366 nm, an intense blue fluorescence appears which disappears almost completely on addition of 1 mL of *hydrochloric acid R*.D. Dissolve about 50 mg in 5 mL of hot *water R*, cool, add 1 mL of *silver nitrate solution R1* and stir with a glass rod. After a few minutes, a white precipitate is formed that dissolves on the addition of *dilute nitric acid R*.

## E. It gives reaction (a) of sulfates (2.3.1).

## F. pH (see Tests).

## TESTS

**Solution S.** Dissolve 0.500 g in 0.1 M *hydrochloric acid* and dilute to 25.0 mL with the same acid.

**Appearance of solution.** Solution S is clear (2.2.1) and not more intensely coloured than reference solution GY<sub>6</sub> (2.2.2, Method II).

Dissolve 0.10 g in *carbon dioxide-free water R* and dilute to 10 mL with the same solvent.

**Specific optical rotation (2.2.7):** + 275 to + 290 (dried substance), determined on solution S.

**Other cinchona alkaloids.** Liquid chromatography (2.2.29): use the normalisation procedure.

**Test solution.** Dissolve 20 mg of the substance to be examined in 5 mL of the mobile phase, with gentle heating if necessary, and dilute to 10 mL with the mobile phase.

**Reference solution (a).** Dissolve 20 mg of *quinine sulfate CRS* (impurity A) in 5 mL of the mobile phase, with gentle heating if necessary, and dilute to 10 mL with the mobile phase.

**Reference solution (b).** Dissolve 20 mg of *quinidine sulfate CRS* in 5 mL of the mobile phase, with gentle heating if necessary, and dilute to 10 mL with the mobile phase.

**Reference solution (c).** To 1 mL of reference solution (a) add 1 mL of reference solution (b).

**Reference solution (d).** Dilute 1.0 mL of reference solution (a) to 10.0 mL with the mobile phase. Dilute 1.0 mL of this solution to 50.0 mL with the mobile phase.

**Reference solution (e).** Dissolve 10 mg of *thiourea R* in the mobile phase and dilute to 10 mL with the mobile phase.

## Column:

– size:  $l = 0.15\text{--}0.25$  m,  $\varnothing = 4.6$  mm;

– stationary phase: octadecylsilyl silica gel for chromatography R (5–10  $\mu$ m).

**Mobile phase:** dissolve 6.8 g of *potassium dihydrogen phosphate R* and 3.0 g of *hexylamine R* in 700 mL of *water R*, adjust to pH 2.8 with *dilute phosphoric acid R*, add 60 mL of *acetonitrile R* and dilute to 1000 mL with *water R*.

**Flow rate:** 1.5 mL/min.

**Detection:** spectrophotometer at 250 nm for reference solution (e) and at 316 nm for the other solutions.

**Injection:** 10  $\mu$ L.

**Run time:** 2.5 times the retention time of quinidine.

**Identification of peaks:** use the chromatogram obtained with reference solution (a) to identify the peaks due to impurity A and dihydroquinine; use the chromatogram obtained with reference solution (b) to identify the peaks due to quinidine and impurity C; the chromatogram obtained with reference solution (c) shows 4 peaks due to quinidine, impurity A, impurity C and dihydroquinine which are identified by comparison of their retention times with those of the corresponding peaks in the chromatograms obtained with reference solutions (a) and (b).

**Relative retention** with reference to impurity A: dihydroquinine = about 1.4.

**Relative retention** with reference to quinidine: impurity C = about 1.5.

## System suitability:

– resolution: minimum 3.0 between the peaks due to impurity A and quinidine and minimum 2.0 between the peaks due to impurities C and A in the chromatogram obtained with reference solution (c);

– signal-to-noise ratio: minimum 4 for the principal peak in the chromatogram obtained with reference solution (d);

– mass distribution ratio: 3.5 to 4.5 for the peak due to quinidine in the chromatogram obtained with reference solution (b),  $t_R$  being calculated from the peak due to thiourea in the chromatogram obtained with reference solution (e); if necessary, adjust the concentration of acetonitrile in the mobile phase.

## Limits:

– impurity C: maximum 15 per cent;

– any impurity eluted before quinidine: for each impurity, maximum 5 per cent;



- *any other impurity*: for each impurity, maximum 2.5 per cent;
- *disregard limit*: the area of the principal peak in the chromatogram obtained with reference solution (d) (0.2 per cent).

01/2008:0018  
corrected 6.0

**Boron**: maximum 5 ppm. *Avoid where possible the use of glassware.*

**Test solution.** Dissolve 1.00 g in a mixture of 0.5 mL of *hydrochloric acid R* and 4.0 mL of *water R*.

**Reference solution.** Dissolve 0.572 g of *boric acid R* in *water R* and dilute to 1000.0 mL with the same solvent. Dilute 5.0 mL of the solution to 100.0 mL with *water R*. To 1.0 mL of this solution add 3.0 mL of *water R* and 0.5 mL of *hydrochloric acid R*.

**Blank solution.** Add 0.5 mL of *hydrochloric acid R* to 4.0 mL of *water R*.

Add 3.0 mL of a 100 g/L solution of *2-ethylhexane-1,3-diol R* in *methylene chloride R* to the test solution, to the reference solution and to the blank solution, then shake for 1 min. Allow to stand for 6 min. To 1.0 mL of the lower layer, add 2.0 mL of a 3.75 g/L solution of *curcumin R* in *anhydrous acetic acid R* and 0.3 mL of *sulfuric acid R*. Mix and after 20 min add 25.0 mL of *ethanol (96 per cent) R*. Mix. The blank solution is yellow. Any red colour in the test solution is not more intense than that in the reference solution.

**Loss on drying (2.2.32)**: 3.0 per cent to 5.0 per cent, determined on 1.000 g by drying in an oven at 130 °C.

**Sulfated ash (2.4.14)**: maximum 0.1 per cent, determined on 1.0 g.

#### ASSAY

Dissolve 0.200 g in 20 mL of *acetic anhydride R*. Titrate with 0.1 M *perchloric acid*, using 0.15 mL of *naphtholbenzein solution R* as indicator.

1 mL of 0.1 M *perchloric acid* is equivalent to 24.90 mg of  $C_{20}H_{25}N_4O_2$ .

#### STORAGE

Protected from light.

#### IMPURITIES

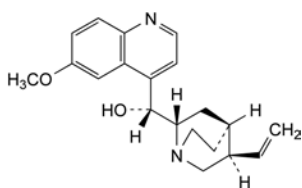

A. (R)-[(2S,4S,5R)-5-ethenyl-1-azabicyclo[2.2.2]oct-2-yl](6-methoxyquinolin-4-yl)methanol (quinine),

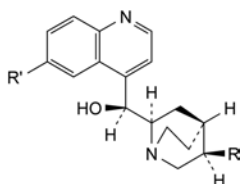

B. R = CH=CH<sub>2</sub>, R' = H: (S)-[(2R,4S,5R)-5-ethenyl-1-azabicyclo[2.2.2]oct-2-yl](quinolin-4-yl)methanol (cinchonine),

C. R = C<sub>2</sub>H<sub>5</sub>, R' = OCH<sub>3</sub>: (S)-[(2R,4S,5R)-5-ethyl-1-azabicyclo[2.2.2]oct-2-yl](6-methoxyquinolin-4-yl)methanol (dihydroquinidine).

## QUININE HYDROCHLORIDE

### Chinini hydrochloridum

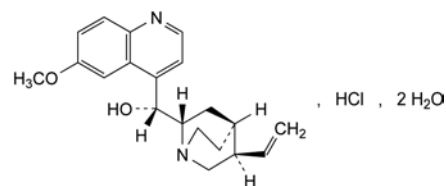

$C_{20}H_{25}ClN_4O_2 \cdot 2H_2O$   
[6119-47-7]

$M_r$  396.9

#### DEFINITION

**Content**: 99.0 per cent to 101.0 per cent of alkaloid monohydrochlorides, expressed as (R)-[(2S,4S,5R)-5-ethenyl-1-azabicyclo[2.2.2]oct-2-yl](6-methoxyquinolin-4-yl)methanol hydrochloride (dried substance).

#### CHARACTERS

**Appearance**: white or almost white or colourless, fine, silky needles, often in clusters.

**Solubility**: soluble in water, freely soluble in ethanol (96 per cent).

#### IDENTIFICATION

A. Thin-layer chromatography (2.2.27).

**Test solution.** Dissolve 0.10 g of the substance to be examined in *methanol R* and dilute to 10 mL with the same solvent.

**Reference solution.** Dissolve 0.10 g of *quinine sulfate CRS* in *methanol R* and dilute to 10 mL with the same solvent.

**Plate**: TLC silica gel G plate R.

**Mobile phase**: *diethylamine R*, *ether R*, *toluene R* (10:24:40 V/V/V).

**Application**: 5 µL.

**Development**: twice over a path of 15 cm; dry in a current of air for 15 min between the 2 developments.

**Drying**: at 105 °C for 30 min and allow to cool.

**Detection**: spray with *iodoplatinate reagent R*.

**Results**: the principal spot in the chromatogram obtained with the test solution is similar in position, colour and size to the principal spot in the chromatogram obtained with the reference solution.

B. Dissolve about 10 mg in *water R* and dilute to 10 mL with the same solvent. To 5 mL of this solution add 0.2 mL of *bromine water R* and 1 mL of *dilute ammonia R2*. A green colour develops.

C. Dissolve 0.1 g in 3 mL of *dilute sulfuric acid R* and dilute to 100 mL with *water R*. When examined in ultraviolet light at 366 nm, an intense blue fluorescence appears which disappears almost completely on the addition of 1 mL of *hydrochloric acid R*.

D. It gives the reactions of chlorides (2.3.1).

E. pH (see Tests).

#### TESTS

**Solution S.** Dissolve 1.0 g in *carbon dioxide-free water R* prepared from *distilled water R* and dilute to 50 mL with the same solvent.

**Appearance of solution.** Solution S is clear (2.2.1) and not more intensely coloured than reference solution Y<sub>6</sub> (2.2.2, *Method II*).

**pH (2.2.3)**: 6.0 to 6.8.

Dilute 10 mL of solution S to 20 mL with *carbon dioxide-free water R*.

**Specific optical rotation** (2.2.7):  $-245$  to  $-258$  (dried substance).

Dissolve  $0.500$  g in  $0.1$  M hydrochloric acid and dilute to  $25.0$  mL with the same acid.

**Other cinchona alkaloids.** Liquid chromatography (2.2.29): use the normalisation procedure.

**Test solution.** Dissolve  $20$  mg of the substance to be examined in  $5$  mL of the mobile phase, with gentle heating if necessary, and dilute to  $10$  mL with the mobile phase.

**Reference solution (a).** Dissolve  $20$  mg of *quinine sulfate CRS* in  $5$  mL of the mobile phase, with gentle heating if necessary, and dilute to  $10$  mL with the mobile phase.

**Reference solution (b).** Dissolve  $20$  mg of *quinidine sulfate CRS* (impurity A) in  $5$  mL of the mobile phase, with gentle heating if necessary, and dilute to  $10$  mL with the mobile phase.

**Reference solution (c).** To  $1$  mL of reference solution (a) add  $1$  mL of reference solution (b).

**Reference solution (d).** Dilute  $1.0$  mL of reference solution (a) to  $10.0$  mL with the mobile phase. Dilute  $1.0$  mL of this solution to  $50.0$  mL with the mobile phase.

**Reference solution (e).** Dissolve  $10$  mg of *thiourea R* in the mobile phase and dilute to  $10$  mL with the mobile phase.

**Column:**

- size:  $l = 0.15\text{--}0.25$  m,  $\varnothing = 4.6$  mm;
- stationary phase = octadecylsilyl silica gel for chromatography R (5–10  $\mu\text{m}$ ).

**Mobile phase:** dissolve  $6.8$  g of *potassium dihydrogen phosphate R* and  $3.0$  g of *hexylamine R* in  $700$  mL of *water R*, adjust to pH 2.8 with *dilute phosphoric acid R*, add  $60$  mL of *acetonitrile R* and dilute to  $1000$  mL with *water R*.

**Flow rate:**  $1.5$  mL/min.

**Detection:** spectrophotometer at  $250$  nm for reference solution (e) and at  $316$  nm for the other solutions.

**Injection:**  $10$   $\mu\text{L}$ .

**Run time:** 2.5 times the retention time of quinine.

**Identification of peaks:** use the chromatogram obtained with reference solution (a) to identify the peaks due to quinine and impurity C; use the chromatogram obtained with reference solution (b) to identify the peaks due to impurity A and dihydroquinidine; the chromatogram obtained with reference solution (c) shows 4 peaks due to impurity A, quinine, dihydroquinidine and impurity C, which are identified by comparison of their retention times with those of the corresponding peaks in the chromatograms obtained with reference solutions (a) and (b).

**Relative retention** with reference to quinine: impurity C = about 1.4.

**Relative retention** with reference to impurity A: dihydroquinidine = about 1.5.

**System suitability:**

- resolution: minimum 3.0 between the peaks due to quinine and impurity A and minimum 2.0 between the peaks due to dihydroquinidine and quinine in the chromatogram obtained with reference solution (c);
- signal-to-noise ratio: minimum 4 for the principal peak in the chromatogram obtained with reference solution (d);
- mass distribution ratio: 3.5 to 4.5 for the peak due to impurity A in the chromatogram obtained with reference solution (b),  $t_{\text{r}}$  being calculated from the peak due to thiourea in the chromatogram obtained with reference solution (e); if necessary, adjust the concentration of acetonitrile in the mobile phase.

**Limits:**

- impurity C: maximum 10 per cent;
- any impurity eluted before quinine: for each impurity, maximum 5 per cent;

- any other impurity: for each impurity, maximum 2.5 per cent;
- disregard limit: the area of the principal peak in the chromatogram obtained with reference solution (d) (0.2 per cent).

**Sulfates** (2.4.13): maximum 500 ppm, determined on solution S.

**Barium.** To  $15$  mL of solution S add  $1$  mL of *dilute sulfuric acid R*. Allow to stand for  $15$  min. Any opalescence in the solution is not more intense than that in a mixture of  $15$  mL of solution S and  $1$  mL of *distilled water R*.

**Loss on drying** (2.2.32): 6.0 per cent to 10.0 per cent, determined on  $1.000$  g by drying in an oven at  $105$  °C.

**Sulfated ash** (2.4.14): maximum 0.1 per cent, determined on  $1.0$  g.

**ASSAY**

Dissolve  $0.250$  g in  $50$  mL of *ethanol (96 per cent) R* and add  $5.0$  mL of  $0.01$  M hydrochloric acid. Titrate with  $0.1$  M sodium hydroxide, determining the end-point potentiometrically (2.2.20). Read the volume added between the 2 inflexion points.

$1$  mL of  $0.1$  M sodium hydroxide is equivalent to  $36.09$  mg of  $\text{C}_{20}\text{H}_{25}\text{ClN}_2\text{O}_2$

**STORAGE**

Protected from light.

**IMPURITIES**

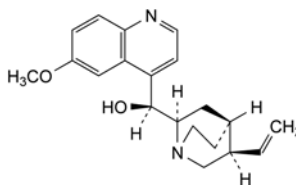

- A. (S)-[(2R,4S,5R)-5-ethenyl-1-azabicyclo[2.2.2]oct-2-yl]-(6-methoxyquinolin-4-yl)methanol (quinidine),

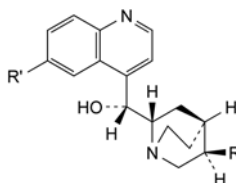

- B. R = CH=CH<sub>2</sub>, R' = H: (R)-[(2S,4S,5R)-5-ethenyl-1-azabicyclo[2.2.2]oct-2-yl]-(quinolin-4-yl)methanol (cinchonidine),
- C. R = C<sub>2</sub>H<sub>5</sub>, R' = OCH<sub>3</sub>: (R)-[(2S,4S,5R)-5-ethyl-1-azabicyclo[2.2.2]oct-2-yl]-(6-methoxyquinolin-4-yl)methanol (dihydroquinine).

01/2008:0019  
corrected 6.0

## QUININE SULFATE

Chinini sulfas

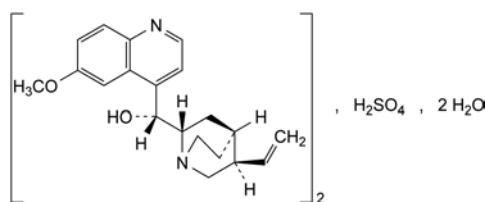

$\text{C}_{40}\text{H}_{50}\text{N}_4\text{O}_8\text{S}_2\cdot 2\text{H}_2\text{O}$   
[6119-70-6]

$M_r$  783

## DEFINITION

**Content:** 99.0 per cent to 101.0 per cent of alkaloid monosulfates, expressed as bis[(R)-{(2S,4S,5R)-5-ethenyl-1-azabicyclo[2.2.2]oct-2-yl}[(6-methoxyquinolin-4-yl)methanol] sulfate (dried substance).

## CHARACTERS

**Appearance:** white or almost white, crystalline powder or fine, colourless needles.

**Solubility:** slightly soluble in water, sparingly soluble in boiling water and in ethanol (96 per cent).

## IDENTIFICATION

## A. Thin-layer chromatography (2.2.27).

**Test solution.** Dissolve 0.10 g of the substance to be examined in *methanol R* and dilute to 10 mL with the same solvent.

**Reference solution.** Dissolve 0.10 g of *quinine sulfate CRS* in *methanol R* and dilute to 10 mL with the same solvent.

**Plate:** TLC silica gel G plate *R*.

**Mobile phase:** *diethylamine R*, *ether R*, *toluene R* (10:24:40 V/V/V).

**Application:** 5 µL.

**Development:** twice over a path of 15 cm; dry in a current of air for 15 min between the 2 developments.

**Drying:** at 105 °C for 30 min and allow to cool.

**Detection:** spray with *iodoplatinate reagent R*.

**Results:** the principal spot in the chromatogram obtained with the test solution is similar in position, colour and size to the principal spot in the chromatogram obtained with the reference solution.

- B. Dissolve about 5 mg in 5 mL of *water R*. Add 0.2 mL of *bromine water R* and 1 mL of *dilute ammonia R2*. A green colour develops.
- C. Dissolve 0.1 g in 3 mL of *dilute sulfuric acid R* and dilute to 100 mL with *water R*. When examined in ultraviolet light at 366 nm, an intense blue fluorescence appears which disappears almost completely on the addition of 1 mL of *hydrochloric acid R*.
- D. Dissolve about 45 mg in 5 mL of *dilute hydrochloric acid R*. The solution gives reaction (a) of sulfates (2.3.1).
- E. pH (see Tests).

## TESTS

**Solution S.** Dissolve 0.500 g in 0.1 M *hydrochloric acid* and dilute to 25.0 mL with the same acid.

**Appearance of solution.** Solution S is clear (2.2.1) and not more intensely coloured than reference solution GY<sub>6</sub> (2.2.2, Method II).

**pH** (2.2.3): 5.7 to 6.6 for a 10 g/L suspension in *water R*.

**Specific optical rotation** (2.2.7): -237 to -245 (dried substance), determined on solution S.

**Other cinchona alkaloids.** Liquid chromatography (2.2.29): use the normalisation procedure.

**Test solution.** Dissolve 20 mg of the substance to be examined in 5 mL of the mobile phase, with gentle heating if necessary, and dilute to 10 mL with the mobile phase.

**Reference solution (a).** Dissolve 20 mg of *quinine sulfate CRS* in 5 mL of the mobile phase, with gentle heating if necessary, and dilute to 10 mL with the mobile phase.

**Reference solution (b).** Dissolve 20 mg of *quinidine sulfate CRS* (impurity A) in 5 mL of the mobile phase, with gentle heating if necessary, and dilute to 10 mL with the mobile phase.

**Reference solution (c).** To 1 mL of reference solution (a) add 1 mL of reference solution (b).

**Reference solution (d).** Dilute 1.0 mL of reference solution (a) to 10.0 mL with the mobile phase. Dilute 1.0 mL of this solution to 50.0 mL with the mobile phase.

**Reference solution (e).** Dissolve 10 mg of *thiourea R* in the mobile phase and dilute to 10 mL with the mobile phase.

**Column:**

– **size:**  $l = 0.15\text{--}0.25$  m,  $\varnothing = 4.6$  mm;

– **stationary phase:** *octadecylsilyl silica gel for chromatography R* (5-10 µm).

**Mobile phase:** dissolve 6.8 g of *potassium dihydrogen phosphate R* and 3.0 g of *hexylamine R* in 700 mL of *water R*, adjust to pH 2.8 with *dilute phosphoric acid R*, add 60 mL of *acetonitrile R* and dilute to 1000 mL with *water R*.

**Flow rate:** 1.5 mL/min.

**Detection:** spectrophotometer at 250 nm for reference solution (e) and at 316 nm for the other solutions.

**Injection:** 10 µL.

**Run time:** 2.5 times the retention time of quinine.

**Identification of peaks:** use the chromatogram obtained with reference solution (a) to identify the peaks due to quinine and impurity C; use the chromatogram obtained with reference solution (b) to identify the peaks due to impurity A and dihydroquinidine; the chromatogram obtained with reference solution (c) shows 4 peaks due to impurity A, quinine, dihydroquinidine and impurity C which are identified by comparison of their retention times with those of the corresponding peaks in the chromatograms obtained with reference solutions (a) and (b).

**Relative retention** with reference to quinine: impurity C = about 1.4.

**Relative retention** with reference to impurity A: dihydroquinidine = about 1.5.

**System suitability:**

- **resolution:** minimum 3.0 between the peaks due to quinine and impurity A and minimum 2.0 between the peaks due to dihydroquinidine and quinine in the chromatogram obtained with reference solution (c);
- **signal-to-noise ratio:** minimum 4 for the principal peak in the chromatogram obtained with reference solution (d);
- **mass distribution ratio:** 3.5 to 4.5 for the peak due to impurity A in the chromatogram obtained with reference solution (b),  $t_R$  being calculated from the peak due to thiourea in the chromatogram obtained with reference solution (e); if necessary, adjust the concentration of acetonitrile in the mobile phase.

**Limits:**

- **impurity C:** maximum 10 per cent;
- **any impurity eluted before quinine:** for each impurity, maximum 5 per cent;
- **any other impurity:** for each impurity, maximum 2.5 per cent;
- **disregard limit:** the area of the principal peak in the chromatogram obtained with reference solution (d) (0.2 per cent).

**Loss on drying** (2.2.32): 3.0 per cent to 5.0 per cent, determined on 1.000 g by drying in an oven at 105 °C.

**Sulfated ash** (2.4.14): maximum 0.1 per cent, determined on 1.0 g.

## ASSAY

Dissolve 0.300 g in a mixture of 10 mL of *chloroform R* and 20 mL of *acetic anhydride R*. Titrate with 0.1 M *perchloric acid*, determining the end-point potentiometrically (2.2.20).

1 mL of 0.1 M *perchloric acid* is equivalent to 24.90 mg of C<sub>40</sub>H<sub>50</sub>N<sub>4</sub>O<sub>8</sub>S.

## STORAGE

Protected from light.

## IMPURITIES

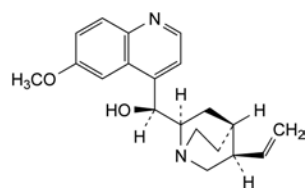

A. (*S*)-[(2*R*,4*S*,5*R*)-5-ethenyl-1-azabicyclo[2.2.2]oct-2-yl](6-methoxyquinolin-4-yl)methanol (quinidine),

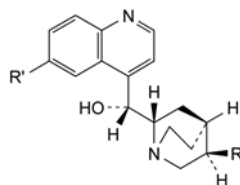

B.  $R = \text{CH}=\text{CH}_2$ ,  $R' = \text{H}$ : (*R*)-[(2*S*,4*S*,5*R*)-5-ethenyl-1-azabicyclo[2.2.2]oct-2-yl](quinolin-4-yl)methanol (cinchonidine),

C.  $R = \text{C}_2\text{H}_5$ ,  $R' = \text{OCH}_3$ : (*R*)-[(2*S*,4*S*,5*R*)-5-ethyl-1-azabicyclo[2.2.2]oct-2-yl](6-methoxyquinolin-4-yl)methanol (dihydroquinine).

07/2008:2171 *Mobile phase:*

corrected 6.3

- *mobile phase A:* dissolve 1.0 g of *potassium dihydrogen phosphate R* in *water R*, adjust to pH 2.5 with *phosphoric acid R* and dilute to 1000 mL with *water R*;
- *mobile phase B:* *acetonitrile R1*;

## RACECADOTRIL

## Racecadotrilum

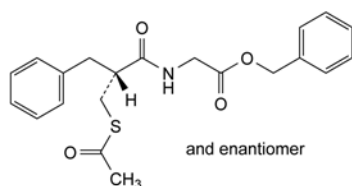
C<sub>21</sub>H<sub>23</sub>NO<sub>4</sub>S  
[81110-73-8]M<sub>r</sub> 385.5

## DEFINITION

Benzyl [[(2*RS*)-2-[(acetylsulfanyl)methyl]-3-phenylpropano-yl]amino]acetate.*Content:* 98.0 per cent to 102.0 per cent (dried substance).

## CHARACTERS

*Appearance:* white or almost white powder.*Solubility:* practically insoluble in water, freely soluble in methanol and in methylene chloride.

## IDENTIFICATION

A. Infrared absorption spectrophotometry (2.2.24).

*Comparison:* *racecadotril CRS*.

## TESTS

**Appearance of solution.** The solution is clear (2.2.1) and not more intensely coloured than reference solution Y<sub>6</sub> (2.2.2, *Method II*).Dissolve 5.0 g in 10 mL of *acetone R*.**Related substances.** Liquid chromatography (2.2.29).*Solvent mixture:* mobile phase A, mobile phase B (50:50 V/V).*Test solution (a).* Dissolve 50.0 mg of the substance to be examined in the solvent mixture and dilute to 25.0 mL with the solvent mixture.*Test solution (b).* Dilute 5.0 mL of test solution (a) to 25.0 mL with the solvent mixture.*Reference solution (a).* Dilute 1.0 mL of test solution (a) to 100.0 mL with the solvent mixture. Dilute 1.0 mL of this solution to 10.0 mL with the solvent mixture.*Reference solution (b).* Dilute 500 µL of *racecadotril impurity A CRS* in *acetonitrile R* and dilute to 250.0 mL with the same solvent. Dilute 1.0 mL of the solution to 10.0 mL with the solvent mixture. Dilute 1.0 mL of this solution to 100.0 mL with the solvent mixture.*Reference solution (c).* Dissolve 5 mg of *racecadotril impurity G CRS* in the solvent mixture and dilute to 50 mL with the solvent mixture. To 5 mL of this solution add 1 mL of test solution (b) and dilute to 100 mL with the solvent mixture.*Reference solution (d).* Dissolve 50.0 mg of *racecadotril CRS* in the solvent mixture and dilute to 25.0 mL with the solvent mixture. Dilute 5.0 mL of this solution to 25.0 mL with the solvent mixture.*Reference solution (e).* Dissolve 2 mg of *racecadotril for peak identification CRS* (containing impurities C, E and F) in 1.0 mL of the solvent mixture.*Column:*

- *size:* *l* = 0.25 m, Ø = 4.0 mm;
- *stationary phase:* *end-capped octadecylsilyl silica gel for chromatography R* (5 µm);
- *temperature:* 30 °C.

Time (min)	Mobile phase A (per cent V/V)	Mobile phase B (per cent V/V)
0 - 5	60	40
5 - 25	60 → 20	40 → 80
25 - 35	20	80

*Flow rate:* 1.0 mL/min.*Detection:* spectrophotometer at 210 nm.*Injection:* 10 µL of the solvent mixture, test solution (a) and reference solutions (a), (b), (c) and (e).*Identification of impurities:* use the chromatogram supplied with *racecadotril for peak identification CRS* and the chromatogram obtained with reference solution (e) to identify the peaks due to impurities C, E and F.*Relative retention* with reference to *racecadotril* (retention time = about 16 min): impurity A = about 0.2; impurity C = about 0.3; impurity E = about 0.5; impurity F = about 0.9.*System suitability:* reference solution (c):

- *resolution:* minimum 1.5 between the peaks due to impurity G and *racecadotril*.

*Limits:*

- *correction factors:* for the calculation of content, multiply the peak areas of the following impurities by the corresponding correction factor: impurity C = 1.4; impurity E = 0.6; impurity F = 0.7;
- *impurities C, E, F:* for each impurity, not more than twice the area of the principal peak in the chromatogram obtained with reference solution (a) (0.2 per cent);
- *impurity A:* not more than the area of the corresponding peak in the chromatogram obtained with reference solution (b) (0.1 per cent);
- *unspecified impurities:* for each impurity, not more than the area of the principal peak in the chromatogram obtained with reference solution (a) (0.10 per cent);
- *total:* not more than 5 times the area of the principal peak in the chromatogram obtained with reference solution (a) (0.5 per cent);
- *disregard limit:* 0.5 times the area of the principal peak in the chromatogram obtained with reference solution (a) (0.05 per cent).

**Loss on drying** (2.2.32): maximum 0.5 per cent, determined on 1.000 g by drying *in vacuo* at 60 °C for 4 h.**Sulfated ash** (2.4.14): maximum 0.1 per cent, determined on 1.0 g.

## ASSAY

Liquid chromatography (2.2.29) as described in the test for related substances with the following modification.

*Injection:* test solution (b) and reference solution (d).Calculate the percentage content of C<sub>21</sub>H<sub>23</sub>NO<sub>4</sub>S from the declared content of *racecadotril CRS*.

## IMPURITIES

*Specified impurities:* A, C, E, F.*Other detectable impurities* (the following substances would, if present at a sufficient level, be detected by one or other of the tests in the monograph. They are limited by the general acceptance criterion for other/unspecified impurities and/or by the general monograph *Substances for pharmaceutical use* (2034). It is therefore not necessary to identify these impurities for demonstration of compliance. See also 5.10. *Control of impurities in substances for pharmaceutical use*): B, D, G, H.

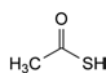

A. ethanethioic acid (thioacetic acid),

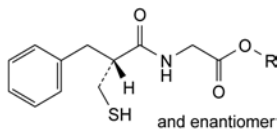

B. R = H: [(2*RS*)-2-benzyl-3-sulfanylpropanoyl]amino]acetic acid,

G. R = CH<sub>2</sub>-C<sub>6</sub>H<sub>5</sub>: benzyl [(2*RS*)-2-benzyl-3-sulfanylpropanoyl]amino]acetate,

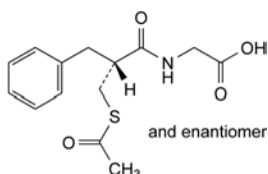

C. [(2*RS*)-2-[(acetylsulfanyl)methyl]-3-phenylpropanoyl]-amino]acetic acid,

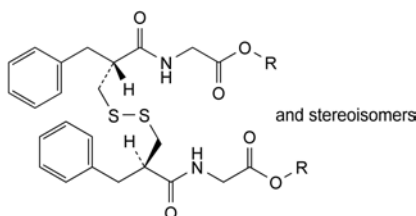

D. R = H: 5,10-dibenzyl-4,11-dioxo-7,8-dithia-3,12-diazatetradecanedioic acid,

H. R = CH<sub>2</sub>-C<sub>6</sub>H<sub>5</sub>: dibenzyl 5,10-dibenzyl-4,11-dioxo-7,8-dithia-3,12-diazatetradecanedioate,

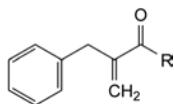

E. R = OH: 2-benzylprop-2-enoic acid (2-benzylacrylic acid),

F. R = NH-CH<sub>2</sub>-CO-O-CH<sub>2</sub>-C<sub>6</sub>H<sub>5</sub>: benzyl [(2-benzylprop-2-enoyl)amino]acetate.

## IDENTIFICATION

A. Infrared absorption spectrophotometry (2.2.24).

*Comparison: raloxifene hydrochloride CRS.*

B. Dissolve 20 mg of the substance to be examined in 2 mL of *methanol R*. The solution gives reaction (a) of chlorides (2.3.1).

## TESTS

**Related substances.** Liquid chromatography (2.2.29).

*Solvent mixture: acetonitrile R*, mobile phase A (30:70 V/V).

*Test solution.* Dissolve 30 mg of the substance to be examined in the solvent mixture and dilute to 10.0 mL with the solvent mixture.

*Reference solution (a).* Dilute 1.0 mL of the test solution to 100.0 mL with the solvent mixture. Dilute 1.0 mL of this solution to 10.0 mL with the solvent mixture.

*Reference solution (b).* In order to produce impurity C *in situ*, to 6 mg of the substance to be examined add 15 mL of *acetonitrile R*, 3 mL of *water R* and 5 mL of stabilised *strong hydrogen peroxide solution R*. Store at 30 °C for at least 6 h then dilute to 50.0 mL with mobile phase A. To 1.0 mL of this solution add 3 mg of the substance to be examined dissolved in the solvent mixture and dilute to 10.0 mL with the solvent mixture.

*Reference solution (c).* Dissolve 3 mg of *raloxifene for peak identification CRS* (containing impurity A) in the solvent mixture and dilute to 10.0 mL with the solvent mixture.

*Column:*

– *size:* *l* = 0.25 m, Ø = 4.6 mm;

– *stationary phase:* *base-deactivated octylsilyl silica gel for chromatography R* (5 µm);

– *temperature:* 35 °C.

*Mobile phase:*

– *mobile phase A:* 9.0 g/L solution of *potassium dihydrogen phosphate R* adjusted to pH 3.0 with *phosphoric acid R*;

– *mobile phase B:* *acetonitrile R*;

Time (min)	Mobile phase A (per cent V/V)	Mobile phase B (per cent V/V)
0 - 9	75	25
9 - 40	75 → 50	25 → 50

*Flow rate:* 1.0 mL/min.

*Detection:* spectrophotometer at 280 nm.

*Injection:* 10 µL.

*Identification of impurity A:* use the chromatogram supplied with *raloxifene for peak identification CRS* and the chromatogram obtained with reference solution (c) to identify the peak due to impurity A.

*Relative retention* with reference to raloxifene (retention time = about 18 min): impurity A = about 0.7; impurity C = about 1.2.

*System suitability:*

– *resolution:* minimum 3.0 between the peaks due to raloxifene and impurity C in the chromatogram obtained with reference solution (b);

– *symmetry factor:* maximum 1.8 for the principal peak in the chromatogram obtained with reference solution (a).

*Limits:*

– *impurity A:* not more than twice the area of the principal peak in the chromatogram obtained with reference solution (a) (0.2 per cent);

– *unspecified impurities:* for each impurity, not more than the area of the principal peak in the chromatogram obtained with reference solution (a) (0.10 per cent);

– *total:* not more than 5 times the area of the principal peak in the chromatogram obtained with reference solution (a) (0.5 per cent);

01/2010:2375

## RALOXIFENE HYDROCHLORIDE

### Raloxifeni hydrochloridum

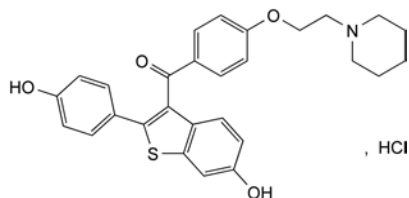

, HCl

C<sub>28</sub>H<sub>28</sub>ClNO<sub>4</sub>S  
[82640-04-8]

M<sub>r</sub> 510.0

## DEFINITION

[6-Hydroxy-2-(4-hydroxyphenyl)-1-benzothiophen-3-yl][4-(2-piperidin-1-yl)ethoxy]phenyl]methanone hydrochloride.

*Content:* 97.5 per cent to 102.0 per cent (dried substance).

## CHARACTERS

*Appearance:* almost white or pale-yellow powder.

*Solubility:* very slightly soluble or practically insoluble in water and in acetone, slightly soluble in ethanol (96 per cent V/V).

- *disregard limit*: 0.5 times the area of the principal peak in the chromatogram obtained with reference solution (a) (0.05 per cent).

**Heavy metals** (2.4.8): maximum 10 ppm.

2.0 g complies with test C. Prepare the reference solution using 2 mL of *lead standard solution* (10 ppm Pb) R.

**Loss on drying** (2.2.32): maximum 0.5 per cent, determined on 1.000 g by drying in an oven at 105 °C for 3 h.

**Sulfated ash** (2.4.14): maximum 0.1 per cent determined on 1.0 g.

#### ASSAY

Liquid chromatography (2.2.29).

*Buffer solution pH 2.5*. 7.2 g/L Solution of *potassium dihydrogen phosphate R* adjusted to pH 2.5 with *phosphoric acid R*.

*Test solution*. Dissolve 50.0 mg of the substance to be examined in the mobile phase and dilute to 100.0 mL with the mobile phase. Dilute 5.0 mL of this solution to 50.0 mL with the mobile phase.

*Reference solution (a)*. Dissolve 50.0 mg of *raloxifene hydrochloride CRS* in the mobile phase and dilute to 100.0 mL with the mobile phase. Dilute 5.0 mL of this solution to 50.0 mL with the mobile phase.

*Reference solution (b)*. In order to produce impurity C *in situ*, to 6 mg of the substance to be examined add 15 mL of *acetonitrile R*, 3 mL of *water R* and 5 mL of stabilised *strong hydrogen peroxide solution R*. Store at 30 °C for at least 6 h, then dilute to 50.0 mL with *buffer solution pH 2.5*.

*Column*:

- *size*:  $l = 0.15$  m,  $\varnothing = 4.6$  mm;
- *stationary phase*: *base-deactivated octylsilyl silica gel for chromatography R* (3.5  $\mu$ m);
- *temperature*: 35 °C.

*Mobile phase*: *acetonitrile R*, *buffer solution pH 2.5* (33:67 V/V).

*Flow rate*: 1.5 mL/min.

*Detection*: spectrophotometer at 280 nm.

*Injection*: 10  $\mu$ L.

*Run time*: twice the retention time of *raloxifene*.

*Relative retention* with reference to *raloxifene* (retention time = about 3 min): impurity C = about 1.2.

*System suitability*:

- *resolution*: minimum 2.0 between the peaks due to *raloxifene* and impurity C in the chromatogram obtained with reference solution (b); if necessary, adjust the concentration of *acetonitrile* in the mobile phase;
- *symmetry factor*: maximum 1.8 for the principal peak in the chromatogram obtained with reference solution (a).

Calculate the percentage content of  $C_{28}H_{28}ClNO_4S$  from the declared content of *raloxifene hydrochloride CRS*.

#### IMPURITIES

*Specified impurities*: A.

*Other detectable impurities* (the following substances would, if present at a sufficient level, be detected by one or other of the tests in the monograph. They are limited by the general acceptance criterion for other/unspecified impurities and/or by the general monograph *Substances for pharmaceutical use* (2034). It is therefore not necessary to identify these impurities for demonstration of compliance. See also 5.10. *Control of impurities in substances for pharmaceutical use*): B, C.

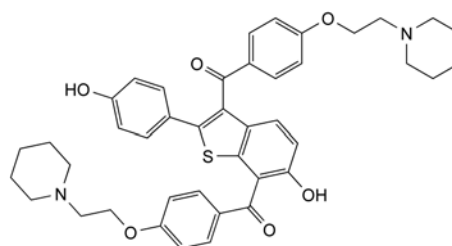

A. [6-hydroxy-2-(4-hydroxyphenyl)-7-[4-[2-(piperidin-1-yl)ethoxy]benzoyl]-1-benzothiophen-3-yl][4-[2-(piperidin-1-yl)ethoxy]phenyl]methanone,

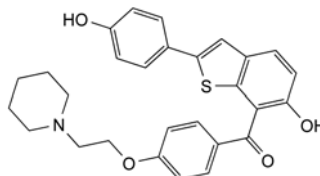

B. [6-hydroxy-2-(4-hydroxyphenyl)-1-benzothiophen-7-yl][4-[2-(piperidin-1-yl)ethoxy]phenyl]methanone,

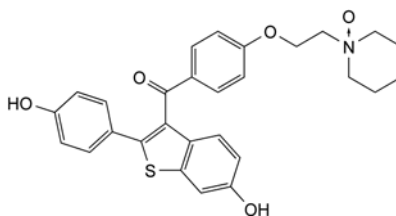

C. [6-hydroxy-2-(4-hydroxyphenyl)-1-benzothiophen-3-yl][4-[2-(piperidin-1-yl)ethoxy]phenyl]methanone *N*-oxide.

07/2008:1368  
corrected 7.0

## RAMIPRIL

### Ramiprilum

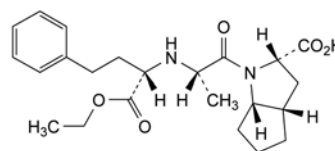

$C_{23}H_{32}N_2O_5$   
[87333-19-5]

$M_r$  416.5

#### DEFINITION

(2*S*,3*aS*,6*aS*)-1-[(2*S*)-2-[(1*S*)-1-(ethoxycarbonyl)-3-phenylpropyl]amino]propanoyl]octahydrocyclopenta[*b*]pyrrole-2-carboxylic acid.

*Content*: 98.0 per cent to 101.0 per cent (dried substance).

#### CHARACTERS

*Appearance*: white or almost white, crystalline powder.

*Solubility*: sparingly soluble in water, freely soluble in methanol.

#### IDENTIFICATION

A. Specific optical rotation (see Tests).

B. Infrared absorption spectrophotometry (2.2.24).

*Comparison*: *ramipril CRS*.

#### TESTS

**Appearance of solution**. The solution is clear (2.2.1) and colourless (2.2.2, *Method II*).

Dissolve 0.1 g in *methanol R* and dilute to 10 mL with the same solvent.

**Specific optical rotation** (2.2.7): + 32.0 to + 38.0 (dried substance).

Dissolve 0.250 g in a mixture of 14 volumes of *hydrochloric acid R1* and 86 volumes of *methanol R* and dilute to 25.0 mL with the same mixture of solvents.

**Related substances.** Liquid chromatography (2.2.29).

**Test solution.** Dissolve 20.0 mg of the substance to be examined in mobile phase A and dilute to 20.0 mL with mobile phase A.

**Reference solution (a).** Dissolve 5 mg of *ramipril impurity A CRS*, 5 mg of *ramipril impurity B CRS*, 5 mg of *ramipril impurity C CRS* and 5 mg of *ramipril impurity D CRS* in 5 mL of the test solution, and dilute to 10 mL with mobile phase B.

**Reference solution (b).** Dilute 5.0 mL of the test solution to 100.0 mL with mobile phase B. Dilute 5.0 mL of this solution to 50.0 mL with mobile phase B.

**Reference solution (c).** Dilute 1.0 mL of reference solution (b) to 10.0 mL with mobile phase B.

**Column:**

- size:  $l = 0.25$  m,  $\varnothing = 4.0$  mm;
- stationary phase: octadecylsilyl silica gel for chromatography R (3  $\mu$ m);
- temperature: 65 °C.

**Mobile phase:**

- mobile phase A: dissolve 2.0 g of *sodium perchlorate R* in a mixture of 0.5 mL of *triethylamine R* and 800 mL of *water R*; adjust to pH 3.6 with *phosphoric acid R* and add 200 mL of *acetonitrile R1*;
- mobile phase B: dissolve 2.0 g of *sodium perchlorate R* in a mixture of 0.5 mL of *triethylamine R* and 300 mL of *water R*; adjust to pH 2.6 with *phosphoric acid R* and add 700 mL of *acetonitrile R1*;

Time (min)	Mobile phase A (per cent V/V)	Mobile phase B (per cent V/V)
0 - 6	90	10
6 - 7	90 → 75	10 → 25
7 - 20	75 → 65	25 → 35
20 - 30	65 → 25	35 → 75
30 - 50	25	75

**Flow rate:** 1.0 mL/min.

**Detection:** spectrophotometer at 210 nm.

**Equilibration:** with the mobile phase at the initial composition for at least 35 min; if a suitable baseline cannot be obtained, use another grade of triethylamine.

**Injection:** 10  $\mu$ L.

**Relative retention** with reference to ramipril (retention time = about 18 min): impurity A = about 0.8; impurity B = about 1.3; impurity G = about 1.4; impurity C = about 1.5; impurity D = about 1.7; impurity O = about 2.4.

**System suitability:**

- resolution: minimum 3.0 between the peaks due to impurity A and ramipril in the chromatogram obtained with reference solution (a);
- signal-to-noise ratio: minimum 3 for the principal peak in the chromatogram obtained with reference solution (c);
- symmetry factor: 0.8 to 2.0 for the peak due to ramipril in the chromatogram obtained with the test solution.

**Limits:**

- correction factor: for the calculation of content, multiply the peak area of impurity C by 2.4;
- impurities A, B, C, D: for each impurity, not more than the area of the principal peak in the chromatogram obtained with reference solution (b) (0.5 per cent);

- unspecified impurities: for each impurity, not more than 0.2 times the area of the principal peak in the chromatogram obtained with reference solution (b) (0.10 per cent);
- total: not more than twice the area of the principal peak in the chromatogram obtained with reference solution (b) (1.0 per cent);
- disregard limit: the area of the principal peak in the chromatogram obtained with reference solution (c) (0.05 per cent).

**Palladium:** maximum 20 ppm.

Atomic absorption spectrometry (2.2.23, Method I).

**Test solution.** Dissolve 0.200 g in a mixture of 0.3 volumes of *nitric acid R* and 99.7 volumes of *water R*, and dilute to 100.0 mL with the same mixture of solvents.

**Reference solutions.** Use solutions containing 0.02  $\mu$ g, 0.03  $\mu$ g and 0.05  $\mu$ g of palladium per millilitre, freshly prepared by dilution of *palladium standard solution (0.5 ppm Pd) R* with a mixture of 0.3 volumes of *nitric acid R* and 99.7 volumes of *water R*.

**Modifier solution.** Dissolve 0.150 g of *magnesium nitrate R* in a mixture of 0.3 volumes of *nitric acid R* and 99.7 volumes of *water R*, and dilute to 100.0 mL with the same mixture of solvents.

**Injection:** 20  $\mu$ L of the test solution and the reference solution, and 10  $\mu$ L of the modifier solution.

**Source:** palladium hollow-cathode lamp using a transmission band preferably of 1 nm and a graphite tube.

**Wavelength:** 247.6 nm.

**Loss on drying** (2.2.32): maximum 0.2 per cent, determined on 1.000 g by drying in an oven under high vacuum at 60 °C for 4 h.

**Sulfated ash** (2.4.14): maximum 0.1 per cent, determined on 1.0 g.

## ASSAY

Dissolve 0.300 g in 25 mL of *methanol R* and add 25 mL of *water R*. Titrate with 0.1 M *sodium hydroxide*, determining the end-point potentiometrically (2.2.20). Carry out a blank titration.

1 mL of 0.1 M *sodium hydroxide* is equivalent to 41.65 mg of  $C_{23}H_{32}N_2O_5$ .

## STORAGE

Protected from light.

## IMPURITIES

**Specified impurities:** A, B, C, D.

**Other detectable impurities** (the following substances would, if present at a sufficient level, be detected by one or other of the tests in the monograph. They are limited by the general acceptance criterion for other/unspecified impurities and/or by the general monograph *Substances for pharmaceutical use (2034)*. It is therefore not necessary to identify these impurities for demonstration of compliance. See also 5.10. *Control of impurities in substances for pharmaceutical use*): E, F, G, H, I, J, K, L, M, N, O.

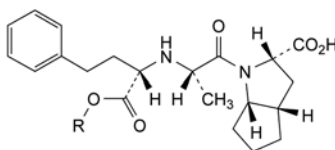

- A. R = CH<sub>3</sub>: (2*S*,3*aS*,6*aS*)-1-[(2*S*)-2-[[1*S*]-1-(methoxycarbonyl)-3-phenylpropyl]amino]propanoyl]octahydrocyclopenta[*b*]pyrrole-2-carboxylic acid (ramipril methyl ester),
- B. R = CH(CH<sub>3</sub>)<sub>2</sub>: (2*S*,3*aS*,6*aS*)-1-[(2*S*)-2-[[1*S*]-1-[(1-methylethoxy)carbonyl]-3-phenylpropyl]amino]propanoyl]octahydrocyclopenta[*b*]pyrrole-2-carboxylic acid (ramipril isopropyl ester),



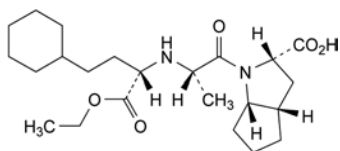

C. (2*S*,3*aS*,6*aS*)-1-[(2*S*)-2-[(1*S*)-3-cyclohexyl-1-(ethoxycarbonyl)propyl]amino]propanoyl]octahydrocyclopenta[*b*]pyrrole-2-carboxylic acid (hexahydorramipril),

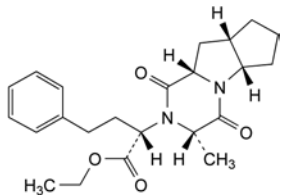

D. ethyl (2*S*)-2-[(3*S*,5*aS*,8*aS*,9*aS*)-3-methyl-1,4-dioxodecahydro-2*H*-cyclopenta[4,5]pyrrolo[1,2-*a*]pyrazin-2-yl]-4-phenylbutanoate (ramipril dihydrochloride),

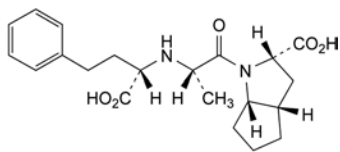

E. (2*S*,3*aS*,6*aS*)-1-[(2*S*)-2-[(1*S*)-1-carboxy-3-phenylpropyl]amino]propanoyl]octahydrocyclopenta[*b*]pyrrole-2-carboxylic acid (ramipril diacid),

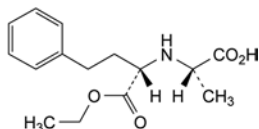

F. (2*S*)-2-[(1*S*)-1-(ethoxycarbonyl)-3-phenylpropyl]amino]propanoic acid,

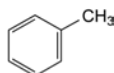

G. methylbenzene (toluene),

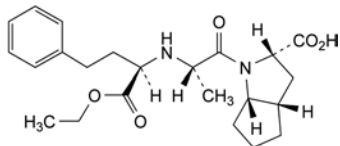

H. (2*S*,3*aS*,6*aS*)-1-[(2*S*)-2-[(1*R*)-1-(ethoxycarbonyl)-3-phenylpropyl]amino]propanoyl]octahydrocyclopenta[*b*]pyrrole-2-carboxylic acid ((*R*,*S*,*S*,*S*,*S*)-epimer of ramipril),

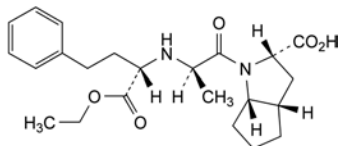

I. (2*S*,3*aS*,6*aS*)-1-[(2*R*)-2-[(1*S*)-1-(ethoxycarbonyl)-3-phenylpropyl]amino]propanoyl]octahydrocyclopenta[*b*]pyrrole-2-carboxylic acid ((*S*,*R*,*S*,*S*,*S*)-epimer of ramipril),

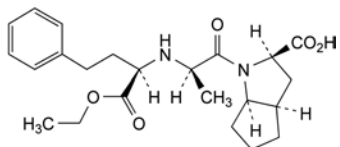

J. (2*R*,3*aR*,6*aR*)-1-[(2*R*)-2-[(1*R*)-1-(ethoxycarbonyl)-3-phenylpropyl]amino]propanoyl]octahydrocyclopenta[*b*]pyrrole-2-carboxylic acid (enantiomer of ramipril),

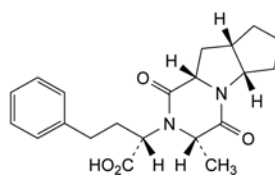

K. (2*S*)-2-[(3*S*,5*aS*,8*aS*,9*aS*)-3-methyl-1,4-dioxodecahydro-2*H*-cyclopenta[4,5]pyrrolo[1,2-*a*]pyrazin-2-yl]-4-phenylbutanoic acid (ramipril diketopiperazine acid),

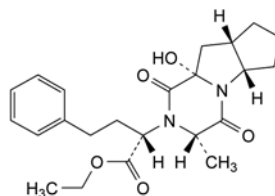

L. ethyl (2*S*)-2-[(3*S*,5*aS*,8*aS*,9*aS*)-9*a*-hydroxy-3-methyl-1,4-dioxodecahydro-2*H*-cyclopenta[4,5]pyrrolo[1,2-*a*]pyrazin-2-yl]-4-phenylbutanoate (ramipril hydroxydiketopiperazine),

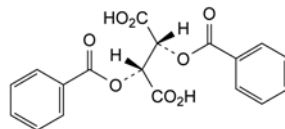

M. (2*R*,3*R*)-2,3-bis(benzoyloxy)butanedioic acid (dibenzoyltartric acid),

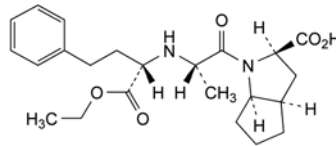

N. (2*R*,3*aR*,6*aR*)-1-[(2*S*)-2-[(1*S*)-1-(ethoxycarbonyl)-3-phenylpropyl]amino]propanoyl]octahydrocyclopenta[*b*]pyrrole-2-carboxylic acid ((*S*,*S*,*R*,*R*)-isomer of ramipril),

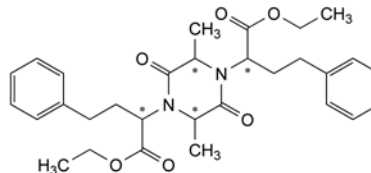

O. diethyl 2,2'-(2,5-dimethyl-3,6-dioxopiperazine-1,4-diyl)bis(4-phenylbutanoate).

01/2008:0946  
corrected 7.0

## RANITIDINE HYDROCHLORIDE

### Ranitidini hydrochloridum

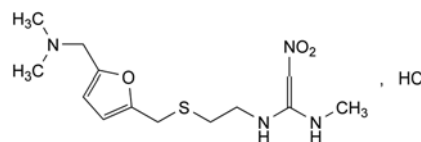

$C_{13}H_{23}ClN_4O_3S$   
[66357-59-3]

$M_r$  350.9

#### DEFINITION

*N*-[2-[[[5-[(Dimethylamino)methyl]furan-2-yl]methyl]sulfonyl]ethyl]-*N'*-methyl-2-nitroethene-1,1-diamine hydrochloride.

*Content*: 98.5 per cent to 101.5 per cent (dried substance).

#### CHARACTERS

*Appearance*: white or pale yellow, crystalline powder.

**Solubility:** freely soluble in water, sparingly soluble or slightly soluble in anhydrous ethanol, very slightly soluble in methylene chloride.

It shows polymorphism (5.9).

#### IDENTIFICATION

##### A. Infrared absorption spectrophotometry (2.2.24).

**Comparison:** ranitidine hydrochloride CRS.

If the spectra obtained in the solid state show differences, dissolve 10 mg of the substance to be examined and 10 mg of the reference substance separately in 0.5 mL of *methanol R* in an agate mortar. Evaporate to dryness under a stream of *nitrogen R*. Dry the residues under vacuum for 30 min. Add 3 drops of *liquid paraffin R* to the residues and triturate until the mull shows a milky appearance. Compress the mulls between 2 plates transparent to infrared radiation and record new spectra.

##### B. It gives reaction (a) of chlorides (2.3.1).

#### TESTS

**Solution S.** Dissolve 1.0 g in *carbon dioxide-free water R* and dilute to 100.0 mL with the same solvent.

**Appearance of solution.** Solution S is clear (2.2.1) and not more intensely coloured than reference solution BY<sub>5</sub> (2.2.2, Method II).

**pH (2.2.3):** 4.5 to 6.0 for solution S.

**Related substances.** Liquid chromatography (2.2.29).

**Buffer solution.** Dissolve 6.8 g of *potassium dihydrogen phosphate R* in 950 mL of *water R*. Adjust to pH 7.1 with *strong sodium hydroxide solution R* and dilute to 1000 mL with *water R*.

**Test solution.** Dissolve 13 mg of the substance to be examined in mobile phase A and dilute to 100.0 mL with mobile phase A.

**Reference solution (a).** Dissolve 6.5 mg of *ranitidine for system suitability CRS* (containing impurities A, D and H) in mobile phase A and dilute to 50.0 mL with mobile phase A.

**Reference solution (b).** Dilute 1.0 mL of the test solution to 100.0 mL with mobile phase A.

**Reference solution (c).** Dissolve the contents of a vial of *ranitidine impurity J CRS* in 1.0 mL of test solution.

**Column:**

- size:  $l = 0.1$  m,  $\emptyset = 4.6$  mm;
- stationary phase: octadecylsilyl amorphous organosilica polymer R (3.5  $\mu$ m);
- temperature: 35 °C.

**Mobile phase:**

- mobile phase A: acetonitrile R, buffer solution (2:98 V/V);
- mobile phase B: acetonitrile R, buffer solution (22:78 V/V);

Time (min)	Mobile phase A (per cent V/V)	Mobile phase B (per cent V/V)
0 - 10	100 → 0	0 → 100
10 - 15	0	100

**Flow rate:** 1.5 mL/min.

**Detection:** spectrophotometer at 230 nm.

**Injection:** 10  $\mu$ L of the test solution, reference solutions (a), (b) and (c) and mobile phase A as a blank.

**Relative retention** with reference to ranitidine (retention time = about 6.8 min): impurity H = about 0.1; impurity G = about 0.2; impurity F = about 0.4; impurity B = about 0.5; impurity C = about 0.6; impurity E = about 0.7; impurity D = about 0.8; impurity J = about 0.9; impurity I = about 1.3; impurity A = about 1.7.

**System suitability:**

- resolution: minimum 1.5 between the peaks due to impurity J and ranitidine in the chromatogram obtained with reference solution (c);
- the chromatogram obtained with reference solution (a) is similar to the chromatogram supplied with *ranitidine for system suitability CRS*;
- the chromatogram obtained with the blank solution does not show any peak with the same relative retention as the peak due to impurity A in the chromatogram obtained with reference solution (a).

**Limits:**

- correction factor: for the calculation of content, multiply the peak area of impurity J by 2;
- impurity A: not more than 0.5 times the area of the principal peak in the chromatogram obtained with reference solution (b) (0.5 per cent);
- impurities B, C, D, E, F, G, H, I, J: for each impurity, not more than 0.2 times the area of the principal peak in the chromatogram obtained with reference solution (b) (0.2 per cent);
- unspecified impurities: for each impurity, not more than 0.1 times the area of the principal peak in the chromatogram obtained with reference solution (b) (0.10 per cent);
- sum of impurities other than A: not more than 0.5 times the area of the principal peak in the chromatogram obtained with reference solution (b) (0.5 per cent);
- disregard limit: 0.05 times the area of the principal peak in the chromatogram obtained with reference solution (b) (0.05 per cent); disregard any peak due to the blank.

**Heavy metals (2.4.8):** maximum 20 ppm.

1.0 g complies with test C. Prepare the reference solution using 2 mL of *lead standard solution (10 ppm Pb) R*.

**Loss on drying (2.2.32):** maximum 0.75 per cent, determined on 1.000 g by drying under high vacuum at 60 °C.

**Sulfated ash (2.4.14):** maximum 0.1 per cent, determined on 1.0 g.

#### ASSAY

Dissolve 0.280 g in 35 mL of *water R*. Titrate with 0.1 M *sodium hydroxide*, determining the end-point potentiometrically (2.2.20).

1 mL of 0.1 M *sodium hydroxide* is equivalent to 35.09 mg of C<sub>13</sub>H<sub>23</sub>ClN<sub>4</sub>O<sub>3</sub>S.

#### STORAGE

In airtight container, protected from light.

#### IMPURITIES

**Specified impurities:** A, B, C, D, E, F, G, H, I, J.

**Other detectable impurities** (the following substances would, if present at a sufficient level, be detected by one or other of the tests in the monograph. They are limited by the general acceptance criterion for other/unspecified impurities and/or by the general monograph *Substances for pharmaceutical use (2034)*. It is therefore not necessary to identify these impurities for demonstration of compliance. See also 5.10. *Control of impurities in substances for pharmaceutical use*): K.

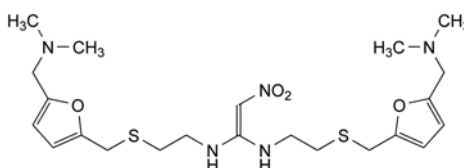

A. *N,N'*-bis[2-[[[5-[(dimethylamino)methyl]furan-2-yl]methyl]sulfanyl]ethyl]-2-nitroethene-1,1-diamine,

01/2010:1369

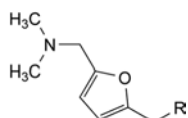

B. R = S-CH<sub>2</sub>-CH<sub>2</sub>-NH<sub>2</sub>: 2-[[[5-[(dimethylamino)methyl]furan-2-yl]methyl]sulfanyl]ethanamine,

D. R = S-CH<sub>2</sub>-CH<sub>2</sub>-NH-CO-CH<sub>2</sub>-NO<sub>2</sub>: *N*-2-[[[5-[(dimethylamino)methyl]furan-2-yl]methyl]sulfanyl]ethyl]-2-nitroacetamide,

F. R = OH: [5-[(dimethylamino)methyl]furan-2-yl]methanol,

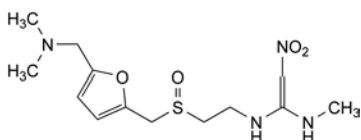

C. *N*-2-[[[5-[(dimethylamino)methyl]furan-2-yl]methyl]sulfanyl]ethyl]-*N'*-methyl-2-nitroethene-1,1-diamine,

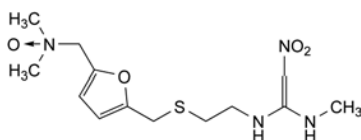

E. *N*-2-[[[5-[(dimethyloxidoamino)methyl]furan-2-yl]methyl]sulfanyl]ethyl]-*N'*-methyl-2-nitroethene-1,1-diamine,

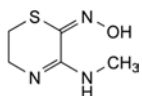

G. 3-(methylamino)-5,6-dihydro-2*H*-1,4-thiazin-2-one-oxime,

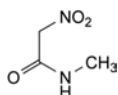

H. *N*-methyl-2-nitroacetamide,

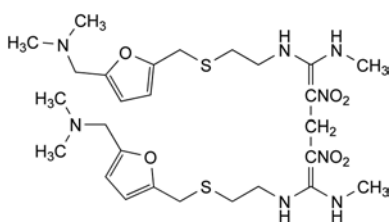

I. 2,2'-methylenebis[*N*-2-[[[5-[(dimethylamino)methyl]furan-2-yl]methyl]sulfanyl]ethyl]-*N'*-methyl-2-nitroethene-1,1-diamine],

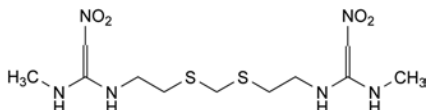

J. 1,1'-*N*-[methylenebis(sulfanediylethylene)]bis(*N'*-methyl-2-nitroethene-1,1-diamine),

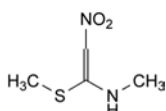

K. *N*-methyl-1-methylthio-2-nitroethenamine.

## RAPSEED OIL, REFINED

### Rapae oleum raffinatum

#### DEFINITION

Fatty oil obtained from the seeds of *Brassica napus* L. and *Brassica campestris* L. by mechanical expression or by extraction. It is then refined. A suitable antioxidant may be added.

#### CHARACTERS

*Appearance*: clear, light yellow liquid.

*Solubility*: practically insoluble in water and in ethanol (96 per cent), miscible with light petroleum (bp: 40-60 °C).

*Relative density*: about 0.917.

*Refractive index*: about 1.473.

#### IDENTIFICATION

Identification of fatty oils by thin-layer chromatography (2.3.2).

*Results*: the chromatogram obtained is similar to the corresponding chromatogram shown in Figure 2.3.2-1.

#### TESTS

**Acid value** (2.5.1): maximum 0.5, determined on 10.0 g.

**Peroxide value** (2.5.5, Method A): maximum 10.0.

**Unsaponifiable matter** (2.5.7): maximum 1.5 per cent, determined on 5.0 g.

**Alkaline impurities** (2.4.19). It complies with the test.

**Composition of fatty acids** (2.4.22, Method A). Use the mixture of calibrating substances in Table 2.4.22-3.

*Composition of the fatty-acid fraction of the oil*:

- *palmitic acid*: 2.5 per cent to 6.0 per cent,
- *stearic acid*: maximum 3.0 per cent,
- *oleic acid*: 50.0 per cent to 67.0 per cent,
- *linoleic acid*: 16.0 per cent to 30.0 per cent,
- *linolenic acid*: 6.0 per cent to 14.0 per cent,
- *eicosenoic acid*: maximum 5.0 per cent,
- *erucic acid*: maximum 2.0 per cent.

**Water** (2.5.32): maximum 0.1 per cent, determined on 1.00 g.

#### STORAGE

In an airtight, well-filled container, protected from light.

#### LABELLING

The label states whether the oil is obtained by mechanical expression or by extraction.

01/2008:2135  
corrected 6.0

## REPAGLINIDE

### Repaglinidum

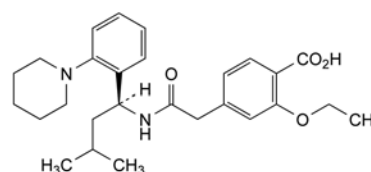

C<sub>27</sub>H<sub>36</sub>N<sub>2</sub>O<sub>4</sub>  
[135062-02-1]

M<sub>r</sub> 452.6

## DEFINITION

2-Ethoxy-4-[2-[[[(1S)-3-methyl-1-[2-(piperidin-1-yl)phenyl]butyl]amino]-2-oxoethyl]benzoic acid.

*Content*: 99.0 per cent to 101.0 per cent (dried substance).

## CHARACTERS

*Appearance*: white or almost white powder.

*Solubility*: practically insoluble in water, freely soluble in methanol and in methylene chloride.

It shows polymorphism (5.9).

## IDENTIFICATION

A. Specific optical rotation (2.2.7): + 6.3 to + 7.7.

Dissolve 1.00 g in *methanol R* and dilute to 20.0 mL with the same solvent.

B. Infrared absorption spectrophotometry (2.2.24).

*Comparison*: repaglinide CRS.

If the spectra obtained in the solid state show differences, dissolve the substance to be examined and the reference substance separately in *anhydrous ethanol R*, evaporate to dryness and record new spectra using the residues.

## TESTS

**Enantiomeric purity.** Liquid chromatography (2.2.29). Prepare the solutions in amber flasks and vials.

*Test solution.* Dissolve 10.0 mg of the substance to be examined in *methanol R* and dilute to 10.0 mL with the same solvent.

*Reference solution (a).* Dissolve 5.0 mg of repaglinide impurity E CRS in *methanol R* and dilute to 50.0 mL with the same of solvent.

*Reference solution (b).* Dilute 2.0 mL of reference solution (a) to 100.0 mL with *methanol R*.

*Reference solution (c).* Mix 1.0 mL of the test solution and 10 mL of reference solution (a) and dilute to 50.0 mL with *methanol R*.

*Column*:

- size:  $l = 0.1$  m,  $\varnothing = 4.0$  mm,
- stationary phase: silica gel AGP for chiral chromatography R (5  $\mu$ m).

*Mobile phase*:

- mobile phase A: 1.0 g/L solution of potassium dihydrogen phosphate R adjusted to pH 4.7 with dilute sodium hydroxide solution R;
- mobile phase B: acetonitrile R;

Time (min)	Mobile phase A (per cent V/V)	Mobile phase B (per cent V/V)
0 - 4	80 → 60	20 → 40
4 - 6	60	40

*Equilibration after installation of the column for use:* using water R, slowly increase the flow rate from 0.2 mL/min to 0.5 mL/min. Maintain the flow rate at 0.5 mL/min for 5 min. The column must be washed for 1 h at a flow rate of 1 mL/min with water R and for 1 h with the mobile phase at the initial composition prior to the 1<sup>st</sup> analysis.

*Flow rate*: 1.0 mL/min.

*Detection*: spectrophotometer at 240 nm.

*Injection*: 10  $\mu$ L of the test solution and reference solutions (b) and (c).

*Retention time*: repaglinide = about 3.3 min; impurity E = about 5.0 min.

*System suitability*: reference solution (c):

- resolution: minimum 1.5 between the peaks due to repaglinide and impurity E.

*Limit*:

- impurity E: not more than the area of the principal peak in the chromatogram obtained with reference solution (b) (0.2 per cent).

**Related substances.** Liquid chromatography (2.2.29).

*Test solution.* Dissolve 30.0 mg of the substance to be examined in acetonitrile R and dilute to 10.0 mL with the same solvent.

*Reference solution (a).* Dilute 5.0 mL of the test solution to 100.0 mL with acetonitrile R. Dilute 2.0 mL of this solution to 100.0 mL with acetonitrile R.

*Reference solution (b).* With the aid of an ultrasonic bath, dissolve the contents of 1 vial of repaglinide for system suitability CRS in 2.0 mL of acetonitrile R.

*Column*:

- size:  $l = 0.15$  m,  $\varnothing = 4.6$  mm,
- stationary phase: silica gel for chromatography, alkyl-bonded for use with highly aqueous mobile phases R (5  $\mu$ m),
- temperature: 45 °C.

*Mobile phase*:

- mobile phase A: 4.0 g/L solution of potassium dihydrogen phosphate R adjusted to pH 3.2 with dilute phosphoric acid R;
- mobile phase B: mobile phase A, acetonitrile R (300:700 V/V);

Time (min)	Mobile phase A (per cent V/V)	Mobile phase B (per cent V/V)
0 - 20	50 → 7	50 → 93
20 - 30	7	93

*Flow rate*: 1.5 mL/min.

*Detection*: spectrophotometer at 240 nm.

*Injection*: 10  $\mu$ L.

*Relative retention* with reference to repaglinide (retention time = about 10 min): impurity A = about 0.2; impurity B = about 0.3; impurity C = about 0.4; impurity D = about 1.5.

*System suitability*: reference solution (b):

- resolution: minimum 5.0 between the peaks due to impurity B and impurity C,
- the chromatogram obtained is similar to the chromatogram supplied with repaglinide for system suitability CRS.

*Limits*:

- correction factors: for the calculation of contents, multiply the peak areas of the following impurities by the corresponding correction factor: impurity A = 0.6; impurity B = 0.7; impurity C = 3.1;
- impurities A, B, C, D: for each impurity, not more than the area of the principal peak in the chromatogram obtained with reference solution (a) (0.1 per cent);
- any other impurity: for each impurity, not more than the area of the principal peak in the chromatogram obtained with reference solution (a) (0.1 per cent);
- total: not more than 5 times the area of the principal peak in the chromatogram obtained with reference solution (a) (0.5 per cent);
- disregard limit: 0.5 times the area of the principal peak in the chromatogram obtained with reference solution (a) (0.05 per cent).

**Loss on drying** (2.2.32): maximum 0.5 per cent, determined on 1.000 g by drying in an oven at 105 °C.

**Sulfated ash** (2.4.14): maximum 0.1 per cent, determined on 1.0 g.

## ASSAY

Dissolve 0.320 g in 10 mL *methanol R* and add 60 mL of *anhydrous acetic acid R*. Titrate with 0.1 M *perchloric acid*, determining the end-point potentiometrically (2.2.20).

1 mL of 0.1 M *perchloric acid* is equivalent to 45.26 mg of  $C_{27}H_{36}N_2O_4$ .

## STORAGE

Protected from light.

## IMPURITIES

*Specified impurities: A, B, C, D, E.*

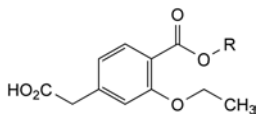

A. R = H: 4-(carboxymethyl)-2-ethoxybenzoic acid,

B. R =  $C_2H_5$ : [3-ethoxy-4-(ethoxycarbonyl)phenyl]acetic acid,

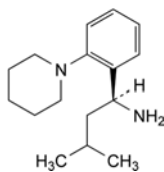

C. (1S)-3-methyl-1-[2-(piperidin-1-yl)phenyl]butan-1-amine,

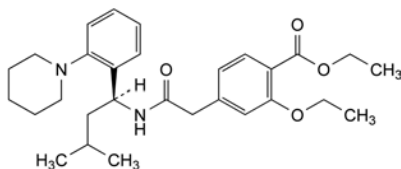

D. ethyl 2-ethoxy-4-[2-[[[(1S)-3-methyl-1-[2-(piperidin-1-yl)phenyl]butyl]amino]-2-oxoethyl]benzoate,

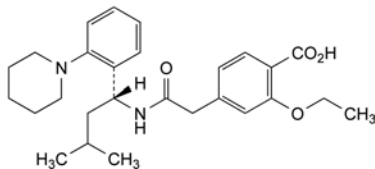

E. 2-ethoxy-4-[2-[[[(1R)-3-methyl-1-[2-(piperidin-1-yl)phenyl]butyl]amino]-2-oxoethyl]benzoic acid.

01/2008:0528

## RESERPINE

## Reserpinum

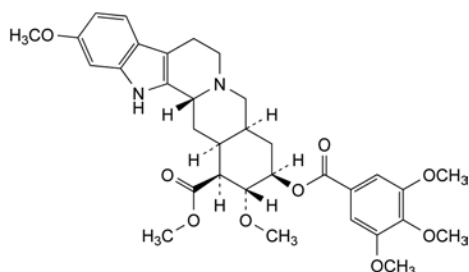

$C_{33}H_{40}N_2O_9$   
[50-55-5]

$M_r$  609

## DEFINITION

Methyl 11,17 $\alpha$ -dimethoxy-18 $\beta$ -[(3,4,5-trimethoxybenzoyl)oxy]-3 $\beta$ ,20 $\alpha$ -yohimban-16 $\beta$ -carboxylate.

*Content:*

– *reserpine*: 98.0 per cent to 102.0 per cent (dried substance),

– *total alkaloids*: 99.0 per cent to 101.0 per cent (dried substance).

## CHARACTERS

*Appearance*: white or slightly yellow, small crystals or crystalline powder, darkening slowly on exposure to light.

*Solubility*: practically insoluble in water, very slightly soluble in ethanol (96 per cent).

## IDENTIFICATION

*First identification: B.*

*Second identification: A, C, D, E.*

A. Ultraviolet and visible absorption spectrophotometry (2.2.25).

*Test solution.* Dissolve 20.0 mg in *chloroform R* and dilute to 10.0 mL with the same solvent. Dilute 1.0 mL of this solution to 100.0 mL with *ethanol (96 per cent) R*. Examine immediately.

*Spectral range*: 230-350 nm.

*Absorption maximum*: at 268 nm.

*Specific absorbance at the absorption maximum*: 265 to 285.

Over the range 288-295 nm, the curve shows a slight absorption minimum followed by a shoulder or a slight absorption maximum; over this range, the specific absorbance is about 170.

B. Infrared absorption spectrophotometry (2.2.24).

*Preparation*: discs.

*Comparison*: *reserpine CRS*.

C. To about 1 mg add 0.1 mL of a 1 g/L solution of *sodium molybdate R* in *sulfuric acid R*. A yellow colour is produced which becomes blue within 2 min.

D. To about 1 mg add 0.2 mL of a freshly prepared 10 g/L solution of *vanillin R* in *hydrochloric acid R*. A pink colour develops within 2 min.

E. Mix about 0.5 mg with 5 mg of *dimethylaminobenzaldehyde R* and 0.2 mL of *glacial acetic acid R* and add 0.2 mL of *sulfuric acid R*. A green colour is produced. Add 1 mL of *glacial acetic acid R*. The colour becomes red.

## TESTS

**Specific optical rotation** (2.2.7): – 116 to – 128 (dried substance).

Dissolve 0.250 g in *chloroform R* and dilute to 25.0 mL with the same solvent. Examine immediately.

**Oxidation products.** Dissolve 20 mg in *glacial acetic acid R* and dilute to 100.0 mL with the same acid. The absorbance (2.2.25) measured immediately at the absorption maximum at 388 nm is not greater than 0.10.

**Loss on drying** (2.2.32): maximum 0.5 per cent, determined on 0.500 g by drying at 60 °C over *diphosphorus pentoxide R* at a pressure not exceeding 667 Pa for 3 h.

**Sulfated ash** (2.4.14): maximum 0.1 per cent, determined on 0.5 g.

## ASSAY

**Total alkaloids.** Dissolve 0.500 g in a mixture of 6 mL of *acetic anhydride R* and 40 mL of *anhydrous acetic acid R*. Titrate with 0.1 M *perchloric acid*, determining the end-point potentiometrically (2.2.20).

1 mL of 0.1 M *perchloric acid* is equivalent to 60.9 mg of total alkaloids.

**Reserpine.** *Protect the solutions from light.* Moisten 25.0 mg with 2 mL of *ethanol (96 per cent) R*, add 2 mL of 0.25 M *sulfuric acid* and 10 mL of *ethanol (96 per cent) R*, and warm gently to dissolve. Cool and dilute to 100.0 mL with *ethanol (96 per cent) R*. Dilute 5.0 mL of this solution to 50.0 mL with *ethanol (96 per cent) R*. Prepare a reference solution in the

same manner using 25.0 mg of *reserpine CRS*. Place 10.0 mL of each solution separately in 2 boiling-tubes, add 2.0 mL of 0.25 M *sulfuric acid* and 2.0 mL of a freshly prepared 3 g/L solution of *sodium nitrite R*. Mix and heat in a water-bath at 55 °C for 35 min. Cool, add 1.0 mL of a freshly prepared 50 g/L solution of *sulfamic acid R* and dilute to 25.0 mL with *ethanol (96 per cent) R*. Measure the absorbance (2.2.25) of each solution at the absorption maximum at 388 nm, using as the compensation liquid 10.0 mL of the same solution prepared at the same time in the same manner, but omitting the sodium nitrite.

Calculate the content of  $C_{33}H_{40}N_2O_9$  from the absorbances measured and the concentrations of the solutions.

#### STORAGE

Protected from light.

01/2008:0290

## RESORCINOL

### Resorcinolum

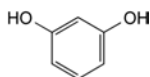

$C_6H_6O_2$   
[108-46-3]

$M_r$  110.1

#### DEFINITION

Resorcinol contains not less than 98.5 per cent and not more than the equivalent of 101.0 per cent of benzene-1,3-diol, calculated with reference to the dried substance.

#### CHARACTERS

A colourless or slightly pinkish-grey, crystalline powder or crystals, turning red on exposure to light and air, very soluble in water and in alcohol.

#### IDENTIFICATION

- Melting point (2.2.14): 109 °C to 112 °C.
- Dissolve 0.1 g in 1 mL of *water R*, add 1 mL of *strong sodium hydroxide solution R* and 0.1 mL of *chloroform R*, heat and allow to cool. An intense, deep-red colour develops which becomes pale yellow on the addition of a slight excess of *hydrochloric acid R*.
- Thoroughly mix about 10 mg with about 10 mg of *potassium hydrogen phthalate R*, both finely powdered. Heat over a naked flame until an orange-yellow colour is obtained. Cool and add 1 mL of *dilute sodium hydroxide solution R* and 10 mL of *water R* and shake to dissolve. The solution shows an intense green fluorescence.

#### TESTS

**Solution S.** Dissolve 2.5 g in *carbon dioxide-free water R* and dilute to 25 mL with the same solvent.

**Appearance of solution.** Solution S is clear (2.2.1) and not more intensely coloured than reference solution B<sub>5</sub> or R<sub>5</sub> (2.2.2, *Method II*) and remains so when heated in a water-bath for 5 min.

**Acidity or alkalinity.** To 10 mL of solution S add 0.05 mL of *bromophenol blue solution R2*. Not more than 0.05 mL of 0.1 M *hydrochloric acid* or 0.1 M *sodium hydroxide* is required to change the colour of the indicator.

**Related substances.** Examine by thin-layer chromatography (2.2.27), using *silica gel G R* as the coating substance.

**Test solution.** Dissolve 0.5 g of the substance to be examined in *methanol R* and dilute to 10 mL with the same solvent.

**Reference solution.** Dilute 0.1 mL of the test solution to 20 mL with *methanol R*.

Apply separately to the plate 2 µL of each solution. Develop over a path of 15 cm using a mixture of 40 volumes of *ethyl acetate R* and 60 volumes of *hexane R*. Allow the plate to dry in air for 15 min and expose it to iodine vapour. Any spot in the chromatogram obtained with the test solution, apart from the principal spot, is not more intense than the spot in the chromatogram obtained with the reference solution (0.5 per cent).

**Pyrocatechol.** To 2 mL of solution S add 1 mL of *ammonium molybdate solution R2* and mix. Any yellow colour in the solution is not more intense than that in a standard prepared at the same time in the same manner using 2 mL of a 0.1 g/L solution of *pyrocatechol R*.

**Loss on drying (2.2.32).** Not more than 1.0 per cent, determined on 1.00 g of powdered substance by drying in a desiccator for 4 h.

**Sulfated ash (2.4.14).** Not more than 0.1 per cent, determined on 1.0 g.

#### ASSAY

Dissolve 0.500 g in *water R* and dilute to 250.0 mL with the same solvent. To 25.0 mL of the solution in a ground-glass-stoppered flask add 1.0 g of *potassium bromide R*, 50.0 mL of 0.0167 M *potassium bromate*, 15 mL of *chloroform R* and 15.0 mL of *hydrochloric acid R1*. Stopper the flask, shake and allow to stand in the dark for 15 min, shaking occasionally. Add 10 mL of a 100 g/L solution of *potassium iodide R*, shake thoroughly, allow to stand for 5 min and titrate with 0.1 M *sodium thiosulfate*, using 1 mL of *starch solution R* as indicator.

1 mL of 0.0167 M *potassium bromate* is equivalent to 1.835 mg of  $C_6H_6O_2$ .

#### STORAGE

Store protected from light.

01/2008:2109  
corrected 6.0

## RIBAVIRIN

### Ribavirinum

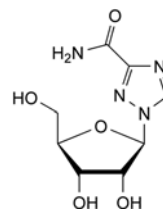

$C_8H_{12}N_4O_5$   
[36791-04-5]

$M_r$  244.2

#### DEFINITION

1-β-D-Ribofuranosyl-1H-1,2,4-triazole-3-carboxamide.

**Content:** 98.0 per cent to 102.0 per cent (dried substance).

#### CHARACTERS

**Appearance:** white or almost white, crystalline powder.

**Solubility:** freely soluble in water, slightly soluble in ethanol (96 per cent), slightly soluble or very slightly soluble in methylene chloride.

It shows polymorphism (5.9).

#### IDENTIFICATION

Infrared absorption spectrophotometry (2.2.24).

**Comparison:** *ribavirin CRS*.

If the spectra obtained in the solid state show differences, dissolve the substance to be examined and the reference substance separately in *methylene chloride R*, evaporate to dryness and record new spectra using the residues.

## TESTS

**pH** (2.2.3): 4.0 to 6.5.

Dissolve 0.200 g in *carbon dioxide-free water R* and dilute to 10.0 mL with the same solvent.

**Specific optical rotation** (2.2.7): –33 to –37 (dried substance).

Dissolve 0.250 g in *water R* and dilute to 25.0 mL with the same solvent. Determine the specific optical rotation within 10 min of preparing the solution.

**Related substances.** Liquid chromatography (2.2.29).

**Test solution (a).** Dissolve 50.0 mg of the substance to be examined in the mobile phase and dilute to 100.0 mL with the mobile phase.

**Test solution (b).** Dissolve 25.0 mg of the substance to be examined in the mobile phase and dilute to 100.0 mL with the mobile phase. Dilute 10.0 mL of the solution to 100.0 mL with the mobile phase.

**Reference solution (a).** Dilute 1.0 mL of test solution (a) to 100.0 mL with the mobile phase. Dilute 1.0 mL of this solution to 10.0 mL with the mobile phase.

**Reference solution (b).** Dissolve the contents of a vial of *ribavirin for system suitability CRS* in 2.0 mL of the mobile phase.

**Reference solution (c).** Dissolve 25.0 mg of *ribavirin CRS* in the mobile phase and dilute to 100.0 mL with the mobile phase. Dilute 10.0 mL of the solution to 100.0 mL with the mobile phase.

**Column:**

- size:  $l = 0.10$  m,  $\varnothing = 7.8$  mm,
- stationary phase: strong cation-exchange resin R (9  $\mu\text{m}$ ),
- temperature: 40 °C.

**Mobile phase:** *water R* adjusted to pH 2.5 with *sulfuric acid R*.

**Flow rate:** 1 mL/min.

**Detection:** spectrophotometer at 207 nm.

**Injection:** 10  $\mu\text{L}$  of test solution (a) and reference solutions (a) and (b).

**Run time:** 11 times the retention time of ribavirin.

**Relative retention** with reference to ribavirin (retention time = about 4 min): impurity F = about 1.2.

**System suitability:** reference solution (b):

- **peak-to-valley ratio:** minimum 1.2, where  $H_p$  = height above the baseline of the peak due to impurity F and  $H_v$  = height above the baseline of the lowest point of the curve separating this peak from the peak due to ribavirin.

**Limits:**

- **impurity F:** not more than the area of the principal peak in the chromatogram obtained with reference solution (a) (0.1 per cent),
- **any other impurity:** for each impurity, not more than the area of the principal peak in the chromatogram obtained with reference solution (a) (0.1 per cent),
- **total:** not more than twice the area of the principal peak in the chromatogram obtained with reference solution (a) (0.2 per cent),
- **disregard limit:** 0.5 times the area of the principal peak in the chromatogram obtained with reference solution (a) (0.05 per cent).

**Heavy metals** (2.4.8): maximum 10 ppm.

Dissolve 4.0 g in 20 mL of *water R*, with heating if necessary. 12 mL of the solution complies with limit test A. Prepare the reference solution using 10 mL of *lead standard solution (2 ppm Pb) R*.

**Loss on drying** (2.2.32): maximum 0.5 per cent, determined on 1.000 g by drying in an oven at 105 °C for 5 h.

**Sulfated ash** (2.4.14): maximum 0.1 per cent, determined on 1.0 g.

## ASSAY

Liquid chromatography (2.2.29) as described in the test for related substances with the following modification.

**Injection:** test solution (b) and reference solution (c).

Calculate the percentage content of  $\text{C}_8\text{H}_{12}\text{N}_4\text{O}_5$  using the declared content of *ribavirin CRS*.

## STORAGE

Protected from light.

## IMPURITIES

**Specified impurities:** F.

**Other detectable impurities** (the following substances would, if present at a sufficient level, be detected by one or other of the tests in the monograph. They are limited by the general acceptance criterion for other/unspecified impurities and/or by the general monograph *Substances for pharmaceutical use (2034)*. It is therefore not necessary to identify these impurities for demonstration of compliance. See also 5.10. **Control of impurities in substances for pharmaceutical use**): A, B, C, D, E, G.

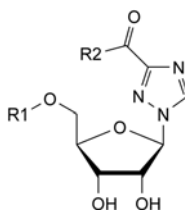

A. R1 = H, R2 = OH: 1- $\beta$ -D-ribofuranosyl-1H-1,2,4-triazole-3-carboxylic acid,

E. R1 =  $\text{CO-C}_6\text{H}_5$ , R2 =  $\text{NH}_2$ : 1-(5-O-benzoyl- $\beta$ -D-ribofuranosyl)-1H-1,2,4-triazole-3-carboxamide (5'-O-benzoylribavirin),

F. R1 =  $\text{CO-CH}_3$ , R2 =  $\text{NH}_2$ : 1-(5-O-acetyl- $\beta$ -D-ribofuranosyl)-1H-1,2,4-triazole-3-carboxamide (5'-O-acetylribavirin),

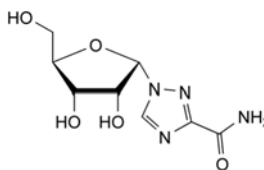

B. 1- $\alpha$ -D-ribofuranosyl-1H-1,2,4-triazole-3-carboxamide (anomer),

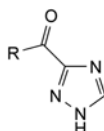

C. R = OH: 1H-1,2,4-triazole-3-carboxylic acid,

D. R =  $\text{NH}_2$ : 1H-1,2,4-triazole-3-carboxamide,

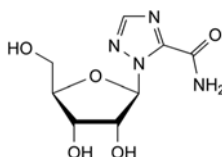

G. 1- $\beta$ -D-ribofuranosyl-1H-1,2,4-triazole-5-carboxamide (N-isomer).

## RIBOFLAVIN

## Riboflavinum

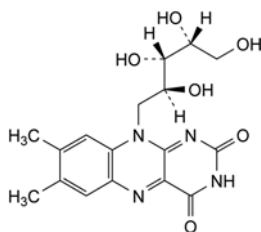

C<sub>17</sub>H<sub>20</sub>N<sub>4</sub>O<sub>6</sub>  
[83-88-5]

M<sub>r</sub> 376.4

## DEFINITION

7,8-Dimethyl-10-[(2*S*,3*S*,4*R*)-2,3,4,5-tetrahydroxy-pentyl]-benzo[*g*]pteridine-2,4(3*H*,10*H*)-dione.

This monograph applies to riboflavin produced by fermentation.

Content: 97.0 per cent to 103.0 per cent (dried substance).

## CHARACTERS

Appearance: yellow or orange-yellow, crystalline powder.

Solubility: very slightly soluble in water, practically insoluble in ethanol (96 per cent).

Solutions deteriorate on exposure to light, especially in the presence of alkali.

It shows polymorphism (5.9).

## IDENTIFICATION

A. Specific optical rotation (see Tests).

B. Thin-layer chromatography (2.2.27).

*Test solution.* Suspend 25 mg of the substance to be examined in 10 mL of water R, shake for 5 min and filter the suspension to remove the undissolved material.

*Reference solution.* Suspend 25 mg of riboflavin CRS in 10 mL of water R, shake for 5 min and filter the suspension to remove the undissolved material.

*Plate:* TLC silica gel plate R (2-10 µm).

*Mobile phase:* water R.

*Application:* as follows, drying in a current of cold air after each individual application:

- 1<sup>st</sup> application: 2 µL of methylene chloride R then 2 µL of the test solution;
- 2<sup>nd</sup> application: 2 µL of methylene chloride R then 2 µL of the reference solution.

*Development:* over a path of 6 cm.

*Drying:* in a current of cold air.

*Detection:* examine in ultraviolet light at 365 nm.

*Results:* the principal spot in the chromatogram obtained with the test solution is similar in position and size to the principal spot in the chromatogram obtained with the reference solution.

C. Dissolve about 1 mg in 100 mL of water R. The solution has, by transmitted light, a pale greenish-yellow colour, and, by reflected light, an intense yellowish-green fluorescence which disappears on the addition of mineral acids or alkalis.

## TESTS

**Specific optical rotation** (2.2.7): – 115 to – 135 (dried substance).

Dissolve 50.0 mg in 0.05 M sodium hydroxide free from carbonate and dilute to 10.0 mL with the same alkaline solution. Measure the optical rotation within 30 min of dissolution.

## 01/2008:0292 Absorbance (2.2.25).

*Test solution.* Dilute the final solution prepared for the assay with an equal volume of water R.

*Absorption maxima:* at 223 nm, 267 nm, 373 nm and 444 nm.

*Absorbance ratios:*

- $A_{373}/A_{267} = 0.31$  to 0.33;
- $A_{444}/A_{267} = 0.36$  to 0.39.

**Related substances.** Liquid chromatography (2.2.29). Prepare the solutions immediately before use and protect from light.

*Solution A:* 13.6 g/L solution of sodium acetate R.

*Test solution.* With the aid of ultrasound, dissolve 0.120 g of the substance to be examined in 10 mL of 0.1 M sodium hydroxide and dilute to 100 mL with solution A.

*Reference solution (a).* Dilute 1.0 mL of the test solution to 10.0 mL with solution A. Dilute 1.0 mL of this solution to 100.0 mL with solution A.

*Reference solution (b).* With the aid of ultrasound, dissolve the contents of a vial of riboflavin for peak identification CRS (containing impurities C and D) in 1.0 mL of a mixture of 1 volume of mobile phase B and 9 volumes of mobile phase A.

*Reference solution (c).* In order to prepare *in situ* impurities A and B, dissolve 10 mg of the substance to be examined in 1 mL of 0.5 M sodium hydroxide. Expose to daylight for 1.5 h. Add 0.5 mL of acetic acid R and dilute to 100 mL with water R.

*Column:*

- size:  $l = 0.25$  m,  $\varnothing = 4.6$  mm;
- stationary phase: end-capped octadecylsilyl silica gel for chromatography R (5 µm).

*Mobile phase:*

- mobile phase A: phosphoric acid R, water R (1:1000 V/V);
- mobile phase B: acetonitrile R;

Time (min)	Mobile phase A (per cent V/V)	Mobile phase B (per cent V/V)
0 - 5	90	10
5 - 20	90 → 80	10 → 20
20 - 25	80	20
25 - 35	80 → 50	20 → 50
35 - 45	50	50

*Flow rate:* 1.0 mL/min.

*Detection:* spectrophotometer at 267 nm.

*Injection:* 10 µL.

*Identification of impurities:* use the chromatogram supplied with riboflavin for peak identification CRS and the chromatogram obtained with reference solution (b) to identify the peaks due to impurities C and D.

*Relative retention* with reference to riboflavin (retention time = about 16 min): impurity C = about 0.2; impurity D = about 0.5; impurity A = about 1.4; impurity B = about 1.9.

*System suitability:*

- resolution: minimum 5 between the peaks due to impurities A and B in the chromatogram obtained with reference solution (c);
- the chromatogram obtained with reference solution (b) is similar to the chromatogram supplied with riboflavin for peak identification CRS.

*Limits:*

- correction factors: for the calculation of content, multiply the peak areas of the following impurities by the corresponding correction factor: impurity A = 0.7; impurity B = 1.4; impurity C = 2.3; impurity D = 1.4;
- impurity A: not more than 0.25 times the area of the principal peak in the chromatogram obtained with reference solution (a) (0.025 per cent);



- *impurities B, C, D*: for each impurity, not more than twice the area of the principal peak in the chromatogram obtained with reference solution (a) (0.2 per cent);
- *unspecified impurities*: for each impurity, not more than the area of the principal peak in the chromatogram obtained with reference solution (a) (0.10 per cent);
- *total*: not more than 5 times the area of the principal peak in the chromatogram obtained with reference solution (a) (0.5 per cent);
- *disregard limit for peaks other than those due to impurity A*: 0.5 times the area of the principal peak in the chromatogram obtained with reference solution (a) (0.05 per cent).

**Loss on drying** (2.2.32): maximum 1.5 per cent, determined on 1.000 g by drying in an oven at 105 °C.

**Sulfated ash** (2.4.14): maximum 0.1 per cent, determined on the residue obtained in the test for loss on drying.

#### ASSAY

Carry out the assay protected from light.

In a brown-glass 500 mL volumetric flask, suspend 65.0 mg in 5 mL of *water R* ensuring that it is completely wetted and dissolve in 5 mL of *dilute sodium hydroxide solution R*. As soon as dissolution is complete, add 100 mL of *water R* and 2.5 mL of *glacial acetic acid R* and dilute to 500.0 mL with *water R*. Place 20.0 mL of this solution in a 200 mL brown-glass volumetric flask, add 3.5 mL of a 14 g/L solution of *sodium acetate R* and dilute to 200.0 mL with *water R*. Measure the absorbance (2.2.25) at the absorption maximum at 444 nm.

Calculate the content of  $C_{17}H_{20}N_4O_6$  taking the specific absorbance to be 328.

#### STORAGE

In an airtight container, protected from light.

#### IMPURITIES

*Specified impurities: A, B, C, D.*

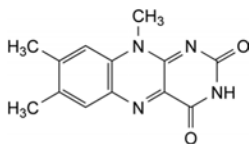

- A. 7,8,10-trimethylbenzo[*g*]pteridine-2,4(3*H*,10*H*)-dione (lumiflavine),

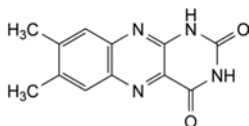

- B. 7,8-dimethylbenzo[*g*]pteridine-2,4(1*H*,3*H*)-dione,

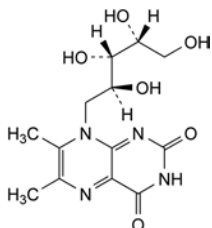

- C. 6,7-dimethyl-8-[(2*S*,3*S*,4*R*)-2,3,4,5-tetrahydroxypentyl]-pteridine-2,4(3*H*,8*H*)-dione,

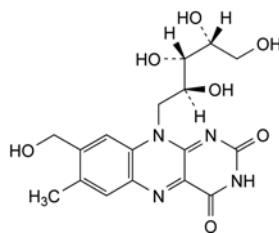

- D. 8-(hydroxymethyl)-7-methyl-10-[(2*S*,3*S*,4*R*)-2,3,4,5-tetrahydroxypentyl]benzo[*g*]pteridine-2,4(3*H*,10*H*)-dione.

01/2008:0786  
corrected 6.0

## RIBOFLAVIN SODIUM PHOSPHATE

### Riboflavini natrii phosphas

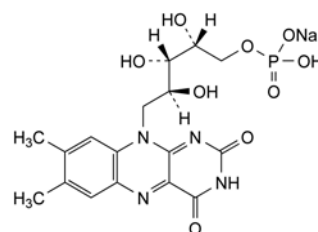

$C_{17}H_{20}N_4NaO_9P$   
[130-405]

$M_r$  478.3

#### DEFINITION

Mixture containing riboflavin 5'-(sodium hydrogen phosphate) as the main component and other riboflavin sodium monophosphates.

*Content*: 73.0 per cent to 79.0 per cent of riboflavin ( $C_{17}H_{20}N_4O_6$ ;  $M_r$  376.4) (dried substance).

It contains a variable amount of water.

#### CHARACTERS

*Appearance*: yellow or orange-yellow, crystalline, hygroscopic powder.

*Solubility*: soluble in water, very slightly soluble in ethanol (96 per cent).

#### IDENTIFICATION

- A. Ultraviolet and visible absorption spectrophotometry (2.2.25).

*Test solution*. Dissolve 50.0 mg in *phosphate buffer solution pH 7.0 R* and dilute to 100.0 mL with the same buffer solution. Dilute 2.0 mL of this solution to 100.0 mL with *phosphate buffer solution pH 7.0 R*.

*Spectral range*: 230-350 nm.

*Absorption maximum*: at 266 nm.

*Specific absorbance at the absorption maximum*: 580 to 640.

- B. Examine the chromatograms obtained in the test for related substances.

*Results*: the principal peak in the chromatogram obtained with the test solution is similar in position and approximate size to the principal peak in the chromatogram obtained with reference solution (b).

- C. Dissolve about 10 mg in *dilute sodium hydroxide solution R* and dilute to 100 mL with the same solution. Expose 1 mL of this solution to ultraviolet light at 254 nm for 5 min, add sufficient *acetic acid R* to make the solution acidic to *blue litmus paper R* and shake with 2 mL of *methylene chloride R*. The lower layer shows yellow fluorescence.

D. To 0.5 g add 10 mL of *nitric acid R* and evaporate the mixture to dryness on a water-bath. Ignite the residue until it becomes white, dissolve the residue in 5 mL of *water R* and filter. The filtrate gives reaction (a) of sodium and reaction (b) of phosphates (2.3.1).

## TESTS

**pH** (2.2.3): 5.0 to 6.5.

Dissolve 0.5 g in *carbon dioxide-free water R* and dilute to 50 mL with the same solvent.

**Specific optical rotation** (2.2.7): + 38.0 to + 43.0 (dried substance).

Dissolve 0.300 g in 18.2 mL of *hydrochloric acid R1* and dilute to 25.0 mL with *water R*.

**Impurity E.** To about 35 mg add 10 mL of *methylene chloride R*, shake for 5 min and filter. The filtrate is not more intensely coloured than reference solution BY<sub>6</sub> (2.2.2, *Method II*).

**Related substances.** Liquid chromatography (2.2.29). *Carry out the test protected from actinic light.*

**Test solution.** Dissolve 0.100 g of the substance to be examined in 50 mL of *water R* and dilute to 100.0 mL with the mobile phase. Dilute 8.0 mL of this solution to 50.0 mL with the mobile phase.

**Reference solution (a).** Dissolve 60 mg of *riboflavin CRS* (impurity D) in 1 mL of *hydrochloric acid R* and dilute to 250.0 mL with *water R*. Dilute 4.0 mL of this solution to 100.0 mL with the mobile phase.

**Reference solution (b).** Dissolve 0.100 g of *riboflavin sodium phosphate CRS* in 50 mL of *water R* and dilute to 100.0 mL with the mobile phase. Dilute 8.0 mL of this solution to 50.0 mL with the mobile phase.

**Column:**

- size:  $l = 0.25$  m,  $\varnothing = 4.6$  mm;
- stationary phase: octadecylsilyl silica gel for chromatography R (5  $\mu$ m).

**Mobile phase:** *methanol R*, 7.35 g/L solution of *potassium dihydrogen phosphate R* (150:850 V/V).

**Flow rate:** 2 mL/min.

**Detection:** spectrophotometer at 266 nm.

**Injection:** 100  $\mu$ L.

**Run time:** until the peak due to riboflavin can be clearly evaluated.

**Relative retention** with reference to riboflavin 5'-monophosphate (retention time = about 20 min): impurity A = about 0.2; impurity B = about 0.3; impurity C = about 0.5; riboflavin 3'-monophosphate = about 0.7; riboflavin 4'-monophosphate = about 0.9; impurity D = about 2.

**System suitability:** reference solution (b):

- resolution: minimum 1.5 between the peaks due to riboflavin 4'-monophosphate and riboflavin 5'-monophosphate.

Calculate the percentage content of free riboflavin (impurity D) and of riboflavin in the form of the diphosphates of riboflavin (impurities A, B, C) from the areas of the peaks in the chromatogram obtained with the test solution and the amount of free riboflavin in reference solution (a).

**Limits:**

- impurity D: maximum 6.0 per cent (dried substance);
- sum of impurities A, B and C: maximum 6.0 per cent (dried substance).

The thresholds indicated under Related substances (Table 2034.1) in the general monograph *Substances for pharmaceutical use* (2034) do not apply.

**Inorganic phosphate:** maximum 1.5 per cent.

Dissolve 0.10 g in *water R* and dilute to 100 mL with the same solvent. To 5 mL of this solution, add 10 mL of *water R*, 5 mL

of *buffered copper sulfate solution pH 4.0 R*, 2 mL of a 30 g/L solution of *ammonium molybdate R*, 1 mL of a freshly prepared solution containing 20 g/L of *4-methylaminophenol sulfate R* and 50 g/L of *sodium metabisulfite R*, and 1 mL of a 3 per cent V/V solution of *perchloric acid R*. Dilute to 25.0 mL with *water R* and measure, within 15 min of its preparation, the absorbance (2.2.25) of the solution at 800 nm, using as the compensation liquid a solution prepared in the same manner but without the substance to be examined. The absorbance is not greater than that of a solution prepared as follows: to 15 mL of *phosphate standard solution (5 ppm PO<sub>4</sub>) R*, add 5 mL of *buffered copper sulfate solution pH 4.0 R*, 2 mL of a 30 g/L solution of *ammonium molybdate R*, 1 mL of a freshly prepared solution containing 20 g/L of *4-methylaminophenol sulfate R* and 50 g/L of *sodium metabisulfite R*, and 1 mL of a 3 per cent V/V solution of *perchloric acid R*; dilute to 25.0 mL with *water R*.

**Heavy metals** (2.4.8): maximum 10 ppm.

To 2.0 g in a silica crucible add 2 mL of *nitric acid R*, dropwise, followed by 0.25 mL of *sulfuric acid R*. Heat cautiously until white fumes are evolved and ignite. Extract the cooled residue with 2 quantities, each of 2 mL, of *hydrochloric acid R* and evaporate the extracts to dryness. Dissolve the residue in 2 mL of *dilute acetic acid R* and dilute to 20 mL with *water R*. 12 mL of the solution complies with test A. Prepare the reference solution using 10 mL of *lead standard solution (1 ppm Pb) R*.

**Loss on drying** (2.2.32): maximum 8.0 per cent, determined on 1.000 g by drying in an oven at 105 °C at a pressure not exceeding 0.7 kPa for 5 h.

## ASSAY

*Carry out the assay protected from light.*

Dissolve 0.100 g in 150 mL of *water R*, add 2 mL of *glacial acetic acid R* and dilute to 1000.0 mL with *water R*. To 10.0 mL of this solution add 3.5 mL of a 14 g/L solution of *sodium acetate R* and dilute to 50.0 mL with *water R*. Measure the absorbance (2.2.25) at the absorption maximum at 444 nm.

Calculate the content of C<sub>17</sub>H<sub>20</sub>N<sub>4</sub>O<sub>6</sub> taking the specific absorbance to be 328.

## STORAGE

In an airtight container, protected from light.

## IMPURITIES

*Specified impurities: A, B, C, D, E.*

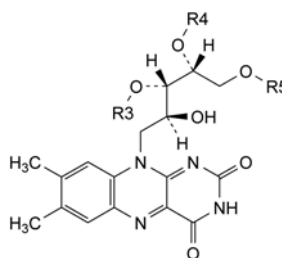

- A. R<sub>3</sub> = R<sub>4</sub> = PO<sub>3</sub>H<sub>2</sub>, R<sub>5</sub> = H: riboflavin 3',4'-diphosphate,
- B. R<sub>3</sub> = R<sub>5</sub> = PO<sub>3</sub>H<sub>2</sub>, R<sub>4</sub> = H: riboflavin 3',5'-diphosphate,
- C. R<sub>3</sub> = H, R<sub>4</sub> = R<sub>5</sub> = PO<sub>3</sub>H<sub>2</sub>: riboflavin 4',5'-diphosphate,
- D. R<sub>3</sub> = R<sub>4</sub> = R<sub>5</sub> = H: riboflavin,

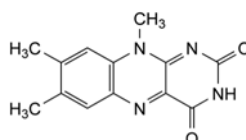

- E. 7,8,10-trimethylbenzo[g]pteridine-2,4(3H,10H)-dione (lumiflavin).

01/2009:0349

01/2008:1657  
corrected 6.0**RICE STARCH****Oryzae amyllum****DEFINITION**

Rice starch is obtained from the caryopsis of *Oryza sativa* L.

**CHARACTERS**

*Appearance*: very fine, white or almost white powder, which creaks when pressed between the fingers.

*Solubility*: practically insoluble in cold water and in ethanol (96 per cent).

Rice starch does not contain starch grains of any other origin. It may contain traces of, if any, fragments of the endosperm tissue of the fruit.

**IDENTIFICATION**

- A. Examined under a microscope using a mixture of equal volumes of *glycerol R* and *water R*, it presents polyhedral, simple grains 1-10 µm, mostly 4-6 µm, in size. These simple grains often gather in ellipsoidal, compound grains 50-100 µm in diameter. The grains have a poorly visible central hilum and there are no concentric striations. Between orthogonally orientated polarising plates or prisms, the starch grains show a distinct black cross intersecting at the hilum.
- B. Suspend 1 g in 50 mL of *water R*, boil for 1 min and cool. A thin, cloudy mucilage is formed.
- C. To 1 mL of the mucilage obtained in identification test B add 0.05 mL of *iodine solution RI*. An orange-red to dark blue colour is produced, which disappears on heating.

**TESTS**

**pH** (2.2.3): 5.0 to 8.0.

Shake 5.0 g with 25.0 mL of *carbon dioxide-free water R* for 60 s. Allow to stand for 15 min.

**Iron** (2.4.9): maximum 10 ppm for the filtrate.

Shake 1.5 g with 15 mL of *dilute hydrochloric acid R*. Filter.

**Foreign matter**. Examine under a microscope using a mixture of equal volumes of *glycerol R* and *water R*. Not more than traces of matter other than starch granules are present. No starch grains of any other origin are present.

**Loss on drying** (2.2.32): maximum 15.0 per cent, determined on 1.00 g by drying in an oven at 130 °C for 90 min.

**Sulfated ash** (2.4.14): maximum 0.6 per cent, determined on 1.0 g.

**Oxidising substances** (2.5.30): maximum 0.002 per cent, calculated as H<sub>2</sub>O<sub>2</sub>.

**Sulfur dioxide** (2.5.29): maximum 50 ppm.

**Microbial contamination**

TAMC: acceptance criterion 10<sup>3</sup> CFU/g (2.6.12).

TYMC: acceptance criterion 10<sup>2</sup> CFU/g (2.6.12).

Absence of *Escherichia coli* (2.6.13).

Absence of *Salmonella* (2.6.13).

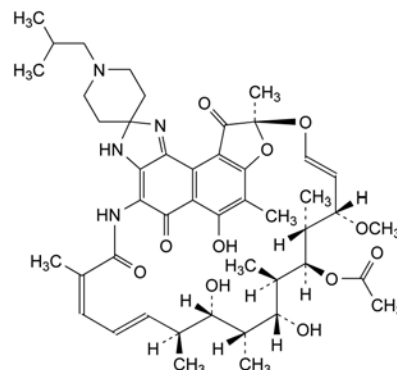
**RIFABUTIN****Rifabutinum**

C<sub>46</sub>H<sub>62</sub>N<sub>4</sub>O<sub>11</sub>  
[72559-06-9]

M<sub>r</sub> 847

**DEFINITION**

(9S,12E,14S,15R,16S,17R,18R,19R,20S,21S,22E,24Z)-6,18,20-trihydroxy-14-methoxy-7,9,15,17,19,21,25-heptamethyl-1'-(2-methylpropyl)-5,10,26-trioxo-3,5,9,10-tetrahydrospiro[9,4-(epoxypentadeca[1,11,13]trienimino)-2H-furo[2',3':7,8]naphtho[1,2-d]imidazole-2,4'-piperidine]-16-yl acetate.

Semi-synthetic product derived from a fermentation product.

*Content*: 96.0 per cent to 102.0 per cent (anhydrous substance).

**CHARACTERS**

*Appearance*: reddish-violet amorphous powder.

*Solubility*: slightly soluble in water, soluble in methanol, slightly soluble in alcohol.

**IDENTIFICATION**

- A. Infrared absorption spectrophotometry (2.2.24).

*Preparation*: discs.

*Comparison*: *rifabutin CRS*.

- B. Examine the chromatograms obtained in the test for related substances.

*Results*: the principal peak in the chromatogram obtained with the test solution is similar in retention time and size to the principal peak in the chromatogram obtained with reference solution (a).

**TESTS**

- Impurity A**. Thin-layer chromatography (2.2.27).

*Test solution*. Dissolve 0.100 g of the substance to be examined in a mixture of equal volumes of *methanol R* and *methylene chloride R* and dilute to 10 mL with the same mixture of solvents.

*Reference solution*. Dissolve 10 mg of *rifabutin impurity A CRS* in a mixture of equal volumes of *methanol R* and *methylene chloride R* and dilute to 10 mL with the same mixture of solvents. Dilute 3 mL of the solution to 100 mL with a mixture of equal volumes of *methanol R* and *methylene chloride R*.

*Plate*: TLC silica gel F<sub>254</sub> plate R.

*Mobile phase*: *acetone R*, *light petroleum R* (23:77 V/V).

*Application*: 10 µL.

*Development*: over 2/3 of the plate.

*Drying*: in air.

*Detection*: expose the plate to iodine vapour for about 5 min, then spray with *potassium iodide and starch solution R* and allow to stand for 5 min.

**Limit:**

- **impurity A:** any spot corresponding to impurity A is not more intense than the spot in the chromatogram obtained with the reference solution (0.3 per cent).

**Related substances.** Liquid chromatography (2.2.29).

**Test solution.** Dissolve 50.0 mg of the substance to be examined in the mobile phase and dilute to 50.0 mL with the mobile phase.

**Reference solution (a).** Dissolve 50.0 mg of *rifabutin CRS* in the mobile phase and dilute to 50.0 mL with the mobile phase.

**Reference solution (b).** Dilute 1.0 mL of reference solution (a) to 100.0 mL with the mobile phase.

**Reference solution (c).** Dissolve about 10 mg of *rifabutin CRS* in 2 mL of *methanol R*, add 1 mL of *dilute sodium hydroxide solution R* and allow to stand for about 4 min. Add 1 mL of *dilute hydrochloric acid R* and dilute to 50 mL with the mobile phase.

**Column:**

- **size:**  $l = 0.110$  m,  $\varnothing = 4.6$  mm,
- **stationary phase:** *octylsilyl silica gel for chromatography R* (5  $\mu$ m).

**Mobile phase:** mix equal volumes of *acetonitrile R* and a 13.6 g/L solution of *potassium dihydrogen phosphate R* adjusted to pH 6.5 with *dilute sodium hydroxide solution R*.

**Flow rate:** 1 mL/min.

**Detection:** spectrophotometer at 254 nm.

**Injection:** 20  $\mu$ L.

**Run time:** 2.5 times the retention time of rifabutin.

**Relative retention** with reference to rifabutin (retention time = about 9 min): impurity E = about 0.5; impurity B = about 0.6; impurity D = about 0.9; impurity C = about 1.3.

**System suitability:** reference solution (c):

- **resolution:** minimum 2.0 between the second peak of the 3 peaks due to degradation products and the peak due to rifabutin.

**Limits:**

- **any impurity:** not more than the area of the principal peak in the chromatogram obtained with reference solution (b) (1.0 per cent); not more than 1 such peak has an area greater than half the area of the principal peak in the chromatogram obtained with reference solution (b) (0.5 per cent),
- **total:** not more than 3 times the area of the principal peak in the chromatogram obtained with reference solution (b) (3.0 per cent),
- **disregard limit:** 0.05 times the area of the principal peak in the chromatogram obtained with reference solution (b) (0.05 per cent).

**Water** (2.5.12): maximum 2.5 per cent, determined on 0.200 g.

**Sulfated ash** (2.4.14): maximum 0.3 per cent, determined on 1.0 g.

**ASSAY**

Liquid chromatography (2.2.29) as described in the test for related substances with the following modification.

**Injection:** test solution and reference solution (a).

Calculate the percentage content of rifabutin.

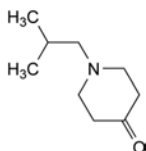
**IMPURITIES**

A. 1-(2-methylpropyl)piperidin-4-one,

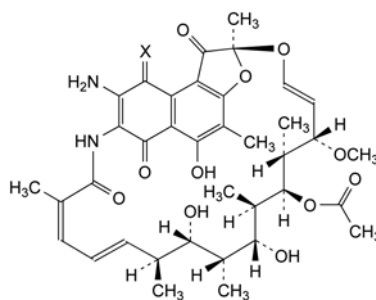

B. X = O: 3-aminorifamycin S,

D. X = NH: 3-amino-4-imidorifamycin S,

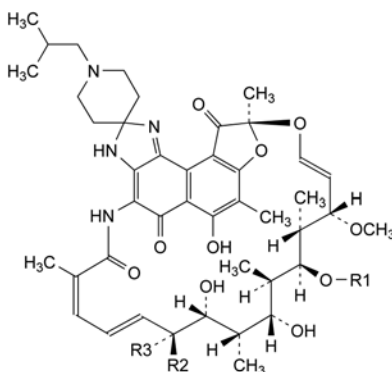

C. R1 = CO-CH<sub>3</sub>, R2 + R3 = CH<sub>2</sub>: 21,31-didehydrorifabutin,

E. R1 = R3 = H, R2 = CH<sub>3</sub>: 16-deacetyl rifabutin.

01/2008:0052

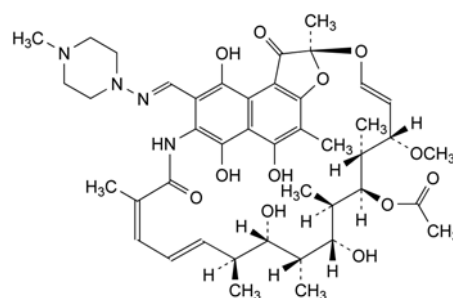
**RIFAMPICIN****Rifampicinum**

C<sub>43</sub>H<sub>58</sub>N<sub>4</sub>O<sub>12</sub>  
[13292-46-1]

$M_r$  823

**DEFINITION**

(2*S*,12*Z*,14*E*,16*S*,17*S*,18*R*,19*R*,20*R*,21*S*,22*R*,23*S*,24*E*)-5,6,9,17,19-Pentahydroxy-23-methoxy-2,4,12,16,18,20,22-heptamethyl-8-[[[(4-methylpiperazin-1-yl)imino]methyl]-1,11-dioxo-1,2-dihydro-2,7-(epoxypentadeca[1,11,13]trienimino)naphtho[2,1-*b*]furan-21-yl]acetate.

Semisynthetic antibiotic obtained from rifamycin SV.

**Content:** 97.0 per cent to 102.0 per cent (dried substance).

**CHARACTERS**

**Appearance:** reddish-brown or brownish-red, crystalline powder.

**Solubility:** slightly soluble in water, soluble in methanol, slightly soluble in acetone and in ethanol (96 per cent).

**IDENTIFICATION**

A. Ultraviolet and visible absorption spectrophotometry (2.2.25).

**Test solution.** Dissolve 50 mg in 50 mL of *methanol R*.

Dilute 1 mL of this solution to 50 mL with *phosphate buffer solution pH 7.4 R*.

*Spectral range:* 220-500 nm.

*Absorption maxima:* at 237 nm, 254 nm, 334 nm and 475 nm.

*Absorbance ratio:*  $A_{334}/A_{475}$  = about 1.75.

**B.** Infrared absorption spectrophotometry (2.2.24).

*Preparation:* mulls in *liquid paraffin R*.

*Comparison:* *rifampicin CRS*.

**C.** Suspend about 25 mg in 25 mL of *water R*, shake for 5 min and filter. To 5 mL of the filtrate add 1 mL of a 100 g/L solution of *ammonium persulfate R* in *phosphate buffer solution pH 7.4 R* and shake for a few minutes. The colour changes from orange-yellow to violet-red and no precipitate is formed.

**TESTS**

**pH** (2.2.3): 4.5 to 6.5 for a 10 g/L suspension in *carbon dioxide-free water R*.

**Related substances.** Liquid chromatography (2.2.29). Prepare the test solution and the reference solution immediately before use.

**Solvent mixture.** To 10 volumes of a 210.1 g/L solution of *citric acid R* add 23 volumes of a 136.1 g/L solution of *potassium dihydrogen phosphate R*, 77 volumes of a 174.2 g/L solution of *dipotassium hydrogen phosphate R*, 250 volumes of *acetonitrile R* and 640 volumes of *water R*.

**Test solution.** Dissolve 20.0 mg of the substance to be examined in *acetonitrile R* and dilute to 10.0 mL with the same solvent. Dilute 5.0 mL of this solution to 50.0 mL with the solvent mixture.

**Reference solution.** Dissolve 20.0 mg of *rifampicin quinone CRS* (impurity A) in *acetonitrile R* and dilute to 100.0 mL with the same solvent. To 1.0 mL of this solution add 1.0 mL of the test solution and dilute to 100.0 mL with the solvent mixture.

**Column:**

- size:  $l = 0.12$  m,  $\varnothing = 4.6$  mm;
- stationary phase: *octylsilyl silica gel for chromatography R* (5  $\mu$ m).

**Mobile phase:** mix 35 volumes of *acetonitrile R* and 65 volumes of a solution containing 0.1 per cent V/V of *phosphoric acid R*, 1.9 g/L of *sodium perchlorate R*, 5.9 g/L of *citric acid R* and 20.9 g/L of *potassium dihydrogen phosphate R*.

**Flow rate:** 1.5 mL/min.

**Detection:** spectrophotometer at 254 nm.

**Injection:** 20  $\mu$ L.

**Run time:** twice the retention time of rifampicin.

**System suitability:** reference solution:

- resolution: minimum 4.0 between the peaks due to rifampicin and impurity A; if necessary, adjust the concentration of acetonitrile in the mobile phase.

**Limits:**

- **impurity A:** not more than 1.5 times the area of the corresponding peak in the chromatogram obtained with the reference solution (1.5 per cent);
- **any other impurity:** for each impurity, not more than the area of the peak due to rifampicin in the chromatogram obtained with the reference solution (1.0 per cent);
- **sum of impurities other than A:** not more than 3.5 times the area of the peak due to rifampicin in the chromatogram obtained with the reference solution (3.5 per cent);

- **disregard limit:** 0.05 times the area of the peak due to rifampicin in the chromatogram obtained with the reference solution (0.05 per cent).

**Heavy metals** (2.4.8): maximum 20 ppm.

1.0 g complies with test C. Prepare the reference solution using 2 mL of *lead standard solution (10 ppm Pb) R*.

**Loss on drying** (2.2.32): maximum 1.0 per cent, determined on 1.000 g by drying at 80 °C at a pressure not exceeding 0.67 kPa for 4 h.

**Sulfated ash** (2.4.14): maximum 0.1 per cent, determined on 2.0 g.

**ASSAY**

Dissolve 0.100 g in *methanol R* and dilute to 100.0 mL with the same solvent. Dilute 2.0 mL of this solution to 100.0 mL with *phosphate buffer solution pH 7.4 R*. Measure the absorbance (2.2.25) at the absorption maximum at 475 nm, using *phosphate buffer solution pH 7.4 R* as the compensation liquid.

Calculate the content of  $C_{43}H_{58}N_4O_{12}$ , taking the specific absorbance to be 187.

**STORAGE**

Under nitrogen in an airtight container, protected from light, at a temperature not exceeding 25 °C.

**IMPURITIES**

**Specified impurities:** A.

**Other detectable impurities** (the following substances would, if present at a sufficient level, be detected by one or other of the tests in the monograph. They are limited by the general acceptance criterion for other/unspecified impurities and/or by the general monograph *Substances for pharmaceutical use (2034)*. It is therefore not necessary to identify these impurities for demonstration of compliance. See also 5.10. *Control of impurities in substances for pharmaceutical use*): B.

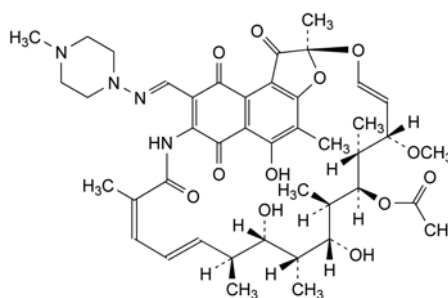

A. rifampicin quinone,

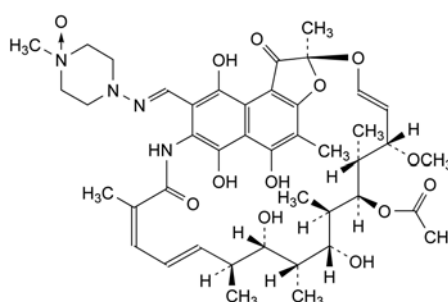

B. rifampicin N-oxide.

**01/2008:0432** *Test solution.* Dissolve 50.0 mg of the substance to be examined in the solvent mixture and dilute to 50.0 ml with the solvent mixture.  
**corrected 7.0**

## RIFAMYCIN SODIUM

### Rifamycinum natrium

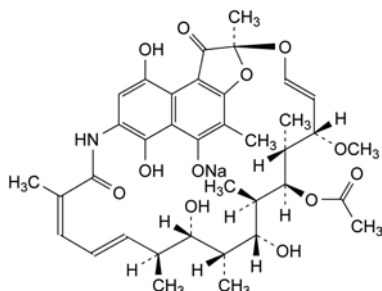

$C_{37}H_{46}NNaO_{12}$   
[14897-39-3]

$M_r$  720

#### DEFINITION

Sodium (2*S*,12*Z*,14*E*,16*S*,17*S*,18*R*,19*R*,20*R*,21*S*,22*R*,23*S*,24*E*)-21-(acetyloxy)-6,9,17,19-tetrahydroxy-23-methoxy-2,4,12,16,18,20,22-heptamethyl-1,11-dioxo-1,2-dihydro-2,7-(epoxypentadeca[1,11,13]trienimino)naphtho[2,1-*b*]furan-5-olate.

Monosodium salt of rifamycin SV, obtained by chemical transformation of rifamycin B, which is produced during the growth of certain strains of *Amycolatopsis mediterranei*. Rifamycin SV may also be obtained directly from certain *A. mediterranei* mutants.

*Potency*: minimum 900 IU/mg (anhydrous substance).

#### PRODUCTION

It is produced by methods of manufacture designed to minimise or eliminate substances lowering blood pressure.

The manufacturing process is validated to demonstrate that the product, if tested, would comply with the following test.

**Abnormal toxicity** (2.6.9). Inject into each mouse 4 mg dissolved in 0.5 mL of water for injections *R*.

#### CHARACTERS

*Appearance*: fine or slightly granular, red powder.

*Solubility*: soluble in water, freely soluble in anhydrous ethanol.

#### IDENTIFICATION

A. Infrared absorption spectrophotometry (2.2.24).

*Preparation*: discs of potassium bromide *R*.

*Comparison*: rifamycin sodium CRS.

B. It gives reaction (a) of sodium (2.3.1).

#### TESTS

**pH** (2.2.3): 6.5 to 8.0.

Dissolve 0.5 g in carbon dioxide-free water *R* and dilute to 10 mL with the same solvent.

**Absorbance** (2.2.25). Dissolve 20.0 mg in 5 mL of methanol *R* and dilute to 100.0 mL with freshly prepared phosphate buffer solution pH 7.0 *R1* to which 1 g/L of ascorbic acid *R* has been added immediately before use. Dilute 5.0 mL of this solution to 50.0 mL with the same phosphate buffer solution containing ascorbic acid. Allow to stand for 30 min. The solution shows an absorption maximum at 445 nm. The specific absorbance at this absorption maximum is 190 to 210 (anhydrous substance).

**Related substances.** Liquid chromatography (2.2.29). Prepare the solutions immediately before use.

*Solvent mixture.* Mix 50 volumes of a 3.9 g/L solution of sodium dihydrogen phosphate *R*, adjusted to pH 3.0 with phosphoric acid *R*, and 50 volumes of acetonitrile *R*.

*Reference solution (a).* Dissolve 10.0 mg of rifamycin B CRS (impurity A) and 40.0 mg of rifamycin S CRS (impurity B) in the solvent mixture and dilute to 200.0 mL with the solvent mixture. Dilute 5.0 mL of this solution to 50.0 mL with the solvent mixture.

*Reference solution (b).* Dissolve 25 mg of the substance to be examined and 8 mg of rifamycin S CRS in the solvent mixture and dilute to 250.0 mL with the solvent mixture.

#### Column:

- size:  $l = 0.25$  m,  $\varnothing = 4.6$  mm;
- stationary phase: octadecylsilyl silica gel for chromatography *R* (5  $\mu$ m).

#### Mobile phase:

- mobile phase A: mix 10 volumes of acetonitrile *R* and 90 volumes of a 3.9 g/L solution of sodium dihydrogen phosphate *R* adjusted to pH 7.5 with dilute sodium hydroxide solution *R*;
- mobile phase B: mix 30 volumes of a 3.9 g/L solution of sodium dihydrogen phosphate *R* adjusted to pH 7.5 with dilute sodium hydroxide solution *R* and 70 volumes of acetonitrile *R*;
- temperature: minimum 20 °C;

Time (min)	Mobile phase A (per cent V/V)	Mobile phase B (per cent V/V)
0 - 40	80 → 20	20 → 80
40 - 45	20	80
45 - 47	20 → 80	80 → 20

*Flow rate*: 1 mL/min.

*Detection*: spectrophotometer at 254 nm.

*Injection*: 20  $\mu$ L.

*Elution order*: impurity A, rifamycin SV, impurity B.

*System suitability*: reference solution (b):

- resolution: minimum 5.0 between the peaks due to rifamycin SV and impurity B.

#### Limits:

- impurity B: not more than the area of the corresponding peak in the chromatogram obtained with reference solution (a) (2 per cent);
- impurity A: not more than the area of the corresponding peak in the chromatogram obtained with reference solution (a) (0.5 per cent);
- sum of impurities other than A and B: not more than the area of the peak due to impurity B in the chromatogram obtained with reference solution (a) (2 per cent);
- disregard limit: the area of the peak due to impurity B in the chromatogram obtained with reference solution (a) (0.1 per cent).

**Heavy metals** (2.4.8): maximum 10 ppm.

2.0 g complies with test C. Prepare the reference solution using 2 mL of lead standard solution (10 ppm Pb) *R*.

**Water** (2.5.12): 12.0 per cent to 17.0 per cent, determined on 0.200 g.

**Bacterial endotoxins** (2.6.14): less than 0.50 IU/mg, if intended for use in the manufacture of parenteral preparations without a further appropriate procedure for removal of bacterial endotoxins.

#### ASSAY

Carry out the microbiological assay of antibiotics (2.7.2).

## STORAGE

In an airtight container, protected from light at a temperature of 2 °C to 8 °C. If the substance is sterile, store in a sterile, airtight, tamper-proof container.

## IMPURITIES

*Specified impurities:* A, B.

*Other detectable impurities* (the following substances would, if present at a sufficient level, be detected by one or other of the tests in the monograph. They are limited by the general acceptance criterion for other/unspecified impurities and/or by the general monograph *Substances for pharmaceutical use* (2034). It is therefore not necessary to identify these impurities for demonstration of compliance. See also 5.10. *Control of impurities in substances for pharmaceutical use*): C.

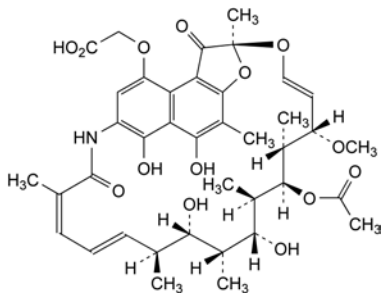

A. rifamycin B,

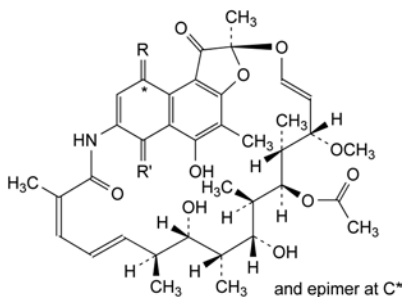

B. R = R' = O: rifamycin S,

C. -R- = -O-CO-CH<sub>2</sub>-O-, R' = O: rifamycin O.

07/2009:2362

## RIFAXIMIN

## Rifaximinum

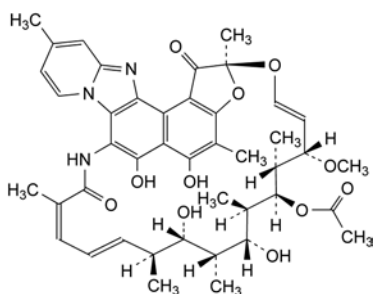

C<sub>43</sub>H<sub>51</sub>N<sub>3</sub>O<sub>11</sub>  
[80621-81-4]

M<sub>r</sub> 786

## DEFINITION

(2*S*,16*Z*,18*E*,20*S*,21*S*,22*R*,23*R*,24*R*,25*S*,26*R*,27*S*,28*E*)-5,6,21,23-Tetrahydroxy-27-methoxy-2,4,11,16,20,22,24,26-octamethyl-1,15-dioxo-1,2-dihydro-2,7-(epoxypentadeca[1,11,13]trienoimino)benzofuro[4,5-*e*]pyrido[1,2-*a*]benzimidazol-25-yl acetate.

Semi-synthetic product derived from a fermentation product.

*Content:* 97.0 per cent to 102.0 per cent (anhydrous substance).

## CHARACTERS

*Appearance:* red-orange, crystalline, hygroscopic powder.

*Solubility:* practically insoluble in water, soluble in acetone and in methanol.

It shows polymorphism (5.9).

## IDENTIFICATION

Infrared absorption spectrophotometry (2.2.24).

*Comparison:* rifaximin CRS.

## TESTS

**Related substances.** Liquid chromatography (2.2.29).

*Solvent mixture:* acetonitrile R, water R (40:60 V/V).

*Test solution (a).* Dissolve 0.100 g of the substance to be examined in 8 mL of acetonitrile R and dilute to 20 mL with water R.

*Test solution (b).* Dissolve 40.0 mg of the substance to be examined in the solvent mixture and dilute to 100.0 mL with the solvent mixture. Dilute 5.0 mL of this solution to 50.0 mL with the solvent mixture.

*Reference solution (a).* Dilute 1.0 mL of test solution (a) to 50.0 mL with the solvent mixture. Dilute 1.0 mL of this solution to 10.0 mL with the solvent mixture.

*Reference solution (b).* Dissolve 5 mg of rifaximin for system suitability CRS (containing impurity H) in 4 mL of the solvent mixture.

*Reference solution (c).* Dissolve 40.0 mg of rifaximin CRS in the solvent mixture and dilute to 100.0 mL with the solvent mixture. Dilute 5.0 mL of this solution to 50.0 mL with the solvent mixture.

*Column:*

– size: *l* = 0.25 m, Ø = 4.6 mm;

– stationary phase: end-capped octadecylsilyl silica gel for chromatography R (5 µm);

– temperature: 40 °C.

*Mobile phase:* mix 37 volumes of a 3.16 g/L solution of ammonium formate R adjusted to pH 7.2 with dilute ammonia R1 and 63 volumes of a mixture of equal volumes of acetonitrile R and methanol R.

*Flow rate:* 1.4 mL/min.

*Detection:* spectrophotometer at 276 nm.

*Injection:* 20 µL of test solution (a) and reference solutions (a) and (b).

*Run time:* 3 times the retention time of rifaximin.

*Relative retention* with reference to rifaximin (retention time = about 12 min): impurities D and H = about 0.7.

*System suitability:* reference solution (b):

– resolution: minimum 3.0 between the peaks due to impurity H and rifaximin.

*Limits:*

– sum of impurities D and H: not more than 2.5 times the area of the principal peak in the chromatogram obtained with reference solution (a) (0.5 per cent);

– unspecified impurities: for each impurity, not more than 0.5 times the area of the principal peak in the chromatogram obtained with reference solution (a) (0.10 per cent);

– total: not more than 5 times the area of the principal peak in the chromatogram obtained with reference solution (a) (1.0 per cent);

– disregard limit: 0.25 times the area of the principal peak in the chromatogram obtained with reference solution (a) (0.05 per cent).

**Heavy metals** (2.4.8): maximum 20 ppm.

1.0 g complies with test C. Prepare the reference solution using 20 mL of lead standard solution (1 ppm Pb) R.

**Water** (2.5.12): maximum 4.5 per cent, determined on 0.50 g.

**Sulfated ash (2.4.14):** maximum 0.1 per cent, determined on 1.0 g.

#### ASSAY

Liquid chromatography (2.2.29) as described in the test for related substances with the following modification.

**Injection:** test solution (b) and reference solution (c).

Calculate the percentage content of  $C_{43}H_{51}N_3O_{11}$  using the chromatogram obtained with reference solution (c) and the declared content of *rifaximin CRS*.

#### STORAGE

In an airtight container, protected from light.

#### IMPURITIES

**Specified impurities:** D, H.

**Other detectable impurities** (the following substances would, if present at a sufficient level, be detected by one or other of the tests in the monograph. They are limited by the general acceptance criterion for other/unspecified impurities and/or by the general monograph *Substances for pharmaceutical use (2034)*. It is therefore not necessary to identify these impurities for demonstration of compliance. See also 5.10. *Control of impurities in substances for pharmaceutical use*): A, B, C, E, F, G.

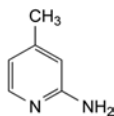

A. 4-methylpyridin-2-amine,

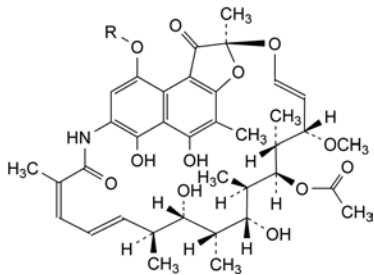

B. R =  $CH_2CO_2H$ : rifamycin B,

C. R = H: rifamycin SV,

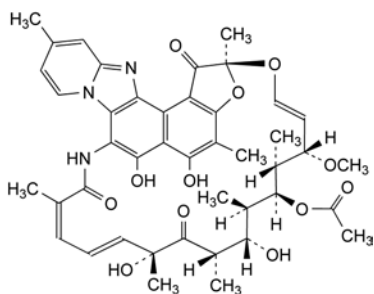

D. rifaximin Y,

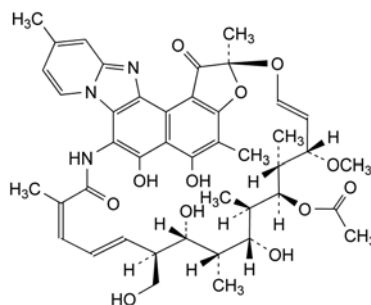

H. (2*S*,16*Z*,18*E*,20*R*,21*S*,22*R*,23*R*,24*R*,25*S*,26*R*,27*S*,28*E*)-5,6,21,23-tetrahydroxy-20-(hydroxymethyl)-27-methoxy-2,4,11,16,22,24,26-heptomethyl-1,15-dioxo-1,2-dihydro-2,7-(epoxypentadeca[1,11,13]trienoinimo)benzofuro[4,5-*e*]pyrido[1,2-*a*]benzimidazol-25-yl acetate (hydroxy-rifaximin),

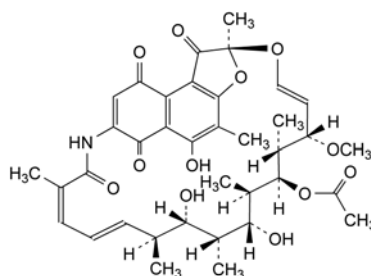

E. rifamycin S,

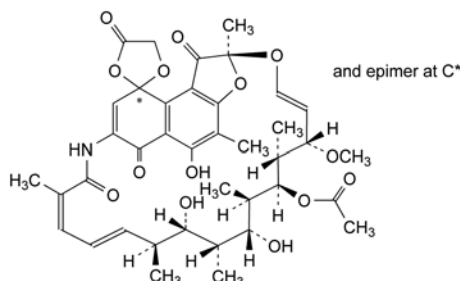

F. rifamycin O,

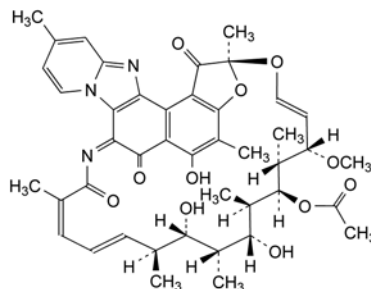

G. (2*S*,16*Z*,18*E*,20*S*,21*S*,22*R*,23*R*,24*R*,25*S*,26*R*,27*S*,28*E*)-5,21,23-trihydroxy-27-methoxy-2,4,11,16,20,22,24,26-octamethyl-1,6,15-trioxo-1,2,6,7-tetrahydro-2,7-(epoxypentadeca[1,11,13]trienonitrilo)benzofuro[4,5-*e*]pyrido[1,2-*a*]benzimidazol-25-yl acetate (oxidised rifaximin).



01/2008:2020 Injection: 20 µL.

**RILMENIDINE DIHYDROGEN PHOSPHATE**

Rilmenidini dihydrogenophosphas

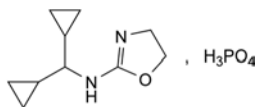
C<sub>10</sub>H<sub>19</sub>N<sub>2</sub>O<sub>5</sub>P  
[85409-38-7]M<sub>r</sub> 278.2**DEFINITION***N*-(Dicyclopropylmethyl)-4,5-dihydro-oxazol-2-amine dihydrogen phosphate.*Content*: 99.0 per cent to 101.0 per cent (dried substance).**CHARACTERS***Appearance*: white or almost white powder.*Solubility*: freely soluble in water, slightly soluble in alcohol, practically insoluble in methylene chloride.**IDENTIFICATION**

A. Infrared absorption spectrophotometry (2.2.24).

*Comparison*: Ph. Eur. reference spectrum of rilmenidine dihydrogen phosphate.B. Dissolve 10 mg in *water R* and dilute to 1 mL with the same solvent. The solution gives reaction (b) of phosphates (2.3.1).**TESTS****Related substances.** Liquid chromatography (2.2.29).*Test solution.* Dissolve 60.0 mg of the substance to be examined in *water R* and dilute to 20.0 mL with the same solvent.*Reference solution (a).* Dilute 1.0 mL of the test solution to 100.0 mL with *water R* and dilute 10.0 mL of this solution to 50.0 mL with the same solvent.*Reference solution (b).* Dilute 5.0 mL of reference solution (a) to 20.0 mL with *water R*.*Reference solution (c).* Dissolve 15.0 mg of *rilmenidine for system suitability CRS* in *water R* and dilute to 5.0 mL with the same solvent.*Column*:

- *size*:  $l = 0.15$  m,  $\varnothing = 3$  mm,
- *stationary phase*: base-deactivated octadecylsilyl silica gel for chromatography *R* (5 µm) with a pore size of 10 nm and a carbon loading of 25 per cent,
- *temperature*: 40 °C.

*Mobile phase*:

- *mobile phase A*: dissolve 3 g of *sodium heptanesulfonate R* in *water R* and dilute to 860 mL with the same solvent; add 130 mL of *methanol R2*, 10 mL of *tetrahydrofuran for chromatography R* and 1.0 mL of *phosphoric acid R*,
- *mobile phase B*: dissolve 3 g of *sodium heptanesulfonate R* in *water R* and dilute to 600 mL with the same solvent; add 350 mL of *acetonitrile for chromatography R*, 50 mL of *tetrahydrofuran for chromatography R* and 1.0 mL of *phosphoric acid R*,

Time (min)	Mobile phase A (per cent V/V)	Mobile phase B (per cent V/V)
0 - 14	100 → 0	0 → 100
14 - 15	0 → 100	100 → 0
15 - 30	100	0

*Flow rate*: 1 mL/min.*Detection*: spectrophotometer at 205 nm.*Relative retention* with reference to rilmenidine (retention time = about 13 min): impurity A = about 0.6; impurity B = about 0.9; impurity C = about 1.4.With these conditions the inflexion of the baseline, corresponding to the beginning of the gradient, appears on the recorder after a minimum time  $t$  of 5 min. If this is not the case ( $t < 5$  min) modify the chromatographic sequence by adding an isocratic elution with 100 per cent of mobile phase A for a time corresponding to (5- $t$ ) min before the linear gradient.*System suitability*: reference solution (c):

- *peak-to-valley ratio*: minimum 3, where  $H_p$  = height above the baseline of the peak due to impurity B and  $H_v$  = height above the baseline of the lowest point of the curve separating this peak from the peak due to rilmenidine.

*Limits*:

- *any impurity*: not more than 0.5 times the area of the principal peak in the chromatogram obtained with reference solution (a) (0.1 per cent),
- *total*: not more than the area of the principal peak in the chromatogram obtained with reference solution (a) (0.2 per cent),
- *disregard limit*: area of the principal peak in the chromatogram obtained with reference solution (b) (0.05 per cent).

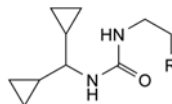
**Loss on drying** (2.2.32): maximum 0.5 per cent, determined on 1.000 g by drying in an oven *in vacuo* at 50 °C over *diphosphorus pentoxide R* for 2 h.**ASSAY**Dissolve 0.200 g in 50 mL of *anhydrous acetic acid R*. Titrate with 0.1 M *perchloric acid*, determining the end-point potentiometrically (2.2.20).1 mL of 0.1 M *perchloric acid* is equivalent to 27.82 mg of C<sub>10</sub>H<sub>19</sub>N<sub>2</sub>O<sub>5</sub>P.**IMPURITIES***Specified impurities*: A, B, C.

A. R = OH: 1-(dicyclopropylmethyl)-3-(2-hydroxyethyl)urea,

B. R = Cl: 1-(2-chloroethyl)-3-(dicyclopropylmethyl)urea,

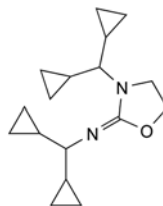
C. *N*,3-bis(dicyclopropylmethyl)oxazolidin-2-imine.

01/2011:1559

**RISPERIDONE**

Risperidonum

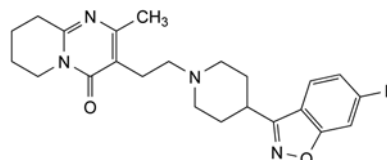
C<sub>23</sub>H<sub>27</sub>N<sub>4</sub>O<sub>2</sub>  
[106266-06-2]M<sub>r</sub> 410.5

## DEFINITION

3-[2-[4-(6-Fluoro-1,2-benzisoxazol-3-yl)piperidin-1-yl]ethyl]-2-methyl-6,7,8,9-tetrahydro-4*H*-pyrido[1,2-*a*]pyrimidin-4-one.

*Content*: 99.0 per cent to 101.0 per cent (dried substance).

## CHARACTERS

*Appearance*: white or almost white powder.

*Solubility*: practically insoluble in water, freely soluble in methylene chloride, sparingly soluble in ethanol (96 per cent). It dissolves in dilute acid solutions.

It shows polymorphism (5.9).

## IDENTIFICATION

Infrared absorption spectrophotometry (2.2.24).

*Comparison*: risperidone CRS.

If the spectra obtained show differences, dissolve the substance to be examined and the reference substance separately in acetone R, evaporate to dryness and record new spectra using the residues.

## TESTS

**Appearance of solution.** The solution is clear (2.2.1) and colourless (2.2.2, Method II).

Dissolve 0.1 g in a 7.5 g/L solution of tartaric acid R and dilute to 100 mL with the same acid solution.

**Related substances.** Liquid chromatography (2.2.29).

*Test solution.* Dissolve 0.100 g of the substance to be examined in methanol R and dilute to 10.0 mL with the same solvent.

*Reference solution (a).* Dissolve 10 mg of risperidone for system suitability CRS (containing impurities A, B, C, D and E) in 1.0 mL of methanol R.

*Reference solution (b).* Dilute 1.0 mL of the test solution to 100.0 mL with methanol R. Dilute 5.0 mL of this solution to 25.0 mL with methanol R.

*Reference solution (c).* Dissolve the contents of a vial of risperidone impurity K CRS in 1.0 mL of methanol R.

*Column*:

- size:  $l = 0.10$  m,  $\varnothing = 4.6$  mm;
- stationary phase: base-deactivated octadecylsilyl silica gel for chromatography R (3  $\mu$ m).

*Mobile phase*:

- mobile phase A: 5 g/L solution of ammonium acetate R;
- mobile phase B: methanol R;

Time (min)	Mobile phase A (per cent V/V)	Mobile phase B (per cent V/V)
0 - 2	70	30
2 - 17	70 → 30	30 → 70
17 - 22	30	70

*Flow rate*: 1.5 mL/min.

*Detection*: spectrophotometer at 260 nm.

*Injection*: 10  $\mu$ L.

*Identification of impurities*: use the chromatogram supplied with risperidone for system suitability CRS and the chromatogram obtained with reference solution (a) to identify the peaks due to impurities A, B, C, D and E; use the chromatogram obtained with reference solution (c) to identify the peak due to impurity K.

*Relative retention* with reference to risperidone (retention time = about 12 min): impurity A = about 0.7; impurity B = about 0.75; impurity C = about 0.8; impurity K = about 0.9; impurity D = about 0.94; impurity E = about 1.1.

*System suitability*: reference solution (a):

- the chromatogram obtained is similar to the chromatogram supplied with risperidone for system suitability CRS;
- *peak-to-valley ratio*: minimum 1.5, where  $H_p$  = height above the baseline of the peak due to impurity D and  $H_v$  = height above the baseline of the lowest point of the curve separating this peak from the peak due to risperidone.

*Limits*:

- *impurities A, B, C, D, E*: for each impurity, not more than the area of the principal peak in the chromatogram obtained with reference solution (b) (0.2 per cent);
- *impurity K*: not more than 0.75 times the area of the principal peak in the chromatogram obtained with reference solution (b) (0.15 per cent);
- *unspecified impurities*: for each impurity, not more than 0.5 times the area of the principal peak in the chromatogram obtained with reference solution (b) (0.10 per cent);
- *total*: not more than 1.5 times the area of the principal peak in the chromatogram obtained with reference solution (b) (0.3 per cent);
- *disregard limit*: 0.25 times the area of the principal peak in the chromatogram obtained with reference solution (b) (0.05 per cent).

**Loss on drying** (2.2.32): maximum 0.5 per cent, determined on 1.000 g by drying in an oven at 105 °C for 4 h.

**Sulfated ash** (2.4.14): maximum 0.1 per cent, determined on 1.0 g in a platinum crucible.

## ASSAY

Dissolve 0.160 g in 70 mL of a mixture of 1 volume of anhydrous acetic acid R and 7 volumes of methyl ethyl ketone R and titrate with 0.1 M perchloric acid. Determine the end-point potentiometrically (2.2.20).

1 mL of 0.1 M perchloric acid is equivalent to 20.53 mg of C<sub>23</sub>H<sub>27</sub>FN<sub>4</sub>O<sub>2</sub>.

## STORAGE

Protected from light.

## IMPURITIES

*Specified impurities*: A, B, C, D, E, K.

*Other detectable impurities* (the following substances would, if present at a sufficient level, be detected by one or other of the tests in the monograph. They are limited by the general acceptance criterion for other/unspecified impurities and/or by the general monograph *Substances for pharmaceutical use* (2034). It is therefore not necessary to identify these impurities for demonstration of compliance. See also 5.10. *Control of impurities in substances for pharmaceutical use*): F, H, I, J, L, M.

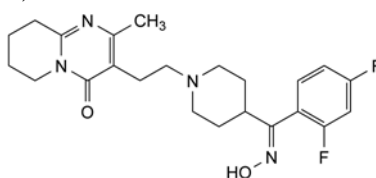

A. 3-[2-[4-(*E*)-(2,4-difluorophenyl)(hydroxyimino)methyl]piperidin-1-yl]ethyl]-2-methyl-6,7,8,9-tetrahydro-4*H*-pyrido[1,2-*a*]pyrimidin-4-one,

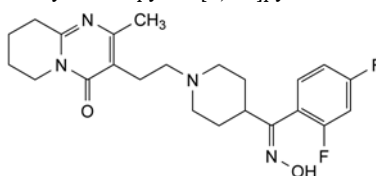

B. 3-[2-[4-(*Z*)-(2,4-difluorophenyl)(hydroxyimino)methyl]piperidin-1-yl]ethyl]-2-methyl-6,7,8,9-tetrahydro-4*H*-pyrido[1,2-*a*]pyrimidin-4-one,

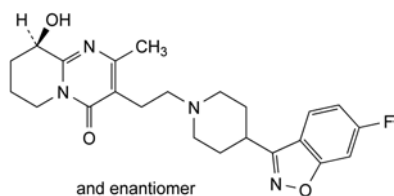

- C. (9*S*)-3-[2-[4-(6-fluoro-1,2-benzisoxazol-3-yl)piperidin-1-yl]ethyl]-9-hydroxy-2-methyl-6,7,8,9-tetrahydro-4*H*-pyrido[1,2-*a*]pyrimidin-4-one,

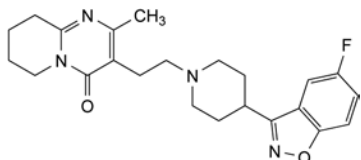

- D. 3-[2-[4-(5-fluoro-1,2-benzisoxazol-3-yl)piperidin-1-yl]ethyl]-2-methyl-6,7,8,9-tetrahydro-4*H*-pyrido[1,2-*a*]pyrimidin-4-one,

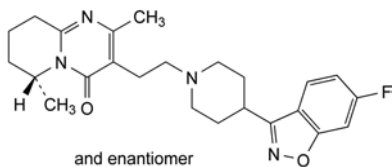

- E. (6*RS*)-3-[2-[4-(6-fluoro-1,2-benzisoxazol-3-yl)piperidin-1-yl]ethyl]-2,6-dimethyl-6,7,8,9-tetrahydro-4*H*-pyrido[1,2-*a*]pyrimidin-4-one,

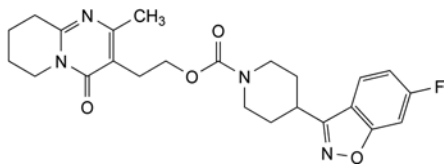

- F. 2-[2-methyl-4-oxo-6,7,8,9-tetrahydro-4*H*-pyrido[1,2-*a*]pyrimidin-3-yl]ethyl 4-(6-fluoro-1,2-benzisoxazol-3-yl)piperidin-1-carboxylate,

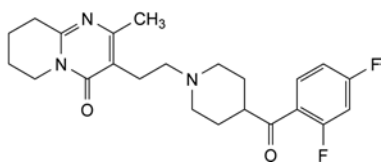

- H. 3-[2-[4-(2,4-difluorobenzoyl)piperidin-1-yl]ethyl]-2-methyl-6,7,8,9-tetrahydro-4*H*-pyrido[1,2-*a*]pyrimidin-4-one,

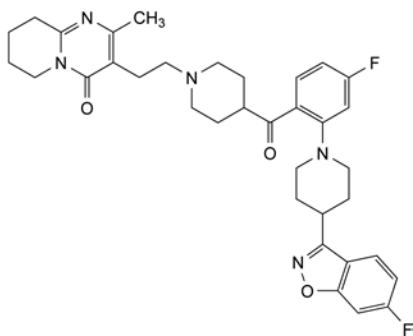

- I. 3-[2-[4-[4-fluoro-2-[4-(6-fluoro-1,2-benzisoxazol-3-yl)piperidin-1-yl]benzoyl]piperidin-1-yl]ethyl]-2-methyl-6,7,8,9-tetrahydro-4*H*-pyrido[1,2-*a*]pyrimidin-4-one,

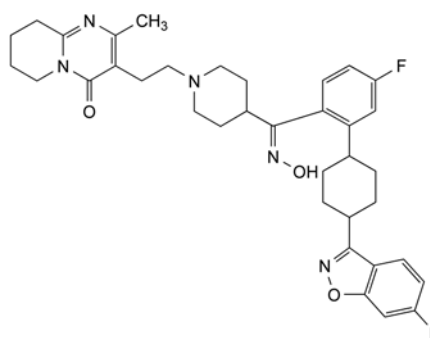

- J. 3-[2-[4-(*Z*)-[4-fluoro-2-[4-(6-fluoro-1,2-benzisoxazol-3-yl)piperidin-1-yl]phenyl](hydroxyimino)methyl]piperidin-1-yl]ethyl]-2-methyl-6,7,8,9-tetrahydro-4*H*-pyrido[1,2-*a*]pyrimidin-4-one,

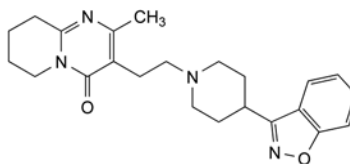

- K. 3-[2-[4-(1,2-benzisoxazol-3-yl)piperidin-1-yl]ethyl]-2-methyl-6,7,8,9-tetrahydro-4*H*-pyrido[1,2-*a*]pyrimidin-4-one (desfluoro risperidone),

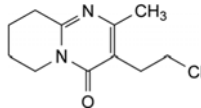

- L. 3-(2-chloroethyl)-2-methyl-6,7,8,9-tetrahydro-4*H*-pyrido[1,2-*a*]pyrimidin-4-one (piperidopyrimidinone intermediate),

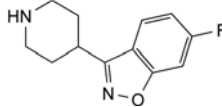

- M. 6-fluoro-3-(piperidin-4-yl)-1,2-benzisoxazole.

01/2008:2136

## RITONAVIR

## Ritonavirum

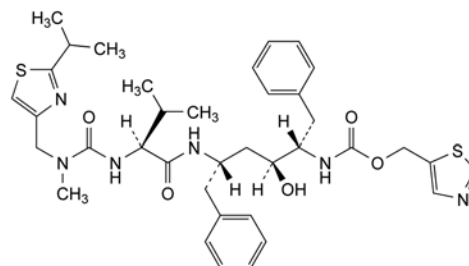

$C_{37}H_{48}N_6O_5S_2$   
[155213-67-5]

$M_r$  721

## DEFINITION

Thiazol-5-ylmethyl [(1*S*,2*S*,4*S*)-1-benzyl-2-hydroxy-4-[(2*S*)-3-methyl-2-[[methyl][2-(1-methylethyl)thiazol-4-yl]methyl]carbonyl]amino]butanoyl]amino]-5-phenylpentyl]carbamate.

*Content*: 97.0 per cent to 102.0 per cent (anhydrous substance).

## PRODUCTION

The production method is validated to demonstrate suitable enantiomeric purity of the final product.

## CHARACTERS

*Appearance*: white or almost white powder.

*Solubility*: practically insoluble in water, freely soluble in methanol and in methylene chloride, very slightly soluble in acetonitrile.

It shows polymorphism (5.9).

## IDENTIFICATION

Infrared absorption spectrophotometry (2.2.24).

*Comparison*: ritonavir CRS.

If the spectra obtained in the solid state show differences dissolve the substance to be examined and the reference substance separately in *methylene chloride R*, evaporate to dryness and record new spectra using the residues.

## TESTS

**Related substances.** Liquid chromatography (2.2.29).

*Solvent mixture.* Mix equal volumes of *acetonitrile R* and a 4.1 g/L solution of *potassium dihydrogen phosphate R*.

*Test solution (a).* Dissolve 10.0 mg of the substance to be examined in the solvent mixture and dilute to 10.0 mL with the solvent mixture. Sonicate if necessary.

*Test solution (b).* Dilute 5.0 mL of test solution (a) to 10.0 mL with the solvent mixture. Dilute 1.0 mL of this solution to 20.0 mL with the solvent mixture.

*Reference solution (a).* Dissolve 5.0 mg of *ritonavir for peak identification CRS* (containing impurities E, F, L, O and T) in the solvent mixture and dilute to 5.0 mL with the solvent mixture. Sonicate if necessary.

*Reference solution (b).* Dilute 1.0 mL of test solution (a) to 10.0 mL with the solvent mixture. Dilute 1.0 mL of this solution to 100.0 mL with the solvent mixture.

*Reference solution (c).* Dissolve 10.0 mg of *ritonavir CRS* in the solvent mixture and dilute to 10.0 mL with the solvent mixture. Sonicate if necessary. Dilute 5.0 mL of this solution to 10.0 mL with the solvent mixture. Dilute 1.0 mL of this solution to 20.0 mL with the solvent mixture.

*Column*:

- *size*:  $l = 0.15$  m,  $\varnothing = 4.6$  mm;
- *stationary phase*: end-capped butylsilyl silica gel for chromatography R (3  $\mu$ m);
- *temperature*: 60 °C.

*Mobile phase*:

- *mobile phase A*: mix 5 volumes of *butanol R*, 8 volumes of *tetrahydrofuran R*, 18 volumes of *acetonitrile R* and 69 volumes of a 4.1 g/L solution of *potassium dihydrogen phosphate R* filtered through a 0.45  $\mu$ m nylon membrane;
- *mobile phase B*: mix 5 volumes of *butanol R*, 8 volumes of *tetrahydrofuran R*, 40 volumes of a 4.1 g/L solution of *potassium dihydrogen phosphate R* filtered through a 0.45  $\mu$ m nylon membrane and 47 volumes of *acetonitrile R*;

Time (min)	Mobile phase A (per cent V/V)	Mobile phase B (per cent V/V)
0 - 60	100	0
60 - 120	100 → 0	0 → 100
120 - 120.1	0 → 100	100 → 0
120.1 - 155	100	0

*Flow rate*: 1.0 mL/min.

*Detection*: spectrophotometer at 240 nm.

*Injection*: 50  $\mu$ L of test solution (a) and reference solutions (a) and (b).

*Identification of impurities*: use the chromatogram supplied with *ritonavir for peak identification CRS* and the chromatogram obtained with reference solution (a) to identify the peaks due to impurities E, F, L, O and T.

*Relative retention* with reference to ritonavir (retention time = about 34 min): impurity E = about 0.39; impurity F = about 0.40; impurity L = about 0.8; impurity O = about 1.1; impurity T = about 2.6.

*System suitability*: reference solution (a):

- *peak-to-valley ratio*: minimum 1.2, where  $H_p$  = height above the baseline of the peak due to impurity E and  $H_v$  = height above the baseline of the lowest point of the curve separating this peak from the peak due to impurity F.

*Limits*:

- *correction factors*: for the calculation of content, multiply the peak areas of the following impurities by the corresponding correction factor: impurity F = 1.4; impurity L = 1.9; impurity T = 1.4;
- *impurities E, O*: for each impurity, not more than 3 times the area of the principal peak in the chromatogram obtained with reference solution (b) (0.3 per cent);
- *impurity T*: not more than twice the area of the principal peak in the chromatogram obtained with reference solution (b) (0.2 per cent);
- *impurities F, L*: for each impurity, not more than the area of the principal peak in the chromatogram obtained with reference solution (b) (0.1 per cent);
- *unspecified impurities*: for each impurity, not more than the area of the principal peak in the chromatogram obtained with reference solution (b) (0.10 per cent);
- *total*: not more than 10 times the area of the principal peak in the chromatogram obtained with reference solution (b) (1.0 per cent);
- *disregard limit*: 0.5 times the area of the principal peak in the chromatogram obtained with reference solution (b) (0.05 per cent).

**Heavy metals** (2.4.8): maximum 20 ppm.

1.0 g complies with test C. Prepare the reference solution using 2 mL of *lead standard solution (10 ppm Pb) R*.

**Water** (2.5.12): maximum 0.5 per cent, determined on 0.500 g.

**Sulfated ash** (2.4.14): maximum 0.2 per cent, determined on 1.0 g.

## ASSAY

Liquid chromatography (2.2.29) as described in the test for related substances with the following modification.

*Injection*: test solution (b) and reference solution (c).

Calculate the percentage content of  $C_{37}H_{48}N_6O_5S_2$  from the declared content of *ritonavir CRS*.

## STORAGE

Protected from light.

## IMPURITIES

*Specified impurities*: E, F, L, O, T.

*Other detectable impurities* (the following substances would, if present at a sufficient level, be detected by one or other of the tests in the monograph. They are limited by the general acceptance criterion for other/unspecified impurities and/or by the general monograph *Substances for pharmaceutical use* (2034). It is therefore not necessary to identify these impurities for demonstration of compliance. See also 5.10. *Control of impurities in substances for pharmaceutical use*): A, B, C, D, G, H, I, J, K, M, N, P, Q, R, S, U.

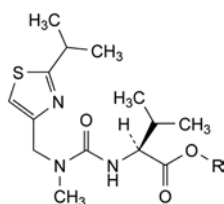

A. R = H: (2S)-3-methyl-2-[[methyl[[2-(1-methylethyl)thiazol-4-yl]methyl]carbamoyl]amino]butanoic acid,

M. R = CH<sub>2</sub>CH(CH<sub>3</sub>)<sub>2</sub>: 2-methylpropyl (2S)-3-methyl-2-[[methyl[[2-(1-methylethyl)thiazol-4-yl]methyl]carbamoyl]amino]butanoate,

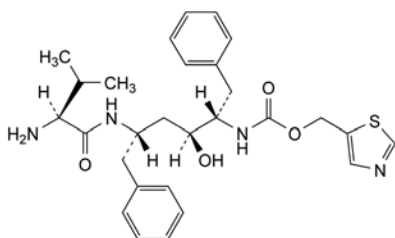

B. thiazol-5-ylmethyl [(1S,2S,4S)-4-[[2-(2-amino-3-methylbutanoyl)amino]-1-benzyl-2-hydroxy-5-phenylpentyl]carbamate,

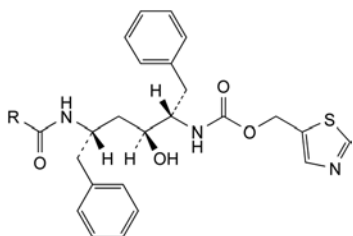

C. R = CH<sub>3</sub>: thiazol-5-ylmethyl [(1S,2S,4S)-4-(acetylamino)-1-benzyl-2-hydroxy-5-phenylpentyl]carbamate,

J. R = O-C(CH<sub>3</sub>)<sub>3</sub>: thiazol-5-ylmethyl [(1S,2S,4S)-1-benzyl-4-[[1,1-dimethylethoxy]carbonyl]amino]-2-hydroxy-5-phenylpentyl]carbamate,

K. R = O-CH<sub>2</sub>-CH(CH<sub>3</sub>)<sub>2</sub>: thiazol-5-ylmethyl [(1S,2S,4S)-1-benzyl-2-hydroxy-4-[[2-(2-methylpropoxy)carbonyl]amino]-5-phenylpentyl]carbamate,

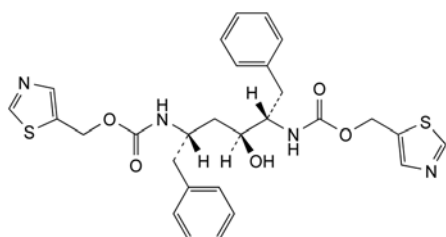

D. thiazol-5-ylmethyl [(1S,2S,4S)-1-benzyl-2-hydroxy-5-phenyl-4-[[thiazol-5-ylmethoxy]carbonyl]amino]pentyl]carbamate,

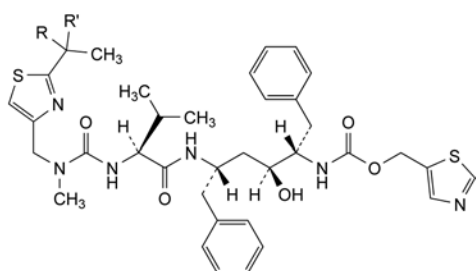

E. R = OH, R' = CH<sub>3</sub>: thiazol-5-ylmethyl [(1S,2S,4S)-1-benzyl-2-hydroxy-4-[[2-(2S)-2-[[[2-(1-hydroxy-1-methylethyl)thiazol-4-yl]methyl]methyl]carbamoyl]amino]-3-methylbutanoyl]amino]-5-phenylpentyl]carbamate,

G. R = OOH, R' = CH<sub>3</sub>: thiazol-5-ylmethyl [(1S,2S,4S)-1-benzyl-4-[[2-(2S)-2-[[[2-(1-hydroperoxy-1-methylethyl)thiazol-4-yl]methyl]methyl]carbamoyl]amino]-3-methylbutanoyl]amino]-2-hydroxy-5-phenylpentyl]carbamate,

I. R = R' = H: thiazol-5-ylmethyl [(1S,2S,4S)-1-benzyl-4-[[2-(2S)-2-[[[2-ethylthiazol-4-yl]methyl]methyl]carbamoyl]amino]-3-methylbutanoyl]amino]-2-hydroxy-5-phenylpentyl]carbamate,

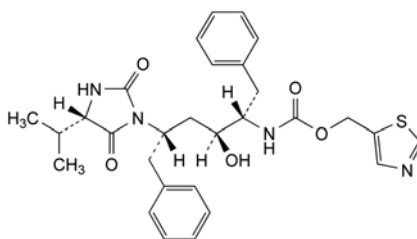

F. thiazol-5-ylmethyl [(1S,2S,4S)-1-benzyl-4-[[2-(2S)-1-benzyl-2-hydroxy-4-[(4S)-4-(1-methylethyl)-2,5-dioximidazolidin-1-yl]-5-phenylpentyl]carbamate,

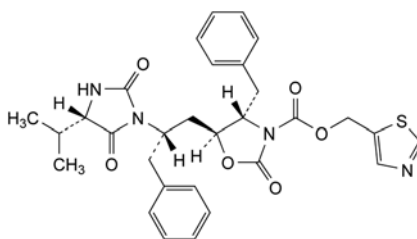

H. thiazol-5-ylmethyl (4S,5S)-4-benzyl-5-[(2S)-2-[(4S)-4-(1-methylethyl)-2,5-dioximidazolidin-1-yl]-3-phenylpropyl]-2-oxooxazolidine-3-carboxylate,

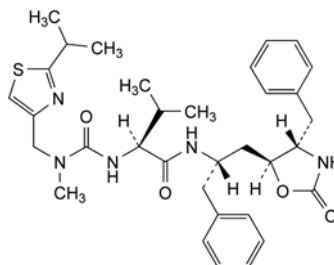

L. (4S,5S)-4-benzyl-5-[(2S)-2-[[2-(2S)-3-methyl-2-[[methyl[[2-(1-methylethyl)thiazol-4-yl]methyl]carbamoyl]amino]butanoyl]amino]-3-phenylpropyl]oxazolidin-2-one,

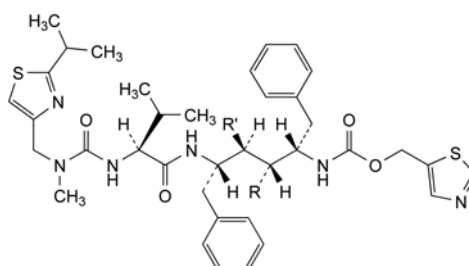

N. R = H, R' = OH: thiazol-5-ylmethyl [(1S,3S,4S)-1-benzyl-3-hydroxy-4-[[2-(2S)-3-methyl-2-[[methyl[[2-(1-methylethyl)thiazol-4-yl]methyl]carbamoyl]amino]butanoyl]amino]-5-phenylpentyl]carbamate,

O. R = OH, R' = H: thiazol-5-ylmethyl [(1S,2R,4S)-1-benzyl-2-hydroxy-4-[[2-(2S)-3-methyl-2-[[methyl[[2-(1-methylethyl)thiazol-4-yl]methyl]carbamoyl]amino]butanoyl]amino]-5-phenylpentyl]carbamate,

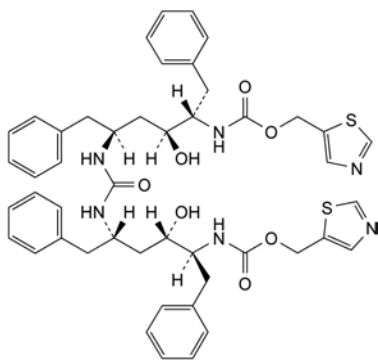

P. bis(thiazol-5-ylmethyl) [carbonylbis[imino[(2S,3S,5S)-3-hydroxy-1,6-diphenylhexane-5,2-diyl]]dicarbamate,

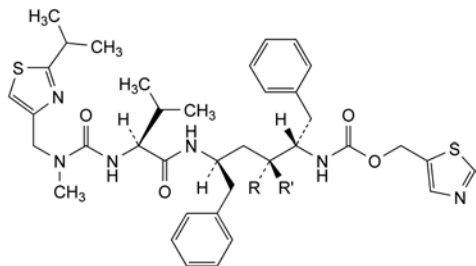

Q. R = OH, R' = H: thiazol-5-ylmethyl [(1S,2R,4R)-1-benzyl-2-hydroxy-4-[[2-(2S)-3-methyl-2-[[methyl][2-(1-methylethyl)thiazol-4-yl]methyl]carbamoyl]amino]butanoyl]amino]-5-phenylpentyl]carbamate,

R. R = H, R' = OH: thiazol-5-ylmethyl [(1S,2S,4R)-1-benzyl-2-hydroxy-4-[[2-(2S)-3-methyl-2-[[methyl][2-(1-methylethyl)thiazol-4-yl]methyl]carbamoyl]amino]butanoyl]amino]-5-phenylpentyl]carbamate,

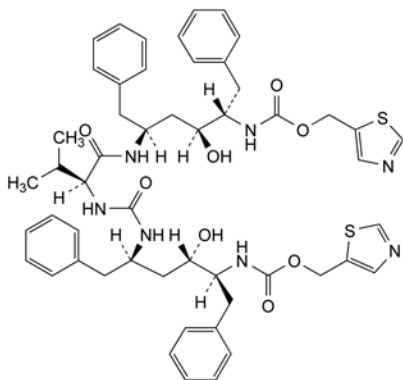

S. thiazol-5-ylmethyl [(1S,2S,4S)-1-benzyl-4-[[2-(2S)-2-[[[(1S,3S,4S)-1-benzyl-3-hydroxy-5-phenyl-4-[[thiazol-5-ylmethoxy]carbonyl]amino]pentyl]carbamoyl]amino]-3-methylbutanoyl]amino]-2-hydroxy-5-phenylpentyl]carbamate,

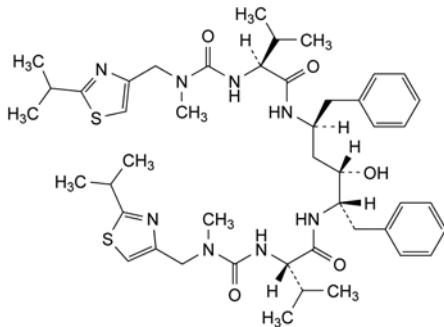

T. (2S)-N-[(1S,2S,4S)-1-benzyl-2-hydroxy-4-[[2-(2S)-3-methyl-2-[[methyl][2-(1-methylethyl)thiazol-4-yl]methyl]carbamoyl]amino]butanoyl]amino]-5-phenylpentyl]-3-methyl-2-[[methyl][2-(1-methylethyl)thiazol-4-yl]methyl]carbamoyl]amino]butanamide,

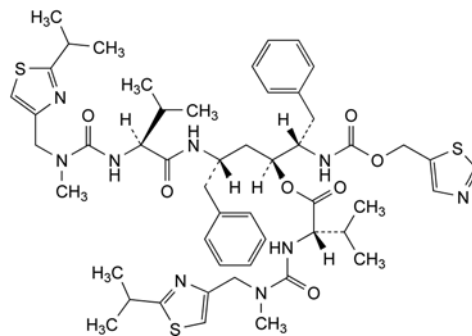

U. (1S,3S)-3-[[2-(2S)-3-methyl-2-[[methyl][2-(1-methylethyl)thiazol-4-yl]methyl]carbamoyl]amino]butanoyl]amino]-4-phenyl-1-[(1S)-2-phenyl-1-[[thiazol-5-ylmethoxy]carbonyl]amino]ethyl]butyl (2S)-3-methyl-2-[[methyl][2-(1-methylethyl)thiazol-4-yl]methyl]carbamoyl]amino]butanoate.

01/2008:1764

## ROCURONIUM BROMIDE

### Rocuronii bromidum

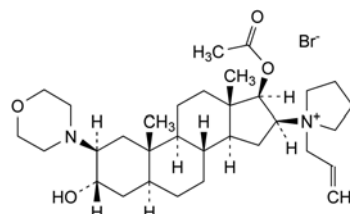
 $C_{32}H_{53}BrN_2O_4$ 
 $M_r$  610

#### DEFINITION

1-[17β-(Acetyloxy)-3α-hydroxy-2β-(morpholin-4-yl)-5α-androstan-16β-yl]-1-(prop-2-enyl)pyrrolidinium bromide.

*Content*: 99.0 per cent to 101.0 per cent (anhydrous substance).

#### CHARACTERS

*Appearance*: almost white or pale yellow, slightly hygroscopic powder.

*Solubility*: freely soluble in water and in anhydrous ethanol.

#### IDENTIFICATION

A. Infrared absorption spectrophotometry (2.2.24).

*Comparison*: Ph. Eur. reference spectrum of rocuronium bromide.

B. Solution S (see Tests) gives reaction (a) of bromides (2.3.1).

#### TESTS

**Solution S.** Dissolve 0.10 g in carbon dioxide-free water R and dilute to 10 mL with the same solvent.

**Appearance of solution.** Solution S is clear (2.2.1) and not more intensely coloured than reference solution BY<sub>5</sub> (2.2.2, Method II).

**Specific optical rotation** (2.2.7): + 28.5 to + 32.0 (anhydrous substance).

Dissolve 0.250 g in a 5.15 g/L solution of hydrochloric acid R and dilute to 25.0 mL with the same solution.

**pH** (2.2.3): 8.9 to 9.5 for solution S.

**Related substances.** Liquid chromatography (2.2.29).

*Solvent mixture*: water R, acetonitrile R1 (10:90 V/V).

*Test solution.* Dissolve 0.100 g of the substance to be examined in the solvent mixture and dilute to 10.0 mL with the solvent mixture.

**Reference solution (a).** Dilute 1.0 mL of the test solution to 100.0 mL with the solvent mixture. Dilute 1.0 mL of this solution to 10.0 mL with the mobile phase.

**Reference solution (b).** Dissolve 5 mg of rocuronium for peak identification CRS (containing impurities A, B, C, F, G and H) in the solvent mixture and dilute to 5 mL with the solvent mixture.

**Column:**

- size:  $l = 0.25$  m,  $\emptyset = 4.6$  mm,
- stationary phase: silica gel for chromatography R (5  $\mu$ m),
- temperature: 30 °C.

**Mobile phase:** mix 100 volumes of a 4.53 g/L solution of tetramethylammonium hydroxide R adjusted to pH 7.4 with phosphoric acid R and 900 volumes of acetonitrile R1.

**Flow rate:** 2.0 mL/min.

**Detection:** spectrophotometer at 210 nm.

**Injection:** 5  $\mu$ L of the test solution, reference solutions (a) and (b) and the solvent mixture (blank).

**Run time:** 2.5 times the retention time of rocuronium.

**Relative retention** with reference to rocuronium (retention time = about 9 min): impurity A = about 0.20; impurity G = about 0.44; impurity F = about 0.75; impurity B = about 0.80; impurity D = about 0.90; impurity H = about 0.95; impurity C = about 1.20; impurity E = about 1.53.

**System suitability:** reference solution (b):

- the chromatogram obtained is similar to the chromatogram supplied with rocuronium for peak identification CRS.

**Limits:**

- **correction factors:** for the calculation of content, multiply the peak areas of the following impurities by the corresponding correction factor: impurity A = 0.47; impurity F = 1.26; impurity G = 0.43; impurity H = 0.35;
- **impurity A:** not more than twice the area of the principal peak in the chromatogram obtained with reference solution (a) (0.2 per cent);
- **impurities B, C:** for each impurity, not more than 3 times the area of the principal peak in the chromatogram obtained with reference solution (a) (0.3 per cent);
- **impurities D, E, F, G, H:** for each impurity, not more than the area of the principal peak in the chromatogram obtained with reference solution (a) (0.1 per cent);
- **unspecified impurities:** for each impurity, not more than the area of the principal peak in the chromatogram obtained with reference solution (a) (0.1 per cent);
- **total:** not more than 15 times the area of the principal peak in the chromatogram obtained with reference solution (a) (1.5 per cent);
- **disregard limit:** 0.5 times the area of the principal peak in the chromatogram obtained with reference solution (a) (0.05 per cent); disregard the peaks due to the blank and to bromide ion eluting just before impurity A.

**Chlorides.** Liquid chromatography (2.2.29).

**Test solution.** Dissolve 20.0 mg of the substance to be examined in water R and dilute to 20.0 mL with the same solvent.

**Reference solution (a).** Dissolve 0.824 g of sodium chloride R and 0.644 g of sodium bromide R in water R and dilute to 1000.0 mL with the same solvent. Dilute 1.0 mL of this solution to 50.0 mL with water R.

**Reference solution (b).** Dissolve 0.824 g of sodium chloride R in water R and dilute to 1000.0 mL with the same solvent. Dilute 5.0 mL of the solution to 50.0 mL with water R. Dilute 2.0 mL of this solution to 50.0 mL with water R.

**Blank solution.** Water R.

**Precolumn:**

- size:  $l = 0.05$  m,  $\emptyset = 4.0$  mm,
- stationary phase: anion exchange resin R (13  $\mu$ m).

**Column:**

- size:  $l = 0.25$  m,  $\emptyset = 4.0$  mm,
- stationary phase: anion exchange resin R (13  $\mu$ m).

**Mobile phase:** a solution containing 0.063 g/L of sodium hydrogen carbonate R and 0.212 g/L of anhydrous sodium carbonate R.

**Flow rate:** 2.0 mL/min.

**Detection:** conductivity detector set at 100  $\mu$ S/V and maintained at 30 °C.

Use a self-generating anion suppressor.

**Injection:** 25  $\mu$ L.

**Retention times:** chloride = about 1.7 min; bromide = about 2.8 min.

**System suitability:** reference solution (a):

- **resolution:** minimum 2.5 between the peaks due to chloride and bromide.

**Limit:**

- **chlorides:** not more than 0.5 times the area of the principal peak in the chromatogram obtained with reference solution (b) (0.1 per cent).

**Heavy metals (2.4.8):** maximum 10 ppm.

2.0 g complies with test C. Prepare the reference solution using 2 mL of lead standard solution (10 ppm Pb) R.

**Water (2.5.12):** maximum 4.0 per cent, determined on 0.400 g.

**Sulfated ash (2.4.14):** maximum 0.1 per cent, determined on 1.0 g.

**ASSAY**

Dissolve 0.400 g in 40 mL of glacial acetic acid R. Titrate with 0.1 M perchloric acid, determining the end-point potentiometrically (2.2.20).

1 mL of 0.1 M perchloric acid is equivalent to 60.97 mg of  $C_{32}H_{53}BrN_2O_4$ .

**STORAGE**

In an airtight container, protected from light.

**IMPURITIES**

**Specified impurities:** A, B, C, D, E, F, G, H.

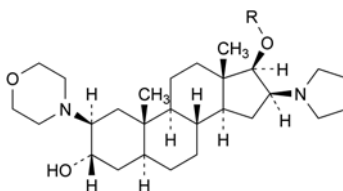

A. R = CO-CH<sub>3</sub>: 3 $\alpha$ -hydroxy-2 $\beta$ -(morpholin-4-yl)-16 $\beta$ -(pyrrolidin-1-yl)-5 $\alpha$ -androstan-17 $\beta$ -yl acetate,

G. R = H: 2 $\beta$ -(morpholin-4-yl)-16 $\beta$ -(pyrrolidin-1-yl)-5 $\alpha$ -androstan-3 $\alpha$ , 17 $\beta$ -diol,

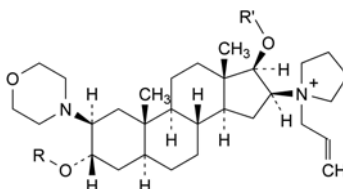

B. R = R' = CO-CH<sub>3</sub>: 1-[3 $\alpha$ , 17 $\beta$ -bis(acetyloxy)-2 $\beta$ -(morpholin-4-yl)-5 $\alpha$ -androstan-16 $\beta$ -yl]-1-(prop-2-enyl)pyrrolidinium,

C. R = R' = H: 1-[3 $\alpha$ , 17 $\beta$ -dihydroxy-2 $\beta$ -(morpholin-4-yl)-5 $\alpha$ -androstan-16 $\beta$ -yl]-1-(prop-2-enyl)pyrrolidinium,

D. R = CO-CH<sub>3</sub>, R' = H: 1-[3 $\alpha$ -(acetyloxy)-17 $\beta$ -hydroxy-2 $\beta$ -(morpholin-4-yl)-5 $\alpha$ -androstan-16 $\beta$ -yl]-1-(prop-2-enyl)pyrrolidinium,

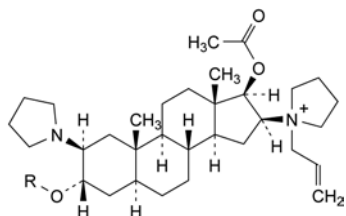

- E. R = H: 1-[17β-(acetyloxy)-3α-hydroxy-2β-(pyrrolidin-1-yl)-5α-androstan-16β-yl]-1-(prop-2-enyl)pyrrolidinium,  
 F. R = CO-CH<sub>3</sub>: 1-[3α,17β-bis(acetyloxy)-2β-(pyrrolidin-1-yl)-5α-androstan-16β-yl]-1-(prop-2-enyl)pyrrolidinium,

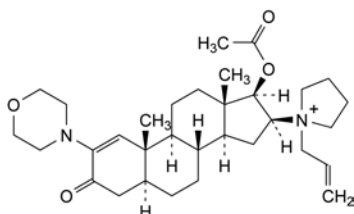

- H. 1-[17β-(acetyloxy)-2-(morpholin-4-yl)-3-oxo-5α-androst-1-en-16β-yl]-1-(prop-2-enyl)pyrrolidinium.

01/2008:2335

## ROPIVACAINE HYDROCHLORIDE MONOHYDRATE

### Ropivacaini hydrochloridum monohydricum

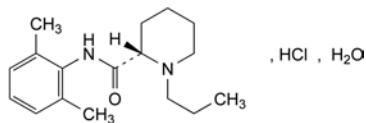

C<sub>17</sub>H<sub>27</sub>ClN<sub>2</sub>O<sub>2</sub>·H<sub>2</sub>O  
 [132112-35-7]

M<sub>r</sub> 328.9

#### DEFINITION

(-)-(2*S*)-*N*-(2,6-Dimethylphenyl)-1-propylpiperidine-2-carboxamide hydrochloride monohydrate.

*Content*: 99.0 per cent to 101.0 per cent (anhydrous substance).

#### CHARACTERS

*Appearance*: white or almost white, crystalline powder.

*Solubility*: soluble in water and in ethanol (96 per cent), slightly soluble in methylene chloride.

#### IDENTIFICATION

Carry out either tests A, C, D or tests A, B, C.

A. Infrared absorption spectrophotometry (2.2.24).

*Comparison*: ropivacaine hydrochloride monohydrate CRS.

B. Specific optical rotation (2.2.7): -64.0 to -74.0 (anhydrous substance).

Mix 2 mL of a 200 g/L solution of sodium hydroxide R and 30 mL of water R and dilute to 100.0 mL with ethanol (96 per cent) R (solution A). Dissolve 0.500 g of the substance to be examined in solution A and dilute to 50.0 mL with solution A.

C. It gives reaction (a) of chlorides (2.3.1).

D. Enantiomeric purity (see Tests).

#### TESTS

**Solution S.** Dissolve 0.50 g in carbon dioxide-free water R and dilute to 25.0 mL with the same solvent.

**Appearance of solution.** Solution S is clear (2.2.1).

**pH** (2.2.3): 4.5 to 6.0 for solution S.

**Absorbance** (2.2.25): maximum 0.030 at 405 nm and maximum 0.025 at 436 nm, determined on solution S prepared immediately before use, with a path length of 5 cm and using water R as the compensation liquid.

**Related substances.** Liquid chromatography (2.2.29).

*Test solution.* Dissolve 55 mg of the substance to be examined in the mobile phase and dilute to 20 mL with the mobile phase.

*Reference solution (a).* Dilute 1.0 mL of the test solution to 100.0 mL with the mobile phase. Dilute 1.0 mL of this solution to 10.0 mL with the mobile phase.

*Reference solution (b).* Dissolve 5 mg of the substance to be examined and 5 mg of bupivacaine hydrochloride CRS (impurity A) in the mobile phase and dilute to 5 mL with the mobile phase. Dilute 1 mL of this solution to 100 mL with the mobile phase.

*Column*:

– *size*: *l* = 0.15 m, Ø = 3.9 mm;

– *stationary phase*: spherical end-capped octadecylsilyl silica gel for chromatography R (4 µm).

*Mobile phase*: mix 1.3 mL of a 138 g/L solution of sodium dihydrogen phosphate R and 32.5 mL of an 89 g/L solution of disodium hydrogen phosphate R and dilute to 1000 mL with water R; mix equal volumes of this solution (pH 8.0) and acetonitrile R.

*Flow rate*: 1.0 mL/min.

*Injection*: 20 µL.

*Detection*: spectrophotometer at 240 nm.

*Run time*: 2.5 times the retention time of ropivacaine.

*Relative retention* with reference to ropivacaine (retention time = about 6 min): impurity A = about 1.6.

*System suitability*: reference solution (b):

– *resolution*: minimum 6.0 between the peaks due to ropivacaine and impurity A.

*Limits*:

– *impurity A*: not more than twice the area of the principal peak in the chromatogram obtained with reference solution (a) (0.2 per cent);

– *unspecified impurities*: for each impurity, not more than the area of the principal peak in the chromatogram obtained with reference solution (a) (0.10 per cent);

– *total*: not more than 5 times the area of the principal peak in the chromatogram obtained with reference solution (a) (0.5 per cent);

– *disregard limit*: 0.5 times the area of the principal peak in the chromatogram obtained with reference solution (a) (0.05 per cent).

**Impurity H.** Liquid chromatography (2.2.29) as described in the test for related substances with the following modifications.

*Test solution.* Dissolve 0.100 g of the substance to be examined in the mobile phase and dilute to 10.0 mL with the mobile phase.

*Reference solution.* Dissolve 13.0 mg of 2,6-dimethylaniline hydrochloride R in the mobile phase and dilute to 100.0 mL with the mobile phase. Dilute 1.0 mL of the solution to 100.0 mL with the mobile phase. Dilute 1.0 mL of this solution to 10.0 mL with the mobile phase.

*Retention time*: impurity H = about 2-3 min.

*Limit*:

– *impurity H*: not more than the area of the principal peak in the chromatogram obtained with the reference solution (10 ppm).

**Enantiomeric purity.** Capillary electrophoresis (2.2.47): use the normalisation procedure.

*Test solution.* Dissolve 50 mg of the substance to be examined in water R and dilute to 25 mL with the same solvent.

*Reference solution (a).* Dilute 1.0 mL of the test solution to 200.0 mL with water R.



**Reference solution (b).** Dissolve 1.5 mg of the substance to be examined and 1.5 mg of *ropivacaine impurity G CRS* in *water R* and dilute to 100 mL with the same solvent.

**Capillary:**

- **material:** fused silica;
- **size:** effective length = about 72 cm, total length = 80 cm,  $\varnothing = 50 \mu\text{m}$ .

**Temperature:** 30 °C.

**CZE buffer:** prepare a 13.3 g/L solution of *dimethyl- $\beta$ -cyclodextrin R* in an 11.5 g/L solution of *phosphoric acid R* previously adjusted to pH 3.0 with *triethanolamine R*. The CZE buffer is prepared and filtered through a membrane filter (nominal pore size 0.45  $\mu\text{m}$ ) immediately before use.

**Detection:** spectrophotometer at 206 nm.

**Preconditioning of the capillary:** rinse the capillary at 100 kPa with *water R* for 1 min, with 0.1 M *sodium hydroxide* for 10 min and with *water R* for 3 min. If the capillary is new or dry, increase the sodium hydroxide rinse to 30 min.

**Between-run rinsing:** rinse the capillary at 100 kPa with *water R* for 1 min, with 0.1 M *sodium hydroxide* for 4 min, with *water R* for 1 min and with the CZE buffer for 4 min.

**Injection:** under pressure (5 kPa) for 5 s.

**Migration:** apply a field strength of 375 V/cm with an initial ramp of 500 V/s and a positive polarity corresponding to a current of 40–45  $\mu\text{A}$ .

**Run time:** 30 min.

**System suitability:**

- **resolution:** minimum 3.7 between the peaks due to impurity G (1<sup>st</sup> peak) and (S)-ropivacaine in the electropherogram obtained with reference solution (b); if necessary, increase the dimethyl- $\beta$ -cyclodextrin concentration in the CZE buffer or vary the pH between 2.9 and 3.1 or lower the temperature;
- **signal-to-noise ratio:** minimum 10 for the principal peak in the electropherogram obtained with reference solution (a).

**Limit:**

- **impurity G:** maximum 0.5 per cent.

**Heavy metals (2.4.8):** maximum 10 ppm.

Dissolve 2.0 g in a mixture of 15 volumes of *water R* and 85 volumes of *methanol R* and dilute to 20 mL with the same mixture of solvents. 12 mL of the solution complies with test B. Prepare the reference solution using lead standard solution (1 ppm Pb) obtained by diluting *lead standard solution R (100 ppm Pb)* with a mixture of 15 volumes of *water R* and 85 volumes of *methanol R*.

**Water (2.5.12):** 5.0 per cent to 6.0 per cent, determined on 0.100 g.

**Sulfated ash (2.4.14):** maximum 0.1 per cent, determined on 1.0 g.

**ASSAY**

Dissolve 0.250 g in a mixture of 10 mL of *water R* and 40 mL of *ethanol (96 per cent) R*. Add 5.0 mL of 0.01 M *hydrochloric acid*. Carry out a potentiometric titration (2.2.20), using 0.1 M *sodium hydroxide*. Read the volume added between the 2 points of inflexion.

1 mL of 0.1 M *sodium hydroxide* is equivalent to 31.09 mg of  $\text{C}_{41}\text{H}_{76}\text{N}_2\text{O}_{15}$ .

**IMPURITIES**

**Specified impurities:** A, G, H.

**Other detectable impurities** (the following substances would, if present at a sufficient level, be detected by one or other of the tests in the monograph. They are limited by the general acceptance criterion for other/unspecified impurities and/or by the general monograph *Substances for pharmaceutical use (2034)*. It is therefore not necessary to identify these impurities for demonstration of compliance. See also 5.10. *Control of impurities in substances for pharmaceutical use*): B, C, D, E, F.

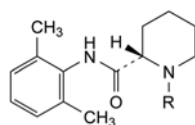

A. R =  $[\text{CH}_2]_3\text{-CH}_3$ : (S)-bupivacaine,

B. R = H: (-)-(2S)-N-(2,6-dimethylphenyl)piperidine-2-carboxamide,

C. R =  $\text{CH}_3$ : (-)-(2S)-N-(2,6-dimethylphenyl)-1-methylpiperidine-2-carboxamide ((S)-mepivacaine),

D. R =  $\text{C}_2\text{H}_5$ : (-)-(2S)-N-(2,6-dimethylphenyl)-1-ethylpiperidine-2-carboxamide,

E. R =  $\text{CH}(\text{CH}_3)_2$ : (-)-(2S)-N-(2,6-dimethylphenyl)-1-(1-methylethyl)piperidine-2-carboxamide,

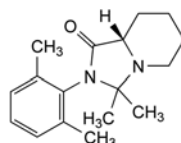

F. (8aS)-2-(2,6-dimethylphenyl)-3,3-dimethylhexahydroimidazo[1,5-a]pyridin-1(5H)-one (acetone adduct),

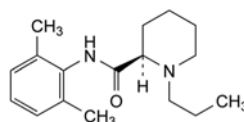

G. (+)-(2R)-N-(2,6-dimethylphenyl)-1-propylpiperidine-2-carboxamide ((R)-ropivacaine),

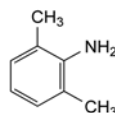

H. 2,6-dimethylaniline.

01/2008:1146  
corrected 6.0

## ROXITHROMYCIN

### Roxithromycinum

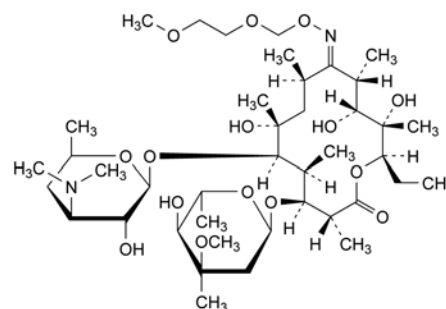

$\text{C}_{41}\text{H}_{76}\text{N}_2\text{O}_{15}$   
[80214-83-1]

$M_r$  837

**DEFINITION**

(3R,4S,5S,6R,7R,9R,11S,12R,13S,14R)-4-[(2,6-Dideoxy-3-C-methyl-3-O-methyl- $\alpha$ -L-ribo-hexopyranosyl)oxy]-14-ethyl-7,12,13-trihydroxy-10-[(E)-[(2-methoxyethoxy)methoxy]imino]-3,5,7,9,11,13-hexamethyl-6-[[3,4,6-trideoxy-3-(dimethylamino)- $\beta$ -D-xyllo-hexopyranosyl]oxy]oxacyclotetradecan-2-one (erythromycin 9-(E)-[O-[(2-methoxyethoxy)methyl]oxime]).

Semi-synthetic product derived from a fermentation product.

**Content:** 96.0 per cent to 102.0 per cent (anhydrous substance).

**CHARACTERS**

**Appearance:** white or almost white, crystalline powder.

**Solubility:** very slightly soluble in water, freely soluble in acetone, in alcohol and in methylene chloride. It is slightly soluble in dilute hydrochloric acid.

It shows polymorphism (5.9).

#### IDENTIFICATION

##### A. Infrared absorption spectrophotometry (2.2.24).

**Comparison:** roxithromycin CRS.

If the spectra obtained shows differences, prepare further spectra using 90 g/L solutions in *methylene chloride R*.

##### B. Examine the chromatograms obtained in the assay.

**Results:** the principal peak in the chromatogram obtained with the test solution is similar in retention time and size to the principal peak in the chromatogram obtained with reference solution (a).

#### TESTS

**Appearance of solution.** The solution is clear (2.2.1) and colourless (2.2.2, Method II).

Dissolve 0.2 g in *methanol R* and dilute to 20 mL with the same solvent.

**Specific optical rotation (2.2.7):** –93 to –96 (anhydrous substance).

Dissolve 0.500 g in *acetone R* and dilute to 50.0 mL with the same solvent.

**Related substances.** Liquid chromatography (2.2.29).

**Solution A.** Mix 30 volumes of *acetonitrile R* and 70 volumes of a 48.6 g/L solution of *ammonium dihydrogen phosphate R*, adjusted to pH 5.3 with *dilute sodium hydroxide solution R*.

**Test solution.** Dissolve 50.0 mg of the substance to be examined in solution A and dilute to 25.0 mL with solution A.

**Reference solution (a).** Dissolve 50.0 mg of *roxithromycin CRS* in solution A and dilute to 25.0 mL with solution A.

**Reference solution (b).** Dilute 1.0 mL of reference solution (a) to 100.0 mL with solution A.

**Reference solution (c).** Dissolve 2.0 mg of *roxithromycin for system suitability CRS* in solution A and dilute to 1.0 mL with solution A.

**Reference solution (d).** Dilute 1.0 mL of *toluene R* to 100.0 mL with *acetonitrile R*. Dilute 0.2 mL of this solution to 200.0 mL with solution A.

**Column:**

- size:  $l = 0.15$  m,  $\varnothing = 4.6$  mm,
- stationary phase: spherical *end-capped octadecylsilyl silica gel for chromatography R* (5  $\mu$ m) with a 10 nm pore size and a carbon loading of about 19 per cent,
- temperature: 15 °C.

**Mobile phase:**

- mobile phase A: mix 26 volumes of *acetonitrile R* and 74 volumes of a 59.7 g/L solution of *ammonium dihydrogen phosphate R*, adjusted to pH 4.3 with *dilute sodium hydroxide solution R*,
- mobile phase B: *water R*, *acetonitrile R* (30:70 V/V),

Time (min)	Mobile phase A (per cent V/V)	Mobile phase B (per cent V/V)
0 - 50	100	0
50 - 51	100 → 90	0 → 10
51 - 80	90	10
80 - 81	90 → 100	10 → 0
81 - 100	100	0

**Flow rate:** 1.1 mL/min.

**Detection:** spectrophotometer at 205 nm.

**Injection:** 20  $\mu$ L, using an injector maintained at 8 °C, of the test solution and reference solutions (b), (c) and (d).

**Relative retention** with reference to roxithromycin (retention time = about 22 min): impurity A = about 0.28; impurity B = about 0.31; impurity C = about 0.33; impurity D = about 0.62; impurity E = about 0.67; impurity F = about 0.83; impurity G = about 1.15; impurity K = about 1.7; impurity H = about 1.85; impurity J = about 2.65; impurity I = about 3.1.

**System suitability:** reference solution (c):

- **peak-to-valley ratio:** minimum 2.0, where  $H_p$  = height above the baseline of the peak due to impurity G and  $H_v$  = height above the baseline of the lowest point of the curve separating this peak from the peak due to roxithromycin.

**Limits:**

- **impurity G:** not more than the area of the principal peak in the chromatogram obtained with reference solution (b) (1.0 per cent),
- **impurities A, B, C, D, E, F, H, I, J:** for each impurity, not more than 0.5 times the area of the principal peak in the chromatogram obtained with reference solution (b) (0.5 per cent),
- **total:** not more than 3 times the area of the principal peak in the chromatogram obtained with reference solution (b) (3.0 per cent),
- **disregard limit:** 0.05 times the area of the principal peak in the chromatogram obtained with reference solution (b) (0.05 per cent). Disregard any peak due to toluene (use reference solution (d) to identify it).

**Heavy metals (2.4.8):** maximum 10 ppm.

Dissolve 2.0 g in a mixture of 15 volumes of *water R* and 85 volumes of *acetone R* and dilute to 20 mL with the same mixture of solvents. 12 mL of the solution complies with the limit test B. Prepare the standard using lead standard solution (1 ppm Pb) obtained by diluting *lead standard solution (100 ppm Pb) R* with a mixture of 15 volumes of *water R* and 85 volumes of *acetone R*.

**Water (2.5.12):** maximum 3.0 per cent, determined on 0.200 g.

**Sulfated ash (2.4.14):** maximum 0.1 per cent, determined on 1.0 g.

#### ASSAY

Liquid chromatography (2.2.29) as described in the test for related substances, with the following modifications.

**Column:**

- size:  $l = 0.25$  m.

**Mobile phase:** mix 307 volumes of *acetonitrile R* and 693 volumes of a 49.1 g/L solution of *ammonium dihydrogen phosphate R* adjusted to pH 5.3 with *dilute sodium hydroxide solution R*.

**Flow rate:** 1.5 mL/min.

**Injection:** test solution and reference solutions (a) and (c).

**Retention time:** roxithromycin = about 12 min.

**System suitability:** reference solution (c):

- **peak-to-valley ratio:** minimum 1.5, where  $H_p$  = height above the baseline of the peak due to impurity G and  $H_v$  = height above the baseline of the lowest point of the curve separating this peak from the peak due to roxithromycin.

#### STORAGE

In an airtight container.

#### IMPURITIES

**Specified impurities:** A, B, C, D, E, F, G, H, I, J.

**Other detectable impurities** (the following substances would, if present at a sufficient level, be detected by one or other of the tests in the monograph. They are limited by the general acceptance criterion for other/unspecified impurities and/or by the general monograph *Substances for pharmaceutical use*

(2034). It is therefore not necessary to identify these impurities for demonstration of compliance. See also 5.10. *Control of impurities in substances for pharmaceutical use*: K.

- A. (3*R*,4*S*,5*S*,6*R*,7*R*,9*R*,11*R*,12*R*,13*S*,14*R*)-4-[(2,6-dideoxy-3-*C*-methyl-3-*O*-methyl- $\alpha$ -*L*-ribo-hexopyranosyl)oxy]-14-ethyl-7,12,13-trihydroxy-3,5,7,9,11,13-hexamethyl-6-[[3,4,6-trideoxy-3-(dimethylamino)- $\beta$ -*D*-xylo-hexopyranosyl]oxy]oxacyclotetradecane-2,10-dione (erythromycin A),

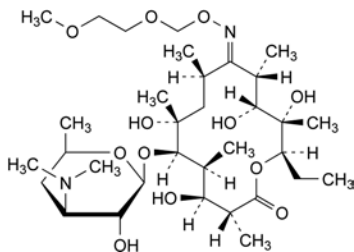

- B. 3-*O*-de(2,6-dideoxy-3-*C*-methyl-3-*O*-methyl- $\alpha$ -*L*-ribo-hexopyranosyl)erythromycin 9-(*E*)-[*O*-[(2-methoxyethoxy)methyl]oxime],

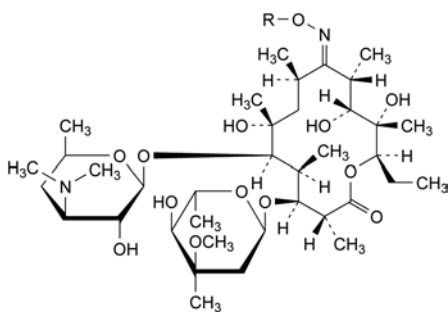

- C. R = H: erythromycin 9-(*E*)-oxime,
- G. R = CH<sub>2</sub>-O-CH<sub>2</sub>-O-CH<sub>2</sub>-CH<sub>2</sub>-OCH<sub>3</sub>: erythromycin 9-(*E*)-[*O*-[(2-methoxyethoxy)methoxy]methyl]oxime],
- J. R = CH<sub>2</sub>-O-CH<sub>2</sub>-CH<sub>2</sub>Cl: erythromycin 9-(*E*)-[*O*-[(2-chloroethoxy)methyl]oxime],
- K. R = CH<sub>2</sub>-O-CH<sub>2</sub>-CH<sub>2</sub>-O-CH<sub>2</sub>OH: erythromycin 9-(*E*)-[*O*-[2-(hydroxymethoxy)ethoxy]methyl]oxime],

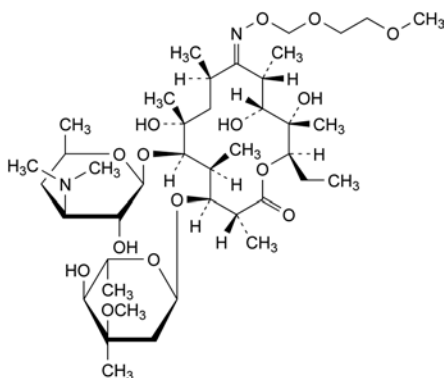

- D. erythromycin 9-(*Z*)-[*O*-[(2-methoxyethoxy)methyl]oxime],

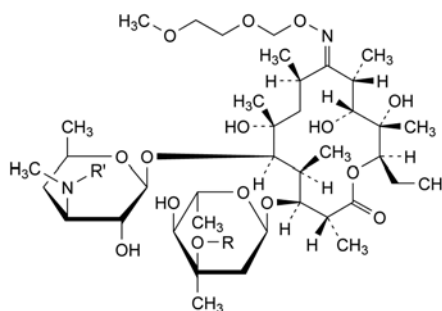

- E. R = H, R' = CH<sub>3</sub>: 3''-*O*-demethylerythromycin 9-(*E*)-[*O*-[(2-methoxyethoxy)methyl]oxime],

- F. R = CH<sub>3</sub>, R' = H: 3'-*N*-demethylerythromycin 9-(*E*)-[*O*-[(2-methoxyethoxy)methyl]oxime],

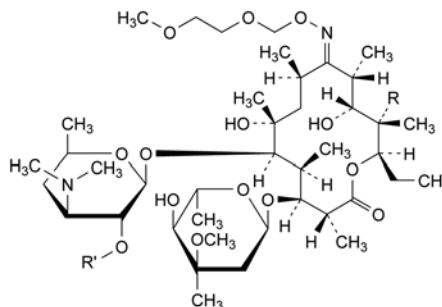

- H. R = R' = H: 12-deoxyerythromycin 9-(*E*)-[*O*-[(2-methoxyethoxy)methyl]oxime],

- I. R = OH, R' = CH<sub>2</sub>-O-CH<sub>2</sub>-CH<sub>2</sub>-OCH<sub>3</sub>: 2'-*O*-[(2-methoxyethoxy)methyl]erythromycin 9-(*E*)-[*O*-[(2-methoxyethoxy)methyl]oxime].

01/2008:1795  
corrected 7.0

## RUTOSIDE TRIHYDRATE

### Rutosidum trihydricum

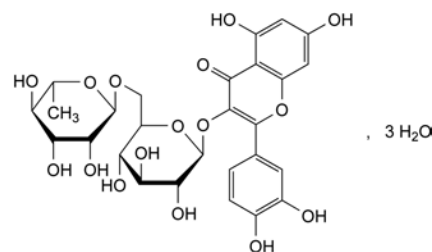

C<sub>27</sub>H<sub>30</sub>O<sub>16</sub>·3H<sub>2</sub>O

M<sub>r</sub> 665

#### DEFINITION

3-[[6-*O*-(6-Deoxy- $\alpha$ -*L*-mannopyranosyl)- $\beta$ -*D*-glucopyranosyl]oxy]-2-(3,4-dihydroxyphenyl)-5,7-dihydroxy-4*H*-1-benzopyran-4-one.

*Content*: 95.0 per cent to 101.0 per cent (anhydrous substance).

#### CHARACTERS

*Appearance*: yellow or greenish-yellow, crystalline powder.

*Solubility*: practically insoluble in water, soluble in methanol, sparingly soluble in ethanol (96 per cent), practically insoluble in methylene chloride. It dissolves in solutions of alkali hydroxides.

#### IDENTIFICATION

*First identification*: B.

*Second identification*: A, C, D.

- A. Dissolve 50.0 mg in *methanol R*, dilute to 250.0 mL with the same solvent and filter if necessary. Dilute 5.0 mL of the solution to 50.0 mL with *methanol R*. Examined between

210 nm and 450 nm (2.2.25), the solution shows 2 absorption maxima, at 257 nm and 358 nm. The specific absorbance at the maximum at 358 nm is 305 to 330, calculated with reference to the anhydrous substance.

B. Infrared absorption spectrophotometry (2.2.24).

*Comparison: rutoside trihydrate CRS.*

C. Thin-layer chromatography (2.2.27).

*Test solution.* Dissolve 25 mg of the substance to be examined in *methanol R* and dilute to 10.0 mL with the same solvent.

*Reference solution.* Dissolve 25 mg of *rutoside trihydrate CRS* in *methanol R* and dilute to 10.0 mL with the same solvent.

*Plate: TLC silica gel G plate R.*

*Mobile phase: butanol R, anhydrous acetic acid R, water R, methyl ethyl ketone R, ethyl acetate R* (5:10:10:30:50 V/V/V/V/V).

*Application: 10 µL.*

*Development: over a path of 10 cm.*

*Drying: in air.*

*Detection: spray with a mixture of 7.5 mL of a 10 g/L solution of potassium ferricyanide R and 2.5 mL of ferric chloride solution R1 and examine for 10 min.*

*Results: the principal spot in the chromatogram obtained with the test solution is similar in position, colour and size to the principal spot in the chromatogram obtained with the reference solution.*

D. Dissolve 10 mg in 5 mL of *ethanol (96 per cent) R*, add 1 g of *zinc R* and 2 mL of *hydrochloric acid R1*. A red colour develops.

## TESTS

**Light absorbing impurities (2.2.25):** maximum 0.10 at wavelengths between 450 nm and 800 nm.

Dissolve 0.200 g in 40 mL of *2-propanol R*. Stir for 15 min, dilute to 50.0 mL with *2-propanol R* and filter.

**Substances insoluble in methanol:** maximum 3 per cent.

Shake 2.5 g for 15 min in 50 mL of *methanol R* at 20-25 °C. Filter under reduced pressure through a sintered-glass filter (1.6) (2.1.2) previously dried for 15 min at 100-105 °C, allowed to cool in a desiccator and tared. Wash the filter 3 times with 20 mL of *methanol R*. Dry the filter for 30 min at 100-105 °C. Allow to cool and weigh. The residue weighs a maximum of 75 mg.

**Related substances.** Liquid chromatography (2.2.29).

*Test solution.* Dissolve 0.10 g of the substance to be examined in 20 mL of *methanol R* and dilute to 100.0 mL with mobile phase B.

*Reference solution (a).* Dissolve 10.0 mg of *rutoside trihydrate CRS* in 10.0 mL of *methanol R*.

*Reference solution (b).* Dilute 1.0 mL of reference solution (a) to 50.0 mL with mobile phase B.

*Column:*

- *size: l* = 0.25 m,  $\varnothing$  = 4.0 mm,
- *stationary phase: octylsilyl silica gel for chromatography R* (5 µm),
- *temperature: 30 °C.*

*Mobile phase:*

- *mobile phase A: mix 5 volumes of tetrahydrofuran R with 95 volumes of a 15.6 g/L solution of sodium dihydrogen phosphate R adjusted to pH 3.0 with phosphoric acid R,*
- *mobile phase B: mix 40 volumes of tetrahydrofuran R with 60 volumes of a 15.6 g/L solution of sodium dihydrogen phosphate R adjusted to pH 3.0 with phosphoric acid R,*

Time (min)	Mobile phase A (per cent V/V)	Mobile phase B (per cent V/V)
0 - 10	50 → 0	50 → 100
10 - 15	0	100

*Flow rate: 1 mL/min.*

*Detection: spectrophotometer at 280 nm.*

*Injection: 20 µL.*

*Relative retention* with reference to rutoside (retention time = about 7 min): impurity B = about 1.1; impurity A = about 1.2; impurity C = about 2.5.

*System suitability: reference solution (a):*

- *peak-to-valley ratio:* minimum 10, where  $H_p$  = height above the baseline of the peak due to impurity B and  $H_v$  = height above the baseline of the lowest point of the curve separating this peak from the peak due to rutoside.

*Limits: locate the impurities by comparison with the chromatogram provided with rutoside trihydrate CRS:*

- *correction factors:* for the calculation of contents, multiply the peak areas of the following impurities by the corresponding correction factor: impurity A = 0.8; impurity C = 0.5,
- *impurity A:* not more than the area of the principal peak in the chromatogram obtained with reference solution (b) (2.0 per cent),
- *impurity B:* not more than the area of the principal peak in the chromatogram obtained with reference solution (b) (2.0 per cent),
- *impurity C:* not more than the area of the principal peak in the chromatogram obtained with reference solution (b) (2.0 per cent),
- *total:* not more than twice the area of the principal peak in the chromatogram obtained with reference solution (b) (4.0 per cent),
- *disregard limit:* 0.05 times the area of the principal peak in the chromatogram obtained with reference solution (b) (0.1 per cent).

**Water (2.5.12):** 7.5 per cent to 9.5 per cent, determined on 0.100 g.

**Sulfated ash (2.4.14):** maximum 0.1 per cent, determined on 1.0 g.

## ASSAY

Dissolve 0.200 g in 20 mL of *dimethylformamide R*. Titrate with 0.1 M *tetrabutylammonium hydroxide*, determining the end-point potentiometrically (2.2.20).

1 mL of 0.1 M *tetrabutylammonium hydroxide* is equivalent to 30.53 mg of  $C_{27}H_{30}O_{16}$ .

## STORAGE

Protected from light.

## IMPURITIES

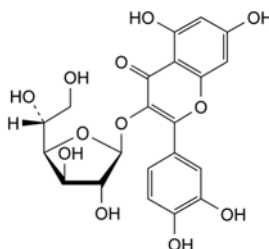

- A. 2-(3,4-dihydroxyphenyl)-3-(β-D-glucopyranosyloxy)-5,7-dihydroxy-4H-1-benzopyran-4-one (isoquercitrin),

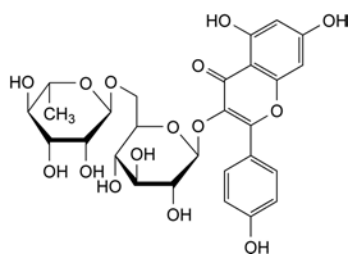

B. 3-[[6-O-(6-deoxy- $\alpha$ -L-mannopyranosyl)- $\beta$ -D-glucopyranosyl]oxy]-5,7-dihydroxy-2-(4-hydroxyphenyl)-4H-1-benzopyran-4-one (kaempferol 3-rutinoside),

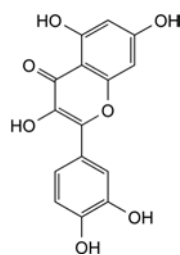

C. 2-(3,4-dihydroxyphenyl)-3,5,7-trihydroxy-4H-1-benzopyran-4-one (quercetin).

## SACCHARIN

## Saccharinum

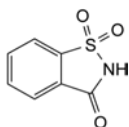

$C_7H_5NO_3S$   
[81-07-2]

$M_r$  183.2

## DEFINITION

1,2-Benzisothiazol-3(2H)-one 1,1-dioxide.

Content: 99.0 per cent to 101.0 per cent (dried substance).

## CHARACTERS

Appearance: white or almost white, crystalline powder or colourless crystals.

Solubility: sparingly soluble in boiling water and in ethanol (96 per cent), slightly soluble in cold water. It dissolves in dilute solutions of alkali hydroxides and carbonates.

## IDENTIFICATION

First identification: C.

Second identification: A, B, D, E.

A. A saturated solution, prepared without heating, turns *blue litmus paper R* red.

B. Melting point (2.2.14): 226 °C to 230 °C.

C. Infrared absorption spectrophotometry (2.2.24).

Preparation: discs.

Comparison: *saccharin CRS*.

D. Mix about 10 mg with about 10 mg of *resorcinol R*, add 0.25 mL of *sulfuric acid R* and carefully heat the mixture over a naked flame until a dark green colour is produced. Allow to cool, add 10 mL of *water R* and *dilute sodium hydroxide solution R* until an alkaline reaction is produced. An intense green fluorescence develops.

E. To 0.2 g add 1.5 mL of *dilute sodium hydroxide solution R*, evaporate to dryness and heat the residue carefully until it melts, avoiding carbonisation. Allow to cool, dissolve the mass in about 5 mL of *water R*, add *dilute hydrochloric acid R* until a weak acid reaction is produced and filter, if necessary. To the filtrate add 0.2 mL of *ferric chloride solution R2*. A violet colour develops.

## TESTS

**Solution S.** Dissolve 5.0 g in 20 mL of a 200 g/L solution of *sodium acetate R* and dilute to 25 mL with the same solution.

**Appearance of solution.** Solution S is clear (2.2.1) and colourless (2.2.2, *Method II*).

**o- and p-Toluenesulfonamide.** Gas chromatography (2.2.28).

**Internal standard solution.** Dissolve 25 mg of *caffeine R* in *methylene chloride R* and dilute to 100 mL with the same solvent.

**Test solution.** Suspend 10.0 g of the substance to be examined in 20 mL of *water R* and dissolve using 5-6 mL of *strong sodium hydroxide solution R*. If necessary adjust the solution to pH 7-8 with 1 M *sodium hydroxide* or 1 M *hydrochloric acid* and dilute to 50 mL with *water R*. Shake the solution with 4 quantities, each of 50 mL, of *methylene chloride R*. Combine the lower layers, dry over *anhydrous sodium sulfate R* and filter. Wash the filter and the sodium sulfate with 10 mL of *methylene chloride R*. Combine the solution and the washings and evaporate almost to dryness in a water-bath at a temperature not exceeding 40 °C. Using a small quantity

of *methylene chloride R*, quantitatively transfer the residue into a suitable 10 mL tube, evaporate to dryness in a current of nitrogen and dissolve the residue in 1.0 mL of the internal standard solution.

**Blank solution.** Evaporate 200 mL of *methylene chloride R* to dryness in a water-bath at a temperature not exceeding 40 °C. Dissolve the residue in 1 mL of *methylene chloride R*.

**Reference solution.** Dissolve 20.0 mg of *o-toluenesulfonamide R* and 20.0 mg of *p-toluenesulfonamide R* in *methylene chloride R* and dilute to 100.0 mL with the same solvent. Dilute 5.0 mL of the solution to 50.0 mL with *methylene chloride R*. Evaporate 5.0 mL of the final solution to dryness in a current of nitrogen. Dissolve the residue in 1.0 mL of the internal standard solution.

Column:

- material: fused silica,
- size:  $l = 10$  m,  $\varnothing = 0.53$  mm,
- stationary phase: *polymethylphenylsiloxane R* (film thickness 2  $\mu$ m).

Carrier gas: *nitrogen for chromatography R*.

Flow rate: 10 mL/min.

Split ratio: 1:2.

Temperature:

- column: 180 °C,
- injection port and detector: 250 °C.

Detection: flame ionisation.

Injection: 1  $\mu$ L.

Order of elution: *o-toluenesulfonamide*, *p-toluenesulfonamide*, *caffeine*.

System suitability:

- resolution: minimum 1.5 between the peaks due to *o-toluenesulfonamide* and *p-toluenesulfonamide* in the chromatogram obtained with the reference solution,
- the chromatogram obtained with the blank solution does not show any peak with the same retention times as the internal standard, *o-toluenesulfonamide* and *p-toluenesulfonamide*.

Limits:

- *o-toluenesulfonamide*: the ratio of its area to that of the internal standard is not greater than the corresponding ratio in the chromatogram obtained with the reference solution (10 ppm),
- *p-toluenesulfonamide*: the ratio of its area to that of the internal standard is not greater than the corresponding ratio in the chromatogram obtained with the reference solution (10 ppm).

**Readily carbonisable substances.** Dissolve 0.20 g in 5 mL of *sulfuric acid R* and keep at 48-50 °C for 10 min. When viewed against a white background, the solution is not more intensely coloured than a solution prepared by mixing 0.1 mL of red primary solution, 0.1 mL of blue primary solution and 0.4 mL of yellow primary solution (2.2.2) with 4.4 mL of *water R*.

**Heavy metals (2.4.8):** maximum 20 ppm.

Dilute 10 mL of solution S to 20 mL with *water R*. 12 mL of the solution complies with test A. Prepare the reference solution using *lead standard solution (2 ppm Pb) R*.

**Loss on drying (2.2.32):** maximum 1.0 per cent, determined on 1.000 g by drying in an oven at 105 °C for 2 h.

**Sulfated ash (2.4.14):** maximum 0.2 per cent, determined on 1.0 g.

## ASSAY

Dissolve 0.500 g in 40 mL of *ethanol (96 per cent) R*. Add 40 mL of *water R*. Titrate with 0.1 M *sodium hydroxide*, using a 10 g/L solution of *phenolphthalein R* in *ethanol (96 per cent) R* as indicator. Carry out a blank titration.

1 mL of 0.1 M *sodium hydroxide* is equivalent to 18.32 mg of  $C_7H_5NO_3S$ .

01/2008:0787

## SACCHARIN SODIUM

## Saccharinum natricum

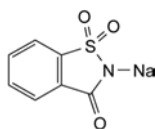

$C_7H_4NNaO_3S$   
[128-44-9]

 $M_r$  205.2

## DEFINITION

2-Sodio-1,2-benzisothiazol-3(2H)-one 1,1-dioxide.

*Content*: 99.0 per cent to 101.0 per cent (anhydrous substance).

It may contain a variable quantity of water.

## CHARACTERS

*Appearance*: white or almost white, crystalline powder or colourless crystals, efflorescent in dry air.*Solubility*: freely soluble in water, sparingly soluble in ethanol (96 per cent).

## IDENTIFICATION

*First identification*: B, E.*Second identification*: A, C, D, E.

A. Melting point (2.2.14): 226 °C to 230 °C.

To 5 mL of solution S (see Tests) add 3 mL of dilute hydrochloric acid R. A white precipitate is formed. Filter and wash with water R. Dry the precipitate at 100-105 °C.

B. Infrared absorption spectrophotometry (2.2.24).

*Preparation*: discs; dry the substances at 100-105 °C before use.*Comparison*: saccharin sodium CRS.

C. Mix about 10 mg with about 10 mg of resorcinol R, add 0.25 mL of sulfuric acid R and carefully heat the mixture over a naked flame until a dark green colour is produced. Allow to cool, add 10 mL of water R and dilute sodium hydroxide solution R until an alkaline reaction is produced. An intense green fluorescence develops.

D. To 0.2 g add 1.5 mL of dilute sodium hydroxide solution R, evaporate to dryness and heat the residue carefully until it melts, avoiding carbonisation. Allow to cool, dissolve the mass in about 5 mL of water R, add dilute hydrochloric acid R until a weak acid reaction is produced and filter, if necessary. To the filtrate add 0.2 mL of ferric chloride solution R2. A violet colour develops.

E. Solution S gives reaction (a) of sodium (2.3.1).

## TESTS

**Solution S.** Dissolve 5.0 g in carbon dioxide-free water R and dilute to 50.0 mL with the same solvent.**Appearance of solution.** The solution is clear (2.2.1) and colourless (2.2.2, Method II).

Dissolve 5.0 g in 25 mL of carbon dioxide-free water R.

**Acidity or alkalinity.** To 10 mL of solution S add about 0.05 mL of a 10 g/L solution of phenolphthalein R in ethanol (96 per cent) R. The solution is not pink. Add 0.1 mL of sodium hydroxide 0.1 M. The solution becomes pink.**o- and p-Toluenesulfonamide.** Gas chromatography (2.2.28).*Internal standard solution.* Dissolve 25 mg of caffeine R in methylene chloride R and dilute to 100 mL with the same solvent.*Test solution.* Dissolve 10.0 g of the substance to be examined in 50 mL of water R. If necessary adjust the solution to pH 7-8 by addition of 1 M sodium hydroxide or 1 M hydrochloric*acid.* Shake the solution with 4 quantities, each of 50 mL, of methylene chloride R. Combine the lower layers, dry over anhydrous sodium sulfate R and filter. Wash the filter and the sodium sulfate with 10 mL of methylene chloride R. Combine the solution and the washings and evaporate almost to dryness in a water-bath at a temperature not exceeding 40 °C. Using a small quantity of methylene chloride R, quantitatively transfer the residue into a suitable 10 mL tube, evaporate to dryness in a current of nitrogen R and add 1.0 mL of the internal standard solution.*Blank solution.* Evaporate 200 mL of methylene chloride R to dryness in a water-bath at a temperature not exceeding 40 °C. Dissolve the residue in 1 mL of methylene chloride R.*Reference solution.* Dissolve 20.0 mg of o-toluenesulfonamide R and 20.0 mg of p-toluenesulfonamide R in methylene chloride R and dilute to 100.0 mL with the same solvent. Dilute 5.0 mL of the solution to 50.0 mL with methylene chloride R. Evaporate 5.0 mL of the final solution to dryness in a current of nitrogen R. Take up the residue using 1.0 mL of the internal standard solution.*Column*:

- *material*: fused silica,
- *size*:  $l = 10$  m,  $\varnothing = 0.53$  mm,
- *stationary phase*: polymethylphenylsiloxane R (film thickness 2  $\mu$ m).

*Carrier gas*: nitrogen for chromatography R.*Flow rate*: 10 mL/min.*Split ratio*: 1:2.*Temperature*:

- *column*: 180 °C,
- *injection port and detector*: 250 °C.

*Detection*: flame ionisation.*Injection*: 1  $\mu$ L.*Elution order*: o-toluenesulfonamide, p-toluenesulfonamide, caffeine.*System suitability*:

- *resolution*: minimum 1.5 between the peaks due to o-toluenesulfonamide and p-toluenesulfonamide in the chromatogram obtained with the reference solution,
- the chromatogram obtained with the blank solution does not show any peak with the same retention times as the internal standard, o-toluenesulfonamide and p-toluenesulfonamide.

*Limits*:

- *o-toluenesulfonamide*: the ratio of its area to that of the internal standard is not greater than the corresponding ratio in the chromatogram obtained with the reference solution (10 ppm),
- *p-toluenesulfonamide*: the ratio of its area to that of the internal standard is not greater than the corresponding ratio in the chromatogram obtained with the reference solution (10 ppm).

**Readily carbonisable substances.** Dissolve 0.20 g in 5 mL of sulfuric acid R and keep at 48-50 °C for 10 min. When viewed against a white background, the solution is not more intensely coloured than a solution prepared by mixing 0.1 mL of red primary solution, 0.1 mL of blue primary solution and 0.4 mL of yellow primary solution (2.2.2) with 4.4 mL of water R.**Heavy metals** (2.4.8): maximum 20 ppm.

12 mL of solution S complies with test A. Prepare the reference solution using lead standard solution (2 ppm Pb) R.

**Water** (2.5.12): maximum 15.0 per cent, determined on 0.200 g.

## ASSAY

Dissolve 0.150 g in 50 mL of anhydrous acetic acid R, with slight heating if necessary. Titrate with 0.1 M perchloric acid, determining the end-point potentiometrically (2.2.20). Carry out a blank titration.

1 mL of 0.1 M perchloric acid is equivalent to 20.52 mg of  $C_7H_4NNaO_3S$ .

## STORAGE

In an airtight container.

01/2010:2088

## SAFFLOWER OIL, REFINED

## Carthami oleum raffinatum

## DEFINITION

Fatty oil obtained from seeds of *Carthamus tinctorius* L. (type I) or from seeds of hybrids of *Carthamus tinctorius* L. (type II), by expression and/or extraction followed by refining. Type II refined safflower oil is rich in oleic (*cis*-9-octadecenoic) acid. A suitable antioxidant may be added.

## CHARACTERS

*Appearance*: clear, viscous, yellow or pale yellow liquid.

*Solubility*: practically insoluble in ethanol (96 per cent), miscible with light petroleum (bp: 40-60 °C).

	Type I refined safflower oil	Type II refined safflower oil
Relative density	about 0.922	about 0.914
Refractive index	about 1.476	about 1.472

## IDENTIFICATION

*First identification*: B.

*Second identification*: A.

A. Identification of fatty oils by thin-layer chromatography (2.3.2).

*Results*: the chromatogram obtained is similar to the corresponding chromatogram for type I or type II shown in Figure 2.3.2.-1.

B. Composition of fatty acids (see Tests).

## TESTS

**Acid value** (2.5.1): maximum 0.5.

**Peroxide value** (2.5.5, *Method A*): maximum 10.0, or maximum 5.0 if intended for use in the manufacture of parenteral preparations.

**Unsaponifiable matter** (2.5.7): maximum 1.5 per cent, determined on 5.0 g.

**Alkaline impurities** (2.4.19). It complies with the test.

**Composition of fatty acids** (2.4.22, *Method A*). Use the mixture of calibrating substances in Table 2.4.22.-3.

*Composition of the fatty-acid fraction of type I refined safflower oil*:

- saturated fatty acids of chain length less than C14: maximum 0.2 per cent;
- myristic acid: maximum 0.2 per cent;
- palmitic acid: 4.0 per cent to 10.0 per cent;
- stearic acid: 1.0 per cent to 5.0 per cent;
- oleic acid: 8.0 per cent to 21.0 per cent;
- linoleic acid: 68.0 per cent to 83.0 per cent;
- linolenic acid: maximum 0.5 per cent;
- arachidic acid: maximum 0.5 per cent;
- eicosenoic acid: maximum 0.5 per cent;
- behenic acid: maximum 1.0 per cent.

*Composition of the fatty-acid fraction of type II refined safflower oil*:

- saturated fatty acids of chain length less than C14: maximum 0.2 per cent;
- myristic acid: maximum 0.2 per cent;

- palmitic acid: 3.6 per cent to 6.0 per cent;
- stearic acid: 1.0 per cent to 5.0 per cent;
- oleic acid: 70.0 per cent to 84.0 per cent;
- linoleic acid: 7.0 per cent to 23.0 per cent;
- linolenic acid: maximum 0.5 per cent;
- arachidic acid: maximum 1.0 per cent;
- eicosenoic acid: maximum 1.0 per cent;
- behenic acid: maximum 1.2 per cent.

**Brassicasterol** (2.4.23): maximum 0.3 per cent in the sterol fraction of the oil.

**Water** (2.5.32): maximum 0.1 per cent, determined on 1.00 g.

## STORAGE

In a well-filled, airtight container, protected from light.

## LABELLING

The label states:

- where applicable, that the substance is suitable for use in the manufacture of parenteral preparations;
- the type of oil (type I or type II).

01/2011:0529

## SALBUTAMOL

## Salbutamolium

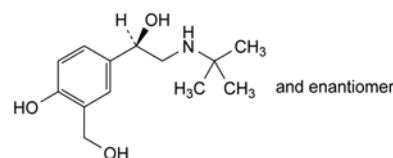

$C_{13}H_{21}NO_3$   
[18559-94-9]

$M_r$  239.3

## DEFINITION

(1*RS*)-2-[(1,1-Dimethylethyl)amino]-1-[4-hydroxy-3-(hydroxymethyl)phenyl]ethanol.

*Content*: 98.0 per cent to 101.0 per cent (dried substance).

## CHARACTERS

*Appearance*: white or almost white, crystalline powder.

*Solubility*: sparingly soluble in water, soluble in ethanol (96 per cent).

mp: about 155 °C, with decomposition.

## IDENTIFICATION

*First identification*: B.

*Second identification*: A, C, D.

A. Ultraviolet and visible absorption spectrophotometry (2.2.25).

*Test solution*. Dissolve 80.0 mg in a 10 g/L solution of hydrochloric acid R and dilute to 100.0 mL with the same acid. Dilute 10.0 mL of the solution to 100.0 mL with a 10 g/L solution of hydrochloric acid R.

*Spectral range*: 230-350 nm.

*Absorption maximum*: at 276 nm.

*Specific absorbance at the absorption maximum*: 66 to 75.

B. Infrared absorption spectrophotometry (2.2.24).

*Comparison*: salbutamol CRS.

C. Thin-layer chromatography (2.2.27).

*Test solution*. Dissolve 10 mg of the substance to be examined in methanol R and dilute to 50 mL with the same solvent.

*Reference solution*. Dissolve 10 mg of salbutamol CRS in methanol R and dilute to 50 mL with the same solvent.



*Plate:* TLC silica gel plate R.

*Mobile phase:* concentrated ammonia R, water R, ethyl acetate R, 2-propanol R, methyl isobutyl ketone R (3:18:35:45:50 V/V/V/V/V).

*Application:* 5 µL.

*Development:* over 3/4 of the plate.

*Drying:* in air.

*Detection:* spray with a 1 g/L solution of methylbenzothiazolone hydrazone hydrochloride R in a 90 per cent V/V solution of methanol R, followed by a 20 g/L solution of potassium ferricyanide R in a mixture of 1 volume of concentrated ammonia R1 and 3 volumes of water R, followed by a further spraying with a 1 g/L solution of methylbenzothiazolone hydrazone hydrochloride R in a 90 per cent V/V solution of methanol R.

*Results:* the principal spot in the chromatogram obtained with the test solution is similar in position, colour and size to the principal spot in the chromatogram obtained with the reference solution.

- D. Dissolve about 10 mg in 50 mL of a 20 g/L solution of disodium tetraborate R. Add 1 mL of a 30 g/L solution of aminopyrazolone R, 10 mL of methylene chloride R and 10 mL of a 20 g/L solution of potassium ferricyanide R. Shake and allow to separate. An orange-red colour develops in the methylene chloride layer.

#### TESTS

**Solution S.** Dissolve 0.50 g in methanol R and dilute to 25.0 mL with the same solvent.

**Appearance of solution.** Solution S is clear (2.2.1) and not more intensely coloured than reference solution BY<sub>5</sub> (2.2.2, Method II).

**Optical rotation** (2.2.7):  $-0.10^\circ$  to  $+0.10^\circ$ , determined on solution S.

**Related substances.** Liquid chromatography (2.2.29).

*Test solution.* Dissolve 0.100 g of the substance to be examined in the mobile phase and dilute to 50.0 mL with the mobile phase.

*Reference solution (a).* Dissolve 2.0 mg of salbutamol CRS, 2 mg of salbutamol impurity B CRS, 3.0 mg of salbutamol impurity D CRS, 3.0 mg of salbutamol impurity F CRS and 3.0 mg of salbutamol impurity G CRS in the mobile phase and dilute to 10.0 mL with the mobile phase. Dilute 2.0 mL of this solution to 100.0 mL with the mobile phase.

*Reference solution (b).* Dissolve the contents of a vial of salbutamol impurity I CRS in 1.0 mL of the mobile phase.

*Reference solution (c).* Dilute 1.0 mL of the test solution to 100.0 mL with the mobile phase. Dilute 1.0 mL of this solution to 20.0 mL with the mobile phase.

*Column:*

- size:  $l = 0.15$  m,  $\emptyset = 3.9$  mm;
- stationary phase: spherical end-capped octylsilyl silica gel for chromatography R (5 µm) with a specific surface area of 335 m<sup>2</sup>/g, a pore size of 10 nm and a carbon loading of 11.7 per cent.

*Mobile phase:* mix 22 volumes of acetonitrile R1 and 78 volumes of a solution containing 2.87 g/L of sodium heptanesulfonate R and 2.5 g/L of potassium dihydrogen phosphate R previously adjusted to pH 3.65 with dilute phosphoric acid R.

*Flow rate:* 1 mL/min.

*Detection:* spectrophotometer at 220 nm.

*Injection:* 20 µL.

*Run time:* 25 times the retention time of salbutamol.

*Identification of impurities:* use the chromatogram obtained with reference solution (a) to identify the peaks due to impurities B, D, F and G; use the chromatogram obtained with reference solution (b) to identify the peak due to impurity I.

*Relative retention* with reference to salbutamol (retention time = about 2 min): impurity B = about 1.3; impurity A = about 1.7; impurity C = about 2.0; impurity D = about 2.7; impurity H = about 3.0; impurity E = about 3.1; impurity G = about 4.1; impurity F = about 6.2; impurity I = about 23.2.

*System suitability:* reference solution (a):

- resolution: minimum 3.0 between the peaks due to salbutamol and impurity B.

*Limits:*

- impurity D: not more than the area of the corresponding peak in the chromatogram obtained with reference solution (a) (0.3 per cent);
- impurity F: not more than the area of the corresponding peak in the chromatogram obtained with reference solution (a) (0.3 per cent);
- impurity G: not more than the area of the corresponding peak in the chromatogram obtained with reference solution (a) (0.3 per cent);
- impurities A, B, C, E, H, I: for each impurity, not more than 1.5 times the area of the peak due to salbutamol in the chromatogram obtained with reference solution (a) (0.3 per cent);
- unspecified impurities: for each impurity, not more than 0.5 times the area of the peak due to salbutamol in the chromatogram obtained with reference solution (a) (0.10 per cent);
- total: maximum 1.0 per cent;
- disregard limit: the area of the principal peak in the chromatogram obtained with reference solution (c) (0.05 per cent).

**Impurity J:** maximum 0.2 per cent.

Dissolve 50.0 mg in a 1 g/L solution of hydrochloric acid R and dilute to 25.0 mL with the same solvent. The absorbance (2.2.25) of the solution measured at 310 nm is not greater than 0.10.

**Boron:** maximum 50 ppm.

*Test solution.* To 50 mg of the substance to be examined add 5 mL of a solution containing 13 g/L of anhydrous sodium carbonate R and 17 g/L of potassium carbonate R. Evaporate to dryness on a water-bath and dry at 120 °C. Ignite the residue rapidly until the organic matter has been destroyed, allow to cool and add 0.5 mL of water R and 3.0 mL of a freshly prepared 1.25 g/L solution of curcumin R in glacial acetic acid R. Warm gently to effect solution, allow to cool and add 3.0 mL of a mixture prepared by adding 5 mL of sulfuric acid R, slowly and with stirring, to 5 mL of glacial acetic acid R. Mix and allow to stand for 30 min. Dilute to 100.0 mL with ethanol (96 per cent) R, filter and use the filtrate.

*Reference solution.* Dissolve 0.572 g of boric acid R in 1000.0 mL of water R. Dilute 1.0 mL of the solution to 100.0 mL with water R. To 2.5 mL of this solution add 5 mL of a solution containing 13 g/L of anhydrous sodium carbonate R and 17 g/L of potassium carbonate R, and treat this mixture in the same manner as the test solution.

Measure the absorbance (2.2.25) of the test solution and of the reference solution at the absorption maximum at about 555 nm. The absorbance of the test solution is not greater than that of the reference solution.

**Loss on drying** (2.2.32): maximum 0.5 per cent, determined on 1.000 g by drying in an oven at 105 °C.

**Sulfated ash** (2.4.14): maximum 0.1 per cent, determined on 1.0 g.

#### ASSAY

Dissolve 0.200 g in 30 mL of anhydrous acetic acid R. Titrate with 0.1 M perchloric acid, determining the end-point potentiometrically (2.2.20).

1 mL of 0.1 M perchloric acid is equivalent to 23.93 mg of  $C_{13}H_{21}NO_3$ .

## STORAGE

Protected from light.

## IMPURITIES

Specified impurities: A, B, C, D, E, F, G, H, I, J.

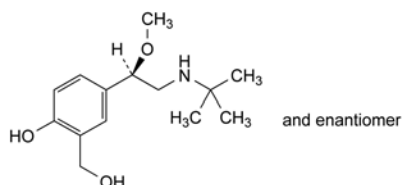

A. 5-[(1*R*)-2-[(1,1-dimethylethyl)amino]-1-methoxyethyl]-2-hydroxyphenyl]methanol,

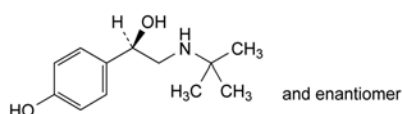

B. (1*R*)-2-[(1,1-dimethylethyl)amino]-1-(4-hydroxyphenyl)ethanol,

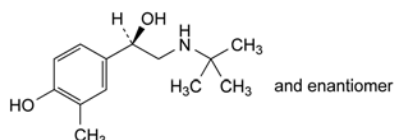

C. (1*R*)-2-[(1,1-dimethylethyl)amino]-1-(4-hydroxy-3-methylphenyl)ethanol,

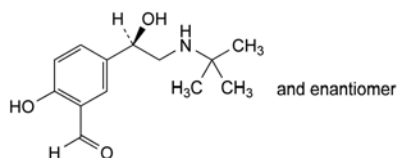

D. 5-[(1*R*)-2-[(1,1-dimethylethyl)amino]-1-hydroxyethyl]-2-hydroxybenzaldehyde,

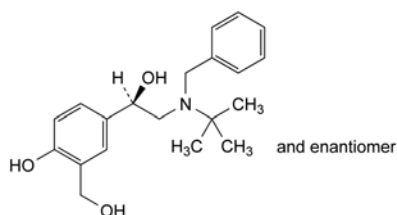

E. (1*R*)-2-[benzyl(1,1-dimethylethyl)amino]-1-[4-hydroxy-3-(hydroxymethyl)phenyl]ethanol,

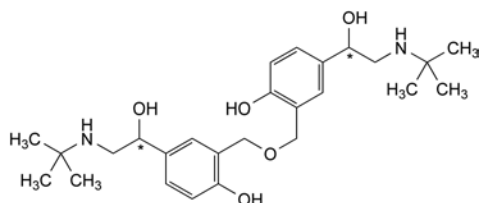

F. 1,1'-[oxybis[methylene(4-hydroxy-1,3-phenylene)]]bis[2-[(1,1-dimethylethyl)amino]ethanol],

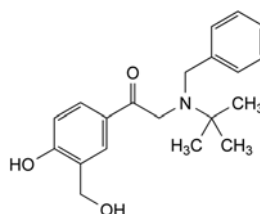

G. 2-[benzyl(1,1-dimethylethyl)amino]-1-[4-hydroxy-3-(hydroxymethyl)phenyl]ethanone,

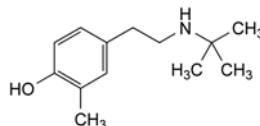

H. 4-[2-[(1,1-dimethylethyl)amino]ethyl]-2-methylphenol,

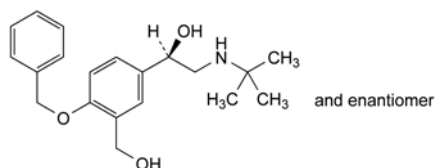

I. (1*R*)-2-[(1,1-dimethylethyl)amino]-1-[4-(benzyloxy)-3-(hydroxymethyl)phenyl]ethanol,

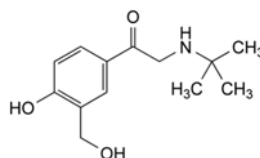

J. 2-[(1,1-dimethylethyl)amino]-1-[4-hydroxy-3-(hydroxymethyl)phenyl]ethanone (salbutamone).

07/2010:0687  
corrected 7.0

## SALBUTAMOL SULFATE

## Salbutamoli sulfas

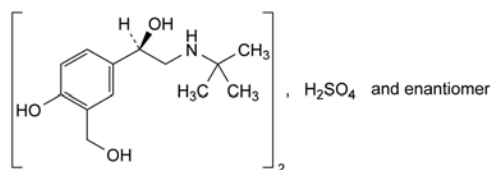

$C_{26}H_{44}N_2O_{10}S$   
[51022-70-9]

$M_r$  576.7

## DEFINITION

Bis[(1*R*)-2-[(1,1-dimethylethyl)amino]-1-[4-hydroxy-3-(hydroxymethyl)phenyl]ethanol] sulfate.

*Content*: 98.0 per cent to 101.0 per cent (dried substance).

## CHARACTERS

*Appearance*: white or almost white, crystalline powder.

*Solubility*: freely soluble in water, practically insoluble or very slightly soluble in ethanol (96 per cent) and in methylene chloride.

It shows polymorphism (5.9).

## IDENTIFICATION

*First identification*: B, E.

*Second identification*: A, C, D, E.

A. Ultraviolet and visible absorption spectrophotometry (2.2.25).

**Test solution.** Dissolve 80.0 mg in a 10 g/L solution of hydrochloric acid R and dilute to 100.0 mL with the same acid. Dilute 10.0 mL of the solution to 100.0 mL with a 10 g/L solution of hydrochloric acid R.

**Spectral range:** 230-350 nm.

**Absorption maximum:** at 276 nm.

**Specific absorbance at the absorption maximum:** 55 to 64.

**B. Infrared absorption spectrophotometry (2.2.24).**

**Comparison:** salbutamol sulfate CRS.

If the spectra obtained show differences, dissolve the substance to be examined and the reference substance separately in anhydrous ethanol R. Dry the residues and record new spectra using the residues.

**C. Thin-layer chromatography (2.2.27).**

**Test solution.** Dissolve 12 mg of the substance to be examined in water R and dilute to 10 mL with the same solvent.

**Reference solution.** Dissolve 12 mg of salbutamol sulfate CRS in water R and dilute to 10 mL with the same solvent.

**Plate:** TLC silica gel plate R.

**Mobile phase:** concentrated ammonia R, water R, ethyl acetate R, 2-propanol R, methyl isobutyl ketone R (3:18:35:45:50 V/V/V/V/V).

**Application:** 1 µL.

**Development:** over 2/3 of the plate.

**Drying:** in air.

**Detection:** spray with a 1 g/L solution of methylbenzothiazolone hydrazone hydrochloride R in a 90 per cent V/V solution of methanol R, followed by a 20 g/L solution of potassium ferricyanide R in a mixture of 1 volume of concentrated ammonia R1 and 3 volumes of water R, followed by a further spraying with a 1 g/L solution of methylbenzothiazolone hydrazone hydrochloride R in a 90 per cent V/V solution of methanol R.

**Results:** the principal spot in the chromatogram obtained with the test solution is similar in position, colour and size to the principal spot in the chromatogram obtained with the reference solution.

**D. Dissolve about 10 mg in 50 mL of a 20 g/L solution of disodium tetraborate R. Add 1 mL of a 30 g/L solution of aminopyrazolone R, 10 mL of methylene chloride R and 10 mL of a 20 g/L solution of potassium ferricyanide R. Shake and allow to separate. An orange-red colour develops in the methylene chloride layer.**

**E. It gives reaction (a) of sulfates (2.3.1).**

**TESTS**

**Solution S.** Dissolve 0.250 g in carbon dioxide-free water R and dilute to 25.0 mL with the same solvent.

**Appearance of solution.** Solution S is clear (2.2.1) and not more intensely coloured than reference solution BY<sub>6</sub> (2.2.2, Method II).

**Optical rotation (2.2.7):** -0.10° to +0.10°, determined on solution S.

**Acidity or alkalinity.** To 10 mL of solution S add 0.15 mL of methyl red solution R and 0.2 mL of 0.01 M sodium hydroxide. The solution is yellow. Not more than 0.4 mL of 0.01 M hydrochloric acid is required to change the colour of the indicator to red.

**Related substances.** Liquid chromatography (2.2.29).

**Test solution.** Dissolve 20.0 mg of the substance to be examined in mobile phase A and dilute to 50.0 mL with mobile phase A.

**Reference solution (a).** Dissolve 3.0 mg each of salbutamol impurity D CRS and 3.0 mg of salbutamol impurity F CRS in mobile phase A and dilute to 50.0 mL with mobile phase A. Dilute 2.0 mL of this solution to 100.0 mL with mobile phase A.

**Reference solution (b).** Dilute 1.0 mL of the test solution to 100.0 mL with mobile phase A. Dilute 1.0 mL of this solution to 10.0 mL with mobile phase A.

**Reference solution (c).** With the aid of ultrasounds, dissolve the contents of a vial of salbutamol impurity J CRS in 1.0 mL of the test solution.

**Reference solution (d).** Dissolve 1 mg of salbutamol impurity D CRS in mobile phase A and dilute to 100.0 mL with mobile phase A.

**Reference solution (e).** Dissolve 10 mg of salbutamol sulfate for system suitability CRS (containing impurities C, F, N and O) in mobile phase A, add 1.0 mL of reference solution (d) and dilute to 50.0 mL with mobile phase A.

**Column:**

- size:  $l = 0.15$  m,  $\varnothing = 4.6$  mm;
- stationary phase: spherical end-capped octylsilyl silica gel for chromatography R (3 µm);
- temperature: 30 °C.

**Mobile phase:**

- mobile phase A: dissolve 3.45 g of sodium dihydrogen phosphate monohydrate R in 900 mL of a 0.05 per cent V/V solution of triethylamine R, adjust to pH 3.0 with dilute phosphoric acid R and dilute to 1000 mL with a 0.05 per cent V/V solution of triethylamine R;
- mobile phase B: methanol R, acetonitrile R (35:65 V/V);

Time (min)	Mobile phase A (per cent V/V)	Mobile phase B (per cent V/V)
0 - 5	95	5
5 - 30	95 → 10	5 → 90

**Flow rate:** 1.0 mL/min.

**Detection:** spectrophotometer at 273 nm.

**Injection:** 20 µl of the test solution and reference solutions (a), (b), (c) and (e).

**Relative retention** with reference to salbutamol (retention time = about 7 min): impurity J = about 0.9; impurity C = about 1.6; impurity D = about 1.69; impurity N = about 1.71; impurity F = about 1.77; impurity O = about 1.82.

**Identification of impurities:** use the chromatogram obtained with reference solution (e) to identify the peaks due to impurities C, D, F, N and O; use the chromatogram obtained with reference solution (c) to identify the peak due to impurity J.

**System suitability:**

- peak-to-valley ratio: minimum 4, where  $H_p$  = height above the baseline of the peak due to impurity D and  $H_v$  = height above the baseline of the lowest point of the curve separating this peak from the peak due to impurity N in the chromatogram obtained with reference solution (e);
- resolution: minimum 1.5 between the peaks due to impurity J and salbutamol in the chromatogram obtained with the reference solution (c).

**Limits:**

- impurities D, F: for each impurity, not more than the area of the corresponding peak in the chromatogram obtained with reference solution (a) (0.3 per cent);
- impurities C, N, O: for each impurity, not more than twice the area of the principal peak in the chromatogram obtained with reference solution (b) (0.2 per cent);
- unspecified impurities: for each impurity, not more than the area of the principal peak in the chromatogram obtained with reference solution (b) (0.10 per cent);
- total: not more than 9 times the area of the principal peak in the chromatogram obtained with reference solution (b) (0.9 per cent);
- disregard limit: 0.5 times the area of the principal peak in the chromatogram obtained with reference solution (b) (0.05 per cent).

**Boron:** maximum 50 ppm.

**Test solution.** To 50 mg of the substance to be examined add 5 mL of a solution containing 13 g/L of *anhydrous sodium carbonate R* and 17 g/L of *potassium carbonate R*. Evaporate to dryness on a water-bath and dry at 120 °C. Ignite the residue rapidly until the organic matter has been destroyed, allow to cool and add 0.5 mL of *water R* and 3.0 mL of a freshly prepared 1.25 g/L solution of *curcumin R* in *glacial acetic acid R*. Warm gently to effect solution, allow to cool and add 3.0 mL of a mixture prepared by adding 5 mL of *sulfuric acid R*, slowly and with stirring, to 5 mL of *glacial acetic acid R*. Mix and allow to stand for 30 min. Dilute to 100.0 mL with *ethanol (96 per cent) R*, filter and use the filtrate.

**Reference solution.** Dissolve 0.572 g of *boric acid R* in 1000.0 mL of *water R*. Dilute 1.0 mL of the solution to 100.0 mL with *water R*. To 2.5 mL of this solution add 5 mL of a solution containing 13 g/L of *anhydrous sodium carbonate R* and 17 g/L of *potassium carbonate R*, and treat this mixture in the same manner as the test solution.

Measure the absorbance (2.2.25) of the test solution and of the reference solution at the absorption maximum at about 555 nm. The absorbance of the test solution is not greater than that of the reference solution.

**Loss on drying (2.2.32):** maximum 0.5 per cent, determined on 1.000 g by drying in an oven at 105 °C.

**Sulfated ash (2.4.14):** maximum 0.1 per cent, determined on 1.0 g.

#### ASSAY

Dissolve 0.400 g in 5 mL of *anhydrous formic acid R* and add 35 mL of *anhydrous acetic acid R*. Titrate with 0.1 M *perchloric acid*, determining the end-point potentiometrically (2.2.20).

1 mL of 0.1 M *perchloric acid* is equivalent to 57.67 mg of  $C_{26}H_{44}N_2O_{10}S$ .

#### STORAGE

Protected from light.

#### IMPURITIES

*Specified impurities: C, D, F, N, O.*

*Other detectable impurities* (the following substances would, if present at a sufficient level, be detected by one or other of the tests in the monograph. They are limited by the general acceptance criterion for other/unspecified impurities and/or by the general monograph *Substances for pharmaceutical use (2034)*. It is therefore not necessary to identify these impurities for demonstration of compliance. See also 5.10. *Control of impurities in substances for pharmaceutical use*): A, B, E, G, I, J, K, L, M.

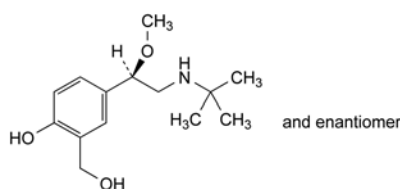

A. [5-[(1*R*)-2-[(1,1-dimethylethyl)amino]-1-methoxyethyl]-2-hydroxyphenyl]methanol,

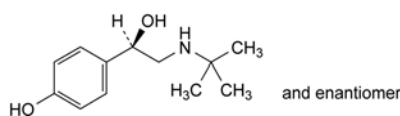

B. (1*R*)-2-[(1,1-dimethylethyl)amino]-1-(4-hydroxyphenyl)ethanol,

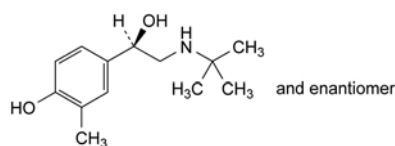

C. (1*R*)-2-[(1,1-dimethylethyl)amino]-1-(4-hydroxy-3-methylphenyl)ethanol,

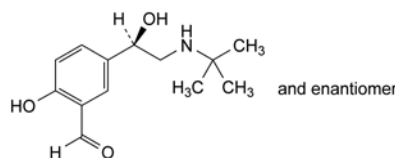

D. 5-[(1*R*)-2-[(1,1-dimethylethyl)amino]-1-hydroxyethyl]-2-hydroxybenzaldehyde,

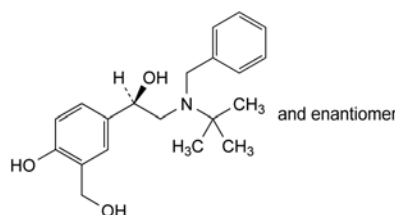

E. (1*R*)-2-[benzyl(1,1-dimethylethyl)amino]-1-[4-hydroxy-3-(hydroxymethyl)phenyl]ethanol,

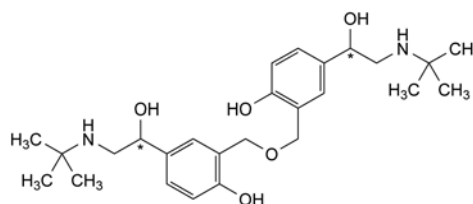

F. 1,1'-[oxybis[methylene(4-hydroxy-1,3-phenylene)]]bis[2-[(1,1-dimethylethyl)amino]ethanol],

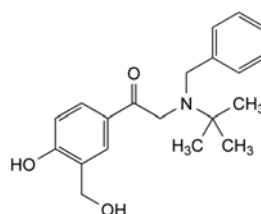

G. 2-[benzyl(1,1-dimethylethyl)amino]-1-[4-hydroxy-3-(hydroxymethyl)phenyl]ethanone,

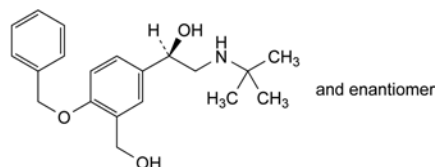

I. (1*R*)-2-[(1,1-dimethylethyl)amino]-1-[4-(benzyloxy)-3-(hydroxymethyl)phenyl]ethanol,

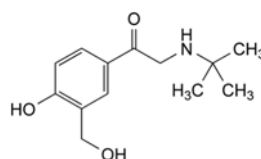

J. 2-[(1,1-dimethylethyl)amino]-1-[4-hydroxy-3-(hydroxymethyl)phenyl]ethanone (salbutamone),

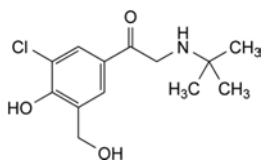

K. 2-[(1,1-dimethylethyl)amino]-1-[3-chloro-4-hydroxy-5-(hydroxymethyl)phenyl]ethanone,

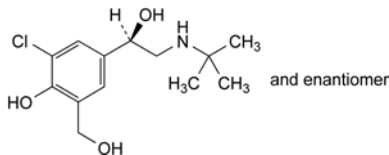

L. (1*R,S*)-2-[(1,1-diméthyléthyl)amino]-1-[3-chloro-4-hydroxy-5-(hydroxyméthyl)phényl]éthanol,

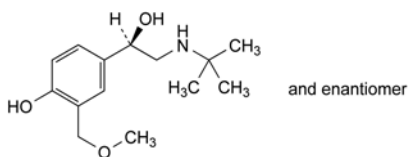

M. (1*R,S*)-2-[(1,1-dimethylethyl)amino]-1-[4-hydroxy-3-(methoxymethyl)phenyl]ethanol,

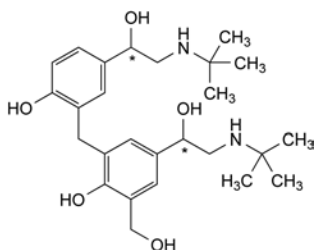

N. 2-[(1,1-dimethylethyl)amino]-1-[3-[[5-[2-[(1,1-dimethylethyl)amino]-1-hydroxyethyl]-2-hydroxyphenyl]methyl]-4-hydroxy-5-(hydroxymethyl)phenyl]ethanol,

O. unknown structure.

C. Dissolve about 30 mg in 5 mL of 0.05 *M* sodium hydroxide, neutralise if necessary and dilute to 20 mL with water *R*. 1 mL of the solution gives reaction (a) of salicylates (2.3.1).

#### TESTS

**Solution S.** Dissolve 2.5 g in 50 mL of boiling distilled water *R*, cool and filter.

**Appearance of solution.** The solution is clear (2.2.1) and colourless (2.2.2, Method II).

Dissolve 1 g in 10 mL of ethanol (96 per cent) *R*.

**Related substances.** Liquid chromatography (2.2.29).

**Test solution.** Dissolve 0.50 g of the substance to be examined in the mobile phase and dilute to 100.0 mL with the mobile phase.

**Reference solution (a).** Dissolve 10 mg of phenol *R* (impurity C) in the mobile phase and dilute to 100.0 mL with the mobile phase.

**Reference solution (b).** Dissolve 5 mg of salicylic acid impurity B *CRS* in the mobile phase and dilute to 20.0 mL with the mobile phase.

**Reference solution (c).** Dissolve 50 mg of 4-hydroxybenzoic acid *R* (impurity A) in the mobile phase and dilute to 100.0 mL with the mobile phase.

**Reference solution (d).** Dilute 1.0 mL of reference solution (a) to 10.0 mL with the mobile phase.

**Reference solution (e).** Dilute a mixture of 1.0 mL of each of reference solutions (a), (b) and (c) to 10.0 mL with the mobile phase.

**Reference solution (f).** Dilute a mixture of 0.1 mL of each of reference solutions (a), (b) and (c) to 10.0 mL with the mobile phase.

#### Column:

– size:  $l = 0.15$  m,  $\varnothing = 4.6$  mm;

– stationary phase: non-deactivated octadecylsilyl silica gel for chromatography *R* (5  $\mu$ m).

**Mobile phase:** glacial acetic acid *R*, methanol *R*, water *R* (1:40:60 *V/V/V*).

**Flow rate:** 0.5 mL/min.

**Detection:** spectrophotometer at 270 nm.

**Injection:** 10  $\mu$ L of the test solution and reference solutions (d), (e) and (f).

**Relative retention** with reference to impurity C: impurity A = about 0.70; impurity B = about 0.90.

**System suitability:** reference solution (e):

- the 3<sup>rd</sup> peak in the chromatogram corresponds to the peak due to phenol in the chromatogram obtained with reference solution (d);
- resolution: minimum 1.0 between the peaks due to impurities B and C; if necessary, adjust the quantity of acetic acid in the mobile phase.

#### Limits:

- impurity A: not more than the area of the corresponding peak in the chromatogram obtained with reference solution (f) (0.1 per cent);
- impurity B: not more than the area of the corresponding peak in the chromatogram obtained with reference solution (f) (0.05 per cent);
- impurity C: not more than the area of the corresponding peak in the chromatogram obtained with reference solution (f) (0.02 per cent);
- any other impurity: for each impurity, not more than the area of the peak due to impurity B in the chromatogram obtained with reference solution (f) (0.05 per cent);
- total: not more than twice the area of the peak due to impurity A in the chromatogram obtained with reference solution (f) (0.2 per cent);
- disregard limit: 0.01 times the area of the principal peak in the chromatogram obtained with reference solution (f).

01/2008:0366  
corrected 6.0

## SALICYLIC ACID

### Acidum salicylicum

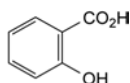

$C_7H_6O_3$   
[69-72-7]

$M_r$  138.1

#### DEFINITION

2-Hydroxybenzenecarboxylic acid.

**Content:** 99.0 per cent to 100.5 per cent (dried substance).

#### CHARACTERS

**Appearance:** white or almost white, crystalline powder or white or colourless, acicular crystals.

**Solubility:** slightly soluble in water, freely soluble in ethanol (96 per cent), sparingly soluble in methylene chloride.

#### IDENTIFICATION

**First identification:** A, B.

**Second identification:** A, C.

A. Melting point (2.2.14): 158 °C to 161 °C.

B. Infrared absorption spectrophotometry (2.2.24).

**Comparison:** salicylic acid *CRS*.

**Chlorides** (2.4.4): maximum 100 ppm.

Dilute 10 mL of solution S to 15 mL with *water R*.

**Sulfates**: maximum 200 ppm.

Dissolve 1.0 g in 5 mL of *dimethylformamide R* and add 4 mL of *water R*. Mix thoroughly. Add 0.2 mL of *dilute hydrochloric acid R* and 0.5 mL of a 25 per cent *m/m* solution of *barium chloride R*. After 15 min any opalescence in the solution is not more intense than that in a standard prepared as follows: to 2 mL of *sulfate standard solution (100 ppm SO<sub>4</sub>) R* add 0.2 mL of *dilute hydrochloric acid R*, 0.5 mL of a 25 per cent *m/m* solution of *barium chloride R*, 3 mL of *water R* and 5 mL of *dimethylformamide R*.

**Heavy metals** (2.4.8): maximum 20 ppm.

Dissolve 2.0 g in 15 mL of *ethanol (96 per cent) R* and add 5 mL of *water R*. 12 mL of the solution complies with test B. Prepare the reference solution using lead standard solution (2 ppm Pb) prepared by diluting *lead standard solution (100 ppm Pb) R* with a mixture of 5 volumes of *water R* and 15 volumes of *ethanol (96 per cent) R*.

**Loss on drying** (2.2.32): maximum 0.5 per cent, determined on 1.000 g by drying in a desiccator.

**Sulfated ash** (2.4.14): maximum 0.1 per cent, determined on 2.0 g.

#### ASSAY

Dissolve 0.120 g in 30 mL of *ethanol (96 per cent) R* and add 20 mL of *water R*. Titrate with 0.1 M *sodium hydroxide*, using 0.1 mL of *phenol red solution R* as indicator.

1 mL of 0.1 M *sodium hydroxide* is equivalent to 13.81 mg of C<sub>7</sub>H<sub>6</sub>O<sub>3</sub>.

#### STORAGE

Protected from light.

#### IMPURITIES

*Specified impurities: A, B, C.*

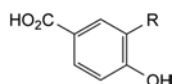

A. R = H: 4-hydroxybenzoic acid,

B. R = CO<sub>2</sub>H: 4-hydroxyisophthalic acid,

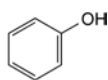

C. phenol.

01/2008:1765

## SALMETEROL XINAFOATE

### Salmeteroli xinafoas

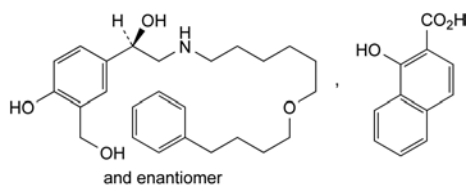

C<sub>36</sub>H<sub>45</sub>NO<sub>7</sub>  
[94749-08-3]

M<sub>r</sub> 604

#### DEFINITION

(1*R*S)-1-[4-Hydroxy-3-(Hydroxymethyl)phenyl]-2-[[[6-(4-phenylbutoxy)hexyl]amino]ethanol 1-hydroxynaphthalene-2-carboxylate.

*Content*: 97.0 per cent to 102.0 per cent (anhydrous substance).

#### CHARACTERS

*Appearance*: white or almost white powder.

*Solubility*: practically insoluble in water, soluble in methanol, slightly soluble in anhydrous ethanol.

#### IDENTIFICATION

Infrared absorption spectrophotometry (2.2.24).

*Comparison*: *salmeterol xinafoate CRS*.

#### TESTS

**Related substances.** Liquid chromatography (2.2.29). *Protect the solutions from light.*

*Solvent mixture*: *acetonitrile R*, *water R* (50:50 V/V).

*Test solution.* Dissolve 50.0 mg of the substance to be examined in the solvent mixture and dilute to 10.0 mL with the solvent mixture.

*Reference solution (a).* Dissolve 11 mg of *salmeterol xinafoate for system suitability CRS* (salmeterol containing impurities E and G) in the solvent mixture and dilute to 2 mL with the solvent mixture.

*Reference solution (b).* Dilute 1.0 mL of the test solution to 100.0 mL with the solvent mixture. Dilute 1.0 mL of this solution to 10.0 mL with the solvent mixture.

*Column*:

- *size*: *l* = 0.15 m, Ø = 4.6 mm,
- *stationary phase*: *octadecylsilyl silica gel for chromatography R* (5 µm).

*Mobile phase*:

- *mobile phase A*: mix 24 volumes of a 7.71 g/L solution of *ammonium acetate R* with 24 volumes of a 28.84 g/L solution of *sodium dodecyl sulfate R* and adjust to pH 2.7 with *glacial acetic acid R*; mix with 52 volumes of *acetonitrile R*;
- *mobile phase B*: *acetonitrile R*;

Time (min)	Mobile phase A (per cent V/V)	Mobile phase B (per cent V/V)
0 - 16	100	0
16 - 36	100 → 30	0 → 70
36 - 45	30	70
45 - 50	30 → 100	70 → 0

*Flow rate*: 2 mL/min.

*Detection*: spectrophotometer at 278 nm.

*Injection*: 20 µL; inject the solvent mixture as a blank solution.

*Relative retention* with reference to salmeterol (retention time = about 13 min): xinafoic acid = about 0.2; impurity A = about 0.3; impurity B = about 0.5; impurity C = about 0.7; impurity D = about 0.8; impurity E = about 0.9; impurity F = about 1.6; impurity G = about 2.7.

*System suitability*: reference solution (a):

- *peak-to-valley ratio*: minimum 10, where *H<sub>p</sub>* = height above the baseline of the peak due to impurity E and *H<sub>v</sub>* = height above the baseline of the lowest point of the curve separating this peak from the peak due to salmeterol,
- the chromatogram obtained is similar to the chromatogram supplied with *salmeterol xinafoate for system suitability CRS*.

*Limits*:

- *impurity D*: not more than 3 times the area of the principal peak in the chromatogram obtained with reference solution (b) (0.3 per cent),
- *impurities A, F, G*: for each impurity, not more than twice the area of the principal peak in the chromatogram obtained with reference solution (b) (0.2 per cent),

- *impurities B, C, E*: for each impurity, not more than the area of the principal peak in the chromatogram obtained with reference solution (b) (0.1 per cent),
- *any other impurity*: for each impurity, not more than the area of the principal peak in the chromatogram obtained with reference solution (b) (0.1 per cent),
- *total*: not more than 9 times the area of the principal peak in the chromatogram obtained with reference solution (b) (0.9 per cent),
- *disregard limit*: 0.5 times the area of the principal peak in the chromatogram obtained with reference solution (b) (0.05 per cent); disregard the peak due to xinafoic acid and any peaks due to the blank.

**Water** (2.5.12): maximum 0.5 per cent, determined on 1.000 g. Dissolve the sample with 30 mL of *anhydrous methanol R*.

**Sulfated ash** (2.4.14): maximum 0.1 per cent, determined on 1.0 g.

#### ASSAY

Liquid chromatography (2.2.29).

**Test solution.** Dissolve 12.50 mg of the substance to be examined in the mobile phase and dilute to 50.0 mL with the mobile phase.

**Reference solution (a).** Dissolve 12.50 mg of *salmeterol xinafoate CRS* in the mobile phase and dilute to 50.0 mL with the mobile phase.

**Reference solution (b).** Dilute 1 mL of reference solution (a) described in the test for related substances to 20 mL with the mobile phase.

**Column:**

- *size*:  $l = 0.15$  m,  $\varnothing = 4.6$  mm,
- *stationary phase*: *octadecylsilyl silica gel for chromatography R* (5  $\mu$ m).

**Mobile phase:** mix 24 volumes of a 7.71 g/L solution of *ammonium acetate R* with 24 volumes of a 28.84 g/L solution of *sodium dodecyl sulfate R* and adjust to pH 2.7 with *glacial acetic acid R*. Mix with 52 volumes of *acetonitrile R*.

**Flow rate:** 2 mL/min.

**Detection:** spectrophotometer at 278 nm.

**Injection:** 20  $\mu$ L.

**Run time:** until complete elution of the peak due to salmeterol (about 16 min).

**System suitability:** reference solution (b):

- *peak-to-valley ratio*: minimum 10, where  $H_p$  = height above the baseline of the peak due to impurity E and  $H_v$  = height above the baseline of the lowest point of the curve separating this peak from the peak due to salmeterol.

The stationary phase may be regenerated using the gradient described under the test for related substances.

Calculate the percentage content of  $C_{36}H_{45}NO_7$  using the chromatogram obtained with reference solution (a) and the declared content of  $C_{36}H_{45}NO_7$  in *salmeterol xinafoate CRS*.

#### STORAGE

Protected from light.

#### IMPURITIES

**Specified impurities:** A, B, C, D, E, F, G.

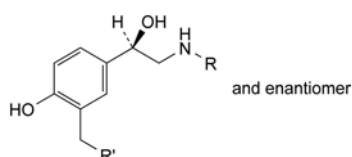

A. R =  $[CH_2]_4-C_6H_5$ , R' = OH: (1*RS*)-1-[4-hydroxy-3-(hydroxymethyl)phenyl]-2-[[4-(phenylbutyl)amino]ethanol,

- B. R =  $[CH_2]_6-O-[CH_2]_2-C_6H_5$ , R' = OH: (1*RS*)-1-[4-hydroxy-3-(hydroxymethyl)phenyl]-2-[[6-(2-phenylethoxy)hexyl]amino]ethanol,
- C. R =  $[CH_2]_6-O-[CH_2]_3-C_6H_5$ , R' = OH: (1*RS*)-1-[4-hydroxy-3-(hydroxymethyl)phenyl]-2-[[6-(3-phenylpropoxy)hexyl]amino]ethanol,
- F. R =  $[CH_2]_6-O-[CH_2]_4-C_6H_5$ , R' = H: (1*RS*)-1-(4-hydroxy-3-methylphenyl)-2-[[6-(4-phenylbutoxy)hexyl]amino]ethanol,

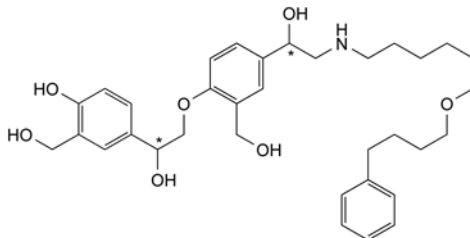

- D. 1-[4-[2-hydroxy-2-[4-hydroxy-3-(hydroxymethyl)phenyl]ethoxy]-3-(hydroxymethyl)phenyl]-2-[[6-(3-phenylbutoxy)hexyl]amino]ethanol,

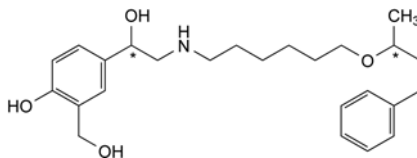

- E. 1-[4-hydroxy-3-(hydroxymethyl)phenyl]-2-[[6-(1-methyl-3-phenylpropoxy)hexyl]amino]ethanol,

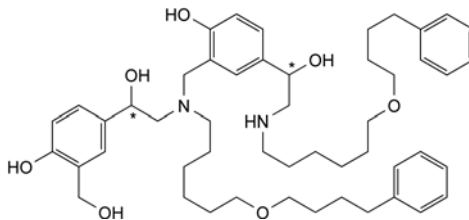

- G. 1-[4-hydroxy-3-[[[2-hydroxy-2-[4-hydroxy-3-(hydroxymethyl)phenyl]ethyl][6-(4-phenylbutoxy)hexyl]amino]methyl]phenyl]-2-[[6-(4-phenylbutoxy)hexyl]amino]ethanol.

01/2008:1910

## SALMON OIL, FARMED

### Salmonis domestici oleum

#### DEFINITION

Purified fatty oil obtained from fresh farmed *Salmo salar*. The positional distribution ( $\beta$ (2)-acyl) is 60-70 per cent for cervonic (docosahexaenoic) acid (C22:6 n-3; DHA), 25-35 per cent for timnodonic (eicosapentaenoic) acid (C20:5 n-3; EPA) and 40-55 per cent for moroctic acid (C18:4 n-3).

**Content:**

- sum of the contents of EPA and DHA (expressed as triglycerides): 10.0 per cent to 28.0 per cent.

Authorised antioxidants in concentrations not exceeding the levels specified by the competent authority may be added.

#### PRODUCTION

The fish shall only be given feed with a composition that is in accordance with the relevant EU or other applicable regulations. The oil is produced by mechanical expression of fresh raw materials, either from the whole fish, or fish where the fillets have been removed, at a temperature not exceeding 100 °C, and without using solvents. After centrifugation, solid substances may be removed from the oil by cooling and filtering (winterisation).

## CHARACTERS

**Appearance:** pale pink liquid.

**Solubility:** practically insoluble in water, very soluble in acetone and in heptane, slightly soluble in anhydrous ethanol.

## IDENTIFICATION

Examine the  $^{13}\text{C}$  NMR spectra obtained in the assay for positional distribution ( $\beta(2)$ -acyl) of fatty acids. The spectra contain peaks between 172 ppm and 173 ppm with shifts similar to those in the type spectrum (Figure 1910.-2). The oil to be examined complies with the limits of this assay.

## TESTS

**Absorbance (2.2.25):** minimum 0.10, measured at the maximum between 470 nm and 480 nm.

Dissolve 5.0 mL in 5.0 mL of *trimethylpentane R*.

**Acid value (2.5.1):** maximum 2.0.

**Anisidine value (2.5.36):** maximum 10.0.

**Peroxide value (2.5.5, Method A):** maximum 5.0.

**Unsaponifiable matter (2.5.7):** maximum 1.5 per cent, determined on 5.0 g.

**Linoleic acid (2.4.29):** maximum 11.0 per cent.

Identify the peak due to linoleic acid using the chromatogram in Figure 1910.-1. Determine the percentage content by normalisation.

## ASSAY

**Positional distribution ( $\beta(2)$ -acyl) of fatty acids (2.2.33)** Use a high resolution FT-NMR spectrometer operating at minimum 300 MHz.

**Test solution.** Dissolve 190-210 mg of fresh salmon oil in 500  $\mu\text{L}$  of *deuterated chloroform R*. Prepare at least 3 samples and examine within 3 days.

**Acquisition of  $^{13}\text{C}$  NMR spectra.** The following parameters may be used.

- *sweep width:* 200 ppm (–5 to 195 ppm),
- *irradiation frequency offset:* 95 ppm,
- *time domain:* 64 K,
- *pulse delay:* 2 s,
- *pulse program:* zgig 30 (inverse gated, 30° excitation pulse),
- *dummy scans:* 4,
- *number of scans:* 4096.

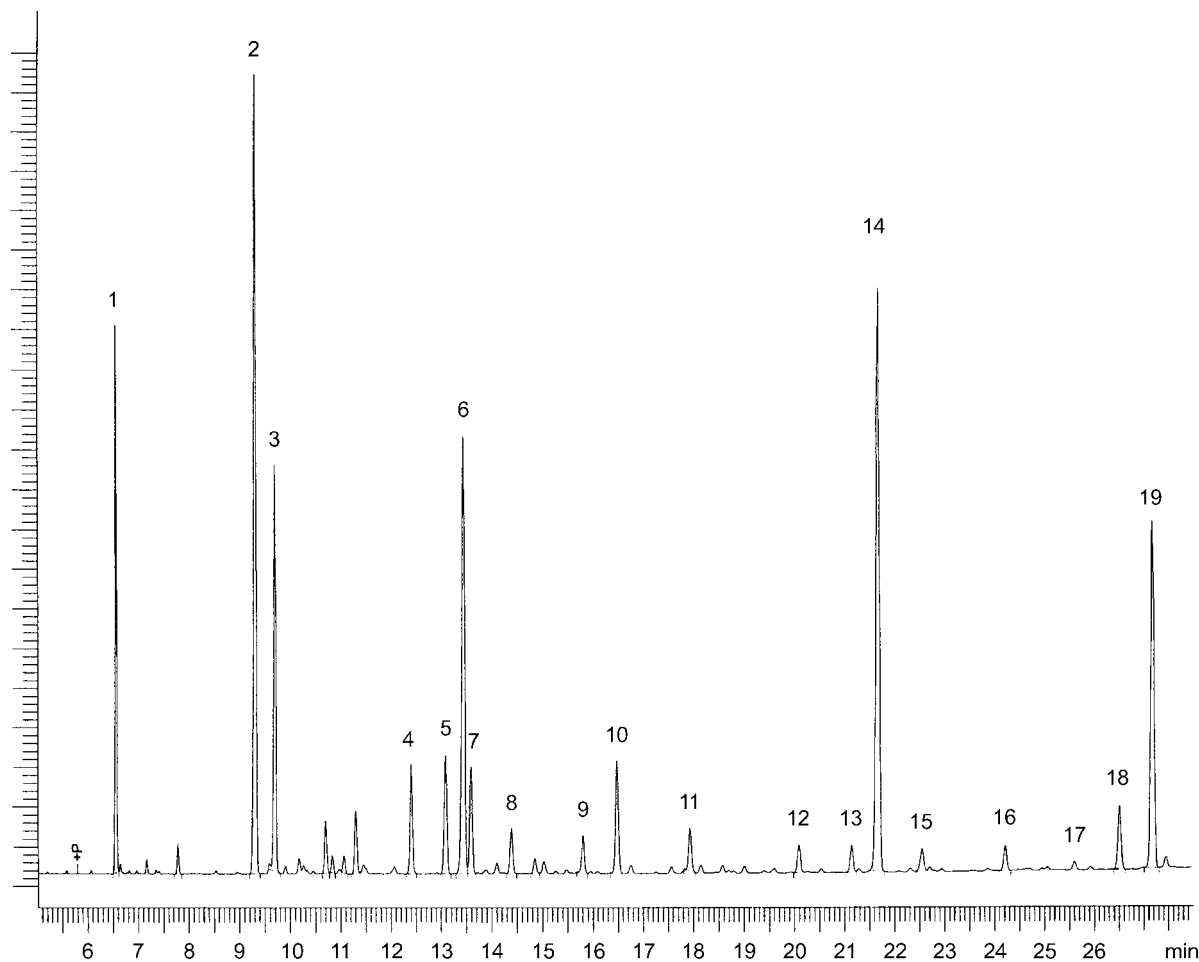

1. C14:0	5. C18:0	9. C18:3 n-3	13. C20:4 n-3	17. C22:5 n-6
2. C16:0	6. C18:1 n-9	10. C18:4 n-3	14. EPA	18. C22:5 n-3
3. C16:1 n-7	7. C18:1 n-7	11. C20:1 n-9	15. C22:1 n-11	19. DHA
4. C16:4 n-1	8. C18:2 n-6	12. C20:4 n-6	16. C21:5 n-3	

Figure 1910.-1. – Chromatogram for the composition of fatty acids in farmed salmon oil



*Processing and plotting.* The following parameters may be used:

- *size*: 64 K (zero-filling),
- *window multiplication*: exponential,
- *Lorentzian broadening factor*: 0.2 Hz.

Use the CDCl<sub>3</sub> signal for shift referencing. The shift of the central peak of the 1:1:1 triplet is set to 77.16 ppm.

Plot the spectral region δ 171.5-173.5 ppm. Compare the spectrum with the reference spectrum in Figure 1910.-2. The shift values lie within the ranges given in Table 1910.-1.

Table 1910.-1 – *Shift values*

Signal	Shift range (ppm)
β DHA	172.05 - 172.09
α DHA	172.43 - 172.47
β EPA	172.52 - 172.56
α EPA	172.90 - 172.94
β C18:4	172.56 - 172.60
α C18:4	172.95 - 172.99

*System suitability:* calculate the signal-to-noise ratio for the smallest relevant peak corresponding to α C18:4 signal (in the range δ 172.95-172.99 ppm). Measure the peak width at half-height for the central CDCl<sub>3</sub> signal (at δ 77.16 ppm). The system suitability criteria in Table 1910.-2 are fulfilled.

Table 1910.-2 – *System suitability criteria*

S/N smallest peak	Peak width (ppm)
minimum 5	maximum 0.02

*Calculation of positional distribution:* calculate the positional distribution (β(2)-acyl) using the expression:

$$\frac{\beta}{\alpha + \beta} \times 100$$

- α = peak area of the corresponding α-carbonyl peak,  
 β = peak area of β-carbonyl peak from C22:6 n-3, C20:5 n-3 or C18:4 n-3, respectively.

*Limits:*

	Positional distribution (mole %)		
	β DHA	β EPA	β C18:4
Limits	60 - 70	25 - 35	40 - 55

**EPA and DHA (2.4.29).** See Figure 1910.-1.

**STORAGE**

In an airtight, well-filled container, protected from light, under inert gas.

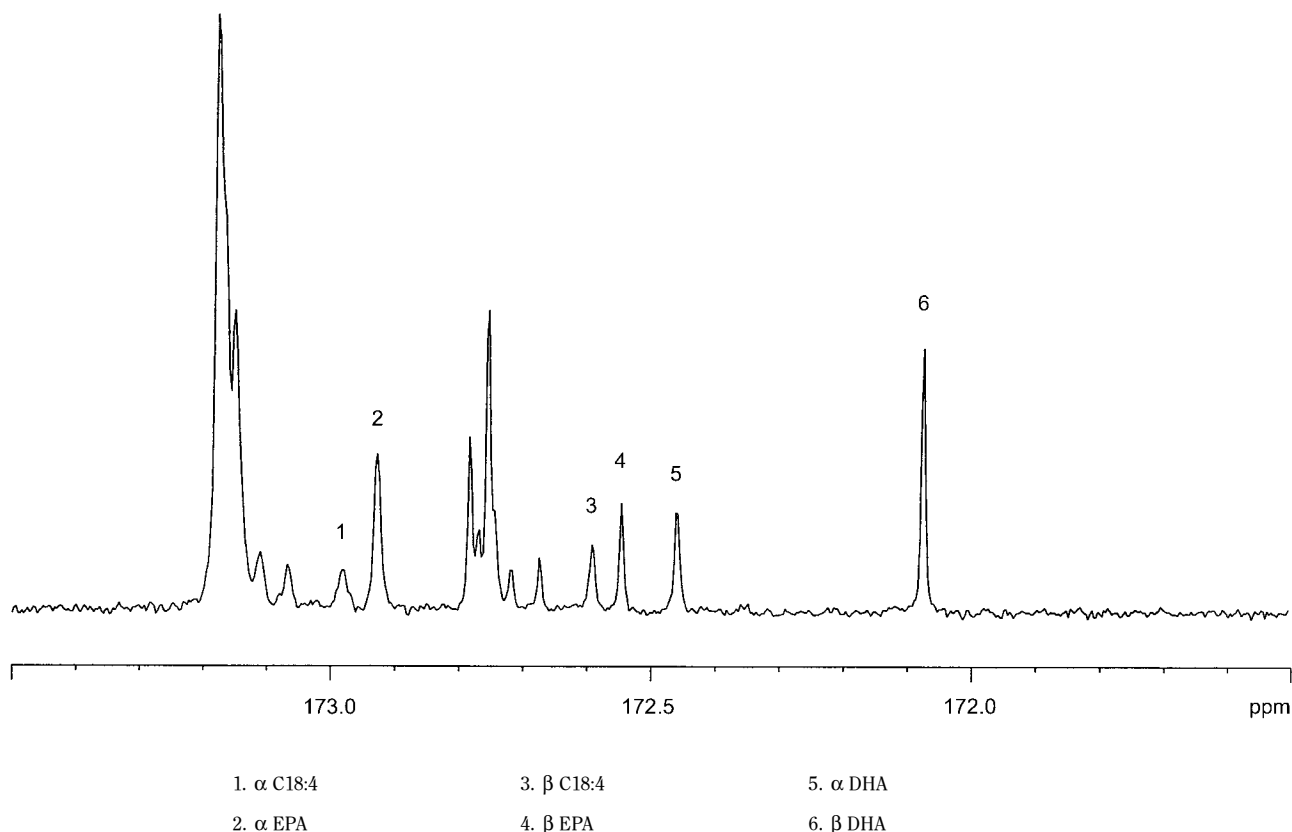
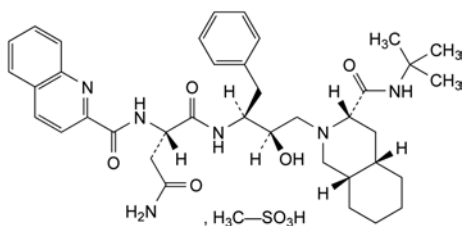

Figure 1910.-2. – <sup>13</sup>C NMR spectrum carbonyl region of farmed salmon oil

## SAQUINAVIR MESILATE

## Saquinaviri mesilas



$C_{39}H_{54}N_6O_8S$   
[149845-06-7]

$M_r$  767

## DEFINITION

(2*S*)-*N*<sup>1</sup>-[(1*S*,2*R*)-1-Benzyl-3-[(3*S*,4*aS*,8*aS*)-3-[(1,1-dimethylethyl)carbamoyl]octahydroisoquinolin-2(1*H*)-yl]-2-hydroxypropyl]-2-[(quinolin-2-ylcarbonyl)amino]butanediamide methanesulfonate.

*Content*: 97.5 per cent to 102.0 per cent (anhydrous substance).

## PRODUCTION

The production method must be evaluated to determine the potential for formation of alkyl mesilates, which is particularly likely to occur if the reaction medium contains lower alcohols. Where necessary, the production method is validated to demonstrate that alkyl mesilates are not detectable in the final product.

## CHARACTERS

*Appearance*: white or almost white, slightly hygroscopic powder.

*Solubility*: practically insoluble in water, sparingly soluble in methanol, slightly soluble in ethanol (96 per cent).

## IDENTIFICATION

A. Specific optical rotation (see Tests).

B. Infrared absorption spectrophotometry (2.2.24).

*Comparison*: saquinavir mesilate CRS.

## TESTS

**Specific optical rotation** (2.2.7): –35.0 to –42.0 (anhydrous substance).

Dissolve 0.25 g in *anhydrous methanol R* and dilute to 50.0 mL with the same solvent.

**Related substances**. Liquid chromatography (2.2.29).

*Solvent mixture*: water for chromatography R, acetonitrile R1 (47:53 V/V).

*Test solution*. Dissolve 30.0 mg of the substance to be examined in the solvent mixture, using sonication, and dilute to 100.0 mL with the same solvent.

*Reference solution (a)*. Dilute 1.0 mL of the test solution to 100.0 mL with the solvent mixture. Dilute 1.0 mL of this solution to 10.0 mL with the solvent mixture.

*Reference solution (b)*. Dissolve the contents of a vial of saquinavir for system suitability CRS (containing impurities A, B, C and D) in 1.0 mL of the solvent mixture and sonicate for 2 min.

*Reference solution (c)*. Dissolve 30.0 mg of saquinavir mesilate CRS in the solvent mixture, using sonication, and dilute to 100.0 mL with the same solvent.

*Column*:

– size:  $l = 0.15$  m,  $\varnothing = 4.6$  mm;

01/2009:2267 – *stationary phase*: spherical end-capped octadecylsilyl silica gel for chromatography R (3.5  $\mu$ m).

*Mobile phase*:

– *mobile phase A*: to 2.5 mL of strong sodium hydroxide solution R add 900 mL of water for chromatography R, adjust to pH 1.8 with perchloric acid R and dilute to 1000 mL with water for chromatography R;

– *mobile phase B*: mobile phase A, acetonitrile R1 (38:62 V/V);

Time (min)	Mobile phase A (per cent)	Mobile phase B (per cent)
0 - 1	50	50
1 - 31	50 → 0	50 → 100

*Flow rate*: 1.0 mL/min.

*Detection*: spectrophotometer at 210 nm.

*Injection*: 10  $\mu$ L of the test solution and reference solutions (a) and (b).

*Identification of impurities*: use the chromatogram supplied with saquinavir for system suitability CRS and the chromatogram obtained with reference solution (b) to identify the peaks due to impurities A, B, C and D.

*Relative retention* with reference to saquinavir (retention time = about 17 min): impurity A = about 0.2; impurity B = about 0.3; impurity C = about 0.5; impurity D = about 0.9.

*System suitability*: reference solution (b):

– *peak-to-valley ratio*: minimum 3, where  $H_p$  = height above the baseline of the peak due to impurity D and  $H_v$  = height above the baseline of the lowest point of the curve separating this peak from the peak due to saquinavir.

*Limits*:

– *correction factors*: for the calculation of content, multiply the peak areas of the following impurities by the corresponding correction factor: impurity A = 0.5; impurity B = 0.5; impurity C = 2.5;

– *impurities A, B, C*: for each impurity, not more than 1.5 times the area of the principal peak in the chromatogram obtained with reference solution (a) (0.15 per cent);

– *unspecified impurities*: for each impurity, not more than 0.5 times the area of the principal peak in the chromatogram obtained with reference solution (a) (0.05 per cent);

– *total*: not more than 5 times the area of the principal peak in the chromatogram obtained with reference solution (a) (0.5 per cent);

– *disregard limit*: not more than 0.3 times the area of the principal peak in the chromatogram obtained with reference solution (a) (0.03 per cent).

**Heavy metals** (2.4.8): maximum 10 ppm.

0.50 g complies with test G. Prepare the reference solution using 0.5 mL of lead standard solution (10 ppm Pb) R. The solution may become yellow again after pH-adjustment. Filter the solutions through a membrane filter (nominal pore size 0.45  $\mu$ m).

**Water** (2.5.12): maximum 1.0 per cent, determined on 0.250 g.

**Sulfated ash** (2.4.14): maximum 0.1 per cent, determined on 1.0 g.

## ASSAY

Liquid chromatography (2.2.29) as described in the test for related substances with the following modification.

*Injection*: 10  $\mu$ L of the test solution and reference solution (c).

Calculate the percentage content of saquinavir mesilate from the declared content of saquinavir mesilate CRS.

## STORAGE

In an airtight container, protected from light.

## IMPURITIES

Specified impurities: A, B, C.

Other detectable impurities (the following substances would, if present at a sufficient level, be detected by one or other of the tests in the monograph. They are limited by the general acceptance criterion for other/unspecified impurities and/or by the general monograph *Substances for pharmaceutical use* (2034). It is therefore not necessary to identify these impurities for demonstration of compliance. See also 5.10. *Control of impurities in substances for pharmaceutical use*): D, E, F, G, H.

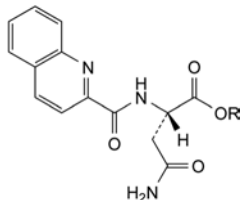

A. R = H: (2S)-4-amino-4-oxo-2-[(quinolin-2-ylcarbonyl)amino]butanoic acid,

B. R = C<sub>2</sub>H<sub>5</sub>: ethyl (2S)-4-amino-4-oxo-2-[(quinolin-2-ylcarbonyl)amino]butanoate,

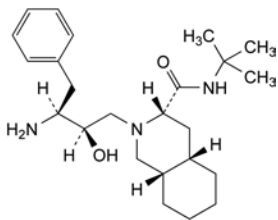

C. (3S,4aS,8aS)-2-[(2R,3S)-3-amino-2-hydroxy-4-phenylbutyl]-N-(1,1-dimethylethyl)decahydroisoquinoline-3-carboxamide,

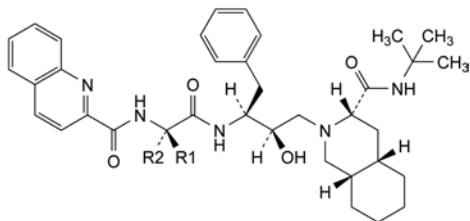

D. R<sub>1</sub> = CH<sub>2</sub>-CO-NH<sub>2</sub>, R<sub>2</sub> = H: (2R)-N<sup>1</sup>-[(1S,2R)-1-benzyl-3-[(3S,4aS,8aS)-3-[(1,1-dimethylethyl)carbamoyl]octahydroisoquinolin-2(1H)-yl]-2-hydroxypropyl]-2-[(quinolin-2-ylcarbonyl)amino]butanediamide (2-*epi*-saquinavir),

E. R<sub>1</sub> = H, R<sub>2</sub> = CH<sub>2</sub>-CO<sub>2</sub>H: (3S)-4-[[[(1S,2R)-1-benzyl-3-[(3S,4aS,8aS)-3-[(1,1-dimethylethyl)carbamoyl]octahydroisoquinolin-2(1H)-yl]-2-hydroxypropyl]amino]-4-oxo-3-[(quinolin-2-ylcarbonyl)amino]butanoic acid,

F. R<sub>1</sub> = H, R<sub>2</sub> = CH<sub>2</sub>-CN: N-[(1S)-2-[[[(1S,2R)-1-benzyl-3-[(3S,4aS,8aS)-3-[(1,1-dimethylethyl)carbamoyl]octahydroisoquinolin-2(1H)-yl]-2-hydroxypropyl]amino]-1-(cyanomethyl)-2-oxoethyl]quinoline-2-carboxamide,

G. R<sub>1</sub> = H, R<sub>2</sub> = CH<sub>2</sub>-CO-OCH<sub>3</sub>: methyl (3S)-4-[[[(1S,2R)-1-benzyl-3-[(3S,4aS,8aS)-3-[(1,1-dimethylethyl)carbamoyl]octahydroisoquinolin-2(1H)-yl]-2-hydroxypropyl]amino]-4-oxo-3-[(quinolin-2-ylcarbonyl)amino]butanoate,

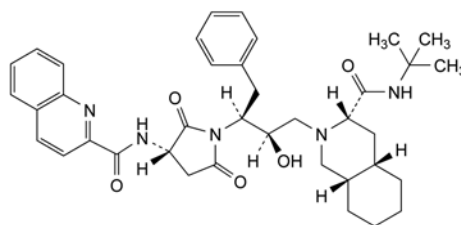

H. N-[(3S)-1-[(1S,2R)-1-benzyl-3-[(3S,4aS,8aS)-3-[(1,1-dimethylethyl)carbamoyl]octahydroisoquinolin-2(1H)-yl]-2-hydroxypropyl]-2,5-dioxopyrrolidin-3-yl]quinoline-2-carboxamide.

04/2008:2268

## SELAMECTIN FOR VETERINARY USE

## Selamectinum ad usum veterinarium

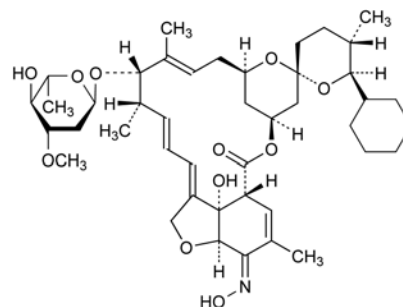

C<sub>43</sub>H<sub>63</sub>NO<sub>11</sub>  
[165108-07-6]

M<sub>r</sub> 770

## DEFINITION

(2*aE*,2'*R*,4*E*,5'*S*,6*S*,6'*S*,7*S*,8*E*,11*R*,15*S*,17*aR*,20*Z*,20*aR*,20*bS*)-6'-cyclohexyl-7-[(2,6-dideoxy-3-*O*-methyl- $\alpha$ -L-arabino-hexopyranosyl)oxy]-20*b*-hydroxy-20-(hydroxyimino)-5',6,8,19-tetramethyl-3',4',5',6,6',7,10,11,14,15,17*a*,20,20*a*,20*b*-tetradecahydrospiro[2*H*,17*H*]-11,15-methanofuro[4,3,2-*pq*][2,6]benzodioxacyclooctadecine-13,2'-pyran]-17-one ((5*Z*,25*S*)-25-cyclohexyl-4'-*O*-de(2,6-dideoxy-3-*O*-methyl- $\alpha$ -L-arabino-hexopyranosyl)-5-demethoxy-25-de(1-methylpropyl)-22,23-dihydro-5-(hydroxyimino)avermectin A<sub>1a</sub>).

Semi-synthetic product derived from a fermentation product.

*Content*: 96.0 per cent to 102.0 per cent (anhydrous substance).

## CHARACTERS

*Appearance*: white or almost white, hygroscopic powder.

*Solubility*: practically insoluble in water, freely soluble in isopropyl alcohol, soluble in acetone and in methylene chloride, sparingly soluble in methanol.

## IDENTIFICATION

Infrared absorption spectrophotometry (2.2.24).

*Comparison*: selamectin CRS.

## TESTS

**Related substances.** Liquid chromatography (2.2.29).

*Solvent mixture*: water R, acetonitrile R (40:60 V/V).

*Test solution.* Dissolve 25 mg of the substance to be examined in the solvent mixture and dilute to 50 mL with the solvent mixture.

*Reference solution (a).* Dilute 1.0 mL of the test solution to 100.0 mL with the solvent mixture.

*Reference solution (b).* Dissolve 2.5 mg of selamectin for system suitability CRS (containing impurities A, B, C and D) in the solvent mixture and dilute to 5 mL with the solvent mixture.

*Column*:

– size: *l* = 0.15 m,  $\varnothing$  = 3.9 mm;

- *stationary phase: end-capped octadecylsilyl silica gel for chromatography R* (4 µm);
- *temperature: 30 °C.*

*Mobile phase:*

- *mobile phase A: water R;*
- *mobile phase B: acetonitrile R;*

Time (min)	Mobile phase A (per cent V/V)	Mobile phase B (per cent V/V)
0 - 28	40	60
28 - 45	40 → 20	60 → 80

*Flow rate: 2.0 mL/min.*

*Detection: spectrophotometer at 243 nm.*

*Injection: 20 µL.*

*Identification of impurities:* use the chromatogram supplied with *selamectin for system suitability CRS* and the chromatogram obtained with reference solution (b) to identify the peaks due to impurities A, B, C and D.

*Relative retention* with reference to selamectin (retention time = about 22 min): impurity A = about 0.2; impurity B = about 0.4; impurity C = about 0.5; impurity D = about 1.7.

*System suitability: reference solution (b):*

- *resolution:* minimum 4.0 between the peaks due to impurities B and C.

*Limits:*

- *correction factor:* for the calculation of content, multiply the peak area of impurity D by 1.5;
- *impurities A, B:* for each impurity, not more than twice the area of the principal peak in the chromatogram obtained with reference solution (a) (2.0 per cent);
- *impurities C, D:* for each impurity, not more than 1.5 times the area of the principal peak in the chromatogram obtained with reference solution (a) (1.5 per cent);
- *any other impurity:* for each impurity, not more than the area of the principal peak in the chromatogram obtained with reference solution (a) (1.0 per cent);
- *total:* not more than 4 times the area of the principal peak in the chromatogram obtained with reference solution (a) (4.0 per cent);
- *disregard limit:* 0.2 times the area of the principal peak in the chromatogram obtained with reference solution (a) (0.2 per cent).

**Heavy metals** (2.4.8): maximum 20 ppm.

Dissolve 2.0 g in *ethanol (96 per cent) R* and dilute to 20.0 mL with the same solvent. 12 mL of the solution complies with test B. Prepare the reference solution using lead standard solution (2 ppm Pb) obtained by diluting *lead standard solution (100 ppm Pb) R* with *ethanol (96 per cent) R*. Filter the solution through a membrane filter (nominal pore size 0.45 µm). Compare the spots on the filters obtained with the different solutions. Any brownish-black colour in the spot from the test solution is not more intense than that in the spot from the reference solution.

**Water** (2.5.12, *Method A*): maximum 4.0 per cent, determined on 0.20 g.

**Sulfated ash** (2.4.14): maximum 0.1 per cent, determined on 1.0 g.

ASSAY

Liquid chromatography (2.2.29).

*Test solution.* Dissolve 50.0 mg of the substance to be examined in the mobile phase and dilute to 250.0 mL with the mobile phase.

*Reference solution.* Dissolve 50.0 mg of *selamectin CRS* in the mobile phase and dilute to 250.0 mL with the mobile phase.

*Column:*

- *size: l = 0.15 m, Ø = 3.9 mm;*

– *stationary phase: end-capped octadecylsilyl silica gel for chromatography R* (4 µm);

- *temperature: 30 °C.*

*Mobile phase: water R, acetonitrile R* (20:80 V/V).

*Flow rate: 1.0 mL/min.*

*Detection: spectrophotometer at 243 nm.*

*Injection: 20 µL.*

*Run time: twice the retention time of selamectin.*

*Retention time: selamectin = about 9 min.*

Calculate the percentage content of C<sub>43</sub>H<sub>63</sub>NO<sub>11</sub> from the declared content of *selamectin CRS*.

STORAGE

In an airtight container.

IMPURITIES

*Specified impurities: A, B, C, D.*

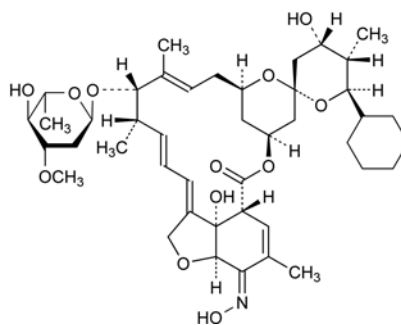

A. (2*aE*,2'*R*,4*E*,4'*S*,5'*S*,6*S*,6'*R*,7*S*,8*E*,11*R*,15*S*,17*aR*,20*Z*,20*aR*,20*bS*)-6'-cyclohexyl-7-[(2,6-dideoxy-3-*O*-methyl- $\alpha$ -*L*-arabino-hexopyranosyl)oxy]-4',20*b*-dihydroxy-20-(hydroxyimino)-5',6,8,19-tetramethyl-3',4',5',6,6',7,10,11,14,15,17*a*,20,20*a*,20*b*-tetradecahydrospiro[2*H*,17*H*-11,15-methanofuro[4,3,2-*pq*][2,6]benzodioxacyclooctadecine-13,2'-pyran]-17-one ((5*Z*,21*R*,23*S*,25*R*)-25-cyclohexyl-4'-*O*-de(2,6-dideoxy-3-*O*-methyl- $\alpha$ -*L*-arabino-hexopyranosyl)-5-demethoxy-25-de(1-methylpropyl)-22,23-dihydro-23-hydroxy-5-(hydroxyimino)avermectin A<sub>1a</sub>),

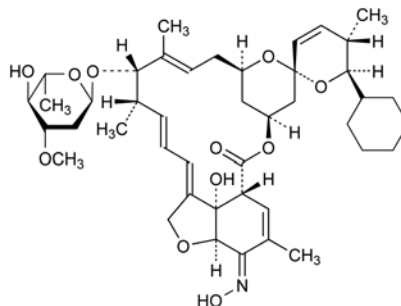

B. (2*aE*,2'*S*,4*E*,5'*S*,6*S*,6'*R*,7*S*,8*E*,11*R*,15*S*,17*aR*,20*Z*,20*aR*,20*bS*)-6'-cyclohexyl-7-[(2,6-dideoxy-3-*O*-methyl- $\alpha$ -*L*-arabino-hexopyranosyl)oxy]-20*b*-hydroxy-20-(hydroxyimino)-5',6,8,19-tetramethyl-5',6,6',7,10,11,14,15,17*a*,20,20*a*,20*b*-dodecahydrospiro[2*H*,17*H*-11,15-methanofuro[4,3,2-*pq*][2,6]benzodioxacyclooctadecine-13,2'-pyran]-17-one ((5*Z*,25*R*)-25-cyclohexyl-4'-*O*-de(2,6-dideoxy-3-*O*-methyl- $\alpha$ -*L*-arabino-hexopyranosyl)-5-demethoxy-25-de(1-methylpropyl)-5-(hydroxyimino)avermectin A<sub>1a</sub>),

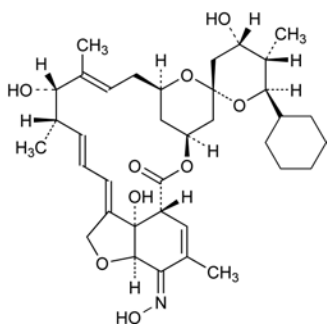

- C. (2aE,2'R,4E,4'S,5'S,6S,6'R,7S,8E,11R,15S,17aR,20Z,20aR,20bS)-6'-cyclohexyl-4',7,20b-trihydroxy-20-(hydroxyimino)-5',6,8,19-tetramethyl-3',4',5',6,6',7,10,11,14,15,17a,20,20a,20b-tetradecahydrospiro[2H,17H-11,15-methanofuro[4,3,2-pq][2,6]benzodioxacyclooctadecine-13,2'-pyran]-17-one ((5Z,13S,25R)-25-cyclohexyl-25-demethyl-5-deoxy-13-hydroxy-5-(hydroxyimino)milbemycin  $\alpha_1$ ),

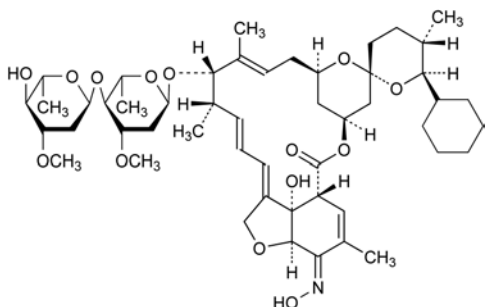

- D. (2aE,2'R,4E,5'S,6S,6'S,7S,8E,11R,15S,17aR,20Z,20aR,20bS)-6'-cyclohexyl-7-[(2,6-dideoxy-3-O-methyl- $\alpha$ -L-arabino-hexopyranosyl-(1 $\rightarrow$ 4)-2,6-dideoxy-3-O-methyl- $\alpha$ -L-arabino-hexopyranosyl)oxy]-20b-hydroxy-20-(hydroxyimino)-5',6,8,19-tetramethyl-3',4',5',6,6',7,10,11,14,15,17a,20,20a,20b-tetradecahydrospiro[2H,17H-11,15-methanofuro[4,3,2-pq][2,6]benzodioxacyclooctadecine-13,2'-pyran]-17-one ((5Z,21R,25S)-25-cyclohexyl-5-demethoxy-25-de(1-methylpropyl)-22,23-dihydro-5-(hydroxyimino)avermectin  $A_{1a}$ ).

01/2008:1260

## SELEGILINE HYDROCHLORIDE

### Selegilini hydrochloridum

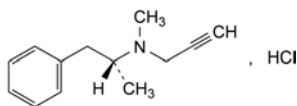

$C_{13}H_{18}ClN$   
[14611-52-0]

$M_r$  223.7

#### DEFINITION

*N*-Methyl-*N*-[(1*R*)-1-methyl-2-phenylethyl]prop-2-yn-1-amine hydrochloride.

*Content*: 99.0 per cent to 101.0 per cent (dried substance).

#### CHARACTERS

*Appearance*: white or almost white, crystalline powder.

*Solubility*: freely soluble in water and in methanol, slightly soluble in acetone.

*mp*: about 143 °C.

#### IDENTIFICATION

- A. Specific optical rotation (2.2.7):  $-10.0$  to  $-12.0$  (dried substance).

Dissolve 2.000g in carbon dioxide-free water *R* and dilute to 20.0 mL with the same solvent.

- B. Infrared absorption spectrophotometry (2.2.24).

*Preparation*: discs of potassium chloride *R*.

*Comparison*: selegiline hydrochloride CRS.

- C. It gives reaction (a) of chlorides (2.3.1).

#### TESTS

**pH** (2.2.3): 3.5 to 4.5.

Dissolve 0.20 g in carbon dioxide-free water *R* and dilute to 10 mL with the same solvent.

**Related substances.** Liquid chromatography (2.2.29).

*Test solution.* Dissolve 20 mg of the substance to be examined in the mobile phase and dilute to 10.0 mL with the mobile phase.

*Reference solution (a).* Dissolve 50.0 mg of selegiline hydrochloride CRS and 10.0 mg of butyl parahydroxybenzoate *R* in the mobile phase and dilute to 50.0 mL with the mobile phase. Dilute 1.0 mL of this solution to 20.0 mL with the mobile phase.

*Reference solution (b).* Dilute 1.0 mL of the test solution to 10.0 mL with the mobile phase. Dilute 1.0 mL of this solution to 50.0 mL with the mobile phase.

*Column*:

– *size*:  $l = 0.25$  m,  $\varnothing = 4.6$  mm;

– *stationary phase*: octylsilyl silica gel for chromatography *R* (5  $\mu$ m).

*Mobile phase*: dilute 500 mL of acetonitrile *R* to 1000.0 mL with a butylammonium acetate buffer solution pH 6.5 prepared as follows: dissolve 4 mL of butylamine *R* in 900 mL of water *R*, adjust to pH 6.5 with acetic acid *R* and dilute to 1000.0 mL with water *R*.

*Flow rate*: 1 mL/min.

*Detection*: spectrophotometer at 215 nm.

*Injection*: 20  $\mu$ L.

*Run time*: 1.7 times the retention time of selegiline.

*System suitability*: reference solution (a):

– *resolution*: minimum 3 between the peaks due to selegiline and butyl parahydroxybenzoate.

*Limits*:

– *impurities A, B, C, D*: for each impurity, not more than the area of the peak in the chromatogram obtained with reference solution (b) (0.2 per cent);

– *total*: not more than 2.5 times the area of the principal peak in the chromatogram obtained with reference solution (b) (0.5 per cent);

– *disregard limit*: 0.1 times the area of the principal peak in the chromatogram obtained with reference solution (b) (0.02 per cent); disregard any peak due to chlorides.

**Impurity E.** Liquid chromatography (2.2.29).

*Test solution.* Dissolve 20.0 mg of the substance to be examined in a mixture of 10  $\mu$ L of butylamine *R* and 1 mL of 2-propanol *R* and dilute to 10.0 mL with the mobile phase.

*Reference solution (a).* Dissolve 8.0 mg of (*RS*)-selegiline hydrochloride CRS in a mixture of 10  $\mu$ L of butylamine *R* and 1 mL of 2-propanol *R* and dilute to 10.0 mL with the mobile phase.

*Reference solution (b).* Dilute 0.5 mL of reference solution (a) to 20.0 mL with the mobile phase.

*Column*:

– *size*:  $l = 0.25$  m,  $\varnothing = 4.6$  mm;

– *stationary phase*: silica gel OD for chiral separations *R*.

*Mobile phase*: 2-propanol *R*, cyclohexane *R* (0.2:99.8 *V/V*).

*Flow rate*: 1 mL/min.

*Detection*: spectrophotometer at 220 nm.

*Injection*: 20  $\mu$ L.

*Retention time*: impurity E = about 10 min.

*System suitability*: reference solution (a):

- *resolution*: minimum 1.5 between the peaks due to impurity E and (*R*)-selegiline; if necessary, adjust the concentration of 2-propanol in the mobile phase.

*Limit*:

- *impurity E*: not more than the area of the corresponding peak in the chromatogram obtained with reference solution (b) (0.5 per cent).

**Loss on drying** (2.2.32): maximum 0.5 per cent, determined on 1.000 g by drying at 60 °C at a pressure not exceeding 0.5 kPa.

**Sulfated ash** (2.4.14): maximum 0.1 per cent, determined on 1.0 g.

#### ASSAY

Dissolve 0.180 g in 50 mL of *acetic anhydride R*. Titrate with 0.1 M *perchloric acid*, determining the end-point potentiometrically (2.2.20).

1 mL of 0.1 M *perchloric acid* is equivalent to 22.37 mg of C<sub>13</sub>H<sub>18</sub>N.

#### STORAGE

Protected from light.

#### IMPURITIES

*Specified impurities*: A, B, C, D, E.

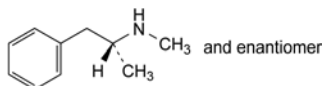

- A. (2*RS*)-*N*-methyl-1-phenylpropan-2-amine [(*RS*)-metamfetamine],
- B. (2*R*)-1-phenylpropan-2-amine (amfetamine),
- C. (1*RS*,2*SR*)-2-amino-1-phenylpropan-1-ol (phenylpropanolamine),

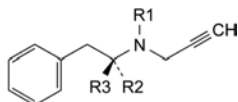

- D. R<sub>1</sub> = R<sub>3</sub> = H, R<sub>2</sub> = CH<sub>3</sub>: *N*-[(1*R*)-1-methyl-2-phenylethyl]prop-2-yn-1-amine (demethylselegiline),
- E. R<sub>1</sub> = R<sub>3</sub> = CH<sub>3</sub>, R<sub>2</sub> = H: *N*-methyl-*N*-[(1*S*)-1-methyl-2-phenylethyl]prop-2-yn-1-amine [(*S*)-selegiline].

01/2008:1147

## SELENIUM DISULFIDE

### Selenii disulfidum

SeS<sub>2</sub>  
[7488-56-4]

*M*<sub>r</sub> 143.1

#### DEFINITION

*Content*: 52.0 per cent to 55.5 per cent of Se.

#### CHARACTERS

*Appearance*: bright orange or reddish-brown powder.

*Solubility*: practically insoluble in water.

#### IDENTIFICATION

- A. Gently boil about 50 mg with 5 mL of *nitric acid R* for 30 min. Dilute to 50 mL with *water R* and filter. To 5 mL of the filtrate add 10 mL of *water R* and 5 g of *urea R*. Heat to boiling, cool and add 1.5 mL of *potassium iodide solution R*. A yellow or orange colour is produced which darkens rapidly on standing. This solution is used in identification test B.

- B. Allow the coloured solution obtained under identification A to stand for 10 min and filter through *kieselguhr for chromatography R*. 5 mL of the filtrate gives reaction (a) of sulfates (2.3.1).

#### TESTS

**Soluble selenium compounds**: maximum 5 ppm, calculated as Se.

To 10 g add 100 mL of *water R*, mix well, allow to stand for 1 h with frequent shaking and filter. To 10 mL of the filtrate add 2 mL of a 115 g/L solution of *anhydrous formic acid R*, dilute to 50 mL with *water R* and adjust to pH 2.0-3.0 with an 115 g/L solution of *anhydrous formic acid R*. Add 2 mL of a 5 g/L solution of 3,3'-*diaminobenzidine tetrahydrochloride R*. Allow to stand for 45 min and then adjust to pH 6.0-7.0 with *dilute ammonia R1*. Shake the solution for 1 min with 10 mL of *toluene R* and allow the phases to separate. The absorbance (2.2.25) of the upper layer measured at 420 nm is not greater than that of a standard prepared at the same time and in the same manner beginning at the words "add 2 mL of an 115 g/L solution of *anhydrous formic acid R*" and using 5 mL of *selenium standard solution (1 ppm Se) R* instead of 10 mL of the filtrate.

#### ASSAY

To 0.100 g add 25 mL of *fuming nitric acid R* and heat on a water-bath for 1 h; a small insoluble residue may remain. Cool and dilute to 100.0 mL with *water R*. To 25.0 mL of this solution add 50 mL of *water R* and 5 g of *urea R* and heat to boiling. Cool, add 7 mL of *potassium iodide solution R* and 3 mL of *starch solution R*. Titrate immediately with 0.1 M *sodium thiosulfate*. Carry out a blank titration.

1 mL of 0.1 M *sodium thiosulfate* is equivalent to 1.974 mg of Se.

01/2008:0788  
corrected 6.0

## SERINE

### Serinum

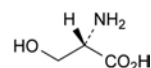

C<sub>3</sub>H<sub>7</sub>NO<sub>3</sub>  
[56-45-1]

*M*<sub>r</sub> 105.1

#### DEFINITION

Serine contains not less than 98.5 per cent and not more than the equivalent of 101.0 per cent of (*S*)-2-amino-3-hydroxypropanoic acid, calculated with reference to the dried substance.

#### CHARACTERS

A white or almost white, crystalline powder or colourless crystals, freely soluble in water, practically insoluble in alcohol.

#### IDENTIFICATION

*First identification*: A, B.

*Second identification*: A, C, D.

- A. Specific optical rotation (see Tests).
- B. Examine by infrared absorption spectrophotometry (2.2.24), comparing with the spectrum obtained with *serine CRS*. Examine the substances prepared as discs.
- C. Examine the chromatograms obtained in the test for ninhydrin-positive substances. The principal spot in the chromatogram obtained with test solution (b) is similar in position, colour and size to the principal spot in the chromatogram obtained with reference solution (a).

D. To 1 mL of a 10 g/L solution of the substance to be examined in a test-tube, add 5 mL of a 20 g/L solution of *sodium periodate R*. Heat on a water-bath and collect the vapour on glass wool moistened with *water R* and inserted in the opening of the test tube. After heating for 5 min, transfer the glass wool to a test-tube containing 1 mL of a 15 g/L solution of *chromotropic acid, sodium salt R* and 3 mL of *sulfuric acid R*. Heat on a water-bath for 10 min. A violet-red colour is produced.

## TESTS

**Solution S.** Dissolve 2.5 g in *distilled water R* and dilute to 50 mL with the same solvent.

**Appearance of solution.** Solution S is clear (2.2.1) and not more intensely coloured than reference solution BY<sub>6</sub> (2.2.2, Method II).

**Specific optical rotation (2.2.7).** Dissolve 2.50 g in *dilute hydrochloric acid R* and dilute to 25.0 mL with the same acid. The specific optical rotation is + 14.0 to + 16.0, calculated with reference to the dried substance.

**Ninhydrin-positive substances.** Examine by thin-layer chromatography (2.2.27), using a *TLC silica gel plate R*.

**Test solution (a).** Dissolve 0.10 g of the substance to be examined in 0.1 M *hydrochloric acid* and dilute to 10 mL with the same acid.

**Test solution (b).** Dilute 1 mL of test solution (a) to 50 mL with *water R*.

**Reference solution (a).** Dissolve 10 mg of *serine CRS* in 0.1 M *hydrochloric acid* and dilute to 50 mL with the same acid.

**Reference solution (b).** Dilute 5 mL of test solution (b) to 20 mL with *water R*.

**Reference solution (c).** Dissolve 10 mg of *methionine CRS* and 10 mg of *serine CRS* in 0.1 M *hydrochloric acid* and dilute to 25 mL with the same acid.

Apply to the plate 5 µL of each solution. Develop over a path of 15 cm using a mixture of 20 volumes of *glacial acetic acid R*, 20 volumes of *water R* and 60 volumes of *butanol R*. Allow the plate to dry in air, spray with *ninhydrin solution R* and heat at 100 °C to 105 °C for 15 min. Any spot in the chromatogram obtained with test solution (a), apart from the principal spot, is not more intense than the spot in the chromatogram obtained with reference solution (b) (0.5 per cent). The test is not valid unless the chromatogram obtained with reference solution (c) shows two clearly separated spots.

**Chlorides (2.4.4).** Dilute 5 mL of solution S to 15 mL with *water R*. The solution complies with the limit test for chlorides (200 ppm).

**Sulfates (2.4.13).** Dilute 10 mL of solution S to 15 mL with *distilled water R*. The solution complies with the limit test for sulfates (300 ppm).

**Ammonium (2.4.1).** 50 mg complies with limit test B for ammonium (200 ppm). Prepare the standard using 0.1 mL of *ammonium standard solution (100 ppm NH<sub>4</sub>) R*.

**Iron (2.4.9).** In a separating funnel, dissolve 1.0 g in 10 mL of *dilute hydrochloric acid R*. Shake with three quantities, each of 10 mL, of *methyl isobutyl ketone RI*, shaking for 3 min each time. To the combined organic layers add 10 mL of *water R* and shake for 3 min. The aqueous layer complies with the limit test for iron (10 ppm).

**Heavy metals (2.4.8).** Dissolve 2.0 g in *water R* and dilute to 20 mL with the same solvent. 12 mL of the solution complies with limit test A for heavy metals (10 ppm). Prepare the standard using *lead standard solution (1 ppm Pb) R*.

**Loss on drying (2.2.32).** Not more than 0.5 per cent, determined on 1.000 g by drying in an oven at 105 °C.

**Sulfated ash (2.4.14).** Not more than 0.1 per cent, determined on 1.0 g.

## ASSAY

Dissolve 0.100 g in 3 mL of *anhydrous formic acid R*. Add 30 mL of *anhydrous acetic acid R*. Using 0.1 mL of *naphtholbenzein solution R* as indicator, titrate with 0.1 M *perchloric acid* until the colour changes from brownish-yellow to green.

1 mL of 0.1 M *perchloric acid* is equivalent to 10.51 mg of C<sub>20</sub>H<sub>16</sub>Cl<sub>3</sub>N<sub>3</sub>O<sub>4</sub>S.

## STORAGE

Store protected from light.

01/2008:1148  
corrected 6.1

## SERTAONAZOLE NITRATE

## Sertaconazoli nitras

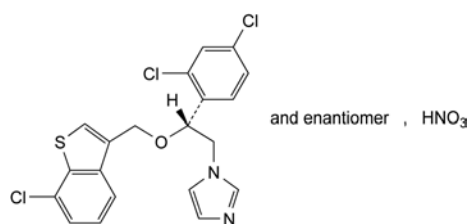

C<sub>20</sub>H<sub>16</sub>Cl<sub>3</sub>N<sub>3</sub>O<sub>4</sub>S  
[99592-39-9]

M<sub>r</sub> 500.8

## DEFINITION

(*RS*)-1-[2-[(7-Chloro-1-benzothiophen-3-yl)methoxy]-2-(2,4-dichlorophenyl)ethyl]-1*H*-imidazole nitrate.

**Content:** 98.5 per cent to 101.0 per cent (anhydrous substance).

## CHARACTERS

**Appearance:** white or almost white powder.

**Solubility:** practically insoluble in water, soluble in methanol, sparingly soluble in ethanol (96 per cent) and in methylene chloride.

## IDENTIFICATION

**First identification:** A, C.

**Second identification:** A, B, D, E.

A. Melting point (2.2.14): 156 °C to 161 °C.

B. Ultraviolet and visible absorption spectrophotometry (2.2.25).

**Test solution.** Dissolve 0.1 g in *methanol R* and dilute to 100 mL with the same solvent. Dilute 10 mL of this solution to 100 mL with *methanol R*.

**Spectral range:** 240-320 nm.

**Absorption maxima:** at 260 nm, 293 nm and 302 nm.

**Absorbance ratio:** A<sub>302</sub>/A<sub>293</sub> = 1.16 to 1.28.

C. Infrared absorption spectrophotometry (2.2.24).

**Preparation:** dry the substances at 100-105 °C for 2 h and examine as discs of *potassium bromide R*.

**Comparison:** *sertaconazole nitrate CRS*.

D. Thin-layer chromatography (2.2.27).

**Solvent mixture:** *concentrated ammonia R*, *methanol R* (10:90 V/V).

**Test solution.** Dissolve 40 mg of the substance to be examined in the solvent mixture and dilute to 10 mL with the solvent mixture.

**Reference solution (a).** Dissolve 40 mg of *sertaconazole nitrate CRS* in the solvent mixture and dilute to 10 mL with the solvent mixture.

**Reference solution (b).** Dissolve 20 mg of *miconazole nitrate CRS* in reference solution (a) and dilute to 5 mL with reference solution (a).

**Plate:** *TLC silica gel G plate R*.

*Mobile phase: concentrated ammonia R, toluene R, dioxan R (1:40:60 V/V/V).*

*Application: 5 µL.*

*Development: over a path of 15 cm.*

*Drying: in a current of air for 15 min.*

*Detection: expose to iodine vapour for 30 min.*

*System suitability: reference solution (b):*

– the chromatogram shows 2 clearly separated spots.

*Results: the principal spot in the chromatogram obtained with the test solution is similar in position, colour and size to the principal spot in the chromatogram obtained with reference solution (a).*

E. About 1 mg gives the reaction of nitrates (2.3.1).

#### TESTS

**Appearance of solution.** The solution is clear (2.2.1) and not more intensely coloured than reference solution Y<sub>5</sub> (2.2.2, Method II).

Dissolve 0.1 g in *ethanol (96 per cent) R* and dilute to 10 mL with the same solvent.

**Related substances.** Liquid chromatography (2.2.29).

*Test solution.* Dissolve 10.0 mg of the substance to be examined in the mobile phase and dilute to 10.0 mL with the mobile phase.

*Reference solution (a).* Dilute 5.0 mL of the test solution to 100.0 mL with the mobile phase. Dilute 1.0 mL of this solution to 20.0 mL with the mobile phase.

*Reference solution (b).* Dissolve 5.0 mg of *sertaconazole nitrate CRS* and 5.0 mg of *miconazole nitrate CRS* in the mobile phase and dilute to 20.0 mL with the mobile phase. Dilute 1.0 mL of this solution to 50.0 mL with the mobile phase.

*Column:*

- *size: l = 0.25 m, Ø = 4.0 mm;*
- *stationary phase: nitrile silica gel for chromatography R1 (10 µm).*

*Mobile phase: acetonitrile R1, 1.5 g/L solution of sodium dihydrogen phosphate R (37:63 V/V).*

*Flow rate: 1.6 mL/min.*

*Detection: spectrophotometer at 220 nm.*

*Injection: 20 µL.*

*Run time: 1.3 times the retention time of sertaconazole.*

*Retention time: nitrate ion = about 1 min; miconazole = about 17 min; sertaconazole = about 19 min.*

*System suitability: reference solution (b):*

- *resolution: minimum 2.0 between the peaks due to miconazole and sertaconazole.*

*Limits:*

- *impurities A, B, C: for each impurity, not more than the area of the principal peak in the chromatogram obtained with reference solution (a) (0.25 per cent);*
- *total: not more than twice the area of the principal peak in the chromatogram obtained with reference solution (a) (0.5 per cent);*
- *disregard limit: 0.2 times the area of the principal peak in the chromatogram obtained with reference solution (a) (0.05 per cent); disregard the peak due to the nitrate ion.*

**Water (2.5.12):** maximum 1.0 per cent, determined on 0.50 g.

**Sulfated ash (2.4.14):** maximum 0.1 per cent, determined on 1.0 g.

#### ASSAY

Dissolve 0.400 g in 50 mL of a mixture of equal volumes of *anhydrous acetic acid R* and *methyl ethyl ketone R*. Titrate with 0.1 M *perchloric acid*, determining the end-point potentiometrically (2.2.20). Carry out a blank titration.

1 mL of 0.1 M *perchloric acid* is equivalent to 50.08 mg of C<sub>20</sub>H<sub>16</sub>Cl<sub>2</sub>N<sub>3</sub>O<sub>4</sub>S.

#### STORAGE

Protected from light.

#### IMPURITIES

*Specified impurities: A, B, C.*

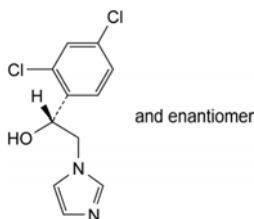

A. (1RS)-1-(2,4-dichlorophenyl)-2-(1H-imidazol-1-yl)ethanol,

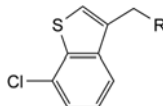

B. R = Br: 3-(bromomethyl)-7-chloro-1-benzothiophen,

C. R = OH: (7-chloro-1-benzothiophen-3-yl)methanol.

01/2011:1705

## SERTRALINE HYDROCHLORIDE

### Sertralini hydrochloridum

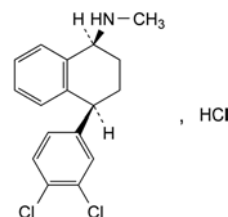

C<sub>17</sub>H<sub>18</sub>Cl<sub>3</sub>N  
[79559-97-0]

M<sub>r</sub> 342.7

#### DEFINITION

(1S,4S)-4-(3,4-Dichlorophenyl)-N-methyl-1,2,3,4-tetrahydronaphthalen-1-amine hydrochloride.

*Content: 97.5 per cent to 102.0 per cent (anhydrous substance).*

#### CHARACTERS

*Appearance: white or almost white, crystalline powder.*

*Solubility: slightly soluble in water, sparingly soluble or slightly soluble in anhydrous ethanol, slightly soluble in acetone and in 2-propanol.*

It shows polymorphism (5.9).

#### IDENTIFICATION

Carry out either tests A, B, C or tests B, C, D.

A. Specific optical rotation (2.2.7): + 38.8 to + 43.0 (anhydrous substance), measured at 25 °C.

*Solvent mixture.* Dilute 1 volume of a 103 g/L solution of *hydrochloric acid R* to 20 volumes with *methanol R*.

Dissolve 0.250 g in the solvent mixture and dilute to 25.0 mL with the solvent mixture.

B. Infrared absorption spectrophotometry (2.2.24).

*Comparison: sertraline hydrochloride CRS.*

If the spectra obtained in the solid state show differences, record new spectra using 10 g/L solutions in *methylene chloride R*.

C. Dissolve 10 mg in 5 mL of *anhydrous ethanol R* and add 5 mL of *water R*. The solution gives reaction (a) of chlorides (2.3.1).

D. Enantiomeric purity (see Tests).



## TESTS

**Enantiomeric purity.** Liquid chromatography (2.2.29).

*Solvent mixture:* diethylamine R, hexane R, 2-propanol R (1:40:60 V/V/V).

*Test solution.* Dissolve 60.0 mg of the substance to be examined in the solvent mixture and dilute to 10.0 mL with the solvent mixture.

*Reference solution (a).* Dissolve the contents of a vial of sertraline for system suitability CRS (containing impurity G) in 1.0 mL of the solvent mixture.

*Reference solution (b).* Dilute 0.5 mL of the test solution to 100.0 mL with the solvent mixture.

*Column:*

- size:  $l = 0.25$  m,  $\emptyset = 4.6$  mm;
- stationary phase: silica gel AD for chiral separation R (5  $\mu$ m).

*Mobile phase:* mix 30 volumes of hexane R and 70 volumes of a mixture of 1 volume of diethylamine R, 25 volumes of 2-propanol R and 975 volumes of hexane R.

*Flow rate:* 0.4 mL/min.

*Detection:* spectrophotometer at 275 nm.

*Injection:* 20  $\mu$ L.

*Run time:* 30 min.

*Elution order:* sertraline, impurity G.

*System suitability:*

- resolution: minimum 1.5 between the peaks due to sertraline and impurity G in the chromatogram obtained with reference solution (a);
- signal-to-noise ratio: minimum 10 for the peak due to sertraline in the chromatogram obtained with reference solution (b).

*Limit:*

- impurity G: not more than 3 times the area of the principal peak in the chromatogram obtained with reference solution (b) (1.5 per cent).

**Impurity E.** Liquid chromatography (2.2.29).

*Solvent mixture:* mobile phase A, mobile phase B (50:50 V/V).

*Test solution.* Dissolve 50.0 mg of the substance to be examined in the solvent mixture and dilute to 50.0 mL with the solvent mixture.

*Reference solution (a).* Dissolve 5.0 mg of mandelic acid CRS (impurity E) in the solvent mixture and dilute to 25.0 mL with the solvent mixture. Dilute 1.0 mL of this solution to 100.0 mL with the solvent mixture.

*Reference solution (b).* Dissolve 10 mg of benzoic acid R and 20 mg of mandelic acid R (impurity E) in the solvent mixture and dilute to 50.0 mL with the solvent mixture. Dilute 1.0 mL of this solution to 50.0 mL with the solvent mixture.

*Column:*

- size:  $l = 0.25$  m,  $\emptyset = 4.6$  mm;
- stationary phase: end-capped octadecylsilyl silica gel for chromatography R (3  $\mu$ m).

*Mobile phase:*

- mobile phase A: dissolve 1.0 g of sodium laurilsulfate R in 800 mL of water R and add 200 mL of acetonitrile RI; add 1.0 mL of phosphoric acid R and mix;
- mobile phase B: dissolve 1.0 g of sodium laurilsulfate R in 100 mL of water R and add 900 mL of acetonitrile RI; add 1.0 mL of phosphoric acid R and mix;

Time (min)	Mobile phase A (per cent V/V)	Mobile phase B (per cent V/V)
0 - 8	60	40
8 - 9	60 → 10	40 → 90
9 - 16	10	90

*Flow rate:* 1 mL/min.

*Detection:* spectrophotometer at 220 nm.

*Injection:* 10  $\mu$ L.

*Relative retention* with reference to sertraline (retention time = about 18 min): impurity E = about 0.2; benzoic acid = about 0.3.

*System suitability:* reference solution (b):

- resolution: minimum 5.0 between the peaks due to impurity E and benzoic acid.

*Limit:*

- impurity E: not more than the area of the principal peak in the chromatogram obtained with reference solution (a) (0.2 per cent).

**Related substances.** Gas chromatography (2.2.28): use the normalisation procedure.

*Test solution.* Introduce 0.250 g of the substance to be examined into a 15 mL stoppered centrifuge tube, add 2.0 mL of methanol R and 0.20 mL of a 25 per cent solution of potassium carbonate R and mix in a vortex mixer for 30 s. Add 8.0 mL of methylene chloride R, stopper the tube and mix in a vortex mixer for 60 s. Add 1 g of anhydrous sodium sulfate R, mix well and then centrifuge for about 5 min.

*Reference solution (a).* Dissolve the contents of a vial of sertraline for peak identification CRS (containing impurities A, B, C and F) in 0.2 mL of methylene chloride R.

*Reference solution (b).* Dilute 1.0 mL of the test solution to 100.0 mL with methylene chloride R. Dilute 1.0 mL of this solution to 20.0 mL with methylene chloride R.

*Column:*

- material: fused silica;
- size:  $l = 30$  m,  $\emptyset = 0.53$  mm;
- stationary phase: polymethylphenylsiloxane R (film thickness 1.0  $\mu$ m).

*Carrier gas:* helium for chromatography R.

*Flow rate:* 9 mL/min.

*Split ratio:* 1:10.

*Temperature:*

	Time (min)	Temperature (°C)
Column	0 - 1	200
	1 - 31	200 → 260
	31 - 39	260
Injection port		250
Detector		280

*Detection:* flame ionisation.

*Injection:* 1  $\mu$ L.

*Identification of impurities:* use the chromatogram supplied with sertraline for peak identification CRS and the chromatogram obtained with reference solution (a) to identify the peaks due to impurities A, B, C and F.

*Relative retention* with reference to sertraline (retention time = about 24 min): impurity B = about 0.5; impurities C and D = about 0.7; impurity A = about 1.05; impurity F = about 1.1.

**System suitability:** reference solution (a):

- **peak-to-valley ratio:** minimum 15, where  $H_p$  = height above the baseline of the peak due to impurity A and  $H_v$  = height above the baseline of the lowest point of the curve separating this peak from the peak due to sertraline.

**Limits:**

- **impurities A, B, F:** for each impurity, maximum 0.2 per cent;
- **sum of impurities C and D:** maximum 0.8 per cent;
- **unspecified impurities:** for each impurity, maximum 0.10 per cent;
- **total:** maximum 1.5 per cent;
- **disregard limit:** the area of the principal peak in the chromatogram obtained with reference solution (b) (0.05 per cent).

**Heavy metals (2.4.8):** maximum 20 ppm.

Dissolve 1.0 g in *ethanol (96 per cent) R* and dilute to 20.0 mL with the same solvent. 12 mL of the solution complies with test B. Prepare the reference solution using lead standard solution (1 ppm Pb) obtained by diluting *lead standard solution (100 ppm Pb) R* with *ethanol (96 per cent) R*.

**Water (2.5.12):** maximum 0.5 per cent, determined on 2.00 g.

**Sulfated ash (2.4.14):** maximum 0.2 per cent, determined on 1.0 g.

## ASSAY

Liquid chromatography (2.2.29).

**Buffer solution.** To 28.6 mL of *glacial acetic acid R* slowly add, while stirring and cooling, 34.8 mL of *triethylamine R*, and dilute to 100 mL with *water R*. Dilute 10 mL of this solution to 1000 mL with *water R*.

**Test solution.** Dissolve 55.0 mg of the substance to be examined in the mobile phase and dilute to 50.0 mL with the mobile phase. Dilute 5.0 mL of this solution to 100.0 mL with the mobile phase.

**Reference solution.** Dissolve 55.0 mg of *sertraline hydrochloride CRS* in the mobile phase and dilute to 50.0 mL with the mobile phase. Dilute 5.0 mL of this solution to 100.0 mL with the mobile phase.

**Column:**

- **size:**  $l = 0.15$  m,  $\varnothing = 3.9$  mm;
- **stationary phase:** *octadecylsilyl silica gel for chromatography R* (4  $\mu$ m);
- **temperature:** 30 °C.

**Mobile phase:** *methanol R*, buffer solution, *acetonitrile R* (15:40:45 V/V/V).

**Flow rate:** 1.8 mL/min.

**Detection:** spectrophotometer at 254 nm.

**Injection:** 20  $\mu$ L.

**Run time:** twice the retention time of sertraline.

**Retention time:** sertraline = about 1.9 min.

Calculate the percentage content of  $C_{17}H_{18}Cl_3N$  from the declared content of *sertraline hydrochloride CRS*.

## STORAGE

Protected from light.

## IMPURITIES

**Specified impurities:** A, B, C, D, E, F, G.

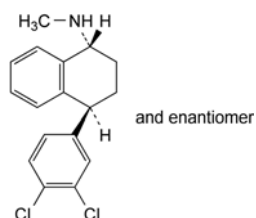

A. (1*RS*,4*SR*)-4-(3,4-dichlorophenyl)-*N*-methyl-1,2,3,4-tetrahydronaphthalen-1-amine,

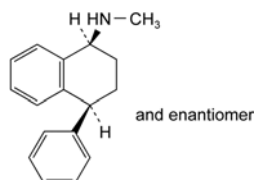

B. (1*RS*,4*RS*)-*N*-methyl-4-phenyl-1,2,3,4-tetrahydronaphthalen-1-amine,

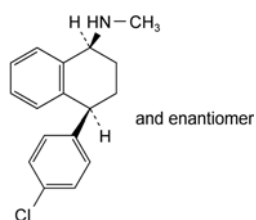

C. (1*RS*,4*RS*)-4-(4-chlorophenyl)-*N*-methyl-1,2,3,4-tetrahydronaphthalen-1-amine,

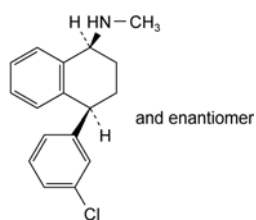

D. (1*RS*,4*RS*)-4-(3-chlorophenyl)-*N*-methyl-1,2,3,4-tetrahydronaphthalen-1-amine,

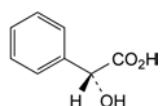

E. (2*R*)-hydroxyphenylacetic acid ((*R*)-mandelic acid),

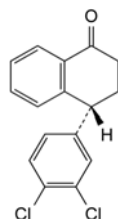

F. (4*R*)-4-(3,4-dichlorophenyl)-3,4-dihydronaphthalen-1(2*H*)-one,

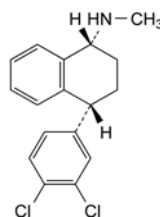

G. (1*R*,4*R*)-4-(3,4-dichlorophenyl)-*N*-methyl-1,2,3,4-tetrahydronaphthalen-1-amine (sertraline enantiomer).

01/2010:0433  
corrected 6.7

## SESAME OIL, REFINED

### Sesami oleum raffinatum

#### DEFINITION

Fatty oil obtained from the ripe seeds of *Sesamum indicum* L. by expression or extraction. It is then refined. Improved colour and odour may be obtained by further refining. It may contain a suitable antioxidant.

#### CHARACTERS

*Appearance*: clear, light yellow liquid, almost colourless.

*Solubility*: practically insoluble in ethanol (96 per cent), miscible with light petroleum.

*Relative density*: about 0.919.

*Refractive index*: about 1.473.

It solidifies to a butter-like mass at about  $-4\text{ }^{\circ}\text{C}$ .

#### IDENTIFICATION

*First identification*: A.

*Second identification*: B.

A. Composition of triglycerides (see Tests).

B. Identification of fatty oils by thin-layer chromatography (2.3.2).

*Results*: the chromatogram obtained is similar to the corresponding chromatogram shown in Figure 2.3.2-1.

#### TESTS

**Acid value** (2.5.1): maximum 0.5, determined on 10.0 g; maximum 0.3 if intended for use in the manufacture of parenteral preparations.

**Peroxide value** (2.5.5): maximum 10.0; maximum 5.0 if intended for use in the manufacture of parenteral preparations.

**Unsaponifiable matter** (2.5.7): maximum 2.0 per cent, determined on 5.0 g.

**Alkaline impurities** (2.4.19). It complies with the test for alkaline impurities in fatty oils.

**Cottonseed oil**. Mix 5 mL in a test-tube with 5 mL of a mixture of equal volumes of *pentanol R* and a 10 g/L solution of *sulfur R* in *carbon disulfide R*. Warm the mixture carefully until the carbon disulfide is expelled, and immerse the tube to 1/3 of its depth in boiling *saturated sodium chloride solution R*. No reddish colour develops within 15 min.

**Composition of triglycerides**. Liquid chromatography (2.2.29).

*Test solution*. Dilute 50.0 mg of the substance to be examined to 10.0 mL with a mixture of equal volumes of *acetone R* and *methylene chloride R*.

*Reference solutions*. Dissolve 80.0 mg of *triolein R* in a mixture of equal volumes of *acetone R* and *methylene chloride R* and dilute to 50.0 mL with the same mixture of solvents. Prepare 5 reference solutions by dilution of this solution so as to cover concentrations ranging from the disregard limit (0.5 per cent) to the upper limit for OLL (30.0 per cent).

Plot the logarithm of the area of the peak due to triolein against the logarithm of the concentration of triolein in the reference solution.

*Column*: 2 columns coupled in series:

- *size of each column*:  $l = 0.25\text{ m}$ ,  $\varnothing = 4\text{ mm}$ ;
- *stationary phase*: octadecylsilyl silica gel for chromatography R (4  $\mu\text{m}$ ).

*Mobile phase*:

- *mobile phase A*: *acetone R*, *methylene chloride R*, *acetonitrile R* (5:15:80 V/V/V);
- *mobile phase B*: *acetone R*, *acetonitrile R*, *methylene chloride R* (20:20:60 V/V/V);

Time (min)	Mobile phase A (per cent V/V)	Mobile phase B (per cent V/V)
0 - 15	100 → 75	0 → 25
15 - 25	75	25
25 - 70	75 → 0	25 → 100
70 - 75	0 → 100	100 → 0
75 - 80	100	0

*Flow rate*: 1.0 mL/min.

*Detection*: evaporative light-scattering detector; the following settings have been found to be suitable; if the detector has different setting parameters, adjust the detector settings so as to comply with the system suitability criterion:

- *carrier gas*: *nitrogen R*;
- *flow rate*: 0.7 L/min;
- *evaporator temperature*: 85  $^{\circ}\text{C}$ ;
- *nebuliser temperature*: 45  $^{\circ}\text{C}$ .

*Injection*: 20  $\mu\text{L}$ .

*Identification of peaks*: use the chromatograms obtained with the reference solutions to identify the peak due to triolein; identify the other peaks using the chromatogram shown in Figure 0433-1. The fatty acids are designated as linolenic (Ln), linoleic (L), oleic (O), palmitic (P) and stearic (S).

*System suitability*: test solution:

- *resolution*: minimum 1.5 between the peaks due to OOO (triolein) and SOL.

Using the calibration curve obtained with the reference solutions, determine the percentage content of each peak with an area greater than that of the peak corresponding to the disregard limit (0.5 per cent). Assuming that the sum of these percentage contents is 100 per cent, normalise the percentage content of each of the 8 triglycerides specified below.

*Composition of triglycerides*:

- *LLL*: 7.0 per cent to 19.0 per cent;
- *OLL*: 13.0 per cent to 30.0 per cent;
- *PLL*: 5.0 per cent to 9.0 per cent;
- *OOL*: 12.0 per cent to 23.0 per cent;
- *POL*: 6.0 per cent to 14.0 per cent;
- *OOO*: 5.0 per cent to 14.0 per cent;
- *SOL*: 2.0 per cent to 8.0 per cent;
- *POO*: 2.0 per cent to 10.0 per cent.

**Water** (2.5.32): maximum 0.1 per cent, determined on 1.00 g.

#### STORAGE

In an airtight, well-filled container, protected from light; if intended for use in the manufacture of parenteral preparations store under an inert gas in an airtight container.

When the container has been opened, its contents are to be used as soon as possible. Any part of the contents not used at once is protected by an atmosphere of an inert gas.

#### LABELLING

The label states:

- whether the oil is obtained by expression or extraction;
- where applicable, that the substance is suitable for use in the manufacture of parenteral preparations;
- where applicable, the name of the inert gas used.

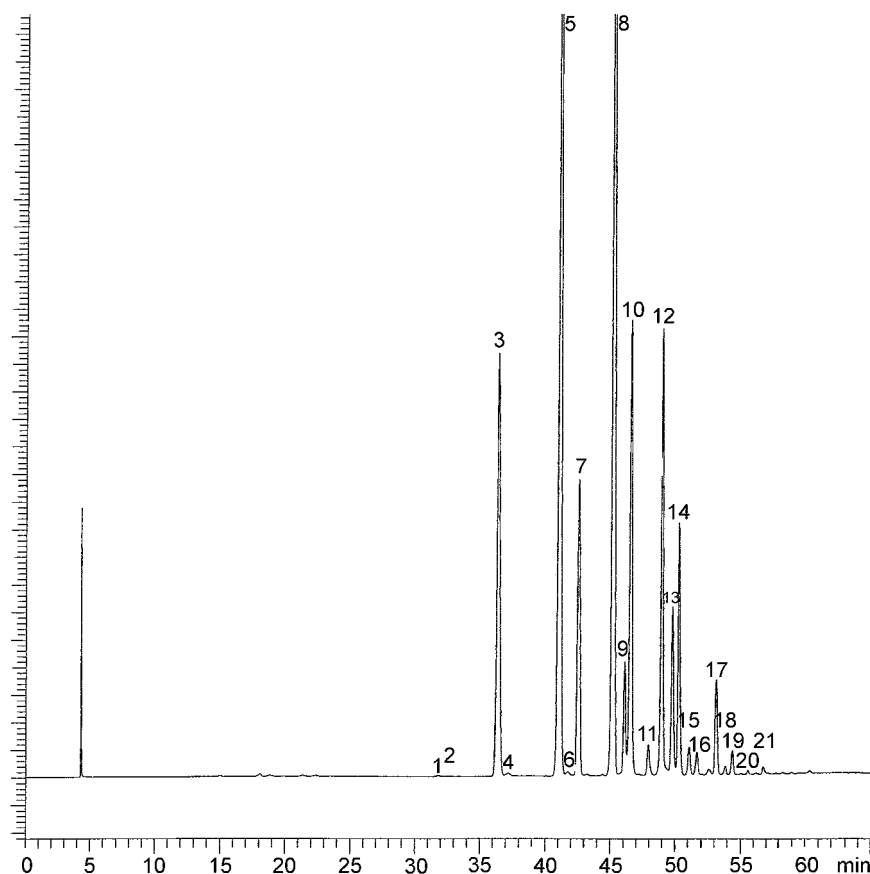

1. LLLn	4. OLLn	7. PLL	10. POL	13. SOL	16. PPO	19. SSL
2. OLnLn	5. OLL	8. OOL	11. PPL	14. POO	17. SOO	20. PPS
3. LLL	6. OOLn	9. SLL	12. OOO	15. PSL	18. PSO	21. SSO

Figure 0433.-1. – Chromatogram for the composition of triglycerides in refined sesame oil

#### 01/2009:2269 TESTS

## SEVOFLURANE

### Sevofluranum

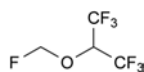

$C_4H_3F_7O$   
[28523-86-6]

$M_r$  200.1

#### DEFINITION

1,1,1,3,3,3-Hexafluoro-2-(fluoromethoxy)propane.

#### CHARACTERS

*Appearance*: clear, colourless, volatile liquid.

*Solubility*: slightly soluble in water, miscible with ethanol (96 per cent).

*Relative density*: about 1.52.

bp: about 59 °C.

It is non-flammable.

It decomposes in the presence of Lewis acids; this decomposition is inhibited by water in sufficient quantity.

#### IDENTIFICATION

Infrared absorption spectrophotometry (2.2.24).

*Preparation*: examine the substance in the gaseous state or in the liquid state.

*Comparison*: sevoflurane CRS.

**Acidity or alkalinity.** Introduce 20.0 mL of the substance to be examined and 20 mL of carbon dioxide-free water R into a separating funnel, shake for 3 min and allow to stand. Collect the aqueous upper layer and add 0.2 mL of bromocresol purple solution R. Not more than 0.10 mL of 0.01 M sodium hydroxide or not more than 0.60 mL of 0.01 M hydrochloric acid is required to change the colour of the indicator.

**Refractive index (2.2.6)**: 1.2745 to 1.2760.

**Related substances.** Gas chromatography (2.2.28).

*Internal standard*: methylal R.

*Test solution.* Introduce 20.0 mL of the substance to be examined into a vial and seal with a cap and septum. Using a microsyringe, add 5 µL of the internal standard and mix thoroughly.

*Reference solution (a).* Introduce 2.0 mL of ethylene chloride R into a screw-cap vial and immediately seal with a cap and septum. Using a microsyringe, add about 20 µL of the substance to be examined. Record the quantity added, in milligrams, of the substance to be examined ( $M_2$ ). Then, using a microsyringe, add about 20 µL of the internal standard. Record the quantity added, in milligrams, of the internal standard ( $M_1$ ).

*Reference solution (b)*: sevoflurane CRS (containing impurities A and B).

*Reference solution (c).* Introduce 20.0 mL of ethylene chloride R into a vial and seal with a cap and septum. Using a microsyringe, add 20 µL of the substance to be examined and mix thoroughly. Dilute 0.5 mL of this solution to 100.0 mL with ethylene chloride R.

**Column:**

- *material*: fused silica;
- *size*:  $l = 30$  m,  $\varnothing = 0.32$  mm;
- *stationary phase*: poly[(cyanopropyl)(phenyl)]-[dimethyl]siloxane R (film thickness 3  $\mu$ m).

*Carrier gas*: helium for chromatography R.

*Flow rate*: 1.0 mL/min.

*Split ratio*: 1:20.

*Temperature*:

	Time (min)	Temperature (°C)
Column	0 - 10	40
	10 - 26	40 → 200
	26 - 40	200
Injection port		200
Detector		225

*Detection*: flame ionisation.

*Injection*: 2  $\mu$ L.

Rinse the syringe with a solution containing *ethylene chloride R* before the injection of the reference solutions. Rinse the syringe with the substance to be examined before the injection of the test solution.

*Identification of impurities*: use the chromatogram supplied with *sevoflurane CRS* and the chromatogram obtained with reference solution (b) to identify the peaks due to impurities A and B.

*Relative retention* with reference to sevoflurane (retention time = about 6.6 min): impurity A = about 0.78; impurity B = about 0.83; internal standard = about 1.35.

*System suitability*: reference solution (b):

- *resolution*: minimum 2.0 between the peaks due to impurities A and B.

Calculate the relative response factor ( $F_1$ ) for reference solution (a), using the following expression:

$$\frac{M_1 \times R}{M_2}$$

- $M_1$  = mass of the internal standard in reference solution (a), in milligrams;
- $M_2$  = mass of the substance to be examined in reference solution (a), in milligrams;
- $R$  = ratio of the area of the peak due to sevoflurane to the area of the peak due to the internal standard from the chromatogram obtained with reference solution (a).

Calculate the quantity of each impurity in the substance to be examined, in parts per million, using the following expression:

$$\frac{0.859 \times R_1 \times 250}{1.52 \times F_1}$$

- 0.859 = relative density of the internal standard;
- 1.52 = relative density of sevoflurane;
- $R_1$  = ratio of the area of the peak due to the impurity to the area of the peak due to the internal standard from the chromatogram obtained with the test solution;
- $F_1$  = relative response factor for reference solution (a).

*Limits*:

- *impurity A*: maximum 25 ppm;
- *impurity B*: maximum 100 ppm;
- *unspecified impurities*: for each impurity, maximum 100 ppm;

- *total*: maximum 300 ppm;
- *disregard limit*: the area of the peak due to sevoflurane in the chromatogram obtained with reference solution (c) (5 ppm).

**Fluorides**: maximum 2  $\mu$ g/mL.

Potentiometry (2.2.36, Method I). Use plastic utensils throughout this test.

*Buffer solution*. Dissolve 0.5 g of *sodium citrate R* and 55 g of *sodium chloride R* in 350 mL of *water R*. Carefully add 75 g of *sodium hydroxide R* and shake to dissolve. Cool to room temperature and carefully add 225 mL of *glacial acetic acid R* while stirring. Cool and add 300 mL of *isopropyl alcohol R*. Dilute with *water R* to 1000.0 mL. The apparent pH of this solution is between 5.0 and 5.5.

*Test solution*. Introduce 50.0 mL of the substance to be examined and 50.0 mL of *water R* into a separating funnel, shake vigorously for 3 min and allow the layers to separate completely. Dilute 25.0 mL of the aqueous upper layer to 50.0 mL with the buffer solution.

*Fluoride standard solution (1000 ppm F)*. Dissolve 221.0 mg of *sodium fluoride R*, previously dried at 150 °C for 4 h, in *water R*. Add 1.0 mL of 0.01 M *sodium hydroxide* and dilute to 100.0 mL with *water R*.

*Reference stock solutions*. Dilute the fluoride standard solution (1000 ppm F) diluted with *water R* to obtain solutions having known concentrations of about 5  $\mu$ g, 2  $\mu$ g, 0.5  $\mu$ g, and 0.2  $\mu$ g of fluoride per millilitre.

*Reference solutions*. Dilute 25.0 mL of each reference stock solution to 50.0 mL with the buffer solution.

*Indicator electrode*: fluoride-selective.

*Reference electrode*: glass-sleeved calomel.

*Apparatus*: voltmeter capable of a minimum reproducibility of  $\pm 0.2$  mV.

Carry out the measurements on the reference solutions and test solution. To take measurements, transfer the solution under test to a 100 mL beaker containing a polytetrafluoroethylene-coated magnetic stirring bar, and immerse the electrodes. Allow to stir on a magnetic stirrer with an insulated top until equilibrium is attained (about 2-3 min), and record the potential. Rinse the electrodes with the buffer solution and dry, taking care to avoid damaging the crystal of the specific-ion electrode.

Calculate the concentration of fluorides using the calibration curve.

**Non-volatile residue**: maximum 100 mg/L.

Transfer 10.0 mL to a tared evaporating dish, evaporate to dryness on a water-bath and dry the residue at 105 °C for 2 h. The residue weighs a maximum of 1.0 mg.

**Water (2.5.12)**: maximum 0.050 per cent *m/m*, determined on 10.0 mL.

**STORAGE**

In an airtight, stainless-steel container, protected from light.

**IMPURITIES**

*Specified impurities*: A, B.

*Other detectable impurities* (the following substances would, if present at a sufficient level, be detected by one or other of the tests in the monograph. They are limited by the general acceptance criterion for other/unspecified impurities and/or by the general monograph *Substances for pharmaceutical use (2034)*. It is therefore not necessary to identify these impurities for demonstration of compliance. See also 5.10. *Control of impurities in substances for pharmaceutical use*): C.

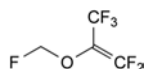

- A. 1,1,1,3,3,3-pentafluoro-2-(fluoromethoxy)prop-1-ene,

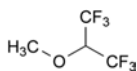

B. 1,1,1,3,3,3-hexafluoro-2-methoxypropane,

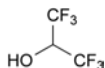

C. 1,1,1,3,3,3-hexafluoropropan-2-ol.

01/2008:1149

## SHELLAC

### Lacca

#### DEFINITION

Purified material obtained from the resinous secretion of the female insect *Kerria lacca* (Kerr) Lindinger (*Laccifer lacca* Kerr). There are 4 types of shellac depending on the nature of the treatment of crude secretion (seedlac): wax-containing shellac, bleached shellac, dewaxed shellac and bleached, dewaxed shellac.

Wax-containing shellac is obtained from seedlac: it is purified by filtration of the molten substance and/or by hot extraction using a suitable solvent.

Bleached shellac is obtained from seedlac by treatment with sodium hypochlorite after dissolution in a suitable alkaline solution, precipitation by dilute acid and drying.

Dewaxed shellac is obtained from wax-containing shellac or seedlac by treatment with a suitable solvent and removal of the insoluble wax by filtering.

Bleached, dewaxed shellac is obtained from wax-containing shellac or seedlac by treatment with sodium hypochlorite after dissolution in a suitable alkaline solution; the insoluble wax is removed by filtration. It is precipitated by dilute acid and dried.

#### CHARACTERS

**Appearance:** brownish-orange or yellow, shining, translucent, hard or brittle, more or less thin flakes (wax-containing shellac and dewaxed shellac), or a creamy white or brownish-yellow powder (bleached shellac and bleached, dewaxed shellac).

**Solubility:** practically insoluble in water, gives a more or less opalescent solution (wax containing shellac and bleached shellac) or a clear solution (dewaxed shellac and bleached, dewaxed shellac) in anhydrous ethanol. When warmed it is sparingly soluble or soluble in alkaline solutions.

#### IDENTIFICATION

A. Thin-layer chromatography (2.2.27).

**Test solution.** Heat 0.25 g of the powdered substance (500) (2.9.12) on a water-bath with 2 mL of *dilute sodium hydroxide solution R* for 5 min. Cool, add 5 mL of *ethyl acetate R* and slowly, with stirring, 2 mL of *dilute acetic acid R*. Shake and filter the upper layer through *anhydrous sodium sulfate R*.

**Reference solution.** Dissolve 6.0 mg of *aleuritic acid R* in 1.0 mL of *methanol R*, heating slightly if necessary.

**Plate:** TLC silica gel  $F_{254}$  plate *R*.

**Mobile phase:** *acetic acid R*, *methanol R*, *methylene chloride R*, *ethyl acetate R* (1:8:32:60 V/V/V/V).

**Application:** 10 µL, as bands.

**Development:** twice over a path of 15 cm.

**Drying:** in air.

**Detection:** spray with *anisaldehyde solution R*, heat at 100-105 °C for 5-10 min and examine in daylight.

**Results:** the chromatogram obtained with the test solution shows several coloured zones, one of which is similar in position and colour to the zone in the chromatogram obtained with the reference solution. Above this zone the chromatogram obtained with the test solution shows a pink

zone and below it several violet zones. Below the zone due to aleuritic acid, there is a light blue zone (shellolic acid) accompanied by zones of the same colour but of lower intensity. Other faint grey and violet zones may be visible.

B. Examine the chromatograms obtained in the test for colophony.

**Results:** for wax-containing shellac, in the chromatogram obtained with the test solution, a more or less strong bluish-grey zone is visible, just above the zone due to thymolphthalein in the chromatogram obtained with the reference solution; for dewaxed shellac, no such zone is visible just above the zone due to thymolphthalein in the chromatogram obtained with the reference solution.

#### TESTS

**Acid value (2.5.1):** 65 to 95 (dried substance).

Examine 1.00 g of the coarsely ground substance. Determine the end-point potentiometrically (2.2.20).

**Colophony.** Thin-layer chromatography (2.2.27) as described under identification test A with the following modifications.

**Test solution.** Dissolve 50 mg of the powdered substance (500) (2.9.12), with heating, in a mixture of 0.5 mL of *methylene chloride R* and 0.5 mL of *methanol R*.

**Reference solution.** Dissolve 2.0 mg of *thymolphthalein R* in 1.0 mL of *methanol R*.

**Detection:** examine in ultraviolet light at 254 nm; mark the quenching zones in the chromatogram obtained with the test solution that have similar  $R_f$  values to that of the quenching zone due to thymolphthalein in the chromatogram obtained with the reference solution; spray with *anisaldehyde solution R*, heat at 100-105 °C for 5-10 min and examine in daylight.

**Results:** the chromatogram obtained with the reference solution shows a principal zone with a reddish-violet colour (thymolphthalein). None of the quenching zones in the chromatogram obtained with the test solution that have an  $R_f$  value similar to the zone due to thymolphthalein in the reference solution show a more or less strong violet or brownish colour (colophony). Disregard any faint violet zone at this level that does not show quenching before spraying and heating.

**Arsenic (2.4.2, Method A):** maximum 3 ppm.

Introduce 0.33 g of the substance to be examined and 5 mL of *sulfuric acid R* into a combustion flask. Carefully add a few millilitres of *strong hydrogen peroxide solution R* and heat to boiling until a clear, colourless solution is obtained. Continue heating to eliminate the water and as much sulfuric acid as possible and dilute to 25 mL with *water R*.

**Heavy metals (2.4.8):** maximum 10 ppm.

2.0 g complies with test D. Prepare the reference solution using 2 mL of *lead standard solution (10 ppm Pb) R*.

**Loss on drying (2.2.32):** maximum 2.0 per cent for unbleached shellac and maximum 6.0 per cent for bleached shellac, determined on 1.000 g of the powdered substance (500) (2.9.12) by drying in an oven at 40-45 °C for 24 h.

#### STORAGE

Protected from light. Store bleached shellac and bleached, dewaxed shellac at a temperature not exceeding 15 °C.

#### LABELLING

The label indicates the type of shellac.

01/2011:0434

## SILICA, COLLOIDAL ANHYDROUS

### Silica colloidalis anhydrica

$\text{SiO}_2$   
[7631-86-9]

$M_r$  60.1

## DEFINITION

**Content:** 99.0 per cent to 100.5 per cent of SiO<sub>2</sub> (ignited substance).

## CHARACTERS

**Appearance:** white or almost white, light, fine, amorphous powder, with a particle size of about 15 nm.

**Solubility:** practically insoluble in water and in mineral acids except hydrofluoric acid. It dissolves in hot solutions of alkali hydroxides.

## IDENTIFICATION

About 20 mg gives the reaction of silicates (2.3.1).

## TESTS

**pH (2.2.3):** 3.5 to 5.5.

Shake 1.0 g with 30 mL of *carbon dioxide-free water R*.

**Chlorides (2.4.4):** maximum 250 ppm.

To 1.0 g add a mixture of 20 mL of *dilute nitric acid R* and 30 mL of *water R* and heat on a water-bath for 15 min, shaking frequently. Dilute to 50 mL with *water R* if necessary, filter and cool. Dilute 10 mL of the filtrate to 15 mL with *water R*.

**Heavy metals (2.4.8):** maximum 25 ppm.

Suspend 2.5 g in sufficient *water R* to produce a semi-fluid slurry. Dry at 140 °C. When the dried substance is white, break up the mass with a glass rod. Add 25 mL of 1 M *hydrochloric acid* and boil gently for 5 min, stirring frequently with the glass rod. Centrifuge for 20 min and filter the supernatant liquid through a membrane filter. To the residue in the centrifuge tube add 3 mL of *dilute hydrochloric acid R* and 9 mL of *water R* and boil. Centrifuge for 20 min and filter the supernatant liquid through the same membrane filter. Wash the residue with small quantities of *water R*, combine the filtrates and washings and dilute to 50 mL with *water R*. To 20 mL of the solution add 50 mg of *ascorbic acid R* and 1 mL of *concentrated ammonia R*. Neutralise with *dilute ammonia R2*. Dilute to 25 mL with *water R*. 12 mL of the solution complies with test A. Prepare the reference solution using *lead standard solution (1 ppm Pb) R*.

**Loss on ignition:** maximum 5.0 per cent, determined on 0.200 g by ignition in a platinum crucible at 900 ± 50 °C for 2 h. Allow to cool in a desiccator before weighing.

## ASSAY

To the residue obtained in the test for loss on ignition add 0.2 mL of *sulfuric acid R* and sufficient *ethanol (96 per cent) R* to moisten the residue completely. Add 6 mL of *hydrofluoric acid R* and evaporate to dryness on a hot-plate at 95-105 °C, taking care to avoid loss from sputtering. Wash down the sides of the dish with 6 mL of *hydrofluoric acid R* and evaporate to dryness. Ignite at 900 ± 50 °C, allow to cool in a desiccator and weigh.

The difference between the mass of the final residue and the mass of the residue obtained in the test for loss on ignition gives the amount of SiO<sub>2</sub> in the quantity of the substance to be examined used.

## FUNCTIONALITY-RELATED CHARACTERISTICS

*This section provides information on characteristics that are recognised as being relevant control parameters for one or more functions of the substance when used as an excipient (see chapter 5.15). This section is a non-mandatory part of the monograph and it is not necessary to verify the characteristics to demonstrate compliance. Control of these characteristics can however contribute to the quality of a medicinal product by improving the consistency of the manufacturing process and the performance of the medicinal product during use. Where control methods are cited, they are recognised as being suitable for the purpose, but other methods can also be used. Wherever results for a particular characteristic are reported, the control method must be indicated.*

*The following characteristic may be relevant for colloidal anhydrous silica used as glidant in tablets and capsules.*

**Specific surface area (2.9.26, Method I).** Determine the specific surface area in the  $P/P_0$  range of 0.05 to 0.30.

**Sample outgassing:** 20 min at 160 °C.

01/2008:0738  
corrected 6.0

## SILICA, COLLOIDAL HYDRATED

## Silica colloidalis hydrica

[63231-67-4]

## DEFINITION

Colloidal hydrated silica contains not less than 98.0 per cent and not more than the equivalent of 100.5 per cent of SiO<sub>2</sub> ( $M_r$  60.1), determined on the ignited substance.

## CHARACTERS

A white or almost white, light, fine, amorphous powder, practically insoluble in water and in mineral acids, with the exception of hydrofluoric acid. It dissolves in hot solutions of alkali hydroxides.

## IDENTIFICATION

A. About 20 mg gives the reaction of silicates (2.3.1).

B. When heated in an oven at 100 °C to 105 °C for 2 h, it shows a loss of mass not less than 3.0 per cent.

## TESTS

**Solution S.** To 2.5 g add 50 mL of *hydrochloric acid R* and mix. Heat on a water-bath for 30 min, stirring from time to time. Maintain the original volume by adding *dilute hydrochloric acid R*. Evaporate to dryness. Add to the residue a mixture of 8 mL of *dilute hydrochloric acid R* and 24 mL of *water R*. Heat to boiling and filter under reduced pressure through a sintered-glass filter (16) (2.1.2). Wash the residue on the filter with a hot mixture of 3 mL of *dilute hydrochloric acid R* and 9 mL of *water R*. Wash with small quantities of *water R*, combine the filtrate and washings and dilute to 50 mL with *water R*.

**pH (2.2.3).** Suspend 1.0 g in 30 mL of a 75 g/L solution of *potassium chloride R*. The pH of the suspension is 4.0 to 7.0.

**Water-absorption capacity.** In a mortar, triturate 5 g with 5 mL of *water R*, added drop by drop. The mixture remains powdery.

**Substances soluble in hydrochloric acid.** In a platinum dish, evaporate to dryness 10.0 mL of solution S and dry to constant mass at 100 °C to 105 °C. The mass of the residue is not more than 10 mg (2.0 per cent).

**Chlorides (2.4.4).** Heat 0.5 g with 50 mL of *water R* on a water-bath for 15 min. Dilute to 100 mL with *water R* and centrifuge at 1500 g for 5 min. 10 mL of the supernatant solution diluted to 15 mL with *water R* complies with the limit test for chlorides (0.1 per cent).

**Sulfates (2.4.13).** Dilute 2 mL of solution S to 100 mL with *distilled water R*. 15 mL of the solution complies with the limit test for sulfates (1 per cent).

**Iron (2.4.9).** To 2 mL of solution S add 28 mL of *water R*. 10 mL of the solution complies with the limit test for iron (300 ppm).

**Heavy metals (2.4.8).** To 20 mL of solution S add 50 mg of *hydroxylamine hydrochloride R* and 1 mL of *concentrated ammonia R*. Adjust to pH 3.5 by adding *dilute ammonia R2*, monitoring the pH potentiometrically. Dilute to 25 mL with *water R*. 12 mL of the solution complies with limit test A for heavy metals (25 ppm). Prepare the standard using *lead standard solution (1 ppm Pb) R*.

**Loss on ignition.** Not more than 20.0 per cent, determined on 0.200 g in a platinum crucible by heating at 100 °C to 105 °C for 1 h and then at 900 ± 50 °C for 2 h.

#### ASSAY

To the residue obtained in the test for loss on ignition add 0.2 mL of *sulfuric acid R* and a quantity of *alcohol R* sufficient to moisten the residue completely. Add 6 mL of *hydrofluoric acid R* and evaporate to dryness at 95 °C to 105 °C, taking care to avoid loss from sputtering. Wash the inside of the dish with 6 mL of *hydrofluoric acid R* and evaporate to dryness again. Ignite at 900 ± 50 °C, allow to cool in a desiccator and weigh. The difference between the mass of the final residue and that of the mass obtained in the test for loss on ignition corresponds to the mass of SiO<sub>2</sub> in the test sample.

01/2011:1562

## SILICA, DENTAL TYPE

### Silica ad usum dentalem

#### DEFINITION

Amorphous silica (precipitated, gel or obtained by flame hydrolysis).

*Content:* 94.0 per cent to 100.5 per cent of SiO<sub>2</sub> (ignited substance).

#### CHARACTERS

*Appearance:* white or almost white, light, fine, amorphous powder.

*Solubility:* practically insoluble in water and in mineral acids. It dissolves in hydrofluoric acid and hot solutions of alkali hydroxides.

#### IDENTIFICATION

About 20 mg gives the reaction of silicates (2.3.1).

#### TESTS

**Solution S.** To 2.5 g add 50 mL of *hydrochloric acid R* and mix. Heat on a water-bath for 30 min, stirring from time to time. Evaporate to dryness. Add to the residue a mixture of 8 mL of *dilute hydrochloric acid R* and 24 mL of *water R*. Heat to boiling and filter under reduced pressure through a sintered-glass filter (16) (2.1.2). Wash the residue on the filter with a hot mixture of 3 mL of *dilute hydrochloric acid R* and 9 mL of *water R*. Wash with small quantities of *water R*, combine the washings and the filtrate, and dilute to 50 mL with *water R*.

**pH** (2.2.3): 3.2 to 8.9.

Suspend 5 g in a mixture of 5 mL of a 7.46 g/L solution of *potassium chloride R* and 90 mL of *carbon dioxide-free water R*.

**Chlorides.** Liquid chromatography (2.2.29) as described in the test for sulfates.

*Retention time:* chlorides = about 4 min.

*Limit:*

– *chlorides:* not more than the area of the corresponding peak in the chromatogram obtained with the reference solution (0.3 per cent).

**Sulfates.** Liquid chromatography (2.2.29).

*Test solution.* To 0.625 g of the substance to be examined add 30 mL of *water R* and boil for 2 h. Allow to cool and quantitatively transfer to a 50 mL graduated flask. Dilute to 50.0 mL with *water R*. Dilute 5.0 mL of the supernatant to 50.0 mL with *water R* and filter through a membrane filter (nominal pore size 0.45 µm).

*Reference solution.* Dissolve 0.50 g of *anhydrous sodium sulfate R* and 0.062 g of *sodium chloride R* in *water R* and dilute to 1000.0 mL with *water R*. Dilute 5.0 mL of the solution to 50.0 mL with *water R*.

*Column:*

- *material:* non-metallic;
- *size:*  $l = 0.25$  m,  $\varnothing = 4.6$  mm;
- *stationary phase:* suitable anion-exchange resin (30-50 µm).

*Mobile phase:* dissolve 0.508 g of *sodium carbonate R* and 0.05 g of *sodium hydrogen carbonate R* in *water R* and dilute to 1000 mL with the same solvent.

*Flow rate:* 1.2 mL/min.

*Detection:* conductivity detector.

*Injection:* 25 µL.

*Retention time:* sulfates = about 8 min.

*Limit:*

- *sulfates:* not more than the area of the corresponding peak in the chromatogram obtained with the reference solution (4.0 per cent, expressed as sodium sulfate).

**Iron** (2.4.9): maximum 400 ppm.

Dilute 2 mL of solution S to 40 mL with *water R*.

**Heavy metals** (2.4.8): maximum 25 ppm.

To 20 mL of solution S, add 50 mg of *hydroxylamine hydrochloride R* and 1 mL of *concentrated ammonia R*. Adjust to pH 3.5 with *dilute ammonia R2*, monitoring the pH potentiometrically. Dilute to 25 mL with *water R*. 12 mL of the solution complies with test A. Prepare the reference solution using *lead standard solution (1 ppm Pb) R*.

**Loss on ignition:** maximum 25.0 per cent, determined on 0.200 g by heating in a platinum crucible at 100-105 °C for 1 h and then at 1000 ± 50 °C for 2 h.

#### ASSAY

To the residue obtained in the test for loss on ignition add 0.2 mL of *sulfuric acid R* and a quantity of *ethanol (96 per cent) R* sufficient to moisten the residue completely. Add 6 mL of *hydrofluoric acid R* and evaporate to dryness at 95-105 °C, taking care to avoid loss from sputtering. Wash the inside of the crucible with 6 mL of *hydrofluoric acid R* and evaporate to dryness again. Ignite at 900 ± 50 °C, allow to cool in a desiccator and weigh. The difference between the mass of the final residue and that of the mass obtained in the test for loss on ignition corresponds to the mass of SiO<sub>2</sub> in the test sample.

#### FUNCTIONALITY-RELATED CHARACTERISTICS

*This section provides information on characteristics that are recognised as being relevant control parameters for one or more functions of the substance when used as an excipient (see chapter 5.15). This section is a non-mandatory part of the monograph and it is not necessary to verify the characteristics to demonstrate compliance. Control of these characteristics can however contribute to the quality of a medicinal product by improving the consistency of the manufacturing process and the performance of the medicinal product during use. Where control methods are cited, they are recognised as being suitable for the purpose, but other methods can also be used. Wherever results for a particular characteristic are reported, the control method must be indicated.*

*The following characteristic may be relevant for dental type silica used as abrasive.*

**Specific surface area** (2.9.26, Method I). Determine the specific surface area in the  $P/P_0$  range of 0.05 to 0.30.

*Sample outgasing:* 60 min at 160 °C.

01/2011:2208

## SILICA, HYDROPHOBIC COLLOIDAL

### Silica hydrophobica colloidalis

#### DEFINITION

Colloidal silicon dioxide partly alkylated for hydrophobation.



*Content:* 99.0 per cent to 101.0 per cent SiO<sub>2</sub> (ignited substance).

#### CHARACTERS

*Appearance:* white or almost white, light, fine, amorphous powder, not wettable by water.

*Solubility:* practically insoluble in water and mineral acids except hydrofluoric acid. It dissolves slowly in hot solutions of alkali hydroxides.

#### IDENTIFICATION

A. About 25 mg ignited in a platinum crucible at 900 ± 50 °C for 2 h gives the reaction of silicates (2.3.1).

B. Water-dispersible fraction (see Tests).

#### TESTS

**Chlorides** (2.4.4): maximum 250 ppm.

To 1.0 g add 30 mL of *methanol R* and 20 mL of *dilute nitric acid R*. Heat on a water-bath for 15 min stirring frequently. Cool, dilute to 50 mL with *water R* and filter. Dilute 10 mL of the filtrate to 15 mL with *water R*.

**Heavy metals** (2.4.8): maximum 25 ppm.

Suspend 2.5 g in 30 mL of *methanol R*, stir and add 30 mL of *dilute ammonia R1*. With frequent stirring evaporate on a water-bath and dry the residue in an oven at 140 °C. When the dried substance is white, break up the mass with a glass rod. Reduce the residue to a powder and add 15 mL of *methanol R* and 25 mL of 1 M *hydrochloric acid*. Boil gently for 5 min, stirring frequently with the glass rod. Centrifuge for 20 min and filter the supernatant liquid through a membrane filter. To the residue in the centrifuge tube add 3 mL of *dilute hydrochloric acid R* and 9 mL of *water R* and boil. Centrifuge for 20 min and filter the supernatant liquid through the same membrane filter. Wash the residue with small quantities of *water R*, combine the filtrates and washings and dilute to 50 mL with *water R*. To 20 mL of this solution add 50 mg of *ascorbic acid R* and 1 mL of *concentrated ammonia R*. Neutralise with *dilute ammonia R2*. Dilute to 25 mL with *water R*. 12 mL of the solution complies with test A. Prepare the reference solution using *lead standard solution (1 ppm Pb) R*.

**Water-dispersible fraction:** maximum 3.0 per cent.

Place 0.400 g in a 500 mL separating funnel, add 100 mL of *water R* and shake for 1 min. Allow to stand for 1 h. Allow 90 mL of the aqueous phase to run out dropwise without filtration into a suitable dish dried at 140 °C and cooled in a desiccator. Evaporate to dryness at 140 °C, starting at a low temperature to avoid splashing. Cool in a desiccator. The residue weighs a maximum of 12 mg.

**Loss on ignition:** maximum 6.0 per cent, determined on 0.200 g by ignition in a platinum crucible at 900 ± 50 °C for 2 h. It is advisable to place the crucible in a cold oven and then to heat up the oven. Allow to cool in a desiccator before weighing.

#### ASSAY

To the residue obtained in the test for loss on ignition add sufficient *ethanol (96 per cent) R* to moisten the residue completely and 0.2 mL of *sulfuric acid R*. Add 6 mL of *hydrofluoric acid R* and evaporate to dryness on a hot-plate at about 100 °C, taking care to avoid loss from sputtering. Wash down the sides of the platinum crucible with 6 mL of *hydrofluoric acid R* and evaporate to dryness. Ignite at 900 ± 50 °C, allow to cool in a desiccator and weigh.

The difference between the mass of the residue obtained in the test for loss on ignition and the mass of the final residue gives the amount of SiO<sub>2</sub> in the quantity of the substance to be examined.

#### FUNCTIONALITY-RELATED CHARACTERISTICS

*This section provides information on characteristics that are recognised as being relevant control parameters for one or more functions of the substance when used as an excipient*

*(see chapter 5.15). This section is a non-mandatory part of the monograph and it is not necessary to verify the characteristics to demonstrate compliance. Control of these characteristics can however contribute to the quality of a medicinal product by improving the consistency of the manufacturing process and the performance of the medicinal product during use.*

*Where control methods are cited, they are recognised as being suitable for the purpose, but other methods can also be used. Wherever results for a particular characteristic are reported, the control method must be indicated.*

*The following characteristic may be relevant for hydrophobic colloidal silica used as glidant in tablets and capsules.*

**Specific surface area** (2.9.26, Method I). Determine the specific surface area in the *P/P<sub>0</sub>* range of 0.05 to 0.30.

*Sample outgassing:* 20 min at 160 °C.

01/2008:2281  
corrected 6.0

## SILVER, COLLOIDAL, FOR EXTERNAL USE

### Argentum colloidal ad usum externum

#### DEFINITION

Colloidal metallic silver containing protein.

*Content:* 70.0 per cent to 80.0 per cent of Ag (dried substance).

#### CHARACTERS

*Appearance:* green or bluish-black metallic shiny flakes or powder, hygroscopic.

*Solubility:* freely soluble or soluble in water, practically insoluble in ethanol (96 per cent) and in methylene chloride.

#### IDENTIFICATION

A. To 5 mL of the filtrate obtained in the test for alkalinity (see Tests) add 0.05 mL of *copper sulfate solution R* and 1 mL of *dilute sodium hydroxide solution R*. Shake. A violet colour appears within 15 min.

B. To 1 mL of solution S (see Tests), add 2 mL of *sodium chloride solution R*. A precipitate is formed which dissolves in an excess of water.

C. Ignite 0.05 g of the substance to be examined. Dissolve the residue in 10 mL of *nitric acid R*. The filtrate gives the reaction of silver (2.3.1).

#### TESTS

**Solution S.** Dissolve 1.25 g of the substance to be examined in *carbon dioxide-free water R* and dilute to 50.0 mL with the same solvent. Allow to stand for 5 min then shake vigorously. Filter through a tared sintered-glass filter (16) (2.1.2) after 30 min.

**Alkalinity.** To 40.0 mL of solution S add 10.0 mL of 0.05 M *sulfuric acid R* and 2.0 g of *anhydrous sodium sulfate R*. Shake and filter several times if necessary. To 25.0 mL of the clear and colourless solution add 0.1 mL of *phenolphthalein solution R*. Not less than 1.5 mL of 0.1 M *sodium hydroxide* is required to change the colour of the indicator to pink.

**Silver ions.** To 0.50 g of the substance to be examined add 5 mL of *anhydrous ethanol R*. Shake for 1 min, filter and add 2 mL of *hydrochloric acid R* to the filtrate. No precipitate is formed.

**Sensitivity to electrolytes.** Dissolve 0.1 g of the substance to be examined in 100 mL of *water R*. Transfer a part of the solution into a test tube. When examined viewing horizontally the solution appears clear and reddish-brown. When examined viewing vertically, the solution appears turbid with a greenish-brown fluorescence. To 5 mL of the solution add 5 mL of a solution of 0.50 g/L *sodium chloride R* and mix by shaking for 1 minute. When examined viewing horizontally the solution remains clear and reddish-brown.

**Water insoluble substances:** maximum 1.0 per cent.

Wash the residue obtained on the filter during preparation of solution S 5 times with 10 mL of *water R*. Dry the filter to constant mass at 100-105 °C. The residue weighs a maximum of 12.5 mg.

**Loss on drying (2.2.32):** maximum 8.0 per cent, determined on 0.500 g by drying in an oven at 80 °C.

#### ASSAY

Ignite 0.200 g of the substance to be examined at 650 ± 50 °C until the residue is white. Allow to cool, add 10 mL of a mixture of equal volumes of *nitric acid R* and *water R* and boil for 1 min. Transfer the contents of the crucible into a flask and titrate with 0.1 M *ammonium thiocyanate* using 50 mg *ferric sulfate R* as indicator, until a reddish-brown colour appears.

1 mL of 0.1 M *ammonium thiocyanate* is equivalent to 10.79 mg of Ag.

#### STORAGE

In an airtight container.

01/2008:0009  
corrected 6.0

## SILVER NITRATE

### Argenti nitras

AgNO<sub>3</sub>  
[7761-88-8]

*M<sub>r</sub>* 169.9

#### DEFINITION

**Content:** 99.0 per cent to 100.5 per cent.

#### CHARACTERS

**Appearance:** white or almost white, crystalline powder or transparent, colourless crystals.

**Solubility:** very soluble in water, soluble in ethanol (96 per cent).

#### IDENTIFICATION

- 10 mg gives the reaction of nitrates (2.3.1).
- 10 mg gives the reaction of silver (2.3.1).

#### TESTS

**Solution S.** Dissolve 2.0 g in *water R* and dilute to 50 mL with the same solvent.

**Appearance of solution.** Solution S is clear (2.2.1) and colourless (2.2.2, *Method II*).

**Acidity or alkalinity.** To 2 mL of solution S add 0.1 mL of *bromocresol green solution R*. The solution is blue. To 2 mL of solution S add 0.1 mL of *phenol red solution R*. The solution is yellow.

**Foreign salts:** maximum 0.3 per cent.

To 30 mL of solution S, add 7.5 mL of *dilute hydrochloric acid R*, shake vigorously, heat for 5 min on a water-bath and filter. Evaporate 20 mL of the filtrate to dryness on a water-bath and dry at 100-105 °C. The residue weighs a maximum of 2 mg.

**Aluminium, lead, copper and bismuth.** Dissolve 1.0 g in a mixture of 4 mL of *concentrated ammonia R* and 6 mL of *water R*. The solution is clear (2.2.1) and colourless (2.2.2, *Method II*).

#### ASSAY

Dissolve 0.300 g in 50 mL of *water R*, add 2 mL of *dilute nitric acid R* and 2 mL of *ferric ammonium sulfate solution R2*. Titrate with 0.1 M *ammonium thiocyanate* until a reddish-yellow colour is obtained.

1 mL of 0.1 M *ammonium thiocyanate* is equivalent to 16.99 mg of AgNO<sub>3</sub>.

#### STORAGE

In a non-metallic container, protected from light.

01/2008:1470

## SIMETICONE

### Simeticonum

#### DEFINITION

Simeticone is prepared by incorporation of 4 per cent to 7 per cent silica into poly(dimethylsiloxane) with a degree of polymerisation between 20 and 400.

**Content:** 90.5 per cent to 99.0 per cent of poly(dimethylsiloxane).

#### PRODUCTION

Poly(dimethylsiloxane) is obtained by hydrolysis and polycondensation of dichlorodimethylsilane and chlorotrimethylsilane and the silica is modified at the surface by incorporation of methylsilyl groups.

#### CHARACTERS

**Appearance:** viscous, greyish-white, opalescent liquid.

**Solubility:** practically insoluble in water, very slightly soluble or practically insoluble in anhydrous ethanol, practically insoluble in methanol, partly miscible with ethyl acetate, with methylene chloride, with methyl ethyl ketone and with toluene.

#### IDENTIFICATION

A. Infrared absorption spectrophotometry (2.2.24).

**Preparation:** thin films between plates of *sodium chloride R*.  
**Absorption maxima:** at 2964 cm<sup>-1</sup>, 2905 cm<sup>-1</sup>, 1412 cm<sup>-1</sup>, 1260 cm<sup>-1</sup> and 1020 cm<sup>-1</sup>.

B. Heat 0.5 g in a test-tube over a small flame until white fumes begin to appear. Invert the tube over a 2<sup>nd</sup> tube containing 1 mL of a 1 g/L solution of *chromotropic acid, sodium salt R* in *sulfuric acid R* so that the fumes reach the solution. Shake the 2<sup>nd</sup> tube for about 10 s and heat on a water-bath for 5 min. The solution is violet.

C. The residue obtained in the test for silica under Assay, gives the reaction of silicates (2.3.1).

#### TESTS

**Acidity.** To 2.0 g add 25 mL of a mixture of equal volumes of *anhydrous ethanol R* and *ether R* previously neutralised to 0.2 mL of *bromothymol blue solution R1*, and shake. Not more than 3.0 mL of 0.01 M *sodium hydroxide* is required to change the colour of the solution to blue.

#### Defoaming activity

**Foaming solution.** Dissolve 5.0 g of *docosate sodium R* in 1 L of *water R*, warm to 50 °C if necessary.

**Defoaming solution.** To 50 mL of *methyl ethyl ketone R* add 0.250 g of the substance to be examined, warm to not more than 50 °C with shaking.

Into a 250 mL cylindrical tube about 5 cm in diameter introduce 100 mL of foaming solution and 1 mL of defoaming solution. Close tightly and fix the tube on a suitable oscillating shaker that complies with the following conditions:

- 250-300 oscillations per minute,
- angle of oscillation of about 10°,
- oscillation radius of about 10 cm.

Shake for 10 s and record the time between the end of the shaking and the instant the 1<sup>st</sup> portion of foam-free liquid surface appears.

This duration is not longer than 15 s.

**Mineral oils.** Place 2.0 g in a test-tube and examine in ultraviolet light at 365 nm. The fluorescence is not more intense than that of a solution containing 0.1 ppm of *quinine sulfate R* in 0.005 M *sulfuric acid* examined in the same conditions.

04/2009:1563

**Phenylated compounds:** the corrected absorbance (2.2.25) is not greater than 0.2.

**Test solution.** Dissolve 5.0 g with shaking in 10.0 mL of *cyclohexane R*.

**Spectral range:** 200-350 nm.

Calculate the corrected absorbance using the following expression:

$$B - C$$

$B$  = absorbance at the absorption maximum between 250 nm and 270 nm,

$C$  = absorbance at 300 nm.

**Heavy metals:** maximum 5 ppm.

Mix 1.0 g with *methylene chloride R* and dilute to 20 mL with the same solvent. Add 1.0 mL of a freshly prepared 0.02 g/L solution of *dithizone R* in *methylene chloride R*, 0.5 mL of *water R* and 0.5 mL of a mixture of 1 volume of *dilute ammonia R2* and 9 volumes of a 2 g/L solution of *hydroxylamine hydrochloride R*. At the same time, prepare the reference solution as follows: to 20 mL of *methylene chloride R* add 1.0 mL of a freshly prepared 0.02 g/L solution of *dithizone R* in *methylene chloride R*, 0.5 mL of *lead standard solution (10 ppm Pb) R* and 0.5 mL of a mixture of 1 volume of *dilute ammonia R2* and 9 volumes of a 2 g/L solution of *hydroxylamine hydrochloride R*. Immediately shake each solution vigorously for 1 min. Any red colour in the test solution is not more intense than that in the reference solution.

**Volatile matter:** maximum 1.0 per cent, determined on 1.00 g by heating in an oven at 150 °C for 2 h. Carry out the test using a dish 60 mm in diameter and 10 mm deep.

#### ASSAY

**Silica.** Heat not less than 20.0 mg to 800 °C increasing the temperature by 20 °C/min under a current of *nitrogen R* at a flow rate of 200 mL/min and weigh the residue (silica).

**Poly(dimethylsiloxane).** Infrared absorption spectrophotometry (2.2.24).

**Test solution.** Place about 50 mg ( $E$ ) in a screw-capped 125 mL cylindrical tube, add 25.0 mL of *toluene R*, swirl manually to disperse and add 50 mL of *dilute hydrochloric acid R*, close the tube and place on a vortex mixer; shake for 5 min. Transfer the contents of the tube to a separating funnel, allow to settle and transfer 5 mL of the upper layer to a screw-capped test tube containing 0.5 g of *anhydrous sodium sulfate R*. Cap and shake vigorously manually. Centrifuge to obtain a clear solution.

**Reference solution.** Introduce about 0.20 g of *dimeticone CRS* (poly(dimethylsiloxane)) into 100.0 mL of *toluene R*. Prepare the reference solution in the same way as for the test solution, using 25.0 mL of the dimeticone solution obtained above.

**Blank solution.** Shake 10 mL of *toluene R* with 1 g of *anhydrous sodium sulfate R*. Centrifuge the resulting suspension.

Record the infrared absorption spectra for the test solution and the reference solution in 0.5 mm cells, from 1330  $\text{cm}^{-1}$  to 1180  $\text{cm}^{-1}$ . Determine the absorbance of the band at 1260  $\text{cm}^{-1}$ .

Calculate the percentage content of poly(dimethylsiloxane) using the following expression:

$$\frac{25 \times C \times A_M \times 100}{A_E \times E}$$

$A_M$  = absorbance of the test solution,

$A_E$  = absorbance of the reference solution,

$C$  = concentration of the reference solution, in milligrams per millilitre,

$E$  = mass of the substance to be examined, in milligrams.

## SIMVASTATIN

### Simvastatinum

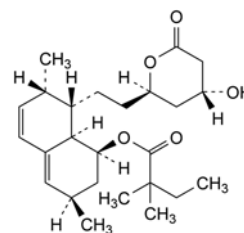

$\text{C}_{25}\text{H}_{38}\text{O}_5$   
[79902-63-9]

$M_r$  418.6

#### DEFINITION

(1*S*,3*R*,7*S*,8*S*,8*aR*)-8-[2-[(2*R*,4*R*)-4-Hydroxy-6-oxo-tetrahydro-2*H*-pyran-2-yl]ethyl]-3,7-dimethyl-1,2,3,7,8,8*a*-hexahydronaphthalen-1-yl 2,2-dimethylbutanoate.

**Content:** 97.0 per cent to 102.0 per cent (dried substance). A suitable antioxidant may be added.

#### CHARACTERS

**Appearance:** white or almost white, crystalline powder.

**Solubility:** practically insoluble in water, very soluble in methylene chloride, freely soluble in ethanol (96 per cent).

#### IDENTIFICATION

A. Specific optical rotation (see Tests).

B. Infrared absorption spectrophotometry (2.2.24).

*Comparison: simvastatin CRS.*

#### TESTS

**Appearance of solution.** The solution is clear (2.2.1) and not more intensely coloured than reference solution BY<sub>7</sub> (2.2.2, Method II).

Dissolve 0.20 g in *methanol R* and dilute to 20 mL with the same solvent.

**Specific optical rotation (2.2.7):** + 285 to + 300 (dried substance).

Dissolve 0.125 g in *acetonitrile R* and dilute to 25.0 mL with the same solvent.

**Related substances.** Liquid chromatography (2.2.29). Prepare the solutions immediately before use.

**Solvent mixture.** Mix 40 volumes of a 1.4 g/L solution of *potassium dihydrogen phosphate R*, adjusted to pH 4.0 with *phosphoric acid R*, and 60 volumes of *acetonitrile R*. Filter.

**Test solution.** Dissolve 75.0 mg of the substance to be examined in the solvent mixture and dilute to 50.0 mL with the solvent mixture.

**Reference solution (a).** Dissolve 1.0 mg of *simvastatin CRS* and 1.0 mg of *lovastatin CRS* (impurity E) in the solvent mixture and dilute to 50.0 mL with the solvent mixture.

**Reference solution (b).** Dilute 0.5 mL of the test solution to 100.0 mL with the solvent mixture.

**Reference solution (c).** Dissolve 75.0 mg of *simvastatin CRS* in the solvent mixture and dilute to 50.0 mL with the solvent mixture.

**Reference solution (d).** Dissolve 5 mg of *simvastatin for peak identification CRS* (containing impurities A, B, C, D, E, F and G) in 5.0 mL of the solvent mixture.

#### Column:

– size:  $l = 0.033$  m,  $\varnothing = 4.6$  mm;

– stationary phase: end-capped octadecylsilyl silica gel for chromatography R (3  $\mu\text{m}$ ).

**Bacterial endotoxins** (2.6.14): less than 5 IU/g if intended for use in the manufacture of parenteral preparations without a further appropriate procedure for the removal of bacterial endotoxins.

#### ASSAY

Dissolve a quantity of the substance to be examined corresponding to 75.0 mg of sodium lactate in a mixture of 10 mL of *glacial acetic acid R* and 20 mL of *acetic anhydride R*. Allow to stand for 15 min. Add 1 mL of *naphtholbenzein solution R* and titrate with *0.1 M perchloric acid*.

1 mL of *0.1 M perchloric acid* is equivalent to 11.21 mg of  $C_3H_5NaO_3$ .

**(S)-enantiomer.** Transfer a quantity of the substance to be examined corresponding to 2.50 g of sodium lactate into a 50 mL volumetric flask, dilute with about 30 mL of *water R* and add 5.0 g of *ammonium molybdate R*. Dissolve and dilute with *water R* to 50.0 mL. Measure the angle of optical rotation (2.2.7). Calculate the percentage content of (S)-enantiomer using the expression:

$$50 + \left( 24.04 \times \alpha \times \frac{5.0}{m} \times \frac{50}{c} \right)$$

$\alpha$  = angle of optical rotation (absolute value),

$m$  = mass of the substance to be examined, in grams,

$c$  = percentage content of  $C_3H_5NaO_3$  in the substance to be examined.

The complex of sodium (S)-lactate formed under these test conditions is leavorotatory.

#### LABELLING

The label states:

- where applicable, that the substance is suitable for use in the manufacture of dialysis, haemodialysis and haemofiltration solutions,
- where applicable, that the substance is suitable for use in the manufacture of parenteral preparations,
- the declared content of sodium lactate.

01/2008:0098

## SODIUM LAURILSULFATE

### Natrii laurilsulfas

#### DEFINITION

Mixture of sodium alkyl sulfates consisting chiefly of sodium dodecyl sulfate ( $C_{12}H_{25}NaO_4S$ ;  $M_r$  288.4).

*Content:*

- *sodium alkyl sulfates*: minimum 85.0 per cent, expressed as  $C_{12}H_{25}NaO_4S$ .

#### CHARACTERS

*Appearance:* white or pale yellow, powder or crystals.

*Solubility:* freely soluble in water giving an opalescent solution, partly soluble in ethanol (96 per cent).

#### IDENTIFICATION

- Dissolve 0.1 g in 10 mL of *water R* and shake. A copious foam is formed.
- To 0.1 mL of the solution prepared for identification test A, add 0.1 mL of a 1 g/L solution of *methylene blue R* and 2 mL of *dilute sulfuric acid R*. Add 2 mL of *methylene chloride R* and shake. An intense blue colour develops in the methylene chloride layer.

- Mix about 10 mg with 10 mL of *anhydrous ethanol R*.

Heat to boiling on a water-bath, shaking frequently. Filter immediately and evaporate the ethanol. Dissolve the residue in 8 mL of *water R*, add 3 mL of *dilute hydrochloric acid R*, evaporate the solution to half its volume and allow to cool. Separate the congealed fatty alcohols by filtration. To the filtrate add 1 mL of *barium chloride solution R1*. A white, crystalline precipitate is formed.

- Ignite 0.5 g. The residue gives reaction (a) of sodium (2.3.1).

#### TESTS

**Alkalinity.** Dissolve 1.0 g in 100 mL of *carbon dioxide-free water R* and add 0.1 mL of *phenol red solution R*. Not more than 0.5 mL of *0.1 M hydrochloric acid* is required to change the colour of the indicator.

**Non-esterified alcohols:** maximum 4 per cent.

Dissolve 10 g in 100 mL of *water R*, add 100 mL of *ethanol (96 per cent) R* and shake the solution with 3 quantities, each of 50 mL, of *pentane R*, adding *sodium chloride R*, if necessary, to promote separation of the 2 layers. Wash the combined organic layers with 3 quantities, each of 50 mL, of *water R*, dry over *anhydrous sodium sulfate R*, filter and evaporate on a water-bath until the solvent has evaporated. Heat the residue at 105 °C for 15 min and cool. The residue weighs a maximum of 0.4 g.

**Sodium chloride and sodium sulfate:** maximum 8.0 per cent for the total percentage content.

**Sodium chloride.** Dissolve 5.00 g in 50 mL of *water R*, add *dilute nitric acid R* dropwise until the solution is neutral to *blue litmus paper R*, add 2 mL of *potassium chromate solution R* and titrate with *0.1 M silver nitrate*.

1 mL of *0.1 M silver nitrate* is equivalent to 5.844 mg of NaCl.

**Sodium sulfate.** Dissolve 0.500 g in 20 mL of *water R*, warming gently if necessary, then add 1 mL of a 0.5 g/L solution of *dithizone R1* in *acetone R*. If the solution is red, add *1 M nitric acid*, dropwise, until the solution becomes bluish-green. Add 2.0 mL of *dichloroacetic acid solution R* and 80 mL of *acetone R*. Titrate with *0.01 M lead nitrate* until a persistent violet-red or orange-red colour is obtained. Carry out a blank titration.

1 mL of *0.01 M lead nitrate* is equivalent to 1.420 mg of  $Na_2SO_4$ .

#### ASSAY

Dissolve 1.15 g in *water R*, warming if necessary, and dilute to 1000.0 mL with the same solvent. To 20.0 mL of the solution add 15 mL of *chloroform R* and 10 mL of *dimidium bromide-sulfan blue mixed solution R*. Titrate with *0.004 M benzethonium chloride*, shaking vigorously and allowing the layers to separate before each addition, until the pink colour of the chloroform layer is completely discharged and a greyish-blue colour is obtained.

1 mL of *0.004 M benzethonium chloride* is equivalent to 1.154 mg of sodium alkyl sulfates, expressed as  $C_{12}H_{25}NaO_4S$ .

01/2008:0849

## SODIUM METABISULFITE

### Natrii metabisulfis

$Na_2S_2O_5$   
[7681-57-4]

$M_r$  190.1

#### DEFINITION

Sodium metabisulfite also called sodium disulfite.

*Content:* 95.0 per cent to 100.5 per cent.

01/2008:0411 **Heavy metals** (2.4.8): maximum 10 ppm.**SODIUM ACETATE TRIHYDRATE**

Natrii acetat trihydricus

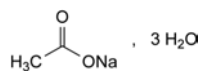
C<sub>2</sub>H<sub>3</sub>NaO<sub>2</sub>·3H<sub>2</sub>O  
[6131-90-4]M<sub>r</sub> 136.1

## DEFINITION

Sodium ethanoate trihydrate.

*Content*: 99.0 per cent to 101.0 per cent (dried substance).

## CHARACTERS

*Appearance*: colourless crystals.*Solubility*: very soluble in water, soluble in ethanol (96 per cent).

## IDENTIFICATION

- A. 1 mL of solution S (see Tests) gives reaction (b) of acetates (2.3.1).
- B. 1 mL of solution S gives reaction (a) of sodium (2.3.1).
- C. Loss on drying (see Tests).

## TESTS

**Solution S.** Dissolve 10.0 g in *carbon dioxide-free water R* prepared from *distilled water R* and dilute to 100 mL with the same solvent.**Appearance of solution.** Solution S is clear (2.2.1) and colourless (2.2.2, *Method II*).**pH** (2.2.3): 7.5 to 9.0.Dilute 5 mL of solution S to 10 mL with *carbon dioxide-free water R*.**Reducing substances.** Dissolve 5.0 g in 50 mL of *water R*, then add 5 mL of *dilute sulfuric acid R* and 0.5 mL of 0.002 M *potassium permanganate*. The pink colour persists for at least 1 h. Prepare a blank in the same manner but without the substance to be examined.**Chlorides** (2.4.4): maximum 200 ppm.Dilute 2.5 mL of solution S to 15 mL with *water R*.**Sulfates** (2.4.13): maximum 200 ppm.Dilute 7.5 mL of solution S to 15 mL with *distilled water R*.**Aluminium** (2.4.17): maximum 0.2 ppm, if intended for use in the manufacture of dialysis solutions.*Prescribed solution.* Dissolve 20 g in 100 mL of *water R* and adjust to pH 6.0 by the addition of 1 M *hydrochloric acid* (about 10 mL).*Reference solution.* Mix 2 mL of *aluminium standard solution* (2 ppm Al) R, 10 mL of *acetate buffer solution pH 6.0 R* and 98 mL of *water R*.*Blank solution.* Mix 10 mL of *acetate buffer solution pH 6.0 R* and 100 mL of *water R*.**Arsenic** (2.4.2, *Method A*): maximum 2 ppm, determined on 0.5 g.**Calcium and magnesium:** maximum 50 ppm, calculated as Ca.To 200 mL of *water R* add 10 mL of *ammonium chloride buffer solution pH 10.0 R*, 0.1 g of *mordant black II tritrate R*, 2.0 mL of 0.05 M *zinc chloride* and, dropwise, 0.02 M *sodium edetate* until the colour changes from violet to blue. Add to the solution 10.0 g of the substance to be examined and shake to dissolve. Titrate with 0.02 M *sodium edetate* until the blue colour is restored. Not more than 0.65 mL of 0.02 M *sodium edetate* is required.12 mL of solution S complies with test A. Prepare the reference solution using *lead standard solution* (1 ppm Pb) R.**Iron** (2.4.9): maximum 10 ppm, determined on 10 mL of solution S.**Loss on drying** (2.2.32): 39.0 per cent to 40.5 per cent, determined on 1.000 g by drying in an oven at 130 °C. Introduce the substance to be examined into the oven while the latter is cold.

## ASSAY

Dissolve 0.250 g in 50 mL of *anhydrous acetic acid R*, add 5 mL of *acetic anhydride R*, mix and allow to stand for 30 min. Using 0.3 mL of *naphtholbenzein solution R* as indicator, titrate with 0.1 M *perchloric acid* until a green colour is obtained.1 mL of 0.1 M *perchloric acid* is equivalent to 8.20 mg of C<sub>2</sub>H<sub>3</sub>NaO<sub>2</sub>.

## STORAGE

In an airtight container.

## LABELLING

The label states, where applicable, that the substance is suitable for use in the manufacture of dialysis solutions.

01/2008:1564  
corrected 6.3**SODIUM ALENDRONATE**

Natrii alendronas

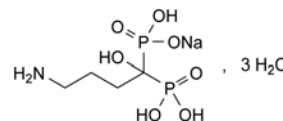
C<sub>4</sub>H<sub>12</sub>NNaO<sub>7</sub>P<sub>2</sub>·3H<sub>2</sub>O  
[121268-17-5]M<sub>r</sub> 325.1

## DEFINITION

Sodium alendronate contains not less than 98.0 per cent and not more than the equivalent of 102.0 per cent of (4-amino-1-hydroxybutylidene)bisphosphonic acid monosodium salt, calculated with reference to the dried substance.

## CHARACTERS

A white or almost white, crystalline powder, soluble in water, very slightly soluble in methanol, practically insoluble in methylene chloride.

## IDENTIFICATION

- A. Examine by infrared absorption spectrophotometry (2.2.24), comparing with the spectrum obtained with *sodium alendronate CRS*. Examine the substances prepared as discs.
- B. It gives reaction (a) of sodium (2.3.1).

## TESTS

**Solution S.** Dissolve 0.5 g in *carbon dioxide-free water R* prepared from *distilled water R* and dilute to 50 mL with the same solvent.**Appearance of solution.** Solution S is clear (2.2.1) and not more intensely coloured than reference solution B<sub>7</sub> or BY<sub>7</sub> (2.2.2, *Method II*).**pH** (2.2.3). The pH of solution S is 4.0 to 5.0.**4-aminobutanoic acid.** Examine by thin-layer chromatography (2.2.27), using a *TLC silica gel plate R*.*Test solution.* Dissolve 0.10 g of the substance to be examined in *water R* and dilute to 10 mL with the same solvent.*Reference solution (a).* Dissolve 0.10 g of *4-aminobutanoic acid R* in *water R* and dilute to 200 mL with the same solvent.

Reference solution (b). Dilute 1 mL of reference solution (a) to 10 mL with *water R*.

Apply to the plate 5 µL of the test solution and 5 µL of reference solution (b). Allow the plate to dry in air. Develop over a path of 15 cm using a mixture of 20 volumes of *water R*, 20 volumes of *glacial acetic acid R* and 60 volumes of *butanol R*. Dry the plate in a current of warm air. Spray with *ninhydrin solution R* and heat at 100 °C to 105 °C for 15 min. Any spots corresponding to 4-aminobutanoic acid in the chromatogram obtained with the test solution are not more intense than the spot in the chromatogram obtained with reference solution (b) (0.5 per cent).

**Phosphate and phosphite.** Examine the chromatograms obtained in the assay. In the chromatogram obtained with the test solution: the area of any peak corresponding to phosphate is not greater than that of the peak due to phosphate in the chromatogram obtained with reference solution (d) (0.5 per cent); the area of any peak corresponding to phosphite is not greater than that of the peak due to phosphite in the chromatogram obtained with reference solution (d) (0.5 per cent).

**Heavy metals (2.4.8).** 1.0 g complies with limit test F for heavy metals (20 ppm). Prepare the reference solution using 2 mL of *lead standard solution (10 ppm Pb) R*.

**Loss on drying (2.2.32):** 16.1 per cent to 17.1 per cent, determined on 1.000 g by drying in an oven at 140 °C to 145 °C.

#### ASSAY

Examine by liquid chromatography (2.2.29).

**Test solution.** Dissolve 50.0 mg of the substance to be examined in *water R* and dilute to 25.0 mL with the same solvent.

**Reference solution (a).** Dissolve 50.0 mg of *sodium alendronate CRS* in *water R* and dilute to 25.0 mL with the same solvent.

**Reference solution (b).** Dissolve 3.0 g of *phosphoric acid R* in *water R* and dilute to 100.0 mL with the same solvent. Dilute 1.0 mL of the solution to 100.0 mL with *water R*.

**Reference solution (c).** Dissolve 2.5 g of *phosphorous acid R* in *water R* and dilute to 100.0 mL with the same solvent. Dilute 1.0 mL of the solution to 100.0 mL with *water R*.

**Reference solution (d).** Mix 2.0 mL of reference solution (b) and 2.0 mL of reference solution (c) and dilute to 50.0 mL with *water R*.

The chromatographic procedure may be carried out using:

- a column 0.15 m long and 4.6 mm in internal diameter packed with *anion exchange resin RI (7 µm)*,
- as mobile phase at a flow rate of 1.2 mL/min a solution of 0.2 mL of *anhydrous formic acid R* in 1000 mL of *water R*, adjusted to pH 3.5 with 2 M *sodium hydroxide R*,
- as detector a refractometer,
- a 100 µL loop injector,

maintaining the temperature of the column at 35 °C.

Inject reference solution (a) six times. The assay is not valid unless the relative standard deviation of the peak area of sodium alendronate is at most 1.0 per cent. Inject the test solution, reference solution (a) and reference solution (d). The retention time of sodium alendronate is about 16 min and the relative retention times are: phosphate about 1.3 and phosphite about 1.6. Record the chromatograms for twice the retention time of the principal peak in the chromatogram obtained with the test solution.

Calculate the percentage content of C<sub>4</sub>H<sub>12</sub>NNaO<sub>7</sub>P<sub>2</sub> from the peak areas and the declared content of *sodium alendronate CRS*.

#### IMPURITIES



- A. 4-aminobutanoic acid,
- B. phosphate,

C. phosphite.

01/2010:0625  
corrected 7.0

## SODIUM ALGINATE

### Natrii alginas

#### DEFINITION

Sodium alginate consists mainly of the sodium salt of alginic acid, which is a mixture of polyuronic acids [(C<sub>6</sub>H<sub>8</sub>O<sub>6</sub>)<sub>n</sub>] composed of units of D-mannuronic acid and L-guluronic acid. Sodium alginate is obtained mainly from algae belonging to the Phaeophyceae.

#### CHARACTERS

**Appearance:** white or pale yellowish-brown powder.

**Solubility:** slowly soluble in water forming a viscous, colloidal solution, practically insoluble in ethanol (96 per cent).

#### IDENTIFICATION

- A. Dissolve 0.2 g with shaking in 20 mL of *water R*. To 5 mL of this solution add 1 mL of *calcium chloride solution R*. A voluminous gelatinous mass is formed.
- B. To 10 mL of the solution prepared in identification test A add 1 mL of *dilute sulfuric acid R*. A gelatinous mass is formed.
- C. To 5 mg add 5 mL of *water R*, 1 mL of a freshly prepared 10 g/L solution of *1,3-dihydroxynaphthalene R* in *ethanol (96 per cent) R* and 5 mL of *hydrochloric acid R*. Boil for 3 min, cool, add 5 mL of *water R*, and shake with 15 mL of *di-isopropyl ether R*. Carry out a blank test. The upper layer obtained with the substance to be examined exhibits a deeper bluish-red colour than that obtained with the blank.
- D. Sulfated ash (see Tests). The residue obtained, dissolved in 2 mL of *water R*, gives reaction (a) of sodium (2.3.1).

#### TESTS

**Solution S.** Dissolve 0.10 g in *water R* with constant stirring, dilute to 30 mL with the same solvent and allow to stand for 1 h.

**Appearance of solution.** The solution is not more opalescent than reference suspension II (2.2.1) and not more intensely coloured than intensity 6 of the range of reference solutions of the most appropriate colour (2.2.2, *Method II*).

Dilute 1 mL of solution S to 10 mL with *water R*.

**Chlorides:** maximum 1.0 per cent.

To 2.50 g add 50 mL of *dilute nitric acid R*, shake for 1 h and dilute to 100.0 mL with *dilute nitric acid R*. Filter. To 50.0 mL of the filtrate add 10.0 mL of 0.1 M *silver nitrate* and 5 mL of *toluene R*. Titrate with 0.1 M *ammonium thiocyanate*, using 2 mL of *ferric ammonium sulfate solution R2* as indicator and shaking vigorously towards the end point.

1 mL of 0.1 M *silver nitrate* is equivalent to 3.545 mg of Cl.

**Calcium:** maximum 1.5 per cent.

Atomic absorption spectrometry (2.2.23, *Method II*).

**Test solution.** Dissolve 0.10 g in 50 mL of *dilute ammonia R2*, heating on a water-bath. Allow to cool and dilute to 100.0 mL with *distilled water R* (solution (a)). Dilute 3.0 mL of solution (a) to 100.0 mL with *distilled water R*.

**Reference solutions.** Prepare 3 reference solutions in the same manner as the test solution but add 0.75 mL, 1.0 mL and 1.5 mL respectively of *calcium standard solution (100 ppm Ca) R* to the 3.0 mL of solution (a).

Set the zero of the instrument using a mixture of 1.5 volumes of *dilute ammonia R2* and 98.5 volumes of *distilled water R*.

**Source:** calcium hollow-cathode lamp.

**Wavelength:** 422.7 nm.

**Atomisation device:** air-acetylene flame.

**Heavy metals** (2.4.8): maximum 20 ppm.

1.0 g complies with test F. Prepare the reference solution using 2 mL of *lead standard solution* (10 ppm Pb) R.

**Loss on drying** (2.2.32): maximum 15.0 per cent, determined on 0.1000 g by drying in an oven at 105 °C for 4 h.

**Sulfated ash** (2.4.14): 30.0 per cent to 36.0 per cent (dried substance), determined on 0.1000 g.

#### Microbial contamination

TAMC: acceptance criterion 10<sup>3</sup> CFU/g (2.6.12).

TYMC: acceptance criterion 10<sup>2</sup> CFU/g (2.6.12).

Absence of *Escherichia coli* (2.6.13).

Absence of *Salmonella* (2.6.13).

#### FUNCTIONALITY-RELATED CHARACTERISTICS

*This section provides information on characteristics that are recognised as being relevant control parameters for one or more functions of the substance when used as an excipient (see chapter 5.15). This section is a non-mandatory part of the monograph and it is not necessary to verify the characteristics to demonstrate compliance. Control of these characteristics can however contribute to the quality of a medicinal product by improving the consistency of the manufacturing process and the performance of the medicinal product during use. Where control methods are cited, they are recognised as being suitable for the purpose, but other methods can also be used. Wherever results for a particular characteristic are reported, the control method must be indicated.*

*The following characteristic may be relevant for sodium alginate used as viscosity-increasing agent or binder.*

**Apparent viscosity** (2.2.10). Carry out the test on a 10 g/L solution (dried substance). Determine the dynamic viscosity at 20 °C using a rotating viscometer at 20 r/min.

- B. Examine the chromatograms obtained in the test for related substances. The principal spot in the chromatogram obtained with test solution (b) is similar in position and size to the principal spot in the chromatogram obtained with reference solution (b).
- C. Heat 50 mg gently in a small porcelain dish over a naked flame. Violet vapour is evolved.
- D. It gives reaction (a) of sodium (2.3.1).

#### TESTS

**Solution S.** Dissolve 10 g in *carbon dioxide-free water R* and dilute to 20 mL with the same solvent.

**Appearance of solution.** Dilute 1 mL of solution S to 10 mL with *water R*. The solution is clear (2.2.1) and colourless (2.2.2, Method II).

**pH** (2.2.3). The pH of solution S is 7.5 to 9.5.

**Related substances.** Examine by thin-layer chromatography (2.2.27), using a *TLC silica gel GF<sub>254</sub> plate R*. Prepare the solutions in subdued light and develop the chromatograms protected from light.

**Test solution (a).** Dissolve 0.50 g of the substance to be examined in a 3 per cent V/V solution of *ammonia R* in *methanol R* and dilute to 10 mL with the same solution.

**Test solution (b).** Dilute 1 mL of test solution (a) to 10 mL with a 3 per cent V/V solution of *ammonia R* in *methanol R*.

**Reference solution (a).** Dilute 1 mL of test solution (b) to 50 mL with a 3 per cent V/V solution of *ammonia R* in *methanol R*.

**Reference solution (b).** Dissolve 50 mg of *sodium amidotrizoate CRS* in a 3 per cent V/V solution of *ammonia R* in *methanol R* and dilute to 10 mL with the same solution.

Apply separately to the plate 2 µL of each solution. Develop over a path of 15 cm using a mixture of 20 volumes of *anhydrous formic acid R*, 25 volumes of *methyl ethyl ketone R* and 60 volumes of *toluene R*. Allow the plate to dry until the solvents have evaporated and examine in ultraviolet light at 254 nm. Any spot in the chromatogram obtained with test solution (a), apart from the principal spot, is not more intense than the spot in the chromatogram obtained with reference solution (a) (0.2 per cent).

**Free aromatic amines.** *Maintain the solutions and reagents in iced water, protected from light.* To 0.50 g in a 50 mL volumetric flask add 15 mL of *water R*. Shake and add 1 mL of *dilute sodium hydroxide solution R*. Cool in iced water, add 5 mL of a freshly prepared 5 g/L solution of *sodium nitrite R* and 12 mL of *dilute hydrochloric acid R*. Shake gently and allow to stand for exactly 2 min after adding the hydrochloric acid. Add 10 mL of a 20 g/L solution of *ammonium sulfamate R*. Allow to stand for 5 min, shaking frequently, and add 0.15 mL of a 100 g/L solution of *α-naphthol R* in *alcohol R*. Shake and allow to stand for 5 min. Add 3.5 mL of *buffer solution pH 10.9 R*, mix and dilute to 50.0 mL with *water R*. The absorbance (2.2.25), measured within 20 min at 485 nm using as the compensation liquid a solution prepared at the same time and in the same manner but omitting the substance to be examined, is not greater than 0.30.

**Free iodine and iodides.** Not more than 50 ppm. Dissolve 1.0 g in *distilled water R* and dilute to 10 mL with the same solvent. Add dropwise *dilute nitric acid R* until the precipitation is complete, then add 3 mL of *dilute nitric acid R*. Filter and wash the precipitate with 5 mL of *water R*. Collect the filtrate and washings. Add 1 mL of *strong hydrogen peroxide solution R* and 1 mL of *methylene chloride R*. Shake. The lower layer is not more intensely coloured than a reference solution prepared simultaneously and in the same manner, using a mixture of 5 mL of *iodide standard solution (10 ppm I) R*, 3 mL of *dilute nitric acid R* and 15 mL of *water R*.

01/2008:1150

## SODIUM AMIDOTRIZOATE

### Natrii amidotrizoas

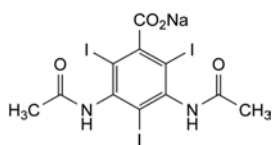

C<sub>11</sub>H<sub>8</sub>I<sub>3</sub>N<sub>2</sub>NaO<sub>4</sub>  
[737-31-5]

M<sub>r</sub> 636

#### DEFINITION

Sodium amidotrizoate contains not less than 98.0 per cent and not more than the equivalent of 101.0 per cent of sodium 3,5-bis(acetylamino)-2,4,6-tri-iodobenzoate, calculated with reference to the anhydrous substance.

#### CHARACTERS

A white or almost white powder, freely soluble in water, slightly soluble in alcohol, practically insoluble in acetone.

It melts at about 261 °C with decomposition.

#### IDENTIFICATION

*First identification:* A, D.

*Second identification:* B, C, D.

- A. Examine by infrared absorption spectrophotometry (2.2.24), comparing with the spectrum obtained with *sodium amidotrizoate CRS*. Dry both the substance to be examined and the reference substance at 100 °C to 105 °C for 3 h.

**Heavy metals** (2.4.8). Dilute 4 mL of solution S to 20 mL with *water R*. 12 mL of this solution complies with limit test A for heavy metals (20 ppm). Prepare the standard using *lead standard solution (2 ppm Pb) R*.

**Water** (2.5.12). Not more than 11.0 per cent, determined on 0.400 g by the semi-micro determination of water.

#### ASSAY

To 0.150 g in a 250 mL round-bottomed flask add 5 mL of *strong sodium hydroxide solution R*, 20 mL of *water R*, 1 g of *zinc powder R* and a few glass beads. Boil under a reflux condenser for 30 min. Allow to cool and rinse the condenser with 20 mL of *water R*, adding the rinsings to the flask. Filter through a sintered-glass filter (2.1.2) and wash the filter with several quantities of *water R*. Collect the filtrate and washings. Add 40 mL of *dilute sulfuric acid R* and titrate immediately with 0.1 M *silver nitrate*. Determine the end-point potentiometrically (2.2.20), using a suitable electrode system such as silver-mercurous sulfate.

1 mL of 0.1 M *silver nitrate* is equivalent to 21.20 mg of  $C_{11}H_8I_3N_2NaO_4$ .

#### STORAGE

Store protected from light.

#### IMPURITIES

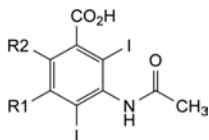

- A. R1 = NH<sub>2</sub>, R2 = I: 3-acetylamino-5-amino-2,4,6-tri-iodobenzoic acid,  
 B. R1 = NHCOCH<sub>3</sub>, R2 = H: 3,5-bis(acetylamino)-2,4-di-iodobenzoic acid.

01/2008:1993  
corrected 7.0

## SODIUM AMINOSALICYLATE DIHYDRATE

Natrii aminosalicylas dihydricus

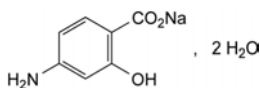

$C_7H_6NNaO_3 \cdot 2H_2O$   
[6018-19-5]

$M_r$  211.2

#### DEFINITION

Sodium 4-amino-2-hydroxybenzoate dihydrate.

*Content*: 99.0 per cent to 101.0 per cent (dried substance).

#### CHARACTERS

*Appearance*: white or almost white crystalline powder or crystals, slightly hygroscopic.

*Solubility*: freely soluble in water, sparingly soluble in alcohol, practically insoluble in methylene chloride.

#### IDENTIFICATION

*First identification*: A, E.

*Second identification*: B, C, D, E.

A. Infrared absorption spectrophotometry (2.2.24).

*Comparison*: Ph. Eur. reference spectrum of sodium aminosalicylate dihydrate.

- B. Introduce 0.3 g into a porcelain crucible. Cautiously heat on a small flame until vapour is evolved. Cover the crucible with a watch glass and collect the white sublimate. The melting point (2.2.14) of the sublimate is 120 °C to 124 °C.  
 C. To 0.1 mL of solution S (see Tests) add 5 mL of *water R* and 0.1 mL of *ferric chloride solution R1*. A reddish-brown colour develops.  
 D. 2 mL of solution S gives the reaction of primary aromatic amines (2.3.1).  
 E. 0.5 mL of solution S gives reaction (a) of sodium (2.3.1).

#### TESTS

**Solution S**. Dissolve 0.50 g in *carbon dioxide-free water R* and dilute to 25 mL with the same solvent.

**Appearance of solution**. The freshly prepared solution is clear (2.2.1) and not more intensely coloured than reference solution B<sub>5</sub> (2.2.2, *Method II*).

Dissolve 2.5 g in *water R* and dilute to 25 mL with the same solvent.

**pH** (2.2.3): 6.5 to 8.5 for solution S.

**Related substances**. Liquid chromatography (2.2.29). Use freshly prepared solutions and mobile phases.

*Test solution*. Dissolve 50.0 mg of the substance to be examined in *water R* and dilute to 50.0 mL with the same solvent.

*Reference solution (a)*. Dissolve 5.0 mg of 3-aminophenol R in *water R* and dilute to 100.0 mL with the same solvent.

*Reference solution (b)*. Dissolve 5.0 mg of mesalazine CRS in *water R* and dilute to 100.0 mL with the same solvent. To 10.0 mL of this solution add 1.0 mL of reference solution (a) and dilute to 50.0 mL with *water R*.

*Column*:

- size:  $l = 0.25$  m,  $\varnothing = 4.6$  mm,
- stationary phase: spherical base-deactivated octylsilyl silica gel for chromatography R (5  $\mu$ m).

*Mobile phase*:

- mobile phase A: dissolve 2.2 g of perchloric acid R and 1.0 g of phosphoric acid R in *water R* and dilute to 1000.0 mL with the same solvent,
- mobile phase B: dissolve 1.7 g of perchloric acid R and 1.0 g of phosphoric acid R in acetonitrile R and dilute to 1000.0 mL with the same solvent,

Time (min)	Mobile phase A (per cent V/V)	Mobile phase B (per cent V/V)
0 - 15	100	0
15 - 30	100 → 40	0 → 60

*Flow rate*: 1.25 mL/min.

*Detection*: spectrophotometer at 220 nm.

*Injection*: 10  $\mu$ L.

*Relative retention* with reference to 4-aminosalicylate (retention time = about 12 min): impurity A = about 0.30; impurity B = about 0.37.

*System suitability*: reference solution (b):

- resolution: minimum 4.0 between the peaks due to impurity A and impurity B.

*Limits*:

- impurity A: not more than the area of the corresponding peak in the chromatogram obtained with reference solution (b) (0.1 per cent),
- impurity B: not more than the area of the corresponding peak in the chromatogram obtained with reference solution (b) (1.0 per cent),



- *any other impurity*: for each impurity, not more than 0.1 times the area of the peak due to impurity B in the chromatogram obtained with reference solution (b) (0.1 per cent),
- *total*: not more than the area of the peak due to impurity B in the chromatogram obtained with reference solution (b) (1.0 per cent),
- *disregard limit*: 0.05 times the area of the peak due to impurity B in the chromatogram obtained with reference solution (b) (0.05 per cent).

**Heavy metals** (2.4.8): maximum 10 ppm.

2.0 g complies with limit test C. Prepare the standard using 2 mL of *lead standard solution (10 ppm Pb) R*.

**Loss on drying** (2.2.32): 16.0 per cent to 17.5 per cent, determined on 1.000 g by drying in an oven at 105 °C.

**Pyrogens** (2.6.8). If intended for use in the manufacture of parenteral preparations without a further appropriate procedure for the removal of pyrogens, it complies with the test for pyrogens. Inject per kilogram of the rabbit's mass, 10 mL of a 20 mg/mL solution of the substance to be examined in *water for injections R*.

#### ASSAY

Dissolve 0.150 g in 20 mL of *water R*. Add 10 mL of a 500 g/L solution of *sodium bromide R* and 25 mL of *glacial acetic acid R*. Add 5 mL of 0.1 M *sodium nitrite* rapidly and continue the titration with the same titrant, determining the end-point potentiometrically (2.2.20).

1 mL of 0.1 M *sodium nitrite* is equivalent to 17.52 mg of  $C_7H_6NNaO_3$ .

#### STORAGE

In an airtight container, protected from light. If the substance is sterile, store in a sterile, airtight, tamper-proof container.

#### IMPURITIES

*Specified impurities*: A, B.

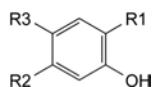

A. R1 = R3 = H, R2 = NH<sub>2</sub>: 3-aminophenol,

B. R1 = CO<sub>2</sub>H, R2 = H, R3 = NH<sub>2</sub>: 5-amino-2-hydroxybenzoic acid (mesalazine).

01/2011:1791

## SODIUM ASCORBATE

Natrii ascorbas

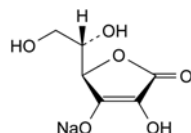

$C_6H_7NaO_6$   
[134-03-2]

$M_r$  198.1

#### DEFINITION

Sodium (2*R*)-2-[(1*S*)-1,2-dihydroxyethyl]-4-hydroxy-5-oxo-2,5-dihydrofuran-3-olate.

*Content*: 99.0 per cent to 101.0 per cent (dried substance).

#### CHARACTERS

*Appearance*: white or yellowish, crystalline powder or crystals.

*Solubility*: freely soluble in water, sparingly soluble in ethanol (96 per cent), practically insoluble in methylene chloride.

#### IDENTIFICATION

*First identification*: B, D.

*Second identification*: A, C, D.

A. Specific optical rotation (2.2.7) (see Tests).

B. Infrared absorption spectrophotometry (2.2.24).

*Comparison*: *sodium ascorbate CRS*.

C. To 1 mL of solution S (see Tests) add 0.2 mL of *dilute nitric acid R* and 0.2 mL of *silver nitrate solution R2*. A grey precipitate is formed.

D. 1 mL of solution S gives reaction (a) of sodium (2.3.1).

#### TESTS

**Solution S**. Dissolve 10.0 g in *carbon dioxide-free water R* prepared from *distilled water R* and dilute to 100.0 mL with the same solvent.

**Appearance of solution**. Solution S is clear (2.2.1) and not more intensely coloured than reference solution Y<sub>6</sub> or BY<sub>6</sub> (2.2.2, *Method II*); examine the colour immediately after preparation of the solution.

**pH** (2.2.3): 7.0 to 8.0 determined on freshly prepared solution S.

**Specific optical rotation** (2.2.7): + 103 to + 108 (dried substance), determined on freshly prepared solution S.

**Impurity E**: maximum 0.3 per cent.

*Test solution*. Dissolve 0.25 g in 5 mL of *water R*. Add 1 mL of *dilute acetic acid R* and 0.5 mL of *calcium chloride solution R*.

*Reference solution*. Dissolve 70 mg of *oxalic acid R* in *water R* and dilute to 500 mL with the same solvent; to 5 mL of the solution add 1 mL of *dilute acetic acid R* and 0.5 mL of *calcium chloride solution R*.

Allow the solutions to stand for 1 h. Any opalescence in the test solution is not more intense than that in the reference solution.

**Related substances**. Liquid chromatography (2.2.29). *Prepare the solutions immediately before use*.

*Phosphate buffer solution*. Dissolve 6.8 g of *potassium dihydrogen phosphate R* in *water R* and dilute to about 175 mL with the same solvent. Filter through a membrane filter (nominal pore size 0.45 µm) and dilute to 1000 mL with *water R*.

*Test solution*. Dissolve 0.500 g of the substance to be examined in the phosphate buffer solution and dilute to 10.0 mL with the phosphate buffer solution.

*Reference solution (a)*. Dissolve 10.0 mg of *ascorbic acid impurity C CRS* in the mobile phase and dilute to 5.0 mL with the mobile phase.

*Reference solution (b)*. Dissolve 5.0 mg of *ascorbic acid impurity D CRS* and 5.0 mg of *ascorbic acid CRS* in the mobile phase, add 2.5 mL of reference solution (a) and dilute to 100.0 mL with the mobile phase.

*Reference solution (c)*. Dilute 1.0 mL of the test solution to 200.0 mL with the mobile phase. Mix 1.0 mL of this solution with 1.0 mL of reference solution (a).

*Column*:

– *size*:  $l = 0.25$  m,  $\varnothing = 4.6$  mm;

– *stationary phase*: aminopropylsilyl silica gel for chromatography R (5 µm);

– *temperature*: 45 °C.

*Mobile phase*: phosphate buffer solution, *acetonitrile R1* (25:75 V/V).

*Flow rate*: 1.0 mL/min.

*Detection*: spectrophotometer at 210 nm.

*Injection*: 20 µL of the test solution and reference solutions (b) and (c).

*Run time*: 2.5 times the retention time of ascorbic acid.

*Identification of impurities*: use the chromatogram obtained with reference solution (b) to identify the peaks due to impurities C and D.

*Relative retention* with reference to ascorbic acid (retention time = about 11 min): impurity D = about 0.4; impurity C = about 1.7.

*System suitability*:

- *resolution*: minimum 3.0 between the peaks due to ascorbic acid and impurity C in the chromatogram obtained with reference solution (c);
- *signal-to-noise ratio*: minimum 20 for the peak due to impurity C in the chromatogram obtained with reference solution (b).

*Limits*:

- *impurities C, D*: for each impurity, not more than 1.5 times the area of the corresponding peak in the chromatogram obtained with reference solution (b) (0.15 per cent);
- *unspecified impurities*: for each impurity, not more than the area of the peak due to ascorbic acid in the chromatogram obtained with reference solution (b) (0.10 per cent);
- *total of impurities other than C and D*: not more than twice the area of the peak due to ascorbic acid in the chromatogram obtained with reference solution (b) (0.2 per cent);
- *disregard limit*: 0.5 times the area of the peak due to ascorbic acid in the chromatogram obtained with reference solution (b) (0.05 per cent).

**Sulfates** (2.4.13): maximum 150 ppm.

To 10 mL of solution S add 2 mL of *hydrochloric acid R1* and dilute to 15 mL with *distilled water R*.

**Copper**: maximum 5 ppm.

Atomic absorption spectrometry (2.2.23, *Method I*).

*Test solution*. Dissolve 2.0 g in 0.1 M *nitric acid* and dilute to 25.0 mL with the same acid.

*Reference solutions*. Prepare the reference solutions (0.2 ppm, 0.4 ppm and 0.6 ppm) by diluting *copper standard solution (10 ppm Cu) R* with 0.1 M *nitric acid*.

*Source*: copper hollow-cathode lamp.

*Wavelength*: 324.8 nm.

*Atomisation device*: air-acetylene flame.

**Iron**: maximum 2 ppm.

Atomic absorption spectrometry (2.2.23, *Method I*).

*Test solution*. Dissolve 5.0 g in 0.1 M *nitric acid* and dilute to 25.0 mL with the same acid.

*Reference solutions*. Prepare the reference solutions (0.2 ppm, 0.4 ppm and 0.6 ppm) by diluting *iron standard solution (20 ppm Fe) R* with 0.1 M *nitric acid*.

*Source*: iron hollow-cathode lamp.

*Wavelength*: 248.3 nm.

*Atomisation device*: air-acetylene flame.

**Nickel**: maximum 1 ppm.

Atomic absorption spectrometry (2.2.23, *Method I*).

*Test solution*. Dissolve 10.0 g in 0.1 M *nitric acid* and dilute to 25.0 mL with the same acid.

*Reference solutions*. Prepare the reference solutions (0.2 ppm, 0.4 ppm and 0.6 ppm) by diluting *nickel standard solution (10 ppm Ni) R* with 0.1 M *nitric acid*.

*Source*: nickel hollow-cathode lamp.

*Wavelength*: 232.0 nm.

*Atomisation device*: air-acetylene flame.

**Heavy metals** (2.4.8): maximum 10 ppm.

Dissolve 2.0 g in *water R* and dilute to 20 mL with the same solvent. 12 mL of the solution complies with test A. Prepare the reference solution using *lead standard solution (1 ppm Pb) R*.

**Loss on drying** (2.2.32): maximum 0.25 per cent, determined on 1.000 g by drying in an oven at 105 °C.

## ASSAY

Dissolve 80 mg in a mixture of 10 mL of *dilute sulfuric acid R* and 80 mL of *carbon dioxide-free water R*. Add 1 mL of *starch solution R*. Titrate with 0.05 M *iodine* until a persistent violet-blue colour is obtained.

1 mL of 0.05 M *iodine* is equivalent to 9.91 mg of C<sub>6</sub>H<sub>7</sub>NaO<sub>6</sub>.

## STORAGE

In a non-metallic container, protected from light.

## IMPURITIES

*Specified impurities*: C, D, E.

*Other detectable impurities* (the following substances would, if present at a sufficient level, be detected by one or other of the tests in the monograph. They are limited by the general acceptance criterion for other/unspecified impurities and/or by the general monograph *Substances for pharmaceutical use (2034)*. It is therefore not necessary to identify these impurities for demonstration of compliance. See also 5.10. *Control of impurities in substances for pharmaceutical use*): A, F, G, H.

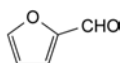

A. 2-furaldehyde,

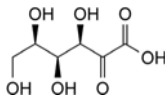

C. D-xylo-hex-2-ulosonic acid (D-sorbosonic acid),

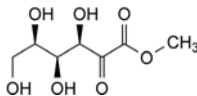

D. methyl D-xylo-hex-2-ulosonate (methyl D-sorbosonate),

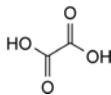

E. oxalic acid,

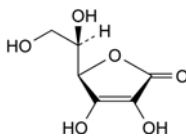

F. (5R)-5-[(1R)-1,2-dihydroxyethyl]-3,4-dihydroxyfuran-2(5H)-one,

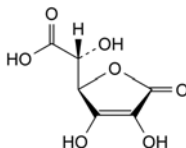

G. (2R)-2-[(2R)-3,4-dihydroxy-5-oxo-2,5-dihydrofuran-2-yl]-2-hydroxyacetic acid,

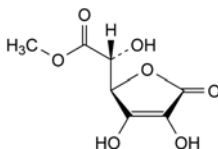

H. methyl (2R)-2-[(2R)-3,4-dihydroxy-5-oxo-2,5-dihydrofuran-2-yl]-2-hydroxyacetate.

01/2008:1994  
corrected 6.0

## SODIUM AUROTHIOMALATE

## Natrii aurothiomalatas

## DEFINITION

Mixture of monosodium and disodium salts of (2*RS*)-2-(aurosulfanyl)butanedioic acid.

## Content:

- gold (Au; *A*, 197.0): 44.5 per cent to 46.0 per cent (dried substance);
- sodium (Na; *A*, 22.99): 10.8 per cent to 11.8 per cent (dried substance).

## CHARACTERS

*Appearance*: fine, pale yellow, hygroscopic powder.

*Solubility*: very soluble in water, practically insoluble in ethanol (96 per cent) and in methylene chloride.

## IDENTIFICATION

- Dissolve 20 mg in *water R* and dilute to 2 mL with the same solvent. Add 2 mL of *strong hydrogen peroxide solution R* and 1 mL of *sodium hydroxide solution R*. Carefully heat to boiling and boil for 30 s. A precipitate is produced that appears brownish-black by reflected light and bluish-green by transmitted light.
- To 20 mg add 2 mL of *water R*. The solution gives reaction (a) of sodium (2.3.1).
- Ignite 100 mg, dissolve the residue in *hydrochloric acid R* and dilute to 10 mL with the same acid. Allow to stand. 5 mL of the clear supernatant gives reaction (a) of sulfates (2.3.1).

## TESTS

**Appearance of solution.** Dissolve 1.0 g in *water R* and dilute to 10 mL with the same solvent. Filter, seal in an ampoule and heat at 100 °C for 1 h. Cool and dilute the contents of the ampoule to 100 mL with *water R*. The solution remains clear and is not more intensely coloured than a 0.100 g/L solution of *potassium ferricyanide R*.

**pH (2.2.3):** 6.0 to 7.0.

Dissolve 1.0 g in *carbon dioxide-free water R* and dilute to 10 mL with the same solvent.

**Related substances.** Liquid chromatography (2.2.29). Prepare the solutions immediately before use.

*Test solution.* Dissolve 0.200 g of the substance to be examined in *water R* and dilute to 100.0 mL with the same solvent.

*Reference solution (a).* Dissolve 10.0 mg of *fumaric acid R* and 100.0 mg of *thiomalic acid R* in *water R* and dilute to 100.0 mL with the same solvent. Dilute 1.0 mL of this solution to 25.0 mL with *water R*.

*Reference solution (b).* Dissolve 12.0 mg of *thiomalic acid R* in *water R* and dilute to 100.0 mL with the same solvent.

*Reference solution (c).* Dissolve 10.0 mg of *maleic acid R* in *water R* and dilute to 100.0 mL with the same solvent. Dilute 1.0 mL of this solution to 25.0 mL with *water R*.

## Column:

- size:  $l = 0.25$  m,  $\varnothing = 4.6$  mm;
- stationary phase: base-deactivated end-capped octadecylsilyl silica gel for chromatography *R* (5  $\mu$ m).

*Mobile phase:* mix 90 volumes of a 10.5 g/L solution of *phosphoric acid R*, 100 volumes of *methanol R2* and 810 volumes of *water R*.

*Flow rate:* 1.0 mL/min.

*Detection:* spectrophotometer at 205 nm.

*Injection:* 10  $\mu$ L.

*Run time:* twice the retention time of impurity C.

*Relative retention* with reference to impurity C (retention time = about 8 min): impurity A = about 0.4; impurity B = about 0.6. Aurothiomalate does not elute under the chromatographic conditions described.

*System suitability:* reference solution (a):

- *resolution:* minimum 5.0 between the peaks due to impurities B and C.

## Limits:

- *impurity A:* not more than the area of the principal peak in the chromatogram obtained with reference solution (c) (0.2 per cent);
- *impurity B:* not more than the area of the corresponding peak in the chromatogram obtained with reference solution (a) (0.2 per cent);
- *impurity C:* not more than the area of the principal peak in the chromatogram obtained with reference solution (b) (6.0 per cent).

**Glycerol:** maximum 8.0 per cent.

*Test solution.* Dissolve 0.50 g of the substance to be examined in *water R* and dilute to 10 mL with the same solvent.

*Reference solution (a).* Dilute 0.80 g of *glycerol R* to 100.0 mL with *water R*.

*Reference solution (b).* To 2.5 mL of reference solution (a) add 7.5 mL of *water R*.

*Reference solution (c).* To 5.0 mL of reference solution (a) add 5.0 mL of *water R*.

*Reference solution (d).* To 7.5 mL of reference solution (a) add 2.5 mL of *water R*.

*Blank solution.* 10 mL of *water R*.

To the test solution, reference solutions (b), (c) and (d) and the blank solution, add 2.5 mL of a freshly prepared 235 g/L solution of *sodium hydroxide R* and mix. Add dropwise in 0.2 mL increments a 38.0 g/L solution of *cupric chloride R*, shaking vigorously after each addition, until the solutions become slightly turbid. Then add 0.2 mL of the 38.0 g/L solution of *cupric chloride R*. Stopper and shake vigorously for 1 min. Dilute to 25.0 mL with *water R* and mix. Centrifuge for 2 min. Measure the absorbance (2.2.25) of the supernatant solution of a 1 cm layer at 635 nm. Use the solution prepared from the blank solution as the compensation liquid. Draw a calibration curve and calculate the content of glycerol in the sample.

**Loss on drying (2.2.32):** maximum 2.0 per cent, determined on 1.000 g by drying over *diphosphorus pentoxide R* at a pressure not exceeding 0.7 kPa for 24 h.

## ASSAY

**Gold.** Heat 0.2 g with 10 mL of *sulfuric acid R* and continue to boil gently until a clear, pale yellow liquid is produced. Cool, add about 1 mL of *nitric acid R* dropwise and boil for 1 h. Cool, dilute to 70 mL with *water R*, boil for 5 min and filter. Wash the residue of gold with *water R* at 60 °C. Dry and ignite at a temperature of at least 600 °C for 3 h. Weigh the residue and calculate the percentage content of Au.

**Sodium.** Evaporate to dryness the filtrate and washings obtained in the assay for gold, moisten with *sulfuric acid R* and ignite at 600  $\pm$  50 °C for 3 h.

1.000 g of residue is equivalent to 0.324 g of Na.

## STORAGE

In an airtight container.

## IMPURITIES

*Specified impurities:* A, B, C.



A. (*Z*)-butenedioic acid (maleic acid),

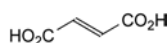

B. (*E*)-butenedioic acid (fumaric acid),

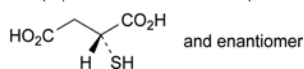

C. (*2R,3S*)-2-sulfanylbutedioic acid (thiomalic acid).

01/2008:0123  
corrected 6.0

## SODIUM BENZOATE

Natrii benzoas

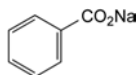

$C_7H_5NaO_2$   
[532-32-1]

$M_r$  144.1

### DEFINITION

Sodium benzenecarboxylate.

*Content*: 99.0 per cent to 100.5 per cent (dried substance).

### CHARACTERS

*Appearance*: white or almost white, crystalline or granular powder or flakes, slightly hygroscopic.

*Solubility*: freely soluble in water, sparingly soluble in ethanol (90 per cent *V/V*).

### IDENTIFICATION

A. It gives reactions (b) and (c) of benzoates (2.3.1).

B. It gives reaction (a) of sodium (2.3.1).

### TESTS

**Solution S.** Dissolve 10.0 g in *carbon dioxide-free water R* and dilute to 100 mL with the same solvent.

**Appearance of solution.** Solution S is clear (2.2.1) and not more intensely coloured than reference solution  $Y_6$  (2.2.2, *Method II*).

**Acidity or alkalinity.** To 10 mL of solution S add 10 mL of *carbon dioxide-free water R* and 0.2 mL of *phenolphthalein solution R*. Not more than 0.2 mL of 0.1 M *sodium hydroxide* or 0.1 M *hydrochloric acid* is required to change the colour of the indicator.

**Halogenated compounds:** maximum 200 ppm for ionised chlorine and maximum 300 ppm for total chlorine.

*All glassware used must be chloride-free and may be prepared by soaking overnight in a 500 g/L solution of nitric acid R, rinsed with water R and stored full of water R. It is recommended that glassware be reserved exclusively for this test.*

*Test solution.* To 20.0 mL of solution S add 5 mL of *water R* and dilute to 50.0 mL with *ethanol (96 per cent) R*.

#### Determination of ionised chlorine

In three 25 mL volumetric flasks, prepare the following solutions.

*Solution (a).* To 4.0 mL of the test solution add 3 mL of *dilute sodium hydroxide solution R* and 3 mL of *ethanol (96 per cent) R*. This solution is used to prepare solution A.

*Solution (b).* To 3 mL of *dilute sodium hydroxide solution R* add 2 mL of *water R* and 5 mL of *ethanol (96 per cent) R*. This solution is used to prepare solution B.

*Solution (c).* To 4.0 mL of *chloride standard solution (8 ppm Cl) R* add 6.0 mL of *water R*. This solution is used to prepare solution C.

In a fourth 25 mL volumetric flask, place 10 mL of *water R*. To each flask add 5 mL of *ferric ammonium sulfate solution R5*, mix and add dropwise and with swirling 2 mL of

*nitric acid R* and 5 mL of *mercuric thiocyanate solution R*. Shake. Dilute the contents of each flask to 25.0 mL with *water R* and allow the solutions to stand in a water-bath at 20 °C for 15 min. Measure at 460 nm in a 2 cm cell the absorbance (2.2.25) of solution A using solution B as the compensation liquid, and the absorbance of solution C using the solution obtained with 10 mL of *water R* as the compensation liquid. The absorbance of solution A is not greater than that of solution C.

#### Determination of total chlorine

*Solution (a).* To 10.0 mL of the test solution add 7.5 mL of *dilute sodium hydroxide solution R* and 0.125 g of *nickel-aluminium alloy R* and heat on a water-bath for 10 min. Allow to cool to room temperature, filter into a 25 mL volumetric flask and wash the filter with 3 quantities, each of 2 mL, of *ethanol (96 per cent) R* (a slight precipitate may form that disappears on acidification). Dilute the filtrate and washings to 25.0 mL with *water R*. This solution is used to prepare solution A.

*Solution (b).* In the same manner, prepare a similar solution replacing the test solution by a mixture of 5 mL of *ethanol (96 per cent) R* and 5 mL of *water R*. This solution is used to prepare solution B.

*Solution (c).* To 6.0 mL of *chloride standard solution (8 ppm Cl) R* add 4.0 mL of *water R*. This solution is used to prepare solution C.

In four 25 mL volumetric flasks, place separately 10 mL of solution (a), 10 mL of solution (b), 10 mL of solution (c) and 10 mL of *water R*. To each flask add 5 mL of *ferric ammonium sulfate solution R5*, mix and add dropwise and with swirling 2 mL of *nitric acid R* and 5 mL of *mercuric thiocyanate solution R*. Shake. Dilute the contents of each flask to 25.0 mL with *water R* and allow the solutions to stand in a water-bath at 20 °C for 15 min. Measure at 460 nm in a 2 cm cell the absorbance (2.2.25) of solution A using solution B as the compensation liquid, and the absorbance of solution C using the solution obtained with 10 mL of *water R* as the compensation liquid. The absorbance of solution A is not greater than that of solution C.

**Heavy metals (2.4.8):** maximum 10 ppm.

2.0 g complies with test C. Prepare the reference solution using 2 mL of *lead standard solution (10 ppm Pb) R*.

**Loss on drying (2.2.32):** maximum 2.0 per cent, determined on 1.00 g by drying in an oven at 105 °C.

### ASSAY

Dissolve 0.250 g in 20 mL of *anhydrous acetic acid R*, heating to 50 °C if necessary. Cool. Using 0.05 mL of *naphtholbenzein solution R* as indicator, titrate with 0.1 M *perchloric acid* until a green colour is obtained.

1 mL of 0.1 M *perchloric acid* is equivalent to 14.41 mg of  $C_7H_5NaO_2$ .

01/2008:0190  
corrected 6.0

## SODIUM BROMIDE

Natrii bromidum

NaBr  
[7647-15-6]

$M_r$  102.9

### DEFINITION

*Content*: 98.0 per cent to 100.5 per cent (dried substance).

### CHARACTERS

*Appearance*: white or almost white, granular powder or small, colourless, transparent or opaque crystals, slightly hygroscopic.

*Solubility*: freely soluble in water, soluble in alcohol.

## IDENTIFICATION

- A. It gives reaction (a) of bromides (2.3.1).  
 B. Solution S (see Tests) gives the reactions of sodium (2.3.1).

## TESTS

**Solution S.** Dissolve 10.0 g in *carbon dioxide-free water R* prepared from *distilled water R* and dilute to 100 mL with the same solvent.

**Appearance of solution.** Solution S is clear (2.2.1) and colourless (2.2.2, *Method II*).

**Acidity or alkalinity.** To 10 mL of solution S add 0.1 mL of *bromothymol blue solution R1*. Not more than 0.5 mL of 0.01 M *hydrochloric acid* or 0.01 M *sodium hydroxide* is required to change the colour of the indicator.

**Bromates.** To 10 mL of solution S add 1 mL of *starch solution R*, 0.1 mL of a 100 g/L solution of *potassium iodide R* and 0.25 mL of 0.5 M *sulfuric acid* and allow to stand protected from light for 5 min. No blue or violet colour develops.

**Chlorides:** maximum 0.6 per cent.

In a conical flask, dissolve 1.000 g in 20 mL of *dilute nitric acid R*. Add 5 mL of *strong hydrogen peroxide solution R* and heat on a water-bath until the solution is completely decolourised. Wash down the sides of the flask with a little *water R* and heat on a water-bath for 15 min. Allow to cool, dilute to 50 mL with *water R* and add 5.0 mL of 0.1 M *silver nitrate* and 1 mL of *dibutyl phthalate R*. Shake and titrate with 0.1 M *ammonium thiocyanate*, using 5 mL of *ferric ammonium sulfate solution R2* as indicator. Not more than 1.7 mL of 0.1 M *silver nitrate* is used. Note the volume of 0.1 M *silver nitrate* used (see Assay). Carry out a blank test.

**Iodides.** To 5 mL of solution S add 0.15 mL of *ferric chloride solution R1* and 2 mL of *methylene chloride R*. Shake and allow to separate. The lower layer is colourless (2.2.2, *Method I*).

**Sulfates (2.4.13):** maximum 100 ppm.

15 mL of solution S complies with the limit test for sulfates.

**Iron (2.4.9):** maximum 20 ppm.

5 mL of solution S diluted to 10 mL with *water R* complies with the limit test for iron.

**Magnesium and alkaline-earth metals (2.4.7):** maximum 200 ppm, calculated as Ca.

10.0 g complies with the limit test for magnesium and alkaline-earth metals. The volume of 0.01 M *sodium edetate* used does not exceed 5.0 mL.

**Heavy metals (2.4.8):** maximum 10 ppm.

12 mL of solution S complies with limit test A. Prepare the standard using *lead standard solution (1 ppm Pb) R*.

**Loss on drying (2.2.32):** maximum 3.0 per cent, determined on 1.000 g by drying in an oven at 105 °C for 3 h.

## ASSAY

Dissolve 2.000 g in *water R* and dilute to 100.0 mL with the same solvent. To 10.0 mL of the solution add 50 mL of *water R*, 5 mL of *dilute nitric acid R*, 25.0 mL of 0.1 M *silver nitrate* and 2 mL of *dibutyl phthalate R*. Shake. Titrate with 0.1 M *ammonium thiocyanate*, using 2 mL of *ferric ammonium sulfate solution R2* as indicator and shaking vigorously towards the end-point.

1 mL of 0.1 M *silver nitrate* is equivalent to 10.29 mg of NaBr. Calculate the percentage content of NaBr from the expression:

$$a - 2.902 b$$

- a* = percentage content of NaBr and NaCl obtained in the assay and calculated as NaBr,  
*b* = percentage content of Cl in the test for chlorides.

## STORAGE

In an airtight container.

01/2008:0231

## SODIUM CALCIUM EDETATE

## Natrii calcii edetas

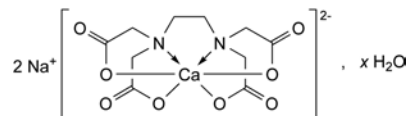

$C_{10}H_{12}CaN_2Na_2O_8 \cdot xH_2O$   $M_r$  374.3 (anhydrous substance) [62-33-9]

## DEFINITION

Disodium [(ethylenedinitrilo)tetraacetato]calciate(2-).

**Content:** 98.0 per cent to 102.0 per cent (anhydrous substance). It contains a variable amount of water of crystallisation.

## CHARACTERS

**Appearance:** white or almost white, hygroscopic powder.

**Solubility:** freely soluble in water, practically insoluble in ethanol (96 per cent).

## IDENTIFICATION

**First identification:** A, C, D.

**Second identification:** B, C, D.

A. Infrared absorption spectrophotometry (2.2.24).

**Preparation:** discs.

**Comparison:** *sodium calcium edetate CRS*.

B. Dissolve 2 g in 10 mL of *water R*, add 6 mL of *lead nitrate solution R*, shake and add 3 mL of *potassium iodide solution R*. No yellow precipitate is formed. Make alkaline to *red litmus paper R* by the addition of *dilute ammonia R2* and add 3 mL of *ammonium oxalate solution R*. A white precipitate is formed.

C. Ignite. The residue gives reaction (b) of calcium (2.3.1).

D. Dissolve 0.5 g in 10 mL of *water R* and add 10 mL of *potassium pyroantimonate solution R*. A white, crystalline precipitate is formed. The formation of the precipitate is accelerated by rubbing the wall of the tube with a glass rod.

## TESTS

**Solution S.** Dissolve 5.0 g in *water R* and dilute to 100 mL with the same solvent.

**Appearance of solution.** Solution S is clear (2.2.1) and colourless (2.2.2, *Method II*).

**pH (2.2.3):** 6.5 to 8.0.

Dissolve 5.0 g in *carbon dioxide-free water R* and dilute to 25 mL with the same solvent.

**Impurity A.** Liquid chromatography (2.2.29). *Carry out the test protected from light.*

**Solvent mixture.** Dissolve 10.0 g of *ferric sulfate pentahydrate R* in 20 mL of 0.5 M *sulfuric acid* and add 780 mL of *water R*. Adjust to pH 2.0 with 1 M *sodium hydroxide* and dilute to 1000 mL with *water R*.

**Test solution.** Dissolve 0.100 g of the substance to be examined in the solvent mixture and dilute to 25.0 mL with the solvent mixture.

**Reference solution.** Dissolve 40.0 mg of *nitrilotriacetic acid R* (impurity A) in the solvent mixture and dilute to 100.0 mL with the solvent mixture. To 1.0 mL of this solution add 0.1 mL of the test solution and dilute to 100.0 mL with the solvent mixture.

**Column:**

– size:  $l = 0.10$  m,  $\varnothing = 4.6$  mm;

– *stationary phase*: spherical graphitised carbon for chromatography R1 (5 µm) with a specific surface area of 120 m<sup>2</sup>/g and a pore size of 25 nm.

*Mobile phase*: dissolve 50.0 mg of ferric sulfate pentahydrate R in 50 mL of 0.5 M sulfuric acid and add 750 mL of water R; adjust to pH 1.5 with 0.5 M sulfuric acid or 1 M sodium hydroxide, add 20 mL of ethylene glycol R and dilute to 1000 mL with water R.

*Flow rate*: 1 mL/min.

*Detection*: spectrophotometer at 273 nm.

*Injection*: 20 µL; filter the solutions and inject immediately.

*Run time*: 4 times the retention time of the iron complex of impurity A.

*Retention time*: iron complex of impurity A = about 5 min; iron complex of edetic acid = about 10 min.

*System suitability*: reference solution:

- *resolution*: minimum 7 between the peaks due to the iron complex of impurity A and the iron complex of edetic acid;
- *signal-to-noise ratio*: minimum 50 for the peak due to impurity A.

*Limit*:

- *impurity A*: not more than the area of the corresponding peak in the chromatogram obtained with the reference solution (0.1 per cent).

**Disodium edetate**: maximum 1.0 per cent.

Dissolve 5.0 g in 250 mL of water R. Add 10 mL of ammonium chloride buffer solution pH 10.0 R and about 50 mg of mordant black 11 triturate R. Not more than 1.5 mL of 0.1 M magnesium chloride is required to change the colour of the indicator to violet.

**Chlorides**: maximum 0.1 per cent.

Dissolve 0.7 g in water R and dilute to 20 mL with the same solvent. Add 30 mL of dilute nitric acid R, allow to stand for 30 min and filter. Dilute 10 mL of the filtrate to 50 mL with water R. Use this solution as the test solution. Prepare the reference solution using 0.40 mL of 0.01 M hydrochloric acid, add 6 mL of dilute nitric acid R and dilute to 50 mL with water R. Filter both solutions if necessary. Add 1 mL of silver nitrate solution R2 to the test solution and to the reference solution and mix. After standing for 5 min protected from light, any opalescence in the test solution is not more intense than that in the reference solution.

**Iron (2.4.9)**: maximum 80 ppm.

Dilute 2.5 mL of solution S to 10 mL with water R. Add 0.25 g of calcium chloride R to the test solution and the standard before the addition of the thioglycollic acid R.

**Heavy metals (2.4.8)**: maximum 20 ppm.

1.0 g complies with test F. Prepare the reference solution using 2 mL of lead standard solution (10 ppm Pb) R.

**Water (2.5.12)**: 5.0 per cent to 13.0 per cent, determined on 0.200 g.

**ASSAY**

Dissolve 0.500 g in water R and dilute to 200 mL with the same solvent. To 20.0 mL of this solution, add 80 mL of water R and adjust to pH 2 with dilute nitric acid R. Titrate with 0.01 M bismuth nitrate, using 0.1 mL of a 1 g/L solution of xylenol orange R as indicator. The colour of the solution changes from yellow to red.

1 mL of 0.01 M bismuth nitrate is equivalent to 3.74 mg of C<sub>10</sub>H<sub>12</sub>CaN<sub>2</sub>Na<sub>2</sub>O<sub>8</sub>.

**STORAGE**

In an airtight container, protected from light.

**IMPURITIES**

*Specified impurities*: A.

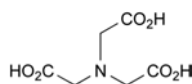

A. nitrilotriacetic acid.

01/2008:1471  
corrected 6.0

## SODIUM CAPRYLATE

Natrii caprylas

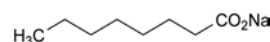

C<sub>8</sub>H<sub>15</sub>NaO<sub>2</sub>  
[1984-06-1]

*M<sub>r</sub>* 166.2

**DEFINITION**

Sodium octanoate.

*Content*: 99.0 per cent to 101.0 per cent (anhydrous substance).

**CHARACTERS**

*Appearance*: white or almost white, crystalline powder.

*Solubility*: very soluble or freely soluble in water, freely soluble in acetic acid, sparingly soluble in ethanol (96 per cent), practically insoluble in acetone.

**IDENTIFICATION**

A. Examine the chromatograms obtained in the test for related substances.

*Results*: the principal peak in the chromatogram obtained with the test solution is similar in retention time and size to the principal peak in the chromatogram obtained with reference solution (a).

B. To 0.2 mL of solution S (see Tests) add 0.3 mL of water R. The solution gives reaction (b) of sodium (2.3.1).

**TESTS**

**Solution S**. Dissolve 2.5 g in carbon dioxide-free water R and dilute to 25 mL with the same solvent.

**Appearance of solution**. Solution S is clear (2.2.1) and colourless (2.2.2, Method II).

**pH (2.2.3)**: 8.0 to 10.5 for solution S.

**Related substances**. Gas chromatography (2.2.28): use the normalisation procedure.

*Test solution*. Dissolve 0.116 g in water R and dilute to 5 mL with the same solvent. Add 1 mL of a 2.8 per cent V/V solution of sulfuric acid R and shake with 10 mL of ethyl acetate R. Separate the organic layer and dry over anhydrous sodium sulfate R.

*Reference solution (a)*. Dissolve 0.10 g of caprylic acid CRS in ethyl acetate R and dilute to 10 mL with the same solvent.

*Reference solution (b)*. Dilute 1 mL of the test solution to 100 mL with ethyl acetate R. Dilute 5 mL of this solution to 50 mL with ethyl acetate R.

*Column*:

- *material*: fused silica;
- *size*: *l* = 30 m,  $\varnothing$  = 0.25 mm;
- *stationary phase*: macrogol 20 000 2-nitroterephthalate R (film thickness 0.25 µm).

*Carrier gas*: helium for chromatography R.

*Flow rate*: 1.5 mL/min.

*Split ratio*: 1:100.

Temperature:

01/2008:0773

	Time (min)	Temperature (°C)
Column	0 - 1	100
	1 - 25	100 → 220
	25 - 35	220
Injection port		250
Detector		250

Detection: flame ionisation.

Injection: 1 µL.

System suitability: reference solution (b):

– signal-to-noise ratio: minimum 5 for the principal peak.

Limits:

- any impurity: for each impurity, maximum 0.3 per cent;
- total: maximum 0.5 per cent;
- disregard limit: 0.5 times the area of the principal peak in the chromatogram obtained with reference solution (b) (0.05 per cent).

Heavy metals (2.4.8): maximum 10 ppm.

Dissolve 2.0 g in glacial acetic acid R and dilute to 10 mL with the same acid. Add 10 mL of ethanol (96 per cent) R. 12 mL of the solution complies with test B. Prepare the reference solution using 1 mL of lead standard solution (10 ppm Pb) R and 9 mL of a mixture of equal volumes of glacial acetic acid R and ethanol (96 per cent) R.

Water (2.5.12): maximum 3.0 per cent, determined on 1.000 g.

#### ASSAY

Dissolve 0.150 g in 50 mL of anhydrous acetic acid R. Titrate with 0.1 M perchloric acid, determining the end-point potentiometrically (2.2.20).

1 mL of 0.1 M perchloric acid is equivalent to 16.62 mg of C<sub>8</sub>H<sub>15</sub>NaO<sub>2</sub>.

#### IMPURITIES

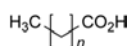

- A.  $n = 4$ : hexanoic acid,
- B.  $n = 5$ : heptanoic acid,
- C.  $n = 7$ : nonanoic acid,
- D.  $n = 8$ : decanoic acid,

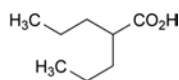

- E. 2-propylpentanoic acid (valproic acid),

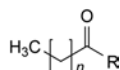

- F. R = OCH<sub>3</sub>,  $n = 6$ : methyl octanoate,
- G. R = OC<sub>2</sub>H<sub>5</sub>,  $n = 6$ : ethyl octanoate,
- H. R = OCH<sub>3</sub>,  $n = 8$ : methyl decanoate,
- I. R = CH<sub>3</sub>,  $n = 8$ : undecan-2-one,

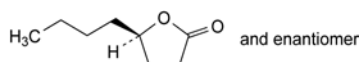

- J. (RS)-5-butyltetrahydrofuran-2-one (γ-hydroxyoctanoic acid lactone).

## SODIUM CARBONATE, ANHYDROUS

### Natrii carbonas anhydricus

Na<sub>2</sub>CO<sub>3</sub>  
[497-19-8]

M<sub>r</sub> 106.0

#### DEFINITION

Content: 99.5 per cent to 100.5 per cent (dried substance).

#### CHARACTERS

Appearance: white or almost white, slightly granular powder, hygroscopic.

Solubility: freely soluble in water, practically insoluble in ethanol (96 per cent).

#### IDENTIFICATION

- A. Dissolve 1 g in water R and dilute to 10 mL with the same solvent. The solution is strongly alkaline (2.2.4).
- B. The solution prepared for identification test A gives the reaction of carbonates (2.3.1).
- C. The solution prepared for identification test A gives reaction (a) of sodium (2.3.1).
- D. Loss on drying (see Tests).

#### TESTS

**Solution S.** Dissolve 2.0 g in portions in a mixture of 5 mL of hydrochloric acid R and 25 mL of distilled water R. Heat to boiling and cool. Add dilute sodium hydroxide solution R until the solution is neutral and dilute to 50 mL with distilled water R.

**Appearance of solution.** The solution is clear (2.2.1) and not more intensely coloured than reference solution Y<sub>6</sub> (2.2.2, Method I).

Dissolve 2.0 g in 10 mL of water R.

**Alkali hydroxides and bicarbonates.** Dissolve 0.4 g in 20 mL of water R. Add 20 mL of barium chloride solution R1 and filter. To 10 mL of the filtrate add 0.1 mL of phenolphthalein solution R. The solution does not become red. Boil the remainder of the filtrate for 2 min. The solution remains clear (2.2.1).

**Chlorides (2.4.4):** maximum 125 ppm.

Dissolve 0.4 g in water R, add 4 mL of dilute nitric acid R and dilute to 15 mL with water R.

**Sulfates (2.4.13):** maximum 250 ppm, determined on solution S.

**Arsenic (2.4.2, Method A):** maximum 5 ppm, determined on 5 mL of solution S.

**Iron (2.4.9):** maximum 50 ppm.

Dilute 5 mL of solution S to 10 mL with water R.

**Heavy metals (2.4.8):** maximum 50 ppm.

12 mL of solution S complies with test A. Prepare the reference solution using lead standard solution (2 ppm Pb) R.

**Loss on drying (2.2.32):** maximum 1.0 per cent, determined on 1.000 g by drying at 300 ± 15 °C.

#### ASSAY

Dissolve 1.000 g in 25 mL of water R. Add 0.2 mL of methyl orange solution R as indicator. Titrate with 1 M hydrochloric acid until the colour changes from yellow to red.

1 mL of 1 M hydrochloric acid is equivalent to 52.99 mg of Na<sub>2</sub>CO<sub>3</sub>.

#### STORAGE

In an airtight container.

01/2008:0191

01/2008:0192

**SODIUM CARBONATE DECAHYDRATE****SODIUM CARBONATE MONOHYDRATE**

Natrii carbonas decahydricus

Natrii carbonas monohydricus

Na<sub>2</sub>CO<sub>3</sub>·10H<sub>2</sub>O  
[6132-02-1]M<sub>r</sub> 286.1Na<sub>2</sub>CO<sub>3</sub>·H<sub>2</sub>O  
[5968-11-6]M<sub>r</sub> 124.0

## DEFINITION

*Content*: 36.7 per cent to 40.0 per cent of Na<sub>2</sub>CO<sub>3</sub>.

## CHARACTERS

*Appearance*: white or almost white, crystalline powder or colourless, transparent crystals, efflorescent.*Solubility*: freely soluble in water, practically insoluble in ethanol (96 per cent).

## IDENTIFICATION

- A. Dissolve 1 g in *water R* and dilute to 10 mL with the same solvent. The solution is strongly alkaline (2.2.4).
- B. The solution prepared for identification test A gives the reaction of carbonates (2.3.1).
- C. The solution prepared for identification test A gives reaction (a) of sodium (2.3.1).

## TESTS

**Solution S.** Dissolve 5.0 g in portions in a mixture of 5 mL of *hydrochloric acid R* and 25 mL of *distilled water R*. Heat the solution to boiling and cool. Add *dilute sodium hydroxide solution R* until the solution is neutral and dilute to 50 mL with *distilled water R*.**Appearance of solution.** The solution is clear (2.2.1) and not more intensely coloured than reference solution Y<sub>6</sub> (2.2.2, *Method I*).Dissolve 4.0 g in 10 mL of *water R*.**Alkali hydroxides and bicarbonates.** Dissolve 1.0 g in 20 mL of *water R*, add 20 mL of *barium chloride solution R1* and filter. To 10 mL of the filtrate add 0.1 mL of *phenolphthalein solution R*. The solution does not become red. Heat the remainder of the filtrate to boiling for 2 min. The solution remains clear (2.2.1).**Chlorides** (2.4.4): maximum 50 ppm.Dissolve 1.0 g in *water R*, add 4 mL of *dilute nitric acid R* and dilute to 15 mL with *water R*.**Sulfates** (2.4.13): maximum 100 ppm, determined on solution S.**Arsenic** (2.4.2, *Method A*): maximum 2 ppm, determined on 5 mL of solution S.**Iron** (2.4.9): maximum 20 ppm.Dilute 5 mL of solution S to 10 mL with *water R*.**Heavy metals** (2.4.8): maximum 20 ppm.12 mL of solution S complies with test A. Prepare the reference solution using *lead standard solution (2 ppm Pb) R*.

## ASSAY

Dissolve 2.000 g in 25 mL of *water R*. Titrate with 1 M *hydrochloric acid*, using 0.2 mL of *methyl orange solution R* as indicator.1 mL of 1 M *hydrochloric acid* is equivalent to 52.99 mg of Na<sub>2</sub>CO<sub>3</sub>.

## STORAGE

In an airtight container.

## DEFINITION

*Content*: 83.0 per cent to 87.5 per cent of Na<sub>2</sub>CO<sub>3</sub>.

## CHARACTERS

*Appearance*: white or almost white, crystalline powder or colourless crystals.*Solubility*: freely soluble in water, practically insoluble in ethanol (96 per cent).

## IDENTIFICATION

- A. Dissolve 1 g in *water R* and dilute to 10 mL with the same solvent. The solution is strongly alkaline (2.2.4).
- B. The solution prepared for identification test A gives the reaction of carbonates (2.3.1).
- C. The solution prepared for identification test A gives reaction (a) of sodium (2.3.1).

## TESTS

**Solution S.** Dissolve 2.0 g in portions in a mixture of 5 mL of *hydrochloric acid R* and 25 mL of *distilled water R*. Heat the solution to boiling and cool. Add *dilute sodium hydroxide solution R* until the solution is neutral and dilute to 50 mL with *distilled water R*.**Appearance of solution.** The solution is clear (2.2.1) and not more intensely coloured than reference solution Y<sub>6</sub> (2.2.2, *Method I*).Dissolve 2.0 g in 10 mL of *water R*.**Alkali hydroxides and bicarbonates.** Dissolve 0.4 g in 20 mL of *water R*, add 20 mL of *barium chloride solution R1* and filter. To 10 mL of the filtrate add 0.1 mL of *phenolphthalein solution R*. The solution does not become red. Heat the remainder of the filtrate to boiling for 2 min. The solution remains clear (2.2.1).**Chlorides** (2.4.4): maximum 125 ppm.Dissolve 0.4 g in *water R*, add 4 mL of *dilute nitric acid R* and dilute to 15 mL with *water R*.**Sulfates** (2.4.13): maximum 250 ppm, determined on solution S.**Arsenic** (2.4.2, *Method A*): maximum 5 ppm, determined on 5 mL of solution S.**Iron** (2.4.9): maximum 50 ppm.Dilute 5 mL of solution S to 10 mL with *water R*.**Heavy metals** (2.4.8): maximum 50 ppm.12 mL of solution S complies with test A. Prepare the reference solution using *lead standard solution (2 ppm Pb) R*.

## ASSAY

Dissolve 1.000 g in 25 mL of *water R*. Titrate with 1 M *hydrochloric acid*, using 0.2 mL of *methyl orange solution R* as indicator.1 mL of 1 M *hydrochloric acid* is equivalent to 52.99 mg of Na<sub>2</sub>CO<sub>3</sub>.

## STORAGE

In an airtight container.



01/2008:0847 TESTS

## SODIUM CETOSTEARYL SULFATE

Natrii cetylo- et stearylosulfas.

## DEFINITION

Mixture of sodium cetyl sulfate ( $C_{16}H_{33}NaO_4S$ ;  $M_r$  344.5) and sodium stearyl sulfate ( $C_{18}H_{37}NaO_4S$ ;  $M_r$  372.5). A suitable buffer may be added.

## Content:

- *sodium cetostearyl sulfate*: minimum 90.0 per cent (anhydrous substance),
- *sodium cetyl sulfate*: minimum 40.0 per cent (anhydrous substance).

## CHARACTERS

*Appearance*: white or pale yellow, amorphous or crystalline powder.

*Solubility*: soluble in hot water giving an opalescent solution, practically insoluble in cold water, partly soluble in ethanol (96 per cent).

## IDENTIFICATION

*First identification*: B, D, F.

*Second identification*: A, C, D, E, F.

## A. Thin-layer chromatography (2.2.27).

*Test solution*. Dissolve 50 mg of the substance to be examined in 10 mL of *ethanol (70 per cent V/V) R*, heating on a water-bath.

*Reference solution*. Dissolve 50 mg of *sodium cetostearyl sulfate CRS* in 10 mL of *ethanol (70 per cent V/V) R*, heating on a water-bath.

*Plate*: TLC silanised silica gel plate R.

*Mobile phase*: *water R*, *acetone R*, *methanol R* (20:40:40 V/V/V).

*Application*: 2  $\mu$ L.

*Development*: over a path of 12 cm.

*Drying*: in air.

*Detection*: spray with a 50 g/L solution of *phosphomolybdic acid R* in *ethanol (96 per cent) R*. Heat at 120 °C until the spots appear (about 3 h).

*Results*: the principal spots in the chromatogram obtained with the test solution are similar in position and colour to the principal spots in the chromatogram obtained with the reference solution.

## B. Examine the chromatograms obtained in the assay.

*Results*: the 2 principal peaks in the chromatogram obtained with test solution (c) are similar in retention time to the 2 principal peaks in the chromatogram obtained with the reference solution.

C. Dissolve 0.1 g in 10 mL of *water R* and shake. A foam is formed.

## D. It gives a yellow colour to a non-luminous flame.

E. To 0.1 mL of the solution prepared for identification test C add 0.1 mL of a 1 g/L solution of *methylene blue R* and 2 mL of *dilute sulfuric acid R*. Add 2 mL of *methylene chloride R* and shake. The methylene chloride layer has an intense blue colour.F. Mix about 10 mg with 10 mL of *anhydrous ethanol R*. Heat to boiling on a water-bath, shaking frequently. Filter immediately and evaporate to dryness. Dissolve the residue in 7 mL of *water R*, add 3 mL of *dilute hydrochloric acid R* and evaporate the solution to half its volume. Allow to cool. Filter. To the filtrate add 1 mL of *barium chloride solution RI*. A white, crystalline precipitate is formed.

**Acidity or alkalinity**. Dissolve 0.5 g with heating in a mixture of 10 mL of *water R* and 15 mL of *ethanol (90 per cent V/V) R*. Add 0.1 mL of *phenolphthalein solution RI*. The solution is colourless. Add 0.1 mL of 0.1 M *sodium hydroxide*. The solution is red.

**Sodium chloride and sodium sulfate**: maximum 8.0 per cent for the sum of the percentage contents.

*Sodium chloride*. Dissolve 5.00 g in 50 mL of *water R*, add *dilute nitric acid R* dropwise until the solution is neutral to *blue litmus paper R*. Add 2 mL of *potassium chromate solution R* and titrate with 0.1 M *silver nitrate*.

1 mL of 0.1 M *silver nitrate* is equivalent to 5.844 mg of NaCl.

*Sodium sulfate*. Dissolve 0.500 g in 20 mL of *water R*, warming gently if necessary, and add 1 mL of a 0.5 g/L solution of *dithizone R* in *acetone R*. If the solution is red, add 1 M *nitric acid*, dropwise, until a bluish-green colour is obtained. Add 2.0 mL of *dichloroacetic acid solution R* and 80 mL of *acetone R*. Titrate with 0.01 M *lead nitrate* until a persistent orange-red colour is obtained.

1 mL of 0.01 M *lead nitrate* is equivalent to 1.420 mg of  $Na_2SO_4$ .

**Free cetostearyl alcohol**: maximum 4.0 per cent.

From the chromatogram obtained with test solution (a) in the assay, calculate the percentage content of free cetostearyl alcohol in the substance to be examined, using the following expression:

$$S \frac{100 \times m_H}{S_{Ha(\text{corr})} \times m}$$

$S$  = sum of the areas of the peaks due to cetyl alcohol and stearyl alcohol in the chromatogram obtained with test solution (a),

$m_H$  = mass of the internal standard added in the preparation of test solution (a), in milligrams,

$S_{Ha(\text{corr})}$  = corrected area of the peak due to the internal standard in the chromatogram obtained with test solution (a),

$m$  = mass of sodium cetostearyl sulfate used for the preparation of test solution (a), in milligrams.

**Water (2.5.12)**: maximum 1.5 per cent, determined on 5.00 g.

## ASSAY

Gas chromatography (2.2.28).

*Internal standard solution*. Dissolve 0.20 g of *heptadecanol CRS* in *anhydrous ethanol R* and dilute to 50 mL with the same solvent.

*Test solution (a)*. Dissolve 0.300 g of the substance to be examined in 50 mL of *anhydrous ethanol R* and add 2 mL of the internal standard solution and 48 mL of *water R*. Shake with 4 quantities, each of 25 mL, of *pentane R*, adding *sodium chloride R*, if necessary, to facilitate the separation of the layers. Combine the organic layers. Reserve the hydro-alcoholic layer for the preparation of test solutions (c) and (d). Wash the organic layer with 2 quantities, each of 30 mL, of *water R*. Dry over *anhydrous sodium sulfate R* and filter.

*Test solution (b)*. Dissolve 0.300 g of the substance to be examined in 50 mL of *anhydrous ethanol R* and add 50 mL of *water R*. Shake with 4 quantities, each of 25 mL, of *pentane R*, adding *sodium chloride R*, if necessary, to facilitate the separation of the layers. Combine the organic layers, wash with 2 quantities, each of 30 mL, of *water R*. Dry over *anhydrous sodium sulfate R* and filter.

*Test solution (c)*. Transfer 25 mL of the hydro-alcoholic solution obtained in the preparation of test solution (a) to a 200 mL flask that can be fitted with a reflux condenser. Add 20 mL of *hydrochloric acid R* and 10 mL of the internal standard solution. Boil under a reflux condenser for 2 h. Allow to cool and shake with 4 quantities, each of 20 mL, of *pentane R*.

Combine the organic layers and wash with 2 quantities, each of 20 mL, of *water R*. Dry over *anhydrous sodium sulfate R* and filter.

**Test solution (d).** Transfer 25 mL of the hydro-alcoholic solution obtained in the preparation of test solution (a) to a 200 mL flask that can be fitted with a reflux condenser. Add 20 mL of *hydrochloric acid R* and 10 mL of *anhydrous ethanol R*. Boil under a reflux condenser for 2 h. Allow to cool and shake with 4 quantities, each of 20 mL, of *pentane R*. Combine the organic layers and wash with 2 quantities, each of 20 mL, of *water R*. Dry over *anhydrous sodium sulfate R* and filter.

**Reference solution.** Dissolve 50 mg of *cetyl alcohol CRS* and 50 mg of *stearyl alcohol CRS* in *anhydrous ethanol R* and dilute to 10 mL with the same solvent.

**Column:**

- **material:** fused silica,
- **size:**  $l = 25$  m,  $\varnothing = 0.25$  mm,
- **stationary phase:** *poly(dimethyl)siloxane R* or another suitable polar phase.

**Carrier gas:** *nitrogen for chromatography R*.

**Flow rate:** 1 mL/min.

**Split ratio:** 1:100.

**Temperature:**

	Time (min)	Temperature (°C)
Column	0 - 20	150 → 250
Injection port		250
Detector		250

**Detection:** flame ionisation.

**Elution order:** *cetyl alcohol*, *heptadecanol* (internal standard) and *stearyl alcohol*.

Inject 1 µL of test solution (a) and test solution (b). If the chromatogram obtained with test solution (b) shows a peak with the same retention time as the peak due to the internal standard in the chromatogram obtained with test solution (a), calculate the ratio  $r$  using the following expression:

$$\frac{S_{ci}}{S_i}$$

$S_{ci}$  = area of the peak due to *cetyl alcohol* in the chromatogram obtained with test solution (b),

$S_i$  = area of the peak with the same retention time as the peak due to the internal standard in the chromatogram obtained with test solution (a).

If  $r$  is less than 300, calculate the corrected area  $S'_{Ha(corr)}$  of the peak due to the internal standard in the chromatogram obtained with test solution (a) using the following expression:

$$S'_{Ha} - \frac{S_i \times S_c}{S_{ci}}$$

$S'_{Ha}$  = area of the peak due to the internal standard in the chromatogram obtained with test solution (a),

$S_c$  = area of the peak due to *cetyl alcohol* in the chromatogram obtained with test solution (a).

Inject 1 µL of test solution (c) and test solution (d). Carry out the correction for interference in the same manner as for test solution (a) and calculate the corrected area  $S'_{Hc(corr)}$  of the peak due to the internal standard in the chromatogram obtained with test solution (c).

Inject equal volumes of the reference solution, test solution (c) and test solution (d). Identify the peaks in the chromatograms obtained with the test solutions by comparison of their retention times with those of the peaks in the chromatogram obtained with the reference solution. Determine the area of each peak.

Calculate the percentage content of *sodium cetyl sulfate* in the substance to be examined, using the following expression:

$$\frac{(A \times 1.421) \times m'_H \times 100}{S_{Hc(corr)} \times m'}$$

$A$  = area of the peak due to *cetyl alcohol* in the chromatogram obtained with test solution (c),

$m'_H$  = mass of the internal standard added in the preparation of test solution (c), in milligrams,

$S_{Hc(corr)}$  = corrected area of the peak due to the internal standard in the chromatogram obtained with test solution (c),

$m'$  = mass of the substance to be examined in test solution (c), in milligrams.

Calculate the percentage content of *sodium stearyl sulfate* in the substance to be examined, using the following expression:

$$\frac{(B \times 1.377) \times m'_H \times 100}{S_{Hc(corr)} \times m'}$$

$B$  = area of the peak due to *stearyl alcohol* in the chromatogram obtained with test solution (c).

The percentage content of *sodium cetostearyl sulfate* corresponds to the sum of the percentage content of *sodium cetyl sulfate* and the percentage content of *sodium stearyl sulfate*.

#### LABELLING

The label states, where appropriate, the name and concentration of any added buffer.

01/2008:0193  
corrected 7.0

## SODIUM CHLORIDE

### Natrii chloridum

NaCl  
[7647-14-5]

$M_r$  58.44

#### DEFINITION

**Content:** 99.0 per cent to 100.5 per cent (dried substance).

#### CHARACTERS

**Appearance:** white or almost white, crystalline powder or colourless crystals or white or almost white pearls.

**Solubility:** freely soluble in water, practically insoluble in anhydrous ethanol.

#### IDENTIFICATION

A. It gives the reactions of chlorides (2.3.1).

B. It gives the reactions of sodium (2.3.1).

#### TESTS

*If the substance is in the form of pearls crush before use.*

**Solution S.** Dissolve 20.0 g in *carbon dioxide-free water R* prepared from *distilled water R* and dilute to 100.0 mL with the same solvent.

**Appearance of solution.** Solution S is clear (2.2.1) and colourless (2.2.2, *Method II*).

**Acidity or alkalinity.** To 20 mL of solution S add 0.1 mL of *bromothymol blue solution R1*. Not more than 0.5 mL of 0.01 M *hydrochloric acid* or 0.01 M *sodium hydroxide* is required to change the colour of the indicator.

**Bromides:** maximum 100 ppm.

To 0.5 mL of solution S add 4.0 mL of *water R*, 2.0 mL of *phenol red solution R2* and 1.0 mL of a 0.1 g/L solution of

*chloramine R* and mix immediately. After exactly 2 min, add 0.15 mL of 0.1 M sodium thiosulfate, mix and dilute to 10.0 mL with *water R*. The absorbance (2.2.25) of the solution measured at 590 nm, using *water R* as the compensation liquid, is not greater than that of a standard prepared at the same time and in the same manner, using 5.0 mL of a 3.0 mg/L solution of *potassium bromide R*.

**Ferrocyanides.** Dissolve 2.0 g in 6 mL of *water R*. Add 0.5 mL of a mixture of 5 mL of a 10 g/L solution of *ferric ammonium sulfate R* in a 2.5 g/L solution of *sulfuric acid R* and 95 mL of a 10 g/L solution of *ferrous sulfate R*. No blue colour develops within 10 min.

**Iodides.** Moisten 5 g by the dropwise addition of a freshly prepared mixture of 0.15 mL of *sodium nitrite solution R*, 2 mL of 0.5 M *sulfuric acid*, 25 mL of *iodide-free starch solution R* and 25 mL of *water R*. After 5 min, examine in daylight. The mixture shows no blue colour.

**Nitrites.** To 10 mL of solution S add 10 mL of *water R*. The absorbance (2.2.25) is not greater than 0.01 at 354 nm.

**Phosphates (2.4.11):** maximum 25 ppm.

Dilute 2 mL of solution S to 100 mL with *water R*.

**Sulfates (2.4.13):** maximum 200 ppm.

Dilute 7.5 mL of solution S to 30 mL with *distilled water R*.

**Aluminium (2.4.17):** maximum 0.2 ppm, if intended for use in the manufacture of peritoneal dialysis solutions, haemodialysis solutions or haemofiltration solutions.

**Prescribed solution.** Dissolve 20.0 g in 100 mL of *water R* and add 10 mL of *acetate buffer solution pH 6.0 R*.

**Reference solution.** Mix 2 mL of *aluminium standard solution (2 ppm Al) R*, 10 mL of *acetate buffer solution pH 6.0 R* and 98 mL of *water R*.

**Blank solution.** Mix 10 mL of *acetate buffer solution pH 6.0 R* and 100 mL of *water R*.

**Arsenic (2.4.2, Method A):** maximum 1 ppm, determined on 5 mL of solution S.

**Barium.** To 5 mL of solution S add 5 mL of *distilled water R* and 2 mL of *dilute sulfuric acid R*. After 2 h, any opalescence in the solution is not more intense than that in a mixture of 5 mL of solution S and 7 mL of *distilled water R*.

**Iron (2.4.9):** maximum 2 ppm, determined on solution S.

Prepare the standard using a mixture of 4 mL of *iron standard solution (1 ppm Fe) R* and 6 mL of *water R*.

**Magnesium and alkaline-earth metals (2.4.7):** maximum 100 ppm, calculated as Ca and determined on 10.0 g.

Use 150 mg of *mordant black 11 tritrate R*. The volume of 0.01 M *sodium edetate* used is not more than 2.5 mL.

**Potassium:** maximum 500 ppm, if intended for use in the manufacture of parenteral preparations or haemodialysis, haemofiltration or peritoneal dialysis solutions.

Atomic emission spectrometry (2.2.22, Method I).

**Test solution.** Dissolve 1.00 g in *water R* and dilute to 100.0 mL with the same solvent.

**Reference solutions.** Dissolve 1.144 g of *potassium chloride R*, previously dried at 100-105 °C for 3 h, in *water R* and dilute to 1000.0 mL with the same solvent (600 µg of K per millilitre).

Dilute as required.

**Wavelength:** 766.5 nm.

**Heavy metals (2.4.8):** maximum 5 ppm.

12 mL of solution S complies with test A. Prepare the reference solution using *lead standard solution (1 ppm Pb) R*.

**Loss on drying (2.2.32):** maximum 0.5 per cent, determined on 1.000 g by drying in an oven at 105 °C for 2 h.

**Bacterial endotoxins (2.6.14):** less than 5 IU/g, if intended for use in the manufacture of parenteral preparations without a further appropriate procedure for removal of bacterial endotoxins.

## ASSAY

Dissolve 50.0 mg in *water R* and dilute to 50 mL with the same solvent. Titrate with 0.1 M *silver nitrate* determining the end-point potentiometrically (2.2.20).

1 mL of 0.1 M *silver nitrate* is equivalent to 5.844 mg of NaCl.

## LABELLING

The label states:

- where applicable, that the substance is suitable for use in the manufacture of parenteral preparations,
- where applicable, that the substance is suitable for use in the manufacture of peritoneal dialysis solutions, haemodialysis solutions or haemofiltration solutions.

01/2008:0412  
corrected 6.0

## SODIUM CITRATE

### Natrii citras

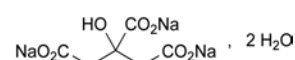

$\text{C}_6\text{H}_5\text{Na}_3\text{O}_7 \cdot 2\text{H}_2\text{O}$   
[6132-04-3]

$M_r$  294.1

## DEFINITION

Trisodium 2-hydroxypropane-1,2,3-tricarboxylate dihydrate.

**Content:** 99.0 per cent to 101.0 per cent (anhydrous substance).

## CHARACTERS

**Appearance:** white or almost white, crystalline powder or white or almost white, granular crystals, slightly deliquescent in moist air.

**Solubility:** freely soluble in water, practically insoluble in ethanol (96 per cent).

## IDENTIFICATION

A. To 1 mL of solution S (see Tests) add 4 mL of *water R*. The solution gives the reaction of citrates (2.3.1).

B. 1 mL of solution S gives reaction (a) of sodium (2.3.1).

## TESTS

**Solution S.** Dissolve 10.0 g in *carbon dioxide-free water R* prepared from *distilled water R* and dilute to 100 mL with the same solvent.

**Appearance of solution.** Solution S is clear (2.2.1) and colourless (2.2.2, Method II).

**Acidity or alkalinity.** To 10 mL of solution S add 0.1 mL of *phenolphthalein solution R*. Not more than 0.2 mL of 0.1 M *hydrochloric acid* or 0.1 M *sodium hydroxide* is required to change the colour of the indicator.

**Readily carbonisable substances.** To 0.20 g of the powdered substance to be examined add 10 mL of *sulfuric acid R* and heat in a water-bath at  $90 \pm 1$  °C for 60 min. Cool rapidly. The solution is not more intensely coloured than reference solution Y<sub>2</sub> or GY<sub>2</sub> (2.2.2, Method II).

**Chlorides (2.4.4):** maximum 50 ppm.

Dilute 10 mL of solution S to 15 mL with *water R*.

**Oxalates:** maximum 300 ppm.

Dissolve 0.50 g in 4 mL of *water R*, add 3 mL of *hydrochloric acid R* and 1 g of *zinc R* in granules and heat on a water-bath for 1 min. Allow to stand for 2 min, decant the liquid into a test-tube containing 0.25 mL of a 10 g/L solution of *phenylhydrazine hydrochloride R* and heat to boiling. Cool rapidly, transfer to a graduated cylinder and add an equal volume of *hydrochloric acid R* and 0.25 mL of *potassium ferricyanide solution R*. Shake and allow to stand for 30 min. Any pink colour in the solution is not more intense than that in a standard prepared

at the same time in the same manner using 4 mL of a 50 mg/L solution of *oxalic acid R*.

**Sulfates (2.4.13):** maximum 150 ppm.

To 10 mL of solution S add 2 mL of *hydrochloric acid R1* and dilute to 15 mL with *distilled water R*.

**Heavy metals (2.4.8):** maximum 10 ppm.

12 mL of solution S complies with test A. Prepare the reference solution using *lead standard solution (1 ppm Pb) R*.

**Water (2.5.12):** 11.0 per cent to 13.0 per cent, determined on 0.300 g. After adding the substance to be examined, stir for 15 min before titrating.

**Pyrogens (2.6.8).** If intended for use in the manufacture of large-volume parenteral preparations, the competent authority may require that it comply with the test for pyrogens. Inject per kilogram of the rabbit's mass 10 mL of a freshly prepared solution in *water for injections R* containing per millilitre 10.0 mg of the substance to be examined and 7.5 mg of pyrogen-free *calcium chloride R*.

#### ASSAY

Dissolve 0.150 g in 20 mL of *anhydrous acetic acid R*, heating to about 50 °C. Allow to cool. Titrate with 0.1 M *perchloric acid*, using 0.25 mL of *naphtholbenzein solution R* as indicator until a green colour is obtained.

1 mL of 0.1 M *perchloric acid* is equivalent to 8.602 mg of  $C_{23}H_{14}Na_2O_{11}$ .

#### STORAGE

In an airtight container.

01/2008:0562  
corrected 6.0

## SODIUM CROMOGLICATE

### Natrii cromoglicas

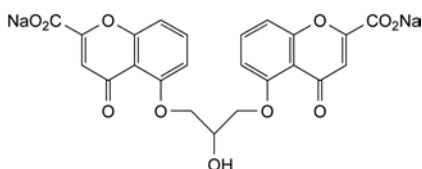

$C_{23}H_{14}Na_2O_{11}$   
[15826-37-6]

$M_r$  512.3

#### DEFINITION

Sodium cromoglicate contains not less than 98.0 per cent and not more than the equivalent of 101.0 per cent of disodium 5,5'-[(2-hydroxypropane-1,3-diyl)bis(oxy)]bis(4-oxo-4H-1-benzopyran-2-carboxylate, calculated with reference to the dried substance.

#### CHARACTERS

A white or almost white, crystalline powder, hygroscopic, soluble in water, practically insoluble in alcohol.

#### IDENTIFICATION

*First identification:* B, D.

*Second identification:* A, C, D.

A. Dissolve 10.0 mg in *phosphate buffer solution pH 7.4 R* and dilute to 100.0 mL with the same solvent. Dilute 10.0 mL of this solution to 100.0 mL with the same solvent. Examined between 230 nm and 350 nm (2.2.25), the solution shows

two absorption maxima, at 239 nm and 327 nm. The ratio of the absorbance at the maximum at 327 nm to that at the maximum at 239 nm is 0.25 to 0.30.

B. Examine by infrared absorption spectrophotometry (2.2.24), comparing with the spectrum obtained with *sodium cromoglicate CRS*. Examine the substances prepared as discs.

C. Dissolve about 5 mg in 0.5 mL of *methanol R*. Add 3 mL of a solution in *methanol R* containing 5 g/L of *aminopyrazolone R* and 1 per cent V/V of *hydrochloric acid R*. Allow to stand for 5 min. The solution shows an intense yellow colour.

D. It gives reaction (a) of sodium (2.3.1).

#### TESTS

**Solution S.** Dissolve 0.5 g in *carbon dioxide-free water R* and dilute to 25 mL with the same solvent.

**Appearance of solution.** Solution S is not more opalescent than reference suspension II (2.2.1) and not more intensely coloured than reference solution BY<sub>5</sub> (2.2.2, Method II).

**Acidity or alkalinity.** To 10 mL of solution S add 0.1 mL of *phenolphthalein solution R*. The solution is colourless. Add 0.2 mL of 0.01 M *sodium hydroxide*. The solution is pink. Add 0.4 mL of 0.01 M *hydrochloric acid*. The solution is colourless. Add 0.25 mL of *methyl red solution R*. The solution is red.

**Related substances.** Examine by thin-layer chromatography (2.2.27), using *silica gel GF<sub>254</sub> R* as the coating substance.

**Test solution.** Dissolve 0.2 g of the substance to be examined in a mixture of 1 volume of *acetone R*, 4 volumes of *tetrahydrofuran R* and 6 volumes of *water R* and dilute to 10 mL with the same mixture of solvents.

**Reference solution.** Dissolve 10 mg of *1,3-bis(2-acetyl-3-hydroxyphenoxy)-2-propanol CRS* in *chloroform R* and dilute to 100 mL with the same solvent.

Apply separately to the plate 5 µL of each solution. Develop over a path of 10 cm using a mixture of 5 volumes of *glacial acetic acid R*, 50 volumes of *ethyl acetate R* and 50 volumes of *toluene R*. Allow the plate to dry in air and examine in ultraviolet light at 254 nm. Any spot in the chromatogram obtained with the test solution, apart from the principal spot (which remains at the point of application), is not more intense than the spot in the chromatogram obtained with the reference solution (0.5 per cent).

**Oxalate.** Dissolve 0.10 g in 20 mL of *water R*, add 5.0 mL of *iron salicylate solution R* and dilute to 50.0 mL with *water R*. Determine the absorbance (2.2.25) at 480 nm. The absorbance is not less than that of a standard prepared in the same manner using 0.35 mg of *oxalic acid R* instead of the substance to be examined.

**Heavy metals (2.4.8).** 1.0 g complies with limit test C for heavy metals (20 ppm). Prepare the standard using 2 mL of *lead standard solution (10 ppm Pb) R*.

**Loss on drying (2.2.32).** Not more than 10.0 per cent, determined on 1.000 g by drying over *diphosphorus pentoxide R* at 105 °C and at a pressure of 300 Pa to 600 Pa.

#### ASSAY

Dissolve 0.200 g with heating in a mixture of 5 mL of *2-propanol R* and 25 mL of *ethylene glycol R*. Cool and add 30 mL of *dioxan R*. Titrate with 0.1 M *perchloric acid*, determining the end-point potentiometrically (2.2.20).

1 mL of 0.1 M *perchloric acid* is equivalent to 25.62 mg of  $C_{23}H_{14}Na_2O_{11}$ .

#### STORAGE

Store in an airtight container, protected from light.

01/2008:0774 Application: 2 µL.

corrected 6.0 Development: over a path of 12 cm.

Drying: in a current of warm air, then heat at 105 °C for 5 min.

Detection: spray the hot plate with *strong sodium hypochlorite solution R* diluted to a concentration of 5 g/L of active chlorine. Place in a current of cold air until an area of coating below the points of application gives at most a faint blue colour with a drop of *potassium iodide and starch solution R*; avoid prolonged exposure to cold air. Spray with *potassium iodide and starch solution R* and examine the chromatograms within 5 min.

Limit: test solution (a):

- *impurity A*: any spot due to impurity A is not more intense than the corresponding spot in the chromatogram obtained with reference solution (b) (0.1 per cent).

**Impurities B, C and D.** Gas chromatography (2.2.28).

*Internal standard solution.* Dissolve 2 µL of *tetradecane R* in *methylene chloride R* and dilute to 100 mL with the same solvent.

*Test solution.* Dissolve 2.00 g of the substance to be examined in 20 mL of *water R*, add 0.5 mL of *strong sodium hydroxide solution R* and shake with 30 mL of *toluene R*. Shake 20 mL of the upper layer with 4 mL of a mixture of equal volumes of *dilute acetic acid R* and *water R*. Separate the lower layer, add 0.5 mL of *strong sodium hydroxide solution R* and 0.5 mL of the internal standard solution and shake. Use the lower layer immediately after separation.

*Reference solution.* Dissolve 10.0 mg (about 12 µL) of *cyclohexylamine R* (impurity C), 1.0 mg (about 1.1 µL) of *dicyclohexylamine R* (impurity D) and 1.0 mg (about 1 µL) of *aniline R* (impurity B) in *water R*, then dilute to 1000 mL with the same solvent. Dilute 10.0 mL of this solution to 100.0 mL with *water R* (solution A). To 20.0 mL of solution A, add 0.5 mL of *strong sodium hydroxide solution R* and extract with 30 mL of *toluene R*. Shake 20 mL of the upper layer with 4 mL of a mixture of equal volumes of *dilute acetic acid R* and *water R*. Separate the lower layer, add 0.5 mL of *strong sodium hydroxide solution R* and 0.5 mL of the internal standard solution and shake. Use the lower layer immediately after separation.

Column:

- *material*: fused silica;
- *size*:  $l = 25$  m,  $\varnothing = 0.32$  mm;
- *stationary phase*: *poly(dimethyl)(diphenyl)siloxane R* (film thickness 0.51 µm).

Carrier gas: helium for chromatography R.

Flow rate: 1.8 mL/min.

Temperature:

	Time (min)	Temperature (°C)
Column	0 - 1	85
	1 - 9	85 → 150
	9 - 13	150
Injection port		250
Detector		270

Detection: flame ionisation.

Injection: 1.5 µL; use a split vent at a flow rate of 20 mL/min.

Relative retention with reference to impurity C (retention time = about 2.3 min): impurity B = about 1.4; tetradecane = about 4.3; impurity D = about 4.5.

Limits:

- *impurity C*: maximum 10 ppm;
- *impurities B, D*: for each impurity, maximum 1 ppm.

**Sulfates** (2.4.13): maximum 0.1 per cent.Dilute 1.5 mL of solution S to 15 mL with *distilled water R*.

## SODIUM CYCLAMATE

## Natrii cyclamas

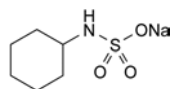
C<sub>6</sub>H<sub>12</sub>NNaO<sub>3</sub>S  
[139-05-9]M<sub>r</sub> 201.2

## DEFINITION

Sodium *N*-cyclohexylsulfamate.

Content: 98.5 per cent to 101.0 per cent (dried substance).

## CHARACTERS

Appearance: white or almost white, crystalline powder or colourless crystals.

Solubility: freely soluble in water, slightly soluble in ethanol (96 per cent).

## IDENTIFICATION

First identification: A, E.

Second identification: B, C, D, E.

A. Infrared absorption spectrophotometry (2.2.24).

Comparison: *sodium cyclamate CRS*.

B. Examine the chromatograms obtained in the test for impurity A.

Results: the principal spot in the chromatogram obtained with test solution (b) is similar in position, colour and size to the principal spot in the chromatogram obtained with reference solution (a).

C. To 1 mL of solution S (see Tests), add 1 mL of *water R* and 2 mL of *silver nitrate solution RI*, then shake. A white, crystalline precipitate is formed.D. To 1 mL of solution S add 5 mL of *water R*, 2 mL of *dilute hydrochloric acid R* and 4 mL of *barium chloride solution RI* and mix. The solution is clear. Add 2 mL of *sodium nitrite solution R*. A voluminous white precipitate is formed and gas is given off.E. A mixture of 1 mL of solution S and 1 mL of *water R* gives reaction (a) of sodium (2.3.1).

## TESTS

**Solution S.** Dissolve 5 g in *carbon dioxide-free water R* prepared from *distilled water R* and dilute to 50 mL with the same solvent.

**Appearance of solution.** Solution S is clear (2.2.1) and colourless (2.2.2, Method II).

pH (2.2.3): 5.5 to 7.5 for solution S.

**Absorbance** (2.2.25): maximum 0.10, determined at 270 nm on solution S.

**Impurity A.** Thin-layer chromatography (2.2.27).

Test solution (a). Solution S.

Test solution (b). Dilute 1 mL of test solution (a) to 10 mL with *water R*.

Reference solution (a). Dissolve 0.10 g of *sodium cyclamate CRS* in *water R* and dilute to 10 mL with the same solvent.

Reference solution (b). Dissolve 10 mg of *sulfamic acid R* (impurity A) in *water R* and dilute to 100 mL with the same solvent.

Plate: TLC silica gel G plate R.

Mobile phase: concentrated ammonia R, water R, ethyl acetate R, propanol R (10:10:20:70 V/V/V/V).

**Heavy metals** (2.4.8): maximum 10 ppm.

12 mL of solution S complies with test A. Prepare the reference solution using *lead standard solution (1 ppm Pb) R*.

**Loss on drying** (2.2.32): maximum 1.0 per cent, determined on 1.000 g by drying in an oven at 105 °C for 4 h.

#### ASSAY

Dissolve without heating 0.150 g in 60 mL of *anhydrous acetic acid R*. Titrate with 0.1 M *perchloric acid*, determining the end-point potentiometrically (2.2.20).

1 mL of 0.1 M *perchloric acid* is equivalent to 20.12 mg of  $C_6H_{12}NNaO_3S$ .

#### IMPURITIES

*Specified impurities: A, B, C, D.*

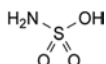

A. sulfamic acid,

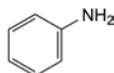

B. aniline (phenylamine),

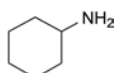

C. cyclohexanamine,

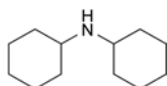

D. *N*-cyclohexylcyclohexanamine.

**Reducing substances.** To 5 mL of solution S add 0.25 mL of 0.02 M *potassium permanganate* and 5 mL of *dilute sulfuric acid R* and heat in a water-bath for 5 min. The solution retains a slight red colour.

**Chlorides** (2.4.4): maximum 200 ppm.

Dilute 2.5 mL of solution S to 15 mL with *water R*.

**Sulfates** (2.4.13): maximum 300 ppm.

To 5 mL of solution S add 0.5 mL of *hydrochloric acid R* and dilute to 15 mL with *distilled water R*.

**Arsenic** (2.4.2, *Method A*): maximum 2 ppm, determined on 0.5 g.

**Iron** (2.4.9): maximum 10 ppm, determined on solution S.

**Heavy metals** (2.4.8): maximum 10 ppm.

12 mL of solution S complies with test A. Prepare the reference solution using *lead standard solution (1 ppm Pb) R*.

**Loss on drying** (2.2.32): 21.5 per cent to 24.0 per cent, determined on 0.50 g by drying in an oven at 130 °C.

#### ASSAY

Dissolve 2.500 g in 40 mL of *water R*. Titrate with carbonate-free 1 M *sodium hydroxide*, determining the end-point potentiometrically (2.2.20).

1 mL of 1 M *sodium hydroxide* is equivalent to 0.120 g of  $NaH_2PO_4$ .

01/2008:0514

## SODIUM FLUORIDE

### Natrii fluoridum

NaF  
[7681-49-4]

$M_r$  41.99

01/2008:0194  
corrected 6.0

## SODIUM DIHYDROGEN PHOSPHATE DIHYDRATE

### Natrii dihydrogenophosphas dihydricus

$NaH_2PO_4 \cdot 2H_2O$   $M_r$  156.0  
[13472-35-0]

#### DEFINITION

*Content*: 98.0 per cent to 100.5 per cent (dried substance).

#### CHARACTERS

*Appearance*: white or almost white powder or colourless crystals.

*Solubility*: very soluble in water, very slightly soluble in ethanol (96 per cent).

#### IDENTIFICATION

- Solution S (see Tests) is slightly acid (2.2.4).
- Solution S gives the reactions of phosphates (2.3.1).
- Solution S previously neutralised using a 100 g/L solution of *potassium hydroxide R* gives reaction (a) of sodium (2.3.1).

#### TESTS

**Solution S.** Dissolve 10.0 g in *carbon dioxide-free water R* prepared from *distilled water R* and dilute to 100 mL with the same solvent.

**Appearance of solution.** Solution S is clear (2.2.1) and colourless (2.2.2, *Method II*).

**pH** (2.2.3): 4.2 to 4.5.

To 5 mL of solution S add 5 mL of *carbon dioxide-free water R*.

#### DEFINITION

*Content*: 98.5 per cent to 100.5 per cent (dried substance).

#### CHARACTERS

*Appearance*: white or almost white powder or colourless crystals.

*Solubility*: soluble in water, practically insoluble in ethanol (96 per cent).

#### IDENTIFICATION

- To 2 mL of solution S (see Tests) add 0.5 mL of *calcium chloride solution R*. A gelatinous white precipitate is formed that dissolves on adding 5 mL of *ferric chloride solution R1*.
- To about 4 mg add a mixture of 0.1 mL of *alizerin S solution R* and 0.1 mL of *zirconyl nitrate solution R* and mix. The colour changes from red to yellow.
- Solution S gives reaction (a) of sodium (2.3.1).

#### TESTS

**Solution S.** Dissolve 2.5 g in *carbon dioxide-free water R* without heating and dilute to 100 mL with the same solvent.

**Appearance of solution.** Solution S is clear (2.2.1) and colourless (2.2.2, *Method II*).

**Acidity or alkalinity.** Dissolve 2.5 g of *potassium nitrate R* in 40 mL of solution S and dilute to 50 mL with *carbon dioxide-free water R*. Cool to 0 °C and add 0.2 mL of *phenolphthalein solution R*. If the solution is colourless, not more than 1.0 mL of 0.1 M *sodium hydroxide* is required to produce a red colour that persists for at least 15 s. If the solution is red, not more than 0.25 mL of 0.1 M *hydrochloric acid* is required to change the colour of the indicator.

**Chlorides** (2.4.4): maximum 200 ppm.

Dilute 10 mL of solution S to 15 mL with *water R*.

**Fluorosilicates.** Heat to boiling the neutralised solution obtained in the test for acidity or alkalinity and titrate whilst hot. Not more than 0.75 mL of 0.1 M sodium hydroxide is required to change the colour of the indicator to red.

**Sulfates** (2.4.13): maximum 200 ppm.

Dissolve 0.25 g in 10 mL of a saturated solution of boric acid R in distilled water R. Add 5 mL of distilled water R and 0.6 mL of hydrochloric acid R1. Prepare the standard by mixing 0.6 mL of hydrochloric acid R1, 5 mL of sulfate standard solution (10 ppm SO<sub>4</sub>) R and 10 mL of a saturated solution of boric acid R in distilled water R.

**Loss on drying** (2.2.32): maximum 0.5 per cent, determined on 1.000 g by drying in an oven at 130 °C for 3 h.

#### ASSAY

Dissolve 0.100 g in water R and dilute to 60 mL with the same solvent. Titrate with 0.1 M lanthanum nitrate, determining the end-point potentiometrically (2.2.20) using a fluoride-selective indicator electrode and a silver-silver chloride reference electrode.

1 mL of 0.1 M lanthanum nitrate is equivalent to 12.60 mg of NaF.

01/2008:0848

## SODIUM FUSIDATE

### Natrii fusidas

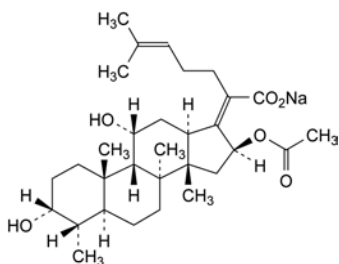

C<sub>31</sub>H<sub>47</sub>NaO<sub>6</sub>  
[751-94-0]

M<sub>r</sub> 538.7

#### DEFINITION

Sodium (*Z*)-*ent*-16 $\alpha$ -(acetyloxy)-3 $\beta$ ,11 $\beta$ -dihydroxy-4 $\beta$ ,8,14-trimethyl-18-nor-5 $\beta$ ,10 $\alpha$ -cholesta-17(20),24-dien-21-oate.

Antimicrobial substance produced by the growth of certain strains of *Fusidium coccineum* or by any other means.

**Content:** 97.5 per cent to 101.0 per cent (anhydrous substance).

#### CHARACTERS

**Appearance:** white or almost white, crystalline powder, slightly hygroscopic.

**Solubility:** freely soluble in water and in ethanol (96 per cent).

#### IDENTIFICATION

A. Infrared absorption spectrophotometry (2.2.24).

**Preparation:** dissolve 0.1 g in 5 mL of water R, add 5 mL of chloroform R and 0.1 mL of dilute phosphoric acid R. Shake vigorously for 1 min, allow to separate and filter the lower layer through absorbent cotton covered with anhydrous sodium sulfate R. Repeat the extraction with 2 quantities, each of 5 mL, of chloroform R and evaporate the combined extracts to dryness under reduced pressure. Dry the residue over diphosphorus pentoxide R under reduced pressure for 2 h, dissolve in 1 mL of chloroform R.

**Comparison:** Ph. Eur. reference spectrum of fusidic acid.

B. Thin-layer chromatography (2.2.27).

**Test solution.** Dissolve 20 mg of the substance to be examined in methanol R and dilute to 10 mL with the same solvent.

**Reference solution.** Dissolve 24 mg of diethanolamine fusidate CRS in methanol R and dilute to 10 mL with the same solvent.

**Plate:** TLC silica gel F<sub>254</sub> plate R.

**Mobile phase:** methanol R, cyclohexane R, glacial acetic acid R, chloroform R (2.5:10:10:80 V/V/V/V).

**Application:** 10  $\mu$ L.

**Development:** over a path of 15 cm.

**Drying:** in a current of warm air.

**Detection:** examine in ultraviolet light at 254 nm.

**Results:** the principal spot in the chromatogram obtained with the test solution is similar in position and size to the principal spot in the chromatogram obtained with the reference solution.

C. Ignite 1 g. The residue gives reaction (a) of sodium (2.3.1).

#### TESTS

**Appearance of solution.** The solution is not more intensely coloured than reference solution B<sub>6</sub> (2.2.2, Method II).

Dissolve 1.5 g in 10 mL of water R.

**pH** (2.2.3): 7.5 to 9.0.

Dissolve 0.125 g in 10 mL of carbon dioxide-free water R.

**Related substances.** Liquid chromatography (2.2.29).

**Test solution.** Dissolve 50 mg of the substance to be examined in the mobile phase and dilute to 10.0 mL with the mobile phase.

**Reference solution (a).** Dissolve 5 mg of 3-ketofusidic acid CRS in 5 mL of the mobile phase. To 1.0 mL of this solution add 0.20 mL of the test solution and dilute to 20.0 mL with the mobile phase.

**Reference solution (b).** Dilute 20  $\mu$ L of the test solution to 100.0 mL with the mobile phase.

**Column:**

- size:  $l = 0.125\text{--}0.15$  m,  $\varnothing = 4\text{--}5$  mm;
- stationary phase: octadecylsilyl silica gel for chromatography R (5  $\mu$ m).

**Mobile phase:** methanol R, 10 g/L solution of phosphoric acid R, water R, acetonitrile R (10:20:20:50 V/V/V/V).

**Flow rate:** 2 mL/min.

**Detection:** spectrophotometer at 235 nm.

**Injection:** 20  $\mu$ L.

**Run time:** 3.5 times the retention time of sodium fusidate.

**System suitability:**

- resolution: minimum 2.5 between the peaks due to 3-ketofusidic acid and sodium fusidate in the chromatogram obtained with reference solution (a);
- signal-to-noise ratio: minimum 3 for the principal peak in the chromatogram obtained with reference solution (b).

**Limits:**

- total: not more than twice the area of the peak due to sodium fusidate in the chromatogram obtained with reference solution (a) (2.0 per cent);
- disregard limit: the area of the principal peak in the chromatogram obtained with reference solution (b) (0.02 per cent).

**Water** (2.5.12): maximum 2.0 per cent, determined on 0.50 g.

#### ASSAY

Dissolve 0.500 g in 30 mL of water R and add 40 mL of ethanol (96 per cent) R. Titrate with 0.1 M hydrochloric acid, determining the end-point potentiometrically (2.2.20).

1 mL of 0.1 M hydrochloric acid is equivalent to 53.87 mg of C<sub>31</sub>H<sub>47</sub>NaO<sub>6</sub>.

#### STORAGE

In an airtight container, protected from light, at a temperature of 2 °C to 8 °C.

01/2009:1995  
corrected 6.6**SODIUM GLYCEROPHOSPHATE,  
HYDRATED**

Natrii glycerophosphas hydricus

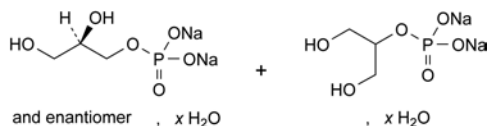
 $C_3H_7Na_2O_6P, xH_2O$  $M_r$  216.0 (anhydrous substance)

## DEFINITION

Mixture of variable proportions of sodium (2*RS*)-2,3-dihydroxypropyl phosphate and sodium 2-hydroxy-1-(hydroxymethyl)ethyl phosphate. The mixture may contain various amounts of other glycerophosphate esters. The degree of hydration is 4 to 6.

*Content*: 98.0 per cent to 105.0 per cent (anhydrous substance).

## CHARACTERS

*Appearance*: white or almost white, crystalline powder or crystals.

*Solubility*: freely soluble in water, practically insoluble in acetone and in ethanol (96 per cent).

## IDENTIFICATION

- Solution S (see Tests) gives reaction (a) of sodium (2.3.1).
- To 0.1 g add 5 mL of *dilute nitric acid R*. Heat to boiling and boil for 1 min. Cool. The solution gives reaction (b) of phosphates (2.3.1).
- In a test-tube fitted with a glass tube, mix 0.1 g with 5 g of *potassium hydrogen sulfate R*. Heat strongly and direct the white vapour into 5 mL of *decolorised fuchsin solution R*. A violet-red colour develops which becomes violet upon heating for 30 min on a water-bath.

## TESTS

**Solution S.** Dissolve 10.0 g in *carbon dioxide-free water R* prepared from *distilled water R* and dilute to 100 mL with the same solvent.

**Appearance of solution.** Solution S is not more opalescent than reference suspension II (2.2.1) and not more intensely coloured than reference solution Y<sub>6</sub> (2.2.2, *Method II*).

**Alkalinity.** To 10 mL of solution S add 0.2 mL of *phenolphthalein solution R*. Not more than 1.0 mL of 0.1 *M hydrochloric acid* is required to change the colour of the indicator ( $n_2$ ).

**Glycerol and ethanol (96 per cent)-soluble substances:** maximum 1.0 per cent.

Shake 1.000 g with 25 mL of *ethanol (96 per cent) R* for 10 min. Filter. Evaporate the filtrate on a water-bath and dry the residue at 70 °C for 1 h. The residue weighs not more than 10 mg.

**Chlorides (2.4.4):** maximum 200 ppm.

Dilute 2.5 mL of solution S to 15 mL with *water R*.

**Phosphates (2.4.11):** maximum 0.1 per cent.

Dilute 1 mL of solution S to 10 mL with *water R*. Dilute 1 mL of this solution to 100 mL with *water R*.

**Sulfates (2.4.13):** maximum 500 ppm.

Dilute 3 mL of solution S to 15 mL with *water R*.

**Iron (2.4.9):** maximum 20 ppm.

Dilute 5 mL of solution S to 10 mL with *water R*.

**Heavy metals (2.4.8):** maximum 20 ppm.

Dilute 10 mL of solution S to 20 mL with *water R*. 12 mL of the solution complies with test A. Prepare the reference solution using 10 mL of *lead standard solution (1 ppm Pb) R*.

**Water (2.5.12):** 25.0 per cent to 35.0 per cent, determined on 0.100 g.

## ASSAY

Dissolve 0.250 g in 30 mL of *water R*. Titrate with 0.05 *M sulfuric acid*, determining the end-point potentiometrically (2.2.20), ( $n_1$ ).

Calculate the percentage content of sodium glycerophosphate (anhydrous substance) using the following expression:

$$\frac{216.0 \left( n_1 - \frac{n_2}{4} \right)}{m (100 - a)}$$

$a$  = percentage content of water;

$n_1$  = volume of 0.05 *M sulfuric acid* used in the assay, in millilitres;

$n_2$  = volume of 0.1 *M hydrochloric acid* used in the test for alkalinity, in millilitres;

$m$  = mass of the substance to be examined, in grams.

01/2011:1472

**SODIUM HYALURONATE**

Natrii hyaluronas

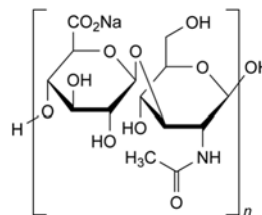
 $(C_{14}H_{20}NNaO_{11})_n$   
[9067-32-7]

## DEFINITION

Sodium salt of hyaluronic acid, a glycosaminoglycan consisting of D-glucuronic acid and N-acetyl-D-glucosamine disaccharide units. It is extracted from cocks' combs or obtained by fermentation from *Streptococci*, Lancefield Groups A and C.

*Content*: 95.0 per cent to 105.0 per cent (dried substance).

*Intrinsic viscosity*: 90 per cent to 120 per cent of the value stated on the label.

## PRODUCTION

Where applicable, the animals from which sodium hyaluronate is derived must fulfil the requirements for the health of animals suitable for human consumption.

When produced by fermentation of gram-positive bacteria, the process must be shown to reduce or eliminate pyrogenic or inflammatory components of the cell wall.

## CHARACTERS

*Appearance*: white or almost white, very hygroscopic powder or fibrous aggregate.

*Solubility*: sparingly soluble or soluble in water, practically insoluble in acetone and in anhydrous ethanol.

## IDENTIFICATION

A. Infrared absorption spectrophotometry (2.2.24).

*Comparison*: Ph. Eur. reference spectrum of sodium hyaluronate.



B. It gives reaction (a) of sodium (2.3.1).

#### TESTS

**Solution S.** Weigh a quantity of the substance to be examined equivalent to 0.10 g of the dried substance and add 30.0 mL of a 9 g/L solution of *sodium chloride R*. Mix gently on a shaker until dissolved (about 12 h).

**Appearance of solution.** Solution S is clear (2.2.1) and its absorbance (2.2.25) at 600 nm is not greater than 0.01.

**pH (2.2.3):** 5.0 to 8.5.

Dissolve the substance to be examined in *carbon dioxide-free water R* to obtain a solution containing a quantity equivalent to 5 mg of the dried substance per millilitre.

**Intrinsic viscosity.** *Sodium hyaluronate is very hygroscopic and must be protected from moisture during weighing.*

**Buffer solution (0.15 M sodium chloride in 0.01 M phosphate buffer solution pH 7.0).** Dissolve 0.78 g of *sodium dihydrogen phosphate R* and 4.50 g of *sodium chloride R* in *water R* and dilute to 500.0 mL with the same solvent (solution A). Dissolve 1.79 g of *disodium hydrogen phosphate R* and 4.50 g of *sodium chloride R* in *water R* and dilute to 500.0 mL with the same solvent (solution B). Mix solutions A and B until a pH of 7.0 is reached. Filter through a sintered-glass filter (4) (2.1.2).

**Test solution (a).** Weigh 0.200 g ( $m_{0p}$ ) (*NOTE: this value is only indicative and should be adjusted after an initial measurement of the viscosity of test solution (a)*) of the substance to be examined and dilute with 50.0 g ( $m_{0s}$ ) of buffer solution at 4 °C. Mix the solution by shaking at 4 °C during 24 h. Weigh 5.00 g ( $m_{1p}$ ) of the solution and dilute with 100.0 g ( $m_{1s}$ ) of buffer solution at 25 °C. Mix this solution by shaking for 20 min. Filter the solution through a sintered-glass filter (100) (2.1.2), and discard the first 10 mL.

**Test solution (b).** Weigh 30.0 g ( $m_{2p}$ ) of test solution (a) and dilute with 10.0 g ( $m_{2s}$ ) of buffer solution at 25 °C. Mix this solution by shaking for 20 min. Filter the solution through a sintered-glass filter (100) (2.1.2) and discard the first 10 mL.

**Test solution (c).** Weigh 20.0 g ( $m_{3p}$ ) of test solution (a) and dilute with 20.0 g ( $m_{3s}$ ) of buffer solution at 25 °C. Mix this solution by shaking for 20 min. Filter the solution through a sintered-glass filter (100) (2.1.2) and discard the first 10 mL.

**Test solution (d).** Weigh 10.0 g ( $m_{4p}$ ) of test solution (a) and dilute with 30.0 g ( $m_{4s}$ ) of buffer solution at 25 °C. Mix this solution by shaking for 20 min. Filter the solution through a sintered-glass filter (100) (2.1.2) and discard the first 10 mL.

Determine the flow-times (2.2.9) for the buffer solution ( $t_0$ ) and for the 4 test solutions ( $t_1$ ,  $t_2$ ,  $t_3$  and  $t_4$ ), at  $25.00 \pm 0.03$  °C.

Use an appropriate suspended level viscometer (specifications: viscometer constant about  $0.005 \text{ mm}^2/\text{s}^2$ , kinematic viscosity of 1-5  $\text{mm}^2/\text{s}$ , internal diameter of tube *R* 0.53 mm, volume of bulb *C* 5.6 mL, internal diameter of tube *N* 2.8-3.2 mm) with a funnel-shaped lower capillary end. Use the same viscometer for all measurements; measure all outflow times in triplicate. The test is not valid unless the results do not differ by more than 0.35 per cent from the mean and if the flow time  $t_1$  is not less than 1.6 and not more than 1.8 times  $t_0$ . If this is not the case, adjust the value of  $m_{0p}$  and repeat the procedure.

#### Calculation of the relative viscosities

Since the densities of the sodium hyaluronate solutions and of the solvent are almost equal, the relative viscosities  $\eta_{ri}$  (being  $\eta_{r1}$ ,  $\eta_{r2}$ ,  $\eta_{r3}$  and  $\eta_{r4}$ ) can be calculated from the ratio of the flow times for the respective solutions  $t_i$  (being  $t_1$ ,  $t_2$ ,  $t_3$  and  $t_4$ ) to the flow time of the solvent  $t_0$ , but taking into account the kinetic energy correction factor for the capillary ( $B = 30\,800 \text{ s}^3$ ), using the following expression:

$$\frac{t_i - \frac{B}{t_i^2}}{t_0 - \frac{B}{t_0^2}}$$

#### Calculation of the concentrations

Calculate the concentration  $c_1$  (expressed in  $\text{kg}/\text{m}^3$ ) of sodium hyaluronate in test solution (a) using the following expression:

$$\frac{m_{0p} \times x \times (100 - h) \times m_{1p} \times \rho_{25}}{100 \times 100 \times (m_{0p} + m_{0s}) \times (m_{1p} + m_{1s})}$$

$x$  = percentage content of sodium hyaluronate as determined under Assay;

$h$  = percentage loss on drying;

$\rho_{25}$  =  $1005 \text{ kg}/\text{m}^3$  (density of the test solution at 25 °C).

Calculate the concentration  $c_2$  (expressed in  $\text{kg}/\text{m}^3$ ) of sodium hyaluronate in test solution (b) using the following expression:

$$c_1 \times \frac{m_{2p}}{m_{2s} + m_{2p}}$$

Calculate the concentration  $c_3$  (expressed in  $\text{kg}/\text{m}^3$ ) of sodium hyaluronate in test solution (c) using the following expression:

$$c_1 \times \frac{m_{3p}}{m_{3s} + m_{3p}}$$

Calculate the concentration  $c_4$  (expressed in  $\text{kg}/\text{m}^3$ ) of sodium hyaluronate in test solution (d) using the following expression:

$$c_1 \times \frac{m_{4p}}{m_{4s} + m_{4p}}$$

#### Calculation of the intrinsic viscosity

Calculate the intrinsic viscosity  $[\eta]$  by linear least-squares regression analysis using the Martin equation:

$$\log \left( \frac{\eta_r - 1}{c} \right) = \log [\eta] + k [\eta] c$$

The decimal antilogarithm of the intercept is the intrinsic viscosity expressed in  $\text{m}^3/\text{kg}$ .

**Sulfated glycosaminoglycans:** maximum 1 per cent, if the product is extracted from cocks' combs.

*Appropriate safety precautions are to be taken when handling perchloric acid at elevated temperature.*

**Test solution.** Introduce a quantity of the substance to be examined equivalent to 50.0 mg of the dried substance into a test-tube 150 mm long and 16 mm in internal diameter and dissolve in 1.0 mL of *perchloric acid R*.

**Reference solution.** Dissolve 0.149 g of *anhydrous sodium sulfate R* in *water R* and dilute to 100.0 mL with the same solvent. Dilute 10.0 mL of this solution to 100.0 mL with *water R*. Evaporate 1.0 mL in a test-tube 150 mm long and 16 mm in internal diameter in a heating block at 90-95 °C, and dissolve the residue in 1.0 mL of *perchloric acid R*.

Plug each test-tube with a piece of glass wool. Place the test-tubes in a heating block or a silicone oil bath maintained at 180 °C and heat until clear, colourless solutions are obtained (about 12 h). Remove the test-tubes and cool to room temperature. Add to each test-tube 3.0 mL of a 33.3 g/L solution of *barium chloride R*, cap and shake vigorously. Allow the test-tubes to stand for 30 min. Shake each test-tube once again, and determine the absorbance (2.2.25) at 660 nm, using *water R* as a blank.

The absorbance obtained with the test solution is not greater than the absorbance obtained with the reference solution.

**Nucleic acids.** The absorbance (2.2.25) of solution S at 260 nm is maximum 0.5.

**Protein:** maximum 0.3 per cent; maximum 0.1 per cent, if intended for use in the manufacture of parenteral preparations.

**Test solution (a).** Dissolve the substance to be examined in *water R* to obtain a solution containing a quantity equivalent to about 10 mg of the dried substance per millilitre.

**Test solution (b).** Mix equal volumes of test solution (a) and *water R*.

**Reference solutions.** Prepare a 0.5 mg/mL stock solution of *bovine albumin R* in *water R*. Prepare 5 dilutions of the stock solution containing between 5 µg/mL and 50 µg/mL of *bovine albumin R*.

Add 2.5 mL of freshly prepared *cupri-tartaric solution R3* to test-tubes containing 2.5 mL of *water R* (blank), 2.5 mL of the test solutions (a) or (b) or 2.5 mL of the reference solutions. Mix after each addition. After about 10 min, add to each test-tube 0.50 mL of a mixture of equal volumes of *phosphomolybdotungstic reagent R* and *water R* prepared immediately before use. Mix after each addition. After 30 min, measure the absorbance (2.2.25) of each solution at 750 nm against the blank. From the calibration curve obtained with the 5 reference solutions determine the content of protein in the test solutions.

**Chlorides (2.4.4):** maximum 0.5 per cent.

Dissolve 67 mg in 100 mL of *water R*.

**Iron:** maximum 80 ppm.

Atomic absorption spectrometry (2.2.23, *Method II*).

**Test solution.** Dissolve a quantity of the substance to be examined equivalent to 0.25 g of the dried substance in 1 mL of *nitric acid R* by heating on a water-bath. Cool and dilute to 10.0 mL with *water R*.

**Reference solutions.** Prepare 2 reference solutions in the same manner as the test solution, adding 1.0 mL and 2.0 mL respectively of *iron standard solution (10 ppm Fe) R* to the dissolved substance to be examined.

**Source:** iron hollow-cathode lamp using a transmission band of 0.2 nm.

**Wavelength:** 248.3 nm.

**Atomisation device:** air-acetylene flame.

**Heavy metals (2.4.8):** maximum 20 ppm; maximum 10 ppm if intended for use in the manufacture of parenteral preparations.

1.0 g complies with test F. Prepare the reference solution using 2.0 mL of *lead standard solution (10 ppm Pb) R*.

**Loss on drying (2.2.32):** maximum 20.0 per cent, determined on 0.500 g by drying at 100-110 °C over *diphosphorus pentoxide R* for 6 h.

#### Microbial contamination

TAMC: acceptance criterion 10<sup>2</sup> CFU/g (2.6.12). Use 1 g of the substance to be examined.

**Bacterial endotoxins (2.6.14):** less than 0.5 IU/mg, if intended for use in the manufacture of parenteral preparations without a further appropriate procedure for the removal of bacterial endotoxins; less than 0.05 IU/mg, if intended for use in the manufacture of intra-ocular preparations or intra-articular preparations without a further appropriate procedure for the removal of bacterial endotoxins.

#### ASSAY

Determine the glucuronic acid content by reaction with carbazole as described below.

**Reagent A.** Dissolve 0.95 g of *disodium tetraborate R* in 100.0 mL of *sulfuric acid R*.

**Reagent B.** Dissolve 0.125 g of *carbazole R* in 100.0 mL of *anhydrous ethanol R*.

**Test solution.** Prepare this solution in triplicate. Dissolve 0.170 g of the substance to be examined in *water R* and dilute to 100.0 g with the same solvent. Dilute 10.0 g of this solution to 200.0 g with *water R*.

**Reference stock solution.** Dissolve 0.100 g of *D-glucuronic acid R*, previously dried to constant mass in vacuum over *diphosphorus pentoxide R (2.2.32)*, in *water R* and dilute to 100.0 g with the same solvent.

**Reference solutions.** Prepare 5 dilutions of the reference stock solution containing between 6.5 µg/g and 65 µg/g of *D-glucuronic acid R*.

Place 25 test-tubes, numbered 1 to 25, in iced water. Add 1.0 mL of the 5 reference solutions in triplicate to the test-tubes 1 to 15 (reference tubes), 1.0 mL of the 3 test solutions in triplicate to the test-tubes 16 to 24 (sample tubes), and 1.0 mL of *water R* to test-tube 25 (blank). Add to each test-tube 5.0 mL of freshly prepared reagent A, previously cooled in iced water. Tightly close the test-tubes with plastic caps, shake the contents, and place on a water bath for exactly 15 min. Cool in iced water, and add to each test tube 0.20 mL of reagent B. Recap the tubes, shake, and put them again on a water-bath for exactly 15 min. Cool to room temperature and measure the absorbance (2.2.25) of the solutions at 530 nm, against the blank.

From the calibration curve obtained with the mean absorbances read for each reference solution, determine the mean concentrations of D-glucuronic acid in the test solutions.

Calculate the percentage content of sodium hyaluronate using the following expression:

$$\frac{c_g}{c_s} \times Z \times \frac{100}{100 - h} \times \frac{401.3}{194.1}$$

$c_g$  = mean of concentrations of D-glucuronic acid in the test solutions, in milligrams per gram;

$c_s$  = mean of concentrations of the substance to be examined in the test solutions, in milligrams per gram;

$Z$  = determined percentage content of C<sub>6</sub>H<sub>10</sub>O<sub>7</sub> in *D-glucuronic acid R*;

$h$  = percentage loss on drying;

401.3 = relative molecular mass of the disaccharide fragment;

194.1 = relative molecular mass of glucuronic acid.

#### STORAGE

In an airtight container, protected from light and humidity. If the substance is sterile, store in a sterile, airtight, tamper-proof container.

#### LABELLING

The label states:

- the intrinsic viscosity;
- the origin of the substance;
- the intended use of the substance;
- where applicable, that the substance is suitable for parenteral administration other than intra-articular administration;
- where applicable, that the substance is suitable for parenteral administration, including intra-articular administration;
- where applicable that the material is suitable for intra-ocular use.

01/2008:0195  
corrected 6.0

## SODIUM HYDROGEN CARBONATE

Natrii hydrogenocarbonas

NaHCO<sub>3</sub>  
[144-55-8]

$M_r$  84.0

#### DEFINITION

**Content:** 99.0 per cent to 101.0 per cent.

## CHARACTERS

*Appearance*: white or almost white, crystalline powder.

*Solubility*: soluble in water, practically insoluble in ethanol (96 per cent).

When heated in the dry state or in solution, it gradually changes into sodium carbonate.

## IDENTIFICATION

- A. To 5 mL of solution S (see Tests) add 0.1 mL of *phenolphthalein solution R*. A pale pink colour is produced. Heat; gas is evolved and the solution becomes red.
- B. It gives the reaction of carbonates and bicarbonates (2.3.1).
- C. Solution S gives reaction (a) of sodium (2.3.1).

## TESTS

**Solution S.** Dissolve 5.0 g in 90 mL of *carbon dioxide-free water R* and dilute to 100.0 mL with the same solvent.

**Appearance of solution.** Solution S is clear (2.2.1) and colourless (2.2.2, *Method II*).

**Carbonates.** The pH (2.2.3) of freshly prepared solution S is not greater than 8.6.

**Chlorides** (2.4.4): maximum 150 ppm.

To 7 mL of solution S add 2 mL of *nitric acid R* and dilute to 15 mL with *water R*.

**Sulfates** (2.4.13): maximum 150 ppm.

To a suspension of 1.0 g in 10 mL of *distilled water R* add *hydrochloric acid R* until neutral and about 1 mL in excess. Dilute to 15 mL with *distilled water R*.

**Ammonium** (2.4.1): maximum 20 ppm.

Dilute 10 mL of solution S to 15 mL with *water R*. Prepare the standard using a mixture of 5 mL of *water R* and 10 mL of *ammonium standard solution (1 ppm NH<sub>4</sub>) R*.

**Arsenic** (2.4.2, *Method A*): maximum 2 ppm, determined on 0.5 g.

**Calcium** (2.4.3): maximum 100 ppm.

To a suspension of 1.0 g in 10 mL of *distilled water R* add *hydrochloric acid R* until neutral and dilute to 15 mL with *distilled water R*.

**Iron** (2.4.9): maximum 20 ppm.

Dissolve 0.5 g in 5 mL of *dilute hydrochloric acid R* and dilute to 10 mL with *water R*.

**Heavy metals** (2.4.8): maximum 10 ppm.

Dissolve 2.0 g in a mixture of 2 mL of *hydrochloric acid R* and 18 mL of *water R*. 12 mL of the solution complies with test A. Prepare the reference solution using *lead standard solution (1 ppm Pb) R*.

## ASSAY

Dissolve 1.500 g in 50 mL of *carbon dioxide-free water R*. Titrate with *1 M hydrochloric acid*, using 0.2 mL of *methyl orange solution R* as indicator.

1 mL of *1 M hydrochloric acid* is equivalent to 84.0 mg of NaHCO<sub>3</sub>.

01/2008:0677  
corrected 6.0

## SODIUM HYDROXIDE

## Natrii hydroxidum

NaOH  
[1310-73-2]

*M<sub>r</sub>* 40.00

## DEFINITION

*Content*: 97.0 per cent to 100.5 per cent.

## CHARACTERS

*Appearance*: white or almost white, crystalline masses, supplied as pellets, sticks or slabs, deliquescent, readily absorbing carbon dioxide.

*Solubility*: very soluble in water, freely soluble in ethanol (96 per cent).

## IDENTIFICATION

A. pH (2.2.3): minimum 11.0.

Dissolve 0.1 g in 10 mL of *water R*. Dilute 1 mL of the solution to 100 mL with *water R*.

B. 2 mL of solution S (see Tests) gives reaction (a) of sodium (2.3.1).

## TESTS

**Solution S.** Carry out the procedure described below with caution. Dissolve 5.0 g in 12 mL of *distilled water R*. Add 17 mL of *hydrochloric acid R1*, adjust to pH 7 with *1 M hydrochloric acid* and dilute to 50 mL with *distilled water R*.

**Appearance of solution.** The solution is clear (2.2.1) and colourless (2.2.2, *Method II*).

Dissolve 1.0 g in 10 mL of *water R*.

**Carbonates:** maximum 2.0 per cent, calculated as Na<sub>2</sub>CO<sub>3</sub> as determined in the assay.

**Chlorides** (2.4.4): maximum 50 ppm.

Dissolve 1.0 g in 5 mL of *water R*, acidify the solution with about 4 mL of *nitric acid R* and dilute to 15 mL with *water R*. The solution, without addition of *dilute nitric acid R*, complies with the test.

**Sulfates** (2.4.13): maximum 50 ppm.

Dissolve 3.0 g in 6 mL of *distilled water R*, adjust to pH 7 with *hydrochloric acid R* (about 7.5 mL) and dilute to 15 mL with *distilled water R*.

**Iron** (2.4.9): maximum 10 ppm, determined on solution S.

**Heavy metals** (2.4.8): maximum 20 ppm.

12 mL of solution S complies with test A. Prepare the reference solution using *lead standard solution (2 ppm Pb) R*.

## ASSAY

Dissolve 2.000 g in about 80 mL of *carbon dioxide-free water R*. Add 0.3 mL of *phenolphthalein solution R* and titrate with *1 M hydrochloric acid*. Add 0.3 mL of *methyl orange solution R* and continue the titration with *1 M hydrochloric acid*.

1 mL of *1 M hydrochloric acid* used in the 2<sup>nd</sup> part of the titration is equivalent to 0.1060 g of Na<sub>2</sub>CO<sub>3</sub>.

1 mL of *1 M hydrochloric acid* used in the combined titrations is equivalent to 40.00 mg of total alkali, calculated as NaOH.

## STORAGE

In an airtight, non-metallic container.

01/2008:0196  
corrected 6.0

## SODIUM IODIDE

## Natrii iodidum

NaI  
[7681-82-5]

*M<sub>r</sub>* 149.9

## DEFINITION

*Content*: 99.0 per cent to 100.5 per cent (dried substance).

## CHARACTERS

*Appearance*: white or almost white, crystalline powder or colourless crystals, hygroscopic.

*Solubility*: very soluble in water, freely soluble in ethanol (96 per cent).

## IDENTIFICATION

- A. Solution S (see Tests) gives the reactions of iodides (2.3.1).  
 B. Solution S gives the reactions of sodium (2.3.1).

## TESTS

**Solution S.** Dissolve 10.0 g in *carbon dioxide-free water R* prepared from *distilled water R* and dilute to 100 mL with the same solvent.

**Appearance of solution.** Solution S is clear (2.2.1) and colourless (2.2.2, *Method II*).

**Alkalinity.** To 12.5 mL of solution S add 0.1 mL of *bromothymol blue solution R1*. Not more than 0.7 mL of 0.01 M *hydrochloric acid* is required to change the colour of the indicator.

**Iodates.** To 10 mL of solution S add 0.25 mL of *iodide-free starch solution R* and 0.2 mL of *dilute sulfuric acid R* and allow to stand protected from light for 2 min. No blue colour develops.

**Sulfates** (2.4.13): maximum 150 ppm.

Dilute 10 mL of solution S to 15 mL with *distilled water R*.

**Thiosulfates.** To 10 mL of solution S add 0.1 mL of *starch solution R* and 0.1 mL of 0.005 M *iodine*. A blue colour is produced.

**Iron** (2.4.9): maximum 20 ppm.

Dilute 5 mL of solution S to 10 mL with *water R*.

**Heavy metals** (2.4.8): maximum 10 ppm.

12 mL of solution S complies with test A. Prepare the reference solution using *lead standard solution (1 ppm Pb) R*.

**Loss on drying** (2.2.32): maximum 3.0 per cent, determined on 1.00 g by drying in an oven at 105 °C for 3 h.

## ASSAY

Dissolve 1.300 g in *water R* and dilute to 100.0 mL with the same solvent. To 20.0 mL of the solution add 40 mL of *hydrochloric acid R* and titrate with 0.05 M *potassium iodate* until the colour changes from red to yellow. Add 5 mL of *chloroform R* and continue the titration, shaking vigorously, until the chloroform layer is decolorised.

1 mL of 0.05 M *potassium iodate* is equivalent to 14.99 mg of NaI.

## STORAGE

Protected from light.

## TESTS

**Solution S.** Dilute a quantity of the substance to be examined corresponding to 40.0 g of sodium lactate to 200 mL with *distilled water R*.

**Appearance of solution.** The substance to be examined is clear (2.2.1) and not more intensely coloured than reference solution BY<sub>7</sub> (2.2.2, *Method II*).

**pH** (2.2.3): 6.5 to 9.0 for the substance to be examined.

**Reducing sugars and sucrose.** To 5 mL of the substance to be examined add 0.2 mL of *copper sulfate solution R* and 2 mL of *dilute sodium hydroxide solution R*. The solution is clear and blue and remains so on boiling. Add to the hot solution 4 mL of *hydrochloric acid R*. Boil for 1 min. Add 6 mL of *strong sodium hydroxide solution R* and heat to boiling again. The solution is clear and blue.

**Methanol.** Gas chromatography (2.4.24).

## Limit:

- *methanol*: maximum 50 ppm, calculated with reference to sodium lactate, if intended for use in the manufacture of parenteral preparations, dialysis, haemodialysis or haemofiltration solutions.

**Chlorides** (2.4.4): maximum 50 ppm calculated with reference to sodium lactate.

Dilute 5 mL of solution S to 15 mL with *water R*. The solution complies with the test for chlorides.

**Oxalates and phosphates.** To 1 mL of the substance to be examined add 15 mL of *ethanol (96 per cent) R* and 2 mL of *calcium chloride solution R*. Heat at 75 °C for 5 min. Any opalescence in the solution is not more intense than that of a standard prepared at the same time and in the same manner using a mixture of 1 mL of the substance to be examined, 15 mL of *ethanol (96 per cent) R* and 2 mL of *water R*.

**Sulfates** (2.4.13): maximum 100 ppm calculated with reference to sodium lactate.

To 7.5 mL of solution S, add 1.9 mL of *hydrochloric acid R1* and dilute to 15 mL with *distilled water R*. The solution complies with the test for sulfates without addition of 0.5 mL of *acetic acid R*. Acidify the standard solution with 0.05 mL of *hydrochloric acid R1* instead of 0.5 mL of *acetic acid R*.

**Aluminium:** maximum 0.1 ppm, if intended for use in the manufacture of parenteral preparations, dialysis, haemodialysis or haemofiltration solutions.

Atomic absorption spectrometry (2.2.23, *Method I*). For the preparation of the solutions, use equipment that is aluminium-free or that will not release aluminium under the conditions of use (glass, polyethylene, etc).

**Modifier solution.** Dissolve 100.0 g of *ammonium nitrate R* in a mixture of 4 mL of *nitric acid R* and 50 mL of *water R* and dilute to 200 mL with *water R*.

**Blank solution.** Dilute to 2.0 mL of the modifier solution to 25.0 mL with *water R*.

**Test solution.** To 5.0 g add 2.0 mL of the modifier solution and dilute to 25.0 mL with *water R*.

**Reference solutions.** Prepare the reference solutions immediately before use (0.010 ppm to 0.050 ppm of aluminium) using *aluminium standard solution (200 ppm Al) R*.

**Source:** aluminium hollow-cathode lamp.

**Wavelength:** 309.3 nm.

**Atomisation device:** a graphite furnace.

**Carrier gas:** argon R.

**Conditions:** the device is equipped with a non-specific absorption correction system. Heat the oven to 120 °C for as many seconds as there are microlitres of solution introduced into the apparatus, then heat at 1000 °C for 30 s and finally at 2700 °C for 6 s.

01/2011:1151

## SODIUM LACTATE SOLUTION

## Natrii lactatis solutio

## DEFINITION

Solution of a mixture of the enantiomers of sodium 2-hydroxypropanoate in approximately equal proportions.

**Content:** minimum declared content 50 per cent *m/m* of sodium 2-hydroxypropanoate (C<sub>3</sub>H<sub>5</sub>NaO<sub>3</sub>; *M<sub>r</sub>* 112.1); 96.0 per cent to 104.0 per cent of the content of sodium lactate stated on the label.

## CHARACTERS

**Appearance:** clear, colourless, slightly syrupy liquid.

**Solubility:** miscible with water and with ethanol (96 per cent).

## IDENTIFICATION

- A. To 0.1 mL add 10 mL of *water R*. 5 mL of the solution gives the reaction of lactates (2.3.1).  
 B. It gives reaction (a) of sodium (2.3.1).

**Barium.** To 10 mL of solution S add 10 mL of *calcium sulfate solution R*. Allow to stand for 30 min. Any opalescence (2.2.1) in the solution is not more intense than that of a standard prepared at the same time and in the same manner using a mixture of 10 mL of solution S and 10 mL of *distilled water R*.

**Iron (2.4.9):** maximum 10 ppm calculated with reference to sodium lactate.

Dilute 5 mL of solution S to 10 mL with *water R*. The solution complies with the test for iron.

**Heavy metals (2.4.8):** maximum 10 ppm calculated with reference to sodium lactate.

12 mL of solution S complies with test A. Prepare the reference solution using *lead standard solution (2 ppm Pb) R*.

**Bacterial endotoxins (2.6.14):** less than 5 IU/g, if intended for use in the manufacture of parenteral preparations without a further appropriate procedure for the removal of bacterial endotoxins.

#### ASSAY

Dissolve a quantity of the substance to be examined corresponding to 75.0 mg of sodium lactate in a mixture of 10 mL of *glacial acetic acid R* and 20 mL of *acetic anhydride R*. Allow to stand for 15 min. Add 1 mL of *naphtholbenzein solution R* and titrate with *0.1 M perchloric acid*.

1 mL of *0.1 M perchloric acid* is equivalent to 11.21 mg of  $C_3H_5NaO_3$ .

#### LABELLING

The label states:

- where applicable, that the substance is suitable for use in the manufacture of dialysis, haemodialysis and haemofiltration solutions,
- where applicable, that the substance is suitable for use in the manufacture of parenteral preparations,
- the declared content of sodium lactate.

01/2008:2033

## SODIUM (S)-LACTATE SOLUTION

### Natrii (S)-lactatis solutio

#### DEFINITION

**Content:** minimum 50.0 per cent *m/m* of sodium (S)-2-hydroxypropanoate ( $C_3H_5NaO_3$ ;  $M_r$  112.1); 96.0 per cent to 104.0 per cent of the content of sodium lactate stated on the label, not less than 95.0 per cent of which is the (S)-enantiomer.

#### CHARACTERS

**Appearance:** clear, colourless, slightly syrupy liquid.

**Solubility:** miscible with water and with alcohol.

#### IDENTIFICATION

- To 0.1 mL add 10 mL of *water R*. 5 mL of the solution gives the reaction of lactates (2.3.1).
- It gives reaction (a) of sodium (2.3.1).
- It complies with the limits of the assay.

#### TESTS

**Solution S.** Dilute a quantity of the substance to be examined corresponding to 40.0 g of sodium lactate to 200 mL with *distilled water R*.

**Appearance of solution.** The substance to be examined is clear (2.2.1) and not more intensely coloured than reference solution BY<sub>7</sub> (2.2.2, *Method II*).

**pH (2.2.3):** 6.5 to 9.0 for the substance to be examined.

**Reducing sugars and sucrose.** To 5 mL of the substance to be examined add 2 mL of *dilute sodium hydroxide solution R* and 0.2 mL of *copper sulfate solution R*. The solution is clear and

blue and remains so on boiling. Add to the hot solution 4 mL of *hydrochloric acid R*. Boil for 1 min. Add 6 mL of *strong sodium hydroxide solution R* and heat to boiling again. The solution is clear and blue.

**Methanol.** Gas chromatography (2.4.24).

**Limit:**

- *methanol:* maximum 50 ppm, calculated with reference to sodium lactate, if intended for use in the manufacture of parenteral preparations, dialysis, haemodialysis or haemofiltration solutions.

**Chlorides (2.4.4):** maximum 50 ppm calculated with reference to sodium lactate.

Dilute 5 mL of solution S to 15 mL with *water R*. The solution complies with the limit test for chlorides.

**Oxalates and phosphates.** To 1 mL of the substance to be examined add 15 mL of *alcohol R* and 2 mL of *calcium chloride solution R*. Heat at 75 °C for 5 min. Any opalescence in the solution is not more intense than that of a standard prepared at the same time and in the same manner using a mixture of 1 mL of the substance to be examined, 15 mL of *alcohol R* and 2 mL of *water R*.

**Sulfates (2.4.13):** maximum 100 ppm calculated with reference to sodium lactate.

To 7.5 mL of solution S, add 1.9 mL of *hydrochloric acid R1* and dilute to 15 mL with *distilled water R*. The solution complies with the limit test for sulfates without addition of 0.5 mL of *acetic acid R*. Acidify the standard solution with 0.05 mL of *hydrochloric acid R1* instead of 0.5 mL of *acetic acid R*.

**Aluminium:** maximum 0.1 ppm, if intended for use in the manufacture of parenteral preparations, dialysis, haemodialysis or haemofiltration solutions.

Atomic absorption spectrometry (2.2.23, *Method I*). For the preparation of the solutions, use equipment that is aluminium-free or that will not release aluminium under the conditions of use (glass, polyethylene, etc).

**Modifier solution.** Dissolve 100.0 g of *ammonium nitrate R* in a mixture of 50 mL of *water R* and 4 mL of *nitric acid R* and dilute to 200 mL with *water R*.

**Blank solution.** Dilute 2.0 mL of the modifier solution to 25.0 mL with *water R*.

**Test solution.** To 1.25 g add 2.0 mL of the modifier solution and dilute to 25.0 mL with *water R*.

**Reference solutions.** Prepare the reference solutions immediately before use (0.010 ppm to 0.050 ppm of aluminium) using *aluminium standard solution (200 ppm Al) R*.

**Source:** aluminium hollow-cathode lamp.

**Wavelength:** 309.3 nm.

**Atomisation device:** a graphite furnace.

**Carrier gas:** argon R.

**Conditions:** the device is equipped with a non-specific absorption correction system. Heat the oven to 120 °C for as many seconds as there are microlitres of solution introduced into the apparatus, then heat at 1000 °C for 30 s and finally at 2700 °C for 6 s.

**Barium.** To 10 mL of solution S add 10 mL of *calcium sulfate solution R*. Allow to stand for 30 min. Any opalescence (2.2.1) in the solution is not more intense than that of a standard prepared at the same time and in the same manner using a mixture of 10 mL of solution S and 10 mL of *distilled water R*.

**Iron (2.4.9):** maximum 10 ppm calculated with reference to sodium lactate.

Dilute 5 mL of solution S to 10 mL with *water R*. The solution complies with the limit test for iron.

**Heavy metals (2.4.8):** maximum 10 ppm calculated with reference to sodium lactate.

12 mL of solution S complies with limit test A. Prepare the standard using *lead standard solution (2 ppm Pb) R*.

**Bacterial endotoxins** (2.6.14): less than 5 IU/g if intended for use in the manufacture of parenteral preparations without a further appropriate procedure for the removal of bacterial endotoxins.

#### ASSAY

Dissolve a quantity of the substance to be examined corresponding to 75.0 mg of sodium lactate in a mixture of 10 mL of *glacial acetic acid R* and 20 mL of *acetic anhydride R*. Allow to stand for 15 min. Add 1 mL of *naphtholbenzein solution R* and titrate with *0.1 M perchloric acid*.

1 mL of *0.1 M perchloric acid* is equivalent to 11.21 mg of  $C_3H_5NaO_3$ .

**(S)-enantiomer.** Transfer a quantity of the substance to be examined corresponding to 2.50 g of sodium lactate into a 50 mL volumetric flask, dilute with about 30 mL of *water R* and add 5.0 g of *ammonium molybdate R*. Dissolve and dilute with *water R* to 50.0 mL. Measure the angle of optical rotation (2.2.7). Calculate the percentage content of (S)-enantiomer using the expression:

$$50 + \left( 24.04 \times \alpha \times \frac{5.0}{m} \times \frac{50}{c} \right)$$

$\alpha$  = angle of optical rotation (absolute value),

$m$  = mass of the substance to be examined, in grams,

$c$  = percentage content of  $C_3H_5NaO_3$  in the substance to be examined.

The complex of sodium (S)-lactate formed under these test conditions is leavorotatory.

#### LABELLING

The label states:

- where applicable, that the substance is suitable for use in the manufacture of dialysis, haemodialysis and haemofiltration solutions,
- where applicable, that the substance is suitable for use in the manufacture of parenteral preparations,
- the declared content of sodium lactate.

01/2008:0098

## SODIUM LAURILSULFATE

### Natrii laurilsulfas

#### DEFINITION

Mixture of sodium alkyl sulfates consisting chiefly of sodium dodecyl sulfate ( $C_{12}H_{25}NaO_4S$ ;  $M_r$  288.4).

*Content:*

- *sodium alkyl sulfates*: minimum 85.0 per cent, expressed as  $C_{12}H_{25}NaO_4S$ .

#### CHARACTERS

*Appearance:* white or pale yellow, powder or crystals.

*Solubility:* freely soluble in water giving an opalescent solution, partly soluble in ethanol (96 per cent).

#### IDENTIFICATION

- Dissolve 0.1 g in 10 mL of *water R* and shake. A copious foam is formed.
- To 0.1 mL of the solution prepared for identification test A, add 0.1 mL of a 1 g/L solution of *methylene blue R* and 2 mL of *dilute sulfuric acid R*. Add 2 mL of *methylene chloride R* and shake. An intense blue colour develops in the methylene chloride layer.

- Mix about 10 mg with 10 mL of *anhydrous ethanol R*.

Heat to boiling on a water-bath, shaking frequently. Filter immediately and evaporate the ethanol. Dissolve the residue in 8 mL of *water R*, add 3 mL of *dilute hydrochloric acid R*, evaporate the solution to half its volume and allow to cool. Separate the congealed fatty alcohols by filtration. To the filtrate add 1 mL of *barium chloride solution R1*. A white, crystalline precipitate is formed.

- Ignite 0.5 g. The residue gives reaction (a) of sodium (2.3.1).

#### TESTS

**Alkalinity.** Dissolve 1.0 g in 100 mL of *carbon dioxide-free water R* and add 0.1 mL of *phenol red solution R*. Not more than 0.5 mL of *0.1 M hydrochloric acid* is required to change the colour of the indicator.

**Non-esterified alcohols:** maximum 4 per cent.

Dissolve 10 g in 100 mL of *water R*, add 100 mL of *ethanol (96 per cent) R* and shake the solution with 3 quantities, each of 50 mL, of *pentane R*, adding *sodium chloride R*, if necessary, to promote separation of the 2 layers. Wash the combined organic layers with 3 quantities, each of 50 mL, of *water R*, dry over *anhydrous sodium sulfate R*, filter and evaporate on a water-bath until the solvent has evaporated. Heat the residue at 105 °C for 15 min and cool. The residue weighs a maximum of 0.4 g.

**Sodium chloride and sodium sulfate:** maximum 8.0 per cent for the total percentage content.

**Sodium chloride.** Dissolve 5.00 g in 50 mL of *water R*, add *dilute nitric acid R* dropwise until the solution is neutral to *blue litmus paper R*, add 2 mL of *potassium chromate solution R* and titrate with *0.1 M silver nitrate*.

1 mL of *0.1 M silver nitrate* is equivalent to 5.844 mg of NaCl.

**Sodium sulfate.** Dissolve 0.500 g in 20 mL of *water R*, warming gently if necessary, then add 1 mL of a 0.5 g/L solution of *dithizone R1* in *acetone R*. If the solution is red, add *1 M nitric acid*, dropwise, until the solution becomes bluish-green. Add 2.0 mL of *dichloroacetic acid solution R* and 80 mL of *acetone R*. Titrate with *0.01 M lead nitrate* until a persistent violet-red or orange-red colour is obtained. Carry out a blank titration.

1 mL of *0.01 M lead nitrate* is equivalent to 1.420 mg of  $Na_2SO_4$ .

#### ASSAY

Dissolve 1.15 g in *water R*, warming if necessary, and dilute to 1000.0 mL with the same solvent. To 20.0 mL of the solution add 15 mL of *chloroform R* and 10 mL of *dimidium bromide-sulfan blue mixed solution R*. Titrate with *0.004 M benzethonium chloride*, shaking vigorously and allowing the layers to separate before each addition, until the pink colour of the chloroform layer is completely discharged and a greyish-blue colour is obtained.

1 mL of *0.004 M benzethonium chloride* is equivalent to 1.154 mg of sodium alkyl sulfates, expressed as  $C_{12}H_{25}NaO_4S$ .

01/2008:0849

## SODIUM METABISULFITE

### Natrii metabisulfis

$Na_2S_2O_5$   
[7681-57-4]

$M_r$  190.1

#### DEFINITION

Sodium metabisulfite also called sodium disulfite.

*Content:* 95.0 per cent to 100.5 per cent.

## CHARACTERS

*Appearance*: white or almost white, crystalline powder or colourless crystals.

*Solubility*: freely soluble in water, slightly soluble in ethanol (96 per cent).

## IDENTIFICATION

- A. pH (see Tests).  
 B. To 0.4 mL of *iodinated potassium iodide solution R* add 8 mL of *distilled water R* and 1 mL of solution S diluted 1 to 10 in *distilled water R*. The solution is colourless and gives reaction (a) of sulfates (2.3.1).  
 C. Solution S gives reaction (a) of sodium (2.3.1).

## TESTS

**Solution S.** Dissolve 5.0 g in *carbon dioxide-free water R* prepared from *distilled water R* and dilute to 100 mL with the same solvent.

**Appearance of solution.** Solution S is clear (2.2.1) and colourless (2.2.2, *Method II*).

**pH** (2.2.3): 3.5 to 5.0 for solution S.

**Thiosulfates.** To 5 mL of solution S add 5 mL of *dilute hydrochloric acid R*. The solution remains clear (2.2.1) for at least 15 min.

**Arsenic** (2.4.2, *Method A*): maximum 5 ppm.

Mix 0.20 g with 2 mL of *water R* in a dish. Add, drop by drop, 1.5 mL of *nitric acid R*. Evaporate the mixture to dryness on a water-bath. Heat over a flame until no more vapour is evolved. Take up the residue in 25 mL of *water R*.

**Iron** (2.4.9): maximum 20 ppm, determined on solution S.

**Heavy metals** (2.4.8): maximum 20 ppm.

To 40 mL of solution S in a silica crucible, add 10 mL of *hydrochloric acid R* and evaporate to dryness. Dissolve the residue in 19 mL of *water R* and add 1 mL of a 40 g/L solution of *sodium fluoride R*. 12 mL of the solution complies with test A. Prepare the reference solution using *lead standard solution* (2 ppm Pb) *R*.

## ASSAY

Dissolve 0.200 g in 50.0 mL of 0.05 M *iodine*. Add 5 mL of *dilute hydrochloric acid R*. Titrate with 0.1 M *sodium thiosulfate* using 1 mL of *starch solution R*, added towards the end of the titration, as indicator.

1 mL of 0.05 M *iodine* is equivalent to 4.753 mg of Na<sub>2</sub>S<sub>2</sub>O<sub>5</sub>.

## STORAGE

Protected from light.

07/2010:1262

## SODIUM METHYL PARAHYDROXYBENZOATE

Methylis parahydroxybenzoas natricus

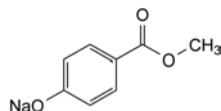

C<sub>8</sub>H<sub>7</sub>NaO<sub>3</sub>  
[5026-62-0]

M<sub>r</sub> 174.1

## DEFINITION

Sodium 4-(methoxycarbonyl)phenolate.

*Content*: 95.0 per cent to 102.0 per cent (anhydrous substance).

## CHARACTERS

*Appearance*: white or almost white, hygroscopic crystalline powder.

*Solubility*: freely soluble in water, sparingly soluble in ethanol (96 per cent), practically insoluble in methylene chloride.

## IDENTIFICATION

*First identification*: B, D.

*Second identification*: A, C, D.

A. Dissolve 0.5 g in 50 mL of *water R*. Immediately add 5 mL of *hydrochloric acid R1*. Filter and wash the precipitate with *water R*. Dry under vacuum at 80 °C for 2 h. The precipitate obtained melts (2.2.14) at 125 °C to 128 °C.

B. Infrared absorption spectrophotometry (2.2.24).

*Preparation*: precipitate obtained in identification test A.

*Comparison*: *methyl parahydroxybenzoate CRS*.

C. Thin-layer chromatography (2.2.27).

*Test solution (a)*. Dissolve 0.10 g in 10 mL of *water R*.

Immediately add 2 mL of *hydrochloric acid R* and shake with 50 mL of *ether R*. Evaporate the upper layer to dryness and take up the residue with 10 mL of *acetone R*.

*Test solution (b)*. Dilute 1 mL of test solution (a) to 10 mL with *acetone R*.

*Reference solution (a)*. Dissolve 10 mg of *methyl parahydroxybenzoate CRS* in *acetone R* and dilute to 10 mL with the same solvent.

*Reference solution (b)*. Dissolve 10 mg of *ethyl parahydroxybenzoate CRS* in 1 mL of test solution (a) and dilute to 10 mL with *acetone R*.

*Plate*: TLC octadecylsilyl silica gel F<sub>254</sub> plate *R*.

*Mobile phase*: *glacial acetic acid R*, *water R*, *methanol R* (1:30:70 V/V/V).

*Application*: 5 µL of test solution (b) and reference solutions (a) and (b).

*Development*: over 2/3 of the plate.

*Drying*: in air.

*Detection*: examine in ultraviolet light at 254 nm.

*System suitability*: reference solution (b):

– the chromatogram shows 2 clearly separated principal spots.

*Results*: the principal spot in the chromatogram obtained with test solution (b) is similar in position and size to the principal spot in the chromatogram obtained with reference solution (a).

D. To 1 mL of solution S (see Tests) add 1 mL of *water R*. The solution gives reaction (a) of sodium (2.3.1).

## TESTS

**Solution S.** Dissolve 5.0 g in *carbon dioxide-free water R* prepared from *distilled water R* and dilute to 50 mL with the same solvent.

**Appearance of solution.** Solution S examined immediately after preparation is clear (2.2.1) and not more intensely coloured than reference solution BY<sub>6</sub> (2.2.2, *Method II*).

**pH** (2.2.3). Dilute 1 mL of solution S to 100 mL with *carbon dioxide-free water R*. The pH of the solution is 9.5 to 10.5.

**Related substances.** Liquid chromatography (2.2.29).

*Test solution.* Dissolve 50.0 mg of the substance to be examined in 2.5 mL of *methanol R* and dilute to 50.0 mL with the mobile phase. Dilute 10.0 mL of this solution to 100.0 mL with the mobile phase.

*Reference solution (a).* Dissolve 5 mg of *4-hydroxybenzoic acid R* (impurity A) and 5 mg of the substance to be examined in the mobile phase and dilute to 100.0 mL with the mobile phase. Dilute 1.0 mL of this solution to 10.0 mL with the mobile phase.

*Reference solution (b).* Dissolve 50.0 mg of *methyl parahydroxybenzoate CRS* in 2.5 mL of *methanol R* and dilute to 50.0 mL with the mobile phase. Dilute 10.0 mL of this solution to 100.0 mL with the mobile phase.

**Reference solution (c).** Dilute 1.0 mL of the test solution to 20.0 mL with the mobile phase. Dilute 1.0 mL of this solution to 10.0 mL with the mobile phase.

**Column:**

- size:  $l = 0.15$  m,  $\varnothing = 4.6$  mm;
- stationary phase: end-capped octadecylsilyl silica gel for chromatography R (5  $\mu$ m).

**Mobile phase:** 6.8 g/L solution of potassium dihydrogen phosphate R, methanol R (35:65 V/V).

**Flow rate:** 1.3 mL/min.

**Detection:** spectrophotometer at 272 nm.

**Injection:** 10  $\mu$ L of the test solution and reference solutions (a) and (c).

**Run time:** 5 times the retention time of methyl parahydroxybenzoate.

**Relative retention** with reference to methyl parahydroxybenzoate (retention time = about 2.3 min): impurity A = about 0.6.

**System suitability:** reference solution (a):

- resolution: minimum 2.0 between the peaks due to impurity A and methyl parahydroxybenzoate.

**Limits:**

- correction factor: for the calculation of content, multiply the peak area of impurity A by 1.4;
- impurity A: not more than 6 times the area of the principal peak in the chromatogram obtained with reference solution (c) (3.0 per cent);
- unspecified impurities: for each impurity, not more than the area of the principal peak in the chromatogram obtained with reference solution (c) (0.5 per cent);
- sum of impurities other than A: not more than twice the area of the principal peak in the chromatogram obtained with reference solution (c) (1.0 per cent);
- disregard limit: 0.2 times the area of the principal peak in the chromatogram obtained with reference solution (c) (0.1 per cent).

**Chlorides (2.4.4):** maximum 350 ppm.

To 10 mL of solution S, add 30 mL of water R and 1 mL of nitric acid R and dilute to 50 mL with water R. Shake and filter. Dilute 10 mL of the filtrate to 15 mL with water R. Prepare the standard using 14 mL of chloride standard solution (5 ppm Cl) R to which 1 mL of water R has been added.

**Sulfates (2.4.13):** maximum 300 ppm.

To 25 mL of solution S, add 5 mL of distilled water R and 10 mL of hydrochloric acid R and dilute to 50 mL with distilled water R. Shake and filter. Dilute 10 mL of the filtrate to 15 mL with distilled water R.

**Heavy metals (2.4.8):** maximum 10 ppm.

2.0 g complies with test C. Prepare the reference solution using 2 mL of lead standard solution (10 ppm Pb) R.

**Water (2.5.12):** maximum 5.0 per cent, determined on 0.500 g.

**ASSAY**

Liquid chromatography (2.2.29) as described in the test for related substances with the following modification.

**Injection:** test solution and reference solution (b).

Calculate the percentage content of  $C_8H_7NaO_3$  using the declared content of methyl parahydroxybenzoate CRS and multiplying by a correction factor of 1.145.

**STORAGE**

In an airtight container.

**IMPURITIES**

**Specified impurities: A.**

**Other detectable impurities** (the following substances would, if present at a sufficient level, be detected by one or other of the tests in the monograph. They are limited by the general

acceptance criterion for other/unspecified impurities and/or by the general monograph *Substances for pharmaceutical use (2034)*. It is therefore not necessary to identify these impurities for demonstration of compliance. See also 5.10. *Control of impurities in substances for pharmaceutical use*): B, C, D.

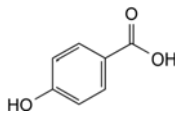

A. 4-hydroxybenzoic acid,

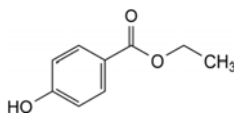

B. ethyl 4-hydroxybenzoate (ethyl parahydroxybenzoate),

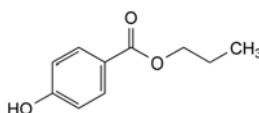

C. propyl 4-hydroxybenzoate (propyl parahydroxybenzoate),

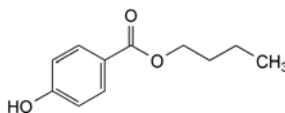

D. butyl 4-hydroxybenzoate (butyl parahydroxybenzoate).

01/2008:1565  
corrected 6.3

## SODIUM MOLYBDATE DIHYDRATE

Natrii molybdati dihydricus

$MoNa_2O_4 \cdot 2H_2O$   
[10102-40-6]

$M_r$  241.9

**DEFINITION**

**Content:** 98.0 per cent to 100.5 per cent (dried substance).

**CHARACTERS**

**Appearance:** white or almost white powder or colourless crystals.

**Solubility:** freely soluble in water.

**IDENTIFICATION**

- Loss on drying (see Tests).
- Dissolve 0.2 g in 5 mL of a mixture of equal volumes of nitric acid R and water R and add 0.1 g of ammonium chloride R. Add 0.3 mL of disodium hydrogen phosphate solution R and heat slowly at 50-60 °C. A yellow precipitate is formed.
- Dissolve 0.15 g in 2 mL of water R, the solution gives reaction (a) of sodium (2.3.1).

**TESTS**

**Solution S.** Dissolve 10.0 g in water R and dilute to 50 mL with the same solvent.

**Appearance of solution.** Solution S is clear (2.2.1) and colourless (2.2.2, Method II).

**Chlorides:** maximum 50 ppm.

To 10 mL of a mixture of equal volumes of nitric acid R and water R add 10 mL of solution S with shaking. Add 1 mL of 0.1 M silver nitrate. Any opalescence in the solution is not more intense after 5 min than that of a standard solution prepared at the same time in the same manner with 2 mL of chloride standard solution (50 ppm Cl) R.



**Phosphates:** maximum 200 ppm.

Dissolve 2.0 g by heating in 13 mL of *water R*. In the still-hot solution, dissolve 8.0 g of *ammonium nitrate RI*. Add this solution to 27 mL of a mixture of equal volumes of *nitric acid R* and *water R*. Any yellow colour or opalescence in the solution is not more intense within 3 h than that in a standard solution prepared at the same time in the same manner as follows: dissolve 1.0 g in 12 mL of *water R* and add 1 mL of *phosphate standard solution (200 ppm PO<sub>4</sub>) R*.

**Ammonium (2.4.1, Method B):** maximum 10 ppm, determined on 0.10 g.

Prepare the standard using 1 mL of *ammonium standard solution (1 ppm NH<sub>4</sub>) R*.

**Heavy metals:** maximum 10 ppm.

To 10 mL of solution S, add 2 mL of *water R*, 6 mL of a 168 g/L solution of *sodium hydroxide R* and 2 mL of *concentrated ammonia R* (solution A). To 0.5 mL of *thioacetamide reagent R* add a mixture of 15 mL of solution A and 5 mL of *water R*. Any coloration of the solution is not more intense after 2 min than that of a reference solution prepared at the same time as follows: to 0.5 mL of *thioacetamide reagent R* add a mixture of 5 mL of solution A, 1 mL of *lead standard solution (10 ppm Pb) R* and 14 mL of *water R*.

**Loss on drying (2.2.32):** 14.0 per cent to 16.0 per cent, determined on 1.000 g by drying in an oven at 140 °C for 3 h.

#### ASSAY

Dissolve 0.100 g in 30 mL of *water R*, add 0.5 g of *hexamethylenetetramine R* and 0.1 mL of a 250 g/L solution of *nitric acid R*. Heat to 60 °C. Titrate with 0.05 M *lead nitrate* using 4-(2-pyridylazo)resorcinol monosodium salt *R* as indicator.

1 mL of 0.05 M *lead nitrate* is equivalent to 10.30 mg of Na<sub>2</sub>MoO<sub>4</sub>.

01/2008:1996

## SODIUM NITRITE

### Natrii nitris

NaNO<sub>2</sub> *M<sub>r</sub>* 69.0  
[7632-00-0]

#### DEFINITION

*Content:* 98.5 per cent to 100.5 per cent (dried substance).

#### CHARACTERS

*Appearance:* colourless crystals or mass or yellowish rods, hygroscopic.

*Solubility:* freely soluble in water, soluble in alcohol.

#### IDENTIFICATION

- Dilute 1 mL of solution S1 (see Tests) to 25 mL with *water R*. To 0.1 mL of the solution add 1 mL of *sulfanilic acid solution RI*. Allow to stand for 2-3 min. Add 1 mL of *β-naphthol solution R* and 1 mL of *dilute sodium hydroxide solution R*. An intense red colour develops.
- To 1 mL of the solution prepared for identification test A add 3 mL of a 20 g/L solution of *phenazone R* and 0.4 mL of *dilute sulfuric acid R*. An intense green colour develops.
- To 0.15 mL of solution S1, add 0.35 mL of *water R*. The solution gives reaction (b) of sodium (2.3.1).

#### TESTS

**Solution S1.** Dissolve 2.5 g in *carbon dioxide-free water R* and dilute to 50 mL with the same solvent.

**Solution S2.** Dissolve 3 g in *distilled water R*. Cautiously add 10 mL of *nitric acid R* and evaporate to dryness. Dissolve the residue in 10 mL of *distilled water R*, neutralise with *dilute sodium hydroxide solution R* and dilute to 30 mL with *distilled water R*.

**Appearance of solution.** Solution S1 is clear (2.2.1) and not more intensely coloured than reference solution B<sub>6</sub> (2.2.2, Method II).

**Acidity or alkalinity.** To 10 mL of solution S1, add 0.05 mL of *phenol red solution R*. Add 0.1 mL of 0.01 M *sodium hydroxide*. The solution is red. Add 0.3 mL of 0.01 M *hydrochloric acid*. The solution is yellow.

**Chlorides (2.4.4):** maximum 50 ppm.

Dilute 10 mL of solution S2 to 15 mL with *water R*. The solution complies with the limit test for chlorides.

**Sulfates (2.4.13):** maximum 200 ppm.

Dilute 7.5 mL of solution S2 to 15 mL with *distilled water R*. The solution complies with the limit test for sulfates.

**Heavy metals (2.4.8):** maximum 20 ppm.

Dilute 10 mL of solution S2 to 20 mL with *water R*. 12 mL of the solution complies with limit test A. Prepare the standard using *lead standard solution (1 ppm Pb) R*.

**Loss on drying (2.2.32):** maximum 1.0 per cent, determined on 1.000 g by drying *in vacuo*.

#### ASSAY

Dissolve 0.400 g in 100.0 mL of *water R*. Introduce 20.0 mL of the solution, while stirring continuously and keeping the tip of the pipette below the surface of the liquid, into a conical flask containing 30.0 mL of 0.1 M *cerium sulfate*. Immediately stopper the flask and allow to stand for 2 min. Add 10 mL of a 200 g/L solution of *potassium iodide R* and 2 mL of *starch solution R*.

While stirring continuously, titrate with 0.1 M *sodium thiosulfate* until the blue colour disappears. Carry out a blank titration.

1 mL of 0.1 M *cerium sulfate* is equivalent to 3.45 mg of NaNO<sub>2</sub>.

#### STORAGE

In an airtight container.

01/2008:0565

## SODIUM NITROPRUSSIDE

### Natrii nitroprussias

Na<sub>2</sub>[Fe(CN)<sub>5</sub>(NO)]·2H<sub>2</sub>O *M<sub>r</sub>* 298.0  
[13755-38-9]

#### DEFINITION

Sodium pentacyanonitrosylferrate (III) dihydrate.

*Content:* 99.0 per cent to 100.5 per cent (anhydrous substance).

#### CHARACTERS

*Appearance:* reddish-brown powder or crystals.

*Solubility:* freely soluble in water, slightly soluble in ethanol (96 per cent).

#### IDENTIFICATION

- Ultraviolet and visible absorption spectrophotometry (2.2.25).

*Test solution.* Dissolve 0.700 g in *water R* and dilute to 100.0 mL with the same solvent. Examine the solution immediately after preparation.

*Spectral range:* 350-600 nm.

*Absorption maximum:* at 395 nm.

*Shoulder:* at about 510 nm.

*Absorption minimum*: at 370 nm.

*Specific absorbance at the absorption maximum*: 0.65 to 0.80.

- B. Dissolve about 20 mg in 2 mL of *water R* and add 0.1 mL of *sodium sulfide solution R*. A deep violet-red colour is produced.
- C. Dissolve 50 mg in 1 mL of *water R* and acidify the solution by the addition of *hydrochloric acid R*. Place a drop of the solution in an oxidising flame. A persistent yellow colour is produced.

#### TESTS

**Insoluble matter**: maximum 100 ppm.

Dissolve 10 g without heating in 50 mL of *water R*. Allow to stand for 30 min and filter through a sintered-glass filter (16) (2.1.2). Wash the filter with cold *water R* until the filtrate is colourless. Dry the residue on the filter at 105 °C. The residue weighs a maximum of 1 mg.

**Chlorides** (2.4.4): maximum 200 ppm.

In a metallic crucible (nickel) mix 1.0 g with 8 mL of a 200 g/L solution of *sodium hydroxide R*. Heat slowly and evaporate carefully to dryness over a small flame, then heat to a dull red colour for 30 min. Allow to cool and transfer the solid residue with 3 quantities, each of 8 mL, of *dilute sulfuric acid R*.

Filter the sulfuric acid extracts on a filter paper and collect the filtrates. Render the filtrate acid to *litmus paper R* by adding, if necessary, a few drops of *dilute sulfuric acid R*. Wash the crucible and the filter paper with 3 quantities, each of 10 mL, of *water R*, add the washings to the main sulfuric acid solution and dilute to 60 mL with *water R*. Mix.

**Ferricyanides**: maximum 200 ppm.

Dissolve 1.25 g in *acetate buffer solution pH 4.6 R* and dilute to 50.0 mL with the same buffer solution. Use three 50 mL volumetric flasks (A, B, C). To flask B add 1.0 mL of *ferricyanide standard solution (50 ppm Fe(CN)<sub>6</sub><sup>3-</sup> R*. To flasks A and B add 1 mL of a 5 g/L solution of *ferrous ammonium sulfate R*. To the 3 flasks add 10.0 mL of the solution of the substance to be examined. Dilute the contents of each flask to 50.0 mL with *water R*. Allow to stand for 30 min. The absorbance (2.2.25) of the solution in flask A measured at 720 nm using the solution in flask C as the compensation liquid is not greater than the absorbance of the solution in flask B measured at 720 nm using the solution in flask A as the compensation liquid.

**Ferrocyanides**: maximum 200 ppm.

Dissolve 4.0 g in *water R* and dilute to 100.0 mL with the same solvent. Use three 50 mL volumetric flasks (A, B, C). To flask B add 2.0 mL of *ferrocyanide standard solution (100 ppm Fe(CN)<sub>6</sub><sup>4-</sup> R*. To flasks A and B add 1 mL of *ferric chloride solution R2*. To the 3 flasks add 25.0 mL of the solution of the substance to be examined. Dilute the contents of each flask to 50.0 mL with *water R*. Allow to stand for 30 min. The absorbance (2.2.25) of the solution in flask A measured at 695 nm using the solution in flask C as the compensation liquid is not greater than the absorbance of the solution in flask B measured at 695 nm using the solution in flask A as the compensation liquid.

**Sulfates**: maximum 100 ppm.

*Test solution*. Dissolve 3.6 g in 120 mL of *distilled water R*, add with mixing 4 mL of *sulfate standard solution (10 ppm SO<sub>4</sub><sup>2-</sup> R* and 20 mL of a 250 g/L solution of *cupric chloride R* and dilute to 150.0 mL with *distilled water R*. Allow to stand for 16 h and filter or centrifuge until a clear light-blue solution is obtained.

*Reference solution*. To 40 mL of *sulfate standard solution (10 ppm SO<sub>4</sub><sup>2-</sup> R* add 80 mL of *distilled water R* and 12-13 mL of a 250 g/L solution of *cupric chloride R*. Dilute to 150.0 mL with *distilled water R*. The volume of cupric chloride solution added is such that the colour of the final solution matches that of the test solution.

Allow the solutions to stand. Filter both solutions, discarding the first 25 mL of filtrate. To 100 mL of each filtrate, add 0.5 mL of *acetic acid R*. Mix and add 2 mL of a 250 g/L solution of *barium chloride R* and mix again. The test solution is not more opalescent than the reference solution.

**Water** (2.5.12): 9.0 per cent to 15.0 per cent, determined on 0.250 g.

#### ASSAY

Dissolve 0.250 g in 100 mL of *water R* and add 0.1 mL of *dilute sulfuric acid R*. Titrate with 0.1 M *silver nitrate*, determining the end-point potentiometrically (2.2.20) with a silver-mercurous sulfate electrode system.

1 mL of 0.1 M *silver nitrate* is equivalent to 13.10 mg of Na<sub>2</sub>[Fe(CN)<sub>5</sub>(NO)].

#### STORAGE

Protected from light.

01/2008:1997  
corrected 6.0

## SODIUM PERBORATE, HYDRATED

### Natrii perboras hydricus

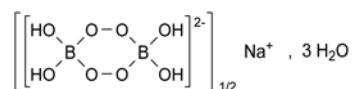

NaBO<sub>3</sub>·4H<sub>2</sub>O or NaBO<sub>2</sub>·H<sub>2</sub>O<sub>2</sub>·3H<sub>2</sub>O

*M<sub>r</sub>* 153.9

#### DEFINITION

*Content*: 96.0 per cent to 103.0 per cent.

#### CHARACTERS

*Appearance*: colourless, prismatic crystals or white or almost white powder, stable in the crystalline form.

*Solubility*: sparingly soluble in water, with slow decomposition. It dissolves in dilute mineral acids.

#### IDENTIFICATION

- A. Mix 1 mL of a saturated solution with a mixture of 1 mL of *dilute sulfuric acid R* and 0.2 mL of a 70 g/L solution of *potassium dichromate R*, shake with 2 mL of *ether R* and allow to stand. A blue colour is produced in the ether layer.
- B. The mixture obtained by treating about 100 mg with 0.1 mL of *sulfuric acid R* and 5 mL of *methanol R* burns with a greenish flame when ignited.
- C. It gives reaction (a) of sodium (2.3.1).

#### TESTS

**Chlorides** (2.4.4): maximum 330 ppm.

Dissolve 0.15 g in 15 mL of *water R*. The solution complies with the limit test for chlorides.

**Sulfates** (2.4.13): maximum 1.2 per cent.

Dissolve 0.13 g in 150 mL of *distilled water R*. 15 mL of the solution complies with the limit test for sulfates.

**Iron** (2.4.9): maximum 20 ppm.

Dissolve 2.5 g in 10 mL of *dilute hydrochloric acid R* with heating, evaporate to dryness, with stirring, and dissolve the residue in 25 mL of hot *water R*. Dilute 5 mL of the obtained solution to 10 mL with *water R*. The solution complies with the limit test for iron.

**Heavy metals** (2.4.8): maximum 10 ppm.

12 mL of the solution obtained in the test for iron complies with limit test A. Prepare the standard using *lead standard solution (1 ppm Pb) R*.

## ASSAY

Dissolve 0.300 g in 50.0 mL of *water R*. Dilute 10.0 mL of the solution to 50 mL with *water R* and add 10 mL of *dilute sulfuric acid R*. Titrate with 0.02 M *potassium permanganate*.

1 mL of 0.02 M *potassium permanganate* is equivalent to 7.693 mg of  $\text{NaH}_8\text{BO}_7$ .

## STORAGE

In an airtight container.

04/2008:2183

## SODIUM PHENYL BUTYRATE

## Natrii phenylbutyras

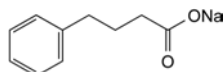

$\text{C}_{10}\text{H}_{11}\text{NaO}_2$   
[1716-12-7]

$M_r$  186.2

## DEFINITION

Sodium 4-phenylbutanoate.

*Content*: 99.0 per cent to 101.0 per cent (anhydrous substance).

## CHARACTERS

*Appearance*: white or yellowish-white powder.

*Solubility*: freely soluble in water and in methanol, practically insoluble in methylene chloride.

## IDENTIFICATION

A. Infrared absorption spectrophotometry (2.2.24).

*Comparison*: *sodium phenylbutyrate CRS*.

B. Dissolve 0.15 g in 2 mL of *water R*. The solution gives reaction (a) of sodium (2.3.1).

## TESTS

**pH** (2.2.3): 6.5 to 7.5.

Dissolve 0.20 g in *carbon dioxide-free water R* and dilute to 10 mL with the same solvent.

**Impurity C**. Gas chromatography (2.2.28).

*Silylation solution*. To 2 mL of *N,O-bis(trimethylsilyl)tri-fluoroacetamide R* add 0.04 mL of *chlorotrimethylsilane R* and mix.

*Test solution*. Dissolve 50.0 mg of the substance to be examined in 3 mL of *water R* and add 0.5 mL of *hydrochloric acid R*. Extract with 2 quantities, each of 5 mL, of *methylene chloride R*. Evaporate the combined methylene chloride extracts to dryness in a vial with a screw cap and add 0.5 mL of the silylation solution. Seal the vial and heat at  $70 \pm 5$  °C for 20 min.

*Reference solution (a)*. Dissolve 5.0 mg of *sodium phenylbutyrate impurity C CRS* in *methylene chloride R* and dilute to 10.0 mL with the same solvent.

*Reference solution (b)*. Dilute 1.0 mL of reference solution (a) to 10.0 mL with *methylene chloride R*. Place 1.0 mL of this solution in a vial with a screw cap, evaporate to dryness and add 0.5 mL of the silylation solution. Seal the vial and heat at  $70 \pm 5$  °C for 20 min.

*Reference solution (c)*. Dissolve 10 mg of the substance to be examined in 25 mL of *water R*. To 3 mL of this solution add 0.1 mL of *hydrochloric acid R*. Extract with 2 quantities, each of 5 mL, of *methylene chloride R*. Combine the methylene chloride extracts in a vial with a screw cap and add 2 mL of reference solution (a). Evaporate to dryness and add 0.5 mL of the silylation solution. Seal the vial and heat at  $70 \pm 5$  °C for 20 min.

## Column:

- *material*: fused silica;
- *size*:  $l = 25$  m,  $\varnothing = 0.25$  mm;
- *stationary phase*: *poly(dimethyl)(diphenyl)siloxane R* (film thickness 1.0  $\mu\text{m}$ ).

*Carrier gas*: *helium for chromatography R*.

*Flow rate*: 0.9 mL/min.

*Split ratio*: 1:100.

## Temperature:

	Time (min)	Temperature (°C)
Column	0 - 5	50
	5 - 27	50 → 270
	27 - 32	270
Injection port		270
Detector		270

*Detection*: flame ionisation.

*Injection*: 1  $\mu\text{L}$ .

*Relative retention* with reference to phenylbutyrate (retention time = about 20 min): *impurity C* = about 0.98.

*System suitability*: reference solution (c):

- *resolution*: minimum 3.0 between the peaks due to *impurity C* and phenylbutyrate.

## Limit:

- *impurity C*: not more than the area of the corresponding peak in the chromatogram obtained with reference solution (b) (0.1 per cent).

**Related substances**. Liquid chromatography (2.2.29).

*Test solution*. Dissolve 0.20 g of the substance to be examined in 10 mL of *methanol R* and dilute to 50.0 mL with *water R*.

*Reference solution (a)*. Dissolve 4.0 mg of  *$\alpha$ -tetralone R* (*impurity B*) in 10 mL of *methanol R* and dilute to 200.0 mL with the same solvent.

*Reference solution (b)*. Dissolve 0.20 g of the substance to be examined in 10 mL of *methanol R*, add 1 mL of reference solution (a) and dilute to 50 mL with *water R*.

*Reference solution (c)*. Dilute 1.0 mL of reference solution (a) to 50.0 mL with *water R*.

*Reference solution (d)*. Dissolve 5.0 mg of *3-benzoylpropionic acid R* (*impurity A*) in 2.5 mL of *methanol R* and dilute to 50.0 mL with the same solvent. Dilute 1.0 mL of this solution to 50.0 mL with *water R*.

## Column:

- *size*:  $l = 0.25$  m,  $\varnothing = 4.6$  mm;
- *stationary phase*: *base-deactivated end-capped octadecylsilyl silica gel for chromatography R* (5  $\mu\text{m}$ ).

*Mobile phase*: *glacial acetic acid R*, *methanol R*, *water R* (1:49:50 V/V/V).

*Flow rate*: 1.3 mL/min.

*Detection*: spectrophotometer at 245 nm.

*Injection*: 20  $\mu\text{L}$  of the test solution and reference solutions (b), (c) and (d).

*Run time*: twice the retention time of phenylbutyrate.

*Relative retention* with reference to phenylbutyrate (retention time = about 17 min): *impurity A* = about 0.3; *impurity B* = about 0.7.

*System suitability*: reference solution (b):

- *resolution*: minimum 6 between the peaks due to *impurity B* and phenylbutyrate.

## Limits:

- *impurity A*: not more than twice the area of the corresponding peak in the chromatogram obtained with reference solution (d) (0.1 per cent);

- *impurity B*: not more than the area of the corresponding peak in the chromatogram obtained with reference solution (c) (0.01 per cent);
- *unspecified impurities*: for each impurity, not more than the area of the principal peak in the chromatogram obtained with reference solution (d) (0.05 per cent);
- *total*: not more than twice the area of the principal peak in the chromatogram obtained with reference solution (d) (0.1 per cent);
- *disregard limit of impurities other than B*: 0.6 times the area of the principal peak in the chromatogram obtained with reference solution (d) (0.03 per cent).

**Heavy metals** (2.4.8): maximum 10 ppm.

Dissolve 2.0 g in a mixture of 25 volumes of *water R* and 75 volumes of *ethanol (96 per cent) R* and dilute to 20 mL with the same mixture of solvents. 12 mL of the solution complies with test B. Prepare the reference solution using lead standard solution (1 ppm Pb) obtained by diluting *lead standard solution (100 ppm Pb) R* with a mixture of 25 volumes of *water R* and 75 volumes of *ethanol (96 per cent) R*.

**Water** (2.5.12): maximum 0.5 per cent, determined on 2.00 g.

#### ASSAY

Disperse 0.150 g in 50 mL of *anhydrous acetic acid R*. The opalescence of the solution disappears during the titration. Titrate with 0.1 M *perchloric acid*, determining the end-point potentiometrically (2.2.20).

1 mL of 0.1 M *perchloric acid* is equivalent to 18.62 mg of  $C_{10}H_{11}NaO_2$ .

#### IMPURITIES

*Specified impurities: A, B, C.*

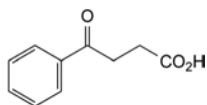

A. 4-oxo-4-phenylbutanoic acid (3-benzoylpropionic acid),

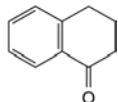

B. 3,4-dihydronaphthalen-1(2H)-one ( $\alpha$ -tetralone),

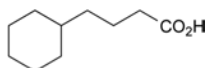

C. 4-cyclohexylbutanoic acid.

*Solubility*: freely soluble in water, slightly soluble in ethanol 96 per cent.

#### IDENTIFICATION

*First identification: A, E.*

*Second identification: B, C, D, E.*

A. Infrared absorption spectrophotometry (2.2.24).

*Comparison: sodium picosulfate CRS.*

B. Thin-layer chromatography (2.2.27).

*Test solution.* Dissolve 20 mg of the substance to be examined in *methanol R* and dilute to 5 mL with the same solvent.

*Reference solution.* Dissolve 20 mg of *sodium picosulfate CRS* in *methanol R* and dilute to 5 mL with the same solvent.

*Plate: TLC silica gel GF<sub>254</sub> plate R.*

*Mobile phase: anhydrous formic acid R, water R, methanol R, ethyl acetate R (2.5:12.5:25:60 V/V/V/V).*

*Application: 5  $\mu$ L.*

*Development: over half of the plate.*

*Drying: in a current of hot air for 15 min.*

*Detection: examine in ultraviolet light at 254 nm.*

*Results:* the principal spot in the chromatogram obtained with the test solution is similar in position and size to the principal spot in the chromatogram obtained with the reference solution.

C. To 5 mL of solution S (see Tests) add 1 mL of *dilute hydrochloric acid R* and heat to boiling. Add 1 mL of *barium chloride solution R1*. A white precipitate is formed.

D. To about 10 mg add 3 mL of *sulfuric acid R* and 0.1 mL of *potassium dichromate solution R1*. A violet colour develops.

E. Solution S gives reaction (a) of sodium (2.3.1).

#### TESTS

**Solution S.** Dissolve 2.5 g in *carbon dioxide-free water R* prepared from *distilled water R* and dilute to 50 mL with the same solvent.

**Appearance of solution.** Solution S is clear (2.2.1) and not more intensely coloured than reference solution GY<sub>7</sub> (2.2.2, *Method II*).

**Acidity or alkalinity.** To 10 mL of solution S add 0.05 mL of *phenolphthalein solution R*. The solution is colourless. Not more than 0.25 mL of 0.01 M *sodium hydroxide* is required to change the colour of the indicator to pink.

**Related substances.** Liquid chromatography (2.2.29).

*Test solution.* Dissolve 50 mg of the substance to be examined in the mobile phase and dilute to 100.0 mL with the mobile phase.

*Reference solution (a).* Dilute 1.0 mL of the test solution to 100.0 mL with the mobile phase. Dilute 10.0 mL of this solution to 100.0 mL with the mobile phase.

*Reference solution (b).* Dissolve the contents of a vial of *picosulfate for system suitability CRS* (containing impurities A and B) in 1.0 mL of the mobile phase.

*Column:*

– *size: l* = 0.25 m,  $\varnothing$  = 4.0 mm;

– *stationary phase:* spherical *end-capped octadecylsilyl silica gel for chromatography R1* (5  $\mu$ m);

– *temperature:* 40 °C.

*Mobile phase:* dissolve 2.3 g of *disodium hydrogen phosphate dihydrate R* in 800 mL of *water for chromatography R*, add 0.2 g of *cetyltrimethylammonium bromide R*, adjust to pH 7.5 with *phosphoric acid R* and dilute to 1000 mL with *water for chromatography R*; mix 550 mL of this solution and 450 mL of *acetonitrile R* (if necessary vary the buffer/acetonitrile proportion in 10 mL increments in order to fulfil the resolution requirement).

07/2009:1031

## SODIUM PICOSULFATE

### Natrii picosulfas

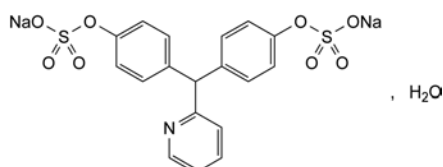

$C_{18}H_{13}NNa_2O_8S_2 \cdot H_2O$

$M_r$  499.4

#### DEFINITION

4,4'-(Pyridin-2-yl)methylene]diphenyl bis(sodium sulfate) monohydrate.

*Content:* 98.5 per cent to 100.5 per cent (anhydrous substance).

#### CHARACTERS

*Appearance:* white or almost white, crystalline powder.

Flow rate: 1.0 mL/min.

Detection: spectrophotometer at 263 nm.

Injection: 40 µL.

Run time: twice the retention time of picosulfate.

Identification of impurities: use the chromatogram supplied with *picosulfate for system suitability CRS* and the chromatogram obtained with reference solution (b) to identify the peaks due to impurities A and B.

Relative retention with reference to picosulfate (retention time = about 7.4 min): impurity B = about 0.5; impurity A = about 0.7.

System suitability: reference solution (b):

- resolution: minimum 4.0 between the peaks due to impurities B and A.

Limits:

- correction factors: for the calculation of content, multiply the peak areas of the following impurities by the corresponding correction factor: impurity A = 0.7; impurity B = 0.5;
- impurities A, B: for each impurity, not more than twice the area of the principal peak in the chromatogram obtained with reference solution (a) (0.2 per cent);
- unspecified impurities: for each impurity, not more than the area of the principal peak in the chromatogram obtained with reference solution (a) (0.10 per cent);
- total: not more than 5 times the area of the principal peak in the chromatogram obtained with reference solution (a) (0.5 per cent);
- disregard limit: 0.5 times the area of the principal peak in the chromatogram obtained with reference solution (a) (0.05 per cent).

**Chlorides** (2.4.4): maximum 200 ppm.

Dilute 5 mL of solution S to 15 mL with *water R*.

**Sulfates** (2.4.13): maximum 400 ppm.

Dilute 7.5 mL of solution S to 15 mL with *distilled water R*.

**Water** (2.5.12): 3.0 per cent to 5.0 per cent, determined on 0.500 g.

ASSAY

Dissolve 0.400 g in 80 mL of *methanol R*. Titrate with 0.1 M *perchloric acid*, determining the end-point potentiometrically (2.2.20).

1 mL of 0.1 M *perchloric acid* is equivalent to 48.14 mg of  $C_{18}H_{13}NNa_2O_8S_2$ .

IMPURITIES

Specified impurities: A, B.

Other detectable impurities (the following substances would, if present at a sufficient level, be detected by one or other of the tests in the monograph. They are limited by the general acceptance criterion for other/unspecified impurities and/or by the general monograph *Substances for pharmaceutical use* (2034). It is therefore not necessary to identify these impurities for demonstration of compliance. See also 5.10. *Control of impurities in substances for pharmaceutical use*): C.

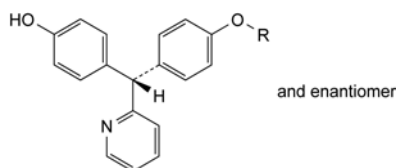

A. R =  $SO_3Na$ : 4-[(*RS*)-(4-hydroxyphenyl)(pyridin-2-yl)methyl]phenyl sodium sulfate,

B. R = H: 4,4'-[(pyridin-2-yl)methylene]diphenol,

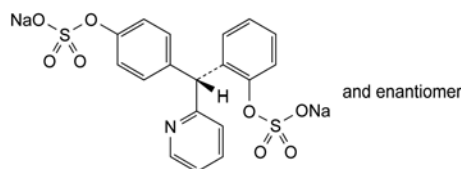

C. 2-[(*RS*)-(pyridin-2-yl)[4-(sulfonatoxy)phenyl]methyl]phenyl disodium sulfate.

01/2009:1909

## SODIUM POLYSTYRENE SULFONATE

### Natrii polystyrenesulfonas

#### DEFINITION

Polystyrene sulfonate resin prepared in the sodium form.

*Exchange capacity*: 2.8 mmol to 3.4 mmol of potassium per gram (dried substance).

*Content*: 9.4 per cent to 11.0 per cent of Na (dried substance).

#### CHARACTERS

*Appearance*: almost white or light brown powder.

*Solubility*: practically insoluble in water, in ethanol (96 per cent) and in methylene chloride.

#### IDENTIFICATION

A. Infrared absorption spectrophotometry (2.2.24).

*Preparation*: discs using finely ground substance.

*Comparison*: *Ph. Eur. reference spectrum of sodium polystyrene sulfonate*.

B. Suspend 0.1 g in *water R*, add 2 mL of a 150 g/L solution of *potassium carbonate R*, and heat to boiling. Allow to cool and filter. To the filtrate add 4 mL of *potassium pyroantimonate solution R* and heat to boiling. Allow to cool in iced water and if necessary rub the inside of the test-tube with a glass rod. A dense white precipitate is formed.

#### TESTS

**Styrene**. Liquid chromatography (2.2.29).

*Test solution*. Shake 10.0 g of the substance to be examined with 10 mL of *acetone R* for 30 min, centrifuge and use the supernatant liquid.

*Reference solution*. Dissolve 10 mg of *styrene R* in *acetone R* and dilute to 100 mL with the same solvent. Dilute 1 mL of this solution to 100 mL with *acetone R*.

*Column*:

- size:  $l = 0.25$  m,  $\varnothing = 4$  mm;
- stationary phase: octadecylsilyl silica gel for chromatography R (5 µm).

*Mobile phase*: *acetonitrile R*, *water R* (1:1 V/V).

*Flow rate*: 2 mL/min.

*Detection*: spectrophotometer at 254 nm.

*Injection*: 20 µL.

*Limit*:

- *styrene*: not more than the area of the principal peak in the chromatogram obtained with the reference solution (1 ppm).

**Calcium**: maximum 0.10 per cent.

Atomic emission spectrometry (2.2.22, *Method I*).

*Test solution*. To 1.10 g add 5 mL of *hydrochloric acid R*, heat to boiling, cool and add 10 mL of *water R*. Filter, wash the filter and residue with *water R* and dilute the filtrate and washing to 25.0 mL with *water R*.

*Reference solutions*. Prepare the reference solutions using *calcium standard solution (400 ppm Ca) R*, diluted as necessary with *water R*.

*Wavelength*: 422.7 nm.

01/2008:2041  
corrected 6.0**Potassium:** maximum 0.10 per cent.

Atomic emission spectrometry (2.2.22, Method I).

**Test solution.** To 1.10 g add 5 mL of *hydrochloric acid R*, heat to boiling, cool and add 10 mL of *water R*. Filter, wash the filter and residue with *water R* and dilute the filtrate and washings to 25.0 mL with *water R*.

**Reference solutions.** Prepare the reference solutions using *potassium standard solution (100 ppm K) R*, diluted as necessary with *water R*.

Wavelength: 766.5 nm.

**Heavy metals (2.4.8):** maximum 10 ppm.

Treat 1.0 g as described in limit test F. After the addition of the *buffer solution pH 3.5 R* and of the *thioacetamide reagent R*, dilute to 50 mL with *water R* and continue as described in limit test E, beginning at the words "mix and allow to stand for 10 min...".

Prepare the standard using 10 mL of *lead standard solution (1 ppm Pb) R*.

**Loss on drying (2.2.32):** maximum 7.0 per cent, determined on 1.000 g by drying in an oven at 105 °C.

**Microbial contamination (2.6.13)**

Bile-tolerant gram-negative bacteria: acceptance criterion less than 10<sup>2</sup> CFU/g.

## ASSAY

**Sodium.** Atomic emission spectrometry (2.2.22, Method I).

**Test solution.** In a platinum crucible moisten 0.90 g with a few drops of *sulfuric acid R*, ignite very gently and allow to cool. Moisten with a few drops of *sulfuric acid R* again, ignite at 800 ± 50 °C until a carbon-free ash is obtained and allow to cool.

Add 20 mL of *water R* to the crucible, warm gently on a water-bath until dissolution, cool, transfer quantitatively to a 100 mL graduated flask and dilute to 100.0 mL with *water R*. Dilute 5 mL of this solution to 1000.0 mL with *water R*.

**Reference solutions.** Prepare the reference solutions using *sodium standard solution (200 ppm Na) R*, diluted as necessary with *water R*.

Wavelength: 589 nm.

**Exchange capacity.** Atomic emission spectrometry (2.2.22, Method I).Solution A. 9.533 g/L solution of *potassium chloride R*.

**Test solution.** To 1.6 g of the substance to be examined in a dry 250 mL ground-glass-stoppered flask add 100 mL of solution A, stopper and shake for 15 min. Filter, discard the first 20 mL of the filtrate and dilute 4 mL of the filtrate to 1000 mL with *water R*.

**Reference solutions.** Prepare the reference solutions by diluting 0, 1, 2, 3 and 4 mL of solution A respectively and 4, 3, 2, 1 and 0 mL of a 7.63 g/L solution of *sodium chloride R* to 1000 mL with *water R*.

Wavelength: 766.5 nm.

Prepare a calibration curve using the reference solutions and calculate the potassium exchange capacity of the substance to be examined in millimoles per gram taking the concentration of potassium in solution A as 128 mmol/L of K per litre.

## STORAGE

In an airtight container.

## IMPURITIES

Specified impurities: A.

A. styrene.

## SODIUM PROPIONATE

Natrii propionas

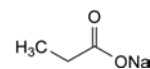
C<sub>3</sub>H<sub>5</sub>NaO<sub>2</sub>  
[137-40-6]M<sub>r</sub> 96.1

## DEFINITION

Sodium propanoate.

Content: 99.0 per cent to 101.0 per cent (dried substance).

## CHARACTERS

**Appearance:** colourless crystals or, white or almost white powder, slightly hygroscopic.

**Solubility:** freely soluble in water, sparingly soluble in alcohol, practically insoluble in methylene chloride.

## IDENTIFICATION

First identification: A, D.

Second identification: B, C, D.

A. Infrared absorption spectrophotometry (2.2.24).

Comparison: Ph. Eur. reference spectrum of sodium propionate.

B. Dissolve 0.1 g in a mixture of 2 mL of *copper sulfate solution R* and 2 mL of *methylene chloride R*. Shake vigorously and allow to stand. Both the upper and the lower layer show a blue colour.

C. To 5 mL of solution S (see Tests) add 2 mL of 0.1 M *silver nitrate*. A white precipitate is formed.

D. Solution S gives reaction (a) of sodium (2.3.1).

## TESTS

**Solution S.** Dissolve 10 g in *carbon dioxide-free water R* prepared from *distilled water R* and dilute to 100 mL with the same solvent.

**Appearance of solution.** Solution S is clear (2.2.1) and colourless (2.2.2, Method II).

pH (2.2.3): 7.8 to 9.2.

Dilute 1 mL of solution S to 5 mL with *water R*.**Related substances.** Liquid chromatography (2.2.29).

**Test solution.** Dissolve 0.250 g of the substance to be examined in *water R* and dilute to 100 mL with the same solvent.

**Reference solution (a).** Dissolve 10 mg of the substance to be examined and 10 mg of *sodium acetate R* in *water R* and dilute to 100 mL with the same solvent.

**Reference solution (b).** Dilute 1.0 mL of the test solution to 100 mL with *water R*.

Column:

– size: l = 0.25 m, Ø = 4.6 mm,

– stationary phase: octadecylsilyl silica gel for chromatography R (5 µm).

Mobile phase: dilute 1 mL of *phosphoric acid R* to 1000 mL with *water R*.

Flow rate: 1 mL/min.

Detection: spectrophotometer at 210 nm.

Injection: 20 µL.

System suitability: reference solution (a):

– resolution: minimum 5 between the peaks due to sodium acetate and sodium propionate.

**Limits:**

- **any impurity:** not more than 0.1 times the area of the principal peak in the chromatogram obtained with reference solution (b) (0.1 per cent),
- **total:** not more than half the area of the principal peak in the chromatogram obtained with reference solution (b) (0.5 per cent),
- **disregard limit:** 0.05 times the area of the principal peak in the chromatogram obtained with reference solution (b) (0.05 per cent).

**Readily oxidisable substances.** In a ground-glass-stoppered conical flask introduce 10 g of the substance to be examined. Add 100 mL of *water R* and stir to dissolve. Add 25 mL of *sodium hypobromite solution R* and 10 mL of a 200 g/L solution of *sodium acetate R*, stopper the flask and allow to stand for 15 min. Add 10 mL of *potassium iodide solution R* and 20 mL of *hydrochloric acid R* while cooling. Titrate with 0.2 M *sodium thiosulfate*, adding 2 mL of *starch solution R* towards the end of the titration. Carry out a blank titration. The difference between the volumes used in the 2 titrations is not greater than 2.2 mL.

**Iron (2.4.9):** maximum 10 ppm.

10 mL of solution S complies with the limit test for iron.

**Heavy metals (2.4.8):** maximum 10 ppm.

12 mL of solution S complies with limit test A. Prepare the standard using *lead standard solution (1 ppm Pb) R*.

**Loss on drying (2.2.32):** maximum 0.5 per cent, determined on 1.000 g by heating in an oven at 105 °C for 3 h.

**ASSAY**

Dissolve 80.0 mg in 30 mL of *anhydrous acetic acid R*. Titrate with 0.1 M *perchloric acid*, determining the end-point potentiometrically (2.2.20).

1 mL of 0.1 M *perchloric acid* is equivalent to 9.61 mg of C<sub>3</sub>H<sub>5</sub>NaO<sub>2</sub>.

**STORAGE**

In an airtight container.

01/2011:1263

## SODIUM PROPYL PARAHYDROXYBENZOATE

Propylis parahydroxybenzoas natricus

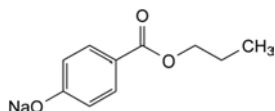

C<sub>10</sub>H<sub>11</sub>NaO<sub>3</sub>  
[35285-69-9]

M<sub>r</sub> 202.2

**DEFINITION**

Sodium 4-(propoxycarbonyl)phenolate.

**Content:** 94.0 per cent to 102.0 per cent (anhydrous substance).

**CHARACTERS**

**Appearance:** white or almost white, hygroscopic, crystalline powder.

**Solubility:** freely soluble in water, sparingly soluble in ethanol (96 per cent), practically insoluble in methylene chloride.

**IDENTIFICATION**

**First identification:** B, D.

**Second identification:** A, C, D.

A. Dissolve 0.5 g in 50 mL of *water R*. Immediately add 5 mL of *hydrochloric acid R1*. Filter and wash the precipitate with *water R*. Dry in *vacuo* at 80 °C for 2 h. The melting point (2.2.14) of the precipitate is 96 °C to 99 °C.

B. Infrared absorption spectrophotometry (2.2.24).

**Preparation:** precipitate obtained in identification test A.

**Comparison:** *propyl parahydroxybenzoate CRS*.

C. Thin-layer chromatography (2.2.27).

**Test solution (a).** Dissolve 0.10 g of the substance to be examined in 10 mL of *water R*. Immediately add 2 mL of *hydrochloric acid R* and shake with 50 mL of *ether R*. Evaporate the upper layer to dryness and take up the residue with 10 mL of *acetone R*.

**Test solution (b).** Dilute 1 mL of test solution (a) to 10 mL with *acetone R*.

**Reference solution (a).** Dissolve 10 mg of *propyl parahydroxybenzoate CRS* in *acetone R* and dilute to 10 mL with the same solvent.

**Reference solution (b).** Dissolve 10 mg of *ethyl parahydroxybenzoate CRS* in 1 mL of test solution (a) and dilute to 10 mL with *acetone R*.

**Plate:** *TLC octadecylsilyl silica gel F<sub>254</sub> plate R*.

**Mobile phase:** *glacial acetic acid R, water R, methanol R* (1:30:70 V/V/V).

**Application:** 5 µL of test solution (b) and reference solutions (a) and (b).

**Development:** over 2/3 of the plate.

**Drying:** in air.

**Detection:** examine in ultraviolet light at 254 nm.

**System suitability:** reference solution (b):

- the chromatogram shows 2 clearly separated principal spots.

**Results:** the principal spot in the chromatogram obtained with test solution (b) is similar in position and size to the principal spot in the chromatogram obtained with reference solution (a).

D. To 1 mL of solution S (see Tests) add 1 mL of *water R*. The solution gives reaction (a) of sodium (2.3.1).

**TESTS**

**Solution S.** Dissolve 5.0 g in *carbon dioxide-free water R* prepared from *distilled water R*, and dilute to 50 mL with the same solvent.

**Appearance of solution.** Solution S, examined immediately after preparation, is clear (2.2.1) and not more intensely coloured than reference solution BY<sub>6</sub> (2.2.2, *Method II*).

**pH (2.2.3):** 9.5 to 10.5.

Dilute 1 mL of solution S to 100 mL with *carbon dioxide-free water R*.

**Related substances.** Liquid chromatography (2.2.29).

**Test solution.** Dissolve 50.0 mg of the substance to be examined in 2.5 mL of *methanol R* and dilute to 50.0 mL with the mobile phase. Dilute 10.0 mL of the solution to 100.0 mL with the mobile phase.

**Reference solution (a).** Dissolve 5 mg of *ethyl parahydroxybenzoate CRS (impurity C)*, 5 mg of *4-hydroxybenzoic acid R (impurity A)* and 5 mg of the substance to be examined in the mobile phase and dilute to 100.0 mL with the mobile phase. Dilute 1.0 mL of the solution to 10.0 mL with the mobile phase.

**Reference solution (b).** Dissolve 50.0 mg of *propyl parahydroxybenzoate CRS* in 2.5 mL of *methanol R* and dilute to 50.0 mL with the mobile phase. Dilute 10.0 mL of the solution to 100.0 mL with the mobile phase.

**Reference solution (c).** Dilute 1.0 mL of the test solution to 20.0 mL with the mobile phase. Dilute 1.0 mL of this solution to 10.0 mL with the mobile phase.

**Column:**

- size:  $l = 0.15$  m,  $\varnothing = 4.6$  mm;
- stationary phase: end-capped octadecylsilyl silica gel for chromatography R (5  $\mu$ m).

Mobile phase: 6.8 g/L solution of potassium dihydrogen phosphate R, methanol R (35:65 V/V).

Flow rate: 1.3 mL/min.

Detection: spectrophotometer at 272 nm.

Injection: 10  $\mu$ L of the test solution and reference solutions (a) and (c).

Run time: 2.5 times the retention time of propyl parahydroxybenzoate.

Relative retention with reference to propyl parahydroxybenzoate (retention time = about 4.5 min): impurity A = about 0.3; impurity C = about 0.7.

System suitability: reference solution (a):

- resolution: minimum 5.0 between the peaks due to impurity C and propyl parahydroxybenzoate.

**Limits:**

- correction factor: for the calculation of content, multiply the peak area of impurity A by 1.4;
- impurity A: not more than 8 times the area of the principal peak in the chromatogram obtained with reference solution (c) (4.0 per cent);
- unspecified impurities: for each impurity, not more than the area of the principal peak in the chromatogram obtained with reference solution (c) (0.5 per cent);
- sum of impurities other than A: not more than twice the area of the principal peak in the chromatogram obtained with reference solution (c) (1.0 per cent);
- disregard limit: 0.2 times the area of the principal peak in the chromatogram obtained with reference solution (c) (0.1 per cent).

**Chlorides** (2.4.4): maximum 350 ppm.

To 10 mL of solution S add 1 mL of nitric acid R and 30 mL of water R and dilute to 50 mL with water R. Shake and filter. Dilute 10 mL of the filtrate to 15 mL with water R. Prepare the standard using 14 mL of chloride standard solution (5 ppm Cl) R to which 1 mL of water R has been added.

**Sulfates** (2.4.13): maximum 300 ppm.

To 25 mL of solution S add 5 mL of distilled water R and 10 mL of hydrochloric acid R and dilute to 50 mL with distilled water R. Shake and filter. Dilute 10 mL of the filtrate to 15 mL with distilled water R.

**Heavy metals** (2.4.8): maximum 10 ppm.

2.0 g complies with test C. Prepare the reference solution using 2 mL of lead standard solution (10 ppm Pb) R.

**Water** (2.5.12): maximum 5.0 per cent, determined on 0.500 g.

**ASSAY**

Liquid chromatography (2.2.29) as described in the test for related substances with the following modification.

Injection: test solution and reference solution (b).

Calculate the percentage content of  $C_{10}H_{11}NaO_3$  from the declared content of propyl parahydroxybenzoate CRS, multiplied by a correction factor of 1.122.

**STORAGE**

In an airtight container.

**IMPURITIES**

Specified impurities: A.

Other detectable impurities (the following substances would, if present at a sufficient level, be detected by one or other of the tests in the monograph. They are limited by the general acceptance criterion for other/unspecified impurities and/or by the general monograph Substances for pharmaceutical use

(2034). It is therefore not necessary to identify these impurities for demonstration of compliance. See also 5.10. Control of impurities in substances for pharmaceutical use): B, C, D.

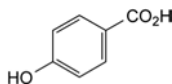

A. 4-hydroxybenzoic acid,

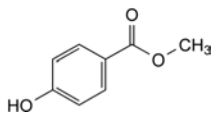

B. methyl 4-hydroxybenzoate (methyl parahydroxybenzoate),

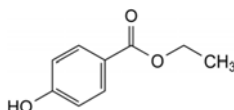

C. ethyl 4-hydroxybenzoate (ethyl parahydroxybenzoate),

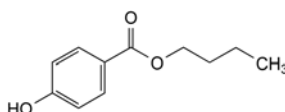

D. butyl 4-hydroxybenzoate (butyl parahydroxybenzoate).

01/2008:0413  
corrected 6.0

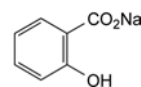
**SODIUM SALICYLATE****Natrii salicylas**

$C_7H_5NaO_3$   
[54-21-7]

$M_r$ , 160.1

**DEFINITION**

Sodium 2-hydroxybenzenecarboxylate.

Content: 99.0 per cent to 101.0 per cent (dried substance).

**CHARACTERS**

Appearance: white or almost white, crystalline powder or small, colourless crystals or shiny flakes.

Solubility: freely soluble in water, sparingly soluble in ethanol (96 per cent).

**IDENTIFICATION**

First identification: A, C.

Second identification: B, C.

A. Infrared absorption spectrophotometry (2.2.24).

Comparison: sodium salicylate CRS.

B. Solution S (see Tests) gives the reactions of salicylates (2.3.1).

C. It gives reaction (b) of sodium (2.3.1).

**TESTS**

**Solution S.** Dissolve 5.0 g in carbon dioxide-free water R prepared from distilled water R and dilute to 50 mL with the same solvent.

**Appearance of solution.** Solution S is clear (2.2.1) and not more intensely coloured than reference solution BY<sub>6</sub> (2.2.2, Method II).

**Acidity.** To 20 mL of solution S add 0.1 mL of phenol red solution R. The solution is yellow. Not more than 2.0 mL of 0.01 M sodium hydroxide is required to change the colour of the indicator to violet-red.



**Chlorides** (2.4.4): maximum 200 ppm.

To 5 mL of solution S add 5 mL of *water R* and 10 mL of *dilute nitric acid R* and filter. Dilute 10 mL of the filtrate to 15 mL with *water R*.

**Sulfates** (2.4.13): maximum 600 ppm.

Dilute 2.5 mL of solution S to 15 mL with *distilled water R*.

**Heavy metals** (2.4.8): maximum 20 ppm.

Dissolve 1.6 g in 16 mL of a mixture of 5 volumes of *water R* and 10 volumes of *ethanol (96 per cent) R*. 12 mL of the solution complies with test B. Prepare the reference solution using lead standard solution (2 ppm Pb) obtained by diluting *lead standard solution (100 ppm Pb) R* with a mixture of 5 volumes of *water R* and 10 volumes of *ethanol (96 per cent) R*.

**Loss on drying** (2.2.32): maximum 0.5 per cent, determined on 1.00 g by drying in an oven at 105 °C.

#### ASSAY

Dissolve 0.130 g in 30 mL of *anhydrous acetic acid R*. Titrate with 0.1 M *perchloric acid*, determining the end-point potentiometrically (2.2.20).

1 mL of 0.1 M *perchloric acid* is equivalent to 16.01 mg of  $C_7H_5NaO_3$ .

#### STORAGE

In an airtight container, protected from light.

01/2008:1677

## SODIUM SELENITE PENTAHYDRATE

### Natrii selenis pentahydricus

$Na_2SeO_3 \cdot 5H_2O$   
[26970-82-1]

*M*, 263.0

#### DEFINITION

*Content*: 98.5 per cent to 101.5 per cent.

#### CHARACTERS

*Appearance*: white or almost white, crystalline powder, hygroscopic.

*Solubility*: freely soluble in water, practically insoluble in ethanol (96 per cent).

#### IDENTIFICATION

- Dissolve 50 mg in 5 mL of a mixture of equal volumes of *dilute hydrochloric acid R* and *water R* and heat to boiling. Add 0.05 g of *ascorbic acid R*; a red precipitate is formed which may become black.
- Dissolve 50 mg in a mixture of 1 mL of *dilute hydrochloric acid R* and 5 mL of *water R*. Add 1 mL of *barium chloride solution R1*; the solution remains clear.
- It gives reaction (a) of sodium (2.3.1).
- It complies with the limits of the assay.

#### TESTS

**Solution S.** Dissolve 5.0 g in *carbon dioxide-free water R* and dilute to 50.0 mL with the same solvent.

**Appearance of solution.** Solution S is clear (2.2.1) and colourless (2.2.2, *Method II*).

**pH** (2.2.3): 9.8 to 10.8 for solution S.

**Chlorides** (2.4.4): maximum 50 ppm.

To 10 mL of solution S add 2 mL of *nitric acid R* and dilute to 15 mL with *water R*.

**Sulfates and selenates** (2.4.13): maximum 300 ppm (determined as sulfates).

Dissolve 0.5 g in 10 mL of *distilled water R*. Add 0.5 mL of *hydrochloric acid R1* and dilute to 15 mL with *distilled water R*.

**Iron**: maximum 50 ppm.

To 2 mL of solution S add 2 mL of a 200 g/L solution of *sulfosalicylic acid R*, 5 mL of *concentrated ammonia R* and dilute to 10 mL with *water R*. The solution is not more intensely coloured than a reference solution prepared in the same manner using 1 mL of *iron standard solution (10 ppm Fe) R*.

#### ASSAY

Dissolve 0.120 g in 50 mL of *water R*, add 7 mL of *glacial acetic acid R*, 25.0 mL of 0.1 M *sodium thiosulfate* and 0.5 g of *potassium iodide R*. Titrate immediately with 0.05 M *iodine solution* using *starch solution R* as indicator.

1 mL of 0.1 M *sodium thiosulfate* is equivalent to 6.575 mg of  $Na_2SeO_3 \cdot 5H_2O$ .

#### STORAGE

In an airtight container.

01/2008:0983

## SODIUM STARCH GLYCOLATE (TYPE A)

### Carboxymethylamylum natricum A

#### DEFINITION

Sodium salt of a cross-linked partly *O*-carboxymethylated potato starch.

*Content*: 2.8 per cent to 4.2 per cent of Na (*A*, 22.99) (substance washed with ethanol (80 per cent *V/V*) and dried).

#### CHARACTERS

*Appearance*: white or almost white, fine, free-flowing powder, very hygroscopic.

*Solubility*: practically insoluble in methylene chloride. It gives a translucent suspension in water.

*Examined under a microscope* it is seen to consist of: granules, irregularly shaped, ovoid or pear-shaped, 30-100 µm in size, or rounded, 10-35 µm in size; compound granules consisting of 2-4 components occur occasionally; the granules have an eccentric hilum and clearly visible concentric striations; between crossed nicol prisms, the granules show a distinct black cross intersecting at the hilum; small crystals are visible at the surface of the granules. The granules show considerable swelling in contact with water.

#### IDENTIFICATION

- pH (see Tests).
- Prepare with shaking and without heating a mixture of 4.0 g of the substance to be examined and 20 mL of *carbon dioxide-free water R*. The mixture has the appearance of a gel. Add 100 mL of *carbon dioxide-free water R* and shake. A suspension forms that settles after standing.
- To an acidified solution, add *iodinated potassium iodide solution R1*. The solution becomes blue or violet.
- Solution S2 (see Tests) gives reaction (a) of sodium (2.3.1).

#### TESTS

**Solution S1.** Centrifuge the suspension obtained in identification test B at 2500 *g* for 10 min. Collect carefully the supernatant liquid.

**Solution S2.** Place 2.5 g in a silica or platinum crucible and add 2 mL of a 500 g/L solution of *sulfuric acid R*. Heat on a water-bath, then cautiously over a naked flame, raising the temperature progressively, then incinerate in a muffle furnace at  $600 \pm 25$  °C. Continue heating until all black particles have disappeared. Allow to cool, add a few drops of *dilute sulfuric acid R*, heat and incinerate as above. Allow to cool, add a few drops of *ammonium carbonate solution R*, evaporate to dryness and incinerate cautiously. Allow to cool and dissolve the residue in 50 mL of *water R*.

01/2008:0984

**Appearance of solution S1.** Solution S1 is clear (2.2.1) and colourless (2.2.2, Method II).

**pH (2.2.3):** 5.5 to 7.5.

Disperse 1.0 g in 30 mL of *water R*.

**Sodium glycolate:** maximum 2.0 per cent. Carry out the test protected from light.

**Test solution.** Place 0.20 g in a beaker. Add 5 mL of *acetic acid R* and 5 mL of *water R*. Stir until dissolution is complete (about 10 min). Add 50 mL of *acetone R* and 1 g of *sodium chloride R*. Filter through a fast filter paper impregnated with *acetone R*, rinse the beaker and filter with *acetone R*. Combine the filtrate and washings and dilute to 100.0 mL with *acetone R*. Allow to stand for 24 h without shaking. Use the clear supernatant liquid.

**Reference solution.** Dissolve 0.310 g of *glycollic acid R*, previously dried *in vacuo* over *diphosphorus pentoxide R* at room temperature overnight, in *water R* and dilute to 500.0 mL with the same solvent. To 5.0 mL of this solution add 5 mL of *acetic acid R* and allow to stand for about 30 min. Add 50 mL of *acetone R* and 1 g of *sodium chloride R*. Filter through a fast filter paper impregnated with *acetone R*, rinse the beaker and filter with *acetone R*. Combine the filtrate and washings and dilute to 100.0 mL with *acetone R*. Allow to stand for 24 h without shaking. Use the clear supernatant liquid.

Heat 2.0 mL of the test solution on a water-bath for 20 min. Cool to room temperature and add 20.0 mL of *2,7-dihydroxynaphthalene solution R*. Shake and heat in a water-bath for 20 min. Cool under running water, transfer to a volumetric flask and dilute to 25.0 mL with *sulfuric acid R*, maintaining the flask under running water. Within 10 min, measure the absorbance at 540 nm (2.2.25) using *water R* as the compensation liquid. The absorbance of the solution prepared with the test solution is not greater than that of a solution prepared at the same time and in the same manner with 2.0 mL of the reference solution.

**Sodium chloride:** maximum 7.0 per cent.

Place 0.500 g in a beaker and suspend in 100 mL of *water R*. Add 1 mL of *nitric acid R*. Titrate with *0.1 M silver nitrate*, determining the end-point potentiometrically (2.2.20), using a silver indicator electrode.

1 mL of *0.1 M silver nitrate* is equivalent to 5.844 mg of NaCl.

**Iron (2.4.9):** maximum 20 ppm determined on 10 mL of solution S2.

**Heavy metals (2.4.8):** maximum 20 ppm.

1.0 g complies with test D. Prepare the reference solution using 2 mL of *lead standard solution (10 ppm Pb) R*.

**Loss on drying (2.2.32):** maximum 10.0 per cent, determined on 1.000 g by drying in an oven at 130 °C for 1.5 h.

**Microbial contamination.** It complies with the test for *Escherichia coli* and *Salmonella* (2.6.13).

#### ASSAY

Shake 1.000 g with 20 mL of *ethanol (80 per cent V/V) R*, stir for 10 min and filter. Repeat the operation until chloride has been completely extracted and verify the absence of chloride using *silver nitrate solution R2*. Dry the residue at 105 °C to constant mass. To 0.700 g of the dried residue, add 80 mL of *glacial acetic acid R* and heat under a reflux condenser for 2 h. Cool the solution to room temperature. Titrate with *0.1 M perchloric acid*, determining the end-point potentiometrically (2.2.20). Carry out a blank titration.

1 mL of *0.1 M perchloric acid* is equivalent to 2.299 mg of Na.

#### STORAGE

In an airtight container, protected from light.

## SODIUM STARCH GLYCOLATE (TYPE B)

### Carboxymethylamylum natricum B

#### DEFINITION

Sodium salt of a cross-linked partly *O*-carboxymethylated potato starch.

**Content:** 2.0 per cent to 3.4 per cent of Na (A, 22.99) (substance washed with ethanol (80 per cent V/V) and dried).

#### CHARACTERS

**Appearance:** white or almost white, fine, free-flowing powder, very hygroscopic.

**Solubility:** practically insoluble in methylene chloride. It gives a translucent suspension in water.

**Examined under a microscope** it is seen to consist of: granules, irregularly shaped, ovoid or pear shaped, 30-100 µm in size, or rounded, 10-35 µm in size; compound granules consisting of 2-4 components occur occasionally; the granules have an eccentric hilum and clearly visible concentric striations; between crossed nicol prisms, the granules show a distinct black cross intersecting at the hilum; small crystals are visible at the surface of the granules. The granules show considerable swelling in contact with water.

#### IDENTIFICATION

- pH (see Tests).
- Prepare with shaking and without heating a mixture of 4.0 g of the substance to be examined and 20 mL of *carbon dioxide-free water R*. The mixture has the appearance of a gel. Add 100 mL of *carbon dioxide-free water R* and shake. A suspension forms that settles after standing.
- To an acidified solution, add *iodinated potassium iodide solution R1*. The solution becomes blue or violet.
- Solution S2 (see Tests) gives reaction (a) of sodium (2.3.1).

#### TESTS

**Solution S1.** Centrifuge the suspension obtained in identification test B at 2500 *g* for 10 min. Collect carefully the supernatant liquid.

**Solution S2.** Place 2.5 g in a silica or platinum crucible and add 2 mL of a 500 g/L solution of *sulfuric acid R*. Heat on a water-bath, then cautiously over a naked flame, raising the temperature progressively, and then incinerate in a muffle furnace at 600 ± 25 °C. Continue heating until all black particles have disappeared. Allow to cool, add a few drops of *dilute sulfuric acid R* and heat and incinerate as above. Allow to cool, add a few drops of *ammonium carbonate solution R*, evaporate to dryness and incinerate cautiously. Allow to cool and dissolve the residue in 50 mL of *water R*.

**Appearance of solution S1.** Solution S1 is clear (2.2.1) and colourless (2.2.2, Method II).

**pH (2.2.3):** 3.0 to 5.0.

Disperse 1.0 g in 30 mL of *water R*.

**Sodium glycolate:** maximum 2.0 per cent. Carry out the test protected from light.

**Test solution.** Place 0.20 g in a beaker. Add 5 mL of *acetic acid R* and 5 mL of *water R*. Stir until dissolution is complete (about 10 min). Add 50 mL of *acetone R* and 1 g of *sodium chloride R*. Filter through a fast filter paper impregnated with *acetone R*, rinse the beaker and filter with *acetone R*. Combine the filtrate and washings and dilute to 100.0 mL with *acetone R*. Allow to stand for 24 h without shaking. Use the clear supernatant liquid.

**Reference solution.** Dissolve 0.310 g of *glycollic acid R*, previously dried *in vacuo* over *diphosphorus pentoxide R* at room temperature overnight, in *water R* and dilute to 500.0 mL with the same solvent. To 5.0 mL of this solution add 5 mL of

*acetic acid R* and allow to stand for about 30 min. Add 50 mL of *acetone R* and 1 g of *sodium chloride R*. Filter through a fast filter paper impregnated with *acetone R*, rinse the beaker and filter with *acetone R*. Combine the filtrate and washings and dilute to 100.0 mL with *acetone R*. Allow to stand for 24 h without shaking. Use the clear supernatant liquid.

Heat 2.0 mL of the test solution on a water-bath for 20 min. Cool to room temperature and add 20.0 mL of *2,7-dihydroxynaphthalene solution R*. Shake and heat in a water-bath for 20 min. Cool under running water, transfer quantitatively to a volumetric flask and dilute to 25.0 mL with *sulfuric acid R*, maintaining the flasks under running water. Within 10 min, measure the absorbance at 540 nm (2.2.25) using *water R* as the compensation liquid. The absorbance of the solution prepared with the test solution is not greater than that of a solution prepared at the same time and in the same manner with 2.0 mL of the reference solution.

**Sodium chloride:** maximum 7.0 per cent.

Place 0.500 g in a beaker and suspend in 100 mL of *water R*. Add 1 mL of *nitric acid R*. Titrate with *0.1 M silver nitrate*, determining the end-point potentiometrically (2.2.20) using a silver indicator electrode.

1 mL of *0.1 M silver nitrate* is equivalent to 5.844 mg of NaCl.

**Iron (2.4.9):** maximum 20 ppm determined on 10 mL of solution S2.

**Heavy metals (2.4.8):** maximum 20 ppm.

1.0 g complies with test D. Prepare the reference solution using 2 mL of *lead standard solution (10 ppm Pb) R*.

**Loss on drying (2.2.32):** maximum 10.0 per cent, determined on 1.000 g by drying in an oven at 130 °C for 1.5 h.

**Microbial contamination.** It complies with the test for *Escherichia coli* and *Salmonella* (2.6.13).

#### ASSAY

Shake 1.000 g with 20 mL of *ethanol (80 per cent V/V) R*, stir for 10 min and filter. Repeat the operation until chloride has been completely extracted and verify the absence of chloride using *silver nitrate R2*. Dry the residue at 105 °C to constant mass. To 0.700 g of the dried residue, add 80 mL of *glacial acetic acid R* and heat under a reflux condenser for 2 h. Cool the solution to room temperature. Titrate with *0.1 M perchloric acid*, determining the end-point potentiometrically (2.2.20). Carry out a blank titration.

1 mL of *0.1 M perchloric acid* is equivalent to 2.299 mg of Na.

#### STORAGE

In an airtight container, protected from light.

01/2008:1566  
corrected 6.0

## SODIUM STARCH GLYCOLATE (TYPE C)

### Carboxymethylamylum natricum C

#### DEFINITION

Sodium salt of a partly *O*-carboxymethylated starch, cross-linked by physical dehydration.

**Content:** 2.8 per cent to 5.0 per cent of Na (*A*, 22.99) (substance washed with ethanol (80 per cent *V/V*) and dried).

#### CHARACTERS

**Appearance:** white or almost white, fine, free-flowing powder, very hygroscopic.

**Microscopic examination:** it is seen to consist of granules, irregularly shaped, ovoid or pear-shaped, 30-100 µm in size, or rounded, 10-35 µm in size; compound granules consisting of 2-4 components occur occasionally; the granules have an eccentric hilum and clearly visible concentric striations; between crossed nicol prisms, the granules show a distinct

black cross intersecting at the hilum; small crystals are visible at the surface of the granules. The granules show considerable swelling in contact with water.

**Solubility:** soluble in water, practically insoluble in methylene chloride. It gives a translucent gel-like product in water.

#### IDENTIFICATION

A. pH (see Tests).

B. Prepare with shaking and without heating a mixture of 4.0 g of the substance to be examined and 20 mL of *carbon dioxide-free water R*. The mixture has the appearance of a gel. Add 100 mL of *carbon dioxide-free water R* and shake: the gel remains stable (difference from types A and B). Keep the gel for the tests for appearance of gel and pH.

C. To 5 mL of the gel obtained in identification test B add 0.05 mL of *iodine solution R1*. A dark blue colour is produced.

D. Solution S (see Tests) gives reaction (a) of sodium (2.3.1).

#### TESTS

**Solution S.** Place 2.5 g in a silica or platinum crucible and add 2 mL of a 500 g/L solution of *sulfuric acid R*. Heat on a water-bath, then cautiously over a naked flame, raising the temperature progressively, and then incinerate in a muffle furnace at 600 ± 25 °C. Continue heating until all black particles have disappeared. Allow to cool, add a few drops of *sulfuric acid R*, heat and incinerate as above. Allow to cool, add a few drops of *ammonium carbonate solution R*, evaporate to dryness and incinerate cautiously. Allow to cool and dissolve the residue in 50 mL of *water R*.

**Appearance of gel.** The gel obtained in identification test B is colourless (2.2.2, *Method II*).

**pH (2.2.3):** 5.5 to 7.5 for the gel obtained in identification test B.

**Sodium glycolate:** maximum 2.0 per cent. Carry out the test protected from light.

**Test solution.** Place 0.20 g in a beaker. Add 5 mL of *acetic acid R* and 5 mL of *water R*. Stir until dissolution is complete (about 10 min). Add 50 mL of *acetone R* and 1 g of *sodium chloride R*. Filter through a fast filter paper impregnated with *acetone R*, rinse the beaker and filter with *acetone R*. Combine the filtrate and washings and dilute to 100.0 mL with *acetone R*. Allow to stand for 24 h without shaking. Use the clear supernatant liquid.

**Reference solution.** Dissolve 0.310 g of *glycollic acid R*, previously dried *in vacuo* over *diphosphorus pentoxide R*, in *water R* and dilute to 500.0 mL with the same solvent. To 5.0 mL of this solution, add 5 mL of *acetic acid R* and allow to stand for about 30 min. Add 50 mL of *acetone R* and 1 g of *sodium chloride R* and dilute to 100.0 mL with *acetone R*.

Heat 2.0 mL of the test solution on a water-bath for 20 min. Cool to room temperature and add 20.0 mL of *2,7-dihydroxynaphthalene solution R*. Shake and heat on a water-bath for 20 min. Cool under running water, transfer to a volumetric flask and dilute to 25.0 mL with *sulfuric acid R*, maintaining the flask under running water. Within 10 min, measure the absorbance (2.2.25) at 540 nm using *water R* as the compensation liquid. The absorbance of the solution prepared with the test solution is not greater than that of a solution prepared at the same time and in the same manner with 2.0 mL of the reference solution.

**Sodium chloride:** maximum 1 per cent.

Shake 1.00 g with 20 mL of *ethanol (80 per cent V/V) R* for 10 min and filter. Repeat the operation 4 times. Dry the residue to constant mass at 100 °C and set aside for the assay. Combine the filtrates. Evaporate to dryness, take up the residue with *water R* and dilute to 25.0 mL with the same solvent. To 10.0 mL of the solution add 30 mL of *water R* and 5 mL of *dilute nitric acid R*. Titrate with *0.1 M silver nitrate*, determining the end-point potentiometrically (2.2.20), using a silver indicator electrode.

1 mL of 0.1 M silver nitrate is equivalent to 5.844 mg of NaCl.

**Iron** (2.4.9): maximum 20 ppm, determined on solution S.

**Heavy metals** (2.4.8): maximum 20 ppm.

1.0 g complies with test D. Prepare the reference solution using 2 mL of lead standard solution (10 ppm Pb) R.

**Loss on drying** (2.2.32): maximum 7.0 per cent, determined on 1.000 g by drying in an oven at 105 °C for 4 h.

**Microbial contamination.** It complies with the test for *Escherichia coli* and *Salmonella* (2.6.13).

#### ASSAY

To 0.500 g of the dried and crushed residue obtained in the test for sodium chloride add 80 mL of anhydrous acetic acid R and heat under a reflux condenser for 2 h. Cool the solution to room temperature. Titrate with 0.1 M perchloric acid, determining the end-point potentiometrically (2.2.20). Carry out a blank test.

1 mL of 0.1 M perchloric acid is equivalent to 2.299 mg of Na.

#### STORAGE

In an airtight container, protected from light.

01/2009:2058  
corrected 7.0

## SODIUM STEARATE

### Natrii stearas

#### DEFINITION

Mixture of sodium salts of different fatty acids consisting mainly of stearic (octadecanoic) acid [C<sub>17</sub>H<sub>35</sub>COONa; M<sub>r</sub> 306.5] and palmitic (hexadecanoic) acid [C<sub>15</sub>H<sub>31</sub>COONa; M<sub>r</sub> 278.4].

#### Content:

- sodium: 7.4 per cent to 8.5 per cent (A, 22.99) (dried substance);
- stearic acid in the fatty acid fraction: minimum 40 per cent;
- sum of stearic acid and palmitic acid in the fatty acid fraction: minimum 90 per cent.

#### CHARACTERS

**Appearance:** white or yellowish, fine powder, greasy to the touch.

**Solubility:** slightly soluble in water and in ethanol (96 per cent).

#### IDENTIFICATION

**First identification:** C, D.

**Second identification:** A, B, D.

- A. Freezing point (2.2.18): minimum 53 °C for the residue obtained in the preparation of solution S (see Tests).
- B. Acid value (2.5.1): 195 to 210, determined on 0.200 g of the residue obtained in the preparation of solution S dissolved in 25 mL of the prescribed mixture of solvents.
- C. Examine the chromatograms obtained in the assay of stearic acid and palmitic acid.

**Results:** the 2 principal peaks in the chromatogram obtained with the test solution are similar in retention time and size to the 2 principal peaks in the chromatogram obtained with the reference solution.

- D. Solution S gives reaction (b) of sodium (2.3.1).

#### TESTS

**Solution S.** To 10.0 g add 100 mL of peroxide-free ether R and 80 mL of acetic acid R. Boil under a reflux condenser until dissolution is complete. Allow to cool. In a separating funnel, separate the aqueous layer and shake the ether layer with 2 quantities, each of 8 mL, of acetic acid R. Combine the aqueous layers, wash with 30 mL of peroxide-free ether R and dilute

to 100 mL with distilled water R (solution S). Evaporate the ether layers to dryness on a water-bath and dry the residue at 100-105 °C.

**Acidity or alkalinity.** Suspend 2.0 g in 50 mL of previously neutralised ethanol (96 per cent) R. Heat under reflux to dissolve and add 3 drops of phenolphthalein solution R; the solution is colourless. Not less than 0.60 mL and not more than 0.85 mL of 0.1 M sodium hydroxide is required to change the colour of the indicator.

**Chlorides** (2.4.4): maximum 0.2 per cent.

Dilute 0.25 mL of solution S to 15 mL with water R.

**Sulfates** (2.4.13): maximum 0.3 per cent.

Dilute 0.5 mL of solution S to 15 mL with distilled water R.

**Nickel:** maximum 5 ppm.

Atomic absorption spectrometry (2.2.23, Method II).

**Test solution.** Place 50.0 mg of the substance to be examined in a polytetrafluoroethylene digestion flask and add 0.5 mL of a mixture of 1 volume of heavy metal-free hydrochloric acid R and 5 volumes of heavy metal-free nitric acid R. Allow to digest at 170 °C for 5 h. Allow to cool. Dissolve the residue in water R and dilute to 5.0 mL with the same solvent.

**Reference solutions.** Prepare the reference solutions using nickel standard solution (10 ppm Ni) R, diluted as necessary with water R.

**Source:** nickel hollow-cathode lamp.

**Wavelength:** 232.0 nm.

**Atomisation device:** air-acetylene flame.

**Loss on drying** (2.2.32): maximum 5.0 per cent.

In a weighing glass introduce 1.0 g of previously washed sand R, dry at 105 °C and weigh. Add 0.500 g of the substance to be examined and 10 mL of ethanol (96 per cent) R. Evaporate at 80 °C and dry the residue at 105 °C for 4 h.

#### Microbial contamination

TAMC: acceptance criterion 10<sup>3</sup> CFU/g (2.6.12).

TYMC: acceptance criterion 10<sup>2</sup> CFU/g (2.6.12).

Absence of *Escherichia coli* (2.6.13).

Absence of *Salmonella* (2.6.13).

#### ASSAY

**Sodium.** Dissolve 0.250 g with gentle heating in a mixture of 5 mL of acetic anhydride R and 20 mL of anhydrous acetic acid R. Cool and add 20 mL of dioxan R. Titrate with 0.1 M perchloric acid, determining the end-point potentiometrically (2.2.20).

1 mL of 0.1 M perchloric acid is equivalent to 2.299 mg of Na.

**Stearic acid and palmitic acid.** Gas chromatography (2.2.28): use the normalisation procedure.

**Test solution.** In a conical flask fitted with a reflux condenser, dissolve 0.10 g of the substance to be examined in 5 mL of boron trifluoride-methanol solution R. Boil under a reflux condenser for 10 min. Add 4 mL of heptane R through the condenser and boil again under a reflux condenser for 10 min. Allow to cool. Add 20 mL of saturated sodium chloride solution R. Shake and allow the layers to separate. Remove about 2 mL of the organic layer and dry over 0.2 g of anhydrous sodium sulfate R. Dilute 1.0 mL of the solution to 100.0 mL with heptane R.

**Reference solution.** Prepare the reference solution in the same manner as the test solution using 50.0 mg of palmitic acid CRS and 50.0 mg of stearic acid CRS instead of the substance to be examined.

#### Column:

- material: fused silica;
- size: l = 30 m, Ø = 0.32 mm;
- stationary phase: macrogol 20 000 R (film thickness 0.5 µm).

**Carrier gas:** helium for chromatography R.

Flow rate: 2.4 mL/min.

Temperature:

	Time (min)	Temperature (°C)
Column	0 - 2	70
	2 - 36	70 → 240
	36 - 41	240
Injection port		220
Detector		260

Detection: flame ionisation.

Injection: 1 µL.

Relative retention with reference to methyl stearate (retention time = about 40 min): methyl palmitate = about 0.88.

System suitability: reference solution:

– resolution: minimum 5.0 between the peaks due to methyl stearate and methyl palmitate.

Calculate the content of stearic acid and palmitic acid.

#### STORAGE

In an airtight container, protected from light.

07/2010:1567

## SODIUM STEARYL FUMARATE

### Natrii stearylis fumaras

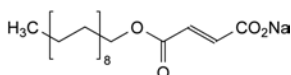

C<sub>22</sub>H<sub>39</sub>NaO<sub>4</sub>  
[4070-80-8]

M<sub>r</sub> 390.5

#### DEFINITION

Sodium octadecyl (*E*)-butenedioate.

Content: 99.0 per cent to 101.5 per cent (anhydrous substance).

#### CHARACTERS

Appearance: white or almost white, fine powder with agglomerates of flat, circular particles.

Solubility: practically insoluble in water, slightly soluble in methanol, practically insoluble in acetone and in anhydrous ethanol.

#### IDENTIFICATION

Infrared absorption spectrophotometry (2.2.24).

Comparison: sodium stearyl fumarate CRS.

#### TESTS

**Related substances.** Gas chromatography (2.2.28): use the normalisation procedure.

**Silylation solution.** To 2 mL of *N,O*-bis(trimethylsilyl)trifluoroacetamide *R* add 0.02 mL of chlorotrimethylsilane *R* and mix.

**Test solution.** Introduce 15.0 mg of the substance to be examined in a vial with a screw cap and add 1 mL of the silylation solution. Seal the vial and heat at about 70 °C for 1 h. After the reaction a precipitate remains in the vial; filter the solution through a nylon filter (pore size 0.45 µm).

**Reference solution.** Introduce 1.0 mg of sodium stearyl maleate CRS and 1.0 mg of sodium stearyl fumarate CRS into a vial with a screw cap and add 1 mL of the silylation solution. Seal the vial and heat at about 70 °C for 1 h.

Column:

- material: fused silica;
- size: *l* = 15 m, Ø = 0.53 mm;

– stationary phase: poly(dimethyl)siloxane *R* (film thickness 0.15 µm).

Carrier gas: helium for chromatography *R*.

Flow rate: 2 mL/min.

Split ratio: 1:25.

Temperature:

	Time (min)	Temperature (°C)
Column	0 - 1	180
	1 - 21	180 → 320
	21 - 26	320
Injection port		250
Detector		320

Detection: flame ionisation.

Injection: 2 µL.

Relative retention with reference to stearyl trimethylsilyl fumarate (retention time = about 9 min): stearyl alcohol = 0.30; stearyl trimethylsilyl ether = 0.35; palmityl trimethylsilyl fumarate = 0.80; heptadecyl trimethylsilyl fumarate = 0.85; stearyl trimethylsilyl maleate = 0.90; nonadecyl trimethylsilyl fumarate = 1.05; eicos-11-enyl trimethylsilyl fumarate = 1.15; distearyl fumarate = 2.25.

System suitability:

– resolution: minimum 1.5 between the peaks in the chromatogram obtained with the reference solution.

Limits:

- any impurity: maximum 0.5 per cent;
- total: maximum 5.0 per cent.

**Water** (2.5.12): maximum 5.0 per cent, determined on 0.250 g.

#### ASSAY

Dissolve 0.250 g, accurately weighed, in 10 mL of methylene chloride *R* and add 30 mL of anhydrous acetic acid *R*. Titrate with 0.1 M perchloric acid, determining the end-point potentiometrically (2.2.20).

1 mL of 0.1 M perchloric acid is equivalent to 39.05 mg of C<sub>22</sub>H<sub>39</sub>NaO<sub>4</sub>.

#### FUNCTIONALITY-RELATED CHARACTERISTICS

This section provides information on characteristics that are recognised as being relevant control parameters for one or more functions of the substance when used as an excipient (see chapter 5.15). This section is a non-mandatory part of the monograph and it is not necessary to verify the characteristics to demonstrate compliance. Control of these characteristics can however contribute to the quality of a medicinal product by improving the consistency of the manufacturing process and the performance of the medicinal product during use. Where control methods are cited, they are recognised as being suitable for the purpose, but other methods can also be used. Wherever results for a particular characteristic are reported, the control method must be indicated.

The following characteristics may be relevant for sodium stearyl fumarate used as a lubricant in tablets and capsules.

**Particle-size distribution** (2.9.31).

**Specific surface area** (2.9.26, Method I).

01/2008:0099  
corrected 6.0

## SODIUM SULFATE, ANHYDROUS

### Natrii sulfas anhydricus

Na<sub>2</sub>SO<sub>4</sub>  
[7757-82-6]

M<sub>r</sub> 142.0

## DEFINITION

*Content*: 98.5 per cent to 101.0 per cent (dried substance).

01/2008:0100  
corrected 6.0

## CHARACTERS

*Appearance*: white or almost white powder, hygroscopic.

*Solubility*: freely soluble in water.

## IDENTIFICATION

A. It gives the reactions of sulfates (2.3.1).

B. It gives the reactions of sodium (2.3.1).

C. Loss on drying (see Tests).

## TESTS

**Solution S.** Dissolve 2.2 g in *carbon dioxide-free water R* prepared from *distilled water R* and dilute to 100 mL with the same solvent.

**Appearance of solution.** Solution S is clear (2.2.1) and colourless (2.2.2, *Method II*).

**Acidity or alkalinity.** To 10 mL of solution S add 0.1 mL of *bromothymol blue solution RI*. Not more than 0.5 mL of 0.01 M *hydrochloric acid* or 0.01 M *sodium hydroxide* is required to change the colour of the indicator.

**Chlorides** (2.4.4): maximum 450 ppm.

5 mL of solution S diluted to 15 mL with *water R* complies with the limit test for chlorides.

**Calcium** (2.4.3): maximum 450 ppm, if intended for use in the manufacture of parenteral preparations.

10 mL of solution S diluted to 15 mL with *distilled water R* complies with the limit test for calcium.

**Iron** (2.4.9): maximum 90 ppm, if intended for use in the manufacture of parenteral preparations.

5 mL of solution S diluted to 10 mL with *water R* complies with the limit test for iron.

**Magnesium:** maximum 200 ppm, if intended for use in the manufacture of parenteral preparations.

To 10 mL of solution S add 1 mL of *glycerol (85 per cent) R*, 0.15 mL of *titan yellow solution R*, 0.25 mL of *ammonium oxalate solution R* and 5 mL of *dilute sodium hydroxide solution R* and shake. Any pink colour in the test solution is not more intense than that in a standard prepared at the same time in the same manner using a mixture of 5 mL of *magnesium standard solution (10 ppm Mg) R* and 5 mL of *water R*.

**Heavy metals** (2.4.8): maximum 45 ppm.

12 mL of solution S complies with test A. Prepare the reference solution using *lead standard solution (1 ppm Pb) R*.

**Loss on drying** (2.2.32): maximum 0.5 per cent, determined on 1.000 g by drying in an oven at 130 °C.

## ASSAY

Dissolve 0.100 g in 40 mL of *water R*. Add a mixture of 0.2 mL of 0.1 M *hydrochloric acid* and 80 mL of *methanol R*. Carry out a potentiometric titration (2.2.20), using 0.1 M *lead nitrate* and as indicator electrode a lead-selective electrode and as reference electrode a silver-silver chloride electrode.

1 mL of 0.1 M *lead nitrate* is equivalent to 14.20 mg of Na<sub>2</sub>SO<sub>4</sub>.

## STORAGE

Store in an airtight container.

## LABELLING

The label states, where applicable, that the substance is suitable for use in the manufacture of parenteral preparations.

## SODIUM SULFATE DECAHYDRATE

## Natrii sulfas decahydricus

Na<sub>2</sub>SO<sub>4</sub>·10H<sub>2</sub>O  
[7727-73-3]

M<sub>r</sub> 322.2

## DEFINITION

*Content*: 98.5 per cent to 101.0 per cent (dried substance).

## CHARACTERS

*Appearance*: white or almost white, crystalline powder or colourless, transparent crystals.

*Solubility*: freely soluble in water, practically insoluble in alcohol. It partly dissolves in its own water of crystallisation at about 33 °C.

## IDENTIFICATION

A. It gives the reactions of sulfates (2.3.1).

B. It gives the reactions of sodium (2.3.1).

C. Loss on drying (see Tests).

## TESTS

**Solution S.** Dissolve 5.0 g in *carbon dioxide-free water R* prepared from *distilled water R* and dilute to 100 mL with the same solvent.

**Appearance of solution.** Solution S is clear (2.2.1) and colourless (2.2.2, *Method II*).

**Acidity or alkalinity.** To 10 mL of solution S add 0.1 mL of *bromothymol blue solution RI*. Not more than 0.5 mL of 0.01 M *hydrochloric acid* or 0.01 M *sodium hydroxide* is required to change the colour of the indicator.

**Chlorides** (2.4.4): maximum 200 ppm.

5 mL of solution S diluted to 15 mL with *water R* complies with the limit test for chlorides.

**Calcium** (2.4.3): maximum 200 ppm, if intended for use in the manufacture of parenteral preparations.

10 mL of solution S diluted to 15 mL with *distilled water R* complies with the limit test for calcium.

**Iron** (2.4.9): maximum 40 ppm, if intended for use in the manufacture of parenteral preparations.

5 mL of solution S diluted to 10 mL with *water R* complies with the limit test for iron.

**Magnesium:** maximum 100 ppm, if intended for use in the manufacture of parenteral preparations.

To 10 mL of solution S add 1 mL of *glycerol (85 per cent) R*, 0.15 mL of *titan yellow solution R*, 0.25 mL of *ammonium oxalate solution R* and 5 mL of *dilute sodium hydroxide solution R* and shake. Any pink colour in the test solution is not more intense than that in a standard prepared at the same time in the same manner using a mixture of 5 mL of *magnesium standard solution (10 ppm Mg) R* and 5 mL of *water R*.

**Heavy metals** (2.4.8): maximum 20 ppm.

12 mL of solution S complies with test A. Prepare the reference solution using *lead standard solution (1 ppm Pb) R*.

**Loss on drying** (2.2.32): 52.0 per cent to 57.0 per cent, determined on 1.000 g by drying at 30 °C for 1 h, then at 130 °C.

## ASSAY

Dissolve 0.250 g in 40 mL of *water R*. Add a mixture of 0.2 mL of 0.1 M hydrochloric acid and 80 mL of *methanol R*. Carry out a potentiometric titration (2.2.20), using 0.1 M lead nitrate and as indicator electrode a lead-selective electrode and as reference electrode a silver-silver chloride electrode.

1 mL of 0.1 M lead nitrate is equivalent to 14.20 mg of Na<sub>2</sub>SO<sub>4</sub>.

## LABELLING

The label states, where applicable, that the substance is suitable for use in the manufacture of parenteral preparations.

01/2008:0775  
corrected 7.0

## SODIUM SULFITE, ANHYDROUS

## Natrii sulfis anhydricus

Na<sub>2</sub>SO<sub>3</sub>  
[7757-83-7]

M<sub>r</sub> 126.0

## DEFINITION

*Content*: 95.0 per cent to 100.5 per cent of Na<sub>2</sub>SO<sub>3</sub>.

## CHARACTERS

*Appearance*: white or almost white powder.

*Solubility*: freely soluble in water, very slightly soluble in ethanol (96 per cent).

## IDENTIFICATION

- Solution S (see Tests) is slightly alkaline (2.2.4).
- To 5 mL of solution S add 0.5 mL of 0.05 M iodine. The solution is colourless and gives reaction (a) of sulfates (2.3.1).
- Solution S gives reaction (a) of sodium (2.3.1).
- It complies with the limits of the assay.

## TESTS

**Solution S.** Dissolve 5 g in *water R* and dilute to 100 mL with the same solvent.

**Solution S1.** To 10.0 g add 25 mL of *water R*. Shake until mostly dissolved, carefully and progressively add 15 mL of *hydrochloric acid R*. Heat to boiling. Cool and dilute to 100.0 mL with *water R*.

**Appearance of solution.** Solution S is clear (2.2.1) and colourless (2.2.2, *Method I*).

**Thiosulfates:** maximum 0.1 per cent.

To 2.00 g add 100 mL of *water R*. Shake, add 10 mL of *formaldehyde solution R* and 10 mL of *acetic acid R*. Allow to stand for 5 min. Add 0.5 mL of *starch solution R* and titrate with 0.05 M iodine. Carry out a blank titration. The difference between the volumes used in the titrations is not more than 0.15 mL.

**Iron (2.4.9):** maximum 10 ppm, determined on solution S1.

**Selenium:** maximum 10 ppm.

To 3.0 g add 10 mL of *formaldehyde solution R*, carefully and progressively add 2 mL of *hydrochloric acid R*. Heat on a water-bath for 20 min. Any pink colour in the solution is not more intense than that of a standard prepared at the same time and in the same manner using 1.0 g of the substance to be examined to which 0.2 mL of *selenium standard solution (100 ppm Se) R* has been added.

**Zinc:** maximum 25 ppm.

Atomic absorption spectrometry (2.2.23, *Method I*).

*Test solution.* Dilute 2.0 mL of solution S1 to 10.0 mL with *water R*.

*Reference solutions.* Prepare the reference solutions using *zinc standard solution (100 ppm Zn) R*, diluting with *water R*.

*Source:* zinc hollow-cathode lamp.

*Wavelength:* 213.9 nm.

*Atomisation device:* air-acetylene flame.

**Heavy metals (2.4.8):** maximum 10 ppm.

Evaporate 20 mL of solution S1 almost to dryness. Add 10 mL of *water R*, neutralise with *concentrated ammonia R* and dilute to 20 mL with *water R*. 12 mL of this solution complies with test A. Prepare the reference solution using *lead standard solution (1 ppm Pb) R*.

## ASSAY

Introduce 0.250 g into a 500 mL conical flask containing 50.0 mL of 0.05 M iodine. Shake until completely dissolved. Add 1 mL of *starch solution R* and titrate the excess of iodine with 0.1 M sodium thiosulfate. Carry out a blank titration. 1 mL of 0.05 M iodine is equivalent to 6.30 mg of Na<sub>2</sub>SO<sub>3</sub>.

01/2008:0776  
corrected 7.0

## SODIUM SULFITE HEPTAHYDRATE

## Natrii sulfis heptahydricus

Na<sub>2</sub>SO<sub>3</sub>·7H<sub>2</sub>O  
[10102-15-5]

M<sub>r</sub> 252.2

## DEFINITION

*Content*: 48.0 per cent to 52.5 per cent of Na<sub>2</sub>SO<sub>3</sub>.

## CHARACTERS

*Appearance*: colourless crystals.

*Solubility*: freely soluble in water, very slightly soluble in ethanol (96 per cent).

## IDENTIFICATION

- Solution S (see Tests) is slightly alkaline (2.2.4).
- To 5 mL of solution S add 0.5 mL of 0.05 M iodine. The solution is colourless and gives reaction (a) of sulfates (2.3.1).
- Solution S gives reaction (a) of sodium (2.3.1).
- It complies with the limits of the assay.

## TESTS

**Solution S.** Dissolve 10 g in *water R* and dilute to 100 mL with the same solvent.

**Solution S1.** To 20.0 g add 25 mL of *water R*. Shake until mostly dissolved, and carefully and progressively, add 15 mL of *hydrochloric acid R*. Heat to boiling. Cool and dilute to 100.0 mL with *water R*.

**Appearance of solution.** Solution S is clear (2.2.1) and colourless (2.2.2, *Method I*).

**Thiosulfates:** maximum 0.05 per cent.

To 4.00 g add 100 mL of *water R*. Shake to dissolve, add 10 mL of *formaldehyde solution R* and 10 mL of *acetic acid R*. Allow to stand for 5 min, then add 0.5 mL of *starch solution R* and titrate with 0.05 M iodine. Carry out a blank titration. The difference between the volumes used in the titrations is not more than 0.15 mL.

**Iron (2.4.9):** maximum 5 ppm, determined on solution S1.

**Selenium:** maximum 5 ppm.

To 6.0 g add 10 mL of *formaldehyde solution R*, carefully and progressively add 2 mL of *hydrochloric acid R*. Heat on a water-bath for 20 min. Any pink colour in the solution is not more intense than that of a standard prepared at the same time and in the same manner using 2.0 g of the substance to be examined to which 0.2 mL of *selenium standard solution (100 ppm Se) R* has been added.

**Zinc:** maximum 12 ppm.

Atomic absorption spectrometry (2.2.23, *Method I*).

*Test solution.* Dilute 2.0 mL of solution S1 to 10.0 mL with *water R*.

*Reference solutions.* Prepare the reference solutions using *zinc standard solution (100 ppm Zn) R*, diluting with *water R*.

*Source:* zinc hollow-cathode lamp.

*Wavelength:* 213.9 nm.

*Atomisation device:* air-acetylene flame.

**Heavy metals (2.4.8):** maximum 5 ppm.

Evaporate 20 mL of solution S1 almost to dryness. Add 10 mL of *water R*, neutralise with *concentrated ammonia R* and dilute to 20 mL with *water R*. 12 mL of this solution complies with test A. Prepare the reference solution using *lead standard solution (1 ppm Pb) R*.

ASSAY

Introduce 0.500 g into a 500 mL conical flask containing 50.0 mL of 0.05 M *iodine*. Shake until completely dissolved. Add 1 mL of *starch solution R* and titrate the excess of iodine with 0.1 M *sodium thiosulfate*. Carry out a blank titration.

1 mL of 0.05 M *iodine* is equivalent to 6.30 mg of Na<sub>2</sub>S<sub>2</sub>O<sub>3</sub>.

01/2008:0414

## SODIUM THIOSULFATE

### Natrii thiosulfas

Na<sub>2</sub>S<sub>2</sub>O<sub>3</sub>·5H<sub>2</sub>O  
[10102-17-7]

*M*<sub>r</sub> 248.2 C<sub>8</sub>H<sub>15</sub>NaO<sub>2</sub>  
[1069-66-5]

DEFINITION

*Content:* 99.0 per cent to 101.0 per cent of Na<sub>2</sub>S<sub>2</sub>O<sub>3</sub>·5H<sub>2</sub>O.

CHARACTERS

*Appearance:* transparent, colourless crystals, efflorescent in dry air.

*Solubility:* very soluble in water, practically insoluble in ethanol 96 per cent. It dissolves in its water of crystallisation at about 49 °C.

IDENTIFICATION

- It decolourises *iodinated potassium iodide solution R*.
- To 0.5 mL of solution S (see Tests) add 0.5 mL of *water R* and 2 mL of *silver nitrate solution R2*. A white precipitate is formed which rapidly becomes yellowish and then black.
- To 2.5 mL of solution S add 2.5 mL of *water R* and 1 mL of *hydrochloric acid R*. A precipitate of sulfur is formed and gas is evolved which gives a blue colour to *starch iodate paper R*.
- 1 mL of solution S gives reaction (a) of sodium (2.3.1).

TESTS

**Solution S.** Dissolve 10.0 g in *carbon dioxide-free water R* prepared from *distilled water R* and dilute to 100 mL with the same solvent.

**Appearance of solution.** The freshly prepared solution is clear (2.2.1) and colourless (2.2.2, *Method II*).

Dissolve 10.0 g in 50 mL of *distilled water R*, add 1 mL of 0.1 M *sodium hydroxide* and dilute to 100 mL with the same solvent.

**pH (2.2.3):** 6.0 to 8.4 for the freshly prepared solution S.

**Sulfates and sulfites (2.4.13):** maximum 0.2 per cent.

Dilute 2.5 mL of freshly prepared solution S to 10 mL with *distilled water R*. To 3 mL of this solution first add 2 mL of *iodinated potassium iodide solution R* and continue the addition dropwise until a very faint persistent yellow colour appears. Dilute to 15 mL with *distilled water R*.

**Sulfides.** To 10 mL of solution S add 0.05 mL of a freshly prepared 50 g/L solution of *sodium nitroprusside R*. The solution does not become violet.

**Heavy metals:** maximum 10 ppm.

To 10 mL of solution S add 0.05 mL of *sodium sulfide solution R*. After 2 min, any brown colour in the solution is not more intense than that in a reference solution prepared at the same time and in the same manner using 10 mL of *lead standard solution (1 ppm Pb) R*.

ASSAY

Dissolve 0.500 g in 20 mL of *water R* and titrate with 0.05 M *iodine*, using 1 mL of *starch solution R*, added towards the end of the titration, as indicator.

1 mL of 0.05 M *iodine* is equivalent to 24.82 mg of Na<sub>2</sub>S<sub>2</sub>O<sub>3</sub>·5H<sub>2</sub>O.

STORAGE

In an airtight container.

01/2008:0678  
corrected 6.0

## SODIUM VALPROATE

### Natrii valproas

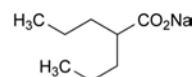

*M*<sub>r</sub> 166.2

DEFINITION

Sodium 2-propylpentanoate.

*Content:* 98.5 per cent to 101.0 per cent (dried substance).

CHARACTERS

*Appearance:* white or almost white, crystalline, hygroscopic powder.

*Solubility:* very soluble in water, slightly or freely soluble in ethanol (96 per cent).

IDENTIFICATION

- Infrared absorption spectrophotometry (2.2.24).

*Comparison:* *sodium valproate CRS*.

If the spectra obtained in the solid state show differences, record new spectra using discs prepared by placing 50 µL of a 100 g/L solution in *methanol R* on a disc of *potassium bromide R* and evaporating the solvent *in vacuo*. Examine immediately.

- Examine the chromatograms obtained in the test for related substances.

*Results:* the principal peak in the chromatogram obtained with test solution (b) is similar in retention time to the principal peak in the chromatogram obtained with reference solution (b).

- 2 mL of solution S (see Tests) gives reaction (a) of sodium (2.3.1).

TESTS

**Solution S.** Dissolve 1.25 g in 20 mL of *distilled water R* in a separating funnel, add 5 mL of *dilute nitric acid R* and shake. Allow the mixture to stand for 12 h. Use the lower layer.

**Appearance of solution.** The solution is not more opalescent than reference suspension II (2.2.1) and not more intensely coloured than reference solution Y<sub>6</sub> (2.2.2, *Method II*).

Dissolve 2.0 g in *water R* and dilute to 10 mL with the same solvent.



**Acidity or alkalinity.** Dissolve 1.0 g in 10 mL of *water R*. Add 0.1 mL of *phenolphthalein solution R*. Not more than 0.75 mL of 0.1 M *hydrochloric acid* or 0.1 M *sodium hydroxide* is required to change the colour of the indicator.

**Related substances.** Gas chromatography (2.2.28).

**Internal standard solution.** Dissolve 10 mg of *butyric acid R* in *heptane R* and dilute to 200 mL with the same solvent.

**Test solution (a).** Dissolve 0.500 g of the substance to be examined in 10 mL of *water R*. Add 5 mL of *dilute sulfuric acid R* and shake with 3 quantities, each of 20 mL, of *heptane R*. Add 10.0 mL of the internal standard solution to the combined upper layers, shake with *anhydrous sodium sulfate R*, filter and evaporate the filtrate, at a temperature not exceeding 30 °C, using a rotary evaporator. Take up the residue with *heptane R* and dilute to 10.0 mL with the same solvent. Dilute 1.0 mL of this solution to 10.0 mL with *heptane R*.

**Test solution (b).** Dissolve 40 mg of the substance to be examined in 100 mL of *water R*. To 10 mL of this solution add 0.5 mL of *dilute sulfuric acid R* and shake with 3 quantities, each of 5 mL, of *heptane R*. Shake with *anhydrous sodium sulfate R*, filter and evaporate the filtrate, at a temperature not exceeding 30 °C, to a volume of about 10 mL, using a rotary evaporator.

**Reference solution (a).** Dissolve 20 mg of 2-(1-methylethyl)pentanoic acid CRS (impurity C) in 5.0 mL of test solution (b) and dilute to 10 mL with *heptane R*. Dilute 1 mL of this solution to 10 mL with *heptane R*.

**Reference solution (b).** Prepare as prescribed for test solution (b), using *sodium valproate CRS* instead of the substance to be examined.

**Column:**

- *material:* wide-bore fused silica;
- *size:*  $l = 30$  m,  $\varnothing = 0.53$  mm;
- *stationary phase:* *macrogol 20 000 2-nitrotetraphthalate R* (film thickness 0.5  $\mu$ m).

**Carrier gas:** *helium for chromatography R*.

**Flow rate:** 8 mL/min.

**Temperature:**

	Time (min)	Temperature (°C)
Column	0 - 10	130
	10 - 30	130 → 190
Injection port		220
Detector		220

**Detection:** flame ionisation.

**Injection:** 1  $\mu$ L.

**System suitability:** reference solution (a):

- *resolution:* minimum 3.0 between the peaks due to impurity C and valproic acid.

**Limits:** test solution (a):

- *any impurity:* for each impurity, not more than the area of the peak due to the internal standard (0.1 per cent);
- *total:* not more than 3 times the area of the peak due to the internal standard (0.3 per cent);
- *disregard limit:* 0.1 times the area of the peak due to the internal standard (0.01 per cent).

**Chlorides (2.4.4):** maximum 200 ppm.

To 5 mL of solution S add 10 mL of *water R*.

**Sulfates (2.4.13):** maximum 200 ppm, determined on Solution S.

**Heavy metals (2.4.8):** maximum 20 ppm.

1.0 g complies with test C. Prepare the reference solution using 2 mL of *lead standard solution (10 ppm Pb) R*.

**Loss on drying (2.2.32):** maximum 2.0 per cent, determined on 1.000 g by drying in an oven at 105 °C.

**ASSAY**

Dissolve 0.1500 g in 25 mL of *anhydrous acetic acid R*. Titrate with 0.1 M *perchloric acid*, determining the end-point potentiometrically (2.2.20).

1 mL of 0.1 M *perchloric acid* is equivalent to 16.62 mg of  $C_8H_{15}NaO_2$ .

**STORAGE**

In an airtight container.

**IMPURITIES**

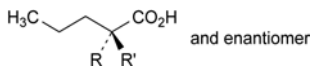

- A. R = R' = H: pentanoic acid (valeric acid),
- B. R = H, R' =  $CH_2-CH_3$ : (2*RS*)-2-ethylpentanoic acid,
- C. R = H, R' =  $CH(CH_3)_2$ : (2*RS*)-2-(1-methylethyl)pentanoic acid,
- D. R = R' =  $CH_2-CH_2-CH_3$ : 2,2-dipropylpentanoic acid,

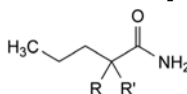

- E. R = R' = H: pentanamide (valeramide),
- F. R = H, R' =  $CH_2-CH_2-CH_3$ : 2-propylpentanamide,
- G. R = R' =  $CH_2-CH_2-CH_3$ : 2,2-dipropylpentanamide,

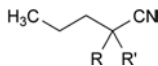

- H. R = R' = H: pentanenitrile (valeronitrile),
- I. R = H, R' =  $CH_2-CH_2-CH_3$ : 2-propylpentanenitrile,
- J. R = R' =  $CH_2-CH_2-CH_3$ : 2,2-dipropylpentanenitrile.

01/2008:1264

## SOLUTIONS FOR ORGAN PRESERVATION

### Solutiones ad conservationem partium corporis

**DEFINITION**

Solutions for organ preservation are sterile, aqueous preparations, intended for storage, protection and/or perfusion of mammalian body organs that are in particular destined for transplantation.

They contain electrolytes that are typically at a concentration close to the intracellular electrolyte composition.

They may contain carbohydrates (such as glucose or mannitol), amino acids, calcium-complexing agents (such as citrate or phosphate), hydrocolloids (such as starch or gelatin derivatives) and other excipients, for example to make the preparation isotonic with blood, to adjust or buffer the pH, to prevent deterioration of the ingredients, but not to adversely affect the intended action of the preparation or, at the concentration used, to cause toxicity or undue local irritation. Solutions for organ preservation may also contain active substances or these may be added immediately before use.

Solutions for organ preservation, examined under suitable conditions of visibility, are clear and practically free from particles.

Solutions for organ preservation may also be presented as concentrated solutions. They are diluted to the prescribed volume with a prescribed liquid immediately before use. After dilution, they comply with the requirements for solutions for organ preservation.

Before use, the solutions for organ preservation are cooled below room temperature, typically to 2 °C to 6 °C, to reduce the temperature of the body organ and its metabolism.

Where applicable, the containers for solutions for organ preservation comply with the requirements for *Materials used for the manufacture of containers* (3.1 and subsections) and *Containers* (3.2 and subsections). Solutions for organ preservation are supplied in glass containers (3.2.1) or in other containers such as plastic containers (3.2.2 and 3.2.8). The tightness of the container is ensured by suitable means. Closures ensure a good seal, prevent the access of micro-organisms and other contaminants and usually permit the withdrawal of a part or the whole of the contents without removal of the closure. The plastic materials or elastomers of which the closure is composed are sufficiently firm and elastic to allow the passage of a needle with the least possible shedding of particles.

#### PRODUCTION

Solutions for organ preservation are prepared using materials and methods designed to ensure their sterility and to avoid the introduction of contaminants and the growth of micro-organisms; recommendations on this aspect are provided in the text on *Methods of preparation of sterile products* (5.1.1). Unless otherwise justified and authorised, solutions for organ preservation are prepared from *water for injections R* and do not contain antimicrobial preservatives.

#### TESTS

**pH** (2.2.3). Carry out the test at room temperature. The pH of the solution is 5.0 to 8.0.

**Osmolality** (2.2.35). The osmolality of the solution is 250 mosmol/kg to 380 mosmol/kg.

**Hydroxymethylfurfural**. If the solution contains glucose, it complies with the following test: to a volume of the preparation to be examined containing the equivalent of 25 mg of glucose, add 5.0 mL of a 100 g/L solution of *p-toluidine R* in *2-propanol R* containing 10 per cent V/V of *glacial acetic acid R* and 1.0 mL of a 5 g/L solution of *barbituric acid R*. The absorbance (2.2.25), determined at 550 nm after allowing the mixture to stand for 2 min to 3 min, is not greater than that of a standard prepared at the same time in the same manner using a solution containing 10 µg of *hydroxymethylfurfural R* in the same volume as the preparation to be examined.

**Particulate contamination**. Carry out the test for sub-visible particles (2.9.19) using 50 mL of preparation to be examined. The solution contains not more than 50 particles per millilitre larger than 10 µm and not more than 5 particles per millilitre larger than 25 µm.

Products for which the label states that the product is to be used with a final filter are exempted from these requirements.

**Sterility** (2.6.1). The solution complies with the test for sterility.

**Bacterial endotoxins** (2.6.14): less than 0.5 IU/mL.

**Pyrogens** (2.6.8). Solutions for which a validated test for bacterial endotoxins cannot be carried out comply with the test for pyrogens. Inject per kilogram of the rabbit's mass 10 mL of the solution, unless otherwise justified and authorised.

#### LABELLING

The label states:

- that the solution is not to be used for injection,
- the formula of the solution for organ preservation expressed in grams per litre and in millimoles per litre,
- the nominal volume of the solution for organ preservation in the container,
- the osmolality, expressed in milliosmoles per kilogram,
- that any unused portion of the ready-to-use solution, of the concentrated solution or of the diluted solution must be discarded,
- the storage conditions,
- if applicable, that the solution is to be used in conjunction with a final filter.

In addition, for concentrated solutions the label states that the solution must be diluted with a suitable liquid immediately before use.

01/2011:0949

## SOMATOSTATIN

### Somatostatinum

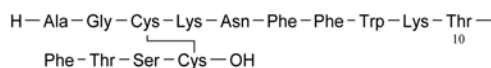

$\text{C}_{76}\text{H}_{104}\text{N}_{18}\text{O}_{19}\text{S}_2$   $M_r$  1638  
[38916-34-6]

#### DEFINITION

L-Alanylglycyl-L-cysteinyll-L-lysyl-L-asparaginyl-L-phenylalanyl-L-phenylalanyl-L-tryptophyll-L-lysyl-L-threonyll-L-phenylalanyl-L-threonyll-L-seryl-L-cysteine cyclic (3→14)-disulfide.

Synthetic cyclic tetradecapeptide having the structure of the hypothalamic hormone that inhibits the release of human growth hormone. It contains a variable amount of acetic acid. It is available in the freeze-dried form.

**Content:** 95.0 per cent to 104.0 per cent (anhydrous and acetic acid-free substance).

#### CHARACTERS

**Appearance:** white or almost white, amorphous powder.

**Solubility:** freely soluble in water and in acetic acid, practically insoluble in methylene chloride.

#### IDENTIFICATION

A. Thin-layer chromatography (2.2.27).

**Test solution.** Dissolve 1.0 mg of the substance to be examined in 1.0 mL of *water R*.

**Reference solution.** Dissolve the contents of a vial of *somatostatin CRS* in *water R* and dilute with the same solvent to obtain a final concentration of 1 mg/mL.

**Plate:** TLC silica gel plate R.

**Mobile phase:** *glacial acetic acid R*, *pyridine R*, *water R*, *butanol R* (10:15:20:45 V/V/V/V).

**Application:** 20 µL.

**Development:** over a path of 15 cm.

**Drying:** in a current of warm air.

**Detection:** spray with a 1 g/L solution of *ninhydrin R* and heat in an oven at 110 °C for about 5 min.

**Results:** the principal spot in the chromatogram obtained with the test solution is similar in position, colour and size to the principal spot in the chromatogram obtained with the reference solution.

B. Examine the chromatograms obtained in the assay.

**Results:** the principal peak in the chromatogram obtained with the test solution is similar in retention time to the principal peak in the chromatogram obtained with the reference solution.

C. Amino acid analysis (2.2.56). For hydrolysis use Method 1 and for analysis use Method 1.

Express the content of each amino acid in moles. Calculate the relative proportions of the amino acids taking 1/8 of the sum of the number of moles of aspartic acid, alanine, lysine, glycine and phenylalanine as equal to 1. The values fall within the following limits: aspartic acid: 0.90 to 1.10; glycine: 0.90 to 1.10; alanine: 0.90 to 1.10; phenylalanine: 2.7 to 3.3; serine: 0.7 to 1.05; threonine: 1.4 to 2.1; half-cystine: 1.4 to 2.1; lysine: 1.8 to 2.2. Not more than traces of other amino acids are present.

## TESTS

01/2008:0951  
corrected 7.0

**Specific optical rotation** (2.2.7): –37 to –47 (anhydrous and acetic acid-free substance).

Dissolve 2.0 mg in 1.0 mL of a 1 per cent *V/V* solution of *glacial acetic acid R*.

**Absorbance** (2.2.25): maximum 0.20 at 280 nm (calculated with reference to the peptide content as determined in the assay).

Dissolve 5.0 mg in a 9 g/L solution of *sodium chloride R* and dilute to 100.0 mL with the same solvent.

**Related substances.** Liquid chromatography (2.2.29): use the normalisation procedure.

**Test solution.** Dissolve 5.0 mg of the substance to be examined in *water R* and dilute to 10.0 mL with the same solvent.

**Column:**

- size:  $l = 0.05$  m,  $\varnothing = 4.6$  mm;
- stationary phase: octadecylsilyl silica gel for chromatography *R* (5  $\mu$ m).

**Mobile phase:**

- mobile phase A: dilute 11 mL of *phosphoric acid R* with *water R*, adjust to pH 2.3 with *triethylamine R* and dilute to 1000 mL with *water R*;
- mobile phase B: *acetonitrile for chromatography R*;

Time (min)	Mobile phase A (per cent <i>V/V</i> )	Mobile phase B (per cent <i>V/V</i> )
0 - 18	79 → 60	21 → 40
18 - 20	60	40
20 - 21	60 → 79	40 → 21
21 - 26	79	21

**Flow rate:** 1.5 mL/min.

**Detection:** spectrophotometer at 215 nm.

**Injection:** 25  $\mu$ L.

**Limits:**

- any impurity: maximum 1 per cent;
- total: maximum 2 per cent;
- disregard limit: 0.03 per cent.

**Acetic acid** (2.5.34): 3.0 per cent to 15.0 per cent.

**Test solution.** Dissolve 7.0 mg of the substance to be examined in a mixture of 5 volumes of mobile phase B and 95 volumes of mobile phase A, then dilute to 10.0 mL with the same mixture of mobile phases.

**Water** (2.5.12): maximum 8.0 per cent, determined on 10.0 mg.

**Bacterial endotoxins** (2.6.14): less than 10 IU/mg, if intended for use in the manufacture of parenteral preparations without a further appropriate procedure for the removal of bacterial endotoxins.

## ASSAY

Liquid chromatography (2.2.29) as described in the test for related substances with the following modifications.

**Reference solution.** Dissolve the contents of a vial of *somatostatin CRS* in *water R* and dilute with the same solvent to obtain a final concentration of 0.5 mg/mL.

**Mobile phase:** mobile phase B, mobile phase A (25:75 *V/V*).

**Run time:** 15 min.

Calculate the content of somatostatin ( $C_{76}H_{104}N_{18}O_{19}S_2$ ) from the declared content of  $C_{76}H_{104}N_{18}O_{19}S_2$  in *somatostatin CRS*.

## STORAGE

In an airtight container protected from light, at a temperature of 2 °C to 8 °C. If the substance is sterile, store in a sterile, airtight, tamper-proof container.

## SOMATROPIN

## Somatotropinum

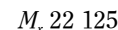
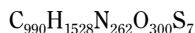
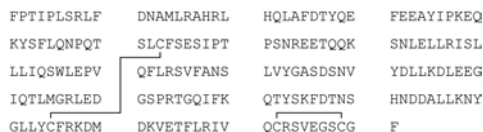

## DEFINITION

Protein having the structure (191 amino-acid residues) of the major component of growth hormone produced by the human pituitary.

**Content:** 91.0 per cent to 105.0 per cent (anhydrous substance).

By convention, for the purpose of labelling somatotropin preparations, 1 mg of anhydrous somatotropin ( $C_{990}H_{1528}N_{262}O_{300}S_7$ ) is equivalent to 3.0 IU of biological activity.

## PRODUCTION

Somatropin is produced by a method based on recombinant DNA (rDNA) technology. During the course of product development, it must be demonstrated that the manufacturing process produces a product having a biological activity of not less than 2.5 IU/mg, using a validated bioassay based on growth promotion and approved by the competent authority.

Somatropin complies with the following additional requirements.

**Host-cell-derived proteins.** The limit is approved by the competent authority.

**Host-cell- and vector-derived DNA.** The limit is approved by the competent authority.

## CHARACTERS

**Appearance:** white or almost white powder.

## IDENTIFICATION

A. Capillary electrophoresis (2.2.47) as described in the test for charged variants with the following modifications.

**Injection:** test solution (b); under pressure or vacuum, using the following sequence: sample injection for at least 3 s then CZE buffer injection for 1 s.

**Results:** in the electropherogram obtained, only 1 principal peak, corresponding to somatotropin, is detected: no doubling of this peak is observed.

B. Examine the chromatograms obtained in the test for related proteins.

**Results:** the principal peak in the chromatogram obtained with the test solution is similar in retention time and size to the principal peak in the chromatogram obtained with the reference solution.

C. Peptide mapping (2.2.55).

## SELECTIVE CLEAVAGE OF THE PEPTIDE BONDS

**Test solution.** Prepare a solution of the substance to be examined in 0.05 M *tris-hydrochloride buffer solution pH 7.5 R* to obtain a solution containing 2.0 mg/mL of somatotropin and transfer about 1.0 mL to a tube made from a suitable material such as polypropylene. Prepare a 1 mg/mL solution of *trypsin for peptide mapping R* in 0.05 M *tris-hydrochloride buffer solution pH 7.5 R* and add 30  $\mu$ L to the solution of the substance to be examined. Cap the tube and place in a water-bath at 37 °C for 4 h. Remove from the water-bath and stop the reaction immediately, for example by freezing. If analysed immediately using an automatic injector, maintain at 2–8 °C.

**Reference solution.** Prepare at the same time and in the same manner as for the test solution, but using *somatropin CRS* instead of the substance to be examined.

**CHROMATOGRAPHIC SEPARATION.** Liquid chromatography (2.2.29).

**Column:**

- size:  $l = 0.25$  m,  $\varnothing = 4.6$  mm;
- stationary phase: octylsilyl silica gel for chromatography R (5–10  $\mu$ m) with a pore size of 30 nm;
- temperature: 30 °C.

**Mobile phase:**

- mobile phase A: dilute 1 mL of trifluoroacetic acid R to 1000 mL with water R;
- mobile phase B: to 100 mL of water R, add 1 mL of trifluoroacetic acid R and dilute to 1000 mL with acetonitrile for chromatography R;

Time (min)	Mobile phase A (per cent V/V)	Mobile phase B (per cent V/V)
0 - 20	100 → 80	0 → 20
20 - 40	80 → 75	20 → 25
40 - 65	75 → 50	25 → 50
65 - 70	50 → 20	50 → 80

**Flow rate:** 1 mL/min.

**Detection:** spectrophotometer at 214 nm.

**Injection:** 100  $\mu$ L.

**System suitability:** the chromatograms obtained with the test solution and the reference solution are similar to the chromatogram of somatropin digest supplied with *somatropin CRS*.

**Results:** the profile of the chromatogram obtained with the test solution corresponds to that of the chromatogram obtained with the reference solution.

**D.** Examine the chromatograms obtained in the assay.

**Results:** the principal peak in the chromatogram obtained with the test solution is similar in retention time and size to the principal peak in the chromatogram obtained with the reference solution.

**TESTS**

**Related proteins.** Liquid chromatography (2.2.29): use the normalisation procedure. *Maintain the solutions at 2–8 °C and use within 24 h. If an automatic injector is used, maintain it at 2–8 °C.*

**Test solution.** Prepare a solution of the substance to be examined in 0.05 M tris-hydrochloride buffer solution pH 7.5 R, containing 2.0 mg/mL of somatropin.

**Reference solution.** Prepare a solution of *somatropin CRS* in 0.05 M tris-hydrochloride buffer solution pH 7.5 R, containing 2.0 mg/mL of somatropin.

**Resolution solution.** Dissolve the contents of a vial of *somatropin/desamidomatropin resolution mixture CRS* in 0.05 M tris-hydrochloride buffer solution pH 7.5 R to obtain a concentration of 2 mg/mL of somatropin.

**Column:**

- size:  $l = 0.25$  m,  $\varnothing = 4.6$  mm;
- stationary phase: a suitable singly end-capped butylsilyl silica gel, with a granulometry of 5  $\mu$ m and a porosity of 30 nm; a silica saturation column is placed between the pump and the injector valve;
- temperature: 45 °C.

**Mobile phase:** propanol R, 0.05 M tris-hydrochloride buffer solution pH 7.5 R (29:71 V/V).

**Flow rate:** 0.5 mL/min.

**Detection:** spectrophotometer at 220 nm.

**Preconditioning of the column:** rinse with 200–500 mL of a 0.1 per cent V/V solution of trifluoroacetic acid R in a 50 per cent V/V solution of acetonitrile R; repeat as necessary, to improve column performance.

**Injection:** 20  $\mu$ L.

**Relative retention** with reference to somatropin (retention time = about 33 min; if necessary adjust the concentration of propanol R in the mobile phase): desamidomatropin = about 0.85.

**System suitability:** resolution solution:

- resolution: minimum 1.0 between the peaks due to desamidomatropin and somatropin;
- symmetry factor: 0.9 to 1.8 for the peak due to somatropin.

**Limit:**

- total: maximum 6.0 per cent.

**Dimer and related substances of higher molecular mass.**

Size-exclusion chromatography (2.2.30): use the normalisation procedure.

**Test solution.** Prepare a solution of the substance to be examined in 0.025 M phosphate buffer solution pH 7.0 R, containing 1.0 mg/mL of somatropin.

**Reference solution.** Dissolve the contents of a vial of *somatropin CRS* in 0.025 M phosphate buffer solution pH 7.0 R and dilute with the same solution to obtain a concentration of 1.0 mg/mL.

**Resolution solution.** Place 1 vial of *somatropin CRS* in an oven at 50 °C for a period sufficient to generate 1–2 per cent of dimer (typically 12–24 h). Dissolve its contents in 0.025 M phosphate buffer solution pH 7.0 R and dilute with the same solution to obtain a concentration of 1.0 mg/mL.

**Column:**

- size:  $l = 0.30$  m,  $\varnothing = 7.8$  mm;
- stationary phase: hydrophilic silica gel for chromatography R of a grade suitable for fractionation of globular proteins in the relative molecular mass range of 5000 to 150 000.

**Mobile phase:** 2-propanol R, 0.063 M phosphate buffer solution pH 7.0 R (3:97 V/V); filter and degas.

**Flow rate:** 0.6 mL/min.

**Detection:** spectrophotometer at 214 nm.

**Injection:** 20  $\mu$ L.

**Relative retention** with reference to somatropin monomer (retention time = 12 min to 17 min): related substances of higher molecular mass = about 0.65; somatropin dimer = about 0.9.

**System suitability:** resolution solution:

- peak-to-valley ratio: minimum 2.5, where  $H_p$  = height above the baseline of the peak due to the dimer and  $H_v$  = height above the baseline of the lowest point of the curve separating this peak from the peak due to the monomer.

**Limit:**

- sum of the peaks with retention times less than that of the principal peak: maximum 4.0 per cent.

**Charged variants.** Capillary electrophoresis (2.2.47).

**Test solution (a).** Prepare a solution of the substance to be examined containing 1 mg/mL of somatropin.

**Test solution (b).** Mix equal volumes of test solution (a) and the reference solution.

**Reference solution.** Dissolve the contents of a vial of *somatropin CRS* in water R and dilute with the same solvent to obtain a concentration of 1 mg/mL.

**Capillary:**

- material: uncoated fused silica;
  - size: effective length = at least 70 cm,  $\varnothing = 50$   $\mu$ m.
- Temperature:** 30 °C.

**CZE buffer:** 13.2 g/L solution of ammonium phosphate R adjusted to pH 6.0 with phosphoric acid R and filtered.

**Detection:** spectrophotometer at 200 nm.

Set the autosampler to store the samples at 4 °C during analysis.

**Preconditioning of the capillary:** rinse with 1 M sodium hydroxide for 20 min, with water R for 10 min and with the CZE buffer for 20 min.

**Between-run rinsing:** rinse with 0.1 M sodium hydroxide for 2 min and with the CZE buffer for 6 min.

**Note:** rinsing times may be adapted according to the length of the capillary and the equipment used.

**Injection:** test solution (a) and the reference solution; under pressure or vacuum, using the following sequence: sample injection for at least 3 s then CZE buffer injection for 1 s.

The injection time and pressure may be adapted in order to meet the system suitability criteria.

**Migration:** apply a field strength of 217 V/cm (20 kV for capillaries of 92 cm total length) for 80 min, using the CZE buffer as the electrolyte in both buffer reservoirs.

**Relative migration** with reference to somatotropin: deamidated forms = 1.02 to 1.11.

**System suitability:** reference solution:

- the electropherogram obtained is similar to the electropherogram of somatotropin supplied with somatotropin CRS; 2 peaks ( $I_1$ ,  $I_2$ ) eluting prior to the principal peak and at least 2 peaks ( $I_3$ ,  $I_4$ ) eluting after the principal peak are clearly visible.

**Note:** peak  $I_2$  corresponds to the cleaved form and peak  $I_4$  corresponds to the deamidated forms, eluting as a doublet.

**Limits:**

- deamidated forms: maximum 5.0 per cent;
- any other impurity: for each impurity, maximum 2.0 per cent;
- total: maximum 10.0 per cent.

**Water (2.5.32):** maximum 10.0 per cent.

**Bacterial endotoxins (2.6.14):** less than 5 IU/mg, if intended for use in the manufacture of parenteral preparations without a further appropriate procedure for removal of bacterial endotoxins.

#### ASSAY

Size-exclusion chromatography (2.2.30) as described in the test for dimer and related substances of higher molecular mass.

Calculate the content of somatotropin ( $C_{990}H_{1528}N_{262}O_{300}S_7$ ) from the declared content of  $C_{990}H_{1528}N_{262}O_{300}S_7$  in somatotropin CRS.

#### STORAGE

In an airtight container, at a temperature of 2 °C to 8 °C. If the substance is sterile, store in a sterile, airtight, tamper-proof container.

#### DEFINITION

Solution containing a protein having the structure (191 amino-acid residues) of the major component of growth hormone produced by the human pituitary. It may contain buffer salts and other auxiliary substances.

**Content:** 91.0 per cent to 105.0 per cent of the amount of somatotropin stated on the label.

By convention, for the purpose of labelling somatotropin preparations, 1 mg of anhydrous somatotropin ( $C_{990}H_{1528}N_{262}O_{300}S_7$ ) is equivalent to 3.0 IU of biological activity.

#### PRODUCTION

Somatotropin concentrated solution is produced by a method based on recombinant DNA (rDNA) technology. During the course of product development, it must be demonstrated that the manufacturing process produces a product having a biological activity of at least 2.5 IU/mg, using a validated bioassay based on growth promotion and approved by the competent authority.

Somatotropin concentrated solution complies with the following additional requirements.

**Host-cell-derived proteins.** The limit is approved by the competent authority.

**Host-cell- and vector-derived DNA.** The limit is approved by the competent authority.

#### CHARACTERS

**Appearance:** clear or slightly turbid, colourless solution.

#### IDENTIFICATION

A. Capillary electrophoresis (2.2.47) as described in the test for charged variants with the following modifications.

**Injection:** test solution (b); under pressure or vacuum, using the following sequence: sample injection for at least 3 s then CZE buffer injection for 1 s.

**Results:** in the electropherogram obtained, only 1 principal peak, corresponding to somatotropin, is detected: no doubling of this peak is observed.

B. Examine the chromatograms obtained in the test for related proteins.

**Results:** the principal peak in the chromatogram obtained with the test solution is similar in retention time and size to the principal peak in the chromatogram obtained with the reference solution.

C. Peptide mapping (2.2.55).

##### SELECTIVE CLEAVAGE OF THE PEPTIDE BONDS

**Test solution.** Dilute the solution to be examined with 0.05 M tris-hydrochloride buffer solution pH 7.5 R so that it contains 2.0 mg/mL of somatotropin and transfer about 1.0 mL to a tube made from a suitable material such as polypropylene. Prepare a 1 mg/mL solution of trypsin for peptide mapping R in 0.05 M tris-hydrochloride buffer solution pH 7.5 R and add 30 µL to the solution of the substance to be examined. Cap the tube and place in a water-bath at 37 °C for 4 h. Remove from the water-bath and stop the reaction immediately, for example by freezing. If analysed immediately using an automatic injector, maintain at 2-8 °C.

**Note:** If a 2 mg/mL somatotropin concentration is not obtainable, a similar digest relationship (micrograms of trypsin per milligram of somatotropin) may be used.

**Reference solution.** Prepare at the same time and in the same manner as for the test solution, but using somatotropin CRS instead of the substance to be examined.

**CHROMATOGRAPHIC SEPARATION.** Liquid chromatography (2.2.29).

01/2008:0950  
corrected 7.0

## SOMATROPIN CONCENTRATED SOLUTION

### Somatropini solutio concentrata

FPTIPLSRLF	DNAMLRARHL	HQLAFDTYQE	FEEAYIPKEQ
KYSFLQNPQT	SLCFSESIPT	PSNREETQOK	SNLELLRISL
LLIQSWLEPV	QFLRSVFANS	LVYGASDSNV	YDLLKDL EEG
IQTLMGRLED	GSFRTGQIFK	QTYSKFD TNS	HND DALLKNY
GLLYCFRKDM	DKVETFLRIV	QCRSVEGSCG	F

$C_{990}H_{1528}N_{262}O_{300}S_7$

$M_r$  22 125

**Column:**

- size:  $l = 0.25$  m,  $\emptyset = 4.6$  mm;
- stationary phase: octylsilyl silica gel for chromatography R (5-10  $\mu$ m) with a pore size of 30 nm;
- temperature: 30 °C.

**Mobile phase:**

- mobile phase A: dilute 1 mL of trifluoroacetic acid R to 1000 mL with water R;
- mobile phase B: to 100 mL of water R, add 1 mL of trifluoroacetic acid R and dilute to 1000 mL with acetonitrile for chromatography R;

Time (min)	Mobile phase A (per cent V/V)	Mobile phase B (per cent V/V)
0 - 20	100 → 80	0 → 20
20 - 40	80 → 75	20 → 25
40 - 65	75 → 50	25 → 50
65 - 70	50 → 20	50 → 80

Flow rate: 1 mL/min.

Detection: spectrophotometer at 214 nm.

Injection: 100  $\mu$ L.

**System suitability:** the chromatograms obtained with the test solution and the reference solution are similar to the chromatogram of somatropin digest supplied with somatropin CRS.

**Results:** the profile of the chromatogram obtained with the test solution corresponds to that of the chromatogram obtained with the reference solution.

**D. Examine the chromatograms obtained in the assay.**

**Results:** the principal peak in the chromatogram obtained with the test solution is similar in retention time and size to the principal peak in the chromatogram obtained with the reference solution.

**TESTS**

**Related proteins.** Liquid chromatography (2.2.29): use the normalisation procedure. Maintain the solutions at 2-8 °C and use within 24 h. If an automatic injector is used, maintain it at 2-8 °C.

**Test solution.** Dilute the solution to be examined in 0.05 M tris-hydrochloride buffer solution pH 7.5 R, so as to contain 2.0 mg/mL of somatropin. A weaker solution may be prepared, in which case the injection volume is adjusted accordingly.

**Reference solution.** Prepare a solution of somatropin CRS in 0.05 M tris-hydrochloride buffer solution pH 7.5 R, containing 2.0 mg/mL of somatropin.

**Resolution solution.** Dissolve the contents of a vial of somatropin/desamidomatropin resolution mixture CRS in 0.05 M tris-hydrochloride buffer solution pH 7.5 R to obtain a concentration of 2 mg/mL of somatropin.

**Column:**

- size:  $l = 0.25$  m,  $\emptyset = 4.6$  mm;
- stationary phase: a suitable singly end-capped butylsilyl silica gel, with a granulometry of 5  $\mu$ m and a porosity of 30 nm; a silica saturation column is placed between the pump and the injector valve;
- temperature: 45 °C.

**Mobile phase:** propanol R, 0.05 M tris-hydrochloride buffer solution pH 7.5 R (29:71 V/V).

Flow rate: 0.5 mL/min.

Detection: spectrophotometer at 220 nm.

**Preconditioning of the column:** rinse with 200-500 mL of a 0.1 per cent V/V solution of trifluoroacetic acid R in a 50 per cent V/V solution of acetonitrile R; repeat as necessary, to improve column performance.

Injection: 20  $\mu$ L.

**Relative retention** with reference to somatropin (retention time = about 33 min; if necessary adjust the concentration of propanol R in the mobile phase): desamidomatropin = about 0.85.

**System suitability:** resolution solution:

- resolution: minimum 1.0 between the peaks due to desamidomatropin and somatropin;
- symmetry factor: 0.9 to 1.8 for the peak due to somatropin.

**Limit:**

- total: maximum 6.0 per cent.

**Dimer and related substances of higher molecular mass.**

Size-exclusion chromatography (2.2.30): use the normalisation procedure.

**Test solution.** Dilute the solution to be examined in 0.025 M phosphate buffer solution pH 7.0 R, so as to contain 1.0 mg/mL of somatropin.

**Reference solution.** Dissolve the contents of a vial of somatropin CRS in 0.025 M phosphate buffer solution pH 7.0 R and dilute with the same solution to obtain a concentration of 1.0 mg/mL.

**Resolution solution.** Place 1 vial of somatropin CRS in an oven at 50 °C for a period sufficient to generate 1-2 per cent of dimer (typically 12-24 h). Dissolve its contents in 0.025 M phosphate buffer solution pH 7.0 R and dilute with the same solution to obtain a concentration of 1.0 mg/mL.

**Column:**

- size:  $l = 0.30$  m,  $\emptyset = 7.8$  mm;
- stationary phase: hydrophilic silica gel for chromatography R of a grade suitable for fractionation of globular proteins in the relative molecular mass range of 5000 to 150 000.

**Mobile phase:** 2-propanol R, 0.063 M phosphate buffer solution pH 7.0 R (3:97 V/V); filter and degas.

Flow rate: 0.6 mL/min.

Detection: spectrophotometer at 214 nm.

Injection: 20  $\mu$ L.

**Relative retention** with reference to somatropin monomer (retention time = 12 min to 17 min): related substances of higher molecular mass = about 0.65; somatropin dimer = about 0.9.

**System suitability:** resolution solution:

- peak-to-valley ratio: minimum 2.5, where  $H_p$  = height above the baseline of the peak due to the dimer and  $H_v$  = height above the baseline of the lowest point of the curve separating this peak from the peak due to the monomer.

**Limit:**

- sum of the peaks with retention times less than that of the principal peak: maximum 4.0 per cent.

**Charged variants.** Capillary electrophoresis (2.2.47).

**Test solution (a).** Dilute the solution to be examined so as to obtain a concentration of 1 mg/mL of somatropin.

**Test solution (b).** Mix equal volumes of test solution (a) and the reference solution.

**Reference solution.** Dissolve the contents of a vial of somatropin CRS in water R and dilute with the same solvent to obtain a concentration of 1 mg/mL.

**Capillary:**

- material: uncoated fused silica;
  - size: effective length = at least 70 cm,  $\emptyset = 50$   $\mu$ m.
- Temperature: 30 °C.

**CZE buffer:** 13.2 g/L solution of ammonium phosphate R adjusted to pH 6.0 with phosphoric acid R and filtered.

**Detection:** spectrophotometer at 200 nm.

Set the autosampler to store the samples at 4 °C during analysis.

**Preconditioning of the capillary:** rinse with 1 M sodium hydroxide for 20 min, with water R for 10 min and with the CZE buffer for 20 min.

**Between-run rinsing:** rinse with 0.1 M sodium hydroxide for 2 min and with the CZE buffer for 6 min.

**Note:** rinsing times may be adapted according to the length of the capillary and the equipment used.

**Injection:** test solution (a) and the reference solution; under pressure or vacuum, using the following sequence: sample injection for at least 3 s then CZE buffer injection for 1 s. The injection time and pressure may be adapted in order to meet the system suitability criteria.

**Migration:** apply a field strength of 217 V/cm (20 kV for capillaries of 92 cm total length) for 80 min, using the CZE buffer as the electrolyte in both buffer reservoirs.

**Relative migration** with reference to somatropin: deamidated forms = 1.02 to 1.11.

**System suitability:** reference solution:

- the electropherogram obtained is similar to the electropherogram of somatropin supplied with *somatropin CRS*; 2 peaks ( $I_1$ ,  $I_2$ ) eluting prior to the principal peak and at least 2 peaks ( $I_3$ ,  $I_4$ ) eluting after the principal peak are clearly visible.

**Note:** peak  $I_2$  corresponds to the cleaved form and peak  $I_4$  corresponds to the deamidated forms, eluting as a doublet.

**Limits:**

- *deamidated forms*: maximum 5.0 per cent;
- *any other impurity*: for each impurity, maximum 2.0 per cent;
- *total*: maximum 10.0 per cent.

**Bacterial endotoxins (2.6.14):** less than 5 IU in the volume that contains 1 mg of somatropin, if intended for use in the manufacture of parenteral preparations without a further appropriate procedure for removal of bacterial endotoxins.

#### ASSAY

Size-exclusion chromatography (2.2.30) as described in the test for dimer and related substances of higher molecular mass.

Calculate the content of somatropin ( $C_{990}H_{1528}N_{262}O_{300}S_7$ ) from the declared content of  $C_{990}H_{1528}N_{262}O_{300}S_7$  in *somatropin CRS*.

#### STORAGE

In an airtight container at a temperature of –20 °C. Avoid repeated freezing and thawing. If the solution is sterile, store in a sterile, airtight, tamper-proof container.

#### LABELLING

The label states:

- the content of somatropin in milligrams per millilitre;
- the name and concentration of any auxiliary substance.

01/2008:0952  
corrected 7.0

## SOMATROPIN FOR INJECTION

### Somatropinum iniectionabile

FPTIPLSRLF	DNAMLRARHL	HQLAFDTYQE	FEEAYIPKEQ
KYSFLQNPQT	SLCFSES IPT	PSNREETQOK	SNLELLRISL
LLIQSWLEPV	QFLRSVFANS	LVIYASDSNV	YDLLKDL EEG
IQTLMGRL ED	GSFRTGQIFK	QTYSKFD TNS	HND DALLKNY
GLLYCFR KDM	DKVETFLRIV	QCRSVEGSCG	F

$C_{990}H_{1528}N_{262}O_{300}S_7$

$M_r$  22 125

#### DEFINITION

Freeze-dried, sterile preparation of a protein having the structure (191 amino-acid residues) of the major component of growth hormone produced by the human pituitary.

**Content:** 89.0 per cent to 105.0 per cent of the amount of somatropin stated on the label.

By convention, for the purpose of labelling somatropin preparations, 1 mg of anhydrous somatropin ( $C_{990}H_{1528}N_{262}O_{300}S_7$ ) is equivalent to 3.0 IU of biological activity.

Somatropin for injection complies with the requirements of the monograph *Parenteral preparations (0520)*.

#### PRODUCTION

Somatropin for injection is prepared either from *Somatropin (0951)* or from *Somatropin concentrated solution (0950)*, or by a method based on recombinant DNA (rDNA) technology in which the injectable preparation is produced without the isolation of an intermediate solid or liquid bulk. In the latter case, during the course of product development, it must be demonstrated that the manufacturing process produces a product having a biological activity of not less than 2.5 IU/mg, using a validated bioassay based on growth promotion and approved by the competent authority. The purified preparation, to which buffers and stabilisers may be added, is filtered through a bacteria-retentive filter, aseptically distributed in sterile containers of glass type I (3.2.1) and freeze-dried. The containers are immediately sealed so as to exclude microbial contamination and moisture.

Somatropin for injection complies with the following additional requirements.

**Host-cell-derived proteins.** The limit is approved by the competent authority.

**Host-cell- and vector-derived DNA.** The limit is approved by the competent authority.

Where somatropin for injection is prepared from *Somatropin (0951)* or from *Somatropin concentrated solution (0950)*, compliance with the requirements for *host-cell-derived proteins, host-cell- and vector-derived DNA, identification test A, identification test C and charged variants need not be reconfirmed by the manufacturer during subsequent production of somatropin for injection*.

#### CHARACTERS

**Appearance:** white or almost white powder.

#### IDENTIFICATION

A. Capillary electrophoresis (2.2.47) as described in the test for charged variants with the following modifications.

**Injection:** test solution (b); under pressure or vacuum, using the following sequence: sample injection for at least 3 s then CZE buffer injection for 1 s.

**Results:** in the electropherogram obtained, only 1 principal peak, corresponding to somatropin, is detected: no doubling of this peak is observed.

B. Examine the chromatograms obtained in the test for related proteins.

**Results:** the principal peak in the chromatogram obtained with the test solution is similar in retention time and size to the principal peak in the chromatogram obtained with the reference solution.

C. Peptide mapping (2.2.55).

#### SELECTIVE CLEAVAGE OF THE PEPTIDE BONDS

**Test solution.** Prepare a solution of the substance to be examined in 0.05 M *tris-hydrochloride buffer solution pH 7.5 R* to obtain a solution containing 2.0 mg/mL of somatropin and transfer about 1.0 mL to a tube made from a suitable material such as polypropylene. Prepare a 1 mg/mL solution of *trypsin for peptide mapping R* in 0.05 M *tris-hydrochloride buffer solution pH 7.5 R* and add 30 µL to the solution of the substance to be examined. Cap

the tube and place in a water-bath at 37 °C for 4 h. Remove from the water-bath and stop the reaction immediately, for example by freezing. If analysed immediately using an automatic injector, maintain at 2-8 °C.

**Reference solution.** Prepare at the same time and in the same manner as for the test solution, but using *somatropin CRS* instead of the substance to be examined.

**CHROMATOGRAPHIC SEPARATION.** Liquid chromatography (2.2.29).

**Column:**

- size:  $l = 0.25$  m,  $\varnothing = 4.6$  mm;
- stationary phase: octylsilyl silica gel for chromatography R (5-10  $\mu$ m) with a pore size of 30 nm;
- temperature: 30 °C.

**Mobile phase:**

- mobile phase A: dilute 1 mL of trifluoroacetic acid R to 1000 mL with water R;
- mobile phase B: to 100 mL of water R add 1 mL of trifluoroacetic acid R and dilute to 1000 mL with acetonitrile for chromatography R;

Time (min)	Mobile phase A (per cent V/V)	Mobile phase B (per cent V/V)
0 - 20	100 → 80	0 → 20
20 - 40	80 → 75	20 → 25
40 - 65	75 → 50	25 → 50
65 - 70	50 → 20	50 → 80

**Flow rate:** 1 mL/min.

**Detection:** spectrophotometer at 214 nm.

**Injection:** 100  $\mu$ L.

**System suitability:** the chromatograms obtained with the test solution and the reference solution are similar to the chromatogram of somatropin digest supplied with *somatropin CRS*.

**Results:** the profile of the chromatogram obtained with the test solution corresponds to that of the chromatogram obtained with the reference solution.

#### D. Examine the chromatograms obtained in the assay.

**Results:** the principal peak in the chromatogram obtained with the test solution is similar in retention time and size to the principal peak in the chromatogram obtained with the reference solution.

## TESTS

**Related proteins.** Liquid chromatography (2.2.29): use the normalisation procedure. Maintain the solutions at 2-8 °C and use within 24 h. If an automatic injector is used, maintain at 2-8 °C.

**Test solution.** Prepare a solution of the substance to be examined in 0.05 M tris-hydrochloride buffer solution pH 7.5 R, containing 2.0 mg/mL of somatropin.

**Reference solution.** Prepare a solution of *somatropin CRS* in 0.05 M tris-hydrochloride buffer solution pH 7.5 R, containing 2.0 mg/mL of somatropin.

**Resolution solution.** Dissolve the contents of a vial of *somatropin/desamidomatropin resolution mixture CRS* in 0.05 M tris-hydrochloride buffer solution pH 7.5 R to obtain a concentration of 2 mg/mL of somatropin.

**Column:**

- size:  $l = 0.25$  m,  $\varnothing = 4.6$  mm;
- stationary phase: a suitable singly end-capped butylsilyl silica gel, with a granulometry of 5  $\mu$ m and a porosity of 30 nm; a silica saturation column is placed between the pump and the injector valve;

– temperature: 45 °C.

**Mobile phase:** propanol R, 0.05 M tris-hydrochloride buffer solution pH 7.5 R (29:71 V/V).

**Flow rate:** 0.5 mL/min.

**Detection:** spectrophotometer at 220 nm.

**Preconditioning of the column:** rinse with 200-500 mL of a 0.1 per cent V/V solution of trifluoroacetic acid R in a 50 per cent V/V solution of acetonitrile R; repeat as necessary, to improve column performance.

**Injection:** 20  $\mu$ L.

**Relative retention** with reference to somatropin (retention time = about 33 min; if necessary adjust the concentration of propanol R in the mobile phase): desamidomatropin = about 0.85.

**System suitability:** resolution solution:

- resolution: minimum 1.0 between the peaks due to desamidomatropin and somatropin;
- symmetry factor: 0.9 to 1.8 for the peak due to somatropin.

**Limit:**

- total: maximum 13.0 per cent.

### Dimer and related substances of higher molecular mass.

Size-exclusion chromatography (2.2.30): use the normalisation procedure.

**Test solution.** Prepare a solution of the substance to be examined in 0.025 M phosphate buffer solution pH 7.0 R, containing 1.0 mg/mL of somatropin.

**Reference solution.** Dissolve the contents of a vial of *somatropin CRS* in 0.025 M phosphate buffer solution pH 7.0 R and dilute with the same solution to obtain a concentration of 1.0 mg/mL.

**Resolution solution.** Place 1 vial of *somatropin CRS* in an oven at 50 °C for a period sufficient to generate 1-2 per cent of dimer (typically 12-24 h). Dissolve its contents in 0.025 M phosphate buffer solution pH 7.0 R and dilute with the same solution to obtain a concentration of 1.0 mg/mL.

**Column:**

- size:  $l = 0.30$  m,  $\varnothing = 7.8$  mm;
- stationary phase: hydrophilic silica gel for chromatography R of a grade suitable for fractionation of globular proteins in the relative molecular mass range of 5000 to 150 000.

**Mobile phase:** 2-propanol R, 0.063 M phosphate buffer solution pH 7.0 R (3:97 V/V); filter and degas.

**Flow rate:** 0.6 mL/min.

**Detection:** spectrophotometer at 214 nm.

**Injection:** 20  $\mu$ L.

**Relative retention** with reference to somatropin monomer (retention time = 12 min to 17 min): related substances of higher molecular mass = about 0.65; somatropin dimer = about 0.9.

**System suitability:** resolution solution:

- peak-to-valley ratio: minimum 2.5, where  $H_p$  = height above the baseline of the peak due to the dimer and  $H_v$  = height above the baseline of the lowest point of the curve separating this peak from the peak due to the monomer.

**Limit:**

- sum of the peaks with retention times less than that of the principal peak: maximum 6.0 per cent.

### Charged variants.

Capillary electrophoresis (2.2.47).

**Test solution (a).** Prepare a solution of the substance to be examined containing 1 mg/mL of somatropin.

**Test solution (b).** Mix equal volumes of test solution (a) and the reference solution.

**Reference solution.** Dissolve the contents of a vial of *somatropin CRS* in water R and dilute with the same solvent to obtain a concentration of 1 mg/mL.



01/2008:0592

**Capillary:**

- *material*: uncoated fused silica;
- *size*: effective length = at least 70 cm,  $\varnothing = 50 \mu\text{m}$ .

*Temperature*: 30 °C.*CZE buffer*: 13.2 g/L solution of ammonium phosphate R adjusted to pH 6.0 with phosphoric acid R and filtered.*Detection*: spectrophotometer at 200 nm.

Set the autosampler to store the samples at 4 °C during analysis.

*Preconditioning of the capillary*: rinse with 1 M sodium hydroxide for 20 min, with water R for 10 min and with the CZE buffer for 20 min.*Between-run rinsing*: rinse with 0.1 M sodium hydroxide for 2 min and with the CZE buffer for 6 min.*Note*: rinsing times may be adapted according to the length of the capillary and the equipment used.*Injection*: test solution (a) and the reference solution; under pressure or vacuum, using the following sequence: sample injection for at least 3 s then CZE buffer injection for 1 s.

The injection time and pressure may be adapted in order to meet the system suitability criteria.

*Migration*: apply a field strength of 217 V/cm (20 kV for capillaries of 92 cm total length) for 80 min, using CZE buffer as the electrolyte in both buffer reservoirs.*Relative migration* with reference to somatropin: deamidated forms = 1.02 to 1.11.*System suitability*: reference solution:

- the electropherogram obtained is similar to the electropherogram of somatropin supplied with somatropin CRS; 2 peaks ( $I_1, I_2$ ) eluting prior to the principal peak and at least 2 peaks ( $I_3, I_4$ ) eluting after the principal peak are clearly visible.

*Note*: peak  $I_2$  corresponds to the cleaved form and peak  $I_4$  corresponds to the deamidated forms, eluting as a doublet.*Limits*:

- *deamidated forms*: maximum 6.5 per cent;
- *any other impurity*: for each impurity, maximum 2.0 per cent;
- *total*: maximum 11.5 per cent.

**Water** (2.5.32): maximum 3.0 per cent, unless otherwise justified and authorised.**Bacterial endotoxins** (2.6.14): less than 5 IU/mg.**ASSAY**

Size-exclusion chromatography (2.2.30) as described in the test for dimer and related substances of higher molecular mass.

Calculate the content of somatropin ( $\text{C}_{990}\text{H}_{1528}\text{N}_{262}\text{O}_{300}\text{S}_7$ ) from the declared content of  $\text{C}_{990}\text{H}_{1528}\text{N}_{262}\text{O}_{300}\text{S}_7$  in somatropin CRS.**STORAGE**

In a sterile, airtight, tamper-proof container, at a temperature of 2 °C to 8 °C.

**LABELLING**

The label states:

- the content of somatropin in the container, in milligrams;
- the composition and volume of the liquid to be added for reconstitution;
- the time within which the reconstituted solution shall be used and the storage conditions during this period;
- the name and quantity of any excipient;
- the storage temperature;
- that the preparation shall not be shaken during reconstitution.

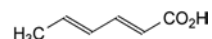
**SORBIC ACID****Acidum sorbicum** $\text{C}_6\text{H}_8\text{O}_2$   
[110-44-1] $M_r$  112.1**DEFINITION***(E,E)*-Hexa-2,4-dienoic acid.*Content*: 99.0 per cent to 101.0 per cent (anhydrous substance).**CHARACTERS***Appearance*: white or almost white, crystalline powder.*Solubility*: slightly soluble in water, freely soluble in ethanol (96 per cent).**IDENTIFICATION***First identification*: A, C.*Second identification*: A, B, D.

A. Melting point (2.2.14): 132 °C to 136 °C.

B. Ultraviolet and visible absorption spectrophotometry (2.2.25).

*Test solution*. Dissolve 50.0 mg in water R and dilute to 250.0 mL with the same solvent. Dilute 2.0 mL of this solution to 200.0 mL with 0.1 M hydrochloric acid.*Spectral range*: 230-350 nm.*Absorption maximum*: at 264 nm.*Specific absorbance at the absorption maximum*: 2150 to 2550.

C. Infrared absorption spectrophotometry (2.2.24).

*Comparison*: sorbic acid CRS.

D. Dissolve 0.2 g in 2 mL of ethanol (96 per cent) R and add 0.2 mL of bromine water R. The solution is decolorised.

**TESTS****Solution S**. Dissolve 1.25 g in ethanol (96 per cent) R and dilute to 25 mL with the same solvent.**Appearance of solution**. Solution S is clear (2.2.1) and colourless (2.2.2, Method II).**Aldehydes**: maximum 0.15 per cent, calculated as  $\text{C}_2\text{H}_4\text{O}$ .Dissolve 1.0 g in a mixture of 30 mL of water R and 50 mL of 2-propanol R, adjust to pH 4 with 0.1 M hydrochloric acid or 0.1 M sodium hydroxide and dilute to 100 mL with water R. To 10 mL of this solution add 1 mL of decolorised fuchsin solution R and allow to stand for 30 min. Any colour in the solution is not more intense than that in a standard prepared at the same time by adding 1 mL of decolorised fuchsin solution R to a mixture of 1.5 mL of acetaldehyde standard solution (100 ppm  $\text{C}_2\text{H}_4\text{O}$ ) R, 4 mL of 2-propanol R and 4.5 mL of water R.**Heavy metals** (2.4.8): maximum 10 ppm.

12 mL of solution S complies with test B. Prepare the reference solution using 5 mL of lead standard solution (1 ppm Pb) R and 5 mL of ethanol (96 per cent) R.

**Water** (2.5.12): maximum 1.0 per cent, determined on 2.000 g.**Sulfated ash** (2.4.14): maximum 0.2 per cent, determined on 1.0 g.**ASSAY**

Dissolve 0.1000 g in 20 mL of ethanol (96 per cent) R. Using 0.2 mL of phenolphthalein solution R as indicator, titrate with 0.1 M sodium hydroxide until a pink colour is obtained.

1 mL of 0.1 M sodium hydroxide is equivalent to 11.21 mg of  $\text{C}_6\text{H}_8\text{O}_2$ .

## STORAGE

Protected from light.

01/2008:1041

## SORBITAN OLEATE

## Sorbitani oleas

01/2008:1040

## SORBITAN LAURATE

## Sorbitani lauras

## DEFINITION

Mixture usually obtained by partial esterification of sorbitol and its mono- and di-anhydrides with lauric (dodecanoic) acid.

## CHARACTERS

*Appearance*: brownish-yellow, viscous liquid.

*Solubility*: practically insoluble, but dispersible in water, miscible with alcohol.

*Relative density*: about 0.98.

## IDENTIFICATION

A. Hydroxyl value (see Tests).

B. Iodine value (see Tests).

C. Composition of fatty acids (see Tests).

## TESTS

**Acid value** (2.5.1): maximum 7.0, determined on 5.0 g.

**Hydroxyl value** (2.5.3, Method A): 330 to 358.

**Iodine value** (2.5.4): maximum 10.

**Peroxide value** (2.5.5): maximum 5.0.

**Saponification value** (2.5.6): 158 to 170.

Carry out the saponification for 1 h.

**Composition of fatty acids**. Gas chromatography (2.4.22, Method C).

Prepare reference solution (a) as indicated in tables 2.4.22.-1 and 2.4.22.-2.

*Composition of the fatty acid fraction of the substance*:

- *caproic acid*: maximum 1.0 per cent,
- *caprylic acid*: maximum 10.0 per cent,
- *capric acid*: maximum 10.0 per cent,
- *lauric acid*: 40.0 per cent to 60.0 per cent,
- *myristic acid*: 14.0 per cent to 25.0 per cent,
- *palmitic acid*: 7.0 per cent to 15.0 per cent,
- *stearic acid*: maximum 7.0 per cent,
- *oleic acid*: maximum 11.0 per cent,
- *linoleic acid*: maximum 3.0 per cent.

**Heavy metals** (2.4.8): maximum 10 ppm.

2.0 g complies with test D. Prepare the reference solution using 2 mL of lead standard solution (10 ppm Pb) R.

**Water** (2.5.12): maximum 1.5 per cent, determined on 1.00 g.

**Total ash** (2.4.16): maximum 0.5 per cent.

## STORAGE

Protected from light.

## DEFINITION

Mixture usually obtained by esterification of 1 mole of sorbitol and its mono- and di-anhydrides per mole of oleic (*cis*-9-octadecenoic) acid. A suitable antioxidant may be added.

## CHARACTERS

*Appearance*: brownish-yellow, viscous liquid.

*Solubility*: practically insoluble but dispersible in water, soluble in fatty oils producing a hazy solution, miscible with alcohol.

*Relative density*: about 0.99.

## IDENTIFICATION

A. Hydroxyl value (see Tests).

B. Iodine value (see Tests).

C. Composition of fatty acids (see Tests).

*Margaric acid*: maximum 0.2 per cent for oleic acid of vegetable origin and maximum 4.0 per cent for oleic acid of animal origin.

## TESTS

**Acid value** (2.5.1): maximum 8.0, determined on 5.0 g.

**Hydroxyl value** (2.5.3, Method A): 190 to 210.

**Iodine value** (2.5.4): 62 to 76.

**Peroxide value** (2.5.5): maximum 10.0.

**Saponification value** (2.5.6): 145 to 160.

Carry out the saponification for 1 h.

**Composition of fatty acids**. Gas chromatography (2.4.22, Method C).

*Composition of the fatty acid fraction of the substance*:

- *myristic acid*: maximum 5.0 per cent,
- *palmitic acid*: maximum 16.0 per cent,
- *palmitoleic acid*: maximum 8.0 per cent,
- *stearic acid*: maximum 6.0 per cent,
- *oleic acid*: 65.0 per cent to 88.0 per cent,
- *linoleic acid*: maximum 18.0 per cent,
- *linolenic acid*: maximum 4.0 per cent,
- *fatty acids with chain length greater than C<sub>18</sub>*: maximum 4.0 per cent.

**Heavy metals** (2.4.8): maximum 10 ppm.

2.0 g complies with test D. Prepare the reference solution using 2 mL of lead standard solution (10 ppm Pb) R.

**Water** (2.5.12): maximum 1.5 per cent, determined on 1.000 g.

**Total ash** (2.4.16): maximum 0.5 per cent, determined on 1.5 g.

## STORAGE

Protected from light.

## LABELLING

The label states the origin of the oleic acid used (animal or vegetable).

01/2008:1042 C. Composition of fatty acids (see Tests).

*Margaric acid*: maximum 0.2 per cent for oleic acid of vegetable origin and maximum 4.0 per cent for oleic acid of animal origin.

## SORBITAN PALMITATE

### Sorbitani palmitas

#### DEFINITION

Mixture usually obtained by partial esterification of sorbitol and its mono- and di-anhydrides with palmitic (hexadecanoic) acid.

#### CHARACTERS

*Appearance*: yellow or yellowish powder, waxy flakes or hard masses.

*Solubility*: practically insoluble in water, soluble in fatty oils, slightly soluble in alcohol.

#### IDENTIFICATION

A. Melting point (2.2.15): 44 °C to 51 °C.

Introduce the melted substance into the glass capillary tubes and allow to stand at a temperature below 10 °C for 24 h.

B. Hydroxyl value (see Tests).

C. Composition of fatty acids (see Tests).

#### TESTS

**Acid value** (2.5.1): maximum 8.0, determined on 5.0 g.

**Hydroxyl value** (2.5.3, Method A): 270 to 305.

**Peroxide value** (2.5.5): maximum 5.0.

**Saponification value** (2.5.6): 140 to 155.

Carry out the saponification for 1 h.

**Composition of fatty acids**. Gas chromatography (2.4.22, Method C).

*Composition of the fatty acid fraction of the substance*:

- *palmitic acid*: minimum 92.0 per cent,
- *stearic acid*: maximum 6.0 per cent.

**Heavy metals** (2.4.8): maximum 10 ppm.

2.0 g complies with test D. Prepare the reference solution using 2 mL of *lead standard solution (10 ppm Pb) R*.

**Water** (2.5.12): maximum 1.5 per cent, determined on 1.00 g.

**Total ash** (2.4.16): maximum 0.5 per cent.

#### STORAGE

Protected from light.

01/2008:1916

## SORBITAN SESQUIOLEATE

### Sorbitani sesquioleas

#### DEFINITION

Mixture usually obtained by esterification of 2 moles of sorbitol and its mono- and di-anhydrides per 3 moles of oleic (*cis*-9-octadecenoic) acid. A suitable antioxidant may be added.

#### CHARACTERS

*Appearance*: pale yellow or slightly brownish-yellow paste, which becomes a viscous, oily, brownish-yellow liquid at about 25 °C.

*Solubility*: dispersible in water, soluble in fatty oils, slightly soluble in ethanol.

*Relative density*: about 0.99.

#### IDENTIFICATION

A. Hydroxyl value (see Tests).

B. Iodine value (see Tests).

#### TESTS

**Acid value** (2.5.1): maximum 16.0, determined on 5.0 g.

**Hydroxyl value** (2.5.3, Method A): 180 to 215.

**Iodine value** (2.5.4): 70 to 95.

**Peroxide value** (2.5.5): maximum 10.0.

**Saponification value** (2.5.6): 145 to 166.

Carry out the saponification for 1 h.

**Composition of fatty acids**. Gas chromatography (2.4.22, Method C).

*Composition of the fatty acid fraction of the substance*:

- *myristic acid*: maximum 5.0 per cent,
- *palmitic acid*: maximum 16.0 per cent,
- *palmitoleic acid*: maximum 8.0 per cent,
- *stearic acid*: maximum 6.0 per cent,
- *oleic acid*: 65.0 per cent to 88.0 per cent,
- *linoleic acid*: maximum 18.0 per cent,
- *linolenic acid*: maximum 4.0 per cent,
- *fatty acids with chain length greater than C<sub>18</sub>*: maximum 4.0 per cent.

**Heavy metals** (2.4.8): maximum 10 ppm.

2.0 g complies with test D. Prepare the reference solution using 2 mL of *lead standard solution (10 ppm Pb) R*.

**Water** (2.5.12): maximum 1.5 per cent, determined on 1.000 g.

**Total ash** (2.4.16): maximum 0.5 per cent, determined on 1.5 g.

#### STORAGE

Protected from light.

#### LABELLING

The label states the origin of the oleic acid used (animal or vegetable).

01/2008:1043

## SORBITAN STEARATE

### Sorbitani stearas

#### DEFINITION

Mixture usually obtained by partial esterification of sorbitol and its mono- and di-anhydrides with *Stearic acid 50 (1474)* or *Stearic acid 70 (1474)*.

#### CHARACTERS

*Appearance*: pale yellow, waxy solid.

*Solubility*: practically insoluble, but dispersible in water, slightly soluble in alcohol.

#### IDENTIFICATION

A. Melting point (2.2.15): 50 °C to 60 °C.

Introduce the melted substance into the capillary tubes and allow to stand at a temperature below 10 °C for 24 h.

B. Hydroxyl value (see Tests).

C. Composition of fatty acids (see Tests).

#### TESTS

**Acid value** (2.5.1): maximum 10.0, determined on 5.0 g.

**Hydroxyl value** (2.5.3, Method A): 235 to 260.

**Peroxide value** (2.5.5): maximum 5.0.

**Saponification value** (2.5.6): 147 to 157.

Carry out the saponification for 1 h.

**Composition of fatty acids.** Gas chromatography (2.4.22, Method C).

*Composition of the fatty acid fraction of the substance:*

	Type of fatty acid used	Composition of fatty acids
Sorbitan stearate (type I)	Stearic acid 50	<i>Stearic acid:</i> 40.0 per cent to 60.0 per cent, <i>Sum of the contents of palmitic and stearic acids:</i> minimum 90.0 per cent.
Sorbitan stearate (type II)	Stearic acid 70	<i>Stearic acid:</i> 60.0 per cent to 80.0 per cent, <i>Sum of the contents of palmitic and stearic acids:</i> minimum 90.0 per cent.

**Heavy metals** (2.4.8): maximum 10 ppm.

2.0 g complies with test D. Prepare the reference solution using 2 mL of *lead standard solution (10 ppm Pb) R*.

**Water** (2.5.12): maximum 1.5 per cent, determined on 1.00 g.

**Total ash** (2.4.16): maximum 0.5 per cent.

STORAGE

Protected from light.

LABELLING

The label states the type of sorbitan stearate.

01/2008:1044

## SORBITAN TRIOLEATE

### Sorbitani trioleas

DEFINITION

Mixture usually obtained by esterification of 1 mole of sorbitol and its mono-anhydride per 3 moles of oleic (*cis*-9-octadecenoic) acid. A suitable antioxidant may be added.

CHARACTERS

*Appearance:* pale yellow, light yellowish or brown solid, which becomes a viscous, oily, brownish-yellow liquid at about 25 °C.

*Solubility:* practically insoluble but dispersible in water, soluble in fatty oils, slightly soluble in alcohol.

*Relative density:* about 0.98.

IDENTIFICATION

A. Hydroxyl value (see Tests).

B. Iodine value (see Tests).

C. Composition of fatty acids (see Tests).

*Margaric acid:* maximum 0.2 per cent for oleic acid of vegetable origin and maximum 4.0 per cent for oleic acid of animal origin.

TESTS

**Acid value** (2.5.1): maximum 16.0, determined on 5.0 g.

**Hydroxyl value** (2.5.3, Method A): 55 to 75.

**Iodine value** (2.5.4): 76 to 90.

**Peroxide value** (2.5.5): maximum 10.0.

**Saponification value** (2.5.6): 170 to 190.

Carry out the saponification for 1 h.

**Composition of fatty acids.** Gas chromatography (2.4.22, Method C).

*Composition of the fatty acid fraction of the substance:*

- *myristic acid:* maximum 5.0 per cent,
- *palmitic acid:* maximum 16.0 per cent,
- *palmitoleic acid:* maximum 8.0 per cent,
- *stearic acid:* maximum 6.0 per cent,
- *oleic acid:* 65.0 per cent to 88.0 per cent,

- *linoleic acid:* maximum 18.0 per cent,
- *linolenic acid:* maximum 4.0 per cent,
- *fatty acids with chain length greater than C<sub>18</sub>:* maximum 4.0 per cent.

**Heavy metals** (2.4.8): maximum 10 ppm.

2.0 g complies with test D. Prepare the reference solution using 2 mL of *lead standard solution (10 ppm Pb) R*.

**Water** (2.5.12): maximum 1.5 per cent, determined on 1.000 g.

**Total ash** (2.4.16): maximum 0.5 per cent, determined on 1.5 g.

STORAGE

Protected from light.

LABELLING

The label states the origin of the oleic acid used (animal or vegetable).

04/2009:0435

## SORBITOL

### Sorbitolum

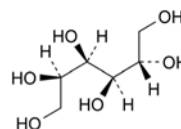

C<sub>6</sub>H<sub>14</sub>O<sub>6</sub>  
[50-70-4]

M<sub>r</sub> 182.2

DEFINITION

D-Glucitol (D-sorbitol).

*Content:* 97.0 per cent to 102.0 per cent (anhydrous substance).

CHARACTERS

*Appearance:* white or almost white, crystalline powder.

*Solubility:* very soluble in water, practically insoluble in ethanol (96 per cent).

It shows polymorphism (5.9).

IDENTIFICATION

*First identification:* A.

*Second identification:* B, C, D.

A. Examine the chromatograms obtained in the assay.

*Results:* the principal peak in the chromatogram obtained with the test solution is similar in retention time and size to the principal peak in the chromatogram obtained with reference solution (a).

B. Dissolve 0.5 g with heating in a mixture of 0.5 mL of *pyridine R* and 5 mL of *acetic anhydride R*. After 10 min, pour the solution into 25 mL of *water R* and allow to stand in iced water for 2 h. The precipitate, recrystallised from a small volume of *ethanol (96 per cent) R* and dried *in vacuo*, melts (2.2.14) at 98 °C to 104 °C.

C. Thin-layer chromatography (2.2.27).

*Test solution.* Dissolve 25 mg of the substance to be examined in *water R* and dilute to 10 mL with the same solvent.

*Reference solution (a).* Dissolve 25 mg of *sorbitol CRS* in *water R* and dilute to 10 mL with the same solvent.

*Reference solution (b).* Dissolve 25 mg of *mannitol CRS* and 25 mg of *sorbitol CRS* in *water R* and dilute to 10 mL with the same solvent.

*Plate:* TLC silica gel G plate R.

*Mobile phase:* *water R*, *ethyl acetate R*, *propanol R* (10:20:70 V/V/V).

*Application:* 2 µL.

*Development:* over a path of 17 cm.

**Drying:** in air.

**Detection:** spray with 4-aminobenzoic acid solution R; dry in a current of cold air until the acetone is removed; heat at 100 °C for 15 min; allow to cool and spray with a 2 g/L solution of sodium periodate R; dry in a current of cold air; heat at 100 °C for 15 min.

**System suitability:** reference solution (b):

– the chromatogram shows 2 clearly separated spots.

**Results:** the principal spot in the chromatogram obtained with the test solution is similar in position, colour and size to the principal spot in the chromatogram obtained with reference solution (a).

**D. Specific optical rotation (2.2.7):** + 4.0 to + 7.0 (anhydrous substance).

Dissolve 5.00 g of the substance to be examined and 6.4 g of disodium tetraborate R in 40 mL of water R. Allow to stand for 1 h, shaking occasionally, and dilute to 50.0 mL with water R. Filter if necessary.

**TESTS**

**Appearance of solution.** The solution is clear (2.2.1) and colourless (2.2.2, Method II).

Dissolve 5 g in water R and dilute to 50 mL with the same solvent.

**Conductivity (2.2.38):** maximum 20  $\mu\text{S}\cdot\text{cm}^{-1}$ .

Dissolve 20.0 g in carbon dioxide-free water R prepared from distilled water R and dilute to 100.0 mL with the same solvent. Measure the conductivity of the solution while gently stirring with a magnetic stirrer.

**Reducing sugars:** maximum 0.2 per cent, expressed as glucose equivalent.

Dissolve 5.0 g in 6 mL of water R with the aid of gentle heat. Cool and add 20 mL of cupri-citric solution R and a few glass beads. Heat so that boiling begins after 4 min and maintain boiling for 3 min. Cool rapidly and add 100 mL of a 2.4 per cent V/V solution of glacial acetic acid R and 20.0 mL of 0.025 M iodine. With continuous shaking, add 25 mL of a mixture of 6 volumes of hydrochloric acid R and 94 volumes of water R and, when the precipitate has dissolved, titrate the excess of iodine with 0.05 M sodium thiosulfate using 1 mL of starch solution R, added towards the end of the titration, as indicator. Not less than 12.8 mL of 0.05 M sodium thiosulfate is required.

**Related substances.** Liquid chromatography (2.2.29).

**Test solution.** Dissolve 5.0 g of the substance to be examined in 20 mL of water R and dilute to 100.0 mL with the same solvent.

**Reference solution (a).** Dissolve 0.50 g of sorbitol CRS in 2 mL of water R and dilute to 10.0 mL with the same solvent.

**Reference solution (b).** Dilute 2.0 mL of the test solution to 100.0 mL with water R.

**Reference solution (c).** Dilute 5.0 mL of reference solution (b) to 100.0 mL with water R.

**Reference solution (d).** Dissolve 0.5 g of sorbitol R and 0.5 g of mannitol R (impurity A) in 5 mL of water R and dilute to 10.0 mL with the same solvent.

**Column:**

- size:  $l = 0.3$  m,  $\varnothing = 7.8$  mm;
- stationary phase: strong cation exchange resin (calcium form) R (9  $\mu\text{m}$ );
- temperature:  $85 \pm 1$  °C.

**Mobile phase:** degassed water R.

**Flow rate:** 0.5 mL/min.

**Detection:** refractometer maintained at a constant temperature.

**Injection:** 20  $\mu\text{L}$  of the test solution and reference solutions (b), (c) and (d).

**Run time:** 3 times the retention time of sorbitol.

**Relative retention** with reference to sorbitol (retention time = about 27 min): impurity C = about 0.6; impurity A = about 0.8; impurity B = about 1.1.

**System suitability:** reference solution (d):

– resolution: minimum 2 between the peaks due to impurity A and sorbitol.

**Limits:**

- any impurity: for each impurity, not more than the area of the principal peak in the chromatogram obtained with reference solution (b) (2 per cent);
- total: not more than 1.5 times the area of the principal peak in the chromatogram obtained with reference solution (b) (3 per cent);
- disregard limit: the area of the principal peak in the chromatogram obtained with reference solution (c) (0.1 per cent).

**Lead (2.4.10):** maximum 0.5 ppm.

**Nickel (2.4.15):** maximum 1 ppm.

Dissolve the substance to be examined in 150.0 mL of the prescribed mixture of solvents.

**Water (2.5.12):** maximum 1.5 per cent, determined on 1.00 g.

**Microbial contamination**

If intended for use in the manufacture of parenteral preparations:

– TAMC: acceptance criterion  $10^2$  CFU/g (2.6.12).

If not intended for use in the manufacture of parenteral preparations:

- TAMC: acceptance criterion  $10^3$  CFU/g (2.6.12);
- TYMC: acceptance criterion  $10^2$  CFU/g (2.6.12);
- absence of *Escherichia coli* (2.6.13);
- absence of *Salmonella* (2.6.13).

**Bacterial endotoxins (2.6.14).** If intended for use in the manufacture of parenteral preparations without a further appropriate procedure for the removal of bacterial endotoxins:

- less than 4 IU/g for parenteral preparations having a concentration of less than 100 g/L of sorbitol;
- less than 2.5 IU/g for parenteral preparations having a concentration of 100 g/L or more of sorbitol.

**ASSAY**

Liquid chromatography (2.2.29) as described in the test for related substances with the following modification.

**Injection:** test solution and reference solution (a).

Calculate the percentage content of D-sorbitol from the declared content of sorbitol CRS.

**LABELLING**

The label states:

- where applicable, the maximum concentration of bacterial endotoxins;
- where applicable, that the substance is suitable for use in the manufacture of parenteral preparations.

**IMPURITIES**

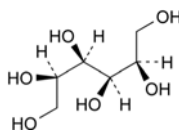

A. D-mannitol,

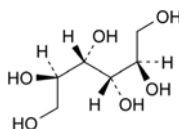

B. D-idoitol,

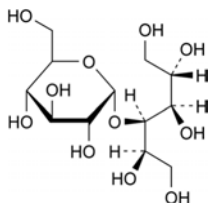

C. 4-*O*-α-D-glucopyranosyl-D-glucitol (D-maltitol).

FUNCTIONALITY-RELATED CHARACTERISTICS

This section provides information on characteristics that are recognised as being relevant control parameters for one or more functions of the substance when used as an excipient (see chapter 5.15). This section is a non-mandatory part of the monograph and it is not necessary to verify the characteristics to demonstrate compliance. Control of these characteristics can however contribute to the quality of a medicinal product by improving the consistency of the manufacturing process and the performance of the medicinal product during use. Where control methods are cited, they are recognised as being suitable for the purpose, but other methods can also be used. Wherever results for a particular characteristic are reported, the control method must be indicated.

The following characteristics may be relevant for sorbitol used as filler and binder in tablets.

**Particle-size distribution** (2.9.31 or 2.9.38).

**Powder flow** (2.9.36).

01/2008:0436

## SORBITOL, LIQUID (CRYSTALLISING)

### Sorbitolum liquidum cristallisabile

DEFINITION

Aqueous solution of a hydrogenated, partly hydrolysed starch.

**Content:**

- anhydrous substance: 68.0 per cent *m/m* to 72.0 per cent *m/m*,
- D-glucitol (D-sorbitol, C<sub>6</sub>H<sub>14</sub>O<sub>6</sub>): 92.0 per cent to 101.0 per cent (anhydrous substance).

CHARACTERS

**Appearance:** clear, colourless, syrupy liquid, miscible with water.

IDENTIFICATION

A. Examine the chromatograms obtained in the assay.

**Results:** the principal peak in the chromatogram obtained with the test solution is similar in retention time to the principal peak in the chromatogram obtained with reference solution (a).

B. To 7.0 g add 40 mL of *water R* and 6.4 g of *disodium tetraborate R*, allow to stand for 1 h, shaking occasionally, and dilute to 50.0 mL with *water R*. Filter if necessary. The angle of rotation (2.2.7) is 0° to + 1.5°.

C. It is a clear, syrupy liquid at a temperature of 25 °C.

TESTS

**Appearance of solution.** The solution is clear (2.2.1) and colourless (2.2.2, *Method II*).

Dilute 7.0 g to 50 mL with *water R*.

**Conductivity** (2.2.38): maximum 10 μS·cm<sup>-1</sup> measured on the undiluted liquid sorbitol (crystallising) while gently stirring with a magnetic stirrer.

**Reducing sugars:** maximum 0.2 per cent calculated as glucose equivalent.

To 5.0 g add 6 mL of *water R*, 20 mL of *cupri-citric solution R* and a few glass beads. Heat so that boiling begins after 4 min

and maintain boiling for 3 min. Cool rapidly and add 100 mL of a 2.4 per cent *V/V* solution of *glacial acetic acid R* and 20.0 mL of 0.025 *M* iodine. With continuous shaking, add 25 mL of a mixture of 6 volumes of *hydrochloric acid R* and 94 volumes of *water R* and, when the precipitate has dissolved, titrate the excess of iodine with 0.05 *M* sodium thiosulfate using 1 mL of *starch solution R*, added towards the end of the titration, as indicator. Not less than 12.8 mL of 0.05 *M* sodium thiosulfate is required.

**Lead** (2.4.10): maximum 0.5 ppm.

**Nickel** (2.4.15): maximum 1 ppm.

**Water** (2.5.12): 28.0 per cent to 32.0 per cent *m/m*, determined on 0.1 g.

ASSAY

Liquid chromatography (2.2.29).

**Test solution.** Mix 1.00 g of the substance to be examined with 20 mL of *water R* and dilute to 50.0 mL with the same solvent.

**Reference solution (a).** Dissolve 65.0 mg of *sorbitol CRS* in 2 mL of *water R* and dilute to 5.0 mL with the same solvent.

**Reference solution (b).** Dissolve 65 mg of *mannitol R* and 65 mg of *sorbitol R* in 2 mL of *water R* and dilute to 5.0 mL with the same solvent.

**Column:**

- size: *l* = 0.3 m, Ø = 7.8 mm,
- stationary phase: strong cation exchange resin (calcium form) *R* (9 μm),
- temperature: 85 ± 1 °C.

**Mobile phase:** degassed *water R*.

**Flow rate:** 0.5 mL/min.

**Detection:** refractometer maintained at a constant temperature.

**Injection:** 20 μL.

**Run time:** 3 times the retention time of sorbitol.

**Relative retention** with reference to sorbitol (retention time = about 27 min): mannitol = about 0.8.

**System suitability:** reference solution (b):

- resolution: minimum 2 between the peaks due to mannitol and to sorbitol.

Calculate the percentage content of D-sorbitol from the areas of the peaks and the declared content of *sorbitol CRS*.

01/2008:0437

## SORBITOL, LIQUID (NON-CRYSTALLISING)

### Sorbitolum liquidum non cristallisabile

DEFINITION

Aqueous solution of a hydrogenated, partly hydrolysed starch.

**Content:**

- anhydrous substance: 68.0 per cent *m/m* to 72.0 per cent *m/m*,
- D-glucitol (D-sorbitol, C<sub>6</sub>H<sub>14</sub>O<sub>6</sub>): 72.0 per cent to 92.0 per cent (anhydrous substance).

CHARACTERS

**Appearance:** clear, colourless, syrupy liquid, miscible with water.

IDENTIFICATION

A. Examine the chromatograms obtained in the assay.

**Results:** the principal peak in the chromatogram obtained with the test solution is similar in retention time to the principal peak in the chromatogram obtained with reference solution (a).

- B. To 7.0 g add 40 mL of *water R* and 6.4 g of *disodium tetraborate R*. Allow to stand for 1 h, shaking occasionally, and dilute to 50.0 mL with *water R*. Filter if necessary. The angle of rotation (2.2.7) is + 1.5° to + 3.5°.
- C. It is a clear, syrupy liquid at 25 °C.

## TESTS

**Appearance of solution.** The solution is clear (2.2.1) and colourless (2.2.2, *Method II*).

Dilute 7.0 g to 50 mL with *water R*.

**Conductivity** (2.2.38): maximum 10  $\mu\text{S}\cdot\text{cm}^{-1}$  measured on the undiluted liquid sorbitol (non crystallising) while gently stirring with a magnetic stirrer.

**Reducing sugars:** maximum 0.2 per cent calculated as glucose equivalent.

To 5.0 g add 6 mL of *water R*, 20 mL of *cupri-citric solution R* and a few glass beads. Heat so that boiling begins after 4 min and maintain boiling for 3 min. Cool rapidly and add 100 mL of a 2.4 per cent *V/V* solution of *glacial acetic acid R* and 20.0 mL of 0.025 *M* iodine. With continuous shaking, add 25 mL of a mixture of 6 volumes of *hydrochloric acid R* and 94 volumes of *water R* and, when the precipitate has dissolved, titrate the excess of iodine with 0.05 *M* sodium thiosulfate using 1 mL of *starch solution R*, added towards the end of the titration, as indicator. Not less than 12.8 mL of 0.05 *M* sodium thiosulfate is required.

**Reducing sugars after hydrolysis:** maximum 9.3 per cent calculated as glucose equivalent.

To 6.0 g add 35 mL of *water R*, 40 mL of 1 *M* *hydrochloric acid* and a few glass beads. Boil under a reflux condenser for 4 h. Cool and neutralise with *dilute sodium hydroxide solution R* using 0.2 mL of *bromothymol blue solution RI* as indicator. Cool and dilute to 100.0 mL with *water R*. To 3.0 mL of the solution add 5 mL of *water R*, 20 mL of *cupri-citric solution R* and a few glass beads. Heat so that boiling begins after 4 min and maintain boiling for 3 min. Cool rapidly and add 100 mL of a 2.4 per cent *V/V* solution of *glacial acetic acid R* and 20.0 mL of 0.025 *M* iodine. With continuous shaking, add 25 mL of a mixture of 6 volumes of *hydrochloric acid R* and 94 volumes of *water R*. When the precipitate has dissolved, titrate the excess of iodine with 0.05 *M* sodium thiosulfate using 1 mL of *starch solution R*, added towards the end of the titration, as indicator. Not less than 8.0 mL of 0.05 *M* sodium thiosulfate is required.

**Lead** (2.4.10): maximum 0.5 ppm.

**Nickel** (2.4.15): maximum 1 ppm.

**Water** (2.5.12): 28.0 per cent to 32.0 per cent *m/m*, determined on 0.1 g.

## ASSAY

Liquid chromatography (2.2.29).

**Test solution.** Mix 1.00 g of the substance to be examined with 20 mL of *water R* and dilute to 50.0 mL with the same solvent.

**Reference solution (a).** Dissolve 55.0 mg of *sorbitol CRS* in 2 mL of *water R* and dilute to 5.0 mL with the same solvent.

**Reference solution (b).** Dissolve 55 mg of *mannitol R* and 55 mg of *sorbitol R* in 2 mL of *water R* and dilute to 5.0 mL with the same solvent.

**Column:**

- size:  $l = 0.3$  m,  $\varnothing = 7.8$  mm,
- stationary phase: strong cation exchange resin (calcium form) *R* (9  $\mu\text{m}$ ),
- temperature:  $85 \pm 1$  °C.

**Mobile phase:** degassed *water R*.

**Flow rate:** 0.5 mL/min.

**Detection:** refractometer maintained at a constant temperature.

**Injection:** 20  $\mu\text{L}$ .

**Run time:** 3 times the retention time of sorbitol.

**Relative retention** with reference to sorbitol (retention time = about 27 min): mannitol = about 0.8.

**System suitability:** reference solution (b):

- resolution: minimum 2 between the peaks due to mannitol and to sorbitol.

Calculate the percentage content of D-sorbitol from the areas of the peaks and the declared content of *sorbitol CRS*.

01/2009:2048

## SORBITOL, LIQUID, PARTIALLY DEHYDRATED

## Sorbitolum liquidum partim deshydricum

## DEFINITION

Partially dehydrated liquid sorbitol is obtained by acid-catalysed partial internal dehydration of liquid sorbitol. It contains not less than 68.0 per cent *m/m* and not more than 85.0 per cent *m/m* of anhydrous substances, composed of a mixture of mainly D-sorbitol and 1,4-sorbitan, with mannitol, hydrogenated oligo- and disaccharides, and sorbitans.

**Content** (nominal value):

- 1,4-sorbitan ( $\text{C}_6\text{H}_{12}\text{O}_5$ ): minimum 15.0 per cent (anhydrous substance);
- D-sorbitol ( $\text{C}_6\text{H}_{14}\text{O}_6$ ): minimum 25.0 per cent (anhydrous substance).

The contents of 1,4-sorbitan and D-sorbitol are within 95.0 per cent to 105.0 per cent of the nominal values.

## CHARACTERS

**Appearance:** clear, colourless, syrupy liquid.

**Solubility:** miscible with water, practically insoluble in mineral oils and vegetable oils.

## IDENTIFICATION

Examine the chromatograms obtained in the assay.

**Results:** the 2 principal peaks in the chromatogram obtained with the test solution are similar in retention time and size to the peaks in the chromatogram obtained with reference solution (a).

## TESTS

**Solution S.** Dilute the substance to be examined with *carbon dioxide-free water R* prepared from *distilled water R* to obtain a solution containing 50.0 per cent *m/m* of anhydrous substance.

**Appearance of solution.** Solution S is clear (2.2.1) and colourless (2.2.2, *Method II*).

**Conductivity** (2.2.38): maximum 20  $\mu\text{S}\cdot\text{cm}^{-1}$ .

Measure the conductivity of solution S, while gently stirring with a magnetic stirrer.

**Reducing sugars:** maximum 0.3 per cent, calculated as glucose (anhydrous substance).

To an amount of the substance to be examined equivalent to 3.3 g of anhydrous substance, add 3 mL of *water R*, 20.0 mL of *cupri-citric solution R* and a few glass beads. Heat so that boiling begins after 4 min. Maintain boiling for 3 min. Cool rapidly and add 100 mL of a 2.4 per cent *V/V* solution of *glacial acetic acid R* and 20.0 mL of 0.025 *M* iodine. With continuous shaking, add 25 mL of a mixture of 6 mL of *hydrochloric acid R* and 94 mL of *water R*. When the precipitate has dissolved, titrate the excess of iodine with 0.05 *M* sodium thiosulfate using 2 mL of *starch solution R*, added towards the end of the titration, as indicator. Not less than 12.8 mL of 0.05 *M* sodium thiosulfate is required.

**Nickel** (2.4.15): maximum 1 ppm (anhydrous substance).

**Water** (2.5.12): 15.0 per cent to 32.0 per cent, determined on 0.10 g.

**Microbial contamination**

TAMC: acceptance criterion  $10^3$  CFU/g (2.6.12).

TYMC: acceptance criterion  $10^2$  CFU/g (2.6.12).

Absence of *Escherichia coli* (2.6.13).

Absence of *Salmonella* (2.6.13).

**ASSAY**

Liquid chromatography (2.2.29).

**Test solution.** Dissolve 0.400 g of the substance to be examined in water R and dilute to 20.0 mL with the same solvent.

**Reference solution (a).** Dissolve 50.0 mg of sorbitol CRS and 20.0 mg of 1,4-sorbitan CRS in water R and dilute to 5.0 mL with the same solvent.

**Reference solution (b).** Dissolve 0.100 g of mannitol R and 0.100 g of sorbitol R in water R and dilute to 10.0 mL with the same solvent.

**Column:**

- size:  $l = 0.3$  m,  $\emptyset = 7.8$  mm;
- stationary phase: strong cation exchange resin (calcium form) R (9  $\mu$ m);
- temperature:  $80 \pm 5$  °C.

**Mobile phase:** degassed water R.

**Flow rate:** 0.5 mL/min.

**Detection:** refractometer maintained at a constant temperature of about 30-35 °C.

**Injection:** 40  $\mu$ L.

**Relative retention** with reference to D-sorbitol (retention time = about 25 min): 1,4-sorbitan = about 0.5; mannitol = about 0.8.

**System suitability:** reference solution (b):

- resolution: minimum 2.0 between the peaks due to mannitol and D-sorbitol.

Calculate the percentage contents of 1,4-sorbitan and D-sorbitol using the chromatogram obtained with reference solution (a) and the declared contents of 1,4-sorbitan CRS and of sorbitol CRS.

**LABELLING**

The label states the content of D-sorbitol and the content of 1,4-sorbitan (= nominal values).

01/2008:2004  
corrected 6.0

**SOTALOL HYDROCHLORIDE**

## Sotaloli hydrochloridum

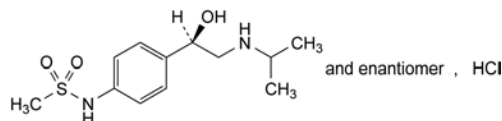

$C_{12}H_{21}ClN_2O_3S$   
[959-24-0]

$M_r$  308.8

**DEFINITION**

*N*[4-[(1*R*S)-1-hydroxy-2-[(1-methylethyl)amino]ethyl]phenyl]methanesulfonamide hydrochloride.

**Content:** 99.0 per cent to 101.0 per cent (dried substance).

**CHARACTERS**

**Appearance:** white or almost white powder.

**Solubility:** freely soluble in water, soluble in alcohol, practically insoluble in methylene chloride.

**IDENTIFICATION**

A. Infrared absorption spectrophotometry (2.2.24).

*Comparison:* sotalol hydrochloride CRS.

B. It gives reaction (a) of chlorides (2.3.1).

**TESTS**

**Solution S.** Dissolve 5.0 g in carbon dioxide-free water R and dilute to 50.0 mL with the same solvent.

**Appearance of solution.** Solution S is not more opalescent than reference suspension III (2.2.1) and not more intensely coloured than reference solution  $Y_6$  (2.2.2, Method II).

**pH** (2.2.3): 4.0 to 5.0.

Dilute 5.0 mL of solution S to 10.0 mL with carbon dioxide-free water R.

**Optical rotation** (2.2.7):  $-0.10^\circ$  to  $+0.10^\circ$ .

Dilute 25.0 mL of solution S to 50.0 mL with water R.

**Related substances.** Liquid chromatography (2.2.29).

**Test solution.** Dissolve 20.0 mg of the substance to be examined in the mobile phase and dilute to 10.0 mL with the mobile phase.

**Reference solution (a).** Dilute 1.0 mL of the test solution to 100.0 mL with the mobile phase. Dilute 3.0 mL of this solution to 10.0 mL with the mobile phase.

**Reference solution (b).** Dissolve 8.0 mg of sotalol impurity B CRS in the mobile phase and dilute to 10.0 mL with the mobile phase.

**Reference solution (c).** Dilute 1.0 mL of reference solution (b) to 100.0 mL with the mobile phase.

**Reference solution (d).** Dilute 1.5 mL of reference solution (b) to 100 mL with the mobile phase. To 1 mL of this solution add 1 mL of reference solution (a).

**Column:**

- size:  $l = 0.25$  m,  $\emptyset = 4.6$  mm,
- stationary phase: octadecylsilyl silica gel for chromatography R (5  $\mu$ m).

**Mobile phase:** dissolve 2 g of sodium octanesulfonate R in 790 mL of water R. Adjust to pH 3.0 with phosphoric acid R and add 210 mL of acetonitrile R.

**Flow rate:** 1 mL/min.

**Detection:** spectrophotometer at 228 nm.

**Injection:** 10  $\mu$ L; inject the test solution and reference solutions (a), (c) and (d).

**Run time:** 2.5 times the retention time of sotalol.

**System suitability:** reference solution (d):

- resolution: minimum 4.0 between the peaks due to sotalol and to impurity B.

**Limits:**

- impurity B: not more than 0.25 times the area of the principal peak in the chromatogram obtained with reference solution (c) (0.1 per cent),
- any other impurity: not more than the area of the principal peak in the chromatogram obtained with reference solution (a) (0.3 per cent), and not more than 1 such peak has an area greater than 0.3 times the area of the principal peak in the chromatogram obtained with reference solution (a) (0.1 per cent),
- total of other impurities: not more than 1.65 times the area of the principal peak in the chromatogram obtained with reference solution (a) (0.5 per cent),
- disregard limit: 0.17 times the area of the principal peak in the chromatogram obtained with reference solution (a) (0.05 per cent).

**Palladium:** maximum 0.5 ppm.

Atomic absorption spectrometry (2.2.23, Method I).



**Test solution.** Dissolve 1.00 g in a mixture of 0.25 volumes of *nitric acid R*, 0.75 volumes of *hydrochloric acid R* and 99.0 volumes of *water R* and dilute to 20.0 mL with the same mixture of solvents.

**Reference solutions.** Use solutions containing 0.02 µg, 0.03 µg and 0.05 µg of palladium per millilitre, freshly prepared by dilution of *palladium standard solution (0.5 ppm Pd) R* with a mixture of 0.25 volumes of *nitric acid R*, 0.75 volumes of *hydrochloric acid R* and 99.0 volumes of *water R*.

**Source:** palladium hollow-cathode lamp.

**Wavelength:** 247.6 nm.

Use a graphite tube.

**Heavy metals (2.4.8):** maximum 20 ppm.

To 10 mL of solution S add 10 mL of *water R*. 12 mL of the solution complies with limit test A. Prepare the standard using *lead standard solution (1 ppm Pb) R*.

**Loss on drying (2.2.32):** maximum 0.5 per cent, determined on 1.000 g by drying in an oven at 105 °C.

**Sulfated ash (2.4.14):** maximum 0.1 per cent, determined on 1.0 g.

#### ASSAY

*In order to avoid overheating during the titration, mix thoroughly throughout and stop the titration immediately after the end-point has been reached.*

Dissolve 0.250 g in 10 mL of *anhydrous formic acid R*, if necessary with the aid of ultrasound. Add 40 mL of *acetic anhydride R* and titrate immediately with 0.1 M *perchloric acid*. Determine the end-point potentiometrically (2.2.20).

1 mL of 0.1 M *perchloric acid* is equivalent to 30.88 mg of C<sub>12</sub>H<sub>21</sub>ClN<sub>2</sub>O<sub>3</sub>S.

#### STORAGE

Protected from light.

#### IMPURITIES

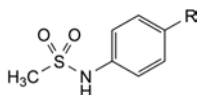

- A. R = CH<sub>2</sub>-CH<sub>2</sub>-NH-CH(CH<sub>3</sub>)<sub>2</sub>: *N*-[4-[2-[(1-methylethyl)amino]ethyl]phenyl]methanesulfonamide,
- B. R = CO-CH<sub>2</sub>-NH-CH(CH<sub>3</sub>)<sub>2</sub>: *N*-[4-[[1-(1-methylethyl)amino]acetyl]phenyl]methanesulfonamide,
- C. R = CHO: *N*-(4-formylphenyl)methanesulfonamide,

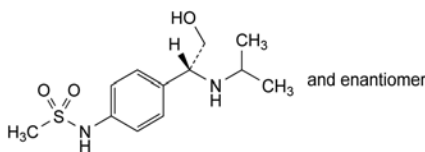

- D. *N*-[4-[(1*R*,2*S*)-2-hydroxy-1-[(1-methylethyl)amino]ethyl]phenyl]methanesulfonamide.

07/2010:1265  
corrected 7.0

## SOYA-BEAN OIL, HYDROGENATED

### Soiae oleum hydrogenatum

#### DEFINITION

Product obtained by refining, bleaching, hydrogenation and deodorisation of oil obtained from seeds of *Glycine max* (L.) Merr. (*G. hispida* (Moench) Maxim.). The product consists mainly of triglycerides of palmitic and stearic acids.

#### CHARACTERS

**Appearance:** white or almost white mass or powder which melts to a clear, pale yellow liquid when heated.

**Solubility:** practically insoluble in water, freely soluble in methylene chloride, in light petroleum (bp: 65-70 °C) after heating and in toluene, very slightly soluble in ethanol (96 per cent).

#### IDENTIFICATION

A. Melting point (see Tests).

B. Composition of fatty acids (see Tests).

#### TESTS

**Melting point (2.2.15):** 66 °C to 72 °C.

**Acid value (2.5.1):** maximum 0.5.

Dissolve 10.0 g in 50 mL of a hot mixture of equal volumes of *ethanol (96 per cent) R* and *toluene R*, previously neutralised with 0.1 M *potassium hydroxide* using 0.5 mL of *phenolphthalein solution R1* as indicator. Titrate the solution immediately while still hot.

**Peroxide value (2.5.5, Method A):** maximum 5.0.

**Unsaponifiable matter (2.5.7):** maximum 1.0 per cent, determined on 5.0 g.

**Alkaline impurities (2.4.19).** Dissolve 2.0 g with gentle heating in a mixture of 1.5 mL of *ethanol (96 per cent) R* and 3 mL of *toluene R*. Add 0.05 mL of a 0.4 g/L solution of *bromophenol blue R* in *ethanol (96 per cent) R*. Not more than 0.4 mL of 0.01 M *hydrochloric acid* is required to change the colour to yellow.

**Composition of fatty acids (2.4.22, Method A).** Use the mixture of calibrating substances in Table 2.4.22.-3.

**Column:**

- *material:* fused silica;
- *size:* *l* = 25 m, Ø = 0.25 mm;
- *stationary phase:* *poly(cyanopropyl)siloxane R* (film thickness 0.2 µm).

**Carrier gas:** *helium for chromatography R*.

**Flow rate:** 0.65 mL/min.

**Split ratio:** 1:100.

**Temperature:**

- *column:* 180 °C for 20 min;
- *injection port and detector:* 250 °C.

**Detection:** flame ionisation.

**Composition of the fatty-acid fraction of the oil:**

- *saturated fatty acids of chain length less than C<sub>14</sub>:* maximum 0.1 per cent;
- *myristic acid:* maximum 0.5 per cent;
- *palmitic acid:* 9.0 per cent to 16.0 per cent;
- *stearic acid:* 79.0 per cent to 89.0 per cent;
- *oleic acid and isomers:* maximum 4.0 per cent;
- *linoleic acid and isomers:* maximum 1.0 per cent;
- *linolenic acid and isomers:* maximum 0.2 per cent;
- *arachidic acid:* maximum 1.0 per cent;
- *behenic acid:* maximum 1.0 per cent.

**Nickel:** maximum 1 ppm.

**Atomic absorption spectrometry (2.2.23, Method II).**

**Test solution.** Introduce 5.0 g into a platinum or silica crucible, previously tared after calcination. Cautiously heat and introduce into the substance a wick formed from twisted ashless filter paper. Light the wick. When the substance is alight stop heating. After combustion, ignite in a muffle furnace at about 600 ± 50 °C. Continue the ignition until white ash is obtained. After cooling, take up the residue with 2 quantities, each of 2 mL, of *dilute hydrochloric acid R* and transfer into a 25 mL graduated flask. Add 0.3 mL of *nitric acid R* and dilute to 25.0 mL with *water R*.

**Reference solutions.** Prepare 3 reference solutions by adding 1.0 mL, 2.0 mL and 4.0 mL of *nickel standard solution* (0.2 ppm Ni) *R* to 2.0 mL of the test solution and diluting to 10.0 mL with *water R*.

**Source:** nickel hollow-cathode lamp.

**Wavelength:** 232 nm.

**Atomisation device:** graphite furnace.

**Carrier gas:** argon *R*.

#### STORAGE

Protected from light.

01/2010:1473  
corrected 6.7

## SOYA-BEAN OIL, REFINED

### Soiae oleum raffinatum

#### DEFINITION

Fatty oil obtained from seeds of *Glycine max* (L.) Merr. (*Glycine hispida* (Moench) Maxim.) by extraction and subsequent refining. It may contain a suitable antioxidant.

#### CHARACTERS

**Appearance:** clear, pale yellow liquid.

**Solubility:** practically insoluble in ethanol (96 per cent), miscible with light petroleum (bp: 50-70 °C).

**Relative density:** about 0.922.

**Refractive index:** about 1.475.

#### IDENTIFICATION

Identification of fatty oils by thin-layer chromatography (2.3.2).

**Results:** the chromatogram obtained is similar to the corresponding chromatogram shown in Figure 2.3.2-1.

#### TESTS

**Acid value** (2.5.1): maximum 0.5.

**Peroxide value** (2.5.5, *Method A*): maximum 10.0, and maximum 5.0 if intended for use in the manufacture of parenteral preparations.

**Unsaponifiable matter** (2.5.7): maximum 1.5 per cent, determined on 5.0 g.

**Alkaline impurities** (2.4.19). It complies with the test.

**Composition of fatty acids** (2.4.22, *Method A*). Use the mixture of calibrating substances in Table 2.4.22-3.

**Composition of the fatty-acid fraction of the oil:**

- saturated fatty acids of chain length less than  $C_{14}$ : maximum 0.1 per cent;
- *myristic acid*: maximum 0.2 per cent;
- *palmitic acid*: 9.0 per cent to 13.0 per cent;
- *palmitoleic acid*: maximum 0.3 per cent;
- *stearic acid*: 2.5 per cent to 5.0 per cent;
- *oleic acid*: 17.0 per cent to 30.0 per cent;
- *linoleic acid*: 48.0 per cent to 58.0 per cent;
- *linolenic acid*: 5.0 per cent to 11.0 per cent;
- *arachidic acid*: maximum 1.0 per cent;
- *eicosenoic acid*: maximum 1.0 per cent;
- *behenic acid*: maximum 1.0 per cent.

**Brassicasterol** (2.4.23): maximum 0.3 per cent in the sterol fraction of the oil.

**Water** (2.5.32): maximum 0.1 per cent, determined on 1.00 g.

#### STORAGE

In a well-filled container, protected from light, at a temperature not exceeding 25 °C.

#### LABELLING

The label states, where applicable, that the substance is suitable for use in the manufacture of parenteral preparations.

01/2008:1152

## SPECTINOMYCIN DIHYDROCHLORIDE PENTAHYDRATE

### Spectinomycini dihydrochloridum pentahydricum

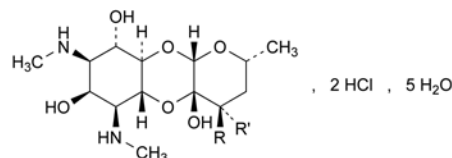

Compound	R	R'	Molec. Formula	$M_r$
spectinomycin	R + R' = O		$C_{14}H_{26}Cl_2N_2O_7 \cdot 5H_2O$	495.4
(4 <i>R</i> )-dihydro-spectinomycin	OH	H	$C_{14}H_{28}Cl_2N_2O_7 \cdot 5H_2O$	497.4

#### DEFINITION

Mixture of (2*R*,4*aR*,5*aR*,6*S*,7*S*,8*R*,9*S*,9*aR*,10*aS*)-4*a*,7,9-trihydroxy-2-methyl-6,8-bis(methylamino)decahydro-4*H*-pyrano[2,3-*b*][1,4]benzodioxin-4-one dihydrochloride pentahydrate (spectinomycin dihydrochloride pentahydrate) and of (2*R*,4*R*,4*aS*,5*aR*,6*S*,7*S*,8*R*,9*S*,9*aR*,10*aS*)-2-methyl-6,8-bis(methylamino)decahydro-2*H*-pyrano[2,3-*b*][1,4]benzodioxine-4,4*a*,7,9-tetrol dihydrochloride pentahydrate ((4*R*)-dihydro-spectinomycin dihydrochloride pentahydrate). It is produced by *Streptomyces spectabilis* or by any other means.

#### Content:

- (4*R*)-dihydro-spectinomycin dihydrochloride: maximum 9.0 per cent (anhydrous substance);
- sum of the contents of spectinomycin dihydrochloride and (4*R*)-dihydro-spectinomycin dihydrochloride: 93.0 per cent to 102.0 per cent (anhydrous substance).

#### CHARACTERS

**Appearance:** white or almost white, slightly hygroscopic powder.

**Solubility:** freely soluble in water, very slightly soluble in ethanol (96 per cent).

#### IDENTIFICATION

A. Infrared absorption spectrophotometry (2.2.24).

*Comparison:* spectinomycin hydrochloride *CRS*.

B. Dilute 1.0 mL of solution S (see Tests) to 10 mL with *water R*. The solution gives reaction (a) of chlorides (2.3.1).

#### TESTS

**Solution S.** Dissolve 2.50 g in carbon dioxide-free *water R* and dilute to 25.0 mL with the same solvent.

**Appearance of solution.** The solution is clear (2.2.1) and colourless (2.2.2, *Method II*).

Dilute 2.0 mL of solution S to 20.0 mL with *water R*.

**pH** (2.2.3): 3.8 to 5.6 for solution S.

**Specific optical rotation** (2.2.7): + 15.0 to + 21.0 (anhydrous substance), determined on solution S within 20 min of preparation.

**Related substances.** Liquid chromatography (2.2.29). In order to avoid formation of anomers, prepare the solutions immediately before use.

**Test solution.** Dissolve 15.0 mg of the substance to be examined in the mobile phase and dilute to 100.0 mL with the mobile phase.

**Reference solution (a).** Dissolve 3 mg of spectinomycin for system suitability CRS in the mobile phase and dilute to 20 mL with the mobile phase.

**Reference solution (b).** Dilute 1.0 mL of the test solution to 100.0 mL with the mobile phase.

**Reference solution (c).** Dilute 3.0 mL of reference solution (b) to 10.0 mL with the mobile phase.

**Column:**

- size:  $l = 0.25$  m,  $\varnothing = 4.6$  mm;
- stationary phase: octylsilyl silica gel for chromatography R (5  $\mu$ m);
- temperature: ambient and constant.

**Mobile phase:** dissolve 4.2 g of oxalic acid R and 2.0 mL of heptafluorobutyric acid R in water R and dilute to 1000 mL with water R; adjust to pH 3.2 with sodium hydroxide solution R, add 105 mL of acetonitrile R and mix; filter through a 0.45  $\mu$ m filter and degas with helium for chromatography R for 10 min.

**Flow rate:** 1.0 mL/min.

**Post-column solution:** carbonate-free sodium hydroxide solution R diluted with carbon dioxide-free water R to obtain a final concentration of NaOH of 21 g/L. Degas the solution with helium for chromatography R for 10 min before use. Add it pulse-less to the column effluent using a 375  $\mu$ L polymeric mixing coil.

**Post-column flow rate:** 0.5 mL/min.

**Detection:** pulsed amperometric detection or equivalent with a gold indicator electrode having preferably a diameter of 1.4 mm or greater, a suitable reference electrode and a stainless steel counter electrode, held at + 0.12 V detection, + 0.70 V oxidation and – 0.60 V reduction potentials respectively, with pulse durations according to the instrument used. Keep the detection cell at ambient and constant temperature. Clean the gold indicator electrode with an eraser and damp precision wipe prior to start-up of the system to enhance the detector sensitivity and increase the signal-to-noise ratio.

**Injection:** 20  $\mu$ L.

**Run time:** 1.5 times the retention time of spectinomycin.

**Identification of impurities:** use the chromatogram supplied with spectinomycin for system suitability CRS and the chromatogram obtained with reference solution (a) to identify the peaks due to impurities A, D and E.

**Relative retention** with reference to spectinomycin (retention time = 11 min to 20 min): impurity A = about 0.5; impurity F = about 0.53; impurity G = about 0.6; impurity D = about 0.7; impurity E = about 0.9; (4R)-dihydrospectinomycin = about 1.3; impurity C = about 1.4.

**System suitability:** reference solution (a):

- resolution: minimum 1.5 between the peaks due to impurity E and spectinomycin.

**Limits:**

- correction factor: for the calculation of content, multiply the peak area of impurity A by 0.4;
- impurities A, C, F, G: for each impurity, not more than the area of the principal peak in the chromatogram obtained with reference solution (b) (1.0 per cent);

- impurities D, E: for each impurity, not more than 4 times the area of the principal peak in the chromatogram obtained with reference solution (b) (4.0 per cent);
- any other impurity: for each impurity, not more than the area of the principal peak in the chromatogram obtained with reference solution (b) (1.0 per cent);
- total: not more than 6 times the area of the principal peak in the chromatogram obtained with reference solution (b) (6.0 per cent);
- disregard limit: the area of the principal peak in the chromatogram obtained with reference solution (c) (0.3 per cent); disregard the peak due to (4R)-dihydrospectinomycin.

**Water** (2.5.12): 16.0 per cent to 20.0 per cent, determined on 0.100 g.

**Sulfated ash** (2.4.14): maximum 1.0 per cent, determined on 1.0 g.

**Bacterial endotoxins** (2.6.14): less than 0.09 IU/mg, if intended for use in the manufacture of parenteral preparations without a further appropriate procedure for the removal of bacterial endotoxins. Prepare the solutions using a 0.42 per cent *m/m* solution of sodium hydrogen carbonate R.

**ASSAY**

Liquid chromatography (2.2.29) as described in the test for related substances with the following modifications.

**Test solution.** Dissolve 40.0 mg of the substance to be examined in water R and dilute to 50.0 mL with the same solvent. Allow to stand for not less than 15 h and not more than 72 h (formation of anomers). Dilute 5.0 mL of this solution to 50.0 mL with the mobile phase.

**Reference solution.** Dissolve 40.0 mg of spectinomycin hydrochloride CRS (containing (4R)-dihydrospectinomycin) in water R and dilute to 50.0 mL with the same solvent. Allow to stand for the same period of time as the test solution (formation of anomers). Dilute 5.0 mL of this solution to 50.0 mL with the mobile phase.

**System suitability:**

- repeatability: maximum relative standard deviation of 3.0 per cent for the principal peak after 6 injections of the reference solution.

Calculate the sum of the percentage contents of spectinomycin dihydrochloride and (4R)-dihydrospectinomycin dihydrochloride from the declared contents of  $C_{14}H_{26}Cl_2N_2O_7$  and  $C_{14}H_{28}Cl_2N_2O_7$  in spectinomycin hydrochloride CRS.

**STORAGE**

In an airtight container. If the substance is sterile, store in a sterile, airtight, tamper-proof container.

**IMPURITIES**

**Specified impurities:** A, C, D, E, F, G.

**Other detectable impurities** (the following substances would, if present at a sufficient level, be detected by one or other of the tests in the monograph. They are limited by the general acceptance criterion for other/unspecified impurities and/or by the general monograph *Substances for pharmaceutical use* (2034). It is therefore not necessary to identify these impurities for demonstration of compliance. See also 5.10. *Control of impurities in substances for pharmaceutical use*): B.

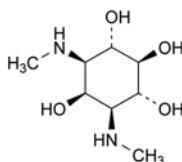

A. 1,3-dideoxy-1,3-bis(methylamino)-myo-inositol (actinamine),

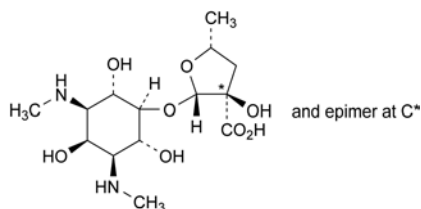

- B. (2*S*,3*R*,5*R*)-3-hydroxy-5-methyl-2-[[1*r*,2*R*,3*S*,4*r*,5*R*,6*S*)-2,4,6-trihydroxy-3,5-bis(methylamino)cyclohexyl]oxy]-tetrahydrofuran-3-carboxylic acid (actinospectinoic acid),

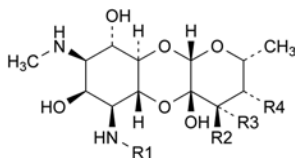

- C. R1 = CH<sub>3</sub>, R2 = R4 = H, R3 = OH: (2*R*,4*S*,4*aS*,5*aR*,6*S*,7*S*,8*R*,9*S*,9*aR*,10*aS*)-2-methyl-6,8-bis(methylamino)decahydro-2*H*-pyran[2,3-*b*][1,4]benzodioxine-4,4*a*,7,9-tetrol ((4*S*)-dihydro-spectinomycin),
- D. R1 = CH<sub>3</sub>, R2 = H, R3 = R4 = OH: (2*R*,3*R*,4*S*,4*aS*,5*aR*,6*S*,7*S*,8*R*,9*S*,9*aR*,10*aS*)-2-methyl-6,8-bis(methylamino)decahydro-2*H*-pyran[2,3-*b*][1,4]benzodioxine-3,4,4*a*,7,9-pentol (dihydroxyspectinomycin),
- E. R1 = R4 = H, R2 + R3 = O: (2*R*,4*aR*,5*aR*,6*S*,7*R*,8*R*,9*S*,9*aR*,10*aS*)-6-amino-4*a*,7,9-trihydroxy-2-methyl-8-(methylamino)decahydro-4*H*-pyran[2,3-*b*][1,4]-benzodioxin-4-one (*N*-desmethylspectinomycin),
- G. R1 = CH<sub>3</sub>, R2 + R3 = O, R4 = OH: (2*R*,3*S*,4*aR*,5*aR*,6*S*,7*S*,8*R*,9*S*,9*aR*,10*aS*)-3,4*a*,7,9-tetrahydroxy-2-methyl-6,8-bis(methylamino)decahydro-4*H*-pyran[2,3-*b*][1,4]-benzodioxin-4-one (tetrahydroxyspectinomycin),

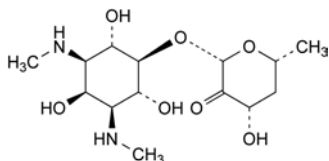

- F. (2*S*,4*S*,6*R*)-4-hydroxy-6-methyl-2-[[1*r*,2*R*,3*S*,4*r*,5*R*,6*S*)-2,4,6-trihydroxy-3,5-bis(methylamino)cyclohexyl]oxy]dihydro-2*H*-pyran-3(4*H*)-one (triol spectinomycin).

01/2008:1658

## SPECTINOMYCIN SULFATE TETRAHYDRATE FOR VETERINARY USE

Spectinomycini sulfas tetrahydricus ad usum  
veterinarium

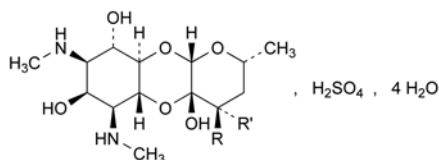

Compound	R	R'	Molec. Formula	M <sub>r</sub>
spectinomycin	R + R' = O		C <sub>14</sub> H <sub>26</sub> N <sub>2</sub> O <sub>11</sub> S, 4H <sub>2</sub> O	502.5
(4 <i>R</i> )-dihydro-spectinomycin	OH	H	C <sub>14</sub> H <sub>28</sub> N <sub>2</sub> O <sub>11</sub> S, 4H <sub>2</sub> O	504.5

### DEFINITION

Mixture of (2*R*,4*aR*,5*aR*,6*S*,7*S*,8*R*,9*S*,9*aR*,10*aS*)-4*a*,7,9-trihydroxy-2-methyl-6,8-bis(methylamino)decahydro-4*H*-pyran[2,3-*b*][1,4]benzodioxin-4-one sulfate tetrahydrate

(spectinomycin sulfate tetrahydrate) and (2*R*,4*R*,4*aS*,5*aR*,6*S*,7*S*,8*R*,9*S*,9*aR*,10*aS*)-2-methyl-6,8-bis(methylamino)decahydro-2*H*-pyran[2,3-*b*][1,4]benzodioxine-4,4*a*,7,9-tetrol sulfate tetrahydrate ((4*R*)-dihydro-spectinomycin sulfate tetrahydrate). It is produced by *Streptomyces spectabilis* or by any other means.

### Content:

- (4*R*)-dihydro-spectinomycin sulfate: maximum 2.0 per cent (anhydrous substance);
- sum of the contents of spectinomycin sulfate and (4*R*)-dihydro-spectinomycin sulfate: 93.0 per cent to 102.0 per cent (anhydrous substance).

### CHARACTERS

**Appearance:** white or almost white powder.

**Solubility:** freely soluble in water, insoluble in ethanol (96 per cent).

### IDENTIFICATION

A. Infrared absorption spectrophotometry (2.2.24).

*Comparison:* spectinomycin sulfate tetrahydrate CRS.

B. Dilute 1.0 mL of solution S (see Tests) to 10 mL with water R. The solution gives reaction (a) of sulfates (2.3.1).

### TESTS

**Solution S.** Dissolve 2.50 g in carbon dioxide-free water R and dilute to 25.0 mL with the same solvent.

**Appearance of solution.** Solution S is clear (2.2.1) and colourless (2.2.2, Method II).

**pH** (2.2.3): 3.8 to 5.6 for solution S.

**Specific optical rotation** (2.2.7): + 10.0 to + 14.0 (anhydrous substance).

Dissolve 2.50 g in an 8 mL/L solution of concentrated ammonia R1 and dilute to 25.0 mL with the same solvent. Allow the solution to stand at room temperature for not less than 30 min and not more than 2 h prior to determination.

**Related substances.** Liquid chromatography (2.2.29). In order to avoid the formation of anomers, prepare the solutions immediately before use.

**Test solution.** Dissolve 15.0 mg of the substance to be examined in the mobile phase and dilute to 100.0 mL with the mobile phase.

**Reference solution (a).** Dissolve 3 mg of spectinomycin for system suitability CRS in the mobile phase and dilute to 20 mL with the mobile phase.

**Reference solution (b).** Dilute 1.0 mL of the test solution to 100.0 mL with the mobile phase.

**Reference solution (c).** Dilute 3.0 mL of reference solution (b) to 10.0 mL with the mobile phase.

**Column:**

- size:  $l = 0.25$  m,  $\varnothing = 4.6$  mm;
- stationary phase: octylsilyl silica gel for chromatography R (5  $\mu$ m);
- temperature: ambient and constant.

**Mobile phase:** dissolve 4.2 g of oxalic acid R and 2.0 mL of heptafluorobutyric acid R in water R and dilute to 1000 mL with water R; adjust to pH 3.2 with sodium hydroxide solution R; add 105 mL of acetonitrile R and mix; filter through a 0.45  $\mu$ m filter and degas with helium for chromatography R for 10 min.

**Flow rate:** 1.0 mL/min.

**Post-column solution:** carbonate-free sodium hydroxide solution R diluted with carbon dioxide-free water R to obtain a final concentration of NaOH of 21 g/L. Degas the solution with helium for chromatography R for 10 min before use. Add it pulse-less to the column effluent using a 375  $\mu$ L polymeric mixing coil.

**Post-column flow rate:** 0.5 mL/min.

**Detection:** pulsed amperometric detection or equivalent with a gold indicator electrode having preferably a diameter of 1.4 mm or greater, a suitable reference electrode and a stainless steel counter electrode, held at + 0.12 V detection, + 0.70 V oxidation and – 0.60 V reduction potentials respectively, with pulse durations according to the instrument used. Keep the detection cell at ambient and constant temperature. Clean the gold indicator electrode with an eraser and damp precision wipe prior to start-up of the system to enhance the detector sensitivity and increase the signal-to-noise ratio.

**Injection:** 20 µL.

**Run time:** 1.5 times the retention time of spectinomycin.

**Identification of impurities:** use the chromatogram supplied with *spectinomycin for system suitability CRS* and the chromatogram obtained with reference solution (a) to identify the peaks due to impurities A, D and E.

**Relative retention** with reference to spectinomycin (retention time = 11 min to 20 min): impurity A = about 0.5; impurity D = about 0.7; impurity E = about 0.9; (4*R*)-dihydrospectinomycin = about 1.3.

**System suitability:** reference solution (a):

- **resolution:** minimum 1.5 between the peaks due to impurity E and spectinomycin.

**Limits:**

- **correction factor:** for the calculation of content, multiply the peak area of impurity A by 0.4;
- **impurities A, E:** for each impurity, not more than the area of the principal peak in the chromatogram obtained with reference solution (b) (1.0 per cent);
- **impurity D:** not more than 4 times the area of the principal peak in the chromatogram obtained with reference solution (b) (4.0 per cent);
- **any other impurity:** for each impurity, not more than the area of the principal peak in the chromatogram obtained with reference solution (b) (1.0 per cent);
- **total:** not more than 6 times the area of the principal peak in the chromatogram obtained with reference solution (b) (6.0 per cent);
- **disregard limit:** the area of the principal peak in the chromatogram obtained with reference solution (c) (0.3 per cent); disregard the peak due to (4*R*)-dihydrospectinomycin.

**Water (2.5.12):** 12.0 per cent to 16.5 per cent, determined on 0.100 g.

**Sulfated ash (2.4.14):** maximum 1.0 per cent, determined on 1.0 g.

**Bacterial endotoxins (2.6.14):** less than 0.17 IU/mg, if intended for use in the manufacture of parenteral preparations without a further appropriate procedure for the removal of bacterial endotoxins. Prepare the solutions using a 0.42 per cent *m/m* solution of *sodium hydrogen carbonate R*.

#### ASSAY

Liquid chromatography (2.2.29) as described in the test for related substances with the following modifications.

**Test solution.** Dissolve 40.0 mg of the substance to be examined in *water R* and dilute to 50.0 mL with the same solvent. Allow to stand for not less than 15 h and not more than 72 h (formation of anomers). Dilute 5.0 mL of this solution to 50.0 mL with the mobile phase.

**Reference solution.** Dissolve 40.0 mg of *spectinomycin hydrochloride CRS* (containing (4*R*)-dihydrospectinomycin) in *water R* and dilute to 50.0 mL with the same solvent. Allow to stand for the same period of time as the test solution (formation of anomers). Dilute 5.0 mL of this solution to 50.0 mL with the mobile phase.

**System suitability:**

- **repeatability:** maximum relative standard deviation of 3.0 per cent for the principal peak after 6 injections of the reference solution.

Calculate the sum of the percentage contents of spectinomycin sulfate and (4*R*)-dihydrospectinomycin sulfate from the declared contents of C<sub>14</sub>H<sub>26</sub>Cl<sub>2</sub>N<sub>2</sub>O<sub>7</sub> and C<sub>14</sub>H<sub>28</sub>Cl<sub>2</sub>N<sub>2</sub>O<sub>7</sub> in *spectinomycin hydrochloride CRS*, applying a correction factor of 1.062.

#### STORAGE

In an airtight container. If the substance is sterile, store in a sterile, airtight, tamper-proof container.

#### IMPURITIES

**Specified impurities:** A, D, E.

**Other detectable impurities** (the following substances would, if present at a sufficient level, be detected by one or other of the tests in the monograph. They are limited by the general acceptance criterion for other/unspecified impurities and/or by the general monograph *Substances for pharmaceutical use (2034)*. It is therefore not necessary to identify these impurities for demonstration of compliance. See also 5.10. *Control of impurities in substances for pharmaceutical use*): B, C, F, G.

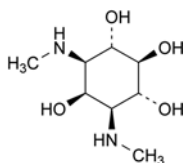

A. 1,3-dideoxy-1,3-bis(methylamino)-*myo*-inositol (actinamine),

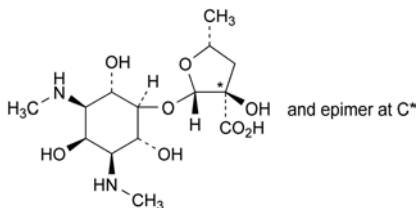

B. (2*S*,3*RS*,5*R*)-3-hydroxy-5-methyl-2-[(1*r*,2*R*,3*S*,4*r*,5*R*,6*S*)-2,4,6-trihydroxy-3,5-bis(methylamino)cyclohexyl]oxy]tetrahydrofuran-3-carboxylic acid (actinospectinoic acid),

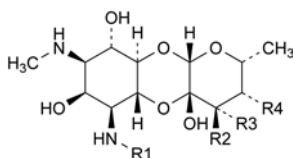

C. R<sub>1</sub> = CH<sub>3</sub>, R<sub>2</sub> = R<sub>4</sub> = H, R<sub>3</sub> = OH: (2*R*,4*S*,4*aS*,5*aR*,6*S*,7*S*,8*R*,9*S*,9*aR*,10*aS*)-2-methyl-6,8-bis(methylamino)decahydro-2*H*-pyrano[2,3-*b*][1,4]benzodioxine-4,4*a*,7,9-tetrol ((4*S*)-dihydrospectinomycin),

D. R<sub>1</sub> = CH<sub>3</sub>, R<sub>2</sub> = H, R<sub>3</sub> = R<sub>4</sub> = OH: (2*R*,3*R*,4*S*,4*aS*,5*aR*,6*S*,7*S*,8*R*,9*S*,9*aR*,10*aS*)-2-methyl-6,8-bis(methylamino)decahydro-2*H*-pyrano[2,3-*b*][1,4]benzodioxine-3,4,4*a*,7,9-pentol (dihydroxyspectinomycin),

E. R<sub>1</sub> = R<sub>4</sub> = H, R<sub>2</sub> + R<sub>3</sub> = O: (2*R*,4*aR*,5*aR*,6*S*,7*R*,8*R*,9*S*,9*aR*,10*aS*)-6-amino-4*a*,7,9-trihydroxy-2-methyl-8-(methylamino)decahydro-4*H*-pyrano[2,3-*b*][1,4]benzodioxin-4-one (*N*-desmethylspectinomycin),

G. R<sub>1</sub> = CH<sub>3</sub>, R<sub>2</sub> + R<sub>3</sub> = O, R<sub>4</sub> = OH: (2*R*,3*S*,4*aR*,5*aR*,6*S*,7*S*,8*R*,9*S*,9*aR*,10*aS*)-3,4*a*,7,9-tetrahydroxy-2-methyl-6,8-bis(methylamino)decahydro-4*H*-pyrano[2,3-*b*][1,4]benzodioxin-4-one (tetrahydroxyspectinomycin),

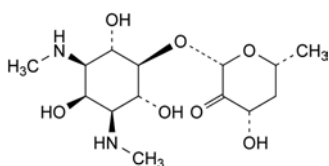

- F. (2*S*,4*S*,6*R*)-4-hydroxy-6-methyl-2-[[[1*r*,2*R*,3*S*,4*r*,5*R*,6*S*)-2,4,6-trihydroxy-3,5-bis(methylamino)cyclohexyl]oxy]dihydro-2*H*-pyran-3(4*H*)-one (triol spectinomycin).

04/2008:0293

## SPIRAMYCIN

## Spiramycinum

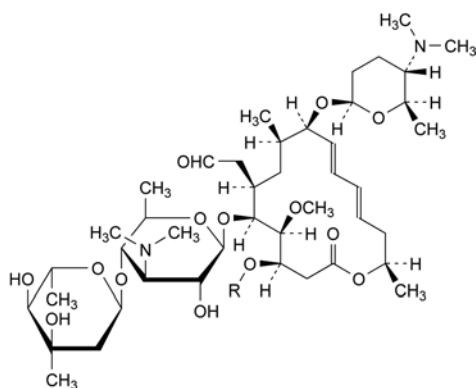

Compound	R	Molec Formula	<i>M<sub>r</sub></i>
Spiramycin I	H	C <sub>43</sub> H <sub>74</sub> N <sub>2</sub> O <sub>14</sub>	843.1
Spiramycin II	CO-CH <sub>3</sub>	C <sub>45</sub> H <sub>76</sub> N <sub>2</sub> O <sub>15</sub>	885.1
Spiramycin III	CO-CH <sub>2</sub> -CH <sub>3</sub>	C <sub>46</sub> H <sub>78</sub> N <sub>2</sub> O <sub>15</sub>	899.1

## DEFINITION

Macrolide antibiotic produced by the growth of certain strains of *Streptomyces ambofaciens* or obtained by any other means. The main component is (4*R*,5*S*,6*S*,7*R*,9*R*,10*R*,11*E*,13*E*,16*R*)-6-[[[3,6-dideoxy-4-*O*-(2,6-dideoxy-3-*C*-methyl- $\alpha$ -*L*-ribo-hexopyranosyl)-3-(dimethylamino)- $\beta$ -*D*-glucopyranosyl]oxy]-4-hydroxy-5-methoxy-9,16-dimethyl-7-(2-oxoethyl)-10-[[[2,3,4,6-tetraoxy-4-(dimethylamino)-*D*-erythro-hexopyranosyl]oxy]oxacyclohexadeca-11,13-dien-2-one (spiramycin I; *M<sub>r</sub>* 843). Spiramycin II (4-*O*-acetylspiramycin I) and spiramycin III (4-*O*-propanoylspiramycin I) are also present.

*Potency*: minimum 4100 IU/mg (dried substance).

## CHARACTERS

*Appearance*: white or slightly yellowish powder, slightly hygroscopic.

*Solubility*: slightly soluble in water, freely soluble in acetone, in ethanol (96 per cent) and in methanol.

## IDENTIFICATION

- A. Ultraviolet and visible absorption spectrophotometry (2.2.25).

*Test solution*. Dissolve 0.10 g of the substance to be examined in *methanol R* and dilute to 100.0 mL with the same solvent. Dilute 1.0 mL of this solution to 100.0 mL with *methanol R*.

*Spectral range*: 220-350 nm.

*Absorption maximum*: at 232 nm.

*Specific absorbance at the absorption maximum*: about 340.

- B. Thin-layer chromatography (2.2.27).

*Test solution*. Dissolve 40 mg of the substance to be examined in *methanol R* and dilute to 10 mL with the same solvent.

*Reference solution (a)*. Dissolve 40 mg of *spiramycin CRS* in *methanol R* and dilute to 10 mL with the same solvent.

*Reference solution (b)*. Dissolve 40 mg of *erythromycin A CRS* in *methanol R* and dilute to 10 mL with the same solvent.

*Plate*: TLC silica gel G plate *R*.

*Mobile phase*: the upper layer of a mixture of 4 volumes of 2-propanol *R*, 8 volumes of a 150 g/L solution of ammonium acetate *R* previously adjusted to pH 9.6 with strong sodium hydroxide solution *R*, and 9 volumes of ethyl acetate *R*.

*Application*: 5  $\mu$ L.

*Development*: over 3/4 of the plate.

*Drying*: in air.

*Detection*: spray with anisaldehyde solution *R1* and heat at 110 °C for 5 min.

*Results*: the principal spot in the chromatogram obtained with the test solution is similar in position, colour and size to the principal spot in the chromatogram obtained with reference solution (a). If in the chromatogram obtained with the test solution 1 or 2 spots occur with *R<sub>F</sub>* values slightly higher than that of the principal spot, these spots are similar in position and colour to the secondary spots in the chromatogram obtained with reference solution (a) and differ from the spots in the chromatogram obtained with reference solution (b).

- C. Dissolve 0.5 g in 10 mL of 0.05 *M* sulfuric acid and add 25 mL of water *R*. Adjust to about pH 8 with 0.1 *M* sodium hydroxide and dilute to 50 mL with water *R*. To 5 mL of this solution add 2 mL of a mixture of 1 volume of water *R* and 2 volumes of sulfuric acid *R*. A brown colour develops.

## TESTS

*pH* (2.2.3): 8.5 to 10.5.

Dissolve 0.5 g in 5 mL of *methanol R* and dilute to 100 mL with carbon dioxide-free water *R*.

*Specific optical rotation* (2.2.7): -80 to -85 (dried substance).

Dissolve 1.00 g in a 10 per cent *V/V* solution of dilute acetic acid *R* and dilute to 50.0 mL with the same acid solution.

*Composition*. Liquid chromatography (2.2.29) as described in the test for related substances.

*Injection*: test solution and reference solution (a).

Calculate the percentage content using the declared content of spiramycins I, II and III in *spiramycin CRS*.

*Composition of spiramycins* (dried substance):

- *spiramycin I*: minimum 80.0 per cent,
- *spiramycin II*: maximum 5.0 per cent,
- *spiramycin III*: maximum 10.0 per cent,
- *sum of spiramycins I, II and III*: minimum 90.0 per cent.

*Related substances*. Liquid chromatography (2.2.29). Prepare the solutions immediately before use.

*Solvent mixture*: *methanol R*, *water R* (30:70 *V/V*).

*Test solution*. Dissolve 25.0 mg of the substance to be examined in the solvent mixture and dilute to 25.0 mL with the solvent mixture.

*Reference solution (a)*. Dissolve 25.0 mg of *spiramycin CRS* in the solvent mixture and dilute to 25.0 mL with the solvent mixture.

*Reference solution (b)*. Dilute 2.0 mL of reference solution (a) to 100.0 mL with the solvent mixture.

*Reference solution (c)*. Dissolve 5 mg of *spiramycin CRS* in 15 mL of buffer solution pH 2.2 *R* and dilute to 25 mL with water *R*, then heat in a water-bath at 60 °C for 5 min and cool under cold water.

*Blank solution*. The solvent mixture.

## Column:

- size:  $l = 0.25$  m,  $\varnothing = 4.6$  mm;
- stationary phase: end-capped polar-embedded octadecylsilyl amorphous organosilica polymer R (5  $\mu$ m) (polar-embedded octadecylsilyl methylsilica gel), with a pore size of 12.5 nm and a carbon loading of 15 per cent;
- temperature: 70 °C.

Mobile phase: mix 5 volumes of a 34.8 g/L solution of dipotassium hydrogen phosphate R adjusted to pH 6.5 with a 27.2 g/L solution of potassium dihydrogen phosphate R, 40 volumes of acetonitrile R and 55 volumes of water R.

Flow rate: 1.0 mL/min.

Detection: spectrophotometer at 232 nm.

Injection: 20  $\mu$ L of the blank solution, the test solution and reference solutions (b) and (c).

Run time: 3 times the retention time of spiramycin I.

Identification of spiramycins: use the chromatogram supplied with spiramycin CRS and the chromatogram obtained with reference solution (a) to identify the peaks due to spiramycins I, II and III.

Relative retention with reference to spiramycin I (retention time = 20 min to 30 min): impurity F = about 0.41; impurity A = about 0.45; impurity D = about 0.50; impurity G = about 0.66; impurity B = about 0.73; impurity H = about 0.87; spiramycin II = about 1.4; spiramycin III = about 2.0; impurity E = about 2.5.

If necessary adjust the composition of the mobile phase by changing the amount of acetonitrile.

System suitability: reference solution (c):

- resolution: minimum 10.0 between the peaks due to impurity A and spiramycin I.

## Limits:

- impurities A, B, D, E, F, G, H: for each impurity, not more than the area of the principal peak in the chromatogram obtained with reference solution (b) (2.0 per cent);
- any other impurity: for each impurity, not more than the area of the principal peak in the chromatogram obtained with reference solution (b) (2.0 per cent);
- total: not more than 5 times the area of the principal peak in the chromatogram obtained with reference solution (b) (10.0 per cent);
- disregard limit: 0.05 times the area of the principal peak in the chromatogram obtained with reference solution (b) (0.1 per cent); disregard any peak due to the blank and the peaks due to spiramycins I, II and III.

Heavy metals (2.4.8): maximum 20 ppm.

1.0 g complies with test F. Prepare the reference solution using 2 mL of lead standard solution (10 ppm Pb) R.

Loss on drying (2.2.32): maximum 3.5 per cent, determined on 0.500 g by drying at 80 °C over diphosphorus pentoxide R at a pressure not exceeding 0.67 kPa for 6 h.

Sulfated ash (2.4.14): maximum 0.1 per cent, determined on 1.0 g.

## ASSAY

Carry out the microbiological assay of antibiotics (2.7.2).

## STORAGE

In an airtight container.

## IMPURITIES

Specified impurities: A, B, D, E, F, G, H.

Other detectable impurities (the following substances would, if present at a sufficient level, be detected by one or other of the tests in the monograph. They are limited by the general acceptance criterion for other/unspecified impurities and/or by the general monograph *Substances for pharmaceutical use (2034)*. It is therefore not necessary to identify these impurities for demonstration of compliance. See also 5.10. *Control of impurities in substances for pharmaceutical use*): C.

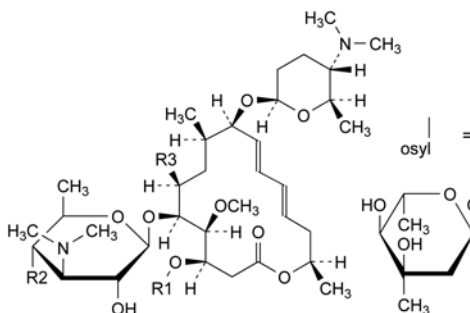

- A. R1 = H, R2 = OH, R3 = CH<sub>2</sub>-CHO: (4*R*,5*S*,6*S*,7*R*,9*R*,10*R*,11*E*,13*E*,16*R*)-6-[[3,6-dideoxy-3-(dimethylamino)-β-D-glucopyranosyl]oxy]-4-hydroxy-5-methoxy-9,16-dimethyl-7-(2-oxoethyl)-10-[[2,3,4,6-tetra-deoxy-4-(dimethylamino)-β-D-erythro-hexopyranosyl]oxy]oxacyclohexadeca-11,13-dien-2-one (neospiramycin I),
- B. R1 = H, R2 = osyl, R3 = CH<sub>2</sub>-CH<sub>2</sub>OH: (4*R*,5*S*,6*S*,7*R*,9*R*,10*R*,11*E*,13*E*,16*R*)-6-[[3,6-dideoxy-4-*O*-(2,6-dideoxy-3-*C*-methyl-α-*L*-ribo-hexopyranosyl)-3-(dimethylamino)-β-D-glucopyranosyl]oxy]-4-hydroxy-7-(2-hydroxyethyl)-5-methoxy-9,16-dimethyl-10-[[2,3,4,6-tetra-deoxy-4-(dimethylamino)-β-D-erythro-hexopyranosyl]oxy]oxacyclohexadeca-11,13-dien-2-one (spiramycin IV),
- C. R1 = H, R2 = osyl, R3 = C(=CH<sub>2</sub>)-CHO: (4*R*,5*S*,6*S*,7*S*,9*R*,10*R*,11*E*,13*E*,16*R*)-6-[[3,6-dideoxy-4-*O*-(2,6-dideoxy-3-*C*-methyl-α-*L*-ribo-hexopyranosyl)-3-(dimethylamino)-β-D-glucopyranosyl]oxy]-7-(1-formylethenyl)-4-hydroxy-5-methoxy-9,16-dimethyl-10-[[2,3,4,6-tetra-deoxy-4-(dimethylamino)-β-D-erythro-hexopyranosyl]oxy]oxacyclohexadeca-11,13-dien-2-one (17-methylenespiramycin I),
- E. R1 = H, R2 = osyl, R3 = CH<sub>2</sub>-CH<sub>3</sub>: (4*R*,5*S*,6*S*,7*S*,9*R*,10*R*,11*E*,13*E*,16*R*)-6-[[3,6-dideoxy-4-*O*-(2,6-dideoxy-3-*C*-methyl-α-*L*-ribo-hexopyranosyl)-3-(dimethylamino)-β-D-glucopyranosyl]oxy]-7-ethyl-4-hydroxy-5-methoxy-9,16-dimethyl-10-[[2,3,4,6-tetra-deoxy-4-(dimethylamino)-β-D-erythro-hexopyranosyl]oxy]oxacyclohexadeca-11,13-dien-2-one (18-deoxy-18-dihydrospiramycin I or DSPM),
- G. R1 = CO-CH<sub>3</sub>, R2 = OH, R3 = CH<sub>2</sub>-CHO: (4*R*,5*S*,6*S*,7*R*,9*R*,10*R*,11*E*,13*E*,16*R*)-6-[[3,6-dideoxy-3-(dimethylamino)-β-D-glucopyranosyl]oxy]-5-methoxy-9,16-dimethyl-2-oxo-7-(2-oxoethyl)-10-[[2,3,4,6-tetra-deoxy-4-(dimethylamino)-β-D-erythro-hexopyranosyl]oxy]oxacyclohexadeca-11,13-dien-4-yl acetate (neospiramycin II),
- H. R1 = CO-C<sub>2</sub>H<sub>5</sub>, R2 = OH, R3 = CH<sub>2</sub>-CHO: (4*R*,5*S*,6*S*,7*R*,9*R*,10*R*,11*E*,13*E*,16*R*)-6-[[3,6-dideoxy-3-(dimethylamino)-β-D-glucopyranosyl]oxy]-5-methoxy-9,16-dimethyl-2-oxo-7-(2-oxoethyl)-10-[[2,3,4,6-tetra-deoxy-4-(dimethylamino)-β-D-erythro-hexopyranosyl]oxy]oxacyclohexadeca-11,13-dien-4-yl propanoate (neospiramycin III),

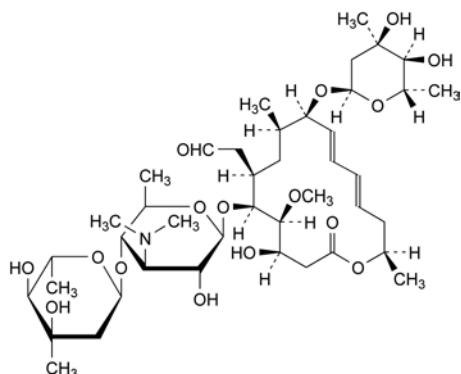

D. (4*R*,5*S*,6*S*,7*R*,9*R*,10*R*,11*E*,13*E*,16*R*)-6-[[3,6-dideoxy-4-*O*-(2,6-dideoxy-3-*C*-methyl- $\alpha$ -*L*-ribo-hexopyranosyl)-3-(dimethylamino)- $\beta$ -*D*-glucopyranosyl]oxy]-10-[(2,6-dideoxy-3-*C*-methyl- $\alpha$ -*L*-ribo-pyranosyl)oxy]-4-hydroxy-5-methoxy-9,16-dimethyl-7-(2-oxoethyl)oxacyclohexadeca-11,13-dien-2-one (spiramycin V),

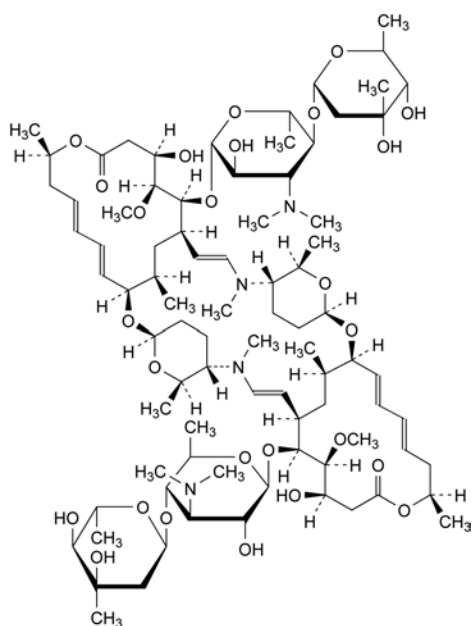

F. spiramycin dimer.

01/2008:1766  
corrected 7.0

### SPIRAPRIL HYDROCHLORIDE MONOHYDRATE

Spirapril hydrochloridum monohydricum

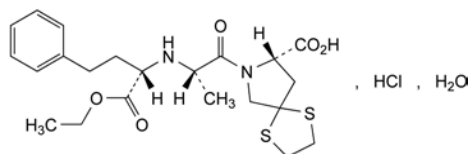

C<sub>22</sub>H<sub>31</sub>ClN<sub>2</sub>O<sub>5</sub>S<sub>2</sub>·H<sub>2</sub>O

M<sub>r</sub> 521.1

**DEFINITION**

(8*S*)-7-[(2*S*)-2-[[1*S*]-1-(Ethoxycarbonyl)-3-phenylpropyl]amino]propanoyl]-1,4-dithia-7-azaspiro[4.4]nonane-8-carboxylic acid hydrochloride monohydrate.

*Content*: 97.0 per cent to 102.0 per cent (anhydrous substance).

**CHARACTERS**

*Appearance*: white or almost white, fine crystalline powder.

*Solubility*: very slightly soluble in water, soluble in methanol, slightly soluble in acetonitrile, practically insoluble in methylene chloride.

**IDENTIFICATION**

- A. Specific optical rotation (see Tests).
- B. Infrared absorption spectrophotometry (2.2.24).  
*Preparation*: discs of *potassium bromide R*.  
*Comparison*: *spirapril hydrochloride monohydrate CRS*.
- C. It gives the reactions of chlorides (2.3.1).

**TESTS**

**Specific optical rotation** (2.2.7): – 11.0 to – 13.0 (anhydrous substance).  
Dissolve 0.200 g in *dimethylformamide R* and dilute to 20.0 mL with the same solvent.

**Related substances**. Liquid chromatography (2.2.29).

*Solvent mixture*: *acetonitrile R1*, *water R* (2:8 V/V).  
*Test solution*. Dissolve 50.0 mg of the substance to be examined in the solvent mixture and dilute to 20.0 mL with the solvent mixture.

*Reference solution (a)*. Dissolve 6 mg of *spirapril for system suitability CRS* (containing impurities B and D) in the solvent mixture and dilute to 20 mL with the solvent mixture.

*Reference solution (b)*. Dilute 5.0 mL of the test solution to 100.0 mL with the solvent mixture. Dilute 5.0 mL of this solution to 50.0 mL with the solvent mixture.

*Reference solution (c)*. Dilute 1.0 mL of reference solution (b) to 10.0 mL with the solvent mixture.

**Column**:

- *size*: *l* = 0.125 m,  $\varnothing$  = 4.6 mm;
- *stationary phase*: *octadecylsilyl silica gel for chromatography R* (5  $\mu$ m);
- *temperature*: 70 °C.

**Mobile phase**:

- *mobile phase A*: dissolve 4.5 g of *tetramethylammonium hydroxide R* in 900 mL of *water R*, add 100 mL of *acetonitrile R1* and adjust to pH 2.2 with *phosphoric acid R*;
- *mobile phase B*: dissolve 4.5 g of *tetramethylammonium hydroxide R* in 400 mL of *water R*, add 600 mL of *acetonitrile R1* and adjust to pH 2.2 with *phosphoric acid R*;

Time (min)	Mobile phase A (per cent V/V)	Mobile phase B (per cent V/V)
0 - 4	90	10
4 - 14	90 → 10	10 → 90
14 - 20	10	90

*Flow rate*: 2.0 mL/min.

*Detection*: spectrophotometer at 210 nm.

*Injection*: 20  $\mu$ L.

*Relative retention* with reference to spirapril (retention time = about 10 min): impurity C = about 0.6; impurity B = about 0.7; impurity A = about 1.26; impurity D = about 1.38.

*System suitability*: reference solution (a):

- *resolution*: minimum 3.5 between the peaks due to impurity B and spirapril, and minimum 5.5 between the peaks due to spirapril and impurity D.

**Limits**:

- *impurity D*: not more than 0.8 times the area of the principal peak in the chromatogram obtained with reference solution (b) (0.4 per cent);
- *impurity B*: not more than 0.6 times the area of the principal peak in the chromatogram obtained with reference solution (b) (0.3 per cent);



- *impurities A, C*: for each impurity, not more than 0.4 times the area of the principal peak in the chromatogram obtained with reference solution (b) (0.2 per cent);
- *unspecified impurities*: for each impurity, not more than 0.2 times the area of the principal peak in the chromatogram obtained with reference solution (b) (0.10 per cent);
- *total*: not more than twice the area of the principal peak in the chromatogram obtained with reference solution (b) (1.0 per cent);
- *disregard limit*: area of the principal peak in the chromatogram obtained with reference solution (c) (0.05 per cent); disregard any peak due to the blank (solvent mixture).

**Water (2.5.12)**: 3.0 per cent to 4.0 per cent, determined on 0.200 g.

**Sulfated ash (2.4.14)**: maximum 0.1 per cent, determined on 1.0 g.

**ASSAY**

Liquid chromatography (2.2.29).

*Solvent mixture*. Mix equal volumes of *acetonitrile R1* and *water R*.

*Test solution*. Dissolve 20.0 mg of the substance to be examined in the solvent mixture and dilute to 100.0 mL with the solvent mixture.

*Reference solution (a)*. Dissolve 20.0 mg of *spirapril hydrochloride monohydrate CRS* in the solvent mixture and dilute to 100.0 mL with the solvent mixture.

*Reference solution (b)*. Dissolve 6.0 mg of *spirapril for system suitability CRS* (spirapril spiked with impurity B and impurity D) in a mixture of 2 volumes of *acetonitrile R* and 8 volumes of *water R* and dilute to 20 mL with the same mixture of solvents.

*Solution A*. Dissolve 4.5 g of *tetramethylammonium hydroxide R* in 900 mL of *water R*, adjust to pH 1.75 with *phosphoric acid R* and add 100 mL of *acetonitrile R1*.

*Solution B*. Dissolve 4.5 g of *tetramethylammonium hydroxide R* in 400 mL of *water R*, adjust to pH 1.75 with *phosphoric acid R* and add 600 mL of *acetonitrile R1*.

*Column*:

- *size*:  $l = 0.125$  m,  $\varnothing = 4.6$  mm;
- *stationary phase*: octadecylsilyl silica gel for chromatography R (5  $\mu$ m);
- *temperature*: 70 °C.

*Mobile phase*: solution A, solution B (45:55 V/V).

*Flow rate*: 2.0 mL/min.

*Detection*: spectrophotometer at 210 nm.

*Injection*: 20  $\mu$ L.

*Retention time*: spirapril = 1.6 min to 2.9 min; impurity D = about 13 min. Adjust the proportion of solution B in the mobile phase if necessary.

*System suitability*: reference solution (b):

- *resolution*: minimum 15 between the peaks due to spirapril and impurity D.

Calculate the percentage content of  $C_{22}H_{31}ClN_2O_5S_2$  from the chromatograms obtained with the test solution and reference solution (a) and the declared content of *spirapril hydrochloride monohydrate CRS*.

**STORAGE**

In an airtight container, protected from light.

**IMPURITIES**

*Specified impurities*: A, B, C, D.

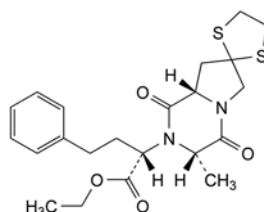

A. ethyl (2S)-2-[(3'S,8'aS)-3'-methyl-1',4'-dioxohexahydrospiro[1,3-dithiolane-2,7'(6'H)-pyrrolo[1,2-a]pyrazin]-2'-yl]-4-phenylbutanoate,

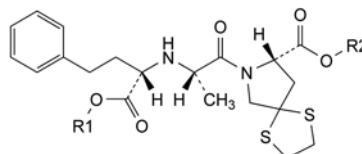

B. R1 = R2 = H: (8S)-7-[(2S)-2-[(1S)-1-carboxy-3-phenylpropyl]amino]propanoyl]-1,4-dithia-7-azaspiro[4.4]nonane-8-carboxylic acid (spiraprilat),

D. R1 = C<sub>2</sub>H<sub>5</sub>, R2 = CH(CH<sub>3</sub>)<sub>2</sub>: 1-methylethyl (8S)-7-[(2S)-2-[[[(1S)-1-(ethoxycarbonyl)-3-phenylpropyl]amino]propanoyl]-1,4-dithia-7-azaspiro[4.4]nonane-8-carboxylate,

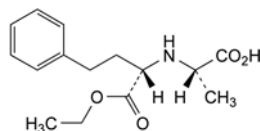

C. (2S)-2-[[[(1S)-1-(ethoxycarbonyl)-3-phenylpropyl]amino]propanoic acid.

01/2011:0688

**SPIRONOLACTONE**

Spirolactonum

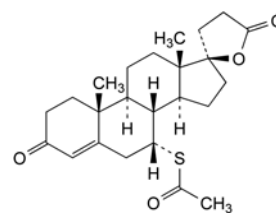

C<sub>24</sub>H<sub>32</sub>O<sub>4</sub>S  
[52-01-7]

M<sub>r</sub> 416.6

**DEFINITION**

(2'R)-7 $\alpha$ -(Acetylsulfanyl)-3',4'-dihydro-5'H-spiro[androst-4-ene-17,2'-furan]-3,5'-dione.

*Content*: 97.5 per cent to 102.0 per cent (dried substance).

**CHARACTERS**

*Appearance*: white or yellowish-white powder.

*Solubility*: practically insoluble in water, soluble in ethanol (96 per cent).

It shows polymorphism (5.9).

**IDENTIFICATION**

*First identification*: A.

*Second identification*: B, C.

A. Infrared absorption spectrophotometry (2.2.24).

*Comparison*: spirinolactone CRS.

If the spectra obtained in the solid state shows differences, dissolve the substance to be examined and the reference substance separately in the minimum volume of *methanol R*, evaporate to dryness and record new spectra using the residues.

#### B. Thin-layer chromatography (2.2.27).

**Test solution.** Dissolve 20 mg of the substance to be examined in *methylene chloride R* and dilute to 10 mL with the same solvent.

**Reference solution.** Dissolve 20 mg of *spironolactone CRS* in *methylene chloride R* and dilute to 10 mL with the same solvent.

**Plate:** *TLC silica gel F<sub>254</sub> plate R*.

**Mobile phase:** *water R, cyclohexane R, ethyl acetate R* (1:24:75 V/V/V).

**Application:** 5 µL.

**Development:** over 3/4 of the plate.

**Drying:** in air.

**Detection:** examine in ultraviolet light at 254 nm.

**Results:** the principal spot in the chromatogram obtained with the test solution is similar in position and size to the principal spot in the chromatogram obtained with the reference solution.

- C. To about 10 mg add 2 mL of a 50 per cent V/V solution of *sulfuric acid R* and shake. An orange solution with an intense yellowish-green fluorescence is produced. Heat the solution gently; the colour becomes deep red and hydrogen sulfide, which blackens *lead acetate paper R*, is evolved. Add the solution to 10 mL of *water R*; a greenish-yellow solution is produced, showing opalescence or a precipitate.

#### TESTS

**Specific optical rotation (2.2.7):** –41 to –46 (dried substance). Dissolve 0.100 g in *ethanol (96 per cent) R* and dilute to 10.0 mL with the same solvent.

**Related substances.** Liquid chromatography (2.2.29). Prepare the solutions immediately before use.

**Solvent mixture:** *acetonitrile R, water R* (50:50 V/V).

**Test solution (a).** Dissolve 50.0 mg of the substance to be examined in 2.5 mL of *tetrahydrofuran R* and dilute to 25.0 mL with the solvent mixture.

**Test solution (b).** Dilute 1.0 mL of test solution (a) to 100.0 mL with the solvent mixture.

**Reference solution (a).** Dilute 1.0 mL of test solution (b) to 10.0 mL with the solvent mixture.

**Reference solution (b).** Dissolve with the aid of ultrasound the contents of a vial of *spironolactone for system suitability CRS* (containing impurities A, C, D, E and I) in 1.0 mL of the solvent mixture.

**Reference solution (c).** Dissolve 50.0 mg of *spironolactone CRS* in 2.5 mL of *tetrahydrofuran R* and dilute to 25.0 mL with the solvent mixture. Dilute 1.0 mL of this solution to 100.0 mL with the solvent mixture.

**Reference solution (d).** Dissolve 5.0 mg of *canrenone CRS* (impurity F) in 2.5 mL of *tetrahydrofuran R* and dilute to 25.0 mL with the solvent mixture. Dilute 3.0 mL of this solution to 100.0 mL with the solvent mixture.

**Column:**

- size:  $l = 0.15$  m,  $\varnothing = 4.6$  mm;
- stationary phase: *end-capped octadecylsilyl silica gel for chromatography R* (3 µm);
- temperature: 40 °C.

**Mobile phase:** *acetonitrile R, tetrahydrofuran R, methanol R1, water R* (15:20:425:540 V/V/V/V).

**Flow rate:** 1.0 mL/min.

**Detection:** spectrophotometer at 254 nm.

**Injection:** 20 µL of test solution (a) and reference solutions (a), (b) and (d).

**Run time:** 2.5 times the retention time of spironolactone.

**Identification of impurities:** use the chromatogram supplied with *spironolactone for system suitability CRS* and the chromatogram obtained with reference solution (b) to identify the peaks due to impurities A, C, D, E and I; use the chromatogram obtained with reference solution (d) to identify the peak due to impurity F.

**Relative retention** with reference to spironolactone (retention time = about 26 min): impurity A = about 0.95; impurity F = about 1.2; impurity C = about 1.5; impurity D = about 1.6; impurity E = about 1.7; impurity I = about 1.9.

**System suitability:** reference solution (b):

- **peak-to-valley ratio:** minimum 1.5, where  $H_p$  = height above the baseline of the peak due to impurity A and  $H_v$  = height above the baseline of the lowest point of the curve separating this peak from the peak due to spironolactone.

**Limits:**

- **correction factor:** for the calculation of content, multiply the peak area of impurity F by 2.3;
- **impurity I:** not more than 5 times the area of the principal peak in the chromatogram obtained with reference solution (a) (0.5 per cent);
- **impurities E, F:** for each impurity, not more than 3 times the area of the principal peak in the chromatogram obtained with reference solution (a) (0.3 per cent);
- **impurities A, C:** for each impurity, not more than twice the area of the principal peak in the chromatogram obtained with reference solution (a) (0.2 per cent);
- **impurity D:** not more than 1.5 times the area of the principal peak in the chromatogram obtained with reference solution (a) (0.15 per cent);
- **unspecified impurities:** for each impurity, not more than the area of the principal peak in the chromatogram obtained with reference solution (a) (0.10 per cent);
- **total:** not more than 7 times the area of the principal peak in the chromatogram obtained with reference solution (a) (0.7 per cent);
- **disregard limit:** 0.5 times the area of the principal peak in the chromatogram obtained with reference solution (a) (0.05 per cent).

**Free thiol compounds.** To 2.0 g add 20 mL of *water R*, shake for 1 min and filter. To 10 mL of the filtrate add 0.05 mL of 0.01 M *iodine* and 0.1 mL of *starch solution R* and mix. A blue colour develops.

**Chromium:** maximum 50 ppm.

To 0.20 g in a platinum crucible add 1 g of *potassium carbonate R* and 0.3 g of *potassium nitrate R*. Heat gently until fused, and ignite at 600-650 °C until carbon is removed. Cool, dissolve the residue as completely as possible in 10 mL of *water R* with the aid of gentle heat, filter, and dilute to 20 mL with *water R*. To 10 mL of this solution add 0.5 g of *urea R*, and add a 14 per cent V/V solution of *sulfuric acid R* until the solution is just acid. When effervescence ceases, add a further 1 mL of the 14 per cent V/V solution of *sulfuric acid R*, dilute to 20 mL with *water R* and add 0.5 mL of *diphenylcarbazide solution R*. The solution is not more intensely coloured than a standard prepared by adding 1 mL of a 14 per cent V/V solution of *sulfuric acid R* to 0.50 mL of a freshly prepared 28.3 mg/L solution of *potassium dichromate R*, diluting to 20 mL with *water R* and adding 0.5 mL of *diphenylcarbazide solution R*.

**Loss on drying (2.2.32):** maximum 0.5 per cent, determined on 1.000 g by drying in an oven at 105 °C for 3 h.

**Sulfated ash (2.4.14):** maximum 0.1 per cent, determined on 1.0 g.

## ASSAY

Liquid chromatography (2.2.29) as described in the test for related substances with the following modification.

*Injection*: test solution (b) and reference solution (c).

Calculate the percentage content of  $C_{24}H_{32}O_4S$  from the declared content of *spironolactone CRS*.

## STORAGE

Protected from light.

## IMPURITIES

*Specified impurities*: A, C, D, E, F, I.

*Other detectable impurities* (the following substances would, if present at a sufficient level, be detected by one or other of the tests in the monograph. They are limited by the general acceptance criterion for other/unspecified impurities and/or by the general monograph *Substances for pharmaceutical use (2034)*. It is therefore not necessary to identify these impurities for demonstration of compliance. See also 5.10. *Control of impurities in substances for pharmaceutical use*): B, G, H.

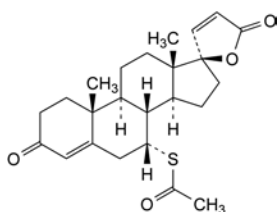

A. (2'R)-7α-(acetylsulfanyl)-5'H-spiro[androst-4-ene-17,2'-furan]-3,5'-dione (Δ20-spirolactone),

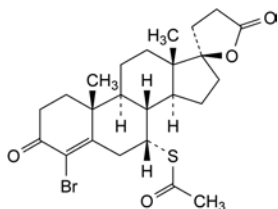

B. (2'R)-7α-(acetylsulfanyl)-4-bromo-3',4'-dihydro-5'H-spiro[androst-4-ene-17,2'-furan]-3,5'-dione (4-bromospironolactone),

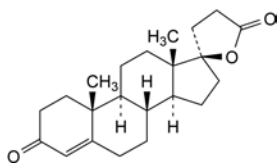

C. (2'R)-3',4'-dihydro-5'H-spiro[androst-4-ene-17,2'-furan]-3,5'-dione (aldone),

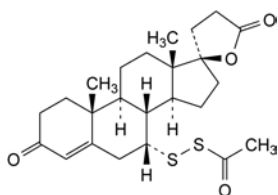

D. (2'R)-7α-(acetyldisulfanyl)-3',4'-dihydro-5'H-spiro[androst-4-ene-17,2'-furan]-3,5'-dione (disulfanyl-spirolactone),

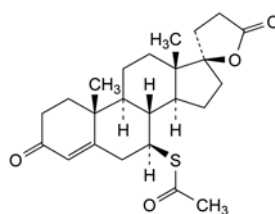

E. (2'R)-7β-(acetylsulfanyl)-3',4'-dihydro-5'H-spiro[androst-4-ene-17,2'-furan]-3,5'-dione (7β-spirolactone),

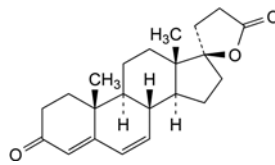

F. (2'R)-3',4'-dihydro-5'H-spiro[androst-4,6-diene-17,2'-furan]-3,5'-dione (canrenone),

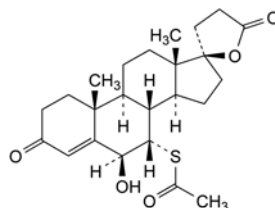

G. (2'R)-7α-(acetylsulfanyl)-6β-hydroxy-3',4'-dihydro-5'H-spiro[androst-4-ene-17,2'-furan]-3,5'-dione (6β-hydroxy-spirolactone),

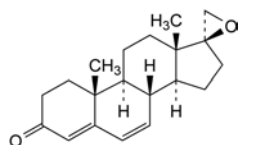

H. (2'S)-spiro[androst-4,6-diene-17,2'-oxiran]-3-one,

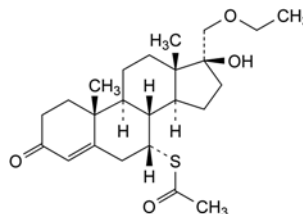

I. S-[17α-(ethoxymethyl)-17-hydroxy-3-oxoandrost-4-en-7α-yl] ethanethioate.

01/2008:1630

## SQUALANE

## Squalanum

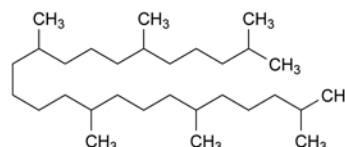

$C_{30}H_{62}$   
[111-01-3]

$M_r$  422.8

## DEFINITION

2,6,10,15,19,23-Hexamethyltetracosane (perhydrosqualene). It may be of vegetable (unsaponifiable matter of olive oil) or animal (shark liver oil) origin.

*Content*: 96.0 per cent to 103.0 per cent.

## CHARACTERS

**Appearance:** clear, colourless, oily liquid.

**Solubility:** practically insoluble in water, miscible with most fats and oils, freely soluble in acetone and in cyclohexane, practically insoluble in ethanol (96 per cent).

**Relative density:** about 0.815.

## IDENTIFICATION

## A. Infrared absorption spectrophotometry (2.2.24).

**Comparison:** *squalane CRS*.

## B. Refractive index (see Tests).

## C. Examine the chromatograms obtained in the assay.

**Results:** the principal peak in the chromatogram obtained with the test solution is similar in retention time and size to the principal peak in the chromatogram obtained with reference solution (a).

The chromatogram obtained with squalane of vegetable origin shows a peak corresponding to cyclosqualane (Figure 1630.-1 and Figure 1630.-2).

## TESTS

**Appearance.** The substance to be examined is clear (2.2.1) and colourless (2.2.2, Method II).

**Refractive index (2.2.6):** 1.450 to 1.454.

**Acid value (2.5.1):** maximum 0.2.

**Iodine value (2.5.4, Method A):** maximum 4.0.

**Saponification value (2.5.6):** maximum 3.0.

**Nickel (2.4.31):** maximum 1 ppm.

**Total ash (2.4.16):** maximum 0.5 per cent, determined on 1.000 g.

## ASSAY

Gas chromatography (2.2.28).

**Internal standard solution.** To 1.0 mL of *dimethylacetamide R*, add 100.0 mL of *heptane R*.

**Test solution.** Dissolve 0.100 g in the internal standard solution and dilute to 25.0 mL with the same solution.

**Reference solution (a).** Dissolve 0.100 g of *squalane CRS* in the internal standard solution and dilute to 25.0 mL with the same solution.

**Reference solution (b).** To 0.1 mL of *methyl erucate R* add 0.100 g of the substance to be examined, dissolve in the internal standard solution and dilute to 25.0 mL with the same solution.

**Column:**

- **material:** fused silica;
- **size:**  $l = 30$  m,  $\varnothing = 0.32$  mm;
- **stationary phase:** *poly(dimethyl)siloxane R* (film thickness 1  $\mu$ m).

**Carrier gas:** *helium for chromatography R*.

**Flow rate:** 1.7 mL/min.

**Split ratio:** 1:12.

**Temperature:**

	Time (min)	Temperature (°C)
Column	0 - 39	60 - 290
	39 - 50	290
Injection port		275
Detector		300

**Detection:** flame ionisation.

**Injection:** 1  $\mu$ L.

**Relative retentions** with reference to squalane (retention time = about 41 min): internal standard = about 0.2; methyl erucate = about 0.9; cyclosqualane = 1.05.

**System suitability:** reference solution (b):

- **resolution:** minimum 5 between the peaks due to methyl erucate and squalane.

Calculate the percentage content of squalane from the declared content of *squalane CRS*.

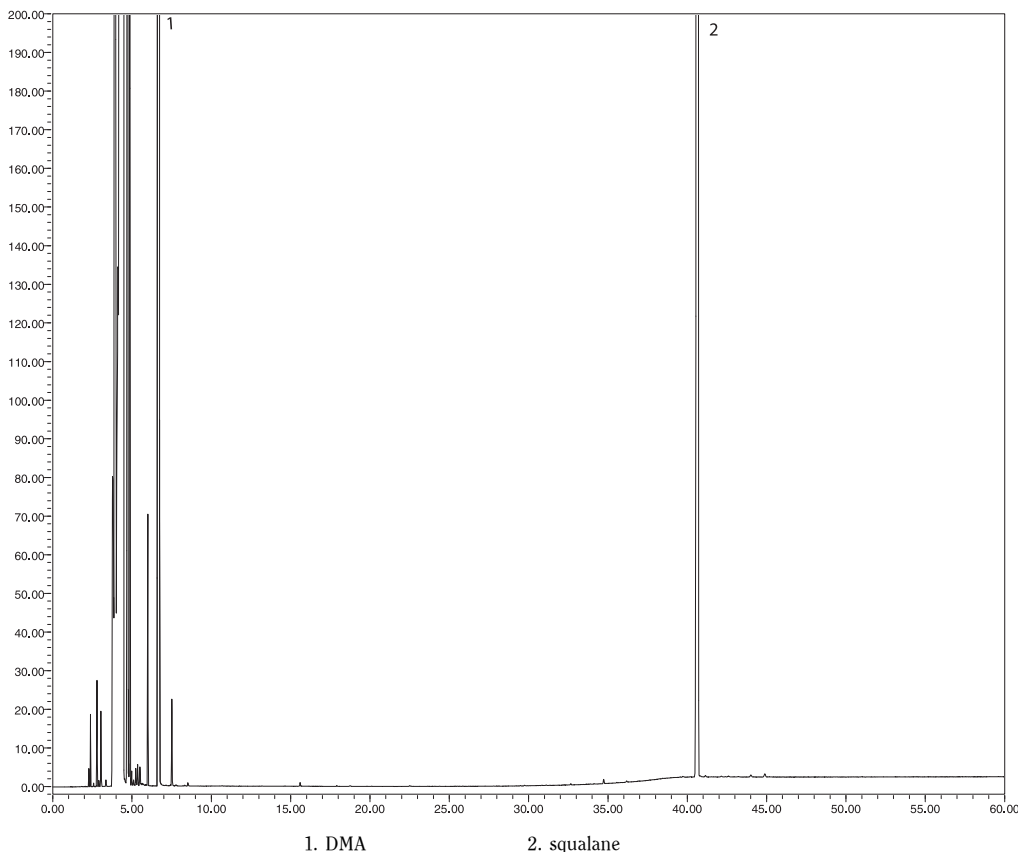

Figure 1630.-1. – Chromatogram of squalane of animal origin

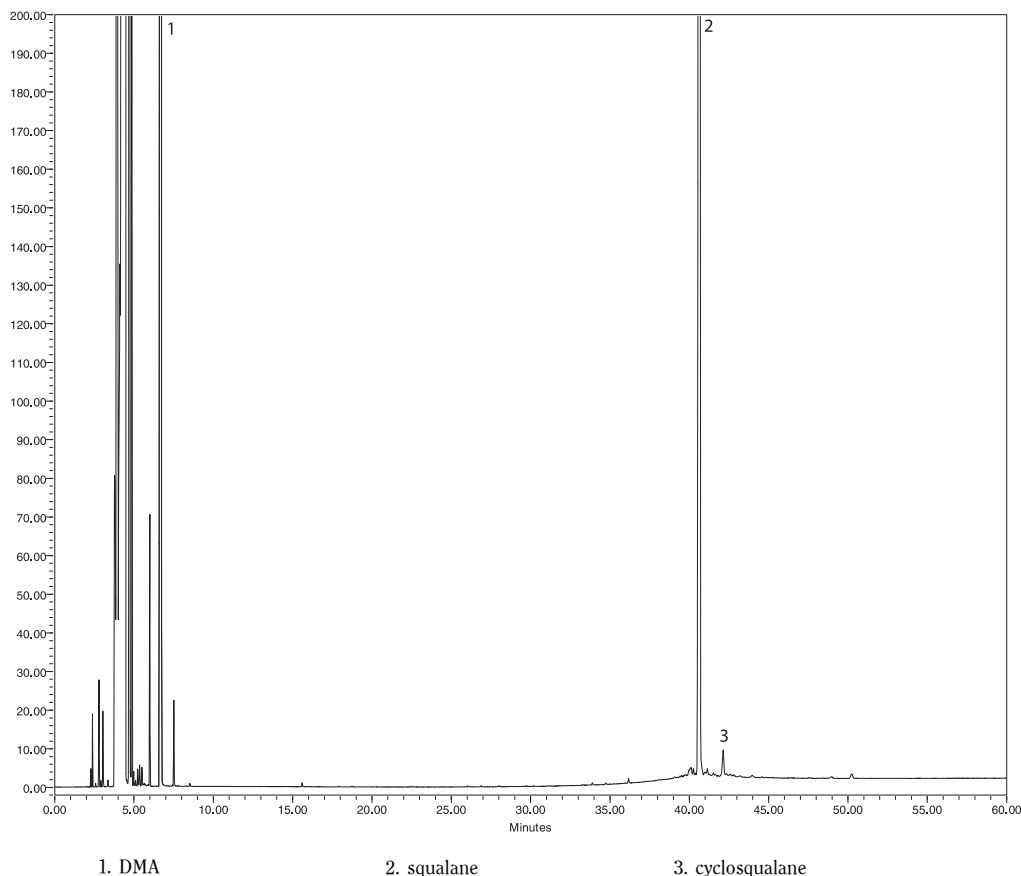

Figure 1630.-2. – Chromatogram of squalane of vegetable origin

## LABELLING

The label states the origin of squalane (vegetable or animal).

01/2008:1266  
corrected 6.0

## STANNOUS CHLORIDE DIHYDRATE

## Stannosi chloridum dihydricum

$\text{SnCl}_2 \cdot 2\text{H}_2\text{O}$   
[10025-69-1]

$M_r$  225.6

## DEFINITION

Content: 98.0 per cent to 102.0 per cent.

## CHARACTERS

**Appearance:** white or almost white, crystalline powder or colourless crystals, efflorescent in air.

**Solubility:** freely soluble in water (the solution becomes cloudy after standing or on dilution), freely soluble in ethanol (96 per cent). It dissolves in dilute hydrochloric acid.

## IDENTIFICATION

- To 1 mL of solution S1 (see Tests) add 5 mL of *water R* and 0.05 mL of *mercuric chloride solution R*. A blackish-grey precipitate is formed.
- Dissolve 1.0 g in 3.0 mL of *water R*. Add 0.5 mL of *dilute sodium hydroxide solution R* to the cloudy solution; a yellowish flocculent precipitate is formed. Add 6.5 mL of *water R*. To 1.0 mL of the previously shaken suspension add 1.0 mL of *strong sodium hydroxide solution R*; the precipitate dissolves and the resulting solution is clear and colourless.
- Dissolve 10 mg in 2 mL of *dilute nitric acid R*. The solution gives reaction (a) of chlorides (2.3.1).

## TESTS

**Solution S1.** To 0.40 g add 1 mL of *dilute hydrochloric acid R* and dilute to 20 mL with *distilled water R*.

**Solution S2.** Dissolve 1.0 g in *dilute hydrochloric acid R* and dilute to 30 mL with the same acid. Heat to boiling. Add 30 mL of *thioacetamide solution R* and boil for 15 min (solution A). Take 5 mL, filter and heat the filtrate to boiling. Add 5 mL of *thioacetamide solution R* and boil for 15 min. If a precipitate is formed, add the remainder of solution A (solution A') to the mixture. Add 10 mL of *thioacetamide solution R* and boil. Repeat the series of operations from "Take 5 mL" until a precipitate is no longer formed on addition of *thioacetamide solution R* to the filtrate obtained from the 5 mL of solution A (solution A', solution A'', etc. respectively). If no precipitate is formed or if no more precipitate is formed combine the solution obtained with the remainder of solution A (solution A', solution A'', etc. respectively), filter and wash the precipitate with 10 mL of *water R*. Heat the filtrate until the resulting vapour no longer turns a moistened piece of *lead acetate paper R* blackish-grey. Allow to cool and dilute to 50 mL with *water R*.

**Appearance of solution.** The solution is clear (2.2.1) and colourless (2.2.2, Method II).

Dissolve 10.0 g in *dilute hydrochloric acid R* and dilute to 20 mL with the same acid.

**Substances not precipitated by thioacetamide:** maximum 0.2 per cent.

Evaporate 25 mL of solution S2 to dryness and ignite at  $600 \pm 50$  °C. The residue weighs a maximum of 1 mg.

**Sulfates (2.4.13):** maximum 500 ppm, determined on solution S1.

**Iron (2.4.9):** maximum 100 ppm.

Dilute 5 mL of solution S2 to 10 mL with *water R*.

**Heavy metals:** maximum 50 ppm.

Dissolve 1.0 g in 2 mL of a mixture of 1 volume of *nitric acid R* and 3 volumes of *hydrochloric acid R*. Heat on a water-bath until nitrous vapour is no longer evolved. Dissolve the residue in *water R* and dilute to 25 mL with the same solvent. To 5 mL of this solution add 3 mL of *strong sodium hydroxide solution R* and 2 mL of *water R*. Heat until a clear solution is obtained, then cool and add 0.5 mL of *thioacetamide reagent R*. After 2 min, any colour in the solution is not more intense than that of a mixture of 1.0 mL of *lead standard solution (10 ppm Pb) R*, 6 mL of *water R*, 3 mL of *strong sodium hydroxide solution R* and 0.5 mL of *thioacetamide reagent R*.

#### ASSAY

Dissolve 0.100 g in 50 mL of *water R*, freed from oxygen by purging with carbon dioxide or nitrogen for 15 min. Add 1.5 mL of *hydrochloric acid R1*, 5 g of *sodium potassium tartrate R*, 10 g of *sodium hydrogen carbonate R* and 1 mL of *starch solution R*. Titrate immediately with 0.05 M *iodine*. Carry out a blank titration.

1 mL of 0.05 M *iodine* is equivalent to 11.28 mg of  $\text{SnCl}_2 \cdot 2\text{H}_2\text{O}$ .

#### STORAGE

In an airtight container.

01/2008:1568

## STANOZOLOL

### Stanozololum

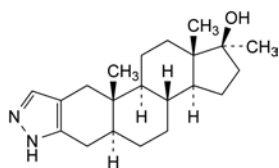

$\text{C}_{21}\text{H}_{32}\text{N}_2\text{O}$   
[10418-03-8]

$M_r$  328.5

#### DEFINITION

Stanozolol contains not less than 98.5 per cent and not more than the equivalent of 101.0 per cent of 17-methyl-2'H-5 $\alpha$ -androst-2-eno[3,2-c]pyrazol-17 $\beta$ -ol, calculated with reference to the dried substance.

#### CHARACTERS

A white or almost white crystalline powder, hygroscopic, practically insoluble in water, soluble in dimethylformamide, slightly soluble in ethanol (96 per cent), very slightly soluble in methylene chloride.

It shows polymorphism (5.9).

#### IDENTIFICATION

- Examine by infrared spectrophotometry (2.2.24), comparing with the spectrum obtained with *stanozolol CRS*. If the spectra obtained in the solid state show differences, dissolve the substance to be examined and the reference substance separately in the minimum volume of methylene chloride, evaporate to dryness at room temperature under an air-stream and record new spectra using the residues.
- Examine the chromatograms obtained in the test for related substances. The principal spot in the chromatogram obtained with test solution (b) is similar in position, colour and size to the principal spot in the chromatogram obtained with reference solution (c).

#### TESTS

**Specific optical rotation** (2.2.7). Dissolve 0.10 g in *chloroform R* and dilute to 10.0 mL with the same solvent. The specific optical rotation is + 34 to + 40, calculated with reference to the dried substance.

**Related substances.** Examine by thin-layer chromatography (2.2.27), using a *TLC silica gel F<sub>254</sub> plate R*.

**Test solution (a).** Dissolve 0.10 g of the substance to be examined in a mixture of 1 volume of *methanol R* and 9 volumes of *methylene chloride R* and dilute to 5 mL with the same mixture of solvents.

**Test solution (b).** Dilute 1 mL of test solution (a) to 10 mL with a mixture of 1 volume of *methanol R* and 9 volumes of *methylene chloride R*.

**Reference solution (a).** Dilute 1.0 mL of test solution (a) to 200 mL with a mixture of 1 volume of *methanol R* and 9 volumes of *methylene chloride R*.

**Reference solution (b).** Dissolve 5 mg of *stanozolol impurity A CRS* in reference solution (a) and dilute to 50 mL with the same solution.

**Reference solution (c).** Dissolve 10 mg of *stanozolol CRS* in a mixture of 1 volume of *methanol R* and 9 volumes of *methylene chloride R* and dilute to 5 mL with the same mixture of solvents.

Apply to the plate 5  $\mu\text{L}$  of each solution. Develop over a path corresponding to two thirds of the plate height using a mixture of 10 volumes of *methanol R* and 90 volumes of *methylene chloride R*. Allow the plate to dry in air, spray with *alcoholic solution of sulfuric acid R*, heat at 105 °C for 15 min and examine under ultraviolet light at 365 nm. Any secondary spot in the chromatogram obtained with test solution (a) is not more intense than the spot in the chromatogram obtained with reference solution (a) (0.5 per cent). The test is not valid unless the chromatogram obtained with reference solution (b) shows two clearly separated spots.

**Loss on drying** (2.2.32). Not more than 1.0 per cent, determined on 1.000 g by drying at 100 °C at a pressure not exceeding 0.7 kPa.

#### ASSAY

Dissolve 0.250 g in 50 mL of *anhydrous acetic acid R*. Titrate with 0.1 M *perchloric acid*, determining the end-point potentiometrically (2.2.20).

1 mL of 0.1 M *perchloric acid* is equivalent to 32.85 mg of  $\text{C}_{21}\text{H}_{32}\text{N}_2\text{O}$ .

#### STORAGE

Store in an airtight container, protected from light.

#### IMPURITIES

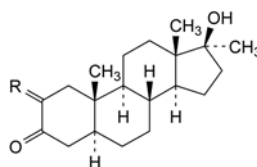

- R = H<sub>2</sub>: 17 $\beta$ -hydroxy-17-methyl-5 $\alpha$ -androst-3-one (mestanolone),
- R = CH-OH: 17 $\beta$ -hydroxy-2-(hydroxymethylene)-17-methyl-5 $\alpha$ -androst-3-one (oxymetholone).

01/2011:2165

## STARCH, HYDROXYPROPYL

### Amylum hydroxypropylum

[9049-76-7]

#### DEFINITION

Hydroxypropyl starch is a partially substituted 2-hydroxypropylether of *Maize starch (0344)*, *Potato starch (0355)*, cassava starch, *Rice starch (0349)* or *Pea starch (2403)* chemically modified by of etherification with the reagent

propylene oxide. In addition, this starch may be partially hydrolysed using acids or enzymes to obtain 'thinned starch' with reduced viscosity.

Hydroxypropyl starches obtained from different botanical sources may not have identical properties with respect to their use for specific pharmaceutical purposes. Therefore, types of hydroxypropyl starch must not be interchanged unless performance equivalency has been ascertained and the agreement of the competent authority has been given.

Mixing of starches from different botanical sources prior to chemical modification is not allowed.

#### PRODUCTION

The production of the hydroxypropyl starch shall be in compliance with the requirements of the European legislation for food additives.

#### CHARACTERS

*Appearance*: white or slightly yellowish powder.

*Solubility*: practically insoluble in cold water and in ethanol (96 per cent).

#### IDENTIFICATION

A. Examined under a microscope, using not less than 20 × magnification and using a mixture of equal volumes of *glycerol R* and *water R*, it appears as follows according to the botanical source stated on the label.

- *Maize-based hydroxypropyl starch*: it presents either angular polyhedral granules of irregular sizes with diameters of about 2-23 µm or as rounded or spheroidal granules of irregular sizes with diameters of about 25-35 µm. The central hilum consists of a distinct cavity or 2-to-5-rayed cleft and there are no concentric striations. Between orthogonally orientated polarising plates or prisms, the starch granules show a distinct black cross intersecting at the hilum.
- *Potato-based hydroxypropyl starch*: it presents granules, either irregularly shaped, ovoid or pear-shaped, usually 30-100 µm in size but occasionally exceeding 100 µm, or rounded, 10-35 µm in size. There are occasional compound granules having 2-4 components. The ovoid and pear-shaped granules have an eccentric hilum and the rounded granules a centric or slightly eccentric hilum. All granules show clearly visible concentric striations. Between orthogonally orientated polarising plates or prisms, the starch granules show a distinct black cross intersecting at the hilum.
- *Cassava-based hydroxypropyl starch*: it presents spherical granules with one truncated side, typically 5-35 µm in diameter and having a circular or several-rayed central cleft. Some granules may also be egg-shaped or cap-shaped. The hilum is centric, sometimes slightly fissured. Between orthogonally orientated polarising plates or prisms, the starch granules show a distinct black cross intersecting at the hilum.
- *Rice-based hydroxypropyl starch*: it presents polyhedral, simple granules 1-10 µm, mostly 4-6 µm, in size. These simple granules often gather in ellipsoidal, compound granules 50-100 µm in diameter. The granules have a poorly visible central hilum and there are no concentric striations. Between orthogonally orientated polarising plates or prisms, the starch granules show a distinct black cross intersecting at the hilum.
- *Pea-based hydroxypropyl starch*: it presents a majority of large elliptical granules, 25-45 µm in size, sometimes irregular or reniform. It also presents a minority of small rounded granules, 5-8 µm in size. Granules can present cracks or irregularities. Sometimes, granules show barely visible concentric striations. Exceptionally, granules

show a slit along the main axis. Between orthogonally orientated polarising plates or prisms, the starch granules show a distinct black cross.

- B. Suspend 1 g in 50 mL of *water R*, boil for 1 min and cool. A translucent or clear mucilage is formed.
- C. To 1 mL of the mucilage obtained in identification test B add 0.05 mL of *iodine solution R1*. An orange-red or dark blue colour is produced, which disappears on heating.
- D. Introduce 0.1 g into a 100 mL volumetric flask and add 12.5 mL of *dilute sulfuric acid R*. Place the flask in a water-bath and heat until the sample is dissolved. Cool and dilute to 100 mL with *water R*. Introduce 1 mL of this solution into a 25 mL graduated test-tube with glass stopper and, with the tube immersed in cold water, add drop-wise 8 mL of *sulfuric acid R*. Mix well and place the tube in a boiling water-bath for exactly 3 min. Immediately transfer the tube to an ice-bath until the solution is chilled. Add 0.6 mL of *ninhydrin solution R2*, carefully allowing the reagent to run down the walls of the test-tube. Immediately shake well, and place the tube in a water-bath at 25 °C for 100 min. Dilute to 25 mL with *sulfuric acid R* and mix by inverting the tube several times. Do not shake. A violet colour develops within 5 min.

#### TESTS

*pH* (2.2.3): 4.5 to 8.0.

Shake 5.0 g with 25.0 mL of *carbon dioxide-free water R* for 60 s. Allow to stand for 15 min.

**Foreign matter.** Examined under a microscope using a mixture of equal volumes of *glycerol R* and *water R*, not more than traces of matter other than starch granules are present.

**Hydroxypropyl groups.** Nuclear magnetic resonance spectrometry (2.2.33).

*Internal standard solution.* Disperse 50.0 mg of *3-trimethylsilyl-1-propane sulfonic acid sodium salt R* in about 5 g of *deuterium oxide R1*, weighed to the nearest 0.1 mg. Store in a sealed bottle.

*Test solution.* Disperse 20 g of the substance to be examined in 200.0 mL of *carbon dioxide-free water R* at room temperature. Agitate for 15 min and filter. Repeat the operation twice. If problems of poor dispersibility or slow filtration are encountered, use cooled *carbon dioxide-free water R* for the washing operation. Dry the washed starch for at least 4 h in an oven *in vacuo* at 30 ± 5 °C. Determine the moisture content (*W*) on 5 g of this washed and dried sample using the loss on drying test. Weigh 12.0 mg (dry basis) of the washed and dried sample in a 5 mm NMR tube. Add 0.75 mL of *deuterium oxide R1* and 0.1 mL of *deuterium chloride solution R*. Cap the tube, mix, and place it in a boiling water-bath until a clear solution is obtained (3 min to 1 h maximum). When a clear solution is obtained, allow to cool to room temperature. Dry the exterior of the tube and weigh to the nearest 0.1 mg. Add 0.05 mL of internal standard solution and weigh to the nearest 0.1 mg. Determine the mass of the internal standard solution introduced. Mix thoroughly.

*Apparatus*: FT-NMR spectrometer at minimum 300 MHz.

*Acquisition of <sup>1</sup>H NMR spectra.* The following parameters may be used:

- *sweep width*: 8 ppm (– 1.0 to + 7 ppm);
- *irradiation frequency offset*: none;
- *time domain*: 64 K at least;
- *pulse width*: 90°;
- *pulse delay*: 10 s;
- *dummy scans*: 0;
- *number of scans*: 8.

Use the CH<sub>3</sub> signal of the internal standard for shift referencing. The shift of the central peak of the multiplet is set to 0 ppm. Record the FID signal.

01/2010:1267

Call the integration sub-routine after phase corrections and baseline correction between  $-0.5$  ppm and  $+6$  ppm.

Measure the peak areas of the doublet from the methyl groups of the hydroxypropyl function at  $+1.2$  ppm ( $A_2$ ), and of the methyl groups at  $0$  ppm of the internal standard ( $A_1$ ) without  $^{13}\text{C}$ -satellites.

The signal from the 3 protons of the methyl group in the hydroxypropyl function is measured. Calculate the content of hydroxypropyl groups as a percentage  $m/m$  (dried substance) using the following expression:

$$\frac{3A_2}{A_1} \times \frac{W_1 \times m_1}{218} \times 59 \times \frac{100}{m} \times \frac{100}{100 - W}$$

- 3 = numerical value representing the 3 methyl groups in the internal standard;
- $A_1$  = area of the methyl groups in the internal standard;
- $A_2$  = area of the methyl groups of hydroxypropyl;
- $W_1$  = mass fraction of the internal standard in the internal standard solution, in milligrams per gram;
- $m_1$  = mass of the internal standard solution in the NMR tube, in grams;
- 218 = molar mass of the internal standard, in grams per mol;
- 59 = molar mass of hydroxypropyl group, in grams per mol;
- $m$  = mass of the washed and dried test sample in the NMR tube, in milligrams;
- $W$  = moisture content, as a percentage ( $m/m$ ).

**Limit:**

– *hydroxypropyl groups*: maximum 7.0 per cent.

**Oxidising substances (2.5.30)**: maximum 20 ppm, calculated as  $\text{H}_2\text{O}_2$ .

**Sulfur dioxide (2.5.29)**: maximum 50 ppm.

**Iron (2.4.9)**

- For hydroxypropyl starch obtained from maize, potato, cassava or rice: maximum 20 ppm.  
Shake 1.0 g with 20 mL of *dilute hydrochloric acid R*. Filter. The filtrate complies with the test for iron.
- For hydroxypropyl starch obtained from pea: maximum 50 ppm.  
Shake 1.0 g with 50 mL of *dilute hydrochloric acid R*. Filter. The filtrate complies with the test for iron.

**Loss on drying (2.2.32)** determined on 1.000 g by drying in an oven at  $130^\circ\text{C}$  for 90 min:

- maximum 15.0 per cent for hydroxypropyl starch obtained from maize, cassava, rice or pea;
- maximum 20.0 per cent for hydroxypropyl starch obtained from potato.

**Sulfated ash (2.4.14)**: maximum 0.6 per cent, determined on 1.0 g.

**Microbial contamination**

TAMC: acceptance criterion  $10^3$  CFU/g (2.6.12).

TYMC: acceptance criterion  $10^2$  CFU/g (2.6.12).

Absence of *Escherichia coli* (2.6.13).

Absence of *Salmonella* (2.6.13).

**LABELLING**

The label states the botanical source of the starch and the type of modification.

## STARCH, PREGELATINISED

### *Amylum pregelificatum*

**DEFINITION**

Pregelatinised starch is prepared from *Maize starch (0344)*, *Potato starch (0355)* or *Rice starch (0349)* by mechanical processing in the presence of water, with or without heat, to rupture all or part of the starch granules, and subsequent drying. It contains no added substances but it may be modified to render it compressible and to improve its flow characteristics.

**CHARACTERS**

*Appearance*: white or yellowish-white powder.

It swells in cold water.

**IDENTIFICATION**

- A. Examined under a microscope using a mixture of equal volumes of *glycerol R* and *water R* it presents irregular, translucent, white or yellowish-white flakes or pieces with an uneven surface. Under polarised light (between crossed nicol prisms), starch granules with a distinct black cross intersecting at the hilum may be seen.
- B. Disperse 0.5 g in 2 mL of *water R* without heating and add 0.05 mL of *iodine solution R1*. A reddish-violet or blue colour is produced.

**TESTS**

**pH (2.2.3)**: 4.5 to 7.0.

Progressively add 3.0 g to 100.0 mL of *carbon dioxide-free water R*, stirring continuously. Determine the pH when a homogeneous solution is obtained.

**Oxidising substances (2.5.30)**. It complies with the test for oxidising substances. Use a mixture of equal volumes of *methanol R* and *water R* as solvent.

**Sulfur dioxide (2.5.29)**: maximum 50 ppm.

**Iron (2.4.9)**: maximum 20 ppm.

Dissolve the residue obtained in the test for sulfated ash in 20 mL of *dilute hydrochloric acid R*. Filter. The filtrate complies with the test.

**Foreign matter**. Examined under a microscope using a mixture of equal volumes of *glycerol R* and *water R*, not more than traces of matter other than starch granules are present.

**Loss on drying (2.2.32)**: maximum 15.0 per cent, determined on 1.000 g by drying in an oven at  $130^\circ\text{C}$  for 90 min.

**Sulfated ash (2.4.14)**: maximum 0.6 per cent, determined on 1.0 g.

**Microbial contamination**

TAMC: acceptance criterion  $10^3$  CFU/g (2.6.12).

TYMC: acceptance criterion  $10^2$  CFU/g (2.6.12).

Absence of *Escherichia coli* (2.6.13).

Absence of *Salmonella* (2.6.13).

**LABELLING**

The label states the type of starch used as starting material.

**FUNCTIONALITY-RELATED CHARACTERISTICS**

*This section provides information on characteristics that are recognised as being relevant control parameters for one or more functions of the substance when used as an excipient (see chapter 5.15). This section is a non-mandatory part of the monograph and it is not necessary to verify the characteristics to demonstrate compliance. Control of these characteristics can however contribute to the quality of a medicinal product by improving the consistency of the manufacturing process and the performance of the medicinal product during use. Where control methods are cited, they are recognised as being*



suitable for the purpose, but other methods can also be used. Wherever results for a particular characteristic are reported, the control method must be indicated.

The following characteristics may be relevant for pregelatinised starch used as filler, binder or disintegrant in tablets and in hard capsules.

**Cold-water-soluble matter.** Transfer 100 mL of water *R* at  $25 \pm 1$  °C into a beaker and add 1.000-3.000 g of the substance to be examined while stirring. Continue to stir for 10 min. Transfer 35 mL of the dispersion to a centrifuge tube and centrifuge at 3000 *g* for 15 min. Transfer 25 mL of the supernatant to a crucible that has previously been dried in an oven at  $120 \pm 2$  °C for 4 h and weighed to the nearest 0.1 mg. Evaporate to dryness on a water-bath, then place the crucible in an oven at  $120 \pm 2$  °C for 4 h. Allow to cool in a desiccator. Weigh the crucible to the nearest 0.1 mg again.

Determine the percentage of cold-water-soluble matter using the following expression:

$$\frac{(B - A) \times \frac{100}{25} \times 100}{S \times \frac{100 - C}{100}}$$

*A* = initial crucible mass, in grams;

*B* = final crucible mass, in grams;

*C* = loss on drying, in per cent;

*S* = sample mass, in grams.

**Particle-size distribution** (2.9.31 or 2.9.38).

**Powder flow** (2.9.36).

01/2011:1785

## STARCHES, HYDROXYETHYL

### Amyla hydroxyethyla

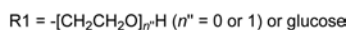
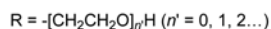
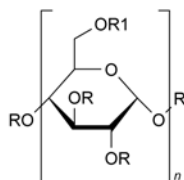

$[\text{C}_6\text{H}_{10}\text{O}_5(\text{C}_2\text{H}_4\text{O})_x]_n$  with *x* = molar substitution [9005-27-0]

#### DEFINITION

Hydroxyethyl starches are partially substituted poly(2-hydroxyethyl)ethers of waxy maize starch or potato starch, which primarily consist of amylopectine. The type of hydroxyethyl starch is defined by 2 numbers: the mean molecular weight (*Mw*) and the number of hydroxyethyl groups per anhydroglucose unit expressed as the molar substitution (*MS*). Hydroxyethyl starch is also characterised by the number of hydroxyethyl groups located at the C2 group over the number of hydroxyethyl groups located at C6, expressed as the C2/C6 ratio. The parameters *Mw*, *MS* and C2/C6 ratio are determined by the reaction conditions of the production.

#### PRODUCTION

Hydroxyethyl starches are produced from waxy maize starch or potato starch by acidic hydrolysis and reaction with ethylene oxide and purified by ultrafiltration.

#### CHARACTERS

**Appearance:** white or almost white powder.

**Solubility:** freely soluble in water and in dimethyl sulfoxide, practically insoluble in anhydrous ethanol.

Hydroxyethyl starches are hygroscopic until they reach a water content of about 12 per cent to 15 per cent.

#### IDENTIFICATION

**First identification:** A, C.

**Second identification:** B, C.

A. Infrared absorption spectrophotometry (2.2.24).

**Comparison:** medium *Mw* hydroxyethyl starch CRS.

**Results:** the spectrum obtained shows the same absorption bands as the spectrum obtained with medium *Mw* hydroxyethyl starch CRS. Due to the difference in the substitution of the substance, the intensity of some absorption bands can vary.

B. To 5 mL of solution S (see Tests), add 0.1 mL of 0.05 *M* iodine. A reddish-brown or blue-violet colour appears.

C. Molecular weight (see Tests).

#### TESTS

**Solution S.** Dissolve 5.0 g of the substance to be examined (dried substance) in carbon dioxide-free water *R* and dilute to 100.0 mL with the same solvent.

**Appearance of solution.** Solution S is not more opalescent than reference suspension II (2.2.1).

**pH** (2.2.3): 4.5 to 7.0.

To 25 mL of solution S, add 0.2 mL of a saturated solution of potassium chloride *R*.

**Absorbance** (2.2.25): maximum 0.025, determined at 400 nm on solution S filtered through a 0.2 µm filter.

**Molecular weight (*Mw*) and molecular weight distribution.**

Size-exclusion chromatography (2.2.30).

**Buffer solution.** Dissolve 54.34 g of sodium acetate *R* in water *R*, add 100.0 mL of glacial acetic acid *R* and dilute to 1000.0 mL with water *R*.

**Test stock solution.** Dissolve 2.0 g of the substance to be examined (dried substance) in water *R* and dilute to 50 mL with the same solvent. Add 10.0 mL of the buffer solution and dilute to 100.0 mL with water *R*.

**Reference solution (a).** To prepare the reference solution (a),

- if the nominal *Mw* of the substance to be examined is below 300 000, use medium *Mw* hydroxyethyl starch CRS;
- if the nominal *Mw* of the substance to be examined is above 300 000, use high *Mw* hydroxyethyl starch CRS.

Dissolve 0.4 g of medium *Mw* hydroxyethyl starch CRS or high *Mw* hydroxyethyl starch CRS in 10 mL of water *R*. Add 2.0 mL of the buffer solution and dilute to 20.0 mL with water *R*.

**Reference solution (b).** Dilute 10.0 mL of reference solution (a) to 20.0 mL with the mobile phase.

**Reference solution (c).** Dilute 10.0 mL of reference solution (b) to 20.0 mL with the mobile phase.

**Reference solution (d).** Dilute 10.0 mL of reference solution (c) to 20.0 mL with the mobile phase.

**Column:**

- stationary phase: hydroxylated polymethacrylate gel *R*,
- 4 columns to be connected in series:

Length in m	Internal diameter in mm	Particle size in µm	Pore size in nm
0.30	7.5	17	> 100
0.30	7.5	17	100
0.30	7.5	10	20
0.30	7.5	10	12.5

**Mobile phase.** Dilute 100.0 mL of the buffer solution to 1 L with water R.

**Flow rate:** 0.5-1.0 mL/min.

**Detection:** multiple-angle laser light scattering detector and refractometer maintained at a constant temperature, connected in series.

**Injection volume:** 50 µL.

Determine the suitable working solution as follows: inject reference solutions (a) and (b), the mean *M<sub>w</sub>* determined with reference solution (b) does not deviate by more than 3 per cent from the mean *M<sub>w</sub>* determined with reference solution (a). If the deviation meets the requirement, use reference solution (a) to check the system suitability criterion.

If the deviation is higher, inject reference solution (c) and determine the mean *M<sub>w</sub>*. The mean *M<sub>w</sub>* determined with reference solution (c) does not deviate by more than 3 per cent from the mean *M<sub>w</sub>* determined with reference solution (b). If the deviation meets the requirement, use reference solution (b) to check the system suitability criterion.

If the deviation is higher, inject reference solution (d) and determine the mean *M<sub>w</sub>*. The mean *M<sub>w</sub>* determined with reference solution (d) does not deviate by more than 3 per cent from the mean *M<sub>w</sub>* determined with reference solution (c). If the deviation meets the requirement, use reference solution (c) to check the system suitability criterion.

**System suitability:**

- **mean *M<sub>w</sub>*:** within 5 per cent of the value assigned to the *medium *M<sub>w</sub>* hydroxyethyl starch CRS* or *high *M<sub>w</sub>* hydroxyethyl starch CRS*.

If necessary, dilute the test stock solution in order to have the same concentration as that of the reference solution used to check the system suitability.

**Results:** use a suitable integrator to determine the mean *M<sub>w</sub>* and the *M<sub>w</sub>* of the lowest and highest 10 per cent mass fraction.

Low <i>M<sub>w</sub></i> 2000 - 100 000	Medium <i>M<sub>w</sub></i> 100 000 - 300 000	High <i>M<sub>w</sub></i> 300 000 - 900 000
Determined <i>M<sub>w</sub></i> = nominal <i>M<sub>w</sub></i> ± 15 per cent		
<i>M<sub>w</sub></i> at 10 per cent lowest fraction > 10 per cent of nominal <i>M<sub>w</sub></i>	<i>M<sub>w</sub></i> at 10 per cent lowest fraction > 15 000	<i>M<sub>w</sub></i> at 10 per cent lowest fraction > 15 000
<i>M<sub>w</sub></i> at 10 per cent highest fraction < 300 per cent of nominal <i>M<sub>w</sub></i>	<i>M<sub>w</sub></i> at 10 per cent highest fraction < 300 per cent of nominal <i>M<sub>w</sub></i>	<i>M<sub>w</sub></i> at 10 per cent highest fraction < 500 per cent of nominal <i>M<sub>w</sub></i>

**C2/C6 ratio.** Gas chromatography (2.2.28).

**Solution A.** Mix equal volumes of dilute sulfuric acid R and water R.

**Test solution.** Introduce 0.18 g of the substance to be examined into a 5 mL vial. Add 3.0 mL of solution A, cap, seal the vial and shake until dissolution. Heat the vials for 4 h in a heating block already preheated to 100 °C, shaking them from time to time. Cool to room temperature. Open the vial and carefully add 0.9 g of barium carbonate R. Shake carefully and then centrifuge at about 9000 *g* for about 15 min. Test the clear supernatant for neutral pH with pH paper. If the solution is still acid, add more barium carbonate R in portions of 0.2 g until the solution is neutral. Filter the clear supernatant (pore size 0.45 µm). Introduce 0.5 mL of the filtrate into a autosampler vial and evaporate to dryness at 40 °C (several hours are usually needed). Take up the residue with 0.50 mL of pyridine R, 0.25 mL of *N,O*-bis(trimethylsilyl)acetamide R and 25 µL of chlorotrimethylsilane R. Seal the vial and heat to 40 °C for 1 h shaking from time to time. Cool to room temperature. Place the vial into the autosampler and perform 3 injections from each vial. Prepare in duplicate.

**Reference solution.** Prepare as prescribed for the test solution but using *medium *M<sub>w</sub>* hydroxyethyl starch CRS* instead of the substance to be examined.

**Column:**

- **size:** *l* = 15 m, Ø = 0.32 mm;
- **stationary phase:** poly(dimethyl)siloxane R (film thickness 0.25 µm).

**Carrier gas:** hydrogen for chromatography R at a constant pressure of 69 kPa.

**Split ratio:** 1:20.

	Time (min)	Temperature (°C)
Column	0 - 1	150
	1 - 25	150 → 270
	25 - 28	270
Injection port		250
Detector		300

**Detection:** flame ionisation.

**Injection:** 1 µL.

**Identification of peaks:** use the chromatogram supplied with *medium *M<sub>w</sub>* hydroxyethyl starch CRS* and the chromatogram obtained with the reference solution to identify the peaks due to derivatised product 1, derivatised product 2, derivatised product 3, 2-*O*-hydroxyethyl-α-D-glucose, 6-*O*-hydroxyethyl-α-D-glucose, 2-*O*-hydroxyethyl-β-D-glucose and 6-*O*-hydroxyethyl-β-D-glucose.

**System suitability:** reference solution:

- **resolution:** minimum 1.5 between the peaks due to 2-*O*-hydroxyethyl-β-D-glucose and 6-*O*-hydroxyethyl-β-D-glucose;
- **symmetry factor:** 0.6 to 1.5 for the peak due to derivatised product 1;
- **repeatability:** maximum relative standard deviation of 5.0 per cent for derivatised product 1 after 3 injections.

Calculate the C2/C6 ratio using the following expression:

$$\frac{A_1 + A_2 + A_3 + A_4 + A_5}{A_6 + A_7}$$

- A*<sub>1</sub> = area of the peak due to derivatised product 1;
- A*<sub>2</sub> = area of the peak due to derivatised product 2;
- A*<sub>3</sub> = area of the peak due to derivatised product 3;
- A*<sub>4</sub> = area of the peak due to 2-*O*-hydroxyethyl-α-D-glucose;
- A*<sub>5</sub> = area of the peak due to 2-*O*-hydroxyethyl-β-D-glucose;
- A*<sub>6</sub> = area of the peak due to 6-*O*-hydroxyethyl-α-D-glucose;
- A*<sub>7</sub> = area of the peak due to 6-*O*-hydroxyethyl-β-D-glucose.

Calculate the mean C2/C6 ratio from the values obtained with the 2 test solutions.

The test is not valid unless the difference of the 2 values is not more than 5 per cent.

**Limit:** within 20.0 per cent of the nominal value.

**Molar substitution (MS).** Gas chromatography (2.2.28).

The content of hydroxyethyl groups is determined after hydrolysis with hydriodic acid as iodoethane.

**Internal standard solution.** Dilute 1.0 mL of toluene R to 200.0 mL with xylene R.

**Test solution.** Introduce 50.0 mg of the substance to be examined and about 0.10-0.15 g of adipic acid R in a 5 mL vial. Add 1.0 mL of the internal standard solution and 2.0 mL of hydriodic acid R. Tightly seal and cap the vial with a septum and an aluminium, centre tear-off seal. Prepare the test solution 5 times.

**Reference solutions.** In each of 7 vials of 5 mL, introduce about 0.10-0.15 g of adipic acid R. To each vial add 1.0 mL of the internal standard solution and 2.0 mL of hydriodic acid R. Tightly seal and cap the vials with a septum and an aluminium,

centre tear-off seal. Weigh the vials with an accuracy of 0.01 mg. Introduce respectively 10 mg, 20 mg, 30 mg, 40 mg, 50 mg, 60 mg and 70 mg of *iodoethane R* with a 100 µL syringe piercing the septa carefully. Weigh the vials again with an accuracy of 0.01 mg and calculate the exact amount of *iodoethane R* added.

Determine the mass of the vials to the nearest 1 mg. Place the vials for 10 h into a heating block already preheated to 150 °C. After cooling to room temperature, determine the mass of each vial to the nearest 1 mg. Disregard any vial with a loss in mass of more than 5 mg. From 4 vials of the test solution and 5 of the reference solutions, take-up 100 µL of the upper layer. Introduce in an autosampler vial and dilute with 1.0 mL of *xylene R*. Seal immediately the vials and shortly shake.

**Column:**

- *material*: fused silica;
- *size*:  $l = 30$  m,  $\varnothing = 0.53$  mm;
- *stationary phase*: poly[(cyanopropyl)(phenyl)]dimethylsiloxane *R* (film thickness 3 µm).

*Carrier gas*: helium for chromatography *R*.

*Flow rate*: 8 mL/min.

*Split ratio*: 1:20.

	Time (min)	Temperature (°C)
Column	0 - 4	50
	4 - 16	50 → 230
	16 - 20	230
Injection port		200
Detector		280

*Detection*: flame ionisation.

*Injection volume*: 1 µL; inject each solution twice.

*Elution order*: iodoethane, toluene.

*System suitability*: reference solutions:

- *resolution*: minimum 1.5 between the peaks due to iodoethane and toluene.
- calculate the ratio of the area of the peak due to *iodoethane R* to the area of the peak due to the internal standard for each chromatogram. Calculate the linear regression curve plotting the ratios calculated for the reference solutions against the quantity of *iodoethane R* added (in milligrams). The coefficient of determination  $R^2$  is not less than 0.990.

*Results*: calculate the quantity ( $T$ ) of iodoethane in milligrams present in the test solution using the following expression:

$$\frac{A - B}{M}$$

$A$  = ratio of the area of the peak due to iodoethane to the area of the peak due to the internal standard in the chromatogram obtained with the test solution;

$B$  = y-intercept of the curve;

$M$  = slope of the curve.

Then calculate the percentage content of ethylene oxide ( $C$ ) using the following expression:

$$\frac{44.05 \times T \times 100}{155.97 \times m}$$

$m$  = mass of the substance to be examined, in milligrams;

44.05 = molecular mass of ethylene oxide;

155.97 = molecular mass of iodoethane.

Then calculate the  $MS$  using the following expression:

$$\frac{C \times 162.14}{(100 - C) \times 44.05}$$

162.14 = molecular mass of anhydroglucose;

44.05 = molecular mass of ethylene oxide.

Calculate the mean  $MS$  from the values obtained with the 4 test solutions.

*Limit*: 0.05 to 2.4, and within 8.0 per cent of the nominal value.

**Ethylene glycol.** Liquid chromatography (2.2.29).

*Test solution.* Dissolve 1.0 g of the substance to be examined (dried substance) in *water R* and dilute to 50.0 mL with the same solvent.

*Reference solution.* Dissolve 0.800 g of *ethylene glycol R* in *water R* and dilute to 100.0 mL with the same solvent. Dilute 2.0 mL of this solution to 200.0 mL with *water R*. Dilute 2.0 mL of this solution to 200.0 mL with *water R*.

**Precolumn:**

- *size*:  $l = 0.01$  m,  $\varnothing = 4.0$  mm;
- *stationary phase*: octadecylsilyl silica gel for chromatography *R* (5 µm).

**Column:**

- *size*:  $l = 0.25$  m,  $\varnothing = 4.6$  mm;
- *stationary phase*: octadecylsilyl silica gel for chromatography *R* (5 µm);
- *temperature*: 30 °C.

*Mobile phase*: *water R*.

*Flow rate*: 1.0 mL/min.

*Post-column solution.* Dilute 750 mL of 2 *M sodium hydroxide R* to 1000 mL with *water R*.

*Flow rate of post-column solution*: 0.2 mL/min.

*Detection*: pulsed amperometric detector.

*Injection*: 20 µL;

*Run time*: 2.5 times the retention time of ethylene glycol.

*Retention time*: ethylene glycol = about 4 min.

*System suitability*: reference solution:

- *signal-to-noise ratio*: minimum 10 for the principal peak;
- *repeatability*: maximum relative standard deviation of 10.0 per cent after 6 injections.

After a maximum of 8 sample injections, wash the column using the following program.

*Rinsing solution*: acetonitrile for chromatography *R*, *water R* (20:80 V/V).

Time (min)	Mobile phase (per cent V/V)	Rinsing solution (per cent V/V)
0 - 15	75	25
15 - 20	75 → 0	25 → 100
20 - 25	0	100
25 - 30	0 → 100	100 → 0
30 - 100	100	0

**Limit:**

- *ethylene glycol*: not more than the area of the corresponding peak in the chromatogram obtained with the reference solution (40 ppm).

**2-Chloroethanol.** Gas chromatography (2.2.28).

*Solvent mixture*: *methanol R*, *acetonitrile R* (25:75 V/V).

*Internal standard solution.* Dissolve 0.250 g of *2,6-dimethylaniline R* in the solvent mixture and dilute to 50.0 mL with the solvent mixture. Dilute 0.5 mL of this solution to 50.0 mL with the solvent mixture.

*Test solution.* Introduce 1.0 g of the substance to be examined in a 20 mL vial. Add 10.0 mL of the solvent mixture. Close tightly. Treat in an ultrasonic bath for 3.5 h. Allow to cool at room temperature. To 1.0 mL of this solution, add 0.8 mL of the internal standard solution.

**Reference solution.** Dissolve 0.250 g of 2-chloroethanol R in water R and dilute to 50.0 mL with the same solvent. Dilute 1.0 mL of this solution to 100.0 mL with water R. Dilute 1.0 mL of this solution to 100.0 mL with water R. To 1.0 mL of this solution, add 0.8 mL of the internal standard solution.

**Precolumn:**

- material: fused silica;
- size:  $l = 10$  m,  $\varnothing = 0.53$  mm;
- stationary phase: polar-deactivated polyethyleneglycol R.

**Column:**

- material: fused silica;
- size:  $l = 30$  m,  $\varnothing = 0.32$  mm;
- stationary phase: macrogol 20 000 R (film thickness 0.25  $\mu\text{m}$ )

**Carrier gas:** hydrogen for chromatography R.

**Flow rate:** 2.9 mL/min.

**Split program:**

Time (min)	Split state	Split ratio
initial	on	1:20
0.01	off	1:20
0.50	on	1:20

**Temperature:**

	Time (min)	Temperature (°C)
Column	0 - 4	45
	4 - 23.5	45 → 240
	23.5 - 28.5	240
Injection port		250
Detector		270

**Detection:** flame ionisation.

**Injection:** 1  $\mu\text{L}$ .

**System suitability:** reference solution:

- signal-to-noise ratio: minimum 10 for the peak due to 2-chloroethanol;
- repeatability: maximum relative standard deviation of 10.0 per cent after 6 injections.

**Limit:**

- 2-chloroethanol: calculate the ratio ( $R$ ) of the area of the peak due to 2-chloroethanol to the area of the peak due to the internal standard from the chromatogram obtained with the reference solution; calculate the ratio of the area of the peak due to 2-chloroethanol to the area of the peak due to the internal standard from the chromatogram obtained with the test solution: this ratio is not greater than  $R$  (5 ppm).

**Ethylene oxide.** Head-space gas chromatography (2.2.28).

**Test solution.** Dissolve 1.0 g of the substance to be examined in 1.0 mL of water R. Close the vial tightly. Prepare in duplicate.

**Reference stock solution.** Introduce 80 mL of water R in a 100 mL volumetric flask. Cool at about 4°C for at least 30 min. Place the flask on an analytical balance and slowly introduce 1.0 g of ethylene oxide R. Determine the precise quantity of ethylene oxide by differential weighing. Dilute to 100.0 mL with water R. Store in the refrigerator and use within 4 weeks.

**Reference solution (a).** Dilute 1.0 mL of the reference stock solution to 100.0 mL with water R. Dilute 1.0 mL of this solution to 100.0 mL with water R. Use within 24 h.

**Reference solution (b).** Dissolve 1.0 g of the substance to be examined in 1.0 mL of reference solution (a). Close the vial tightly. Prepare in duplicate.

**Column:**

- material: quartz;
- size:  $l = 30$  m,  $\varnothing = 0.32$  mm;
- stationary phase: poly[(cyanopropyl)(phenyl)][dimethylsiloxane R (film thickness 1.5  $\mu\text{m}$ ).

**Carrier gas:** helium for chromatography R at a pressure of 110.3 kPa.

**Split ratio:** 1:35.

**Static head-space conditions which may be used:**

- equilibration temperature: 80 °C;
- equilibration time: 40 min;
- transfer-line temperature: 150 °C;
- pressurisation time: 2.0 min;
- injection time: 3 s.

**Temperature:**

	Time (min)	Temperature (°C)
Column	0 - 20	40
	20 - 30	40 → 240
	30 - 40	240
Injection port		140
Detector		250

**Detection:** flame ionisation.

**Injection:** inject a suitable volume of the gaseous phase of the test solution and reference solution (b).

**System suitability:**

- signal-to-noise ratio: minimum 10 for the peak due to ethylene oxide in the chromatogram obtained with reference solution (b).

**Limit:**

- ethylene oxide: not more than 0.5 times the area of the corresponding peak in the chromatogram obtained with reference solution (b) (1 ppm).

**Sodium chloride:** maximum 0.1 per cent.

**Test solution.** In a 250 mL conical flask, dissolve 10.0 g of the substance to be examined in 100 mL of water R. Add 2 mL of dilute nitric acid R and 5.0 mL of a 9 g/L solution of sodium chloride R.

**Reference solution.** In a 250 mL conical flask, dilute 5.0 mL of a 9 g/L solution of sodium chloride R with 100 mL of water R. Add 2 mL of dilute nitric acid R.

Carry out a potentiometric titration (2.2.20) with 0.1 M silver nitrate. Calculate the percentage content of sodium chloride using the following expression:

$$\frac{(n_1 - n_2) \times 5.844 \times 100}{m}$$

- $n_1$  = volume of 0.1 M silver nitrate used for the test solution, in millilitres;
- $n_2$  = volume of 0.1 M silver nitrate used for the reference solution, in millilitres;
- $m$  = mass of the substance to be examined in the test solution, in milligrams.

**Heavy metals (2.4.8):** maximum 10 ppm.

Dissolve 2 g in water R and dilute to 20 mL with the same solvent. 12 mL complies with test A. Prepare the reference solution using lead standard solution (1 ppm Pb) R.

**Loss on drying (2.2.32):** maximum 15.0 per cent, determined on 1.000 g by drying at 105 °C.

**Bacterial endotoxins (2.6.14):** less than 2.5 IU/g.

**Microbial contamination**

TAMC: acceptance criterion 10<sup>2</sup> CFU/g (2.6.12).

## LABELLING

The label states the mean molecular weight, molar substitution and C2/C6 ratio (nominal values).

01/2008:2130  
corrected 7.0

## STAVUDINE

## Stavudinum

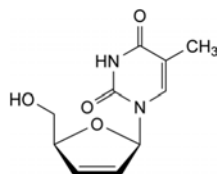

C<sub>10</sub>H<sub>12</sub>N<sub>2</sub>O<sub>4</sub>  
[3056-17-5]

M<sub>r</sub> 224.2

## DEFINITION

1-(2,3-Dideoxy-β-D-glycero-pent-2-enofuranosyl)-5-methylpyrimidine-2,4(1H,3H)-dione.

Content: 97.0 per cent to 102.0 per cent (anhydrous substance).

## CHARACTERS

Appearance: white or almost white powder.

Solubility: soluble in water, sparingly soluble in ethanol (96 per cent), slightly soluble in methylene chloride.

It shows polymorphism (5.9).

## IDENTIFICATION

A. Specific optical rotation (2.2.7): –39.5 to –45.9 (anhydrous substance).

Dissolve 0.100 g in water R and dilute to 10.0 mL with the same solvent.

B. Infrared absorption spectrophotometry (2.2.24).

Comparison: stavudine CRS.

If the spectra obtained show differences, dissolve the substance to be examined and the reference substance separately in anhydrous ethanol R, evaporate to dryness and record new spectra using the residues.

## TESTS

**Related substances.** Liquid chromatography (2.2.29). Prepare the solutions immediately before use or maintain at 2–8 °C until use.

**Test solution.** Dissolve 25.0 mg of the substance to be examined in water R and dilute to 50.0 mL with the same solvent.

**Reference solution (a).** Dilute 0.5 mL of the test solution to 100.0 mL with water R.

**Reference solution (b).** Dilute 20 mL of reference solution (a) to 100.0 mL with water R.

**Reference solution (c).** Dissolve 5 mg of stavudine for system suitability CRS (containing impurities A to H) in water R and dilute to 10.0 mL with the same solvent.

Column:

- size:  $l = 0.25$  m,  $\emptyset = 4.6$  mm;
- stationary phase: octadecylsilyl silica gel for chromatography R (5 μm).

Mobile phase:

- mobile phase A: mix 35 volumes of acetonitrile for chromatography R and 965 volumes of a 0.77 g/L solution of ammonium acetate R;
- mobile phase B: mix 250 volumes of acetonitrile for chromatography R and 750 volumes of a 0.77 g/L solution of ammonium acetate R;

Time (min)	Mobile phase A (per cent V/V)	Mobile phase B (per cent V/V)
0 - 10	100	0
10 - 20	100 → 0	0 → 100
20 - 30	0	100

Flow rate: 2 mL/min.

Detection: spectrophotometer at 254 nm.

Injection: 10 μL.

Identification of impurities: use the chromatogram supplied with stavudine for system suitability CRS to identify the peaks due to impurities A to H.

Relative retention with reference to stavudine (retention time = 9.5–12.5 min): impurity A = about 0.3; impurity B = about 0.50; impurity C = about 0.53; impurity E = about 1.1.

System suitability: reference solution (c):

- peak-to-valley ratio: minimum 1.5, where  $H_p$  = height above the baseline of the peak due to impurity C and  $H_v$  = height above the baseline of the lowest point of the curve separating this peak from the peak due to impurity B; minimum 1.5, where  $H_p$  = height above the baseline of the peak due to impurity E and  $H_v$  = height above the baseline of the lowest point of the curve separating this peak from the peak due to stavudine.

Limits:

- correction factor: for the calculation of content, multiply the peak area of impurity A by 0.7;
- impurity A: not more than the area of the principal peak in the chromatogram obtained with reference solution (a) (0.5 per cent);
- unspecified impurities: for each impurity, not more than the area of the principal peak in the chromatogram obtained with reference solution (b) (0.10 per cent);
- total: not more than twice the area of the principal peak in the chromatogram obtained with reference solution (a) (1.0 per cent);
- disregard limit: 0.5 times the area of the principal peak in the chromatogram obtained with reference solution (b) (0.05 per cent).

Water (2.5.12): maximum 0.5 per cent, determined on 0.500 g.

Sulfated ash (2.4.14): maximum 0.1 per cent, determined on 1.0 g.

## ASSAY

Liquid chromatography (2.2.29). Prepare the solutions immediately before use or maintain at 2–8 °C until use.

**Test solution.** Dissolve 10.0 mg of the substance to be examined in water R and dilute to 100.0 mL with the same solvent. Dilute 10.0 mL of the solution to 50.0 mL with water R.

**Reference solution (a).** Dissolve 10.0 mg of stavudine CRS in water R and dilute to 100.0 mL with the same solvent. Dilute 10.0 mL of the solution to 50.0 mL with water R.

**Reference solution (b).** Dissolve 5 mg of thymine R and 7.5 mg of thymidine R in water R and dilute to 100 mL with the same solvent. Dilute 10 mL of the solution to 50 mL with water R.

Column:

- size:  $l = 0.033$  m,  $\emptyset = 4.0$  mm;
- stationary phase: octadecylsilyl silica gel for chromatography R (3 μm).

Mobile phase: mix 5 volumes of acetonitrile for chromatography R and 95 volumes of a 0.77 g/L solution of ammonium acetate R.

Flow rate: 0.7 mL/min.

Detection: spectrophotometer at 254 nm.

Injection: 25 μL.

*Retention time*: stavudine = 2.8 min to 5.0 min.

*System suitability*:

- *symmetry factor*: maximum 1.6 for the peak due to stavudine in the chromatogram obtained with reference solution (a);
- *resolution*: minimum 3.5 between the peaks due to impurity A and impurity C in the chromatogram obtained with reference solution (b).

Calculate the percentage content of  $C_{10}H_{12}N_2O_4$  using the chromatograms obtained with the test solution and reference solution (a) and the declared content of *stavudine CRS*.

**STORAGE**

Protected from light and humidity.

**IMPURITIES**

*Specified impurities*: A.

*Other detectable impurities* (the following substances would, if present at a sufficient level, be detected by one or other of the tests in the monograph. They are limited by the general acceptance criterion for other/unspecified impurities and/or by the general monograph *Substances for pharmaceutical use (2034)*. It is therefore not necessary to identify these impurities for demonstration of compliance. See also 5.10. *Control of impurities in substances for pharmaceutical use*): B, C, D, E, F, G, H.

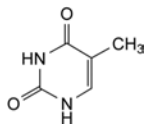

A. 5-methylpyrimidine-2,4(1*H*,3*H*)-dione (thymine),

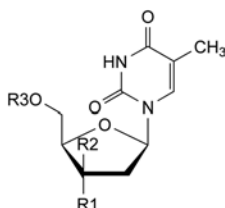

B. R1 = R3 = H, R2 = OH: 1-(2-deoxy- $\beta$ -D-*threo*-pentofuranosyl)-5-methylpyrimidine-2,4(1*H*,3*H*)-dione (3'-epithymidine),

C. R1 = OH, R2 = R3 = H: 1-(2-deoxy- $\beta$ -D-*erythro*-pentofuranosyl)-5-methylpyrimidine-2,4(1*H*,3*H*)-dione (thymidine),

H. R1 = H, R2 = OH, R3 =  $CH(CH_3)_2$ : 1-[2-deoxy-5-*O*-(1-methylethyl)- $\beta$ -D-*erythro*-pentofuranosyl]-5-methylpyrimidine-2,4(1*H*,3*H*)-dione,

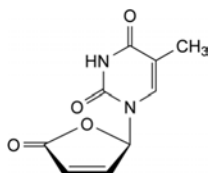

D. 1-[(2*R*)-5-oxo-2,5-dihydrofuran-2-yl]-5-methylpyrimidine-2,4(1*H*,3*H*)-dione,

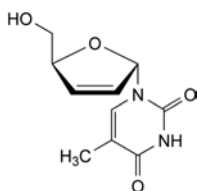

E. 1-(2,3-dideoxy- $\alpha$ -D-*glycero*-pent-2-enofuranosyl)-5-methylpyrimidine-2,4(1*H*,3*H*)-dione (stavudine anomer  $\alpha$ ),

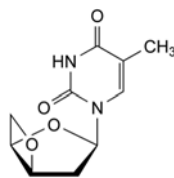

F. 1-(3,5-anhydro-2-deoxy- $\beta$ -D-*threo*-pentofuranosyl)-5-methylpyrimidine-2,4(1*H*,3*H*)-dione,

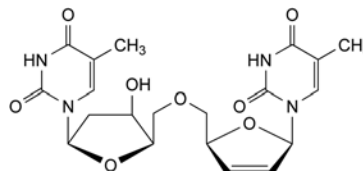

G. 5'-O-[(2*S*,5*R*)-5-(5-methyl-2,4-dioxo-3,4-dihydropyrimidine-1(2*H*)-yl)-2,5-dihydrofuran-2-yl]methyl]-3'-epithymidine.

07/2010:1474

## STEARIC ACID

### Acidum stearicum

**DEFINITION**

Mixture consisting mainly of stearic (octadecanoic) acid ( $C_{18}H_{36}O_2$ ;  $M_r$  284.5) and palmitic (hexadecanoic) acid ( $C_{16}H_{32}O_2$ ;  $M_r$  256.4) obtained from fats or oils of vegetable or animal origin.

*Content*:

Stearic acid 50	<i>Stearic acid</i> : 40.0 per cent to 60.0 per cent. <i>Sum of the contents of stearic and palmitic acids</i> : minimum 90.0 per cent.
Stearic acid 70	<i>Stearic acid</i> : 60.0 per cent to 80.0 per cent. <i>Sum of the contents of stearic and palmitic acids</i> : minimum 90.0 per cent.
Stearic acid 95	<i>Stearic acid</i> : minimum 90.0 per cent. <i>Sum of the contents of stearic and palmitic acids</i> : minimum 96.0 per cent.

**CHARACTERS**

*Appearance*: white or almost white, waxy, flaky crystals, white or almost white hard masses, or white or yellowish-white powder.

*Solubility*: practically insoluble in water, soluble in ethanol (96 per cent) and in light petroleum (bp: 50-70 °C).

**IDENTIFICATION**

A. Freezing point (see Tests).

B. Acid value (2.5.1): 194 to 212, determined on 0.5 g.

C. Examine the chromatograms obtained in the assay.

*Results*: the principal peaks in the chromatogram obtained with the test solution are similar in retention time to those in the chromatogram obtained with the reference solution.

**TESTS**

**Appearance**. Heat the substance to be examined to about 75 °C. The resulting liquid is not more intensely coloured than reference solution  $Y_7$  or  $BY_7$  (2.2.2, *Method I*).

**Acidity**. Melt 5.0 g, shake for 2 min with 10 mL of hot *carbon dioxide-free water R*, cool slowly and filter. To the filtrate add 0.05 mL of *methyl orange solution R*. No red colour develops.

**Iodine value** (2.5.4). See Table 1474.-1.

**Freezing point** (2.2.18). See Table 1474.-1.

Table 1474.-1.

Type	Iodine value	Freezing point (°C)
Stearic acid 50	maximum 4.0	53 - 59
Stearic acid 70	maximum 4.0	57 - 64
Stearic acid 95	maximum 1.5	64 - 69

**Nickel** (2.4.31): maximum 1 ppm.

#### ASSAY

Gas chromatography (2.2.28): use the normalisation procedure.

**Test solution.** In a conical flask fitted with a reflux condenser, dissolve 0.100 g of the substance to be examined in 5 mL of *boron trifluoride-methanol solution R*. Boil under reflux for 10 min. Add 4.0 mL of *heptane R* through the condenser and boil again under reflux for 10 min. Allow to cool. Add 20 mL of a saturated solution of *sodium chloride R*. Shake and allow the layers to separate. Remove about 2 mL of the organic layer and dry it over 0.2 g of *anhydrous sodium sulfate R*. Dilute 1.0 mL of this solution to 10.0 mL with *heptane R*.

**Reference solution.** Prepare the reference solution in the same manner as the test solution using 50 mg of *palmitic acid CRS* and 50 mg of *stearic acid CRS* instead of the substance to be examined.

**Column:**

- *material*: fused silica;
- *size*:  $l = 30$  m,  $\varnothing = 0.32$  mm;
- *stationary phase*: *macrogol 20 000 R* (film thickness 0.5  $\mu$ m).

**Carrier gas:** *helium for chromatography R*.

**Flow rate:** 2.4 mL/min.

**Temperature:**

	Time (min)	Temperature (°C)
Column	0 - 2	70
	2 - 36	70 → 240
	36 - 41	240
Injection port		220
Detector		260

**Detection:** flame ionisation.

**Injection:** 1  $\mu$ L.

**Relative retention** with reference to methyl stearate: methyl palmitate = about 0.9.

**System suitability:** reference solution:

- **resolution**: minimum 5.0 between the peaks due to methyl palmitate and methyl stearate;
- **repeatability**: maximum relative standard deviation of 3.0 per cent for the areas of the peaks due to methyl palmitate and methyl stearate, after 6 injections; maximum 1.0 per cent for the ratio of the areas of the peaks due to methyl palmitate to the areas of the peaks due to methyl stearate, after 6 injections.

#### LABELLING

The label states the type of stearic acid (50, 70, 95).

#### FUNCTIONALITY-RELATED CHARACTERISTICS

*This section provides information on characteristics that are recognised as being relevant control parameters for one or more functions of the substance when used as an excipient (see chapter 5.15). This section is a non-mandatory part of the monograph and it is not necessary to verify the characteristics*

*to demonstrate compliance. Control of these characteristics can however contribute to the quality of a medicinal product by improving the consistency of the manufacturing process and the performance of the medicinal product during use. Where control methods are cited, they are recognised as being suitable for the purpose, but other methods can also be used. Wherever results for a particular characteristic are reported, the control method must be indicated.*

*The following characteristics may be relevant for stearic acid used as a lubricant in tablets and capsules.*

**Particle-size distribution** (2.9.31).

**Specific surface area** (2.9.26, Method I).

01/2008:1268  
corrected 6.0

## STEAROYL MACROGOLGLYCERIDES

### Macrogolglyceridorum stearates

#### DEFINITION

Mixtures of monoesters, diesters and triesters of glycerol and monoesters and diesters of macrogols with a mean relative molecular mass between 300 and 4000.

They are obtained by partial alcoholysis of saturated oils containing mainly triglycerides of stearic (octadecanoic) acid, using macrogol, or by esterification of glycerol and macrogol with saturated fatty acids, or by mixture of glycerol esters and condensates of ethylene oxide with the fatty acids of these hydrogenated oils.

The hydroxyl value is within 15 units of the nominal value. The saponification value is within 10 units of the nominal value.

#### CHARACTERS

**Appearance:** pale yellow waxy solid.

**Solubility:** dispersible in warm water and in warm liquid paraffin, freely soluble in methylene chloride, soluble in warm anhydrous ethanol.

#### IDENTIFICATION

A. Thin-layer chromatography (2.2.27).

**Test solution.** Dissolve 1.0 g of the substance to be examined in *methylene chloride R* and dilute to 20 mL with the same solvent.

**Plate:** *TLC silica gel plate R*.

**Mobile phase:** *hexane R, ether R* (30:70 V/V).

**Application:** 10  $\mu$ L.

**Development:** over a path of 15 cm.

**Drying:** in air.

**Detection:** spray with a 0.1 g/L solution of *rhodamine B R* in *ethanol (96 per cent) R* and examine in ultraviolet light at 365 nm.

**Results:** the chromatogram shows a spot due to triglycerides with an  $R_f$  value of about 0.9 ( $R_{st}$  1) and spots due to 1,3-diglycerides ( $R_{st}$  0.7), to 1,2-diglycerides ( $R_{st}$  0.6), to monoglycerides ( $R_{st}$  0.1) and to esters of macrogol ( $R_{st}$  0).

B. Hydroxyl value (see Tests).

C. Saponification value (see Tests).

D. Fatty acid composition (see Tests).

#### TESTS

**Acid value** (2.5.1): maximum 2.0, determined on 2.0 g.

**Hydroxyl value** (2.5.3, Method A): within 15 units of the nominal value, determined on 1.0 g.

**Peroxide value** (2.5.5, Method A): maximum 6.0, determined on 2.0 g.

**Saponification value** (2.5.6): within 10 units of the nominal value, determined on 2.0 g.

**Alkaline impurities.** Into a test-tube introduce 5.0 g and carefully add a mixture, neutralised if necessary with 0.01 M hydrochloric acid or with 0.01 M sodium hydroxide, of 0.05 mL of a 0.4 g/L solution of bromophenol blue R in ethanol (96 per cent) R, 0.3 mL of water R and 10 mL of ethanol (96 per cent) R. Shake and allow to stand. Not more than 1.0 mL of 0.01 M hydrochloric acid is required to change the colour of the upper layer to yellow.

**Free glycerol:** maximum 3.0 per cent.

Dissolve 1.20 g in 25.0 mL of methylene chloride R. Heat if necessary. After cooling, add 100 mL of water R. Shake and add 25.0 mL of periodic acetic acid solution R. Shake and allow to stand for 30 min. Add 40 mL of a 75 g/L solution of potassium iodide R. Allow to stand for 1 min. Add 1 mL of starch solution R. Titrate the iodine with 0.1 M sodium thiosulfate. Carry out a blank titration.

1 mL of 0.1 M sodium thiosulfate is equivalent to 2.3 mg of glycerol.

**Composition of fatty acids.** Gas chromatography (2.4.22, Method A).

*Composition of the fatty-acid fraction of the substance:*

- lauric acid: maximum 5.0 per cent;
- myristic acid: maximum 5.0 per cent;
- stearic acid and palmitic acid: different nominal amounts and minimum 90.0 per cent for the sum of C<sub>18</sub>H<sub>36</sub>O<sub>2</sub> and C<sub>16</sub>H<sub>32</sub>O<sub>2</sub>.

**Ethylene oxide and dioxan (2.4.25):** maximum 1 ppm of ethylene oxide and maximum 10 ppm of dioxan.

**Heavy metals (2.4.8):** maximum 10 ppm.

2.0 g complies with test C. Prepare the reference solution using 2 mL of lead standard solution (10 ppm Pb) R.

**Water (2.5.12):** maximum 1.0 per cent, determined on 1.0 g. Use a mixture of 30 volumes of anhydrous methanol R and 70 volumes of methylene chloride R as solvent.

**Total ash (2.4.16):** maximum 0.2 per cent.

#### LABELLING

The label states:

- the nominal hydroxyl value;
- the nominal saponification value;
- the type of the macrogol used (mean relative molecular mass) or the number of moles of ethylene oxide reacted per mole of substance (nominal value).

01/2008:0753

## STEARYL ALCOHOL

### Alcohol stearylcus

#### DEFINITION

Mixture of solid alcohols, mainly octadecan-1-ol (C<sub>18</sub>H<sub>38</sub>O; M<sub>r</sub> 270.5), of animal or vegetable origin.

*Content:* minimum 95.0 per cent of C<sub>18</sub>H<sub>38</sub>O.

#### CHARACTERS

*Appearance:* white or almost white, unctuous flakes, granules or mass.

*Solubility:* practically insoluble in water, soluble in ethanol (96 per cent). When melted, it is miscible with fatty oils, with liquid paraffin and with melted wool fat.

#### IDENTIFICATION

Examine the chromatograms obtained in the assay.

*Results:* the principal peak in the chromatogram obtained with the test solution is similar in retention time to the principal peak in the chromatogram obtained with reference solution (b).

#### TESTS

**Appearance of solution.** The solution is clear (2.2.1) and not more intensely coloured than reference solution B<sub>6</sub> (2.2.2, Method II).

Dissolve 0.50 g in 20 mL of boiling ethanol (96 per cent) R. Allow to cool.

**Melting point (2.2.14):** 57 °C to 60 °C.

**Acid value (2.5.1):** maximum 1.0.

**Hydroxyl value (2.5.3, Method A):** 197 to 217.

**Iodine value (2.5.4, Method A):** maximum 2.0.

Dissolve 2.00 g in methylene chloride R, warming if necessary and dilute to 25 mL with the same solvent.

**Saponification value (2.5.6):** maximum 2.0.

#### ASSAY

Gas chromatography (2.2.28): use the normalisation procedure. *Test solution.* Dissolve 0.100 g of the substance to be examined in ethanol (96 per cent) R and dilute to 10.0 mL with the same solvent.

*Reference solution (a).* Dissolve 50 mg of cetyl alcohol R in ethanol (96 per cent) R and dilute to 10 mL with the same solvent.

*Reference solution (b).* Dissolve 50 mg of stearyl alcohol CRS in ethanol (96 per cent) R and dilute to 5 mL with the same solvent.

*Reference solution (c).* Mix 1 mL of reference solution (a) and 1 mL of reference solution (b) and dilute to 10 mL with ethanol (96 per cent) R.

*Column:*

- size:  $l = 30$  m,  $\varnothing = 0.32$  mm,
- stationary phase: poly(dimethyl)siloxane R (1 µm).

*Carrier gas:* helium for chromatography R.

*Flow rate:* 1 mL/min.

*Split ratio:* 1:100.

*Temperature:*

	Time (min)	Temperature (°C)
Column	0 - 20	150 → 250
	20 - 40	250
Injection port		250
Detector		250

*Detection:* flame ionisation.

*Injection:* 1 µL of the test solution and reference solutions (b) and (c).

*System suitability:* reference solution (c):

- resolution: minimum 5.0 between the peaks due to cetyl alcohol and stearyl alcohol.

Calculate the percentage content of C<sub>18</sub>H<sub>38</sub>O.

07/2008:0356

## STREPTOKINASE CONCENTRATED SOLUTION

### Streptokinasi solutio concentrata

#### DEFINITION

Streptokinase concentrated solution is a preparation of a protein obtained from culture filtrates of certain strains of haemolytic *Streptococcus* group C; it has the property of combining with human plasminogen to form plasminogen activator. It may contain buffer salts and other excipients. The potency is not less than 510 IU per microgram of nitrogen.



## PRODUCTION

The method of manufacture is validated to demonstrate that the product, if tested, would comply with the following test.

**Abnormal toxicity** (2.6.9). Inject into each mouse a quantity of the preparation to be examined (if necessary, dilute with *water for injections R*) equivalent to 50 000 IU of streptokinase activity, the injection lasting 15-20 s.

## CHARACTERS

*Appearance*: clear, colourless liquid.

## IDENTIFICATION

- A. Place 0.5 mL of citrated human plasma in a polystyrene tube maintained in a water-bath at 37 °C. Add 0.1 mL of a dilution of the preparation to be examined containing 10 000 IU of streptokinase activity per millilitre in *phosphate buffer solution pH 7.2 R* and 0.1 mL of a solution of *human thrombin R* containing 20 IU/mL in *phosphate buffer solution pH 7.2 R*. Mix immediately. A clot forms and lyses within 30 min. Repeat the procedure using citrated bovine plasma. The clot does not lyse within 60 min.
- B. Perform an immunochemical test using double immunodiffusion techniques (2.7.1). Place in the central cavity about 80 µL of goat or rabbit antistreptokinase serum containing about 10 000 units of antistreptokinase activity per millilitre; place in each of the surrounding cavities about 80 µL of a dilution of the preparation to be examined containing 125 000 IU of streptokinase activity per millilitre. Allow the plates to stand in a humidified tank for 24 h. Only one precipitation arc appears and it is well defined.

## TESTS

**pH** (2.2.3): 6.8 to 7.5.

Dilute the preparation to be examined in *carbon dioxide-free water R* to obtain a solution containing at least 1000 000 IU of streptokinase activity per millilitre.

**Streptodornase**: maximum 10 IU of streptodornase activity per 100 000 IU of streptokinase activity.

*Test solution*. Dilute the preparation to be examined in *imidazole buffer solution pH 6.5 R* to obtain a solution containing 150 000 IU of streptokinase activity per millilitre.

*Reference solution*. Dissolve in *imidazole buffer solution pH 6.5 R* a reference preparation of streptodornase, calibrated in International Units against the International Standard of streptodornase, to obtain a solution containing 20 IU of streptodornase activity per millilitre. The equivalence in International Units of the International Standard is stated by the World Health Organisation.

To each of 8 numbered centrifuge tubes, add 0.5 mL of a 1 g/L solution of *sodium deoxyribonucleate R* in *imidazole buffer solution pH 6.5 R*. To tube number 1 and tube number 2 add 0.25 mL of *imidazole buffer solution pH 6.5 R*, 0.25 mL of the test solution and, immediately, 3.0 mL of perchloric acid (25 g/L HClO<sub>4</sub>). Mix, centrifuge at about 3000 *g* for 5 min and measure the absorbances (2.2.25) of the supernatant liquids at 260 nm, using as the compensation liquid a mixture of 1.0 mL of *imidazole buffer solution pH 6.5 R* and 3.0 mL of perchloric acid (25 g/L HClO<sub>4</sub>) (absorbances A<sub>1</sub> and A<sub>2</sub>). To the other 6 tubes (numbers 3 to 8) add 0.25 mL, 0.25 mL, 0.125 mL, 0.125 mL, 0 mL and 0 mL respectively of *imidazole buffer solution pH 6.5 R*; add to each tube 0.25 mL of the test solution and 0 mL, 0 mL, 0.125 mL, 0.125 mL, 0.25 mL and 0.25 mL respectively of the reference solution. Mix the contents of each tube and heat at 37 °C for 15 min. To each tube add 3.0 mL of perchloric acid (25 g/L HClO<sub>4</sub>), mix and centrifuge. Measure the absorbances (2.2.25) of the supernatant liquids at 260 nm using the compensation liquid described above (absorbances A<sub>3</sub> to A<sub>8</sub>). The absorbances comply with the following requirement:

$$(A_3 + A_4) - (A_1 + A_2) < \frac{(A_5 + A_6 + A_7 + A_8)}{2} - (A_3 + A_4)$$

**Streptolysin**. In a polystyrene tube, use a quantity of the preparation to be examined equivalent to 500 000 IU of streptokinase activity and dilute to 0.5 mL with a mixture of 1 volume of *phosphate buffer solution pH 7.2 R* and 9 volumes of a 9 g/L solution of *sodium chloride R*. Add 0.4 mL of a 23 g/L solution of *sodium thioglycollate R*. Heat in a water-bath at 37 °C for 10 min. Add 0.1 mL of a solution of a reference preparation of human antistreptolysin O containing 5 IU/mL. Heat at 37 °C for 5 min. Add 1 mL of *rabbit erythrocyte suspension R*. Heat at 37 °C for 30 min. Centrifuge at about 1000 *g*. In the same manner, prepare a polystyrene tube in which the solution of the preparation to be examined has been replaced by 0.5 mL of a mixture of 1 volume of *phosphate buffer solution pH 7.2 R* and 9 volumes of a 9 g/L solution of *sodium chloride R*. Measure the absorbances (2.2.25) of the supernatant liquids at 550 nm. The absorbance of the test solution is not more than 50 per cent greater than that of the reference solution.

**Related substances**. Liquid chromatography (2.2.29): use the normalisation procedure.

*Test solution*. Dilute the preparation to be examined with *water R* to obtain a concentration of about 0.5-1 g/L, depending on the chromatographic system used.

*Reference solution*. Dilute 1 volume of *streptokinase for system suitability CRS* with 49 volumes of *water R*.

*Column*:

- *size*: *l* = 0.10 m, Ø = 4.6 mm;
- *stationary phase*: *styrene-divinylbenzene copolymer R* (10 µm) with a pore size of 200 nm;
- *temperature*: 25 °C.

*Mobile phase*:

- *mobile phase A*: *trifluoroacetic acid R*, *water for injections R* (1:1000 V/V); degas;
- *mobile phase B*: *trifluoroacetic acid R*, *acetonitrile for chromatography R* (1:1000 V/V); degas;

Time (min)	Mobile phase A (per cent V/V)	Mobile phase B (per cent V/V)
0 - 1	68	32
1 - 4	68 → 52	32 → 48
4 - 5	52	48
5 - 7	0	100
7 - 10	68	32

The above conditions may be modified to improve the separation efficiency of the chromatographic system.

*Flow rate*: 5 mL/min.

*Detection*: spectrophotometer at 280 nm.

*Injection*: 20 µL.

*Retention time*: streptokinase = 2.3 min to 2.8 min.

*System suitability*: reference solution:

- *symmetry factor*: maximum 1.9 for the peak due to streptokinase;
- *peak-to-valley ratio*: minimum 2, where *H<sub>p</sub>* = height above the baseline of the 1<sup>st</sup> peak eluting after the principal peak and *H<sub>v</sub>* = height above the baseline of the lowest point of the curve separating this peak from the 2<sup>nd</sup> peak eluting after the principal peak;
- the chromatogram obtained with the reference solution is similar to the chromatogram supplied with *streptokinase for system suitability CRS*.

*Limit*:

- *total*: maximum 5 per cent.

01/2008:0053

**Bacterial endotoxins (2.6.14):** less than 0.02 IU per 100 IU of streptokinase activity, if intended for use without a further appropriate procedure for the removal of bacterial endotoxins.

## ASSAY

**Nitrogen (2.5.9).**

**Potency**

The potency of streptokinase is determined by comparing its capacity to activate plasminogen to form plasmin with the same capacity of a reference preparation of streptokinase calibrated in International Units; the formation of plasmin is determined using a suitable chromogenic substrate.

The International Unit is the activity of a stated amount of the International Standard for streptokinase. The equivalence in International Units of the International Standard is stated by the World Health Organisation.

*Reference and test solutions*

Prepare 2 independent series of at least 3 dilutions of each of the preparation to be examined and of the reference preparation of streptokinase in *tris(hydroxymethyl)aminomethane sodium chloride buffer solution pH 7.4 R1*, in the linear range of the assay (a range of 0.5–4.0 IU/mL has been found suitable).

Prepare and maintain all solutions at 37 °C.

*Substrate solution*

Mix 1.0 mL of *tris(hydroxymethyl)aminomethane buffer solution pH 7.4 R* with 1.0 mL of *chromogenic substrate R3*. Add 5 µL of a 100 g/L solution of *polysorbate 20 R*. Keep at 37 °C in a water-bath. Immediately before commencing the activation assay, add 45 µL of a 1 mg/mL solution of *human plasminogen R*.

*Method*

Analyse each streptokinase dilution, maintained at 37 °C, in duplicate. Initiate the activation reaction by adding 60 µL of each dilution to 40 µL of substrate solution. For blank wells, use 60 µL of *tris(hydroxymethyl)aminomethane sodium chloride buffer solution pH 7.4 R1* instead of the reference and test solutions. Allow the reaction to proceed at 37 °C for 20 min and read the absorbance (2.2.25) at 405 nm. If a suitable thermostatted plate reader is available, this may be used to monitor the reaction. Alternatively, it may be necessary to stop the reaction after 20 min using 50 µL of a 50 per cent *V/V* solution of *glacial acetic acid R*. Best results are obtained when the absorbance for the highest streptokinase concentration is between 0.1 and 0.2 (after blank subtraction). If necessary, adjust the time of incubation in order to reach this range of absorbances.

Calculate the regression of the absorbance on log concentrations of the solutions of the preparation to be examined and of the reference preparation of streptokinase and calculate the potency of the preparation to be examined using a suitable statistical method, for example the parallel-line assay (5.3).

The estimated potency is not less than 90 per cent and not more than 111 per cent of the stated potency. The confidence limits ( $P = 0.95$ ) are not less than 80 per cent and not more than 125 per cent of the estimated potency.

## STORAGE

In an airtight container, protected from light and at a temperature of –20 °C. If the preparation is sterile, store in a sterile, airtight, tamper-proof container.

## LABELLING

The label states:

- the number of International Units of streptokinase activity per milligram, calculated with reference to the dried preparation;
- that the preparation is suitable for use in the manufacture of parenteral preparations.

## STREPTOMYCIN SULFATE

## Streptomycini sulfas

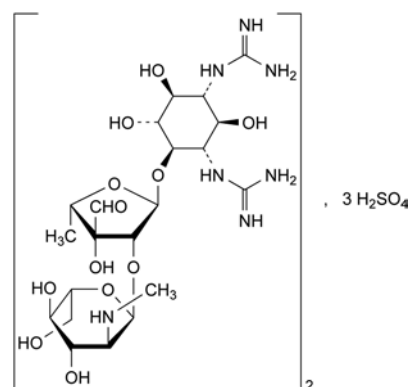

$C_{42}H_{84}N_{14}O_{36}S_3$   
[3810-74-0]

$M_r$  1457

## DEFINITION

Streptomycin sulfate is bis[*N,N*-bis(aminoiminomethyl)-4-*O*-[5-deoxy-2-*O*-[2-deoxy-2-(methylamino)- $\alpha$ -*L*-glucopyranosyl]-3-*C*-formyl- $\alpha$ -*L*-lyxofuranosyl]-*D*-streptamine] trisulfate, a substance produced by the growth of certain strains of *Streptomyces griseus* or obtained by any other means. Stabilisers may be added. The potency is not less than 720 IU/mg, calculated with reference to the dried substance.

## PRODUCTION

It is produced by methods of manufacture designed to eliminate or minimise substances lowering blood pressure.

The method of manufacture is validated to demonstrate that the product if tested would comply with the following test:

**Abnormal toxicity (2.6.9).** Inject into each mouse 1 mg of the substance to be examined dissolved in 0.5 mL of *water for injections R*.

## CHARACTERS

A white or almost white powder, hygroscopic, very soluble in water, practically insoluble in ethanol.

## IDENTIFICATION

A. Examine by thin-layer chromatography (2.2.27), using a plate coated with a 0.75 mm layer of the following mixture: mix 0.3 g of *carbomer R* with 240 mL of *water R* and allow to stand, with moderate shaking, for 1 h; adjust to pH 7 by the gradual addition, with continuous shaking, of *dilute sodium hydroxide solution R* and add 30 g of *silica gel H R*.

Heat the plate at 110 °C for 1 h, allow to cool and use immediately.

**Test solution.** Dissolve 10 mg of the substance to be examined in *water R* and dilute to 10 mL with the same solvent.

**Reference solution (a).** Dissolve 10 mg of *streptomycin sulfate CRS* in *water R* and dilute to 10 mL with the same solvent.

**Reference solution (b).** Dissolve 10 mg of *kanamycin monosulfate CRS*, 10 mg of *neomycin sulfate CRS* and 10 mg of *streptomycin sulfate CRS* in *water R* and dilute to 10 mL with the same solvent.

Apply separately to the plate 10 µL of each solution. Develop over a path of 12 cm using a 70 g/L solution of *potassium dihydrogen phosphate R*. Dry the plate in a current of warm air, and spray with a mixture of equal volumes of a 2 g/L solution of *1,3-dihydroxynaphthalene R* in *alcohol R* and a 460 g/L solution of *sulfuric acid R*. Heat at 150 °C for 5 min

to 10 min. The principal spot in the chromatogram obtained with the test solution is similar in position, colour and size to the spot in the chromatogram obtained with reference solution (a). The test is not valid unless the chromatogram obtained with reference solution (b) shows three clearly separated spots.

- B. Dissolve 5 mg to 10 mg in 4 mL of *water R* and add 1 mL of 1 M *sodium hydroxide*. Heat in a water-bath for 4 min. Add a slight excess of *dilute hydrochloric acid R* and 0.1 mL of *ferric chloride solution RI*. A violet colour develops.
- C. Dissolve 0.1 g in 2 mL of *water R*, add 1 mL of  $\alpha$ -*naphthol solution R* and 2 mL of a mixture of equal volumes of *strong sodium hypochlorite solution R* and *water R*. A red colour develops.
- D. Dissolve about 10 mg in 5 mL of *water R* and add 1 mL of 1 M *hydrochloric acid*. Heat in a water-bath for 2 min. Add 2 mL of a 5 g/L solution of  $\alpha$ -*naphthol R* in 1 M *sodium hydroxide* and heat in a water-bath for 1 min. A faint yellow colour develops.
- E. It gives the reactions of sulfates (2.3.1).

#### TESTS

**Solution S.** Dissolve 2.5 g in *carbon dioxide-free water R* and dilute to 10 mL with the same solvent.

**Appearance of solution.** Solution S is not more intensely coloured than intensity 3 of the range of reference solutions of the most appropriate colour (2.2.2, *Method II*). Allow to stand protected from light, at a temperature of about 20 °C for 24 h. Solution S is not more opalescent than reference suspension II (2.2.1).

**pH** (2.2.3). The pH of solution S is 4.5 to 7.0.

**Methanol.** Examine by gas chromatography (2.2.28).

**Test solution.** Dissolve 1.00 g of the substance to be examined in *water R* and dilute to 25.0 mL with the same solvent.

**Reference solution.** Dilute 12.0 mg of *methanol R* to 100 mL with *water R*.

The chromatographic procedure may be carried out using:

- a column 1.5 m to 2.0 m long and 2 mm to 4 mm in internal diameter, packed with *ethylvinylbenzene-divinylbenzene copolymer R* (150 µm to 180 µm),
- *nitrogen for chromatography R* as the carrier gas at a constant flow rate of 30 mL to 40 mL per minute,
- a flame-ionisation detector.

Maintain the column at a constant temperature between 120 °C and 140 °C and the injection port and the detector at a temperature at least 50 °C higher than that of the column. Inject the test solution and the reference solution. The area of the peak corresponding to methanol in the chromatogram obtained with the test solution is not greater than the area of the peak in the chromatogram obtained with the reference solution (0.3 per cent).

**Streptomycin B.** Examine by thin-layer chromatography (2.2.27), using *silica gel G R* as the coating substance.

**Test solution.** Dissolve 0.2 g of the substance to be examined in a freshly prepared mixture of 3 volumes of *sulfuric acid R* and 97 volumes of *methanol R* and dilute to 5 mL with the same mixture of solvents. Heat under a reflux condenser for 1 h, cool, rinse the condenser with *methanol R* and dilute to 20 mL with the same solvent (10 g/L solution).

**Reference solution.** Dissolve 36 mg of *mannose R* in a freshly prepared mixture of 3 volumes of *sulfuric acid R* and 97 volumes of *methanol R* and dilute to 5 mL with the same mixture of solvents. Heat under a reflux condenser for 1 h, cool, rinse the condenser with *methanol R* and dilute to 50 mL with the same solvent. Dilute 5 mL of the solution to 50 mL with *methanol R* (0.3 g/L solution expressed as streptomycin B; 1 mg of *mannose R* is equivalent to 4.13 mg of streptomycin B).

Apply separately to the plate 10 µL of each solution. Develop over a path of 13 cm to 15 cm using a mixture of 25 volumes of *glacial acetic acid R*, 25 volumes of *methanol R* and 50 volumes of *toluene R*. Allow the plate to dry in air and spray with a freshly prepared mixture of equal volumes of a 2 g/L solution of *1,3-dihydroxynaphthalene R* in *alcohol R* and a 20 per cent V/V solution of *sulfuric acid R* and heat at 110 °C for 5 min. Any spot corresponding to streptomycin B in the chromatogram obtained with the test solution is not more intense than the spot in the chromatogram obtained with the reference solution (3.0 per cent).

**Loss on drying** (2.2.32). Not more than 7.0 per cent, determined on 1.000 g by drying at 60 °C over *diphosphorus pentoxide R* at a pressure not exceeding 0.1 kPa for 24 h.

**Sulfated ash** (2.4.14). Not more than 1.0 per cent, determined on 1.000 g.

**Sulfate.** 18.0 per cent to 21.5 per cent of sulfate (SO<sub>4</sub>), calculated with reference to the dried substance. Dissolve 0.250 g in 100 mL of *water R* and adjust the solution to pH 11 using *concentrated ammonia R*. Add 10.0 mL of 0.1 M *barium chloride* and about 0.5 mg of *phthalein purple R*. Titrate with 0.1 M *sodium edetate* adding 50 mL of *alcohol R* when the colour of the solution begins to change and continue the titration until the violet-blue colour disappears. 1 mL of 0.1 M *barium chloride* is equivalent to 9.606 mg of sulfate (SO<sub>4</sub>).

**Colorimetric test.** Dry the substance to be examined and *streptomycin sulfate CRS* at 60 °C over *diphosphorus pentoxide R* at a pressure not exceeding 0.1 kPa for 24 h. Dissolve 0.100 g of the dried substance to be examined in *water R* and dilute to 100.0 mL with the same solvent. Prepare a reference solution in the same manner using 0.100 g of the dried *streptomycin sulfate CRS*. Place 5.0 mL of each solution separately in two volumetric flasks and in a third flask place 5 mL of *water R*. To each flask add 5.0 mL of 0.2 M *sodium hydroxide* and heat for exactly 10 min in a water-bath. Cool in ice for exactly 5 min, add 3 mL of a 15 g/L solution of *ferric ammonium sulfate R* in 0.5 M *sulfuric acid*, dilute to 25.0 mL with *water R* and mix. Exactly 20 min after the addition of the ferric ammonium sulfate solution measure the absorbance (2.2.25) of the test solution and the reference solution in a 2 cm cell at the maximum at 525 nm, using as compensation liquid the solution prepared from 5 mL of *water R*. The absorbance of the test solution is not less than 90.0 per cent of that of the reference solution.

**Bacterial endotoxins** (2.6.14): less than 0.25 IU/mg, if intended for use in the manufacture of parenteral preparations without a further appropriate procedure for removal of bacterial endotoxins.

#### ASSAY

Carry out the microbiological assay of antibiotics (2.7.2).

#### STORAGE

Store in an airtight container. If the substance is sterile, store in a sterile, airtight, tamper-proof container.

01/2008:0357  
corrected 6.0

## SUCCINYL-SULFATHIAZOLE

### Succinylsulfathiazolum

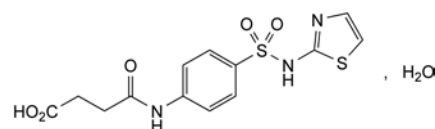

C<sub>13</sub>H<sub>13</sub>N<sub>3</sub>O<sub>5</sub>S<sub>2</sub>·H<sub>2</sub>O  
[116-43-8]

M<sub>r</sub> 373.4

## DEFINITION

4-Oxo-4-[[4-(thiazol-2-ylsulfamoyl)phenyl]amino]butanoic acid monohydrate.

*Content*: 99.0 per cent to 101.0 per cent (dried substance).

## CHARACTERS

*Appearance*: white or yellowish-white, crystalline powder.

*Solubility*: very slightly soluble in water, slightly soluble in acetone and in ethanol (96 per cent). It dissolves in solutions of alkali hydroxides and carbonates.

## IDENTIFICATION

*First identification*: A, D.

*Second identification*: B, C, D, E.

## A. Infrared absorption spectrophotometry (2.2.24).

*Comparison*: succinylsulfathiazole CRS.

If the spectra obtained in the solid state show differences, dissolve the substance to be examined and the reference substance separately in hot *water R*, allow to crystallise, dry the crystals carefully between 2 sheets of filter paper and prepare new discs.

B. To 2 g add 10 mL of *water R* and 10 mL of strong sodium hydroxide solution *R* and boil for 10 min. Cool and adjust to pH 3.0 with *hydrochloric acid R1*. Cool, adjust to pH 7.0 with *sodium hydrogen carbonate solution R* and filter. The precipitate, washed with *water R* and dried at 100-105 °C, melts (2.2.14) at 196 °C to 204 °C. Introduce the capillary containing the precipitate into the bath at a temperature of 190 °C.C. Heat 0.1 g in a test-tube over a small flame. Fumes are evolved which blacken *lead acetate paper R*.D. Place 0.1 g in a borosilicate-glass tube of about 30 mL, add 0.5 g of *hydroquinone R* and 1 mL of *sulfuric acid R*. Heat in a glycerin bath at 135 °C for 10 min, mixing at the beginning of heating to obtain a homogeneous liquid phase. Allow to cool and place in iced water. Add carefully and with shaking 15 mL of *water R*. Add 5 mL of *toluene R*, shake for 5-10 s and allow to stand for 2 min; promote separation of the 2 layers using a stirrer. The upper layer (toluene) is intense pink.E. Dissolve about 10 mg of the precipitate obtained in identification test B in 200 mL of 0.1 M *hydrochloric acid*. 2 mL of this solution gives the reaction of primary aromatic amines (2.3.1) with formation of an orange precipitate.

## TESTS

**Appearance of solution.** The solution is clear (2.2.1) and not more intensely coloured than reference solution Y<sub>4</sub> or BY<sub>4</sub> (2.2.2, *Method II*).

Dissolve 1.0 g in a mixture of 5 mL of *dilute sodium hydroxide solution R* and 15 mL of *water R*.

**Acidity.** To 2.0 g add 20 mL of *water R*, shake continuously for 30 min and filter. To 10 mL of the filtrate add 0.1 mL of *phenolphthalein solution R*. Not more than 2 mL of 0.1 M *sodium hydroxide* is required to change the colour of the indicator.

**Sulfathiazole and other primary aromatic amines:** maximum 0.75 per cent.

Dissolve 20 mg in a mixture of 3.5 mL of *water R*, 6 mL of *dilute hydrochloric acid R* and 25 mL of *ethanol (96 per cent) R*, previously cooled to 15 °C. Place immediately in iced water and add 1 mL of a 2.5 g/L solution of *sodium nitrite R*. Allow to stand for 3 min, add 2.5 mL of a 40 g/L solution of *sulfamic acid R* and allow to stand for 5 min. Add 1 mL of a 4 g/L solution of *naphthylethylenediamine dihydrochloride R* and dilute to 50 mL with *water R*. The absorbance (2.2.25) measured at 550 nm is not greater than that of a standard prepared at the same time and in the same manner using a mixture of 1.5 mL of a 100 mL aqueous solution containing 10 mg of *sulfathiazole R* and 0.5 mL of *hydrochloric acid R*;

2 mL of *water R*; 6 mL of *dilute hydrochloric acid R*; and 25 mL of *ethanol (96 per cent) R*.

**Heavy metals** (2.4.8): maximum 20 ppm.

1.0 g complies with test D. Prepare the reference solution using 2 mL of *lead standard solution (10 ppm Pb) R*.

**Loss on drying** (2.2.32): 4.0 per cent to 5.5 per cent, determined on 1.00 g by drying in an oven at 105 °C.

**Sulfated ash** (2.4.14): maximum 0.1 per cent, determined on 1.0 g.

## ASSAY

Dissolve 0.300 g in 100 mL of a mixture of 1 volume of *hydrochloric acid R* and 2 volumes of *water R*. Heat under a reflux condenser for 1 h. Carry out the determination of primary aromatic amino-nitrogen (2.5.8), determining the end-point electrometrically.

1 mL of 0.1 M *sodium nitrite* is equivalent to 35.54 mg of C<sub>13</sub>H<sub>13</sub>N<sub>3</sub>O<sub>5</sub>S<sub>2</sub>.

## STORAGE

Protected from light.

01/2011:1796

## SUCRALFATE

## Sucralfatum

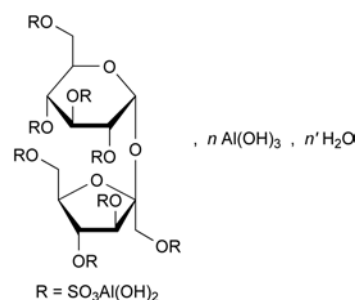

in which  $n = 8$  to 10 and  $n' = 22$  to 31

## DEFINITION

β-D-Fructofuranosyl-α-D-glucopyranoside octakis(dihydroxyaluminium sulfate) with 8-10 molecules of aluminium hydroxide and 22-31 molecules of water.

*Content*:

- β-D-fructofuranosyl-α-D-glucopyranoside octakis sulfate (sucrose octasulfate) (C<sub>12</sub>H<sub>14</sub>O<sub>35</sub>S<sub>8</sub><sup>8-</sup>; M<sub>r</sub> 975): 30.0 per cent to 36.0 per cent;
- aluminium (Al; A, 26.98): 16.5 per cent to 18.5 per cent.

## CHARACTERS

*Appearance*: white or almost white, amorphous powder.

*Solubility*: practically insoluble in water, in ethanol (96 per cent) and in methylene chloride. It dissolves in dilute solutions of mineral acids and alkali hydroxides.

## IDENTIFICATION

## A. Infrared absorption spectrophotometry (2.2.24).

*Comparison*: sucralfate CRS.

B. To 2 g add 10 mL of 0.1 M *hydrochloric acid* and boil. Cool and neutralise with 0.1 M *sodium hydroxide*. To 5 mL of the solution add 0.15 mL of freshly prepared *copper sulfate solution R* and 2 mL of freshly prepared *dilute sodium hydroxide solution R*. The solution is blue and clear and remains so after boiling. To the hot solution add 4 mL of

dilute hydrochloric acid R and boil for 1 min. Add 4 mL of dilute sodium hydroxide solution R; an orange precipitate is formed immediately.

- C. Dissolve about 15 mg in a mixture of 0.5 mL of dilute hydrochloric acid R and 2 mL of water R. The solution gives the reaction of aluminium (2.3.1).

TESTS

**Impurity A.** Liquid chromatography (2.2.29).

**Test solution.** Dissolve 450.0 mg of the substance to be examined in a mixture of equal volumes of an 88 g/L solution of sodium hydroxide R and a 196.2 g/L solution of sulfuric acid R and dilute to 10.0 mL with the same mixture of solvents. Without delay, while shaking at a moderate rate, add a volume (V), accurately measured in millilitres, of a 4 g/L solution of sodium hydroxide R to adjust the solution to approximately pH 2.3. Dilute the solution with (15.0 - V) mL of water R. Shake for 1 min. If the pH is not between 2.3 and 3.5, repeat the test using a different volume of a 4 g/L solution of sodium hydroxide R.

**Reference solution (a).** Dissolve 40.0 mg of potassium sucrose octasulfate CRS in the mobile phase and dilute to 5.0 mL with the mobile phase.

**Reference solution (b).** Dilute 1.0 mL of reference solution (a) to 10.0 mL with the mobile phase.

**Column:**

- size:  $l = 0.25$  m,  $\varnothing = 4.0$  mm;
- stationary phase: aminopropylsilyl silica gel for chromatography R (5  $\mu$ m).

**Mobile phase:** 70 g/L solution of ammonium sulfate R, adjusted to pH 3.5 with concentrated phosphoric acid R.

**Flow rate:** 1 mL/min.

**Detection:** differential refractometer.

**Injection:** 50  $\mu$ L of the test solution and reference solution (b).

**Relative retention** with reference to sucrose octasulfate (retention time = about 6 min): impurity A = about 0.6.

**System suitability:** reference solution (b):

- number of theoretical plates: minimum 400;
- symmetry factor: maximum 4.0.

**Limit:**

- impurity A: not more than 1.5 times the area of the principal peak in the chromatogram obtained with reference solution (b) (5.0 per cent).

**Neutralising capacity.** Disperse 0.25 g in 100.0 mL of 0.1 M hydrochloric acid, previously heated at 37 °C, stir continuously for 1 h in a water-bath at 37 °C and cool. Titrate 20.0 mL of this solution with 0.1 M sodium hydroxide to pH 3.5; not more than 14.0 mL of 0.1 M sodium hydroxide is required.

**Chlorides (2.4.4):** maximum 0.50 per cent.

Dissolve 0.10 g in 5 mL of dilute nitric acid R and dilute to 50 mL with water R. Dilute 5 mL of this solution to 15 mL with water R.

**Arsenic (2.4.2, Method A):** maximum 4 ppm.

Introduce 0.25 g of the substance to be examined and 5 mL of sulfuric acid R into a combustion flask. Carefully add a few millilitres of strong hydrogen peroxide solution R and heat to boiling until a clear, colourless solution is obtained. Continue heating to eliminate the water and as much sulfuric acid as possible and dilute to 25 mL with water R.

**Heavy metals (2.4.8):** maximum 10 ppm.

2.0 g complies with test F. Prepare the reference solution using 2 mL of lead standard solution (10 ppm Pb) R.

ASSAY

**Aluminium.** Disperse 1.0 g in 10 mL of 6 M hydrochloric acid R. Heat with continuous stirring in a water-bath at 70 °C for 5 min. Cool to room temperature, transfer quantitatively to

a volumetric flask, dilute to 250.0 mL with water R, and mix. Filter the solution, discarding the 1<sup>st</sup> portion of the filtrate. To 10.0 mL of the solution, add 10.0 mL of 0.1 M sodium edetate and 30 mL of a mixture of equal volumes of ammonium acetate solution R and dilute acetic acid R. Heat in a water-bath at 70 °C for 5 min, then cool. Add 25 mL of ethanol (96 per cent) R and 1 mL of a freshly prepared 0.25 g/L solution of dithizone R in ethanol (96 per cent) R. Titrate the excess of sodium edetate with 0.1 M zinc sulfate until the colour changes to pink.

1 mL of 0.1 M sodium edetate is equivalent to 2.698 mg of Al.

**Sucrose octasulfate.** Liquid chromatography (2.2.29) as described in the test for impurity A with the following modifications.

**Mobile phase:** 132 g/L solution of ammonium sulfate R, adjusted to pH 3.5 with concentrated phosphoric acid R.

**Injection:** test solution and reference solution (a).

Calculate the percentage content of C<sub>12</sub>H<sub>14</sub>O<sub>35</sub>S<sub>8</sub> from the declared content of potassium sucrose octasulfate CRS and by multiplying the potassium sucrose octasulfate content by 0.757.

IMPURITIES

**Specified impurities: A.**

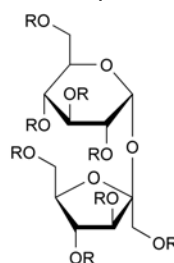

R = SO<sub>3</sub>H

and H in a 7 to 1 ratio

- A.  $\beta$ -D-fructofuranosyl- $\alpha$ -D-glucopyranoside heptakis (hydrogensulfate).

01/2009:0204

SUCROSE

Saccharum

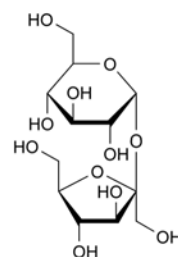

C<sub>12</sub>H<sub>22</sub>O<sub>11</sub>  
[57-50-1]

M<sub>r</sub>, 342.3

DEFINITION

$\beta$ -D-Fructofuranosyl  $\alpha$ -D-glucopyranoside.

It contains no additives.

CHARACTERS

**Appearance:** white or almost white, crystalline powder, or lustrous, colourless or white or almost white crystals.

**Solubility:** very soluble in water, slightly soluble in ethanol (96 per cent), practically insoluble in anhydrous ethanol.

IDENTIFICATION

**First identification: A.**

**Second identification: B, C.**

## A. Infrared absorption spectrophotometry (2.2.24).

*Comparison: sucrose CRS.*

## B. Thin-layer chromatography (2.2.27).

*Test solution.* Dissolve 10 mg of the substance to be examined in a mixture of 2 volumes of *water R* and 3 volumes of *methanol R* and dilute to 20 mL with the same mixture of solvents.

*Reference solution (a).* Dissolve 10 mg of *sucrose CRS* in a mixture of 2 volumes of *water R* and 3 volumes of *methanol R* and dilute to 20 mL with the same mixture of solvents.

*Reference solution (b).* Dissolve 10 mg each of *fructose CRS*, *glucose CRS*, *lactose CRS* and *sucrose CRS* in a mixture of 2 volumes of *water R* and 3 volumes of *methanol R* and dilute to 20 mL with the same mixture of solvents.

*Plate: TLC silica gel G plate R.*

*Mobile phase: cold saturated boric acid solution R*, 60 per cent *V/V* solution of *glacial acetic acid R*, *ethanol R*, *acetone R*, *ethyl acetate R* (10:15:20:60:60 *V/V/V/V/V*).

*Application: 2 µL.*

*Development: in an unsaturated tank over a path of 15 cm.*

*Drying: in a current of warm air.*

*Detection: spray with a solution of 0.5 g of thymol R in a mixture of 5 mL of sulfuric acid R and 95 mL of alcohol R. Heat the plate at 130 °C for 10 min.*

*System suitability: the chromatogram obtained with reference solution (b) shows 4 clearly separated spots.*

*Results: the principal spot in the chromatogram obtained with the test solution is similar in position, colour and size to the principal spot in the chromatogram obtained with reference solution (a).*

- C. Dilute 1 mL of solution S (see Tests) to 100 mL with *water R*. To 5 mL of the solution add 0.15 mL of freshly prepared *copper sulfate solution R* and 2 mL of freshly prepared *dilute sodium hydroxide solution R*. The solution is blue and clear and remains so after boiling. To the hot solution add 4 mL of *dilute hydrochloric acid R* and boil for 1 min. Add 4 mL of *dilute sodium hydroxide solution R*. An orange precipitate is formed immediately.

## TESTS

**Solution S.** Dissolve 50.0 g in *water R* and dilute to 100 mL with the same solvent.

**Appearance of solution.** Solution S is clear (2.2.1).

**Conductivity** (2.2.38): maximum 35 µS·cm<sup>-1</sup> at 20 °C.

Dissolve 31.3 g in *carbon dioxide-free water R* prepared from *distilled water R* and dilute to 100 mL with the same solvent. Measure the conductivity of the solution (*C*<sub>1</sub>), while gently stirring with a magnetic stirrer, and that of the water used for preparing the solution (*C*<sub>2</sub>). The readings must be stable within 1 per cent over a period of 30 s. Calculate the conductivity of the solution of the substance to be examined from the following expression:

$$C_1 - 0.35 C_2$$

**Specific optical rotation** (2.2.7): + 66.3 to + 67.0.

Dissolve 26.0 g in *water R* and dilute to 100.0 mL with the same solvent.

**Colour value:** maximum 45.

Dissolve 50.0 g in 50.0 mL of *water R*. Mix, filter (diameter of pores 0.45 µm) and degas. Measure the absorbance (2.2.25) at 420 nm, using a cell of minimum 4 cm (a cell length of 10 cm or more is preferred).

Calculate the colour value using the following expression:

$$\frac{A \times 1000}{b \times c}$$

*A* = absorbance measured at 420 nm;

*b* = path length in centimetres;

*c* = concentration of the solution, in grams per millilitre, calculated from the refractive index (2.2.6) of the solution; use Table 0204.-1 and interpolate the values if necessary.

Table 0204.-1

<sup>20</sup> <i>n</i> <sub>D</sub>	<i>c</i> (g/mL)
1.4138	0.570
1.4159	0.585
1.4179	0.600
1.4200	0.615
1.4221	0.630
1.4243	0.645
1.4264	0.661

*System suitability:*

– *repeatability:* the absolute difference between 2 results is not greater than 3.

**Dextrins.** If intended for use in the manufacture of large-volume parenteral preparations, it complies with the test for dextrins. To 2 mL of solution S add 8 mL of *water R*, 0.05 mL of *dilute hydrochloric acid R* and 0.05 mL of 0.05 *M iodine*. The solution remains yellow.

**Reducing sugars.** To 5 mL of solution S in a test-tube about 150 mm long and 16 mm in diameter add 5 mL of *water R*, 1.0 mL of 1 *M sodium hydroxide* and 1.0 mL of a 1 g/L solution of *methylene blue R*. Mix and place in a water-bath. After exactly 2 min, take the tube out of the bath and examine the solution immediately. The blue colour does not disappear completely. Ignore any blue colour at the air/solution interface.

**Sulfites:** maximum 10 ppm, calculated as SO<sub>2</sub>.

Determine the sulfites content by a suitable enzymatic method based on the following reactions. Sulfite is oxidised by sulfite oxidase to sulfate and hydrogen peroxide which in turn is reduced by nicotinamide-adenine dinucleotide-peroxidase in the presence of reduced nicotinamide-adenine dinucleotide (NADH). The amount of NADH oxidised is proportional to the amount of sulfite.

*Test solution.* Dissolve 4.0 g of the substance to be examined in freshly prepared *distilled water R* and dilute to 10.0 mL with the same solvent.

*Reference solution.* Dissolve 4.0 g of the substance to be examined in freshly prepared *distilled water R*, add 0.5 mL of *sulfite standard solution (80 ppm SO<sub>2</sub>) R* and dilute to 10.0 mL with freshly prepared *distilled water R*.

*Blank solution.* Freshly prepared *distilled water R*.

Separately introduce 2.0 mL each of the test solution, the reference solution and the blank in 10 mm cuvettes and add the reagents as described in the instructions in the kit for sulfite determination. Measure the absorbance (2.2.25) at the absorption maximum at about 340 nm before and at the end of the reaction time and subtract the value obtained with the blank.

The absorbance difference of the test solution is not greater than half the absorbance difference of the reference solution.

**Loss on drying** (2.2.32): maximum 0.1 per cent, determined on 2.000 g by drying in an oven at 105 °C for 3 h.

**Bacterial endotoxins (2.6.14):** less than 0.25 IU/mg, if intended for use in the manufacture of large-volume parenteral preparations.

**LABELLING**

The label states, where applicable, that the substance is suitable for use in the manufacture of large-volume parenteral preparations.

07/2009:2319

**SUCROSE MONOPALMITATE**

Sacchari monopalmitas

**DEFINITION**

Mixture of sucrose monoesters, mainly sucrose monopalmitate, obtained by transesterification of palmitic acid methyl esters of vegetable origin with *Sucrose (0204)*. The manufacture of the fatty acid methyl esters includes a distillation step.

It contains variable quantities of mono-, di-, tri- and polyesters.

**Content:**

- *monoesters*: minimum 55.0 per cent;
- *diesters*: maximum 40.0 per cent;
- *sum of triesters and polyesters*: maximum 20.0 per cent.

**CHARACTERS**

**Appearance:** white or almost white, unctuous powder.

**Solubility:** very slightly soluble in water, sparingly soluble in ethanol (96 per cent).

**IDENTIFICATION**

- A. Composition of fatty acids (see Tests).
- B. It complies with the limits of the assay.

**TESTS**

**Acid value (2.5.1):** maximum 6.0, determined on 3.00 g.

Use a freshly neutralised mixture of 1 volume of *water R* and 2 volumes of *2-propanol R* as solvent and heat gently.

**Composition of fatty acids (2.4.22, Method C).** Use the mixture of calibrating substances in Table 2.4.22.-1.

**Composition of the fatty-acid fraction of the substance:**

- *lauric acid*: maximum 3.0 per cent;
- *myristic acid*: maximum 3.0 per cent;
- *palmitic acid*: 70.0 per cent to 85.0 per cent;
- *stearic acid*: 10.0 per cent to 25.0 per cent;
- *sum of the contents of palmitic acid and stearic acid*: minimum 90.0 per cent.

**Free sucrose.** Liquid chromatography (2.2.29).

**Solvent mixture:** *water for chromatography R*, *tetrahydrofuran for chromatography R* (12.5:87.5 V/V).

**Test solution.** Dissolve 0.200 g of the substance to be examined in the solvent mixture and dilute to 4.0 mL with the solvent mixture.

**Reference solution (a).** Dissolve 20.0 mg of *sucrose CRS* in the solvent mixture and dilute to 10.0 mL with the solvent mixture. Dilute 1.0 mL of this solution to 10.0 mL with the solvent mixture.

**Reference solution (b).** In 4 volumetric flasks, introduce respectively 5.0 mg, 10.0 mg, 20.0 mg and 25.0 mg of *sucrose CRS*, dissolve in the solvent mixture and dilute to 10.0 mL with the solvent mixture.

**Column:**

- *size*:  $l = 0.25$  m,  $\varnothing = 4.6$  mm;

– *stationary phase*: spherical *aminopropylsilyl silica gel for chromatography R* (4  $\mu$ m).

**Mobile phase:**

- *mobile phase A*: 0.01 g/L solution of *ammonium acetate R* in *acetonitrile for chromatography R*;
- *mobile phase B*: 0.01 g/L solution of *ammonium acetate R* in a mixture of 10 volumes of *water for chromatography R* and 90 volumes of *tetrahydrofuran for chromatography R*;

Time (min)	Mobile phase A (per cent V/V)	Mobile phase B (per cent V/V)	Flow rate (mL/min)
0 - 1	100	0	1.0
1 - 9	100 → 0	0 → 100	1.0
9 - 16	0	100	1.0
16 - 16.01	0	100	1.0 → 2.5
16.01 - 32	0	100	2.5
32 - 33	0 → 100	100 → 0	2.5
33 - 36	100	0	2.5 → 1.0

**Detection:** evaporative light-scattering detector; the following settings have been found to be suitable; if the detector has different setting parameters, adjust the detector settings so as to comply with the system suitability criterion:

- *carrier gas*: *nitrogen R*;
- *flow rate*: 1.0 mL/min;
- *evaporator temperature*: 45 °C;
- *nebuliser temperature*: 40 °C.

**Injection:** 20  $\mu$ L.

**Retention time:** about 26 min.

**System suitability:** reference solution (a):

- *signal-to-noise ratio*: minimum 10.

**Limit:** maximum 4.0 per cent.

**Water (2.5.12):** maximum 4.0 per cent, determined on 0.20 g.

**Total ash (2.4.16):** maximum 1.5 per cent.

**ASSAY**

Size-exclusion chromatography (2.2.30): use the normalisation procedure.

**Test solution.** Dissolve 60.0 mg of the substance to be examined in *tetrahydrofuran R* and dilute to 4.0 mL with the same solvent.

**Column:**

- *size*:  $l = 0.6$  m,  $\varnothing = 7$  mm;
- *stationary phase*: *styrene-divinylbenzene copolymer R* (5  $\mu$ m) with a pore size of 10 nm.

**Mobile phase:** *tetrahydrofuran R*.

**Flow rate:** 1.2 mL/min.

**Detection:** differential refractometer.

**Injection:** 20  $\mu$ L.

**Relative retention** with reference to monoesters (retention time = about 10 min): diesters = about 0.92; triesters and polyesters = about 0.90.

**Calculations:**

- *disregard limit*: disregard the peaks having a signal-to-noise ratio less than 10;
- *free fatty acids (D)*: calculate the percentage content of free fatty acids, using the following expression:

$$\frac{I_A \times 256}{561.1}$$

$I_A$  = acid value.

- *monoesters*: calculate the percentage content of monoesters using the following expression:

$$\frac{A \times (100 - D - S - E)}{100}$$

- *diesters*: calculate the percentage content of diesters using the following expression:

$$\frac{B \times (100 - D - S - E)}{100}$$

- *sum of triesters and polyesters*: calculate the sum of the percentage contents of triesters and polyesters using the following expression:

$$\frac{C \times (100 - D - S - E)}{100}$$

- A* = percentage content of monoesters determined by the normalisation procedure;  
*S* = percentage content of free sucrose (see Tests);  
*E* = percentage content of water (see Tests);  
*B* = percentage content of diesters determined by the normalisation procedure;  
*C* = sum of the percentage contents of triesters and polyesters determined by the normalisation procedure.

#### STORAGE

Protected from humidity.

07/2009:2318

## SUCROSE STEARATE

### Sacchari stearas

#### DEFINITION

Mixture of sucrose esters, mainly sucrose stearate, obtained by transesterification of stearic acid methyl esters of vegetable origin with *sucrose* (0204). The manufacture of the fatty acid methyl esters includes a distillation step.

It contains variable quantities of mono-, di-, tri- and polyesters.

#### Content:

##### Sucrose stearate type I:

- *monoesters*: minimum 50.0 per cent;
- *diesters*: maximum 40.0 per cent;
- *sum of triesters and polyesters*: maximum 25.0 per cent;

##### Sucrose stearate type II:

- *monoesters*: 20.0 per cent to 45.0 per cent;
- *diesters*: 30.0 per cent to 40.0 per cent;
- *sum of triesters and polyesters*: maximum 30.0 per cent;

##### Sucrose stearate type III:

- *monoesters*: 15.0 per cent to 25.0 per cent;
- *diesters*: 30.0 per cent to 45.0 per cent;
- *sum of triesters and polyesters*: 35.0 per cent to 50.0 per cent.

#### CHARACTERS

*Appearance*: white or almost white, unctuous powder.

*Solubility*: very slightly soluble in water, sparingly soluble in ethanol (96 per cent).

#### IDENTIFICATION

- A. Composition of fatty acids (see Tests).
- B. It complies with the limits of the assay.

#### TESTS

**Acid value** (2.5.1): maximum 6.0, determined on 3.00 g.

Use a freshly neutralised mixture of 1 volume of *water R* and 2 volumes of *2-propanol R* as solvent and heat gently.

**Composition of fatty acids** (2.4.22, Method C). Use the mixture of calibrating substances in Table 2.4.22-1.

*Composition of the fatty-acid fraction of the substance*:

- *lauric acid*: maximum 3.0 per cent;
- *myristic acid*: maximum 3.0 per cent;
- *palmitic acid*: 25.0 per cent to 40.0 per cent;
- *stearic acid*: 55.0 per cent to 75.0 per cent;
- *sum of the contents of palmitic acid and stearic acid*: minimum 90.0 per cent.

**Free sucrose**. Liquid chromatography (2.2.29).

*Solvent mixture*: *water for chromatography R*, *tetrahydrofuran for chromatography R* (12.5:87.5 V/V).

*Test solution*. Dissolve 0.200 g of the substance to be examined in the solvent mixture and dilute to 4.0 mL with the solvent mixture.

*Reference solution (a)*. Dissolve 20.0 mg of *sucrose CRS* in the solvent mixture and dilute to 10.0 mL with the solvent mixture. Dilute 1.0 mL of this solution to 10.0 mL with the solvent mixture.

*Reference solution (b)*. In 4 volumetric flasks, introduce respectively 5.0 mg, 10.0 mg, 20.0 mg and 25.0 mg of *sucrose CRS*, dissolve in the solvent mixture and dilute to 10.0 mL with the solvent mixture.

#### Column:

- *size*:  $l = 0.25$  m,  $\varnothing = 4.6$  mm;
- *stationary phase*: spherical *aminopropylsilyl silica gel for chromatography R* (4  $\mu$ m).

#### Mobile phase:

- *mobile phase A*: 0.01 g/L solution of *ammonium acetate R* in *acetonitrile for chromatography R*;
- *mobile phase B*: 0.01 g/L solution of *ammonium acetate R* in a mixture of 10 volumes of *water for chromatography R* and 90 volumes of *tetrahydrofuran for chromatography R*;

Time (min)	Mobile phase A (per cent V/V)	Mobile phase B (per cent V/V)	Flow rate (mL/min)
0 - 1	100	0	1.0
1 - 9	100 → 0	0 → 100	1.0
9 - 16	0	100	1.0
16 - 16.01	0	100	1.0 → 2.5
16.01 - 32	0	100	2.5
32 - 33	0 → 100	100 → 0	2.5
33 - 36	100	0	2.5 → 1.0

*Detection*: evaporative light-scattering detector; the following settings have been found to be suitable; if the detector has different setting parameters, adjust the detector settings so as to comply with the system suitability criterion:

- *carrier gas*: *nitrogen R*;
- *flow rate*: 1.0 mL/min;
- *evaporator temperature*: 45 °C;
- *nebuliser temperature*: 40 °C.

*Injection*: 20  $\mu$ L.

*Retention time*: about 26 min.

*System suitability*: reference solution (a):

- *signal-to-noise ratio*: minimum 10.

#### Limit:

- *sucrose*: maximum 4.0 per cent.

**Water** (2.5.12): maximum 4.0 per cent, determined on 0.20 g.

**Total ash** (2.4.16): maximum 1.5 per cent.



## ASSAY

01/2008:1569

Size-exclusion chromatography (2.2.30): use the normalisation procedure.

**Test solution.** Dissolve 60.0 mg of the substance to be examined in *tetrahydrofuran R* and dilute to 4.0 mL with the same solvent.

**Column:**

- size:  $l = 0.6$  m,  $\emptyset = 7$  mm;
- stationary phase: *styrene-divinylbenzene copolymer R* (5  $\mu$ m) with a pore size of 10 nm.

**Mobile phase:** *tetrahydrofuran R*.

**Flow rate:** 1.2 mL/min.

**Detection:** differential refractometer.

**Injection:** 20  $\mu$ L.

**Relative retention** with reference to monoesters (retention time = about 10 min): diesters = about 0.92; triesters and polyesters = about 0.90.

**Calculations:**

- **disregard limit:** disregard the peaks having a signal-to-noise ratio less than 10;
- **free fatty acids (D):** calculate the percentage content of free fatty acids, using the following expression:

$$\frac{I_A \times 284.5}{561.1}$$

$I_A$  = acid value;

- **monoesters:** calculate the percentage content of monoesters using the following expression:

$$\frac{A \times (100 - D - S - E)}{100}$$

- **diesters:** calculate the percentage content of diesters using the following expression:

$$\frac{B \times (100 - D - S - E)}{100}$$

- **sum of triesters and polyesters:** calculate the sum of the percentage contents of triesters and polyesters using the following expression:

$$\frac{C \times (100 - D - S - E)}{100}$$

$A$  = percentage content of monoesters determined by the normalisation procedure;

$S$  = percentage content of free sucrose (see Tests);

$E$  = percentage content of water (see Tests);

$B$  = percentage content of diesters determined by the normalisation procedure;

$C$  = sum of the percentage contents of triesters and polyesters determined by the normalisation procedure.

## LABELLING

The label states the type of sucrose stearate (type I, II or III).

## STORAGE

Protected from humidity.

## SUFENTANIL

## Sufentanilum

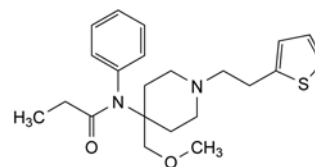

$C_{22}H_{30}N_2O_2S$   
[56030-54-7]

$M_r$  386.6

## DEFINITION

*N*-[4-(Methoxymethyl)-1-[2-(thiophen-2-yl)ethyl]piperidin-4-yl]-*N*-phenylpropanamide.

**Content:** 99.0 per cent to 101.0 per cent (dried substance).

## CHARACTERS

**Appearance:** white or almost white powder.

**Solubility:** practically insoluble in water, freely soluble in ethanol (96 per cent) and in methanol.

mp: about 98 °C.

## IDENTIFICATION

Infrared absorption spectrophotometry (2.2.24).

**Comparison:** *Ph. Eur. reference spectrum of sufentanil.*

## TESTS

**Appearance of solution.** The solution is clear (2.2.1) and colourless (2.2.2, *Method II*).

Dissolve 0.10 g in *methanol R* and dilute to 20 mL with the same solvent.

**Related substances.** Liquid chromatography (2.2.29).

**Test solution.** Dissolve 0.100 g of the substance to be examined in *methanol R* and dilute to 10.0 mL with the same solvent.

**Reference solution (a).** In order to produce impurity E *in situ*, dissolve 10 mg of the substance to be examined in 10.0 mL of *dilute hydrochloric acid R*. Heat on a water-bath under a reflux condenser for 4 h. Add 10.0 mL of *dilute sodium hydroxide solution R*. Evaporate to dryness on a water-bath. Cool and take up the residue in 10 mL of *methanol R*. Filter.

**Reference solution (b).** Dilute 1.0 mL of the test solution to 100.0 mL with *methanol R*. Dilute 5.0 mL of this solution to 20.0 mL with *methanol R*.

**Column:**

- size:  $l = 0.1$  m,  $\emptyset = 4.6$  mm;
- stationary phase: *octadecylsilyl silica gel for chromatography R* (3  $\mu$ m).

**Mobile phase:**

- **mobile phase A:** 5 g/L solution of *ammonium carbonate R* in a mixture of 10 volumes of *tetrahydrofuran R* and 90 volumes of *water R*;
- **mobile phase B:** *acetonitrile R*;

Time (min)	Mobile phase A (per cent V/V)	Mobile phase B (per cent V/V)
0 - 15	90 → 40	10 → 60
15 - 20	40	60

**Flow rate:** 1.5 mL/min.

**Detection:** spectrophotometer at 220 nm.

**Equilibration:** with *acetonitrile R* for at least 30 min and then with the mobile phase at the initial composition for at least 5 min.

**Injection:** 10  $\mu$ L; inject *methanol R* as a blank.

**Retention time:** impurity E = about 12 min; sufentanil = about 13 min.

**System suitability:** reference solution (a):

- **resolution:** minimum 4.0 between the peaks due to impurity E and sufentanil; if necessary, adjust the concentration of acetonitrile in the mobile phase or adjust the time programme for the linear gradient elution.

**Limits:**

- **impurities D, F, H:** for each impurity, not more than the area of the principal peak in the chromatogram obtained with reference solution (b) (0.25 per cent);
- **total:** not more than twice the area of the principal peak in the chromatogram obtained with reference solution (b) (0.5 per cent);
- **disregard limit:** 0.2 times the area of the principal peak in the chromatogram obtained with reference solution (b) (0.05 per cent).

**Loss on drying (2.2.32):** maximum 0.5 per cent, determined on 1.000 g by drying *in vacuo* at 60 °C for 2 h.

#### ASSAY

Dissolve 0.300 g in 50 mL of a mixture of 1 volume of *anhydrous acetic acid R* and 7 volumes of *methyl ethyl ketone R* and titrate with 0.1 M *perchloric acid*, using 0.2 mL of *naphtholbenzein solution R* as indicator.

1 mL of 0.1 M *perchloric acid* is equivalent to 38.66 mg of  $C_{22}H_{30}N_2O_2S$ .

#### STORAGE

Protected from light.

#### IMPURITIES

**Specified impurities:** D, F, H.

**Other detectable impurities** (the following substances would, if present at a sufficient level, be detected by one or other of the tests in the monograph. They are limited by the general acceptance criterion for other/unspecified impurities and/or by the general monograph *Substances for pharmaceutical use (2034)*. It is therefore not necessary to identify these impurities for demonstration of compliance. See also 5.10. **Control of impurities in substances for pharmaceutical use**): A, B, C, E, G, I.

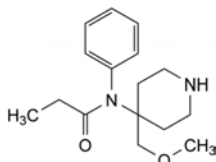

A. *N*-[4-(methoxymethyl)piperidin-4-yl]-*N*-phenylpropanamide,

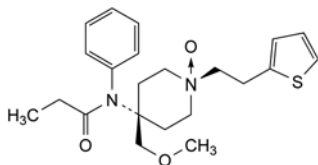

B. *cis*-4-(methoxymethyl)-4-(phenylpropanoylamino)-1-[2-(thiophen-2-yl)ethyl]piperidine 1-oxide,

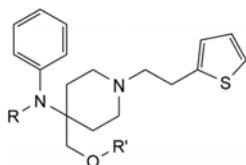

C. R = R' = H: [4-(phenylamino)-1-[2-(thiophen-2-yl)ethyl]piperidin-4-yl]methanol,

D. R = CO-CH<sub>3</sub>, R' = CH<sub>3</sub>: *N*-[4-(methoxymethyl)-1-[2-(thiophen-2-yl)ethyl]piperidin-4-yl]-*N*-phenylacetamide,

E. R = H, R' = CH<sub>3</sub>: 4-(methoxymethyl)-*N*-phenyl-1-[2-(thiophen-2-yl)ethyl]piperidin-4-amine,

G. R = R' = CO-CH<sub>2</sub>-CH<sub>3</sub>: [4-(phenylpropanoylamino)-1-[2-(thiophen-2-yl)ethyl]piperidin-4-yl]methyl propanoate,

H. R = CO-CH<sub>2</sub>-CH<sub>2</sub>-CH<sub>3</sub>, R' = CH<sub>3</sub>: *N*-[4-(methoxymethyl)-1-[2-(thiophen-2-yl)ethyl]piperidin-4-yl]-*N*-phenylbutanamide,

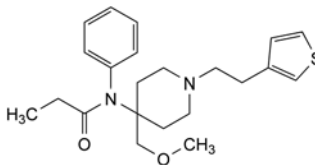

F. *N*-[4-(methoxymethyl)-1-[2-(thiophen-3-yl)ethyl]piperidin-4-yl]-*N*-phenylpropanamide,

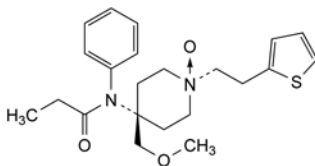

I. *trans*-4-(methoxymethyl)-4-(phenylpropanoylamino)-1-[2-(thiophen-2-yl)ethyl]piperidine 1-oxide.

01/2008:1269

## SUFENTANIL CITRATE

### Sufentanili citras

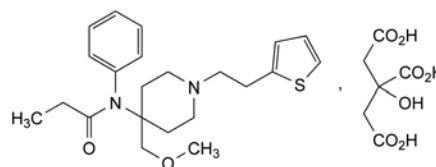

$C_{28}H_{38}N_2O_9S$   
[60561-17-3]

$M_r$  578.7

#### DEFINITION

*N*-[4-(Methoxymethyl)-1-[2-(thiophen-2-yl)ethyl]piperidin-4-yl]-*N*-phenylpropanamide citrate.

**Content:** 99.0 per cent to 101.0 per cent (dried substance).

#### CHARACTERS

**Appearance:** white or almost white powder.

**Solubility:** soluble in water and in ethanol (96 per cent), freely soluble in methanol.

mp: about 140 °C, with decomposition.

#### IDENTIFICATION

Infrared absorption spectrophotometry (2.2.24).

**Comparison:** *Ph. Eur. reference spectrum of sufentanil citrate.*

#### TESTS

**Appearance of solution.** The solution is clear (2.2.1) and colourless (2.2.2, *Method II*).

Dissolve 0.2 g in *water R* and dilute to 20 mL with the same solvent.

**Related substances.** Liquid chromatography (2.2.29).

**Test solution.** Dissolve 0.100 g of the substance to be examined in *methanol R* and dilute to 10.0 mL with the same solvent.

**Reference solution (a).** In order to produce impurity E *in situ*, dissolve 10 mg of the substance to be examined in 10.0 mL of *dilute hydrochloric acid R*. Heat on a water-bath under a reflux condenser for 4 h. Add 10.0 mL of *dilute sodium hydroxide solution R*. Evaporate to dryness on a water-bath. Cool and take up the residue in 10 mL of *methanol R*. Filter.

*Reference solution (b).* Dilute 5.0 mL of the test solution to 100.0 mL with *methanol R*. Dilute 1.0 mL of this solution to 10.0 mL with *methanol R*.

*Column:*

- size:  $l = 0.1$  m,  $\emptyset = 4.6$  mm;
- stationary phase: octadecylsilyl silica gel for chromatography R (3  $\mu$ m).

*Mobile phase:*

- mobile phase A: 5 g/L solution of ammonium carbonate R in a mixture of 10 volumes of tetrahydrofuran R and 90 volumes of water R;
- mobile phase B: acetonitrile R;

Time (min)	Mobile phase A (per cent V/V)	Mobile phase B (per cent V/V)
0 - 15	90 → 40	10 → 60
15 - 20	40	60

*Flow rate:* 1.5 mL/min.

*Detection:* spectrophotometer at 220 nm.

*Equilibration:* with acetonitrile R for at least 30 min and then with the mobile phase at the initial composition for at least 5 min.

*Injection:* 10  $\mu$ L; inject *methanol R* as a blank.

*Retention time:* impurity E = about 12 min; sufentanil = about 13 min.

*System suitability:* reference solution (a):

- resolution: minimum 4.0 between the peaks due to impurity E and sufentanil; if necessary, adjust the concentration of acetonitrile in the mobile phase or adjust the time programme for the linear gradient elution.

*Limits:*

- impurities A, B, C, D, E, F, G, H, I: for each impurity, not more than the area of the principal peak in the chromatogram obtained with reference solution (b) (0.5 per cent);
- total: not more than twice the area of the principal peak in the chromatogram obtained with reference solution (b) (1 per cent);
- disregard limit: 0.1 times the area of the principal peak in the chromatogram obtained with reference solution (b) (0.05 per cent); disregard any peak with a retention time relative to sufentanil of 0.05 or less.

**Loss on drying (2.2.32):** maximum 0.5 per cent, determined on 1.000 g by drying *in vacuo* at 60 °C.

**ASSAY**

Dissolve 0.400 g in 50 mL of a mixture of 1 volume of *anhydrous acetic acid R* and 7 volumes of *methyl ethyl ketone R* and titrate with 0.1 M *perchloric acid*, using 0.2 mL of *naphtholbenzein solution R* as indicator.

1 mL of 0.1 M *perchloric acid* is equivalent to 57.87 mg of  $C_{28}H_{38}N_2O_9S$ .

**STORAGE**

Protected from light.

**IMPURITIES**

*Specified impurities:* A, B, C, D, E, F, G, H, I.

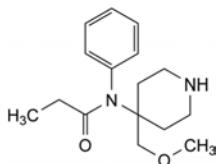

A. *N*-[4-(methoxymethyl)piperidin-4-yl]-*N*-phenylpropanamide,

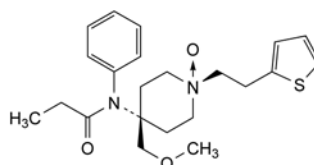

B. *cis*-4-(methoxymethyl)-4-(phenylpropanoylamino)-1-[2-(thiophen-2-yl)ethyl]piperidine 1-oxide,

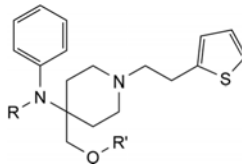

C. R = R' = H: [4-(phenylamino)-1-[2-(thiophen-2-yl)ethyl]piperidin-4-yl]methanol,

D. R = CO-CH<sub>3</sub>, R' = CH<sub>3</sub>: *N*-[4-(methoxymethyl)-1-[2-(thiophen-2-yl)ethyl]piperidin-4-yl]-*N*-phenylacetamide,

E. R = H, R' = CH<sub>3</sub>: 4-(methoxymethyl)-*N*-phenyl-1-[2-(thiophen-2-yl)ethyl]piperidin-4-amine,

G. R = R' = CO-CH<sub>2</sub>-CH<sub>3</sub>: [4-(phenylpropanoylamino)-1-[2-(thiophen-2-yl)ethyl]piperidin-4-yl]methyl propanoate,

H. R = CO-CH<sub>2</sub>-CH<sub>2</sub>-CH<sub>3</sub>, R' = CH<sub>3</sub>: *N*-[4-(methoxymethyl)-1-[2-(thiophen-2-yl)ethyl]piperidin-4-yl]-*N*-phenylbutanamide,

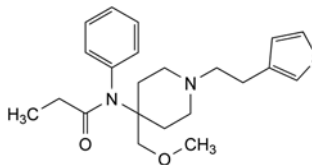

F. *N*-[4-(methoxymethyl)-1-[2-(thiophen-3-yl)ethyl]piperidin-4-yl]-*N*-phenylpropanamide,

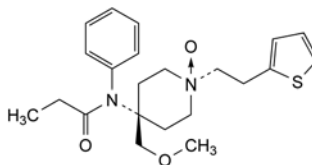

I. *trans*-4-(methoxymethyl)-4-(phenylpropanoylamino)-1-[2-(thiophen-2-yl)ethyl]piperidine 1-oxide.

01/2009:1570

## SUGAR SPHERES

### Sacchari sphaerae

**DEFINITION**

Sugar spheres contain not more than 92 per cent of sucrose, calculated on the dried basis. The remainder consists of maize starch and may also contain starch hydrolysates and colour additives. The diameter of sugar spheres varies usually from 200  $\mu$ m to 2000  $\mu$ m and the upper and lower limits of the size of the sugar spheres are stated on the label.

**IDENTIFICATION**

A. Examine by thin-layer chromatography (2.2.27), using a *TLC silica gel G plate R*.

*Solvent mixture:* water R, *methanol R* (2:3 V/V).

*Test solution.* Mix 2 mL of solution S (see Tests) with 3 mL of *methanol R* and dilute to 20 mL with the solvent mixture.

*Reference solution (a).* Dissolve 10 mg of *sucrose CRS* in the solvent mixture and dilute to 20 mL with the solvent mixture.

*Reference solution (b).* Dissolve 10 mg of *fructose CRS*, 10 mg of *glucose CRS*, 10 mg of *lactose CRS* and 10 mg of *sucrose CRS* in the solvent mixture and dilute to 20 mL with the solvent mixture.

Apply to the plate 2 µL of each solution and thoroughly dry the points of application. Develop over a path of 15 cm using a mixture of 10 volumes of *water R*, 15 volumes of *methanol R*, 25 volumes of *anhydrous acetic acid R* and 50 volumes of *ethylene chloride R*, measured accurately as a slight excess of water causes cloudiness of the solution. Dry the plate in a current of warm air. Repeat the development immediately after renewing the mobile phase. Dry the plate in a current of warm air and spray evenly with a 5 g/L solution of *thymol R* in a mixture of 5 volumes of *sulfuric acid R* and 95 volumes of *ethanol (96 per cent) R*. Heat at 130 °C for 10 min. The principal spot in the chromatogram obtained with the test solution is similar in position, colour and size to the principal spot in the chromatogram obtained with reference solution (a). The test is not valid unless the chromatogram obtained with reference solution (b) shows 4 clearly separated spots.

B. To a water slurry of the insoluble portion obtained in the assay, add 0.05 mL of *iodine solution RI*. A dark-blue colour is produced, which disappears on heating.

C. To 5 mL of solution S add 0.15 mL of freshly prepared *copper sulfate solution R* and 2 mL of freshly prepared *dilute sodium hydroxide solution R*. The solution is blue and clear and remains so after boiling. To the hot solution add 4 mL of *dilute hydrochloric acid R* and boil for 1 min. Add 4 mL of *dilute sodium hydroxide solution R*. An orange precipitate is formed immediately.

#### TESTS

**Solution S.** To 0.5 g in a 100 mL volumetric flask add 80 mL of *water R* and shake until the sucrose is dissolved. Dilute to 100.0 mL with *water R*. Filter under vacuum to obtain a clear solution.

**Fineness (2.9.35):** not less than 90 per cent *m/m* of the sugar spheres are between the lower and the upper limits of the size of the sugar spheres stated on the label.

**Heavy metals (2.4.8):** maximum 5 ppm.

2.0 g complies with test C. Prepare the reference solution using 1.0 mL of *lead standard solution (10 ppm Pb) R*.

**Loss on drying (2.2.32):** maximum 5.0 per cent, determined on 1.000 g by drying in an oven at 105 °C for 4 h.

**Sulfated ash (2.4.14):** maximum 0.2 per cent, determined on 2 g.

#### Microbial contamination

TAMC: acceptance criterion 10<sup>3</sup> CFU/g (2.6.12).

TYMC: acceptance criterion 10<sup>2</sup> CFU/g (2.6.12).

Absence of *Escherichia coli* (2.6.13).

Absence of *Salmonella* (2.6.13).

#### ASSAY

##### Sucrose content

Weigh 10.000 g of ground sugar spheres in a 100 mL flask and make up to 100.0 mL with *water R*. Stir and decant. Filter under vacuum to obtain a clear solution (the insoluble portion is used for identification test B). Measure the angle of optical rotation (2.2.7) and calculate the sucrose percentage content using the following expression:

$$\frac{10^6 \times \alpha}{66.5 \times l \times m \times (100 - H)}$$

$\alpha$  = angle of rotation;

$l$  = length of the polarimeter tube, in decimetres;

$m$  = exact mass of the sample, in grams;

$H$  = loss on drying.

#### LABELLING

The label states the upper and the lower limits of the size of the sugar spheres.

01/2008:2209  
corrected 6.2

## SULBACTAM SODIUM

### Sulbactamum natrium

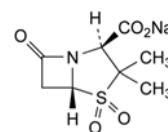

C<sub>9</sub>H<sub>10</sub>NNaO<sub>5</sub>S  
[69388-84-7]

*M*<sub>r</sub> 255.2

#### DEFINITION

Sodium (2*S*,5*R*)-3,3-dimethyl-7-oxo-4-thia-1-azabicyclo[3.2.0]heptane-2-carboxylate 4,4-dioxide.

Semi-synthetic product derived from a fermentation product.

*Content:* 97.0 per cent to 102.0 per cent (anhydrous substance).

#### CHARACTERS

*Appearance:* white or almost white, hygroscopic, crystalline powder.

*Solubility:* freely soluble in water, sparingly soluble in ethyl acetate, very slightly soluble in ethanol (96 per cent). It is freely soluble in dilute acids.

#### IDENTIFICATION

A. Infrared absorption spectrophotometry (2.2.24).

*Comparison:* *sulbactam sodium CRS*.

B. It gives reaction (a) of sodium (2.3.1).

#### TESTS

**Appearance of solution.** The solution is clear (2.2.1).

Dissolve 2.0 g in *water R* and dilute to 20 mL with the same solvent.

**Absorbance (2.2.25):** maximum 0.10 at 430 nm.

Dissolve 1.0 g in *water R* and dilute to 100.0 mL with the same solvent.

**pH (2.2.3):** 4.5 to 7.2; if the substance is sterile: 5.2 to 7.2.

Dissolve 1.0 g in *carbon dioxide-free water R* and dilute to 20 mL with the same solvent.

**Specific optical rotation (2.2.7):** + 219 to + 233 (anhydrous substance).

Dissolve 0.500 g in *water R* and dilute to 50.0 mL with the same solvent.

**Related substances.** Liquid chromatography (2.2.29).

*Solution A.* 2.72 g/L solution of *potassium dihydrogen phosphate R* adjusted to pH 4.0 with *dilute phosphoric acid R*.

*Solution B.* Dilute 2 mL of *acetonitrile RI* to 100.0 mL with solution A.

*Test solution.* Suspend 77.0 mg of the substance to be examined in 2 mL of *acetonitrile RI* and sonicate for about 5 min. Dilute to 100.0 mL with solution A.

*Reference solution (a).* Suspend 70.0 mg of *sulbactam CRS* in 2 mL of *acetonitrile RI* and sonicate for about 5 min. Dilute to 100.0 mL with solution A.

**Reference solution (b).** Dilute 1.0 mL of reference solution (a) to 100.0 mL with solution B. Dilute 1.0 mL of this solution to 10.0 mL with solution B.

**Reference solution (c).** Dissolve 15.0 mg of 6-aminopenicillanic acid *R* in solution A and dilute to 50.0 mL with solution A.

**Reference solution (d).** Mix 1 mL of reference solution (a) and 1 mL of reference solution (c) and dilute to 25.0 mL with solution B.

**Reference solution (e).** Dissolve 8 mg of *sulbactam for peak identification CRS* (containing impurities A, C, D, E and F) in 1 mL of acetonitrile *R1*, sonicate for about 5 min and dilute to 10 mL with solution B.

**Column:**

- size:  $l = 0.10$  m,  $\varnothing = 4.0$  mm;
- stationary phase: octadecylsilyl silica gel for chromatography *R* (3.0  $\mu$ m);
- temperature: 40 °C.

**Mobile phase:**

- mobile phase A: 5.44 g/L solution of potassium dihydrogen phosphate *R* adjusted to pH 4.0 with dilute phosphoric acid *R*;
- mobile phase B: acetonitrile *R1*;

Time (min)	Mobile phase A (per cent V/V)	Mobile phase B (per cent V/V)
0 - 7.5	98 → 50	2 → 50
7.5 - 8.5	50	50
8.5 - 9.0	50 → 98	50 → 2
9.0 - 12.5	98	2

**Flow rate:** 1.0 mL/min.

**Detection:** spectrophotometer at 215 nm.

**Injection:** 20  $\mu$ L of the test solution, solution B and reference solutions (b), (d) and (e).

**Relative retention** with reference to *sulbactam* (retention time = about 2.5 min): impurity A = about 0.4; impurity B = about 0.6; impurity C = about 1.6; impurity D = about 2.0; impurity E = about 2.1; impurity F = about 2.5.

**Identification of impurities:** use the chromatogram supplied with *sulbactam for peak identification CRS* and the chromatogram obtained with reference solution (e) to identify the peaks due to impurities A, C, D, E and F.

**System suitability:** reference solution (d):

- resolution: minimum 7.0 between the peaks due to impurity B and *sulbactam*.

**Limits:**

- correction factors: for the calculation of content, multiply the peak areas of the following impurities by the corresponding correction factor: impurity A = 0.6; impurity B = 0.5; impurity D = 0.5; impurity F = 0.6;
- impurity A: not more than 5 times the area of the principal peak in the chromatogram obtained with reference solution (b) (0.5 per cent);
- impurities B, D, F: for each impurity, not more than the area of the principal peak in the chromatogram obtained with reference solution (b) (0.1 per cent);
- impurities C, E: for each impurity, not more than twice the area of the principal peak in the chromatogram obtained with reference solution (b) (0.2 per cent);
- unspecified impurities: for each impurity, not more than the area of the principal peak in the chromatogram obtained with reference solution (b) (0.10 per cent);

- total: not more than 10 times the area of the principal peak in the chromatogram obtained with reference solution (b) (1.0 per cent);
- disregard limit: 0.5 times the area of the principal peak in the chromatogram obtained with reference solution (b) (0.05 per cent).

**2-Ethylhexanoic acid (2.4.28):** maximum 0.5 per cent *m/m*.

**Heavy metals (2.4.8):** maximum 20 ppm.

Dissolve 1.0 g in *water R* and dilute to 20 mL with the same solvent. 12 mL of the solution complies with test A. Prepare the reference solution using 10.0 mL of *lead standard solution (2 ppm Pb) R*.

**Water (2.5.12):** maximum 1.0 per cent, determined on 1.00 g.

**Bacterial endotoxins (2.6.14, Method A):** less than 0.17 IU/mg, if intended for use in the manufacture of parenteral preparations without a further appropriate procedure for the removal of bacterial endotoxins.

## ASSAY

Liquid chromatography (2.2.29) as described in the test for related substances with the following modification.

**Injection:** test solution and reference solution (a).

Calculate the percentage content of *sulbactam sodium* by multiplying the percentage content of *sulbactam* by 1.094 and using the declared content of *sulbactam CRS*.

## STORAGE

In an airtight container. If the substance is sterile, store in a sterile, airtight, tamper-proof container.

## IMPURITIES

**Specified impurities:** A, B, C, D, E, F.

**Other detectable impurities** (the following substances would, if present at a sufficient level, be detected by one or other of the tests in the monograph. They are limited by the general acceptance criterion for other/unspecified impurities and/or by the general monograph *Substances for pharmaceutical use (2034)*. It is therefore not necessary to identify these impurities for demonstration of compliance. See also 5.10. *Control of impurities in substances for pharmaceutical use*): G.

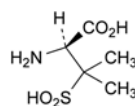

A. (2*S*)-2-amino-3-methyl-3-sulfinobutanoic acid,

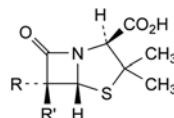

B. R = NH<sub>2</sub>, R' = H: (2*S*,5*R*,6*R*)-6-amino-3,3-dimethyl-7-oxo-4-thia-1-azabicyclo[3.2.0]heptane-2-carboxylic acid (6-aminopenicillanic acid),

D. R = Br, R' = H: (2*S*,5*R*,6*R*)-6-bromo-3,3-dimethyl-7-oxo-4-thia-1-azabicyclo[3.2.0]heptane-2-carboxylic acid (6-bromopenicillanic acid),

F. R = R' = Br: (2*S*,5*R*)-6,6-dibromo-3,3-dimethyl-7-oxo-4-thia-1-azabicyclo[3.2.0]heptane-2-carboxylic acid (6,6-dibromopenicillanic acid),

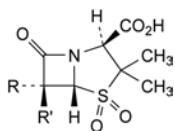

C. R = Br, R' = H: (2*S*,5*R*,6*R*)-6-bromo-3,3-dimethyl-7-oxo-4-thia-1-azabicyclo[3.2.0]heptane-2-carboxylic acid 4,4-dioxide (6-bromopenicillanic acid sulfone),

E. R = R' = Br: (2*S*,5*R*)-6,6-dibromo-3,3-dimethyl-7-oxo-4-thia-1-azabicyclo[3.2.0]heptane-2-carboxylic acid 4,4-dioxide (6,6-dibromopenicillanic acid sulfone),

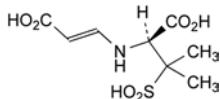

G. (2*E*)-3-[(1*S*)-1-carboxy-2-methyl-2-sulfinopropyl]amino]prop-2-enoic acid.

07/2008:0107

## SULFACETAMIDE SODIUM

### Sulfacetamidum natrium

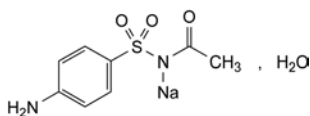

$C_8H_9N_2NaO_3S \cdot H_2O$

$M_r$  254.2

#### DEFINITION

Sodium acetyl[(4-aminophenyl)sulfonyl]azanide.

*Content*: 99.0 per cent to 101.0 per cent (anhydrous substance).

#### CHARACTERS

*Appearance*: white or yellowish-white, crystalline powder.

*Solubility*: freely soluble in water, slightly soluble in anhydrous ethanol.

#### IDENTIFICATION

*First identification*: B, F.

*Second identification*: A, C, E, F.

A. Ultraviolet and visible absorption spectrophotometry (2.2.25).

*Test solution*. Dissolve 0.1 g in *phosphate buffer solution pH 7.0 R* and dilute to 100.0 mL with the same buffer solution. Dilute 1.0 mL of this solution to 100.0 mL with *phosphate buffer solution pH 7.0 R*.

*Spectral range*: 230-350 nm.

*Absorption maximum*: at 255 nm.

*Specific absorbance at the absorption maximum*: 660 to 720 (anhydrous substance).

B. Infrared absorption spectrophotometry (2.2.24).

*Comparison*: *sulfacetamide sodium CRS*.

C. Melting point (2.2.14): 181 °C to 185 °C.

Dissolve 1 g in 10 mL of *water R*, add 6 mL of *dilute acetic acid R* and filter. Wash the precipitate with a small quantity of *water R* and dry at 100-105 °C for 4 h.

E. Dissolve about 1 mg of the precipitate obtained in identification C, with heating, in 1 mL of *water R*. The solution gives the reaction of primary aromatic amines (2.3.1) with formation of an orange-red precipitate.

F. Solution S (see Tests) gives the reactions of sodium (2.3.1).

#### TESTS

**Solution S**. Dissolve 1.25 g in *carbon dioxide-free water R* and dilute to 25 mL with the same solvent.

**Appearance of solution**. Solution S is clear (2.2.1) and not more intensely coloured than reference solution GY<sub>4</sub> (2.2.2, *Method II*).

**pH** (2.2.3): 8.0 to 9.5 for solution S.

**Related substances**. Liquid chromatography (2.2.29). *Prepare the solutions immediately before use and carry out the test protected from light*.

*Test solution*. Dissolve 0.200 g of the substance to be examined in the mobile phase and dilute to 10.0 mL with the mobile phase.

*Reference solution (a)*. Dissolve 5 mg of *sulfacetamide sodium CRS* and 5 mg of *sulfanilamide R* (impurity A) in 1.0 mL of the mobile phase.

*Reference solution (b)*. Dilute 1.0 mL of the test solution to 100.0 mL with the mobile phase. Dilute 1.0 mL of this solution to 10.0 mL with the mobile phase.

*Column*:

– *size*:  $l = 0.125$  m,  $\varnothing = 4$  mm;

– *stationary phase*: *end-capped octadecylsilyl silica gel for chromatography R* (5 µm).

*Mobile phase*: *glacial acetic acid R*, *methanol R*, *water for chromatography R* (1:10:89 V/V/V).

*Flow rate*: 0.8 mL/min.

*Detection*: spectrophotometer at 254 nm.

*Injection*: 10 µL.

*Run time*: 7 times the retention time of sulfacetamide.

*Relative retention* with reference to sulfacetamide (retention time = about 5 min): impurity A = about 0.5.

*System suitability*: reference solution (a):

– *resolution*: minimum 5.0 between the peaks due to impurity A and sulfacetamide.

*Limits*:

– *correction factor*: for the calculation of the content, multiply the peak area of impurity A by 0.5;

– *impurity A*: not more than twice the area of the principal peak in the chromatogram obtained with reference solution (b) (0.2 per cent);

– *unspecified impurities*: for each impurity, not more than the area of the principal peak in the chromatogram obtained with reference solution (b) (0.10 per cent);

– *total*: not more than 5 times the area of the principal peak in the chromatogram obtained with reference solution (b) (0.5 per cent);

– *disregard limit*: 0.5 times the area of the principal peak in the chromatogram obtained with reference solution (b) (0.05 per cent).

**Sulfates** (2.4.13): maximum 200 ppm.

Dissolve 2.5 g in *distilled water R* and dilute to 25 mL with the same solvent. Add 25 mL of *dilute acetic acid R*, shake for 30 min and filter. 15 mL of the filtrate complies with the limit test for sulfates.

**Heavy metals** (2.4.8): maximum 20 ppm.

12 mL of the filtrate obtained in the test for sulfates complies with test A. Prepare the reference solution using *lead standard solution (1 ppm Pb) R*.

**Water** (2.5.12). 6.0 per cent to 8.0 per cent, determined on 0.200 g.

#### ASSAY

Dissolve 0.500 g in a mixture of 50 mL of *water R* and 20 mL of *dilute hydrochloric acid R*. Cool the solution in a bath of iced water and carry out the determination of primary aromatic amino-nitrogen (2.5.8), determining the end-point electrometrically.

1 mL of 0.1 M *sodium nitrite* is equivalent to 23.62 mg of  $C_8H_9N_2NaO_3S$ .

## STORAGE

Protected from light.

## IMPURITIES

*Specified impurities:* A.

*Other detectable impurities* (the following substances would, if present at a sufficient level, be detected by one or other of the tests in the monograph. They are limited by the general acceptance criterion for other/unspecified impurities and/or by the general monograph *Substances for pharmaceutical use (2034)*. It is therefore not necessary to identify these impurities for demonstration of compliance. See also 5.10. *Control of impurities in substances for pharmaceutical use*): B, C, D.

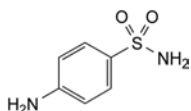

A. 4-aminobenzenesulfonamide (sulfanilamide),

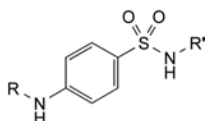

B. R = CO-CH<sub>3</sub>, R' = H: *N*-(4-sulfamoylphenyl)acetamide,

C. R = R' = CO-CH<sub>3</sub>: *N*-[[4-(acetamino)phenyl]sulfonyl]-acetamide,

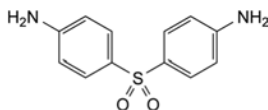

D. 4,4'-sulfonyldianiline (dapson).

01/2008:0294  
corrected 6.0

## SULFADIAZINE

## Sulfadiazinum

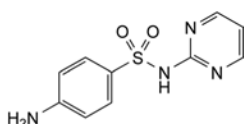

C<sub>10</sub>H<sub>10</sub>N<sub>4</sub>O<sub>2</sub>S  
[68-35-9]

*M<sub>r</sub>* 250.3

## DEFINITION

Sulfadiazine contains not less than 99.0 per cent and not more than the equivalent of 101.0 per cent of 4-amino-*N*-pyrimidin-2-ylbenzenesulfonamide, calculated with reference to the dried substance.

## CHARACTERS

White, yellowish-white or pinkish-white, crystalline powder or crystals, practically insoluble in water, slightly soluble in acetone, very slightly soluble in alcohol. It dissolves in solutions of alkali hydroxides and in dilute mineral acids.

It melts at about 255 °C, with decomposition.

## IDENTIFICATION

*First identification:* A, B.

*Second identification:* B, C, D.

A. Examine by infrared absorption spectrophotometry (2.2.24), comparing with the spectrum obtained with *sulfadiazine CRS*. Examine the substances prepared as discs.

B. Examine the chromatograms obtained in the test for related substances. The principal spot in the chromatogram obtained with test solution (a) corresponds in position and size to the principal spot in the chromatogram obtained with reference solution (a).

C. Place 3 g in a dry tube. Immerse the lower part of the tube, inclined at 45°, in a silicone oil bath and heat to about 270 °C. The substance to be examined decomposes and a white or yellowish-white sublimate is formed which, after recrystallisation from *toluene R* and drying at 100 °C, melts (2.2.14) at 123 °C to 127 °C.

D. Dissolve about 5 mg in 10 mL of 1 *M hydrochloric acid*. Dilute 1 mL of the solution to 10 mL with *water R*. The solution, without further acidification, gives the reaction of primary aromatic amines (2.3.1).

## TESTS

**Appearance of solution.** Dissolve 0.8 g in a mixture of 5 mL of *dilute sodium hydroxide solution R* and 5 mL of *water R*. The solution is not more intensely coloured than reference solution Y<sub>5</sub>, BY<sub>5</sub> or GY<sub>5</sub> (2.2.2, *Method II*).

**Acidity.** To 1.25 g, finely powdered, add 25 mL of *carbon dioxide-free water R*. Heat at about 70 °C for 5 min. Cool in iced water for about 15 min and filter. To 20 mL of the filtrate add 0.1 mL of *bromothymol blue solution R1*. Not more than 0.2 mL of 0.1 *M sodium hydroxide* is required to change the colour of the indicator.

**Related substances.** Examine by thin-layer chromatography (2.2.27), using *silica gel GF<sub>254</sub> R* as the coating substance.

*Test solution (a).* Dissolve 20 mg of the substance to be examined in 3 mL of a mixture of 2 volumes of *concentrated ammonia R* and 48 volumes of *methanol R* and dilute to 5.0 mL with the same mixture of solvents.

*Test solution (b).* Dissolve 0.10 g of the substance to be examined in 0.5 mL of *concentrated ammonia R* and dilute to 5.0 mL with *methanol R*. If the solution is not clear, heat gently until dissolution is complete.

*Reference solution (a).* Dissolve 20 mg of *sulfadiazine CRS* in 3 mL of a mixture of 2 volumes of *concentrated ammonia R* and 48 volumes of *methanol R* and dilute to 5.0 mL with the same mixture of solvents.

*Reference solution (b).* Dilute 1.25 mL of test solution (a) to 50 mL with a mixture of 2 volumes of *concentrated ammonia R* and 48 volumes of *methanol R*.

Apply to the plate 5 µL of each solution. Develop over a path of 15 cm using a mixture of 3 volumes of *dilute ammonia R1*, 5 volumes of *water R*, 40 volumes of *nitromethane R* and 50 volumes of *dioxan R*. Dry the plate at 100 °C to 105 °C and examine in ultraviolet light at 254 nm. Any spot in the chromatogram obtained with test solution (b), apart from the principal spot, is not more intense than the spot in the chromatogram obtained with reference solution (b) (0.5 per cent).

**Heavy metals** (2.4.8). 1.0 g complies with limit test D for heavy metals (20 ppm). Prepare the standard using 2 mL of *lead standard solution (10 ppm Pb) R*.

**Loss on drying** (2.2.32). Not more than 0.5 per cent, determined on 1.00 g by drying in an oven at 105 °C.

**Sulfated ash** (2.4.14). Not more than 0.1 per cent, determined on 1.0 g.

## ASSAY

Dissolve 0.200 g in a mixture of 20 mL of *dilute hydrochloric acid R* and 50 mL of *water R*. Cool the solution in iced water. Carry out the determination of primary aromatic amino-nitrogen (2.5.8), determining the end-point electrometrically.

1 mL of 0.1 *M sodium nitrite* is equivalent to 25.03 mg of C<sub>10</sub>H<sub>10</sub>N<sub>4</sub>O<sub>2</sub>S.

## STORAGE

Store protected from light.

01/2008:0295  
corrected 6.0

## SULFADIMIDINE

## Sulfadimidinum

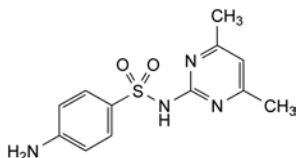

$C_{12}H_{14}N_4O_2S$   
[57-68-1]

$M_r$  278.3

## DEFINITION

Sulfadimidine contains not less than 99.0 per cent and not more than the equivalent of 101.0 per cent of 4-amino-*N*-(4,6-dimethylpyrimidin-2-yl)benzenesulfonamide, calculated with reference to the dried substance.

## CHARACTERS

White or almost white powder or crystals, very slightly soluble in water, soluble in acetone, slightly soluble in alcohol. It dissolves in solutions of alkali hydroxides and in dilute mineral acids.

It melts at about 197 °C, with decomposition.

## IDENTIFICATION

First identification: A, B.

Second identification: B, C, D.

- Examine by infrared absorption spectrophotometry (2.2.24), comparing with the spectrum obtained with *sulfadimidine CRS*. Examine the substances prepared as discs.
- Examine the chromatograms obtained in the test for related substances. The principal spot in the chromatogram obtained with test solution (a) corresponds in position and size to the principal spot in the chromatogram obtained with reference solution (a).
- Place 3 g in a dry tube. Immerse the lower part of the tube, inclined at 45°, in a silicone oil bath and heat to about 270 °C. The substance to be examined decomposes and a white or yellowish-white sublimate is formed which, after recrystallisation from *toluene R* and drying at 100 °C, melts (2.2.14) at 150 °C to 154 °C.
- Dissolve about 5 mg in 10 mL of 1 M hydrochloric acid. Dilute 1 mL of the solution to 10 mL with *water R*. The solution, without further acidification, gives the reaction of primary aromatic amines (2.3.1).

## TESTS

**Appearance of solution.** Dissolve 0.5 g in a mixture of 5 mL of *dilute sodium hydroxide solution R* and 5 mL of *water R*. The solution is not more intensely coloured than reference solution  $Y_5$ ,  $BY_5$  or  $GY_5$  (2.2.2, Method II).

**Acidity.** To 1.25 g, finely powdered, add 25 mL of *carbon dioxide-free water R*. Heat at about 70 °C for 5 min. Cool in iced water for about 15 min and filter. To 20 mL of the filtrate add 0.1 mL of *bromothymol blue solution R1*. Not more than 0.2 mL of 0.1 M sodium hydroxide is required to change the colour of the indicator.

**Related substances.** Examine by thin-layer chromatography (2.2.27), using *silica gel GF<sub>254</sub> R* as the coating substance.

**Test solution (a).** Dissolve 20 mg of the substance to be examined in 3 mL of a mixture of 2 volumes of *concentrated*

*ammonia R* and 48 volumes of *methanol R* and dilute to 5.0 mL with the same mixture of solvents.

**Test solution (b).** Dissolve 0.10 g of the substance to be examined in 0.5 mL of *concentrated ammonia R* and dilute to 5.0 mL with *methanol R*. If the solution is not clear, heat gently until dissolution is complete.

**Reference solution (a).** Dissolve 20 mg of *sulfadimidine CRS* in 3 mL of a mixture of 2 volumes of *concentrated ammonia R* and 48 volumes of *methanol R* and dilute to 5.0 mL with the same mixture of solvents.

**Reference solution (b).** Dilute 1.25 mL of test solution (a) to 50 mL with a mixture of 2 volumes of *concentrated ammonia R* and 48 volumes of *methanol R*.

Apply to the plate 5 µL of each solution. Develop over a path of 15 cm using a mixture of 3 volumes of *dilute ammonia R1*, 5 volumes of *water R*, 40 volumes of *nitromethane R* and 50 volumes of *dioxan R*. Dry the plate at 100 °C to 105 °C and examine in ultraviolet light at 254 nm. Any spot in the chromatogram obtained with test solution (b), apart from the principal spot, is not more intense than the spot in the chromatogram obtained with reference solution (b) (0.5 per cent).

**Heavy metals (2.4.8).** 1.0 g complies with limit test D for heavy metals (20 ppm). Prepare the standard using 2 mL of *lead standard solution (10 ppm Pb) R*.

**Loss on drying (2.2.32).** Not more than 0.5 per cent, determined on 1.00 g by drying in an oven at 105 °C.

**Sulfated ash (2.4.14).** Not more than 0.1 per cent, determined on 1.0 g.

## ASSAY

Dissolve 0.250 g in a mixture of 20 mL of *dilute hydrochloric acid R* and 50 mL of *water R*. Cool the solution in iced water. Carry out the determination of primary aromatic amino-nitrogen (2.5.8), determining the end-point electrometrically.

1 mL of 0.1 M sodium nitrite is equivalent to 27.83 mg of  $C_{12}H_{14}N_4O_2S$ .

## STORAGE

Store protected from light.

01/2008:0740  
corrected 6.0

## SULFADOXINE

## Sulfadoxinum

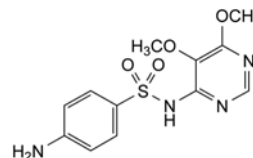

$C_{12}H_{14}N_4O_4S$   
[2447-57-6]

$M_r$  310.3

## DEFINITION

Sulfadoxine contains not less than 99.0 per cent and not more than the equivalent of 101.0 per cent of 4-amino-*N*-(5,6-dimethoxypyrimidin-4-yl)benzenesulfonamide, calculated with reference to the dried substance.

## CHARACTERS

White or yellowish-white crystalline powder or crystals, very slightly soluble in water, slightly soluble in alcohol and in methanol. It dissolves in solutions of alkali hydroxides and in dilute mineral acids.

It melts at about 198 °C, with decomposition.



## IDENTIFICATION

*First identification:* A, C.

*Second identification:* B, C, D.

- A. Examine by infrared absorption spectrophotometry (2.2.24), comparing with the spectrum obtained with *sulfadoxine CRS*. Examine the substances prepared as discs.
- B. Examine the chromatograms obtained in the test for related substances. The principal spot in the chromatogram obtained with test solution (b) is similar in position and size to the principal spot in the chromatogram obtained with reference solution (a).
- C. Dissolve 0.5 g in 1 mL of a 40 per cent V/V solution of *sulfuric acid R*, heating gently. Continue heating until a crystalline precipitate appears (about 2 min). Allow to cool and add 10 mL of *dilute sodium hydroxide solution R*. Cool again. Add 25 mL of *ether R* and shake for 5 min. Separate the ether layer, dry over *anhydrous sodium sulfate R* and filter. Evaporate the solvent by heating in a water-bath. The residue melts (2.2.14) at 80 °C to 82 °C or at 90 °C to 92 °C.
- D. Dissolve about 5 mg in 10 mL of *1 M hydrochloric acid*. Dilute 1 mL of the solution to 10 mL with *water R*. The solution, without further acidification, gives the reaction of primary aromatic amines (2.3.1).

## TESTS

**Appearance of solution.** Dissolve 1.0 g in a mixture of 5 mL of *dilute sodium hydroxide solution R* and 5 mL of *water R*. The solution is not more intensely coloured than reference solution Y<sub>5</sub>, BY<sub>5</sub> or GY<sub>5</sub> (2.2.2, Method II).

**Acidity.** To 1.25 g, finely powdered, add 25 mL of *carbon dioxide-free water R*. Heat at 70 °C for 5 min. Cool in a bath of iced water for about 15 min and filter. To 20 mL of the filtrate add 0.1 mL of *bromothymol blue solution R1*. Not more than 0.2 mL of *0.1 M sodium hydroxide* is required to change the colour of the indicator.

**Related substances.** Examine by thin-layer chromatography (2.2.27), using *silica gel GF<sub>254</sub> R* as the coating substance.

*Test solution (a).* Dissolve 0.10 g of the substance to be examined in 3 mL of a mixture of 2 volumes of *concentrated ammonia R* and 48 volumes of *methanol R* and dilute to 5 mL with the same mixture of solvents.

*Test solution (b).* Dilute 1 mL of test solution (a) to 5 mL with a mixture of 2 volumes of *concentrated ammonia R* and 48 volumes of *methanol R*.

*Reference solution (a).* Dissolve 20 mg of *sulfadoxine CRS* in 3 mL of a mixture of 2 volumes of *concentrated ammonia R* and 48 volumes of *methanol R* and dilute to 5 mL with the same mixture of solvents.

*Reference solution (b).* Dilute 2.5 mL of test solution (b) to 100 mL with a mixture of 2 volumes of *concentrated ammonia R* and 48 volumes of *methanol R*.

Apply to the plate 5 µL of each solution. Develop over a path of 15 cm using a mixture of 3 volumes of *dilute ammonia R1*, 5 volumes of *water R*, 40 volumes of *nitromethane R* and 50 volumes of *dioxan R*. Dry the plate at 100 °C to 105 °C and examine in ultraviolet light at 254 nm. Any spot in the chromatogram obtained with test solution (a), apart from the principal spot, is not more intense than the spot in the chromatogram obtained with reference solution (b) (0.5 per cent).

**Heavy metals** (2.4.8). 1.0 g complies with limit test D for heavy metals (20 ppm). Prepare the standard using 2 mL of *lead standard solution (10 ppm Pb) R*.

**Loss on drying** (2.2.32). Not more than 0.5 per cent, determined on 1.000 g by drying in an oven at 105 °C.

**Sulfated ash** (2.4.14). Not more than 0.1 per cent, determined on 1.0 g.

## ASSAY

Carry out the determination of primary aromatic amino-nitrogen (2.5.8), using 0.250 g and determining the end-point electrometrically.

1 mL of *0.1 M sodium nitrite* is equivalent to 31.03 mg of C<sub>12</sub>H<sub>14</sub>N<sub>4</sub>O<sub>4</sub>S.

## STORAGE

Store protected from light.

01/2008:0741  
corrected 6.0

## SULFAFURAZOLE

## Sulfafurazolum

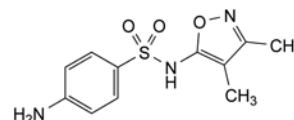

C<sub>11</sub>H<sub>13</sub>N<sub>3</sub>O<sub>3</sub>S  
[127-69-5]

M<sub>r</sub> 267.3

## DEFINITION

Sulfafurazole contains not less than 99.0 per cent and not more than the equivalent of 101.0 per cent of 4-amino-*N*-(3,4-dimethylisoxazol-5-yl)benzenesulfonamide, calculated with reference to the dried substance.

## CHARACTERS

White or yellowish-white, crystalline powder or crystals, practically insoluble in water, sparingly soluble in alcohol, slightly soluble in methylene chloride. It dissolves in solutions of alkali hydroxides and in dilute mineral acids.

It melts at about 197 °C, with decomposition.

## IDENTIFICATION

*First identification:* A, C.

*Second identification:* B, C, D.

- A. Examine by infrared absorption spectrophotometry (2.2.24), comparing with the spectrum obtained with *sulfafurazole CRS*. Examine the substances prepared as discs.
- B. Examine the chromatograms obtained in the test for related substances. The principal spot in the chromatogram obtained with test solution (b) is similar in position and size to the principal spot in the chromatogram obtained with reference solution (a).
- C. To 0.5 g add 1 mL of a 40 per cent V/V solution of *sulfuric acid R* and heat over a low flame to dissolve. Continue heating until a crystalline precipitate appears (about 2 min). Allow to cool and add 10 mL of *dilute sodium hydroxide solution R*. Cool. Shake the solution for 5 min with 25 mL of *ether R*. Separate the ether layer, dry over *anhydrous sodium sulfate R* and filter. Evaporate the solvent by heating on a water-bath. The residue melts (2.2.14) at 119 °C to 123 °C.
- D. Dissolve about 5 mg in 10 mL of *1 M hydrochloric acid*. Dilute 1 mL of the solution to 10 mL with *water R*. The solution, without further acidification, gives the reaction of primary aromatic amines (2.3.1).

## TESTS

**Appearance of solution.** Dissolve 0.4 g in a mixture of 5 mL of *dilute sodium hydroxide solution R* and 5 mL of *water R*, with gently warming if necessary. The solution is not more intensely coloured than reference solution Y<sub>6</sub>, BY<sub>6</sub> or GY<sub>6</sub> (2.2.2, Method II).

**Sulfated ash** (2.4.14): not more than 0.1 per cent, determined on 1.0 g.

#### ASSAY

Dissolve 0.175 g in 50 mL of *dilute hydrochloric acid R*. Cool the solution in iced water. Carry out the determination of primary aromatic amino-nitrogen (2.5.8), determining the end-point electrometrically.

1 mL of 0.1 M sodium nitrite is equivalent to 21.42 mg of  $C_7H_{10}N_4O_2S$ .

#### STORAGE

Store protected from light.

#### IMPURITIES

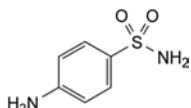

A. 4-aminobenzenesulfonamide (sulfanilamide),

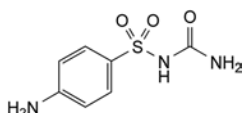

B. *N*-[(4-aminophenyl)sulfonyl]urea (sulfacarbamide).

01/2008:0358  
corrected 6.0

## SULFAMERAZINE

### Sulfamerazinum

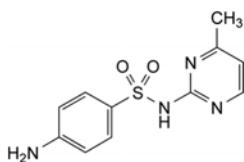

$C_{11}H_{12}N_4O_2S$   
[127-79-7]

$M_r$  264.3

#### DEFINITION

Sulfamerazine contains not less than 99.0 per cent and not more than the equivalent of 101.0 per cent of 4-amino-*N*-(4-methyl-2-pyrimidinyl)benzenesulfonamide, calculated with reference to the dried substance.

#### CHARACTERS

White, yellowish-white or pinkish-white, crystalline powder or crystals, very slightly soluble in water, sparingly soluble in acetone, slightly soluble in alcohol, very slightly soluble in methylene chloride. It dissolves in solutions of alkali hydroxides and in dilute mineral acids.

It melts at about 235 °C, with decomposition.

#### IDENTIFICATION

*First identification*: A, B.

*Second identification*: B, C, D.

A. Examine by infrared absorption spectrophotometry (2.2.24), comparing with the spectrum obtained with *sulfamerazine CRS*. Examine the substances as discs.

B. Examine the chromatograms obtained in the test for related substances. The principal spot in the chromatogram obtained with test solution (b) is similar in position, colour and size to the principal spot in the chromatogram obtained with reference solution (a).

C. Place 3 g in a dry tube. Incline the tube by about 45°, immerse the bottom of the tube in a silicone-oil bath and heat to about 270 °C. The substance decomposes, producing a white or yellowish-white sublimate which, after recrystallisation from *toluene R* and drying at 100 °C, melts (2.2.14) at 157 °C to 161 °C.

D. Dissolve about 20 mg in 0.5 mL of *dilute hydrochloric acid R* and add 1 mL of *water R*. The solution gives, without further addition of acid, the identification reaction of primary aromatic amines (2.3.1).

#### TESTS

**Appearance of solution.** Dissolve 0.8 g in a mixture of 5 mL of *dilute sodium hydroxide solution R* and 5 mL of *water R*. The solution is not more intensely coloured than reference solution  $Y_4$ ,  $BY_4$  or  $GY_4$  (2.2.2, *Method II*).

**Acidity.** To 1.25 g, finely powdered, add 40 mL of *carbon dioxide-free water R* and heat at about 70 °C for 5 min. Cool for about 15 min in iced water and filter. To 20 mL of the filtrate add 0.1 mL of *bromothymol blue solution R1*. Not more than 0.2 mL of 0.1 M sodium hydroxide is required to change the colour of the indicator.

**Related substances.** Examine by thin-layer chromatography (2.2.27) using *silica gel GF<sub>254</sub> R* as the coating substance.

*Test solution (a).* Dissolve 0.10 g of the substance to be examined in 3 mL of a mixture of 2 volumes of *concentrated ammonia R* and 48 volumes of *methanol R* and dilute to 5 mL with the same mixture of solvents.

*Test solution (b).* Dilute 1 mL of test solution (a) to 10 mL with a mixture of 2 volumes of *concentrated ammonia R* and 48 volumes of *methanol R*.

*Reference solution (a).* Dissolve 10 mg of *sulfamerazine CRS* in 3 mL of a mixture of 2 volumes of *concentrated ammonia R* and 48 volumes of *methanol R* and dilute to 5 mL with the same mixture of solvents.

*Reference solution (b).* Dilute 2.5 mL of test solution (b) to 50 mL with a mixture of 2 volumes of *concentrated ammonia R* and 48 volumes of *methanol R*.

Apply to the plate 5 µL of each solution. Develop over a path of 15 cm with a mixture of 3 volumes of *dilute ammonia R1*, 5 volumes of *water R*, 40 volumes of *nitromethane R* and 50 volumes of *dioxan R*. Dry the plate at 100 °C to 105 °C and examine in ultraviolet light at 254 nm. Any spot in the chromatogram obtained with test solution (a), apart from the principal spot, is not more intense than the spot in the chromatogram obtained with reference solution (b) (0.5 per cent).

**Heavy metals** (2.4.8). 1.0 g complies with limit test C for heavy metals (20 ppm). Prepare the standard using 2 mL of *lead standard solution (10 ppm Pb) R*.

**Loss on drying** (2.2.32). Not more than 0.5 per cent, determined on 1.000 g by drying in an oven at 105 °C.

**Sulfated ash** (2.4.14). Not more than 0.1 per cent, determined on 1.0 g.

#### ASSAY

Dissolve 0.2500 g in a mixture of 20 mL of *dilute hydrochloric acid R* and 50 mL of *water R*. Cool the solution in iced water. Carry out the determination of primary aromatic amino-nitrogen (2.5.8), determining the end-point electrometrically. 1 mL of 0.1 M sodium nitrite is equivalent to 26.43 mg of  $C_{11}H_{12}N_4O_2S$ .

#### STORAGE

Store protected from light.

**01/2008:0637** *Reference solution (b).* Dilute 1 mL of test solution (b) to 20 mL with *acetone R*.

**corrected 6.0**

## SULFAMETHIZOLE

### Sulfamethizolum

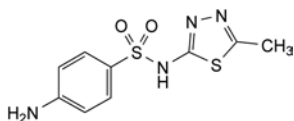

$C_9H_{10}N_4O_2S_2$   
[144-82-1]

$M_r$  270.3

#### DEFINITION

Sulfamethizole contains not less than 99.0 per cent and not more than the equivalent of 101.0 per cent of 4-amino-*N*-(5-methyl-1,3,4-thiadiazol-2-yl)benzenesulfonamide, calculated with reference to the dried substance.

#### CHARACTERS

White or yellowish-white crystalline powder or crystals, very slightly soluble in water, soluble in acetone, sparingly soluble in alcohol. It dissolves in dilute solutions of alkali hydroxides and in dilute mineral acids.

It melts at about 210 °C.

#### IDENTIFICATION

*First identification:* A, B.

*Second identification:* B, C, D.

- Examine by infrared absorption spectrophotometry (2.2.24), comparing with the spectrum obtained with *sulfamethizole CRS*. Examine the substances prepared as discs.
- Examine the chromatograms obtained in the test for related substances. The principal spot in the chromatogram obtained with test solution (b) is similar in position and size to the principal spot in the chromatogram obtained with reference solution (a).
- Dissolve 50 mg in 4 mL of *methanol R* and add 0.2 mL of a 40 g/L solution of *copper acetate R*. A flocculent, yellowish-green precipitate is formed, changing to dark green.
- Dissolve about 5 mg in 1 M *hydrochloric acid* and dilute to 10 mL with the same solvent. Dilute 1 mL of this solution to 10 mL with *water R*. The solution, without further acidification, gives the reaction of primary aromatic amines (2.3.1).

#### TESTS

**Appearance of solution.** Dissolve 1.0 g in a mixture of 5 mL of *dilute sodium hydroxide solution R* and 5 mL of *water R*. The solution is not more intensely coloured than reference solution  $Y_5$ ,  $BY_5$  or  $GY_5$  (2.2.2, *Method II*).

**Acidity.** To 1.25 g add 25 mL of *carbon dioxide-free water R* and heat at 70 °C for 5 min. Cool for about 15 min in iced water and filter. To 20 mL of the filtrate add 0.1 mL of *bromothymol blue solution R1*. Not more than 0.5 mL of 0.1 M *sodium hydroxide* is required to change the colour of the indicator.

**Related substances.** Examine by thin-layer chromatography (2.2.27), using *silica gel GF<sub>254</sub> R* as the coating substance.

*Test solution (a).* Dissolve 0.30 g of the substance to be examined in *acetone R* and dilute to 10 mL with the same solvent.

*Test solution (b).* Dilute 1 mL of test solution (a) to 10 mL with *acetone R*.

*Reference solution (a).* Dissolve 30 mg of *sulfamethizole CRS* in *acetone R* and dilute to 10 mL with the same solvent.

Apply to the plate 2 µL of each solution. Develop over a path of 15 cm using a mixture of 15 volumes of *methanol R* and 80 volumes of *chloroform R*. Dry the plate at 100 °C to 105 °C and examine in ultraviolet light at 254 nm. Any spot in the chromatogram obtained with test solution (a), apart from the principal spot, is not more intense than the spot in the chromatogram obtained with reference solution (b) (0.5 per cent).

**Heavy metals** (2.4.8). 1.0 g complies with limit test D for heavy metals (20 ppm). Prepare the standard using 2 mL of *lead standard solution (10 ppm Pb) R*.

**Loss on drying** (2.2.32). Not more than 0.5 per cent, determined on 1.000 g by drying in an oven at 105 °C.

**Sulfated ash** (2.4.14). Not more than 0.1 per cent, determined on 1.0 g.

#### ASSAY

Carry out the determination of primary aromatic amino-nitrogen (2.5.8), using 0.2500 g and determining the end-point electrometrically.

1 mL of 0.1 M *sodium nitrite* is equivalent to 27.03 mg of  $C_9H_{10}N_4O_2S_2$ .

#### STORAGE

Store protected from light.

**01/2008:0108**

**corrected 6.0**

## SULFAMETHOXAZOLE

### Sulfamethoxazololum

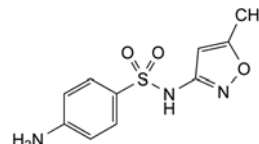

$C_{10}H_{11}N_3O_3S$   
[723-46-6]

$M_r$  253.3

#### DEFINITION

4-Amino-*N*-(5-methylisoxazol-3-yl)benzenesulfonamide.

*Content:* 99.0 per cent to 101.0 per cent (dried substance).

#### CHARACTERS

*Appearance:* white or almost white, crystalline powder.

*Solubility:* practically insoluble in water, freely soluble in acetone, sparingly soluble in ethanol (96 per cent). It dissolves in dilute solutions of sodium hydroxide and in dilute acids.

#### IDENTIFICATION

*First identification:* A, B.

*Second identification:* A, C, D.

- Melting point (2.2.14): 169 °C to 172 °C.
- Infrared absorption spectrophotometry (2.2.24).  
*Comparison:* *sulfamethoxazole CRS*.
- Thin-layer chromatography (2.2.27).

*Test solution.* Dissolve 20 mg of the substance to be examined in 3 mL of a mixture of 2 volumes of *concentrated ammonia R* and 48 volumes of *methanol R* and dilute to 5 mL with the same mixture of solvents.

*Reference solution.* Dissolve 20 mg of *sulfamethoxazole CRS* in 3 mL of a mixture of 2 volumes of *concentrated ammonia R* and 48 volumes of *methanol R* and dilute to 5 mL with the same mixture of solvents.

*Plate:* TLC silica gel  $F_{254}$  plate *R*.

*Mobile phase:* dilute ammonia R1, water R, nitromethane R, dioxan R (3:5:41:51 V/V/V/V).

*Application:* 5 µL.

*Development:* over 3/4 of the plate.

*Drying:* at 100-105 °C.

*Detection:* examine in ultraviolet light at 254 nm.

*Results:* the principal spot in the chromatogram obtained with the test solution is similar in position and size to the principal spot in the chromatogram obtained with the reference solution.

- D. Dissolve about 5 mg in 10 mL of 1 M hydrochloric acid. Dilute 1 mL of the solution to 10 mL with water R. The solution, without further acidification, gives the reaction of primary aromatic amines (2.3.1).

## TESTS

**Appearance of solution.** The solution is clear (2.2.1) and not more intensely coloured than reference solution Y<sub>5</sub>, BY<sub>5</sub> or GY<sub>5</sub> (2.2.2, Method II).

Dissolve 1.0 g in a mixture of 5 mL of dilute sodium hydroxide solution R and 5 mL of water R.

**Acidity.** To 1.25 g, finely powdered, add 25 mL of water R. Heat at 70 °C for 5 min. Cool in iced water for about 15 min and filter. To 20 mL of the filtrate add 0.1 mL of bromothymol blue solution R1. Not more than 0.3 mL of 0.1 M sodium hydroxide is required to change the colour of the indicator.

**Related substances.** Liquid chromatography (2.2.29).

*Test solution.* Dissolve 50.0 mg of the substance to be examined in 45 mL of the mobile phase, sonicate at about 45 °C for 10 min, cool and dilute to 50.0 mL with the mobile phase.

*Reference solution (a).* Dilute 1.0 mL of the test solution to 10.0 mL with the mobile phase. Dilute 1.0 mL of this solution to 100.0 mL with the mobile phase.

*Reference solution (b).* Dissolve 1 mg of the substance to be examined and 1 mg of sulfamethoxazole impurity A CRS in the mobile phase and dilute to 10.0 mL with the mobile phase.

*Reference solution (c).* Dissolve 1.0 mg of sulfamethoxazole impurity F CRS in the mobile phase and dilute to 10.0 mL with the mobile phase. Dilute 1.0 mL of this solution to 100.0 mL with the mobile phase.

*Column:*

- size:  $l = 0.25$  m,  $\varnothing = 4.0$  mm,
- stationary phase: octylsilyl silica gel for chromatography R (5 µm),
- temperature: 30 °C.

*Mobile phase:* mix 35 volumes of methanol R2 and 65 volumes of a 13.6 g/L solution of potassium dihydrogen phosphate R previously adjusted to pH 5.3 with a 20 g/L solution of potassium hydroxide R.

*Flow rate:* 0.9 mL/min.

*Detection:* spectrophotometer at 210 nm.

*Injection:* 20 µL.

*Run time:* 3 times the retention time of sulfamethoxazole.

*Relative retention* with reference to sulfamethoxazole (retention time = about 10 min): impurity D = about 0.3; impurity E = about 0.35; impurity F = about 0.45; impurity C = about 0.5; impurity A = about 1.2; impurity B = about 2.0.

*System suitability:* reference solution (b):

- resolution: minimum 3.5 between the peaks due to sulfamethoxazole and impurity A.

*Limits:*

- impurities A, B, C, D, E: for each impurity, not more than the area of the principal peak in the chromatogram obtained with reference solution (a) (0.1 per cent),
- impurity F: not more than the area of the principal peak in the chromatogram obtained with reference solution (c) (0.1 per cent),
- any other impurity: for each impurity, not more than the area of the principal peak in the chromatogram obtained with reference solution (a) (0.1 per cent),
- total: not more than 3 times the area of the principal peak in the chromatogram obtained with reference solution (a) (0.3 per cent),
- disregard limit: 0.25 times the area of the principal peak in the chromatogram obtained with reference solution (a) (0.025 per cent).

**Heavy metals (2.4.8):** maximum 20 ppm.

1.0 g complies with test D. Prepare the reference solution using 2 mL of lead standard solution (10 ppm Pb) R.

**Loss on drying (2.2.32):** maximum 0.5 per cent, determined on 1.000 g by drying in an oven at 105 °C.

**Sulfated ash (2.4.14):** maximum 0.1 per cent, determined on 1.0 g.

## ASSAY

Carry out the assay of primary aromatic amino-nitrogen (2.5.8), using 0.200 g and determining the end-point electrometrically.

1 mL of 0.1 M sodium nitrite is equivalent to 25.33 mg of C<sub>10</sub>H<sub>11</sub>N<sub>3</sub>O<sub>3</sub>S.

## STORAGE

Protected from light.

## IMPURITIES

*Specified impurities:* A, B, C, D, E, F.

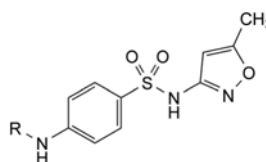

A. R = CO-CH<sub>3</sub>: N-[4-[(5-methylisoxazol-3-yl)sulfamoyl]phenyl]acetamide,

B. R = SO<sub>2</sub>-C<sub>6</sub>H<sub>4</sub>-pNH<sub>2</sub>: 4-[[[(4-aminophenyl)sulfonyl]amino]-N-(5-methylisoxazol-3-yl)benzenesulfonamide],

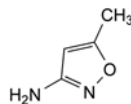

C. 5-methylisoxazol-3-amine,

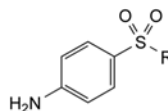

D. R = OH: 4-aminobenzenesulfonic acid (sulfanilic acid),

E. R = NH<sub>2</sub>: 4-aminobenzenesulfonamide (sulfanilamide),

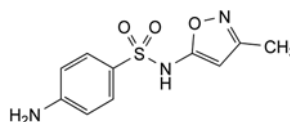

F. 4-amino-N-(3-methylisoxazol-5-yl)benzenesulfonamide.

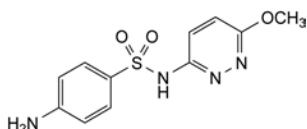
01/2008:0638  
corrected 6.0**SULFAMETHOXYPYRIDAZINE FOR  
VETERINARY USE****Sulfamethoxypyridazinum  
ad usum veterinarium**C<sub>11</sub>H<sub>12</sub>N<sub>4</sub>O<sub>3</sub>S  
[80-35-3]M<sub>r</sub> 280.3**DEFINITION**

Sulfamethoxypyridazine for veterinary use contains not less than 99.0 per cent and not more than the equivalent of 101.0 per cent of 4-amino-*N*-(6-methoxypyridazin-3-yl)benzenesulfonamide, calculated with reference to the dried substance.

**CHARACTERS**

A white or slightly yellowish, crystalline powder, colouring slowly on exposure to light, practically insoluble in water, sparingly soluble in acetone, slightly soluble in alcohol, very slightly soluble in methylene chloride. It dissolves in solutions of alkali hydroxides and in dilute mineral acids.

It melts at about 180 °C, with decomposition.

**IDENTIFICATION**

*First identification:* A, B.

*Second identification:* B, C, D.

- A. Examine by infrared absorption spectrophotometry (2.2.24), comparing with the spectrum obtained with *sulfamethoxypyridazine CRS*. Examine the substances prepared as discs.
- B. Examine the chromatograms obtained in the test for related substances. The principal spot in the chromatogram obtained with test solution (b) is similar in position and size to the principal spot in the chromatogram obtained with reference solution (a).
- C. Dissolve 0.5 g in 1 mL of a 40 per cent *V/V* solution of *sulfuric acid R*, heating gently. Continue heating until a crystalline precipitate appears (about 2 min). Cool and add 10 mL of *dilute sodium hydroxide solution R*. Cool again, add 25 mL of *ether R* and shake the solution for 5 min. Separate the ether layer, dry over *anhydrous sodium sulfate R* and filter. Evaporate the ether by heating in a water-bath. An oily residue is obtained which becomes crystalline on cooling; if necessary, scratch the wall of the container with a glass rod. The residue melts (2.2.14) at 102 °C to 106 °C.
- D. Dissolve about 5 mg in 10 mL of 1 *M* *hydrochloric acid*. Dilute 1 mL of the solution to 10 mL with *water R*. The solution, without further acidification, gives the reaction of primary aromatic amines (2.3.1).

**TESTS**

**Appearance of solution.** Dissolve 1.0 g in a mixture of 10 mL of 1 *M* *sodium hydroxide* and 15 mL of *water R*. The solution is clear (2.2.1) and not more intensely coloured than reference solution Y<sub>4</sub> or BY<sub>4</sub> (2.2.2, *Method II*).

**Acidity.** To 1.25 g, finely powdered, add 25 mL of *carbon dioxide-free water R*. Heat at 70 °C for 5 min. Cool in iced water for about 15 min and filter. To 20 mL of the filtrate add 0.1 mL of *bromothymol blue solution R1*. Not more than 0.5 mL of 0.1 *M* *sodium hydroxide* is required to change the colour of the indicator.

**Related substances.** Examine by thin layer chromatography (2.2.27), using *TLC silica gel GF<sub>254</sub> plate R*.

**Test solution (a).** Dissolve 0.10 g of the substance to be examined in *acetone R* and dilute to 5 mL with the same solvent.

**Test solution (b).** Dilute 1 mL of test solution (a) to 10 mL with *acetone R*.

**Reference solution (a).** Dissolve 20 mg of *sulfamethoxypyridazine CRS* in *acetone R* and dilute to 10 mL with the same solvent.

**Reference solution (b).** Dilute 2.5 mL of test solution (b) to 50 mL with *acetone R*.

Apply separately to the plate 5 µL of each solution. Develop over a path of 15 cm using a mixture of 1 volume of *dilute ammonia R1*, 9 volumes of *water R*, 30 volumes of 2-*propanol R* and 50 volumes of *ethyl acetate R*. Dry the plate at 100-105 °C and examine in ultraviolet light at 254 nm. Any spot in the chromatogram obtained with test solution (a), apart from the principal spot, is not more intense than the spot in the chromatogram obtained with reference solution (b) (0.5 per cent).

**Heavy metals** (2.4.8). 1.0 g complies with limit test D for heavy metals (20 ppm). Prepare the standard using 2 mL of *lead standard solution (10 ppm Pb) R*.

**Loss on drying** (2.2.32). Not more than 0.5 per cent, determined on 1.000 g by drying in an oven at 105 °C.

**Sulfated ash** (2.4.14). Not more than 0.1 per cent, determined on 1.0 g.

**ASSAY**

Carry out the assay of primary aromatic amino-nitrogen (2.5.8), using 0.2500 g, determining the end-point electrometrically.

1 mL of 0.1 *M* *sodium nitrite* is equivalent to 28.03 mg of C<sub>11</sub>H<sub>12</sub>N<sub>4</sub>O<sub>3</sub>S.

**STORAGE**

Protected from light.

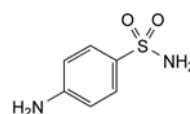
01/2008:1571  
corrected 6.0**SULFANILAMIDE****Sulfanilamidum**C<sub>6</sub>H<sub>8</sub>N<sub>2</sub>O<sub>2</sub>S  
[63-74-1]M<sub>r</sub> 172.2**DEFINITION**

Sulfanilamide contains not less than 99.0 per cent and not more than the equivalent of 101.0 per cent of 4-aminobenzenesulfonamide, calculated with reference to the dried substance.

**CHARACTERS**

White or yellowish-white crystals or fine powder, slightly soluble in water, freely soluble in acetone, sparingly soluble in alcohol, practically insoluble in methylene chloride. It dissolves in solutions of alkali hydroxides and in dilute mineral acids.

**IDENTIFICATION**

*First identification:* B.

*Second identification:* A, C, D.

A. Melting point (2.2.14): 164.5 °C to 166.0 °C.

- B. Examine by infrared absorption spectrophotometry (2.2.24), comparing with the spectrum obtained with *sulfanilamide CRS*. Examine the substances prepared as discs.
- C. Examine the chromatograms obtained in the test for related substances. The principal spot in the chromatogram obtained with test solution (a) is similar in position and size to the principal spot in the chromatogram obtained with reference solution (a).
- D. Dissolve about 5 mg in 10 mL of 1 M hydrochloric acid. Dilute 1 mL of the solution to 10 mL with *water R*. The solution, without further acidification, gives the reaction of primary aromatic amines (2.3.1).

## TESTS

**Solution S.** To 2.5 g add 50 mL of *carbon dioxide-free water R*. Heat at about 70 °C for about 5 min. Cool in iced water for about 15 min and filter.

**Acidity.** To 20 mL of solution S add 0.1 mL of *bromothymol blue solution R1*. Not more than 0.2 mL of 0.1 M *sodium hydroxide* is required to change the colour of the indicator.

**Related substances.** Examine by thin-layer chromatography (2.2.27), using a *TLC silica gel F<sub>254</sub> plate R*.

**Test solution (a).** Dissolve 20 mg of the substance to be examined in 3 mL of a mixture of 2 volumes of *concentrated ammonia R* and 48 volumes of *methanol R* and dilute to 5 mL with the same mixture of solvents.

**Test solution (b).** Dissolve 0.10 g of the substance to be examined in 0.5 mL of *concentrated ammonia R* and dilute to 5 mL with *methanol R*. If the solution is not clear, heat gently until dissolution is complete.

**Reference solution (a).** Dissolve 20 mg of *sulfanilamide CRS* in 3 mL of a mixture of 2 volumes of *concentrated ammonia R* and 48 volumes of *methanol R* and dilute to 5 mL with the same mixture of solvents.

**Reference solution (b).** Dilute 1.25 mL of test solution (a) to 50 mL with a mixture of 2 volumes of *concentrated ammonia R* and 48 volumes of *methanol R*.

**Reference solution (c).** Dissolve 20 mg of the substance to be examined and 20 mg of *sulfamerazine CRS* in 3 mL of a mixture of 2 volumes of *concentrated ammonia R* and 48 volumes of *methanol R* and dilute to 5 mL with the same mixture of solvents.

Apply to the plate 5 µL of each solution. Develop over a path corresponding to two-thirds of the plate height using a mixture of 3 volumes of *dilute ammonia R1*, 5 volumes of *water R*, 40 volumes of *nitromethane R* and 50 volumes of *dioxan R*. Dry the plate at 100 °C to 105 °C and examine in ultraviolet light at 254 nm. Any spot in the chromatogram obtained with test solution (b), apart from the principal spot, is not more intense than the spot in the chromatogram obtained with reference solution (b) (0.5 per cent). The test is not valid unless the chromatogram obtained with reference solution (c) shows two clearly separated principal spots.

**Heavy metals (2.4.8).** 12 mL of solution S complies with limit test A for heavy metals (20 ppm). Prepare the standard using *lead standard solution (1 ppm Pb) R*.

**Loss on drying (2.2.32).** Not more than 0.5 per cent, determined on 1.000 g by drying in an oven at 105 °C.

**Sulfated ash (2.4.14).** Not more than 0.1 per cent, determined on 1.0 g.

## ASSAY

Carry out the determination of primary aromatic amino-nitrogen (2.5.8), using 0.140 g and determining the end-point electrometrically.

1 mL of 0.1 M *sodium nitrite* is equivalent to 17.22 mg of C<sub>18</sub>H<sub>14</sub>N<sub>4</sub>O<sub>5</sub>S.

## STORAGE

Store protected from light.

01/2008:0863  
corrected 7.0

## SULFASALAZINE

## Sulfasalazinum

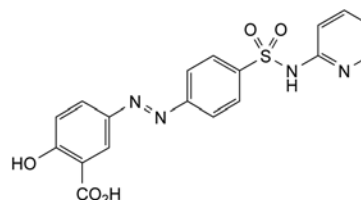

C<sub>18</sub>H<sub>14</sub>N<sub>4</sub>O<sub>5</sub>S  
[599-79-1]

M<sub>r</sub> 398.4

## DEFINITION

2-Hydroxy-5-[2-[4-(pyridin-2-ylsulfamoyl)phenyl]diazanyl]benzoic acid.

**Content:** 97.0 per cent to 101.5 per cent (dried substance).

## CHARACTERS

**Appearance:** bright yellow or brownish-yellow, fine powder.

**Solubility:** practically insoluble in water, very slightly soluble in ethanol (96 per cent), practically insoluble in methylene chloride. It dissolves in dilute solutions of alkali hydroxides.

## IDENTIFICATION

Infrared absorption spectrophotometry (2.2.24).

**Preparation:** discs.

**Comparison:** *sulfasalazine CRS*.

## TESTS

**Related substances.** Liquid chromatography (2.2.29).

**Test solution.** Dissolve 25.0 mg of the substance to be examined in *dilute ammonia R3* and dilute to 25.0 mL with the same solvent.

**Reference solution (a).** Dilute 1.0 mL of the test solution to 100.0 mL with *dilute ammonia R3*.

**Reference solution (b).** Dissolve 1.0 mg of *sulfasalazine derivative for resolution CRS* in 10.0 mL of reference solution (a). Dilute 1.0 mL of this solution to 10.0 mL with reference solution (a).

**Column:**

- **size:** *l* = 0.25 m, Ø = 4.6 mm;
- **stationary phase:** *octadecylsilyl silica gel for chromatography R* (5 µm).

**Mobile phase:**

- **mobile phase A:** in a 1000 mL volumetric flask dissolve 1.13 g of *sodium dihydrogen phosphate R* and 2.5 g of *sodium acetate R* in 900 mL of *water R*; adjust to pH 4.8 with *glacial acetic acid R* and dilute to 1000 mL with *water R*;
- **mobile phase B:** mobile phase A, *methanol R* (10:40 V/V);

Time (min)	Mobile phase A (per cent V/V)	Mobile phase B (per cent V/V)
0 - 15	60 → 45	40 → 55
15 - 25	45	55
25 - 60	45 → 0	55 → 100
60 - 65	0	100

**Flow rate:** 1 mL/min.

**Detection:** spectrophotometer at 320 nm.

**Injection:** 20 µL.

**Relative retention** with reference to sulfasalazine:  
impurity H = about 0.16; impurity I = about 0.28;  
impurity C = about 0.80; impurity F = about 0.85;  
impurity G = about 1.39; impurity E = about 1.63;  
impurity B = about 1.85; impurity D = about 1.90;  
impurity A = about 2.00.

**System suitability:** reference solution (b):

- **resolution:** minimum 3.0 between the peaks due to sulfasalazine and sulfasalazine derivative for resolution.

**Limits:**

- **impurities A, B, C, D, E, F, G, I:** for each impurity, not more than the area of the principal peak in the chromatogram obtained with reference solution (a) (1 per cent);
- **total:** not more than 4 times the area of the principal peak in the chromatogram obtained with reference solution (a) (4 per cent);
- **disregard limit:** 0.05 times the area of the principal peak in the chromatogram obtained with reference solution (a) (0.05 per cent); disregard any peak with a retention time less than 6 min (due to impurities H and J).

**Impurities H and J.** Liquid chromatography (2.2.29).

**Test solution.** Dissolve 25.0 mg of the substance to be examined in *dilute ammonia R3* and dilute to 25.0 mL with the same solvent.

**Reference solution (a).** Dissolve 5.0 mg of *salicylic acid R* (impurity H) and 5.0 mg of *sulfapyridine CRS* (impurity J) in *dilute ammonia R3* and dilute to 10.0 mL with the same solvent.

**Reference solution (b).** Dilute 2.0 mL of reference solution (a) to 100.0 mL with *dilute ammonia R3*.

**Column:**

- **size:**  $l = 0.25$ ,  $\emptyset = 4.6$  mm;
- **stationary phase:** *octadecylsilyl silica gel for chromatography R* (5 µm).

**Mobile phase:** mobile phase B (described in the test for related substances), mobile phase A (described in the test for related substances) (30:70 V/V).

**Flow rate:** 1 mL/min.

**Detection:** spectrophotometer at 300 nm.

**Injection:** 20 µL of the test solution and reference solution (b).

**Run time:** 10 min.

**Retention time:** impurity H = about 6 min; impurity J = about 7 min.

**System suitability:** reference solution (b):

- **resolution:** minimum 2 between the peaks due to impurities H and J.

**Limits:**

- **impurities H, J:** for each impurity, not more than 0.5 times the area of the corresponding peak in the chromatogram obtained with reference solution (b) (0.5 per cent);
- **disregard limit:** 0.05 times the area of the principal peak in the chromatogram obtained with reference solution (b) (0.05 per cent).

**Chlorides (2.4.4):** maximum 140 ppm.

To 1.25 g add 50 mL of *distilled water R*. Heat at about 70 °C for 5 min. Cool and filter. To 20 mL of the filtrate add 1 mL of *nitric acid R*, allow to stand for 5 min and filter to obtain a clear solution.

**Sulfates (2.4.13):** maximum 400 ppm.

To 20 mL of the filtrate prepared for the test for chlorides add 1 mL of *dilute hydrochloric acid R*, allow to stand for 5 min and filter.

**Heavy metals (2.4.8):** maximum 10 ppm.

2.0 g complies with test D. Prepare the reference solution using 2 mL of *lead standard solution (10 ppm Pb) R*.

**Loss on drying (2.2.32):** maximum 1.0 per cent, determined on 1.000 g by drying in an oven at 105 °C for 2 h.

**Sulfated ash (2.4.14):** maximum 0.5 per cent, determined on 1.0 g.

**ASSAY**

Dissolve 0.150 g in 0.1 M *sodium hydroxide* and dilute to 100.0 mL with the same solvent. Transfer 5.0 mL of this solution to a 1000 mL volumetric flask containing about 750 mL of *water R*. Add 20.0 mL of 0.1 M *acetic acid* and dilute to 1000.0 mL with *water R*. Prepare a standard solution at the same time and in the same manner using 0.150 g of *sulfasalazine CRS*. Measure the absorbance (2.2.25) of the 2 solutions at the absorption maximum at 359 nm.

Calculate the content of  $C_{18}H_{14}N_4O_5S$  from the absorbances measured and the concentration of the solutions.

**STORAGE**

Protected from light.

**IMPURITIES**

**Specified impurities:** A, B, C, D, E, F, G, H, I, J.

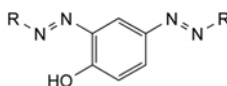
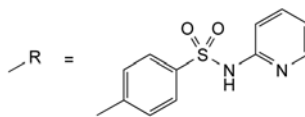

A. 4,4'-[(4-hydroxy-1,3-phenylene)bis(diazenediyl)]bis[N-(pyridin-2-yl)benzenesulfonamide],

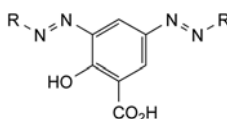

B. 2-hydroxy-3,5-bis[2-[4-(pyridin-2-yl)sulfamoyl]phenyl]diazanyl]benzoic acid,

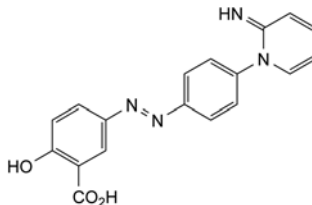

C. 2-hydroxy-5-[2-[4-(2-iminopyridin-1(2H)-yl)phenyl]diazanyl]benzoic acid,

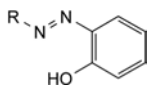

D. 4-[2-(2-hydroxyphenyl)diazanyl]-N-(pyridin-2-yl)benzenesulfonamide,

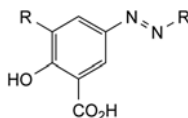

E. 2-hydroxy-4'-(pyridin-2-ylsulfamoyl)-5-[2-[4-(pyridin-2-yl)sulfamoyl]phenyl]diazanyl]biphenyl-3-carboxylic acid,

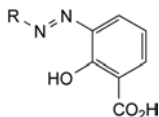

F. 2-hydroxy-3-[2-[4-(pyridin-2-yl)sulfamoyl]phenyl]diazanyl]benzoic acid,

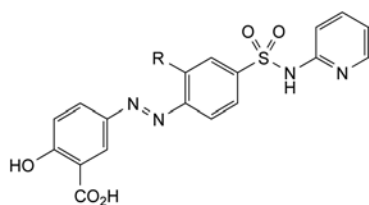

- G. 5-[2-[4',5-bis(pyridin-2-ylsulfamoyl)biphenyl-2-yl]diazenyl]-2-hydroxybenzoic acid,

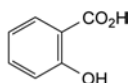

- H. 2-hydroxybenzenecarboxylic acid (salicylic acid),

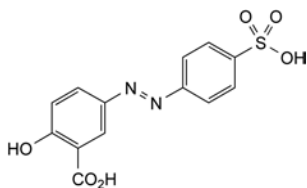

- I. 2-hydroxy-5-[2-(4-sulfophenyl)diazenyl]benzoic acid,  
 J. H<sub>2</sub>N-R: 4-amino-*N*-(pyridin-2-yl)benzenesulfonamide (sulfapyridine).

01/2008:0742  
corrected 6.0

## SULFATHIAZOLE

### Sulfathiazolum

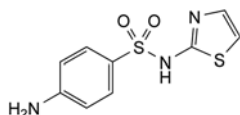

C<sub>9</sub>H<sub>9</sub>N<sub>3</sub>O<sub>2</sub>S<sub>2</sub>  
[72-14-0]

*M<sub>r</sub>* 255.3

#### DEFINITION

Sulfathiazole contains not less than 99.0 per cent and not more than the equivalent of 101.0 per cent of 4-amino-*N*-(thiazol-2-yl)benzenesulfonamide, calculated with reference to the dried substance.

#### CHARACTERS

A white or slightly yellowish, crystalline powder, practically insoluble in water, slightly soluble in alcohol, practically insoluble in methylene chloride. It dissolves in dilute solutions of alkali hydroxides and in dilute mineral acids.

#### IDENTIFICATION

*First identification:* A, B.

*Second identification:* A, C, D, E.

- A. Melting point (2.2.14): 200 °C to 203 °C. Melting may occur at about 175 °C, followed by solidification and a second melting between 200 °C and 203 °C.
- B. Examine by infrared absorption spectrophotometry (2.2.24), comparing with the spectrum obtained with *sulfathiazole CRS*. Examine the substances prepared as discs. If the spectra obtained show differences, dissolve the substance to be examined and the reference substance separately in *alcohol R*, evaporate to dryness *in vacuo* and record the spectra again using the residues.

- C. Examine the chromatograms obtained in the test for related substances. The principal spot in the chromatogram obtained with test solution (b) is similar in position, colour and size to the principal spot in the chromatogram obtained with reference solution (a).
- D. Dissolve about 10 mg in a mixture of 10 mL of *water R* and 2 mL of 0.1 *M sodium hydroxide* and add 0.5 mL of *copper sulfate solution R*. A greyish-blue or purple precipitate is formed.
- E. Dissolve about 5 mg in 10 mL of 1 *M hydrochloric acid*. Dilute 1 mL of the solution to 10 mL with *water R*. The solution, without further addition of acid, gives the reaction of primary aromatic amines (2.3.1).

#### TESTS

**Appearance of solution.** Dissolve 1.0 g in 10 mL of 1 *M sodium hydroxide*. The solution is clear (2.2.1) and not more intensely coloured than reference solution GY<sub>4</sub> (2.2.2, *Method II*).

**Acidity.** To 1.0 g add 50 mL of *carbon dioxide-free water R*. Heat to 70 °C for 5 min. Cool rapidly to 20 °C and filter. To 25 mL of the filtrate add 0.1 mL of *bromothymol blue solution R1*. Not more than 0.1 mL of 0.1 *M sodium hydroxide* is required to change the colour of the indicator.

**Related substances.** Examine by thin-layer chromatography (2.2.27), using *silica gel HR* as the coating substance.

*Test solution (a).* Dissolve 0.10 g of the substance to be examined in a mixture of 1 volume of *concentrated ammonia R* and 9 volumes of *alcohol R* and dilute to 10 mL with the same mixture of solvents.

*Test solution (b).* Dilute 1 mL of test solution (a) to 5 mL with a mixture of 1 volume of *concentrated ammonia R* and 9 volumes of *alcohol R*.

*Reference solution (a).* Dissolve 20 mg of *sulfathiazole CRS* in a mixture of 1 volume of *concentrated ammonia R* and 9 volumes of *alcohol R* and dilute to 10 mL with the same mixture of solvents.

*Reference solution (b).* Dissolve 50 mg of *sulfanilamide R* in a mixture of 1 volume of *concentrated ammonia R* and 9 volumes of *alcohol R* and dilute to 100 mL with the same mixture of solvents. Dilute 1 mL of this solution to 10 mL with the same mixture of solvents.

Apply to the plate 10 µL of each solution. Develop over a path of 15 cm using a mixture of 18 volumes of *ammonia R* and 90 volumes of *butanol R*. Dry the plate at 100 °C to 105 °C for 10 min and spray with a 1 g/L solution of *dimethylaminobenzaldehyde R* in *alcohol R* containing 1 per cent *V/V* of *hydrochloric acid R*. Any spot in the chromatogram obtained with test solution (a), apart from the principal spot, is not more intense than the spot in the chromatogram obtained with reference solution (b) (0.5 per cent).

**Heavy metals** (2.4.8). 1.0 g complies with limit test C for heavy metals (20 ppm). Prepare the standard using 2 mL of *lead standard solution (10 ppm Pb) R*.

**Loss on drying** (2.2.32). Not more than 0.5 per cent, determined on 1.000 g by drying in an oven at 105 °C.

**Sulfated ash** (2.4.14). Not more than 0.1 per cent, determined on 1.0 g.

#### ASSAY

Carry out the determination of primary aromatic amino-nitrogen (2.5.8), using 0.200 g, determining the end-point electrometrically.

1 mL of 0.1 *M sodium nitrite* is equivalent to 25.53 mg of C<sub>9</sub>H<sub>9</sub>N<sub>3</sub>O<sub>2</sub>S<sub>2</sub>.

#### STORAGE

Store protected from light.



**01/2011:0790** *Reference solution (b).* Dissolve 5.0 mg of *sulfinpyrazone impurity A CRS* and 5.0 mg of *sulfinpyrazone impurity B CRS* in the solvent mixture and dilute to 5.0 mL with the solvent mixture.

## SULFINPYRAZONE

### Sulfinpyrazonum

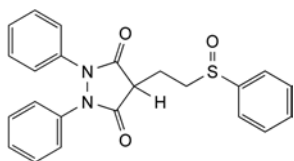

$C_{23}H_{20}N_2O_3S$   
[57-96-5]

$M_r$  404.5

#### DEFINITION

1,2-Diphenyl-4-[2-(phenylsulfinyl)ethyl]pyrazolidine-3,5-dione.

*Content:* 99.0 per cent to 101.0 per cent (dried substance).

#### CHARACTERS

*Appearance:* white or almost white powder.

*Solubility:* very slightly soluble in water, sparingly soluble in ethanol (96 per cent). It dissolves in dilute solutions of alkali hydroxides.

#### IDENTIFICATION

*First identification:* A, C.

*Second identification:* A, B, D.

A. Melting point (2.2.16): 131 °C to 135 °C.

B. Ultraviolet and visible absorption spectrophotometry (2.2.25).

*Test solution.* Dissolve 30.0 mg in 0.01 M sodium hydroxide and dilute to 100.0 mL with the same alkaline solution. Dilute 1.0 mL of this solution to 20.0 mL with 0.01 M sodium hydroxide.

*Spectral range:* 230-350 nm.

*Absorption maximum:* at 260 nm.

*Specific absorbance at the absorption maximum:* 530 to 580.

C. Infrared absorption spectrophotometry (2.2.24).

*Comparison:* *sulfinpyrazone CRS*.

D. Dissolve about 10 mg in 3 mL of *acetone R* and add a mixture of 0.2 mL of *ferric chloride solution R2* and 3 mL of *water R*. A red to violet colour develops.

#### TESTS

**Appearance of solution in acetone.** The solution is clear (2.2.1) and its absorbance (2.2.25) at 420 nm using a path length of 4 cm is not greater than 0.10.

Dissolve 1.25 g in *acetone R* and dilute to 25 mL with the same solvent.

**Appearance of solution in 1 M sodium hydroxide.** The solution is clear (2.2.1) and its absorbance (2.2.25) at 420 nm using a path length of 4 cm is not greater than 0.15.

Dissolve 1.25 g, heating gently if necessary, in 25 mL of 1 M sodium hydroxide.

**Related substances.** Liquid chromatography (2.2.29). Prepare the solutions immediately before use.

*Solvent mixture:* *water R*, *acetonitrile R* (10:40 V/V).

*Test solution.* Dissolve 10.0 mg of the substance to be examined in the solvent mixture and dilute to 10.0 mL with the solvent mixture.

*Reference solution (a).* Dilute 1.0 mL of the test solution to 100.0 mL with the solvent mixture.

*Reference solution (c).* Dilute 1.0 mL of reference solution (b) to 100.0 mL with the solvent mixture.

*Reference solution (d).* Dissolve the contents of a vial of *sulfinpyrazone for system suitability CRS* (containing impurity C) in 1.0 mL of the solvent mixture.

*Reference solution (e).* Dilute 1.0 mL of reference solution (a) to 10.0 mL with the solvent mixture.

*Column:*

– *size:*  $l = 0.125$  m,  $\varnothing = 4.6$  mm;

– *stationary phase:* end-capped octadecylsilyl silica gel for chromatography R (5  $\mu$ m).

*Mobile phase:* tetrahydrofuran for chromatography R, acetonitrile R, 0.3 per cent V/V solution of phosphoric acid R (7:35:58 V/V/V).

*Flow rate:* 2.0 mL/min.

*Detection:* spectrophotometer at 235 nm.

*Injection:* 20  $\mu$ l.

*Run time:* 7 times the retention time of sulfinpyrazone.

*Identification of impurities:* use the chromatogram supplied with *sulfinpyrazone for system suitability CRS* and the chromatogram obtained with reference solution (d) to identify the peak due to impurity C; use the chromatogram obtained with reference solution (b) to identify the peaks due to impurities A and B.

*Relative retention* with reference to sulfinpyrazone (retention time = about 3.5 min): impurity C = about 0.8; impurity A = about 1.6; impurity B = about 4.8.

*System suitability:* reference solution (d):

– *resolution:* minimum 2.0 between the peaks due to impurity C and sulfinpyrazone.

*Limits:*

– *impurities A, B:* for each impurity, not more than the area of the corresponding peak in the chromatogram obtained with reference solution (c) (1.0 per cent);

– *impurity C:* not more than twice the area of the principal peak in the chromatogram obtained with reference solution (e) (0.2 per cent);

– *unspecified impurities:* for each impurity, not more than the area of the principal peak in the chromatogram obtained with reference solution (e) (0.10 per cent);

– *total:* not more than twice the area of the principal peak in the chromatogram obtained with reference solution (a) (2.0 per cent);

– *disregard limit:* 0.5 times the area of the principal peak in the chromatogram obtained with reference solution (e) (0.05 per cent).

**Heavy metals** (2.4.8): maximum 10 ppm.

*Solvent mixture:* *acetone R*, *ethanol (96 per cent) R* (50:50 V/V).

0.250 g complies with test H. Prepare the reference solution using 2.5 mL of *lead standard solution (1 ppm Pb) R*.

To each solution, add 10 mL of *water R* and 2 mL of *buffer solution pH 3.5 R*.

**Loss on drying** (2.2.32): maximum 0.5 per cent, determined on 1.000 g by drying in an oven at 105 °C.

**Sulfated ash** (2.4.14): maximum 0.1 per cent, determined on 1.0 g.

#### ASSAY

Dissolve 0.300 g in 25 mL of *acetone R*. Add 0.5 mL of *bromothymol blue solution R1*. Titrate with 0.1 M sodium hydroxide until the colour changes from yellow to blue.

1 mL of 0.1 M sodium hydroxide is equivalent to 40.45 mg of  $C_{23}H_{20}N_2O_3S$ .

## STORAGE

Protected from light.

## IMPURITIES

Specified impurities: A, B, C.

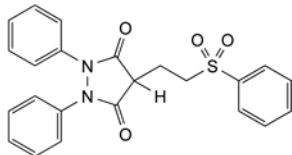

A. 1,2-diphenyl-4-[2-(phenylsulfonyl)ethyl]pyrazolidine-3,5-dione,

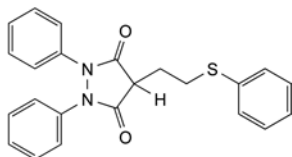

B. 1,2-diphenyl-4-[2-(phenylsulfanyl)ethyl]pyrazolidine-3,5-dione,

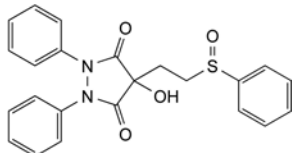

C. 4-hydroxy-1,2-diphenyl-4-[2-(phenylsulfinyl)ethyl]pyrazolidine-3,5-dione.

01/2008:0639  
corrected 6.0

## SULFISOMIDINE

## Sulfisomidinum

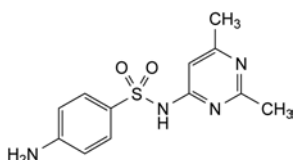

$C_{12}H_{14}N_4O_2S$   
[515-64-0]

$M_r$  278.3

## DEFINITION

Sulfisomidine contains not less than 99.0 per cent and not more than the equivalent of 101.0 per cent of 4-amino-*N*-(2,6-dimethylpyrimidin-4-yl)benzenesulfonamide, calculated with reference to the dried substance.

## CHARACTERS

White or yellowish-white powder or crystals, very slightly soluble in water, slightly soluble in acetone and in alcohol. It dissolves in dilute solutions of the alkali hydroxides and in dilute mineral acids.

It melts at about 240 °C with decomposition.

## IDENTIFICATION

First identification: A, B.

Second identification: B, C, D.

A. Examine by infrared absorption spectrophotometry (2.2.24), comparing with the spectrum obtained with *sulfisomidine CRS*. Examine the substances prepared as discs.

B. Examine the chromatograms obtained in the test for related substances. The principal spot in the chromatogram obtained with test solution (b) is similar in position and size to the principal spot in the chromatogram obtained with reference solution (a).

C. Dissolve 50 mg with heating in 4 mL of *methanol R*. Cool and filter. Add to the filtrate 0.2 mL of a 40 g/L solution of *copper acetate R*. The solution becomes yellowish-green.

D. Dissolve about 5 mg in 10 mL of 1 M *hydrochloric acid*. Dilute 1 mL of the solution to 10 mL with *water R*. The solution, without further acidification, gives the reaction of primary aromatic amines (2.3.1).

## TESTS

**Appearance of solution.** Dissolve 1.0 g in a mixture of 5 mL of *dilute sodium hydroxide solution R* and 5 mL of *water R*. The solution is not more intensely coloured than reference solution  $Y_5$ ,  $BY_5$  or  $GY_5$  (2.2.2, *Method II*).

**Acidity.** To 1.25 g, finely powdered, add 25 mL of *carbon dioxide-free water R*. Heat at 70 °C for 5 min. Cool in a bath of iced water for about 15 min and filter. To 20 mL of the filtrate add 0.1 mL of *bromothymol blue solution R1*. Not more than 0.2 mL of 0.1 M *sodium hydroxide* is required to change the colour of the indicator.

**Related substances.** Examine by thin-layer chromatography (2.2.27), using *silica gel GF<sub>254</sub> R* as the coating substance.

**Test solution (a).** Dissolve 0.10 g of the substance to be examined in 3 mL of a mixture of 2 volumes of *concentrated ammonia R* and 48 volumes of *methanol R* and dilute to 5 mL with the same mixture of solvents.

**Test solution (b).** Dilute 1 mL of test solution (a) to 5 mL with a mixture of 2 volumes of *concentrated ammonia R* and 48 volumes of *methanol R*.

**Reference solution (a).** Dissolve 20 mg of *sulfisomidine CRS* in 3 mL of a mixture of 2 volumes of *concentrated ammonia R* and 48 volumes of *methanol R* and dilute to 5 mL with the same mixture of solvents.

**Reference solution (b).** Dilute 1.25 mL of test solution (b) to 50 mL with a mixture of 2 volumes of *concentrated ammonia R* and 48 volumes of *methanol R*.

Apply to the plate 5 µL of each solution. Develop over a path of 15 cm using a mixture of 3 volumes of *dilute ammonia R1*, 5 volumes of *water R*, 40 volumes of *nitromethane R* and 50 volumes of *dioxan R*. Dry the plate at 100 °C to 105 °C and examine in ultraviolet light at 254 nm. Any spot in the chromatogram obtained with test solution (a), apart from the principal spot, is not more intense than the spot in the chromatogram obtained with reference solution (b) (0.5 per cent).

**Heavy metals** (2.4.8). 1.0 g complies with limit test D for heavy metals (20 ppm). Prepare the standard using 2 mL of *lead standard solution (10 ppm Pb) R*.

**Loss on drying** (2.2.32). Not more than 0.5 per cent, determined on 1.000 g by drying in an oven at 105 °C.

**Sulfated ash** (2.4.14). Not more than 0.1 per cent, determined on 1.0 g.

## ASSAY

Carry out the determination of primary aromatic amino-nitrogen (2.5.8), using 0.2500 g and determining the end-point electrometrically.

1 mL of 0.1 M *sodium nitrite* is equivalent to 27.83 mg of  $C_{12}H_{14}N_4O_2S$ .

## STORAGE

Store protected from light.

01/2008:0953 1 mL of 0.1 M sodium hydroxide is equivalent to 1.603 mg of S.

## SULFUR FOR EXTERNAL USE

### Sulfur ad usum externum

S A<sub>r</sub> 32.07  
[7704-34-9]

#### DEFINITION

*Content:* 99.0 per cent to 101.0 per cent.

#### CHARACTERS

*Appearance:* yellow powder.

*Solubility:* practically insoluble in water, soluble in carbon disulfide, slightly soluble in vegetable oils.

mp: about 120 °C.

The size of most of the particles is not greater than 20 µm and that of almost all the particles is not greater than 40 µm.

#### IDENTIFICATION

- A. Heated in the presence of air, it burns with a blue flame, emitting sulfur dioxide which changes the colour of moistened *blue litmus paper R* to red.
- B. Heat 0.1 g with 0.5 mL of *bromine water R* until decolourised. Add 5 mL of *water R* and filter. The solution gives reaction (a) of sulfates (2.3.1).

#### TESTS

**Solution S.** To 5 g add 50 mL of *carbon dioxide-free water R* prepared from *distilled water R*. Allow to stand for 30 min with frequent shaking and filter.

**Appearance of solution.** Solution S is colourless (2.2.2, *Method II*).

**Odour** (2.3.4). It has no perceptible odour of hydrogen sulfide.

**Acidity or alkalinity.** To 5 mL of solution S add 0.1 mL of *phenolphthalein solution R1*. The solution is colourless. Add 0.2 mL of 0.01 M sodium hydroxide. The solution is red. Add 0.3 mL of 0.01 M hydrochloric acid. The solution is colourless. Add 0.15 mL of *methyl red solution R*. The solution is orange-red.

**Chlorides** (2.4.4): maximum 100 ppm.

Dilute 5 mL of solution S to 15 mL with *water R*.

**Sulfates** (2.4.13): maximum 100 ppm, determined on solution S.

**Sulfides.** To 10 mL of solution S add 2 mL of *buffer solution pH 3.5 R* and 1 mL of a freshly prepared 1.6 g/L solution of *lead nitrate R* in *carbon dioxide-free water R*. Shake. After 1 min any colour in the solution is not more intense than that in a reference solution prepared at the same time using 1 mL of *lead standard solution (10 ppm Pb) R*, 9 mL of *carbon dioxide-free water R*, 2 mL of *buffer solution pH 3.5 R* and 1.2 mL of *thioacetamide reagent R*.

**Sulfated ash** (2.4.14): maximum 0.2 per cent, determined on 1.0 g.

#### ASSAY

Carry out the oxygen-flask method (2.5.10), using 60.0 mg in a 1000 mL combustion flask. Absorb the combustion products in a mixture of 5 mL of *dilute hydrogen peroxide solution R* and 10 mL of *water R*. Heat to boiling, boil gently for 2 min and cool. Using 0.2 mL of *phenolphthalein solution R* as indicator, titrate with 0.1 M sodium hydroxide until the colour changes from colourless to red. Carry out a blank titration under the same conditions.

#### STORAGE

Protected from light.

01/2008:1572

## SULFURIC ACID

### Acidum sulfuricum

H<sub>2</sub>SO<sub>4</sub> M<sub>r</sub> 98.1  
[7664-93-9]

#### DEFINITION

*Content:* 95.0 per cent *m/m* to 100.5 per cent *m/m*.

#### CHARACTERS

*Appearance:* colourless, oily liquid, very hygroscopic.

*Solubility:* miscible with water and with ethanol (96 per cent) producing intense heat.

*Relative density:* about 1.84.

#### IDENTIFICATION

- A. Carefully add 1 mL to 100 mL of *water R*. The solution is strongly acid (2.2.4).
- B. The solution obtained in identification test A gives reaction (a) of sulfates (2.3.1).

#### TESTS

**Appearance of solution.** The solution is clear (2.2.1) and colourless (2.2.2, *Method II*).

Carefully pour, while cooling, 5 mL into 30 mL of *water R* and dilute to 50 mL with the same solvent.

**Chlorides** (2.4.4): maximum 50 ppm.

Mix carefully, while cooling, 3.3 g with 30 mL of *water R*. Neutralise with *ammonia R* and dilute to 50 mL with *water R*.

**Nitrates.** Add 5 mL to 5 mL of *water R*. Cool to room temperature and add 0.5 mL of *indigo carmine solution R*. The blue colour persists for at least 1 min.

**Arsenic** (2.4.2, *Method A*): maximum 1 ppm.

Mix, while cooling, 1 g with 20 mL of *water R* and dilute to 25 mL with the same solvent.

**Iron** (2.4.9): maximum 25 ppm.

Cautiously evaporate 10.0 g and ignite to dull redness. Dissolve the ignition residue in 1 mL of *dilute hydrochloric acid R* with gentle heating and dilute to 25 mL with *water R*. Dilute 1 mL of this solution to 10 mL with *water R*.

**Heavy metals** (2.4.8): maximum 5 ppm.

4.0 g complies with test F. Prepare the reference solution using 2 mL of *lead standard solution (10 ppm Pb) R*.

#### ASSAY

Weigh accurately a ground-glass-stoppered flask containing 30 mL of *water R*. Introduce 0.2 mL, cool and weigh again. Titrate with 1 M sodium hydroxide, determining the end-point potentiometrically (2.2.20).

1 mL of 1 M sodium hydroxide is equivalent to 49.04 mg of H<sub>2</sub>SO<sub>4</sub>.

#### STORAGE

In an airtight container.

01/2008:0864  
corrected 6.0

## SULINDAC

## Sulindacum

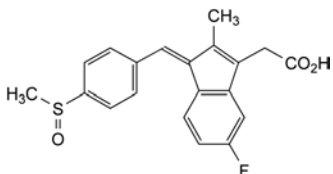
C<sub>20</sub>H<sub>17</sub>FO<sub>3</sub>S  
[38194-50-2]M<sub>r</sub> 356.4

## DEFINITION

(Z)-[5-Fluoro-2-methyl-1-[4-(methylsulfinyl)benzylidene]-1H-inden-3-yl]acetic acid.

Content: 99.0 per cent to 101.0 per cent (dried substance).

## CHARACTERS

*Appearance*: yellow, crystalline powder.*Solubility*: very slightly soluble in water, soluble in methylene chloride, sparingly soluble in ethanol (96 per cent). It dissolves in dilute solutions of alkali hydroxides.

It shows polymorphism (5.9).

## IDENTIFICATION

*First identification*: C.*Second identification*: A, B, D, E.

A. Melting point (2.2.14): 182 °C to 186 °C.

B. Ultraviolet and visible absorption spectrophotometry (2.2.25).

*Test solution*. Dissolve 50 mg in a 0.3 per cent V/V solution of hydrochloric acid R in methanol R and dilute to 100 mL with the same acid solution. Dilute 2 mL of this solution to 50 mL with a 0.3 per cent V/V solution of hydrochloric acid R in methanol R.*Spectral range*: 230-350 nm.*Absorption maxima*: at 284 nm and 327 nm.*Shoulder*: at about 258 nm.*Absorbance ratio*:  $A_{284}/A_{327} = 1.10$  to 1.20.

C. Infrared absorption spectrophotometry (2.2.24).

*Preparation*: discs.*Comparison*: sulindac CRS.

If the spectra obtained show differences, dissolve the substance to be examined and the reference substance separately in the minimum volume of hot methanol R, evaporate to dryness and record new spectra using the residues.

D. Thin-layer chromatography (2.2.27).

*Test solution*. Dissolve 10 mg of the substance to be examined in methylene chloride R and dilute to 10 mL with the same solvent.*Reference solution (a)*. Dissolve 10 mg of sulindac CRS in methylene chloride R and dilute to 10 mL with the same solvent.*Reference solution (b)*. Dissolve 10 mg of diflunisal CRS in methylene chloride R and dilute to 10 mL with the same solvent. Dilute 1 mL of this solution to 2 mL with reference solution (a).*Plate*: TLC silica gel GF<sub>254</sub> plate R.*Mobile phase*: glacial acetic acid R, methylene chloride R, acetone R (1:49:50 V/V/V).*Application*: 5 µL.*Development*: over a path of 15 cm.*Drying*: in a current of warm air.*Detection*: examine in ultraviolet light at 254 nm.*System suitability*: reference solution (b):

– the chromatogram shows 2 clearly separated principal spots.

*Results*: the principal spot in the chromatogram obtained with the test solution is similar in position and size to the principal spot in the chromatogram obtained with reference solution (a).

E. Mix about 5 mg with 45 mg of heavy magnesium oxide R and ignite in a crucible until an almost white residue is obtained (usually less than 5 min). Allow to cool, add 1 mL of water R, 0.05 mL of phenolphthalein solution R1 and about 1 mL of dilute hydrochloric acid R to render the solution colourless. Filter. Add 1.0 mL of the filtrate to a freshly prepared mixture of 0.1 mL of alizarin S solution R and 0.1 mL of zirconyl nitrate solution R. Mix, allow to stand for 5 min and compare the colour of the solution with that of a blank prepared in the same manner. The test solution is yellow and the blank is red.

## TESTS

**Related substances**. Liquid chromatography (2.2.29).*Test solution*. Dissolve 0.10 g of the substance to be examined in the mobile phase and dilute to 50.0 mL with the mobile phase.*Reference solution (a)*. Dilute 1.0 mL of the test solution to 100.0 mL with the mobile phase. Dilute 5.0 mL of this solution to 10.0 mL with the mobile phase.*Reference solution (b)*. Dissolve 20.0 mg of sulindac CRS (which has an assigned content of E-isomer) in the mobile phase and dilute to 10.0 mL with the mobile phase.*Column*:– size:  $l = 0.25$  m,  $\varnothing = 4.6$  mm;

– stationary phase: silica gel for chromatography R (10 µm).

*Mobile phase*: glacial acetic acid R, ethanol (96 per cent) R, ethyl acetate R, ethanol-free chloroform R (1:4:100:400 V/V/V/V).*Flow rate*: 2 mL/min.*Detection*: spectrophotometer at 280 nm.*Injection*: 20 µL.*Run time*: twice the retention time of sulindac.*Identification of peaks*: the chromatogram obtained with reference solution (b) shows a principal peak due to sulindac and a peak due to the E-isomer.*Relative retention* with reference to sulindac: E-isomer = about 1.75.

From the chromatograms obtained with the test solution and reference solution (b), determine the percentage content of E-isomer, taking into account the assigned content of this isomer in sulindac CRS.

*Limits*:

– E-isomer: maximum 0.5 per cent;

– impurities A, B, C: for each impurity, not more than the area of the principal peak in the chromatogram obtained with reference solution (a) (0.5 per cent);

– total: not more than twice the area of the principal peak in the chromatogram obtained with reference solution (a) (1 per cent).

**Heavy metals** (2.4.8): maximum 10 ppm.

2.0 g complies with test D. Prepare the reference solution using 2 mL of lead standard solution (10 ppm Pb) R.

**Loss on drying** (2.2.32): maximum 0.5 per cent, determined on 1.000 g by drying in an oven at 105 °C at a pressure not exceeding 0.7 kPa.**Sulfated ash** (2.4.14): maximum 0.1 per cent, determined on 1.0 g.

## ASSAY

Dissolve 0.300 g in 50 mL of *methanol R*. Titrate with 0.1 M *sodium hydroxide*, determining the end-point potentiometrically (2.2.20).

1 mL of 0.1 M *sodium hydroxide* is equivalent to 35.64 mg of  $C_{20}H_{17}FO_3S$ .

## STORAGE

Protected from light.

## IMPURITIES

Specified impurities: A, B, C.

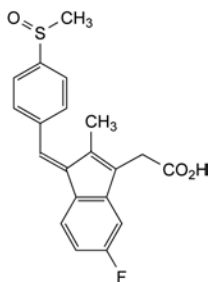

A. (*E*)-[5-fluoro-2-methyl-1-[4-(methylsulfinyl)benzylidene]-1H-inden-3-yl]acetic acid,

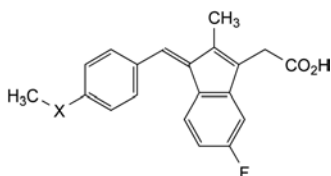

B. X = SO<sub>2</sub>: (*Z*)-[5-fluoro-2-methyl-1-[4-(methylsulfonyl)benzylidene]-1H-inden-3-yl]acetic acid,

C. X = S: (*Z*)-[5-fluoro-2-methyl-1-[4-methylsulfanyl)benzylidene]-1H-inden-3-yl]acetic acid.

01/2008:1045  
corrected 6.0

## SULPIRIDE

## Sulpiridum

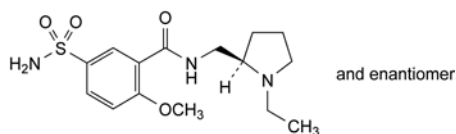

$C_{15}H_{23}N_3O_4S$   
[15676-16-1]

$M_r$  341.4

## DEFINITION

(*RS*)-*N*-[(1-Ethylpyrrolidin-2-yl)methyl]-2-methoxy-5-sulfamoylbenzamide.

Content: 98.5 per cent to 101.0 per cent (dried substance).

## CHARACTERS

Appearance: white or almost white, crystalline powder.

Solubility: practically insoluble in water, sparingly soluble in methanol, slightly soluble in ethanol (96 per cent) and in methylene chloride. It dissolves in dilute solutions of mineral acids and alkali hydroxides.

## IDENTIFICATION

First identification: A, B.

Second identification: A, C, D.

A. Melting point (2.2.14): 177 °C to 181 °C.

B. Infrared absorption spectrophotometry (2.2.24).

Preparation: discs.

Comparison: *sulpiride CRS*.

C. Examine the chromatograms obtained in test A for related substances.

Detection: examine in ultraviolet light at 254 nm.

Results: the principal spot in the chromatogram obtained with test solution (b) is similar in position and size to the principal spot in the chromatogram obtained with reference solution (a).

D. To about 1 mg in a porcelain dish, add 0.5 mL of *sulfuric acid R* and 0.05 mL of *formaldehyde solution R*. Examined in ultraviolet light at 365 nm, the solution shows blue fluorescence.

## TESTS

Appearance of solution. The solution is clear (2.2.1) and not more intensely coloured than reference solution Y<sub>6</sub> (2.2.2, Method I).

Dissolve 1.0 g in *dilute acetic acid R* and dilute to 10 mL with the same acid.

## Related substances

A. Thin-layer chromatography (2.2.27).

Test solution (a). Dissolve 0.20 g of the substance to be examined in *methanol R* and dilute to 10 mL with the same solvent. Sonicate until complete dissolution.

Test solution (b). Dilute 1 mL of test solution (a) to 10 mL with *methanol R*.

Reference solution (a). Dissolve 20 mg of *sulpiride CRS* in *methanol R* and dilute to 10 mL with the same solvent.

Reference solution (b). Dissolve 5 mg of *sulpiride impurity A CRS* in *methanol R* and dilute to 25 mL with the same solvent.

Reference solution (c). Dilute 1.0 mL of reference solution (b) to 10 mL with *methanol R*.

Plate: TLC silica gel F<sub>254</sub> plate R.

Mobile phase: concentrated ammonia R, dioxan R, methanol R, methylene chloride R (2:10:14:90 V/V/V/V).

Application: 10 µL.

Development: over a path of 10 cm.

Drying: in air.

Detection: examine in ultraviolet light at 254 nm for identification test C and then spray with *ninhydrin solution R*; heat at 100-105 °C for 15 min and examine in daylight.

Limit: test solution (a):

– *impurity A*: any spot due to *impurity A* is not more intense than the corresponding spot in the chromatogram obtained with reference solution (c) (0.1 per cent).

B. Liquid chromatography (2.2.29).

Test solution. Dissolve 0.100 g of the substance to be examined in the mobile phase and dilute to 100.0 mL with the mobile phase.

Reference solution (a). Dilute 3.0 mL of the test solution to 100.0 mL with the mobile phase. Dilute 1.0 mL of this solution to 10.0 mL with the mobile phase.

Reference solution (b). Dissolve 10 mg of *sulpiride CRS* and 10 mg of *sulpiride impurity B CRS* in the mobile phase and dilute to 100.0 mL with the mobile phase.

Column:

– size:  $l = 0.25$  m,  $\varnothing = 4.6$  mm;

– stationary phase: octylsilyl silica gel for chromatography R (5 µm) in spherical micro-particles.

Mobile phase: mix 10 volumes of *acetonitrile R*, 10 volumes of *methanol R* and 80 volumes of a solution containing 6.8 g/L of *potassium dihydrogen phosphate R* and 1 g/L of *sodium octanesulfonate R*, adjusted to pH 3.3 using *phosphoric acid R*.

Flow rate: 1.5 mL/min.

**Detection:** spectrophotometer at 240 nm.

**Injection:** 10 µL.

**Run time:** 2.5 times the retention time of sulpiride.

**System suitability:** reference solution (b):

- **resolution:** minimum 2.5 between the peaks due to impurity B and sulpiride.

**Limit:**

- **total:** not more than the area of the principal peak in the chromatogram obtained with reference solution (a) (0.3 per cent).

**Chlorides (2.4.4):** maximum 100 ppm.

Shake 1.0 g with 20 mL of *water R*. Filter through a sintered-glass filter (40) (2.1.2). To 10 mL of the filtrate add 5 mL of *water R*.

**Iron (2.4.9):** maximum 10 ppm.

Ignite 1.0 g in a silica crucible. To the residue add 1 mL of 1 *M hydrochloric acid*, 3 mL of *water R* and 0.1 mL of *nitric acid R*. Heat on a water-bath for a few minutes. Place the solution in a test-tube. Rinse the crucible with 4 mL of *water R*. Collect the rinsings in the test-tube and dilute to 10 mL with *water R*.

**Heavy metals (2.4.8):** maximum 10 ppm.

1.0 g complies with test C. Prepare the reference solution using 1 mL of *lead standard solution (10 ppm Pb) R*.

**Loss on drying (2.2.32):** maximum 0.5 per cent, determined on 1.000 g by drying in an oven at 105 °C.

**Sulfated ash (2.4.14):** maximum 0.1 per cent, determined on 1.0 g.

#### ASSAY

Dissolve 0.250 g in 80 mL of *anhydrous acetic acid R*. Titrate with 0.1 *M perchloric acid*, determining the end-point potentiometrically (2.2.20).

1 mL of 0.1 *M perchloric acid* is equivalent to 34.14 mg of C<sub>15</sub>H<sub>23</sub>N<sub>3</sub>O<sub>4</sub>S.

#### IMPURITIES

**Specified impurities:** A.

**Other detectable impurities** (the following substances would, if present at a sufficient level, be detected by one or other of the tests in the monograph. They are limited by the general acceptance criterion for other/unspecified impurities and/or by the general monograph *Substances for pharmaceutical use (2034)*. It is therefore not necessary to identify these impurities for demonstration of compliance. See also 5.10. **Control of impurities in substances for pharmaceutical use**): B, C, D, E, F, G.

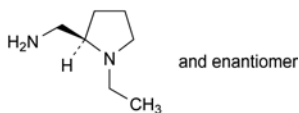

A. [(2*RS*)-1-ethylpyrrolidin-2-yl]methanamine,

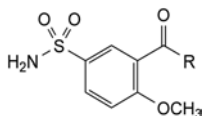

B. R = O-CH<sub>3</sub>: methyl 2-methoxy-5-sulfamoylbenzoate,

C. R = O-C<sub>2</sub>H<sub>5</sub>: ethyl 2-methoxy-5-sulfamoylbenzoate,

D. R = OH: 2-methoxy-5-sulfamoylbenzoic acid,

E. R = NH<sub>2</sub>: 2-methoxy-5-sulfamoylbenzamide,

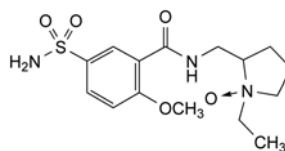

F. 1-ethyl-2-[(2-methoxy-5-sulfamoylbenzoyl)amino]methylpyrrolidine 1-oxide,

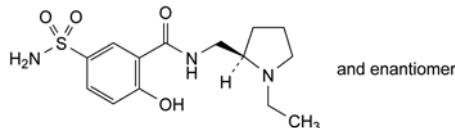

G. (*RS*)-*N*-[(1-ethylpyrrolidin-2-yl)methyl]-2-hydroxy-5-sulfamoylbenzamide.

04/2008:2211

## SULTAMICILLIN

### Sultamicillinum

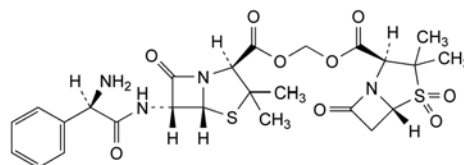

C<sub>25</sub>H<sub>30</sub>N<sub>4</sub>O<sub>9</sub>S<sub>2</sub>  
[76497-13-7]

M<sub>r</sub> 594.7

#### DEFINITION

Methylene (2*S*,5*R*,6*R*)-6-[[[(2*R*)-aminophenylacetyl]amino]-3,3-dimethyl-7-oxo-4-thia-1-azabicyclo[3.2.0]heptane-2-carboxylate (2*S*,5*R*)-3,3-dimethyl-4,4,7-trioxo-4λ<sup>6</sup>-thia-1-azabicyclo[3.2.0]heptane-2-carboxylate.

Semi-synthetic product derived from a fermentation product.

**Content:** 96.0 per cent to 102.0 per cent (anhydrous substance).

#### CHARACTERS

**Appearance:** white or almost white, slightly hygroscopic, crystalline powder.

**Solubility:** practically insoluble in water, very slightly soluble in methanol, practically insoluble in ethanol (96 per cent).

#### IDENTIFICATION

Infrared absorption spectrophotometry (2.2.24).

**Comparison:** *sultamicillin CRS*.

#### TESTS

**Specific optical rotation (2.2.7):** + 190 to + 210 (anhydrous substance).

Dissolve 0.500 g in *dimethylformamide R* and dilute to 50.0 mL with the same solvent.

**Related substances.** Liquid chromatography (2.2.29). *Prepare the solutions immediately before use or keep at 2-8 °C for not more than 6 h.*

**Solution A:** *methanol R1, acetonitrile R1* (20:80 *V/V*).

**Solution B.** Dissolve 1.56 g of *sodium dihydrogen phosphate R* in 900 mL of *water R*. Add 7.0 mL of *phosphoric acid R* and dilute to 1000 mL with *water R*.

**Blank solution:** solution B, solution A (30:70 *V/V*).

**Test solution.** Dissolve 50.0 mg of the substance to be examined in 35 mL of solution A and sonicate for about 1 min. Add 13 mL of solution B, mix and sonicate for about 1 min. Dilute to 50.0 mL with solution B and mix.

**Reference solution (a).** Dissolve 70.0 mg of *sultamicillin tosilate CRS* in 35 mL of solution A and sonicate for about 1 min. Add 13 mL of solution B, mix and sonicate for about 1 min. Dilute to 50.0 mL with solution B and mix.

**Reference solution (b).** Suspend 15 mg of *sultamicillin tosilate CRS* in 20 mL of a 0.4 g/L solution of *sodium hydroxide R* and sonicate in an ultrasonic bath for about 5 min. Add 20 mL of a 0.36 g/L solution of *hydrochloric acid R* and dilute to 100 mL with *water R*.

**Reference solution (c).** Dilute 1.0 mL of reference solution (a) to 100.0 mL with the blank solution.

**Reference solution (d).** Dissolve 17.3 mg of *ampicillin trihydrate CRS* (impurity C) and 15.0 mg of *subactam CRS* (impurity A) in *water R* and dilute to 50.0 mL with the same solvent. Dilute 1.0 mL of this solution to 100.0 mL with *water R*.

**Reference solution (e).** Dissolve 5 mg of *sultamicillin for peak identification CRS* (containing impurity G) in 7.0 mL of solution A and sonicate for about 1 min. Dilute to 10.0 mL with solution B, mix and sonicate for about 1 min.

**Column:**

- size:  $l = 0.10$  m,  $\varnothing = 4.6$  mm;
- stationary phase: *octadecylsilyl silica gel for chromatography R* (3.5  $\mu\text{m}$ );
- temperature: 25 °C.

**Mobile phase:**

- mobile phase A: 4.68 g/L solution of *sodium dihydrogen phosphate R* adjusted to pH 3.0 with *phosphoric acid R*;
- mobile phase B: *acetonitrile R1*;

Time (min)	Mobile phase A (per cent V/V)	Mobile phase B (per cent V/V)
0 - 15	95 → 30	5 → 70
15 - 16	30	70
16 - 16.5	30 → 95	70 → 5
16.5 - 20	95	5

**Flow rate:** 1.0 mL/min.

**Detection:** spectrophotometer at 215 nm.

**Injection:** 5  $\mu\text{L}$  of the blank solution, the test solution and reference solutions (b), (c), (d) and (e).

**Identification of impurities:** use the chromatogram supplied with *sultamicillin for peak identification CRS* and the chromatogram obtained with reference solution (e) to identify the peak due to impurity G.

**Relative retention** with reference to *sultamicillin* (retention time = about 9.3 min): impurity A = about 0.41; *ampicillin penicilloic acid* = about 0.47; impurity B = about 0.50; impurity C = about 0.55; impurity D = about 0.94; impurity E = about 1.09; impurity F = about 1.26; impurity G = about 1.42.

**System suitability:** reference solution (b):

- resolution: minimum 2.5 between the peaks due to *ampicillin penicilloic acid* and impurity B and minimum 2.5 between the peaks due to impurities B and C.

**Limits:**

- impurity G: not more than the area of the peak due to *sultamicillin* in the chromatogram obtained with reference solution (c) (1.0 per cent);
- impurity A: not more than the area of the corresponding peak in the chromatogram obtained with reference solution (d) (0.3 per cent);
- impurity B: not more than the area of the corresponding peak in the chromatogram obtained with reference solution (c) (0.3 per cent);
- impurity C: not more than the area of the corresponding peak in the chromatogram obtained with reference solution (d) (0.3 per cent);

- impurities D, E, F: for each impurity, not more than 0.3 times the area of the peak due to *sultamicillin* in the chromatogram obtained with reference solution (c) (0.3 per cent);
- any other impurity: for each impurity, not more than 0.3 times the area of the peak due to *sultamicillin* in the chromatogram obtained with reference solution (c) (0.3 per cent);
- total: not more than 3 times the area of the peak due to *sultamicillin* in the chromatogram obtained with reference solution (c) (3.0 per cent);
- disregard limit: 0.1 times the area of the peak due to *sultamicillin* in the chromatogram obtained with reference solution (c) (0.1 per cent).

**Ethyl acetate.** Head-space gas chromatography (2.2.28).

**Test solution.** Dissolve 0.200 g in 7.0 mL of a mixture of 1 volume of *water R* and 99 volumes of *dimethylformamide R*.

**Reference solution.** Dissolve 0.200 g of *ethyl acetate R* in 240 mL of a mixture of 1 volume of *water R* and 99 volumes of *dimethylformamide R* and dilute to 250.0 mL with the same mixture of solvents. Dilute 5.0 mL of this solution to 7.0 mL with a mixture of 1 volume of *water R* and 99 volumes of *dimethylformamide R*.

Close the vials immediately with a tight rubber membrane stopper coated with *polytetrafluoroethylene* and secure with an aluminium crimped cap. Shake to obtain a homogeneous solution.

**Column:**

- material: fused silica;
- size:  $l = 50$  m,  $\varnothing = 0.32$  mm;
- stationary phase: *poly(dimethyl)siloxane R* (film thickness: 1.8  $\mu\text{m}$  or 3  $\mu\text{m}$ ).

**Carrier gas:** *helium for chromatography R*.

**Linear velocity:** 35 cm/s.

**Split ratio:** 1:5.

**Static head-space conditions that may be used:**

- equilibration temperature: 105 °C;
- equilibration time: 45 min;
- transfer-line temperature: 110 °C;
- pressurisation time: 30 s.

**Temperature:**

	Time (min)	Temperature (°C)
Column	0 - 6	70
	6 - 16	70 → 220
	16 - 18	220
Injection port		140
Detector		250

**Detection:** flame ionisation.

**Injection:** 1 mL.

**Relative retention** with reference to *dimethylformamide* (retention time = about 14 min): *ethyl acetate* = about 0.7.

**Limit:**

- *ethyl acetate*: maximum 2.5 per cent.

**Heavy metals** (2.4.8): maximum 20 ppm.

Dissolve 2.0 g in a mixture of 40 volumes of *methanol R* and 60 volumes of *acetonitrile R* and dilute to 20.0 mL with the same mixture of solvents. 12 mL of the solution complies with test B. Prepare the reference solution using lead standard solution (2 ppm Pb) obtained by diluting *lead standard solution (100 ppm Pb) R* with a mixture of 40 volumes of *methanol R* and 60 volumes of *acetonitrile R*.

**Water** (2.5.12): maximum 1.0 per cent, determined on 0.50 g.

**Sulfated ash (2.4.14):** maximum 0.1 per cent, determined on 1.0 g.

#### ASSAY

Liquid chromatography (2.2.29) as described in the test for related substances with the following modifications.

**Injection:** test solution and reference solution (a).

Calculate the percentage content of sultamicillin ( $C_{25}H_{30}N_4O_9S_2$ ) from the declared content of  $C_{25}H_{30}N_4O_9S_2$  in *sultamicillin tosilate CRS* and by multiplying the sultamicillin tosilate content by 0.7752.

#### STORAGE

In an airtight container.

#### IMPURITIES

**Specified impurities:** A, B, C, D, E, F, G.

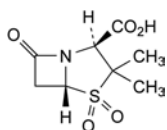

- A. (2*S*,5*R*)-3,3-dimethyl-7-oxo-4-thia-1-azabicyclo[3.2.0]heptane-2-carboxylic acid 4,4-dioxide (sulbactam),

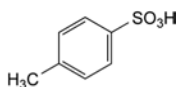

- B. 4-methylbenzenesulfonic acid (*p*-toluenesulfonic acid),

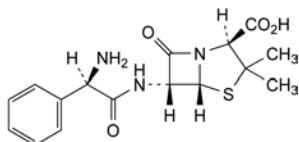

- C. (2*S*,5*R*,6*R*)-6-[[[(2*R*)-2-amino-2-phenylacetyl]amino]-3,3-dimethyl-7-oxo-4-thia-1-azabicyclo[3.2.0]heptane-2-carboxylic acid (ampicillin),

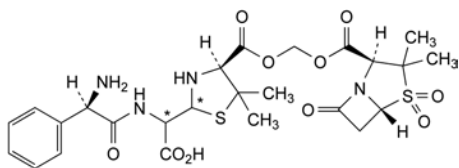

- D. [[(2*R*)-aminophenylacetyl]amino] [(4*S*)-4-[[[(2*S*,5*R*)-3,3-dimethyl-4,4,7-trioxo-4λ<sup>6</sup>-thia-1-azabicyclo[3.2.0]hept-2-yl]carbonyl]oxy]methoxy]carbonyl]-5,5-dimethylthiazolidin-2-yl]acetic acid (penicilloic acids of sultamicillin),

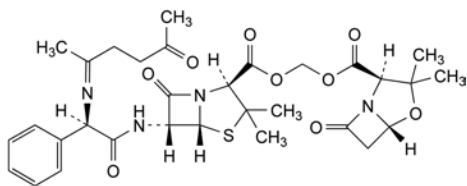

- E. methylene (2*S*,5*R*,6*R*)-3,3-dimethyl-6-[[[(2*R*)-[(1-methyl-4-oxopentylidene)amino]phenylacetyl]amino]-7-oxo-4-thia-1-azabicyclo[3.2.0]heptane-2-carboxylate (2*S*,5*R*)-3,3-dimethyl-7-oxo-4-oxa-1-azabicyclo[3.2.0]heptane-2-carboxylate,

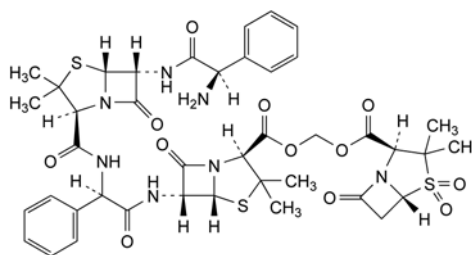

- F. methylene (2*S*,5*R*,6*R*)-6-[[[(2*R*)-[[[(2*S*,5*R*,6*R*)-6-[[[(2*R*)-aminophenylacetyl]amino]-3,3-dimethyl-7-oxo-4-thia-1-azabicyclo[3.2.0]hept-2-yl]carbonyl]amino]phenylacetyl]amino]-3,3-dimethyl-7-oxo-4-thia-1-azabicyclo[3.2.0]heptane-2-carboxylate (2*S*,5*R*)-3,3-dimethyl-4,4,7-trioxo-4λ<sup>6</sup>-thia-1-azabicyclo[3.2.0]heptane-2-carboxylate (ampicillin sultamicillin amide),

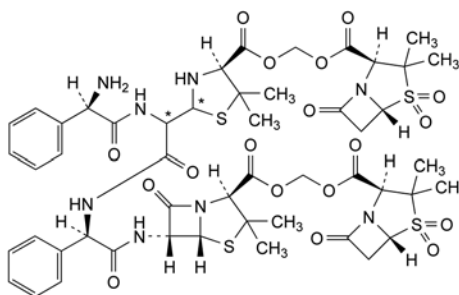

- G. methylene (2*S*,5*R*,6*R*)-6-[[[(2*R*)-[[[(2*R*)-aminophenylacetyl]amino] [(4*S*)-4-[[[(2*S*,5*R*)-3,3-dimethyl-4,4,7-trioxo-4λ<sup>6</sup>-thia-1-azabicyclo[3.2.0]hept-2-yl]carbonyl]oxy]methoxy]carbonyl]-5,5-dimethylthiazolidin-2-yl]acetyl]amino]phenylacetyl]amino]-3,3-dimethyl-7-oxo-4-thia-1-azabicyclo[3.2.0]heptane-2-carboxylate (2*S*,5*R*)-3,3-dimethyl-4,4,7-trioxo-4λ<sup>6</sup>-thia-1-azabicyclo[3.2.0]heptane-2-carboxylate (sultamicillin dimer).

01/2008:2212  
corrected 6.3

## SULTAMICILLIN TOSILATE DIHYDRATE

### Sultamicillini tosilas dihydricus

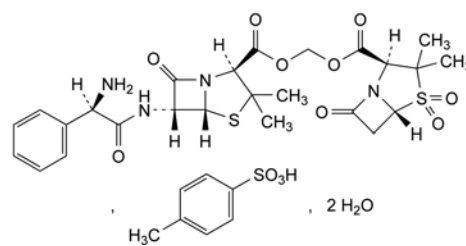

$C_{32}H_{38}N_4O_{12}S_3 \cdot 2H_2O$

$M_r$  803

#### DEFINITION

4-Methylbenzenesulfonate of methylene (2*S*,5*R*,6*R*)-6-[[[(2*R*)-aminophenylacetyl]amino]-3,3-dimethyl-7-oxo-4-thia-1-azabicyclo[3.2.0]heptane-2-carboxylate (2*S*,5*R*)-3,3-dimethyl-4,4,7-trioxo-4λ<sup>6</sup>-thia-1-azabicyclo[3.2.0]heptane-2-carboxylate dihydrate.

Semi-synthetic product derived from a fermentation product.

**Content:** 95.0 per cent to 102.0 per cent (anhydrous substance).

#### CHARACTERS

**Appearance:** white or almost white, crystalline powder.

**Solubility:** practically insoluble in water, sparingly soluble in ethanol (96 per cent).

#### IDENTIFICATION

Infrared absorption spectrophotometry (2.2.24).



Comparison: sultamicillin tosilate CRS.

#### TESTS

**Specific optical rotation** (2.2.7): + 178 to + 195 (anhydrous substance).

Dissolve 1.000 g in *dimethylformamide R* and dilute to 50.0 mL with the same solvent.

**Related substances.** Liquid chromatography (2.2.29). Prepare the solutions immediately before use or keep at 2-8 °C for not more than 6 h.

**Solution A:** *methanol R1*, *acetonitrile R1* (20:80 V/V).

**Solution B.** Dissolve 1.56 g of *sodium dihydrogen phosphate R* in 900 mL of *water R*. Add 7.0 mL of *phosphoric acid R* and dilute to 1000 mL with *water R*.

**Blank solution:** solution B, solution A (30:70 V/V).

**Test solution.** Dissolve 70.0 mg of the substance to be examined in 35 mL of solution A and sonicate for about 1 min. Add 13 mL of solution B, mix and sonicate for about 1 min. Dilute to 50.0 mL with solution B and mix.

**Reference solution (a).** Dissolve 70.0 mg of *sultamicillin tosilate CRS* in 35 mL of solution A and sonicate for about 1 min. Add 13 mL of solution B, mix and sonicate for about 1 min. Dilute to 50.0 mL with solution B and mix.

**Reference solution (b).** Suspend 15 mg of the substance to be examined in 20 mL of a 0.4 g/L solution of *sodium hydroxide R* and sonicate in an ultrasonic bath for about 5 min. Add 20 mL of a 0.36 g/L solution of *hydrochloric acid R* and dilute to 100.0 mL with *water R*.

**Reference solution (c).** Dissolve 0.200 g of the substance to be examined in 70.0 mL of solution A and sonicate for about 1 min. Add 25.0 mL of solution B, mix and sonicate for about 1 min. Dilute to 100.0 mL with solution B and mix. Dilute 1.0 mL of this solution to 100.0 mL with the blank solution.

**Reference solution (d).** Dissolve 32.3 mg of *ampicillin trihydrate CRS* (impurity B) and 7.0 mg of *subactam CRS* (impurity A) in *water R* and dilute to 1000 mL with the same solvent.

**Column:**

- size:  $l = 0.10$  m,  $\varnothing = 4.6$  mm;
- stationary phase: *octadecylsilyl silica gel for chromatography R* (3.5  $\mu$ m);
- temperature: 25 °C.

**Mobile phase:**

- mobile phase A: 4.68 g/L solution of *sodium dihydrogen phosphate R* adjusted to pH 3.0 with *phosphoric acid R*;
- mobile phase B: *acetonitrile R1*;

Time (min)	Mobile phase A (per cent V/V)	Mobile phase B (per cent V/V)
0 - 15	95 → 30	5 → 70
15 - 16	30	70
16 - 16.5	30 → 95	70 → 5
16.5 - 20	95	5

**Flow rate:** 1.0 mL/min.

**Detection:** spectrophotometer at 215 nm.

**Injection:** 5  $\mu$ L of the blank solution, the test solution and reference solutions (b), (c) and (d).

**Relative retention** with reference to sultamicillin (retention time = about 9.3 min): impurity A = about 0.41; ampicillin penicilloic acid = about 0.47; tosilate = about 0.50; impurity B = about 0.55; impurity C = about 0.94; impurity D = about 1.09; impurity F = about 1.23; impurity E = about 1.26; impurity G = about 1.42.

**System suitability:** reference solution (b):

- resolution: minimum 2.5 between the peaks due to ampicillin penicilloic acid and tosilate and minimum 2.5 between the peaks due to tosilate and impurity B.

**Limits:**

- impurity B: not more than the area of the corresponding peak in the chromatogram obtained with reference solution (d) (2.0 per cent);
- impurity A: not more than the area of the corresponding peak in the chromatogram obtained with reference solution (d) (0.5 per cent);
- impurities C, D, E, F, G: for each impurity, not more than 0.5 times the area of the peak due to sultamicillin in the chromatogram obtained with reference solution (c) (0.5 per cent);
- any other impurity: for each impurity, not more than 0.5 times the area of the peak due to sultamicillin in the chromatogram obtained with reference solution (c) (0.5 per cent);
- total: not more than 4 times the area of the peak due to sultamicillin in the chromatogram obtained with reference solution (c) (4.0 per cent);
- disregard limit: 0.1 times the area of the peak due to sultamicillin in the chromatogram obtained with reference solution (c) (0.1 per cent).

**Ethyl acetate.** Head space gas chromatography (2.2.28).

**Test solution.** Dissolve 0.200 g in 7.0 mL of a mixture of 1 volume of *water R* and 99 volumes of *dimethylformamide R*.

**Reference solution.** Dissolve 0.200 g of *ethyl acetate R* in 240 mL of a mixture of 1 volume of *water R* and 99 volumes of *dimethylformamide R* and dilute to 250.0 mL with the same mixture of solvents. Dilute 5.0 mL of this solution to 7.0 mL with a mixture of 1 volume of *water R* and 99 volumes of *dimethylformamide R*.

Immediately close the vials with a tight rubber membrane stopper coated with polytetrafluoroethylene and secure with an aluminium crimped cap. Shake to obtain a homogeneous solution.

**Column:**

- material: fused silica;
- size:  $l = 50$  m,  $\varnothing = 0.32$  mm;
- stationary phase: *poly(dimethyl)siloxane R* (film thickness: 1.8  $\mu$ m or 3  $\mu$ m).

**Carrier gas:** helium for chromatography R.

**Linear velocity:** 35 cm/s.

**Split ratio:** 1:5.

**Static head-space conditions that may be used:**

- equilibration temperature: 105 °C;
- equilibration time: 45 min;
- transfer-line temperature: 110 °C;
- pressurisation time: 30 s.

**Temperature:**

	Time (min)	Temperature (°C)
Column	0 - 6	70
	6 - 16	70 → 220
	16 - 18	220
Injection port		140
Detector		250

**Detection:** flame ionisation.

**Injection:** 1 mL.

**Relative retention** with reference to dimethylformamide (retention time = about 14 min): ethyl acetate = about 0.7.

**Limit:**

– *ethyl acetate*: maximum 2.0 per cent.

**Heavy metals (2.4.8):** maximum 20 ppm.

Dissolve 2.0 g in a mixture of 40 volumes of *methanol R* and 60 volumes of *acetonitrile R* and dilute to 20.0 mL with the same mixture of solvents. 12 mL of the solution complies with test B. Prepare the reference solution using lead standard solution (2 ppm Pb) obtained by diluting *lead standard solution (100 ppm Pb) R* with a mixture of 40 volumes of *methanol R* and 60 volumes of *acetonitrile R*.

**Water (2.5.12):** 4.0 per cent to 6.0 per cent, determined on 0.200 g.

**Sulfate ash (2.4.14):** maximum 0.2 per cent, determined on 1.0 g.

**ASSAY**

Liquid chromatography (2.2.29) as described in the test for related substances with the following modification.

**Injection:** test solution and reference solution (a).

Calculate the percentage content of sultamicillin tosylate ( $C_{32}H_{38}N_4O_{12}S_3$ ) from the declared content of *sultamicillin tosylate CRS*.

**STORAGE**

In an airtight container.

**IMPURITIES**

**Specified impurities:** A, B, C, D, E, F, G.

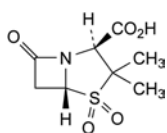

A. (2*S*,5*R*)-3,3-dimethyl-7-oxo-4-thia-1-azabicyclo[3.2.0]heptane-2-carboxylic acid 4,4-dioxide (sulbactam),

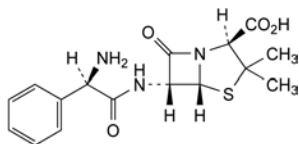

B. (2*S*,5*R*,6*R*)-6-[(2*R*)-2-amino-2-phenylacetyl]amino]-3,3-dimethyl-7-oxo-4-thia-1-azabicyclo[3.2.0]heptane-2-carboxylic acid (ampicillin),

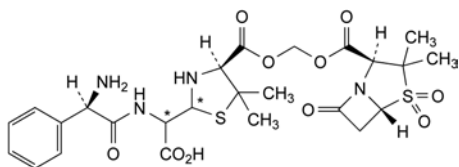

C. [(2*R*)-aminophenylacetyl]amino][(4*S*)-4-[[[(2*S*,5*R*)-3,3-dimethyl-4,4,7-trioxo-4λ<sup>6</sup>-thia-1-azabicyclo[3.2.0]hept-2-yl]carbonyl]oxy]methoxy]carbonyl]-5,5-dimethylthiazolidin-2-yl]acetic acid (penicilloic acids of sultamicillin),

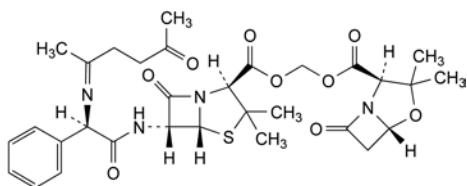

D. methylene (2*S*,5*R*,6*R*)-3,3-dimethyl-6-[(2*R*)-[(1-methyl-4-oxopentylidene)amino]phenylacetyl]amino]-7-oxo-4-thia-1-azabicyclo[3.2.0]heptane-2-carboxylate (2*S*,5*R*)-3,3-dimethyl-7-oxo-4-oxa-1-azabicyclo[3.2.0]heptane-2-carboxylate,

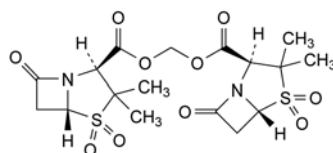

E. methylene bis[(2*S*,5*R*)-3,3-dimethyl-4,4,7-trioxo-4λ<sup>6</sup>-thia-1-azabicyclo[3.2.0]heptane-2-carboxylate] (sulbactam methylene ester),

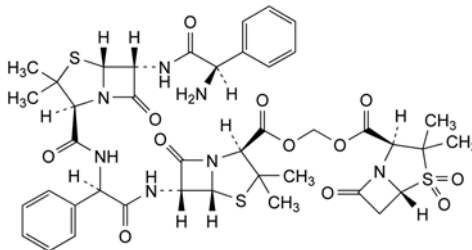

F. methylene (2*S*,5*R*,6*R*)-6-[(2*R*)-[[[(2*S*,5*R*,6*R*)-6-[(2*R*)-aminophenylacetyl]amino]-3,3-dimethyl-7-oxo-4-thia-1-azabicyclo[3.2.0]hept-2-yl]carbonyl]amino]phenylacetyl]amino]-3,3-dimethyl-7-oxo-4-thia-1-azabicyclo[3.2.0]heptane-2-carboxylate (2*S*,5*R*)-3,3-dimethyl-4,4,7-trioxo-4λ<sup>6</sup>-thia-1-azabicyclo[3.2.0]heptane-2-carboxylate (ampicillin sultamicillin amide),

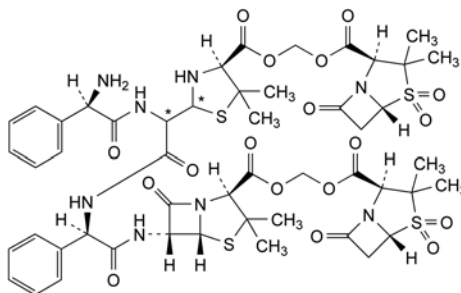

G. methylene (2*S*,5*R*,6*R*)-6-[(2*R*)-[[[(2*R*)-amino-phenylacetyl]amino][(4*S*)-4-[[[(2*S*,5*R*)-3,3-dimethyl-4,4,7-trioxo-4λ<sup>6</sup>-thia-1-azabicyclo[3.2.0]hept-2-yl]carbonyl]oxy]methoxy]carbonyl]-5,5-dimethylthiazolidin-2-yl]acetyl]amino]phenylacetyl]amino]-3,3-dimethyl-7-oxo-4-thia-1-azabicyclo[3.2.0]heptane-2-carboxylate (2*S*,5*R*)-3,3-dimethyl-4,4,7-trioxo-4λ<sup>6</sup>-thia-1-azabicyclo[3.2.0]heptane-2-carboxylate (sultamicillin dimer).

01/2009:1573

**SUMATRIPTAN SUCCINATE**

## Sumatriptani succinas

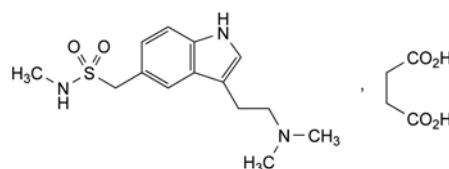

$C_{18}H_{27}N_3O_6S$   
[103628-48-4]

$M_r$  413.5

**DEFINITION**

[3-[2-(Dimethylamino)ethyl]-1*H*-indol-5-yl]-*N*-methylmethanesulfonamide hydrogen butanedioate.

**Content:** 97.5 per cent to 102.0 per cent (anhydrous substance).

**CHARACTERS**

**Appearance:** white or almost white powder.

**Solubility:** freely soluble in water, sparingly soluble in methanol, practically insoluble in methylene chloride.

## IDENTIFICATION

Infrared absorption spectrophotometry (2.2.24).

Preparation: discs.

Comparison: sumatriptan succinate CRS.

## TESTS

**Solution S.** Dissolve 1.0 g in carbon dioxide-free water R and dilute to 25.0 mL with the same solvent.

**pH** (2.2.3): 4.5 to 5.3.

Dilute 2.5 mL of solution S to 10 mL with carbon dioxide-free water R.

**Absorbance** (2.2.25): maximum 0.10, measured at 440 nm on solution S.

**Impurities A and H.** Liquid chromatography (2.2.29).

**Test solution.** Dissolve 30.0 mg of the substance to be examined in the mobile phase and dilute to 10.0 mL with the mobile phase.

**Reference solution (a).** Dilute 1.0 mL of the test solution to 100.0 mL with the mobile phase. Dilute 1.0 mL of this solution to 10.0 mL with the mobile phase.

**Reference solution (b).** Dissolve the contents of a vial of sumatriptan for system suitability CRS (containing impurities A and H) in the mobile phase and dilute to 1 mL with the mobile phase.

**Column:**

- size:  $l = 0.25$  m,  $\emptyset = 4.6$  mm;
- stationary phase: silica gel for chromatography R (5  $\mu$ m).

**Mobile phase:** mix 10 volumes of a 771 g/L solution of ammonium acetate R and 90 volumes of methanol R.

**Flow rate:** 2.0 mL/min.

**Detection:** spectrophotometer at 282 nm.

**Injection:** 20  $\mu$ L.

**Run time:** 5 times the retention time of sumatriptan.

**Relative retention** with reference to sumatriptan (retention time = about 2.5 min): impurity A = about 2.2; impurity H = about 3.0.

**System suitability:** reference solution (b):

- the chromatogram is similar to the chromatogram supplied with sumatriptan for system suitability CRS;
- resolution: minimum 3.0 between the peaks due to impurities A and H.

**Limits:**

- correction factor: for the calculation of content, multiply the peak area of impurity A by 0.6;
- impurity A: not more than 6 times the area of the principal peak in the chromatogram obtained with reference solution (a) (0.6 per cent);
- impurity H: not more than 3 times the area of the principal peak in the chromatogram obtained with reference solution (a) (0.3 per cent).

**Related substances.** Liquid chromatography (2.2.29).

**Solution A.** Dissolve 2.925 g of sodium dihydrogen phosphate R in 600 mL of water R, adjust to pH 6.5 with strong sodium hydroxide solution R, dilute to 750 mL with water R, add 250 mL of acetonitrile R and mix.

**Test solution (a).** Dissolve 30.0 mg of the substance to be examined in the mobile phase and dilute to 10.0 mL with the mobile phase.

**Test solution (b).** Dissolve 15.0 mg of the substance to be examined in solution A and dilute to 100.0 mL with solution A.

**Reference solution (a).** Dilute 1.0 mL of test solution (a) to 100.0 mL with the mobile phase. Dilute 1.0 mL of this solution to 10.0 mL with the mobile phase.

**Reference solution (b).** Dissolve the contents of a vial of sumatriptan impurity mixture CRS (containing impurities B, C, D and E) in the mobile phase and dilute to 1 mL with the mobile phase.

**Reference solution (c).** Dissolve 15.0 mg of sumatriptan succinate CRS in solution A and dilute to 100.0 mL with solution A.

**Column:**

- size:  $l = 0.25$  m,  $\emptyset = 4$  mm;
- stationary phase: octadecylsilyl silica gel for chromatography R (5  $\mu$ m).

**Mobile phase:** mix 25 volumes of acetonitrile R with 75 volumes of a solution prepared as follows: dissolve 0.970 g of dibutylamine R, 0.735 g of phosphoric acid R and 2.93 g of sodium dihydrogen phosphate R in 750 mL of water R, adjust to pH 6.5 with strong sodium hydroxide solution R and dilute to 1000 mL with water R.

**Flow rate:** 1.5 mL/min.

**Detection:** spectrophotometer at 282 nm.

**Injection:** 10  $\mu$ L of test solution (a) and reference solutions (a) and (b).

**Run time:** 4 times the retention time of sumatriptan.

**Identification of impurities:** use the chromatogram obtained with reference solution (b) and the chromatogram supplied with sumatriptan impurity mixture CRS to identify the peaks due to impurities B, C, D and E.

**Relative retention** with reference to sumatriptan (retention time = about 7 min): impurity E = about 0.5; impurity B = about 0.6; impurity D = about 0.7; impurity C = about 0.8.

**System suitability:** reference solution (b):

- resolution: minimum 1.5 between the peaks due to impurity C and sumatriptan;
- the chromatogram shows 5 clearly separated peaks.

**Limits:**

- impurities B, C, D: for each impurity, not more than 5 times the area of the principal peak in the chromatogram obtained with reference solution (a) (0.5 per cent);
- impurity E: not more than the area of the principal peak in the chromatogram obtained with reference solution (a) (0.1 per cent);
- unspecified impurities: for each impurity, not more than the area of the principal peak in the chromatogram obtained with reference solution (a) (0.10 per cent);
- total: not more than 6 times the area of the principal peak in the chromatogram obtained with reference solution (a) (0.6 per cent);
- disregard limit: 0.5 times the area of the principal peak in the chromatogram obtained with reference solution (a) (0.05 per cent).

**Water** (2.5.12): maximum 1.0 per cent, determined on 0.500 g.

**Sulfated ash** (2.4.14): maximum 0.1 per cent, determined on 1.0 g.

## ASSAY

Liquid chromatography (2.2.29) as described in the test for related substances with the following modification.

**Injection:** test solution (b) and reference solution (c).

Calculate the percentage content of  $C_{18}H_{27}N_3O_6S$  from the declared content of sumatriptan succinate CRS.

## STORAGE

Protected from light.

## IMPURITIES

**Specified impurities:** A, B, C, D, E, H.

**Other detectable impurities** (the following substances would, if present at a sufficient level, be detected by one or other of the tests in the monograph. They are limited by the general acceptance criterion for other/unspecified impurities and/or by the general monograph *Substances for pharmaceutical use*

(2034). It is therefore not necessary to identify these impurities for demonstration of compliance. See also 5.10. *Control of impurities in substances for pharmaceutical use*: F, G.

01/2010:1371

## SUNFLOWER OIL, REFINED

## Helianthi annui oleum raffinatum

## DEFINITION

Fatty oil obtained from the seeds of *Helianthus annuus* L. by mechanical expression or by extraction. It is then refined. A suitable antioxidant may be added.

## CHARACTERS

*Appearance*: clear, light yellow liquid.

*Solubility*: practically insoluble in water and in ethanol (96 per cent), miscible with light petroleum (bp: 40-60 °C).

*Relative density*: about 0.921.

*Refractive index*: about 1.474.

## IDENTIFICATION

Identification of fatty oils by thin-layer chromatography (2.3.2).

*Results*: the chromatogram obtained is similar to the corresponding chromatogram shown in Figure 2.3.2.-1.

## TESTS

**Acid value** (2.5.1): maximum 0.5, determined on 10.0 g.

**Peroxide value** (2.5.5, Method A): maximum 10.0.

**Unsaponifiable matter** (2.5.7): maximum 1.5 per cent, determined on 5.0 g.

**Alkaline impurities** (2.4.19). It complies with the test.

**Composition of fatty acids** (2.4.22, Method A). Use the mixture of calibrating substances in Table 2.4.22.-3.

*Composition of the fatty-acid fraction of the oil*:

- *palmitic acid*: 4.0 per cent to 9.0 per cent,
- *stearic acid*: 1.0 per cent to 7.0 per cent,
- *oleic acid*: 14.0 per cent to 40.0 per cent,
- *linoleic acid*: 48.0 per cent to 74.0 per cent.

**Water** (2.5.32): maximum 0.1 per cent, determined on 1.00 g.

## STORAGE

In an airtight, well-filled container, protected from light.

## LABELLING

The label states whether the oil is obtained by mechanical expression or by extraction.

01/2008:0248

## SUXAMETHONIUM CHLORIDE

## Suxamethonii chloridum

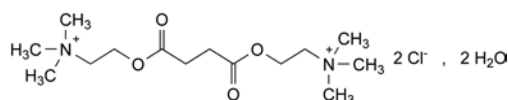

$C_{14}H_{30}Cl_2N_2O_4 \cdot 2H_2O$   
[6101-15-1]

$M_r$  397.3

## DEFINITION

Suxamethonium chloride contains not less than 98.0 per cent and not more than the equivalent of 102.0 per cent of 2,2'-[butanedioylbis(oxy)]bis(*N,N,N*-trimethylethanaminium) dichloride, calculated with reference to the anhydrous substance.

## CHARACTERS

A white or almost white, crystalline powder, hygroscopic, freely soluble in water, slightly soluble in alcohol.

It melts at about 160 °C, determined without previous drying.

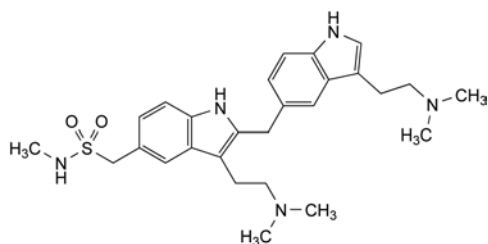

- A. [3-[2-(dimethylamino)ethyl]-2-[[3-[2-(dimethylamino)ethyl]-1H-indol-5-yl]methyl]-1H-indol-5-yl]-N-methylmethanesulfonamide,

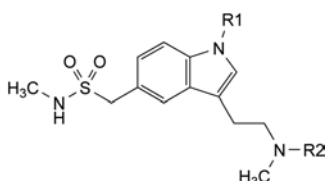

- B. R1 = R2 = H: *N*-methyl[3-[2-(methylamino)ethyl]-1H-indol-5-yl]methanesulfonamide,

- C. R1 = CH<sub>2</sub>-OH, R2 = CH<sub>3</sub>: [3-[2-(dimethylamino)ethyl]-1-(hydroxymethyl)-1H-indol-5-yl]-N-methylmethanesulfonamide,

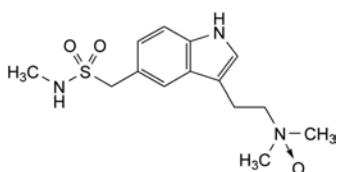

- D. *N,N*-dimethyl-2-[5-[(methylsulfamoyl)methyl]-1H-indol-3-yl]ethanamine *N*-oxide,

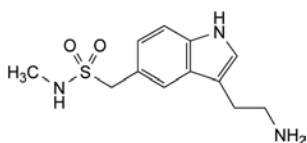

- E. [3-(2-aminoethyl)-1H-indol-5-yl]-N-methylmethanesulfonamide,

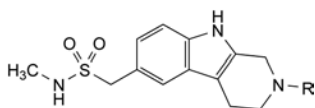

- F. R = H: *N*-methyl(2,3,4,9-tetrahydro-1H-pyrido[3,4-*b*]indol-6-yl)methanesulfonamide,

- G. R = CH<sub>3</sub>: *N*-methyl(2-methyl-2,3,4,9-tetrahydro-1H-pyrido[3,4-*b*]indol-6-yl)methanesulfonamide,

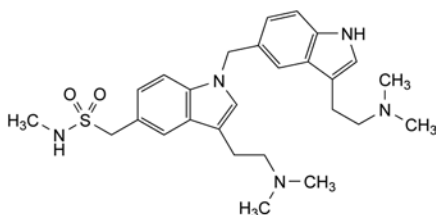

- H. [3-[2-(dimethylamino)ethyl]-1-[[3-[2-(dimethylamino)ethyl]-1H-indol-5-yl]methyl]-1H-indol-5-yl]-N-methylmethanesulfonamide.

01/2008:1574  
corrected 6.0

## IDENTIFICATION

First identification: A, D.

Second identification: B, C, D.

A. Examine by infrared absorption spectrophotometry (2.2.24), comparing with the spectrum obtained with *suxamethonium chloride* CRS. Examine the substances prepared as discs.

B. To 1 mL of solution S (see Tests) add 9 mL of *water R*, 10 mL of *dilute sulfuric acid R* and 30 mL of *ammonium reineckate solution R*. A pink precipitate is formed. Allow to stand for 30 min, filter, wash with *water R*, with *alcohol R* and then with *ether R* and dry at 80 °C. The melting point (2.2.14) of the precipitate is 180 °C to 185 °C.

C. Dissolve about 25 mg in 1 mL of *water R* and add 0.1 mL of a 10 g/L solution of *cobalt chloride R* and 0.1 mL of *potassium ferrocyanide solution R*. A green colour is produced.

D. About 20 mg gives reaction (a) of chlorides (2.3.1).

## TESTS

**Solution S.** Dissolve 1.0 g in *carbon dioxide-free water R* and dilute to 20 mL with the same solvent.

**Appearance of solution.** Solution S is clear (2.2.1). Dilute 4 mL of solution S to 10 mL with *water R*. The solution is colourless (2.2.2, *Method II*).

**pH** (2.2.3). Dilute 1 mL of solution S to 10 mL with *carbon dioxide-free water R*. The pH of the solution is 4.0 to 5.0.

**Choline chloride.** Examine by thin-layer chromatography (2.2.27), using *cellulose for chromatography R1* as the coating substance.

**Test solution.** Dissolve 0.4 g of the substance to be examined in *methanol R* and dilute to 10 mL with the same solvent.

**Reference solution.** Dissolve 0.4 g of *suxamethonium chloride* CRS and 2 mg of *choline chloride R* in *methanol R* and dilute to 10 mL with the same solvent.

Apply to the plate 5 µL of each solution. Prepare the mobile phase as follows: shake together for 10 min, 10 volumes of *anhydrous formic acid R*, 40 volumes of *water R* and 50 volumes of *butanol R*; allow to stand and use the upper layer. Develop over a path of 15 cm. Dry the plate in a current of air and spray with *potassium iodobismuthate solution R*. Any spot in the chromatogram obtained with the test solution, apart from the principal spot, is not more intense than the spot corresponding to choline chloride in the chromatogram obtained with the reference solution (0.5 per cent). The test is not valid unless the chromatogram obtained with the reference solution shows two clearly separated spots.

**Water** (2.5.12). 8.0 per cent to 10.0 per cent, determined on 0.30 g by the semi-micro determination of water.

**Sulfated ash** (2.4.14). Not more than 0.1 per cent, determined on 1.0 g.

## ASSAY

Dissolve 0.150 g in 50 mL of *acetic anhydride R*. Titrate with 0.1 M *perchloric acid*, determining the end-point potentiometrically (2.2.20).

1 mL of 0.1 M *perchloric acid* is equivalent to 18.07 mg of  $C_{14}H_{30}Cl_2N_2O_4$ .

## STORAGE

Store in an airtight container, protected from light.

## SUXIBUZONE

## Suxibuzonum

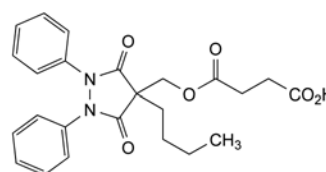

$C_{24}H_{26}N_2O_6$   
[27470-51-5]

$M_r$  438.5

## DEFINITION

4-[(4-Butyl-3,5-dioxo-1,2-diphenylpyrazolidin-4-yl)methoxy]-4-oxobutanoic acid.

**Content:** 99.0 per cent to 101.0 per cent (dried substance).

## CHARACTERS

**Appearance:** white or almost white, crystalline powder.

**Solubility:** practically insoluble in water, freely soluble in acetone, soluble in ethanol (96 per cent), practically insoluble in cyclohexane.

## IDENTIFICATION

Infrared absorption spectrophotometry (2.2.24).

**Comparison:** *suxibuzone* CRS.

## TESTS

**Appearance of solution.** The solution is clear (2.2.1) and colourless (2.2.2, *Method II*).

Dissolve 1 g in *anhydrous ethanol R* and dilute to 20 mL with the same solvent.

**Related substances.** Liquid chromatography (2.2.29).

**Test solution.** Dissolve 0.10 g of the substance to be examined in *acetonitrile R* and dilute to 25.0 mL with the same solvent.

**Reference solution (a).** Dissolve 2.8 mg of *phenylbutazone* CRS (impurity A), 2.8 mg of *suxibuzone impurity B* CRS and 2.8 mg of *suxibuzone impurity C* CRS in *acetonitrile R* and dilute to 10.0 mL with the same solvent. Dilute 1.0 mL of the solution to 10.0 mL with *acetonitrile R*.

**Reference solution (b).** Dissolve 4 mg of *phenylbutazone* CRS (impurity A) in *acetonitrile R* and dilute to 100.0 mL with the same solvent. Dilute 1.0 mL of the solution to 10.0 mL with *acetonitrile R*.

**Reference solution (c).** Dissolve 10 mg of *phenylbutazone* CRS (impurity A) in *acetonitrile R* and dilute to 25.0 mL with the same solvent. Mix 10.0 mL of this solution with 1.0 mL of the test solution and dilute the mixture to 25.0 mL with *acetonitrile R*.

**Column:**

- size:  $l = 0.125$  m,  $\varnothing = 4.0$  mm;
- stationary phase: octadecylsilyl silica gel for chromatography R (5 µm).

**Mobile phase:** mix 44 volumes of *acetonitrile R* and 56 volumes of a solution prepared as follows: dissolve 6.7 g of *citric acid R* and 2.4 g of *tris(hydroxymethyl)aminomethane R* in 950 mL of *water R*, adjust to pH 3.0 with *citric acid R* and dilute to 1000 mL with *water R*.

**Flow rate:** 1 mL/min.

**Detection:** spectrophotometer at 250 nm.

**Injection:** 10 µL.

**Relative retention** with reference to *suxibuzone* (retention time = about 7 min): impurity C = 0.7; impurity A = 1.4; impurity B = 3.3.

*System suitability*: reference solution (c):

- *resolution*: minimum of 2.0 between the peaks due to suxibuzone and impurity A.

*Limits*:

- *impurity A*: not more than the area of the corresponding peak in the chromatogram obtained with reference solution (a) (0.7 per cent);
- *impurity B*: not more than the area of the corresponding peak in the chromatogram obtained with reference solution (a) (0.7 per cent);
- *impurity C*: not more than the area of the corresponding peak in the chromatogram obtained with reference solution (a) (0.7 per cent);
- *unspecified impurities*: for each impurity, not more than the area of the principal peak in the chromatogram obtained with reference solution (b) (0.10 per cent);
- *total*: not more than 10 times the area of the principal peak in the chromatogram obtained with reference solution (b) (1.0 per cent);
- *disregard limit*: 0.1 times the area of the peak due to impurity A in the chromatogram obtained with reference solution (a) (0.07 per cent).

**Heavy metals** (2.4.8): maximum 10 ppm.

2.0 g complies with test C. Prepare the reference solution using 2 mL of *lead standard solution* (10 ppm Pb) R.

**Loss on drying** (2.2.32): maximum 0.5 per cent, determined on 1.000 g by drying in an oven *in vacuo* at 60 °C.

**Sulfated ash** (2.4.14): maximum 0.1 per cent, determined on 1.0 g.

#### ASSAY

Dissolve 0.400 g in previously neutralised *anhydrous ethanol* R and dilute to 10 mL with the same solvent. Carry out a potentiometric titration (2.2.20) using 0.1 M sodium hydroxide. 1 mL of 0.1 M sodium hydroxide is equivalent to 43.85 mg of  $C_{24}H_{26}N_2O_6$ .

#### STORAGE

Protected from light.

#### IMPURITIES

*Specified impurities*: A, B, C.

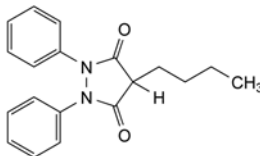

A. 4-butyl-1,2-diphenylpyrazolidine-3,5-dione (phenylbutazone),

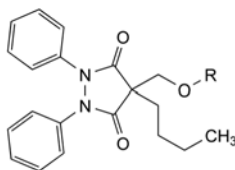

B. R = CO-CH<sub>2</sub>-CH<sub>2</sub>-CO-O-CH<sub>2</sub>-CH<sub>3</sub>: (4-butyl-3,5-dioxo-1,2-diphenylpyrazolidin-4-yl)methyl ethyl butanedioate,

C. R = H: 4-butyl-4-(hydroxymethyl)-1,2-diphenyl-1,2-dihydro-4H-pyrazole-3,5-dione.

01/2011:0438 *Solubility*: practically insoluble in water, in ethanol (96 per cent) and in dilute solutions of acids and alkali hydroxides.

## TALC

### Talcum

[14807-96-6]

#### DEFINITION

Powdered, selected, natural, hydrated magnesium silicate. Pure talc has the formula  $\text{Mg}_3\text{Si}_4\text{O}_{10}(\text{OH})_2$  ( $M_r$  379.3). It may contain variable amounts of associated minerals among which chlorites (hydrated aluminium and magnesium silicates), magnesite (magnesium carbonate), calcite (calcium carbonate) and dolomite (calcium and magnesium carbonate) are predominant.

#### PRODUCTION

Talc derived from deposits that are known to contain associated asbestos is not suitable for pharmaceutical use. The manufacturer is responsible for demonstrating by the test for amphiboles and serpentines that the product is free from asbestos. The presence of amphiboles and of serpentines is revealed by X-ray diffraction or by infrared spectrophotometry (see A and B). If detected, the specific morphological criteria of asbestos are investigated by a suitable method of optical microscopy to determine whether tremolite asbestos or chrysotile is present, as described below.

##### A. Infrared absorption spectrophotometry (2.2.24).

*Preparation*: discs of *potassium bromide R*.

In the range  $740\text{ cm}^{-1}$  to  $760\text{ cm}^{-1}$  using scale expansion, any absorption band at  $758 \pm 1\text{ cm}^{-1}$  may indicate the presence of tremolite or of chlorite. If the absorption band remains after ignition of the substance to be examined at  $850 \pm 50\text{ }^\circ\text{C}$  for at least 30 min, it indicates the presence of the tremolite. In the range  $600\text{ cm}^{-1}$  to  $650\text{ cm}^{-1}$  using scale expansion, any absorption band or shoulder may indicate the presence of serpentines.

##### B. X-ray diffraction.

*Preparation*: place the sample on the sample holder; pack and smooth its surface with a polished glass microscope slide.

*Radiation*: Cu  $K\alpha$  monochromatic, 40 kV, 24-30 mA.

*Incident slit*:  $1^\circ$ .

*Detection slit*:  $0.2^\circ$ .

*Goniometer speed*:  $1/10^\circ$   $2\theta/\text{min}$ .

*Scanning range*:  $10\text{-}13^\circ$   $2\theta$  and  $24\text{-}26^\circ$   $2\theta$ .

*Sample*: not oriented.

*Results*: the presence of amphiboles is detected by a diffraction peak at  $10.5 \pm 0.1^\circ$   $2\theta$ , the presence of serpentines is detected by diffraction peaks at  $24.3 \pm 0.1^\circ$   $2\theta$  and at  $12.1 \pm 0.1^\circ$   $2\theta$ .

If, by one of the 2 methods, amphiboles and/or serpentine are detected, examine by a suitable method of optical microscopy to determine the asbestos character.

The presence of asbestos is shown if the following 2 criteria are met:

- a range of length to width ratios of 20:1 to 100:1, or higher for fibres longer than  $5\text{ }\mu\text{m}$ ;
  - capability of splitting into very thin fibrils;
- and if at least 2 of the following 4 criteria are met:
- parallel fibres occurring in bundles;
  - fibre bundles displaying frayed ends;
  - fibres in the form of thin needles;
  - matted masses of individual fibres and/or fibres showing curvature.

#### CHARACTERS

*Appearance*: light, homogeneous, white or almost white powder, greasy to the touch (non abrasive).

#### IDENTIFICATION

*First identification*: A.

*Second identification*: B, C.

##### A. Infrared absorption spectrophotometry (2.2.24).

*Preparation*: discs of *potassium bromide R*.

*Absorption bands*: at  $3677 \pm 2\text{ cm}^{-1}$ ,  $1018 \pm 2\text{ cm}^{-1}$  and  $669 \pm 2\text{ cm}^{-1}$ .

B. In a platinum crucible, melt a mixture of 0.2 g of *anhydrous sodium carbonate R* and 2.0 g of *potassium carbonate R*. To the melted mass add 0.1 g of the substance to be examined and heat until the mixture is completely melted. Allow to cool and transfer the melted mass into an evaporating dish with 50 mL of hot *water R*. Add *hydrochloric acid R* until effervescence ceases. Add 10 mL of *hydrochloric acid R* and evaporate to dryness on a water-bath. Allow to cool. Add 20 mL of *water R*, heat to boiling and filter (the residue is used for identification test C). To 5 mL of the filtrate add 1 mL of *ammonia R* and 1 mL of *ammonium chloride solution R* and filter. To the filtrate add 1 mL of *disodium hydrogen phosphate solution R*. A white, crystalline precipitate is formed.

C. The residue obtained in identification test B gives the reaction of silicates (2.3.1).

#### TESTS

**Solution S1.** Weigh 10.0 g into a conical flask fitted with a reflux condenser, add 50 mL of *0.5 M hydrochloric acid* gradually while stirring and heat on a water-bath for 30 min. Allow to cool. Transfer the mixture to a beaker and allow the undissolved material to settle. Filter the supernatant through medium-speed filter paper into a 100 mL volumetric flask, retaining as much as possible of the insoluble material in the beaker. Wash the residue and the beaker with 3 quantities, each of 10 mL, of hot *water R*. Wash the filter with 15 mL of hot *water R*, allow the filtrate to cool and dilute to 100.0 mL with the same solvent.

**Solution S2.** *Perchlorates mixed with heavy metals are known to be explosive. Take proper precautions while performing this procedure.* Weigh 0.5 g in a 100 mL polytetrafluoroethylene dish, add 5 mL of *hydrochloric acid R*, 5 mL of *lead-free nitric acid R* and 5 mL of *perchloric acid R*. Stir gently then add 35 mL of *hydrofluoric acid R* and evaporate slowly to dryness on a hot plate. To the residue, add 5 mL of *hydrochloric acid R*, cover with a watch-glass, heat to boiling and allow to cool. Rinse the watch-glass and the dish with *water R*. Transfer into a volumetric flask, rinse the dish with *water R* and dilute to 50.0 mL with the same solvent.

**Acidity or alkalinity.** Boil 2.5 g with 50 mL of *carbon dioxide-free water R* under reflux. Filter *in vacuo*. To 10 mL of the filtrate add 0.1 mL of *bromothymol blue solution R1*; not more than 0.4 mL of *0.01 M hydrochloric acid* is required to change the colour of the indicator to green. To 10 mL of the filtrate add 0.1 mL of *phenolphthalein solution R1*; not more than 0.3 mL of *0.01 M sodium hydroxide* is required to change the colour of the indicator to pink.

**Water-soluble substances**: maximum 0.2 per cent.

To 10.0 g add 50 mL of *carbon dioxide-free water R*, heat to boiling and maintain boiling under a reflux condenser for 30 min. Allow to cool, filter through a medium-speed filter paper and dilute to 50.0 mL with *carbon dioxide-free water R*. Take 25.0 mL of the filtrate, evaporate to dryness and heat at  $105\text{ }^\circ\text{C}$  for 1 h. The residue weighs a maximum of 10 mg.

**Aluminium**: maximum 2.0 per cent.

Atomic absorption spectrometry (2.2.23, *Method I*).

*Test solution.* To 5.0 mL of solution S2 add 10 mL of a 25.34 g/L solution of *caesium chloride R*, 10.0 mL of *hydrochloric acid R* and dilute to 100.0 mL with *water R*.

**Reference solutions.** Into 4 identical volumetric flasks, each containing 10.0 mL of *hydrochloric acid R* and 10 mL of a 25.34 g/L solution of *caesium chloride R*, introduce respectively 5.0 mL, 10.0 mL, 15.0 mL and 20.0 mL of *aluminium standard solution (100 ppm Al) R* and dilute to 100.0 mL with *water R*.

**Source:** aluminium hollow-cathode lamp.

**Wavelength:** 309.3 nm.

**Atomisation device:** nitrous oxide-acetylene flame.

**Calcium:** maximum 0.9 per cent.

Atomic absorption spectrometry (2.2.23, *Method I*).

**Test solution.** To 5.0 mL of solution S2 add 10.0 mL of *hydrochloric acid R*, 10 mL of *lanthanum chloride solution R* and dilute to 100.0 mL with *water R*.

**Reference solutions.** Into 4 identical volumetric flasks, each containing 10.0 mL of *hydrochloric acid R* and 10 mL of *lanthanum chloride solution R*, introduce respectively 1.0 mL, 2.0 mL, 3.0 mL and 5.0 mL of *calcium standard solution (100 ppm Ca) R1* and dilute to 100.0 mL with *water R*.

**Source:** calcium hollow-cathode lamp.

**Wavelength:** 422.7 nm.

**Atomisation device:** nitrous oxide-acetylene flame.

**Iron:** maximum 0.25 per cent.

Atomic absorption spectrometry (2.2.23, *Method I*).

**Test solution.** To 2.5 mL of solution S1, add 50.0 mL of 0.5 M *hydrochloric acid* and dilute to 100.0 mL with *water R*.

**Reference solutions.** Into 4 identical volumetric flasks, each containing 50.0 mL of 0.5 M *hydrochloric acid*, introduce respectively 2.0 mL, 2.5 mL, 3.0 mL and 4.0 mL of *iron standard solution (250 ppm Fe) R* and dilute to 100.0 mL with *water R*.

**Source:** iron hollow-cathode lamp.

**Wavelength:** 248.3 nm.

**Atomisation device:** air-acetylene flame.

**Correction:** deuterium lamp.

**Lead:** maximum 10 ppm.

Atomic absorption spectrometry (2.2.23, *Method I*).

**Test solution.** Use solution S1.

**Reference solutions.** Into 4 identical volumetric flasks, each containing 50.0 mL of 0.5 M *hydrochloric acid*, introduce respectively 5.0 mL, 7.5 mL, 10.0 mL and 12.5 mL of *lead standard solution (10 ppm Pb) R1* and dilute to 100.0 mL with *water R*.

**Source:** lead hollow-cathode lamp.

**Wavelength:** 217.0 nm.

**Atomisation device:** air-acetylene flame.

**Magnesium:** 17.0 per cent to 19.5 per cent.

Atomic absorption spectrometry (2.2.23, *Method I*).

**Test solution.** Dilute 0.5 mL of solution S2 to 100.0 mL with *water R*. To 4.0 mL of the solution, add 10.0 mL of *hydrochloric acid R*, 10 mL of *lanthanum chloride solution R* and dilute to 100.0 mL with *water R*.

**Reference solutions.** Into 4 identical volumetric flasks, each containing 10.0 mL of *hydrochloric acid R* and 10 mL of *lanthanum chloride solution R*, introduce respectively 2.5 mL, 3.0 mL, 4.0 mL and 5.0 mL of *magnesium standard solution (10 ppm Mg) R1* and dilute to 100.0 mL with *water R*.

**Source:** magnesium hollow-cathode lamp.

**Wavelength:** 285.2 nm.

**Atomisation device:** air-acetylene flame.

**Loss on ignition:** maximum 7.0 per cent, determined on 1.00 g by ignition to constant weight at 1050-1100 °C.

#### Microbial contamination

If intended for cutaneous administration:

- TAMC: acceptance criterion 10<sup>2</sup> CFU/g (2.6.12).

If intended for oral administration:

- TAMC: acceptance criterion 10<sup>3</sup> CFU/g (2.6.12);
- TYMC: acceptance criterion 10<sup>2</sup> CFU/g (2.6.12).

#### LABELLING

The label states, where applicable, that the substance is suitable for oral or cutaneous administration.

#### FUNCTIONALITY-RELATED CHARACTERISTICS

*This section provides information on characteristics that are recognised as being relevant control parameters for one or more functions of the substance when used as an excipient (see chapter 5.15). This section is a non-mandatory part of the monograph and it is not necessary to verify the characteristics to demonstrate compliance. Control of these characteristics can however contribute to the quality of a medicinal product by improving the consistency of the manufacturing process and the performance of the medicinal product during use. Where control methods are cited, they are recognised as being suitable for the purpose, but other methods can also be used. Wherever results for a particular characteristic are reported, the control method must be indicated.*

*The following characteristics may be relevant for talc used as lubricant or glidant in tablets and capsules or as antiadhesive in coated and film-coated tablets.*

**Particle-size distribution** (2.9.31).

**Specific surface area** (2.9.26).

01/2008:1046

## TAMOXIFEN CITRATE

Tamoxifeni citras

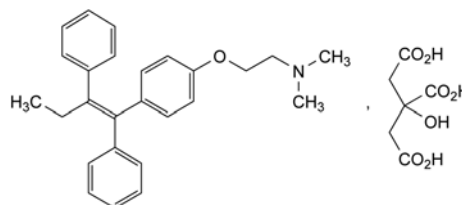

C<sub>32</sub>H<sub>37</sub>NO<sub>8</sub>  
[54965-24-1]

M<sub>r</sub> 563.6

#### DEFINITION

2-[4-[(Z)-1,2-Diphenylbut-1-enyl]phenoxy]-N,N-dimethylethanamine dihydrogen 2-hydroxypropane-1,2,3-tricarboxylate.

**Content:** 99.0 per cent to 101.0 per cent (dried substance).

#### CHARACTERS

**Appearance:** white or almost white, crystalline powder.

**Solubility:** slightly soluble in water, soluble in methanol, slightly soluble in acetone.

It shows polymorphism (5.9).

#### IDENTIFICATION

**First identification:** B.

**Second identification:** A, C, D.

A. Ultraviolet and visible absorption spectrophotometry (2.2.25).

**Test solution.** Dissolve 20 mg in *methanol R* and dilute to 50.0 mL with the same solvent. Dilute 5.0 mL of this solution to 100.0 mL with *methanol R*.

**Spectral range:** 220-350 nm.

**Absorption maxima:** at 237 nm and 275 nm.

**Absorption ratio:** A<sub>237</sub>/A<sub>275</sub> = 1.45 to 1.65.



## B. Infrared absorption spectrophotometry (2.2.24).

*Preparation:* discs.

*Comparison:* tamoxifen citrate CRS.

If the spectra obtained in the solid state show differences, dissolve the substance to be examined and the reference substance separately in *acetone R*, evaporate to dryness and record new spectra using the residues.

## C. Thin-layer chromatography (2.2.27).

*Test solution.* Dissolve 10 mg of the substance to be examined in *methanol R* and dilute to 10 mL with the same solvent.

*Reference solution (a).* Dissolve 10 mg of *tamoxifen citrate CRS* in *methanol R* and dilute to 10 mL with the same solvent.

*Reference solution (b).* Dissolve 10 mg of *tamoxifen citrate CRS* and 10 mg of *clomifene citrate CRS* in *methanol R* and dilute to 10 mL with the same solvent.

*Plate:* TLC silica gel  $F_{254}$  plate *R*.

*Mobile phase:* triethylamine *R*, toluene *R* (10:90 V/V).

*Application:* 5  $\mu$ L.

*Development:* over a path of 15 cm.

*Drying:* in air.

*Detection:* examine in ultraviolet light at 254 nm.

*System suitability:* reference solution (b):

- the chromatogram shows 2 clearly separated spots.

*Results:* the principal spot in the chromatogram obtained with the test solution is similar in position and size to the principal spot in the chromatogram obtained with reference solution (a).

D. Dissolve about 10 mg in 4 mL of *pyridine R* with shaking and add 2 mL of *acetic anhydride R*; a yellow colour is produced. Heat on a water-bath for 2 min; a pink or red colour is produced.

## TESTS

**Related substances.** Liquid chromatography (2.2.29). Prepare the solutions immediately before use and protect from light.

*Test solution.* Dissolve 15.0 mg of the substance to be examined in the mobile phase and dilute to 10.0 mL with the mobile phase.

*Reference solution (a).* Dissolve 15.0 mg of *tamoxifen citrate for performance test CRS* in the mobile phase and dilute to 10.0 mL with the mobile phase.

*Reference solution (b).* Dilute 1.0 mL of the test solution to 100.0 mL with the mobile phase.

*Column:*

- size:  $l = 0.25$  m,  $\varnothing = 4.6$  mm;
- stationary phase: octadecylsilyl silica gel for chromatography *R* (5  $\mu$ m).

*Mobile phase:* mix 40 volumes of *acetonitrile R* and 60 volumes of *water R* containing 0.9 g/L of *sodium dihydrogen phosphate R* and 4.8 g/L of *N,N-dimethyloctylamine R*; adjust to pH 3.0 with *phosphoric acid R*.

*Flow rate:* 1.2 mL/min.

*Detection:* spectrophotometer at 240 nm.

*Equilibration:* with the mobile phase for about 30 min.

*Injection:* 10  $\mu$ L.

*Run time:* twice the retention time of tamoxifen.

*System suitability:* reference solution (a):

- the chromatogram obtained is similar to the chromatogram supplied with *tamoxifen citrate for performance test CRS*; there is baseline separation of the peak due to impurity F from the following peak of the principal component;
- resolution: minimum 3 between the peaks due to impurities A and F.

*Limits:*

- impurities A, B, C, D, E, F, G, H: for each impurity, not more than 0.3 times the area of the principal peak in the chromatogram obtained with reference solution (b) (0.3 per cent);
- sum of impurities other than A: not more than 0.5 times the area of the principal peak in the chromatogram obtained with reference solution (b) (0.5 per cent);
- disregard limit: 0.05 times the area of the principal peak in the chromatogram obtained with reference solution (b) (0.05 per cent); disregard any peak due to the citrate (retention time = about 2.5 min).

**Loss on drying** (2.2.32): maximum 0.5 per cent, determined on 1.000 g by drying *in vacuo* at 65 °C for 4 h.

**Sulfated ash** (2.4.14): maximum 0.1 per cent, determined on 1.0 g.

## ASSAY

Dissolve 0.400 g in 75 mL of *anhydrous acetic acid R*. Titrate with 0.1 M *perchloric acid* using 0.1 mL of *naphtholbenzein solution R* as indicator.

1 mL of 0.1 M *perchloric acid* is equivalent to 56.36 mg of  $C_{32}H_{37}NO_8$ .

## IMPURITIES

*Specified impurities:* A, B, C, D, E, F, G, H.

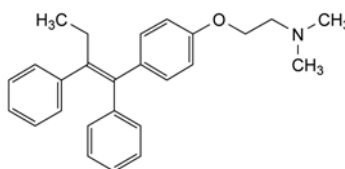

A. 2-[4-[(*E*)-1,2-diphenylbut-1-enyl]phenoxy]-*N,N*-dimethylethanamine (*E*-isomer),

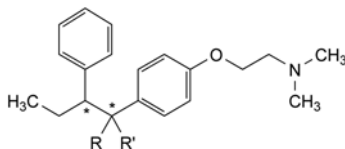

B. R = OH, R' =  $C_6H_5$ : 1-[4-[2-(dimethylamino)ethoxy]phenyl]-1,2-diphenylbutan-1-ol,

G. R + R' = O: (2*RS*)-1-[4-[2-(dimethylamino)ethoxy]phenyl]-2-phenylbutan-1-one,

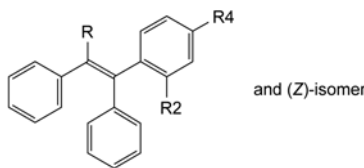

C. R = R2 = H, R4 =  $O-CH_2-CH_2-N(CH_3)_2$ : 2-[4-[(*EZ*)-1,2-diphenylethenyl]phenoxy]-*N,N*-dimethylethanamine,

D. R =  $CH_3$ , R2 = H, R4 =  $O-CH_2-CH_2-N(CH_3)_2$ : 2-[4-[(*EZ*)-1,2-diphenylprop-1-enyl]phenoxy]-*N,N*-dimethylethanamine,

E. R =  $C_2H_5$ , R2 =  $O-CH_2-CH_2-N(CH_3)_2$ , R4 = H: 2-[2-[(*EZ*)-1,2-diphenylbut-1-enyl]phenoxy]-*N,N*-dimethylethanamine,

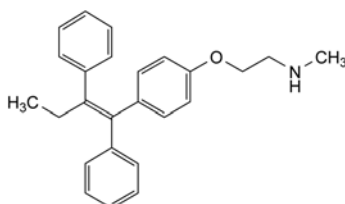

F. 2-[4-[(*Z*)-1,2-diphenylbut-1-enyl]phenoxy]-*N*-methylethanamine,

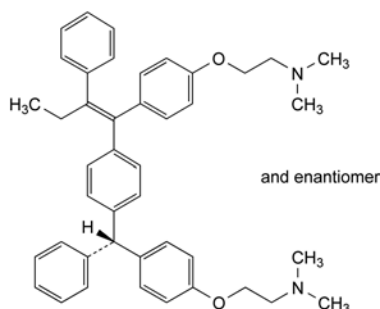

H. 2-[4-[(Z)-1-[4-[(RS)-[4-[2-(dimethylamino)ethoxy]-phenyl]phenylmethyl]phenyl]-2-phenylbut-1-enyl]-phenoxy]-N,N-dimethylethanamine.

01/2008:2131  
corrected 6.5

## TAMSULOSIN HYDROCHLORIDE

### Tamsulosini hydrochloridum

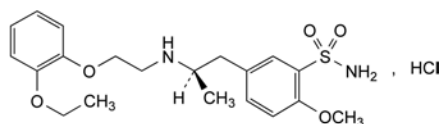

$C_{20}H_{26}ClN_2O_5S$   
[106463-17-6]

$M_r$  445.0

#### DEFINITION

5-[(2R)-2-[[2-(2-Ethoxyphenoxy)ethyl]amino]propyl]-2-methoxybenzenesulfonamide hydrochloride.

*Content*: 98.5 per cent to 101.0 per cent (dried substance).

#### CHARACTERS

*Appearance*: white or almost white powder.

*Solubility*: slightly soluble in water, freely soluble in formic acid, slightly soluble in anhydrous ethanol.

mp: about 230 °C.

#### IDENTIFICATION

Carry out either tests A, C, D or tests A, B, D.

A. Infrared absorption spectrophotometry (2.2.24).

*Comparison*: tamsulosin hydrochloride CRS.

B. Specific optical rotation (2.2.7): – 17.5 to – 20.5 (dried substance).

Dissolve with heating 0.15 g in *water R* and dilute to 20.0 mL with the same solvent.

C. Enantiomeric purity (see Tests).

D. Dissolve with heating 0.75 g in *water R* and dilute to 100.0 mL with the same solvent. Take 5 mL of the solution and cool in an ice-bath. Add 3 mL of *dilute nitric acid R* and shake. Allow to stand at room temperature for 30 min and filter. The filtrate gives reaction (a) of chlorides (2.3.1).

#### TESTS

##### Related substances.

A. Impurities eluting before tamsulosin. Liquid chromatography (2.2.29).

*Test solution*. Dissolve 50.0 mg of the substance to be examined in the mobile phase and dilute to 10.0 mL with the mobile phase.

*Reference solution (a)*. Dilute 1.0 mL of the test solution to 100.0 mL with the mobile phase. Dilute 1.0 mL of this solution to 10.0 mL with the mobile phase.

*Reference solution (b)*. Dissolve 4 mg of *tamsulosin impurity D CRS* and 4 mg of the substance to be examined in the mobile phase and dilute to 20.0 mL with the mobile phase. Dilute 2.0 mL of this solution to 20.0 mL with the mobile phase.

*Reference solution (c)*. Dissolve 4 mg of *tamsulosin impurity H CRS* and 4 mg of the substance to be examined in the mobile phase and dilute to 20.0 mL with the mobile phase. Dilute 2.0 mL of this solution to 20.0 mL with the mobile phase.

##### Column:

- *size*:  $l = 0.15$  m,  $\varnothing = 4.6$  mm;
- *stationary phase*: octadecylsilyl silica gel for chromatography R (5  $\mu$ m);
- *temperature*: 40 °C.

*Mobile phase*: dissolve 3.0 g of *sodium hydroxide R* in a mixture of 8.7 mL of *perchloric acid R* and 1.9 L of *water R*; adjust to pH 2.0 with 0.5 M *sodium hydroxide* and dilute to 2 L with *water R*; to 1.4 L of this solution, add 600 mL of *acetonitrile R*.

*Flow rate*: 1.3 mL/min.

*Detection*: spectrophotometer at 225 nm.

*Injection*: 10  $\mu$ L of the test solution and reference solutions (a) and (b).

*Run time*: 1.5 times the retention time of tamsulosin (retention time = about 6 min).

*System suitability*: reference solution (b):

- *resolution*: minimum 6 between the peaks due to impurity D and tamsulosin.

##### Limits:

- *unspecified impurities*: for each impurity, not more than the area of the principal peak in the chromatogram obtained with reference solution (a) (0.10 per cent);
- *disregard limit*: 0.5 times the area of the principal peak in the chromatogram obtained with reference solution (a) (0.05 per cent).

B. Impurities eluting after tamsulosin. Liquid chromatography (2.2.29) as described in test A with the following modifications.

*Mobile phase*: dissolve 3.0 g of *sodium hydroxide R* in a mixture of 8.7 mL of *perchloric acid R* and 1.9 L of *water R*; adjust to pH 2.0 with 0.5 M *sodium hydroxide* and dilute to 2 L with *water R*; add 2 L of *acetonitrile R*.

*Flow rate*: 1.0 mL/min.

*Injection*: 10  $\mu$ L of the test solution and reference solutions (a) and (c).

*Run time*: 5 times the retention time of tamsulosin (retention time = about 2.5 min).

*System suitability*: reference solution (c):

- *resolution*: minimum 2 between the peaks due to tamsulosin and impurity H.

##### Limits:

- *unspecified impurities*: for each impurity, not more than the area of the principal peak in the chromatogram obtained with reference solution (a) (0.10 per cent);
- *sum of impurities eluting before tamsulosin in test A and after tamsulosin in test B*: not more than the area of the principal peak in the chromatogram obtained with reference solution (a) (0.2 per cent);
- *disregard limit*: 0.5 times the area of the principal peak in the chromatogram obtained with reference solution (a) (0.05 per cent).

**Enantiomeric purity.** Liquid chromatography (2.2.29).

*Test solution*. Dissolve 50.0 mg of the substance to be examined in *methanol R* and dilute to 25.0 mL with the same solvent.

**Reference solution (a).** Dilute 1.0 mL of the test solution to 100.0 mL with *methanol R*. Dilute 1.0 mL of this solution to 10.0 mL with *methanol R*.

**Reference solution (b).** Dissolve 5.0 mg of *tamsulosin racemate CRS* in *methanol R* and dilute to 25.0 mL with the same solvent. Dilute 2.0 mL of this solution to 10.0 mL with *methanol R*.

**Column:**

- size:  $l = 0.25$  m,  $\varnothing = 4.6$  mm;
- stationary phase: silica gel AD for chiral separation R;
- temperature: 40 °C.

**Mobile phase:** *diethylamine R*, *methanol R*, *anhydrous ethanol R*, *hexane R* (1:150:200:650 V/V/V/V).

**Flow rate:** 0.5 mL/min.

**Detection:** spectrophotometer at 225 nm.

**Injection:** 10 µL.

**Relative retention** with reference to tamsulosin (retention time = about 14 min): impurity G = about 0.8.

**System suitability:** reference solution (b):

- resolution: minimum 2 between the peaks due to impurity G and tamsulosin.

**Limit:**

- impurity G: not more than the area of the principal peak in the chromatogram obtained with reference solution (a) (0.1 per cent).

**Heavy metals (2.4.8):** maximum 20 ppm.

1.0 g complies with test C. Prepare the reference solution using 2 mL of *lead standard solution (10 ppm Pb) R*.

**Loss on drying (2.2.32):** maximum 0.5 per cent, determined on 1.000 g by drying in an oven at 105 °C for 2 h.

**Sulfated ash (2.4.14):** maximum 0.1 per cent, determined on 1.0 g.

**ASSAY**

Dissolve 0.350 g in 5.0 mL of *anhydrous formic acid R*, add 75 mL of a mixture of 2 volumes of *acetic anhydride R* and 3 volumes of *glacial acetic acid R*. Titrate immediately with 0.1 M *perchloric acid*, determining the end-point potentiometrically (2.2.20). Carry out a blank titration.

1 mL of 0.1 M *perchloric acid* is equivalent to 44.50 mg of  $C_{20}H_{29}ClN_2O_5S$ .

**IMPURITIES**

**Specified impurities: G.**

**Other detectable impurities** (the following substances would, if present at a sufficient level, be detected by one or other of the tests in the monograph. They are limited by the general acceptance criterion for other/unspecified impurities and/or by the general monograph *Substances for pharmaceutical use (2034)*. It is therefore not necessary to identify these impurities for demonstration of compliance. See also 5.10. *Control of impurities in substances for pharmaceutical use*): A, B, C, D, E, F, H, I.

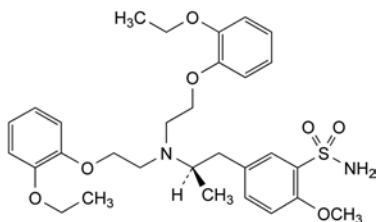

A. 5-[(2R)-2-bis[2-(2-ethoxyphenoxy)ethyl]amino]propyl]-2-methoxybenzenesulfonamide,

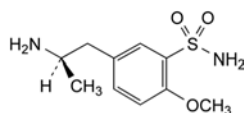

B. 5-[(2R)-2-aminopropyl]-2-methoxybenzenesulfonamide,

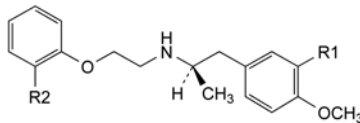

C. R1 =  $SO_2NH_2$ , R2 = H: 2-methoxy-5-[(2R)-2-[(2-phenoxyethyl)amino]propyl]benzenesulfonamide,

D. R1 =  $SO_2NH_2$ , R2 =  $OCH_3$ : 2-methoxy-5-[(2R)-2-[[2-(2-methoxyphenoxy)ethyl]amino]propyl]benzenesulfonamide,

H. R1 = H, R2 =  $OC_2H_5$ : (2R)-N-[2-(2-ethoxyphenoxy)ethyl]-1-(4-methoxyphenyl)propan-2-amine,

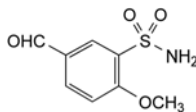

E. 5-formyl-2-methoxybenzenesulfonamide,

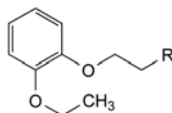

F. R =  $NH_2$ : 2-(2-ethoxyphenoxy)ethanamine,

I. R = Br: 1-(2-bromoethoxy)-2-ethoxybenzene,

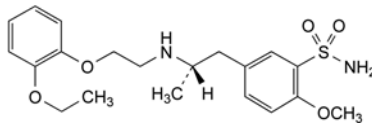

G. 5-[(2S)-2-[[2-(2-ethoxyphenoxy)ethyl]amino]propyl]-2-methoxybenzenesulfonamide.

01/2008:1477  
corrected 6.0

## TANNIC ACID

### Tanninum

**DEFINITION**

Mixture of esters of glucose with gallic acid and 3-galloylgallic acid.

**CHARACTERS**

**Appearance:** yellowish-white or slightly brown amorphous light powder or shiny plates.

**Solubility:** very soluble in water, freely soluble in acetone, in ethanol (96 per cent) and in glycerol (85 per cent), practically insoluble in methylene chloride.

**IDENTIFICATION**

A. Dilute 0.1 mL of solution S (see Tests) to 5 mL with *water R*. Add 0.1 mL of *ferric chloride solution R1*. A blackish-blue colour is produced which becomes green on the addition of 1 mL of *dilute sulfuric acid R*.

B. To 1 mL of solution S, add 3 mL of a 1 g/L solution of *gelatin R*. The mixture becomes turbid and a flocculent precipitate is formed.

C. Dilute 0.1 mL of solution S to 5 mL with *water R*. Add 0.3 mL of *barium hydroxide solution R*. A greenish-blue precipitate is formed.

## TESTS

**Solution S.** Dissolve 4.0 g in *carbon dioxide-free water R* and dilute to 20 mL with the same solvent.

**Appearance of solution.** Solution S is not more opalescent than reference suspension II (2.2.1).

**Dextrins, gum, salts, sugars.** To 2 mL of solution S, add 2 mL of *ethanol (96 per cent) R*. The solution is clear. Add 1 mL of *ether R*. The solution remains clear for at least 10 min.

**Resins.** To 5 mL of solution S, add 5 mL of *water R*. The mixture remains clear (2.2.1) for at least 15 min.

**Loss on drying (2.2.32):** maximum 12.0 per cent, determined on 0.200 g by drying at 105 °C.

**Sulfated ash (2.4.14):** maximum 0.1 per cent, determined on 1.0 g.

## STORAGE

Protected from light.

01/2008:0460  
corrected 6.0

## TARTARIC ACID

Acidum tartaricum

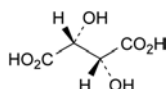

C<sub>4</sub>H<sub>6</sub>O<sub>6</sub>  
[87-69-4]

M<sub>r</sub> 150.1

## DEFINITION

(2*R*,3*R*)-2,3-Dihydroxybutanedioic acid.

**Content:** 99.5 per cent to 101.0 per cent (dried substance).

## CHARACTERS

**Appearance:** white or almost white, crystalline powder or colourless crystals.

**Solubility:** very soluble in water, freely soluble in ethanol (96 per cent).

## IDENTIFICATION

A. Solution S (see Tests) is strongly acid (2.2.4).

B. It gives the reactions of tartrates (2.3.1).

## TESTS

**Solution S.** Dissolve 5.0 g in *distilled water R* and dilute to 50 mL with the same solvent.

**Appearance of solution.** Solution S is clear (2.2.1) and not more intensely coloured than reference solution Y<sub>6</sub> (2.2.2, *Method II*).

**Specific optical rotation (2.2.7):** + 12.0 to + 12.8 (dried substance).

Dissolve 5.00 g in *water R* and dilute to 25.0 mL with the same solvent.

**Oxalic acid:** maximum 350 ppm, calculated as anhydrous oxalic acid.

Dissolve 0.80 g in 4 mL of *water R*. Add 3 mL of *hydrochloric acid R* and 1 g of *zinc R* in granules and boil for 1 min. Allow to stand for 2 min. Collect the liquid in a test-tube containing 0.25 mL of a 10 g/L solution of *phenylhydrazine hydrochloride R* and heat to boiling. Cool rapidly, transfer to a graduated cylinder and add an equal volume of *hydrochloric acid R* and 0.25 mL of a 50 g/L solution of *potassium ferricyanide R*. Shake and allow to stand for 30 min. Any pink colour in the solution is not more intense than that in a standard prepared at the same time in the same manner using 4 mL of a 0.1 g/L solution of *oxalic acid R*.

**Chlorides (2.4.4):** maximum 100 ppm.

Dilute 5 mL of solution S to 15 mL with *water R*.

**Sulfates (2.4.13):** maximum 150 ppm.

Dilute 10 mL of solution S to 15 mL with *distilled water R*.

**Calcium (2.4.3):** maximum 200 ppm.

To 5 mL of solution S add 10 mL of a 50 g/L solution of *sodium acetate R* in *distilled water R*.

**Heavy metals (2.4.8):** maximum 10 ppm.

2.0 g complies with test C. Prepare the reference solution using 2 mL of *lead standard solution (10 ppm Pb) R*.

**Loss on drying (2.2.32):** maximum 0.2 per cent, determined on 1.000 g by drying in an oven at 105 °C.

**Sulfated ash (2.4.14):** maximum 0.1 per cent, determined on 1.0 g.

## ASSAY

Dissolve 0.650 g in 25 mL of *water R*. Titrate with 1 M *sodium hydroxide* using 0.5 mL of *phenolphthalein solution R* as indicator, until a pink colour is obtained.

1 mL of 1 M *sodium hydroxide* is equivalent to 75.05 mg of C<sub>4</sub>H<sub>6</sub>O<sub>6</sub>.

01/2009:2358  
corrected 6.6

## TEICOPLANIN

Teicoplaninum

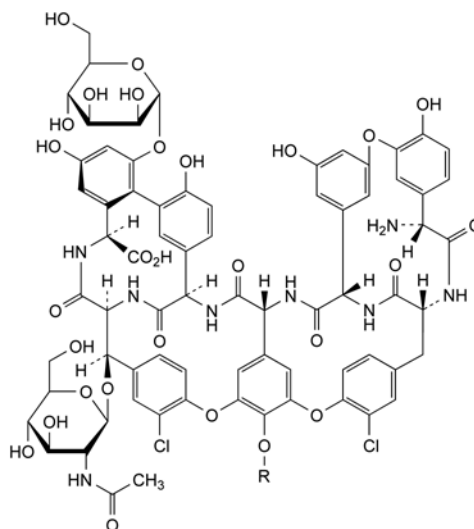

Teicoplanin	R	R'
A <sub>2</sub> -1 C <sub>88</sub> H <sub>95</sub> Cl <sub>2</sub> N <sub>9</sub> O <sub>33</sub> M. W.: 1878		
A <sub>2</sub> -2 C <sub>88</sub> H <sub>97</sub> Cl <sub>2</sub> N <sub>9</sub> O <sub>33</sub> M. W.: 1880		
A <sub>2</sub> -3 C <sub>88</sub> H <sub>97</sub> Cl <sub>2</sub> N <sub>9</sub> O <sub>33</sub> M. W.: 1880		
A <sub>2</sub> -4 C <sub>89</sub> H <sub>99</sub> Cl <sub>2</sub> N <sub>9</sub> O <sub>33</sub> M. W.: 1894		
A <sub>2</sub> -5 C <sub>89</sub> H <sub>99</sub> Cl <sub>2</sub> N <sub>9</sub> O <sub>33</sub> M. W.: 1894		
A <sub>3</sub> -1 C <sub>72</sub> H <sub>68</sub> Cl <sub>2</sub> N <sub>6</sub> O <sub>28</sub> M. W.: 1564	H	

## DEFINITION

Mixture of glycopeptides produced by certain strains of *Actinoplanes teichomyceticus* sp.; the 6 principal components of the mixture are teicoplanin A<sub>2-1</sub> to A<sub>2-5</sub> and teicoplanin A<sub>3-1</sub>.

Fermentation product.

**Potency:** minimum 900 IU/mg (anhydrous and sodium chloride-free substance).

## CHARACTERS

**Appearance:** yellowish, amorphous powder.

**Solubility:** freely soluble in water, sparingly soluble in dimethylformamide, practically insoluble in ethanol (96 per cent V/V).

## IDENTIFICATION

## A. Infrared absorption spectrophotometry (2.2.24).

**Comparison:** teicoplanin for identification CRS.

## B. Examine the chromatograms obtained in the test for composition and related substances.

**Results:** the principal peaks (teicoplanins A<sub>3-1</sub>, A<sub>2-1</sub>, A<sub>2-2</sub>, A<sub>2-3</sub>, A<sub>2-4</sub> and A<sub>2-5</sub>) in the chromatogram obtained with the test solution are similar in retention time and size to the principal peaks in the chromatogram obtained with reference solution (a).

## TESTS

**Appearance of solution.** The solution is clear (2.2.1) and not more intensely coloured than reference solution BY<sub>3</sub> or B<sub>4</sub> (2.2.2, Method I).

Dissolve 0.8 g in 10 mL of water R.

**pH** (2.2.3): 6.5 to 7.5.

Dissolve 0.50 g in carbon dioxide-free water R and dilute to 10 mL with the same solvent.

**Composition and related substances.** Liquid chromatography (2.2.29): use the normalisation procedure.

**Test solution.** Dissolve 0.100 g of the substance to be examined in water R and dilute to 50.0 mL with the same solvent.

**Reference solution (a).** Dissolve 20 mg of teicoplanin for identification CRS in water R and dilute to 10.0 mL with the same solvent.

**Reference solution (b).** Dilute 1.0 mL of reference solution (a) to 10.0 mL with water R. Dilute 1.0 mL of this solution to 20.0 mL with water R.

**Reference solution (c).** Dissolve 50.0 mg of mesityl oxide CRS in water R and dilute to 25.0 mL with the same solvent. Dilute 1.0 mL of the solution to 10.0 mL with water R. Dilute 1.0 mL of this solution to 100.0 mL with water R.

**Column:**

- size:  $l = 0.25$  m,  $\varnothing = 4.6$  mm;
- stationary phase: spherical end-capped octadecylsilyl silica gel for chromatography R (5  $\mu$ m).

**Mobile phase:**

- mobile phase A: mix 900 mL of a 3.0 g/L solution of anhydrous sodium dihydrogen phosphate R, adjusted to pH 6.0 with 1 M sodium hydroxide, and 100 mL of acetonitrile R;
- mobile phase B: mix 300 mL of a 3.0 g/L solution of anhydrous sodium dihydrogen phosphate R, adjusted to pH 6.0 with 1 M sodium hydroxide, and 700 mL of acetonitrile R;

Time (min)	Mobile phase A (per cent V/V)	Mobile phase B (per cent V/V)
0 - 30	100 → 50	0 → 50
30 - 31	50 → 10	50 → 90
31 - 35	10	90

**Flow rate:** 2.3 mL/min.

**Detection:** spectrophotometer at 254 nm.

**Injection:** 20  $\mu$ L.

**Identification:** use the chromatogram supplied with teicoplanin for identification CRS and the chromatogram obtained with reference solution (a) to identify the groups and impurities.

**Relative retention** of groups and impurities with reference to teicoplanin A<sub>2-2</sub>:

- teicoplanin A<sub>3</sub> group  $\leq 0.70$ ;
- teicoplanin A<sub>2</sub> group  $> 0.70$  and  $\leq 1.25$  and within this group:
  - teicoplanin A<sub>2-2</sub> = 1;
  - teicoplanin A<sub>2-1</sub> group  $< 1$ ;
  - teicoplanin A<sub>2-3</sub> group  $> 1$  and  $< 1.12$ ;
  - teicoplanin A<sub>2-4</sub> = about 1.12;
  - teicoplanin A<sub>2-5</sub> group  $> 1.12$  and  $\leq 1.25$ ;
- impurities  $> 1.25$ .

**Relative retention** of principal peaks of the groups with reference to teicoplanin A<sub>2-2</sub> (retention time = about 18 min): teicoplanin A<sub>3-1</sub> = about 0.43; teicoplanin A<sub>2-1</sub> = about 0.93; teicoplanin A<sub>2-3</sub> = about 1.04; teicoplanin A<sub>2-4</sub> = about 1.12; teicoplanin A<sub>2-5</sub> = about 1.14.

**System suitability:** reference solution (a):

- the chromatogram obtained is similar to the chromatogram supplied with teicoplanin for identification CRS;
- resolution: minimum 1.0 between the peaks due to teicoplanin A<sub>2-4</sub> and teicoplanin A<sub>2-5</sub>.

Calculate the percentage content of the different components using the following equations:

$$\text{teicoplanin A}_2 \text{ group} = \frac{S_a}{S_a + 0.83 \times S_b + S_c} \times 100$$

$$\text{teicoplanin A}_{2-2} = \frac{S_2}{S_a + 0.83 \times S_b + S_c} \times 100$$

$$\text{teicoplanin A}_{2-1} \text{ group} = \frac{S_1}{S_a + 0.83 \times S_b + S_c} \times 100$$

$$\text{teicoplanin A}_{2-3} \text{ group} = \frac{S_3}{S_a + 0.83 \times S_b + S_c} \times 100$$

$$\text{teicoplanin A}_{2-4} = \frac{S_4}{S_a + 0.83 \times S_b + S_c} \times 100$$

$$\text{teicoplanin A}_{2-5} \text{ group} = \frac{S_5}{S_a + 0.83 \times S_b + S_c} \times 100$$

$$\text{teicoplanin A}_3 \text{ group} = \frac{0.83 \times S_b}{S_a + 0.83 \times S_b + S_c} \times 100$$

$$\text{impurities} = \frac{S_c}{S_a + 0.83 \times S_b + S_c} \times 100$$

$S_a$  = sum of the areas of the peaks due to teicoplanin A<sub>2</sub> group in the chromatogram obtained with the test solution;

$S_b$  = sum of the areas of the peaks due to teicoplanin A<sub>3</sub> group in the chromatogram obtained with the test solution; disregard any peak due to mesityl oxide;

$S_c$  = sum of the areas of the peaks with a relative retention more than 1.25;

$S_1$  = sum of the areas of the peaks due to teicoplanin A<sub>2-1</sub> group in the chromatogram obtained with the test solution;

$S_2$  = area of the peak due to teicoplanin A<sub>2-2</sub> in the chromatogram obtained with the test solution;

07/2008:2154  
corrected 6.3

- $S_3$  = sum of the areas of the peaks due to telmoplanin  $A_{2,3}$  group in the chromatogram obtained with the test solution;
- $S_4$  = area of the peak due to telmoplanin  $A_{2,4}$  in the chromatogram obtained with the test solution;
- $S_5$  = sum of the areas of the peaks due to telmoplanin  $A_{2,5}$  group in the chromatogram obtained with the test solution.

**Limits:**

- *telmoplanin*  $A_2$  group: minimum 80.0 per cent;
- *telmoplanin*  $A_{2,2}$ : 35.0 per cent to 55.0 per cent;
- *telmoplanin*  $A_{2,1}$  group: maximum 20.0 per cent;
- *telmoplanin*  $A_{2,3}$  group: maximum 20.0 per cent;
- *telmoplanin*  $A_{2,4}$ : maximum 20.0 per cent;
- *telmoplanin*  $A_{2,5}$  group: maximum 20.0 per cent;
- *telmoplanin*  $A_3$  group: maximum 15.0 per cent;
- *total of impurities other than mesityl oxide with a relative retention more than 1.25*: maximum 5.0 per cent;
- *disregard limit*: the area of the peak due to telmoplanin  $A_{2,2}$  in the chromatogram obtained with reference solution (b) (0.25 per cent).

**Chlorides:** maximum 5.0 per cent, expressed as sodium chloride (anhydrous substance).

Dissolve 1.000 g in 300 mL of *water R*, stir and acidify with 2 mL of *nitric acid R*. Titrate with 0.1 M *silver nitrate*, determining the end-point potentiometrically (2.2.20).

1 mL of 0.1 M *silver nitrate* is equivalent to 5.844 mg of NaCl.

**Heavy metals** (2.4.8): maximum 20 ppm.

0.50 g complies with test G. Prepare the reference solution using 100  $\mu$ L of *lead standard solution (100 ppm Pb) R*. Filter the solutions through a membrane filter (nominal pore size 0.45  $\mu$ m).

**Impurity A.** Liquid chromatography (2.2.29) as described in the test for composition and related substances with the following modifications.

**Injection:** 20  $\mu$ L of the test solution and reference solution (c).

**Relative retention** with reference to telmoplanin  $A_{2,2}$  (retention time = about 18 min): impurity A = about 0.6.

**Limits:**

- *impurity A*: maximum twice the area of the principal peak in the chromatogram obtained with reference solution (c) (0.2 per cent).

**Water** (2.5.12): maximum 15.0 per cent, determined on 0.300 g.

**Bacterial endotoxins** (2.6.14): less than 0.31 IU/mg.

**ASSAY**

Carry out the microbiological assay of antibiotics (2.7.2), using the diffusion method. Use *telmoplanin CRS* as the reference substance.

**STORAGE**

Protected from light, at a temperature of 2 °C to 8 °C.

**IMPURITIES**

**Specified impurities:** A.

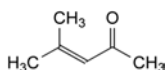

A. 4-methylpent-3-en-2-one (mesityl oxide).

**TELMISARTAN**

## Telmisartanum

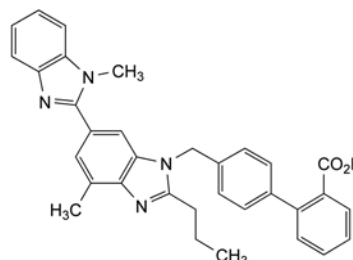

$C_{33}H_{30}N_4O_2$   
[144701-48-4]

$M_r$  514.6

**DEFINITION**

4'-[[4-Methyl-6-(1-methyl-1*H*-benzimidazol-2-yl)-2-propyl-1*H*-benzimidazol-1-yl]methyl]biphenyl-2-carboxylic acid.

**Content:** 99.0 per cent to 101.0 per cent (dried substance).

**CHARACTERS**

**Appearance:** white or slightly yellowish, crystalline powder.

**Solubility:** practically insoluble in water, slightly soluble in methanol, sparingly soluble in methylene chloride. It dissolves in 1 M sodium hydroxide.

It shows polymorphism (5.9).

**IDENTIFICATION**

Infrared absorption spectrophotometry (2.2.24).

**Comparison:** *telmisartan CRS*.

If the spectra obtained in the solid state show differences, dissolve the substance to be examined and the reference substance separately in hot *anhydrous ethanol R*, evaporate to dryness and record new spectra using the residues.

**TESTS**

**Appearance of solution.** The solution is not more intensely coloured than reference solution  $Y_4$  (2.2.2, *Method II*).

Dissolve 0.5 g in 1 M *sodium hydroxide* and dilute to 10 mL with the same solvent.

**Related substances.** Liquid chromatography (2.2.29).

**Test solution.** To 25 mg of the substance to be examined add about 5 mL of *methanol R* and 100  $\mu$ L of a 40 g/L solution of *sodium hydroxide R*. Dissolve with the aid of ultrasound and dilute to 50 mL with *methanol R*.

**Reference solution (a).** Dilute 1.0 mL of the test solution to 10.0 mL with *methanol R*. Dilute 1.0 mL of this solution to 100.0 mL with *methanol R*.

**Reference solution (b).** Dissolve the contents of a vial of *telmisartan for system suitability CRS* (containing impurities A, B, C, E and F) in 2 mL of *methanol R*.

**Reference solution (c).** To 5 mg of *telmisartan for peak identification CRS* (containing impurity D) add about 5 mL of *methanol R* and 100  $\mu$ L of a 40 g/L solution of *sodium hydroxide R*. Dissolve with the aid of ultrasound and dilute to 10 mL with *methanol R*.

**Column:**

- *size:*  $l = 0.125$  m,  $\emptyset = 4.0$  mm;
- *stationary phase:* octadecylsilyl silica gel for chromatography  $R$  (5  $\mu$ m) with a pore size of 10 nm;
- *temperature:* 40 °C.

**Mobile phase:**

- **mobile phase A:** dissolve 2.0 g of *potassium dihydrogen phosphate R* and 3.8 g of *sodium pentanesulfonate monohydrate R1* in *water R*, adjust to pH 3.0 with *dilute phosphoric acid R* and dilute to 1000 mL with *water R*;
- **mobile phase B:** *methanol R2*, *acetonitrile R1* (20:80 V/V);

Time (min)	Mobile phase A (per cent V/V)	Mobile phase B (per cent V/V)
0 - 3	70	30
3 - 28	70 → 20	30 → 80

**Flow rate:** 1 mL/min.

**Detection:** spectrophotometer at 230 nm.

**Injection:** 10 µL.

**Identification of impurities:** use the chromatogram supplied with *telmisartan for system suitability CRS* and the chromatogram obtained with reference solution (b) to identify the peaks due to impurities A, B, C, E and F; use the chromatogram supplied with *telmisartan for peak identification CRS* and the chromatogram obtained with reference solution (c) to identify the peak due to impurity D.

**Relative retention** with reference to telmisartan (retention time = about 15 min): impurity A = about 0.2; impurity E = about 0.6; impurity F = about 0.7; impurity B = about 0.9; impurity C = about 1.5; impurity D = about 1.6.

**System suitability:** reference solution (b):

- the chromatogram obtained with reference solution (b) is similar to the chromatogram supplied with *telmisartan for system suitability CRS*;
- **resolution:** minimum 3.0 between the peaks due to impurity B and telmisartan.

**Limits:**

- **impurities C, D:** for each impurity, not more than twice the area of the principal peak in the chromatogram obtained with reference solution (a) (0.2 per cent);
- **impurities A, B:** for each impurity, not more than 1.5 times the area of the principal peak in the chromatogram obtained with reference solution (a) (0.15 per cent);
- **unspecified impurities:** for each impurity, not more than the area of the principal peak in the chromatogram obtained with reference solution (a) (0.10 per cent);
- **total:** not more than 10 times the area of the principal peak in the chromatogram obtained with reference solution (a) (1.0 per cent);
- **disregard limit:** 0.5 times the area of the principal peak in the chromatogram obtained with reference solution (a) (0.05 per cent).

**Loss on drying** (2.2.32): maximum 0.5 per cent, determined on 1.000 g by drying in an oven at 105 °C.

**Sulfated ash** (2.4.14): maximum 0.1 per cent, determined on 1.0 g.

**ASSAY**

Dissolve 0.190 g in 5 mL of *anhydrous formic acid R*. Add 75 mL of *acetic anhydride R*. Titrate with 0.1 M *perchloric acid*, determining the end-point potentiometrically (2.2.20).

1 mL of 0.1 M *perchloric acid* is equivalent to 25.73 mg of C<sub>33</sub>H<sub>30</sub>N<sub>4</sub>O<sub>2</sub>.

**IMPURITIES**

**Specified impurities:** A, B, C, D.

**Other detectable impurities** (the following substances would, if present at a sufficient level, be detected by one or other of the tests in the monograph. They are limited by the general

acceptance criterion for other/unspecified impurities and/or by the general monograph *Substances for pharmaceutical use* (2034). It is therefore not necessary to identify these impurities for demonstration of compliance. See also 5.10. *Control of impurities in substances for pharmaceutical use*): E, F, G, H.

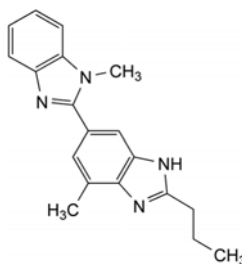

A. 4-methyl-6-(1-methyl-1*H*-benzimidazol-2-yl)-2-propyl-1*H*-benzimidazole,

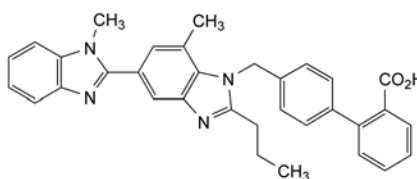

B. 4'-[[7-methyl-5-(1-methyl-1*H*-benzimidazol-2-yl)-2-propyl-1*H*-benzimidazol-1-yl]methyl]biphenyl-2-carboxylic acid,

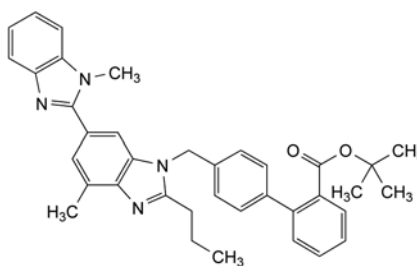

C. 1,1-dimethylethyl 4'-[[4-methyl-6-(1-methyl-1*H*-benzimidazol-2-yl)-2-propyl-1*H*-benzimidazol-1-yl]methyl]biphenyl-2-carboxylate,

D. unidentified impurity,

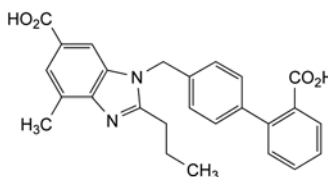

E. 1-(2'-carboxybiphenyl-4-yl)methyl-4-methyl-2-propyl-1*H*-benzimidazol-6-carboxylic acid,

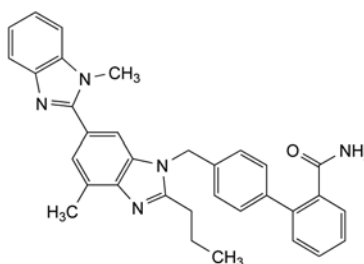

F. 4'-[[4-methyl-6-(1-methyl-1*H*-benzimidazol-2-yl)-2-propyl-1*H*-benzimidazol-1-yl]methyl]biphenyl-2-carboxamide,

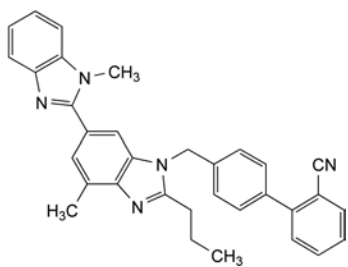

G. 4'-[[4-methyl-6-(1-methyl-1H-benzimidazol-2-yl)-2-propyl-1H-benzimidazol-1-yl]methyl]biphenyl-2-carbonitrile,

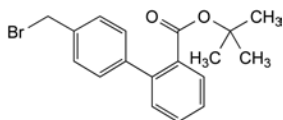

H. 1,1-dimethylethyl 4'-(bromomethyl)biphenyl-2-carboxylate.

01/2008:0954  
corrected 6.0

## TEMAZEPAM

### Temazepamum

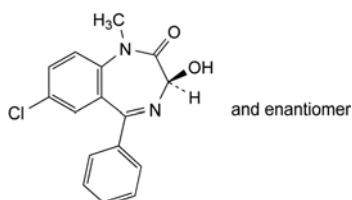

$C_{16}H_{13}ClN_2O_2$   
[846-50-4]

$M_r$  300.7

#### DEFINITION

(3*RS*)-7-Chloro-3-hydroxy-1-methyl-5-phenyl-1,3-dihydro-2*H*-1,4-benzodiazepin-2-one.

*Content*: 99.0 per cent to 101.0 per cent (dried substance).

#### CHARACTERS

*Appearance*: white or almost white, crystalline powder.

*Solubility*: practically insoluble in water, freely soluble in methylene chloride, sparingly soluble in ethanol (96 per cent).

#### IDENTIFICATION

Infrared absorption spectrophotometry (2.2.24).

*Comparison*: temazepam CRS.

#### TESTS

**Impurity A**: maximum 0.05 per cent.

Dissolve 0.400 g in *methylene chloride R* and dilute to 20.0 mL with the same solvent. The absorbance (2.2.25) is not greater than 0.30 at 409 nm.

**Related substances**. Liquid chromatography (2.2.29).

*Test solution*. Dissolve 10.0 mg of the substance to be examined in a mixture of 1 volume of *water R* and 9 volumes of *methanol R* and dilute to 50.0 mL with the same mixture of solvents.

*Reference solution (a)*. Dilute 1.0 mL of the test solution to 100.0 mL with a mixture of 1 volume of *water R* and 9 volumes of *methanol R*. Dilute 2.0 mL of this solution to 10.0 mL with a mixture of 1 volume of *water R* and 9 volumes of *methanol R*.

*Reference solution (b)*. Dissolve 1 mg of *oxazepam R*, 1 mg of *temazepam impurity F CRS* and 1 mg of *temazepam impurity G CRS* in a mixture of 1 volume of *water R* and 9 volumes of *methanol R* and dilute to 25 mL with the same mixture of solvents.

*Reference solution (c)*. Dissolve 1 mg of *temazepam impurity C CRS* and 1 mg of *temazepam impurity D CRS* with a mixture of 1 volume of *water R* and 9 volumes of *methanol R* and dilute to 25 mL with the same mixture of solvents.

#### Column:

– *size*:  $l = 0.15$  m,  $\varnothing = 4.6$  mm;

– *stationary phase*: end-capped octadecylsilyl silica gel for chromatography *R* (3.5  $\mu$ m).

#### Mobile phase:

– *mobile phase A*: solution containing 4.9 g/L of *sodium dihydrogen phosphate R* and 0.63 g/L of *disodium hydrogen phosphate R* (pH 5.6);

– *mobile phase B*: *methanol R*;

– *mobile phase C*: *acetonitrile R*;

Time (min)	Mobile phase A (per cent V/V)	Mobile phase B (per cent V/V)	Mobile phase C (per cent V/V)
0 - 18	54	39	7
18 - 25	54 → 22	39 → 63	7 → 15
25 - 31	22	63	15
31 - 37	22 → 54	63 → 39	15 → 7

*Flow rate*: 1.5 mL/min.

*Detection*: spectrophotometer at 230 nm.

*Injection*: 20  $\mu$ L.

*Relative retention* with reference to temazepam (retention time = about 16 min): *impurity E* = about 0.55; *impurity F* = about 0.67; *impurity G* = about 0.73; *impurity B* = about 0.8; *impurity D* = about 1.2; *impurity C* = about 1.3; *impurity A* = about 1.5.

*System suitability*: reference solution (b):

– *resolution*: minimum 1.5 between the peaks due to *impurity F* and *impurity G*;

– *peak-to-valley ratio*: minimum 1.7, where  $H_p$  = height above the baseline of the peak due to *impurity G* and  $H_v$  = height above the baseline of the lowest point of the curve separating this peak from the peak due to *impurity B*.

#### Limits:

– *correction factors*: for the calculation of contents, multiply the peak areas of the following impurities by the corresponding correction factor: *impurity F* = 3.2; *impurity G* = 3.1;

– *impurities B, C, D, E, F, G*: for each impurity, not more than the area of the principal peak in the chromatogram obtained with reference solution (a) (0.2 per cent);

– *unspecified impurities*: for each impurity, not more than 0.5 times the area of the principal peak in the chromatogram obtained with reference solution (a) (0.10 per cent);

– *total*: not more than 2.5 times the area of the principal peak in the chromatogram obtained with reference solution (a) (0.5 per cent);

– *disregard limit*: 0.25 times the area of the principal peak in the chromatogram obtained with reference solution (a) (0.05 per cent).

**Loss on drying** (2.2.32): maximum 0.5 per cent, determined on 1.000 g by drying in an oven at 105 °C for 4 h.

**Sulfated ash** (2.4.14): maximum 0.1 per cent, determined on 1.0 g.

#### ASSAY

Dissolve 0.250 g in 50 mL of *nitroethane R*. Titrate with 0.1 *M perchloric acid*, determining the end-point potentiometrically (2.2.20).

1 mL of 0.1 *M perchloric acid* is equivalent to 30.07 mg of  $C_{16}H_{13}ClN_2O_2$ .



## STORAGE

Protected from light.

## IMPURITIES

Specified impurities: A, B, C, D, E, F, G.

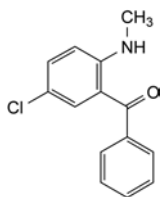

A. [5-chloro-2-(methylamino)phenyl]phenylmethanone,

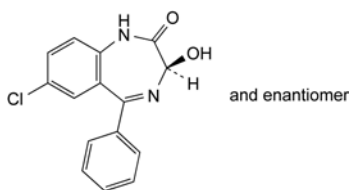

B. (3*RS*)-7-chloro-3-hydroxy-5-phenyl-1,3-dihydro-2*H*-1,4-benzodiazepin-2-one (oxazepam),

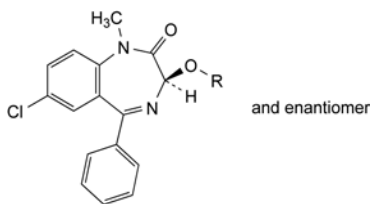

C. R = CO-CH<sub>3</sub>: (3*RS*)-7-chloro-1-methyl-2-oxo-5-phenyl-2,3-dihydro-1*H*-1,4-benzodiazepin-3-yl acetate,

D. R = CH<sub>3</sub>: (3*RS*)-7-chloro-3-methoxy-1-methyl-5-phenyl-1,3-dihydro-2*H*-1,4-benzodiazepin-2-one,

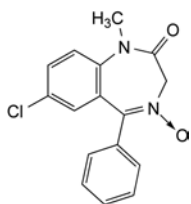

E. 7-chloro-1-methyl-5-phenyl-1,3-dihydro-2*H*-1,4-benzodiazepin-2-one 4-oxide,

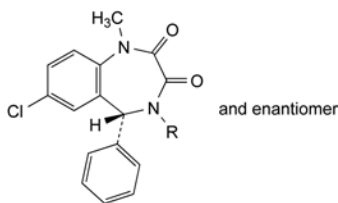

F. R = H: (5*RS*)-7-chloro-1-methyl-5-phenyl-4,5-dihydro-1*H*-1,4-benzodiazepine-2,3-dione,

G. R = CH<sub>3</sub>: (5*RS*)-7-chloro-1,4-dimethyl-5-phenyl-4,5-dihydro-1*H*-1,4-benzodiazepine-2,3-dione.

## TENOXICAM

## Tenoxicamum

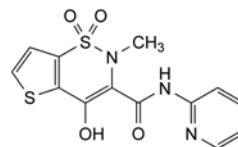

C<sub>13</sub>H<sub>11</sub>N<sub>3</sub>O<sub>4</sub>S<sub>2</sub>  
[59804-37-4]

*M*, 337.4

## DEFINITION

4-Hydroxy-2-methyl-*N*-(pyridin-2-yl)-2*H*-thieno[2,3-*e*]1,2-thiazine-3-carboxamide 1,1-dioxide.

*Content*: 99.0 per cent to 101.0 per cent (anhydrous substance).

## CHARACTERS

*Appearance*: yellow, crystalline powder.

*Solubility*: practically insoluble in water, sparingly soluble in methylene chloride, very slightly soluble in anhydrous ethanol. It dissolves in solutions of acids and alkalis.

It shows polymorphism (5.9).

## IDENTIFICATION

Infrared absorption spectrophotometry (2.2.24).

*Comparison*: tenoxicam CRS.

If the spectra obtained in the solid state show differences, dissolve the substance to be examined and the reference substance separately in the minimum volume of *methylene chloride R*, evaporate to dryness and record new spectra using the residues.

## TESTS

**Appearance of solution.** The solution is clear (2.2.1).

Dissolve 0.10 g in *methylene chloride R* and dilute to 20 mL with the same solvent.

**Related substances.** Liquid chromatography (2.2.29). Carry out the test protected from light.

*Solvent mixture.* Mix equal volumes of *acetonitrile R* and *water R*. Adjust to apparent pH 3.2 with *dilute phosphoric acid R1*.

*Test solution.* Dissolve 35 mg of the substance to be examined in the solvent mixture, sonicate and dilute to 50.0 mL with the solvent mixture.

*Reference solution (a).* Dilute 1.0 mL of the test solution to 100.0 mL with the solvent mixture. Dilute 1.0 mL of this solution to 10.0 mL with the solvent mixture.

*Reference solution (b).* Dissolve 7 mg of *pyridin-2-amine R* (impurity A) in the solvent mixture and dilute to 100.0 mL with the solvent mixture. Dilute 1.0 mL of this solution to 100.0 mL with the solvent mixture.

*Reference solution (c).* Dissolve the contents of a vial of *tenoxicam impurity mixture CRS* (impurities B, G and H) in 1.0 mL of the test solution.

*Column*:

- *size*: *l* = 0.15 m, Ø = 4.6 mm;
- *stationary phase*: cyanosilyl silica gel for chromatography *R* (3.5 µm);
- *temperature*: 35 °C.

*Mobile phase*:

- *mobile phase A*: mix 25 volumes of *methanol R2* and 75 volumes of *water R* and adjust to apparent pH 3.2 with *dilute phosphoric acid R1*;

- *mobile phase B*: mix 25 volumes of *water R* and 75 volumes of *methanol R2* and adjust to apparent pH 3.2 with *dilute phosphoric acid R1*;

Time (min)	Mobile phase A (per cent V/V)	Mobile phase B (per cent V/V)
0 - 5	96	4
5 - 16	96 → 76	4 → 24
16 - 25	76	24

*Flow rate*: 1.0 mL/min.

*Detection*: spectrophotometer at 230 nm.

*Injection*: 20 µL.

*Identification of impurities*:

- use the chromatogram obtained with reference solution (b) to identify the peak due to impurity A;
- use the chromatogram supplied with *tenoxicam impurity mixture CRS* and the chromatogram obtained with reference solution (c) to identify the peaks due to impurities B, G and H; for identification of impurities G and H, which may be inverted in the elution order, take into account the heights of the corresponding peaks in the chromatogram supplied with *tenoxicam impurity mixture CRS*.

*Relative retention* with reference to tenoxicam (retention time = about 12 min): impurity A = about 0.1; impurity G = about 0.85; impurity H = about 0.9; impurity B = about 1.3.

*System suitability*: reference solution (c):

- *resolution*: minimum 1.3 between the peaks due to impurity H (or G if peaks are inverted) and tenoxicam, and between the peaks due to impurities G and H; if necessary, optimise the apparent pH of the mobile phases within the range 3.0-3.4.

*Limits*:

- *correction factors*: for the calculation of content, multiply the peak areas of the following impurities by the corresponding correction factor: impurity A = 0.2; impurity B = 2.0;
- *impurities A, B*: for each impurity, not more than 1.5 times the area of the principal peak in the chromatogram obtained with reference solution (a) (0.15 per cent);
- *unspecified impurities*: for each impurity, not more than the area of the principal peak in the chromatogram obtained with reference solution (a) (0.10 per cent);
- *total*: not more than 3 times the area of the principal peak in the chromatogram obtained with reference solution (a) (0.3 per cent);
- *disregard limit*: 0.5 times the area of the principal peak in the chromatogram obtained with reference solution (a) (0.05 per cent).

**Heavy metals** (2.4.8): maximum 20 ppm.

0.5 g complies with test C. Prepare the reference solution using 5 mL of *lead standard solution (2 ppm Pb) R*.

**Water** (2.5.12): maximum 0.5 per cent, determined on 1.000 g.

**Sulfated ash** (2.4.14): maximum 0.1 per cent, determined on 1.0 g.

ASSAY

Dissolve 0.250 g in 5 mL of *anhydrous formic acid R*. Add 70 mL of *anhydrous acetic acid R*. Titrate with 0.1 M *perchloric acid*, determining the end-point potentiometrically (2.2.20).

1 mL of 0.1 M *perchloric acid* is equivalent to 33.74 mg of C<sub>13</sub>H<sub>11</sub>N<sub>3</sub>O<sub>4</sub>S<sub>2</sub>.

STORAGE

Protected from light.

IMPURITIES

*Specified impurities: A, B.*

*Other detectable impurities* (the following substances would, if present at a sufficient level, be detected by one or other of the tests in the monograph. They are limited by the general acceptance criterion for other/unspecified impurities and/or by the general monograph *Substances for pharmaceutical use (2034)*. It is therefore not necessary to identify these impurities for demonstration of compliance. See also 5.10. *Control of impurities in substances for pharmaceutical use*): C, D, E, F, G, H.

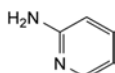

A. pyridin-2-amine,

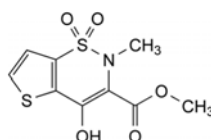

B. methyl 4-hydroxy-2-methyl-2H-thieno[2,3-e]1,2-thiazine-3-carboxylate 1,1-dioxide,

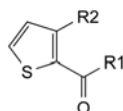

C. R1 = NH-CH<sub>3</sub>, R2 = H: *N*-methylthiophene-2-carboxamide,

H. R1 = OH, R2 = SO<sub>2</sub>-NH-CH<sub>3</sub>: 3-[(methylamino)sulfonyl]-thiophene-2-carboxylic acid,

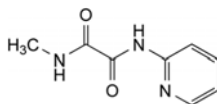

D. *N*-methyl-*N'*-(pyridin-2-yl)-ethanediamide,

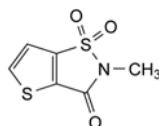

E. 2-methylthieno[2,3-d]isothiazol-3(2H)-one 1,1-dioxide,

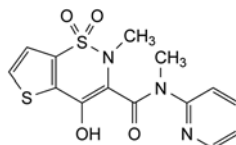

F. 4-hydroxy-*N*,2-dimethyl-*N*-(pyridin-2-yl)-2H-thieno[2,3-e]1,2-thiazine-3-carboxamide 1,1-dioxide,

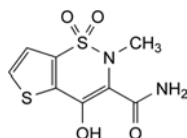

G. 4-hydroxy-2-methyl-2H-thieno[2,3-e]1,2-thiazine-3-carboxamide 1,1-dioxide.

01/2008:2021 *Detection*: spectrophotometer at 210 nm.**TERAZOSIN HYDROCHLORIDE  
DIHYDRATE**

Terazosini hydrochloridum dihydricum

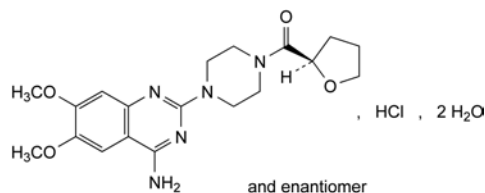
 $C_{19}H_{26}ClN_5O_4 \cdot 2H_2O$   
 [70024-40-7]
 $M_r$  459.9**DEFINITION**

1-(4-Amino-6,7-dimethoxyquinazolin-2-yl)-4-[(2*RS*)-tetrahydrofuran-2-yl]carbonylpiperazine hydrochloride dihydrate.

*Content*: 99.0 per cent to 101.0 per cent (anhydrous substance).

**CHARACTERS**

*Appearance*: white or slightly yellow, crystalline powder.

*Solubility*: sparingly soluble in water, slightly soluble in methanol, very slightly soluble in ethanol (96 per cent), practically insoluble in acetone.

**IDENTIFICATION**

A. Infrared absorption spectrophotometry (2.2.24).

*Comparison*: terazosin hydrochloride dihydrate CRS.

B. It gives reaction (a) of chlorides (2.3.1).

**TESTS**

**Solution S.** Dissolve 1.00 g in carbon dioxide-free water *R* and dilute to 50.0 mL with the same solvent.

**Appearance of solution.** The solution is clear (2.2.1) and not more intensely coloured than reference solution  $Y_7$  (2.2.2, Method II).

Dilute 10 mL of solution S to 20 mL with water *R*.

**pH** (2.2.3): 3.0 to 5.0 for solution S.

**Impurities N and O.** Liquid chromatography (2.2.29).

*Solvent mixture*: acetonitrile *R1*, water *R* (20:80 V/V).

*Test solution.* Dissolve 50.0 mg of the substance to be examined in the solvent mixture and dilute to 50.0 mL with the solvent mixture.

*Reference solution (a).* Dissolve 5 mg of terazosin impurity A CRS and 5.0 mg of terazosin impurity N CRS in acetonitrile *R1* using sonication, add 5.0 mL of the test solution and dilute to 50.0 mL with acetonitrile *R1*. Dilute 10.0 mL of this solution to 100.0 mL with the solvent mixture.

*Reference solution (b).* Dilute 10.0 mL of reference solution (a) to 100.0 mL with the solvent mixture.

*Column*:

- size:  $l = 0.25$  m,  $\varnothing = 4.0$  mm;
- stationary phase: octadecylsilyl silica gel for chromatography *R* (5  $\mu$ m);
- temperature: 25 °C.

*Mobile phase*: dissolve 2.80 g of sodium laurilsulfate *R* in 1000.0 mL of water *R* and add 11.0 mL of a solution containing 202.4 g/L of triethylamine *R* and 230.0 g/L of phosphoric acid *R*; adjust to pH 2.5 with phosphoric acid *R*; mix 600 volumes of this solution with 400 volumes of acetonitrile *R1*.

*Flow rate*: 1.0 mL/min.

*Injection*: 20  $\mu$ L.

*Run time*: 4 times the retention time of terazosin.

*Relative retention* with reference to terazosin (retention time = about 10 min): impurity O = about 0.2; impurity N = about 0.3; impurity A = about 0.4.

*System suitability*: reference solution (a):

- resolution: minimum 1.5 between the peaks due to impurities A and N.

*Limits*:

- impurity N: not more than the area of the corresponding peak in the chromatogram obtained with reference solution (b) (0.1 per cent);
- impurity O: not more than the area of the peak due to terazosin in the chromatogram obtained with reference solution (b) (0.1 per cent).

**Related substances.** Liquid chromatography (2.2.29).

*Test solution.* Dissolve 50.0 mg of the substance to be examined in the mobile phase and dilute to 100.0 mL with the mobile phase.

*Reference solution (a).* Dilute 2.0 mL of the test solution to 100.0 mL with the mobile phase. Dilute 5.0 mL of this solution to 100.0 mL with the mobile phase.

*Reference solution (b).* Dissolve the contents of a vial of terazosin for system suitability CRS (containing impurities A, B, C, J, K and M) in the mobile phase and dilute to 10 mL with the mobile phase.

*Reference solution (c).* Dissolve 5.0 mg of terazosin impurity L CRS in the mobile phase and dilute to 100.0 mL with the mobile phase. Dilute 1.0 mL of this solution to 100.0 mL with the mobile phase.

*Reference solution (d).* To 5 mg of terazosin impurity E CRS, add 70 mL of methanol *R* and 30 mL of water *R*. Allow to stand for at least 1 h to dissolve the substance. Use sonication if necessary.

*Column*:

- size:  $l = 0.25$  m,  $\varnothing = 4.6$  mm;
- stationary phase: octylsilyl silica gel for chromatography *R* (5  $\mu$ m);
- temperature: 30 °C.

*Mobile phase*: mix 2 volumes of triethylamine *R*, 350 volumes of acetonitrile *R*, and 1650 volumes of a solution containing 6 g/L of sodium citrate *R* and 14.25 g/L of anhydrous citric acid *R*.

*Flow rate*: 1.0 mL/min.

*Detection*: spectrophotometer at 245 nm.

*Injection*: 20  $\mu$ L.

*Run time*: 4 times the retention time of terazosin.

*Identification of impurities*: use the chromatogram supplied with terazosin for system suitability CRS and the chromatogram obtained with reference solution (b) to identify the peaks due to impurities A, B, C, J, K and M; use the chromatograms obtained with reference solutions (c) and (d) to identify the peaks due to impurities L and E respectively.

*Retention time*: terazosin = about 11 min.

*System suitability*: reference solution (b):

- resolution: minimum 1.5 between the peaks due to impurities B and J; if necessary, adjust the proportion of the aqueous component in the mobile phase (an increase in the proportion of the aqueous component increases the retention times);
- the chromatogram obtained is similar to the chromatogram supplied with terazosin for system suitability CRS; in case of insufficient separation of the impurities, reduce the amount of triethylamine in the mobile phase.

**Limits:**

- *correction factors*: for the calculation of content, multiply the peak areas of the following impurities by the corresponding correction factor: impurity C = 0.7; impurity M = 1.6;
- *impurities A, C, E, K*: for each impurity, not more than 5 times the area of the principal peak in the chromatogram obtained with reference solution (a) (0.5 per cent);
- *impurity L*: not more than the area of the corresponding peak in the chromatogram obtained with reference solution (c) (0.1 per cent);
- *impurities B, J, M*: for each impurity, not more than the area of the principal peak in the chromatogram obtained with reference solution (a) (0.1 per cent);
- *unspecified impurities*: for each impurity, not more than the area of the principal peak in the chromatogram obtained with reference solution (a) (0.10 per cent);
- *total*: not more than 5 times the area of the principal peak in the chromatogram obtained with reference solution (a) (0.5 per cent);
- *disregard limit*: 0.5 times the area of the principal peak in the chromatogram obtained with reference solution (a) (0.05 per cent).

**Heavy metals** (2.4.8): maximum 20 ppm.

1.0 g complies with test C. Prepare the reference solution using 2 mL of *lead standard solution* (10 ppm) *Pb R*.

**Water** (2.5.12): 7.0 per cent to 8.6 per cent, determined on 0.200 g.

**Sulfated ash** (2.4.14): maximum 0.1 per cent, determined on 1.0 g.

**ASSAY**

Dissolve 0.300 g in a mixture of 5.0 mL of 0.01 M *hydrochloric acid* and 50 mL of *methanol R*. Titrate with 0.1 M *sodium hydroxide*, determining the end-point potentiometrically (2.2.20). Read the volume added between the 2 points of inflexion.

1 mL of 0.1 M *sodium hydroxide* is equivalent to 42.39 mg of  $C_{19}H_{26}ClN_5O_4$ .

**STORAGE**

Protected from light.

**IMPURITIES**

*Specified impurities: A, B, C, E, J, K, L, M, N, O.*

*Other detectable impurities* (the following substances would, if present at a sufficient level, be detected by one or other of the tests in the monograph. They are limited by the general acceptance criterion for other/unspecified impurities and/or by the general monograph *Substances for pharmaceutical use* (2034). It is therefore not necessary to identify these impurities for demonstration of compliance. See also 5.10. *Control of impurities in substances for pharmaceutical use*): *D, F, G, H, I.*

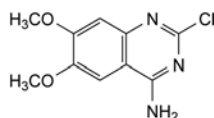

A. 2-chloro-6,7-dimethoxyquinazolin-4-amine,

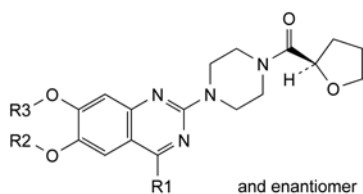

B.  $R_1 = OH, R_2 = R_3 = CH_3$ : 1-(4-hydroxy-6,7-dimethoxyquinazolin-2-yl)-4-[(2*RS*)-tetrahydrofuran-2-yl]carbonylpiperazine,

G.  $R_1 = NH_2, R_2 = H, R_3 = CH_3$ : 1-(4-amino-6-hydroxy-7-methoxyquinazolin-2-yl)-4-[(2*RS*)-tetrahydrofuran-2-yl]carbonylpiperazine,

H.  $R_1 = NH_2, R_2 = CH_3, R_3 = H$ : 1-(4-amino-7-hydroxy-6-methoxyquinazolin-2-yl)-4-[(2*RS*)-tetrahydrofuran-2-yl]carbonylpiperazine,

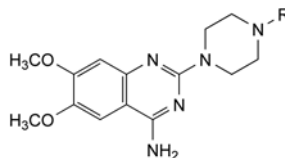

C.  $R = H$ : 6,7-dimethoxy-2-(piperazin-1-yl)quinazolin-4-amine,

D.  $R = CHO$ : 1-(4-amino-6,7-dimethoxyquinazolin-2-yl)-4-formylpiperazine,

F.  $R = CO-[CH_2]_4-OH$ : 1-(4-amino-6,7-dimethoxyquinazolin-2-yl)-4-(5-hydroxypentanoyl)piperazine,

J.  $R = CO-CH(OH)-CH_2-CH_2-CH_3$ : 1-(4-amino-6,7-dimethoxyquinazolin-2-yl)-4-[(2*RS*)-2-hydroxypentanoyl]piperazine,

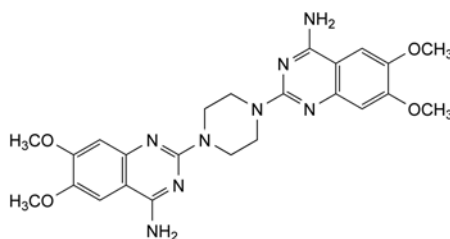

E. 2,2'-(piperazine-1,4-diyl)bis(6,7-dimethoxyquinazolin-4-amine),

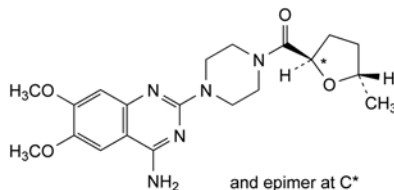

I. 1-(4-amino-6,7-dimethoxyquinazolin-2-yl)-4-[(2*RS*,5*S*)-5-methyltetrahydrofuran-2-yl]carbonylpiperazine,

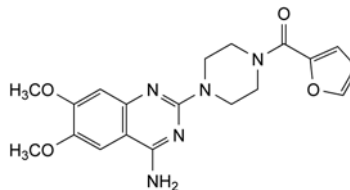

K. 1-(4-amino-6,7-dimethoxyquinazolin-2-yl)-4-(furan-2-ylcarbonyl)piperazine (prazosin),

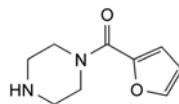

L. 1-(furan-2-ylcarbonyl)piperazine,

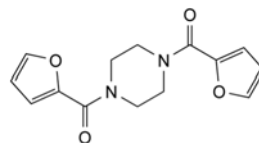

M. 1,4-bis(furan-2-ylcarbonyl)piperazine,

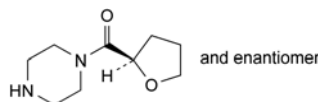

N. 1-[(2*RS*)-tetrahydrofuran-2-yl]carbonylpiperazine,

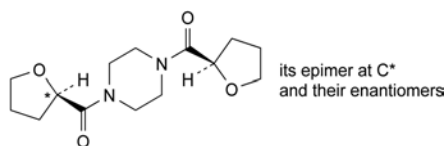

O. 1,4-bis[(tetrahydrofuran-2-yl)carbonyl]piperazine.

01/2010:1734

## TERBINAFINE HYDROCHLORIDE

### Terbinafini hydrochloridum

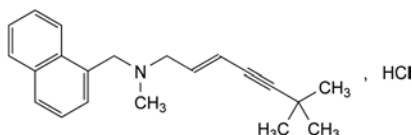

C<sub>21</sub>H<sub>26</sub>ClN  
[78628-80-5]

M<sub>r</sub> 327.9

#### DEFINITION

(2*E*)-*N*,6,6-Trimethyl-*N*-(naphthalen-1-ylmethyl)hept-2-en-4-yn-1-amine hydrochloride.

*Content*: 99.0 per cent to 101.0 per cent (dried substance).

#### CHARACTERS

*Appearance*: white or almost white powder.

*Solubility*: very slightly or slightly soluble in water, freely soluble in anhydrous ethanol and in methanol, slightly soluble in acetone.

#### IDENTIFICATION

A. Infrared absorption spectrophotometry (2.2.24).

*Comparison*: terbinafine hydrochloride CRS.

B. It gives reaction (a) of chlorides (2.3.1) using *anhydrous ethanol R* as solvent.

#### TESTS

**Related substances.** Liquid chromatography (2.2.29). Carry out the test protected from light.

*Solvent mixture A*: acetonitrile R, water R (50:50 V/V).

*Solvent mixture B*: acetonitrile R, methanol R (40:60 V/V).

*Buffer solution.* Dilute 2.0 mL of triethylamine R1 to 950 mL with water R. Adjust to pH 7.5 with a mixture of 5 volumes of glacial acetic acid R and 95 volumes of water R and dilute to 1000.0 mL with water R.

*Test solution.* Dissolve 25 mg of the substance to be examined in solvent mixture A and dilute to 50.0 mL with solvent mixture A.

*Reference solution (a).* Dissolve 5 mg of terbinafine for system suitability CRS (containing impurities B and E) in 10.0 mL of solvent mixture A.

*Reference solution (b).* Dilute 1.0 mL of the test solution to 100.0 mL with solvent mixture A. Dilute 1.0 mL of this solution to 10.0 mL with solvent mixture A.

*Column*:

- size:  $l = 0.15$  m,  $\varnothing = 3.0$  mm;
- stationary phase: spherical end-capped octadecylsilyl silica gel for chromatography R (5  $\mu$ m);
- temperature: 40 °C.

*Mobile phase*:

- mobile phase A: buffer solution, solvent mixture B (30:70 V/V);

- mobile phase B: buffer solution, solvent mixture B (5:95 V/V);

Time (min)	Mobile phase A (per cent V/V)	Mobile phase B (per cent V/V)
0 - 4	100	0
4 - 25	100 → 0	0 → 100
25 - 30	0	100

*Flow rate*: 0.8 mL/min.

*Detection*: spectrophotometer at 280 nm.

*Injection*: 20  $\mu$ L.

*Identification of impurities*: use the chromatogram supplied with terbinafine for system suitability CRS and the chromatogram obtained with reference solution (a) to identify the peaks due to impurities B and E.

*Relative retention* with reference to terbinafine (retention time = about 15 min): impurity B = about 0.9; impurity E = about 1.7.

*System suitability*: reference solution (a):

- resolution: minimum 2.0 between the peaks due to impurity B and terbinafine.

*Limits*:

- correction factor: for the calculation of content, multiply the peak area of impurity E by 0.5;
- impurity B: not more than 1.5 times the area of the principal peak in the chromatogram obtained with reference solution (b) (0.15 per cent);
- impurity E: not more than 0.5 times the area of the principal peak in the chromatogram obtained with reference solution (b) (0.05 per cent);
- unspecified impurities: for each impurity, not more than the area of the principal peak in the chromatogram obtained with reference solution (b) (0.10 per cent);
- total: not more than 3 times the area of the principal peak in the chromatogram obtained with reference solution (b) (0.3 per cent);
- disregard limit: 0.5 times the area of the principal peak in the chromatogram obtained with reference solution (b) (0.05 per cent).

**Loss on drying** (2.2.32): maximum 0.5 per cent, determined on 1.000 g by drying in an oven at 105 °C.

**Sulfated ash** (2.4.14): maximum 0.1 per cent, determined on 1.0 g.

#### ASSAY

Dissolve 0.250 g in 50 mL of ethanol (96 per cent) R, add 5 mL of 0.01 M hydrochloric acid. Titrate with 0.1 M sodium hydroxide determining the end-point potentiometrically (2.2.20). Read the volume added between the 2 points of inflexion.

1 mL of 0.1 M sodium hydroxide is equivalent to 32.79 mg of C<sub>21</sub>H<sub>26</sub>ClN.

#### STORAGE

Protected from light.

#### IMPURITIES

*Specified impurities*: B, E.

*Other detectable impurities* (the following substances would, if present at a sufficient level, be detected by one or other of the tests in the monograph. They are limited by the general acceptance criterion for other/unspecified impurities and/or by the general monograph *Substances for pharmaceutical use* (2034). It is therefore not necessary to identify these impurities for demonstration of compliance. See also 5.10. *Control of impurities in substances for pharmaceutical use*): A, C, D, F.

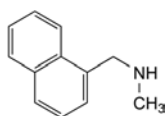
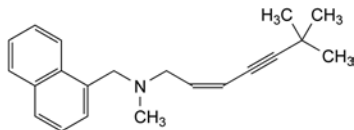
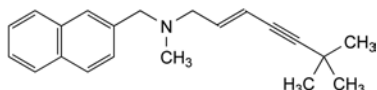
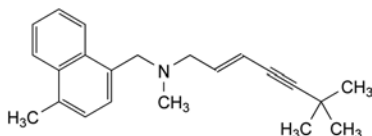
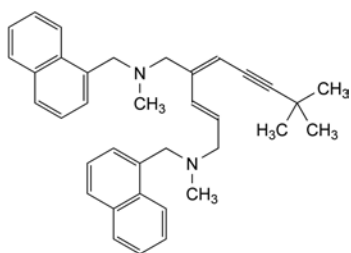
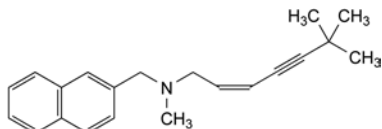
A. *N*-methyl-*N*-(naphthalen-1-yl)methanamine,B. (2*Z*)-*N*,6,6-trimethyl-*N*-(naphthalen-1-ylmethyl)hept-2-en-4-yn-1-amine (*cis*-terbinafine),C. (2*E*)-*N*,6,6-trimethyl-*N*-(naphthalen-2-ylmethyl)hept-2-en-4-yn-1-amine (*trans*-isoterbinafine),D. (2*E*)-*N*,6,6-trimethyl-*N*-[(4-methylnaphthalen-1-yl)methyl]hept-2-en-4-yn-1-amine (4-methylterbinafine),E. (2*E*,4*E*)-4-(4,4-dimethylpent-2-yn-1-ylidene)-*N,N'*-dimethyl-*N,N'*-bis(naphthalen-1-ylmethyl)pent-2-ene-1,5-diamine,F. (2*Z*)-*N*,6,6-trimethyl-*N*-(naphthalen-2-ylmethyl)hept-2-en-4-yn-1-amine (*cis*-isoterbinafine).

**Solubility:** freely soluble in water, slightly soluble in ethanol (96 per cent).

It shows polymorphism (5.9).

## IDENTIFICATION

A. Infrared absorption spectrophotometry (2.2.24).

**Comparison:** *terbutaline sulfate CRS*.

If the spectra obtained in the solid state show differences, dissolve the substance to be examined and the reference substance separately in *aldehyde-free methanol R*, evaporate to dryness and record new spectra using the residues.

B. 5 mL of solution S (see Tests) gives reaction (a) of sulfates (2.3.1).

## TESTS

**Solution S.** Dissolve 1.0 g in *carbon dioxide-free water R* and dilute to 50 mL with the same solvent.

**Appearance of solution.** Solution S is clear (2.2.1) and its absorbance (2.2.25) at 400 nm in a 2 cm cell is not greater than 0.11.

**Acidity.** To 10 mL of solution S add 0.05 mL of *methyl red solution R*. Not more than 1.2 mL of 0.01 M *sodium hydroxide* is required to change the colour of the indicator to yellow.

**Optical rotation** (2.2.7):  $-0.10^{\circ}$  to  $+0.10^{\circ}$ , determined on solution S.

**Related substances.** Liquid chromatography (2.2.29).

**Test solution.** Dissolve 75.0 mg of the substance to be examined in the mobile phase and dilute to 50.0 mL with the mobile phase.

**Reference solution (a).** Dissolve 7.5 mg of *terbutaline impurity C CRS* and 22.5 mg of *terbutaline sulfate CRS* in the mobile phase and dilute to 50.0 mL with the mobile phase. Dilute 1.0 mL of this solution to 100.0 mL with the mobile phase.

**Reference solution (b).** Dilute 1.0 mL of the test solution to 50.0 mL with the mobile phase. Dilute 2.0 mL of this solution to 20.0 mL with the mobile phase.

**Column:**

- size:  $l = 0.15$  m,  $\varnothing = 4.6$  mm;
- stationary phase: *base-deactivated octadecylsilyl silica gel for chromatography R* (5  $\mu$ m).

**Mobile phase:** dissolve 4.23 g of *sodium hexanesulfonate R* in 770 mL of 0.050 M ammonium formate solution prepared as follows: dissolve 3.15 g of *ammonium formate R* in about 980 mL of *water R*; adjust to pH 3.0 by adding about 8 mL of *anhydrous formic acid R* and dilute to 1000 mL with *water R*; then add 230 mL of *methanol R*.

**Flow rate:** 1.0 mL/min.

**Detection:** spectrophotometer at 276 nm.

**Injection:** 20  $\mu$ L.

**Run time:** 6 times the retention time of terbutaline.

**Retention time:** impurity C = about 9 min; terbutaline = about 11 min.

**System suitability:** reference solution (a):

- **resolution:** minimum 2.0 between the peaks due to impurity C and terbutaline; if necessary adjust the composition of the mobile phase, decrease the content of methanol to increase the retention time.

**Limits:**

- **impurity C:** not more than twice the area of the corresponding peak in the chromatogram obtained with reference solution (a) (0.2 per cent);
- **impurities A, B, D:** for each impurity, not more than the area of the principal peak in the chromatogram obtained with reference solution (b) (0.2 per cent);
- **sum of impurities other than C:** not more than twice the area of the principal peak in the chromatogram obtained with reference solution (b) (0.4 per cent);

01/2008:0690  
corrected 6.0

## TERBUTALINE SULFATE

## Terbutalini sulfas

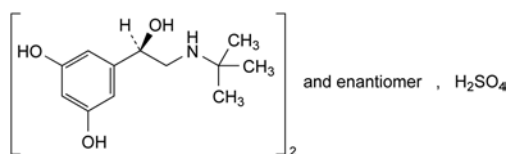

$C_{24}H_{40}N_2O_{10}S$   
[23031-32-5]

$M_r$  548.7

## DEFINITION

Bis[(1*R*S)-1-(3,5-dihydroxyphenyl)-2-[(1,1-dimethylethyl)amino]ethanol] sulfate.

**Content:** 98.0 per cent to 101.0 per cent (dried substance).

## CHARACTERS

**Appearance:** white or almost white, crystalline powder.

– *disregard limit*: 0.1 times the area of the principal peak in the chromatogram obtained with reference solution (b) (0.02 per cent).

**Loss on drying** (2.2.32): maximum 0.5 per cent, determined on 1.000 g by drying in an oven at 105 °C for 3 h.

#### ASSAY

Dissolve 0.400 g in 70 mL of *anhydrous acetic acid R* with heating. Titrate with 0.1 M *perchloric acid*, determining the end-point potentiometrically (2.2.20).

1 mL of 0.1 M *perchloric acid* is equivalent to 54.87 mg of  $C_{24}H_{40}N_2O_{10}S$ .

#### IMPURITIES

*Specified impurities: A, B, C, D.*

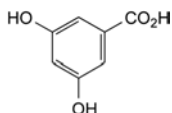

A. 3,5-dihydroxybenzoic acid ( $\alpha$ -resorcylic acid),

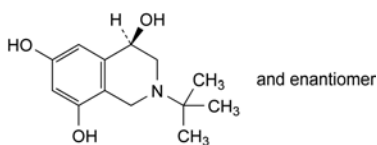

B. (4*RS*)-2-(1,1-dimethylethyl)-1,2,3,4-tetrahydroisoquinoline-4,6,8-triol,

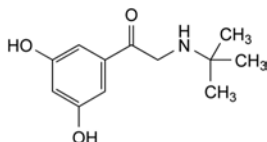

C. 1-(3,5-dihydroxyphenyl)-2-[(1,1-dimethylethyl)amino]ethanone,

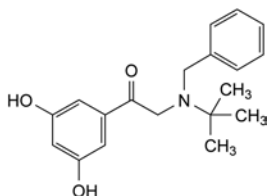

D. 2-[benzyl-(1,1-dimethylethyl)amino]-1-(3,5-dihydroxyphenyl)ethanone.

01/2008:1270  
corrected 6.1

## TERCONAZOLE

### Terconazolium

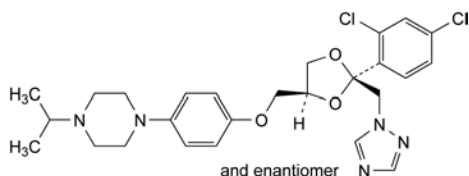

$C_{26}H_{31}Cl_2N_5O_3$   
[67915-31-5]

$M_r$  532.5

#### DEFINITION

1-[4-[(2*RS*,4*SR*)-2-(2,4-Dichlorophenyl)-2-[(1*H*-1,2,4-triazol-1-yl)methyl]-1,3-dioxolan-4-yl]methoxy]phenyl]-4-(1-methylethyl)piperazine.

*Content*: 99.0 per cent to 101.0 per cent (dried substance).

#### CHARACTERS

*Appearance*: white or almost white powder.

*Solubility*: practically insoluble in water, freely soluble in methylene chloride, soluble in acetone, sparingly soluble in ethanol (96 per cent).

It shows polymorphism (5.9).

#### IDENTIFICATION

*First identification: A.*

*Second identification: B, C.*

A. Infrared absorption spectrophotometry (2.2.24).

*Comparison: terconazole CRS.*

If the spectra obtained in the solid state show differences, dissolve the substance to be examined and the reference substance separately in the minimum volume of *acetone R*, evaporate to dryness in a current of air and record new spectra using the residues.

B. Thin-layer chromatography (2.2.27).

*Test solution.* Dissolve 30 mg of the substance to be examined in *methanol R* and dilute to 5 mL with the same solvent.

*Reference solution (a).* Dissolve 30 mg of *terconazole CRS* in *methanol R* and dilute to 5 mL with the same solvent.

*Reference solution (b).* Dissolve 30 mg of *terconazole CRS* and 30 mg of *ketoconazole CRS* in *methanol R* and dilute to 5 mL with the same solvent.

*Plate: TLC octadecylsilyl silica gel plate R.*

*Mobile phase: ammonium acetate solution R, dioxan R, methanol R* (20:40:40 V/V/V).

*Application: 5 µL.*

*Development: in an unsaturated tank over a path of 10 cm.*

*Drying: in a current of warm air for 15 min.*

*Detection: expose to iodine vapour until the spots appear and examine in daylight.*

*System suitability: reference solution (b):*

– the chromatogram shows 2 clearly separated spots.

*Results: the principal spot in the chromatogram obtained with the test solution is similar in position, colour and size to the principal spot in the chromatogram obtained with reference solution (a).*

C. To 30 mg in a porcelain crucible add 0.3 g of *anhydrous sodium carbonate R*. Heat over an open flame for 10 min. Allow to cool. Take up the residue with 5 mL of *dilute nitric acid R* and filter. To 1 mL of the filtrate add 1 mL of *water R*. The solution gives reaction (a) of chlorides (2.3.1).

#### TESTS

**Optical rotation** (2.2.7):  $-0.10^\circ$  to  $+0.10^\circ$ .

Dissolve 1.0 g in *methylene chloride R* and dilute to 10 mL with the same solvent.

**Related substances.** Liquid chromatography (2.2.29).

*Test solution.* Dissolve 0.100 g of the substance to be examined in *methanol R* and dilute to 10.0 mL with the same solvent.

*Reference solution (a).* Dissolve 2.5 mg of *terconazole CRS* and 2.0 mg of *ketoconazole CRS* in *methanol R* and dilute to 100.0 mL with the same solvent.

*Reference solution (b).* Dilute 1.0 mL of the test solution to 100.0 mL with *methanol R*. Dilute 5.0 mL of this solution to 20.0 mL with *methanol R*.

*Column:*

– *size: l* = 0.1 m,  $\varnothing$  = 4.6 mm;

– *stationary phase: base-deactivated octadecylsilyl silica gel for chromatography R* (3 µm).

*Mobile phase:*

– *mobile phase A: 3.4 g/L solution of tetrabutylammonium hydrogen sulfate R;*

– mobile phase B: acetonitrile R1;

01/2008:0955  
corrected 6.1

Time (min)	Mobile phase A (per cent V/V)	Mobile phase B (per cent V/V)
0 - 10	95 → 50	5 → 50
10 - 15	50	50

Flow rate: 2 mL/min.

Detection: spectrophotometer at 220 nm.

Equilibration: with acetonitrile R1 for at least 30 min and then with the mobile phase at the initial composition for at least 5 min.

Injection: 10 µL; inject methanol R as a blank.

Retention time: ketoconazole = about 6 min; terconazole = about 7.5 min.

System suitability: reference solution (a):

- resolution: minimum 13 between the peaks due to ketoconazole and terconazole; if necessary, adjust the concentration of acetonitrile in the mobile phase or adjust the time programme for the linear gradient elution.

Limits:

- impurities A, B: for each impurity, not more than the area of the principal peak in the chromatogram obtained with reference solution (b) (0.25 per cent);
- total: not more than twice the area of the principal peak in the chromatogram obtained with reference solution (b) (0.5 per cent);
- disregard limit: 0.2 times the area of the principal peak in the chromatogram obtained with reference solution (b) (0.05 per cent).

Loss on drying (2.2.32): maximum 0.5 per cent, determined on 1.000 g by drying in an oven at 105 °C.

Sulfated ash (2.4.14): maximum 0.1 per cent, determined on 1.0 g.

#### ASSAY

Dissolve 0.150 g in 70 mL of a mixture of 1 volume of anhydrous acetic acid R and 7 volumes of methyl ethyl ketone R. Titrate with 0.1 M perchloric acid, determining the end-point potentiometrically at the 2<sup>nd</sup> point of inflexion (2.2.20).

1 mL of 0.1 M perchloric acid is equivalent to 17.75 mg of C<sub>26</sub>H<sub>31</sub>Cl<sub>2</sub>N<sub>5</sub>O<sub>3</sub>.

#### STORAGE

Protected from light.

#### IMPURITIES

Specified impurities: A, B.

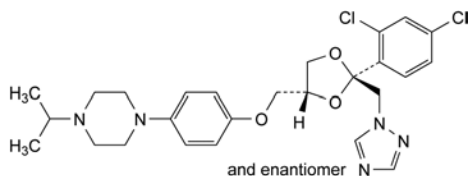

- A. 1-[4-[[[(2RS,4RS)-2-(2,4-dichlorophenyl)-2-[(1H-1,2,4-triazol-1-yl)methyl]-1,3-dioxolan-4-yl]methoxy]phenyl]-4-(1-methylethyl)piperazine,

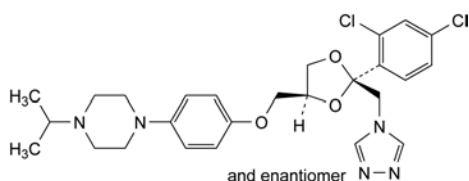

- B. 1-[4-[[[(2RS,4SR)-2-(2,4-dichlorophenyl)-2-[(4H-1,2,4-triazol-4-yl)methyl]-1,3-dioxolan-4-yl]methoxy]phenyl]-4-(1-methylethyl)piperazine.

## TERFENADINE

### Terfenadinum

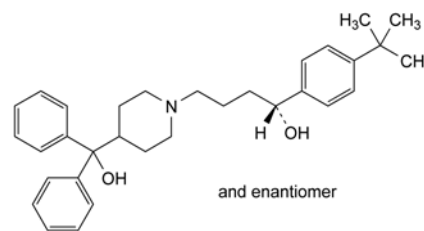

C<sub>32</sub>H<sub>41</sub>NO<sub>2</sub>  
[50679-08-8]

M<sub>r</sub> 471.7

#### DEFINITION

(1RS)-1-[4-(1,1-Dimethylethyl)phenyl]-4-[4-(hydroxy-diphenylmethyl)piperidin-1-yl]butan-1-ol.

Content: 98.5 per cent to 101.0 per cent (dried substance).

#### CHARACTERS

Appearance: white or almost white, crystalline powder.

Solubility: very slightly soluble in water, freely soluble in methylene chloride, soluble in methanol. It is very slightly soluble in dilute hydrochloric acid.

It shows polymorphism (5.9).

#### IDENTIFICATION

First identification: C.

Second identification: A, B, D.

A. Melting point (2.2.14): 146 °C to 152 °C.

B. Ultraviolet and visible absorption spectrophotometry (2.2.25).

Test solution. Dissolve 50.0 mg in methanol R and dilute to 100.0 mL with the same solvent.

Spectral range: 230-350 nm.

Absorption maximum: at 259 nm.

Shoulders: at 253 nm and 270 nm.

Specific absorbance at the absorption maximum: 13.5 to 14.9.

C. Infrared absorption spectrophotometry (2.2.24).

Comparison: terfenadine CRS.

D. Thin-layer chromatography (2.2.27).

Test solution. Dissolve 50 mg of the substance to be examined in methylene chloride R and dilute to 10 mL with the same solvent.

Reference solution. Dissolve 50 mg of terfenadine CRS in methylene chloride R and dilute to 10 mL with the same solvent.

Plate: TLC silica gel F<sub>254</sub> plate R.

Mobile phase: methanol R, methylene chloride R (10:90 V/V).

Application: 10 µL.

Development: over a path of 15 cm.

Drying: in air.

Detection: examine in ultraviolet light at 254 nm.

Results: the principal spot in the chromatogram obtained with the test solution is similar in position and size to the principal spot in the chromatogram obtained with the reference solution.



## TESTS

**Related substances.** Liquid chromatography (2.2.29).

**Test solution.** Dissolve 15 mg of the substance to be examined in the mobile phase and dilute to 10.0 mL with the mobile phase.

**Reference solution (a).** Dilute 1.0 mL of the test solution to 10.0 mL with the mobile phase. Dilute 1.0 mL of this solution to 20.0 mL with the mobile phase.

**Reference solution (b).** Dissolve 15 mg of *terfenadine impurity A CRS* in the mobile phase and dilute to 10.0 mL with the mobile phase. To 5.0 mL of this solution, add 5.0 mL of the test solution and dilute to 50.0 mL with the mobile phase.

**Reference solution (c).** Dilute 10.0 mL of reference solution (a) to 25.0 mL with the mobile phase.

**Reference solution (d).** Dissolve 0.1 g of *potassium iodide R* in the mobile phase and dilute to 100 mL with the mobile phase. Dilute 1 mL of this solution to 100 mL with the mobile phase.

**Column:**

- size:  $l = 0.25$  m,  $\varnothing = 4.6$  mm;
- stationary phase: octylsilyl silica gel for chromatography R (5  $\mu$ m).

**Mobile phase:** dilute 600 mL of acetonitrile R1 to 1 L with diethylammonium phosphate buffer solution pH 6.0 R.

**Flow rate:** 1 mL/min.

**Detection:** spectrophotometer at 217 nm.

**Injection:** 20  $\mu$ L.

**Run time:** 5 times the retention time of terfenadine.

**System suitability:** reference solution (b):

- resolution: minimum 5.0 between the peaks due to terfenadine and impurity A;
- mass distribution ratio: minimum 2.0 for the peak due to terfenadine; use *potassium iodide R* as the unretained compound (reference solution (d)).

**Limits:**

- impurities A, B, C, D, E, F, G, H, I, J: for each impurity, not more than the area of the principal peak in the chromatogram obtained with reference solution (c) (0.2 per cent);
- total: not more than the area of the principal peak in the chromatogram obtained with reference solution (a) (0.5 per cent);
- disregard limit: 0.025 times the area of the principal peak in the chromatogram obtained with reference solution (c) (0.005 per cent).

**Loss on drying (2.2.32):** maximum 0.5 per cent, determined on 1.000 g by drying at 60 °C at a pressure not exceeding 0.5 kPa.

**Sulfated ash (2.4.14):** maximum 0.1 per cent, determined on 1.0 g.

## ASSAY

Dissolve 0.400 g in 50 mL of *anhydrous acetic acid R*. Titrate with 0.1 M *perchloric acid*, determining the end-point potentiometrically (2.2.20).

1 mL of 0.1 M *perchloric acid* is equivalent to 47.17 mg of  $C_{32}H_{41}NO_2$ .

## STORAGE

Protected from light.

## IMPURITIES

**Specified impurities:** A, B, C, D, E, F, G, H, I, J.

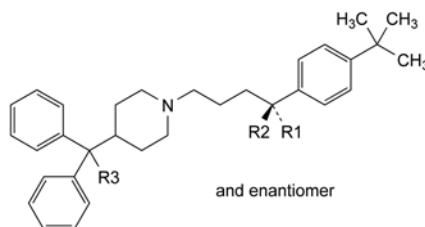

- A.  $R_1 + R_2 = O$ ,  $R_3 = OH$ : 1-[4-(1,1-dimethylethyl)phenyl]-4-[4-(hydroxydiphenylmethyl)piperidin-1-yl]butan-1-one,
- B.  $R_1 = OH$ ,  $R_2 = R_3 = H$ : (1*RS*)-1-[4-(1,1-dimethylethyl)phenyl]-4-[4-(diphenylmethyl)piperidin-1-yl]butan-1-ol,
- H.  $R_1 = R_2 = H$ ,  $R_3 = OH$ : [1-[4-[4-(1,1-dimethylethyl)phenyl]butyl]piperidin-4-yl]diphenylmethanol,

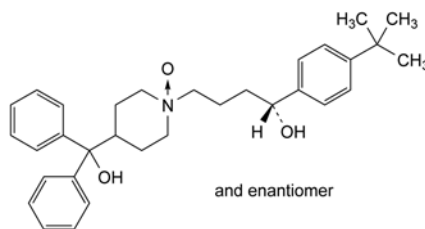

- C. 1-[(4*RS*)-4-[4-(1,1-dimethylethyl)phenyl]-4-hydroxybutyl]-4-(hydroxydiphenylmethyl)piperidine 1-oxide,

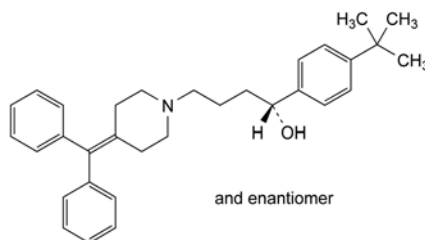

- D. (1*RS*)-1-[4-(1,1-dimethylethyl)phenyl]-4-[4-(diphenylmethylene)piperidin-1-yl]butan-1-ol,

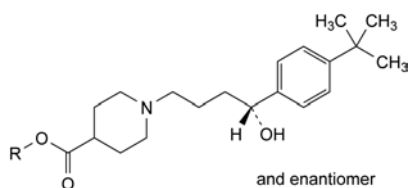

- E.  $R = H$ : 1-[(4*RS*)-4-[4-(1,1-dimethylethyl)phenyl]-4-hydroxybutyl]piperidine-4-carboxylic acid,

- J.  $R = C_2H_5$ : ethyl 1-[(4*RS*)-4-[4-(1,1-dimethylethyl)phenyl]-4-hydroxybutyl]piperidine-4-carboxylate,

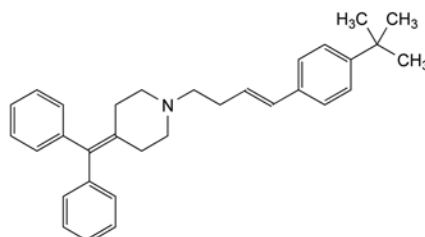

- F. 1-[4-[4-(1,1-dimethylethyl)phenyl]but-3-enyl]-4-(diphenylmethylene)piperidine,

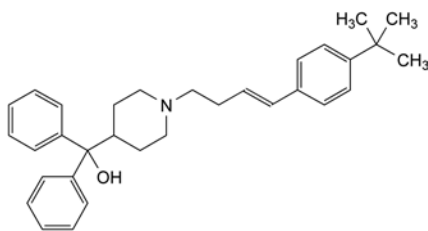

G. [1-[4-[4-(1,1-dimethylethyl)phenyl]but-3-enyl]piperidin-4-yl]diphenylmethanol,

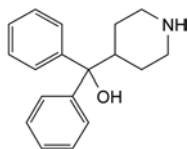

I. diphenyl(piperidin-4-yl)methanol.

01/2008:1373  
corrected 7.0

## TESTOSTERONE

### Testosteronum

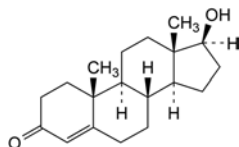

C<sub>19</sub>H<sub>28</sub>O<sub>2</sub>  
[58-22-0]

M<sub>r</sub> 288.4

#### DEFINITION

17β-Hydroxyandrost-4-en-3-one.

Content: 97.0 per cent to 103.0 per cent (dried substance).

#### CHARACTERS

Appearance: white or almost white crystalline powder, or colourless or yellowish-white crystals.

Solubility: practically insoluble in water, freely soluble in alcohol and in methylene chloride, practically insoluble in fatty oils.

mp: about 155 °C.

#### IDENTIFICATION

Infrared absorption spectrophotometry (2.2.24).

Comparison: testosterone CRS.

#### TESTS

Specific optical rotation (2.2.7): + 106 to + 114 (dried substance).

Dissolve 0.250 g in ethanol R and dilute to 25.0 mL with the same solvent.

Impurities D and F. Thin-layer chromatography (2.2.27).

Test solution. Dissolve 0.100 g of the substance to be examined in methanol R and dilute to 10 mL with the same solvent.

Reference solution (a). Dissolve 1 mg of stanolone R in methanol R and dilute to 10 mL with the same solvent. In 1 mL of this solution, dissolve 10 mg of testosterone for impurity D identification CRS (testosterone spiked with about 1 per cent of impurity D).

Reference solution (b). Dilute 1.0 mL of the test solution to 100.0 mL with methanol R.

Reference solution (c). Dilute 2.0 mL of reference solution (b) to 10.0 mL with methanol R.

Reference solution (d). Dilute 1.0 mL of reference solution (b) to 10.0 mL with methanol R.

Plate: TLC silica gel F<sub>254</sub> plate R (6-8 μm).

Preconditioning (in the dark): add about 5 g of powdered silver nitrate R to 100 mL of methanol R. Stir the suspension for 30 min. Filter or decant the suspension and immerse the plate in the silver nitrate solution for at least 30 min. Dry at 75 °C for 30 min.

A pre-conditioned plate can be stored in the dark for 5-7 days.

Mobile phase: acetic acid R, ethanol R, dioxan R, methylene chloride R (1:2:10:90 V/V/V/V).

Application: 2 μL.

Development: in a saturated tank over 3/4 of the plate.

Drying: allow to stand at room temperature and protected from light for 30 min.

Detection: spray with a 200 g/L solution of toluenesulfonic acid R in ethanol R and heat at 105 °C for 10 min. Examine in ultraviolet light at 365 nm.

System suitability: the chromatogram obtained with reference solution (a) shows 3 clearly separated spots; impurity D R<sub>F</sub> = about 0.5; testosterone R<sub>F</sub> = about 0.65; impurity F R<sub>F</sub> = about 0.7.

Limits:

- impurity D: any spot due to impurity D is not more intense than the spot in the chromatogram obtained with reference solution (c) (0.2 per cent),
- impurity F: any spot due to impurity F is not more intense than the spot in the chromatogram obtained with reference solution (d) (0.1 per cent).

Related substances. Liquid chromatography (2.2.29).

Test solution. Dissolve 0.100 g of the substance to be examined in methanol R and dilute to 10.0 mL with the same solvent.

Reference solution (a). Dissolve 10 mg of testosterone for system suitability CRS (containing impurities C and I) in 1 mL of methanol R.

Reference solution (b). Dilute 1.0 mL of the test solution to 20.0 mL with methanol R. Dilute 1.0 mL of this solution to 10.0 mL with methanol R.

Reference solution (c). Dilute 2.0 mL of reference solution (b) to 10.0 mL with methanol R.

Column:

- size: l = 0.25 m, Ø = 4.6 mm,
- stationary phase: spherical end-capped octadecylsilyl silica gel for chromatography R (5 μm) with a pore size of 15 nm,
- temperature: 40 °C.

Mobile phase:

- mobile phase A: water for chromatography R, methanol R (45:55 V/V),
- mobile phase B: methanol R,

Time (min)	Mobile phase A (per cent V/V)	Mobile phase B (per cent V/V)
0 - 4	100	0
4 - 24	100 → 60	0 → 40
24 - 53	60 → 0	40 → 100
53 - 55	0	100

Flow rate: 1.0 mL/min.

Detection: spectrophotometer at 254 nm.

Injection: 20 μL.

Relative retention with reference to testosterone (retention time = about 18 min): impurity G = about 0.6; impurity H = about 0.8; impurity A = about 0.9; impurity I = about 0.95; impurity C = about 1.2; impurity E = about 1.7; impurity J = about 2.1; impurity B = about 2.5.

*System suitability*: reference solution (a):

- *resolution*: minimum baseline separation between the peaks due to impurity I and testosterone.

*Limits*: use the chromatogram obtained with reference solution (a) to identify the peaks due to impurities C and I:

- *correction factor*: for the calculation of content, multiply the peak area of impurity I by 2.9,
- *impurity C*: not more than the area of the principal peak in the chromatogram obtained with reference solution (b) (0.5 per cent),
- *impurity I*: not more than twice the area of the principal peak in the chromatogram obtained with reference solution (c) (0.2 per cent),
- *impurities A, B, E, G, H, J*: for each impurity, not more than the area of the principal peak in the chromatogram obtained with reference solution (c) (0.1 per cent),
- *any other impurity*: for each impurity, not more than the area of the principal peak in the chromatogram obtained with reference solution (c) (0.1 per cent),
- *total*: not more than 1.2 times the area of the principal peak in the chromatogram obtained with reference solution (b) (0.6 per cent),
- *disregard limit*: 0.5 times the area of the principal peak in the chromatogram obtained with reference solution (c) (0.05 per cent).

**Loss on drying** (2.2.32): maximum 1.0 per cent, determined on 0.500 g by drying in an oven at 105 °C for 2 h.

#### ASSAY

Dissolve 50.0 mg in *alcohol R* and dilute to 100.0 mL with the same solvent. Dilute 2.0 mL to 100.0 mL with *alcohol R*. Measure the absorbance (2.2.25) at the absorption maximum at 241 nm.

Calculate the content of  $C_{19}H_{28}O_2$  taking the specific absorbance to be 569.

#### STORAGE

Protected from light.

#### IMPURITIES

*Specified impurities*: A, B, C, D, E, F, G, H, I, J.

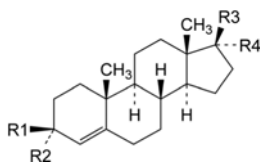

- A.  $R_1 + R_2 = R_3 + R_4 = O$ : androst-4-ene-3,17-dione (androstenedione),
- C.  $R_1 + R_2 = O$ ,  $R_3 = H$ ,  $R_4 = OH$ :  $17\alpha$ -hydroxyandrost-4-en-3-one (epitestosterone),
- D.  $R_1 = R_3 = OH$ ,  $R_2 = R_4 = H$ : androst-4-ene- $3\beta$ , $17\beta$ -diol ( $\Delta^4$ -androstenediol),
- E.  $R_1 + R_2 = O$ ,  $R_3 = O-CO-CH_3$ ,  $R_4 = H$ : 3-oxoandrost-4-en- $17\beta$ -yl acetate (testosterone acetate),

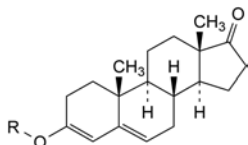

- B.  $R = C_2H_5$ : 3-ethoxyandrost-4,5-dien-17-one (androstenedione ethyleneoether),
- J.  $R = CH_3$ : 3-methoxyandrost-4,5-dien-17-one (androstenedione methyleneoether),

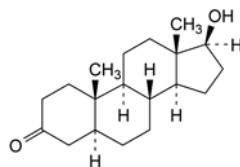

- F.  $17\beta$ -hydroxy- $5\alpha$ -androstan-3-one (androstanolone, stanolone),

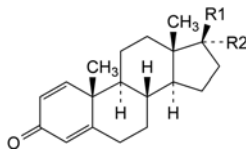

- G.  $R_1 + R_2 = O$ : androsta-1,4-diene-3,17-dione (androstadienedione).

- H.  $R_1 = OH$ ,  $R_2 = H$ :  $17\beta$ -hydroxyandrosta-1,4-dien-3-one (boldenone),

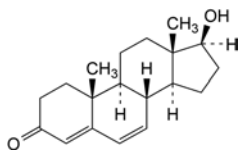

- I.  $17\beta$ -hydroxyandrosta-4,6-dien-3-one ( $\Delta^6$ -testosterone).

01/2008:1736

## TESTOSTERONE DECANOATE

### Testosteroni decanoas

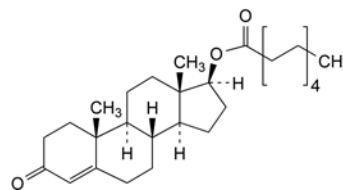

$C_{29}H_{46}O_3$

$M_r$  442.7

#### DEFINITION

3-Oxoandrost-4-en- $17\beta$ -yl decanoate.

*Content*: 97.0 per cent to 102.0 per cent (dried substance).

#### CHARACTERS

*Appearance*: white or almost white powder.

*Solubility*: practically insoluble in water, very soluble in acetone, in methylene chloride and in anhydrous ethanol, freely soluble in fatty oils.

#### IDENTIFICATION

- A. Infrared absorption spectrophotometry (2.2.24).

*Comparison*: testosterone decanoate CRS.

- B. Examine the chromatograms obtained in the assay.

*Results*: the principal peak in the chromatogram obtained with the test solution is similar in retention time and size to the principal peak in the chromatogram obtained with reference solution (c).

#### TESTS

**Appearance of solution.** The solution is clear (2.2.1) and not more intensely coloured than reference solution BY<sub>6</sub> (2.2.2, Method II).

Dissolve 0.20 g in 20 mL of *methanol R*.

**Specific optical rotation** (2.2.7): + 75.0 to + 80.0 (dried substance).

Dissolve 0.200 g in *anhydrous ethanol R* and dilute to 20.0 mL with the same solvent.

**Related substances.** Liquid chromatography (2.2.29).

**Test solution.** Dissolve 20.0 mg of the substance to be examined in the mobile phase and dilute to 50.0 mL with the mobile phase.

**Reference solution (a).** Dissolve the contents of a vial of *testosterone decanoate for system suitability CRS* (containing impurities A, B, C, D, E and F) in 1 mL of the mobile phase.

**Reference solution (b).** Dilute 10.0 mL of the test solution to 100.0 mL with the mobile phase. Dilute 1.0 mL of this solution to 20.0 mL with the mobile phase.

**Reference solution (c).** Dissolve 20.0 mg of *testosterone decanoate CRS* in the mobile phase and dilute to 50.0 mL with the mobile phase.

**Column:**

- size:  $l = 0.25$  m,  $\varnothing = 4.6$  mm;
- stationary phase: end-capped octadecylsilyl silica gel for chromatography R (5  $\mu$ m);
- temperature: 40 °C.

**Mobile phase:** water R, acetonitrile R (5:95 V/V).

**Flow rate:** 1.0 mL/min.

**Detection:** spectrophotometer at 240 nm.

**Injection:** 20  $\mu$ L of the test solution and reference solutions (a) and (b).

**Run time:** twice the retention time of testosterone decanoate.

**Identification of impurities:** use the chromatogram supplied with *testosterone decanoate for system suitability CRS* and the chromatogram obtained with reference solution (a) to identify the peaks due to impurities A, B, C, D, E and F.

**Relative retention** with reference to testosterone decanoate (retention time = about 20 min): impurity A = about 0.2; impurity B = about 0.6; impurities C and G = about 0.79; impurity D = about 0.83; impurity E = about 1.3; impurity F = about 1.7.

**System suitability:** reference solution (a):

- resolution: minimum 1.5 between the peaks due to impurities C and D.

**Limits:**

- correction factors: for the calculation of content, multiply the peak area of impurity A by 0.7;
- impurities A, B, D, E, F: for each impurity, not more than the area of the principal peak in the chromatogram obtained with reference solution (b) (0.5 per cent);
- sum of impurities C and G: not more than the area of the principal peak in the chromatogram obtained with reference solution (b) (0.5 per cent);
- unspecified impurities: for each impurity, not more than 0.2 times the area of the principal peak in the chromatogram obtained with reference solution (b) (0.10 per cent);
- total: not more than twice the area of the principal peak in the chromatogram obtained with reference solution (b) (1.0 per cent);
- disregard limit: 0.1 times the area of the principal peak in the chromatogram obtained with reference solution (b) (0.05 per cent).

**Free acid.** Dissolve 0.65 g in 10 mL of *ethanol (96 per cent) R*, previously neutralised to *bromothymol blue solution R3*, and titrate immediately with 0.01 M sodium hydroxide, using 0.1 mL of *bromothymol blue solution R3* as indicator. Not more than 0.6 mL of 0.01 M sodium hydroxide is required to change the colour of the indicator to blue.

**Loss on drying (2.2.32):** maximum 0.5 per cent, determined on 1.000 g over *diphosphorus pentoxide R* at a pressure not exceeding 0.7 kPa.

**ASSAY**

Liquid chromatography (2.2.29) as described in the test for related substances with the following modification.

**Injection:** 20  $\mu$ L of the test solution and reference solution (c).

Calculate the percentage content of  $C_{29}H_{46}O_3$  from the declared content of *testosterone decanoate CRS*.

**STORAGE**

At a temperature of 2 °C to 8 °C.

**IMPURITIES**

**Specified impurities:** A, B, C, D, E, F, G.

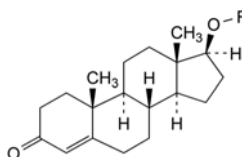

- A. R = H: testosterone,  
 B. R = CO-[CH<sub>2</sub>]<sub>6</sub>-CH<sub>3</sub>: 3-oxoandrost-4-en-17 $\beta$ -yl octanoate (testosterone octanoate),  
 C. R = CO-[CH<sub>2</sub>]<sub>7</sub>-CH<sub>3</sub>: 3-oxoandrost-4-en-17 $\beta$ -yl nonanoate (testosterone nonanoate),  
 D. R = CO-[CH<sub>2</sub>]<sub>8</sub>-CH=CH<sub>2</sub>: 3-oxoandrost-4-en-17 $\beta$ -yl undec-10-enoate (testosterone undecylenate),  
 E. R = CO-[CH<sub>2</sub>]<sub>9</sub>-CH<sub>3</sub>: 3-oxoandrost-4-en-17 $\beta$ -yl undecanoate (testosterone undecanoate),  
 F. R = CO-[CH<sub>2</sub>]<sub>10</sub>-CH<sub>3</sub>: 3-oxoandrost-4-en-17 $\beta$ -yl dodecanoate (testosterone laurate),

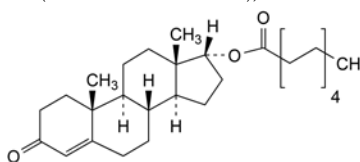

- G. 3-oxoandrost-4-en-17 $\alpha$ -yl decanoate (epitestosterone decanoate).

01/2008:1048

## TESTOSTERONE ENANTATE

### Testosteroni enantas

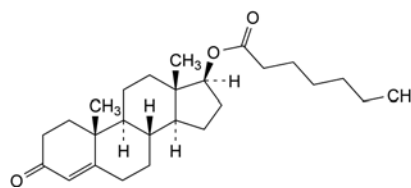

$C_{26}H_{40}O_3$   
[315-37-7]

$M_r$  400.6

**DEFINITION**

3-Oxoandrost-4-en-17 $\beta$ -yl heptanoate.

**Content:** 97.0 per cent to 103.0 per cent (dried substance).

**CHARACTERS**

**Appearance:** white or yellowish-white, crystalline powder.

**Solubility:** practically insoluble in water, very soluble in anhydrous ethanol, freely soluble in fatty oils.

**IDENTIFICATION**

**First identification:** B.

**Second identification:** A, C, D.

- A. Melting point (2.2.14): 34 °C to 39 °C.  
 B. Infrared absorption spectrophotometry (2.2.24).  
*Comparison:* testosterone enantate CRS.

C. Thin-layer chromatography (2.2.27).

*Solvent mixture:* methanol R, methylene chloride R (10:90 V/V).

**Test solution.** Dissolve 5 mg of the substance to be examined in the solvent mixture and dilute to 10 mL with the solvent mixture.

**Reference solution (a).** Dissolve 5 mg of *testosterone enantate CRS* in the solvent mixture and dilute to 10 mL with the solvent mixture.

**Reference solution (b).** Dissolve 5 mg of *testosterone enantate CRS*, 5 mg of *testosterone decanoate CRS* and 5 mg of *testosterone isocaproate CRS* in the solvent mixture and dilute to 10 mL with the solvent mixture.

**Plate:** TLC octadecylsilyl silica gel  $F_{254}$  plate R.

**Mobile phase:** water R, acetonitrile R, 2-propanol R (20:40:60 V/V/V).

**Application:** 5  $\mu$ L.

**Development:** over a path of 15 cm.

**Drying:** in air, then at 100 °C for 10 min; allow to cool.

**Detection A:** examine in ultraviolet light at 254 nm.

**Results A:** the principal spot in the chromatogram obtained with the test solution is similar in position and size to the principal spot in the chromatogram obtained with reference solution (a).

**Detection B:** spray with alcoholic solution of sulfuric acid R; heat at 120 °C for 10 min; allow to cool and examine in daylight.

**Results B:** the principal spot in the chromatogram obtained with the test solution is green and is similar in position and size to the principal spot in the chromatogram obtained with reference solution (a).

**System suitability:** reference solution (b):

- the chromatogram shows 3 clearly separated principal spots by each method of visualisation.

- D. To about 25 mg add 2 mL of a 10 g/L solution of *potassium hydroxide R* in *methanol R* and boil under a reflux condenser for 1 h. Cool. Add 10 mL of *water R*. Acidify with dilute hydrochloric acid R until blue litmus paper R turns red. Filter and wash the precipitate with a small quantity of *water R*. The residue, after drying at 60 °C at a pressure not exceeding 0.7 kPa for 3 h, melts (2.2.14) at 150 °C to 153 °C.

## TESTS

**Specific optical rotation (2.2.7):** + 77 to + 82 (dried substance).

Dissolve 0.250 g in *dioxan R* and dilute to 25.0 mL with the same solvent.

**Impurity A:** maximum 0.16 per cent.

Dissolve 0.50 g in 10 mL of *ethanol (96 per cent) R* previously neutralised to *bromothymol blue solution R3*. Titrate immediately with 0.01 M *sodium hydroxide*. Not more than 0.6 mL of 0.01 M *sodium hydroxide* is required to change the colour of the indicator to blue.

**Impurities C and D.** Thin-layer chromatography (2.2.27).

**Solvent mixture:** *methanol R*, *methylene chloride R* (10:90 V/V).

**Test solution.** Dissolve 0.20 g of the substance to be examined in the solvent mixture and dilute to 10 mL with the solvent mixture.

**Reference solution (a).** Dilute 1 mL of the test solution to 100 mL with the solvent mixture.

**Reference solution (b).** Dissolve 20 mg of *testosterone propionate CRS* in the solvent mixture, add 1 mL of the test solution and dilute to 100 mL with the solvent mixture.

**Plate:** TLC silica gel G plate R.

**Mobile phase:** *ethyl acetate R*, *toluene R* (20:80 V/V).

**Application:** 5  $\mu$ L.

**Development:** over a path of 15 cm.

**Drying:** in air.

**Detection:** spray with alcoholic solution of sulfuric acid R and heat at 120 °C for 10 min.

**System suitability:** reference solution (b):

- the chromatogram shows 2 clearly separated principal spots.

**Limit:**

- *impurities C, D:* any spot, apart from the principal spot, is not more intense than the principal spot in the chromatogram obtained with reference solution (a) (1.0 per cent).

**Impurity B.** Liquid chromatography (2.2.29).

**Test solution.** Dissolve 50.0 mg of the substance to be examined in the mobile phase and dilute to 50.0 mL with the mobile phase.

**Reference solution (a).** Dissolve 10.0 mg of *testosterone caproate CRS* (impurity B) in the mobile phase and dilute to 20.0 mL with the mobile phase. Dilute 1.0 mL of this solution to 50.0 mL with the mobile phase.

**Reference solution (b).** Dilute 1.0 mL of the test solution to 100.0 mL with the mobile phase. To 1 mL of this solution add 1 mL of reference solution (a).

**Column:**

- *size:*  $l = 0.12$  m,  $\varnothing = 4$  mm;
- *stationary phase:* octadecylsilyl silica gel for chromatography R (5  $\mu$ m).

**Mobile phase:** *water R*, *acetonitrile R* (30:70 V/V).

**Flow rate:** 1.0 mL/min.

**Detection:** spectrophotometer at 240 nm.

**Injection:** 20  $\mu$ L.

**System suitability:** reference solution (b):

- *relative retention* with reference to testosterone enantate: impurity B = about 0.7.

**Limit:**

- *impurity B:* not more than the area of the corresponding peak in the chromatogram obtained with reference solution (a) (1.0 per cent).

**Loss on drying (2.2.32):** maximum 0.5 per cent, determined on 1.000 g by drying in a desiccator over *diphosphorus pentoxide R* at a pressure not exceeding 0.7 kPa.

## ASSAY

Dissolve 50.0 mg in *anhydrous ethanol R* and dilute to 100.0 mL with the same solvent. Dilute 2.0 mL of this solution to 100.0 mL with *anhydrous ethanol R*. Measure the absorbance (2.2.25) at the absorption maximum at 241 nm.

Calculate the content of  $C_{26}H_{40}O_3$  taking the specific absorbance to be 422.

## STORAGE

Protected from light, at a temperature of 2 °C to 8 °C.

## IMPURITIES

**Specified impurities:** A, B, C, D.



A. heptanoic acid,

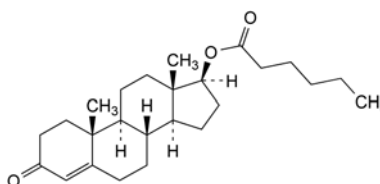

B. 3-oxoandrost-4-en-17 $\beta$ -yl hexanoate (testosterone caproate),

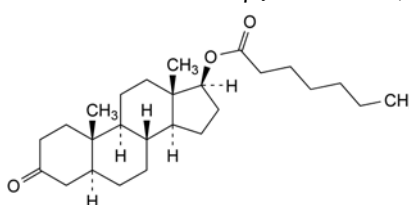

C. 3-oxo-5 $\alpha$ -androstan-17 $\beta$ -yl heptanoate,

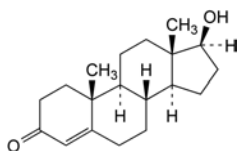

D. 17β-hydroxyandrost-4-en-3-one (testosterone).

01/2008:1737

## TESTOSTERONE ISOCAPROATE

### Testosteroni isocaproas

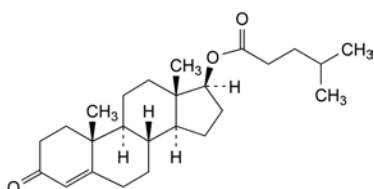
C<sub>25</sub>H<sub>38</sub>O<sub>3</sub>M<sub>r</sub> 386.6

#### DEFINITION

3-Oxoandrost-4-en-17β-yl 4-methylpentanoate.

Content: 97.0 per cent to 102.0 per cent (dried substance).

#### CHARACTERS

Appearance: white or almost white powder.

Solubility: practically insoluble in water, very soluble in acetone and in methylene chloride, freely soluble in fatty oils.

#### IDENTIFICATION

A. Infrared absorption spectrophotometry (2.2.24).

Comparison: testosterone isocaproate CRS.

B. Examine the chromatograms obtained in the assay.

Results: the principal peak in the chromatogram obtained with the test solution is similar in retention time and size to the principal peak in the chromatogram obtained with reference solution (c).

#### TESTS

Appearance of solution. The solution is clear (2.2.1) and not more intensely coloured than reference solution BY<sub>6</sub> (2.2.2, Method II).

Dissolve 0.20 g in 20 mL of methanol R.

Specific optical rotation (2.2.7): + 82.0 to + 88.0 (dried substance).

Dissolve 0.200 g in anhydrous ethanol R and dilute to 20.0 mL with the same solvent.

Related substances. Liquid chromatography (2.2.29).

Test solution. Dissolve 20.0 mg of the substance to be examined in the mobile phase and dilute to 100.0 mL with the mobile phase.

Reference solution (a). Dissolve 2 mg of testosterone isocaproate for system suitability CRS (containing impurities A, B, C, D, E, F and G) in 10 mL of the mobile phase.

Reference solution (b). Dilute 10.0 mL of the test solution to 100.0 mL with the mobile phase. Dilute 1.0 mL of this solution to 20.0 mL with the mobile phase.

Reference solution (c). Dissolve 20.0 mg of testosterone isocaproate CRS in the mobile phase and dilute to 100.0 mL with the mobile phase.

Column:

- size:  $l = 0.25$  m,  $\varnothing = 4.6$  mm;
- stationary phase: end-capped octadecylsilyl silica gel for chromatography R (5  $\mu$ m);
- temperature: 40 °C.

Mobile phase: water R, acetonitrile R (15:85 V/V).

Flow rate: 1.0 mL/min.

Detection: spectrophotometer at 240 nm.

Injection: 20  $\mu$ L of the test solution and reference solutions (a) and (b).

Run time: twice the retention time of testosterone isocaproate.

Identification of impurities: use the chromatogram supplied with testosterone isocaproate for system suitability CRS and the chromatogram obtained with reference solution (a) to identify the peaks due to impurities A, B, C, D, E, F and G.

Relative retention with reference to testosterone isocaproate (retention time = about 14 min): impurity A = about 0.2; impurity B = about 0.4; impurity C = about 0.5; impurity D = about 0.7; impurity G = about 0.8; impurity E = about 1.1; impurity F = about 1.4.

System suitability: reference solution (a):

- peak-to-valley ratio: minimum 2.5, where  $H_p$  = height above the baseline of the peak due to impurity E and  $H_v$  = height above the baseline of the lowest point of the curve separating this peak from the peak due to testosterone isocaproate.

Limits:

- impurities A, B, C, D, E, F, G: for each impurity, not more than the area of the principal peak in the chromatogram obtained with reference solution (b) (0.5 per cent);
- unspecified impurities: for each impurity, not more than 0.2 times the area of the principal peak in the chromatogram obtained with reference solution (b) (0.10 per cent);
- total: not more than twice the area of the principal peak in the chromatogram obtained with reference solution (b) (1.0 per cent);
- disregard limit: 0.1 times the area of the principal peak in the chromatogram obtained with reference solution (b) (0.05 per cent).

Free acid. Dissolve 0.44 g in 10 mL of ethanol (96 per cent) R, previously neutralised to bromothymol blue solution R3, and titrate immediately with 0.01 M sodium hydroxide, using 0.1 mL of bromothymol blue solution R3 as indicator. Not more than 0.6 mL of 0.01 M sodium hydroxide is required to change the colour of the indicator to blue.

Loss on drying (2.2.32): maximum 0.5 per cent, determined on 1.000 g over diphosphorus pentoxide R at a pressure not exceeding 0.7 kPa.

#### ASSAY

Liquid chromatography (2.2.29) as described in the test for related substances with the following modification.

Injection: 20  $\mu$ L of the test solution and reference solution (c). Calculate the percentage content of C<sub>25</sub>H<sub>38</sub>O<sub>3</sub> from the declared content of testosterone isocaproate CRS.

#### IMPURITIES

Specified impurities: A, B, C, D, E, F, G.

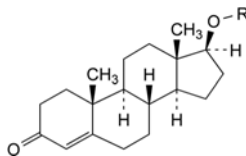

- A. R = H: testosterone,
- B. R = CO-CH<sub>3</sub>: 3-oxoandrost-4-en-17β-yl acetate (testosterone acetate),
- C. R = CO-C<sub>2</sub>H<sub>5</sub>: testosterone propionate,
- D. R = CO-CH(CH<sub>3</sub>)<sub>2</sub>: 3-oxoandrost-4-en-17β-yl 2-methylpropanoate (testosterone isobutyrate),
- E. R = CO-[CH<sub>2</sub>]<sub>4</sub>-CH<sub>3</sub>: 3-oxoandrost-4-en-17β-yl hexanoate (testosterone caproate),
- F. R = CO-[CH<sub>2</sub>]<sub>5</sub>-CH<sub>3</sub>: testosterone enantate,

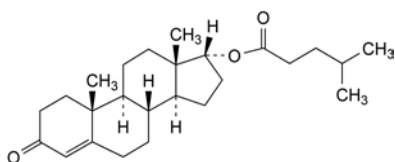

G. 3-oxoandrost-4-en-17 $\alpha$ -yl 4-methylpentanoate (epitestosterone isocaproate).

01/2008:0297  
corrected 6.0

## TESTOSTERONE PROPIONATE

### Testosteroni propionas

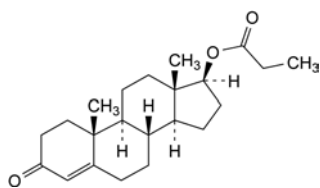

$C_{22}H_{32}O_3$   
[57-85-2]

$M_r$  344.5

#### DEFINITION

3-Oxoandrost-4-en-17 $\beta$ -yl propanoate.

*Content*: 97.0 per cent to 103.0 per cent (dried substance).

#### CHARACTERS

*Appearance*: white or almost white powder or colourless crystals.

*Solubility*: practically insoluble in water, freely soluble in acetone and in alcohol, soluble in fatty oils.

#### IDENTIFICATION

Infrared absorption spectrophotometry (2.2.24).

*Comparison*: *Ph. Eur. reference spectrum of testosterone propionate*.

#### TESTS

**Specific optical rotation** (2.2.7): + 84 to + 90 (dried substance).

Dissolve 0.250 g in *ethanol R* and dilute to 25.0 mL with the same solvent.

**Related substances**. Liquid chromatography (2.2.29).

*Test solution*. Dissolve 50.0 mg of the substance to be examined in *methanol R* and dilute to 50.0 mL with the same solvent.

*Reference solution (a)*. Dissolve 2 mg of the substance to be examined and 2 mg of *testosterone acetate CRS* in *methanol R* and dilute to 50.0 mL with the same solvent.

*Reference solution (b)*. Dilute 1.0 mL of the test solution to 100.0 mL with *methanol R*.

*Column*:

- *size*:  $l = 0.25$  m,  $\varnothing = 4.6$  mm,
- *stationary phase*: octadecylsilyl silica gel for chromatography R (5  $\mu$ m).

*Mobile phase*: *water R*, *methanol R* (20:80 V/V).

*Flow rate*: 1.5 mL/min.

*Detection*: spectrophotometer at 254 nm.

*Injection*: 20  $\mu$ L.

*Run time*: twice the retention time of testosterone propionate.

*Relative retention* with reference to testosterone propionate (retention time = about 9 min): impurity C = about 0.5; impurity A = about 0.7; impurity D = about 0.8; impurity B = about 1.4.

*System suitability*: reference solution (a):

- *resolution*: minimum 4.0 between the peaks due to testosterone propionate and to impurity A.

*Limits*:

- *any impurity*: not more than 0.5 times the area of the principal peak in the chromatogram obtained with reference solution (b) (0.5 per cent),
- *total*: not more than the area of the principal peak in the chromatogram obtained with reference solution (b) (1.0 per cent),
- *disregard limit*: 0.05 times the area of the principal peak in the chromatogram obtained with reference solution (b) (0.05 per cent).

**Loss on drying** (2.2.32): maximum 0.5 per cent, determined on 0.500 g by drying in an oven at 105 °C for 2 h.

#### ASSAY

Dissolve 25.0 mg in *ethanol R* and dilute to 250.0 mL with the same solvent. Dilute 10.0 mL of the solution to 100.0 mL with *ethanol R*. Measure the absorbance (2.2.25) at the maximum at 240 nm.

Calculate the content of  $C_{22}H_{32}O_3$  taking the specific absorbance to be 490.

#### IMPURITIES

*Specified impurities*: A, B, C, D.

*Other detectable impurities* (the following substances would, if present at a sufficient level, be detected by one or other of the tests in the monograph. They are limited by the general acceptance criterion for other/unspecified impurities and/or by the general monograph *Substances for pharmaceutical use* (2034). It is therefore not necessary to identify these impurities for demonstration of compliance. See also 5.10. *Control of impurities in substances for pharmaceutical use*): E.

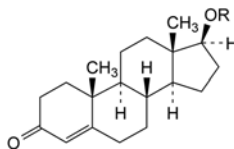

A. R = CO-CH<sub>3</sub>: 3-oxoandrost-4-en-17 $\beta$ -yl acetate (testosterone acetate),

B. R = CO-CH(CH<sub>3</sub>)<sub>2</sub>: 3-oxoandrost-4-en-17 $\beta$ -yl 2-methylpropanoate (testosterone isobutyrate),

C. R = H: testosterone,

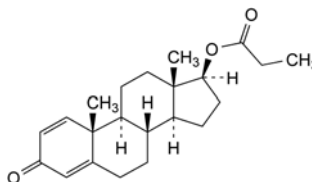

D. 3-oxoandrost-1,4-dien-17 $\beta$ -yl propanoate,

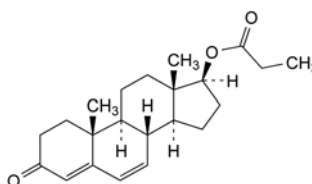

E. 3-oxoandrost-4,6-dien-17 $\beta$ -yl propanoate.

04/2008:0057 – stationary phase: octadecylsilyl silica gel for chromatography R (5 µm);

– temperature: 30 °C.

Mobile phase:

– mobile phase A: dissolve 1.36 g of potassium dihydrogen phosphate R in water R, add 0.5 mL of phosphoric acid R and dilute to 1000 mL with water R;

– mobile phase B: acetonitrile R;

## TETRACAINE HYDROCHLORIDE

### Tetracaini hydrochloridum

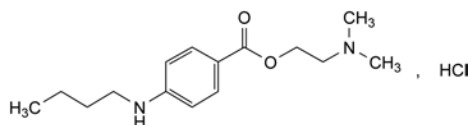

C<sub>15</sub>H<sub>25</sub>ClN<sub>2</sub>O<sub>2</sub>  
[136-47-0]

M<sub>r</sub> 300.8

#### DEFINITION

2-(Dimethylamino)ethyl 4-(butylamino)benzoate hydrochloride.

Content: 99.0 per cent to 101.0 per cent (dried substance).

#### CHARACTERS

Appearance: white or almost white, slightly hygroscopic, crystalline powder.

Solubility: freely soluble in water, soluble in ethanol (96 per cent).

It melts at about 148 °C or it may occur in either of 2 other crystalline forms which melt respectively at about 134 °C and 139 °C. Mixtures of these forms melt within the range 134 °C to 147 °C.

#### IDENTIFICATION

First identification: A, B, D.

Second identification: B, C, D.

A. Infrared absorption spectrophotometry (2.2.24).

Comparison: tetracaine hydrochloride CRS.

B. To 10 mL of solution S (see Tests) add 1 mL of ammonium thiocyanate solution R. A white, crystalline precipitate is formed which, after recrystallisation from water R and drying at 80 °C for 2 h, melts (2.2.14) at about 131 °C.

C. To about 5 mg add 0.5 mL of fuming nitric acid R. Evaporate to dryness on a water-bath, allow to cool and dissolve the residue in 5 mL of acetone R. Add 1 mL of 0.1 M alcoholic potassium hydroxide. A violet colour develops.

D. Solution S gives reaction (a) of chlorides (2.3.1).

#### TESTS

**Solution S.** Dissolve 5.0 g in carbon dioxide-free water R and dilute to 50 mL with the same solvent.

**Appearance of solution.** The solution is clear (2.2.1) and colourless (2.2.2, Method II).

Dilute 2 mL of solution S to 10 mL with water R.

pH (2.2.3): 4.5 to 6.5.

Dilute 1 mL of solution S to 10 mL with carbon dioxide-free water R.

**Related substances.** Liquid chromatography (2.2.29). Prepare the solutions immediately before use or store them at a temperature of 2-8 °C.

Solvent mixture: acetonitrile R, water R (20:80 V/V).

Test solution. Dissolve 50 mg of the substance to be examined in the solvent mixture and dilute to 50 mL with the solvent mixture.

Reference solution (a). Dilute 1.0 mL of the test solution to 100.0 mL with the solvent mixture. Dilute 1.0 mL of this solution to 10.0 mL with the solvent mixture.

Reference solution (b). Dissolve the contents of a vial of tetracaine for system suitability CRS (containing impurities A, B and C) in 2 mL of the solvent mixture.

Column:

– size: l = 0.15 m, Ø = 4.6 mm;

Time (min)	Mobile phase A (per cent V/V)	Mobile phase B (per cent V/V)
0 - 3	80	20
3 - 18	80 → 40	20 → 60
18 - 23	40	60

Flow rate: 1.5 mL/min.

Detection: spectrophotometer at 300 nm.

Injection: 10 µL.

Identification of impurities: use the chromatogram supplied with tetracaine for system suitability CRS and the chromatogram obtained with reference solution (b) to identify the peaks due to impurities A, B and C.

Relative retention with reference to tetracaine (retention time = about 8 min): impurity A = about 0.3; impurity B = about 1.7; impurity C = about 2.1.

System suitability: reference solution (b):

– resolution: minimum 5.0 between the peaks due to tetracaine and impurity B.

Limits:

– correction factors: for the calculation of content, multiply the peak areas of the following impurities by the corresponding correction factor: impurity B = 0.6; impurity C = 0.7;

– impurity A: not more than 0.5 times the area of the principal peak in the chromatogram obtained with reference solution (a) (0.05 per cent);

– impurities B, C: for each impurity, not more than the area of the principal peak in the chromatogram obtained with reference solution (a) (0.1 per cent);

– unspecified impurities: for each impurity, not more than the area of the principal peak in the chromatogram obtained with reference solution (a) (0.10 per cent);

– total: not more than 5 times the area of the principal peak in the chromatogram obtained with reference solution (a) (0.5 per cent);

– disregard limit: 0.5 times the area of the principal peak in the chromatogram obtained with reference solution (a) (0.05 per cent).

**Heavy metals** (2.4.8): maximum 10 ppm.

12 mL of solution S complies with test A. Prepare the reference solution using lead standard solution (1 ppm Pb) R.

**Loss on drying** (2.2.32): maximum 1.0 per cent, determined on 1.000 g by drying in an oven at 105 °C.

**Sulfated ash** (2.4.14): maximum 0.1 per cent, determined on 1.0 g.

#### ASSAY

Dissolve 0.250 g in 50 mL of ethanol (96 per cent) R and add 5.0 mL of 0.01 M hydrochloric acid. Carry out a potentiometric titration (2.2.20), using 0.1 M sodium hydroxide. Read the volume added between the 2 points of inflexion.

1 mL of 0.1 M sodium hydroxide is equivalent to 30.08 mg of C<sub>15</sub>H<sub>25</sub>ClN<sub>2</sub>O<sub>2</sub>.

#### STORAGE

In an airtight container, protected from light.



## IMPURITIES

Specified impurities: A, B, C.

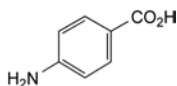

A. 4-aminobenzoic acid,

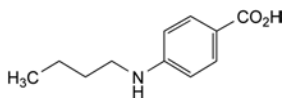

B. 4-(butylamino)benzoic acid,

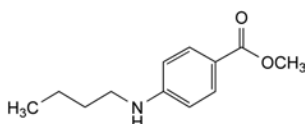

C. methyl 4-(butylamino)benzoate.

04/2010:0644

## TETRACOSACTIDE

### Tetracosactidum

H - Ser - Tyr - Ser - Met - Glu - His - Phe - Arg - Trp - Gly -  
Lys - Pro - Val - Gly - Lys - Lys - Arg - Arg - Pro - Val -  
Lys - Val - Tyr - Pro - OH

$C_{136}H_{210}N_{40}O_{31}S$   
[16960-16-0]

$M_r$  2933

## DEFINITION

Synthetic tetracosapeptide, in which the sequence of amino acids is the same as that of the first 24 residues of human corticotropin. It increases the rate at which corticoid hormones are secreted by the adrenal glands. It is available as an acetate.

**Content:** 90 per cent to 102 per cent (anhydrous and acetic acid-free substance). By convention, 1 µg of tetracosactide is equivalent to 1 IU of tetracosactide.

## CHARACTERS

**Appearance:** white or yellow, amorphous powder.

**Solubility:** sparingly soluble in water.

## IDENTIFICATION

A. Examine the chromatograms obtained in the test for related peptides.

**Results:** the principal peak in the chromatogram obtained with the test solution is similar in retention time and size to the principal peak in the chromatogram obtained with the reference solution.

B. Amino acid analysis (2.2.56). For hydrolysis use Method 1 and for analysis use Method 1.

Express the content of each amino acid in moles. Calculate the relative proportions of the amino acids, taking that of valine to be equivalent to 3. The values fall within the following limits: lysine 3.5 to 4.7; histidine 0.9 to 1.1; arginine 2.7 to 3.3; serine 1.1 to 2.2; glutamic acid 0.9 to 1.1; proline 2.5 to 3.5; glycine 1.8 to 2.2; methionine 0.9 to 1.1; tyrosine 1.7 to 2.2; phenylalanine 0.9 to 1.1. Not more than traces of other amino acids are present.

## TESTS

**Specific optical rotation** (2.2.7): -99 to -109 (anhydrous and acetic acid-free substance).

Dissolve 10.0 mg in 1.0 mL of a mixture of 1 volume of *glacial acetic acid R* and 99 volumes of *water R*.

**Absorbance** (2.2.25): 0.51 to 0.61 (anhydrous and acetic acid-free substance), determined at the absorption maximum between 240 nm and 280 nm, at 276 nm. The ratio of the absorbance at the maximum at 276 nm to the absorbance at 248 nm is 2.4 to 2.9.

Dissolve 1.0 mg in 0.1 M *hydrochloric acid* and dilute to 5.0 mL with the same acid.

**Related peptides.** Liquid chromatography (2.2.29): use the normalisation procedure.

**Test solution.** Dissolve an accurately weighed quantity of the substance to be examined in *water R* to obtain the same concentration as in reference solution (a).

**Reference solution (a).** Dissolve the contents of a vial of *tetracosactide CRS* in *water R* to obtain a concentration of about 1 mg/mL, as indicated in the leaflet provided with the reference standard.

**Reference solution (b).** In order to prepare impurity A *in situ*, dissolve 1.0 mg of the substance to be examined in 1 mL of a 1 per cent V/V solution of *glacial acetic acid R*, add 50 µL of a mixture of 1 volume of *strong hydrogen peroxide solution R* and 999 volumes of *water R*, and allow to stand for 2 h.

**Column:**

- size:  $l = 0.15$  m,  $\emptyset = 4.6$  mm;
- stationary phase: octadecylsilyl silica gel for chromatography R (3 µm);
- temperature: 25 °C.

**Mobile phase:**

- mobile phase A: mix 5.0 mL of *glacial acetic acid R*, 60 mL of *acetonitrile R* and 5.0 g of *ammonium sulfate R* and dilute to 1000 mL with *water R*;
- mobile phase B: mix 5.0 mL of *glacial acetic acid R*, 310 mL of *acetonitrile R* and 5.0 g of *ammonium sulfate R* and dilute to 1000 mL with *water R*;
- mobile phase C: *acetonitrile R*.

Time (min)	Mobile phase A (per cent V/V)	Mobile phase B (per cent V/V)	Mobile phase C (per cent V/V)
0 - 50	55 → 40	45 → 60	0
50 - 50.1	40 → 0	60 → 15	0 → 85
50.1 - 55	0	15	85
55 - 55.1	0 → 55	15 → 45	85 → 0
55.1 - 60	55	45	0

**Flow rate:** 0.8 mL/min.

**Detection:** spectrophotometer at 275 nm.

**Injection:** 20 µL.

**Identification of impurities:** use the chromatogram supplied with *tetracosactide CRS* and the chromatogram obtained with reference solution (a) to identify the peak due to impurity B; use the chromatogram obtained with reference solution (b) to identify the peak due to impurity A.

**Relative retention** with reference to tetracosactide (retention time = about 26 min): impurity A = about 0.3; impurity B = about 0.95.

**System suitability:** reference solution (a):

- peak-to-valley ratio: minimum 3, where  $H_p$  = height above the baseline of the peak due to impurity B and  $H_v$  = height above the baseline of the lowest point of the curve separating this peak from the peak due to tetracosactide.

**Limits:**

- impurity A: maximum 3 per cent;
- impurity B: maximum 4 per cent;
- unspecified impurities: for each impurity, maximum 2.5 per cent;
- sum of impurities other than A: maximum 9 per cent.

**Acetic acid** (2.5.34): 8.0 per cent to 13.0 per cent.

**Test solution.** Dissolve 10.0 mg of the substance to be examined in a mixture of 5 volumes of mobile phase B and 95 volumes of mobile phase A and dilute to 10.0 mL with the same mixture of mobile phases.

**Water** (2.5.32): maximum 14.0 per cent, determined on 20.0-50.0 mg.

**Bacterial endotoxins** (2.6.14): less than 10 IU/mg, if intended for use in the manufacture of parenteral preparations without a further appropriate procedure for the removal of bacterial endotoxins.

#### ASSAY

Liquid chromatography (2.2.29) as described in the test for related peptides.

Calculate the content of  $C_{136}H_{210}N_{40}O_{31}S$  using the declared content of *tetracosactide CRS*.

#### STORAGE

Protected from light, at a temperature of 2 °C to 8 °C.

#### LABELLING

The label states:

- the mass of peptide in the container;
- where applicable, that the substance is suitable for use in the manufacture of parenteral preparations.

#### IMPURITIES

*Specified impurities: A, B.*

- A. tetracosactide sulfoxide,
- B. unidentified impurity.

**Reference solution (a).** Dissolve 5 mg of *tetracycline hydrochloride CRS* in *methanol R* and dilute to 10 mL with the same solvent.

**Reference solution (b).** Dissolve 5 mg of *tetracycline hydrochloride CRS*, 5 mg of *demeclocycline hydrochloride R* and 5 mg of *oxytetracycline hydrochloride R* in *methanol R* and dilute to 10 mL with the same solvent.

**Plate:** *TLC octadecylsilyl silica gel F<sub>254</sub> plate R.*

**Mobile phase:** mix 20 volumes of *acetonitrile R*, 20 volumes of *methanol R* and 60 volumes of a 63 g/L solution of *oxalic acid R* previously adjusted to pH 2 with *concentrated ammonia R*.

**Application:** 1 µL.

**Development:** over 3/4 of the plate.

**Drying:** in air.

**Detection:** examine in ultraviolet light at 254 nm.

**System suitability:** the chromatogram obtained with reference solution (b) shows 3 clearly separated spots.

**Results:** the principal spot in the chromatogram obtained with the test solution is similar in position and size to the principal spot in the chromatogram obtained with reference solution (a).

- B. To about 2 mg add 5 mL of *sulfuric acid R*. A violet-red colour develops. Add the solution to 2.5 mL of *water R*. The colour becomes yellow.
- C. Dissolve about 10 mg in a mixture of 1 mL of *dilute nitric acid R* and 5 mL of *water R*. Shake and add 1 mL of *silver nitrate solution R2*. Any opalescence in the solution is not more intense than that in a mixture of 1 mL of *dilute nitric acid R*, 5 mL of *water R* and 1 mL of *silver nitrate solution R2*.

#### TESTS

**pH** (2.2.3): 3.5 to 6.0.

Suspend 0.1 g in 10 mL of *carbon dioxide-free water R*.

**Specific optical rotation** (2.2.7): –260 to –280 (dried substance).

Dissolve 0.250 g in 0.1 M *hydrochloric acid* and dilute to 50.0 mL with the same acid.

**Related substances.** Liquid chromatography (2.2.29). *Prepare the solutions immediately before use.*

**Test solution.** Dissolve 25.0 mg of the substance to be examined in 0.01 M *hydrochloric acid* and dilute to 25.0 mL with the same acid.

**Reference solution (a).** Dissolve 25.0 mg of *tetracycline hydrochloride CRS* in 0.01 M *hydrochloric acid* and dilute to 25.0 mL with the same acid.

**Reference solution (b).** Dissolve 12.5 mg of *4-epitetracycline hydrochloride CRS* in 0.01 M *hydrochloric acid* and dilute to 50.0 mL with the same acid.

**Reference solution (c).** Dissolve 10.0 mg of *anhydrotetracycline hydrochloride CRS* in 0.01 M *hydrochloric acid* and dilute to 100.0 mL with the same acid.

**Reference solution (d).** Dissolve 10.0 mg of *4-epianhydrotetracycline hydrochloride CRS* in 0.01 M *hydrochloric acid* and dilute to 50.0 mL with the same acid.

**Reference solution (e).** Mix 1.0 mL of reference solution (a), 2.0 mL of reference solution (b) and 5.0 mL of reference solution (d) and dilute to 25.0 mL with 0.01 M *hydrochloric acid*.

**Reference solution (f).** Mix 40.0 mL of reference solution (b), 20.0 mL of reference solution (c) and 5.0 mL of reference solution (d) and dilute to 200.0 mL with 0.01 M *hydrochloric acid*.

**Reference solution (g).** Dilute 1.0 mL of reference solution (c) to 50.0 mL with 0.01 M *hydrochloric acid*.

**Column:**

- size:  $l = 0.25$  m,  $\varnothing = 4.6$  mm;

01/2008:0211  
corrected 6.0

## TETRACYCLINE

### Tetracyclinum

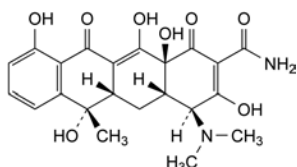

$C_{22}H_{24}N_2O_8$   
[60-54-8]

$M_r$  444.4

#### DEFINITION

(4S,4aS,5aS,6S,12aS)-4-(Dimethylamino)-3,6,10,12,12a-pentahydroxy-6-methyl-1,11-dioxo-1,4,4a,5,5a,6,11,12a-octahydrotetracene-2-carboxamide.

Substance produced by certain strains of *Streptomyces aerofaciens* or obtained by any other means.

**Content:** 88.0 per cent to 102.0 per cent (dried substance).

#### CHARACTERS

**Appearance:** yellow, crystalline powder.

**Solubility:** very slightly soluble in water, soluble in ethanol (96 per cent) and in methanol, sparingly soluble in acetone. It dissolves in dilute acid and alkaline solutions.

#### IDENTIFICATION

A. Thin-layer chromatography (2.2.27).

**Test solution.** Dissolve 5 mg of the substance to be examined in *methanol R* and dilute to 10 mL with the same solvent.

- *stationary phase*: styrene-divinylbenzene copolymer *R* (8 µm);
- *temperature*: 60 °C.

*Mobile phase*: weigh 80.0 g of 2-methyl-2-propanol *R* and transfer to a 1000 mL volumetric flask with the aid of 200 mL of water *R*; add 100 mL of a 35 g/L solution of dipotassium hydrogen phosphate *R* adjusted to pH 9.0 with dilute phosphoric acid *R*, 200 mL of a 10 g/L solution of tetrabutylammonium hydrogen sulfate *R* adjusted to pH 9.0 with dilute sodium hydroxide solution *R* and 10 mL of a 40 g/L solution of sodium edetate *R* adjusted to pH 9.0 with dilute sodium hydroxide solution *R*; dilute to 1000.0 mL with water *R*.

*Flow rate*: 1.0 mL/min.

*Detection*: spectrophotometer at 254 nm.

*Injection*: 20 µL; inject the test solution and reference solutions (e), (f) and (g).

*System suitability*:

- *resolution*: minimum 2.5 between the peaks due to impurity A (1<sup>st</sup> peak) and tetracycline (2<sup>nd</sup> peak) and minimum 8.0 between the peaks due to tetracycline and impurity D (3<sup>rd</sup> peak) in the chromatogram obtained with reference solution (e); if necessary, adjust the concentration of 2-methyl-2-propanol in the mobile phase;
- *signal-to-noise ratio*: minimum 3 for the principal peak in the chromatogram obtained with reference solution (g);
- *symmetry factor*: maximum 1.25 for the peak due to tetracycline in the chromatogram obtained with reference solution (e).

*Limits*:

- *impurity A*: not more than the area of the corresponding peak in the chromatogram obtained with reference solution (f) (5.0 per cent);
- *impurity B* (eluting on the tail of the principal peak): not more than 0.4 times the area of the peak due to impurity A in the chromatogram obtained with reference solution (f) (2.0 per cent);
- *impurity C*: not more than the area of the corresponding peak in the chromatogram obtained with reference solution (f) (1.0 per cent);
- *impurity D*: not more than the area of the corresponding peak in the chromatogram obtained with reference solution (f) (0.5 per cent).

**Heavy metals** (2.4.8): maximum 50 ppm.

0.5 g complies with test C. Prepare the reference solution using 2.5 mL of lead standard solution (10 ppm Pb) *R*.

**Loss on drying** (2.2.32): maximum 13.0 per cent, determined on 1.000 g by drying in an oven at 105 °C.

**Sulfated ash** (2.4.14): maximum 0.5 per cent, determined on 1.0 g.

#### ASSAY

Liquid chromatography (2.2.29) as described in the test for related substances with the following modification.

*Injection*: test solution and reference solution (a).

Calculate the percentage content of C<sub>22</sub>H<sub>24</sub>N<sub>2</sub>O<sub>8</sub>.

#### STORAGE

Protected from light.

#### IMPURITIES

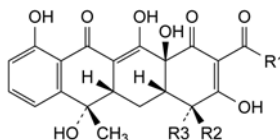

- A. R<sub>1</sub> = NH<sub>2</sub>, R<sub>2</sub> = H, R<sub>3</sub> = N(CH<sub>3</sub>)<sub>2</sub>: (4*R*,4*aS*,5*aS*,6*S*,12*aS*)-4-(dimethylamino)-3,6,10,12,12*a*-pentahydroxy-6-methyl-1,11-dioxo-1,4,4*a*,5,5*a*,6,11,12*a*-octahydrotetracycane-2-carboxamide (4-epitetracycline),
- B. R<sub>1</sub> = CH<sub>3</sub>, R<sub>2</sub> = N(CH<sub>3</sub>)<sub>2</sub>, R<sub>3</sub> = H: (4*S*,4*aS*,5*aS*,6*S*,12*aS*)-2-acetyl-4-(dimethylamino)-3,6,10,12,12*a*-pentahydroxy-6-methyl-4*a*,5*a*,6,12*a*-tetrahydrotetracycane-1,11(4*H*,5*H*)-dione (2-acetyl-2-decarbamoylepitanolol tetracycline),

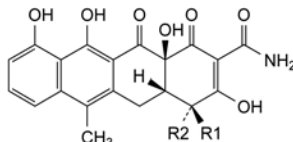

- C. R<sub>1</sub> = N(CH<sub>3</sub>)<sub>2</sub>, R<sub>2</sub> = H: (4*S*,4*aS*,12*aS*)-4-(dimethylamino)-3,10,11,12*a*-tetrahydroxy-6-methyl-1,12-dioxo-1,4,4*a*,5,12,12*a*-hexahydrotetracycane-2-carboxamide (anhydrotetracycline),
- D. R<sub>1</sub> = H, R<sub>2</sub> = N(CH<sub>3</sub>)<sub>2</sub>: (4*R*,4*aS*,12*aS*)-4-(dimethylamino)-3,10,11,12*a*-tetrahydroxy-6-methyl-1,12-dioxo-1,4,4*a*,5,12,12*a*-hexahydrotetracycane-2-carboxamide (4-epianhydrotetracycline).

01/2008:0210  
corrected 6.0

## TETRACYCLINE HYDROCHLORIDE

### Tetracyclini hydrochloridum

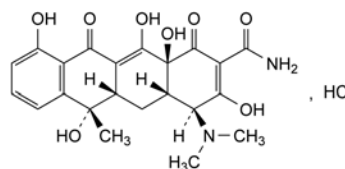

C<sub>22</sub>H<sub>25</sub>ClN<sub>2</sub>O<sub>8</sub>  
[64-75-5]

*M*<sub>r</sub> 480.9

#### DEFINITION

(4*S*,4*aS*,5*aS*,6*S*,12*aS*)-4-(Dimethylamino)-3,6,10,12,12*a*-pentahydroxy-6-methyl-1,11-dioxo-1,4,4*a*,5,5*a*,6,11,12*a*-octahydrotetracycane-2-carboxamide hydrochloride.

Substance produced by certain strains of *Streptomyces aerofaciens* or obtained by any other means.

*Content*: 95.0 per cent to 102.0 per cent (dried substance).

#### CHARACTERS

*Appearance*: yellow, crystalline powder.

*Solubility*: soluble in water, slightly soluble in ethanol (96 per cent), practically insoluble in acetone. It dissolves in solutions of alkali hydroxides and carbonates. Solutions in water become turbid on standing, owing to the precipitation of tetracycline.

#### IDENTIFICATION

A. Thin-layer chromatography (2.2.27).

*Test solution*. Dissolve 5 mg of the substance to be examined in methanol *R* and dilute to 10 mL with the same solvent.

*Reference solution (a)*. Dissolve 5 mg of tetracycline hydrochloride CRS in methanol *R* and dilute to 10 mL with the same solvent.

*Reference solution (b).* Dissolve 5 mg of tetracycline hydrochloride CRS, 5 mg of demeclocycline hydrochloride R and 5 mg of oxytetracycline hydrochloride R in methanol R and dilute to 10 mL with the same solvent.

*Plate:* TLC octadecylsilyl silica gel F<sub>254</sub> plate R.

*Mobile phase:* mix 20 volumes of acetonitrile R, 20 volumes of methanol R and 60 volumes of a 63 g/L solution of oxalic acid R previously adjusted to pH 2 with concentrated ammonia R.

*Application:* 1 µL.

*Development:* over 3/4 of the plate.

*Drying:* in air.

*Detection:* examine in ultraviolet light at 254 nm.

*System suitability:* the chromatogram obtained with reference solution (b) shows 3 clearly separated spots.

*Results:* the principal spot in the chromatogram obtained with the test solution is similar in position and size to the principal spot in the chromatogram obtained with reference solution (a).

B. To about 2 mg add 5 mL of sulfuric acid R. A violet-red colour develops. Add the solution to 2.5 mL of water R. The colour becomes yellow.

C. It gives reaction (a) of chlorides (2.3.1).

## TESTS

**pH** (2.2.3): 1.8 to 2.8.

Dissolve 0.1 g in 10 mL of carbon dioxide-free water R.

**Specific optical rotation** (2.2.7): –240 to –255 (dried substance).

Dissolve 0.250 g in 0.1 M hydrochloric acid and dilute to 25.0 mL with the same acid.

**Related substances.** Liquid chromatography (2.2.29). Prepare the solutions immediately before use.

*Test solution.* Dissolve 25.0 mg of the substance to be examined in 0.01 M hydrochloric acid and dilute to 25.0 mL with the same acid.

*Reference solution (a).* Dissolve 25.0 mg of tetracycline hydrochloride CRS in 0.01 M hydrochloric acid and dilute to 25.0 mL with the same acid.

*Reference solution (b).* Dissolve 15.0 mg of 4-epitetracycline hydrochloride CRS in 0.01 M hydrochloric acid and dilute to 50.0 mL with the same acid.

*Reference solution (c).* Dissolve 10.0 mg of anhydrotetracycline hydrochloride CRS in 0.01 M hydrochloric acid and dilute to 100.0 mL with the same acid.

*Reference solution (d).* Dissolve 10.0 mg of 4-epianhydrotetracycline hydrochloride CRS in 0.01 M hydrochloric acid and dilute to 50.0 mL with the same acid.

*Reference solution (e).* Mix 1.0 mL of reference solution (a), 2.0 mL of reference solution (b) and 5.0 mL of reference solution (d) and dilute to 25.0 mL with 0.01 M hydrochloric acid.

*Reference solution (f).* Mix 20.0 mL of reference solution (b), 10.0 mL of reference solution (c) and 5.0 mL of reference solution (d) and dilute to 200.0 mL using 0.01 M hydrochloric acid.

*Reference solution (g).* Dilute 1.0 mL of reference solution (c) to 50.0 mL with 0.01 M hydrochloric acid.

*Column:*

– size:  $l = 0.25$  m,  $\varnothing = 4.6$  mm;

– stationary phase: styrene-divinylbenzene copolymer R (8 µm);

– temperature: 60 °C.

*Mobile phase:* weigh 80.0 g of 2-methyl-2-propanol R and transfer to a 1000 mL volumetric flask with the aid of 200 mL of water R; add 100 mL of a 35 g/L solution of dipotassium hydrogen phosphate R adjusted to pH 9.0 with dilute phosphoric acid R, 200 mL of a 10 g/L solution of tetrabutylammonium hydrogen sulfate R adjusted to pH 9.0 with dilute sodium hydroxide solution R and 10 mL of a 40 g/L solution of sodium edetate R adjusted to pH 9.0 with dilute sodium hydroxide solution R; dilute to 1000.0 mL with water R.

*Flow rate:* 1.0 mL/min.

*Detection:* spectrophotometer at 254 nm.

*Injection:* 20 µL; inject the test solution and reference solutions (e), (f) and (g).

*System suitability:*

– resolution: minimum 2.5 between the peaks due to impurity A (1<sup>st</sup> peak) and tetracycline (2<sup>nd</sup> peak) and minimum 8.0 between the peaks due to tetracycline and impurity D (3<sup>rd</sup> peak) in the chromatogram obtained with reference solution (e); if necessary, adjust the concentration of 2-methyl-2-propanol in the mobile phase;

– signal-to-noise ratio: minimum 3 for the principal peak in the chromatogram obtained with reference solution (g);

– symmetry factor: maximum 1.25 for the peak due to tetracycline in the chromatogram obtained with reference solution (e).

*Limits:*

– impurity A: not more than the area of the corresponding peak in the chromatogram obtained with reference solution (f) (3.0 per cent);

– impurity B (eluting on the tail of the principal peak): not more than 0.5 times the area of the peak due to impurity A in the chromatogram obtained with reference solution (f) (1.5 per cent);

– impurity C: not more than the area of the corresponding peak in the chromatogram obtained with reference solution (f) (0.5 per cent);

– impurity D: not more than the area of the corresponding peak in the chromatogram obtained with reference solution (f) (0.5 per cent).

**Heavy metals** (2.4.8): maximum 50 ppm.

0.5 g complies with test C. Prepare the reference solution using 2.5 mL of lead standard solution (10 ppm Pb) R.

**Loss on drying** (2.2.32): maximum 2.0 per cent, determined on 1.000 g by drying at 60 °C over diphosphorus pentoxide R at a pressure not exceeding 670 Pa for 3 h.

**Sulfated ash** (2.4.14): maximum 0.5 per cent, determined on 1.0 g.

**Bacterial endotoxins** (2.6.14): less than 0.5 IU/mg, if intended for use in the manufacture of parenteral preparations without a further appropriate procedure for the removal of bacterial endotoxins.

## ASSAY

Liquid chromatography (2.2.29) as described in the test for related substances with the following modification.

*Injection:* test solution and reference solution (a).

Calculate the percentage content of C<sub>22</sub>H<sub>25</sub>ClN<sub>2</sub>O<sub>8</sub>.

## STORAGE

Protected from light. If the substance is sterile, store in a sterile, tamper-proof container.

## IMPURITIES

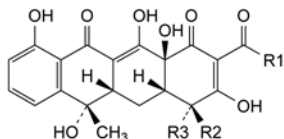

- A. R1 = NH<sub>2</sub>, R2 = H, R3 = N(CH<sub>3</sub>)<sub>2</sub>: (4*R*,4*aS*,5*aS*,6*S*,12*aS*)-4-(dimethylamino)-3,6,10,12,12*a*-pentahydroxy-6-methyl-1,11-dioxo-1,4,4*a*,5,5*a*,6,11,12*a*-octahydrotetracene-2-carboxamide (4-epitetrazepam),
- B. R1 = CH<sub>3</sub>, R2 = N(CH<sub>3</sub>)<sub>2</sub>, R3 = H: (4*S*,4*aS*,5*aS*,6*S*,12*aS*)-2-acetyl-4-(dimethylamino)-3,6,10,12,12*a*-pentahydroxy-6-methyl-4*a*,5*a*,6,12*a*-tetrahydrotetracene-1,11(4*H*,5*H*)-dione (2-acetyl-2-decarbamoylepitetrazepam),

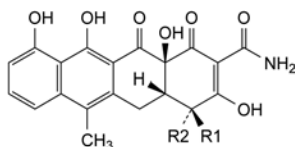

- C. R1 = N(CH<sub>3</sub>)<sub>2</sub>, R2 = H: (4*S*,4*aS*,12*aS*)-4-(dimethylamino)-3,10,11,12*a*-tetrahydroxy-6-methyl-1,12-dioxo-1,4,4*a*,5,12,12*a*-hexahydrotetracene-2-carboxamide (anhydrotetrazepam),
- D. R1 = H, R2 = N(CH<sub>3</sub>)<sub>2</sub>: (4*R*,4*aS*,12*aS*)-4-(dimethylamino)-3,10,11,12*a*-tetrahydroxy-6-methyl-1,12-dioxo-1,4,4*a*,5,12,12*a*-hexahydrotetracene-2-carboxamide (4-epianhydrotetrazepam).

01/2008:1738  
corrected 7.0

## TETRAZEPAM

## Tetrazepamum

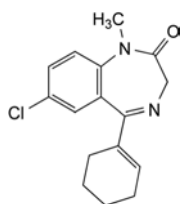

C<sub>16</sub>H<sub>17</sub>ClN<sub>2</sub>O  
[10379-14-3]

M<sub>r</sub> 288.8

## DEFINITION

7-Chloro-5-(cyclohex-1-enyl)-1-methyl-1,3-dihydro-2*H*-1,4-benzodiazepin-2-one.

*Content*: 99.0 per cent to 101.0 per cent (dried substance).

## CHARACTERS

*Appearance*: light yellow or yellow crystalline powder.

*Solubility*: practically insoluble in water, freely soluble in methylene chloride, soluble in acetonitrile.

## IDENTIFICATION

Infrared absorption spectrophotometry (2.2.24).

*Comparison*: Ph. Eur. reference spectrum of tetrazepam.

## TESTS

**Related substances.** Liquid chromatography (2.2.29).

*Test solution.* Dissolve 25.0 mg of the substance to be examined in acetonitrile *R* and dilute to 25.0 mL with the same solvent.

*Reference solution (a).* Dissolve 5.0 mg of the substance to be examined and 5.0 mg of tetrazepam impurity C CRS in acetonitrile *R* and dilute to 10.0 mL with the same solvent. Dilute 1.0 mL of the solution to 10.0 mL with acetonitrile *R*.

*Reference solution (b).* Dilute 1.0 mL of the test solution to 50.0 mL with acetonitrile *R*. Dilute 1.0 mL of this solution to 10.0 mL with acetonitrile *R*.

*Column*:

- *size*: *l* = 0.25 m, Ø = 4.6 mm;
- *stationary phase*: octadecylsilyl silica gel for chromatography *R* (5 µm).

*Mobile phase*:

- *mobile phase A*: mix 40 volumes of acetonitrile *R* and 60 volumes of a 3.4 g/L solution of potassium dihydrogen phosphate *R*;
- *mobile phase B*: acetonitrile *R*;

Time (min)	Mobile phase A (per cent V/V)	Mobile phase B (per cent V/V)
0 - 35	100	0
35 - 40	100 → 55	0 → 45
40 - 50	55	45

*Flow rate*: 1.5 mL/min.

*Detection*: a spectrophotometer at 229 nm.

*Injection*: 20 µL.

*System suitability*: reference solution (a):

- *resolution*: minimum 2.0 between the peaks due to tetrazepam and to impurity C.

*Limits*:

- *any impurity*: not more than the area of the principal peak in the chromatogram obtained with reference solution (b) (0.2 per cent);
- *total*: not more than 5 times the area of the principal peak in the chromatogram obtained with reference solution (b) (1.0 per cent);
- *disregard limit*: 0.25 times the area of the principal peak in the chromatogram obtained with reference solution (b) (0.05 per cent).

**Chlorides** (2.4.4): maximum 100 ppm.

Dissolve 0.750 g in 10 mL of methylene chloride *R* and add 15 mL of water *R*. Shake and separate the 2 layers. Dilute 10 mL of the aqueous layer to 15 mL with water *R*. The solution obtained complies with the limit test for chlorides.

**Loss on drying** (2.2.32): maximum 0.5 per cent, determined on 1.000 g by drying in an oven at 105 °C.

**Sulfated ash** (2.4.14): maximum 0.1 per cent, determined on 1.0 g.

## ASSAY

Dissolve 0.230 g in 50.0 mL of anhydrous acetic acid *R*. Titrate with 0.1 *M* perchloric acid, determining the end-point potentiometrically (2.2.20).

1 mL of 0.1 *M* perchloric acid is equivalent to 28.88 mg of C<sub>16</sub>H<sub>17</sub>ClN<sub>2</sub>O.

## STORAGE

Protected from light.

## IMPURITIES

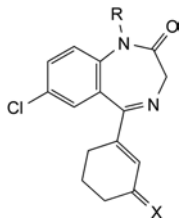

- A. R = CH<sub>3</sub>, X = O: 7-chloro-1-methyl-5-(3-oxocyclohex-1-enyl)-1,3-dihydro-2H-1,4-benzodiazepin-2-one,  
 E. R = H, X = H<sub>2</sub>: 7-chloro-5-(cyclohex-1-enyl)-1,3-dihydro-2H-1,4-benzodiazepin-2-one,

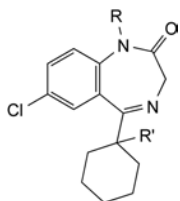

- B. R = R' = H: 7-chloro-5-cyclohexyl-1,3-dihydro-2H-1,4-benzodiazepin-2-one,  
 C. R = CH<sub>3</sub>, R' = H: 7-chloro-5-cyclohexyl-1-methyl-1,3-dihydro-2H-1,4-benzodiazepin-2-one,  
 D. R = CH<sub>3</sub>, R' = Cl: 7-chloro-5-(1-chlorocyclohexyl)-1-methyl-1,3-dihydro-2H-1,4-benzodiazepin-2-one.

01/2008:2101  
corrected 6.0

## TETRYZOLINE HYDROCHLORIDE

## Tetryzolini hydrochloridum

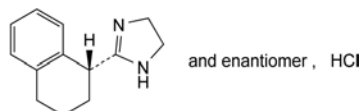

C<sub>13</sub>H<sub>17</sub>ClN<sub>2</sub>  
[522-48-5]

M<sub>r</sub> 236.7

## DEFINITION

2-[(1*R*S)-1,2,3,4-Tetrahydronaphthalen-1-yl]-4,5-dihydro-1*H*-imidazole hydrochloride.

*Content*: 98.0 per cent to 101.0 per cent (dried substance).

## CHARACTERS

*Appearance*: white or almost white, crystalline powder.

*Solubility*: freely soluble in water, in anhydrous ethanol and in ethanol (96 per cent), practically insoluble in acetone.

## IDENTIFICATION

A. Infrared absorption spectrophotometry (2.2.24).

*Comparison*: tetryzoline hydrochloride CRS.

B. Dissolve 50 mg in 10 mL of *water R*. The solution gives reaction (a) of chlorides (2.3.1).

## TESTS

**Appearance of solution.** The solution is clear (2.2.1) and colourless (2.2.2, *Method II*).

Dissolve 1.0 g in *water R* and dilute to 10 mL with the same solvent.

**Related substances.** Gas chromatography (2.2.28).

*Test solution.* Dissolve 1.0 g of the substance to be examined in a mixture of 25 volumes of 1 M sodium hydroxide and

75 volumes of *methanol R* and dilute to 10 mL with the same mixture of solvents.

*Reference solution.* Dilute 1.0 mL of the test solution to 100.0 mL with a mixture of 25 volumes of 1 M sodium hydroxide and 75 volumes of *methanol R*. Dilute 1.0 mL of this solution to 10.0 mL with a mixture of 25 volumes of 1 M sodium hydroxide and 75 volumes of *methanol R*.

*Column*:

- *material*: fused silica,
- *size*: *l* = 25 m, Ø = 0.32 mm,
- *stationary phase*: poly(dimethyl)siloxane R (1 µm).

*Carrier gas*: helium for chromatography R.

*Split ratio*: 1:40.

*Flow rate*: 2.5 mL/min.

*Temperature*:

	Time (min)	Temperature (°C)
Column	0 - 8	160
	8 - 11	160 → 220
	11 - 15	220
Injection port		220
Detector		220

*Detection*: flame ionisation.

*Injection*: 1 µL.

*Relative retention* with reference to tetryzoline (retention time = about 12 min): impurity A = about 0.5.

*System suitability*: reference solution:

- *signal-to-noise ratio*: minimum 50 for the principal peak.

*Limits*:

- *impurity A*: not more than the area of the principal peak in the chromatogram obtained with the reference solution (0.1 per cent),
- *any other impurity*: for each impurity, not more than the area of the principal peak in the chromatogram obtained with the reference solution (0.1 per cent),
- *total*: not more than twice the area of the principal peak in the chromatogram obtained with the reference solution (0.2 per cent),
- *disregard limit*: 0.5 times the area of the principal peak in the chromatogram obtained with the reference solution (0.05 per cent).

**Loss on drying** (2.2.32): maximum 0.5 per cent, determined on 1.000 g by drying in an oven at 105 °C.

**Sulfated ash** (2.4.14): maximum 0.1 per cent, determined on 1.0 g.

## ASSAY

Dissolve 0.200 g in 100 mL of a mixture of 3 volumes of *anhydrous acetic acid R* and 7 volumes of *acetic anhydride R*. Titrate with 0.1 M perchloric acid, determining the end-point potentiometrically (2.2.20). Carry out a blank titration.

1 mL of 0.1 M perchloric acid is equivalent to 23.67 mg of C<sub>13</sub>H<sub>17</sub>ClN<sub>2</sub>.

## IMPURITIES

*Specified impurities*: A.

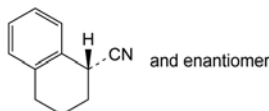

- A. (1*R*S)-1,2,3,4-tetrahydronaphthalene-1-carbonitrile (α-cyanotetraline).

**01/2008:0298 corrected 6.0** **Sulfated ash (2.4.14).** Not more than 0.1 per cent, determined on 1.0 g.

## THEOBROMINE

### Theobrominum

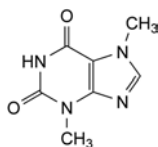

$C_7H_8N_4O_2$   
[83-67-0]

$M_r$  180.2

#### DEFINITION

Theobromine contains not less than 99.0 per cent and not more than the equivalent of 101.0 per cent of 3,7-dimethyl-3,7-dihydro-1*H*-purine-2,6-dione, calculated with reference to the dried substance.

#### CHARACTERS

A white or almost white powder, very slightly soluble in water and in ethanol, slightly soluble in ammonia. It dissolves in dilute solutions of alkali hydroxides and in mineral acids.

#### IDENTIFICATION

*First identification:* A, C.

*Second identification:* B, C.

- Examine by infrared absorption spectrophotometry (2.2.24), comparing with the spectrum obtained with *theobromine CRS*.
- Dissolve about 20 mg in 2 mL of *dilute ammonia R1*, warming slightly, and cool. Add 2 mL of *silver nitrate solution R2*. The solution remains clear. Boil the solution for a few minutes. A white, crystalline precipitate is formed.
- It gives the reaction of xanthines (2.3.1).

#### TESTS

**Acidity.** To 0.4 g add 20 mL of boiling *water R* and boil for 1 min. Allow to cool and filter. Add 0.05 mL of *bromothymol blue solution R1*. The solution is yellow or yellowish-green. Not more than 0.2 mL of 0.01 *M sodium hydroxide* is required to change the colour of the indicator to blue.

**Related substances.** Examine by thin-layer chromatography (2.2.27), using *silica gel GF<sub>254</sub> R* as the coating substance.

**Test solution.** To 0.2 g of the finely powdered substance to be examined add 10 mL of a mixture of 4 volumes of *methanol R* and 6 volumes of *chloroform R*. Heat under a reflux condenser on a water-bath for 15 min, shaking occasionally. Cool and filter.

**Reference solution.** Dissolve 5 mg of *theobromine CRS* in a mixture of 4 volumes of *methanol R* and 6 volumes of *chloroform R* and dilute to 50 mL with the same mixture of solvents.

Apply separately to the plate 10 µL of each solution. Develop over a path of 15 cm using a mixture of 10 volumes of *concentrated ammonia R*, 30 volumes of *acetone R*, 30 volumes of *chloroform R* and 40 volumes of *butanol R*. Allow the plate to dry in air and examine in ultraviolet light at 254 nm. Any spot in the chromatogram obtained with the test solution, apart from the principal spot, is not more intense than the spot in the chromatogram obtained with the reference solution (0.5 per cent).

**Heavy metals (2.4.8).** 1.0 g complies with limit test C for heavy metals (20 ppm). Prepare the standard using 2 mL of *lead standard solution (10 ppm Pb) R*.

**Loss on drying (2.2.32).** Not more than 0.5 per cent, determined on 1.000 g by drying in an oven at 105 °C.

#### ASSAY

Dissolve 0.150 g in 125 mL of boiling *water R*, cool to 50 °C to 60 °C and add 25 mL of 0.1 *M silver nitrate*. Using 1 mL of *phenolphthalein solution R* as indicator, titrate with 0.1 *M sodium hydroxide* until a pink colour is obtained.

1 mL of 0.1 *M sodium hydroxide* is equivalent to 18.02 mg of  $C_7H_8N_4O_2$ .

**01/2008:0299 corrected 6.0**

## THEOPHYLLINE

### Theophyllinum

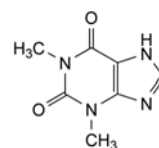

$C_7H_8N_4O_2$   
[58-55-9]

$M_r$  180.2

#### DEFINITION

1,3-Dimethyl-3,7-dihydro-1*H*-purine-2,6-dione.

*Content:* 99.0 per cent to 101.0 per cent (dried substance).

#### CHARACTERS

*Appearance:* white or almost white, crystalline powder.

*Solubility:* slightly soluble in water, sparingly soluble in ethanol (96 per cent). It dissolves in solutions of alkali hydroxides, in ammonia and in mineral acids.

#### IDENTIFICATION

*First identification:* B, D.

*Second identification:* A, C, D, E.

- Melting point (2.2.14): 270 °C to 274 °C, determined after drying at 100-105 °C.
- Infrared absorption spectrophotometry (2.2.24).  
*Comparison:* Ph. Eur. reference spectrum of *theophylline*.
- Heat 10 mg with 1.0 mL of a 360 g/L solution of *potassium hydroxide R* in a water-bath at 90 °C for 3 min, then add 1.0 mL of *diazotised sulfanilic acid solution R*. A red colour slowly develops. Carry out a blank test.
- Loss on drying (see Tests).
- It gives the reaction of xanthines (2.3.1).

#### TESTS

**Solution S.** Dissolve 0.5 g with heating in *carbon dioxide-free water R*, cool and dilute to 75 mL with the same solvent.

**Appearance of solution.** Solution S is clear (2.2.1) and colourless (2.2.2, *Method II*).

**Acidity.** To 50 mL of solution S add 0.1 mL of *methyl red solution R*. The solution is red. Not more than 1.0 mL of 0.01 *M sodium hydroxide* is required to change the colour of the indicator to yellow.

**Related substances.** Liquid chromatography (2.2.29).

**Test solution.** Dissolve 40.0 mg of the substance to be examined in the mobile phase and dilute to 20.0 mL with the mobile phase.

**Reference solution (a).** Dilute 1.0 mL of the test solution to 100.0 mL with the mobile phase. Dilute 1.0 mL of this solution to 10.0 mL with the mobile phase.

**Reference solution (b).** Dissolve 10 mg of *theobromine R* in the mobile phase, add 5 mL of the test solution and dilute to 100 mL with the mobile phase. Dilute 5 mL of this solution to 50 mL with the mobile phase.

**Column:**

- size:  $l = 0.25$  m,  $\varnothing = 4$  mm;
- stationary phase: octadecylsilyl silica gel for chromatography R (7  $\mu$ m).

**Mobile phase:** mix 7 volumes of acetonitrile for chromatography R and 93 volumes of a 1.36 g/L solution of sodium acetate R containing 5.0 mL/L of glacial acetic acid R.

**Flow rate:** 2.0 mL/min.

**Detection:** spectrophotometer at 272 nm.

**Injection:** 20  $\mu$ L.

**Run time:** 3.5 times the retention time of theophylline.

**Relative retention** with reference to theophylline (retention time = about 6 min): impurity C = about 0.3; impurity B = about 0.4; impurity D = about 0.5; impurity A = about 2.5.

**System suitability:** reference solution (b):

- resolution: minimum 2.0 between the peaks due to theobromine and theophylline.

**Limits:**

- impurities A, B, C, D: for each impurity, not more than the area of the principal peak in the chromatogram obtained with reference solution (a) (0.1 per cent);
- any other impurity: for each impurity, not more than the area of the principal peak in the chromatogram obtained with reference solution (a) (0.1 per cent);
- total: not more than 5 times the area of the principal peak in the chromatogram obtained with reference solution (a) (0.5 per cent);
- disregard limit: 0.5 times the area of the principal peak in the chromatogram obtained with reference solution (a) (0.05 per cent).

**Heavy metals (2.4.8):** maximum 20 ppm.

1.0 g complies with test C. Prepare the reference solution using 2 mL of lead standard solution (10 ppm Pb) R.

**Loss on drying (2.2.32):** maximum 0.5 per cent, determined on 1.000 g by drying in an oven at 105 °C.

**Sulfated ash (2.4.14):** maximum 0.1 per cent, determined on 1.0 g.

#### ASSAY

Dissolve 0.150 g in 100 mL of *water R*, add 20 mL of 0.1 M silver nitrate and shake. Add 1 mL of bromothymol blue solution RI. Titrate with 0.1 M sodium hydroxide.

1 mL of 0.1 M sodium hydroxide is equivalent to 18.02 mg of  $C_7H_8N_4O_2$ .

#### IMPURITIES

**Specified impurities:** A, B, C, D.

**Other detectable impurities** (the following substances would, if present at a sufficient level, be detected by one or other of the tests in the monograph. They are limited by the general acceptance criterion for other/unspecified impurities and/or by the general monograph *Substances for pharmaceutical use (2034)*. It is therefore not necessary to identify these impurities for demonstration of compliance. See also 5.10. *Control of impurities in substances for pharmaceutical use*): E, F.

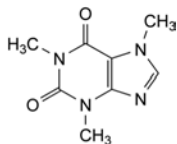

A. 1,3,7-trimethyl-3,7-dihydro-1H-purine-2,6-dione (caffeine),

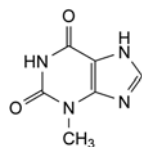

B. 3-methyl-3,7-dihydro-1H-purine-2,6-dione,

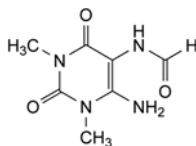

C. *N*-(6-amino-1,3-dimethyl-2,4-dioxo-1,2,3,4-tetrahydropyrimidin-5-yl)formamide,

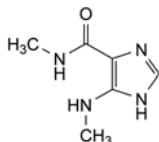

D. *N*-methyl-5-(methylamino)-1H-imidazole-4-carboxamide (theophyllidine),

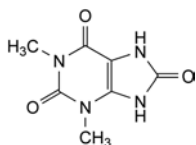

E. 1,3-dimethyl-7,9-dihydro-1H-purine-2,6,8(3H)-trione,

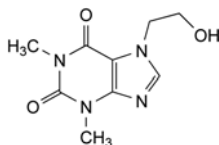

F. 7-(2-hydroxyethyl)-1,3-dimethyl-3,7-dihydro-1H-purine-2,6-dione (etofylline).

01/2008:0302  
corrected 6.0

## THEOPHYLLINE MONOHYDRATE

### Theophyllinum monohydricum

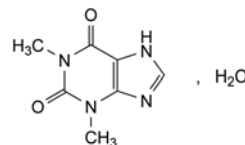

$C_7H_8N_4O_2 \cdot H_2O$   
[5967-84-0]

$M_r$  198.2

#### DEFINITION

1,3-Dimethyl-3,7-dihydro-1H-purine-2,6-dione monohydrate.

**Content:** 99.0 per cent to 101.0 per cent (anhydrous substance).

#### CHARACTERS

**Appearance:** white or almost white, crystalline powder.

**Solubility:** slightly soluble in water, sparingly soluble in ethanol (96 per cent). It dissolves in solutions of alkali hydroxides, in ammonia and in mineral acids.

#### IDENTIFICATION

**First identification:** B, D.

**Second identification:** A, C, D, E.

A. Melting point (2.2.14): 270 °C to 274 °C, determined after drying at 100-105 °C.



## B. Infrared absorption spectrophotometry (2.2.24).

*Preparation:* dry the substance to be examined at 100-105 °C before use.

*Comparison:* Ph. Eur. reference spectrum of theophylline.

## C. Heat 10 mg with 1.0 mL of a 360 g/L solution of potassium hydroxide R in a water-bath at 90 °C for 3 min, then add 1.0 mL of diazotised sulfanilic acid solution R. A red colour slowly develops. Carry out a blank test.

## D. Water (see Tests).

## E. It gives the reaction of xanthines (2.3.1).

## TESTS

**Solution S.** Dissolve 0.5 g with heating in carbon dioxide-free water R, cool and dilute to 75 mL with the same solvent.

**Appearance of solution.** Solution S is clear (2.2.1) and colourless (2.2.2, Method II).

**Acidity.** To 50 mL of solution S add 0.1 mL of methyl red solution R. The solution is red. Not more than 1.0 mL of 0.01 M sodium hydroxide is required to change the colour of the indicator to yellow.

**Related substances.** Liquid chromatography (2.2.29).

*Test solution.* Dissolve 40.0 mg of the substance to be examined in the mobile phase and dilute to 20.0 mL with the mobile phase.

*Reference solution (a).* Dilute 1.0 mL of the test solution to 100.0 mL with the mobile phase. Dilute 1.0 mL of this solution to 10.0 mL with the mobile phase.

*Reference solution (b).* Dissolve 10 mg of theobromine R in the mobile phase, add 5 mL of the test solution and dilute to 100 mL with the mobile phase. Dilute 5 mL of this solution to 50 mL with the mobile phase.

*Column:*

- size:  $l = 0.25$  m,  $\varnothing = 4$  mm;
- stationary phase: octadecylsilyl silica gel for chromatography R (7  $\mu$ m).

*Mobile phase:* mix 7 volumes of acetonitrile for chromatography R and 93 volumes of a 1.36 g/L solution of sodium acetate R containing 5.0 mL/L of glacial acetic acid R.

*Flow rate:* 2.0 mL/min.

*Detection:* spectrophotometer at 272 nm.

*Injection:* 20  $\mu$ L.

*Run time:* 3.5 times the retention time of theophylline.

*Relative retention* with reference to theophylline (retention time = about 6 min): impurity C = about 0.3; impurity B = about 0.4; impurity D = about 0.5; impurity A = about 2.5.

*System suitability:* reference solution (b):

- resolution: minimum 2.0 between the peaks due to theobromine and theophylline.

*Limits:*

- impurities A, B, C, D: for each impurity, not more than the area of the principal peak in the chromatogram obtained with reference solution (a) (0.1 per cent);
- any other impurity: for each impurity, not more than the area of the principal peak in the chromatogram obtained with reference solution (a) (0.1 per cent);
- total: not more than 5 times the area of the principal peak in the chromatogram obtained with reference solution (a) (0.5 per cent);
- disregard limit: 0.5 times the area of the principal peak in the chromatogram obtained with reference solution (a) (0.05 per cent).

**Heavy metals** (2.4.8): maximum 20 ppm.

1.0 g complies with test C. Prepare the reference solution using 2 mL of lead standard solution (10 ppm Pb) R.

**Water** (2.5.12): 8.0 per cent to 9.5 per cent, determined on 0.20 g.

**Sulfated ash** (2.4.14): maximum 0.1 per cent, determined on 1.0 g.

## ASSAY

Dissolve 0.160 g in 100 mL of water R, add 20 mL of 0.1 M silver nitrate and shake. Add 1 mL of bromothymol blue solution R1. Titrate with 0.1 M sodium hydroxide.

1 mL of 0.1 M sodium hydroxide is equivalent to 18.02 mg of C<sub>7</sub>H<sub>8</sub>N<sub>4</sub>O<sub>2</sub>.

## IMPURITIES

*Specified impurities:* A, B, C, D.

*Other detectable impurities* (the following substances would, if present at a sufficient level, be detected by one or other of the tests in the monograph. They are limited by the general acceptance criterion for other/unspecified impurities and/or by the general monograph *Substances for pharmaceutical use* (2034). It is therefore not necessary to identify these impurities for demonstration of compliance. See also 5.10. *Control of impurities in substances for pharmaceutical use*): E, F.

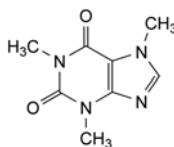

A. 1,3,7-trimethyl-3,7-dihydro-1H-purine-2,6-dione (caffeine),

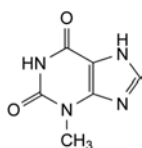

B. 3-methyl-3,7-dihydro-1H-purine-2,6-dione,

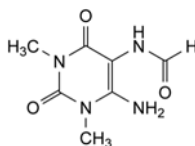

C. N-(6-amino-1,3-dimethyl-2,4-dioxo-1,2,3,4-tetrahydropyrimidin-5-yl)formamide,

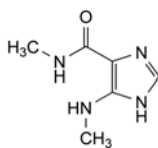

D. N-methyl-5-(methylamino)-1H-imidazole-4-carboxamide (theophyllidine),

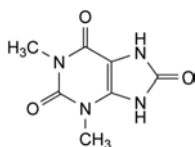

E. 1,3-dimethyl-7,9-dihydro-1H-purine-2,6,8(3H)-trione,

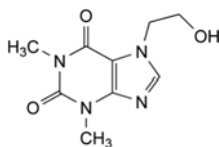

F. 7-(2-hydroxyethyl)-1,3-dimethyl-3,7-dihydro-1H-purine-2,6-dione (etofylline).

07/2010:0300

## THEOPHYLLINE-ETHYLENEDIAMINE, ANHYDROUS

Theophyllinum et ethylenediaminum  
anhydricum

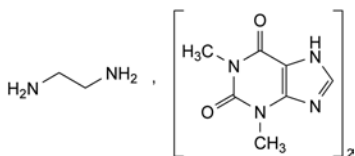

$C_{16}H_{24}N_{10}O_4$   
[317-34-0]

$M_r$  420.4

### DEFINITION

#### Content:

- *theophylline* ( $C_7H_8N_4O_2$ ;  $M_r$  180.2): 84.0 per cent to 87.4 per cent (anhydrous substance);
- *ethylenediamine* ( $C_2H_8N_2$ ;  $M_r$  60.1): 13.5 per cent to 15.0 per cent (anhydrous substance).

### CHARACTERS

**Appearance:** white or slightly yellowish powder, sometimes granular, hygroscopic.

**Solubility:** freely soluble in water (the solution becomes cloudy through absorption of carbon dioxide), practically insoluble in anhydrous ethanol.

### IDENTIFICATION

**First identification:** B, C, E.

**Second identification:** A, C, D, E, F.

Dissolve 1.0 g in 10 mL of *water R* and add 2 mL of *dilute hydrochloric acid R* dropwise with shaking. Filter. Use the precipitate for identification tests A, B, D and F and the filtrate for identification test C.

A. Melting point (2.2.14): 270 °C to 274 °C, determined after washing the precipitate with *water R* and drying at 105 °C.

B. Infrared absorption spectrophotometry (2.2.24).

**Preparation:** precipitate, washed with *water R* and dried at 105 °C.

**Comparison:** *theophylline CRS*.

C. To the filtrate add 0.2 mL of *benzoyl chloride R*, make alkaline with *dilute sodium hydroxide solution R* and shake vigorously. Filter the precipitate, wash with 10 mL of *water R*, dissolve in 5 mL of hot *ethanol (96 per cent) R* and add 5 mL of *water R*. A precipitate is formed, which, when washed and dried at 105 °C, melts (2.2.14) at 248 °C to 252 °C.

D. Heat about 10 mg of the precipitate with 1.0 mL of a 360 g/L solution of *potassium hydroxide R* in a water-bath at 90 °C for 3 min, then add 1.0 mL of *diazotised sulfanilic acid solution R*. A red colour slowly develops. Carry out a blank test.

E. Water (see Tests).

F. The precipitate gives the reaction of xanthines (2.3.1).

### TESTS

**Appearance of solution.** The solution is not more opalescent than reference suspension II (2.2.1) and not more intensely coloured than reference solution GY<sub>6</sub> (2.2.2, Method II).

Dissolve 0.5 g with gentle warming in 10 mL of *carbon dioxide-free water R*.

**Related substances.** Liquid chromatography (2.2.29).

**Test solution.** Dissolve 47 mg of the substance to be examined in the mobile phase and dilute to 20.0 mL with the mobile phase.

**Reference solution (a).** Dilute 1.0 mL of the test solution to 100.0 mL with the mobile phase. Dilute 1.0 mL of this solution to 10.0 mL with the mobile phase.

**Reference solution (b).** Dissolve 10 mg of *theobromine R* (impurity G) in the mobile phase, add 5 mL of the test solution and dilute to 100 mL with the mobile phase. Dilute 5 mL of this solution to 50 mL with the mobile phase.

**Column:**

- **size:**  $l = 0.25$  m,  $\varnothing = 4$  mm;
- **stationary phase:** *octadecylsilyl silica gel for chromatography R* (7  $\mu$ m).

**Mobile phase:** mix 7 volumes of *acetonitrile for chromatography R* and 93 volumes of a 1.36 g/L solution of *sodium acetate R* containing 0.50 per cent (V/V) of *glacial acetic acid R*.

**Flow rate:** 2.0 mL/min.

**Detection:** spectrophotometer at 272 nm.

**Injection:** 20  $\mu$ L.

**Run time:** 3.5 times the retention time of theophylline.

**Relative retention** with reference to theophylline (retention time = about 6 min): impurity G = about 0.6.

**System suitability:** reference solution (b):

- **resolution:** minimum 2.0 between the peaks due to impurity G and theophylline.

**Limits:**

- **unspecified impurities:** for each impurity, not more than the area of the principal peak in the chromatogram obtained with reference solution (a) (0.10 per cent);
- **total:** not more than the area of the principal peak in the chromatogram obtained with reference solution (a) (0.1 per cent);
- **disregard limit:** 0.5 times the area of the principal peak in the chromatogram obtained with reference solution (a) (0.05 per cent).

**Heavy metals** (2.4.8): maximum 20 ppm.

**Solvent:** *water R*.

0.500 g complies with test H. Prepare the reference solution using 1 mL of *lead standard solution (10 ppm Pb) R*. The substance precipitates after addition of *buffer solution pH 3.5 R*. Dilute to 100 mL with *water R*; the substance re-dissolves completely.

**Water** (2.5.12): maximum 1.5 per cent, determined on 0.50 g.

**Sulfated ash** (2.4.14): maximum 0.1 per cent, determined on 1.0 g.

### ASSAY

**Ethylenediamine.** Dissolve 0.250 g in 30 mL of *water R*. Add 0.1 mL of *bromocresol green solution R*. Titrate with 0.1 M *hydrochloric acid* until a green colour is obtained.

1 mL of 0.1 M *hydrochloric acid* is equivalent to 3.005 mg of  $C_2H_8N_2$ .

**Theophylline.** Heat 0.200 g to constant mass in an oven at 135 °C. Dissolve the residue with heating in 100 mL of *water R*, allow to cool, add 20 mL of 0.1 M *silver nitrate* and shake. Add 1 mL of *bromothymol blue solution R1*. Titrate with 0.1 M *sodium hydroxide*.

1 mL of 0.1 M *sodium hydroxide* is equivalent to 18.02 mg of  $C_7H_8N_4O_2$ .

### STORAGE

In an airtight container, protected from light.

### IMPURITIES

**Other detectable impurities** (the following substances would, if present at a sufficient level, be detected by one or other of the tests in the monograph. They are limited by the general acceptance criterion for other/unspecified impurities and/or by the general monograph *Substances for pharmaceutical use*

07/2010:0301

(2034). It is therefore not necessary to identify these impurities for demonstration of compliance. See also 5.10. *Control of impurities in substances for pharmaceutical use*: A, B, C, D, E, F, G.

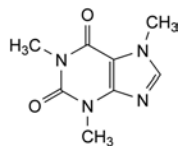

A. 1,3,7-trimethyl-3,7-dihydro-1H-purine-2,6-dione (caffeine),

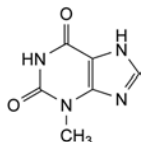

B. 3-methyl-3,7-dihydro-1H-purine-2,6-dione,

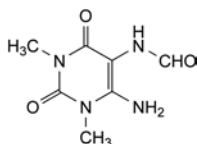
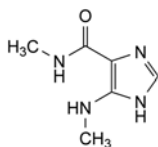
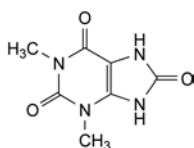
C. *N*-(6-amino-1,3-dimethyl-2,4-dioxo-1,2,3,4-tetrahydropyrimidin-5-yl)formamide,D. *N*-methyl-5-(methylamino)-1H-imidazole-4-carboxamide,

E. 1,3-dimethyl-7,9-dihydro-1H-purine-2,6,8(3H)-trione,

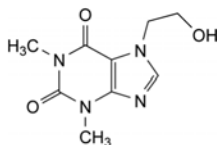

F. 7-(2-hydroxyethyl)-1,3-dimethyl-3,7-dihydro-1H-purine-2,6-dione (etofylline),

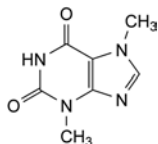

G. 3,7-dimethyl-3,7-dihydro-1H-purine-2,6-dione (theobromine).

## THEOPHYLLINE-ETHYLENEDIAMINE HYDRATE

### Theophyllum et ethylenediaminum hydricum

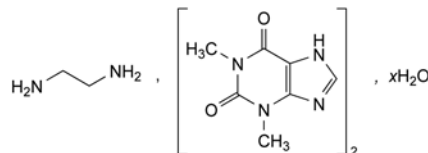

$C_{16}H_{24}N_{10}O_4 \cdot xH_2O$   
[72487-55-9]

$M_r$  420.4 (anhydrous substance)

#### DEFINITION

##### Content:

- *theophylline* ( $C_7H_8N_4O_2$ ;  $M_r$  180.2): 84.0 per cent to 87.4 per cent (anhydrous substance);
- *ethylenediamine* ( $C_2H_8N_2$ ;  $M_r$  60.1): 13.5 per cent to 15.0 per cent (anhydrous substance).

#### CHARACTERS

*Appearance*: white or slightly yellowish powder, sometimes granular.

*Solubility*: freely soluble in water (the solution becomes cloudy through absorption of carbon dioxide), practically insoluble in anhydrous ethanol.

#### IDENTIFICATION

*First identification*: B, C, E.

*Second identification*: A, C, D, E, F.

Dissolve 1.0 g in 10 mL of *water R* and add 2 mL of *dilute hydrochloric acid R* dropwise with shaking. Filter. Use the precipitate for identification tests A, B, D and F and the filtrate for identification test C.

- Melting point (2.2.14): 270 °C to 274 °C, determined after washing the precipitate with *water R* and drying at 105 °C.
- Infrared absorption spectrophotometry (2.2.24).

*Preparation*: precipitate, washed with *water R* and dried at 105 °C.

*Comparison*: *theophylline CRS*.

- To the filtrate add 0.2 mL of *benzoyl chloride R*, make alkaline with *dilute sodium hydroxide solution R* and shake vigorously. Filter the precipitate, wash with 10 mL of *water R*, dissolve in 5 mL of hot *ethanol (96 per cent) R* and add 5 mL of *water R*. A precipitate is formed, which, when washed and dried at 105 °C, melts (2.2.14) at 248 °C to 252 °C.
- Heat about 10 mg of the precipitate with 1.0 mL of a 360 g/L solution of *potassium hydroxide R* in a water-bath at 90 °C for 3 min, then add 1.0 mL of *diazotised sulfanilic acid solution R*. A red colour slowly develops. Carry out a blank test.

E. Water (see Tests).

F. The precipitate gives the reaction of xanthines (2.3.1).

#### TESTS

**Appearance of solution.** The solution is not more opalescent than reference suspension II (2.2.1) and not more intensely coloured than reference solution GY<sub>6</sub> (2.2.2, *Method II*).

Dissolve 0.5 g with gentle warming in 10 mL of *carbon dioxide-free water R*.

**Related substances.** Liquid chromatography (2.2.29).

*Test solution.* Dissolve 50 mg of the substance to be examined in the mobile phase and dilute to 20.0 mL with the mobile phase.

**Reference solution (a).** Dilute 1.0 mL of the test solution to 100.0 mL with the mobile phase. Dilute 1.0 mL of this solution to 10.0 mL with the mobile phase.

**Reference solution (b).** Dissolve 10 mg of *theobromine R* (impurity G) in the mobile phase, add 5 mL of the test solution and dilute to 100 mL with the mobile phase. Dilute 5 mL of this solution to 50 mL with the mobile phase.

**Column:**

- size:  $l = 0.25$  m,  $\varnothing = 4$  mm;
- stationary phase: octadecylsilyl silica gel for chromatography R (7  $\mu$ m).

**Mobile phase:** mix 7 volumes of acetonitrile for chromatography R and 93 volumes of a 1.36 g/L solution of sodium acetate R containing 0.50 per cent (V/V) of glacial acetic acid R.

**Flow rate:** 2.0 mL/min.

**Detection:** spectrophotometer at 272 nm.

**Injection:** 20  $\mu$ L.

**Run time:** 3.5 times the retention time of theophylline.

**Relative retention** with reference to theophylline (retention time = about 6 min): impurity G = about 0.6.

**System suitability:** reference solution (b):

- resolution: minimum 2.0 between the peaks due to impurity G and theophylline.

**Limits:**

- *unspecified impurities:* for each impurity, not more than the area of the principal peak in the chromatogram obtained with reference solution (a) (0.10 per cent);
- *total:* not more than the area of the principal peak in the chromatogram obtained with reference solution (a) (0.1 per cent);
- *disregard limit:* 0.5 times the area of the principal peak in the chromatogram obtained with reference solution (a) (0.05 per cent).

**Heavy metals (2.4.8):** maximum 20 ppm.

**Solvent:** water R.

0.500 g complies with test H. Prepare the reference solution using 1 mL of *lead standard solution (10 ppm Pb) R*. The substance precipitates after addition of *buffer solution pH 3.5 R*. Dilute to 100 mL with water R; the substance re-dissolves completely.

**Water (2.5.12):** 3.0 per cent to 8.0 per cent, determined on 0.50 g.

**Sulfated ash (2.4.14):** maximum 0.1 per cent, determined on 1.0 g.

**ASSAY**

**Ethylenediamine.** Dissolve 0.250 g in 30 mL of water R. Add 0.1 mL of *bromocresol green solution R*. Titrate with 0.1 M *hydrochloric acid* until a green colour is obtained.

1 mL of 0.1 M *hydrochloric acid* is equivalent to 3.005 mg of  $C_2H_8N_2$ .

**Theophylline.** Heat 0.200 g to constant mass in an oven at 135 °C. Dissolve the residue with heating in 100 mL of water R, allow to cool, add 20 mL of 0.1 M *silver nitrate* and shake. Add 1 mL of *bromothymol blue solution R1*. Titrate with 0.1 M *sodium hydroxide*.

1 mL of 0.1 M *sodium hydroxide* is equivalent to 18.02 mg of  $C_7H_8N_4O_2$ .

**STORAGE**

In a well-filled, airtight container, protected from light.

## IMPURITIES

*Other detectable impurities* (the following substances would, if present at a sufficient level, be detected by one or other of the tests in the monograph. They are limited by the general acceptance criterion for other/unspecified impurities and/or by the general monograph *Substances for pharmaceutical use (2034)*. It is therefore not necessary to identify these impurities for demonstration of compliance. See also 5.10. *Control of impurities in substances for pharmaceutical use*): A, B, C, D, E, F, G.

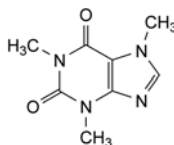

A. 1,3,7-trimethyl-3,7-dihydro-1H-purine-2,6-dione (caffeine),

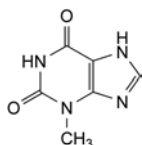

B. 3-methyl-3,7-dihydro-1H-purine-2,6-dione,

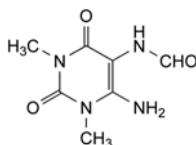

C. *N*-(6-amino-1,3-dimethyl-2,4-dioxo-1,2,3,4-tetrahydropyrimidin-5-yl)formamide,

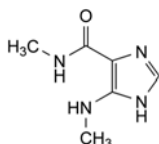

D. *N*-methyl-5-(methylamino)-1H-imidazole-4-carboxamide,

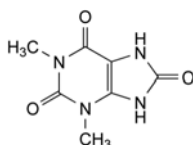

E. 1,3-dimethyl-7,9-dihydro-1H-purine-2,6,8(3H)-trione,

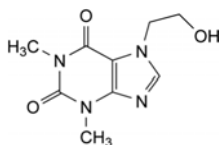

F. 7-(2-hydroxyethyl)-1,3-dimethyl-3,7-dihydro-1H-purine-2,6-dione (etofylline),

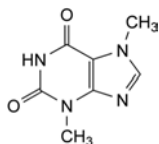

G. 3,7-dimethyl-3,7-dihydro-1H-purine-2,6-dione (theobromine).

## THIAMAZOLE

## Thiamazolium

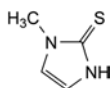

C<sub>4</sub>H<sub>6</sub>N<sub>2</sub>S  
[60-56-0]

M<sub>r</sub> 114.2

## DEFINITION

1-Methyl-1,3-dihydro-2H-imidazole-2-thione.

Content: 98.0 per cent to 101.0 per cent (dried substance).

## CHARACTERS

Appearance: white or pale brown, crystalline powder.

Solubility: freely soluble in water, freely soluble in methylene chloride, freely soluble or soluble in ethanol (96 per cent).

## IDENTIFICATION

First identification: A, C.

Second identification: A, B, D.

A. Melting point (2.2.14): 143 °C to 146 °C.

B. Dissolve 25 mg in 10 mL of a 0.28 per cent V/V solution of sulfuric acid R and dilute to 50.0 mL with the same solution. Dilute 1.0 mL of this solution to 100.0 mL with a 0.28 per cent V/V solution of sulfuric acid R. Examined between 200 nm and 300 nm (2.2.25), the solution shows 2 absorption maxima, at 211 nm and 251 nm. The ratio of the absorbance measured at the absorption maximum at 251 nm to that measured at the absorption maximum at 211 nm is 2.5 to 2.7.

C. Infrared absorption spectrophotometry (2.2.24).

Preparation: discs.

Comparison: thiamazole CRS.

D. Thin-layer chromatography (2.2.27).

Test solution. Dissolve 5.0 mg of the substance to be examined in methanol R and dilute to 5.0 mL with the same solvent.

Reference solution (a). Dissolve 5.0 mg of thiamazole CRS in methanol R and dilute to 5.0 mL with the same solvent.

Reference solution (b). Dissolve 5.0 mg of 2-methylimidazole R in methanol R and dilute to 5.0 mL with the same solvent. Dilute 1.0 mL of this solution to 2.0 mL with the test solution.

Plate: TLC silica gel F<sub>254</sub> plate R.

Mobile phase: concentrated ammonia R1, 2-propanol R, toluene R (1:24:75 V/V/V).

Application: 10 µL.

Development: over 2/3 of the plate.

Drying: in air.

Detection: examine in ultraviolet light at 254 nm.

System suitability: reference solution (b):

- expose the plate to iodine vapour for 30 min; the chromatogram shows 2 clearly separated spots.

Results: the principal spot in the chromatogram obtained with the test solution is similar in position and size to the principal spot in the chromatogram obtained with reference solution (a).

## 01/2008:1706 TESTS

corrected 6.0

**Solution S.** Dissolve 2.0 g in water R and dilute to 20.0 mL with the same solvent.

**Appearance of solution.** Solution S is clear (2.2.1) and not more intensely coloured than reference solution B<sub>6</sub> (2.2.2, Method II).

**Related substances.** Gas chromatography (2.2.28).

**Test solution.** Dissolve 0.100 g of the substance to be examined in chloroform R and dilute to 10.0 mL with the same solvent.

**Reference solution (a).** Dilute 1.0 mL of the test solution to 100.0 mL with chloroform R. Dilute 1.0 mL of this solution to 10.0 mL with chloroform R.

**Reference solution (b).** Dissolve 5.0 mg of thiamazole impurity A CRS, 5.0 mg of 1-methylimidazole R1 and 5.0 mg of thiamazole impurity C CRS in chloroform R and dilute to 50.0 mL with the same solvent. Dilute 1.0 mL of this solution to 10.0 mL with chloroform R.

Column:

- material: fused silica,
- size: *l* = 30.0 m, Ø = 0.25 mm,
- stationary phase: poly(dimethyl)(diphenyl)siloxane R with special deactivation for basic compounds (film thickness 0.5 µm).

Carrier gas: helium for chromatography R.

Flow rate: 1.5 mL/min.

Split ratio: 3:20.

Temperature:

	Time (min)	Temperature (°C)
Column	0 - 2	100
	2 - 7	100 → 250
	7 - 22	250
Injection port		150
Detector		250

Detection: flame ionisation.

Injection: 1 µL.

Relative retention with reference to thiamazole (retention time = about 6.5 min): impurity A = about 0.3; impurity B = about 0.4; impurity C = about 0.7.

System suitability: reference solution (b):

- resolution: minimum 1.5 between the peaks due to impurity A and impurity B.

Limits:

- impurities A, B, C: for each impurity, not more than the area of the corresponding peak in the chromatogram obtained with reference solution (b) (0.1 per cent),
- any other impurity: for each impurity, not more than the area of the principal peak in the chromatogram obtained with reference solution (a) (0.1 per cent),
- total: not more than 5 times the area of the principal peak in the chromatogram obtained with reference solution (a) (0.5 per cent),
- disregard limit: 0.2 times the area of the principal peak in the chromatogram obtained with reference solution (a) (0.02 per cent).

Heavy metals (2.4.8): maximum 10 ppm.

12 mL of solution S complies with limit test A. Prepare the reference solution using lead standard solution (1 ppm Pb) R.

Loss on drying (2.2.32): maximum 0.5 per cent, determined on 1.000 g by drying in an oven at 105 °C for 2 h.

Sulfated ash (2.4.14): maximum 0.1 per cent, determined on 1.0 g.

## ASSAY

Dissolve 0.250 g in 75 mL of *water R*. Add 15.0 mL of 0.1 M *sodium hydroxide*, mix and add with stirring, about 30 mL of 0.1 M *silver nitrate*. Continue the titration with 0.1 M *sodium hydroxide*, determining the end-point potentiometrically (2.2.20).

1 mL of 0.1 M *sodium hydroxide* is equivalent to 11.42 mg of  $C_4H_6N_2S$ .

## IMPURITIES

Specified impurities: A, B, C.

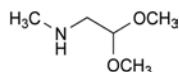

A. 2,2-dimethoxy-N-methylethanamine,

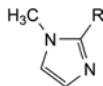

B. R = H: 1-methyl-1H-imidazole,

C. R = SCH<sub>3</sub>: 1-methyl-2-(methylsulfonyl)-1H-imidazole.

01/2008:0303

## THIAMINE HYDROCHLORIDE

## Thiamini hydrochloridum

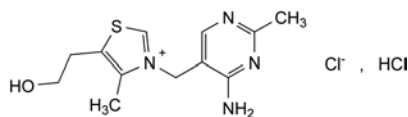

$C_{12}H_{18}Cl_2N_4OS$   
[67-03-8]

$M_r$  337.3

## DEFINITION

3-[(4-Amino-2-methylpyrimidin-5-yl)methyl]-5-(2-hydroxyethyl)-4-methylthiazolium chloride hydrochloride.

Content: 98.5 per cent to 101.0 per cent (anhydrous substance).

## CHARACTERS

Appearance: white or almost white, crystalline powder or colourless crystals.

Solubility: freely soluble in water, soluble in glycerol, slightly soluble in alcohol.

## IDENTIFICATION

First identification: A, C.

Second identification: B, C.

A. Infrared absorption spectrophotometry (2.2.24).

Comparison: *thiamine hydrochloride CRS*.

B. Dissolve about 20 mg in 10 mL of *water R*, add 1 mL of *dilute acetic acid R* and 1.6 mL of 1 M *sodium hydroxide*, heat on a water-bath for 30 min and allow to cool. Add 5 mL of *dilute sodium hydroxide solution R*, 10 mL of *potassium ferricyanide solution R* and 10 mL of *butanol R* and shake vigorously for 2 min. The upper alcoholic layer shows an intense light-blue fluorescence, especially in ultraviolet light at 365 nm. Repeat the test using 0.9 mL of 1 M *sodium hydroxide* and 0.2 g of *sodium sulfite R* instead of 1.6 mL of 1 M *sodium hydroxide*. Practically no fluorescence is seen.

C. It gives reaction (a) of chlorides (2.3.1).

## TESTS

**Solution S.** Dissolve 2.5 g in *distilled water R* and dilute to 25 mL with the same solvent.

**Appearance of solution.** The solution is clear (2.2.1) and not more intensely coloured than reference solution Y<sub>7</sub> or GY<sub>7</sub> (2.2.2, Method II).

Dilute 2.5 mL of solution S to 5 mL with *water R*.

pH (2.2.3): 2.7 to 3.3.

Dilute 2.5 mL of solution S to 10 mL with *water R*.

**Related substances.** Liquid chromatography (2.2.29).

**Solution A.** Add 5 volumes of *glacial acetic acid R* to 95 volumes of *water R* and mix.

**Test solution.** Dissolve 0.35 g of the substance to be examined in 15.0 mL of solution A and dilute to 100.0 mL with *water R*.

**Reference solution (a).** Dissolve 5 mg of the substance to be examined and 5 mg of *thiamine impurity E CRS* in 4 mL of solution A and dilute to 25.0 mL with *water R*. Dilute 5.0 mL of the solution to 25.0 mL with *water R*.

**Reference solution (b).** Dilute 1.0 mL of the test solution to 50.0 mL with *water R*. Dilute 5.0 mL of this solution to 25.0 mL with *water R*.

Column:

– size:  $l = 0.25$  m,  $\varnothing = 4.0$  mm,

– stationary phase: spherical *end-capped octadecylsilyl silica gel for chromatography R* (5  $\mu$ m) with a specific surface area of 350 m<sup>2</sup>/g and a pore size of 10 nm,

– temperature: 45 °C.

Mobile phase:

– mobile phase A: 3.764 g/L solution of *sodium hexanesulfonate R* adjusted to pH 3.1 with *phosphoric acid R*,

– mobile phase B: *methanol R2*,

Time (min)	Mobile phase A (per cent V/V)	Mobile phase B (per cent V/V)
0 - 25	90 → 70	10 → 30
25 - 33	70 → 50	30 → 50
33 - 40	50	50
40 - 45	50 → 90	50 → 10

Flow rate: 1.0 mL/min.

Detection: spectrophotometer at 248 nm.

Injection: 25  $\mu$ L.

Relative retention with reference to thiamine (retention time = about 30 min): impurity A = about 0.3; impurity B = about 0.9; impurity C = about 1.2.

System suitability: reference solution (a):

– resolution: minimum 1.6 between the peaks due to impurity E and to thiamine.

Limits:

– any impurity: not more than the area of the principal peak in the chromatogram obtained with reference solution (b) (0.4 per cent),

– total: not more than 2.5 times the area of the principal peak in the chromatogram obtained with reference solution (b) (1.0 per cent),

– disregard limit: 0.125 times the area of the principal peak in the chromatogram obtained with reference solution (b) (0.05 per cent).

**Sulfates** (2.4.13): maximum 300 ppm.

5 mL of solution S diluted to 15 mL with *distilled water R* complies with the limit test for sulfates.

**Heavy metals** (2.4.8): maximum 20 ppm.

12 mL of solution S complies with limit test A. Prepare the standard using *lead standard solution (2 ppm Pb) R*.

**Water** (2.5.12): maximum 5.0 per cent, determined on 0.40 g.

**Sulfated ash** (2.4.14): maximum 0.1 per cent, determined on 1.0 g.

## ASSAY

Dissolve 0.110 g in 5 mL of *anhydrous formic acid R* and add 50 mL of *acetic anhydride R*. Titrate immediately with 0.1 M *perchloric acid*, determining the end-point potentiometrically (2.2.20) and carrying out the titration within 2 min. Carry out a blank titration.

1 mL of 0.1 M *perchloric acid* is equivalent to 16.86 mg of  $C_{12}H_{18}Cl_2N_4OS$ .

## STORAGE

In a non-metallic container, protected from light.

## IMPURITIES

*Specified impurities: A, B, C.*

*Other detectable impurities* (the following substances would, if present at a sufficient level, be detected by one or other of the tests in the monograph. They are limited by the general acceptance criterion for other/unspecified impurities and/or by the general monograph *Substances for pharmaceutical use (2034)*. It is therefore not necessary to identify these impurities for demonstration of compliance. See also 5.10. *Control of impurities in substances for pharmaceutical use*): D, E, F, G, H.

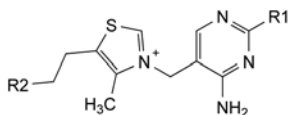

- A. R1 = CH<sub>3</sub>, R2 = O-SO<sub>3</sub><sup>-</sup>: 3-[(4-amino-2-methylpyrimidin-5-yl)methyl]-4-methyl-5-[2-(sulfonatoxy)ethyl]thiazolium (thiamine sulfate ester),
- B. R1 = H, R2 = OH: 3-[(4-aminopyrimidin-5-yl)methyl]-5-(2-hydroxyethyl)-4-methylthiazolium (desmethylthiamine),
- C. R1 = CH<sub>3</sub>, R2 = Cl: 3-[(4-amino-2-methylpyrimidin-5-yl)methyl]-5-(2-chloroethyl)-4-methylthiazolium (chlorothiamine),
- F. R1 = C<sub>2</sub>H<sub>5</sub>, R2 = OH: 3-[(4-amino-2-ethylpyrimidin-5-yl)methyl]-5-(2-hydroxyethyl)-4-methylthiazolium (ethylthiamine),
- G. R1 = CH<sub>3</sub>, R2 = O-CO-CH<sub>3</sub>: 5-[2-(acetyloxy)ethyl]-3-[(4-amino-2-methylpyrimidin-5-yl)methyl]-4-methylthiazolium (acetylthiamine),

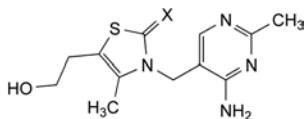

- D. X = O: 3-[(4-amino-2-methylpyrimidin-5-yl)methyl]-5-(2-hydroxyethyl)-4-methylthiazol-2(3H)-one (oxothiamine),
- E. X = S: 3-[(4-amino-2-methylpyrimidin-5-yl)methyl]-5-(2-hydroxyethyl)-4-methylthiazol-2(3H)-thione (thioxothiamine),

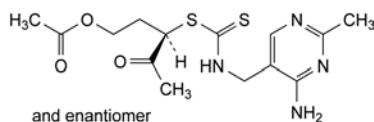

- H. (3*R*S)-3-[[[(4-amino-2-methylpyrimidin-5-yl)methyl]thiocarbonyl]sulfanyl]-4-oxopentyl acetate (ketodithiocarbamate).

01/2008:0531  
corrected 6.0

## THIAMINE NITRATE

## Thiamini nitras

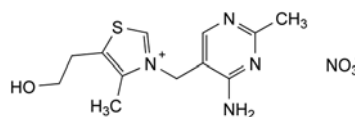

$C_{12}H_{17}N_5O_4S$   
[532-43-4]

$M_r$  327.4

## DEFINITION

3-[(4-Amino-2-methylpyrimidin-5-yl)methyl]-5-(2-hydroxyethyl)-4-methylthiazolium nitrate.

*Content*: 98.0 per cent to 101.0 per cent (dried substance).

## CHARACTERS

*Appearance*: white or almost white, crystalline powder or small, colourless crystals.

*Solubility*: sparingly soluble in water, freely soluble in boiling water, slightly soluble in alcohol and in methanol.

## IDENTIFICATION

*First identification: A, C.*

*Second identification: B, C.*

A. Infrared absorption spectrophotometry (2.2.24).

*Comparison: Ph. Eur. reference spectrum of thiamine nitrate.*

B. Dissolve about 20 mg in 10 mL of *water R*, add 1 mL of *dilute acetic acid R* and 1.6 mL of 1 M *sodium hydroxide*, heat on a water-bath for 30 min and allow to cool. Add 5 mL of *dilute sodium hydroxide solution R*, 10 mL of *potassium ferricyanide solution R* and 10 mL of *butanol R* and shake vigorously for 2 min. The upper alcoholic layer shows an intense light-blue fluorescence, especially in ultraviolet light at 365 nm. Repeat the test using 0.9 mL of 1 M *sodium hydroxide* and 0.2 g of *sodium sulfite R* instead of 1.6 mL of 1 M *sodium hydroxide*. Practically no fluorescence is produced.

C. About 5 mg gives the reaction of nitrates (2.3.1).

## TESTS

**Solution S.** Dissolve 1.0 g in *carbon dioxide-free water R* and dilute to 50 mL with the same solvent.

**Appearance of solution.** Solution S is clear (2.2.1) and not more intensely coloured than reference solution Y<sub>7</sub> (2.2.2, *Method II*).

**pH** (2.2.3): 6.8 to 7.6 for solution S.

**Related substances.** Liquid chromatography (2.2.29).

**Solution A.** Add 5 volumes of *glacial acetic acid R* to 95 volumes of *water R* and mix.

**Test solution.** Dissolve 0.35 g of the substance to be examined in 15.0 mL of solution A and dilute to 100.0 mL with *water R*.

**Reference solution (a).** Dissolve 5 mg of the substance to be examined and 5 mg of *thiamine impurity E CRS* in 4 mL of solution A and dilute to 25.0 mL with *water R*. Dilute 5.0 mL of the solution to 25.0 mL with *water R*.

**Reference solution (b).** Dilute 1.0 mL of the test solution to 100.0 mL with *water R*.

**Column:**

- *size*:  $l = 0.25$  m,  $\varnothing = 4.0$  mm,
- *stationary phase*: spherical *end-capped octadecylsilyl silica gel for chromatography R* (4  $\mu$ m) with a specific surface area of 350 m<sup>2</sup>/g and a pore size of 10 nm,
- *temperature*: 45 °C.

## Mobile phase:

- mobile phase A: 3.764 g/L solution of sodium hexanesulfonate *R* adjusted to pH 3.1 with phosphoric acid *R*,
- mobile phase B: methanol *R2*,

Time (min)	Mobile phase A (per cent V/V)	Mobile phase B (per cent V/V)
0 - 25	90 → 70	10 → 30
25 - 33	70 → 50	30 → 50
33 - 40	50	50
40 - 45	50 → 90	50 → 10

Flow rate: 1.0 mL/min.

Detection: spectrophotometer at 248 nm.

Injection: 25 µL.

Relative retention with reference to thiamine (retention time = about 30 min): impurity A = about 0.3; impurity B = about 0.9; impurity C = about 1.2.

System suitability: reference solution (a):

- resolution: minimum 1.6 between the peaks due to impurity E and to thiamine.

## Limits:

- any impurity: not more than the area of the principal peak in the chromatogram obtained with reference solution (b) (1.0 per cent),
- total: not more than 1.5 times the area of the principal peak in the chromatogram obtained with reference solution (b) (1.5 per cent),
- disregard limit: 0.05 times the area of the principal peak in the chromatogram obtained with reference solution (b) (0.05 per cent).

Heavy metals (2.4.8): maximum 20 ppm.

1.0 g complies with limit test D. Prepare the standard using 2 mL of lead standard solution (10 ppm Pb) *R*.

Loss on drying (2.2.32): maximum 1.0 per cent, determined on 1.000 g by drying in an oven at 105 °C.

Sulfated ash (2.4.14): maximum 0.1 per cent, determined on 1.0 g.

## ASSAY

Dissolve 0.140 g in 5 mL of anhydrous formic acid *R* and add 50 mL of acetic anhydride *R*. Titrate immediately with 0.1 M perchloric acid, determining the end-point potentiometrically (2.2.20) and carrying out the titration within 2 min. Carry out a blank titration.

1.0 mL of 0.1 M perchloric acid is equivalent to 16.37 mg of C<sub>12</sub>H<sub>17</sub>N<sub>5</sub>O<sub>4</sub>S.

## STORAGE

In a non-metallic container, protected from light.

## IMPURITIES

Specified impurities: A, B, C.

Other detectable impurities (the following substances would, if present at a sufficient level, be detected by one or other of the tests in the monograph. They are limited by the general acceptance criterion for other/unspecified impurities and/or by the general monograph *Substances for pharmaceutical use* (2034). It is therefore not necessary to identify these impurities for demonstration of compliance. See also 5.10. *Control of impurities in substances for pharmaceutical use*): D, E, F, G, H.

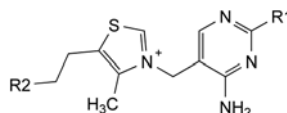

- A. R1 = CH<sub>3</sub>, R2 = O-SO<sub>3</sub><sup>-</sup>: 3-[(4-amino-2-methylpyrimidin-5-yl)methyl]-4-methyl-5-[2-(sulfonatoxy)ethyl]thiazolium (thiamine sulfate ester),
- B. R1 = H, R2 = OH: 3-[(4-aminopyrimidin-5-yl)methyl]-5-(2-hydroxyethyl)-4-methylthiazolium (desmethylthiamine),
- C. R1 = CH<sub>3</sub>, R2 = Cl: 3-[(4-amino-2-methylpyrimidin-5-yl)methyl]-5-(2-chloroethyl)-4-methylthiazolium (chlorothiamine),
- F. R1 = C<sub>2</sub>H<sub>5</sub>, R2 = OH: 3-[(4-amino-2-ethylpyrimidin-5-yl)methyl]-5-(2-hydroxyethyl)-4-methylthiazolium (ethylthiamine),
- G. R1 = CH<sub>3</sub>, R2 = O-CO-CH<sub>3</sub>: 5-[2-(acetyloxy)ethyl]-3-[(4-amino-2-methylpyrimidin-5-yl)methyl]-4-methylthiazolium (acetylthiamine),

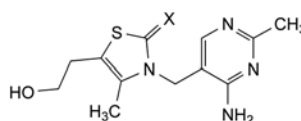

- D. X = O: 3-[(4-amino-2-methylpyrimidin-5-yl)methyl]-5-(2-hydroxyethyl)-4-methylthiazol-2(3*H*)-one (oxothiamine),
- E. X = S: 3-[(4-amino-2-methylpyrimidin-5-yl)methyl]-5-(2-hydroxyethyl)-4-methylthiazol-2(3*H*)-thione (thioxothiamine),

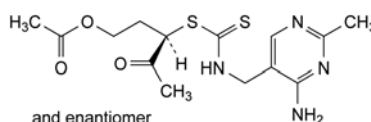

- H. (3*RS*)-3-[[[(4-amino-2-methylpyrimidin-5-yl)methyl]thiocarbonyl]sulfanyl]-4-oxopentyl acetate (ketodithiocarbamate).

01/2008:0109  
corrected 6.0

## THIAMPHENICOL

## Thiamphenicolum

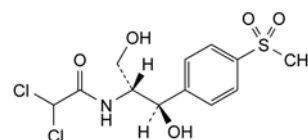

C<sub>12</sub>H<sub>15</sub>Cl<sub>2</sub>NO<sub>5</sub>S  
[15318-45-3]

*M*<sub>r</sub> 356.2

## DEFINITION

2,2-Dichloro-*N*-[(1*R*,2*R*)-2-hydroxy-1-(hydroxymethyl)-2-[4-(methylsulfonyl)phenyl]ethyl]acetamide.

Content: 98.0 per cent to 100.5 per cent (dried substance).

## CHARACTERS

Appearance: fine, white or yellowish-white, crystalline powder or crystals.

Solubility: slightly soluble in water, very soluble in dimethylacetamide, freely soluble in acetonitrile and in dimethylformamide, soluble in methanol, sparingly soluble in acetone and in anhydrous ethanol, slightly soluble in ethyl acetate.

A solution in anhydrous ethanol is dextrorotatory and a solution in dimethylformamide is laevorotatory.



## IDENTIFICATION

## A. Infrared absorption spectrophotometry (2.2.24).

*Preparation:* dry the substance to be examined and the reference substance at 100-105 °C for 2 h; examine as discs of *potassium bromide R*.

*Comparison:* *thiamphenicol CRS*.

## B. Thin-layer chromatography (2.2.27).

*Test solution.* Dissolve 0.1 g of the substance to be examined in *methanol R* and dilute to 10 mL with the same solvent.

*Reference solution.* Dissolve 0.1 g of *thiamphenicol CRS* in *methanol R* and dilute to 10 mL with the same solvent.

*Plate:* *silica gel GF<sub>254</sub> R* as the coating substance.

*Mobile phase:* *methanol R, ethyl acetate R* (3:97 V/V).

*Application:* 5 µL.

*Development:* over a path of 10 cm.

*Drying:* in air.

*Detection:* examine in ultraviolet light at 254 nm.

*Results:* the principal spot in the chromatogram obtained with the test solution is similar in position and size to the spot in the chromatogram obtained with the reference solution.

C. To 50 mg in a porcelain crucible add 0.5 g of *anhydrous sodium carbonate R*. Heat over an open flame for 10 min. Allow to cool. Take up the residue with 5 mL of *dilute nitric acid R* and filter. To 1 mL of the filtrate add 1 mL of *water R*. The solution gives reaction (a) of chlorides (2.3.1).

## TESTS

**Acidity or alkalinity.** Shake 0.1 g with 20 mL of *carbon dioxide-free water R* and add 0.1 mL of *bromothymol blue solution R1*. Not more than 0.1 mL of *0.02 M hydrochloric acid* or *0.02 M sodium hydroxide* is required to change the colour of the indicator.

**Specific optical rotation** (2.2.7): – 21 to – 24 (dried substance). Dissolve 1.25 g in *dimethylformamide R* and dilute to 25.0 mL with the same solvent.

**Melting point** (2.2.14): 163 °C to 167 °C.

**Absorbance** (2.2.25).

*Test solution (a).* Dissolve 20 mg in *water R*, heating to about 40 °C, and dilute to 100.0 mL with the same solvent.

*Test solution (b).* Dilute 2.5 mL of test solution (a) to 50.0 mL with *water R*.

*Spectral range:* 240-300 nm for test solution (a); 200-240 nm for test solution (b).

*Absorption maxima:* at 266 nm and 273 nm for test solution (a); at 224 nm for test solution (b).

*Specific absorbances at the absorption maxima:*

- at 266 nm: 25 to 28 for test solution (a),
- at 273 nm: 21.5 to 23.5 for test solution (a),
- at 224 nm: 370 to 400 for test solution (b).

**Chlorides** (2.4.4): maximum 200 ppm.

Shake 0.5 g with 30 mL of *water R* for 5 min and filter.

**Heavy metals** (2.4.8): maximum 10 ppm.

1.0 g complies with test C. Prepare the reference solution using 1 mL of *lead standard solution (10 ppm Pb) R*.

**Loss on drying** (2.2.32): maximum 1.0 per cent, determined on 1.000 g by drying in an oven at 105 °C.

**Sulfated ash** (2.4.14): maximum 0.1 per cent, determined on 2.0 g.

## ASSAY

Dissolve 0.300 g in 30 mL of *ethanol (96 per cent) R*, add 20 mL of a 500 g/L solution of *potassium hydroxide R*, mix and heat under a reflux condenser for 4 h. Cool, add 100 mL of *water R*, neutralise with *dilute nitric acid R* and add 5 mL of the same acid in excess. Titrate with *0.1 M silver nitrate*, determining the

end-point potentiometrically (2.2.20), using a silver indicator electrode and a mercurous sulfate reference electrode or any other appropriate electrode. Carry out a blank test.

1 mL of *0.1 M silver nitrate* is equivalent to 17.81 mg of  $C_{12}H_{15}Cl_2NO_5S$ .

## STORAGE

In an airtight container, protected from light.

01/2008:1648

## THIOCTIC ACID

## Acidum thiocticum

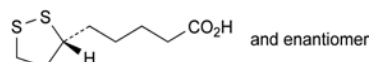

$C_8H_{14}O_2S_2$   
[1077-28-7]

$M_r$  206.3

## DEFINITION

5-[(3*RS*)-1,2-Dithiolan-3-yl]pentanoic acid.

*Content:* 97.0 per cent to 102.0 per cent (dried substance).

## CHARACTERS

*Appearance:* yellow, crystalline powder.

*Solubility:* very slightly soluble in water, very soluble in dimethylformamide, freely soluble in methanol.

mp: about 61 °C.

## IDENTIFICATION

Infrared absorption spectrophotometry (2.2.24).

*Comparison:* *thioctic acid CRS*.

## TESTS

**Appearance of solution.** The solution is clear (2.2.1).

Dissolve 0.50 g in a 20 g/L solution of *sodium hydroxide R* and dilute to 10 mL with the same solution.

**Impurity B.** Thin-layer chromatography (2.2.27).

*Test solution.* Dissolve 0.20 g of the substance to be examined in *dimethylformamide R* and dilute to 10 mL with the same solvent.

*Reference solution.* Dissolve 20 mg of *thioctic acid containing impurity B CRS* in *dimethylformamide R* and dilute to 1.0 mL with the same solvent (1.0 per cent impurity B solution).

*Plate:* *TLC silica gel plate R*.

*Mobile phase:* 25 per cent V/V solution of *ammonia R, water R, ethyl acetate R, propanol R* (5:10:40:40 V/V/V/V).

*Application:* 5 µL.

*Development:* over 2/3 of the plate.

*Drying:* at 50 °C for 20 min.

*Detection:* expose to iodine vapour for 30 min or until the spots appear.

*System suitability:* reference solution:

- the chromatogram shows 2 clearly separated principal spots due to impurity B ( $R_f = 0.0$ ) and thioctic acid ( $R_f =$  about 0.3).

*Limit:*

- *impurity B:* any spot due to impurity B is not more intense than the corresponding spot in the chromatogram obtained with the reference solution (1.0 per cent).

**Related substances.** Liquid chromatography (2.2.29). *Protect the solutions from light.*

*Solvent mixture:* a mixture of equal volumes of *acetonitrile R1* and a 0.7 g/L solution of *potassium dihydrogen phosphate R* previously adjusted to pH 3.6 with *phosphoric acid R*.

*Test solution.* Dissolve 50.0 mg of the substance to be examined in the solvent mixture and dilute to 50.0 mL with the solvent mixture.

**Reference solution (a).** Dissolve 5 mg of *thioctic acid* for system suitability CRS (containing impurity A) in the solvent mixture and dilute to 5 mL with the solvent mixture.

**Reference solution (b).** Dilute 1.0 mL of the test solution to 100.0 mL with the solvent mixture. Dilute 1.0 mL of this solution to 10.0 mL with the solvent mixture.

**Reference solution (c).** Dissolve 50.0 mg of *thioctic acid* CRS in the solvent mixture and dilute to 50.0 mL with the solvent mixture.

**Blank solution.** Solvent mixture.

**Column:**

- size:  $l = 0.25$  m,  $\varnothing = 4.6$  mm;
- stationary phase: octadecylsilyl silica gel for chromatography R (5  $\mu$ m);
- temperature: 35 °C.

**Mobile phase:** mix 8 volumes of *acetonitrile* R1, 41 volumes of a 0.7 g/L solution of *potassium dihydrogen phosphate* R previously adjusted to pH 3.0 with *phosphoric acid* R, and 51 volumes of *methanol* R.

**Flow rate:** 1.2 mL/min.

**Detection:** spectrophotometer at 215 nm.

**Injection:** 20  $\mu$ L.

**Run time:** 2.5 times the retention time of *thioctic acid*.

**Relative retention** with reference to *thioctic acid* (retention time = about 6 min): impurity A = about 2.2.

**System suitability:**

- resolution: minimum 6.0 between the peaks due to *thioctic acid* and impurity A in the chromatogram obtained with reference solution (a);
- symmetry factor: maximum 2.0 for the peak due to *thioctic acid* in the chromatogram obtained with reference solution (c).

**Limits:**

- correction factor: for the calculation of content, multiply the peak area of impurity A by 0.6;
- impurity A: not more than twice the area of the principal peak in the chromatogram obtained with reference solution (b) (0.2 per cent);
- unspecified impurities: for each impurity, not more than the area of the principal peak in the chromatogram obtained with reference solution (b) (0.10 per cent);
- total: not more than 3 times the area of the principal peak in the chromatogram obtained with reference solution (b) (0.3 per cent);
- disregard limit: 0.5 times the area of the principal peak in the chromatogram obtained with reference solution (b) (0.05 per cent).

**Loss on drying** (2.2.32): maximum 0.2 per cent, determined on 1.000 g by drying *in vacuo* at 40 °C for 3 h.

**Sulfated ash** (2.4.14): maximum 0.1 per cent, determined on 1.0 g.

**ASSAY**

Liquid chromatography (2.2.29) as described in the test for related substances with the following modification.

**Injection:** test solution and reference solution (c).

Calculate the percentage content of  $C_8H_{14}O_2S_2$  from the peak areas and the declared content of *thioctic acid* CRS.

**STORAGE**

Protected from light.

**IMPURITIES**

**Specified impurities:** A, B.

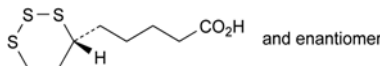

A. 5-[(4RS)-1,2,3-trithian-4-yl]pentanoic acid,

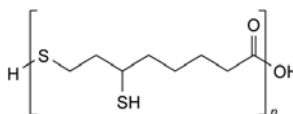

B.  $\alpha$ -hydro- $\omega$ -hydroxypoly[sulfanediy] (3-sulfanyl-8-oxooctane-1,8-diyl) (mixture of *thioctic acid* polymers).

01/2008:1625

## THIOMERSAL

### Thiomersalum

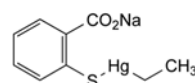

$C_9H_9HgNaO_2S$   
[54-64-8]

$M_r$  404.8

**DEFINITION**

Sodium ethyl[2-sulfanylbenzoato(2-)-O,S]mercurate(1-).

**Content:** 97.0 per cent to 101.0 per cent (dried substance).

**CHARACTERS**

**Appearance:** white or almost white, crystalline powder.

**Solubility:** freely soluble in water, sparingly soluble or soluble in ethanol (96 per cent), practically insoluble in methylene chloride.

**IDENTIFICATION**

**First identification:** B, D.

**Second identification:** A, C, D.

A. Melting point (2.2.14): 103 °C to 115 °C.

Dissolve 0.5 g in *water* R and dilute to 10 mL with the same solvent. Add 2 mL of *dilute hydrochloric acid* R. A white precipitate is formed. Wash the precipitate with *water* R and dry over *diphosphorus pentoxide* R at a pressure not exceeding 0.7 kPa.

B. Infrared absorption spectrophotometry (2.2.24).

**Comparison:** *thiomersal* CRS.

C. Treat 50 mg by the oxygen-flask method (2.5.10). Use a mixture of 1 mL of *strong hydrogen peroxide solution* R and 50 mL of *water* R to absorb the combustion products. To the solution add 5 mL of *dilute nitric acid* R. 0.1 mL of this solution gives reaction (a) of mercury (2.3.1). To the remaining part of the solution add 10 mL of *dilute hydrochloric acid* R and filter. 5 mL of the filtrate, without further addition of acid, gives reaction (a) of sulfates (2.3.1).

D. Solution S (see Tests) gives reaction (a) of sodium (2.3.1).

**TESTS**

**Solution S.** Dissolve 2.0 g in *carbon dioxide-free water* R and dilute to 25 mL with the same solvent.

**Appearance of solution.** Solution S is not more opalescent than reference suspension II (2.2.1) and not more intensely coloured than reference solution B<sub>6</sub> (2.2.2, Method II).

**pH** (2.2.3): 6.0 to 8.0.

Dilute 5 mL of solution S to 50 mL with *carbon dioxide-free water* R.

**Inorganic mercury compounds:** maximum 0.70 per cent.

*Protect the solutions from light throughout the procedure.*

**Test solution.** Dissolve 25 mg of the substance to be examined in *water R* and dilute to 25.0 mL with the same solvent.

**Reference solution.** Dissolve 95.0 mg of *mercuric chloride R* in *water R* and dilute to 50.0 mL with the same solvent. Dilute 1.0 mL of the solution to 20.0 mL with *water R*.

**Test, reference and blank preparations.** Label five 10 mL volumetric flasks A, B, C, D and E. Place 5 mL of the test solution in flasks A, B, C and D. To each of the flasks C and D add 0.5 mL of the reference solution. Dilute the contents of flasks A and C to 10 mL with *water R* (blank preparations A and C). Dilute the contents of flasks B and D to 10 mL with a freshly prepared 332 g/L solution of *potassium iodide R* (test preparation B and reference preparation D). Place 5 mL of a 332 g/L solution of *potassium iodide R* in flask E. Dilute to 10 mL with *water R* (blank preparation E).

Measure the absorbance (2.2.25) of each solution ( $A_a$ ,  $A_b$ ,  $A_c$ ,  $A_d$  and  $A_e$ ) at 323 nm using *water R* as the compensation liquid. Calculate the content of inorganic mercury compounds, expressed as Hg from the expression:

$$\frac{(A_b - A_a - A_e) \times m_R \times 0.1847}{(A_d - A_c - A_b + A_a) \times m_T}$$

$m_R$  = mass of mercuric chloride in the reference solution in milligrams,

$m_T$  = mass of the substance to be examined in milligrams.

**Loss on drying (2.2.32):** maximum 0.5 per cent, determined on 1.000 g by drying in a desiccator over *diphosphorus pentoxide R* at a pressure not exceeding 0.7 kPa for 24 h.

#### ASSAY

Place 0.5 g in a 100 mL long-necked combustion flask, add 5 mL of *sulfuric acid R* and heat gently until charring occurs, continue to heat and add dropwise *strong hydrogen peroxide solution R* until the mixture is colourless. Dilute with *water R*, evaporate until slight fuming occurs, dilute to 10 mL with *water R*, cool down and titrate with 0.1 M *ammonium thiocyanate* using *ferric ammonium sulfate solution R2* as indicator.

1 mL of 0.1 M *ammonium thiocyanate* is equivalent to 20.24 mg of  $C_9H_9HgNaO_2S$ .

#### STORAGE

Protected from light.

01/2008:0212

## THIOPENTAL SODIUM AND SODIUM CARBONATE

### Thiopentalum natricum et natrii carbonas

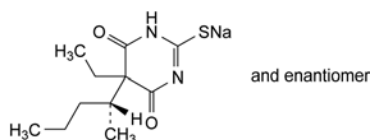

#### DEFINITION

Thiopental sodium and sodium carbonate is a mixture of the sodium derivative of 5-ethyl-5-[(1*RS*)-1-methylbutyl]-2-thioxo-2,3-dihydropyrimidine-4,6-(1*H*,5*H*)-dione ( $C_{11}H_{17}N_2NaO_2S$ ;  $M_r$  264.3) and anhydrous sodium carbonate, containing the equivalent of not less than 84.0 per cent and not more than 87.0 per cent of thiopental and not less than 10.2 per cent and not more than 11.2 per cent of Na, both calculated with reference to the dried substance.

#### CHARACTERS

A yellowish-white powder, hygroscopic, freely soluble in water, partly soluble in ethanol.

#### IDENTIFICATION

**First identification:** A, B, E.

**Second identification:** A, C, D, E.

A. Acidify 10 mL of solution S (see Tests) with *dilute hydrochloric acid R*. An effervescence is produced. Shake with 20 mL of *ether R*. Separate the ether layer, wash with 10 mL of *water R*, dry over *anhydrous sodium sulfate R* and filter. Evaporate the filtrate to dryness and dry the residue at 100 °C to 105 °C (test residue). Determine the melting point (2.2.14) of the test residue. Mix equal parts of the test residue and *thiopental CRS* and determine the melting point of the mixture. The difference between the melting points (which are about 160 °C) is not greater than 2 °C.

B. Examine by infrared absorption spectrophotometry (2.2.24), comparing the test residue (see identification test A) with the spectrum obtained with *thiopental CRS*.

C. Examine by thin-layer chromatography (2.2.27), using *silica gel GF<sub>254</sub> R* as the coating substance.

**Test solution.** Dissolve 0.1 g of the substance to be examined in *water R* and dilute to 100 mL with the same solvent.

**Reference solution.** Dissolve 85 mg of *thiopental CRS* in 10 mL of *dilute sodium hydroxide solution R* and dilute to 100 mL with *water R*.

Apply separately to the plate 10 µL of each solution. Develop over a path of 18 cm using the lower layer of a mixture of 5 volumes of *concentrated ammonia R*, 15 volumes of *alcohol R* and 80 volumes of *chloroform R*. Examine immediately in ultraviolet light at 254 nm. The principal spot in the chromatogram obtained with the test solution is similar in position and size to the principal spot in the chromatogram obtained with the reference solution.

D. It gives the reaction of non-nitrogen substituted barbiturates (2.3.1).

E. It gives reaction (a) of sodium (2.3.1).

#### TESTS

**Solution S.** Dissolve 5.0 g in *carbon dioxide-free water R* and dilute to 50 mL with the same solvent.

**Appearance of solution.** Solution S is clear (2.2.1) and not more intensely coloured than reference solution GY<sub>3</sub> (2.2.2, Method II).

**Related substances.** Examine by thin-layer chromatography (2.2.27), using *silica gel GF<sub>254</sub> R* as the coating substance.

**Test solution.** Dissolve 1.0 g of the substance to be examined in *water R* and dilute to 100 mL with the same solvent. Disregard any slight residue.

**Reference solution.** Dilute 0.5 mL of the test solution to 100 mL with *water R*.

Apply separately to the plate 20 µL of each solution. Develop over a path of 15 cm using the lower layer of a mixture of 5 volumes of *concentrated ammonia R*, 15 volumes of *alcohol R* and 80 volumes of *chloroform R*. Examine immediately in ultraviolet light at 254 nm. Any spot in the chromatogram obtained with the test solution, apart from the principal spot, is not more intense than the spot in the chromatogram obtained with the reference solution (0.5 per cent). Disregard any spot at the point of application.

**Chlorides (2.4.4).** To 5 mL of solution S add 35 mL of *water R* and 10 mL of *dilute nitric acid R*. Shake with three quantities, each of 25 mL, of *ether R* and discard the ether layers. Eliminate the ether from the aqueous layer by heating on a water-bath. 15 mL of the aqueous layer complies with the limit test for chlorides (330 ppm).

**Loss on drying (2.2.32).** Not more than 2.5 per cent, determined on 0.50 g by drying in vacuo at 100 °C for 4 h.

## ASSAY

**Sodium.** Dissolve 0.400 g in 30 mL of *water R*. Add 0.1 mL of *methyl red solution R* and titrate with 0.1 M hydrochloric acid until a red colour is obtained. Boil gently for 2 min. Cool and, if necessary, continue the titration with 0.1 M hydrochloric acid until the red colour is again obtained.

1 mL of 0.1 M hydrochloric acid is equivalent to 2.299 mg of Na.

**Thiopental.** Dissolve 0.150 g in 5 mL of *water R*. Add 2 mL of *dilute sulfuric acid R* and shake with four quantities, each of 10 mL, of *chloroform R*. Combine the chloroform layers, filter and evaporate the filtrate to dryness on a water-bath. Dissolve the residue in 30 mL of previously neutralised *dimethylformamide R* and add 0.1 mL of a 2 g/L solution of *thymol blue R* in *methanol R*. Titrate immediately with 0.1 M *lithium methoxide* until a blue colour is obtained. Protect the solution from atmospheric carbon dioxide during the titration. 1 mL of 0.1 M *lithium methoxide* is equivalent to 24.23 mg of C<sub>11</sub>H<sub>18</sub>N<sub>2</sub>O<sub>2</sub>S.

## STORAGE

Store in an airtight container, protected from light.

01/2008:2005  
corrected 7.0

## THIORIDAZINE

## Thioridazinum

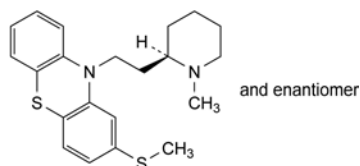

C<sub>21</sub>H<sub>26</sub>N<sub>2</sub>S<sub>2</sub>  
[50-52-2]

*M<sub>r</sub>* 370.6

## DEFINITION

10-[2-[(2*RS*)-1-Methylpiperidin-2-yl]ethyl]-2-(methylsulfonyl)-10*H*-phenothiazine

*Content:* 99.0 per cent to 101.0 per cent (dried substance).

## CHARACTERS

*Appearance:* white or almost white powder.

*Solubility:* practically insoluble in water, very soluble in methylene chloride, freely soluble in methanol, soluble in ethanol (96 per cent).

## IDENTIFICATION

Infrared absorption spectrophotometry (2.2.24).

*Comparison:* thioridazine CRS.

## TESTS

**Solution S.** Dissolve 1.25 g in *methanol R* and dilute to 25 mL with the same solvent.

**Appearance of solution.** Solution S is clear (2.2.1) and not more intensely coloured than intensity 6 of the range of reference solutions of the most appropriate colour (2.2.2, *Method II*).

**Related substances.** Liquid chromatography (2.2.29). Carry out the test as quickly as possible and protected from light.

*Test solution.* Dissolve 20 mg of the substance to be examined in *methanol R* and dilute to 100 mL with the same solvent.

*Reference solution (a).* Dilute 5.0 mL of the test solution to 100.0 mL with *methanol R*. Dilute 2.0 mL of this solution to 100.0 mL with *methanol R*.

*Reference solution (b).* Dissolve the contents of a vial of *thioridazine for system suitability CRS* (containing impurities A, B, C, D and E) in 1.0 mL of *methanol R*.

## Column:

– *size:* *l* = 0.25 m, Ø = 4.0 mm;

– *stationary phase:* end-capped octadecylsilyl silica gel for chromatography *R* resistant to bases up to pH 11.

## Mobile phase:

– *mobile phase A:* triethylamine *R1*, acetonitrile *R*, water *R* (2:400:600 V/V/V);

– *mobile phase B:* triethylamine *R1*, acetonitrile *R* (2:1000 V/V);

Time (min)	Mobile phase A (per cent V/V)	Mobile phase B (per cent V/V)
0 - 5	100	0
5 - 35	100 → 5	0 → 95
35 - 40	5	95

*Flow rate:* 1.0 mL/min.

*Detection:* spectrophotometer at 275 nm.

*Injection:* 25 µL.

*Identification of impurities:* use the chromatogram supplied with *thioridazine for system suitability CRS* and the chromatogram obtained with reference solution (b) to identify the peaks due to impurities A, B, C, D and E.

*Relative retention* with reference to thioridazine (retention time = about 30 min): impurity D = about 0.1; impurity A = about 0.3; impurity C = about 0.4; impurity B = about 0.5; impurity E = about 0.6.

*System suitability:* reference solution (b):

– *resolution:* minimum 3.5 between the peaks due to impurities C and B.

## Limits:

– *correction factors:* for the calculation of content, multiply the peak areas of the following impurities by the corresponding correction factor: impurity A = 1.9; impurity B = 2.4; impurity C = 0.5; impurity D = 1.5;

– *impurities A, B, C, D, E:* for each impurity, not more than the area of the principal peak in the chromatogram obtained with reference solution (a) (0.1 per cent);

– *unspecified impurities:* for each impurity, not more than the area of the principal peak in the chromatogram obtained with reference solution (a) (0.10 per cent);

– *total:* not more than 5 times the area of the principal peak in the chromatogram obtained with reference solution (a) (0.5 per cent);

– *disregard limit:* 0.5 times the area of the principal peak in the chromatogram obtained with reference solution (a) (0.05 per cent).

**Heavy metals** (2.4.8): maximum 20 ppm.

1.0 g complies with test C. Prepare the reference solution using 2 mL of *lead standard solution (10 ppm Pb) R*.

**Loss on drying** (2.2.32): maximum 0.5 per cent, determined on 1.000 g *in vacuo* at 50 °C for 4 h.

**Sulfated ash** (2.4.14): maximum 0.1 per cent, determined on 1.0 g.

## ASSAY

Dissolve 0.300 g in 60 mL of *anhydrous acetic acid R*. Titrate with 0.1 M *perchloric acid*, determining the end-point potentiometrically (2.2.20).

1 mL of 0.1 M *perchloric acid* is equivalent to 37.06 mg of C<sub>21</sub>H<sub>26</sub>N<sub>2</sub>S<sub>2</sub>.

## STORAGE

Protected from light.

## IMPURITIES

Specified impurities: A, B, C, D, E.

Other detectable impurities (the following substances would, if present at a sufficient level, be detected by one or other of the tests in the monograph. They are limited by the general acceptance criterion for other/unspecified impurities and/or by the general monograph *Substances for pharmaceutical use (2034)*. It is therefore not necessary to identify these impurities for demonstration of compliance. See also 5.10. *Control of impurities in substances for pharmaceutical use*): F.

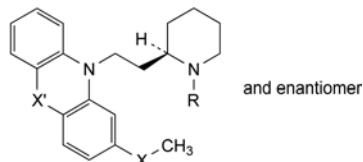

- A. R = CH<sub>3</sub>, X = X' = SO<sub>2</sub>: 10-[2-[(2RS)-1-methylpiperidin-2-yl]ethyl]-2-(methylsulfonyl)-10H-phenothiazine 5,5-dioxide,
- B. R = CH<sub>3</sub>, X = SO, X' = S: 10-[2-[(2RS)-1-methylpiperidin-2-yl]ethyl]-2-(methylsulfinyl)-10H-phenothiazine (mesoridazine),
- C. R = CH<sub>3</sub>, X = S, X' = SO: 10-[2-[(2RS)-1-methylpiperidin-2-yl]ethyl]-2-(methylsulfanyl)-10H-phenothiazine 5-oxide,
- D. R = CH<sub>3</sub>, X = X' = SO: 10-[2-[(2RS)-1-methylpiperidin-2-yl]ethyl]-2-(methylsulfinyl)-10H-phenothiazine 5-oxide,
- E. R = CH<sub>3</sub>, X = SO<sub>2</sub>, X' = S: 10-[2-[(2RS)-1-methylpiperidin-2-yl]ethyl]-2-(methylsulfonyl)-10H-phenothiazine (sulforidazine),
- F. R = H, X = X' = S: 2-(methylsulfanyl)-10-[2-[(2RS)-piperidin-2-yl]ethyl]-10H-phenothiazine (northioridazine).

01/2008:0586  
corrected 7.0

## THIORIDAZINE HYDROCHLORIDE

## Thioridazini hydrochloridum

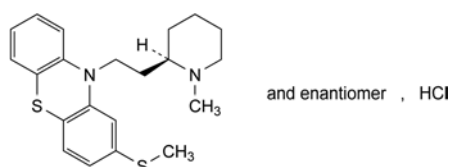

C<sub>21</sub>H<sub>27</sub>ClN<sub>2</sub>S<sub>2</sub>  
[130.61-0]

M<sub>r</sub> 407.0

## DEFINITION

10-[2-[(2RS)-1-Methylpiperidin-2-yl]ethyl]-2-(methylsulfanyl)-10H-phenothiazine hydrochloride.

Content: 99.0 per cent to 101.0 per cent (dried substance).

## CHARACTERS

Appearance: white or almost white, crystalline powder.

Solubility: freely soluble in water and in methanol, soluble in ethanol 96 per cent.

## IDENTIFICATION

A. Infrared absorption spectrophotometry (2.2.24).

Comparison: thioridazine hydrochloride CRS.

B. 0.2 g gives reaction (b) of chlorides (2.3.1).

## TESTS

Carry out all operations protected from light.

Appearance of solution. The solution is clear (2.2.1) and not more intensely coloured than intensity 6 of the range of reference solutions of the most appropriate colour (2.2.2, Method II).

Dissolve 1.0 g in methanol R and dilute to 20 mL with the same solvent.

Optical rotation (2.2.7): -0.10° to +0.10°.

Dissolve 1.0 g in methanol R and dilute to 20.0 mL with the same solvent.

Related substances. Liquid chromatography (2.2.29). Carry out the test as quickly as possible and protected from light.

Test solution. Dissolve 20.0 mg of the substance to be examined in methanol R and dilute to 100.0 mL with the same solvent.

Reference solution (a). Dilute 5.0 mL of the test solution to 100.0 mL with methanol R. Dilute 2.0 mL of this solution to 100.0 mL with methanol R.

Reference solution (b). Dissolve the contents of a vial of thioridazine for system suitability CRS (containing impurities A, B, C, D and E) in 1.0 mL of methanol R.

Column:

– size:  $l = 0.25$  m,  $\varnothing = 4.0$  mm;

– stationary phase: end-capped octadecylsilyl silica gel for chromatography R (5  $\mu$ m) resistant to bases up to pH 11.

Mobile phase:

– mobile phase A: triethylamine R1, acetonitrile R, water R (2:400:600 V/V/V);

– mobile phase B: triethylamine R1, acetonitrile R (2:1000 V/V);

Time (min)	Mobile phase A (per cent V/V)	Mobile phase B (per cent V/V)
0 - 5	100	0
5 - 35	100 → 5	0 → 95
35 - 40	5	95

Flow rate: 1.0 mL/min.

Detection: spectrophotometer at 275 nm.

Injection: 25  $\mu$ L.

Identification of impurities: use the chromatogram supplied with thioridazine for system suitability CRS to identify the peaks due to impurities A, B, C, D and E.

Relative retention with reference to thioridazine (retention time = about 30 min): impurity D = about 0.1; impurity A = about 0.3; impurity C = about 0.4; impurity B = about 0.5; impurity E = about 0.6; impurity F = about 0.9.

System suitability: reference solution (b):

– resolution: minimum 3.5 between the peaks due to impurities C and B.

Limits:

– correction factors: for the calculation of content, multiply the peak areas of the following impurities by the corresponding correction factor: impurity A = 1.9; impurity B = 2.4; impurity C = 0.5; impurity D = 1.5;

– impurities A, B, C, D, E: for each impurity, not more than the area of the principal peak in the chromatogram obtained with reference solution (a) (0.1 per cent);

– unspecified impurities: for each impurity, not more than the area of the principal peak in the chromatogram obtained with reference solution (a) (0.1 per cent);

– total: not more than 5 times the area of the principal peak in the chromatogram obtained with reference solution (a) (0.5 per cent);

– disregard limit: 0.5 times the area of the principal peak in the chromatogram obtained with reference solution (a) (0.05 per cent).

**Heavy metals** (2.4.8): maximum 20 ppm.

Dissolve 1.0 g in 20 mL of *water R*. 12 mL of the solution complies with test A. Prepare the reference solution using *lead standard solution (1 ppm Pb) R*.

**Loss on drying** (2.2.32): maximum 0.5 per cent, determined on 1.000 g by drying in an oven at 105 °C for 4 h.

**Sulfated ash** (2.4.14): maximum 0.1 per cent, determined on 1.0 g.

#### ASSAY

Dissolve 0.300 g in a mixture of 10 mL of *anhydrous acetic acid R* and 60 mL of *acetic anhydride R*. Titrate with 0.1 M *perchloric acid*, determining the end-point potentiometrically (2.2.20).

1 mL of 0.1 M *perchloric acid* is equivalent to 40.70 mg of C<sub>21</sub>H<sub>27</sub>ClN<sub>2</sub>S<sub>2</sub>.

#### STORAGE

Protected from light.

#### IMPURITIES

*Specified impurities: A, B, C, D, E.*

*Other detectable impurities* (the following substances would, if present at a sufficient level, be detected by one or other of the tests in the monograph. They are limited by the general acceptance criterion for other/unspecified impurities and/or by the general monograph *Substances for pharmaceutical use (2034)*. It is therefore not necessary to identify these impurities for demonstration of compliance. See also 5.10. *Control of impurities in substances for pharmaceutical use*): *F*.

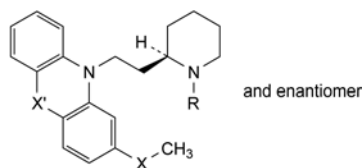

- A. R = CH<sub>3</sub>, X = X' = SO<sub>2</sub>: 10-[2-[(2*RS*)-1-methylpiperidin-2-yl]ethyl]-2-(methylsulfonyl)-10*H*-phenothiazine 5,5-dioxide,
- B. R = CH<sub>3</sub>, X = SO, X' = S: 10-[2-[(2*RS*)-1-methylpiperidin-2-yl]ethyl]-2-(methylsulfinyl)-10*H*-phenothiazine,
- C. R = CH<sub>3</sub>, X = S, X' = SO: 10-[2-[(2*RS*)-1-methylpiperidin-2-yl]ethyl]-2-(methylsulfanyl)-10*H*-phenothiazine 5-oxide,
- D. R = CH<sub>3</sub>, X = X' = SO: 10-[2-[(2*RS*)-1-methylpiperidin-2-yl]ethyl]-2-(methylsulfinyl)-10*H*-phenothiazine 5-oxide,
- E. R = CH<sub>3</sub>, X = SO<sub>2</sub>, X' = S: 10-[2-[(2*RS*)-1-methylpiperidin-2-yl]ethyl]-2-(methylsulfonyl)-10*H*-phenothiazine,
- F. R = H, X = X' = S: 2-(methylsulfanyl)-10-[2-[(2*RS*)-piperidin-2-yl]ethyl]-10*H*-phenothiazine.

01/2008:1049  
corrected 6.0

## THREONINE

### Threoninum

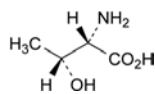

C<sub>4</sub>H<sub>9</sub>NO<sub>3</sub>  
[72-19-5]

M<sub>r</sub> 119.1

#### DEFINITION

Threonine contains not less than 99.0 per cent and not more than the equivalent of 101.0 per cent of (2*S*,3*R*)-2-amino-3-hydroxybutanoic acid, calculated with reference to the dried substance.

#### CHARACTERS

A white or almost white, crystalline powder or colourless crystals, soluble in water, practically insoluble in alcohol.

#### IDENTIFICATION

*First identification: A, B.*

*Second identification: A, C, D.*

- A. Specific optical rotation (see Tests).
- B. Examine by infrared absorption spectrophotometry (2.2.24), comparing with the spectrum obtained with *threonine CRS*. Examine the substances prepared as discs.
- C. Examine the chromatograms obtained in the test for ninhydrin-positive substances. The principal spot in the chromatogram obtained with test solution (b) is similar in position, colour and size to the principal spot in the chromatogram obtained with reference solution (a).
- D. Mix 1 mL of a 2 g/L solution of the substance to be examined with 1 mL of a 20 g/L solution of *sodium periodate R*. Add 0.2 mL of *piperidine R* and 0.1 mL of a 25 g/L solution of *sodium nitroprusside R*. A blue colour develops that changes to yellow after a few minutes.

#### TESTS

**Solution S.** Dissolve 2.5 g in *carbon dioxide-free water R* and dilute to 100 mL with the same solvent.

**Appearance of solution.** Solution S is clear (2.2.1) and colourless (2.2.2, *Method II*).

**pH** (2.2.3). The pH of solution S is 5.0 to 6.5.

**Specific optical rotation** (2.2.7). Dissolve 1.50 g in *water R* and dilute to 25.0 mL with the same solvent. The specific optical rotation is –27.6 to –29.0, calculated with reference to the dried substance.

**Ninhydrin-positive substances.** Examine by thin-layer chromatography (2.2.27), using a *TLC silica gel plate R*.

*Test solution (a).* Dissolve 0.10 g of the substance to be examined in *dilute hydrochloric acid R* and dilute to 10 mL with the same acid.

*Test solution (b).* Dilute 1 mL of test solution (a) to 50 mL with *water R*.

*Reference solution (a).* Dissolve 10 mg of *threonine CRS* in a 1 per cent *V/V* solution of *hydrochloric acid R* and dilute to 50 mL with the same acid solution.

*Reference solution (b).* Dilute 5 mL of test solution (b) to 20 mL with *water R*.

*Reference solution (c).* Dissolve 10 mg of *threonine CRS* and 10 mg of *proline CRS* in a 1 per cent *V/V* solution of *hydrochloric acid R* and dilute to 25 mL with the same acid solution.

Apply to the plate 5 µL of each solution. Allow the plate to dry in air. Develop over a path of 15 cm using a mixture of 20 volumes of *glacial acetic acid R*, 20 volumes of *water R* and 60 volumes of *butanol R*. Allow the plate to dry in air, spray with *ninhydrin solution R* and heat at 100 °C to 105 °C for 15 min. Any spot in the chromatogram obtained with test solution (a), apart from the principal spot, is not more intense than the spot in the chromatogram obtained with reference solution (b) (0.5 per cent). The test is not valid unless the chromatogram obtained with reference solution (c) shows two clearly separated principal spots.

**Chlorides** (2.4.4). Dilute 10 mL of solution S to 15 mL with *water R*. The solution complies with the limit test for chlorides (200 ppm).

**Sulfates** (2.4.13). Dissolve 0.5 g in *distilled water R* and dilute to 15 mL with the same solvent. The solution complies with the limit test for sulfates (300 ppm).

**Ammonium** (2.4.1). 0.10 g complies with limit test B for ammonium (200 ppm). Prepare the standard using 0.2 mL of *ammonium standard solution (100 ppm NH<sub>4</sub>) R*.

**Iron (2.4.9).** In a separating funnel, dissolve 1.0 g in 10 mL of *dilute hydrochloric acid R*. Shake with three quantities, each of 10 mL, of *methyl isobutyl ketone RI*, shaking for 3 min each time. To the combined organic layers add 10 mL of *water R* and shake for 3 min. The aqueous layer complies with the limit test for iron (10 ppm).

**Heavy metals (2.4.8).** 2.0 g complies with limit test C for heavy metals (10 ppm). Prepare the standard using 2 mL of *lead standard solution (10 ppm Pb) R*.

**Loss on drying (2.2.32).** Not more than 0.5 per cent, determined on 1.000 g by drying in an oven at 105 °C.

**Sulfated ash (2.4.14).** Not more than 0.1 per cent, determined on 1.0 g.

#### ASSAY

Dissolve 0.100 g in 5 mL of *anhydrous formic acid R*. Add 30 mL of *anhydrous acetic acid R*. Titrate with 0.1 M *perchloric acid*, determining the end-point potentiometrically (2.2.20).

1 mL of 0.1 M *perchloric acid* is equivalent to 11.91 mg of  $C_4H_9NO_3$ .

#### STORAGE

Store protected from light.

01/2008:0791

## THYMOL

### Thymolum

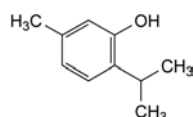

$C_{10}H_{14}O$   
[89-83-8]

$M_r$  150.2

#### DEFINITION

5-Methyl-2-(methylethyl)phenol.

#### CHARACTERS

**Appearance:** colourless crystals.

**Solubility:** very slightly soluble in water, very soluble in ethanol (96 per cent), freely soluble in essential oils and in fatty oils, sparingly soluble in glycerol. It dissolves in dilute solutions of alkali hydroxides.

#### IDENTIFICATION

**First identification:** B.

**Second identification:** A, C, D.

A. Melting point (2.2.14): 48 °C to 52 °C.

B. Infrared absorption spectrophotometry (2.2.24).

**Comparison:** *thymol CRS*.

C. Dissolve 0.2 g with heating in 2 mL of *dilute sodium hydroxide solution R* and add 0.2 mL of *chloroform R*. Heat on a water-bath. A violet colour develops.

D. Dissolve about 2 mg in 1 mL of *anhydrous acetic acid R*. Add 0.15 mL of *sulfuric acid R* and 0.05 mL of *nitric acid R*. A bluish-green colour develops.

#### TESTS

**Appearance of solution.** The solution is not more opalescent than reference suspension IV (2.2.1) and not more intensely coloured than reference solution  $R_6$  (2.2.2, *Method II*).

Dissolve 1.0 g in 10 mL of *dilute sodium hydroxide solution R*.

**Acidity.** To 1.0 g in a 100 mL glass-stoppered conical flask add 20 mL of *water R*. Boil until dissolution is complete, cool and stopper the flask. Shake vigorously for 1 min. Add a few crystals of the substance to be examined to initiate crystallisation.

Shake vigorously for 1 min and filter. To 5 mL of the filtrate add 0.05 mL of *methyl red solution R* and 0.05 mL of 0.01 M *sodium hydroxide*. The solution is yellow.

**Related substances.** Gas chromatography (2.2.28).

**Test solution.** Dissolve 0.100 g of the substance to be examined in *ethanol (96 per cent) R* and dilute to 10.0 mL with the same solvent.

**Reference solution (a).** Dilute 1 mL of the test solution to 100 mL with *ethanol (96 per cent) R*.

**Reference solution (b).** Dilute 1 mL of reference solution (a) to 10 mL with *ethanol (96 per cent) R*.

**Reference solution (c).** Dilute 5 mL of reference solution (b) to 10 mL with *ethanol (96 per cent) R*.

#### Column:

- **material:** glass or steel;
- **size:**  $l = 4$  m,  $\varnothing = 2$  mm;
- **stationary phase:** *diatomaceous earth for gas chromatography R*, impregnated with a mixture suitable for the separation of free fatty acids.

**Carrier gas:** *nitrogen for chromatography R*.

**Flow rate:** 30 mL/min.

#### Temperature:

	Time (min)	Temperature (°C)
Column	0 - 2	80
	2 - 22	80 → 240
	22 - 37	240
Injection port		250
Detector		300

**Detection:** flame ionisation.

**Injection:** 1 µL.

**System suitability:** reference solution (b):

- **signal-to-noise ratio:** minimum 5 for the principal peak.

#### Limits:

- **total:** not more than the area of the principal peak in the chromatogram obtained with reference solution (a) (1.0 per cent);
- **disregard limit:** the area of the principal peak in the chromatogram obtained with reference solution (c) (0.05 per cent).

**Residue on evaporation:** maximum 0.05 per cent.

Evaporate 2.00 g on a water-bath and heat in an oven at 100-105 °C for 1 h. The residue weighs not more than 1.0 mg.

#### STORAGE

Protected from light.

01/2008:0866

## TIABENDAZOLE

### Tiabendazolium

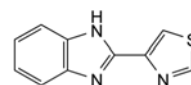

$C_{10}H_7N_3S$   
[148-79-8]

$M_r$  201.2

#### DEFINITION

Tiabendazole contains not less than 98.0 per cent and not more than the equivalent of 101.0 per cent of 2-(thiazol-4-yl)-1H-benzimidazole, calculated with reference to the anhydrous substance.

## CHARACTERS

A white or almost white, crystalline powder, practically insoluble in water, slightly soluble in alcohol and in methylene chloride. It dissolves in dilute mineral acids. It melts at about 300 °C.

## IDENTIFICATION

*First identification:* B.

*Second identification:* A, C, D.

- A. Dissolve 25 mg in 0.1 M hydrochloric acid and dilute to 100.0 mL with the same acid. Dilute 2.0 mL of the solution to 100.0 mL with 0.1 M hydrochloric acid. Examined between 230 nm and 350 nm (2.2.25), the solution shows two absorption maxima, at 243 nm and 302 nm. The ratio of the absorbance measured at the maximum at 302 nm to that measured at the maximum at 243 nm is 1.8 to 2.1.
- B. Examine by infrared absorption spectrophotometry (2.2.24), comparing with the spectrum obtained with *tiabendazole CRS*. Examine the substances prepared as discs.
- C. Examine the chromatograms obtained in the test for related substances in ultraviolet light at 254 nm. The principal spot in the chromatogram obtained with test solution (b) is similar in position and size to the principal spot in the chromatogram obtained with reference solution (a).
- D. Dissolve about 5 mg in 0.1 M hydrochloric acid and dilute to 5 mL with the same acid. Add 3 mg of *p*-phenylenediamine dihydrochloride *R* and shake until dissolved. Add 0.1 g of zinc powder *R*, mix, allow to stand for 2 min and add 5 mL of ferric ammonium sulfate solution *R2*. A bluish-violet colour develops.

## TESTS

**Related substances.** Examine by thin-layer chromatography (2.2.27), using *silica gel HF<sub>254</sub> R* as the coating substance.

*Test solution (a).* Dissolve 0.10 g of the substance to be examined in *methanol R* and dilute to 10 mL with the same solvent.

*Test solution (b).* Dilute 2 mL of test solution (a) to 20 mL with *methanol R*.

*Reference solution (a).* Dissolve 20 mg of *tiabendazole CRS* in *methanol R* and dilute to 20 mL with the same solvent.

*Reference solution (b).* Dilute 1 mL of test solution (b) to 10 mL with *methanol R*.

*Reference solution (c).* Dilute 1 mL of test solution (b) to 25 mL with *methanol R*.

Apply separately to the plate 20 µL of each solution. Develop over a path of 15 cm using a mixture of 2.5 volumes of *water R*, 10 volumes of *acetone R*, 25 volumes of *glacial acetic acid R* and 62.5 volumes of *toluene R*. Allow the plate to dry in air and examine in ultraviolet light at 254 nm. Any spot in the chromatogram obtained with test solution (a), apart from the principal spot, is not more intense than the spot in the chromatogram obtained with reference solution (b) (1.0 per cent) and at most one such spot is more intense than the spot in the chromatogram obtained with reference solution (c) (0.4 per cent).

***o*-Phenylenediamine.** To 5.0 g in a flask fitted with a ground-glass stopper, add 25 mL of a mixture of 1 volume of *methanol R* and 2 volumes of *water R*. Shake for 3 min. Filter through a sintered-glass filter (16) (2.1.2) under reduced pressure. To 10 mL of the filtrate add 0.5 mL of *hydrochloric acid R* and 0.5 mL of *acetylacetone R* and shake until the solution is clear. The solution is not more intensely coloured than reference solution *R<sub>7</sub>* (2.2.2, *Method I*) (10 ppm).

**Heavy metals** (2.4.8). 1.0 g complies with limit test D for heavy metals (20 ppm). Prepare the standard using 2 mL of *lead standard solution (10 ppm Pb) R*.

**Water** (2.5.12). Not more than 0.5 per cent, determined on 1.00 g by the semi-micro determination of water.

**Sulfated ash** (2.4.14). Not more than 0.2 per cent, determined on 1.0 g.

## ASSAY

Dissolve 0.150 g in 30 mL of *anhydrous acetic acid R*. Titrate with 0.1 M perchloric acid, determining the end-point potentiometrically (2.2.20).

1 mL of 0.1 M perchloric acid is equivalent to 20.12 mg of C<sub>10</sub>H<sub>7</sub>N<sub>3</sub>S.

## STORAGE

Store protected from light.

## IMPURITIES

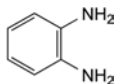

A. benzene-1,2-diamine.

01/2008:1660  
corrected 6.5

## TIAMULIN FOR VETERINARY USE

## Tiamulinum ad usum veterinarium

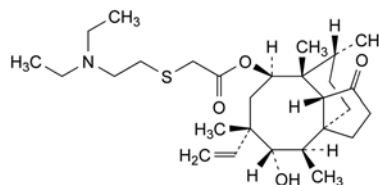

C<sub>28</sub>H<sub>47</sub>NO<sub>4</sub>S  
[55297-95-5]

*M<sub>r</sub>* 493.8

## DEFINITION

(3*a*S,4*R*,5*S*,6*S*,8*R*,9*R*,9*a**R*,10*R*)-6-Ethenyl-5-hydroxy-4,6,9,10-tetramethyl-1-oxodecahydro-3*a*,9-propano-3*aH*-cyclopentacycloocten-8-yl [[2-(diethylamino)ethyl]sulfanyl]acetate.

Semi-synthetic product derived from a fermentation product.

*Content:* 96.5 per cent to 102.0 per cent (dried substance).

## CHARACTERS

*Appearance:* sticky, translucent yellowish mass, slightly hygroscopic.

*Solubility:* practically insoluble in water, very soluble in methylene chloride, freely soluble in anhydrous ethanol.

## IDENTIFICATION

Infrared absorption spectrophotometry (2.2.24).

*Comparison:* *Ph. Eur. reference spectrum of tiamulin.*

## TESTS

**Appearance of solution.** The solution is clear (2.2.1) and its absorbance (2.2.25) at 420 nm is not greater than 0.050.

Dissolve 2.5 g in 50 mL of *methanol R*.

**Related substances.** Liquid chromatography (2.2.29).

*Ammonium carbonate buffer solution pH 10.0.* Dissolve 10.0 g of *ammonium carbonate R* in *water R*, add 22 mL of *perchloric acid solution R* and dilute to 1000.0 mL with *water R*. Adjust to pH 10.0 with *concentrated ammonia R1*.

*Solvent mixture: acetonitrile R1, ammonium carbonate buffer solution pH 10.0 (50:50 V/V).*

*Test solution.* Dissolve 0.200 g of the substance to be examined in the solvent mixture and dilute to 50.0 mL with the solvent mixture.



**Reference solution (a).** Dissolve 0.250 g of *tiamulin hydrogen fumarate CRS* in the solvent mixture and dilute to 50.0 mL with the solvent mixture.

**Reference solution (b).** Dilute 1.0 mL of the test solution to 100.0 mL with the solvent mixture.

**Reference solution (c).** Dilute 0.1 mL of *toluene R* to 100 mL with *acetonitrile R*. Dilute 0.1 mL of this solution to 100.0 mL with the solvent mixture.

**Column:**

- size:  $l = 0.15$  m,  $\varnothing = 4.6$  mm;
- stationary phase: *end-capped octadecylsilyl silica gel for chromatography R* ( $5 \mu\text{m}$ );
- temperature:  $30 \text{ }^\circ\text{C}$ .

**Mobile phase:** *acetonitrile R1*, ammonium carbonate buffer solution pH 10.0, *methanol R1* (21:30:49 V/V/V).

**Flow rate:** 1.0 mL/min.

**Detection:** spectrophotometer at 212 nm.

**Injection:** 20  $\mu\text{L}$ .

**Run time:** 3 times the retention time of tiamulin.

**Relative retention** with reference to tiamulin (retention time = about 18 min): impurity A = about 0.22; impurity B = about 0.5; impurity C = about 0.66; impurity D = about 1.1; impurity F = about 1.6; impurity E = about 2.4.

**System suitability:** reference solution (a):

- baseline separation between the peaks due to tiamulin and impurity D.

**Limits:**

- **impurities A, B, C, D, E, F:** for each impurity, not more than the area of the principal peak in the chromatogram obtained with reference solution (b) (1.0 per cent);
- **any other impurity:** for each impurity, not more than 0.2 times the area of the principal peak in the chromatogram obtained with reference solution (b) (0.2 per cent);
- **total:** not more than 3 times the area of the principal peak in the chromatogram obtained with reference solution (b) (3.0 per cent);
- **disregard limit:** 0.1 times the area of the principal peak in the chromatogram obtained with reference solution (b) (0.1 per cent); disregard any peak present in the chromatogram obtained with reference solution (c).

**Loss on drying (2.2.32):** maximum 1.0 per cent, determined on 1.000 g by drying in an oven at  $80 \text{ }^\circ\text{C}$ .

**Bacterial endotoxins (2.6.14, Method D):** less than 0.4 IU/mg, determined in a 1 mg/mL solution in *anhydrous ethanol R* (endotoxin free) diluted 1:40 with water for bacterial endotoxins test.

**ASSAY**

Liquid chromatography (2.2.29) as described in the test for related substances with the following modification.

**Injection:** test solution and reference solution (a).

Calculate the percentage content of  $\text{C}_{28}\text{H}_{47}\text{NO}_4\text{S}$ , from the declared content of *tiamulin hydrogen fumarate CRS*.

**STORAGE**

Protected from light.

**IMPURITIES**

**Specified impurities:** A, B, C, D, E, F.

**Other detectable impurities** (the following substances would, if present at a sufficient level, be detected by one or other of the tests in the monograph. They are limited by the general acceptance criterion for other/unspecified impurities and/or by the general monograph *Substances for pharmaceutical use (2034)*. It is therefore not necessary to identify these impurities

for demonstration of compliance. See also 5.10. *Control of impurities in substances for pharmaceutical use*): G, H, I, J, K, L, M, N, O, P, Q, R.

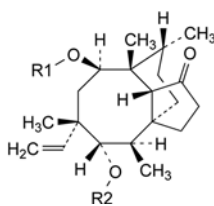

- A.  $\text{R1} = \text{R2} = \text{H}$ : (3a*S*,4*R*,5*S*,6*S*,8*R*,9*R*,9a*R*,10*R*)-6-ethenyl-5,8-dihydroxy-4,6,9,10-tetramethyloctahydro-3a,9-propano-3a*H*-cyclopentacycloocten-1(4*H*)-one (mutilin),
- G.  $\text{R1} = \text{CO-CH}_2\text{OH}$ ,  $\text{R2} = \text{H}$ : (3a*S*,4*R*,5*S*,6*S*,8*R*,9*R*,9a*R*,10*R*)-6-ethenyl-5-hydroxy-4,6,9,10-tetramethyl-1-oxodecahydro-3a,9-propano-3a*H*-cyclopentacycloocten-8-yl hydroxyacetate (pleuromutilin),
- J.  $\text{R1} = \text{CO-CH}_3$ ,  $\text{R2} = \text{H}$ : (3a*S*,4*R*,5*S*,6*S*,8*R*,9*R*,9a*R*,10*R*)-6-ethenyl-5-hydroxy-4,6,9,10-tetramethyl-1-oxodecahydro-3a,9-propano-3a*H*-cyclopentacycloocten-8-yl acetate (mutilin 14-acetate),
- K.  $\text{R1} = \text{H}$ ,  $\text{R2} = \text{CO-CH}_3$ : (3a*S*,4*R*,5*S*,6*S*,8*R*,9*R*,9a*R*,10*R*)-6-ethenyl-8-hydroxy-4,6,9,10-tetramethyl-1-oxodecahydro-3a,9-propano-3a*H*-cyclopentacycloocten-5-yl acetate (mutilin 11-acetate),
- L.  $\text{R1} = \text{CO-CH}_2\text{-O-SO}_2\text{-C}_6\text{H}_4\text{-}p\text{CH}_3$ ,  $\text{R2} = \text{H}$ : (3a*S*,4*R*,5*S*,6*S*,8*R*,9*R*,9a*R*,10*R*)-6-ethenyl-5-hydroxy-4,6,9,10-tetramethyl-1-oxodecahydro-3a,9-propano-3a*H*-cyclopentacycloocten-8-yl [(4-methylphenyl)sulfonyl]oxy]acetate (pleuromutilin 22-tosylate),
- M.  $\text{R1} = \text{R2} = \text{CO-CH}_3$ : (3a*S*,4*R*,5*S*,6*S*,8*R*,9*R*,9a*R*,10*R*)-6-ethenyl-4,6,9,10-tetramethyl-1-oxodecahydro-3a,9-propano-3a*H*-cyclopentacycloocten-5,8-diyl diacetate (mutilin 11,14-diacetate),
- P.  $\text{R1} = \text{CO-CH}_2\text{-O-SO}_2\text{-C}_6\text{H}_5$ ,  $\text{R2} = \text{H}$ : (3a*S*,4*R*,5*S*,6*S*,8*R*,9*R*,9a*R*,10*R*)-6-ethenyl-5-hydroxy-4,6,9,10-tetramethyl-1-oxodecahydro-3a,9-propano-3a*H*-cyclopentacycloocten-8-yl [(phenylsulfonyl)oxy]acetate,

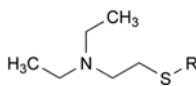

- B.  $\text{R} = \text{CH}_2\text{-C}_6\text{H}_5$ : 2-(benzylsulfanyl)-*N,N*-diethylethanamine,
- C.  $\text{R} = \text{S-CH}_2\text{-CH}_2\text{-N}(\text{C}_2\text{H}_5)_2$ : 2,2'-(disulfane-1,2-diyl)bis(*N,N*-diethylethanamine),
- O.  $\text{R} = \text{H}$ : 2-(diethylamino)ethanethiol,

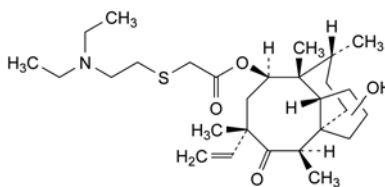

- D. (3a*R*,4*R*,6*S*,8*R*,9*R*,9a*R*,10*R*)-6-ethenylhydroxy-4,6,9,10-tetramethyl-5-oxodecahydro-3a,9-propano-3a*H*-cyclopentacycloocten-8-yl [[2-(diethylamino)ethyl]sulfanyl]acetate,

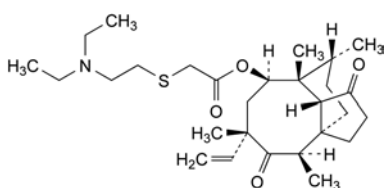

- E. (3a*S*,4*R*,6*S*,8*R*,9*R*,9a*R*,10*R*)-6-ethenyl-4,6,9,10-tetramethyl-1,5-dioxodecahydro-3a,9-propano-3a*H*-cyclopentacycloocten-8-yl [[2-(diethylamino)ethyl]sulfanyl]acetate (11-oxotiamulin),

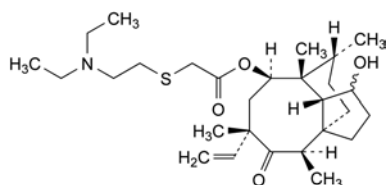
01/2008:1659  
corrected 6.0

F. (1*RS*,3*aR*,4*R*,6*S*,8*R*,9*R*,9*aR*,10*R*)-6-ethenyl-1-hydroxy-4,6,9,10-tetramethyl-5-oxodecahydro-3*a*,9-propano-3*aH*-cyclopentacycloocten-8-yl [[2-(diethylamino)ethyl]sulfanyl]acetate (1-hydroxy-11-oxotiamulin),

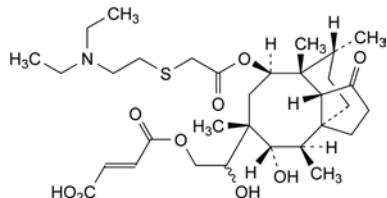

H. (2*E*)-4-[[2-(2*RS*)-2-[(3*aS*,4*R*,5*S*,6*R*,8*R*,9*R*,9*aR*,10*R*)-8-[[[2-(diethylamino)ethyl]sulfanyl]acetyl]oxy]-5-hydroxy-4,6,9,10-tetramethyl-1-oxodecahydro-3*a*,9-propano-3*aH*-cyclopentacycloocten-6-yl]-2-hydroxyethoxy]-4-oxobut-2-enoic acid (19,20-dihydroxytiamulin 20-fumarate),

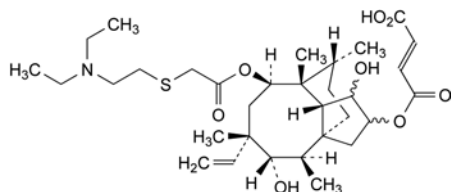

I. (2*E*)-4-[[[(3*aS*,4*R*,5*S*,6*S*,8*R*,9*R*,9*aR*,10*R*)-8-[[[2-(diethylamino)ethyl]sulfanyl]acetyl]oxy]-6-ethenyl-1,5-dihydroxy-4,6,9,10-tetramethyldecahydro-3*a*,9-propano-3*aH*-cyclopentacycloocten-2-yl]oxy]-4-oxobut-2-enoic acid (2,3-dihydroxytiamulin 2-fumarate),

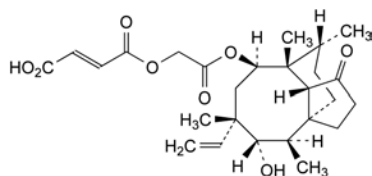

N. (2*E*)-4-[2-[[[(3*aS*,4*R*,5*S*,6*S*,8*R*,9*R*,9*aR*,10*R*)-6-ethenyl-5-hydroxy-4,6,9,10-tetramethyl-1-oxodecahydro-3*a*,9-propano-3*aH*-cyclopentacycloocten-8-yl]oxy]-2-oxoethoxy]-4-oxobut-2-enoic acid (pleuromutilin 22-fumarate),

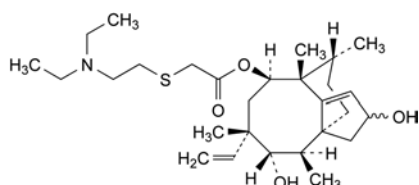

Q. (3*aS*,4*R*,5*S*,6*S*,8*R*,9*R*,10*R*)-6-ethenyl-2,5-dihydroxy-4,6,9,10-tetramethyl-2,3,4,5,6,7,8,9-octahydro-3*a*,9-propano-3*aH*-cyclopentacycloocten-8-yl [[2-(diethylamino)ethyl]sulfanyl]acetate (3,4-didehydro-2-hydroxytiamulin),

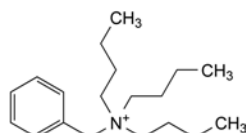

R. *N*-benzyl-*N,N*-dibutylbutan-1-aminium.

## TIAMULIN HYDROGEN FUMARATE FOR VETERINARY USE

Tiamulini hydrogenofumaras ad usum  
veterinarium

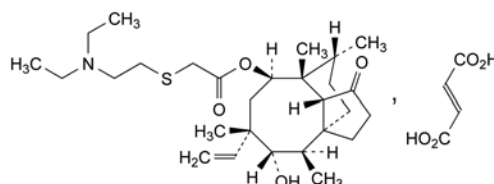

$C_{32}H_{51}NO_8S$   
[55297-96-6]

$M_r$  610

### DEFINITION

(3*aS*,4*R*,5*S*,6*S*,8*R*,9*R*,9*aR*,10*R*)-6-Ethenyl-5-hydroxy-4,6,9,10-tetramethyl-1-oxodecahydro-3*a*,9-propano-3*aH*-cyclopentacycloocten-8-yl [[2-(diethylamino)ethyl]sulfanyl]acetate hydrogen (*E*)-butenedioate.

Semi-synthetic product derived from a fermentation product.

*Content*: 96.5 per cent to 102.0 per cent (dried substance).

### CHARACTERS

*Appearance*: white or light yellow, crystalline powder.

*Solubility*: soluble in water, freely soluble in anhydrous ethanol and soluble in methanol.

### IDENTIFICATION

Infrared absorption spectrophotometry (2.2.24).

*Comparison*: tiamulin hydrogen fumarate CRS.

### TESTS

**pH** (2.2.3): 3.1 to 4.1.

Dissolve 0.5 g in carbon dioxide-free water *R* and dilute to 50 mL with the same solvent.

**Related substances**. Liquid chromatography (2.2.29).

*Ammonium carbonate buffer solution pH 10.0*. Dissolve 10.0 g of ammonium carbonate *R* in water *R*, add 22 mL of perchloric acid solution *R* and dilute to 1000.0 mL with water *R*. Adjust to pH 10.0 with concentrated ammonia *R1*.

*Solvent mixture*: ammonium carbonate buffer solution pH 10.0, acetonitrile *R1* (50:50 *V/V*).

*Test solution*. Dissolve 0.200 g of the substance to be examined in the solvent mixture and dilute to 50.0 mL with the solvent mixture.

*Reference solution (a)*. Dissolve 0.200 g of tiamulin hydrogen fumarate CRS in the solvent mixture and dilute to 50.0 mL with the solvent mixture.

*Reference solution (b)*. Dilute 1.0 mL of the test solution to 100.0 mL with the solvent mixture.

*Reference solution (c)*. Dissolve 40.0 mg of fumaric acid *R* in the solvent mixture and dilute to 50.0 mL with the solvent mixture.

*Reference solution (d)*. Dissolve 4 mg of tiamulin for peak identification CRS (tiamulin hydrogen fumarate containing impurities B, C, D, F, H and I) in the solvent mixture and dilute to 1 mL with the solvent mixture.

*Column*:

– size:  $l = 0.15$  m,  $\varnothing = 4.6$  mm,

– stationary phase: end-capped octadecylsilyl silica gel for chromatography *R* (5  $\mu$ m),

– temperature: 30 °C.

*Mobile phase:* acetonitrile R1, ammonium carbonate buffer solution pH 10.0, *methanol R1* (21:30:49 V/V/V).

*Flow rate:* 1.0 mL/min.

*Detection:* spectrophotometer at 212 nm.

*Injection:* 20 µL.

*Run time:* 3 times the retention time of tiamulin.

*Identification of impurities:* use the chromatogram supplied with *tiamulin for peak identification CRS* and the chromatogram obtained with reference solution (d) to identify the peaks due to impurities B and H.

*Relative retention* with reference to tiamulin (retention time = about 18 min): impurity G = about 0.2; impurity A = about 0.22; impurity H = about 0.23; impurity I = about 0.3; impurity J = about 0.4; impurity K = about 0.45; impurity B = about 0.5; impurity L = about 0.65; impurity C = about 0.66; impurity F = about 0.8; impurity M = about 0.85; impurity D = about 1.1; impurity S = about 1.4; impurity T = about 1.6; impurity E = 2.4.

*System suitability:* reference solution (a):

- baseline separation between the peaks due to tiamulin and impurity D.

*Limits:*

- *impurities B, H:* for each impurity, not more than 1.5 times the area of the principal peak in the chromatogram obtained with reference solution (b) (1.5 per cent),
- *impurities A, C, D, E, F, G, I, J, K, L, M, S, T:* for each impurity, not more than the area of the principal peak in the chromatogram obtained with reference solution (b) (1.0 per cent),
- *any other impurity:* for each impurity, not more than 0.2 times the area of the principal peak in the chromatogram obtained with reference solution (b) (0.2 per cent),
- *total:* not more than 3 times the area of the principal peak in the chromatogram obtained with reference solution (b) (3.0 per cent),
- *disregard limit:* 0.1 times the area of the principal peak in the chromatogram obtained with reference solution (b) (0.1 per cent); disregard any peak present in reference solution (c).

**Loss on drying** (2.2.32): maximum 0.5 per cent, determined on 1.000 g by drying in an oven at 105 °C.

## ASSAY

Liquid chromatography (2.2.29) as described in the test for related substances with the following modification.

*Injection:* test solution and reference solution (a).

Calculate the percentage content of C<sub>32</sub>H<sub>51</sub>NO<sub>8</sub>S from the declared content of *tiamulin hydrogen fumarate CRS*.

## STORAGE

Protected from light.

## IMPURITIES

*Specified impurities:* A, B, C, D, E, F, G, H, I, J, K, L, M, S, T.

*Other detectable impurities* (the following substances would, if present at a sufficient level, be detected by one or other of the tests in the monograph. They are limited by the general acceptance criterion for other/unspecified impurities and/or by the general monograph *Substances for pharmaceutical use* (2034). It is therefore not necessary to identify these impurities for demonstration of compliance. See also 5.10. *Control of impurities in substances for pharmaceutical use*): N, O, P, Q, R.

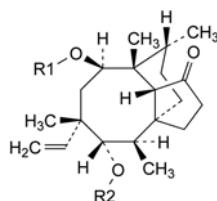

- A. R1 = R2 = H: (3a*S*,4*R*,5*S*,6*S*,8*R*,9*R*,9a*R*,10*R*)-6-ethenyl-5,8-dihydroxy-4,6,9,10-tetramethyloctahydro-3a,9-propano-3a*H*-cyclopentacycloocten-1(4*H*)-one (mutilin),
- G. R1 = CO-CH<sub>2</sub>OH, R2 = H: (3a*S*,4*R*,5*S*,6*S*,8*R*,9*R*,9a*R*,10*R*)-6-ethenyl-5-hydroxy-4,6,9,10-tetramethyl-1-oxodecahydro-3a,9-propano-3a*H*-cyclopentacycloocten-8-yl hydroxyacetate (pleuromutilin),
- J. R1 = CO-CH<sub>3</sub>, R2 = H: (3a*S*,4*R*,5*S*,6*S*,8*R*,9*R*,9a*R*,10*R*)-6-ethenyl-5-hydroxy-4,6,9,10-tetramethyl-1-oxodecahydro-3a,9-propano-3a*H*-cyclopentacycloocten-8-yl acetate (mutilin 14-acetate),
- K. R1 = H, R2 = CO-CH<sub>3</sub>: (3a*S*,4*R*,5*S*,6*S*,8*R*,9*R*,9a*R*,10*R*)-6-ethenyl-8-hydroxy-4,6,9,10-tetramethyl-1-oxodecahydro-3a,9-propano-3a*H*-cyclopentacycloocten-5-yl acetate (mutilin 11-acetate),
- L. R1 = CO-CH<sub>2</sub>-O-SO<sub>2</sub>-C<sub>6</sub>H<sub>4</sub>-*p*-CH<sub>3</sub>, R2 = H: (3a*S*,4*R*,5*S*,6*S*,8*R*,9*R*,9a*R*,10*R*)-6-ethenyl-5-hydroxy-4,6,9,10-tetramethyl-1-oxodecahydro-3a,9-propano-3a*H*-cyclopentacycloocten-8-yl [[(4-methylphenyl)sulfonyl]oxy]acetate (pleuromutilin 22-tosylate),
- M. R1 = R2 = CO-CH<sub>3</sub>: (3a*S*,4*R*,5*S*,6*S*,8*R*,9*R*,9a*R*,10*R*)-6-ethenyl-4,6,9,10-tetramethyl-1-oxodecahydro-3a,9-propano-3a*H*-cyclopentacycloocten-5,8-diyl diacetate (mutilin 11,14-diacetate),
- P. R1 = CO-CH<sub>2</sub>-O-SO<sub>2</sub>-C<sub>6</sub>H<sub>5</sub>, R2 = H: (3a*S*,4*R*,5*S*,6*S*,8*R*,9*R*,9a*R*,10*R*)-6-ethenyl-5-hydroxy-4,6,9,10-tetramethyl-1-oxodecahydro-3a,9-propano-3a*H*-cyclopentacycloocten-8-yl [(phenylsulfonyl)oxy]acetate,
- T. R1 = CO-CH<sub>2</sub>-[S-CH<sub>2</sub>-CH<sub>2</sub>]<sub>2</sub>N(C<sub>2</sub>H<sub>5</sub>)<sub>2</sub>, R2 = H: (3a*S*,4*R*,5*S*,6*S*,8*R*,9*R*,9a*R*,10*R*)-6-ethenyl-5-hydroxy-4,6,9,10-tetramethyl-1-oxodecahydro-3a,9-propano-3a*H*-cyclopentacycloocten-8-yl [[2-[[2-(diethylamino)ethyl]sulfonyl]ethyl]sulfonyl]acetate,

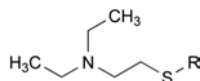

- B. R = CH<sub>2</sub>-C<sub>6</sub>H<sub>5</sub>: 2-(benzylsulfanyl)-*N,N*-diethylethanamine,
- C. R = S-CH<sub>2</sub>-CH<sub>2</sub>-N(C<sub>2</sub>H<sub>5</sub>)<sub>2</sub>: 2,2'-(disulfane-1,2-diyl)bis(*N,N*-diethylethanamine),
- O. R = H: 2-(diethylamino)ethanethiol,

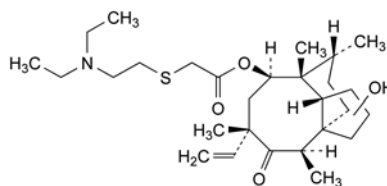

- D. (3a*R*,4*R*,6*S*,8*R*,9*R*,9a*R*,10*R*)-6-ethenylhydroxy-4,6,9,10-tetramethyl-5-oxodecahydro-3a,9-propano-3a*H*-cyclopentacycloocten-8-yl [[2-(diethylamino)ethyl]sulfonyl]acetate,

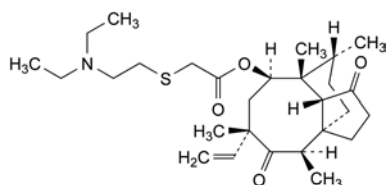

E. (3*aS*,4*R*,6*S*,8*R*,9*R*,9*aR*,10*R*)-6-ethenyl-4,6,9,10-tetramethyl-1,5-dioxodecahydro-3*a*,9-propano-3*aH*-cyclopentacycloocten-8-yl [[2-(diethylamino)ethyl]sulfanyl]acetate (11-oxotiamulin),

F. impurity of unknown structure with a relative retention of about 0.8,

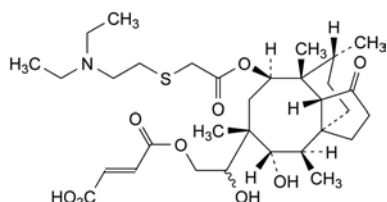

H. (2*E*)-4-[[2-(2*R*,3*S*)-2-[(3*aS*,4*R*,5*S*,6*R*,8*R*,9*R*,9*aR*,10*R*)-8-[[[2-(diethylamino)ethyl]sulfanyl]acetyl]oxy]-5-hydroxy-4,6,9,10-tetramethyl-1-oxodecahydro-3*a*,9-propano-3*aH*-cyclopentacycloocten-6-yl]-2-hydroxyethoxy]-4-oxobut-2-enoic acid (19,20-dihydroxytiamulin 20-fumarate),

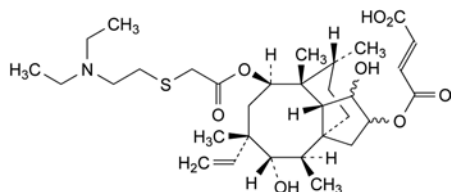

I. (2*E*)-4-[[3*aS*,4*R*,5*S*,6*S*,8*R*,9*R*,9*aR*,10*R*)-8-[[[2-(diethylamino)ethyl]sulfanyl]acetyl]oxy]-6-ethenyl-1,5-dihydroxy-4,6,9,10-tetramethyldecahydro-3*a*,9-propano-3*aH*-cyclopentacycloocten-2-yl]oxy]-4-oxobut-2-enoic acid (2,3-dihydroxytiamulin 2-fumarate),

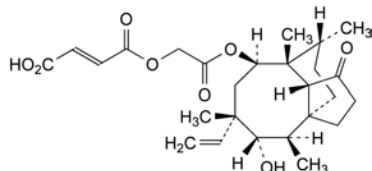

N. (2*E*)-4-[2-[[3*aS*,4*R*,5*S*,6*S*,8*R*,9*R*,9*aR*,10*R*)-6-ethenyl-5-hydroxy-4,6,9,10-tetramethyl-1-oxodecahydro-3*a*,9-propano-3*aH*-cyclopentacycloocten-8-yl]oxy]-2-oxoethoxy]-4-oxobut-2-enoic acid (pleuromutilin 22-fumarate),

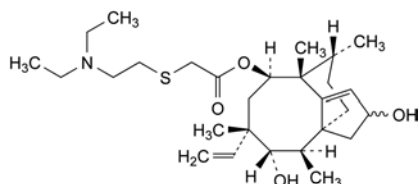

Q. (3*aS*,4*R*,5*S*,6*S*,8*R*,9*R*,10*R*)-6-ethenyl-2,5-dihydroxy-4,6,9,10-tetramethyl-2,3,4,5,6,7,8,9-octahydro-3*a*,9-propano-3*aH*-cyclopentacycloocten-8-yl [[2-(diethylamino)ethyl]sulfanyl]acetate (3,4-didehydro-2-hydroxytiamulin),

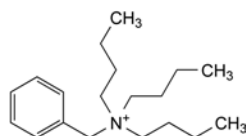

R. *N*-benzyl-*N,N*-dibutylbutan-1-aminium,

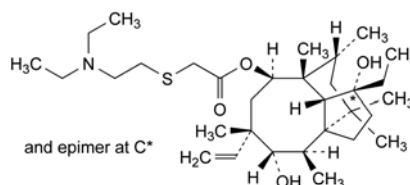

S. (1*R*,2*S*,3*aR*,4*R*,5*S*,6*S*,8*R*,9*R*,9*aR*,10*R*)-6-ethenyl-1-ethyl-1,5-dihydroxy-4,6,9,10,12,12-hexamethyldecahydro-3*a*,9-propano-3*aH*-cyclopentacycloocten-8-yl [[2-(diethylamino)ethyl]sulfanyl]acetate.

01/2008:2022

## TIANEPTINE SODIUM

### Tianeptinum natricum

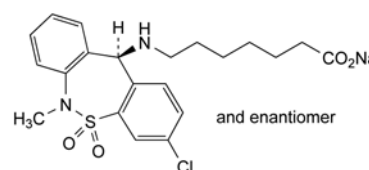

C<sub>21</sub>H<sub>24</sub>ClN<sub>2</sub>NaO<sub>4</sub>S  
[30123-17-2]

*M*<sub>r</sub> 458.9

#### DEFINITION

Sodium 7-[[1*RS*]-3-chloro-6-methyl-6,11-dihydrodibenzo[*c,f*][1,2]thiazepin-11-yl]amino]heptanoate *S,S*-dioxide.

*Content*: 99.0 per cent to 101.0 per cent (anhydrous substance).

#### CHARACTERS

*Appearance*: white or yellowish powder, very hygroscopic.

*Solubility*: freely soluble in water, in methanol and in methylene chloride.

#### IDENTIFICATION

A. Infrared absorption spectrophotometry (2.2.24).

*Comparison*: *Ph. Eur. reference spectrum of tianeptine sodium*.

B. It gives reaction (a) of sodium (2.3.1).

#### TESTS

**Impurity A.** Gas chromatography (2.2.28).

*Internal standard solution.* Dilute 1 mL of *ethyl 5-bromovalerate R* in *ethanol R* and dilute to 100.0 mL with the same solvent. Dilute 1.0 mL of the solution to 250.0 mL with *ethanol R*.

*Test solution.* Dissolve 0.1000 g of the substance to be examined in the internal standard solution and dilute to 2.0 mL with the same solution.

*Reference solution.* Dissolve 10.0 mg of *tianeptine impurity A CRS* in the internal standard solution and dilute to 200.0 mL with the same solution.

*Column*:

- *material*: fused silica,
- *size*: *l* = 25 m, Ø = 0.25 mm,
- *stationary phase*: *poly(cyanopropyl)siloxane R* (film thickness 0.2 µm).

*Carrier gas*: *helium for chromatography R*.

*Linear velocity*: 26 cm/s.

*Split ratio*: 1:100.

*Temperature*:

- *column*: 150 °C,
- *injection port and detector*: 210 °C.

*Detection*: flame ionisation.

*Injection*: 1 µL.

**Run time:** twice the retention time of ethyl 5-bromovalerate.

**System suitability:** reference solution:

- **elution order:** ethanol, ethyl 5-bromovalerate, impurity A,
- **resolution:** minimum 10 between the peaks due to ethyl 5-bromovalerate and impurity A,
- **signal-to-noise ratio:** minimum 20 for the peak due to impurity A.

**Limit:**

- **impurity A:** not more than the area of the corresponding peak in the chromatogram obtained with the reference solution (0.1 per cent).

**Related substances.** Liquid chromatography (2.2.29).

**Solvent mixture.** Mix 50 volumes of *methanol R* and 50 volumes of *water for chromatography R*.

**Test solution.** Dissolve 50.0 mg of the substance to be examined in the solvent mixture and dilute to 50.0 mL with the solvent mixture.

**Reference solution (a).** Dilute 1.0 mL of the test solution to 100.0 mL with the solvent mixture. Dilute 1.0 mL of this solution to 20.0 mL with the solvent mixture.

**Reference solution (b).** Dissolve 20.0 mg of *sodium tianeptine for system suitability CRS* in the solvent mixture and dilute to 200.0 mL with the solvent mixture.

**Column:**

- **size:**  $l = 0.15$  m,  $\varnothing = 4.6$  mm,
- **stationary phase:** *octadecylsilyl silica gel for chromatography R* (3  $\mu$ m) with a pore size of 0.01  $\mu$ m,
- **temperature:** 30 °C.

**Mobile phase:**

- **mobile phase A:** mix 21 volumes of *methanol R1*, 31.5 volumes of *acetonitrile R1* and 47.5 volumes of a 2 g/L solution of *sodium laurilsulfate R*, adjusted to pH 2.5 with *phosphoric acid R*,
- **mobile phase B:** mix 20 volumes of *methanol R1*, 20 volumes of a 2 g/L solution of *sodium laurilsulfate R*, adjusted to pH 2.5 with *phosphoric acid R* and 60 volumes of *acetonitrile R1*,

Time (min)	Mobile phase A (per cent V/V)	Mobile phase B (per cent V/V)
0 - 35	100	0
35 - 45	100 → 40	0 → 60
45 - 60	40	60
60 - 70	40 → 100	60 → 0

**Flow rate:** 1 mL/min.

**Detection:** spectrophotometer at 220 nm.

**Injection:** 10  $\mu$ L.

**Relative retention** with reference to tianeptine (retention time = about 30 min): impurity C = about 0.4; impurity D1 = about 0.6; impurity D2 = about 0.8; impurity E = about 1.1; impurity B = about 1.7.

**System suitability:** reference solution (b):

- **resolution:** minimum 2.5 between the peaks due to tianeptine and impurity E.

**Limits:**

- **any impurity:** not more than twice the area of the principal peak in the chromatogram obtained with reference solution (a) (0.1 per cent),
- **total:** not more than 8 times the area of the principal peak in the chromatogram obtained with reference solution (a) (0.4 per cent),
- **disregard limit:** area of the principal peak in the chromatogram obtained with reference solution (a) (0.05 per cent).

**Water (2.5.12):** maximum 5.0 per cent, determined on 0.100 g.

**ASSAY**

Dissolve 0.165 g in 50 mL of *anhydrous acetic acid R*. Titrate with 0.1 M *perchloric acid*, determining the end-point potentiometrically (2.2.20).

1 mL of 0.1 M *perchloric acid* is equivalent to 22.95 mg of  $C_{21}H_{24}ClN_2NaO_4S$ .

**STORAGE**

In an airtight container.

**IMPURITIES**

A.  $Br-[CH_2]_6-CO-O-C_2H_5$ : ethyl 7-bromoheptanoate,

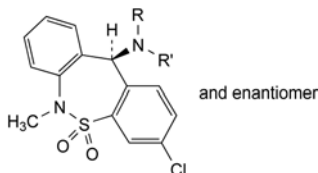

B.  $R = H, R' = [CH_2]_6-CO-O-C_2H_5$ : ethyl 7-[(11*RS*)-3-chloro-6-methyl-6,11-dihydrodibenzo[*c,f*][1,2]thiazepin-11-yl]amino]heptanoate *S,S*-dioxide,

E.  $R = R' = [CH_2]_6-CO_2H$ : 7,7'-[(11*RS*)-3-chloro-6-methyl-6,11-dihydrodibenzo[*c,f*][1,2]thiazepin-11-yl]imino]diheptanoic acid *S,S*-dioxide,

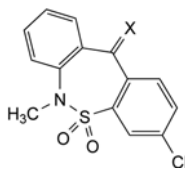

C.  $X = O$ : 3-chloro-6-methyl-6,11-dihydrodibenzo[*c,f*][1,2]thiazepin-11(6*H*)-one *S,S*-dioxide,

D.  $X = N-[CH_2]_6-CO_2H$ : 7-[(11*RS*)-3-chloro-6-methyl-6,11-dihydrodibenzo[*c,f*][1,2]thiazepin-11(6*H*)-ylidene]amino]heptanoic acid *S,S*-dioxide.

01/2008:1575  
corrected 6.0

## TIAPRIDE HYDROCHLORIDE

### Tiapridi hydrochloridum

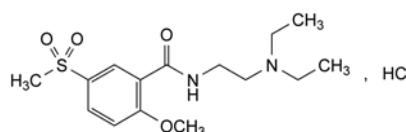

$C_{15}H_{25}ClN_2O_4S$   
[51012-33-0]

$M_r$  364.9

**DEFINITION**

*N*-[2-(Diethylamino)ethyl]-2-methoxy-5-(methylsulfonyl)-benzamide hydrochloride.

**Content:** 98.5 per cent to 101.0 per cent (dried substance).

**CHARACTERS**

**Appearance:** white or almost white, crystalline powder.

**Solubility:** very soluble in water, soluble in methanol, slightly soluble in anhydrous ethanol.

**IDENTIFICATION**

A. Infrared absorption spectrophotometry (2.2.24).

**Preparation:** discs.

**Comparison:** *tiapride hydrochloride CRS*.

B. Solution S (see Tests) gives reaction (a) of chlorides (2.3.1).

## TESTS

**Solution S.** Dissolve 2.5 g in *carbon dioxide-free water R* and dilute to 50.0 mL with the same solvent.

**Appearance of solution.** Solution S is clear (2.2.1) and its absorbance (2.2.25) at 450 nm is not greater than 0.030.

**pH** (2.2.3): 4.0 to 6.0 for solution S.

**Impurity C.** Thin-layer chromatography (2.2.27).

**Test solution.** Dissolve 0.400 g of the substance to be examined in *methanol R* and dilute to 10 mL with the same solvent.

**Reference solution.** Dissolve 20.0 mg of *metoclopramide impurity E CRS* (impurity C) in *methanol R* and dilute to 50 mL with the same solvent. Dilute 2.0 mL of this solution to 20 mL with *methanol R*.

**Plate:** TLC silica gel G plate R.

**Mobile phase:** concentrated ammonia R, dioxan R, methanol R, methylene chloride R (2:10:14:90 V/V/V/V).

**Application:** 10 µL.

**Development:** over a path of 12 cm.

**Drying:** in air.

**Detection:** spray with a 2 g/L solution of *ninhydrin R* in *butanol R* and heat at 100 °C for 15 min.

**Limit:**

- *impurity C*: any spot due to impurity C is not more intense than the corresponding spot in the chromatogram obtained with the reference solution (0.1 per cent).

**Related substances.** Liquid chromatography (2.2.29).

**Test solution.** Dissolve 0.100 g of the substance to be examined in the mobile phase and dilute to 100.0 mL with the mobile phase.

**Reference solution (a).** Dilute 1.0 mL of the test solution to 10.0 mL with the mobile phase. Dilute 1.0 mL of this solution to 100.0 mL with the mobile phase.

**Reference solution (b).** Dissolve 5.0 mg of *tiapride hydrochloride CRS* and 5.0 mg of *tiapride N-oxide CRS* in the mobile phase and dilute to 100.0 mL with the mobile phase.

**Column:**

- *size*:  $l = 0.25$  m,  $\varnothing = 4.6$  mm;
- *stationary phase*: octylsilyl silica gel for chromatography R (5 µm);
- *temperature*: 40 °C.

**Mobile phase:** dissolve 5.44 g of *potassium dihydrogen phosphate R* and 0.08 g of *sodium octanesulfonate R* in 780 mL of *water R*, adjust to pH 2.7 using *phosphoric acid R* and dilute to 800 mL with *water R*; add 150 mL of *methanol R* and 50 mL of *acetonitrile R* and mix.

**Flow rate:** 1.5 mL/min.

**Detection:** spectrophotometer at 240 nm.

**Injection:** 10 µL.

**Run time:** 3 times the retention time of tiapride.

**Retention time:** tiapride = about 9 min; tiapride N-oxide = about 13 min.

**System suitability:** reference solution (b):

- *resolution*: minimum 4.0 between the peaks due to tiapride and tiapride N-oxide.

**Limits:**

- *impurities A, B*: for each impurity, not more than the area of the principal peak in the chromatogram obtained with reference solution (a) (0.1 per cent);
- *total*: not more than 3 times the area of the principal peak in the chromatogram obtained with reference solution (a) (0.3 per cent);
- *disregard limit*: 0.5 times the area of the principal peak in the chromatogram obtained with reference solution (a) (0.05 per cent).

**Heavy metals** (2.4.8): maximum 20 ppm.

Dissolve 2.0 g in *water R* and dilute to 20 mL with the same solvent. 12 mL of the solution complies with test A. Prepare the reference solution using *lead standard solution (2 ppm Pb) R*.

**Loss on drying** (2.2.32): maximum 0.5 per cent, determined on 1.000 g by drying in an oven at 105 °C.

**Sulfated ash** (2.4.14): maximum 0.1 per cent, determined on 1.0 g.

## ASSAY

Dissolve 0.300 g in 20 mL of *anhydrous acetic acid R*. Add 20 mL of *acetic anhydride R*. Titrate with 0.1 M *perchloric acid*, determining the end-point potentiometrically (2.2.20).

1 mL of 0.1 M *perchloric acid* is equivalent to 36.49 mg of  $C_{15}H_{25}ClN_2O_4S$ .

## IMPURITIES

*Specified impurities: A, B, C.*

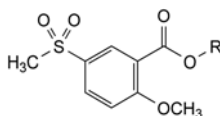

A. R = CH<sub>3</sub>: methyl 2-methoxy-5-(methylsulfonyl)benzoate,

B. R = H: 2-methoxy-5-(methylsulfonyl)benzoic acid,

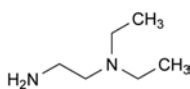

C. *N,N*-diethylethane-1,2-diamine.

01/2008:1157

## TIAPROFENIC ACID

## Acidum tiaprofenicum

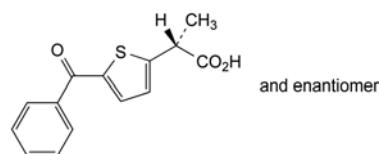

and enantiomer

$C_{14}H_{12}O_3S$   
[33005-95-7]

$M_r$  260.3

## DEFINITION

(2*RS*)-2-(5-Benzoylthiophen-2-yl)propanoic acid.

*Content*: 99.0 per cent to 101.0 per cent (dried substance).

## CHARACTERS

*Appearance*: white or almost white, crystalline powder.

*Solubility*: practically insoluble in water, freely soluble in acetone, in ethanol (96 per cent) and in methylene chloride.

## IDENTIFICATION

*First identification: C.*

*Second identification: A, B, D.*

A. Melting point (2.2.14): 95 °C to 99 °C.

B. Ultraviolet and visible absorption spectrophotometry (2.2.25).

**Test solution.** Dissolve 25.0 mg in *ethanolic hydrochloric acid R* and dilute to 50.0 mL with the same solvent. Dilute 1.0 mL of this solution to 50.0 mL with *ethanolic hydrochloric acid R*.

**Spectral range:** 220-350 nm.

*Absorption maximum*: at 305 nm.

*Shoulder*: at 262 nm.

*Specific absorbance at the absorption maximum*: 550 to 590.

C. Infrared absorption spectrophotometry (2.2.24).

*Comparison*: tiaprofenic acid CRS.

D. Thin-layer chromatography (2.2.27).

*Test solution*. Dissolve 10 mg of the substance to be examined in *methylene chloride R* and dilute to 10 mL with the same solvent.

*Reference solution (a)*. Dissolve 10 mg of *tiaprofenic acid CRS* in *methylene chloride R* and dilute to 10 mL with the same solvent.

*Reference solution (b)*. Dissolve 10 mg of *ketoprofen CRS* in *methylene chloride R* and dilute to 10 mL with the same solvent. Dilute 1 mL of this solution to 2 mL with reference solution (a).

*Plate*: TLC silica gel  $F_{254}$  plate R.

*Mobile phase*: acetic acid R, methylene chloride R, acetone R (1:20:80 V/V/V).

*Application*: 10  $\mu$ L.

*Development*: over a path of 15 cm.

*Drying*: in air.

*Detection*: examine in ultraviolet light at 254 nm.

*System suitability*: reference solution (b):

- the chromatogram shows 2 clearly separated principal spots.

*Results*: the principal spot in the chromatogram obtained with the test solution is similar in position and size to the principal spot in the chromatogram obtained with reference solution (a).

## TESTS

**Appearance of solution.** The solution is clear (2.2.1) and not more intensely coloured than reference solution  $Y_6$  (2.2.2, Method II).

Dissolve 2.0 g in *ethanol (96 per cent) R* and dilute to 20 mL with the same solvent.

**Optical rotation** (2.2.7):  $-0.10^\circ$  to  $+0.10^\circ$ .

Dissolve 0.50 g in *ethyl acetate R* and dilute to 10.0 mL with the same solvent.

**Related substances.** Liquid chromatography (2.2.29).

*Test solution*. Dissolve 20.0 mg of the substance to be examined in the mobile phase and dilute to 20.0 mL with the mobile phase.

*Reference solution (a)*. Dilute 1.0 mL of the test solution to 50.0 mL with the mobile phase. Dilute 1.0 mL of this solution to 10.0 mL with the mobile phase.

*Reference solution (b)*. Dilute 5.0 mL of reference solution (a) to 10.0 mL with the mobile phase.

*Reference solution (c)*. Dissolve 10.0 mg of *tiaprofenic acid impurity C CRS* in the mobile phase and dilute to 100.0 mL with the mobile phase. Dilute 1.0 mL of this solution to 50.0 mL with the mobile phase.

*Reference solution (d)*. Dilute 1.0 mL of reference solution (a) to 2.0 mL with reference solution (c).

*Column*:

- size:  $l = 0.25$  m,  $\varnothing = 4.6$  mm;
- stationary phase: silica gel for chromatography R (5  $\mu$ m).

*Mobile phase*: water R, glacial acetic acid R, hexane R, methylene chloride R (0.25:20:500:500 V/V/V/V); add the water to the acetic acid, then hexane and methylene chloride; sonicate the mixture for 2 min. Do not degas with helium during analysis.

*Flow rate*: 1 mL/min.

*Detection*: spectrophotometer at 250 nm.

*Injection*: 20  $\mu$ L.

*Run time*: twice the retention time of tiaprofenic acid.

*Relative retention* with reference to tiaprofenic acid: impurity A = about 0.19; impurity B = about 0.43; impurity C = about 0.86.

*System suitability*: reference solution (d):

- resolution: minimum 3.0 between the peaks due to impurity C and tiaprofenic acid.

*Limits*:

- impurity C: not more than the area of the corresponding peak in the chromatogram obtained with reference solution (c) (0.2 per cent);
- unspecified impurities: for each impurity, not more than the area of the principal peak in the chromatogram obtained with reference solution (b) (0.10 per cent);
- sum of impurities other than C: not more than 1.5 times the area of the principal peak in the chromatogram obtained with reference solution (a) (0.3 per cent);
- disregard limit: 0.5 times the area of the principal peak in the chromatogram obtained with reference solution (b) (0.05 per cent).

**Heavy metals** (2.4.8): maximum 10 ppm.

2.0 g complies with test C. Prepare the reference solution using 2 mL of lead standard solution (10 ppm Pb) R.

**Loss on drying** (2.2.32): maximum 0.5 per cent, determined on 1.000 g by drying in an oven at 60 °C at a pressure not exceeding 0.7 kPa for 3 h.

**Sulfated ash** (2.4.14): maximum 0.1 per cent, determined on 1.0 g.

## ASSAY

Dissolve 0.250 g in 25 mL of *ethanol (96 per cent) R*. Add 25 mL of *water R* and 0.5 mL of *phenolphthalein solution R*. Titrate with 0.1 M sodium hydroxide.

1 mL of 0.1 M sodium hydroxide is equivalent to 26.03 mg of  $C_{14}H_{12}O_3S$ .

## STORAGE

Protected from light.

## IMPURITIES

*Specified impurities*: C.

*Other detectable impurities* (the following substances would, if present at a sufficient level, be detected by one or other of the tests in the monograph. They are limited by the general acceptance criterion for other/unspecified impurities and/or by the general monograph *Substances for pharmaceutical use* (2034). It is therefore not necessary to identify these impurities for demonstration of compliance. See also 5.10. *Control of impurities in substances for pharmaceutical use*): A, B, D, E, F.

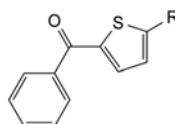

A. R =  $C_2H_5$ : (5-ethylthiophen-2-yl)phenylmethanone,

B. R =  $CO-CH_3$ : 1-(5-benzoylthiophen-2-yl)ethanone,

F. R = Br: (5-bromothiophen-2-yl)phenylmethanone,

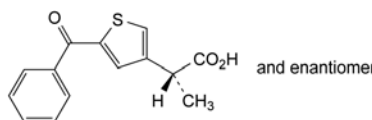

C. (2RS)-2-(5-benzoylthiophen-3-yl)propanoic acid,

D. benzoic acid,

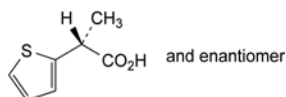

E. (2*RS*)-2-(thiophen-2-yl)propanoic acid.

01/2008:1739  
corrected 6.0

## TIBOLONE

### Tibolonum

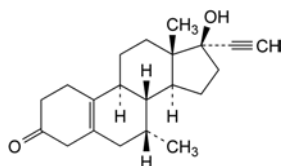

$C_{21}H_{28}O_2$

$M_r$  312.5

#### DEFINITION

17-Hydroxy-7 $\alpha$ -methyl-19-nor-17 $\alpha$ -pregn-5(10)-en-20-yn-3-one.

*Content*: 99.0 per cent to 101.0 per cent (dried substance).

#### CHARACTERS

*Appearance*: white or almost white, crystalline powder or crystals.

*Solubility*: practically insoluble in water, soluble in acetone and in methanol.

It shows polymorphism (5.9).

#### IDENTIFICATION

Infrared absorption spectrophotometry (2.2.24).

*Comparison*: *Ph. Eur. reference spectrum of tibolone*.

If the spectra obtained in the solid state show differences, dissolve the substance to be examined in the minimum volume of *anhydrous ethanol R*, evaporate to dryness on a water-bath and record a new spectrum using the residue.

#### TESTS

**Specific optical rotation** (2.2.7): + 100 to + 106 (dried substance).

Dissolve 0.250 g in *anhydrous ethanol R* and dilute to 25.0 mL with the same solvent.

**Related substances**. Liquid chromatography (2.2.29).

*Select a brand of acetonitrile such that the formation of possible artefact peaks, eluting after impurity C at relative retentions 0.6 to 0.8, is avoided.*

*Solvent mixture*: water R, acetonitrile R1 (25:75 V/V).

*Test solution*. Dissolve 40.0 mg of the substance to be examined in the solvent mixture and dilute to 10.0 mL with the solvent mixture.

*Reference solution (a)*. Dissolve 4 mg of *tibolone for system suitability CRS* (containing impurities A, B, C, D and E) in 1 mL of the solvent mixture.

*Reference solution (b)*. Dilute 1.0 mL of the test solution to 100.0 mL with the solvent mixture.

*Column*:

- *size*:  $l = 0.15$  m,  $\varnothing = 4.6$  mm;
- *stationary phase*: spherical *end-capped octylsilyl silica gel for chromatography R* (5  $\mu$ m).

*Mobile phase*: methanol R, acetonitrile R1, water R (8:40:52 V/V/V).

*Flow rate*: 1.0 mL/min.

*Detection*: spectrophotometer at 205 nm.

*Injection*: 5  $\mu$ L.

*Run time*: 3 times the retention time of tibolone.

*Identification of impurities*: use the chromatogram supplied with *tibolone for system suitability CRS* and the chromatogram obtained with reference solution (a) to identify the peaks due to impurities A, B, C, D and E.

*Relative retention* with reference to tibolone (retention time = about 14 min): impurity A = about 0.22; impurity B = about 0.24; impurity C = about 0.58; impurity D = about 1.12; impurity E = about 2.24.

*System suitability*: reference solution (a):

- *peak-to-valley ratio*: minimum 2.0, where  $H_p$  = height above the baseline of the peak due to impurity D and  $H_v$  = height above the baseline of the lowest point of the curve separating this peak from the peak due to tibolone.

*Limits*:

- *correction factors*: for the calculation of content, multiply the peak areas of the following impurities by the corresponding correction factor: impurity A = 1.7; impurity B = 1.5; impurity C = 2.1;
- *impurities A, E*: for each impurity, not more than 0.1 times the area of the principal peak in the chromatogram obtained with reference solution (b) (0.1 per cent);
- *impurity B*: not more than 0.4 times the area of the principal peak in the chromatogram obtained with reference solution (b) (0.4 per cent);
- *impurity C*: not more than 0.5 times the area of the principal peak in the chromatogram obtained with reference solution (b) (0.5 per cent);
- *impurity D*: not more than 0.2 times the area of the principal peak in the chromatogram obtained with reference solution (b) (0.2 per cent);
- *unspecified impurities*: for each impurity, not more than 0.1 times the area of the principal peak in the chromatogram obtained with reference solution (b) (0.10 per cent);
- *total*: not more than the area of the principal peak in the chromatogram obtained with reference solution (b) (1.0 per cent);
- *disregard limit*: 0.05 times the area of the principal peak in the chromatogram obtained with reference solution (b) (0.05 per cent).

**Loss on drying** (2.2.32): maximum 0.5 per cent, determined on 1.000 g by drying in an oven at 105 °C for 3 h.

**Sulfated ash** (2.4.14): maximum 0.1 per cent, determined on 1.0 g.

#### ASSAY

Dissolve 0.250 g in 60 mL of *tetrahydrofuran R*. Add 25 mL of a 100 g/L solution of *silver nitrate R*. Titrate with 0.1 M *sodium hydroxide*, determining the end-point potentiometrically (2.2.20).

1 mL of 0.1 M *sodium hydroxide* is equivalent to 31.25 mg of  $C_{21}H_{28}O_2$ .

#### STORAGE

At a temperature of 2 °C to 8 °C.

#### IMPURITIES

*Specified impurities*: A, B, C, D, E.



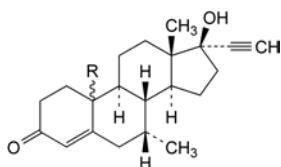

- A. R = OH: 10,17-dihydroxy-7 $\alpha$ -methyl-19-nor-10 $\xi$ ,17 $\alpha$ -pregn-4-en-20-yn-3-one,  
 B. R = O-OH: 10-hydroperoxy-17-hydroxy-7 $\alpha$ -methyl-19-nor-10 $\xi$ ,17 $\alpha$ -pregn-4-en-20-yn-3-one,  
 C. R = H: 17-hydroxy-7 $\alpha$ -methyl-19-nor-10 $\xi$ ,17 $\alpha$ -pregn-4-en-20-yn-3-one,

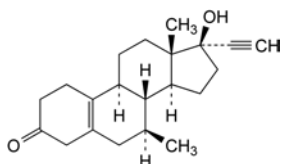

- D. 17-hydroxy-7 $\beta$ -methyl-19-nor-17 $\alpha$ -pregn-5(10)-en-20-yn-3-one,

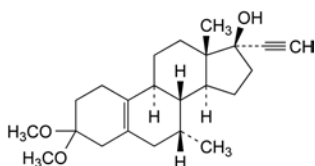

- E. 3,3-dimethoxy-7 $\alpha$ -methyl-19-nor-17 $\alpha$ -pregn-5(10)-en-20-yn-17-ol.

01/2008:0956  
corrected 6.0

## TICARCILLIN SODIUM

### Ticarcillinum natrium

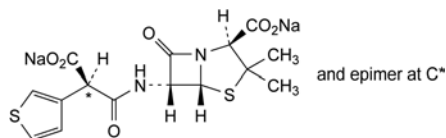

$C_{15}H_{14}N_2Na_2O_6S_2$   
[4697-14-7]

$M_r$  428.4

#### DEFINITION

Disodium (2*S*,5*R*,6*R*)-6-[[*(2R*)-2-carboxylato-2-(thiophen-3-yl)acetyl]amino]-3,3-dimethyl-7-oxo-4-thia-1-azabicyclo[3.2.0]heptane-2-carboxylate.

Semi-synthetic product derived from a fermentation product.

*Content*: 89.0 per cent to 102.0 per cent (anhydrous substance).

#### CHARACTERS

*Appearance*: white or slightly yellow, hygroscopic powder.

*Solubility*: freely soluble in water, soluble in methanol.

#### IDENTIFICATION

*First identification*: A, D, E.

*Second identification*: B, C, D.

A. Infrared absorption spectrophotometry (2.2.24).

*Preparation*: dissolve 50 mg of the substance to be examined in 1 mL of *water R*, add 0.1 mL of *hydrochloric acid RI*, swirl and allow to stand in iced water for 10 min. Filter the precipitate and rinse with 2 mL of *water R*. Dissolve in a mixture of 1 volume of *water R* and 9 volumes of *acetone R*. Evaporate the solvent almost to dryness, then dry in an oven at 60 °C for 30 min.

*Comparison*: repeat the operations using *ticarcillin monosodium CRS*.

B. Thin-layer chromatography (2.2.27).

*Test solution*. Dissolve 25 mg of the substance to be examined in *methanol R* and dilute to 5 mL with the same solvent.

*Reference solution (a)*. Dissolve 25 mg of *ticarcillin monosodium CRS* in *methanol R* and dilute to 5 mL with the same solvent.

*Reference solution (b)*. Dissolve 25 mg of *carbenicillin sodium CRS* and 25 mg of *ticarcillin monosodium CRS* in *methanol R* and dilute to 5 mL with the same solvent.

*Plate*: TLC silanised silica gel plate *R*.

*Mobile phase*: mix 10 volumes of *acetone R* and 90 volumes of a 154 g/L solution of *ammonium acetate R*, adjusted to pH 5.0 with *glacial acetic acid R*.

*Application*: 1  $\mu$ L.

*Development*: over a path of 12 cm.

*Drying*: in a current of hot air.

*Detection*: expose to iodine vapour.

*System suitability*: reference solution (b):

– the chromatogram shows 2 clearly separated spots.

*Results*: the principal spot in the chromatogram obtained with the test solution is similar in position, colour and size to the principal spot in the chromatogram obtained with reference solution (a).

C. Place about 2 mg in a test-tube about 15 cm long and 15 mm in diameter. Moisten with 0.05 mL of *water R* and add 2 mL of *sulfuric acid-formaldehyde reagent R*. Mix the contents of the tube by swirling; the solution is brown. Place the test-tube in a water-bath for 1 min; a dark reddish-brown colour develops.

D. It gives reaction (a) of sodium (2.3.1).

E. Specific optical rotation (see Tests).

#### TESTS

**Solution S**. Dissolve 2.50 g in *carbon dioxide-free water R* and dilute to 50 mL with the same solvent.

**Appearance of solution**. Solution S is clear (2.2.1) and not more intensely coloured than reference solution  $Y_5$  (2.2.2, *Method II*).

**pH** (2.2.3): 5.5 to 7.5 for solution S.

**Specific optical rotation** (2.2.7): + 172 to + 187 (anhydrous substance).

Dissolve 0.250 g in *water R* and dilute to 25.0 mL with the same solvent.

**Related substances**. Liquid chromatography (2.2.29).

*Test solution*. Dissolve 25.0 mg of the substance to be examined in mobile phase A and dilute to 25.0 mL with mobile phase A.

*Reference solution (a)*. Dissolve 20.0 mg of *ticarcillin impurity A CRS* in mobile phase A and dilute to 100.0 mL with mobile phase A. Dilute 5.0 mL of this solution to 50.0 mL with mobile phase A.

*Reference solution (b)*. Dilute 1 mL of the test solution to 50 mL with mobile phase A.

*Column*:

– *size*:  $l = 0.25$  m,  $\varnothing = 4$  mm;

– *stationary phase*: octadecylsilyl silica gel for chromatography *R* (5  $\mu$ m).

*Mobile phase*:

– *mobile phase A*: 1.3 g/L solution of *ammonium phosphate R* adjusted to pH 7.0 with *phosphoric acid R*;

– *mobile phase B*: *methanol R*, mobile phase A (50:50 V/V);

Time (min)	Mobile phase A (per cent V/V)	Mobile phase B (per cent V/V)
0 - 30	100 $\rightarrow$ 30	0 $\rightarrow$ 70
30 - 40	30	70

*Flow rate*: 1.0 mL/min.

**Detection:** spectrophotometer at 220 nm.

**Injection:** 20 µL.

**System suitability:** reference solution (b):

- **resolution:** minimum 2.0 between the 2 principal peaks (diastereoisomers).

**Limits:**

- **impurity A:** not more than twice the area of the principal peak in the chromatogram obtained with reference solution (a) (4 per cent);
- **any other impurity:** for each impurity, not more than 1.25 times the area of the principal peak in the chromatogram obtained with reference solution (a) (2.5 per cent).

***N,N*-Dimethylaniline** (2.4.26, Method B): maximum 20 ppm.

**2-Ethylhexanoic acid** (2.4.28): maximum 0.5 per cent *m/m*.

**Water** (2.5.12): maximum 5.5 per cent, determined on 0.150 g.

**Bacterial endotoxins** (2.6.14): less than 0.05 IU/mg, if intended for use in the manufacture of parenteral preparations without a further appropriate procedure for the removal of bacterial endotoxins.

#### ASSAY

Liquid chromatography (2.2.29).

**Test solution.** Dissolve 50.0 mg of the substance to be examined in the mobile phase and dilute to 100.0 mL with the mobile phase. Dilute 10.0 mL of this solution to 50.0 mL with the mobile phase.

**Reference solution.** Dissolve 50.0 mg of *ticarcillin monosodium CRS* in the mobile phase and dilute to 100.0 mL with the mobile phase. Dilute 10.0 mL of this solution to 50.0 mL with the mobile phase.

**Column:**

- **size:**  $l = 0.25$  m,  $\varnothing = 4$  mm;
- **stationary phase:** octadecylsilyl silica gel for chromatography R (5 µm).

**Mobile phase:** mix 20 volumes of *methanol R* and 80 volumes of a 1.3 g/L solution of *ammonium phosphate R* adjusted to pH 7.0 with *phosphoric acid R*.

**Flow rate:** 1 mL/min.

**Detection:** spectrophotometer at 220 nm.

**Injection:** 20 µL.

**System suitability:** reference solution:

- **resolution:** minimum 2.5 between the 2 principal peaks;
- **repeatability:** maximum relative standard deviation of 1.0 per cent for the 2 peaks due to *ticarcillin* after 6 injections.

Calculate the percentage content of *ticarcillin sodium* as the sum of the areas of the 2 peaks, multiplying the content of *ticarcillin monosodium* by 1.054.

#### STORAGE

In an airtight container, at a temperature of 2 °C to 8 °C. If the substance is sterile, store in a sterile, airtight, tamper-proof container.

#### IMPURITIES

**Specified impurities:** A.

**Other detectable impurities** (the following substances would, if present at a sufficient level, be detected by one or other of the tests in the monograph. They are limited by the general acceptance criterion for other/unspecified impurities and/or by the general monograph *Substances for pharmaceutical use* (2034). It is therefore not necessary to identify these impurities for demonstration of compliance. See also 5.10. *Control of impurities in substances for pharmaceutical use*): B, C, D, E.

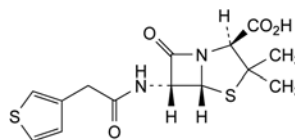

- A. (2*S*,5*R*,6*R*)-3,3-dimethyl-7-oxo-6-[[2-(thiophen-3-yl)acetyl]amino]-4-thia-1-azabicyclo[3.2.0]heptane-2-carboxylic acid (decarboxy ticarcillin),

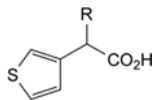

- B. R = H: (thiophen-3-yl)acetic acid,

- C. R = CO<sub>2</sub>H: 2-(thiophen-3-yl)propanedioic acid (3-thienylmalonic acid),

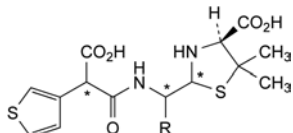

- D. R = CO<sub>2</sub>H: (4*S*)-2-[carboxy[[2-carboxy-2-(thiophen-3-yl)acetyl]amino]methyl]-5,5-dimethylthiazolidine-4-carboxylic acid (penicilloic acids of ticarcillin),

- E. R = H: (4*S*)-2-[[[2-carboxy-2-(thiophen-3-yl)acetyl]amino]methyl]-5,5-dimethylthiazolidine-4-carboxylic acid (penicilloic acids of ticarcillin).

01/2008:1050

## TICLOPIDINE HYDROCHLORIDE

### Ticlopidini hydrochloridum

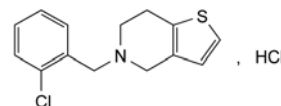

C<sub>14</sub>H<sub>15</sub>Cl<sub>2</sub>NS  
[53885-35-1]

*M<sub>r</sub>*, 300.2

#### DEFINITION

5-(2-Chlorobenzyl)-4,5,6,7-tetrahydrothieno[3,2-*c*]pyridine hydrochloride.

**Content:** 99.0 per cent to 101.0 per cent (anhydrous substance).

#### CHARACTERS

**Appearance:** white or almost white, crystalline powder.

**Solubility:** sparingly soluble in water and in anhydrous ethanol, very slightly soluble in ethyl acetate.

#### IDENTIFICATION

**First identification:** B, D.

**Second identification:** A, C, D.

- A. Ultraviolet and visible absorption spectrophotometry (2.2.25).

**Test solution (a).** Dissolve 40 mg in *water R* and dilute to 100.0 mL with the same solvent.

**Test solution (b).** Dilute 5.0 mL of test solution (a) to 100.0 mL with *water R*.

**Spectral range:** 250-350 nm for test solution (a); 200-350 nm for test solution (b).

**Absorption maxima:** at 268 nm and 275 nm for test solution (a); at 214 nm and 232 nm for test solution (b).

**Absorption ratio:**  $A_{268}/A_{275} = 1.1$  to 1.2.

- B. Infrared absorption spectrophotometry (2.2.24).

**Preparation:** discs.

**Comparison:** ticlopidine hydrochloride CRS.

- C. Mix about 6 mg of *citric acid R* and 0.3 mL of *acetic anhydride R*. Add about 5 mg of the substance to be examined and heat in a water-bath at 80 °C. A red colour develops.
- D. About 20 mg gives reaction (a) of chlorides (2.3.1).

## TESTS

**Appearance of solution.** The solution is clear (2.2.1) and colourless (2.2.2, Method II).

Dissolve 0.5 g in a 1 per cent V/V solution of *hydrochloric acid R* and dilute to 20 mL with the same solution.

**pH (2.2.3):** 3.5 to 4.0.

Dissolve 0.5 g in *carbon dioxide-free water R* and dilute to 20 mL with the same solvent.

**Related substances.** Liquid chromatography (2.2.29).

**Solvent mixture:** mobile phase B, mobile phase A (20:80 V/V).

**Test solution.** Dissolve 0.250 g of the substance to be examined in the solvent mixture and dilute to 50.0 mL with the solvent mixture.

**Reference solution.** Dissolve 5.0 mg of *ticlopidine impurity F CRS* in the solvent mixture. Add 1.00 mL of the test solution and dilute to 100.0 mL with the solvent mixture. Dilute 1.0 mL of this solution to 10.0 mL with the solvent mixture.

**Column:**

- size:  $l = 0.15$  m,  $\varnothing = 4.6$  mm;
- stationary phase: *octadecylsilyl silica gel for chromatography R* (5  $\mu$ m);
- temperature: 40 °C.

**Mobile phase:**

- mobile phase A: 0.95 g/L solution of *sodium pentanesulfonate monohydrate R*, adjusted to pH 3.4 with a 50 per cent V/V solution of *phosphoric acid R*;
- mobile phase B: *methanol R*;

Time (min)	Mobile phase A (per cent V/V)	Mobile phase B (per cent V/V)
0 - 45	80 → 20	20 → 80
45 - 50	20	80

**Flow rate:** 1.3 mL/min.

**Detection:** spectrophotometer at 220 nm.

**Injection:** 10  $\mu$ L; inject the solvent mixture as a blank.

**Retention time:** ticlopidine = about 15 min.

**System suitability:** reference solution:

- resolution: minimum 2.0 between the peaks due to ticlopidine and impurity F; if necessary, adjust the pH of mobile phase A;
- signal-to-noise ratio: minimum 50 for the peak due to ticlopidine.

**Limits:**

- impurity F: not more than 0.5 times the area of the corresponding peak in the chromatogram obtained with the reference solution (0.05 per cent);
- any other impurity: for each impurity, not more than 0.5 times the area of the peak due to ticlopidine in the chromatogram obtained with the reference solution (0.05 per cent);
- total: not more than the area of the peak due to ticlopidine in the chromatogram obtained with the reference solution (0.1 per cent);
- disregard limit: 0.1 times the area of the peak due to ticlopidine in the chromatogram obtained with the reference solution (0.01 per cent).

**Formaldehyde:** maximum 20 ppm.

Dissolve 0.200 g in 4.0 mL of *water R*. Add 0.4 mL of *dilute sodium hydroxide solution R*. Centrifuge, filter the supernatant

liquid through cotton previously impregnated with *water R* and dilute to 5.0 mL with *water R*. Transfer to a test-tube. Add 5.0 mL of *acetylacetone reagent R1*. Place the test-tube in a water-bath at 40 °C for 40 min. The test solution is not more intensely coloured than a standard prepared at the same time and in the same manner using 5.0 mL of a 0.8 ppm solution of formaldehyde (CH<sub>2</sub>O), obtained by dilution of *formaldehyde standard solution (5 ppm CH<sub>2</sub>O) R* with *water R*. Examine the tubes down their vertical axis.

**Heavy metals (2.4.8):** maximum 10 ppm.

Dissolve 2.0 g in a 85 per cent V/V solution of *methanol R* and dilute to 20.0 mL with the same solvent. 12 mL of the solution complies with test B. Prepare the reference solution using 10 mL of *lead standard solution (1 ppm Pb) R*.

**Water (2.5.12):** maximum 0.5 per cent, determined on 0.500 g.

**Sulfated ash (2.4.14):** maximum 0.1 per cent, determined on 1.0 g.

## ASSAY

Dissolve 0.150 g in 15 mL of *anhydrous acetic acid R*. Add 35 mL of *acetic anhydride R*. Titrate with 0.1 M *perchloric acid*, determining the end-point potentiometrically (2.2.20).

1 mL of 0.1 M *perchloric acid* is equivalent to 30.02 mg of C<sub>14</sub>H<sub>15</sub>Cl<sub>2</sub>NS.

## IMPURITIES

**Specified impurities: F.**

**Other detectable impurities** (the following substances would, if present at a sufficient level, be detected by one or other of the tests in the monograph. They are limited by the general acceptance criterion for other/unspecified impurities and/or by the general monograph *Substances for pharmaceutical use (2034)*. It is therefore not necessary to identify these impurities for demonstration of compliance. See also 5.10. *Control of impurities in substances for pharmaceutical use*): A, B, C, D, E, G, H, I, J, K, L.

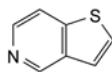

A. thieno[3,2-c]pyridine,

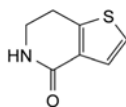

B. 6,7-dihydrothieno[3,2-c]pyridin-4(5H)-one,

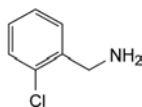

C. (2-chlorophenyl)methanamine,

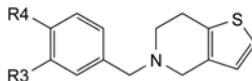

D. R<sub>3</sub> = R<sub>4</sub> = H: 5-benzyl-4,5,6,7-tetrahydrothieno[3,2-c]pyridine,

G. R<sub>3</sub> = Cl, R<sub>4</sub> = H: 5-(3-chlorobenzyl)-4,5,6,7-tetrahydrothieno[3,2-c]pyridine,

H. R<sub>3</sub> = H, R<sub>4</sub> = Cl: 5-(4-chlorobenzyl)-4,5,6,7-tetrahydrothieno[3,2-c]pyridine,

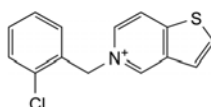

E. 5-(2-chlorobenzyl)thieno[3,2-c]pyridinium,

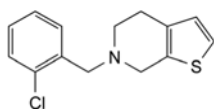

F. 6-(2-chlorobenzyl)-4,5,6,7-tetrahydrothieno[2,3-c]pyridine,

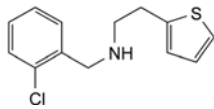

I. *N*-(2-chlorobenzyl)-2-(thiophen-2-yl)ethanamine,

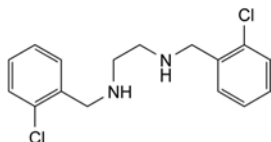

J. *N,N'*-bis(2-chlorobenzyl)ethane-1,2-diamine,

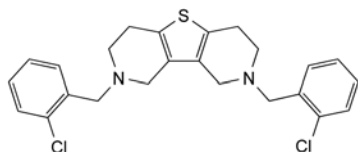

K. 2,8-bis(2-chlorobenzyl)-1,2,3,4,6,7,8,9-octahydrothieno[3,2-c:4,5-c']dipyridine (bis-ticlopidine),

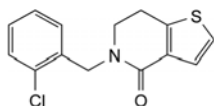

L. 5-(2-chlorobenzyl)-6,7-dihydrothieno[3,2-c]pyridin-4(5*H*)-one.

01/2008:1767  
corrected 7.0

## TILIDINE HYDROCHLORIDE HEMIHYDRATE

### Tilidini hydrochloridum hemihydricum

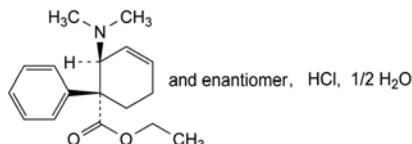

$C_{17}H_{24}ClNO_2 \cdot \frac{1}{2}H_2O$

$M_r$  318.9

#### DEFINITION

Ethyl (1*RS*,2*SR*)-2-(dimethylamino)-1-phenylcyclohex-3-enecarboxylate hydrochloride hemihydrate.

*Content*: 99.0 per cent to 101.0 per cent (anhydrous substance).

A suitable antioxidant may be added.

#### CHARACTERS

*Appearance*: white or almost white, crystalline powder.

*Solubility*: freely soluble in water, very soluble in methylene chloride, freely soluble in ethanol (96 per cent).

#### IDENTIFICATION

A. Infrared absorption spectrophotometry (2.2.24).

*Comparison*: *Ph. Eur. reference spectrum of tilidine hydrochloride hemihydrate*.

B. It gives reaction (a) of chlorides (2.3.1).

#### TESTS

**Solution S.** Dissolve 1.0 g in carbon dioxide-free water *R* and dilute to 20 mL with the same solvent.

**Appearance of solution.** Solution S is clear (2.2.1) and not more intensely coloured than reference solution Y<sub>7</sub> (2.2.2, *Method II*).

**Acidity or alkalinity.** To 20 mL of solution S add 0.2 mL of 0.01 *M* sodium hydroxide. The pH is not less than 4.1. Add 0.4 mL of 0.01 *M* hydrochloric acid. The pH is not more than 4.3.

**Related substances.** Liquid chromatography (2.2.29).

*Test solution.* Dissolve 50.0 mg of the substance to be examined in water *R* and dilute to 50.0 mL with the same solvent.

*Reference solution (a).* Dilute 0.5 mL of the test solution to 100.0 mL with water *R*.

*Reference solution (b).* Dilute 2.0 mL of reference solution (a) to 10.0 mL with water *R*.

*Precolumn*:

– *size*:  $l = 4$  mm,  $\varnothing = 4.0$  mm;

– *stationary phase*: spherical octadecylsilyl silica gel for chromatography *R* (5  $\mu$ m).

*Column*:

– *size*:  $l = 0.125$  m,  $\varnothing = 4.0$  mm;

– *stationary phase*: spherical octadecylsilyl silica gel for chromatography *R* (5  $\mu$ m).

*Mobile phase*: mix equal volumes of acetonitrile *R* and a 0.98 g/L solution of ammonium carbonate *R*.

*Flow rate*: 0.8 mL/min.

*Detection*: spectrophotometer at 220 nm.

*Injection*: 10  $\mu$ L.

*Run time*: twice the retention time of tilidine.

*Relative retention* with reference to tilidine (retention

time = about 11 min): impurity C = about 0.5;

impurity B = about 0.7; impurity A = about 1.5.

*Limits*:

– *impurities A, B, C*: for each impurity, not more than the area of the principal peak in the chromatogram obtained with reference solution (a) (0.5 per cent);

– *unspecified impurities*: for each impurity, not more than the area of the principal peak in the chromatogram obtained with reference solution (b) (0.10 per cent);

– *total*: not more than the area of the principal peak in the chromatogram obtained with reference solution (a) (0.5 per cent);

– *disregard limit*: 0.5 times the area of the principal peak in the chromatogram obtained with reference solution (b) (0.05 per cent).

**Heavy metals** (2.4.8): maximum 20 ppm.

Dissolve 2.0 g in 20 mL of water *R*. 12 mL of the solution complies with test A. Prepare the reference solution using lead standard solution (2 ppm Pb) *R*.

**Water** (2.5.12): 2.5 per cent to 3.1 per cent, determined on 0.300 g.

**Bacterial endotoxins** (2.6.14): less than 0.25 IU/mg, if intended for use in the manufacture of parenteral preparations without a further appropriate procedure for the removal of bacterial endotoxins.

#### ASSAY

Dissolve 0.250 g in a mixture of 10 mL of anhydrous acetic acid *R* and 50 mL of acetic anhydride *R*. Titrate with 0.1 *M* perchloric acid, determining the end-point potentiometrically (2.2.20).

1 mL of 0.1 *M* perchloric acid is equivalent to 30.99 mg of  $C_{17}H_{24}ClNO_2$ .

#### STORAGE

Protected from light.

#### IMPURITIES

*Specified impurities*: A, B, C.

*Other detectable impurities* (the following substances would, if present at a sufficient level, be detected by one or other of the tests in the monograph. They are limited by the general acceptance criterion for other/unspecified impurities and/or by the general monograph *Substances for pharmaceutical use* (2034). It is therefore not necessary to identify these impurities for demonstration of compliance. See also 5.10. *Control of impurities in substances for pharmaceutical use*): D.

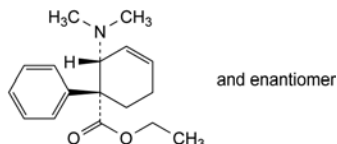

A. ethyl (1*RS*,2*RS*)-2-(dimethylamino)-1-phenylcyclohex-3-enecarboxylate,

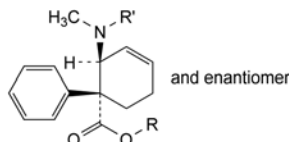

B. R = R' = CH<sub>3</sub>: methyl (1*RS*,2*SR*)-2-(dimethylamino)-1-phenylcyclohex-3-enecarboxylate,

C. R = C<sub>2</sub>H<sub>5</sub>, R' = H: ethyl (1*RS*,2*SR*)-2-(methylamino)-1-phenylcyclohex-3-enecarboxylate,

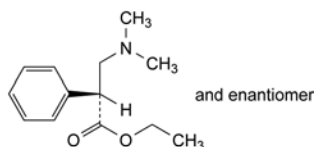

D. ethyl (2*RS*)-3-dimethylamino-2-phenylpropanoate.

01/2011:0572

## TIMOLOL MALEATE

### Timololi maleas

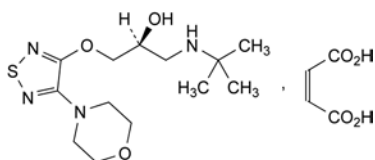

C<sub>17</sub>H<sub>28</sub>N<sub>4</sub>O<sub>5</sub>S  
[26921-17-5]

M<sub>r</sub> 432.5

#### DEFINITION

(2*S*)-1-[(1,1-Dimethylethyl)amino]-3-[[4-(morpholin-4-yl)-1,2,5-thiadiazol-3-yl]oxy]propan-2-ol (*Z*)-butenedioate.

*Content*: 98.5 per cent to 101.0 per cent (dried substance).

#### CHARACTERS

*Appearance*: white or almost white, crystalline powder or colourless crystals.

*Solubility*: soluble in water and in ethanol (96 per cent).

mp: about 199 °C, with decomposition.

#### IDENTIFICATION

*First identification*: A, B.

*Second identification*: A, C, D.

A. Specific optical rotation (2.2.7): –5.7 to –6.2.

Dissolve 1.000 g in 1 M hydrochloric acid and dilute to 10.0 mL with the same acid.

B. Infrared absorption spectrophotometry (2.2.24).

*Comparison*: timolol maleate CRS.

C. Thin-layer chromatography (2.2.27).

*Test solution*. Dissolve 5 mg of the substance to be examined in methanol R and dilute to 5 mL with the same solvent.

*Reference solution*. Dissolve 5 mg of timolol maleate CRS in methanol R and dilute to 5 mL with the same solvent.

*Plate*: TLC silica gel GF<sub>254</sub> plate R.

*Mobile phase*: concentrated ammonia R, methanol R, methylene chloride R (1:20:80 V/V/V).

*Application*: 10 µL.

*Development*: over 2/3 of the plate.

*Drying*: in air.

*Detection*: expose to iodine vapour for 2 h.

*Results*: the principal spot in the chromatogram obtained with the test solution is similar in position, colour and size to the principal spot in the chromatogram obtained with the reference solution.

D. Triturate 0.1 g with a mixture of 1 mL of dilute sodium hydroxide solution R and 3 mL of water R. Shake with 3 quantities, each of 5 mL, of ether R. To 0.1 mL of the aqueous layer add a solution containing 10 mg of resorcinol R in 3 mL of sulfuric acid R. Heat on a water-bath for 15 min; no violet-red colour develops. Neutralise the remainder of the aqueous layer with dilute sulfuric acid R and add 1 mL of bromine water R. Heat on a water-bath for 15 min, then heat to boiling and cool. To 0.2 mL of this solution add a solution containing 10 mg of resorcinol R in 3 mL of sulfuric acid R. Heat on a water-bath for 15 min; a violet-red colour develops. Add 0.2 mL of a 100 g/L solution of potassium bromide R and heat for 5 min on a water-bath; the colour becomes violet-blue.

#### TESTS

**Solution S**. Dissolve 0.5 g in carbon dioxide-free water R and dilute to 25 mL with the same solvent.

**Appearance of solution**. Solution S is clear (2.2.1) and not more intensely coloured than reference solution B<sub>8</sub> (2.2.2, Method II).

**pH** (2.2.3): 3.8 to 4.3 for solution S.

**Enantiomeric purity**. Liquid chromatography (2.2.29). Carry out the test protected from actinic light.

*Solvent mixture*: methylene chloride R, 2-propanol R (10:30 V/V).

*Test solution*. Dissolve 30.0 mg of the substance to be examined in the solvent mixture and dilute to 10.0 mL with the solvent mixture.

*Reference solution (a)*. Dissolve 30 mg of timolol maleate CRS in the solvent mixture and dilute to 10 mL with the solvent mixture.

*Reference solution (b)*. Dissolve 15.0 mg of (*R*)-timolol CRS (impurity A) in the solvent mixture and dilute to 10.0 mL with the solvent mixture. Dilute 1.0 mL of this solution to 50.0 mL with the solvent mixture.

*Reference solution (c)*. Dilute 1 mL of reference solution (a) to 100 mL with the solvent mixture. Mix 1 mL of this solution with 1 mL of reference solution (b).

*Reference solution (d)*. Dilute 1.0 mL of the test solution to 100.0 mL with the solvent mixture.

*Column*:

– size: *l* = 0.25 m, Ø = 4.6 mm;

– stationary phase: silica gel OD for chiral separations R (5 µm).

*Mobile phase*: diethylamine R, 2-propanol R, hexane R (2:40:960 V/V/V).

*Flow rate*: 1 mL/min.

*Detection*: spectrophotometer at 297 nm.

*Injection*: 5 µL.

*Elution order*: impurity A is eluted first.

**System suitability:**

- **resolution:** minimum 4.0 between the peaks due to impurity A and the (S)-enantiomer in the chromatogram obtained with reference solution (c);
- the retention times of the principal peaks due to the (S)-enantiomer in the chromatograms obtained with the test solution and reference solution (a) are identical.

**Limit:**

- **impurity A:** not more than the area of the principal peak in the chromatogram obtained with reference solution (d) (1.0 per cent).

**Related substances.** Liquid chromatography (2.2.29).

**Test solution.** Dissolve 0.100 g of the substance to be examined in mobile phase A and dilute to 20 mL with mobile phase A.

**Reference solution (a).** Dilute 1.0 mL of the test solution to 100.0 mL with mobile phase A. Dilute 1.0 mL of this solution to 10.0 mL with mobile phase A.

**Reference solution (b).** Dissolve the contents of a vial of *timolol for system suitability CRS* (containing impurities B, C, D and F) in 1.0 mL of mobile phase A.

**Reference solution (c).** Dissolve 2 mg of the substance to be examined and 20 mg of *maleic acid R* in 10 mL of *acetonitrile R*. Evaporate 1 mL of the solution to dryness under a stream of *nitrogen R* in an amber glass vial. Heat the open vial at 105 °C for 1 h. Reconstitute the residue with 1.0 mL of mobile phase A.

**Column:**

- **size:**  $l = 0.125$  m,  $\varnothing = 4$  mm;
- **stationary phase:** *octadecylsilyl silica gel for chromatography R* (5  $\mu$ m).

**Mobile phase:**

- **mobile phase A:** mixture of equal volumes of *methanol R* and a 4.32 g/L solution of *sodium octanesulfonate R* previously adjusted to pH 3.0 with *glacial acetic acid R*;
- **mobile phase B:** *methanol R*;

Time (min)	Mobile phase A (per cent V/V)	Mobile phase B (per cent V/V)
0 - 10	97.5	2.5
10 - 11	97.5 → 70	2.5 → 30
11 - 14.5	70	30

**Flow rate:** 2.0 mL/min.

**Detection:** spectrophotometer at 295 nm.

**Injection:** 20  $\mu$ L.

**Identification of impurities:** use the chromatogram supplied with *timolol for system suitability CRS* and the chromatogram obtained with reference solution (b) to identify the peaks due to impurities B, C, D and F. Use the chromatogram obtained with reference solution (c) to identify the peak due to impurity E.

**Relative retention** with reference to timolol (retention time = about 5 min): maleic acid = about 0.1; impurity D = about 0.3; impurity E = about 0.4; impurity F = about 0.6; impurity B = about 0.7; impurity C = about 2.8.

**System suitability:** reference solution (b):

- **resolution:** minimum 1.5 between the peaks due to impurity F and impurity B.

**Limits:**

- **correction factor:** for the calculation of content, multiply the peak area of impurity D by 0.6;
- **impurities B, C, D, E, F:** for each impurity, not more than twice the area of the principal peak in the chromatogram obtained with reference solution (a) (0.2 per cent);
- **unspecified impurities:** for each impurity, not more than the area of the principal peak in the chromatogram obtained with reference solution (a) (0.10 per cent);

- **total:** not more than 4 times the area of the principal peak in the chromatogram obtained with reference solution (a) (0.4 per cent);
- **disregard limit:** 0.5 times the area of the principal peak in the chromatogram obtained with reference solution (a) (0.05 per cent); disregard any peak due to maleic acid.

**Loss on drying** (2.2.32): maximum 0.5 per cent, determined on 1.000 g by drying in an oven at 105 °C.

**Sulfated ash** (2.4.14): maximum 0.1 per cent, determined on 1.0 g.

**ASSAY**

Dissolve 0.350 g in 60 mL of *anhydrous acetic acid R*. Titrate with 0.1 M *perchloric acid* determining the end-point potentiometrically (2.2.20).

1 mL of 0.1 M *perchloric acid* is equivalent to 43.25 mg of  $C_{17}H_{28}N_4O_7S$ .

**STORAGE**

Protected from light.

**IMPURITIES**

**Specified impurities:** A, B, C, D, E, F.

**Other detectable impurities** (the following substances would, if present at a sufficient level, be detected by one or other of the tests in the monograph. They are limited by the general acceptance criterion for other/unspecified impurities and/or by the general monograph *Substances for pharmaceutical use* (2034). It is therefore not necessary to identify these impurities for demonstration of compliance. See also 5.10. *Control of impurities in substances for pharmaceutical use*): G, H, I, J.

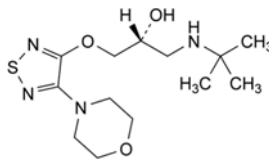

A. (2R)-1-[(1,1-dimethylethyl)amino]-3-[[4-(morpholin-4-yl)-1,2,5-thiadiazol-3-yl]oxy]propan-2-ol ((R)-timolol),

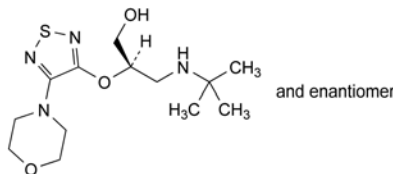

B. (2RS)-3-[(1,1-dimethylethyl)amino]-2-[[4-(morpholin-4-yl)-1,2,5-thiadiazol-3-yl]oxy]propan-1-ol,

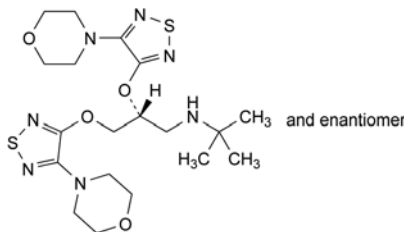

C. (2RS)-N-(1,1-dimethylethyl)-2,3-bis[[4-(morpholin-4-yl)-1,2,5-thiadiazol-3-yl]oxy]propan-1-amine,

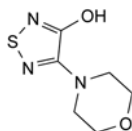

D. 4-(morpholin-4-yl)-1,2,5-thiadiazol-3-ol,

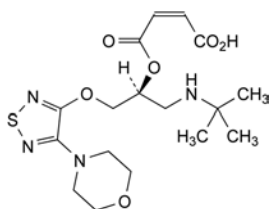

- E. (2Z)-4-[(1S)-1-[(1,1-dimethylethyl)amino]methyl]-2-[[4-(morpholin-4-yl)-1,2,5-thiadiazol-3-yl]oxy]ethoxy]-4-oxobut-2-enoic acid,

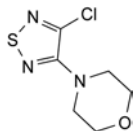

- F. 4-(4-chloro-1,2,5-thiadiazol-3-yl)morpholine,

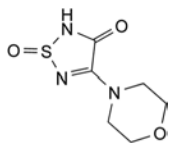

- G. 4-(morpholin-4-yl)-1,2,5-thiadiazol-3(2H)-one 1-oxide,

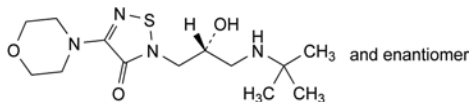

- H. 2-[(2RS)-3-[(1,1-dimethylethyl)amino]-2-hydroxypropyl]-4-(morpholin-4-yl)-1,2,5-thiadiazol-3(2H)-one, and enantiomer

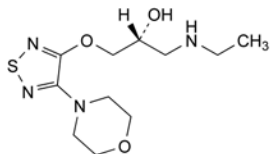

- I. (2RS)-1-(ethylamino)-3-[[4-(morpholin-4-yl)-1,2,5-thiadiazol-3-yl]oxy]propan-2-ol,

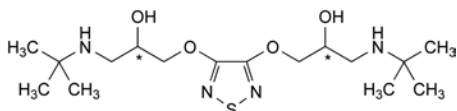

- J. 1,1'-[1,2,5-thiadiazol-3,4-diylbis(oxy)]bis[3-[(1,1-dimethylethyl)amino]propan-2-ol].

## IDENTIFICATION

First identification: A, C.

Second identification: A, B, D, E.

- A. Melting point (2.2.14): 125 °C to 128 °C.  
B. Ultraviolet and visible absorption spectrophotometry (2.2.25).

*Test solution.* Dissolve 10.0 mg in *methanol R* and dilute to 100.0 mL with the same solvent. Dilute 1.0 mL of this solution to 10.0 mL with *methanol R*.

*Spectral range:* 220-350 nm.

*Absorption maximum:* at 310 nm.

*Specific absorbance at the absorption maximum:* 340 to 360.

- C. Infrared absorption spectrophotometry (2.2.24).

*Comparison:* *tinidazole CRS*.

- D. Thin-layer chromatography (2.2.27).

*Test solution.* Dissolve 20 mg of the substance to be examined in *methanol R* and dilute to 10 mL with the same solvent.

*Reference solution.* Dissolve 20 mg of *tinidazole CRS* in *methanol R* and dilute to 10 mL with the same solvent.

*Plate:* TLC silica gel GF<sub>254</sub> plate R.

*Pretreatment:* heat at 110 °C for 1 h and allow to cool.

*Mobile phase:* *butanol R*, *ethyl acetate R* (25:75 V/V).

*Application:* 10 µL.

*Development:* over 2/3 of the plate.

*Drying:* in air.

*Detection:* examine in ultraviolet light at 254 nm.

*Results:* the principal spot in the chromatogram obtained with the test solution is similar in position and size to the principal spot in the chromatogram obtained with the reference solution.

- E. To about 10 mg add about 10 mg of *zinc powder R*, 0.3 mL of *hydrochloric acid R* and 1 mL of *water R*. Heat in a water-bath for 5 min and cool. The solution gives the reaction of primary aromatic amines (2.3.1).

## TESTS

**Appearance of solution.** The solution is clear (2.2.1) and not more intensely coloured than reference solution Y<sub>5</sub> (2.2.2, Method II).

Dissolve 1.0 g in *acetone R* and dilute to 20 mL with the same solvent.

**Related substances.** Liquid chromatography (2.2.29). *Protect solutions from light.*

*Test solution.* Dissolve 10.0 mg of the substance to be examined in 10.0 mL of *methanol R* and dilute to 100.0 mL with the mobile phase.

*Reference solution (a).* Dilute 1.0 mL of the test solution to 100.0 mL with the mobile phase. Dilute 1.0 mL of this solution to 10.0 mL with the mobile phase.

*Reference solution (b).* Dissolve 5.0 mg of *tinidazole impurity A CRS* and 5.0 mg of *tinidazole impurity B CRS* in 10.0 mL of *methanol R* and dilute to 100.0 mL with the mobile phase. Dilute 2.0 mL of this solution to 10.0 mL with the mobile phase.

*Reference solution (c).* Dilute 1.0 mL of reference solution (b) to 50.0 mL with the mobile phase.

**Column:**

- size:  $l = 0.25$  m,  $\varnothing = 3.0$  mm;
- stationary phase: *octylsilyl silica gel for chromatography R* (5 µm).

Regular column conditioning by subsequent flushing with 50 mL of *water R*, 100 mL of *methanol R*, 25 mL of *water R* and 100 mL of the mobile phase is recommended.

07/2008:1051

## TINIDAZOLE

### Tinidazolium

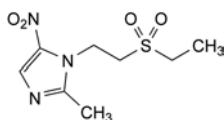

C<sub>8</sub>H<sub>13</sub>N<sub>3</sub>O<sub>4</sub>S  
[19387-91-8]

*M*<sub>r</sub> 247.3

## DEFINITION

1-[2-(Ethylsulfonyl)ethyl]-2-methyl-5-nitro-1*H*-imidazole.

*Content:* 98.0 per cent to 101.0 per cent (dried substance).

## CHARACTERS

*Appearance:* almost white or pale yellow, crystalline powder.

*Solubility:* practically insoluble in water, soluble in acetone and in methylene chloride, sparingly soluble in methanol.

01/2008:1271

Mobile phase: acetonitrile R, methanol R, water R (10:20:70 V/V/V).

Flow rate: 0.5 mL/min.

Detection: spectrophotometer at 320 nm.

Injection: 20 µL.

Run time: 1.5 times the retention time of tinidazole.

Relative retention with reference to tinidazole (retention time = about 6 min): impurity A = about 0.6; impurity B = about 0.7.

System suitability: reference solution (b):

- resolution: minimum 2.0 between the peaks due to impurities A and B.

Limits:

- impurities A, B: for each impurity, not more than the area of the corresponding peak in the chromatogram obtained with reference solution (c) (0.2 per cent);
- unspecified impurities: for each impurity, not more than the area of the principal peak in the chromatogram obtained with reference solution (a) (0.10 per cent);
- total: not more than 4 times the area of the principal peak in the chromatogram obtained with reference solution (a) (0.4 per cent);
- disregard limit: 0.5 times the area of the principal peak in the chromatogram obtained with reference solution (a) (0.05 per cent).

Heavy metals (2.4.8): maximum 20 ppm.

1.0 g complies with test D. Prepare the reference solution using 2 mL of lead standard solution (10 ppm Pb) R.

Loss on drying (2.2.32): maximum 0.5 per cent, determined on 1.000 g by drying in an oven at 105 °C.

Sulfated ash (2.4.14): maximum 0.1 per cent, determined on 1.0 g.

#### ASSAY

Dissolve 0.150 g in 25 mL of anhydrous acetic acid R. Titrate with 0.1 M perchloric acid, determining the end-point potentiometrically (2.2.20).

1 mL of 0.1 M perchloric acid is equivalent to 24.73 mg of C<sub>8</sub>H<sub>13</sub>N<sub>3</sub>O<sub>4</sub>S.

#### STORAGE

Protected from light.

#### IMPURITIES

Specified impurities: A, B.

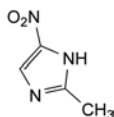

A. 2-methyl-5-nitro-1H-imidazole,

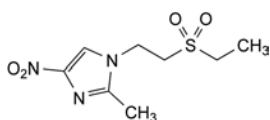

B. 1-[2-(ethylsulfonyl)ethyl]-2-methyl-4-nitro-1H-imidazole.

## TINZAPARIN SODIUM

### Tinzaparinum natriicum

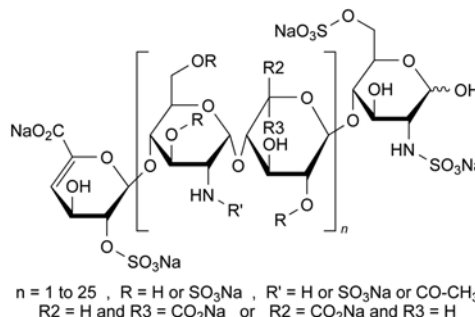

#### DEFINITION

Tinzaparin sodium is the sodium salt of a low-molecular-mass heparin that is obtained by controlled enzymatic depolymerisation of heparin from porcine intestinal mucosa using heparinase from *Flavobacterium heparinum*. The majority of the components have a 2-O-sulfo-4-enepyranosuronic acid structure at the non-reducing end and a 2-N,6-O-disulfo-D-glucosamine structure at the reducing end of their chain.

Tinzaparin sodium complies with the monograph on Low-molecular-mass heparins (0828) with the modifications and additional requirements below.

The mass-average relative molecular mass ranges between 5500 and 7500 with a characteristic value of about 6500.

The degree of sulfatation is 1.8 to 2.5 per disaccharide unit.

The potency is not less than 70 IU and not more than 120 IU of anti-factor Xa activity per milligram calculated with reference to the dried substance. The ratio of the anti-factor Xa activity to anti-factor IIa activity is between 1.5 and 2.5.

#### IDENTIFICATION

Carry out identification test A as described in the monograph for Low-molecular-mass heparins (0828) using tinzaparin sodium CRS.

Carry out identification test C as described in the monograph for Low-molecular-mass heparins (0828). The following requirements apply.

The mass-average relative molecular mass ranges between 5500 and 7500. The mass percentage of chains lower than 2000 is not more than 10.0 per cent. The mass percentage of chains between 2000 and 8000 ranges between 60.0 and 72.0 per cent. The mass percentage of chains above 8000 ranges between 22.0 and 36.0 per cent.

#### TESTS

**Appearance of solution.** Dissolve 1.0 g in 10 mL of water R. The solution is clear (2.2.1) and not more intensely coloured than intensity 5 of the range of reference solutions of the most appropriate colour (2.2.2, Method II).

**Absorbance (2.2.25).** Dissolve 50.0 mg in 100 mL of 0.01 M hydrochloric acid. The specific absorbance, measured at 231 nm and calculated with reference to the dried substance, is 8.0 to 12.5.



## TIOCONAZOLE

## Tioconazolium

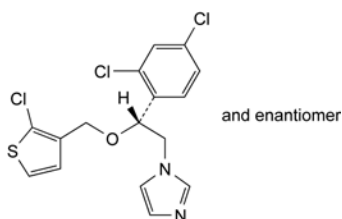

$C_{16}H_{13}Cl_3N_2OS$   
[65899-73-2]

$M_r$  387.7

## DEFINITION

1-[(2*RS*)-2-[(2-chlorothiophen-3-yl)methoxy]-2-(2,4-dichlorophenyl)ethyl]-1*H*-imidazole.

*Content*: 99.0 per cent to 101.0 per cent (anhydrous substance).

## CHARACTERS

*Appearance*: white or almost white, crystalline powder.

*Solubility*: very slightly soluble in water, very soluble in methylene chloride, freely soluble in alcohol.

## IDENTIFICATION

Infrared absorption spectrophotometry (2.2.24).

*Comparison*: Ph. Eur. reference spectrum of tioconazole.

## TESTS

**Related substances.** Liquid chromatography (2.2.29).

*Test solution.* Dissolve 20.0 mg of the substance to be examined in the mobile phase and dilute to 10.0 mL with the mobile phase.

*Reference solution (a).* Dilute 1.0 mL of the test solution to 100.0 mL with the mobile phase. Dilute 2.0 mL of this solution to 10.0 mL with the mobile phase.

*Reference solution (b).* Dissolve 5 mg of tioconazole for system suitability CRS in the mobile phase and dilute to 2.5 mL with the mobile phase.

*Column*:

- *size*:  $l = 0.25$  m,  $\varnothing = 4.6$  mm,
- *stationary phase*: end-capped octadecylsilyl silica gel for chromatography R (5  $\mu$ m) with a specific surface area of 170 m<sup>2</sup>/g, a pore size of 12 nm and a carbon loading of 10 per cent.

*Mobile phase*: mix 1 volume of a 1.7 g/L solution of tetrabutylammonium dihydrogen phosphate R previously adjusted to pH 7.4 with dilute ammonia R2 and 3 volumes of methanol R.

*Flow rate*: 1 mL/min.

*Detection*: spectrophotometer at 218 nm.

*Injection*: 20  $\mu$ L.

*Run time*: 2.5 times the retention time of tioconazole.

*System suitability*: reference solution (b):

- *resolution*: minimum 1.0 between the peaks due to impurity B and impurity C (locate impurities A, B and C by comparison with the chromatogram provided with tioconazole for system suitability CRS).

## 01/2008:2074 Limits:

- *correction factors*: for the calculation of contents, multiply the peak areas of the following impurities by the corresponding correction factor: impurity B = 1.7; impurity C = 1.7.
- *impurities A, B, C*: for each impurity, not more than 1.5 times the area of the principal peak in the chromatogram obtained with reference solution (a) (0.3 per cent),
- *unspecified impurities*: for each impurity, not more than 0.5 times the area of the principal peak in the chromatogram obtained with reference solution (a) (0.10 per cent),
- *total*: not more than 5 times the area of the principal peak in the chromatogram obtained with reference solution (a) (1.0 per cent),
- *disregard limit*: 0.25 times the area of the principal peak in the chromatogram obtained with reference solution (a) (0.05 per cent).

**Water** (2.5.12): maximum 0.5 per cent, determined on 1.00 g.

**Sulfated ash** (2.4.14): maximum 0.1 per cent, determined on 1.0 g.

## ASSAY

Dissolve 0.300 g in 50 mL of *anhydrous acetic acid R*. Titrate with 0.1 M perchloric acid, determining the end-point potentiometrically (2.2.20).

1 mL of 0.1 M perchloric acid is equivalent to 38.77 mg of  $C_{16}H_{13}Cl_3N_2OS$ .

## STORAGE

Protected from light.

## IMPURITIES

*Specified impurities*: A, B, C.

*Other detectable impurities* (the following substances would, if present at a sufficient level, be detected by one or other of the tests in the monograph. They are limited by the general acceptance criterion for other/unspecified impurities and/or by the general monograph *Substances for pharmaceutical use* (2034). It is therefore not necessary to identify these impurities for demonstration of compliance. See also 5.10. *Control of impurities in substances for pharmaceutical use*): D.

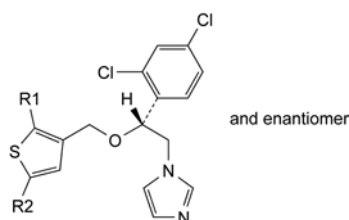

- A. R1 = R2 = H: 1-[(2*RS*)-2-(2,4-dichlorophenyl)-2-[(thiophen-3-yl)methoxy]ethyl]-1*H*-imidazole,
- B. R1 = R2 = Cl: 1-[(2*RS*)-2-(2,4-dichlorophenyl)-2-[(2,5-dichlorothiophen-3-yl)methoxy]ethyl]-1*H*-imidazole,
- C. R1 = Cl, R2 = Br: 1-[(2*RS*)-2-[(5-bromo-2-chlorothiophen-3-yl)methoxy]-2-(2,4-dichlorophenyl)ethyl]-1*H*-imidazole,

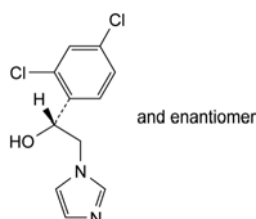

- D. (1*RS*)-1-(2,4-dichlorophenyl)-2-(1*H*-imidazol-1-yl)ethanol.

07/2010:2420 – *impurity H*: any spot due to impurity H is not more intense than the corresponding spot in the chromatogram obtained with reference solution (a) (0.1 per cent).

## TIOTROPIUM BROMIDE MONOHYDRATE

Tiotropii bromidum monohydricum

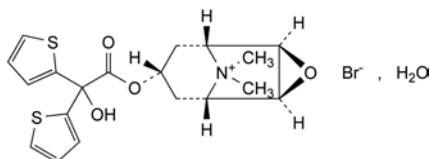

$C_{19}H_{22}BrNO_4S_2 \cdot H_2O$

$M_r$  490.4

### DEFINITION

(1*R*,2*R*,4*S*,5*S*,7*S*)-7-[(2-Hydroxy-2,2-dithiophen-2-ylacetyl)oxy]-9,9-dimethyl-3-oxa-9-azoniatricyclo[3.3.1.0<sup>2,4</sup>]nonane bromide monohydrate.

*Content*: 98.5 per cent to 101.5 per cent (anhydrous substance).

### CHARACTERS

*Appearance*: white or yellowish-white powder or crystals.

*Solubility*: sparingly soluble in water, soluble in methanol, practically insoluble in methylene chloride.

### IDENTIFICATION

A. Infrared absorption spectrophotometry (2.2.24).

*Comparison*: tiotropium bromide monohydrate CRS.

B. It gives reaction (a) of bromides (2.3.1).

### TESTS

**Appearance of solution.** The solution is clear (2.2.1) and not more intensely coloured than reference solution  $Y_6$  (2.2.2, *Method II*).

Dissolve 0.2 g in *water R* and dilute to 20 mL with the same solvent.

**Impurities G and H.** Thin-layer chromatography (2.2.27). Prepare the solutions immediately before use.

*Solvent mixture.* Dilute 1 volume of 1 M hydrochloric acid to 100 volumes with *methanol R*.

*Test solution.* Dissolve 0.40 g of the substance to be examined in the solvent mixture and dilute to 10 mL with the solvent mixture.

*Reference solution (a).* Dissolve the contents of a vial of *tiotropium impurity mixture CRS* (40 µg each of impurities G and H) in 1.0 mL of the solvent mixture.

*Reference solution (b).* Mix 0.1 mL of the test solution with 0.1 mL of reference solution (a).

*Plate*: TLC silica gel  $F_{254}$  plate *R* (2-10 µm).

*Mobile phase*: *water R*, *anhydrous formic acid R*, *acetonitrile R*, *methylene chloride R* (10:15:35:50 V/V/V/V).

*Application*: 10 µL of the test solution and reference solution (a) and 20 µL of reference solution (b).

*Development*: over 2/3 of the plate.

*Drying*: in air.

*Detection*: expose to iodine vapour until the spots are clearly visible (about 15 min). Remove the plate and examine immediately.

*Retardation factors*: impurity G = about 0.33; impurity H = about 0.38; tiotropium = about 0.64.

*System suitability*: reference solution (b):

– the chromatogram shows 3 clearly separated spots.

*Limits*:

– *impurity G*: any spot due to impurity G is not more intense than the corresponding spot in the chromatogram obtained with reference solution (a) (0.1 per cent);

**Related substances.** Liquid chromatography (2.2.29). Prepare all solutions protected from light.

*Test solution.* Dissolve 50.0 mg of the substance to be examined in mobile phase B and dilute to 25.0 mL with mobile phase B.

*Reference solution (a).* Dissolve 5.0 mg of *tiotropium impurity F CRS* in mobile phase B and dilute to 100.0 mL with mobile phase B. Dilute 1.0 mL of this solution to 25.0 mL with mobile phase B.

*Reference solution (b).* Dissolve 4 mg of *tiotropium for system suitability CRS* (containing impurities A, C and E) in 2.0 mL of mobile phase B.

*Reference solution (c).* Dilute 1.0 mL of the test solution to 100.0 mL with mobile phase B. Dilute 1.0 mL of this solution to 10.0 mL with mobile phase B.

*Column*:

– *size*:  $l = 0.15$  m,  $\varnothing = 3.0$  mm;

– *stationary phase*: propylsilyl silica gel for chromatography *R* (3.5 µm);

– *temperature*: 50 °C.

*Mobile phase*:

– *mobile phase A*: dissolve 1.0 g of *sodium methanesulfonate R* and 5.0 g of *potassium dihydrogen phosphate R* in about 980 mL of *water R*, adjust to pH 3.0 with *dilute phosphoric acid R* and dilute to 1000 mL with *water R*;

– *mobile phase B*: *methanol R*, *acetonitrile R*, mobile phase A (10:40:50 V/V/V);

Time (min)	Mobile phase A (per cent V/V)	Mobile phase B (per cent V/V)
0 - 3	90	10
3 - 17	90 → 80	10 → 20
17 - 28	80 → 25	20 → 75
28 - 30	25	75

*Flow rate*: 1.2 mL/min.

*Detection*: spectrophotometer at 240 nm.

*Injection*: 5 µL.

*Identification of impurities*: use the chromatogram supplied with *tiotropium for system suitability CRS* and the chromatogram obtained with reference solution (b) to identify the peaks due to impurities A, C and E.

*Relative retention* with reference to tiotropium (retention time = about 15 min): impurity A = about 0.5; impurity C = about 1.2; impurity E = about 1.7; impurity F = about 1.8.

*System suitability*: reference solution (b):

– *resolution*: minimum 2.4 between the peaks due to tiotropium and impurity C.

*Limits*:

– *correction factors*: for the calculation of content, multiply the peak areas of the following impurities by the corresponding correction factor: impurity A = 0.5; impurity E = 0.5;

– *impurity C*: not more than 3 times the area of the principal peak in the chromatogram obtained with reference solution (c) (0.3 per cent);

– *impurity F*: not more than 1.5 times the area of the principal peak in the chromatogram obtained with reference solution (a) (0.15 per cent);

– *impurities A, E*: for each impurity, not more than 1.5 times the area of the principal peak in the chromatogram obtained with reference solution (c) (0.15 per cent);

– *unspecified impurities*: for each impurity, not more than the area of the principal peak in the chromatogram obtained with reference solution (c) (0.10 per cent);

- *total*: not more than 3 times the area of the principal peak in the chromatogram obtained with reference solution (c) (0.3 per cent);
- *disregard limit*: 0.5 times the area of the principal peak in the chromatogram obtained with reference solution (c) (0.05 per cent).

**Heavy metals** (2.4.8): maximum 10 ppm.

*Solvent mixture*: water R, methanol R (10:90 V/V).

Dissolve 0.50 g of the substance to be examined in 20 mL of the solvent mixture using sonication for about 10 min. The solution complies with test H. Prepare the reference solution using 0.5 mL of *lead standard solution (10 ppm Pb) R*.

**Water** (2.5.12): 2.5 per cent to 4.0 per cent, determined on 0.300 g.

**Sulfated ash** (2.4.14): maximum 0.1 per cent, determined on 1.0 g.

#### ASSAY

Dissolve 0.35 g in 100 mL of *water R*. Add 10 mL of *dilute nitric acid R2*. Titrate with 0.1 M *silver nitrate* determining the end-point potentiometrically (2.2.20).

1 mL of 0.1 M *silver nitrate* is equivalent to 47.24 mg of  $C_{19}H_{22}BrNO_4S_2$ .

#### IMPURITIES

*Specified impurities*: A, C, E, F, G, H.

*Other detectable impurities* (the following substances would, if present at a sufficient level, be detected by one or other of the tests in the monograph. They are limited by the general acceptance criterion for other/unspecified impurities and/or by the general monograph *Substances for pharmaceutical use (2034)*. It is therefore not necessary to identify these impurities for demonstration of compliance. See also 5.10. *Control of impurities in substances for pharmaceutical use*): B, D, I, J, K.

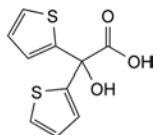

A. 2-hydroxy-2,2-dithiophen-2-ylacetic acid,

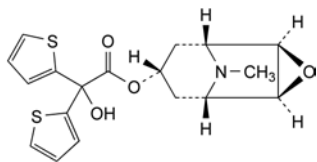

B. (1R,2R,4S,5S,7s)-9-methyl-3-oxa-9-azatricyclo[3.3.1.0<sup>2,4</sup>]nonan-7-yl 2-hydroxy-2,2-dithiophen-2-ylacetate,

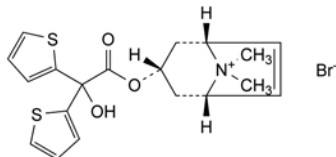

C. (1R,3s,5S)-3-[(2-hydroxy-2,2-dithiophen-2-ylacetyl)oxy]-8,8-dimethyl-8-azoniabicyclo[3.2.1]oct-6-ene bromide,

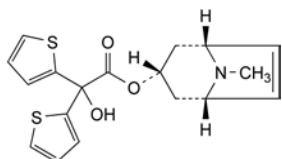

D. (1R,3s,5S)-8-methyl-8-azabicyclo[3.2.1]oct-6-en-3-yl 2-hydroxy-2,2-dithiophen-2-ylacetate,

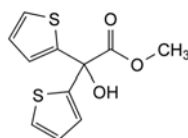

E. methyl 2-hydroxy-2,2-dithiophen-2-ylacetate,

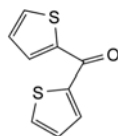

F. dithiophen-2-ylmethanone,

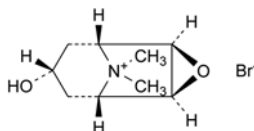

G. (1R,2R,4S,5S,7s)-7-hydroxy-9,9-dimethyl-3-oxa-9-azoniatricyclo[3.3.1.0<sup>2,4</sup>]nonane bromide,

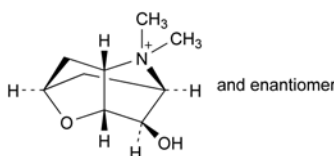

H. (1s,3RS,4RS,5RS,7SR)-4-hydroxy-6,6-dimethyl-2-oxa-6-azoniatricyclo[3.3.1.0<sup>3,7</sup>]nonane bromide,

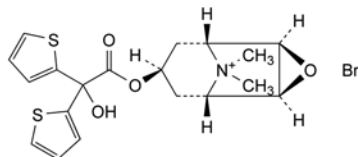

I. (1R,2R,4S,5S,7r)-7-[(2-hydroxy-2,2-dithiophen-2-ylacetyl)oxy]-9,9-dimethyl-3-oxa-9-azoniatricyclo[3.3.1.0<sup>2,4</sup>]nonane bromide,

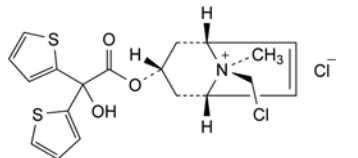

J. (1R,3s,5S,8s)-8-(chloromethyl)-3-[(2-hydroxy-2,2-dithiophen-2-ylacetyl)oxy]-8-methyl-8-azoniabicyclo[3.2.1]oct-6-ene chloride,

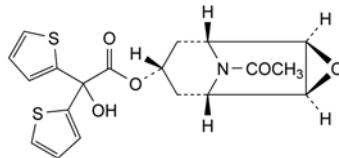

K. (1R,2R,4S,5S,7s)-9-acetyl-3-oxa-9-azatricyclo[3.3.1.0<sup>2,4</sup>]nonan-7-yl 2-hydroxy-2,2-dithiophen-2-ylacetate.

01/2011:0150

## TITANIUM DIOXIDE

Titanii dioxidum

TiO<sub>2</sub>  
[13463-67-7]

M<sub>r</sub> 79.9

#### DEFINITION

*Content*: 98.0 per cent to 100.5 per cent.

## CHARACTERS

**Appearance:** white or almost white powder.

**Solubility:** practically insoluble in water. It does not dissolve in dilute mineral acids but dissolves slowly in hot concentrated sulfuric acid.

## IDENTIFICATION

- A. When strongly heated, it becomes pale yellow; the colour disappears on cooling.
- B. To 5 mL of solution S2 (see Tests) add 0.1 mL of *strong hydrogen peroxide solution R*. An orange-red colour appears.
- C. To 5 mL of solution S2 add 0.5 g of *zinc R* in granules. After 45 min, the mixture has a violet-blue colour.

## TESTS

**Solution S1.** Shake 20.0 g with 30 mL of *hydrochloric acid R* for 1 min. Add 100 mL of *distilled water R* and heat the mixture to boiling. Filter the hot mixture through a hardened filter paper until a clear filtrate is obtained. Wash the filter with 60 mL of *distilled water R* and dilute the combined filtrate and washings to 200 mL with *distilled water R*.

**Solution S2.** Mix 0.500 g (*m* g) with 5 g of *anhydrous sodium sulfate R* in a 300 mL long-necked combustion flask. Add 10 mL of *water R* and mix. Add 10 mL of *sulfuric acid R* and boil vigorously, with the usual precautions, until a clear solution is obtained. Cool, add slowly a cooled mixture of 30 mL of *water R* and 10 mL of *sulfuric acid R*, cool again and dilute to 100.0 mL with *water R*.

**Appearance of solution.** Solution S2 is not more opalescent than reference suspension II (2.2.1) and is colourless (2.2.2, *Method II*).

**Acidity or alkalinity.** Shake 5.0 g with 50 mL of *carbon dioxide-free water R* for 5 min. Centrifuge or filter until a clear solution is obtained. To 10 mL of the solution add 0.1 mL of *bromothymol blue solution R1*. Not more than 1.0 mL of 0.01 *M hydrochloric acid* or 0.01 *M sodium hydroxide* is required to change the colour of the indicator.

**Water-soluble substances:** maximum 0.5 per cent.

To 10.0 g add a solution of 0.5 g of *ammonium sulfate R* in 150 mL of *water R* and boil for 5 min. Cool, dilute to 200 mL with *water R* and filter until a clear solution is obtained. Evaporate 100 mL of the solution to dryness in a tared evaporating dish and ignite. The residue weighs a maximum of 25 mg.

**Antimony:** maximum 100 ppm.

To 10 mL of solution S2 add 10 mL of *hydrochloric acid R* and 10 mL of *water R*. Cool to 20 °C, if necessary, and add 0.15 mL of *sodium nitrite solution R*. After 5 min, add 5 mL of a 10 g/L solution of *hydroxylamine hydrochloride R* and 10 mL of a freshly prepared 0.1 g/L solution of *rhodamine B R*. Mix thoroughly after each addition. Shake vigorously with 10.0 mL of *toluene R* for 1 min. Allow to separate and centrifuge for 2 min if necessary. Any pink colour in the toluene phase is not more intense than that in the toluene phase of a standard prepared at the same time in the same manner using a mixture of 5.0 mL of *antimony standard solution (1 ppm Sb) R*, 10 mL of *hydrochloric acid R* and 15 mL of a solution containing 0.5 g of *anhydrous sodium sulfate R* and 2 mL of *sulfuric acid R* instead of the mixture of 10 mL of solution S2, 10 mL of *hydrochloric acid R* and 10 mL of *water R*.

**Arsenic (2.4.2, Method A):** maximum 5 ppm.

Place 0.50 g in a 250 mL round-bottomed flask, fitted with a thermometer, a funnel with stopcock and a vapour-outlet tube connected to a flask containing 30 mL of *water R*. Add 50 mL of *water R*, 0.5 g of *hydrazine sulfate R*, 0.5 g of *potassium bromide R* and 20 g of *sodium chloride R*. Through the funnel, add dropwise 25 mL of *sulfuric acid R*, heat and maintain the

temperature of the liquid at 110-115 °C for 20 min. Collect the vapour in the flask containing 30 mL of *water R*. Dilute to 50 mL with *water R*. 20 mL of the solution complies with the test.

**Barium.** To 10 mL of solution S1 add 1 mL of *dilute sulfuric acid R*. After 30 min, any opalescence in the solution is not more intense than that in a mixture of 10 mL of solution S1 and 1 mL of *distilled water R*.

**Iron:** maximum 200 ppm.

To 8 mL of solution S2 add 4 mL of *water R*. Mix and add 0.05 mL of *bromine water R*. Allow to stand for 5 min and remove the excess of bromine with a current of air. Add 3 mL of *potassium thiocyanate solution R*. Any colour in the solution is not more intense than that in a standard prepared at the same time in the same manner using a mixture of 4 mL of *iron standard solution (2 ppm Fe) R* and 8 mL of a 200 g/L solution of *sulfuric acid R*.

**Heavy metals (2.4.8):** maximum 20 ppm.

To 10 mL of solution S1, add dropwise *concentrated ammonia R* to adjust to pH 4 and dilute to 20 mL with *water R*. 12 mL of the solution complies with test A. Prepare the reference solution using *lead standard solution (1 ppm Pb) R*.

## ASSAY

To 300 g of *zinc R* in granules (710) add 300 mL of a 20 g/L solution of *mercuric nitrate R* and 2 mL of *nitric acid R*, shake for 10 min and wash with *water R*. Pack the amalgamated zinc into a glass tube about 400 mm long and about 20 mm in diameter fitted with a tap and a filter plate. Pass through the column 100 mL of *dilute sulfuric acid R* followed by 100 mL of *water R*, making sure that the amalgam is always covered with liquid. Pass slowly at a rate of about 3 mL/min through the column a mixture of 100 mL of *dilute sulfuric acid R* and 100 mL of *water R* followed by 100 mL of *water R*. Collect the eluate in a 500 mL conical flask containing 50.0 mL of a 150 g/L solution of *ferric ammonium sulfate R* in a mixture of 1 volume of *sulfuric acid R* and 3 volumes of *water R*. Add 0.1 mL of *ferroin R* and titrate immediately with 0.1 *M ammonium and cerium nitrate* until a greenish colour is obtained ( $n_1$  mL). Pass slowly at a rate of about 3 mL/min through the column a mixture of 50 mL of *dilute sulfuric acid R* and 50 mL of *water R*, followed by 20.0 mL of solution S2, a mixture of 50 mL of *dilute sulfuric acid R* and 50 mL of *water R* and finally 100 mL of *water R*. Collect the eluate in a 500 mL conical flask containing 50.0 mL of a 150 g/L solution of *ferric ammonium sulfate R* in a mixture of 1 volume of *sulfuric acid R* and 3 volumes of *water R*. Rinse the lower end of the column with *water R*, add 0.1 mL of *ferroin R* and titrate immediately with 0.1 *M ammonium and cerium nitrate* until a greenish colour is obtained ( $n_2$  mL).

Calculate the percentage content of TiO<sub>2</sub> using the following expression:

$$\frac{3.99 \times (n_2 - n_1)}{m}$$

$m$  = mass of the substance to be examined used for the preparation of solution S2, in grams.

## FUNCTIONALITY-RELATED CHARACTERISTICS

*This section provides information on characteristics that are recognised as being relevant control parameters for one or more functions of the substance when used as an excipient (see chapter 5.15). This section is a non-mandatory part of the monograph and it is not necessary to verify the characteristics to demonstrate compliance. Control of these characteristics can however contribute to the quality of a medicinal product by improving the consistency of the manufacturing process and the performance of the medicinal product during use. Where control methods are cited, they are recognised as being*

*suitable for the purpose, but other methods can also be used. Wherever results for a particular characteristic are reported, the control method must be indicated.*

*The following characteristics may be relevant for titanium dioxide used as opacifier in solid oral dosage forms and in preparations for cutaneous application.*

**Particle-size distribution** (2.9.31).

**Bulk and tapped density** (2.9.34).

01/2008:0645  
corrected 6.2

## TOBRAMYCIN

### Tobramycinum

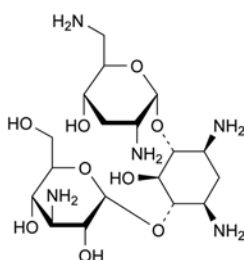

C<sub>18</sub>H<sub>37</sub>N<sub>5</sub>O<sub>9</sub>  
[32986-56-4]

M<sub>r</sub> 467.5

#### DEFINITION

4-O-(3-Amino-3-deoxy-α-D-glucopyranosyl)-2-deoxy-6-O-(2,6-diamino-2,3,6-trideoxy-α-D-ribo-hexopyranosyl)-L-streptamine.

Substance produced by *Streptomyces tenebrarius* or obtained by any other means.

*Content*: 97.0 per cent to 102.0 per cent (anhydrous substance).

#### PRODUCTION

It is produced by methods of manufacture designed to eliminate or minimise substances lowering blood pressure.

#### CHARACTERS

*Appearance*: white or almost white powder.

*Solubility*: freely soluble in water, very slightly soluble in ethanol (96 per cent).

#### IDENTIFICATION

*First identification*: A.

*Second identification*: B, C.

A. Nuclear magnetic resonance spectrometry (2.2.33).

*Preparation*: 100 g/L solution in *deuterium oxide R*.

*Comparison*: 100 g/L solution of *tobramycin CRS* in *deuterium oxide R*.

B. Thin-layer chromatography (2.2.27).

*Test solution*. Dissolve 20 mg of the substance to be examined in *water R* and dilute to 5 mL with the same solvent.

*Reference solution (a)*. Dissolve 20 mg of *tobramycin CRS* in *water R* and dilute to 5 mL with the same solvent.

*Reference solution (b)*. Dissolve 4 mg of *neomycin sulfate CRS* and 4 mg of *kanamycin monosulfate CRS* in 1 mL of reference solution (a).

*Plate*: TLC silica gel plate R.

*Mobile phase*: *methylene chloride R*, *concentrated ammonia R*, *methanol R* (17:33:50 V/V/V).

*Application*: 5 µL.

*Development*: over 2/3 of the plate.

*Drying*: in a current of warm air.

*Detection*: spray with a mixture of equal volumes of a 2 g/L solution of *1,3-dihydroxynaphthalene R* in *ethanol (96 per cent) R* and a 460 g/L solution of *sulfuric acid R*; heat at 105 °C for 5-10 min.

*System suitability*: the chromatogram obtained with reference solution (b) shows 3 major spots which are clearly separated.

*Results*: the principal spot in the chromatogram obtained with the test solution is similar in position, colour and size to the principal spot in the chromatogram obtained with reference solution (a).

C. Dissolve about 5 mg in 5 mL of *water R*. Add 5 mL of a 1 g/L solution of *ninhydrin R* in *ethanol (96 per cent) R* and heat in a water-bath for 3 min. A violet-blue colour develops.

#### TESTS

**pH** (2.2.3): 9.0 to 11.0.

Dissolve 1.0 g in 10 mL of *carbon dioxide-free water R*.

**Specific optical rotation** (2.2.7): + 138 to + 148 (anhydrous substance).

Dissolve 1.00 g in *water R* and dilute to 25.0 mL with the same solvent.

**Related substances**. Liquid chromatography (2.2.29).

*Test solution (a)*. Dissolve 25.0 mg of the substance to be examined in the mobile phase and dilute to 25.0 mL with the mobile phase.

*Test solution (b)*. Dilute 10.0 mL of test solution (a) to 100.0 mL with the mobile phase.

*Reference solution (a)*. Dissolve 25.0 mg of *tobramycin CRS* in the mobile phase and dilute to 100.0 mL with the mobile phase.

*Reference solution (b)*. Dilute 1.0 mL of reference solution (a) to 100.0 mL with the mobile phase.

*Reference solution (c)*. Dilute 1.0 mL of reference solution (a) to 50.0 mL with the mobile phase.

*Reference solution (d)*. Dissolve 10.0 mg of *kanamycin B sulfate CRS* in 20.0 mL of the mobile phase. To 1.0 mL of this solution, add 2.0 mL of reference solution (a) and dilute to 10.0 mL with the mobile phase.

*Reference solution (e)*. Dilute 10.0 mL of reference solution (a) to 25.0 mL with the mobile phase.

*Column*:

– *size*: *l* = 0.25 m, Ø = 4.6 mm;

– *stationary phase*: *styrene-divinylbenzene copolymer R* (8 µm) with a pore size of 100 nm;

– *temperature*: 55 °C.

*Mobile phase*: mixture prepared with *carbon dioxide-free water R* containing 52 g/L of *anhydrous sodium sulfate R*, 1.5 g/L of *sodium octanesulfonate R*, 3 mL/L of *tetrahydrofuran R* stabilised with *butylhydroxytoluene R*, and 50 mL/L of 0.2 M *potassium dihydrogen phosphate R* previously adjusted to pH 3.0 with *dilute phosphoric acid R*. Degas.

*Flow rate*: 1.0 mL/min.

*Post-column solution*: *carbonate-free sodium hydroxide solution R* diluted 25-fold with *carbon dioxide-free water R*, which is added pulselessly to the column effluent using a 375 µL polymeric mixing coil.

*Flow rate*: 0.3 mL/min.

*Detection*: pulsed amperometric detector or equivalent with a gold working electrode, a silver-silver chloride reference electrode and a stainless steel auxiliary electrode which is the cell body, held at respectively + 0.05 V detection, + 0.75 V oxidation and – 0.15 V reduction potentials, with pulse durations according to the instrument used. The temperature of the detector is set at 35 °C.

*NOTE*: to prevent problems due to salt precipitation, the electrochemical cell can be flushed with *water R* overnight.

**Injection:** 20  $\mu$ L using a refrigerated injector (4–8 °C); inject test solution (a) and reference solutions (b), (c) and (d).

**Run time:** 1.5 times the retention time of tobramycin.

**Relative retention** with reference to tobramycin (retention time = about 18 min): impurity C = about 0.35; impurity B = about 0.40, impurity A = about 0.70.

**System suitability:**

- **resolution:** minimum 3.0 between the peaks due to impurity A and to tobramycin in the chromatogram obtained with reference solution (d); if necessary, adjust the concentration of sodium octanesulfonate in the mobile phase;
- **signal-to-noise ratio:** minimum 10 for the principal peak in the chromatogram obtained with reference solution (b).

**Limits:**

- **any impurity:** not more than twice the area of the principal peak in the chromatogram obtained with reference solution (c) (1.0 per cent) and not more than 1 such peak has an area greater than the area of the principal peak in the chromatogram obtained with reference solution (c) (0.5 per cent);
- **total:** not more than 3 times the area of the principal peak in the chromatogram obtained with reference solution (c) (1.5 per cent);
- **disregard limit:** the area of the principal peak in the chromatogram obtained with reference solution (b) (0.25 per cent).

**2-Methyl-1-propanol** (2.4.24, System B): maximum 1.0 per cent *m/m*.

**Water** (2.5.12): maximum 8.0 per cent, determined on 0.30 g.

**Sulfated ash** (2.4.14): maximum 0.3 per cent, determined on 1.0 g.

**Bacterial endotoxins** (2.6.14): less than 2.0 IU/mg, if intended for use in the manufacture of parenteral preparations without a further appropriate procedure for the removal of bacterial endotoxins.

#### ASSAY

Liquid chromatography (2.2.29) as described in the test for related substances with the following modifications.

**Injection:** test solution (b) and reference solution (e).

Calculate the percentage content of tobramycin.

#### STORAGE

If the substance is sterile, store in a sterile, airtight, tamper-proof container.

#### IMPURITIES

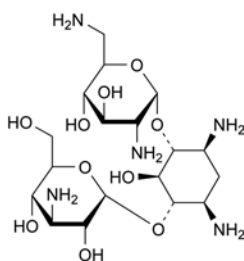

- A. 4-*O*-(3-amino-3-deoxy- $\alpha$ -D-glucopyranosyl)-2-deoxy-6-*O*-(2,6-diamino-2,6-dideoxy- $\alpha$ -D-glucopyranosyl)-L-streptamine (kanamycin B),

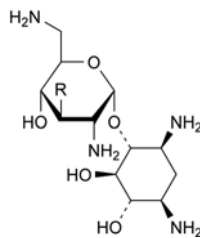

- B. R = H: 2-deoxy-4-*O*-(2,6-diamino-2,3,6-trideoxy- $\alpha$ -D-ribohexopyranosyl)-D-streptamine (nebramine),  
C. R = OH: 2-deoxy-4-*O*-(2,6-diamino-2,6-dideoxy- $\alpha$ -D-glucopyranosyl)-D-streptamine (neamine).

01/2008:0692  
corrected 7.0

## all-*rac*- $\alpha$ -TOCOPHEROL

### int-*rac*- $\alpha$ -Tocopherolum

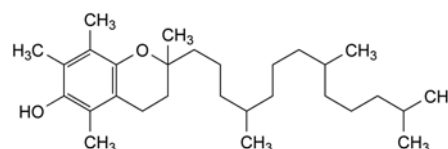

C<sub>29</sub>H<sub>50</sub>O<sub>2</sub>  
[10191-41-0]

M<sub>r</sub> 430.7

#### DEFINITION

all-*rac*-2,5,7,8-Tetramethyl-2-(4,8,12-trimethyltridecyl)-3,4-dihydro-2*H*-1-benzopyran-6-ol.

**Content:** 96.0 per cent to 102.0 per cent.

#### CHARACTERS

**Appearance:** clear, colourless or yellowish-brown, viscous, oily liquid.

**Solubility:** practically insoluble in water, freely soluble in acetone, in anhydrous ethanol, in methylene chloride and in fatty oils.

#### IDENTIFICATION

**First identification:** A, B.

**Second identification:** A, C.

A. Optical rotation (2.2.7):  $-0.01^\circ$  to  $+0.01^\circ$ .

Dissolve 2.50 g in *anhydrous ethanol R* and dilute to 25.0 mL with the same solvent.

B. Infrared absorption spectrophotometry (2.2.24).

**Comparison:**  $\alpha$ -tocopherol CRS.

C. Thin-layer chromatography (2.2.27).

**Test solution.** Dissolve 10 mg of the substance to be examined in 2 mL of *cyclohexane R*.

**Reference solution.** Dissolve 10 mg of  $\alpha$ -tocopherol CRS in 2 mL of *cyclohexane R*.

**Plate:** TLC silica gel F<sub>254</sub> plate R.

**Mobile phase:** ether R, cyclohexane R (20:80 V/V).

**Application:** 10  $\mu$ L.

**Development:** over 2/3 of the plate.

**Drying:** in a current of air.

**Detection:** examine in ultraviolet light at 254 nm.

**Results:** the principal spot in the chromatogram obtained with the test solution is similar in position and size to the principal spot in the chromatogram obtained with the reference solution.

## TESTS

**Related substances.** Gas chromatography (2.2.28): use the normalisation procedure.

**Internal standard solution.** Dissolve 1.0 g of *squalane R* in *cyclohexane R* and dilute to 100.0 mL with the same solvent.

**Test solution (a).** Dissolve 0.100 g of the substance to be examined in 10.0 mL of the internal standard solution.

**Test solution (b).** Dissolve 0.100 g of the substance to be examined in 10 mL of *cyclohexane R*.

**Reference solution (a).** Dissolve 0.100 g of  $\alpha$ -tocopherol CRS in 10.0 mL of the internal standard solution.

**Reference solution (b).** Dissolve 10 mg of the substance to be examined and 10 mg of  $\alpha$ -tocopheryl acetate *R* in *cyclohexane R* and dilute to 100.0 mL with the same solvent.

**Reference solution (c).** Dissolve 10 mg of *all-rac- $\alpha$ -tocopherol for peak identification CRS* (containing impurities A and B) in *cyclohexane R* and dilute to 1 mL with the same solvent.

**Reference solution (d).** Dilute 1.0 mL of test solution (b) to 100.0 mL with *cyclohexane R*. Dilute 1.0 mL of this solution to 10.0 mL with *cyclohexane R*.

**Column:**

- **material:** fused silica;
- **size:**  $l = 30$  m,  $\varnothing = 0.25$  mm;
- **stationary phase:** *poly(dimethyl)siloxane R* (film thickness 0.25  $\mu$ m).

**Carrier gas:** helium for chromatography *R*.

**Flow rate:** 1 mL/min.

**Split ratio:** 1:100.

**Temperature:**

- **column:** 280 °C;
- **injection port and detector:** 290 °C.

**Detection:** flame ionisation.

**Injection:** 1  $\mu$ L of test solution (b) and reference solutions (b), (c) and (d).

**Run time:** twice the retention time of *all-rac- $\alpha$ -tocopherol*.

**Identification of impurities:** use the chromatogram supplied with *all-rac- $\alpha$ -tocopherol for peak identification CRS* and the chromatogram obtained with reference solution (c) to identify the peaks due to impurities A and B.

**Relative retention** with reference to *all-rac- $\alpha$ -tocopherol* (retention time = about 13 min): *squalane* = about 0.5; impurity A = about 0.7; impurity B = about 0.8; impurities C and D = about 1.05 (eluting immediately after the *all-rac- $\alpha$ -tocopherol* peak).

**System suitability:** reference solution (b):

- **resolution:** minimum 3.5 between the peaks due to *all-rac- $\alpha$ -tocopherol* and  $\alpha$ -tocopheryl acetate.

**Limits:**

- **impurity A:** maximum 0.5 per cent;
- **impurity B:** maximum 1.5 per cent;
- **sum of impurities C and D:** maximum 1.0 per cent;
- **any other impurity:** for each impurity, maximum 0.25 per cent;
- **total:** maximum 2.5 per cent;
- **disregard limit:** the area of the principal peak in the chromatogram obtained with reference solution (d) (0.1 per cent).

The thresholds indicated under Related substances (Table 2034.-1) in the general monograph *Substances for pharmaceutical use (2034)* do not apply.

## ASSAY

Gas chromatography (2.2.28) as described in the test for related substances with the following modification.

**Injection:** test solution (a) and reference solution (a).

Calculate the percentage content of  $C_{29}H_{50}O_2$  from the declared content of  $\alpha$ -tocopherol CRS.

## STORAGE

Under an inert gas, protected from light.

## IMPURITIES

**Specified impurities:** A, B, C, D.

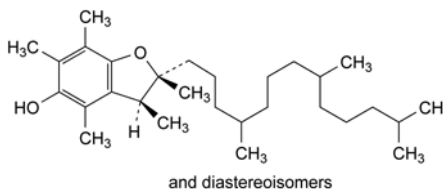

A. *all-rac-trans*-2,3,4,6,7-pentamethyl-2-(4,8,12-trimethyltridecyl)-2,3-dihydrobenzofuran-5-ol,

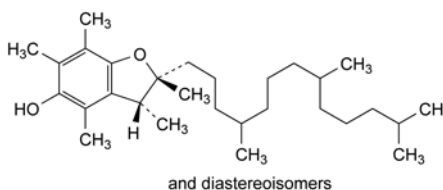

B. *all-rac-cis*-2,3,4,6,7-pentamethyl-2-(4,8,12-trimethyltridecyl)-2,3-dihydrobenzofuran-5-ol.

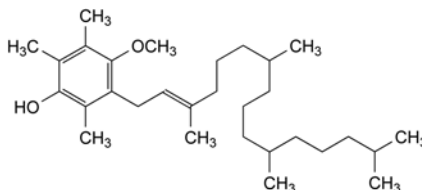

C. 4-methoxy-2,3,6-trimethyl-5-[(*all-RS,E*)-3,7,11,15-tetramethylhexadec-2-enyl]phenol,

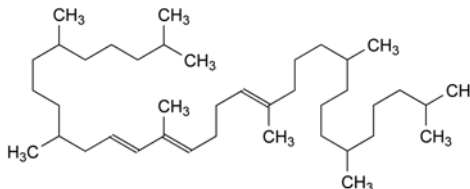

D. (*all-RS,all-E*)-2,6,10,14,19,23,27,31-octamethyldotriaconta-12,14,18-triene.

01/2008:1256

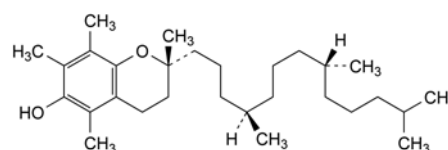
RRR- $\alpha$ -TOCOPHEROLRRR- $\alpha$ -Tocopherolum

$C_{29}H_{50}O_2$   
[59-02-9]

$M_r$  430.7

## DEFINITION

(2*R*)-2,5,7,8-Tetramethyl-2-[(4*R*,8*R*)-4,8,12-trimethyltridecyl]-3,4-dihydro-2*H*-1-benzopyran-6-ol.

**Content:** 94.5 per cent to 102.0 per cent.

## CHARACTERS

**Appearance:** clear, colourless or yellowish-brown, viscous, oily liquid.

**Solubility:** practically insoluble in water, freely soluble in acetone, in anhydrous ethanol, in methylene chloride and in fatty oils.

## IDENTIFICATION

**First identification:** A, B.

**Second identification:** A, C.

A. Optical rotation (2.2.7): + 0.05° to + 0.10°.

Dissolve 2.50 g in *anhydrous ethanol R* and dilute to 25.0 mL with the same solvent.

B. Infrared absorption spectrophotometry (2.2.24).

**Comparison:**  $\alpha$ -tocopherol CRS.

C. Thin-layer chromatography (2.2.27).

**Test solution.** Dissolve 10 mg of the substance to be examined in 2 mL of *cyclohexane R*.

**Reference solution.** Dissolve 10 mg of  $\alpha$ -tocopherol CRS in 2 mL of *cyclohexane R*.

**Plate:** TLC silica gel  $F_{254}$  plate *R*.

**Mobile phase:** ether *R*, *cyclohexane R* (20:80 V/V).

**Application:** 10  $\mu$ L.

**Development:** over 2/3 of the plate.

**Drying:** in a current of air.

**Detection:** examine in ultraviolet light at 254 nm.

**Results:** the principal spot in the chromatogram obtained with the test solution is similar in position and size to the principal spot in the chromatogram obtained with the reference solution.

## TESTS

**Related substances.** Gas chromatography (2.2.28): use the normalisation procedure.

**Internal standard solution.** Dissolve 1.0 g of *squalane R* in *cyclohexane R* and dilute to 100.0 mL with the same solvent.

**Test solution (a).** Dissolve 0.100 g of the substance to be examined in 10.0 mL of the internal standard solution.

**Test solution (b).** Dissolve 0.100 g of the substance to be examined in 10 mL of *cyclohexane R*.

**Reference solution (a).** Dissolve 0.100 g of  $\alpha$ -tocopherol CRS in 10.0 mL of the internal standard solution.

**Reference solution (b).** Dissolve 10 mg of  $\alpha$ -tocopherol *R* and 10 mg of  $\alpha$ -tocopheryl acetate *R* in *cyclohexane R* and dilute to 100.0 mL with the same solvent.

**Column:**

- **material:** fused silica;
- **size:**  $l = 30$  m,  $\varnothing = 0.25$  mm;
- **stationary phase:** poly(dimethyl)siloxane *R* (film thickness 0.25  $\mu$ m).

**Carrier gas:** helium for chromatography *R*.

**Flow rate:** 1 mL/min.

**Split ratio:** 1:100.

**Temperature:**

	Time (min)	Temperature (°C)
Column	0 - 15	280
Injection port		290
Detector		290

**Detection:** flame ionisation.

**Injection:** 1  $\mu$ L of test solution (b) and reference solution (b).

**System suitability:** reference solution (b):

- **resolution:** minimum 3.5 between the peaks due to  $\alpha$ -tocopherol and  $\alpha$ -tocopheryl acetate.

## Limits:

- **total:** maximum 4.0 per cent;
- **disregard limit:** 0.1 per cent.

The thresholds indicated under Related substances (Table 2034.1) in the general monograph *Substances for pharmaceutical use (2034)* do not apply.

## ASSAY

Gas chromatography (2.2.28) as described in the test for related substances with the following modification.

**Injection:** test solution (a) and reference solution (a).

Calculate the percentage content of  $C_{29}H_{50}O_2$  taking into account the declared content of  $\alpha$ -tocopherol CRS.

## STORAGE

Under an inert gas, protected from light.

## IMPURITIES

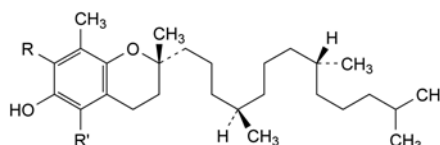

- A. R = R' = H: (2*R*)-2,8-dimethyl-2-[(4*R*,8*R*)-4,8,12-trimethyltridecyl]-3,4-dihydro-2*H*-1-benzopyran-6-ol (*RRR*- $\delta$ -tocopherol),
- B. R = H, R' = CH<sub>3</sub>: (2*R*)-2,5,8-trimethyl-2-[(4*R*,8*R*)-4,8,12-trimethyltridecyl]-3,4-dihydro-2*H*-1-benzopyran-6-ol (*RRR*- $\beta$ -tocopherol),
- C. R = CH<sub>3</sub>, R' = H: (2*R*)-2,7,8-trimethyl-2-[(4*R*,8*R*)-4,8,12-trimethyltridecyl]-3,4-dihydro-2*H*-1-benzopyran-6-ol (*RRR*- $\gamma$ -tocopherol).

01/2008:0439

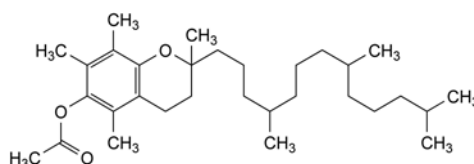
all-*rac*- $\alpha$ -TOCOPHERYL ACETATEint-*rac*- $\alpha$ -Tocopherylis acetate

$C_{31}H_{52}O_3$   
[7695-91-2]

$M_r$  472.7

## DEFINITION

all-*rac*-2,5,7,8-Tetramethyl-2-(4,8,12-trimethyltridecyl)-3,4-dihydro-2*H*-1-benzopyran-6-yl acetate.

**Content:** 96.5 per cent to 102.0 per cent.

## CHARACTERS

**Appearance:** clear, colourless or slightly greenish-yellow, viscous, oily liquid.

**Solubility:** practically insoluble in water, freely soluble in acetone, in anhydrous ethanol and in fatty oils.

## IDENTIFICATION

**First identification:** A, B.

**Second identification:** A, C.

A. Optical rotation (2.2.7): - 0.01° to + 0.01°.

Dissolve 2.50 g in *anhydrous ethanol R* and dilute to 25.0 mL with the same solvent.

B. Infrared absorption spectrophotometry (2.2.24).

**Comparison:**  $\alpha$ -tocopheryl acetate CRS.



## C. Thin-layer chromatography (2.2.27).

**Test solution.** Dissolve about 10 mg of the substance to be examined in 2 mL of *cyclohexane R*.

**Reference solution.** Dissolve about 10 mg of  *$\alpha$ -tocopheryl acetate CRS* in 2 mL of *cyclohexane R*.

**Plate:** *TLC silica gel F<sub>254</sub> plate R*.

**Mobile phase:** *ether R, cyclohexane R* (20:80 V/V).

**Application:** 10  $\mu$ L.

**Development:** over 2/3 of the plate.

**Drying:** in a current of air.

**Detection:** examine in ultraviolet light at 254 nm.

**Results:** the principal spot in the chromatogram obtained with the test solution is similar in position and size to the principal spot in the chromatogram obtained with the reference solution.

## TESTS

**Related substances.** Gas chromatography (2.2.28): use the normalisation procedure.

**Internal standard solution.** Dissolve 1.0 g of *squalane R* in *cyclohexane R* and dilute to 100.0 mL with the same solvent.

**Test solution (a).** Dissolve 0.100 g of the substance to be examined in 10.0 mL of the internal standard solution.

**Test solution (b).** Dissolve 0.100 g of the substance to be examined in 10 mL of *cyclohexane R*.

**Reference solution (a).** Dissolve 0.100 g of  *$\alpha$ -tocopheryl acetate CRS* in 10.0 mL of the internal standard solution.

**Reference solution (b).** Dissolve 10 mg of the substance to be examined and 10 mg of  *$\alpha$ -tocopherol R* in *cyclohexane R* and dilute to 100.0 mL with the same solvent.

**Reference solution (c).** Dissolve 10 mg of *all-*rac*- $\alpha$ -tocopheryl acetate for peak identification CRS* (containing impurities A and B) in *cyclohexane R* and dilute to 1 mL with the same solvent.

**Reference solution (d).** Dilute 1.0 mL of test solution (b) to 100.0 mL with *cyclohexane R*. Dilute 1.0 mL of this solution to 10.0 mL with *cyclohexane R*.

**Column:**

- **material:** fused silica;
- **size:**  $l = 30$  m,  $\varnothing = 0.25$  mm;
- **stationary phase:** *poly(dimethyl)siloxane R* (film thickness 0.25  $\mu$ m).

**Carrier gas:** *helium for chromatography R*.

**Flow rate:** 1 mL/min.

**Split ratio:** 1:100.

**Temperature:**

- **column:** 280 °C;
- **injection port and detector:** 290 °C.

**Detection:** flame ionisation.

**Injection:** 1  $\mu$ L of test solution (b) and reference solutions (a), (b), (c) and (d); inject directly onto the column or via a sufficiently inert, glass-lined injection port using an automatic injection device or other reproducible injection method.

**Run time:** twice the retention time of *all-*rac*- $\alpha$ -tocopheryl acetate*.

**Identification of impurities:** use the chromatogram supplied with *all-*rac*- $\alpha$ -tocopheryl acetate for peak identification CRS* and the chromatogram obtained with reference solution (c) to identify the peaks due to impurities A and B.

**Relative retention** with reference to *all-*rac*- $\alpha$ -tocopheryl acetate* (retention time = about 15 min): *squalane* = about 0.4; impurity A = about 0.7; impurity B = about 0.8; impurity C = about 0.9; impurities D and E = about 1.05 (eluting immediately after the *all-*rac*- $\alpha$ -tocopheryl acetate* peak).

**System suitability:**

- **resolution:** minimum 3.5 between the peaks due to impurity C and *all-*rac*- $\alpha$ -tocopheryl acetate* in the chromatogram obtained with reference solution (b);
- in the chromatogram obtained with reference solution (a), the area of the peak due to impurity C is not greater than 0.2 per cent of the area of the peak due to *all-*rac*- $\alpha$ -tocopheryl acetate*.

**Limits:**

- **impurities A, C:** for each impurity, maximum 0.5 per cent;
- **impurity B:** maximum 1.5 per cent;
- **sum of impurities D and E:** maximum 1.0 per cent;
- **any other impurity:** for each impurity, maximum 0.25 per cent;
- **total:** maximum 2.5 per cent;
- **disregard limit:** the area of the principal peak in the chromatogram obtained with reference solution (d) (0.1 per cent).

The thresholds indicated under Related substances (Table 2034.1) in the general monograph *Substances for pharmaceutical use (2034)* do not apply.

## ASSAY

Gas chromatography (2.2.28) as described in the test for related substances with the following modification.

**Injection:** test solution (a) and reference solution (a).

Calculate the percentage content of  $C_{31}H_{52}O_3$  from the declared content of  *$\alpha$ -tocopheryl acetate CRS*.

## STORAGE

Protected from light.

## IMPURITIES

**Specified impurities:** A, B, C, D, E.

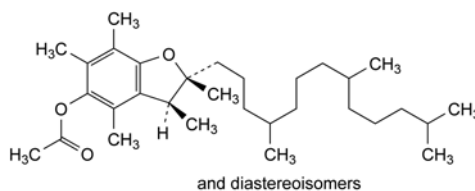

- A. *all-*rac*-trans*-2,3,4,6,7-pentamethyl-2-(4,8,12-trimethyltridecyl)-2,3-dihydrobenzofuran-5-yl acetate,

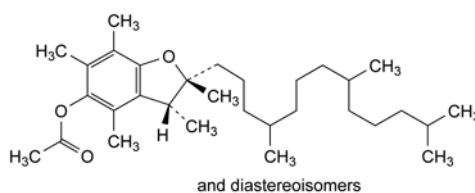

- B. *all-*rac*-cis*-2,3,4,6,7-pentamethyl-2-(4,8,12-trimethyltridecyl)-2,3-dihydrobenzofuran-5-yl acetate,

- C. *all-*rac*- $\alpha$ -tocopherol*,

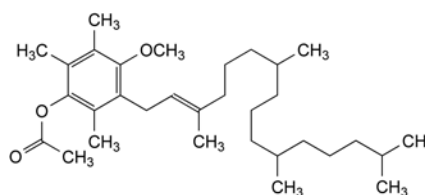

- D. 4-methoxy-2,3,6-trimethyl-5-[(*all-RS,E*)-3,7,11,15-tetramethylhexadec-2-enyl]phenyl acetate,

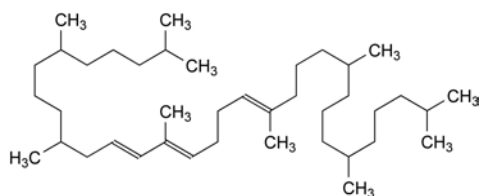

E. (all-*RS*,all-*E*)-2,6,10,14,19,23,27,31-octamethyldotriaconta-12,14,18-triene.

01/2008:1257

## RRR- $\alpha$ -TOCOPHERYL ACETATE

### RRR- $\alpha$ -Tocopherylis acetas

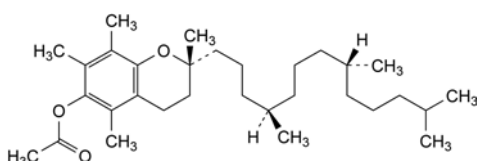

$C_{31}H_{52}O_3$

$M_r$  472.7

#### DEFINITION

(2*R*)-2,5,7,8-Tetramethyl-2-[(4*R*,8*R*)-4,8,12-trimethyltridecyl]-3,4-dihydro-2*H*-1-benzopyran-6-yl acetate.

Content: 95.0 per cent to 101.0 per cent.

#### CHARACTERS

**Appearance:** clear, colourless or slightly greenish-yellow, viscous, oily liquid.

**Solubility:** practically insoluble in water, freely soluble in acetone, in anhydrous ethanol and in fatty oils, soluble in ethanol (96 per cent).

#### IDENTIFICATION

First identification: A, B.

Second identification: A, C.

A. Optical rotation (2.2.7): + 0.25° to + 0.35°.

Dissolve 2.50 g in anhydrous ethanol *R* and dilute to 25.0 mL with the same solvent.

B. Infrared absorption spectrophotometry (2.2.24).

Comparison:  $\alpha$ -tocopheryl acetate CRS.

C. Thin-layer chromatography (2.2.27).

Test solution (a). Dissolve 10 mg of the substance to be examined in 2 mL of cyclohexane *R*.

Test solution (b). In a ground-glass-stoppered tube, dissolve about 10 mg of the substance to be examined in 2 mL of 2.5 *M* alcoholic sulfuric acid *R*. Heat on a water-bath for 5 min. Cool and add 2 mL of water *R* and 2 mL of cyclohexane *R*. Shake for 1 min. Use the upper layer.

Reference solution (a). Dissolve 10 mg of  $\alpha$ -tocopheryl acetate CRS in 2 mL of cyclohexane *R*.

Reference solution (b). Prepare as described for test solution (b), using  $\alpha$ -tocopheryl acetate CRS instead of the substance to be examined.

Plate: TLC silica gel  $F_{254}$  plate *R*.

Mobile phase: ether *R*, cyclohexane *R* (20:80 V/V).

Application: 10  $\mu$ L.

Development: over 2/3 of the plate.

Drying: in a current of air.

Detection: examine in ultraviolet light at 254 nm.

Results: the principal spot in the chromatogram obtained with test solution (a) is similar in position and size to the principal spot in the chromatogram obtained with

reference solution (a). In the chromatograms obtained with test solution (b) and reference solution (b), there may be 2 spots depending on the degree of hydrolysis: the spot with the higher  $R_f$  value is due to  $\alpha$ -tocopheryl acetate and corresponds to the spot in the chromatogram obtained with reference solution (a); the spot with the lower  $R_f$  value is due to  $\alpha$ -tocopherol.

#### TESTS

**Related substances.** Gas chromatography (2.2.28): use the normalisation procedure.

**Internal standard solution.** Dissolve 1.0 g of squalane *R* in cyclohexane *R* and dilute to 100.0 mL with the same solvent.

Test solution (a). Dissolve 0.100 g of the substance to be examined in 10.0 mL of the internal standard solution.

Test solution (b). Dissolve 0.100 g of the substance to be examined in 10 mL of cyclohexane *R*.

Reference solution (a). Dissolve 0.100 g of  $\alpha$ -tocopheryl acetate CRS in 10.0 mL of the internal standard solution.

Reference solution (b). Dissolve 10 mg of  $\alpha$ -tocopherol *R* and 10 mg of  $\alpha$ -tocopheryl acetate *R* in cyclohexane *R* and dilute to 100.0 mL with the same solvent.

Column:

– material: fused silica;

– size:  $l = 30$  m,  $\varnothing = 0.25$  mm;

– stationary phase: poly(dimethyl)siloxane *R* (film thickness 0.25  $\mu$ m).

Carrier gas: helium for chromatography *R*.

Flow rate: 1 mL/min.

Split ratio: 1:100.

Temperature:

	Time (min)	Temperature (°C)
Column	0 - 15	280
Injection port		290
Detector		290

Detection: flame ionisation.

Injection: 1  $\mu$ L of test solution (b) and reference solutions (a) and (b); inject directly onto the column or via a sufficiently inert, glass-lined injection port using an automatic injection device or other reproducible injection method.

System suitability:

– resolution: minimum 3.5 between the peaks due to  $\alpha$ -tocopherol and  $\alpha$ -tocopheryl acetate in the chromatogram obtained with reference solution (b);

– in the chromatogram obtained with reference solution (a), the area of the peak due to  $\alpha$ -tocopherol is not greater than 0.2 per cent of the area of the peak due to  $\alpha$ -tocopheryl acetate.

Limits:

– total: maximum 4.0 per cent;

– disregard limit: 0.1 per cent.

The thresholds indicated under Related substances (Table 2034.1) in the general monograph Substances for pharmaceutical use (2034) do not apply.

#### ASSAY

Gas chromatography (2.2.28) as described in the test for related substances with the following modification.

Injection: test solution (a) and reference solution (a).

Calculate the percentage content of  $C_{31}H_{52}O_3$  taking into account the declared content of  $\alpha$ -tocopheryl acetate CRS.

#### STORAGE

Protected from light.

## IMPURITIES

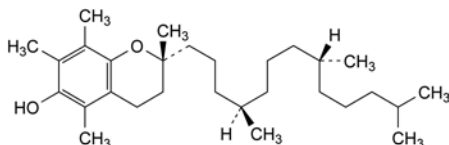

- A. (2*R*)-2,5,7,8-tetramethyl-2-[(4*R*,8*R*)-4,8,12-trimethyltridecyl]-3,4-dihydro-2*H*-1-benzopyran-6-ol (*RRR*- $\alpha$ -tocopherol),

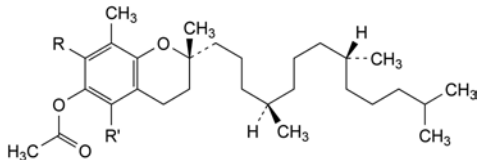

- B. R = H, R' = CH<sub>3</sub>: (2*R*)-2,5,8-trimethyl-2-[(4*R*,8*R*)-4,8,12-trimethyltridecyl]-3,4-dihydro-2*H*-1-benzopyran-6-yl acetate (*RRR*- $\beta$ -tocopheryl acetate),  
 C. R = CH<sub>3</sub>, R' = H: (2*R*)-2,7,8-trimethyl-2-[(4*R*,8*R*)-4,8,12-trimethyltridecyl]-3,4-dihydro-2*H*-1-benzopyran-6-yl acetate (*RRR*- $\gamma$ -tocopheryl acetate),  
 D. R = R' = H: (2*R*)-2,8-dimethyl-2-[(4*R*,8*R*)-4,8,12-trimethyltridecyl]-3,4-dihydro-2*H*-1-benzopyran-6-yl acetate (*RRR*- $\delta$ -tocopheryl acetate).

01/2011:0691

## $\alpha$ -TOCOPHERYL ACETATE CONCENTRATE (POWDER FORM)

### $\alpha$ -Tocopherylis acetatis pulvis

## DEFINITION

Preparation obtained either by finely dispersing *all-rac*- $\alpha$ -Tocopheryl acetate (0439) in a suitable carrier of suitable quality (for example gelatin, acacia, carbohydrates, lactoproteins or a mixture thereof) or by adsorbing *all-rac*- $\alpha$ -Tocopheryl acetate (0439) on silicic acid of suitable quality.

**Content:** 90.0 per cent to 115.0 per cent of the  $\alpha$ -tocopheryl acetate content stated on the label, which is not less than 25 g per 100 g of concentrate.

## CHARACTERS

**Appearance:** almost white, yellowish or light brown, small particles.

**Solubility:** practically insoluble or swells or forms a dispersion in water, depending on the formulation.

## IDENTIFICATION

**First identification:** B.

**Second identification:** A.

- A. Thin-layer chromatography (2.2.27).

**Test solution.** To a quantity of the preparation to be examined corresponding to 50 mg of  $\alpha$ -tocopheryl acetate add 5 mL of 0.01 M hydrochloric acid and treat with ultrasound at 60 °C. Add 5 mL of anhydrous ethanol R and 10 mL of cyclohexane R, shake for 1 min and centrifuge for 5 min. Use the upper layer.

**Reference solution.** Dissolve 50 mg of  $\alpha$ -tocopheryl acetate CRS in cyclohexane R and dilute to 10 mL with the same solvent.

**Plate:** TLC silica gel F<sub>254</sub> plate R.

**Mobile phase:** ether R, cyclohexane R (20:80 V/V).

**Application:** 10  $\mu$ L.

**Development:** 3/4 of the plate.

**Drying:** in a current of air.

**Detection:** examine in ultraviolet light at 254 nm.

**Results:** the principal spot in the chromatogram obtained with the test solution is similar in position and size to the principal spot in the chromatogram obtained with the reference solution.

- B. Examine the chromatograms obtained in the assay.

**Results:**

- the principal peak in the chromatogram obtained with the test solution is similar in retention time and size to the principal peak in the chromatogram obtained with reference solution (a);
- in the chromatogram obtained with reference solution (c) no additional principal peak is observed when compared with the chromatogram obtained with the test solution.

## ASSAY

Gas chromatography (2.2.28).

**Internal standard solution.** Dissolve 1.0 g of squalane R in cyclohexane R and dilute to 500.0 mL with the same solvent.

**Test solution.** Weigh accurately a quantity of the preparation to be examined corresponding to about 0.100 g of  $\alpha$ -tocopheryl acetate into a 250 mL conical flask. Add 20 mL of 1 M hydrochloric acid and sonicate at 70 °C for 20 min. Add 50 mL of anhydrous ethanol R and 50.0 mL of the internal standard solution. Mix thoroughly for 30 min using a magnetic stirrer. Allow the 2 layers to separate and use the upper layer.

**Reference solution (a).** Dissolve 0.100 g of  $\alpha$ -tocopheryl acetate CRS in 50.0 mL of the internal standard solution.

**Reference solution (b).** Dissolve 10 mg of  $\alpha$ -tocopherol R and 10 mg of  $\alpha$ -tocopheryl acetate CRS in 5.0 mL of cyclohexane R.

**Reference solution (c).** Mix 1.0 mL of the test solution and 1.0 mL of reference solution (a).

**Column:**

- **material:** fused silica;
- **size:**  $l = 30$  m,  $\varnothing = 0.25$  mm;
- **stationary phase:** poly(dimethyl)siloxane R (film thickness 0.25  $\mu$ m).

**Carrier gas:** helium for chromatography R.

**Flow rate:** 1 mL/min.

**Split ratio:** 1:100.

**Temperature:**

- **column:** 280 °C;
- **injection port and detector:** 290 °C.

**Detection:** flame ionisation.

**Injection:** 1  $\mu$ L; inject directly onto the column or via a sufficiently inert, glass-lined injection port.

**Run time:** 1.1 times the retention time of  $\alpha$ -tocopheryl acetate.

**Relative retention** with reference to  $\alpha$ -tocopheryl acetate (retention time = about 12 min): squalane = about 0.5;  $\alpha$ -tocopherol = about 0.9.

**System suitability:**

- **resolution:** minimum 3.5 between the peaks due to  $\alpha$ -tocopherol and  $\alpha$ -tocopheryl acetate in the chromatogram obtained with reference solution (b);
- in the chromatogram obtained with reference solution (a), the area of the peak due to  $\alpha$ -tocopherol is not greater than 0.002 times the area of the peak due to  $\alpha$ -tocopheryl acetate (0.2 per cent).

Calculate the percentage content of C<sub>31</sub>H<sub>52</sub>O<sub>3</sub> from the declared content of  $\alpha$ -tocopheryl acetate CRS.

## STORAGE

In an airtight, well-filled container, protected from light.

## LABELLING

The label states the content of  $\alpha$ -tocopheryl acetate, expressed in grams per 100 g of concentrate.

01/2008:1258

## DL- $\alpha$ -TOCOPHERYL HYDROGEN SUCCINATE

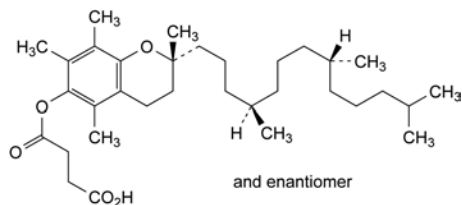
DL- $\alpha$ -Tocopherylis hydrogenosuccinas $C_{33}H_{54}O_5$  $M_r$  530.8

### DEFINITION

(2*RS*)-2,5,7,8-Tetramethyl-2-[(4*RS*,8*RS*)-4,8,12-trimethyltridecyl]-3,4-dihydro-2*H*-1-benzopyran-6-yl hydrogen succinate.

*Content*: 96.0 per cent to 102.0 per cent.

### CHARACTERS

*Appearance*: white or almost white, crystalline powder.

*Solubility*: practically insoluble in water, very soluble in methylene chloride, soluble in acetone and in anhydrous ethanol.

### IDENTIFICATION

*First identification*: B, D.

*Second identification*: A, C, D.

A. Absorbance (see Tests).

B. Infrared absorption spectrophotometry (2.2.24).

*Comparison*: RRR- $\alpha$ -tocopheryl hydrogen succinate CRS.

C. Thin-layer chromatography (2.2.27).

*Test solution (a)*. Dissolve 10 mg of the substance to be examined in 2 mL of cyclohexane R.

*Test solution (b)*. In a ground-glass-stoppered tube, dissolve 10 mg of the substance to be examined in 2 mL of 2.5 M alcoholic sulfuric acid R. Heat on a water-bath for 5 min. Cool and add 2 mL of water R and 2 mL of cyclohexane R. Shake for 1 min. Use the upper layer.

*Reference solution (a)*. Dissolve 10 mg of RRR- $\alpha$ -tocopheryl hydrogen succinate CRS in 2 mL of cyclohexane R.

*Reference solution (b)*. Prepare as described for test solution (b), using RRR- $\alpha$ -tocopheryl hydrogen succinate CRS instead of the substance to be examined.

*Plate*: TLC silica gel  $F_{254}$  plate R.

*Mobile phase*: glacial acetic acid R, ether R, cyclohexane R (0.2:20:80 V/V/V).

*Application*: 10  $\mu$ L.

*Development*: over a path of 15 cm.

*Drying*: in a current of air.

*Detection A*: examine in ultraviolet light at 254 nm.

*Results A*: the principal spot in the chromatogram obtained with test solution (a) is similar in position and size to the principal spot in the chromatogram obtained with reference solution (a). In the chromatograms obtained with test solution (b) and reference solution (b), there are 2 spots: the spot with the higher  $R_f$  value is due to  $\alpha$ -tocopherol, the spot with the lower  $R_f$  value is due to DL- $\alpha$ -tocopheryl hydrogen succinate and corresponds to the spot obtained with reference solution (a). Depending on the degree of hydrolysis, the lower spot may be weak or even absent.

*Detection B*: spray with a mixture of 10 volumes of hydrochloric acid R, 40 volumes of a 2.5 g/L solution of ferric chloride R in ethanol (96 per cent) R and 40 volumes of a 10 g/L solution of phenanthroline hydrochloride R in ethanol (96 per cent) R.

*Results B*: in the chromatograms obtained with test solution (b) and reference solution (b), the spot due to  $\alpha$ -tocopherol is orange.

D. Optical rotation (see Tests).

### TESTS

**Optical rotation** (2.2.7):  $-0.01^\circ$  to  $+0.01^\circ$ .

Dissolve 2.50 g in anhydrous ethanol R and dilute to 25.0 mL with the same solvent.

**Absorbance** (2.2.25).

*Solution A*. Dissolve 0.150 g in anhydrous ethanol R and dilute to 100 mL with the same solvent.

*Test solution (a)*. Dilute 10.0 mL of solution A to 100.0 mL with anhydrous ethanol R.

*Test solution (b)*. Dilute 20.0 mL of solution A to 50.0 mL with anhydrous ethanol R.

*Absorption maximum*: at 284 nm for test solution (a).

*Absorption minimum*: at 254 nm for test solution (b).

*Specific absorbance at the absorption maximum*: 35 to 38 for test solution (a).

*Specific absorbance at the absorption minimum*: 6.0 to 8.0 for test solution (b).

**Acid value** (2.5.1): 101 to 108, determined on 1.00 g.

**Free tocopherol**: maximum 1.0 per cent.

Dissolve 0.500 g in 100 mL of 0.25 M alcoholic sulfuric acid R. Add 20 mL of water R and 0.1 mL of a 2.5 g/L solution of diphenylamine R in sulfuric acid R. Titrate with 0.01 M ammonium and cerium sulfate until a blue colour is obtained that persists for at least 5 s. Carry out a blank titration.

1 mL of 0.01 M ammonium and cerium sulfate is equivalent to 2.154 mg of free tocopherol.

### Related substances

The thresholds indicated under Related substances (Table 2034.1) in the general monograph *Substances for pharmaceutical use* (2034) do not apply.

**Heavy metals** (2.4.8): maximum 20 ppm.

0.50 g complies with test D. Prepare the reference solution using 1 mL of lead standard solution (10 ppm Pb) R.

**Sulfated ash** (2.4.14): maximum 0.1 per cent, determined on 1.0 g.

### ASSAY

Gas chromatography (2.2.28).

*Internal standard solution*. Dissolve 0.300 g of dotriacontane R in hexane R and dilute to 100.0 mL with the same solvent.

*Test solution*. Weigh 30.0 mg of the substance to be examined into a 20 mL vial. Add 2.0 mL of methanol R, 1.0 mL of dimethoxypropane R and 0.1 mL of hydrochloric acid R. Cap tightly and sonicate. Allow to stand in the dark for 1 h  $\pm$  5 min. Remove from the dark, uncap and evaporate just to dryness on a steam bath with the aid of a stream of nitrogen. Add 10.0 mL of the internal standard solution. Vortex into solution.

*Reference solution*. Weigh 30.0 mg of RRR- $\alpha$ -tocopheryl hydrogen succinate CRS into a 20 mL vial. Add 2.0 mL of methanol R, 1.0 mL of dimethoxypropane R and 0.1 mL of hydrochloric acid R. Cap tightly and sonicate. Allow to stand in the dark for 1 h  $\pm$  5 min. Remove from the dark, uncap and evaporate just to dryness on a steam bath with the aid of a stream of nitrogen. Add 10.0 mL of the internal standard solution. Vortex into solution.

**Column:**

- *material*: fused silica;
- *size*:  $l = 15$  m,  $\varnothing = 0.32$  mm;
- *stationary phase*: poly(dimethyl)siloxane R (film thickness 0.25  $\mu$ m).

*Carrier gas*: helium for chromatography R.

*Flow rate*: 3-6 mL/min.

*Split ratio*: 1:10 to 1:20.

*Temperature*:

	Time (min)	Temperature (°C)
Column	0 - 10	200 → 250
	10 - 20	250
Injection port		300
Detector		330

*Detection*: flame ionisation.

*Injection*: 1  $\mu$ L; inject directly onto the column or via a glass-lined injection port using an automatic injection device or some other reproducible injection method.

*System suitability*: reference solution:

- *resolution*: minimum 12.0 between the peaks due to dotriacontane and DL- $\alpha$ -tocopheryl hydrogen succinate.

*Interference test*. Dissolve 0.100 g of the substance to be examined in hexane R and dilute to 50.0 mL with the same solvent. Inject 1  $\mu$ L of the solution and record the chromatogram. If a peak is detected with the same retention time as that of the peak due to dotriacontane, calculate the area of this peak relative to the peak area of the substance to be examined. If the relative peak area is greater than 0.5 per cent, use the corrected peak area  $S'_{D(\text{corr})}$  for the final calculation.

$$S'_{D(\text{corr})} = S'_D - \frac{S_I \times S'_T}{S_{TI}}$$

- $S'_D$  = area of the peak due to dotriacontane in the chromatogram obtained with the test solution;
- $S_I$  = area of the peak with the same retention time as that of the peak due to dotriacontane in the chromatogram obtained in the interference test;
- $S'_T$  = area of the peak due to DL- $\alpha$ -tocopheryl hydrogen succinate in the chromatogram obtained with the test solution;
- $S_{TI}$  = area of the peak due to DL- $\alpha$ -tocopheryl hydrogen succinate in the chromatogram obtained in the interference test.

Measure the areas of the peaks due to RRR- $\alpha$ -tocopheryl hydrogen succinate CRS ( $S_T$ ) and dotriacontane ( $S_D$ ) in the chromatogram obtained with the reference solution and the areas of the peaks due to DL- $\alpha$ -tocopheryl hydrogen succinate ( $S'_T$ ) and dotriacontane ( $S'_D$ ) in the chromatogram obtained with the test solution.

Determine the response factor (RF) for DL- $\alpha$ -tocopheryl hydrogen succinate from the areas of the peaks due to RRR- $\alpha$ -tocopheryl hydrogen succinate CRS and dotriacontane in the chromatogram obtained with the reference solution, using the following expression:

$$\frac{S_D \times m_T}{S_T \times m_D}$$

Calculate the percentage content of DL- $\alpha$ -tocopheryl hydrogen succinate using the following expression:

$$\frac{100 \times S'_T \times m_D \times \text{RF}}{S'_{D(\text{corr})} \times m}$$

- $S_D$  = area of the peak due to dotriacontane in the chromatogram obtained with the reference solution;
- $S'_{D(\text{corr})}$  = corrected area of the peak due to dotriacontane in the chromatogram obtained with the test solution;
- $S_T$  = area of the peak due to RRR- $\alpha$ -tocopheryl hydrogen succinate CRS in the chromatogram obtained with the reference solution;
- $S'_T$  = area of the peak due to DL- $\alpha$ -tocopheryl hydrogen succinate in the chromatogram obtained with the test solution;
- $m_D$  = mass of dotriacontane in the test solution and in the reference solution, in milligrams;
- $m_T$  = mass of RRR- $\alpha$ -tocopheryl hydrogen succinate CRS in the reference solution, in milligrams;
- $m$  = mass of the substance to be examined in the test solution, in milligrams.

**STORAGE**

Protected from light.

01/2008:1259

## RRR- $\alpha$ -TOCOPHERYL HYDROGEN SUCCINATE

### RRR- $\alpha$ -Tocopheryl hydrogen succinate

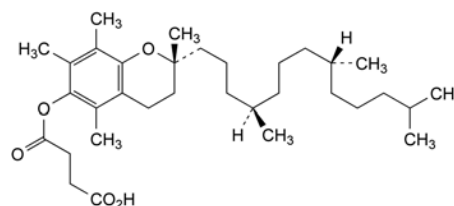

$C_{33}H_{54}O_5$   
[4345-03-3]

$M_r$  530.8

**DEFINITION**

(2R)-2,5,7,8-Tetramethyl-2-[(4R,8R)-4,8,12-trimethyltridecyl]-3,4-dihydro-2H-1-benzopyran-6-yl hydrogen succinate.

*Content*: 96.0 per cent to 102.0 per cent.

**CHARACTERS**

*Appearance*: white or almost white, crystalline powder.

*Solubility*: practically insoluble in water, very soluble in methylene chloride, soluble in acetone and in anhydrous ethanol.

**IDENTIFICATION**

*First identification*: B, D.

*Second identification*: A, C, D.

A. Absorbance (see Tests).

B. Infrared absorption spectrophotometry (2.2.24).

*Comparison*: RRR- $\alpha$ -tocopheryl hydrogen succinate CRS.

C. Thin-layer chromatography (2.2.27).

*Test solution (a)*. Dissolve 10 mg of the substance to be examined in 2 mL of cyclohexane R.

*Test solution (b)*. In a ground-glass-stoppered tube, dissolve 10 mg of the substance to be examined in 2 mL of 2.5 M alcoholic sulfuric acid R. Heat on a water-bath for 5 min. Cool and add 2 mL of water R and 2 mL of cyclohexane R. Shake for 1 min. Use the upper layer.

*Reference solution (a)*. Dissolve 10 mg of RRR- $\alpha$ -tocopheryl hydrogen succinate CRS in 2 mL of cyclohexane R.

*Reference solution (b).* Prepare as described for test solution (b), using *RRR- $\alpha$ -tocopheryl hydrogen succinate CRS* instead of the substance to be examined.

*Plate:* TLC silica gel F<sub>254</sub> plate R.

*Mobile phase:* glacial acetic acid R, ether R, cyclohexane R (0.2:20:80 V/V/V).

*Application:* 10  $\mu$ L.

*Development:* over a path of 15 cm.

*Drying:* in a current of air.

*Detection A:* examine in ultraviolet light at 254 nm.

*Results A:* the principal spot in the chromatogram obtained with test solution (a) is similar in position and size to the principal spot in the chromatogram obtained with reference solution (a). In the chromatograms obtained with test solution (b) and reference solution (b), there are 2 spots: the spot with the higher *R<sub>F</sub>* value is due to  $\alpha$ -tocopherol, the spot with the lower *R<sub>F</sub>* value is due to *RRR- $\alpha$ -tocopheryl hydrogen succinate* and corresponds to the spot obtained with reference solution (a). Depending on the degree of hydrolysis, the lower spot may be weak or even absent.

*Detection B:* spray with a mixture of 10 volumes of *hydrochloric acid R*, 40 volumes of a 2.5 g/L solution of *ferric chloride R* in *ethanol (96 per cent) R* and 40 volumes of a 10 g/L solution of *phenanthroline hydrochloride R* in *ethanol (96 per cent) R*.

*Results B:* in the chromatograms obtained with test solution (b) and reference solution (b), the spot due to  $\alpha$ -tocopherol is orange.

- D. After saponification, the resulting *RRR- $\alpha$ -tocopherol* is dextrorotatory (2.2.7). The specific optical rotation after oxidation to the quinone form is not less than + 24.

*Carry out the test avoiding exposure to actinic light.*

Transfer 1.0 g to a round bottomed, ground-glass-stoppered, 250 mL flask, dissolve in 30 mL of *anhydrous ethanol R* and heat under reflux for 3 min. While the solution is boiling, add, through the condenser, 20 mL of 2 M *alcoholic potassium hydroxide solution R*. Continue heating under reflux for 20 min and, without cooling, add 4.0 mL of *hydrochloric acid R* dropwise through the condenser. Cool, rinse the condenser with 10 mL of *anhydrous ethanol R*, transfer the contents of the flask to a 500 mL separating funnel, and rinse the flask with 4 quantities, each of 25 mL, of *water R* and 4 quantities, each of 25 mL, of *ether R*. Add the rinsings to the separating funnel. Shake vigorously for 2 min, allow the layers to separate and collect each of the 2 layers in individual separating funnels. Shake the aqueous layer with 2 quantities, each of 50 mL, of *ether R* and add these extracts to the main ether extract. Wash the combined ether extracts with 4 quantities, each of 100 mL, of *water R* and discard the washings.

To the ether solution add 40 mL of a 100 g/L solution of *potassium ferricyanide R* in an 8 g/L solution of *sodium hydroxide R* and shake for 3 min. Wash the ether solution with 4 quantities, each of 50 mL, of *water R*, discard the washings and dry the ether layer over *anhydrous sodium sulfate R*. Evaporate the ether on a water-bath under reduced pressure or in an atmosphere of nitrogen until a few millilitres remain, then complete the evaporation removing the last traces of ether without the application of heat. Immediately dissolve the residue in 25.0 mL of *trimethylpentane R* and determine the optical rotation.

Calculate the specific optical rotation of the substance in the test solution using as *c* the number of grams equivalent to  $\alpha$ -tocopherol (factor 0.811) in 1000 mL.

TESTS

**Absorbance** (2.2.25).

*Solution A.* Dissolve 0.150 g in *anhydrous ethanol R* and dilute to 100 mL with the same solvent.

*Test solution (a).* Dilute 10.0 mL of solution A to 100.0 mL with *anhydrous ethanol R*.

*Test solution (b).* Dilute 20.0 mL of solution A to 50.0 mL with *anhydrous ethanol R*.

*Absorption maximum:* at 284 nm for test solution (a).

*Absorption minimum:* at 254 nm for test solution (b).

*Specific absorbance at the absorption maximum:* 35 to 38 for test solution (a).

*Specific absorbance at the absorption minimum:* 6.0 to 8.0 for test solution (b).

**Acid value** (2.5.1): 101 to 108, determined on 1.00 g.

**Free tocopherol:** maximum 1.0 per cent.

Dissolve 0.500 g in 100 mL of 0.25 M *alcoholic sulfuric acid R*. Add 20 mL of *water R* and 0.1 mL of a 2.5 g/L solution of *diphenylamine R* in *sulfuric acid R*. Titrate with 0.01 M *ammonium and cerium sulfate* until a blue colour is obtained that persists for at least 5 s. Carry out a blank titration.

1 mL of 0.01 M *ammonium and cerium sulfate* is equivalent to 2.154 mg of free tocopherol.

**Related substances**

The thresholds indicated under Related substances (Table 2034-1) in the general monograph *Substances for pharmaceutical use (2034)* do not apply.

**Heavy metals** (2.4.8): maximum 20 ppm.

0.50 g complies with test D. Prepare the reference solution using 1 mL of *lead standard solution (10 ppm Pb) R*.

**Sulfated ash** (2.4.14): maximum 0.1 per cent, determined on 1.0 g.

ASSAY

Gas chromatography (2.2.28).

*Internal standard solution.* Dissolve 0.300 g of *dotriacontane R* in *hexane R* and dilute to 100.0 mL with the same solvent.

*Test solution.* Weigh 30.0 mg of the substance to be examined into a 20 mL vial. Add 2.0 mL of *methanol R*, 1.0 mL of *dimethoxypropane R* and 0.1 mL of *hydrochloric acid R*. Cap tightly and sonicate. Allow to stand in the dark for 1 h  $\pm$  5 min. Remove from the dark, uncap and evaporate just to dryness on a steam bath with the aid of a stream of nitrogen. Add 10.0 mL of the internal standard solution. Vortex into solution.

*Reference solution.* Weigh 30.0 mg of *RRR- $\alpha$ -tocopheryl hydrogen succinate CRS* into a 20 mL vial. Add 2.0 mL of *methanol R*, 1.0 mL of *dimethoxypropane R* and 0.1 mL of *hydrochloric acid R*. Cap tightly and sonicate. Allow to stand in the dark for 1 h  $\pm$  5 min. Remove from the dark, uncap and evaporate just to dryness on a steam bath with the aid of a stream of nitrogen. Add 10.0 mL of the internal standard solution. Vortex into solution.

*Column:*

- *material:* fused silica;
- *size:* *l* = 15 m,  $\varnothing$  = 0.32 mm;
- *stationary phase:* *poly(dimethyl)siloxane R* (film thickness 0.25  $\mu$ m).

*Carrier gas:* *helium for chromatography R*.

*Flow rate:* 3-6 mL/min.

*Split ratio:* 1:10 to 1:20.

*Temperature:*

	Time (min)	Temperature (°C)
Column	0 - 10	200 $\rightarrow$ 250
	10 - 20	250
Injection port		300
Detector		330

*Detection:* flame ionisation.

**Injection:** 1 µL; inject directly onto the column or via a glass-lined injection port using an automatic injection device or some other reproducible injection method.

**System suitability:** reference solution:

- **resolution:** minimum 12.0 between the peaks due to dotriacontane and *RRR*-α-tocopheryl hydrogen succinate.

**Interference test.** Dissolve 0.100 g of the substance to be examined in *hexane R* and dilute to 50.0 mL with the same solvent. Inject 1 µL of the solution and record the chromatogram. If a peak is detected with the same retention time as that of the peak due to dotriacontane, calculate the area of this peak relative to the peak area of the substance to be examined. If the relative peak area is greater than 0.5 per cent, use the corrected peak area  $S'_{D(\text{corr})}$  for the final calculation.

$$S'_{D(\text{corr})} = S'_D - \frac{S_I \times S'_T}{S_{T1}}$$

- $S'_D$  = area of the peak due to dotriacontane in the chromatogram obtained with the test solution;
- $S_I$  = area of the peak with the same retention time as that of the peak due to dotriacontane in the chromatogram obtained in the interference test;
- $S'_T$  = area of the peak due to *RRR*-α-tocopheryl hydrogen succinate in the chromatogram obtained with the test solution;
- $S_{T1}$  = area of the peak due to *RRR*-α-tocopheryl hydrogen succinate in the chromatogram obtained in the interference test.

Measure the areas of the peaks due to *RRR*-α-tocopheryl hydrogen succinate CRS ( $S'_T$ ) and dotriacontane ( $S_D$ ) in the chromatogram obtained with the reference solution and the areas of the peaks due to *RRR*-α-tocopheryl hydrogen succinate ( $S'_T$ ) and dotriacontane ( $S'_D$ ) in the chromatogram obtained with the test solution.

Determine the response factor (RF) for *RRR*-α-tocopheryl hydrogen succinate from the areas of the peaks due to *RRR*-α-tocopheryl hydrogen succinate CRS and dotriacontane in the chromatogram obtained with the reference solution, using the following expression:

$$\frac{S_D \times m_T}{S_T \times m_D}$$

Calculate the percentage content of *RRR*-α-tocopheryl hydrogen succinate using the following expression:

$$\frac{100 \times S'_T \times m_D \times \text{RF}}{S'_{D(\text{corr})} \times m}$$

- $S_D$  = area of the peak due to dotriacontane in the chromatogram obtained with the reference solution;
- $S'_{D(\text{corr})}$  = corrected area of the peak due to dotriacontane in the chromatogram obtained with the test solution;
- $S_T$  = area of the peak due to *RRR*-α-tocopheryl hydrogen succinate CRS in the chromatogram obtained with the reference solution;
- $S'_T$  = area of the peak due to *RRR*-α-tocopheryl hydrogen succinate in the chromatogram obtained with the test solution;
- $m_D$  = mass of dotriacontane in the test solution and in the reference solution, in milligrams;
- $m_T$  = mass of *RRR*-α-tocopheryl hydrogen succinate CRS in the reference solution, in milligrams;
- $m$  = mass of the substance to be examined in the test solution, in milligrams.

## STORAGE

Protected from light.

01/2011:0304

## TOLBUTAMIDE

### Tolbutamidum

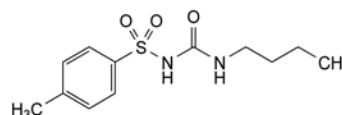

$C_{12}H_{18}N_2O_3S$   
[64-77-7]

$M_r$  270.3

## DEFINITION

1-Butyl-3-[(4-methylphenyl)sulfonyl]urea.

**Content:** 99.0 per cent to 101.0 per cent (dried substance).

## CHARACTERS

**Appearance:** white or almost white, crystalline powder.

**Solubility:** practically insoluble in water, soluble in acetone and in ethanol (96 per cent). It dissolves in dilute solutions of alkali hydroxides.

## IDENTIFICATION

**First identification:** A, C.

**Second identification:** A, B, D.

A. Melting point (2.2.14): 126 °C to 130 °C.

B. Ultraviolet and visible absorption spectrophotometry (2.2.25).

**Test solution (a).** Dissolve 25.0 mg in *methanol R* and dilute to 100.0 mL with the same solvent.

**Test solution (b).** Dilute 10.0 mL of test solution (a) to 250.0 mL with *methanol R*.

**Spectral range:** 245-300 nm for test solution (a); 220-235 nm for test solution (b).

**Absorption maxima:** at 258 nm, 263 nm and 275 nm for test solution (a); at 228 nm for test solution (b).

**Shoulder:** at 268 nm for test solution (a).

**Specific absorbance at the absorption maximum:** 480 to 520 for test solution (b).

C. Infrared absorption spectrophotometry (2.2.24).

**Comparison:** *tolbutamide CRS*.

D. To 0.2 g add 8 mL of a 500 g/L solution of *sulfuric acid R* and heat under a reflux condenser for 30 min. Allow to cool. Crystals are formed which, after recrystallisation from hot *water R* and drying at 105 °C, melt (2.2.14) at 135 °C to 140 °C.

## TESTS

**Appearance of solution.** The solution is clear (2.2.1) and colourless (2.2.2, *Method II*).

Dissolve 0.2 g in 5 mL of *dilute sodium hydroxide solution R* and add 5 mL of *water R*.

**pH (2.2.3):** 4.5 to 5.5.

To 2.0 g add 50 mL of *carbon dioxide-free water R* and heat at 70 °C for 5 min. Cool rapidly and filter.

**Related substances.** Liquid chromatography (2.2.29). Prepare the solutions immediately before use.

**Test solution.** Dissolve 50 mg of the substance to be examined in the mobile phase and dilute to 50.0 mL with the mobile phase.

**Reference solution (a).** Dilute 1.0 mL of the test solution to 100.0 mL with the mobile phase. Dilute 1.0 mL of this solution to 10.0 mL with the mobile phase.

**Reference solution (b).** Dissolve 10 mg of *toluenesulfonamide R* (impurity A) and 10 mg of *toluenesulfonylurea R* (impurity B) in the mobile phase and dilute to 10.0 mL with the mobile phase. Dilute 1.0 mL of this solution to 100.0 mL with the mobile phase.

**Column:**

- size:  $l = 0.25$  m,  $\varnothing = 4.6$  mm;
- stationary phase: *end-capped octadecylsilyl silica gel for chromatography R* (5  $\mu$ m).

**Mobile phase:** mix 35 volumes of *acetonitrile R1* and 65 volumes of a 1.36 g/L solution of *potassium dihydrogen phosphate R* adjusted to pH 3.5 with *phosphoric acid R*.

**Flow rate:** 1.5 mL/min.

**Detection:** spectrophotometer at 230 nm.

**Injection:** 20  $\mu$ L.

**Run time:** 1.5 times the retention time of tolbutamide.

**Identification of impurities:** use the chromatogram obtained with reference solution (b) to identify the peak due to impurities A and B.

**Relative retention** with reference to tolbutamide (retention time = about 18 min): impurity B = about 0.2; impurity A = about 0.3.

**System suitability:** reference solution (b):

- resolution: minimum 2.0 between the peaks due to impurities A and B.

**Limits:**

- *unspecified impurities:* for each impurity, not more than the area of the principal peak in the chromatogram obtained with reference solution (a) (0.10 per cent);
- *total:* not more than 3 times the area of the principal peak in the chromatogram obtained with reference solution (a) (0.3 per cent);
- *disregard limit:* 0.5 times the area of the principal peak in the chromatogram obtained with reference solution (a) (0.05 per cent).

**Heavy metals (2.4.8):** maximum 10 ppm.

Dissolve 1.0 g in a mixture of 15 volumes of *water R* and 85 volumes of *acetone R* and dilute to 20 mL with the same mixture of solvents. 12 mL of the solution complies with test B. Prepare the reference solution using lead standard solution (0.5 ppm Pb) obtained by diluting *lead standard solution (100 ppm Pb) R* with a mixture of 15 volumes of *water R* and 85 volumes of *acetone R*.

**Loss on drying (2.2.32):** maximum 0.5 per cent, determined on 1.000 g by drying in an oven at 105 °C.

**Sulfated ash (2.4.14):** maximum 0.1 per cent, determined on 1.0 g.

**ASSAY**

Dissolve 0.250 g in a mixture of 20 mL of *water R* and 40 mL of *ethanol (96 per cent) R*. Titrate with 0.1 M *sodium hydroxide*, using 1 mL of *phenolphthalein solution R* as indicator.

1 mL of 0.1 M *sodium hydroxide* is equivalent to 27.03 mg of  $C_{12}H_{18}N_2O_3S$ .

**STORAGE**

In an airtight container.

**IMPURITIES**

**Other detectable impurities** (the following substances would, if present at a sufficient level, be detected by one or other of the tests in the monograph. They are limited by the general acceptance criterion for other/unspecified impurities and/or by the general monograph *Substances for pharmaceutical use (2034)*. It is therefore not necessary to identify these impurities for demonstration of compliance. See also 5.10. *Control of impurities in substances for pharmaceutical use*): A, B, C.

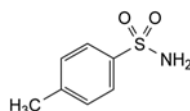

A. (4-methylphenyl)sulfonamide (toluenesulfonamide),

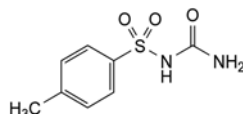

B. 1-[(4-methylphenyl)sulfonyl]urea (toluenesulfonylurea),

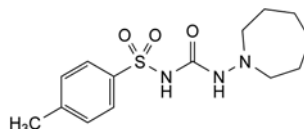

C. 1-azepan-1-yl-3-[(4-methylphenyl)sulfonyl]urea (tolazamide).

01/2008:2039  
corrected 7.0

## TOLFENAMIC ACID

### Acidum tolfenamicum

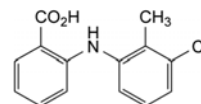

$C_{14}H_{12}ClNO_2$   
[13710-19-5]

$M_r$  261.7

**DEFINITION**

2-[(3-Chloro-2-methylphenyl)amino]benzoic acid.

**Content:** 99.0 per cent to 101.0 per cent (dried substance).

**CHARACTERS**

**Appearance:** white or slightly yellow, crystalline powder.

**Solubility:** practically insoluble in water, soluble in dimethylformamide, sparingly soluble in ethanol and in methylene chloride. It dissolves in dilute solutions of alkali hydroxides.

mp: about 213 °C.

**IDENTIFICATION**

**First identification:** B.

**Second identification:** A, C.

- A. Dissolve 20 mg in a mixture of 1 volume of 1 M *hydrochloric acid* and 99 volumes of *methanol R* and dilute to 100 mL with the same mixture of solvents. Dilute 5.0 mL of the solution to 50 mL with a mixture of 1 volume of 1 M *hydrochloric acid* and 99 volumes of *methanol R*. Examined between 250 nm and 380 nm (2.2.25), the solution shows 2 absorption maxima, at 286 nm and 345 nm. The ratio of the absorbance measured at the maximum at 286 nm to that measured at the maximum at 345 nm is 1.2 to 1.4.

- B. Infrared absorption spectrophotometry (2.2.24).

**Comparison:** *tolfenamic acid CRS*.

- C. Thin-layer chromatography (2.2.27).

**Test solution.** Dissolve 25 mg of the substance to be examined in a mixture of 1 volume of *methanol R* and 3 volumes of *methylene chloride R* and dilute to 10 mL with the same mixture of solvents.

**Reference solution.** Dissolve 25 mg of *tolfenamic acid CRS* in a mixture of 1 volume of *methanol R* and 3 volumes of *methylene chloride R* and dilute to 10 mL with the same mixture of solvents.

**Plate:** TLC silica gel GF<sub>254</sub> plate R.



*Mobile phase:* glacial acetic acid R, dioxan R, toluene R (1:25:90 V/V/V).

*Application:* 10 µL.

*Development:* over 2/3 of the plate.

*Drying:* in a current of warm air.

*Detection:* ultraviolet light at 254 nm.

*Results:* the principal spot in the chromatogram obtained with the test solution is similar in position, colour and size to the principal spot in the chromatogram obtained with the reference solution.

## TESTS

**Related substances.** Liquid chromatography (2.2.29).

*Test solution.* Dissolve 50.0 mg of the substance to be examined in 5 mL of ethanol R and dilute to 50.0 mL with the mobile phase.

*Reference solution (a).* Dissolve 25 mg of 2-chlorobenzoic acid R and 25 mg of 3-chloro-2-methylaniline R in 5 mL of ethanol R and dilute to 50.0 mL with the mobile phase. Dilute 1.0 mL of the solution to 50.0 mL with the mobile phase. Dilute 1.0 mL of this solution to 10.0 mL with the mobile phase.

*Reference solution (b).* Dilute 1.0 mL of the test solution to 10.0 mL with the mobile phase. Dilute 1.0 mL of this solution to 100.0 mL with the mobile phase.

*Column:*

- *size:*  $l = 0.25$  m,  $\varnothing = 4.6$  mm,
- *stationary phase:* spherical end-capped octadecylsilyl silica gel for chromatography R (5 µm) with a specific surface area of 450 m<sup>2</sup>/g and a pore size of 8 nm.

*Mobile phase:* glacial acetic acid R, water R, ethanol R (2:350:650 V/V/V).

*Flow rate:* 0.8 mL/min.

*Detection:* spectrophotometer at 232 nm.

*Injection:* 20 µL.

*Run time:* 3 times the retention time of tolfenamic acid.

*Relative retention* with reference to tolfenamic acid (retention time = about 15 min): impurity A = about 0.25; impurity B = about 0.34.

*System suitability:* reference solution (a):

- *resolution:* minimum 2.5 between the peaks due to impurity A and to impurity B.

*Limits:*

- *impurity A:* not more than the area of the corresponding peak in the chromatogram obtained with reference solution (a) (0.1 per cent),
- *impurity B:* not more than half the area of the corresponding peak in the chromatogram obtained with reference solution (a) (0.05 per cent),
- *any other impurity:* not more than the area of the principal peak in the chromatogram obtained with reference solution (b) (0.1 per cent),
- *total:* not more than 5 times the area of the principal peak in the chromatogram obtained with reference solution (b) (0.5 per cent),
- *disregard limit:* 0.1 times the area of the principal peak in the chromatogram obtained with reference solution (b) (0.01 per cent).

**Copper:** maximum 10 ppm.

Atomic absorption spectrometry (2.2.23, Method I).

*Test solution.* Place 1.00 g of the substance to be examined in a silica crucible, moisten with sulfuric acid R, heat cautiously on a flame for 30 min and then progressively to about 650 ± 50 °C. Continue ignition until all black particles have disappeared. Allow to cool, dissolve the residue in 0.1 M hydrochloric acid and dilute to 25.0 mL with the same acid.

*Reference solutions.* Prepare the reference solutions using copper standard solution (0.1 per cent Cu) R, diluted as necessary using 0.1 M nitric acid.

*Source:* copper hollow-cathode lamp.

*Wavelength:* 324.8 nm.

*Flame:* air-acetylene.

**Loss on drying** (2.2.32): maximum 0.5 per cent, determined on 1.000 g by drying in an oven at 105 °C.

**Sulfated ash** (2.4.14): maximum 0.1 per cent, determined on 1.0 g.

## ASSAY

Dissolve 0.200 g with the aid of ultrasound in 100 mL of ethanol R. Add 0.1 mL of phenol red solution R and titrate with 0.1 M sodium hydroxide.

1 mL of 0.1 M sodium hydroxide is equivalent to 26.17 mg of C<sub>14</sub>H<sub>12</sub>ClNO<sub>2</sub>.

## STORAGE

Protected from light.

## IMPURITIES

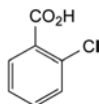

A. 2-chlorobenzoic acid,

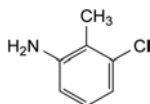

B. 3-chloro-2-methylaniline,

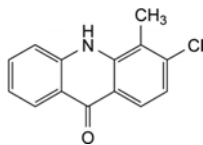

C. 3-chloro-4-methyl-9-oxo-9,10-dihydroacridine.

07/2009:1158

## TOLNAFTATE

### Tolnaftatum

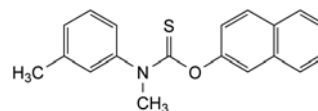

C<sub>19</sub>H<sub>17</sub>NO<sub>2</sub>  
[2398-96-1]

*M*, 307.4

## DEFINITION

*O*-Naphthalen-2-yl methyl(3-methylphenyl)carbamothioate.

*Content:* 97.0 per cent to 103.0 per cent (dried substance).

## CHARACTERS

*Appearance:* white or yellowish-white powder.

*Solubility:* practically insoluble in water, freely soluble in acetone and in methylene chloride, very slightly soluble in ethanol (96 per cent).

## IDENTIFICATION

Infrared absorption spectrophotometry (2.2.24).

*Comparison:* tolnaftate CRS.

## TESTS

**Impurity D.** Liquid chromatography (2.2.29).

**Test solution.** Dissolve 0.400 g of the substance to be examined in 2 mL of *methylene chloride R*. Extract with 3 quantities, each of 3 mL, of 0.01 M *hydrochloric acid*. Combine the aqueous phases and dilute to 10.0 mL with 0.01 M *hydrochloric acid*.

**Reference solution (a).** Dissolve 20.0 mg of *N-methyl-m-toluidine R* (impurity D) in 50.0 mL of *methylene chloride R*.

**Reference solution (b).** Dilute 1.0 mL of reference solution (a) to 100.0 mL with *methylene chloride R*. Take 2.0 mL of this solution and extract with 3 quantities, each of 3 mL, of 0.01 M *hydrochloric acid*. Combine the aqueous phases and dilute to 10.0 mL with 0.01 M *hydrochloric acid*.

**Reference solution (c).** Dissolve 10 mg of the substance to be examined in 25 mL of *methanol R*. Add 2 mL of this solution to 2 mL of reference solution (a) and dilute to 25 mL with *methanol R*.

**Column:**

- size:  $l = 0.15$  m,  $\varnothing = 4.6$  mm;
- stationary phase: octadecylsilyl silica gel for chromatography R (5  $\mu$ m).

**Mobile phase:**

- mobile phase A: trifluoroacetic acid R, *methanol R*, water R (0.1:10:90 V/V/V);
- mobile phase B: trifluoroacetic acid R, water R, *methanol R* (0.1:10:90 V/V/V);

Time (min)	Mobile phase A (per cent V/V)	Mobile phase B (per cent V/V)
0 - 3	70	30
3 - 8	70 → 0	30 → 100
8 - 20	0	100

**Flow rate:** 1.0 mL/min.

**Detection:** spectrophotometer at 254 nm.

**Injection:** 100  $\mu$ L of the test solution and reference solution (b); 10  $\mu$ L of reference solution (c).

**Relative retention** with reference to tolinaftate (retention time = about 15 min): impurity D = about 0.25.

**System suitability:** reference solution (c):

- resolution: minimum 5.0 between the peaks due to impurity D and tolinaftate.

**Limit:**

- impurity D: not more than the area of the principal peak in the chromatogram obtained with reference solution (b) (20 ppm).

**Related substances.** Liquid chromatography (2.2.29).

**Test solution.** Dissolve 25 mg of the substance to be examined in 5 mL of *methanol R* and dilute to 25.0 mL with the same solvent.

**Reference solution (a).** Dilute 1.0 mL of the test solution to 100.0 mL with *methanol R*. Dilute 1.0 mL of this solution to 10.0 mL with *methanol R*.

**Reference solution (b).** Dissolve 5 mg of tolinaftate for system suitability CRS (containing resolution component A) in 5.0 mL of *methanol R*.

**Column:**

- size:  $l = 0.15$  m,  $\varnothing = 4.6$  mm;
- stationary phase: octadecylsilyl silica gel for chromatography R (5  $\mu$ m).

**Mobile phase:**

- mobile phase A: trifluoroacetic acid R, water R, *methanol R* (0.1:30:70 V/V/V);
- mobile phase B: trifluoroacetic acid R, water R, *methanol R* (0.1:10:90 V/V/V);

Time (min)	Mobile phase A (per cent V/V)	Mobile phase B (per cent V/V)
0 - 12	100	0
12 - 30	100 → 0	0 → 100
30 - 33	0	100

**Flow rate:** 1.0 mL/min.

**Detection:** spectrophotometer at 254 nm.

**Injection:** 10  $\mu$ L.

**Relative retention** with reference to tolinaftate (retention time = about 18 min): resolution component A = about 0.7.

**System suitability:** reference solution (b):

- resolution: minimum 5.0 between the peaks due to resolution component A and tolinaftate.

**Limits:**

- unspecified impurities: for each impurity, not more than the area of the principal peak in the chromatogram obtained with reference solution (a) (0.10 per cent);
- total: not more than twice the area of the principal peak in the chromatogram obtained with reference solution (a) (0.2 per cent);
- disregard limit: 0.5 times the area of the principal peak in the chromatogram obtained with reference solution (a) (0.05 per cent).

**Loss on drying** (2.2.32): maximum 0.5 per cent, determined on 1.000 g by drying at 60 °C at a pressure not exceeding 0.7 kPa for 3 h.

**Sulfated ash** (2.4.14): maximum 0.1 per cent, determined on 1.0 g.

## ASSAY

Dissolve 50.0 mg in *methanol R* and dilute to 250.0 mL with the same solvent. Dilute 2.0 mL of this solution to 50.0 mL with *methanol R*. Measure the absorbance (2.2.25) at the absorption maximum at 257 nm.

Calculate the content of C<sub>19</sub>H<sub>17</sub>NOS taking the specific absorbance to be 720.

## STORAGE

Protected from light.

## IMPURITIES

**Specified impurities: D.**

**Other detectable impurities** (the following substances would, if present at a sufficient level, be detected by one or other of the tests in the monograph. They are limited by the general acceptance criterion for other/unspecified impurities and/or by the general monograph *Substances for pharmaceutical use* (2034). It is therefore not necessary to identify these impurities for demonstration of compliance. See also 5.10. *Control of impurities in substances for pharmaceutical use*): A, B.

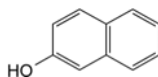

A. naphthalen-2-ol ( $\beta$ -naphthol),

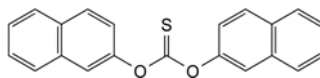

B. O,O-dinaphthalen-2-yl carbonothioate,

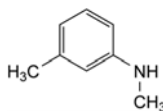

D. N,3-dimethylaniline (*N*-methyl-*m*-toluidine).

01/2008:2132 *System suitability*: reference solution (a):

corrected 6.0

**TORASEMIDE, ANHYDROUS**

## Torasemidum anhydricum

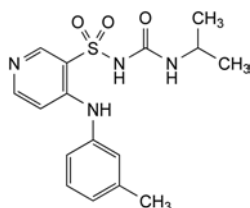
C<sub>16</sub>H<sub>20</sub>N<sub>4</sub>O<sub>3</sub>S  
[56211-40-6]M<sub>r</sub> 348.4

## DEFINITION

1-(1-Methylethyl)-3-[[4-[(3-methylphenyl)amino]pyridin-3-yl]sulfonyl]urea.

*Content*: 99.0 per cent to 101.0 per cent (dried substance).

## CHARACTERS

*Appearance*: white or almost white powder.*Solubility*: practically insoluble in water, slightly soluble in ethanol (96 per cent). It is sparingly soluble in dilute solutions of alkali hydroxides and slightly soluble in dilute acids.

It shows polymorphism (5.9).

## IDENTIFICATION

Infrared absorption spectrophotometry (2.2.24).

*Comparison*: anhydrous torasemide CRS.If the spectra obtained in the solid state show differences, dissolve the substance to be examined and the reference substance separately in *methanol R*, evaporate to dryness and record new spectra using the residues.

## TESTS

**Related substances.** Liquid chromatography (2.2.29).*Solution A.* Dissolve 2.7 g of *potassium dihydrogen phosphate R* in 950 mL of *water R*, adjust to pH 3.5 with *phosphoric acid R* and dilute to 1000 mL with *water R*.*Test solution.* Dissolve 20.0 mg of the substance to be examined in 15 mL of *methanol R*, sonicate for 15 min. Add 22.5 mL of solution A, cool to room temperature and dilute to 50.0 mL with the mobile phase.*Reference solution (a).* Dissolve the contents of a vial of *torasemide for system suitability CRS* (containing impurities A, B, C and D) in 0.5 mL of *methanol R*. Add 0.5 mL of solution A.*Reference solution (b).* Dilute 1.0 mL of the test solution to 100.0 mL with the mobile phase. Dilute 1.0 mL of this solution to 10.0 mL with the mobile phase.*Column*:

- *size*:  $l = 0.125$  m,  $\varnothing = 4.0$  mm;
- *stationary phase*: octadecylsilyl silica gel for chromatography R (5  $\mu$ m);
- *temperature*: 30 °C.

*Mobile phase*: *methanol R*, solution A (40:60 V/V).*Flow rate*: 0.8 mL/min.*Detection*: spectrophotometer at 288 nm.*Injection*: 20  $\mu$ L.*Run time*: 2.5 times the retention time of torasemide.*Relative retention* with reference to torasemide (retention time = about 10 min): impurity A = about 0.3; impurity B = about 0.4; impurity C = about 0.5; impurity D = about 2.3.

- *resolution*: minimum 3.0 between the peaks due to impurity B and impurity C;
- the chromatogram obtained is similar to the chromatogram supplied with *torasemide for system suitability CRS*.

*Limits*:

- *correction factors*: for the calculation of content, multiply the peak areas of the following impurities by the corresponding correction factor: impurity A = 5.1; impurity B = 0.76;
- *impurities A, C, D*: for each impurity, not more than the area of the principal peak in the chromatogram obtained with reference solution (b) (0.1 per cent);
- *impurity B*: not more than 5 times the area of the principal peak in the chromatogram obtained with reference solution (b) (0.5 per cent);
- *any other impurity*: for each impurity, not more than the area of the principal peak in the chromatogram obtained with reference solution (b) (0.1 per cent);
- *total*: not more than 6 times the area of the principal peak in the chromatogram obtained with reference solution (b) (0.6 per cent);
- *disregard limit*: 0.5 times the area of the principal peak in the chromatogram obtained with reference solution (b) (0.05 per cent).

**Heavy metals** (2.4.8): maximum 10 ppm.2.0 g complies with limit test F. Prepare the reference solution using 2 mL of *lead standard solution (10 ppm Pb) R*.**Loss on drying** (2.2.32): maximum 0.5 per cent, determined on 1.000 g by drying in an oven at 105 °C for 3 h.**Sulfated ash** (2.4.14): maximum 0.1 per cent, determined on 1.0 g.

## ASSAY

Dissolve 0.300 g in 50 mL of *anhydrous acetic acid R*. Titrate with 0.1 M *perchloric acid*, determining the end-point potentiometrically (2.2.20).1 mL of 0.1 M *perchloric acid* is equivalent to 34.84 mg of C<sub>16</sub>H<sub>20</sub>N<sub>4</sub>O<sub>3</sub>S.

## STORAGE

Protected from light.

## IMPURITIES

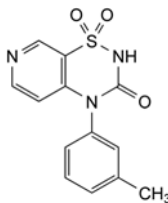
*Specified impurities*: A, B, C, D.

A. 4-(3-methylphenyl)-2H-pyrido[4,3-e]-1,2,4-thiadiazin-3(4H)-one 1,1-dioxide,

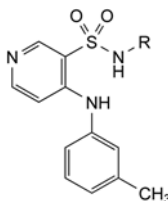

B. R = H: 4-[(3-methylphenyl)amino]pyridine-3-sulfonamide,

C. R = CO-NH-C<sub>2</sub>H<sub>5</sub>: 1-ethyl-3-[[4-[(3-methylphenyl)amino]pyridin-3-yl]sulfonyl]urea,D. R = CO-NH-[CH<sub>2</sub>]<sub>3</sub>-CH<sub>3</sub>: 1-butyl-3-[[4-[(3-methylphenyl)amino]pyridin-3-yl]sulfonyl]urea.

01/2008:0381  
corrected 6.001/2008:1681  
corrected 6.0

## TOSYLCHLORAMIDE SODIUM

## Tosylchloramidum natricum

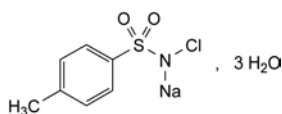
 $C_7H_7ClNaO_2S \cdot 3H_2O$  $M_r$  281.7

## DEFINITION

Sodium *N*-chloro-4-methylbenzenesulfonimide trihydrate.*Content*: 98.0 per cent to 103.0 per cent of  $C_7H_7ClNaO_2S \cdot 3H_2O$ .

## CHARACTERS

*Appearance*: white or slightly yellow, crystalline powder.*Solubility*: freely soluble in water, soluble in ethanol (96 per cent).

## IDENTIFICATION

- Solution S (see Tests) turns *red litmus paper R* blue and then bleaches it.
- To 10 mL of solution S add 10 mL of *dilute hydrogen peroxide solution R*. A white precipitate is formed which dissolves on heating. Filter the hot solution and allow to cool. White crystals are formed which, when washed and dried at 100-105 °C, melt (2.2.14) at 137 °C to 140 °C.
- Ignite cautiously 1 g, because of the risk of deflagration. Dissolve the residue in 10 mL of *water R*. The solution gives reaction (a) of chlorides (2.3.1).
- The solution prepared for identification test C gives reaction (a) of sulfates (2.3.1).
- The solution prepared for identification test C gives reaction (b) of sodium (2.3.1).

## TESTS

**Solution S.** Dissolve 1.0 g in *carbon dioxide-free water R* and dilute to 20 mL with the same solvent.**Appearance of solution.** Solution S is not more opalescent than reference suspension II (2.2.1) and is colourless (2.2.2, *Method II*).**pH** (2.2.3): 8.0 to 10.0 for solution S.**Ortho compound.** To 2 g add 10 mL of *water R*, mix, add 1 g of *sodium metabisulfite R* and heat to boiling. Cool to 0 °C, filter rapidly and wash with 3 quantities, each of 5 mL, of *iced water R*. The precipitate, dried over *diphosphorus pentoxide R* at a pressure not exceeding 600 Pa, melts (2.2.14) at a minimum of 134 °C.**Residue insoluble in anhydrous ethanol:** maximum 2 per cent.Shake 1.00 g with 20 mL of *anhydrous ethanol R* for 30 min, filter on a tared filter, wash any residue with 5 mL of *anhydrous ethanol R* and dry at 100-105 °C. The residue weighs a maximum of 20 mg.

## ASSAY

Dissolve 0.125 g in 100 mL of *water R* in a ground-glass-stoppered flask. Add 1 g of *potassium iodide R* and 5 mL of *dilute sulfuric acid R*. Allow to stand for 3 min. Titrate with 0.1 M *sodium thiosulfate*, using 1 mL of *starch solution R* as indicator.1 mL of 0.1 M *sodium thiosulfate* is equivalent to 14.08 mg of  $C_7H_7ClNaO_2S \cdot 3H_2O$ .

## STORAGE

In an airtight container, protected from light.

## TRAMADOL HYDROCHLORIDE

## Tramadoli hydrochloridum

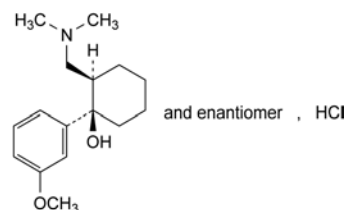
 $C_{16}H_{26}ClNO_2$   
[36282-47-0] $M_r$  299.8

## DEFINITION

(1*S*,2*RS*)-2-[(Dimethylamino)methyl]-1-(3-methoxyphenyl)cyclohexanol hydrochloride.*Content*: 99.0 per cent to 101.0 per cent (anhydrous substance).

## CHARACTERS

*Appearance*: white or almost white, crystalline powder.*Solubility*: freely soluble in water and in methanol, very slightly soluble in acetone.

## IDENTIFICATION

*First identification*: B, D.*Second identification*: A, C, D.

- Melting point (2.2.14): 180 °C to 184 °C.
- Infrared absorption spectrophotometry (2.2.24).  
*Comparison*: tramadol hydrochloride CRS.

C. Chromatograms obtained in the test for impurity E.

*Results*: the principal spot in the chromatogram obtained with test solution (b) is similar in position and size to the principal spot in the chromatogram obtained with reference solution (a).

D. It gives reaction (a) of chlorides (2.3.1).

## TESTS

**Solution S.** Dissolve 1.0 g in *water R* and dilute to 20 mL with the same solvent.**Appearance of solution.** Solution S is clear (2.2.1) and colourless (2.2.2, *Method II*).**Acidity.** To 10 mL of solution S, add 0.2 mL of *methyl red solution R* and 0.2 mL of 0.01 M *hydrochloric acid*. The solution is red. Not more than 0.4 mL of 0.01 M *sodium hydroxide* is required to change the colour of the indicator to yellow.**Optical rotation** (2.2.7):  $-0.10^\circ$  to  $+0.10^\circ$ , determined on solution S.**Impurity E.** Thin-layer chromatography (2.2.27).*Test solution (a).* Dissolve 0.10 g in *methanol R* and dilute to 2 mL with the same solvent.*Test solution (b).* Dilute 1 mL of test solution (a) to 10 mL with *methanol R*.*Reference solution (a).* Dissolve 25 mg of *tramadol hydrochloride CRS* in *methanol R* and dilute to 5 mL with the same solvent.*Reference solution (b).* Dissolve 5 mg of *tramadol impurity E CRS* in 5 mL of *methanol R*. Dilute 1 mL of the solution to 10 mL with *methanol R*.*Reference solution (c).* Dissolve 5 mg of *tramadol impurity A CRS* in 1 mL of reference solution (a).*Plate*: TLC silica gel  $F_{254}$  plate R, prewashed with *methanol R*.

**Mobile phase:** concentrated ammonia R, 2-propanol R, toluene R (1:19:80 V/V/V).

**Application:** 10 µL.

**Development:** over 2/3 of the plate. Saturate the plate for 20 min with concentrated ammonia R. For this, add concentrated ammonia R to one trough of a twin trough tank. Just before developing, add the mobile phase to the other trough. Place the plate in the chromatographic tank, ensuring that the layer of silica gel is orientated towards the middle of the tank.

**Drying:** in air.

**Detection:** expose the plate to iodine vapour for 1 h, examine in ultraviolet light at 254 nm.

**System suitability:** the chromatogram obtained with reference solution (c) shows 2 clearly separated spots.

**Limit:** test solution (a):

- **impurity E:** any spot corresponding to impurity E is not more intense and not greater than the spot in the chromatogram obtained with reference solution (b) (0.2 per cent).

**Related substances.** Liquid chromatography (2.2.29).

**Test solution.** Dissolve 0.15 g of the substance to be examined in the mobile phase and dilute to 100 mL with the mobile phase.

**Reference solution (a).** Dilute 2.0 mL of the test solution to 10.0 mL with the mobile phase. Dilute 1.0 mL of this solution to 100 mL with the mobile phase.

**Reference solution (b).** Dissolve 5 mg of tramadol impurity A CRS in 4.0 mL of the test solution and dilute to 100 mL with the mobile phase.

**Column:**

- **size:**  $l = 0.25$  m,  $\varnothing = 4.0$  mm;
- **stationary phase:** base-deactivated end-capped octylsilyl silica gel for chromatography R (5 µm).

**Mobile phase:** 295 volumes of acetonitrile R and 705 volumes of a mixture of 0.2 mL of trifluoroacetic acid R and 100 mL of water R.

**Flow rate:** 1.0 mL/min.

**Detection:** spectrophotometer at 270 nm.

**Injection:** 20 µL.

**Run time:** 4 times the retention time of tramadol.

**Relative retention** with reference to tramadol (retention time = about 5 min): impurity A = about 0.85.

**System suitability:** reference solution (b):

- **resolution:** minimum 2.0 between the peaks due to impurity A and tramadol.

**Limits:**

- **impurity A:** not more than the area of the principal peak in the chromatogram obtained with reference solution (a) (0.2 per cent);
- **unspecified impurities:** for each impurity, not more than 0.5 times the area of the principal peak in the chromatogram obtained with reference solution (a) (0.10 per cent);
- **total:** not more than twice the area of the principal peak in the chromatogram obtained with reference solution (a) (0.4 per cent);
- **disregard limit:** 0.1 times the area of the principal peak in the chromatogram obtained with reference solution (a) (0.02 per cent).

**Heavy metals** (2.4.8): maximum 20 ppm.

Dissolve 2.0 g in water R and dilute to 20 mL with the same solvent. 12 mL of this solution complies with test A. Prepare the reference solution using lead standard solution (2 ppm Pb) R.

**Water** (2.5.12): maximum 0.5 per cent, determined on 1.000 g.

**Sulfated ash** (2.4.14): maximum 0.1 per cent, determined on 1.0 g.

#### ASSAY

Dissolve 0.180 g in 25 mL of anhydrous acetic acid R and add 10 mL of acetic anhydride R. Titrate with 0.1 M perchloric acid, determining the end-point potentiometrically (2.2.20).

1 mL of 0.1 M perchloric acid is equivalent to 29.98 mg of  $C_{16}H_{26}ClNO_2$ .

#### STORAGE

Protected from light.

#### IMPURITIES

**Specified impurities:** A, E.

**Other detectable impurities** (the following substances would, if present at a sufficient level, be detected by one or other of the tests in the monograph. They are limited by the general acceptance criterion for other/unspecified impurities and/or by the general monograph *Substances for pharmaceutical use* (2034). It is therefore not necessary to identify these impurities for demonstration of compliance. See also 5.10. *Control of impurities in substances for pharmaceutical use*): B, C, D.

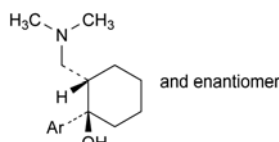
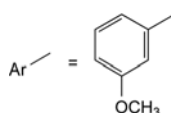

A. (1RS,2SR)-2-[(dimethylamino)methyl]-1-(3-methoxyphenyl)cyclohexanol,

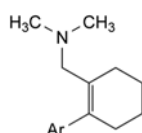

B. [2-(3-methoxyphenyl)cyclohex-1-enyl]-N,N-dimethylmethanamine,

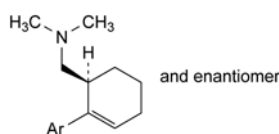

C. (1RS)-[2-(3-methoxyphenyl)cyclohex-2-enyl]-N,N-dimethylmethanamine,

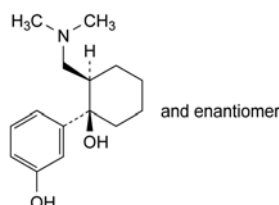

D. (1RS,2RS)-2-[(dimethylamino)methyl]-1-(3-hydroxyphenyl)cyclohexanol,

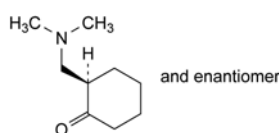

E. (2RS)-2-[(dimethylamino)methyl]cyclohexanone.

01/2008:1597 *Limits:***TRAMAZOLINE HYDROCHLORIDE MONOHYDRATE**

Tramazolini hydrochloridum monohydricum

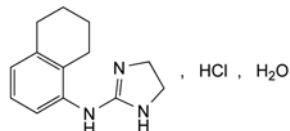
C<sub>13</sub>H<sub>18</sub>ClN<sub>3</sub>·H<sub>2</sub>O  
[74195-73-6]M<sub>r</sub> 269.8**DEFINITION**

N-(5,6,7,8-Tetrahydronaphthalen-1-yl)-4,5-dihydro-1H-imidazol-2-amine hydrochloride monohydrate.

*Content:* 98.5 per cent to 101.5 per cent (anhydrous substance).**CHARACTERS***Appearance:* white or almost white, crystalline powder.*Solubility:* soluble in water and in ethanol (96 per cent).**IDENTIFICATION**

A. Infrared absorption spectrophotometry (2.2.24).

*Comparison:* tramazoline hydrochloride monohydrate CRS.

B. It gives reaction (a) of chlorides (2.3.1).

**TESTS****Solution S.** Dissolve 2.5 g in carbon dioxide-free water R and dilute to 50 mL with the same solvent.**Appearance of solution.** Solution S is clear (2.2.1) and not more intensely coloured than reference solution Y<sub>6</sub> (2.2.2, Method II).**pH** (2.2.3): 4.9 to 6.3 for solution S.**Related substances.** Liquid chromatography (2.2.29).*Test solution.* Dissolve 50.0 mg of the substance to be examined in a mixture of 50 volumes of acetonitrile R and 50 volumes of water R and dilute to 50.0 mL with the same mixture of solvents.*Reference solution (a).* Dissolve 5.0 mg of tramazoline impurity A CRS and 5.0 mg of tramazoline impurity B CRS in 5 mL of a mixture of 50 volumes of acetonitrile R and 50 volumes of water R and add 5 mL of the test solution.*Reference solution (b).* Dilute 0.2 mL of reference solution (a) to 100 mL with a mixture of 50 volumes of acetonitrile R and 50 volumes of water R.*Column:*

- size:  $l = 0.125$  m,  $\varnothing = 4$  mm,
- stationary phase: octadecylsilyl silica gel for chromatography R (5  $\mu$ m).

*Mobile phase:* 2.0 g/L solution of sodium dodecyl sulfate R in a mixture of 6 volumes of 2-propanol R, 42 volumes of acetonitrile R and 52 volumes of water R.*Flow rate:* 1.2 mL/min.*Detection:* spectrophotometer at 215 nm.*Injection:* 5  $\mu$ L.*Run time:* 3 times the retention time of tramazoline.*Relative retention* with reference to tramazoline (retention time = about 6.5 min): impurity A = about 0.71; impurity B = about 0.86.*System suitability:* reference solution (a):

- the chromatogram obtained shows 3 clearly separated peaks,
- resolution: minimum 1.5 between tramazoline and impurity B.

– *impurity A:* not more than 3 times the area of the corresponding peak in the chromatogram obtained with reference solution (b) (0.3 per cent),– *impurity B:* not more than 3 times the area of the corresponding peak in the chromatogram obtained with reference solution (b) (0.3 per cent),– *any other impurity:* not more than the area of the peak due to impurity B in the chromatogram obtained with reference solution (b) (0.1 per cent),– *sum of other impurities:* not more than twice the area of the peak due to impurity B in the chromatogram obtained with reference solution (b) (0.2 per cent),– *disregard limit:* 0.2 times the area of the peak due to impurity B in the chromatogram obtained with reference solution (b) (0.02 per cent).**Water** (2.5.12): 6.2 per cent to 7.2 per cent, determined on 0.500 g.**Sulfated ash** (2.4.14): maximum 0.1 per cent, determined on 1.0 g.**ASSAY**

Dissolve 2.000 g in a mixture of 5 mL of 0.1 M hydrochloric acid and 75 mL of ethanol (96 per cent) R. Carry out a potentiometric titration (2.2.20) using 1 M sodium hydroxide. Read the volume added between the 2 points of inflexion.

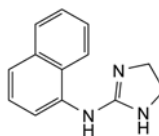
1 mL of 1 M sodium hydroxide is equivalent to 251.8 mg of C<sub>13</sub>H<sub>18</sub>ClN<sub>3</sub>.**IMPURITIES**

A. N-(naphthalen-1-yl)-4,5-dihydro-1H-imidazol-2-amine,

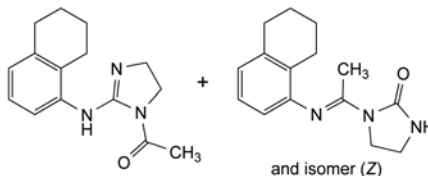

B. mixture of 1-acetyl-N-(5,6,7,8-tetrahydronaphthalen-1-yl)-4,5-dihydro-1H-imidazol-2-amine and 1-[(E)-1-[(5,6,7,8-tetrahydronaphthalen-1-yl)imino]ethyl]imidazolidin-2-one.

01/2008:2245  
corrected 7.0**TRANDOLAPRIL**

Trandolaprilum

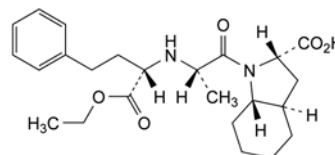
C<sub>24</sub>H<sub>34</sub>N<sub>2</sub>O<sub>5</sub>  
[87679-37-6]M<sub>r</sub> 430.5**DEFINITION**

(2S,3aR,7aS)-1-[(2S)-2-[[[(1S)-1-(Ethoxycarbonyl)-3-phenylpropyl]amino]propanoyl]octahydro-1H-indole-2-carboxylic acid.

*Content:* 99.0 per cent to 101.0 per cent (anhydrous substance).

## CHARACTERS

*Appearance*: white or almost white powder.

*Solubility*: practically insoluble in water, freely soluble in methylene chloride, sparingly soluble in anhydrous ethanol.

## IDENTIFICATION

A. Specific optical rotation (see Tests).

B. Infrared absorption spectrophotometry (2.2.24).

*Comparison*: trandolapril CRS.

## TESTS

**Appearance of solution.** The solution is not more intensely coloured than reference solution Y<sub>7</sub> (2.2.2, Method II).

Dissolve 1.0 g in *methanol R* and dilute to 10 mL with the same solvent.

**Specific optical rotation** (2.2.7): – 16.5 to – 18.5 (anhydrous substance).

Dissolve 1.0 g in *anhydrous ethanol R* and dilute to 50.0 mL with the same solvent.

**Related substances.** Liquid chromatography (2.2.29).

*Test solution.* Dissolve 25.0 mg of the substance to be examined in mobile phase A and dilute to 10.0 mL with mobile phase A.

*Reference solution (a).* Dilute 1.0 mL of the test solution to 10.0 mL with mobile phase A. Dilute 1.0 mL of this solution to 100.0 mL with mobile phase A.

*Reference solution (b).* Dissolve 5 mg of *trandolapril impurity C CRS* and 5 mg of *trandolapril impurity D CRS* in mobile phase A and dilute to 5 mL with mobile phase A. Dilute 1 mL of this solution to 20 mL with mobile phase A.

*Column*:

- *size*:  $l = 0.15$  m,  $\varnothing = 4.6$  mm,
- *stationary phase*: end-capped polar-embedded octadecylsilyl amorphous organosilica polymer R (3.5  $\mu$ m),
- *temperature*: 40 °C.

*Mobile phase*:

- *mobile phase A*: mix 25 volumes of *acetonitrile R*, and 75 volumes of a 6.8 g/L solution of *potassium dihydrogen phosphate R* previously adjusted to pH 2.5  $\pm$  0.1 with *phosphoric acid R*;
- *mobile phase B*: mix equal volumes of *acetonitrile R*, and a 6.8 g/L solution of *potassium dihydrogen phosphate R* previously adjusted to pH 2.2  $\pm$  0.1 with *phosphoric acid R*;

Time (min)	Mobile phase A (per cent V/V)	Mobile phase B (per cent V/V)
0 - 20	95	5
20 - 35	95 $\rightarrow$ 5	5 $\rightarrow$ 95
35 - 45	5	95

*Flow rate*: 1.3 mL/min.

*Detection*: spectrophotometer at 210 nm.

*Injection*: 20  $\mu$ L.

*Relative retention* with reference to trandolapril (retention time = about 14.5 min): impurity C = about 2.1; impurity D = about 2.5.

*System suitability*: reference solution (b):

- *resolution*: minimum 4 between the peaks due to impurity C and impurity D.

*Limits*:

- *correction factor*: for the calculation of content, multiply the peak area of impurity C by 2.2,
- *impurity C*: not more than twice the area of the principal peak in the chromatogram obtained with reference solution (a) (0.2 per cent),
- *impurity D*: not more than 5 times the area of the principal peak in the chromatogram obtained with reference solution (a) (0.5 per cent),
- *unspecified impurities*: for each impurity, not more than the area of the principal peak in the chromatogram obtained with reference solution (a) (0.1 per cent),
- *sum of impurities other than D*: not more than 5 times the area of the principal peak in the chromatogram obtained with reference solution (a) (0.5 per cent),
- *disregard limit*: 0.5 times the area of the principal peak in the chromatogram obtained with reference solution (a) (0.05 per cent).

**Palladium**: maximum 5 ppm.

Atomic absorption spectrometry (2.2.23, Method I).

*Solvent mixture*: *nitric acid R*, *water R* (1:99 V/V).

*Test solution.* To the residue of the test for sulfated ash add 3 mL of *hydrochloric acid R* and 1 mL of *fuming nitric acid R*. Cover the crucible with a watch glass and heat at 160-170 °C for 1 h to dissolve the residue. Afterwards continue heating in the open crucible and evaporate the solution. Stop heating before the residue is completely dried, add 1 mL of *nitric acid R*, heat at 160-170 °C for further 10 min, and after cooling dilute to 10.0 mL with *water R*.

*Reference solutions.* Prepare reference solutions containing 0.5  $\mu$ g, 1.0  $\mu$ g and 1.5  $\mu$ g of Pd per millilitre by diluting *palladium standard solution (500 ppm Pd) R* with the solvent mixture.

*Source*: palladium hollow-cathode lamp.

*Wavelength*: 244.8 nm.

*Atomisation device*: air-acetylene flame.

**Water** (2.5.32): maximum 0.2 per cent, determined on 1.000 g.

**Sulfated ash** (2.4.14): maximum 0.1 per cent, determined on 2.0 g in a porcelain or quartz crucible.

## ASSAY

Dissolve 0.300 g in 50 mL of *anhydrous acetic acid R*. Titrate with 0.1 M *perchloric acid*, determining the end-point potentiometrically (2.2.20).

1 mL of 0.1 M *perchloric acid* is equivalent to 43.05 mg of C<sub>24</sub>H<sub>34</sub>N<sub>2</sub>O<sub>5</sub>.

## STORAGE

Protected from light.

## IMPURITIES

*Specified impurities*: C, D.

*Other detectable impurities* (the following substances would, if present at a sufficient level, be detected by one or other of the tests in the monograph. They are limited by the general acceptance criterion for other/unspecified impurities and/or by the general monograph *Substances for pharmaceutical use* (2034). It is therefore not necessary to identify these impurities for demonstration of compliance. See also 5.10. *Control of impurities in substances for pharmaceutical use*): A, B, E, F.

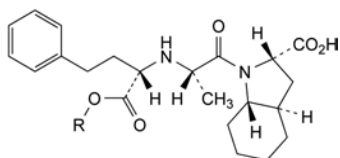

- A. R = CH<sub>3</sub>: (2*S*,3*aR*,7*aS*)-1-[(2*S*)-2-[[1*S*]-1-(methoxycarbonyl)-3-phenylpropyl]amino]propanoyl]octahydro-1*H*-indole-2-carboxylic acid (methyl ester derivative),
- B. R = CH(CH<sub>3</sub>)<sub>2</sub>: (2*S*,3*aR*,7*aS*)-1-[(2*S*)-2-[[1*S*]-1-(1-methylethoxy)carbonyl]-3-phenylpropyl]amino]propanoyl]octahydro-1*H*-indole-2-carboxylic acid (isopropyl ester derivative),
- E. R = H: (2*S*,3*aR*,7*aS*)-1-[(2*S*)-2-[[1*S*]-1-carboxy-3-phenylpropyl]amino]propanoyl]octahydro-1*H*-indole-2-carboxylic acid (trandolaprilate),

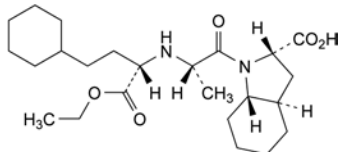

- C. (2*S*,3*aR*,7*aS*)-1-[(2*S*)-2-[[1*S*]-3-cyclohexyl-1-(ethoxycarbonyl)propyl]amino]propanoyl]octahydro-1*H*-indole-2-carboxylic acid (hexahydrotrandolapril),

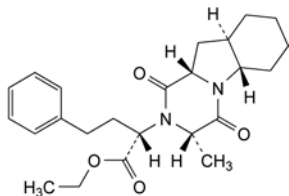

- D. ethyl (2*S*)-2-[(3*S*,5*aS*,9*aR*,10*aS*)-3-methyl-1,4-dioxodecahydropyrazino[1,2-*a*]indol-2(1*H*)-yl]-4-phenylbutanoate (trandolapril diketopiperazine),

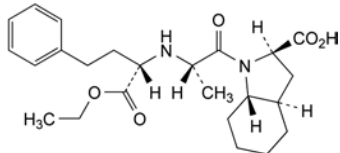

- F. (2*R*,3*aR*,7*aS*)-1-[(2*S*)-2-[[1*S*]-1-(ethoxycarbonyl)-3-phenylpropyl]amino]propanoyl]octahydro-1*H*-indole-2-carboxylic acid.

## IDENTIFICATION

Infrared absorption spectrophotometry (2.2.24).

Preparation: discs.

Comparison: tranexamic acid CRS.

## TESTS

pH (2.2.3): 7.0 to 8.0.

Dissolve 2.5 g in carbon dioxide-free water *R* and dilute to 50 mL with the same solvent.

Related substances. Liquid chromatography (2.2.29).

Test solution. Dissolve 0.20 g of the substance to be examined in water *R* and dilute to 20.0 mL with the same solvent.

Reference solution (a). Dilute 5.0 mL of the test solution to 100.0 mL with water *R*. Dilute 1.0 mL of this solution to 10.0 mL with water *R*.

Reference solution (b). Dissolve 20 mg of tranexamic acid CRS (containing impurity C) in water *R* and dilute to 2 mL with the same solvent.

Reference solution (c). Dissolve 12 mg of 4-aminomethylbenzoic acid *R* (impurity D) in water *R* and dilute to 100 mL with the same solvent. Dilute 1 mL of the solution to 50 mL with water *R*. Dilute 5 mL of this solution to 200 mL with water *R*.

Column:

- size:  $l = 0.25$  m,  $\varnothing = 4.6$  mm or  $l = 0.25$  m,  $\varnothing = 6.0$  mm;
- stationary phase: octadecylsilyl silica gel for chromatography *R* (5  $\mu$ m).

Mobile phase: dissolve 11.0 g of anhydrous sodium dihydrogen phosphate *R* in 500 mL of water *R* and add 5 mL of triethylamine *R* and 1.4 g of sodium laurilsulfate *R*. Adjust to pH 2.5 with dilute phosphoric acid *R* and dilute to 600 mL with water *R*. Add 400 mL of methanol *R* and mix.

Flow rate: 0.9 mL/min.

Detection: spectrophotometer at 220 nm.

Injection: 20  $\mu$ L.

Run time: 3 times the retention time of tranexamic acid.

Identification of impurities: use the chromatogram supplied with tranexamic acid CRS and the chromatogram obtained with reference solution (b) to identify the peak due to impurity C; use the chromatogram obtained with reference solution (c) to identify the peak due to impurity D.

Relative retention with reference to tranexamic acid (retention time = about 13 min): impurity C = about 1.1; impurity D = about 1.3; impurity B = about 1.5; impurity A = about 2.1.

System suitability: reference solution (b):

- resolution: minimum 1.5 between the peaks due to tranexamic acid and impurity C.

Limits:

- correction factors: for the calculation of content, multiply the peak areas of the following impurities by the corresponding correction factor: impurity B = 1.2; impurity C = 0.005; impurity D = 0.006;
- impurity A: not more than 0.2 times the area of the principal peak in the chromatogram obtained with reference solution (a) (0.1 per cent);
- impurity B: not more than 0.4 times the area of the principal peak in the chromatogram obtained with reference solution (a) (0.2 per cent);
- unspecified impurities: for each impurity, not more than 0.2 times the area of the principal peak in the chromatogram obtained with reference solution (a) (0.10 per cent);
- sum of unspecified impurities: not more than 0.4 times the area of the principal peak in the chromatogram obtained with reference solution (a) (0.2 per cent);
- disregard limit: 0.05 times the area of the principal peak in the chromatogram obtained with reference solution (a) (0.025 per cent).

01/2008:0875  
corrected 6.0

## TRANEXAMIC ACID

## Acidum tranexamicum

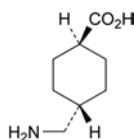

C<sub>8</sub>H<sub>15</sub>NO<sub>2</sub>  
[1197-18-8]

*M*<sub>r</sub> 157.2

## DEFINITION

*trans*-4-(Aminomethyl)cyclohexanecarboxylic acid.

Content: 99.0 per cent to 101.0 per cent (dried substance).

## CHARACTERS

Appearance: white or almost white, crystalline powder.

Solubility: freely soluble in water and in glacial acetic acid, practically insoluble in acetone and in ethanol (96 per cent).



01/2008:1576

**Halides expressed as chlorides (2.4.4):** maximum 140 ppm.

Dissolve 1.2 g in *water R* and dilute to 50 mL with the same solvent.

**Heavy metals (2.4.8):** maximum 10 ppm.

Dissolve 2.0 g in *water R* and dilute to 20 mL with the same solvent. 12 mL of this solution complies with test A. Prepare the reference solution using *lead standard solution (1 ppm Pb) R*.

**Loss on drying (2.2.32):** maximum 0.5 per cent, determined on 1.000 g by drying in an oven at 105 °C for 2 h.

**Sulfated ash (2.4.14):** maximum 0.1 per cent, determined on 1.0 g.

#### ASSAY

Dissolve 0.140 g in 20 mL of *anhydrous acetic acid R*. Titrate with *0.1 M perchloric acid*, determining the end-point potentiometrically (2.2.20).

1 mL of *0.1 M perchloric acid* is equivalent to 15.72 mg of  $C_{10}H_{15}NO_5$ .

#### IMPURITIES

*Specified impurities: A, B.*

*Other detectable impurities* (the following substances would, if present at a sufficient level, be detected by one or other of the tests in the monograph. They are limited by the general acceptance criterion for other/unspecified impurities and/or by the general monograph *Substances for pharmaceutical use (2034)*. It is therefore not necessary to identify these impurities for demonstration of compliance. See also 5.10. *Control of impurities in substances for pharmaceutical use*): *C, D.*

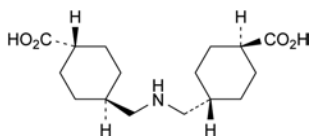

A. *trans,trans*-4,4'-(iminodimethylene)di(cyclohexanecarboxylic acid),

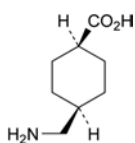

B. *cis*-4-(aminomethyl)cyclohexanecarboxylic acid,

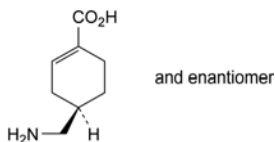

C. (*RS*)-4-(aminomethyl)cyclohex-1-enecarboxylic acid,

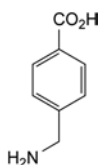

D. 4-aminomethylbenzoic acid.

## TRAPIDIL

### Trapidilum

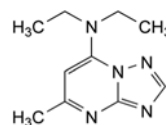

$C_{10}H_{15}N_5$   
[15421-84-8]

$M_r$  205.3

#### DEFINITION

*N,N*-Diethyl-5-methyl-[1,2,4]triazolo[1,5-*a*]pyrimidin-7-amine.

*Content*: 99.0 per cent to 101.0 per cent (dried substance).

#### CHARACTERS

*Appearance*: white or almost white, crystalline powder.

*Solubility*: freely soluble in water, soluble in ethanol and in methylene chloride.

mp: about 102 °C.

#### IDENTIFICATION

Infrared absorption spectrophotometry (2.2.24).

*Comparison*: *trapidil CRS*.

#### TESTS

**Solution S.** Dissolve 2.0 g in *carbon dioxide-free water R* and dilute to 100 mL with the same solvent.

**Appearance of solution.** Solution S is clear (2.2.1) and colourless (2.2.2, *Method II*).

**Acidity or alkalinity.** To 10 mL of solution S add 0.2 mL of *methyl red solution R* and 0.2 mL of *0.01 M hydrochloric acid*. The solution is red. Add 0.4 mL of *0.01 M sodium hydroxide*. The solution is yellow.

**Related substances.** Liquid chromatography (2.2.29).

*Test solution.* Dissolve 20.0 mg of the substance to be examined in the mobile phase and dilute to 10.0 mL with the mobile phase.

*Reference solution (a).* Dissolve 5.0 mg of *trapidil impurity A CRS* in the mobile phase and dilute to 50.0 mL with the mobile phase. Dilute 1.0 mL of the solution to 50.0 mL with the mobile phase.

*Reference solution (b).* Dissolve 5.0 mg of *trapidil impurity B CRS* in the mobile phase and dilute to 50.0 mL with the mobile phase. Dilute 1.0 mL of the solution to 50.0 mL with the mobile phase.

*Reference solution (c).* Mix equal volumes of reference solution (a) and reference solution (b).

*Column*:

- *size*:  $l = 0.125$  m,  $\varnothing = 4.0$  mm,
- *stationary phase*: *base-deactivated octadecylsilyl silica gel for chromatography R (5  $\mu$ m)*,

*Mobile phase*: 50 mL of *methanol R*, 75 mL of *acetonitrile R* and 800 mL of a 1.7 g/L solution of *potassium dihydrogen phosphate R* adjusted to pH 2.45 with *phosphoric acid R*; dilute to 1000 mL with *water R*.

*Flow rate*: 1.0 mL/min.

*Detection*: spectrophotometer at 205 nm.

*Injection*: 10  $\mu$ L.

*Run time*: 3 times the retention time of *trapidil*.

*System suitability*:

- *resolution*: minimum of 4.0 between the peaks due to impurity A and impurity B in the chromatogram obtained with reference solution (c).

07/2010:2297

## Limits:

- *impurity A*: not more than the area of the principal peak in the chromatogram obtained with reference solution (a) (0.1 per cent),
- *impurity B*: not more than the area of the principal peak in the chromatogram obtained with reference solution (b) (0.1 per cent),
- *any other impurity*: not more than the area of the principal peak in the chromatogram obtained with reference solution (a) (0.1 per cent),
- *total*: not more than 5 times the area of the principal peak in the chromatogram obtained with reference solution (a) (0.5 per cent),
- *disregard limit*: 0.1 times the area of the principal peak in the chromatogram obtained with reference solution (a) (0.01 per cent).

**Chlorides** (2.4.4): maximum 100 ppm.

Dissolve 0.25 g in 10 mL of *water R* and dilute to 15 mL with *water R*. The solution complies with the limit test for chlorides. Prepare the standard using 5 mL of *chloride standard solution (5 ppm Cl) R*.

**Ammonium** (2.4.1): maximum 20 ppm.

0.50 g complies with limit test A. Prepare the standard using 0.1 mL of *ammonium standard solution (100 ppm NH<sub>4</sub>) R*.

**Heavy metals** (2.4.8): maximum 10 ppm.

Dissolve 2.0 g in 20 mL of *water R*. 12 mL of the solution complies with limit test A. Prepare the standard using 1 mL of *lead standard solution (10 ppm Pb) R*.

**Loss on drying** (2.2.32): maximum 0.5 per cent, determined on 1.000 g by drying *in vacuo* at 60 °C for 3 h.

**Sulfated ash** (2.4.14): maximum 0.1 per cent, determined on 1.0 g.

## ASSAY

Dissolve 0.180 g in 50 mL of *anhydrous acetic acid R*. Titrate with 0.1 M *perchloric acid*, determining the end-point potentiometrically (2.2.20).

1 mL of 0.1 M *perchloric acid* is equivalent to 20.53 mg of C<sub>10</sub>H<sub>15</sub>N<sub>5</sub>.

## STORAGE

Protected from light.

## IMPURITIES

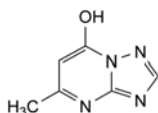

A. 5-methyl-[1,2,4]triazolo[1,5-a]pyrimidin-7-ol,

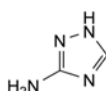

B. 1,2,4-triazol-3-amine.

## TREHALOSE DIHYDRATE

## Trehalosum dihydricum

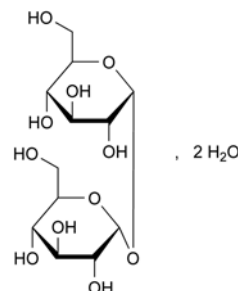

C<sub>12</sub>H<sub>22</sub>O<sub>11</sub>·2H<sub>2</sub>O  
[6138-23-4]

M<sub>r</sub> 378.3

## DEFINITION

α-D-Glucopyranosyl α-D-glucopyranoside dihydrate (α,α-trehalose dihydrate). It is obtained by enzymatic modification of starch.

*Content*: 97.0 per cent to 102.0 per cent (anhydrous substance).

## CHARACTERS

*Appearance*: white or almost white, crystalline powder.

*Solubility*: freely soluble in water, slightly soluble in methanol, practically insoluble in ethanol (96 per cent).

## IDENTIFICATION

A. Infrared absorption spectrophotometry (2.2.24).

*Comparison*: *trehalose dihydrate CRS*.

B. Dissolve 2 g in 5 mL of *water R*. To 1 mL of this solution add 0.4 mL of a 50 g/L solution of α-naphthol *R* in *ethanol (96 per cent) R* and mix thoroughly. Carefully add 2 mL of *sulfuric acid R*. A violet colour develops at the interface.

C. Dissolve 1 g in 25 mL of *water R*. To 2 mL of this solution add 1 mL of *dilute hydrochloric acid R* and mix. Keep the solution for 20 min at room temperature. Add 4 mL of a 40 g/L solution of *sodium hydroxide R* and 2 mL of a 40 g/L solution of *glycine R* and mix. Heat the solution in a water-bath for 10 min. No brown colour develops.

## TESTS

**Solution S**. Dissolve 10.0 g in *carbon dioxide-free water R* prepared from *distilled water R* and dilute to 100.0 mL with the same solvent.

**Appearance of solution**. Solution S is clear (2.2.1) and colourless (2.2.2, *Method II*).

**pH** (2.2.3): 4.5 to 6.5 for solution S.

**Specific optical rotation** (2.2.7): + 197 to + 201 (anhydrous substance), determined on solution S.

**Related substances**. Liquid chromatography (2.2.29).

*Test solution*. Dissolve 0.100 g of the substance to be examined in *water R* and dilute to 10.0 mL with the same solvent.

*Reference solution (a)*. Dissolve 0.100 g of *trehalose dihydrate CRS* in *water R* and dilute to 10.0 mL with the same solvent.

*Reference solution (b)*. Dilute 1.0 mL of the test solution to 100.0 mL with *water R*.

*Reference solution (c)*. Dilute 5.0 mL of reference solution (b) to 25.0 mL with *water R*.

*Reference solution (d)*. Dissolve 25 mg of *glucose R* (impurity A) and 25 mg of *maltotriose R* in *water R*, add 2.5 mL of reference solution (a) and dilute to 10.0 mL with *water R*.

*Column*:

– *size*: *l* = 0.3 m, Ø = 8 mm;

- *stationary phase*: strong cation-exchange resin (sodium form) *R* (6 µm);
  - *temperature*: 80 °C.
- Mobile phase*: water *R*.
- Flow rate*: 0.4 mL/min.
- Detection*: refractometer maintained at 40 °C.
- Injection*: 20 µL of the test solution and reference solutions (b), (c) and (d).
- Run time*: twice the retention time of trehalose.
- Identification of impurities*: use the chromatogram obtained with reference solution (d) to identify the peaks due to impurities A and B; impurity B has the same retention time as maltotriose.
- Relative retention* with reference to trehalose (retention time = about 15 min): impurity B = about 0.9; impurity A = about 1.2.

*System suitability*: reference solution (d):

- *resolution*: minimum 1.5 between the peaks due to maltotriose and trehalose.

*Limits*:

- *impurities A, B*: for each impurity, not more than 0.5 times the area of the principal peak in the chromatogram obtained with reference solution (b) (0.5 per cent);
- *unspecified impurities*: for each impurity, not more than the area of the principal peak in the chromatogram obtained with reference solution (c) (0.2 per cent);
- *total*: not more than the area of the principal peak in the chromatogram obtained with reference solution (b) (1.0 per cent);
- *disregard limit*: 0.5 times the area of the principal peak in the chromatogram obtained with reference solution (c) (0.1 per cent).

**Chlorides** (2.4.4): maximum 125 ppm.

Dilute 4 mL of solution S to 15 mL with water *R*.

**Sulfates** (2.4.13): maximum 200 ppm.

Dilute 7.5 mL of solution S to 15 mL with distilled water *R*.

**Heavy metals** (2.4.8): maximum 5 ppm.

Dissolve 4.0 g in water *R* and dilute to 20 mL with the same solvent. 12 mL of the solution complies with test A. Prepare the reference solution using lead standard solution (1 ppm Pb) *R*.

**Soluble starch**. Dissolve 1 g in 10 mL of water *R*. Add 0.1 mL of iodine solution *R1*. No blue colour develops.

**Water** (2.5.12): 9.0 per cent to 11.0 per cent, determined on 0.10 g.

**Sulfated ash** (2.4.14): maximum 0.1 per cent, determined on 1.0 g.

#### Microbial contamination

If intended for use in the manufacture of parenteral preparations:

- TAMC: acceptance criterion 10<sup>2</sup> CFU/g (2.6.12).

If not intended for use in the manufacture of parenteral preparations:

- TAMC: acceptance criterion 10<sup>3</sup> CFU/g (2.6.12);
- TYMC: acceptance criterion 10<sup>2</sup> CFU/g (2.6.12);
- absence of *Escherichia coli* (2.6.13);
- absence of *Salmonella* (2.6.13).

**Bacterial endotoxins** (2.6.14). If intended for use in the manufacture of parenteral preparations without a further appropriate procedure for the removal of bacterial endotoxins:

- less than 4 IU/g for parenteral preparations having a concentration of 100 g/L or less of trehalose dihydrate;
- less than 2.5 IU/g for parenteral preparations having a concentration of more than 100 g/L of trehalose dihydrate.

#### ASSAY

Liquid chromatography (2.2.29) as described in the test for related substances with the following modification.

*Injection*: test solution and reference solution (a).

Calculate the percentage content of trehalose from the declared content of trehalose dihydrate *CRS*.

#### LABELLING

The label states:

- where applicable, the maximum concentration of bacterial endotoxins;
- where applicable, that the substance is suitable for use in the manufacture of parenteral preparations.

#### IMPURITIES

*Specified impurities*: A, B.

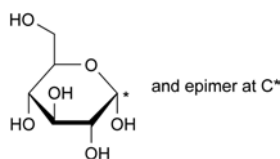

A. (+)-D-glucopyranose (glucose),

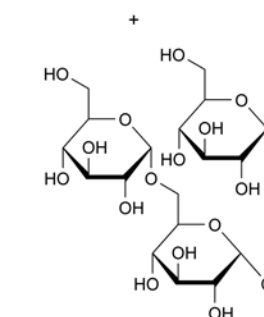
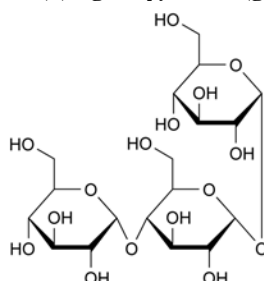

B. oligosaccharides, mainly glucosyltrehalose: mixture of α-D-glucopyranosyl α-D-glucopyranosyl-(1→4)-α-D-glucopyranoside (4-O-glucosyltrehalose or α-D-maltosyl α-D-glucoside) and α-D-glucopyranosyl-(1→6)-α-D-glucopyranosyl α-D-glucopyranoside (6-O-glucosyltrehalose or α-D-isomaltosyl α-D-glucoside).

01/2011:0693

## TRETINOIN

### Tretinoinum

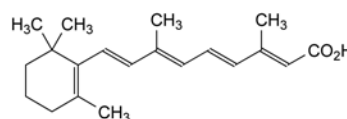

C<sub>20</sub>H<sub>28</sub>O<sub>2</sub>  
[302-79-4]

M<sub>r</sub> 300.4

#### DEFINITION

(2*E*,4*E*,6*E*,8*E*)-3,7-Dimethyl-9-(2,6,6-trimethylcyclohex-1-enyl)nona-2,4,6,8-tetraenoic acid.

*Content*: 98.0 per cent to 102.0 per cent (dried substance).

## CHARACTERS

*Appearance*: yellow or light orange, crystalline powder.

*Solubility*: practically insoluble in water, soluble in methylene chloride, slightly soluble in ethanol (96 per cent).

mp: about 182 °C, with decomposition.

It is sensitive to air, heat and light, especially in solution.

*Carry out all operations as rapidly as possible and avoid exposure to actinic light; use freshly prepared solutions.*

## IDENTIFICATION

*First identification*: A.

*Second identification*: B, C.

A. Infrared absorption spectrophotometry (2.2.24).

*Comparison*: tretinoin CRS.

B. Thin-layer chromatography (2.2.27).

*Test solution*. Dissolve 10 mg of the substance to be examined in *methylene chloride R* and dilute to 10 mL with the same solvent.

*Reference solution*. Dissolve 10 mg of *tretinoin CRS* in *methylene chloride R* and dilute to 10 mL with the same solvent.

*Plate*: TLC silica gel GF<sub>254</sub> plate R.

*Mobile phase*: glacial acetic acid R, acetone R, peroxide-free ether R, cyclohexane R (2:4:40:54 V/V/V/V).

*Application*: 5 µL.

*Development*: over 3/4 of the plate.

*Drying*: in air.

*Detection*: examine in ultraviolet light at 254 nm.

*Results*: the principal spot in the chromatogram obtained with the test solution is similar in position and size to the principal spot in the chromatogram obtained with the reference solution.

C. Dissolve about 5 mg in 2 mL of *antimony trichloride solution R*. An intense red colour develops and later becomes violet.

## TESTS

**Related substances.** Liquid chromatography (2.2.29).

*Test solution*. Dissolve 0.100 g of the substance to be examined in *methanol R* and dilute to 50.0 mL with the same solvent.

*Reference solution (a)*. Dissolve 10.0 mg of *isotretinoin CRS* (impurity A) in *methanol R* and dilute to 10.0 mL with the same solvent.

*Reference solution (b)*. Mix 1.0 mL of reference solution (a) with 0.5 mL of the test solution and dilute to 25.0 mL with *methanol R*.

*Reference solution (c)*. Dilute 0.5 mL of the test solution to 100.0 mL with *methanol R*.

*Column*:

– *size*:  $l = 0.15$  m,  $\varnothing = 4.6$  mm;

– *stationary phase*: octadecylsilyl silica gel for chromatography R (3 µm).

*Mobile phase*: glacial acetic acid R, water R, *methanol R* (5:225:770 V/V/V).

*Flow rate*: 1.0 mL/min.

*Detection*: spectrophotometer at 355 nm.

*Injection*: 10 µL.

*Run time*: 1.2 times the retention time of tretinoin.

*Identification of impurities*: use the chromatogram obtained with reference solution (a) to identify the peak due to impurity A.

*Relative retention* with reference to tretinoin (retention time = about 29 min): impurity A = about 0.75.

*System suitability*: reference solution (b):

– *resolution*: minimum 5.0 between the peaks due to impurity A and tretinoin.

## Limits:

- *impurity A*: not more than the area of the principal peak in the chromatogram obtained with reference solution (c) (0.5 per cent);
- *unspecified impurities*: for each impurity, not more than 0.4 times the area of the principal peak in the chromatogram obtained with reference solution (c) (0.2 per cent);
- *total*: not more than twice the area of the principal peak in the chromatogram obtained with reference solution (c) (1.0 per cent);
- *disregard limit*: 0.1 times the area of the principal peak in the chromatogram obtained with reference solution (c) (0.05 per cent).

The thresholds indicated under Related substances (Table 2034-1) in the general monograph *Substances for Pharmaceutical use (2034)* do not apply.

**Heavy metals (2.4.8)**: maximum 20 ppm.

0.5 g complies with test D. Prepare the reference solution using 1 mL of *lead standard solution (10 ppm Pb) R*.

**Loss on drying (2.2.32)**: maximum 0.5 per cent, determined on 1.000 g by drying *in vacuo* for 16 h.

**Sulfated ash (2.4.14)**: maximum 0.1 per cent, determined on 1.0 g.

## ASSAY

Dissolve 0.200 g in 70 mL of *acetone R*. Titrate with 0.1 M *tetrabutylammonium hydroxide in 2-propanol*, determining the end-point potentiometrically (2.2.20).

1 mL of 0.1 M *tetrabutylammonium hydroxide in 2-propanol* is equivalent to 30.04 mg of C<sub>20</sub>H<sub>28</sub>O<sub>2</sub>.

## STORAGE

Under an inert gas, in an airtight container, protected from light.

It is recommended that the contents of an opened container be used as soon as possible and any unused part be protected by an atmosphere of inert gas.

## IMPURITIES

*Specified impurities*: A.

*Other detectable impurities* (the following substances would, if present at a sufficient level, be detected by one or other of the tests in the monograph. They are limited by the general acceptance criterion for other/unspecified impurities. It is therefore not necessary to identify these impurities for demonstration of compliance. See also 5.10. *Control of impurities in substances for pharmaceutical use*): B, C, D.

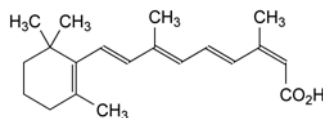

A. (2Z,4E,6E,8E)-3,7-dimethyl-9-(2,6,6-trimethylcyclohex-1-enyl)nona-2,4,6,8-tetraenoic acid (isotretinoin),

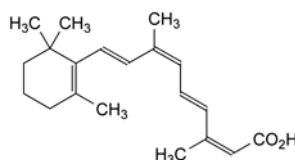

B. (2Z,4E,6Z,8E)-3,7-dimethyl-9-(2,6,6-trimethylcyclohex-1-enyl)nona-2,4,6,8-tetraenoic acid (9,13-dicis-retinoic acid),

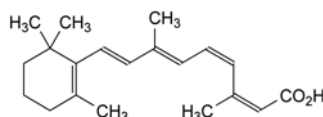

C. (2Z,4Z,6E,8E)-3,7-dimethyl-9-(2,6,6-trimethylcyclohex-1-enyl)nona-2,4,6,8-tetraenoic acid (11,13-dicis-retinoic acid),

01/2008:1376

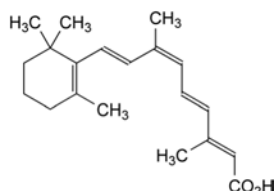

D. (2*E*,4*E*,6*Z*,8*E*)-3,7-dimethyl-9-(2,6,6-trimethylcyclohex-1-enyl)nona-2,4,6,8-tetraenoic acid (9-*cis*-retinoic acid).

01/2008:1106  
corrected 6.0

## TRIACETIN

### Triacetinum

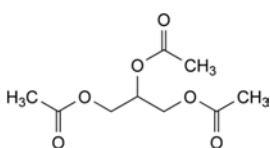

C<sub>9</sub>H<sub>14</sub>O<sub>6</sub>  
[102-76-1]

M<sub>r</sub> 218.2

#### DEFINITION

Propane-1,2,3-triyl triacetate.

*Content*: 97.0 per cent to 100.5 per cent (anhydrous substance).

#### CHARACTERS

*Appearance*: clear, colourless, slightly viscous oily liquid.

*Solubility*: soluble in water, miscible with ethanol (96 per cent) and toluene.

bp: about 260 °C.

#### IDENTIFICATION

Infrared absorption spectrophotometry (2.2.24).

*Comparison*: Ph. Eur. reference spectrum of triacetin.

#### TESTS

**Appearance.** It is clear (2.2.1) and not more intensely coloured than reference solution Y<sub>6</sub> (2.2.2, Method II).

**Acidity.** Dissolve 5.00 g in 25 mL of *anhydrous ethanol R*, previously neutralised to 0.2 mL of *phenolphthalein solution R* and add 0.20 mL of 0.1 M *sodium hydroxide*. The pink colour of the mixture persists for 15 s.

**Relative density** (2.2.5): 1.159 to 1.164.

**Refractive index** (2.2.6): 1.429 to 1.432.

**Water** (2.5.12): maximum 0.2 per cent, determined on 5.00 g.

#### ASSAY

Introduce 0.300 g into a 250 mL borosilicate glass flask fitted with a reflux condenser. Add 25.0 mL of 0.5 M *alcoholic potassium hydroxide* and a few glass beads. Attach the condenser and heat under reflux for 30 min. Add 1 mL of *phenolphthalein solution R1* and titrate immediately with 0.5 M *hydrochloric acid*. Carry out a blank test under the same conditions. Calculate the content from the difference in consumption of alkali in the main and the blank procedure.

1 mL of 0.5 M *alcoholic potassium hydroxide* is equivalent to 36.37 mg of C<sub>9</sub>H<sub>14</sub>O<sub>6</sub>.

#### STORAGE

In a well-filled container.

## TRIAMCINOLONE

### Triamcinolonum

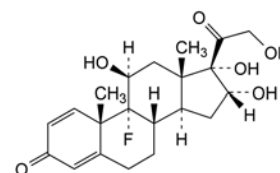

C<sub>21</sub>H<sub>27</sub>FO<sub>6</sub>  
[124-94-7]

M<sub>r</sub> 394.4

#### DEFINITION

9-Fluoro-11β,16α,17,21-tetrahydroxypregna-1,4-diene-3,20-dione.

*Content*: 97.0 per cent to 103.0 per cent (anhydrous substance).

#### CHARACTERS

*Appearance*: white or almost white, crystalline powder.

*Solubility*: practically insoluble in water, slightly soluble in methanol, practically insoluble in methylene chloride.

It shows polymorphism (5.9).

#### IDENTIFICATION

A. Infrared absorption spectrophotometry (2.2.24).

*Comparison*: triamcinolone CRS.

If the spectra obtained show differences, dissolve the substance to be examined and the reference substance separately in *methanol R*, evaporate to dryness, dry the residues at 60 °C at a pressure not exceeding 0.7 kPa and record new spectra using the residues.

B. Thin-layer chromatography (2.2.27). Prepare the solutions immediately before use and protect from light. Examine the plate under ultraviolet light immediately after development.

*Test solution.* Dissolve 10 mg of the substance to be examined in *methanol R* and dilute to 10 mL with the same solvent.

*Reference solution (a).* Dissolve 20 mg of triamcinolone CRS in *methanol R* and dilute to 20 mL with the same solvent.

*Reference solution (b).* Dissolve 10 mg of dexamethasone CRS in reference solution (a) and dilute to 10 mL with the same solution.

*Plate*: TLC silica gel F<sub>254</sub> plate R.

*Mobile phase*: add a mixture of 1.2 volumes of *water R* and 8 volumes of *methanol R* to a mixture of 15 volumes of *ether R* and 77 volumes of *methylene chloride R*.

*Application*: 5 µL.

*Development*: over a path of 15 cm.

*Drying*: in air.

*Detection*: examine in ultraviolet light at 254 nm.

*System suitability*: the chromatogram obtained with reference solution (b) shows 2 clearly separated spots.

*Results*: the principal spot in the chromatogram obtained with the test solution is similar in position and size to the principal spot in the chromatogram obtained with reference solution (a).

#### TESTS

**Specific optical rotation** (2.2.7): + 65 to + 72 (anhydrous substance).

Dissolve 0.100 g in *dimethylformamide R* and dilute to 10.0 mL with the same solvent.

**Related substances.** Liquid chromatography (2.2.29). Prepare the solutions immediately before use and protect from light.

**Test solution.** Dissolve 25.0 mg of the substance to be examined in a mixture of equal volumes of *methanol R* and *water R* and dilute to 10.0 mL with the same mixture of solvents.

**Reference solution (a).** Dissolve 2 mg of *triamcinolone CRS* and 2 mg of *triamcinolone impurity C CRS* in a mixture of equal volumes of *methanol R* and *water R* and dilute to 100.0 mL with the same mixture of solvents.

**Reference solution (b).** Dilute 1.0 mL of the test solution to 100.0 mL with a mixture of equal volumes of *methanol R* and *water R*.

**Blank:** *methanol R*.

**Column:**

- size:  $l = 0.25$  m,  $\varnothing = 4.6$  mm,
- stationary phase: base-deactivated end-capped octadecylsilyl silica gel for chromatography *R* (5  $\mu$ m).

**Mobile phase:** a mixture prepared as follows: in a 1000 mL volumetric flask mix 525 mL of *methanol R* with 400 mL of *water R* and allow to equilibrate; adjust the volume to 1000 mL with *water R* and mix again.

**Flow rate:** 1 mL/min.

**Detection:** spectrophotometer set at 238 nm.

**Injection:** 20  $\mu$ L.

**Run time:** 4.5 times the retention time of triamcinolone.

**Retention time:** triamcinolone = about 11 min.

**System suitability:** reference solution (a):

- resolution: minimum of 1.8 between the peaks due to triamcinolone and to impurity C.

**Limits:**

- any impurity: not more than the area of the principal peak in the chromatogram obtained with reference solution (b) (1 per cent) and not more than 2 such peaks have an area greater than half the area of the principal peak in the chromatogram obtained with reference solution (b) (0.5 per cent),
- total: not more than twice the area of the principal peak in the chromatogram obtained with reference solution (b) (2 per cent),
- disregard limit: 0.05 times the area of the principal peak in the chromatogram obtained with reference solution (b) (0.05 per cent).

**Water (2.5.12):** maximum 1.0 per cent, determined on 0.500 g.

## ASSAY

Prepare the solutions immediately before use and protect from light.

Dissolve 50.0 mg in *alcohol R* and dilute to 50.0 mL with the same solvent. Dilute 2.0 mL of the solution to 100.0 mL with *alcohol R*. Measure the absorbance (2.2.25) at the maximum at 238 nm.

Calculate the content of  $C_{21}H_{27}FO_6$  taking the specific absorbance to be 389.

## STORAGE

Protected from light.

## IMPURITIES

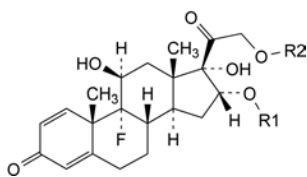

A.  $R_1 = R_2 = CO-CH_3$ : 9-fluoro-11 $\beta$ ,17-dihydroxy-3,20-dioxopregna-1,4-diene-16 $\alpha$ ,21-diyl diacetate (triamcinolone 16,21-diacetate),

B.  $R_1 = H, R_2 = CO-CH_3$ : 9-fluoro-11 $\beta$ ,16 $\alpha$ ,17-trihydroxy-3,20-dioxopregna-1,4-dien-21-yl acetate (triamcinolone 21-acetate),

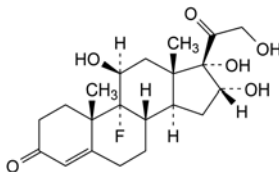

C. 9-fluoro-11 $\beta$ ,16 $\alpha$ ,17,21-tetrahydroxypregn-4-ene-3,20-dione (pretriamcinolone).

01/2008:0533

## TRIAMCINOLONE ACETONIDE

### Triamcinoloni acetonidum

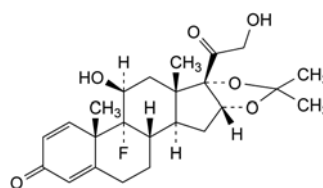

$C_{24}H_{31}FO_6$   
[76-25-5]

$M_r$  434.5

## DEFINITION

9-Fluoro-11 $\beta$ ,21-dihydroxy-16 $\alpha$ ,17-(1-methylethylidenedioxy)pregna-1,4-diene-3,20-dione.

**Content:** 97.0 per cent to 103.0 per cent (anhydrous substance).

## CHARACTERS

**Appearance:** white or almost white, crystalline powder.

**Solubility:** practically insoluble in water, sparingly soluble in ethanol (96 per cent).

It shows polymorphism (5.9).

## IDENTIFICATION

**First identification:** A, B.

**Second identification:** C, D.

A. Infrared absorption spectrophotometry (2.2.24).

**Comparison:** *triamcinolone acetonide CRS*.

If the spectra obtained in the solid state show differences, dissolve the substance to be examined and the reference substance separately in the minimum volume of *methanol R* and evaporate to dryness. Using the residues, prepare halogen salt discs or mulls in *liquid paraffin R* and record new spectra.

B. Thin-layer chromatography (2.2.27). Prepare the solutions immediately before use and protect from light.

**Test solution.** Dissolve 10 mg of the substance to be examined in *methanol R* and dilute to 10 mL with the same solvent.

**Reference solution (a).** Dissolve 20 mg of *triamcinolone acetonide CRS* in *methanol R* and dilute to 20 mL with the same solvent.

**Reference solution (b).** Dissolve 10 mg of *triamcinolone hexacetonide CRS* in reference solution (a) and dilute to 10 mL with reference solution (a).

**Plate:** TLC silica gel  $F_{254}$  plate *R*.

**Mobile phase:** add a mixture of 1.2 volumes of *water R* and 8 volumes of *methanol R* to a mixture of 15 volumes of *ether R* and 77 volumes of *methylene chloride R*.

**Application:** 5  $\mu$ L.

**Development:** over a path of 15 cm.

**Drying:** in air.

**Detection:** examine in ultraviolet light at 254 nm, immediately after development.

**System suitability:** reference solution (b):

- the chromatogram shows 2 clearly separated spots.

**Results:** the principal spot in the chromatogram obtained with the test solution is similar in position and size to the principal spot in the chromatogram obtained with reference solution (a).

C. Thin-layer chromatography (2.2.27). Prepare the solutions immediately before use and protect from light.

**Test solution (a).** Dissolve 10 mg of the substance to be examined in *methanol R* and dilute to 10 mL with the same solvent.

**Test solution (b).** In a separating funnel, dissolve 10 mg of the substance to be examined in 1.5 mL of *glacial acetic acid R*, add 0.5 mL of a 20 g/L solution of *chromium trioxide R* and allow to stand for 60 min. Add 5 mL of *water R*, 2 mL of *methylene chloride R* and shake vigorously for 2 min. Allow to separate and use the lower layer.

**Reference solution (a).** Dissolve 10 mg of *triamcinolone acetonide CRS* in *methanol R* and dilute to 10 mL with the same solvent.

**Reference solution (b).** In a separating funnel, dissolve 10 mg of *triamcinolone acetonide CRS* in 1.5 mL of *glacial acetic acid R*, add 0.5 mL of a 20 g/L solution of *chromium trioxide R* and allow to stand for 60 min. Add 5 mL of *water R*, 2 mL of *methylene chloride R* and shake vigorously for 2 min. Allow to separate and use the lower layer.

**Plate:** TLC silica gel  $F_{254}$  plate *R*.

**Mobile phase:** add a mixture of 1.2 volumes of *water R* and 8 volumes of *methanol R* to a mixture of 15 volumes of *ether R* and 77 volumes of *methylene chloride R*.

**Application:** 5  $\mu$ L.

**Development:** over a path of 15 cm.

**Drying:** in air.

**Detection:** examine in ultraviolet light at 254 nm, immediately after development.

**Results:** the principal spot in each of the chromatograms obtained with the test solutions is similar in position and size to the principal spot in the chromatogram obtained with the corresponding reference solution. The principal spot in the chromatograms obtained with test solution (b) and reference solution (b) has an  $R_f$  value distinctly higher than that of the principal spot in the chromatograms obtained with test solution (a) and reference solution (a).

D. Mix about 5 mg with 45 mg of *heavy magnesium oxide R* and ignite in a crucible until an almost white residue is obtained (usually less than 5 min). Allow to cool, add 1 mL of *water R*, 0.05 mL of *phenolphthalein solution R1* and about 1 mL of *dilute hydrochloric acid R* to render the solution colourless. Filter. To a freshly prepared mixture of 0.1 mL of *alizarin S solution R* and 0.1 mL of *zirconyl nitrate solution R*, add 1.0 mL of the filtrate. Mix, allow to stand for 5 min and compare the colour of the solution to that of a blank prepared in the same manner. The test solution is yellow and the blank is red.

## TESTS

**Specific optical rotation (2.2.7):** + 100 to + 107 (anhydrous substance).

Dissolve 0.100 g in *dioxan R* and dilute to 10.0 mL with the same solvent.

**Related substances.** Liquid chromatography (2.2.29). Carry out the test protected from light.

**Test solution.** Dissolve 25.0 mg of the substance to be examined in 7 mL of *methanol R* and dilute to 10.0 mL with *water R*.

**Reference solution (a).** Dissolve 2 mg of *triamcinolone acetonide CRS* and 2 mg of *triamcinolone R* (impurity A) in the mobile phase and dilute to 100.0 mL with the mobile phase.

**Reference solution (b).** Dilute 1.0 mL of the test solution to 100.0 mL with the mobile phase.

**Column:**

- size:  $l = 0.25$  m,  $\varnothing = 4.6$  mm;
- stationary phase: *octadecylsilyl silica gel for chromatography R* (5  $\mu$ m).

**Mobile phase:** in a 1000 mL volumetric flask mix 525 mL of *methanol R* with 400 mL of *water R* and allow to equilibrate; dilute to 1000 mL with *water R* and mix again.

**Flow rate:** 1.5 mL/min.

**Detection:** spectrophotometer at 254 nm.

**Equilibration:** with the mobile phase for about 10 min.

**Injection:** 20  $\mu$ L.

**Run time:** 3.5 times the retention time of triamcinolone acetonide.

**Retention time:** impurity A = about 5 min; triamcinolone acetonide = about 17 min.

**System suitability:** reference solution (a):

- resolution: minimum 15 between the peaks due to impurity A and triamcinolone acetonide; if necessary, adjust the concentration of methanol in the mobile phase.

**Limits:**

- impurity A: not more than 0.25 times the area of the principal peak in the chromatogram obtained with reference solution (b) (0.25 per cent);
- total: not more than 0.5 times the area of the principal peak in the chromatogram obtained with reference solution (b) (0.5 per cent);
- disregard limit: 0.05 times the area of the principal peak in the chromatogram obtained with reference solution (b) (0.05 per cent).

**Water (2.5.12):** maximum 2.0 per cent, determined on 0.500 g.

## ASSAY

Protect the solutions from light throughout the assay.

Dissolve 50.0 mg in *ethanol (96 per cent) R* and dilute to 50.0 mL with the same solvent. Dilute 2.0 mL of this solution to 100.0 mL with *ethanol (96 per cent) R*. Measure the absorbance (2.2.25) at the absorption maximum at 238.5 nm.

Calculate the content of  $C_{24}H_{31}FO_6$  taking the specific absorbance to be 355.

## STORAGE

Protected from light.

## IMPURITIES

**Specified impurities:** A.

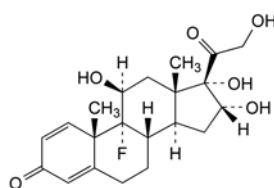

A. 9-fluoro-11 $\beta$ ,16 $\alpha$ ,17,21-tetrahydroxypregna-1,4-diene-3,20-dione (triamcinolone),

01/2008:0867 **Related substances.** Liquid chromatography (2.2.29). Carry out the test protected from light.

## TRIAMCINOLONE HEXACETONIDE

### Triamcinoloni hexacetonidum

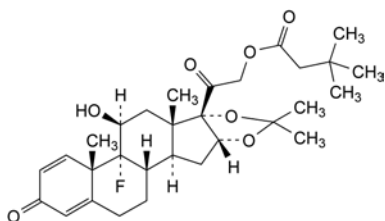

$C_{30}H_{41}FO_7$   
[5611-51-8]

$M_r$  532.6

#### DEFINITION

9-Fluoro-11 $\beta$ -hydroxy-16 $\alpha$ ,17-(1-methylethylidenedioxy)-3,20-dioxopregna-1,4-diene-21-yl 3,3-dimethylbutanoate.

*Content:* 97.0 per cent to 103.0 per cent (anhydrous substance).

#### CHARACTERS

*Appearance:* white or almost white, crystalline powder.

*Solubility:* practically insoluble in water, sparingly soluble in anhydrous ethanol and in methanol.

#### IDENTIFICATION

A. Infrared absorption spectrophotometry (2.2.24).

*Comparison:* triamcinolone hexacetonide CRS.

B. Thin-layer chromatography (2.2.27). Prepare the solutions immediately before use and protect from light.

*Test solution.* Dissolve 10 mg of the substance to be examined in methanol R and dilute to 10 mL with the same solvent.

*Reference solution (a).* Dissolve 20 mg of triamcinolone hexacetonide CRS in methanol R and dilute to 20 mL with the same solvent.

*Reference solution (b).* Dissolve 10 mg of triamcinolone acetonide CRS in reference solution (a) and dilute to 10 mL with reference solution (a).

*Plate:* TLC silica gel  $F_{254}$  plate R.

*Mobile phase:* add a mixture of 1.2 volumes of water R and 8 volumes of methanol R to a mixture of 15 volumes of ether R and 77 volumes of methylene chloride R.

*Application:* 5  $\mu$ L.

*Development:* over a path of 15 cm.

*Drying:* in air.

*Detection:* examine in ultraviolet light at 254 nm, immediately after development.

*System suitability:* reference solution (b):

– the chromatogram shows 2 clearly separated spots.

*Results:* the principal spot in the chromatogram obtained with the test solution is similar in position and size to the principal spot in the chromatogram obtained with reference solution (a).

#### TESTS

**Specific optical rotation** (2.2.7): + 92 to + 98 (anhydrous substance).

Dissolve 0.100 g in methylene chloride R and dilute to 10.0 mL with the same solvent.

*Test solution.* Dissolve 25.0 mg of the substance to be examined in methanol R and dilute to 10.0 mL with the same solvent.

*Reference solution (a).* Dissolve 2 mg of triamcinolone hexacetonide CRS and 2 mg of triamcinolone acetonide CRS (impurity A) in the mobile phase and dilute to 100.0 mL with the mobile phase.

*Reference solution (b).* Dilute 1.0 mL of the test solution to 100.0 mL with the mobile phase.

*Column:*

– size:  $l = 0.25$  m,  $\varnothing = 4.6$  mm;

– stationary phase: octadecylsilyl silica gel for chromatography R (5  $\mu$ m).

*Mobile phase:* in a 1000 mL volumetric flask mix 750 mL of methanol R with 200 mL of water R and allow to equilibrate; dilute to 1000 mL with water R and mix again.

*Flow rate:* 2 mL/min.

*Detection:* spectrophotometer at 254 nm.

*Equilibration:* with the mobile phase for about 10 min.

*Injection:* 20  $\mu$ L.

*Run time:* 3 times the retention time of triamcinolone hexacetonide.

*Retention time:* impurity A = about 3 min; triamcinolone hexacetonide = about 12 min.

*System suitability:* reference solution (a):

– resolution: minimum 20.0 between the peaks due to impurity A and triamcinolone hexacetonide; if necessary, adjust the concentration of methanol in the mobile phase.

*Limits:*

– impurity A: not more than 0.5 times the area of the principal peak in the chromatogram obtained with reference solution (b) (0.5 per cent);

– total: not more than the area of the principal peak in the chromatogram obtained with reference solution (b) (1 per cent);

– disregard limit: 0.05 times the area of the principal peak in the chromatogram obtained with reference solution (b) (0.05 per cent).

**Water** (2.5.12): maximum 2.0 per cent, determined on 0.50 g.

#### ASSAY

Dissolve 50.0 mg in ethanol (96 per cent) R and dilute to 50.0 mL with the same solvent. Dilute 2.0 mL of this solution to 100.0 mL with ethanol (96 per cent) R. Measure the absorbance (2.2.25) at the absorption maximum at 238 nm.

Calculate the content of  $C_{30}H_{41}FO_7$  taking the specific absorbance to be 291.

#### STORAGE

Protected from light.

#### IMPURITIES

*Specified impurities:* A.

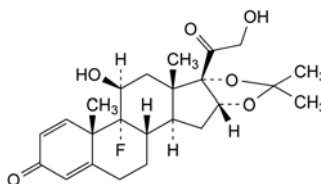

A. 9-fluoro-11 $\beta$ ,21-dihydroxy-16 $\alpha$ ,17-(1-methylethylidenedioxy)pregna-1,4-diene-3,20-dione (triamcinolone acetonide).



04/2008:0058  
corrected 6.3

## TRIAMTERENE

### Triamterenum

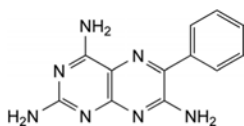

C<sub>12</sub>H<sub>11</sub>N<sub>7</sub>  
[396-01-0]

M<sub>r</sub> 253.3

#### DEFINITION

6-Phenylpteridine-2,4,7-triamine.

Content: 99.0 per cent to 101.0 per cent (dried substance).

#### CHARACTERS

Appearance: yellow, crystalline powder.

Solubility: very slightly soluble in water and in ethanol (96 per cent).

#### IDENTIFICATION

Infrared absorption spectrophotometry (2.2.24).

Comparison: triamterene CRS.

#### TESTS

**Acidity.** Boil 1.0 g with 20 mL of water R for 5 min, cool, filter and wash the filter with 3 quantities, each of 10 mL, of water R. Combine the filtrate and washings and add 0.3 mL of phenolphthalein solution R. Not more than 1.5 mL of 0.01 M sodium hydroxide is required to change the colour of the indicator.

**Impurity D.** Gas chromatography (2.2.28).

**Internal standard solution.** Dilute 0.1 mL of nitrobenzene R to 100 mL with methanol R. Dilute 1 mL of this solution to 50 mL with methanol R.

**Test solution.** Introduce 0.800 g of the substance to be examined into a suitable vial, add 5 mL of dimethyl sulfoxide R and heat until the sample is dissolved (do not heat to boiling). Allow to cool. Add 5 mL of cold methanol R to enhance the precipitation of triamterene. Filter and wash the filter with 5 mL of methanol R. Combine the filtrate and washing, add 2.0 mL of the internal standard solution and dilute to 20.0 mL with methanol R.

**Reference solution.** Dissolve 20.0 mg of benzyl cyanide R (impurity D) in methanol R and dilute to 100.0 mL with the same solvent. Dilute 5.0 mL of the solution to 50.0 mL with methanol R. To 2.0 mL of this solution add 2.0 mL of the internal standard solution and 5 mL of dimethyl sulfoxide R and dilute to 20.0 mL with methanol R.

**Blank solution.** Dilute 5 mL of dimethyl sulfoxide R to 20 mL with methanol R.

Column:

- material: fused silica;
- size:  $l = 30$  m,  $\varnothing = 0.25$  mm;
- stationary phase: macrogol 20 000 R (0.5  $\mu$ m).

Carrier gas: helium for chromatography R.

Flow rate: 1.5 mL/min.

Split ratio: 1:15.

Temperature:

- column: 170 °C;
- injection port: 210 °C;
- detector: 230 °C.

Detection: flame ionisation.

Injection: 1  $\mu$ L.

Run time: twice the retention time of the internal standard.

Relative retention with reference to the internal standard (retention time = about 6 min): impurity D = about 1.6.

System suitability: reference solution:

- resolution: minimum 2.0 between the peak due to impurity D and the nearest peak due to the solvent (blank solution);
- signal-to-noise ratio: minimum 10 for the peak due to impurity D.

Limit:

- impurity D: calculate the ratio ( $R$ ) of the area of the peak due to impurity D to the area of the peak due to the internal standard from the chromatogram obtained with the reference solution; from the chromatogram obtained with the test solution, calculate the ratio of the area of the peak due to impurity D to the area of the peak due to the internal standard: this ratio is not greater than  $R$  (50 ppm).

**Related substances.** Liquid chromatography (2.2.29).

**Test solution.** Dissolve 10.0 mg of the substance to be examined in the mobile phase and dilute to 10.0 mL with the mobile phase.

**Reference solution (a).** Dilute 1.0 mL of the test solution to 100.0 mL with the mobile phase. Dilute 1.0 mL of this solution to 10.0 mL with the mobile phase.

**Reference solution (b).** Dissolve 5.0 mg of nitrosotriaminopyrimidine CRS (impurity A) in the mobile phase and dilute to 100.0 mL with the mobile phase. Dilute 1.0 mL of the solution to 100.0 mL with the mobile phase. Dilute 1.0 mL of this solution to 10.0 mL with the mobile phase.

**Reference solution (c).** Dissolve the contents of a vial of triamterene impurity B CRS in 200  $\mu$ L of dimethyl sulfoxide R. Add 5.0 mL of the test solution and dilute to 50.0 mL with the mobile phase. Filter the solution through a membrane filter (nominal pore size 0.45  $\mu$ m) before injection.

Column:

- size:  $l = 0.25$  m,  $\varnothing = 4.0$  mm;
- stationary phase: spherical end-capped octylsilyl silica gel for chromatography R (5  $\mu$ m).

Mobile phase: butylamine R, acetonitrile R, methanol R, water R (2:200:200:600 V/V/V/V), adjusted to pH 5.3 with acetic acid R.

Flow rate: 1 mL/min.

Detection: spectrophotometer at 320 nm and at 355 nm.

Injection: 50  $\mu$ L.

Relative retention with reference to triamterene (retention time = about 5 min): impurity A = about 0.6; impurity B = about 0.8; impurity C = about 1.7.

System suitability:

- resolution: minimum 1.5 between the peaks due to impurity B and triamterene in the chromatogram obtained with reference solution (c) at 355 nm; if necessary, increase the quantity of water R in the mobile phase;
- signal-to-noise ratio: minimum 10 for the principal peak in the chromatogram obtained with reference solution (b) at 320 nm.

Limits:

- correction factors: for the calculation of content, multiply the peak areas of the following impurities by the corresponding correction factor: impurity B = 1.8; impurity C = 1.5;
- impurity A at 320 nm: not more than the area of the corresponding peak in the chromatogram obtained with reference solution (b) (50 ppm);
- impurities B, C at 355 nm: for each impurity, not more than the area of the principal peak in the chromatogram obtained with reference solution (a) (0.1 per cent);
- unspecified impurities at 355 nm: for each impurity, not more than the area of the principal peak in the chromatogram obtained with reference solution (a) (0.10 per cent);

- *total at 355 nm*: not more than twice the area of the principal peak in the chromatogram obtained with reference solution (a) (0.2 per cent);
- *disregard limit at 355 nm*: 0.5 times the area of the principal peak in the chromatogram obtained with reference solution (a) (0.05 per cent).

**Loss on drying** (2.2.32): maximum 1.0 per cent, determined on 1.000 g by drying in an oven at 105 °C.

**Sulfated ash** (2.4.14): maximum 0.1 per cent, determined on 1.0 g.

#### ASSAY

Dissolve 0.150 g in 5 mL of *anhydrous formic acid R* and add 100 mL of *anhydrous acetic acid R*. Titrate with 0.1 M *perchloric acid*, determining the end-point potentiometrically (2.2.20).

1 mL of 0.1 M *perchloric acid* is equivalent to 25.33 mg of  $C_{12}H_{11}N_7$ .

#### STORAGE

Protected from light.

#### IMPURITIES

*Specified impurities: A, B, C, D.*

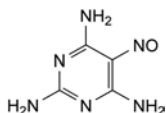

A. 5-nitrosopyrimidine-2,4,6-triamine (nitrosotriaminopyrimidine),

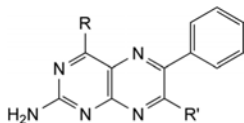

B. R = OH, R' = NH<sub>2</sub>; 2,7-diamino-6-phenylpteridin-4-ol,

C. R = NH<sub>2</sub>, R' = OH; 2,4-diamino-6-phenylpteridin-7-ol,

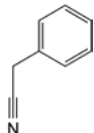

D. phenylacetonitrile (benzyl cyanide).

**Solubility**: practically insoluble in water, very soluble in acetone, in methanol and in methylene chloride.

#### IDENTIFICATION

Infrared absorption spectrophotometry (2.2.24).

*Preparation*: discs.

*Comparison*: *tribenoside CRS*.

#### TESTS

**Solution S**. Dissolve 4.00 g in *methanol R* and dilute to 20 mL with the same solvent.

**Appearance of solution**. Solution S is clear (2.2.1) and its absorbance (2.2.25) at 420 nm has a maximum of 0.10.

**Specific optical rotation** (2.2.7): –31.0 to –40.0.

Dilute 2.0 mL of solution S to 20.0 mL with *methanol R*.

**Related substances**. Liquid chromatography (2.2.29).

*Test solution (a)*. Dissolve 1.000 g of the substance to be examined in a mixture of 5 volumes of *water R* and 95 volumes of *acetonitrile R* and dilute to 25.0 mL with the same mixture of solvents.

*Test solution (b)*. Dissolve 50.0 mg of the substance to be examined in a mixture of 5 volumes of *water R* and 95 volumes of *acetonitrile R* and dilute to 50.0 mL with the same mixture of solvents.

*Reference solution (a)*. Dilute 25.0 mg of *benzaldehyde R* and 30.0 mg of *tribenoside impurity A CRS* to 100.0 mL with *acetonitrile R*. Introduce 20.0 mL of this solution into a 50 mL volumetric flask, add 2.5 mL of *water R* and dilute to 50.0 mL with *acetonitrile R*.

*Reference solution (b)*. Dissolve 50.0 mg of *tribenoside CRS* in a mixture of 5 volumes of *water R* and 95 volumes of *acetonitrile R* and dilute to 50.0 mL with the same mixture of solvents.

*Reference solution (c)*. Dissolve 12.0 mg of *benzyl ether R* in a mixture of 5 volumes of *water R* and 95 volumes of *acetonitrile R* and dilute to 100.0 mL with the same mixture of solvents.

#### Column:

- *size*:  $l = 0.15$  m,  $\varnothing = 4.6$  mm,
- *stationary phase*: octadecylsilyl silica gel for chromatography R (3  $\mu$ m).

#### Mobile phase:

- *mobile phase A*: 0.1 per cent V/V solution of *phosphoric acid R*,
- *mobile phase B*: *acetonitrile R*,

01/2008:1740  
corrected 7.0

## TRIBENOSIDE

### Tribenosidum

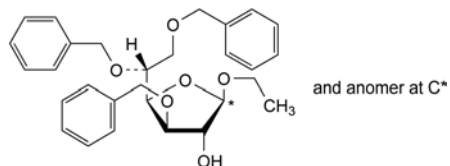

$C_{29}H_{34}O_6$   
[10310-32-4]

$M_r$  478.6

#### DEFINITION

Mixture of  $\alpha$ - and  $\beta$ -anomers of ethyl 3,5,6-tri-*O*-benzyl-D-glucofuranoside.

*Content*: 96.0 per cent to 102.0 per cent.

#### CHARACTERS

*Appearance*: yellowish to pale yellow, clear, viscous liquid.

Time (min)	Mobile phase A (per cent V/V)	Mobile phase B (per cent V/V)
0 - 40	55 → 10	45 → 90
40 - 55	10	90

*Flow rate*: 1.3 mL/min.

*Detection*: spectrophotometer at 254 nm.

*Injection*: 20  $\mu$ L; inject test solution (a) and reference solutions (a), (b) and (c).

*Relative retentions* with reference to the  $\beta$ -anomer of tribenoside (retention time = about 18 min):  $\alpha$ -anomer = about 1.1; impurity C = about 0.2; impurity B = about 0.6; impurity D = about 0.8; impurity A = about 1.4.

*System suitability*: reference solution (b):

- *resolution*: minimum 3.0 between the peaks due to the  $\alpha$ -anomer and to the  $\beta$ -anomer of tribenoside.

#### Limits:

- *impurity A*: not more than 1.7 times the area of the corresponding peak in the chromatogram obtained with reference solution (a) (0.5 per cent),

- *impurity C*: not more than twice the area of the corresponding peak in the chromatogram obtained with reference solution (a) (0.5 per cent); if the area of the peak due to impurity C in the chromatogram obtained with the test solution is greater than the area of the corresponding peak in the chromatogram obtained with reference solution (a) (0.25 per cent), dilute the test solution to obtain an area equal to or smaller than the area of the peak in the chromatogram obtained with reference solution (a); calculate the content of impurity C taking into account the dilution factor;
- *impurity D*: not more than the area of the principal peak in the chromatogram obtained with reference solution (c) (0.3 per cent),
- *any other impurity*: not more than the area of the peak due to impurity A in the chromatogram obtained with reference solution (a) (0.3 per cent),
- *total*: not more than 6.7 times the area of the peak due to impurity A in the chromatogram obtained with reference solution (a) (2.0 per cent),
- *disregard limit*: 0.17 times the area of the peak due to impurity A in the chromatogram obtained with reference solution (a) (0.05 per cent).

**Heavy metals (2.4.8)**: maximum 20 ppm.

Dilute 5.0 mL of solution S to 20.0 mL with *methanol R*. 12 mL of the solution complies with limit test B. Prepare the standard using lead standard solution (1 ppm Pb) obtained by diluting *lead standard solution (100 ppm Pb) R* with *methanol R*.

#### ASSAY

Liquid chromatography (2.2.29) as described in the test for related substances with the following modification.

*Injection*: test solution (b) and reference solution (b).

Calculate the sum of the percentage contents of the  $\alpha$ -anomer and the  $\beta$ -anomer of tribenoside.

#### STORAGE

Under nitrogen, in an airtight container.

#### IMPURITIES

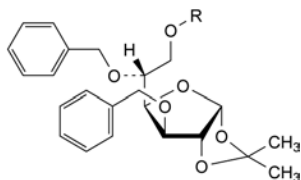

- A. R = CH<sub>2</sub>-C<sub>6</sub>H<sub>5</sub>: 3,5,6-tri-*O*-benzyl-1,2-*O*-(1-methylethylidene)- $\alpha$ -D-glucopyranose,
- B. R = H: 3,5-di-*O*-benzyl-1,2-*O*-(1-methylethylidene)- $\alpha$ -D-glucopyranose,
- C. C<sub>6</sub>H<sub>5</sub>-CHO: benzaldehyde,
- D. C<sub>6</sub>H<sub>5</sub>-CH<sub>2</sub>-O-CH<sub>2</sub>-C<sub>6</sub>H<sub>5</sub>: dibenzyl ether.

01/2009:1770  
corrected 6.6

## TRIBUTYL ACETYLACRYLATE

### Tributylis acetylacrylas

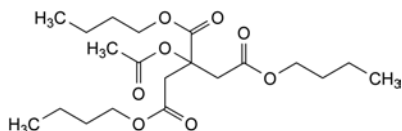

C<sub>20</sub>H<sub>34</sub>O<sub>8</sub>  
[77-90-7]

*M<sub>r</sub>* 402.5

#### DEFINITION

Tributyl 2-(acetyloxy)propane-1,2,3-tricarboxylate.

*Content*: 99.0 per cent to 101.0 per cent (anhydrous substance).

#### CHARACTERS

*Appearance*: clear, oily liquid.

*Solubility*: not miscible with water, miscible with ethanol (96 per cent) and with methylene chloride.

#### IDENTIFICATION

Infrared absorption spectrophotometry (2.2.24).

*Preparation*: thin films between 2 sodium chloride plates.

*Comparison*: *tributyl acetylacrylate CRS*.

#### TESTS

**Appearance.** The substance to be examined is clear (2.2.1) and not more intensely coloured than reference solution BY<sub>6</sub> (2.2.2, *Method II*).

**Acidity.** Dilute 10 g with 10 mL of previously neutralised *ethanol (96 per cent) R* and add 0.5 mL of *bromothymol blue solution R2*. Not more than 0.3 mL of 0.1 M *sodium hydroxide* is required to change the colour of the indicator to blue.

**Refractive index (2.2.6)**: 1.442 to 1.445.

**Related substances.** Gas chromatography (2.2.28).

*Test solution.* Dissolve 0.5 g of the substance to be examined in *methylene chloride R* and dilute to 20 mL with the same solvent.

*Reference solution (a).* Dissolve 50 mg of the substance to be examined and 50 mg of *tributyl citrate R* (impurity A) in *methylene chloride R* and dilute to 20 mL with the same solvent.

*Reference solution (b).* Dilute 1.0 mL of the test solution to 20.0 mL with *methylene chloride R*. Dilute 1.0 mL of this solution to 25.0 mL with *methylene chloride R*.

*Reference solution (c).* Dissolve the contents of a vial of *tributyl acetylacrylate for peak identification CRS* (containing impurities B and C) in 1 mL of *methylene chloride R*.

*Column*:

- *material*: fused silica;
- *size*: *l* = 30 m,  $\varnothing$  = 0.25 mm;
- *stationary phase*: poly[(cyanopropyl)(methyl)-[(phenyl)(methyl)siloxane R (film thickness 0.25  $\mu$ m)].

*Carrier gas*: helium for chromatography R.

*Linear velocity*: 36 cm/s.

*Split ratio*: 1:20.

*Temperature*:

	Time (min)	Temperature (°C)
Column	0 - 7	70 → 210
	7 - 50	210
Injection port		250
Detector		250

*Detection*: flame ionisation.

*Injection*: 1  $\mu$ L; inject via an inert, glass-lined injection port using an automatic injection device.

*Identification of impurities*: use the chromatogram supplied with *tributyl acetylacrylate for peak identification CRS* and the chromatogram obtained with reference solution (c) to identify the peaks due to impurities B and C; use the chromatogram obtained with reference solution (a) to identify the peak due to impurity A.

*Relative retention* with reference to tributyl acetylacrylate (retention time = about 24 min): impurity B = about 0.70; impurity C = about 0.83; impurity A = about 0.87.

*System suitability:*

- *resolution*: minimum 2.0 between the peaks due to impurity A and tributyl acetylacrylate in the chromatogram obtained with reference solution (a);
- *repeatability*: maximum relative standard deviation of 5.0 per cent after 6 injections of reference solution (b).

*Limits:*

- *impurity A*: not more than 3 times the area of the principal peak in the chromatogram obtained with reference solution (b) (0.6 per cent);
- *impurity C*: not more than twice the area of the principal peak in the chromatogram obtained with reference solution (b) (0.4 per cent);
- *impurity B*: not more than the area of the principal peak in the chromatogram obtained with reference solution (b) (0.2 per cent);
- *unspecified impurities*: for each impurity, not more than 0.5 times the area of the principal peak in the chromatogram obtained with reference solution (b) (0.10 per cent);
- *total*: not more than 5 times the area of the principal peak in the chromatogram obtained with reference solution (b) (1.0 per cent);
- *disregard limit*: 0.25 times the area of the principal peak in the chromatogram obtained with reference solution (b) (0.05 per cent).

**Heavy metals** (2.4.8): maximum 10 ppm.

2.0 g complies with test F. Prepare the reference solution using 2 mL of *lead standard solution* (10 ppm Pb) R.

**Water** (2.5.12): maximum 0.25 per cent, determined on 2.00 g.

**Sulfated ash** (2.4.14): maximum 0.1 per cent, determined on 1.0 g.

## ASSAY

Introduce 1.500 g into a 250 mL borosilicate glass flask. Add 25 mL of *2-propanol* R, 50 mL of *water* R, 25.0 mL of *1 M sodium hydroxide* and a few glass beads. Heat under a reflux condenser for 3 h. Allow to cool. Add 1 mL of *phenolphthalein solution* R1 and titrate with *1 M hydrochloric acid*. Carry out a blank titration.

1 mL of *1 M sodium hydroxide* is equivalent to 100.6 mg of C<sub>20</sub>H<sub>34</sub>O<sub>8</sub>.

## IMPURITIES

*Specified impurities: A, B, C.*

*Other detectable impurities* (the following substances would, if present at a sufficient level, be detected by one or other of the tests in the monograph. They are limited by the general acceptance criterion for other/unspecified impurities and/or by the general monograph *Substances for pharmaceutical use* (2034). It is therefore not necessary to identify these impurities for demonstration of compliance. See also 5.10. *Control of impurities in substances for pharmaceutical use*): D, E.

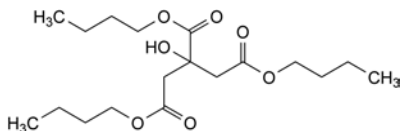

A. tributyl 2-hydroxypropane-1,2,3-tricarboxylate (tributyl citrate),

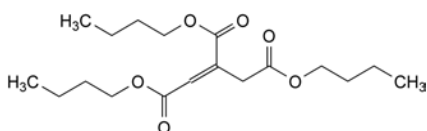

B. tributyl propene-1,2,3-tricarboxylate (tributyl aconitate),

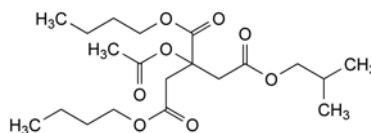

C. 1,2-dibutyl 3-(2-methylpropyl) 2-(acetyloxy)propane-1,2,3-tricarboxylate,



D. R = H: butan-1-ol,

E. R = CO-CH<sub>3</sub>: butyl acetate.

07/2010:1682

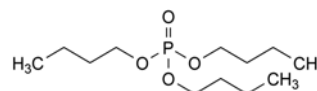
TRI-*n*-BUTYL PHOSPHATETri-*n*-butylis phosphas

C<sub>12</sub>H<sub>27</sub>O<sub>4</sub>P  
[126-73-8]

*M*<sub>r</sub> 266.3

## CHARACTERS

*Appearance*: clear, colourless or pale yellow liquid.

*Solubility*: slightly soluble in water, miscible with ethanol (96 per cent V/V).

bp: about 289 °C, with decomposition.

## IDENTIFICATION

Infrared absorption spectrophotometry (2.2.24).

*Comparison*: tri-*n*-butyl phosphate CRS.

## TESTS

**Appearance.** The substance to be examined is clear (2.2.1) and not more intensely coloured than reference solution Y<sub>6</sub> (2.2.2, Method II).

**Acidity.** Dissolve 50 mL in 50 mL of *ethanol* (96 per cent V/V) R previously adjusted with 0.02 M *potassium hydroxide* or 0.02 M *hydrochloric acid* to a bluish-green colour, using 0.5 mL of *bromothymol blue solution* R1 as indicator. Titrate with 0.02 M *potassium hydroxide* to the initial bluish-green coloration. Not more than 0.8 mL of 0.02 M *potassium hydroxide* is required.

**Related substances.** Gas chromatography (2.2.28): use the normalisation procedure.

*Test solution.* The substance to be examined.

*Reference solution.* Dissolve 10 mg of the substance to be examined and 10 mg of *methyl myristate* R in *methylene chloride* R and dilute to 10 mL with the same solvent.

*Column*:

- *material*: fused silica;
  - *size*: *l* = 30 m, Ø = 0.32 mm;
  - *stationary phase*: poly(dimethyl)siloxane R (5 µm).
- Carrier gas*: helium for chromatography R.

*Linear velocity*: 32 cm/s.

*Split ratio*: 65:1.

*Temperature*:

- *column*: 250 °C;
- *injection port and detector*: 250 °C.

*Detection*: flame ionisation.

*Injection*: 1 µL.

*Run time*: twice the retention time of tri-*n*-butyl phosphate.

*System suitability*: reference solution:

- *resolution*: minimum 10 between the peaks due to tri-*n*-butyl phosphate and methyl myristate.

**Limits:**

- *any impurity*: for each impurity, maximum 0.3 per cent;
- *total*: maximum 0.5 per cent;
- *disregard limit*: 0.01 per cent.

**Chlorides** (2.4.4): maximum 200 ppm.

Dissolve 0.25 g in 15 mL of *ethanol* (70 per cent V/V) R. The solution complies with the test. Prepare the reference solution using 10 mL of *chloride standard solution* (5 ppm Cl) R and 5 mL of *anhydrous ethanol* R.

**Heavy metals** (2.4.8): maximum 20 ppm.

Dissolve 2.0 g in 13 mL of *ethanol* (96 per cent V/V) R and dilute to 20.0 mL with *water* R. 12 mL of the solution complies with test B. Prepare the reference solution using lead standard solution (2 ppm Pb) obtained by diluting *lead standard solution* (100 ppm Pb) R with a mixture of 5 volumes of *water* R and 13 volumes of *ethanol* (96 per cent V/V) R.

**Water** (2.5.32): maximum 0.1 per cent, determined on 1.0 g.

**STORAGE**

Protected from light.

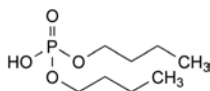
**IMPURITIES**

A. dibutyl hydrogen phosphate,

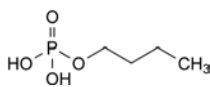

B. butyl dihydrogen phosphate,

C. H<sub>3</sub>C-[CH<sub>2</sub>]<sub>3</sub>-OH: butan-1-ol,

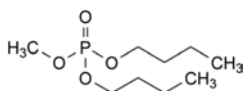

D. dibutyl methyl phosphate,

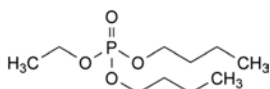

E. dibutyl ethyl phosphate,

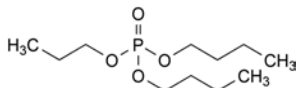

F. dibutyl propyl phosphate,

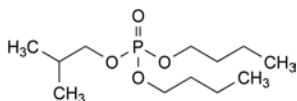

G. dibutyl 2-methylpropyl phosphate,

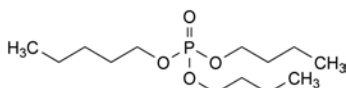

H. dibutyl pentyl phosphate,

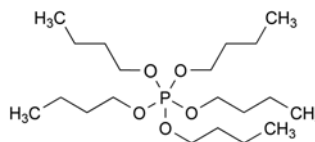

I. pentabutyl phosphate.

01/2008:1967  
corrected 6.0

**TRICHLOROACETIC ACID**

## Acidum trichloroaceticum

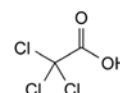

C<sub>2</sub>HCl<sub>3</sub>O<sub>2</sub>  
[76-03-9]

M<sub>r</sub> 163.4

**DEFINITION**

2,2,2-Trichloroacetic acid.

*Content*: 98.0 per cent to 100.5 per cent.

**CHARACTERS**

*Appearance*: white or almost white, crystalline mass or colourless crystals, very deliquescent.

*Solubility*: very soluble in water, in alcohol and in methylene chloride.

**IDENTIFICATION**

*First identification*: A.

*Second identification*: B, C.

A. Infrared absorption spectrophotometry (2.2.24).

*Comparison*: Ph. Eur. reference spectrum of trichloroacetic acid.

B. To 0.5 mL of solution S (see Tests) add 2 mL of *pyridine* R and 5 mL of *strong sodium hydroxide solution* R. Shake vigorously and heat in a water-bath at 60-70 °C for 5 min. The upper layer shows an intense red colour.

C. Solution S is strongly acidic (2.2.4).

**TESTS**

**Solution S**. Dissolve 2.5 g in *water* R and dilute to 25 mL with the same solvent.

**Appearance of solution**. Solution S is clear (2.2.1) and not more intensely coloured than reference solution BY<sub>7</sub> (2.2.2, *Method II*).

**Chlorides** (2.4.4): maximum 100 ppm.

Dilute 5 mL of solution S to 15 mL with *water* R. The solution complies with the limit test for chlorides.

**Sulfated ash** (2.4.14): maximum 0.1 per cent, determined on 1.0 g.

**ASSAY**

Dissolve 0.150 g in 20 mL of *water* R. Titrate with 0.1 M *sodium hydroxide*, determining the end-point potentiometrically (2.2.20).

1 mL of 0.1 M *sodium hydroxide* is equivalent to 16.34 mg of C<sub>2</sub>HCl<sub>3</sub>O<sub>2</sub>.

**STORAGE**

In an airtight container.

01/2008:1479 Retention time: triethyl citrate = about 13.6 min.

System suitability: reference solution:

- resolution: minimum 1.5 between the peaks due to triethyl citrate and methyl tridecanoate.

Limits:

- any impurity: for each impurity, maximum 0.2 per cent;
- total: maximum 0.5 per cent;
- disregard limit: 0.04 per cent.

Heavy metals (2.4.8): maximum 5 ppm.

Dissolve 4.0 g in 8 mL of ethanol (96 per cent) R and dilute to 20 mL with water R. 12 mL of the solution complies with test B. Prepare the reference solution using lead standard solution (1 ppm) obtained by diluting lead standard solution (100 ppm Pb) R with a mixture of equal volumes of ethanol (96 per cent) R and water R.

Water (2.5.12): maximum 0.25 per cent, determined on 1.000 g.

Sulfated ash (2.4.14): maximum 0.1 per cent, determined on 1.0 g.

ASSAY

Introduce 1.500 g into a 250 mL borosilicate-glass flask fitted with a reflux condenser. Add 25 mL of 2-propanol R, 50 mL of water R, 25.0 mL of 1 M sodium hydroxide and a few glass beads. Heat under a reflux condenser for 1 h. Allow to cool. Add 1 mL of phenolphthalein solution R1 and titrate with 1 M hydrochloric acid. Carry out a blank titration.

1 mL of 1 M sodium hydroxide is equivalent to 92.1 mg of C<sub>12</sub>H<sub>20</sub>O<sub>7</sub>.

STORAGE

In an airtight container.

IMPURITIES

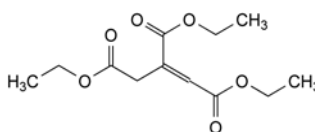

A. triethyl propene-1,2,3-tricarboxylate (triethyl aconitate).

## TRIETHYL CITRATE

### Triethylis citras

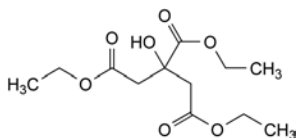
C<sub>12</sub>H<sub>20</sub>O<sub>7</sub>  
[77-93-0]M<sub>r</sub> 276.3

## DEFINITION

Triethyl 2-hydroxypropane-1,2,3-tricarboxylate.

Content: 98.5 per cent to 101.0 per cent (anhydrous substance).

## CHARACTERS

Appearance: clear, viscous, colourless or almost colourless, hygroscopic liquid.

Solubility: soluble in water, miscible with ethanol (96 per cent), slightly soluble in fatty oils.

## IDENTIFICATION

First identification: A, B.

Second identification: A, C, D.

A. Refractive index (see Tests).

B. Infrared absorption spectrophotometry (2.2.24).

Comparison: Ph. Eur. reference spectrum of triethyl citrate.

C. It gives the reaction of esters (2.3.1).

D. To 0.5 mL add 5 mL of ethanol (96 per cent) R and 4 mL of dilute sodium hydroxide solution R. Boil under reflux for about 10 min. 2 mL of the solution gives the reaction of citrates (2.3.1).

## TESTS

Appearance. The substance to be examined is clear (2.2.1) and not more intensely coloured than reference solution BY<sub>6</sub> (2.2.2, Method II).

Acidity. Dilute 10 g with 10 mL of previously neutralised ethanol (96 per cent) R, add 0.5 mL of bromothymol blue solution R2. Not more than 0.3 mL of 0.1 M sodium hydroxide is required to change the colour of the indicator to blue.

Refractive index (2.2.6): 1.440 to 1.446.

Related substances. Gas chromatography (2.2.28): use the normalisation procedure.

Test solution. Dissolve 1.0 mL of the substance to be examined in methylene chloride R and dilute to 50.0 mL with the same solvent.

Reference solution. Dissolve 1.0 mL of the substance to be examined and 0.5 mL of methyl tridecanoate R in methylene chloride R, then dilute to 50.0 mL with the same solvent.

Column:

- material: fused silica;
- size: l = 30 m, Ø = 0.32 mm;
- stationary phase: poly(dimethyl)siloxane R (5 µm).

Carrier gas: helium for chromatography R.

Linear velocity: about 26 cm/s.

Split ratio: about 1:50.

Temperature:

- column: 200 °C;
- injection port and detector: 220 °C.

Detection: flame ionisation.

Injection: 1.0 µL.

Run time: twice the retention time of triethyl citrate.

01/2008:0059  
corrected 6.0

## TRIFLUOPERAZINE HYDROCHLORIDE

### Trifluoperazini hydrochloridum

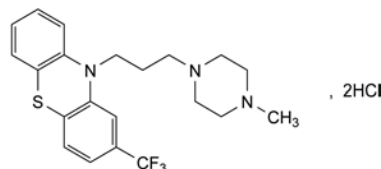
C<sub>21</sub>H<sub>26</sub>Cl<sub>2</sub>F<sub>3</sub>N<sub>3</sub>S  
[440-17-5]M<sub>r</sub> 480.4

## DEFINITION

Trifluoperazine hydrochloride contains not less than 99.0 per cent and not more than the equivalent of 101.0 per cent of 10-[3-(4-methylpiperazin-1-yl)propyl]-2-(trifluoromethyl)-10H-phenothiazine dihydrochloride, calculated with reference to the dried substance.

## CHARACTERS

A white to pale yellow, crystalline powder, hygroscopic, freely soluble in water, soluble in alcohol.

It melts at about 242 °C, with decomposition.

01/2011:1377

## IDENTIFICATION

- A. *Protect the solutions from bright light and measure the absorbances immediately.* Dissolve 50 mg in 0.1 M hydrochloric acid and dilute to 500 mL with the same acid. Examined between 280 nm and 350 nm, the solution shows an absorption maximum (2.2.25) at 305 nm. Dilute 5 mL of the solution to 100 mL with 0.1 M hydrochloric acid. Examined between 230 nm and 280 nm, this solution shows an absorption maximum at 255 nm. The specific absorbance at this maximum is about 650.
- B. It complies with the identification test for phenothiazines by thin-layer chromatography (2.3.3): use trifluoperazine hydrochloride CRS to prepare the reference solution.
- C. Place 0.25 g in a 100 mL separating funnel, add 5 mL of water R and 2 mL of dilute sodium hydroxide solution R. Shake vigorously with 20 mL of ether R. Wash the ether layer with 5 mL of water R, add 0.15 g of maleic acid R and evaporate the ether. The residue, recrystallised from 30 mL of alcohol R and dried, melts (2.2.14) at about 192 °C.
- D. Dissolve about 0.5 mg in 1 mL of water R, add 0.1 mL of bromine water R and shake for about 1 min. Add dropwise 1 mL of sulfuric acid R with constant, vigorous agitation. A red colour develops.
- E. Dissolve about 50 mg in 5 mL of water R and add 2 mL of nitric acid R. A dark-red colour develops which turns to pale yellow. The solution gives reaction (a) of chlorides (2.3.1).

## TESTS

**pH** (2.2.3). Dissolve 2.0 g in carbon dioxide-free water R and dilute to 20 mL with the same solvent. The pH of the solution is 1.6 to 2.5.

**Related substances.** Carry out the test protected from bright light.

Examine by thin-layer chromatography (2.2.27), using a TLC silica gel GF<sub>254</sub> plate R.

**Test solution.** Dissolve 0.2 g of the substance to be examined in a mixture of 5 volumes of diethylamine R and 95 volumes of methanol R and dilute to 10 mL with the same mixture of solvents. Prepare immediately before use.

**Reference solution.** Dilute 1 mL of the test solution to 200 mL with a mixture of 5 volumes of diethylamine R and 95 volumes of methanol R.

Apply to the plate 10 µL of each solution. Develop over a path of 12 cm using a mixture of 10 volumes of acetone R, 10 volumes of diethylamine R and 80 volumes of cyclohexane R. Allow the plate to dry in air and examine in ultraviolet light at 254 nm. Any spot in the chromatogram obtained with the test solution, apart from the principal spot, is not more intense than the spot in the chromatogram obtained with the reference solution (0.5 per cent).

**Loss on drying** (2.2.32). Not more than 1.5 per cent, determined on 1.000 g by drying in an oven at 105 °C.

**Sulfated ash** (2.4.14). Not more than 0.1 per cent, determined on 1.0 g.

## ASSAY

Dissolve 0.200 g in 50 mL of alcohol R and add 5.0 mL of 0.01 M hydrochloric acid. Carry out a potentiometric titration (2.2.20), using 0.1 M sodium hydroxide. Read the volume added between the 2 points of inflexion.

1 mL of 0.1 M sodium hydroxide is equivalent to 48.04 mg of C<sub>10</sub>H<sub>7</sub>F<sub>3</sub>O<sub>4</sub>.

## STORAGE

Store in an airtight container, protected from light.

## TRIFLUSAL

## Triflusalum

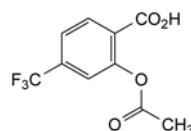

C<sub>10</sub>H<sub>7</sub>F<sub>3</sub>O<sub>4</sub>  
[322-79-2]

M<sub>r</sub> 248.2

## DEFINITION

2-(Acetyloxy)-4-(trifluoromethyl)benzoic acid.

**Content:** 98.5 per cent to 101.5 per cent (dried substance).

## CHARACTERS

**Appearance:** white or almost white, crystalline powder.

**Solubility:** practically insoluble in water, very soluble in anhydrous ethanol, freely soluble in methylene chloride.

mp: about 118 °C, with decomposition.

## IDENTIFICATION

Infrared absorption spectrophotometry (2.2.24).

**Comparison:** triflusal CRS.

## TESTS

**Related substances.** Liquid chromatography (2.2.29).

**Test solution.** Dissolve 0.200 g of the substance to be examined in acetonitrile R and dilute to 20.0 mL with the same solvent. Prepare the solution immediately before use.

**Reference solution (a).** Dissolve 5.0 mg of triflusal impurity B CRS in acetonitrile R and dilute to 10.0 mL with the same solvent.

**Reference solution (b).** Dilute 1.0 mL of reference solution (a) to 25.0 mL with acetonitrile R.

**Reference solution (c).** Dissolve 2.5 mg of the substance to be examined in acetonitrile R, add 5 mL of reference solution (a) and dilute to 10.0 mL with acetonitrile R. Prepare the solution immediately before use.

## Column:

- size:  $l = 0.15$  m,  $\varnothing = 4.0$  mm;
- stationary phase: end-capped octadecylsilyl silica gel for chromatography R (4-5 µm).

## Mobile phase:

- mobile phase A: 0.5 per cent V/V solution of phosphoric acid R;
- mobile phase B: acetonitrile R;

Time (min)	Mobile phase A (per cent V/V)	Mobile phase B (per cent V/V)
0 - 20	80 → 30	20 → 70
20 - 25	30	70

**Flow rate:** 1.2 mL/min.

**Detection:** spectrophotometer at 237 nm.

**Injection:** 10 µL of the test solution and reference solutions (b) and (c).

**Identification of impurities:** use the chromatogram obtained with reference solution (b) to identify the peak due to impurity B.

**Relative retention** with reference to triflusal (retention time = about 11 min): impurity B = about 1.2.

**System suitability:** reference solution (c):

- resolution: minimum 3.0 between the peaks due to triflusal and impurity B.

01/2010:0868

## Limits:

- *impurity B*: not more than 1.5 times the area of the corresponding peak in the chromatogram obtained with reference solution (b) (0.3 per cent);
- *unspecified impurities*: for each impurity, not more than 0.5 times the area of the peak due to impurity B in the chromatogram obtained with reference solution (b) (0.10 per cent);
- *sum of impurities other than B*: not more than 0.5 times the area of the peak due to impurity B in the chromatogram obtained with reference solution (b) (0.1 per cent);
- *disregard limit*: 0.25 times the area of the peak due to impurity B in the chromatogram obtained with reference solution (b) (0.05 per cent).

**Heavy metals** (2.4.8): maximum 10 ppm.

Dissolve 2.0 g in 12 mL of *ethanol* (96 per cent) R and dilute to 20 mL with *water* R. 12 mL of the solution complies with test B. Prepare the reference solution using lead standard solution (1 ppm Pb) obtained by diluting *lead standard solution* (100 ppm Pb) R with a mixture of 2 volumes of *water* R and 3 volumes of *ethanol* (96 per cent) R.

**Loss on drying** (2.2.32): maximum 0.5 per cent, determined on 1.000 g by drying *in vacuo*.

**Sulfated ash** (2.4.14): maximum 0.1 per cent, determined on 1.0 g in a platinum crucible.

## ASSAY

Dissolve 0.200 g in 50 mL of *anhydrous ethanol* R. Titrate with 0.1 M *sodium hydroxide*, determining the end-point potentiometrically (2.2.20).

1 mL of 0.1 M *sodium hydroxide* is equivalent to 24.82 mg of  $C_{10}H_7F_3O_4$ .

## STORAGE

In an airtight container, at a temperature not exceeding 25 °C.

## IMPURITIES

*Specified impurities*: B.

*Other detectable impurities* (the following substances would, if present at a sufficient level, be detected by one or other of the tests in the monograph. They are limited by the general acceptance criterion for other/unspecified impurities and/or by the general monograph *Substances for pharmaceutical use* (2034). It is therefore not necessary to identify these impurities for demonstration of compliance. See also 5.10. *Control of impurities in substances for pharmaceutical use*): A, C, D.

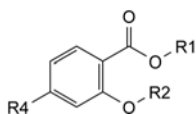

- A. R1 = H, R2 = CO-CH<sub>3</sub>, R4 = CO<sub>2</sub>H: 2-(acetyloxy)benzene-1,4-dicarboxylic acid (2-acetoxyterephthalic acid),
- B. R1 = R2 = H, R4 = CF<sub>3</sub>: 2-hydroxy-4-(trifluoromethyl)benzoic acid (4-(trifluoromethyl)salicylic acid),
- C. R1 = R2 = CO-CH<sub>3</sub>, R4 = CF<sub>3</sub>: acetic 2-(acetyloxy)-4-(trifluoromethyl)benzoic anhydride,

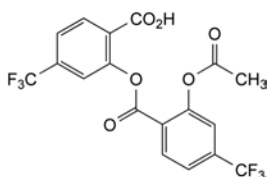

- D. 2-[[2-(acetyloxy)-4-(trifluoromethyl)benzoyl]oxy]-4-(trifluoromethyl)benzoic acid.

## TRIGLYCERIDES, MEDIUM-CHAIN

## Triglycerida saturata media

## DEFINITION

Mixture of triglycerides of saturated fatty acids, mainly of caprylic (octanoic) acid and of capric (decanoic) acid. The fatty acids are obtained from the oil extracted from the hard, dried fraction of the endosperm of *Cocos nucifera* L. or from the dried endosperm of *Elaeis guineensis* Jacq.

*Content*: minimum 95.0 per cent of saturated fatty acids with 8 and 10 carbon atoms.

## CHARACTERS

*Appearance*: colourless or slightly yellowish, oily liquid.

*Solubility*: practically insoluble in water, miscible with ethanol (96 per cent), with methylene chloride, with light petroleum and with fatty oils.

## IDENTIFICATION

*First identification*: B, C.

*Second identification*: A, D.

- A. Heat 3.0 g under a reflux condenser for 30 min with 50 mL of a mixture of equal volumes of *ethanol* (96 per cent) R and 2 M *alcoholic potassium hydroxide* R. Reserve 10 mL of the mixture for identification test D. To 40 mL of the mixture add 30 mL of *water* R, evaporate the ethanol and acidify the hot solution with 25 mL of *dilute hydrochloric acid* R. After cooling, shake with 50 mL of *peroxide-free ether* R. Wash the ether layer with 3 quantities, each of 10 mL, of *sodium chloride solution* R, dry over *anhydrous sodium sulfate* R and filter. Evaporate the ether and determine the acid value (2.5.1) of the residue, using 0.300 g. The acid value is 350 to 390.
- B. Saponification value (see Tests).
- C. Composition of fatty acids (see Tests).
- D. Evaporate 10 mL of the alcoholic mixture obtained in identification test A to dryness on a water-bath. Transfer the residue into a test-tube, add 0.3 mL of *sulfuric acid* R and close the test-tube with a stopper through which a U-shaped glass tube is inserted. One end of the U-tube is dipped into 3 mL of a 10 g/L solution of *tryptophan* R in a mixture of equal volumes of *sulfuric acid* R and *water* R. Heat the test-tube in a silicone-oil bath at 180 °C for 10 min and collect the liberated fumes in the tryptophan reagent. Heat the tryptophan reagent on a water-bath for 1 min. A violet colour develops.

## TESTS

**Appearance**. The substance to be examined is clear (2.2.1) and not more intensely coloured than reference solution Y<sub>3</sub> (2.2.2, *Method I*).

**Alkaline impurities**. Dissolve 2.00 g in a mixture of 1.5 mL of *ethanol* (96 per cent) R and 3.0 mL of *ether* R. Add 0.05 mL of *bromophenol blue solution* R. Not more than 0.15 mL of 0.01 M *hydrochloric acid* is required to change the colour of the indicator to yellow.

**Relative density** (2.2.5): 0.93 to 0.96.

**Refractive index** (2.2.6): 1.440 to 1.452.

**Viscosity** (2.2.9): 25 mPas to 33 mPas.

**Acid value** (2.5.1): maximum 0.2.

**Hydroxyl value** (2.5.3, *Method A*): maximum 10.

**Iodine value** (2.5.4): maximum 1.0.

**Peroxide value** (2.5.5, *Method A*): maximum 1.0.

**Saponification value** (2.5.6): 310 to 360.



**Unsaponifiable matter** (2.5.7): maximum 0.5 per cent, determined on 5.0 g.

**Composition of fatty acids.** Gas chromatography (2.4.22, Method C).

**Column:**

- *material*: fused silica;
- *size*:  $l = 30$  m,  $\varnothing = 0.32$  mm;
- *stationary phase*: macrogol 20 000 R (film thickness 0.5  $\mu$ m).

*Carrier gas*: helium for chromatography R.

*Flow rate*: 1.3 mL/min.

*Temperature:*

	Time (min)	Temperature (°C)
Column	0 - 1	70
	1 - 35	70 → 240
	35 - 50	240
Injection port		250
Detector		250

*Detection*: flame ionisation.

*Split ratio*: 1:100.

*Composition of the fatty-acid fraction of the substance:*

- *caproic acid*: maximum 2.0 per cent;
- *caprylic acid*: 50.0 per cent to 80.0 per cent;
- *capric acid*: 20.0 per cent to 50.0 per cent;
- *lauric acid*: maximum 3.0 per cent;
- *myristic acid*: maximum 1.0 per cent.

**Chromium:** maximum 0.05 ppm, if intended for use in parenteral nutrition.

Atomic absorption spectrometry (2.2.23, Method II).

*Test solution.* Dissolve 2.0 g of the substance to be examined in methyl isobutyl ketone R3 and dilute to 10.0 mL with the same solvent.

*Solution A.* Dilute 0.100 mL of chromium liposoluble standard solution (1000 ppm Cr) R to 10.0 mL with methyl isobutyl ketone R3.

*Stock solution.* Dilute 0.100 mL of solution A to 10.0 mL with methyl isobutyl ketone R3.

*Reference solutions.* Prepare 3 reference solutions by dissolving for each 2.0 g of the substance to be examined in the minimum volume of methyl isobutyl ketone R3, adding 0.5 mL, 1.0 mL and 2.0 mL, respectively, of stock solution and diluting to 10.0 mL with methyl isobutyl ketone R3.

*Source:* chromium hollow-cathode lamp.

*Wavelength:* 357.8 nm.

*Atomic generator:* graphite furnace.

*Carrier gas:* argon R.

**Copper:** maximum 0.1 ppm, if intended for use in parenteral nutrition.

Atomic absorption spectrometry (2.2.23, Method II).

*Test solution.* Dissolve 2.0 g of the substance to be examined in methyl isobutyl ketone R3 and dilute to 10.0 mL with the same solvent.

*Solution A.* Dilute 0.100 mL of copper liposoluble standard solution (1000 ppm Cu) R to 10.0 mL with methyl isobutyl ketone R3.

*Stock solution.* Dilute 0.100 mL of solution A to 10.0 mL with methyl isobutyl ketone R3.

*Reference solutions.* Prepare 3 reference solutions by dissolving for each 2.0 g of the substance to be examined in the minimum volume of methyl isobutyl ketone R3, adding 1.0 mL, 2.0 mL and 4.0 mL, respectively, of stock solution and diluting to 10.0 mL with methyl isobutyl ketone R3.

*Source:* copper hollow-cathode lamp.

*Wavelength:* 324.7 nm.

*Atomic generator:* graphite furnace.

*Carrier gas:* argon R.

**Lead:** maximum 0.1 ppm, if intended for use in parenteral nutrition.

Atomic absorption spectrometry (2.2.23, Method II).

*Test solution.* Dissolve 2.0 g of the substance to be examined in methyl isobutyl ketone R3 and dilute to 10.0 mL with the same solvent.

*Solution A.* Dilute 0.100 mL of lead liposoluble standard solution (1000 ppm Pb) R to 10.0 mL with methyl isobutyl ketone R3.

*Stock solution.* Dilute 0.100 mL of solution A to 10.0 mL with methyl isobutyl ketone R3.

*Reference solutions.* Prepare 3 reference solutions by dissolving for each 2.0 g of the substance to be examined in the minimum volume of methyl isobutyl ketone R3, adding 1.0 mL, 2.0 mL and 4.0 mL, respectively, of stock solution and diluting to 10.0 mL with methyl isobutyl ketone R3.

*Source:* lead hollow-cathode lamp.

*Wavelength:* 283.3 nm.

*Atomic generator:* graphite furnace coated inside with palladium carbide; calcination is carried out in the presence of oxygen at a temperature below 800 °C.

*Carrier gas:* argon R.

**Nickel:** maximum 0.2 ppm, if intended for use in parenteral nutrition.

Atomic absorption spectrometry (2.2.23, Method II).

*Test solution.* Dissolve 2.0 g of the substance to be examined in methyl isobutyl ketone R3 and dilute to 10.0 mL with the same solvent.

*Solution A.* Dilute 0.100 mL of nickel liposoluble standard solution (1000 ppm Ni) R to 10.0 mL with methyl isobutyl ketone R3.

*Stock solution.* Dilute 0.100 mL of solution A to 10.0 mL with methyl isobutyl ketone R3.

*Reference solutions.* Prepare 3 reference solutions by dissolving for each 2.0 g of the substance to be examined in the minimum volume of methyl isobutyl ketone R3, adding 1.0 mL, 2.0 mL and 4.0 mL, respectively, of stock solution and diluting to 10.0 mL with methyl isobutyl ketone R3.

*Source:* nickel hollow-cathode lamp.

*Wavelength:* 232 nm.

*Atomic generator:* graphite furnace.

*Carrier gas:* argon R.

**Tin:** maximum 0.1 ppm, if intended for use in parenteral nutrition.

Atomic absorption spectrometry (2.2.23, Method II).

*Test solution.* Dissolve 2.0 g of the substance to be examined in methyl isobutyl ketone R3 and dilute to 10.0 mL with the same solvent.

*Solution A.* Dilute 0.100 mL of tin liposoluble standard solution (1000 ppm Sn) R to 10.0 mL with methyl isobutyl ketone R3.

*Stock solution.* Dilute 0.100 mL of solution A to 10.0 mL with methyl isobutyl ketone R3.

*Reference solutions.* Prepare 3 reference solutions by dissolving for each 2.0 g of the substance to be examined in the minimum volume of methyl isobutyl ketone R3, adding 1.0 mL, 2.0 mL and 4.0 mL, respectively, of stock solution and diluting to 10.0 mL with methyl isobutyl ketone R3.

*Source:* tin hollow-cathode lamp.

*Wavelength:* 286.3 nm.

*Atomic generator:* graphite furnace coated inside with palladium carbide.

*Carrier gas:* argon R.

**Heavy metals** (2.4.8): maximum 10 ppm, if intended for use other than parenteral nutrition.

2.0 g complies with test D. Prepare the reference solution using 2 mL of *lead standard solution* (10 ppm Pb) R.

**Water** (2.5.12): maximum 0.2 per cent, determined on 10.00 g.

**Total ash** (2.4.16): maximum 0.1 per cent, determined on 2.0 g.

#### STORAGE

In a well-filled container, protected from light.

#### LABELLING

The label states, where applicable, that the substance is intended for use in parenteral nutrition.

01/2008:1626  
corrected 6.0

## TRIHXYPHENIDYL HYDROCHLORIDE

### Trihexyphenidyli hydrochloridum

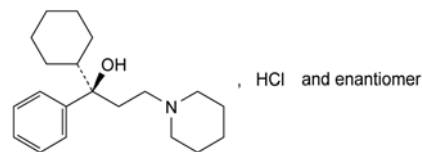

C<sub>20</sub>H<sub>32</sub>ClNO  
[52-49-3]

M<sub>r</sub> 337.9

04/2008:2032

## TRIGLYCEROL DIISOSTEARATE

### Triglyceroli diisostearas

#### DEFINITION

Mixture of polyglycerol diesters of mainly isostearic acid, obtained by esterification of polyglycerol and isostearic acid. The polyglycerol consists mainly of triglycerol.

#### CHARACTERS

*Appearance*: clear, yellowish, viscous liquid.

*Solubility*: practically insoluble in water, miscible with ethanol (96 per cent) and with fatty oils.

#### IDENTIFICATION

A. Infrared absorption spectrophotometry (2.2.24).

*Preparation*: film between 2 plates of *sodium chloride* R.

*Comparison*: *triglycerol diisostearate* CRS.

B. Composition of fatty acids (see Tests).

#### TESTS

**Appearance of solution.** The solution is not more intensely coloured than reference solution BY<sub>3</sub> (2.2.2, *Method* I).

Mix 10 mL with 10 mL of *ethanol* (96 per cent) R.

**Acid value** (2.5.1): maximum 3.0, determined on 1.0 g.

**Hydroxyl value** (2.5.3, *Method* A): 180 to 230, determined on 0.25 g.

**Iodine value** (2.5.4, *Method* B): maximum 3.0.

**Peroxide value** (2.5.5, *Method* B): maximum 6.0.

**Saponification value** (2.5.6): 128 to 160.

**Composition of fatty acids** (2.4.22, *Method* B). Use the mixture of calibrating substances in Table 2.4.22.-1.

*Composition of the fatty-acid fraction of the substance*:

- *sum of the contents of the fatty acids eluting between palmitic acid and stearic acid*: minimum 60.0 per cent;
- *sum of the contents of myristic acid, palmitic acid and stearic acid*: maximum 11.0 per cent.

**Water** (2.5.12): maximum 0.5 per cent, determined on 2.00 g.

**Sulfated ash**: maximum 0.5 per cent, determined on 1.0 g.

Heat a silica crucible to redness for 30 min, allow to cool in a desiccator and weigh. Evenly distribute 1.00 g of the substance to be examined in the crucible and weigh. Dry at 100-105 °C for 1 h and ignite in a muffle furnace at 600 °C ± 25 °C, until the substance is thoroughly charred. Carry out the test for sulfated ash (2.4.14) on the residue obtained, starting with "Moisten the substance to be examined...".

#### STORAGE

In an airtight container, protected from light.

#### DEFINITION

(1*R*)-1-Cyclohexyl-1-phenyl-3-(piperidin-1-yl)propan-1-ol hydrochloride.

*Content*: 99.0 per cent to 101.0 per cent (dried substance).

#### CHARACTERS

*Appearance*: white or almost white, crystalline powder.

*Solubility*: slightly soluble in water, sparingly soluble in ethanol (96 per cent) and in methylene chloride.

mp: about 250 °C, with decomposition.

#### IDENTIFICATION

*First identification*: A, D.

*Second identification*: B, C, D.

A. Infrared absorption spectrophotometry (2.2.24).

*Comparison*: *trihexyphenidyl hydrochloride* CRS.

B. Thin-layer chromatography (2.2.27).

*Test solution.* Dissolve 25 mg of the substance to be examined in a mixture of 20 volumes of *methanol* R and 80 volumes of *methylene chloride* R and dilute to 10 mL with the same mixture of solvents.

*Reference solution.* Dissolve 25 mg of *trihexyphenidyl hydrochloride* CRS in a mixture of 20 volumes of *methanol* R and 80 volumes of *methylene chloride* R and dilute to 10 mL with the same mixture of solvents.

*Plate*: TLC silica gel G plate R.

*Mobile phase*: *diethylamine* R, *hexane* R (5:95 V/V).

*Application*: 5 µL.

*Development*: over 2/3 of the plate.

*Drying*: in air.

*Detection*: spray with a 0.1 g/L solution of *chloroplatinic acid* R in *hydrochloric acid* R containing 0.4 per cent V/V of *hydriodic acid* R.

*Results*: the principal spot in the chromatogram obtained with the test solution is similar in position, colour and size to the principal spot in the chromatogram obtained with the reference solution.

C. Dissolve 0.5 g in 5 mL of warm *methanol* R and make just alkaline to *red litmus paper* R with *sodium hydroxide solution* R. A precipitate is formed which, after recrystallisation from *methanol* R, melts (2.2.14) at about 113 °C to 115 °C.

D. It gives reaction (a) of chlorides (2.3.1).

#### TESTS

**pH** (2.2.3): 5.2 to 6.2.

Dissolve 0.5 g with heating in 25 mL of *carbon dioxide-free water* R. Cool to room temperature and dilute to 50 mL with *carbon dioxide-free water* R.

**Optical rotation** (2.2.7): –0.10° to +0.10°.

Dissolve 1.25 g in a mixture of 20 volumes of *methanol* R and 80 volumes of *methylene chloride* R and dilute to 25.0 mL with the same mixture of solvents.

01/2011:2182

**Related substances.** Liquid chromatography (2.2.29).

**Test solution.** Dissolve 20.0 mg of the substance to be examined in the mobile phase and dilute to 10.0 mL with the mobile phase.

**Reference solution (a).** Dilute 1.0 mL of the test solution to 200.0 mL with the mobile phase. Dilute 10.0 mL to 50.0 mL with the mobile phase.

**Reference solution (b).** Dissolve 10.0 mg of *trihexyphenidyl impurity A CRS* in the mobile phase and dilute to 10.0 mL with the mobile phase.

**Reference solution (c).** Dilute 1.0 mL of reference solution (b) to 100.0 mL with the mobile phase.

**Reference solution (d).** To 1 mL of reference solution (b), add 1 mL of the test solution and dilute to 100 mL with the mobile phase.

**Column:**

- size:  $l = 0.15$  m,  $\emptyset = 4.6$  mm;
- stationary phase: octadecylsilyl silica gel for chromatography R (5  $\mu$ m).

**Mobile phase:** mix 200 mL of water R with 0.2 mL of triethylamine R. Adjust to pH 4.0 with phosphoric acid R and add 800 mL of acetonitrile R.

**Flow rate:** 1.0 mL/min.

**Detection:** spectrophotometer at 210 nm.

**Injection:** 20  $\mu$ L.

**Run time:** 3 times the retention time of trihexyphenidyl.

**System suitability:** reference solution (d):

- resolution: minimum 4.0 between the peaks corresponding to trihexyphenidyl and to impurity A.

**Limits:**

- impurity A: not more than the area of the principal peak in the chromatogram obtained with reference solution (c) (0.5 per cent);
- unspecified impurities: for each impurity, not more than the area of the principal peak in the chromatogram obtained with reference solution (a) (0.10 per cent);
- total: not more than 0.5 per cent;
- disregard limit: 0.2 times the area of the principal peak in the chromatogram obtained with reference solution (a) (0.02 per cent).

**Loss on drying (2.2.32):** maximum 0.5 per cent, determined on 1.000 g by drying in an oven at 105 °C.

**Sulfated ash (2.4.14):** maximum 0.1 per cent, determined on 1.0 g.

**ASSAY**

Dissolve 0.250 g in 50 mL of ethanol (96 per cent) R and add 5.0 mL of 0.01 M hydrochloric acid. Carry out a potentiometric titration (2.2.20), using 0.1 M sodium hydroxide. Read the volume added between the 2 points of inflexion.

1 mL of 0.1 M sodium hydroxide is equivalent to 33.79 mg of  $C_{26}H_{33}NO_9$ .

**IMPURITIES**

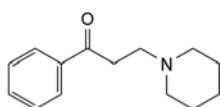

A. 1-phenyl-3-(piperidin-1-yl)propan-1-one.

## TRIMEBUTINE MALEATE

### Trimebutini maleas

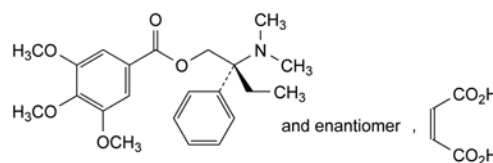

$C_{26}H_{33}NO_9$   
[34140-59-5]

$M_r$  503.5

**DEFINITION**

(2*RS*)-2-(Dimethylamino)-2-phenylbutyl 3,4,5-trimethoxybenzoate (*Z*)-butenedioate.

**Content:** 99.0 per cent to 101.5 per cent (dried substance).

**CHARACTERS**

**Appearance:** white or almost white, crystalline powder.

**Solubility:** slightly soluble in water, soluble in acetonitrile, sparingly soluble in acetone, slightly soluble in ethanol (96 per cent).

mp: about 133 °C.

**IDENTIFICATION**

Infrared absorption spectrophotometry (2.2.24).

**Comparison:** trimebutine maleate CRS.

**TESTS**

**Appearance of solution.** The solution is clear (2.2.1) and colourless (2.2.2, Method II).

Dissolve 0.5 g in acetone R, sonicate and dilute to 100 mL with the same solvent.

**Related substances.** Liquid chromatography (2.2.29).

**Solvent mixture.** Dissolve 0.24 g of anhydrous sodium dihydrogen phosphate R in 180 mL of water R and adjust to pH 2.5 with dilute phosphoric acid R; dilute to 200 mL with water R. Add 50 mL of acetonitrile R and mix.

**Test solution.** Dissolve 10 mg of the substance to be examined in the solvent mixture and dilute to 10.0 mL with the solvent mixture.

**Reference solution (a).** Dilute 1.0 mL of the test solution to 100.0 mL with the solvent mixture. Dilute 1.0 mL of this solution to 10.0 mL with the solvent mixture.

**Reference solution (b).** Dissolve 5 mg of methyl 3,4,5-trimethoxybenzoate R (impurity C) in 10.0 mL of the solvent mixture. Dilute 1.0 mL of this solution to 20.0 mL with the solvent mixture.

**Reference solution (c).** Dissolve the contents of a vial of trimebutine for system suitability CRS (containing impurities D and E) in 1.0 mL of reference solution (b).

**Column:**

- size:  $l = 0.25$  m,  $\emptyset = 4.6$  mm;
- stationary phase: end-capped octadecylsilyl silica gel for chromatography R (5  $\mu$ m);
- temperature: 25 °C.

**Mobile phase:**

- mobile phase A: dissolve 3.6 g of anhydrous sodium dihydrogen phosphate R in 990 mL of water R and adjust to pH 3.0 with phosphoric acid R; dilute to 1000 mL with water R;

– mobile phase B: acetonitrile R1;

Time (min)	Mobile phase A (per cent V/V)	Mobile phase B (per cent V/V)
0 - 3	78	22
3 - 6.5	78 → 65	22 → 35
6.5 - 15	65 → 60	35 → 40
15 - 35	60	40

Flow rate: 1.5 mL/min.

Detection: spectrophotometer at 215 nm.

Injection: 20 µL of the test solution and reference solutions (a) and (c).

Identification of impurities: use the chromatogram supplied with *trimebutine for system suitability CRS* and the chromatogram obtained with reference solution (c) to identify the peaks due to impurities C, D and E.

Relative retention with reference to trimebutine (retention time = about 12 min): maleic acid = about 0.17; impurity E = about 0.9; impurity D = about 1.3; impurity C = about 1.4.

System suitability: reference solution (c):

- resolution: minimum 1.5 between the peaks due to impurities D and C;
- peak-to-valley ratio: minimum 10, where  $H_p$  = height above the baseline of the peak due to impurity E and  $H_v$  = height above the baseline of the lowest point of the curve separating this peak from the peak due to trimebutine.

Limits:

- impurity E: not more than 6 times the area of the principal peak in the chromatogram obtained with reference solution (a) (0.6 per cent);
- unspecified impurities: for each impurity, not more than the area of the principal peak in the chromatogram obtained with reference solution (a) (0.10 per cent);
- total: not more than 10 times the area of the principal peak in the chromatogram obtained with reference solution (a) (1.0 per cent);
- disregard limit: 0.5 times the area of the principal peak in the chromatogram obtained with reference solution (a) (0.05 per cent); disregard any peak due to maleic acid.

Heavy metals (2.4.8): maximum 10 ppm.

Dissolve 2.0 g in 20 mL of a mixture of 15 volumes of *water R* and 85 volumes of *dioxan R*. 12 mL of the solution complies with test B. Prepare the reference solution using lead standard solution (1 ppm Pb) obtained by diluting *lead standard solution (100 ppm Pb) R* with a mixture of 15 volumes of *water R* and 85 volumes of *dioxan R*.

Loss on drying (2.2.32): maximum 0.5 per cent, determined on 1.000 g by drying in an oven at 105 °C.

Sulfated ash (2.4.14): maximum 0.1 per cent, determined on 1.0 g.

#### ASSAY

Dissolve 0.300 g in 50 mL of *anhydrous acetic acid R*. Titrate with 0.1 M *perchloric acid*, determining the end-point potentiometrically (2.2.20).

1 mL of 0.1 M *perchloric acid* is equivalent to 50.35 mg of  $C_{26}H_{33}NO_9$ .

#### IMPURITIES

Specified impurities: E.

Other detectable impurities (the following substances would, if present at a sufficient level, be detected by one or other of the tests in the monograph. They are limited by the general acceptance criterion for other/unspecified impurities and/or by the general monograph *Substances for pharmaceutical use*

(2034). It is therefore not necessary to identify these impurities for demonstration of compliance. See also 5.10. *Control of impurities in substances for pharmaceutical use*): A, B, C, D.

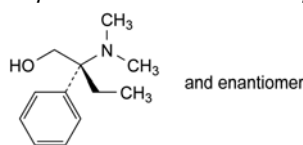

A. (2RS)-2-(dimethylamino)-2-phenylbutanol,

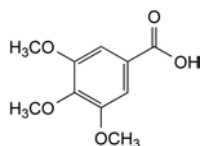

B. 3,4,5-trimethoxybenzoic acid,

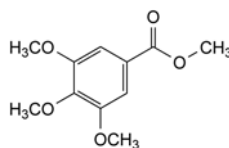

C. methyl 3,4,5-trimethoxybenzoate,

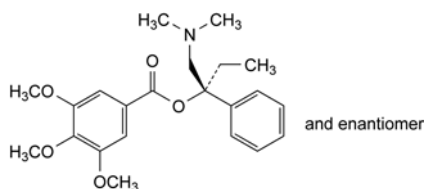

D. (1RS)-1-[(dimethylamino)methyl]-1-phenylpropyl 3,4,5-trimethoxybenzoate,

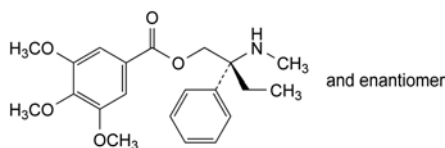

E. (2RS)-2-(methylamino)-2-phenylbutyl 3,4,5-trimethoxybenzoate.

01/2008:1741  
corrected 6.0

## TRIMETAZIDINE DIHYDROCHLORIDE

### Trimetazidini dihydrochloridum

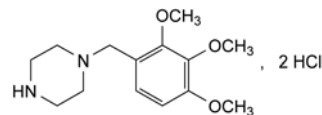

$C_{14}H_{24}Cl_2N_2O_3$   
[13171-25-0]

$M_r$  339.3

#### DEFINITION

1-(2,3,4-Trimethoxybenzyl)piperazine dihydrochloride.

Content: 98.5 per cent to 101.5 per cent (dried substance).

#### CHARACTERS

Appearance: white or almost white, crystalline powder, slightly hygroscopic.

Solubility: freely soluble in water, sparingly soluble in alcohol.

#### IDENTIFICATION

A. Infrared absorption spectrophotometry (2.2.24).

Comparison: Ph. Eur. reference spectrum of trimetazidine dihydrochloride.

B. Dissolve 25 mg in 5 mL of *water R*. 2 mL of the solution gives reaction (a) of chlorides (2.3.1).

#### TESTS

**Appearance of solution.** The solution is clear (2.2.1) and not more intensely coloured than reference solution BY<sub>6</sub> (2.2.2, Method II).

Dissolve 1.0 g in *water R* and dilute to 10 mL with the same solvent.

**Related substances.** Liquid chromatography (2.2.29).

**Test solution.** Dissolve 0.200 g of the substance to be examined in *water R* and dilute to 50.0 mL with the same solvent.

**Reference solution (a).** Dissolve 20.0 mg of *trimetazidine for system suitability CRS* in *water R* and dilute to 5.0 mL with the same solvent.

**Reference solution (b).** Dilute 2.0 mL of the test solution to 100.0 mL with *water R*. Dilute 5.0 mL of this solution to 100.0 mL with *water R*.

**Reference solution (c).** Dilute 25.0 mL of reference solution (b) to 50.0 mL with *water R*.

**Column:**

- size:  $l = 0.15$  m,  $\varnothing = 4.6$  mm,
- stationary phase: spherical octadecylsilyl silica gel for chromatography R (5  $\mu$ m) with a pore size of 10 nm,
- temperature: 30 °C.

**Mobile phase:**

- mobile phase A: mix 357 volumes of *methanol R* and 643 volumes of a 2.87 g/L solution of *sodium heptanesulfonate R* adjusted to pH 3.0 with *dilute phosphoric acid R*,
- mobile phase B: *methanol R*,

Time (min)	Mobile phase A (per cent V/V)	Mobile phase B (per cent V/V)
0 - 50	95 → 75	5 → 25
50 - 52	75 → 95	25 → 5

**Flow rate:** 1.2 mL/min.

**Detection:** spectrophotometer at 240 nm.

**Equilibration:** for at least 1 h with the mobile phase at the initial composition.

**Injection:** 10  $\mu$ L.

**Relative retention** with reference to trimetazidine (retention time = about 25 min): impurity D = about 0.2; impurity C = about 0.4; impurity H = about 0.6; impurities A and I = about 0.9; impurity E = about 0.95; impurity F = about 1.4; impurity B = about 1.8.

**System suitability:**

- **peak-to-valley ratio:** minimum 3, where  $H_p$  = height above the baseline of the peak due to impurity E and  $H_v$  = height above the baseline of the lowest point of the curve separating this peak from the principal peak in the chromatogram obtained with reference solution (a);

- **signal-to-noise ratio:** minimum 10 for the principal peak in the chromatogram obtained with reference solution (c).

**Limits:**

- **correction factors:** for the calculation of contents, multiply the peak areas of the following impurities by the corresponding correction factor: impurity B = 0.55; impurity C = 0.37; impurity F = 0.71;
- **impurities A, B, C, D, E, F, H, I:** for each impurity, not more than the area of the principal peak in the chromatogram obtained with reference solution (b) (0.1 per cent);
- **any other impurity:** for each impurity, not more than the area of the principal peak in the chromatogram obtained with reference solution (b) (0.1 per cent);

- **total:** not more than twice the area of the principal peak in the chromatogram obtained with reference solution (b) (0.2 per cent);
- **disregard limit:** area of the principal peak in the chromatogram obtained with reference solution (c) (0.05 per cent).

**Impurity G.** Thin-layer chromatography (2.2.27).

**Test solution.** Dissolve 0.10 g of the substance to be examined in *methanol R* and dilute to 10 mL with the same solvent.

**Reference solution.** Dissolve 22.6 mg of *piperazine hydrate R* in *methanol R* and dilute to 100 mL with the same solvent. Dilute 10 mL of the solution to 100 mL with *methanol R*.

**Plate:** TLC silica gel plate R.

**Mobile phase:** concentrated ammonia R, alcohol R (20:80 V/V).

**Application:** 10  $\mu$ L.

**Development:** over 2/3 of the plate.

**Drying:** at 100-105 °C for 30 min.

**Detection:** spray with *iodoplatinate reagent R*.

**Limit:**

- **impurity G:** any spot due to impurity G is not more intense than the spot in the chromatogram obtained with the reference solution (0.1 per cent, expressed as anhydrous piperazine).

**Loss on drying** (2.2.32): maximum 2.5 per cent, determined on 1.000 g by drying in an oven at 105 °C over *diphosphorus pentoxide R* at a pressure not exceeding 15 kPa.

**Sulfated ash** (2.4.14): maximum 0.1 per cent, determined on 1.0 g.

#### ASSAY

Dissolve 0.120 g in 50.0 mL of *water R*. Add 1 mL of *nitric acid R* and titrate with 0.1 M *silver nitrate*, determining the end-point potentiometrically (2.2.20).

1 mL of 0.1 M *silver nitrate* is equivalent to 16.96 mg of C<sub>14</sub>H<sub>24</sub>Cl<sub>2</sub>N<sub>2</sub>O<sub>3</sub>.

#### STORAGE

In an airtight container.

#### IMPURITIES

**Specified impurities:** A, B, C, D, E, F, G, H, I.

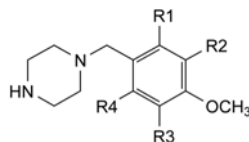

- A. R1 = R4 = H, R2 = R3 = OCH<sub>3</sub>: 1-(3,4,5-trimethoxybenzyl)piperazine,  
 E. R1 = R3 = OCH<sub>3</sub>, R2 = R4 = H: 1-(2,4,5-trimethoxybenzyl)piperazine,  
 F. R1 = R4 = OCH<sub>3</sub>, R2 = R3 = H: 1-(2,4,6-trimethoxybenzyl)piperazine,

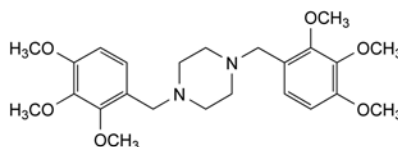

- B. 1,4-bis(2,3,4-trimethoxybenzyl)piperazine,

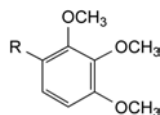

- C. R = CHO: 2,3,4-trimethoxybenzaldehyde,  
 D. R = CH<sub>2</sub>OH: (2,3,4-trimethoxyphenyl)methanol,



G. piperazine,

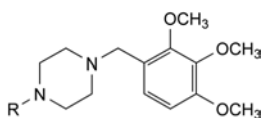

H. R = COOC<sub>2</sub>H<sub>5</sub>: ethyl 4-(2,3,4-trimethoxybenzyl)piperazine-1-carboxylate,

I. R = CH<sub>3</sub>: 1-methyl-4-(2,3,4-trimethoxybenzyl)piperazine (*N*-methyltrimetazidine).

01/2008:0440

## TRIMETHADIONE

### Trimethadionum

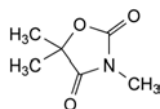

C<sub>6</sub>H<sub>9</sub>NO<sub>3</sub>  
[127-48-0]

*M*<sub>r</sub> 143.1

#### DEFINITION

3,5,5-Trimethyloxazolidine-2,4-dione.

*Content*: 98.0 per cent to 102.0 per cent (dried substance).

#### CHARACTERS

*Appearance*: colourless or almost colourless crystals.

*Solubility*: soluble in water, very soluble in ethanol (96 per cent).

#### IDENTIFICATION

*First identification*: B.

*Second identification*: A, C, D.

A. Melting point (2.2.14): 45 °C to 47 °C, determined without previous drying.

B. Infrared absorption spectrophotometry (2.2.24).

*Preparation*: discs prepared using 3 mg of substance per 0.4 g of potassium bromide R.

*Comparison*: trimethadione CRS.

C. To 2 mL of solution S (see Tests) add 1 mL of barium hydroxide solution R. A white precipitate is formed, which dissolves on addition of 1 mL of dilute hydrochloric acid R.

D. Dissolve 0.3 g in a mixture of 5 mL of alcoholic potassium hydroxide solution R and 5 mL of ethanol (96 per cent) R. Allow to stand for 10 min. Add 0.05 mL of phenolphthalein solution R1 and neutralise exactly with hydrochloric acid R. Evaporate to dryness on a water-bath and take up the residue with 4 quantities, each of 5 mL, of ether R. Filter the combined ether layers and evaporate to dryness. The residue, recrystallised from 5 mL of toluene R and dried, melts (2.2.14) at about 80 °C.

#### TESTS

**Solution S.** Dissolve 2.0 g in carbon dioxide-free water R and dilute to 40 mL with the same solvent.

**Appearance of solution.** Solution S is clear (2.2.1) and colourless (2.2.2, Method II).

**Acidity or alkalinity.** To 10 mL of solution S add 0.1 mL of methyl red solution R. Not more than 0.1 mL of 0.01 M hydrochloric acid or 0.01 M sodium hydroxide is required to change the colour of the indicator.

**Heavy metals** (2.4.8): maximum 20 ppm.

12 mL of solution S complies with test A. Prepare the reference solution using lead standard solution (1 ppm Pb) R.

**Loss on drying** (2.2.32): maximum 0.5 per cent, determined on 1.00 g by drying in a desiccator over anhydrous silica gel R for 6 h.

**Sulfated ash** (2.4.14): maximum 0.1 per cent, determined on 1.0 g.

#### ASSAY

Gas chromatography (2.2.28).

*Internal standard solution.* Dissolve 0.125 g of decanol R in anhydrous ethanol R and dilute to 25 mL with the same solvent.

*Test solution.* Dissolve 0.100 g of the substance to be examined in the internal standard solution and dilute to 10.0 mL with the same solution.

*Reference solution.* Dissolve 0.100 g of trimethadione CRS in the internal standard solution and dilute to 10.0 mL with the same solution.

*Column*:

- *material*: stainless steel,
- *size*: *l* = 0.75 m,  $\varnothing$  = 3 mm,
- *stationary phase*: styrene-divinylbenzene copolymer R (125-150  $\mu$ m).

*Carrier gas*: nitrogen for chromatography R.

*Flow rate*: 20 mL/min.

*Temperature*:

- *column*: 210 °C,
- *injection port*: 240 °C,
- *detector*: 270 °C.

*Detection*: flame ionisation.

*Injection*: 1  $\mu$ L.

Calculate the content of C<sub>6</sub>H<sub>9</sub>NO<sub>3</sub> from the declared content of trimethadione CRS.

#### STORAGE

Protected from light.

01/2008:0060  
corrected 6.0

## TRIMETHOPRIM

### Trimethoprimum

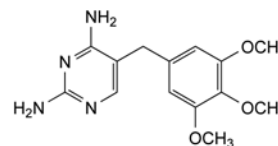

C<sub>14</sub>H<sub>18</sub>N<sub>4</sub>O<sub>3</sub>  
[738-70-5]

*M*<sub>r</sub> 290.3

#### DEFINITION

5-(3,4,5-Trimethoxybenzyl)pyrimidine-2,4-diamine.

*Content*: 98.5 per cent to 101.0 per cent (dried substance).

#### CHARACTERS

*Appearance*: white or yellowish-white powder.

*Solubility*: very slightly soluble in water, slightly soluble in ethanol (96 per cent).

#### IDENTIFICATION

*First identification*: C.

*Second identification*: A, B, D.

A. Melting point (2.2.14): 199 °C to 203 °C.

B. Dissolve about 20 mg in 0.1 M sodium hydroxide and dilute to 100.0 mL with the same solvent. Dilute 1.0 mL of this solution to 10.0 mL with 0.1 M sodium hydroxide. Examined between 230 nm and 350 nm (2.2.25), the solution shows an absorption maximum at 287 nm. The specific absorbance at the absorption maximum is 240 to 250.

C. Infrared absorption spectrophotometry (2.2.24).

*Preparation:* discs.

*Comparison:* trimethoprim CRS.

D. Dissolve about 25 mg, heating if necessary, in 5 mL of 0.005 M sulfuric acid and add 2 mL of a 16 g/L solution of potassium permanganate R in 0.1 M sodium hydroxide. Heat to boiling and add to the hot solution 0.4 mL of formaldehyde R. Mix, add 1 mL of 0.5 M sulfuric acid, mix and heat again to boiling. Cool and filter. To the filtrate, add 2 mL of methylene chloride R and shake vigorously. The organic layer, examined in ultraviolet light at 365 nm, shows green fluorescence.

## TESTS

**Appearance of solution.** The solution is not more intensely coloured than reference solution BY<sub>7</sub> (2.2.2, Method II).

Dissolve 0.5 g in 10 mL of a mixture of 1 volume of water R, 4.5 volumes of methanol R and 5 volumes of methylene chloride R.

## Related substances

A. Liquid chromatography (2.2.29).

*Test solution.* Dissolve 25.0 mg of the substance to be examined in the mobile phase and dilute to 25.0 mL with the mobile phase.

*Reference solution (a).* Dilute 1.0 mL of the test solution to 200.0 mL with the mobile phase.

*Reference solution (b).* Dissolve the contents of a vial of trimethoprim for system suitability CRS (containing impurity E) in 1 mL of the mobile phase.

*Column:*

- *size:*  $l = 0.250$  m,  $\varnothing = 4.0$  mm;
- *stationary phase:* base-deactivated octadecylsilyl silica gel for chromatography R (5  $\mu\text{m}$ ).

*Mobile phase:* mix 30 volumes of methanol R and 70 volumes of a 1.4 g/L solution of sodium perchlorate R adjusted to pH 3.6 with phosphoric acid R.

*Flow rate:* 1.3 mL/min.

*Detection:* spectrophotometer at 280 nm.

*Injection:* 20  $\mu\text{L}$  loop injector.

*Run time:* 11 times the retention time of trimethoprim.

*Relative retention* with reference to trimethoprim (retention time = about 5 min): impurity C = about 0.8; impurity E = about 0.9; impurity A = about 1.5; impurity D = about 2.0; impurity G = about 2.1; impurity B = about 2.3; impurity J = about 2.7; impurity F = about 4.0.

*System suitability:* reference solution (b):

- *resolution:* minimum 2.5 between the peaks due to impurity E and trimethoprim.

*Limits:*

- *correction factors:* for the calculation of content, multiply the peak areas of the following impurities by the corresponding correction factor: impurity B = 0.43; impurity E = 0.53; impurity J = 0.66;
- *any impurity:* not more than 0.2 times the area of the principal peak in the chromatogram obtained with reference solution (a) (0.1 per cent);
- *total:* not more than 0.4 times the area of the principal peak in the chromatogram obtained with reference solution (a) (0.2 per cent);

- *disregard limit:* 0.04 times the area of the principal peak in the chromatogram obtained with reference solution (a) (0.02 per cent); disregard any peak corresponding to impurity H (relative retention = about 10.3).

B. Liquid chromatography (2.2.29).

*Test solution.* Dissolve 25.0 mg of the substance to be examined in the mobile phase and dilute to 25.0 mL with the mobile phase.

*Reference solution (a).* Dilute 1.0 mL of the test solution to 200.0 mL with the mobile phase.

*Reference solution (b).* Dissolve 5.0 mg of trimethoprim CRS and 5.0 mg of trimethoprim impurity B CRS in the mobile phase and dilute to 100.0 mL with the mobile phase.

*Column:*

- *size:*  $l = 0.25$  m,  $\varnothing = 4.6$  mm;
- *stationary phase:* nitrile silica gel for chromatography R (5  $\mu\text{m}$ ) with a specific surface area of 350  $\text{m}^2/\text{g}$  and a pore diameter of 10 nm.

*Mobile phase:* dissolve 1.14 g of sodium hexane sulfonate R in 600 mL of a 13.6 g/L solution of potassium dihydrogen phosphate R; adjust to pH 3.1 with phosphoric acid R and mix with 400 mL of methanol R.

*Flow rate:* 0.8 mL/min.

*Detection:* spectrophotometer at 280 nm.

*Injection:* 20  $\mu\text{L}$  loop injector.

*Run time:* 6 times the retention time of trimethoprim.

*Relative retention* with reference to trimethoprim (retention time = about 4 min): impurity H = about 1.8; impurity I = about 4.9.

*System suitability:* reference solution (b):

- *resolution:* minimum 2.0 between the peaks due to trimethoprim and impurity B.

*Limits:*

- *correction factors:* for the calculation of content, multiply the peak areas of the following impurities by the corresponding correction factor: impurity H = 0.50; impurity I = 0.28;
- *any impurity:* not more than 0.2 times the area of the principal peak in the chromatogram obtained with reference solution (a) (0.1 per cent);
- *total:* not more than 0.4 times the area of the principal peak in the chromatogram obtained with reference solution (a) (0.2 per cent);
- *disregard limit:* 0.04 times the area of the principal peak in the chromatogram obtained with reference solution (a) (0.02 per cent); disregard any peak due to impurity B (relative retention = about 1.3).

**Impurity K.** Gas chromatography (2.2.28).

*Test solution.* Dissolve 0.500 g of the substance to be examined in 35.0 mL of citrate buffer solution pH 5.0 R, add 10.0 mL of 1,1-dimethylethyl methyl ether R, shake thoroughly and centrifuge for 10 min. Use the upper layer.

*Reference solution.* Dilute 5.0 mL of hydrochloric acid R to 50.0 mL with water R, add 12.5 mg of aniline R and shake thoroughly. Add 10.0  $\mu\text{L}$  of this solution and 10.0 mL of 1,1-dimethylethyl methyl ether R to 35.0 mL of citrate buffer solution pH 5.0 R, shake thoroughly and centrifuge for 10 min. Use the upper layer.

*Column:*

- *material:* fused silica;
- *size:*  $l = 30$  m,  $\varnothing = 0.53$  mm;
- *stationary phase:* poly(dimethyl)siloxane R (film thickness 3  $\mu\text{m}$ ).

*Carrier gas:* helium for chromatography R.

*Flow rate:* 12 mL/min.

*Temperature:*

- *column:* 80 °C;

– injection port: 230 °C;

– detector: 270 °C.

Detection: nitrogen-phosphorus detector.

Injection: 3 µL.

Run time: 15 min.

System suitability: reference solution:

– repeatability: maximum relative standard deviation of 5.0 per cent after 6 injections.

Limit:

– impurity K: not more than the area of the corresponding peak in the chromatogram obtained with the reference solution (5 ppm).

**Heavy metals** (2.4.8): maximum 20 ppm.

1.0 g complies with test C. Prepare the reference solution using 2 mL of lead standard solution (10 ppm Pb) R

**Loss on drying** (2.2.32): maximum 1.0 per cent, determined on 1.000 g by drying in an oven at 105 °C.

**Sulfated ash** (2.4.14): maximum 0.1 per cent, determined on 1.0 g.

#### ASSAY

Dissolve 0.250 g in 50 mL of anhydrous acetic acid R. Titrate with 0.1 M perchloric acid, determining the end-point potentiometrically (2.2.20).

1 mL of 0.1 M perchloric acid is equivalent to 29.03 mg of C<sub>14</sub>H<sub>18</sub>N<sub>4</sub>O<sub>3</sub>.

#### IMPURITIES

By liquid chromatography A: A, B, C, D, E, F, G, H, J.

By liquid chromatography B: B, H, I.

By gas chromatography: K.

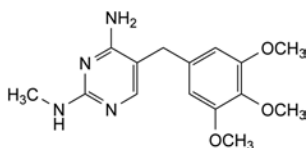

A. N<sup>2</sup>-methyl-5-(3,4,5-trimethoxybenzyl)pyrimidine-2,4-diamine,

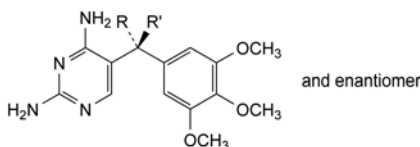

B. R + R' = O: (2,4-diaminopyrimidin-5-yl)(3,4,5-trimethoxyphenyl)methanone,

C. R = OH, R' = H: (RS)-(2,4-diaminopyrimidin-5-yl)(3,4,5-trimethoxyphenyl)methanol,

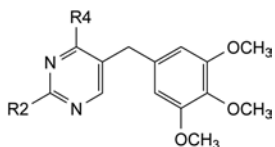

D. R<sub>2</sub> = NH<sub>2</sub>, R<sub>4</sub> = OH: 2-amino-5-(3,4,5-trimethoxybenzyl)pyrimidin-4-ol,

E. R<sub>2</sub> = OH, R<sub>4</sub> = NH<sub>2</sub>: 4-amino-5-(3,4,5-trimethoxybenzyl)pyrimidin-2-ol,

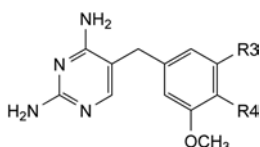

F. R<sub>3</sub> = Br, R<sub>4</sub> = OCH<sub>3</sub>: 5-(3-bromo-4,5-dimethoxybenzyl)pyrimidine-2,4-diamine,

G. R<sub>3</sub> = OCH<sub>3</sub>, R<sub>4</sub> = OC<sub>2</sub>H<sub>5</sub>: 5-(4-ethoxy-3,5-dimethoxybenzyl)pyrimidine-2,4-diamine,

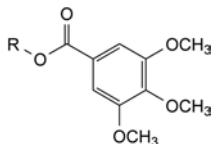

H. R = CH<sub>3</sub>: methyl 3,4,5-trimethoxybenzoate,

J. R = H: 3,4,5-trimethoxybenzoic acid,

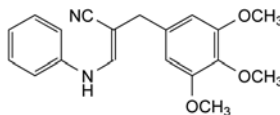

I. 3-(phenylamino)-2-(3,4,5-trimethoxybenzyl)prop-2-enenitrile,

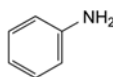

K. aniline.

01/2008:0534

## TRIMIPRAMINE MALEATE

### Trimipramini maleas

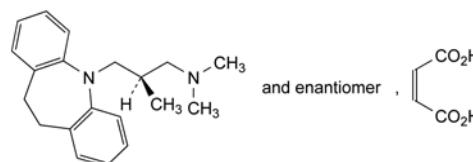

C<sub>24</sub>H<sub>30</sub>N<sub>2</sub>O<sub>4</sub>  
[521-78-8]

M<sub>r</sub> 410.5

#### DEFINITION

(2*RS*)-3-(10,11-Dihydro-5*H*-dibenzo[*b,f*]azepin-5-yl)-*N,N*,2-trimethylpropan-1-amine (*Z*)-butenedioate.

Content: 98.0 per cent to 101.0 per cent (dried substance).

#### CHARACTERS

Appearance: white or almost white, crystalline powder.

Solubility: slightly soluble in water and in ethanol (96 per cent).

#### IDENTIFICATION

First identification: A, C.

Second identification: A, B, D, E.

A. Melting point (2.2.14): 140 °C to 144 °C.

B. Ultraviolet and visible absorption spectrophotometry (2.2.25).

Test solution. Dissolve 40.0 mg in 0.01 M hydrochloric acid and dilute to 100.0 mL with the same acid. Dilute 5.0 mL of this solution to 100.0 mL with 0.01 M hydrochloric acid.

Spectral range: 230-350 nm.

Absorption maximum: at 250 nm.

Shoulder: at 270 nm.

Specific absorbance at the absorption maximum: 205 to 235.

C. Infrared absorption spectrophotometry (2.2.24).

Comparison: trimipramine maleate CRS.

D. Thin-layer chromatography (2.2.27). Prepare the solutions immediately before use.

Test solution. Dissolve 0.50 g of the substance to be examined in methanol R and dilute to 10 mL with the same solvent. Dilute 1 mL of this solution to 20 mL with methanol R.



**Reference solution.** Dissolve 25 mg of *trimipramine maleate CRS* in *methanol R* and dilute to 10 mL with the same solvent.

**Plate:** TLC silica gel G plate R.

**Mobile phase:** concentrated ammonia R, anhydrous ethanol R, toluene R (0.7:10:90 V/V/V).

**Application:** 5 µL.

**Development:** over 2/3 of the plate.

**Drying:** in air for 15 min.

**Detection:** spray with a 5 g/L solution of *potassium dichromate R* in a mixture of 1 volume of *sulfuric acid R* and 4 volumes of *water R* and examine immediately.

**Results:** the principal spot in the chromatogram obtained with the test solution is similar in position, colour and size to the principal spot in the chromatogram obtained with the reference solution.

#### E. Thin-layer chromatography (2.2.27).

**Test solution.** Dissolve 0.20 g of the substance to be examined in *methanol R* and dilute to 10 mL with the same solvent.

**Reference solution.** Dissolve 56 mg of *maleic acid R* in *methanol R* and dilute to 10 mL with the same solvent.

**Plate:** TLC silica gel GF<sub>254</sub> R.

**Mobile phase:** *water R*, *anhydrous formic acid R*, *di-isopropyl ether R* (3:7:90 V/V/V).

**Application:** 5 µL as bands of 10 mm.

**Development:** over 2/3 of the plate.

**Drying:** in a current of air for a few minutes and then at 120 °C for 10 min.

**Detection:** examine in ultraviolet light at 254 nm.

**Results:** the chromatogram obtained with the test solution shows 2 zones: one is on the line of application and the other is similar in position and size to the principal zone in the chromatogram obtained with the reference solution.

#### TESTS

**Related substances.** Liquid chromatography (2.2.29). Carry out the test protected from light.

**Buffer solution pH 7.7:** 2.64 g/L solution of *ammonium phosphate R* in *water for chromatography R*; adjust to pH 7.7 with *phosphoric acid R*.

**Test solution.** Dissolve 50 mg of the substance to be examined in the mobile phase and dilute to 100 mL with the mobile phase.

**Reference solution (a).** Dissolve 5 mg of the substance to be examined and 5 mg of *iminodibenzyl R* (impurity F) in the mobile phase and dilute to 10 mL with the mobile phase.

**Reference solution (b).** Dilute 1.0 mL of the test solution to 100.0 mL with the mobile phase. Dilute 1.0 mL of this solution to 10.0 mL with the mobile phase.

**Reference solution (c).** Dissolve the contents of a vial of *trimipramine for peak identification CRS* (containing impurities A, B, C, D and E) in 1 mL of *acetonitrile R1*.

**Column:**

- size:  $l = 0.125$  m,  $\varnothing = 4.0$  mm;
- stationary phase: end-capped octadecylsilyl silica gel for chromatography R (5 µm).

**Mobile phase:** *acetonitrile R1*, buffer solution pH 7.7 (38:62 V/V).

**Flow rate:** 1.5 mL/min.

**Detection:** spectrophotometer at 210 nm.

**Injection:** 20 µL.

**Run time:** 3 times the retention time of trimipramine.

**Identification of impurities:** use the chromatogram supplied with *trimipramine for peak identification CRS* and the chromatogram obtained with reference solution (c) to identify the peaks due to impurities A, B, C, D and E; doubling of the peak due to impurity E may be observed.

**Relative retention** with reference to trimipramine (retention time = about 27 min): impurity A = about 0.1; impurity B = about 0.3; impurity C = about 0.4; impurity D = about 0.5; impurity F = about 1.4; impurity E = about 1.5.

**System suitability:**

- **resolution:** minimum 3.5 between the peaks due to trimipramine and impurity F in the chromatogram obtained with reference solution (a);
- the chromatogram obtained with reference solution (c) is similar to the chromatogram supplied with *trimipramine for peak identification CRS*.

**Limits:**

- **correction factor:** for the calculation of content, multiply the peak area of impurity F by 0.5;
- **impurity E:** not more than 3 times the area of the principal peak in the chromatogram obtained with reference solution (b) (0.3 per cent);
- **impurity F:** not more than 2 times the area of the principal peak in the chromatogram obtained with reference solution (b) (0.2 per cent);
- **impurities A, B, C, D:** for each impurity, not more than 1.5 times the area of the principal peak in the chromatogram obtained with reference solution (b) (0.15 per cent);
- **unspecified impurities:** for each impurity, not more than the area of the principal peak in the chromatogram obtained with reference solution (b) (0.10 per cent);
- **total:** not more than 10 times the area of the principal peak in the chromatogram obtained with reference solution (b) (1.0 per cent);
- **disregard limit:** 0.5 times the area of the principal peak in the chromatogram obtained with reference solution (b) (0.05 per cent).

**Heavy metals (2.4.8):** maximum 20 ppm.

2.0 g complies with test C. Prepare the reference solution using 4 mL of *lead standard solution (10 ppm Pb) R*.

**Loss on drying (2.2.32):** maximum 0.5 per cent, determined on 1.000 g by drying in an oven at 105 °C.

**Sulfated ash (2.4.14):** maximum 0.1 per cent, determined on 1.0 g.

#### ASSAY

Dissolve 0.350 g in 50 mL of *anhydrous acetic acid R*. Titrate with 0.1 M *perchloric acid* determining the end-point potentiometrically (2.2.20).

1 mL of 0.1 M *perchloric acid* is equivalent to 41.05 mg of C<sub>24</sub>H<sub>30</sub>N<sub>2</sub>O<sub>4</sub>.

#### STORAGE

Protected from light.

#### IMPURITIES

**Specified impurities:** A, B, C, D, E, F.

**Other detectable impurities** (the following substances would, if present at a sufficient level, be detected by one or other of the tests in the monograph. They are limited by the general acceptance criterion for other/unspecified impurities and/or by the general monograph *Substances for pharmaceutical use (2034)*. It is therefore not necessary to identify these impurities for demonstration of compliance. See also 5.10. *Control of impurities in substances for pharmaceutical use*): G.

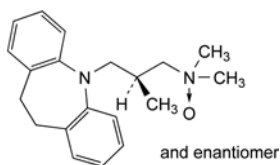

- A. (2*RS*)-3-(10,11-dihydro-5*H*-dibenzo[*b,f*]azepin-5-yl)-*N,N*,2-trimethylpropan-1-amine *N*-oxide,

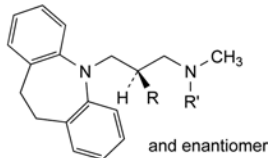

- B. R = CH<sub>3</sub>, R' = H: (2*RS*)-3-(10,11-dihydro-5*H*-dibenzo[*b,f*]azepin-5-yl)-*N,N*,2-dimethylpropan-1-amine,

- D. R = H, R' = CH<sub>3</sub>: imipramine,

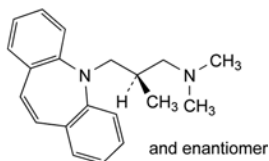

- C. (2*RS*)-3-(5*H*-dibenzo[*b,f*]azepin-5-yl)-*N,N*,2-trimethylpropan-1-amine,

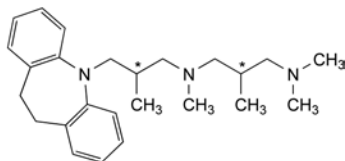

- E. mixture of the stereoisomers of *N*-[3-(10,11-dihydro-5*H*-dibenzo[*b,f*]azepin-5-yl)-2-methylpropyl]-*N,N',N'*,2-tetramethylpropane-1,3-diamine,

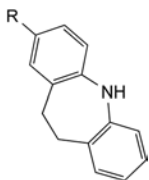

- F. R = H: 10,11-dihydro-5*H*-dibenzo[*b,f*]azepine,

- G. R = CH<sub>3</sub>: 2-methyl-10,11-dihydro-5*H*-dibenzo[*b,f*]azepine.

## CHARACTERS

**Appearance:** clear, viscous, colourless or slightly yellow liquid, very hygroscopic.

**Solubility:** miscible with water and with ethanol (96 per cent), soluble in methylene chloride.

## IDENTIFICATION

**First identification:** B, C.

**Second identification:** A, B, D.

A. Relative density (2.2.5): 1.120 to 1.130.

B. Refractive index (2.2.6): 1.482 to 1.485.

C. Examine the chromatograms obtained in the test for related substances.

**Results:** the principal peak in the chromatogram obtained with the test solution is similar in retention time and size to the principal peak in the chromatogram obtained with reference solution (a).

D. To 1 mL add 0.3 mL of *copper sulfate solution R*. A blue colour develops. Add 2.5 mL of *dilute sodium hydroxide solution R* and heat to boiling. The blue colour remains unchanged.

## TESTS

**Solution S.** Dissolve 12 g in *water R* and dilute to 20 mL with the same solvent.

**Appearance of solution.** Solution S is clear (2.2.1) and not more intensely coloured than reference solution B<sub>6</sub> (2.2.2, *Method II*).

**Related substances.** Gas chromatography (2.2.28).

**Internal standard solution.** Dissolve 5.0 g of 3-aminopropanol *R* in *water R* and dilute to 100.0 mL with the same solvent.

**Test solution.** Dissolve 10.0 g of the substance to be examined in *water R*. Add 1.0 mL of the internal standard solution and dilute to 100.0 mL with *water R*.

**Reference solution (a).** Dissolve 1.0 g of *trolamine CRS* in *water R* and dilute to 10.0 mL with the same solvent.

**Reference solution (b).** Dissolve 0.1 g of *trolamine impurity A CRS*, 0.5 g of *trolamine impurity B CRS* and 0.1 g of *trolamine CRS* in *water R* and dilute to 10.0 mL with the same solvent. To 1.0 mL of this solution add 1.0 mL of the internal standard solution and dilute to 100.0 mL with *water R*.

**Column:**

- **material:** fused silica;
- **size:** *l* = 25 m, Ø = 0.25 mm;
- **stationary phase:** poly(dimethyl)(diphenyl)siloxane *R* (film thickness 0.50 µm).

**Carrier gas:** helium for chromatography *R*.

**Flow rate:** 1 mL/min.

**Split ratio:** 1:35.

**Temperature:**

	Time (min)	Temperature (°C)
Column	0	60
	0 - 8.5	60 → 230
	8.5 - 14	230
Injection port		260
Detector		280

**Detection:** flame ionisation.

**Injection:** 2 µL; if necessary inject a blank solution.

**Elution order:** impurity A, 3-aminopropanol, impurity B, trolamine.

**System suitability:** reference solution (b):

- **resolution:** minimum 2.0 between the peaks due to 3-aminopropanol and impurity A.

07/2010:1577

## TROLAMINE

### Trolaminum

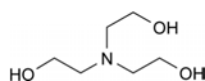

C<sub>6</sub>H<sub>15</sub>NO<sub>3</sub>  
[102-71-6]

*M*<sub>r</sub> 149.2

## DEFINITION

2,2',2''-Nitrilotriethanol.

**Content:** 99.0 per cent *m/m* to 103.0 per cent *m/m* of total bases (anhydrous substance).

**Limits:**

- **impurity A:** calculate the ratio (*R1*) of the area of the peak due to impurity A to the area of the peak due to the internal standard from the chromatogram obtained with reference solution (b); from the chromatogram obtained with the test solution, calculate the ratio of the area of any peak due to impurity A to the area of the peak due to the internal standard: this ratio is not greater than *R1* (0.1 per cent);
- **impurity B:** calculate the ratio (*R2*) of the area of the peak due to impurity B to the area of the peak due to the internal standard from the chromatogram obtained with reference solution (b); from the chromatogram obtained with the test solution, calculate the ratio of the area of any peak due to impurity B to the area of the peak due to the internal standard: this ratio is not greater than *R2* (0.5 per cent);
- **total:** calculate the ratio (*R4*) of the area of the peak due to trolamine to the area of the peak due to the internal standard from the chromatogram obtained with reference solution (b); from the chromatogram obtained with the test solution, calculate the ratio of the sum of the areas of any peaks, apart from the principal peak and the peak due to the internal standard, to the area of the peak due to the internal standard: this ratio is not greater than 10 times *R4* (1.0 per cent);
- **disregard limit:** 0.5 times the ratio of the area of the peak due to trolamine to the area of the peak due to the internal standard from the chromatogram obtained with reference solution (b) (0.05 per cent).

**Impurity C.** Gas chromatography (2.2.28).

**Solvent mixture:** acetone R, chloroform R (10:50 V/V).

**Preparation of solid phase extraction columns**

**Column A.** Fill a glass chromatography column (*l* = 400 mm;  $\emptyset$  = 20 mm) fitted with a teflon stopcock and a sintered-glass filter (160) (2.1.2) with 3 g of anhydrous sodium sulfate R and cover with a mixture of 17 g of kieselguhr for chromatography R and 3 g of potassium carbonate R. Settle the column bed by gently tapping the column.

**Column B.** Fill a glass chromatography column (*l* = 400 mm;  $\emptyset$  = 20 mm) fitted with a teflon stopcock and a sintered-glass filter (160) (2.1.2) with a slurry of 25 g of silica gel for chromatography R (0.063 to 0.200 mm) in the solvent mixture. Apply slight pressure to settle the column and cover the column bed with 5 g of anhydrous sodium sulfate R.

**Standard solution (a).** Dissolve 50  $\mu$ L of *N*-nitrosodiethanolamine R (impurity C) in methanol R and dilute to 50.0 mL with the same solvent. Dilute 100  $\mu$ L of this solution to 100.0 mL with methanol R.

**Standard solution (b).** Dilute 10.0 mL of standard solution (a) to 50.0 mL with methanol R.

**Standard solution (c).** Dissolve 50 mg of *N*-nitrosodiisopropanolamine R in methanol R and dilute to 50.0 mL with the same solvent. Dilute 100  $\mu$ L of this solution to 100.0 mL with methanol R.

**Test solution.** To 2.000 g of the substance to be examined add 200  $\mu$ L of methanol R and 0.5 g of sulfamic acid R. Dissolve in 8 mL of water for chromatography R and apply the solution to column A. Rinse the vessel twice with 1.5 mL of water for chromatography R, applying the rinsings to the column as well. After 15 min of equilibration time elute the column with 100 mL of ethyl acetate R, collecting the eluate in a 250 mL distillation flask. Evaporate the eluate to dryness. Take up the residue in 1 mL of the solvent mixture, apply to column B and let it settle. Rinse the flask twice with 2 mL of the solvent mixture, apply the rinsings to the column and let it settle. Wash the column with 100 mL of the solvent mixture and discard. Elute the column with 120 mL of acetone R, collecting the eluate in a 250 mL distillation flask. Evaporate the eluate to dryness. Transfer the residue with the aid of a small volume of acetone R into a vial and evaporate again to dryness under a stream of nitrogen R. Dissolve the residue in

100  $\mu$ L of trimethylpentane for chromatography R, add 100  $\mu$ L of *N*-methyltrimethylsilyl-trifluoroacetamide R and heat at 70 °C for 1 h.

**Reference solution (a).** To 2.000 g of the substance to be examined add 200  $\mu$ L of standard solution (b) and 0.5 g of sulfamic acid R. Dissolve in 8 mL of water for chromatography R, then proceed exactly as described for the test solution.

**Reference solution (b).** To 1.0 mL of standard solution (a) add 4.0 mL of standard solution (c) and mix. Transfer 500  $\mu$ L of the solution to a vial and evaporate to dryness under a stream of nitrogen R. Dissolve the residue in 200  $\mu$ L of trimethylpentane for chromatography R, add 200  $\mu$ L of *N*-methyltrimethylsilyl-trifluoroacetamide R and heat at 70 °C for 1 h.

**Reference solution (c).** In a vial, evaporate 200  $\mu$ L of standard solution (b) to dryness under a stream of nitrogen R. Dissolve the residue in 100  $\mu$ L of trimethylpentane for chromatography R, add 100  $\mu$ L of *N*-methyltrimethylsilyl-trifluoroacetamide R and heat at 70 °C for 1 h.

**Blank solution.** In a gas chromatography vial, evaporate 200  $\mu$ L of methanol R to dryness under a stream of nitrogen R. Dissolve the residue in 100  $\mu$ L of trimethylpentane for chromatography R add 100  $\mu$ L of *N*-methyltrimethylsilyl-trifluoroacetamide R and heat at 70 °C for 1 h.

**Column:**

- **material:** fused silica;
- **size:** *l* = 30 m;  $\emptyset$  = 0.25 mm;
- **stationary phase:** base-deactivated poly(dimethyl)-(diphenyl)siloxane R (film thickness 1  $\mu$ m).

**Carrier gas:** helium for chromatography R.

**Flow rate:** 2 mL/min.

**Split ratio:** 1:10.

**Temperature:**

	Time (min)	Temperature (°C)
Column	0 - 5	180 → 280
	5 - 10	280
Injection port		220

**Detection:** chemoluminescence:

- dual plasma burner in nitrosamine mode;
- burner temperature: 450 °C;
- oxygen flow rate: 4.4-5.0 mL/min.

**Injection:** 4  $\mu$ L.

**System suitability:**

- **resolution:** minimum 1.3 between the peaks due to impurity C and *N*-nitrosodiisopropanolamine in the chromatogram obtained with reference solution (b);
- **recovery:** minimum 50 per cent. The difference between the area of the peak due to impurity C in the chromatogram obtained with reference solution (a) and the area of the corresponding peak in the chromatogram obtained with the test solution is not less than 0.5 times the area of the corresponding peak in the chromatogram obtained with reference solution (c).

**Limits:**

- **impurity C:** not more than the difference between the area of the peak due to impurity C in the chromatogram obtained with reference solution (a) and the area of the corresponding peak in the chromatogram obtained with the test solution (24 ppb).

**Heavy metals (2.4.8):** maximum 10 ppm.

Dilute 5 mL of solution S to 30 mL with water R. The solution complies with test A. Prepare the reference solution using lead standard solution (1 ppm Pb) R.

**Water** (2.5.12): maximum 1.0 per cent, determined on 1.000 g. Open the titration vessel, introduce the substance to be examined directly into the previously titrated solvent. Stopper the flask immediately.

**Sulfated ash** (2.4.14): maximum 0.1 per cent, determined on 1.0 g. Do not carry out the initial heating on a water-bath.

#### ASSAY

Dissolve 1.200 g in 75 mL of *carbon dioxide-free water R*. Add 0.3 mL of *methyl red solution R*. Titrate with 1 M *hydrochloric acid*.

1 mL of 1 M *hydrochloric acid* is equivalent to 0.149 g of  $C_4H_{11}NO_3$ .

#### STORAGE

In an airtight container, protected from light.

#### IMPURITIES

*Specified impurities: A, B, C.*

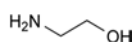

A. 2-aminoethanol (ethanolamine),

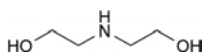

B. 2,2'-iminodiethanol (diethanolamine),

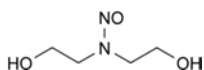

C. 2,2'-(nitrosoimino)diethanol (*N*-nitrosodiethanolamine).

01/2008:1053  
corrected 6.0

## TROMETAMOL

### Trometamolum

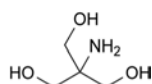

$C_4H_{11}NO_3$   
[77-86-1]

$M_r$  121.1

#### DEFINITION

Trometamol contains not less than 99.0 per cent and not more than the equivalent of 100.5 per cent of aminomethylidynetri(methanol), calculated with reference to the dried substance.

#### CHARACTERS

A white or almost white, crystalline powder, or colourless crystals, freely soluble in water, sparingly soluble in alcohol, very slightly soluble in ethyl acetate.

#### IDENTIFICATION

*First identification: B, C.*

*Second identification: A, B, D.*

A. Solution S (see Tests) is strongly alkaline (2.2.4).

B. Melting point (2.2.14): 168 °C to 174 °C.

C. Examine by infrared absorption spectrophotometry (2.2.24), comparing with the spectrum obtained with *trometamol CRS*.

D. Examine the chromatograms obtained in the test for related substances. The principal spot in the chromatogram obtained with test solution (b) is similar in position, colour and size to the principal spot in the chromatogram obtained with reference solution (a).

#### TESTS

**Solution S.** Dissolve 2.5 g in *carbon dioxide-free water R* and dilute to 50 mL with the same solvent.

**Appearance of solution.** Solution S is clear (2.2.1) and colourless (2.2.2, *Method II*).

**pH** (2.2.3). The pH of freshly prepared solution S is 10.0 to 11.5.

**Related substances.** Examine by thin-layer chromatography (2.2.27), using *silica gel G R* as the coating substance. Wash the plate with *methanol R* before applying the solutions.

*Test solution (a).* Dissolve 0.20 g in 1 mL of *water R*, with heating, and dilute to 10 mL with *methanol R*.

*Test solution (b).* Dilute 1 mL of test solution (a) to 10 mL with *methanol R*.

*Reference solution (a).* Dissolve 20 mg of *trometamol CRS* in *methanol R* and dilute to 10 mL with the same solvent.

*Reference solution (b).* Dilute 1 mL of test solution (a) to 100 mL with *methanol R*.

Apply to the plate 10 µL of each solution. Develop over a path of 10 cm using a mixture of 10 volumes of *dilute ammonia RI* and 90 volumes of *2-propanol R*. Dry the plate at 100 °C to 105 °C. Spray with a 5 g/L solution of *potassium permanganate R* in a 10 g/L solution of *sodium carbonate R*. After about 10 min examine in daylight. Any spot in the chromatogram obtained with test solution (a), apart from the principal spot, is not more intense than the spot in the chromatogram obtained with reference solution (b) (1.0 per cent).

**Chlorides** (2.4.4). To 10 mL of solution S add 2.5 mL of *dilute nitric acid R* and dilute to 15 mL with *water R*. The solution complies with the limit test for chlorides (100 ppm).

**Heavy metals** (2.4.8). Dissolve 2.0 g in 10 mL of *water R*. Neutralise the solution with *hydrochloric acid RI* and dilute to 20 mL with *water R*. 12 mL of the solution complies with limit test A for heavy metals (10 ppm). Prepare the standard using *lead standard solution (1 ppm Pb) R*.

**Iron** (2.4.9). Dissolve 1.0 g in *water R* and dilute to 10 mL with the same solvent. The solution complies with the limit test for iron (10 ppm).

**Loss on drying** (2.2.32). Not more than 0.5 per cent, determined on 1.000 g by drying in an oven at 105 °C.

**Sulfated ash** (2.4.14). Not more than 0.1 per cent, determined on 1.0 g.

**Bacterial endotoxins** (2.6.14): less than 0.03 IU/mg, if intended for use in the manufacture of parenteral preparations without a further appropriate procedure for the removal of bacterial endotoxins.

#### ASSAY

Dissolve 0.100 g in 20 mL of *water R*. Add 0.2 mL of *methyl red solution R*. Titrate with 0.1 M *hydrochloric acid* until the colour changes from yellow to red.

1 mL of 0.1 M *hydrochloric acid* is equivalent to 12.11 mg of  $C_4H_{11}NO_3$ .

#### IMPURITIES

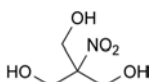

A. nitromethylidynetri(methanol).

01/2011:1159 **Optical rotation** (2.2.7):  $-0.1^{\circ}$  to  $+0.1^{\circ}$ .**TROPICAMIDE**

## Tropicamidum

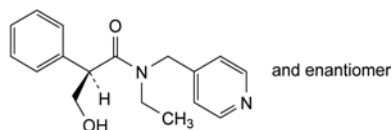

$C_{17}H_{20}N_2O_2$   
[1508-75-4]

 $M_r$  284.4**DEFINITION**

(2*RS*)-*N*-Ethyl-3-hydroxy-2-phenyl-*N*-(pyridin-4-ylmethyl)propanamide.

*Content*: 99.0 per cent to 101.0 per cent (dried substance).

**CHARACTERS**

*Appearance*: white or almost white, crystalline powder.

*Solubility*: slightly soluble in water, freely soluble in ethanol (96 per cent) and in methylene chloride.

**IDENTIFICATION**

*First identification*: C.

*Second identification*: A, B, D, E.

A. Melting point (2.2.14):  $95^{\circ}\text{C}$  to  $98^{\circ}\text{C}$ .

B. Ultraviolet and visible absorption spectrophotometry (2.2.25).

*Test solution*. Dissolve 20.0 mg in 0.1 *M* hydrochloric acid and dilute to 50.0 mL with the same acid. Dilute 2.0 mL of this solution to 20.0 mL with 0.1 *M* hydrochloric acid.

*Spectral range*: 230-350 nm.

*Absorption maximum*: at 254 nm.

*Specific absorbance at the absorption maximum*: 170 to 190.

C. Infrared absorption spectrophotometry (2.2.24).

*Comparison*: tropicamide CRS.

D. Thin-layer chromatography (2.2.27).

*Test solution*. Dissolve 10 mg of the substance to be examined in methylene chloride *R* and dilute to 10 mL with the same solvent.

*Reference solution*. Dissolve 10 mg of tropicamide CRS in methylene chloride *R* and dilute to 10 mL with the same solvent.

*Plate*: TLC silica gel  $F_{254}$  plate *R*.

*Mobile phase*: concentrated ammonia *R*, methanol *R*, methylene chloride *R* (0.5:5:95 V/V/V).

*Application*: 10  $\mu\text{L}$ .

*Development*: over 2/3 of the plate.

*Drying*: in air.

*Detection*: examine in ultraviolet light at 254 nm.

*Results*: the principal spot in the chromatogram obtained with the test solution is similar in position and size to the spot in the chromatogram obtained with the reference solution.

E. Dissolve about 5 mg in 3 mL of a mixture of 9 mL of acetic anhydride *R*, 1 mL of acetic acid *R* and 0.1 g of citric acid *R*. Heat on a water-bath for 5-10 min. A reddish-yellow colour is produced.

**TESTS**

**Appearance of solution**. The solution is clear (2.2.1) and colourless (2.2.2, Method II).

Dissolve 0.1 g in ethanol (96 per cent) *R* and dilute to 10 mL with the same solvent.

Dissolve 2.5 g in anhydrous ethanol *R* and dilute to 25.0 mL with the same solvent.

**Related substances**. Liquid chromatography (2.2.29).

*Test solution*. Dissolve 50.0 mg of the substance to be examined in 3 mL of acetonitrile *R1* and dilute to 50.0 mL with water for chromatography *R*.

*Reference solution (a)*. Dilute 1.0 mL of the test solution to 100.0 mL with water for chromatography *R*. Dilute 1.0 mL of this solution to 10.0 mL with water for chromatography *R*.

*Reference solution (b)*. Dissolve 5 mg of 4-[(ethylamino)methyl]pyridine *R* (impurity A), 5.0 mg of tropicamide impurity C CRS and 5.0 mg of tropicamide impurity D CRS in 2 mL of acetonitrile *R1* and dilute to 50.0 mL with water for chromatography *R*. Dilute 1.0 mL of this solution to 10.0 mL with water for chromatography *R*.

*Reference solution (c)*. Dissolve 5 mg of tropicamide for peak identification CRS (containing impurity B) in 1.0 mL of acetonitrile *R1* and dilute to 10.0 mL with water for chromatography *R*.

*Reference solution (d)*. To 1 mL of reference solution (b) add 1 mL of reference solution (c).

*Reference solution (e)*. Dilute 1.5 mL of reference solution (b) to 10.0 mL with water for chromatography *R*.

*Column*:

– *size*:  $l = 0.15\text{ m}$ ,  $\varnothing = 4.6\text{ mm}$ ;

– *stationary phase*: end-capped octadecylsilyl silica gel for chromatography *R* (3  $\mu\text{m}$ );

– *temperature*:  $40^{\circ}\text{C}$ .

*Mobile phase*. Dissolve 0.135 g of sodium dodecyl sulfate *R* and 3.4 mL of phosphoric acid *R* in 950 mL of water for chromatography *R*. Adjust to pH 3.0 with strong sodium hydroxide solution *R* and dilute to 1000 mL with water for chromatography *R*. Mix 73 volumes of this solution with 27 volumes of acetonitrile *R1*.

*Flow rate*: 0.8 mL/min.

*Detection*: spectrophotometer at 210 nm and at 254 nm.

*Injection*: 15  $\mu\text{L}$ .

*Run time*: 3 times the retention time of tropicamide.

*Identification of impurities*: use the chromatogram obtained with reference solution (c) to identify the peak due to impurity B; use the chromatogram obtained with reference solution (b) to identify the peaks due to impurities A, C and D.

*Relative retention* with reference to tropicamide (retention time = about 11 min): impurity C = about 0.4; impurity A = about 0.5; impurity D = about 0.8; impurity B = about 2.3.

*System suitability*: reference solution (d):

– *resolution at 210 nm*: minimum 2.0 between the peaks due to impurities C and A;

– *resolution at 254 nm*: minimum 2.0 between the peaks due to impurities A and D.

*Limits*:

– *correction factors*: for the calculation of content, multiply the peak areas of the following impurities by the corresponding correction factor: impurity A = 0.8; impurity B = 0.6;

– *impurity B at 254 nm*: not more than 3 times the area of the principal peak in the chromatogram obtained with reference solution (a) (0.3 per cent);

– *impurity A at 254 nm*: not more than 1.5 times the area of the principal peak in the chromatogram obtained with reference solution (a) (0.15 per cent);

– *impurity C at 210 nm*: not more than the area of the corresponding peak in the chromatogram obtained with reference solution (e) (0.15 per cent);

– *impurity D at 210 nm*: not more than the area of the corresponding peak in the chromatogram obtained with reference solution (e) (0.15 per cent);

01/2008:2102  
corrected 6.0

- *unspecified impurities at 254 nm*: for each impurity, not more than the area of the principal peak in the chromatogram obtained with reference solution (a) (0.10 per cent);
- *sum of impurities other than C and D at 254 nm*: not more than 5 times the area of the principal peak in the chromatogram obtained with reference solution (a) (0.5 per cent);
- *disregard limit at 254 nm*: 0.5 times the area of the principal peak in the chromatogram obtained with reference solution (a) (0.05 per cent).

**Chlorides (2.4.4)**: maximum 100 ppm.

Dissolve 1.0 g with heating in 8 mL of *acetic acid R*, cool and dilute to 10 mL with the same acid. Dilute 5 mL of this solution to 15 mL with *water R*.

**Loss on drying (2.2.32)**: maximum 0.5 per cent, determined on 1.000 g by drying in an oven at 80 °C at a pressure not exceeding 0.7 kPa for 4 h.

**Sulfated ash (2.4.14)**: maximum 0.1 per cent, determined on 1.0 g.

#### ASSAY

Dissolve 0.200 g in 50 mL of *anhydrous acetic acid R*. Add 0.2 mL of *naphtholbenzein solution R* and titrate with 0.1 M *perchloric acid* until the colour changes from orange to green.

1 mL of 0.1 M *perchloric acid* is equivalent to 28.44 mg of  $C_{17}H_{21}N_2O_2$ .

#### STORAGE

Protected from light.

#### IMPURITIES

*Specified impurities: A, B, C, D.*

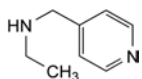

A. *N*-(pyridin-4-ylmethyl)ethanamine,

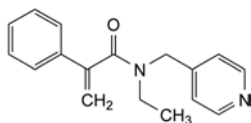

B. *N*-ethyl-2-phenyl-*N*-(pyridin-4-ylmethyl)propanamide,

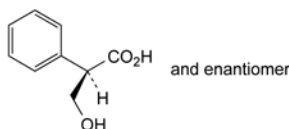

C. (2*RS*)-3-hydroxy-2-phenylpropanoic acid (tropic acid),

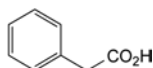

D. phenylacetic acid.

## TROPISETRON HYDROCHLORIDE

### Tropisetroni hydrochloridum

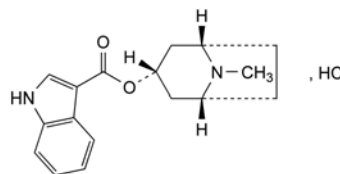

$C_{17}H_{21}ClN_2O_2$   
[105826-92-4]

$M_r$  320.8

#### DEFINITION

Hydrochloride of (1*R*,3*r*,5*S*)-8-methyl-8-azabicyclo[3.2.1]oct-3-yl 1*H*-indole-3-carboxylate.

*Content*: 99.0 per cent to 101.0 per cent (dried substance).

#### CHARACTERS

*Appearance*: white or almost white powder.

*Solubility*: freely soluble or soluble in water, sparingly soluble in ethanol (96 per cent), very slightly soluble in methylene chloride.

#### IDENTIFICATION

*First identification: B, D.*

*Second identification: A, C, D.*

A. Ultraviolet and visible absorption spectrophotometry (2.2.25).

*Test solution*. Dissolve 50 mg in *methanol R* and dilute to 25.0 mL with the same solvent. Dilute 1.0 mL of this solution to 100.0 mL with *methanol R*.

*Spectral range*: 220-360 nm.

*Absorption maxima*: at 228 nm and 282 nm.

*Absorbance ratio*:  $A_{228}/A_{282} = 1.3$  to 1.4.

B. Infrared absorption spectrophotometry (2.2.24).

*Comparison: tropisetron hydrochloride CRS.*

C. Thin-layer chromatography (2.2.27).

*Test solution*. Dissolve 5 mg of the substance to be examined in a mixture of equal volumes of *methanol R* and *methylene chloride R* and dilute to 5 mL with the same mixture of solvents.

*Reference solution*. Dissolve 5 mg of *tropisetron hydrochloride CRS* in a mixture of equal volumes of *methanol R* and *methylene chloride R* and dilute to 5 mL with the same mixture of solvents.

*Plate: TLC silica gel F<sub>254</sub> plate R.*

*Mobile phase: anhydrous formic acid R, water R, methanol R, methylene chloride R (2:2:30:70 V/V/V/V).*

*Application*: 5 µL.

*Development*: over 2/3 of the plate.

*Drying*: in cold air.

*Detection A*: examine in ultraviolet light at 254 nm.

*Detection B*: spray first with a solution prepared as follows: dissolve 0.85 g of *bismuth subnitrate R* in a mixture of 10 mL of *acetic acid R* and 40 mL of *water R*; to 5 mL of this solution add 5 mL of a 400 g/L solution of *potassium iodide R* and dilute to 100 mL with *water R*. Then spray with *strong hydrogen peroxide solution R*.

*Results*: for both detection methods, the principal spot in the chromatogram obtained with the test solution is similar in position and size to the principal spot in the chromatogram obtained with the reference solution.

D. It gives reaction (a) of chlorides (2.3.1).

## TESTS

**Appearance of solution.** The solution is clear (2.2.1) and not more intensely coloured than reference solution B<sub>7</sub> (2.2.2, Method II).

Dissolve 1.00 g in *water R* and dilute to 20 mL with the same solvent.

**Impurity A.** Thin-layer chromatography (2.2.27).

**Test solution.** Dissolve 0.200 g of the substance to be examined in a mixture of equal volumes of *methanol R* and *methylene chloride R* and dilute to 5.0 mL with the same mixture of solvents.

**Reference solution (a).** Dissolve 5.0 mg of *tropine CRS* (impurity A) in a mixture of equal volumes of *methanol R* and *methylene chloride R* and dilute to 25.0 mL with the same mixture of solvents.

**Reference solution (b).** Dilute 1.0 mL of the test solution to 20.0 mL with a mixture of equal volumes of *methanol R* and *methylene chloride R*. To 0.1 mL of this solution add 1.0 mL of reference solution (a).

**Plate:** TLC silica gel F<sub>254</sub> plate R.

**Mobile phase:** ammonia R, *methanol R*, *methylene chloride R* (5:40:60 V/V/V).

**Application:** 10 µL.

**Development:** over 2/3 of the plate.

**Drying:** in a current of cold air.

**Detection:** dip the plate in *potassium iodobismuthate solution RI*.

**System suitability:** reference solution (b):

- the chromatogram shows 2 clearly separated spots.

**Limit:**

- **impurity A:** any spot due to impurity A is not more intense than the spot in the chromatogram obtained with reference solution (a) (0.5 per cent).

**Related substances.** Liquid chromatography (2.2.29).

**Test solution.** Dissolve 0.100 g of the substance to be examined in mobile phase A and dilute to 20.0 mL with mobile phase A.

**Reference solution (a).** Dilute 1.0 mL of the test solution to 100.0 mL with mobile phase A. Dilute 1.0 mL of this solution to 10.0 mL with mobile phase A.

**Reference solution (b).** Dissolve 5.0 mg of *tropisetron impurity B CRS* and 5 mg of *ethyl indole-3-carboxylate CRS* in mobile phase A and dilute to 20.0 mL with mobile phase A. Dilute 1.0 mL of this solution to 50.0 mL with mobile phase A.

**Column:**

- **size:**  $l = 0.25$  m,  $\emptyset = 4.6$  mm;
- **stationary phase:** *octylsilyl silica gel for chromatography R* (5 µm).

**Mobile phase:**

- **mobile phase A:** *triethylamine R*, *acetonitrile R*, *water R*, *methanol R* (0.3:35:400:565 V/V/V/V);
- **mobile phase B:** *triethylamine R*, *acetonitrile R*, *water R*, *methanol R* (0.3:100:100:800 V/V/V/V);

Time (min)	Mobile phase A (per cent V/V)	Mobile phase B (per cent V/V)
0 - 14	100	0
14 - 32	100 → 0	0 → 100
32 - 36	0	100
36 - 37	0 → 100	100 → 0
37 - 52	100	0

**Flow rate:** 2 mL/min.

**Detection:** spectrophotometer at 280 nm.

**Injection:** 20 µL.

**Relative retention** with reference to tropisetron (retention time = about 22 min): impurity B = about 0.05; ethyl indole-3-carboxylate = about 0.2.

**System suitability:** reference solution (b):

- **resolution:** minimum 4 between the peaks due to impurity B and ethyl indole-3-carboxylate.

**Limits:**

- **impurity B:** not more than the area of the corresponding peak in the chromatogram obtained with reference solution (b) (0.1 per cent);
- **unspecified impurities:** for each impurity, not more than the area of the principal peak in the chromatogram obtained with reference solution (a) (0.10 per cent);
- **total:** not more than 3 times the area of the principal peak in the chromatogram obtained with reference solution (a) (0.3 per cent);
- **disregard limit:** 0.5 times the area of the principal peak in the chromatogram obtained with reference solution (a) (0.05 per cent).

**N,N-Dimethylaniline.** Liquid chromatography (2.2.29).

**Prepare the solutions immediately before use.**

**Test solution.** Dissolve 250 mg of the substance to be examined in mobile phase A and dilute to 5.0 mL with mobile phase A.

**Reference solution.** Dissolve 10.0 mg of *N,N-dimethylaniline R* in mobile phase A and dilute to 100.0 mL with mobile phase A. Dilute 1.0 mL of this solution to 100.0 mL with mobile phase A.

**Column:**

- **size:**  $l = 0.25$  m,  $\emptyset = 4.6$  mm;
- **stationary phase:** *octylsilyl silica gel for chromatography R* (5 µm).

**Mobile phase:**

- **mobile phase A:** *triethylamine R*, *acetonitrile R*, *water R*, *methanol R* (0.3:35:400:565 V/V/V/V);
- **mobile phase B:** *triethylamine R*, *acetonitrile R*, *water R*, *methanol R* (0.3:100:100:800 V/V/V/V);

Time (min)	Mobile phase A (per cent V/V)	Mobile phase B (per cent V/V)
0 - 10	100	0
10 - 11	100 → 0	0 → 100
11 - 30	0	100
30 - 31	0 → 100	100 → 0
31 - 50	100	0

**Flow rate:** 1 mL/min.

**Detection:** spectrophotometer at 248 nm.

**Injection:** 20 µL.

**Limit:**

- **N,N-dimethylaniline:** not more than the area of the principal peak in the chromatogram obtained with the reference solution (20 ppm).

**Loss on drying** (2.2.32): maximum 0.3 per cent, determined on 1.000 g by drying in an oven at 105 °C.

**Sulfated ash** (2.4.14): maximum 0.1 per cent, determined on 1.0 g.

## ASSAY

Dissolve 0.250 g in 10 mL of *anhydrous acetic acid R* and add 70 mL of *acetic anhydride R*. Titrate with 0.1 M *perchloric acid*, determining the end-point potentiometrically (2.2.20).

1 mL of 0.1 M *perchloric acid* is equivalent to 32.08 mg of C<sub>17</sub>H<sub>21</sub>ClN<sub>2</sub>O<sub>2</sub>.

## IMPURITIES

Specified impurities: A, B.

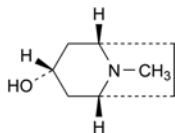
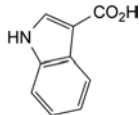
A. (1*R*,3*r*,5*S*)-8-methyl-8-azabicyclo[3.2.1]octan-3-ol (tropine),B. 1*H*-indole-3-carboxylic acid.01/2008:1798  
corrected 6.0

## TROSPIUM CHLORIDE

## Tropii chloridum

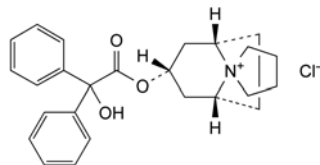
C<sub>25</sub>H<sub>30</sub>ClNO<sub>3</sub>  
[10405-02-4]M<sub>r</sub> 428.0

## DEFINITION

(1*R*,3*r*,5*S*)-3-[(Hydroxydiphenylacetyl)oxy]spiro[8-azoniabicyclo[3.2.1]octane-8,1'-pyrrolidinium] chloride.

Content: 99.0 per cent to 101.0 per cent (dried substance).

## CHARACTERS

*Appearance*: white or almost white, crystalline powder.*Solubility*: very soluble in water, freely soluble in methanol, practically insoluble in methylene chloride.

## IDENTIFICATION

A. Infrared absorption spectrophotometry (2.2.24).

*Comparison*: tropium chloride CRS.

B. It gives reaction (a) of chlorides (2.3.1).

## TESTS

**Solution S.** Dissolve 3.0 g in carbon dioxide-free water R and dilute to 30 mL with the same solvent.**Appearance of solution.** Solution S is clear (2.2.1) and not more intensely coloured than reference solution B<sub>7</sub> (2.2.2, Method II).**pH** (2.2.3): 5.0 to 7.0.

Dilute 5 mL of solution S to 50 mL with carbon dioxide-free water R.

**Impurity C.** Thin-layer chromatography (2.2.27).*Test solution.* Dissolve 0.20 g of the substance to be examined in 2.0 mL of methanol R.*Reference solution (a).* Dissolve 1.0 mg of tropium impurity C CRS in 2.0 mL of methanol R.*Reference solution (b).* Dilute 1.0 mL of test solution to 10.0 mL with methanol R. To 50 µL of this solution add 1 mL of reference solution (a).*Plate*: TLC silica gel plate R.*Mobile phase*: glacial acetic acid R, hydrochloric acid R, acetonitrile R (1:3.5:45 V/V/V).*Application*: 10 µL as bands.*Development*: over 2/3 of the plate.*Drying*: in a current of warm air until the odour of acetic acid is no longer perceptible.*Detection*: spray with potassium iodobismuthate solution R and subsequently with a 5 g/L solution of sodium nitrite R.*System suitability*: reference solution (b):

– the chromatogram shows 2 clearly visible and separated zones.

*Limit*:– *impurity C*: any zone due to impurity C is not more intense than the zone in the chromatogram obtained with reference solution (a) (0.5 per cent).**Related substances.** Liquid chromatography (2.2.29).*Test solution.* Dissolve 30.0 mg of the substance to be examined in the mobile phase and dilute to 10.0 mL with the mobile phase.*Reference solution (a).* Dissolve 6.0 mg of tropium impurity A CRS in the mobile phase and dilute to 20.0 mL with the mobile phase.*Reference solution (b).* Dissolve 7.5 mg of tropium impurity B CRS in the mobile phase and dilute to 5.0 mL with the mobile phase.*Reference solution (c).* Dilute a mixture of 0.3 mL of the test solution, 1.0 mL of reference solution (a) and 1.0 mL of reference solution (b) to 100.0 mL with the mobile phase.*Column*:– *size*: *l* = 0.25 m, Ø = 4.6 mm;– *stationary phase*: end-capped octylsilyl silica gel for chromatography R (5 µm);– *temperature*: 40 °C.*Mobile phase*: mix 1 volume of triethylamine R and 3 volumes of phosphoric acid R with 700 volumes of water R and add 300 volumes of acetonitrile R.*Flow rate*: 1 mL/min.*Detection*: spectrophotometer at 215 nm.*Injection*: 20 µL.*Run time*: 3 times the retention time of tropium.*Relative retention* with reference to tropium (retention time = about 10 min): impurity B = about 0.7; impurity A = about 1.9.*System suitability*: reference solution (c):– *resolution*: minimum 3 between the peaks due to impurity B and tropium.*Limits*:– *impurity B*: not more than the area of the corresponding peak in the chromatogram obtained with reference solution (c) (0.5 per cent);– *impurity A*: not more than 3 times the area of the corresponding peak in the chromatogram obtained with reference solution (c) (0.3 per cent);– *unspecified impurities*: for each impurity, not more than 0.2 times the area of the peak due to impurity B in the chromatogram obtained with reference solution (c) (0.10 per cent);– *total*: not more than twice the area of the peak due to impurity B in the chromatogram obtained with reference solution (c) (1.0 per cent);– *disregard limit*: 0.1 times the area of the peak due to impurity B in the chromatogram obtained with reference solution (c) (0.05 per cent).**Loss on drying** (2.2.32): maximum 0.5 per cent, determined on 1.000 g by drying in an oven at 105 °C.**Sulfated ash** (2.4.14): maximum 0.1 per cent, determined on 1.0 g.



## ASSAY

Dissolve 0.300 g in 50 mL of *water R*. Titrate with 0.1 M silver nitrate, determining the end-point potentiometrically (2.2.20).

1 mL of 0.1 M silver nitrate is equivalent to 42.80 mg of  $C_{25}H_{30}ClNO_3$ .

## STORAGE

Protected from light.

## IMPURITIES

Specified impurities: A, B, C.

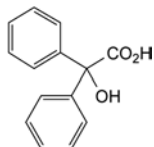

A. hydroxydiphenylacetic acid (benzilic acid),

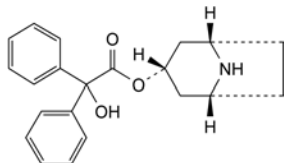

B. (1*R*,3*r*,5*S*)-8-azabicyclo[3.2.1]oct-3-yl hydroxydiphenylacetate,

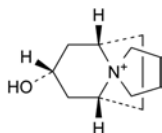

C. (1*R*,3*r*,5*S*)-3-hydroxyspiro[8-azoniabicyclo[3.2.1]octane-8,1'-pyrrolidinium].

01/2008:2133  
corrected 6.0

## TROXERUTIN

## Troxerutinum

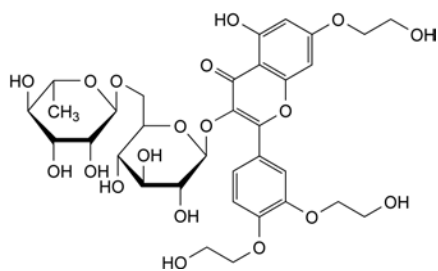

$C_{33}H_{42}O_{19}$

$M_r$  743

## DEFINITION

Mixture of *O*-hydroxyethylated derivatives of rutin containing minimum 80 per cent of 2-[3,4-bis(2-hydroxyethoxy)phenyl]-3-[[6-*O*-(6-deoxy- $\alpha$ -L-mannopyranosyl)- $\beta$ -D-glucopyranosyl]oxy]-5-hydroxy-7-(2-hydroxyethoxy)-4*H*-1-benzopyran-4-one (tris(hydroxyethyl)rutin).

*Content*: 95.0 per cent to 105.0 per cent (dried substance).

## CHARACTERS

*Appearance*: yellowish-green, crystalline powder, hygroscopic.

*Solubility*: freely soluble in water, slightly soluble in ethanol (96 per cent) and practically insoluble in methylene chloride.

## IDENTIFICATION

A. Infrared absorption spectrophotometry (2.2.24).

*Comparison*: troxerutin CRS.

B. Examine the chromatograms obtained in the test for composition.

*Results*: the principal peak in the chromatogram obtained with the test solution is similar in position and size to the principal peak in the chromatogram obtained with the reference solution (a).

## TESTS

**Composition.** Liquid chromatography (2.2.29): use the normalisation procedure.

*Test solution.* Dissolve 10.0 mg of the substance to be examined in the mobile phase, if necessary using an ultrasonic bath and dilute to 10.0 mL with the mobile phase.

*Reference solution (a).* Dissolve 10.0 mg of troxerutin CRS in the mobile phase, if necessary using an ultrasonic bath and dilute to 10.0 mL with the mobile phase.

*Reference solution (b).* Dilute 1 mL of reference solution (a) to 10 mL with the mobile phase. Dilute 1 mL of this solution to 100 mL with the mobile phase.

*Column*:

– *size*:  $l = 0.25$  m,  $\varnothing = 4.6$  mm,

– *stationary phase*: end-capped octadecylsilyl silica gel for chromatography R (5  $\mu$ m).

*Mobile phase*: mix 20 volumes of acetonitrile R and 80 volumes of a 15.6 g/L solution of sodium dihydrogen phosphate R adjusted to pH 4.4 with dilute phosphoric acid R or dilute sodium hydroxide solution R.

*Flow rate*: 0.5 mL/min.

*Detection*: spectrophotometer at 350 nm.

*Injection*: 10  $\mu$ L.

*Run time*: twice the retention time of the main compound of troxerutin (tris(hydroxyethyl)rutin).

*Relative retention* with reference to tris(hydroxyethyl)rutin (retention time = about 25 min): tetrakis(hydroxyethyl)rutin = about 0.5; mono(hydroxyethyl)rutin = about 0.8; bis(hydroxyethyl)rutin = about 1.1.

*System suitability*: reference solution (a):

– *peak-to-valley ratio*: minimum 2.0, where  $H_p$  = height above the baseline of the peak due to bis(hydroxyethyl)rutin and  $H_v$  = height above the baseline of the lowest point of the curve separating this peak from the peak due to tris(hydroxyethyl)rutin;

– *signal-to-noise ratio*: minimum 10 for the principal peak in the chromatogram obtained with reference solution (b).

*Limits*:

– *principal peak*: minimum 80 per cent,

– *any other peak*: for each peak, maximum 5 per cent, except for 1 peak which can be maximum 10 per cent.

– *disregard limit*: area of the principal peak in the chromatogram obtained with reference solution (b).

**Ethylene oxide.** Head-space gas chromatography (2.2.28).

*Test solution.* To 1.00 g of the substance to be examined in a vial, add 1.0 mL of *water R*. Mix to obtain a homogeneous solution. Heat at 70 °C for 45 min.

*Reference solution.* To 1.00 g of the substance to be examined in a vial, add 50  $\mu$ L of ethylene oxide solution R4 and 950  $\mu$ L of *water R* and close tightly. Mix to obtain a homogeneous solution. Heat at 70 °C for 45 min.

*Column*:

– *material*: fused silica,

– *size*:  $l = 30$  m,  $\varnothing = 0.32$  mm,

– *stationary phase*: poly(cyanopropyl)(7)(phenyl)(7)methyl(86)siloxane R (film thickness 1  $\mu$ m).

*Carrier gas*: helium for chromatography R.

*Flow rate*: 1.1 mL/min.

Static head-space conditions which may be used:

- equilibration temperature: 80 °C,
- equilibration time: 45 min,
- transfer line temperature: 110 °C,
- pressurisation time: 2 min,
- injection time: 12 s.

Temperature:

	Time (min)	Temperature (°C)
Column	0 - 5	40
	5 - 18	40 → 200
Injection port		150
Detector		250

Detection: flame ionisation.

Injection: 1.0 mL.

The peak due to ethylene oxide is identified by injecting solutions of ethylene oxide of increasing concentration.

Determine the content of ethylene oxide (ppm) in the substance to be examined using the following expression:

$$\frac{A_1 \times m_1}{(A_2 \times m_2) - (A_1 \times m_3)}$$

- $A_1$  = area of the peak due to ethylene oxide in the chromatogram obtained with the test solution,
- $A_2$  = area of the peak due to ethylene oxide in the chromatogram obtained with the reference solution,
- $m_1$  = mass of ethylene oxide in the reference solution, in micrograms,
- $m_2$  = mass of the substance to be examined in the test solution, in grams,
- $m_3$  = mass of the substance to be examined in the reference solution, in grams.

Limit:

- ethylene oxide: maximum 1 ppm.

**Heavy metals** (2.4.8): maximum 20 ppm.

1.0 g complies with test F. Prepare the reference solution using 2 mL of lead standard solution (10 ppm Pb) R.

**Loss on drying** (2.2.32): maximum 5.0 per cent, determined on 1.000 g by drying in an oven at 105 °C for 4 h.

**Sulfated ash** (2.4.14): maximum 0.4 per cent, determined on 1.0 g.

ASSAY

Dissolve 0.200 g in 100.0 mL of water R. Dilute 10.0 mL of this solution to 100.0 mL with water R. Dilute 10.0 mL to 100.0 mL with water R. Measure the absorbance (2.2.25) at the absorption maximum at 350 nm.

Calculate the percentage content of C<sub>33</sub>H<sub>42</sub>O<sub>19</sub> taking the specific absorbance to be 250.

STORAGE

In an airtight container, protected from light.

DEFINITION

Trypsin is a proteolytic enzyme obtained by the activation of trypsinogen extracted from the pancreas of mammals. It has an activity of not less than 0.5 microkatal per milligram, calculated with reference to the dried substance. In solution, it has maximum enzymic activity at pH 8; the activity is reversibly inhibited at pH 3, the pH at which it is most stable.

PRODUCTION

The animals from which trypsin is derived must fulfil the requirements for the health of animals suitable for human consumption.

The method of manufacture is validated to demonstrate that the product, if tested, would comply with the following test.

**Histamine** (2.6.10): not more than 1 µg of histamine base per 0.2 microkatal of trypsin activity. Use a 10 g/L solution of the substance to be examined in 0.0015 M borate buffer solution pH 8.0 R inactivated by heating on a water-bath for 30 min. Carry out dilutions with a 9 g/L solution of sodium chloride R.

CHARACTERS

**Appearance:** white or almost white, crystalline or amorphous powder, hygroscopic if amorphous.

**Solubility:** sparingly soluble in water.

IDENTIFICATION

- A. Dilute 1 mL of solution S (see Tests) to 100 mL with water R. In a depression in a white spot-plate, mix 0.1 mL of this solution with 0.2 mL of tosylarginine methyl ester hydrochloride solution R. A reddish-violet colour develops within 3 min.
- B. Dilute 0.5 mL of solution S to 5 mL with water R. Add 0.1 mL of a 20 g/L solution of tosyl-lysyl-chloromethane hydrochloride R. Adjust to pH 7.0, shake for 2 h and dilute to 50 mL with water R. In one of the depressions of a white spot-plate, mix 0.1 mL of this solution with 0.2 mL of tosylarginine methyl ester hydrochloride solution R. No reddish-violet colour develops within 3 min.

TESTS

**Solution S.** Dissolve 0.10 g in carbon dioxide-free water R and dilute to 10.0 mL with the same solvent.

**Appearance of solution.** Solution S is not more opalescent than reference suspension III (2.2.1).

**pH** (2.2.3): 3.0 to 6.0 for solution S.

**Specific absorbance** (2.2.25): 13.5 to 16.5, determined at the absorption maximum at 280 nm; maximum 7.0, determined at the absorption minimum at 250 nm.

Dissolve 30.0 mg in 0.001 M hydrochloric acid and dilute to 100.0 mL with the same acid.

**Chymotrypsin.**

**Test solution.** To 1.8 mL of buffer solution pH 8.0 R add 7.4 mL of water R and 0.5 mL of 0.2 M acetyltyrosine ethyl ester R. While shaking the solution, add 0.3 mL of solution S and start a timer. After exactly 5 min, measure the pH (2.2.3).

**Reference solution.** Prepare in the same manner as the test solution, replacing solution S by 0.3 mL of a 0.5 g/L solution of chymotrypsin BRP, and measure the pH (2.2.3) exactly 5 min after adding the chymotrypsin.

The pH of the test solution is higher than that of the reference solution.

**Loss on drying** (2.2.32): not more than 5.0 per cent, determined on 0.500 g by drying at 60 °C at a pressure not exceeding 0.67 kPa for 2 h.

**Microbial contamination**

TAMC: acceptance criterion 10<sup>4</sup> CFU/g (2.6.12).

TYMC: acceptance criterion 10<sup>2</sup> CFU/g (2.6.12).

01/2011:0694

## TRYPSIN

Trypsinum

[9002-07-7]

Absence of *Escherichia coli* (2.6.13).

Absence of *Salmonella* (2.6.13).

01/2009:1272  
corrected 7.0

## ASSAY

The activity of trypsin is determined by comparing the rate at which it hydrolyses *benzoylarginine ethyl ester hydrochloride R* with the rate at which *trypsin BRP* hydrolyses the same substrate in the same conditions.

**Apparatus.** Use a reaction vessel of about 30 mL capacity provided with:

- a device that will maintain a temperature of  $25.0 \pm 0.1$  °C;
- a stirring device (for example, a magnetic stirrer);
- a lid with holes for the insertion of electrodes, the tip of a burette, a tube for the admission of nitrogen and the introduction of reagents.

An automatic or manual titration device may be used. For the latter, the burette is graduated in 0.005 mL and the pH meter is provided with a wide-range scale and glass-calomel or glass-silver-silver chloride electrodes.

**Test solution.** Dissolve sufficient of the substance to be examined in 0.001 M hydrochloric acid and dilute to 25.0 mL with the same acid in order to obtain a solution containing approximately 700 nanokatals per millilitre.

**Reference solution.** Dissolve 25.0 mg of *trypsin BRP* in 0.001 M hydrochloric acid and dilute to 25.0 mL with the same acid.

Store the solutions at 0-5 °C. Warm 1 mL of each solution to about 25 °C over 15 min and use 50 µL of each solution for each titration. Carry out the titration in an atmosphere of nitrogen. Transfer 10.0 mL of 0.0015 M borate buffer solution pH 8.0 R to the reaction vessel and, while stirring, add 1.0 mL of a freshly prepared 6.86 g/L solution of *benzoylarginine ethyl ester hydrochloride R*. When the temperature is steady at  $25.0 \pm 0.1$  °C (after about 5 min) adjust to pH 8.0 exactly with 0.1 M sodium hydroxide. Add 50 µL of the test solution and start a timer. Maintain at pH 8.0 by the addition of 0.1 M sodium hydroxide, the tip of the microburette being immersed in the solution; note the volume added every 30 s. Follow the reaction for 8 min. Calculate the volume of 0.1 M sodium hydroxide used per second. Carry out a titration in the same manner using the reference solution and calculate the volume of 0.1 M sodium hydroxide used per second.

Calculate the activity in microkatals per milligram using the following expression:

$$\frac{m' \times V}{m \times V'} \times A$$

- m* = mass of the substance to be examined, in milligrams;  
*m'* = mass of *trypsin BRP*, in milligrams;  
*V* = volume of 0.1 M sodium hydroxide used per second by the test solution;  
*V'* = volume of 0.1 M sodium hydroxide used per second by the reference solution;  
*A* = activity of *trypsin BRP*, in microkatals per milligram.

## STORAGE

In an airtight container, protected from light, at a temperature of 2 °C to 8 °C.

## LABELLING

The label states:

- the activity in microkatals per milligram;
- for the amorphous substance, that it is hygroscopic.

## TRYPTOPHAN

### Tryptophanum

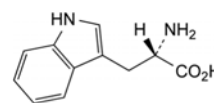

$C_{11}H_{12}N_2O_2$   
[73-22-3]

$M_r$  204.2

## DEFINITION

(S)-2-Amino-3-(1*H*-indol-3-yl)propanoic acid.

**Content:** 98.5 per cent to 101.0 per cent (dried substance).

## CHARACTERS

**Appearance:** white or almost white, crystalline or amorphous powder.

**Solubility:** sparingly soluble in water, slightly soluble in ethanol (96 per cent). It dissolves in dilute solutions of mineral acids and alkali hydroxides.

## IDENTIFICATION

**First identification:** A, B.

**Second identification:** A, C, D.

A. Specific optical rotation (see Tests).

B. Infrared absorption spectrophotometry (2.2.24).

**Preparation:** discs.

**Comparison:** *tryptophan CRS*.

C. Examine the chromatograms obtained in the test for ninhydrin-positive substances.

**Results:** the principal spot in the chromatogram obtained with test solution (b) is similar in position, colour and size to the principal spot in the chromatogram obtained with reference solution (a).

D. Dissolve about 20 mg in 10 mL of *water R*. Add 5 mL of *dimethylaminobenzaldehyde solution R6* and 2 mL of *hydrochloric acid R1*. Heat on a water-bath. A purple-blue colour develops.

## TESTS

**Appearance of solution.** The solution is clear (2.2.1) and not more intensely coloured than reference solution BY<sub>6</sub> (2.2.2, *Method II*).

Dissolve 0.1 g in 1 M hydrochloric acid and dilute to 10 mL with the same acid.

**Specific optical rotation** (2.2.7):  $-30.0$  to  $-33.0$  (dried substance).

Dissolve 0.25 g in *water R*, heating on a water-bath if necessary, and dilute to 25.0 mL with the same solvent.

**Ninhydrin-positive substances.** Thin-layer chromatography (2.2.27).

**Solvent mixture:** *glacial acetic acid R*, *water R* (50:50 V/V).

**Test solution (a).** Dissolve 0.10 g of the substance to be examined in the solvent mixture and dilute to 10 mL with the solvent mixture.

**Test solution (b).** Dilute 1 mL of test solution (a) to 50 mL with the solvent mixture.

**Reference solution (a).** Dissolve 10 mg of *tryptophan CRS* in the solvent mixture and dilute to 50 mL with the solvent mixture.

**Reference solution (b).** Dilute 5 mL of test solution (b) to 20 mL with the solvent mixture.

**Reference solution (c).** Dissolve 10 mg of *tryptophan CRS* and 10 mg of *tyrosine CRS* in the solvent mixture and dilute to 25 mL with the solvent mixture.

**Plate:** *TLC silica gel plate R*.

**Mobile phase:** *glacial acetic acid R, water R, butanol R* (20:20:60 V/V/V).

**Application:** 5 µL.

**Development:** over a path of 15 cm.

**Drying:** in air.

**Detection:** spray with *ninhydrin solution R* and heat at 100-105 °C for 15 min.

**System suitability:** reference solution (c):

- the chromatogram shows 2 clearly separated spots.

**Limit:** test solution (a):

- **any impurity:** any spot, apart from the principal spot, is not more intense than the principal spot in the chromatogram obtained with reference solution (b) (0.5 per cent).

**Impurity A and other related substances.** Liquid chromatography (2.2.29). Prepare the standard, test and reference solutions immediately before use.

**Buffer solution pH 2.3.** Dissolve 3.90 g of *sodium dihydrogen phosphate R* in 1000 mL of *water R*. Add about 700 mL of a 2.9 g/L solution of *phosphoric acid R* and adjust to pH 2.3 with the same acid solution.

**Solvent mixture:** *acetonitrile R, water R* (10:90 V/V).

**Standard solution.** Dissolve 10.0 mg of *N-acetyltryptophan R* in the solvent mixture and dilute to 100.0 mL with the solvent mixture. Dilute 2.0 mL of this solution to 100.0 mL with the solvent mixture.

**Test solution (a).** Dissolve 0.10 g of the substance to be examined in the solvent mixture and dilute to 10.0 mL with the solvent mixture.

**Test solution (b).** Dissolve 0.10 g of the substance to be examined in the standard solution and dilute to 10.0 mL with the standard solution.

**Reference solution (a).** Dissolve the contents of a vial of *1,1'-ethylidenebistryptophan CRS* (impurity A) in 1.0 mL of the solvent mixture.

**Reference solution (b).** Dissolve the contents of a vial of *1,1'-ethylidenebistryptophan CRS* (impurity A) in 1.0 mL of the standard solution.

**Reference solution (c).** Dilute 0.5 mL of reference solution (a) to 5.0 mL with the solvent mixture.

**Column:**

- **size:**  $l = 0.25$  m,  $\varnothing = 4.6$  mm;
- **stationary phase:** *octadecylsilyl silica gel for chromatography R* (5 µm);
- **temperature:** 40 °C.

**Mobile phase:**

- **mobile phase A:** *acetonitrile R*, buffer solution pH 2.3 (115:885 V/V);
- **mobile phase B:** *acetonitrile R*, buffer solution pH 2.3 (350:650 V/V);

Time (min)	Mobile phase A (per cent V/V)	Mobile phase B (per cent V/V)
0 - 10	100	0
10 - 45	100 → 0	0 → 100
45 - 65	0	100

**Flow rate:** 0.7 mL/min.

**Detection:** spectrophotometer at 220 nm.

**Injection:** 20 µL of test solutions (a) and (b) and reference solutions (b) and (c).

**Retention time:** tryptophan = about 8 min; *N-acetyltryptophan* = about 29 min; impurity A = about 34 min.

**System suitability:**

- **resolution:** minimum 8.0 between the peaks due to *N-acetyltryptophan* and impurity A in the chromatogram obtained with reference solution (b); if necessary, adjust the time programme for the elution gradient (an increase in the duration of elution with mobile phase A produces longer retention times and a better resolution);
- **signal-to-noise ratio:** minimum 15 for the principal peak in the chromatogram obtained with reference solution (c);
- **symmetry factor:** maximum 3.5 for the peak due to impurity A in the chromatogram obtained with reference solution (b).
- in the chromatogram obtained with test solution (a) there is no peak with the same retention time as *N-acetyltryptophan* (in such case correct the area of the *N-acetyltryptophan* peak).

**Limits:** test solution (b):

- **impurity A:** not more than 0.5 times the area of the principal peak in the chromatogram obtained with reference solution (c) (10 ppm);
- **sum of impurities with a retention time less than that of tryptophan:** not more than 0.6 times the area of the peak due to *N-acetyltryptophan* in the chromatogram obtained with reference solution (b) (100 ppm);
- **sum of impurities with a retention time greater than that of tryptophan and up to 1.8 times the retention time of N-acetyltryptophan:** not more than 1.9 times the area of the peak due to *N-acetyltryptophan* in the chromatogram obtained with reference solution (b) (300 ppm);
- **disregard limit:** 0.02 times the area of the peak due to *N-acetyltryptophan* in the chromatogram obtained with reference solution (b); disregard the peak due to *N-acetyltryptophan*.

**Chlorides (2.4.4):** maximum 200 ppm.

Dissolve 0.25 g in 3 mL of *dilute nitric acid R* and dilute to 15 mL with *water R*. The solution, without any further addition of nitric acid, complies with the test.

**Sulfates (2.4.13):** maximum 300 ppm.

Dissolve 0.5 g in a mixture of 5 volumes of *dilute hydrochloric acid R* and 25 volumes of *distilled water R*, and dilute to 15 mL with the same mixture of solvents.

**Ammonium (2.4.1, Method B):** maximum 200 ppm, determined on 0.10 g.

Prepare the standard using 0.2 mL of *ammonium standard solution (100 ppm NH<sub>4</sub>) R*.

**Iron (2.4.9):** maximum 20 ppm.

In a separating funnel, dissolve 0.50 g in 10 mL of *dilute hydrochloric acid R*. Shake with 3 quantities, each of 10 mL, of *methyl isobutyl ketone RI*, shaking for 3 min each time. To the combined organic layers add 10 mL of *water R* and shake for 3 min. Examine the aqueous layer.

**Heavy metals (2.4.8):** maximum 10 ppm.

2.0 g complies with test D. Prepare the reference solution using 2 mL of *lead standard solution (10 ppm Pb) R*.

**Loss on drying (2.2.32):** maximum 0.5 per cent, determined on 1.000 g by drying in an oven at 105 °C.

**Sulfated ash (2.4.14):** maximum 0.1 per cent, determined on 1.0 g.

**ASSAY**

Dissolve 0.150 g in 3 mL of *anhydrous formic acid R*. Add 30 mL of *anhydrous acetic acid R*. Titrate with 0.1 M *perchloric acid*, using 0.1 mL of *naphtholbenzein solution R* as indicator.

1 mL of 0.1 M *perchloric acid* is equivalent to 20.42 mg of C<sub>11</sub>H<sub>12</sub>N<sub>2</sub>O<sub>2</sub>.

## STORAGE

Protected from light.

## IMPURITIES

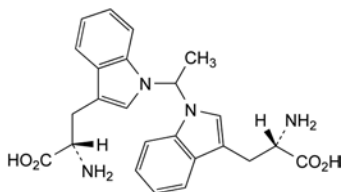

- A. 3,3'-[ethylidenebis(1*H*-indole-1,3-diy)]bis[(2*S*)-2-aminopropanoic] acid (1,1'-ethylidenebistryptophan),

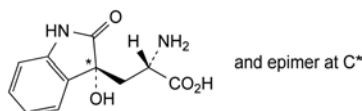

- B. (*S*)-2-amino-3-[(3*RS*)-3-hydroxy-2-oxo-2,3-dihydro-1*H*-indol-3-yl]propanoic acid (dioxyindolylalanine),

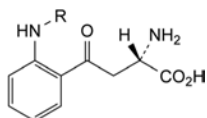

- C. R = H: (*S*)-2-amino-4-(2-aminophenyl)-4-oxobutanoic acid (kynurenine),

- E. R = CHO: (*S*)-2-amino-4-[2-(formylamino)phenyl]-4-oxobutanoic acid (*N*-formylkynurenine),

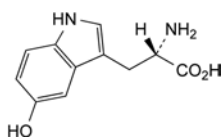

- D. (*S*)-2-amino-3-(5-hydroxy-1*H*-indol-3-yl)propanoic acid (5-hydroxytryptophan),

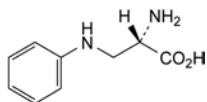

- F. (*S*)-2-amino-3-(phenylamino)propanoic acid (3-phenylaminoalanine),

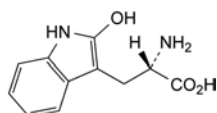

- G. (*S*)-2-amino-3-(2-hydroxy-1*H*-indol-3-yl)propanoic acid (2-hydroxytryptophan),

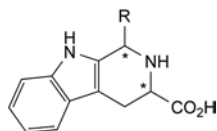

- H. R = H: (3*RS*)-1,2,3,4-tetrahydro-9*H*- $\beta$ -carboline-3-carboxylic acid,

- I. R = CH<sub>3</sub>: 1-methyl-1,2,3,4-tetrahydro-9*H*- $\beta$ -carboline-3-carboxylic acid,

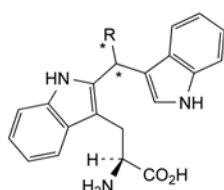

- J. R = CHOH-CH<sub>2</sub>-OH: (*S*)-2-amino-3-[2-[2,3-dihydroxy-1-(1*H*-indol-3-yl)propyl]-1*H*-indol-3-yl]propanoic acid,

- K. R = H: (*S*)-2-amino-3-[2-(1*H*-indol-3-ylmethyl)-1*H*-indol-3-yl]propanoic acid,

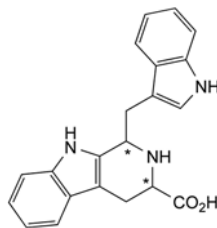

- L. 1-(1*H*-indol-3-ylmethyl)-1,2,3,4-tetrahydro-9*H*- $\beta$ -carboline-3-carboxylic acid.

01/2008:0152

## TUBERCULIN FOR HUMAN USE, OLD

## Tuberculinum pristinum ad usum humanum

## DEFINITION

Old tuberculin for human use consists of a filtrate, concentrated by heating, containing the soluble products of the culture and lysis of one or more strains of *Mycobacterium bovis* and/or *Mycobacterium tuberculosis* that is capable of demonstrating a delayed hypersensitivity in an animal sensitised to micro-organisms of the same species.

Old tuberculin for human use in concentrated form is a transparent, viscous, yellow or brown liquid.

## PRODUCTION

## GENERAL PROVISIONS

The production of old tuberculin is based on a seed-lot system. The production method shall have been shown to yield consistently old tuberculin of adequate potency and safety in man. A batch of old tuberculin, calibrated in International Units by the method described under Assay and for which adequate clinical information is available as to its activity in man, is set aside to serve as a reference preparation.

The International Unit is the activity of a stated quantity of the International Standard. The equivalence in International Units of the International Standard is stated by the World Health Organisation.

## SEED LOTS

The strains of mycobacteria used shall be identified by historical records that include information on their origin and subsequent manipulation.

The working seed lots used to inoculate the media for the production of a concentrated harvest shall not have undergone more than 4 subcultures from the master seed lot.

Only seed lots that comply with the following requirements may be used for propagation.

**Identification.** The species of mycobacterium of the master and working seed lots is identified.

**Bacterial and fungal contamination.** Carry out the test for sterility (2.6.1), using 10 mL for each medium. The working seed lot complies with the test for sterility except for the presence of mycobacteria.

## PROPAGATION AND HARVEST

The bacteria are grown in a liquid medium which may be a glycerolated broth or a synthetic medium. Growth must be typical for the strain. The culture is inactivated by a suitable method, such as treatment in an autoclave (121 °C for not less than 30 min) or in flowing steam at a temperature not less than 100 °C for at least 1 h. The culture liquid, from which the micro-organisms may or may not have been separated by filtration, is concentrated by evaporation, usually to one-tenth of its initial volume. The preparation is free from live mycobacteria. The concentrated harvest is shown to comply with the test

for mycobacteria (2.6.2) before addition of any antimicrobial preservative or other substance that might interfere with the test. Phenol (5 g/L) or another suitable antimicrobial preservative that does not give rise to false positive reactions may be added.

Only a concentrated harvest that complies with the following requirements may be used in the preparation of the final bulk tuberculin.

**pH (2.2.3).** The pH of the concentrated harvest is 6.5 to 8.

**Glycerol.** Where applicable, determine the glycerol content of the concentrated harvest. The amount is within the limits approved for the particular product.

**Antimicrobial preservative.** Where applicable, determine the amount of antimicrobial preservative by a suitable chemical or physico-chemical method. The content is not less than 85 per cent and not more than 115 per cent of the intended amount. If phenol has been used in the preparation, the concentration is not more than 5 g/L (2.5.15).

**Sensitisation.** Carry out the test described under Tests.

**Sterility (2.6.1).** The concentrated harvest complies with the test for sterility, carried out using 10 mL for each medium.

**Potency.** Determine the potency as described under Assay.

#### FINAL BULK TUBERCULIN

The concentrated harvest is diluted aseptically.

Only a final bulk tuberculin that complies with the following requirement may be used in the preparation of the final lot.

**Sterility (2.6.1).** The final bulk tuberculin complies with the test for sterility, carried out using 10 mL for each medium.

#### FINAL LOT

The final bulk tuberculin is distributed aseptically into sterile containers which are then closed so as to prevent contamination.

Only a final lot that is satisfactory with respect to each of the requirements given below under Identification, Tests and Assay may be released for use.

The following tests may be omitted on the final lot if they have been carried out at the stages indicated:

- live mycobacteria: concentrated harvest,
- sensitisation: concentrated harvest,
- toxicity: concentrated harvest or final bulk tuberculin,
- antimicrobial preservative: final bulk tuberculin.

#### IDENTIFICATION

Inject increasing doses of the preparation to be examined intradermally into healthy, white or pale-coloured guinea-pigs, specifically sensitised (for example, as described under Assay). A reaction varying from erythema to necrosis is produced at the site of the injection. Similar injections administered to non-sensitised guinea-pigs do not stimulate a reaction. The assay may also serve as identification.

#### TESTS

*Old tuberculin for human use in concentrated form ( $\geq 100\,000$  IU/mL) complies with each of the tests prescribed below; the diluted product complies with the tests for antimicrobial preservative and sterility.*

**Toxicity.** Inject a quantity equivalent to 50 000 IU subcutaneously into each of two healthy guinea-pigs weighing 250 g to 350 g and which have not been subjected to any treatment likely to interfere with the test. Observe the animals for 7 days. No adverse effect is produced.

**Sensitisation.** Use 3 guinea-pigs that have not been subjected to any treatment likely to interfere with the test. On 3 occasions at intervals of 5 days, inject intradermally into each guinea-pig

about 500 IU of the preparation to be examined in a volume of 0.1 mL. 2 to 3 weeks after the third injection, administer the same dose intradermally to the same animals and to a control group of 3 guinea-pigs of the same mass that have not previously received injections of tuberculin. After 24 h to 72 h, the reactions in the 2 groups of animals are not substantially different.

**Antimicrobial preservative.** Where applicable, determine the amount of antimicrobial preservative by a suitable chemical or physico-chemical method. The content is not less than the minimum amount shown to be effective and not more than 115 per cent of the amount stated on the label. If phenol has been used in the preparation, the concentration is not more than 5 g/L (2.5.15).

**Live mycobacteria (2.6.2).** It complies with the test for mycobacteria.

**Sterility (2.6.1).** It complies with the test for sterility.

#### ASSAY

The potency of old tuberculin is determined by comparing the reactions produced by the intradermal injection of increasing doses of the preparation to be examined into sensitised guinea-pigs with the reactions produced by known concentrations of the reference preparation.

Prepare a suspension containing a suitable amount (0.1 mg to 0.4 mg/mL) of heat-inactivated, dried mycobacteria in mineral oil with or without emulsifier; use mycobacteria of a strain of the same species as that used in the preparation to be examined. Sensitise not fewer than 6 pale-coloured guinea-pigs weighing not less than 300 g by injecting intramuscularly or intradermally a total of about 0.5 mL of the suspension, divided between several sites if necessary. Carry out the test after the period of time required for optimal sensitisation which is usually 4 to 8 weeks after sensitisation. Depilate the flanks of the animals so that it is possible to make at least three injections on each side and not more than a total of 12 injection points per animal. Use at least three different doses of the reference preparation and at least 3 different doses of the preparation to be examined. For both preparations, use doses such that the highest dose is about 10 times the lowest dose. Choose the doses such that when they are injected the lesions produced have a diameter of not less than 8 mm and not more than 25 mm. In any given test, the order of the dilutions injected at each point is chosen at random in a Latin square design. Inject each dose intradermally in a constant volume of 0.1 mL or 0.2 mL. Measure the diameters of the lesions 24 h to 48 h later and calculate the results of the test by the usual statistical methods, assuming that the diameters of the lesions are directly proportional to the logarithm of the concentration of the preparation.

The estimated potency is not less than 80 per cent and not more than 125 per cent of the stated potency. The confidence limits ( $P = 0.95$ ) are not less than 64 per cent and not more than 156 per cent of the stated potency.

#### STORAGE

Store protected from light.

#### LABELLING

The label states:

- the number of International Units per millilitre,
- the species of mycobacterium used to prepare the product,
- the name and quantity of any antimicrobial preservative or any other excipient,
- the expiry date,
- where applicable, that old tuberculin is not to be injected in its concentrated form but diluted so as to administer not more than 100 IU per dose.

01/2008:0535

## TUBERCULIN PURIFIED PROTEIN DERIVATIVE, AVIAN

### Tuberculini aviarii derivatum proteinosum purificatum

#### DEFINITION

Avian tuberculin purified protein derivative (avian tuberculin PPD) is a preparation obtained from the heat-treated products of growth and lysis of *Mycobacterium avium* capable of revealing a delayed hypersensitivity in an animal sensitised to micro-organisms of the same species.

#### PRODUCTION

It is obtained from the water-soluble fractions prepared by heating in free-flowing steam and subsequently filtering cultures of *M. avium* grown in a liquid synthetic medium. The active fraction of the filtrate, consisting mainly of protein, is isolated by precipitation, washed and re-dissolved. An antimicrobial preservative that does not give rise to false positive reactions, such as phenol, may be added. The final sterile preparation, free from mycobacteria, is distributed aseptically into sterile tamper-proof glass containers, which are then closed so as to prevent contamination. The preparation may be freeze-dried.

*The identification, the tests and the determination of potency apply to the liquid form and to the freeze-dried form after reconstitution as stated on the label.*

#### IDENTIFICATION

Inject a range of graded doses intradermally at different sites into suitably sensitised albino guinea-pigs, each weighing not less than 250 g. After 24-28 h, reactions appear in the form of oedematous swellings with erythema, with or without necrosis, at the points of injection. The size and severity of the reactions vary according to the dose. Unsensitised guinea-pigs show no reactions to similar injections.

#### TESTS

**pH** (2.2.3): 6.5 to 7.5.

**Phenol** (2.5.15): maximum 5 g/L, if the preparation to be examined contains phenol.

**Sensitising effect.** Use a group of 3 guinea-pigs that have not been treated with any material that will interfere with the test. On 3 occasions at intervals of 5 days, inject intradermally into each guinea-pig a dose of the preparation to be examined equivalent to 500 IU in 0.1 mL. 15-21 days after the 3<sup>rd</sup> injection, inject the same dose (500 IU) intradermally into these animals and into a control group of 3 guinea-pigs of the same mass, which have not previously received injections of tuberculin. 24-28 h after the last injections, the reactions of the 2 groups are not significantly different.

**Toxicity.** Use 2 guinea-pigs, each weighing not less than 250 g, that have not previously been treated with any material that will interfere with the test. Inject subcutaneously into each guinea-pig 0.5 mL of the preparation to be examined. Observe the animals for 7 days. No abnormal effects occur during the observation period.

**Sterility.** It complies with the test for sterility prescribed in the monograph *Vaccines for veterinary use* (0062).

#### POTENCY

The potency of avian tuberculin purified protein derivative is determined by comparing the reactions produced in sensitised guinea-pigs by the intradermal injection of a series of dilutions of the preparation to be examined with those produced by known concentrations of a reference preparation calibrated in International Units.

The International Unit is the activity contained in a stated amount of the International Standard. The equivalence in International Units of the International Standard is stated by the World Health Organisation.

Sensitise not fewer than 8 albino guinea-pigs, each weighing 400-600 g, by the deep intramuscular injection of a suitable dose of inactivated or live *M. avium*. Not less than 4 weeks after the sensitisation of the guinea-pigs, shave their flanks to provide space for not more than 4 injection sites on each side. Prepare dilutions of the preparation to be examined and of the reference preparation using isotonic phosphate-buffered saline (pH 6.5-7.5) containing 0.005 g/L of *polysorbate 80 R*. Use not fewer than 3 doses of the reference preparation and not fewer than 3 doses of the preparation to be examined. Choose the doses such that the lesions produced have a diameter of not less than 8 mm and not more than 25 mm. Allocate the dilutions randomly to the sites, for example using a Latin square design. Inject each dose intradermally in a constant volume of 0.1 mL or 0.2 mL. Measure the diameters of the lesions after 24-28 h and calculate the results of the test using the usual statistical methods (for example, 5.3) and assuming that the diameters of the lesions are directly proportional to the logarithm of the concentration of the tuberculins.

The test is not valid unless the confidence limits ( $P = 0.95$ ) are not less than 50 per cent and not more than 200 per cent of the estimated potency. The estimated potency is not less than 75 per cent and not more than 133 per cent of the stated potency. The stated potency is not less than 20 000 IU/mL.

#### STORAGE

Protected from light, at a temperature of  $5 \pm 3$  °C.

#### LABELLING

The label states:

- the potency in International Units per millilitre;
- the name and quantity of any excipient;
- for freeze-dried preparations:
  - the name and volume of the reconstituting liquid to be added;
  - that the product is to be used immediately after reconstitution.

01/2008:0536

## TUBERCULIN PURIFIED PROTEIN DERIVATIVE, BOVINE

### Tuberculini bovini derivatum proteinosum purificatum

#### DEFINITION

Bovine tuberculin purified protein derivative (bovine tuberculin PPD) is a preparation obtained from the heat-treated products of growth and lysis of *Mycobacterium bovis* capable of revealing a delayed hypersensitivity in an animal sensitised to micro-organisms of the same species.

#### PRODUCTION

It is obtained from the water-soluble fractions prepared by heating in free-flowing steam and subsequently filtering cultures of *M. bovis* grown in a liquid synthetic medium. The active fraction of the filtrate, consisting mainly of protein, is isolated by precipitation, washed and re-dissolved. An antimicrobial preservative that does not give rise to false positive reactions, such as phenol, may be added. The final sterile preparation, free from mycobacteria, is distributed aseptically into sterile, tamper-proof glass containers, which are then closed so as to prevent contamination. The preparation may be freeze-dried.

The identification, the tests and the determination of potency apply to the liquid form and to the freeze-dried form after reconstitution as stated on the label.

#### IDENTIFICATION

Inject a range of graded doses intradermally at different sites into suitably sensitised albino guinea-pigs, each weighing not less than 250 g. After 24-28 h, reactions appear in the form of oedematous swellings with erythema, with or without necrosis, at the points of injection. The size and severity of the reactions vary according to the dose. Unsensitised guinea-pigs show no reactions to similar injections.

#### TESTS

**pH (2.2.3):** 6.5 to 7.5.

**Phenol (2.5.15):** maximum 5 g/L, if the preparation to be examined contains phenol.

**Sensitising effect.** Use a group of 3 guinea-pigs that have not been treated with any material that will interfere with the test. On 3 occasions at intervals of 5 days, inject intradermally into each guinea-pig a dose of the preparation to be examined equivalent to 500 IU in 0.1 mL. 15-21 days after the 3<sup>rd</sup> injection, inject the same dose (500 IU) intradermally into these animals and into a control group of 3 guinea-pigs of the same mass, which have not previously received injections of tuberculin. 24-28 h after the last injections, the reactions of the 2 groups are not significantly different.

**Toxicity.** Use 2 guinea-pigs, each weighing not less than 250 g, that have not previously been treated with any material that will interfere with the test. Inject subcutaneously into each guinea-pig 0.5 mL of the preparation to be examined. Observe the animals for 7 days. No abnormal effects occur during the observation period.

**Sterility.** It complies with the test for sterility prescribed in the monograph *Vaccines for veterinary use (0062)*.

#### POTENCY

The potency of bovine tuberculin purified protein derivative is determined by comparing the reactions produced in sensitised guinea-pigs by the intradermal injection of a series of dilutions of the preparation to be examined with those produced by known concentrations of a reference preparation calibrated in International Units.

The International Unit is the activity contained in a stated amount of the International Standard. The equivalence in International Units of the International Standard is stated by the World Health Organisation.

Sensitise not fewer than 8 albino guinea-pigs, each weighing 400-600 g, by the deep intramuscular injection of 0.0001 mg of wet mass of living *M. bovis* of strain AN5 suspended in 0.5 mL of a 9 g/L solution of *sodium chloride R*. Not less than 4 weeks after the sensitisation of the guinea-pigs, shave their flanks to provide space for not more than 4 injection sites on each side. Prepare dilutions of the preparation to be examined and of the reference preparation using isotonic phosphate-buffered saline (pH 6.5-7.5) containing 0.005 g/L of *polysorbate 80 R*. Use not fewer than 3 doses of the reference preparation and not fewer than 3 doses of the preparation to be examined. Choose the doses such that the lesions produced have a diameter of not less than 8 mm and not more than 25 mm. Allocate the dilutions randomly to the sites, for example using a Latin square design. Inject each dose intradermally in a constant volume of 0.1 mL or 0.2 mL. Measure the diameters of the lesions after 24-28 h and calculate the results of the test using the usual statistical methods (for example, 5.3) and assuming that the diameters of the lesions are directly proportional to the logarithm of the concentration of the tuberculins.

The test is not valid unless the confidence limits ( $P = 0.95$ ) are not less than 50 per cent and not more than 200 per cent of the estimated potency. The estimated potency is not less than 66 per cent and not more than 150 per cent of the stated potency. The stated potency is not less than 20 000 IU/mL.

#### STORAGE

Protected from light, at a temperature of  $5 \pm 3$  °C.

#### LABELLING

The label states:

- the potency in International Units per millilitre;
- the name and quantity of any excipient;
- for freeze-dried preparations:
  - the name and volume of the reconstituting liquid to be added;
  - that the product is to be used immediately after reconstitution.

01/2008:0151

## TUBERCULIN PURIFIED PROTEIN DERIVATIVE FOR HUMAN USE

### Tuberculini derivatum proteinosum purificatum ad usum humanum

#### DEFINITION

Tuberculin purified protein derivative (tuberculin PPD) for human use is a preparation obtained by precipitation from the heated products of the culture and lysis of *Mycobacterium bovis* and/or *Mycobacterium tuberculosis* and capable of demonstrating a delayed hypersensitivity in an animal sensitised to micro-organisms of the same species.

Tuberculin PPD is a colourless or pale-yellow liquid; the diluted preparation may be a freeze-dried powder which upon dissolution gives a colourless or pale-yellow liquid.

#### PRODUCTION

##### GENERAL PROVISIONS

The production of tuberculin PPD is based on a seed-lot system. The production method shall have been shown to yield consistently tuberculin PPD of adequate potency and safety in man. A batch of tuberculin PPD, calibrated in International Units by method A described under Assay and for which adequate clinical information is available as to its activity in man, is set aside to serve as a reference preparation.

The International Unit is the activity of a stated quantity of the International Standard. The equivalence in International Units of the International Standard is stated by the World Health Organisation.

##### SEED LOTS

The strains of mycobacteria used shall be identified by historical records that include information on their origin and subsequent manipulation.

The working seed lots used to inoculate the media for production of a concentrated harvest shall not have undergone more than 4 subcultures from the master seed lot.

Only seed lots that comply with the following requirements may be used for propagation.

**Identification.** The species of mycobacterium of the master and working seed lots is identified.

**Bacterial and fungal contamination.** Carry out the test for sterility (2.6.1), using 10 mL for each medium. The working seed lot complies with the test for sterility except for the presence of mycobacteria.



**PROPAGATION AND HARVEST**

The bacteria are grown in a liquid synthetic medium. Growth must be typical for the strain. The culture is inactivated by a suitable method such as treatment in an autoclave (121 °C for not less than 30 min) or in flowing steam at a temperature not less than 100 °C for at least 1 h and filtered. The active fraction of the filtrate, consisting mainly of protein, is isolated by precipitation, washed and re-dissolved. The preparation is free from mycobacteria. The concentrated harvest is shown to comply with the test for mycobacteria (2.6.2) before addition of any antimicrobial preservative or other substance that might interfere with the test. Phenol (5 g/L) or another suitable antimicrobial preservative that does not give rise to false positive reactions may be added; a suitable stabiliser intended to prevent adsorption on glass or plastic surfaces may be added. The concentrated harvest may be freeze-dried. Phenol is not added to preparations that are to be freeze-dried.

Only a concentrated harvest that complies with the following requirements may be used in the preparation of the final bulk tuberculin PPD.

**Antimicrobial preservative.** Where applicable, determine the amount of antimicrobial preservative by a suitable chemical or physico-chemical method. The content is not less than 85 per cent and not more than 115 per cent of the intended amount. If phenol has been used in the preparation, the concentration is not more than 5 g/L (2.5.15).

**Sensitisation.** Carry out the test described under Tests.

**Sterility (2.6.1).** The concentrated harvest, reconstituted if necessary, complies with the test for sterility, carried out using 10 mL for each medium.

**Potency.** Determine the potency as described under Assay.

**FINAL BULK TUBERCULIN PPD**

The concentrated harvest is diluted aseptically, after reconstitution if necessary.

Only a final bulk tuberculin PPD that complies with the following requirement may be used in the preparation of the final lot.

**Sterility (2.6.1).** The final bulk tuberculin PPD complies with the test for sterility, carried out using 10 mL for each medium.

**FINAL LOT**

The final bulk tuberculin PPD is distributed aseptically into sterile containers which are then closed so as to prevent contamination. It may be freeze-dried.

Only a final lot that is satisfactory with respect to each of the requirements given below under Identification, Tests and Assay may be released for use.

The following tests may be omitted on the final lot if they have been carried out at the stages indicated:

- live mycobacteria: concentrated harvest
- sensitisation: concentrated harvest
- toxicity: concentrated harvest or final bulk tuberculin PPD
- antimicrobial preservative: final bulk tuberculin PPD.

**IDENTIFICATION**

Inject increasing doses of the preparation to be examined intradermally into healthy, white or pale-coloured guinea-pigs, specifically sensitised (for example as described under Assay). A reaction varying from erythema to necrosis is produced at the site of the injection. Similar injections administered to non-sensitised guinea-pigs do not stimulate a reaction. The assay may also serve as identification.

**TESTS**

*Tuberculin purified protein derivative for human use in concentrated form ( $\geq 100\,000$  IU/mL) complies with each of the tests prescribed below; the diluted product complies with the tests for pH, antimicrobial preservative and sterility.*

**pH (2.2.3).** The pH of the preparation, reconstituted if necessary as stated on the label, is 6.5 to 7.5.

**Toxicity.** Inject subcutaneously 50 000 IU of the preparation to be examined into each of two healthy guinea-pigs weighing 250 g to 350 g and which have not been subjected to any treatment likely to interfere with the test. Observe the animals for 7 days. No adverse effect is produced.

**Sensitisation.** Use 3 guinea-pigs that have not been subjected to any treatment likely to interfere with the test. On 3 occasions at intervals of 5 days, inject intradermally into each guinea-pig about 500 IU of the preparation to be examined in a volume of 0.1 mL. 2 to 3 weeks after the third injection, administer the same dose intradermally to the same animals and to a control group of three guinea-pigs of the same mass that have not previously received injections of tuberculin. After 24 h to 72 h, the reactions in the 2 groups of animals are not substantially different.

**Antimicrobial preservative.** Where applicable, determine the amount of antimicrobial preservative by a suitable chemical or physico-chemical method. The content is not less than the minimum amount shown to be effective and not more than 115 per cent of the amount stated on the label. If phenol has been used in the preparation, the concentration is not more than 5 g/L (2.5.15).

**Live mycobacteria (2.6.2).** It complies with the test for mycobacteria.

**Sterility (2.6.1).** It complies with the test for sterility.

**ASSAY**

Use method A or, where the preparation contains 1 IU to 2 IU, use method B.

**METHOD A**

The potency of tuberculin PPD is determined by comparing the reactions produced by the intradermal injection of increasing doses of the preparation to be examined into sensitised guinea-pigs with the reactions produced by known concentrations of the reference preparation.

Prepare a suspension containing a suitable amount (0.1 mg/mL to 0.4 mg/mL) of heat-inactivated, dried mycobacteria in mineral oil with or without emulsifier; use mycobacteria of a strain of the same species as that used in the preparation to be examined. Sensitise not fewer than six pale-coloured guinea-pigs weighing not less than 300 g by injecting intramuscularly or intradermally a total of about 0.5 mL of the suspension, divided between several sites if necessary. Carry out the test after the period of time required for optimal sensitisation which is usually 4 to 8 weeks after sensitisation. Depilate the flanks of the animals so that it is possible to make at least 3 injections on each side but not more than a total of 12 injection points per animal. Prepare dilutions of the preparation to be examined and of the reference preparation using isotonic phosphate-buffered saline (pH 6.5 to 7.5) containing 50 mg/L of *polysorbate 80 R*. If the preparation to be examined is freeze-dried and does not contain a stabiliser, reconstitute it using the liquid described above. Use at least 3 different doses of the reference preparation and at least 3 different doses of the preparation to be examined. For both preparations, use doses such that the highest dose is about 10 times the lowest dose. Choose the doses such that when they are injected the lesions produced have a diameter of not less than 8 mm and not more than 25 mm. In any given test, the order of the dilutions injected at each point is chosen at random in a Latin square design. Inject each dose intradermally in a constant volume of 0.1 mL or 0.2 mL. Measure the diameters of the lesions 24 h to 48 h later and calculate the results of the test by the usual statistical methods, assuming that the diameters of the lesions are directly proportional to the logarithm of the concentration of the preparation.

01/2008:0305

The estimated potency is not less than 80 per cent and not more than 125 per cent of the stated potency. The confidence limits ( $P = 0.95$ ) are not less than 64 per cent and not more than 156 per cent of the stated potency.

**METHOD B**

The potency of tuberculin PPD is determined by comparing the reactions produced by the intradermal injection of the preparation to be examined into sensitised guinea-pigs with the reactions produced by known concentrations of the reference preparation.

Prepare a suspension in mineral oil with or without emulsifier and containing a suitable amount (0.1 mg/mL to 0.4 mg/mL) of heat-inactivated, dried mycobacteria; use mycobacteria of a strain of the same species as that used in the preparation to be examined. Sensitise not fewer than 6 pale-coloured guinea-pigs weighing not less than 300 g by injecting intramuscularly or intradermally a total of about 0.5 mL of the suspension, divided between several sites if necessary. Carry out the test after the period of time required for optimal sensitisation which is usually 4 to 8 weeks after sensitisation. Depilate the flanks of the animals so that it is possible to make at least 3 injections on each side but not more than a total of 12 injection points per animal. Prepare dilutions of the reference preparation using isotonic phosphate-buffered saline (pH 6.5 to 7.5) containing 50 mg/L of *polysorbate 80 R*. Use at least 3 different doses of the reference preparation such that the highest dose is about 10 times the lowest dose and the median dose is the same as that of the preparation to be examined. In any given test, the order of the dilutions injected at each point is chosen at random in a Latin square design. Inject the preparation to be examined and each dilution of the reference preparation intradermally in a constant volume of 0.1 mL or 0.2 mL. Measure the diameters of the lesions 24 h to 48 h later and calculate the results of the test by the usual statistical methods, assuming that the areas of the lesions are directly proportional to the logarithm of the concentration of the preparation to be examined. (This dose relationship applies to this assay and not necessarily to other test systems.)

The estimated potency is not less than 80 per cent and not more than 125 per cent of the stated potency. The confidence limits ( $P = 0.95$ ) are not less than 64 per cent and not more than 156 per cent of the stated potency.

**STORAGE**

Store protected from light.

**LABELLING**

The label states:

- the number of International Units per container,
- the species of mycobacteria used to prepare the product,
- the name and quantity of any antimicrobial preservative or any other excipient,
- the expiry date,
- for freeze-dried products, a statement that the product is to be reconstituted using the liquid provided by the manufacturer,
- where applicable, that tuberculin PPD is not to be injected in its concentrated form but diluted so as to administer not more than 100 IU per dose.

If the package does not contain a leaflet warning that the inhalation of concentrated tuberculin PPD may produce toxic effects, this warning must be shown on the label on the container together with a statement that the powder must be handled with care.

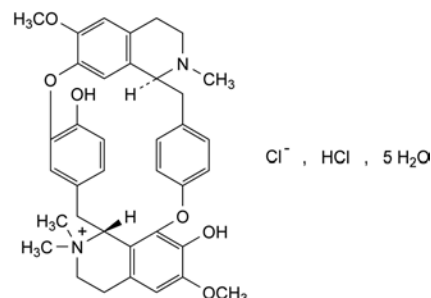
**TUBOCURARINE CHLORIDE****Tubocurarini chloridum**

$\text{C}_{37}\text{H}_{42}\text{Cl}_2\text{N}_2\text{O}_6 \cdot 5\text{H}_2\text{O}$   
[6989-98-6]

$M_r$  772

**DEFINITION**

Tubocurarine chloride contains not less than 98.0 per cent and not more than the equivalent of 102.0 per cent of (3a*R*,16a*S*)-8,23-dihydroxy-24,29-dimethoxy-3,3,16-trimethyl-2,3,3a,4,15,16,16a,17-octahydro-1*H*-11,13:18,21-dietheno-5,9-metheno-14*H*-pyrido[3',2':14,15][1,11]dioxacycloicosino[2,3,4-*ij*]isoquinolinium chloride hydrochloride, calculated with reference to the anhydrous substance.

**CHARACTERS**

A white or slightly yellowish, crystalline powder, soluble in water and in alcohol, practically insoluble in acetone. It dissolves in solutions of alkali hydroxides.

It melts at about 270 °C, with decomposition.

**IDENTIFICATION**

*First identification:* B, E.

*Second identification:* A, C, D, E, F.

- A. Dissolve 50.0 mg in *water R* and dilute to 1000.0 mL with the same solvent. Examined between 230 nm and 350 nm (2.2.25), the solution shows an absorption maximum at 280 nm and a minimum at 255 nm. The specific absorbance at the maximum is 113 to 123, calculated with reference to the anhydrous substance.
- B. Examine by infrared absorption spectrophotometry (2.2.24), comparing with the spectrum obtained with *tubocurarine chloride CRS*.
- C. Dissolve about 25 mg in 1 mL of *water R*. Add 0.2 mL of *ferric chloride solution R2* and heat in a water-bath for 1 min. The solution is green. Carry out a blank test; after heating in a water-bath, the colour is brown.
- D. To 1 mL of solution S (see Tests) add 1 mL of *nitric acid solution of mercury R*. A red colour develops slowly.
- E. It gives reaction (a) of chlorides (2.3.1).
- F. It gives the reaction of alkaloids (2.3.1).

**TESTS**

**Solution S.** Dissolve 0.25 g in *carbon dioxide-free water R* and dilute to 25.0 mL with the same solvent.

**Appearance of solution.** Solution S is clear (2.2.1) and not more intensely coloured than reference solution  $Y_6$  (2.2.2, *Method II*).  
**pH** (2.2.3). The pH of solution S is 4.0 to 6.0.

**Specific optical rotation** (2.2.7): + 210 to + 222, determined on solution S 3 h after preparation and calculated with reference to the anhydrous substance.

**Chloroform-soluble substances.** Dissolve 0.25 g in 150 mL of *water R*. Add 5 mL of a saturated solution of *sodium bicarbonate R* and shake with three quantities, each of 20 mL, of *chloroform R*. Wash the combined chloroform layers with

10 mL of *water R*, filter the chloroform solution into a tared beaker and wash the filter with two quantities, each of 5 mL, of *chloroform R*. Add the washings to the filtrate. Evaporate to dryness on a water-bath and dry at 100-105 °C for 1 h. The residue weighs not more than 5 mg. The residue does not dissolve in 10 mL of *water R*, but dissolves on the addition of 1 mL of *dilute hydrochloric acid R*.

**Related substances.** Examine by thin-layer chromatography (2.2.27), using *silica gel G R* as the coating substance.

**Test solution.** Dissolve 0.25 g of the substance to be examined in *water R* and dilute to 10 mL with the same solvent.

**Reference solution (a).** Dilute 1.5 mL of the test solution to 100 mL with *water R*.

**Reference solution (b).** Dilute 5 mL of reference solution (a) to 10 mL with *water R*.

Apply to the plate 5 µL of each solution. Develop in an unsaturated tank over a path of 15 cm using the lower layer of a mixture of equal volumes of *chloroform R*, *methanol R* and a 125 g/L solution of *trichloroacetic acid R*. Dry the plate in a current of cold air. Spray with a mixture of 1 volume of *potassium ferricyanide solution R*, 1 volume of *water R* and 2 volumes of *ferric chloride solution R1*, prepared immediately before use. Any spot in the chromatogram obtained with the test solution, apart from the principal spot, is not more intense than the spot in the chromatogram obtained with reference solution (a) (1.5 per cent) and at most one such spot is more intense than the spot in the chromatogram obtained with reference solution (b) (0.75 per cent).

**Water (2.5.12):** 9.0 per cent to 12.0 per cent, determined on 0.30 g by the semi-micro determination of water.

**Sulfated ash (2.4.14).** Not more than 0.25 per cent, determined on 0.2 g.

#### ASSAY

Dissolve 25.0 mg in *water R* and dilute to 500.0 mL with the same solvent. In the same manner, prepare a reference solution using 25.0 mg of *tubocurarine chloride CRS*. Measure the absorbance (2.2.25) at the maximum at 280 nm.

Calculate the content of  $C_{37}H_{42}Cl_2N_2O_6$  from the absorbances measured, the concentrations of the solutions and the declared content of anhydrous tubocurarine chloride in *tubocurarine chloride CRS*.

#### STORAGE

Store in an airtight container.

01/2008:1273

## TYLOSIN FOR VETERINARY USE

### Tylosinum ad usum veterinarium

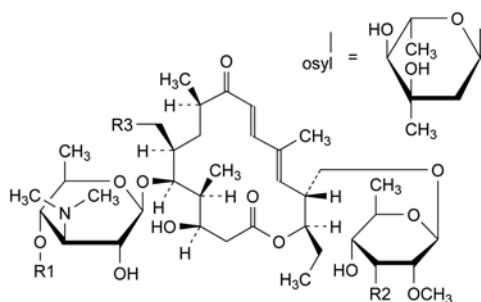

Name	Mol. Formula	R1	R2	R3
tylosin A	$C_{46}H_{77}NO_{17}$	osyl	OCH <sub>3</sub>	CHO
tylosin B	$C_{39}H_{65}NO_{14}$	H	OCH <sub>3</sub>	CHO
tylosin C	$C_{45}H_{75}NO_{17}$	osyl	OH	CHO
tylosin D	$C_{46}H_{79}NO_{17}$	osyl	OCH <sub>3</sub>	CH <sub>2</sub> OH

#### DEFINITION

Mixture of macrolide antibiotics produced by a strain of *Streptomyces fradiae* or by any other means. The main component of the mixture is (4*R*,5*S*,6*S*,7*R*,9*R*,11*E*,13*E*,15*R*,16*R*)-15-[[[(6-deoxy-2,3-di-*O*-methyl-β-D-allopyranosyl)oxy]methyl]-6-[[[3,6-dideoxy-4-*O*-(2,6-dideoxy-3-*C*-methyl-α-*L*-ribo-hexopyranosyl)-3-(dimethylamino)-β-D-glucopyranosyl]oxy]-16-ethyl-4-hydroxy-5,9,13-trimethyl-7-(2-oxoethyl)oxacyclohexadeca-11,13-diene-2,10-dione (tylosin A,  $M_r$  916). Tylosin B (desmycosin,  $M_r$  772), tylosin C (macrocin,  $M_r$  902) and tylosin D (relomycin,  $M_r$  918) may also be present. They contribute to the potency of the substance to be examined. **Potency:** minimum 900 IU/mg (dried substance).

#### CHARACTERS

**Appearance:** almost white or slightly yellow powder.

**Solubility:** slightly soluble in water, freely soluble in anhydrous ethanol and in methylene chloride. It dissolves in dilute solutions of mineral acids.

#### IDENTIFICATION

A. Infrared absorption spectrophotometry (2.2.24).

**Comparison:** *tylosin CRS*.

B. Examine the chromatograms obtained in the test for composition.

**Results:** the principal peak in the chromatogram obtained with the test solution is similar in retention time and size to the principal peak in the chromatogram obtained with reference solution (a).

C. Dissolve about 30 mg in a mixture of 0.15 mL of *water R*, 2.5 mL of *acetic anhydride R* and 7.5 mL of *pyridine R*. Allow to stand for about 10 min. No green colour develops.

#### TESTS

**pH (2.2.3):** 8.5 to 10.5.

Suspend 0.25 g in 10 mL of *carbon dioxide-free water R*.

**Composition.** Liquid chromatography (2.2.29): use the normalisation procedure. *Prepare the solutions immediately before use.*

**Solvent mixture:** *acetonitrile R*, *water R* (50:50 V/V).

**Test solution.** Dissolve 20.0 mg of the substance to be examined in the solvent mixture and dilute to 100.0 mL with the solvent mixture.

**Reference solution (a).** Dissolve 2 mg of *tylosin phosphate for peak identification CRS* (containing tylosins A, B, C and D) in the solvent mixture and dilute to 10 mL with the solvent mixture.

**Reference solution (b).** Dissolve 2 mg of *tylosin CRS* and 2 mg of *tylosin D CRS* in the solvent mixture and dilute to 10 mL with the solvent mixture.

**Column:**

- size:  $l = 0.20$  m,  $\varnothing = 4.6$  mm;
- stationary phase: *octadecylsilyl silica gel for chromatography R* (5 µm);
- temperature: 35 °C.

**Mobile phase:** mix 40 volumes of *acetonitrile R* and 60 volumes of a 200 g/L solution of *sodium perchlorate R* previously adjusted to pH 2.5 using 1 M *hydrochloric acid*.

**Flow rate:** 1.0 mL/min.

**Detection:** spectrophotometer at 290 nm.

**Injection:** 20 µL.

**Retention time:** tylosin A = about 12 min.

**Identification of peaks:** use the chromatogram supplied with *tylosin phosphate for peak identification CRS* and the chromatogram obtained with reference solution (a) to identify the peaks due to tylosins A, B, C and D.

*System suitability*: reference solution (b):

01/2008:1661

- *resolution*: minimum 2.0 between the peaks due to tylosins A and D.

*Limits*:

- *tylosin A*: minimum 80.0 per cent;
- *sum of tylosins A, B, C and D*: minimum 95.0 per cent.

**Tyramine**: maximum 0.35 per cent and maximum 0.15 per cent, if intended for use in the manufacture of parenteral preparations.

In a 25.0 mL volumetric flask, dissolve 50.0 mg in 5.0 mL of a 3.4 g/L solution of *phosphoric acid R*. Add 1.0 mL of *pyridine R* and 2.0 mL of a saturated solution of *ninhydrin R* (about 40 g/L). Close the flask with a piece of aluminium foil and heat in a water-bath at 85 °C for 30 min. Cool the solution rapidly and dilute to 25.0 mL with *water R*. Mix and measure immediately the absorbance (2.2.25) of the solution at 570 nm using a blank solution as the compensation liquid. The absorbance is not greater than that of a standard prepared at the same time and in the same manner using 5.0 mL of a 35 mg/L solution of *tyramine R* in a 3.4 g/L solution of *phosphoric acid R*. If intended for use in the manufacture of parenteral preparations, the absorbance is not greater than that of a standard prepared at the same time and in the same manner using 5.0 mL of a 15 mg/L solution of *tyramine R* in a 3.4 g/L solution of *phosphoric acid R*.

**Loss on drying** (2.2.32): maximum 5.0 per cent, determined on 1.000 g by drying in an oven at 60 °C at a pressure not exceeding 0.7 kPa for 3 h.

**Sulfated ash** (2.4.14): maximum 3.0 per cent, determined on 1.0 g.

#### ASSAY

Carry out the microbiological assay of antibiotics (2.7.2). Use *tylosin CRS* as the chemical reference substance.

#### STORAGE

Protected from light.

#### IMPURITIES

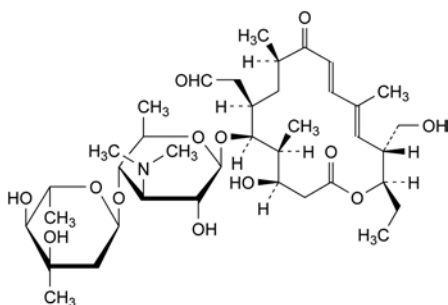

A. desmynosyltylosin,

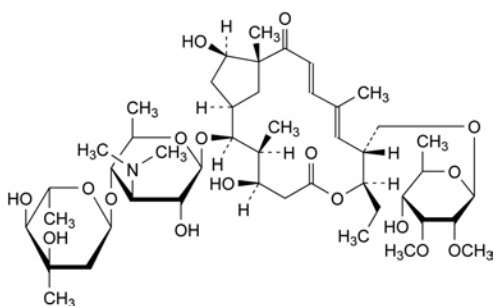

B. tylosin A aldol.

## TYLOSIN PHOSPHATE BULK SOLUTION FOR VETERINARY USE

### Tylosini phosphatis solutio ad usum veterinarium

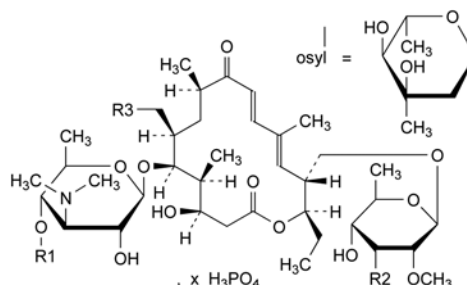

Tylosin	R1	R2	R3	Mol. Formula	$M_r$
A	osyl	OCH <sub>3</sub>	CHO	C <sub>46</sub> H <sub>77</sub> NO <sub>17</sub>	916
B	H	OCH <sub>3</sub>	CHO	C <sub>39</sub> H <sub>65</sub> NO <sub>14</sub>	772
C	osyl	OH	CHO	C <sub>45</sub> H <sub>75</sub> NO <sub>17</sub>	902
D	osyl	OCH <sub>3</sub>	CH <sub>2</sub> OH	C <sub>46</sub> H <sub>79</sub> NO <sub>17</sub>	918

#### DEFINITION

Solution of the dihydrogen phosphate of a mixture of macrolide antibiotics produced by a strain of *Streptomyces fradiae* or by any other means.

The main component is the phosphate of (4*R*,5*S*,6*S*,7*R*,9*R*,11*E*,13*E*,15*R*,16*R*)-15-[[[(6-deoxy-2,3-di-*O*-methyl-β-*D*-allopyranosyl)oxy]methyl]-6-[[[3,6-dideoxy-4-*O*-(2,6-dideoxy-3-*C*-methyl-α-*L*-ribo-hexopyranosyl)-3-(dimethylamino)-β-*D*-glucopyranosyl]oxy]-16-ethyl-4-hydroxy-5,9,13-trimethyl-7-(2-oxoethyl)oxacyclohexadeca-11,13-diene-2,10-dione (tylosin A phosphate). The phosphates of tylosin B (desmocosin phosphate), tylosin C (macrocin phosphate) and tylosin D (relomycin phosphate) may also be present. The solution also contains sodium dihydrogen phosphate.

**Potency**: minimum 800 IU per milligram of dry residue. Tylosins A, B, C and D contribute to the potency.

#### CHARACTERS

**Appearance**: yellow or brownish-yellow, viscous liquid.

**Solubility**: miscible with water.

#### IDENTIFICATION

A. Ultraviolet and visible absorption spectrophotometry (2.2.25).

**Test solution**. Dilute an amount of the preparation to be examined equivalent to 400 000 IU of tylosin phosphate to 100.0 mL with *water R*. Dilute 1.0 mL of this solution to 100.0 mL with *water R*.

**Spectral range**: 230-350 nm.

**Absorption maximum**: at 290 nm.

**Absorbance at the absorption maximum**: minimum 0.70.

B. Examine the chromatograms obtained in the test for composition.

**Results**: the principal peak in the chromatogram obtained with the test solution is similar in retention time and size to the principal peak in the chromatogram obtained with reference solution (a).

C. Dilute an amount of the preparation to be examined equivalent to 400 000 IU of tylosin phosphate in 10 mL of *water R*. The solution gives reaction (a) of phosphates (2.3.1).

## TESTS

**pH** (2.2.3): 5.5 to 6.5.

Dilute 1.0 g in 10 mL of *carbon dioxide-free water R*.

**Composition.** Liquid chromatography (2.2.29): use the normalisation procedure. *Prepare the solutions immediately before use.*

**Test solution.** Dilute an amount of the preparation to be examined equivalent to 50 000 IU of tylosin phosphate to 200 mL with a mixture of equal volumes of *acetonitrile R* and *water R*.

**Reference solution (a).** Dissolve 2 mg of *tylosin phosphate for peak identification CRS* (containing tylosins A, B, C and D) in a mixture of equal volumes of *acetonitrile R* and *water R* and dilute to 10 mL with the same mixture of solvents.

**Reference solution (b).** Dissolve 2 mg of *tylosin CRS* and 2 mg of *tylosin D CRS* in a mixture of equal volumes of *acetonitrile R* and *water R* and dilute to 10 mL with the same mixture of solvents.

**Reference solution (c).** Dilute 1.0 mL of reference solution (a) to 100.0 mL with a mixture of equal volumes of *acetonitrile R* and *water R*. Dilute 1.0 mL of this solution to 10.0 mL with a mixture of equal volumes of *acetonitrile R* and *water R*.

**Column:**

- size:  $l = 0.20$  m,  $\varnothing = 4.6$  mm;
- stationary phase: *octadecylsilyl silica gel for chromatography R* (5  $\mu$ m);
- temperature: 35 °C.

**Mobile phase:** mix 40 volumes of *acetonitrile R* and 60 volumes of a 200 g/L solution of *sodium perchlorate R* previously adjusted to pH 2.5 using a 36.5 g/L solution of *hydrochloric acid R*.

**Flow rate:** 1.0 mL/min.

**Detection:** spectrophotometer at 290 nm.

**Injection:** 20  $\mu$ L.

**Run time:** 1.8 times the retention time of tylosin A.

**Identification of tylosins:** use the chromatogram supplied with *tylosin phosphate for peak identification CRS* and the chromatogram obtained with reference solution (a) to identify the peaks due to tylosins A, B, C and D.

**Relative retention** with reference to tylosin A (retention time = about 12 min): impurity A = about 0.35; tylosin C = about 0.5; tylosin B = about 0.6; tylosin D = about 0.85; impurity B = about 0.9.

**System suitability:** reference solution (b):

- resolution: minimum 2.0 between the peaks due to tylosin D and tylosin A.

**Limits:**

- *tylosin A*: minimum 80.0 per cent;
- *sum of the contents of tylosin A, tylosin B, tylosin C and tylosin D*: minimum 95.0 per cent;
- *disregard limit*: area of the principal peak in the chromatogram obtained with reference solution (c).

**Tyramine.** In a 25.0 mL volumetric flask, dissolve an amount of the preparation to be examined equivalent to 50 000 IU of tylosin phosphate in 5.0 mL of a 3.4 g/L solution of *phosphoric acid R*. Add 1.0 mL of *pyridine R* and 2.0 mL of a saturated solution of *ninhydrin R* (about 40 g/L). Close the flask with aluminium foil and heat in a water-bath at 85 °C for 20-30 min. Cool the solution rapidly and dilute to 25.0 mL with *water R*. Mix and measure immediately the absorbance (2.2.25) of the solution at 570 nm using a blank solution as the compensation liquid.

The absorbance is not greater than that of a standard prepared at the same time and in the same manner using 5.0 mL of

a 35 mg/L solution of *tyramine R* in a 3.4 g/L solution of *phosphoric acid R*.

**Phosphate:** 8.5 per cent to 10.0 per cent of  $\text{PO}_4$ , calculated with reference to the dry residue (see Assay).

**Test solution.** Dissolve an amount of the preparation to be examined equivalent to 200 000 IU of tylosin phosphate in 50 mL of *water R*. Add 5.0 mL of *dilute sulfuric acid R* and dilute to 100.0 mL with *water R*. To 2.0 mL of this solution add successively, mixing after each addition, 10.0 mL of *water R*, 5.0 mL of *ammonium molybdate reagent R2*, 1.0 mL of *hydroquinone solution R* and 1.0 mL of a 200 g/L solution of *sodium metabisulfite R*. Allow to stand for at least 20 min and dilute to 50.0 mL with *water R*. Mix thoroughly.

**Reference solution (a).** To 1.0 mL of a standard solution containing 0.430 g/L of *potassium dihydrogen phosphate R* (corresponds to 300 ppm of  $\text{PO}_4$ ) add successively, mixing after each addition, 10.0 mL of *water R*, 5.0 mL of *ammonium molybdate reagent R2*, 1.0 mL of *hydroquinone solution R* and 1.0 mL of a 200 g/L solution of *sodium metabisulfite R*. Allow to stand for at least 20 min and dilute to 50.0 mL with *water R*. Mix thoroughly.

**Reference solution (b).** Prepare as reference solution (a) but using 2.0 mL of the standard solution.

**Reference solution (c).** Prepare as reference solution (a) but using 5.0 mL of the standard solution.

**Compensation liquid.** Prepare as reference solution (a) but omitting the standard solution.

Measure the absorbance (2.2.25) of the test solution and of the reference solutions at 650 nm. Draw a calibration curve with the absorbances of the 3 reference solutions as a function of the quantity of phosphate in the solutions and read from the curve the quantity of phosphate in the test solution. Determine the percentage content of  $\text{PO}_4$ , calculated with reference to the dry residue (see Assay).

## ASSAY

Carry out the microbiological assay of antibiotics (2.7.2).

Use *tylosin CRS* as the reference substance. Calculate the potency from the mass of the dry residue and the activity of the solution.

**Dry residue.** Dry 3.0 g of the preparation to be examined *in vacuo* at 60 °C for 3 h and weigh.

## STORAGE

Protected from light, at a temperature of 2 °C to 8 °C.

## LABELLING

The label states the concentration of the solution in International Units per milligram of preparation.

## IMPURITIES

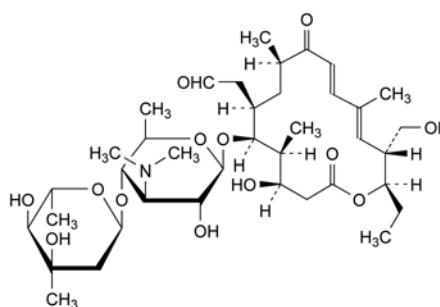

A. desmicynosyltylosin A,

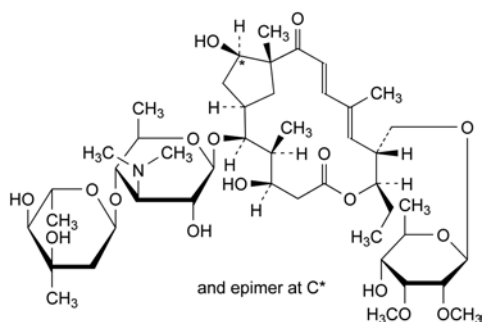

- B. (1*R*,2*S*,3*S*,4*R*,8*R*,9*R*,10*E*,12*E*,15*R*,16*RS*)-9-[[[(6-deoxy-2,3-di-*O*-methyl-β-*D*-allopyranosyl)oxy]methyl]-2-[[[3,6-dideoxy-4-*O*-(2,6-dideoxy-3-*C*-methyl-α-*L*-ribo-hexopyranosyl)-3-(dimethylamino)-β-*D*-glucopyranosyl]oxy]-8-ethyl-4,16-dihydroxy-3,11,15-trimethyl-7-oxabicyclo[13.2.1]octadeca-10,12-diene-6,14-dione (tylosin A aldol).

01/2008:1274

## TYLOSIN TARTRATE FOR VETERINARY USE

Tylosini tartras ad usum veterinarium

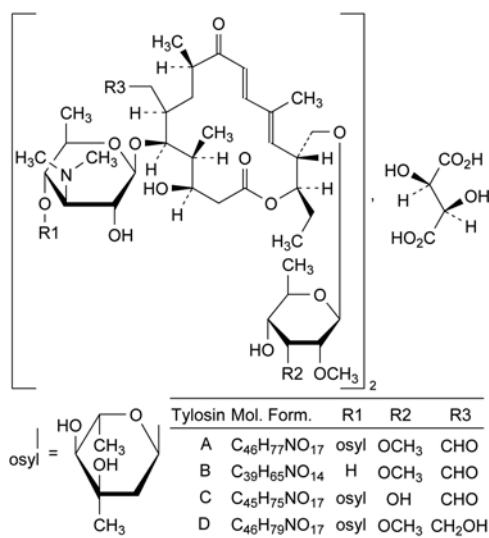

### DEFINITION

Tartrate of a mixture of macrolide antibiotics produced by a strain of *Streptomyces fradiae* or by any other means. The main component of the mixture is (4*R*,5*S*,6*S*,7*R*,9*R*,11*E*,13*E*,15*R*,16*R*)-15-[[[(6-deoxy-2,3-di-*O*-methyl-β-*D*-allopyranosyl)oxy]methyl]-6-[[[3,6-dideoxy-4-*O*-(2,6-dideoxy-3-*C*-methyl-α-*L*-ribo-hexopyranosyl)-3-(dimethylamino)-β-*D*-glucopyranosyl]oxy]-16-ethyl-4-hydroxy-5,9,13-trimethyl-7-(2-oxoethyl)oxacyclohexadeca-11,13-diene-2,10-dione (tylosin A, tartrate *M<sub>r</sub>* 1982). Tylosin B (desmycosin, tartrate *M<sub>r</sub>* 1694), tylosin C (macrocin, tartrate *M<sub>r</sub>* 1954) and tylosin D (relomycin, tartrate *M<sub>r</sub>* 1986) may also be present. They contribute to the potency of the substance to be examined.

**Potency:** minimum 800 IU/mg (dried substance).

### CHARACTERS

**Appearance:** almost white or slightly yellow, hygroscopic powder.

**Solubility:** freely soluble in water and in methylene chloride, slightly soluble in anhydrous ethanol. It dissolves in dilute solutions of mineral acids.

### IDENTIFICATION

- A. Infrared absorption spectrophotometry (2.2.24).

**Comparison:** Ph. Eur. reference spectrum of tylosin tartrate.

- B. Examine the chromatograms obtained in the test for composition.

**Results:** the principal peak in the chromatogram obtained with the test solution is similar in retention time and size to the principal peak in the chromatogram obtained with reference solution (a).

- C. Dissolve about 30 mg in a mixture of 0.15 mL of *water R*, 2.5 mL of *acetic anhydride R* and 7.5 mL of *pyridine R*. Allow to stand for about 10 min. A green colour is produced.

### TESTS

**pH (2.2.3):** 5.0 to 7.2.

Dissolve 0.25 g in 10 mL of *carbon dioxide-free water R*.

**Composition.** Liquid chromatography (2.2.29): use the normalisation procedure. Prepare the solutions immediately before use.

**Solvent mixture:** acetonitrile *R*, *water R* (50:50 V/V).

**Test solution.** Dissolve 20.0 mg of the substance to be examined in the solvent mixture and dilute to 100.0 mL with the solvent mixture.

**Reference solution (a).** Dissolve 2 mg of *tylosin phosphate for peak identification CRS* (containing tylosins A, B, C and D) in the solvent mixture and dilute to 10 mL with the solvent mixture.

**Reference solution (b).** Dissolve 2 mg of *tylosin CRS* and 2 mg of *tylosin D CRS* in the solvent mixture and dilute to 10 mL with the solvent mixture.

**Column:**

- **size:** *l* = 0.20 m, Ø = 4.6 mm;
- **stationary phase:** octadecylsilyl silica gel for chromatography *R* (5 µm);
- **temperature:** 35 °C.

**Mobile phase:** mix 40 volumes of *acetonitrile R* and 60 volumes of a 200 g/L solution of *sodium perchlorate R* previously adjusted to pH 2.5 using 1 *M hydrochloric acid*.

**Flow rate:** 1.0 mL/min.

**Detection:** spectrophotometer at 290 nm.

**Injection:** 20 µL.

**Retention time:** tylosin A = about 12 min.

**Identification of peaks:** use the chromatogram supplied with *tylosin phosphate for peak identification CRS* and the chromatogram obtained with reference solution (a) to identify the peaks due to tylosins A, B, C and D.

**System suitability:** reference solution (b):

- **resolution:** minimum 2.0 between the peaks due to tylosins A and D.

**Limits:**

- **tylosin A:** minimum 80.0 per cent;
- **sum of tylosins A, B, C and D:** minimum 95.0 per cent.

**Tyramine:** maximum 0.35 per cent and maximum 0.15 per cent, if it is intended for use in the manufacture of parenteral preparations.

In a 25.0 mL volumetric flask, dissolve 50.0 mg in 5.0 mL of a 3.4 g/L solution of *phosphoric acid R*. Add 1.0 mL of *pyridine R* and 2.0 mL of a saturated solution of *ninhydrin R* (about 40 g/L). Close the flask with a piece of aluminium foil and heat in a water-bath at 85 °C for 30 min. Cool the solution rapidly and dilute to 25.0 mL with *water R*. Mix and measure immediately the absorbance (2.2.25) of the solution at 570 nm using a blank solution as the compensation liquid. The absorbance is not greater than that of a standard prepared at the same time and in the same manner using 5.0 mL of a 35 g/L solution of *tyramine R* in a 3.4 g/L solution of

*phosphoric acid R*. If intended for use in the manufacture of parenteral preparations, the absorbance is not greater than that of a standard prepared at the same time and in the same manner using 5.0 mL of a 15 mg/L solution of *tyramine R* in a 3.4 g/L solution of *phosphoric acid R*.

**Loss on drying** (2.2.32): maximum 4.5 per cent, determined on 1.000 g by drying at 60 °C at a pressure not exceeding 0.7 kPa for 3 h.

**Sulfated ash** (2.4.14): maximum 2.5 per cent, determined on 1.0 g.

#### ASSAY

Carry out the microbiological assay of antibiotics (2.7.2). Use *tylosin CRS* as the chemical reference substance.

#### STORAGE

In an airtight container, protected from light.

#### IMPURITIES

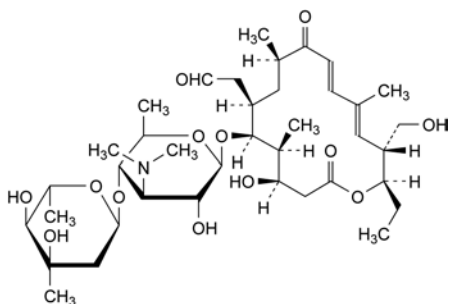

A. desmycinosyltylosin,

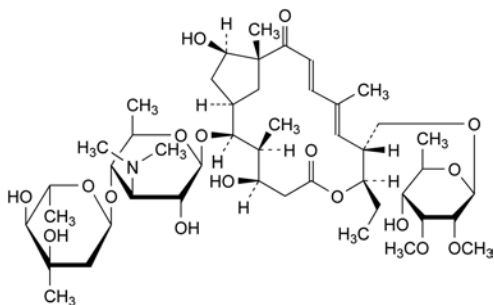

B. tylosin A aldol.

01/2008:1161  
corrected 6.0

## TYROSINE

### Tyrosinum

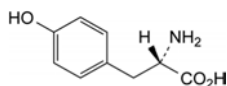

$C_9H_{11}NO_3$   
[60-18-4]

$M_r$  181.2

#### DEFINITION

Tyrosine contains not less than 99.0 per cent and not more than the equivalent of 101.0 per cent of (S)-2-amino-3-(4-hydroxyphenyl)propanoic acid, calculated with reference to the dried substance.

#### CHARACTERS

A white or almost white crystalline powder or colourless crystals, very slightly soluble in water, practically insoluble in alcohol. It dissolves in dilute mineral acids and in dilute solutions of alkali hydroxides.

#### IDENTIFICATION

*First identification*: A, B.

*Second identification*: A, C, D, E.

- Specific optical rotation (see Tests).
- Examine by infrared absorption spectrophotometry (2.2.24), comparing with the spectrum obtained with *tyrosine CRS*. Examine the substances prepared as discs.
- Examine the chromatograms obtained in the test for ninhydrin-positive substances. The principal spot in the chromatogram obtained with test solution (b) is similar in position, colour and size to the principal spot in the chromatogram obtained with reference solution (a).
- To about 50 mg add 1 mL of *dilute nitric acid R*. A dark red colour is produced within 15 min.
- Dissolve about 30 mg in 2 mL of *dilute sodium hydroxide solution R*. Add 3 mL of a freshly prepared mixture of equal volumes of a 100 g/L solution of *sodium nitrite R* and a solution of 0.5 g of *sulfanilic acid R* in a mixture of 6 mL of *hydrochloric acid R1* and 94 mL of *water R*. An orange-red colour is produced.

#### TESTS

**Appearance of solution.** Dissolve 0.5 g in *dilute hydrochloric acid R* and dilute to 20 mL with the same acid. The solution is clear (2.2.1) and not more intensely coloured than reference solution  $Y_7$  (2.2.2, Method II).

**Specific optical rotation** (2.2.7). Dissolve 1.25 g in a mixture of equal volumes of *dilute hydrochloric acid R* and *water R* and dilute to 25.0 mL with the same mixture of solvents. The specific optical rotation is  $-11.0$  to  $-12.3$ , calculated with reference to the dried substance.

**Ninhydrin-positive substances.** Examine by thin-layer chromatography (2.2.27), using a *TLC silica gel plate R*.

*Test solution (a).* Dissolve 0.10 g of the substance to be examined in *dilute ammonia R2* and dilute to 10 mL with the same solvent.

*Test solution (b).* Dilute 1 mL of test solution (a) to 50 mL with *water R*.

*Reference solution (a).* Dissolve 10 mg of *tyrosine CRS* in 1 mL of *dilute ammonia R2* and dilute to 50 mL with *water R*.

*Reference solution (b).* Dilute 5 mL of test solution (b) to 20 mL with *water R*.

*Reference solution (c).* Dissolve 10 mg of *tyrosine CRS* and 10 mg of *phenylalanine CRS* in 1 mL of *dilute ammonia R2* and dilute to 25 mL with *water R*.

Apply to the plate 5  $\mu$ L of each solution. Develop over a path of 15 cm using a mixture of 30 volumes of *concentrated ammonia R1* and 70 volumes of *propanol R*. Allow the plate to dry in air, spray with *ninhydrin solution R* and heat at 100 °C to 105 °C for 15 min. Any spot in the chromatogram obtained with test solution (a), apart from the principal spot, is not more intense than the spot in the chromatogram obtained with reference solution (b) (0.5 per cent). The test is not valid unless the chromatogram obtained with reference solution (c) shows two clearly separated spots.

**Chlorides** (2.4.4). Dissolve 0.25 g in 3 mL of *dilute nitric acid R* and dilute to 15 mL with *water R*. The solution complies with the limit test for chlorides, without any further addition of nitric acid (200 ppm).

**Sulfates** (2.4.13). Dissolve with gentle heating, 0.5 g in 5 mL of *dilute hydrochloric acid R* and dilute to 15 mL with *distilled water R*. The solution complies with the limit test for sulfates (300 ppm).

**Ammonium** (2.4.1). 0.10 g complies with limit test B for ammonium (200 ppm). Prepare the standard using 0.2 mL of *ammonium standard solution (100 ppm  $NH_4$ ) R*. Replace the *heavy magnesium oxide R* by 2.0 mL of *strong sodium hydroxide solution R*.

**Iron (2.4.9).** In a separating funnel, dissolve 1.0 g in 10 mL of *dilute hydrochloric acid R*. Shake with three quantities, each of 10 mL, of *methyl isobutyl ketone RI*, shaking for 3 min each time. To the combined organic layers add 10 mL of *water R* and shake for 3 min. The aqueous layer complies with the limit test for iron (10 ppm).

**Heavy metals (2.4.8).** 2.0 g complies with limit test C for heavy metals (10 ppm). Prepare the standard using 2 mL of *lead standard solution (10 ppm Pb) R*.

**Loss on drying (2.2.32).** Not more than 0.5 per cent, determined on 1.000 g by drying in an oven at 105 °C.

**Sulfated ash (2.4.14).** Not more than 0.1 per cent, determined on 1.0 g.

#### ASSAY

Dissolve 0.150 g in 5 mL of *anhydrous formic acid R*. Add 30 mL of *anhydrous acetic acid R*. Titrate with 0.1 M *perchloric acid*, determining the end-point potentiometrically (2.2.20).

1 mL of 0.1 M *perchloric acid* is equivalent to 18.12 mg of  $C_9H_{11}NO_3$ .

#### STORAGE

Store protected from light.

01/2008:1662

## TYROTHRINICIN

### Tyrothricinum

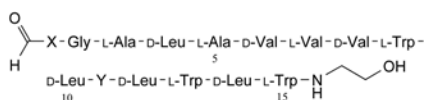

Gramicidin	Mol. formula	$M_r$	X	Y
A1	$C_{99}H_{140}N_{20}O_{17}$	1882	L-Val	L-Trp
A2	$C_{100}H_{142}N_{20}O_{17}$	1896	L-Ile	L-Trp
C1	$C_{97}H_{139}N_{19}O_{18}$	1859	L-Val	L-Tyr
C2	$C_{98}H_{141}N_{19}O_{18}$	1873	L-Ile	L-Tyr

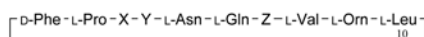

Tyrocidin	Mol. formula	$M_r$	X	Y	Z
A	$C_{66}H_{88}N_{13}O_{13}$	1271	L-Phe	D-Phe	L-Tyr
B	$C_{68}H_{89}N_{14}O_{13}$	1311	L-Trp	D-Phe	L-Tyr
C	$C_{70}H_{90}N_{15}O_{13}$	1350	L-Trp	D-Trp	L-Tyr
D	$C_{72}H_{91}N_{16}O_{12}$	1373	L-Trp	D-Trp	L-Trp
E	$C_{66}H_{88}N_{13}O_{12}$	1255	L-Phe	D-Phe	L-Phe

#### DEFINITION

Mixture of antimicrobial linear and cyclic polypeptides, isolated from the fermentation broth of *Brevibacillus brevis* Dubos. It consists mainly of gramicidins and tyrocidins as described above; other related compounds may be present in smaller amounts.

**Potency:** 180 IU/mg to 280 IU/mg (dried substance).

#### CHARACTERS

**Appearance:** white or almost white powder.

**Solubility:** practically insoluble in water, soluble in ethanol (96 per cent) and in methanol.

#### IDENTIFICATION

**First identification:** B.

**Second identification:** A.

A. Thin-layer chromatography (2.2.27).

**Test solution.** Dissolve 5 mg of the substance to be examined in 4.0 mL of *ethanol (96 per cent) R*.

**Reference solution.** Dissolve 5 mg of *tyrothricin CRS* in 4.0 mL of *ethanol (96 per cent) R*.

**Plate:** *TLC silica gel F<sub>254</sub> plate R*.

**Mobile phase:** *methanol R, butanol R, water R, acetic acid R, butyl acetate R* (2.5:7.5:12:20:40 V/V/V/V).

**Application:** 1 µL.

**Development:** over 2/3 of the plate.

**Drying:** in a current of warm air.

**Detection A:** examine in ultraviolet light at 254 nm.

**Results A:** the principal spots or groups of principal spots in the chromatogram obtained with the test solution are similar in position and size to the principal spots or groups of principal spots in the chromatogram obtained with the reference solution. The upper group corresponds to gramicidins, the lower group to tyrocidins.

**Detection B:** spray with *dimethylaminobenzaldehyde solution R2*. Heat the plate in a current of warm air until the spots appear.

**System suitability:** reference solution:

– the chromatogram shows 2 clearly separated spots or groups of spots.

**Results B:** the principal spots or groups of principal spots in the chromatogram obtained with the test solution are similar in position, colour and size to the principal spots or groups of principal spots in the chromatogram obtained with the reference solution. The upper group corresponds to gramicidins, the lower group to tyrocidins.

B. Composition (see Tests).

#### TESTS

**Composition.** Liquid chromatography (2.2.29): use the normalisation procedure. *Prepare the solutions immediately before use.*

**Test solution.** Dissolve 5 mg of the substance to be examined in 2 mL of *methanol R* and dilute to 5.0 mL with the mobile phase.

**Reference solution (a).** Dissolve 5 mg of *tyrothricin CRS* in 2 mL of *methanol R* and dilute to 5.0 mL with the mobile phase.

**Reference solution (b).** Dilute 1.0 mL of reference solution (a) to 50.0 mL with the mobile phase.

**Column:**

– **size:**  $l = 0.25$  m,  $\varnothing = 4.6$  mm,

– **stationary phase:** *octadecylsilyl silica gel for chromatography R* (5 µm),

– **temperature:** 60 °C.

**Mobile phase:** 0.79 g/L solution of *ammonium sulfate R*, *methanol R* (25:75 V/V).

**Flow rate:** 1.2 mL/min.

**Detection:** spectrophotometer at 280 nm.

**Injection:** 25 µL.

**Run time:** 6 times the retention time of gramicidin A1. Use the chromatogram obtained with reference solution (a) and the chromatogram supplied with *tyrothricin CRS* to identify the peaks due to gramicidin A1, gramicidin A2 and the tyrocidins.

**Relative retention** with reference to gramicidin A1 (retention time = about 10 min): gramicidin C1 = about 0.8; gramicidin C2 = about 0.9; gramicidin A2 = about 1.1; tyrocidins = about 1.5 to 6.



*System suitability*: reference solution (a):

- *peak-to-valley ratio*: minimum 3.0, where  $H_p$  = height above the baseline of the peak due to gramicidin A2 and  $H_v$  = height above the baseline of the lowest point of the curve separating this peak from the peak due to gramicidin A1.

*Composition*:

- *sum of gramicidins*: 25 per cent to 50 per cent,
- *sum of tyrocidins*: 50 per cent to 70 per cent,
- *total*: minimum 85 per cent,
- *disregard limit*: the sum of the areas of the peaks due to gramicidins in the chromatogram obtained with reference solution (b).

**Loss on drying** (2.2.32): maximum 4.0 per cent, determined on 1.000 g by drying under high vacuum at 60 °C for 3 h.

**Sulfated ash** (2.4.14): maximum 1.5 per cent, determined on 1.0 g.

#### ASSAY

Carry out the microbiological assay of antibiotics (2.7.2) using the turbidimetric method. Use *gramicidin CRS* as the reference substance.

*Test solution*. Prepare a solution of tyrothricin containing about the same amount of gramicidin as the corresponding solution of *gramicidin CRS* i.e. 5 times more concentrated.

#### STORAGE

In an airtight container, protected from light.

**01/2008:1578** *Mobile phase: ethanol R, methanol R2 (20:80 V/V).*  
**corrected 6.0** *Flow rate: 2 mL/min.*

## UBIDECARENONE

### Ubidecarenonum

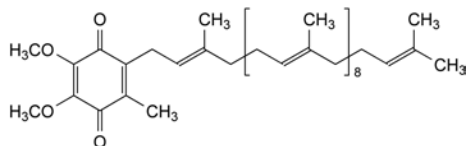

$C_{59}H_{90}O_4$   
 [303-98-0]

$M_r$  863

#### DEFINITION

2-[(all-*E*)-3,7,11,15,19,23,27,31,35,39-Decamethyltetracontane-2,6,10,14,18,22,26,30,34,38-decaenyl]-5,6-dimethoxy-3-methylbenzene-1,4-dione.

*Content:* 97.0 per cent to 103.0 per cent.

#### CHARACTERS

*Appearance:* yellow or orange, crystalline powder.

*Solubility:* practically insoluble in water, soluble in acetone, very slightly soluble in ethanol.

It gradually decomposes and darkens on exposure to light.

mp: about 48 °C.

*Carry out all operations avoiding exposure to light.*

#### IDENTIFICATION

A. Infrared absorption spectrophotometry (2.2.24).

*Preparation:* discs.

*Comparison:* ubidecarenone CRS.

B. Examine the chromatograms obtained in the test for related substances.

*Results:* the retention time of the principal peak in the chromatogram obtained with the test solution is similar to that of the principal peak in the chromatogram obtained with reference solution (a).

#### TESTS

**Related substances.** Liquid chromatography (2.2.29).

*Test solution.* Dissolve 25.0 mg of the substance to be examined in 25.0 mL of *ethanol R* by heating at about 50 °C for 2 min. Allow to cool.

*Reference solution (a).* Dissolve 5 mg of *ubidecarenone CRS* in 5 mL of *ethanol R* by heating at about 50 °C for 2 min. Allow to cool.

*Reference solution (b).* Dissolve 2 mg of *ubidecarenone impurity D CRS* in 2 mL of the test solution by heating at about 50 °C for 2 min. Allow to cool. Dilute 1 mL to 50 mL with *ethanol R*.

*Reference solution (c).* Dilute 1.0 mL of the test solution to 100.0 mL with *ethanol R*.

*Column:*

- *size:*  $l = 0.15$  m,  $\emptyset = 4.6$  mm,
- *stationary phase:* octadecylsilyl silica gel for chromatography R (5 µm).

*Detection:* spectrophotometer at 275 nm.

*Injection:* 10 µL.

*Run time:* 2 times the retention time of ubidecarenone.

*Relative retention* with reference to ubidecarenone (retention time = about 12 min): impurity D = about 0.67.

*System suitability:* reference solution (b):

- *resolution:* minimum 6.5 between the peaks due to impurity D and to ubidecarenone.

*Limits:*

- *any impurity:* not more than half the area of the principal peak in the chromatogram obtained with reference solution (c) (0.5 per cent),
- *total:* not more than the area of the principal peak in the chromatogram obtained with reference solution (c) (1.0 per cent),
- *disregard limit:* 0.05 times the area of the principal peak in the chromatogram obtained with reference solution (c) (0.05 per cent).

**Impurity F.** Liquid chromatography (2.2.29).

*Test solution.* Dissolve 25.0 mg of the substance to be examined in 25.0 mL of *hexane R*.

*Reference solution (a).* Dissolve the contents of a vial of *ubidecarenone for system suitability CRS* in 1 mL of *hexane R*.

*Reference solution (b).* Dilute 1.0 mL of the test solution to 100.0 mL with *hexane R*.

*Column:*

- *size:*  $l = 0.25$  m,  $\emptyset = 4.0$  mm,
- *stationary phase:* silica gel for chromatography R (7 µm).

*Mobile phase:* ethyl acetate R, hexane R (3:97 V/V).

*Flow rate:* 2 mL/min.

*Detection:* spectrophotometer at 275 nm.

*Injection:* 20 µL.

*Run time:* 1.2 times the retention time of ubidecarenone.

*Relative retention* with reference to ubidecarenone (retention time = about 10 min): impurity F = about 0.85.

*System suitability:* reference solution (a):

- *resolution:* minimum 1.5 between the peaks due to impurity F and to ubidecarenone.

*Limit:*

- *impurity F:* not more than 0.5 times the area of the principal peak in the chromatogram obtained with reference solution (b) (0.5 per cent).

**Sulfated ash (2.4.14):** maximum 0.1 per cent, determined on 1.0 g.

#### ASSAY

Dissolve 50.0 mg in 1.0 mL of *hexane R* and dilute to 50.0 mL with *ethanol R*. Dilute 2.0 mL of the solution to 50.0 mL with *ethanol R*. Measure the absorbance (2.2.25) at the maximum at 275 nm. Calculate the content of  $C_{59}H_{90}O_4$  taking the specific absorbance to be 169.

#### STORAGE

Store in an airtight container, protected from light.

## IMPURITIES

Specified impurities: A, B, C, D, E, F.

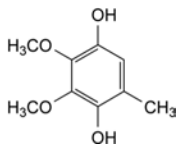

A. 2,3-dimethoxy-5-methylbenzene-1,4-diol,

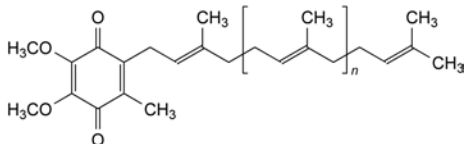

B.  $n = 5$ : 2-[(all-*E*)-3,7,11,15,19,23,27-heptamethyloctadocosa-2,6,10,14,18,22,26-heptaenyl]-5,6-dimethoxy-3-methylbenzene-1,4-dione (ubiquinone-7),

C.  $n = 6$ : 5,6-dimethoxy-3-methyl-2-[(all-*E*)-3,7,11,15,19,23,27,31-octamethyldotriaconta-2,6,10,14,18,22,26,30-octaenyl]benzene-1,4-dione (ubiquinone-8),

D.  $n = 7$ : 5,6-dimethoxy-3-methyl-2-[(all-*E*)-3,7,11,15,19,23,27,31,35-nonamethylhexatriaconta-2,6,10,14,18,22,26,30,34-nonaenyl]benzene-1,4-dione (ubiquinone-9),

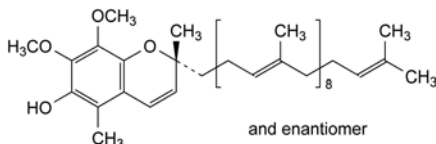

E. (2*RS*)-7,8-dimethoxy-2,5-dimethyl-2-[(all-*E*)-4,8,12,16,20,24,28,32,36-nonamethylheptatriaconta-3,7,11,15,19,23,27,31,35-nonaenyl]-2*H*-1-benzopyran-6-ol (ubiquinol),

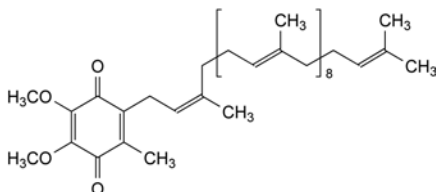

F. 2-[(2*Z*,6*E*,10*E*,14*E*,18*E*,22*E*,26*E*,30*E*,34*E*,38*E*)-3,7,11,15,19,23,27,31,35,39-decamethyl-2,6,10,14,18,22,26,30,34,38-tetracontadecaenyl]-5,6-dimethoxy-3-methylbenzene-1,4-dione (ubidecarenone (*Z*)-isomer).

B. Freezing point (2.2.18): 21 °C to 24 °C.

C. To 2.0 g add 2 mL of freshly distilled *aniline R* and boil under a reflux condenser for 10 min. Allow to cool and add 30 mL of *ether R*. Shake with 3 quantities, each of 20 mL, of *dilute hydrochloric acid R* and then with 20 mL of *water R*. Evaporate the organic layer to dryness on a water-bath. After recrystallising twice from *ethanol (70 per cent V/V) R* and drying *in vacuo* for 3 h, the residue melts (2.2.14) at 66 °C to 68 °C.

D. Dissolve 0.1 g in a mixture of 2 mL of *dilute sulfuric acid R* and 5 mL of *glacial acetic acid R*. Add dropwise 0.25 mL of *potassium permanganate solution R*. The colour of the potassium permanganate is discharged.

## TESTS

**Peroxide value** (2.5.5, *Method A*): maximum 10.

**Fixed and mineral oils.** To 1.0 g add 5 mL of *sodium carbonate solution R* and 25 mL of *water R* and boil for 3 min. The hot solution is not more opalescent than reference suspension II (2.2.1).

**Water-soluble acids.** To 1.0 g add 20 mL of *water R* heated to 35-45 °C and shake for 2 min. Cool and filter the aqueous layer through a moistened filter. To 10 mL of the filtrate add 0.1 mL of *phenolphthalein solution R*. Not more than 0.1 mL of 0.1 *M sodium hydroxide* is required to change the colour of the indicator.

**Degree of unsaturation.** Dissolve 85.0 mg in a mixture of 5 mL of *dilute hydrochloric acid R* and 30 mL of *glacial acetic acid R*. Using 0.05 mL of *indigo carmine solution R1* as indicator, added towards the end of the titration, titrate with 0.0167 *M bromide-bromate* until the colour changes from blue to yellow. 8.9 mL to 9.4 mL of 0.0167 *M bromide-bromate* is required. Carry out a blank titration.

**Sulfated ash** (2.4.14): maximum 0.1 per cent, determined on 0.50 g.

## ASSAY

Dissolve 0.750 g in 10 mL of *ethanol (96 per cent) R*. Titrate with 0.5 *M sodium hydroxide* using 0.1 mL of *phenolphthalein solution R* as indicator, until a pink colour is obtained.

1 mL of 0.5 *M sodium hydroxide* is equivalent to 92.14 mg of C<sub>11</sub>H<sub>20</sub>O<sub>2</sub>.

## STORAGE

In a non-metallic container, protected from light.

01/2008:0461

01/2008:0743  
corrected 6.0

## UNDECYLENIC ACID

Acidum undecylenicum



C<sub>11</sub>H<sub>20</sub>O<sub>2</sub>  
[112-38-9]

*M<sub>r</sub>* 184.3

## DEFINITION

Undec-10-enoic acid.

*Content*: 97.0 per cent to 102.0 per cent.

## CHARACTERS

*Appearance*: white or very pale yellow, crystalline mass or colourless or pale yellow liquid.

*Solubility*: practically insoluble in water, freely soluble in ethanol (96 per cent) and in fatty and essential oils.

## IDENTIFICATION

A. Refractive index (2.2.6): 1.447 to 1.450, determined at 25 ± 0.5 °C.

## UREA

Ureum

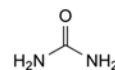

CH<sub>4</sub>N<sub>2</sub>O  
[57-13-6]

*M<sub>r</sub>* 60.1

## DEFINITION

Carbamide.

*Content*: 98.5 per cent to 101.5 per cent (dried substance).

## CHARACTERS

*Appearance*: white or almost white, crystalline powder or transparent crystals, slightly hygroscopic.

*Solubility*: very soluble in water, soluble in alcohol, practically insoluble in methylene chloride.

## IDENTIFICATION

*First identification*: A, B.

*Second identification: A, C, D.*

- A. Melting point (2.2.14): 132 °C to 135 °C.  
 B. Infrared absorption spectrophotometry (2.2.24).

*Preparation: discs.*

*Comparison: urea CRS.*

- C. Dissolve 0.1 g in 1 mL of *water R*. Add 1 mL of *nitric acid R*. A white, crystalline precipitate is formed.  
 D. Heat 0.5 g in a test tube until it liquefies and the liquid becomes turbid. Cool, dissolve in a mixture of 1 mL of *dilute sodium hydroxide solution R* and 10 mL of *water R* and add 0.05 mL of *copper sulfate solution R*. A reddish-violet colour is produced.

#### TESTS

**Solution S.** Dissolve 10.0 g in *water R* and dilute to 50 mL with the same solvent.

**Appearance of solution.** The solution is clear (2.2.1) and colourless (2.2.2, *Method II*).

To 2.5 mL of solution S add 7.5 mL of *water R*.

**Alkalinity.** To 2.5 mL of solution S add 7.5 mL of *water R*, 0.1 mL of *methyl red solution R* and 0.4 mL of 0.01 M *hydrochloric acid*. The solution is red to orange.

**Biuret:** maximum 0.1 per cent.

To 10 mL of solution S add 5 mL of *water R*, 0.5 mL of a 5 g/L solution of *copper sulfate R* and 0.5 mL of *strong sodium hydroxide solution R*. Allow to stand for 5 min. Any reddish-violet colour in the solution is not more intense than that in a standard prepared at the same time in the same manner using 10 mL of a 0.2 g/L solution of *biuret R*.

**Ammonium** (2.4.1): maximum 500 ppm, determined on 0.1 mL of solution S.

**Heavy metals** (2.4.8): maximum 10 ppm.

Dilute 10 mL of solution S to 20 mL with *water R*. 12 mL of the solution complies with limit test A. Prepare the standard using *lead standard solution (1 ppm Pb) R*.

**Loss on drying** (2.2.32): maximum 1.0 per cent, determined on 1.000 g by drying in an oven at 105 °C for 1 h.

**Sulfated ash** (2.4.14): maximum 0.1 per cent, determined on 1.0 g.

#### ASSAY

Dissolve 0.2000 g in *water R* and dilute to 50.0 mL with the same solvent. Introduce 1.0 mL of this solution into a combustion flask. Add 4 g of a powdered mixture of 100 g of *dipotassium sulfate R*, 5 g of *copper sulfate R* and 2.5 g of *selenium R*, and 3 glass beads. Wash any adhering particles from the neck into the flask with 5 mL of *sulfuric acid R*, allowing it to run down the sides of the flask, and mix the contents by rotation. Close the mouth of the flask loosely, for example by means of a glass bulb with a short stem, to avoid excessive loss of sulfuric acid. Heat gradually at first, then increase the temperature until there is vigorous boiling with condensation of sulfuric acid in the neck of the flask; take precautions to prevent the upper part of the flask from becoming overheated. Continue the heating for 30 min. Cool, dissolve the solid material by cautiously adding to the mixture 25 mL of *water R*, cool again and place in a steam-distillation apparatus. Add 30 mL of *strong sodium hydroxide solution R* and distil immediately by passing steam through the mixture. Collect the distillate in 15 mL of a 40 g/L solution of *boric acid R* to which has been added 0.2 mL of *methyl red mixed solution R* and enough *water R* to cover the tip of the condenser. Towards the end of the distillation, lower the receiver so that the tip of the condenser is above the surface of the acid. Take precautions to prevent any water on the outer surface of the condenser from reaching the contents of the receiver. Titrate the distillate with 0.01 M *sulfuric acid*. 1 mL of 0.01 M *sulfuric acid* is equivalent to 0.6006 mg of  $\text{CH}_4\text{N}_2\text{O}$ .

#### STORAGE

In an airtight container.

01/2008:0958

## UROFOLLITROPIN

### Urofollitropinum

[97048-13-0]

#### DEFINITION

Urofollitropin is a dry preparation containing menopausal gonadotrophin obtained from the urine of post-menopausal women. It has follicle-stimulating activity and no or virtually no luteinising activity. The potency is not less than 90 International Units of follicle-stimulating hormone (hFSH) per milligram. The ratio of units of luteinising hormone (interstitial-cell-stimulating hormone) [hLH(ICSH)] to units of follicle-stimulating hormone is not more than 1/60.

#### PRODUCTION

It may be prepared by a suitable fractionation procedure followed by immunoaffinity chromatography.

#### CHARACTERS

*Appearance:* almost white or slightly yellowish powder.

*Solubility:* soluble in water.

#### IDENTIFICATION

When administered as prescribed in the assay it causes enlargement of the ovaries of immature female rats.

#### TESTS

**Hepatitis virus antigens.** Examined by a suitably sensitive immunochemical method (2.7.1), hepatitis virus antigens are not detected.

**HIV antigen.** Examined by a suitably sensitive immunochemical method (2.7.1), HIV antigen is not detected.

**Residual luteinising activity.** The International Units of FSH and LH are the activities contained in stated amounts of the International Standard of human urinary follicle-stimulating hormone and luteinising hormone (interstitial-cell-stimulating hormone) which consists of a mixture of a freeze-dried extract of urine of post-menopausal women with lactose. The equivalence in International Units of the International Standard is stated by the World Health Organisation. Use immature female rats approximately 21 days old and having masses such that the difference between the heaviest and the lightest rat is not more than 10 g. Assign the rats at random to 4 equal groups of at least 6 animals. If sets of 4 litter mates are available, assign one litter mate at random from each set to each group and mark according to litter.

Inject subcutaneously into each rat 50 IU of *serum gonadotrophin R* on the first day and 25 IU of *chorionic gonadotrophin R* on the fourth day, each in 0.5 mL of *phosphate-albumin buffered saline pH 7.2 R*.

Choose 3 doses of the reference preparation such that the smallest dose produces a depletion of the ovarian ascorbic acid content in all the rats and the largest dose does not produce a maximal depletion in all the rats. Use doses in geometric progression; as an initial approximation, total doses of 0.5 IU, 1.0 IU and 2.0 IU may be tried although the dose to be used will depend on the sensitivity of the animals.

Choose a dose of the preparation to be examined expected to contain 60X IU of follicle-stimulating hormone (hFSH), in which X = the number of IU of hLH in the middle dose of the reference preparation.

Dissolve separately the total quantities of the preparation to be examined and of the reference preparation in 1.0 mL of *phosphate-albumin buffered saline pH 7.2 R*. Inject into a tail

vein to each separate group of rats 6 days after the injection of chorionic gonadotrophin. Exactly 4 h after the injection, euthanise the rats and remove the ovaries from each animal. Remove any extraneous fluid and tissue from the ovaries and weigh the ovaries immediately.

Treat the combined ovaries from each rat separately, as follows. Crush and homogenise within 2 min in a freshly prepared 25 g/L solution of *metaphosphoric acid R* at a temperature of 4 °C and dilute to 7 mL with the same solution. Allow the homogenate to stand for 30 min at 4 °C and centrifuge at 4 °C at approximately 2500 g. Filter the supernatant liquid, if necessary, through a 0.22 µm filter.

Prepare a fresh solution consisting of a mixture of 2 mL of a 45.3 g/L solution of *sodium acetate R* adjusted to pH 7 with *acetic acid R*, 3 mL of *water R* and 2 mL of *dichlorophenolindophenol standard solution R*. Mix 2 mL of this solution with 2 mL of the clear supernatant liquid. 30 s after mixing, measure the absorbance (2.2.25) of the solution at the maximum at about 520 nm. Use as reference a solution with a known content of *ascorbic acid CRS* in a 25 g/L solution of *metaphosphoric acid R*, treated by the same process.

Calculate the amount of ascorbic acid from the ascorbic acid standard curve obtained and express in milligrams per 0.1 g of ovary to obtain the ascorbic acid content of the ovaries. Calculate the mean and its variance of the ascorbic acid content of the ovaries of the rats treated with the preparation to be examined.

For each dose-group of the reference preparation, plot the mean ascorbic acid content of the ovaries as a function of the logarithm of the dose and analyse the regression of the ascorbic acid content on the logarithm of the dose injected, using standard methods of analysis (the method of least squares).

The test is not valid unless:

- the slope constant *b* is significant at the 5 per cent level of significance,
- for the groups treated with the reference preparation, the sum of squares due to linear regression is equal to at least 95 per cent of the total sum of squares of the ascorbic acid content,
- the within-group variance of the ascorbic acid content of the group receiving the preparation to be examined is not significantly different at the 5 per cent level of significance from the within-group variance of the ascorbic acid content of the groups receiving the reference preparation.

The mean ascorbic acid content of the ovaries of the rats treated with the preparation to be examined is not significantly lower than that of the rats treated with the middle dose of the reference preparation (calculated from the regression equation) at the 5 per cent level of significance.

**Water** (2.5.32): maximum 5.0 per cent.

**Bacterial endotoxins** (2.6.14, *Method C*): less than 0.40 IU per IU of urofollitropin, if intended for use in the manufacture of parenteral preparations without a further appropriate procedure for the removal of bacterial endotoxins.

#### ASSAY

The follicle-stimulating activity of urofollitropin is estimated by comparing under given conditions its effect in enlarging the ovaries of immature rats treated with chorionic gonadotrophin with the same effect of the International Standard preparation of human urinary follicle-stimulating hormone and luteinising hormone or of a reference preparation calibrated in International Units. The International Units of FSH and LH are the activities contained in stated amounts of the International Standard of human urinary follicle-stimulating hormone and luteinising hormone (interstitial-cell-stimulating hormone) which consists of a mixture of a freeze-dried extract of urine of post-menopausal women with lactose. The equivalence in International Units of the International Standard is stated by the World Health Organisation.

Use immature female rats of the same strain, 19 to 28 days old, differing in age by not more than 3 days and having masses such that the difference between the heaviest and the lightest rat is not more than 10 g. Assign the rats at random to 6 equal groups of at least 5 animals. If sets of 6 litter mates are available, assign one litter mate from each set to each group and mark according to litter.

Choose 3 doses of the reference preparation and 3 doses of the preparation to be examined such that the smallest dose produces a positive response in some of the rats and the largest dose does not produce a maximal response in all the rats. Use doses in geometric progression and as an initial approximation total doses of 1.5 IU, 3.0 IU and 6.0 IU may be tried although the dose will depend on the sensitivity of the animals used, which may vary widely.

Dissolve separately the total quantities of the preparation to be examined and of the reference preparation corresponding to the daily doses to be used in sufficient *phosphate-albumin buffered saline pH 7.2 R* such that the daily dose is administered in a volume of about 0.5 mL. The buffer solution shall contain in the daily dose not less than 14 IU of chorionic gonadotrophin to ensure complete luteinisation. Add a suitable antimicrobial preservative such as 4 g/L of phenol or 0.02 g/L of thiomersal. Store the solutions at 5 ± 3 °C.

Inject subcutaneously into each rat the daily dose allocated to its group. Repeat the injection of each dose 24 h and 48 h after the first injection. About 24 h after the last injection, euthanise the rats and remove the ovaries from each animal. Remove any extraneous fluid and tissue from the ovaries and weigh the 2 combined ovaries of each animal immediately. Calculate the results by the usual statistical methods, using the mass of the 2 combined ovaries as the response. (The precision of the assay may be improved by a suitable correction of the organ mass with reference to the mass of the animal from which it was taken; an analysis of covariance may be used).

The estimated potency is not less than 80 per cent and not more than 125 per cent of the stated potency. The confidence limits (*P* = 0.95) of the estimated potency are not less than 64 per cent and not more than 156 per cent of the stated potency.

#### STORAGE

In an airtight, tamper-proof container, protected from light, at a temperature of 2 °C to 8 °C. If the substance is sterile, store in a sterile, airtight, tamper-proof container.

#### LABELLING

The label states:

- the activity expressed in International Units of follicle-stimulating hormone per container,
- the potency expressed in International Units of follicle-stimulating hormone per milligram.

01/2008:0695

## UROKINASE

### Urokinasum

[9039-53-6]

#### DEFINITION

Enzyme, obtained from human urine, that activates plasminogen. It consists of a mixture of low-molecular-mass (LMM) (*M<sub>r</sub>* 33 000) and high-molecular-mass (HMM) (*M<sub>r</sub>* 54 000) forms, the high-molecular-mass form being predominant.

*Potency*: not less than 70 000 IU per milligram of protein.

#### PRODUCTION

It is produced by validated methods of manufacturing designed to minimise or eliminate vasoactive substances.

## CHARACTERS

**Appearance:** white or almost white, amorphous powder.

**Solubility:** soluble in water.

## IDENTIFICATION

- A. Place separately in two haemolysis tubes 0.5 mL of citrated human plasma and 0.5 mL of citrated bovine plasma and maintain in a water-bath at 37 °C. To each tube add 0.1 mL of a solution containing a quantity of the substance to be examined equivalent to 1000 IU/mL in *phosphate buffer solution pH 7.4 R* and 0.1 mL of a solution containing a quantity of *humanthrombin R* equivalent to 20 IU/mL in *phosphate buffer solution pH 7.4 R*. Shake immediately. In both tubes, a clot forms and lyses within 30 min.
- B. Carry out identification by a suitable immunodiffusion test.

## TESTS

**Appearance of solution.** The solution is clear (2.2.1) and colourless (2.2.2, *Method II*).

Dissolve 10 mg in 10 mL of *water R*.

**Hepatitis B surface antigen.** Examine by a suitably sensitive method such as radio-immunoassay. Hepatitis B surface antigen is not detected.

**Thromboplastic contaminants**

**Test solutions.** Dissolve suitable quantities of the substance to be examined in *barbital buffer solution pH 7.4 R* to obtain solutions with activities of 5000 IU/mL, 2500 IU/mL, 1250 IU/mL, 625 IU/mL and 312 IU/mL.

To each of six haemolysis tubes 1 cm in internal diameter add 0.1 mL of *citrated rabbit plasma R*. Allocate the test solutions one to each of five of the tubes; add to each tube 0.1 mL of the solution allocated to it and to the sixth tube add 0.1 mL of *barbital buffer solution pH 7.4 R* (blank). Incubate the tubes at  $25 \pm 0.5$  °C for 5 min and add 0.1 mL of a 3.675 g/L solution of *calcium chloride R*. Measure with a stop-watch the coagulation time for each tube. Plot the shortening of the recalcification time (clotting time of the blank minus clotting time measured) against log concentration in International Units. Extrapolate the best-fitting straight line through the five points until it reaches the log-concentration axis. The urokinase activity at the intersection point, which represents the limit concentration for coagulant activity (zero coagulant activity), is not less than 150 IU/mL.

**Molecular fractions.** Size-exclusion chromatography (2.2.30).

**Test solution.** Dissolve about 1 mg in 1.0 mL of 0.02 M *phosphate buffer pH 8.0 R*. Prepare immediately before use.

**Column:**

- size:  $l = 0.9$  m,  $\emptyset = 16$  mm;
- stationary phase: cross-linked dextran for chromatography R3;
- temperature: 5 °C.

**Mobile phase:** 17.5 g/L solution of *sodium chloride R* in 0.02 M *phosphate buffer solution pH 8.0 R*.

**Flow rate:** 0.1 mL/min.

Apply the test solution to the head of the column rinsing twice with 0.5 mL portions of the buffer and carry out the elution. The eluate may be collected in fractions of 1 mL. Measure the absorbance (2.2.25) of the eluate at the maximum at 280 nm and plot the individual values on a graph. Draw perpendicular lines towards the axis of the abscissae from the minima before the HMM peak, between the HMM and the LMM peaks, and after the LMM peak, thus identifying the fractions to be considered in calculating the HMM/LMM activity ratio. Pool the HMM fractions and, separately, the LMM fractions. Determine separately the urokinase activity in International Units of each of the fraction pools by the method prescribed under Assay. The ratio of the urokinase activity in the HMM fraction pool to that in the LMM fraction pool is not less than 2.0.

**Total protein.** Determine the nitrogen content, using 10 mg, by the method of sulfuric acid digestion (2.5.9) and calculate the quantity of protein by multiplying by 6.25.

**Pyrogens (2.6.8).** If intended for use in the manufacture of parenteral preparations without a further appropriate procedure for the removal of pyrogen, it complies with the test for pyrogens. Inject per kilogram of the rabbit's mass 1.0 mL of a sterile 9 g/L solution of *sodium chloride R* containing a quantity of the substance to be examined equivalent to 20 000 IU/mL.

## ASSAY

The potency of urokinase is determined by comparing its capacity to activate plasminogen to form plasmin with the same capacity of a reference preparation of urokinase calibrated in International Units; the formation of plasmin is measured by the determination of the lysis time of a fibrin clot in given conditions.

The International Unit is the activity contained in a stated amount of the International Reference Preparation, which consists of freeze-dried urokinase with lactose. The equivalence in International Units of the International Reference Preparation is stated by the World Health Organisation.

Unless otherwise prescribed, use *phosphate buffer solution pH 7.4 R* containing 30 g/L of *bovine albumin R* for the preparation of the solutions and dilutions used in the assay.

**Test solution.** Prepare a solution of the substance to be examined expected to have an activity of 1000 IU/mL.

**Reference solution.** Prepare a solution of a reference preparation having an activity of 1000 IU/mL.

Keep the test solution and the reference solution in iced water and use within 6 h. Prepare three serial 1.5-fold dilutions of the reference preparation such that the longest clot-lysis time is less than 20 min and the shortest clot-lysis time is greater than 3 min. Prepare three similar dilutions of the test solution. Keep the solutions in iced water and use within 1 h. Use twenty-four tubes 8 mm in diameter. Label the tubes  $T_1$ ,  $T_2$  and  $T_3$  for the dilutions of the test solution and  $S_1$ ,  $S_2$  and  $S_3$  for the dilutions of the reference solution, allocating four tubes to each dilution. Place the tubes in iced water. Into each tube, introduce 0.2 mL of the appropriate dilution, 0.2 mL of *phosphate buffer solution pH 7.4 R* containing 30 g/L of *bovine albumin R* and 0.1 mL of a solution of *humanthrombin R* having an activity of not less than 20 IU/mL. Place the tubes in a water-bath at 37 °C and allow to stand for 2 min to attain temperature equilibrium. Using an automatic pipette, introduce into the bottom of the first tube 0.5 mL of a 10 g/L solution of *bovine eglobulins R*, ensuring mixing. At intervals of 5 s, introduce successively into the remaining tubes 0.5 mL of a 10 g/L solution of *bovine eglobulins R*. Using a stop-watch, measure for each tube the time in seconds that elapses between the addition of the eglobulins solution and the lysis of the clot. Plot the logarithms of the lysis times for the substance to be examined and for the reference preparation against the logarithms of the concentration and calculate the activity of the substance to be examined using the usual statistical methods.

The estimated potency is not less than 90 per cent and not more than 111 per cent of the stated potency. The confidence limits ( $P = 0.95$ ) of the estimated potency are not less than 80 per cent and not more than 125 per cent of the stated potency.

## STORAGE

Store in an airtight container, protected from light, at a temperature not exceeding 8 °C. If the substance is sterile, store in a sterile, airtight, tamper-proof container.

## LABELLING

The label states the potency in International Units per milligram of protein.

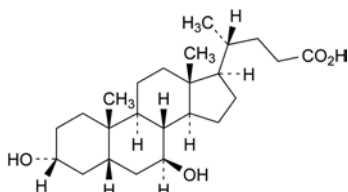
04/2010:1275 *Development*: over 2/3 of the plate.**URSODEOXYCHOLIC ACID****Acidum ursodeoxycholicum**C<sub>24</sub>H<sub>40</sub>O<sub>4</sub>  
[128-13-2]M<sub>r</sub> 392.6**DEFINITION**3 $\alpha$ ,7 $\beta$ -Dihydroxy-5 $\beta$ -cholan-24-oic acid.*Content*: 99.0 per cent to 101.0 per cent (dried substance).**CHARACTERS***Appearance*: white or almost white powder.*Solubility*: practically insoluble in water, freely soluble in ethanol (96 per cent), slightly soluble in acetone, practically insoluble in methylene chloride.

mp: about 202 °C.

**IDENTIFICATION***First identification*: A.*Second identification*: B, C.

A. Infrared absorption spectrophotometry (2.2.24).

*Comparison*: ursodeoxycholic acid CRS.

B. Examine the chromatograms obtained in the test for impurity C.

*Results*: the principal spot in the chromatogram obtained with test solution (b) is similar in position, colour and size to the principal spot in the chromatogram obtained with reference solution (a).

C. Dissolve about 10 mg in 1 mL of sulfuric acid R. Add 0.1 mL of formaldehyde solution R and allow to stand for 5 min. Add 5 mL of water R. The suspension obtained is greenish-blue.

**TESTS****Specific optical rotation** (2.2.7): + 58.0 to + 62.0 (dried substance).

Dissolve 0.500 g in anhydrous ethanol R and dilute to 25.0 mL with the same solvent.

**Impurity C**. Thin-layer chromatography (2.2.27).*Solvent mixture*: water R, acetone R (10:90 V/V).*Test solution (a)*. Dissolve 0.40 g of the substance to be examined in the solvent mixture and dilute to 10 mL with the solvent mixture.*Test solution (b)*. Dilute 1 mL of test solution (a) to 10 mL with the solvent mixture.*Reference solution (a)*. Dissolve 40 mg of ursodeoxycholic acid CRS in the solvent mixture and dilute to 10 mL with the solvent mixture.*Reference solution (b)*. Dissolve 20 mg of lithocholic acid CRS (impurity C) in the solvent mixture and dilute to 10.0 mL with the solvent mixture (solution A). Dilute 2.0 mL of this solution to 100.0 mL with the solvent mixture.*Reference solution (c)*. To 5 mL of solution A add 10 mg of chenodeoxycholic acid CRS (impurity A) and dilute to 50 mL with the solvent mixture.*Plate*: TLC silica gel plate R.*Mobile phase*: glacial acetic acid R, acetone R, methylene chloride R (1:30:60 V/V/V).*Application*: 5  $\mu$ L.*Drying*: at 120 °C for 10 min.*Detection*: spray immediately with a 47.6 g/L solution of phosphomolybdic acid R in a mixture of 1 volume of sulfuric acid R and 20 volumes of glacial acetic acid R and heat at 120 °C until blue spots appear on a lighter background.*System suitability*: reference solution (c):

– the chromatogram shows 2 clearly separated principal spots.

*Limit*: test solution (a):– *impurity C*: any spot due to impurity C is not more intense than the principal spot in the chromatogram obtained with reference solution (b) (0.1 per cent).**Related substances**. Liquid chromatography (2.2.29).*Solvent mixture*: methanol R, mobile phase (10:90 V/V).*Test solution*. Dissolve 60 mg of the substance to be examined in the solvent mixture and dilute to 20.0 mL with the solvent mixture.*Reference solution (a)*. Dissolve the contents of a vial of ursodeoxycholic acid for system suitability CRS (containing impurities A and H) in 1.0 mL of the solvent mixture.*Reference solution (b)*. Dilute 1.0 mL of the test solution to 100.0 mL with the solvent mixture. Dilute 1.0 mL of this solution to 10.0 mL with the solvent mixture.*Column*:– *size*:  $l = 0.25$  m,  $\varnothing = 4.6$  mm;– *stationary phase*: end-capped octadecylsilyl silica gel for chromatography R (5  $\mu$ m);– *temperature*: 40 °C  $\pm$  1 °C.*Mobile phase*: mix 30 volumes of acetonitrile R, 37 volumes of a 0.78 g/L solution of sodium dihydrogen phosphate R adjusted to pH 3 with phosphoric acid R, and 40 volumes of methanol R.*Flow rate*: 0.8 mL/min.*Detection*: refractometer at 35  $\pm$  1 °C.*Injection*: 150  $\mu$ L.*Run time*: 4 times the retention time of ursodeoxycholic acid.*Identification of impurities*: use the chromatogram supplied with ursodeoxycholic acid for system suitability CRS and the chromatogram obtained with reference solution (a) to identify the peaks due to impurities A and H.*Relative retention* with reference to ursodeoxycholic acid (retention time = about 14 min): impurity H = about 0.9; impurity A = about 2.8.*System suitability*: reference solution (a):– *resolution*: minimum 1.5 between the peaks due to impurity H and ursodeoxycholic acid.*Limits*:– *impurity A*: not more than 10 times the area of the principal peak in the chromatogram obtained with reference solution (b) (1.0 per cent);– *unspecified impurities*: for each impurity, not more than the area of the principal peak in the chromatogram obtained with reference solution (b) (0.10 per cent);– *total*: not more than 15 times the area of the principal peak in the chromatogram obtained with reference solution (b) (1.5 per cent);– *disregard limit*: 0.5 times the area of the principal peak in the chromatogram obtained with reference solution (b) (0.05 per cent).**Heavy metals** (2.4.8): maximum 20 ppm.

1.0 g complies with test C. Prepare the reference solution using 2 mL of lead standard solution (10 ppm Pb) R.

**Loss on drying** (2.2.32): maximum 1.0 per cent, determined on 1.000 g by drying in an oven at 105 °C.**Sulfated ash** (2.4.14): maximum 0.1 per cent, determined on 1.0 g.

## ASSAY

Dissolve 0.350 g in 50 mL of *ethanol (96 per cent) R*, previously neutralised to 0.2 mL of *phenolphthalein solution R*. Add 50 mL of *water R* and titrate with 0.1 M sodium hydroxide until a pink colour is obtained.

1 mL of 0.1 M sodium hydroxide is equivalent to 39.26 mg of  $C_{24}H_{40}O_4$ .

## IMPURITIES

*Specified impurities: A, C.*

*Other detectable impurities* (the following substances would, if present at a sufficient level, be detected by one or other of the tests in the monograph. They are limited by the general acceptance criterion for other/unspecified impurities and/or by the general monograph *Substances for pharmaceutical use (2034)*. It is therefore not necessary to identify these impurities for demonstration of compliance. See also 5.10. *Control of impurities in substances for pharmaceutical use*): B, D, E, F, G, H, I.

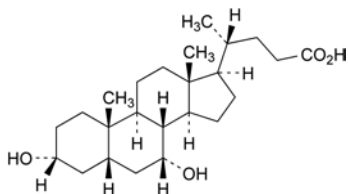

A. 3 $\alpha$ ,7 $\alpha$ -dihydroxy-5 $\beta$ -cholan-24-oic acid (chenodeoxycholic acid),

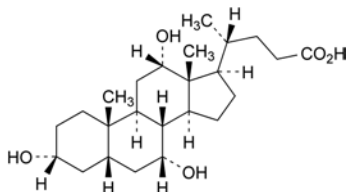

B. 3 $\alpha$ ,7 $\alpha$ ,12 $\alpha$ -trihydroxy-5 $\beta$ -cholan-24-oic acid (cholic acid),

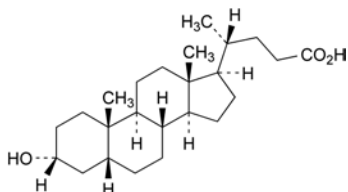

C. 3 $\alpha$ -hydroxy-5 $\beta$ -cholan-24-oic acid (lithocholic acid),

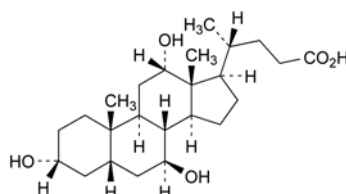

D. 3 $\alpha$ ,7 $\beta$ ,12 $\alpha$ -trihydroxy-5 $\beta$ -cholan-24-oic acid (ursodeoxycholic acid),

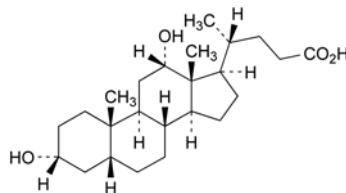

E. 3 $\alpha$ ,12 $\alpha$ -dihydroxy-5 $\beta$ -cholan-24-oic acid (deoxycholic acid),

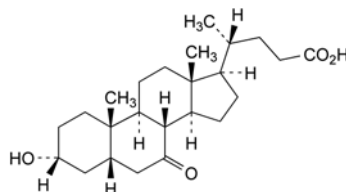

F. 3 $\alpha$ -hydroxy-7-oxo-5 $\beta$ -cholan-24-oic acid,

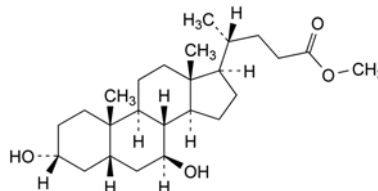

G. methyl 3 $\alpha$ ,7 $\beta$ -dihydroxy-5 $\beta$ -cholan-24-oate,

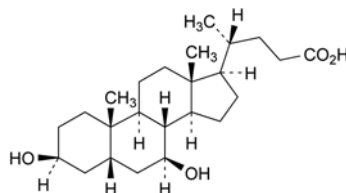

H. 3 $\beta$ ,7 $\beta$ -dihydroxy-5 $\beta$ -cholan-24-oic acid,

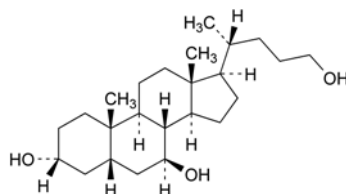

I. 5 $\beta$ -cholane-3 $\alpha$ ,7 $\beta$ ,24-triol.



01/2011:1768

## VALACICLOVIR HYDROCHLORIDE, ANHYDROUS

Valacicloviri hydrochloridum anhydricum

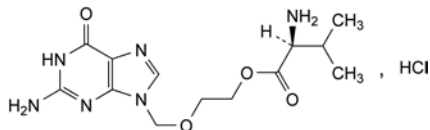

$C_{13}H_{21}ClN_6O_4$   
[124832-27-5]

$M_r$  360.8

### DEFINITION

2-[(2-Amino-6-oxo-1,6-dihydro-9H-purin-9-yl)methoxy]ethyl L-valinate hydrochloride.

*Content:* 95.0 per cent to 102.0 per cent (anhydrous substance).

### CHARACTERS

*Appearance:* white or almost white powder.

*Solubility:* freely soluble in water, slightly soluble in anhydrous ethanol.

It shows polymorphism (5.9).

### IDENTIFICATION

Carry out either tests A, B, C or tests A, B, D.

A. Infrared absorption spectrophotometry (2.2.24).

*Comparison:* anhydrous valaciclovir hydrochloride CRS.

If the spectra obtained in the solid state show differences, dissolve the substance to be examined and the reference substance separately in the minimum volume of *anhydrous ethanol R* and evaporate to dryness in a desiccator, under high vacuum, over *diphosphorus pentoxide R*. Record new spectra using the residues.

B. It gives reaction (a) of chlorides (2.3.1).

C. It complies with the limit for impurity R given in related substances test A.

D. Optical rotation (2.2.7): laevorotatory.

Dissolve 2.50 g in *water R* and dilute to 50.0 mL with the same solvent.

### TESTS

**Impurities E, F and G.** Thin-layer chromatography (2.2.27).

*Test solution.* Dissolve 0.250 g of the substance to be examined in 2 mL of *water R* and dilute to 5.0 mL with *ethanol (96 per cent) R*.

*Reference solution (a).* Dissolve 5 mg of *valaciclovir impurity D CRS*, 5.0 mg of *valaciclovir impurity E CRS*, 5.0 mg of *valaciclovir impurity G CRS* and 8.4 mg of *valaciclovir impurity F para-toluenesulfonate CRS* in a mixture of 2 mL of *water R* and 6 mL of *ethanol (96 per cent) R*, and dilute to 10.0 mL with *ethanol (96 per cent) R*.

*Reference solution (b).* Dilute 3.0 mL of reference solution (a) to 10.0 mL with *ethanol (96 per cent) R*.

*Reference solution (c).* Dilute 2.0 mL of reference solution (a) to 10.0 mL with *ethanol (96 per cent) R*.

*Reference solution (d).* Dilute 0.5 mL of reference solution (a) to 10.0 mL with *ethanol (96 per cent) R*.

*Plate:* TLC silica gel  $F_{254}$  plate *R* (2-10  $\mu\text{m}$ ).

*Pretreatment:* wash the plate with *methanol R* until the solvent front has migrated over at least 4/5 of the plate; allow the plate to dry.

*Mobile phase:* concentrated ammonia *R*, tetrahydrofuran *R*, methanol *R*, methylene chloride *R* (3:12:34:54 V/V/V/V); use freshly prepared mobile phase.

*Application:* 4  $\mu\text{L}$  of the test solution and reference solutions (b), (c) and (d).

*Development:* over 4/5 of the plate.

*Drying:* in a current of air.

*Detection:* examine in ultraviolet light at 254 nm for impurities E and G; spray with a 0.1 g/L solution of *fluorescamine R* in *ethylene chloride R* and examine in ultraviolet light at 365 nm for impurity F.

*Retardation factors:* impurity A = about 0; impurity B = about 0.2; valaciclovir = about 0.3; impurity C = about 0.5; impurity D = about 0.6; impurity E = about 0.7; impurity F = about 0.75; impurity G = about 0.79; impurity C is masked by the leading edge of the spot due to valaciclovir; impurities F and G may co-elute, but this does not adversely affect their quantification because they are visualised differently.

*System suitability:* the chromatograms obtained with reference solutions (b), (c) and (d) each show 3 clearly separated spots when examined under ultraviolet light at 254 nm, due to impurities D, E and G.

### Limits:

- *impurity E:* any spot due to impurity E is not more intense than the corresponding spot in the chromatogram obtained with reference solution (c) (0.2 per cent);
- *impurity F:* any spot due to impurity F is not more intense than the corresponding spot in the chromatogram obtained with reference solution (b) (0.3 per cent calculated as hydrochloride salt);
- *impurity G:* any spot due to impurity G is not more intense than the corresponding spot in the chromatogram obtained with reference solution (d) (0.05 per cent).

### Related substances.

A. Impurities A, B, I and R. Liquid chromatography (2.2.29): use the normalisation procedure.

*Test solution.* Dissolve 50.0 mg of the substance to be examined in a 0.5 per cent V/V solution of *hydrochloric acid R* and dilute to 100.0 mL with the same solution.

*Reference solution (a).* Dissolve 2.5 mg of *valaciclovir for system suitability CRS* (containing impurities A, B, C, D, H, I, J, M and R) in a 0.5 per cent V/V solution of *hydrochloric acid R* and dilute to 5.0 mL with the same solution.

*Reference solution (b).* Dissolve 50.0 mg of *anhydrous valaciclovir hydrochloride CRS* in a 0.5 per cent V/V solution of *hydrochloric acid R* and dilute to 100.0 mL with the same solution.

*Reference solution (c).* Dilute 3.0 mL of the test solution to 100.0 mL with a 0.5 per cent V/V solution of *hydrochloric acid R*. Dilute 1.0 mL of this solution to 100.0 mL with a 0.5 per cent V/V solution of *hydrochloric acid R*.

### Column:

- *size:*  $l = 0.15$  m,  $\varnothing = 4.0$  mm;
- *stationary phase:* crown-ether silica gel for chromatography *R* (5  $\mu\text{m}$ );
- *temperature:* 10 °C.

*Mobile phase:* perchloric acid *R*, methanol *R*, water *R* (0.5:5:95 V/V/V).

*Flow rate:* 0.75 mL/min.

*Detection:* spectrophotometer at 254 nm.

*Injection:* 10  $\mu\text{L}$  of the test solution and reference solution (a).

*Run time:* 1.5 times the retention time of valaciclovir.

*Identification of impurities:* use the chromatogram supplied with *valaciclovir for system suitability CRS* and the chromatogram obtained with reference solution (a) to identify the peaks due to impurities A + B, C + R, D, I and M.

*Relative retention* with reference to valaciclovir (retention time = about 21 min): impurities A and B = about 0.2; impurity I = about 0.4; impurities C and R = about 0.6; impurity D = about 0.7; impurity M = about 1.3.

*System suitability*: reference solution (a):

- *peak-to-valley ratio*: minimum 1.5, where  $H_p$  = height above the baseline of the peak due to impurity D and  $H_v$  = height above the baseline of the lowest point of the curve separating this peak from the peak due to impurities C and R.

*Limits*:

- *correction factor*: for the calculation of content, multiply the peak area of impurities A and B by 0.7;
- *impurity R*: maximum 3.0 per cent; for the calculation, subtract the content of impurity C as determined in related substances test B from the content of the coeluting impurities C and R as determined in this test;
- *sum of impurities A and B*: maximum 2.0 per cent;
- *impurity I*: maximum 0.2 per cent;
- *disregard limit*: the area of the principal peak in the chromatogram obtained with reference solution (c) (0.03 per cent); disregard any peaks due to impurities other than A + B, C + R or I.

B. Liquid chromatography (2.2.29): use the normalisation procedure. Use the solutions within 24 h of preparation.

*Solvent mixture*: ethanol (96 per cent) R, water R (20:80 V/V).

*Test solution*. Dissolve 40 mg of the substance to be examined in the solvent mixture and dilute to 100 mL with the solvent mixture.

*Reference solution (a)*. Dissolve 2.5 mg of valaciclovir for system suitability CRS (containing impurities A, B, C, D, H, I, J, M and R) in the solvent mixture and dilute to 5.0 mL with the solvent mixture.

*Reference solution (b)*. Dilute 1.0 mL of the test solution to 100.0 mL with the solvent mixture. Dilute 1.0 mL of this solution to 20.0 mL with the solvent mixture.

*Column*:

- *size*:  $l = 0.25$  m,  $\varnothing = 4.6$  mm;
- *stationary phase*: phenylhexylsilyl silica gel for chromatography R (5  $\mu$ m);
- *temperature*: 15 °C.

*Mobile phase*:

- *mobile phase A*: trifluoroacetic acid R, water R (2:1000 V/V);
- *mobile phase B*: trifluoroacetic acid R, methanol R2 (2:1000 V/V);

Time (min)	Mobile phase A (per cent V/V)	Mobile phase B (per cent V/V)
0 - 5	90	10
5 - 35	90 → 60	10 → 40

*Flow rate*: 0.8 mL/min.

*Detection*: spectrophotometer at 254 nm.

*Injection*: 10  $\mu$ L.

*Identification of impurities*: use the chromatogram supplied with valaciclovir for system suitability CRS and the chromatogram obtained with reference solution (a) to identify the peaks due to impurities A, B, C, D, H, I, J and M.

*Relative retention* with reference to valaciclovir (retention time = about 19 min): impurity A = about 0.3; impurity B = about 0.4; impurity H = about 0.5; impurity C = about 1.06; impurity I = about 1.09; impurity D = about 1.2; impurity J = about 1.3; impurity M = about 1.6.

*System suitability*: reference solution (a):

- *peak-to-valley ratio*: minimum 2.5, where  $H_p$  = height above the baseline of the peak due to impurity C and  $H_v$  = height above the baseline of the lowest point of the curve separating this peak from the peak due to valaciclovir;
- the chromatogram obtained is similar to the chromatogram supplied with valaciclovir for system suitability CRS.

*Limits*:

- *impurity M*: maximum 1.5 per cent;
- *impurity D*: maximum 0.5 per cent;
- *impurity C*: maximum 0.3 per cent;
- *impurity H*: maximum 0.1 per cent;
- *impurity J*: maximum 0.1 per cent;
- *unspecified impurities*: for each impurity, maximum 0.05 per cent;
- *disregard limit*: 0.6 times the area of the principal peak in the chromatogram obtained with reference solution (b) (0.03 per cent); disregard the peaks due to impurities A, B and I.

*Limit*:

- *total for tests A and B*: maximum 5.0 per cent.

**Chloride**: 9.4 to 9.9 per cent (anhydrous and solvent-free substance).

Dissolve 0.350 g in 100 mL of water R and add 0.2 mL of nitric acid R. Carry out a potentiometric titration (2.2.20), using 0.1 M silver nitrate. Use a silver indicator electrode and a silver-silver chloride reference electrode or a combined silver electrode. Discard the result from the first titration, which is used to condition the electrodes. Carry out a blank titration. 1 mL of 0.1 M silver nitrate is equivalent to 3.543 mg of Cl.

**Palladium**: maximum 10 ppm.

Atomic emission spectrometry (2.2.22, Method I).

*Test solution*. Dissolve 0.1 g in a 2 per cent V/V solution of hydrochloric acid R in dimethyl sulfoxide R and dilute to 10.0 mL with the same solution.

*Reference solutions*. Prepare the reference solutions using a solution containing 1000  $\mu$ g of Pd per millilitre, diluted as necessary with a 2 per cent V/V solution of hydrochloric acid R in dimethyl sulfoxide R.

*Wavelength*: 340.5 nm.

**Heavy metals** (2.4.8): maximum 20 ppm.

Dissolve 2.0 g in water R and dilute to 20 mL with the same solvent. 12 mL of the solution complies with test A. Prepare the reference solution using 10 mL of lead standard solution (2 ppm) Pb R.

**Water** (2.5.12): maximum 2.0 per cent, determined on 0.250 g.

**Sulfated ash** (2.4.14): maximum 0.1 per cent, determined on 1.0 g.

ASSAY

Liquid chromatography (2.2.29) as described in related substances test A with the following modification.

*Injection*: test solution and reference solution (b).

Calculate the percentage content of  $C_{13}H_{21}ClN_6O_4$  from the declared content of anhydrous valaciclovir hydrochloride CRS.

IMPURITIES

*Specified impurities*: A, B, C, D, E, F, G, H, I, J, M, R.

*Other detectable impurities* (the following substances would, if present at a sufficient level, be detected by one or other of the tests in the monograph. They are limited by the general acceptance criterion for other/unspecified impurities and/or by the general monograph Substances for pharmaceutical use (2034). It is therefore not necessary to identify these impurities

for demonstration of compliance. See also 5.10. *Control of impurities in substances for pharmaceutical use*): K, L, N, O, P, Q.

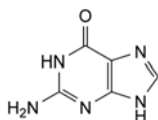

A. 2-amino-1,9-dihydro-6*H*-purin-6-one (guanine),

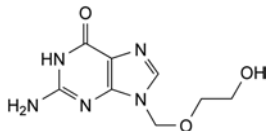

B. 2-amino-9-[(2-hydroxyethoxy)methyl]-1,9-dihydro-6*H*-purin-6-one (aciclovir),

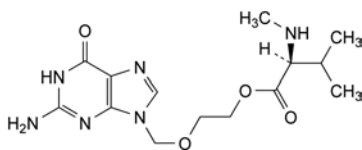

C. 2-[(2-amino-6-oxo-1,6-dihydro-9*H*-purin-9-yl)methoxy]ethyl *N*-methyl-L-valinate,

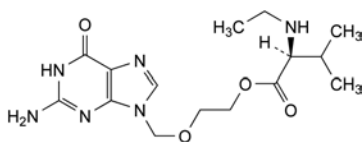

D. 2-[(2-amino-6-oxo-1,6-dihydro-9*H*-purin-9-yl)methoxy]ethyl *N*-ethyl-L-valinate,

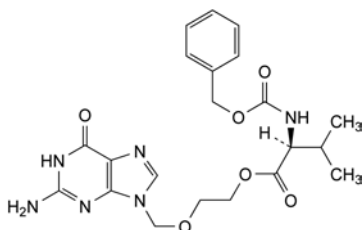

E. 2-[(2-amino-6-oxo-1,6-dihydro-9*H*-purin-9-yl)methoxy]ethyl *N*-[(benzyloxy)carbonyl]-L-valinate,

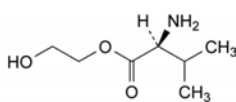

F. 2-hydroxyethyl *L*-valinate,

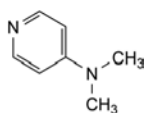

G. *N,N*-dimethylpyridin-4-amine,

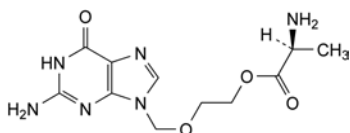

H. 2-[(2-amino-6-oxo-1,6-dihydro-9*H*-purin-9-yl)methoxy]ethyl *L*-alaninate,

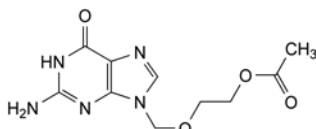

I. 2-[(2-amino-6-oxo-1,6-dihydro-9*H*-purin-9-yl)methoxy]ethyl acetate,

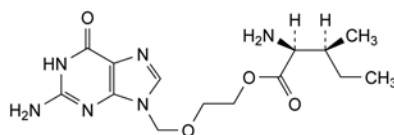

J. 2-[(2-amino-6-oxo-1,6-dihydro-9*H*-purin-9-yl)methoxy]ethyl *L*-isoleucinate,

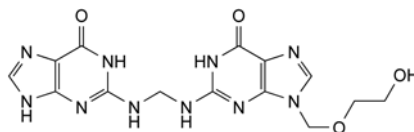

K. 9-[(2-hydroxyethoxy)methyl]-2-[[[(6-oxo-6,9-dihydro-1*H*-purin-2-yl)amino]methyl]amino]-1,9-dihydro-6*H*-purin-6-one,

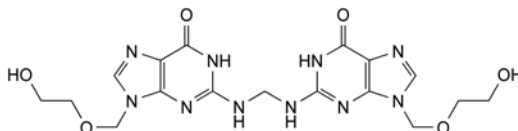

L. 2,2'-(methylene-diimino)bis[9-[(2-hydroxyethoxy)methyl]-1,9-dihydro-6*H*-purin-6-one],

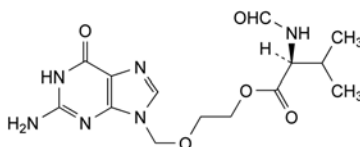

M. 2-[(2-amino-6-oxo-1,6-dihydro-9*H*-purin-9-yl)methoxy]ethyl *N*-formyl-L-valinate,

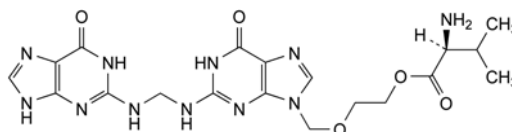

N. 2-[[6-oxo-2-[[[(6-oxo-6,9-dihydro-1*H*-purin-2-yl)amino]methyl]amino]-1,6-dihydro-9*H*-purin-9-yl]methoxy]ethyl *L*-valinate,

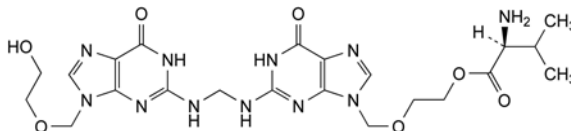

O. 2-[[2-[[[9-[(2-hydroxyethoxy)methyl]-6-oxo-6,9-dihydro-1*H*-purin-2-yl]amino]methyl]amino]-6-oxo-1,6-dihydro-9*H*-purin-9-yl]methoxy]ethyl *L*-valinate,

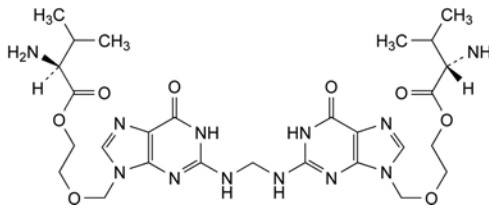

P. 2,2'-[methylenebis(imino(6-oxo-1,6-dihydro-9*H*-purine-9,2-diy)methyleneoxy)]diethyl di(*L*-valinate),

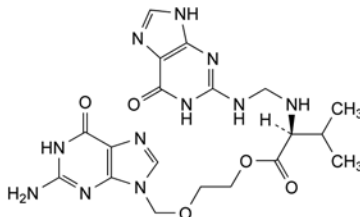

Q. 2-[(2-amino-6-oxo-1,6-dihydro-9*H*-purin-9-yl)methoxy]ethyl *N*-[[[(6-oxo-6,9-dihydro-1*H*-purin-2-yl)amino]methyl]-*L*-valinate,

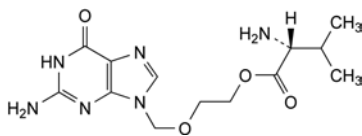

R. 2-[(2-amino-6-oxo-1,6-dihydro-9H-purin-9-yl)methoxy]ethyl D-valinate.

01/2008:0796  
corrected 6.0

## VALINE

### Valinum

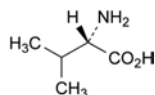

$C_5H_{11}NO_2$   
[72-18-4]

$M_r$  117.1

#### DEFINITION

Valine contains not less than 98.5 per cent and not more than the equivalent of 101.0 per cent of (S)-2-amino-3-methylbutanoic acid, calculated with reference to the dried substance.

#### CHARACTERS

White or almost white, crystalline powder or colourless crystals, soluble in water, very slightly soluble in alcohol.

#### IDENTIFICATION

First identification: A, B.

Second identification: A, C.

- Specific optical rotation (see Tests).
- Examine by infrared absorption spectrophotometry (2.2.24), comparing with the spectrum obtained with *valine CRS*. Examine the substances prepared as discs.
- Examine the chromatograms obtained in the test for ninhydrin-positive substances. The principal spot in the chromatogram obtained with test solution (b) is similar in position, colour and size to the principal spot in the chromatogram obtained with reference solution (a).

#### TESTS

**Solution S.** Dissolve 2.5 g in *water R* and dilute to 100 mL with the same solvent.

**Appearance of solution.** Solution S is clear (2.2.1) and not more intensely coloured than reference solution BY<sub>6</sub> (2.2.2, Method II).

**Specific optical rotation (2.2.7).** Dissolve 2.00 g in *hydrochloric acid R1* and dilute to 25.0 mL with the same acid. The specific optical rotation is + 26.5 to + 29.0, calculated with reference to the dried substance.

**Ninhydrin-positive substances.** Examine by thin-layer chromatography (2.2.27), using a *TLC silica gel plate R*.

**Test solution (a).** Dissolve 0.10 g of the substance to be examined in *dilute hydrochloric acid R* and dilute to 10 mL with the same acid.

**Test solution (b).** Dilute 1 mL of test solution (a) to 50 mL with *water R*.

**Reference solution (a).** Dissolve 10 mg of *valine CRS* in 0.1 M *hydrochloric acid* and dilute to 50 mL with the same acid.

**Reference solution (b).** Dilute 5 mL of test solution (b) to 20 mL with *water R*.

**Reference solution (c).** Dissolve 10 mg of *phenylalanine CRS* and 10 mg of *valine CRS* in 0.1 M *hydrochloric acid* and dilute to 25 mL with the same acid.

Apply to the plate 5 µL of each solution. Develop over a path of 15 cm using a mixture of 20 volumes of *glacial acetic acid R*, 20 volumes of *water R* and 60 volumes of *butanol R*. Allow the plate to dry in air, spray with *ninhydrin solution R* and heat at 100 °C to 105 °C for 15 min. Any spot in the chromatogram obtained with test solution (a), apart from the principal spot, is not more intense than the spot in the chromatogram obtained with reference solution (b) (0.5 per cent). The test is not valid unless the chromatogram obtained with reference solution (c) shows two clearly separated spots.

**Chlorides (2.4.4).** Dilute 10 mL of solution S to 15 mL with *water R*. The solution complies with the limit test for chlorides (200 ppm).

**Sulfates (2.4.13).** Dissolve 0.5 g in *distilled water R* and dilute to 15 mL with the same solvent. The solution complies with the limit test for sulfates (300 ppm).

**Ammonium (2.4.1).** 50 mg complies with limit test B for ammonium (200 ppm). Prepare the standard using 0.1 mL of *ammonium standard solution (100 ppm NH<sub>4</sub>) R*.

**Iron (2.4.9).** In a separating funnel, dissolve 1.0 g in 10 mL of *dilute hydrochloric acid R*. Shake with three quantities, each of 10 mL, of *methyl isobutyl ketone R1*, shaking for 3 min each time. To the combined organic layers add 10 mL of *water R* and shake for 3 min. The aqueous layer complies with the limit test for iron (10 ppm).

**Heavy metals (2.4.8).** 2.0 g complies with limit test D for heavy metals (10 ppm). Prepare the standard using 2 mL of *lead standard solution (10 ppm Pb) R*.

**Loss on drying (2.2.32).** Not more than 0.5 per cent, determined on 1.000 g by drying in an oven at 105 °C.

**Sulfated ash (2.4.14).** Not more than 0.1 per cent, determined on 1.0 g.

#### ASSAY

Dissolve 0.100 g in 3 mL of *anhydrous formic acid R*. Add 30 mL of *anhydrous acetic acid R*. Using 0.1 mL of *naphtholbenzein solution R* as indicator, titrate with 0.1 M *perchloric acid* until the colour changes from brownish-yellow to green.

1 mL of 0.1 M *perchloric acid* is equivalent to 11.71 mg of  $C_5H_{11}NO_2$ .

#### STORAGE

Store protected from light.

01/2008:2137

## VALNEMULIN HYDROCHLORIDE FOR VETERINARY USE

### Valnemulini hydrochloridum ad usum veterinarium

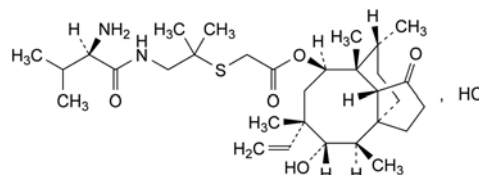

$C_{31}H_{53}ClN_2O_5S$   
[133868-46-9]

$M_r$  601

#### DEFINITION

(3a*S*,4*R*,5*S*,6*S*,8*R*,9*R*,9a*R*,10*R*)-6-Ethenyl-5-hydroxy-4,6,9,10-tetramethyl-1-oxodecahydro-3a,9-propano-3a*H*-cyclopenta[8]annulen-8-yl [[2-[(2*R*)-2-amino-3-methylbutanoyl]amino]-1,1-dimethylethyl]sulfanyl]acetate hydrochloride.

Semi-synthetic product derived from a fermentation product.

**Content:** 96.0 per cent to 102.0 per cent (anhydrous substance).

#### CHARACTERS

**Appearance:** white or yellowish, amorphous powder, hygroscopic.

**Solubility:** freely soluble in water and in anhydrous ethanol, practically insoluble in *tert*-butyl methyl ether.

#### IDENTIFICATION

A. Infrared absorption spectrophotometry (2.2.24).

*Comparison:* valnemulin hydrochloride CRS.

B. It gives reaction (a) of chlorides (2.3.1).

#### TESTS

**pH** (2.2.3): 3.0 to 6.0.

Dissolve 2.0 g in carbon dioxide-free water R and dilute to 20 mL with the same solvent.

**Specific optical rotation** (2.2.7): + 15.5 to + 18.0 (anhydrous substance).

Dissolve 0.250 g in water R and dilute to 25.0 mL with the same solvent.

**Related substances.** Liquid chromatography (2.2.29).

**Phosphate buffer solution pH 2.5.** Dissolve 8.0 g of disodium hydrogen phosphate R and 3.0 g of potassium dihydrogen phosphate R in water for chromatography R and dilute to 1000.0 mL with the same solvent. Adjust to pH 2.5 with phosphoric acid R.

**Solvent mixture.** Mix equal volumes of acetonitrile R1 and water for chromatography R.

**Test solution.** Dissolve 0.100 g of the substance to be examined in the solvent mixture and dilute to 10.0 mL with the solvent mixture.

**Reference solution (a).** Dilute 1.0 mL of the test solution to 100.0 mL with the solvent mixture.

**Reference solution (b).** Dissolve 5 mg of valnemulin impurity E CRS and 5 mg of the substance to be examined in the solvent mixture and dilute to 25 mL with the solvent mixture.

**Reference solution (c).** Dissolve the contents of a vial of valnemulin for peak identification CRS (containing impurities A, B and C) in 1 mL of the solvent mixture.

**Column:**

- size:  $l = 0.15$  m,  $\emptyset = 4.6$  mm;
- stationary phase: octadecylsilyl silica gel for chromatography R (3  $\mu$ m);
- temperature: 50 °C.

**Mobile phase:**

- mobile phase A: phosphate buffer solution pH 2.5, water R (25:75 V/V);
- mobile phase B: phosphate buffer solution pH 2.5, acetonitrile R1 (25:75 V/V);

Time (min)	Mobile phase A (per cent V/V)	Mobile phase B (per cent V/V)
0 - 2	95 → 55	5 → 45
2 - 4.5	55 → 50	45 → 50
4.5 - 5.5	50 → 35	50 → 65
5.5 - 6.85	35	65
6.85 - 10	35 → 0	65 → 100
10 - 13	0	100
13 - 14	0 → 95	100 → 5
14 - 20	95	5

**Flow rate:** 1.5 mL/min.

**Detection:** spectrophotometer at 200 nm.

**Injection:** 5  $\mu$ L.

**Identification of impurities:** use the chromatogram supplied with valnemulin for peak identification CRS and the chromatogram obtained with reference solution (c) to identify the peaks due to impurities A, B and C.

**Relative retention** with reference to valnemulin (retention time = about 7 min): impurity D = about 0.2; impurity A = about 0.7; impurity B = about 0.85; impurity E = about 0.9; impurity C = about 1.1.

**System suitability:** reference solution (b):

- resolution: minimum 1.5 between the peaks due to impurity E and valnemulin.

**Limits:**

- correction factors: for the calculation of content multiply the peak areas of the following impurities by the corresponding correction factor: impurity B = 3.2; impurity E = 4.2;
- impurity A: not more than 0.5 times the area of the principal peak in the chromatogram obtained with reference solution (a) (0.5 per cent);
- impurity B: not more than twice the area of the principal peak in the chromatogram obtained with reference solution (a) (2.0 per cent);
- impurity C: not more than the area of the principal peak in the chromatogram obtained with reference solution (a) (1.0 per cent);
- any other impurity: for each impurity, not more than 0.2 times the area of the principal peak in the chromatogram obtained with reference solution (a) (0.2 per cent);
- total: not more than 3 times the area of the principal peak in the chromatogram obtained with reference solution (a) (3.0 per cent);
- disregard limit: 0.1 times the area of the principal peak in the chromatogram obtained with reference solution (a) (0.1 per cent); disregard the peak due to the chloride ion.

**Water** (2.5.12): maximum 4.0 per cent, determined on 0.500 g.

#### ASSAY

Liquid chromatography (2.2.29).

**Test solution.** Dissolve 40.0 mg of the substance to be examined in a mixture of equal volumes of acetonitrile R1 and water R and dilute to 50.0 mL with the same mixture of solvents.

**Reference solution.** Dissolve 50.0 mg of valnemulin hydrogen tartrate CRS in a mixture of equal volumes of acetonitrile R1 and water R and dilute to 50.0 mL with the same mixture of solvents.

**Column:**

- size:  $l = 0.125$  m,  $\emptyset = 4.6$  mm;
- stationary phase: octadecylsilyl silica gel for chromatography R (3  $\mu$ m);
- temperature: 45 °C.

**Mobile phase:** mix 43 volumes of acetonitrile R1 and 57 volumes of a solution containing 0.94 g/L of disodium hydrogen phosphate R and 8.7 g/L of potassium dihydrogen phosphate R previously adjusted to pH 2.5 with phosphoric acid R.

**Flow rate:** 1.2 mL/min.

**Detection:** spectrophotometer at 210 nm.

**Injection:** 5  $\mu$ L.

**Run time:** 3 times the retention time of valnemulin (retention time = about 2.4 min).

Calculate the percentage content of  $C_{31}H_{53}ClN_2O_5S$ , using the declared content of valnemulin hydrogen tartrate CRS and by multiplying by 0.841.

#### STORAGE

In an airtight container, protected from light.

#### IMPURITIES

**Specified impurities:** A, B, C.

*Other detectable impurities* (the following substances would, if present at a sufficient level, be detected by one or other of the tests in the monograph. They are limited by the general acceptance criterion for other/unspecified impurities and/or by the general monograph *Substances for pharmaceutical use* (2034). It is therefore not necessary to identify these impurities for demonstration of compliance. See also 5.10. *Control of impurities in substances for pharmaceutical use*): D, E.

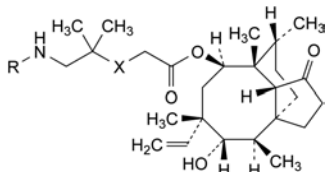

- A. R = D-Val, X = SO: (3a*S*,4*R*,5*S*,6*S*,8*R*,9*R*,9a*R*,10*R*)-6-ethenyl-5-hydroxy-4,6,9,10-tetramethyl-1-oxodecahydro-3a,9-propano-3a*H*-cyclopenta[8]annulen-8-yl [[2-[(2*R*)-2-amino-3-methylbutanoyl]amino]-1,1-dimethylethyl]sulfanyl]acetate (valnemulin sulfoxide),
- B. R = H, X = S: (3a*S*,4*R*,5*S*,6*S*,8*R*,9*R*,9a*R*,10*R*)-6-ethenyl-5-hydroxy-4,6,9,10-tetramethyl-1-oxodecahydro-3a,9-propano-3a*H*-cyclopenta[8]annulen-8-yl [(2-amino-1,1-dimethylethyl)sulfanyl]acetate (dimethyl cysteaminy pleuromulin),
- C. R = D-Val-D-Val, X = S: (3a*S*,4*R*,5*S*,6*S*,8*R*,9*R*,9a*R*,10*R*)-6-ethenyl-5-hydroxy-4,6,9,10-tetramethyl-1-oxodecahydro-3a,9-propano-3a*H*-cyclopenta[8]annulen-8-yl [[2-[(2*R*)-2-[(2*R*)-2-amino-3-methylbutanoyl]amino]-3-methylbutanoyl]amino]-1,1-dimethylethyl]sulfanyl]acetate (valyl-valneumulin),

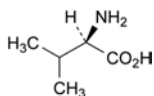

- D. (2*R*)-2-amino-3-methylbutanoic acid (D-valine),

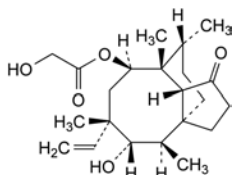

- E. (3a*S*,4*R*,5*S*,6*S*,8*R*,9*R*,9a*R*,10*R*)-6-ethenyl-5-hydroxy-4,6,9,10-tetramethyl-1-oxodecahydro-3a,9-propano-3a*H*-cyclopenta[8]annulen-8-yl 2-hydroxyacetate (pleuromulin).

01/2008:1378

## VALPROIC ACID

### Acidum valproicum

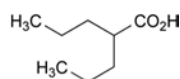

C<sub>8</sub>H<sub>16</sub>O<sub>2</sub>  
[99-66-1]

M<sub>r</sub> 144.2

#### DEFINITION

2-Propylpentanoic acid.

*Content*: 99.0 per cent to 101.0 per cent.

#### CHARACTERS

*Appearance*: colourless or very slightly yellow, clear liquid, slightly viscous.

*Solubility*: very slightly soluble in water, miscible with ethanol (96 per cent) and with methylene chloride. It dissolves in dilute solutions of alkali hydroxides.

#### IDENTIFICATION

*First identification*: B.

*Second identification*: A, C, D.

A. Refractive index (2.2.5): 1.422 to 1.425.

B. Infrared absorption spectrophotometry (2.2.24).

*Comparison*: valproic acid CRS.

C. Thin-layer chromatography (2.2.27).

*Test solution*. Dissolve 50 mg of the substance to be examined in *methanol R* and dilute to 5 mL with the same solvent.

*Reference solution*. Dissolve 50 mg of *valproic acid CRS* in *methanol R* and dilute to 5 mL with the same solvent.

*Plate*: TLC silica gel plate *R*.

*Mobile phase*: ether *R*, methylene chloride *R* (50:50 V/V).

*Application*: 2 µL.

*Development*: over a path of 15 cm.

*Drying*: in air.

*Detection*: spray with *bromocresol green solution R*.

*Results*: the principal spot in the chromatogram obtained with the test solution is similar in position, colour and size to the principal spot in the chromatogram obtained with the reference solution.

D. To 1 mL add 3 mL of *dilute sodium hydroxide solution R*. Add 3 mL of *water R* and 1 mL of a 100 g/L solution of *cobalt nitrate R*. A violet precipitate is formed. Filter. The precipitate dissolves in *methylene chloride R*.

#### TESTS

**Appearance of solution.** The solution is clear (2.2.1) and not more intensely coloured than reference solution Y<sub>5</sub> (2.2.2, *Method II*).

Dissolve 2.0 g in *dilute sodium hydroxide solution R* and dilute to 10 mL with the same alkaline solution.

**Related substances.** Gas chromatography (2.2.28).

*Internal standard solution*. Dissolve 10 mg of *butyric acid R* in *heptane R* and dilute to 200 mL with the same solvent.

*Test solution*. Dissolve 0.250 g of the substance to be examined in the internal standard solution and dilute to 5.0 mL with the internal standard solution. Dilute 1.0 mL of this solution to 10.0 mL with *heptane R*.

*Reference solution*. Dissolve 20 mg of the substance to be examined and 20 mg of *2-(1-methylethyl)pentanoic acid CRS* (impurity C) in *heptane R* and dilute to 10 mL with the same solvent. Dilute 1 mL of this solution to 10 mL with *heptane R*.

*Column*:

– *material*: wide-bore fused silica;

– *size*: *l* = 30 m, Ø = 0.53 mm;

– *stationary phase*: *macrogol 20 000 2-nitroterephthalate R* (film thickness 0.5 µm).

*Carrier gas*: helium for chromatography *R*.

*Flow rate*: 8 mL/min.

*Temperature*:

	Time (min)	Temperature (°C)
Column	0 - 10	130
	10 - 30	130 → 190
Injection port		220
Detector		220

*Detection*: flame ionisation.

*Injection*: 1 µL.

*System suitability*: reference solution:

– *resolution*: minimum 3.0 between the peaks due to impurity C and valproic acid.

**Limits:**

- *any impurity*: for each impurity, not more than the area of the peak due to the internal standard (0.1 per cent);
- *total*: not more than 3 times the area of the peak due to the internal standard (0.3 per cent);
- *disregard limit*: 0.1 times the area of the peak due to the internal standard (0.01 per cent).

**Heavy metals (2.4.8):** maximum 20 ppm.

Dissolve 2.0 g in *ethanol (80 per cent V/V) R* and dilute to 20 mL with the same solvent. 12 mL of the solution complies with test B. Prepare the reference solution using lead standard solution (2 ppm Pb) obtained by diluting *lead standard solution (100 ppm Pb) R* with *ethanol (80 per cent V/V) R*.

**Sulfated ash (2.4.14):** maximum 0.1 per cent, determined on 1.0 g.**ASSAY**

Dissolve 0.100 g in 25 mL of *ethanol (96 per cent) R*. Add 2 mL of *water R*. Titrate with 0.1 M *sodium hydroxide*, determining the end-point potentiometrically (2.2.20).

1 mL of 0.1 M *sodium hydroxide* is equivalent to 14.42 mg of C<sub>8</sub>H<sub>16</sub>O<sub>2</sub>.

**STORAGE**

In an airtight container.

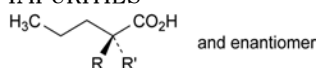
**IMPURITIES**

- R = R' = H: pentanoic acid (valeric acid),
- R = H, R' = CH<sub>2</sub>-CH<sub>3</sub>: (2*RS*)-2-ethylpentanoic acid,
- R = H, R' = CH(CH<sub>3</sub>)<sub>2</sub>: (2*RS*)-2-(1-methylethyl)pentanoic acid,
- R = R' = CH<sub>2</sub>-CH<sub>2</sub>-CH<sub>3</sub>: 2,2-dipropylpentanoic acid,

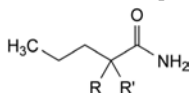

- R = R' = H: pentanamide (valeramide),
- R = H, R' = CH<sub>2</sub>-CH<sub>2</sub>-CH<sub>3</sub>: 2-propylpentanamide,
- R = R' = CH<sub>2</sub>-CH<sub>2</sub>-CH<sub>3</sub>: 2,2-dipropylpentanamide,

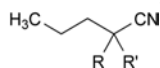

- R = R' = H: pentanenitrile (valeronitrile),
- R = H, R' = CH<sub>2</sub>-CH<sub>2</sub>-CH<sub>3</sub>: 2-propylpentanenitrile,
- R = R' = CH<sub>2</sub>-CH<sub>2</sub>-CH<sub>3</sub>: 2,2-dipropylpentanenitrile.

01/2010:2423

**VALSARTAN**

## Valsartanum

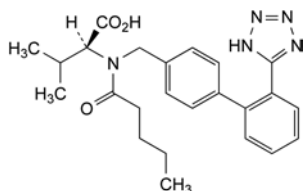

C<sub>24</sub>H<sub>29</sub>N<sub>5</sub>O<sub>3</sub>  
[137862-53-4]

M<sub>r</sub> 435.5**DEFINITION**

(2*S*)-3-Methyl-2-[pentanoyl[[2'-(1*H*-tetrazol-5-yl)biphenyl-4-yl]methyl]amino]butanoic acid.

*Content*: 99.0 per cent to 101.0 per cent (anhydrous substance).

**CHARACTERS**

*Appearance*: white or almost white, hygroscopic powder.

*Solubility*: practically insoluble in water, freely soluble in anhydrous ethanol, sparingly soluble in methylene chloride.

**IDENTIFICATION**

Carry out either tests A, B or tests A, C.

A. Infrared absorption spectrophotometry (2.2.24).

*Comparison*: valsartan CRS.

B. Enantiomeric purity (see Tests).

C. Specific optical rotation (2.2.7): –64.0 to –69.0 (anhydrous substance).

Dissolve 0.200 g in *methanol R* and dilute to 20.0 mL with the same solvent.

**TESTS**

**Enantiomeric purity.** Liquid chromatography (2.2.29).

*Test solution.* Dissolve 50 mg of the substance to be examined in the mobile phase and dilute to 50.0 mL with the mobile phase.

*Reference solution (a).* Dissolve 5 mg of *valsartan for peak identification CRS* (containing impurity A) in the mobile phase and dilute to 5.0 mL with the mobile phase.

*Reference solution (b).* Dilute 1.0 mL of the test solution to 100.0 mL with the mobile phase.

*Column*:

– *size*: *l* = 0.25 m, Ø = 4.6 mm;

– *stationary phase*: silica gel OD for chiral separations R.

*Mobile phase*: trifluoroacetic acid R, 2-propanol R, hexane R (0.1:15:85 V/V/V).

*Flow rate*: 0.8 mL/min.

*Detection*: spectrophotometer at 230 nm.

*Injection*: 10 µL.

*Run time*: 1.5 times the retention time of valsartan.

*Identification of impurities*: use the chromatogram supplied with *valsartan for peak identification CRS* and the chromatogram obtained with reference solution (a) to identify the peak due to impurity A.

*Relative retention* with reference to valsartan (retention time = about 13 min): impurity A = about 0.6.

*System suitability*: reference solution (a):

– *resolution*: minimum 2.0 between the peaks due to impurity A and valsartan.

*Limit*:

– *impurity A*: not more than the area of the principal peak in the chromatogram obtained with reference solution (b) (1.0 per cent).

**Related substances.** Liquid chromatography (2.2.29).

*Test solution.* Dissolve 50 mg of the substance to be examined in the mobile phase and dilute to 100.0 mL with the mobile phase.

*Reference solution (a).* Dilute 1.0 mL of the test solution to 100.0 mL with the mobile phase. Dilute 1.0 mL of this solution to 10.0 mL with the mobile phase.

*Reference solution (b).* Dissolve the contents of a vial of *valsartan for system suitability CRS* (containing impurity C) in 1.0 mL of the mobile phase.

*Column*:

– *size*: *l* = 0.125 m, Ø = 3.0 mm;

– *stationary phase*: end-capped octadecylsilyl silica gel for chromatography R (5 µm).

*Mobile phase*: glacial acetic acid R, acetonitrile R1, water R (1:500:500 V/V/V).

*Flow rate*: 0.4 mL/min.

*Detection*: spectrophotometer at 225 nm.

*Injection*: 10 µL.

*Run time*: 6 times the retention time of valsartan.

**Identification of impurities:** use the chromatogram supplied with *valsartan for system suitability CRS* and the chromatogram obtained with reference solution (b) to identify the peak due to impurity C.

**Relative retention** with reference to valsartan (retention time = about 5 min): impurity C = about 0.8.

**System suitability:** reference solution (b):

– **resolution:** minimum 3.0 between the peaks due to impurity C and valsartan.

**Limits:**

- **impurity C:** not more than twice the area of the principal peak in the chromatogram obtained with reference solution (a) (0.2 per cent);
- **unspecified impurities:** for each impurity, not more than the area of the principal peak in the chromatogram obtained with reference solution (a) (0.10 per cent);
- **total:** not more than 3 times the area of the principal peak in the chromatogram obtained with reference solution (a) (0.3 per cent);
- **disregard limit:** 0.5 times the area of the principal peak in the chromatogram obtained with reference solution (a) (0.05 per cent).

**Heavy metals (2.4.8):** maximum 20 ppm.

Dissolve 1.0 g in a mixture of 15 volumes of *water R* and 85 volumes of *acetone R* and dilute to 20 mL with the same mixture of solvents. 12 mL of the solution complies with test B. Prepare the reference solution using 10 mL of *lead standard solution (1 ppm Pb) R*.

**Water (2.5.12):** maximum 2.0 per cent, determined on 0.500 g.

**Sulfated ash (2.4.14):** maximum 0.1 per cent, determined on 1.0 g.

#### ASSAY

Dissolve 0.170 g in 70 mL of *2-propanol R*. Titrate with 0.1 M *tetrabutylammonium hydroxide in 2-propanol*, determining the endpoint potentiometrically (2.2.20). Perform all operations under nitrogen.

1 mL of 0.1 M *tetrabutylammonium hydroxide in 2-propanol* is equivalent to 21.78 mg of  $C_{24}H_{29}N_5O_3$ .

#### STORAGE

In an airtight container.

#### IMPURITIES

**Specified impurities:** A, C.

**Other detectable impurities** (the following substances would, if present at a sufficient level, be detected by one or other of the tests in the monograph. They are limited by the general acceptance criterion for other/unspecified impurities and/or by the general monograph *Substances for pharmaceutical use (2034)*. It is therefore not necessary to identify these impurities for demonstration of compliance. See also 5.10. *Control of impurities in substances for pharmaceutical use*): B.

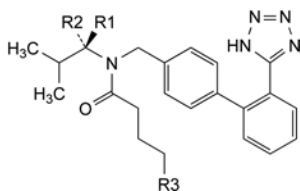

- A. R1 = H, R2 = CO<sub>2</sub>H, R3 = CH<sub>3</sub>: (2*R*)-3-methyl-2-[pentanoyl][[2'-(1*H*-tetrazol-5-yl)biphenyl-4-yl]methyl]amino]butanoic acid,
- C. R1 = CO<sub>2</sub>H, R2 = R3 = H: (2*S*)-2-[butanoyl][[2'-(1*H*-tetrazol-5-yl)biphenyl-4-yl]methyl]amino]-3-methylbutanoic acid,

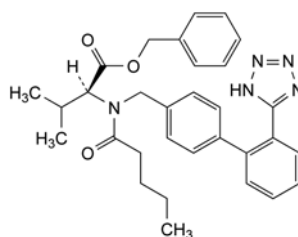

B. benzyl (2*S*)-3-methyl-2-[pentanoyl][[2'-(1*H*-tetrazol-5-yl)biphenyl-4-yl]methyl]amino]butanoate.

01/2008:1058  
corrected 7.0

## VANCOMYCIN HYDROCHLORIDE

### Vancomycini hydrochloridum

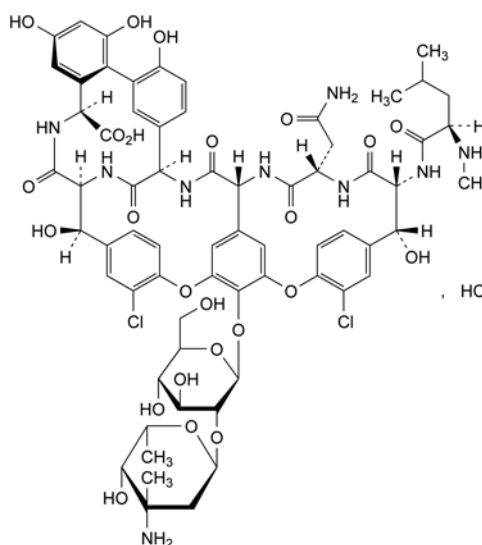

$C_{66}H_{76}Cl_3N_9O_{24}$

$M_r$  1486

#### DEFINITION

Hydrochloride of a mixture of related glycopeptides, consisting principally of the monohydrochloride of (3*S*,6*R*,7*R*,22*R*,23*S*,26*S*,30*aS*,36*R*,38*aR*)-3-(2-amino-2-oxoethyl)-44-[[2-*O*-(3-amino-2,3,6-trideoxy-3-*C*-methyl- $\alpha$ -*L*-lyxo-hexopyranosyl)- $\beta$ -*D*-glucopyranosyl]oxy]-10,19-dichloro-7,22,28,30,32-pentahydroxy-6-[[*(2R)*-4-methyl-2-(methylamino)pentanoyl]amino]-2,5,24,38,39-pentaoxo-2,3,4,5,6,7,23,24,25,26,36,37,38,38*a*-tetradecahydro-22*H*-8,11:18,21-dietheno-23,36-(iminomethano)-13,16:31,35-dimetheno-1*H*,13*H*-[1,6,9]oxadiazacyclohexadecino[4,5-*m*][10,2,16]benzoxadiazacyclotetracosine-26-carboxylic acid (vancomycin B).

Substance produced by certain strains of *Amycolatopsis orientalis* or obtained by any other means.

**Potency:** minimum 1050 IU/mg (anhydrous substance).

#### CHARACTERS

**Appearance:** white or almost white, hygroscopic powder.

**Solubility:** freely soluble in water, slightly soluble in ethanol (96 per cent).

#### IDENTIFICATION

A. Examine the chromatograms obtained in the test for vancomycin B.

**Results:** the principal peak in the chromatogram obtained with test solution (a) is similar in retention time to the principal peak in the chromatogram obtained with the reference solution.

B. It gives reaction (a) of chlorides (2.3.1).



## TESTS

**Appearance of solution.** The solution is clear (2.2.1) and its absorbance (2.2.25) at 450 nm is not greater than 0.10.

Dissolve 2.50 g in *water R* and dilute to 25.0 mL with the same solvent.

**pH (2.2.3):** 2.5 to 4.5.

Dissolve 0.50 g in *carbon dioxide-free water R* and dilute to 10 mL with the same solvent.

**Vancomycin B.** Liquid chromatography (2.2.29). Use the solutions within 4 h of preparation.

**Test solution (a).** Dissolve 10.0 mg of the substance to be examined in mobile phase A and dilute to 5.0 mL with mobile phase A.

**Test solution (b).** Dilute 2.0 mL of test solution (a) to 50.0 mL with mobile phase A.

**Test solution (c).** Dilute 0.5 mL of test solution (b) to 20.0 mL with mobile phase A.

**Reference solution.** Dissolve the contents of a vial of *vancomycin hydrochloride CRS* in *water R* and dilute with the same solvent to obtain a solution containing 0.5 mg/mL. Heat at 65 °C for 24 h. Allow to cool.

**Column:**

- size:  $l = 0.25$  m,  $\varnothing = 4.6$  mm;
- stationary phase: octadecylsilyl silica gel for chromatography R (5  $\mu$ m).

**Mobile phase:**

- mobile phase A: to 4 mL of *triethylamine R* add 1996 mL of *water R* and adjust to pH 3.2 with *phosphoric acid R*; to 920 mL of this solution add 10 mL of *tetrahydrofuran R* and 70 mL of *acetonitrile R*;
- mobile phase B: to 4 mL of *triethylamine R* add 1996 mL of *water R* and adjust to pH 3.2 with *phosphoric acid R*; to 700 mL of this solution add 10 mL of *tetrahydrofuran R* and 290 mL of *acetonitrile R*;

Time (min)	Mobile phase A (per cent V/V)	Mobile phase B (per cent V/V)
0 - 13	100	0
13 - 22	100 $\rightarrow$ 0	0 $\rightarrow$ 100

**Flow rate:** 1.0 mL/min.

**Detection:** spectrophotometer at 280 nm.

**Injection:** 20  $\mu$ L.

**System suitability:**

- resolution: minimum 5.0 between the 2 principal peaks in the chromatogram obtained with the reference solution;
- signal-to-noise ratio: minimum 5 for the principal peak in the chromatogram obtained with test solution (c);
- symmetry factor: maximum 1.6 for the peak due to vancomycin in the chromatogram obtained with test solution (b).

Calculate the percentage content of vancomycin B hydrochloride using the following expression:

$$\frac{A_b \times 100}{A_b + \left(\frac{A_t}{25}\right)}$$

$A_b$  = area of the peak due to vancomycin B in the chromatogram obtained with test solution (b);

$A_t$  = sum of the areas of the peaks due to impurities in the chromatogram obtained with test solution (a).

**Limit:**

- *vancomycin B*: minimum 93.0 per cent.

**Related substances.** Liquid chromatography (2.2.29) as described in the test for vancomycin B with the following modifications.

**Injection:** test solution (a), (b) and (c).

Calculate the percentage content of each impurity using the following expression:

$$\frac{\left(\frac{A_i}{25}\right) \times 100}{A_b + \left(\frac{A_t}{25}\right)}$$

$A_i$  = area of the peak due to an impurity in the chromatogram obtained with test solution (a);

$A_b$  = area of the peak due to vancomycin B in the chromatogram obtained with test solution (b);

$A_t$  = sum of the areas of the peaks due to impurities in the chromatogram obtained with test solution (a).

**Limits:**

- any impurity: for each impurity, maximum 4.0 per cent;
- total: maximum 7.0 per cent;
- disregard limit: the area of the principal peak in the chromatogram obtained with test solution (c) (0.1 per cent).

**Heavy metals (2.4.8):** maximum 30 ppm.

1.0 g complies with test C. Prepare the reference solution using 3.0 mL of *lead standard solution (10 ppm Pb) R*.

**Water (2.5.12):** maximum 5.0 per cent, determined on 0.500 g.

**Sulfated ash (2.4.14):** maximum 1.0 per cent, determined on 1.00 g.

**Bacterial endotoxins (2.6.14):** less than 0.25 IU/mg, if intended for use in the manufacture of parenteral preparations without a further appropriate procedure for the removal of bacterial endotoxins.

## ASSAY

Carry out the microbiological assay of antibiotics (2.7.2). Use *vancomycin hydrochloride CRS* as the chemical reference substance.

## STORAGE

In an airtight container, protected from light. If the substance is sterile, store in a sterile, airtight, tamper-proof container.

## IMPURITIES

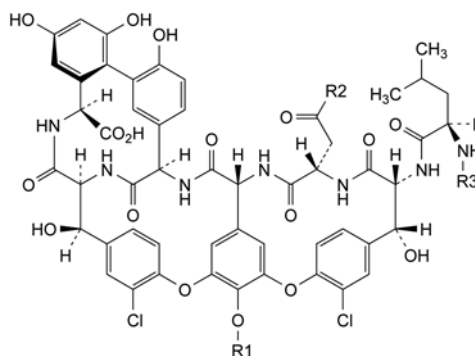

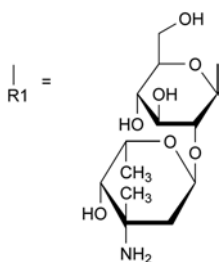

- A. R2 = NH<sub>2</sub>, R3 = H: *N*-demethylvancomycin B,  
 C. R1 = H, R2 = NH<sub>2</sub>, R3 = CH<sub>3</sub>: aglucovancomycin B,

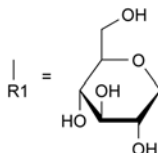

- D. R2 = NH<sub>2</sub>, R3 = CH<sub>3</sub>: desvancosaminylvancomycin B,

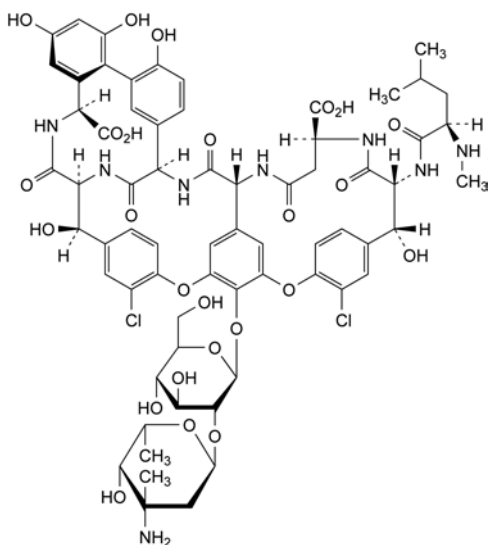

- B. (4*S*,7*R*,8*R*,23*R*,24*S*,27*S*,31*aS*,37*R*,39*aR*)-45-[[2-*O*-(3-amino-2,3,6-trideoxy-3-*C*-methyl- $\alpha$ -*L*-lyxohexopyranosyl)- $\beta$ -*D*-glucopyranosyl]oxy]-11,20-dichloro-8,23,29,31,33-pentahydroxy-7-[[2*R*]-4-methyl-2-(methylamino)pentanoyl]amino]-2,6,25,39,40-penta-oxo-1,2,3,4,5,6,7,8,24,25,26,27,37,38,39,39a-hexadecahydro-23*H*-9,12:19,22-dietheno-24,37-(iminomethano)-14,17:32,36-dimetheno-14*H*][1,6,10]oxadiazacycloheptadecino[4,5-*m*][10,2,16]benzoxadiazacyclotetracosine-4,27-dicarboxylic acid ([ $\beta$  Asp<sup>3</sup>]vancomycin B).

01/2008:0747

## VANILLIN

### Vanillinum

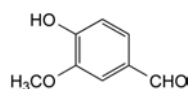

C<sub>8</sub>H<sub>8</sub>O<sub>3</sub>  
 [121-33-5]

M<sub>r</sub> 152.1

#### DEFINITION

Vanillin contains not less than 99.0 per cent and not more than the equivalent of 101.0 per cent of 4-hydroxy-3-methoxybenzaldehyde, calculated with reference to the dried substance.

#### CHARACTERS

White or slightly yellowish, crystalline powder or needles, slightly soluble in water, freely soluble in alcohol and in methanol. It dissolves in dilute solutions of alkali hydroxides.

#### IDENTIFICATION

*First identification: B.*

*Second identification: A, C, D.*

- A. Melting point (2.2.14): 81 °C to 84 °C.  
 B. Examine by infrared absorption spectrophotometry (2.2.24), comparing with the spectrum obtained with *vanillin CRS*. Examine the substances prepared as discs.  
 C. Examine the chromatograms obtained in the test for related substances in daylight after spraying. The principal spot in the chromatogram obtained with test solution (b) is similar in position, colour and size to the principal spot in the chromatogram obtained with reference solution (a).  
 D. To 5 mL of a saturated solution of the substance to be examined add 0.2 mL of *ferric chloride solution R1*. A blue colour is produced. Heat to 80 °C. The solution becomes brown. On cooling, a white precipitate is formed.

#### TESTS

**Appearance of solution.** Dissolve 1.0 g in *alcohol R* and dilute to 20 mL with the same solvent. The solution is clear (2.2.1) and not more intensely coloured than reference solution B<sub>6</sub> (2.2.2, *Method II*).

**Related substances.** Examine by thin-layer chromatography (2.2.27), using *silica gel GF<sub>254</sub> R* as the coating substance.

*Test solution (a).* Dissolve 0.1 g of the substance to be examined in *methanol R* and dilute to 5 mL with the same solvent.

*Test solution (b).* Dilute 1 mL of test solution (a) to 10 mL with *methanol R*.

*Reference solution (a).* Dissolve 10 mg of *vanillin CRS* in *methanol R* and dilute to 5 mL with the same solvent.

*Reference solution (b).* Dilute 0.5 mL of test solution (a) to 100 mL with *methanol R*.

Apply to the plate 5  $\mu$ L of each solution. Develop in an unsaturated tank over a path of 10 cm using a mixture of 0.5 volumes of *anhydrous acetic acid R*, 1 volume of *methanol R* and 98.5 volumes of *methylene chloride R*. Dry the plate in a current of cold air. Examine in ultraviolet light at 254 nm. Any spot in the chromatogram obtained with test solution (a), apart from the principal spot, is not more intense than the spot in the chromatogram obtained with reference solution (b) (0.5 per cent). Spray with *dinitrophenylhydrazine-aceto-hydrochloric solution R* and examine in daylight. Any spot in the chromatogram obtained with test solution (a), apart from the principal spot, is not more intense than the spot in the chromatogram obtained with reference solution (b) (0.5 per cent).

**Reaction with sulfuric acid.** Dissolve 50 mg in 5 mL of *sulfuric acid R*. After 5 min, the solution is not more intensely coloured than a mixture of 4.9 mL of yellow primary solution and 0.1 mL of red primary solution or a mixture of 4.9 mL of yellow primary solution and 0.1 mL of blue primary solution (2.2.2, *Method I*).

**Loss on drying** (2.2.32). Not more than 1.0 per cent, determined on 1.000 g by drying in a desiccator for 4 h.

**Sulfated ash** (2.4.14). Not more than 0.05 per cent, determined on 2.0 g.

#### ASSAY

Dissolve 0.120 g in 20 mL of *alcohol R* and add 60 mL of *carbon dioxide-free water R*. Titrate with 0.1 M *sodium hydroxide*, determining the end-point potentiometrically (2.2.20).

1 mL of 0.1 M *sodium hydroxide* is equivalent to 15.21 mg of C<sub>8</sub>H<sub>8</sub>O<sub>3</sub>.

## STORAGE

Store protected from light.

01/2008:1769

## VECURONIUM BROMIDE

## Vecuronii bromidum

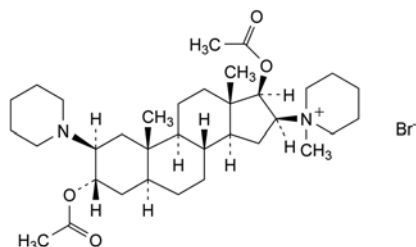

$C_{34}H_{57}BrN_2O_4$   
[50700-72-6]

$M_r$  638

## DEFINITION

1-[3 $\alpha$ ,17 $\beta$ -Bis(acetyloxy)-2 $\beta$ -(piperidin-1-yl)-5 $\alpha$ -androstan-16 $\beta$ -yl]-1-methylpiperidinium bromide.

Content: 99.0 per cent to 101.0 per cent (anhydrous substance).

## CHARACTERS

**Appearance:** white or almost white crystals or crystalline powder.

**Solubility:** slightly soluble in water, freely soluble in methylene chloride, sparingly soluble in acetonitrile and in anhydrous ethanol.

## IDENTIFICATION

- A. Specific optical rotation (see Tests).  
 B. Infrared absorption spectrophotometry (2.2.24).  
*Comparison: vecuronium bromide CRS.*  
 C. It gives reaction (a) of bromides (2.3.1).

## TESTS

**Appearance of solution.** The solution is clear (2.2.1) and not more intensely coloured than reference solution BY<sub>7</sub> (2.2.2, Method II).

Dissolve 0.1 g in *water R* and dilute to 10 mL with the same solvent.

**Specific optical rotation** (2.2.7): + 30.5 to + 35.0 (anhydrous substance).

Dissolve 0.250 g in 0.05 M *hydrochloric acid* and dilute to 25.0 mL with the same solvent.

**Impurity B.** Thin-layer chromatography (2.2.27).

**Test solution.** Dissolve 0.10 g of the substance to be examined in *methylene chloride R* and dilute to 5.0 mL with the same solvent.

**Reference solution (a).** Dissolve 5 mg of the substance to be examined and 5 mg of *pancuronium bromide CRS* (impurity B) in *methylene chloride R* and dilute to 5 mL with the same solvent.

**Reference solution (b).** Dissolve 5.0 mg of *pancuronium bromide CRS* (impurity B) in *methylene chloride R* and dilute to 100.0 mL with the same solvent.

**Stationary phase:** TLC silica gel plate R (2-10  $\mu$ m).

**Mobile phase:** dissolve 1 g of *sodium bromide R* in 5 mL of *water R*. Add 85 mL of *2-propanol R*, then 10 mL of *acetonitrile R*.

**Application:** 1  $\mu$ L.

**Development:** in an unsaturated tank, over 2/3 of the plate.

**Drying:** in air for 30 min.

**Detection:** spray with a 2.5 g/L solution of *iodine R* in a mixture of equal volumes of *methanol R* and *methylene chloride R*.

**System suitability:** reference solution (a):

- the chromatogram obtained shows 2 clearly separated spots.

**Limit:**

- **impurity B:** any spot due to impurity B is not more intense than the spot in the chromatogram obtained with reference solution (b) (0.25 per cent).

**Related substances.** Liquid chromatography (2.2.29). Use freshly prepared solutions.

**Test solution.** Dissolve 40.0 mg of the substance to be examined in a 0.2 g/L solution of *hydrochloric acid R* in *methanol R* and dilute to 20.0 mL with the same solution.

**Reference solution (a).** Dissolve 4 mg of *vecuronium for peak identification CRS* (containing impurities A, C, D and E) in a 0.2 g/L solution of *hydrochloric acid R* in *methanol R* and dilute to 2 mL with the same solution.

**Reference solution (b).** Dilute 5.0 mL of the test solution to 100.0 mL with a 0.2 g/L solution of *hydrochloric acid R* in *methanol R*. Dilute 5.0 mL of this solution to 100.0 mL with a 0.2 g/L solution of *hydrochloric acid R* in *methanol R*.

**Reference solution (c).** Dilute 10.0 mL of reference solution (b) to 50.0 mL with a 0.2 g/L solution of *hydrochloric acid R* in *methanol R*.

**Column:**

- **size:**  $l = 0.25$  m,  $\varnothing = 4.6$  mm;
- **stationary phase:** spherical octadecylsilyl silica gel for chromatography R (5  $\mu$ m);
- **temperature:** 40 °C.

**Mobile phase:** mix 50 volumes of a 18.0 g/L solution of *tetramethylammonium hydroxide R* adjusted to pH 6.5 with *phosphoric acid R*, 250 volumes of *methanol R* and 700 volumes of *acetonitrile R*.

**Flow rate:** 2.0 mL/min.

**Detection:** spectrophotometer at 210 nm.

**Injection:** 20  $\mu$ L.

**Run time:** 2.5 times the retention time of vecuronium.

**Identification of impurities:** use the chromatogram supplied with *vecuronium for peak identification CRS* and the chromatogram obtained with reference solution (a) to identify the peaks due to impurities A, C, D and E. The elution order may vary, but the quantity of each impurity in the CRS is different so that a clear identification of the impurities is possible.

**Relative retention** with reference to vecuronium (retention time = about 5 min): impurity C = about 0.8; impurity D = about 0.9; impurity E = about 1.2; impurity A = about 1.3.

**System suitability:** reference solution (a):

- **peak-to-valley ratio:** minimum 2.0, where  $H_p$  = height above the baseline of the peak due to impurity D and  $H_v$  = height above the baseline of the lowest point of the curve separating this peak from the principal peak; if necessary, increase the volume of the buffer solution while simultaneously decreasing the volume of acetonitrile in the mobile phase; do not change the volume of methanol;
- **symmetry factor:** maximum 3.5 for the principal peak.

**Limits:**

- **correction factors:** for the calculation of content, multiply the peak areas of the following impurities by the corresponding correction factor: impurity A = 0.6; impurity C = 1.4;
- **impurities A, C, D, E:** for each impurity, not more than the area of the principal peak in the chromatogram obtained with reference solution (b) (0.25 per cent);
- **unspecified impurities:** for each impurity, not more than twice the area of the principal peak in the chromatogram obtained with reference solution (c) (0.10 per cent);

- *total*: not more than 2.8 times the area of the principal peak in the chromatogram obtained with reference solution (b) (0.7 per cent);
- *disregard limit*: the area of the principal peak in the chromatogram obtained with reference solution (c) (0.05 per cent).

**Water** (2.5.12): maximum 4.0 per cent, determined on 0.300 g.

**Sulfated ash** (2.4.14): maximum 0.1 per cent, determined on 1.0 g.

#### ASSAY

Dissolve 0.450 g in 50 mL of *glacial acetic acid R*. Titrate with 0.1 M *perchloric acid*, determining the end-point potentiometrically (2.2.20).

1 mL of 0.1 M *perchloric acid* is equivalent to 63.8 mg of  $C_{34}H_{57}BrN_2O_4$ .

#### STORAGE

In an airtight container, protected from light and moisture.

#### IMPURITIES

*Specified impurities: A, B, C, D, E.*

*Other detectable impurities* (the following substances would, if present at a sufficient level, be detected by one or other of the tests in the monograph. They are limited by the general acceptance criterion for other/unspecified impurities and/or by the general monograph *Substances for pharmaceutical use* (2034). It is therefore not necessary to identify these impurities for demonstration of compliance. See also 5.10. *Control of impurities in substances for pharmaceutical use*): *F*.

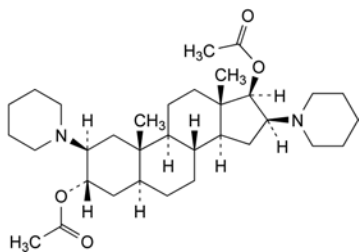

- A. 2β,16β-bis(piperidin-1-yl)-5α-androstane-3α,17β-diyl diacetate,

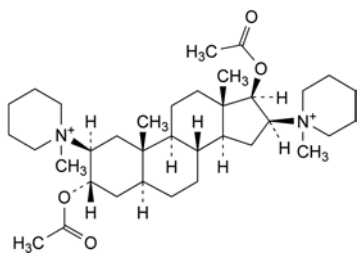

- B. 1,1'-[3α,17β-bis(acetyloxy)-5α-androstane-2β,16β-diyl]bis(1-methylpiperidinium) (pancuronium),

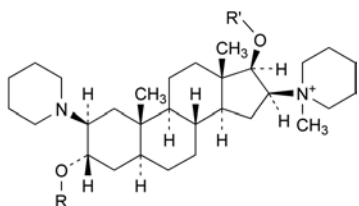

- C. R = H, R' = CO-CH<sub>3</sub>: 1-[17β-(acetyloxy)-3α-hydroxy-2β-(piperidin-1-yl)-5α-androstan-16β-yl]-1-methylpiperidinium,
- D. R = R' = H: 1-[3α,17β-dihydroxy-2β-(piperidin-1-yl)-5α-androstan-16β-yl]-1-methylpiperidinium,
- E. R = CO-CH<sub>3</sub>, R' = H: 1-[3α-(acetyloxy)-17β-hydroxy-2β-(piperidin-1-yl)-5α-androstan-16β-yl]-1-methylpiperidinium,

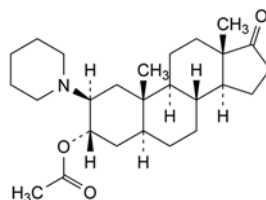

- F. 2β-(piperidin-1-yl)-17-oxo-5α-androstan-3α-yl acetate.

07/2009:2248

## VEDAPROFEN FOR VETERINARY USE

### Vedaprofenum ad usum veterinarium

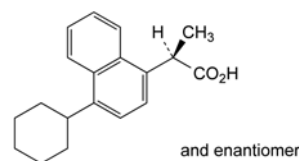

$C_{19}H_{22}O_2$   
[71109-09-6]

$M_r$  282.4

#### DEFINITION

(2*RS*)-2-(4-Cyclohexyl-1-naphthyl)propanoic acid.

*Content*: 98.5 per cent to 101.0 per cent (dried substance).

#### CHARACTERS

*Appearance*: white or almost white powder.

*Solubility*: practically insoluble in water, freely soluble in acetone, soluble in methanol. It dissolves in dilute solutions of alkali hydroxides.

#### IDENTIFICATION

Infrared absorption spectrophotometry (2.2.24).

*Comparison*: *vedaprofen CRS*.

#### TESTS

**Appearance of solution.** The solution is clear (2.2.1) and not more intensely coloured than reference solution Y<sub>5</sub> (2.2.2, *Method II*).

Dissolve 2.0 g in *acetone R* and dilute to 20.0 mL with the same solvent.

**Related substances.** Liquid chromatography (2.2.29).

*Test solution.* Dissolve 25 mg of the substance to be examined in *methanol R* and dilute to 50.0 mL with the same solvent.

*Reference solution (a).* Dilute 1.0 mL of the test solution to 50.0 mL with *methanol R*. Dilute 1.0 mL of this solution to 10.0 mL with *methanol R*.

*Reference solution (b).* Dissolve the contents of a vial of *vedaprofen impurity mixture CRS* (impurities A, B and C) in 1.0 mL of reference solution (a).

*Column*:

- *size*:  $l = 0.10$  m,  $\varnothing = 3.0$  mm;
- *stationary phase*: *octadecylsilyl silica gel for chromatography R* (5  $\mu$ m);
- *temperature*: 35 °C.

*Mobile phase*: dissolve 1.70 g of *tetrabutylammonium hydrogen sulfate R* in 1000 mL of a mixture of 20 volumes of *water R* and 80 volumes of *methanol R*.

*Flow rate*: 0.4 mL/min.

*Detection*: spectrophotometer at 288 nm.

*Injection*: 10  $\mu$ L.

*Run time*: 5 times the retention time of vedaprofen.

**Identification of impurities:** use the chromatogram supplied with *vedaprofen impurity mixture CRS* and the chromatogram obtained with reference solution (b) to identify the peaks due to impurities A, B and C.

**Relative retention** with reference to vedaprofen (retention time = about 6 min): impurity C = about 0.8; impurity A = about 1.8; impurity B = about 3.7.

**System suitability:** reference solution (b):

- **resolution:** minimum 2.0 between the peaks due to impurity C and vedaprofen.

**Limits:**

- **correction factor:** for the calculation of content, multiply the peak area of impurity B by 0.7;
- **impurities A, B:** for each impurity, not more than twice the area of the principal peak in the chromatogram obtained with reference solution (a) (0.4 per cent);
- **unspecified impurities:** for each impurity, not more than the area of the principal peak in the chromatogram obtained with reference solution (a) (0.20 per cent);
- **total:** not more than 2.5 times the area of the principal peak in the chromatogram obtained with reference solution (a) (0.5 per cent);
- **disregard limit:** 0.5 times the area of the principal peak in the chromatogram obtained with reference solution (a) (0.1 per cent).

**Heavy metals (2.4.8):** maximum 10 ppm.

Dissolve 1.0 g in a mixture of 15 volumes of *water R* and 85 volumes of *acetone R* and dilute to 20 mL with the same mixture of solvents. 12 mL of the solution complies with test B. Prepare the reference solution using lead standard solution (0.5 ppm Pb) obtained by diluting *lead standard solution (100 ppm Pb) R* with a mixture of 15 volumes of *water R* and 85 volumes of *acetone R*.

**Loss on drying (2.2.32):** maximum 0.5 per cent, determined on 1.000 g by drying in an oven at 105 °C.

**Sulfated ash (2.4.14):** maximum 0.3 per cent, determined on 0.500 g.

**ASSAY**

Dissolve 0.200 g in 50 mL of *ethanol (96 per cent) R* and add 1.0 mL of 0.1 M *hydrochloric acid*. Carry out a potentiometric titration (2.2.20), using 0.1 M *sodium hydroxide*. Read the volume added between the 2 points of inflexion.

1 mL of 0.1 M *sodium hydroxide* is equivalent to 28.24 mg of  $C_{19}H_{22}O_2$ .

**IMPURITIES**

**Specified impurities:** A, B.

**Other detectable impurities** (the following substances would, if present at a sufficient level, be detected by one or other of the tests in the monograph. They are limited by the general acceptance criterion for other/unspecified impurities and/or by the general monograph *Substances for pharmaceutical use (2034)*. It is therefore not necessary to identify these impurities for demonstration of compliance. See also 5.10. *Control of impurities in substances for pharmaceutical use*): C, D.

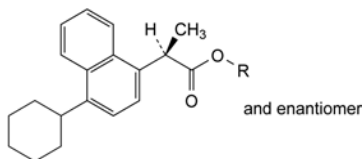

- A. R = CH<sub>3</sub>: methyl (2RS)-2-(4-cyclohexyl-1-naphthyl)propanoate,  
 B. R = C(CH<sub>3</sub>)<sub>3</sub>: 1,1-dimethylethyl (2RS)-2-(4-cyclohexyl-1-naphthyl)propanoate,

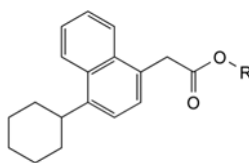

- C. R = H: (4-cyclohexyl-1-naphthyl)acetic acid,  
 D. R = CH<sub>3</sub>: methyl (2RS)-2-(4-cyclohexyl-1-naphthyl)acetate.

01/2008:2119

## VENLAFAXINE HYDROCHLORIDE

### Venlafaxini hydrochloridum

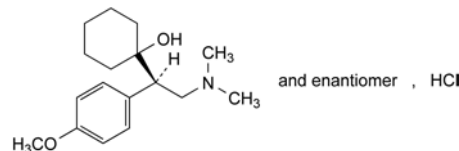

$C_{17}H_{28}ClNO_2$   
 [99300-78-4]

$M_r$  313.9

**DEFINITION**

1-[(1RS)-2-(Dimethylamino)-1-(4-methoxyphenyl)ethyl]-cyclohexanol hydrochloride.

**Content:** 99.0 per cent to 101.0 per cent (dried substance).

**CHARACTERS**

**Appearance:** white or almost white powder.

**Solubility:** freely soluble in water and in methanol, soluble in anhydrous ethanol, slightly soluble or practically insoluble in acetone.

It shows polymorphism (5.9).

**IDENTIFICATION**

A. Infrared absorption spectrophotometry (2.2.24).

**Comparison:** *venlafaxine hydrochloride CRS*.

If the spectra obtained in the solid state show differences, dissolve the substance to be examined and the reference substance separately in 2-propanol *R*, evaporate to dryness and record new spectra using the residues.

B. It gives reaction (a) of chlorides (2.3.1).

**TESTS**

**Acidity or alkalinity.** Dissolve 0.20 g in *carbon dioxide-free water R* and dilute to 10 mL with the same solvent. Add 0.05 mL of *methyl red solution R* and 0.1 mL of 0.01 M *hydrochloric acid*. The solution is pink. Not more than 0.2 mL of 0.01 M *sodium hydroxide* is required to change the colour of the indicator to yellow.

**Related substances.** Liquid chromatography (2.2.29).

**Test solution.** Dissolve 25.0 mg of the substance to be examined in the mobile phase and dilute to 25.0 mL with the mobile phase.

**Reference solution (a).** Dilute 1.0 mL of the test solution to 10.0 mL with the mobile phase. Dilute 1.0 mL of this solution to 100.0 mL with the mobile phase.

**Reference solution (b).** Dissolve the contents of a vial of *venlafaxine for system suitability CRS* (containing impurities D and F) in 1.0 mL of the mobile phase.

**Column:**

- **size:**  $l = 0.25$  m,  $\varnothing = 4.6$  mm;
- **stationary phase:** end-capped octylsilyl silica gel for chromatography *R* (5  $\mu$ m) with a pore size of 10 nm.

**Mobile phase:** mix 510 volumes of *acetonitrile R* and 1490 volumes of a solution prepared as follows: dissolve 17 g of *ammonium dihydrogen phosphate R* in 1490 mL of *water R* and adjust to pH 4.4 using *phosphoric acid R*.

Flow rate: 1.2 mL/min.

Detection: spectrophotometer at 225 nm.

Injection: 20 µL.

Run time: 10 times the retention time of venlafaxine.

Relative retention with reference to venlafaxine (retention time = about 9 min): impurity D = about 0.9; impurity F = about 3.4.

System suitability: reference solution (b):

– resolution: minimum 1.5 between the peaks due to impurity D and venlafaxine.

Limits:

- impurity F: not more than the area of the principal peak in the chromatogram obtained with reference solution (a) (0.1 per cent);
- unspecified impurities: for each impurity, not more than the area of the principal peak in the chromatogram obtained with reference solution (a) (0.10 per cent);
- total: not more than twice the area of the principal peak in the chromatogram obtained with reference solution (a) (0.2 per cent);
- disregard limit: 0.5 times the area of the principal peak in the chromatogram obtained with reference solution (a) (0.05 per cent).

Heavy metals (2.4.8): maximum 20 ppm.

Dissolve 1.0 g in 20 mL of water R. 12 mL of the solution complies with test A. Prepare the reference solution using lead standard solution (1 ppm Pb) R.

Loss on drying (2.2.32): maximum 0.5 per cent, determined on 1.000 g by drying *in vacuo* at 80 °C for 3 h.

Sulfated ash (2.4.14): maximum 0.1 per cent, determined on 1.0 g.

ASSAY

Dissolve 0.250 g in a mixture of 5.0 mL of 0.01 M hydrochloric acid and 50 mL of ethanol (96 per cent) R. Carry out a potentiometric titration (2.2.20), using 0.1 M sodium hydroxide. Read the volume added between the 2 points of inflexion. Carry out a blank titration.

1 mL of 0.1 M sodium hydroxide is equivalent to 31.39 mg of C<sub>17</sub>H<sub>28</sub>ClNO<sub>2</sub>.

IMPURITIES

Specified impurities: F.

Other detectable impurities (the following substances would, if present at a sufficient level, be detected by one or other of the tests in the monograph. They are limited by the general acceptance criterion for other/unspecified impurities and/or by the general monograph *Substances for pharmaceutical use* (2034). It is therefore not necessary to identify these impurities for demonstration of compliance. See also 5.10. *Control of impurities in substances for pharmaceutical use*): A, B, C, D, E, G, H.

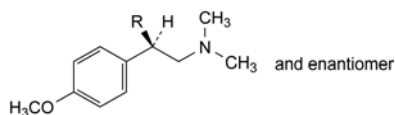

- A. R = H: 2-(4-methoxyphenyl)-N,N-dimethylethanamine,  
 B. R = CO-O-C<sub>2</sub>H<sub>5</sub>: ethyl (2*RS*)-3-(dimethylamino)-2-(4-methoxyphenyl)propanoate,

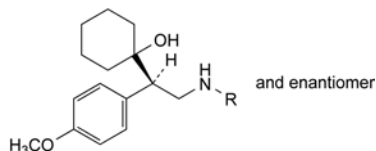

- C. R = H: 1-[(1*RS*)-2-amino-1-(4-methoxyphenyl)ethyl]-cyclohexanol,

D. R = CH<sub>3</sub>: 1-[(1*RS*)-1-(4-methoxyphenyl)-2-(methylamino)ethyl]cyclohexanol,

H. R = CH<sub>2</sub>-CH<sub>2</sub>-C<sub>6</sub>H<sub>4</sub>-*p*-OCH<sub>3</sub>: 1-[(1*RS*)-1-(4-methoxyphenyl)-2-[[2-(4-methoxyphenyl)ethyl]amino]ethyl]cyclohexanol,

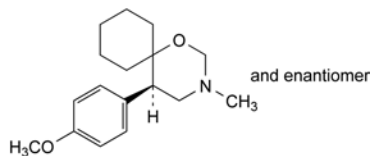

E. (5*RS*)-5-(4-methoxyphenyl)-3-methyl-1-oxa-3-azaspiro[5.5]undecane,

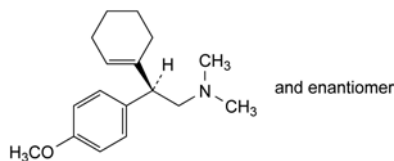

F. (2*RS*)-2-(cyclohex-1-enyl)-2-(4-methoxyphenyl)-N,N-dimethylethanamine,

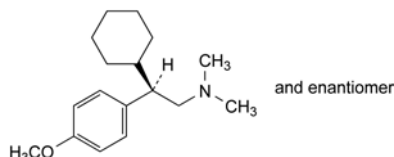

G. (2*RS*)-2-cyclohexyl-2-(4-methoxyphenyl)-N,N-dimethylethanamine.

01/2008:0573  
corrected 7.0

## VERAPAMIL HYDROCHLORIDE

### Verapamili hydrochloridum

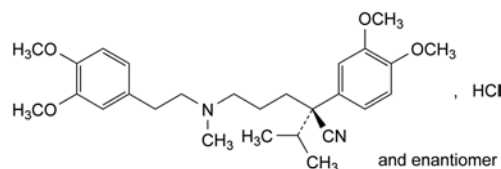

C<sub>27</sub>H<sub>39</sub>ClN<sub>2</sub>O<sub>4</sub>  
[152-11-4]

M<sub>r</sub> 491.1

DEFINITION

(2*RS*)-2-(3,4-Dimethoxyphenyl)-5-[[2-(3,4-dimethoxyphenyl)ethyl](methyl)amino]-2-(1-methylethyl)pentanenitrile hydrochloride.

Content: 99.0 per cent to 101.0 per cent (dried substance).

CHARACTERS

Appearance: white or almost white, crystalline powder.

Solubility: soluble in water, freely soluble in methanol, sparingly soluble in ethanol (96 per cent).

mp: about 144 °C.

IDENTIFICATION

First identification: B, D.

Second identification: A, C, D.

A. Ultraviolet and visible absorption spectrophotometry (2.2.25).

Test solution. Dissolve 20.0 mg in 0.01 M hydrochloric acid and dilute to 100.0 mL with the same acid. Dilute 5.0 mL of this solution to 50.0 mL with 0.01 M hydrochloric acid.

Spectral range: 210-340 nm.

Absorption maxima: at 229 nm and 278 nm.

*Shoulder*: at 282 nm.

*Absorbance ratio*:  $A_{278}/A_{229} = 0.35$  to 0.39.

**B. Infrared absorption spectrophotometry (2.2.24).**

*Preparation*: discs.

*Comparison*: verapamil hydrochloride CRS.

**C. Thin-layer chromatography (2.2.27).**

*Test solution*. Dissolve 10 mg of the substance to be examined in *methylene chloride R* and dilute to 5 mL with the same solvent.

*Reference solution (a)*. Dissolve 20 mg of *verapamil hydrochloride CRS* in *methylene chloride R* and dilute to 10 mL with the same solvent.

*Reference solution (b)*. Dissolve 5 mg of *papaverine hydrochloride CRS* in reference solution (a) and dilute to 5 mL with reference solution (a).

*Plate*: TLC silica gel  $F_{254}$  plate R.

*Mobile phase*: diethylamine R, cyclohexane R (15:85 V/V).

*Application*: 5 µL.

*Development*: over a path of 15 cm.

*Drying*: in air.

*Detection*: examine in ultraviolet light at 254 nm.

*System suitability*: reference solution (b):

- the chromatogram shows 2 clearly separated principal spots.

*Results*: the principal spot in the chromatogram obtained with the test solution is similar in position and size to the principal spot in the chromatogram obtained with reference solution (a).

**D. It gives reaction (b) of chlorides (2.3.1).**

**TESTS**

**Solution S**. Dissolve 1.0 g in *carbon dioxide-free water R* while gently heating and dilute to 20.0 mL with the same solvent.

**Appearance of solution**. Solution S is clear (2.2.1) and colourless (2.2.2, Method II).

**pH (2.2.3)**: 4.5 to 6.0 for solution S.

**Optical rotation (2.2.7)**:  $-0.10^\circ$  to  $+0.10^\circ$ , determined on solution S.

**Related substances**. Liquid chromatography (2.2.29).

*Test solution*. Dissolve 25.0 mg of the substance to be examined in the initial mobile phase composition and dilute to 10.0 mL with the initial mobile phase composition.

*Reference solution (a)*. Dissolve 5 mg of *verapamil hydrochloride CRS*, 5 mg of *verapamil impurity I CRS* and 5 mg of *verapamil impurity M CRS* in the initial mobile phase composition and dilute to 20 mL with the initial mobile phase composition. Dilute 1 mL of this solution to 10 mL with the initial mobile phase composition.

*Reference solution (b)*. Dilute 1.0 mL of the test solution to 100.0 mL with the initial mobile phase composition. Dilute 1.0 mL of this solution to 10.0 mL with the initial mobile phase composition.

*Column*:

- *size*:  $l = 0.25$  m,  $\varnothing = 4.6$  mm;
- *stationary phase*: end-capped palmitamidopropylsilyl silica gel for chromatography R (5 µm).

*Mobile phase*:

- *mobile phase A*: 6.97 g/L solution of dipotassium hydrogen phosphate R adjusted to pH 7.20 with phosphoric acid R;
- *mobile phase B*: acetonitrile R;

Time (min)	Mobile phase A (per cent V/V)	Mobile phase B (per cent V/V)
0 - 22	63	37
22 - 27	63 → 35	37 → 65
27 - 35	35	65

*Flow rate*: 1.5 mL/min.

*Detection*: spectrophotometer at 278 nm.

*Injection*: 10 µL.

*Retention time*: verapamil = about 16 min; impurity I = about 21 min; impurity M eluting as a doublet = about 32 min.

*System suitability*: reference solution (a):

- *resolution*: minimum 5.0 between the peaks due to verapamil and impurity I;
- impurity M elutes from the column.

*Limits*:

- *any impurity*: for each impurity, not more than the area of the principal peak in the chromatogram obtained with reference solution (b) (0.1 per cent);
- *total*: not more than 3 times the area of the principal peak in the chromatogram obtained with reference solution (b) (0.3 per cent);
- *disregard limit*: 0.1 times the area of the principal peak in the chromatogram obtained with reference solution (b) (0.01 per cent).

**Heavy metals (2.4.8)**: maximum 10 ppm.

1.0 g complies with test C. Prepare the reference solution using 1 mL of *lead standard solution (10 ppm Pb) R*.

**Loss on drying (2.2.32)**: maximum 0.5 per cent, determined on 1.000 g by drying in an oven at 105 °C.

**Sulfated ash (2.4.14)**: maximum 0.1 per cent, determined on 1.0 g.

**ASSAY**

Dissolve 0.400 g in 50 mL of *anhydrous ethanol R* and add 5.0 mL of 0.01 M hydrochloric acid. Titrate with 0.1 M sodium hydroxide, determining the end-point potentiometrically (2.2.20). Measure the volume added between the 2 points of inflexion.

1 mL of 0.1 M sodium hydroxide is equivalent to 49.11 mg of  $C_{27}H_{39}ClN_2O_4$ .

**STORAGE**

Protected from light.

**IMPURITIES**

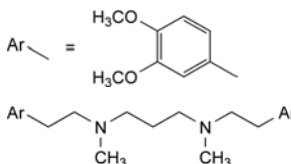

A. *N,N'*-bis[2-(3,4-dimethoxyphenyl)ethyl]-*N,N'*-dimethylpropane-1,3-diamine,

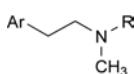

B. R = H: 2-(3,4-dimethoxyphenyl)-*N*-methylethanamine,

C. R = CH<sub>3</sub>: 2-(3,4-dimethoxyphenyl)-*N,N*-dimethylethanamine,

D. R = CH<sub>2</sub>-CH<sub>2</sub>-CH<sub>2</sub>-Cl: 3-chloro-*N*-[2-(3,4-dimethoxyphenyl)ethyl]-*N*-methylpropan-1-amine,

E. Ar-CH<sub>2</sub>OH: (3,4-dimethoxyphenyl)methanol,

01/2008:0748

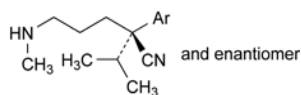

F. (2*RS*)-2-(3,4-dimethoxyphenyl)-5-(methylamino)-2-(1-methylethyl)pentanenitrile,

G. Ar-CHO: 3,4-dimethoxybenzaldehyde,

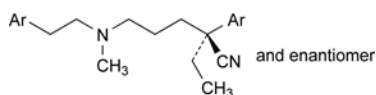

H. (2*RS*)-2-(3,4-dimethoxyphenyl)-5-[[2-(3,4-dimethoxyphenyl)ethyl](methylamino)-2-ethyl]pentanenitrile,

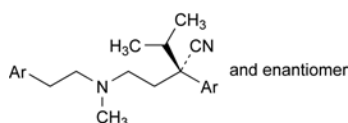

I. (2*RS*)-2-(3,4-dimethoxyphenyl)-2-[2-[[2-(3,4-dimethoxyphenyl)ethyl](methylamino)ethyl]-3-methylbutanenitrile,

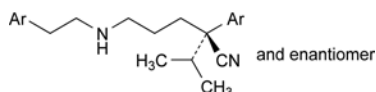

J. (2*RS*)-2-(3,4-dimethoxyphenyl)-5-[[2-(3,4-dimethoxyphenyl)ethyl]amino]-2-(1-methylethyl)pentanenitrile (*N*-norverapamil),

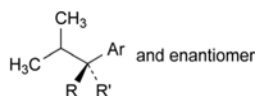

K. R = H, R' = CN: (2*RS*)-2-(3,4-dimethoxyphenyl)-3-methylbutanenitrile,

L. R+ R' = O: 1-(3,4-dimethoxyphenyl)-2-methylpropan-1-one,

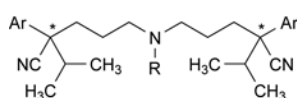

M. R = CH<sub>2</sub>-CH<sub>2</sub>-Ar: 5,5'-[[2-(3,4-dimethoxyphenyl)ethyl]imino]bis[2-(3,4-dimethoxyphenyl)-2-(1-methylethyl)pentanenitrile],

N. R = CH<sub>3</sub>: 5,5'-(methylimino)bis[2-(3,4-dimethoxyphenyl)-2-(1-methylethyl)pentanenitrile],

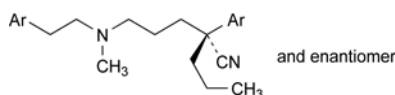

O. (2*RS*)-2-(3,4-dimethoxyphenyl)-5-[[2-[[2-(3,4-dimethoxyphenyl)ethyl](methylamino)-2-propyl]pentanenitrile,

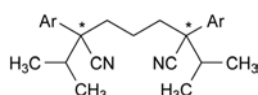

P. 2,6-bis(3,4-dimethoxyphenyl)-2,6-bis(1-methylethyl)-heptane-1,7-dinitrile.

## VINBLASTINE SULFATE

### Vinblastini sulfas

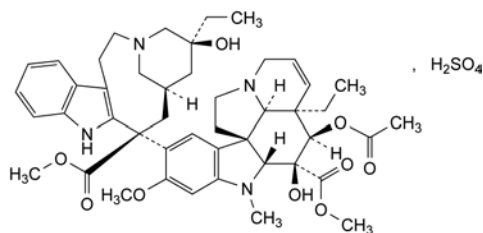

C<sub>46</sub>H<sub>60</sub>N<sub>4</sub>O<sub>13</sub>S  
[143-67-9]

M<sub>r</sub> 909

#### DEFINITION

Vinblastine sulfate contains not less than 95.0 per cent and not more than the equivalent of 104.0 per cent of methyl (3*aR*,4*R*,5*S*,5*aR*,10*bR*,13*aR*)-4-(acetyloxy)-3*a*-ethyl-9-[(5*S*,7*R*,9*S*)-5-ethyl-5-hydroxy-9-(methoxycarbonyl)-1,4,5,6,7,8,9,10-octahydro-2*H*-3,7-methanoazacycloundecino[5,4-*b*]indol-9-yl]-5-hydroxy-8-methoxy-6-methyl-3*a*,4,5,5*a*,6,11,12,13*a*-octahydro-1*H*-indolizino[8,1-*cd*]carbazole-5-carboxylate sulfate, calculated with reference to the dried substance.

#### CHARACTERS

A white or slightly yellowish, crystalline powder, very hygroscopic, freely soluble in water, practically insoluble in alcohol.

#### IDENTIFICATION

- Examine by infrared absorption spectrophotometry (2.2.24), comparing with the *Ph. Eur. reference spectrum of vinblastine sulfate*.
- Examine the chromatograms obtained in the assay. The principal peak in the chromatogram obtained with the test solution is similar in position and approximate size to the principal peak in the chromatogram obtained with reference solution (a).

#### TESTS

**Solution S.** Dissolve 50.0 mg in *carbon dioxide-free water R* and dilute to 10.0 mL with the same solvent.

**Appearance of solution.** Solution S is clear (2.2.1) and not more intensely coloured than reference solution Y<sub>7</sub> (2.2.2, *Method I*).

**pH (2.2.3).** Dilute 3 mL of solution S to 10 mL with *carbon dioxide-free water R*. The pH of this solution is 3.5 to 5.0.

**Related substances.** Examine the chromatograms obtained in the assay. In the chromatogram obtained with the test solution, the area of any peak apart from the principal peak is not greater than the area of the principal peak in the chromatogram obtained with reference solution (c) (2.0 per cent) and the sum of the areas of any such peaks is not greater than 2.5 times the area of the principal peak in the chromatogram obtained with reference solution (c) (5.0 per cent). Disregard any peak with an area less than that of the peak in the chromatogram obtained with reference solution (d).

**Loss on drying.** Not more than 15.0 per cent, determined on 3 mg by thermogravimetry (2.2.34). Heat to 200 °C at a rate of 5 °C/min, under a stream of *nitrogen for chromatography R*, at a flow rate of 40 mL/min.

#### ASSAY

Examine by liquid chromatography (2.2.29).

*Keep the solutions in iced water before use.*

**Test solution.** Dilute 1.0 mL of solution S (see Tests) to 5.0 mL with *water R*.



**Reference solution (a).** Dissolve the contents of a vial of *vinblastine sulfate CRS* in 5.0 mL of *water R* to obtain a concentration of 1.0 mg/mL.

**Reference solution (b).** Dissolve 1.0 mg of *vincristine sulfate CRS* in 1.0 mL of reference solution (a).

**Reference solution (c).** Dilute 1.0 mL of reference solution (a) to 50.0 mL with *water R*.

**Reference solution (d).** Dilute 1.0 mL of reference solution (c) to 20.0 mL with *water R*.

The chromatographic procedure may be carried out using:

- a stainless steel column 0.25 m long and 4.6 mm in internal diameter packed with *octylsilyl silica gel for chromatography R* (5 µm). Place between the injector and the column a precolumn packed with suitable silica gel,
- as mobile phase at a flow rate of 1.0 mL/min a mixture of 38 volumes of a 1.5 per cent V/V solution of *diethylamine R* adjusted to pH 7.5 with *phosphoric acid R*, 12 volumes of *acetonitrile R* and 50 volumes of *methanol R*,
- as detector a spectrophotometer set at 262 nm,
- a loop injector.

Inject 10 µL of each solution and record the chromatograms for three times the retention time of the peak corresponding to *vinblastine*. The assay is not valid unless: in the chromatogram obtained with reference solution (b) the resolution between the peaks corresponding to *vincristine* and *vinblastine* is not less than four; the peak in the chromatogram obtained with reference solution (d) has a signal-to-noise ratio not less than five. Calculate the percentage content of  $C_{46}H_{60}N_4O_{13}S$  from the area of the principal peak in each of the chromatograms obtained with the test solution and reference solution (a) and from the declared content of *vinblastine sulfate CRS*.

#### STORAGE

Store in an airtight, glass container, protected from light, at a temperature not exceeding –20 °C. If the substance is sterile, store in an sterile, airtight, tamper-proof glass container.

01/2008:0749  
corrected 7.0

## VINCRIStINE SULFATE

### Vincristini sulfas

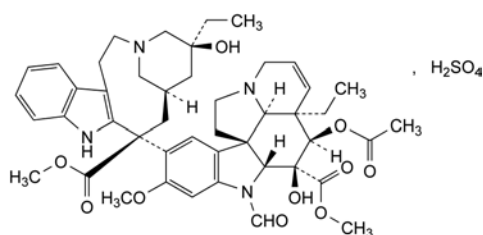

$C_{46}H_{58}N_4O_{14}S$   
[2068-78-2]

$M_r$  923

#### DEFINITION

Methyl (3*aR*,4*R*,5*S*,5*aR*,10*bR*,13*aR*)-4-(acetyloxy)-3*a*-ethyl-9-[(5*S*,7*R*,9*S*)-5-ethyl-5-hydroxy-9-(methoxycarbonyl)-1,4,5,6,7,8,9,10-octahydro-2*H*-3,7-methanoazacycloundecino[5,4-*b*]indol-9-yl]-6-formyl-5-hydroxy-8-methoxy-3*a*,4,5,5*a*,6,11,12,13*a*-octahydro-1*H*-indolizino[8,1-*cd*]carbazole-5-carboxylate sulfate.

**Content:** 95.0 per cent to 104.0 per cent (dried substance).

#### CHARACTERS

**Appearance:** white or slightly yellowish, crystalline powder, very hygroscopic.

**Solubility:** freely soluble in water, slightly soluble in alcohol.

#### IDENTIFICATION

Infrared absorption spectrophotometry (2.2.24).

**Comparison:** *Ph. Eur. reference spectrum of vincristine sulfate*.

#### TESTS

**Solution S.** Dissolve 50.0 mg in *carbon dioxide-free water R* and dilute to 10.0 mL with the same solvent. *Keep the solution in iced water to carry out the test for related substances.*

**Appearance of solution.** Solution S is clear (2.2.1) and not more intensely coloured than reference solution  $Y_7$  (2.2.2, *Method I*).

**pH** (2.2.3): 3.5 to 4.5.

Dilute 2 mL of solution S to 10 mL with *carbon dioxide-free water R*.

**Related substances.** Liquid chromatography (2.2.29). *Keep the solutions in iced water before use.*

**Test solution.** Dilute 1.0 mL of solution S to 5.0 mL with *water R*.

**Reference solution (a).** Dissolve the contents of a vial of *vincristine sulfate CRS* in 5.0 mL of *water R* to obtain a concentration of 1.0 mg/mL.

**Reference solution (b).** Dissolve 1.0 mg of *vinblastine sulfate CRS* in 1.0 mL of reference solution (a).

**Reference solution (c).** Dilute 1.0 mL of the test solution to 50.0 mL with *water R*.

**Reference solution (d).** Dilute 1.0 mL of reference solution (c) to 20.0 mL with *water R*.

**Precolumn:**

- **stationary phase:** *octylsilyl silica gel for chromatography R*.

**Column:**

- **size:**  $l = 0.25$  m,  $\varnothing = 4.6$  mm,
- **stationary phase:** *octylsilyl silica gel for chromatography R* (5 µm).

**Mobile phase:**

- **mobile phase A:** 1.5 per cent V/V solution of *diethylamine R* adjusted to pH 7.5 with *phosphoric acid R*,
- **mobile phase B:** *methanol R*,

Time (min)	Mobile phase A (per cent V/V)	Mobile phase B (per cent V/V)
0 - 12	38	62
12 - 27	38 → 8	62 → 92

**Flow rate:** 2 mL/min.

**Detection:** spectrophotometer at 297 nm.

**Injection:** 20 µL.

**System suitability:** reference solution (b):

- **resolution:** minimum 4 between the peaks due to *vincristine* and *vinblastine*.

**Limits:**

- **any impurity:** not more than the area of the principal peak in the chromatogram obtained with reference solution (c) (2.0 per cent),
- **total:** not more than 2.5 times the area of the principal peak in the chromatogram obtained with reference solution (c) (5.0 per cent),
- **disregard limit:** area of the peak in the chromatogram obtained with reference solution (d) (0.1 per cent).

**Loss on drying:** maximum 12.0 per cent, determined on 3 mg by thermogravimetry (2.2.34). Heat the substance to be examined to 200 °C increasing the temperature by 5 °C/min, under a current of *nitrogen for chromatography R*, at a flow rate of 40 mL/min.

#### ASSAY

Liquid chromatography (2.2.29) as described in the test for related substances, with the following modifications.

**Mobile phase:** mix 30 volumes of a 1.5 per cent *V/V* solution of *diethylamine R* adjusted to pH 7.5 with *phosphoric acid R* and 70 volumes of *methanol R*.

**Flow rate:** 1.0 mL/min.

Calculate the percentage content of  $C_{46}H_{58}N_4O_{14}S$  using the chromatogram obtained with reference solution (a) and the declared content of *vincristine sulfate CRS*.

#### STORAGE

In an airtight, glass container, protected from light, at a temperature not exceeding  $-20\text{ }^{\circ}\text{C}$ . If the substance is sterile, store in a sterile, airtight, tamper-proof glass container.

#### IMPURITIES

**Specified impurities:** A, B, C, D, H.

**Other detectable impurities** (the following substances would, if present at a sufficient level, be detected by one or other of the tests in the monograph. They are limited by the general acceptance criterion for other/unspecified impurities and/or by the general monograph *Substances for pharmaceutical use (2034)*. It is therefore not necessary to identify these impurities for demonstration of compliance. See also 5.10. *Control of impurities in substances for pharmaceutical use*): E, F, G.

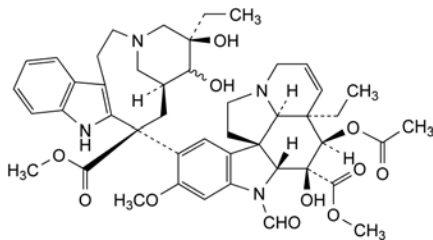

A. methyl (3*aR*,4*R*,5*S*,5*aR*,10*bR*,13*aR*)-4-(acetyloxy)-3*a*-ethyl-9-[(5*R*,7*S*,9*S*)-5-ethyl-5,6-dihydroxy-9-(methoxycarbonyl)-1,4,5,6,7,8,9,10-octahydro-2*H*-3,7-methanoazacycloundecino[5,4-*b*]indol-9-yl]-6-formyl-5-hydroxy-8-methoxy-3*a*,4,5,5*a*,6,11,12,13*a*-octahydro-1*H*-indolizino[8,1-*cd*]carbazole-5-carboxylate (3'-hydroxy-VCR),

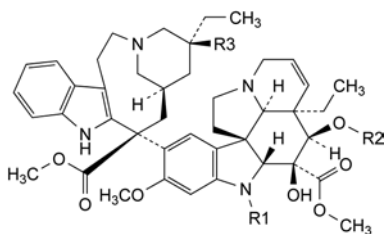

B. R1 = CHO, R2 = CO-CH<sub>3</sub>, R3 = H: methyl (3*aR*,4*R*,5*S*,5*aR*,10*bR*,13*aR*)-4-(acetyloxy)-3*a*-ethyl-9-[(5*R*,7*S*,9*S*)-5-ethyl-9-(methoxycarbonyl)-1,4,5,6,7,8,9,10-octahydro-2*H*-3,7-methanoazacycloundecino[5,4-*b*]indol-9-yl]-6-formyl-5-hydroxy-8-methoxy-3*a*,4,5,5*a*,6,11,12,13*a*-octahydro-1*H*-indolizino[8,1-*cd*]carbazole-5-carboxylate (4'-deoxyvincristine),

C. R1 = H, R2 = CO-CH<sub>3</sub>, R3 = OH: methyl (3*aR*,4*R*,5*S*,5*aR*,10*bS*,13*aR*)-4-(acetyloxy)-3*a*-ethyl-9-[(5*S*,7*R*,9*S*)-5-ethyl-5-hydroxy-9-(methoxycarbonyl)-1,4,5,6,7,8,9,10-octahydro-2*H*-3,7-methanoazacycloundecino[5,4-*b*]indol-9-yl]-5-hydroxy-8-methoxy-3*a*,4,5,5*a*,6,11,12,13*a*-octahydro-1*H*-indolizino[8,1-*cd*]carbazole-5-carboxylate (*N*-desmethylvinblastine),

D. R1 = CHO, R2 = H, R3 = OH: methyl (3*aR*,4*R*,5*S*,5*aR*,10*bR*,13*aR*)-3*a*-ethyl-9-[(5*S*,7*R*,9*S*)-5-ethyl-5-hydroxy-9-(methoxycarbonyl)-1,4,5,6,7,8,9,10-octahydro-2*H*-3,7-methanoazacycloundecino[5,4-*b*]indol-9-yl]-6-formyl-4,5-dihydroxy-8-methoxy-3*a*,4,5,5*a*,6,11,12,13*a*-octahydro-1*H*-indolizino[8,1-*cd*]carbazole-5-carboxylate (deacetylvincristine),

E. R1 = CH<sub>3</sub>, R2 = H, R3 = OH: methyl (3*aR*,4*R*,5*S*,5*aR*,10*bR*,13*aR*)-3*a*-ethyl-9-[(5*S*,7*R*,9*S*)-5-ethyl-5-hydroxy-9-(methoxycarbonyl)-1,4,5,6,7,8,9,10-octahydro-2*H*-3,7-methanoazacycloundecino[5,4-*b*]indol-9-yl]-4,5-dihydroxy-8-methoxy-6-methyl-3*a*,4,5,5*a*,6,11,12,13*a*-octahydro-1*H*-indolizino[8,1-*cd*]carbazole-5-carboxylate (deacetylvinblastine),

H. R1 = CH<sub>3</sub>, R2 = CO-CH<sub>3</sub>, R3 = OH: vinblastine,

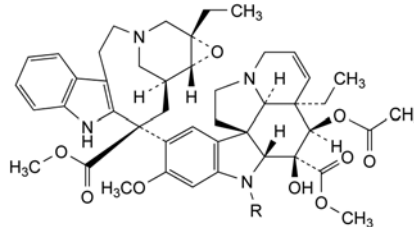

F. R = CH<sub>3</sub>: methyl (3*aR*,4*R*,5*S*,5*aR*,10*bR*,13*aR*)-4-(acetyloxy)-3*a*-ethyl-9-[(1*aS*,11*S*,13*S*,13*aR*)-1*a*-ethyl-11-(methoxycarbonyl)-1*a*,4,5,10,11,12,13,13*a*-octahydro-2*H*-3,13-methano-oxireno[9,10]azacycloundecino[5,4-*b*]indol-11-yl]-5-hydroxy-8-methoxy-6-methyl-3*a*,4,5,5*a*,6,11,12,13*a*-octahydro-1*H*-indolizino[8,1-*cd*]carbazole-5-carboxylate (leurosine),

G. R = CHO: methyl (3*aR*,4*R*,5*S*,5*aR*,10*bR*,13*aR*)-4-(acetyloxy)-3*a*-ethyl-9-[(1*aS*,11*S*,13*S*,13*aR*)-1*a*-ethyl-11-(methoxycarbonyl)-1*a*,4,5,10,11,12,13,13*a*-octahydro-2*H*-3,13-methano-oxireno[9,10]azacycloundecino[5,4-*b*]indol-11-yl]-6-formyl-5-hydroxy-8-methoxy-3*a*,4,5,5*a*,6,11,12,13*a*-octahydro-1*H*-indolizino[8,1-*cd*]carbazole-5-carboxylate (formylleurosine).

01/2008:1276

## VINDESINE SULFATE

### Vindesini sulfas

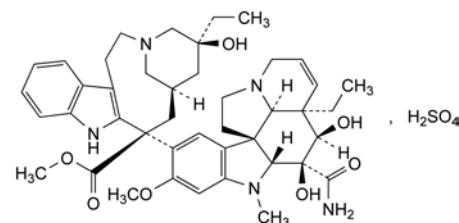

$C_{43}H_{57}N_5O_{11}S$   
[59917-39-4]

$M_r$  852

#### DEFINITION

Methyl (5*S*,7*R*,9*S*)-9-[(3*aR*,4*R*,5*S*,5*aR*,10*bR*,13*aR*)-5-carbamoyl-3*a*-ethyl-4,5-dihydroxy-8-methoxy-6-methyl-3*a*,4,5,5*a*,6,11,12,13*a*-octahydro-1*H*-indolizino[8,1-*cd*]carbazol-9-yl]-5-ethyl-5-hydroxy-1,4,5,6,7,8,9,10-octahydro-2*H*-3,7-methanoazacycloundecino[4,5-*b*]indole-9-carboxylate sulfate.

**Content:** 96.0 per cent to 103.0 per cent (dried substance).

#### CHARACTERS

**Appearance:** white or almost white, amorphous, hygroscopic substance.

**Solubility:** freely soluble in water and in methanol, practically insoluble in cyclohexane.

#### IDENTIFICATION

Infrared absorption spectrophotometry (2.2.24).

**Comparison:** *Ph. Eur. reference spectrum of vindesine sulfate.*

#### TESTS

**Solution S.** Dissolve 50 mg in *carbon dioxide-free water R* and dilute to 10 mL with the same solvent.

**Appearance of solution.** Solution S is clear (2.2.1) and not more intensely coloured than reference solution Y<sub>7</sub> (2.2.2, Method D).

**pH** (2.2.3): 3.5 to 5.5 for solution S.

**Related substances.** Liquid chromatography (2.2.29). *Keep the solutions in iced water before use.*

**Test solution.** Dissolve 10.0 mg of the substance to be examined in water R and dilute to 10.0 mL with the same solvent.

**Reference solution (a).** Dilute 1.0 mL of the test solution to 50.0 mL with water R.

**Reference solution (b).** Dissolve 1.0 mg of *desacetylvinblastine CRS* in water R, add 1.0 mL of the test solution and dilute to 50.0 mL with water R.

**Reference solution (c).** Dilute 1.0 mL of reference solution (a) to 200.0 mL with water R.

**Column:**

- size:  $l = 0.15$  m,  $\varnothing = 4.6$  mm;
- stationary phase: octadecylsilyl silica gel for chromatography R (5  $\mu$ m).

**Mobile phase:**

- mobile phase A: 1.5 per cent V/V solution of diethylamine R adjusted to pH 7.4 with phosphoric acid R;
- mobile phase B: methanol R;

Time (min)	Mobile phase A (per cent V/V)	Mobile phase B (per cent V/V)
0 - 40	49	51
40 - 49	49 → 30	51 → 70
49 - end	30	70

**Flow rate:** 2 mL/min.

**Detection:** spectrophotometer at 270 nm.

**Injection:** 200  $\mu$ L.

**Run time:** twice the retention time of vindesine.

**System suitability:** reference solution (b):

- the retention time of vindesine is less than 40 min;
- resolution: minimum 2.0 between the peaks due to vindesine and desacetylvinblastine;
- symmetry factor: maximum 2.0 for the peak due to vindesine.

**Limits:**

- impurities A, B, C: for each impurity, not more than 0.5 times the area of the principal peak in the chromatogram obtained with reference solution (a) (1 per cent);
- total: not more than the area of the principal peak in the chromatogram obtained with reference solution (a) (2 per cent);
- disregard limit: the area of the principal peak in the chromatogram obtained with reference solution (c) (0.01 per cent).

**Acetonitrile.** Gas chromatography (2.2.28).

**Internal standard solution (a).** Dilute 0.500 g of propanol R to 100 mL with water R.

**Internal standard solution (b).** Dilute 10.0 mL of internal standard solution (a) to 50.0 mL with water R.

**Reference solution.** Dilute 10.0 g of acetonitrile R to 1000 mL with water R. To 3.0 mL of this solution add 10.0 mL of internal standard solution (a) and dilute to 50.0 mL with water R.

**Test solution.** Dissolve 40 mg of the substance to be examined in 1.0 mL of internal standard solution (b).

**Column:**

- material: glass;
- size:  $l = 1.25$  m,  $\varnothing = 3$  mm;
- stationary phase: ethylvinylbenzene-divinylbenzene copolymer R.

**Carrier gas:** helium for chromatography R.

**Flow rate:** 60 mL/min.

**Temperature:**

- column: 170 °C;
- injection port and detector: 250 °C.

**Detection:** flame ionisation.

**Injection:** 3  $\mu$ L.

**System suitability:** reference solution:

- resolution: minimum 1.5 between the peaks due to acetonitrile and propanol;
- symmetry factor: maximum 1.6 for the peak due to acetonitrile.

**Limit:**

- acetonitrile: maximum 1.5 per cent m/m.

**Loss on drying:** maximum 10.0 per cent, determined on 9.00 mg by thermogravimetry (2.2.34). Heat to 200 °C at a rate of 5 °C/min, under a stream of nitrogen for chromatography R at a flow rate of 40 mL/min.

**ASSAY**

Liquid chromatography (2.2.29). *Keep the solutions in iced water before use.*

**Test solution.** Dissolve 5.0 mg of the substance to be examined in water R and dilute to 10.0 mL with the same solvent.

**Reference solution (a).** Dissolve and dilute the entire contents of a vial of vindesine sulfate CRS with water R to yield a concentration of approximately 0.50 mg/mL.

**Reference solution (b).** Add 1.0 mg of desacetylvinblastine CRS to 2.0 mL of reference solution (a).

**Column:**

- size:  $l = 0.15$  m, 4.6 mm;
- stationary phase: octadecylsilyl silica gel for chromatography R (5  $\mu$ m).

**Mobile phase:** mix 38 volumes of a 1.5 per cent V/V solution of diethylamine R, previously adjusted to pH 7.4 with phosphoric acid R, and 62 volumes of methanol R.

**Flow rate:** 1 mL/min.

**Detection:** spectrophotometer at 270 nm.

**Injection:** 20  $\mu$ L.

**System suitability:** reference solution (b):

- resolution: minimum 1.5 between the peaks due to vindesine and desacetylvinblastine;
- symmetry factor: maximum 2.0 for the peak due to vindesine;
- repeatability: maximum relative standard deviation of 1.5 per cent for the peak due to vindesine after 5 injections.

Calculate the percentage content of C<sub>43</sub>H<sub>57</sub>N<sub>5</sub>O<sub>11</sub>S from the declared content of vindesine sulfate CRS.

**STORAGE**

In an airtight polypropylene container with a polypropylene cap, at a temperature of –50 °C or below. If the substance is sterile, store in a sterile, airtight, tamper-proof container.

**IMPURITIES**

**Specified impurities:** A, B, C.

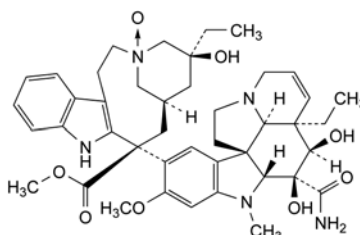

A. vindesine 3'-N-oxide,

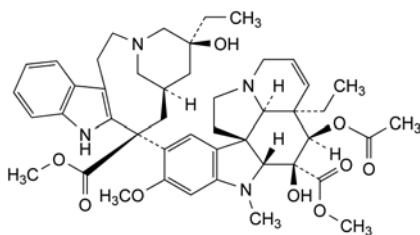

- B. methyl (3a*R*,4*R*,5*S*,5a*R*,10b*R*,13a*R*)-4-(acetyloxy)-3a-ethyl-9-[(5*S*,7*R*,9*S*)-5-ethyl-5-hydroxy-9-(methoxycarbonyl)-1,4,5,6,7,8,9,10-octahydro-2*H*-3,7-methanoazacycloundecino[5,4-*b*]indol-9-yl]-5-hydroxy-8-methoxy-6-methyl-3a,4,5,5a,6,11,12,13a-octahydro-1*H*-indolizino[8,1-*cd*]carbazole-5-carboxylate (vinblastine),

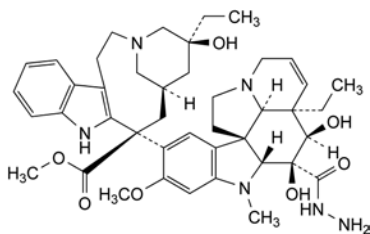

- C. desacetylvinblastine hydrazide.

01/2008:2107  
corrected 7.0

## VINORELBINE TARTRATE

### Vinorelbini tartras

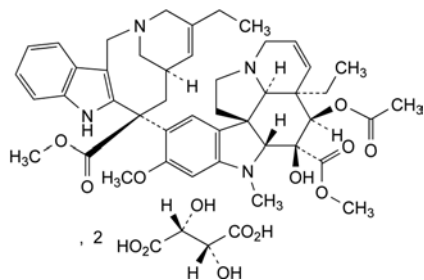

C<sub>53</sub>H<sub>66</sub>N<sub>4</sub>O<sub>20</sub>  
[125317-39-7]

M<sub>r</sub> 1079

#### DEFINITION

Methyl (3a*R*,4*R*,5*S*,5a*R*,10b*R*,13a*R*)-4-(acetyloxy)-3a-ethyl-9-[(6*R*,8*S*)-4-ethyl-8-(methoxycarbonyl)-1,3,6,7,8,9-hexahydro-2,6-methano-2*H*-azacyclodecino[4,3-*b*]indol-8-yl]-5-hydroxy-8-methoxy-6-methyl-3a,4,5,5a,6,11,12,13a-octahydro-1*H*-indolizino[8,1-*cd*]carbazole-5-carboxylate dihydrogen bis[(2*R*,3*R*)-2,3-dihydroxybutanedioate].

*Content*: 98.0 per cent to 102.0 per cent (anhydrous substance).

#### CHARACTERS

*Appearance*: white or almost white powder, hygroscopic.

*Solubility*: freely soluble in water and in methanol, practically insoluble in hexane.

#### IDENTIFICATION

- A. Infrared absorption spectrophotometry (2.2.24).

*Preparation*: dissolve 10 mg in 5 mL of *water R*. Add 0.5 mL of *sodium hydroxide solution R*. Extract with 5 mL of *methylene chloride R*. Dry the organic layer over *anhydrous sodium sulfate R*, filter and reduce its volume to about 0.5 mL by evaporation and apply to a disc of *potassium bromide R*. Evaporate and record the spectrum.

*Comparison*: *vinorelbine tartrate CRS*, treated as described above.

- B. It gives reaction (b) of tartrates (2.3.1).

#### TESTS

**Solution S.** Dissolve a quantity equivalent to 0.140 g of the anhydrous substance in *water R* and dilute to 10.0 mL with the same solvent.

**Appearance of solution.** Solution S is clear (2.2.1) and its absorbance (2.2.25) at 420 nm is not greater than 0.030.

**pH** (2.2.3): 3.3 to 3.8 for solution S.

**Related substances.** Liquid chromatography (2.2.29): use the normalisation procedure.

*Test solution.* Dissolve 35.0 mg of the substance to be examined in the mobile phase and dilute to 25 mL with the mobile phase.

*Reference solution (a).* Dissolve 7 mg of *vinorelbine impurity B CRS* in *water R* and dilute to 50 mL with the same solvent. To 1 mL of this solution add 14 mg of *vinorelbine tartrate CRS*, dissolve in *water R* and dilute to 10 mL with the same solvent. Expose this solution for 1 h to a xenon lamp apparatus at a wavelength of 310-880 nm, supplying a dose of 1600 kJ/m<sup>2</sup> at a fluence rate of 500 W/m<sup>2</sup> in order to generate impurity A.

*Reference solution (b).* Dilute 1.0 mL of the test solution to 20.0 mL with *water R*. Dilute 1.0 mL of this solution to 100.0 mL with the mobile phase.

*Column*:

- *size*:  $l = 0.15$  m,  $\varnothing = 3.9$  mm,
- *stationary phase*: spherical *end-capped octadecylsilyl silica gel for chromatography R* (5  $\mu$ m) with a specific surface area of 125 m<sup>2</sup>/g, a pore size of 30 nm and a carbon loading of 7 per cent,
- *temperature*: 35  $\pm$  5 °C.

*Mobile phase*: dissolve 1.22 g of *sodium decanesulfonate R* in 620 mL of *methanol R* and add 380 mL of a 7.80 g/L solution of *sodium dihydrogen phosphate R* previously adjusted to pH 4.2 with *dilute phosphoric acid R*.

*Flow rate*: 1.0 mL/min.

*Detection*: spectrophotometer at 267 nm.

*Injection*: 20  $\mu$ L.

*Run time*: twice the retention time of vinorelbine.

*Relative retention* with reference to vinorelbine (retention time = about 14 min): impurity A = about 0.8; impurity B = about 1.2.

*System suitability*:

- *peak-to-valley ratio*: minimum 4, where  $H_p$  = height above the baseline of the peak due to impurity B and  $H_v$  = height above the baseline of the lowest point of the curve separating this peak from the peak due to vinorelbine in the chromatogram obtained with reference solution (a),
- *signal-to-noise ratio*: minimum 10 for the principal peak in the chromatogram obtained with reference solution (b).

*Limits*:

- *impurity A*: maximum 0.3 per cent,
- *any other impurity*: for each impurity, maximum 0.2 per cent,
- *sum of impurities other than A*: maximum 0.7 per cent,
- *disregard limit*: the area of the principal peak in the chromatogram obtained with reference solution (b).

**Boron**: maximum 50 ppm.

*Test solution.* Dissolve 0.10 g of the substance to be examined in 2 mL of *water R*. Slowly add 10.0 mL of *sulfuric acid R* while cooling in iced water. Stir and allow to warm to room temperature. Add 10.0 mL of a 0.5 g/L solution of *carminic acid R* in *sulfuric acid R*.

*Reference solution.* Dilute 2.5 mL of a 0.572 g/L solution of *boric acid R* to 100.0 mL with *water R*. To 2.0 mL of this solution slowly add 10.0 mL of *sulfuric acid R* while cooling in iced water. Stir and allow to warm to room temperature. Add 10.0 mL of a 0.5 g/L solution of *carminic acid R* in *sulfuric acid R*.

**Blank solution.** To 2.0 mL of *water R* slowly add 10.0 mL of *sulfuric acid R* while cooling in iced water. Stir and allow to warm to room temperature. Add 10.0 mL of a 0.5 g/L solution of *carminic acid R* in *sulfuric acid R*.

After 45 min, measure the absorbance (2.2.25) of the test solution and the reference solution, between 560 nm and 650 nm, using the blank solution as compensation liquid. The maximum absorbance value of the test solution is not greater than that of the reference solution.

**Fluorides:** maximum 50 ppm.

Potentiometry (2.2.36, *Method I*) using a fluoride-selective indicator electrode and a silver-silver chloride reference electrode.

**Test solution.** Dissolve 0.19 g of the substance to be examined in 20 mL of *water R*. Add 5.0 mL of *total-ionic-strength-adjustment buffer R* and dilute to 50 mL with *water R*.

**Reference solutions.** To 0.6 mL, 0.8 mL, 1.0 mL, 1.2 mL and 1.4 mL of *fluoride standard solution (10 ppm F) R*, add 5.0 mL of *total-ionic-strength-adjustment buffer R* and dilute to 50 mL with *water R*.

Introduce the electrodes into the reference solutions and allow to stand for 5 min. Determine the potential difference between the electrodes after 1 min of stabilisation. Using semi-logarithmic paper plot the potential difference obtained for each reference solution as a function of concentration of fluoride. Using exactly the same conditions, determine the potential difference obtained with the test solution and calculate the content of fluoride.

**Silver:** maximum 5 ppm.

Atomic absorption spectrometry (2.2.23, *Method I*).

**Test solution.** Dissolve 0.500 g of the substance to be examined in 10.0 mL of *water R*.

**Reference solutions.** Prepare the reference solutions using *silver standard solution (5 ppm Ag) R* and diluting with a 6.5 per cent *V/V* solution of *lead-free nitric acid R*.

**Source:** silver hollow-cathode lamp.

**Wavelength:** 328.1 nm.

**Atomisation device:** air-acetylene flame.

**Water (2.5.12):** maximum 4.0 per cent, determined on 0.250 g.

**Bacterial endotoxins (2.6.14):** less than 2 IU/mg (expressed as vinorelbine base), if intended for use in the manufacture of parenteral preparations without a further appropriate procedure for the removal of bacterial endotoxins.

#### ASSAY

Dissolve 0.350 g in 40 mL of *glacial acetic acid R*. Titrate with 0.1 *M perchloric acid*, determining the end-point potentiometrically (2.2.20).

1 mL of 0.1 *M perchloric acid* is equivalent to 53.96 mg of  $C_{53}H_{66}N_4O_{20}$ .

#### STORAGE

Under an inert gas, protected from light, at a temperature not exceeding  $-15\text{ }^{\circ}\text{C}$ .

#### IMPURITIES

**Specified impurities:** A.

**Other detectable impurities** (the following substances would, if present at a sufficient level, be detected by one or other of the tests in the monograph. They are limited by the general acceptance criterion for other/unspecified impurities and/or by the general monograph *Substances for pharmaceutical use (2034)*. It is therefore not necessary to identify these impurities for demonstration of compliance. See also 5.10. *Control of impurities in substances for pharmaceutical use*): B, C, D, E, F, G, H, I, J.

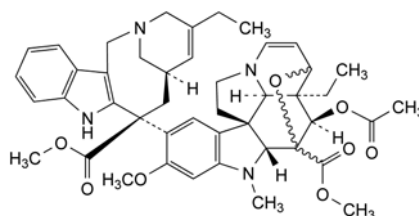

A. methyl (3a*S*,4*R*,5a*R*,10b*R*,13a*R*)-4-(acetyloxy)-3,5-epoxy-3a-ethyl-9-[(6*R*,8*S*)-4-ethyl-8-(methoxycarbonyl)-1,3,6,7,8,9-hexahydro-2,6-methano-2*H*-azacyclodecino[4,3-*b*]indol-8-yl]-8-methoxy-6-methyl-3a,4,5,5a,6,11,12,13a-octahydro-3*H*-indolizino[8,1-*cd*]carbazole-5-carboxylate,

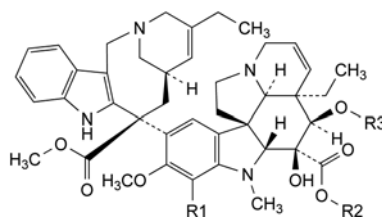

B. R1 = R3 = H, R2 = CH<sub>3</sub>: methyl (3a*R*,4*R*,5*S*,5a*R*,10b*R*,13a*R*)-3a-ethyl-9-[(6*R*,8*S*)-4-ethyl-8-(methoxycarbonyl)-1,3,6,7,8,9-hexahydro-2,6-methano-2*H*-azacyclodecino[4,3-*b*]indol-8-yl]-4,5-dihydroxy-8-methoxy-6-methyl-3a,4,5,5a,6,11,12,13a-octahydro-1*H*-indolizino[8,1-*cd*]carbazole-5-carboxylate,

H. R1 = R2 = H, R3 = CO-CH<sub>3</sub>: (3a*R*,4*R*,5*S*,5a*R*,10b*R*,13a*R*)-4-(acetyloxy)-3a-ethyl-9-[(6*R*,8*S*)-4-ethyl-8-(methoxycarbonyl)-1,3,6,7,8,9-hexahydro-2,6-methano-2*H*-azacyclodecino[4,3-*b*]indol-8-yl]-5-hydroxy-8-methoxy-6-methyl-3a,4,5,5a,6,11,12,13a-octahydro-1*H*-indolizino[8,1-*cd*]carbazole-5-carboxylic acid,

I. R1 = Br, R2 = CH<sub>3</sub>, R3 = CO-CH<sub>3</sub>: methyl (3a*R*,4*R*,5*S*,5a*R*,10b*R*,13a*R*)-4-(acetyloxy)-7-bromo-3a-ethyl-9-[(6*R*,8*S*)-4-ethyl-8-(methoxycarbonyl)-1,3,6,7,8,9-hexahydro-2,6-methano-2*H*-azacyclodecino[4,3-*b*]indol-8-yl]-5-hydroxy-8-methoxy-6-methyl-3a,4,5,5a,6,11,12,13a-octahydro-1*H*-indolizino[8,1-*cd*]carbazole-5-carboxylate,

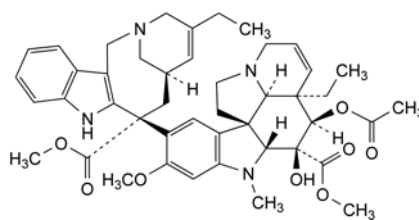

C. methyl (3a*R*,4*R*,5*S*,5a*R*,10b*R*,13a*R*)-4-(acetyloxy)-3a-ethyl-9-[(6*R*,8*R*)-4-ethyl-8-(methoxycarbonyl)-1,3,6,7,8,9-hexahydro-2,6-methano-2*H*-azacyclodecino[4,3-*b*]indol-8-yl]-5-hydroxy-8-methoxy-6-methyl-3a,4,5,5a,6,11,12,13a-octahydro-1*H*-indolizino[8,1-*cd*]carbazole-5-carboxylate,

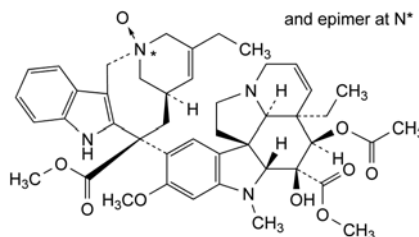

D. methyl (3a*R*,4*R*,5*S*,5a*R*,10b*R*,13a*R*)-4-(acetyloxy)-3a-ethyl-9-[(2*R*,6*R*,8*S*)-4-ethyl-8-(methoxycarbonyl)-2-oxido-1,3,6,7,8,9-hexahydro-2,6-methano-2*H*-azacyclodecino[4,3-*b*]indol-8-yl]-5-hydroxy-8-methoxy-6-methyl-3a,4,5,5a,6,11,12,13a-octahydro-1*H*-indolizino[8,1-*cd*]carbazole-5-carboxylate,

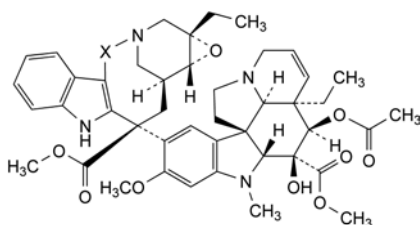

- E. X = CH<sub>2</sub>-CH<sub>2</sub>: methyl (1a*S*,11*S*,13*S*,13a*R*)-11-[(3a*R*,4*R*,5*S*,5a*R*,10b*R*,13a*R*)-4-(acetyloxy)-3a-ethyl-5-hydroxy-8-methoxy-5-(methoxycarbonyl)-6-methyl-3a,4,5,5a,6,11,12,13a-octahydro-1*H*-indolizino[8,1-*cd*]carbazol-9-yl]-1a-ethyl-1a,4,5,10,11,12,13,13a-octahydro-2*H*-3,13-methanooxireno[9,10]azacycloundecino[5,4-*b*]indole-11-carboxylate (leurosine),
- G. X = CH<sub>2</sub>: methyl (1a*S*,10*S*,12*S*,12a*R*)-10-[(3a*R*,4*R*,5*S*,5a*R*,10b*R*,13a*R*)-4-(acetyloxy)-3a-ethyl-5-hydroxy-8-methoxy-5-(methoxycarbonyl)-6-methyl-3a,4,5,5a,6,11,12,13a-octahydro-1*H*-indolizino[8,1-*cd*]carbazol-9-yl]-1a-ethyl-1a,2,4,9,10,11,12,12a-octahydro-3,12-methano-3*H*-oxireno[8,9]azacyclodecino[4,3-*b*]indole-10-carboxylate,

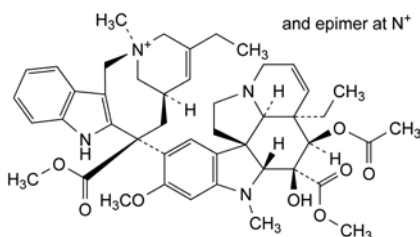

- F. (2*R*,6*R*,8*S*)-8-[(3a*R*,4*R*,5*S*,5a*R*,10b*R*,13a*R*)-4-(acetyloxy)-3a-ethyl-5-hydroxy-8-methoxy-5-(methoxycarbonyl)-6-methyl-3a,4,5,5a,6,11,12,13a-octahydro-1*H*-indolizino[8,1-*cd*]carbazol-9-yl]-4-ethyl-8-(methoxycarbonyl)-2-methyl-1,3,6,7,8,9-hexahydro-2,6-methano-2*H*-azacyclodecino[4,3-*b*]indolium,

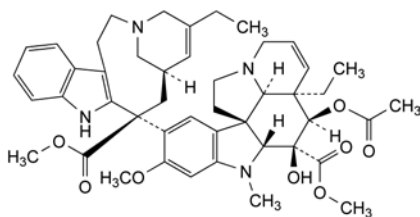

- J. methyl (3a*R*,4*R*,5*S*,5a*R*,10b*R*,13a*R*)-4-(acetyloxy)-3a-ethyl-9-[(7*R*,9*S*)-5-ethyl-9-(methoxycarbonyl)-1,4,7,8,9,10-hexahydro-2*H*-3,7-methanoazacycloundecino[5,4-*b*]indol-9-yl]-5-hydroxy-8-methoxy-6-methyl-3a,4,5,5a,6,11,12,13a-octahydro-1*H*-indolizino[8,1-*cd*]carbazole-5-carboxylate.

01/2008:2139  
corrected 6.7

## VINPOCETINE

### Vinpocetinum

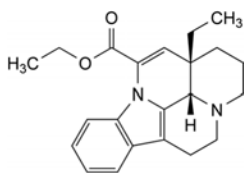

C<sub>22</sub>H<sub>26</sub>N<sub>2</sub>O<sub>5</sub>  
[42971-09-5]

*M*<sub>r</sub> 350.5

#### DEFINITION

Ethyl (13a*S*,13b*S*)-13a-ethyl-2,3,5,6,13a,13b-hexahydro-1*H*-indolo[3,2,1-*de*]pyrido[3,2,1-*ij*][1,5]naphthyridine-12-carboxylate.

*Content*: 98.5 per cent to 101.5 per cent (dried substance).

#### CHARACTERS

*Appearance*: white or slightly yellow, crystalline powder.

*Solubility*: practically insoluble in water, soluble in methylene chloride, slightly soluble in anhydrous ethanol.

#### IDENTIFICATION

A. Specific optical rotation (see Tests).

B. Infrared absorption spectrophotometry (2.2.24).

*Comparison*: vinpocetine CRS.

#### TESTS

**Specific optical rotation** (2.2.7): + 127 to + 134 (dried substance).

Dissolve 0.25 g in *dimethylformamide R* and dilute to 25.0 mL with the same solvent.

**Related substances**. Liquid chromatography (2.2.29).

*Test solution*. Dissolve 50.0 mg of the substance to be examined in the mobile phase and dilute to 50.0 mL with the mobile phase.

*Reference solution (a)*. Dilute 1.0 mL of the test solution to 50.0 mL with the mobile phase.

*Reference solution (b)*. Dissolve 5.0 mg of *vinpocetine impurity B CRS*, 6.0 mg of *vinpocetine impurity A CRS*, 5.0 mg of *vinpocetine impurity C CRS* and 5.0 mg of *vinpocetine impurity D CRS* in the mobile phase and dilute to 50.0 mL with the mobile phase.

*Reference solution (c)*. Dilute 1.0 mL of reference solution (a) and 1.0 mL of reference solution (b) to 20.0 mL with the mobile phase.

*Column*:

– *size*: *l* = 0.25 m, Ø = 4.6 mm;

– *stationary phase*: octadecylsilyl end-capped silica gel for chromatography R (5 µm).

*Mobile phase*: 15.4 g/L solution of ammonium acetate R, acetonitrile R (45:55 V/V).

*Flow rate*: 1.0 mL/min.

*Detection*: spectrophotometer at 280 nm.

*Injection*: 15 µL.

*Run time*: 3 times the retention time of vinpocetine.

*Relative retention* with reference to vinpocetine (retention time = about 16 min): impurity A = about 0.4; impurity D = about 0.68; impurity B = about 0.75; impurity C = about 0.83.

*System suitability*: reference solution (c):

– *resolution*: minimum 2.0 between the peaks due to impurities D and B.

*Limits*:

– *impurity A*: not more than the area of the corresponding peak in the chromatogram obtained with reference solution (c) (0.6 per cent);

– *impurities B, D*: for each impurity, not more than the area of the corresponding peak in the chromatogram obtained with reference solution (c) (0.5 per cent);

– *impurity C*: not more than 0.6 times the area of the corresponding peak in the chromatogram obtained with reference solution (c) (0.3 per cent);

– *unspecified impurities*: for each impurity, not more than the area of the peak due to vinpocetine in the chromatogram obtained with reference solution (c) (0.10 per cent);

– *total*: not more than 10 times the area of the peak due to vinpocetine in the chromatogram obtained with reference solution (c) (1.0 per cent);

– *disregard limit*: 0.5 times the area of the peak due to vinpocetine in the chromatogram obtained with reference solution (c) (0.05 per cent).

**Loss on drying** (2.2.32): maximum 0.5 per cent, determined on 1.000 g by drying *in vacuo* in an oven at 100 °C for 3 h.

**Sulfated ash** (2.4.14): maximum 0.1 per cent, determined on 1.0 g.

## ASSAY

Dissolve 0.300 g in 50 mL of a mixture of equal volumes of *acetic anhydride R* and *anhydrous acetic acid R*. Titrate with 0.1 M *perchloric acid*, determining the end-point potentiometrically (2.2.20).

1 mL of 0.1 M *perchloric acid* is equivalent to 35.05 mg of  $C_{22}H_{26}N_2O_2$ .

## IMPURITIES

Specified impurities: A, B, C, D.

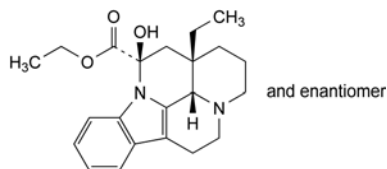

- A. ethyl (12*RS*,13a*SR*,13b*SR*)-13a-ethyl-12-hydroxy-2,3,5,6,12,13,13a,13b-octahydro-1*H*-indolo[3,2,1-*de*]pyrido[3,2,1-*ij*][1,5]naphthyridine-12-carboxylate (ethyl vincamine),

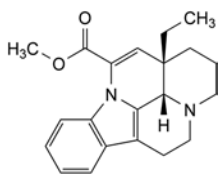

- B. methyl (13a*S*,13b*S*)-13a-ethyl-2,3,5,6,13a,13b-hexahydro-1*H*-indolo[3,2,1-*de*]pyrido[3,2,1-*ij*][1,5]naphthyridine-12-carboxylate (apovincamine),

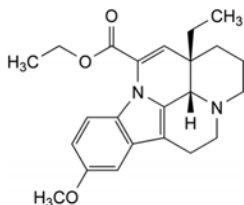

- C. ethyl (13a*S*,13b*S*)-13a-ethyl-10-methoxy-2,3,5,6,13a,13b-hexahydro-1*H*-indolo[3,2,1-*de*]pyrido[3,2,1-*ij*][1,5]naphthyridine-12-carboxylate (methoxyvinpocetine),

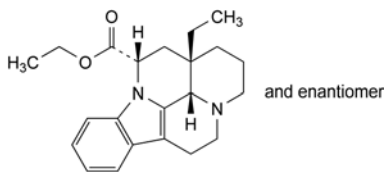

- D. ethyl (12*RS*,13a*RS*,13b*RS*)-13a-ethyl-2,3,5,6,12,13,13a,13b-octahydro-1*H*-indolo[3,2,1-*de*]pyrido[3,2,1-*ij*][1,5]naphthyridine-12-carboxylate (dihydrovinpocetine).

01/2008:0034  
corrected 6.0

## VISCOSE WADDING, ABSORBENT

### Lanugo cellulosi absorbens

## DEFINITION

Absorbent viscose wadding consists of bleached, carefully carded, new fibres of regenerated cellulose obtained by the viscose process, with or without the addition of titanium dioxide, of linear density 1.0 dtex to 8.9 dtex (dtex = mass of 10 000 m of fibre, expressed in grams) and cut to a suitable staple length. It does not contain any compensatory colouring matter.

## CHARACTERS

It is white or very slightly yellow, has a lustrous or matt appearance, and is soft to the touch.

## IDENTIFICATION

- A. Viscose rayon fibres may be solid or hollow; hollow fibres may have a continuous lumen or be compartmented. The fibres have an average length of 25 mm to 80 mm and when examined under a microscope in the dry state, or when mounted in *alcohol R* and *water R*, the following characters are observed. They are usually of a more or less uniform width, with many longitudinal parallel lines distributed unequally over the width. The ends are cut more or less straight. Matt fibres contain numerous granular particles of approximately 1 µm average diameter.

**Solid fibres.** In longitudinal view, the surface of the fibres may be uneven or crenate. Fibres having an approximately circular or elliptical cross section have a diameter of about 10 µm to 20 µm and those that are flattened and twisted ribbons vary in width from 15 µm to 20 µm as the twisting of the filament reveals first the major axis and then the minor axis. They are about 4 µm in thickness. Other solid cross sections are Y-shaped and have protruding limbs with the major axis 5 µm to 25 µm in length and the minor axis 2 µm to 8 µm wide.

**Hollow fibres.** Fibres with a continuous, hollow lumen have a diameter of up to about 30 µm; they are thin-walled, with a wall thickness of about 5 µm. When mounted in *alcohol R* and *water R*, the lumen is clearly indicated in many fibres by the presence of many entrapped air bubbles.

**Compartmented fibres.** These fibres may have a diameter of up to 80 µm; they are hollow, having a central lumen which is divided up into several compartments. Individual compartments vary in size but typically may be up to about 60 µm in length and there may be more than one compartment across the width of each fibre. Some compartments show entrapped air bubbles when the fibres are mounted in *alcohol R* and *water R*.

- B. When treated with *iodinated zinc chloride solution R*, the fibres become violet.
- C. To 0.1 g add 10 mL of *zinc chloride-formic acid solution R*. Heat to 40 °C and allow to stand for 2 h 30 min, shaking occasionally. It dissolves completely except for the matt variety where titanium dioxide particles remain.
- D. Dissolve the residue obtained in the test for sulfated ash by warming gently with 5 mL of *sulfuric acid R*. Allow to cool and add 0.2 mL of *dilute hydrogen peroxide solution R*. The solution obtained from the lustrous variety undergoes no change in colour; that from the matt variety shows an orange-yellow colour, the intensity of which depends on the quantity of titanium dioxide present.

## TESTS

**Solution S.** Place 15.0 g in a suitable vessel, add 150 mL of *water R*, close the vessel and allow to macerate for 2 h. Decant the solution, squeeze the residual liquid carefully from the sample with a glass rod and mix. Reserve 10 mL of the solution for the test for surface-active substances and filter the remainder.

**Acidity or alkalinity.** To 25 mL of solution S add 0.1 mL of *phenolphthalein solution R* and to another 25 mL add 0.05 mL of *methyl orange solution R*. Neither solution is pink.

**Foreign fibres.** Examined under a microscope, it is seen to consist exclusively of viscose fibres, except that occasionally a few isolated foreign fibres may be present.

**Fluorescence.** Examine a layer about 5 mm in thickness under ultraviolet light at 365 nm. It displays only a slight brownish-violet fluorescence. It shows no intense blue fluorescence, apart from that which may be shown by a few isolated fibres.

**Absorbency**

**Apparatus.** A dry cylindrical copper-wire basket 8.0 cm high and 5.0 cm in diameter. The wire of which the basket is constructed is about 0.4 mm in diameter, the mesh is 1.5 cm to 2.0 cm wide and the mass of the basket is  $2.7 \pm 0.3$  g.

**Sinking time.** Not more than 10 s. Weigh the basket to the nearest centigram ( $m_1$ ). Take a total of 5.00 g in approximately equal quantities from 5 different places in the product to be examined, place loosely in the basket and weigh the filled basket to the nearest centigram ( $m_2$ ). Fill a beaker 11 cm to 12 cm in diameter to a depth of 10 cm with water at about 20 °C. Hold the basket horizontally and drop it from a height of about 10 mm into the water. Measure with a stopwatch the time taken for the basket to sink below the surface of the water. Calculate the result as the average of 3 tests.

**Water-holding capacity.** Not less than 18.0 g of water per gram. After the sinking time has been measured, remove the basket from the water, allow it to drain for exactly 30 s suspended in a horizontal position over the beaker, transfer it to a tared beaker ( $m_3$ ) and weigh to the nearest centigram ( $m_4$ ). Calculate the water-holding capacity per gram of absorbent viscose wadding using the following expression:

$$\frac{m_4 - (m_2 + m_3)}{m_2 - m_1}$$

Calculate the result as the average of 3 tests.

**Ether-soluble substances.** Not more than 0.30 per cent. In an extraction apparatus, extract 5.00 g with *ether R* for 4 h at a rate of at least 4 extractions per hour. Evaporate the ether extract and dry the residue to constant mass at 100 °C to 105 °C.

**Extractable colouring matter.** In a narrow percolator, slowly extract 10.0 g with *alcohol R* until 50 mL of extract is obtained. The liquid obtained is not more intensely coloured (2.2.2, *Method II*) than reference solution  $Y_5$ ,  $GY_6$  or a reference solution prepared as follows: to 3.0 mL of blue primary solution add 7.0 mL of hydrochloric acid (10 g/L HCl) and dilute 0.5 mL of this solution to 10.0 mL with hydrochloric acid (10 g/L HCl).

**Surface-active substances.** Introduce the 10 mL portion of solution S reserved before filtration into a 25 mL graduated ground-glass-stoppered cylinder with an external diameter of 20 mm and a wall thickness of not greater than 1.5 mm, previously rinsed 3 times with *sulfuric acid R* and then with *water R*. Shake vigorously 30 times in 10 s, allow to stand for 1 min and repeat the shaking. After 5 min, any foam present does not cover the entire surface of the liquid.

**Water-soluble substances.** Not more than 0.70 per cent. Boil 5.00 g in 500 mL of *water R* for 30 min, stirring frequently. Replace the water lost by evaporation. Decant the liquid, squeeze the residual liquid carefully from the sample with a glass rod and mix. Filter the liquid whilst hot. Evaporate 400 mL of the filtrate (corresponding to 4/5 of the mass of the sample taken) and dry the residue to constant mass at 100 °C to 105 °C.

**Hydrogen sulfide.** To 10 mL of solution S add 1.9 mL of *water R*, 0.15 mL of *dilute acetic acid R* and 1 mL of *lead acetate solution R*. After 2 min, the solution is not more intensely coloured than a reference solution prepared at the same time using 0.15 mL of *dilute acetic acid R*, 1.2 mL of *thioacetamide reagent R*, 1.7 mL of *lead standard solution (10 ppm Pb) R* and 10 mL of solution S.

**Loss on drying (2.2.32).** Not more than 13.0 per cent, determined on 5.000 g by drying in an oven at 105 °C.

**Sulfated ash (2.4.14).** Not more than 0.45 per cent for the lustrous variety and not more than 1.7 per cent for the matt variety. Introduce 5.00 g into a previously heated and cooled, tared crucible. Heat cautiously over a naked flame and then carefully to dull redness at 600 °C. Allow to cool, add a few drops of *dilute sulfuric acid R*, then heat and incinerate until all the black particles have disappeared. Allow to cool. Add a

few drops of *ammonium carbonate solution R*. Evaporate and incinerate carefully, allow to cool and weigh again. Repeat the incineration for periods of 5 min to constant mass.

**STORAGE**

Store in a dust-proof package in a dry place.

01/2008:0217

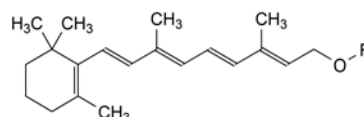
**VITAMIN A****Vitaminum A**

Substance	R	Molecular formula	$M_r$
all-( <i>E</i> )-retinol	H	$C_{20}H_{30}O$	286.5
all-( <i>E</i> )-retinol acetate	CO-CH <sub>3</sub>	$C_{22}H_{32}O_2$	328.5
all-( <i>E</i> )-retinol propionate	CO-C <sub>2</sub> H <sub>5</sub>	$C_{23}H_{34}O_2$	342.5
all-( <i>E</i> )-retinol palmitate	CO-C <sub>15</sub> H <sub>31</sub>	$C_{36}H_{60}O_2$	524.9

**DEFINITION**

*Vitamin A* refers to a number of substances of very similar structure (including (*Z*)-isomers) found in animal tissues and possessing similar activity. The principal and biologically most active substance is all-(*E*)-retinol (all-(*E*)-3,7-dimethyl-9-(2,6,6-trimethylcyclohex-1-enyl)nona-2,4,6,8-tetraen-1-ol;  $C_{20}H_{30}O$ ). Vitamin A is generally used in the form of esters such as the acetate, propionate and palmitate.

*Synthetic retinol ester* refers to an ester (acetate, propionate or palmitate) or a mixture of synthetic retinol esters.

The activity of vitamin A is expressed in retinol equivalents (R.E.). 1 mg R.E. corresponds to the activity of 1 mg of all-(*E*)-retinol. The activity of the other retinol esters is calculated stoichiometrically, so that 1 mg R.E. of vitamin A corresponds to the activity of:

- 1.147 mg of all-(*E*)-retinol acetate,
- 1.195 mg of all-(*E*)-retinol propionate,
- 1.832 mg of all-(*E*)-retinol palmitate.

International Units (IU) are also used to express the activity of vitamin A. 1 IU of vitamin A is equivalent to the activity of 0.300 µg of all-(*E*)-retinol. The activity of the other retinol esters is calculated stoichiometrically, so that 1 IU of vitamin A is equivalent to the activity of:

- 0.344 µg of all-(*E*)-retinol acetate,
- 0.359 µg of all-(*E*)-retinol propionate,
- 0.550 µg of all-(*E*)-retinol palmitate,

1 mg of retinol equivalent is equivalent to 3333 IU.

**CHARACTERS****Appearance:**

Retinol acetate: pale-yellow crystals (mp: about 60 °C). Once melted retinol acetate tends to yield a supercooled melt.

Retinol propionate: reddish-brown oily liquid.

Retinol palmitate: a fat-like, light yellow solid or a yellow oily liquid, if melted (mp: about 26 °C).

**Solubility:** all retinol esters are practically insoluble in water, soluble or partly soluble in anhydrous ethanol and miscible with organic solvents.

Vitamin A and its esters are very sensitive to the action of air, oxidising agents, acids, light and heat.



Carry out the assay and all tests as rapidly as possible, avoiding exposure to actinic light and air, oxidising agents, oxidation catalysts (e.g. copper, iron), acids and heat; use freshly prepared solutions.

## IDENTIFICATION

## A. Thin-layer chromatography (2.2.27).

**Test solution.** Prepare a solution containing about 3.3 IU of vitamin A per microlitre in *cyclohexane R* containing 1 g/L of *butylhydroxytoluene R*.

**Reference solution.** Prepare a 10 mg/mL solution of *retinol esters CRS* (i.e. 3.3 IU of each ester per microlitre) in *cyclohexane R* containing 1 g/L of *butylhydroxytoluene R*.

**Plate:** TLC silica gel  $F_{254}$  plate *R*.

**Mobile phase:** ether *R*, *cyclohexane R* (20:80 V/V).

**Application:** 3  $\mu$ L.

**Development:** over 2/3 of the plate.

**Drying:** in air.

**Detection:** examine in ultraviolet light at 254 nm.

**System suitability:** reference solution:

- the chromatogram shows the individual spots of the corresponding esters. The elution order from bottom to top is: retinol acetate, retinol propionate and retinol palmitate.

**Results:** the composition of esters is confirmed by the correspondence of the principal spot or spots of the test solution with those obtained with the reference solution.

## B. Related substances (see Tests).

## TESTS

**Retinol.** Thin-layer chromatography (2.2.27).

**Test solution.** Prepare a solution in *cyclohexane R*, stabilised with a solution containing 1 g/L of *butylhydroxytoluene R*, containing about 330 IU of vitamin A per microlitre.

**Reference solution.** Shake 1 mL of the test solution with 20 mL of 0.1 M *tetrabutylammonium hydroxide* in 2-propanol for 2 min and dilute to 100 mL with *cyclohexane R*, stabilised with a solution containing 1 g/L of *butylhydroxytoluene R*.

**Plate:** TLC silica gel  $F_{254}$  plate *R*.

**Mobile phase:** ether *R*, *cyclohexane R* (20:80 V/V).

**Application:** 3  $\mu$ L.

**Development:** over a path of 15 cm.

**Drying:** in air.

**Detection:** examine in ultraviolet light at 254 nm.

**System suitability:** reference solution:

- in the chromatogram obtained no or only traces of the retinol esters are seen.

**Limit:** any spot corresponding to retinol in the chromatogram obtained with the test solution is not more intense than the spot in the chromatogram obtained with the reference solution (1.0 per cent).

**Related substances.** Ultraviolet and visible absorption spectrophotometry (2.2.25).

**Test solution.** The solution described under Activity.

**Absorption maximum:** at 325 nm to 327 nm.

**Absorbance ratios:**

- $A_{300}/A_{326}$  = maximum 0.60;
- $A_{350}/A_{326}$  = maximum 0.54;
- $A_{370}/A_{326}$  = maximum 0.14.

The thresholds indicated under Related substances (Table 2034.-1) in the general monograph *Substances for pharmaceutical use (2034)* do not apply.

## ACTIVITY

The activity of the substance is determined in order to be taken into account for the production of concentrates.

Dissolve 25-100 mg, weighed with an accuracy of 0.1 per cent, in 5 mL of *pentane R* and dilute with 2-propanol *RI* to a presumed concentration of 10 IU/mL to 15 IU/mL. Measure the absorbance (2.2.25) at the absorption maximum at 326 nm. Calculate the activity of vitamin A in International Units per gram from the expression:

$$\frac{A_{326} \times V \times 1900}{100 \times m}$$

$A_{326}$  = absorbance at 326 nm,

$m$  = mass of the substance to be examined, in grams,

$V$  = total volume to which the substance to be examined is diluted to give 10 IU/mL to 15 IU/mL,

1900 = factor to convert the specific absorbance of esters of retinol into International Units per gram.

## STORAGE

In an airtight container, protected from light.

Once the container has been opened, its contents are to be used as soon as possible; any part of the contents not used at once should be protected by an atmosphere of inert gas.

## LABELLING

The label states:

- the number of International Units per gram,
- the name of the ester or esters.

## IMPURITIES

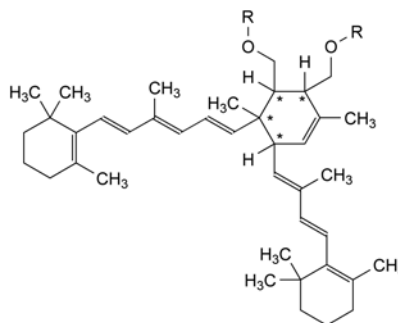

A. R = H, CO-CH<sub>3</sub>: kitols (Diels-Alder dimers of vitamin A),

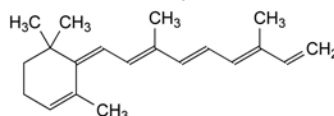

B. (3*E*,5*E*,7*E*)-3,7-dimethyl-9-[(1*Z*)-2,6,6-trimethylcyclohex-2-enylidene]nona-1,3,5,7-tetraene (anhydro-vitamin A),

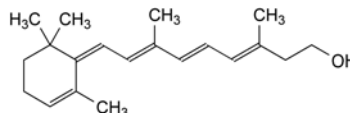

C. (3*E*,5*E*,7*E*)-3,7-dimethyl-9-[(1*Z*)-2,6,6-trimethylcyclohex-2-enylidene]nona-3,5,7-trien-1-ol (*retro*-vitamin A),

D. oxidation products of vitamin A.

01/2008:0219

**VITAMIN A CONCENTRATE (OILY FORM),  
SYNTHETIC**

Vitaminum A syntheticum densatum oleosum

## DEFINITION

Oily concentrate prepared from synthetic retinol ester (0217) as is or by dilution with a suitable vegetable fatty oil.

**Content:** 95.0 per cent to 110.0 per cent of the vitamin A content stated on the label, which is not less than 500 000 IU/g.

It may contain suitable stabilisers such as antioxidants.

## CHARACTERS

**Appearance:** yellow or brownish-yellow, oily liquid.

**Solubility:** practically insoluble in water, soluble or partly soluble in anhydrous ethanol, miscible with organic solvents.

Partial crystallisation may occur in highly concentrated solutions.

## IDENTIFICATION

Thin-layer chromatography (2.2.27).

**Test solution.** Prepare a solution containing about 3.3 IU of vitamin A per microlitre in *cyclohexane R* containing 1 g/L of *butylhydroxytoluene R*.

**Reference solution.** Prepare a 10 mg/mL solution of *retinol esters CRS* (i.e. 3.3 IU of each ester per microlitre) in *cyclohexane R* containing 1 g/L of *butylhydroxytoluene R*.

**Plate:** TLC silica gel  $F_{254}$  plate *R*.

**Mobile phase:** ether *R*, *cyclohexane R* (20:80 V/V).

**Application:** 3 µL.

**Development:** immediately, over a path of 15 cm.

**Drying:** in air.

**Detection:** examine in ultraviolet light at 254 nm.

**System suitability:** reference solution:

- the chromatogram shows the individual spots of the corresponding esters. The elution order from bottom to top is: retinol acetate, retinol propionate and retinol palmitate.

**Results:** the composition of the test solution is confirmed by the correspondence of the principal spot or spots with those obtained with the reference solution.

## TESTS

**Acid value (2.5.1):** maximum 2.0, determined on 2.0 g.

**Peroxide value (2.5.5, Method A):** maximum 10.0.

**Related substances.** The thresholds indicated under Related substances (Table 2034-1) in the general monograph *Substances for pharmaceutical use (2034)* do not apply.

## ASSAY

Carry out the assay as rapidly as possible, avoiding exposure to actinic light, air, oxidising agents, oxidation catalysts (e.g. copper, iron), acids and prolonged heat; use freshly prepared solutions. If partial crystallisation has occurred, homogenise the material at a temperature of about 65 °C, but avoid prolonged heating.

Carry out the assay according to Method A. If the assay is not shown to be valid, use Method B.

**Method A.** Ultraviolet absorption spectrophotometry (2.2.25).

Dissolve 25-100 mg, weighed with an accuracy of 0.1 per cent, in 5 mL of *pentane R* and dilute with *2-propanol RI* to a presumed concentration of 10-15 IU/mL.

Verify that the absorption maximum of the solution lies between 325 nm and 327 nm and measure the absorbances at 300 nm, 326 nm, 350 nm and 370 nm. Repeat the readings at each wavelength and take the mean values. Calculate the ratio  $A_{\lambda}/A_{326}$  for each wavelength.

If the ratios do not exceed: 0.60 at 300 nm, 0.54 at 350 nm, 0.14 at 370 nm, calculate the content of vitamin A in International Units per gram using the following expression:

$$\frac{A_{326} \times V \times 1900}{100 \times m}$$

$A_{326}$  = absorbance at 326 nm,

$m$  = mass of the preparation to be examined, in grams,

$V$  = total volume to which the preparation to be examined is diluted to give 10-15 IU/mL,

1900 = factor to convert the specific absorbance of esters of retinol into International Units per gram.

If one or more of the ratios  $A_{\lambda}/A_{326}$  exceeds the values given, or if the wavelength of the absorption maximum does not lie between 325 nm and 327 nm, use Method B.

**Method B.** Liquid chromatography (2.2.29).

**Test solution (a).** Introduce 0.100 g of the preparation to be examined into a 100 mL volumetric flask and dissolve immediately in 5 mL of *pentane R*. Add 40 mL of 0.1 M *tetrabutylammonium hydroxide in 2-propanol*. Swirl gently and let the mixture react for 10 minutes at 60-65 °C for hydrolysis, swirling occasionally. Allow to cool to room temperature, dilute to 100.0 mL with *2-propanol R* containing 1 g/L *butylhydroxytoluene R*, and homogenise carefully to avoid air-bubbles.

**Test solution (b).** Dilute test solution (a) with *2-propanol R* to a final concentration of 100 IU/mL.

**Reference solution (a).** Introduce about 0.100 g of *retinol acetate CRS* into a 100 mL volumetric flask and proceed as described for test solution (a).

**Reference solution (b).** Introduce into a 50 mL volumetric flask 5.0 mL of reference solution (a) and dilute to 50.0 mL with *2-propanol R*. Homogenise carefully to avoid air-bubbles.

**Column:**

– size:  $l = 0.125$  m,  $\varnothing = 4$  mm,

– stationary phase: octadecylsilyl silica gel for chromatography *R* (5 µm).

**Mobile phase:** water *R*, methanol *R* (5:95 V/V).

**Flow rate:** 1 mL/min.

**Detection:** spectrophotometer at 325 nm.

**Injection:** 10 µL of test solution (b) and reference solution (b).

**Run time:** 1.5 times the retention time of retinol.

**Retention time:** retinol = about 3 min.

Calculate the content of vitamin A in International Units per gram using the following expression:

$$\frac{A_1 \times C \times m_2}{A_2 \times m_1}$$

$A_1$  = area of the peak due to retinol in the chromatogram obtained with test solution (b),

$A_2$  = area of the peak due to retinol in the chromatogram obtained with reference solution (b),

$C$  = concentration of *retinol acetate CRS* in International Units per gram, determined by method A; the absorption ratios  $A_{\lambda}/A_{326}$  must conform,

$m_1$  = mass of the substance to be examined in test solution (a), in milligrams,

$m_2$  = mass of *retinol acetate CRS* in reference solution (a), in milligrams.

## STORAGE

In an airtight container, protected from light.

Once the container has been opened, its contents are to be used as soon as possible; any part of the contents not used at once should be protected by an atmosphere of inert gas.

## LABELLING

The label states:

- the number of International Units per gram,
- the name of the ester or esters,
- the name of any added stabilisers,
- the method of restoring the solution if partial crystallisation has occurred.

01/2008:0218

## VITAMIN A CONCENTRATE (POWDER FORM), SYNTHETIC

### Vitamiini sintetici densati A pulvis

## DEFINITION

Powder concentrate obtained by dispersing a synthetic retinol ester (0217) in a matrix of *Gelatin* (0330) or *Acacia* (0307) or other suitable material.

*Content*: 95.0 per cent to 115.0 per cent of the vitamin A content stated on the label, which is not less than 250 000 IU/g.

It may contain suitable stabilisers such as antioxidants.

## CHARACTERS

*Appearance*: yellowish powder usually in the form of particles of almost uniform size.

*Solubility*: practically insoluble in water, swells or forms an emulsion, depending on the formulation.

## IDENTIFICATION

Thin-layer chromatography (2.2.27).

*Test solution*. Introduce a quantity of the preparation to be examined containing about the equivalent of 17 000 IU of vitamin A into a 20 mL glass-stoppered test tube. Add about 20 mg of *bromelains R*, 2 mL of *water R* and about 150 µL of *2-propanol R*, swirling gently for 2-5 min in a water-bath at 60-65 °C. Cool to below 30 °C and add 5 mL of *2-propanol R* containing 1 g/L of *butylhydroxytoluene R*. Shake vigorously for 1 min, allow to stand for a few minutes and use the supernatant solution.

*Reference solution*. Prepare a 10 mg/mL solution of *retinol esters CRS* (i.e. 3.3 IU of each ester per microlitre) in *2-propanol R* containing 1 g/L of *butylhydroxytoluene R*.

*Plate*: TLC silica gel *F<sub>254</sub>* plate *R*.

*Mobile phase*: *ether R*, *cyclohexane R* (20:80 V/V).

*Application*: 3 µL.

*Development*: over a path of 15 cm.

*Drying*: in air.

*Detection*: examine in ultraviolet light at 254 nm.

*System suitability*: reference solution:

- the chromatogram shows the individual spots of the corresponding esters. The elution order from bottom to top is: retinol acetate, retinol propionate and retinol palmitate.

*Results*: the composition of the test solution is confirmed by the correspondence of the principal spot or spots with those obtained with the reference solution.

## TESTS

**Related substances.** The thresholds indicated under Related substances (Table 2034.-1) in the general monograph *Substances for pharmaceutical use (2034)* do not apply.

## ASSAY

Carry out the assay as rapidly as possible, avoiding exposure to actinic light, air, oxidising agents, oxidation catalysts (e.g. copper, iron), acids and prolonged heat.

Liquid chromatography (2.2.29).

*Test solution (a)*. Introduce 0.200 g of the preparation to be examined into a 100 mL volumetric flask. Add 20-30 mg of *bromelains R*, 5.0 mL of *water R* and 0.15 mL of *2-propanol R*. Heat gently in a water-bath at 60 °C for about 5 min, swirling occasionally. Add 40 mL of 0.1 M *tetrabutylammonium hydroxide in 2-propanol*. Swirl gently and let the mixture react for 10 min at 60-65 °C for hydrolysis, swirling occasionally. Ensure that all sample material is wetted. Allow to cool to room temperature, dilute to 100.0 mL with *2-propanol R* containing 1 g/L *butylhydroxytoluene R*, and homogenise carefully to avoid air-bubbles. The solution may be turbid.

*Test solution (b)*. Dilute test solution (a) with *2-propanol R* to a final concentration of 100 IU/mL. Filter before injection.

*Reference solution (a)*. Introduce about 0.100 g of *retinol acetate CRS* into a 100 mL volumetric flask and dissolve immediately in 5 mL of *pentane R*. Add 40 mL of 0.1 M *tetrabutylammonium hydroxide in 2-propanol*. Swirl gently and let the mixture react for 10 min at 60-65 °C for hydrolysis, swirling occasionally. Allow to cool to room temperature, dilute to 100.0 mL with *2-propanol R* containing 1 g/L *butylhydroxytoluene R*, and homogenise carefully to avoid air-bubbles.

*Reference solution (b)*. Introduce into a 50 mL volumetric flask 5.0 mL of reference solution (a) and dilute to 50.0 mL with *2-propanol R*. Homogenise carefully to avoid air-bubbles.

*Column*:

- *size*:  $l = 0.125$  m,  $\varnothing = 4$  mm,
- *stationary phase*: octadecylsilyl silica gel for chromatography *R* (5 µm).

*Mobile phase*: *water R*, *methanol R* (5:95 V/V).

*Flow rate*: 1 mL/min.

*Detection*: spectrophotometer at 325 nm.

*Injection*: 10 µL of test solution (b) and reference solution (b).

*Run time*: 1.5 times the retention time of retinol.

*Retention time*: retinol = about 3 min.

Calculate the content of vitamin A using the following expression:

$$\frac{A_1 \times C \times m_2}{A_2 \times m_1}$$

- $A_1$  = area of the peak due to retinol in the chromatogram obtained with test solution (b),
- $A_2$  = area of the peak due to retinol in the chromatogram obtained with reference solution (b),
- $C$  = concentration of *retinol acetate CRS* in International Units per gram, determined by the method below,
- $m_1$  = mass of the substance to be examined in test solution (a), in milligrams,
- $m_2$  = mass of *retinol acetate CRS* in reference solution (a), in milligrams.

The exact concentration of *retinol acetate CRS* is assessed by ultraviolet absorption spectrophotometry (2.2.25). Dissolve 25-100 mg of *retinol acetate CRS*, weighed with an accuracy of 0.1 per cent, in 5 mL of *pentane R* and dilute with *2-propanol R1* to a presumed concentration of 10-15 IU/mL.

Verify that the absorption maximum of the solution lies between 325 nm and 327 nm and measure the absorbances at 300 nm, 326 nm, 350 nm and 370 nm. Repeat the readings at each wavelength and take the mean values. Calculate the ratio  $A_\lambda/A_{326}$  for each wavelength.

If the ratios do not exceed: 0.60 at 300 nm, 0.54 at 350 nm, 0.14 at 370 nm, calculate the content of vitamin A in International Units per gram using the following expression:

$$\frac{A_{326} \times V \times 1900}{100 \times m}$$

- $A_{326}$  = absorbance at 326 nm,  
 $m$  = mass of *retinol acetate CRS*, in grams,  
 $V$  = total volume to which the *retinol acetate CRS* is diluted to give 10-15 IU/mL,  
 1900 = factor to convert the specific absorbance of esters of retinol into International Units per gram.

The absorbance ratios  $A_{\lambda}/A_{326}$  must conform.

#### STORAGE

In an airtight container, protected from light. Once the container has been opened, its contents are to be used as soon as possible; any part of the contents not used at once should be protected by an atmosphere of inert gas.

#### LABELLING

- The label states:
- the number of International Units per gram,
  - the name of the ester or esters,
  - the name of the principal excipient or excipients used and the name of any added stabilisers.

01/2008:0220

## VITAMIN A CONCENTRATE (SOLUBILISATE/EMULSION), SYNTHETIC

### Vitaminum A syntheticum, solubilisatum densatum in aqua dispergibile

#### DEFINITION

Liquid concentrate (water is generally used as solvent) of a synthetic retinol ester (0217) and a suitable solubiliser.

*Content*: 95.0 per cent to 115.0 per cent of the vitamin A content stated on the label, which is not less than 100 000 IU/g. It may contain suitable stabilisers such as antimicrobial preservatives and antioxidants.

#### CHARACTERS

*Appearance*: yellow or yellowish liquid of variable opalescence and viscosity. Highly concentrated solutions may become cloudy at low temperature or take the form of a gel.

A mixture of 1 g with 10 mL of *water R* previously warmed to 50 °C gives, after cooling to 20 °C, a uniform, slightly opalescent and slightly yellow dispersion.

#### IDENTIFICATION

Thin-layer chromatography (2.2.27).

*Test solution*. Introduce a quantity of the preparation to be examined containing about the equivalent of 17 000 IU of vitamin A into a 20 mL glass-stoppered test-tube. Add 5 mL of *2-propanol R* containing 1 g/L of *butylhydroxytoluene R* and mix thoroughly.

*Reference solution*. Prepare a 10 mg/mL solution of *retinol esters CRS* (i.e. 3.3 IU of each ester per microlitre) in *2-propanol R* containing 1 g/L of *butylhydroxytoluene R*.

*Plate*: TLC silica gel  $F_{254}$  plate *R*.

*Mobile phase*: ether *R*, cyclohexane *R* (20:80 V/V).

*Application*: 3 µL.

*Development*: over a path of 15 cm.

*Drying*: in air.

*Detection*: examine in ultraviolet light at 254 nm.

*System suitability*: reference solution:

- the chromatogram shows the individual spots of the corresponding esters. The elution order from bottom to top is: retinol acetate, retinol propionate and retinol palmitate.

*Results*: the composition of the test solution is confirmed by the correspondence of the principal spot or spots with those obtained with the reference solution.

#### TESTS

**Related substances.** The thresholds indicated under Related substances (Table 2034.-1) in the general monograph *Substances for pharmaceutical use (2034)* do not apply.

#### ASSAY

Carry out the assay as rapidly as possible, avoiding exposure to actinic light, air, oxidising agents, oxidation catalysts (e.g. copper, iron), acids and prolonged heat.

Liquid chromatography (2.2.29).

*Test solution (a)*. Introduce 0.200 g of the preparation to be examined into a 100 mL volumetric flask. Add 40 mL of 0.1 M tetrabutylammonium hydroxide in *2-propanol*. Swirl into dispersion and let the mixture react for 10 min at 60-65 °C for hydrolysis, swirling occasionally. Ensure that all sample material is wetted. Allow to cool to room temperature, dilute to 100.0 mL with *2-propanol R* containing 1 g/L *butylhydroxytoluene R* and homogenise carefully to avoid air-bubbles. Residue of the matrix may make the solution more or less cloudy.

*Test solution (b)*. Dilute test solution (a) with *2-propanol R* to a final concentration of 100 IU/mL. Filter before injection.

*Reference solution (a)*. Introduce about 0.100 g of *retinol acetate CRS* into a 100 mL volumetric flask and dissolve immediately in 5 mL of *pentane R*. Add 40 mL of 0.1 M tetrabutylammonium hydroxide in *2-propanol*. Swirl gently and let the mixture react for 10 min at 60-65 °C for hydrolysis, swirling occasionally. Allow to cool to room temperature, dilute to 100.0 mL with *2-propanol R* containing 1 g/L *butylhydroxytoluene R*, and homogenise carefully to avoid air-bubbles.

*Reference solution (b)*. Introduce into a 50 mL volumetric flask 5.0 mL of reference solution (a) and dilute to 50.0 mL with *2-propanol R*. Homogenise carefully to avoid air-bubbles.

*Column*:

- *size*:  $l = 0.125$  m,  $\varnothing = 4$  mm,
- *stationary phase*: octadecylsilyl silica gel for chromatography *R* (5 µm).

*Mobile phase*: water *R*, methanol *R* (5:95 V/V).

*Flow rate*: 1 mL/min.

*Detection*: spectrophotometer at 325 nm.

*Injection*: 10 µL of test solution (b) and reference solution (b).

*Run time*: 1.5 times the retention time of retinol.

*Retention time*: retinol = about 3 min.

Calculate the content of vitamin A using the following expression:

$$\frac{A_1 \times C \times m_2}{A_2 \times m_1}$$

- $A_1$  = area of the peak due to retinol in the chromatogram obtained with test solution (b),  
 $A_2$  = area of the peak due to retinol in the chromatogram obtained with reference solution (b),  
 $C$  = concentration of *retinol acetate CRS* in International Units per gram, determined by the method below,  
 $m_1$  = mass of the substance to be examined in test solution (a), in milligrams,  
 $m_2$  = mass of *retinol acetate CRS* in reference solution (a), in milligrams.

The exact concentration of *retinol acetate CRS* is assessed by ultraviolet absorption spectrophotometry (2.2.25). Dissolve 25-100 mg of *retinol acetate CRS*, weighed with an accuracy of 0.1 per cent, in 5 mL of *pentane R* and dilute with *2-propanol RI* to a presumed concentration of 10-15 IU/mL.

Verify that the absorption maximum of the solution lies between 325 nm and 327 nm and measure the absorbances at 300 nm, 326 nm, 350 nm and 370 nm. Repeat the readings at each wavelength and take the mean values. Calculate the ratio  $A_{\lambda}/A_{326}$  for each wavelength.

If the ratios do not exceed: 0.60 at 300 nm, 0.54 at 350 nm, 0.14 at 370 nm, calculate the content of vitamin A in International

Units per gram using the following expression:

$$\frac{A_{326} \times V \times 1900}{100 \times m}$$

$A_{326}$  = absorbance at 326 nm,

$m$  = mass of *retinol acetate CRS*, in grams,

$V$  = total volume to which the *retinol acetate CRS* is diluted to give 10-15 IU/mL,

1900 = factor to convert the specific absorbance of esters of retinol into International Units per gram.

The absorbance ratios  $A_{\lambda}/A_{326}$  must conform.

#### STORAGE

In an airtight container, protected from light, at the temperature stated on the label.

Once the container has been opened, its contents are to be used as soon as possible; any part of the contents not used at once should be protected by an atmosphere of inert gas.

#### LABELLING

The label states:

- the number of International Units per gram,
- the name of the ester or esters,
- the name of the principal solubiliser or solubilisers used and the name of any added stabilisers,
- the storage temperature.

01/2008:0698 Flow rate: 1.5 mL/min.

Detection: spectrophotometer at 260 nm.

Injection: 20 µL.

Run time: twice the retention time of warfarin.

Relative retention with reference to warfarin (retention time = about 9 min): impurity B = about 0.4; impurity C = about 0.6.

System suitability: reference solution (a):

– resolution: minimum 2.0 between the peaks due to impurities B and C.

Limits:

– correction factors: for the calculation of content, multiply the peak areas of the following impurities by the corresponding correction factor: impurity B = 0.5; impurity C = 0.4;

– impurities B, C: for each impurity, not more than the area of the principal peak in the chromatogram obtained with reference solution (b) (0.1 per cent);

– unspecified impurities: for each impurity, not more than the area of the principal peak in the chromatogram obtained with reference solution (b) (0.10 per cent);

– total: not more than 3 times the area of the principal peak in the chromatogram obtained with reference solution (b) (0.3 per cent);

– disregard limit: 0.5 times the area of the principal peak in the chromatogram obtained with reference solution (b) (0.05 per cent).

**Phenolic ketones.** Dissolve 1.25 g in a 20 g/L solution of sodium hydroxide R and dilute to 10.0 mL with the same solvent. The absorbance (2.2.25) is maximum 0.20 measured at 385 nm within 15 min of preparing the solution.**Water (2.5.12):** maximum 4.0 per cent, determined on 0.750 g.

## ASSAY

Dissolve 0.100 g in 0.01 M sodium hydroxide and dilute to 100.0 mL with the same solvent. Dilute 10.0 mL of the solution to 100.0 mL with 0.01 M sodium hydroxide. Dilute 10.0 mL of this solution to 100.0 mL with 0.01 M sodium hydroxide. Measure the absorbance (2.2.25) at the absorption maximum at 308 nm.

Calculate the percentage content of C<sub>19</sub>H<sub>15</sub>NaO<sub>4</sub> taking the specific absorbance to be 431.

## STORAGE

In an airtight container, protected from light.

## IMPURITIES

Specified impurities: B, C.

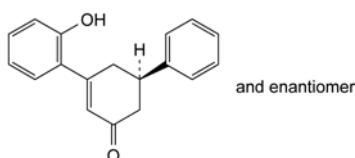
Other detectable impurities (the following substances would, if present at a sufficient level, be detected by one or other of the tests in the monograph. They are limited by the general acceptance criterion for other/unspecified impurities and/or by the general monograph *Substances for pharmaceutical use (2034)*. It is therefore not necessary to identify these impurities for demonstration of compliance. See also 5.10. *Control of impurities in substances for pharmaceutical use*): A.

A. (5RS)-3-(2-hydroxyphenyl)-5-phenylcyclohex-2-enone,

## WARFARIN SODIUM

## Warfarinum natricum

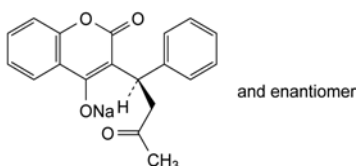
C<sub>19</sub>H<sub>15</sub>NaO<sub>4</sub>  
[129-06-6]M<sub>r</sub> 330.3

## DEFINITION

Sodium 2-oxo-3-[(1RS)-3-oxo-1-phenylbutyl]-2H-1-benzopyran-4-olate.

Content: 98.0 per cent to 102.0 per cent (anhydrous substance).

## CHARACTERS

Appearance: white or almost white, hygroscopic, amorphous powder.

Solubility: very soluble in water and in ethanol (96 per cent), soluble in acetone, very slightly soluble in methylene chloride.

## IDENTIFICATION

A. Infrared absorption spectrophotometry (2.2.24).

Comparison: warfarin sodium CRS.

B. Dissolve 1 g in 10 mL of water R, add 5 mL of nitric acid R and filter. To the filtrate add 2 mL of potassium dichromate solution R1 and shake for 5 min. Allow to stand for 20 min. The solution is not greenish-blue when compared with a blank.

C. It gives reaction (b) of sodium (2.3.1).

## TESTS

**Appearance of solution.** The solution is clear (2.2.1) and colourless (2.2.2, Method II).

Dissolve 1.0 g in water R and dilute to 20 mL with the same solvent.

pH (2.2.3): 7.6 to 8.6.

Dissolve 1.0 g in carbon dioxide-free water R and dilute to 100 mL with the same solvent.

**Related substances.** Liquid chromatography (2.2.29).

Solvent mixture: methanol R, water R (25:75 V/V).

Test solution. Dissolve 40.0 mg of the substance to be examined in the solvent mixture and dilute to 50.0 mL with the solvent mixture.

Reference solution (a). Dissolve 2 mg of 4-hydroxycoumarin R (impurity B) and 2 mg of benzalacetone R (impurity C) in 25 mL of methanol R and dilute to 100 mL with water R.

Reference solution (b). Dilute 1.0 mL of the test solution to 100.0 mL with the solvent mixture. Dilute 1.0 mL of this solution to 10.0 mL with the solvent mixture.

Column:

- size:  $l = 0.25$  m,  $\varnothing = 4.0$  mm;
- stationary phase: spherical nitrile silica gel for chromatography R (5 µm);
- temperature: 30 °C.

Mobile phase: glacial acetic acid R, acetonitrile R, water R (1:25:75 V/V/V).

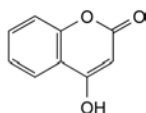

B. 4-hydroxy-2H-1-benzopyran-2-one (4-hydroxycoumarin),

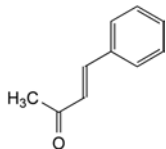

C. (3E)-4-phenylbut-3-en-2-one (benzalacetone).

*Reference solution (a).* Dissolve 2 mg of 4-hydroxycoumarin R (warfarin impurity B) and 2 mg of benzalacetone R (warfarin impurity C) in 25 mL of methanol R and dilute to 100 mL with water R.

*Reference solution (b).* Dilute 1.0 mL of the test solution to 100.0 mL with the solvent mixture. Dilute 1.0 mL of this solution to 10.0 mL with the solvent mixture.

*Column:*

- size:  $l = 0.25$  m,  $\varnothing = 4.0$  mm;
- stationary phase: spherical nitrile silica gel for chromatography R (5  $\mu$ m);
- temperature: 30 °C.

*Mobile phase:* glacial acetic acid R, acetonitrile R, water R (1:25:75 V/V/V).

*Flow rate:* 1.5 mL/min.

*Detection:* spectrophotometer at 260 nm.

*Injection:* 20  $\mu$ L.

*Run time:* twice the retention time of warfarin.

*Relative retention* with reference to warfarin (retention time = about 9 min): impurity B = about 0.4; impurity C = about 0.6.

*System suitability:* reference solution (a):

- resolution: minimum 2.0 between the peaks due to impurities B and C.

*Limits:*

- correction factors: for the calculation of content, multiply the peak areas of the following impurities by the corresponding correction factor: impurity B = 0.5; impurity C = 0.4;
- impurities B, C: for each impurity, not more than the area of the principal peak in the chromatogram obtained with reference solution (b) (0.1 per cent);
- unspecified impurities: for each impurity, not more than the area of the principal peak in the chromatogram obtained with reference solution (b) (0.10 per cent);
- total: not more than 3 times the area of the principal peak in the chromatogram obtained with reference solution (b) (0.3 per cent);
- disregard limit: 0.5 times the area of the principal peak in the chromatogram obtained with reference solution (b) (0.05 per cent).

**Phenolic ketones:** the absorbance (2.2.25) is maximum 0.20 measured at 385 nm within 15 min of preparing the solution.

Dissolve 1.25 g in a 20 g/L solution of sodium hydroxide R and dilute to 10.0 mL with the same solvent.

**Propan-2-ol.** Gas chromatography (2.2.28).

*Internal standard solution.* Dilute 1.0 mL of propanol R to 200.0 mL with water R.

*Test solution (a).* Dissolve 0.250 g of the substance to be examined in water R and dilute to 5.0 mL with the same solvent.

*Test solution (b).* Dissolve 0.50 g of the substance to be examined in the internal standard solution and dilute to 10.0 mL with the internal standard solution.

*Reference solution.* Dilute 0.50 mL of 2-propanol R to 100.0 mL with the internal standard solution.

*Column:*

- size:  $l = 1.5$  m,  $\varnothing = 4$  mm;
- stationary phase: ethylvinylbenzene-divinylbenzene copolymer R (125-150  $\mu$ m).

*Carrier gas:* nitrogen for chromatography R.

*Flow rate:* 40 mL/min.

*Temperature:*

- column: 150 °C;
- injection port: 180 °C;
- detector: 200 °C.

*Detection:* flame ionisation.

01/2008:0699

## WARFARIN SODIUM CLATHRATE

### Warfarinum natricum clathratum

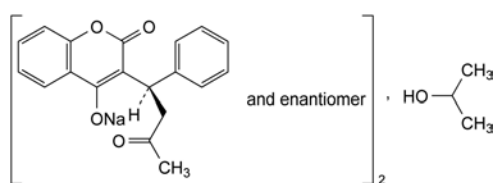

#### DEFINITION

Mixture, in the form of a clathrate, of warfarin sodium (sodium 2-oxo-3-[(1R,S)-3-oxo-1-phenylbutyl]-2H-1-benzopyran-4-olate) and propan-2-ol in molecular proportions 2:1 (equivalent to about 92 per cent of warfarin sodium).

*Content:*

- warfarin sodium: 98.0 per cent to 102.0 per cent (anhydrous and propan-2-ol-free substance);
- propan-2-ol: 8.0 per cent to 8.5 per cent.

#### CHARACTERS

*Appearance:* white or almost white, crystalline powder.

*Solubility:* very soluble in water, freely soluble in ethanol (96 per cent), soluble in acetone, very slightly soluble in methylene chloride.

#### IDENTIFICATION

A. Infrared absorption spectrophotometry (2.2.24).

*Comparison:* warfarin sodium clathrate CRS.

B. Dissolve 1 g in 10 mL of water R, add 5 mL of nitric acid R and filter. To the filtrate add 2 mL of potassium dichromate solution R1 and shake for 5 min. Allow to stand for 20 min. The solution is greenish-blue when compared with a blank.

C. It gives reaction (b) of sodium (2.3.1).

#### TESTS

**Appearance of solution.** The solution is clear (2.2.1) and colourless (2.2.2, Method II).

Dissolve 1.0 g in water R and dilute to 20 mL with the same solvent.

**pH** (2.2.3): 7.6 to 8.6.

Dissolve 1.0 g in carbon dioxide-free water R and dilute to 100 mL with the same solvent.

**Related substances.** Liquid chromatography (2.2.29).

*Solvent mixture:* methanol R, water R (25:75 V/V).

*Test solution.* Dissolve 40.0 mg of the substance to be examined in the solvent mixture and dilute to 50.0 mL with the solvent mixture.

**Injection:** the chosen volume of the test solutions and the reference solution.

01/2009:0169

Calculate the content of propan-2-ol taking its density at 20 °C to be 0.785 g/mL.

**Limit:**

– *propan-2-ol*: 8.0 per cent to 8.5 per cent.

**Water (2.5.12):** maximum 0.3 per cent, determined on 2.500 g.

#### ASSAY

Dissolve 0.100 g in 0.01 M sodium hydroxide and dilute to 100.0 mL with the same solvent. Dilute 10.0 mL of the solution to 100.0 mL with 0.01 M sodium hydroxide. Dilute 10.0 mL of this solution to 100.0 mL with 0.01 M sodium hydroxide. Measure the absorbance (2.2.25) at the absorption maximum at 308 nm.

Calculate the percentage content of warfarin sodium (C<sub>19</sub>H<sub>15</sub>NaO<sub>4</sub>) taking the specific absorbance to be 431.

#### STORAGE

In an airtight container, protected from light.

#### IMPURITIES

*Specified impurities:* B, C.

*Other detectable impurities* (the following substances would, if present at a sufficient level, be detected by one or other of the tests in the monograph. They are limited by the general acceptance criterion for other/unspecified impurities and/or by the general monograph *Substances for pharmaceutical use (2034)*. It is therefore not necessary to identify these impurities for demonstration of compliance. See also 5.10. *Control of impurities in substances for pharmaceutical use*): A.

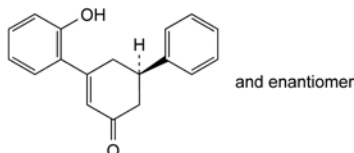

A. (5*RS*)-3-(2-hydroxyphenyl)-5-phenylcyclohex-2-enone,

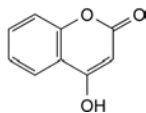

B. 4-hydroxy-2*H*-1-benzopyran-2-one (4-hydroxycoumarin),

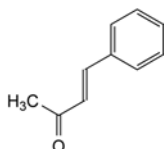

C. (3*E*)-4-phenylbut-3-en-2-one (benzalacetone).

## WATER FOR INJECTIONS

### Aqua ad iniectionabile

H<sub>2</sub>OM<sub>r</sub> 18.02

#### DEFINITION

Water for the preparation of medicines for parenteral administration when water is used as vehicle (water for injections in bulk) and for dissolving or diluting substances or preparations for parenteral administration (sterilised water for injections).

### Water for injections in bulk

#### PRODUCTION

Water for injections in bulk is obtained from water that complies with the regulations on water intended for human consumption laid down by the competent authority or from purified water by distillation in an apparatus of which the parts in contact with the water are of neutral glass, quartz or a suitable metal and which is fitted with an effective device to prevent the entrainment of droplets. The correct maintenance of the apparatus is essential. The first portion of the distillate obtained when the apparatus begins to function is discarded and the distillate is collected.

In order to ensure the appropriate quality of the water, validated procedures and in-process-monitoring of the electrical conductivity and regular microbial monitoring are applied.

Water for injections in bulk is stored and distributed in conditions designed to prevent growth of micro-organisms and to avoid any other contamination.

**Microbiological monitoring.** During production and subsequent storage, appropriate measures are taken to ensure that the microbial count is adequately controlled and monitored. Appropriate alert and action levels are set so as to detect adverse trends. Under normal conditions, an appropriate action level is a microbial count of 10 CFU per 100 mL when determined by filtration through a membrane with a nominal pore size not greater than 0.45 µm, using R2A agar, using at least 200 mL of water for injections in bulk and incubating at 30-35 °C for not less than 5 days. For aseptic processing, stricter alert levels may need to be applied.

#### R2A agar

Yeast extract	0.5 g
Proteose peptone	0.5 g
Casein hydrolysate	0.5 g
Glucose	0.5 g
Starch	0.5 g
Dipotassium hydrogen phosphate	0.3 g
Magnesium sulfate, anhydrous	0.024 g
Sodium pyruvate	0.3 g
Agar	15.0 g
Purified water	to 1000 mL

Adjust the pH so that after sterilisation it is 7.2 ± 0.2. Sterilise by heating in an autoclave at 121 °C for 15 min.



*Growth promotion of R2A agar*

- **Preparation of test strains.** Use standardised stable suspensions of test strains or prepare them as stated in Table 0169.-1. Seed lot culture maintenance techniques (seed-lot systems) are used so that the viable micro-organisms used for inoculation are not more than 5 passages removed from the original master seed-lot. Grow each of the bacterial strains separately as described in Table 0169.-1. Use buffered sodium chloride-peptone solution pH 7.0 or phosphate buffer solution pH 7.2 to make test suspensions. Use the suspensions within 2 h, or within 24 h if stored at 2-8 °C. As an alternative to preparing and then diluting a fresh suspension of vegetative cells of *Bacillus subtilis*, a stable spore suspension is prepared and then an appropriate volume of the spore suspension is used for test inoculation. The stable spore suspension may be maintained at 2-8 °C for a validated period of time.
- **Growth promotion.** Test each batch of ready-prepared medium and each batch of medium, prepared either from dehydrated medium or from the ingredients described. Inoculate plates of R2A agar separately with a small number (not more than 100 CFU) of the micro-organisms indicated in Table 0169.-1. Incubate under the conditions described in the table. Growth obtained must not differ by a factor greater than 2 from the calculated value for a standardised inoculum. For a freshly prepared inoculum, growth of the micro-organisms must be comparable to that obtained with a previously tested and approved batch of medium.

Table 0169.-1. – *Growth promotion of R2A agar*

Micro-organism	Preparation of the test strain	Growth promotion
<i>Pseudomonas aeruginosa</i> such as: ATCC 9027 NCIMB 8626 CIP 82.118 NBRC 13275	Casein soyabean digest agar or casein soyabean digest broth 30-35 °C 18-24 h	R2A agar ≤ 100 CFU 30-35 °C ≤ 3 days
<i>Bacillus subtilis</i> such as: ATCC 6633 NCIMB 8054 CIP 52.62 NBRC 3134	Casein soyabean digest agar or casein soyabean digest broth 30-35 °C 18-24 h	R2A agar ≤ 100 CFU 30-35 °C ≤ 3 days

**Total organic carbon (2.2.44):** maximum 0.5 mg/L.

**Conductivity.** Determine the conductivity off-line or in-line under the following conditions.

**EQUIPMENT***Conductivity cell:*

- electrodes of a suitable material such as stainless steel;
- cell constant: the cell constant is generally certified by the supplier and is subsequently verified at suitable intervals using a certified reference solution with a conductivity less than 1500 µS·cm<sup>-1</sup> or by comparison with a cell having a certified cell constant. The cell constant is confirmed if the value found is within 2 per cent of the certified value, otherwise re-calibration must be performed.

*Conductometer:* accuracy of 0.1 µS·cm<sup>-1</sup> or better at the lowest range.

*System calibration (conductivity cell and conductometer):*

- against one or more suitable certified reference solutions;
- accuracy: within 3 per cent of the measured conductivity plus 0.1 µS·cm<sup>-1</sup>.

*Conductometer calibration:* calibration is carried out for each range of measurement to be used, after disconnection of the conductivity cell, using certified precision resistors or equivalent devices with an uncertainty not greater than 0.1 per cent of the certified value.

If in-line conductivity cells cannot be dismantled, system calibration may be performed against a calibrated conductivity-measuring instrument with a conductivity cell placed close to the cell to be calibrated in the water flow.

*Temperature measurement:* tolerance ± 2 °C.

**PROCEDURE***Stage 1*

1. Measure the conductivity without temperature compensation, recording simultaneously the temperature. Temperature-compensated measurement may be performed after suitable validation.
2. Using Table 0169.-2, find the closest temperature value that is not greater than the measured temperature. The corresponding conductivity value is the limit at that temperature.
3. If the measured conductivity is not greater than the value in Table 0169.-2, the water to be examined meets the requirements of the test for conductivity. If the conductivity is higher than the value in Table 0169.-2, proceed with stage 2.

Table 0169.-2. – *Stage 1*  
*Temperature and conductivity requirements (for non-temperature-compensated conductivity measurements)*

Temperature (°C)	Conductivity (µS·cm <sup>-1</sup> )
0	0.6
5	0.8
10	0.9
15	1.0
20	1.1
25	1.3
30	1.4
35	1.5
40	1.7
45	1.8
50	1.9
55	2.1
60	2.2
65	2.4
70	2.5
75	2.7
80	2.7
85	2.7
90	2.7
95	2.9
100	3.1

*Stage 2*

4. Transfer a sufficient amount of the water to be examined (100 mL or more) to a suitable container, and stir the test sample. Adjust the temperature, if necessary, and while maintaining it at 25 ± 1 °C, begin vigorously agitating the test sample while periodically observing the conductivity. When the change in conductivity (due to uptake of atmospheric carbon dioxide) is less than 0.1 µS·cm<sup>-1</sup> per 5 min, note the conductivity.
5. If the conductivity is not greater than 2.1 µS·cm<sup>-1</sup>, the water to be examined meets the requirements of the test for conductivity. If the conductivity is greater than 2.1 µS·cm<sup>-1</sup>, proceed with stage 3.

## Stage 3

6. Perform this test within approximately 5 min of the conductivity determination in step 5 under stage 2, while maintaining the sample temperature at  $25 \pm 1$  °C. Add a recently prepared saturated solution of *potassium chloride R* to the test sample (0.3 mL per 100 mL of the test sample), and determine the pH (2.2.3) to the nearest 0.1 pH unit.
7. Using Table 0169.-3, determine the conductivity limit at the measured pH value in step 6. If the measured conductivity in step 4 under stage 2 is not greater than the conductivity requirements for the pH determined, the water to be examined meets the requirements of the test for conductivity. If either the measured conductivity is greater than this value or the pH is outside the range of 5.0-7.0, the water to be examined does not meet the requirements of the test for conductivity.

Table 0169.-3. – Stage 3  
pH and conductivity requirements (for atmosphere- and temperature-equilibrated samples)

pH	Conductivity ( $\mu\text{S}\cdot\text{cm}^{-1}$ )
5.0	4.7
5.1	4.1
5.2	3.6
5.3	3.3
5.4	3.0
5.5	2.8
5.6	2.6
5.7	2.5
5.8	2.4
5.9	2.4
6.0	2.4
6.1	2.4
6.2	2.5
6.3	2.4
6.4	2.3
6.5	2.2
6.6	2.1
6.7	2.6
6.8	3.1
6.9	3.8
7.0	4.6

## CHARACTERS

*Appearance*: clear and colourless liquid.

## TESTS

**Nitrates**: maximum 0.2 ppm.

Place 5 mL in a test-tube immersed in iced water, add 0.4 mL of a 100 g/L solution of *potassium chloride R*, 0.1 mL of *diphenylamine solution R* and, dropwise with shaking, 5 mL of *nitrogen-free sulfuric acid R*. Transfer the tube to a water-bath at 50 °C. After 15 min, any blue colour in the solution is not more intense than that in a reference solution prepared at the same time in the same manner using a mixture of 4.5 mL of *nitrate-free water R* and 0.5 mL of *nitrate standard solution (2 ppm NO<sub>3</sub>) R*.

**Aluminium (2.4.17)**: maximum 10 ppb, if intended for use in the manufacture of dialysis solutions.

*Prescribed solution*. To 400 mL of the water to be examined add 10 mL of *acetate buffer solution pH 6.0 R* and 100 mL of *distilled water R*.

*Reference solution*. Mix 2 mL of *aluminium standard solution (2 ppm Al) R*, 10 mL of *acetate buffer solution pH 6.0 R* and 98 mL of *distilled water R*.

*Blank solution*. Mix 10 mL of *acetate buffer solution pH 6.0 R* and 100 mL of *distilled water R*.

**Bacterial endotoxins (2.6.14)**: less than 0.25 IU/mL.

## Sterilised water for injections

## DEFINITION

Water for injections in bulk that has been distributed into suitable containers, closed and sterilised by heat in conditions which ensure that the product still complies with the test for bacterial endotoxins. Sterilised water for injections is free from any added substances.

Examined in suitable conditions of visibility, it is clear and colourless.

Each container contains a sufficient quantity of water for injections to permit the nominal volume to be withdrawn.

## TESTS

**Acidity or alkalinity**. To 20 mL add 0.05 mL of *phenol red solution R*. If the solution is yellow, it becomes red on the addition of 0.1 mL of 0.01 M *sodium hydroxide*; if red, it becomes yellow on the addition of 0.15 mL of 0.01 M *hydrochloric acid*.

**Conductivity**: maximum 25  $\mu\text{S}\cdot\text{cm}^{-1}$  for containers with a nominal volume of 10 mL or less; maximum 5  $\mu\text{S}\cdot\text{cm}^{-1}$  for containers with a nominal volume greater than 10 mL.

Use equipment and the calibration procedure as defined under Water for injections in bulk, maintaining the sample temperature at  $25 \pm 1$  °C.

**Oxidisable substances**. For containers with a nominal volume less than 50 mL: heat 100 mL to boiling with 10 mL of *dilute sulfuric acid R*, add 0.4 mL of 0.02 M *potassium permanganate* and boil for 5 min; the solution remains faintly pink.

For containers with a nominal volume equal to or greater than 50 mL: heat 100 mL to boiling with 10 mL of *dilute sulfuric acid R*, add 0.2 mL of 0.02 M *potassium permanganate* and boil for 5 min; the solution remains faintly pink.

**Chlorides (2.4.4)**: maximum 0.5 ppm for containers with a nominal volume of 100 mL or less.

15 mL complies with the limit test for chlorides. Prepare the standard using a mixture of 1.5 mL of *chloride standard solution (5 ppm Cl) R* and 13.5 mL of *water R*. Examine the solutions down the vertical axes of the tubes.

For containers with a nominal volume greater than 100 mL, use the following test: to 10 mL add 1 mL of *dilute nitric acid R* and 0.2 mL of *silver nitrate solution R2*. The solution shows no change in appearance for at least 15 min.

**Nitrates**: maximum 0.2 ppm.

Place 5 mL in a test-tube immersed in iced water, add 0.4 mL of a 100 g/L solution of *potassium chloride R*, 0.1 mL of *diphenylamine solution R* and, dropwise with shaking, 5 mL of *nitrogen-free sulfuric acid R*. Transfer the tube to a water-bath at 50 °C. After 15 min, any blue colour in the solution is not more intense than that in a reference solution prepared at the same time in the same manner using a mixture of 4.5 mL of *nitrate-free water R* and 0.5 mL of *nitrate standard solution (2 ppm NO<sub>3</sub>) R*.

**Sulfates**. To 10 mL add 0.1 mL of *dilute hydrochloric acid R* and 0.1 mL of *barium chloride solution R1*. The solution shows no change in appearance for at least 1 h.

**Aluminium (2.4.17):** maximum 10 ppb, if intended for use in the manufacture of dialysis solutions.

**Prescribed solution.** To 400 mL of the water to be examined add 10 mL of acetate buffer solution pH 6.0 R and 100 mL of distilled water R.

**Reference solution.** Mix 2 mL of aluminium standard solution (2 ppm Al) R, 10 mL of acetate buffer solution pH 6.0 R and 98 mL of distilled water R.

**Blank solution.** Mix 10 mL of acetate buffer solution pH 6.0 R and 100 mL of distilled water R.

**Ammonium:** for containers with a nominal volume less than 50 mL: maximum 0.6 ppm; for containers with a nominal volume equal to or greater than 50 mL: maximum 0.2 ppm.

Containers with a nominal volume less than 50 mL: to 20 mL add 1 mL of alkaline potassium tetraiodomercurate solution R; after 5 min, examine the solution down the vertical axis of the tube; the solution is not more intensely coloured than a standard prepared at the same time by adding 1 mL of alkaline potassium tetraiodomercurate solution R to a mixture of 4 mL of ammonium standard solution (3 ppm NH<sub>4</sub>) R and 16 mL of ammonium-free water R.

Containers with a nominal volume equal to or greater than 50 mL: to 20 mL add 1 mL of alkaline potassium tetraiodomercurate solution R; after 5 min, examine the solution down the vertical axis of the tube; the solution is not more intensely coloured than a standard prepared at the same time by adding 1 mL of alkaline potassium tetraiodomercurate solution R to a mixture of 4 mL of ammonium standard solution (1 ppm NH<sub>4</sub>) R and 16 mL of ammonium-free water R.

**Calcium and magnesium.** To 100 mL add 2 mL of ammonium chloride buffer solution pH 10.0 R, 50 mg of mordant black 11 triturate R and 0.5 mL of 0.01 M sodium edetate. A pure blue colour is produced.

**Residue on evaporation:** maximum 4 mg (0.004 per cent) for containers with a nominal volume of 10 mL or less; maximum 3 mg (0.003 per cent) for containers with a nominal volume greater than 10 mL.

Evaporate 100 mL to dryness on a water-bath and dry in an oven at 100-105 °C.

**Particulate contamination: sub-visible particles (2.9.19).** It complies with test A or test B, as appropriate.

**Sterility (2.6.1).** It complies with the test for sterility.

**Bacterial endotoxins (2.6.14):** less than 0.25 IU/mL.

In order to ensure the appropriate quality of the water, validated procedures and in-process monitoring of the electrical conductivity and regular microbial monitoring are applied.

Highly purified water is stored in bulk and distributed in conditions designed to prevent growth of micro-organisms and to avoid any other contamination.

**Microbiological monitoring.** During production and subsequent storage, appropriate measures are taken to ensure that the microbial count is adequately controlled and monitored. Appropriate alert and action levels are set so as to detect adverse trends. Under normal conditions, an appropriate action level is a microbial count of 10 CFU per 100 mL when determined by filtration through a membrane with a nominal pore size not greater than 0.45 µm, using R2A agar, at least 200 mL of highly purified water and incubating at 30-35 °C for not less than 5 days.

#### R2A agar

Yeast extract	0.5 g
Proteose peptone	0.5 g
Casein hydrolysate	0.5 g
Glucose	0.5 g
Starch	0.5 g
Dipotassium hydrogen phosphate	0.3 g
Magnesium sulfate, anhydrous	0.024 g
Sodium pyruvate	0.3 g
Agar	15.0 g
Purified water	to 1000 mL

Adjust the pH so that after sterilisation it is 7.2 ± 0.2. Sterilise by heating in an autoclave at 121 °C for 15 min.

#### Growth promotion of R2A agar

- **Preparation of test strains.** Use standardised stable suspensions of test strains or prepare them as stated in Table 1927.-1. Seed lot culture maintenance techniques (seed-lot systems) are used so that the viable micro-organisms used for inoculation are not more than 5 passages removed from the original master seed-lot. Grow each of the bacterial strains separately as described in Table 1927.-1. Use buffered sodium chloride-peptone solution pH 7.0 or phosphate buffer solution pH 7.2 to make test suspensions. Use the suspensions within 2 h, or within 24 h if stored at 2-8 °C. As an alternative to preparing and then diluting a fresh suspension of vegetative cells of *Bacillus subtilis*, a stable spore suspension is prepared and then an appropriate volume of the spore suspension is used for test inoculation. The stable spore suspension may be maintained at 2-8 °C for a validated period of time.

01/2009:1927

## WATER, HIGHLY PURIFIED

### Aqua valde purificata

H<sub>2</sub>O

M<sub>r</sub> 18.02

#### DEFINITION

Water intended for use in the preparation of medicinal products where water of high biological quality is needed, except where *Water for injections (0169)* is required.

#### PRODUCTION

Highly purified water is obtained from water that complies with the regulations on water intended for human consumption laid down by the competent authority.

Current production methods include, for example, double-pass reverse osmosis coupled with other suitable techniques such as ultrafiltration and deionisation. Correct operation and maintenance of the system is essential.

Table 1927.-1. – Growth promotion of R2A agar

Micro-organism	Preparation of the test strain	Growth promotion
<i>Pseudomonas aeruginosa</i> such as: ATCC 9027 NCIMB 8626 CIP 82.118 NBRC 13275	Casein soyabean digest agar or casein soyabean digest broth 30-35 °C 18-24 h	R2A agar ≤ 100 CFU 30-35 °C ≤ 3 days
<i>Bacillus subtilis</i> such as: ATCC 6633 NCIMB 8054 CIP 52.62 NBRC 3134	Casein soyabean digest agar or casein soyabean digest broth 30-35 °C 18-24 h	R2A agar ≤ 100 CFU 30-35 °C ≤ 3 days

- *Growth promotion.* Test each batch of ready-prepared medium and each batch of medium, prepared either from dehydrated medium or from the ingredients described. Inoculate plates of R2A agar separately with a small number (not more than 100 CFU) of the micro-organisms indicated in Table 1927.-1. Incubate under the conditions described in the table. Growth obtained must not differ by a factor greater than 2 from the calculated value for a standardised inoculum. For a freshly prepared inoculum, growth of the micro-organisms must be comparable to that obtained with a previously tested and approved batch of medium.

**Total organic carbon (2.2.44):** maximum 0.5 mg/L.

**Conductivity.** Determine the conductivity off-line or in-line under the following conditions.

#### EQUIPMENT

*Conductivity cell:*

- electrodes of a suitable material such as stainless steel;
- cell constant: the cell constant is generally certified by the supplier and is subsequently verified at suitable intervals using a certified reference solution with a conductivity less than  $1500 \mu\text{S}\cdot\text{cm}^{-1}$  or by comparison with a cell having a certified cell constant; the cell constant is confirmed if the value found is within 2 per cent of the certified value, otherwise re-calibration must be performed.

*Conductometer:* accuracy of  $0.1 \mu\text{S}\cdot\text{cm}^{-1}$  or better at the lowest range.

*System calibration (conductivity cell and conductometer):*

- against one or more suitable certified reference solutions;
- accuracy: within 3 per cent of the measured conductivity plus  $0.1 \mu\text{S}\cdot\text{cm}^{-1}$ .

*Conductometer calibration:* calibration is carried out for each range of measurement to be used, after disconnection of the conductivity cell, using certified precision resistors or equivalent devices with an uncertainty not greater than 0.1 per cent of the certified value.

If in-line conductivity cells cannot be dismantled, system calibration may be performed against a calibrated conductivity-measuring instrument with a conductivity cell placed close to the cell to be calibrated in the water flow.

*Temperature measurement:* tolerance  $\pm 2 \text{ }^\circ\text{C}$ .

#### PROCEDURE

##### Stage 1

1. Measure the conductivity without temperature compensation, recording simultaneously the temperature. Temperature-compensated measurement may be performed after suitable validation.
2. Using Table 1927.-2, find the closest temperature value that is not greater than the measured temperature. The corresponding conductivity value is the limit at that temperature.
3. If the measured conductivity is not greater than the value in Table 1927.-2, the water to be examined meets the requirements of the test for conductivity. If the conductivity is higher than the value in Table 1927.-2, proceed with stage 2.

##### Stage 2

4. Transfer a sufficient amount of the water to be examined (100 mL or more) to a suitable container, and stir the test sample. Adjust the temperature, if necessary, and while

maintaining it at  $25 \pm 1 \text{ }^\circ\text{C}$ , begin vigorously agitating the test sample while periodically observing the conductivity. When the change in conductivity (due to uptake of atmospheric carbon dioxide) is less than  $0.1 \mu\text{S}\cdot\text{cm}^{-1}$  per 5 min, note the conductivity.

5. If the conductivity is not greater than  $2.1 \mu\text{S}\cdot\text{cm}^{-1}$ , the water to be examined meets the requirements of the test for conductivity. If the conductivity is greater than  $2.1 \mu\text{S}\cdot\text{cm}^{-1}$ , proceed with stage 3.

##### Stage 3

6. Perform this test within approximately 5 min of the conductivity determination in step 5 under stage 2, while maintaining the sample temperature at  $25 \pm 1 \text{ }^\circ\text{C}$ . Add a recently prepared saturated solution of *potassium chloride R* to the test sample (0.3 mL per 100 mL of the test sample), and determine the pH (2.2.3) to the nearest 0.1 pH unit.
7. Using Table 1927.-3, determine the conductivity limit at the measured pH value in step 6. If the measured conductivity in step 4 under stage 2 is not greater than the conductivity requirements for the pH determined, the water to be examined meets the requirements of the test for conductivity. If either the measured conductivity is greater than this value or the pH is outside the range of 5.0-7.0, the water to be examined does not meet the requirements of the test for conductivity.

Table 1927.-2. – Stage 1  
Temperature and conductivity requirements (for non-temperature-compensated conductivity measurements)

Temperature ( $^\circ\text{C}$ )	Conductivity ( $\mu\text{S}\cdot\text{cm}^{-1}$ )
0	0.6
5	0.8
10	0.9
15	1.0
20	1.1
25	1.3
30	1.4
35	1.5
40	1.7
45	1.8
50	1.9
55	2.1
60	2.2
65	2.4
70	2.5
75	2.7
80	2.7
85	2.7
90	2.7
95	2.9
100	3.1

Table 1927-3. – Stage 3 - pH and conductivity requirements (for atmosphere and temperature equilibrated samples)

01/2009:0008

pH	Conductivity ( $\mu\text{S}\cdot\text{cm}^{-1}$ )
5.0	4.7
5.1	4.1
5.2	3.6
5.3	3.3
5.4	3.0
5.5	2.8
5.6	2.6
5.7	2.5
5.8	2.4
5.9	2.4
6.0	2.4
6.1	2.4
6.2	2.5
6.3	2.4
6.4	2.3
6.5	2.2
6.6	2.1
6.7	2.6
6.8	3.1
6.9	3.8
7.0	4.6

## CHARACTERS

*Appearance*: clear and colourless liquid.

## TESTS

**Nitrates**: maximum 0.2 ppm.

Place 5 mL in a test-tube immersed in iced water, add 0.4 mL of a 100 g/L solution of *potassium chloride R*, 0.1 mL of *diphenylamine solution R* and, dropwise with shaking, 5 mL of *nitrogen-free sulfuric acid R*. Transfer the tube to a water-bath at 50 °C. After 15 min, any blue colour in the solution is not more intense than that in a reference solution prepared at the same time in the same manner using a mixture of 4.5 mL of *nitrate-free water R* and 0.5 mL of *nitrate standard solution (2 ppm NO<sub>3</sub>) R*.

**Aluminium (2.4.17)**: maximum 10 ppb, if intended for use in the manufacture of dialysis solutions.

*Prescribed solution*. To 400 mL of the water to be examined add 10 mL of *acetate buffer solution pH 6.0 R* and 100 mL of *distilled water R*.

*Reference solution*. Mix 2 mL of *aluminium standard solution (2 ppm Al) R*, 10 mL of *acetate buffer solution pH 6.0 R* and 98 mL of *distilled water R*.

*Blank solution*. Mix 10 mL of *acetate buffer solution pH 6.0 R* and 100 mL of *distilled water R*.

**Bacterial endotoxins (2.6.14)**: less than 0.25 IU/mL.

## LABELLING

The label states, where applicable, that the substance is suitable for use in the manufacture of dialysis solutions.

## WATER, PURIFIED

## Aqua purificata

H<sub>2</sub>OM<sub>r</sub> 18.02

## DEFINITION

Water for the preparation of medicines other than those that are required to be both sterile and apyrogenic, unless otherwise justified and authorised.

## Purified water in bulk

## PRODUCTION

Purified water in bulk is prepared by distillation, by ion exchange, by reverse osmosis or by any other suitable method from water that complies with the regulations on water intended for human consumption laid down by the competent authority.

Purified water in bulk is stored and distributed in conditions designed to prevent growth of micro-organisms and to avoid any other contamination.

**Microbiological monitoring**. During production and subsequent storage, appropriate measures are taken to ensure that the microbial count is adequately controlled and monitored. Appropriate alert and action levels are set so as to detect adverse trends. Under normal conditions, an appropriate action level is a microbial count of 100 CFU/mL, determined by filtration through a membrane with a nominal pore size not greater than 0.45  $\mu\text{m}$ , using R2A agar and incubating at 30-35 °C for not less than 5 days. The size of the sample is to be chosen in relation to the expected result.

*R2A agar*

Yeast extract	0.5 g
Proteose peptone	0.5 g
Casein hydrolysate	0.5 g
Glucose	0.5 g
Starch	0.5 g
Dipotassium hydrogen phosphate	0.3 g
Magnesium sulfate, anhydrous	0.024 g
Sodium pyruvate	0.3 g
Agar	15.0 g
Purified water	to 1000 mL

Adjust the pH so that after sterilisation it is  $7.2 \pm 0.2$ . Sterilise by heating in an autoclave at 121 °C for 15 min.

*Growth promotion of R2A agar*

– *Preparation of test strains*. Use standardised stable suspensions of test strains or prepare them as stated in Table 0008.-1. Seed lot culture maintenance techniques (seed-lot systems) are used so that the viable micro-organisms used for inoculation are not more than 5 passages removed from the original master seed-lot. Grow each of the bacterial strains separately as described in Table 0008.-1. Use buffered sodium chloride-peptone solution pH 7.0 or phosphate buffer solution pH 7.2 to make test suspensions. Use the suspensions within 2 h, or within 24 h if stored at 2-8 °C. As an alternative to preparing and then diluting a fresh suspension of vegetative cells of *Bacillus subtilis*, a stable spore suspension is prepared and then an appropriate volume of the spore suspension is used for test inoculation. The stable spore suspension may be maintained at 2-8 °C for a validated period of time.

– *Growth promotion*. Test each batch of ready-prepared medium and each batch of medium, prepared either from dehydrated medium or from the ingredients described.

Inoculate plates of R2A agar separately with a small number (not more than 100 CFU) of the micro-organisms indicated in Table 0008.-1. Incubate under the conditions described in the table. Growth obtained must not differ by a factor greater than 2 from the calculated value for a standardised inoculum. For a freshly prepared inoculum, growth of the micro-organisms must be comparable to that obtained with a previously tested and approved batch of medium.

Table 0008.-1. – Growth promotion of R2A agar

Micro-organism	Preparation of the test strain	Growth promotion
<i>Pseudomonas aeruginosa</i> such as: ATCC 9027 NCIMB 8626 CIP 82.118 NBRC 13275	Casein soyabean digest agar or casein soyabean digest broth 30-35 °C 18-24 h	R2A agar ≤ 100 CFU 30-35 °C ≤ 3 days
<i>Bacillus subtilis</i> such as: ATCC 6633 NCIMB 8054 CIP 52.62 NBRC 3134	Casein soyabean digest agar or casein soyabean digest broth 30-35 °C 18-24 h	R2A agar ≤ 100 CFU 30-35 °C ≤ 3 days

**Total organic carbon or oxidisable substances.** Carry out the test for total organic carbon (2.2.44) with a limit of 0.5 mg/L or alternatively the following test for oxidisable substances: to 100 mL add 10 mL of dilute sulfuric acid R and 0.1 mL of 0.02 M potassium permanganate and boil for 5 min; the solution remains faintly pink.

**Conductivity.** Determine the conductivity off-line or in-line under the following conditions.

#### EQUIPMENT

##### Conductivity cell:

- electrodes of a suitable material such as stainless steel;
- cell constant: the cell constant is generally certified by the supplier and is subsequently verified at suitable intervals using a certified reference solution with a conductivity less than 1500  $\mu\text{S}\cdot\text{cm}^{-1}$  or by comparison with a cell having a certified cell constant; the cell constant is confirmed if the value found is within 2 per cent of the certified value, otherwise re-calibration must be performed.

**Conductometer:** accuracy of 0.1  $\mu\text{S}\cdot\text{cm}^{-1}$  or better at the lowest range.

##### System calibration (conductivity cell and conductometer):

- against one or more suitable certified reference solutions;
- accuracy: within 3 per cent of the measured conductivity plus 0.1  $\mu\text{S}\cdot\text{cm}^{-1}$ .

**Conductometer calibration:** calibration is carried out for each range of measurement to be used, after disconnection of the conductivity cell, using certified precision resistors or equivalent devices with an uncertainty not greater than 0.1 per cent of the certified value.

If in-line conductivity cells cannot be dismantled, system calibration may be performed against a calibrated conductivity-measuring instrument with a conductivity cell placed close to the cell to be calibrated in the water flow.

**Temperature measurement:** tolerance  $\pm 2$  °C.

#### PROCEDURE

Measure the conductivity without temperature compensation, recording simultaneously the temperature. Temperature-compensated measurement may be performed after suitable validation.

The water to be examined meets the requirements if the measured conductivity at the recorded temperature is not greater than the value in Table 0008.-2.

Table 0008.-2. – Temperature and conductivity requirements

Temperature (°C)	Conductivity ( $\mu\text{S}\cdot\text{cm}^{-1}$ )
0	2.4
10	3.6
20	4.3
25	5.1
30	5.4
40	6.5
50	7.1
60	8.1
70	9.1
75	9.7
80	9.7
90	9.7
100	10.2

For temperatures not listed in Table 0008.-2, calculate the maximal permitted conductivity by interpolation between the next lower and next higher data points in the table.

**Heavy metals.** If purified water in bulk complies with the requirement for conductivity prescribed for *Water for injections (0169)* in bulk, it is not necessary to carry out the test for heavy metals prescribed below.

#### CHARACTERS

**Appearance:** clear and colourless liquid.

#### TESTS

**Nitrates:** maximum 0.2 ppm.

Place 5 mL in a test-tube immersed in iced water, add 0.4 mL of a 100 g/L solution of potassium chloride R, 0.1 mL of diphenylamine solution R and, dropwise with shaking, 5 mL of nitrogen-free sulfuric acid R. Transfer the tube to a water-bath at 50 °C. After 15 min, any blue colour in the solution is not more intense than that in a reference solution prepared at the same time in the same manner using a mixture of 4.5 mL of nitrate-free water R and 0.5 mL of nitrate standard solution (2 ppm  $\text{NO}_3^-$ ) R.

**Aluminium (2.4.17):** maximum 10 ppb, if intended for use in the manufacture of dialysis solutions.

**Prescribed solution.** To 400 mL of the water to be examined add 10 mL of acetate buffer solution pH 6.0 R and 100 mL of distilled water R.

**Reference solution.** Mix 2 mL of aluminium standard solution (2 ppm Al) R, 10 mL of acetate buffer solution pH 6.0 R and 98 mL of distilled water R.

**Blank solution.** Mix 10 mL of acetate buffer solution pH 6.0 R and 100 mL of distilled water R.

**Heavy metals (2.4.8):** maximum 0.1 ppm.

To 200 mL add 0.15 mL of 0.1 M nitric acid and heat in a glass evaporating dish on a water-bath until the volume is reduced to 20 mL. 12 mL of the concentrated solution complies with test A. Prepare the reference solution using 10 mL of lead standard solution (1 ppm Pb) R and adding 0.075 mL of 0.1 M nitric acid. Prepare the blank solution adding 0.075 mL of 0.1 M nitric acid.

**Bacterial endotoxins (2.6.14):** less than 0.25 IU/mL, if intended for use in the manufacture of dialysis solutions without a further appropriate procedure for removal of bacterial endotoxins.

#### LABELLING

The label states, where applicable, that the substance is suitable for use in the manufacture of dialysis solutions.

## Purified water in containers

### DEFINITION

Purified water in bulk that has been filled and stored in conditions designed to assure the required microbiological quality. It is free from any added substances.

### CHARACTERS

*Appearance*: clear and colourless liquid.

### TESTS

It complies with the tests prescribed in the section on Purified water in bulk and with the following additional tests.

**Acidity or alkalinity.** To 10 mL, freshly boiled and cooled in a borosilicate glass flask, add 0.05 mL of *methyl red solution R*. The solution is not coloured red.

To 10 mL add 0.1 mL of *bromothymol blue solution R1*. The solution is not coloured blue.

**Oxidisable substances.** To 100 mL add 10 mL of *dilute sulfuric acid R* and 0.1 mL of *0.02 M potassium permanganate* and boil for 5 min. The solution remains faintly pink.

**Chlorides.** To 10 mL add 1 mL of *dilute nitric acid R* and 0.2 mL of *silver nitrate solution R2*. The solution shows no change in appearance for at least 15 min.

**Sulfates.** To 10 mL add 0.1 mL of *dilute hydrochloric acid R* and 0.1 mL of *barium chloride solution R1*. The solution shows no change in appearance for at least 1 h.

**Ammonium:** maximum 0.2 ppm.

To 20 mL add 1 mL of *alkaline potassium tetraiodomercurate solution R*. After 5 min, examine the solution down the vertical axis of the tube. The solution is not more intensely coloured than a standard prepared at the same time by adding 1 mL of *alkaline potassium tetraiodomercurate solution R* to a mixture of 4 mL of *ammonium standard solution (1 ppm NH<sub>4</sub>) R* and 16 mL of *ammonium-free water R*.

**Calcium and magnesium.** To 100 mL add 2 mL of *ammonium chloride buffer solution pH 10.0 R*, 50 mg of *mordant black 11 tritrate R* and 0.5 mL of *0.01 M sodium edetate*. A pure blue colour is produced.

**Residue on evaporation:** maximum 0.001 per cent.

Evaporate 100 mL to dryness on a water-bath and dry in an oven at 100-105 °C. The residue weighs a maximum of 1 mg.

### Microbial contamination

TAMC: acceptance criterion 10<sup>2</sup> CFU/mL (2.6.12). Use casein soya bean digest agar.

### LABELLING

The label states, where applicable, that the substance is suitable for use in the manufacture of dialysis solutions.

### IDENTIFICATION

A. Examined under a microscope using equal volumes of *glycerol R* and *water R*, it presents large and small granules, and, very rarely, intermediate sizes. The large granules, 10-60 µm in diameter, are discoid or, more rarely, reniform when seen face-on. The central hilum and striations are invisible or barely visible and the granules sometimes show cracks on the edges. Seen in profile, the granules are elliptical and fusiform and the hilum appears as a slit along the main axis. The small granules, rounded or polyhedral, are 2-10 µm in diameter. Between orthogonally orientated polarising plates or prisms, the granules show a distinct black cross intersecting at the hilum.

B. Suspend 1 g in 50 mL of *water R*, boil for 1 min and cool. A thin, cloudy mucilage is formed.

C. To 1 mL of the mucilage obtained in identification test B add 0.05 mL of *iodine solution R1*. A dark blue colour is produced, which disappears on heating.

### TESTS

**pH (2.2.3):** 4.5 to 7.0.

Shake 5.0 g with 25.0 mL of *carbon dioxide-free water R* for 60 s. Allow to stand for 15 min.

**Foreign matter.** Examined under a microscope using a mixture of equal volumes of *glycerol R* and *water R*, not more than traces of matter other than starch granules are present. No starch grains of any other origin are present.

**Total protein:** maximum 0.3 per cent of total protein (corresponding to 0.048 per cent N<sub>2</sub>, conversion factor: 6.25), determined on 6.0 g by sulfuric acid digestion (2.5.9) modified as follows: wash any adhering particles from the neck into the flask with 25 mL of *sulfuric acid R*; continue the heating until a clear solution is obtained; add 45 mL of *strong sodium hydroxide solution R*.

**Oxidising substances (2.5.30):** maximum 20 ppm, calculated as H<sub>2</sub>O<sub>2</sub>.

**Sulfur dioxide (2.5.29):** maximum 50 ppm.

**Iron (2.4.9):** maximum 10 ppm.

Shake 1.5 g with 15 mL of *dilute hydrochloric acid R*. Filter. The filtrate complies with the test.

**Loss on drying (2.2.32):** maximum 15.0 per cent, determined on 1.000 g by drying in an oven at 130 °C for 90 min.

**Sulfated ash (2.4.14):** maximum 0.6 per cent, determined on 1.0 g.

### Microbial contamination

TAMC: acceptance criterion 10<sup>3</sup> CFU/g (2.6.12).

TYMC: acceptance criterion 10<sup>2</sup> CFU/g (2.6.12).

Absence of *Escherichia coli* (2.6.13).

Absence of *Salmonella* (2.6.13).

01/2009:0359

01/2010:1379

## WHEAT STARCH

### Tritici amylum

### DEFINITION

Wheat starch is obtained from the caryopsis of *Triticum aestivum* L. (*T. vulgare* Vill.).

### CHARACTERS

*Appearance*: very fine, white or almost white powder that creaks when pressed between the fingers.

*Solubility*: practically insoluble in cold water and in ethanol (96 per cent).

Wheat starch does not contain starch grains of any other origin. It may contain a minute quantity, if any, of tissue fragments of the original plant.

## WHEAT-GERM OIL, REFINED

### Tritici aestivi oleum raffinatum

### DEFINITION

Fatty oil obtained from the germ of the grain of *Triticum aestivum* L. by cold expression or by other suitable mechanical means and/or by extraction. It is then refined. A suitable antioxidant may be added.

### CHARACTERS

*Appearance*: clear, light yellow liquid.

*Solubility*: practically insoluble in water and in ethanol (96 per cent), miscible with light petroleum (bp: 40-60 °C).

*Relative density*: about 0.925.

*Refractive index*: about 1.475.

## IDENTIFICATION

A. Identification of fatty oils by thin-layer chromatography (2.3.2).

*Results:* the chromatogram obtained is similar to the corresponding chromatogram shown in Figure 2.3.2-1.

B. Composition of fatty acids (see Tests).

## TESTS

**Acid value** (2.5.1): maximum 0.9, or maximum 0.3 if intended for use in the manufacture of parenteral preparations.

**Peroxide value** (2.5.5, Method A): maximum 10.0, or maximum 5.0 if intended for use in the manufacture of parenteral preparations.

**Unsaponifiable matter** (2.5.7): maximum 5.0 per cent, determined on 5.0 g.

**Alkaline impurities** (2.4.19). It complies with the test.

**Composition of fatty acids** (2.4.22, Method C). Use the mixture of calibrating substances in Table 2.4.22-3.

*Composition of the fatty-acid fraction of the oil:*

- *palmitic acid*: 14.0 per cent to 19.0 per cent;
- *stearic acid*: maximum 2.0 per cent;
- *oleic acid*: 12.0 per cent to 23.0 per cent;
- *linoleic acid*: 52.0 per cent to 59.0 per cent;
- *linolenic acid*: 3.0 per cent to 10.0 per cent;
- *eicosenoic acid*: maximum 2.0 per cent.

**Brassicasterol** (2.4.23): maximum 0.3 per cent in the sterol fraction of the oil.

**Water** (2.5.32): maximum 0.1 per cent, determined on 1.00 g.

## STORAGE

In an airtight, well-filled container, protected from light.

## LABELLING

The label states:

- where applicable, that the substance is suitable for use in the manufacture of parenteral preparations;
- whether the oil is obtained by mechanical means, by extraction or by a combination of the 2.

01/2010:1480

## WHEAT-GERM OIL, VIRGIN

## Tritici aestivi oleum virginale

## DEFINITION

Fatty oil obtained from the germ of the grain of *Triticum aestivum* L. by cold expression or other suitable mechanical means.

## CHARACTERS

*Appearance:* clear, light yellow or golden-yellow liquid.

*Solubility:* practically insoluble in water and in ethanol (96 per cent), miscible with light petroleum (bp: 40-60 °C).

*Relative density:* about 0.925.

*Refractive index:* about 1.475.

## IDENTIFICATION

A. Identification of fatty oils by thin-layer chromatography (2.3.2).

*Results:* the chromatogram obtained is similar to the corresponding chromatogram shown in Figure 2.3.2-1.

B. Composition of fatty acids (see Tests).

## TESTS

**Acid value** (2.5.1): maximum 20.0.

**Peroxide value** (2.5.5, Method A): maximum 15.0.

**Unsaponifiable matter** (2.5.7): maximum 5.0 per cent, determined on 5.0 g.

**Composition of fatty acids** (2.4.22, Method C).

*Composition of the fatty-acid fraction of the oil:*

- *palmitic acid*: 14.0 per cent to 19.0 per cent,
- *stearic acid*: maximum 2.0 per cent,
- *oleic acid*: 12.0 per cent to 23.0 per cent,
- *linoleic acid*: 52.0 per cent to 59.0 per cent,
- *linolenic acid*: 3.0 per cent to 10.0 per cent,
- *eicosenoic acid*: maximum 2.0 per cent.

**Brassicasterol** (2.4.23): maximum 0.3 per cent in the sterol fraction of the oil.

**Water** (2.5.32): maximum 0.1 per cent, determined on 1.00 g.

## STORAGE

In an airtight, well-filled container, protected from light.

01/2008:0593  
corrected 6.0

## WOOL ALCOHOLS

## Alcoholes adipis lanæ

## DEFINITION

Mixture of sterols and higher aliphatic alcohols from wool fat. It may contain not more than 200 ppm of butylhydroxytoluene.

*Content:* minimum 30.0 per cent of cholesterol.

## CHARACTERS

*Appearance:* pale-yellow or brownish-yellow, brittle mass becoming plastic on heating.

*Solubility:* practically insoluble in water, soluble in methylene chloride and in boiling ethanol, slightly soluble in alcohol (90 per cent V/V).

## IDENTIFICATION

Dissolve 50 mg in 5 mL of *methylene chloride R* and add 1 mL of *acetic anhydride R* and 0.1 mL of *sulfuric acid R*. Within a few seconds, a green colour develops.

## TESTS

**Appearance of solution.** To 1.0 g add 10 mL of *light petroleum R1* and shake while warming in a water-bath. The substance dissolves completely. After cooling, the solution is clear (2.2.1).

**Alkalinity.** Dissolve 2.0 g in 25 mL of hot *alcohol (90 per cent V/V) R* and add 0.5 mL of *phenolphthalein solution R1*. No red colour develops.

**Melting point** (2.2.15): minimum 58 °C.

Melt the substance to be examined by heating in a water-bath at a temperature which exceeds the expected melting point by not more than 10 °C; introduce the substance to be examined into the capillary tubes and allow to stand at 15-17 °C for not less than 16 h.

**Acid value** (2.5.1): maximum 2.0.

If necessary, heat in a water-bath under a reflux condenser to dissolve the substance to be examined.

**Hydroxyl value** (2.5.3, Method A): 120 to 180.

**Peroxide value** (2.5.5, Method A): maximum 15.

Take from the substance to be examined wedge-shaped pieces whose base consists of part of the surface. Melt the pieces before carrying out the determination. Before adding 0.5 mL of *saturated potassium iodide solution R*, cool the solution obtained to room temperature.

**Saponification value** (2.5.6): maximum 12.0, determined on 2.00 g. Heat under reflux for 4 h.



**Butylhydroxytoluene.** Gas chromatography (2.2.28).

01/2008:0134  
corrected 6.0

**Internal standard solution.** Dissolve 0.20 g of *methyl decanoate R* in *carbon disulfide R* and dilute to 100.0 mL with the same solvent. Dilute 1.0 mL of the solution to 10.0 mL with *carbon disulfide R*.

**Test solution (a).** Dissolve 1.0 g of the substance to be examined in *carbon disulfide R* and dilute to 10.0 mL with the same solvent.

**Test solution (b).** Dissolve 1.0 g of the substance to be examined in *carbon disulfide R*, add 1.0 mL of the internal standard solution and dilute to 10.0 mL with *carbon disulfide R*.

**Reference solution.** Dissolve 0.20 g of *butylhydroxytoluene R* in *carbon disulfide R* and dilute to 100.0 mL with the same solvent. Dilute 1.0 mL of the solution to 10.0 mL with *carbon disulfide R*. To 1.0 mL of this solution add 1.0 mL of the internal standard solution and dilute to 10.0 mL with *carbon disulfide R*.

**Precolumn:** column filled with silanised glass wool.

**Column:**

- size:  $l = 1.5$  m,  $\emptyset = 4$  mm,
- stationary phase: silanised diatomaceous earth for gas chromatography *R* impregnated with 10 per cent *m/m* of poly(dimethyl)siloxane *R*.

**Carrier gas:** nitrogen for chromatography *R*.

**Flow rate:** 40 mL/min.

**Temperature:**

- column: 150 °C,
- injection port: 180 °C,
- detector: 300 °C.

**Detection:** flame ionisation.

**Limit:**

- *butylhydroxytoluene*: maximum 200 ppm.

**Loss on drying (2.2.32):** maximum 0.5 per cent, determined on 2.000 g by drying in an oven at 105 °C.

**Total ash (2.4.16):** maximum 0.1 per cent.

**Water-absorption capacity.** Place 0.6 g of the substance to be examined and 9.4 g of *white soft paraffin R* in a mortar and melt on a water-bath. Allow to cool and incorporate 20 mL of *water R*, added in portions. Within 24 h no water is released from the almost white, ointment-like emulsion.

#### ASSAY

Dissolve 0.1000 g in 12 mL of hot *alcohol (90 per cent V/V) R*. Allow to stand for 18 h, filter through a sintered-glass filter (16) (2.1.2) and wash the filter with 2 quantities, each of 15 mL, of *alcohol (90 per cent V/V) R*. Combine the filtrate and washings, add 20 mL of a freshly prepared 10 g/L solution of *digitonin R* in *alcohol (90 per cent V/V) R* and heat to about 60 °C. Allow to cool, filter through a sintered-glass filter (16) (2.1.2), wash the residue with 10 mL of *alcohol (90 per cent V/V) R* and dry to constant mass at 100-105 °C.

1 g of residue is equivalent to 0.239 g of cholesterol.

#### STORAGE

In a well-filled container, protected from light.

#### LABELLING

The label states, where applicable, the concentration of any added butylhydroxytoluene.

## WOOL FAT

### Adeps lanae

#### DEFINITION

Purified, anhydrous, waxy substance obtained from the wool of sheep (*Ovis aries*). It may contain not more than 200 ppm of butylhydroxytoluene.

#### CHARACTERS

**Appearance:** yellow, unctuous substance. When melted, it is a clear or almost clear, yellow liquid. A solution in light petroleum is opalescent.

**Solubility:** practically insoluble in water, slightly soluble in boiling anhydrous ethanol.

It has a characteristic odour.

#### IDENTIFICATION

- A. In a test-tube, dissolve 0.5 g in 5 mL of *methylene chloride R* and add 1 mL of *acetic anhydride R* and 0.1 mL of *sulfuric acid R*. A green colour develops.
- B. Dissolve 50 mg in 5 mL of *methylene chloride R*, add 5 mL of *sulfuric acid R* and shake. A red colour develops and an intense green fluorescence appears in the lower layer when examined in daylight, with illumination from the rear of the observer.

#### TESTS

**Water-soluble acid or alkaline substances.** Melt 5.0 g on a water-bath and shake vigorously for 2 min with 75 mL of *water R* previously heated to 90-95 °C. Allow to cool and filter through filter paper previously rinsed with *water R*. To 60 mL of the filtrate (which may not be clear) add 0.25 mL of *bromothymol blue solution R1*. Not more than 0.2 mL of 0.02 M *hydrochloric acid* or 0.15 mL of 0.02 M *sodium hydroxide* is required to change the colour of the indicator.

**Drop point (2.2.17):** 38 °C to 44 °C.

To fill the metal cup, melt the wool fat on a water-bath, cool to about 50 °C, pour into the cup and allow to stand at 15-20 °C for 24 h.

**Water-absorption capacity.** Place 10 g of molten wool fat in a mortar and allow to cool to room temperature. Weigh the mortar. Add *water R* in portions of 0.2-0.5 mL from a burette, stirring vigorously after each addition to incorporate the *water R*. Instead of a pestle, use a high-density polypropylene cylindrical rod (120 mm long and 10 mm in diameter, for example). The end-point is reached when visible droplets remain which cannot be incorporated. Weigh the mortar again and determine the amount of water absorbed by weight difference. Not less than 20 g of *water R* is absorbed.

**Acid value (2.5.1):** maximum 1.0, determined on 5.0 g dissolved in 25 mL of the prescribed mixture of solvents.

**Peroxide value (2.5.5, Method A):** maximum 20.

Before adding 0.5 mL of *saturated potassium iodide solution R*, cool the solution obtained to room temperature.

**Saponification value (2.5.6):** 90 to 105, determined on 2.00 g while heating under reflux for 4 h.

**Water-soluble oxidisable substances.** To 10 mL of the filtrate obtained in the test for water-soluble acid or alkaline substances add 1 mL of *dilute sulfuric acid R* and 0.1 mL of 0.02 M *potassium permanganate*. After 10 min, the solution is not completely decolourised.

**Butylhydroxytoluene.** Gas chromatography (2.2.28).

**Internal standard solution.** Dissolve 0.2 g of *methyl decanoate R* in *carbon disulfide R* and dilute to 100.0 mL with

the same solvent. Dilute 1.0 mL of the solution to 10.0 mL with carbon disulfide R.

**Test solution (a).** Dissolve 1.0 g of the substance to be examined in carbon disulfide R and dilute to 10.0 mL with the same solvent.

**Test solution (b).** Dissolve 1.0 g of the substance to be examined in carbon disulfide R, add 1.0 mL of the internal standard solution and dilute to 10.0 mL with carbon disulfide R.

**Reference solution.** Dissolve 0.2 g of butylhydroxytoluene R in carbon disulfide R and dilute to 100.0 mL with the same solvent. Dilute 1.0 mL of the solution to 10.0 mL with carbon disulfide R. To 1.0 mL of this solution add 1.0 mL of the internal standard solution and dilute to 10.0 mL with carbon disulfide R.

**Column:**

- size:  $l = 1.5$  m,  $\emptyset = 4$  mm;
- stationary phase: silanised diatomaceous earth for gas chromatography R impregnated with 10 per cent *m/m* of poly(dimethyl)siloxane R.

The column is preceded by a column containing silanised glass wool.

**Carrier gas:** nitrogen for chromatography R.

**Flow rate:** 40 mL/min.

**Temperature:**

- column: 150 °C;
- injection port: 180 °C;
- detector: 300 °C.

**Detection:** flame ionisation.

**Limit:**

- butylhydroxytoluene: maximum 200 ppm.

**Paraffins:** maximum 1.0 per cent.

*The tap and cotton plugs used must be free from grease.* Prepare a column of anhydrous aluminium oxide 0.23 m long and 20 mm in diameter by adding a slurry of anhydrous aluminium oxide R and light petroleum R1 to a glass tube fitted with a tap and containing light petroleum R1 (before use, dehydrate the anhydrous aluminium oxide by heating it in an oven at 600 °C for 3 h). Allow to settle and reduce the depth of the layer of solvent above the column to about 40 mm. Dissolve 3.0 g of the substance to be examined in 50 mL of warm light petroleum R1, cool, pass the solution through the column at a flow rate of 3 mL/min and wash with 250 mL of light petroleum R1. Concentrate the combined eluate and washings to low bulk by distillation, evaporate to dryness on a water-bath and heat the residue at 105 °C for periods of 10 min until 2 successive weighings do not differ by more than 1 mg. The residue weighs a maximum of 30 mg.

**Pesticide residues:** maximum 0.05 ppm for each organochlorine pesticide, 0.5 ppm for each other pesticide and 1 ppm for the sum of all the pesticides.

*All glassware used is thoroughly washed using phosphate-free detergent as follows. The glassware is immersed in a bath of detergent solution (5 per cent in deionised water) and allowed to soak for 24 h. The detergent is washed off with copious amounts of acetone and hexane for pesticide analysis. It is important to keep glassware specifically for pesticide analyses, it must not be mixed up with glassware used for other applications. The glassware used must be free of chlorinated solvents, plastics and rubber materials, in particular phthalate plasticisers, oxygenated compounds and nitrogenated solvents such as acetonitrile. Use hexane, toluene and acetone for pesticide analysis. Use HPLC grade reagents for ethyl acetate, cyclohexane and water.*

The test consists of the isolation of pesticide residues by size-exclusion chromatography (2.2.30) followed by solid phase extraction and identification by gas chromatography coupled with an electron capture detector or a thermionic detector.

**ISOLATION OF THE PESTICIDE RESIDUES.** As detector, use a UV-visible spectrophotometer set at a wavelength of 254 nm to calibrate the chromatographic column for gel permeation.

Calibration is extremely important in gel permeation chromatography to check that the pressure, solvent flow rate, solvent ratio, temperature and column conditions remain constant. The gel permeation column is to be calibrated at regular intervals using a standard mixture prepared as follows: into a 1000 mL volumetric flask, introduce 50.00 g of maize oil R, 2.00 g of di(2-ethylhexyl) phthalate R, 0.20 g of methoxychlor R, 50.0 mg of perylene R, 50.0 mg of naphthalene R, and 80.0 mg of sulfur R. Dilute to 1000.0 mL with a mixture of equal volumes of cyclohexane R and ethyl acetate R.

To calibrate the column, set the mobile phase at a flow rate of 5 mL/min with a mixture of equal volumes of cyclohexane R and ethyl acetate R. Inject 5 mL of the standard mixture and record the resulting chromatogram. The retention times for the analytes must not vary by more than  $\pm 5$  per cent between calibrations. If the retention time shift is greater than  $\pm 5$  per cent, take corrective action. Excessive retention time shifts may be caused by:

- poor laboratory temperature control;
- the pump containing air; this can be verified by measuring the flow rate: collect 25 mL of column eluate in a volumetric flask and record the time ( $300 \pm 5$  s);
- a leak in the system.

Changes in pressure, in mobile phase flow rate or in column temperature conditions, as well as column contamination, can affect pesticide retention times and are to be monitored. If the flow rate or column pressure are outside desired bands the precolumn or column is to be replaced.

**Test solution.** In a volumetric flask, dissolve 1 g of wool fat, accurately weighed, in a mixture of 1 volume of ethyl acetate R and 7 volumes of cyclohexane R. Add 1 mL of an internal standard (2 ppm) either isodrin R or ditalimphos R and dilute to 20 mL. *The internal standard solutions are used to establish that recoveries of the pesticides from the GPC purification stage, evaporation and solid phase extraction stage are at acceptable levels. Recovery levels of the internal standard solutions from the wool fat are determined by comparing the peak areas of the wool fat extracts with peak areas of solutions of the internal standards.*

**Precolumn:**

- size:  $l = 0.075$  m,  $\emptyset = 21.2$  mm;
- stationary phase: styrene-divinylbenzene copolymer R (5  $\mu$ m).

**Gel permeation column:**

- size:  $l = 0.3$  m,  $\emptyset = 21.2$  mm;
- stationary phase: styrene-divinylbenzene copolymer R (5  $\mu$ m).

**Mobile phase:** ethyl acetate R, cyclohexane R (1:7 V/V).

**Flow rate:** 5 mL/min.

**Detection:** spectrophotometer at 254 nm.

Inject 5 mL of the test solution. Discard the first 95 mL (19 min) of eluate containing the substance to be examined. Collect the next 155 mL of eluate (31 min) containing any pesticide residues in an evaporating vessel.

Place the 155 mL of the eluate collected from the gel permeation chromatography column into an evaporating vessel. Place this vessel in an autoevaporator setting the water-bath temperature at 45 °C and the nitrogen pressure at 55 kPa. Evaporate the eluate down to 0.5 mL.

To prepare the solid phase extraction cartridges take some magnesium silicate for pesticide residue analysis R and heat it in a muffle furnace at 700 °C for 4 h to remove moisture and polychlorinated biphenyls. Subsequently allow the magnesium silicate to cool for 2 h and transfer it directly to an oven at 100-105 °C, and allow to stand for 30 min. Transfer

the magnesium silicate to a stoppered glass jar and allow to equilibrate for 48 h. This material may be used for up to 2 weeks. After that period the magnesium silicate is to be reactivated, by heating at 600 °C for 2 h in a muffle furnace. Remove the magnesium silicate from the furnace, cool and store in a stoppered glass jar. The magnesium silicate is deactivated by adding 1 per cent of *water R*. After the water has been added, shake the magnesium silicate intermittently over 15 min just prior to use. The deactivated magnesium silicate is suitable for use for up to 1 week. It is essential that only deactivated magnesium silicate is used.

Take a 6 mL empty solid phase extraction cartridge and weigh into the cartridge 1 g of the deactivated magnesium silicate.

At this stage the GPC fraction still contains about 10 per cent of the substance to be examined, so further clean-up is necessary. A separate isolation procedure is carried out a) for organochlorine and synthetic pyrethroid pesticides and b) for organophosphorus pesticides. Place a preconditioned solid phase extraction cartridge containing 1 g of deactivated *magnesium silicate for pesticide residue analysis R* onto a vacuum manifold.

Condition the cartridge by adding 10 mL of *toluene R* and allowing the solvent to elute through the cartridge. Place the 0.5 mL of the solvent fraction from the evaporating vessel on the preconditioned cartridge. Elute the pesticide fractions from the cartridges using 20 mL of either of the 2 different solvent systems shown below:

- for determination of the organochlorine and synthetic pyrethroid pesticides: *toluene R*; a very small amount of the substance to be examined is co-eluted;
- for determination of the organophosphorus pesticides: a mixture of 2 volumes of *acetone R* and 98 volumes of *toluene R*; this solvent system is used to elute all the pesticides including the more polar organophosphorus pesticides; unfortunately, some of the substance to be examined is co-eluted with this solvent system, which can interfere with the electron capture detector.

Collect the eluate from the extraction cartridges in 25 mL glass vials. Quantitatively transfer the eluate to an evaporating vessel, washing the vial with 3 quantities, each of 10 mL, of *hexane R*.

Place the evaporating vessel on the autoevaporator and evaporate the solid phase extraction fractions down to 0.5 mL. The water-bath temperature is set at 45 °C and the nitrogen pressure is 55 kPa.

Examine the residues by gas chromatography (2.2.28) using electron capture and thermionic detectors as described below.

**Recovery.** Calculate the recovery correction factor ( $R_{cf}$ ) of the internal standards (*ditalimphos R* or *isodrin R*) added to the test solution using the following expression:

$$\frac{A_2}{A_1} \times 100$$

- $A_1$  = peak area of an internal standard 1 ppm in solution;  
 $A_2$  = peak area of internal standard extracted from the test solution.

5 mL of the 20 mL test solution containing 1 mL of 2 ppm internal standard concentrated to 0.5 mL is equivalent to 1 ppm of the internal standard in the solution.

If the recovery of the internal standards falls outside the range of 70 per cent to 110 per cent the test is not valid.

**Reference solutions.** Prepare reference solutions of pesticides using the pesticides standards at a concentration of 0.5 ppm (see composition of reference solutions A to D in Table 0134.-1). Commercially available pesticides may be purchased. The individual standards have a concentration of 10 ppm.

At the same time prepare solutions of pesticides equivalent to the limit of detection of the method (see recommended compositions in Table 0134.-1). These reference solutions are

used to optimise the electron capture detector and thermionic detector to achieve the detection limits of the method (reference solutions E and F).

To prepare the reference solutions at the different concentrations use a calibrated pipette and volumetric flasks. To prepare the internal standard solutions G and H use a four-place analytical balance, pipette and volumetric flasks.

Table 0134.-1. – *Composition of the reference solutions*

<b>Reference solution A (0.5 ppm or 0.5 mg/L) (organochlorine and synthetic pyrethroid pesticides)</b>	<b>Reference solution B (0.5 ppm or 0.5 mg/L) (organochlorine and synthetic pyrethroid pesticides)</b>
<i>Cyhalothrin R</i>	<i>Aldrin R</i>
<i>Cypermethrin R</i>	<i>o,p'-DDT R</i>
<i>o,p'-DDE R</i>	<i>o,p'-DDD R</i>
<i>p,p'-DDE R</i>	<i>p,p'-DDD R</i>
<i>p,p'-DDT R</i>	<i>Dieldrin R</i>
<i>Deltamethrin R</i>	<i>α-Endosulfan R</i>
<i>Endrin R</i>	<i>β-Endosulfan R</i>
<i>Heptachlor R</i>	<i>Fenvalerate R</i>
<i>Heptachlor epoxide R</i>	<i>α-Hexachlorocyclohexane R</i>
<i>Hexachlorobenzene R</i>	<i>β-Hexachlorocyclohexane R</i>
<i>Lindane R</i>	<i>δ-Hexachlorocyclohexane R</i>
<i>Tecnazene R</i>	<i>Methoxychlor R</i>
	<i>Permethrin R</i>
<b>Reference solution C (0.5 ppm or 0.5 mg/L) (organophosphorus pesticides)</b>	<b>Reference solution D (0.5 ppm or 0.5 mg/L) (organophosphorus pesticides)</b>
<i>Bromophos-ethyl R</i>	<i>Bromophos R</i>
<i>Carbophenothion R</i>	<i>Chlorpyrifos R</i>
<i>Chlorfenvinphos R</i>	<i>Chlorpyrifos-methyl R</i>
<i>Diazinon R</i>	<i>Coumaphos R</i>
<i>Dichlofenthion R</i>	<i>Phosalone R</i>
<i>Ethion R</i>	<i>Pirimiphos-ethyl R</i>
<i>Fenchlorphos R</i>	<i>Tetrachlorovinphos R</i>
<i>Malathion R</i>	
<i>Propetamphos R</i>	
<b>Reference solution E (electron capture detector calibration mixture)</b>	<b>Reference solution F (thermionic detector calibration mixture)</b>
<i>Aldrin R</i> (0.01 mg/L)	<i>Chlorfenvinphos R</i> (0.05 mg/L)
<i>Cypermethrin R</i> (0.1 mg/L)	<i>Diazinon R</i> (0.05 mg/L)
<i>o,p'-DDD R</i> (0.01 mg/L)	<i>Ethion R</i> (0.05 mg/L)
<i>Deltamethrin R</i> (0.1 mg/L)	<i>Fenchlorphos R</i> (0.05 mg/L)
<i>Endrin R</i> (0.01 mg/L)	<i>Propetamphos R</i> (0.05 mg/L)
<i>β-Hexachlorocyclohexane R</i> (0.01 mg/L)	
<b>Reference solution G (internal standard organo- phosphorus pesticide)</b>	<b>Reference solution H (internal standard organo- chlorine pesticide)</b>
<i>Ditalimphos R</i> (2 ppm or 2.0 mg/L)	<i>Isodrin R</i> (2 ppm or 2.0 mg/L)
<i>Ditalimphos R</i> (1 ppm or 1.0 mg/L)	<i>Isodrin R</i> (1 ppm or 1.0 mg/L)

**IDENTIFICATION AND QUANTIFICATION OF THE PESTICIDE RESIDUES.** To identify any pesticide residues compare the chromatograms obtained with chromatograms obtained with reference solutions A to D.

The identity of the pesticides can be confirmed by spiking samples or overlaying chromatograms using an integration package on a computer. The interpretation of pesticides in trace residue analyses is extremely complex. The detectors, particularly the electron capture detector, are prone to interference, both from the substance to be examined itself, and from solvents, reagents and apparatus used in the extraction. These peaks can easily be misinterpreted or quoted as a false

positive. Confirmation of pesticides can be achieved by running samples and standards on different capillary columns (see chromatographic systems A or B described below). The peaks can be identified by using the information in Table 0134.-2.

Table 0134.-2. – *Elution order of the pesticides on chromatographic systems A and B*

Chromatographic system A	Chromatographic system B
Tecnazene	Tecnazene
α-Hexachlorocyclohexane	Hexachlorobenzene
Hexachlorobenzene	α-Hexachlorocyclohexane
β-Hexachlorocyclohexane	Diazinon
Lindane	Lindane
Propetamphos	Propetamphos
δ-Hexachlorocyclohexane	Heptachlor
Diazinon	Dichlofenthion
Dichlofenthion	Aldrin
Chlorpyrifos-methyl	Chlorpyrifos-methyl
Heptachlor	Fenclorphos
Fenclorphos	β-Hexachlorocyclohexane
Aldrin	δ-Hexachlorocyclohexane
Malathion	Pirimiphos-ethyl
Chlorpyrifos	Chlorpyrifos
Bromophos	Bromophos
Pirimiphos-ethyl	Malathion
Heptachlor epoxide	Heptachlor epoxide
Chlorfenvinphos (E)	o,p'-DDE
Chlorfenvinphos (Z)	Chlorfenvinphos (E)
Bromophos-ethyl	α-Endosulfan
o,p'-DDE	Chlorfenvinphos (Z)
α-Endosulfan	Bromophos-ethyl
Tetrachlorvinphos	p,p'-DDE
Dieldrin	Dieldrin
p,p'-DDE	Tetrachlorvinphos
o,p'-DDT	o,p'-DDT
Endrin	Endrin
β-Endosulfan	o,p'-DDD
o,p'-DDD	p,p'-DDD
p,p'-DDD	β-Endosulfan
Ethion	Ethion
Carbophenothion	p,p'-DDT
p,p'-DDT	Carbophenothion
Methoxychlor	Methoxychlor
Phosalone	Cyhalothrin
Cyhalothrin (2 isomers)	cis-Permethrin
cis-Permethrin	Phosalone
trans-Permethrin	trans-Permethrin
Coumaphos	Cypermethrin (4 isomers)
Cypermethrin (4 isomers)	Coumaphos
Fenvalerate (2 isomers)	Fenvalerate (2 isomers)
Deltamethrin	Deltamethrin

A knowledge of the different responses the pesticides have with the 2 detectors is useful in identification of unknown peaks.

Once the pesticides have been identified, calculate the content of each pesticide using the following expression:

$$C_P = \frac{P_P \times D \times C_e}{P_e} \times \frac{100}{R_{cf}}$$

- $C_p$  = concentration of identified pesticide (ppm);  
 $P_p$  = peak area of the individual pesticide in the test sample obtained;  
 $C_e$  = concentration of the individual pesticide in the external standard (ppm);  
 $P_e$  = peak area of the individual pesticide in the external standard;  
 $D$  = dilution factor;  
 $R_{cf}$  = recovery correction factor.

The dilution factor ( $D$ ) can be defined as follows:

$$\frac{V_1}{m \times \frac{V_2}{V_3}}$$

- $V_1$  = volume of sample obtained after the 2<sup>nd</sup> evaporation stage;  
 $m$  = sample weight;  
 $V_2$  = GPC injection volume;  
 $V_3$  = sample volumetric flask volume.

*Chromatographic system A:*

*Precolumn:*

- *material:* deactivated silica;
- *size:*  $l = 4.5$  m,  $\emptyset = 0.53$  mm.

*Column:*

- *material:* fused silica;
- *size:*  $l = 60$  m,  $\emptyset = 0.25$  mm;
- *stationary phase:* poly(dimethyl)(diphenyl)siloxane R (film thickness 0.25 µm).

*Carrier gas:* helium for chromatography R.

*Linear velocity:* 25 cm/s.

*Pressure:* 180 kPa.

*Temperature:*

	Time (min)	Temperature (°C)
Column	0 - 1	75
	1 - 5	75 → 175
	5 - 30	175 → 275
	30 - 40	275 → 285
	40 - 55	285
Injection port		300
Detector		350

*Detection:* electron capture or thermionic specific detector.

*Injection:* 2 µL.

*Chromatographic system B* which may be used for confirmation analysis:

*Precolumn:*

- *material:* deactivated silica;
- *size:*  $l = 4.5$  m,  $\emptyset = 0.53$  mm.

*Column:*

- *material:* fused silica;
- *size:*  $l = 60$  m,  $\emptyset = 0.25$  mm;
- *stationary phase:* poly(cyanopropyl)(7)(phenyl)(7)(methyl)(86)siloxane R (film thickness 0.25 µm).

*Carrier gas:* helium for chromatography R.

*Linear velocity:* 25 cm/s.

*Pressure:* 180 kPa.

## Temperature:

	Time (min)	Temperature (°C)
Column	0 - 1	75
	1 - 5	75 → 175
	5 - 30	175 → 275
	30 - 40	275 → 285
	40 - 55	285
Injection port		300
Detector		350

**Detection:** electron capture or thermionic specific detector.

**Injection:** 2 µL.

**Chlorides:** maximum 150 ppm.

Boil 1.0 g with 20 mL of *ethanol (90 per cent V/V) R* in a round-bottomed flask fitted with a reflux condenser for 5 min. Cool, add 40 mL of *water R* and 0.5 mL of *nitric acid R* and filter. To the filtrate add 0.15 mL of a 10 g/L solution of *silver nitrate R* in *ethanol (90 per cent V/V) R*. Allow to stand for 5 min protected from light. Any opalescence in the solution is not more intense than that in a standard prepared at the same time by adding 0.15 mL of a 10 g/L solution of *silver nitrate R* in *ethanol (90 per cent V/V) R* to a mixture of 0.2 mL of 0.02 M *hydrochloric acid*, 20 mL of *ethanol (90 per cent V/V) R*, 40 mL of *water R* and 0.5 mL of *nitric acid R*.

**Loss on drying (2.2.32):** maximum 0.5 per cent, determined on 1.000 g by drying in an oven at 105 °C for 1 h.

**Sulfated ash (2.4.14):** maximum 0.15 per cent.

Ignite 5.0 g and use the residue to determine the sulfated ash.

## STORAGE

At a temperature not exceeding 25 °C.

## LABELLING

The label states, where applicable, the concentration of added butylhydroxytoluene.

01/2008:0969  
corrected 6.0

## WOOL FAT, HYDROGENATED

## Adeps lanae hydrogenatus

## DEFINITION

Mixture of higher aliphatic alcohols and sterols obtained from the direct, high-pressure, high-temperature hydrogenation of *wool fat (0134)* during which the esters and acids present are reduced to the corresponding alcohols. It may contain butylhydroxytoluene.

## CHARACTERS

**Appearance:** white or pale yellow, unctuous substance.

**Solubility:** practically insoluble in water, soluble in boiling alcohol and in light petroleum.

## IDENTIFICATION

**First identification:** B.

**Second identification:** A, C.

A. Melting point (see Tests).

B. Examine the chromatograms obtained in the test for fatty alcohols and sterols.

**Results:** the principal peaks in the chromatogram obtained with the test solution are similar in retention time and size to the principal peaks in the chromatogram obtained with reference solution (a).

C. Dissolve 50 mg in 5 mL of *methylene chloride R* and add 1 mL of *acetic anhydride R* and 0.1 mL of *sulfuric acid R*. A green colour is produced.

## TESTS

**Melting point (2.2.15):** 45 °C to 55 °C. Allow to stand at 20 °C for 16 h.

**Acid value (2.5.1):** maximum 1.0, determined on 5.0 g.

**Hydroxyl value (2.5.3, Method A):** 140 to 180.

**Saponification value (2.5.6):** maximum 8.0. Heat under reflux for 4 h.

**Fatty alcohols and sterols.** Gas chromatography (2.2.28).

**Test solution.** Dissolve 0.25 g of the substance to be examined in 60 mL of *ethanol R* and dilute to 100.0 mL with the same solvent.

**Reference solution (a).** Dissolve 0.25 g of *hydrogenated wool fat CRS* in 60 mL of *ethanol R* and dilute to 100.0 mL with the same solvent.

**Reference solution (b).** Dissolve 50 mg of *cetyl alcohol CRS* and 50 mg of *stearyl alcohol CRS* in 60 mL of *ethanol R* and dilute to 100.0 mL with the same solvent.

**Column:**

- **material:** fused silica,
- **size:**  $l = 30$  m,  $\varnothing = 0.25$  mm,
- **stationary phase:** *poly(dimethyl)siloxane R* or another non-polar phase (film thickness: 0.25 µm).

**Carrier gas:** *helium for chromatography R* at a pressure of 100 kPa

**Temperature:**

	Time (min)	Temperature (°C)
Column	0 - 5	100
	5 - 45	100 → 300
	45 - 60	300
Injection port		325
Detector		350

**Detection:** flame ionisation.

**Injection:** 1 µL.

The chromatogram obtained with the test solution does not differ significantly from the chromatogram obtained with reference solution (a) (Figure 0969-1) and it does not show enhanced peaks with retention times corresponding to cetyl alcohol and stearyl alcohol present in the chromatogram obtained with reference solution (b).

**Heavy metals (2.4.8):** maximum 10 ppm.

2.0 g complies with test C. Prepare the reference solution using 2 mL of *lead standard solution (10 ppm Pb) R*.

**Loss on drying (2.2.32):** maximum 3.0 per cent, determined on 2.000 g by drying in an oven at 105 °C for 1 h.

**Total ash (2.4.16):** maximum 0.1 per cent, determined on 5.0 g.

## STORAGE

In a well-filled container, protected from light.

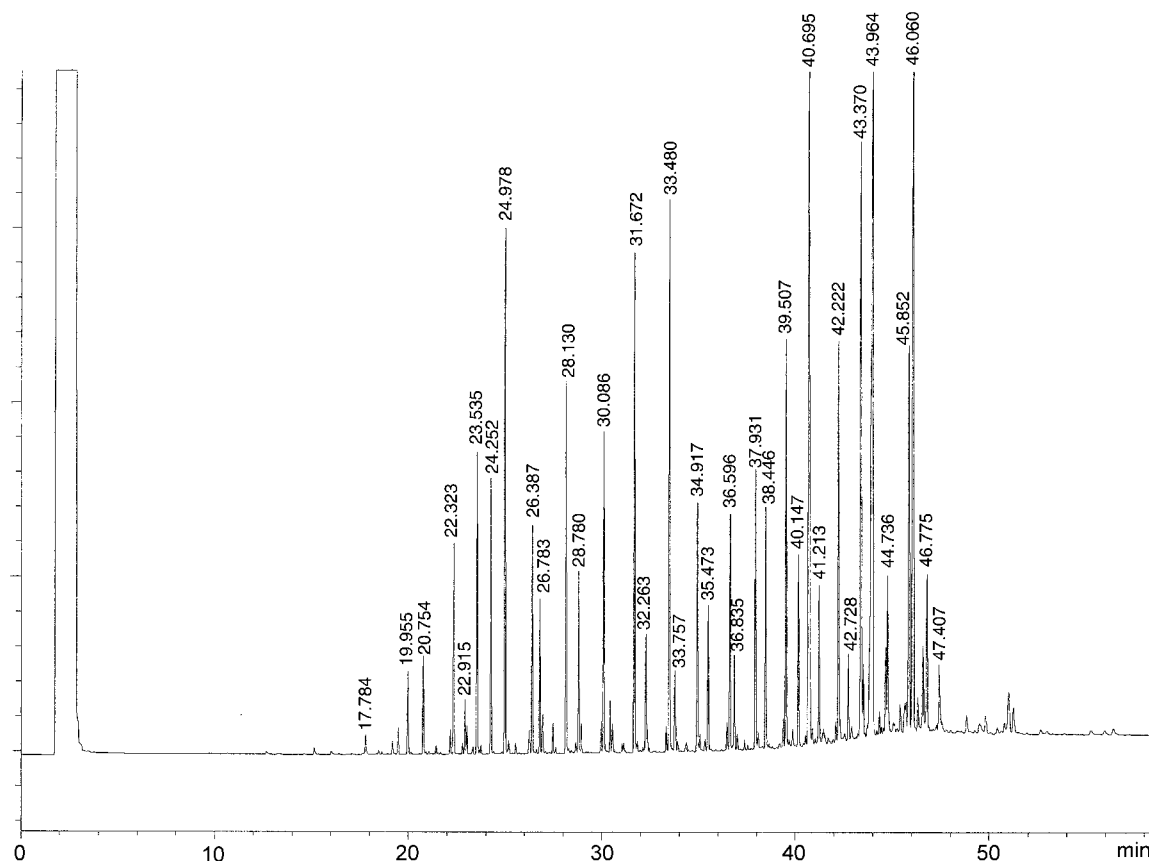

Figure 0969.-1. – Chromatogram for the test for fatty alcohols and sterols (reference solution (a)) in hydrogenated wool fat

## WOOL FAT, HYDROUS

### Adeps lanae cum aqua

#### DEFINITION

Mixture of 75 per cent *m/m* of wool fat and 25 per cent *m/m* of water. It is obtained by the gradual addition of water to melted wool fat with continuous stirring. It may contain not more than 150 ppm of butylhydroxytoluene.

#### CHARACTERS

*Appearance*: pale yellow, unctuous substance.

#### IDENTIFICATION

- In a test-tube, dissolve 0.5 g in 5 mL of *chloroform R* and add 1 mL of *acetic anhydride R* and 0.1 mL of *sulfuric acid R*. A green colour develops.
- Dissolve 50 mg in 5 mL of *chloroform R*, add 5 mL of *sulfuric acid R* and shake. A red colour develops and an intense green fluorescence appears in the lower layer.

#### TESTS

**Water-soluble acid or alkaline substances.** Melt 6.7 g on a water-bath and shake vigorously for 2 min with 75 mL of *water R* previously heated to 90-95 °C. Allow to cool and filter through filter paper previously rinsed with *water R*. To 60 mL of the filtrate (which may not be clear) add 0.25 mL of *bromothymol blue solution RI*. Not more than 0.2 mL of 0.02 M *hydrochloric acid* or 0.15 mL of 0.02 M *sodium hydroxide* is required to change the colour of the indicator.

**Drop point (2.2.17):** 38 °C to 44 °C.

To fill the metal cup, melt the residue obtained in the test for wool-fat content on a water-bath, cool to about 50 °C, pour into the cup and allow to stand at 15-20 °C for 24 h.

**01/2008:0135 Water-absorption capacity.** Place 10 g of the residue obtained in the test for wool-fat content in a mortar. Add *water R* in portions of 0.2-0.5 mL from a burette, stirring vigorously after each addition to incorporate the *water R*. The end-point is reached when visible droplets remain which cannot be incorporated. Not less than 20 mL of *water R* is absorbed.

**Acid value (2.5.1):** maximum 0.8, determined on 5.0 g dissolved in 25 mL of the prescribed mixture of solvents.

**Peroxide value (2.5.5, Method A):** maximum 15.

**Saponification value (2.5.6):** 67 to 79, determined on 2.00 g while heating under reflux for 4 h.

**Water-soluble oxidisable substances.** To 10 mL of the filtrate obtained in the test for water-soluble acid or alkaline substances add 1 mL of *dilute sulfuric acid R* and 0.1 mL of 0.02 M *potassium permanganate*. After 10 min, the solution is not completely decolourised.

**Butylhydroxytoluene.** Gas chromatography (2.2.28).

**Internal standard solution.** Dissolve 0.2 g of *methyl decanoate R* in *carbon disulfide R* and dilute to 100.0 mL with the same solvent. Dilute 1.0 mL of this solution to 10.0 mL with *carbon disulfide R*.

**Test solution (a).** Dissolve 1.0 g of the residue obtained in the test for wool-fat content in *carbon disulfide R* and dilute to 10.0 mL with the same solvent.

**Test solution (b).** Dissolve 1.0 g of the residue obtained in the test for wool-fat content in *carbon disulfide R*, add 1.0 mL of the internal standard solution and dilute to 10.0 mL with *carbon disulfide R*.

**Reference solution.** Dissolve 0.2 g of *butylhydroxytoluene R* in *carbon disulfide R* and dilute to 100.0 mL with the same solvent. Dilute 1.0 mL of the solution to 10.0 mL with *carbon disulfide R*. To 1.0 mL of this solution add 1.0 mL of the internal standard solution and dilute to 10.0 mL with *carbon disulfide R*.

**Column:**

- size:  $l = 1.5$  m,  $\varnothing = 4$  mm;
- stationary phase: silanised diatomaceous earth for gas chromatography R impregnated with 10 per cent *m/m* of poly(dimethyl)siloxane R.

The column is preceded by a column containing silanised glass wool.

Carrier gas: nitrogen for chromatography R.

Flow rate: 40 mL/min.

**Temperature:**

- column: 150 °C;
- injection port: 180 °C;
- detector: 300 °C.

Detection: flame ionisation.

**Limit:**

- butylhydroxytoluene: maximum 150 ppm.

**Paraffins:** maximum 1.0 per cent.

*The tap and cotton plugs used must be free from grease.*

Prepare a column of anhydrous aluminium oxide 230 mm long and 20 mm in diameter by adding a slurry of anhydrous aluminium oxide R and light petroleum R1 to a glass tube fitted with a tap and containing light petroleum R1. Allow to settle and reduce the depth of the layer of solvent above the column to about 40 mm. Dissolve 3.0 g of the residue obtained in the test for wool-fat content in 50 mL of warm light petroleum R1, cool, pass the solution through the column at a rate of 3 mL/min and wash with 250 mL of light petroleum R1.

Concentrate the combined eluate and washings to low bulk by distillation, evaporate to dryness on a water-bath and heat the residue at 105 °C for periods of 10 min until 2 successive weighings do not differ by more than 1 mg. The residue weighs a maximum of 30 mg.

**Chlorides:** maximum 115 ppm.

Boil 1.3 g with 20 mL of ethanol (90 per cent V/V) R under a reflux condenser for 5 min. Cool, add 40 mL of water R and 0.5 mL of nitric acid R and filter. To the filtrate add 0.15 mL of a 10 g/L solution of silver nitrate R in ethanol (90 per cent V/V) R. Allow to stand for 5 min, protected from light. Any opalescence in the solution is not more intense than that in a standard prepared at the same time by adding 0.15 mL of a 10 g/L solution of silver nitrate R in ethanol (90 per cent V/V) R to a mixture of 0.2 mL of 0.02 M hydrochloric acid, 20 mL of ethanol (90 per cent V/V) R, 40 mL of water R and 0.5 mL of nitric acid R.

**Sulfated ash (2.4.14):** maximum 0.1 per cent.

Ignite 5.0 g and use the residue.

**Wool-fat content:** 72.5 per cent to 77.5 per cent.

In a suitable tared dish containing a glass rod, heat 30.0 g to constant mass on a water-bath, stirring continuously. Weigh the residue.

**STORAGE**

At a temperature not exceeding 25 °C.

**LABELLING**

The label states, where applicable, the concentration of added butylhydroxytoluene.

**XANTHAN GUM****Xanthani gummi**

[11138-66-2]

**DEFINITION**

High-molecular-mass anionic polysaccharide produced by fermentation of carbohydrates with *Xanthomonas campestris*. It consists of a principal chain of  $\beta(1\rightarrow4)$ -linked D-glucose units with trisaccharide side chains, on alternating anhydroglucose units, consisting of 1 glucuronic acid unit included between 2 mannose units. Most of the terminal units contain a pyruvate moiety and the mannose unit adjacent to the principal chain may be acetylated at C-6.

Xanthan gum has a relative molecular mass of approximately  $1 \times 10^6$ . It exists as the sodium, potassium or calcium salt.

*Content*: minimum 1.5 per cent of pyruvoyl groups ( $C_3H_3O_2$ ;  $M_r$  71.1) (dried substance).

**CHARACTERS**

*Appearance*: white or yellowish-white, free-flowing powder.

*Solubility*: soluble in water giving a highly viscous solution, practically insoluble in organic solvents.

**IDENTIFICATION**

A. In a flask, suspend 1 g in 15 mL of 0.1 M hydrochloric acid. Close the flask with a fermentation bulb containing barium hydroxide solution R and heat carefully for 5 min. The barium hydroxide solution shows a white turbidity.

B. To 300 mL of water R, previously heated to 80 °C and stirred rapidly with a mechanical stirrer in a 400 mL beaker, add, at the point of maximum agitation, a dry blend of 1.5 g of carob bean gum R and 1.5 g of the substance to be examined. Stir until the mixture forms a solution, and then continue stirring for 30 min or longer. Do not allow the water temperature to drop below 60 °C during stirring. Discontinue stirring and allow the mixture to stand for at least 2 h. A firm rubbery gel forms after the temperature drops below 40 °C but no such gel forms in a 1 per cent control solution of the sample prepared in the same manner but omitting the carob bean gum.

**TESTS**

**pH (2.2.3)**: 6.0 to 8.0 for a 10.0 g/L solution.

**2-Propanol**. Gas chromatography (2.2.28).

*Internal standard solution*. Dilute 0.50 g of 2-methyl-2-propanol R to 500 mL with water R.

*Test solution*. To 200 mL of water R in a 1000 mL round-bottomed flask, add 5.0 g of the substance to be examined and 1 mL of a 10 g/L emulsion of dimeticone R in liquid paraffin R, stopper the flask and shake for 1 h. Distil about 90.0 mL, mix the distillate with 4.0 mL of the internal standard solution and dilute to 100.0 mL with water R.

*Reference solution*. Dilute a suitable quantity of 2-propanol R, accurately weighed, with water R to obtain a solution having a known concentration of 2-propanol of about 1 mg/mL. To 4.0 mL of this solution add 4.0 mL of the internal standard solution and dilute to 100.0 mL with water R.

*Column*:

- size:  $l = 1.8$  m,  $\varnothing = 4.0$  mm;
- stationary phase: styrene-divinylbenzene copolymer R (149-177  $\mu$ m).

*Carrier gas*: helium for chromatography R.

*Flow rate*: 30 mL/min.

**04/2009:1277** *Temperature*:

- column: 165 °C;
- injection port and detector: 200 °C.

*Detection*: flame ionisation.

*Injection*: 5  $\mu$ L.

*Relative retention* with reference to 2-propanol: 2-methyl-2-propanol = about 1.5.

*Limit*:

- 2-propanol: maximum 750 ppm.

**Other polysaccharides**. Thin-layer chromatography (2.2.27).

*Test solution*. To 10 mg of the substance to be examined in a thick-walled centrifuge test tube add 2 mL of a 230 g/L solution of trifluoroacetic acid R, shake vigorously to dissolve the forming gel, stopper the test tube, and heat the mixture at 120 °C for 1 h. Centrifuge the hydrolysate, transfer the clear supernatant liquid carefully into a 50 mL flask, add 10 mL of water R and evaporate the solution to dryness under reduced pressure. Take up the residue thus obtained in 10 mL of water R and evaporate to dryness under reduced pressure. Wash 3 times with 20 mL of methanol R and evaporate under reduced pressure. To the resulting clear film which has no odour of acetic acid, add 0.1 mL of water R and 1 mL of methanol R. Centrifuge to separate the amorphous precipitate. Dilute the supernatant liquid, if necessary, to 1 mL with methanol R.

*Reference solution*. Dissolve 10 mg of glucose R and 10 mg of mannose R in 2 mL of water R and dilute to 10 mL with methanol R.

*Plate*: TLC silica gel plate R.

*Mobile phase*: 16 g/L solution of sodium dihydrogen phosphate R, butanol R, acetone R (10:40:50 V/V/V).

*Application*: 5  $\mu$ L as bands.

*Development*: over a path of 15 cm.

*Detection*: spray with a solution of 0.5 g of diphenylamine R in 25 mL of methanol R to which 0.5 mL of aniline R and 2.5 mL of phosphoric acid R have been added. Heat for 5 min at 120 °C and examine in daylight.

*System suitability*: reference solution:

- the chromatogram shows 2 clearly separated greyish-brown zones due to glucose and mannose in the middle third.

*Results*: the chromatogram obtained with the test solution shows 2 zones corresponding to the zones due to glucose and mannose in the chromatogram obtained with the reference solution. In addition, 1 weak reddish and 2 faint bluish-grey bands may be visible just above the line of application. 1 or 2 bluish-grey bands may also be seen in the upper quarter of the chromatogram. No other bands are visible.

**Loss on drying (2.2.32)**: maximum 15.0 per cent, determined on 1.000 g by drying in an oven at 105 °C for 2.5 h.

**Total ash (2.4.16)**: 6.5 per cent to 16.0 per cent.

**Microbial contamination**

TAMC: acceptance criterion  $10^3$  CFU/g (2.6.12).

TYMC: acceptance criterion  $10^2$  CFU/g (2.6.12).

**ASSAY**

*Test solution*. Dissolve a quantity of the substance to be examined corresponding to 120.0 mg of the dried substance in water R and dilute to 20.0 mL with the same solvent.

*Reference solution*. Dissolve 45.0 mg of pyruvic acid R in water R and dilute to 500.0 mL with the same solvent.

Place 10.0 mL of the test solution in a 50 mL round-bottomed flask, add 20.0 mL of 0.1 M hydrochloric acid and weigh. Boil on a water-bath under a reflux condenser for 3 h.

Weigh and adjust to the initial mass with water R. In a separating funnel mix 2.0 mL of the solution with 1.0 mL of dinitrophenylhydrazine-hydrochloric solution R. Allow to stand for 5 min and add 5.0 mL of ethyl acetate R. Shake and allow the solids to settle. Collect the upper layer and shake with



3 quantities, each of 5.0 mL, of *sodium carbonate solution R*. Combine the aqueous layers and dilute to 50.0 mL with *sodium carbonate solution R*. Mix. Treat 10.0 mL of the reference solution at the same time and in the same manner as for the test solution.

Immediately measure the absorbance (2.2.25) of the 2 solutions at 375 nm, using *sodium carbonate solution R* as the compensation liquid.

The absorbance of the test solution is not less than that of the reference solution, which corresponds to a content of pyruvoyl groups of not less than 1.5 per cent.

#### FUNCTIONALITY-RELATED CHARACTERISTICS

*This section provides information on characteristics that are recognised as being relevant control parameters for one or more functions of the substance when used as an excipient (see chapter 5.15). This section is a non-mandatory part of the monograph and it is not necessary to verify the characteristics to demonstrate compliance. Control of these characteristics can however contribute to the quality of a medicinal product by improving the consistency of the manufacturing process and the performance of the medicinal product during use. Where control methods are cited, they are recognised as being suitable for the purpose, but other methods can also be used. Wherever results for a particular characteristic are reported, the control method must be indicated.*

*The following characteristics may be relevant for xanthan gum used as viscosity-increasing agent.*

**Apparent viscosity** (2.2.10): typically minimum 600 mPa·s.

Add 3.0 g within 45-90 s into 250 mL of a 12 g/L solution of *potassium chloride R* in a 500 mL beaker stirring with a low-pitch propeller-type stirrer rotating at 800 r/min. When adding the substance take care that agglomerates are destroyed. Add an additional quantity of 44 mL of *water R*, to rinse any adhering residue from the walls of the beaker. Stir the preparation at 800 r/min for 2 h whilst maintaining the temperature at  $24 \pm 1$  °C. Determine the viscosity within 15 min at  $24 \pm 1$  °C using a rotating viscosimeter set at 60 r/min and equipped with a rotating spindle 1.6 mm high and 12.7 mm in diameter which is attached to a shaft 3.2 mm in diameter. The distance from the top of the cylinder to the lower tip of the shaft should be 25.4 mm and the immersion depth 50.0 mm.

*The following characteristics may be relevant for xanthan gum used as matrix former in prolonged-release tablets.*

**Apparent viscosity**: see test above.

**Particle-size distribution** (2.9.31 or 2.9.38).

**Powder flow** (2.9.36).

#### CHARACTERS

**Appearance**: white or almost white, crystalline powder, hygroscopic.

**Solubility**: freely soluble in water, very soluble in methanol, freely soluble in methylene chloride.

#### IDENTIFICATION

A. Infrared absorption spectrophotometry (2.2.24).

*Comparison: xylazine hydrochloride CRS.*

B. It gives reaction (b) of chlorides (2.3.1).

#### TESTS

**Solution S**. Dissolve 5.0 g in *carbon dioxide-free water R* prepared from *distilled water R*, heating at 60 °C if necessary; allow to cool and dilute to 50.0 mL with the same solvent.

**Appearance of solution**. Solution S is not more opalescent than reference suspension II (2.2.1) and is colourless (2.2.2, Method II).

**pH** (2.2.3): 4.0 to 5.5 for solution S.

**Impurity A**: maximum 100 ppm.

**Solution A**. Dissolve 0.25 g of the substance to be examined in *methanol R* and dilute to 10 mL with the same solvent. This solution is used to prepare the test solution.

**Solution B**. Dissolve 50 mg of *2,6-dimethylaniline R* in *methanol R* and dilute to 100 mL with the same solvent. Dilute 1 mL of the solution to 100 mL with *methanol R*. This solution is used to prepare the reference solution.

Using 2 flat-bottomed tubes with an inner diameter of about 10 mm, place in the first tube 2 mL of solution A, and in the second tube 1 mL of solution B and 1 mL of *methanol R*. To each tube add 1 mL of a freshly prepared 10 g/L solution of *dimethylaminobenzaldehyde R* in *methanol R* and 2 mL of *glacial acetic acid R* and allow to stand at room temperature for 10 min. Compare the colours in diffused daylight, viewing vertically against a white background. Any yellow colour in the test solution is not more intense than that in the reference solution.

**Related substances**. Liquid chromatography (2.2.29). Prepare the solutions immediately before use.

**Solvent mixture**. Mix 8 volumes of *acetonitrile R*, 30 volumes of *methanol R* and 62 volumes of a 2.72 g/L solution of *potassium dihydrogen phosphate R* adjusted to pH 7.2 with *dilute sodium hydroxide solution R*.

**Test solution**. Dissolve 0.100 g of the substance to be examined in the solvent mixture and dilute to 20.0 mL with the solvent mixture.

**Reference solution (a)**. Dissolve 5.0 mg of the substance to be examined, 5.0 mg of *2,6-dimethylaniline R* (impurity A), 5.0 mg of *xylazine impurity C CRS* and 5.0 mg of *xylazine impurity E CRS* in *acetonitrile R* and dilute to 100.0 mL with the same solvent. Dilute 1.0 mL of this solution to 10.0 mL with the solvent mixture.

**Reference solution (b)**. With the aid of ultrasound, dissolve the contents of a vial of *xylazine impurity mixture CRS* (impurities B and D) in 1.0 mL of the solvent mixture.

**Column**:

- size:  $l = 0.15$  m,  $\varnothing = 3.9$  mm;
- stationary phase: end-capped octylsilyl silica gel for chromatography with polar incorporated groups R (5 µm);
- temperature: 40 °C.

**Mobile phase**:

- mobile phase A: mix 30 volumes of *methanol R* and 70 volumes of a 2.72 g/L solution of *potassium dihydrogen phosphate R* adjusted to pH 7.2 with *dilute sodium hydroxide solution R*;

07/2010:1481

## XYLAZINE HYDROCHLORIDE FOR VETERINARY USE

Xylazini hydrochloridum ad usum  
veterinarium

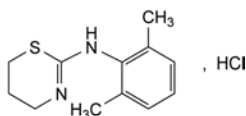

$C_{12}H_{17}ClN_2S$   
[23076-35-9]

$M_r$  256.8

#### DEFINITION

*N*-(2,6-Dimethylphenyl)-5,6-dihydro-4*H*-1,3-thiazin-2-amine hydrochloride.

**Content**: 98.0 per cent to 102.0 per cent (dried substance).

– mobile phase B: methanol R, acetonitrile R (30:70 V/V);

Time (min)	Mobile phase A (per cent V/V)	Mobile phase B (per cent V/V)
0 - 15	89 → 28	11 → 72
15 - 21	28	72

Flow rate: 1.0 mL/min.

Detection: spectrophotometer at 230 nm.

Equilibration: with a mixture of 28 volumes of mobile phase A and 72 volumes of mobile phase B for at least 30 min.

Injection: 20 µL.

Identification of impurities: use the chromatogram supplied with xylazine impurity mixture CRS and the chromatogram obtained with reference solution (b) to identify the peaks due to impurities B and D; use the chromatogram obtained with reference solution (a) to identify the peaks due to impurities A, C and E.

Relative retention with reference to xylazine (retention time = about 7.5 min): impurity D = about 0.5; impurity A = about 0.8; impurity B = about 1.3; impurity E = about 1.6; impurity C = about 2.2.

System suitability: reference solution (a):

– resolution: minimum 4.0 between the peaks due to impurity A and xylazine.

Limits:

- impurities B, D: for each impurity, not more than twice the area of the peak due to xylazine in the chromatogram obtained with reference solution (a) (0.2 per cent);
- impurities C, E: for each impurity, not more than twice the area of the corresponding peak in the chromatogram obtained with reference solution (a) (0.2 per cent);
- unspecified impurities: for each impurity, not more than twice the area of the peak due to xylazine in the chromatogram obtained with reference solution (a) (0.2 per cent);
- total of impurities other than B, C, D and E: not more than twice the area of the peak due to xylazine in the chromatogram obtained with reference solution (a) (0.2 per cent);
- disregard limit: 0.5 times the area of the peak due to xylazine in the chromatogram obtained with reference solution (a) (0.05 per cent); disregard any peak due to the blank.

Heavy metals (2.4.8): maximum 10 ppm.

12 mL of solution S complies with test A. Prepare the reference solution using 10 mL of lead standard solution (1 ppm Pb) R.

Loss on drying (2.2.32): maximum 0.5 per cent, determined on 1.000 g by drying in an oven at 105 °C for 2 h.

Sulfated ash (2.4.14): maximum 0.1 per cent, determined on 1.0 g.

#### ASSAY

Dissolve 0.200 g in 25 mL of ethanol (96 per cent) R. Add 25 mL of water R. Titrate with 0.1 M sodium hydroxide, determining the end-point potentiometrically (2.2.20).

1 mL of 0.1 M sodium hydroxide is equivalent to 25.68 mg of C<sub>12</sub>H<sub>17</sub>ClN<sub>2</sub>S.

#### STORAGE

In an airtight container, protected from light.

#### IMPURITIES

Specified impurities: A, B, C, D, E.

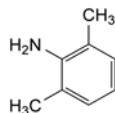

A. 2,6-dimethylaniline (2,6-xylidine),

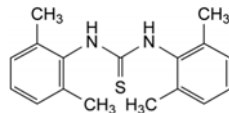

B. N,N'-bis(2,6-dimethylphenyl)thiourea,

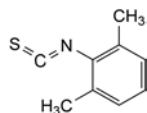

C. 2,6-dimethylphenyl isothiocyanate,

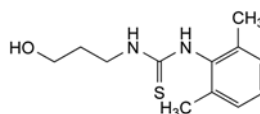

D. N-(2,6-dimethylphenyl)-N'-(3-hydroxypropyl)thiourea,

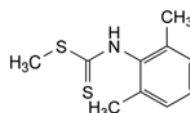

E. methyl (2,6-dimethylphenyl)carbamodithioate.

01/2009:1381

## XYLITOL

### Xylitolum

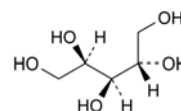

C<sub>5</sub>H<sub>12</sub>O<sub>5</sub>  
[87-99-0]

M<sub>r</sub> 152.1

#### DEFINITION

Meso-xylitol.

Content: 98.0 per cent to 102.0 per cent (anhydrous substance).

#### CHARACTERS

Appearance: white or almost white, crystalline powder or crystals.

Solubility: very soluble in water, sparingly soluble in ethanol (96 per cent).

#### IDENTIFICATION

First identification: B.

Second identification: A, C.

A. Melting point (2.2.14): 92 °C to 96 °C.

B. Infrared absorption spectrophotometry (2.2.24).

Preparation: mulls in liquid paraffin R.

Comparison: xylitol CRS.

C. Thin-layer chromatography (2.2.27).

Test solution. Dissolve 25 mg of the substance to be examined in water R and dilute to 5 mL with the same solvent.

Reference solution (a). Dissolve 25 mg of xylitol CRS in water R and dilute to 5 mL with the same solvent.

**Reference solution (b).** Dissolve 25 mg of *mannitol CRS* and 25 mg of *xylitol CRS* in *water R* and dilute to 5 mL with the same solvent.

**Plate:** *TLC silica gel G plate R*.

**Mobile phase:** *water R*, *ethyl acetate R*, *propanol R* (10:20:70 *V/V/V*).

**Application:** 2  $\mu$ L.

**Development:** over 3/4 of the plate.

**Drying:** in air.

**Detection:** spray with *4-aminobenzoic acid solution R*, dry in a current of cold air until the acetone is removed, then heat at 100 °C for 15 min; allow to cool, spray with a 2 g/L solution of *sodium periodate R*, dry in a current of cold air, then heat at 100 °C for 15 min.

**System suitability:** reference solution (b):

– the chromatogram shows 2 clearly separated spots.

**Results:** the principal spot in the chromatogram obtained with the test solution is similar in position, colour and size to the principal spot in the chromatogram obtained with reference solution (a).

## TESTS

**Appearance of solution.** The solution is not more opalescent than reference suspension IV (2.2.1) and not more intensely coloured than reference solution BY<sub>7</sub> (2.2.2, Method II).

Dissolve 2.5 g in *water R* and dilute to 50.0 mL with the same solvent.

**Conductivity (2.2.38):** maximum 20  $\mu$ S $\cdot$ cm<sup>-1</sup>.

Dissolve 20.0 g in *carbon dioxide-free water R* prepared from *distilled water R* and dilute to 100.0 mL with the same solvent. Measure the conductivity of the solution while gently stirring with a magnetic stirrer.

**Reducing sugars:** maximum 0.2 per cent, calculated as glucose equivalent.

Dissolve 5.0 g in 6 mL of *water R* with the aid of gentle heat. Cool and add 20 mL of *cupri-citric solution R* and a few glass beads. Heat so that boiling begins after 4 min and maintain boiling for 3 min. Cool rapidly and add 100 mL of a 2.4 per cent *V/V* solution of *glacial acetic acid R* and 20.0 mL of 0.025 *M* iodine. With continuous shaking, add 25 mL of a mixture of 6 volumes of *hydrochloric acid R* and 94 volumes of *water R* and, when the precipitate has dissolved, titrate the excess of iodine with 0.05 *M* sodium thiosulfate using 1 mL of *starch solution R*, added towards the end of the titration, as indicator. Not less than 12.8 mL of 0.05 *M* sodium thiosulfate is required.

**Related substances.** Gas chromatography (2.2.28).

**Internal standard solution.** Dissolve 5 mg of *erythritol R* in *water R* and dilute to 25.0 mL with the same solvent.

**Test solution (a).** Dissolve 5.000 g of the substance to be examined in *water R* and dilute to 100.0 mL with the same solvent.

**Test solution (b).** Dilute 1.0 mL of test solution (a) to 10.0 mL with *water R*.

**Reference solution (a).** Dissolve 5.0 mg each of *L-arabinitol CRS* (impurity A), *galactitol CRS* (impurity B), *mannitol CRS* (impurity C) and *sorbitol CRS* (impurity D) in *water R* and dilute to 20.0 mL with the same solvent.

**Reference solution (b).** Dissolve 50.0 mg of *xylitol CRS* in *water R* and dilute to 10.0 mL with the same solvent.

Pipette 1.0 mL of test solutions (a) and (b) and reference solutions (a) and (b) into 4 separate 100 mL round-bottomed flasks. Add 1.0 mL of the internal standard solution to each of the flasks containing test solution (a) or reference solution (a), and 5.0 mL of the internal standard solution to each of the flasks containing test solution (b) or reference solution (b). Evaporate each mixture to dryness in a water-bath at 60 °C

with the aid of a rotary evaporator. Dissolve each dry residue in 1 mL of *anhydrous pyridine R*, add 1 mL of *acetic anhydride R* to each flask and boil each solution under reflux for 1 h to complete acetylation.

**Column:**

– *size:* *l* = 30 m,  $\varnothing$  = 0.25 mm;

– *stationary phase:* poly(cyanopropylphenyl)(14)(methyl)-(86)siloxane *R* (0.25  $\mu$ m).

**Carrier gas:** *nitrogen R*.

**Flow rate:** 1 mL/min.

**Split ratio:** 1:50 to 1:100.

**Temperature:**

	Time (min)	Temperature (°C)
Column	0 - 1	170
	1 - 6	170 → 230
	6 - 30	230
Injection port		250
Detector		250

**Detection:** flame-ionisation.

**Injection:** 1  $\mu$ L of test solution (a) and reference solution (a) (solutions obtained after derivatisation).

**Relative retention** with reference to xylitol (retention time = about 15 min): internal standard = about 0.6; impurity A = about 0.9; impurity C = about 1.4; impurity B = about 1.45; impurity D = about 1.5.

**System suitability:** reference solution (a):

– *resolution:* minimum 2.0 between the peaks due to impurities B and D.

Calculate the percentage content of each related substance in the substance to be examined using the following expression:

$$100 \times \frac{m_s}{m_u} \times \frac{R_u}{R_s}$$

$m_s$  = mass of the particular component in 1 mL of reference solution (a), in milligrams;

$m_u$  = mass of the substance to be examined in 1 mL of test solution (a), in milligrams;

$R_s$  = ratio of the area of the peak due to the particular derivatised component to the area of the peak due to the derivatised internal standard in the chromatogram obtained with reference solution (a);

$R_u$  = ratio of the area of the peak due to the particular derivatised component to the area of the peak due to the derivatised internal standard in the chromatogram obtained with test solution (a).

The sum of the percentage contents of the related substances in the chromatogram obtained with test solution (a) is not greater than 2.0 per cent. Disregard any peak with an area corresponding to a percentage content of 0.05 per cent or less.

**Lead (2.4.10):** maximum 0.5 ppm.

Dissolve the substance to be examined in 150.0 mL of the prescribed mixture of solvents.

**Nickel (2.4.15):** maximum 1 ppm.

Dissolve the substance to be examined in 150.0 mL of the prescribed mixture of solvents.

**Water (2.5.12):** maximum 1.0 per cent, determined on 1.00 g.

**Bacterial endotoxins (2.6.14):** less than 4 IU/g if the concentration is less than 100 g/L of xylitol and less than 2.5 IU/g if the concentration is 100 g/L or more of xylitol, when intended for use in the manufacture of parenteral preparations without a further appropriate procedure for the removal of bacterial endotoxins.

## ASSAY

01/2008:1162  
corrected 7.0

Gas chromatography (2.2.28) as described in the test for related substances with the following modifications.

*Injection*: 1 µL of test solution (b) and reference solution (b) (solutions obtained after derivatisation).

Calculate the percentage content of C<sub>5</sub>H<sub>12</sub>O<sub>5</sub> using the following expression:

$$T \times \frac{m_t}{m_v} \times \frac{R_v}{R_t}$$

- T = declared percentage content of *xylitol CRS*;
- $m_t$  = mass of *xylitol CRS* in 1 mL of reference solution (b), in milligrams;
- $m_v$  = mass of the substance to be examined in 1 mL of test solution (b), in milligrams;
- $R_t$  = ratio of the area of the peak due to derivatised xylitol to the area of the peak due to the derivatised internal standard in the chromatogram obtained with reference solution (b);
- $R_v$  = ratio of the area of the peak due to derivatised xylitol to the area of the peak due to the derivatised internal standard in the chromatogram obtained with test solution (b).

## LABELLING

The label states:

- where applicable, the maximum concentration of bacterial endotoxins;
- where applicable, that the substance is suitable for use in the manufacture of parenteral preparations.

## IMPURITIES

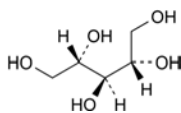

A. L-arabinitol,

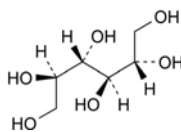

B. *meso*-galactitol,

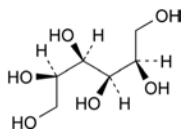

C. D-mannitol,

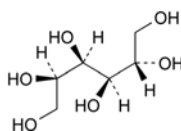

D. D-glucitol (D-sorbitol).

## XYLOMETAZOLINE HYDROCHLORIDE

## Xylometazolini hydrochloridum

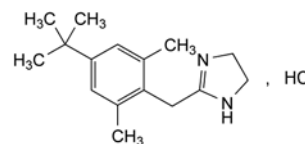

C<sub>16</sub>H<sub>25</sub>ClN<sub>2</sub>  
[1218-35-5]

$M_r$  280.8

## DEFINITION

2-[4-(1,1-Dimethylethyl)-2,6-dimethylbenzyl]-4,5-dihydro-1*H*-imidazole hydrochloride.

*Content*: 99.0 per cent to 101.0 per cent (dried substance).

## CHARACTERS

*Appearance*: white or almost white, crystalline powder.

*Solubility*: freely soluble in water, in ethanol (96 per cent) and in methanol.

## IDENTIFICATION

*First identification*: A, E.

*Second identification*: B, C, D, E.

A. Infrared absorption spectrophotometry (2.2.24).

*Comparison*: *xylometazoline hydrochloride CRS*.

B. Thin-layer chromatography (2.2.27).

*Test solution*. Dissolve 20 mg of the substance to be examined in *methanol R* and dilute to 5 mL with the same solvent.

*Reference solution*. Dissolve 20 mg of *xylometazoline hydrochloride CRS* in *methanol R* and dilute to 5 mL with the same solvent.

*Plate*: TLC silica gel G plate R.

*Mobile phase*: concentrated ammonia R, *methanol R* (5:100 V/V).

*Application*: 5 µL.

*Development*: over 2/3 of the plate.

*Drying*: in air.

*Chlorine treatment*: at the bottom of a chromatographic tank place a beaker containing a mixture of 1 volume of *hydrochloric acid R1*, 1 volume of *water R* and 2 volumes of a 15 g/L solution of *potassium permanganate R*. Close the tank and allow to stand for 15 min. Place the dried plate in the tank and reclose the tank. Leave the plate in contact with the chlorine vapour for 5 min. Withdraw the plate and place it in a current of cold air until the excess of chlorine is removed and an area of the coating below the points of application does not give a blue colour with a drop of *potassium iodide and starch solution R*.

*Detection*: spray with *potassium iodide and starch solution R*.

*Results*: the principal spot in the chromatogram obtained with the test solution is similar in position, colour and size to the principal spot in the chromatogram obtained with the reference solution.

C. Dissolve about 0.5 mg in 1 mL of *methanol R*. Add 0.5 mL of a freshly prepared 50 g/L solution of *sodium nitroprusside R* and 0.5 mL of a 20 g/L solution of *sodium hydroxide R*.

Allow to stand for 10 min and add 1 mL of an 80 g/L solution of *sodium bicarbonate R*. A violet colour develops.

D. Dissolve 0.2 g in 1 mL of *water R*, add 2.5 mL of *ethanol (96 per cent) R* and 2 mL of 1 M *sodium hydroxide*. Mix thoroughly and examine in ultraviolet light at 365 nm.

The solution shows no fluorescence or at most the same fluorescence as a blank solution prepared in the same manner. The identification is not valid unless a solution prepared in the same manner using *naphazoline hydrochloride CRS* instead of the substance to be examined shows a distinct bluish fluorescence.

E. It gives reaction (a) of chlorides (2.3.1).

#### TESTS

**Appearance of solution.** The solution is clear (2.2.1) and not more intensely coloured than reference solution Y<sub>6</sub> (2.2.2, Method II).

Dissolve 2.5 g in *water R* and dilute to 50.0 mL with the same solvent.

**Acidity or alkalinity.** Dissolve 0.25 g in *carbon dioxide-free water R* and dilute to 25 mL with the same solvent. Add 0.1 mL of *methyl red solution R* and 0.1 mL of 0.01 M *hydrochloric acid*. The solution is red. Not more than 0.2 mL of 0.01 M *sodium hydroxide* is required to change the colour of the indicator to yellow.

**Related substances.** Liquid chromatography (2.2.29).

**Test solution.** Dissolve 50.0 mg of the substance to be examined in *water R* and dilute to 50.0 mL with the same solvent. Allow to stand for 1 h before injection.

**Reference solution (a).** Dilute 5.0 mL of the test solution to 100.0 mL with *water R*. Dilute 2.0 mL of this solution to 100.0 mL with *water R*.

**Reference solution (b).** Dissolve 5.0 mg of *xylometazoline impurity A CRS* and 5 mg of the substance to be examined in *water R* and dilute to 50.0 mL with the same solvent. Dilute 10.0 mL of this solution to 50.0 mL with *water R*.

**Reference solution (c).** Dilute 5.0 mL of reference solution (b) to 50.0 mL with *water R*.

**Column:**

- size:  $l = 0.25$  m,  $\varnothing = 4.6$  mm;
- stationary phase: end-capped octadecylsilyl silica gel for chromatography with polar incorporated groups R (5  $\mu$ m).

**Mobile phase:**

- mobile phase A: 1.36 g/L solution of *potassium dihydrogen phosphate R* adjusted to pH 3.0 with *phosphoric acid R*;
- mobile phase B: *acetonitrile R1*;

Time (min)	Mobile phase A (per cent V/V)	Mobile phase B (per cent V/V)
0 - 5	70	30
5 - 20	70 → 15	30 → 85
20 - 35	15	85

**Flow rate:** 1.0 mL/min.

**Detection:** spectrophotometer at 220 nm.

**Injection:** 10  $\mu$ L.

**Relative retention** with reference to *xylometazoline* (retention time = about 7.2 min): impurity A = about 0.79.

**System suitability:** reference solution (b):

- resolution: minimum 2.5 between the peaks due to impurity A and *xylometazoline*.

**Limits:**

- impurity A: not more than the area of the corresponding peak in the chromatogram obtained with reference solution (c) (0.2 per cent);
- unspecified impurities: for each impurity, not more than the area of the principal peak in the chromatogram obtained with reference solution (a) (0.10 per cent);
- total: not more than 5 times the area of the principal peak in the chromatogram obtained with reference solution (a) (0.5 per cent);

- disregard limit: 0.5 times the area of the principal peak in the chromatogram obtained with reference solution (a) (0.05 per cent).

**Loss on drying** (2.2.32): maximum 0.5 per cent, determined on 1.000 g by drying in an oven at 105 °C.

**Sulfated ash** (2.4.14): maximum 0.1 per cent, determined on 1.0 g.

#### ASSAY

Dissolve 0.200 g in 25 mL of *anhydrous acetic acid R* and add 10 mL of *acetic anhydride R*. Titrate with 0.1 M *perchloric acid*, determining the end-point potentiometrically (2.2.20).

1 mL of 0.1 M *perchloric acid* is equivalent to 28.08 mg of C<sub>16</sub>H<sub>25</sub>ClN<sub>2</sub>.

#### STORAGE

Protected from light.

#### IMPURITIES

**Specified impurities:** A.

**Other detectable impurities** (the following substances would, if present at a sufficient level, be detected by one or other of the tests in the monograph. They are limited by the general acceptance criterion for other/unspecified impurities and/or by the general monograph *Substances for pharmaceutical use* (2034). It is therefore not necessary to identify these impurities for demonstration of compliance. See also 5.10. *Control of impurities in substances for pharmaceutical use*): B, C, D, E, F.

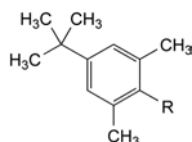

A. R = CH<sub>2</sub>-CO-NH-CH<sub>2</sub>-CH<sub>2</sub>-NH<sub>2</sub>: *N*-(2-aminoethyl)-2-[4-(1,1-dimethylethyl)-2,6-dimethylphenyl]acetamide,

B. R = CH<sub>2</sub>-Cl: 2-(chloromethyl)-5-(1,1-dimethylethyl)-1,3-dimethylbenzene,

C. R = CH<sub>2</sub>-CN: [4-(1,1-dimethylethyl)-2,6-dimethylphenyl]acetonitrile,

D. R = H: 1-(1,1-dimethylethyl)-3,5-dimethylbenzene,

F. CH<sub>2</sub>-CO<sub>2</sub>H: [4-(1,1-dimethylethyl)-2,6-dimethylphenyl]acetic acid,

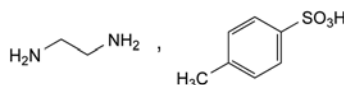

E. ethane-1,2-diamine mono(4-methylbenzenesulfonate).

01/2008:1278  
corrected 6.0

## XYLOSE

### Xylosum

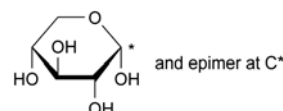

C<sub>5</sub>H<sub>10</sub>O<sub>5</sub>  
[58-86-6]

M<sub>r</sub> 150.1

#### DEFINITION

(+)-D-Xylopyranose.

## CHARACTERS

*Appearance*: white or almost white, crystalline powder or colourless needles.

*Solubility*: freely soluble in water, soluble in hot ethanol (96 per cent).

## IDENTIFICATION

*First identification*: A.

*Second identification*: B, C.

A. Infrared absorption spectrophotometry (2.2.24).

*Preparation*: discs.

*Comparison*: xylose CRS.

B. Thin-layer chromatography (2.2.27).

*Solvent mixture*: water R, methanol R (2:3 V/V).

*Test solution*. Dissolve 10 mg of the substance to be examined in the solvent mixture and dilute to 20 mL with the solvent mixture.

*Reference solution (a)*. Dissolve 10 mg of xylose CRS in the solvent mixture and dilute to 20 mL with the solvent mixture.

*Reference solution (b)*. Dissolve 10 mg of fructose R, 10 mg of glucose R and 10 mg of xylose R in the solvent mixture and dilute to 20 mL with the solvent mixture.

*Plate*: TLC silica gel plate R.

*Mobile phase*: water R, methanol R, anhydrous acetic acid R, ethylene chloride R (10:15:25:50 V/V/V/V); measure the volumes accurately since a slight excess of water produces cloudiness.

*Application*: 2 µL; thoroughly dry the points of application.

*Development*: over a path of 15 cm.

*Drying*: in a current of warm air.

*Detection*: spray with a 5 g/L solution of thymol R in a mixture of 5 volumes of sulfuric acid R and 95 volumes of ethanol (96 per cent) R. Heat in an oven at 130 °C for 10 min.

*System suitability*: reference solution (b):

– the chromatogram shows 3 clearly separated spots.

*Results*: the principal spot in the chromatogram obtained with the test solution is similar in position, colour and size to the principal spot in the chromatogram obtained with reference solution (a).

C. Dissolve 0.1 g in 10 mL of water R. Add 3 mL of cupri-tartaric solution R and heat. An orange or red precipitate is formed.

## TESTS

**Solution S**. Dissolve 10.0 g in carbon dioxide-free water R and dilute to 100 mL with the same solvent.

**Appearance of solution**. Solution S is clear (2.2.1) and colourless (2.2.2, Method II).

**Acidity or alkalinity**. To 50 mL of solution S add 0.3 mL of phenolphthalein solution RI. The solution is colourless. Not more than 0.2 mL of 0.1 M sodium hydroxide is required to change the colour of the indicator to pink.

**Specific optical rotation** (2.2.7): + 18.5 to + 19.5 (dried substance).

Dissolve 10.0 g in 80 mL of water R, add 1 mL of dilute ammonia R2 and dilute to 100.0 mL with water R. Allow to stand for 30 min.

**Chlorides** (2.4.4): maximum 330 ppm.

Dilute 1.5 mL of solution S to 15 mL with water R.

**Heavy metals** (2.4.8): maximum 20 ppm.

12 mL of solution S complies with test A. Prepare the reference solution using lead standard solution (2 ppm Pb) R.

**Loss on drying** (2.2.32): maximum 0.5 per cent, determined on 1.000 g by drying in an oven at 105 °C at a pressure not exceeding 0.7 kPa.

**Sulfated ash** (2.4.14): maximum 0.1 per cent, determined on 1.0 g.

01/2008:2172 *Relative retention* with reference to yohimbine (retention time = about 7 min): impurity F = about 0.65; impurity G = about 0.70; impurity A = about 0.75.

## YOHIMBINE HYDROCHLORIDE

### Yohimbini hydrochloridum

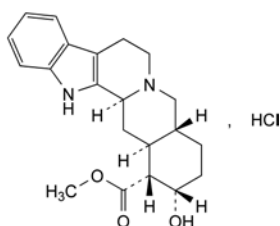

$C_{21}H_{27}ClN_2O_3$   
[65-19-0]

$M_r$  390.9

#### DEFINITION

Methyl 17 $\alpha$ -hydroxyyohimban-16 $\alpha$ -carboxylate hydrochloride.

*Content*: 97.0 per cent to 102.0 per cent (dried substance).

#### CHARACTERS

*Appearance*: white or slightly yellowish, crystalline powder.

*Solubility*: sparingly soluble in water, practically insoluble in ethanol (96 per cent) and in methylene chloride.

#### IDENTIFICATION

A. Infrared absorption spectrophotometry (2.2.24).

*Comparison*: yohimbine hydrochloride CRS.

B. It gives reaction (a) of chlorides (2.3.1).

#### TESTS

**Solution S.** Dissolve 0.500 g in carbon dioxide-free water R with heating, allow to cool to room temperature and dilute to 50.0 mL with the same solvent.

**pH** (2.2.3): 3.5 to 5.5 for solution S.

**Specific optical rotation** (2.2.7): + 101.0 to + 105.0 (dried substance), determined on solution S.

**Related substances.** Liquid chromatography (2.2.29). Prepare the solutions protected from light.

*Test solution.* Dissolve 10.0 mg of the substance to be examined in methanol R and dilute to 50.0 mL with the same solvent.

*Reference solution (a).* Dissolve 5.0 mg of yohimbine hydrochloride CRS (containing impurities A, F and G) in methanol R and dilute to 25.0 mL with the same solvent.

*Reference solution (b).* Dilute 1.0 mL of reference solution (a) to 100.0 mL with methanol R.

*Reference solution (c).* Dilute 1.0 mL of reference solution (b) to 10.0 mL with methanol R.

*Column*:

- size:  $l = 0.125$  m,  $\varnothing = 4.0$  mm;
- stationary phase: octylsilyl silica gel for chromatography R (4  $\mu$ m);
- temperature: 40 °C.

*Mobile phase*: mix 50 mL of a 9.08 g/L solution of potassium dihydrogen phosphate R, 100 mL of an 11.88 g/L solution of disodium hydrogen phosphate dihydrate R, 285 mL of acetonitrile R, 4.0 g of sodium laurylsulfate R and 355 mL of water R.

*Flow rate*: 1.5 mL/min.

*Detection*: spectrophotometer at 229 nm.

*Injection*: 10  $\mu$ L.

*Run time*: 3 times the retention time of yohimbine.

*System suitability*: reference solution (a):

- *peak-to-valley ratio*: minimum 1.3, where  $H_p$  = height above the baseline of the peak due to impurity G and  $H_v$  = height above the baseline of the lowest point of the curve separating this peak from the peak due to impurity A; and minimum 1.3, where  $H_p$  = height above the baseline of the peak due to impurity G and  $H_v$  = height above the baseline of the lowest point of the curve separating this peak from the peak due to impurity F.

*Limits*:

- *sum of impurities A and G*: not more than the area of the principal peak in the chromatogram obtained with reference solution (b) (1.0 per cent);
- *impurity F*: not more than 4 times the area of the principal peak in the chromatogram obtained with reference solution (c) (0.4 per cent);
- *unspecified impurities*: for each impurity, not more than the area of the principal peak in the chromatogram obtained with reference solution (c) (0.10 per cent);
- *total*: not more than twice the area of the principal peak in the chromatogram obtained with reference solution (b) (2.0 per cent);
- *disregard limit*: 0.5 times the area of the principal peak in the chromatogram obtained with reference solution (c) (0.05 per cent).

**Loss on drying** (2.2.32): maximum 0.5 per cent, determined on 1.000 g by drying in an oven at 105 °C.

**Sulfated ash** (2.4.14): maximum 0.1 per cent, determined on 1.0 g.

#### ASSAY

Liquid chromatography (2.2.29) as described in the test for related substances with the following modification.

*Injection*: test solution and reference solution (a).

Calculate the percentage content of  $C_{21}H_{27}ClN_2O_3$  from the declared content of yohimbine hydrochloride CRS.

#### STORAGE

In an airtight container, protected from light.

#### IMPURITIES

*Specified impurities*: A, F, G.

*Other detectable impurities* (the following substances would, if present at a sufficient level, be detected by one or other of the tests in the monograph. They are limited by the general acceptance criterion for other/unspecified impurities and/or by the general monograph *Substances for pharmaceutical use* (2034). It is therefore not necessary to identify these impurities for demonstration of compliance. See also 5.10. *Control of impurities in substances for pharmaceutical use*): B, C, D, E.

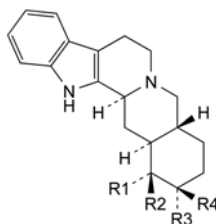

- A. R1 = CO-OCH<sub>3</sub>, R2 = R3 = H, R4 = OH: methyl 17 $\beta$ -hydroxyyohimban-16 $\alpha$ -carboxylate ( $\beta$ -yohimbine),
- C. R1 = R4 = H, R2 = CO-OCH<sub>3</sub>, R3 = OH: methyl 17 $\alpha$ -hydroxyyohimban-16 $\beta$ -carboxylate (corynantheine),

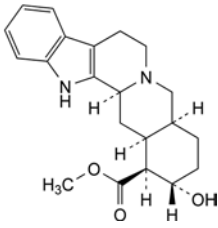

B. methyl 17 $\alpha$ -hydroxy-20 $\alpha$ -yohimban-16 $\beta$ -carboxylate ( $\alpha$ -yohimbine),

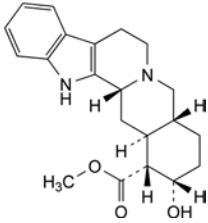

D. methyl 17 $\alpha$ -hydroxy-3 $\beta$ -yohimban-16 $\alpha$ -carboxylate (pseudo-yohimbine),

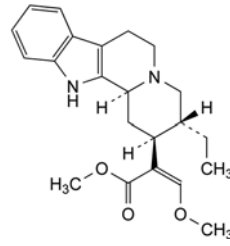

E. methyl (2*Z*)-2-[(2*S*,3*R*,12*bS*)-3-ethyl-1,2,3,4,6,7,12,12*b*-octahydroindolo[2,3-*a*]quinolizin-2-yl]-3-methoxyprop-2-enoate,

F. unknown structure,

G. unknown structure.



07/2009:1059

**ZIDOVUDINE**

## Zidovudinum

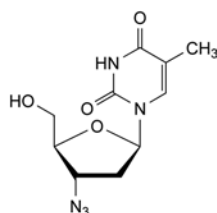

$C_{10}H_{13}N_5O_4$   
[30516-87-1]

 $M_r$  267.2**DEFINITION**

1-(3-Azido-2,3-dideoxy-β-D-erythro-pentofuranosyl)-5-methylpyrimidine-2,4(1*H*,3*H*)-dione.

*Content*: 97.0 per cent to 102.0 per cent (dried substance).

**CHARACTERS**

*Appearance*: white or brownish powder.

*Solubility*: sparingly soluble in water, soluble in anhydrous ethanol.

mp: about 124 °C.

It shows polymorphism (5.9).

**IDENTIFICATION**

Infrared absorption spectrophotometry (2.2.24).

*Comparison*: zidovudine CRS.

If the spectra obtained in the solid state show differences, dissolve the substance to be examined and the reference substance separately in the minimum volume of *water R*, evaporate to dryness in a desiccator, under high vacuum over *diphosphorus pentoxide R* and record new spectra using the residues.

**TESTS**

**Appearance of solution.** The solution is not more intensely coloured than reference solution BY<sub>5</sub> (2.2.2, *Method II*).

Dissolve 0.5 g in 50 mL of *water R*, heating if necessary.

**Specific optical rotation** (2.2.7): + 60.5 to + 63.0 (dried substance).

Dissolve 0.50 g in *anhydrous ethanol R* and dilute to 50.0 mL with the same solvent. Carry out the determination at 25 °C.

**Related substances**

A. Thin-layer chromatography (2.2.27).

*Test solution.* Dissolve 0.20 g of the substance to be examined in *methanol R* and dilute to 10 mL with the same solvent.

*Reference solution (a).* Dissolve 5 mg of *thymine R* (impurity C), 5 mg of *zidovudine impurity A CRS* and 5 mg of *triphenylmethanol R* (impurity D) in *methanol R*, add 0.25 mL of the test solution and dilute to 25 mL with *methanol R*.

*Reference solution (b).* Dilute 5.0 mL of reference solution (a) to 10 mL with *methanol R*.

*Plate*: TLC silica gel  $F_{254}$  plate *R*.

*Mobile phase*: *methanol R*, *methylene chloride R* (10:90 V/V).

*Application*: 10 µL.

*Development*: over a path of 12 cm.

*Drying*: in air.

*Detection A*: examine in ultraviolet light at 254 nm.

*Limits*:

- *impurity A*: any spot due to impurity A is not more intense than the corresponding spot in the chromatogram obtained with reference solution (b) (0.5 per cent);
- *any other impurity*: any other spot apart from the principal spot and any spot due to impurity C (which is limited by liquid chromatography) is not more intense than the spot due to zidovudine in the chromatogram obtained with reference solution (b) (0.5 per cent).

*Detection B*: spray with a 10 g/L solution of *vanillin R* in *sulfuric acid R*.

*Limit*:

- *impurity D*: any spot due to impurity D is not more intense than the corresponding spot in the chromatogram obtained with reference solution (b) (0.5 per cent).

*System suitability*: reference solution (a):

- the chromatogram shows 4 clearly separated spots, due to impurity C, impurity A, zidovudine and impurity D, in order of increasing  $R_F$  value.

B. Liquid chromatography (2.2.29).

*Test solution (a).* Dissolve 50.0 mg of the substance to be examined in the mobile phase and dilute to 50.0 mL with the mobile phase.

*Test solution (b).* Dilute 10.0 mL of test solution (a) to 50.0 mL with the mobile phase.

*Reference solution (a).* Dissolve 10.0 mg of *zidovudine CRS* in the mobile phase and dilute to 50.0 mL with the mobile phase.

*Reference solution (b).* Dissolve 10.0 mg of *thymine R* (impurity C) in *methanol R* and dilute to 50.0 mL with the same solvent. Dilute 5.0 mL of this solution to 50.0 mL with the mobile phase.

*Reference solution (c).* Dissolve 5 mg of *zidovudine impurity B CRS* in 25.0 mL of reference solution (a) and dilute to 50.0 mL with the mobile phase.

*Reference solution (d).* Dilute 5.0 mL of reference solution (c) to 50.0 mL with the mobile phase.

*Reference solution (e).* Dilute 0.25 mL of test solution (a) to 50.0 mL with the mobile phase.

*Column*:

- *size*:  $l = 0.25$  m,  $\varnothing = 4.6$  mm;
- *stationary phase*: *octadecylsilyl silica gel for chromatography R* (5 µm).

*Mobile phase*: *methanol R*, *water R* (20:80 V/V).

*Flow rate*: 1.2 mL/min.

*Detection*: spectrophotometer at 265 nm.

*Equilibration*: with the mobile phase for about 45 min.

*Injection*: 10 µL of test solution (a) and reference solutions (b), (c), (d) and (e).

*Run time*: 1.5 times the retention time of zidovudine.

*Elution order*: impurity C, zidovudine, impurity B.

*System suitability*: reference solution (c):

- *resolution*: minimum 1.5 between the peaks due to zidovudine and impurity B.

**Limits:**

- *impurity C*: not more than the area of the corresponding peak in the chromatogram obtained with reference solution (b) (2 per cent);
- *impurity B*: not more than the area of the corresponding peak in the chromatogram obtained with reference solution (d) (1 per cent);
- *any other impurity*: for each impurity, not more than the area of the principal peak in the chromatogram obtained with reference solution (e) (0.5 per cent);
- *total*: not more than 6 times the area of the principal peak in the chromatogram obtained with reference solution (e) (3.0 per cent);
- *disregard limit*: 0.1 times the area of the principal peak in the chromatogram obtained with reference solution (e) (0.05 per cent).

**Heavy metals** (2.4.8): maximum 20 ppm.

1.00 g complies with test D. Prepare the reference solution using 2 mL of *lead standard solution (10 ppm Pb) R*.

**Loss on drying** (2.2.32): maximum 1.0 per cent, determined on 1.000 g by drying in an oven at 105 °C.

**Sulfated ash** (2.4.14): maximum 0.25 per cent, determined on 1.00 g.

**ASSAY**

Liquid chromatography (2.2.29) as described in the test for related substances with the following modification.

**Injection**: test solution (b) and reference solution (a).

Calculate the content of  $C_{10}H_{13}N_5O_4$  from the declared content of *zidovudine CRS*.

**STORAGE**

Protected from light.

**IMPURITIES**

*Specified impurities: A, B, C, D.*

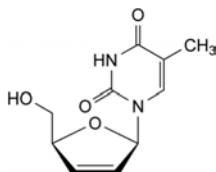

- A. 1-[(2*R*,5*S*)-5-(hydroxymethyl)-2,5-dihydrofuran-2-yl]-5-methylpyrimidine-2,4(1*H*,3*H*)-dione,

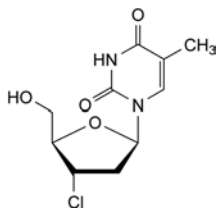

- B. 1-(3-chloro-2,3-dideoxy-β-*D*-*erythro*-pentofuranosyl)-5-methylpyrimidine-2,4(1*H*,3*H*)-dione,

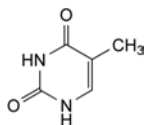

- C. 5-methylpyrimidine-2,4(1*H*,3*H*)-dione (thymine),

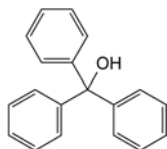

- D. triphenylmethanol.

01/2008:1482

corrected 7.0

**ZINC ACETATE DIHYDRATE****Zinci acetas dihydricus**

$C_4H_6O_4Zn \cdot 2H_2O$   
[5970-45-6]

*M*, 219.5

**DEFINITION**

**Content**: 99.0 per cent to 101.0 per cent of  $C_4H_6O_4Zn \cdot 2H_2O$ .

**CHARACTERS**

**Appearance**: white or almost white crystalline powder or flakes.

**Solubility**: freely soluble in water, soluble in ethanol (96 per cent).

**IDENTIFICATION**

A. It gives reaction (a) of acetates (2.3.1).

B. It gives the reaction of zinc (2.3.1).

**TESTS**

**Solution S**. Dissolve 10.0 g in *carbon dioxide-free water R* prepared from *distilled water R* and dilute to 100 mL with the same solvent.

**Appearance of solution**. Solution S is clear (2.2.1) and colourless (2.2.2, *Method II*).

**pH** (2.2.3): 5.8 to 7.0.

Dilute 10 mL of solution S to 20 mL with *carbon dioxide-free water R*.

**Reducing substances**. Boil for 5 min a mixture of 10 mL of solution S, 90 mL of *water R*, 5 mL of *dilute sulfuric acid R* and 1.5 mL of a 0.3 g/L solution of *potassium permanganate R*. The pink colour of the solution remains.

**Chlorides** (2.4.4): maximum 50 ppm.

Dilute 10 mL of solution S with 15 mL of *water R*.

**Sulfates** (2.4.13): maximum 100 ppm, determined on solution S.

**Aluminium**: maximum 5 ppm.

Atomic absorption spectrometry (2.2.23, *Method I*).

**Test solution**. Dissolve 2.50 g in 20 mL of a 200 g/L solution of *cadmium- and lead-free nitric acid R* and dilute to 25.0 mL with the same acid solution.

**Reference solutions**. Prepare the reference solutions using *aluminium standard solution (200 ppm Al) R*, diluted with a 200 g/L solution of *cadmium- and lead-free nitric acid R*.

**Source**: aluminium hollow-cathode lamp.

**Wavelength**: 309.3 nm.

**Atomisation device**: air-acetylene or acetylene-nitrous oxide flame.

**Arsenic** (2.4.2, *Method A*): maximum 2 ppm, determined on 0.5 g.

**Cadmium**: maximum 2 ppm.

Atomic absorption spectrometry (2.2.23, *Method I*).

**Test solution**. Use the solution described in the test for aluminium.

**Reference solutions**. Prepare the reference solutions using *cadmium standard solution (0.1 per cent Cd) R*, diluted with a 200 g/L solution of *cadmium- and lead-free nitric acid R*.

**Source**: cadmium hollow-cathode lamp.

**Wavelength**: 228.8 nm.

**Atomisation device**: air-acetylene flame.

**Copper**: maximum 50 ppm.

Atomic absorption spectrometry (2.2.23, *Method I*).

**Test solution**. Use the solution described in the test for iron.

**Reference solutions.** Prepare the reference solutions using *copper standard solution (10 ppm Cu) R*, diluted with a 200 g/L solution of *cadmium- and lead-free nitric acid R*.

**Source:** copper hollow-cathode lamp.

**Wavelength:** 324.8 nm.

**Atomisation device:** air-acetylene flame.

**Iron:** maximum 50 ppm.

Atomic absorption spectrometry (2.2.23, Method I).

**Test solution.** Dissolve 1.25 g in 20 mL of a 200 g/L solution of *cadmium- and lead-free nitric acid R* and dilute to 25.0 mL with the same acid solution.

**Reference solutions.** Prepare the reference solutions using *iron standard solution (20 ppm Fe) R*, diluted with a 200 g/L solution of *cadmium- and lead-free nitric acid R*.

**Source:** iron hollow-cathode lamp.

**Wavelength:** 248.3 nm.

**Atomisation device:** air-acetylene flame.

**Lead:** maximum 10 ppm.

Atomic absorption spectrometry (2.2.23, Method I).

**Test solution.** Dissolve 5.00 g in 20 mL of a 200 g/L solution of *cadmium- and lead-free nitric acid R* and dilute to 25.0 mL with the same acid solution.

**Reference solutions.** Prepare the reference solutions using *lead standard solution (0.1 per cent of Pb) R*, diluting with a 200 g/L solution of *cadmium- and lead-free nitric acid R*.

**Source:** lead hollow-cathode lamp.

**Wavelength:** 283.3 nm.

**Atomisation device:** air-acetylene flame.

#### ASSAY

Dissolve 0.200 g in 5 mL of *dilute acetic acid R*. Carry out the complexometric titration of zinc (2.5.11).

1 mL of 0.1 M *sodium edetate* is equivalent to 21.95 mg of  $C_{16}H_{28}N_2O_6Zn$ .

#### STORAGE

In a non-metallic container.

07/2010:1279  
corrected 7.0

## ZINC ACEXAMATE

### Zinci acexamas

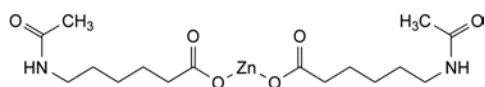

$C_{16}H_{28}N_2O_6Zn$   
[70020-71-2]

$M_r$  409.8

#### DEFINITION

Zinc 6-(acetylamino)hexanoate.

**Content:** 97.5 per cent to 101.0 per cent (dried substance).

#### CHARACTERS

**Appearance:** white or almost white, crystalline powder.

**Solubility:** soluble in water, practically insoluble in acetone and in ethanol (96 per cent). It dissolves in dilute nitric acid.

mp: about 198 °C.

#### IDENTIFICATION

A. Infrared absorption spectrophotometry (2.2.24).

**Comparison:** *zinc acexamate CRS*.

B. 5 mL of solution S (see Tests) gives the reaction of zinc (2.3.1).

#### TESTS

**Solution S.** Dissolve 0.5 g in *carbon dioxide-free water R* and dilute to 20 mL with the same solvent.

**Appearance of solution.** Solution S is not more opalescent than reference suspension IV (2.2.1) and is colourless (2.2.2, Method II).

**pH (2.2.3):** 5.0 to 7.0 for solution S.

**Impurity B.** Thin-layer chromatography (2.2.27).

**Test solution.** Dissolve 0.30 g of the substance to be examined in *water R* and dilute to 10 mL with the same solvent.

**Reference solution.** Dissolve 15 mg of *6-aminohexanoic acid R* (impurity B) in *water R* and dilute to 10 mL with the same solvent. Dilute 1 mL of this solution to 10 mL with *water R*.

**Plate:** *TLC silica gel plate R*.

**Mobile phase:** *ammonia R, water R, ethanol (96 per cent) R* (2:30:68 V/V/V).

**Application:** 5 µL; allow to dry in air.

**Development:** over a path of 15 cm.

**Drying:** in a current of warm air.

**Detection:** spray with *ninhydrin solution R* and heat at 100-105 °C for 15 min.

**Limit:**

- **impurity B:** any spot due to impurity B is not more intense than the corresponding spot in the chromatogram obtained with the reference solution (0.5 per cent).

**Related substances.** Liquid chromatography (2.2.29).

**Test solution (a).** Dissolve 0.50 g of the substance to be examined in *water R* and dilute to 100.0 mL with the same solvent.

**Test solution (b).** To 20.0 mL of test solution (a), add 20 mL of the mobile phase and 0.4 mL of a 100 g/L solution of *phosphoric acid R*, then dilute to 50.0 mL with the mobile phase.

**Reference solution (a).** Dissolve 40 mg of *N-acetyl-ε-caprolactam R* (impurity C) in *water R* and dilute to 100.0 mL with the same solvent.

**Reference solution (b).** Dilute 5.0 mL of reference solution (a) to 100.0 mL with *water R*.

**Reference solution (c).** Dissolve 20 mg of *zinc acexamate impurity A CRS* in *water R* and dilute to 50.0 mL with the same solvent.

**Reference solution (d).** Dissolve 40 mg of *ε-caprolactam R* (impurity D) in *water R* and dilute to 100.0 mL with the same solvent. Dilute 5.0 mL of this solution to 100.0 mL with *water R*.

**Reference solution (e).** To 20.0 mL of test solution (a), add 5.0 mL of reference solution (b), 5.0 mL of reference solution (c), 5.0 mL of reference solution (d) and 0.4 mL of a 100 g/L solution of *phosphoric acid R*, then dilute to 50.0 mL with the mobile phase.

**Reference solution (f).** To 5.0 mL of reference solution (c), add 5.0 mL of reference solution (b), 5.0 mL of reference solution (d) and 0.4 mL of a 100 g/L solution of *phosphoric acid R*, then dilute to 50.0 mL with the mobile phase.

**Column:**

- **size:**  $l = 0.25$  m,  $\phi = 4.0$  mm;
- **stationary phase:** *octadecylsilyl silica gel for chromatography R* (5 µm).

**Mobile phase:** mix 0.2 volumes of *phosphoric acid R*, 8 volumes of *acetonitrile R* and 92 volumes of *water R*, then adjust to pH 4.5 with *dilute ammonia RI*.

**Flow rate:** 1.2 mL/min.

**Detection:** spectrophotometer at 210 nm.

**Injection:** 20 µL of test solution (b) and reference solutions (b), (e) and (f).

**Run time:** 8 times the retention time of zinc acexamate.

*Elution order:* zinc acexamate, impurity D, impurity A, impurity C.

*System suitability:* reference solution (e):

- *resolution:* minimum 3.0 between the peaks due to zinc acexamate and impurity D; if necessary, adjust the mobile phase to pH 4.7 with *dilute ammonia RI*.

*Limits:*

- *impurity A:* not more than the area of the corresponding peak in the chromatogram obtained with reference solution (f) (2 per cent);
- *impurities C, D:* for each impurity, not more than 1.5 times the area of the corresponding peak in the chromatogram obtained with reference solution (f) (0.15 per cent);
- *unspecified impurities:* for each impurity, not more than 0.5 times the area of the peak due to impurity C in the chromatogram obtained with reference solution (f) (0.05 per cent);
- *sum of impurities other than A:* not more than 5 times the area of the peak due to impurity C in the chromatogram obtained with reference solution (f) (0.5 per cent);
- *disregard limit:* 0.5 times the area of the peak due to impurity C in the chromatogram obtained with reference solution (f) (0.05 per cent).

**Arsenic** (2.4.2, *Method A*): maximum 2 ppm, determined on 0.5 g.

**Cadmium:** maximum 2 ppm.

Atomic absorption spectrometry (2.2.23, *Method I*).

*Test solution.* Dissolve 2.50 g in 20 mL of a 200 g/L solution of *cadmium- and lead-free nitric acid R* and dilute to 25.0 mL with the same acid solution.

*Reference solutions.* Prepare the reference solutions using *cadmium standard solution (0.1 per cent Cd) R*, diluting with a 200 g/L solution of *cadmium- and lead-free nitric acid R*.

*Source:* cadmium hollow-cathode lamp.

*Wavelength:* 228.8 nm.

*Atomisation device:* air-acetylene flame.

**Iron:** maximum 50 ppm.

Atomic absorption spectrometry (2.2.23, *Method I*).

*Test solution.* Dissolve 1.25 g in 20 mL of a 200 g/L solution of *cadmium- and lead-free nitric acid R* and dilute to 25.0 mL with the same acid solution.

*Reference solutions.* Prepare the reference solutions using *iron standard solution (20 ppm Fe) R*, diluting with a 200 g/L solution of *cadmium- and lead-free nitric acid R*.

*Source:* iron hollow-cathode lamp.

*Wavelength:* 248.3 nm.

*Atomisation device:* air-acetylene flame.

**Lead:** maximum 10 ppm.

Atomic absorption spectrometry (2.2.23, *Method I*).

*Test solution.* Dissolve 5.00 g in 20 mL of a 200 g/L solution of *cadmium- and lead-free nitric acid R* and dilute to 25.0 mL with the same acid solution.

*Reference solutions.* Prepare the reference solutions using *lead standard solution (0.1 per cent Pb) R*, diluting with a 200 g/L solution of *cadmium- and lead-free nitric acid R*.

*Source:* lead hollow-cathode lamp.

*Wavelength:* 283.3 nm.

*Atomisation device:* air-acetylene flame.

**Loss on drying** (2.2.32): maximum 1.0 per cent, determined on 1.000 g by drying in an oven at 105 °C.

#### ASSAY

Dissolve 0.400 g in 10 mL of *dilute acetic acid R*. Carry out the complexometric titration of zinc (2.5.11).

1 mL of 0.1 M *sodium edetate* is equivalent to 40.98 mg of  $C_{16}H_{28}N_2O_6Zn$ .

#### STORAGE

In a non-metallic container.

#### IMPURITIES

*Specified impurities:* A, B, C, D.

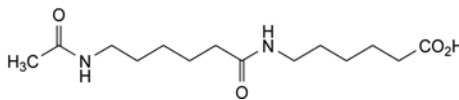

A. 6-[[6-(acetylamino)hexanoyl]amino]hexanoic acid,



B. 6-aminohexanoic acid (6-aminocaproic acid),

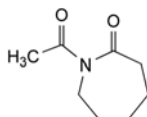

C. 1-acetylhexahydro-2H-azepin-2-one (*N*-acetyl- $\epsilon$ -caprolactam),

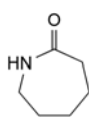

D. hexahydro-2H-azepin-2-one ( $\epsilon$ -caprolactam).

01/2008:0110  
corrected 6.6

## ZINC CHLORIDE

### Zinci chloridum

$ZnCl_2$   
[7646-85-7]

$M_r$  136.3

#### DEFINITION

*Content:* 95.0 per cent to 100.5 per cent.

#### CHARACTERS

*Appearance:* white or almost white, crystalline powder or cast in white or almost white sticks, deliquescent.

*Solubility:* very soluble in water, freely soluble in ethanol (96 per cent) and in glycerol.

#### IDENTIFICATION

- Dissolve 0.5 g in *dilute nitric acid R* and dilute to 10 mL with the same acid. The solution gives reaction (a) of chlorides (2.3.1).
- 5 mL of solution S (see Tests) gives the reaction of zinc (2.3.1).

#### TESTS

**Solution S.** To 2.0 g add 38 mL of *carbon dioxide-free water R* prepared from *distilled water R* and add *dilute hydrochloric acid R* dropwise until dissolution is complete. Dilute to 40 mL with *carbon dioxide-free water R* prepared from *distilled water R*.

**pH** (2.2.3): 4.6 to 5.5.

Dissolve 1.0 g in 9 mL of *carbon dioxide-free water R*, ignoring any slight turbidity.

**Oxychlorides.** Dissolve 10.0 g in 10 mL of *carbon dioxide-free water R*. The solution is not more opalescent than reference suspension II (2.2.1). To 1.5 mL of the solution add 7.5 mL of *ethanol (96 per cent) R*. The solution may become cloudy within 10 min. Any cloudiness disappears on the addition of 0.2 mL of *dilute hydrochloric acid R*.

**Sulfates** (2.4.13): maximum 200 ppm.

Dilute 5 mL of solution S to 15 mL with *distilled water R*. Prepare the standard using a mixture of 5 mL of *sulfate standard solution* (10 ppm  $\text{SO}_4$ ) *R* and 10 mL of *distilled water R*.

**Aluminium, calcium, heavy metals, iron, magnesium.** To 8 mL of solution S add 2 mL of *concentrated ammonia R* and shake. The solution is clear (2.2.1) and colourless (2.2.2, *Method II*). Add 1 mL of *disodium hydrogen phosphate solution R*. The solution remains clear for at least 5 min. Add 0.2 mL of *sodium sulfide solution R*. A white precipitate is formed and the supernatant liquid remains colourless.

**Ammonium** (2.4.1): maximum 400 ppm.

Dilute 0.5 mL of solution S to 15 mL with *water R*.

#### ASSAY

Dissolve 0.250 g in 5 mL of *dilute acetic acid R*. Carry out the complexometric titration of zinc (2.5.11).

1 mL of 0.1 M *sodium edetate* is equivalent to 13.63 mg of  $\text{ZnCl}_2$ .

#### STORAGE

In a non-metallic container.

07/2009:2164  
corrected 7.0

## ZINC GLUCONATE

### Zinci gluconas

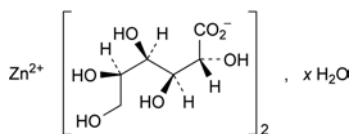

$\text{C}_{12}\text{H}_{22}\text{ZnO}_{14}\cdot x\text{H}_2\text{O}$

$M_r$  455.7 (anhydrous substance)

#### DEFINITION

Anhydrous or hydrated zinc D-gluconate.

*Content*: 98.0 per cent to 102.0 per cent (anhydrous substance).

#### CHARACTERS

*Appearance*: white or almost white, hygroscopic, crystalline powder.

*Solubility*: soluble in water, practically insoluble in anhydrous ethanol and in methylene chloride.

#### IDENTIFICATION

A. Thin-layer chromatography (2.2.27).

*Test solution.* Dissolve 20 mg of the substance to be examined in 1 mL of *water R*.

*Reference solution.* Dissolve 20 mg of *calcium gluconate CRS* in 1 mL of *water R*, heating if necessary in a water-bath at 60 °C.

*Plate*: TLC silica gel plate *R* (5-40  $\mu\text{m}$ ) [or TLC silica gel plate *R* (2-10  $\mu\text{m}$ )].

*Mobile phase*: concentrated ammonia *R*, ethyl acetate *R*, water *R*, ethanol (96 per cent) *R* (10:10:30:50 V/V/V/V).

*Application*: 1  $\mu\text{L}$ .

*Development*: over 3/4 of the plate.

*Drying*: at 100-105 °C for 20 min, then allow to cool to room temperature.

*Detection*: spray with a solution containing 25 g/L of *ammonium molybdate R* and 10 g/L of *cerium sulfate R* in *dilute sulfuric acid R*, and heat at 100-105 °C for about 10 min.

*Results*: the principal spot in the chromatogram obtained with the test solution is similar in position, colour and size to the principal spot in the chromatogram obtained with the reference solution.

B. Dissolve 0.1 g in 5 mL of *water R*. Add 0.5 mL of *potassium ferrocyanide solution R*. A white precipitate is formed that does not dissolve upon the addition of 5 mL of *hydrochloric acid R*.

#### TESTS

**Solution S.** Dissolve 1.0 g in *water R* and dilute to 50 mL with the same solvent.

**Appearance of solution.** Solution S is not more opalescent than reference suspension II (2.2.1) and not more intensely coloured than reference solution  $Y_6$  (2.2.2, *Method II*).

**Sucrose and reducing sugars.** Dissolve 0.5 g in a mixture of 2 mL of *hydrochloric acid R1* and 10 mL of *water R*. Boil for 5 min, allow to cool, add 10 mL of *sodium carbonate solution R* and allow to stand for 10 min. Dilute to 25 mL with *water R* and filter. To 5 mL of the filtrate add 2 mL of *cupri-tartaric solution R* and boil for 1 min. Allow to stand for 2 min. No red precipitate is formed.

**Chlorides** (2.4.4): maximum 500 ppm.

Dilute 5 mL of solution S to 15 mL with *water R*.

**Sulfates** (2.4.13): maximum 500 ppm.

Dissolve 2.0 g in a mixture of 10 mL of *acetic acid R* and 90 mL of *distilled water R*.

**Cadmium**: maximum 2 ppm.

Atomic absorption spectrometry (2.2.23, *Method II*).

*Test solution.* Dissolve 5.00 g in 20 mL of *deionised distilled water R* with the aid of ultrasound and dilute to 25.0 mL with the same solvent.

*Reference solutions.* Prepare the reference solutions using *cadmium standard solution* (0.1 per cent Cd) *R*, diluting with *deionised distilled water R*.

*Source*: cadmium hollow-cathode lamp.

*Wavelength*: 228.8 nm.

*Atomisation device*: air-acetylene flame.

**Heavy metals** (2.4.8): maximum 10 ppm.

Dissolve 2.0 g in 20 mL of *water R*, heating in a water-bath at 60 °C. 12 mL of the solution complies with test A. Prepare the reference solution using *lead standard solution* (1 ppm Pb) *R*.

**Water** (2.5.32): maximum 12.0 per cent, determined on 80.0 mg.

#### Microbial contamination

TAMC: acceptance criterion  $10^3$  CFU/g (2.6.12).

TYMC: acceptance criterion  $10^2$  CFU/g (2.6.12).

#### ASSAY

Dissolve 0.400 g in 5 mL of *dilute acetic acid R*. Carry out the complexometric titration of zinc (2.5.11).

1 mL of 0.1 M *sodium edetate* is equivalent to 45.57 mg of  $\text{C}_{12}\text{H}_{22}\text{ZnO}_{14}$ .

#### STORAGE

In a non-metallic, airtight container.

01/2008:0252  
corrected 7.0

## ZINC OXIDE

### Zinci oxidum

$\text{ZnO}$   
[1314-13-2]

$M_r$  81.4

#### DEFINITION

*Content*: 99.0 per cent to 100.5 per cent (ignited substance).

## CHARACTERS

01/2008:0306  
corrected 7.0

**Appearance:** soft, white or faintly yellowish-white, amorphous powder, free from gritty particles.

**Solubility:** practically insoluble in water and in ethanol (96 per cent). It dissolves in dilute mineral acids.

## IDENTIFICATION

- A. It becomes yellow when strongly heated; the yellow colour disappears on cooling.
- B. Dissolve 0.1 g in 1.5 mL of *dilute hydrochloric acid R* and dilute to 5 mL with *water R*. The solution gives the reaction of zinc (2.3.I).

## TESTS

**Alkalinity.** Shake 1.0 g with 10 mL of boiling *water R*. Add 0.1 mL of *phenolphthalein solution R* and filter. If the filtrate is red, not more than 0.3 mL of 0.1 M *hydrochloric acid* is required to change the colour of the indicator.

**Carbonates and substances insoluble in acids.** Dissolve 1.0 g in 15 mL of *dilute hydrochloric acid R*. It dissolves without effervescence and the solution is not more opalescent than reference suspension II (2.2.1) and is colourless (2.2.2, *Method II*).

**Arsenic** (2.4.2, *Method A*): maximum 5 ppm, determined on 0.2 g.

**Cadmium:** maximum 10 ppm.

Atomic absorption spectrometry (2.2.23, *Method II*).

**Test solution.** Dissolve 2.0 g in 14 mL of a mixture of equal volumes of *water R* and *cadmium- and lead-free nitric acid R*, boil for 1 min, cool and dilute to 100.0 mL with *water R*.

**Reference solutions.** Prepare the reference solutions using *cadmium standard solution (0.1 per cent Cd) R* and diluting with a 3.5 per cent V/V solution of *cadmium- and lead-free nitric acid R*.

**Source:** cadmium hollow-cathode lamp.

**Wavelength:** 228.8 nm.

**Atomisation device:** air-acetylene or air-propane flame.

**Iron** (2.4.9): maximum 200 ppm.

Dissolve 50 mg in 1 mL of *dilute hydrochloric acid R* and dilute to 10 mL with *water R*. Use in this test 0.5 mL of *thioglycollic acid R*.

**Lead:** maximum 50 ppm.

Atomic absorption spectrometry (2.2.23, *Method II*).

**Test solution.** Dissolve 5.0 g in 24 mL of a mixture of equal volumes of *water R* and *cadmium- and lead-free nitric acid R*, boil for 1 min, cool and dilute to 100.0 mL with *water R*.

**Reference solutions.** Prepare the reference solutions using *lead standard solution (0.1 per cent Pb) R* and diluting with a 3.5 per cent V/V solution of *cadmium- and lead-free nitric acid R*.

**Source:** lead hollow-cathode lamp.

**Wavelength:** 283.3 nm; 217.0 nm may be used depending on the apparatus.

**Atomisation device:** air-acetylene flame.

**Loss on ignition:** maximum 1.0 per cent, determined on 1.00 g by ignition to constant mass at  $500 \pm 50$  °C.

## ASSAY

Dissolve 0.150 g in 10 mL of *dilute acetic acid R*. Carry out the complexometric titration of zinc (2.5.11).

1 mL of 0.1 M *sodium edetate* is equivalent to 8.14 mg of ZnO.

## ZINC STEARATE

## Zinci stearas

[557-05-1]

## DEFINITION

Zinc stearate [(C<sub>17</sub>H<sub>35</sub>COO)<sub>2</sub>Zn; M<sub>r</sub> 632] may contain varying proportions of zinc palmitate [(C<sub>15</sub>H<sub>31</sub>COO)<sub>2</sub>Zn; M<sub>r</sub> 576.2] and zinc oleate [(C<sub>17</sub>H<sub>33</sub>COO)<sub>2</sub>Zn; M<sub>r</sub> 628].

**Content:** 10.0 per cent to 12.0 per cent of Zn.

## CHARACTERS

**Appearance:** light, white or almost white, amorphous powder, free from gritty particles.

**Solubility:** practically insoluble in water and in anhydrous ethanol.

## IDENTIFICATION

- A. Freezing point (2.2.18): minimum 53 °C, determined on the residue obtained in the preparation of solution S (see Tests).
- B. Neutralise 5 mL of solution S to *red litmus paper R* with *strong sodium hydroxide solution R*. The solution gives the reaction of zinc (2.3.I).

## TESTS

**Solution S.** To 5.0 g add 50 mL of *ether R* and 40 mL of a 7.5 per cent V/V solution of *cadmium- and lead-free nitric acid R* in *distilled water R*. Heat under a reflux condenser until dissolution is complete. Allow to cool. In a separating funnel, separate the aqueous layer and shake the ether layer with 2 quantities, each of 4 mL, of *distilled water R*. Combine the aqueous layers, wash with 15 mL of *ether R* and heat on a water-bath until ether is completely eliminated. Allow to cool and dilute to 50.0 mL with *distilled water R* (solution S). Evaporate the ether layer to dryness and dry the residue at 105 °C.

**Appearance of solution.** Solution S is not more intensely coloured than reference solution Y<sub>6</sub> (2.2.2, *Method II*).

**Appearance of solution of fatty acids.** Dissolve 0.5 g of the residue obtained in the preparation of solution S in 10 mL of *chloroform R*. The solution is clear (2.2.1) and not more intensely coloured than reference solution Y<sub>5</sub> (2.2.2, *Method II*).

**Acidity or alkalinity.** Shake 1.0 g with 5 mL of *ethanol (96 per cent) R* and add 20 mL of *carbon dioxide-free water R* and 0.1 mL of *phenol red solution R*. Not more than 0.3 mL of 0.1 M *hydrochloric acid* or 0.1 mL of 0.1 M *sodium hydroxide* is required to change the colour of the indicator.

**Acid value of the fatty acids** (2.5.1): 195 to 210.

Dissolve 0.20 g of the residue obtained in the preparation of solution S in 25 mL of the prescribed mixture of solvents.

**Chlorides** (2.4.4): maximum 250 ppm.

Dilute 2 mL of solution S to 15 mL with *water R*.

**Sulfates** (2.4.13): maximum 0.6 per cent.

Dilute 1 mL of solution S to 50 mL with *distilled water R*. Dilute 12.5 mL of this solution to 15 mL with *distilled water R*.

**Cadmium:** maximum 5 ppm.

Atomic absorption spectrometry (2.2.23, *Method II*).

**Test solution.** Dilute 20.0 mL of solution S to 50.0 mL with a 3.5 per cent V/V solution of *cadmium- and lead-free nitric acid R*.

**Reference solutions.** Prepare the reference solutions using *cadmium standard solution (0.1 per cent Cd) R* and diluting with a 3.5 per cent V/V solution of *cadmium- and lead-free nitric acid R*.

Source: cadmium hollow-cathode lamp.

Wavelength: 228.8 nm.

Atomisation device: air-acetylene or an air-propane flame.

**Lead:** maximum 25 ppm.

Atomic absorption spectrometry (2.2.23, Method II).

Test solution. Solution S.

Reference solutions. Prepare the reference solutions using lead standard solution (0.1 per cent Pb) R and diluting with a 3.5 per cent V/V solution of cadmium- and lead-free nitric acid R.

Source: lead hollow-cathode lamp.

Wavelength: 283.3 nm. Depending on the apparatus the line at 217.0 nm may be used.

Atomisation device: air-acetylene flame.

#### ASSAY

To 1.000 g add 50 mL of dilute acetic acid R and boil for at least 10 min or until the layer of fatty acids is clear, adding more water R as necessary to maintain the original volume. Cool and filter. Wash the filter and the flask with water R until the washings are no longer acid to blue litmus paper R. Combine the filtrate and washings. Carry out the complexometric titration of zinc (2.5.11).

1 mL of 0.1 M sodium edetate is equivalent to 6.54 mg of Zn.

01/2008:0111  
corrected 6.0

## ZINC SULFATE HEPTAHYDRATE

### Zinci sulfas heptahydricus

ZnSO<sub>4</sub>·7H<sub>2</sub>O  
[7446-20-0]

M<sub>r</sub> 287.5

#### DEFINITION

Content: 99.0 per cent to 104.0 per cent.

#### CHARACTERS

Appearance: white or almost white, crystalline powder or colourless, transparent crystals, efflorescent.

Solubility: very soluble in water, practically insoluble in alcohol.

#### IDENTIFICATION

- Solution S (see Tests) gives the reactions of sulfates (2.3.1).
- Solution S gives the reaction of zinc (2.3.1).
- It complies with the limits of the assay.

#### TESTS

**Solution S.** Dissolve 2.5 g in carbon dioxide-free water R and dilute to 50 mL with the same solvent.

**Appearance of solution.** Solution S is clear (2.2.1) and colourless (2.2.2, Method II).

**pH (2.2.3):** 4.4 to 5.6 for solution S.

**Chlorides (2.4.4):** maximum 300 ppm.

3.3 mL of solution S diluted to 15 mL with water R complies with the limit test for chlorides.

**Iron (2.4.9):** maximum 100 ppm.

2 mL of solution S diluted to 10 mL with water R complies with the limit test for iron. Use in this test 0.5 mL of thioglycollic acid R.

#### ASSAY

Dissolve 0.200 g in 5 mL of dilute acetic acid R. Carry out the complexometric titration of zinc (2.5.11).

1 mL of 0.1 M sodium edetate is equivalent to 28.75 mg of ZnSO<sub>4</sub>·7H<sub>2</sub>O.

#### STORAGE

In a non-metallic, airtight container.

01/2008:1683  
corrected 6.0

## ZINC SULFATE HEXAHYDRATE

### Zinci sulfas hexahydricus

ZnSO<sub>4</sub>·6H<sub>2</sub>O  
[13986-24-8]

M<sub>r</sub> 269.5

#### DEFINITION

Content: 99.0 per cent to 104.0 per cent.

#### CHARACTERS

Appearance: white or almost white, crystalline powder or colourless transparent crystals, efflorescent.

Solubility: very soluble in water, practically insoluble in alcohol.

#### IDENTIFICATION

- Solution S (see Tests) gives the reactions of sulfates (2.3.1).
- Solution S gives the reaction of zinc (2.3.1).
- It complies with the limits of the assay.

#### TESTS

**Solution S.** Dissolve 2.5 g in carbon dioxide-free water R and dilute to 50 mL with the same solvent.

**Appearance of solution.** Solution S is clear (2.2.1) and colourless (2.2.2, Method II).

**pH (2.2.3):** 4.4 to 5.6 for solution S.

**Chlorides (2.4.4):** maximum 300 ppm.

3.3 mL of solution S diluted to 15 mL with water R complies with the limit test for chlorides.

**Iron (2.4.9):** maximum 100 ppm.

2 mL of solution S diluted to 10 mL with water R complies with the limit test for iron. Use in this test 0.5 mL of thioglycollic acid R.

#### ASSAY

Dissolve 0.200 g in 5 mL of dilute acetic acid R. Carry out the complexometric titration of zinc (2.5.11).

1 mL of 0.1 M sodium edetate is equivalent to 26.95 mg of ZnSO<sub>4</sub>·6H<sub>2</sub>O.

#### STORAGE

In a non-metallic, airtight container.

01/2010:2159

## ZINC SULFATE MONOHYDRATE

### Zinci sulfas monohydricus

ZnSO<sub>4</sub>·H<sub>2</sub>O

M<sub>r</sub> 179.5

#### DEFINITION

Content: 99.0 per cent to 101.0 per cent.

#### CHARACTERS

Appearance: white or almost white, crystalline powder, or colourless, transparent crystals.

Solubility: very soluble in water, practically insoluble in ethanol (96 per cent).

## IDENTIFICATION

- A. Solution S (see Tests) gives the reactions of sulfates (2.3.1).  
 B. Solution S gives the reaction of zinc (2.3.1).  
 C. It complies with the limits of the assay.

## TESTS

**Solution S.** Dissolve 2.5 g in *carbon dioxide-free water R* and dilute to 50 mL with the same solvent.

**Appearance of solution.** Solution S is clear (2.2.1) and colourless (2.2.2, *Method II*).

**pH** (2.2.3): 4.0 to 5.6 for solution S.

**Chlorides** (2.4.4): maximum 300 ppm.

Dilute 3.3 mL of solution S to 15 mL with *water R*.

**Iron** (2.4.9): maximum 100 ppm.

Dilute 2 mL of solution S to 10 mL with *water R*. Use 0.5 mL of *thioglycollic acid R* in this test.

## ASSAY

Dissolve 0.160 g in 5 mL of *dilute acetic acid R*. Carry out the complexometric titration of zinc (2.5.11).

1 mL of 0.1 M *sodium edetate* is equivalent to 17.95 mg of  $ZnSO_4 \cdot H_2O$ .

## STORAGE

In a non-metallic container.

01/2008:0539  
corrected 6.0

## ZINC UNDECYLENATE

## Zinci undecylenas

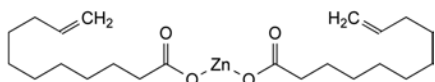

$C_{22}H_{38}O_4Zn$   
[557-08-4]

$M_r$  431.9

## DEFINITION

Zinc di(undec-10-enoate).

*Content*: 98.0 per cent to 102.0 per cent (dried substance).

## CHARACTERS

*Appearance*: white or almost white, fine powder.

*Solubility*: practically insoluble in water and in ethanol (96 per cent).

mp: 116 °C to 121 °C, it may leave a slight solid residue.

## IDENTIFICATION

- A. To 2.5 g add 10 mL of *water R* and 10 mL of *dilute sulfuric acid R*. Shake with 2 quantities, each of 10 mL, of *ether R*. Reserve the aqueous layer for identification test C. Wash the combined ether layers with *water R* and evaporate to dryness. To the residue add 2 mL of freshly distilled *aniline R* and boil under a reflux condenser for 10 min. Allow to cool and add 30 mL of *ether R*. Shake with 3 quantities, each of 20 mL, of *dilute hydrochloric acid R* and then with 20 mL of *water R*. Evaporate the organic layer to dryness on a water-bath. The residue, after recrystallisation twice from *ethanol (70 per cent V/V) R* and drying *in vacuo* for 3 h, melts (2.2.14) at 66 °C to 68 °C.
- B. Dissolve 0.1 g in a mixture of 2 mL of *dilute sulfuric acid R* and 5 mL of *glacial acetic acid R*. Add dropwise 0.25 mL of *potassium permanganate solution R*. The colour of the potassium permanganate solution is discharged.
- C. A mixture of 1 mL of the aqueous layer obtained in identification test A and 4 mL of *water R* gives the reaction of zinc (2.3.1).

## TESTS

**Alkalinity.** Mix 1.0 g with 5 mL of *ethanol (96 per cent) R* and 0.5 mL of *phenol red solution R*. Add 50 mL of *carbon dioxide-free water R* and examine immediately. No reddish colour appears.

**Alkali and alkaline-earth metals:** maximum 2.0 per cent.

To 1.0 g add 25 mL of *water R* and 5 mL of *hydrochloric acid R* and heat to boiling. Filter whilst hot. Wash the filter and the residue with 25 mL of hot *water R*. Combine the filtrate and washings and add *concentrated ammonia R* until alkaline. Add 7.5 mL of *thioacetamide solution R* and heat on a water-bath for 30 min. Filter and wash the precipitate with 2 quantities, each of 10 mL, of *water R*. Combine the filtrate and washings, evaporate to dryness on a water-bath and ignite. The residue weighs a maximum of 20 mg.

**Sulfates** (2.4.13): maximum 500 ppm.

To 0.1 g add a mixture of 2 mL of *dilute hydrochloric acid R* and 10 mL of *distilled water R* and heat to boiling. Cool, filter and dilute to 15 mL with *distilled water R*. Prepare the standard using 5 mL of *sulfate standard solution (10 ppm  $SO_4$ ) R* and 10 mL of *distilled water R*.

**Loss on drying** (2.2.32): maximum 1.5 per cent, determined on 0.500 g by drying in an oven at 105 °C.

**Degree of unsaturation.** Dissolve 0.100 g in a mixture of 5 mL of *dilute hydrochloric acid R* and 30 mL of *glacial acetic acid R*. Using 0.05 mL *indigo carmine solution RI*, added towards the end of the titration as indicator. Titrate with 0.0167 M *bromide-bromate* until the colour changes from blue to yellow. 9.1 mL to 9.4 mL of 0.0167 M *bromide-bromate* is required. Carry out a blank titration.

## ASSAY

To 0.350 g add 25 mL of *dilute acetic acid R* and heat to boiling. Carry out the complexometric titration of zinc (2.5.11).

1 mL of 0.1 M *sodium edetate* is equivalent to 43.19 mg of  $C_{22}H_{38}O_4Zn$ .

## STORAGE

Protected from light.

01/2011:2421

ZIPRASIDONE HYDROCHLORIDE  
MONOHYDRATE

## Ziprasidoni hydrochloridum monohydricum

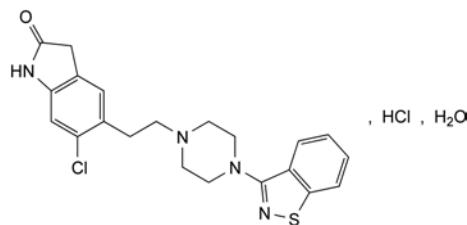

$C_{21}H_{22}Cl_2N_4OS \cdot H_2O$   
[138982-67-9]

$M_r$  467.4

## DEFINITION

5-[2-[4-(1,2-Benzisothiazol-3-yl)piperazin-1-yl]ethyl]-6-chloro-1,3-dihydro-2H-indol-2-one hydrochloride monohydrate.

*Content*: 98.0 per cent to 102.0 per cent (anhydrous substance).

## CHARACTERS

*Appearance*: white or slightly pink powder.

*Solubility*: practically insoluble in water, slightly soluble in methanol and in methylene chloride.

It shows polymorphism (5.9).



## IDENTIFICATION

## A. Infrared absorption spectrophotometry (2.2.24).

*Comparison: ziprasidone hydrochloride monohydrate CRS.*

If the spectra obtained in the solid state show differences, dissolve the substance to be examined and the reference substance separately in *methanol R*, evaporate to dryness and record new spectra using the residues.

B. Suspend 30 mg in 2 mL of *water R*, acidify with 0.15 mL of *dilute nitric acid R* and filter. The clear filtrate gives reaction (a) of chlorides (2.3.1).

## TESTS

**Related substances.** Liquid chromatography (2.2.29). Carry out the test protected from light and prepare the solutions immediately before use.

*Solvent mixture A: water R, methanol R (40:60 V/V).*

*Solvent mixture B: hydrochloric acid R, water R, methanol R (0.04:20:80 V/V/V).*

*Test solution (a).* Dissolve 23 mg of the substance to be examined in solvent mixture A and dilute to 100.0 mL with solvent mixture A.

*Test solution (b).* Dissolve 23 mg of the substance to be examined in solvent mixture B and dilute to 50.0 mL with solvent mixture B.

*Reference solution (a).* Dissolve 2.5 mg of *ziprasidone for system suitability 1 CRS* (containing impurities A, B and C) in solvent mixture B and dilute to 10.0 mL with solvent mixture B.

*Reference solution (b).* Dilute 1.0 mL of test solution (b) to 100.0 mL with solvent mixture B. Dilute 1.0 mL of this solution to 10.0 mL with solvent mixture B.

*Reference solution (c).* Dissolve the contents of a vial of *ziprasidone for system suitability 2 CRS* (containing impurities D and E) in 1.0 mL of solvent mixture B.

## A. Column:

- size:  $l = 0.15$  m,  $\emptyset = 4.6$  mm;
- stationary phase: spherical *octylsilyl silica gel for chromatography R* (5  $\mu$ m);
- temperature: 40 °C.

## Mobile phase:

- mobile phase A: mix 40 volumes of *methanol R* and 60 volumes of a 6.8 g/L solution of *potassium dihydrogen phosphate R* adjusted to pH 3.0 with *phosphoric acid R*;
- mobile phase B: *methanol R*;

Time (min)	Mobile phase A (per cent V/V)	Mobile phase B (per cent V/V)
0 - 20	100	0
20 - 21	100 → 0	0 → 100
21 - 24	0	100

*Flow rate:* 1.5 mL/min.

*Detection:* spectrophotometer at 229 nm.

*Injection:* 20  $\mu$ L of test solutions (a) and (b) and reference solutions (a) and (b).

*Identification of impurities:* use the chromatogram supplied with *ziprasidone for system suitability 1 CRS* and the chromatogram obtained with reference solution (a) to identify the peaks due to impurities A, B and C.

*Relative retention* with reference to ziprasidone (retention time = about 7 min): impurity A = about 0.4; impurity B = about 0.8; impurity C = about 0.9.

*System suitability:* reference solution (a):

- *peak-to-valley ratio:* minimum 1.2, where  $H_p$  = height above the baseline of the peak due to impurity C and  $H_v$  = height above the baseline of the lowest point of the curve separating this peak from the peak due to impurity B.

## Limits:

- *correction factor:* for the calculation of content, multiply the peak area of impurity A by 0.7;
- *impurity B in test solution (b):* not more than twice the area of the principal peak in the chromatogram obtained with reference solution (b) (0.2 per cent);
- *impurity A in test solution (b):* not more than 1.5 times the area of the principal peak in the chromatogram obtained with reference solution (b) (0.15 per cent);
- *impurity C in test solution (a):* not more than 0.75 times the area of the principal peak in the chromatogram obtained with reference solution (b) (0.15 per cent);
- *unspecified impurities in test solution (b):* for each impurity, not more than the area of the principal peak in the chromatogram obtained with reference solution (b) (0.10 per cent);
- *disregard limit in test solution (b):* 0.5 times the area of the principal peak in the chromatogram obtained with reference solution (b) (0.05 per cent); disregard the peak due to impurity C and any peak with a retention time greater than 20 min.

## B. Column:

- size:  $l = 0.15$  m,  $\emptyset = 4.6$  mm;
- stationary phase: spherical *octylsilyl silica gel for chromatography R* (5  $\mu$ m);
- temperature: 35 °C.

*Mobile phase:* mix 5 volumes of *methanol R*, 40 volumes of a 6.8 g/L solution of *potassium dihydrogen phosphate R* adjusted to pH 6.0 with a 280 g/L solution of *potassium hydroxide R*, and 55 volumes of *acetonitrile R1*.

*Flow rate:* 1.0 mL/min.

*Detection:* spectrophotometer at 229 nm.

*Injection:* 20  $\mu$ L of test solution (b) and reference solutions (b) and (c).

*Run time:* 11 times the retention time of ziprasidone.

*Identification of impurities:* use the chromatogram supplied with *ziprasidone for system suitability 2 CRS* and the chromatogram obtained with reference solution (c) to identify the peaks due to impurities D and E.

*Relative retention* with reference to ziprasidone (retention time = about 4.5 min): impurity D = about 2.0; impurity E = about 3.0.

*System suitability:* reference solution (c):

- *resolution:* minimum 6.0 between the peaks due to ziprasidone and impurity D.

## Limits:

- *correction factors:* for the calculation of content, multiply the peak areas of the following impurities by the corresponding correction factor: impurity D = 1.4; impurity E = 0.5;
- *impurities D, E:* for each impurity, not more than 1.5 times the area of the principal peak in the chromatogram obtained with reference solution (b) (0.15 per cent);
- *unspecified impurities:* for each impurity, not more than the area of the principal peak in the chromatogram obtained with reference solution (b) (0.10 per cent);
- *disregard limit:* 0.5 times the area of the principal peak in the chromatogram obtained with reference solution (b) (0.05 per cent); disregard any peak eluting before the peak due to ziprasidone.

## Limit:

- *total for tests A and B:* maximum 0.5 per cent.

**Heavy metals** (2.4.8): maximum 20 ppm.

1.0 g complies with test C. Prepare the reference solution using 2 mL of *lead standard solution (10 ppm Pb) R*.

**Water** (2.5.12): 3.7 per cent to 5.0 per cent, determined on 0.250 g.

**Sulfated ash** (2.4.14): maximum 0.1 per cent, determined on 1.0 g.

#### ASSAY

Liquid chromatography (2.2.29). Carry out the test protected from light and prepare the solutions immediately before use.

**Solvent mixture:** water R, methanol R (40:60 V/V).

**Test solution.** Dissolve 23.0 mg of the substance to be examined in the solvent mixture and dilute to 100.0 mL with the solvent mixture.

**Reference solution.** Dissolve 23.0 mg of ziprasidone hydrochloride monohydrate CRS in the solvent mixture and dilute to 100.0 mL with the solvent mixture.

#### Column:

- size:  $l = 0.15$  m,  $\varnothing = 4.6$  mm;
- stationary phase: spherical octylsilyl silica gel for chromatography R (5  $\mu$ m);
- temperature: 40 °C.

**Mobile phase:** mix 40 volumes of methanol R and 60 volumes of a 6.8 g/L solution of potassium dihydrogen phosphate R adjusted to pH 3.0 with phosphoric acid R.

**Flow rate:** 1.5 mL/min.

**Detection:** spectrophotometer at 229 nm.

**Injection:** 20  $\mu$ L.

**Run time:** twice the retention time of ziprasidone.

**Retention time:** ziprasidone = about 7 min.

**System suitability:** reference solution:

- symmetry factor: maximum 2.0 for the peak due to ziprasidone.

Calculate the percentage content of  $C_{21}H_{22}Cl_2N_4OS$  from the declared content of ziprasidone hydrochloride monohydrate CRS.

#### STORAGE

Protected from light.

#### IMPURITIES

Specified impurities: A, B, C, D, E.

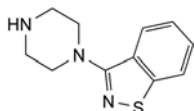

A. 3-piperazin-1-yl-1,2-benzisothiazole,

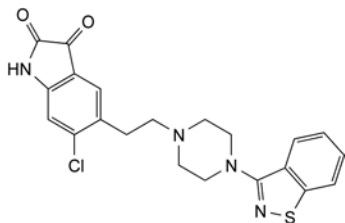

B. 5-[2-[4-(1,2-benzisothiazol-3-yl)piperazin-1-yl]ethyl]-6-chloro-1H-indole-2,3-dione,

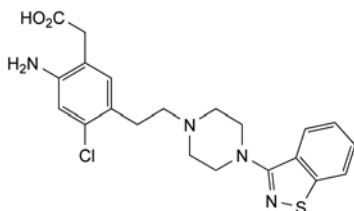

C. 2-[2-amino-5-[2-[4-(1,2-benzisothiazol-3-yl)piperazin-1-yl]ethyl]-4-chlorophenyl]acetic acid,

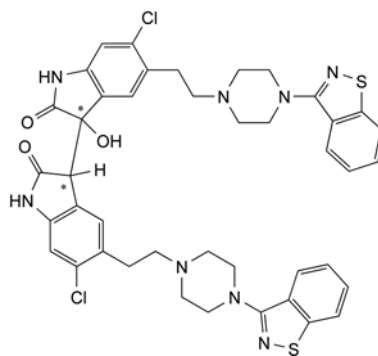

D. 5,5'-bis[2-[4-(1,2-benzisothiazol-3-yl)piperazin-1-yl]ethyl]-6,6'-dichloro-3-hydroxy-1,1',3,3'-tetrahydro-2H,2'H-3,3'-biindole-2,2'-dione,

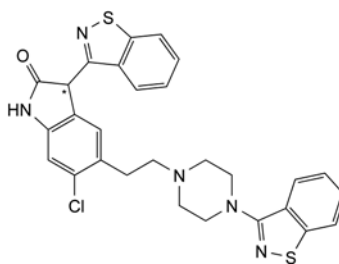

E. 3-(1,2-benzisothiazol-3-yl)-5-[2-[4-(1,2-benzisothiazol-3-yl)piperazin-1-yl]ethyl]-6-chloro-1,3-dihydro-2H-indol-2-one.

01/2011:1280

## ZOLPIDEM TARTRATE

### Zolpidemi tartras

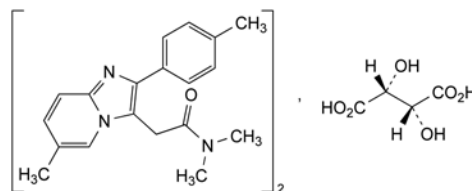

$C_{42}H_{48}N_6O_8$   
[99294-93-6]

$M_r$  765

#### DEFINITION

Bis[N,N-dimethyl-2-[6-methyl-2-(4-methylphenyl)imidazo[1,2-a]pyridin-3-yl]acetamide] (2R,3R)-2,3-dihydroxybutanedioate.

**Content:** 98.5 per cent to 101.0 per cent (anhydrous substance).

#### CHARACTERS

**Appearance:** white or almost white, hygroscopic, crystalline powder.

**Solubility:** slightly soluble in water, sparingly soluble in methanol, practically insoluble in methylene chloride.

#### IDENTIFICATION

**First identification:** A, C.

**Second identification:** B, C.

A. Infrared absorption spectrophotometry (2.2.24).

**Preparation:** dissolve 0.10 g in 10 mL of 0.1 M hydrochloric acid. Add 10 mL of water R. Add dropwise with stirring 1 mL of dilute ammonia R2. Filter and collect the resulting precipitate. Wash the precipitate with water R and then dry at 105 °C for 2 h. Examine the precipitate as a disc.

**Comparison:** repeat the operations using 0.10 g of zolpidem tartrate CRS.

## B. Thin-layer chromatography (2.2.27).

**Test solution.** Dissolve 50 mg of the substance to be examined in 5 mL of *methanol R*, add 0.1 mL of *diethylamine R* and dilute to 10 mL with *methanol R*.

**Reference solution (a).** Dissolve 50 mg of *zolpidem tartrate CRS* in 5 mL of *methanol R*, add 0.1 mL of *diethylamine R* and dilute to 10 mL with *methanol R*.

**Reference solution (b).** Dissolve 50 mg of *flunitrazepam CRS* in 5 mL of *methylene chloride R* and dilute to 10 mL with the same solvent. Mix 1 mL of this solution with 1 mL of reference solution (a).

**Plate:** TLC silica gel  $F_{254}$  plate *R*.

**Mobile phase:** *diethylamine R*, *cyclohexane R*, *ethyl acetate R* (10:45:45 V/V/V).

**Application:** 5  $\mu$ L.

**Development:** over 2/3 of the plate.

**Drying:** in air.

**Detection:** examine in ultraviolet light at 254 nm.

**System suitability:** reference solution (b):

- the chromatogram shows 2 clearly separated spots.

**Results:** the principal spot in the chromatogram obtained with the test solution is similar in position and size to the principal spot in the chromatogram obtained with reference solution (a).

C. Dissolve about 0.1 g in 1 mL of *methanol R* heating gently. 0.1 mL of this solution gives reaction (b) of tartrates (2.3.1).

## TESTS

**Appearance of solution.** The solution is clear (2.2.1) and not more intensely coloured than reference solution  $Y_6$  or  $BY_6$  (2.2.2, *Method II*). Prepare the solutions protected from light and carry out the test as rapidly as possible.

Triturate 0.25 g with 0.125 g of *tartaric acid R*. Dissolve the mixture in 20 mL of *water R* and dilute to 25 mL with the same solvent.

**Related substances.** Liquid chromatography (2.2.29).

**Test solution.** Dissolve 25 mg of the substance to be examined in the mobile phase and dilute to 50.0 mL with the mobile phase.

**Reference solution (a).** Dissolve 5 mg of *zolpidem impurity A CRS* in the mobile phase and dilute to 50.0 mL with the mobile phase.

**Reference solution (b).** Dissolve 5 mg of the substance to be examined in the mobile phase and dilute to 50.0 mL with the mobile phase. To 10 mL of this solution, add 10 mL of reference solution (a).

**Reference solution (c).** Dilute 2.0 mL of the test solution to 100.0 mL with the mobile phase. Dilute 1.0 mL of this solution to 10.0 mL with the mobile phase.

**Column:**

- size:  $l = 0.15$  m,  $\varnothing = 3.9$  mm;
- stationary phase: octadecylsilyl silica gel for chromatography *R* (4  $\mu$ m).

**Mobile phase:** mix 18 volumes of *acetonitrile R*, 23 volumes of *methanol R* and 59 volumes of a 5.6 g/L solution of *phosphoric acid R* adjusted to pH 5.5 with *triethylamine R*.

**Flow rate:** 1.5 mL/min.

**Detection:** spectrophotometer at 254 nm.

**Injection:** 20  $\mu$ L of the test solution and reference solutions (b) and (c).

**Identification of impurities:** use the chromatogram obtained with reference solution (b) to identify the peak due to impurity A.

**Relative retention** with reference to *zolpidem* (retention time = about 10 min): *tartaric acid* = about 0.16; *impurity A* = about 0.8.

**System suitability:** reference solution (b):

- **resolution:** minimum 2.0 between the peaks due to impurity A and *zolpidem*.

**Limits:**

- **unspecified impurities:** for each impurity, not more than 0.5 times the area of the principal peak in the chromatogram obtained with reference solution (c) (0.10 per cent);
- **total:** not more than the area of the principal peak in the chromatogram obtained with reference solution (c) (0.2 per cent);
- **disregard limit:** 0.25 times the area of the principal peak in the chromatogram obtained with reference solution (c) (0.05 per cent); disregard any peak due to *tartaric acid*.

**Water** (2.5.12): maximum 3.0 per cent, determined on 0.50 g.

**Sulfated ash** (2.4.14): maximum 0.1 per cent, determined on 1.0 g.

## ASSAY

Dissolve 0.300 g in a mixture of 20 mL of *anhydrous acetic acid R* and 20 mL of *acetic anhydride R*. Titrate with 0.1 M *perchloric acid R*, determining the end-point potentiometrically (2.2.20). Carry out a blank titration.

1 mL of 0.1 M *perchloric acid* is equivalent to 38.24 mg of  $C_{42}H_{48}N_6O_8$ .

## STORAGE

In an airtight container, protected from light.

## IMPURITIES

**Other detectable impurities** (the following substances would, if present at a sufficient level, be detected by one or other of the tests in the monograph. They are limited by the general acceptance criterion for other/unspecified impurities and/or by the general monograph *Substances for pharmaceutical use* (2034). It is therefore not necessary to identify these impurities for demonstration of compliance. See also 5.10. *Control of impurities in substances for pharmaceutical use*): A.

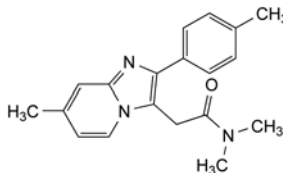

A. *N,N*-dimethyl-2-[7-methyl-2-(4-methylphenyl)imidazo[1,2-*a*]pyridin-3-yl]acetamide.

01/2008:1060

## ZOPICLONE

## Zopiclonum

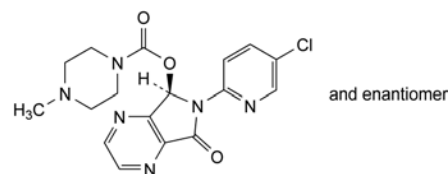

and enantiomer

$C_{17}H_{17}ClN_6O_3$   
[43200-80-2]

$M_r$  388.8

## DEFINITION

(5*RS*)-6-(5-Chloropyridin-2-yl)-7-oxo-6,7-dihydro-5*H*-pyrrolo[3,4-*b*]pyrazin-5-yl 4-methylpiperazine-1-carboxylate.

**Content:** 98.5 per cent to 100.5 per cent.

## CHARACTERS

*Appearance*: white or slightly yellowish powder.

*Solubility*: practically insoluble in water, freely soluble in methylene chloride, sparingly soluble in acetone, practically insoluble in ethanol (96 per cent). It dissolves in dilute mineral acids.

mp: about 177 °C, with decomposition.

## IDENTIFICATION

*First identification*: B.

*Second identification*: A, C.

A. Ultraviolet and visible absorption spectrophotometry (2.2.25).

*Test solution*. Dissolve 50.0 mg in a 3.5 g/L solution of hydrochloric acid R and dilute to 100.0 mL with the same solvent. Dilute 2.0 mL of this solution to 100.0 mL with a 3.5 g/L solution of hydrochloric acid R.

*Spectral range*: 220-350 nm.

*Absorption maximum*: at 303 nm.

*Specific absorbance at the absorption maximum*: 340 to 380.

B. Infrared absorption spectrophotometry (2.2.24).

*Preparation*: discs.

*Comparison*: zopiclone CRS.

C. Thin-layer chromatography (2.2.27).

*Test solution*. Dissolve 10 mg of the substance to be examined in methylene chloride R and dilute to 10 mL with the same solvent.

*Reference solution*. Dissolve 10 mg of zopiclone CRS in methylene chloride R and dilute to 10 mL with the same solvent.

*Plate*: TLC silica gel GF<sub>254</sub> plate R.

*Mobile phase*: triethylamine R, acetone R, ethyl acetate R (2:50:50 V/V/V).

*Application*: 10 µL.

*Development*: over a path of 15 cm.

*Drying*: in air.

*Detection*: examine in ultraviolet light at 254 nm.

*Results*: the principal spot in the chromatogram obtained with the test solution is similar in position and size to the principal spot in the chromatogram obtained with the reference solution.

## TESTS

**Solution S**. Dissolve 1.0 g in dimethylformamide R and dilute to 20.0 mL with the same solvent.

**Appearance of solution**. Solution S is not more opalescent than reference suspension II (2.2.1) and not more intensely coloured than intensity 5 of the range of reference solutions of the most appropriate colour (2.2.2, Method II).

**Optical rotation** (2.2.7): -0.05° to +0.05°.

Dilute 10.0 mL of solution S to 50.0 mL with dimethylformamide R.

**Related substances**. Liquid chromatography (2.2.29). Prepare the solutions immediately before use.

*Test solution*. Dissolve 40.0 mg of the substance to be examined in the mobile phase and dilute to 10.0 mL with the mobile phase.

*Reference solution (a)*. Dilute 3.0 mL of the test solution to 100.0 mL with the mobile phase. Dilute 1.0 mL of this solution to 10.0 mL with the mobile phase.

*Reference solution (b)*. Dilute 1.0 mL of the test solution to 100.0 mL with the mobile phase. Dilute 1.0 mL of this solution to 10.0 mL with the mobile phase.

*Reference solution (c)*. Dissolve 4.0 mg of zopiclone oxide CRS (impurity A) in the mobile phase and dilute to 10.0 mL with the mobile phase. To 10.0 mL of this solution, add 1.0 mL of the test solution and dilute to 100.0 mL with the mobile phase.

*Column*:

– *size*:  $l = 0.25$  m,  $\varnothing = 4.6$  mm;

– *stationary phase*: octadecylsilyl silica gel for chromatography R (5 µm);

– *temperature*: 30 °C.

*Mobile phase*: mix 38 volumes of acetonitrile R and 62 volumes of a solution containing 8.1 g/L of sodium laurilsulfate R and 1.6 g/L of sodium dihydrogen phosphate R adjusted to pH 3.5 with a 10 per cent V/V solution of phosphoric acid R.

*Flow rate*: 1.5 mL/min.

*Detection*: spectrophotometer at 303 nm.

*Injection*: 20 µL.

*Run time*: 1.5 times the retention time of zopiclone.

*Retention time*: zopiclone = 27 min to 31 min; if necessary, adjust the concentration of acetonitrile in the mobile phase (increasing the concentration decreases the retention times).

*System suitability*: reference solution (c):

– *resolution*: minimum 3.0 between the peaks due to impurity A and zopiclone; if necessary, adjust the mobile phase to pH 4.0 with a 10 per cent V/V solution of phosphoric acid R.

*Limits*:

– *impurities A, B, C*: for each impurity, not more than the area of the principal peak in the chromatogram obtained with reference solution (a) (0.3 per cent) and not more than 2 such peaks have an area greater than the area of the principal peak in the chromatogram obtained with reference solution (b) (0.1 per cent).

**2-Propanol**. Gas chromatography (2.2.28).

*Internal standard solution*. Dilute 5 mL of ethanol R1 to 100 mL with ethylene chloride R. Dilute 1 mL of this solution to 10 mL with ethylene chloride R.

*Test solution*. Dissolve 0.25 g of the substance to be examined in ethylene chloride R, add 0.5 mL of the internal standard solution and dilute to 5.0 mL with ethylene chloride R.

*Reference solution*. Dilute 4.5 mL of 2-propanol R to 100.0 mL with ethylene chloride R. To 1.0 mL of this solution, add 10.0 mL of the internal standard solution and dilute to 100.0 mL with ethylene chloride R.

*Column*:

– *material*: fused silica;

– *size*:  $l = 10$  m,  $\varnothing =$  about 0.53 mm;

– *stationary phase*: styrene-divinylbenzene copolymer R (film thickness 20 µm).

*Carrier gas*: helium for chromatography R.

*Flow rate*: 4 mL/min.

*Temperature*:

	Time (min)	Temperature (°C)
Column	0 - 5	50
	5 - 10	50 → 70
	10 - 14	70
	14 - 20.5	70 → 200
	20.5 - 27.5	200
Injection port		150
Detector		250

*Detection*: flame ionisation.

*Injection*: 1 µL.

Calculate the percentage content *m/m* of 2-propanol taking its density to be 0.785 g/mL at 20 °C.

**Limit:**

– 2-propanol: maximum 0.7 per cent *m/m*.

**Heavy metals (2.4.8):** maximum 20 ppm.

1.0 g complies with test C. Prepare the reference solution using 2 mL of lead standard solution (10 ppm Pb) R.

**Sulfated ash (2.4.14):** maximum 0.1 per cent, determined on 1.0 g.

**ASSAY**

Dissolve 0.300 g in a mixture of 10 mL of anhydrous acetic acid R and 40 mL of acetic anhydride R. Titrate with 0.1 M perchloric acid, determining the end-point potentiometrically (2.2.20).

1 mL of 0.1 M perchloric acid is equivalent to 38.88 mg of C<sub>17</sub>H<sub>17</sub>ClN<sub>6</sub>O<sub>3</sub>.

**STORAGE**

Protected from light.

**IMPURITIES**

Specified impurities: A, B, C.

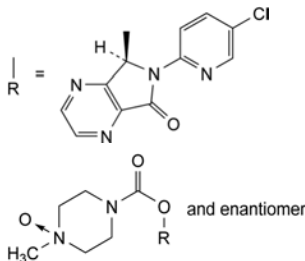

- A. (5*RS*)-6-(5-chloropyridin-2-yl)-7-oxo-6,7-dihydro-5*H*-pyrrolo[3,4-*b*]pyrazin-5-yl 4-methylpiperazine-1-carboxylate 4-oxide (zopiclone oxide),
- B. R-OH and enantiomer: (7*RS*)-6-(5-chloropyridin-2-yl)-7-hydroxy-6,7-dihydro-5*H*-pyrrolo[3,4-*b*]pyrazin-5-one,
- C. R-H: 6-(5-chloropyridin-2-yl)-6,7-dihydro-5*H*-pyrrolo[3,4-*b*]pyrazin-5-one.

01/2008:1707

## ZUCLOPENTHIXOL DECANOATE

### Zuclopenthixoli decanoas

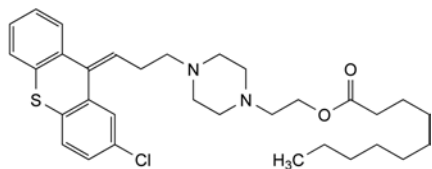

C<sub>32</sub>H<sub>43</sub>ClN<sub>2</sub>O<sub>2</sub>S  
[64053-00-5]

*M<sub>r</sub>* 555.2

**DEFINITION**

2-[4-[3-[(9*Z*)-2-Chloro-9*H*-thioxanthen-9-ylidene]propyl]-piperazin-1-yl]ethyl decanoate.

**Content:** 98.0 per cent to 102.0 per cent (dried substance).

**CHARACTERS**

**Appearance:** yellow, viscous, oily liquid.

**Solubility:** very slightly soluble in water, very soluble in ethanol (96 per cent) and in methylene chloride.

**IDENTIFICATION**

Infrared absorption spectrophotometry (2.2.24).

**Comparison:** Ph. Eur. reference spectrum of zuclopenthixol decanoate.

**TESTS**

**Appearance of solution.** The solution is clear (2.2.1).

Using an ultrasonic bath, dissolve 1.0 g in ethanol (96 per cent) R and dilute to 20.0 mL with the same solvent.

**Related substances.** Liquid chromatography (2.2.29). Carry out the test protected from light and prepare the solutions immediately before use.

**Solution A.** Dissolve 8.89 g of docusate sodium R in water R, stirring for about 6-8 h, and dilute to 1000 mL with the same solvent.

**Test solution.** Dissolve 25.0 mg of the substance to be examined in acetonitrile R and dilute to 100.0 mL with the same solvent.

**Reference solution (a).** Dilute 1.0 mL of the test solution to 100.0 mL with acetonitrile R.

**Reference solution (b).** Dissolve 5.0 mg of zuclopenthixol impurity B CRS in acetonitrile R and dilute to 100.0 mL with the same solvent. Dilute 5.0 mL of this solution to 100.0 mL with acetonitrile R.

**Reference solution (c).** Dissolve the contents of a vial of zuclopenthixol for system suitability CRS (zuclopenthixol decanoate containing impurities A, B and C) in 1 mL of methanol R.

**Column:**

- size: *l* = 0.25 m, Ø = 4.6 mm;
- stationary phase: spherical end-capped octadecylsilyl silica gel for chromatography R (5 µm);
- temperature: 40 °C.

**Mobile phase:** mix 25 volumes of solution A and 75 volumes of anhydrous ethanol R, then add 0.1 volumes of phosphoric acid R.

**Flow rate:** 1.0 mL/min.

**Detection:** spectrophotometer at 270 nm.

**Injection:** 20 µL.

**Run time:** twice the retention time of zuclopenthixol decanoate.

**Identification of impurities:** use the chromatogram supplied with zuclopenthixol for system suitability CRS and the chromatograms obtained with reference solutions (b) and (c) to identify the peaks due to impurities A, B and C.

**Relative retention** with reference to zuclopenthixol decanoate (retention time = about 12 min): impurity C = about 0.4; impurity B = about 0.5; impurity A = about 1.1.

**System suitability:** reference solution (c):

- peak-to-valley ratio: minimum 2.0, where *H<sub>p</sub>* = height above the baseline of the peak due to impurity C and *H<sub>v</sub>* = height above the baseline of the lowest point of the curve separating this peak from the peak due to impurity B; and minimum 2.5, where *H<sub>p</sub>* = height above the baseline of the peak due to impurity A and *H<sub>v</sub>* = height above the baseline of the lowest point of the curve separating this peak from the peak due to zuclopenthixol decanoate.

**Limits:**

- impurity A: not more than 1.3 times the area of the principal peak in the chromatogram obtained with reference solution (a) (1.3 per cent);
- impurity B: not more than 0.2 times the area of the principal peak in the chromatogram obtained with reference solution (b) (0.2 per cent);
- impurity C: not more than 0.3 times the area of the principal peak in the chromatogram obtained with reference solution (a) (0.3 per cent);
- unspecified impurities: for each impurity, not more than 0.1 times the area of the principal peak in the chromatogram obtained with reference solution (a) (0.10 per cent);

- *total*: not more than 1.5 times the area of the principal peak in the chromatogram obtained with reference solution (a) (1.5 per cent);
- *disregard limit*: 0.05 times the area of the principal peak in the chromatogram obtained with reference solution (a) (0.05 per cent).

**Heavy metals** (2.4.8): maximum 20 ppm.

1.0 g complies with test C. Prepare the reference solution using 2 mL of *lead standard solution* (10 ppm Pb) R.

**Loss on drying** (2.2.32): maximum 0.5 per cent, determined on 1.000 g by drying in an oven at 60 °C at a pressure not exceeding 0.7 kPa for 3 h.

**Sulfated ash** (2.4.14): maximum 0.1 per cent, determined on 1.0 g.

#### ASSAY

Dissolve 0.250 g in 50 mL of *anhydrous acetic acid* R. Titrate with 0.1 M *perchloric acid*, determining the end-point potentiometrically (2.2.20).

1 mL of 0.1 M *perchloric acid* is equivalent to 27.76 mg of  $C_{32}H_{43}ClN_2O_2S$ .

#### STORAGE

Under an inert gas in an airtight container, protected from light, at a temperature not exceeding –20 °C.

#### IMPURITIES

*Specified impurities: A, B, C.*

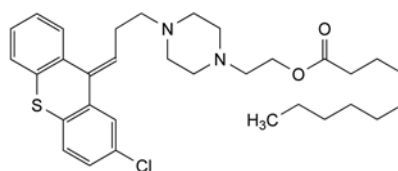

A. 2-[4-[3-[(9*E*)-2-chloro-9*H*-thioxanthen-9-ylidene]propyl]piperazin-1-yl]ethyl decanoate,

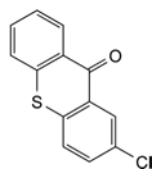

B. 2-chloro-9*H*-thioxanthen-9-one,

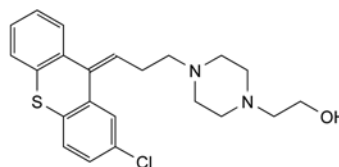

C. 2-[4-[3-[(9*Z*)-2-chloro-9*H*-thioxanthen-9-ylidene]propyl]piperazin-1-yl]ethanol.

# INDEX

*Monographs deleted from the 6<sup>th</sup> Edition are not included in the index; a list of deleted texts is found in the Contents of Volume 1, page xxii.*

English index .....	3267	Latin index .....	3295
---------------------	------	-------------------	------





<b>Numerics</b>		
1. General notices .....	3	
2.1.1. Droppers.	15	
2.1.2. Comparative table of porosity of sintered-glass filters...	15	
2.1.3. Ultraviolet ray lamps for analytical purposes.	15	
2.1.4. Sieves .....	16	
2.1.5. Tubes for comparative tests .....	17	
2.1.6. Gas detector tubes.....	17	
2.1. Apparatus .	15	
2.2.10. Viscosity - Rotating viscometer method.	28	
2.2.11. Distillation range.	30	
2.2.12. Boiling point .....	31	
2.2.13. Determination of water by distillation.....	31	
2.2.14. Melting point - capillary method.....	31	
2.2.15. Melting point - open capillary method .	32	
2.2.16. Melting point - instantaneous method .	32	
2.2.17. Drop point.	32	
2.2.18. Freezing point.	34	
2.2.19. Amperometric titration .	34	
2.2.1. Clarity and degree of opalescence of liquids.....	21	
2.2.20. Potentiometric titration.	34	
2.2.21. Fluorimetry.	35	
2.2.22. Atomic emission spectrometry.	35	
2.2.23. Atomic absorption spectrometry .	36	
2.2.24. Absorption spectrophotometry, infrared.	38	
2.2.25. Absorption spectrophotometry, ultraviolet and visible.	40	
2.2.26. Paper chromatography .	41	
2.2.27. Thin-layer chromatography.	42	
2.2.28. Gas chromatography .	43	
2.2.29. Liquid chromatography .	45	
2.2.2. Degree of coloration of liquids.	22	
2.2.30. Size-exclusion chromatography .	46	
2.2.31. Electrophoresis.	46	
2.2.31. Electrophoresis (5.8.).	621	
2.2.32. Loss on drying. ....	51	
2.2.33. Nuclear magnetic resonance spectrometry .	52	
2.2.34. Thermal analysis.	54	
2.2.35. Osmolality.	57	
2.2.36. Potentiometric determination of ionic concentration using ion-selective electrodes.	57	
2.2.37. X-ray fluorescence spectrometry.	58	
2.2.38. Conductivity.	59	
2.2.39. Molecular mass distribution in dextrans .	60	
2.2.3. Potentiometric determination of pH.	24	
2.2.40. Near-infrared spectrophotometry .....	61	
2.2.41. Circular dichroism.	65	
2.2.42. Density of solids .	66	
2.2.43. Mass spectrometry .	67	
2.2.44. Total organic carbon in water for pharmaceutical use.	69	
2.2.45. Supercritical fluid chromatography.	70	
2.2.46. Chromatographic separation techniques.	70	
2.2.47. Capillary electrophoresis.	77	
2.2.47. Capillary electrophoresis (5.8.).	621	
2.2.48. Raman spectrometry .	82	
2.2.49. Falling ball viscometer method.	83	
2.2.4. Relationship between reaction of solution, approximate pH and colour of certain indicators.	25	
2.2.54. Isoelectric focusing.	83	
2.2.54. Isoelectric focusing (5.8.).	621	
2.2.55. Peptide mapping.	85	
2.2.55. Peptide mapping (5.8.).	621	
2.2.56. Amino acid analysis .	88	
2.2.56. Amino acid analysis (5.8.).	621	
2.2.7. Optical rotation .	26	
2.2.8. Viscosity.	27	
2.2.9. Capillary viscometer method.	27	
2.2. Physical and physicochemical methods.....	21	
2.3.1. Identification reactions of ions and functional groups..	107	
2.3.2. Identification of fatty oils by thin-layer chromatography .	110	
2.3.3. Identification of phenothiazines by thin-layer chromatography.	110	
2.3.4. Odour.	110	
2.3. Identification.	107	
2.4.10. Lead in sugars. ....	117	
2.4.11. Phosphates. ....	117	
2.4.12. Potassium.....	117	
2.4.13. Sulfates.	118	
2.4.14. Sulfated ash.	118	
2.4.14. Sulfated ash (5.8.) .....	622	
2.4.15. Nickel in polyols.	118	
2.4.16. Total ash.	118	
2.4.17. Aluminium.	118	
2.4.18. Free formaldehyde .	118	
2.4.19. Alkaline impurities in fatty oils.	119	
2.4.1. Ammonium.	113	
2.4.21. Foreign oils in fatty oils by thin-layer chromatography .	119	
2.4.22. Composition of fatty acids by gas chromatography ...	119	
2.4.23. Sterols in fatty oils.	121	
2.4.24. Identification and control of residual solvents. ....	123	
2.4.25. Ethylene oxide and dioxan. ....	127	
2.4.26. <i>N,N</i> -Dimethylaniline .....	128	
2.4.27. Heavy metals in herbal drugs and fatty oils. ....	129	
2.4.28. 2-Ethylhexanoic acid .	130	
2.4.29. Composition of fatty acids in oils rich in omega-3 acids.	130	
2.4.2. Arsenic.	113	
2.4.30. Ethylene glycol and diethylene glycol in ethoxylated substances.	132	
2.4.31. Nickel in hydrogenated vegetable oils.	132	
2.4.32. Total cholesterol in oils rich in omega-3 acids .	133	
2.4.3. Calcium.	113	
2.4.4. Chlorides .	113	
2.4.5. Fluorides . ....	114	
2.4.6. Magnesium. ....	114	
2.4.7. Magnesium and alkaline-earth metals . ....	114	
2.4.8. Heavy metals . ....	114	
2.4.9. Iron .....	117	
2.4. Limit tests.	113	
2.5.10. Oxygen-flask method.	139	
2.5.11. Complexometric titrations.	140	
2.5.12. Water: semi-micro determination.	140	
2.5.13. Aluminium in adsorbed vaccines. ....	141	
2.5.14. Calcium in adsorbed vaccines .....	141	
2.5.15. Phenol in immunosera and vaccines .....	141	
2.5.16. Protein in polysaccharide vaccines .....	141	
2.5.17. Nucleic acids in polysaccharide vaccines .	142	
2.5.18. Phosphorus in polysaccharide vaccines.	142	
2.5.19. <i>O</i> -Acetyl in polysaccharide vaccines.	142	
2.5.1. Acid value.	137	
2.5.20. Hexosamines in polysaccharide vaccines.	142	
2.5.21. Methylpentoses in polysaccharide vaccines .	143	
2.5.22. Uronic acids in polysaccharide vaccines .	143	
2.5.23. Sialic acid in polysaccharide vaccines .	143	
2.5.24. Carbon dioxide in gases.	143	
2.5.25. Carbon monoxide in gases.	144	
2.5.26. Nitrogen monoxide and nitrogen dioxide in gases.	145	
2.5.27. Oxygen in gases.	145	

2.5.34. Acetic acid in synthetic peptides .	150	2.7.29. Nucleated cell count and viability.	233
2.5.35. Nitrous oxide in gases	150	2.7.2. Microbiological assay of antibiotics .	202
2.5.36. Anisidine value	150	2.7.30. Assay of human protein C .	234
2.5.3. Hydroxyl value .	137	2.7.31. Assay of human protein S .	235
2.5.4. Iodine value .	137	2.7.32. Assay of human $\alpha$ -1-proteinase inhibitor .	236
2.5.5. Peroxide value .	138	2.7.4. Assay of human coagulation factor VIII .	207
2.5.6. Saponification value .	139	2.7.5. Assay of heparin	208
2.5.7. Unsaponifiable matter .	139	2.7.6. Assay of diphtheria vaccine (adsorbed) .	209
2.5.8. Determination of primary aromatic amino-nitrogen ...	139	2.7.7. Assay of pertussis vaccine .	213
2.5.9. Determination of nitrogen by sulfuric acid digestion ..	139	2.7.8. Assay of tetanus vaccine (adsorbed) .	214
2.5. Assays .	137	2.7.9. Test for Fc function of immunoglobulin .	217
2.6.10. Histamine .	162	2.7. Biological assays .	201
2.6.11. Depressor substances .	162	2.8.10. Solubility in alcohol of essential oils .	240
2.6.12. Microbiological examination of non-sterile products: microbial enumeration tests .	163	2.8.11. Assay of 1,8-cineole in essential oils .	240
2.6.12. Microbiological examination of non-sterile products: microbial enumeration tests (5.8.) .	622	2.8.12. Determination of essential oils in herbal drugs .	241
2.6.13. Microbiological examination of non-sterile products: test for specified micro-organisms .	167	2.8.13. Pesticide residues	242
2.6.13. Microbiological examination of non-sterile products: test for specified micro-organisms (5.8.) .	622	2.8.14. Determination of tannins in herbal drugs .	243
2.6.14. Bacterial endotoxins .	171	2.8.15. Bitterness value	244
2.6.15. Prekallikrein activator .	175	2.8.16. Dry residue of extracts .	244
2.6.16. Tests for extraneous agents in viral vaccines for human use .	176	2.8.17. Loss on drying of extracts .	244
2.6.17. Test for anticomplementary activity of immunoglobulin .	177	2.8.18. Determination of aflatoxin B <sub>1</sub> in herbal drugs .	244
2.6.18. Test for neurovirulence of live virus vaccines .	179	2.8.1. Ash insoluble in hydrochloric acid .	239
2.6.19. Test for neurovirulence of poliomyelitis vaccine (oral) .	179	2.8.20. Herbal drugs: sampling and sample preparation .	246
2.6.1. Sterility	153	2.8.21. Test for aristolochic acids in herbal drugs .	247
2.6.20. Anti-A and anti-B haemagglutinins (indirect method) .	180	2.8.22. Determination of ochratoxin A in herbal drugs .	249
2.6.21. Nucleic acid amplification techniques .	181	2.8.23. Microscopic examination of herbal drugs .	250
2.6.22. Activated coagulation factors .	185	2.8.2. Foreign matter	239
2.6.24. Avian viral vaccines: tests for extraneous agents in seed lots .	185	2.8.3. Stomata and stomatal index .	239
2.6.25. Avian live virus vaccines: tests for extraneous agents in batches of finished product .	188	2.8.4. Swelling index	239
2.6.26. Test for anti-D antibodies in human immunoglobulin for intravenous administration .	191	2.8.5. Water in essential oils	239
2.6.27. Microbiological control of cellular products .	191	2.8.6. Foreign esters in essential oils .	239
2.6.2. Mycobacteria	156	2.8.7. Fatty oils and resinified essential oils in essential oils ..	239
2.6.30. Monocyte-activation test .	192	2.8.8. Odour and taste of essential oils .	240
2.6.31. Microbiological examination of herbal medicinal products for oral use .	197	2.8.9. Residue on evaporation of essential oils .	240
2.6.7. Mycoplasmas	156	2.8. Methods in pharmacognosy .	239
2.6.8. Pyrogens .	161	2.9.10. Ethanol content and alcoholimetric tables .	268
2.6.9. Abnormal toxicity .	162	2.9.11. Test for methanol and 2-propanol .	270
2.6. Biological tests	153	2.9.12. Sieve test	270
2.7.10. Assay of human coagulation factor VII .	219	2.9.14. Specific surface area by air permeability .	271
2.7.11. Assay of human coagulation factor IX .	219	2.9.16. Flowability	272
2.7.12. Assay of heparin in coagulation factors .	220	2.9.17. Test for extractable volume of parenteral preparations .	273
2.7.13. Assay of human anti-D immunoglobulin .	220	2.9.17. Test for extractable volume of parenteral preparations (5.8.)	622
2.7.14. Assay of hepatitis A vaccine .	222	2.9.18. Preparations for inhalation: aerodynamic assessment of fine particles .	274
2.7.15. Assay of hepatitis B vaccine (rDNA) .	223	2.9.19. Particulate contamination: sub-visible particles .	285
2.7.16. Assay of pertussis vaccine (acellular) .	223	2.9.1. Disintegration of tablets and capsules .	253
2.7.17. Assay of human antithrombin III .	224	2.9.20. Particulate contamination: visible particles .	287
2.7.18. Assay of human coagulation factor II .	224	2.9.22. Softening time determination of lipophilic suppositories	288
2.7.19. Assay of human coagulation factor X .	225	2.9.23. Gas pycnometric density of solids .	288
2.7.19. Assay of human coagulation factor X (2.7.19.) .	225	2.9.25. Dissolution test for medicated chewing gums .	289
2.7.1. Immunochemical methods .	201	2.9.26. Specific surface area by gas adsorption .	291
2.7.20. <i>In vivo</i> assay of poliomyelitis vaccine (inactivated) ....	225	2.9.26. Specific surface area by gas adsorption (5.8.)	622
2.7.21. Assay of human von Willebrand factor .	226	2.9.27. Uniformity of mass of delivered doses from multidose containers	294
2.7.22. Assay of human coagulation factor XI .	227	2.9.29. Intrinsic dissolution	294
2.7.23. Numeration of CD34/CD45 <sup>+</sup> cells in haematopoietic products	228	2.9.2. Disintegration of suppositories and pessaries .	255
		2.9.31. Particle size analysis by laser light diffraction .	295
		2.9.32. Porosity and pore-size distribution of solids by mercury porosimetry	299
		2.9.33. Characterisation of crystalline and partially crystalline solids by X-ray powder diffraction (XRPD) .	301
		2.9.34. Bulk density and tapped density of powders .	305

2.9.38. Particle-size distribution estimation by analytical sieving (5.8.).....	623	5.1.10. Guidelines for using the test for bacterial endotoxins..	520
2.9.3. Dissolution test for solid dosage forms .	256	5.11. Characters section in monographs .	637
2.9.40. Uniformity of dosage units.	315	5.1.1. Methods of preparation of sterile products .	503
2.9.41. Friability of granules and spheroids .	318	5.1.2. Biological indicators of sterilisation. ....	504
2.9.42. Dissolution test for lipophilic solid dosage forms.	319	5.1.2. Reference standards.	641
2.9.43. Apparent dissolution .....	320	5.1.3. Efficacy of antimicrobial preservation .	505
2.9.45. Wettability of porous solids including powders.	321	5.1.4. Gene transfer medicinal products for human use .....	647
2.9.4. Dissolution test for transdermal patches .	263	5.1.4. Microbiological quality of non-sterile pharmaceutical preparations and substances for pharmaceutical use .....	507
2.9.5. Uniformity of mass of single-dose preparations. ....	265	5.1.4. Microbiological quality of non-sterile pharmaceutical preparations and substances for pharmaceutical use (5.8.)..	623
2.9.6. Uniformity of content of single-dose preparations. ....	266	5.1.5. Application of the $F_0$ concept to steam sterilisation of aqueous preparations .....	508
2.9.7. Friability of uncoated tablets .	266	5.1.5. Functionality-related characteristics of excipients.	661
2.9.7. Friability of uncoated tablets (5.8.) .	622	5.1.6. Alternative methods for control of microbiological quality .	508
2.9.8. Resistance to crushing of tablets. ....	267	5.17.1. Recommendations on dissolution testing .	665
2.9.9. Measurement of consistency by penetrometry .....	267	5.17. Recommendations on methods for dosage forms testing. ....	665
2.9. Pharmaceutical technical procedures .	253	5.1.7. Viral safety.	518
3.1.10. Materials based on non-plasticised poly(vinyl chloride) for containers for non-injectable, aqueous solutions .	349	5.1.8. Microbiological quality of herbal medicinal products for oral use .	519
3.1.11. Materials based on non-plasticised poly(vinyl chloride) for containers for dry dosage forms for oral administration. ....	350	5.1.9. Guidelines for using the test for sterility .	519
3.1.1.1. Materials based on plasticised poly(vinyl chloride) for containers for human blood and blood components. ....	329	5.1. General texts on microbiology .	503
3.1.1.2. Materials based on plasticised poly(vinyl chloride) for tubing used in sets for the transfusion of blood and blood components. ....	332	5.2.1. Terminology used in monographs on biological products .	527
3.1.1.3. Plastic additives .....	352	5.2.2. Chicken flocks free from specified pathogens for the production and quality control of vaccines .	527
3.1.1.4. Materials based on plasticised poly(vinyl chloride) for containers for aqueous solutions for intravenous infusion..	355	5.2.3. Cell substrates for the production of vaccines for human use .....	530
3.1.1.5. Polyethylene terephthalate for containers for preparations not for parenteral use.....	357	5.2.4. Cell cultures for the production of veterinary vaccines. ....	533
3.1.1. Materials for containers for human blood and blood components.....	329	5.2.5. Substances of animal origin for the production of immunological veterinary medicinal products.....	535
3.1.3. Polyolefines.....	334	5.2.6. Evaluation of safety of veterinary vaccines and immunosera .	536
3.1.4. Polyethylene without additives for containers for parenteral preparations and for ophthalmic preparations ...	337	5.2.7. Evaluation of efficacy of veterinary vaccines and immunosera .	538
3.1.5. Polyethylene with additives for containers for parenteral preparations and for ophthalmic preparations .	338	5.2.8. Minimising the risk of transmitting animal spongiform encephalopathy agents via human and veterinary medicinal products.....	539
3.1.6. Polypropylene for containers and closures for parenteral preparations and ophthalmic preparations. ....	342	5.2.9. Evaluation of safety of each batch of veterinary vaccines and immunosera .....	547
3.1.7. Poly(ethylene - vinyl acetate) for containers and tubing for total parenteral nutrition preparations. ....	345	5.2. General texts on biological products. ....	527
3.1.8. Silicone oil used as a lubricant .	347	5.3. Statistical analysis of results of biological assays and tests.	551
3.1.9. Silicone elastomer for closures and tubing. ....	347	5.4. Residual solvents .....	583
3.1. Materials used for the manufacture of containers .	329	5.5. Alcoholimetric tables .....	593
3.2.1. Glass containers for pharmaceutical use .	363	5.6. Assay of interferons.....	607
3.2.2.1. Plastic containers for aqueous solutions for infusion .....	368	5.7. Table of physical characteristics of radionuclides mentioned in the European Pharmacopoeia .	611
3.2.2. Plastic containers and closures for pharmaceutical use. ....	368	5.8. Pharmacopoeial harmonisation .	621
3.2.3. Sterile plastic containers for human blood and blood components .....	369	5.9. Polymorphism.....	627
3.2.4. Empty sterile containers of plasticised poly(vinyl chloride) for human blood and blood components .	370	<b>A</b>	
3.2.5. Sterile containers of plasticised poly(vinyl chloride) for human blood containing anticoagulant solution .	371	Abbreviations and symbols (1.).....	3
3.2.6. Sets for the transfusion of blood and blood components.	371	Abnormal toxicity (2.6.9.).	162
3.2.8. Sterile single-use plastic syringes .	373	Absorption spectrophotometry, infrared (2.2.24.).	38
3.2.9. Rubber closures for containers for aqueous parenteral preparations, for powders and for freeze-dried powders.	374	Absorption spectrophotometry, ultraviolet and visible (2.2.25.).	40
3.2. Containers .....	363	Acacia.....	1043
4.1.1. Reagents .....	379	Acacia, spray-dried .....	1301
4.1.2. Standard solutions for limit tests. ....	485	Acamprosate calcium .....	1301
4.1.3. Buffer solutions .....	489	Acarbose.....	1302
4.1. Reagents, standard solutions, buffer solutions. ....	379	Acebutolol hydrochloride. ....	1304
4.2.1. Primary standards for volumetric solutions. ....	494	Aceclofenac.....	1306
4.2.2. Volumetric solutions.....	494	Acemetacin .....	1307
4.2. Volumetric analysis.....	494	Acesulfame potassium .	1309
		Acetate trihydrate, sodium. ....	2908
		Acetazolamide.	1310

Acetone.....	1312	Aluminium oxide, hydrated.....	1359
Acetylcholine chloride.....	1313	Aluminium phosphate gel.....	1360
Acetylcysteine.....	1313	Aluminium phosphate, hydrated.....	1361
$\beta$ -Acetyldigoxin.....	1315	Aluminium sodium silicate.....	1361
Acetylsalicylic acid.....	1317	Aluminium sulfate.....	1362
Acetyltryptophan, <i>N</i> .....	1319	Alverine citrate.....	1363
Acetyltyrosine, <i>N</i> .....	1320	Amantadine hydrochloride.....	1364
Aciclovir.....	1321	Ambroxol hydrochloride.....	1365
Acid value (2.5.1.).....	137	Amfetamine sulfate.....	1366
Acitretin.....	1323	Amidotrizoate, sodium.....	2910
Actinobacillosis vaccine (inactivated), porcine.....	926	Amidotrizoic acid dihydrate.....	1366
Activated charcoal.....	1649	Amikacin.....	1367
Activated coagulation factors (2.6.22.).....	185	Amikacin sulfate.....	1369
Adapalene.....	1324	Amiloride hydrochloride.....	1370
Additives, plastic (3.1.13.).....	352	Amino acid analysis (2.2.56.).....	88
Adenine.....	1326	Amino acid analysis (2.2.56.) (5.8.).....	621
Adeno-associated-virus vectors for human use.....	656	Aminobenzoic acid, 4-.....	1371
Adenosine.....	1327	Aminocaproic acid.....	1373
Adipic acid.....	1328	Aminoglutethimide.....	1373
Adrenaline.....	1329	Aminophylline, anhydrous.....	3068
Adrenaline tartrate.....	1330	Aminophylline hydrate.....	3069
Adsorption, gas, specific surface area by (2.9.26.).....	291	Aminosalicylate dihydrate, sodium.....	2911
Adsorption, gas, specific surface area by (2.9.26.) (5.8.).....	622	Amiodarone hydrochloride.....	1375
Aerodynamic assessment of fine particles in preparations for inhalation (2.9.18.).....	274	Amisulpride.....	1376
Aflatoxin B <sub>1</sub> in herbal drugs, determination of (2.8.18.).....	244	Amitriptyline hydrochloride.....	1377
Agar.....	1044	Amlodipine besilate.....	1379
Agnus castus fruit.....	1044	Ammonia ( <sup>13</sup> N) injection.....	965
Agrimony.....	1046	Ammonia solution, concentrated.....	1380
Air, medicinal.....	1331	Ammonio methacrylate copolymer (type A).....	1381
Air, synthetic medicinal.....	1333	Ammonio methacrylate copolymer (type B).....	1382
Alanine.....	1334	Ammonium (2.4.1.).....	113
Albendazole.....	1335	Ammonium bromide.....	1382
Albumin solution, human.....	2165	Ammonium chloride.....	1383
Alchemilla.....	1047	Ammonium glycyrrhizate.....	1384
Alcoholimetric tables (2.9.10.).....	268	Ammonium hydrogen carbonate.....	1385
Alcoholimetric tables (5.5.).....	593	Amobarbital.....	1385
Alcuronium chloride.....	1336	Amobarbital sodium.....	1386
Alendronate, sodium.....	2908	Amoxicillin sodium.....	1386
Alexandrian senna pods.....	1238	Amoxicillin trihydrate.....	1389
Alfacalcidol.....	1337	Amperometric titration (2.2.19.).....	34
Alfadex.....	1338	Amphotericin B.....	1391
Alfentanil hydrochloride.....	1339	Ampicillin, anhydrous.....	1393
Alfuzosin hydrochloride.....	1341	Ampicillin sodium.....	1395
Alginate, sodium.....	2909	Ampicillin trihydrate.....	1397
Alginic acid.....	1342	Amylmetacresol.....	1399
Alkaline-earth metals and magnesium (2.4.7.).....	114	Anaemia vaccine (live), chicken, infectious.....	910
Alkaline impurities in fatty oils (2.4.19.).....	119	Anaesthetic ether.....	1968
Allantoin.....	1342	Analysis, thermal (2.2.34.).....	54
Allergen products.....	671	Analytical sieving, particle-size distribution estimation by (2.9.38.).....	313
Allopurinol.....	1343	Analytical sieving, particle-size distribution estimation by (2.9.38.) (5.8.).....	623
all- <i>rac</i> - $\alpha$ -Tocopherol.....	3104	Angelica root.....	1049
all- <i>rac</i> - $\alpha$ -Tocopheryl acetate.....	3106	Animal anti-T lymphocyte immunoglobulin for human use.....	1404
Almagate.....	1345	Animal immunosera for human use.....	678
Almond oil, refined.....	1346	Animal spongiform encephalopathies, products with risk of transmitting agents of.....	686
Almond oil, virgin.....	1347	Animal spongiform encephalopathy agents, minimising the risk of transmitting via human and veterinary medicinal products (5.2.8.).....	539
Aloes, Barbados.....	1047	Aniseed.....	1052
Aloes, Cape.....	1048	Anise oil.....	1050
Aloes dry extract, standardised.....	1049	Anisidine value (2.5.36.).....	150
Alphacyclodextrin.....	1338	Antazoline hydrochloride.....	1401
Alprazolam.....	1347	Anthrax spore vaccine (live) for veterinary use.....	847
Alprenolol hydrochloride.....	1349	Anthrax vaccine for human use (adsorbed, prepared from culture filtrates).....	745
Alprostadiol.....	1350	Anti-A and anti-B haemagglutinins (indirect method) (2.6.20.).....	180
Alteplase for injection.....	1352	Antibiotics, microbiological assay of (2.7.2.).....	202
Alternative methods for control of microbiological quality (5.1.6.).....	508	Antibodies (anti-D) in human immunoglobulin for intravenous administration, test for (2.6.26.).....	191
Altizide.....	1356	Antibodies for human use, monoclonal.....	682
Alum.....	1357		
Aluminium (2.4.17.).....	118		
Aluminium chloride hexahydrate.....	1357		
Aluminium hydroxide, hydrated, for adsorption.....	1357		
Aluminium in adsorbed vaccines (2.5.13.).....	141		
Aluminium magnesium silicate.....	1358		

- Anticoagulant and preservative solutions for human blood ..... 1401
- Anticomplementary activity of immunoglobulin (2.6.17.)..... 177
- Anti-D antibodies in human immunoglobulin for intravenous administration, test for (2.6.26.)..... 191
- Anti-D immunoglobulin for intravenous administration, human ..... 2167
- Anti-D immunoglobulin, human ..... 2166
- Anti-D immunoglobulin, human, assay of (2.7.13.)..... 220
- Antimicrobial preservation, efficacy of (5.1.3.) ..... 505
- Antiserum, European viper venom ..... 953
- Antithrombin III concentrate, human ..... 2168
- Antithrombin III, human, assay of (2.7.17.) ..... 224
- Anti-T lymphocyte immunoglobulin for human use, animal .. 1404
- Apomorphine hydrochloride ..... 1407
- Apparatus (2.1.) ..... 15
- Apparent dissolution (2.9.43.) ..... 320
- Application of the  $F_0$  concept to steam sterilisation of aqueous preparations (5.1.5.) ..... 508
- Aprotinin ..... 1408
- Aprotinin concentrated solution ..... 1411
- Arachis oil, hydrogenated ..... 1413
- Arachis oil, refined ..... 1413
- Arginine ..... 1414
- Arginine aspartate ..... 1415
- Arginine hydrochloride ..... 1415
- Argon ..... 1416
- Aristolochic acids in herbal drugs, test for (2.8.21) ..... 247
- Arnica flower ..... 1053
- Arnica tincture ..... 1055
- Arsenic (2.4.2.) ..... 113
- Arsenious trioxide for homoeopathic preparations ..... 1286
- Articaine hydrochloride ..... 1417
- Artichoke leaf ..... 1056
- Artichoke leaf dry extract ..... 1058
- Ascorbate, calcium ..... 1548
- Ascorbate, sodium ..... 2912
- Ascorbic acid ..... 1418
- Ascorbyl palmitate ..... 1420
- Ash insoluble in hydrochloric acid (2.8.1.) ..... 239
- Ash leaf ..... 1059
- Ash, sulfated (2.4.14.) ..... 118
- Ash, sulfated (2.4.14.) (5.8.) ..... 622
- Asparagine monohydrate ..... 1421
- Aspartame ..... 1421
- Aspartic acid ..... 1423
- Assay of 1,8-cineole in essential oils (2.8.11.) ..... 240
- Assay of diphtheria vaccine (adsorbed) (2.7.6.) ..... 209
- Assay of heparin (2.7.5.) ..... 208
- Assay of heparin in coagulation factors (2.7.12.) ..... 220
- Assay of hepatitis A vaccine (2.7.14.) ..... 222
- Assay of hepatitis B vaccine (rDNA) (2.7.15.) ..... 223
- Assay of human anti-D immunoglobulin (2.7.13.) ..... 220
- Assay of human antithrombin III (2.7.17.) ..... 224
- Assay of human coagulation factor II (2.7.18.) ..... 224
- Assay of human coagulation factor IX (2.7.11.) ..... 219
- Assay of human coagulation factor VII (2.7.10.) ..... 219
- Assay of human coagulation factor VIII (2.7.4.) ..... 207
- Assay of human coagulation factor X (2.7.19.) ..... 225
- Assay of human coagulation factor XI (2.7.22.) ..... 227
- Assay of human plasmin inhibitor (2.7.25.) ..... 230
- Assay of human protein C (2.7.30.) ..... 234
- Assay of human protein S (2.7.31.) ..... 235
- Assay of human von Willebrand factor (2.7.21.) ..... 226
- Assay of interferons (5.6.) ..... 607
- Assay of pertussis vaccine (2.7.7.) ..... 213
- Assay of pertussis vaccine (acellular) (2.7.16.) ..... 223
- Assay of poliomyelitis vaccine (inactivated), *in vivo* (2.7.20.) ..... 225
- Assay of tetanus vaccine (adsorbed) (2.7.8.) ..... 214
- Assays (2.5.) ..... 137
- Astragalus mongholicus root ..... 1060
- Atenolol ..... 1424
- Atomic absorption spectrometry (2.2.23.) ..... 36
- Atomic emission spectrometry (2.2.22.) ..... 35
- Atomic emission spectrometry, inductively coupled plasma- (2.2.57.) ..... 94
- Atracurium besilate ..... 1425
- Atropine ..... 1427
- Atropine sulfate ..... 1429
- Aujeszky's disease vaccine (inactivated) for pigs ..... 847
- Aujeszky's disease vaccine (live) for pigs for parenteral administration ..... 849
- Avian infectious bronchitis vaccine (inactivated) ..... 851
- Avian infectious bronchitis vaccine (live) ..... 852
- Avian infectious bursal disease vaccine (inactivated) ..... 854
- Avian infectious bursal disease vaccine (live) ..... 856
- Avian infectious encephalomyelitis vaccine (live) ..... 857
- Avian infectious laryngotracheitis vaccine (live) ..... 859
- Avian live virus vaccines: tests for extraneous agents in batches of finished product (2.6.25.) ..... 188
- Avian paramyxovirus 1 (Newcastle disease) vaccine (inactivated) ..... 921
- Avian paramyxovirus 3 vaccine (inactivated) ..... 860
- Avian tuberculin purified protein derivative ..... 3161
- Avian viral tenosynovitis vaccine (live) ..... 861
- Avian viral vaccines: tests for extraneous agents in seed lots (2.6.24.) ..... 185
- Azaperone for veterinary use ..... 1430
- Azathioprine ..... 1431
- Azelastine hydrochloride ..... 1433
- Azithromycin ..... 1434
- B**
- B19 virus (B19V), validation of nucleic acid amplification techniques for the quantification of B19V DNA in plasma pools: guidelines ..... 181
- Bacampicillin hydrochloride ..... 1439
- Bacitracin ..... 1440
- Bacitracin zinc ..... 1443
- Baclofen ..... 1445
- Bacterial endotoxins (2.6.14.) ..... 171
- Bacterial endotoxins, guidelines for using the test for (5.1.10.) ..... 520
- Bambuterol hydrochloride ..... 1446
- Barbados aloes ..... 1047
- Barbital ..... 1447
- Barium chloride dihydrate for homoeopathic preparations .. 1287
- Barium sulfate ..... 1448
- Basic butylated methacrylate copolymer ..... 1448
- BCG for immunotherapy ..... 746
- BCG vaccine, freeze-dried ..... 747
- Bearberry leaf ..... 1061
- Beclometasone dipropionate, anhydrous ..... 1449
- Beclometasone dipropionate monohydrate ..... 1451
- Bee for homoeopathic preparations, honey ..... 1292
- Beeswax, white ..... 1453
- Beeswax, yellow ..... 1454
- Belladonna leaf ..... 1062
- Belladonna leaf dry extract, standardised ..... 1064
- Belladonna leaf tincture, standardised ..... 1065
- Belladonna, prepared ..... 1066
- Benazepril hydrochloride ..... 1454
- Bendroflumethiazide ..... 1456
- Benfluorex hydrochloride ..... 1457
- Benperidol ..... 1458
- Benserazide hydrochloride ..... 1459
- Bentonite ..... 1460
- Benzalkonium chloride ..... 1461
- Benzalkonium chloride solution ..... 1463
- Benzathine benzylpenicillin ..... 1471
- Benzbromarone ..... 1465
- Benzethonium chloride ..... 1466
- Benzocaine ..... 1466
- Benzoic acid ..... 1467
- Benzoin, Siam ..... 1067

Benzoin, Sumatra .....	1068	Borax .....	1503
Benzoin tincture, Siam .....	1069	Boric acid .....	1504
Benzoin tincture, Sumatra .....	1069	Botulinum antitoxin .....	949
Benzoyl peroxide, hydrous .....	1468	Botulinum toxin type A for injection .....	1504
Benzyl alcohol .....	1469	Bovine infectious rhinotracheitis vaccine (live) .....	908
Benzyl benzoate .....	1470	Bovine insulin .....	2239
Benzylpenicillin, benzathine .....	1471	Bovine leptospirosis vaccine (inactivated) .....	862
Benzylpenicillin potassium .....	1473	Bovine parainfluenza virus vaccine (live) .....	864
Benzylpenicillin, procaine .....	1474	Bovine respiratory syncytial virus vaccine (live) .....	865
Benzylpenicillin sodium .....	1476	Bovine serum .....	1506
Betacarotene .....	1477	Bovine tuberculin purified protein derivative .....	3161
Betacyclodextrin .....	1478	Bovine viral diarrhoea vaccine (inactivated) .....	866
Betacyclodextrin, poly(hydroxypropyl) ether .....	2210	Bromazepam .....	1507
Betadex .....	1478	Bromhexine hydrochloride .....	1508
Betahistine dihydrochloride .....	1479	Bromocriptine mesilate .....	1509
Betahistine mesilate .....	1480	Bromperidol .....	1511
Betamethasone .....	1481	Bromperidol decanoate .....	1512
Betamethasone acetate .....	1483	Brompheniramine maleate .....	1514
Betamethasone dipropionate .....	1485	Brotizolam .....	1515
Betamethasone sodium phosphate .....	1486	Brucellosis vaccine (live) ( <i>Brucella melitensis</i> Rev. 1 strain) for veterinary use .....	867
Betamethasone valerate .....	1488	Buccal tablets and sublingual tablets .....	723
Betaxolol hydrochloride .....	1489	Buckwheat herb .....	1084
Bezafibrate .....	1490	Budesonide .....	1516
Bifonazole .....	1491	Bufexamac .....	1518
Bilberry fruit, dried .....	1070	Buffer solutions (4.1.3.) .....	489
Bilberry fruit dry extract, fresh, refined and standardised .....	1130	Buflomedil hydrochloride .....	1519
Bilberry fruit, fresh .....	1070	Bulk density and tapped density of powders (2.9.34.) .....	305
Biological assays (2.7.) .....	201	Bumetanide .....	1520
Biological assays and tests, statistical analysis of results of (5.3.) .....	551	Bupivacaine hydrochloride .....	1521
Biological indicators of sterilisation (5.1.2.) .....	504	Buprenorphine .....	1523
Biological products, general texts on (5.2.) .....	527	Buprenorphine hydrochloride .....	1524
Biological products, terminology used in monographs on (5.2.1.) .....	527	Buserelin .....	1526
Biological tests (2.6.) .....	153	Buspirone hydrochloride .....	1527
Biotin .....	1492	Busulfan .....	1529
Biperiden hydrochloride .....	1493	Butcher's broom .....	1085
Biphasic insulin injection .....	2243	Butylated methacrylate copolymer, basic .....	1448
Biphasic isophane insulin injection .....	2244	Butylhydroxyanisole .....	1531
Birch leaf .....	1071	Butylhydroxytoluene .....	1531
Bisacodyl .....	1495	Butyl parahydroxybenzoate .....	1530
Bismuth subcarbonate .....	1496	<b>C</b>	
Bismuth subgallate .....	1497	Cabergoline .....	1535
Bismuth subnitrate, heavy .....	1498	Cachets .....	709
Bismuth subsalicylate .....	1498	Cadmium sulfate hydrate for homoeopathic preparations .....	1287
Bisoprolol fumarate .....	1499	Caffeine .....	1536
Bistort rhizome .....	1072	Caffeine monohydrate .....	1537
Bitter fennel .....	1124	Calcifediol .....	1538
Bitter-fennel fruit oil .....	1073	Calcipotriol, anhydrous .....	1539
Bitter-fennel herb oil .....	1075	Calcipotriol monohydrate .....	1542
Bitterness value (2.8.15.) .....	244	Calcitonin (salmon) .....	1544
Bitter-orange epicarp and mesocarp .....	1077	Calcitriol .....	1546
Bitter-orange-epicarp and mesocarp tincture .....	1078	Calcium (2.4.3.) .....	113
Bitter-orange flower .....	1078	Calcium acetate, anhydrous .....	1547
Bitter-orange-flower oil .....	1194	Calcium ascorbate .....	1548
Black horehound .....	1079	Calcium carbonate .....	1549
Bleomycin sulfate .....	1502	Calcium carboxymethylcellulose .....	1589
Blood and blood components, empty sterile containers of plasticised poly(vinyl chloride) for (3.2.4.) .....	370	Calcium chloride dihydrate .....	1550
Blood and blood components, materials for containers for (3.1.1.) .....	329	Calcium chloride hexahydrate .....	1550
Blood and blood components, sets for the transfusion of (3.2.6.) .....	371	Calcium dobesilate monohydrate .....	1551
Blood and blood components, sterile plastic containers for (3.2.3.) .....	369	Calcium edetate, sodium .....	2916
Blood, anticoagulant and preservative solutions for .....	1401	Calcium folinate .....	1552
Blood, sterile containers of plasticised poly(vinyl chloride) containing anticoagulant solution (3.2.5.) .....	371	Calcium glucoheptonate .....	1554
Bogbean leaf .....	1080	Calcium gluconate .....	1555
Boiling point (2.2.12.) .....	31	Calcium gluconate, anhydrous .....	1555
Boldo leaf .....	1081	Calcium gluconate for injection .....	1556
Boldo leaf dry extract .....	1083	Calcium glycerophosphate .....	1557
Borage (starflower) oil, refined .....	1503	Calcium hydrogen phosphate, anhydrous .....	1558
		Calcium hydrogen phosphate dihydrate .....	1559
		Calcium hydroxide .....	1560
		Calcium in adsorbed vaccines (2.5.14.) .....	141

Calcium iodide tetrahydrate for homoeopathic preparations . . . . .	1288	Carmellose sodium . . . . .	1589
Calcium lactate, anhydrous . . . . .	1561	Carmellose sodium and microcrystalline cellulose . . . . .	2507
Calcium lactate monohydrate . . . . .	1561	Carmellose sodium, low-substituted . . . . .	1590
Calcium lactate pentahydrate . . . . .	1562	Carmustine . . . . .	1591
Calcium lactate trihydrate . . . . .	1562	Carnauba wax . . . . .	1592
Calcium levofolinate pentahydrate . . . . .	1563	Carprofen for veterinary use . . . . .	1592
Calcium levulinate dihydrate . . . . .	1565	Carrageenan . . . . .	1593
Calcium pantothenate . . . . .	1566	Carteolol hydrochloride . . . . .	1594
Calcium pentetate (sodium) for radiopharmaceutical preparations . . . . .	987	Carvedilol . . . . .	1595
Calcium phosphate . . . . .	1567	Cascara . . . . .	1092
Calcium stearate . . . . .	1567	Cascara dry extract, standardised . . . . .	1094
Calcium sulfate dihydrate . . . . .	1569	Cassia oil . . . . .	1095
Calendula flower . . . . .	1086	Castor oil, hydrogenated . . . . .	1596
Calf coronavirus diarrhoea vaccine (inactivated) . . . . .	868	Castor oil, polyoxyl . . . . .	2398
Calf rotavirus diarrhoea vaccine (inactivated) . . . . .	869	Castor oil, polyoxyl hydrogenated . . . . .	2397
Caliciviriosis vaccine (inactivated), feline . . . . .	895	Castor oil, refined . . . . .	1597
Caliciviriosis vaccine (live), feline . . . . .	896	Castor oil, virgin . . . . .	1598
Camphor, D- . . . . .	1569	Catgut, sterile . . . . .	1027
Camphor, racemic . . . . .	1571	Catgut, sterile, in distributor for veterinary use . . . . .	1037
Canine adenovirus vaccine (inactivated) . . . . .	870	CD34/CD45+ cells in haematopoietic products, numeration of (2.7.23.) . . . . .	228
Canine adenovirus vaccine (live) . . . . .	871	Cefaclor . . . . .	1599
Canine distemper vaccine (live) . . . . .	872	Cefadroxil monohydrate . . . . .	1600
Canine leptospirosis vaccine (inactivated) . . . . .	874	Cefalexin monohydrate . . . . .	1602
Canine parainfluenza virus vaccine (live) . . . . .	875	Cefalotin sodium . . . . .	1603
Canine parvovirus vaccine (inactivated) . . . . .	876	Cefamandole nafate . . . . .	1605
Canine parvovirus vaccine (live) . . . . .	877	Cefapirin sodium . . . . .	1606
Cape aloes . . . . .	1048	Cefatrizine propylene glycol . . . . .	1607
Capillary electrophoresis (2.2.47.) . . . . .	77	Cefazolin sodium . . . . .	1608
Capillary electrophoresis (2.2.47.) (5.8.) . . . . .	621	Cefepime dihydrochloride monohydrate . . . . .	1610
Capillary viscometer method (2.2.9.) . . . . .	27	Cefixime . . . . .	1612
Caprylate, sodium . . . . .	2917	Cefoperazone sodium . . . . .	1613
Caprylic acid . . . . .	1571	Cefotaxime sodium . . . . .	1615
Caprylocaproyl macrogolglycerides . . . . .	1572	Cefoxitin sodium . . . . .	1617
Capsicum . . . . .	1087	Cefpodoxime proxetil . . . . .	1618
Capsicum oleoresin, refined and quantified . . . . .	1089	Cefradine . . . . .	1620
Capsicum tincture, standardised . . . . .	1090	Ceftazidime pentahydrate . . . . .	1622
Capsules . . . . .	707	Ceftazidime pentahydrate with sodium carbonate for injection . . . . .	1624
Capsules and tablets, disintegration of (2.9.1.) . . . . .	253	Ceftriaxone sodium . . . . .	1626
Capsules, gastro-resistant . . . . .	708	Cefuroxime axetil . . . . .	1627
Capsules, hard . . . . .	708	Cefuroxime sodium . . . . .	1629
Capsules, intrauterine . . . . .	715	Celiprolol hydrochloride . . . . .	1630
Capsules, modified-release . . . . .	708	Cell count and viability, nucleated (2.7.29.) . . . . .	233
Capsules, oromucosal . . . . .	723	Cell cultures for the production of veterinary vaccines (5.2.4.) . . . . .	533
Capsules, rectal . . . . .	733	Cell substrates for the production of vaccines for human use (5.2.3.) . . . . .	530
Capsules, soft . . . . .	708	Cellular products, microbiological control of (2.6.27.) . . . . .	191
Capsules, vaginal . . . . .	739	Cellulose acetate . . . . .	1631
Captopril . . . . .	1573	Cellulose acetate butyrate . . . . .	1632
Caraway fruit . . . . .	1090	Cellulose acetate phthalate . . . . .	1633
Caraway oil . . . . .	1091	Cellulose, microcrystalline . . . . .	1634
Carbachol . . . . .	1575	Cellulose (microcrystalline) and carmellose sodium . . . . .	2507
Carbamazepine . . . . .	1576	Cellulose, powdered . . . . .	1638
Carbasalate calcium . . . . .	1577	Centaury . . . . .	1095
Carbidopa . . . . .	1579	Centella . . . . .	1096
Carbimazole . . . . .	1580	Cetirizine dihydrochloride . . . . .	1641
Carbocisteine . . . . .	1581	Cetostearyl alcohol . . . . .	1643
Carbomers . . . . .	1581	Cetostearyl alcohol (type A), emulsifying . . . . .	1643
Carbon dioxide . . . . .	1583	Cetostearyl alcohol (type B), emulsifying . . . . .	1645
Carbon dioxide in gases (2.5.24.) . . . . .	143	Cetostearyl isononanoate . . . . .	1646
Carbon monoxide . . . . .	1584	Cetostearyl sulfate, sodium . . . . .	2920
Carbon monoxide ( <sup>15</sup> O) . . . . .	965	Cetrimide . . . . .	1646
Carbon monoxide in gases (2.5.25.) . . . . .	144	Cetyl alcohol . . . . .	1647
Carboplatin . . . . .	1585	Cetyl palmitate . . . . .	1648
Carboprost trometamol . . . . .	1586	Cetylpyridinium chloride . . . . .	1648
Carboxymethylcellulose . . . . .	1588	Ceylon cinnamon bark oil . . . . .	1101
Carboxymethylcellulose calcium . . . . .	1589	Ceylon cinnamon leaf oil . . . . .	1102
Carboxymethylcellulose sodium . . . . .	1589	CFC assay for human haematopoietic progenitor cells (2.7.28.) . . . . .	232
Carboxymethylcellulose sodium, cross-linked . . . . .	1770	Chamomile flower, Roman . . . . .	1098
Carboxymethylcellulose sodium, low-substituted . . . . .	1590		
Carisoprodol . . . . .	1587		
Carmellose . . . . .	1588		
Carmellose calcium . . . . .	1589		

Characterisation of crystalline and partially crystalline solids by X-ray powder diffraction (XRPD) (2.9.33.)	301	Ciprofibrate	1697
Characters section in monographs (5.11.)	637	Ciprofloxacin	1698
Charcoal, activated	1649	Ciprofloxacin hydrochloride	1700
Chenodeoxycholic acid	1650	Circular dichroism (2.2.41.)	65
Chewing gums, medicated	709	Cisplatin	1701
Chewing gums, medicated, dissolution test for (2.9.25.)	289	Citalopram hydrobromide	1703
Chicken anaemia vaccine (live), infectious	910	Citalopram hydrochloride	1704
Chicken flocks free from specified pathogens for the production and quality control of vaccines (5.2.2.)	527	Citric acid, anhydrous	1705
Chitosan hydrochloride	1651	Citric acid monohydrate	1706
Chlamydiosis vaccine (inactivated), feline	897	Citronella oil	1103
Chloral hydrate	1652	Cladribine	1707
Chlorambucil	1653	Clarithromycin	1708
Chloramine	3118	Clarity and degree of opalescence of liquids (2.2.1.)	21
Chloramphenicol	1653	Clary sage oil	1104
Chloramphenicol palmitate	1654	Classical swine-fever vaccine (live, prepared in cell cultures)	940
Chloramphenicol sodium succinate	1655	Clazuril for veterinary use	1710
Chlorcyclizine hydrochloride	1656	Clebopride malate	1712
Chlordiazepoxide	1657	Clemastine fumarate	1713
Chlordiazepoxide hydrochloride	1658	Clenbuterol hydrochloride	1715
Chlorhexidine diacetate	1659	Clindamycin hydrochloride	1716
Chlorhexidine digluconate solution	1660	Clindamycin phosphate	1717
Chlorhexidine dihydrochloride	1662	Clioquinol	1718
Chlorides (2.4.4.)	113	Clobazam	1719
Chlorobutanol, anhydrous	1663	Clobetasol propionate	1720
Chlorobutanol hemihydrate	1663	Clobetasone butyrate	1722
Chlorocresol	1664	Clodronate disodium tetrahydrate	1723
Chloroquine phosphate	1665	Clofazimine	1724
Chloroquine sulfate	1665	Clofibrate	1725
Chlorothiazide	1666	Clomifene citrate	1726
Chlorphenamine maleate	1667	Clomipramine hydrochloride	1727
Chlorpromazine hydrochloride	1668	Clonazepam	1729
Chlorpropamide	1669	Clonidine hydrochloride	1730
Chlorprothixene hydrochloride	1670	Clopidogrel	1731
Chlortalidone	1671	Clorazepate, dipotassium	1869
Chlortetracycline hydrochloride	1673	Closantel sodium dihydrate for veterinary use	1732
Cholecalciferol	1674	Clostridium botulinum vaccine for veterinary use	878
Cholecalciferol concentrate (oily form)	1675	Clostridium chauvoei vaccine for veterinary use	879
Cholecalciferol concentrate (powder form)	1677	Clostridium novyi alpha antitoxin for veterinary use	957
Cholecalciferol concentrate (water-dispersible form)	1678	Clostridium novyi (type B) vaccine for veterinary use	879
Cholera vaccine	748	Clostridium perfringens beta antitoxin for veterinary use	958
Cholera vaccine, freeze-dried	749	Clostridium perfringens epsilon antitoxin for veterinary use	959
Cholera vaccine (inactivated, oral)	749	Clostridium perfringens vaccine for veterinary use	881
Cholesterol	1680	Clostridium septicum vaccine for veterinary use	883
Cholesterol in oils rich in omega-3 acids, total (2.4.32.)	133	Closures and containers for parenteral preparations and ophthalmic preparations, polypropylene for (3.1.6.)	342
Chondroitin sulfate sodium	1681	Closures and containers for pharmaceutical use, plastic (3.2.2.)	368
Chromatographic separation techniques (2.2.46.)	70	Closures and tubing, silicone elastomer for (3.1.9.)	347
Chromatography, gas (2.2.28.)	43	Closures for containers for aqueous parenteral preparations, for powders and for freeze-dried powders, rubber (3.2.9.)	374
Chromatography, liquid (2.2.29.)	45	Clotrimazole	1734
Chromatography, paper (2.2.26.)	41	Clove	1105
Chromatography, size-exclusion (2.2.30.)	46	Clove oil	1106
Chromatography, supercritical fluid (2.2.45.)	70	Cloxacillin sodium	1735
Chromatography, thin-layer (2.2.27.)	42	Clozapine	1737
Chromium ( <sup>51</sup> Cr) edetate injection	966	Coagulation factor II, assay of (2.7.18.)	224
Chymotrypsin	1683	Coagulation factor IX, human	2172
Ciclopirox	1684	Coagulation factor IX, human, assay of (2.7.11.)	219
Ciclopirox olamine	1686	Coagulation factors, activated (2.6.22.)	185
Ciclosporin	1687	Coagulation factors, assay of heparin (2.7.12.)	220
Cilastatin sodium	1688	Coagulation factor VII, human	2169
Cilazapril	1690	Coagulation factor VII, human, assay of (2.7.10.)	219
Cimetidine	1691	Coagulation factor VIII, human	2170
Cimetidine hydrochloride	1693	Coagulation factor VIII, human, assay of (2.7.4.)	207
Cinchocaine hydrochloride	1694	Coagulation factor VIII (rDNA), human	2171
Cinchona bark	1098	Coagulation factor X, assay of (2.7.19.)	225
Cinchona liquid extract, standardised	1100	Coagulation factor XI, human	2173
Cineole	1695	Coagulation factor XI, human, assay of (2.7.22.)	227
Cineole in essential oils, 1,8-, assay of (2.8.11.)	240	Coated granules	714
Cinnamon	1101	Coated tablets	737
Cinnamon bark oil, Ceylon	1101	Cocaine hydrochloride	1738
Cinnamon leaf oil, Ceylon	1102	Coccidiosis vaccine (live) for chickens	884
Cinnamon tincture	1103		
Cinnarizine	1696		



Coconut oil, refined.....	1739	Containers of plasticised poly(vinyl chloride) for human blood and blood components, empty sterile (3.2.4.) .....	370
Cocoyl caprylocaprate.....	1740	Containers of plasticised poly(vinyl chloride) for human blood containing anticoagulant solution, sterile (3.2.5.) .....	371
Codeine .....	1740	Contamination, microbial: microbial enumeration tests (2.6.12.) .....	163
Codeine hydrochloride dihydrate.....	1742	Contamination, microbial: microbial enumeration tests (2.6.12.) (5.8.) .....	622
Codeine phosphate hemihydrate.....	1743	Contamination, microbial: test for specified micro-organisms (2.6.13.) .....	167
Codeine phosphate sesquihydrate .....	1745	Contamination, microbial: test for specified micro-organisms (2.6.13.) (5.8.) .....	622
Codergocrine mesilate .....	1747	Content uniformity of single-dose preparations (2.9.6.) .....	266
Cod-liver oil, farmed .....	1748	Control of impurities in substances for pharmaceutical use (5.10.) .....	631
Cod-liver oil (type A).....	1752	Control of microbiological quality, alternative methods for (5.1.6.) .....	508
Cod-liver oil (type B).....	1756	Copolymer, basic butylated methacrylate .....	1448
Cola .....	1107	Copolymer, grafted, macrogol poly(vinyl alcohol) .....	2401
Colchicine .....	1759	Copolymer, methacrylic acid - ethyl acrylate (1:1) .....	2459
Cold-water vibriosis vaccine (inactivated) for salmonids .....	943	Copolymer, methacrylic acid - ethyl acrylate (1:1) dispersion 30 per cent .....	2460
Colestyramine .....	1761	Copolymer (type A), ammonio methacrylate .....	1381
Colibacillosis vaccine (inactivated), neonatal piglet.....	918	Copolymer (type B), ammonio methacrylate .....	1382
Colibacillosis vaccine (inactivated), neonatal ruminant .....	920	Copovidone.....	1764
Colistimethate sodium .....	1762	Copper acetate monohydrate for homeopathic preparations .....	1289
Colistin sulfate .....	1763	Copper for homeopathic preparations.....	1289
Colloidal anhydrous silica.....	2901	Copper sulfate, anhydrous .....	1766
Colloidal hydrated silica .....	2902	Copper sulfate pentahydrate .....	1766
Colloidal silica, hydrophobic .....	2903	Coriander .....	1108
Colloidal silver, for external use.....	2904	Coriander oil .....	1108
Colony-forming cell assay for human haematopoietic progenitor cells (2.7.28.) .....	232	Cortisone acetate .....	1767
Colophony .....	1107	Cotton, absorbent .....	1768
Coloration of liquids (2.2.2.) .....	22	Cottonseed oil, hydrogenated .....	1769
Common stinging nettle for homeopathic preparations.....	1288	Couch grass rhizome .....	1109
Comparative table of porosity of sintered-glass filters (2.1.2.)..	15	Creams.....	735
Complexometric titrations (2.5.11.) .....	140	Cresol, crude .....	1770
Composition of fatty acids by gas chromatography (2.4.22.)..	119	Cromoglicate, sodium .....	2923
Composition of fatty acids in oils rich in omega-3 acids (2.4.29.) .....	130	Croscarmellose sodium.....	1770
Compressed lozenges.....	723	Crospovidone .....	1771
Concentrated solutions for haemodialysis .....	2136	Crotamiton .....	1773
Concentrates for injections or infusions.....	725	Crystalline and partially crystalline solids, characterisation by X-ray powder diffraction (XRPD) of (2.9.33.) .....	301
Concentrates for intrauterine solutions.....	715	Cutaneous application, liquid preparations for.....	717
Conductivity (2.2.38.) .....	59	Cutaneous application, powders for .....	726
Coneflower herb, purple .....	1218	Cutaneous application, semi-solid preparations for .....	734
Coneflower root, narrow-leaved.....	1193	Cutaneous application, veterinary liquid preparations for.....	740
Coneflower root, pale .....	1208	Cutaneous foams .....	717
Coneflower root, purple .....	1219	Cutaneous patches .....	734
Conjugated estrogens .....	1958	Cyanocobalamin .....	1774
Consistency by penetrometry, measurement of (2.9.9.) .....	267	Cyanocobalamin ( <sup>57</sup> Co) capsules .....	967
Containers (3.2.).....	363	Cyanocobalamin ( <sup>57</sup> Co) solution .....	968
Containers and closures for parenteral preparations and ophthalmic preparations, polypropylene for (3.1.6.) .....	342	Cyanocobalamin ( <sup>58</sup> Co) capsules .....	968
Containers and closures for pharmaceutical use, plastic (3.2.2.) .....	368	Cyanocobalamin ( <sup>58</sup> Co) solution .....	969
Containers and tubing for total parenteral nutrition preparations, poly(ethylene - vinyl acetate) for (3.1.7.) .....	345	Cyclamate, sodium .....	2924
Containers for aqueous solutions for infusion, plastic (3.2.2.1.) .....	368	Cyclizine hydrochloride.....	1775
Containers for aqueous solutions for intravenous infusion, materials based on plasticised poly(vinyl chloride) for (3.1.14.) .....	355	Cyclopentolate hydrochloride .....	1776
Containers for dry dosage forms for oral administration, materials based on non-plasticised poly(vinyl chloride) for (3.1.11.) .....	350	Cyclophosphamide.....	1777
Containers for human blood and blood components, materials based on plasticised poly(vinyl chloride) for (3.1.1.1.) .....	329	Cyproheptadine hydrochloride .....	1778
Containers for human blood and blood components, materials for (3.1.1.) .....	329	Cyproterone acetate .....	1779
Containers for human blood and blood components, plastic, sterile (3.2.3.) .....	369	Cysteine hydrochloride monohydrate .....	1781
Containers for non-injectable aqueous solutions, materials based on non-plasticised poly(vinyl chloride) for (3.1.10.) .....	349	Cystine.....	1782
Containers for parenteral preparations and for ophthalmic preparations, polyethylene with additives for (3.1.5.) .....	338	Cytarabine .....	1783
Containers for parenteral preparations and for ophthalmic preparations, polyethylene without additives for (3.1.4.) .....	337	<b>D</b>	
Containers for pharmaceutical use, glass (3.2.1.) .....	363	Dacarbazine.....	1787
Containers for preparations not for parenteral use, polyethylene terephthalate for (3.1.15) .....	357	Dalteparin sodium .....	1788
		Danaparoid sodium .....	1789
		Dandelion herb with root .....	1110
		Dandelion root.....	1111
		Dapsone .....	1792

Daunorubicin hydrochloride .....	1792	Dihydrocodeine hydrogen tartrate .....	1845
D-Camphor .....	1569	Dihydroergocristine mesilate .....	1846
Decyl oleate .....	1794	Dihydroergotamine mesilate .....	1849
Deferoxamine mesilate.....	1794	Dihydroergotamine tartrate .....	1850
Degree of coloration of liquids (2.2.2.).....	22	Dihydrostreptomycin sulfate for veterinary use.....	1851
Dembrexine hydrochloride monohydrate for veteri- nary use .....	1795	Dihydrotachysterol .....	1853
Demeclocycline hydrochloride .....	1796	Diltiazem hydrochloride .....	1855
Density of powders, bulk density and tapped (2.9.34.) .....	305	Dimenhydrinate.....	1856
Density of solids (2.2.42.) .....	66	Dimercaprol.....	1858
Density of solids, gas pycnometric (2.9.23.) .....	288	Dimethylacetamide .....	1859
Density, relative (2.2.5.) .....	25	Dimethylaniline, <i>N,N</i> - (2.4.26.).....	128
Dental type silica .....	2903	Dimethyl sulfoxide .....	1858
Depressor substances (2.6.11.).....	162	Dimeticone .....	1860
Deptropine citrate.....	1797	Dimetindene maleate .....	1860
Dequalinium chloride.....	1798	Dinoprostone .....	1863
Desflurane .....	1800	Dinoprost trometamol .....	1862
Desipramine hydrochloride .....	1801	Diosmin .....	1864
Deslanoside .....	1802	Dioxan and ethylene oxide (2.4.25.) .....	127
Desmopressin.....	1803	Dip concentrates .....	740
Desogestrel.....	1804	Diphenhydramine hydrochloride .....	1866
Desoxycortone acetate.....	1805	Diphenoxylate hydrochloride .....	1867
Detector tubes, gas (2.1.6.) .....	17	Diphtheria and tetanus toxins and toxoids, flocculation value (Lf) of, (Ramon assay) (2.7.27.) .....	231
Determination of aflatoxin B <sub>1</sub> in herbal drugs (2.8.18.).....	244	Diphtheria and tetanus vaccine (adsorbed).....	751
Determination of essential oils in herbal drugs (2.8.12.).....	241	Diphtheria and tetanus vaccine (adsorbed, reduced antigen(s) content).....	752
Determination of nitrogen by sulfuric acid digestion (2.5.9.)..	139	Diphtheria antitoxin.....	949
Determination of primary aromatic amino-nitrogen (2.5.8.)..	139	Diphtheria, tetanus and hepatitis B (rDNA) vaccine (adsorbed).....	753
Determination of tannins in herbal drugs (2.8.14.).....	243	Diphtheria, tetanus and pertussis (acellular, component) vaccine (adsorbed).....	754
Determination of water by distillation (2.2.13.) .....	31	Diphtheria, tetanus and pertussis vaccine (adsorbed) .....	755
Detomidine hydrochloride for veterinary use .....	1806	Diphtheria, tetanus and poliomyelitis (inactivated) vaccine (adsorbed, reduced antigen(s) content) .....	756
Devil's claw dry extract .....	1112	Diphtheria, tetanus, pertussis (acellular, component) and haemophilus type b conjugate vaccine (adsorbed) .....	758
Devil's claw root .....	1113	Diphtheria, tetanus, pertussis (acellular, component) and hepatitis B (rDNA) vaccine (adsorbed) .....	760
Dexamethasone .....	1807	Diphtheria, tetanus, pertussis (acellular, component) and poliomyelitis (inactivated) vaccine (adsorbed) .....	762
Dexamethasone acetate .....	1809	Diphtheria, tetanus, pertussis (acellular, component) and poliomyelitis (inactivated) vaccine (adsorbed, reduced anti- gen(s) content) .....	763
Dexamethasone isonicotinate .....	1811	Diphtheria, tetanus, pertussis (acellular, component), hepatitis B (rDNA), poliomyelitis (inactivated) and haemophilus type b conjugate vaccine (adsorbed) .....	765
Dexamethasone sodium phosphate .....	1812	Diphtheria, tetanus, pertussis (acellular, component), poliomyelitis (inactivated) and haemophilus type b conjugate vaccine (adsorbed) .....	768
Dexchlorpheniramine maleate .....	1814	Diphtheria, tetanus, pertussis and poliomyelitis (inactivated) vaccine (adsorbed).....	771
Dexpanthenol .....	1815	Diphtheria, tetanus, pertussis, poliomyelitis (inactivated) and haemophilus type b conjugate vaccine (adsorbed) .....	772
Dextran 1 for injection.....	1816	Diphtheria vaccine (adsorbed) .....	774
Dextran 40 for injection .....	1817	Diphtheria vaccine (adsorbed), assay of (2.7.6.) .....	209
Dextran 60 for injection .....	1818	Diphtheria vaccine (adsorbed, reduced antigen content) .....	776
Dextran 70 for injection .....	1819	Dipivefrine hydrochloride .....	1867
Dextranomer .....	1819	Dipotassium clorazepate .....	1869
Dextrans, molecular mass distribution in (2.2.39.) .....	60	Dipotassium phosphate .....	1870
Dextrin.....	1820	Diprophylline .....	1870
Dextromethorphan hydrobromide .....	1821	Dipyridamole.....	1871
Dextromoramide tartrate .....	1822	Dirithromycin.....	1872
Dextropropoxyphene hydrochloride .....	1823	Disintegration of suppositories and pessaries (2.9.2.) .....	255
Diazepam .....	1824	Disintegration of tablets and capsules (2.9.1.) .....	253
Diazoxide .....	1825	Disodium clodronate tetrahydrate .....	1723
Dibrompropamide diisetonate .....	1826	Disodium edetate .....	1874
Dibutyl phthalate .....	1827	Disodium etidronate .....	1979
Dichloromethane.....	2474	Disodium pamidronate pentahydrate .....	2660
Diclazuril for veterinary use .....	1828	Disodium phosphate, anhydrous .....	1875
Diclofenac potassium .....	1829	Disodium phosphate dihydrate .....	1875
Diclofenac sodium .....	1830	Disodium phosphate dodecahydrate .....	1876
Dicloxacillin sodium .....	1831	Disopyramide.....	1876
Dicycloverine hydrochloride .....	1833	Disopyramide phosphate .....	1877
Didanosine.....	1833		
Dienestrol .....	1835		
Diethylcarbamazine citrate .....	1836		
Diethylene glycol and ethylene glycol in ethoxylated substances (2.4.30.) .....	132		
Diethylene glycol monoethyl ether .....	1837		
Diethylene glycol palmitostearate .....	1839		
Diethyl phthalate .....	1835		
Diethylstilbestrol .....	1839		
Diffraction, laser light, particle size analysis by (2.9.31.) .....	295		
Diflunisal.....	1840		
Digitalis leaf .....	1114		
Digitoxin.....	1841		
Digoxin .....	1842		
Dihydralazine sulfate, hydrated .....	1844		

Dispersible tablets .....	737	Efficacy of veterinary vaccines and immunosera, evaluation of (5.2.7.) .....	538
Dissolution, apparent (2.9.43.) .....	320	Egg drop syndrome '76 vaccine (inactivated) .....	891
Dissolution, intrinsic (2.9.29.) .....	294	Elder flower .....	1117
Dissolution test for lipophilic solid dosage forms (2.9.42.) ...	319	Electrophoresis (2.2.31.) .....	46
Dissolution test for medicated chewing gums (2.9.25.) .....	289	Electrophoresis (2.2.31.) (5.8.) .....	621
Dissolution test for solid dosage forms (2.9.3.) .....	256	Electrophoresis, capillary (2.2.47.) .....	77
Dissolution test for transdermal patches (2.9.4.) .....	263	Electrophoresis, capillary (2.2.47.) (5.8.) .....	621
Dissolution testing, recommendations on (5.17.1.) .....	665	Eleutherococcus .....	1118
Distemper vaccine (live), canine .....	872	Emedastine difumarate .....	1913
Distemper vaccine (live) for mustelids .....	887	Emetine hydrochloride heptahydrate .....	1914
Distillation range (2.2.11.) .....	30	Emetine hydrochloride pentahydrate .....	1915
Distribution estimation by analytical sieving, particle-size (2.9.38.) .....	313	Empty sterile containers of plasticised poly(vinyl chloride) for human blood and blood components (3.2.4.) .....	370
Distribution estimation by analytical sieving, particle-size (2.9.38.) (5.8.) .....	623	Emulsifying cetostearyl alcohol (type A) .....	1643
Disulfiram .....	1878	Emulsifying cetostearyl alcohol (type B) .....	1645
Dithranol .....	1879	Emulsions, solutions and suspensions, oral .....	718
DL-Methionine .....	2466	Enalaprilat dihydrate .....	1918
DL- $\alpha$ -Tocopheryl hydrogen succinate .....	3110	Enalapril maleate .....	1916
Dobesilate monohydrate, calcium .....	1551	Encephalitis vaccine (inactivated), tick-borne .....	834
Dobutamine hydrochloride .....	1880	Endotoxins, bacterial (2.6.14.) .....	171
Docetaxel trihydrate .....	1881	Endotoxins, bacterial, guidelines for using the test for (5.1.10.) .....	520
Docusate sodium .....	1883	Enilconazole for veterinary use .....	1919
Dodecyl gallate .....	1884	Enoxaparin sodium .....	1920
Dog rose .....	1115	Enoxolone .....	1921
Domperidone .....	1885	Enrofloxacin for veterinary use .....	1922
Domperidone maleate .....	1886	Entacapone .....	1924
Dopamine hydrochloride .....	1887	Enzootic pneumonia vaccine (inactivated), porcine .....	927
Dopexamine dihydrochloride .....	1889	Ephedra herb .....	1120
Dorzolamide hydrochloride .....	1890	Ephedrine, anhydrous .....	1925
Dosage forms (glossary) .....	707	Ephedrine hemihydrate .....	1926
Dosage units, uniformity of (2.9.40.) .....	315	Ephedrine hydrochloride .....	1927
Dosulepin hydrochloride .....	1892	Ephedrine hydrochloride, racemic .....	1928
Doxapram hydrochloride .....	1893	Epinastine hydrochloride .....	1928
Doxazosin mesilate .....	1894	Epinephrine .....	1329
Doxepin hydrochloride .....	1895	Epinephrine tartrate .....	1330
Doxorubicin hydrochloride .....	1897	Epirubicin hydrochloride .....	1929
Doxycycline hyclate .....	1898	Equine herpesvirus vaccine (inactivated) .....	892
Doxycycline monohydrate .....	1899	Equine influenza vaccine (inactivated) .....	893
Doxylamine hydrogen succinate .....	1901	Equisetum stem .....	1121
Droperidol .....	1902	Ergocalciferol .....	1931
Droppers (2.1.1.) .....	15	Ergometrine maleate .....	1933
Drop point (2.2.17.) .....	32	Ergotamine tartrate .....	1934
Drops (nasal) and sprays (liquid nasal) .....	720	Erysipelas vaccine (inactivated), swine .....	939
Drops, oral .....	719	Erythritol .....	1935
Drospirenone .....	1903	Erythromycin .....	1936
Dry extracts .....	676	Erythromycin estolate .....	1938
Dry residue of extracts (2.8.16.) .....	244	Erythromycin ethylsuccinate .....	1940
Duck plague vaccine (live) .....	888	Erythromycin lactobionate .....	1942
Duck viral hepatitis type I vaccine (live) .....	889	Erythromycin stearate .....	1944
Dwarf pine oil .....	1116	Erythropoietin concentrated solution .....	1946
Dydrogesterone .....	1905	Eserine salicylate .....	2726
<b>E</b>		Eserine sulfate .....	2727
Ear drops and ear sprays .....	710	Esketamine hydrochloride .....	1950
Ear powders .....	710	Esomeprazole magnesium trihydrate .....	1951
Ear preparations .....	709	Essential oils .....	673
Ear preparations, semi-solid .....	710	Essential oils, assay of 1,8-cineole in (2.8.11.) .....	240
Ear sprays and ear drops .....	710	Essential oils, fatty oils and resinified essential oils in (2.8.7.) .....	239
Ear tampons .....	710	Essential oils, foreign esters in (2.8.6.) .....	239
Ear washes .....	710	Essential oils in herbal drugs, determination of (2.8.12.) .....	241
Ebastine .....	1909	Essential oils, odour and taste (2.8.8.) .....	240
Econazole .....	1910	Essential oils, residue on evaporation (2.8.9.) .....	240
Econazole nitrate .....	1911	Essential oils, solubility in alcohol (2.8.10.) .....	240
Edetate, disodium .....	1874	Essential oils, water in (2.8.5.) .....	239
Edetate, sodium calcium .....	2916	Ester value (2.5.2.) .....	137
Edetic acid .....	1912	Estradiol benzoate .....	1953
Edrophonium chloride .....	1913	Estradiol hemihydrate .....	1954
Effervescent granules .....	714	Estradiol valerate .....	1955
Effervescent powders .....	727	Estriol .....	1956
Effervescent tablets .....	737	Estrogens, conjugated .....	1958
Efficacy of antimicrobial preservation (5.1.3.) .....	505	Etacrynic acid .....	1960

Etamsylate .....	1961	Factor II, human coagulation, assay of (2.7.18.) .....	224
Ethacridine lactate monohydrate .....	1962	Factor IX, human coagulation .....	2172
Ethambutol hydrochloride .....	1963	Factor IX, human coagulation, assay of (2.7.11.) .....	219
Ethanol (96 per cent) .....	1964	Factor VII, human coagulation .....	2169
Ethanol, anhydrous .....	1966	Factor VII, human coagulation, assay of (2.7.10.) .....	219
Ethanol content and alcoholimetric tables (2.9.10.) .....	268	Factor VIII, human coagulation .....	2170
Ether .....	1968	Factor VIII, human coagulation, assay of (2.7.4.) .....	207
Ether, anaesthetic .....	1968	Factor VIII (rDNA), human coagulation .....	2171
Ethinylestradiol .....	1969	Factor X, human coagulation, assay of (2.7.19.) .....	225
Ethionamide .....	1970	Factor XI, human coagulation .....	2173
Ethosuximide .....	1971	Factor XI, human coagulation, assay of (2.7.22.) .....	227
Ethoxylated substances, ethylene glycol and diethylene glycol in (2.4.30.) .....	132	Falling ball viscometer method (2.2.49.) .....	83
Ethyl acetate .....	1972	Famotidine .....	1995
Ethyl acrylate - methacrylic acid copolymer (1:1) .....	2459	Fat, hard .....	2146
Ethyl acrylate - methacrylic acid copolymer (1:1) dispersion 30 per cent .....	2460	Fatty acids, composition by gas chromatography (2.4.22.) ...	119
Ethylcellulose .....	1975	Fatty acids in oils rich in omega-3 acids, composition of (2.4.29.) .....	130
Ethylenediamine .....	1977	Fatty oils, alkaline impurities in (2.4.19.) .....	119
Ethylene glycol and diethylene glycol in ethoxylated substances (2.4.30.) .....	132	Fatty oils and herbal drugs, heavy metals in (2.4.27.) .....	129
Ethylene glycol monopalmitostearate .....	1976	Fatty oils and resinified essential oils in essential oils (2.8.7.) .....	239
Ethylene glycol monostearate .....	1976	Fatty oils, foreign oils in, by thin-layer chromatography (2.4.21.) .....	119
Ethylene oxide and dioxan (2.4.25.) .....	127	Fatty oils, identification by thin-layer chromatography (2.3.2.) .....	110
Ethylhexanoic acid, 2- (2.4.28.) .....	130	Fatty oils, sterols in (2.4.23.) .....	121
Ethylmorphine hydrochloride .....	1978	Fatty oils, vegetable .....	703
Ethyl oleate .....	1973	Fc function of immunoglobulin, test for (2.7.9.) .....	217
Ethyl parahydroxybenzoate .....	1973	Febantel for veterinary use .....	1996
Ethyl parahydroxybenzoate sodium .....	1974	Felbinac .....	1997
Etidronate disodium .....	1979	Feline calicivirus vaccine (inactivated) .....	895
Etilefrine hydrochloride .....	1979	Feline calicivirus vaccine (live) .....	896
Etodolac .....	1981	Feline chlamydiosis vaccine (inactivated) .....	897
Etofenamate .....	1982	Feline infectious enteritis (feline panleucopenia) vaccine (inactivated) .....	898
Etofilline .....	1984	Feline infectious enteritis (feline panleucopenia) vaccine (live) .....	899
Etomidate .....	1985	Feline leukaemia vaccine (inactivated) .....	900
Etoposide .....	1986	Feline panleucopenia vaccine (inactivated) .....	898
Eucalyptus leaf .....	1122	Feline panleucopenia vaccine (live) .....	899
Eucalyptus oil .....	1123	Feline viral rhinotracheitis vaccine (inactivated) .....	901
Eugenol .....	1990	Feline viral rhinotracheitis vaccine (live) .....	902
European goldenrod .....	1142	Felodipine .....	1998
European viper venom antiserum .....	953	Felypressin .....	1999
Evaluation of efficacy of veterinary vaccines and immunosera (5.2.7.) .....	538	Fenbendazole for veterinary use .....	2000
Evaluation of safety of each batch of veterinary vaccines and immunosera (5.2.9.) .....	547	Penbutenolol .....	2001
Evaluation of safety of veterinary vaccines and immunosera (5.2.6.) .....	536	Fennel, bitter .....	1124
Evening primrose oil, refined .....	1991	Fennel, sweet .....	1125
Extractable volume of parenteral preparations, test for (2.9.17.) .....	273	Penofibrate .....	2002
Extractable volume of parenteral preparations, test for (2.9.17.) (5.8.) .....	622	Fenoterol hydrobromide .....	2003
Extracts .....	674	Fentanyl .....	2005
Extracts, dry .....	676	Fentanyl citrate .....	2006
Extracts, dry residue of (2.8.16.) .....	244	Fenticonazole nitrate .....	2007
Extracts, liquid .....	675	Fenugreek .....	1126
Extracts, loss on drying of (2.8.17.) .....	244	Fermentation, products of .....	685
Extracts, soft .....	676	Ferric chloride hexahydrate .....	2008
Extraneous agents in viral vaccines for human use, tests for (2.6.16.) .....	176	Ferrous fumarate .....	2009
Extraneous agents: tests in batches of finished product of avian live virus vaccines (2.6.25.) .....	188	Ferrous gluconate .....	2010
Extraneous agents: tests in seed lots of avian viral vaccines (2.6.24.) .....	185	Ferrous sulfate, dried .....	2011
Eye drops .....	711	Ferrous sulfate heptahydrate .....	2012
Eye lotions .....	711	Feverfew .....	1126
Eye preparations .....	710	Fexofenadine hydrochloride .....	2013
Eye preparations, semi-solid .....	712	Fibrinogen, human .....	2174
<b>F</b>		Fibrin sealant kit .....	2014
$F_0$ concept to steam sterilisation of aqueous preparations, application of (5.1.5.) .....	508	Filgrastim concentrated solution .....	2015
		Finasteride .....	2018
		Fineness, powder (2.9.35.) .....	308
		Fish oil, rich in omega-3 acids .....	2019
		Flavoxate hydrochloride .....	2021
		Flecainide acetate .....	2022
		Flocculation value (Lf) of diphtheria and tetanus toxins and toxoids (Ramon assay) (2.7.27.) .....	231
		Flowability (2.9.16.) .....	272

Flow cytometry (2.7.24.).....	229	Fucus .....	1161
Flubendazole .....	2024	Fumitory .....	1132
Flucloxacillin magnesium octahydrate .....	2025	Functional groups and ions, identification reactions of (2.3.1.).....	107
Flucloxacillin sodium .....	2026	Furosemide .....	2078
Fluconazole .....	2028	Furunculosis vaccine (inactivated, oil-adjuvanted, injectable) for salmonids .....	907
Flucytosine .....	2029	Fusidate, sodium .....	2926
Fludarabine phosphate.....	2031	Fusidic acid .....	2079
Fludeoxyglucose ( <sup>18</sup> F) injection .....	969	<b>G</b>	
Fludrocortisone acetate.....	2033	Galactose .....	2083
Flumazenil .....	2035	Galantamine hydrobromide .....	2083
Flumazenil (N-[ <sup>11</sup> C]methyl) injection .....	972	Gallium ( <sup>67</sup> Ga) citrate injection .....	975
Flumequine .....	2036	Ganciclovir .....	2086
Flumetasone pivalate .....	2037	Gargles.....	722
Flunarizine dihydrochloride.....	2038	Garlic for homeopathic preparations .....	1290
Flunitrazepam.....	2039	Garlic powder.....	1133
Flunixin meglumine for veterinary use.....	2040	Gas adsorption, specific surface area by (2.9.26.).....	291
Fluocinolone acetonide.....	2041	Gas adsorption, specific surface area by (2.9.26.) (5.8.) .....	622
Fluocortolone pivalate.....	2042	Gas chromatography (2.2.28.).....	43
Fluorescein.....	2044	Gas detector tubes (2.1.6.) .....	17
Fluorescein sodium .....	2045	Gases, carbon dioxide in (2.5.24.).....	143
Fluoride ( <sup>18</sup> F) solution for radiolabelling.....	973	Gases, carbon monoxide in (2.5.25.).....	144
Fluorides (2.4.5.).....	114	Gases, nitrogen monoxide and nitrogen dioxide in (2.5.26.)..	145
Fluorimetry (2.2.21.) .....	35	Gases, nitrous oxide in (2.5.35.).....	150
Fluorodopa ( <sup>18</sup> F) (prepared by electrophilic substitution) injection .....	974	Gases, oxygen in (2.5.27.) .....	145
Fluorouracil .....	2046	Gases, water in (2.5.28.).....	145
Fluoxetine hydrochloride .....	2048	Gas-gangrene antitoxin, mixed.....	950
Flupentixol dihydrochloride .....	2049	Gas-gangrene antitoxin (novyi) .....	950
Fluphenazine decanoate .....	2051	Gas-gangrene antitoxin (perfringens) .....	951
Fluphenazine dihydrochloride.....	2052	Gas-gangrene antitoxin (septicum).....	952
Fluphenazine enantate .....	2054	Gas pycnometric density of solids (2.9.23.) .....	288
Flurazepam monohydrochloride .....	2055	Gastro-resistant capsules.....	708
Flurbiprofen .....	2056	Gastro-resistant granules.....	714
Fluspirilene .....	2057	Gastro-resistant tablets .....	738
Flutamide .....	2058	Gelatin .....	2087
Fluticasone propionate .....	2059	Gels.....	735
Flutrimazole.....	2061	Gels for injections .....	725
Fluvastatin sodium .....	2062	Gemcitabine hydrochloride .....	2088
Fluvoxamine maleate .....	2063	Gemfibrozil .....	2090
Foams, cutaneous .....	717	General notices (1.) .....	3
Foams, intrauterine .....	715	General texts on biological products (5.2.) .....	527
Foams, medicated .....	712	General texts on microbiology (5.1.) .....	503
Foams, rectal.....	733	Gene transfer medicinal products for human use (5.14.).....	647
Foams, vaginal .....	740	Gentamicin sulfate.....	2091
Folic acid .....	2065	Gentian root .....	1133
Folate, calcium .....	1552	Gentian tincture .....	1134
Foot-and-mouth disease (ruminants) vaccine (inactivated) ...	904	Gestodene .....	2092
Foreign esters in essential oils (2.8.6.) .....	239	Ginger .....	1135
Foreign matter (2.8.2.).....	239	Gingival solutions .....	722
Foreign oils in fatty oils by thin-layer chromatography (2.4.21.) .....	119	Ginkgo dry extract, refined and quantified .....	1136
Formaldehyde, free (2.4.18.) .....	118	Ginkgo leaf .....	1138
Formaldehyde solution (35 per cent) .....	2066	Ginseng .....	1140
Formoterol fumarate dihydrate .....	2067	Glass containers for pharmaceutical use (3.2.1.) .....	363
Foscarnet sodium hexahydrate.....	2069	Glibenclamide .....	2094
Fosfomycin calcium .....	2070	Gliclazide.....	2096
Fosfomycin sodium .....	2071	Glimepiride .....	2097
Fosfomycin trometamol .....	2072	Glipizide .....	2098
Fosinopril sodium .....	2073	Glossary (dosage forms) .....	707
Fourstamen stephania root.....	1127	Glucagon, human.....	2100
Fowl cholera vaccine (inactivated) .....	905	Glucoheptonate, calcium .....	1554
Fowl-pox vaccine (live).....	906	Glucose, anhydrous .....	2102
Framycetin sulfate .....	2076	Glucose, liquid .....	2103
Frangula bark .....	1128	Glucose, liquid, spray-dried.....	2103
Frangula bark dry extract, standardised .....	1129	Glucose monohydrate .....	2104
Frankincense, Indian .....	1152	Glutamic acid .....	2105
Free formaldehyde (2.4.18.).....	118	Glutathione.....	2106
Freezing point (2.2.18.) .....	34	Glycan analysis of glycoproteins (2.2.59.).....	97
Fresh bilberry fruit dry extract, refined and standardised ...	1130	Glycerol .....	2108
Friability of granules and spheroids (2.9.41.).....	318	Glycerol (85 per cent).....	2109
Friability of uncoated tablets (2.9.7.) .....	266	Glycerol dibehenate .....	2110
Friability of uncoated tablets (2.9.7.) (5.8.) .....	622		
Fructose .....	2077		

Glycerol distearate .....	2111	Hawthorn berries .....	1147
Glycerol monocaprylate .....	2112	Hawthorn leaf and flower .....	1148
Glycerol monocaprylocaprate .....	2113	Hawthorn leaf and flower dry extract .....	1149
Glycerol monolinoleate .....	2114	Hawthorn leaf and flower liquid extract, quantified .....	1150
Glycerol mono-oleate .....	2115	Heavy bismuth subnitrate .....	1498
Glycerol monostearate 40-55 .....	2116	Heavy kaolin .....	2314
Glycerol triacetate .....	3127	Heavy magnesium carbonate .....	2409
Glyceryl trinitrate solution .....	2117	Heavy magnesium oxide .....	2415
Glycine .....	2118	Heavy metals (2.4.8.) .....	114
Glycoproteins, glycan analysis of (2.2.59.) .....	97	Heavy metals in herbal drugs and fatty oils (2.4.27.) .....	129
Glycyrrhizate ammonium .....	1384	Hedera helix for homoeopathic preparations .....	1291
Goldenrod .....	1141	Helium .....	2146
Goldenrod, European .....	1142	Heparin, assay of (2.7.5.) .....	208
Goldenseal rhizome .....	1143	Heparin calcium .....	2147
Gonadorelin acetate .....	2119	Heparin in coagulation factors, assay of (2.7.12.) .....	220
Gonadotrophin, chorionic .....	2120	Heparins, low-molecular-mass .....	2151
Gonadotrophin, equine serum, for veterinary use .....	2121	Heparin sodium .....	2149
Goserelin .....	2121	Hepatitis A immunoglobulin, human .....	2176
Grafted copolymer, macrogol poly(vinyl alcohol) .....	2401	Hepatitis A (inactivated) and hepatitis B (rDNA) vaccine (adsorbed) .....	779
Gramicidin .....	2123	Hepatitis A vaccine, assay of (2.7.14.) .....	222
Granisetron hydrochloride .....	2124	Hepatitis A vaccine (inactivated, adsorbed) .....	780
Granules .....	713	Hepatitis A vaccine (inactivated, virosome) .....	781
Granules and powders for oral solutions and suspensions .....	718	Hepatitis B immunoglobulin for intravenous administration, human .....	2176
Granules and powders for syrups .....	719	Hepatitis B immunoglobulin, human .....	2176
Granules and spheroids, friability of (2.9.41.) .....	318	Hepatitis B (rDNA), diphtheria and tetanus vaccine (adsorbed) .....	753
Granules, coated .....	714	Hepatitis B (rDNA), diphtheria, tetanus and pertussis (acellular, component) vaccine (adsorbed) .....	760
Granules, effervescent .....	714	Hepatitis B (rDNA), diphtheria, tetanus, pertussis (acellular, component), poliomyelitis (inactivated) and haemophilus type b conjugate vaccine (adsorbed) .....	765
Granules, gastro-resistant .....	714	Hepatitis B vaccine (rDNA) .....	784
Granules, modified-release .....	714	Hepatitis B vaccine (rDNA), assay of (2.7.15.) .....	223
Greater celandine .....	1145	Hepatitis C virus (HCV), validation of nucleic acid amplification techniques for the detection of HCV RNA in plasma pools: guidelines .....	181
Griseofulvin .....	2126	Heptaminol hydrochloride .....	2153
Guaiacol .....	2127	Herbal drug preparations .....	676
Guaifenesin .....	2128	Herbal drugs .....	676
Guanethidine monosulfate .....	2129	Herbal drugs and fatty oils, heavy metals in (2.4.27.) .....	129
Guar .....	1146	Herbal drugs, determination of aflatoxin B <sub>1</sub> in (2.8.18.) .....	244
Guar galactomannan .....	2130	Herbal drugs, determination of essential oils in herbal drugs (2.8.12.) .....	241
Guidelines for using the test for bacterial endotoxins (5.1.10.) .....	520	Herbal drugs, determination of tannins (2.8.14.) .....	243
Guidelines for using the test for sterility (5.1.9.) .....	519	Herbal drugs for homoeopathic preparations .....	1275
<b>H</b>			
Haematopoietic products, numeration of CD34/CD45+ cells in (2.7.23.) .....	228	Herbal drugs, microscopic examination of (2.8.23) .....	250
Haematopoietic progenitor cells, human, colony-forming cell assay for (2.7.28.) .....	232	Herbal drugs: sampling and sample preparation (2.8.20.) .....	246
Haematopoietic stem cells, human .....	2175	Herbal drugs, test for aristolochic acids in (2.8.21) .....	247
Haemodiafiltration and haemofiltration, solutions for .....	2138	Herbal medicinal products for oral use, microbial examination (2.6.31.) .....	197
Haemodialysis, concentrated solutions for .....	2136	Herbal medicinal products for oral use, microbiological quality (5.1.8.) .....	519
Haemodialysis solutions, concentrated, water for diluting ..	2135	Herbal preparations .....	676
Haemodialysis, solutions for .....	2136	Herbal substances .....	676
Haemofiltration and haemodiafiltration, solutions for .....	2138	Herbal teas .....	677
Haemophilus type b (conjugate), diphtheria, tetanus and pertussis (acellular, component) vaccine (adsorbed) .....	758	Herpes zoster (shingles) vaccine (live) .....	828
Haemophilus type b (conjugate), diphtheria, tetanus, pertussis (acellular, component) and poliomyelitis (inactivated) vaccine (adsorbed) .....	768	Hexamidone diisetonate .....	2154
Haemophilus type b (conjugate), diphtheria, tetanus, pertussis (acellular, component), hepatitis B (rDNA) and poliomyelitis (inactivated) vaccine (adsorbed) .....	765	Hexetidine .....	2155
Haemophilus type b (conjugate), diphtheria, tetanus, pertussis and poliomyelitis (inactivated) vaccine (adsorbed) .....	772	Hexobarbital .....	2156
Haemophilus type b conjugate vaccine .....	776	Hexosamines in polysaccharide vaccines (2.5.20.) .....	142
Haemorrhagic disease vaccine (inactivated), rabbit .....	933	Hexylresorcinol .....	2157
Halofantrine hydrochloride .....	2141	Highly purified water .....	3222
Haloperidol .....	2142	Histamine (2.6.10.) .....	162
Haloperidol decanoate .....	2143	Histamine dihydrochloride .....	2158
Halothane .....	2144	Histamine phosphate .....	2159
Hamamelis leaf .....	1146	Histidine .....	2159
Hard capsules .....	708	Histidine hydrochloride monohydrate .....	2160
Hard fat .....	2146	Homatropine hydrobromide .....	2161
Hard paraffin .....	2668	Homatropine methylbromide .....	2162
Harmonisation, pharmacopoeial (5.8.) .....	621	Homoeopathic preparations .....	1275
		Homoeopathic preparations, arsenious trioxide for .....	1286

Homoeopathic preparations, calcium iodide tetrahydrate for.....	1288	Hydrochloric acid, dilute.....	2192
Homoeopathic preparations, common stinging nettle for....	1288	Hydrochlorothiazide.....	2193
Homoeopathic preparations, copper acetate monohydrate for.....	1289	Hydrocodone hydrogen tartrate 2.5-hydrate .	2194
Homoeopathic preparations, copper for.....	1289	Hydrocortisone.....	2196
Homoeopathic preparations, garlic for.....	1290	Hydrocortisone acetate.....	2198
Homoeopathic preparations, hederá helix for.....	1291	Hydrocortisone hydrogen succinate.....	2200
Homoeopathic preparations, herbal drugs for.....	1275	Hydrogenated arachis oil.....	1413
Homoeopathic preparations, honey bee for.....	1292	Hydrogenated castor oil.....	1596
Homoeopathic preparations, hyoscyamus for.....	1292	Hydrogenated cottonseed oil.....	1769
Homoeopathic preparations, hypericum for.....	1293	Hydrogenated soya-bean oil.....	2968
Homoeopathic preparations, iron for.....	1294	Hydrogenated vegetable oils, nickel in (2.4.31.).....	132
Homoeopathic preparations, mother tinctures for.....	1286	Hydrogenated wool fat.....	3232
Homoeopathic preparations, oriental cashew for.....	1295	Hydrogen peroxide solution (30 per cent).....	2202
Homoeopathic preparations, saffron for.....	1296	Hydrogen peroxide solution (3 per cent).....	2201
Homoeopathic stocks (methods of preparation of) and potentisation.....	1277	Hydromorphone hydrochloride.....	2202
Honey.....	2163	Hydrophobic colloidal silica.....	2903
Honey bee for homoeopathic preparations.....	1292	Hydrous wool fat.....	3233
Hop strobile.....	1151	Hydroxocobalamin acetate.....	2203
Human $\alpha$ -1-proteinase inhibitor.....	2184	Hydroxocobalamin chloride.....	2204
Human albumin injection, iodinated ( <sup>125</sup> I).....	976	Hydroxocobalamin sulfate.....	2205
Human albumin solution.....	2165	Hydroxycarbamide.....	2206
Human anti-D immunoglobulin.....	2166	Hydroxyethylcellulose.....	2208
Human anti-D immunoglobulin, assay of (2.7.13.).....	220	Hydroxyethylmethylcellulose.....	2476
Human anti-D immunoglobulin for intravenous administration.....	2167	Hydroxyethyl salicylate.....	2207
Human antithrombin III, assay of (2.7.17.).....	224	Hydroxyethyl starches.....	2984
Human antithrombin III concentrate.....	2168	Hydroxyl value (2.5.3.).....	137
Human coagulation factor II, assay of (2.7.18.).....	224	Hydroxypropylbetadex.....	2210
Human coagulation factor IX.....	2172	Hydroxypropylcellulose.....	2211
Human coagulation factor IX, assay of (2.7.11.).....	219	Hydroxypropylmethylcellulose.....	2219
Human coagulation factor VII.....	2169	Hydroxypropylmethylcellulose phthalate.....	2221
Human coagulation factor VII, assay of (2.7.10.).....	219	Hydroxypropyl starch.....	2981
Human coagulation factor VIII.....	2170	Hydroxyzine hydrochloride.....	2212
Human coagulation factor VIII, assay of (2.7.4.).....	207	Hymecromone.....	2213
Human coagulation factor VIII (rdNA).....	2171	Hyoscine.....	2214
Human coagulation factor X, assay of (2.7.19.).....	225	Hyoscine butylbromide.....	2215
Human coagulation factor XI.....	2173	Hyoscine hydrobromide.....	2216
Human coagulation factor XI, assay of (2.7.22.).....	227	Hyoscyamine sulfate.....	2217
Human fibrinogen.....	2174	Hyoscyamus for homoeopathic preparations.....	1292
Human haematopoietic progenitor cells, colony-forming cell assay for (2.7.28.).....	232	Hypericum.....	1241
Human haematopoietic stem cells.....	2175	Hypericum for homoeopathic preparations.....	1293
Human hepatitis A immunoglobulin.....	2176	Hypromellose.....	2219
Human hepatitis B immunoglobulin.....	2176	Hypromellose phthalate.....	2221
Human hepatitis B immunoglobulin for intravenous administration.....	2176		
Human insulin.....	2241	<b>I</b>	
Human measles immunoglobulin.....	2177	Ibuprofen.....	2225
Human normal immunoglobulin.....	2177	Iceland moss.....	1152
Human normal immunoglobulin for intravenous administration.....	2179	ICH (5.8.).....	621
Human papillomavirus vaccine (rdNA).....	785	Ichthammol.....	2227
Human plasma for fractionation.....	2181	Identification (2.3.).....	107
Human plasma (pooled and treated for virus inactivation).....	2182	Identification and control of residual solvents (2.4.24.).....	123
Human plasmin inhibitor, assay of (2.7.25.).....	230	Identification of fatty oils by thin-layer chromatography (2.3.2.).....	110
Human protein C, assay of (2.7.30.).....	234	Identification of phenothiazines by thin-layer chromatography (2.3.3.).....	110
Human protein S, assay of (2.7.31.).....	235	Identification reactions of ions and functional groups (2.3.1.).....	107
Human prothrombin complex.....	2185	Idoxuridine.....	2227
Human rabies immunoglobulin.....	2186	Ifosfamide.....	2228
Human rubella immunoglobulin.....	2187	Imipenem.....	2230
Human tetanus immunoglobulin.....	2187	Imipramine hydrochloride.....	2231
Human varicella immunoglobulin.....	2188	Immunochemical methods (2.7.1.).....	201
Human varicella immunoglobulin for intravenous administration.....	2189	Immunoglobulin for human use, anti-T lymphocyte, animal.....	1404
Human von Willebrand factor.....	2189	Immunoglobulin for intravenous administration, human anti-D.....	2167
Human von Willebrand factor, assay of (2.7.21.).....	226	Immunoglobulin for intravenous administration, human hepatitis B.....	2176
Hyaluronate, sodium.....	2927	Immunoglobulin for intravenous administration, human normal.....	2179
Hyaluronidase.....	2190	Immunoglobulin for intravenous administration, human varicella.....	2189
Hydralazine hydrochloride.....	2191	Immunoglobulin, human anti-D.....	2166
Hydrochloric acid, concentrated.....	2192		

Immunoglobulin, human anti-D, assay of (2.7.13.)	220	Insulin injection, soluble	2244
Immunoglobulin, human hepatitis A	2176	Insulin lispro	2245
Immunoglobulin, human hepatitis B	2176	Insulin, porcine	2247
Immunoglobulin, human measles	2177	Insulin preparations, injectable	2249
Immunoglobulin, human normal	2177	Insulin zinc injectable suspension	2251
Immunoglobulin, human rabies	2186	Insulin zinc injectable suspension (amorphous)	2252
Immunoglobulin, human rubella	2187	Insulin zinc injectable suspension (crystalline)	2252
Immunoglobulin, human tetanus	2187	Interferon alfa-2 concentrated solution	2252
Immunoglobulin, human varicella	2188	Interferon beta-1a concentrated solution	2255
Immunoglobulin, test for anticomplementary activity of (2.6.17.)	177	Interferon gamma-1b concentrated solution	2257
Immunoglobulin, test for Fc function of (2.7.9.)	217	Interferons, assay of (5.6.)	607
Immunological veterinary medicinal products, substances of animal origin for the production of (5.2.5.)	535	International System (SI) units (1.)	3
Immunosera and vaccines, phenol in (2.5.15.)	141	Intramammary preparations for veterinary use	714
Immunosera and vaccines, veterinary, evaluation of efficacy of (5.2.7.)	538	Intraruminal devices	715
Immunosera and vaccines, veterinary, evaluation of safety (5.2.6.)	536	Intrauterine capsules	715
Immunosera and vaccines, veterinary, evaluation of the safety of each batch (5.2.9.)	547	Intrauterine foams	715
Immunosera for human use, animal	678	Intrauterine preparations for veterinary use	715
Immunosera for veterinary use	680	Intrauterine solutions, suspensions	715
Implants	725	Intrauterine sticks	715
Impurities in substances for pharmaceutical use, control of (5.10.)	631	Intrauterine tablets	715
Indapamide	2232	Intrinsic dissolution (2.9.29.)	294
Indian frankincense	1152	<i>In vivo</i> assay of poliomyelitis vaccine (inactivated) (2.7.20.)	225
Indicators, relationship between approximate pH and colour (2.2.4.)	25	Iobenguane ( <sup>123</sup> I) injection	979
Indinavir sulfate	2233	Iobenguane ( <sup>131</sup> I) injection for diagnostic use	980
Indium ( <sup>111</sup> In) chloride solution	977	Iobenguane ( <sup>131</sup> I) injection for therapeutic use	981
Indium ( <sup>111</sup> In) oxine solution	978	Iobenguane sulfate for radiopharmaceutical preparations	982
Indium ( <sup>111</sup> In) pentetate injection	979	Iodinated ( <sup>125</sup> I) human albumin injection	976
Indometacin	2235	Iodinated povidone	2778
Inductively coupled plasma-atomic emission spectrometry (2.2.57.)	94	Iodine	2261
Inductively coupled plasma-mass spectrometry (2.2.58.)	96	Iodine value (2.5.4.)	137
Infectious bovine rhinotracheitis vaccine (live)	908	Iodixanol	2261
Infectious bronchitis vaccine (inactivated), avian	851	Iodomethylnorcholesterol ( <sup>131</sup> I) injection	982
Infectious bronchitis vaccine (live), avian	852	Iohexol	2264
Infectious bursal disease vaccine (inactivated), avian	854	Ionic concentration, potentiometric determination of using ion-selective electrodes (2.2.36.)	57
Infectious bursal disease vaccine (live), avian	856	Ions and functional groups, identification reactions of (2.3.1.)	107
Infectious chicken anaemia vaccine (live)	910	Ion-selective electrodes, potentiometric determination of ionic concentration (2.2.36.)	57
Infectious encephalomyelitis vaccine (live), avian	857	Iopamidol	2266
Infectious laryngotracheitis vaccine (live), avian	859	Iopanoic acid	2268
Influenza vaccine (split virion, inactivated)	788	Iopromide	2269
Influenza vaccine (surface antigen, inactivated)	789	Iotalamic acid	2272
Influenza vaccine (surface antigen, inactivated, prepared in cell cultures)	791	Iotrolan	2273
Influenza vaccine (surface antigen, inactivated, virosome)	793	Ioxaglic acid	2275
Influenza vaccine (whole virion, inactivated)	795	Ipecacuanha liquid extract, standardised	1153
Influenza vaccine (whole virion, inactivated, prepared in cell cultures)	796	Ipecacuanha, prepared	1154
Infrared absorption spectrophotometry (2.2.24.)	38	Ipecacuanha root	1155
Infusions	725	Ipecacuanha tincture, standardised	1156
Inhalation gas, krypton ( <sup>81m</sup> Kr)	983	Ipratropium bromide	2277
Inhalation, preparations for	728	Irbesartan	2278
Inhalation, preparations for: aerodynamic assessment of fine particles (2.9.18.)	274	Iron (2.4.9.)	117
Injectable insulin preparations	2249	Iron for homoeopathic preparations	1294
Injections	724	Irrigation, preparations for	731
Injections, gels for	725	Isoconazole	2279
Injections or infusions, concentrates for	725	Isoconazole nitrate	2281
Injections or infusions, powders for	725	Isoelectric focusing (2.2.54.)	83
Inositol, <i>myo</i>	2236	Isoelectric focusing (2.2.54.) (5.8.)	621
Inserts, ophthalmic	712	Isoflurane	2282
Insulin aspart	2237	Isoleucine	2283
Insulin, bovine	2239	Isomalt	2284
Insulin, human	2241	Isoniazid	2285
Insulin injection, biphasic	2243	Isophane insulin injection	2244
Insulin injection, biphasic isophane	2244	Isoprenaline hydrochloride	2286
Insulin injection, isophane	2244	Isoprenaline sulfate	2287
		Isopropyl alcohol	2287
		Isopropyl myristate	2288
		Isopropyl palmitate	2289
		Isosorbide dinitrate, diluted	2289
		Isosorbide mononitrate, diluted	2291
		Isotretinoin	2293
		Isoxsuprine hydrochloride	2294
		Ispaghula husk	1156



Ispaghula seed.....	1157	Lidocaine.....	2365
Isradipine.....	2296	Lidocaine hydrochloride.....	2366
Itraconazole.....	2297	Light liquid paraffin.....	2669
Ivermectin.....	2299	Light magnesium carbonate.....	2409
Ivy leaf.....	1157	Light magnesium oxide.....	2416
<b>J</b>		Lime flower.....	1168
Javanese turmeric.....	1257	Limit tests (2.4.).....	113
Java tea.....	1158	Limit tests, standard solutions for (4.1.2.).....	485
Josamycin.....	2305	Lincomycin hydrochloride.....	2367
Josamycin propionate.....	2307	Linen thread, sterile, in distributor for veterinary use.....	1038
Juniper.....	1160	Linoleoyl macroglycerides.....	2368
Juniper oil.....	1160	Linseed.....	1168
<b>K</b>		Linseed oil, virgin.....	2369
Kanamycin acid sulfate.....	2313	Liothyronine sodium.....	2370
Kanamycin monosulfate.....	2313	Lipophilic solid dosage forms, dissolution test for (2.9.42.)... 319	
Kaolin, heavy.....	2314	Liquid chromatography (2.2.29.).....	45
Kelp.....	1161	Liquid extracts.....	675
Ketamine hydrochloride.....	2315	Liquid glucose.....	2103
Ketobemidone hydrochloride.....	2316	Liquid glucose, spray-dried.....	2103
Ketoconazole.....	2317	Liquid lactulose.....	2336
Ketoprofen.....	2318	Liquid maltitol.....	2427
Ketorolac trometamol.....	2320	Liquid paraffin.....	2669
Ketotifen hydrogen fumarate.....	2321	Liquid preparations for cutaneous application.....	717
Knotgrass.....	1162	Liquid preparations for cutaneous application, veterinary....	740
Krypton ( <sup>81m</sup> Kr) inhalation gas.....	983	Liquid preparations for inhalation.....	728
<b>L</b>		Liquid preparations for oral use.....	718
Labetalol hydrochloride.....	2327	Liquids, clarity and degree of opalescence of (2.2.1.).....	21
Lactic acid.....	2328	Liquid sorbitol (crystallising).....	2965
Lactic acid, (S)-.....	2328	Liquid sorbitol (non-crystallising).....	2965
Lactitol monohydrate.....	2329	Liquid sorbitol, partially dehydrated.....	2966
Lactobionic acid.....	2331	Liquorice dry extract for flavouring purposes.....	1169
Lactose, anhydrous.....	2331	Liquorice ethanolic liquid extract, standardised.....	1170
Lactose monohydrate.....	2333	Liquorice root.....	1171
Lactulose.....	2334	Lisinopril dihydrate.....	2371
Lactulose, liquid.....	2336	Lithium carbonate.....	2372
Lamivudine.....	2337	Lithium citrate.....	2373
Lamotrigine.....	2339	L-Methionine ([ <sup>14</sup> C]methyl) injection.....	985
Lansoprazole.....	2341	Lobeline hydrochloride.....	2373
Laser light diffraction, particle size analysis by (2.9.31.).....	295	Lomustine.....	2375
Laurilsulfate, sodium.....	2933	Loosestrife.....	1172
Lauromacrogol 400.....	2342	Loperamide hydrochloride.....	2376
Lauroyl macroglycerides.....	2344	Loperamide oxide monohydrate.....	2378
Lavender flower.....	1163	Loratadine.....	2379
Lavender oil.....	1164	Lorazepam.....	2381
Lavender oil, spike.....	1240	Losartan potassium.....	2382
Lead in sugars (2.4.10.).....	117	Loss on drying (2.2.32.).....	51
Leflunomide.....	2345	Loss on drying of extracts (2.8.17.).....	244
Lemon oil.....	1165	Lovage root.....	1172
Lemon verbena leaf.....	1166	Lovastatin.....	2384
Leptospirosis vaccine (inactivated), bovine.....	862	Low-molecular-mass heparins.....	2151
Leptospirosis vaccine (inactivated), canine.....	874	Lozenges and pastilles.....	723
Letrozole.....	2347	Lozenges, compressed.....	723
Leucine.....	2348	Lubricant, silicone oil (3.1.8.).....	347
Leuprorelin.....	2348	Lufenuron (anhydrous) for veterinary use.....	2385
Levamisole for veterinary use.....	2350	Lymecycline.....	2387
Levamisole hydrochloride.....	2351	Lynestrenol.....	2389
Levetiracetam.....	2352	Lyophilisates, oral.....	736
Levocabastine hydrochloride.....	2354	Lysine acetate.....	2390
Levocarnitine.....	2355	Lysine hydrochloride.....	2391
Levodopa.....	2356	<b>M</b>	
Levodropropizine.....	2358	Macrogol 15 hydroxystearate.....	2399
Levofolinate pentahydrate, calcium.....	1563	Macrogol 20 glycerol monostearate.....	2397
Levomenthol.....	2359	Macrogol 40 sorbitol heptaoleate.....	2404
Levomepromazine hydrochloride.....	2360	Macrogol 6 glycerol caprylocaprate.....	2395
Levomepromazine maleate.....	2361	Macrogol cetostearyl ether.....	2395
Levomethadone hydrochloride.....	2362	Macrogolglycerol cocoates.....	2396
Levonorgestrel.....	2363	Macrogolglycerol hydroxystearate.....	2397
Levothyroxine sodium.....	2364	Macrogolglycerol ricinoleate.....	2398
Levulinate dihydrate, calcium.....	1565	Macrogol lauryl ether.....	2400
		Macrogol oleate.....	2400
		Macrogol oleyl ether.....	2401

Macrogol poly(vinyl alcohol) grafted copolymer	2401	Matricaria oil	1180
Macrogols	2402	Meadowsweet	1182
Macrogol stearate	2405	Measles immunoglobulin, human	2177
Macrogol stearyl ether	2405	Measles, mumps and rubella vaccine (live)	798
Magaldrate	2406	Measles, mumps, rubella and varicella vaccine (live)	799
Magnesium (2.4.6.)	114	Measles vaccine (live)	800
Magnesium acetate tetrahydrate	2407	Measurement of consistency by penetrometry (2.9.9.)	267
Magnesium aluminium silicate	1358	Mebendazole	2434
Magnesium and alkaline-earth metals (2.4.7.)	114	Meclozine dihydrochloride	2435
Magnesium aspartate dihydrate	2408	Medicated chewing gums	709
Magnesium carbonate, heavy	2409	Medicated chewing gums, dissolution test for (2.9.25.)	289
Magnesium carbonate, light	2409	Medicated feeding stuffs for veterinary use, premixes for	727
Magnesium chloride 4.5-hydrate	2410	Medicated foams	712
Magnesium chloride hexahydrate	2411	Medicated plasters	735
Magnesium citrate, anhydrous	2411	Medicated tampons	738
Magnesium citrate dodecahydrate	2412	Medicated vaginal tampons	740
Magnesium citrate nonahydrate	2412	Medicinal air	1331
Magnesium gluconate	2413	Medicinal air, synthetic	1333
Magnesium glycerophosphate	2414	Medium-chain triglycerides	3138
Magnesium hydroxide	2414	Medronic acid for radiopharmaceutical preparations	984
Magnesium lactate dihydrate	2415	Medroxyprogesterone acetate	2437
Magnesium oxide, heavy	2415	Mefenamic acid	2438
Magnesium oxide, light	2416	Mefloquine hydrochloride	2440
Magnesium peroxide	2417	Megestrol acetate	2441
Magnesium pidolate	2417	Meglumine	2442
Magnesium stearate	2418	Melilot	1183
Magnesium sulfate heptahydrate	2421	Melissa leaf	1184
Magnesium trisilicate	2421	Melissa leaf dry extract	1185
Maize oil, refined	2422	Meloxicam	2443
Maize starch	2422	Melting point - capillary method (2.2.14.)	31
Malathion	2423	Melting point - instantaneous method (2.2.16.)	32
Maleic acid	2424	Melting point - open capillary method (2.2.15.)	32
Malic acid	2424	Menadione	2444
Mallow flower	1173	Meningococcal group C conjugate vaccine	802
Mallow leaf	1174	Meningococcal polysaccharide vaccine	803
Maltitol	2425	Menthol, racemic	2445
Maltitol, liquid	2427	Mepivacaine hydrochloride	2446
Maltodextrin	2428	Meprobamate	2447
Mandarin oil	1175	Mepyramine maleate	2448
Manganese gluconate	2428	Mercaptopurine	2449
Manganese glycerophosphate, hydrated	2429	Mercuric chloride	2449
Manganese sulfate monohydrate	2430	Mercury porosimetry, porosity and pore-size distribution of solids by (2.9.32.)	299
Mannheimia vaccine (inactivated) for cattle	911	Meropenem trihydrate	2450
Mannheimia vaccine (inactivated) for sheep	913	Mesalazine	2451
Mannitol	2430	Mesna	2453
Maprotiline hydrochloride	2432	Mesterolone	2454
Marbofloxacin for veterinary use	2433	Mestranol	2455
Marek's disease vaccine (live)	914	Metabisulfite, sodium	2933
Marshmallow leaf	1176	Metacresol	2456
Marshmallow root	1177	Metamizole sodium	2457
Mass spectrometry (2.2.43.)	67	Metformin hydrochloride	2458
Mass spectrometry, inductively coupled plasma- (2.2.58.)	96	Methacrylate copolymer, basic butylated	1448
Mass uniformity of delivered doses from multidose containers (2.9.27.)	294	Methacrylic acid - ethyl acrylate copolymer (1:1)	2459
Mass uniformity of single-dose preparations (2.9.5.)	265	Methacrylic acid - ethyl acrylate copolymer (1:1) dispersion 30 per cent	2460
Mastic	1177	Methacrylic acid - methyl methacrylate copolymer (1:1)	2461
Materials based on non-plasticised poly(vinyl chloride) for containers for dry dosage forms for oral administration (3.1.11.)	350	Methacrylic acid - methyl methacrylate copolymer (1:2)	2461
Materials based on non-plasticised poly(vinyl chloride) for containers for non-injectable, aqueous solutions (3.1.10.)	349	Methadone hydrochloride	2462
Materials based on plasticised poly(vinyl chloride) for containers for aqueous solutions for intravenous infusion (3.1.14.)	355	Methanol	2463
Materials based on plasticised poly(vinyl chloride) for containers for human blood and blood components (3.1.1.1.)	329	Methanol and 2-propanol, test for (2.9.11.)	270
Materials based on plasticised poly(vinyl chloride) for tubing used in sets for the transfusion of blood and blood components (3.1.1.2.)	332	Methaqualone	2464
Materials for containers for human blood and blood components (3.1.1.)	329	Methenamine	2465
Materials used for the manufacture of containers (3.1.)	329	Methionine	2466
Matricaria flower	1178	Methionine ( <sup>13</sup> C)methyl injection, L-	985
Matricaria liquid extract	1179	Methionine, DL-	2466
		Methods in pharmacognosy (2.8.)	239
		Methods of preparation of homoeopathic stocks and potentiation	1277
		Methods of preparation of sterile products (5.1.1.)	503
		Methotrexate	2467
		Methylatropine bromide	2469
		Methylatropine nitrate	2470

Methylcellulose.....	2471	Minoxidil.....	2511
Methyldopa.....	2472	Mint oil, partly dementholised.....	1189
Methylene blue.....	2490	Mirtazapine.....	2512
Methylene chloride.....	2474	Misoprostol.....	2513
Methylergometrine maleate.....	2475	Mitomycin.....	2515
Methylhydroxyethylcellulose.....	2476	Mitoxantrone hydrochloride.....	2517
Methyl nicotinate.....	2477	Modafinil.....	2518
Methyl parahydroxybenzoate.....	2477	Modified-release capsules.....	708
Methyl parahydroxybenzoate, sodium.....	2934	Modified-release granules.....	714
Methylpentoses in polysaccharide vaccines (2.5.21.).....	143	Modified-release tablets.....	738
Methylphenidate hydrochloride.....	2479	Mofetil mycophenolate.....	2536
Methylphenobarbital.....	2480	Molecular mass distribution in dextrans (2.2.39.).....	60
Methylprednisolone.....	2481	Molgramostim concentrated solution.....	2519
Methylprednisolone acetate.....	2483	Molsidomine.....	2521
Methylprednisolone hydrogen succinate.....	2485	Molybdate dihydrate, sodium.....	2935
Methylpyrrolidone, <i>N</i> .....	2486	Mometasone furoate.....	2523
Methylrosanilinium chloride.....	2487	Monoclonal antibodies for human use.....	682
Methyl salicylate.....	2488	Monocyte-activation test (2.6.30.).....	192
Methyltestosterone.....	2489	Morantel hydrogen tartrate for veterinary use.....	2525
Methylthioninium chloride.....	2490	Morphine hydrochloride.....	2526
Metixene hydrochloride.....	2491	Morphine sulfate.....	2527
Metoclopramide.....	2492	Moss, Iceland.....	1152
Metoclopramide hydrochloride.....	2493	Mother tinctures for homoeopathic preparations.....	1286
Metolazone.....	2494	Motherwort.....	1190
Metoprolol succinate.....	2495	Mouthwashes.....	722
Metoprolol tartrate.....	2497	Moxidectin for veterinary use.....	2529
Metrifonate.....	2498	Moxifloxacin hydrochloride.....	2531
Metronidazole.....	2500	Moxonidine.....	2532
Metronidazole benzoate.....	2500	Mucoadhesive preparations.....	723
Mexiletine hydrochloride.....	2502	Mullein flower.....	1191
Mianserin hydrochloride.....	2503	Multidose containers, uniformity of mass of delivered doses (2.9.27.).....	294
Miconazole.....	2504	Mumps, measles and rubella vaccine (live).....	798
Miconazole nitrate.....	2506	Mumps, measles, rubella and varicella vaccine (live).....	799
Microbial enumeration tests (microbiological examination of non-sterile products) (2.6.12.).....	163	Mumps vaccine (live).....	805
Microbial enumeration tests (microbiological examination of non-sterile products) (2.6.12.) (5.8.).....	622	Mupirocin.....	2533
Microbiological assay of antibiotics (2.7.2.).....	202	Mupirocin calcium.....	2535
Microbiological control of cellular products (2.6.27.).....	191	Mycobacteria (2.6.2.).....	156
Microbiological examination of herbal medicinal products for oral use (2.6.31.).....	197	Mycophenolate mofetil.....	2536
Microbiological examination of non-sterile products: microbial enumeration tests (2.6.12.).....	163	Mycoplasma gallisepticum vaccine (inactivated).....	916
Microbiological examination of non-sterile products: microbial enumeration tests (2.6.12.) (5.8.).....	622	Mycoplasmas (2.6.7.).....	156
Microbiological examination of non-sterile products: test for specified micro-organisms (2.6.13.).....	167	<i>myo</i> -Inositol.....	2236
Microbiological examination of non-sterile products: test for specified micro-organisms (2.6.13.) (5.8.).....	622	Myrrh.....	1192
Microbiological quality, alternative methods for control of (5.1.6.).....	508	Myrrh tincture.....	1192
Microbiological quality of herbal medicinal products for oral use (5.1.8.).....	519	Myxomatosis vaccine (live) for rabbits.....	917
Microbiological quality of non-sterile pharmaceutical preparations and substances for pharmaceutical use (5.1.4.).....	507	<b>N</b>	
Microbiological quality of non-sterile pharmaceutical preparations and substances for pharmaceutical use (5.1.4.) (5.8.).....	623	Nabumetone.....	2541
Microbiology, general texts on (5.1.).....	503	<i>N</i> -Acetyltryptophan.....	1319
Microcrystalline cellulose.....	1634	<i>N</i> -Acetyltyrosine.....	1320
Microcrystalline cellulose and carmellose sodium.....	2507	Nadolol.....	2542
Micro determination of water (2.5.32.).....	146	Nadroparin calcium.....	2543
Microscopic examination of herbal drugs (2.8.23.).....	250	Naftidrofuryl hydrogen oxalate.....	2545
Microscopy, optical (2.9.37.).....	311	Nalidixic acid.....	2547
Microscopy, optical (2.9.37.) (5.8.).....	622	Naloxone hydrochloride dihydrate.....	2548
Midazolam.....	2508	Naltrexone hydrochloride.....	2549
Milk thistle dry extract, refined and standardised.....	1186	Nandrolone decanoate.....	2551
Milk-thistle fruit.....	1187	Naphazoline hydrochloride.....	2552
Minimising the risk of transmitting animal spongiform encephalopathy agents via human and veterinary medicinal products (5.2.8.).....	539	Naphazoline nitrate.....	2553
Minocycline hydrochloride dihydrate.....	2510	Naproxen.....	2554
		Naproxen sodium.....	2556
		Narrow-leaved coneflower root.....	1193
		Nasal drops and liquid nasal sprays.....	720
		Nasal powders.....	721
		Nasal preparations.....	719
		Nasal preparations, semi-solid.....	721
		Nasal sprays (liquid) and nasal drops.....	719
		Nasal sticks.....	721
		Nasal washes.....	721
		Near-infrared spectrophotometry (2.2.40.).....	61
		Neohesperidin-dihydrochalcone.....	2558
		Neomycin sulfate.....	2559

Neonatal piglet colibacillosis vaccine (inactivated).....	918	Nortriptyline hydrochloride.....	2598
Neonatal ruminant colibacillosis vaccine (inactivated).....	920	Noscapine.....	2599
Neostigmine bromide.....	2560	Noscapine hydrochloride.....	2600
Neostigmine metilsulfate.....	2561	Notoginseng root.....	1197
Neroli oil.....	1194	Nuclear magnetic resonance spectrometry (2.2.33.).....	52
Netilmicin sulfate.....	2562	Nucleated cell count and viability (2.7.29.).....	233
Nettle leaf.....	1196	Nucleic acid amplification techniques (2.6.21.).....	181
Neurovirulence test for poliomyelitis vaccine (oral) (2.6.19.)..	179	Nucleic acids in polysaccharide vaccines (2.5.17.).....	142
Neurovirulence test of live viral vaccines (2.6.18.).....	179	Numeration of CD34/CD45+ cells in haematopoietic products (2.7.23.).....	228
Nevirapine, anhydrous.....	2563	Nutmeg oil.....	1199
Newcastle disease vaccine (inactivated).....	921	Nystatin.....	2602
Newcastle disease vaccine (live).....	923		
Nicergoline.....	2564	<b>O</b>	
Nickel in hydrogenated vegetable oils (2.4.31.).....	132	<i>O</i> -Acetyl in polysaccharide vaccines (2.5.19.).....	142
Nickel in polyols (2.4.15.).....	118	Oak bark.....	1199
Niclosamide, anhydrous.....	2565	Octoxinol 10.....	2607
Niclosamide monohydrate.....	2566	Octyldodecanol.....	2608
Nicotinamide.....	2567	Octyl gallate.....	2607
Nicotine.....	2567	Odour (2.3.4.).....	110
Nicotine resinate.....	2568	Odour and taste of essential oils (2.8.8.).....	240
Nicotinic acid.....	2570	Ofloxacin.....	2609
Nifedipine.....	2571	Oils, essential.....	673
Niflumic acid.....	2572	Oils, fatty, identification by thin-layer chromatography (2.3.2.).....	110
Nifuroxazide.....	2574	Oils, fatty, vegetable.....	703
Nikethamide.....	2575	Oils rich in omega-3 acids, composition of fatty acids in (2.4.29.).....	130
Nilutamide.....	2575	Oils rich in omega-3 acids, total cholesterol in (2.4.32.).....	133
Nimesulide.....	2577	Ointments.....	735
Nimodipine.....	2578	Oleic acid.....	2610
Nitrazepam.....	2579	Oleoresins.....	676
Nitrendipine.....	2580	Oleoyle macroglycerides.....	2610
Nitric acid.....	2581	Oleyl alcohol.....	2611
Nitric oxide.....	2581	Olive leaf.....	1200
Nitrofurantoin.....	2582	Olive leaf dry extract.....	1201
Nitrofurantoin.....	2583	Olive oil, refined.....	2612
Nitrogen.....	2584	Olive oil, virgin.....	2613
Nitrogen determination by sulfuric acid digestion (2.5.9.).....	139	Olsalazine sodium.....	2613
Nitrogen determination, primary aromatic amino (2.5.8.).....	139	Omega-3-acid ethyl esters 60.....	2616
Nitrogen, low-oxygen.....	2585	Omega-3-acid ethyl esters 90.....	2617
Nitrogen monoxide and nitrogen dioxide in gases (2.5.26.)...	145	Omega-3 acids, composition of fatty acids in oils rich in (2.4.29.).....	130
Nitroprusside, sodium.....	2936	Omega-3 acids, fish oil rich in.....	2019
Nitrous oxide.....	2585	Omega-3 acids, total cholesterol in oils rich in (2.4.32.).....	133
Nitrous oxide in gases (2.5.35.).....	150	Omega-3-acid triglycerides.....	2619
Nizatidine.....	2586	Omeprazole.....	2621
<i>N</i> -Methylpyrrolidone.....	2486	Omeprazole magnesium.....	2623
NMR spectrometry (2.2.33.).....	52	Omeprazole sodium.....	2624
<i>N,N</i> -Dimethylaniline (2.4.26.).....	128	Ondansetron hydrochloride dihydrate.....	2625
Nomegestrol acetate.....	2588	Opalescence of liquids, clarity and degree of (2.2.1.).....	21
Nonoxinol 9.....	2589	Ophthalmic inserts.....	712
Non-sterile pharmaceutical preparations and substances for pharmaceutical use, microbiological quality of (5.1.4.).....	507	Opium dry extract, standardised.....	1202
Non-sterile pharmaceutical preparations and substances for pharmaceutical use, microbiological quality of (5.1.4.) (5.8.).....	623	Opium, prepared.....	1203
Non-sterile products, microbiological examination of (microbial enumeration tests) (2.6.12.).....	163	Opium, raw.....	1204
Non-sterile products, microbiological examination of (microbial enumeration tests) (2.6.12.) (5.8.).....	622	Opium tincture, standardised.....	1205
Non-sterile products, microbiological examination of (test for specified micro-organisms) (2.6.13.).....	167	Optical microscopy (2.9.37.).....	311
Non-sterile products, microbiological examination of (test for specified micro-organisms) (2.6.13.) (5.8.).....	622	Optical microscopy (2.9.37.) (5.8.).....	622
Noradrenaline hydrochloride.....	2589	Optical rotation (2.2.7.).....	26
Noradrenaline tartrate.....	2591	Oral drops.....	719
Norepinephrine hydrochloride.....	2589	Oral lyophilisates.....	736
Norepinephrine tartrate.....	2591	Oral powders.....	727
Norethisterone.....	2592	Oral solutions, emulsions and suspensions.....	718
Norethisterone acetate.....	2594	Oral use, liquid preparations for.....	718
Norfloxacin.....	2595	Orbifloxacin for veterinary use.....	2627
Norgestimate.....	2596	Orciprenaline sulfate.....	2628
Norgestrel.....	2597	Oregano.....	1206
Normal immunoglobulin for intravenous administration, human.....	2179	Organ preservation, solutions for.....	2952
Normal immunoglobulin, human.....	2177	Oriental cashew for homoeopathic preparations.....	1295
		Orodispersible tablets.....	737
		Oromucosal capsules.....	723

- Oromucosal drops, oromucosal sprays and sublingual sprays .....722
- Oromucosal preparations ..... 721
- Oromucosal preparations, semi-solid ..... 722
- Oromucosal solutions and oromucosal suspensions ..... 722
- Oromucosal sprays, oromucosal drops and sublingual sprays ..... 721
- Oromucosal suspensions and oromucosal solutions ..... 721
- Orphenadrine citrate ..... 2630
- Orphenadrine hydrochloride ..... 2631
- Osmolality (2.2.35.) ..... 57
- Ouabain ..... 2632
- Oxacillin sodium monohydrate ..... 2633
- Oxaliplatin ..... 2635
- Oxazepam ..... 2638
- Oxeladin hydrogen citrate ..... 2639
- Oxendazole for veterinary use ..... 2640
- Oxidising substances (2.5.30.) ..... 146
- Oxitropium bromide ..... 2641
- Oxolinic acid ..... 2642
- Oxprenolol hydrochloride ..... 2643
- Oxybuprocaine hydrochloride ..... 2644
- Oxybutynin hydrochloride ..... 2645
- Oxycodone hydrochloride ..... 2646
- Oxygen ..... 2648
- Oxygen (<sup>15</sup>O) ..... 986
- Oxygen-flask method (2.5.10.) ..... 139
- Oxygen in gases (2.5.27.) ..... 145
- Oxymetazoline hydrochloride ..... 2648
- Oxytetracycline dihydrate ..... 2649
- Oxytetracycline hydrochloride ..... 2651
- Oxytocin ..... 2653
- Oxytocin concentrated solution ..... 2654
- P**
- Paclitaxel ..... 2657
- Pale coneflower root ..... 1208
- Palmitic acid ..... 2660
- Pamidronate disodium pentahydrate ..... 2660
- Pancreas powder ..... 2661
- Pancuronium bromide ..... 2663
- Pansy, wild (flowering aerial parts) ..... 1266
- Pantoprazole sodium sesquihydrate ..... 2664
- Pantothenate, calcium ..... 1566
- Papaverine hydrochloride ..... 2666
- Paper chromatography (2.2.26.) ..... 41
- Paracetamol ..... 2667
- Paraffin, hard ..... 2668
- Paraffin, light liquid ..... 2669
- Paraffin, liquid ..... 2669
- Paraffin, white soft ..... 2670
- Paraffin, yellow soft ..... 2671
- Parahydroxybenzoate, butyl ..... 1530
- Parahydroxybenzoate, ethyl ..... 1973
- Parahydroxybenzoate, methyl ..... 2477
- Parahydroxybenzoate, propyl ..... 2813
- Parahydroxybenzoate sodium, ethyl ..... 1974
- Parahydroxybenzoate, sodium methyl ..... 2934
- Parahydroxybenzoate, sodium propyl ..... 2942
- Parainfluenza virus vaccine (live), bovine ..... 864
- Parainfluenza virus vaccine (live), canine ..... 875
- Paraldehyde ..... 2671
- Paramyxovirus 1 (Newcastle disease) vaccine (inactivated), avian ..... 921
- Parenteral preparations ..... 723
- Parenteral preparations, test for extractable volume of (2.9.17.) ..... 273
- Parenteral preparations, test for extractable volume of (2.9.17.) (5.8.) ..... 622
- Parnaparin sodium ..... 2672
- Paroxetine hydrochloride, anhydrous ..... 2672
- Paroxetine hydrochloride hemihydrate ..... 2674
- Particles, fine, aerodynamic assessment of in preparations for inhalation (2.9.18.) ..... 274
- Particle size analysis by laser light diffraction (2.9.31.) ..... 295
- Particle-size distribution estimation by analytical sieving (2.9.38.) ..... 313
- Particle-size distribution estimation by analytical sieving (2.9.38.) (5.8.) ..... 623
- Particulate contamination: sub-visible particles (2.9.19.) ..... 285
- Particulate contamination: visible particles (2.9.20.) ..... 287
- Parvovirus vaccine (inactivated), canine ..... 876
- Parvovirus vaccine (inactivated), porcine ..... 930
- Parvovirus vaccine (live), canine ..... 877
- Passion flower ..... 1209
- Passion flower dry extract ..... 1210
- Pastes ..... 735
- Pasteurella vaccine (inactivated) for sheep ..... 925
- Pastilles and lozenges ..... 723
- Patches, cutaneous ..... 734
- Patches, transdermal ..... 726
- Patches, transdermal, dissolution test for (2.9.4.) ..... 263
- Pea starch ..... 2676
- Pefloxacin mesilate dihydrate ..... 2677
- Pelargonium root ..... 1211
- Penbutolol sulfate ..... 2678
- Penetrometry, measurement of consistency by (2.9.9.) ..... 267
- Penicillamine ..... 2679
- Pentaerythrityl tetranitrate, diluted ..... 2681
- Pentamidine diisetonate ..... 2683
- Pentazocine ..... 2684
- Pentazocine hydrochloride ..... 2684
- Pentazocine lactate ..... 2685
- Pentetate sodium calcium for radiopharmaceutical preparations ..... 987
- Pentobarbital ..... 2685
- Pentobarbital sodium ..... 2686
- Pentoxifylline ..... 2687
- Pentoxyverine hydrogen citrate ..... 2689
- Peppermint leaf ..... 1212
- Peppermint leaf dry extract ..... 1213
- Peppermint oil ..... 1214
- Pepsin powder ..... 2690
- Peptide mapping (2.2.55.) ..... 85
- Peptide mapping (2.2.55.) (5.8.) ..... 621
- Peptides, synthetic, acetic acid in (2.5.34.) ..... 150
- Perborate, hydrated sodium ..... 2937
- Pergolide mesilate ..... 2691
- Perindopril *tert*-butylamine ..... 2692
- Peritoneal dialysis, solutions for ..... 2695
- Peroxide value (2.5.5.) ..... 138
- Perphenazine ..... 2697
- Pertussis (acellular, component), diphtheria and tetanus vaccine (adsorbed) ..... 754
- Pertussis (acellular, component), diphtheria, tetanus and haemophilus type b conjugate vaccine (adsorbed) ..... 758
- Pertussis (acellular, component), diphtheria, tetanus and hepatitis B (rDNA) vaccine (adsorbed) ..... 760
- Pertussis (acellular, component), diphtheria, tetanus and poliomyelitis (inactivated) vaccine (adsorbed) ..... 762
- Pertussis (acellular, component), diphtheria, tetanus and poliomyelitis (inactivated) vaccine (adsorbed, reduced antigen(s) content) ..... 763
- Pertussis (acellular, component), diphtheria, tetanus, hepatitis B (rDNA), poliomyelitis (inactivated) and haemophilus type b conjugate vaccine (adsorbed) ..... 765
- Pertussis (acellular, component), diphtheria, tetanus, poliomyelitis (inactivated) and haemophilus type b conjugate vaccine (adsorbed) ..... 768
- Pertussis, diphtheria, tetanus and poliomyelitis (inactivated) vaccine (adsorbed) ..... 771
- Pertussis, diphtheria, tetanus, poliomyelitis (inactivated) and haemophilus type b conjugate vaccine (adsorbed) ..... 772
- Pertussis vaccine (acellular), assay of (2.7.16.) ..... 223
- Pertussis vaccine (acellular, component, adsorbed) ..... 806

Pertussis vaccine (acellular, co-purified, adsorbed) .....	808	Plasma (pooled and treated for virus inactivation), human..	2182
Pertussis vaccine, assay of (2.7.7.) .....	213	Plasmid vectors for human use, bacterial cells used for the	
Pertussis vaccine (whole cell, adsorbed) .....	810	manufacture of .....	649
Peru balsam .....	1215	Plasmin inhibitor, assay of human (2.7.25.) .....	230
Pessaries .....	739	Plasters, medicated .....	734
Pessaries and suppositories, disintegration of (2.9.2.) .....	255	Plastic additives (3.1.13.) .....	352
Pesticide residues (2.8.13.) .....	242	Plastic containers and closures for pharmaceutical use	
Pethidine hydrochloride .....	2698	(3.2.2.) .....	368
Pharmaceutical technical procedures (2.9.) .....	253	Plastic containers for aqueous solutions for infusion	
Pharmacognosy, methods in (2.8.) .....	239	(3.2.2.1.) .....	368
Pharmacopoeial harmonisation (5.8.) .....	621	Plastic containers for human blood and blood components,	
Phenazone .....	2699	sterile (3.2.3.) .....	369
Pheniramine maleate .....	2700	Plastic syringes, single-use, sterile (3.2.8.) .....	373
Phenobarbital .....	2702	Pneumococcal polysaccharide conjugate vaccine	
Phenobarbital sodium .....	2702	(adsorbed) .....	812
Phenol .....	2703	Pneumococcal polysaccharide vaccine .....	813
Phenol in immunosera and vaccines (2.5.15.) .....	141	Pneumonia vaccine (inactivated), porcine enzootic .....	927
Phenolphthalein .....	2704	Poliomyelitis (inactivated), diphtheria and tetanus vaccine	
Phenolsulfonphthalein .....	2704	(adsorbed, reduced antigen(s) content) .....	756
Phenothiazines, identification by thin-layer chromatography		Poliomyelitis (inactivated), diphtheria, tetanus and pertussis	
(2.3.3.) .....	110	(acellular, component) vaccine (adsorbed) .....	762
Phenoxyethanol .....	2705	Poliomyelitis (inactivated), diphtheria, tetanus and pertussis	
Phenoxyethylpenicillin .....	2706	(acellular, component) vaccine (adsorbed, reduced antigen(s)	
Phenoxyethylpenicillin potassium .....	2708	content) .....	763
Phentolamine mesilate .....	2709	Poliomyelitis (inactivated), diphtheria, tetanus and pertussis	
Phenylalanine .....	2711	vaccine (adsorbed) .....	771
Phenylbutazone .....	2711	Poliomyelitis (inactivated), diphtheria, tetanus, pertussis	
Phenylbutyrate, sodium .....	2938	(acellular, component) and haemophilus type b conjugate	
Phenylephrine .....	2713	vaccine (adsorbed) .....	768
Phenylephrine hydrochloride .....	2714	Poliomyelitis (inactivated), diphtheria, tetanus, pertussis	
Phenylmercuric acetate .....	2715	(acellular, component), hepatitis B (rDNA) and haemophilus	
Phenylmercuric borate .....	2716	type b conjugate vaccine (adsorbed) .....	765
Phenylmercuric nitrate .....	2716	Poliomyelitis (inactivated), diphtheria, tetanus, pertussis and	
Phenylpropanolamine hydrochloride .....	2717	haemophilus type b conjugate vaccine (adsorbed) .....	772
Phenytoin .....	2718	Poliomyelitis vaccine (inactivated) .....	815
Phenytoin sodium .....	2719	Poliomyelitis vaccine (inactivated), <i>in vivo</i> assay of (2.7.20.) ..	225
Phloroglucinol, anhydrous .....	2720	Poliomyelitis vaccine (oral) .....	818
Phloroglucinol dihydrate .....	2722	Poliomyelitis vaccine (oral), test for neurovirulence (2.6.19.) ..	179
Pholcodine .....	2724	Poloxamers .....	2751
Phosphates (2.4.11.) .....	117	Polyacrylate dispersion 30 per cent .....	2752
Phosphoric acid, concentrated .....	2725	Polyamide 6/6 suture, sterile, in distributor for veterinary use	
Phosphoric acid, dilute .....	2725	.....	1038
Phosphorus in polysaccharide vaccines (2.5.18.) .....	142	Polyamide 6 suture, sterile, in distributor for veterinary use	
pH, potentiometric determination of (2.2.3.) .....	24	.....	1038
Phthalylsulfathiazole .....	2726	Polyethyleneglycols .....	2402
Physical and physicochemical methods (2.2.) .....	21	Polyethylene terephthalate for containers for preparations not	
Physostigmine salicylate .....	2726	for parenteral use (3.1.15.) .....	357
Physostigmine sulfate .....	2727	Poly(ethylene terephthalate) suture, sterile, in distributor for	
Phytomenadione .....	2728	veterinary use .....	1039
Phytosterol .....	2729	Poly(ethylene - vinyl acetate) for containers and tubing for total	
Picosulfate, sodium .....	2939	parenteral nutrition preparations (3.1.7.) .....	345
Picotamide monohydrate .....	2730	Polyethylene with additives for containers for parenteral	
Pilocarpine hydrochloride .....	2731	preparations and for ophthalmic preparations (3.1.5.) .....	338
Pilocarpine nitrate .....	2732	Polyethylene without additives for containers for parenteral	
Pimobendan .....	2734	preparations and for ophthalmic preparations (3.1.4.) .....	337
Pimozide .....	2734	Polymorphism (5.9.) .....	627
Pindolol .....	2736	Polymyxin B sulfate .....	2753
Pine (dwarf) oil .....	1116	Polyolefines (3.1.3.) .....	334
Pine sylvestris oil .....	1216	Polyoxyl castor oil .....	2398
Pinus pinaster type turpentine oil .....	1258	Polyoxyl hydrogenated castor oil .....	2397
Pipemidic acid trihydrate .....	2737	Polypropylene for containers and closures for parenteral	
Piperacillin .....	2738	preparations and ophthalmic preparations (3.1.6.) .....	342
Piperacillin sodium .....	2739	Polysaccharide vaccines, hexosamines in (2.5.20.) .....	142
Piperazine adipate .....	2741	Polysaccharide vaccines, methylpentoses in (2.5.21.) .....	143
Piperazine citrate .....	2742	Polysaccharide vaccines, nucleic acids in (2.5.17.) .....	142
Piperazine hydrate .....	2743	Polysaccharide vaccines, <i>O</i> -acetyl in (2.5.19.) .....	142
Piracetam .....	2743	Polysaccharide vaccines, phosphorus in (2.5.18.) .....	142
Pirenzepine dihydrochloride monohydrate .....	2744	Polysaccharide vaccines, protein in (2.5.16.) .....	141
Piretanide .....	2746	Polysaccharide vaccines, ribose in (2.5.31.) .....	146
Piroxicam .....	2747	Polysaccharide vaccines, sialic acid in (2.5.23.) .....	143
Pivampicillin .....	2748	Polysaccharide vaccines, uronic acids in (2.5.22.) .....	143
Pivmecillinam hydrochloride .....	2750	Polysorbate 20 .....	2754
Plasma for fractionation, human .....	2181	Polysorbate 40 .....	2755

Polysorbate 60 .....	2756	Powder fineness (2.9.35.) .....	308
Polysorbate 80 .....	2756	Powder flow (2.9.36.) .....	308
Polystyrene sulfonate, sodium .....	2940	Powder flow (2.9.36.) (5.8.) .....	622
Poly(vinyl acetate) .....	2758	Powders and granules for oral solutions and suspensions ...	718
Poly(vinyl acetate) dispersion 30 per cent .....	2759	Powders and granules for syrups .....	719
Poly(vinyl alcohol) .....	2760	Powders and tablets for rectal solutions and suspensions .....	733
Poly(vinyl alcohol) macrogol grafted copolymer .....	2401	Powders, bulk density and tapped density of (2.9.34.) .....	305
Poly(vinyl chloride) (non-plasticised) for containers for dry dosage forms for oral administration, materials based on (3.1.11.) .....	350	Powders, ear .....	710
Poly(vinyl chloride), non-plasticised, materials based on for containers for non-injectable aqueous solutions (3.1.10.) .....	349	Powders, effervescent .....	727
Poly(vinyl chloride), plasticised, empty sterile containers of for human blood and blood components (3.2.4.) .....	370	Powders for cutaneous application .....	726
Poly(vinyl chloride), plasticised, materials based on for containers for aqueous solutions for intravenous infusion (3.1.14.) .....	355	Powders for eye drops and powders for eye lotions .....	711
Poly(vinyl chloride), plasticised, materials based on for containers for human blood and blood components (3.1.1.1.) .....	329	Powders for inhalation .....	730
Poly(vinyl chloride), plasticised, materials based on for tubing used in sets for the transfusion of blood and blood components (3.1.1.2.) .....	332	Powders for injections or infusions .....	725
Poly(vinyl chloride), plasticised, sterile containers of for human blood containing anticoagulant solution (3.2.5.) .....	371	Powders for oral drops .....	719
Poppy petals, red .....	1222	Powders, nasal .....	721
Porcine actinobacillosis vaccine (inactivated) .....	926	Powders, oral .....	727
Porcine enzootic pneumonia vaccine (inactivated) .....	927	Powders, wettability of porous solids including (2.9.45.) .....	321
Porcine influenza vaccine (inactivated) .....	929	Pramipexole dihydrochloride monohydrate .....	2779
Porcine insulin .....	2247	Pravastatin sodium .....	2780
Porcine parvovirus vaccine (inactivated) .....	930	Prazepam .....	2782
Porcine progressive atrophic rhinitis vaccine (inactivated) .....	931	Praziquantel .....	2783
Pore-size distribution of solids by mercury porosimetry, porosity and (2.9.32.) .....	299	Prazosin hydrochloride .....	2784
Porosimetry, mercury, porosity and pore-size distribution of solids by (2.9.32.) .....	299	Prednicarbate .....	2785
Porosity and pore-size distribution of solids by mercury porosimetry (2.9.32.) .....	299	Prednisolone .....	2786
Porosity of sintered-glass filters (2.1.2.) .....	15	Prednisolone acetate .....	2787
Porous solids including powders, wettability of (2.9.45.) .....	321	Prednisolone pivalate .....	2789
Potassium (2.4.12.) .....	117	Prednisolone sodium phosphate .....	2790
Potassium acetate .....	2761	Prednisone .....	2791
Potassium bromide .....	2761	Pregelatinised starch .....	2983
Potassium carbonate .....	2762	Prekallikrein activator (2.6.15.) .....	175
Potassium chloride .....	2763	Premixes for medicated feeding stuffs for veterinary use .....	727
Potassium citrate .....	2763	Preparations for inhalation .....	728
Potassium clavulanate .....	2764	Preparations for inhalation: aerodynamic assessment of fine particles (2.9.18.) .....	274
Potassium clavulanate, diluted .....	2766	Preparations for irrigation .....	731
Potassium dihydrogen phosphate .....	2768	Pressurised pharmaceutical preparations .....	732
Potassium hydrogen aspartate hemihydrate .....	2768	Prilocaine .....	2792
Potassium hydrogen carbonate .....	2769	Prilocaine hydrochloride .....	2794
Potassium hydrogen tartrate .....	2769	Primaquine diphosphate .....	2795
Potassium hydroxide .....	2770	Primary aromatic amino-nitrogen, determination of (2.5.8.) ..	139
Potassium iodide .....	2771	Primary standards for volumetric solutions (4.2.1.) .....	494
Potassium metabisulfite .....	2771	Primidone .....	2796
Potassium nitrate .....	2772	Primula root .....	1217
Potassium perchlorate .....	2773	Probenecid .....	2797
Potassium permanganate .....	2773	Procainamide hydrochloride .....	2798
Potassium sodium tartrate tetrahydrate .....	2774	Procaine benzylpenicillin .....	1474
Potassium sorbate .....	2774	Procaine hydrochloride .....	2798
Potassium sulfate .....	2775	Prochlorperazine maleate .....	2799
Potato starch .....	2775	Products of fermentation .....	685
Potentiometric determination of ionic concentration using ion-selective electrodes (2.2.36.) .....	57	Products of recombinant DNA technology .....	692
Potentiometric determination of pH (2.2.3.) .....	24	Products with risk of transmitting agents of animal spongiform encephalopathies .....	686
Potentiometric titration (2.2.20.) .....	34	Progenitor cells, human haematopoietic, colony-forming cell assay for (2.7.28.) .....	232
Potentiation, methods of preparation of homoeopathic stocks and .....	1277	Progesterone .....	2800
Poultices .....	735	Progressive atrophic rhinitis vaccine (inactivated), porcine ..	931
Pour-on preparations .....	740	Proguanil hydrochloride .....	2801
Povidone .....	2776	Proline .....	2802
Povidone, iodinated .....	2778	Promazine hydrochloride .....	2803
Powdered cellulose .....	1638	Promethazine hydrochloride .....	2804
		Propacetamol hydrochloride .....	2805
		Propafenone hydrochloride .....	2806
		Propanol .....	2808
		Propanol and methanol, 2-, test for (2.9.11.) .....	270
		Propantheline bromide .....	2809
		Propofol .....	2810
		Propranolol hydrochloride .....	2811
		Propylene glycol .....	2814
		Propylene glycol dicaprylocaprate .....	2815
		Propylene glycol dilaurate .....	2815
		Propylene glycol monolaurate .....	2816
		Propylene glycol monopalmitostearate .....	2817
		Propylene glycol monostearate .....	2817

- Propyl gallate .....2812
- Propyl parahydroxybenzoate.....2813
- Propyl parahydroxybenzoate, sodium .....2942
- Propylthiouracil .....2818
- Propyphenazone .....2819
- Protamine hydrochloride .....2820
- Protamine sulfate.....2821
- Protein C, human, assay of (2.7.30.) .....234
- Protein in polysaccharide vaccines (2.5.16.).....141
- Protein S, human, assay of (2.7.31.) .....235
- Protein, total (2.5.33.) .....147
- Prothrombin complex, human .....2185
- Protirelin .....2822
- Proxyphylline .....2823
- Pseudoephedrine hydrochloride .....2824
- Psyllium seed .....1217
- Purified water .....3224
- Purified water, highly .....3222
- Purple coneflower herb.....1218
- Purple coneflower root.....1219
- Pycnometric density of solids, gas (2.9.23.) .....288
- Pygeum africanum bark .....1221
- Pyrantel embonate.....2825
- Pyrazinamide .....2826
- Pyridostigmine bromide .....2827
- Pyridoxine hydrochloride.....2827
- Pyrimethamine .....2829
- Pyrogens (2.6.8.) .....161
- Pyrrolidone.....2829
- Q**
- Quality of non-sterile pharmaceutical preparations and substances for pharmaceutical use, microbiological (5.1.4.).....507
- Quality of non-sterile pharmaceutical preparations and substances for pharmaceutical use, microbiological (5.1.4.) (5.8.).....623
- Quantified hawthorn leaf and flower liquid extract .....1150
- Quinidine sulfate .....2833
- Quinine hydrochloride .....2834
- Quinine sulfate .....2835
- R**
- Rabbit haemorrhagic disease vaccine (inactivated) .....933
- Rabies immunoglobulin, human .....2186
- Rabies vaccine for human use prepared in cell cultures.....822
- Rabies vaccine (inactivated) for veterinary use.....934
- Rabies vaccine (live, oral) for foxes .....936
- Racecadotril .....2841
- Racemic camphor .....1571
- Racemic ephedrine hydrochloride .....1928
- Racemic menthol .....2445
- Raclopride (<sup>14</sup>C)methoxy injection .....988
- Radionuclides, table of physical characteristics (5.7.) .....611
- Radiopharmaceutical preparations .....686
- Radiopharmaceutical preparations, iobenguane sulfate for ..982
- Radiopharmaceutical preparations, medronic acid for .....984
- Radiopharmaceutical preparations, pentetate sodium calcium for .....987
- Radiopharmaceutical preparations, tetra-*O*-acetyl-mannose triflate for .....1020
- Raloxifene hydrochloride .....2842
- Raman spectrometry (2.2.48.) .....82
- Ramipril .....2843
- Ramon assay, flocculation value (Lf) of diphtheria and tetanus toxins and toxoids (2.7.27.) .....231
- Ranitidine hydrochloride.....2845
- Rapeseed oil, refined .....2847
- Reagents (4.) .....379
- Reagents (4.1.1.).....379
- Reagents, standard solutions, buffer solutions (4.1.) .....379
- Recombinant DNA technology, products of .....692
- Recommendations on dissolution testing (5.17.1.) .....665
- Recommendations on methods for dosage forms testing (5.17.).....665
- Rectal capsules .....733
- Rectal foams .....733
- Rectal preparations.....732
- Rectal preparations, semi-solid .....733
- Rectal solutions and suspensions, powders and tablets for...732
- Rectal solutions, emulsions and suspensions .....733
- Rectal tampons .....734
- Red poppy petals .....1222
- Reference standards (5.12.) .....641
- Refractive index (2.2.6.) .....26
- Relationship between reaction of solution, approximate pH and colour of certain indicators (2.2.4.) .....25
- Relative density (2.2.5.) .....25
- Repaglinide .....2847
- Reserpine .....2849
- Residual solvents (5.4.) .....583
- Residual solvents, identification and control (2.4.24.) .....123
- Residue on evaporation of essential oils (2.8.9.) .....240
- Resistance to crushing of tablets (2.9.8.) .....267
- Resorcinol .....2850
- Restharrow root .....1223
- Retroviridae-derived vectors for human use .....654
- Rhatany root .....1223
- Rhatany tincture .....1224
- Rhinotracheitis vaccine (inactivated), viral, feline.....901
- Rhinotracheitis vaccine (live), viral, feline .....902
- Rhubarb .....1224
- Ribavirin .....2850
- Riboflavin .....2852
- Riboflavin sodium phosphate.....2853
- Ribose in polysaccharide vaccines (2.5.31.) .....146
- Ribwort plantain .....1225
- Rice starch .....2855
- Rifabutin .....2855
- Rifampicin .....2856
- Rifamycin sodium .....2858
- Rifaximin .....2859
- Rilmnidine dihydrogen phosphate .....2861
- Risperidone .....2861
- Ritonavir .....2863
- Rocuronium bromide .....2866
- Roman chamomile flower .....1098
- Ropivacaine hydrochloride monohydrate.....2868
- Roselle .....1226
- Rosemary leaf .....1227
- Rosemary oil .....1228
- Rotating viscometer method - viscosity (2.2.10.) .....28
- Rotation, optical (2.2.7.) .....26
- Rotavirus vaccine (live, oral) .....824
- Roxithromycin .....2869
- RRR*- $\alpha$ -Tocopherol .....3105
- RRR*- $\alpha$ -Tocopheryl acetate .....3108
- RRR*- $\alpha$ -Tocopheryl hydrogen succinate .....3111
- Rubber closures for containers for aqueous parenteral preparations, for powders and for freeze-dried powders (3.2.9.) .....374
- Rubella immunoglobulin, human.....2187
- Rubella, measles and mumps vaccine (live) .....798
- Rubella, measles, mumps and varicella vaccine (live) .....799
- Rubella vaccine (live) .....827
- Rutoside trihydrate.....2871
- S**
- Saccharin .....2877
- Saccharin sodium .....2878
- Safety, viral (5.1.7.) .....518
- Safflower flower .....1229
- Safflower oil, refined .....2879
- Saffron for homoeopathic preparations.....1296



Sage leaf ( <i>salvia officinalis</i> ).....	1230	Size-exclusion chromatography (2.2.30.).....	46
Sage leaf, three-lobed.....	1231	(S)-Lactic acid.....	2328
Sage oil, Spanish.....	1239	Smallpox vaccine (live).....	829
Sage tincture.....	1231	Sodium acetate ([1- <sup>11</sup> C]) injection.....	990
Salbutamol.....	2879	Sodium acetate trihydrate.....	2908
Salbutamol sulfate.....	2881	Sodium alendronate.....	2908
Salicylic acid.....	2884	Sodium alginate.....	2909
Salmeterol xinafoate.....	2885	Sodium aluminium silicate.....	1361
Salmonella Enteritidis vaccine (inactivated) for chickens.....	937	Sodium amidotrizoate.....	2910
Salmonella Typhimurium vaccine (inactivated) for chickens.....	938	Sodium aminosalicylate dihydrate.....	2911
Salmon oil, farmed.....	2886	Sodium ascorbate.....	2912
Sanguisorba root.....	1232	Sodium aurothiomalate.....	2914
Saponification value (2.5.6.).....	139	Sodium benzoate.....	2915
Saquinavir mesilate.....	2889	Sodium bromide.....	2915
Saw palmetto fruit.....	1233	Sodium calcium edetate.....	2916
Schisandra fruit.....	1234	Sodium calcium pentetate for radiopharmaceutical preparations.....	987
Scopolamine.....	2214	Sodium caprylate.....	2917
Scopolamine butylbromide.....	2215	Sodium carbonate, anhydrous.....	2918
Scopolamine hydrobromide.....	2216	Sodium carbonate decahydrate.....	2919
Selamectin for veterinary use.....	2890	Sodium carbonate monohydrate.....	2919
Selegiline hydrochloride.....	2892	Sodium carboxymethylcellulose.....	1589
Selenium disulfide.....	2893	Sodium carboxymethylcellulose, cross-linked.....	1770
Semi-micro determination of water (2.5.12.).....	140	Sodium carboxymethylcellulose, low-substituted.....	1590
Semi-solid ear preparations.....	710	Sodium cetostearyl sulfate.....	2920
Semi-solid eye preparations.....	712	Sodium chloride.....	2921
Semi-solid intrauterine preparations.....	715	Sodium chromate ( <sup>51</sup> Cr) sterile solution.....	991
Semi-solid nasal preparations.....	721	Sodium citrate.....	2922
Semi-solid oromucosal preparations.....	722	Sodium cromoglicate.....	2923
Semi-solid preparations for cutaneous application.....	734	Sodium cyclamate.....	2924
Semi-solid rectal preparations.....	733	Sodium dihydrogen phosphate dihydrate.....	2925
Semi-solid vaginal preparations.....	740	Sodium ethyl parahydroxybenzoate.....	1974
Senega root.....	1235	Sodium fluoride.....	2925
Senna leaf.....	1236	Sodium fluoride ( <sup>18</sup> F) injection.....	991
Senna leaf dry extract, standardised.....	1237	Sodium fusidate.....	2926
Senna pods, Alexandrian.....	1238	Sodium glycerophosphate, hydrated.....	2927
Senna pods, Tinnevely.....	1238	Sodium hyaluronate.....	2927
Separation techniques, chromatographic (2.2.46.).....	70	Sodium hydrogen carbonate.....	2929
Serine.....	2893	Sodium hydroxide.....	2930
Sertaconazole nitrate.....	2894	Sodium iodide.....	2930
Sertraline hydrochloride.....	2895	Sodium iodide ( <sup>123</sup> I) injection.....	992
Sesame oil, refined.....	2898	Sodium iodide ( <sup>123</sup> I) solution for radiolabelling.....	993
Sets for the transfusion of blood and blood components (3.2.6.).....	371	Sodium iodide ( <sup>131</sup> I) capsules for diagnostic use.....	994
Sevoflurane.....	2899	Sodium iodide ( <sup>131</sup> I) capsules for therapeutic use.....	995
Shampoos.....	717	Sodium iodide ( <sup>131</sup> I) solution.....	996
Shellac.....	2901	Sodium iodide ( <sup>131</sup> I) solution for radiolabelling.....	996
Shingles (herpes zoster) vaccine (live).....	828	Sodium iodohippurate ( <sup>123</sup> I) injection.....	997
Sialic acid in polysaccharide vaccines (2.5.23.).....	143	Sodium iodohippurate ( <sup>131</sup> I) injection.....	998
Siam benzoin tincture.....	1069	Sodium lactate solution.....	2931
Sieves (2.1.4.).....	16	Sodium laurilsulfate.....	2933
Sieve test (2.9.12.).....	270	Sodium metabisulfite.....	2933
Sieving, analytical, particle-size distribution estimation by (2.9.38.).....	313	Sodium methyl parahydroxybenzoate.....	2934
Sieving, analytical, particle-size distribution estimation by (2.9.38.) (5.8.).....	623	Sodium molybdate ( <sup>99</sup> Mo) solution (fission).....	999
SI (International System) units (1.).....	3	Sodium molybdate dihydrate.....	2935
Silica, colloidal anhydrous.....	2901	Sodium nitrite.....	2936
Silica, colloidal hydrated.....	2902	Sodium nitroprusside.....	2936
Silica, dental type.....	2903	Sodium perborate, hydrated.....	2937
Silica, hydrophobic colloidal.....	2903	Sodium pertechnetate ( <sup>99m</sup> Tc) injection (fission).....	1001
Silicate, aluminium magnesium.....	1358	Sodium pertechnetate ( <sup>99m</sup> Tc) injection (non-fission).....	1002
Silicate, aluminium sodium.....	1361	Sodium phenylbutyrate.....	2938
Silicone elastomer for closures and tubing (3.1.9.).....	347	Sodium phosphate ( <sup>32</sup> P) injection.....	1003
Silicone oil used as a lubricant (3.1.8.).....	347	Sodium picosulfate.....	2939
Silk suture, sterile, braided, in distributor for veterinary use.....	1039	Sodium polystyrene sulfonate.....	2940
Silver, colloidal, for external use.....	2904	Sodium propionate.....	2941
Silver nitrate.....	2905	Sodium propyl parahydroxybenzoate.....	2942
Simeticone.....	2905	Sodium salicylate.....	2943
Simvastatin.....	2906	Sodium selenite pentahydrate.....	2944
Single-dose preparations, uniformity of content (2.9.6.).....	266	Sodium (S)-lactate solution.....	2932
Single-dose preparations, uniformity of mass (2.9.5.).....	265	Sodium starch glycolate (type A).....	2944
Sintered-glass filters (2.1.2.).....	15	Sodium starch glycolate (type B).....	2945
		Sodium starch glycolate (type C).....	2946
		Sodium stearate.....	2947
		Sodium stearyl fumarate.....	2948

Sodium sulfate, anhydrous .....	2948	Sprays (liquid nasal) and drops (nasal) .....	720
Sodium sulfate decahydrate .....	2949	Squalane .....	2978
Sodium sulfite, anhydrous .....	2950	Standard solutions for limit tests (4.1.2.) .....	485
Sodium sulfite heptahydrate .....	2950	Standards, reference (5.12.) .....	641
Sodium thiosulfate .....	2951	Stannous chloride dihydrate .....	2980
Sodium valproate .....	2951	Stanozolol .....	2981
Soft capsules .....	708	Star anise .....	1244
Softening time determination of lipophilic suppositories (2.9.22.) .....	288	Star anise oil .....	1245
Soft extracts .....	676	Starches, hydroxyethyl .....	2984
Solid dosage forms, dissolution test for (2.9.3.) .....	256	Starch glycolate (type A), sodium .....	2944
Solid dosage forms, recommendations on dissolution testing of (5.17.1.) .....	665	Starch glycolate (type B), sodium .....	2945
Solids by mercury porosimetry, porosity and pore-size distribution of (2.9.32.) .....	299	Starch glycolate (type C), sodium .....	2946
Solids, density of (2.2.42.) .....	66	Starch, hydroxypropyl .....	2981
Solids, gas pycnometric density of (2.9.23.) .....	288	Starch, maize .....	2422
Solids (porous) including powders, wettability of (2.9.45.) .....	321	Starch, potato .....	2775
Solubility in alcohol of essential oils (2.8.10.) .....	240	Starch, pregelatinised .....	2983
Soluble tablets .....	737	Starch, rice .....	2855
Solutions, emulsions and suspensions, oral .....	718	Starch, wheat .....	3226
Solutions for haemodialysis .....	2136	Starflower (borage) oil, refined .....	1503
Solutions for haemodialysis, concentrated, water for diluting .....	2135	Statistical analysis of results of biological assays and tests (5.3.) .....	551
Solutions for haemofiltration and haemodiafiltration .....	2138	Stavudine .....	2988
Solutions for organ preservation .....	2952	Steam sterilisation of aqueous preparations, application of the $F_0$ concept (5.1.5.) .....	508
Solutions for peritoneal dialysis .....	2695	Stearic acid .....	2989
Solutions, suspensions, intrauterine .....	715	Stearoyl macroglycerides .....	2990
Solvents, residual (5.4.) .....	583	Stearyl alcohol .....	2991
Solvents, residual, identification and control (2.4.24.) .....	123	Stem cells, human haematopoietic .....	2175
Somatostatin .....	2953	Stephania root, fourstamen .....	1127
Somatropin .....	2954	Sterile braided silk suture in distributor for veterinary use ..	1039
Somatropin concentrated solution .....	2956	Sterile catgut .....	1027
Somatropin for injection .....	2958	Sterile catgut in distributor for veterinary use .....	1037
Sorbic acid .....	2960	Sterile containers of plasticised poly(vinyl chloride) for human blood containing anticoagulant solution (3.2.5.) .....	371
Sorbitan laurate .....	2961	Sterile linen thread in distributor for veterinary use .....	1038
Sorbitan oleate .....	2961	Sterile non-absorbable strands in distributor for veterinary use .....	1039
Sorbitan palmitate .....	2962	Sterile non-absorbable sutures .....	1028
Sorbitan sesquioleate .....	2962	Sterile plastic containers for human blood and blood components (3.2.3.) .....	369
Sorbitan stearate .....	2962	Sterile polyamide 6/6 suture in distributor for veterinary use .....	1038
Sorbitan trioleate .....	2963	Sterile polyamide 6 suture in distributor for veterinary use .....	1038
Sorbitol .....	2963	Sterile poly(ethylene terephthalate) suture in distributor for veterinary use .....	1039
Sorbitol, liquid (crystallising) .....	2965	Sterile products, methods of preparation (5.1.1.) .....	503
Sorbitol, liquid (non-crystallising) .....	2965	Sterile single-use plastic syringes (3.2.8.) .....	373
Sorbitol, liquid, partially dehydrated .....	2966	Sterile synthetic absorbable braided sutures .....	1031
Sotalol hydrochloride .....	2967	Sterile synthetic absorbable monofilament sutures .....	1033
Soya-bean oil, hydrogenated .....	2968	Sterilisation procedures, biological indicators (5.1.2.) .....	504
Soya-bean oil, refined .....	2969	Sterility (2.6.1.) .....	153
Spanish sage oil .....	1239	Sterility, guidelines for using the test for (5.1.9.) .....	519
Specific surface area by air permeability (2.9.14.) .....	271	Sterols in fatty oils (2.4.23.) .....	121
Specific surface area by gas adsorption (2.9.26.) .....	291	Sticks .....	736
Specific surface area by gas adsorption (2.9.26.) (5.8.) .....	622	Sticks, intrauterine .....	715
Spectinomycin dihydrochloride pentahydrate .....	2969	Sticks, nasal .....	721
Spectinomycin sulfate tetrahydrate for veterinary use .....	2971	St. John's wort .....	1241
Spectrometry, atomic absorption (2.2.23.) .....	36	St. John's wort dry extract, quantified .....	1242
Spectrometry, atomic emission (2.2.22.) .....	35	Stomata and stomatal index (2.8.3.) .....	239
Spectrometry, mass (2.2.43.) .....	67	Stramonium leaf .....	1247
Spectrometry, nuclear magnetic resonance (2.2.33.) .....	52	Stramonium, prepared .....	1248
Spectrometry, Raman (2.2.48.) .....	82	Strands, sterile non-absorbable, in distributor for veterinary use .....	1039
Spectrometry, X-ray fluorescence (2.2.37.) .....	58	Streptokinase concentrated solution .....	2991
Spectrophotometry, infrared absorption (2.2.24.) .....	38	Streptomycin sulfate .....	2993
Spectrophotometry, near-infrared (2.2.40.) .....	61	Strontium ( $^{89}\text{Sr}$ ) chloride injection .....	1003
Spectrophotometry, ultraviolet and visible absorption (2.2.25.) .....	40	Subdivision of tablets .....	736
SPF chicken flocks for the production and quality control of vaccines (5.2.2.) .....	527	Sublingual sprays, oromucosal drops and oromucosal sprays .....	721
Spheroids and granules, friability of (2.9.41.) .....	318	Sublingual tablets and buccal tablets .....	723
Spike lavender oil .....	1240	Substances for pharmaceutical use .....	694
Spiramycin .....	2973		
Spirapril hydrochloride monohydrate .....	2975		
Spirolactone .....	2976		
Spot-on preparations .....	740		
Sprays .....	740		

Substances for pharmaceutical use, control of impurities in (5.10.)	631	Tablets and capsules, disintegration of (2.9.1.)	253
Substances of animal origin for the production of immunological veterinary medicinal products (5.2.5.)	535	Tablets, buccal	723
Sub-visible particles, particulate contamination (2.9.19.)	285	Tablets, coated	737
Succinylsulfathiazole	2994	Tablets, dispersible	737
Sucralfate	2995	Tablets, effervescent	737
Sucrose	2996	Tablets for intrauterine solutions and suspensions	715
Sucrose monopalmitate	2998	Tablets for use in the mouth	738
Sucrose stearate	2999	Tablets for vaginal solutions and suspensions	739
Sufentanil	3000	Tablets, gastro-resistant	738
Sufentanil citrate	3001	Tablets, intrauterine	715
Sugars, lead in (2.4.10.)	117	Tablets, modified-release	738
Sugar spheres	3002	Tablets, orodispersible	737
Sulbactam sodium	3003	Tablets, resistance to crushing (2.9.8.)	267
Sulfacetamide sodium	3005	Tablets, soluble	737
Sulfadiazine	3006	Tablets, subdivision of	736
Sulfadimidine	3007	Tablets, sublingual	723
Sulfadoxine	3007	Tablets, uncoated	737
Sulfafurazole	3008	Tablets, uncoated, friability of (2.9.7.)	266
Sulfaguanidine	3009	Tablets, uncoated, friability of (2.9.7.) (5.8.)	622
Sulfamerazine	3010	Tablets, vaginal	739
Sulfamethizole	3011	Talc	3033
Sulfamethoxazole	3011	Tamoxifen citrate	3034
Sulfamethoxy-pyridazine for veterinary use	3013	Tampons, ear	710
Sulfanilamide	3013	Tampons, medicated	738
Sulfasalazine	3014	Tampons, rectal	734
Sulfated ash (2.4.14.)	118	Tampons, vaginal, medicated	740
Sulfated ash (2.4.14.) (5.8.)	622	Tamsulosin hydrochloride	3036
Sulfates (2.4.13.)	118	Tannic acid	3037
Sulfathiazole	3016	Tannins in herbal drugs, determination of (2.8.14.)	243
Sulfapyrazone	3017	Tapped density of powders, bulk density and (2.9.34.)	305
Sulfisomidine	3018	Tartaric acid	3038
Sulfur dioxide (2.5.29.)	145	Teat dips	740
Sulfur for external use	3019	Tea tree oil	1251
Sulfuric acid	3019	Teat sprays	741
Sulindac	3020	Technetium ( <sup>99m</sup> Tc) bismate injection	1004
Sulpiride	3021	Technetium ( <sup>99m</sup> Tc) colloidal rhenium sulfide injection	1005
Sultamicillin	3022	Technetium ( <sup>99m</sup> Tc) colloidal sulfur injection	1006
Sultamicillin tosilate dihydrate	3024	Technetium ( <sup>99m</sup> Tc) colloidal tin injection	1006
Sumatra benzoin	1068	Technetium ( <sup>99m</sup> Tc) etifenin injection	1007
Sumatra benzoin tincture	1069	Technetium ( <sup>99m</sup> Tc) exametazime injection	1008
Sumatriptan succinate	3026	Technetium ( <sup>99m</sup> Tc) gluconate injection	1009
Sunflower oil, refined	3028	Technetium ( <sup>99m</sup> Tc) human albumin injection	1010
Supercritical fluid chromatography (2.2.45.)	70	Technetium ( <sup>99m</sup> Tc) macrolalb injection	1011
Suppositories	733	Technetium ( <sup>99m</sup> Tc) mebrofenin injection	1012
Suppositories and pessaries, disintegration of (2.9.2.)	255	Technetium ( <sup>99m</sup> Tc) medronate injection	1013
Suppositories, lipophilic, softening time determination (2.9.22.)	288	Technetium ( <sup>99m</sup> Tc) mertiatide injection	1014
Suspensions, solutions and emulsions, oral	718	Technetium ( <sup>99m</sup> Tc) microspheres injection	1015
Suspensions, solutions, intrauterine	715	Technetium ( <sup>99m</sup> Tc) pentetate injection	1016
Sutures, sterile non-absorbable	1028	Technetium ( <sup>99m</sup> Tc) sestamibi injection	1017
Sutures, sterile synthetic absorbable braided	1031	Technetium ( <sup>99m</sup> Tc) succimer injection	1018
Sutures, sterile synthetic absorbable monofilament	1033	Technetium ( <sup>99m</sup> Tc) tin pyrophosphate injection	1019
Suxamethonium chloride	3028	Teicoplanin	3038
Suxibuzone	3029	Telmisartan	3040
Sweet fennel	1125	Temazepam	3042
Sweet orange oil	1249	Tenosynovitis avian viral vaccine (live)	861
Swelling index (2.8.4.)	239	Tenoxicam	3043
Swine erysipelas vaccine (inactivated)	939	Terazosin hydrochloride dihydrate	3045
Swine-fever vaccine (live, prepared in cell cultures), classical	940	Terbinafine hydrochloride	3047
Symbols and abbreviations (1.)	3	Terbutaline sulfate	3048
Synthetic absorbable braided sutures, sterile	1031	Terconazole	3049
Synthetic absorbable monofilament sutures, sterile	1033	Terfenadine	3050
Syringes, plastic, sterile single-use (3.2.8.)	373	Terminology used in monographs on biological products (5.2.1.)	527
Syrups	719	Test for anticomplementary activity of immunoglobulin (2.6.17.)	177
		Test for anti-D antibodies in human immunoglobulin for intravenous administration (2.6.26.)	191
		Test for aristolochic acids in herbal drugs (2.8.21.)	247
		Test for extractable volume of parenteral preparations (2.9.17.)	273
		Test for extractable volume of parenteral preparations (2.9.17.) (5.8.)	622
		Test for Fc function of immunoglobulin (2.7.9.)	217
<b>T</b>			
Table of physical characteristics of radionuclides mentioned in the European Pharmacopoeia (5.7.)	611		
Tablets	736		

Test for methanol and 2-propanol (2.9.11.)	270	Thiopental sodium and sodium carbonate	3077
Test for neurovirulence of live virus vaccines (2.6.18.)	179	Thioridazine	3078
Test for neurovirulence of poliomyelitis vaccine (oral) (2.6.19.)	179	Thioridazine hydrochloride	3079
Test for specified micro-organisms (microbiological examination of non-sterile products) (2.6.13.)	167	Three-lobed sage leaf	1231
Test for specified micro-organisms (microbiological examination of non-sterile products) (2.6.13.) (5.8.)	622	Threonine	3080
Testosterone	3052	Thyme	1252
Testosterone decanoate	3053	Thyme oil	1254
Testosterone enantate	3054	Thyme, wild	1267
Testosterone isocaproate	3056	Thymol	3081
Testosterone propionate	3057	Tiabendazole	3081
Tests for extraneous agents in viral vaccines for human use (2.6.16.)	176	Tiamulin for veterinary use	3082
Tetanus and diphtheria toxins and toxoids, flocculation value (Lf) of, (Ramon assay) (2.7.27.)	231	Tiamulin hydrogen fumarate for veterinary use	3084
Tetanus and diphtheria vaccine (adsorbed, reduced antigen(s) content)	752	Tianeptine sodium	3086
Tetanus antitoxin for human use	953	Tiapride hydrochloride	3087
Tetanus antitoxin for veterinary use	960	Tiaprofenic acid	3088
Tetanus, diphtheria and hepatitis B (rDNA) vaccine (adsorbed)	753	Tibolone	3090
Tetanus, diphtheria and pertussis (acellular, component) vaccine (adsorbed)	754	Ticarcillin sodium	3091
Tetanus, diphtheria and poliomyelitis (inactivated) vaccine (adsorbed, reduced antigen(s) content)	756	Tick-borne encephalitis vaccine (inactivated)	834
Tetanus, diphtheria, pertussis (acellular, component) and haemophilus type b conjugate vaccine (adsorbed)	758	Ticlopidine hydrochloride	3092
Tetanus, diphtheria, pertussis (acellular, component) and hepatitis B (rDNA) vaccine (adsorbed)	760	Tilidine hydrochloride hemihydrate	3094
Tetanus, diphtheria, pertussis (acellular, component) and poliomyelitis (inactivated) vaccine (adsorbed)	762	Timolol maleate	3095
Tetanus, diphtheria, pertussis (acellular, component) and poliomyelitis (inactivated) vaccine (adsorbed, reduced antigen(s) content)	763	Tinctures	675
Tetanus, diphtheria, pertussis (acellular, component), hepatitis B (rDNA), poliomyelitis (inactivated) and haemophilus type b conjugate vaccine (adsorbed)	765	Tinidazole	3097
Tetanus, diphtheria, pertussis (acellular, component), poliomyelitis (inactivated) and haemophilus type b conjugate vaccine (adsorbed)	768	Tinnevely senna pods	1238
Tetanus, diphtheria, pertussis and poliomyelitis (inactivated) vaccine (adsorbed)	771	Tinzaparin sodium	3098
Tetanus, diphtheria, pertussis, poliomyelitis (inactivated) and haemophilus type b conjugate vaccine (adsorbed)	772	Tioconazole	3099
Tetanus immunoglobulin, human	2187	Tiotropium bromide monohydrate	3100
Tetanus vaccine (adsorbed)	833	Titanium dioxide	3101
Tetanus vaccine (adsorbed), assay of (2.7.8.)	214	Titration, amperometric (2.2.19.)	34
Tetanus vaccine for veterinary use	941	Titration, potentiometric (2.2.20.)	34
Tetracaine hydrochloride	3058	Titrations, complexometric (2.5.11.)	140
Tetracosactide	3059	Tobramycin	3103
Tetracycline	3060	Tocopherol, all- <i>rac</i> - $\alpha$	3104
Tetracycline hydrochloride	3061	Tocopherol, <i>RRR</i> - $\alpha$	3105
Tetra- <i>O</i> -acetyl-mannose triflate for radiopharmaceutical preparations	1020	Tocopheryl acetate, all- <i>rac</i> - $\alpha$	3106
Tetrazepam	3063	$\alpha$ -Tocopheryl acetate concentrate (powder form)	3109
Tetryzoline hydrochloride	3064	Tocopheryl acetate, <i>RRR</i> - $\alpha$	3108
Thallos ( <sup>201</sup> Tl) chloride injection	1021	Tocopheryl hydrogen succinate, DL- $\alpha$	3110
Theobromine	3065	Tocopheryl hydrogen succinate, <i>RRR</i> - $\alpha$	3111
Theophylline	3065	Tolbutamide	3113
Theophylline-ethylenediamine, anhydrous	3068	Tolfenamic acid	3114
Theophylline-ethylenediamine hydrate	3069	Tolnaftate	3115
Theophylline monohydrate	3066	Tolu balsam	1254
Thermal analysis (2.2.34.)	54	Torasemide, anhydrous	3117
Thermogravimetry (2.2.34.)	54	Tormentil	1255
Thiamazole	3071	Tormentil tincture	1256
Thiamine hydrochloride	3072	Tosylchloramide sodium	3118
Thiamine nitrate	3073	Total ash (2.4.16.)	118
Thiamphenicol	3074	Total cholesterol in oils rich in omega-3 acids (2.4.32.)	133
Thin-layer chromatography (2.2.27.)	42	Total organic carbon in water for pharmaceutical use (2.2.44.)	69
Thioctic acid	3075	Total protein (2.5.33.)	147
Thiomersal	3076	Toxicity, abnormal (2.6.9.)	162
		Toxin, botulinum type A for injection	1504
		Tragacanth	1256
		Tramadol hydrochloride	3118
		Tramazoline hydrochloride monohydrate	3120
		Trandolapril	3120
		Tranexamic acid	3122
		Transdermal patches	726
		Transdermal patches, dissolution test for (2.9.4.)	263
		Trapidil	3123
		Trehalose dihydrate	3124
		Tretinoin	3125
		Triacetin	3127
		Triamcinolone	3127
		Triamcinolone acetonide	3128
		Triamcinolone hexacetonide	3130
		Triamterene	3131
		Tribenoside	3132
		Tributyl acetylcitrate	3133
		Trichloroacetic acid	3135
		Triethanolamine	3148

- Triethyl citrate .....3136  
 Trifluoperazine hydrochloride .....3136  
 Triflusal .....3137  
 Triglycerides, medium-chain .....3138  
 Triglycerides, omega-3-acid .....2619  
 Triglycerol diisostearate .....3140  
 Trihexyphenidyl hydrochloride .....3140  
 Trimebutine maleate .....3141  
 Trimetazidine dihydrochloride .....3142  
 Trimethadione .....3144  
 Trimethoprim .....3144  
 Trimipramine maleate .....3146  
 Tri-*n*-butyl phosphate .....3134  
 Tritiated (<sup>3</sup>H) water injection .....1022  
 Trolamine .....3148  
 Trometamol .....3150  
 Tropicamide .....3151  
 Tropisetron hydrochloride .....3152  
 Trospium chloride .....3154  
 Troxerutin .....3155  
 Trypsin .....3156  
 Tryptophan .....3157  
 TSE, animal, minimising the risk of transmitting via human and veterinary medicinal products (5.2.8.) .....539  
 TSE, animal, products with risk of transmitting agents of .....686  
 Tuberculin for human use, old .....3159  
 Tuberculin purified protein derivative, avian .....3161  
 Tuberculin purified protein derivative, bovine .....3161  
 Tuberculin purified protein derivative for human use .....3162  
 Tubes for comparative tests (2.1.5.) .....17  
 Tubing and closures, silicone elastomer for (3.1.9.) .....347  
 Tubing and containers for total parenteral nutrition preparations, poly(ethylene - vinyl acetate) for (3.1.7.) .....345  
 Tubing used in sets for the transfusion of blood and blood components, materials based on plasticised poly(vinyl chloride) for (3.1.1.2.) .....332  
 Tubocurarine chloride .....3164  
 Turmeric, Javanese .....1257  
 Turpentine oil, Pinus pinaster type .....1258  
 Tylosin for veterinary use .....3165  
 Tylosin phosphate bulk solution for veterinary use .....3166  
 Tylosin tartrate for veterinary use .....3168  
 Typhoid polysaccharide vaccine .....836  
 Typhoid vaccine .....837  
 Typhoid vaccine, freeze-dried .....837  
 Typhoid vaccine (live, oral, strain Ty 21a) .....838  
 Tyrosine .....3169  
 Tyrothricin .....3170
- U**
- Ubidecarenone .....3175  
 Udder-washes .....741  
 Ultraviolet and visible absorption spectrophotometry (2.2.25.) .....40  
 Ultraviolet ray lamps for analytical purposes (2.1.3.) .....15  
 Uncoated tablets .....737  
 Undecylenic acid .....3176  
 Uniformity of content of single-dose preparations (2.9.6.) .....266  
 Uniformity of dosage units (2.9.40.) .....315  
 Uniformity of mass of delivered doses from multidose containers (2.9.27.) .....294  
 Uniformity of mass of single-dose preparations (2.9.5.) .....265  
 Units of the International System (SI) used in the Pharmacopoeia and equivalence with other units (1.) .....3  
 Unsaponifiable matter (2.5.7.) .....139  
 Urea .....3176  
 Urofollitropin .....3177  
 Urokinase .....3178  
 Uronic acids in polysaccharide vaccines (2.5.22.) .....143  
 Ursodeoxycholic acid .....3180
- V**
- Vaccines, adsorbed, aluminium in (2.5.13.) .....141  
 Vaccines, adsorbed, calcium in (2.5.14.) .....141  
 Vaccines and immunosera, phenol in (2.5.15.) .....141  
 Vaccines and immunosera, veterinary, evaluation of efficacy of (5.2.7.) .....538  
 Vaccines and immunosera, veterinary, evaluation of safety (5.2.6.) .....536  
 Vaccines and immunosera, veterinary, evaluation of the safety of each batch (5.2.9.) .....547  
 Vaccines for human use .....695  
 Vaccines for human use, cell substrates for the production of (5.2.3.) .....530  
 Vaccines for human use, viral, tests for extraneous agents in (2.6.16.) .....176  
 Vaccines for veterinary use .....698  
 Vaccines, polysaccharide, hexosamines in (2.5.20.) .....142  
 Vaccines, polysaccharide, methylpentoses in (2.5.21.) .....143  
 Vaccines, polysaccharide, nucleic acids in (2.5.17.) .....142  
 Vaccines, polysaccharide, *O*-acetyl in (2.5.19.) .....142  
 Vaccines, polysaccharide, phosphorus in (2.5.18.) .....142  
 Vaccines, polysaccharide, protein in (2.5.16.) .....141  
 Vaccines, polysaccharide, ribose in (2.5.31.) .....146  
 Vaccines, polysaccharide, sialic acid in (2.5.23.) .....143  
 Vaccines, polysaccharide, uronic acids in (2.5.22.) .....143  
 Vaccines, SPF chicken flocks for the production and quality control of (5.2.2.) .....527  
 Vaccines, veterinary, cell cultures for the production of (5.2.4.) .....533  
 Vaccines, viral live, test for neurovirulence (2.6.18.) .....179  
 Vaginal capsules .....739  
 Vaginal foams .....740  
 Vaginal preparations .....738  
 Vaginal preparations, semi-solid .....740  
 Vaginal solutions and suspensions, tablets for .....739  
 Vaginal solutions, emulsions and suspensions .....739  
 Vaginal tablets .....739  
 Vaginal tampons, medicated .....740  
 Valaciclovir hydrochloride, anhydrous .....3185  
 Valerian dry aqueous extract .....1259  
 Valerian dry hydroalcoholic extract .....1260  
 Valerian root .....1261  
 Valerian root, cut .....1262  
 Valerian tincture .....1263  
 Validation of nucleic acid amplification techniques for the detection of B19 virus (B19V) DNA in plasma pools: guidelines .....181  
 Validation of nucleic acid amplification techniques for the detection of hepatitis C virus (HCV) RNA in plasma pools: guidelines .....181  
 Valine .....3188  
 Valnemulin hydrochloride for veterinary use .....3188  
 Valproate, sodium .....2951  
 Valproic acid .....3190  
 Valsartan .....3191  
 Vancomycin hydrochloride .....3192  
 Vanillin .....3194  
 Varicella immunoglobulin for intravenous administration, human .....2189  
 Varicella immunoglobulin, human .....2188  
 Varicella, measles, mumps and rubella vaccine (live) .....799  
 Varicella vaccine (live) .....839  
 Vectors for human use, adenovirus .....650  
 Vectors for human use, plasmid .....648  
 Vectors for human use, plasmid, bacterial cells used for the manufacture of .....649  
 Vectors for human use, poxvirus .....652  
 Vecuronium bromide .....3195  
 Vedaprofen for veterinary use .....3196  
 Vegetable fatty oils .....703  
 Venlafaxine hydrochloride .....3197  
 Verapamil hydrochloride .....3198

- Verbena herb. ....1264  
 Veterinary liquid preparations for cutaneous application ..... 740  
 Veterinary medicinal products, immunological, substances of animal origin for the production of (5.2.5.) .....535  
 Veterinary vaccines and immunosera, evaluation of efficacy of (5.2.7.).....538  
 Viability, nucleated cell count and (2.7.29.) .....233  
 Vibriosis (cold-water) vaccine (inactivated) for salmonids .....943  
 Vibriosis vaccine (inactivated) for salmonids .....944  
 VICH (5.8.) ..... 621  
 Vinblastine sulfate . ....3200  
 Vincristine sulfate .....3201  
 Vindesine sulfate . ....3202  
 Vinorelbine tartrate. ....3204  
 Vinpocetine. ....3206  
 Viper venom antiserum, European .....953  
 Viral rhinotracheitis vaccine (inactivated), feline..... 901  
 Viral rhinotracheitis vaccine (live), feline .....902  
 Viral safety (5.1.7.) . .... 518  
 Viral vaccines for human use, tests for extraneous agents in (2.6.16.) ..... 176  
 Viscometer method, capillary (2.2.9.) ..... 27  
 Viscometer method, falling ball (2.2.49.) ..... 83  
 Viscose wadding, absorbent .....3207  
 Viscosity (2.2.8.) ..... 27  
 Viscosity - rotating viscometer method (2.2.10.) ..... 28  
 Visible and ultraviolet absorption spectrophotometry (2.2.25.) ..... 40  
 Visible particles, particulate contamination (2.9.20.) .....287  
 Vitamin A .....3208  
 Vitamin A concentrate (oily form), synthetic .....3209  
 Vitamin A concentrate (powder form), synthetic ..... 3211  
 Vitamin A concentrate (solubilisate/emulsion), synthetic ...3212  
 Volumetric analysis (4.2.) .....494  
 Volumetric solutions (4.2.2.).....494  
 Volumetric solutions, primary standards for (4.2.1.) .....494  
 von Willebrand factor, human .....2189  
 von Willebrand factor, human, assay of (2.7.21.) .....226
- W**
- Warfarin sodium. ....3217  
 Warfarin sodium clathrate .....3218  
 Washes, nasal. .... 721  
 Water (<sup>15</sup>O) injection.....1023  
 Water, determination by distillation (2.2.13.) .....31  
 Water for diluting concentrated haemodialysis solutions ....2135  
 Water for injections .....3219  
 Water for pharmaceutical use, total organic carbon in (2.2.44.) ..... 69  
 Water, highly purified . ....3222  
 Water in essential oils (2.8.5.) .....239  
 Water in gases (2.5.28.) ..... 145  
 Water: micro determination (2.5.32.) ..... 146  
 Water, purified. ....3224
- Water: semi-micro determination (2.5.12.)..... 140  
 Wettability of porous solids including powders (2.9.45.)..... 321  
 Wheat-germ oil, refined .....3226  
 Wheat-germ oil, virgin. ....3227  
 Wheat starch . ....3226  
 White beeswax .....1453  
 White horehound. ....1265  
 White soft paraffin. ....2670  
 Wild pansy (flowering aerial parts). ....1266  
 Wild thyme . ....1267  
 Willow bark . ....1268  
 Willow bark dry extract. ....1269  
 Wool alcohols. ....3227  
 Wool fat. ....3228  
 Wool fat, hydrogenated. ....3232  
 Wool fat, hydrous. ....3233  
 Wormwood . ....1270
- X**
- Xanthan gum . ....3237  
 Xenon (<sup>133</sup>Xe) injection. ....1023  
 X-ray fluorescence spectrometry (2.2.37.)..... 58  
 X-ray powder diffraction (XRPD), characterisation of crystalline and partially crystalline solids by (2.9.33.) ..... 301  
 Xylazine hydrochloride for veterinary use .....3238  
 Xylitol. ....3239  
 Xylometazoline hydrochloride . ....3241  
 Xylose. ....3242
- Y**
- Yarrow .....1271  
 Yellow beeswax.....1454  
 Yellow fever vaccine (live) .....840  
 Yellow soft paraffin. ....2671  
 Yohimbine hydrochloride. ....3247
- Z**
- Zidovudine .....3251  
 Zinc acetate dihydrate. ....3252  
 Zinc acexamate . ....3253  
 Zinc chloride . ....3254  
 Zinc gluconate . ....3255  
 Zinc oxide. ....3255  
 Zinc stearate. ....3256  
 Zinc sulfate heptahydrate. ....3257  
 Zinc sulfate hexahydrate . ....3257  
 Zinc sulfate monohydrate. ....3257  
 Zinc undecylenate . ....3258  
 Ziprasidone hydrochloride monohydrate .....3258  
 Zolpidem tartrate . ....3260  
 Zopiclone .....3261  
 Zoster (shingles) vaccine (live), herpes . ....828  
 Zuclopenthixol decanoate. ....3263

## Numerics

*α*-1-Proteinasi inhibitor humanum .....2184

## A

<i>Absinthii herba</i> . . . . .	1270
<i>Acaciae gummi</i> . . . . .	1043
<i>Acaciae gummi dispersione desiccatum</i> . . . . .	1301
<i>Acamprosatum calcicum</i> . . . . .	1301
<i>Acarbosum</i> . . . . .	1302
<i>Acebutololi hydrochloridum</i> . . . . .	1304
<i>Aceclofenacum</i> . . . . .	1306
<i>Acemetacinum</i> . . . . .	1307
<i>Acesulfamum kalicum</i> . . . . .	1309
<i>Acetazolamidum</i> . . . . .	1310
<i>Acetonum</i> . . . . .	1312
<i>Acetylcholini chloridum</i> . . . . .	1313
<i>Acetylcysteinum</i> . . . . .	1313
<i>β</i> -Acetyldigoxinum . . . . .	1315
<i>Aciclovirum</i> . . . . .	1321
<i>Acidi methacrylici et ethylis acrylatis polymerisati 1:1</i> <i>dispersto 30 per centum</i> . . . . .	2460
<i>Acidi methacrylici et ethylis acrylatis polymerisatum</i> <i>1:1</i> . . . . .	2459
<i>Acidi methacrylici et methylis methacrylatis polymerisatum</i> <i>1:1</i> . . . . .	2461
<i>Acidi methacrylici et methylis methacrylatis polymerisatum</i> <i>1:2</i> . . . . .	2461
<i>Acidum 4-aminobenzoicum</i> . . . . .	1371
<i>Acidum aceticum glaciale</i> . . . . .	1311
<i>Acidum acetylsalicylicum</i> . . . . .	1317
<i>Acidum adipicum</i> . . . . .	1328
<i>Acidum alginicum</i> . . . . .	1342
<i>Acidum amidotrizoicum dihydricum</i> . . . . .	1366
<i>Acidum aminocaproicum</i> . . . . .	1373
<i>Acidum ascorbicum</i> . . . . .	1418
<i>Acidum asparticum</i> . . . . .	1423
<i>Acidum benzoicum</i> . . . . .	1467
<i>Acidum boricum</i> . . . . .	1504
<i>Acidum caprylicum</i> . . . . .	1571
<i>Acidum chenodeoxycholicum</i> . . . . .	1650
<i>Acidum citricum anhydricum</i> . . . . .	1705
<i>Acidum citricum monohydricum</i> . . . . .	1706
<i>Acidum edeticum</i> . . . . .	1912
<i>Acidum etacrynicum</i> . . . . .	1960
<i>Acidum folicum</i> . . . . .	2065
<i>Acidum fusidicum</i> . . . . .	2079
<i>Acidum glutamicum</i> . . . . .	2105
<i>Acidum hydrochloridum concentratum</i> . . . . .	2192
<i>Acidum hydrochloridum dilutum</i> . . . . .	2192
<i>Acidum iopanoicum</i> . . . . .	2268
<i>Acidum iotalamicum</i> . . . . .	2272
<i>Acidum ioxaglicum</i> . . . . .	2275
<i>Acidum lacticum</i> . . . . .	2328
<i>Acidum lactobionicum</i> . . . . .	2331
<i>Acidum maleicum</i> . . . . .	2424
<i>Acidum malicum</i> . . . . .	2424
<i>Acidum medronicum ad radiopharmaceutica</i> . . . . .	984
<i>Acidum mefenamicum</i> . . . . .	2438
<i>Acidum nalidixicum</i> . . . . .	2547
<i>Acidum nicotinicum</i> . . . . .	2570
<i>Acidum niflumicum</i> . . . . .	2572
<i>Acidum nitricum</i> . . . . .	2581
<i>Acidum oleicum</i> . . . . .	2610
<i>Acidum oxolinicum</i> . . . . .	2642
<i>Acidum palmiticum</i> . . . . .	2660
<i>Acidum phosphoricum concentratum</i> . . . . .	2725
<i>Acidum phosphoricum dilutum</i> . . . . .	2725
<i>Acidum pipemidicum trihydricum</i> . . . . .	2737
<i>Acidum salicylicum</i> . . . . .	2884
<i>Acidum (S)-lacticum</i> . . . . .	2328
<i>Acidum sorbicum</i> . . . . .	2960
<i>Acidum sulfuricum</i> . . . . .	3019
<i>Acidum tartaricum</i> . . . . .	3038
<i>Acidum thiocticum</i> . . . . .	3075
<i>Acidum tiaprofenicum</i> . . . . .	3088
<i>Acidum tolfenamicum</i> . . . . .	3114
<i>Acidum tranexamicum</i> . . . . .	3122
<i>Acidum trichloroaceticum</i> . . . . .	3135
<i>Acidum undecylenicum</i> . . . . .	3176
<i>Acidum ursodeoxycholicum</i> . . . . .	3180
<i>Acidum valproicum</i> . . . . .	3190
<i>Acitretinum</i> . . . . .	1323
<i>Adapalenum</i> . . . . .	1324
<i>Adeninum</i> . . . . .	1326
<i>Adenosinum</i> . . . . .	1327
<i>Adeps lanae</i> . . . . .	3228
<i>Adeps lanae cum aqua</i> . . . . .	3233
<i>Adeps lanae hydrogenatus</i> . . . . .	3232
<i>Adeps solidus</i> . . . . .	2146
<i>Adrenalini tartras</i> . . . . .	1330
<i>Adrenalinum</i> . . . . .	1329
<i>Aer medicinalis</i> . . . . .	1331
<i>Aer medicinalis artificiosus</i> . . . . .	1333
<i>Aether</i> . . . . .	1968
<i>Aether anaestheticus</i> . . . . .	1968
<i>Aetherolea</i> . . . . .	673
<i>Agar</i> . . . . .	1044
<i>Agni casti fructus</i> . . . . .	1044
<i>Agrimoniae herba</i> . . . . .	1046
<i>Alaninum</i> . . . . .	1334
<i>Albendazolum</i> . . . . .	1335
<i>Albumini humani solutio</i> . . . . .	2165
<i>Alchemillae herba</i> . . . . .	1047
<i>Alcohol benzylicus</i> . . . . .	1469
<i>Alcohol cetylicus</i> . . . . .	1647
<i>Alcohol cetylicus et stearylicus</i> . . . . .	1643
<i>Alcohol cetylicus et stearylicus emulsificans A</i> . . . . .	1643
<i>Alcohol cetylicus et stearylicus emulsificans B</i> . . . . .	1645
<i>Alcholes adipis lanae</i> . . . . .	3227
<i>Alcohol isopropylicus</i> . . . . .	2287
<i>Alcohol oleicus</i> . . . . .	2611
<i>Alcohol stearylicus</i> . . . . .	2991
<i>Alcuronii chloridum</i> . . . . .	1336
<i>Alfacalcidolum</i> . . . . .	1337
<i>Alfadexum</i> . . . . .	1338
<i>Alfentanili hydrochloridum</i> . . . . .	1339
<i>Alfuzosini hydrochloridum</i> . . . . .	1341
<i>Allantoinum</i> . . . . .	1342
<i>Allii sativi bulbi pulvis</i> . . . . .	1133
<i>Allium sativum ad praeparationes homoeopathicas</i> . . . . .	1290
<i>Allopurinolum</i> . . . . .	1343
<i>Almagatum</i> . . . . .	1345
<i>Aloe barbadensis</i> . . . . .	1047
<i>Aloe capensis</i> . . . . .	1048
<i>Aloes extractum siccum normatum</i> . . . . .	1049
<i>Alprazolamum</i> . . . . .	1347
<i>Alprenololi hydrochloridum</i> . . . . .	1349
<i>Alprostadilum</i> . . . . .	1350
<i>Alteplasmum ad iniectabile</i> . . . . .	1352
<i>Althaeae folium</i> . . . . .	1176
<i>Althaeae radix</i> . . . . .	1177
<i>Altizidum</i> . . . . .	1356
<i>Alumen</i> . . . . .	1357
<i>Aluminii chloridum hexahydricum</i> . . . . .	1357
<i>Aluminii hydroxidum hydricum ad adsorptionem</i> . . . . .	1357
<i>Aluminii magnesii silicas</i> . . . . .	1358
<i>Aluminii natrii silicas</i> . . . . .	1361
<i>Aluminii oxidum hydricum</i> . . . . .	1359
<i>Aluminii phosphas hydricus</i> . . . . .	1361
<i>Aluminii phosphatis liquamen</i> . . . . .	1360
<i>Aluminii sulfas</i> . . . . .	1362
<i>Alverini citras</i> . . . . .	1363
<i>Amantadini hydrochloridum</i> . . . . .	1364
<i>Ambroxoli hydrochloridum</i> . . . . .	1365

<i>Amfetamini sulfas</i> .....	1366	<i>Aurantii dulcis aetheroleum</i> .....	1249
<i>Amikacini sulfas</i> .....	1369	<i>Auricularia</i> .....	709
<i>Amikacinum</i> .....	1367	<i>Azaperonum ad usum veterinarium</i> .....	1430
<i>Amiloridi hydrochloridum</i> .....	1370	<i>Azathioprinum</i> .....	1431
<i>Aminoglutethimidum</i> .....	1373	<i>Azelastini hydrochloridum</i> .....	1433
<i>Amiodaroni hydrochloridum</i> .....	1375	<i>Azithromycinum</i> .....	1434
<i>Amisulpridum</i> .....	1376		
<i>Amitriptylini hydrochloridum</i> .....	1377	<b>B</b>	
<i>Amlodipini besilas</i> .....	1379	<i>Bacampicillini hydrochloridum</i> .....	1439
<i>Ammoniae (<sup>15</sup>N) solutio iniectionis</i> .....	965	<i>Bacitracinum</i> .....	1440
<i>Ammoniae solutio concentrata</i> .....	1380	<i>Bacitracinum zincum</i> .....	1443
<i>Ammonii bromidum</i> .....	1382	<i>Baclofenum</i> .....	1445
<i>Ammonii chloridum</i> .....	1383	<i>Ballotae nigrae herba</i> .....	1079
<i>Ammonii glycyrrhizas</i> .....	1384	<i>Balsamum peruvianum</i> .....	1215
<i>Ammonii hydrogenocarbonas</i> .....	1385	<i>Balsamum toltutanum</i> .....	1254
<i>Ammonio methacrylatis copolymerum A</i> .....	1381	<i>Bambuteroli hydrochloridum</i> .....	1446
<i>Ammonio methacrylatis copolymerum B</i> .....	1382	<i>Barbitalum</i> .....	1447
<i>Amobarbitalum</i> .....	1385	<i>Barii chloridum dihydricum ad praeparationes</i> <i>homoeopathicas</i> .....	1287
<i>Amobarbitalum natricum</i> .....	1386	<i>Barii sulfas</i> .....	1448
<i>Amoxicillinum natricum</i> .....	1386	<i>BCG ad immunocurationem</i> .....	746
<i>Amoxicillinum trihydricum</i> .....	1389	<i>Beclometasoni dipropionas anhydricus</i> .....	1449
<i>Amphotericinum B</i> .....	1391	<i>Beclometasoni dipropionas monohydricus</i> .....	1451
<i>Ampicillinum anhydricum</i> .....	1393	<i>Belladonnae folii extractum siccum normatum</i> .....	1064
<i>Ampicillinum natricum</i> .....	1395	<i>Belladonnae folii tinctura normata</i> .....	1065
<i>Ampicillinum trihydricum</i> .....	1397	<i>Belladonnae folium</i> .....	1062
<i>Amygdalae oleum raffinatum</i> .....	1346	<i>Belladonnae pulvis normatus</i> .....	1066
<i>Amygdalae oleum virginale</i> .....	1347	<i>Benazeprili hydrochloridum</i> .....	1454
<i>Amyla hydroxyethyla</i> .....	2984	<i>Bendroflumethiazidum</i> .....	1456
<i>Amylmetacresolum</i> .....	1399	<i>Benfluorexi hydrochloridum</i> .....	1457
<i>Amylum hydroxypropylum</i> .....	2981	<i>Benperidolum</i> .....	1458
<i>Amylum pregelificatum</i> .....	2983	<i>Benserazidi hydrochloridum</i> .....	1459
<i>Angelicae radix</i> .....	1049	<i>Bentonitum</i> .....	1460
<i>Anisi aetheroleum</i> .....	1050	<i>Benzalkonii chloridi solutio</i> .....	1463
<i>Anisi fructus</i> .....	1052	<i>Benzalkonii chloridum</i> .....	1461
<i>Anisi stellati aetheroleum</i> .....	1245	<i>Benzbromaronum</i> .....	1465
<i>Anisi stellati fructus</i> .....	1244	<i>Benzethonii chloridum</i> .....	1466
<i>Antazolini hydrochloridum</i> .....	1401	<i>Benzocainum</i> .....	1466
<i>Anticorpora monoclonalia ad usum humanum</i> .....	682	<i>Benzoe sumatranus</i> .....	1068
<i>Antithrombinum III humanum densatum</i> .....	2168	<i>Benzoe tonkinensis</i> .....	1067
<i>Apis mellifera ad praeparationes homoeopathicas</i> .....	1292	<i>Benzois sumatrani tinctura</i> .....	1069
<i>Apomorphini hydrochloridum</i> .....	1407	<i>Benzois tonkinensis tinctura</i> .....	1069
<i>Aprotinini solutio concentrata</i> .....	1411	<i>Benzoylis peroxidum cum aqua</i> .....	1468
<i>Aprotininum</i> .....	1408	<i>Benzylis benzoas</i> .....	1470
<i>Aqua ad dilutionem solutionum concentratarum ad</i> <i>haemodialysim</i> .....	2135	<i>Benzylpenicillinum benzathinum</i> .....	1471
<i>Aqua ad iniectionabile</i> .....	3219	<i>Benzylpenicillinum kalicum</i> .....	1473
<i>Aquae (<sup>15</sup>O) solutio iniectionis</i> .....	1023	<i>Benzylpenicillinum natricum</i> .....	1476
<i>Aquae trititatae (<sup>3</sup>H) solutio iniectionis</i> .....	1022	<i>Benzylpenicillinum procainum</i> .....	1474
<i>Aqua purificata</i> .....	3224	<i>Betacarotenum</i> .....	1477
<i>Aqua valde purificata</i> .....	3222	<i>Betadexum</i> .....	1478
<i>Arachidis oleum hydrogenatum</i> .....	1413	<i>Betahistini dihydrochloridum</i> .....	1479
<i>Arachidis oleum raffinatum</i> .....	1413	<i>Betahistini mesilas</i> .....	1480
<i>Argenti nitras</i> .....	2905	<i>Betamethasoni acetas</i> .....	1483
<i>Argentum colloidal ad usum externum</i> .....	2904	<i>Betamethasoni dipropionas</i> .....	1485
<i>Arginini aspartas</i> .....	1415	<i>Betamethasoni natrii phosphas</i> .....	1486
<i>Arginini hydrochloridum</i> .....	1415	<i>Betamethasoni valeras</i> .....	1488
<i>Argininum</i> .....	1414	<i>Betamethasonum</i> .....	1481
<i>Argon</i> .....	1416	<i>Betaxololi hydrochloridum</i> .....	1489
<i>Arnicae flos</i> .....	1053	<i>Betulae folium</i> .....	1071
<i>Arnicae tinctura</i> .....	1055	<i>Bezafibratum</i> .....	1490
<i>Arsenii trioxidum ad praeparationes homoeopathicas</i> .....	1286	<i>Bifonazolum</i> .....	1491
<i>Articaini hydrochloridum</i> .....	1417	<i>Biotinum</i> .....	1492
<i>Ascorbylis palmitas</i> .....	1420	<i>Biperideni hydrochloridum</i> .....	1493
<i>Asparaginum monohydricum</i> .....	1421	<i>Bisacodylum</i> .....	1495
<i>Aspartamum</i> .....	1421	<i>Bismuthi subcarbonas</i> .....	1496
<i>Astragali mongholicus radix</i> .....	1060	<i>Bismuthi subgallas</i> .....	1497
<i>Atenololum</i> .....	1424	<i>Bismuthi subnitras ponderosus</i> .....	1498
<i>Atracurii besilas</i> .....	1425	<i>Bismuthi subsalicylas</i> .....	1498
<i>Atropini sulfas</i> .....	1429	<i>Bisoprololi fumaras</i> .....	1499
<i>Atropinum</i> .....	1427	<i>Bistortae rhizoma</i> .....	1072
<i>Aurantii amari epicarpium et mesocarpium tinctura</i> .....	1078	<i>Bleomycini sulfas</i> .....	1502
<i>Aurantii amari epicarpium et mesocarpium</i> .....	1077	<i>Boldi folii extractum siccum</i> .....	1083
<i>Aurantii amari flos</i> .....	1078		



<i>Boldi folium</i> .....	1081	<i>Carbocisteinum</i> .....	1581
<i>Boragonis officinalis oleum raffinatum</i> .....	1503	<i>Carbomera</i> .....	1581
<i>Borax</i> .....	1503	<i>Carbonei dioxidum</i> .....	1583
<i>Bromazepamum</i> .....	1507	<i>Carbonei monoxidum</i> .....	1584
<i>Bromhexini hydrochloridum</i> .....	1508	<i>Carbonei monoxidum (<sup>15</sup>O)</i> .....	965
<i>Bromocriptini mesilas</i> .....	1509	<i>Carboplatinum</i> .....	1585
<i>Bromperidoli decanoas</i> .....	1512	<i>Carboprostum trometamolom</i> .....	1586
<i>Bromperidolum</i> .....	1511	<i>Carboxymethylamylum natricum A</i> .....	2944
<i>Brompheniraminini maleas</i> .....	1514	<i>Carboxymethylamylum natricum B</i> .....	2945
<i>Brotizolamum</i> .....	1515	<i>Carboxymethylamylum natricum C</i> .....	2946
<i>Budesonidum</i> .....	1516	<i>Carisoprodolum</i> .....	1587
<i>Bufexamacum</i> .....	1518	<i>Carmellosum</i> .....	1588
<i>Buflomedili hydrochloridum</i> .....	1519	<i>Carmellosum calcicum</i> .....	1589
<i>Bumetanidum</i> .....	1520	<i>Carmellosum natricum</i> .....	1589
<i>Bupivacaini hydrochloridum</i> .....	1521	<i>Carmellosum natricum conexum</i> .....	1770
<i>Buprenorphini hydrochloridum</i> .....	1524	<i>Carmellosum natricum substitutum humile</i> .....	1590
<i>Buprenorphinum</i> .....	1523	<i>Carmustinum</i> .....	1591
<i>Buserelinum</i> .....	1526	<i>Carprofenum ad usum veterinarium</i> .....	1592
<i>Buspironi hydrochloridum</i> .....	1527	<i>Carrageenanum</i> .....	1593
<i>Busulfanum</i> .....	1529	<i>Carteololi hydrochloridum</i> .....	1594
<i>Butylhydroxyanisolum</i> .....	1531	<i>Carthami flos</i> .....	1229
<i>Butylhydroxytoluenum</i> .....	1531	<i>Carthami oleum raffinatum</i> .....	2879
<i>Butylis parahydroxybenzoas</i> .....	1530	<i>Carvedilolum</i> .....	1595
<b>C</b>		<i>Carvi aetheroleum</i> .....	1091
<i>Cabergolinum</i> .....	1535	<i>Carvi fructus</i> .....	1090
<i>Cadmii sulfas hydricus</i>		<i>Caryophylli floris aetheroleum</i> .....	1106
<i>ad praeparationes homoeopathicas</i> .....	1287	<i>Caryophylli flos</i> .....	1105
<i>Calcifediolum</i> .....	1538	<i>Cefaclorum</i> .....	1599
<i>Calcii acetat anhydricus</i> .....	1547	<i>Cefadroxilum monohydricum</i> .....	1600
<i>Calcii ascorbas</i> .....	1548	<i>Cefalexinum monohydricum</i> .....	1602
<i>Calcii carbonas</i> .....	1549	<i>Cefalotinum natricum</i> .....	1603
<i>Calcii chloridum dihydricum</i> .....	1550	<i>Cefamandoli nafas</i> .....	1605
<i>Calcii chloridum hexahydricum</i> .....	1550	<i>Cefapirinum natricum</i> .....	1606
<i>Calcii dobesilas monohydricus</i> .....	1551	<i>Cefatrizinum propylen glycolom</i> .....	1607
<i>Calcii folinas</i> .....	1552	<i>Cefazolinum natricum</i> .....	1608
<i>Calcii glucoheptonas</i> .....	1554	<i>Cefepimi dihydrochloridum monohydricum</i> .....	1610
<i>Calcii gluconas</i> .....	1555	<i>Cefiximum</i> .....	1612
<i>Calcii gluconas ad iniectionabile</i> .....	1556	<i>Cefoperazonum natricum</i> .....	1613
<i>Calcii gluconas anhydricus</i> .....	1555	<i>Cefotaximum natricum</i> .....	1615
<i>Calcii glycerophosphas</i> .....	1557	<i>Cefoxitinum natricum</i> .....	1617
<i>Calcii hydrogenophosphas anhydricus</i> .....	1558	<i>Cefpodoximum proxetili</i> .....	1618
<i>Calcii hydrogenophosphas dihydricus</i> .....	1559	<i>Cefradinum</i> .....	1620
<i>Calcii hydroxidum</i> .....	1560	<i>Ceftazidinum pentahydricum</i> .....	1622
<i>Calcii iodidum tetrahydricum ad praeparationes</i>		<i>Ceftazidimum pentahydricum et natrii carbonas ad</i>	
<i>homoeopathicas</i> .....	1288	<i>iniectionabile</i> .....	1624
<i>Calcii lactas anhydricus</i> .....	1561	<i>Ceftriaxonum natricum</i> .....	1626
<i>Calcii lactas monohydricus</i> .....	1561	<i>Cefuroximum axetili</i> .....	1627
<i>Calcii lactas pentahydricus</i> .....	1562	<i>Cefuroximum natricum</i> .....	1629
<i>Calcii lactas trihydricus</i> .....	1562	<i>Celiprololi hydrochloridum</i> .....	1630
<i>Calcii laevulinas dihydricus</i> .....	1565	<i>Cellulae stirpes haematopoieticae humanae</i> .....	2175
<i>Calcii levofolinas pentahydricus</i> .....	1563	<i>Cellulosi acetat</i> .....	1631
<i>Calcii pantothenas</i> .....	1566	<i>Cellulosi acetat butyras</i> .....	1632
<i>Calcii stearas</i> .....	1567	<i>Cellulosi acetat phthalas</i> .....	1633
<i>Calcii sulfas dihydricus</i> .....	1569	<i>Cellulosi pulvis</i> .....	1638
<i>Calcipotriolum anhydricum</i> .....	1539	<i>Cellulosum microcrystallinum</i> .....	1634
<i>Calcipotriolum monohydricum</i> .....	1542	<i>Cellulosum microcrystallinum et carmellosum natricum</i> .....	2507
<i>Calcitoninum salmonis</i> .....	1544	<i>Centaurii herba</i> .....	1095
<i>Calcitriolum</i> .....	1546	<i>Centellae asiaticae herba</i> .....	1096
<i>Calendulae flos</i> .....	1086	<i>Cera alba</i> .....	1453
<i>Camphora racemica</i> .....	1571	<i>Cera carnauba</i> .....	1592
<i>Capsici fructus</i> .....	1087	<i>Cera flava</i> .....	1454
<i>Capsici oleoresina raffinata et quantificata</i> .....	1089	<i>Cetirizini dihydrochloridum</i> .....	1641
<i>Capsici tinctura normata</i> .....	1090	<i>Cetobemidoni hydrochloridum</i> .....	2316
<i>Capsulae</i> .....	707	<i>Cetostearyl isononanoas</i> .....	1646
<i>Captoprilum</i> .....	1573	<i>Cetrimidum</i> .....	1646
<i>Carbacholum</i> .....	1575	<i>Cetyl palmitas</i> .....	1648
<i>Carbamazepinum</i> .....	1576	<i>Cetylpyridinii chloridum</i> .....	1648
<i>Carbasalatum calcicum</i> .....	1577	<i>Chamomillae romanae flos</i> .....	1098
<i>Carbidopum</i> .....	1579	<i>Chelidonii herba</i> .....	1145
<i>Carbimazolom</i> .....	1580	<i>Chinidini sulfas</i> .....	2833
<i>Carbo activatus</i> .....	1649	<i>Chinini hydrochloridum</i> .....	2834
		<i>Chinini sulfas</i> .....	2835
		<i>Chitosani hydrochloridum</i> .....	1651

<i>Chlorali hydras</i> .....	1652	<i>Clomipramini hydrochloridum</i> .....	1727
<i>Chlorambucilum</i> .....	1653	<i>Clonazepamum</i> .....	1729
<i>Chloramphenicoli natrii succinas</i> .....	1655	<i>Clonidini hydrochloridum</i> .....	1730
<i>Chloramphenicoli palmitas</i> .....	1654	<i>Clopidium</i> .....	1731
<i>Chloramphenicolium</i> .....	1653	<i>Closantelum natricum dihydricum</i> <i>ad usum veterinarium</i> .....	1732
<i>Chlorcyclizini hydrochloridum</i> .....	1656	<i>Clotrimazolum</i> .....	1734
<i>Chlordiazepoxidi hydrochloridum</i> .....	1658	<i>Cloxacillinum natricum</i> .....	1735
<i>Chlordiazepoxidum</i> .....	1657	<i>Clozapinum</i> .....	1737
<i>Chlorhexidini diacetat</i> .....	1659	<i>Cocaini hydrochloridum</i> .....	1738
<i>Chlorhexidini digluconatis solutio</i> .....	1660	<i>Cocois oleum raffinatum</i> .....	1739
<i>Chlorhexidini dihydrochloridum</i> .....	1662	<i>Cocoylis caprylocapras</i> .....	1740
<i>Chlorobutanolum anhydricum</i> .....	1663	<i>Codeini hydrochloridum dihydricum</i> .....	1742
<i>Chlorobutanolum hemihydricum</i> .....	1663	<i>Codeini phosphas hemihydricus</i> .....	1743
<i>Chlorocresolum</i> .....	1664	<i>Codeini phosphas sesquihydricus</i> .....	1745
<i>Chloroquini phosphas</i> .....	1665	<i>Codeinum</i> .....	1740
<i>Chloroquini sulfas</i> .....	1665	<i>Codergocrini mesilas</i> .....	1747
<i>Chlorothiazidum</i> .....	1666	<i>Coffeinum</i> .....	1536
<i>Chlorphenamini maleas</i> .....	1667	<i>Coffeinum monohydricum</i> .....	1537
<i>Chlorpromazini hydrochloridum</i> .....	1668	<i>Colae semen</i> .....	1107
<i>Chlorpropamidum</i> .....	1669	<i>Colchicinum</i> .....	1759
<i>Chlorprothixeni hydrochloridum</i> .....	1670	<i>Colestyraminum</i> .....	1761
<i>Chlortalidonum</i> .....	1671	<i>Colistimethatum natricum</i> .....	1762
<i>Chlortetracyclini hydrochloridum</i> .....	1673	<i>Colistini sulfas</i> .....	1763
<i>Cholecalciferoli pulvis</i> .....	1677	<i>Colophonium</i> .....	1107
<i>Cholecalciferolum</i> .....	1674	<i>Compressi</i> .....	736
<i>Cholecalciferolum densatum oleosum</i> .....	1675	<i>Copolymerum macrogolo et alcoholi poly(vinyllico)</i> <i>constatum</i> .....	2401
<i>Cholecalciferolum in aqua dispergibile</i> .....	1678	<i>Copolymerum methacrylatis butylati basicum</i> .....	1448
<i>Cholesterolum</i> .....	1680	<i>Copovidonum</i> .....	1764
<i>Chondroitini natrii sulfas</i> .....	1681	<i>Coriandri aetheroleum</i> .....	1108
<i>Chorda resorbilis sterilis</i> .....	1027	<i>Coriandri fructus</i> .....	1108
<i>Chorda resorbilis sterilis in fuso ad usum veterinarium</i> ...	1037	<i>Corpora ad usum pharmaceuticum</i> .....	694
<i>Chromii (<sup>67</sup>Cr) edetatis solutio iniectabilis</i> .....	966	<i>Cortisoni acetat</i> .....	1767
<i>Chymotrypsinum</i> .....	1683	<i>Crataegi folii cum flore</i> <i>extractum fluidum quantificatum</i> .....	1150
<i>Ciclopirox olaminum</i> .....	1686	<i>Crataegi folii cum flore extractum siccum</i> .....	1149
<i>Ciclopiroxum</i> .....	1684	<i>Crataegi folium cum flore</i> .....	1148
<i>Ciclosporinum</i> .....	1687	<i>Crataegi fructus</i> .....	1147
<i>Cilastatinum natricum</i> .....	1688	<i>Cresolum crudum</i> .....	1770
<i>Cilazaprilum</i> .....	1690	<i>Croci stigma ad praeparationes homoeopathicas</i> .....	1296
<i>Cimetidini hydrochloridum</i> .....	1693	<i>Crospovidonum</i> .....	1771
<i>Cimetidinum</i> .....	1691	<i>Crotamitonum</i> .....	1773
<i>Cinchocaini hydrochloridum</i> .....	1694	<i>Cupri acetat monohydricus ad praeparationes</i> <i>homoeopathicas</i> .....	1289
<i>Cinchonae cortex</i> .....	1098	<i>Cupri sulfas anhydricus</i> .....	1766
<i>Cinchonae extractum fluidum normatum</i> .....	1100	<i>Cupri sulfas pentahydricus</i> .....	1766
<i>Cineolum</i> .....	1695	<i>Cuprum ad praeparationes homoeopathicas</i> .....	1289
<i>Cinnamomi cassiae aetheroleum</i> .....	1095	<i>Curcumae xanthorrhizae rhizoma</i> .....	1257
<i>Cinnamomi cortex</i> .....	1101	<i>Cyamopsidis seminis pulvis</i> .....	1146
<i>Cinnamomi corticis tinctura</i> .....	1103	<i>Cyanocobalamini (<sup>67</sup>Co) capsulae</i> .....	967
<i>Cinnamomi zeylanici folii aetheroleum</i> .....	1102	<i>Cyanocobalamini (<sup>67</sup>Co) solutio</i> .....	968
<i>Cinnamomi zeylanicii corticis aetheroleum</i> .....	1101	<i>Cyanocobalamini (<sup>68</sup>Co) capsulae</i> .....	968
<i>Cinnarizinum</i> .....	1696	<i>Cyanocobalamini (<sup>68</sup>Co) solutio</i> .....	969
<i>Ciprofibratum</i> .....	1697	<i>Cyanocobalaminum</i> .....	1774
<i>Ciprofloxacini hydrochloridum</i> .....	1700	<i>Cyclizini hydrochloridum</i> .....	1775
<i>Ciprofloxacinum</i> .....	1698	<i>Cyclopentolati hydrochloridum</i> .....	1776
<i>Cisplatinum</i> .....	1701	<i>Cyclophosphamidum</i> .....	1777
<i>Citaloprami hydrobromidum</i> .....	1703	<i>Cynarae folii extractum siccum</i> .....	1058
<i>Citaloprami hydrochloridum</i> .....	1704	<i>Cynarae folium</i> .....	1056
<i>Citri reticulatae aetheroleum</i> .....	1175	<i>Cyproheptadini hydrochloridum</i> .....	1778
<i>Citronellae aetheroleum</i> .....	1103	<i>Cyproteroni acetat</i> .....	1779
<i>Cladribinum</i> .....	1707	<i>Cysteiini hydrochloridum monohydricum</i> .....	1781
<i>Clarithromycinum</i> .....	1708	<i>Cystinum</i> .....	1782
<i>Clazurilum ad usum veterinarium</i> .....	1710	<i>Cytarabinum</i> .....	1783
<i>Clebopridi malas</i> .....	1712	<b>D</b>	
<i>Clemastini fumaras</i> .....	1713	<i>Dacarbazinum</i> .....	1787
<i>Clenbuteroli hydrochloridum</i> .....	1715	<i>Dalteparinum natricum</i> .....	1788
<i>Clindamycini hydrochloridum</i> .....	1716	<i>Danaparoidum natricum</i> .....	1789
<i>Clindamycini phosphas</i> .....	1717	<i>Dapsonum</i> .....	1792
<i>Clioquinolum</i> .....	1718	<i>Daunorubicini hydrochloridum</i> .....	1792
<i>Clobazamum</i> .....	1719		
<i>Clobetasoli propionas</i> .....	1720		
<i>Clobetasoni butyras</i> .....	1722		
<i>Clofaziminum</i> .....	1724		
<i>Clofibratum</i> .....	1725		
<i>Clomifeni citras</i> .....	1726		

<i>D-Camphora</i> .....	1569	<i>Dinitrogenii oxidum</i> .....	2585
<i>Decylis oleas</i> .....	1794	<i>Dinoprostonum</i> .....	1863
<i>Deferoxamini mesilas</i> .....	1794	<i>Dinoprostum trometamolom</i> .....	1862
<i>Dembrexini hydrochloridum monohydricum ad usum veterinarium</i> .....	1795	<i>Diosminum</i> .....	1864
<i>Demeclocyclini hydrochloridum</i> .....	1796	<i>Diphenhydramini hydrochloridum</i> .....	1866
<i>Deptropini citras</i> .....	1797	<i>Diphenoxylati hydrochloridum</i> .....	1867
<i>Dequalinii chloridum</i> .....	1798	<i>Dipivefrini hydrochloridum</i> .....	1867
<i>Desfluranum</i> .....	1800	<i>Diprophyllinum</i> .....	1870
<i>Desipramini hydrochloridum</i> .....	1801	<i>Dipyridamolom</i> .....	1871
<i>Deslanosidum</i> .....	1802	<i>Dirithromycinum</i> .....	1872
<i>Desmopressinum</i> .....	1803	<i>Disopyramidi phosphas</i> .....	1877
<i>Desogestrelum</i> .....	1804	<i>Disopyramidum</i> .....	1876
<i>Desoxycortoni acetat</i> .....	1805	<i>Disulfiramum</i> .....	1878
<i>Detomidini hydrochloridum ad usum veterinarium</i> .....	1806	<i>Dithranolum</i> .....	1879
<i>Dexamethasoni acetat</i> .....	1809	<i>DL-Methioninum</i> .....	2466
<i>Dexamethasoni isonicotinas</i> .....	1811	<i>DL-<math>\alpha</math>-Tocopherylis hydrogenosuccinas</i> .....	3110
<i>Dexamethasoni natrii phosphas</i> .....	1812	<i>Dobutamini hydrochloridum</i> .....	1880
<i>Dexamethasonum</i> .....	1807	<i>Docetaxelum trihydricum</i> .....	1881
<i>Dexchlorpheniraminini maleas</i> .....	1814	<i>Dodecylis gallas</i> .....	1884
<i>Dexpanthenolum</i> .....	1815	<i>Domperidoni maleas</i> .....	1886
<i>Dextranomerum</i> .....	1819	<i>Domperidonum</i> .....	1885
<i>Dextranum 1 ad iniectabile</i> .....	1816	<i>Dopamini hydrochloridum</i> .....	1887
<i>Dextranum 40 ad iniectabile</i> .....	1817	<i>Dopexamini dihydrochloridum</i> .....	1889
<i>Dextranum 60 ad iniectabile</i> .....	1818	<i>Dorzolamidi hydrochloridum</i> .....	1890
<i>Dextranum 70 ad iniectabile</i> .....	1819	<i>Dosulepini hydrochloridum</i> .....	1892
<i>Dextrinum</i> .....	1820	<i>Doxaprami hydrochloridum</i> .....	1893
<i>Dextromethorphanini hydrobromidum</i> .....	1821	<i>Doxazosini mesilas</i> .....	1894
<i>Dextromoramidi tartras</i> .....	1822	<i>Doxepini hydrochloridum</i> .....	1895
<i>Dextropropoxypheni hydrochloridum</i> .....	1823	<i>Doxorubicini hydrochloridum</i> .....	1897
<i>Diazepamum</i> .....	1824	<i>Doxycyclini hyclas</i> .....	1898
<i>Diazoxidum</i> .....	1825	<i>Doxycyclinum monohydricum</i> .....	1899
<i>Dibrompropamidini diisetionas</i> .....	1826	<i>Doxylamini hydrogenosuccinas</i> .....	1901
<i>Dibutylis phthalas</i> .....	1827	<i>Droperidolum</i> .....	1902
<i>Diclazurilum ad usum veterinarium</i> .....	1828	<i>Drosiprenonum</i> .....	1903
<i>Diclofenacum kalicum</i> .....	1829	<i>Dydrogesteronum</i> .....	1905
<i>Diclofenacum natricum</i> .....	1830	<b>E</b>	
<i>Dicloxacillinum natricum</i> .....	1831	<i>Ebastinum</i> .....	1909
<i>Dicycloverini hydrochloridum</i> .....	1833	<i>Echinaceae angustifoliae radix</i> .....	1193
<i>Didanosinum</i> .....	1833	<i>Echinaceae pallidae radix</i> .....	1208
<i>Dienestrolum</i> .....	1835	<i>Echinaceae purpureae herba</i> .....	1218
<i>Diethylcarbamazini citras</i> .....	1836	<i>Echinaceae purpureae radix</i> .....	1219
<i>Diethylenglycoli aether monoethilicus</i> .....	1837	<i>Econazoli nitras</i> .....	1911
<i>Diethylenglycoli palmitostearas</i> .....	1839	<i>Econazolom</i> .....	1910
<i>Diethylis phthalas</i> .....	1835	<i>Edrophonii chloridum</i> .....	1913
<i>Diethylstilbestrolum</i> .....	1839	<i>Eleutherococci radix</i> .....	1118
<i>Diifunisalum</i> .....	1840	<i>Emedastini difumaras</i> .....	1913
<i>Digitalis purpureae folium</i> .....	1114	<i>Emetini hydrochloridum heptahydricum</i> .....	1914
<i>Digitoxinum</i> .....	1841	<i>Emetini hydrochloridum pentahydricum</i> .....	1915
<i>Digoxinum</i> .....	1842	<i>Emplastra transcutanea</i> .....	726
<i>Dihydralazini sulfas hydricus</i> .....	1844	<i>Enalaprilatum dihydricum</i> .....	1918
<i>Dihydrocodeini hydrogenotartras</i> .....	1845	<i>Enalapriili maleas</i> .....	1916
<i>Dihydroergocristini mesilas</i> .....	1846	<i>Enilconazolom ad usum veterinarium</i> .....	1919
<i>Dihydroergotamini mesilas</i> .....	1849	<i>Enoxaparinum natricum</i> .....	1920
<i>Dihydroergotamini tartras</i> .....	1850	<i>Enoxolonum</i> .....	1921
<i>Dihydrostreptomycini sulfas ad usum veterinarium</i> .....	1851	<i>Enrofloxacinum ad usum veterinarium</i> .....	1922
<i>Dihydrotachysterolum</i> .....	1853	<i>Entacaponum</i> .....	1924
<i>Dikalii clorazepas</i> .....	1869	<i>Ephedrae herba</i> .....	1120
<i>Dikalii phosphas</i> .....	1870	<i>Ephedrini hydrochloridum</i> .....	1927
<i>Diltiazemi hydrochloridum</i> .....	1855	<i>Ephedrini racemici hydrochloridum</i> .....	1928
<i>Dimenhydrinatum</i> .....	1856	<i>Ephedrinum anhydricum</i> .....	1925
<i>Dimercaprolom</i> .....	1858	<i>Ephedrinum hemihydricum</i> .....	1926
<i>Dimethylacetamidum</i> .....	1859	<i>Epinastini hydrochloridum</i> .....	1928
<i>Dimethylis sulfoxidum</i> .....	1858	<i>Epirubicini hydrochloridum</i> .....	1929
<i>Dimeticonum</i> .....	1860	<i>Equiseti herba</i> .....	1121
<i>Dimetindeni maleas</i> .....	1860	<i>Ergocalciferolum</i> .....	1931
<i>Dinatrii clodronas tetrahydricus</i> .....	1723	<i>Ergometrini maleas</i> .....	1933
<i>Dinatrii edetas</i> .....	1874	<i>Ergotamini tartras</i> .....	1934
<i>Dinatrii etidronas</i> .....	1979	<i>Erythritolum</i> .....	1935
<i>Dinatrii pamidronas pentahydricus</i> .....	2660	<i>Erythromycini estolas</i> .....	1938
<i>Dinatrii phosphas anhydricus</i> .....	1875	<i>Erythromycini ethylsuccinas</i> .....	1940
<i>Dinatrii phosphas dihydricus</i> .....	1875	<i>Erythromycini lactobionas</i> .....	1942
<i>Dinatrii phosphas dodecahydricus</i> .....	1876		

<i>Erythromycini stearas</i> .....	1944	<i>Filgrastimi solutio concentrata</i> .....	2015
<i>Erythromycinum</i> .....	1936	<i>Filipendulae ulmariae herba</i> .....	1182
<i>Erythropoietini solutio concentrata</i> .....	1946	<i>Filum bombycis tortum sterile in fuso ad usum veterinarium</i> .....	1039
<i>Eserini sulfas</i> .....	2726	<i>Filum ethyleni polyterephthalici sterile in fuso ad usum veterinarium</i> .....	1039
<i>Eserini sulfas</i> .....	2727	<i>Filum lini sterile in fuso ad usum veterinarium</i> .....	1038
<i>Esketamini hydrochloridum</i> .....	1950	<i>Filum polyamidicum-6/6 sterile in fuso ad usum veterinarium</i> .....	1038
<i>Esomeprazolum magnesticum trihydricum</i> .....	1951	<i>Filum polyamidicum-6 sterile in fuso ad usum veterinarium</i> .....	1038
<i>Estradioli benzoas</i> .....	1953	<i>Finasteridum</i> .....	2018
<i>Estradioli valeras</i> .....	1955	<i>Flavoxati hydrochloridum</i> .....	2021
<i>Estradiolum hemihydricum</i> .....	1954	<i>Flecaainidi acetat</i> .....	2022
<i>Estriolum</i> .....	1956	<i>Flubendazolium</i> .....	2024
<i>Estrogeni coniuncti</i> .....	1958	<i>Flucloxacillinum magnesticum octahydricum</i> .....	2025
<i>Etamsylatum</i> .....	1961	<i>Flucloxacillinum natricum</i> .....	2026
<i>Ethacridini lactas monohydricus</i> .....	1962	<i>Fluconazolium</i> .....	2028
<i>Ethambutoli hydrochloridum</i> .....	1963	<i>Flucytosinum</i> .....	2029
<i>Ethanolum (96 per centum)</i> .....	1964	<i>Fludarabini phosphas</i> .....	2031
<i>Ethanolum anhydricum</i> .....	1966	<i>Fludeoxyglucosi (<sup>18</sup>F) solutio iniectionis</i> .....	969
<i>Ethinylestradiolum</i> .....	1969	<i>Fludrocortisoni acetat</i> .....	2033
<i>Ethionamidum</i> .....	1970	<i>Flumazenili (N-[<sup>11</sup>C]methyl) solutio iniectionis</i> .....	972
<i>Ethosuximidum</i> .....	1971	<i>Flumazenilum</i> .....	2035
<i>Ethylcellulosum</i> .....	1975	<i>Flumequinum</i> .....	2036
<i>Ethylendiaminum</i> .....	1977	<i>Flumetasoni pivalas</i> .....	2037
<i>Ethylenglycoli monopalmitostearas</i> .....	1976	<i>Flunarizini dihydrochloridum</i> .....	2038
<i>Ethylis acetat</i> .....	1972	<i>Flunitrazepamum</i> .....	2039
<i>Ethylis oleas</i> .....	1973	<i>Flunixini megluminum ad usum veterinarium</i> .....	2040
<i>Ethylis parahydroxybenzoas</i> .....	1973	<i>Fluocinolonum acetat</i> .....	2041
<i>Ethylis parahydroxybenzoas natricum</i> .....	1974	<i>Fluocortisoni pivalas</i> .....	2042
<i>Ethylmorphini hydrochloridum</i> .....	1978	<i>Fluoresceinum</i> .....	2044
<i>Etilefrini hydrochloridum</i> .....	1979	<i>Fluoresceinum natricum</i> .....	2045
<i>Etodolacum</i> .....	1981	<i>Fluoridi (<sup>18</sup>F) solutio ad radio-signandum</i> .....	973
<i>Etofenamatum</i> .....	1982	<i>Fluorodopae (<sup>18</sup>F) ab electrophila substitutione solutio iniectionis</i> .....	974
<i>Etofillinum</i> .....	1984	<i>Fluorouracilum</i> .....	2046
<i>Etomidatum</i> .....	1985	<i>Fluoxetini hydrochloridum</i> .....	2048
<i>Etoposidum</i> .....	1986	<i>Flupentixoli dihydrochloridum</i> .....	2049
<i>Eucalypti aetheroleum</i> .....	1123	<i>Fluphenazini decanoas</i> .....	2051
<i>Eucalypti folium</i> .....	1122	<i>Fluphenazini dihydrochloridum</i> .....	2052
<i>Eugenolum</i> .....	1990	<i>Fluphenazini enantas</i> .....	2054
<i>Extracta</i> .....	674	<i>Flurazepamum monohydrochloridum</i> .....	2055
<b>F</b>			
<i>Factor humanus von Willebrandi</i> .....	2189	<i>Flurbiprofenum</i> .....	2056
<i>Factor IX coagulationis humanus</i> .....	2172	<i>Fluspirilenum</i> .....	2057
<i>Factor VII coagulationis humanus</i> .....	2169	<i>Flutamidum</i> .....	2058
<i>Factor VIII coagulationis humanus</i> .....	2170	<i>Fluticasoni propionas</i> .....	2059
<i>Factor VIII coagulationis humanus (ADNr)</i> .....	2171	<i>Flutrimazolium</i> .....	2061
<i>Factor XI coagulationis humanus</i> .....	2173	<i>Fluvastatinum natricum</i> .....	2062
<i>Fagopyri herba</i> .....	1084	<i>Fluvoxamini maleas</i> .....	2063
<i>Famotidinum</i> .....	1995	<i>Foeniculi amari fructus</i> .....	1124
<i>Febantelum ad usum veterinarium</i> .....	1996	<i>Foeniculi amari fructus aetheroleum</i> .....	1073
<i>Felbinacum</i> .....	1997	<i>Foeniculi amari herbae aetheroleum</i> .....	1075
<i>Felodipinum</i> .....	1998	<i>Foeniculi dulcis fructus</i> .....	1125
<i>Felypressinum</i> .....	1999	<i>Formaldehydi solutio (35 per centum)</i> .....	2066
<i>Fenbendazolium ad usum veterinarium</i> .....	2000	<i>Formoteroli fumaras dihydricus</i> .....	2067
<i>Fenbufenum</i> .....	2001	<i>Foscarnetum natricum hexahydricum</i> .....	2069
<i>Fenofibratum</i> .....	2002	<i>Fosfomycinum calcicum</i> .....	2070
<i>Fenoteroli hydrobromidum</i> .....	2003	<i>Fosfomycinum natricum</i> .....	2071
<i>Fentanyl citras</i> .....	2006	<i>Fosfomycinum trometamolium</i> .....	2072
<i>Fentanylum</i> .....	2005	<i>Fosinoprilum natricum</i> .....	2073
<i>Fenticonazoli nitras</i> .....	2007	<i>Framycetini sulfas</i> .....	2076
<i>Ferri chloridum hexahydricum</i> .....	2008	<i>Frangulae cortex</i> .....	1128
<i>Ferrosi fumaras</i> .....	2009	<i>Frangulae corticis extractum siccum normatum</i> .....	1129
<i>Ferrosi gluconas</i> .....	2010	<i>Fraxini folium</i> .....	1059
<i>Ferrosi sulfas desiccatus</i> .....	2011	<i>Fructosum</i> .....	2077
<i>Ferrosi sulfas heptahydricus</i> .....	2012	<i>Fucus vel Ascophyllum</i> .....	1161
<i>Ferrum ad praeparationes homoeopathicas</i> .....	1294	<i>Fumariae herba</i> .....	1132
<i>Fexofenadini hydrochloridum</i> .....	2013	<i>Furosemidum</i> .....	2078
<i>Fibrini glutinum</i> .....	2014	<b>G</b>	
<i>Fibrinogenum humanum</i> .....	2174	<i>Galactosum</i> .....	2083
<i>Fila non resorbilia sterilia</i> .....	1028		
<i>Fila non resorbilia sterilia in fuso ad usum veterinarium</i> .....	1039		
<i>Fila resorbilia synthetica monofilamenta sterilia</i> .....	1033		
<i>Fila resorbilia synthetica torta sterilia</i> .....	1031		

<i>Galantamini hydrobromidum</i> .....	2083	<i>Histamini dihydrochloridum</i> .....	2158
<i>Gallii (<sup>67</sup>Ga) citratis solutio iniectabilis</i> .....	975	<i>Histamini phosphas</i> .....	2159
<i>Ganciclovirum</i> .....	2086	<i>Histidini hydrochloridum monohydricum</i> .....	2160
<i>Gelatina</i> .....	2087	<i>Histidinum</i> .....	2159
<i>Gemcitabini hydrochloridum</i> .....	2088	<i>Homatropini hydrobromidum</i> .....	2161
<i>Gemfibrozilum</i> .....	2090	<i>Homatropini methylbromidum</i> .....	2162
<i>Gentamicini sulfas</i> .....	2091	<i>Hyaluronidasum</i> .....	2190
<i>Gentianae radix</i> .....	1133	<i>Hydralazini hydrochloridum</i> .....	2191
<i>Gentianae tinctura</i> .....	1134	<i>Hydrargyri dichloridum</i> .....	2449
<i>Gestodenum</i> .....	2092	<i>Hydrastis rhizoma</i> .....	1143
<i>Ginkgonis extractum siccum raffinatum et quantificatum</i> .....	1136	<i>Hydrochlorothiazidum</i> .....	2193
<i>Ginkgonis folium</i> .....	1138	<i>Hydrocodoni hydrogenotartras 2.5-hydricus</i> .....	2194
<i>Ginseng radix</i> .....	1140	<i>Hydrocortisoni acetas</i> .....	2198
<i>Glibenclamidum</i> .....	2094	<i>Hydrocortisoni hydrogenosuccinas</i> .....	2200
<i>Gliclazidum</i> .....	2096	<i>Hydrocortisonum</i> .....	2196
<i>Glimepiridum</i> .....	2097	<i>Hydrogenii peroxidum 30 per centum</i> .....	2202
<i>Glipizidum</i> .....	2098	<i>Hydrogenii peroxidum 3 per centum</i> .....	2201
<i>Glossa</i> .....	707	<i>Hydromorphoni hydrochloridum</i> .....	2202
<i>Glucagonum humanum</i> .....	2100	<i>Hydroxocobalamini acetas</i> .....	2203
<i>Glucosum anhydricum</i> .....	2102	<i>Hydroxocobalamini chloridum</i> .....	2204
<i>Glucosum liquidum</i> .....	2103	<i>Hydroxocobalamini sulfas</i> .....	2205
<i>Glucosum liquidum dispersione desiccatum</i> .....	2103	<i>Hydroxycarbamidum</i> .....	2206
<i>Glucosum monohydricum</i> .....	2104	<i>Hydroxyethylcellulosum</i> .....	2208
<i>Glutathionum</i> .....	2106	<i>Hydroxyethylis salicylas</i> .....	2207
<i>Glyceroli dibehenas</i> .....	2110	<i>Hydroxypropylbetadexum</i> .....	2210
<i>Glyceroli distearas</i> .....	2111	<i>Hydroxypropylcellulosum</i> .....	2211
<i>Glyceroli monocaprylas</i> .....	2112	<i>Hydroxyzini hydrochloridum</i> .....	2212
<i>Glyceroli monocaprylocapras</i> .....	2113	<i>Hymecromonum</i> .....	2213
<i>Glyceroli monolinoleas</i> .....	2114	<i>Hyoscini butylbromidum</i> .....	2215
<i>Glyceroli mono-oleas</i> .....	2115	<i>Hyoscini hydrobromidum</i> .....	2216
<i>Glyceroli monostearas 40-55</i> .....	2116	<i>Hyoscinum</i> .....	2214
<i>Glyceroli trinitratis solutio</i> .....	2117	<i>Hyoscyamini sulfas</i> .....	2217
<i>Glycerolum</i> .....	2108	<i>Hyoscyamus niger ad praeparationes homoeopathicas</i> .....	1292
<i>Glycerolum (85 per centum)</i> .....	2109	<i>Hyperici herba</i> .....	1241
<i>Glycinum</i> .....	2118	<i>Hyperici herbae extractum siccum quantificatum</i> .....	1242
<i>Gonadorelini acetas</i> .....	2119	<i>Hypericum perforatum</i>	
<i>Gonadotropinum chortonicum</i> .....	2120	<i>ad praeparationes homoeopathicas</i> .....	1293
<i>Gonadotropinum sericum equinum ad usum</i>		<i>Hypromellosi phthalas</i> .....	2221
<i>veterinarium</i> .....	2121	<i>Hypromellosum</i> .....	2219
<i>Goserelinum</i> .....	2121		
<i>Gossypii oleum hydrogenatum</i> .....	1769	<b>I</b>	
<i>Gramicidinum</i> .....	2123	<i>Ibuprofenum</i> .....	2225
<i>Graminis rhizoma</i> .....	1109	<i>Ichthammolum</i> .....	2227
<i>Granisetroni hydrochloridum</i> .....	2124	<i>Idoxuridinum</i> .....	2227
<i>Granulata</i> .....	713	<i>Iecoris aselli oleum A</i> .....	1752
<i>Griseofulvinum</i> .....	2126	<i>Iecoris aselli oleum B</i> .....	1756
<i>Guaiacolum</i> .....	2127	<i>Iecoris aselli oleum domestici</i> .....	1748
<i>Guafenesinum</i> .....	2128	<i>Ifosamidum</i> .....	2228
<i>Guanethidini monosulfas</i> .....	2129	<i>Imipenemum</i> .....	2230
<i>Guar galactomannanum</i> .....	2130	<i>Imipramini hydrochloridum</i> .....	2231
		<i>Immunoglobulinum anti-T lymphocytorum ex animale ad</i>	
<b>H</b>		<i>usum humanum</i> .....	1404
<i>Halofantrini hydrochloridum</i> .....	2141	<i>Immunoglobulinum humanum anti-D</i> .....	2166
<i>Haloperidoli decanoas</i> .....	2143	<i>Immunoglobulinum humanum anti-D ad usum</i>	
<i>Haloperidolum</i> .....	2142	<i>intravenosum</i> .....	2167
<i>Halothanum</i> .....	2144	<i>Immunoglobulinum humanum hepatitis A</i> .....	2176
<i>Hamamelidis folium</i> .....	1146	<i>Immunoglobulinum humanum hepatitis B</i> .....	2176
<i>Harpagophyti extractum siccum</i> .....	1112	<i>Immunoglobulinum humanum hepatitis B ad usum</i>	
<i>Harpagophyti radix</i> .....	1113	<i>intravenosum</i> .....	2176
<i>Hederae folium</i> .....	1157	<i>Immunoglobulinum humanum morbillicum</i> .....	2177
<i>Hedera helix ad praeparationes homoeopathicas</i> .....	1291	<i>Immunoglobulinum humanum normale</i> .....	2177
<i>Helianthi annui oleum raffinatum</i> .....	3028	<i>Immunoglobulinum humanum normale ad usum</i>	
<i>Helium</i> .....	2146	<i>intravenosum</i> .....	2179
<i>Heparina massae molecularis minoris</i> .....	2151	<i>Immunoglobulinum humanum rabicum</i> .....	2186
<i>Heparinum calcicum</i> .....	2147	<i>Immunoglobulinum humanum rubellae</i> .....	2187
<i>Heparinum natricum</i> .....	2149	<i>Immunoglobulinum humanum tetanicum</i> .....	2187
<i>Heptaminoli hydrochloridum</i> .....	2153	<i>Immunoglobulinum humanum varicellae</i> .....	2188
<i>Hexamidini diisetionas</i> .....	2154	<i>Immunoglobulinum humanum varicellae ad usum</i>	
<i>Hexetidinum</i> .....	2155	<i>intravenosum</i> .....	2189
<i>Hexobarbitalum</i> .....	2156	<i>Immunosera ad usum veterinarium</i> .....	680
<i>Hexylresorcinolum</i> .....	2157	<i>Immunosera ex animale ad usum humanum</i> .....	678
<i>Hibisci sabdariffae flos</i> .....	1226	<i>Immunosera botulinicum</i> .....	949

<i>Immunoserum Clostridii novyi alpha ad usum veterinarium</i> . . . . .	957	<i>Itraconazolum</i> . . . . .	2297
<i>Immunoserum Clostridii perfringentis beta ad usum veterinarium</i> . . . . .	958	<i>Iuniperi aetheroleum</i> . . . . .	1160
<i>Immunoserum Clostridii perfringentis epsilon ad usum veterinarium</i> . . . . .	959	<i>Iuniperi pseudo-fructus</i> . . . . .	1160
<i>Immunoserum contra venena viperarum europaearum</i> . . . . .	953	<i>Ivermectinum</i> . . . . .	2299
<i>Immunoserum diphthericum</i> . . . . .	949	<b>J</b>	
<i>Immunoserum gangraenicum (Clostridium novyi)</i> . . . . .	950	<i>Josamycini propionas</i> . . . . .	2307
<i>Immunoserum gangraenicum (Clostridium perfringens)</i> . . . . .	951	<i>Josamycinum</i> . . . . .	2305
<i>Immunoserum gangraenicum (Clostridium septicum)</i> . . . . .	952	<b>K</b>	
<i>Immunoserum gangraenicum mixtum</i> . . . . .	950	<i>Kalii acetas</i> . . . . .	2761
<i>Immunoserum tetanicum ad usum humanum</i> . . . . .	953	<i>Kalii bromidum</i> . . . . .	2761
<i>Immunoserum tetanicum ad usum veterinarium</i> . . . . .	960	<i>Kalii carbonas</i> . . . . .	2762
<i>Indapamidum</i> . . . . .	2232	<i>Kalii chloridum</i> . . . . .	2763
<i>Indii (<sup>111</sup>In) chloridi solutio</i> . . . . .	977	<i>Kalii citras</i> . . . . .	2763
<i>Indii (<sup>111</sup>In) oxini solutio</i> . . . . .	978	<i>Kalii clavulanas</i> . . . . .	2764
<i>Indii (<sup>111</sup>In) pentetatis solutio iniectionabilis</i> . . . . .	979	<i>Kalii clavulanas dilutus</i> . . . . .	2766
<i>Indinaviri sulfas</i> . . . . .	2233	<i>Kalii dihydrogenophosphas</i> . . . . .	2768
<i>Indometacinum</i> . . . . .	2235	<i>Kalii hydrogenoaspartas hemihydricus</i> . . . . .	2768
<i>Inhalanda</i> . . . . .	728	<i>Kalii hydrogenocarbonas</i> . . . . .	2769
<i>Insulini zinci amorphi suspensio iniectionabilis</i> . . . . .	2252	<i>Kalii hydrogenotartras</i> . . . . .	2769
<i>Insulini zinci cristallini suspensio iniectionabilis</i> . . . . .	2252	<i>Kalii hydroxidum</i> . . . . .	2770
<i>Insulini zinci suspensio iniectionabilis</i> . . . . .	2251	<i>Kalii iodidum</i> . . . . .	2771
<i>Insulinum aspartum</i> . . . . .	2237	<i>Kalii metabisulfis</i> . . . . .	2771
<i>Insulinum biphasicum iniectionabile</i> . . . . .	2243	<i>Kalii natrii tartras tetrahydricus</i> . . . . .	2774
<i>Insulinum bovinum</i> . . . . .	2239	<i>Kalii nitras</i> . . . . .	2772
<i>Insulinum humanum</i> . . . . .	2241	<i>Kalii perchloras</i> . . . . .	2773
<i>Insulinum isophanum biphasicum iniectionabile</i> . . . . .	2244	<i>Kalii permanganas</i> . . . . .	2773
<i>Insulinum isophanum iniectionabile</i> . . . . .	2244	<i>Kalii sorbas</i> . . . . .	2774
<i>Insulinum lisprum</i> . . . . .	2245	<i>Kalii sulfas</i> . . . . .	2775
<i>Insulinum porcinum</i> . . . . .	2247	<i>Kanamycini monosulfas</i> . . . . .	2313
<i>Insulinum solubile iniectionabile</i> . . . . .	2244	<i>Kanamycini sulfas acidus</i> . . . . .	2313
<i>Interferoni alfa-2 solutio concentrata</i> . . . . .	2252	<i>Kaolinum ponderosum</i> . . . . .	2314
<i>Interferoni beta-1a solutio concentrata</i> . . . . .	2255	<i>Ketamini hydrochloridum</i> . . . . .	2315
<i>Interferoni gamma-1b solutio concentrata</i> . . . . .	2257	<i>Ketoconazolum</i> . . . . .	2317
<i>int-rac-<math>\alpha</math>-Tocopherolum</i> . . . . .	3104	<i>Ketoprofenum</i> . . . . .	2318
<i>int-rac-<math>\alpha</math>-Tocopherylis acetas</i> . . . . .	3106	<i>Ketorolacum trometamololum</i> . . . . .	2320
<i>Iobenguani (<sup>123</sup>I) solutio iniectionabilis</i> . . . . .	979	<i>Ketotifeni hydrogenofumaras</i> . . . . .	2321
<i>Iobenguani (<sup>131</sup>I) solutio iniectionabilis ad usum diagnosticum</i> . . . . .	980	<i>Kryptonum (<sup>81m</sup>Kr) ad inhalationem</i> . . . . .	983
<i>Iobenguani (<sup>131</sup>I) solutio iniectionabilis ad usum therapeuticum</i> . . . . .	981	<b>L</b>	
<i>Iobenguani sulfas ad radiopharmaceutica</i> . . . . .	982	<i>Labetaloli hydrochloridum</i> . . . . .	2327
<i>Iodinati (<sup>125</sup>I) humani albumini solutio iniectionabilis</i> . . . . .	976	<i>Lacca</i> . . . . .	2901
<i>Iodixanololum</i> . . . . .	2261	<i>Lactitolum monohydricum</i> . . . . .	2329
<i>Iodomethylnorcholesteroli (<sup>131</sup>I) solutio iniectionabilis</i> . . . . .	982	<i>Lactosum anhydricum</i> . . . . .	2331
<i>Iodum</i> . . . . .	2261	<i>Lactosum monohydricum</i> . . . . .	2333
<i>Iohexolum</i> . . . . .	2264	<i>Lactulosum</i> . . . . .	2334
<i>Iopamidolum</i> . . . . .	2266	<i>Lactulosum liquidum</i> . . . . .	2336
<i>Iopromidum</i> . . . . .	2269	<i>Lamivudinum</i> . . . . .	2337
<i>Iotrolanum</i> . . . . .	2273	<i>Lamotriginum</i> . . . . .	2339
<i>Ipecacuanhae extractum fluidum normatum</i> . . . . .	1153	<i>Lansoprazolum</i> . . . . .	2341
<i>Ipecacuanhae pulvis normatus</i> . . . . .	1154	<i>Lanugo cellulosi absorbens</i> . . . . .	3207
<i>Ipecacuanhae radix</i> . . . . .	1155	<i>Lanugo gossypii absorbens</i> . . . . .	1768
<i>Ipecacuanhae tinctura normata</i> . . . . .	1156	<i>Lauromacrogolum 400</i> . . . . .	2342
<i>Ipratropii bromidum</i> . . . . .	2277	<i>Lavandulae aetheroleum</i> . . . . .	1164
<i>Irbesartanum</i> . . . . .	2278	<i>Lavandulae flos</i> . . . . .	1163
<i>Isoconazoli nitras</i> . . . . .	2281	<i>Leflunomidum</i> . . . . .	2345
<i>Isoconazolum</i> . . . . .	2279	<i>Leonuri cardiaca herba</i> . . . . .	1190
<i>Isofluranum</i> . . . . .	2282	<i>Letrozolum</i> . . . . .	2347
<i>Isoleucinum</i> . . . . .	2283	<i>Leucinum</i> . . . . .	2348
<i>Isomaltum</i> . . . . .	2284	<i>Leuprorelinum</i> . . . . .	2348
<i>Isoniazidum</i> . . . . .	2285	<i>Levamisoli hydrochloridum</i> . . . . .	2351
<i>Isoprenalini hydrochloridum</i> . . . . .	2286	<i>Levamisolum ad usum veterinarium</i> . . . . .	2350
<i>Isoprenalini sulfas</i> . . . . .	2287	<i>Levetiracetamum</i> . . . . .	2352
<i>Isopropylis myristas</i> . . . . .	2288	<i>Levistici radix</i> . . . . .	1172
<i>Isopropylis palmitas</i> . . . . .	2289	<i>Levocabastini hydrochloridum</i> . . . . .	2354
<i>Isosorbidi dinitras dilutus</i> . . . . .	2289	<i>Levocarnitinum</i> . . . . .	2355
<i>Isosorbidi mononitras dilutus</i> . . . . .	2291	<i>Levodopum</i> . . . . .	2356
<i>Isotretinoinum</i> . . . . .	2293	<i>Levodopropizinium</i> . . . . .	2358
<i>Isosuprini hydrochloridum</i> . . . . .	2294	<i>Levomentholum</i> . . . . .	2359
<i>Isradipinum</i> . . . . .	2296	<i>Levomopromazini hydrochloridum</i> . . . . .	2360
		<i>Levomopromazini maleas</i> . . . . .	2361

<i>Levomethadoni hydrochloridum</i> .....	2362	<i>Magnesii subcarbonas ponderosus</i> .....	2409
<i>Levonorgestrelum</i> .....	2363	<i>Magnesii sulfas heptahydricus</i> .....	2421
<i>Levothyroxinum natricum</i> .....	2364	<i>Magnesii trisilicas</i> .....	2421
<i>Lichen islandicus</i> .....	1152	<i>Malathionum</i> .....	2423
<i>Lidocani hydrochloridum</i> .....	2366	<i>Maltitolum</i> .....	2425
<i>Lidocainum</i> .....	2365	<i>Maltitolum liquidum</i> .....	2427
<i>Limonis aetheroleum</i> .....	1165	<i>Maltodextrinum</i> .....	2428
<i>Lincomycini hydrochloridum</i> .....	2367	<i>Malvae folium</i> .....	1174
<i>Lini oleum virginale</i> .....	2369	<i>Malvae sylvestris flos</i> .....	1173
<i>Lini semen</i> .....	1168	<i>Mangani gluconas</i> .....	2428
<i>Liothyroninum natricum</i> .....	2370	<i>Mangani glycerophosphas hydricus</i> .....	2429
<i>Liquiritiae extractum fluidum ethanolicum normatum</i> .....	1170	<i>Mangani sulfas monohydricus</i> .....	2430
<i>Liquiritiae extractum siccum ad saporandum</i> .....	1169	<i>Mannitolum</i> .....	2430
<i>Liquiritiae radix</i> .....	1171	<i>Maprotilini hydrochloridum</i> .....	2432
<i>Lisinoprilum dihydricum</i> .....	2371	<i>Marbofloxacinum ad usum veterinarium</i> .....	2433
<i>Lithii carbonas</i> .....	2372	<i>Marrubii herba</i> .....	1265
<i>Lithii citras</i> .....	2373	<i>Masticabilia gummis medicata</i> .....	709
<i>L-Methionini (<sup>14</sup>C)methyl solutio iniectabilis</i> .....	985	<i>Mastix</i> .....	1177
<i>Lobelini hydrochloridum</i> .....	2373	<i>Matricariae aetheroleum</i> .....	1180
<i>Lomustinum</i> .....	2375	<i>Matricariae extractum fluidum</i> .....	1179
<i>Loperamidi hydrochloridum</i> .....	2376	<i>Matricariae flos</i> .....	1178
<i>Loperamidi oxidum monohydricum</i> .....	2378	<i>Maydis amyllum</i> .....	2422
<i>Loratadinum</i> .....	2379	<i>Maydis oleum raffinatum</i> .....	2422
<i>Lorazepamum</i> .....	2381	<i>Mebendazolum</i> .....	2434
<i>Losartanum kalicum</i> .....	2382	<i>Meclozini dihydrochloridum</i> .....	2435
<i>Lovastatinum</i> .....	2384	<i>Medroxyprogesteroni acetat</i> .....	2437
<i>Lufenuronum anhydricum ad usum veterinarium</i> .....	2385	<i>Mefloquini hydrochloridum</i> .....	2440
<i>Lupuli flos</i> .....	1151	<i>Megestrol acetat</i> .....	2441
<i>Lymecyclinum</i> .....	2387	<i>Megluminum</i> .....	2442
<i>Lynestrenolum</i> .....	2389	<i>Mel</i> .....	2163
<i>Lysini acetat</i> .....	2390	<i>Melaleucae aetheroleum</i> .....	1251
<i>Lysini hydrochloridum</i> .....	2391	<i>Meliloti herba</i> .....	1183
<i>Lythri herba</i> .....	1172	<i>Melissae folii extractum siccum</i> .....	1185
<b>M</b>			
<i>Macrogol 20 glyceroli monostearas</i> .....	2397	<i>Melissae folium</i> .....	1184
<i>Macrogol 40 sorbitoli heptaoleas</i> .....	2404	<i>Meloxicamum</i> .....	2443
<i>Macrogol 6 glyceroli caprylocapras</i> .....	2395	<i>Menadionum</i> .....	2444
<i>Macrogola</i> .....	2402	<i>Menthae arvensis aetheroleum partim mentholum depletum</i> .....	1189
<i>Macrogolglyceridorum caprylocaprates</i> .....	1572	<i>Menthae piperitae aetheroleum</i> .....	1214
<i>Macrogolglyceridorum laurates</i> .....	2344	<i>Menthae piperitae folii extractum siccum</i> .....	1213
<i>Macrogolglyceridorum linoleates</i> .....	2368	<i>Menthae piperitae folium</i> .....	1212
<i>Macrogolglyceridorum oleates</i> .....	2610	<i>Mentholum racemicum</i> .....	2445
<i>Macrogolglyceridorum stearates</i> .....	2990	<i>Menyanthis trifoliatae folium</i> .....	1080
<i>Macrogolglyceroli cocoates</i> .....	2396	<i>Mepivacaini hydrochloridum</i> .....	2446
<i>Macrogolglyceroli hydroxystearas</i> .....	2397	<i>Meprobamatum</i> .....	2447
<i>Macrogolglyceroli ricinoleas</i> .....	2398	<i>Mepyramini maleas</i> .....	2448
<i>Macrogoli 15 hydroxystearas</i> .....	2399	<i>Mercaptopurinum</i> .....	2449
<i>Macrogoli aether cetostearylicus</i> .....	2395	<i>Meropenemum trihydricum</i> .....	2450
<i>Macrogoli aether laurilicus</i> .....	2400	<i>Mesalazinum</i> .....	2451
<i>Macrogoli aether oleicus</i> .....	2401	<i>Mesnum</i> .....	2453
<i>Macrogoli aether stearylicus</i> .....	2405	<i>Mesterololum</i> .....	2454
<i>Macrogoli oleas</i> .....	2400	<i>Mestranolum</i> .....	2455
<i>Macrogoli stearas</i> .....	2405	<i>Metacresolum</i> .....	2456
<i>Magaldratum</i> .....	2406	<i>Metamizolum natricum</i> .....	2457
<i>Magnesii acetat tetrahydricus</i> .....	2407	<i>Metformini hydrochloridum</i> .....	2458
<i>Magnesii aspartas dihydricus</i> .....	2408	<i>Methadoni hydrochloridum</i> .....	2462
<i>Magnesii chloridum 4.5-hydricum</i> .....	2410	<i>Methanololum</i> .....	2463
<i>Magnesii chloridum hexahydricum</i> .....	2411	<i>Methaqualonum</i> .....	2464
<i>Magnesii citras anhydricus</i> .....	2411	<i>Methenaminum</i> .....	2465
<i>Magnesii citras dodecahydricus</i> .....	2412	<i>Methioninum</i> .....	2466
<i>Magnesii citras nonahydricus</i> .....	2412	<i>Methotrexatum</i> .....	2467
<i>Magnesii gluconas</i> .....	2413	<i>Methylatropini bromidum</i> .....	2469
<i>Magnesii glycerophosphas</i> .....	2414	<i>Methylatropini nitras</i> .....	2470
<i>Magnesii hydroxidum</i> .....	2414	<i>Methylcellulosum</i> .....	2471
<i>Magnesii lactas dihydricus</i> .....	2415	<i>Methylidopum</i> .....	2472
<i>Magnesii oxidum leve</i> .....	2416	<i>Methyleni chloridum</i> .....	2474
<i>Magnesii oxidum ponderosum</i> .....	2415	<i>Methylergometrini maleas</i> .....	2475
<i>Magnesii peroxidum</i> .....	2417	<i>Methylhydroxyethylcellulosum</i> .....	2476
<i>Magnesii pidolas</i> .....	2417	<i>Methylis nicotinas</i> .....	2477
<i>Magnesii stearas</i> .....	2418	<i>Methylis parahydroxybenzoas</i> .....	2477
<i>Magnesii subcarbonas levis</i> .....	2409	<i>Methylis parahydroxybenzoas natricus</i> .....	2934
		<i>Methylis salicylas</i> .....	2488
		<i>Methylphenidati hydrochloridum</i> .....	2479

<i>Methylphenobarbitalum</i> .....	2480	<i>Natrii ascorbas</i> .....	2912
<i>Methylprednisoloni acetat</i> .....	2483	<i>Natrii aurothiomalas</i> .....	2914
<i>Methylprednisoloni hydrogenosuccinas</i> .....	2485	<i>Natrii benzoas</i> .....	2915
<i>Methylprednisolonum</i> .....	2481	<i>Natrii bromidum</i> .....	2915
<i>Methylrosanilini chloridum</i> .....	2487	<i>Natrii calcii edetas</i> .....	2916
<i>Methyltestosteronum</i> .....	2489	<i>Natrii calcii pentetas ad radiopharmaceutica</i> .....	987
<i>Methylthioninii chloridum</i> .....	2490	<i>Natrii caprylas</i> .....	2917
<i>Metixeni hydrochloridum</i> .....	2491	<i>Natrii carbonas anhydricus</i> .....	2918
<i>Metoclopramidi hydrochloridum</i> .....	2493	<i>Natrii carbonas decahydricus</i> .....	2919
<i>Metoclopramidum</i> .....	2492	<i>Natrii carbonas monohydricus</i> .....	2919
<i>Metolazonum</i> .....	2494	<i>Natrii cetylo- et stearylosulfas</i> .....	2920
<i>Metoprololi succinas</i> .....	2495	<i>Natrii chloridum</i> .....	2921
<i>Metoprololi tartras</i> .....	2497	<i>Natrii chromatis (<sup>51</sup>Cr) solutio sterilis</i> .....	991
<i>Metrifonatam</i> .....	2498	<i>Natrii citras</i> .....	2922
<i>Metronidazoli benzoas</i> .....	2500	<i>Natrii cromoglicas</i> .....	2923
<i>Metronidazolom</i> .....	2500	<i>Natrii cyclamas</i> .....	2924
<i>Mexiletini hydrochloridum</i> .....	2502	<i>Natrii dihydrogenophosphas dihydricus</i> .....	2925
<i>Mianserini hydrochloridum</i> .....	2503	<i>Natrii docusas</i> .....	1883
<i>Miconazoli nitras</i> .....	2506	<i>Natrii fluoridi (<sup>18</sup>F) solutio iniectionis</i> .....	991
<i>Miconazolom</i> .....	2504	<i>Natrii fluoridum</i> .....	2925
<i>Midazolamum</i> .....	2508	<i>Natrii fusidas</i> .....	2926
<i>Millefolii herba</i> .....	1271	<i>Natrii glycerophosphas hydricus</i> .....	2927
<i>Minocyclini hydrochloridum dihydricum</i> .....	2510	<i>Natrii hyaluronas</i> .....	2927
<i>Minoxidilum</i> .....	2511	<i>Natrii hydrogenocarbonas</i> .....	2929
<i>Mirtazapinum</i> .....	2512	<i>Natrii hydroxidum</i> .....	2930
<i>Misoprostolum</i> .....	2513	<i>Natrii iodidi (<sup>123</sup>I) solutio ad radio-signandum</i> .....	993
<i>Mitomycinum</i> .....	2515	<i>Natrii iodidi (<sup>123</sup>I) solutio iniectionis</i> .....	992
<i>Mitoxantroni hydrochloridum</i> .....	2517	<i>Natrii iodidi (<sup>131</sup>I) capsulae ad usum diagnosticum</i> .....	994
<i>Modafinilum</i> .....	2518	<i>Natrii iodidi (<sup>131</sup>I) capsulae ad usum therapeuticum</i> .....	995
<i>Molgramostimi solutio concentrata</i> .....	2519	<i>Natrii iodidi (<sup>131</sup>I) solutio</i> .....	996
<i>Molsidominum</i> .....	2521	<i>Natrii iodidi (<sup>131</sup>I) solutio ad radio-signandum</i> .....	996
<i>Mometasoni furoas</i> .....	2523	<i>Natrii iodidum</i> .....	2930
<i>Moranteli hydrogenotartras ad usum veterinarium</i> .....	2525	<i>Natrii iodohippurati (<sup>123</sup>I) solutio iniectionis</i> .....	997
<i>Morphini hydrochloridum</i> .....	2526	<i>Natrii iodohippurati (<sup>131</sup>I) solutio iniectionis</i> .....	998
<i>Morphini sulfas</i> .....	2527	<i>Natrii lactatis solutio</i> .....	2931
<i>Moxidectinum ad usum veterinarium</i> .....	2529	<i>Natrii laurilsulfas</i> .....	2933
<i>Moxifloxacini hydrochloridum</i> .....	2531	<i>Natrii metabisulfis</i> .....	2933
<i>Moxonidinum</i> .....	2532	<i>Natrii molybdis dihydricus</i> .....	2935
<i>Mupirocinum</i> .....	2533	<i>Natrii molybdis (<sup>99</sup>Mo) fissionis formati solutio</i> .....	999
<i>Mupirocinum calcicum</i> .....	2535	<i>Natrii nitris</i> .....	2936
<i>Musci medicati</i> .....	712	<i>Natrii nitroprussias</i> .....	2936
<i>Mycophenolas mofetil</i> .....	2536	<i>Natrii perboras hydricus</i> .....	2937
<i>myo-Inositolom</i> .....	2236	<i>Natrii pertechnetatis (<sup>99m</sup>Tc) fissionis formati solutio iniectionis</i> .....	1001
<i>Myristicae fragrantis aetheroleum</i> .....	1199	<i>Natrii pertechnetatis (<sup>99m</sup>Tc) sine fissionis formati solutio iniectionis</i> .....	1002
<i>Myrrha</i> .....	1192	<i>Natrii phenylbutyras</i> .....	2938
<i>Myrrhae tinctura</i> .....	1192	<i>Natrii phosphatis (<sup>32</sup>P) solutio iniectionis</i> .....	1003
<i>Myrtilli fructus recens</i> .....	1070	<i>Natrii picosulfas</i> .....	2939
<i>Myrtilli fructus recentis extractum siccum raffinatum et normatum</i> .....	1130	<i>Natrii polystyrenesulfonas</i> .....	2940
<i>Myrtilli fructus siccus</i> .....	1070	<i>Natrii propionas</i> .....	2941
<b>N</b>		<i>Natrii salicylas</i> .....	2943
<i>Nabumetonum</i> .....	2541	<i>Natrii selenis pentahydricus</i> .....	2944
<i>N-Acetyltryptophanum</i> .....	1319	<i>Natrii (S)-lactatis solutio</i> .....	2932
<i>N-Acetyltyrosinum</i> .....	1320	<i>Natrii stearas</i> .....	2947
<i>Nadololum</i> .....	2542	<i>Natrii stearylis fumaras</i> .....	2948
<i>Nadroparinum calcicum</i> .....	2543	<i>Natrii sulfas anhydricus</i> .....	2948
<i>Naftidrofuryli hydrogenooxalas</i> .....	2545	<i>Natrii sulfas decahydricus</i> .....	2949
<i>Naloxoni hydrochloridum dihydricum</i> .....	2548	<i>Natrii sulfis anhydricus</i> .....	2950
<i>Naltrexoni hydrochloridum</i> .....	2549	<i>Natrii sulfis heptahydricus</i> .....	2950
<i>Nandroloni decanoas</i> .....	2551	<i>Natrii thiosulfas</i> .....	2951
<i>Naphazolini hydrochloridum</i> .....	2552	<i>Natrii valproas</i> .....	2951
<i>Naphazolini nitras</i> .....	2553	<i>Neohesperidin-dihydrochalconum</i> .....	2558
<i>Naproxenum</i> .....	2554	<i>Neomycini sulfas</i> .....	2559
<i>Naproxenum natricum</i> .....	2556	<i>Neostigmini bromidum</i> .....	2560
<i>Nasalia</i> .....	719	<i>Neostigmini metilsulfas</i> .....	2561
<i>Natrii acetat trihydricus</i> .....	2908	<i>Neroli aetheroleum</i> .....	1194
<i>Natrii acetatis ([<sup>11</sup>C]) solutio iniectionis</i> .....	990	<i>Netilmicini sulfas</i> .....	2562
<i>Natrii alendronas</i> .....	2908	<i>Nevirapinum anhydricum</i> .....	2563
<i>Natrii alginas</i> .....	2909	<i>Nicergolinum</i> .....	2564
<i>Natrii amidotrizoas</i> .....	2910	<i>Nicethamidum</i> .....	2575
<i>Natrii aminosalicylas dihydricus</i> .....	2911	<i>Niclosamidum anhydricum</i> .....	2565
		<i>Niclosamidum monohydricum</i> .....	2566



<i>Nicotinamidum</i> .....	2567	<i>Oxprenololi hydrochloridum</i> .....	2643
<i>Nicotini resinas</i> .....	2568	<i>Oxybuprocaini hydrochloridum</i> .....	2644
<i>Nicotinum</i> .....	2567	<i>Oxybutynini hydrochloridum</i> .....	2645
<i>Nifedipinum</i> .....	2571	<i>Oxycodoni hydrochloridum</i> .....	2646
<i>Nifuroxazidum</i> .....	2574	<i>Oxygenium</i> .....	2648
<i>Nilutamidum</i> .....	2575	<i>Oxygenium (<sup>15</sup>O)</i> .....	986
<i>Nimesulidum</i> .....	2577	<i>Oxymetazolini hydrochloridum</i> .....	2648
<i>Nimodipinum</i> .....	2578	<i>Oxytetracyclini hydrochloridum</i> .....	2651
<i>Nitrazepamum</i> .....	2579	<i>Oxytetracyclinum dihydricum</i> .....	2649
<i>Nitrendipinum</i> .....	2580	<i>Oxytocini solutio concentrata</i> .....	2654
<i>Nitrofuralem</i> .....	2582	<i>Oxytocinum</i> .....	2653
<i>Nitrofurantoinum</i> .....	2583		
<i>Nitrogenii oxidum</i> .....	2581	<b>P</b>	
<i>Nitrogenium</i> .....	2584	<i>Paclitaxelum</i> .....	2657
<i>Nitrogenium oxygenio depletum</i> .....	2585	<i>Pancreatis pulvis</i> .....	2661
<i>Nizatidinum</i> .....	2586	<i>Pancuronii bromidum</i> .....	2663
<i>N-Methylpyrrolidonum</i> .....	2486	<i>Pantoprazolum natricum sesquihydricum</i> .....	2664
<i>Nomegestroli acetat</i> .....	2588	<i>Papaverini hydrochloridum</i> .....	2666
<i>Nonoxinolum 9</i> .....	2589	<i>Papaveris rhoeados flos</i> .....	1222
<i>Noradrenalini hydrochloridum</i> .....	2589	<i>Paracetamolum</i> .....	2667
<i>Noradrenalini tartras</i> .....	2591	<i>Paraffinum liquidum</i> .....	2669
<i>Norethisteroni acetat</i> .....	2594	<i>Paraffinum perliquidum</i> .....	2669
<i>Norethisteronum</i> .....	2592	<i>Paraffinum solidum</i> .....	2668
<i>Norfloxacinum</i> .....	2595	<i>Paraldehydum</i> .....	2671
<i>Norgestimatum</i> .....	2596	<i>Parenteralia</i> .....	723
<i>Norgestrelum</i> .....	2597	<i>Parnaparinum natricum</i> .....	2672
<i>Nortriptylini hydrochloridum</i> .....	2598	<i>Paroxetini hydrochloridum anhydricum</i> .....	2672
<i>Noscapini hydrochloridum</i> .....	2600	<i>Paroxetini hydrochloridum hemihydricum</i> .....	2674
<i>Noscapinum</i> .....	2599	<i>Passiflorae herba</i> .....	1209
<i>Notoginseng radix</i> .....	1197	<i>Passiflorae herbae extractum siccum</i> .....	1210
<i>Nystatinum</i> .....	2602	<i>Pefloxacini mesilas dihydricus</i> .....	2677
		<i>Pelargonii radix</i> .....	1211
<b>O</b>		<i>Penbutololi sulfas</i> .....	2678
<i>Octoxinolum 10</i> .....	2607	<i>Penicillaminum</i> .....	2679
<i>Octyldodecanolum</i> .....	2608	<i>Pentaerythryli tetranitras dilutus</i> .....	2681
<i>Octylis gallas</i> .....	2607	<i>Pentamidini diisetionas</i> .....	2683
<i>Oenotherae oleum raffinatum</i> .....	1991	<i>Pentazocini hydrochloridum</i> .....	2684
<i>Ofloxacinum</i> .....	2609	<i>Pentazocini lactas</i> .....	2685
<i>Oleae folii extractum siccum</i> .....	1201	<i>Pentazocinum</i> .....	2684
<i>Oleae folium</i> .....	1200	<i>Pentobarbitalum</i> .....	2685
<i>Olea herbaria</i> .....	703	<i>Pentobarbitalum natricum</i> .....	2686
<i>Olibanum indicum</i> .....	1152	<i>Pentoxifyllinum</i> .....	2687
<i>Olivae oleum raffinatum</i> .....	2612	<i>Pentoxyverini hydrogenocitras</i> .....	2689
<i>Olivae oleum virginale</i> .....	2613	<i>Pepsini pulvis</i> .....	2690
<i>Olsalazinum natricum</i> .....	2613	<i>Pergolidi mesilas</i> .....	2691
<i>Omega-3 acidorum esteri ethylici 60</i> .....	2616	<i>Perphenazinum</i> .....	2697
<i>Omega-3 acidorum esteri ethylici 90</i> .....	2617	<i>Pethidini hydrochloridum</i> .....	2698
<i>Omega-3 acidorum triglycerida</i> .....	2619	<i>Phenazonum</i> .....	2699
<i>Omeprazolum</i> .....	2621	<i>Pheniramini maleas</i> .....	2700
<i>Omeprazolum magnesium</i> .....	2623	<i>Phenobarbitalum</i> .....	2702
<i>Omeprazolum natricum</i> .....	2624	<i>Phenobarbitalum natricum</i> .....	2702
<i>Ondansetroni hydrochloridum dihydricum</i> .....	2625	<i>Phenolphthaleinum</i> .....	2704
<i>Ononidis radix</i> .....	1223	<i>Phenolsulfonphthaleinum</i> .....	2704
<i>Ophthalmica</i> .....	710	<i>Phenolum</i> .....	2703
<i>Opii extractum siccum normatum</i> .....	1202	<i>Phenoxyethanolum</i> .....	2705
<i>Opii pulvis normatus</i> .....	1203	<i>Phenoxymethylpenicillinum</i> .....	2706
<i>Opii tinctura normata</i> .....	1205	<i>Phenoxymethylpenicillinum kalicum</i> .....	2708
<i>Opium crudum</i> .....	1204	<i>Phentolamini mesilas</i> .....	2709
<i>Orbifloxacinum ad usum veterinarium</i> .....	2627	<i>Phenylalaninum</i> .....	2711
<i>Orciprenalini sulfas</i> .....	2628	<i>Phenylbutazonum</i> .....	2711
<i>Origani herba</i> .....	1206	<i>Phenylephrini hydrochloridum</i> .....	2714
<i>Orphenadrini citras</i> .....	2630	<i>Phenylephrinum</i> .....	2713
<i>Orphenadrini hydrochloridum</i> .....	2631	<i>Phenylhydrargyri acetat</i> .....	2715
<i>Orthosiphonis folium</i> .....	1158	<i>Phenylhydrargyri boras</i> .....	2716
<i>Oryzae amyllum</i> .....	2855	<i>Phenylhydrargyri nitras</i> .....	2716
<i>Ouabainum</i> .....	2632	<i>Phenylpropanolamini hydrochloridum</i> .....	2717
<i>Oxacillinum natricum monohydricum</i> .....	2633	<i>Phenyltoinum</i> .....	2718
<i>Oxaliplatinum</i> .....	2635	<i>Phenyltoinum natricum</i> .....	2719
<i>Oxazepamum</i> .....	2638	<i>Phloroglucinolum anhydricum</i> .....	2720
<i>Oxeladini hydrogenocitras</i> .....	2639	<i>Phloroglucinolum dihydricum</i> .....	2722
<i>Oxfendazolum ad usum veterinarium</i> .....	2640	<i>Pholcodinum</i> .....	2724
<i>Oxitropii bromidum</i> .....	2641	<i>Phthalylsulfathiazolum</i> .....	2726

<i>Physostigmini salicylas</i> .....	2726	<i>Prilocaini hydrochloridum</i> .....	2794
<i>Physostigmini sulfas</i> .....	2727	<i>Prilocainum</i> .....	2792
<i>Phytomenadionum</i> .....	2728	<i>Primaquini diphosphas</i> .....	2795
<i>Phytosterolum</i> .....	2729	<i>Primidonum</i> .....	2796
<i>Picotamidum monohydricum</i> .....	2730	<i>Primulae radix</i> .....	1217
<i>Pilocarpini hydrochloridum</i> .....	2731	<i>Probenecidum</i> .....	2797
<i>Pilocarpini nitras</i> .....	2732	<i>Procainamidi hydrochloridum</i> .....	2798
<i>Pimobendanum</i> .....	2734	<i>Procatini hydrochloridum</i> .....	2798
<i>Pimozidum</i> .....	2734	<i>Prochlorperazini maleas</i> .....	2799
<i>Pindololum</i> .....	2736	<i>Producta ab arte ADN recombinandorum</i> .....	692
<i>Pini pumilionis aetheroleum</i> .....	1116	<i>Producta ab fermentatione</i> .....	685
<i>Pini sylvestris aetheroleum</i> .....	1216	<i>Producta allergenica</i> .....	671
<i>Piperacillinum</i> .....	2738	<i>Producta cum possibili transmissione vectorum</i>	
<i>Piperacillinum natricum</i> .....	2739	<i>enkephalopathiarum spongiformium animalium</i> .....	686
<i>Piperazini adipas</i> .....	2741	<i>Progesteronum</i> .....	2800
<i>Piperazini citras</i> .....	2742	<i>Proguanili hydrochloridum</i> .....	2801
<i>Piperazinum hydricum</i> .....	2743	<i>Prolinum</i> .....	2802
<i>Piracetamum</i> .....	2743	<i>Promazini hydrochloridum</i> .....	2803
<i>Pirenzepini dihydrochloridum monohydricum</i> .....	2744	<i>Promethazini hydrochloridum</i> .....	2804
<i>Piretanidum</i> .....	2746	<i>Propacetamoli hydrochloridum</i> .....	2805
<i>Piroxicamum</i> .....	2747	<i>Propafenoni hydrochloridum</i> .....	2806
<i>Piscis oleum omega-3 acidis abundans</i> .....	2019	<i>Propanolum</i> .....	2808
<i>Pisi amyllum</i> .....	2676	<i>Propantheolini bromidum</i> .....	2809
<i>Pivampicillinum</i> .....	2748	<i>Propofolum</i> .....	2810
<i>Pimecillinami hydrochloridum</i> .....	2750	<i>Propranololi hydrochloridum</i> .....	2811
<i>Plantae ad ptisanam</i> .....	677	<i>Propylenglycoli dicaprylocapras</i> .....	2815
<i>Plantae medicinales</i> .....	676	<i>Propylenglycoli dilauras</i> .....	2815
<i>Plantae medicinales ad praeparationes homoeopathicas</i> ..	1275	<i>Propylenglycoli monolauras</i> .....	2816
<i>Plantae medicinales praeparatae</i> .....	676	<i>Propylenglycoli monopalmitostearas</i> .....	2817
<i>Plantaginis lanceolatae folium</i> .....	1225	<i>Propylenglycolum</i> .....	2814
<i>Plantaginis ovatae semen</i> .....	1157	<i>Propylis gallas</i> .....	2812
<i>Plantaginis ovatae seminis tegumentum</i> .....	1156	<i>Propylis parahydroxybenzoas</i> .....	2813
<i>Plasma humanum ad separationem</i> .....	2181	<i>Propylis parahydroxybenzoas natricus</i> .....	2942
<i>Plasma humanum coagmentatum conditumque ad</i>		<i>Propylthiouracilum</i> .....	2818
<i>extinguendum virum</i> .....	2182	<i>Propyphenazonum</i> .....	2819
<i>Poloxamera</i> .....	2751	<i>Protamini hydrochloridum</i> .....	2820
<i>Polyacrylatis dispersio 30 per centum</i> .....	2752	<i>Protamini sulfas</i> .....	2821
<i>Poly(alcohol vinylicus)</i> .....	2760	<i>Prothrombinum multiplex humanum</i> .....	2185
<i>Polygalae radix</i> .....	1235	<i>Protirelinum</i> .....	2822
<i>Polygoni avicularis herba</i> .....	1162	<i>Proxiphyllinum</i> .....	2823
<i>Polymyxini B sulfas</i> .....	2753	<i>Pruni africanae cortex</i> .....	1221
<i>Polysorbatum 20</i> .....	2754	<i>Pseudoephedrini hydrochloridum</i> .....	2824
<i>Polysorbatum 40</i> .....	2755	<i>Psyllii semen</i> .....	1217
<i>Polysorbatum 60</i> .....	2756	<i>Pulveres ad usum dermicum</i> .....	726
<i>Polysorbatum 80</i> .....	2756	<i>Pulveres perorales</i> .....	727
<i>Poly(vinylis acetate)</i> .....	2758	<i>Pyranтели embonas</i> .....	2825
<i>Poly(vinylis acetate) dispersio 30 per centum</i> .....	2759	<i>Pyrazinamidum</i> .....	2826
<i>Povidonum</i> .....	2776	<i>Pyridostigmini bromidum</i> .....	2827
<i>Povidonum iodinatum</i> .....	2778	<i>Pyridoxini hydrochloridum</i> .....	2827
<i>Praeadmixta ad alimenta medicata ad usum veterinarium</i> ..	727	<i>Pyrimethaminum</i> .....	2829
<i>Praeparationes ad irrigationem</i> .....	731	<i>Pyrrolidonum</i> .....	2829
<i>Praeparationes buccales</i> .....	721		
<i>Praeparationes homoeopathicae</i> .....	1275	<b>Q</b>	
<i>Praeparationes insulinii iniectabiles</i> .....	2249	<i>Quercus cortex</i> .....	1199
<i>Praeparationes intramammariae ad usum veterinarium</i> .....	714		
<i>Praeparationes intraruminales</i> .....	715	<b>R</b>	
<i>Praeparationes intra-uterinae ad usum veterinarium</i> .....	715	<i>Racecadotrilum</i> .....	2841
<i>Praeparationes liquidae ad usum dermicum</i> .....	717	<i>Raclopridi (<sup>14</sup>C)methoxy) solutio iniectabilis</i> .....	988
<i>Praeparationes liquidae peroraliae</i> .....	718	<i>Radiopharmaceutica</i> .....	686
<i>Praeparationes liquidae veterinariae ad usum dermicum</i> ..	740	<i>Raloxifeni hydrochloridum</i> .....	2842
<i>Praeparationes molles ad usum dermicum</i> .....	734	<i>Ramiprilum</i> .....	2843
<i>Praeparationes pharmaceuticae in vasis cum pressu</i> .....	732	<i>Ranitidini hydrochloridum</i> .....	2845
<i>Pramipexoli dihydrochloridum monohydricum</i> .....	2779	<i>Rapae oleum raffinatum</i> .....	2847
<i>Pravastatinum natricum</i> .....	2780	<i>Ratanhiae radix</i> .....	1223
<i>Prazepamum</i> .....	2782	<i>Ratanhiae tinctura</i> .....	1224
<i>Praziquantelum</i> .....	2783	<i>Rectalia</i> .....	732
<i>Prazosini hydrochloridum</i> .....	2784	<i>Repaglinidum</i> .....	2847
<i>Prednicarbatum</i> .....	2785	<i>Reserpinum</i> .....	2849
<i>Prednisoloni acetate</i> .....	2787	<i>Resorcinolum</i> .....	2850
<i>Prednisoloni natrii phosphas</i> .....	2790	<i>Rhamni purshianae cortex</i> .....	1092
<i>Prednisoloni pivalas</i> .....	2789	<i>Rhamni purshianae extractum siccum normatum</i> .....	1094
<i>Prednisolonum</i> .....	2786	<i>Rhei radix</i> .....	1224
<i>Prednisonum</i> .....	2791		

<i>Rhenii sulfidi colloidalis et technetii (<sup>99m</sup>Tc) solutio iniectionabilis</i> .....	1005	<i>Silica hydrophobica colloidalis</i> .....	2903
<i>Ribavirinum</i> .....	2850	<i>Silybi mariani extractum siccum raffinatum et normatum</i> .....	1186
<i>Riboflavini natrii phosphas</i> .....	2853	<i>Silybi mariani fructus</i> .....	1187
<i>Riboflavinum</i> .....	2852	<i>Simeticonum</i> .....	2905
<i>Ricini oleum hydrogenatum</i> .....	1596	<i>Simvastatinum</i> .....	2906
<i>Ricini oleum raffinatum</i> .....	1597	<i>Soiae oleum hydrogenatum</i> .....	2968
<i>Ricini oleum virginale</i> .....	1598	<i>Soiae oleum raffinatum</i> .....	2969
<i>Rifabutinum</i> .....	2855	<i>Solani amyllum</i> .....	2775
<i>Rifampicinum</i> .....	2856	<i>Solidaginis herba</i> .....	1141
<i>Rifampicinum natricum</i> .....	2858	<i>Solidaginis virgaureae herba</i> .....	1142
<i>Rifaximinum</i> .....	2859	<i>Solutiones ad conservationem partium corporis</i> .....	2952
<i>Rilmenidini dihydrogenophosphas</i> .....	2861	<i>Solutiones ad haemocolaturam haemodiatolaturamque</i> .....	2138
<i>Risperidonum</i> .....	2861	<i>Solutiones ad haemodialysim</i> .....	2136
<i>Ritonavirum</i> .....	2863	<i>Solutiones ad peritonealem dialysim</i> .....	2695
<i>Rocuronii bromidum</i> .....	2866	<i>Solutiones anticoagulantes et sanguinem humanum conservantes</i> .....	1401
<i>Ropivacaini hydrochloridum monohydricum</i> .....	2868	<i>Somatostatinum</i> .....	2953
<i>Rosae pseudo-fructus</i> .....	1115	<i>Somatropini solutio concentrata</i> .....	2956
<i>Rosmarini aetheroleum</i> .....	1228	<i>Somatropinum</i> .....	2954
<i>Rosmarini folium</i> .....	1227	<i>Somatropinum iniectionabile</i> .....	2958
<i>Roxithromycinum</i> .....	2869	<i>Sorbitani lauras</i> .....	2961
<i>RRR-<math>\alpha</math>-Tocopherolum</i> .....	3105	<i>Sorbitani oleas</i> .....	2961
<i>RRR-<math>\alpha</math>-Tocopherylis acetas</i> .....	3108	<i>Sorbitani palmitas</i> .....	2962
<i>RRR-<math>\alpha</math>-Tocopherylis hydrogenosuccinas</i> .....	3111	<i>Sorbitani sesquioleas</i> .....	2962
<i>Rusci rhizoma</i> .....	1085	<i>Sorbitani stearas</i> .....	2962
<i>Rutosidum trihydricum</i> .....	2871	<i>Sorbitani trioleas</i> .....	2963
<b>S</b>		<i>Sorbitolum</i> .....	2963
<i>Sabalis serrulatae fructus</i> .....	1233	<i>Sorbitolum liquidum cristallisabile</i> .....	2965
<i>Sacchari monopalmitas</i> .....	2998	<i>Sorbitolum liquidum non cristallisabile</i> .....	2965
<i>Saccharinum</i> .....	2877	<i>Sorbitolum liquidum partim deshydricum</i> .....	2966
<i>Saccharinum natricum</i> .....	2878	<i>Sotaloli hydrochloridum</i> .....	2967
<i>Sacchari sphaerae</i> .....	3002	<i>Spectinomycini dihydrochloridum pentahydricum</i> .....	2969
<i>Sacchari stearas</i> .....	2999	<i>Spectinomycini sulfas tetrahydricus ad usum veterinarium</i> .....	2971
<i>Saccharum</i> .....	2996	<i>Spicae aetheroleum</i> .....	1240
<i>Salbutamoli sulfas</i> .....	2881	<i>Spiramycinum</i> .....	2973
<i>Salbutamololum</i> .....	2879	<i>Spiraprioli hydrochloridum monohydricum</i> .....	2975
<i>Salicis cortex</i> .....	1268	<i>Spiroolactonum</i> .....	2976
<i>Salicis corticis extractum siccum</i> .....	1269	<i>Squalanum</i> .....	2978
<i>Salmeteroli xinafoas</i> .....	2885	<i>Stanni colloidalis et technetii (<sup>99m</sup>Tc) solutio iniectionabilis</i> .....	1006
<i>Salmonis domestici oleum</i> .....	2886	<i>Stanni pyrophosphatis et technetii (<sup>99m</sup>Tc) solutio iniectionabilis</i> .....	1019
<i>Salviae lavandulifoliae aetheroleum</i> .....	1239	<i>Stannosi chloridum dihydricum</i> .....	2980
<i>Salviae officinalis folium</i> .....	1230	<i>Stanozololum</i> .....	2981
<i>Salviae sclareae aetheroleum</i> .....	1104	<i>Stavudinum</i> .....	2988
<i>Salviae tinctura</i> .....	1231	<i>Stephaniae tetrandrae radix</i> .....	1127
<i>Salviae trilobae folium</i> .....	1231	<i>Stramonii folium</i> .....	1247
<i>Sambuci flos</i> .....	1117	<i>Stramonii pulvis normatus</i> .....	1248
<i>Sanguisorbae radix</i> .....	1232	<i>Streptokinasi solutio concentrata</i> .....	2991
<i>Saquinaviri mesilas</i> .....	2889	<i>Streptomycini sulfas</i> .....	2993
<i>Schisandrae chinensis fructus</i> .....	1234	<i>Strontii (<sup>90</sup>Sr) chloridi solutio iniectionabilis</i> .....	1003
<i>Scopolamini butylbromidum</i> .....	2215	<i>Styli</i> .....	736
<i>Scopolamini hydrobromidum</i> .....	2216	<i>Succinylsulfathiazolum</i> .....	2994
<i>Scopolaminum</i> .....	2214	<i>Sucralfatum</i> .....	2995
<i>Selamectinum ad usum veterinarium</i> .....	2890	<i>Sufentanili citras</i> .....	3001
<i>Selegilini hydrochloridum</i> .....	2892	<i>Sufentanilum</i> .....	3000
<i>Selenii disulfidum</i> .....	2893	<i>Sulbactamum natricum</i> .....	3003
<i>Semecarpus anacardium ad praeparationes homoeopathicas</i> .....	1295	<i>Sulfacetamidum natricum</i> .....	3005
<i>Sennae folii extractum siccum normatum</i> .....	1237	<i>Sulfadiazinum</i> .....	3006
<i>Sennae folium</i> .....	1236	<i>Sulfadimidinum</i> .....	3007
<i>Sennae fructus acutifoliae</i> .....	1238	<i>Sulfadoxinum</i> .....	3007
<i>Sennae fructus angustifoliae</i> .....	1238	<i>Sulfafurazolum</i> .....	3008
<i>Serinum</i> .....	2893	<i>Sulfaguanidinum</i> .....	3009
<i>Serpylli herba</i> .....	1267	<i>Sulfamerazinum</i> .....	3010
<i>Sertaconazoli nitras</i> .....	2894	<i>Sulfamethizolum</i> .....	3011
<i>Sertralini hydrochloridum</i> .....	2895	<i>Sulfamethoxazolum</i> .....	3011
<i>Serum bovinum</i> .....	1506	<i>Sulfamethoxyipyridazinum ad usum veterinarium</i> .....	3013
<i>Sesami oleum raffinatum</i> .....	2898	<i>Sulfanilamidum</i> .....	3013
<i>Sevofluranum</i> .....	2899	<i>Sulfasalazinum</i> .....	3014
<i>Silica ad usum dentalem</i> .....	2903	<i>Sulfathiazolum</i> .....	3016
<i>Silica colloidalis anhydrica</i> .....	2901	<i>Sulfapyrazolum</i> .....	3017
<i>Silica colloidalis hydrica</i> .....	2902	<i>Sulfisomidinum</i> .....	3018

<i>Sulfur ad usum externum</i> .....	3019	<i>Thymi herba</i> .....	1252
<i>Sulfuris colloidalis et technetii (<sup>99m</sup>Tc) solutio iniectionabilis</i> ..	1006	<i>Thymolum</i> .....	3081
<i>Sulindacum</i> .....	3020	<i>Tiabendazolum</i> .....	3081
<i>Sulpiridum</i> .....	3021	<i>Tiamulini hydrogenuofumaras ad usum veterinarium</i> ..	3084
<i>Sultamicillini tosilas dihydricus</i> .....	3024	<i>Tiamulinum ad usum veterinarium</i> .....	3082
<i>Sultamicillinum</i> .....	3022	<i>Tianeptinum natricum</i> .....	3086
<i>Sumatriptani succinas</i> .....	3026	<i>Tiapridi hydrochloridum</i> .....	3087
<i>Suxamethonii chloridum</i> .....	3028	<i>Tibolonum</i> .....	3090
<i>Suxibuzonum</i> .....	3029	<i>Ticarcillinum natricum</i> .....	3091
<b>T</b>			
<i>Talcum</i> .....	3033	<i>Ticlopidini hydrochloridum</i> .....	3092
<i>Tamoxifeni citras</i> .....	3034	<i>Tiliae flos</i> .....	1168
<i>Tamponae medicatae</i> .....	738	<i>Tilidini hydrochloridum hemihydricum</i> .....	3094
<i>Tamsulosini hydrochloridum</i> .....	3036	<i>Timololi maleas</i> .....	3095
<i>Tanacetii parthenii herba</i> .....	1126	<i>Tincturae maternae ad praeparationes homoeopathicas</i> ..	1286
<i>Tanninum</i> .....	3037	<i>Tinidazolum</i> .....	3097
<i>Taraxaci officinalis herba cum radice</i> .....	1110	<i>Tinzaparinum natricum</i> .....	3098
<i>Taraxaci officinalis radix</i> .....	1111	<i>Tioconazololum</i> .....	3099
<i>Technetii (<sup>99m</sup>Tc) bicusati solutio iniectionabilis</i> .....	1004	<i>Tiotropii bromidum monohydricum</i> .....	3100
<i>Technetii (<sup>99m</sup>Tc) et etifenini solutio iniectionabilis</i> .....	1007	<i>Titanii dioxidum</i> .....	3101
<i>Technetii (<sup>99m</sup>Tc) exametazimi solutio iniectionabilis</i> .....	1008	<i>Tobramycinum</i> .....	3103
<i>Technetii (<sup>99m</sup>Tc) gluconatis solutio iniectionabilis</i> .....	1009	<i>α-Tocopherylis acetatis pulvis</i> .....	3109
<i>Technetii (<sup>99m</sup>Tc) humani albumini solutio iniectionabilis</i> .....	1010	<i>Tolbutamidum</i> .....	3113
<i>Technetii (<sup>99m</sup>Tc) macrosalbi suspensio iniectionabilis</i> .....	1011	<i>Tolnaftatum</i> .....	3115
<i>Technetii (<sup>99m</sup>Tc) mebrofenini solutio iniectionabilis</i> .....	1012	<i>Torasemidum anhydricum</i> .....	3117
<i>Technetii (<sup>99m</sup>Tc) medronati solutio iniectionabilis</i> .....	1013	<i>Tormentillae rhizoma</i> .....	1255
<i>Technetii (<sup>99m</sup>Tc) mertiatidi solutio iniectionabilis</i> .....	1014	<i>Tormentillae tinctura</i> .....	1256
<i>Technetii (<sup>99m</sup>Tc) microsphaerarum suspensio iniectionabilis</i> .....	1015	<i>Tosylchloramidum natricum</i> ..	3118
<i>Technetii (<sup>99m</sup>Tc) pentetatis solutio iniectionabilis</i> .....	1016	<i>Toxinum botulinicum typum A ad iniectionabile</i> ..	1504
<i>Technetii (<sup>99m</sup>Tc) sestamibi solutio iniectionabilis</i> .....	1017	<i>Tragacantha</i> .....	1256
<i>Technetii (<sup>99m</sup>Tc) succimeri solutio iniectionabilis</i> .....	1018	<i>Tramadoli hydrochloridum</i> ..	3118
<i>Teicoplaninum</i> .....	3038	<i>Tramazolini hydrochloridum monohydricum</i> .....	3120
<i>Telmisartanum</i> .....	3040	<i>Trandolaprilum</i> .....	3120
<i>Temazepamum</i> .....	3042	<i>Trapidilum</i> .....	3123
<i>Tenoxicamum</i> .....	3043	<i>Trehalosum dihydricum</i> .....	3124
<i>Terazosini hydrochloridum dihydricum</i> .....	3045	<i>Tretinoinum</i> .....	3125
<i>Terbinafini hydrochloridum</i> .....	3047	<i>Triacetinum</i> .....	3127
<i>Terbutalini sulfas</i> .....	3048	<i>Triamcinoloni acetamidum</i> .....	3128
<i>Terconazololum</i> .....	3049	<i>Triamcinoloni hexacetamidum</i> .....	3130
<i>Terebinthinae aetheroleum a Pino pinastro</i> .....	1258	<i>Triamcinolonum</i> .....	3127
<i>Terfenadinum</i> .....	3050	<i>Triamterenum</i> .....	3131
<i>tert-Butylamini perindoprilum</i> .....	2692	<i>Tribenosidum</i> .....	3132
<i>Testosteroni decanoas</i> .....	3053	<i>Tributylis acetylcitras</i> .....	3133
<i>Testosteroni enantas</i> .....	3054	<i>Tricalcii phosphas</i> .....	1567
<i>Testosteroni isocaproas</i> .....	3056	<i>Triethylis citras</i> .....	3136
<i>Testosteroni propionas</i> .....	3057	<i>Trifluoperazini hydrochloridum</i> .....	3136
<i>Testosteronum</i> .....	3052	<i>Triflusalum</i> .....	3137
<i>Tetracaini hydrochloridum</i> .....	3058	<i>Triglycerida saturata media</i> .....	3138
<i>Tetracosactidum</i> .....	3059	<i>Triglyceroli diisostearas</i> .....	3140
<i>Tetracyclini hydrochloridum</i> .....	3061	<i>Trigonellae foenugraeci semen</i> .....	1126
<i>Tetracyclinum</i> .....	3060	<i>Trihexyphenidylis hydrochloridum</i> .....	3140
<i>Tetra-O-acetylmannosi triflas ad radiopharmaceutica</i> .....	1020	<i>Trimebutini maleas</i> .....	3141
<i>Tetrazepamum</i> .....	3063	<i>Trimetazidini dihydrochloridum</i> .....	3142
<i>Tetryzolini hydrochloridum</i> .....	3064	<i>Trimethadionum</i> .....	3144
<i>Thallosi (<sup>201</sup>Tl) chloridi solutio iniectionabilis</i> .....	1021	<i>Trimethoprimum</i> .....	3144
<i>Theobrominum</i> .....	3065	<i>Trimipramini maleas</i> .....	3146
<i>Theophyllinum</i> .....	3065	<i>Tri-n-butylis phosphas</i> .....	3134
<i>Theophyllinum et ethylenediaminum anhydricum</i> .....	3068	<i>Tritici aestivi oleum raffinatum</i> .....	3226
<i>Theophyllinum et ethylenediaminum hydricum</i> .....	3069	<i>Tritici aestivi oleum virginale</i> .....	3227
<i>Theophyllinum monohydricum</i> .....	3066	<i>Tritici amyllum</i> .....	3226
<i>Thiamazololum</i> .....	3071	<i>Trolaminum</i> .....	3148
<i>Thiamini hydrochloridum</i> .....	3072	<i>Trometamololum</i> .....	3150
<i>Thiamini nitras</i> .....	3073	<i>Tropicamidum</i> .....	3151
<i>Thiamphenicolum</i> .....	3074	<i>Tropisetroni hydrochloridum</i> .....	3152
<i>Thiomersalum</i> .....	3076	<i>Trospii chloridum</i> .....	3154
<i>Thiopentalum natricum et natrii carbonas</i> .....	3077	<i>Troxerutinum</i> .....	3155
<i>Thioridazini hydrochloridum</i> .....	3079	<i>Trypsinum</i> .....	3156
<i>Thioridazinum</i> .....	3078	<i>Tryptophanum</i> .....	3157
<i>Threoninum</i> .....	3080	<i>Tuberculi aviarii derivatum proteinosum purificatum</i> ..	3161
<i>Thymi aetheroleum</i> .....	1254	<i>Tuberculi bovini derivatum proteinosum purificatum</i> ..	3161
		<i>Tuberculi derivatum proteinosum purificatum ad usum humanum</i> ..	3162
		<i>Tuberculinum pristinum ad usum humanum</i> ..	3159
		<i>Tubocurariini chloridum</i> .....	3164

<i>Tylosini phosphatis solutio ad usum veterinarium</i> .....	3166	<i>Vaccinum diphtheriae, tetani, pertussis sine cellulis ex elementis praeparatum et hepatitidis B (ADNr) adsorbatum</i> .....	760
<i>Tylosini tartras ad usum veterinarium</i> .....	3168	<i>Vaccinum diphtheriae, tetani, pertussis sine cellulis ex elementis praeparatum et poliomyelitidis inactivatum adsorbatum</i> .....	762
<i>Tylosinum ad usum veterinarium</i> .....	3165	<i>Vaccinum diphtheriae, tetani, pertussis sine cellulis ex elementis praeparatum et poliomyelitidis inactivatum, anti-<i>geni-o(-is) minutum, adsorbatum</i></i> .....	763
<i>Tyrosinum</i> .....	3169	<i>Vaccinum diphtheriae, tetani, pertussis sine cellulis ex elementis praeparatum, hepatitidis B (ADNr), poliomyelitidis inactivatum et haemophili stirpi b coniugatum adsorbatum</i> .....	765
<i>Tyrothricinum</i> .....	3170	<i>Vaccinum diphtheriae, tetani, pertussis sine cellulis ex elementis praeparatum, poliomyelitidis inactivatum et haemophili stirpi b coniugatum adsorbatum</i> .....	768
<b>U</b>			
<i>Ubidecarenonum</i> .....	3175	<i>Vaccinum encephalitis ixodibus advectae inactivatum</i> .....	834
<i>Ureum</i> .....	3176	<i>Vaccinum encephalomyelitis infectivae aviariae vivum</i> .....	857
<i>Urofollitropinum</i> .....	3177	<i>Vaccinum erysipelas suillae inactivatum</i> .....	939
<i>Urokinasum</i> .....	3178	<i>Vaccinum febris flavae vivum</i> .....	840
<i>Urtica dioica ad praeparationes homoeopathicas</i> .....	1288	<i>Vaccinum febris typhoidi</i> .....	837
<i>Urticae folium</i> .....	1196	<i>Vaccinum febris typhoidi cryodesiccatum</i> .....	837
<i>Uvae ursi folium</i> .....	1061	<i>Vaccinum febris typhoidis polysaccharidicum</i> .....	836
<b>V</b>			
<i>Vaccina ad usum humanum</i> .....	695	<i>Vaccinum febris typhoidis vivum perorale (stirpe Ty 21a)</i> .....	838
<i>Vaccina ad usum veterinarium</i> .....	698	<i>Vaccinum furunculosis inactivatum ad salmonidas cum adiuvatione oleosa ad iniectionem</i> .....	907
<i>Vaccinum actinobacillosidis inactivatum ad suem</i> .....	926	<i>Vaccinum haemophili stirpi b coniugatum</i> .....	776
<i>Vaccinum adenovirosidis caninae vivum</i> .....	871	<i>Vaccinum hepatitidis A inactivatum adsorbatum</i> .....	780
<i>Vaccinum adenovirus caninae inactivatum</i> .....	870	<i>Vaccinum hepatitidis A inactivatum et hepatitidis B (ADNr) adsorbatum</i> .....	779
<i>Vaccinum anaemiae infectivae pulli vivum</i> .....	910	<i>Vaccinum hepatitidis A inactivatum virosomale</i> .....	781
<i>Vaccinum anthracis adsorbatum ab colato culturarum ad usum humanum</i> .....	745	<i>Vaccinum hepatitidis B (ADNr)</i> .....	784
<i>Vaccinum anthracis vivum ad usum veterinarium</i> .....	847	<i>Vaccinum hepatitidis viralis anatis stirpe I vivum</i> .....	889
<i>Vaccinum aphtharum epizooticarum inactivatum ad ruminantes</i> .....	904	<i>Vaccinum herpesvirus equini inactivatum</i> .....	892
<i>Vaccinum bronchitis infectivae aviariae inactivatum</i> .....	851	<i>Vaccinum inactivatum diarrhoeae vituli coronavirillatae</i> .....	868
<i>Vaccinum bronchitis infectivae aviariae vivum</i> .....	852	<i>Vaccinum inactivatum diarrhoeae vituli rotavirillatae</i> .....	869
<i>Vaccinum brucellosis (Brucella melitensis stirpe Rev. 1) vivum ad usum veterinarium</i> .....	867	<i>Vaccinum influenzae equi inactivatum</i> .....	893
<i>Vaccinum bursitis infectivae aviariae inactivatum</i> .....	854	<i>Vaccinum influenzae inactivatum ad suem</i> .....	929
<i>Vaccinum bursitis infectivae aviariae vivum</i> .....	856	<i>Vaccinum influenzae inactivatum ex cellulis corticisque antigeniis praeparatum</i> .....	791
<i>Vaccinum calicivirose felinae inactivatum</i> .....	895	<i>Vaccinum influenzae inactivatum ex cellulis virisque integris praeparatum</i> .....	796
<i>Vaccinum calicivirose felinae vivum</i> .....	896	<i>Vaccinum influenzae inactivatum ex corticis antigeniis praeparatum</i> .....	789
<i>Vaccinum chlamydiosis felinae inactivatum</i> .....	897	<i>Vaccinum influenzae inactivatum ex corticis antigeniis praeparatum virosomale</i> .....	793
<i>Vaccinum cholerae</i> .....	748	<i>Vaccinum influenzae inactivatum ex viris integris praeparatum</i> .....	795
<i>Vaccinum cholerae aviariae inactivatum</i> .....	905	<i>Vaccinum influenzae inactivatum ex virorum fragmentis praeparatum</i> .....	788
<i>Vaccinum cholerae cryodesiccatum</i> .....	749	<i>Vaccinum laryngotracheitis infectivae aviariae vivum</i> .....	859
<i>Vaccinum cholerae perorale inactivatum</i> .....	749	<i>Vaccinum leptospirosis bovinae inactivatum</i> .....	862
<i>Vaccinum Clostridii botulini ad usum veterinarium</i> .....	878	<i>Vaccinum leptospirosis caninae inactivatum</i> .....	874
<i>Vaccinum Clostridii chauvoei ad usum veterinarium</i> .....	879	<i>Vaccinum leucosis felinae inactivatum</i> .....	900
<i>Vaccinum Clostridii novyi B ad usum veterinarium</i> .....	879	<i>Vaccinum mannheimiae inactivatum ad bovinas</i> .....	911
<i>Vaccinum Clostridii perfringentis ad usum veterinarium</i> .....	881	<i>Vaccinum mannheimiae inactivatum ad ovem</i> .....	913
<i>Vaccinum Clostridii septici ad usum veterinarium</i> .....	883	<i>Vaccinum meningococcale classis C coniugatum</i> .....	802
<i>Vaccinum coccidiosidis vivum ad pullum</i> .....	884	<i>Vaccinum meningococcale polysaccharidicum</i> .....	803
<i>Vaccinum colibacillosis fetus a partu recentis inactivatum ad ruminantes</i> .....	920	<i>Vaccinum morbi Aujeszkyi ad suem inactivatum</i> .....	847
<i>Vaccinum colibacillosis fetus a partu recentis inactivatum ad suem</i> .....	918	<i>Vaccinum morbi Aujeszkyi ad suem vivum ad usum parenteralem</i> .....	849
<i>Vaccinum diarrhoeae viralis bovinae inactivatum</i> .....	866	<i>Vaccinum morbi Carrei vivum ad canem</i> .....	872
<i>Vaccinum diphtheriae adsorbatum</i> .....	774	<i>Vaccinum morbi Carrei vivum ad mustelidas</i> .....	887
<i>Vaccinum diphtheriae, antigeniis minutum, adsorbatum</i> .....	776	<i>Vaccinum morbi haemorrhagici cuniculi inactivatum</i> .....	933
<i>Vaccinum diphtheriae et tetani adsorbatum</i> .....	751	<i>Vaccinum morbillorum, parotitidis et rubellae vivum</i> .....	798
<i>Vaccinum diphtheriae et tetani, antigeni(-o(-is) minutum, adsorbatum</i> .....	752	<i>Vaccinum morbillorum, parotitidis, rubellae et varicellae vivum</i> .....	799
<i>Vaccinum diphtheriae, tetani et hepatitidis B (ADNr) adsorbatum</i> .....	753	<i>Vaccinum morbillorum vivum</i> .....	800
<i>Vaccinum diphtheriae, tetani et pertussis adsorbatum</i> .....	755	<i>Vaccinum morbi Marek vivum</i> .....	914
<i>Vaccinum diphtheriae, tetani et pertussis sine cellulis ex elementis praeparatum adsorbatum</i> .....	754	<i>Vaccinum morbi partus diminutionis MCMXXVI inactivatum ad pullum</i> .....	891
<i>Vaccinum diphtheriae, tetani et poliomyelitidis inactivatum, antigeni(-o(-is) minutum, adsorbatum</i> .....	756	<i>Vaccinum Mycoplasmae gallisepticae inactivatum</i> .....	916
<i>Vaccinum diphtheriae, tetani, pertussis et poliomyelitidis inactivatum adsorbatum</i> .....	771		
<i>Vaccinum diphtheriae, tetani, pertussis, poliomyelitidis inactivatum et haemophili stirpi b coniugatum adsorbatum</i> .....	772		
<i>Vaccinum diphtheriae, tetani, pertussis sine cellulis ex elementis praeparatum cumque haemophili stirpi b coniugatum adsorbatum</i> .....	758		

<i>Vaccinum myxomatosis vivum ad cuniculum</i> .....	917	<i>Valsartanum</i> .....	3191
<i>Vaccinum panleucopeniae felinae infectivae inactivatum</i> ..	898	<i>Vancomycini hydrochloridum</i> .....	3192
<i>Vaccinum panleucopeniae felinae infectivae vivum</i> .....	899	<i>Vanillinum</i> .....	3194
<i>Vaccinum papillomaviri humani (ADNr)</i> .....	785	<i>Vaselinum album</i> .....	2670
<i>Vaccinum parainfluenzae viri canini vivum</i> .....	875	<i>Vaselinum flavum</i> .....	2671
<i>Vaccinum paramyxovirus 3 aviarii inactivatum</i> .....	860	<i>Vecuronii bromidum</i> .....	3195
<i>Vaccinum parotitidis vivum</i> .....	805	<i>Vedaprofenum ad usum veterinarium</i> .....	3196
<i>Vaccinum parvovirus caninae inactivatum</i> .....	876	<i>Venlafaxini hydrochloridum</i> .....	3197
<i>Vaccinum parvovirus caninae vivum</i> .....	877	<i>Verapamili hydrochloridum</i> .....	3198
<i>Vaccinum pasteurellae inactivatum ad ovem</i> .....	925	<i>Verbasci flos</i> .....	1191
<i>Vaccinum pertussis ex cellulis integris adsorbatum</i> .....	810	<i>Verbenae citriodoratae folium</i> .....	1166
<i>Vaccinum pertussis sine cellulis copurificatum adsorbatum</i> .....	808	<i>Verbenae herba</i> .....	1264
<i>Vaccinum pertussis sine cellulis ex elementis praeparatum adsorbatum</i> .....	806	<i>Via praeparandi stirpes homoeopathicas et potentificandi</i> .....	1277
<i>Vaccinum pestis anatis vivum</i> .....	888	<i>Vinblastini sulfas</i> .....	3200
<i>Vaccinum pestis classicae suillae vivum ex cellulis</i> .....	940	<i>Vincristini sulfas</i> .....	3201
<i>Vaccinum pneumococcale polysaccharidicum</i> .....	813	<i>Vindesini sulfas</i> .....	3202
<i>Vaccinum pneumococcale polysaccharidicum coniugatum adsorbatum</i> .....	812	<i>Vinorelbini tartras</i> .....	3204
<i>Vaccinum pneumoniae enzooticae suillae inactivatum</i> .....	927	<i>Vinpocetinum</i> .....	3206
<i>Vaccinum poliomyelitis inactivatum</i> .....	815	<i>Violae herba cum flore</i> .....	1266
<i>Vaccinum poliomyelitis perorale</i> .....	818	<i>Vitamiini synthetici densati A pulvis</i> .....	3211
<i>Vaccinum pseudopestis aviariae inactivatum</i> .....	921	<i>Vitaminum A</i> .....	3208
<i>Vaccinum pseudopestis aviariae vivum</i> .....	923	<i>Vitaminum A syntheticum densatum oleosum</i> .....	3209
<i>Vaccinum rabiei ex cellulis ad usum humanum</i> .....	822	<i>Vitaminum A syntheticum, solubilisatum densatum in aqua dispergibile</i> .....	3212
<i>Vaccinum rabiei inactivatum ad usum veterinarium</i> .....	934	<b>W</b>	
<i>Vaccinum rabiei perorale vivum ad vulpem</i> .....	936	<i>Warfarinum natricum</i> .....	3217
<i>Vaccinum rhinitidis atrophicantis ingravescentis suillae inactivatum</i> .....	931	<i>Warfarinum natricum clathratum</i> .....	3218
<i>Vaccinum rhinotracheitidis infectivae bovinae vivum</i> .....	908	<b>X</b>	
<i>Vaccinum rhinotracheitidis viralis felinae inactivatum</i> .....	901	<i>Xanthani gummi</i> .....	3237
<i>Vaccinum rhinotracheitidis viralis felinae vivum</i> .....	902	<i>Xenoni (<sup>133</sup>Xe) solutio iniectabilis</i> .....	1023
<i>Vaccinum rotaviri vivum perorale</i> .....	824	<i>Xylazini hydrochloridum ad usum veterinarium</i> .....	3238
<i>Vaccinum rubellae vivum</i> .....	827	<i>Xylitolum</i> .....	3239
<i>Vaccinum Salmonellae Enteritidis inactivatum ad pullum</i> ..	937	<i>Xylometazolini hydrochloridum</i> .....	3241
<i>Vaccinum Salmonellae Typhimurium inactivatum ad pullum</i> .....	938	<i>Xylosum</i> .....	3242
<i>Vaccinum tenosynovitis viralis aviariae vivum</i> .....	861	<b>Y</b>	
<i>Vaccinum tetani adsorbatum</i> .....	833	<i>Yohimbini hydrochloridum</i> .....	3247
<i>Vaccinum tetani ad usum veterinarium</i> .....	941	<b>Z</b>	
<i>Vaccinum tuberculosis (BCG) cryodesiccatum</i> .....	747	<i>Zidovudinum</i> .....	3251
<i>Vaccinum varicellae vivum</i> .....	839	<i>Zinci acetat dihydricus</i> .....	3252
<i>Vaccinum variolae gallinae vivum</i> .....	906	<i>Zinci acexamas</i> .....	3253
<i>Vaccinum variolae vivum</i> .....	829	<i>Zinci chloridum</i> .....	3254
<i>Vaccinum vibriosidis aquae frigidae inactivatum ad salmonidas</i> .....	943	<i>Zinci gluconas</i> .....	3255
<i>Vaccinum vibriosidis inactivatum ad salmonidas</i> .....	944	<i>Zinci oxidum</i> .....	3255
<i>Vaccinum viri parainfluenzae bovini vivum</i> .....	864	<i>Zinci stearas</i> .....	3256
<i>Vaccinum viri syncytialis meatus spiritus bovini vivum</i> .....	865	<i>Zinci sulfas heptahydricus</i> .....	3257
<i>Vaccinum zonae vivum</i> .....	828	<i>Zinci sulfas hexahydricus</i> .....	3257
<i>Vaginalia</i> .....	738	<i>Zinci sulfas monohydricus</i> .....	3257
<i>Valacicloviri hydrochloridum anhydricum</i> .....	3185	<i>Zinci undecylenas</i> .....	3258
<i>Valerianae extractum aquosum siccum</i> .....	1259	<i>Zingiberis rhizoma</i> .....	1135
<i>Valerianae extractum hydroalcoholicum siccum</i> .....	1260	<i>Ziprasidoni hydrochloridum monohydricum</i> .....	3258
<i>Valerianae radix</i> .....	1261	<i>Zolpidemi tartras</i> .....	3260
<i>Valerianae radix minutata</i> .....	1262	<i>Zopiclonum</i> .....	3261
<i>Valerianae tinctura</i> .....	1263	<i>Zuclophenixoli decanoas</i> .....	3263
<i>Valinum</i> .....	3188		
<i>Valnemulini hydrochloridum ad usum veterinarium</i> .....	3188		

# KEY TO MONOGRAPHS

Carbimazole

EUROPEAN PHARMACOPOEIA 7.0

Version date of the text	01/2008:0884 corrected 7.0
Text reference number	<b>CARBIMAZOLE</b> Carbimazolum

Modification to be taken into account from the publication date of volume 7.0

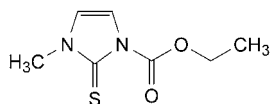

CAS number	C <sub>7</sub> H <sub>10</sub> N <sub>2</sub> O <sub>2</sub> S [22232-54-8]	M <sub>r</sub> 186.2
------------	--	----------------------

**DEFINITION**  
Ethyl 3-methyl-2-thioxo-2,3-dihydro-1H-imidazole-1-carboxylate.  
*Content:* 98.0 per cent to 102.0 per cent (dried substance).

**CHARACTERS**  
*Appearance:* white or yellowish-white, crystalline powder.  
*Solubility:* slightly soluble in water, soluble in acetone and in ethanol (96 per cent).

**IDENTIFICATION**  
*First identification:* B.  
*Second identification:* A, C.  
A. Melting point (2.2.14): 122 °C to 125 °C.  
B. Infrared absorption spectrophotometry (2.2.24).  
*Preparation:* discs.  
*Comparison:* carbimazole CRS.

**REFERENCE STANDARD**  
C. Thin-layer chromatography (2.2.27).  
*Test solution.* Dissolve 10 mg of the substance to be examined in methylene chloride R and dilute to 10 mL with the same solvent.  
*Reference solution.* Dissolve 10 mg of carbimazole CRS in methylene chloride R and dilute to 10 mL with the same solvent.  
*Plate:* TLC silica gel GF<sub>254</sub> plate R.

**REAGENTS**  
*Mobile phase:* acetone R / methylene chloride R (20:80 V/V).  
*Application:* 10 µL.  
*Development:* over a path of 15 cm.  
*Drying:* in air for 30 min.

**DETECTION**  
*Detection:* examine in ultraviolet light at 254 nm.  
*Results:* the principal spot in the chromatogram obtained with the test solution is similar in position and size to the principal spot in the chromatogram obtained with the reference solution.

**TESTS**  
**Related substances.** Liquid chromatography (2.2.29).  
*Test solution.* Dissolve 5.0 mg of the substance to be examined in 10.0 mL of a mixture of 20 volumes of acetonitrile R and 80 volumes of water R. Use this solution within 5 min of preparation.

**REFERENCE SOLUTION**  
*Reference solution (a).* Dissolve 5 mg of thiamazole R and 0.10 g of carbimazole CRS in a mixture of 20 volumes of acetonitrile R and 80 volumes of water R and dilute to 100.0 mL with the same mixture of solvents. Dilute 1.0 mL

of this solution to 10.0 mL with a mixture of 20 volumes of acetonitrile R and 80 volumes of water R.

*Reference solution (b).* Dissolve 5.0 mg of thiamazole R in a mixture of 20 volumes of acetonitrile R and 80 volumes of water R and dilute to 10.0 mL with the same mixture of solvents. Dilute 1.0 mL of this solution to 100.0 mL with a mixture of 20 volumes of acetonitrile R and 80 volumes of water R.

**COLUMN**  
– size: l = 0.15 m, Ø = 3.9 mm,  
– stationary phase: octadecylsilyl silica gel for chromatography R (5 µm).

*Mobile phase:* acetonitrile R, water R (10:90 V/V).

*Flow rate:* 1 mL/min.

*Detection:* spectrophotometer at 254 nm.

*Injection:* 10 µL.

*Run time:* 1.5 times the retention time of carbimazole.

*Retention time:* carbimazole = about 6 min.

*System suitability:* reference solution (a):

– resolution: minimum 5.0 between the peaks due to impurity A and carbimazole.

**LIMITS**

– impurity A: not more than 0.5 times the area of the principal peak in the chromatogram obtained with reference solution (b) (0.5 per cent),

– unspecified impurities: for each impurity, not more than 0.1 times the area of the principal peak in the chromatogram obtained with reference solution (b) (0.10 per cent).

**LOSS ON DRYING** (2.2.32): maximum 0.5 per cent, determined on 1.000 g by drying in a desiccator over diphosphorus pentoxide R at a pressure not exceeding 0.7 kPa for 24 h.

**SULFATED ASH** (2.4.14): maximum 0.1 per cent, determined on 1.0 g.

**ASSAY**

Dissolve 50.0 mg in water R and dilute to 500.0 mL with the same solvent. To 10.0 mL add 10 mL of dilute hydrochloric acid R and dilute to 100.0 mL with water R. Measure the absorbance (2.2.25) at the absorption maximum at 291 nm.

Calculate the content of C<sub>7</sub>H<sub>10</sub>N<sub>2</sub>O<sub>2</sub>S taking the specific absorbance to be 557.

**IMPURITIES**

*Specified impurities:* A.

*Other detectable impurities* (the following substances would, if present at a sufficient level, be detected by one or other of the tests in the monograph. They are limited by the general acceptance criterion for other/unspecified impurities and/or by the general monograph *Substances for pharmaceutical use* (2034). It is therefore not necessary to identify these impurities for demonstration of compliance. See also 5.10. *Control of impurities in substances for pharmaceutical use*): B.

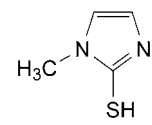

A. 1-methyl-1H-imidazole-2-thiol (thiamazole),